



VICTORIA

GOVERNMENT GAZETTE

Published by Authority

No. 161

WEDNESDAY, FEBRUARY 13

[1974

PROCLAMATIONS

CONSUMER PROTECTION ACT 1972.

PROCLAMATION

By His Excellency the Governor of the State of Victoria and its Dependencies in the Commonwealth of Australia, &c., &c., &c.

Whereas by section 34 of the *Consumer Protection Act 1972*, it is enacted that the Governor in Council may, by Proclamation, specify articles of wearing apparel (including boots and shoes) for the purposes of the said section:

Now, therefore, I, Governor of the State of Victoria in the Commonwealth of Australia by and with the advice of the Executive Council of the said State, do by this my Proclamation specify the following articles of wearing apparel for the purposes of the said section:—

any garment which is—

- (a) an article of nightwear, including pyjamas, overgarments of pyjama style, nightdresses and dressing-gowns, but not including any article of headwear, footwear or handwear; and
- (b) of any of the sizes 0 to 14 inclusive as defined by A.S.1182-1972 being the Australian Standard Size Coding Scheme for Infant's and Children's Clothing approved for publication on behalf of the Council of the Standards Association of Australia on 14th July 1972.

Given under my Hand and Seal of the State of Victoria aforesaid, at Melbourne, this twelfth day of February, in the year of our Lord One thousand nine hundred and seventy-four, and in the twenty-third year of the reign of Her Majesty Queen Elizabeth II.

(L.S.) ROHAN DELACOMBE.

By His Excellency's Command,

J. A. RAFFERTY,
Minister of Consumer Affairs.

GOD SAVE THE QUEEN!

EVIDENCE ACT 1972, No. 8327.

DATE OF COMING INTO OPERATION.

PROCLAMATION

By the Lieutenant-Governor as Deputy for His Excellency the Governor of the State of Victoria and its Dependencies in the Commonwealth of Australia, &c., &c., &c.

Whereas by an Act of Parliament of the State of Victoria passed in the twenty-first year of the reign of Her Majesty Queen Elizabeth II. intituled the *Evidence Act 1972, No. 8327*, it is amongst other things enacted that the said Act shall come into operation on a day to be fixed by Proclamation of the Governor in Council published in the *Government Gazette*:

Now therefore I, the Lieutenant-Governor as Deputy for the Governor of the State of Victoria, acting by and with the advice of the Executive Council thereof, do by this my Proclamation fix Friday the 1st day of March One thousand nine hundred and seventy-four as the day upon which the *Evidence Act 1972 No. 8327* shall come into operation:

Given under my Hand and the Seal of the State of Victoria aforesaid, at Melbourne, this fifth day of February, in the year of our Lord, One thousand nine hundred and seventy-four, and in the twenty-second year of the reign of Her Majesty Queen Elizabeth II.

(L.S.)

H. A. WINNEKE.

By His Excellency's Command,

V. F. WILCOX,
Attorney-General.

GOD SAVE THE QUEEN!

Health Act 1958 (No. 6270).
CONSTITUTION OF MEAT AREAS.

PROCLAMATION

By the Lieutenant-Governor as Deputy for His Excellency the Governor of the State of Victoria and its Dependencies in the Commonwealth of Australia, &c., &c., &c.

By virtue of the powers conferred by the Health Act 1958 (No. 6270), I, the Lieutenant-Governor as Deputy for the Governor of the State of Victoria in the Commonwealth of Australia, on the recommendation of the Commission of Public Health and by and with the advice of the Executive Council of the said State, do by this my Proclamation:—

1. Revoke the constitution of all meat areas in Victoria; and
2. Constitute as meat areas the areas described as follows:—

Name of Meat Area.	Description.	Name of Meat Area.	Description.
Metropolitan	The Municipal Districts of Melbourne, Altona, Box Hill, Brighton, Broadmeadows, Brunswick, Bulla, Camberwell, Caulfield, Chelsea, Coburg, Collingwood, Dandenong, Diamond Valley, Doncaster and Templestowe, Eltham, Essendon, Fitzroy, Footscray, Frankston, Hawthorn, Heidelberg, Keilor, Kew, Knox, Lillydale, Malvern, Melton, Moorabbin, Mordialloc, Northcote, Nunawading, Oakleigh, Port Melbourne, Prahran, Preston, Richmond, Ringwood, St. Kilda, Sandringham, Sherbrooke, South Melbourne, Springvale, Sunshine, Waverley, Werribee, Whittlesea, Williamstown.	Cohuna	All that area of land contained within the boundaries of the Township of Cohuna (as described in the <i>Government Gazette</i> of the 9th day of May, 1934) together with lots 6, 7, 35, 36, 37, and 38 of Crown Allotment 1, Section 1, Parish of Gunbower West.
Alberton	The Shire of Alberton.	Colac	The City of Colac and the Shire of Colac.
Arapiles	The Shire of Arapiles.	Corangamite	The Town of Camperdown, the Shire of Heytesbury, Mortlake and Hampden.
Ararat	The City of Ararat and the Shire of Ararat.	Corio	The Shire of Corio.
Bacchus Marsh	The Shire of Bacchus Marsh.	Cranbourne	The Shire of Cranbourne.
Bairnsdale	The Town of Bairnsdale and the Shire of Bairnsdale.	Daylesford	The Borough of Daylesford and the Shire of Glenlyon other than the Parishes of Yandoit and Franklin within the said Shire.
Ballan	The Shire of Ballan.	Donald	The Crown allotments 1, 2, 3 of Section XII of the Parish of Benyenong in the Shire of Donald.
Ballarat	The City of Ballarat, Borough of Sebastopol and Shire of Bungaree; that area of the Shire of Ballarat within a radius of seven miles from the Ballarat West Post Office; that area of the Shire of Grenville within a radius of seven miles from the General Post Office at Ballarat; that area of the Shire of Buninyong within a radius of three miles from the General Post Office at Ballarat and that portion of the Shire of Creswick south of a line drawn east to west one mile south of the Campbelltown Post Office.	Echuca	The City of Echuca and the Shire of Deakin and that part of the Shire of Rochester within a distance of six miles from the Echuca Post Office.
Bannockburn	The whole of the Barwon riding of the Shire of Bannockburn.	Flinders	The Shire of Flinders.
Barrabool	The Shire of Barrabool.	Geelong	The Cities of Geelong, Geelong West and Newtown.
Bass	The Borough of Wonthaggi, the Shire of Phillip Island and the Shire of Bass.	Gisborne	The Shire of Gisborne.
Bellarine	The Shire of Bellarine.	Hamilton	The City of Hamilton and the Shires of Dundas and Minhamite.
Benalla	The City of Benalla and that part of the Parish of Benalla within the Municipal District of the Shire of Benalla.	Hastings	The Shire of Hastings.
Bendigo	The City of Bendigo, the Borough of Eaglehawk and the Shires of Strathfieldsaye and Marong.	Horsham	The City of Horsham.
Berwick	The Shire of Berwick.	Huntley	The Shire of Huntley.
Broadford	The Shire of Broadford.	Kilmore	The Shire of Kilmore.
Castlemaine	The Town of Castlemaine, the Shire of Metcalfe, the Maldon riding of the Shire of Maldon and all parts of the Shires of Maldon and Newstead and Mount Alexander within eight miles of the Castlemaine Town Hall.	Kyabram	The Borough of Kyabram and the Kyabram riding of the Shire of Rodney.
		Kyneton	The Shire of Kyneton and the Shire of Newham and Woodend.
		Maffra	The Shire of Maffra.
		Maryborough	The Borough of Maryborough and all that part of the Shire of Tullaroop within a distance of six miles from Maryborough Town Hall, with the exception of that part of the said Shire which is within a distance of one mile from the Bowenvale Post Office.
		Mildura	The City of Mildura and that part of the Shire of Mildura enclosed by a boundary commencing at the intersection of the 142nd meridian line with the River Murray in the north-west corner of the Parish of Merbein; thence south by the said 142nd meridian to its intersection with the road forming the north boundaries of the Parishes of Ginqnam and Yatpool; thence east along the said road to the west boundary of the Parish of Karadoc; thence north east north and east by the northern boundary of the Parish of Karadoc to the intersection of the said boundary with the River Murray; thence by the River Murray to its intersection with Benetook-avenue (the boundary of the City and Shire of Mildura); thence south westerly by the said avenue to its intersection with 14th street; thence by the said 14th street north easterly to its intersection with the River Murray; thence by the River Murray to the commencing point.
		Mornington	The Shire of Mornington.
		Morwell	The Town of Yallourn and the Shire of Morwell.

<i>Name of Meat Area.</i>	<i>Description.</i>	<i>Name of Meat Area.</i>	<i>Description.</i>
Mount Rouse ..	The whole of the Penschurst riding of the Shire of Mount Rouse.	Myrtleford—continued	parish and further southerly by a direct line to Mt. Buffalo Trig. Station (The Horn); thence westerly by the southern boundary of the Parish of Dandongdale to its intersection with the south-eastern boundary of allotment 3b, section 6 of the said parish; thence generally south westerly by a road reserve along the southern boundary of that allotment and allotment 3c, section 6 to the Yarrarabula Creek; thence northerly by that creek to the road reserve adjacent to the southern boundary of allotment 4, section 7 of the same parish; thence westerly and south westerly by that road reserve to the Buffalo River; thence generally northerly by that river to the point of commencement.
Myrtleford ..	That part of the Shire of Myrtleford enclosed by the boundary commencing at the junction of the Buffalo River with the Ovens River; thence easterly by the latter river to Barwidgee Creek; thence north easterly by that creek to the western boundary of allotment 31, section A Parish of Barwidgee; thence northerly, easterly and southerly by the western, northern and eastern boundaries of that allotment, further southerly by the eastern boundary of allotment 29 and westerly by a road to the north-eastern angle of allotment 2, section 6; thence south easterly by a road to the north western angle of allotment 2, section 11; thence easterly by a road to the eastern boundary of allotment 3, section 7; thence northerly by that boundary to the Barwidgee Creek; thence easterly by that creek to its source at the western watershed of the Kiewa River; thence south easterly and southerly by that watershed to the northern boundary of allotment 42, Parish of Tawanga; thence south westerly by a road on the boundary of that allotment to the Permanent Forest boundary and further south westerly and easterly by that road through the forest to the point where it again intersects the forest boundary; thence southerly by a direct line to the north eastern angle of allotment 5, section 27; thence southerly by the eastern boundary of that allotment, south westerly by a direct line to the south eastern angle of the Havilah Cemetery, and further south westerly by a direct line to the south eastern angle of allotment 3, section 26, Parish of Barwidgee; thence westerly by the southern boundary of that allotment and north westerly by a line in the direction of Trigonometrical Station No. 26 to a point in line with the western boundary of allotment 4, section 22, thence south westerly by a direct line to the north western angle of allotment B17, no section; thence south westerly by the western boundary of that allotment to the Ovens Highway; thence south easterly by that highway to the western boundary of allotment B3, no section; thence south westerly by that boundary and a line to the Ovens River; thence westerly by that river to a point in line with the western boundary of allotment 8A, section 30; thence southerly by a line and that boundary and generally westerly by a road to the south eastern angle of allotment 2; thence westerly by the southern boundaries of allotments 2, 1, and 3, to a point in line with the eastern boundary of allotment 4; thence southerly by a line and that boundary, westerly and northerly by the southern and western boundaries of that allotment to a point in line with the southern boundary of allotment B14A, no section; thence westerly and north westerly by a line and that boundary to the eastern boundary of the Parish of Myrtleford; thence southerly by the eastern boundary of allotment 14, section 24, in that	Narracan ..	The City of Moe and that part of the Shire of Narracan which includes the parishes of Moe, Neerim East, Tanjil, Yarragon, part Allambee, Allambee East, Darnum, Narracan, Narracan South, Tanjil East and Warragul.
		Newstead ..	The Shire of Newstead.
		Otway ..	The Shire of Otway.
		Port Fairy ..	The Borough of Port Fairy and the Shire of Belfast.
		Portland ..	The Town of Portland and the Shire of Portland.
		Queenscliffe ..	The Borough of Queenscliffe.
		Ripon ..	The Shire of Ripon.
		Rodney ..	That part of the Shire of Rodney enclosed by the boundary commencing at a point at the north-west corner of allotment 131, Parish of Toolamba West; thence due east along the northern boundaries of allotments 131, 130, 129, 123, 122, 121, 120, 110, 109 and 108 to the north-east corner of allotment 108, Parish of Toolamba West; thence due north along the western boundaries of allotments 126, 104, 102, 85, 83, Parish of Mooroopna West, to the north-east corner of allotment 83, Parish of Mooroopna West; thence due east along the north boundaries of allotments 25A, 25, 109, 108, 23, 106, 33A, 32, Parish of Mooroopna, to the north-east corner of allotment 32, Parish of Mooroopna; thence due south along the eastern boundary of allotment 32, Parish of Mooroopna, to a point opposite the north-west corner of allotment 33, Parish of Mooroopna; thence due east along the northern boundaries of allotments 33, 12, 16A, 16, 15, 17, and 64, Parish of Mooroopna, and continuing due east to the back water of the Goulburn River; thence in a southerly direction along this bank, and thence in a south-westerly direction along this bank to the south-eastern corner of allotment 1, Parish of Murchison North, County of Rodney thence westerly along the southern boundary of the said allotment 1 to the south-western corner thereof, then northerly along the western boundary of the said allotment 1, allotment 2, and allotment 3, Parish of Murchison North; thence westerly along the southern boundaries of allotments 27, 28, 30, 31A, 32A, 33A, 33B, 34, 35A, 36A, and 37, Parish of Murchison North; thence northerly along the western boundaries of allotments

Name of Meat Area.	Description.	Name of Meat Area.	Description.
Rodney—continued	37, 37B, 38B, 38A, 77, 78, 109, and 110 to the south-eastern boundary of allotment 2B, Parish of Girgarre East; thence westerly along the southern boundary of the said allotment 2B; thence north-easterly along the north-eastern boundary of the said allotment 2B to the western boundary of allotment 1, Parish of Toolamba West; thence northerly along the western boundaries of allotments 1, 2, 34, 72, 74B, 74A, 75, 76, 77, 135, 134, 132, 131, Parish of Toolamba West, to the commencing point.	Wangaratta—continued	of allotment K, Parish of Tarrawingee; thence south easterly to the south east corner of allotment 6A, Parish of Tarrawingee; thence southerly to the south west corner of allotment 7, Parish of Tarrawingee, to the Ovens River; thence north westerly along the Ovens River to the south west corner of allotment 4, Parish of Wangaratta North; thence southerly to the south west corner of allotment 90; thence south easterly along creek to the Township of Oxley and to the south east corner of allotment C; thence westerly to the Fifteen Mile Creek at the south west corner of allotment 32c; thence northerly along the Fifteen Mile Creek to the north east corner of allotment 1, Parish of Glenrowan; thence westerly to the south west corner of allotment 23A, Parish of Wangaratta South; thence northerly to the south corner of allotment 20, Parish of Wangaratta South; thence westerly to the south west corner of allotment 20, Parish of Wangaratta South; thence northerly to the north west corner of allotment 20, Parish of Wangaratta South; thence easterly to the south west corner of allotment 113B, Parish of Wangaratta South; thence northerly to the north west corner of allotment 113B, Parish of Wangaratta South; thence easterly to the north east corner of allotment 113B; thence northerly to the north west corner of allotment 39A, Parish of Wangaratta South; thence westerly to the south west corner of allotment 38, Parish of Wangaratta South; thence northerly to the north west corner of allotment 38, Parish of Wangaratta South; thence westerly to the south west corner of allotment 107, Parish of Taminick; thence northerly to the south west corner of allotment 104, Parish of Taminick; thence north westerly to the south west corner of allotment 103A, Parish of Taminick; thence northerly to the south west corner of allotment 100, Parish of Taminick; thence north westerly to the north west corner of allotment 101D, Parish of Taminick; thence northerly to the north east corner of allotment 95A, Parish of Taminick; thence northerly to the north east corner of allotment 88A, Parish of Taminick; thence westerly to the north west corner of allotment 81, Parish of Taminick; thence north westerly to the south east corner of allotment 4C, Parish of Killawarra; thence northerly to the north west corner of allotment 90, Parish of Killawarra; thence easterly to the north east corner of allotment 104, Parish of Killawarra; thence north easterly to the Ovens River; thence northerly along the Ovens River to the south west corner of Boorhaman Pre-emptive Purchase; thence north easterly to the south east corner of Boorhaman Pre-emptive Purchase, Parish of Boorhaman; thence easterly to the south east corner of allotment 55B, Parish of Boorhaman; thence northerly to the south west corner of allotment 66B, Parish of Boorhaman; thence easterly to the point of commencement.
Romsey	The Shire of Romsey.		
Sale	The City of Sale together with those parts of the Shire of Avon being allotments 18, 25, and 28 of Section A, allotments 13 and 13A of Section B, allotment 132, Section 1 and Crown Allotment 15 of Section E, Parish of Sale, those parts of the Shire of Rosedale being allotment 42 of Section D, allotments 1 and 2 of Section A, allotment 14A and part of allotment 14 of the Parish of Warruk Warruk.		
Seymour	That portion of the Shire of Seymour within a radius of 9 miles of the Seymour Post Office.		
Shepparton	The City of Shepparton and the North, South, West and Kialla ridings of the Shire of Shepparton.		
South Barwon	The Shire of South Barwon.		
South Gippsland	The Shires of Korumburra and Woorayl.		
Swan Hill	The City of Swan Hill and that portion of the municipal district of the Shire of Swan Hill to the east of the Murray Valley Highway and within the Parishes of Tyntynder and Castle Donnington.		
Traralgon	The City of Traralgon and the Shire of Traralgon.		
Upper Yarra	The Shire of Upper Yarra.		
Wangaratta	The City of Wangaratta and those parts of the Shires of Wangaratta and Oxley contained within the boundary commencing at the north west corner of Timber Reserve west of allotment 126, Parish of Boorhaman; thence southerly along a road to the north west corner of allotment 137; thence easterly to the north east corner of allotment 133, Parish of Bontherambo; thence southerly to the north west corner of allotment 209, Parish of Carragarmungee; thence easterly to the north east corner of allotment 201, Parish of Carragarmungee; thence south easterly to the south east corner of allotment 6, section 25A, Parish of Carragarmungee; thence easterly to the north east corner of allotment 3A, Section 24A, Parish of Carragarmungee; thence southerly to the south west corner of allotment 2, Parish of Byawatha; thence south easterly to the south west corner of allotment 5, section A, Parish of Byawatha; thence south easterly to the south west corner of allotment 17, Parish of Byawatha; thence southerly to the south west corner of allotment 5A, Parish of Tarrawingee; thence easterly to the south east corner of allotment M, Parish of Tarrawingee; thence southerly to the south west corner of allotment K, Parish of Tarrawingee; thence easterly to the south east corner		

Name of Meat Area.	Description:
Warragul	The Shires of Buln Buln and Warragul.
Warrnambool	The City of Warrnambool and the Shire of Warrnambool.
Winchelsea	The Shire of Winchelsea.
Wodonga	The works area of Donga Meats Limited being Crown Allotment 1 and part of Crown Allotment 3, Section C2, Parish and Township of Wodonga as described in Certificate of Title Volume 8502, Folio 796.
Yarrawonga	That part of the Shire of Yarrawonga enclosed by the boundary commencing at a point One thousand three hundred and eighty four feet two inches (1384' 2") on a line bearing Two hundred and seventy degrees nought minutes (270° 0') from the south western corner of Crown allotment 67, Parish of Yarrawonga, County of Moira, thence along a line bearing nought degrees seventeen minutes (0° 17') for a distance of Four hundred and sixty two feet (462') thence along a line bearing Ninety degrees nought minutes (90° 0') for a distance of Three hundred and thirty feet (330'), thence along a line being One hundred and eighty degrees nought three minutes (180° 03') for a distance of Four hundred and sixty two feet (462') thence along a line bearing Two hundred and seventy degrees nought minutes (270° 0') for a distance of Three hundred and thirty feet (330') to the point of commencement.

Given under my Hand and the Seal of the State of Victoria aforesaid, at Melbourne, this fifth day of February, in the year of our Lord One thousand nine hundred and seventy-four, and in the twenty-second year of the reign of Her Majesty Elizabeth II., Queen of Australia.

(L.S.) HENRY WINNEKE.

By His Excellency's Command,

A. J. SCANLAN,
Minister of Health.

GOD SAVE THE QUEEN!

MOTOR ACCIDENTS ACT 1973, No. 8429.

DATE OF COMING INTO OPERATION.

PROCLAMATION

By His Excellency the Governor of the State of Victoria and its Dependencies in the Commonwealth of Australia, &c., &c., &c.

Whereas by an Act of Parliament of the State of Victoria passed, in the twenty-second year of the reign of Her Majesty Elizabeth the Second, Queen of Australia, entitled the *Motor Accidents Act 1973*, No. 8429 it is amongst other things enacted that the several provisions of the said Act shall come into operation on a day or days to be fixed by proclamation or successive proclamations of the Governor in Council published in the *Government Gazette*:

Now therefore I, the Governor of the State of Victoria in the Commonwealth of Australia, by and with the advice of the Executive Council of the said State, do by this my proclamation fix Wednesday, the thirteenth day of February, One thousand nine hundred and seventy-four as the day on which Sections 37 to 53 inclusive, of the said *Motor Accidents Act 1973* No. 8429 shall come into operation.

Given under my Hand and the Seal of the State of Victoria aforesaid, at Melbourne, this twelfth day of February, in the year of our Lord One thousand

nine hundred and seventy-four and in the twenty-third year of the reign of Her Majesty Elizabeth the Second, Queen of Australia.

(L.S.) ROHAN DELACOMBE.

By His Excellency's Command,

E. R. MEAGHER,
for Chief Secretary.

GOD SAVE THE QUEEN!

MENTAL HEALTH ACT 1959, No. 6605.

PROCLAMATION

By the Lieutenant-Governor as Deputy for His Excellency the Governor of the State of Victoria and its Dependencies in the Commonwealth of Australia, &c., &c., &c.

Whereas by sub-section (1) of Section twenty-four of the *Mental Health Act 1959*, it is provided that the Governor in Council may by Proclamation published in the *Government Gazette* proclaim one or more buildings or places provided by the State for the treatment of the mentally ill or the intellectually defective or any part of such building or place to be:—

- a psychiatric hospital;
- a mental hospital;
- a training centre; or
- a repatriation mental hospital:

And whereas by sub-section (2) of the said Section twenty-four it is provided that any Proclamation made under Section twenty-four may at any time be varied or revoked by a Proclamation of the Governor in Council:

And whereas by Proclamation of the Governor in Council made, pursuant to Section thirty-four of the *Mental Hygiene Act 1928* (No. 3721) and dated the ninth day of June, 1953, all buildings on certain land in the Parish of Keelbundora, County of Bourke, shown on a plan annexed to such Proclamation were proclaimed as a mental hospital, to be known as the Mental Hospital, Larundel:

And whereas by Proclamation of the Governor in Council made, pursuant to sub-section (3) of Section thirty-eight of the *Mental Hygiene Act 1958* (No. 6314) and dated the twenty-sixth day of May, 1959, the Proclamation dated the ninth day of June, 1953, was revoked in so far as it applied to certain buildings then known as Wards F1, F2, F3, M1, M2, M3, and the Male and Female Hospital Block:

And whereas by the same Proclamation dated the twenty-sixth day of May, 1959, and pursuant to Section forty-four of the *Mental Hygiene Act 1958* (No. 6314) the buildings then known as Wards F1, F2, F3, M1, M2, M3 and the Male and Female Hospital Block was proclaimed and constituted as from the first day of July, 1959, as a receiving house, to be known as the Receiving House, Larundel:

And whereas by the *Mental Health Act 1959* (No. 6605) it is provided that unless inconsistent with the context or subject-matter any reference in any other Proclamation to a receiving house shall be taken to refer to a psychiatric hospital:

And whereas the buildings referred to in the Proclamation dated the twenty-sixth day of May, 1959, as the Male and Female Hospital Block are now known as Wards A, B and C:

And whereas by Proclamation of the Governor in Council made pursuant to sub-section (2) of Section twenty-four of the *Mental Health Act 1959* (No. 6605) and dated the twenty-second day of April, 1964, the buildings then known as Wards A, B, C, F1, F2, F3, F4, M1, M2, M3, and were proclaimed and constituted as from the first day of May, 1964, as a Psychiatric Hospital to be known as the Psychiatric Hospital, Larundel:

And whereas the buildings referred to in the Proclamation dated the twenty-second day of April, 1964, as Wards F1, F2, F3, F4, M1, M2, M3 and M4, are now known as Wards N1, N2, N3, N4, S1, S2, S3 and S4 respectively:

And whereas it is now desired to revoke the Proclamation in so far as it applies to the buildings presently constituting the Mental Hospital, Larundel, and the Psychiatric Hospital, Larundel, and again to proclaim certain buildings known for the time being as Wards A, B, C, N4, N5 and N6, as a psychiatric hospital to be known as the Psychiatric Hospital, Larundel, and certain buildings known for the time being as Wards N1, N2, N3, N7, N8, N9, S1, S2, S3, S4, S5, S6 and S7, as a mental hospital to be known as the Mental Hospital, Larundel, and certain buildings situated south of Wattle Avenue, Bundoora, as a training centre to be known as the Kingsbury Training Centre:

Now, therefore I, the Lieutenant-Governor as Deputy for the Governor of the State of Victoria, in the Commonwealth of Australia, by and with the advice of the Executive Council of the said State, do by this Proclamation—

- (a) Revoke the Proclamation constituting the Mental Hospital, Larundel;
- (b) Revoke the Proclamation constituting the Psychiatric Hospital, Larundel;
- (c) Proclaim the buildings known for the time being as Wards N1, N2, N3, N7, N8, N9, S1, S2, S3, S4, S5, S6 and S7, as shown hachured, and all buildings hereafter to be erected on the land delineated as Larundel, on the plan hereunder, to be a mental hospital, to be known as the Mental Hospital, Larundel;
- (d) Proclaim the buildings known for the time being as Wards A, B, C, N4, N5, N6, as shown hachured on the plan hereunder, to be a psychiatric hospital, to be known as the Psychiatric Hospital, Larundel; and
- (e) Proclaim the buildings situated south of Wattle Avenue, Bundoora, as cross-hatched, and all buildings hereafter to be erected on the land delineated as Kingsbury, on the plan hereunder, to be a training centre, to be known as the Kingsbury Training Centre.

**BORTION OF HOSPITAL FOR THE INSANE - MONT PARK
PARISH OF KEELBUNDOORA, COUNTY OF BOURKE.**
EXAMINED BY THE SURVEYOR GENERAL DATED 20/11/73 (2000 METRES)
CORRECTED DATA 20/11/73 - 20/11/73 (2000 METRES)

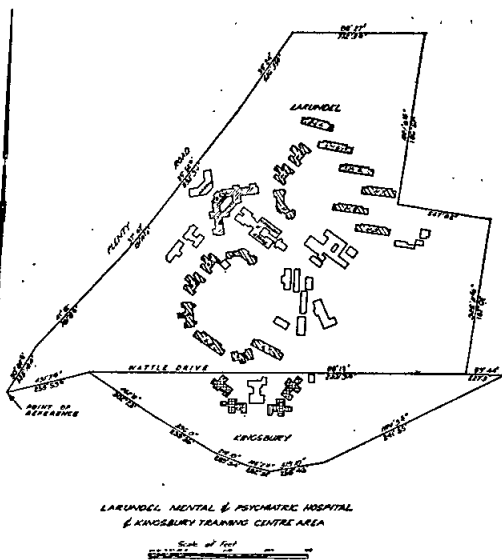

Given under my Hand and the Seal of the State of Victoria aforesaid, at Melbourne, this fifth day of February, in the year of our Lord, One thousand nine hundred and seventy-four, and in the twenty-second year of the reign of Her Majesty Elizabeth the Second, Queen of Australia.

(L.S.) HENRY WINNEKE.
By His Excellency's Command,

A. J. SCANLAN,
Minister of Health.

GOD SAVE THE QUEEN!

Land Act 1958, Section 25.
ROAD PROCLAIMED.

PROCLAMATION

By the Lieutenant-Governor as Deputy for His Excellency the Governor of the State of Victoria and its Dependencies in the Commonwealth of Australia, &c., &c., &c.

In pursuance of the provisions of Section 25 of the Land Act 1958, I, the Lieutenant-Governor as Deputy for the Governor of the State of Victoria by and with the

advice of the Executive Council of the said State do hereby proclaim as road the land in the Parish of Scarsdale County of Grenville as indicated by hatching on the plan hereunder.—(G.75671, S.249⁽¹²⁾).

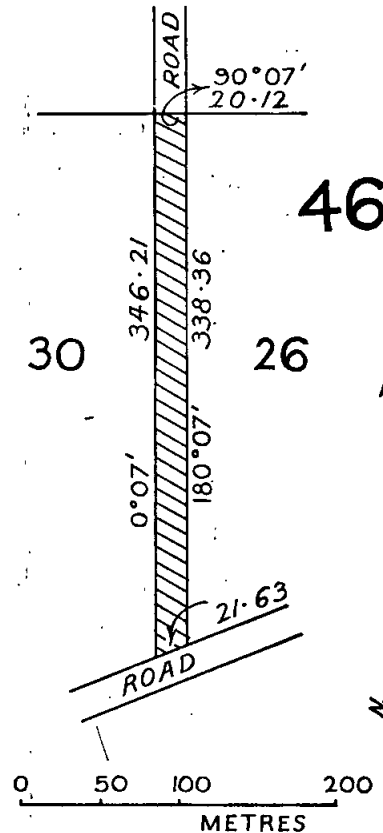

Given under, my Hand and the Seal of the State of Victoria aforesaid, at Melbourne, this fifth day of February, in the year of our Lord One thousand nine hundred and seventy-four, and in the twenty-second year of the reign of Her Majesty Queen Elizabeth II.

(L.S.) H. A. WINNEKE.
By His Excellency's Command,
W. BORTHWICK,
Minister of Lands.

GOD SAVE THE QUEEN!

BANK HALF-HOLIDAY.

PROCLAMATION

By His Excellency the Governor of the State of Victoria and its Dependencies in the Commonwealth of Australia, &c., &c., &c.

In pursuance of the provisions of the Bank Holidays Act 1958, I, the Governor of the State of Victoria, in the Commonwealth of Australia, do by this my Proclamation appoint the day and date named hereunder a special day to be observed as a Bank Half-Holiday at the place mentioned that is to say:—

Bank Half-Holiday from the Hour of eleven a.m.:
TUESDAY, THE 19TH FEBRUARY, 1974, at Warragul.

Given under my Hand and the Seal of the State of Victoria aforesaid, at Melbourne, this twelfth day of February, in the year of our Lord One thousand nine hundred and seventy-four, and in the twenty-third year of the reign of Her Majesty Elizabeth the Second, Queen of Australia.

(L.S.) ROHAN DELACOMBE.
By His Excellency's Command,
E. R. MEAGHER,
for Chief Secretary.

GOD SAVE THE QUEEN!

GOVERNMENT NOTICES

Town and Country Planning Act 1961.
SHIRE OF LILLYDALE PLANNING SCHEME 1958.
 AMENDMENT No. 27, 1971.

Notice of Approval.

In pursuance of the powers conferred by the *Town and Country Planning Act 1961*, the Governor in Council on the 5th February, 1974, approved a planning scheme entitled the Shire of Lillydale Planning Scheme 1958, Amendment No. 27, 1971, in respect of the municipal district of the Shire of Lillydale, and such planning scheme comes into operation on the date this notice of approval is published in the *Government Gazette*.

A copy of the Planning Scheme as approved may be inspected, free of charge, during office hours at the office of the Town and Country Planning Board, 235 Queen Street, Melbourne; at the office of the Shire of Lillydale, at Lillydale, and when available, at the Office of Titles, Melbourne, and at the Central Plan Office of the Department of Crown Lands and Survey, Melbourne.

W. H. CRAIG, Secretary.
 Town and Country Planning Board.

Town and Country Planning Act 1961.
SHIRE OF BUNINYONG PLANNING SCHEME.
 INTERIM DEVELOPMENT ORDER.

Notice of Approval.

In pursuance of the powers conferred by the *Town and Country Planning Act 1961*, the Governor in Council on the 5th day of February, 1974, approved an Interim Development Order made by the Council of the Shire of Buninyong for part of the municipal district of the Shire of Buninyong.

The Interim Development Order provides that the use, subdivision or development of any land within the area described or the erection, construction or carrying out of any buildings, roads or other works thereon is prohibited except in accordance with the provisions of the Order.

A copy of the Interim Development Order and a map showing the area affected may be inspected, free of charge, at the office of the Council of the Shire of Buninyong, at Buninyong, and at the office of the Town and Country Planning Board, 235 Queen Street, Melbourne.

A. C. LORD,
 Shire Secretary.

STATE OF VICTORIA.

Motor Car Traders Act 1973.

APPLICATIONS FOR LICENCES.

Under the provisions of Section 15 of the *Motor Car Traders Act 1973*, No. 8408 all persons carrying on or intending to carry on the business of trading in motor cars whether new or used will be required to be licensed.

Accordingly the Motor Traders Committee calls for applications for licences from interested persons or bodies corporate.

Application forms may be obtained from the Secretary's Office in the Old Treasury Building, Spring Street, Melbourne, 3000, and all enquiries should be directed to him in the first instance.

Applications must be lodged with the Secretary no later than 4 p.m. on 8th March, 1974.

G. H. FOSTER,
 Secretary.

Town and Country Planning Act 1961.
SHIRE OF METCALFE PLANNING SCHEME.

INTERIM DEVELOPMENT ORDER.

Notice of Approval.

In pursuance of the powers conferred by the *Town and Country Planning Act 1961*, the Governor in Council on the 5th day of February, 1974, approved the making of an Interim Development Order by the Council of the Shire of Metcalfe for part of the municipal district of the Shire of Metcalfe.

The Interim Development Order provides that the use, subdivision or development of any land within the area described or the erection, construction or carrying out of any buildings, roads or other works thereon is prohibited except in accordance with the provisions of the Order.

A copy of the Interim Development Order and a map showing the area affected may be inspected, free of charge, at the office of the Council of the Shire of Metcalfe, at Metcalfe, and at the office of the Town and Country Planning Board, 235 Queen Street, Melbourne.

J. R. DENNIS,
 Shire Secretary.

Social Welfare Act 1970.

POLICE GAOLS.

NOTICE.

Whereas it is provided in Part IV., Section 115, of the *Social Welfare Act 1970* that whenever it appears to the Director-General after consultation with the Chief Commissioner of Police to be necessary so to do the Director-General may recommend to the Minister that a lock-up is fit for the reception of prisoners sentenced to imprisonment for a term not exceeding the term the Director-General thinks fit and specifies in his recommendation:

And whereas it is further provided in the said section that upon receiving any such recommendation the Minister may by notice published in the *Government Gazette* proclaim any police lock-up so recommended to be a "police gaol" for the reception of prisoners for any term up to the term specified but not exceeding in any case thirty days:

And whereas by a notice published in the *Government Gazette* of 21st January, 1970, certain police lock-ups were proclaimed to be police gaols for the reception of prisoners sentenced to imprisonment for a term not exceeding a specified period:

And whereas it is further provided in the said section 115 that the Minister may from time to time by notice in the *Government Gazette* revoke or vary any proclamation made under this section:

And whereas by notices published in the *Government Gazette* of 9th December, 1970; 23rd August, 1972; and 1st August, 1973, the Minister did vary certain particulars of the aforementioned proclamation:

And whereas the Director-General after consultation with the Chief Commissioner has recommended that the aforementioned notice published in the *Government Gazette* of 21st January, 1970, and varied by the aforementioned notices published in the *Government Gazette* on 9th December, 1970; 23rd August, 1972; and 1st August, 1973, be further varied:

Now therefore, I, the Minister for Social Welfare of the State of Victoria in the Commonwealth of Australia, in pursuance of the powers conferred by the *Social Welfare Act 1970*, do by this notice further vary the notice published in the *Government Gazette* on 21st January, 1970, and varied by the notices published in the *Government Gazette* on 9th December, 1970; 23rd August, 1972; and 1st August, 1973, by—

- (1) In the Third Schedule thereto—
 deleting all references to the Police lock-up at "Kerang";
- (2) In the Fourth Schedule thereto, immediately following the last mentioned reference to—Lakes Entrance.

inserting the following expression:—

"Kerang, 16 Albert Street, Kerang, rear of Kerang Police Station, brick building 33 ft. 7 in. x 19 ft. 5 in., Township of Kerang, Parish of Kerang, County of Gunbower, section 3."

VASEY HOUGHTON,
 Minister for Social Welfare.

Social Welfare Department,
 Melbourne, 11th February, 1974.

INDUSTRIAL AND PROVIDENT SOCIETIES ACT 1958
 (No. 6277).

Notice is hereby given that the Registrar of Friendly Societies has, pursuant to the *Industrial and Provident Societies Act 1958*, this day cancelled the registration of the Mount Waverley Co-operative Cool Stores Society Limited (Register No. 1300 M), the registered office of which is at Mount Waverley on the grounds that documents were not lodged with the Registrar of Companies pursuant to the provisions of the *Industrial and Provident Societies Act*.

The society (subject to the right of appeal given by the said Act) ceases to enjoy the privileges of a registered society but without prejudice to any liability incurred by the society, which may be enforced against it as if such cancelling had not taken place.

Dated 5th day of February, 1974.

D. J. WATT,
 Registrar of Friendly Societies.

Transport Regulation Act.
TRANSPORT REGULATION BOARD.

HEARING OF APPLICATIONS.

Notice is hereby given that the following applications will be considered by the Transport Regulation Board on 6th March, 1974.

EILDON TRANSPORT & TOURIST SERVICES PTY. LTD., Third Floor, 380 Bourke Street, Melbourne. Application for one commercial passenger vehicle with small seating capacity to operate for the carriage of employees only under contract to Custom Carpet Pty. Ltd. between—1. Alexandra and Eildon via Goulburn Valley Highway. 2. Between Eildon Airport and the premises of Custom Carpet Pty. Ltd., Eildon.

TIME-TABLES.

1. To co-ordinate with shifts at factory. 2. To operate as and when required.

GORANITIS, K. (Mr.), 128 Moreland Road, Brunswick. One commercial passenger vehicle with seating capacity for 12 persons to operate free of charge for the carriage of Greek Sunday and language students between the students' homes and St. Bernards Roman Catholic School, Coburg via the following routes:—1. Commencing at St. Bernards School via Patterson, Hardings, Munro, Shaftsbury, Berry, Chandos, Reynard, Edward, Chambers, Walsh and Patterson Streets to the school.

TIME-TABLE.

Depart School 4.30 p.m. Monday and Thursday. Return 7.15 p.m.

2. Commencing at St. Bernards School via Patterson, Walsh, Chambers, Dare, Rennie, De Carle, Blair and Barrow Streets, The Grove, Butler Grove, Rennie, Walsh and Patterson Streets to the school.

TIME-TABLE.

Depart School 4.45 p.m. Monday and Thursday. Return 7.30 p.m.

GRANT, H. F., 13 Birch Street, Shepparton. Application for one commercial passenger vehicle with seating capacity for forty-eight (48) persons to operate as—1. An additional country stage omnibus on the Melbourne—Shepparton service. 2. A special service omnibus with a pick-up radius of 10 miles from the Shepparton Post Office.

MACKLEY, A., Box 78, Natimuk. One commercial passenger vehicle with seating capacity for sixteen persons to operate for the carriage of school children only between Wyn Wyn and Natimuk under contract to the Education Department.

NORTHERN BUS LINES PTY. LTD., 1 Walter Street, Glenroy. Application for one commercial passenger vehicle with seating capacity for 36 persons to operate as an additional metropolitan stage omnibus under the same terms and conditions as existing M.O. licences held by the applicant company.

O'CONNELL, P. D., 10 Queen Elizabeth Drive, Tallangatta. Application for one commercial passenger vehicle with seating capacity for eleven persons to operate for the carriage of school children only between Springdale and the Bethanga State School, under contract to the Education Department.

PENINSULA BUS LINES LTD., 132-134 Dandenong Road, Frankston. Application for one commercial passenger vehicle with seating capacity for 36 persons to operate as an additional metropolitan stage omnibus under the same terms and conditions as other licences held by the applicant company.

PINCINI, E. J. & L., PTY. LTD., 40 McIntosh Street, Airport West. Application for one commercial passenger vehicle with seating capacity for 44 persons to operate in substitution for but not in addition to any T.S. licensed vehicles held by the applicant company.

SCOFFIN, J., 47 Bieske Road, Grovedale. Application for one commercial passenger vehicle with seating capacity for eighteen persons to operate for the carriage of school children only between Minyip Road and the Lara Lake Primary School under contract to the Education Department.

TOMKINS, G. R. & L. F., 42-44 Torquay Road, Belmont. One commercial passenger vehicle with seating capacity for 41 persons to operate for the carriage of school children only between Anglesea and Geelong under contract to the Education Department.

Applications for renewal of licences as shown by persons listed hereunder to operate under the same terms and conditions:—

BOUSSOUNIS, A., 32 Derby Street, Northcote; M.T.4749.

CHEHADE, Y. T., 58 Brewster Street, Essendon; M.T.4686.

FERGUSON, J. V. & S. V., 103 Stawell Street, Sale; C.O.617, T.S.587, T.S.934, T.S.935, T.S.936, T.S.937, T.S.938.

GEBERT, G. L. & L. M., Bow Street, Rainbow; T.S.365, T.S.645.

HORINIAK, G., 9 Bevan Street, Ormond; M.T.4502.

SPANOS, E., 154 Beaconsfield Parade, Northcote; M.T.4689.

STATHOPOULOS, V., 8 Kalimna Street, Balwyn; M.T.1812.

Notice of any objection should be forwarded to reach the Secretary of the Board not later than 27th February, 1974.

Applicants are advised that it will not be necessary to appear on the hearing date specified, unless advised in writing by the Board.

A. V. C. COOK,
Secretary.

Corner Lygon and Princes Streets, Carlton, Vic. 3053,
Wednesday, 13th February, 1974.

Commercial Goods Vehicles Act.
TRANSPORT REGULATION BOARD.

HEARING OF APPLICATIONS.

Notice is hereby given that the following applications will be considered by the Transport Regulation Board on 6th March, 1974.

BURL, W. F. & P. M., 205 Grimshaw Street, Greensborough, 3088. One commercial goods vehicle (L/C. 127 cwt.) to operate within a 70-mile radius of the premises of Brick and Pipe Industries Ltd. at Brunswick solely on behalf of the said company—bricks.

DUNLOP TYRE SERVICE (VIC.) PTY. LTD., Raglan Parade, Warrnambool, 3280. Application to vary the conditions of licence No. D.A.60416/84 (L/C. 14 cwt.) by deleting "seventy (70) miles" from the existing conditions and adding in lieu "fifty (50) miles."

KEATH'S EXCAVATIONS PTY. LTD., Maroondah Highway, Yarck, 3719. One commercial goods vehicle (L/C. 156 cwt.) to operate: (a) Throughout the State of Victoria in the course of business as "Earth-moving Contractors"—own plant and equipment for use on such contracts. (b) Within a 50-mile radius from any earth-moving site pursuant to paragraph (a) above but excluding operations south of an east/west line drawn through the Township of Craigieburn—metal, stones, screenings, ashes, gravel, sand and earth. (c) Within a 20-mile radius from any earth-moving site pursuant to paragraph (a) above or from the railway station nearest thereto any other materials required for such earth-moving contracts. (d) Within a 25-mile radius from the post office at Yarck—general goods provided that no goods shall be carried whether by one stage or by more than one stage between places within the above radius which are more than thirty (30) road miles apart by the nearest practicable route.

MONIER SERVICES PTY. LTD., Frankston Road, Dandenong, 3175. One commercial goods vehicle (L/C. 187 cwt.) to operate: (a) Within a 25-mile radius of G.P.O., Melbourne in course of business as "Concrete Goods Manufacturers"—own goods. (b) From own pit at Broadford to own plants within a 25-mile radius of G.P.O., Melbourne—quarry products and river sand. (c) From own pit at Anakie to own plants within a 25-mile radius of G.P.O., Melbourne—own scoria. (d) From quarries at Anakie to own plants within a 25-mile radius of G.P.O., Melbourne—crushed scoria. (e) From own plants at Broadford to Premix Concrete Plants within a 25-mile radius of Broadford—quarry products and river sand.

NIELSEN, J., 47-51 Nicholson Street, Bairnsdale, 3875. One commercial goods vehicle (L/C. 35 cwt.) to operate from Melbourne to own premises at Bairnsdale in the course of business as a "Nursery"—seedlings, cut flowers, shrubs, cement pots, anodised pots, wrought iron stands, glass fish tanks; insecticides and poisons and 1 lb. packs of lawn seed.

OSBORNE, J. E., Main Road, Anakie, 3221. Application to vary the conditions of licence No. D.A.32657 (L/C. 137 cwt.) by deleting the existing conditions and adding in lieu—(a) Within a 40-kilometre radius from the post office at Anakie—general goods. (b) Within an 80-kilometre radius from the post office at Anakie—livestock. (c) From and to places within a 16-kilometre radius of Anakie to and from places within a 32-kilometre radius of the G.P.O., Melbourne—general goods but excluding the carriage of restricted goods which may be specified by notice in the Government Gazette from time to time within an 80-kilometre radius of the G.P.O., Melbourne."

OSBORNE, J. E. (trading as W. Osborne & Son), Main Road, Anakie, 3221. Application to vary the conditions of licence No. D.A.32657/1 (L/C. 290 cwt.) by deleting the existing conditions and adding in lieu—“(a) Within a 40-kilometre radius from the post office at Anakie—general goods. (b) Within an 80-kilometre radius from the post office at Anakie—livestock. (c) From and to places within a 16-kilometre radius of Anakie to and from places within a 32-kilometre radius of the G.P.O., Melbourne—general goods but excluding the carriage of restricted goods which may be specified by notice in the *Government Gazette* from time to time within an 80-kilometre radius of the G.P.O., Melbourne.”

PITTS, R. E., Allansford, 3277. Application to vary the conditions of licence No. D.A.1839/1 (L/C. 258 cwt.) by deleting the existing conditions and adding in lieu—“(a) From and to The Shell Co. of Aust. Ltd. Depot at Portland to and from the Shell Co. of Aust. Ltd. Depot at Dennington—petroleum products and empty return containers. (b) Within a 40-kilometre radius of Allansford—general goods. (c) From the Pivot Superphosphate Works at Portland and Geelong direct to farms within 100 road miles of such works—superphosphate.”

PIZZEY LTD., 410 Whitehorse Road, Mitcham, 3132. One commercial goods vehicle (L/C. 8 cwt.) to operate: (a) Within a 50-mile radius from own premises at Mitcham in the course of business as “Merchants, Manufacturers and Distributors”—own goods. (b) Throughout the State of Victoria as “Manufacturers of Agricultural Machinery” for the purpose of servicing and demonstrating agricultural equipment—agricultural equipment for demonstration or for repair or having been repaired, also tools of trade, spare parts and materials required for on site servicing of agricultural machinery and equipment in the field only.

ROBERTSON, C. J., 85 Wilson Street, Horsham, 3400. One (mobile crane) to operate throughout the State of Victoria in the course of business as “Plant Hirers” as a Mobile Crane.

ROBLIFT PTY. LTD., 85 Wilson Street, Horsham, 3400. Three (Mobile Cranes) to operate throughout the State of Victoria in the course of business as “Plant Hirers” as a Mobile Crane.

SPILLER, H. & M. J., Browns Road, Anakie, 3221. Application to vary the conditions of licence No. D.A.66298 (L/C. 202 cwt.) by deleting the existing conditions and adding in lieu—“(a) Within a 40-kilometre radius from the post office at Anakie—general goods. (b) Within a 80-kilometre radius from the post office at Anakie—livestock. (c) From and to places within a 16-kilometre radius of Anakie to and from places within a 32-kilometre radius of the G.P.O., Melbourne—general goods but excluding the carriage of restricted goods which may be specified by notice in the *Government Gazette* from time to time within an 80-kilometre radius of the G.P.O. Melbourne.

STUCHBERY, M. G., 8 Percy Street, Portland, 3305. Two commercial goods vehicles (L/C. 265, 306 cwt.) to operate: (a) Within a 25-mile radius of the chief post office at Portland—general goods. (b) From the City of Melbourne to the Town of Portland for the carriage of bricks, roofing tiles, cement sheets, plaster board, hides, skins, up to 10 drums of tallow, second-hand furniture, potatoes, onions, fresh fruit, fresh vegetables, pressed metal roof-decking, concrete pre-fabricated products, oxygen and acetylene industrial gases in cylinders, packaged petroleum products in containers of less than 44 gallon capacity. (c) From the Town of Portland to the City of Melbourne for the carriage of empty return containers, pallets and wool samples after wool sales. (d) From the City of Ballarat to the Town of Portland—cement roofing tiles. (e) From the Town of Portland to the City of Ballarat—empty return pallets.

SZTYNDA, N., Nowa Nowa, 3887. One commercial goods vehicle (L/C. 332 cwt.) to operate from Nunnet forest areas to the A.P.M. Sawmill at Nowa Nowa—saw-mill logs.

RENEWALS.

Applications for renewal of licences as shown by persons listed hereunder to operate under the same terms and conditions from the expiry shown in each case.

ADAMS, K. & B., AGRICULTURAL SERVICES PTY. LTD., P.O. Box 108, Ferntree Gully, 3156; D.A.63482/1; 1st June, 1974; 23 cwt.

ALLEN, A. W., SALES PTY. LTD., 2-14 Byrne Street, South Melbourne, 3205; T.D.A.2218/13; 31st May, 1974; 46 cwt.

BICKERY, V. B., 12 Ceylon Street, Nunawading, 3131; D.A.63811; 1st June, 1974; 210 cwt.

BUNGE (AUST.) PTY. LTD., 140 William Street, Melbourne, 3000; D.A.28618/7; 29th June, 1974; 167 cwt.; D.A.28618/8; 29th June, 1974; 238 cwt.

CAMPBELL'S TRANSPORT (DROMANA) PTY. LTD., 905 Nepean Highway, Mornington, 3931; D.A.65150/1; 2nd June, 1974; 146 cwt.

COOPER & COOKE (FLORISTS SUPPLY) PTY. LTD., 1204 Glenhuntly Road, Glenhuntly, 3163; D.A.13906; 3rd May, 1974; 32 cwt.

FARMER, E. W., 139 Hedderwick Street, Essendon, 3040; D.A.39484/3; 16th May, 1974; 137 cwt.

FRANCOMBE, W. R., 85 Wonga Road, North Ringwood, 3134; D.A.49003/12; 29th June, 1974; 199 cwt.

INDUSTRIAL ENGINEERING LTD., CONTRACTING PLANT DIV., Dudley Street, West Melbourne, 3003; D.A.63857; 29th June, 1974; 15 cwt.

MOORE ROAD MACHINERY (VIC.) PTY. LTD., 501 Williamstown Road, Port Melbourne, 3207; D.A.10734/20; 1st June, 1974; 14 cwt.

RAMSAY & TREGANOWAN LTD., 475 La Trobe Street, Melbourne, 3000; D.A.31536/18; 1st June, 1974; 10 cwt.

ROCHE BROS. PTY. LTD., 22 Dynon Road, South Kensington, 3031; D.A.1941/51; 29th June, 1974; 252 cwt.

SOUTHERN PLANT HIRE CO. PTY. LTD., 1846 Princes Highway, Clayton, 3168; D.A.39531/6; 14th June, 1974; 136 cwt.; D.A.39531/8; 14th June, 1974; 135 cwt.

RENEWALS WITH VARIATION.

Applications made by the persons listed hereunder for renewal of the licences listed with variation of conditions in the manner set out opposite the names.

CARPENTER, V. R., 17 Miller Street, Heidelberg West, 3081; D.A.4885/1; 27th June, 1974; application to renew and vary the conditions of licence No. D.A.4885/1 (L/C. 148 cwt.) by deleting “L.S.D. Brick Company (Vic.) Pty. Ltd.” from the existing conditions and adding in lieu “Hollostone (Vic.) Ltd.”

FISHER, B. J., 11 Badger Creek Road, Healesville, 3777; D.T.1125; 16th May, 1974; application to renew and vary the conditions of licence No. D.T.1125 (L/C. 337 cwt.) by deleting “Mansfield to sawmills at Mansfield and Benalla” from paragraph (a) of the existing conditions and adding in lieu “Barwon Downs to sawmills at Barwon Downs, Forrest and Colac” and by also adding an additional paragraph (c) From the Otway Ranges to Smorgan's Consolidated Ind. Pty. Ltd. at West Footscray—pulp logs.

Notice of any objection should be forwarded to reach the Secretary of the Board not later than 27th February, 1974.

Applicants are advised that it will not be necessary to appear on the hearing date specified above, unless advised, in writing, by the Board.

A. V. C. COOK,
Secretary.

Corner Lygon and Princes streets, Carlton, 3053, Wednesday, 13th February, 1974.

Stamps Act 1958.

ANNUAL LICENCE.

NOTIFICATION PURSUANT TO SECTION 97.

I hereby notify that stamp duty has been paid for a licence under section 96 of the Stamps Act to carry on assurance and insurance business in Victoria from 1st January, 1974, to 31st December, 1974, by the following:—

THE FENTON INSURANCE COMPANY LIMITED.

R. M. PHIBBS,
Comptroller of Stamps.

Stamp Duties Office,
Melbourne, 13th February, 1974.

Country Fire Authority Act. PERMISSION TO HOLD FIRE BRIGADE DEMONSTRATIONS.

In pursuance of the provisions of section 103 of the *Country Fire Authority Act 1958*, the Country Fire Authority has granted permission for the holding of fire brigade demonstrations as under:—

RURAL FIRE BRIGADES.

At St. Arnaud on Sunday, 17th March, 1974.
At Rosedale on Sunday, 17th March, 1974.
At Geelong on Friday, 22nd March, 1974.
At Boort on Friday, 22nd March, 1974.
At Moonambel on Sunday, 24th March, 1974.
At Maldon on Saturday, 30th March, 1974.
At Woodend on Sunday, 31st March, 1974.
At St. Arnaud on Saturday, 6th April, 1974.

J. L. ALLEN,
Secretary.

7th February, 1974.

Private Agents Act 1966.

NOTICE OF RECEIPT OF APPLICATIONS FOR LICENCES UNDER THE PROVISIONS OF THE PRIVATE AGENTS ACT 1966.

The Clerk(s) of the Magistrates' Court(s) as listed hereunder hereby give notice that applications, as under, have been lodged for hearing by the said Court(s) on the date(s) specified.

Any person desiring to object to any of such applications must—

- (a) lodge with the respective Clerk of the Magistrates' Court a notice in the prescribed form of his objection and of the grounds thereof;
- (b) cause a copy of such notice to be served personally or by post upon the applicant at least three days before the hearing of the application; and
- (c) send or deliver—
 - (i) where the objection is not made by the officer in charge of the police district in which the Court is situated—a copy of the notice to such officer; and
 - (ii) where the objection is not made by the Registrar or Deputy Registrar—a copy to the Registrar.

Full Name of Applicant or in the Case of a Firm or Corporation, of the Nominee.	Place of Abode of Applicant or Nominee.	Name of Firm or Corporation.	Address for Registration.	Type of Licence.	Date of Hearing of Application.
---	---	------------------------------	---------------------------	------------------	---------------------------------

MAGISTRATES' COURT, MORWELL.

Rodda, Gregory William	Flat 1, 40 The Valley Boulevard, Morwell	Central Security	56 Williams Avenue, Churchill	Watchman	22.2.74
------------------------	--	------------------	-------------------------------	----------	---------

Dated at Morwell this 1st day of February, 1974.

D. M. CRANE, Clerk of the Magistrates' Court.

MAGISTRATES' COURT, GEELONG.

Robinson, Deles Charles	133 McKillop Street, Geelong	Geelong Armed and Security Co. Pty. Ltd.	55 The Esplanade, North Shore	Watchman	20.2.74
-------------------------	------------------------------	--	-------------------------------	----------	---------

Dated at Geelong this 31st day of January, 1974.

J. REILLY, Clerk of the Magistrates' Court.

MAGISTRATES' COURT, PRAHRAN.

Towes, Rodney John	39 Blanche Vermont Drive		Suite 12, 614 St. Kilda Road, Melbourne	Commercial Sub-agent	27.2.74
--------------------	--------------------------	--	---	----------------------	---------

Dated at Prahran this 1st day of February, 1974.

B. T. MANSBRIDGE, Clerk of the Magistrates' Court.

MAGISTRATES' COURT, BOX HILL.

Struthers, John	61 Mullens Road, Vermont South		61 Mullens Road, Vermont South	Inquiry Agent	22.2.74
-----------------	--------------------------------	--	--------------------------------	---------------	---------

Dated at Box Hill this 1st day of February, 1974.

K. G. McDONALD, Clerk of the Magistrates' Court.

MAGISTRATES' COURT, BOX HILL.

Crowden, Brian James	5 Conrad Court, Blackburn North		5 Conrad Court, Blackburn North	Process Server	22.2.74
----------------------	---------------------------------	--	---------------------------------	----------------	---------

Dated at Box Hill this 1st day of February, 1974.

K. G. McDONALD, Clerk of the Magistrates' Court.

MAGISTRATES' COURT, CAMBERWELL.

Eastwood, Ronald	32 Prospect Hill Road, Camberwell		32 Prospect Hill Road, Camberwell	Process Server	19.2.74
Ruzicka, Harald Fredrick	9/67 Hewish Road, Croydon		15 Callanish Road, Burwood	"	"
Magill, John Alexander	12 Henley Street, Balwyn		12 Henley Street, Balwyn	"	"

Dated at Camberwell this 29th day of January, 1974.

J. C. TOBIN, Clerk of the Magistrates' Court.

MAGISTRATES' COURT, MELBOURNE.

Scanlin, George	95 Geelong Road, Footscray	Wormald International Security	340 Abbotsford Street, North Melbourne	Watchman	13.3.74
Saunders, Robin Edward	5 Jeffrey Avenue, Noble Park	Brambles Limited	Cnr. Arden and Lothian Streets, North Melbourne	"	"

Dated at Melbourne this 1st day of February, 1974.

G. L. WEBSTER, Clerk of the Magistrates' Court.

MAGISTRATES' COURT, BROADMEADOWS.

Scott, Clifford	22 Acacia Street, Glenroy		22 Acacia Street, Glenroy	Process Server	25.2.74
-----------------	---------------------------	--	---------------------------	----------------	---------

Dated at Broadmeadows this 1st day of February, 1974.

D. SCULLY, Clerk of the Magistrates' Court.

MAGISTRATES' COURT, FOSTER.

Miller, Leslie George	Ameys Track, Foster	Wormald International Security	340 Abbotsford Street, North Melbourne	Watchman	15.3.74
-----------------------	---------------------	--------------------------------	--	----------	---------

Dated at Foster this 4th day of February, 1974.

L. F. HANDLEY, Clerk of the Magistrates' Court.

PRIVATE AGENTS—continued.

Full Name of Applicant or in the Case of a Firm or Corporation, of the Nominee.	Place of Abode of Applicant or Nominee.	Name of Firm or Corporation.	Address for Registration.	Type of Licence.	Date of Hearing of Application.
MAGISTRATES' COURT, CAMBERWELL.					
Kyritsis, Lakis	54 Gordon Street, Balwyn		54 Gordon Street, Balwyn	Process Server ..	26.2.73
Dated at Camberwell this 4th day of February, 1974.					
J. C. TOBIN, Clerk of the Magistrates' Court.					
MAGISTRATES' COURT, OAKLEIGH.					
Reardon, Trevor Stanley ..	46 Beddoe Avenue, East Bentleigh		46 Beddoe Avenue, East Bentleigh	Process Server ..	1.3.74
Reardon, Trevor Stanley ..	" "		" "	Inquiry Agent ..	"
Dated at Oakleigh this 5th day of February, 1974.					
A. J. JOHNSON, Clerk of the Magistrates' Cou					
MAGISTRATES' COURT, WODONGA.					
Damm, John Charles ..	487 Parnell Street, Lavington	Metropolitan Security Services	23A High Street, Wodonga	Watchman ..	12.3.74
Baker, Elwyn John ..	Urana Street, Jindera	" "	Hartwig McLean, Melbourne Road, Wodonga	" ..	"
Dated at Wodonga this 4th day of February, 1974.					
I. O'DONOGHUE, Clerk of the Magistrates' Court.					
MAGISTRATES' COURT, MELBOURNE.					
Miller, David James ..	25 Vincent Crescent, Werribee	Brambles Limited	Cnr. Arden and Lothian Streets, North Melbourne	Watchman ..	6.3.74
Ziebell, Ronald Henry ..	90 Smith Street, Thornbury	" "	" "	" ..	"
Dated at Melbourne this 30th day of January, 1974.					
G. L. WEBSTER, Clerk of the Magistrates' Court.					
MAGISTRATES' COURT, MELBOURNE.					
Berak, Drago ..	239 Hawthorn Road, East Burwood	Wormald International Security	340 Abbotsford Street, North Melbourne	Watchman ..	13.3.74
Easterby, Tony Wayne ..	B.P. Caravan Park, Conners Road, Werribee	Brambles Limited	Cnr. Arden and Lothian Streets, North Melbourne	" ..	"
Dated at Melbourne this 4th day of February, 1974.					
G. L. WEBSTER, Clerk of the Magistrates' Court.					
MAGISTRATES' COURT, WARRAGUL.					
Fraser, John Falconer ..	2 McKindlay Street, Drouin		34 William Street, Warragul	Commercial Sub-Agent	15.2.74
Dated at Warragul this 30th day of January, 1974.					
K. J. CRADDOCK, Clerk of the Magistrates' Court.					
MAGISTRATES' COURT, WILLIAMSTOWN.					
Peters, Willy Maurice ..	46 Simcock Avenue, Spotswood		46 Simcock Avenue, Spotswood	Process Server ..	26.2.74
Dated at Williamstown this 4th day of February, 1974.					
B. J. STOCKS, Clerk of the Magistrates' Court.					
MAGISTRATES' COURT, OAKLEIGH.					
Smith, Lyndon James ..	23 Forster Road, Mt. Waverley		23 Forster Road, Mt. Waverley	Process Server ..	22.2.74
Dated at Oakleigh this 4th day of February, 1974.					
A. J. JOHNSON, Clerk of the Magistrates' Court.					
MAGISTRATES' COURT, PRAHRAN.					
Van Dugteren, Peter Benjamin	c/o Belgrave Caravan Park	Carol Furzer	Suite 12, 614 St. Kilda Road, Melbourne	Commercial Sub-Agent	19.2.74
Dated at Prahran this 29th day of January, 1974.					
B. T. MANSBRIDGE, Clerk of the Magistrates' Court.					
MAGISTRATES' COURT, MELBOURNE.					
Byrne, Donald Gordon ..	16 Greenglade Court, North Blackburn		223 William Street, Melbourne	Watchman ..	13.3.74
Dated at Melbourne this 5th day of February, 1974.					
G. L. WEBSTER, Clerk of the Magistrates' Court.					
MAGISTRATES' COURT, PRAHRAN.					
Brown, Ralph Benjamin ..	8 Sinclair Avenue, Edithvale		Suite 12, 614 St. Kilda Road, Melbourne	Commercial Sub-Agent	4.3.74
Dated at Prahran this 4th day of February, 1974.					
B. T. MANSBRIDGE, Clerk of the Magistrates' Court.					
MAGISTRATES' COURT, MORWELL.					
Lucas, Keith Herbert ..	Midland Highway, Budgerec East, via Boolarra	Valley Central Security	56 Williams Avenue, Churchill	Watchman ..	1.3.74
Dated at Morwell this 5th day of February, 1974.					
D. M. CRANE, Clerk of the Magistrates' Court.					

PRIVATE AGENTS—continued.

Full Name of Applicant or in the Case of a Firm or Corporation, of the Nominee.	Place of Abode of Applicant or Nominee.	Name of Firm or Corporation.	Address for Registration.	Type of Licence.	Date of Hearing of Application.
MAGISTRATES' COURT, BRIGHTON.					
Geddes, Bruce Robert	409 Bay Street, Brighton		409 Bay Street, Brighton	Process Server	27.2.74
Dated at Brighton this 6th day of February, 1974.					
JOHN ARDLIE, Clerk of the Magistrates' Court.					
MAGISTRATES' COURT, BROADMEADOWS.					
Burnett, Roy Hamilton	54 Gowrie Street, Glenroy		54 Gowrie Street, Glenroy	Process Server	6.3.74
Dated at Broadmeadows this 6th day of February, 1974.					
D. SCULLY, Clerk of the Magistrates' Court.					
MAGISTRATES' COURT, CHELSEA.					
Hocking, Sylvia Jean	123 Station Street, Aspendale		123 Station Street, Aspendale	Guard Agent	28.2.74
Simmons, Peter David	10/25 Illawarra Road, Hawthorn	Hockings Security Services	" " "	Watchman	"
Horan, Victor James	23 Keith Avenue, Edithvale	" " "	" " "	"	"
Wing, Douglas Alfred	67 Winston Road, East Rosanna	" " "	" " "	"	"
Carbis, Laurence Victor	42 Westbury Grove, East St. Kilda	" " "	" " "	"	"
Dated at Chelsea this 7th day of February, 1974.					
R. W. LEWIS, Clerk of the Magistrates' Court.					
MAGISTRATES' COURT, PRESTON.					
Link, Graeme Ian	4 Mountain View Road, North Balwyn	Victorian Night Patrol Service	459 Plenty Road, Preston	Watchman	14.2.74
Dated at Preston this 24th day of January, 1974.					
P. C. CLOTHIER, Clerk of the Magistrates' Court.					
MAGISTRATES' COURT, BOX HILL.					
King, Owen Charles Richard	Main Road, Pantom Hill		Main Road, Pantom Hill	Watchman	28.2.74
Dated at Box Hill this 7th day of February, 1974.					
K. McDONALD, Clerk of the Magistrates' Court.					

LOCAL GOVERNMENT DEPARTMENT.

ORDER CONFIRMED.—SHIRE OF HUNTLY.

The Minister of the Crown administering the *Local Government Act 1958*, on the 8th day of February, 1974, confirmed the Order hereinafter referred to in pursuance of section 514 of the said Act namely:

An Order of the Council of the Shire of Huntly made on the 12th September, 1973, directing the compulsory taking of the land described in Crown Grants Volume 772 Folio 361, Volume 2494 Folio 731 and Volume 8941 Folio 361 for the purposes of providing a site for new Shire Offices.

A. J. HUNT,
Minister for Local Government.

Local Government Department,
Melbourne (209.131.1).

LOCAL GOVERNMENT DEPARTMENT.

ORDER CONFIRMED.—SHIRE OF BAIRNSDALE.

The Minister of the Crown administering the *Local Government Act 1958*, on the 8th day of February, 1974, confirmed the Order hereinafter referred to in pursuance of section 514 of the said Act namely:

An Order of the Council of the Shire of Bairnsdale made on the 12th December, 1973, directing the compulsory taking of the land described hereunder for the purpose of re-aligning the River Bank East Road adjacent to the Mitchell River:

1. All that piece of land being part of Crown allotment 76, Parish of Broadlands commencing at the south-west corner of the said Crown allotment thence by lines bearing 2 deg. 59 min. for 893.6 links; 349 deg. 58 min. for 867.5 links; 90 deg. 0 min. for 172.2 links; 164 deg. 36 min. for 361.7 links; 171 deg. 51 min. for 444.4 links; 175 deg. 22 min. for 463.3 links; 185 deg. 45 min. for 498.7 links; and 270 deg. 0 min for 214.2 links to the point of commencement.

2. All that piece of land being part of Crown allotment 77, Parish of Broadlands commencing at the south-west corner of the said Crown allotment thence by lines bearing 336 deg. 11 min. for 1004.7 links; 90 deg. 0 min. for 138.0 links; 155 deg. 42 min. for 1008.6 links and 270 deg. 0 min. for 147.3 links to the point of commencement.

3. All that piece of land being part of Crown allotment 77, Parish of Broadlands commencing at the south-west corner of lot 11 on plan of subdivision No. 1112 thence by lines bearing 327 deg. 15 min. for 493.7 links; 90 deg. 0 min. for 103.0 links; 143 deg. 57½ min. for 513.5 links and 270 deg. 0 min. for 138.0 links to the point of commencement.

4. All that piece of land being part of Crown allotment 77, Parish of Broadlands commencing at the south-west corner of lot 10 on plan of subdivision No. 1112 thence by lines bearing 327 deg. 15 min. for 493.7 links; 90 deg. 0 min. for 68.0 links; 143 deg. 57½ min. for 1027.0 links and 270 deg. 0 min. for 103.0 links to the point of commencement.

5. All that piece of land being part of Crown allotment 78, Parish of Broadlands commencing at the south-west corner of lot 9 on plan of subdivision No. 1112 thence by lines bearing 317 deg. 2 min. for 415.8 links; 130 deg. 53½ min. for 464.9 links and 270 deg. 0 min. for 68.0 links to the point of commencement.

A. J. HUNT,
Minister for Local Government.

Local Government Department,
Melbourne (74/0681).

LOCAL GOVERNMENT DEPARTMENT.

ORDER CONFIRMED.—CITY OF DANDENONG.

The Minister of the Crown administering the *Local Government Act 1958*, on the 8th day of February, 1974, confirmed an Order hereinafter referred to in pursuance of the provisions of section 514 of the said Act namely:

An Order of the Council of the City of Dandenong made on the 17th December, 1973, directing the compulsory taking of certain land being the land described in Book No. 518 Memorial 13 for the purposes of providing car parking facilities.

A. J. HUNT,
Minister for Local Government.

Local Government Department,
Melbourne (74/0947).

MEDICAL BOARD OF VICTORIA.

RECORD OF TEMPORARY MEDICAL REGISTRATIONS AS AT 31st DECEMBER, 1973.

Printed and published under the direction of the Medical Board of Victoria pursuant to the provisions of section 27 of the *Medical Practitioners Act 1970*.

Number of Certificate.	Date of Issue.	To Whom Issued.	Address.	Qualifications.	Limitations and Restrictions.
T. 180	5.7.73	Murray, Douglas Duncan	Austin Hospital ..	M.D., Dalhousie, 1967, (Canada)	Issued for a period not exceeding six (6) months and entitling the holder to work as a medical practitioner only in the service of the Austin Hospital
T. 181	19.7.73	Shrestha, Mrigendra Prasau	Royal Melbourne Hos- pital	M.B., B.S., Mysore, 1962, (India)	Issued for a period not exceeding six (6) months and entitling the holder to work as a medical practitioner only in the service of the Royal Melbourne Hospital
T. 183	19.7.73	Riley, William Barker	Royal Melbourne Hos- pital	M.D., North Caro- lina, 1967, (U.S.A.)	Issued for a period not exceeding eight (8) months and entitling the holder to work as a medical practitioner only in the service of the Royal Melbourne Hospital
T. 185	16.8.73	Sundaravadanam, Suryamurthy	Mental Health Authority	M.B., B.S., Madras, 1968, (India)	Issued for a period not exceeding two (2) years and entitling the holder to work as a medical practitioner only in the service of the Mental Health Authority
T. 186	16.8.73	Steiner, Nelly ..	Royal Childrens Hospital	M.D., Berne, 1973, (Switzerland)	Issued for a period not exceeding one (1) year and entitling the holder to work as a medical practitioner only in the service of the Royal Childrens Hospital
T. 187	16.8.73	Patowary, Bhupendra Nath	St. Vincents Hospital ..	M.B., B.S., Gauhati, 1958, (India)	Issued for a period not exceeding eighteen (18) months and entitling the holder to work as a medical practitioner only in the service of the St. Vincents Hos- pital
T. 188	16.8.73	Gouras, Anthanasios	Mental Health Authority	M.D., Salonica, 1965, (Greece)	Issued for a period not exceeding two (2) years and entitling the holder to work as a medical practitioner only in the service of the Mental Health Authority
T. 189	16.8.73	Sarnquist, Frank H.	St. Vincents Hospital ..	M.D., California, 1969, (U.S.A.)	Issued for a period not exceeding six (6) months and entitling the holder to work as a medical practitioner only in the service of St. Vincents Hospital
T. 190	16.8.73	Silber, Sherman J.	Royal Melbourne Hos- pital	M.D., Michigan, 1966, (U.S.A.)	Issued for a period not exceeding one (1) year and entitling the holder to work as a medical practitioner only in the service of the Royal Melbourne Hospital
T. 191	6.9.73	Przybyszewska, Ewa	Mental Health Authority	M.D., Silesian Medical Acad. 1969 (Poland)	Issued for a period not exceeding two (2) years and entitling the holder to work as a medical practitioner only in the service of the Mental Health Authority
T. 192	4.10.73	Chusilp, Santi ..	Repatriation Department	M.D., Thailand, 1966	Issued for a period not exceeding six (6) months and entitling the holder to work as a medical practitioner only in the service of the Repatriation Department
T. 193	4.10.73	Gilbert, Alain Laurent	St. Vincents Hospital ..	M.D., St. Antonie, 1970, (France)	Issued for a period not exceeding six (6) months and entitling the holder to work as a medical practitioner only in the service of the St. Vincents Hospital
T. 195	1.11.73	Nathaniel, Phillip	Royal Melbourne Hos- pital	M.B., B.S., Madras, 1961, (India)	Issued for a period not exceeding one (1) year and entitling the holder to work as a medical practitioner only in the service of the Royal Melbourne Hospital
T. 196	1.11.73	Liem, Bian Kwan ..	Queen Victoria Hospital	M.D., Surabaja, 1958, (Indonesia)	Issued for a period not exceeding one (1) year and entitling the holder to work as a medical practitioner only in the service of the Queen Victoria Hospital

RECORD OF TEMPORARY MEDICAL REGISTRATIONS AS AT 31ST DECEMBER, 1973—*continued.*

Number of Certificate.	Date of Issue.	To Whom Issued.	Address.	Qualifications.	Limitations and Restrictions.
T. 197	1.11.73	Yemyint	Royal Melbourne Hospital	M.B., B.S., Rangoon 1960, (Burma)	Issued for a period not exceeding one (1) year and entitling the holder to work as a medical practitioner only in the service of the Royal Melbourne Hospital and Open Heart Surgery Unit, University of Melbourne
T. 198	15.11.73	Hua, Andrew Su Ping	Royal Melbourne Hospital	M.B., B.S., Hong Kong, 1969	Issued for a period not exceeding fifteen (15) months and entitling the holder to work as a medical practitioner only in the service of the Royal Melbourne Hospital
T. 199	15.11.73	Chusilp, Sauwaluck	Royal Melbourne Hospital	M.D., Chulalongkorn, 1968, (Thailand)	Issued for a period not exceeding fourteen (14) months and entitling the holder to work as a medical practitioner only in the service of the Royal Melbourne Hospital
T. 200	6.12.73	Sayed, Badi-Uz-Zaman	Mental Health Authority	M.B., B.S., Bombay, 1948, (India)	Issued for a period not exceeding two (2) years and entitling the holder to work as a medical practitioner only in the service of the Mental Health Authority
T. 201	13.12.73	Barua, Ranadhir ..	Prince Henrys Hospital	M.B., B.S., Calcutta, 1959, (India)	Issued for a period not exceeding two (2) years and entitling the holder to work as a medical practitioner only in the service of the Prince Henrys Hospital
T. 202	13.12.73	Nallarattnam, Roy Arulnathan	Mental Health Authority	M.B., B.S., Ceylon, 1958	Issued for a period not exceeding two (2) years and entitling the holder to work as a medical practitioner only in the service of the Mental Health Authority
T. 203	17.12.73	Sturup, Asger Georg	Mental Health Authority	Candidatus Medicine et Chirurgia, 1967, Copenhagen, (Denmark)	Issued for a period not exceeding two (2) years and entitling the holder to work as a medical practitioner only in the service of the Mental Health Authority

Melbourne and Metropolitan
BOARD OF WORKS.

GENERAL NOTICE.

The Melbourne and Metropolitan Board of Works having made provision for carrying off the sewage of each and every property which or any part of which is situate in the Sewerage Areas hereinafter described doth hereby declare that on and after the Eighteenth day of February, 1974, each and every property so situate shall be deemed to be a seweraged property within the meaning of the *Melbourne and Metropolitan Board of Works Act 1958*.

The Sewerage Areas hereinbefore referred to are:—

Sewerage Area No. 2652.

City of Mordialloc.—Commencing at the junction of Rivette Street and Scarlet Street; thence westerly along Scarlet Street, southerly along the eastern boundary of lot 89 Scarlet Street, westerly along the southern boundaries of lots 89 to 93 Scarlet Street and 95 Warren Road, northerly along Warren Road, easterly along the northern boundaries of lots 1 Warren Road, 15 to 18 Lisa Court and 31 Rivette Street, southerly along Rivette Street to the commencing point.

Sewerage Area No. 2653.

City of Doncaster and Templestowe.—Commencing at the junction of Taurus Road and Canopus Drive; thence westerly along Canopus Drive, northerly along the western boundary of lot 198 Canopus Drive, westerly along the southern boundaries of lots 57 to 54 Landscape Drive and 51 to 49 Nolan Close, northerly along the western boundaries of lots 49 to 46 Nolan Close, westerly along the southern boundaries of lots 42 to 40 Landscape Drive, 38 and 37 Octantis Street and 31 Andersons Creek Road, north-easterly along Andersons Creek Road, easterly along the northern boundaries of lots 1 and 2 Landscape Drive and a reserve, southerly by a line to and along the eastern boundaries of lots 11 to 15 Dobell Place, generally easterly along Landscape Drive, south-easterly along the north-eastern boundary of lot 70 Landscape Drive, easterly by

a line to the western angle of lot 127 Frater Court, north-easterly along the north-western boundary of the said lot 127, south-easterly and easterly along Frater Court, south-easterly and south-westerly along the north-eastern and south-eastern boundaries of lot 125 Frater Court, easterly along the northern boundaries of lots 298 Canopus Drive and 300 Polaris Drive, southerly along Polaris Drive, westerly along the southern boundary of the said lot 300, southerly along portion of the eastern boundary of the said lot 298, westerly along Canopus Drive, northerly along the western boundary of lot 296 Canopus Drive, westerly along the southern boundaries of lots 126 and 127 Frater Court, further westerly by a line to and along the southern boundaries of lots 70 to 66 Landscape Drive, southerly and westerly along the eastern and southern boundaries of lot 285 Taurus Road, southerly along Taurus Road to the commencing point.

Sewerage Area No. 2654.

Shire of Cranbourne.—Commencing at the southern end of Marshall Court; thence northerly along Marshall Court, westerly and north-easterly along the southern and north-western boundaries of lot 72 Marshall Court, northerly along the western boundary of lot 71 Pound Road, easterly along Pound Road, southerly along the eastern boundaries of lots 1 Pound Road and 110 to 102 Sinclair Court, westerly along the southern boundaries of lots 102 and 101 Sinclair Court, northerly along the western boundary of the said lot 101, north-westerly by a line to the south-eastern angle of lot 100 Sinclair Court, westerly along the southern boundaries of the said lot 100 and lot 83 Marshall Court to the commencing point.

Sewerage Area No. 2655.

City of Nunawading.—Commencing at the junction of George Road and Morack Road; thence northerly and easterly along Morack Road, southerly along the eastern boundaries of lot 42 Morack Road and a reserve, further southerly along the eastern boundaries of lots 28 and 27 Wynne Court, 15 and 14 Murchison Avenue and 1 Morack Road, westerly along Morack Road to the commencing point.

Sewerage Area No. 2656.

City of Croydon.—Commencing at the junction of Wendover Avenue and Bayswater Road; thence southerly along Bayswater Road, westerly along the southern boundary of lot 2 Bayswater Road to the eastern boundary of lot 2 Newell Street, southerly along the said eastern boundary, westerly along Newell Street, southerly along the eastern boundary of lot 8 Newell Street, easterly along portion of the northern boundary of lot 17 Greenhill Road, southerly and westerly along the eastern and portion of the southern boundaries of the said lot 17, south-easterly along the north-eastern boundary of lot 16 Aloah Street, easterly along Aloah Street, southerly along the eastern boundaries of lots 19 and 21 to 25 Aloah Street, westerly and north-westerly along the southern and south-western boundaries of the said lot 25, generally westerly along Aloah Street, southerly along Greenhill Road, south-easterly along Canterbury Road, westerly along the southern boundaries of a reserve and lots 12 and 13 Alkira Court, southerly along the eastern boundaries of lots 6 to 8 Wayne Court and 14 Miller Road, westerly along the southern boundary of the said lot 14 to the boundary of Sewerage Area No. 2564, generally northerly and generally westerly following the said area boundary to the south-western angle of lot 10 Coven Avenue, northerly along Coven Avenue, a line across Canterbury Road and the western boundaries of lots 1 Canterbury Road and 3 Hume Street, easterly along the northern boundary of the said lot 3, northerly along Hume Street, westerly along the southern boundary of lot 12 Hume Street, northerly along the western boundaries of lots 12 to 28 Hume Street, easterly along the northern boundary of the said lot 28, southerly along Hume Street, easterly along Flora Street, further easterly along Raymond Court to its eastern extremity, north-easterly by a line across a reserve to the western extremity of Wendover Avenue, easterly along Wendover Avenue to the commencing point.

Sewerage Area No. 2657.

City of Ringwood.—Commencing at the junction of Waters Grove and Waterloo Street; thence southerly along Waterloo Street to Dandenong Creek, westerly along the said creek, northerly along the western boundaries of lots 22 and 21 Waterloo Street, 10 Waters Grove and 23 to 17 Bangor Court, easterly along the northern boundaries of lots 17 to 15 Bangor Court and 1 Waterloo Street, southerly along Waterloo Street to the commencing point.

Sewerage Area No. 2658.

City of Nuriawading.—Commencing at the junction of Highland Avenue and Wattle Valley Road; thence south-easterly along Wattle Valley Road, south-westerly along the south-eastern boundaries of lots 2 Wattle Valley Road and 3 to 11 Highland Avenue, westerly along the southern boundary of the said lot 11, north-easterly along Highland Avenue, north-westerly along the south-western boundary of lot 20 Highland Avenue, north-easterly along the north-western boundaries of lots 20 and 21 Highland Avenue, further north-easterly by a line to and along the north-western boundaries of lots 25 and 26 Highland Avenue, south-easterly along portion of the north-eastern boundary of the said lot 26, north-easterly along the north-western boundary of lot 27 Wattle Valley Road, south-easterly along Wattle Valley Road to the commencing point.

Sewerage Area No. 2659.

City of Waverley.—Commencing at the northern extremity of Xavier Drive; thence easterly along the northern boundaries of lots 20 Xavier Drive and 16 to 14 Galway Court, generally southerly along the eastern boundaries of lots 14, 12 and 11 Galway Court, westerly along portion of the southern boundary of lot 9 Xavier Drive, generally southerly along the eastern boundaries of lots 8 to 5 Xavier Drive westerly along the southern boundaries of lots 5 to 1 Xavier Drive to the boundary of Sewerage Area No. 2604, northerly, north-easterly and northerly following the said area boundary to the commencing point.

Sewerage Area No. 2660.

City of Knox.—Commencing at the junction of Brentwood Drive and Beleura Court on the boundary of Sewerage Area No. 2609; thence north-easterly generally easterly and generally southerly following the said area boundary to the south-eastern angle of lot 202 Brentwood Drive, north-westerly along the south-western boundaries of lots 202 and 203 Brentwood Drive, 205 and 206 Seymour Close, 215 to 217 Amberley Court and 232 Amesbury Avenue, north-easterly along Amesbury Avenue, north-westerly along Stokes Road, northerly along the western boundaries of lots 37 to 34 Burlington Crescent to the boundary of Sewerage Area No. 2609, easterly, southerly and generally south-easterly following the said area boundary to the commencing point.

Sewerage Area No. 2661.

City of Moorabbin.—Commencing at the junction of Glamis Street and Vardon Avenue; thence northerly along Vardon Avenue, easterly along the northern boundary of lot 5 Vardon Avenue, southerly along the eastern boundaries of lots 5 to 16 Vardon Avenue, westerly along the southern boundary of the said lot 16 to the commencing point.

Sewerage Area No. 2662.

City of Sunshine.—Commencing at the junction of Nicholson Parade and Canoon Street; thence easterly along Canoon Street, southerly and south-easterly along Ingram Avenue, southerly along the eastern boundaries of lots 454 Kermeen Street, 471 and 472 Hyett Court and 482 Tallintyre Road, westerly along Tallintyre Road, southerly along Cawood Drive, south-easterly along the north-eastern boundary of lot 636 Cawood Drive, southerly along the eastern boundaries of lots 636 to 633 Cawood Drive, westerly along the southern boundaries of lots 633 to 622 Cawood Drive, northerly along the western boundary of the said lot 622, further northerly along Nicholson Parade to the commencing point.

Sewerage Area No. 2663.

City of Oakleigh.—Commencing at the junction of Osborne Avenue and Westall Road; thence southerly along Westall Road to a point about 402 feet south of the southern boundary of Osborne Avenue, westerly by a line to and along the southern boundaries of lots 21 to 29 Miranda Close and a reserve, northerly along the western boundaries of the said reserve and lots 30 to 35 Miranda Close, easterly along Osborne Avenue to the commencing point.

Sewerage Area No. 2664.

City of Doncaster and Templestowe.—Commencing at the junction of Savaris Court and Park Road; thence north-easterly along Park Road, easterly along the northern boundaries of lots 2 Park Road and 6 to 17 Savaris Court, south-westerly along the south-eastern boundary of the said lot 17, southerly by a line to the northern angle of lot 18 Savaris Court, south-easterly and southerly along the north-eastern and eastern boundaries of the said lot 18, westerly along the southern boundaries of lots 19 to 31 Savaris Court and 1 Park Road, north-easterly along Park Road to the commencing point.

Sewerage Area No. 2665.

City of Knox.—Commencing at the junction of Barry Street and Dorset Road; thence southerly along Dorset Road, westerly and south-westerly along Holloway Drive, northerly along McLellan Street, westerly along the southern boundaries of lots 29 McLellan Street, 39 and 44 Reid Street and 75 Holloway Drive, northerly along Holloway Drive, westerly along the southern boundaries of lots 2 and 1 Barry Street, southerly along portion of the eastern boundary of lot 39 Barry Street, north-westerly and northerly along the south-western and western boundaries of the said lot 39, easterly along Barry Street to the commencing point.

Sewerage Area No. 2666.

City of Doncaster and Templestowe.—Commencing at a point in George Street about 470 feet east of the eastern boundary of Williamsons Road; thence northerly along the western boundary of lot 1 George Street, easterly along the northern boundaries of properties on the north side of George Street to the south-western angle of lot 37 Cantala Drive, north-westerly along the south-western boundary of the said lot 37, north-easterly along Cantala Drive, south-easterly and southerly along the north-eastern and eastern boundaries of lot 38 Cantala Drive to the boundary of Sewerage Area No. 2520, westerly, southerly and westerly following the said area boundary to the commencing point.

Sewerage Area No. 2667.

City of Nunawading.—Commencing at the junction of Burwood Highway and Colonial Drive; thence southerly along Colonial Drive, south-easterly along the north-eastern boundary of lot 181 Colonial Drive, southerly along the eastern boundaries of lots 181 to 189 Colonial Drive, westerly along the southern boundary of the said lot 189, southerly along Colonial Drive, westerly along Weeden Drive, southerly along the eastern boundary of lot 110 Weeden Drive, westerly along the southern boundaries of lots 110 and 109 Weeden Drive, southerly along the eastern boundaries of lots 108 to 104 Overland Drive, 102 and 101 Lindau Drive, 99 to 94 Overland Drive and 93 Highbury Road, westerly along Highbury Road, northerly along the western boundaries of lots 91 to 76 Overland Drive and 75 Weeden Drive, westerly along portion of the southern boundary of lot 61 Shearers Court, northerly along the

western boundaries of lots 61 to 58 Shearers Court, 44 to 41 Settlers Court, 26 to 23 Explorers Court and 1 Burwood Highway, easterly along Burwood Highway to the commencing point.

Sewerage Area No. 2668.

City of Nunawading.—Commencing at the junction of Terrara Road and Hanover Road; thence south-westerly along Hanover Road, north-westerly along the south-western boundary of lot 7 Hanover Road, northerly along the western boundary of lot 14 Coltain Street, westerly along Coltain Street, northerly along the western boundary of lot 112 Coltain Street, westerly along the southern boundaries of lots 19 and 20 Citron Court, north-westerly along the south-western boundaries of lots 20 and 21 Citron Court, northerly along the western boundary of lot 26 Spark Court, westerly by a line to the north-eastern angle of lot 27 Spark Court, southerly and north-westerly along the eastern and south-western boundaries of the said lot 27, north-easterly along the north-western boundaries of the said lot 27, lot 28 Spark Court and lot 30 Felgate Parade, north-westerly along the south-western boundaries of lots 31 to 34 Felgate Parade, westerly along Hancock Street, north-westerly along the south-western boundary of lot 135 Hancock Street, westerly and northerly along the southern and western boundaries of lot 41 Hawthorn Road, further northerly along the western boundaries of lots 42 Hawthorn Road and 45 and 46 Nairana Court, easterly along the northern boundaries of lots 46 to 48 Nairana Court and 50 to 54 Hawthorn Road, southerly along the eastern boundary of the said lot 54, easterly along Hawthorn Road, southerly along the eastern boundaries of lots 55 Hawthorn Road and 94 Nolan Close, easterly along the northern boundary of lot 1 Terrara Road, southerly along Terrara Road to the commencing point.

Sewerage Area No. 2669.

Cities of Croydon and Ringwood.—Commencing at the junction of Flora Street and Hume Street; thence northerly along Hume Street, easterly along Walhalla Drive, southerly along Hender Street, easterly along the northern boundary of lot 45 Hender Street, northerly along the western boundaries of lots 19 to 1 Gracedale Avenue, easterly along the northern boundaries of lots 1 and 21 Gracedale Avenue and 1 Tintern Avenue, southerly and easterly along Tintern Avenue, southerly along Rozelle Avenue, south-easterly along the north-eastern boundary of lot 57 Rozelle Avenue and a line in continuation to the western boundary of lot 1 Tintern Avenue, northerly along the said western boundary, easterly along Tintern Avenue, northerly along the western boundaries of lots 32 Tintern Avenue and 32 to 30 and 1 Dunlop Avenue, easterly along the northern boundary of the said lot 1, northerly along Dunlop Avenue, north-westerly along the south-western boundary of lot 5 Dunlop Avenue, north-easterly along the north-western boundary of the said lot 5 and a line in continuation to Long View Road, northerly and easterly along the western and northern boundaries of lot 15 Long View Road, northerly along the western boundaries of lots 9 to 1 Bayswater Road, westerly by a line to and along the southern boundary of lot 11 Tarnagulla Road, northerly along Tarnagulla Road, easterly along Blue Mist Drive, northerly along Bayswater Road, easterly and north-easterly along The Mall, easterly along Eastfield Road, south-westerly along Yvonne Avenue to its southern extremity, westerly along the southern boundary of a reserve, southerly along Bayswater Road to the boundary of Sewerage Area No. 2656 in Wendover Avenue, westerly, south-westerly and westerly following the said area boundary to the commencing point.

Sewerage Area No. 2670.

City of Nunawading.—Commencing at the junction of Salvana Avenue and Dunfield Avenue; thence north-easterly and easterly along Dunfield Avenue, northerly along Venice Avenue to the boundary of Sewerage Area No. 2249 in Springfield Road, north-easterly, southerly, easterly, southerly and westerly following the boundaries of Sewerage Areas Nos. 2249 and 1084 to the junction of Tirana Street and Ormond Avenue, westerly along Ormond Avenue to the boundary of Sewerage Area No. 2243, further westerly and generally northerly following this area boundary to the commencing point.

Sewerage Area No. 2671.

City of Waverley.—Commencing at the junction of Petronella Avenue and Rodney Close; thence south-westerly along Rodney Close, north-westerly along the south-western boundary of lot 91 Rodney Close, south-westerly and north-westerly along the south-eastern and south-western boundaries of lot 97 Adam Avenue, south-westerly along Adam Avenue, westerly along the southern boundary of lot 103 Adam Avenue, southerly along the eastern boundary of lot 294 Alex Avenue, westerly along

Alex Avenue, southerly along Samantha Close, westerly along the southern boundaries of lots 296 Samantha Close, 19 and 20 Stockdale Drive, 22 Trooper Court and 15 Jells Road, northerly along Jells Road, easterly along the northern boundary of lot 101 Jells Road, northerly and north-easterly along the western and north-western boundaries of lot 114 Sundowner Court, easterly along Sundowner Court, southerly along Homestead Drive, easterly along Petronella Avenue, southerly along the eastern boundaries of lots 50 Petronella Avenue and 56 Pioneer Court, south-easterly along the north-eastern boundaries of lots 57 Pioneer Court and 69 to 71 Prospector Court, north-easterly along the north-western boundaries of lots 107 to 110 Adam Avenue, south-easterly along the north-eastern boundaries of lots 110 and 96 Adam Avenue, north-easterly along the north-western boundary of lot 94 Petronella Avenue, south-easterly along Petronella Avenue to the commencing point.

Sewerage Area No. 2672.

City of Nunawading.—Commencing at the junction of Rowan Street and Centre Road; thence westerly along Centre Road to the boundary of Sewerage Area No. 2394, generally north-westerly following the said area boundary to the north-western angle of lot 32 Aubrey Street, north-easterly along Aubrey Street and continuing generally north-easterly along the boundary of Sewerage Area No. 2421 to Heatherdale Road, southerly along Heatherdale Road, westerly along Centre Road to the commencing point.

Sewerage Area No. 2673.

City of Nunawading.—Commencing at the intersection of Orient Avenue and Munro Street on the boundary of Sewerage Area No. 2338; thence northerly, generally easterly and south-easterly following the boundaries of Sewerage Areas Nos. 2338 and 2069 to Purches Street, southerly along Purches Street to a point 145 feet north of the northern boundary of Davison Street, westerly by a line to the north-eastern angle of lot 11 Davison Street, southerly along the eastern boundary of the said lot 11, westerly along Davison Street, southerly along the eastern boundary of lot 16 Davison Street, westerly along the southern boundaries of lots 16 and 18 to 22 Davison Street, northerly along the western boundaries of lots 22 to 27 Davison Street and 29 Orient Avenue, westerly along Orient Avenue to the commencing point.

Sewerage Area No. 2674.

City of Moorabbin.—Commencing at the junction of Cochranes Road and Edgecombe Court; thence northerly along Edgecombe Court, westerly along the southern boundary of lot 8 Edgecombe Court, northerly along the western boundaries of lots 8 to 16 Edgecombe Court, generally easterly along the northern boundaries of lots 16 and 17 Edgecombe Court, southerly along the eastern boundaries of lots 17 to 25 Edgecombe Court and 27 Cochranes Road, westerly along Cochranes Road to the commencing point.

By order of the Board,

W. C. S. ELLIS,

Secretary.

625 Little Collins Street, Melbourne, 3001, 12th February, 1974.

Survey Co-ordination Act 1958.

NOTICE OF ALTERATION OF A NAME.

Pursuant to the powers conferred under section 29 of the above Act, the Place Names Committee hereby gives notice that it has altered the name of the High School mentioned hereunder:—

Previous Name.—Bendigo Girls High School.

Location.—Curtin Street, Flora Hill.

Municipality.—City of Bendigo.

New Name.—Flora Hill High School.

By order of the Committee,

M. J. DWYER,

Secretary.

Private Agents Act 1966.

APPROVED INSURANCE COMPANIES.

Pursuant to the provisions of section 31 (2) of the *Private Agents Act 1966*, I, Her Majesty's Chief Secretary for the State of Victoria hereby approve of the following insurance company for the purposes of the said Act:—

Australian Eagle Insurance Company Limited.

E. R. MEAGHER,

for Chief Secretary.

Chief Secretary's Office,

Melbourne, 4th February, 1974.

COUNTRY ROADS BOARD.

RESOLUTIONS OF THE COUNTRY ROADS BOARD.

The Country Roads Board, in pursuance of the provisions of the Country Roads Act 1958, has passed Resolutions the dates whereof and the terms of which are scheduled hereunder:—

SCHEDULE.

State Highways.

Resolution dated the Fourth day of February, One thousand nine hundred and seventy-four, made pursuant to sections 21, 58 and 74 of the Country Roads Act 1958, declaring the deviation from the Wimmera Highway in the Shire of Kara Kara as indicated by diagonal hatching on plan numbered G.P.13066c hereunder to be part of a State highway within the meaning and for the purposes of the said Act, and also declaring that such deviation shall be in lieu of the existing road or part thereof indicated by cross hatching and vertical hatching on the said plan which part indicated by cross hatching on the said plan shall be discontinued.

the City of Ringwood as shown hatched on plans numbered G.P.6512A, G.P.6512B, G.P.6512C, G.P.6512D, G.P.6513A, G.P.6513B, G.P.6514A, G.P.6514B, G.P.6514C and G.P.6514D hereunder to be part of a State highway within the meaning and for the purposes of the said Act:

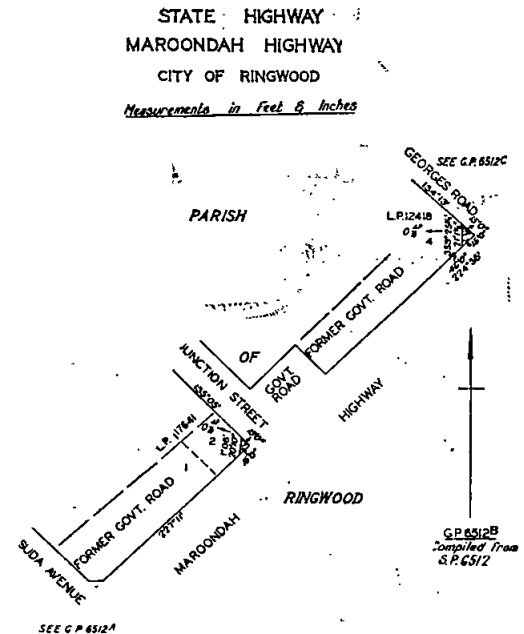
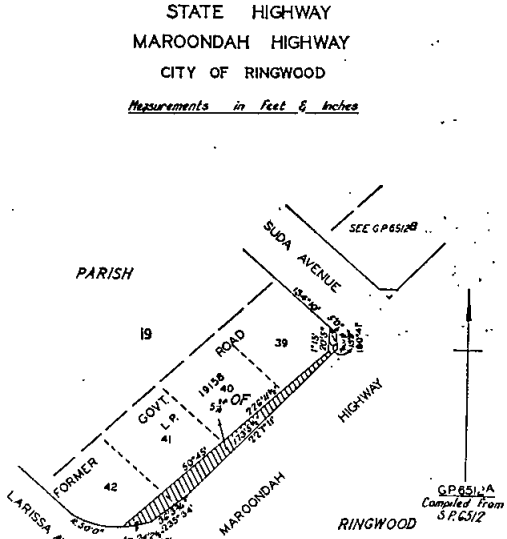
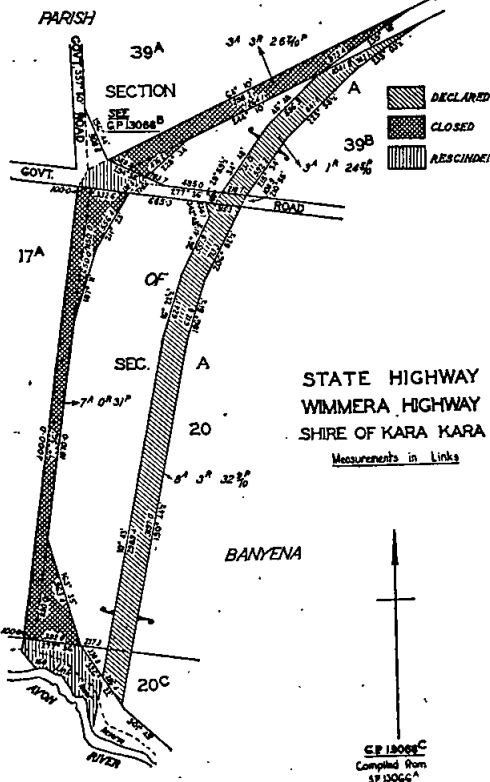

Resolution dated the Fourth day of February, One thousand nine hundred and seventy-four, made pursuant to sections 21 and 74 of the Country Roads Act 1958, declaring the widening of the Maroondah Highway in

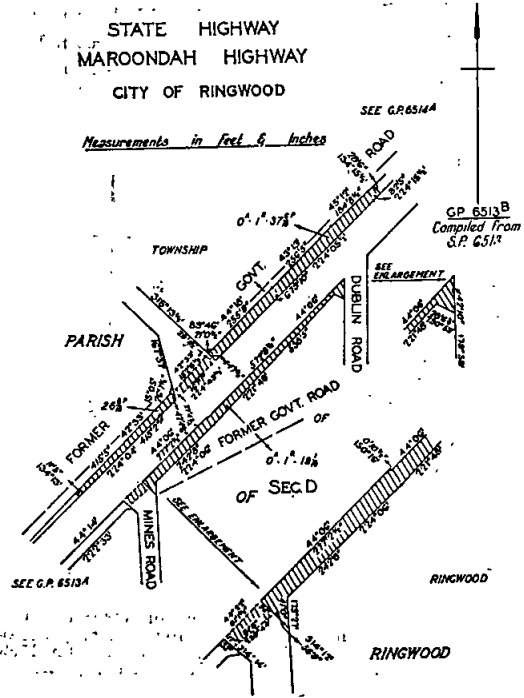
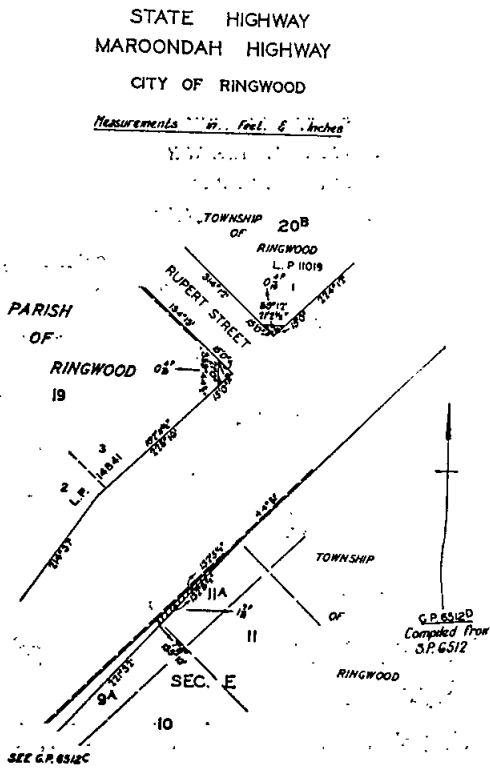
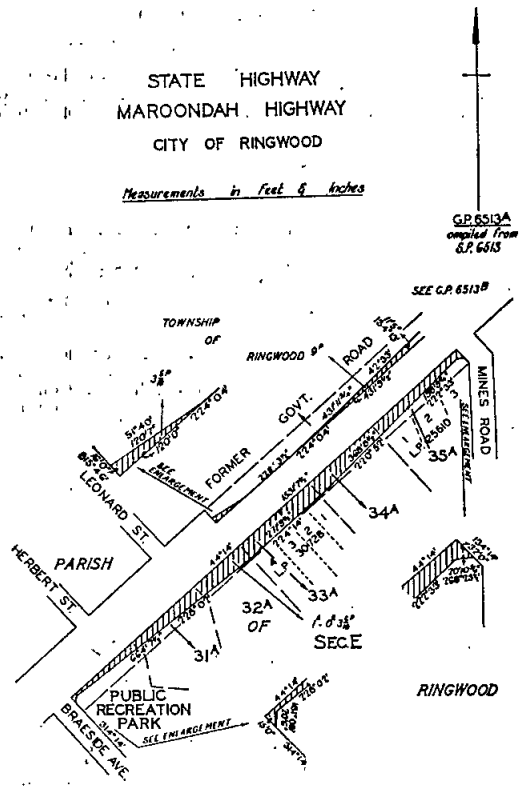
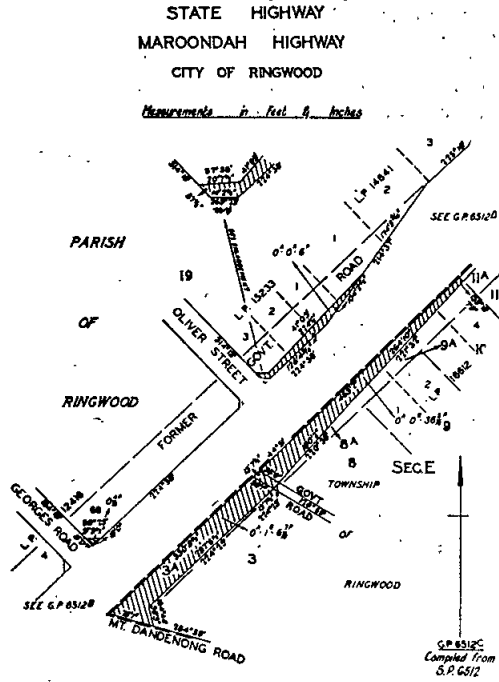

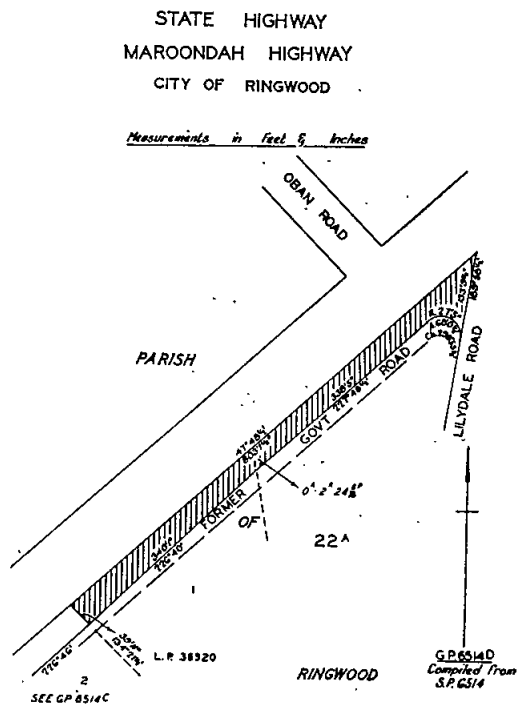
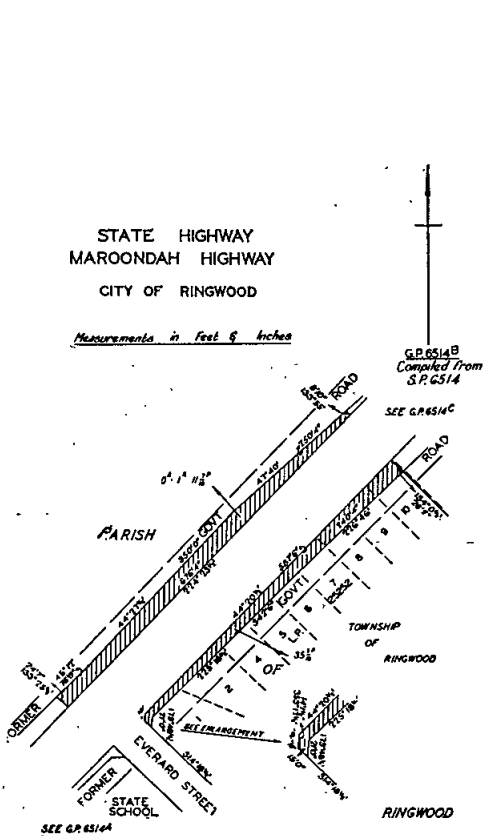
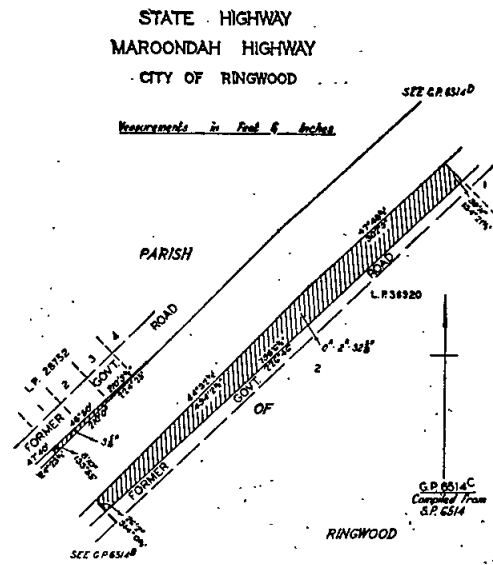
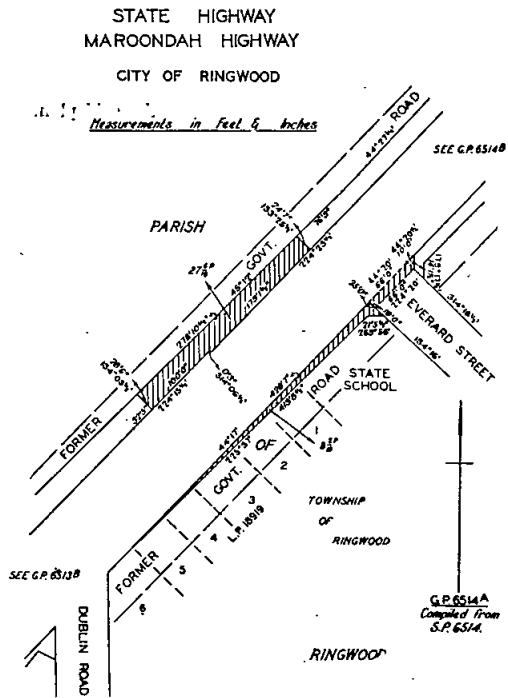

Main Roads.

Resolution dated the Fourth day of February, One thousand nine hundred and seventy-four, made pursuant to section 21 of the Country Roads Act 1958, declaring

the widening of the Doncaster-Mordialloc Road in the City of Box Hill as shown hatched on plan numbered G.P.10737 hereunder to be part of a main road within the meaning and for the purposes of the said Act.

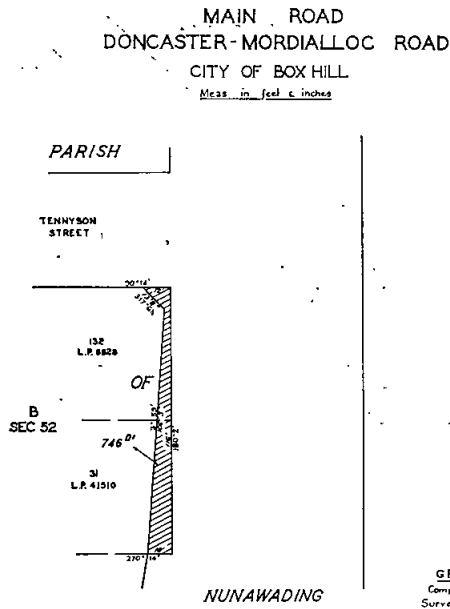

Resolution dated the Fourth day of February, One thousand nine hundred and seventy-four, made pursuant to section 21 of the Country Roads Act 1958, declaring the widening of the Doncaster-Mitcham Road in the City of Doncaster and Templestowe as shown hatched on plan numbered G.P.10516 hereunder to be part of a main road within the meaning and for the purposes of the said Act.

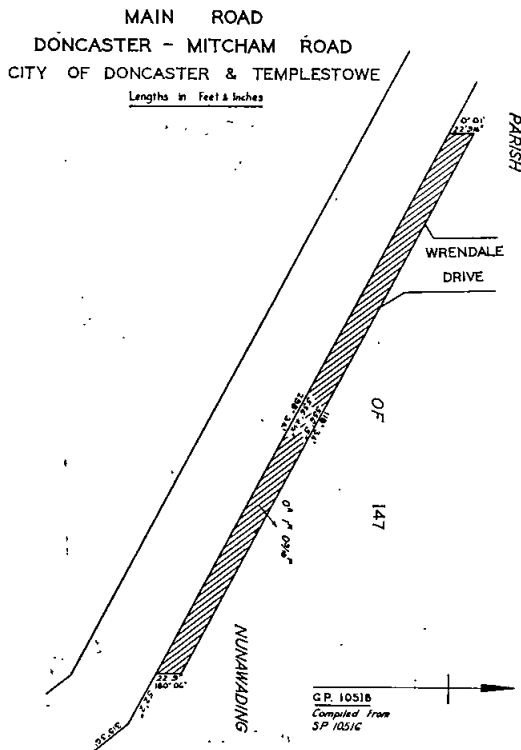

Resolution dated the Fourth day of February, One thousand nine hundred and seventy-four, made pursuant to sections 21 and 58 of the Country Roads Act 1958, declaring the deviation from the Dandenong-Hastings

Road in the Shire of Hastings as indicated by diagonal hatching on plan numbered G.P.12424 hereunder to be part of a main road within the meaning and for the purposes of the said Act, and also declaring that such deviation shall be in lieu of the existing road or part thereof indicated by cross hatching on the said plan.

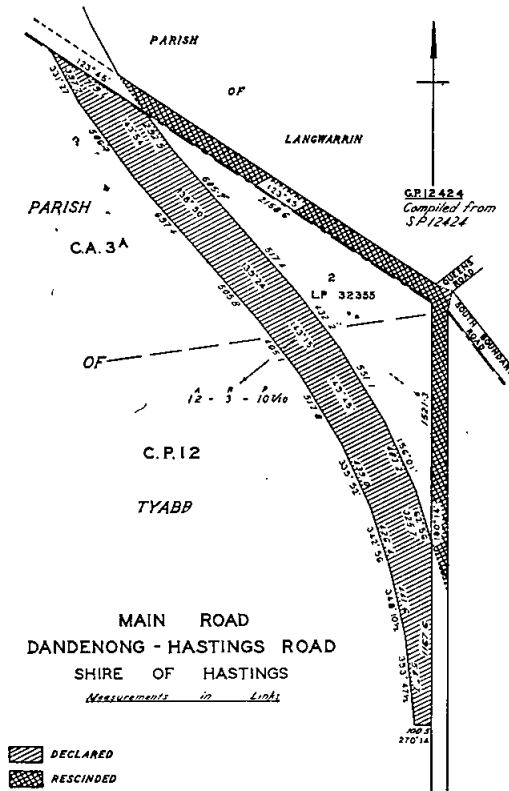

Resolution dated the Fourth day of February, One thousand nine hundred and seventy-four, made pursuant to section 21 of the Country Roads Act 1958, declaring the widening of the Lillydale-Monbulk Road in the Shire of Lillydale as shown hatched on plan numbered G.P.12878 hereunder to be part of a main road within the meaning and for the purposes of the said Act.

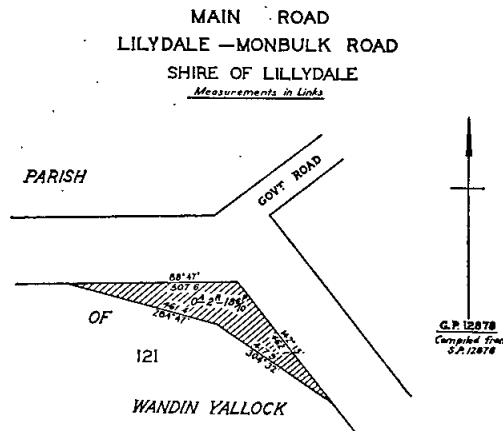

Resolution dated the Fourth day of February, One thousand nine hundred and seventy-four, made pursuant to section 21 of the Country Roads Act 1958, declaring the widening of the Mirboo South Road in the Shire of

Mirboo as shown hatched on plans numbered G.P.13267, G.P.13268 and G.P.13269 hereunder to be part of a main road within the meaning and for the purposes of the said Act.

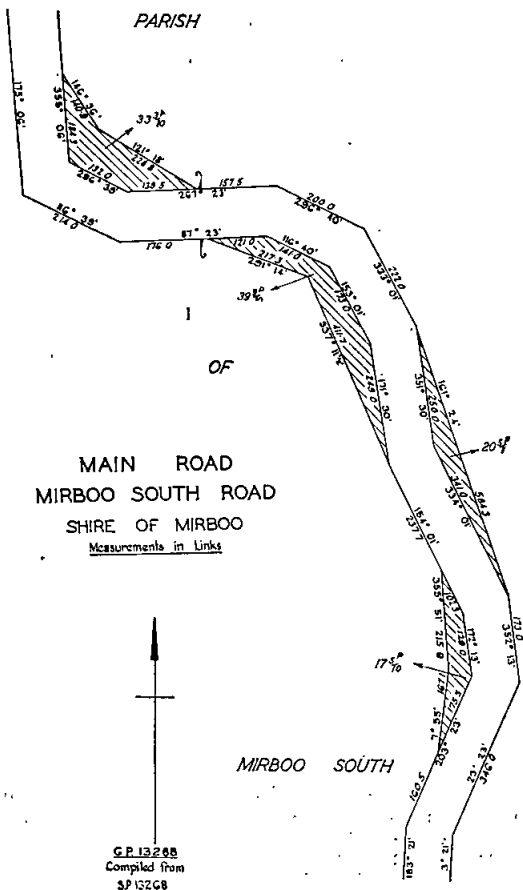
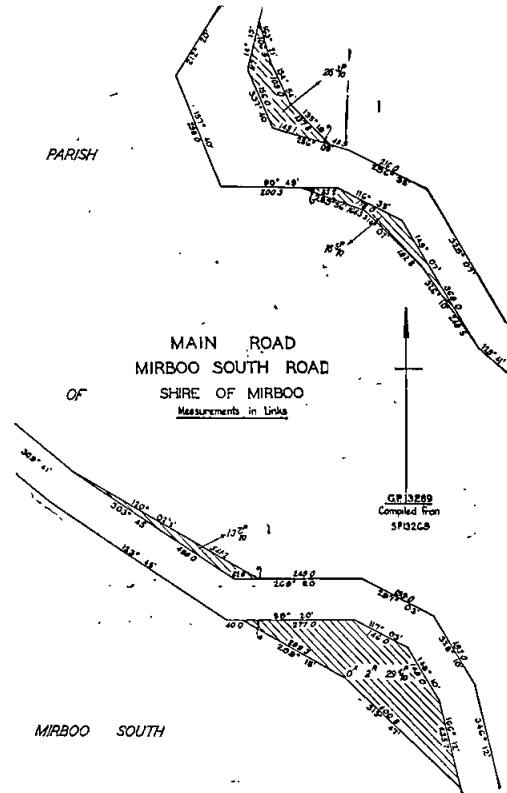
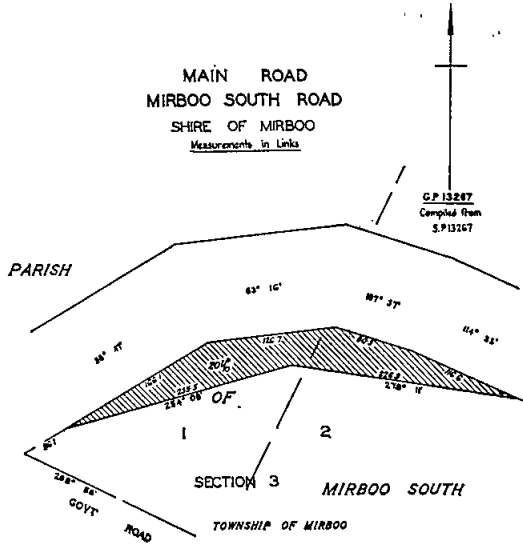

Resolution dated the Fourth day of February, One thousand nine hundred and seventy-four, made pursuant to section 21 of the Country Roads Act 1958, declaring the widening of the Morwell-Mirboo Road in the Shire of Mirboo as shown hatched on plans numbered G.P.13098A and G.P.13098B hereunder to be part of a main road within the meaning and for the purposes of the said Act.

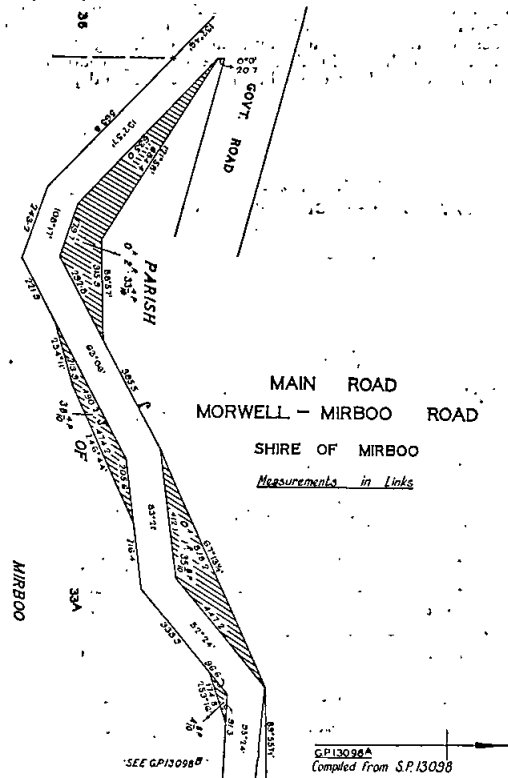

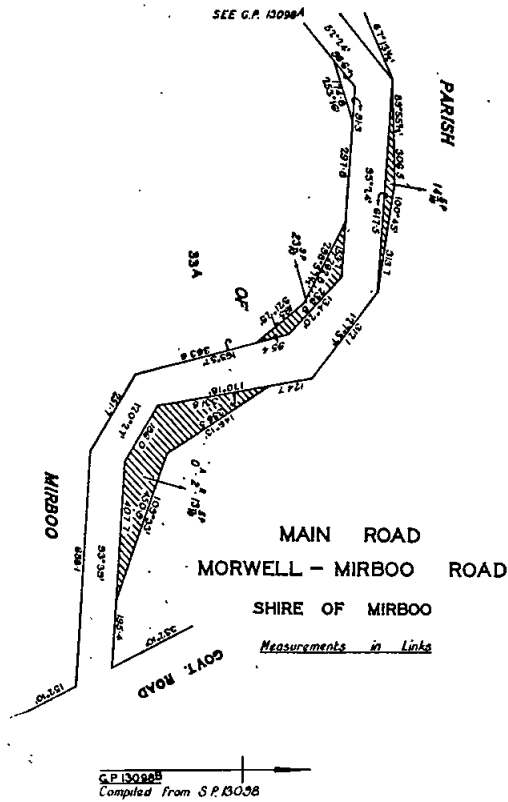

Unclassified Roads.
 Resolution dated the Fourth day of February, One thousand nine hundred and seventy-four, made pursuant to sections 21 and 110 of the *Country Roads Act 1958*, declaring the widening of a road in the Shire of Kara Kara as shown hatched on plan numbered G.P.13066B hereunder to be part of a road within the meaning and for the purposes of the said Act.

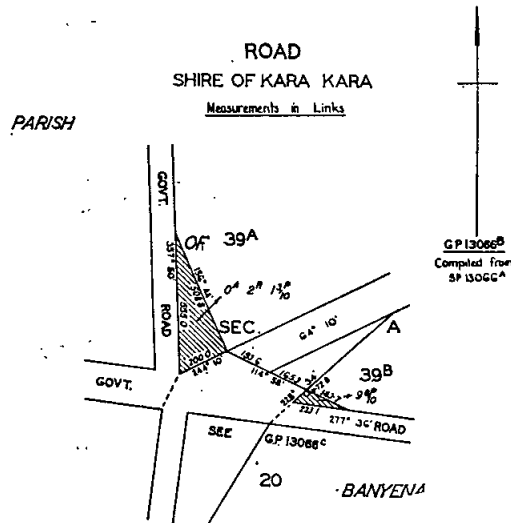

Resolution dated the Fourth day of February, One thousand nine hundred and seventy-four, made pursuant to sections 21 and 110 of the *Country Roads Act 1958*, declaring the widening of a road in the City of Knox as shown hatched on plan numbered G.P.12551 hereunder to be part of a road within the meaning and for the purposes of the said Act.

Resolution dated the Fourth day of February, One thousand nine hundred and seventy-four, made pursuant to sections 21 and 58 of the *Country Roads Act 1958*, declaring the deviation from the Cavendish-Coleraine Road in the Shire of Wannon as indicated by diagonal hatching on plan numbered G.P.12815A hereunder to be part of a main road within the meaning and for the purposes of the said Act, and also declaring that such deviation shall be in lieu of the existing road or part thereof indicated by cross hatching on the said plan.

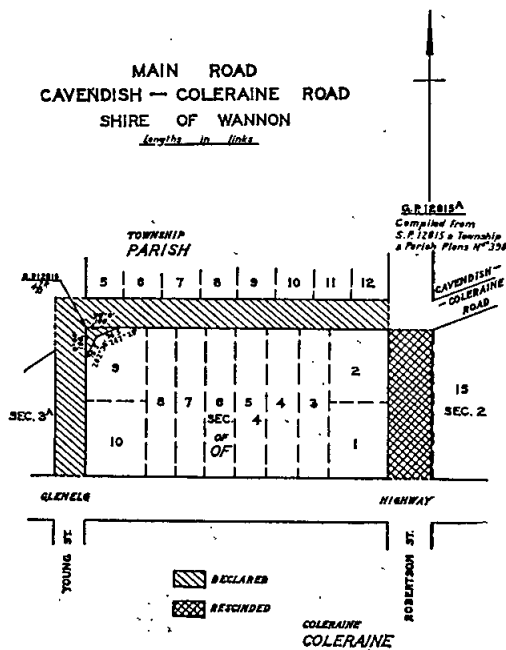

ROAD
 CITY OF KNOX
 Measurements in feet & inches

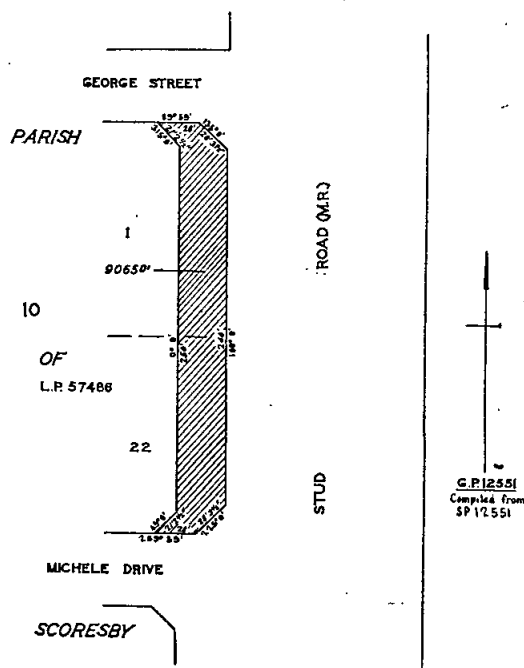

Tourists' Road.
 Resolution dated the Fourth day of February, One thousand nine hundred and seventy-four, made pursuant to sections 21, 58 and 88 of the *Country Roads Act 1958*, declaring the deviation from the Great Ocean Road in

the Shire of Otway as indicated by diagonal hatching on plans numbered G.P.12135A, G.P.12135B, G.P.12136A, G.P.12136B, G.P.12137A, G.P.12137B, G.P.12138 and G.P.12139 hereunder to be part of a tourists' road within the meaning and for the purposes of the said Act, and also declaring that such deviation shall be in lieu of the existing road or part thereof indicated by cross hatching on plans numbered G.P.12136A, G.P.12136B, G.P.12137A, G.P.12138 and G.P.12139 and cross hatching and horizontal hatching on plans numbered G.P.12135A, G.P.12135B and G.P.12137B which part indicated by cross hatching on plans numbered G.P.12136A, G.P.12136B, G.P.12137A, G.P.12138 and G.P.12139 shall be discontinued.

**TOURISTS' ROAD
GREAT OCEAN ROAD
SHIRE OF OTWAY**
Measurements in links

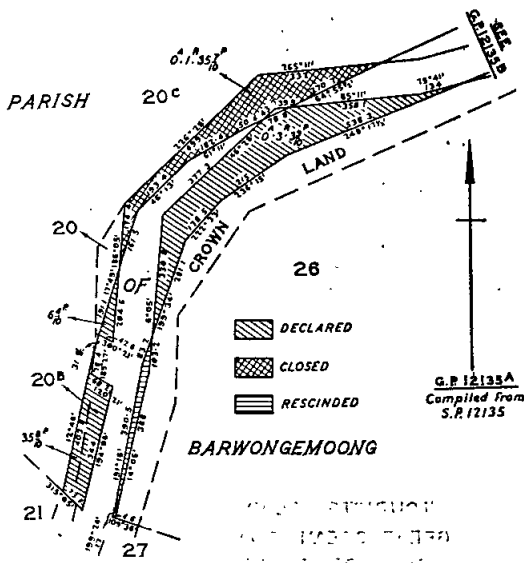

**TOURISTS' ROAD
GREAT OCEAN ROAD
SHIRE OF OTWAY**
Measurements in links

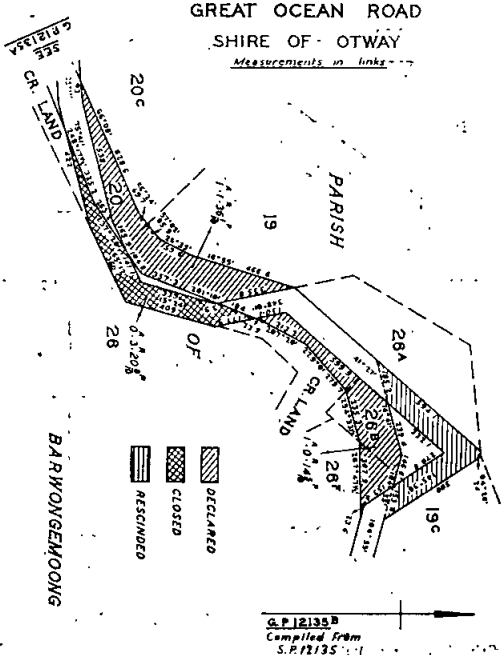

**TOURISTS' ROAD
GREAT OCEAN ROAD
SHIRE OF OTWAY**
Measurements in links

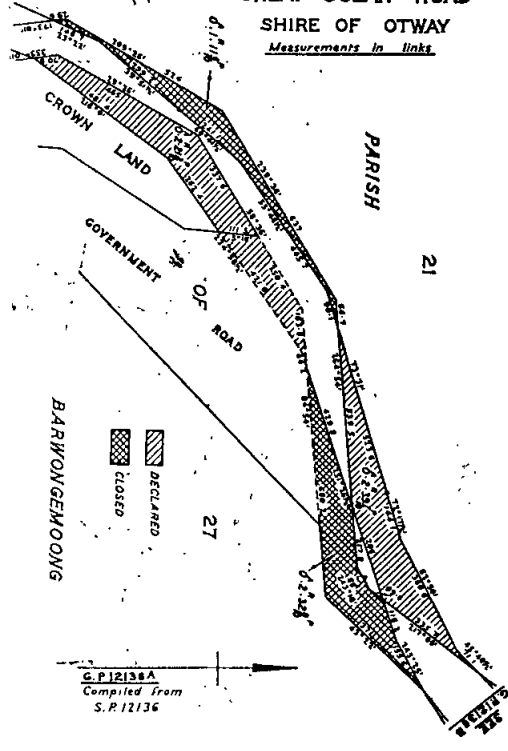

**TOURISTS' ROAD
GREAT OCEAN ROAD
SHIRE OF OTWAY**
Measurements in links

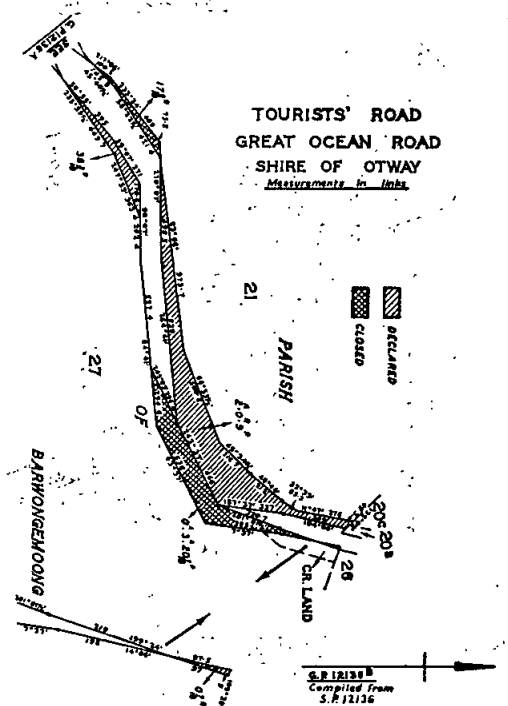

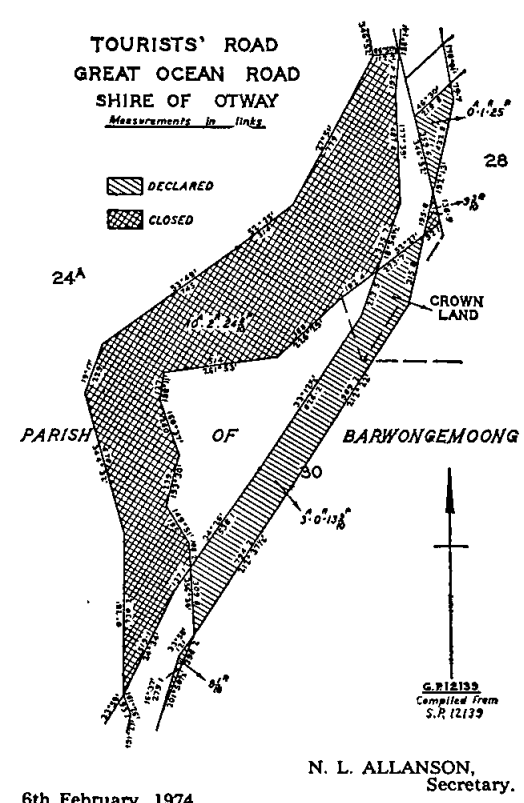
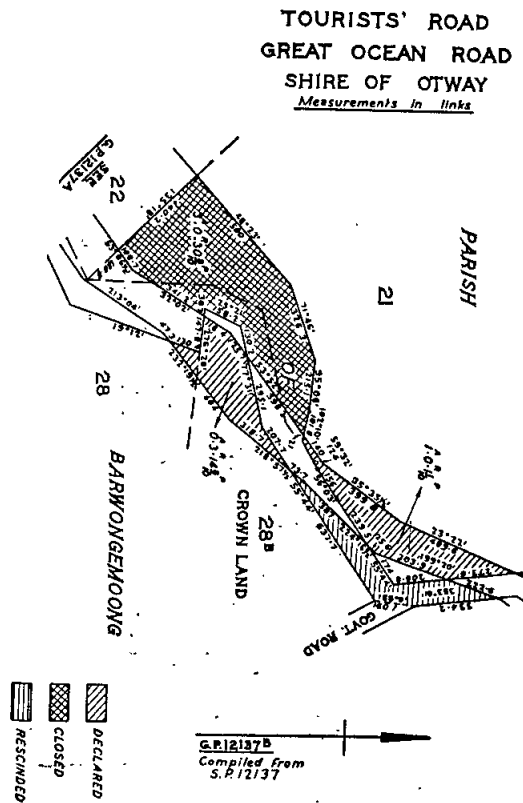
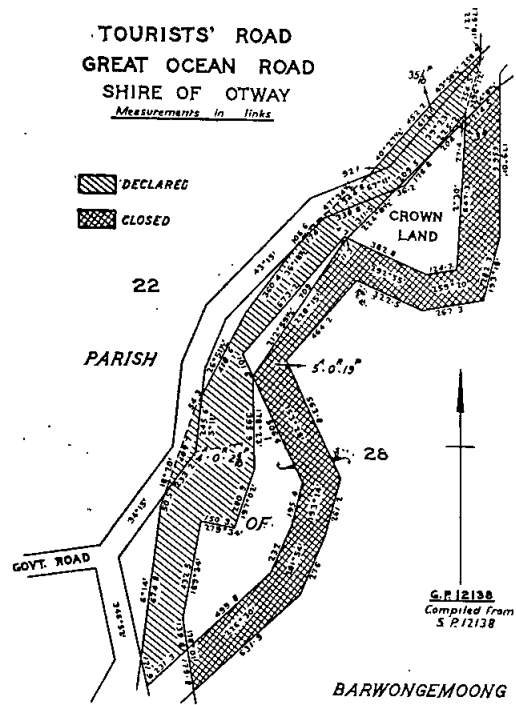
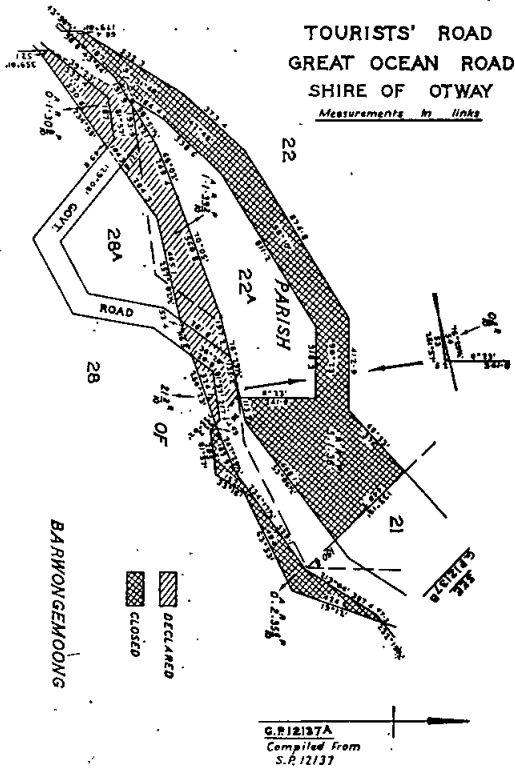

6th February, 1974.

Cemeteries Act 1958.

SCALE OF FEES OF GEELONG WESTERN PUBLIC CEMETERY.

In pursuance of the powers conferred upon them by the Cemeteries Act the trustees of the Geelong Western Public Cemetery hereby make the following scale of fees, which shall come into operation upon publication in the Government Gazette, and from and after such publication every scale of fees heretofore made by the said trustees shall be and is hereby rescinded to the extent to which it conflicts with this scale.

Lawn Section.

Land, 8 ft. x 4 ft.	\$85.00
First interment, at 7 feet	\$60.00
Certificate of Right of Burial	\$5.00
Second (final) interment	\$60.00
Small graves (children only) including interment	\$50.00
Interment of stillborn child (unmarked)	\$10.00
Interment without due notice (extra)	\$10.00

Late Fees—

After 4 p.m. Monday to Friday (extra)	\$10.00
After 4.30 p.m. Monday to Friday (extra)	\$10.00
Sunday and Holidays (when permissible) (extra)	\$25.00
Saturday mornings (extra)	\$25.00
Saturday mornings, late fee after 11.30 a.m. (extra)	\$15.00

General Section.

Land, 4 ft. x 8 ft.	\$55.00
Land, 8 ft. x 8 ft.	\$110.00
Land, 12 ft. x 8 ft.	\$165.00
Land, 16 ft. x 8 ft.	\$220.00

Sinking—

Any depth to 7 ft. 6 in.	\$55.00
For each additional foot or part thereof up to 9 feet	\$5.00
Sinking brick grave (extra)	\$12.00
Certificate of right of burial	\$5.00
Reopening any grave	\$55.00
Ledgers, removal of	\$8.00
Interment without due notice (extra)	\$10.00

Late Fees—

After 4 p.m. Monday to Friday (extra)	\$10.00
After 4.30 p.m. Monday to Friday (extra)	\$10.00
Sundays and Holidays (when permissible) (extra)	\$25.00
Saturday mornings (extra)	\$25.00
Saturday mornings, late fee after 11.30 a.m. (extra)	\$15.00

Public Graves—General Section.

Interment in a public grave	\$10.00
Interment under Government Contract	\$10.00
Interment of a child under 10 years	\$10.00
Interment of a stillborn child	\$10.00
Interment without due notice (extra)	\$10.00

Cremated Remains.

Curbside, 18 in. x 12 in.—1st interment (including plaque)	\$35.00
2nd interment (including plaque)	\$30.00
Bronze Memorial Plaque attached to curb	\$45.00
Columbarium Niche, including bronze plate	\$70.00
Rose Garden—1st interment (including plate)	\$40.00
2nd interment (including plate)	\$50.00
Memorial Cross	\$50.00

Miscellaneous.

Erection Fees—General Section—	
Fees for erections and additions up to and including \$100	\$7.00
Over \$140—5 per cent. on cost	
Erection Fees—Lawn Section—	
Headstones	\$13.00
Additional inscription	\$5.00
Exhumation, minimum charge	\$50.00
Label or name plate, permission to erect	\$1.00
Inspection of plan or register	\$1.00
Copy of register	\$1.00
Copy of rules	\$1.00
Casket, oversize overall (minimum charge) (extra)	\$15.00
Digging grave for rectangular casket (extra) any section	\$20.00

L. COLE, Trustee.
E. I. MYERS, Trustee.
R. W. REID, Trustee.

Approved by the Governor in Council, 22nd January, 1974.—T. J. FORRISTAL, Clerk of the Executive Council.

Cemeteries Act 1958.

SCALE OF FEES OF GOORNONG PUBLIC CEMETERY.

In pursuance of the powers conferred upon them by the Cemeteries Act the trustees of the Goornong Public Cemetery hereby make the following scale of fees, which shall come into operation upon publication in the Government Gazette, and from and after such publication every scale of fees heretofore made by the said trustees shall be and is hereby rescinded to the extent to which it conflicts with this scale.

Public Graves.

Interment in grave without exclusive right—stillborn child	\$8.50
Interment in grave without exclusive right—others	\$17.00
Number Peg or Label	\$4.00

Private Graves.

Land, 8 ft. x 4 ft.	\$28.00
Own selection of land (extra)	\$7.00

Extra Charges.

Interment outside prescribed hours, or on Saturdays, Sundays or Public Holidays	\$14.00
Interment in a private grave without due notice	\$14.00

Miscellaneous Charges.

Interment fee	\$14.00
Certificate of right of burial	\$2.00
Number plate or brick	\$4.00
Permission to erect a headstone or monument—5 per cent of cost with a minimum of \$6.00	
Permission to construct a brick grave or to erect any stone kerb, brick tile-work or concrete	\$6.00
Exhuming the remains of a body (when authorized)	\$60.00
Interment of ashes in a private grave	\$14.00

R. A. RINGE, Trustee.
B. P. HOWARD, Trustee.
J. D. MCKINSTRY, Trustee.
A. C. GEE, Trustee.

Approved by the Governor in Council, 5th February, 1974.—T. J. FORRISTAL, Clerk of the Executive Council.

Cemeteries Act 1958.

SCALE OF FEES OF WERRIBEE PUBLIC CEMETERY.

In pursuance of the powers conferred upon them by the Cemeteries Act the trustees of the Werribee Public Cemetery hereby make the following scale of fees, which shall come into operation upon publication in the Government Gazette, and from and after such publication every scale of fees heretofore made by the said trustees shall be and is hereby rescinded to the extent to which it conflicts with this scale.

Private Graves.

Land, 8 ft. x 4 ft.	\$55.00
Own selection of site (extra)	\$17.00

Public Graves.

Interment in grave without exclusive right—stillborn child	\$12.00
Interment in grave without exclusive right—others	\$24.00
Number peg or label	\$5.00

Sinking Charges for Private Graves.

Sinking grave 6 feet deep	\$46.00
Each additional foot	\$8.00
Sinking oversize grave (extra)	\$16.00
Sinking oversize grave for American type casket (extra)	\$16.00
Cancellation of order to sink (if commenced)	\$8.00

Reopening Charges.

Reopening grave (no cover)	\$40.00
Reopening grave (with cover or kerb)	\$45.00

Extra Charges.

Interment not in the prescribed hours or on Saturdays, Sundays or Public Holidays	\$19.00
Interment in private grave without due notice	\$19.00
Late fee (per half-hour or part thereof in excess of first fifteen minutes)	\$2.50

Miscellaneous Charges.

Interment fee	\$16.00
Certificate of right of burial	\$2.50
Number plate or brick	\$5.00
Inspection of plan or register	\$2.00
Annual maintenance (single grave)	\$17.00
Permission to erect a headstone or monument— 7½ per cent. of cost, with a minimum of \$6.00	
Permission to construct a brick grave or to erect any stone kerb, brick, tilework or concrete	\$7.00
Grave renovations or additional inscription	\$6.00
Exhuming the remains of a body (when authorized)	\$66.00
Interment of ashes in a private grave	\$16.00
Memorial Wall Niche and Plaque	\$50.00

G. W. O'KEEFE, Trustee.
R. N. V. DAWE, Trustee.
N. R. HUDSON, Trustee.

Approved by the Governor in Council, 5th February, 1974.—T. J. FORRISTAL, Clerk of the Executive Council.

Motor Car Act 1958.

EXEMPTIONS FROM FITTING OF SEAT BELTS.

In pursuance of the powers conferred on me by Section 31AA (3) of the Motor Car Act 1958, I, Reginald Jackson, the Chief Commissioner of Police, hereby exempt the under-mentioned motor cars from being fitted with seat belts as required by section 31AA of the Act.

(i) Asphalt Spreader.	Line Marking Machine.
Auto Header.	Mini Paver.
Back Actor.	Motorised Wheel Chair.
Back-end Loader.	Mower.
Back Hoe.	Overhead Loader.
Bean Harvester.	Pavement Roller.
Bottom Dump Truck.	Paver.
Bucket Loader.	Paymower.
Bulldozer.	Power Buggy.
Bullgrader.	Power Grader.
Bulldozer Shovel.	Rear Blade.
Carry Lift Platform.	Rear-end Loader.
Coal Loader.	Ripper.
Concrete Dumper.	Road Grader.
Combine.	Road Heater-Planer.
Combine Harvester.	Road Packer.
Crawler Trencher.	Road Paver.
Digger.	Road Roller.
Ditcher.	Road Sweeper.
Dozer Shovel.	Rock Ripper.
Dragline Excavator.	Rotary Mower.
Dragline Shovel.	Scarifier.
Drain Digger.	Scoop.
Dumper.	Scoopmobile.
Duo pactor.	Scraper Dozer.
Earth Ditcher.	Self-propelled Windrower.
Earth Scoop.	Service Ditcher.
Excavator.	Shovel Loader.
Footpath Roller.	Skid.
Fork Lift.	Skidder.
Fork Loader.	Side Loader.
Front End Loader.	Sprayer.
Golf Buggy.	Stone Loader.
Golf Car.	Street Sweeper.
Grader.	Sweeper Loader.
Grain Combine.	Towmotor.
Grass Cutter.	Tractor.
Harvester.	Tractor-loader.
Hauler.	Tractor-Shovel.
Hay Baler.	Trailer Crane.
Header.	Trench Digger.
Invalid Chair.	Trencher.
Invalid Runabout.	Trench Hoe.
Lawn Roller.	Wheel Log Loader.
Lawn Sulky.	

- (ii) Motor cars having a gross vehicle weight exceeding 10,000 lb.
- (iii) Commercial type motor cars and passenger car derivatives having a gross vehicle weight not exceeding 10,000 lb. with the exception of those with private, station wagon or utility types of bodies; and
- (iv) Pillarless type motor cars and soft top motor cars having private, station wagon or utility types of bodies.

R. JACKSON,
Chief Commissioner.

PUBLIC TRUSTEE ACT 1958 (No. 6350), SECTION 17.

I hereby give notice that on the 26th July, 1973, the Public Trustee filed an election to administer the following deceased person's estate in accordance with section 17 of the Public Trustee Act 1958.

LINAY, RAYMOND ALEXANDER MOORE, formerly of 5 Nocton Street, Reservoir, but late of Mont Park, stereotyper, died 1st February, 1973.

I hereby give notice that on the 15th January, 1974, the Public Trustee filed elections to administer the following deceased persons' estates in accordance with section 17 of the Public Trustee Act 1958.

CREIGHTON, MURIEL EILEEN, late of Ballarat, pensioner, died 8th November, 1973.

LINE, JOSEPHINE EVALYN, also known as Josephine Elizabeth Line, late of 13 Haywood Street, Beaumaris, nursing sister, died 6th October, 1973.

LLOYD, ROSE LOUISE, late of 16 Lillian Street, Clayton, spinster, died 14th November, 1962.

MCLEOD, IRENE OLIVE, formerly of 6 Alandale Road, Mentone, but late of 1 Freda Avenue, Cheltenham, widow, died 21st November, 1973.

I hereby give notice that on the 25th January, 1974, the Public Trustee filed elections to administer the following deceased persons' estates in accordance with section 17 of the Public Trustee Act 1958.

BEAUMONT, BENJAMIN HENRY, late of Plenty Road, Bundoora, pensioner, died 10th October, 1973.

D'HARTY, ANNIE, late of 8 Sargood Street, Toorak, widow, died 21st August, 1973.

GILLICK, NELLIE CHRISTINA, formerly of 43 Gardenia Street, Horsham, but late of Traralgon, widow, died 17th August, 1973.

HUGHES, VIOLET ROSE, late of Ward 4A, Repatriation Hospital, Heidelberg, war widow, died 11th December, 1973.

JONES, WINIFRED ADNEE NORMAN, late of Flat 70 Hedley Sutton Home, 2 Gascoyne (in will called Gascoyne) Street, Canterbury, spinster, died 11th October, 1973.

MEDLEY, JABEZ HENRY, late of 72 Harlington Street, Clayton, retired engine driver, died 10th November, 1973.

TAFT, LILIAN, late of The Netherlands, Sale, widow, died 31st July, 1966.

WILSON, SOPHIA URSULA NELLIE ROSE, also known as Sophia Nellie Rose Wilson, formerly of 1 Holmes Street, Northcote, but late of 61 Dickens Street, Lalor, widow, died 12th November, 1973.

I hereby give notice that on the 18th January, 1974, the Public Trustee filed elections to administer the following deceased persons' estates in accordance with section 17 of the Public Trustee Act 1958.

CRERAR, MELVA MARY, late of 18 Bevan Street, Balwyn, married woman, died 17th November, 1973.

SPONG, MARY LAURA, formerly of 13 Carlyle Street, East Hawthorn, but late of "Bethany", 440 Camberwell Road, Camberwell, widow, died 4th November, 1973.

N. P. BRODY,
Public Trustee.

168 Exhibition Street, Melbourne, 3000, 6th February, 1974.

NOTICE.

Creditors, next of kin and others having claims against the estate of any of the under-mentioned deceased persons are required to send particulars of their claims to the Public Trustee, 168 Exhibition Street, Melbourne, Vic. 3000, the personal representative, on or before the 20th April, 1974, after which date the Public Trustee may convey or distribute the assets having regard only to the claims of which the Public Trustee then has notice:—

ANKERS, ALBERT, late of 38 East Esplanade, St. Albans, retired driver, died 10th January, 1973.

BEATTIE, NELLIE, formerly of Flat 10, 325 Toorak Road, Burwood, but late of Manchester Unity Aged Peoples Centre, Glen Waverley, married woman, died 30th October, 1973.

BEAUMONT, BENJAMIN HENRY, late of Plenty Road, Bundoora, pensioner, died 10th October, 1973.

BY, EDWARD JOHN, late of Morningside, Tyaak, retired labourer, died 14th August, 1973.

CHRISTIE, THOMAS NORMAN, late of 60 Liddiard Street, Hawthorn, pensioner, died 14th July, 1973.

CREIGHTON, MURIEL EILEEN, late of Ballarat, pensioner, died 8th November, 1973.

CRERAR, MELVA MARY, late of 18 Bevan Street, Balwyn, married woman, died 17th November, 1973.

D'HARTY, ANNIE, late of 8 Sargood Street, Toorak, widow, died 21st August, 1973.

GEAR, RONALD CHARLES, also known as Ronald Gear, but late of 67 Drummond Street, Oakleigh, welder, died 27th September, 1973.

GIBSON, MARY ISABEL, late of 35 Davis Street, North Carlton, spinster, died 5th December, 1973.

GILICK, NELLIE CHRISTINA, formerly of 43 Gardenia Street, Horsham, but late of Traralgon, widow, died 17th August, 1973.

GLEDHILL, ROSE RITA, late of 7 Myrtle Avenue, East Kew, widow, died 15th December, 1973.

HUGHES, VIOLET ROSE, late of Ward 4A, Repatriation Hospital, Heidelberg, war widow, died 11th December, 1973.

INGLIS, JESSIE IRENE, late of 9 Plumer Street, Croydon, spinster, died 24th October, 1973.

JEZERSKI, ANDRZEJ, also known as Andrei Jezierski also known as Andrzej Jelierski, also known as Audrzie Jezieski, but late of 10 Barrett Court, Yarraville, boiler attendant, died 12th February, 1972.

JONES, WINIFRED ADNEE NORMAN, late of Flat 70 Hedley Sutton Home, 2 Gascoyne (in will called Gascoine) Street, Canterbury, spinster, died 11th October, 1973.

KEOGH, FRANCES MARY, formerly of 2 Ratcliffe Street, South Kensington, but late of 1 Purcell Court, Werribee, married woman, died 28th August, 1973.

LINAY, RAYMOND ALEXANDER MOORE, formerly of 5 Nocton Street, Reservoir, but late of Mont Park, stereotyper, died 1st February, 1973.

LINE, JOSEPHINE EVALYN, also known as Josephine Elizabeth Line, late of 113 Haywood Street, Beaumaris, nursing sister, died 6th October, 1973.

LLOYD, ROSE LOUISE, late of 16 Lillian Street, Clayton, spinster, died 14th November, 1962.

MEDLEY, JABEZ HENRY, late of 72 Harlington Street, Clayton, retired engine driver, died 10th November, 1973.

MELLAN, JAMES AUGUSTAS, late of "Windsor House", 130 Buckley Street, Middle Footscray, retired wool classer, died 25th September, 1973.

MORRALL, LILIAN ETHEL, formerly of 245 William Street, Sydney, but late of 232 Wood Street, Preston, widow, died 16th July, 1973.

MORRALL, LIONEL ALFRED, formerly of 245 William Street, Sydney, but late of 232 Wood Street, Preston, retired company secretary, died 17th June, 1973.

MOUNTAIN, CARRIE, formerly of 56 Grosvenor Street, South Yarra, but late of "Windsor Hall Rest Home", 8 The Avenue, Windsor, spinster, died 21st November, 1973.

MCLEOD, IRENE OLIVE, formerly of 6 Alandale Road, Mentone, but late of 1 Freda Avenue, Cheltenham, widow, died 21st November, 1973.

O'BRIEN, FRANCIS JOSEPH, late of 17 Denmark Street, Kew, public accountant, died 23rd August, 1973.

O'CONNOR, THOMAS, late of 2A Sydenham Street, Moonee Ponds, retired investor, died 7th October, 1973.

PLANT, JOHANNA, also known as Johanna Amelya Plant, formerly of 315 Punt Road, Richmond, but late of Flat 10, 7 McGrath Court, Richmond, widow, died 30th August, 1973.

RANSFORD, ADA MAY, late of 49 Cornwall Street, West Brunswick, widow, died 27th July, 1973.

SMITH, WILLIAM ALFRED, late of 1 Robb Street, Spotswood, retired labourer, died 1st August, 1973.

SPONG, MARY LAURA, formerly of 13 Carlyle Street, East Hawthorn, but late of "Bethany", 440 Camberwell Road, Camberwell, widow, died 4th November, 1973.

TAFT, LILIAN, late of The Netherlands, Sale, widow, died 31st July, 1966.

THOMLINSON, JOHN ROBERT, late of 578 Bell Street, Pascoe Vale, retired gardener, died 30th November, 1973.

WARD, CHARLES WRINN, also known as Charles Ward, but late of 132 Rossmoyne Street, Thornbury, retired public servant, died 9th November, 1973.

WILSON, SOPHIA URSULA NELLIE ROSE, also known as Sophia Nellie Rose Wilson, formerly of 1 Holmes Street, Northcote, but late of 61 Dickens Street, Lalor, widow, died 12th November, 1973.

N. P. BRODÝ,
Public Trustee.

Melbourne, 6th February, 1974.

CONTRACTS ACCEPTED.—(Series 1973-74.)

PUBLIC WORKS.

873. Yallourn, Technical College, heating and hot-water services, library, \$13,092.00.—Allied Air Conditioning (Contractors) Pty. Ltd.

874. Hughesdale, Primary School 4176, asphalt repairs and drainage, \$7,041.50.—Ajax Constructions.

875. Noble Park, High School, heating and hot-water services, library, \$14,170.00.—Chadstone Air Conditioning Services Pty. Ltd.

876. Oakleigh, High School, heating and hot-water services, library, \$14,140.00.—Chadstone Air Conditioning Services Pty. Ltd.

877. Yallourn, Technical College, erection of library, \$119,523.00.—W. G. Campbell Constructions Pty. Ltd.

878. Greythorn, High School, electrical services, library, \$8,070.00.—Electrite.

879. Macleod, Technical School, electrical services, library, \$7,913.00.—Electrite.

880. Thornbury, High School, electrical services, library, \$7,900.00.—Electrite.

881. Noble Park, High School, erection of library, \$106,772.00.—C. D. Mason Pty. Ltd.

882. Doveton, Technical School, site works, \$43,124.20.—Guenther Mueller.

883. Doveton West, Primary School 4820, asphalt repairs and drainage improvements, \$5,573.60.—Mulcrete Site-works Co.

884. Trafalgar, High School, electrical services, alterations and additions, \$5,989.00.—John McGarry.

885. Numurkah, High School, supply lathes, \$7,367.35.—McPhersons Ltd.

886. P.W.D. Plant Depot, Port Melbourne, supply winches, \$53,760.00.—Eastman Booth Pty. Ltd.

887. Boronia, Technical School, supply workshop equipment, \$4,924.00.—McPhersons Ltd.

888. Box Hill, Technical School, supply lathes, \$7,115.00.—McPhersons Ltd.

889. Mooroolbark, Technical School, supply lathes, \$8,840.00.—McPhersons Ltd.

890. Traralgon, Hobson Park Hospital, supply and fit curtains, \$7,043.63.—G. Jeffrey Pty. Ltd.

891. Williamstown, P.W.D. Dredging Depot, supply diesel marine engine, \$9,002.50.—Detroit Engine & Tool Co.

892. Clayton, Technical School, supply lathes, \$7,115.00.—McPhersons Ltd.

893. Melbourne, Titles Office, supply filing cabinets, \$6,935.85.—Brownbuilt Ltd.

894. Kerang, High School, supply and place furniture, \$6,898.00.—Bera Furniture Pty. Ltd.

G. SERPELL, Director-General of Public Works. 8.2.74.

GENERAL STORES.

Gazette No. 77, 30th July, 1973, Schedule No. 49, Steel (Mild). Item No. 2, substitute (A.A.) Lords Price List of 16th December, 1973, to operate from that date.

PROVISIONS.

Gazette No. 42, 1st June, 1973.—For rates shown opposite the following items, substitute the rates, as set out below from the dates shown:—Schedule No. 6, Ararat District, Sub-schedule No. 4; Item No. 5, \$19.42; Item No. 11, \$9.36; Item No. 20, \$2.87; Item No. 28, \$3.21; Item No. 47, \$3.10; Item No. 50, \$2.80; Item No. 54, \$0.49, as from 1st February, 1974. Sub-schedule No. 5, Jams, Item No. 1, \$5.51; Item No. 2, \$10.27, as from 1st February, 1974. Schedule No. 7, Ballarat District, Sub-schedule No. 4, Teachers' College Hostels; Item No. 3, \$0.45; Item No. 8, Cornflakes Large, \$5.47; All Bran, \$3.34; Item No. 9, 8 oz., \$3.88, 6 lb., \$3.61; Item No. 11, \$9.27; Item No. 12, 25 kg, \$29.67; Item No. 13, \$0.485; Item No. 27, 8 oz., \$5.98, 16 oz., \$10.68; Item No. 29, \$10.29; Item No. 32, \$5.85; Item No. 33, Fresh and in sauce, \$4.89; Item No. 35, \$2.79; Item No. 59, \$3.12; Item No. 75, 25 kg, \$7.00; Item No. 103, \$3.12; Item No. 106, \$3.02; Item No. 115, \$2.42; Item No. 121, \$3.12, as from 1st February, 1974. Sub-schedule No. 5, Lakeside Hospital; Item No. 1, \$3.34; Item No. 12, \$5.49; Item No. 13, \$0.41; Item No. 51, \$2.76, from 1st February, 1974. Sub-schedule No. 6, Jams; Item No. 1, \$5.30, from 1st February, 1974. Schedule No. 21, Pleasant Creek Special School, Stawell, Sub-schedule No. 1; Item No. 2, \$8.84 per 67 kilo bag. Sub-schedule No. 4; Item No. 7, \$0.495; Item No. 8, \$9.38, from 1st February, 1974. Schedule No. 8, Beechworth District, Sub-schedule No. 4; Item No. 13, \$1.45, as from 15th February, 1974. Schedule No. 22, Sunbury District; Sub-schedule

No. 1; Item No. 6, \$0.36; Item No. 9, \$0.70; Item No. 20, \$3.96; Item No. 24, \$1.20; Item No. 28, \$0.20; Item No. 39, \$3.80; Item No. 41, \$7.20; Item No. 49, \$4.40; Item No. 54, \$1.05, as from 1st February, 1974.

MOTOR SPIRIT.

Gazette No. 22, 30th March, 1972.—The following amendment is made to the list for country areas. Healesville—Delete "Mike Grigg Ford" Esso.

E. P. WATSON, Secretary to the Tender Board. 12.2.74.

Police Regulation Act 1958, Section 122.

SALE OF UNCOLLECTED MOTOR VEHICLE.

An owner is required for a 1954 model Holden Sedan, registration No. HTD074, engine No. 275116.

The vehicle came into the possession of Police on the 19th August, 1972, and if not claimed, will be sold by public auction at the Oakleigh Police Station, 82 Atkinson Street, Oakleigh, at 2 p.m., on the 15th March, 1974.

R. JACKSON,
Chief Commissioner of Police.

APPOINTMENTS AND RESIGNATIONS

APPOINTMENTS.

The Lieutenant-Governor as Deputy for His Excellency the Governor of the State of Victoria, by and with the advice of the Executive Council thereof, has, by Orders made on the 5th day of February, 1974, been pleased to make the under-mentioned appointments, viz.:—

MINISTRY OF HEALTH.
Trustees of Cemeteries.

BERT CORP
to be a Trustee of the Violet Town Public Cemetery, vice T. Errey, deceased.

REX RINGE,
BASIL HOWARD,
JOHN MCKINSTRY, and
ALLAN GEE,

to be Trustees of the Goornong Public Cemetery, additional trustees, pursuant to section 3 (1) of the *Cemeteries Act 1958.*

Public Vaccinator.

DONALD NEIL HEWSON, M.B., B.S.
to be Public Vaccinator for the Municipality of the City of Waverley, pursuant to section 151 of the *Health Act 1958.*

Official Visitors.

CHARLES BRIDGES-WEBB, M.B., B.S.,
GARTH HACKFORD, L.L.B.,
DAWN SAUNDERS,
JESSICA JACKA,
Reverend WILFRED GRIFFITHS, and
HELEN JONES,

to be Official Visitors to Hobson Park Psychiatric Hospital, Traralgon, for a period of five years, pursuant to the provisions of section 66 of the *Mental Health Act 1959.*

Medical Officer.

ROSSLYN BYERS ROBINSON, M.B., B.S.
to be a Medical Officer, Mental Hygiene Branch, Department of Health, pursuant to the provisions of section 20 (3) of the *Mental Health Act 1959.*

LAW DEPARTMENT.

Commissioners for Taking Declarations, &c.

HAROLD JOHN LINES, 10 Florida-drive, Ferntree Gully,
ALFRED WILLIAM CARRIGAN, 41 Vanbrook-street, Forest Hill,

TONY MICHAEL RUSS, 8 Scobie-street, Kyabram,
DONALD JOHN STONEHOUSE, 7 Coleman-court, Cheltenham,

PASQUALE LEGGIERO, 13 Legh-street, Reservoir,
WILLIAM PAUL WALSH, 12 Lexington-street, Vermont,
KANUPARTHY JAYARAM NAIDU, care of Bradford Insulation (Victoria) Pty. Ltd., Wellington-road, Clayton,

BRIAN THOMAS COCKERALL, 34 Axford-crescent, South Oakleigh,

IVAN LEWIS ELVISH, 8 Sherlowe-court, East Bentleigh,
GARRY KNOX ENGEL, care of Fitzgerald Gunn & Partners, 470 Collins-street, Melbourne,

CLEVEN JAMES HEALEY, 217 Essex-street, West Footscray,

ALEXANDER WRIGHT ROBERTSON, care of Crawford Bridge & Co. Pty. Ltd., 36 Railway-avenue, Ringwood East,

EON DOUGLAS MACAULAY, care of Echuca District Hospital, Francis-street, Echuca,

BARRY PRIESTLEY, care of A.M.P. Society, 535 Bourke-street, Melbourne,

STIRLING BRUCE WARREN, 27 Coronation-street, East Brighton,

CLIFFORD HARRY STACEY, 1/33 Kingsley-street, Elwood, and

KEITH GORDON MURPHY, care of Bank of New South Wales, 368 Collins-street, Melbourne,
to be Commissioners for taking Declarations and Affidavits under the *Evidence Act 1958.*

Justices of the Peace.

ALBERT WILLIAM DRAYTON, Digney's Bridge-road, Timboon,

JOHN ANTONIADIS, 22 Elizabeth-street, East Coburg,
WILLIAM ALAN LESLIE, 3 Dougherty-street, Horsham, and

MAURICE JAMES O'CONNOR, 9 Dimboola-road, Horsham,
to Keep the Peace in the State of Victoria.

Deputy Prothonotary.

MAXWELL MAURICE SAUNDER
to be Deputy Prothonotary at Hamilton, vice P. W. Westmore, transferred, to take effect from the date of commencement of duty.

Assistant Registrar for County Court.

LEIGH GEOFFREY DENT
to be Assistant Registrar at Ouyen for the County Court at Mildura, vice B. J. Maher absent on recreation leave, to take effect from the date of commencement of duty.

T. J. FORRISTAL,
Clerk of the Executive Council.
At the Executive Council Chamber,
Melbourne, 5th February, 1974.

Imitation Milk Act 1969.

APPOINTMENT OF ADVISORY COMMITTEE.

I, Ian Winton Smith, being the responsible Minister of the Crown for the time being administering the *Imitation Milk Act 1969*, hereby appoint the under-mentioned persons to be members of the Advisory Committee pursuant to section 4 of the said Act for a period of three years from and inclusive of the 6th February, 1974:—

ERNEST JOHN O'BRIEN, Representative of the Department of Agriculture and Chairman of the Committee.

OWEN RUTHERFORD BROWNE, Representative of the Milk Board.

VERNON LESLIE COLLINS, A person nominated by the governing body of the Victorian Branch of the Australian Medical Association.

RUPERT RUSHBY RUDDER, A person nominated by the governing body for Victoria of the Processed Milk Manufacturers Association of Australia Limited.

HERBERT JOHN ROBERTS, A person deemed by the Minister to be representative of dairy farmers in Victoria.

Dated at Melbourne this 6th day of February, 1974.

IAN SMITH,
Minister of Agriculture.

Filled Milk Act 1958.

APPOINTMENT OF ADVISORY COMMITTEE.

I, Ian Winton Smith, being the responsible Minister of the Crown for the time being administering the *Filled Milk Act 1958*, hereby appoint the under-mentioned persons to be members of the Advisory Committee in accordance with section 3 of the said Act for a period of three (3) years from and inclusive of the 6th February, 1974.

ERNEST JOHN O'BRIEN, Chairman of the Committee, who is a representative of the Department of Agriculture.

OWEN RUTHERFORD BROWNE, who is a representative of the Milk Board.

VERNON LESLIE COLLINS, who is a person nominated by the governing body for Victoria of the Australian Medical Association.

RUPERT RUSHBY RUDDER, who is a person nominated by the governing body for Victoria of the Processed Milk Manufacturers Association of Australia Limited.

HERBERT JOHN ROBERTS, who is a person deemed by the Minister to be representative of dairy farmers in Victoria.

Dated at Melbourne this 6th day of February, 1974.

IAN SMITH,
Minister of Agriculture.

Liquor Control Act 1968.

APPOINTMENT OF LICENSING INSPECTOR.

In accordance with the authority conferred upon me by sub-section (1) of section 22 of the *Liquor Control Act 1968*, I, Reginald Jackson, Chief Commissioner of Police, hereby appoint the following Officer of Police as Licensing Inspector for the Division of the Police District as shown :—

Division Number.	Police District.	Rank and Name.
4	Sunshine	Inspector Thomas Owen Daly (from 11.2.74 to 6.3.74)

5.2.1974. R. JACKSON,
Chief Commissioner of Police.

Liquor Control Act 1968.

APPOINTMENT OF LICENSING INSPECTOR.

In accordance with the authority conferred upon me by sub-section (1) of section 22 of the *Liquor Control Act 1968*, I, Reginald Jackson, Chief Commissioner of Police hereby appoint the following Officer of Police as Licensing Inspector for the Division of the Police District as shown :—

Division Number.	Police District.	Rank and Name.
2	Melbourne	Inspector Max Bruce (from 10.2.74 to 1.3.74)

4.2.1974. R. JACKSON,
Chief Commissioner of Police.

RESIGNATIONS.

The Lieutenant-Governor as Deputy for His Excellency the Governor of the State of Victoria, by and with the advice of the Executive Council thereof, has, by Orders made on the 5th day of February, 1974, accepted the resignation of the persons named hereunder of the offices mentioned, viz.:—

LAW DEPARTMENT.

Commissioners for Taking Declarations, &c.

FRANK BARIDON HILL, and
ERIC WILLIAM POTTER,
as Commissioners for taking Declarations and Affidavits under the Evidence Act 1958.

Justices of the Peace.

CLARENCE EDWIN CHAPLIN,
PETER CHATHAM, and
JOHN HERBERT EDWIN PULLMAN,
as Justices of the Peace for the State of Victoria.

T. J. FORRISTAL,
Clerk of the Executive Council.

At the Executive Council Chamber,
Melbourne, 5th February, 1974.

ORDERS IN COUNCIL

CAMPERDOWN SEWERAGE AUTHORITY.

At the Executive Council Chamber, Melbourne, the
fifth day of February, 1974.

PRESENT:

The Lieutenant-Governor as Deputy for His Excellency the
Governor of Victoria.

Mr. Byrne | Mr. Dickie.
Mr. Wilcox

AMENDMENT OF ORDER.

Under the powers conferred by the Sewerage Districts Act and all other powers enabling him in that behalf, the Lieutenant-Governor as Deputy for His Excellency the Governor of the State of Victoria, by and with the advice of the Executive Council of the said State, hereby

amends as follows the Order in Council constituting the Camperdown Sewerage Authority made on 7th March, 1950, as amended by Order made on 21st October, 1952, and published in the *Government Gazette*, dated 15th March, 1950, and 29th October, 1952, respectively.

In clause (d) for the words "Borough of Camperdown" there shall be substituted the words "Town of Camperdown".

And the Honorable Frederick James Granter, Her Majesty's Minister of Water Supply for the State of Victoria, shall give the necessary directions herein accordingly.

T. J. FORRISTAL,
Clerk of the Executive Council.

COUNTRY ROADS BOARD.

At the Executive Council Chamber, Melbourne, the
fifth day of February, 1974.

PRESENT:

The Lieutenant-Governor as Deputy for His Excellency the
Governor of Victoria.

Mr. Byrne | Mr. Dickie.
Mr. Wilcox

ORDER APPROVING OF LAND BEING ACQUIRED AND ROADS, DEVIATIONS OR WIDENINGS BEING MADE.

The Lieutenant-Governor as Deputy for His Excellency the Governor of the State of Victoria, by and with the advice of the Executive Council thereof, being satisfied that there are funds legally available for acquiring the land, doth hereby approve the acquiring of the land described in the schedule hereunder and the making of new roads and deviations from and widenings of existing roads referred to in the said schedule.

SCHEDULE.

Main roads.

The land shown hatched on plan numbered G.P.13307 hereunder required for the widening of the Carrajung-Woodside Road in the Shire of Alberton and making of the widening thereon.

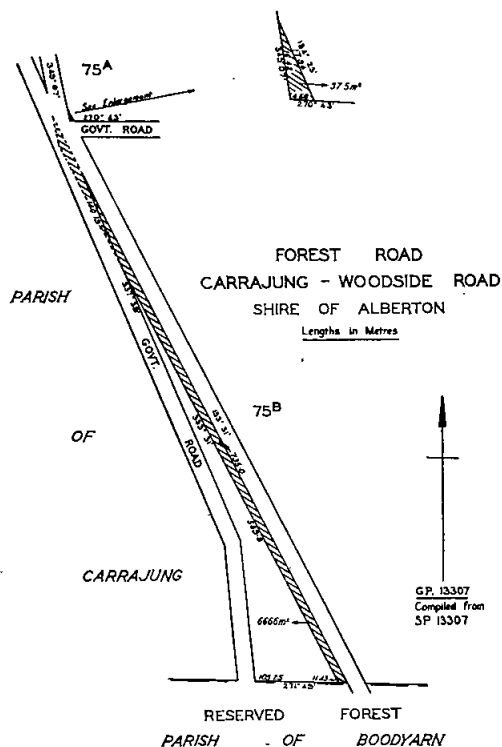

The land shown hatched on plan numbered G.P.13305 hereunder required for the widening of the Yarram-Port Albert Road in the Shire of Alberton and making of the widening thereon.

MAIN ROAD
YARRAM - PORT ALBERT ROAD
SHIRE OF ALBERTON
Lengths in Metres

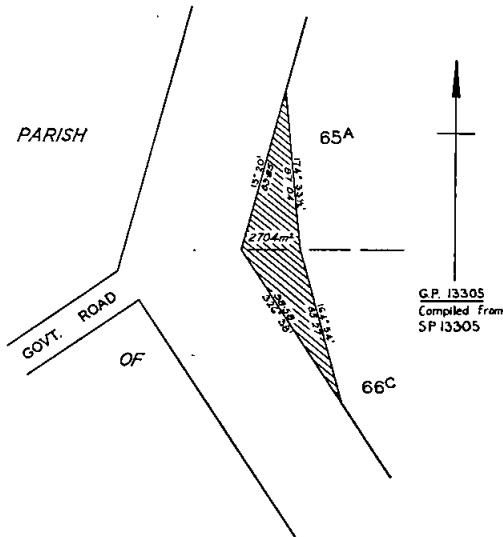

The land shown hatched on plan numbered G.P.13479 hereunder required for the widening of the Warrandyte-Ringwood Road in the City of Doncaster and Templestowe and making of the widening thereon.

MAIN ROAD
WARRANDYTE - RINGWOOD ROAD
CITY OF DONCASTER & TEMPLESTOWE
Lengths in Metres

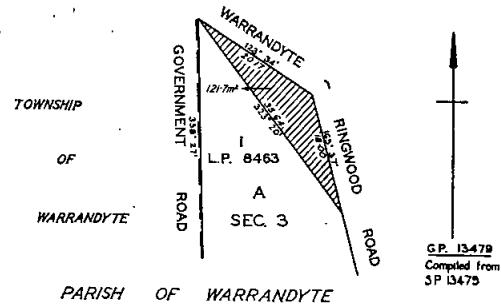

ALBERTON EAST
The land shown hatched on plan numbered G.P.13370 hereunder required for the widening of the Wonthaggi-Loch Road in the Shire of Bass and making of the widening thereon.

MAIN ROAD
WONTHAGGI - LOCH ROAD
SHIRE OF BASS
Lengths in Metres

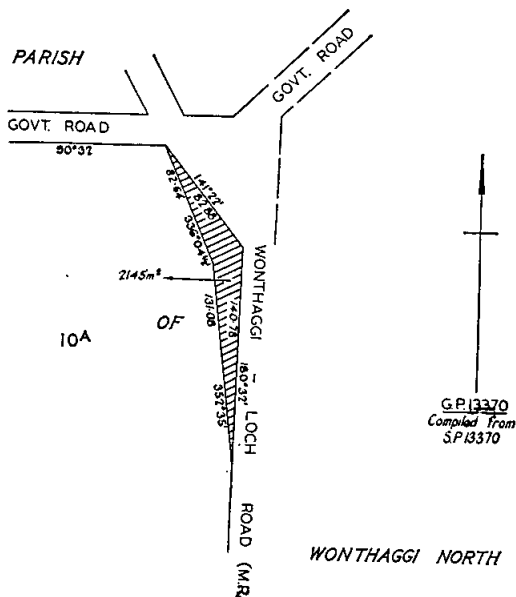

The land shown hatched on plan numbered G.P.13411 hereunder required for the deviation from the Shepparton-Dookie Road in the Shire of Shepparton and making of the deviation thereon.

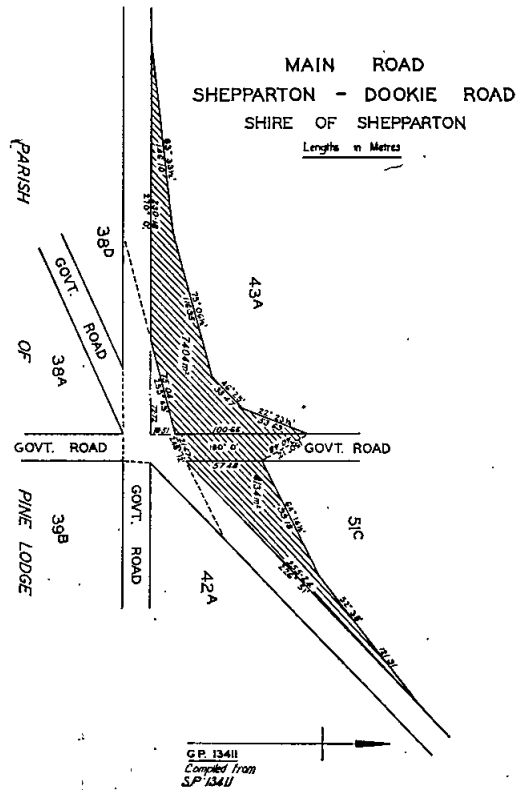

The land shown hatched on plan numbered G.P.13467A, G.P.13467B and G.P.13467C hereunder required for the widening of the Warragul-Leongatha Road in the Shire of Warragul and making of the widening thereon.

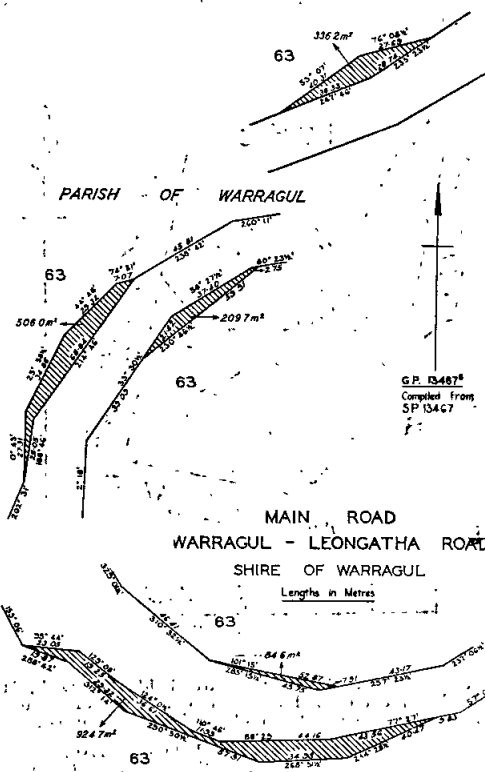
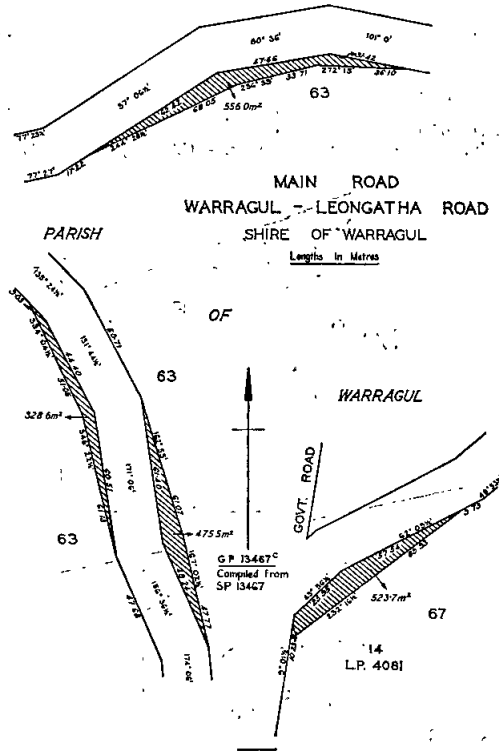
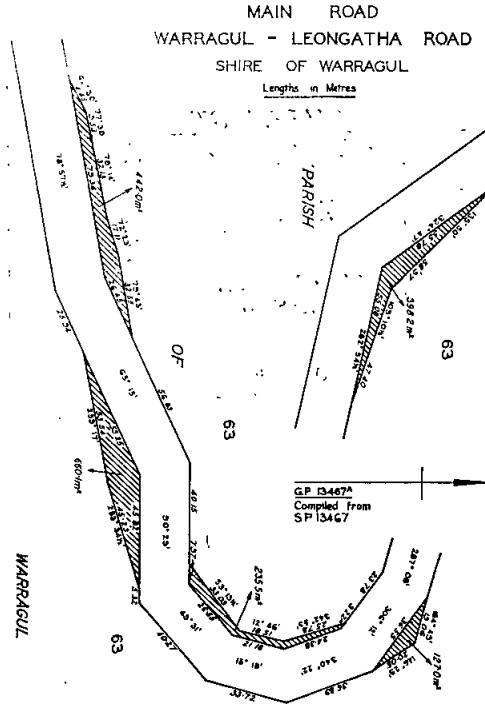

And the Honorable Edward Raymond Meagher, Her Majesty's Minister of Transport for the State of Victoria shall give the necessary directions herein accordingly.

T. J. FORRISTAL,
Clerk of the Executive Council.

CEMETERIES ACT 1958 (No. 6217), SECTION 36.

At the Executive Council Chamber, Melbourne, the fifth day of February, 1974.

PRESENT:

The Lieutenant-Governor as Deputy for His Excellency the Governor of Victoria.
Mr. Byrne | Mr. Dickie.
Mr. Wilcox

Pursuant to Section 36 of the Cemeteries Act 1958, the Lieutenant-Governor as Deputy for His Excellency the Governor of the State of Victoria, by and with the advice of the Executive Council of the said State, hereby directs that the sum of Two thousand dollars (\$2,000), being part of the balance of funds in the hands of the trustees of the Benalla Public Cemetery be expended on the purchase of a gang mower.

And the Honorable Alan Henry Scanlan, Her Majesty's Minister of Health for the State of Victoria, shall give the necessary directions herein accordingly.

T. J. FORRISTAL,
Clerk of the Executive Council.

DEPARTMENT OF CROWN LANDS AND SURVEY.

At the Executive Council Chamber, Melbourne, the fifth day of February, 1974.

PRESENT:

The Lieutenant-Governor as Deputy for His Excellency the Governor of Victoria.
Mr. Byrne | Mr. Dickie.
Mr. Wilcox

LANDS TEMPORARILY RESERVED AS SITES.

The Lieutenant-Governor as Deputy for His Excellency the Governor of the State of Victoria, by and with the advice of the Executive Council thereof, doth hereby, in pursuance of section 14 of the Land Act 1958, reserve

temporarily from sale, from being leased and from having a licence granted in respect thereof, and also except from occupation for mining purposes under any miner's right, the land hereinafter described:—

CHILTERN WEST.—Site for Water Supply purposes, 1.302 hectares, being Crown allotments 175F and 221H, Parish of Chiltern West, County of Bogong, as indicated by hatching on plan hereunder.—(C.381^(a)) (Rs.9829).

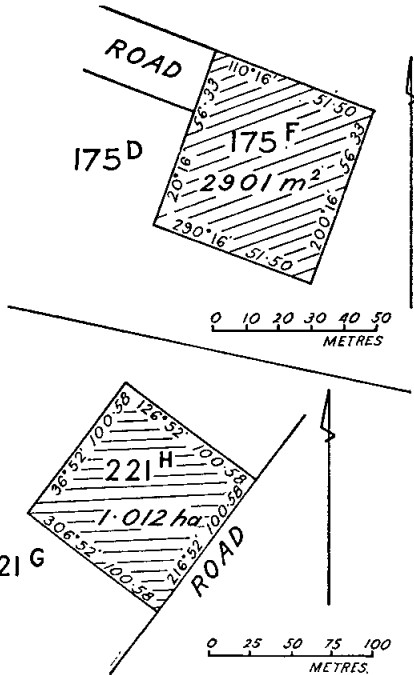

Total Area of Hatched Portions 1.302 ha

ROSEDALE.—Site for Public purposes (Police purposes), 750 square metres, more or less, being Crown allotment 2B, section 1, Township of Rosedale, Parish of Rosedale, County of Buln Buln, as indicated by hatching on plan hereunder.—(R.35^(a)) (Rs.9840).

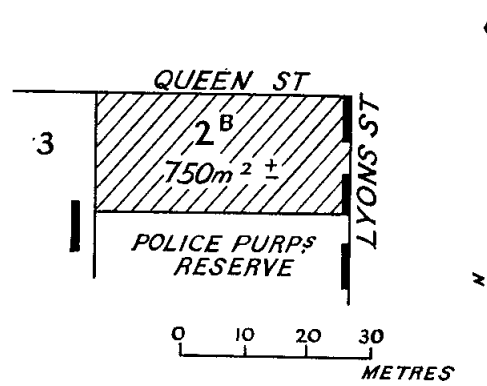

SALE.—Site for State (High) School purposes, 1.06 hectares, more or less, being Crown allotment 2, section 6, Township of Sale, Parish of Sale, County of Tanjil, as indicated by hatching on plan hereunder.—(S.239^(a)) (Rs.894).

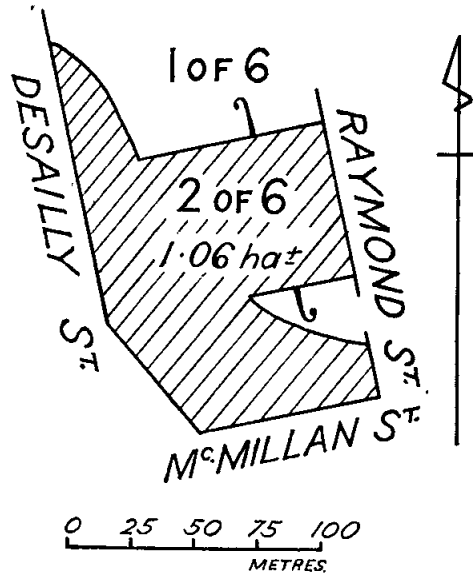

JIKA JIKA (FITZROY).—Site for State (High) School purposes, 4044 square metres, being Crown portion 71B, Parish of Jika Jika, County of Bourke, as indicated by hatching on plan hereunder.—(F.99^(a)) (Rs.9839).

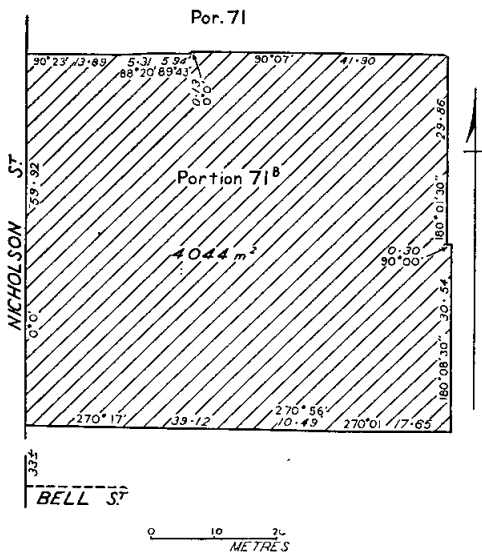

And the Honorable William Archibald Borthwick, Her Majesty's Minister of Lands for the State of Victoria, shall give the necessary directions herein accordingly.

T. J. FORRISTAL,
Clerk of the Executive Council.

DEPARTMENT OF CROWN LANDS AND SURVEY.

Township of Wonthaggi, Parish of Wonthaggi, County of Mornington, being the roads as indicated by hatching on plan hereunder.—(W.345⁽¹⁶⁾(17) (G.69003).

At the Executive Council Chamber, Melbourne, the fifth day of February, 1974.

PRESENT:

The Lieutenant-Governor as Deputy for His Excellency the Governor of Victoria.

Mr. Byrne Mr. Dickie.
Mr. Wilcox

UNUSED ROADS CLOSED.

The Lieutenant-Governor as Deputy for His Excellency the Governor of the State of Victoria, by and with the advice of the Executive Council thereof, and the concurrence in writing of the Council of the municipality concerned, doth hereby direct that in pursuance of the provisions of section 349 of the Land Act 1958, the unused roads referred to hereunder be closed, viz.:—

Parish of Omeo, County of Bogong, being the road indicated by hatching on plan hereunder.—(O.19⁽¹⁰⁾ (H.033941).

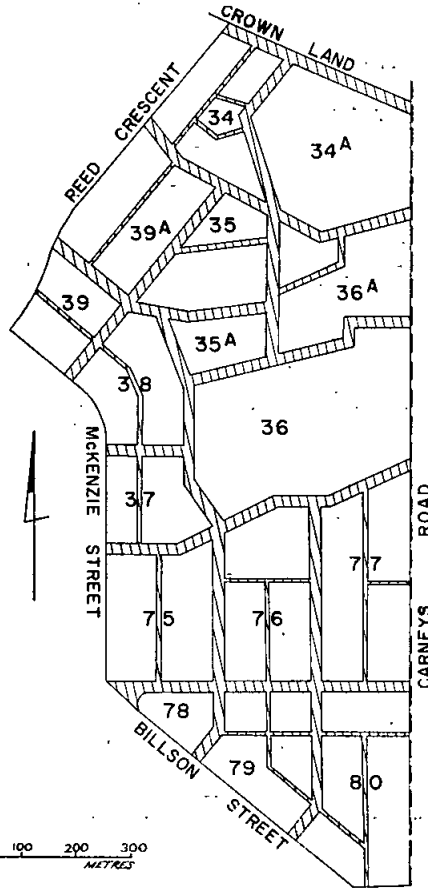
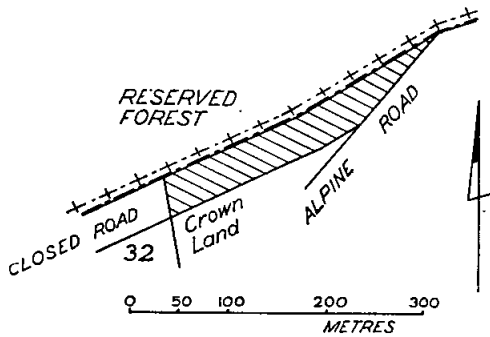

Parishes of Krambruk and Wongarra, County of Polwarth, being the roads as indicated by hatching on plan hereunder.—(K.149⁽¹²⁾, W.374⁽⁵⁾ (Misc.3856).

Parish of Sandhurst, County of Bendigo, being the road as indicated by hatching on plan hereunder.—(S.371⁽⁵⁰⁾ (Rs.1741).

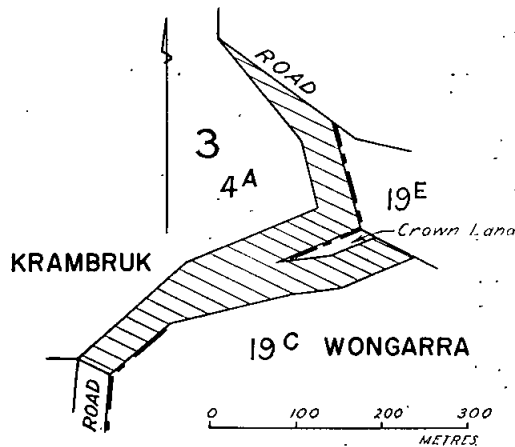
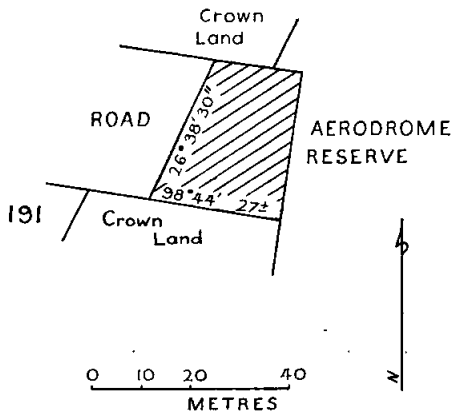

And the Honorable William Archibald Borthwick, Her Majesty's Minister of Lands for the State of Victoria, shall give the necessary directions herein accordingly.

T. J. FORRISTAL,
Clerk of the Executive Council.

LOCAL GOVERNMENT DEPARTMENT.

At the Executive Council Chamber, Melbourne, the
fifth day of February, 1974.

PRESENT:

The Lieutenant-Governor as Deputy for His Excellency the
Governor of Victoria.

Mr. Byrne		Mr. Dickie.
Mr. Wilcox		

CONSENT TO THE INCLUSION OF A PROPERTY
DURING THE CURRENCY OF A SEPARATE RATE—
SHIRE OF ELTHAM.

Whereas:

- (a) By Order published in the *Government Gazette* on the 21st February, 1973, the Governor in Council, pursuant to the provisions of Section 287 of the *Local Government Act 1958*, confirmed a separate rate made by the Council of the Shire of Eltham on the 6th November, 1972 for the purpose of constructing retaining walls in Rattray-road, Montmorency.
- (b) The Council of the Shire of Eltham is now of the opinion that a certain property being Number 174 Rattray-road, Montmorency, not being a property with respect to which the rate is levied would benefit from the works or undertakings carried out or to be carried out with the proceeds of the rate or with any moneys borrowed on the security of the rate; and
- (c) The Council has not sooner than one month after serving written notice on the owner and occupier of the said property made and levied a rate of three point four four (3.44) cents in the dollar on the unimproved capital value of the property.

Now therefore, the Lieutenant-Governor as Deputy for His Excellency the Governor of the State of Victoria, by and with the advice of the Executive Council thereof and in pursuance of the provisions of Section 290 of the said Act hereby consents to the rate so made and levied forming part of the separate rate confirmed by notice published in the *Government Gazette* as aforesaid.

And the Honorable Alan John Hunt, Her Majesty's Minister for Local Government for the State of Victoria, shall give the necessary directions herein accordingly.

T. J. FORRISTAL,
Clerk of the Executive Council.

MOTOR CAR ACT 1958.

At the Executive Council Chamber, Melbourne, the
fifth day of February, 1974.

PRESENT:

The Lieutenant-Governor as Deputy for His Excellency the
Governor of Victoria.

Mr. Byrne		Mr. Dickie.
Mr. Wilcox		

Whereas it is enacted by sub-section (2) of section eighty-three of the *Motor Car Act 1958*, that if a motor car is used on a highway for purposes of racing or of trial of speed, the driver or the person in charge thereof shall be liable to a penalty of not more than One hundred dollars, provided that the said sub-section (2) shall not apply to a motor car used as aforesaid on any highway or portion thereof specified by Order in Council published in the *Government Gazette* and on such days and during such hours as are specified in the Order:

And whereas the Western District Car Club Inc. has requested that such an Order be made so as to enable motor car trials of speed to be conducted by the said Club on Beach Road, between Pousties Road and the 29 Mile Road on Sunday the 10th day of March, 1974, and Sunday, the third day of November, 1974:

Now therefore, the Lieutenant-Governor as Deputy for His Excellency the Governor of the State of Victoria, by and with the advice of the Executive Council thereof, and in pursuance of the powers conferred by the *Motor Car Act 1958*, doth by this Order specify Beach Road, between Pousties Road and the 29 Mile Road, within the municipal district of the Shire of Corio as a highway in respect of which any motor car may, without being subject to the application of the said sub-section (2) of section eighty-three of the *Motor Car Act 1958* be used for purposes of trials of speed under the control and supervision of the said Western District Car Club Inc. on

Sunday the 10th day of March, 1974, between the hours of twelve o'clock noon and five o'clock in the afternoon, and on Sunday, the 3rd day of November, 1974, between the hours of twelve o'clock noon and five o'clock in the afternoon, provided that, on each occasion, the officer in charge of police in attendance is satisfied that such highway is in a satisfactory condition for racing purposes and that adequate arrangements have been made for the safety of the public.

And the Honorable John Frederick Rossiter, Her Majesty's Chief Secretary for the State of Victoria, shall give the necessary directions herein accordingly.

T. J. FORRISTAL,
Clerk of the Executive Council.

SUPERANNUATION ACT 1958.

At the Executive Council Chamber, Melbourne, the
fifth day of February, 1974.

PRESENT:

The Lieutenant-Governor as Deputy for His Excellency the
Governor of Victoria.

Mr. Byrne		Mr. Dickie.
Mr. Wilcox		

Pursuant to the powers conferred by the provisions of paragraph (ja) of sub-section (1) of section 3 of the *Superannuation Act 1958*, the Lieutenant-Governor as Deputy for His Excellency the Governor of the State of Victoria, by and with the advice of the Executive Council thereof, doth by this Order declare that the provisions of the *Superannuation Act* shall apply to Geoffrey Norman Easton being an officer of the State College of Victoria at Toorak, constituted pursuant to the provisions of the *Education Act 1958* No. 6240.

And the Honorable Rupert James Hamer, Her Majesty's Treasurer for the State of Victoria, shall give the necessary directions herein accordingly.

T. J. FORRISTAL,
Clerk of the Executive Council.

SUPERANNUATION ACT 1958.

At the Executive Council Chamber, Melbourne, the
fifth day of February, 1974.

PRESENT:

The Lieutenant-Governor as Deputy for His Excellency the
Governor of Victoria.

Mr. Byrne		Mr. Dickie.
Mr. Wilcox		

Pursuant to the powers conferred by the provisions of paragraph (ja) of sub-section (1) of section 3 of the *Superannuation Act 1958*, the Lieutenant-Governor as Deputy for His Excellency the Governor of the State of Victoria, by and with the advice of the Executive Council thereof, doth by this Order declare that the provisions of the *Superannuation Act* shall apply to:—

Blashki, Susan Adele
Frey, David Loeb
Jehne, Claus, and
Stewart, Douglas Edward
being officers of the State College of Victoria, Rusden, constituted pursuant to the provisions of the *Education Act 1958* No. 6240.

And the Honorable Rupert James Hamer, Her Majesty's Treasurer for the State of Victoria, shall give the necessary directions herein accordingly.

T. J. FORRISTAL,
Clerk of the Executive Council.

SUPERANNUATION ACT 1958.

At the Executive Council Chamber, Melbourne, the
fifth day of February, 1974.

PRESENT:

The Lieutenant-Governor as Deputy for His
Excellency the Governor of Victoria.

Mr. Byrne		Mr. Dickie.
Mr. Wilcox		

Pursuant to the powers conferred by the provisions of paragraph (ja) of sub-section (1) of Section 3 of the *Superannuation Act 1958*, the Lieutenant-Governor as

Deputy of His Excellency the Governor of the State of Victoria, by and with the advice of the Executive Council thereof, doth by this Order declare that the provisions of the Superannuation Act shall apply to:—

Morgan, Maureen Therese,
Wangler, Joy Elizabeth,
Prevett, Patrick Thomas, and
Hook, Robert Malcolm,

being officers of the State College of Victoria at Ballarat constituted, pursuant to the provisions of the Education Act 1958, No. 6240.

And the Honorable Rupert James Hamer, Her Majesty's Treasurer for the State of Victoria, shall give the necessary directions herein accordingly.

T. J. FORRISTAL,
Clerk of the Executive Council.

STATE ELECTRICITY COMMISSION ACT 1958, No. 6377.

At the Executive Council Chamber, Melbourne, the
fifth day of February, 1974.

PRESENT:

The Lieutenant-Governor as Deputy for His Excellency the Governor of Victoria.

Mr. Byrne | Mr. Dickie.
Mr. Wilcox |

Whereas the Lieutenant-Governor as Deputy for His Excellency the Governor of the State of Victoria by and with the advice of the Executive Council thereof, has this day consented pursuant to the provisions of the State Electricity Commission Act 1958 to the State Electricity Commission of Victoria raising by way of loan the sum of Two hundred and fifty-seven thousand seven hundred dollars (\$257,700): And whereas His Excellency the Governor in Council is satisfied that a sufficient proportion of the loan to be raised will fall due and be repaid in each year during the currency of the proposed loan: Now therefore it is directed pursuant to the provisions of section 91 (3) of the said Act, that it shall not be necessary to provide a sinking fund in connection with such loan.

And the Honorable Rupert James Hamer, Her Majesty's Treasurer for the State of Victoria, shall give the necessary directions herein accordingly.

T. J. FORRISTAL,
Clerk of the Executive Council.

TOWN AND COUNTRY PLANNING ACT 1961.

At the Executive Council Chamber, Melbourne, the
fifth day of February, 1974.

PRESENT:

The Lieutenant-Governor as Deputy for His Excellency the Governor of Victoria.

Mr. Byrne | Mr. Dickie.
Mr. Wilcox |

REVOCATION IN PART OF THE BOROUGH OF PORT FAIRY PLANNING SCHEME 1959, REVOCATION No. 1

Whereas it is provided by Sub-sections (4), (4A), (4B) and (4C) of Section 32 of the Town and Country Planning Act 1961 that the Governor in Council, upon application of the Town and Country Planning Board or the Responsible Authority or of any other persons or body of persons may revoke the whole or any part of any planning scheme if he thinks that in the special circumstances of the case it should be revoked;

And whereas an application has been made by the Town and Country Planning Board and the Minister has consulted the Responsible Authority;

And whereas it is provided by Sub-section (5) of Section 32 of the Town and Country Planning Act 1961, that the Governor in Council may by Order prohibit, restrict or regulate the use, or development of any land to which the revoked scheme or part related and shall specify that any use or development permitted under the Order is permitted only subject to the grant of a permit by the Responsible Authority enforcing and carrying out the part of the scheme so revoked;

Now therefore, the Lieutenant-Governor as Deputy for His Excellency the Governor of the State of Victoria, by and with the advice of the Executive Council, doth hereby:—

- (i) revoke the Borough of Port Fairy Planning Scheme 1959, in so far as it applies to all that land described as the land coloured red on the plan attached to Conveyance No. 507 Book 668 being part of Belfast Special Survey in the Parish of Belfast, the boundaries of which are as follows:—

Commencing at a point on the eastern alignment of Gipps-street a distance of 60 feet south of the intersection of the southern alignment of an un-named road 32 ft. 8 in. wide with the eastern alignment of Gipps-street, such intersection being opposite the intersection of the southern alignment of Cox-street with the western alignment of Gipps-street; thence by lines bearing 70 deg. 30 mins. for a distance of 112 feet; 160 deg. 30 mins for a distance of 60 feet; 250 deg. 30 mins. for a distance of 112 feet; 340 deg. 30 mins. along the western alignment of Gipps-street for a distance of 60 feet back to the point of commencement; and

- (ii) order that the said land, subject to the grant of a permit by the Council of the Borough of Port Fairy, may be used or developed for a fish processing workroom and those uses permissible only in the Commercial 'A' Zone of the Borough of Port Fairy Planning Scheme 1959.

And the Honorable Alan John Hunt, Her Majesty's Minister for Local Government for the State of Victoria, shall give the necessary directions herein accordingly.

T. J. FORRISTAL,
Clerk of the Executive Council.

COWES SEWERAGE AUTHORITY.

At the Executive Council Chamber, Melbourne, the
twelfth day of February, 1974.

PRESENT:

His Excellency the Governor of Victoria.
Mr. Borthwick | Mr. Rafferty.
Mr. Houghton |

CONSENT TO BORROWING \$200,000.

Under the powers conferred by the Sewerage Districts Act and all other powers enabling him in that behalf, His Excellency the Governor of the State of Victoria, by and with the advice of the Executive Council of the said State, hereby consents to the Cowes Sewerage Authority borrowing the sum of Two hundred thousand dollars (\$200,000) in two amounts each of One hundred thousand dollars (\$100,000) to meet the cost of sewerage works as set forth in the detailed statement bearing date 7th February, 1974.

And the Honorable Frederick James Granter, Her Majesty's Minister of Water Supply for the State of Victoria, shall give the necessary directions herein accordingly.

T. J. FORRISTAL,
Clerk of the Executive Council.

SALE SEWERAGE AUTHORITY.

At the Executive Council Chamber, Melbourne, the
twelfth day of February, 1974.

PRESENT:

His Excellency the Governor of Victoria.
Mr. Borthwick | Mr. Rafferty.
Mr. Houghton |

CONSENT TO BORROWING \$60,000.

Under the powers conferred by the Sewerage Districts Act and all other powers enabling him in that behalf, His Excellency the Governor of the State of Victoria, by and with the advice of the Executive Council of the said State,

hereby consents to the Sale Sewerage Authority borrowing a sum of Sixty thousand dollars (\$60,000) to meet the cost of sewerage works as set forth in the detailed statement bearing date 6th February, 1974.

And the Honorable Frederick James Granter, Her Majesty's Minister of Water Supply for the State of Victoria, shall give the necessary directions herein accordingly.

T. J. FORRISTAL,
Clerk of the Executive Council.

WONTHAGGI SEWERAGE AUTHORITY.

At the Executive Council Chamber, Melbourne, the twelfth day of February, 1974.

PRESENT:

His Excellency the Governor of Victoria.	
Mr. Borthwick	Mr. Rafferty.
Mr. Houghton	

CONSENT TO BORROWING \$50,000.

Under the powers conferred by the Sewerage Districts Act and all other powers enabling him in that behalf, His Excellency the Governor of the State of Victoria, by and with the advice of the Executive Council of the said State, hereby consents to the Wonthaggi Sewerage Authority borrowing the sum of Fifty thousand dollars (\$50,000) for the carrying out of works in accordance with the provisions of sections 95, 130 and 137 of the Sewerage Districts Act 1958. All moneys received by the said Authority in payment of costs and expenses of the said works, or any of them, shall be set aside for the purpose of and applied in repayment of the said sum so borrowed.

And the Honorable Frederick James Granter, Her Majesty's Minister of Water Supply for the State of Victoria, shall give the necessary directions herein accordingly.

T. J. FORRISTAL,
Clerk of the Executive Council.

DANDENONG VALLEY AUTHORITY.

At the Executive Council Chamber, Melbourne, the twelfth day of February, 1974.

PRESENT:

His Excellency the Governor of Victoria.	
Mr. Borthwick	Mr. Rafferty.
Mr. Houghton	

CONSENT TO BORROWING \$100,000.

Under the powers conferred by the Dandenong Valley Authority Act and all other powers enabling him in that behalf, His Excellency the Governor of the State of Victoria, by and with the advice of the Executive Council of the said State, doth hereby consent to the Dandenong Valley Authority borrowing the sum of One hundred thousand dollars (\$100,000) to meet the cost of river improvement and drainage works.

And the Honorable Frederick James Granter, Her Majesty's Minister of Water Supply for the State of Victoria, shall give the necessary directions herein accordingly.

T. J. FORRISTAL,
Clerk of the Executive Council.

COLERAINE AND CASTERTON WATERWORKS TRUST.

At the Executive Council Chamber, Melbourne, the twelfth day of February, 1974.

PRESENT:

His Excellency the Governor of Victoria.	
Mr. Borthwick	Mr. Rafferty.
Mr. Houghton	

CONSENT TO BORROWING \$20,000.

Under the powers conferred by the Water Act and all other powers enabling him in that behalf, His Excellency the Governor of the State of Victoria, by and with the

advice of the Executive Council of the said State, hereby consents to the Coleraine and Casterton Waterworks Trust borrowing the sum of Twenty thousand dollars (\$20,000) to meet the cost of water supply works.

And the Honorable Frederick James Granter, Her Majesty's Minister of Water Supply for the State of Victoria, shall give the necessary directions herein accordingly.

T. J. FORRISTAL,
Clerk of the Executive Council.

MARYBOROUGH WATERWORKS TRUST.

At the Executive Council Chamber, Melbourne, the twelfth day of February, 1974.

PRESENT:

His Excellency the Governor of Victoria.	
Mr. Borthwick	Mr. Rafferty.
Mr. Houghton	

CONSENT TO BORROWING \$20,000.

Under the powers conferred by the Water Act and all other powers enabling him in that behalf, His Excellency the Governor of the State of Victoria, by and with the advice of the Executive Council of the said State, hereby consents to the Maryborough Waterworks Trust borrowing the sum of Twenty thousand dollars (\$20,000) to meet the cost of water supply works.

And the Honorable Frederick James Granter, Her Majesty's Minister of Water Supply for the State of Victoria, shall give the necessary directions herein accordingly.

T. J. FORRISTAL,
Clerk of the Executive Council.

STATE RIVERS AND WATER SUPPLY COMMISSION.

At the Executive Council Chamber, Melbourne, the twelfth day of February, 1974.

PRESENT:

His Excellency the Governor of Victoria.	
Mr. Borthwick	Mr. Rafferty.
Mr. Houghton	

APPOINTMENT OF AUDITORS.—AMENDMENT OF ORDER.

Under the powers conferred by the Sewerage Districts Act and all other powers enabling him in that behalf, His Excellency the Governor of the State of Victoria, by and with the advice of the Executive Council of the said State, hereby amends as follows the Order in Council made on 4th September, 1973, as amended by Order made on 7th November, 1973, appointing certain persons to audit and report upon the accounts of Sewerage Authorities for the years 1973 and 1974:—

For the name "D. H. McDonald" in column (3) opposite the name "Ocean-grove" in column (1) of the Schedule there shall be substituted the name "G. T. Quinn".

And the Honorable Frederick James Granter, Her Majesty's Minister of Water Supply for the State of Victoria, shall give the necessary directions herein accordingly.

T. J. FORRISTAL,
Clerk of the Executive Council.

LANDS DEPARTMENT NOTICES**APPROACHING LAND SALES.**

Sale of Crown Land, in fee-simple, will be held at the under-mentioned places and dates, viz.:—

	No. of Gazette.
SALE OF CROWN LAND BY AUCTION.	
Beechworth.—Wednesday, 6th March, 1974 ..	7
Bright.—Wednesday, 6th March, 1974 ..	7

COMMON ABOUT TO BE ABOLISHED.

In pursuance of the provisions contained in the *Land Act 1958*, notice is hereby given that it is the intention of the Governor in Council to abolish the common hereinafter mentioned, viz.:—

The following Notice was published 1° on the 23rd January, 1974, pursuant to Order of the 15th January, 1974.

The Edenhope Town Common proclaimed as such by the Governor in Council on the 26th July, 1869, is about to be abolished.—(Rs.666.)

W. BORTHWICK,
Minister of Lands.

COMMITTEES OF MANAGEMENT OF RESERVES.**APPOINTMENTS.**

Notice is hereby given that, in pursuance of Section 221 of the *Land Act 1958*, the following appointments of Committees of Management of reserved Crown Lands have been made by the Minister of Lands:—

"PUBLIC PARK AND RECREATION RESERVE, TOWNSHIP OF ARARAT."

The Corporation of the City of Ararat as the Committee of Management of the land in the Township of Ararat, being Crown allotment 10 of section 51, temporarily reserved pursuant to Order in Council dated the 18th December, 1973, as a site for Public Park and Recreation.—(Corres. No. Rs.9817.)

"PUBLIC PURPOSES RESERVE, PARISH OF BARRARBOOL."

The Geelong Waterworks and Sewerage Trust as the Committee of Management of the land in the Parish of Barrarbool temporarily reserved pursuant to Order in Council dated the 11th December, 1973 as a site for Public purposes.—(Corres. No. C.82635.)

"PUBLIC PURPOSE (HISTORICAL BUILDING) RESERVE, AT BENDIGO."

The Corporation of the City of Bendigo as the Committee of Management of the land in the Parish of Sandhurst, at Bendigo, being allotment 6, temporarily reserved pursuant to Order in Council dated the 18th December, 1973, as a site for Public Purposes (Historical Building).—(Corres. No. Rs.9836.)

"PUBLIC RECREATION RESERVE, TOWNSHIP OF BROADFORD."

The Corporation of the Shire of Broadford as the Committee of Management of the land in the Township of Broadford, being Crown allotment 22, section 38, temporarily reserved pursuant to Order in Council dated the 18th December, 1973, as a site for Public Recreation.—(Corres. No. Rs.5926.)

"PUBLIC PARK RESERVE, TOWNSHIP OF DUNOLLY."

The Corporation of the Shire of Bet Bet as the Committee of Management of the land in the Township of Dunolly, being allotment 22A of section F, temporarily reserved pursuant to Order in Council dated the 18th December, 1973 as a site for a Public Park.—(Corres. No. Rs.9819.)

"PUBLIC PARK AND RECREATION RESERVE, PARISH OF MILDURA."

The Corporation of the Shire of Mildura as the Committee of Management of the land in the Parish of Mildura, being allotment 94B, temporarily reserved pursuant to Order in Council dated the 18th December, 1973, as a site for Public Park and Recreation.—(Corres. No. Rs.9202.)

"PUBLIC PURPOSES (PRE-SCHOOL CENTRE) RESERVE, TOWNSHIP OF PENSURST."

The Corporation of the Shire of Mount Rouse as the Committee of Management of the land in the Township of Penshurst temporarily reserved pursuant to Order in Council dated the 18th December, 1973 as a site for Public purposes (Pre-School Centre).—(Corres. No. Rs.9811.)

"PUBLIC PURPOSES (SEWERAGE DEPOT), RESERVE, WONTHAGGI."

The Wonthaggi Sewerage Authority as the Committee of Management of the land in the Township of Wonthaggi, being Crown allotment 2, section 100, temporarily reserved pursuant to Order in Council dated the 18th December, 1973, as a site for Public purposes (Sewerage Depot).—(Corres. No. Rs.9823.)

W. BORTHWICK,
Minister of Lands.

Department of Crown Lands and Survey,
Melbourne, 7th February, 1974.

PROPOSED REVOCATIONS OF TEMPORARY RESERVATIONS OF LANDS BY ORDERS IN COUNCIL.

In pursuance of the provisions of the *Land Act 1958*, notice is hereby given that it is the intention of the Governor in Council to revoke the temporary reservations of lands by Orders in Council hereunder referred to, viz.:—

The following Notices were published 1° on the 23rd January, 1974, pursuant to Orders of the 15th January, 1974.

BALLAN.—The temporary reservation by Order in Council of the 29th September, 1873 (see *Government Gazette*, 3rd October, 1873, page 1722) of 2023 square metres (2 roods) of land in the Township of Ballan as a site for Temperance Hall purposes is about to be revoked.—(B.23(4) (C.100712).)

BORUNG (KORONG VALE).—The temporary reservation by Order in Council of the 14th April, 1915, of 82.56 hectares (204 acres), more or less, of land in the Parish of Borung as a site for Railway Water Supply purposes is about to be revoked.—(B.89(8) (Rs.4662).)

BORUNG (KORONG VALE).—The temporary reservation by Order in Council of the 23rd March, 1937, of 650 hectares (1,610 acres), more or less, of land in the Parish of Borung as a site for Railway Water Supply Purposes (Korong Vale) is about to be revoked.—(B.89(81) (Rs.4662).)

BYAWATHA.—The temporary reservation as a site for Public purposes (State School) and the withholding from sale, leasing and licensing by Order in Council of the 11th October, 1880, of 2.021 hectares (4 acres 3 roods 39 perches) of land in the Parish of Byawatha are about to be revoked.—(B.615(4) (Rs.9841).)

ELMHURST.—The temporary reservation by Order in Council of the 31st March 1925 of 10.38 hectares (25 acres 2 roods 22 perches) of land in the Township of Elmhurst as a site for Racecourse and other Purposes of Public Recreation is about to be revoked.—(E.21(8) (Rs.648).)

ELMHURST.—The temporary reservation as a site for Cricket Ground and other purposes of Public Recreation and the withholding from sale, leasing and licensing by Order in Council of the 23rd April 1877 of 4.067 hectares (10 acres 8 perches) of land in the Township of Elmhurst are about to be revoked.—(E.21(8) (Rs.302).)

TOOROURRONG (GLENVALE).—The temporary reservation by Order in Council of the 28th November 1864 of 8094 square metres (2 acres) of land in the Parish of Toorourrong (named at Glenvale, Parish of Tourourrong in Order) as a site for a Common School is about to be revoked.—(T.97(1) (C.73465).)

TOOROURRONG (GLENVALE).—The temporary reservation by Order in Council of the 23rd March 1874 (see *Government Gazette* 27th March 1874, page 618) of 1.315 hectares (3 acres 1 rood) of land in the Parish of Toorourrong as a site for State School purposes is about to be revoked.—(T.97(1) (C.73465).)

WERRIBEE.—The temporary reservation by Order in Council of the 15th August 1864 of 6070 square metres (1 acre 2 roods) of land in the Township of Werribee (named Wyndham in Order) as a site for Common School purposes is about to be revoked.—(W.230(4) (Rs.5241).)

BROADWATER (BESSIEBELLE).—The temporary reservation by Order in Council of the 16th July, 1957, of 1012 square metres (1 rood) of land in the Parish of Broadwater as a site for a Swimming Pool is about to be revoked.—(B.577^(*)) (Rs.7645).

CALLAWADDA.—The temporary reservation by Order in Council of the 19th December 1893 of 2023 square metres (2 roods) of land in the Township of Callawadda as a site for a Mechanics Institute is about to be revoked.—(C.368^(*)) (Rs.5841).

KANGAROO FLAT.—The temporary reservation by Order in Council of the 9th May, 1961, of 1 rood, 18 perches (1467 square metres) more or less, of land in the Township of Kangaroo Flat as a site for Public Hall is about to be revoked.—(K.217^(*)) (Rs.8035).

MAFFRA.—The temporary reservation by Order in Council of the 24th April 1899 of 6677 square metres (1 acre 2 roods 24 perches) of land in the Township of Maffra as a site for Charitable purposes is about to be revoked.—(M.89^(*)) (Rs.5713).

PRAHRAN (ORMOND).—The temporary reservation by Order in Council of the 31st May 1943 of 1042 square metres (1 rood 1 2/10 perches) of land in the Parish of Prahran East of Elsternwick as a site for Police Purposes is about to be revoked.—(P.81⁽¹¹⁾) (Rs.5423).

SANDHURST.—The temporary reservation by Order in Council of the 3rd December 1888 of 3.210 hectares (7 acres 3 roods 29 perches) of land in the Parish of Sandhurst as a site for Market purposes is about to be revoked.—(S.371⁽⁴⁹⁾) (Rs.3296).

SORRENTO.—The temporary reservation by Order in Council of the 4th July, 1870 (see *Government Gazette* of the 8th July, 1870, page 972) of 1 acre (4047 square metres) of land in the Township of Sorrento, as a site for Public Offices, is about to be revoked.—(S.467) (Rs.229).

SORRENTO.—The temporary reservation by Order in Council of the 15th March, 1887, of 2 roods (2023 square metres) of land in the Township of Sorrento, as a site for Police purposes, is about to be revoked.—(S.467) (Rs.6919).

SANDHURST (BENDIGO).—The temporary reservation by Order in Council of the 29th August 1950 of 1391 square metres, more or less (1 rood 15 perches), of land at Bendigo, Parish of Sandhurst (named City of Bendigo, Parish of Sandhurst in Order) as a site for Cricket Ground and Public Recreation, revoked as to part by Order of the 22nd August 1961, is about to be revoked so far as the balance thereof containing 1189 square metres, more or less, is concerned.—(S.372⁽¹¹⁶⁾) (Rs.5074).

SANDHURST (BENDIGO).—The temporary reservation by Order in Council of the 22nd March 1949 of 1.720 hectares (4 acres 1 rood) of land at Bendigo, Parish of Sandhurst (named Sandhurst, City of Bendigo in Order) as a site for Cricket Ground and Public Recreation, revoked as to part by Order of the 22nd August 1961, is about to be revoked so far as the balance thereof containing 1.644 hectares, more or less, is concerned.—(S.372⁽¹¹⁸⁾) (Rs.5074).

WANNAEUE (MCCRAE).—The temporary reservation by Order in Council of the 23rd September 1872 (see *Government Gazette* 27th September 1872, page 1784) of 8094 square metres (2 acres), more or less, of land in the Parish of Wannaeue as a site for Lighthouse purposes, revoked as to part by Order of the 6th June 1972, is about to be revoked so far as the balance thereof, containing 6222 square metres, more or less, is concerned.—(W.32^(*)) (C.87964).

VECTIS EAST.—The temporary reservation as a site for Public purposes (State School) and the withholding from sale, leasing and licensing by Order in Council of the 28th February 1876 of 2.023 hectares (5 acres) of land in the Parish of Vectis East are about to be revoked.—(V.12^(*)) (Rs.7242).

MAFFRA.—The temporary reservation as a site for a Pound and the withholding from sale, leasing and licensing by Order in Council of the 8th September 1879 of 1.6794 hectares (4 acres 24 perches) of land in the Township of Maffra, revoked as to part by various Orders, are about to be revoked so far as the balance thereof containing 6070 square metres, is concerned.—(M.89^(*)) (Rs. 5757).

ELMHURST.—The temporary reservation as a site for Race Course and other purposes of Public Recreation and the withholding from sale, leasing and licensing by Order in Council of the 23rd April 1877 of 53.39 hectares (131 acres 3 roods 27 perches) of land in the Township of Elmhurst, revoked as to part by Order of the 21st October 1895, are about to be revoked so far as the balance thereof containing 29.71 hectares (73 acres, 1 rood 26 perches) is concerned.—(E.21^(*)) (Rs.648).

WILBY.—The temporary reservation as a site for Public Purposes (State School) and the withholding from sale, leasing and licensing by Order in Council of the 14th February 1882 of 8094 square metres (2 acres) of land in the Township of Wilby (Town of Pelluebla in Order) is about to be revoked so far only as the portion containing 113 square metres indicated by hatching on plan hereunder, is concerned.—(P.145^(*)) (Rs.9830).

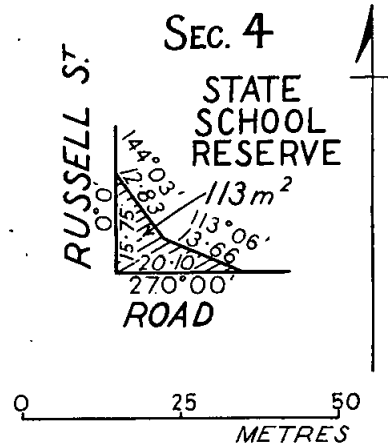

PORTLAND.—The temporary reservation by Order in Council of the 12th July 1966 of 1.958 hectares (4 acres 3 roods 14 perches) of land in the Township of Portland as a site for Public Purposes and Recreation is about to be revoked save and except the area of 6739 square metres indicated by hatching on plan hereunder.—(P.69⁽⁷⁾) (Rs.8614).

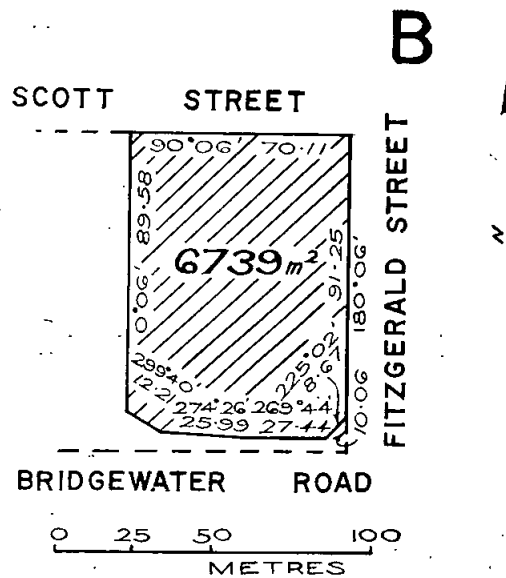

WILBY.—The temporary reservation by Order in Council of the 27th September 1886 (see *Government Gazette* 1886 page 2816) of 19.82 hectares (48 acres 3 roods 37 perches) of land in the Township of Wilby (Parish of Pelluebla in Order) as a site for Water Supply purposes revoked as to part by various Orders is about to be revoked so far only as the portion containing 2.993 hectares indicated by hatching on plan hereunder is concerned.—(P.145^(*)) (Rs.332).

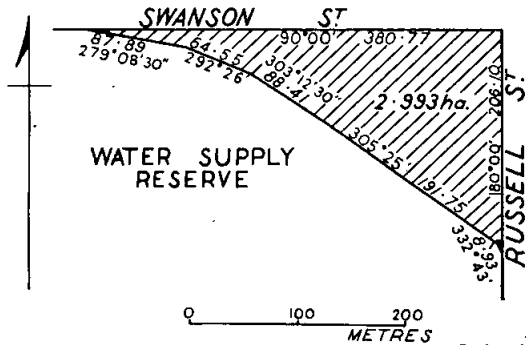

NEWMERELLA.—The temporary reservation by Order in Council of the 22nd September 1931 of 6589 square metres (1 acre 2 roods 20 5/10 perches) of land in the Township of Newmerella as a site for Supply of Gravel is about to be revoked so far only as the portion containing 3199 square metres indicated by hatching on plan hereunder, is concerned.—(N.136^(b)) (Rs.4140).

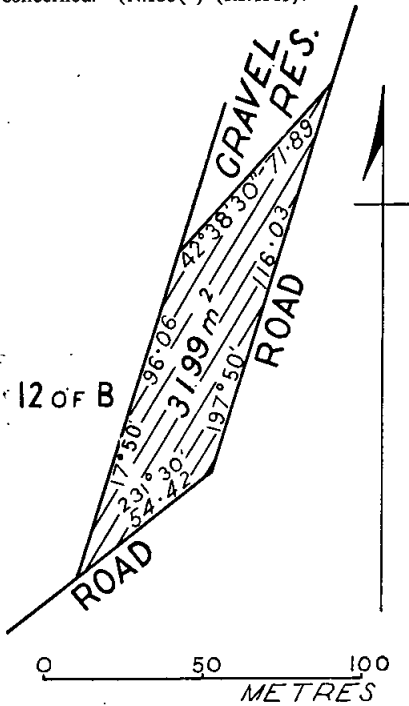

MELBOURNE.—The temporary reservation by Order in Council of the 10th April 1951 of 7841 square metres (1 acre 3 roods 30 perches, more or less), of land in the City of Melbourne as a site for Court House and Police Purposes, revoked as to part by Order of the 1st December 1970, is about to be revoked so far only as the portion containing 296 square metres indicated by hatching on plan hereunder, is concerned.—(M.314^(a)) (Rs.1835).

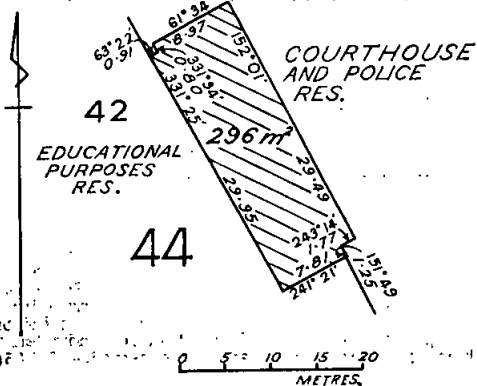

INGLEWOOD.—The temporary reservation by Order in Council of the 9th March 1886 of 1.414 hectares (3 acres 1 rood 39 perches) of land in the Township of Inglewood (called Municipal district of Inglewood in Order) as a site for Public Recreation is about to be revoked so far only as the portion containing 2768 square metres indicated by hatching on plan hereunder, is concerned.—(14^(a)) (Rs.3593).

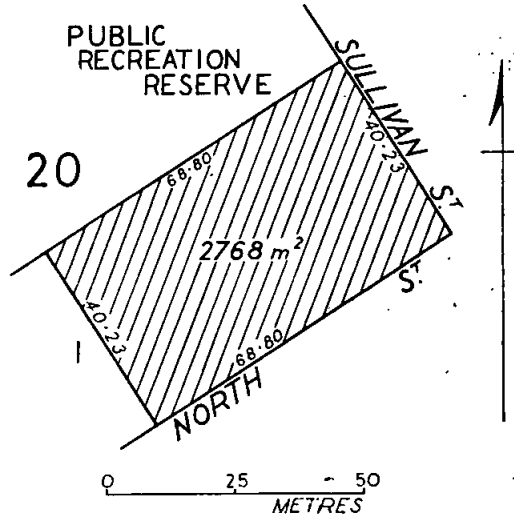

BEECHWORTH.—The temporary reservation by Order in Council of the 10th April 1922 of 9.988 hectares (24 acres 2 roods 28 8/10 perches) of land in the Township of Beechworth as a site for Public Recreation purposes is about to be revoked so far only as the portion containing 7700 square metres, more or less, indicated by hatching on plan hereunder, is concerned.—(B.348^(a)) (Rs.2489).

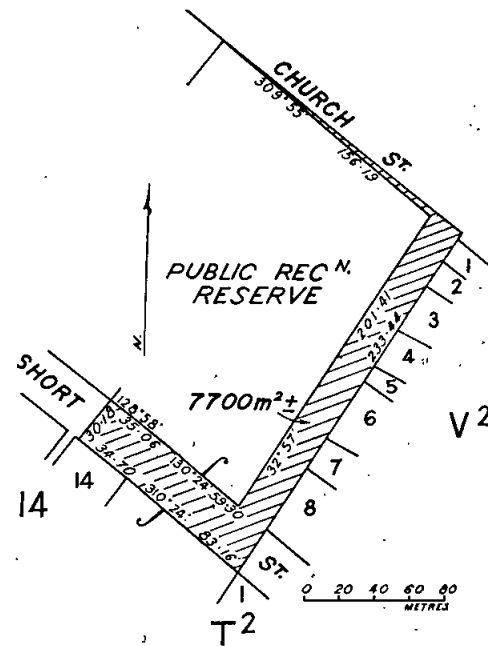

METUNG.—The temporary reservation by Order in Council of the 20th March 1888 of 5.456 hectares (13 acres 1 rood 37 perches) of land in the Township of Metung (Village of Metung in Order) as a site for Public Purposes revoked as to part by Order of the 23rd December 1914, is about to be revoked so far only as the portion containing 3707 square metres indicated by hatching on plan hereunder, is concerned.—(M.515^(a)) (Rs.1157).

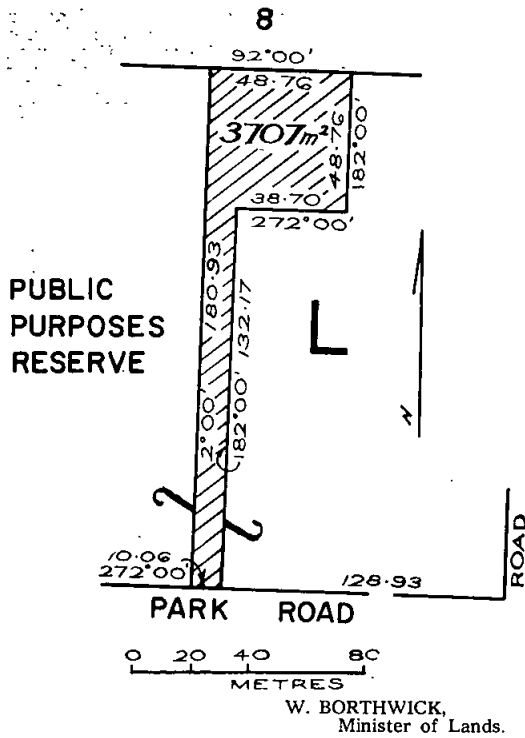

PROPOSED REVOCATION OF TEMPORARY RESERVATION OF LAND BY ORDER IN COUNCIL.

In pursuance of the provisions of the Land Act 1958, notice is hereby given that it is the intention of the Governor in Council to revoke the temporary reservation of land by Order in Council hereunder referred to, viz.:-

The following Notice was published 1° on the 23rd January, 1974, pursuant to Order of the 15th January, 1974.

OMEQ.—The temporary reservation by Order in Council of the 4th November, 1889, of certain unappropriated crown land situate within a distance of 60.35 metres (3 chains) from the banks of the Livingstone Creek for the supply of Gravel and Sand, revoked as to part by various Orders, is about to be revoked so far only as the portion in the Parish of Omeo containing 1300 square metres, more or less, indicated by hatching on plan hereunder, is concerned.—(O.19⁽¹⁰⁾) (C.86890.)

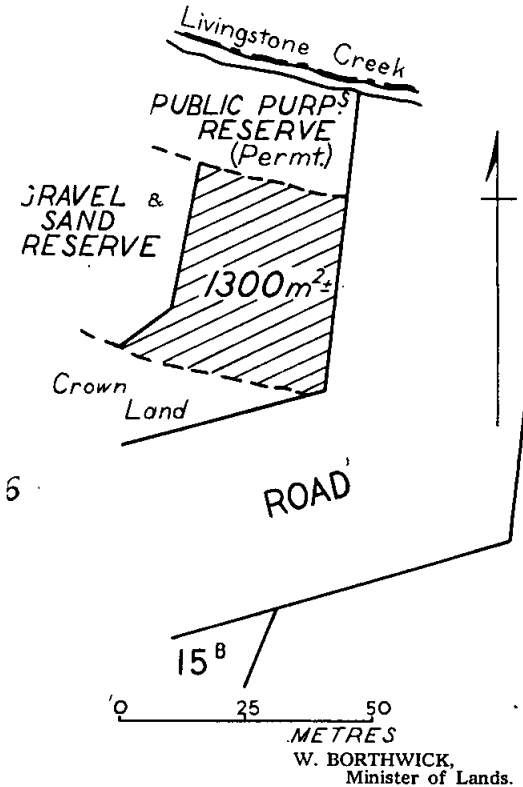

PROPOSED REVOCATIONS OF TEMPORARY RESERVATIONS OF LANDS BY ORDERS IN COUNCIL.

In pursuance of the provisions of the Land Act 1958, notice is hereby given that it is the intention of the Governor in Council to revoke the temporary reservations of lands by Orders in Council hereunder referred to, viz.:-

The following Notices were published 1° on the 13th February, 1974, pursuant to Orders of the 5th February, 1974.

MYRTLEFORD.—The temporary reservation by Order in Council of the 12th September, 1967, of 556 square metres (22 perches) of land in the Parish of Myrtleford as a site for Aboriginal Inhabitants is about to be revoked.—(M.295⁽¹⁰⁾) (Rs.8878).

ST. ARNAUD.—The temporary reservation by Order in Council of the 20th February, 1914, of 2.489 hectares (6 acres 24 perches) of land in the Parish of St. Arnaud as a site for Supply of Gravel is about to be revoked so far only as the portion containing 447 square metres indicated by hatching on plan hereunder, is concerned.—(S.366⁽⁶⁾) (C.73555).

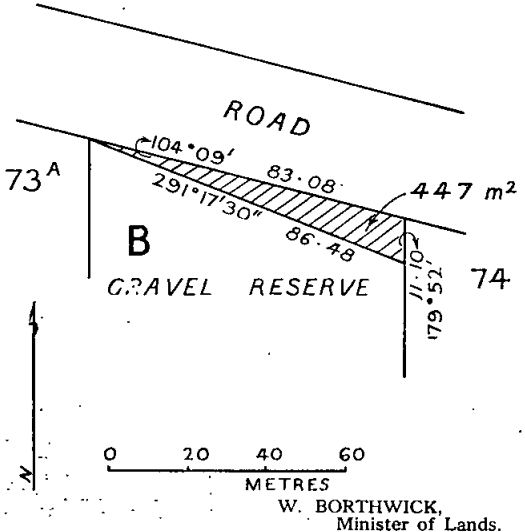

REGULATIONS FOR THE CARE, PROTECTION AND MANAGEMENT OF THE "MOUNT DOOBOOBETIC RESERVE".

I, William Archibald Borthwick, Her Majesty's Minister of Lands in and for the State of Victoria, in pursuance of the powers conferred on me by Section 218 of the Land Act 1958 do hereby make the following Regulations for or with respect to the land in the Parish of Charlton West temporarily reserved pursuant to Order in Council dated the 3rd April, 1973 as a site for Public Purposes (Public Park, Public Recreation and Trigonometrical Survey Station) and hereinafter referred to as "the Reserve".

The Reserve has, pursuant to the provisions of Section 221 of the Land Act 1958, been placed under the Control of the Corporation of the Shire of Charlton as the Committee of Management (hereinafter referred to as "the Committee") with power and authority to enforce the following Regulations.

REGULATIONS.

1. The Reserve shall be open to the public from sunrise to sunset free of charge except on such days as the Reserve or portions thereof may be set apart for cricket or football matches, shows, fêtes, sports or holiday or other amusements on any of which occasions a charge, deemed to be reasonable by the Committee, may be made and taken for admission thereto.

2. Any person, club or association desiring to use the Reserve or portion thereof for any organized games, sports or entertainments may do so subject to the observance of such terms and conditions and the payment of such fees as may be determined by the Committee from time to time.

3. No person shall:—

- (a) enter or remain in the Reserve who may offend against decency as regards dress, language or conduct, behave in a disorderly or offensive manner or create or take part in any disturbance;
- (b) enter or remain in the Reserve whilst under the influence of alcohol or drugs;
- (c) enter, cross, be on or trespass on any playing ground area, enclosure, course, building, room or other structure whilst any sport, game, competition, race, entertainment, amusement or practice thereat is being played, conducted or carried on or at any time between the commencement and conclusion of such event without the consent of the Committee first obtained;
- (d) climb, jump or get upon, on or over or under any fences or gates of the Reserve or cut or in any way remove or damage any of such fences or gates or any of the buildings, seats, equipment, trees or shrubs, provided that authorized survey parties may clear away the natural timber for survey lines;
- (e) erect any structure on any part of the Reserve before reference is made to the Department of Crown Lands and Survey and particularly to the Geodetic Division;
- (f) plant any ornamental trees other than low shrubs;
- (g) make any excavation without the permission of the Department of Crown Lands and Survey;
- (h) mark, write on, deface, damage or interfere with any survey beacon or ground marks;
- (i) stick bills or advertisements or writings on any fences, gates, buildings, seats, equipment or trees in the Reserve;
- (j) dig up or remove any sand, soil, turf or loam in or from the Reserve.
- (k) light a fire in the Reserve;
- (l) enter or remain in any plots which may be set aside for the plantation of young trees, shrubs or plants in the Reserve;
- (m) leave or deposit or cause to be left or deposited any unwanted material or thing or rubbish of any kind in the Reserve;
- (n) carry or discharge any firearms, air gun or other lethal weapon in the Reserve or snare, trap, catch or destroy or interfere in any way with any bird, fish or game in the Reserve;
- (o) bring into the Reserve a dog unless such dog is and continues to be at all times controlled by a chain, cord or leash;
- (p) give out, distribute or throw down any handbills, placards, notices, advertisements, books, pamphlets or papers in the Reserve or litter the same by scattering or throwing down handbills, placards, notices, advertisements, books, pamphlets or papers;
- (q) ride a horse, bicycle or motor cycle or drive a motor vehicle or any other vehicle within the Reserve recklessly or in a manner which is dangerous to the public, having regard to the circumstances of the case, or on any area other than that set aside by the Committee for the particular purpose, and no horse, bicycle, motor cycle, motor vehicle or any other vehicle shall be left or parked in the Reserve for a period longer than twenty four hours;
- (r) remove, displace or disfigure any board, plate or tablet or any support, fastening or fitting used or constructed for the exhibition of any regulation or notice fixed or set up by the Committee in the Reserve;
- (s) wilfully obstruct, disturb, interrupt or annoy any other person in the proper use of the Reserve or wilfully obstruct, disturb, interrupt or annoy any officer or servant of the Committee in the proper execution of his duty or work;

- (t) remain in the Reserve at any time when lawfully directed by a member of the Police Force, Bailiff of Crown Lands or any officer or servant of the Committee to leave the same;
- (u) make a wager for money or play any unlawful game in the Reserve.
- (v) bring into the Reserve any cattle, sheep or other animal except as provided in clause (q) above;
- (w) throw or discharge any missile in the Reserve to the damage, danger or annoyance of any person in the Reserve.

4. No person shall without the consent in writing of the Committee:—

- (a) camp in the Reserve;
- (b) sell or offer for sale in the Reserve any article of food or drink or any other commodity or operate any money-making amusement or erect any tent, booth, building or other structure;
- (c) assemble in the Reserve for fêtes, picnics, concerts or for the purpose of public worship, preaching or public speaking of any kind or for meetings of a like character;
- (d) make or cause to be made any violent outcry, noise, disturbance or sound or play any musical or noisy instrument, or sing in the Reserve;
- (e) preach, declaim, harangue or deliver any address of any kind to members of the public in the Reserve;
- (f) drive, ride, lead or cause to be ridden, driven or led any horse or other animal, on, over or through the Reserve;
- (g) enter or use any building, dressing pavilion or other like building in the Reserve, except those parts of such building or pavilion as are set aside for public use;
- (h) consume in or bring or cause to be brought into the Reserve any intoxicating liquor;
- (i) bring a caravan into the Reserve;
- (j) play, practise or engage in any organized game, sports, or entertainments in the Reserve.

5. No person over the age of fourteen years shall use any of the equipment set up by the Committee in any children's playing area in the Reserve.—(Rs.9731.)

Given under my hand at Melbourne on the seventh day of February, 1974.

W. BORTHWICK,
Minister of Lands.

Every person who contravenes or fails to comply with these Regulations shall, in accordance with the provisions of Section 218 of the *Land Act 1958*, for each offence be liable to a penalty of not more than Fifty Dollars, and every person who contravenes or fails to comply with any such Regulations, and who, after he has been warned by any Bailiff of Crown Lands or by any member of the Police Force, does not desist therefrom may be forthwith apprehended by such Bailiff or member of the Police Force and taken before some justice to be dealt with according to law and shall be liable to a penalty of not more than One Hundred Dollars, provided that every person who contravenes any regulation made under the said section for or with respect to prohibiting the depositing and leaving of any unwanted material or thing or rubbish of any kind on any land to which this section relates shall for each offence be liable to a penalty of not more than Two Hundred Dollars.

REGULATIONS FOR THE CARE, PROTECTION AND MANAGEMENT OF THE "BERWICK SPORTS GROUND".

I, William Archibald Borthwick, Her Majesty's Minister of Lands in and for the State of Victoria, in pursuance of the powers conferred on me by section 218 of the *Land Act 1958*, do hereby make the following Regulations for or with respect to the land in the Parish of Berwick temporarily reserved pursuant to Order in Council dated the 30th June, 1959, as a site for Public Recreation and hereinafter referred to as the "Reserve".

The Reserve has been placed under the control of a Committee of Management (hereinafter referred to as the "Committee") appointed pursuant to the provisions of section 221 of the *Land Act 1958* with power and authority to enforce the following Regulations.

REGULATIONS.

1. The Reserve shall be open to the public from sunrise to sunset free of charge except on such days, not exceeding fifty-two (52) in any one year, as the Reserve may be set

apart for cricket, football, outdoor and holiday amusements on any of which occasions a charge may be made and taken for admission of each person to the Reserve.

2. The Committee may allow any club, association or person to use the Reserve or portion thereof for the purpose of holding fêtes, carnivals, entertainments, musical performances, shows, sports, athletic training, or other physical recreation provided that the Committee shall determine the conditions and the fees payable for such use.

The Committee may authorise any club, association or person to make a charge for admission to the Reserve or (as the case may be) the portion thereof which such club, association or person has been authorised to use.

3. No person shall—

- (a) enter or remain in the Reserve who may offend against decency as regards dress, language or conduct or who may behave in a disorderly, unseemly or offensive manner or creates or takes part in any disturbance.
- (b) enter or remain in the Reserve whilst under the influence of alcohol or drugs.
- (c) obstruct, hinder or interfere with any person employed at the Reserve.
- (d) climb, jump on or climb over any of the gates or fences in or around the Reserve or stick bills or advertisements or cut names thereon, or in any way damage any of the buildings, furniture or fittings, gates, stiles, fences, seats, or other structures in the Reserve.
- (e) interfere with or break or damage or cut any of the trees, shrubs, plants, flowers or grasses in the Reserve.
- (f) leave or deposit any bottles, broken glass or any unwanted material or thing or rubbish of any kind in the Reserve nor roll or throw stones or missiles of any kind therein or leave anything that might injure a person.
- (g) light fires in the Reserve except at such places as are set apart for the purpose by the Committee;
- (h) carry or discharge any firearms or air guns in the Reserve or shoot, snare or destroy any game or birds thereon;
- (i) spit or expectorate on the paths or on or in any structure in the Reserve;
- (j) remove any sand, soil, rock or other materials from the Reserve;
- (k) bring into the Reserve a dog unless such dog is and continues to be at all times controlled by a chain, cord or leash;
- (l) enter any part of the Reserve when a charge for admission is made without first paying the fees chargeable for admission;

4. No person shall without the written consent of the Committee—

- (a) offer any article of food or drink or any other commodity for sale;
- (b) bet publicly in the Reserve, (subject to any statutory requirements);
- (c) erect any building, tent or other structure or camp on any portion of the Reserve, and then only subject to the observance of such conditions and the payment of such fees as may be determined by the Committee from time to time;
- (d) park any motor vehicle, caravan, trailer or other vehicle in the Reserve, and then only subject to the observance of such conditions and the payment of such fees as may be determined by the Committee from time to time;
- (e) take or put or allow to be taken or put in the Reserve any horses, cattle, sheep, goats, pigs or other animals and the owners of any animals found wandering upon any part of the Reserve shall be guilty of an offence against these Regulations;
- (f) play, practise or train or engage in any organised game or sport on the Reserve;
- (g) enter or remain in any building or trespass upon any arena whilst any organised game or sport is being conducted in such building or arena.

5. The driver of a motor car entering the Reserve shall proceed at a speed not exceeding 5 miles per hour in a direction indicated by persons appointed by the Committee to control vehicular traffic in the Reserve.

6. Persons renting or hiring any of the facilities in the Reserve may be required by the Committee to deposit a sum not exceeding Two hundred dollars (\$200) with the Committee by way of guarantee that due care shall be taken of such facilities and the Committee may in its absolute discretion retain all or part of the said sum to compensate it for any damage caused to any of the facilities by the hirer and all persons so renting or hiring shall abide by these Regulations and by any order given by the Committee.

7. No person shall remain in the Reserve at any time when lawfully directed by a member or employee of the Committee or by any member of the Police Force or by a Bailiff of Crown lands to leave the Reserve.—(Rs.1372.)

Given under my hand at Melbourne on the Seventh day of February, 1974.

W. BORTHWICK,
Minister of Lands.

Every person who contravenes or fails to comply with these Regulations shall, in accordance with the provisions of Section 218 of the Land Act 1958, for each offence be liable to a penalty of not more than Fifty Dollars, and every person who contravenes or fails to comply with any such Regulations, and who, after he has been warned by any Bailiff of Crown lands or by any member of the Police Force, does not desist therefrom may be forthwith apprehended by such Bailiff or member of the Police Force and taken before some justice to be dealt with according to law and shall be liable to a penalty of not more than One Hundred Dollars, provided that every person who contravenes any Regulation made under the said section for or with respect to prohibiting the depositing and leaving of any unwanted material or thing, or rubbish of any kind on any land to which this section relates shall for each offence be liable to a penalty of not more than Two Hundred Dollars.

REGULATIONS FOR THE CARE, PROTECTION AND MANAGEMENT OF THE HIGHLANDS PUBLIC HALL, RECREATION, CONVENIENCE OR AMUSEMENT OF THE PEOPLE RESERVE, PARISH OF KOBYBOYN.

I, William Archibald Borthwick, Her Majesty's Minister of Lands in and for the State of Victoria, in pursuance of the powers conferred on me, do hereby declare that in the preamble to the regulations made on the 4th October, 1967, and published in the Government Gazette of the 11th October, 1967, for or with respect to certain Crown lands in the Parish of Kobyboyn, such lands mean the lands in said Parish shown by hachure on the plan hereunder.—(Rs.8800.)

PARISH OF KOBYBOYN

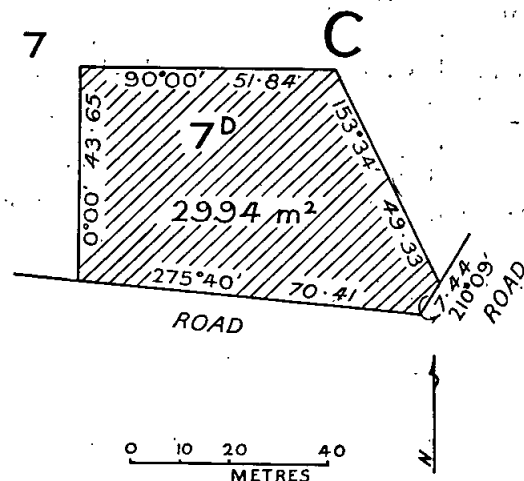

Given under my hand at Melbourne on the 7th day of February, 1974.

W. BORTHWICK,
Minister of Lands.

REGULATIONS FOR THE CARE, PROTECTION AND MANAGEMENT OF THE CAPE SCHANCK NATIONAL PARK.

I, William Archibald Borthwick, Her Majesty's Minister of Lands in and for the State of Victoria in pursuance of the powers conferred on me by Section 218 of the *Land Act 1958*, do hereby make the following Regulations for or with respect to the purchased land in the Parish of Fingal, being Lots 1 and 2 on Plan of Subdivision Number 71626 and Lot 2 on Plan of Subdivision Number 71624 and Lot 82 on Plan of Subdivision Number 53153, deemed to be temporarily reserved pursuant to Section 5 (5) of the *National Parks Act 1970*, (Lands Department reference number Rs.9854), and hereinafter referred to as "the Reserve".

REGULATIONS.

1. The Director of National Parks or his authorized officers are empowered to have carried out such works and improvements considered necessary for the management of the Reserve as a site for a national park and for the control of the public within the Reserve.

2. Without the consent, in writing, of the Director of National Parks or his authorized officers, no person shall—

- (a) Camp within the Reserve or light or maintain any fire therein.
- (b) Deposit any rubbish, debris or material of any kind.
- (c) Interfere with or remove or damage or destroy any tracks, signs, buildings, or any improvements or structures in the Reserve.
- (d) Deposit on or construct within the Reserve any fence, shed, structure or equipment. Any fence, shed, structure or other equipment located within the Reserve without permission will be dismantled and removed from the Reserve.
- (e) Carry a firearm of any description or any weapon or instrument capable of discharging a missile, shoot at, or kill, or injure any animal, bird or other wildlife in the Reserve.

- (f) Carry any poison, traps or snares in the Reserve.
- (g) Poison, trap, snare, catch or otherwise destroy, interfere with or disturb any bird or other animal, or have in his or her possession any skin, egg, feathers, or nests or part thereof in or from the Reserve.
- (h) Bring or allow any animal of any kind into the Reserve. Any dog shall be liable to be destroyed. Any "cattle" as defined by section 3 of the *Pounds Act 1958*, found trespassing within the Reserve shall be liable to be impounded.
- (i) Pluck, cut, dig, pick up, damage or otherwise interfere with or have in his or her possession the whole or any part of any shrubs, flowers, grasses, trees, or plants of any kind.
- (j) Dig or remove any sand, soil or other material in or from the Reserve.
- (k) Drive any vehicle on the Reserve other than on a road or roads provided for the purpose.—
(Rs.9854.)

Given under my hand, at Melbourne, on the Seventh day of February, 1974.

W. BORTHWICK,
Minister of Lands.

Every person who contravenes or fails to comply with these Regulations shall, in accordance with the provisions of Section 218 of the *Land Act 1958*, for each offence be liable to a penalty of not more than Fifty Dollars, and every person who contravenes or fails to comply with any such Regulations, and who, after he has been warned by any bailiff of Crown Lands or by any member of the Police Force, does not desist therefrom may be forthwith apprehended by such bailiff or member of the Police Force and taken before some justice to be dealt with according to law and shall be liable to a penalty of not more than One Hundred Dollars, provided that every person who contravenes any regulation made under the said section for or with respect to prohibiting the depositing and leaving of any unwanted material or thing or rubbish of any kind on any land to which this section relates shall for each offence be liable to a penalty of not more than Two Hundred Dollars.

Land Act 1958.

LICENCES UNDER THE LAND ACTS DECLARED VOID.

Notice is hereby given that the Licences in the Schedule hereunder have been Declared Void for the reason specified in each case.

District.	Corr. No.	Name of Licensee.	Section of Land Act under which Licensed.	Parish.	Allotments.	Section.	Area.	Annual Rental.	Reasons for Voiding
							A. R. P.	\$	
Seymour	178/138	Erskine Brothers	138	Moora	30b	A	3 0 0	20.00	Licence surrendered
Alexandra	82/138	P. B. Buff	138	Goulburn	2	31	1 0 36	10.00	Non-compliance with conditions

Department of Crown Lands and Survey,
Melbourne, 7th February, 1974.

W. BORTHWICK,
Minister of Lands.

TENDERS**PUBLIC WORKS DEPARTMENT**

Tenders will be received at Public Works Department, 2 Treasury-place, Melbourne, until TWO p.m. on dates shown and for purposes mentioned hereunder.

Particulars and tender forms available at Contracts Office, Room 27, Ground Floor, No. 2, Treasury-place, and at places indicated in brackets hereunder.

Abbreviations in brackets mean:—W.O.—Inspector of Works Office; P.S.—Police Station; C.S.—Consolidated School; H.E.S.—Higher Elementary School; H.S.—High School; Pr.S.—Primary School; T.S.—Technical School.

Tenders to be submitted on the Department's printed Tender Form and will not be received by telephone. All tenders must be on a "Firm Tender" basis. The lowest or any tender will not necessarily be accepted.

Address tenders to the Minister of Public Works, and endorse the envelope containing the tender "Tender for , closing Tuesday,".

Hand delivered tenders to be placed in the Tender Box of the Public Works Department, located on the wall of the centre entrance foyer, Ground Floor, 2 Treasury-place, Melbourne.

No preliminary deposit is required with any tender, but a successful tenderer will be required to pay a deposit for any accepted tender of \$4,000 or over.

Tuesday, 19th February, 1974.**Building, Electrical and Mechanical Works.**

BENDIGO.—Erection of Science Block, G.H.S. (W.O., Bendigo.)

BENDIGO.—Mechanical services—Science Block, G.H.S. (W.O., Bendigo.)

BENDIGO.—Addition of kitchen to serve Students' Common Room, State College of Victoria. (W.O., Bendigo.)

BENTLEIGH.—Erection of Library, H.S.

BENTLEIGH.—Electrical services—Library, H.S.

BENTLEIGH.—Mechanical services—Library, H.S.

BRIGHT.—Staff accommodation improvements, Higher Elementary School. (W.O., Wangaratta.)

BURWOOD.—Electrical services—Activities Centre, Allambie Reception Centre.

BURWOOD.—Mechanical services—Activities Centre, Allambie Reception Centre.

CLAYTON.—Heating service to Physical Education Wing, Monash H.S.

DERRINALLUM.—Erection of Manual Arts Wing and conversion of existing rooms, H.S. (W.O., Camperdown and Warrnambool.)

DERRINALLUM.—Electrical installation—Manual Arts Wing, H.S. (W.O., Warrnambool.)

DONCASTER EAST.—Additional classroom and staff accommodation improvements, Pr.S.2096.

GOLDEN SQUARE.—Erection of Science Block, H.S. (W.O., Bendigo.)

GOLDEN SQUARE.—Electrical installation—Science Block, H.S. (W.O., Bendigo.)

GOLDEN SQUARE.—Mechanical services—Science Block, H.S. (W.O., Bendigo.)

HAWKESDALE.—Erection of Manual Arts Wing and conversion of existing room, H.S. (W.O., Hamilton and Warrnambool.)

HAWKESDALE.—Electrical installation—Manual Arts Wing, H.S. (W.O., Warrnambool.)

LANGI KAL KAL.—Heating to sleeping quarters in Dormitories 1 and 2, Youth Training Centre. (W.O., Ballarat.)

MARYSVILLE.—Interior and exterior repairs and painting, Pr.S.1273.

MERBEIN.—Erection of Manual Arts Block and conversion of existing room, H.S. (W.O., Horsham, Swan Hill and Mildura.)

MERBEIN.—Electrical installation—Manual Arts Block, H.S. (W.O., Horsham, Swan Hill and Mildura.)

MILDURA.—Replacement of heating mains—Trades Block, T.S. (W.O., Mildura.)

MOORABBIN.—Erection of two room Science Block, H.S. (Re-advertised.)

MOORABBIN.—Electrical services—Science Block, H.S. (Re-advertised.)

MOORABBIN.—Mechanical services—Science Block, H.S. (Re-advertised.)

MOUNT WAVERLEY.—Internal and external renovations, Pr.S.3432. (Re-advertised, amended specification.)

PASCOE VALE.—Hydraulic hoist for sheep race, Melbourne College of Textiles.

SUNBURY.—Internal and external repairs and painting, Ward M.6A, Mental Hospital.

TRARALGON.—Erection of Library, H.S. (W.O., Traralgon and Warragul.)

TRARALGON.—Electrical services—Library, H.S. (W.O., Traralgon.)

TRARALGON.—Mechanical services—Library, H.S. (W.O., Traralgon.)

WARRAGUL.—Mechanical services—Metalwork Room, H.S. (W.O., Warragul.)

Site Works.

MACLEOD.—Site works, H.S.

MONTMORENCY SOUTH.—Site works, Pr.S.4925. (Re-advertised.) (Amended Specification.)

RINGWOOD EAST.—Site works, Pr.S.4180.

ROWVILLE.—Site works, Pr.S.5000.

Tuesday, 26th February, 1974.**Building, Electrical and Mechanical Works.**

CASTLEMAINE.—Erection of Science Block, H.S. (W.O., Bendigo and Kyneton.)

CASTLEMAINE.—Electrical installation—Science Block, H.S. (W.O., Bendigo and Kyneton.)

CASTLEMAINE.—Mechanical services—Science Block, H.S. (W.O., Bendigo and Kyneton.)

DAYLESFORD.—Internal and external painting and repairs, T.S. (W.O., Ballarat and Kyneton.)

ELWOOD.—External renovations, H.S.

EUROA.—Erection of Science Block, H.S. (W.O., Alexandra and Benalla.)

EUROA.—Mechanical services—Science Block, H.S. (W.O., Shepparton and Wangaratta.)

GEELONG WEST.—External repairs and painting, T.S. (W.O., Geelong.)

MARYBOROUGH.—External repairs and painting, T.C. (W.O., Maryborough.)

MYRTLEFORD.—Erection of Science Block and 2 classrooms, H.S. (W.O., Shepparton and Wangaratta.)

MYRTLEFORD.—Electrical services—Science Block and classrooms, H.S. (W.O., Wangaratta.)

MYRTLEFORD.—Mechanical services—Science Block and classrooms, H.S. (W.O., Wangaratta.)

NATHALIA.—Staff accommodation improvements, additional rooms and science room, H.S. (W.O., Benalla and Shepparton.)

NICHOLLS POINT.—External and internal painting and renovations, Pr.S.3163. (W.O., Mildura.)

SUNBURY.—Heating of Wards M3 and F3, Mental Hospital.

WALPEUP.—Interior repairs and painting, Mallee Research Station. (W.O., Mildura and Swan Hill.)

WODONGA.—Erection of Science Block, H.S. (W.O., Shepparton and Wangaratta.)

WODONGA.—Electrical services—Science Block, H.S. (W.O., Shepparton and Wangaratta.)

WODONGA.—Mechanical services—Science Block, H.S. (W.O., Shepparton and Wangaratta.)

Miscellaneous.

COBURG.—Provision of pipe and chain mesh safety netting, Pentridge Prison.

MELBOURNE.—Maintenance cleaning for the period 15/3/74 to 14/3/77, Royal Mint, William Street.

Tuesday, 5th March, 1974.**Building, Electrical and Mechanical Works.**

BLACKBURN.—Internal repairs and painting, T.C.

BRUNSWICK NORTH WEST.—External repairs and painting, Pr.S.4399.

BURWOOD HEIGHTS.—Staff accommodation improvements, Pr.S.4932.

DROUIN WEST.—Internal and external renovations, Pr.S.1417. (W.O., Warragul.)

ESSENDON.—New cell block and renovations, P.S. (Re-advertised.)

GRANTVILLE.—Internal and external repairs and painting, Pr.S.1414. (W.O., Korumburra.)

HAMILTON NORTH.—External and internal painting and repairs, Pr.S.2035. (W.O., Hamilton.)

MANSFIELD.—Erection of new Police Station. (W.O., Benalla, Alexandra and Shepparton.)

NEWBOROUGH EAST.—External renovations and repairs, Pr.S.4670. (W.O., Traralgon.)

NORLANE.—Internal and external repairs and painting, H.S. (W.O., Geelong.)

PARKDALE.—Staff accommodation improvements, H.S.

SALE.—Erection of a Multi-Purpose brick hall, Prison. (W.O., Bairnsdale and Traralgon.)

SALE.—Electrical services—Multi-Purpose Hall, Prison. (W.O., Bairnsdale and Traralgon.)

SAN REMO.—Internal and external renovations, Residence, Ports and Harbors Division. (W.O., Korumburra.)

WAAIA.—Erection of toilet block, Pr.S.2986. (W.O., Benalla and Shepparton.) (Re-advertised.)

WARRAGUL.—External repairs and painting, H.S. (W.O., Warragul.)

Site Works.

ALTONA WEST.—Site works, Pr.S.4862.

TALLANGATTA.—Site works, H.S. (W.O., Wangaratta.)

Miscellaneous.

BALLARAT.—Supply and delivery of one 100 lb. washer extractor, Lakeside Mental Hospital.

PORT MELBOURNE.—Supply and delivery of 15,000 lbs. capacity 360 degrees slewing mobile crane, Plant Depot.

ROBERTS DUNSTAN,
Minister of Public Works.

Public Works Department,
Melbourne, 11th February, 1974.

PUBLIC SERVICE NOTICES

No. 670.

Public Service Act 1958, Section 39.

REGULATIONS.—PART IV.—SALARIES AND INCREMENTS.

The Public Service Board, in pursuance of the powers conferred by the Public Service Act 1958, hereby amends its Regulations as shown below :—

FOURTH SCHEDULE.

ADMINISTRATIVE DIVISION.

Amount of Salary Assigned to Offices in Class "A1"

Office.	Yearly Rate of Salary.
DEPARTMENT OF LABOUR AND INDUSTRY.	
<i>Delete—</i>	
Assistant Secretary	18,796
<i>Add—</i>	
Deputy Secretary	18,796
Assistant Secretary	14,451

A. J. A. GARDNER, Chairman.
L. R. BROWN, Secretary.

Office of the Public Service Board,
Melbourne, 1st February, 1974.

No. 681.

Public Service Act 1958, Section 50.

REGULATIONS.—PART IV.—SALARIES AND INCREMENTS.

The Public Service Board, in pursuance of the powers conferred by the Public Service Act 1958, hereby amends its Regulations as shown below :—

FIFTH SCHEDULE.

TEMPORARY EMPLOYEES.

DEPARTMENT OF HEALTH.

MENTAL HYGIENE.

Designations of Positions and Rates of Salaries.

Designation of Position.	Yearly Rates of Salary.		Increments (Annual).
	Minimum.	Maximum.	
	\$	\$	
<i>Delete the existing yearly rates of salary for the following positions and insert the rates shown hereunder in lieu thereof :—</i>			
Storeman, Grade II. ..	5,036	5,409	A
Storeman, Grade I.— Junior—			
At 18 years of age	3,406	
At 19 years of age	3,884	
At 20 years of age	4,468	
Adult	4,884φφ	5,176	A

SEVENTH SCHEDULE.

TECHNICAL AND GENERAL DIVISION.

DEPARTMENT OF HEALTH.

MENTAL HYGIENE.

Grades and Salary Scales.

JUNIOR GRADES.

Grade.	Yearly Rate of Salary at Each Age in Years.		
	18.	19.	20.
	\$	\$	\$
<i>Delete—</i>			
J-21	3,152	3,594	4,141
<i>Add—</i>			
J-21	3,406	3,884	4,468

This Regulation shall have effect from the 3rd February, 1974.

A. J. A. GARDNER, Chairman.
L. R. BROWN, Secretary.

Office of the Public Service Board,
Melbourne, 4th February, 1974.

No. 669.

PUBLIC SERVICE ACT 1958.

The Public Service Board, in pursuance of the powers conferred by the Public Service Act 1958, hereby amends its Regulations as shown below :—

PART VIII.—LEAVE OF ABSENCE.

DIVISION V.—STUDY LEAVE.

Regulation 231.

The word "without" is deleted and the word "with" is inserted in lieu thereof.

A. J. A. GARDNER, Chairman.
L. R. BROWN, Secretary.

Office of the Public Service Board,
Melbourne, 1st February, 1974.

No. 667.

Public Service Act 1958, Section 50.
REGULATIONS.—PART IV.—SALARIES AND INCREMENTS.

The Public Service Board, in pursuance of the powers conferred by the *Public Service Act 1958*, hereby amends its Regulations as shown below :—

SIXTH SCHEDULE.
TEMPORARY EMPLOYEES.
Designations of Positions and Rates of Salaries.

Department and Designation of Position.	Yearly Rate of Salary.		Increments (Annual).
	Minimum.	Maximum.	
<i>Delete the existing yearly rates of salary for the following positions and insert the rates shown hereunder in lieu thereof—</i>	\$	\$	
GENERAL.			
Caretaker, Grade II. // ..	5,662	6,056	A
Caretaker, Grade I. // ..	5,060	5,386	A
DEPARTMENT OF AGRICULTURE.			
Caretaker and Overseer, Glenormiston†	5,106	5,409	A

EIGHTH SCHEDULE.
TEMPORARY POSITIONS.

Department and Position.	Scale of Rates of Annual Salary with Incremental Stages.
<i>Delete the existing yearly rates of salary for the following position and insert the rates shown hereunder in lieu thereof—</i>	
DEPARTMENT OF AGRICULTURE.	
Caretaker—Caterer, Horticultural Research Station, Tatura //	\$4,782—\$4,909—\$5,041—\$5,061

This Regulation shall have effect from the 20th January, 1974.
A. J. A. GARDNER, Chairman.
L. R. BROWN, Secretary.
Office of the Public Service Board,
Melbourne, 21st January, 1974.

No. 678.

Public Service Act 1958, Section 50.
REGULATIONS.—PART IV.—SALARIES AND INCREMENTS.

The Public Service Board, in pursuance of the powers conferred by the *Public Service Act 1958*, hereby amends its Regulations as shown below :—

SECOND SCHEDULE.
TECHNICAL AND GENERAL DIVISION.
Grades and Salary Scales.
JUNIOR GRADES.

Grade.	Yearly Rate of Salary at Each Age in Years.				
	Under 17.	17.	18.	19.	20.
<i>Delete—</i>	\$	\$	\$	\$	\$
J-15	3,324	3,838
<i>Add—</i>					
J-15	2,236	2,601	3,051	3,591	4,137
J-37	3,479	4,011

This Regulation shall have effect from the 3rd February, 1974.
A. J. A. GARDNER, Chairman.
L. R. BROWN, Secretary.
Office of the Public Service Board,
Melbourne, 1st February, 1974.

SIXTH SCHEDULE.

TEMPORARY EMPLOYEES.

Designations of Positions and Rates of Salaries.

Department and Designation of Position.	Yearly Rate of Salary.		Increments (Annual).
	Minimum.	Maximum.	
<i>Delete the existing yearly rates of salary for the following positions and insert the rates shown hereunder in lieu thereof :—</i>	\$	\$	
DEPARTMENT OF AGRICULTURE.			
Housekeeper-Caterer, Mallee Research Station, Walpeup	4,517	4,781	A
<i>Dookie Agricultural College.</i>			
Cook	5,293	5,662	A
<i>Longerenong Agricultural College.</i>			
Cook	5,293	5,662	A
DEPARTMENT OF HEALTH.			
<i>Alcoholics and Drug Dependent Persons Services.</i>			
General Reliever	4,377	4,679	A
SOCIAL WELFARE DEPARTMENT.			
<i>Family Welfare Division.</i>			
Cook, Grade III.=	4,720	5,036	A
Cook, Grade II.=	4,576	4,884	A
Cook, Grade I.=	4,377	4,679	A
Cook, "Illoura"—			
Junior=			
At 19 years of age	3,591	
At 20 years of age	4,137	
Adult=	4,517φ	4,781	A
General Reliever—			
Junior—			
Under 17 years of age	2,236	
At 17 years of age	2,601	
At 18 years of age	3,051	
At 19 years of age	3,479	
At 20 years of age	4,011	
Adult	4,377φ	4,679	A
<i>Youth Welfare Division.</i>			
Cook, Grade IV.=	5,293	5,662	A
Cook, Grade III.=	4,720	5,036	A
Cook, Grade II.=	4,576	4,884	A
Cook, Grade I.=	4,377	4,679	A
Cook, Brunswick Intervention Unit=	4,517	4,781	A
General Reliever—			
Junior—			
Under 17 years of age	2,236	
At 17 years of age	2,601	
At 18 years of age	3,051	
At 19 years of age	3,479	
At 20 years of age	4,011	
Adult	4,377φφ	4,679	A

This Regulation shall have effect from the 3rd February, 1974.
A. J. A. GARDNER, Chairman.
L. R. BROWN, Secretary.
Office of the Public Service Board,
Melbourne, 1st February, 1974.

No. 668.

Public Service Act 1958, Section 50.
REGULATIONS.—PART IV.—SALARIES AND INCREMENTS.

The Public Service Board, in pursuance of the powers conferred by the *Public Service Act 1958*, hereby amends its Regulations as shown below :—

FIFTH SCHEDULE.
TEMPORARY EMPLOYEES.
DEPARTMENT OF HEALTH.
MENTAL HYGIENE.

Designations of Positions and Rates of Salaries.

Designation of Position.	Yearly Rate of Salary.		Increments (Annual).
	Minimum.	Maximum.	
<i>Delete the existing yearly rates of salary for the following position and insert the rates shown hereunder in lieu thereof—</i>	\$	\$	
	Supervisor and Caretaker, Marlborough House ^θ ..	5,060 5,386	A

This Regulation shall have effect from the 20th January, 1974.

A. J. A. GARDNER, Chairman.
L. R. BROWN, Secretary.

Office of the Public Service Board,
Melbourne, 30th January, 1974.

No. 672.

Public Service Act 1958, Section 50.
REGULATIONS.—PART IV.—SALARIES AND INCREMENTS.

The Public Service Board, in pursuance of the powers conferred by the *Public Service Act 1958*, hereby amends its Regulations as shown below :—

SECOND SCHEDULE.

TECHNICAL AND GENERAL DIVISION.
Grades and Salary Scales.

For the heading "Junior Grades" substitute the heading "Junior Grades (Not Classified in Eighth Schedule)".

Immediately following the heading "Junior Grades (Not Classified in Eighth Schedule)" and the salary scale relating thereto, insert the following heading and salary scale :—

"JUNIOR GRADES (CLASSIFIED IN EIGHTH SCHEDULE)

Grade.	Yearly Rate of Salary.
ES-1	Δ

Δ Rates prescribed in Eighth Schedule."

SEVENTH SCHEDULE.

TECHNICAL AND GENERAL DIVISION.
DEPARTMENT OF HEALTH.
MENTAL HYGIENE.
Grades and Salary Scales.

For the heading "Junior Grades" substitute the heading "Junior Grades (Not Classified in Eighth Schedule)".

Immediately following the heading "Junior Grades (Not Classified in Eighth Schedule)" and the salary scale relating thereto, insert the following heading and salary scale :—

"JUNIOR GRADES (CLASSIFIED IN EIGHTH SCHEDULE)

Grade.	Yearly Rate of Salary.
ES-1	Δ

Δ Rates prescribed in Eighth Schedule."

This Regulation shall have effect from the 30th December, 1973.

A. J. A. GARDNER, Chairman.
L. R. BROWN, Secretary.

Office of the Public Service Board,
Melbourne, 8th February 1974

No. 666.

Public Service Act 1958, Section 50.
REGULATIONS.—PART IV.—SALARIES AND INCREMENTS.

The Public Service Board, in pursuance of the powers conferred by the *Public Service Act 1958*, hereby amends its Regulations as shown below :—

SIXTH SCHEDULE.

TEMPORARY EMPLOYEES.

Designations of Positions and Rates of Salaries.

Department and Designation of Position.	Yearly Rate of Salary.		Increments (Annual).
	Minimum.	Maximum.	
CHIEF SECRETARY'S DEPARTMENT.	\$	\$	
OFFICE OF THE CHIEF COMMISSIONER OF POLICE.			
<i>Delete—</i>			
Licence Testing Officer, Senior	5,339	5,478	A
Licence Testing Officer	4,905	5,152	A
<i>Add—</i>			
Licence Testing Officer, Senior	5,754	6,080	A
Licence Testing Officer, Grade II.	5,547	5,685	A
Licence Testing Officer, Grade I.	5,339	5,478	A

This Regulation shall have effect from the 20th January, 1974.

A. J. A. GARDNER, Chairman.
L. R. BROWN, Secretary.

Office of the Public Service Board,
Melbourne, 21st January, 1974.

No. 679.

Public Service Act 1958, Section 50.
REGULATIONS.—PART IV.—SALARIES AND INCREMENTS.

The Public Service Board, in pursuance of the powers conferred by the *Public Service Act 1958*, hereby amends its Regulations as shown below :—

SIXTH SCHEDULE.

TEMPORARY EMPLOYEES.

Designations of Positions and Rates of Salaries.

Department and Designation of Position.	Yearly Rate of Salary.		Increments (Annual).
	Minimum.	Maximum.	
DEPARTMENT OF HEALTH.	\$	\$	
<i>Alcoholics and Drug Dependent Persons Services.</i>			
<i>Delete—</i>			
Cook, Grade II.=	5,106	5,500	A
<i>Add—</i>			
Cook, Grade II.=	4,864	5,246	A
Cook, Grade III.=	5,106	5,500	A
<i>Tuberculosis^φ</i>			
<i>State Sanatoria^φ</i>			
<i>Delete—</i>			
Chef=	5,106	5,500	A
<i>Add—</i>			
Chef=	5,455	5,824	A

A. J. A. GARDNER, Chairman.
L. R. BROWN, Secretary.

Office of the Public Service Board,
Melbourne, 21st January, 1974.

No. 674.

Public Service Act 1958, Section 50.

REGULATIONS.—PART IV.—SALARIES AND INCREMENTS.

The Public Service Board, in pursuance of the powers conferred by the Public Service Act 1958, hereby amends its Regulations as shown below :—

SECOND SCHEDULE.
TECHNICAL AND GENERAL DIVISION.
Grades and Salary Scales.
JUNIOR GRADES.

Grade.	Yearly Rate of Salary at Each Age in Years.				
	Under 17.	17.	18.	19.	20.
	\$	\$	\$	\$	\$
Delete— J-5	2,739	3,122	3,610
Add— J-5	2,923	3,332	3,847

SIXTH SCHEDULE.

TEMPORARY EMPLOYEES.

Designations of Positions and Rates of Salaries.

Department and Designation of Position.	Yearly Rate of Salary.		Increments (Annual).
	Minimum.	Maximum.	
	\$	\$	
<i>Delete the existing yearly rates of salary for the following positions and insert the rates shown hereunder in lieu thereof :—</i>			
DEPARTMENT OF HEALTH.			
<i>Maternal and Child Welfare.</i>			
Dental Attendant, Senior ..	4,720	4,802	A
Dental Attendant, Grade II ..	4,398	4,658	A
Dental Attendant, Grade I.— Junior—			
At 18 years of age	2,923	
At 19 years of age	3,332	
At 20 years of age	3,847	
Adult \$	4,194	4,497	A

This Regulation shall have effect from the 3rd February, 1974.

A. J. A. GARDNER, Chairman.
L. R. BROWN, Secretary.

Office of the Public Service Board,
Melbourne, 1st February, 1974.

No. 676.

Public Service Act 1958, Section 50.

REGULATIONS.—PART IV.—SALARIES AND INCREMENTS.

The Public Service Board, in pursuance of the powers conferred by the Public Service Act 1958, hereby amends its Regulations as shown below :—

FIFTH SCHEDULE.

TEMPORARY EMPLOYEES.

DEPARTMENT OF HEALTH.

MENTAL HYGIENE.

Designations of Positions and Rates of Salaries.

Designation of Position.	Yearly Rate of Salary.		Increments (Annual).
	Minimum.	Maximum.	
	\$	\$	
<i>Delete the existing yearly rates of salary for the following positions and insert the rates shown hereunder in lieu thereof :—</i>			
Dental Attendant, Grade II.	4,398	4,658	A
Dental Attendant, Grade I.— Junior—			
At 18 years of age	2,923	
At 19 years of age	3,332	
At 20 years of age	3,847	
Adult \$	4,194	4,497	A
Dental Mechanic	5,940	6,313	A

SEVENTH SCHEDULE.

TECHNICAL AND GENERAL DIVISION.

DEPARTMENT OF HEALTH.

MENTAL HYGIENE.

Grades and Salary Scales.

JUNIOR GRADES.

Grade.	Yearly Rate of Salary at Each Age in Years.				
	Under 17.	17.	18.	19.	20.
	\$	\$	\$	\$	\$
Delete— J-5	2,739	3,122	3,610
Add— J-5	2,923	3,332	3,847

This Regulation shall have effect from the 3rd February, 1974.

A. J. A. GARDNER, Chairman.
L. R. BROWN, Secretary.

Office of the Public Service Board,
Melbourne, 4th February, 1974.

No. 675.

PUBLIC SERVICE ACT 1958.

The Public Service Board, in pursuance of the powers conferred by the Public Service Act 1958, hereby amends its Regulations as shown below :—

PART IV.—SALARIES AND INCREMENTS.

DIVISION IV.—TECHNICAL AND GENERAL DIVISION.

Regulation 114.

In clause (ii) of paragraph (b) the expression "Grade 70" is deleted and the expression "Grade 83" is inserted in lieu thereof.

This Regulation shall have effect from the 3rd February, 1974.

A. J. A. GARDNER, Chairman.
L. R. BROWN, Secretary.

Office of the Public Service Board,
Melbourne, 4th February, 1974.

No. 673.

PUBLIC SERVICE ACT 1958.

The Public Service Board, in pursuance of the powers conferred by the Public Service Act 1958, hereby amends its Regulations as shown below :—

PART IV.—SALARIES AND INCREMENTS.

DIVISION IV.—TECHNICAL AND GENERAL DIVISION.

Regulation 114.

In clause (iii) of paragraph (a) the expression "Grade 70" is deleted and the expression "Grade 83" is inserted in lieu thereof.

This Regulation shall have effect from the 3rd February, 1974.

A. J. A. GARDNER, Chairman.
L. R. BROWN, Secretary.

Office of the Public Service Board,
Melbourne, 1st February, 1974.

No. 680.

Public Service Act 1958, Section 50.

REGULATIONS.—PART IV.—SALARIES AND INCREMENTS.

The Public Service Board, in pursuance of the powers conferred by the Public Service Act 1958, hereby amends its Regulations as shown below :—

SECOND SCHEDULE.

TECHNICAL AND GENERAL DIVISION.

Grades and Salary Scales.

JUNIOR GRADES.

Grade.	Yearly Rate of Salary at Each Age in Years.		
	18.	19.	20.
	\$	\$	\$
Delete— J-21	3,152	3,594	4,141
Add— J-21	3,406	3,884	4,468

SIXTH SCHEDULE.

TEMPORARY EMPLOYEES.

Designations of Positions and Rates of Salaries.

Department and Designation of Position.	Yearly Rate of Salary.		Increments (Annual).
	Minimum.	Maximum.	
	\$	\$	
<i>Delete the existing yearly rates of salary for the following positions and insert the rates shown hereunder in lieu thereof :—</i>			
GENERAL.			
Storeman, Grade II. ..	5,036	5,409	A
Storeman, Grade I.— Junior—			
At 18 years of age	3,406	
At 19 years of age	3,884	
At 20 years of age	4,468	
Adult	4,884φφ	5,176	A

This Regulation shall have effect from the 3rd February, 1974.

A. J. A. GARDNER, Chairman.
L. R. BROWN, Secretary.

Office of the Public Service Board,
Melbourne, 1st February, 1974.

No. 671.

PUBLIC SERVICE ACT 1958.

The Public Service Board, in pursuance of the powers conferred by the Public Service Act 1958, hereby amends its Regulations as shown below :—

PART I.—PRELIMINARY.

REGULATION 2.

Under Part V.—Allowances add the following—

“Division IVA.—Recreation Leave Allowance (R.159A)”.

PART V.—ALLOWANCES.

Immediately following Regulation 159 insert the following heading and Regulation—

“DIVISION IVA.—RECREATION LEAVE ALLOWANCE.

159A. (1) An officer shall, in respect of recreation leave taken after 31st December, 1973 be entitled to be paid, in addition to amounts payable by way of salary as prescribed by these Regulations and other approved emoluments, the greater of the two amounts calculated in accordance with the following (a) or (b)—

(a) an allowance at the rate of 17½ per cent. of the salary of the officer for the period of recreation leave taken, subject to salary for the purposes of calculating this allowance being deemed to

be the salary of the officer as at the 1st January of the year in which recreation leave is taken;

(b) an allowance equal to any additional payments to which an officer would be entitled for shift, Saturday or Sunday duty not in excess of prescribed weekly hours which he would be required to perform if he was not proceeding on approved recreation leave;

Provided that—

(i) the maximum amount of allowance payable under paragraph (a) of this sub-regulation shall not exceed an amount calculated in accordance with paragraph (a) in respect of the salary rate prescribed in these Regulations for Grade 309, Technical and General Division, at the 1st January of the year in which recreation leave is taken;

(ii) where an officer commences employment after 1st January of any year his salary for the purposes of this Regulation shall be the 1st January equivalent of the salary payable to him at the date of the commencement of his employment, or such other salary rate as the Board may determine;

(iii) where an officer is entitled to payments pursuant to paragraph (a) of this sub-regulation while on recreation leave he shall not receive additional payments by way of allowance for shift duty, or rostered time of ordinary duty for work performed during weekends or on public holidays or additional payments of a like nature.

(2) Salary for the purposes of calculating the payment to an officer under paragraph (a) of sub-regulation (1) of this Regulation shall include the salary payable to the officer as prescribed by these Regulations and other additional payments approved by the Board from time to time.

(3) Where it is necessary to calculate a daily rate of allowance for purposes of determining the amount of allowance payable to an officer under paragraph (a) of sub-regulation (1) of this Regulation, such daily rate shall be one-twentieth of the recreation leave allowance payable to an officer for four weeks leave of absence.

(4) The provisions of this Regulation shall not apply to an officer in the Technical and General Division in the Mental Hygiene Branch of the Department of Health who is in receipt of an allowance in accordance with Public Service (Public Service Board) Regulation 157.”

A. J. A. GARDNER, Chairman.
L. R. BROWN, Secretary.

Office of the Public Service Board,
Melbourne, 29th January, 1974.

No. 677.

Public Service Act 1958, Section 50.

REGULATIONS.—PART IV.—SALARIES AND INCREMENTS.

The Public Service Board, in pursuance of the powers conferred by the Public Service Act 1958, hereby amends its Regulations as shown below :—

FIFTH SCHEDULE.

TEMPORARY EMPLOYEES.

DEPARTMENT OF HEALTH.

MENTAL HYGIENE.

Designations of Positions and Rates of Salaries.

Designation of Position.	Yearly Rate of Salary.		Increments (Annual).
	Minimum.	Maximum.	
	\$	\$	
<i>Delete the existing yearly rates of salary for the following position and insert the rates shown hereunder in lieu thereof :—</i>			
General Reliever. . . .	4,377	4,679	A

This Regulation shall have effect from the 3rd February, 1974.

A. J. A. GARDNER, Chairman.
L. R. BROWN, Secretary.

Office of the Public Service Board,
Melbourne, 4th February, 1974.

Teaching Service Act 1958.
TEACHING SERVICE (TEACHERS TRIBUNAL)
REGULATIONS.

AMENDMENT No. 280 (T.T.67).

The Teachers Tribunal, in pursuance of the powers conferred by the *Teaching Service Act 1958*, hereby amends Regulation 14 of the Teaching Service (Teachers Tribunal) Regulations as follows:—

REGULATION 14.

Make the following alterations to the *Staffing Schedule*.—
Special Schools in sub-clause 2 (a):—

In the Schools for Deaf make the alterations indicated for 4683 Glendonald School for Deaf Children:—

Under the Heading: Heads of Schools—Principal, in the column: Special, delete the sign “ † ” and substitute therefor the figure “ 1 ”.

In the column headed: Total Establishment, for the figure “ 28 ” substitute the figure “ 29 ”.

Delete the footnote “ †Professional officer.”.

W. E. SAMPSON, Chairman.

A. F. LE CLERCQ, Secretary.

Office of the Teachers Tribunal,
Melbourne, 23rd January, 1974.

PRIVATE ADVERTISEMENTS

CITY OF BALLAARAT.

By-Law No. 169.

A Bylaw of the City of Ballaarat made under the provisions of the Local Government Act and the Uniform Building Regulations and numbered 169 for the purpose of amending Bylaw No. 154, and prescribing the minimum distance of outer walls from frontages, of buildings of Class 1 or Class 11 occupancy.

In pursuance of the powers conferred by the Local Government Acts and the Uniform Building Regulations, Victoria, and of any and every power it thereunto enabling the Mayor, Councillors and Citizens of the City of Ballaarat order as follows:

1. In Bylaw No. 154, there shall be inserted:

“ 10. No person shall construct a building of Class 1 or Class 11 occupancy the outer walls of which are closer than 25 (twenty five) feet to the frontage of any land referred to in the First Schedule ”.

“ *First Schedule*

A. Sturt Street West from Pleasant Street to Gillies Street—both sides.

B. Wendouree Parade.”

Resolution for passing this Bylaw agreed to by the Council of the City of Ballaarat on the 13th day of August, 1973, and confirmed on the 10th day of September, 1973.

The common seal of the Mayor, Councillors and Citizens of the City of Ballaarat was affixed hereto on the 11th day of September, 1973, in the presence of—

A. C. RIZZOLI, Mayor.
K. C. WEBB, Councillor.
F. J. ROGERS, Town Clerk.

(SEAL)

Approved by the Governor in Council, on the 22nd day of January, 1974.—T. J. FORRISTAL, Clerk of the Executive Council. 6721

CITY OF BOX HILL.

By-Law No. 140.

A By-Law of the City of Box Hill made under Section 198 of the *Local Government Act 1958* and numbered 140 for the purpose of alteration of buildings and of any additions to buildings on certain days and during certain hours.

In pursuance of the powers conferred by the *Local Government Act 1958* (as amended) the Mayor, Councillors and Citizens of the City of Box Hill order as follows:—

(1) This By-Law shall come into operation and have effect immediately upon its publication in the *Government Gazette of Victoria*.

(2) This By-Law shall apply to and have operation throughout the whole of the Municipal District of the City of Box Hill.

(3) The erection construction conversion demolition or alteration of any new or existing building or the erection construction conversion demolition or alteration of any addition to a building or the loading of or unloading of materials in connection therewith in any area within the Municipal District of the City of Box Hill without the written permission of the Council of the said City or the Building Surveyor of the said City is prohibited on Christmas Day, Good Friday and Anzac Day and from 6.00 p.m. on any Saturday to 6.00 a.m. on the following Monday. Provided that this By-Law shall not be applicable:—

(a) to any person who himself performs any work as aforesaid on his own property, or;

(b) to any person who without material reward himself performs any work as aforesaid on any property in which he resides;

(c) to any such work performed by or under the direction of the Mayor, Councillors and Citizens of the City of Box Hill.

(4) Any contravention of this By-Law shall be an offence against this By-Law.

(5) Any person guilty of an offence against this By-Law shall be liable to a penalty of not more than \$100.

Resolution for passing this By-Law agreed to by the Council on the 29th day of October, 1973 and confirmed on the 10th day of December, 1973.

The corporate seal of the Mayor, Councillors and Citizens of the City of Box Hill was hereunto affixed, in the presence of—

(SEAL) E. P. POELMAN, Mayor.
E. H. JAMES, Councillor.
I. G. PORT, Town Clerk.

Approved by the Governor in Council on the 30th day of January, 1974.—T. J. FORRISTAL, Clerk of the Executive Council. 6734

CITY OF COBURG.

PROSECUTING OFFICER.

Notice is hereby given that Senior Sergeant Robert Thomas Mutimer, No. 11830, has been appointed as Prosecuting Officer in lieu of Senior Sergeant Edward Andrew Sharp, No. 10165.

6731 G. W. HARMAN, Town Clerk.

CITY OF GEELONG.

By-Law No. 160.

A By-Law of the City of Geelong made under the provisions of Section 6 of 6 Victoria No. 18 extended to the City of Geelong pursuant to Section 6 of 13 Victoria No. 40 for imposing the rates tolls rents and dues to be levied in the Cattle Market of the City.

In pursuance of the powers conferred by the above-mentioned Acts and every other power enabling it in that behalf it is hereby enacted by the Council of the City of Geelong as follows:—

1. By-Law No. 149 shall be and the same is hereby repealed.

2. The rates tolls and dues to be levied and paid in the Cattle Market of the City shall be as follows:—

- (a) as set out hereunder in respect of any animal sold or exposed for sale in the Cattle Market:
- | | |
|------------------------------------|----------|
| any horse, mare, gelding, foal | 40 cents |
| or head of neat cattle | |
| any pig | 15 cents |
| any calf not more than 6 weeks old | 12 cents |
| any sheep, lamb or goat | 5 cents |
- (b) for any animal yarded in the cattle market per night
- | | |
|--|---------|
| | 5 cents |
|--|---------|

3. Every company firm or person who conducts or arranges the sale by auction of any goods or cattle in any market provided by the Council shall pay the following rents:—

- (i) on appointed market days \$7.00
(ii) on days other than appointed market days \$7.00

Resolution for passing this By-Law agreed to by the Council of the City of Geelong on the 18th of December, 1973.

Confirmed on the 29th day of January, 1974.

The common seal of the Mayor, Councillors and Citizens of the City of Geelong was affixed hereto, in the presence of—

(L.S.) H. G. VERRALL, Mayor.
T. J. T. NEAL, Town Clerk.

6727

CITY OF GEELONG WEST.

CHANGE OF STREET NAME.

Old Name.—Halstead Place.

New Name.—Halstead Street.

Description.—Between Villamanta and Spring Streets.

6772

R. J. HAMMETT, Town Clerk.

CITY OF KEILOR.

LOAN No. 123.

Notice of Intention to Borrow the Sum of \$100,000 for Permanent Works and Undertakings.

Notice is hereby given that the Council of the City of Keilor intends to borrow the principal sum of one hundred thousand dollars (\$100,000) secured by a charge over the general rates of the municipality, such sum to be raised by the grant of a mortgage in accordance with the provisions of the *Local Government Act 1958*.

1. The maximum rate of interest that may be paid is 8.9 per cent. per annum.

2. Such moneys shall be repayable at the Bank of New South Wales, Niddrie.

3. The loan is to be liquidated by providing out of the municipal fund 40 half-yearly instalments of approximately \$5,395.59 each including principal and interest on the 1st day of April and the 1st day of October, during the currency of the loan. The first instalment shall be payable on the 1st day of October, 1974.

4. Purpose for which the loan is to be applied is the purchase of land for Municipal Purposes—Fosters Road—\$100,000.

5. The period of the loan shall be 20 years.

The plans, specifications, estimates of the cost of the proposed works and a statement showing the proposed expenditure of the moneys to be borrowed are open for inspection at the Municipal Offices, Keilor.

6751

R. F. B. KELLY, Town Clerk.

CITY OF KEILOR.

LOAN No. 124.

Notice of Intention to Borrow the Sum of \$500,000 for Permanent Works and Undertakings.

Notice is hereby given that the Council of the City of Keilor intends to borrow the principal sum of Five hundred thousand dollars (\$500,000) secured by a charge over the

general rates of the municipality, such sum to be raised by the grant of a mortgage in accordance with the provisions of the *Local Government Act 1958*.

1. The maximum rate of interest that may be paid is 8.8 per cent. per annum.

2. Such moneys shall be repayable at the Commonwealth Savings Bank of Australia.

3. The loan is to be liquidated by providing out of the municipal fund 30 half-yearly instalments of approximately \$30,335.62 each, including principal and interest on the 1st day of April and the 1st day of October, during the currency of the loan. The first instalment shall be payable on the 1st day of October, 1974.

4. The purpose for which the loan is to be applied is—

	\$
(a) Reconstruction of Broadmeadows Road	50,000
(b) Calder Freeway—Northern Service Road between Woorite Place interchange and Collinson Street	14,000
(c) Land acquisition for road widening	
(i) Fosters Road	50,000
(ii) Kings and Taylors Roads	29,000
(d) Purchase of Plant	66,000
(e) Traffic Signals—Milleara Road	3,500
Dinah Parade near Quinn Grove	5,000
Milleara Road near Groves Street	3,500
(f) Purchase of Properties—Buckley Street Extension	70,000
(g) Government Road Footpaths—Avondale Heights	18,500
(h) Purchase of land for Municipal Purposes—Fosters Road	30,000
(i) St. Albans Swimming Pool	4,500
(j) Reconstruction of Victoria Crescent	20,000
(k) Construction of Car Parking areas—Avondale Heights and Sovereign way Shopping Centres	34,000
(l) Construction of Car Park Railway land—East Esplanade	34,000
(m) Construction of kerb and channel—Keilor Township	16,000
(n) Beautification of Northern Service Road Reserve—Keilor Township	8,000
(o) Pavilion—Spring Street Reserve	10,000
(p) Tennis Facilities—Airport West	20,000
(q) Footpath Construction—North Essendon	8,000
(r) Extensions and Staging—Airport West Community Hall	6,000
	500,000

5. The period of the loan shall be 15 years.

The plans, specifications, estimate of the cost of the proposed works and a statement showing the proposed expenditure of the moneys to be borrowed are open for inspection at the Municipal Offices, Keilor.

6752

R. F. B. KELLY, Town Clerk.

CITY OF WAVERLEY.

Notice is hereby given that in pursuance of the powers conferred by the *Local Government Act* the Council of the City of Waverley did at a meeting held on 5th February, 1974, order that the following alteration be made in the name of portion of the under-mentioned street and that such order take effect from the date of this publication.

Old Name; New Name.

The Deviation commencing on the east side of Jells Road continuing generally in an easterly direction to its intersection with the southern side of Ferntree Gully Road east of Jells Road as shown on Lodged Plan of Subdivision No. 35816; Marykirk Drive. 6808

SHIRE OF ALBERTON.

LOAN No. 30.

Notice of Intention to Borrow the Sum of \$40,000 for Permanent Works and Undertakings.

Notice is hereby given that the Council of the Shire of Alberton proposes to borrow the principal sum of Forty Thousand Dollars secured by a charge over the general rates of the municipality, such sum to be raised by a grant of a mortgage in accordance with the provisions of the *Local Government Act 1958*.

1. The maximum rate of interest that may be paid is 8.8 per centum per annum.

2. The purpose for which the loan is to be applied is the purchase of Land at Yarram.

3. The period of the Loan shall be 15 years.

4. The moneys borrowed shall be repayable by providing out of the municipal fund thirty half-yearly instalments of \$2426.85 each including principal and interest on the 15th day of March and 15th day of September during the currency of the Loan. The first instalment shall be payable on the 15th day of September, 1974.

Such moneys shall be payable at the Australia and New Zealand Savings Bank Ltd., 394-396 Collins Street, Melbourne.

The plans and specifications and the estimate of the cost of the proposed works and a statement showing the proposed expenditure of the moneys to be borrowed are open for inspection at the office of the Council of the Shire of Alberton, Commercial Road, Yarram.

6719

A. W. CURRY, Shire Secretary.

SHIRE OF BACCHUS MARSH.

LOAN No. 29.

Notice of Intention to Borrow the Sum of \$70,000 for Permanent Works and Undertakings.

Notice is hereby given that the Council of the Shire of Bacchus Marsh proposes to borrow the principal sum of \$70,000 secured by a charge over the general rates of the municipality, such sum to be raised by the grant of a mortgage in accordance with the provisions of the *Local Government Act 1958*.

1. The maximum rate of interest that may be paid is 8.8 per cent. per annum.

2. The purpose for which the loan is to be applied is the purchase of land for the establishment of industries.

3. The period of the loan shall be fifteen years.

4. The moneys borrowed shall be repayable by providing out of the municipal fund half-yearly instalments of \$4,246.99 each including principal and interest on the 1st day of April and the first day of October during the currency of the loan. The first instalment shall be payable on the first day of October, 1974.

5. Such moneys shall be repayable to Commonwealth Savings Bank of Australia at Bacchus Marsh.

The plans and specifications and the estimate of the cost of the proposed works and a statement showing the proposed expenditure of the moneys to be borrowed are open for inspection at the office of the Council of the Shire of Bacchus Marsh at Main Street, Bacchus Marsh.

6746

B. E. LEACH, Shire Secretary.

SHIRE OF BERWICK.

ROAD NAME.

Notice is hereby given that pursuant to the provisions of the *Local Government Act 1958* the Council of the Shire of Berwick doth order that the name of the following road within the municipality be gazetted as:—

Old Name.—Un-named.

New Name.—Murphy Lane.

Location.—An unmade Government Road running northerly off Evans Road about 250 metres west of Knight Road intersection, and generally running northerly and north easterly joining the Nar Nar Goon/Longwarry Road about 900 metres east of the Bunyip River.

6723

B. J. WALLIS, Shire Secretary.

SHIRE OF BERWICK.

Notice is hereby given that pursuant to the provisions of the *Local Government Act 1958* the Council of the Shire of Berwick doth order that the name of the following road within the municipality be gazetted as:—

Old Name.—Glissman Road.

New Name.—Glissmann Road.

Location.—A one chain wide private street running northerly from the Princes Highway at Beaconsfield and shown on L.P.64568, Parish of Pakenham as Glissman Road and also on L.P.3783 Parish of Pakenham as Salisbury Street.

6724

B. J. WALLIS, Shire Secretary.

SHIRE OF BERWICK.

LOAN No. 61.

Notice of Intention to Borrow the Sum of \$200,000 for Permanent Works and Undertakings.

Notice is hereby given that the Council of the Shire of Berwick proposes to borrow the principal sum of Two Hundred Thousand Dollars (\$200,000) secured by a charge over the General Rates of the Municipality, such sum to be raised by the grant of a mortgage, in accordance with the provisions of the *Local Government Act, 1958*.

1. The maximum rate of interest that may be paid is 8.8 per centum per annum.

2. The purpose for which the Loan is to be applied is:—

Pakenham Brass Band—Instruments		1,000	
Road Construction			
Unclassified Road construction ..	27,900		
Tivendale Road—Construct & seal 700 ft.		8,000	
Officer—Service Road south side construct and sealing ..		5,000	
Access Road to C.A. 109E		500	
Tynong — Railway Avenue, Construct and seal east from View Street 800 ft.		9,000	
P.H. Road (Main Drain to Murray Road construct and seal ..	36,000		
Hall Road—construct and seal ..	36,000	122,400	
Kerb & Channel, Drainage, Footpaths			
Beaconsfield — Beaconsfield Ave (Wood Street to Highway, Kerb and Channel and seal) ..		26,000	
Beaconsfield to Railway Avenue—U/ground drain ..		1,800	
Pakenham Service Road—U/ground		3,000	
Nar Nar Goon & Bayles Road (Mullcare to Home Road) Footpath ..		1,300	
Garfield Township—Footpaths ..		1,500	
Pakenham—Ahern Road (Hwy. to Gardinia St.) Footpath ..		300	
Pakenham—Army (Bald Hill to Railway) Kerb and Channel ..		700	
Pakenham—McGregor Road (Roger to Main Street) Footpath ..		2,000	
Pakenham — Henty Street (McGregor Street to Savage Street)		1,000	
Pakenham—McGregor Road (Highway to State School) Kerb and Channel, Drainage ..		3,400	
Pakenham — Irving Road Council contribution ..		3,000	
Garfield—Main Street (subway to Ritchie Street) Kerb and Channel		1,200	
Beac. Upper Pre-School Centre—Fencing ..		1,100	46,300
Pakenham Sporting Complex ..			10,000
Land Acquisition—Municipal Purposes			20,300
			<u>\$200,000</u>

3. The period of the Loan shall be fifteen years.

4. The moneys borrowed shall be repayable by providing out of the municipal fund thirty half-yearly instalments of approximately \$12,134.25 each, including principal and interest on the tenth day of October and the tenth day of April during the currency of the Loan. The first instalment shall be payable on the tenth day of October, 1974.

5. Such moneys shall be repayable to the Commercial Savings Bank Limited, Main Street, Pakenham.

The plans and specifications and the estimate of the cost of the proposed works and the statement showing the proposed expenditure of the moneys to be borrowed, are open for inspection at the office of the Council of the Shire of Berwick at Main Street, Pakenham during normal office hours.

6768

B. J. WALLIS, Shire Secretary.

SHIRE OF BERWICK.

ROAD NAME.

Notice is hereby given pursuant to the provisions of the *Local Government Act 1958* the Council of the Shire of Berwick doth order that the name of the following road within the municipality be gazetted as:—

Old Name.—Berry Lane.

New Name.—Strafford Lane.

Location.—Approximately 775 metres south of Nar Nar Goon/Longwarry Road then westerly for approximately 400 metres to Bunyip/Modella Road.

6726

B. J. WALLIS, Shire Secretary.

SHIRE OF BERWICK.

ROAD NAME.

Notice is hereby given pursuant to the provisions of the *Local Government Act 1958* the Council of the Shire of Berwick doth order that the name of the following road within the municipality be gazetted as:—

Old Name.—Un-named.

New Name.—Berry Lane.

Location.—Approximately 775 metres south of Nar Nar Goon/Longwarry Road to Main Drain and being Government Road to the north east and east of Crown Allotments 9 and 46 Parish of Kooweerup East.

6725

B. J. WALLIS, Shire Secretary.

SHIRE OF BRIGHT.

LOAN No. 54.

Notice of Intention to Borrow the Sum of \$25,000 for Permanent Works and Undertakings.

Notice is hereby given that the Council of the Shire of Bright proposes to borrow the principal sum of \$25,000, secured by a charge over the general rates of the municipality, such sum to be raised by a grant of a mortgage in accordance with the provisions of the *Local Government Act 1958*.

1. The maximum rate of interest that may be paid is 8·8 per cent per annum.

2. The purpose for which the loan is to be applied is the construction of a Council Residence.

3. The period of the loan shall be fifteen years.

4. The moneys borrowed shall be repayable by providing out of the municipal fund thirty half-yearly instalments of \$1,516·78 each including principal and interest, on the 14th day of September and the 14th day of March, during the currency of the loan. The first instalment shall be payable on the 14th day of September, 1974.

5. Such moneys shall be repayable at the Australian and New Zealand Savings Bank Limited, Melbourne.

The plans and specifications and the estimate of the cost of the proposed works and a statement showing the proposed expenditure of the moneys to be borrowed, are open for inspection at the office of the Council of the Shire of Bright, Ireland Street, Bright.

Dated the 7th day of February, 1974.

6741

H. G. HAYMES, Shire Secretary.

SHIRE OF BULLA.

BY-LAW No. 46.

A by-Law of the Shire of Bulla, made under the *Health Act 1958*, and numbered 46 for and with respect to:—

(a) Fixing fees payable to the Council under Part XV of the *Health Act 1958*, for the examination and branding of carcasses of animals slaughtered for sale within the Bulla Meat Area.

(b) For fixing the hours of slaughtering in private abattoirs or slaughter yards within the Bulla Meat Area.

(c) Prohibiting the removal of carcasses or meat, unless branded as required by regulations or rendered unfit for human consumption in the prescribed manner.

(d) Prohibiting any diseased animal being brought onto the premises without the permission of the Meat Inspector.

(e) Prevention of cruelty to animals.

A copy of the said By-Law is open for inspection, free of charge, during office hours, at the office of the Council, Macedon Street, Sunbury.

6809

JOHN M. KELLY, Shire Secretary.

SHIRE OF BUNINYONG.

LOAN No. 26.

Notice of Intention to Borrow the Sum of \$64,000 for Permanent Works and Undertakings.

Notice is hereby given that the Council of the Shire of Buninyong proposes to borrow the principal sum of \$64,000 secured by a charge over the general rates of the municipality, such sum to be raised by the grant of a mortgage in accordance with the provisions of the *Local Government Act 1958*.

1. The maximum rate of interest that may be paid is 8·7 per cent. per annum.

2. The purpose for which the loan is to be applied is the purchase of Land being Crown Allotments 1E, 1F, 1J, 1K, 1L, 1M, 1N, 1O, 1P, 37 and J comprising 178 acres and 4 and 1/10 perches or thereabouts, Section 18, Parish of Warrenheip, for the purpose of decentralized industry.

3. The period of the loan shall be twelve years.

4. The moneys borrowed shall be repayable by providing out of the municipal fund half-yearly instalments of approximately \$4,349·32 each including principal and interest on the first day of April and the first day of October during the currency of the loan. The first instalment shall be payable on the first day of October, 1974.

5. Such moneys shall be repayable to The National Bank Savings Bank Limited at the office of the said Bank 271-285 Collins Street, Melbourne.

The plans and specifications and the estimate of the cost of the proposed works and a statement showing the proposed expenditure of the moneys to be borrowed are open for inspection at the office of the Council of the Shire of Buninyong, at Learmonth Street, Buninyong.

Date: 7th February, 1974.

6755

A. C. LORD, Shire Secretary.

SHIRE OF BUNINYONG.

LOAN No. 25.

Notice of Intention to Borrow the Sum of \$44,000 for Permanent Works and Undertakings.

Notice is hereby given that the Council of the Shire of Buninyong proposes to borrow the principal sum of \$44,000 secured by a charge over the general rates of the municipality, such sum to be raised by the grant of a mortgage in accordance with the provisions of the *Local Government Act 1958*.

1. The maximum rate of interest that may be paid is 8·7 per cent. per annum.

2. The purpose for which the loan is to be applied is the making of streets, roads, and drainage as set out hereunder.

Item	Works	Est. Cost
1.	Drainage Works in Hermitage Avenue, Mt. Clear along the frontage of C.A. 8, 8A and 19 from the North-West corner of lot 9 to the easement created through C.A. 19, Section 2, Parish of Ballarat	\$3,600
2.	Completion of street construction throughout Eddy Avenue, Mt. Helen, and in Moss Avenue, Mt. Helen, from the Midland Highway to the North West corner of C.A. 49c, Parish of Buninyong	\$20,000
3.	Street construction (not incl. sealing) in Hocking Avenue, Mt. Clear, from Semillon Grove to Hermitage Avenue	\$6,500
4.	Street construction (not incl. sealing) of Service road (Midlands Highway) Mt. Clear—East side from Olympic Avenue Northerly to the North-West corner of C.A. 14, Section 4, Parish of Ballarat	\$4,000
5.	Service road and carpark construction in Learmonth Street, Buninyong—north side from Warrenheip Street to the South-West corner of C.A. 6, Section 1, Township of Buninyong	\$2,000
6.	Council proportion of kerb and channelling works in Eyre Street, Buninyong—North side, from Lumeah Road Easterly to the South East corner of C.A. 10, Section 56, Township of Buninyong	\$1,700
7.	Underground drainage and Council proportion of Kerbing and Channelling works in Eyre Street, Buninyong—North side, from Warrenheip Street, Westerly to the South-West corner of C.A. 4, Section 42, Township of Buninyong	\$1,200
8.	Council proportion of kerb and channelling works in Winter Street, Buninyong, from Barkly Street to Palmerston Street—West side	\$600
9.	Drainage works and Council Proportion kerb and channelling works in Simpson Street, Buninyong—North side abutting State School Reservation and in Inglis Street—East side from Simpson Street to Yuille Street	\$2,000

Item	Works	Est. Cost
10.	Underground drainage and Council proportion kerb and channelling works in Warrenheip Street, Buninyong—West side from Barkly Street to Elizabeth Street and Warrenheip Street—East side from Barkly Street to a point 25 metres north of Elizabeth Street	\$2,400
Total		\$44,000

3. The period of the loan shall be ten years.

4. The moneys borrowed shall be repayable by providing out of the municipal fund half-yearly instalments of approximately \$3,338.73 each including principal and interest on the first day of April and the first day of October during the currency of the loan. The first instalment shall be payable on the first day of October, 1974.

5. Such moneys shall be repayable to The National Bank Savings Bank Limited at the office of the said Bank 271-285 Collins Street, Melbourne.

The plans and specifications and the estimate of the cost of the proposed works and a statement showing the proposed expenditure of the moneys to be borrowed are open for inspection at the office of the Council of the Shire of Buninyong, at Learmonth Street, Buninyong.

Date: 7th February, 1974.

6754

A. C. LORD, Shire Secretary.

Town and Country Planning Act 1961 (Twelfth Schedule).
SHIRE OF CORIO.—LARA PLANNING SCHEME, 1961.
NOTICE THAT A PLANNING SCHEME HAS BEEN PREPARED AND IS AVAILABLE FOR INSPECTION.

Amendment No. 9, 1973.

Notice is hereby given that the Council of the Shire of Corio in pursuance of its power under the *Town and Country Planning Act 1961* has prepared a Planning Scheme for the following:—

1. Rezone land situated centrally within the area bounded by Princes Highway, McClelland Avenue and Rennie Street, from existing Commercial 'C' to Residential 'A' and from Agricultural 'A', 'C' and P1 "Education Department Purposes" to Special Industrial.

2. Rezone land in Mill Road, comprising Lots 1 to 10 of plan of subdivision number 34297, from Agricultural 'C' to Residential 'A'.

3. Provision of a service road on the westerly side of Princes Highway from the end of the road reservation in plan of subdivision number 33356 north-easterly to Old Melbourne Road.

4. Amend the Planning Scheme Ordinance in regard to Schedule 4 "Restricted Agricultural Uses" to include motor racing tracks and speedways, subject to permit by the Responsible Authority.

A copy of the Planning Scheme has been deposited at the Shire Offices, Osborne House, North Geelong, and at the offices of the Town and Country Planning Board, 235 Queen Street, Melbourne, and will be open for inspection, during office hours, by any person free of charge.

Any persons affected by the Planning Scheme are required to set forth in writing all objections they may have, addressed to the Shire Secretary, Shire of Corio, Osborne House, North Geelong, on or before the 13th day of May, 1974, and state whether they wish to be heard in respect of their objections.

Dated this 13th day of February, 1974.

R. P. METCALF, Shire Secretary.

Osborne House, North Geelong.

6729

Local Government Act 1958.

SHIRE OF DIAMOND VALLEY.

NOTICE TO ALL WHOM IT MAY CONCERN.

The Council of the Shire of Diamond Valley deems it expedient to exercise its powers of taking land compulsorily as provided by the *Local Government Act 1958*, for the purpose of extending A. K. Lines Reserve and the said Council has therefore caused to be prepared such maps and other papers as may be necessary showing the land to be acquired and the names of the owners or reputed owners, lessees or reputed lessees, mortgagees and occupiers of the land so far as those names are known to or can be ascertained by the Council and the said maps and other papers so prepared have been approved by the said Council.

In pursuance of the provisions of the *Local Government Act 1958*, the said Council doth hereby publish and give notice that the description shortly of the purport of the said maps and other papers is as follows—

The extension of A. K. Lines Reserve, Watsonia, and the land which it is necessary and desirable to take compulsory is—

(a) all those pieces of land being Lots 193 and 194 Peters Street, set out on plan of subdivision No. 10622, Parish of Keelbundora, County of Bourke and being more particularly described in Certificate of Title Vol. 8262 Fol. 043 in the name of Heidelberg Development Co. Pty. Ltd.

(b) All that piece of land being Lot 258 Knight Street, set out on plan of subdivision No. 10622, Parish of Keelbundora, County of Bourke and being more particularly described in Certificate of Title Vol. 8464, Fol. 147 in the name of John Quinn & Co. Pty. Ltd.

And the said Council doth hereby give further notice that the said maps and other papers are deposited at the office of the said Council at Civic Drive, Greensborough, and are there open for inspection on all the days and between the hours the said office is appointed to be open for the space of 40 clear days from the date of publication of this notice in the *Government Gazette*.

And the said Council doth hereby call upon all persons affected by the taking of the said land to set forth in writing, addressed to the said Council or the Shire Secretary thereof, at the Civic Centre, Civic Drive, Greensborough, within 40 clear days from the date of the publication of this notice as aforesaid all objections which they may have to the taking of the said land.

The common seal of the President, Councillors and Ratepayers of the Shire of Diamond Valley was hereto affixed by me—

B. J. MORGAN, Shire Secretary.

in the presence of—

6760 (SEAL)

W. H. CRITCHLEY, President.
A. L. GOLDSWORTHY, Councillor.

SHIRE OF DUNMUNKLE.

Notice is hereby given that the Council of the Shire of Dunmunkle has appointed Snr. Const. VERNON DUNCAN BARNES, No. 9598, Prosecuting Officer for the East Riding of the said Shire, in place of Snr. Const. John Murray Sinnott, No. 9881, retired.

6774

K. E. LIEBOLD, Shire Secretary.

SHIRE OF ELTHAM.

NOTICE OF INTENTION TO TAKE LAND COMPULSORILY.

Notice is hereby given that—

1. The Council of the Shire of Eltham deems it expedient to execute the work or undertaking of deviating the Cottles Bridge—Strathewen Road in connection with the reconstruction of the bridge at Cottles Bridge.

2. For the purpose of executing such work the Council deems it expedient to exercise its power of taking compulsorily part of Crown Allotment 1, Section B, Parish of Greensborough, being more particularly described in Certificate of Title, Volume 5104, Folio 717 in the names John Denis Christian as the proprietor and Commercial Bank of Australia Ltd. as mortgagee.

3. The Council has caused to be prepared maps and other papers describing the proposed work or undertaking and the land proposed to be taken, together with the names of every owner or reputed owner, every lessee or reputed lessee, every mortgagee, and the occupier thereof as far as such names can be ascertained by the Council.

4. Such maps and other papers are deposited at the Shire Offices, Main Road, Eltham, where they are and will remain open for inspection by all persons interested, at all reasonable hours, for the space of 40 clear days after publication of this notice in the *Government Gazette*.

5. All persons affected by the proposed work or undertaking are hereby called upon to set forth, in writing, addressed to the Council, or the Shire Secretary of the Shire of Eltham, within 40 clear days from the publication of this notice in the *Government Gazette*, viz., 13th February, 1974, all objections which they may have to the said work or undertaking.

Dated this 13th day of February, 1974.

COLIN J. BOCK, Shire Secretary/Chief Administrator.

6764

SHIRE OF FLINDERS.

LOAN NO. 89.

Notice of Intention to Borrow.

Notice is hereby given that the Council of the Shire of Flinders intends to borrow One hundred and fifty thousand dollars (\$150,000.00) secured by a charge over the general rates of the municipality by the grant of a mortgage in accordance with the provisions of the Local Government Acts.

In connection therewith the following information is stated:

- (a) The amount of the principal moneys which it is proposed to borrow is \$150,000.
- (b) The maximum rate of interest that may be paid is 8.8 per centum per annum.
- (c) The times which the moneys borrowed are to be repayable are the first day of October 1974 and the first days of April and October during the years 1974 to 1990 inclusive and that the place such moneys shall be repayable is at the Bank of New South Wales, Rosebud.
- (d) The purpose for which the loan is to be applied is:

1. Part Payment, Dromana Elderly Citizens Building	\$ 25,000
2. Kerb and Channel, Nepean Highway, Dromana	4,000
3. Purchase of Building from Fluor, for Youth Club, Rosebud	7,000
4. Contribution to Street Works and Widening Dromana, Rosebud	28,000
5. Construction Percy Street, McCrae, Council Proportion	10,000
6. Construction Works, Main Ridge Fire Station	1,000
7. Olympic Park, Rosebud, Construction	25,000
8. Construction of Truemans and Sandy Roads, Boneo	5,000
9. Part Provision, Reconstruction Eastbourne Road, Rosebud	45,000
- (e) The manner in which the loan is to be liquidated is by provision out of the municipal fund in each half year during the currency of the loan of the sum of Nine thousand one hundred dollars and sixty-nine cents (\$9,100.69) which includes principal and interest.

The plans and specifications and estimate of the cost of the works and a statement showing the proposed expenditure of the moneys to be borrowed are open for inspection at the Shire Office, Nepean Highway, Dromana.

Dated this Sixth day of February, 1974.

6739

S. WILLIAMS, Shire Secretary.

SHIRE OF GLENELG.

LOAN NO. 43.

Notice of Intention to Borrow the Sum of \$10,000 for Permanent Works and Undertakings.

Notice is hereby given that the Council of the Shire of Glenelg intends to borrow the sum of (\$10,000) ten thousand dollars, on the credit of the Municipal Revenues of the President, Councillors and Ratepayers of the Shire of Glenelg, such sum to be raised in accordance with the provisions of the Local Government Act 1958.

The maximum amount of interest that may be paid is 8.7 per centum per annum.

The purpose for which the loan is to be applied is the purchase of an articulated Bookmobile.

The period of the loan shall be ten years.

The money borrowed shall be repayable by providing out of the Municipal Fund 20 half yearly instalments of approximately \$758.80 each, including principal and interest, on the 1st day of September and the 1st day of March, during the currency of the loan. The first instalment shall be payable on the 1st day of September 1974.

Such moneys shall be repayable at the National Bank Savings Bank, Melbourne.

The plans, specifications and estimated cost of the proposed works and a statement showing the proposed expenditure of the money to be borrowed, are open for inspection at the Shire Office, Casterton.

6736

D. A. TICKELL, Shire Secretary.

SHIRE OF KOWREE.

LOAN NO. 28.

Notice of Intention to Borrow the Sum of \$35,000 for Permanent Works and Undertakings.

Notice is hereby given that the Council of the Shire of Kowree proposes to borrow the principal sum of \$35,000 secured by a charge over the general rates of the municipality, such sum to be raised by the grant of a mortgage in accordance with the provisions of the Local Government Act 1958.

1. The maximum rate of interest that may be paid is 8.6 per cent. per annum.

2. The purpose for which the loan is to be applied is—Purchase of Plant.

3. The period of the loan shall be 8 years.

4. The moneys borrowed shall be repayable by providing out of the municipal fund half-yearly instalments of \$3070.55 each, including principal and interest, on the 1st day of March and the 1st day of September, during the currency of the loan. The first instalment shall be payable on the 1st day of September, 1974.

5. Such moneys shall be repayable to the National Bank Savings Bank Limited, Edenhope.

6. The plans and specifications and the estimate of the cost of the proposed works and a statement showing the proposed expenditure of the moneys to be borrowed are open for inspection at the Shire Offices, Edenhope.

6753

B. D. HAYES, Shire Secretary.

SHIRE OF MALDON.

LOAN NO. 23.

Notice of Intention to Borrow the Sum of \$30,400 for Permanent Works and Undertakings.

Notice is hereby given that the Council of the Shire of Maldon proposes to borrow the principal sum of Thirty thousand, four hundred dollars secured by a charge over the general rates of the municipality, such sum to be raised by the grant of a mortgage in accordance with the provisions of the Local Government Act 1958.

1. The maximum rate of interest that may be paid is 8.7 per cent. per annum.

2. The purpose for which the loan is to be applied is for purchase of road making plant.

3. The period of the loan shall be ten years.

4. The moneys borrowed shall be repayable by providing out of the municipal fund half-yearly instalments of approximately \$2,307.00 each including principal and interest on the first day of June and the first day of December during the currency of the loan. The first instalment shall be payable on the first day of December, 1974.

5. Such moneys shall be repayable to The Commissioners of The State Savings Bank of Victoria at the office of the said Commissioners, Corner Elizabeth and Bourke Streets, Melbourne.

The plans and specifications and the estimate of the cost of the proposed works and a statement showing the proposed expenditure of the moneys to be borrowed are open for inspection at the office of the Council of the Shire of Maldon at Maldon.

6811

S. R. BEACH, Shire Secretary.

Town and Country Planning Act 1961 (Twelfth Schedule).
SHIRE OF MORNINGTON.—SHIRE OF MORNINGTON
PLANNING SCHEME, 1959.

NOTICE THAT A PLANNING SCHEME HAS BEEN PREPARED AND IS AVAILABLE FOR INSPECTION.

Amendment No. 90, 1973.

Notice is hereby given that the Council of the Shire of Mornington in pursuance of its powers under the *Town and Country Planning Act 1961* has prepared a Planning Scheme for the following areas and purposes:—

Land shown on Plan Number 244/PP/1 in the office of the Council being:—

Land fronting right-of-way/passageway between Kilburn Grove and Irvine Avenue, Mount Martha, to provide a 20 feet road reservation for the purpose of widening such right-of-way/passageway from the existing width of 10 feet to 30 feet width.

A copy of the scheme has been deposited at the office of the Council, Queen Street, Mornington, and at the office of the Town and Country Planning Board, 235 Queen Street, Melbourne, and will be open for inspection during office hours by any person free of charge.

Any persons affected by the Planning Scheme are required to set forth in writing all objections they may have, addressed to the Shire Secretary, Mornington Shire Council, P.O. Box 78, Mornington, 3931, on or before the 13th day of May, 1974, and to state whether they wish to be heard in respect of their objections.

7th February, 1974.

6743 D. G. COLLINGS, Shire Secretary.

SHIRE OF PHILLIP ISLAND.

LOAN No. 63.

Notice of Intention to Borrow the Sum of \$10,000 for Permanent Works and Undertakings.

Notice is hereby given that the Council of the Shire of Phillip Island proposes to borrow the sum of \$10,000 secured by a charge over the general rates of the municipality, such sum to be raised by a grant of a mortgage in accordance with the provisions of the *Local Government Act, 1958*.

1. The maximum rate of interest that may be paid is 8.5% per annum.
2. The purpose for which the loan is to be applied is Purchase of Plant.
3. The period of the loan shall be five years.
4. The moneys borrowed shall be repayable by providing out of the municipal fund half-yearly instalments of \$1,248.30 each including principal and interest, on the first day of October and the first day of April, during the currency of the loan. The first instalment shall be payable on the first day of October, 1974.
5. Such moneys shall be repayable to the National Bank of Australasia Limited, 271-285 Collins Street, Melbourne.

The plans and specifications and the estimate of the cost of the proposed works and a statement showing the proposed expenditure of the moneys borrowed, are open for inspection at the office of the Council of the Shire of Phillip Island at Cowes, 3922.

6765 STAN A. HARRIS, Municipal Clerk.

SHIRE OF PHILLIP ISLAND.

LOAN No. 64.

Notice of Intention to Borrow the Sum of \$25,000 for Permanent Works and Undertakings.

Notice is hereby given that the Council of the Shire of Phillip Island proposes to borrow the principal sum of \$25,000 secured by a charge over the general rates of the municipality, such sum to be raised by a grant of a mortgage in accordance with the provisions of the *Local Government Act, 1958*.

1. The maximum rate of interest that may be paid is 8.7 per cent. per annum.
2. The purpose for which the loan is to be applied is:—

Cowes Camp—Power and Fencing	\$10,250
Newhaven Camp—Power, Toilet Block, Roads	9,500
House Reconstruction, Chapel Street, Cowes	3,500
Foreshore Barbeques	1,750
	\$25,000

3. The loan shall be for the period of 10 years.
 4. The moneys borrowed shall be repayable by providing out of the municipal fund half-yearly instalments of \$1,897.00 each, including principal and interest, on the first day of October and the first day of April, during the currency of the loan. The first instalment shall be payable on the first day of October, 1974.
 5. Such moneys shall be repayable to the National Bank of Australasia Limited, 271-285 Collins Street, Melbourne.
- The plans and specifications and the estimate of the cost of the proposed works and a statement showing the proposed expenditure of the moneys borrowed, are open for inspection at the office of the Council of the Shire of Phillip Island at Cowes, 3922.

6766 STAN. A. HARRIS, Municipal Clerk.

SHIRE OF WARRAGUL.

LOAN No. 92.

Notice of Intention to Borrow the Sum of \$34,000 for Permanent Works and Undertakings.

Notice is hereby given that the Council of the Shire of Warragul proposes to borrow the principal sum of Thirty-four thousand dollars secured by a charge over the general rates of the Municipality, such sum to be raised by the grant of a mortgage in accordance with the provisions of the *Local Government Act 1958*.

1. The maximum rate of interest that may be paid is 8.7 per cent. per annum.
2. The purpose of which the loan is to be applied is—
Roads, Kerb and Channel, Drainage.
3. The period of the loan shall be 10 years.
4. The moneys borrowed shall be repayable by providing out of the Municipal Fund twenty half yearly instalments of approximately \$2,579.93 each, including principal and interest on the 1st day of April and the 1st day of October during the currency of the loan. The first instalment shall be payable on the 1st day of October, 1974.

5. Such moneys shall be repayable to the Bank of New South Wales Savings Bank Limited, Warragul.

The plans and specifications and the estimate of the cost of the proposed works and a statement showing the proposed expenditure of the moneys to be borrowed are open for inspection at the Office of the Council of the Shire of Warragul, Civic Place Warragul.

6737 D. McADIE, Shire Secretary.

SHIRE OF WARRAGUL.

LOAN No. 93.

Notice of Intention to Borrow the Sum of \$53,000 for Permanent Works and Undertakings.

Notice is hereby given that the Council of the Shire of Warragul proposes to borrow the principal sum of Fifty-three thousand dollars secured by a charge over the general rates of the Municipality, such sum to be raised by the grant of a mortgage in accordance with the provisions of the *Local Government Act 1958*.

1. The maximum rate of interest that may be paid is 8.5 per cent. per annum.
2. The purpose for which the loan is to be applied is—
Purchase of Plant and Machinery.
3. The period of the loan shall be 5 years.

4. The moneys borrowed shall be repayable by providing out of the Municipal Fund ten half yearly instalments of approximately \$6,616.00 each, including principal and interest on the 1st day of April and the 1st day of October during the currency of the loan. The first instalment shall be payable on the 1st day of October, 1974.

5. Such moneys shall be repayable to the Bank of New South Wales Savings Bank Limited, Warragul.

The plans and specifications and the estimate of the cost of the proposed works and a statement showing the proposed expenditure of the moneys to be borrowed are open for inspection at the Office of the Council of the Shire of Warragul, Civic Place Warragul.

6738 D. McADIE, Shire Secretary.

SHIRE OF WERRIBEE.

LOAN No. 88.—\$150,000.

Notice of Intention to Borrow the Sum of \$150,000 for Permanent Works and Undertakings.

Notice is hereby given that the Council of the Shire of Werribee proposes to borrow the principal sum of One Hundred and Fifty Thousand Dollars (\$150,000) secured by a charge over the general Rates of the Municipality, such sum to be raised by the grant of a Mortgage in accordance with the provisions of the *Local Government Act 1958*.

1. The maximum rate of Interest that may be paid is 8.7 per cent. per annum.
2. The purpose for which the Loan is to be applied is:—
Drainage Works (Part cost of D-13 Southern Drain, Werribee) \$150,000.
3. The period of the Loan shall be Fourteen (14) years.
4. The moneys borrowed shall be repayable by providing out of the Municipal fund half-yearly instalments of approximately \$9,368.76 each, including principal and interest on the 1st day of March and the 1st day of September during the currency of the Loan. The first instalment shall be payable on the 1st day of September, 1974.

5. Such moneys shall be repayable to the National Bank Savings Bank, Melbourne or such other place or places as the Bank from time to time may require.

The plans and specifications and the estimate of the proposed works and a Statement showing the proposed expenditure of the moneys to be borrowed, are open for inspection at the Office of the Council of the Shire of Werribee, Watton Street, Werribee, 3030.

Dated 8th February, 1974.

6807 J. T. KERR, Shire Secretary.

River Improvement Act 1958.

SHIRE OF WHITTLESEA.

PROPOSED RIVER IMPROVEMENT DISTRICT.

Notice is hereby given that the Council of the Shire of Whittlesea has forwarded to the Minister of Water Supply an application for the constitution of a river improvement district under the jurisdiction and control of a river improvement trust and comprising all of the Municipality excluding that area within the metropolis as defined in Section 3 (1) of the Melbourne and Metropolitan Board of Works Act, under the provisions of the *River Improvement Act 1958*.

Copies of the application and general plan and description of the proposed works have been deposited for inspection at the Offices of—

- (a) The Minister of Water Supply, State Rivers and Water Supply Commission, 90 Orrong Road, Armadale, 3143.
 (b) The Shire of Whittlesea at the Shire Office, Epping, 3076.

6758 R. G. C. COOK, Shire Secretary.

ORBOST WATERWORKS TRUST.

By-Law No. 27.

Water Supply Services By-Law.

I hereby give notice that the Trust has made a By-Law (No. 27). The By-Law has been approved by the Governor in Council and the provisions thereof are now applicable within the whole of the district of the Orbost Waterworks Trust.

The By-Law contains information and regulations in connection with—

1. Interpretation
2. Licensed Plumbers
3. Execution of Works of Water Supply
4. Private Extensions
5. Connections to Main Pipes and Aqueducts
6. Repairs
7. Materials
8. Meters
9. Fire Services
10. General
11. Misuse and Waste of Water
12. Penalties

A copy of the By-Law is open for inspection free of charge at the Trust Office, 4-6 Clarke Street, Orbost.

6749 L. B. FULLARTON, Secretary/Manager.

NOTICE OF INTENTION TO APPLY FOR A LICENCE TO DIVERT WATER AND CUT RACE FROM THE RIVER MURRAY AT IRAAK.

We hereby give notice that we intend to apply for a Licence empowering us to divert water for a term of four years to the extent of 185 Megalitres per annum at a maximum rate of 4 Megalitres per day of 24 hours for the Irrigation of 20.7 Hectares of vines, orchard and vegetables being part of Allotment 28 Parish of Karadoc, and to occupy certain Crown Lands for works of diversion, and to cut a race thereon.

Any objection to such application must be forwarded in writing to reach the State Rivers and Water Supply Commission, Melbourne before 15th March, 1974, being thirty days from the first publication of this Notice.

NORMAN WINSTON FISHER.
 DESMOND WINSTON FISHER.

Box 402, Irymple, Vic. 3498. 6776

NOTICE OF INTENTION TO APPLY FOR A LICENCE TO DIVERT WATER AND CUT RACE (RE-ISSUE) FROM THE GOULBURN RIVER AT WYUNA.

We hereby give notice that we intend to apply for a Licence empowering us to divert water for a term of four years to the extent of fifty-five megalitres per annum at a maximum rate of twelve megalitres per day of 24 hours for the irrigating of Twenty-two and three-tenths hectares being part of Allotment Twenty-six Parish of Wyuna, and to occupy certain Crown Lands for works of diversion, and to cut a race thereon.

Any objection to such application must be forwarded in writing to reach the State Rivers and Water Supply Commission, Melbourne before 15th March, 1974, being thirty days from the first publication of this Notice.

WILLIAM IAN MILLER.
 MARGARET LYNNE MILLER.

Scobie Road, Tongala, 3621. 6775

LAND ACT 1958.

Notice is hereby given that No. 6 Jacuna (F.H.S. Vic.) Pty. Ltd. has applied for a lease pursuant to Sections 134 and 135 of the *Land Act 1958*, for a term of 50 years in respect of Allotment 10 Section 1A Parish of Dousta Galla, containing 1,416 square metres as a site for warehousing, transport and factory premises and purposes ancillary thereto.

6712 L. GIBNEY, for Secretary of Lands.

Notice is hereby given that I, NADA CVIJETIC am not responsible for any debts incurred by my husband, MILORAD CVIJETIC as from the 12th February 1974.

6836 N. CVIJETIC.

I, Peter John Quinlivan of Flat 6, 14 Brennand Street, North Fitzroy in the State of Victoria hereby give notice that I will not be responsible for any debts incurred in my name on or after the date of this publication. 6761

Any persons having business dealings with Truccolo Body Works of 335 Pascoe Vale Road Essendon are hereby notified that from the 1st day of February 1974 FIORENZO and MARIA TRUCCOLO ceased to be proprietors in the business.

GERARD A. CONLAN, solicitor. 6769

Notice is hereby given that the Partnership heretofore subsisting between John Arthur Gordon and Donald John Ballagh carrying on business as upholsterers at 25 Murray Street Colac under the style or firm of "Gordon & Ballagh" has been dissolved as from the 28th day of January 1974 so far as concerns the said John Arthur Gordon who has retired from the said firm.

Dated the 6th day of February, 1974.

CLARKE & BARWOOD.

Clarke & Barwood, solicitors and agents for the said John Arthur Gordon and Donald John Ballagh. 6718

TAKE NOTICE that Samena Eleanor Jaffe of Flat 10, 71 Mathoura Road, Toorak and Anthony Charles Angelos formerly of Flat 1, 641 Punt Road, South Yarra but now of 171 Toorak Road, South Yarra who in partnership have carried on business of designing and retailing men and ladies clothing and accessories under the style or firm name "Tony Angelos Designs" at a lock up shop known as 171 Toorak Road, South Yarra with one another dissolved such partnership as at the 6th day of February, 1974.

Dated this 6th day of February, 1974.

SAMENA ELEANOR JAFFE.
 ANTHONY CHARLES ANGELOS.

6786

R. W. MAISEY & SONS PROPRIETARY LIMITED.

SPECIAL RESOLUTION TO WIND UP, PURSUANT TO SECTION 254 OF THE COMPANIES ACT 1961.

At an extraordinary General Meeting of the above-named company, duly convened and held at Mitchell River Caravan Park, Bairnsdale on the 2nd day of February, 1974, the following resolution was duly passed as a Special Resolution:

"That the company be wound up voluntarily."

And at such last-mentioned meeting Victor Francis Selwyn McGrath was appointed liquidator for the purpose of the winding up.

Notice is hereby given that after twenty-one days from this date I shall proceed to distribute the assets. All creditors having any claims against the company should furnish particulars of same by that date, otherwise I shall proceed to distribute the assets without regard to their claims.

Dated this 2nd day of February, 1974.

V. F. S. McGRATH, Liquidator.

200 Little Lonsdale Street, Melbourne, Vic. 3000. 6720

Companies Act 1961.—In the matter of BELVIEW COURT PROPRIETARY LIMITED (in Voluntary Liquidation).

Notice is hereby given, pursuant to s. 254 (2) (b) of the *Companies Act 1961*, that at the general meeting of the members of Belview Court Pty. Ltd., duly convened and held at the company's registered office on the thirty-first day of January, 1974, the following resolution was passed as a special resolution:—

"That Eddie Kutner be appointed liquidator of the company to fill the vacancy in office caused by the death of Erwin Charles Winter previously appointed liquidator of Belview Court Pty. Ltd."

Dated this 1st day of February, 1974.

6733 EDDIE KUTNER, Liquidator.

Unclaimed Moneys Act 1962.

Register of Unclaimed Moneys held by the—

Name of Owner on Books and Last Known Address.	Total Amount Due to Owner.	Description of Unclaimed Moneys.	Date when Amount First Became Payable.
§ TOWNSHEND HOMES (VIC.) PTY. LTD. TRUST ACCOUNT NO. 1.			
Young (Mr.), 166 Cornwall Road, Sunshine 6744	15.00	Valuation Fee	12.71

The Companies Act 1961.

NAPPIE WASH PROPRIETARY LIMITED.

TAKE NOTICE that on the 17th day of December 1973 the Supreme Court of Victoria ordered that:—

(1) The reduction of the capital of Nappie Wash Proprietary Limited the subject of the Special Resolution passed on the 2nd day of November 1973 be confirmed.

(2) The amount of the share capital of the said company as altered by the confirmation of the said reduction be \$34,850 divided into 100,000 ordinary shares of which—

- (a) 83,000 are of one cent nominal value and have been issued and are fully paid up and—
(b) 17,000 are of \$2 nominal value and have not been issued.

E. P. JOHNSON & DAVIES, solicitors, 339 Collins Street, Melbourne. 6789

Companies Act 1961.—In the matter of W. J. & E. POHL PROPRIETARY LIMITED (in Voluntary Liquidation).

Notice is hereby given, pursuant to s. 254 (2) (b) of the Companies Act 1961, that at the general meeting of the members of W. J. & E. Pohl Pty. Ltd. duly convened and held at the company's registered office on the thirty-first day of January, 1974, the following resolution was passed as a special resolution:—

“That Eddie Kutner be appointed liquidator to fill the vacancy created by the death of Erwin Charles Winter.”

Dated this 1st day of February, 1974.

6732 EDDIE KUTNER, Liquidator.

F.N.B.S. INVESTMENTS PTY. LTD. (IN VOLUNTARY LIQUIDATION).

Notice is hereby given in pursuance of Section 272 (2) of the Companies Act 1961 that the Final Meeting of members of the above company will be held at 12th Floor, 271 William Street, Melbourne at 10.00 a.m. on Wednesday the 6th March, 1974 for the purpose of having an account laid before it showing the manner in which the winding up has been conducted and to hear any explanations that may be given by the Liquidator.

Dated this 6th day of February, 1973.

J. B. HUTCHINS, Liquidator.

Wilson, Bishop, Bowes & Craig, chartered accountants, 271 William-street, Melbourne. 6778

The Companies Act 1961.—In the matter of LAPPINS VAN LINES PROPRIETARY LIMITED.

NOTICE is hereby given that a meeting of creditors of the abovenamed company will be held at the Meeting Room, Morwell Hotel Motel, Princes Highway, Morwell at 11.00 a.m. on Friday, 15th of February, 1974, the company having convened a meeting of its members for the same day for the purpose of considering a Resolution that the company be wound up voluntarily.

T. T. LAPPIN, Director.

Bentley, Wheeler, Cartledge & Co., chartered accountants, 1 Palmerston Crescent, South Melbourne, 3205. 6790

In the matter of the Companies Act 1961 as amended (Section 272).—P.G.H. CERAMICS PTY. LIMITED (in Liquidation).

Notice is hereby given that the Final General Meeting of P.G.H. Ceramics Pty. Limited (in Liquidation) will be held at the offices of Messrs. Spry Walker & Co., 2 Castle-reagh Street, Sydney on 8th March, 1974 at 11 a.m. for the purpose of laying before the Meeting an account showing how the winding up has been conducted and the property of the company has been disposed of and of giving any explanation of the account.

Dated at Sydney this 5th day of February, 1974.

6747 BRUCE MALCOLM ROBERTSON, Liquidator.

Companies Act 1961.

NETA INVESTMENTS PTY. LIMITED (IN VOLUNTARY LIQUIDATION).

NOTICE OF FINAL MEETING.

Notice is hereby given that pursuant to Section 272 of the Companies Act 1961, a general meeting of the members of Neta Investments Pty. Limited will be held on the 12th Floor, 447 Collins Street, Melbourne on the 18th day of March 1974 at 10.30 o'clock in the forenoon.

The purpose of the meeting is to lay accounts before it showing the manner in which the winding up has been conducted and the property of the company disposed of and of hearing any explanation that may be given by the liquidator.

Dated this 11th day of February 1974.

J. M. POULTON, &
D. A. CRAWFORD,

Joint and Several Liquidators.

Peat, Marwick, Mitchell & Co., 447 Collins Street, Melbourne, 3000. 6788

Companies Act 1961.

UTILITY CLEANING (CENTRAL) PTY. LTD. (IN LIQUIDATION).

UTILITY CLEANING (NORTHERN) PTY. LTD. (IN LIQUIDATION).

UTILITY CLEANING (SOUTHERN) PTY. LTD. (IN LIQUIDATION).

UTILITY CLEANING (EASTERN) PTY. LTD. (IN LIQUIDATION).

UTILITY CLEANING (WESTERN) PTY. LTD. (IN LIQUIDATION).

UTILITY OFFICE CLEANING SERVICES PTY. LTD. (IN LIQUIDATION).

UTILITY CLEANING (SUPERVISION) PTY. LTD. (IN LIQUIDATION).

UTILITY WINDOW CLEANING SERVICES PTY. LTD. (IN LIQUIDATION).

UTILITY CLEANING HIRE SERVICE AND MAINTENANCE PTY. LTD. (IN LIQUIDATION).

NOTICE CONVENING FINAL MEETING OF MEMBERS.

NOTICE is hereby given, pursuant to section 272 of the Companies Act 1961, that a Final Meeting of the members of the above companies will be held in the offices of Price Waterhouse & Co, 14th Floor, 447 Collins Street, Melbourne, on Wednesday, 13 March 1974 at 3.00 pm, for the purpose of having an account laid before them showing the manner in which the winding up has been conducted and the property of the companies disposed of, and of hearing any explanation that may be given by the liquidator.

Dated this 8th day of February, 1974.

P. W. HARVEY, Liquidator.

Price Waterhouse & Co., chartered accountants, 447 Collins Street, Melbourne, 3000. 6794

The Companies Act 1961.

STEVENSON DAVIES PROPRIETARY LIMITED (IN LIQUIDATION).

NOTICE CONVENING FINAL MEETING OF MEMBERS AND CREDITORS, PURSUANT TO SECTION 272.

Notice is hereby given pursuant to Section 272 of the Companies Act, 1961, that a General Meeting of the members and creditors of the above-named company will be held in the offices of Kennedy, Smail & Middlemiss, 296-304 Little Lonsdale Street, Melbourne, on Wednesday the Twentieth day of March, 1974, at 11.00 a.m. for the purpose of having an account laid before them showing the manner in which the winding up has been conducted and the property of the company disposed of and of hearing any explanations that may be given by the Liquidator.

Dated this 4th day of February, 1974.

JOHN MARTIN WALSH, Liquidator.

Kennedy, Smail & Middlemiss, 296-304 Little Lonsdale Street, Melbourne, 3000. 6791

The Companies Act 1961.

H. A. BRANCHFLOWER PROPRIETARY LIMITED (IN LIQUIDATION).

NOTICE CONVENING FINAL MEETING OF MEMBERS AND CREDITORS, PURSUANT TO SECTION 272.

Notice is hereby given pursuant to Section 272 of the Companies Act, 1961, that a General Meeting of the members and creditors of the above-named Company will be held in the offices of Kennedy, Smail & Middlemiss, 296-304 Little Lonsdale Street, Melbourne on Wednesday the Twentieth day of March, 1974, at 10.30 a.m. for the purposes of having an account laid before them showing the manner in which the winding up has been conducted and the property of the company disposed of and of hearing any explanation that may be given by the Liquidator.

Dated this 6th day of February, 1974.

JOHN MARTIN WALSH, Liquidator.

Kennedy, Smail & Middlemiss, 296-304 Little Lonsdale Street, Melbourne, 3000. 6792

Companies Act 1961.

PRECISION WATCHES (VIC.) PTY. LTD. (IN LIQUIDATION).

PRECISION WATCHES (N.S.W.) PROPRIETARY LTD. (IN LIQUIDATION).

IMPEX TRADING COMPANY PTY. LTD. (IN LIQUIDATION).

NOTICE CONVENING FINAL MEETING OF MEMBERS.

NOTICE is hereby given, pursuant to section 272 of the Companies Act 1961, that a Final Meeting of the members of the above companies will be held in the offices of Price Waterhouse & Co, 14th Floor, 447 Collins Street, Melbourne, on Tuesday, 12 March 1974 at 3.00 pm, for the purpose of having an account laid before them showing the manner in which the winding up has been conducted and the property of the companies disposed of, and of hearing any explanation that may be given by the liquidator.

Dated this 8th day of February, 1974.

P. W. HARVEY, Liquidator.

Price Waterhouse & Co., chartered accountants, 447 Collins Street, Melbourne, 3000. 6793

In the matter of the Companies Act 1961; and in the matter of ROBBIE'S DOMESTIC APPLIANCES PTY. LIMITED (in Voluntary Liquidation).—Notice of Final Meeting of Members, Pursuant to Section 272.

Notice is hereby given in pursuance of Section 272 of the Companies Act 1961 that a General Meeting of the members of the Company will be held at the office of Messrs. Coopers & Lybrand, 461 Bourke Street, Melbourne, on the 21st day of March 1974, at 10 o'clock in the forenoon for the purpose of having an account laid before it showing the manner in which the winding up has been conducted and the property of the company disposed of, and hearing any explanation that may be given by the liquidator.

Dated this 8th day of February, 1974.

6756 R. W. BETTS, Liquidator.

In the matter of the Companies Act 1961; and in the matter of ROBISON BROTHERS & COMPANY PTY. LIMITED (in Voluntary Liquidation).—Notice of Final Meeting of Members, Pursuant to Section 272.

Notice is hereby given in pursuance of Section 272 of the Companies Act 1961 that a General Meeting of the members of the Company will be held at the office of Messrs.

Coopers & Lybrand, 461 Bourke Street, Melbourne, on the 21st day of March 1974, at 10 o'clock in the forenoon for the purpose of having an account laid before it showing the manner in which the winding up has been conducted and the property of the company disposed of, and hearing any explanation that may be given by the liquidator.

Dated this 8th day of February, 1974.

6771 R. W. BETTS, Liquidator.

In the matter of the Companies Act 1961; and in the matter of KENT PLATE PRODUCTS PTY. LIMITED (in Voluntary Liquidation).—Notice of Final Meeting of Members, pursuant to Section 272.

Notice is hereby given in pursuance of Section 272 of the Companies Act 1961 that a General Meeting of the members of the Company will be held at the office of Messrs. Coopers & Lybrand, 461 Bourke Street, Melbourne, on the 21st day of March 1974, at 10 o'clock in the forenoon for the purpose of having an account laid before it showing the manner in which the winding up has been conducted and the property of the company disposed of, and hearing any explanation that may be given by the liquidator.

Dated this 8th day of February, 1974.

6770 R. W. BETTS, Liquidator.

Companies Act 1961.—In the matter of DINGLEY REAL ESTATE AGENCY PTY. LTD. (in Liquidation).

Notice is hereby given that at an extraordinary Meeting of the Members of the abovenamed Company held on the 7th February, 1974 it was resolved that the Company be wound up voluntarily and at a Meeting of Creditors held on the same day pursuant to Section 260, it was resolved that for such purpose DENNIS JOHN COUGLE of Suite 18, 545 St. Kilda Road, Melbourne, Public Accountant, be appointed Liquidator.

Notice is also given that after twenty-one days from this date I shall proceed to distribute the assets. All creditors having any claims against the Company should furnish particulars of same by that date, otherwise I shall proceed to distribute the assets without regard to their claim.

Dated this 7th day of February, 1974.

D. J. COUGLE, Liquidator.

Bent & Cogle, public accountants, Suite 18, 545 St. Kilda Road, Melbourne, Vic. 3004. 6740

Companies Act 1961.—In the matter of THOMSON GRAPHIC SERVICES PROPRIETARY LIMITED (in Liquidation).

Notice is hereby given that at an extraordinary Meeting of the Members of the abovenamed Company held on the 8th February, 1974, it was resolved that the Company be wound up voluntarily and at a Meeting of Creditors held on the same day pursuant to Section 260, it was resolved that for such purpose BRENDAN JOHN O'CONNOR, Accountant, of 562 St. Kilda Road, Melbourne, be appointed Liquidator.

Notice is also given that after twenty-one days from this date I shall proceed to distribute the assets. All Creditors having any claims against the Company should furnish particulars of same by that date, otherwise I shall proceed to distribute the assets without regard to their claim.

Dated this 12th day of February, 1974.

B. J. O'CONNOR, Liquidator.

Taylor O'Connor & Co., accountants, 562 St. Kilda Road, Melbourne, 3004. Telephone 51 1388. 6750

Companies Act 1961.

AUSTREX (OVERSEAS) PTY. LIMITED.

In the matter of the Companies Act; and in the matter of AUSTREX (OVERSEAS) PTY. LTD.

Notice is hereby given that at an Extraordinary General Meeting of the above named Company duly convened and held at Suite 801, 343 Little Collins Street, Melbourne on the 4th day of February, 1974 at 11.30 a.m. the following special resolution was duly passed:—

SPECIAL RESOLUTION.

"That it has been proved to the satisfaction of this Meeting of Members of Austrex (Overseas) Pty. Ltd. that the Company cannot, by reason of its liabilities, continue in business and it is advisable to wind-up same, and accordingly, that the Company be wound-up voluntarily."

At the same meeting Mr. Bruce Henry Smith of Suite 801, 343 Little Collins Street, Melbourne was nominated Liquidator for the purposes of the winding-up.

Dated this, 7th day of February, 1974.

6773 P. E. FOX, Chairman.

Companies Act 1961, Section 254.

B. W. STEVENS PTY. LTD. (IN VOLUNTARY LIQUIDATION).

Notice is hereby given that at an Extraordinary General Meeting of the members of the abovenamed company duly convened and held at 795 Glenferrie Road, Hawthorn on the 7th day of February, 1974, the following Special Resolution was duly passed—

“That the company be wound up voluntarily and that Herbert Geoffrey Stevens of 795 Glenferrie Road, Hawthorn be appointed liquidator for the purposes of such winding up.”

Dated this 7th day of February, 1974.

6745 H. G. STEVENS, Liquidator.

The *Companies Act 1961*.—In the matter of WESTOS HOTEL-MOTEL (WAURN PONDS) PTY. LTD. (IN LIQUIDATION).

A FIRST DIVIDEND is intended to be declared in the above-mentioned matter. Creditors who have not proved their debts by the 5th day of March, 1974 will be excluded from the dividend.

Dated this 13th day of February, 1974.

EDWARD RONALD SMAIL, Liquidator.

Kennedy, Smail & Middlemiss, 296 Little Lonsdale Street, Melbourne, 3000. 6820

Companies Act 1961.

WESTERN GATE ESTATE PTY. LTD. (IN VOLUNTARY LIQUIDATION).

MEMBERS' VOLUNTARY WINDING UP.

NOTICE IS HEREBY GIVEN that pursuant to S. 272 of the *Companies Act 1961* the final meeting of members of the above named company will be held at the office of Duesbury & Johnston, 446 Collins Street Melbourne on Friday March 15th 1974 at 10 a.m. for the purpose of receiving the Liquidator's account and his report upon the winding up.

Dated this 12th day of February, 1974.

6821 A. I. SINCLAIR, Liquidator.

The *Companies Act 1961*.—In the matter of THE AZTECS PTY. LTD.—Notice of Meeting of Creditors, Pursuant to Section 260 (3).

NOTICE is hereby given that a Meeting of Creditors of The Aztecs Pty Ltd will be held at the Institute of Chartered Accountants, 140 Queen Street, Melbourne, on Tuesday the 12th day of March 1974 at 10.30 a.m. the company having convened a meeting of its members for the same day for the purpose of considering a resolution that the Company be wound up voluntarily.

Dated this 11th day of February, 1974.

E. J. TOI, Director.

Price Waterhouse & Co., chartered accountants, 14th Floor, 447 Collins Street, Melbourne, 3000. 6822

In the Supreme Court of Victoria.—No. C.O.8678 of 1973.—In the matter of HOPEJA INVESTMENTS PTY. LIMITED (in Liquidation); and in the matter of the *Companies Act 1961*.

Take notice that the first meeting of Creditors in the above matter under the Order for Winding Up the Company dated 29th August, 1973 will be held at the meeting room of The Institute of Chartered Accountants in Australia, Ninth Floor, 140 Queen Street, Melbourne in the State of Victoria on Friday 22nd February, 1974 at 3.00 p.m.

At this meeting it will be determined whether or not the Creditors require a Committee of Inspection to act with the Liquidator and if so who are to be members of the Committee.

Additionally an opportunity will be provided to discuss the Statement of Affairs at 29th August, 1973 and to ask questions of the Director who attend.

To entitle to vote thereat your Proof of Debt must be completed and lodged at the office of B. O. Smith & Son, Suite 801, 343 Little Collins Street, Melbourne to reach it before the meeting or the Proof of Debt may be handed to the Chairman at the Commencement of the meeting.

Proxies to be used at the meeting must be lodged with the Liquidator Suite 801, 343 Little Collins Street, Melbourne not later than 2.00 p.m. on Friday 22nd February, 1974.

B. H. SMITH, liquidator, Suite 801, 343 Little Collins-street, Melbourne. 6814

In the Supreme Court of Victoria.—No. Co. 8791.—In the matter of the *Companies Act 1961*; and in the matter of NOEL JAMES PTY. LTD.

NOTICE IS HEREBY GIVEN that a Petition for the winding up of the abovenamed company by the Supreme Court was on the 24th day of January 1974 presented by THE NEW ZEALAND INSURANCE COMPANY LIMITED; and that the said Petition is directed to be heard before the Court sitting at the 14th Court, Law Courts, William Street, Melbourne on the 1st day of March, 1974 at the hour of 10-30 o'clock in the forenoon; and any creditor or contributory of the said company desiring to support or oppose the making of an order on the said Petition may appear at the time of hearing by himself or his Counsel for that purpose; and a copy of the Petition will be furnished to any creditor or contributory of the said company requiring the same by the undersigned on payment of the regulated charge for the same.

The Petitioner's address is 12th floor, 44 Market Street, Melbourne.

The Petitioner's Solicitors are Messrs. Phillips, Fox & Masel of 461 Bourke Street, Melbourne.

Dated the 12th day of February, 1974.

PHILLIPS, FOX & MASEL, Solicitors for the Petitioner.

NOTE.—Any person who intends to appear on the hearing of the said Petition must serve on or send by post to the abovenamed Solicitors notice in writing of his intention to do so. The notice must state the name and address of the person or, if a firm, the name and address of the firm and must be signed by the person or firm or his or their Solicitor (if any) and must be served, or if posted, must be sent by post in sufficient time to reach the abovenamed not later than 4 o'clock in the afternoon of the 28th day of February 1974. 6787

In the Supreme Court of Victoria.—C.O.8678.—In the matter of the *Companies Act 1962*; and in the matter of HOPEJA INVESTMENTS PTY. LTD. (in Liquidation).—Notice under Rules 99 (1) (2) of the Supreme Court (*Companies*) Rules 1962 of Date Fixed for Lodging Proof of Debt.

Notice is hereby given in accordance with Rules 99 (1) (2) of the Supreme Court (*Companies*) Rules 1962 and the *Companies Act 1961*, that I have fixed the 14th day of March, 1974, as being the day on or before which creditors of the company are to prove their debt. Any creditor who fails to make Proof of Debt on or before that date shall be excluded from the benefit of any distribution of assets of the company.

B. H. SMITH, liquidator, Suite 801, 343 Little Collins-street, Melbourne. 6813

In the Supreme Court of Victoria.—1974 No. Co. 8789.—In the matter of the *Companies Act 1961*; and in the matter of ABEL WELDING PTY. LTD.

Notice is hereby given that a Petition for the winding up of the abovenamed Company by the Supreme Court was on the 23rd day of January, 1974 presented by MELSTEEL (VICTORIA) PTY. LTD.; and that the said Petition is directed to be heard before the Court sitting at Melbourne at the hour of 10.30 o'clock on the 13th day of March, 1974; and any Creditor or Contributory of the said Company desiring to support or oppose the making of an Order on the said Petition may appear at the time of hearing by himself or his Counsel for that purpose; and a copy of the Petition will be furnished to any Creditor or Contributory of the said Company requiring the same by the undersigned on payment of the regulated charge for the same.

The Petitioner's address is 53 Argyle Street, Fitzroy, Victoria.

The Petitioner's Solicitor is Messrs. Cleary, Ross & Doherty, of 406 Collins Street, Melbourne.

CLEARY, ROSS & DOHERTY.

NOTE.—Any person who intends to appear on the hearing of the said Petition must serve on or and by post to the abovenamed Solicitors, notice in writing of his intention so to do. The Notice must state the name and address of the person, or, if a firm, the name and address of the firm, or his or their Solicitor (if any), and must be served, or, if posted, must be sent by post in sufficient time to reach the abovenamed not later than 4 o'clock in the afternoon of the 12th day of March, 1974, (the day before the day appointed for the hearing of the Petition). 6777.

*Companies Act 1961, Section 254 (2).***HAMES & YOUNG PTY. LTD. (IN LIQUIDATION).**

Notice is hereby given that at an Extraordinary Meeting of Members of the abovenamed Company held on Monday, 4th February, 1974, the following Special Resolution was duly passed.

"That owing to the Company being unable to meet its debts as and when they become due and payable that the Company be and is hereby wound up voluntarily and that Maxwell George Gee a Registered Liquidator be and is hereby appointed Liquidator to wind the Company up and attend to all matters relative thereto in accordance with the *Companies Act 1961*."

At a meeting of creditors held the same day, my appointment as Liquidator was confirmed.

M. G. GEE, Liquidator.

Max Gee & Co., 325 Warrigal Road, Burwood, 3125.
Telephone 288-5109. 6735

*Trustee Act 1958.***NOTICE TO CLAIMANTS.**

Pursuant to the *Trustee Act 1958*, creditors next of kin and all other persons having claims in respect of the estate of any deceased person named below are required to send particulars to the legal personal representative or representatives at the addresses stated, after which date the representatives will distribute the assets, having regard only to the claims of which notice has been received:—

WILLIAM ROBERT LEWIS late of 48 Elphin Street Newport Retired Boilermaker deceased, died on the 31st day of October 1973. Claims to the Executrix, Ellen Florence Lewis of 48 Elphin Street Newport Widow care of John F. Carroll of 4 Paisley Street, Footscray, Solicitor, by the 15th day of April 1974. JOHN F. CARROLL, LL.B., solicitor, 4 Paisley Street, Footscray. 6815

DANIEL HERBERT SHEEDY late of 152 Market Street Newport Meter Reader deceased, died on the 24th day of September 1973. Claims to the Executrix Marion Jean Sheedy of 152 Market Street Newport Widow care of John F. Carroll of 4 Paisley Street, Footscray, Solicitor, by the 22nd day of April 1974. JOHN F. CARROLL, LL.B., solicitor, 4 Paisley Street, Footscray. 6816

CALEB EMERSON TURNER, late of 45 Darlington Road, Stawell, Shearing Contractor, DECEASED.

Creditors next of kin and others having claimed in respect of the Estate of the Deceased who died on the 7th day of October 1973 are required by the Executor The Union Fidelity Trustee Company of Australia Limited of 101 Lydiard Street North Ballarat to send particulars of their claims to the Company at its address above by the 15th day of April 1974 after which date the said Executor may convey or distribute the assets having regard only to the claims of which it then has notice.

J. H. WEBB & SENG HPA, solicitors, Stawell. 6716

VERA MARION WILLIAMS, late of Young Street, Hallam, Married Woman, DECEASED.

Creditors next of kin and others having claims in respect of the estate of the deceased who died on the Sixteenth day of June 1973 are required by the Executrix and Executor respectively of the Will of the said deceased BETTY JUNE NELSON of 144-146 Athol Road, Springvale South Married Woman and LESLIE CLYDE CARTHEW WILLIAMS of 3 Stanworth Court Preston West Superintendent to send particulars to them in the care of the undermentioned Solicitors by the Twentieth day of April 1974 after which date the said Executrix and Executor may convey or distribute the assets having regard only to the claims of which they then have notice.

MACPHERSON & KELLEY, solicitors, 229 Thomas Street, Dandenong. 6717

SIDNEY JOHN WARD, late of 9 Fourth Street, Parkdale gentleman DECEASED.

Creditors, next of kin and all other persons having claims against the estate of the above-named deceased (who died on the 4th September 1973), are required to send particulars in writing of their claims to the executor, NATIONAL TRUSTEES EXECUTORS & AGENCY CO. OF AUSTRALASIA LTD., of 95 Queen Street, Melbourne, on or before the 15th day of April, 1974, after which date the said executor will distribute the assets, having regard only to the claims which the said company then has notices.

DUFFY & FORREST, solicitors, 343 Little Collins Street, Melbourne. 6722

Creditors next of kin and others having claims in respect of the Will of FRANK DENHAM late of 26 Holland Court South Blackburn Retired who died on the 22nd day of December 1973 are requested to send particulars of their claims to the Executor ROY WALTER LIVERSIDGE care of the undermentioned Solicitor by the 30th day of April 1974 after which date he will distribute the assets having regard only as to the claims of which he then has notice.

JOHN STEWART, of 290 Racecourse Road, Newmarket. 6728

CREDITORS, Next-of-kin and others having claims in respect of the estate of HUBERT FRANCIS LAITY late of 3 Lime Court, West Heidelberg, Gentleman deceased who died on the 11th July 1973 are to send particulars of their claims to the Administratrix Alice Schulz, c/- Messrs. Gill, Kane & Co. 422 Collins Street, Melbourne by the 15th April, 1974 after which date the Administratrix will distribute the Estate having regard only to the claims of which she then has notice.

GILL, KANE & CO., solicitors, 422 Collins Street, Melbourne. 6817

CREDITORS next of kin and other persons having claims against the estate of MARION JEAN ROGERS late of Flat 2, 4 Lalbert Crescent Prahran in the State of Victoria Married Woman deceased who died on the 29th October 1973 ARE REQUIRED to send particulars of their claims to one of the Executors NATIONAL TRUSTEES EXECUTORS AND AGENCY COMPANY OF AUSTRALASIA LIMITED of 95 Queen Street Melbourne by the 16th April 1974 after which date the Executors will distribute the assets having regard only for the claims of which they then have had notice.

JAMES P. OGGE & CO., solicitors, 165 Greville Street, Prahran. 6818

CREDITORS next of kin and others having claims in respect to the Estate of MARY ANN AARONS late of 12 Leonard Crescent Bundoora in the State of Victoria Widow Deceased who died on the 17th February, 1973 are to send particulars of their claims to ROYSTON CAHIR, MARTIN & DILLON Solicitors, of 17 Queen Street Melbourne by the 16th April, 1974 after which date the Executor will distribute the assets of the Estate having regard only to claims to which he then has notice.

ROYSTON CAHIR, MARTIN & DILLON, solicitors, 17 Queen Street, Melbourne. 6823

CREDITORS next of kin and others having claim in respect to the Estate of RUBY EMILY EDMISTON late of Flat 4, Nimmo Court, 17 Nimmo Street Essendon in the State of Victoria Widow Deceased who died on the 30th November, 1973 are to send particulars of their claims to ROYSTON CAHIR, MARTIN & DILLON Solicitors, of 17 Queen Street Melbourne by the 16th April, 1974 after which date the Executors will distribute the assets of the Estate having regard only to claims to which they then have notice.

ROYSTON CAHIR, MARTIN & DILLON, solicitors, 17 Queen Street, Melbourne. 6824

CREDITORS next of kin and others having claim in respect to the Estate of STANLEY JOHN ELLIS late of 13 Butters Street Regent in the State of Victoria Grocer Deceased who died on the 13th October, 1973 are to send particulars of their claims to ROYSTON CAHIR, MARTIN & DILLON Solicitors, of 17 Queen Street Melbourne by the 16th April, 1974 after which date the Executor will distribute the assets of the Estate having regard only to claims to which he then has notice.

ROYSTON CAHIR, MARTIN & DILLON, solicitors, 17 Queen Street, Melbourne. 6825

CREDITORS next of kin and others having claims in respect of the Estate of PHILIP LESLIE FURY late of 46 May Street, Coburg in the State of Victoria Retired Fitter and Turner Deceased who died on the 28th November, 1973 are to send particulars of their claims to ROYSTON CAHIR, MARTIN & DILLON Solicitors, of 17 Queen Street Melbourne by the 16th April, 1974 after which date the Executrix will distribute the assets of the Estate having regard only to claims to which she then has notice.

ROYSTON CAHIR, MARTIN & DILLON, solicitors, 17 Queen Street, Melbourne. 6826

CREDITORS next of kin and others having claims in respect of the estate of JOHN ALEXANDER DAVIDSON late of 37 Gamon Street, Yarraville in the State of Victoria Gentleman deceased who died on the 15th day of July 1973 are required to send particulars of their claims to the executor ALEXANDER DAVIDSON care of the under-mentioned Solicitors by the 14th day of April 1974 after which date the executor will distribute the assets of the estate of the said deceased having regard only to the claims of which he then has had notice.

J. McDONALD SMITH & CO., solicitors, 59-61 Irving Street, Footscray. 6827

CREDITORS Next of Kin and Others having Claims in respect of the Estate of Patrick Francis Morris late of 6 Mandeville Crescent Toorak Retired Public Servant deceased who died on the 11th January 1974 are requested to send particulars of their Claims to the Executor Michael Joseph Mornane of 118 Queen Street, Melbourne Solicitor by the 15th day of April 1974 after which date he will distribute the assets having regard only to the claims of which he then has notice.

M. MORNANE, solicitor, 118 Queen Street, Melbourne. 6828

MARION IONA WATSON, late of 3 Florence Avenue, Kew, married woman, DECEASED.

Creditors next of kin and others having claims in respect of the estate of the said deceased who died on the 27th day of October 1972 are required by The Equity Trustees Executors and Agency Company Limited of 472 Bourke Street Melbourne the Executor to whom probate of the deceased's Will was granted to send particulars of their claims to the said Company by the 30th day of April 1974 after which date the Company will convey or distribute the assets having regard only to the claims of which it then has notice.

ALAN WAINWRIGHT & CO., solicitors, 397 Little Collins Street, Melbourne. 6829

ERIC CHARLES WESTMORE, late of 14 Stafford Street West Preston, Gentleman, DECEASED.

Creditors, next of kin and others having claims in respect of the estate of the deceased (who died on the 22nd day of September 1973) are required by THE PERPETUAL EXECUTORS AND TRUSTEES ASSOCIATION OF AUSTRALIA LIMITED of 50 Queen Street, Melbourne, to send particulars of their claims to the said Company by the 21st day of April 1974 after which date it will convey or distribute the assets, having regard only to the claims of which the Company then has notice.

BEST, HOOPER, RINTOUL & SHALLARD, solicitors, 377 Little Collins Street, Melbourne. 6830

After fourteen clear days application will be made to the Supreme Court of Victoria that Letters of Administration of the Estate of MABEL ETHEL BROWNING late of 92 Addison Street Elwood Spinster deceased with her Will dated the 17th day of October, 1973 annexed be granted to ALICE EVELYN TAYLOR of 2/68 Rose Street Armadale Spinster one of the residuary beneficiaries named in the said Will PHILIP ALAN JENKINS of 101 Elizabeth Street Kooyong Gentleman (in the said Will referred to as ALAN JENKINS) the executor appointed by the said Will having died without applying for Probate.

DAVID THOMAS & FRENKEL, of 303 La Trobe Street, Melbourne. 6780

JOHN MICHAEL FORREST, late of 23 Ward Grove, Pascoe Vale South, retired public servant, DECEASED, intestate.

Creditors next-of-kin and others having claims in respect of the estate of the abovenamed deceased who died on 28th October 1973 are requested to send particulars of their claims in writing to MARJORIE IRIS FORREST care of her solicitors at their address set out below, she being the administrator to whom Letters of Administration of the estate of the abovenamed deceased have been granted, on or before 20th April 1974 after which date she will distribute the estate of the deceased having regard only to the claims of which she then has notice.

JOHN MORAN & HAYES, 422 Collins Street, Melbourne, Solicitors for the Administrator. 6781

CREDITORS next of kin and others having CLAIMS in respect of the ESTATE of PHILLIP CONSTANTINE late of 407 Glenfern Road Upwey Gardener deceased who died on the 9th day of October 1973 and Probate of whose Will has been granted to JOHN SCURRAH CONSTANTINE of 18 Cambewarra Road Bomaderry in the State of New South Wales Salesman are required to SEND PARTICULARS of their claims to the said Executor care of the

under-mentioned Solicitors by the 11th day of April 1974 after which date he will distribute the assets having regard only to the claims of which he then has notice.

PEARCE & WEBSTER, solicitors, 430 Little Collins Street, Melbourne. 6782

ELSIE MAY HOUSTOUN, late of Flat 63, Park House, Seven Sisters Road, Islington, London, England, DECEASED.

Creditors next of kin and others having claims in respect of the estate of the deceased (who died on the 23rd March 1973) are required by the Administrator JAMES HOUSTOUN to send particulars of their claims to him care of the under-mentioned Solicitors by the 15th April 1974, after which date he will distribute the estate having regard only to the claims of which he then has notice.

J. OKNO & CO., solicitors, of 213 Lonsdale Street, Melbourne. 6783

CREDITORS, next-of-kin and others having claims in respect of the Estate of CHARLES WILLIAM BRIEN late of 197, Grange Road, Glenhuntly Company Director deceased who died on the 16th June 1973 are required to send particulars of their claims to MARGUERITE BRIEN of 197 Grange Road, Glenhuntly and JOHN CHARLES BRIEN of 24 Taylors Lane, Rowville by the 15th April 1974 after which date the executors will distribute the assets having regard only to the claims of which they then have notice.

PROUDFOOT, HORTON & COOKE, solicitors, of 406 Lonsdale Street, Melbourne. 6784

NORMAN NELSON, late of 27 Dewrang Crescent, Blackburn, in the State of Victoria, pensioner, DECEASED.

CREDITORS next of kin and others having claims in respect of the Estate of the deceased (who died on the 21st day of February 1973) are required by the executor KEVIN ARTHUR O'DWYER of 18 Huntingdon Road Bentleigh East in the said State Engineer the executor to send particulars to him in care of the undersigned by the 30th day of April 1974 after which date the executor may convey or distribute the assets having regard only to the claims of which he then has notice.

Dated the 7th day of February, 1974.

P. H. PIPPEY & SON, 1 Watts Street, Box Hill, solicitors for the executor. 6785

JANE MACKENZIE, late of 37 May Street, Balwyn, widow, DECEASED.

Creditors next of kin and others having claims in respect of the Estate of the deceased (who died on the twentieth day of September 1973) are required by The Perpetual Executors and Trustees Association of Australia Limited of 50 Queen Street Melbourne to send particulars of their claims to the said Company by the twentieth day of April 1974 after which date it will convey or distribute the assets having regard only to the claims of which the Company then has Notice.

NORMAN SHANKLY & HAMILTON, solicitors, 406 Lonsdale Street, Melbourne. 6786

HAROLD BOWERS, deceased, formerly of 5 Amiens Street, Surrey Hills, in the State of Victoria, but late of Lot 2, David Hill Road, Monbulk, in the said State, gentleman, DECEASED.

CREDITORS next-of-kin and others having claims in respect of the Estate of the abovenamed deceased who died on the 11th day of October 1972 are required to send particulars thereof to the Executor care of the under-mentioned Solicitors on or before the 14th day of April 1974 after which date the said Executor may convey or distribute the assets having regard only to the claims of which he then has notice.

MESSRS. K. P. REES & CO., solicitors, 118 Queen Street, Melbourne. 6796

KATIE DORIS SELBY, late of Flat 2, 7 Wellington Street, Mornington, in the State of Victoria, spinster, DECEASED.

CREDITORS NEXT OF KIN AND OTHERS having claims in respect of the Estate of the Deceased who died on the 23rd day of October 1973 are required by THE PERPETUAL EXECUTORS AND TRUSTEES ASSOCIATION OF AUSTRALIA LIMITED of 50 Queen Street Melbourne and BRUCE KENNETH SELBY of 6 Mackeith Court Mount Eliza Manufacturer the Applicants for a grant of Probate

to send particulars of their claims to the said Applicants in the care of the said Company by the 27th day of April 1974 AFTER which date they will convey or distribute the assets having regard only to the claims of which they then have notice.

RODDA, BALLARD & VROLAND, solicitors, 695 Burke Road, Camberwell. 6797

CREDITORS NEXT-OF-KIN and others having claims in respect of the estate AUBREY REYNOLDS HUBBARD late of 44 St. Vincents Place North Albert Park Retired Painter deceased who died on 31st January 1974 are to send the particulars of their claims to the executor KEITH CLIFFORD McCARTEN in care of Hall & Wilcox, 20 Queen Street Melbourne by the 15th of April 1974 after which date he will distribute assets having regard only to the claims of which he then has notice.

HALL & WILCOX, solicitors, 20 Queen Street, Melbourne. 6798

CREDITORS next of kin and others having claims in respect of the estate of MARGARET ROSS PETTMAN late of 37 Gamon Street, Yarraville in the State of Victoria Widow deceased who died on the 17th day of October 1973 are required to send particulars of their claims to the executor JOHN McDONALD SMITH care of the under-mentioned Solicitors by the 14th day of April 1974 after which date the executor will distribute the assets of the estate of the said deceased having regard only to the claims of which he then has had notice.

J. McDONALD SMITH & CO., solicitors, of 59-61 Irving Street, Footscray. 6799

Creditors next of kin and others having claims in respect of the estate of OLIVE LILLIAN HULL late of 17 Osborne Avenue East Malvern Spinster deceased who died on 6th September 1973 are to send the particulars of their claims to THE TRUSTEES EXECUTORS AND AGENCY COMPANY LIMITED of 401 Collins Street by the fourteenth day of April 1974 after which date it will distribute the assets having regard only to the claims of which it then has notice.

HADEN, SMITH & FITCHETT, solicitors, 423 Bourke Street, Melbourne. 6800

KATHLEEN SARAH LADNER, late of 150 Wood Street, East Preston, widow, DECEASED.

CREDITORS, next-of-kin and others having claims in respect of the Estate of the deceased who died on the 26th September 1973 are requested to send particulars of their claims to the Executor GEORGE ROBERT LADNER c/- the undersigned solicitor by the 14th April 1974 after which date the said Executor will proceed to distribute the Estate having regard only to the claims of which he then has notice.

MARJORY C. COATES, solicitor, of 422 Collins Street, Melbourne, 3000. 6801

PAULA ADELAIDE WILHELMINA FRAME late of 255 Domain Road, South Yarra, in the State of Victoria, spinster, DECEASED.

CREDITORS next of kin and others having claims in respect of the estate of the abovenamed deceased who died on the 3rd day of May 1973 are required by the executor THE TRUSTEES EXECUTORS AND AGENCY COMPANY LIMITED of 401 Collins Street Melbourne in the said State to send particulars to the executor by the 18th day of April 1974 after which date the executor may convey or distribute the assets having regard only to the claims of which it then has notice.

DAVIES, CAMPBELL & PIESSE, solicitors, 401 Collins Street, Melbourne. 6802

CREDITORS next of kin and others having claims in respect of the estate of EMILY CATHERINE DEMPSEY late of Mount Royal Hospital for the Aged Poplar Road Parkville Widow deceased who died on the 28th day of December 1973 to send particulars of their claims to the executors KENNETH McDONALD MARTIN RICHARD JOHN KELLAWAY and BERNARD WALTER TUCK care of the undermentioned Solicitors by the 17th day of April 1974 after which date the said executors will distribute the assets of the said estate having regard only to the claims of which they then have notice.

MARTIN & MARTIN, solicitors, 37 Queen Street, Melbourne, 3000. 6803

CREDITORS next of kin and others having claims in respect of the estate of ERIC GUSTAV HILBIG late of 45 Waverley Parade Pascoe Vale South Retired deceased who died on the 27th day of October 1973 to send particulars of their claims to the executors KENNETH McDONALD MARTIN and RICHARD JOHN KELLAWAY care of the undermentioned Solicitors by the 17th day of April 1974 after which date the said executors will distribute the assets of the said estate having regard only to the claims of which they then have notice.

MARTIN & MARTIN, solicitors, 37 Queen Street, Melbourne, 3000. 6804

Creditors, next-of-kin and others having claims in respect of the Estate of JOHN FYFE late of Denbies Private Hospital 1083 Glenhuntly Road Glenhuntly Retired Company Director deceased who died on the fourth day of October, 1973 are to send the particulars of their claims to THE EQUITY TRUSTEES EXECUTORS AND AGENCY COMPANY LIMITED of 472 Bourke Street, Melbourne, by the fifteenth day of April, 1974 after which date it will distribute the assets having regard only to the claims of which it then has notice.

W. H. FLOOD & PERMEZEL, 388 Bourke Street, Melbourne, solicitors for the said company. 6805

Creditors, next-of-kin and others having claims in respect of the Estate of MONICA MCGEE late of Unit 3, 15 Estella Street Glen Iris Spinster deceased who died on the Eighth day of October, 1973 are to send the particulars of their claims to THE EQUITY TRUSTEES EXECUTORS AND AGENCY COMPANY LIMITED of 472 Bourke Street, Melbourne, by the fifteenth day of April, 1974 after which date it will distribute the assets having regard only to the claims of which it then has notice.

W. H. FLOOD & PERMEZEL, 388 Bourke Street, Melbourne, solicitors for the said company. 6806

FRANCIS FREDERICK JAGER, late of Piangil, in the State of Victoria, farmer, DECEASED.

CREDITORS, next of kin, and others having claims in respect of the estate of the deceased (who died on the 8th day of November, 1973) are required by the executors DOROTHY MARGARET A'DELL, JAGER, RONALD GEORGE JAGER and KENNETH FRANCIS JAGER all of Piangil aforesaid, to send particulars to them care of the undersigned by the 20th day of April, 1974, after which date the executors may convey or distribute the assets, having regard only to the claims of which they then have notice.

ALEC M. HAYES, solicitor, 148 Campbell Street, Swan Hill. 6810

STELLA CAMM, late of Swan Hill, in the State of Victoria, gentlewoman, DECEASED (who died on the 1st January, 1973).

CREDITORS next-of-kin and all other persons having claims against the estate of the deceased are required by the Executrices of the Will, YVONNE RICHARDSON and JOCELYN ELLEN INGRAM to send particulars to them care of the undersigned on or before the 11th day of May 1974 after which date they will distribute the assets having regard only to the claims of which they then have notice.

GARDEN & GREEN, solicitors, 4 McCallum Street, Swan Hill. 6812

CREDITORS, next-of-kin and others having claims against the Estate of ROSY ANITA MACKAY late of Flat 7, 2 Marne Street South Yarra, Widow, deceased, who died on the 23rd day of August 1973 are required by the executor THE UNION-FIDELITY TRUSTEE COMPANY OF AUSTRALIA LIMITED of 100 Exhibition Street Melbourne to send particulars of their claim before the 20th day of April 1974 after which date the said Company will distribute the Estate having regard only to the claims of which it then has notice.

FRANK GREY-SMITH & SON, solicitors, 374 Little Collins Street, Melbourne. 6831

CREDITORS, next-of-kin and others having claims against the Estate of REGINALD HAUSSEN BEGG formerly of Flat 1, 11 Denham Place Toorak Engineer but late of Flat 4, 9 Tintern Avenue Toorak Retired Engineer deceased, who died on the 26th day of August 1973 are required by the executors to send particulars of their claim

to THE UNION-FIDELITY TRUSTEE COMPANY OF AUSTRALIA LIMITED of 100 Exhibition Street Melbourne before the 20th day of April 1974 after which date the executors will distribute the Estate having regard only to the claims of which the said Company then has notice.

FRANK GREY-SMITH & SON, solicitors, 374 Little Collins Street, Melbourne. 6832

CREDITORS next of kin and all other persons having claims against the estate of HENRY WELLS, late of 12A Heyington Place Toorak Retired Army Officer deceased are required by the Executors BRIAN WILLIAM WELLS of 5 Beamsley Street Malvern Victoria Clerk and ALAN DESMOND WELLS of 35 Roebuck Street Red Hill A.C.T. Army Officer to send particulars of their claims to them care of the undersigned by the 15th day of April 1974 after which date they may distribute the estate having regard only to the claims of which they then have notice.

JOHN D. MUSTOW & CO., solicitors, 131 Queen-street, Melbourne. 6833

ROBERT MICHAEL WILLIAMS, late of 37 Gray Street, Brunswick, retired, DECEASED.

Creditors next-of-kin and others having claims in respect of the Estate of the deceased who died on the 2nd day of March, 1973 are required by the Trustee DOROTHY FAY BROWN of 34 Glenbervie Road, Strathmore to send particulars to her at 376 Collins Street, Melbourne by the 24th day of April, 1974 at which date the Trustee may convey or distribute the assets having regard only to the claims of which she then has notice.

Dated the 13th day of February, 1974.

JOHN P. RHODEN, solicitors, 376 Collins Street, Melbourne. 6834

CREDITORS next of Kin and other having claims in respect of the estate of RICHARD STERMAN late of Kingston Centre Warrigal Road Cheltenham in the State of Victoria Pensioner deceased who died on the 21st day of November 1973 are to send particulars of their claims to the Executor NATIONAL TRUSTEES EXECUTORS AND AGENCY COMPANY OF AUSTRALASIA LIMITED of 95 Queen Street Melbourne by the 19th of April 1974 after which date it will distribute the assets of the estate having regard only to the claims of which it then has notice.

HALL & WILCOX, solicitors, 20 Queen Street, Melbourne. 6835

CREDITORS, NEXT-OF-KIN AND OTHERS having claims in respect of the Estate of LILY SOPHIA OVENDEN late of 194 Kay Street, Traralgon in the State of Victoria, widow deceased intestate who died on the 11th April, 1973 are required by the Administrator MICHAEL JOHN OVENDEN to send particulars to him care of the under-mentioned solicitors by the 17th April 1974, after which date the Administrator will distribute the assets having regard only to the claims of which he then has notice.

RICHES & DAVINE, solicitors, 96 Hotham Street, Traralgon. 6767

Creditors next of kin and others having claims in respect of the estate of Thomas McAuliffe formerly of 1 Lethbridge Street, Moonee Ponds but late of 27 Moore Street, Moonee Ponds in the State of Victoria, Retired Farmer deceased who died on the 20th day of May, 1973 are required to send particulars of their claims to NATIONAL TRUSTEES EXECUTORS AND AGENCY COMPANY OF AUSTRALASIA LIMITED of 95 Queen Street, Melbourne by the 10th day of April, 1974 after which date the said executor will distribute the assets having regard only to the claims of which it then has notice.

BERNARD NOLAN & CO., solicitors, 380 Bourke Street, Melbourne. (67-7521.) 6779

JANET MARGARET McDONALD, late of Clunes, widow, DECEASED (who died on the 8th October, 1973).

Creditors next of kin and all persons having claims against the estate of the deceased are required to send particulars to the Executor THE UNION-FIDELITY TRUSTEE COMPANY OF AUSTRALIA LIMITED of 101 Lydiard Street North, Ballarat on or before the 14th April 1974 after which date it will distribute the assets having regard only to the claims of which it shall then have notice.

HEINZ & GORDON, solicitors, 209 Dana Street, Ballarat. 6763

In the Supreme Court of the State of Victoria.

SALE BY THE SHERIFF.

On FRIDAY the 15th of MARCH 1974 at 10.30 a.m. AT THE POLICE STATION BROADMEADOWS (unless process be stayed or satisfied):

ALL the Estate and Interest (if any) of ZVONKO CULIC, fitter & welder and MARIJA CULIC married woman both of 40 Mont Albert Drive, Campbellfield as joint proprietors of an estate in fee simple in the land described in Certificate of Title Volume 8934 Folio 040 upon which is erected a three bedroom brick veneer dwelling known as No. 40 Mont Albert Drive, Campbellfield.

Registered Mortgage No. E.847330 affects the said estate and interest.

TERMS—CASH ONLY.

DOUGLAS S. HALL, Sheriff's Officer.

13th February, 1974.

6819

IMPOUNDINGS

ECHUCA.—Impounded in Echuca Pound, from the Murray Valley Highway, Echuca.

1 dark Jersey heifer, notch top and back near ear, no visible brand

1 Jersey heifer, notch top and back near ear, no visible brand

4 Jersey heifers, clean ears, no visible brand

If not claimed and expenses paid, to be sold on 28th February, 1974.

6748—\$3.85

B. CLEE,
Poundkeeper.

ELTHAM.—Impounded in Eltham Shire Pound by Ranger.

1 chestnut, gelding, approximately 14 hands

If not claimed and expenses paid, to be sold at Croydon Market on 11th March, 1974.

6757—\$2.10

C. J. BOCK,
Shire Secretary.

PAKENHAM.—Impounded in Pakenham Pound from Hallam—Emerald Road, Hallam.

1 black Brahman x bull, mark near rump

If not claimed and expenses paid, to be sold on 26th February, 1974.

6837—\$2.45

H. SMITH,
Poundkeeper.

PLENTY.—Impounded in Yan Yean Road, Plenty Pound, on 18th January, 1974.

1 ewe, no visible brand

If not claimed and expenses paid, to be sold on 28th February, 1974.

6759—\$2.45

B. J. MORGAN,
Shire Secretary.

RINGWOOD.—Impounded in the City of Ringwood Pound, found in East Ringwood Reserve.

1 chocolate coloured gelding, no visible brands

If not claimed and expenses paid, to be sold on 1st March, 1974.

6730—\$2.45

L. T. GRATION,
Poundkeeper.

UPWEY.—Impounded in Upwey Pound by Mr. K. Hocking, from Mountain Flat-road, Narre Warren East, on 26th January, 1974.

6 Hereford heifers, no visible brand

If not claimed and expenses paid, to be sold at the Dandenong Saleyards on 5th March, 1974.

6742—\$2.80

H. P. MEANEY,
Poundkeeper.

WHITTLESEA.—Impounded in Epping Pound by City of Coburg Ranger.

1 black Shetland gelding, with brand M on offside shoulder, 8 over BG on near side shoulder

If not claimed and expenses paid, to be sold at noon on Friday, 1st March, 1974.

6762—\$2.80

W. HERD,
Poundkeeper.

Subordinate Legislation Act 1962.

NOTICE OF MAKING OF STATUTORY RULES.

In pursuance of the provisions of the *Subordinate Legislation Act 1962* and the Regulations made thereunder, notice is given of the making of the following statutory rules:—

No. <i>Medical Practitioners Act 1970</i> (No. 8061).	Price.
53/1974. <i>Medical Practitioners (Amendment) Regulations 1974</i>	15c
<i>Public Works Committee Act 1958.</i>	
54/1974. <i>Public Works Committee (Travelling Expenses) Regulations 1973</i>	10c
<i>Parliamentary Committees Act 1968.</i>	
55/1974. <i>Parliamentary Committees (Travelling Expenses) Regulations 1973</i>	10c
<i>State Development Committee Act 1958.</i>	
56/1974. <i>State Development Committee (Allowances) Regulations 1973</i>	10c

Copies of these statutory rules may be purchased at the Sale of Publications Section of the Government Printing Office, located at 7A Parliament-place, Melbourne, 3002. If ordered by mail, remittance should be addressed to "The Government Printer, Box 203, P.O., North Melbourne, 3051", and should include 7c extra for postage. If a credit account is held at this office, no remittance is required with the mail order.

The annual subscription rate for Statutory Rules (including Bound Volumes) is \$30, payable in advance. The subscription year commences on 1st January.

C. H. RIXON,
Government Printer.

STATE ACTS, 1973

Copies of the following Acts of Parliament of Victoria may be obtained at the Government Printing Office, Sale of Publications Branch, off Parliament-place, Melbourne, phone 63 0321, extension 6181, or from any accredited agent, at the price set opposite to each (these prices do not include postage).

The annual subscription for State Acts 1973 et seq. is \$12.50 payable in advance.

Bound Volumes of State Acts are also available on a subscription basis of \$17.50 per annum.

No.	Price.
8385. The Constitution Act Amendment (Qualifications)	\$0.10
8386. Hungarian Reformed Church of Australia (Victoria District) Incorporation	\$0.20
8387. Melbourne Family Care Organization	\$0.10
8388. Gas and Fuel Corporation (Colonial Gas Holdings Limited)	\$0.10
8389. Boilers and Pressure Vessels	\$0.10
8390. State Electricity Commission (Yallourn Council)	\$0.10
8391. Home Finance (Amendment)	\$0.10
8392. Zoological Gardens (Amendment)	\$0.10
8393. Melba Trust Fund	\$0.10
8394. Hospitals and Charities (Guarantee)	\$0.10
8395. Water (Amendment)	\$0.15
8396. Geelong Harbor Trust (Lands)	\$0.10
8397. Latrobe Valley (Amendment)	\$0.10
8398. Maryborough Land	\$0.10
8399. The Constitution Act Amendment (Presiding Officers)	\$0.10
8400. Constitutional Convention (Alternate Members)	\$0.10
8401. Ballarat (Sovereign Hill) Land	\$0.15
8402. Taxation Appeals (Commencement)	\$0.10
8403. Patriotic Funds (Amendment)	\$0.10
8404. Abattoir and Meat Inspection	\$0.40
8405. Valuation of Land (Valuers)	\$0.20
8406. Egg Industry Stabilization	\$0.40
8407. Recreation Vehicles	\$0.15
8408. Motor Car Traders	\$0.50
8409. Decentralized Industry (Housing)	\$0.15
8410. Crimes (Amendment)	\$0.10
8411. Cattle Compensation	\$0.10
8412. Victorian Inland Meat Authority (Amendment)	\$0.10
8413. Bendigo Aerodrome	\$0.10
8414. Ombudsman	\$0.30
8415. Public Service (Amendment)	\$0.10
8416. Coal Mines (Pensions Increase)	\$0.10
8417. Workers Compensation	\$0.10
8418. Public Records	\$0.20

STATE ACTS, 1973—continued.

No.	Price.
8419. Joint Select Committee (Osteopathy, Chiropractic and Naturography)	\$0.10
8420. Marketing of Primary Products (Citrus Fruit)	\$0.10
8421. Barley Marketing (Amendment)	\$0.10
8422. Margarine	\$0.10
8423. Metric Conversion	\$0.10
8424. Medical Practitioners (Amendment)	\$0.15
8425. Crimes (Theft)	\$0.30
8426. Social Welfare (Amendment)	\$0.20
8427. Magistrates' Courts (Jurisdiction)	\$0.60
8428. Victorian Development Corporation	\$0.40
8429. Motor Accidents	\$0.80
8430. Motor Car (Amendment)	\$0.15
8431. Teaching Service	\$0.10
8432. Lands Compensation	\$0.15
8433. Police Offences (Publications)	\$0.15
8434. The Constitution Act Amendment (Responsible Ministers)	\$0.10
8435. Supply (July to October)	\$0.10
8436. Supply (Supplementary Estimates)	\$0.10
8437. Joint Select Committee (Meat Industry)	\$0.10
8438. Joint Select Committee (Road Safety)	\$0.10
8439. Joint Select Committee (Osteopathy, Chiropractic and Naturography) Amendment	\$0.10
8440. Public Works Committee	\$0.10
8441. The Constitution Act Amendment (Qualifications Joint Select Committee)	\$0.10
8442. Ministry of Consumers Affairs	\$0.10
8443. Ministry for Planning	\$0.10
8444. Volunteer Civil Defence Workers Compensation (Amendment)	\$0.10
8445. Local Government (Rates)	\$0.10
8446. Hospitals Superannuation (Amendment)	\$0.10
8447. Public Works Committee (Attendance Fees)	\$0.10
8448. Unclaimed Moneys	\$0.10
8449. Appropriation	\$1.90
8450. Racing (Amendment)	\$0.10
8451. Ministry for the Arts (Amendment)	\$0.10
8452. Local Authorities Superannuation (Amendment)	\$0.10
8453. Sewerage Districts (Amendment)	\$0.10
8454. Money Lenders (Advertisements)	\$0.15
8455. Tomato Processing Industry (Uniform Agreement)	\$0.20
8456. Poisons (Fees)	\$0.10
8457. Camperdown (Public Park) Land	\$0.10
8458. Maldstone Land	\$0.10
8459. Labour and Industry (Amendment)	\$0.10
8460. Hairdressers Registration (Amendment)	\$0.10
8461. Land (Metric Conversion)	\$0.30
8462. Co-operative Housing Societies (Amendment)	\$0.10
8463. Rosebud Institutions	\$0.10
8464. Gas and Fuel Corporation (Amalgamations)	\$0.15
8465. Stamps	\$0.20
8466. Estate Agents (Fees)	\$0.10
8467. Auction Sales (Licence Fees)	\$0.10
8468. Motor Car (Fees)	\$0.10
8469. Mines (Fees)	\$0.10
8470. The Constitution Act Amendment (Executive Council)	\$0.10
8471. State Forests Works and Services	\$0.10
8472. Entertainments Tax	\$0.10
8473. State College of Victoria (Staff)	\$0.10
8474. Decentralized Industry (Land Tax Rebates) Incentive Payments	\$0.10
8475. Pensions Supplementation	\$0.10
8476. Metropolitan Fire Brigades (Amendment)	\$0.10
8477. Children's Court	\$0.60
8478. Country Fire Authority	\$0.10
8479. Housing (Commonwealth State Agreement)	\$0.20
8480. Probate Duty (Amendment)	\$0.15
8481. Judges Salaries and Allowances	\$0.10
8482. Pay-roll Tax (Amendment)	\$0.10
8483. Land Reform	\$0.15
8484. Flemington Land	\$0.10
8485. Educational Lands	\$0.10
8486. Small Claims Tribunals	\$0.20

C. H. RIXON,
Government Printer.

ACTS REPRINTED IN ACCORDANCE WITH THE AMENDMENTS INCORPORATION ACT 1958 (No. 6422), AND FOR SALE AT THE SALE OF PUBLICATIONS BRANCH OF THE GOVERNMENT PRINTING OFFICE, MACARTHUR-STREET, MELBOURNE, 3002.

(These prices do not include postage.)

No.	Price.
6189. Acts Interpretation (Third Reprint—Incorporating amendments up to No. 7944)	\$0.35
6191. Administration and Probate (Fourth Reprint—Incorporating amendments up to No. 7874)	\$0.75

ACTS REPRINTED IN ACCORDANCE WITH THE AMENDMENTS
INCORPORATION ACT 1958 (No. 6422)—*continued.*

No.	Price.
6194. Agricultural Colleges (<i>First Reprint</i> —Incorporating amendments up to No. 7302)	\$0.15
6198. Anzac Day (<i>First Reprint</i> —Incorporating amendments up to No. 8344)	\$0.15
7117. Appeal Costs Fund Act 1964 (<i>First Reprint</i> —Incorporating amendments up to No. 7488)	\$0.25
6199. Apprenticeship (<i>Second Reprint</i> —Incorporating amendments up to No. 7869)	\$0.40
6201. Architects (<i>First Reprint</i> —Incorporating amendments up to No. 8077)	\$0.30
6203. Audit (<i>First Reprint</i> —Incorporating amendments up to No. 7377)	\$0.35
6208. Benefit Associations (<i>First Reprint</i> —Incorporating amendments up to No. 6961)	\$0.45
8004. Boiler and Pressure Vessels Act 1970 (<i>First Reprint</i> —Incorporating amendments up to No. 8389)	\$0.45
6529. Bread Industry Act 1959 (<i>First Reprint</i> —Incorporating amendments up to No. 7728)	\$0.30
6973. Building Contracts (Deposits) Act 1962 (<i>First Reprint</i> —Incorporating amendments from No. 7315)	\$0.10
6210. Building Societies (<i>Second Reprint</i> —Incorporating amendments up to No. 7911)	\$0.40
6213. Cancer (<i>First Reprint</i> —Incorporating amendments up to No. 7455)	\$0.35
6214. Carriers and Innkeepers (<i>First Reprint</i> —Incorporating amendments up to No. 7971)	\$0.15
6217. Cemeteries (<i>First Reprint</i> —Incorporating amendments up to No. 7672)	\$0.30
6218. Children's Court (<i>Second Reprint</i> —Incorporating amendments up to No. 8124)	\$0.45
6220. Clean Air (<i>Second Reprint</i> —Incorporating amendments up to No. 8196)	\$0.15
6221. Coal Mines (<i>First Reprint</i> —Incorporating amendments up to No. 7628)	\$1.05
6222. Commercial Goods Vehicles (<i>Second Reprint</i> —Incorporating amendments up to No. 7358)	\$0.22
6223. Commonwealth Arrangements (<i>First Reprint</i> —Incorporating amendments from No. 7809)	\$0.10
6839. Companies Act 1961 (<i>Fourth Reprint</i> —Incorporating amendments up to Act No. 8185)	\$5.75
6224. The Constitution Act Amendment (<i>First Reprint</i> —Incorporating amendments up to No. 8086)	\$3.05
8276. Consumer Protection Act 1972 (<i>First Reprint</i> —Incorporating amendments up to No. 8382)	\$0.65
6225. Co-operation Act (<i>Third Reprint</i> —Incorporating amendments up to No. 8339)	\$0.85
6226. Co-operative Housing Societies (<i>Second Reprint</i> —Incorporating amendments up to No. 7575)	\$0.53
6227. Coroners (<i>First Reprint</i> —Incorporating amendments up to No. 7935)	\$0.35
6228. Country Fire Authority (<i>Second Reprint</i> —Incorporating Amendments up to No. 7476)	\$0.50
6229. Country Roads (<i>Third Reprint</i> —Incorporating amendments up to No. 8140)	\$1.05
6230. County Court (<i>Second Reprint</i> —Incorporating amendments up to No. 8132)	\$0.65
6231. Crimes (<i>Fourth Reprint</i> —Incorporating amendments up to Act No. 8338)	\$2.75
6232. Crown Proceedings (<i>First Reprint</i> —Incorporating amendments up to No. 7900)	\$0.30
6233. Dairy Products (<i>First Reprint</i> —Incorporating amendments up to No. 7945)	\$0.20
7060. Dandenong Valley Authority Act 1963 (<i>First Reprint</i> —Incorporating amendments up to No. 7523)	\$0.35
4989. Discharged Servicemen's Preference Act 1943 (<i>First Reprint</i> —Incorporating amendments up to No. 7788)	\$0.20
6815. Disposal of Uncollected Goods Act 1961 (<i>First Reprint</i> —Incorporating amendments up to No. 7181)	\$0.15
6237. Drainage Areas (<i>First Reprint</i> —Incorporating amendments up to No. 7276)	\$0.35
6238. Drainage of Land (<i>First Reprint</i> —Incorporating amendments up to No. 7876)	\$0.15
6239. Dried Fruits Act 1968 (<i>First Reprint</i> —Incorporating amendments up to No. 7337)	\$0.25
6240. Education (<i>First Reprint</i> —Incorporating amendments up to No. 7533)	\$0.45
6241. Electric Light and Power (<i>First Reprint</i> —Incorporating amendments up to No. 7315)	\$0.30
6242. Employers and Employees (Incorporating amendments up to No. 6740)	\$0.18
6243. Entertainments Tax (<i>First Reprint</i> —Incorporating amendments up to No. 7315)	\$0.25

ACTS REPRINTED IN ACCORDANCE WITH THE AMENDMENTS
INCORPORATION ACT 1958 (No. 6422)—*continued.*

No.	Price.
8056. Environment Protection Act 1970 (<i>First Reprint</i> —Incorporating amendments up to No. 8277)	\$0.55
6245. Estate Agents (<i>Fourth Reprint</i> —Incorporating amendments up to No. 8181)	\$0.85
6246. Evidence (<i>Fourth Reprint</i> —Incorporating amendments up to No. 8228)	\$1.05
7499. Extractive Industries Act 1966 (<i>Second Reprint</i> —Incorporating amendments up to No. 7951)	\$0.40
6250. Fertilizers (Incorporating amendments up to No. 7142)	\$0.25
6468. Filled Milk (<i>First Reprint</i> —Incorporating amendments up to No. 6886)	\$0.15
6251. Firearms (<i>Fourth Reprint</i> —Incorporating amendments up to No. 8288)	\$0.75
6916. Foreign Judgments Act 1962 (<i>First Reprint</i> including amendments made by No. 7332)	\$0.15
6585. Forests (Pulpwood Agreement) (Incorporating amendments up to No. 6886)	\$0.15
6254. Forests (<i>First Reprint</i> —Incorporating amendments up to No. 7356)	\$0.60
6255. Friendly Societies (<i>First Reprint</i> —Incorporating amendments up to No. 7554)	\$0.60
6256. Fruit and Vegetables (<i>First Reprint</i> —Incorporating amendments up to No. 6944)	\$0.30
6258. Game (<i>First Reprint</i> —Incorporating amendments up to No. 7389)	\$0.30
6260. Gas and Fuel Corporation (<i>First Reprint</i> —Incorporating amendments up to No. 7422)	\$0.70
6262. Geelong Harbor Trust (<i>First Reprint</i> —Incorporating amendments up to No. 7547)	\$0.45
6263. Geelong Waterworks and Sewerage (<i>First Reprint</i> —Incorporating amendments up to No. 7547)	\$0.75
8176. Gift Duty Act 1971 (<i>First Reprint</i> —Incorporating amendments from No. 8202)	\$0.55
6265. Goods (<i>Fifth Reprint</i> —Incorporating amendments up to No. 8276)	\$0.45
6266. Grain Elevators (<i>First Reprint</i> —Incorporating amendments up to No. 7486)	\$0.35
7849. Groundwater (<i>First Reprint</i> —Incorporating amendments up to No. 8153)	\$0.45
6269. Hawkers and Pedlars (<i>First Reprint</i> —Incorporating amendments up to No. 7876)	\$0.30
6270. Health (<i>Second Reprint</i> —Incorporating amendments up to No. 7490)	\$1.65
6267. Hairdressers Registration (<i>First Reprint</i> —Incorporating amendments up to Act No. 7659)	\$0.30
6531. Hire Purchase Act 1959 (<i>Second Reprint</i> —Incorporating amendments from Act No. 8232)	\$0.55
6933. Home Finance Act 1962 (<i>First Reprint</i> —Incorporating amendments up to No. 7363)	\$0.25
6274. Hospitals and Charities (<i>Second Reprint</i> —Incorporating amendments up to No. 7455)	\$0.50
6275. Housing (<i>Second Reprint</i> —Incorporating amendments up to No. 8052)	\$1.65
6276. Imprisonment of Fraudulent Debtors (<i>First Reprint</i> —Incorporating amendments up to No. 7876)	\$0.35
6277. Industrial and Provident Societies (<i>First Reprint</i> —Incorporating amendments up to No. 7547)	\$0.35
6279. Instruments (<i>Fourth Reprint</i> —Incorporating amendments up to No. 7941)	\$0.75
6280. Judicial Proceedings Reports (<i>First Reprint</i> —Incorporating amendments up to No. 7596)	\$0.15
6282. Justices (<i>Third Reprint</i> —Incorporating amendments up to No. 7966)	\$1.40
6283. Labour and Industry (<i>Fifth Reprint</i> —Incorporating amendments up to No. 8211)	\$1.55
6284. Land Act 1959 (<i>Second Reprint</i> —Incorporating amendments up to No. 8243)	\$3.15
6534. Land Settlement Act 1959 (<i>First Reprint</i> —Incorporating amendments up to No. 7328)	\$0.30
6288. Land Surveyors (<i>First Reprint</i> —Incorporating amendments up to Act No. 7065)	\$0.30
6289. Land Tax (<i>Second Reprint</i> —Incorporating amendments up to No. 7466)	\$0.40
6285. Landlord and Tenant (<i>Third Reprint</i> —Incorporating amendments up to No. 7332)	\$0.68
6286. Lands Compensation (<i>First Reprint</i> —Incorporating amendments up to No. 7332)	\$0.25
6290. Latrobe Valley (<i>First Reprint</i> —Incorporating amendments up to No. 7332)	\$0.35
6291. Legal Profession Practice Act (<i>Third Reprint</i> —Incorporating amendments up to No. 8259)	\$1.15

ACTS REPRINTED IN ACCORDANCE WITH THE AMENDMENTS
INCORPORATION ACT 1958 (No. 6422)—*continued.*

No.	Price.
6292. Libraries (<i>First Reprint</i> —Incorporating amendments up to No. 7364) ..	\$0.15
6295. Limitation of Actions (<i>Second Reprint</i> —Incorporating amendments up to No. 7457) ..	\$0.25
7695. Liquor Control Act 1968 (<i>Second Reprint</i> —Incorporating amendments up to No. 8272) ..	\$1.35
7145. Litter Act 1964 (<i>First Reprint</i> —Incorporating amendments up to No. 7608) ..	\$0.15
6298. Local Authorities Superannuation (<i>Second Reprint</i> —Incorporating amendments up to No. 7161) ..	\$0.40
6299. Local Government. New Parts III. to IX. Section 51 to Section 250—Incorporating amendments up to No. 8291 ..	\$1.70
6299. Local Government. New Parts X. and XI. (being a reprint of portion of No. 7835, as amended by No. 7847) ..	\$0.50
6301. Margarine (<i>First Reprint</i> —Incorporating amendments up to No. 7714) ..	\$0.18
6302. Marine (Incorporating amendments up to No. 7350) ..	\$0.72
6303. Marine Stores and Old Metals (<i>First Reprint</i> —Incorporating amendments up to No. 7876) ..	\$0.35
6304. Marketing of Primary Products (<i>First Reprint</i> —Incorporating amendments up to No. 7491) ..	\$0.45
6305. Markets (<i>First Reprint</i> —Incorporating amendments up to No. 7705) ..	\$0.20
6306. Marriage (<i>First Reprint</i> —Incorporating amendments up to No. 6959) ..	\$0.25
6307. Masseurs (<i>First Reprint</i> —Incorporating amendments up to No. 7566) ..	\$0.20
6309. Medical (<i>Second Reprint</i> —Incorporating amendments up to No. 7408) ..	\$0.40
6310. Melbourne and Metropolitan Board of Works (<i>Third Reprint</i> —Incorporating amendments up to No. 8082) ..	\$1.85
6311. Melbourne and Metropolitan Tramways (<i>First Reprint</i> —Incorporating amendments up to No. 7622) ..	\$0.70
6312. Melbourne Harbor Trust (<i>First Reprint</i> —Incorporating amendments up to No. 7356) ..	\$0.48
6405. Melbourne University (<i>First Reprint</i> —Incorporating amendments up to No. 7871) ..	\$0.40
6605. Mental Health (Incorporating amendments up to No. 7135) ..	\$0.45
6315. Metropolitan Fire Brigades (<i>Second Reprint</i> —Incorporating amendments up to No. 8165) ..	\$0.65
6316. Mildura Irrigation and Water Trusts (<i>First Reprint</i> —Incorporating amendments up to No. 7448) ..	\$0.75
6317. Milk and Dairy Supervision (Incorporating amendments up to No. 6964) ..	\$0.40
6318. Milk Board (Incorporating amendments up to No. 7093) ..	\$0.22
6319. Milk Pasteurization (<i>First Reprint</i> —Incorporating amendments up to No. 7480) ..	\$0.15
6320. Mines (<i>Second Reprint</i> —Incorporating amendments up to No. 7876) ..	\$1.25
6184. Monash University (<i>First Reprint</i> —Incorporating amendments up to No. 7533) ..	\$0.30
6324. Money Lenders (<i>Third Reprint</i> —Incorporating amendments up to No. 8181) ..	\$0.55
6832. Motor Boating Act 1961 (<i>Second Reprint</i> —Incorporating amendments up to No. 6961) ..	\$0.30
6325. Motor Car (<i>Fourth Reprint</i> —Incorporating amendments up to No. 8143) ..	\$2.05
6713. National Fitness Council of Victoria Act 1960 (<i>First Reprint</i> —Incorporating amendments up to No. 8344) ..	\$0.20
6705. Navigable Waters (Oil Pollution) Act 1960. (<i>First Reprint</i> —Incorporating amendments up to No. 7890) ..	\$0.30
6328. Nurses (<i>Second Reprint</i> —Incorporating amendments up to No. 7375) ..	\$0.45
6329. Opticians Registration (<i>First Reprint</i> —Incorporating amendments up to No. 7409) ..	\$0.30
6330. Partnership (<i>Second Reprint</i> —Incorporating amendments up to No. 7315) ..	\$0.30
6331. Patriotic Funds (<i>First Reprint</i> —Incorporating amendments up to No. 7338) ..	\$0.25
6332. Pawnbrokers (<i>First Reprint</i> —Incorporating amendments up to No. 7876) ..	\$0.35
6257. Pesticides Act 1968 (<i>First Reprint</i> —Incorporating amendments up to No. 7595) ..	\$0.15
6334. Petroleum (<i>First Reprint</i> —Incorporating amendments up to No. 7876) ..	\$0.65

ACTS REPRINTED IN ACCORDANCE WITH THE AMENDMENTS
INCORPORATION ACT 1958 (No. 6422)—*continued.*

No.	Price.
6889. Poisons Act 1962 (<i>Second Reprint</i> —Incorporating amendments up to No. 7588) ..	\$0.50
6337. Police Offences (<i>Second Reprint</i> —Incorporating amendments up to No. 7678) ..	\$0.28
6338. Police Regulation (<i>Second Reprint</i> —Incorporating amendments up to No. 8179) ..	\$0.95
6340. Portland Harbor Trust (<i>First Reprint</i> —Incorporating amendments up to No. 7475) ..	\$0.35
6341. Pounds (<i>First Reprint</i> —Incorporating amendments up to No. 7315) ..	\$0.25
7498. Port Phillip Authority Act 1966 (<i>First Reprint</i> —Incorporating amendments from No. 8081) ..	\$0.15
6342. Printers and Newspapers (<i>First Reprint</i> —Incorporating amendments up to No. 7876) ..	\$0.15
7494. Private Agents Act 1966 (<i>First Reprint</i> —Incorporating amendments in No. 7646) ..	\$0.35
6890. Probate Duty (<i>Third Reprint</i> —Incorporating amendments up to No. 8072) ..	\$0.75
6344. Property Law (<i>Third Reprint</i> —Incorporating amendments up to No. 8181) ..	\$1.95
6345. Public Account (<i>First Reprint</i> —Incorporating amendments up to No. 8012) ..	\$0.20
6346. Public Authorities Marks (<i>First Reprint</i> —Incorporating amendments from No. 7315) ..	\$0.10
6349. Public Service (<i>Second Reprint</i> —Incorporating amendments up to No. 7356) ..	\$0.40
6350. Public Trustee (Incorporating amendments up to No. 6961) ..	\$0.35
6353. Racing (<i>Third Reprint</i> —Incorporating amendments up to No. 8080) ..	\$1.45
6355. Railways (<i>First Reprint</i> —Incorporating amendments up to No. 7475) ..	\$0.75
6564. Registration of Births Deaths and Marriages Act 1959 (<i>First Reprint</i> —Incorporating amendments up to No. 7332) ..	\$0.25
6358. River Improvement Act (<i>First Reprint</i> —Incorporating amendments up to No. 8342) ..	\$0.55
2596. River Murray Waters Act 1915 (<i>First Reprint</i> —Incorporating amendments up to No. 7061) ..	\$0.35
6359. Road Traffic (<i>Third Reprint</i> —Incorporating amendments up to No. 8192) ..	\$0.35
6360. Rural Finance (<i>First Reprint</i> —Incorporating amendments up to No. 7328) ..	\$0.15
6846. Rural Finance and Settlement Commission Act 1961 (<i>First Reprint</i> —Incorporating amendments up to No. 7332) ..	\$0.30
6917. Sale of Human Blood Act 1962 (<i>First Reprint</i> —Incorporating amendments from No. 7332) ..	\$0.10
6975. Sale of Land Act 1962 (<i>Second Reprint</i> —Incorporating amendments up to No. 7898) ..	\$0.30
6363. Second-hand Dealers (<i>First Reprint</i> —Incorporating amendments up to No. 7529) ..	\$0.25
7962. Securities Industry Act 1970 (<i>First Reprint</i> —Incorporating amendments made by Act No. 8059) ..	\$0.65
6367. Settled Land (<i>Second Reprint</i> —Incorporating amendments up to No. 7065) ..	\$0.50
6368. Sewerage Districts (<i>Second Reprint</i> —Incorporating amendments up to No. 7547) ..	\$0.75
6369. Shearers Accommodation (<i>First Reprint</i> —Incorporating amendments up to No. 7876) ..	\$0.35
6809. Sheep Owners Protection Act 1961 (<i>Second Reprint</i> —Incorporating amendments up to No. 8179) ..	\$0.20
6372. Soil Conservation and Land Utilization (<i>Second Reprint</i> —Incorporating amendments up to No. 8142) ..	\$0.45
6373. Soldier Settlement (<i>First Reprint</i> —Incorporating amendments up to No. 7328) ..	\$0.42
6375. Stamps (<i>Fifth Reprint</i> —Incorporating amendments up to No. 8274) ..	\$2.15
6377. State Electricity Commission (<i>Second Reprint</i> —Incorporating amendments up to No. 7421) ..	\$0.65
6378. State Relief Committee (<i>First Reprint</i> —Incorporating amendments from No. 6886) ..	\$0.10
6379. State Savings Bank (<i>Second Reprint</i> —Incorporating amendments up to No. 8082) ..	\$0.95
6380. Statistics (<i>First Reprint</i> —Incorporating amendments up to No. 6961) ..	\$0.15
6383. Stock Foods (<i>First Reprint</i> —Incorporating amendments up to No. 7607) ..	\$0.28
6384. Stock Medicines (<i>First Reprint</i> —Incorporating amendments up to No. 7726) ..	\$0.20
7551. Strata Titles Act 1967 (<i>Second Reprint</i> —Incorporating amendments up to No. 8149) ..	\$0.65

ACTS REPRINTED IN ACCORDANCE WITH THE AMENDMENTS INCORPORATION ACT 1958 (No. 6422)—*continued.*

No.	Price.
6886. Subordinate Legislation (Incorporating amendments up to No. 6961) ..	\$0.15
7405. Summary Offences Act 1966 (First Reprint—incorporating amendments up to Act No. 8226) ..	\$0.55
6386. Superannuation (Second Reprint—Incorporating amendments up to No. 7910) ..	\$0.75
6387. Supreme Court (First Reprint—Incorporating amendments up to No. 7522) ..	\$0.75
6388. Survey Co-ordination (First Reprint—Incorporating amendments up to Act No. 8107) ..	\$0.33
6390. Tattersall Consultations (First Reprint—Incorporating amendments up to No. 8289) ..	\$0.15
6391. Teaching Service (First Reprint—Incorporating amendments up to No. 7536) ..	\$0.35
6849. Town and Country Planning Act 1961 (Fourth Reprint—Incorporating amendments up to No. 8380) ..	\$1.15
6401. Trustee (Third Reprint—Incorporating amendments up to No. 7833) ..	\$0.95
6402. Trustee Companies (First Reprint—Incorporating amendments up to No. 7858) ..	\$0.35
7223. Tomato Processing Industry (Uniform Agreement) Act 1964 (First Reprint—Incorporating amendments up to No. 7342) ..	\$0.15
6397. Trade Unions (First Reprint—Incorporating amendments up to No. 6839) ..	\$0.20
6399. Transfer of Land Act (Fourth Reprint—Incorporating amendments up to No. 8181) ..	\$1.15
6400. Transport Regulation (First Reprint—Incorporating amendments up to No. 7358) ..	\$0.22
6879. Unclaimed Moneys (Incorporating amendments up to No. 6961) ..	\$0.12
7095. Underseas Mineral Resources Act 1963 (First Reprint—Incorporating amendments from No. 7591) ..	\$0.10
6653. Valuation of Land Act 1960 (Second Reprint—Incorporating amendments up to No. 7333) ..	\$0.22
6409. Vermin & Noxious Weeds (First Reprint—Incorporating amendments up to No. 7463) ..	\$0.30
6410. Veterinary Surgeons (First Reprint—Incorporating amendments up to No. 7343) ..	\$0.35
6411. Victorian Inland Meat Authority (First Reprint—Incorporating amendments up to No. 8000) ..	\$0.15
7291. Victoria Institute of Colleges Act 1965 (First Reprint—Incorporating amendments up to No. 7644) ..	\$0.30
6412. Warehousemen's Liens (First Reprint—Incorporating amendments up to No. 7876) ..	\$0.25
	\$0.15

ACTS REPRINTED IN ACCORDANCE WITH THE AMENDMENTS INCORPORATION ACT 1958 (No. 6422)—*continued.*

No.	Price.
6413. Water (Second Reprint—Incorporating amendments up to No. 7590) ..	\$1.95
6414. Weights and Measures (Third Reprint—Incorporating amendments up to No. 8068) ..	\$1.05
6415. Wild Flowers and Native Plants Protection (First Reprint—Incorporating amendments up to No. 6976) ..	\$0.15
6416. Wills (First Reprint—Incorporating amendments up to No. 7238) ..	\$0.25
6417. Wire Netting (First Reprint—Incorporating amendments up to No. 7876) ..	\$0.45
6419. Workers Compensation (Fifth Reprint—Incorporating amendments up to No. 8353) ..	\$1.05

C. H. RIXON,
Government Printer.

CONTENTS	PAGE
Acts of Parliament on Sale at the Government Printing Office ..	441
Appointments ..	404
Bank Holiday ..	382
Cemeteries—Scale of Fees ..	401
Contracts ..	403
Country Roads Board ..	393
Estates of Deceased Persons ..	402
Government Notices ..	383
Impoundings ..	440
Lands ..	413
Melbourne and Metropolitan Board of Works—Notice ..	390
Notice of Making of Statutory Rules ..	441
Orders in Council—	
Acts—Sewerage Districts; Country Roads; Cemeteries; Land; Local Government; Motor Car; Superannuation; State Electricity Commission; Sewerage Districts; Dandenong Valley Authority; Water.	405 et seq
Police Sale ..	404
Private Advertisements ..	426
Proclamations ..	377
Public Service Notices ..	421
Regulations—	
Acts—Teaching Service ..	426
Resignations ..	405
Tenders ..	420
Transport Regulation Board—Public Hearings ..	384