



VICTORIA GOVERNMENT GAZETTE

Published by Authority

No. 11

WEDNESDAY, JANUARY 8

[1975

Government House,
Melbourne, 3004,
31st December, 1974.

The Queen has graciously been pleased to signify Her Majesty's intention of conferring the following Honours and Awards in the New Year Honours, 1975:—

TO BE KNIGHTS BACHELOR.

The Honorable Mr. Justice Oliver James Gillard, B.A., LL.B.
William Shearer Philip, Esquire, C.M.G., M.C., F.C.A.(Aust.)
Thomas Langley Webb, Esquire

THE MOST DISTINGUISHED ORDER OF SAINT MICHAEL AND SAINT GEORGE.

To be Companions of the said Most Distinguished Order:
Brigadier Percival Philp Jackson, C.B.E., B.E., F.I.E.(Aust.), F.I.Mech.E., F.A.I.M.
Doctor Margaret Alison Mackie, M.B., B.S., D.G.O., F.R.C.O.G.

THE MOST EXCELLENT ORDER OF THE BRITISH EMPIRE.

To be a Dame Commander of the Civil Division of the said Most Excellent Order:

Lady Jacobena Victoria Alice Angliss, C.B.E.

To be Commanders of the Civil Division of the said Most Excellent Order:

Professor Donald Cochrane, B.Com., Ph.D.
Frank Bertram Daly, Esquire.
Doctor Albert Howard Toyne, C.St.J., M.B., B.S., F.R.C.S.(Eng.), F.R.A.C.S.

To be Officers of the Civil Division of the said Most Excellent Order:

Alexander Foxcroft Bottomley, Esquire, D.D.A., F.A.I.M.
Angus Lindsay Carmichael, Esquire, Q.P.M.
William Alan Catanach, Esquire.
William Clive Smalley Ellis, Esquire, A.A.S.A., A.C.I.S.
Arthur Henry Benjamin Heymanson, Esquire, B.A., LL.B.
Oscar Adolf Mendelsohn, Esquire, B.Sc.(Hons.), F.R.I.C.(London), F.R.A.C.I.
Mrs. Leslie Mary Moorhead.
Doctor Henry Ian Alexander Nowik, D.Sc.Pol.
The Reverend William Walter Saunders.
Doctor Leigh Thornton Wedlick, M.B., B.S., M.R.C.P.(London), D.P.R.M.
Harold Elkan Wexler, Esquire, F.A.I.Q.S., F.A.I.M., F.R.I.C.S., F.I.Arb.

To be Members of the Civil Division of the said Most Excellent Order:

Arthur Edward Beckett, Esquire, J.P.
Miss Vivian Mary Bowler.
Clarence Benjamin Collett, Esquire, J.P.
Mrs. Ada Elizabeth Corder, Mus.B.(Melbourne).
Arthur William Curry, Esquire, F.I.M.A., J.P.
Councillor Clifford Thomas Dodds.

Miss Eunice Elizabeth Perrott Gill, M.A., Dip.Ed., Dip.Phys.Ed., M.A.C.E.
Mrs. Elsa Hallenstein.
Councillor Gerhard Nicolaus Jongebloed.
Councillor Alfred George Leech.
Miss Helen Moffat Paul, B.Sc.(Columb.), Dip.K.T.C. (Melb.), M.A.C.E.
Royce Reginald Pepin, Esquire, Ph.C.
Duncan Cameron Reilly, Esquire, Ph.C., M.P.S., F.A.Ch.A., J.P.
Bruce Carlyle Ruxton, Esquire.
Councillor Henry John Charles Saunders.
Alexander Stuart Sturrock, Esquire.
Mrs. Mary Lila Tanner.
Walter James Tuck, Esquire, J.P.
James Campbell Westcott, Esquire, Dip.For.
Mrs. Myrtle Vera Pearl Whitehead.

AWARDS OF THE BRITISH EMPIRE MEDAL (Civil Division).

Joseph Ormond Allgood, Esquire.
Stanley Willbank Berlyn, Esquire.
Cuthbert Samuel Binder, Esquire.
Melville Earle Blackmore, Esquire.
Mrs. Lillian Grace Bourke.
Andrew James Brodie, Esquire.
Mrs. Dorothy Eudora Victoria Cornall.
Ronald Frederick Stewart Crossbie, Esquire, A.A.S.A., J.P.
Miss Nance Yvonne Dickins, B.A.
Allan Percy Dodd, Esquire.
Albert Alexander Heather, Esquire.
Leslie Thorp Hault, Esquire.
Mrs. Hilda Myrtle Jenkins.
Mrs. Jane Evelyn Lee.
Henry William Linden, Esquire.
Mrs. Jessie Violet Florence Maisie McQuiston.
Peter Thomas Madden, Esquire.
Mrs. Myra Joyce Martin, A.L.C.M., A.L.C.Ch.
Mrs. Ruby Campion Moorfield.
Walter George Morrison, Esquire.
Mrs. Mary Florence Nichols.
Mrs. Margaret Mary Noble.
Sister (Miss) Helen Whitfield Northcott, S.R.N., I.W.C.
Mrs. Mary Muriel Roche.
Mrs. Katharine Margaret Rose.
Mrs. Ida Neave Singleton Sharp.
Thomas Allan Murray Smith, Esquire.
Miss Muriel Jean Trehwella, T.P.T.C.
Mrs. Adelaide May Tyers.
Mrs. Louisa Caroline Tyzack.
Frank Stanley Wallis, Esquire.
Albert Harmon West, Esquire.

AWARDS OF THE QUEEN'S POLICE MEDAL.

Chief Superintendent Henry Michael Duffy.
Chief Superintendent Norman Sydney Sumpter.
Superintendent Henry Robert Hutchins.
Chief Inspector Ellis Irvine McDonald.
Inspector Gregor Allan Cattanach.
Inspector John Osburn Thomas.

TOM FORRISTAL,
Official Secretary to the Governor.

PROCLAMATIONS

BREAD INDUSTRY (AMENDMENT) ACT 1974.

DATE OF COMING INTO OPERATION OF ACT.

PROCLAMATION

By His Excellency the Governor of the State of Victoria and its Dependencies in the Commonwealth of Australia, &c., &c., &c.

Whereas by an Act of the Parliament of the State of Victoria passed in the twenty-third year of the reign of Her Majesty Queen Elizabeth the Second, by the Grace of God Queen of Australia and Her other Realms and Territories, Head of the Commonwealth, intituled the *Bread Industry (Amendment) Act 1974*, it is amongst other things enacted that the said Act shall come into operation on a day to be fixed by proclamation of the Governor in Council published in the *Government Gazette*: Now therefore I, the Governor of the State of Victoria, in the Commonwealth of Australia, by and with the advice of the Executive Council of the said State, do by this my proclamation fix the fifteenth day of January 1975 as the day, upon which the provisions of the said Act shall come into operation.

Given under my Hand and the Seal of the State of Victoria aforesaid, at Melbourne, this twenty-fourth day of December, in the year of our Lord One thousand nine hundred and seventy-four, and in the twenty-third year of the reign of Her Majesty Queen Elizabeth II.

(L.S.) HENRY WINNEKE.

By His Excellency's Command,

J. A. RAFFERTY,
Minister of Labour and Industry.

GOD SAVE THE QUEEN!

ABORIGINAL AFFAIRS (TRANSFER OF FUNCTIONS) ACT 1974.

PROCLAMATION

By His Excellency the Governor of the State of Victoria and its Dependencies in the Commonwealth of Australia, &c., &c., &c.

Pursuant to the provisions of the *Aboriginal Affairs (Transfer of Functions) Act 1974*, the Governor of the State of Victoria, in the Commonwealth of Australia, acting by and with the advice of the Executive Council of the said State do by this my proclamation fix Saturday the eleventh day of January, One thousand nine hundred and seventy-five as the day upon which Sections 5, 6, 8 and 9 of the said Act shall come into operation.

Given under my Hand and the Seal of the State of Victoria aforesaid, at Melbourne, this twenty-fourth day of December, One thousand nine hundred and seventy-four, and in the twenty-third year of the reign of Her Majesty Queen Elizabeth II.

(L.S.) HENRY WINNEKE.

By His Excellency's Command,

VANCE DICKIE,
Minister for Aboriginal Affairs.

GOD SAVE THE QUEEN!

HARBORS AND NAVIGABLE WATERS CONTROL ACT 1974.

PROCLAMATION

By His Excellency the Governor of the State of Victoria and its Dependencies in the Commonwealth of Australia, &c., &c., &c.

Whereas by an Act of the Parliament of the State of Victoria passed in the twenty-third year of the reign of Her Majesty Queen Elizabeth the Second, by the Grace of God Queen of Australia and Her other Realms and Territories, Head of the Commonwealth, intituled the *Harbors and Navigable Waters Control Act 1974*, it is amongst other things enacted that the several provisions of the said Act shall come into operation on a day or the respective days to be fixed by proclamation or successive proclamations of the Governor-in-Council published in the *Government Gazette*:

Now therefore I, the Governor of the State of Victoria, in the Commonwealth of Australia, by and with the advice of the Executive Council of the said State, do by this my

proclamation fix the first day of February 1975 as the day upon which all of the provisions other than section seven of the said Act shall come into operation.

Given under my Hand and the Seal of the State of Victoria aforesaid, at Melbourne, this twenty-fourth day of December, in the year of our Lord One thousand nine hundred and seventy-four, and in the twenty-third year of the reign of Her Majesty Queen Elizabeth II.

(L.S.) HENRY WINNEKE.

By His Excellency's Command,

R. DUNSTAN,
Minister of Public Works.

GOD SAVE THE QUEEN!

Land Act 1958.

DEPARTMENT OF CROWN LANDS AND SURVEY.

PROCLAMATION

By His Excellency the Governor of the State of Victoria and its Dependencies in the Commonwealth of Australia, &c., &c., &c.

In pursuance of the provisions of section 25 (3) (c) of the *Land Act 1958*, I, the Governor of the State of Victoria, by and with the advice of the Executive Council of the said State, do hereby proclaim as road the Crown land in the Parish of Ballarat, County of Grant, being the land indicated by hatching on the plan hereunder.—(B.126⁽¹⁸⁾ (G.75236).

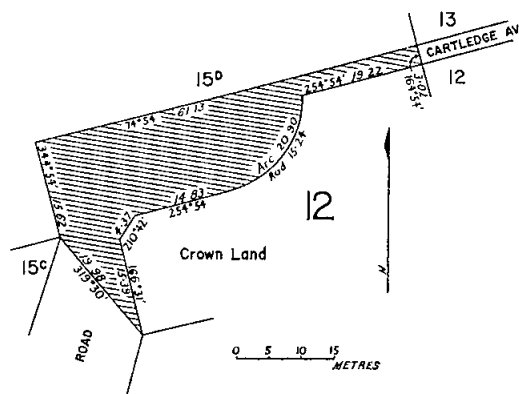

Given under my Hand and the Seal of the State of Victoria aforesaid, at Melbourne, this twenty-fourth day of December, in the year of our Lord One thousand nine hundred and seventy-four, and in the twenty-third year of the reign of Her Majesty Queen Elizabeth II.

(L.S.) HENRY WINNEKE.

By His Excellency's Command,

W. BORTHWICK,
Minister of Lands.

GOD SAVE THE QUEEN!

GOVERNMENT NOTICES

PUBLIC HOLIDAY.—AUSTRALIA DAY.

It is hereby notified that on—

MONDAY, THE 27TH JANUARY, 1975,

the Public Offices will be closed, such day having been appointed by the *Public Service Act 1958*, to be observed as a holiday in the Public Offices throughout the State of Victoria.

This notice relates only to the closing of the State Public Offices. All inquiries regarding the holiday in other offices and in shops and industry should be directed to the Department of Labour and Industry, 110 Exhibition Street, Melbourne, 3000. (Telephone 651 6158 or 651 6859.)

J. F. ROSSITER,
Chief Secretary.

Chief Secretary's Office,
Melbourne, 3rd January, 1975.

Private Agents Act 1966.

NOTICE OF RECEIPT OF APPLICATIONS FOR LICENCES UNDER THE PROVISIONS OF THE PRIVATE AGENTS ACT 1966.

The Clerk(s) of the Magistrates' Court(s) as listed hereunder hereby give notice that applications, as under, have been lodged for hearing by the said Court(s) on the date(s) specified.

Any person desiring to object to any such application must—

- (a) lodge with the prespective Clerk of the Magistrates' Court a notice in the prescribed form of his objection and of the grounds thereof;
- (b) cause a copy of such notice to be served personally or by post upon the applicant at least three days before the hearing of the application; and
- (c) send or deliver—
 - (i) where the objection is not made by the officer in charge of the police district in which the Court is situated—a copy of the notice to such officer; and
 - (ii) where the objection is not made by the Registrar of Deputy Registrar—a copy to the Registrar.

Full Name of Applicant or in the Case of a Firm or Corporation, of the Nominee.	Place of Abode of Applicant or Nominee.	Name of Firm or Corporation.	Address for Registration.	Type of Licence.	Date of Hearing of Application.
---	---	------------------------------	---------------------------	------------------	---------------------------------

MAGISTRATES' COURT, GEELONG.

Williams, Kerry	280 Colac Road, Belmont	Mobile Surveillance Services of Geelong	22 James Street, Geelong	Watchman ..	3.1.75
-----------------------	-------------------------	---	--------------------------	-------------	--------

Dated at Geelong this 17th day of December, 1974.

J. REILLY, Clerk of the Magistrates' Court.

MAGISTRATES' COURT, FOOTSCRAY.

Irwin, Michael Thomas	7 Ester Street, Melton	4 Cross Street, Footscray	Watchman ..	16.1.75
Cox, Frederick	30 McNamara Street, West Preston	" " "	" ..	"
Goldsmith, Barry Anthony	272 Edgars Road, Lalor	" " "	" ..	"

Dated at Footscray this 17th day of December, 1974.

R. BOURKE, Clerk of the Magistrates' Court.

MAGISTRATES' COURT, MELBOURNE.

Turner, John Maxwell	149 Rattray Road East, Montmorency	Wormald International Security	340 Abbotsford Street, North Melbourne	Watchman ..	22.1.75
----------------------------	------------------------------------	--------------------------------	--	-------------	---------

Dated at Melbourne this 13th day of December, 1974.

G. L. WEBSTER, Clerk of the Magistrates' Court.

MAGISTRATES' COURT, BALLARAT.

Thomas, Douglas Gordon	Flat 1, 2 Edlyn Street, Wendouree	Charles Brian Cape-well	17 Walker Street, Doncaster	Commercial Sub-Agent	17.1.75
------------------------------	-----------------------------------	-------------------------	-----------------------------	----------------------	---------

Dated at Ballarat this 12th day of December, 1974.

D. CROFT, Clerk of the Magistrates' Court.

MAGISTRATES' COURT, OAKLEIGH.

Limbrick, Ronald Albert	13 Tular Avenue, South Oakleigh	Mayne Nickless Ltd.	72-74 Atkinson Street, Oakleigh	Provisional Watchman	10.1.75
Mitchell, David	3 Marie Court, Oakleigh	Quebec Co-ordinated Couriers	3 Marie Court, Oakleigh	Guard Agent ..	24.12.74

Dated at Oakleigh this 16th day of December, 1974.

B. R. JENNINGS, Clerk of the Magistrates' Court.

MAGISTRATES' COURT, SOUTH MELBOURNE.

O'Donnell, John Edward	15 Edward Street, Deer Park	94 York Street, South Melbourne	Watchman ..	22.1.75
------------------------------	-----------------------------	---------	---------------------------------	-------------	---------

Dated at South Melbourne this 16th day of December, 1974.

P. M. COUTTS, Clerk of the Magistrates' Court.

MAGISTRATES' COURT, MALVERN.

Haley, Gary James	3/35 Maitland Street, Glen Iris	3/35 Maitland Street, Glen Iris	Guard Agent ..	20.1.75
-------------------------	---------------------------------	---------	---------------------------------	----------------	---------

Dated at Malvern this 18th day of December, 1974.

P. J. RODDA, Clerk of the Magistrates' Court.

MAGISTRATES' COURT, FRANKSTON.

Moore, Bradley Phillip	3 Shirley Avenue, Seaford	1 White Street, Frankston	Process Server ..	16.1.75
------------------------------	---------------------------	---------	---------------------------	-------------------	---------

Dated at Frankston this 18th day of December, 1974.

J. BOUNDY, Clerk of the Magistrates' Court.

MAGISTRATES' COURT, BROADMEADOWS.

McMurray, Vincent Joseph	157 Cuthbert Street, Broadmeadows	McMurrays Security Service	157 Cuthbert Street, Broadmeadows	Guard Agent Corporation	10.1.75
" " "	" " "	" " "	" " "	Guard Agent Individual	"
McMurray, Irene Mary	" " "	" " "	" " "	Guard Agent Individual	"

Dated at Broadmeadows this 18th day of December, 1974.

J. G. DENAHY, Clerk of the Magistrates' Court.

PRIVATE AGENTS—continued.

Full Name of Applicant or in the Case of a Firm or Corporation, of the Nominee.	Place of Abode of Applicant or Nominee.	Name of Firm or Corporation.	Address for Registration.	Type of Licence.	Date of Hearing of Application.
---	---	------------------------------	---------------------------	------------------	---------------------------------

MAGISTRATES' COURT, OAKLEIGH.

Phelan, Maxwell Denis ..	23 Avondale Grove, Mt. Waverley	Quebec Co-ordinated Couriers	23 Avondale Grove, Mt. Waverley	Guard Agent ..	24.12.74
--------------------------	---------------------------------	------------------------------	---------------------------------	----------------	----------

Dated at Oakleigh this 16th day of December, 1974.

A. J. JOHNSON, Clerk of the Magistrates' Court.

MAGISTRATES' COURT, BRIGHTON.

Whip, Paul Eric ..	Flat 1, 71 Martin Street, Gardenvale	Flat 1, 71 Martin Street, Gardenvale	Process Server ..	17.1.75
--------------------	--------------------------------------	-------	--------------------------------------	-------------------	---------

Dated at Brighton this 19th day of December, 1974.

R. BRUCKNER, Clerk of the Magistrates' Court.

MAGISTRATES' COURT, HAWTHORN.

Morrison, Kenneth ..	5 The Avenue, Oakleigh	Mayne Nickless Ltd.	769 Glenferrie Road, Hawthorn	Watchman ..	17.1.75
Letts, Ian Robert ..	80 Army Road, Boronia	" "	" "	" ..	27.1.75
Turner, Raymond Walter ..	28 Martin Street, Pascoe Vale	" "	" "	" ..	17.1.75
Flight, Brian Cyril ..	15 Adam Crescent, Montmorency	" "	" "	" ..	"
Wilkinson, George Proudlove ..	557 Elgar Road, Box Hill North	Security Watching Co. Pty. Ltd.	330 Auburn Road, Hawthorn	" ..	"
Emery, Graham Richard ..	7 Old Geelong Road, Laverton North	" "	" "	" ..	"
Gaulton, Walter Bryce ..	48 Fawkner Street, Essendon	" "	" "	" ..	"
Cartmell, Harold ..	482 North Road, Ormond	" "	" "	" ..	"

Dated at Hawthorn this 20th day of December, 1974.

J. GIDLEY, Clerk of the Magistrates' Court.

MAGISTRATES' COURT, FRANKSTON.

Treweek, Philip John ..	11 Senista Street, Frankston	Wormald International Security	340 Abbotsford Street, North Melbourne	Watchman ..	16.1.75
-------------------------	------------------------------	--------------------------------	--	-------------	---------

Dated at Frankston this 19th day of December, 1974.

J. BOUNDY, Clerk of the Magistrates' Court.

MAGISTRATES' COURT, PRESTON.

Millane, Anthony Michael ..	58 Whitelaw Street, Reservoir	58 Whitelaw Street, Reservoir	Process Server ..	21.1.75
" " " ..	" " " ..	" " " ..	" " " ..	Inquiry Agent ..	"
" " " ..	" " " ..	" " " ..	" " " ..	Guard Agent ..	"

Dated at Preston this 19th day of December, 1974.

M. J. QUIRK, Clerk of the Magistrates' Court.

MAGISTRATES' COURT, PORT MELBOURNE.

Boyd, Albert William ..	296 Spring Street, Springvale	Mayne Nickless Ltd.	538 Williamstown Road, Port Melbourne	Watchman ..	4.2.75
Allman, Leonard ..	18 Chestnut Road, Doveton	" "	" "	" ..	"
Powell, Robert James ..	Flat 1, 52 Raleigh Street, Prahran	" "	" "	" ..	"
Dalton, Michael John ..	54 Heywood Street, Ringwood	" "	" "	" ..	"

Dated at Port Melbourne this 19th day of December, 1974.

JOHN ARDLIE, Clerk of the Magistrates' Court.

MAGISTRATES' COURT, MELBOURNE.

Taylor, George Smart ..	Flat 4, 342 Bell Street, Heidelberg West	Brambles Limited	Brinks Cnr. Arden and Lothian Streets, North Melbourne	Watchman ..	5.2.75
-------------------------	--	------------------	--	-------------	--------

Dated at Melbourne this 19th day of December, 1974.

G. L. WEBSTER, Clerk of the Magistrates' Court.

MAGISTRATES' COURT, COBURG.

Daldy, Gordon Leslie ..	16 Woolart Street, Strathmore	94 York Street, South Melbourne	Watchman ..	16.1.75
-------------------------	-------------------------------	-------	---------------------------------	-------------	---------

Dated at Coburg this 18th day of December, 1974.

G. G. WILLIAMSON, Clerk of the Magistrates' Court.

MAGISTRATES' COURT, BOX HILL.

Ibbotson, Brooke Robert ..	17 Narallah Grove, Box Hill	Mayne Nickless Ltd.	203 Elgar Road, Box Hill	Watchman ..	28.1.75
Bates, Paul Maxwell ..	81 Bowen Road, East Doncaster	81 Bowen Road, East Doncaster	Process Server ..	24.1.75

Dated at Box Hill this 23rd day of December, 1974.

P. C. CLOTHIER, Clerk of the Magistrates' Court.

PRIVATE AGENTS—*continued.*

Full Name of Applicant or in the Case of a Firm or Corporation, of the Nominee.	Place of Abode of Applicant or Nominee.	Name of Firm or Corporation.	Address for Registration.	Type of Licence.	Date of Hearing of Application.
MAGISTRATES' COURT, FOOTSCRAY.					
Bottegaro, Stefano	11 Phillip Road, East Keilor	654 Footscray Road, West Melbourne	Watchman ..	23.1.75
Ellis, Colin	11 Richard Road, Melton South	" "	" ..	"
Dated at Footscray this 30th day of December, 1974.					
P. W. WESTMORE, Clerk of the Magistrates' Court.					
MAGISTRATES' COURT, CAMBERWELL.					
Ashman, Albert William ..	6 Marcia Court, Glen Waverley	27 Morton Road, Burwood	Process Server ..	22.1.75
Dated at Camberwell this 30th day of December, 1974.					
J. C. TOBIN, Clerk of the Magistrates' Court.					
MAGISTRATES' COURT, FITZROY.					
Smith, J. F.	13 Lefevre Street, Sandringham	Crothall Holdings Limited	75 Victoria Parade, Fitzroy	Guard Agent ..	10.1.75
Dated at Fitzroy this 24th day of December, 1974.					
P. D. STREET, Clerk of the Magistrates' Court.					
MAGISTRATES' COURT, SUNBURY.					
Grant, Audrey Elizabeth ..	26A Goode Street, Gisborne	Gisborne Investigation Services	26A Goode Street, Gisborne	Process Server ..	10.1.75
Dated at Sunbury this 20th day of December, 1974.					
A. R. DUNLOP, Clerk of the Magistrates' Court.					
MAGISTRATES' COURT, BENDIGO.					
Byrne, Ivan	31 Caledonia Street, Bendigo	28 Tristania Street, East Doncaster	Commercial Sub-Agent	15.1.75
Dated at Bendigo this 23rd day of December, 1974.					
R. N. HOLLIS, Clerk of the Magistrates' Court.					
MAGISTRATES' COURT, SPRINGVALE.					
Sargent, Robert John ..	3 Worthing Court, Mulgrave	21 Clark Road, Springvale	Watchman ..	21.1.75
Dated at Springvale this 30th day of December, 1974.					
J. B. DENNIS, Clerk of the Magistrates' Court.					

Town and Country Planning Act 1961.
SHIRE OF SOUTH GIPPSLAND PLANNING SCHEME.
AMENDMENT No. 12, 1974.
Notice of Amendment.

In pursuance of the powers conferred by sub-section 6 of section 32 of the *Town and Country Planning Act 1961*, the Governor in Council, on the 17th December, 1974, amended the Shire of South Gippsland Planning Scheme, to convert all lineal and areal dimensions from imperial to metric units.

A copy of the amendment may be inspected during office hours at the office of the Town and Country Planning Board, 235 Queen Street, Melbourne; at the office of the Council of the Shire of South Gippsland, at Foster, and when available at the Office of Titles, Melbourne; and at the Central Plan Office of the Department of Crown Lands and Survey, Melbourne.

W. H. CRAIG, Secretary,
Town and Country Planning Board.

Town and Country Planning Act 1961.
OCEAN ROAD PLANNING SCHEME 1955.
(SHIRE OF OTWAY.)
AMENDMENT No. 12, 1974.
Notice of Amendment.

In pursuance of the powers conferred by sub-section 6 of section 32 of the *Town and Country Planning Act 1961*, the Governor in Council, on the 17th December, 1974, amended the Ocean Road Planning Scheme 1955 (Shire of Otway) to convert all imperial measurements to metric.

A copy of the amendment may be inspected during office hours at the office of the Town and Country Planning Board, 235 Queen Street, Melbourne; at the office of the Council of the Shire of Otway, at Apollo Bay, and when available at the Office of Titles, Melbourne; and at the Central Plan Office of the Department of Crown Lands and Survey, Melbourne.

W. H. CRAIG, Secretary,
Town and Country Planning Board.

Town and Country Planning Act 1961.
SHIRE OF LILLYDALE PLANNING SCHEME.
AMENDMENT No. 52.
Notice of Amendment.

In pursuance of the powers conferred by sub-section 6 of section 32 of the *Town and Country Planning Act 1961*, the Governor in Council, on the 17th December, 1974, amended the Shire of Lillydale Planning Scheme to alter the ordinance provisions relating to service stations within the Residential 'G' Zone.

A copy of the amendment may be inspected during office hours at the office of the Town and Country Planning Board, 235 Queen Street, Melbourne; at the office of the Council of the Shire of Lillydale, at Lillydale, and when available at the Office of Titles, Melbourne; and at the Central Plan Office of the Department of Crown Lands and Survey, Melbourne.

W. H. CRAIG, Secretary,
Town and Country Planning Board.

Town and Country Planning Act 1961.
SHIRE OF GOULBURN PLANNING SCHEME.
INTERIM DEVELOPMENT ORDER.
AMENDMENT NO. 2A.
Notice of Amendment.

In pursuance of the powers conferred by section 26 of the *Town and Country Planning Act 1961*, the Governor in Council on the 17th December, 1974, amended the Shire of Goulburn Planning Scheme Interim Development Order to correct an error in Amendment No. 2 to allow the subdivision of certificate of title, volume 6593, folio 556, in the Rural 'B' Zone, into two allotments.

A copy of the amendment may be inspected during office hours at the office of the Town and Country Planning Board, 235 Queen Street, Melbourne; at the office of the Council of the Shire of Goulburn, at Nagambie.

W. H. CRAIG, Secretary,
Town and Country Planning Board.

Town and Country Planning Act 1961.
SHIRE OF WERRIBEE PLANNING SCHEME 1963.
AMENDMENT No. 13, 1971.

Notice of Approval.

In pursuance of the powers conferred by the *Town and Country Planning Act 1961*, the Governor in Council on the 17th December, 1974, approved a Planning Scheme entitled the Shire of Werribee Planning Scheme 1963, Amendment No. 13, 1971, in respect of part of the municipal district of the Shire of Werribee and such Planning Scheme comes into operation on the date this notice of approval is published in the *Government Gazette*.

A copy of the Planning Scheme as approved may be inspected free of charge during office hours at the office of the Town and Country Planning Board, 235 Queen Street, Melbourne; at the office of the Council of the Shire of Werribee, at Werribee, and when available, at the Office of Titles, Melbourne; and at the Central Plan Office of the Department of Crown Lands and Survey, Melbourne.

W. H. CRAIG, Secretary,
Town and Country Planning Board.

Town and Country Planning Act 1961.
SEYMOUR PLANNING SCHEME.
AMENDMENT No. 12, 1974.

Notice of Approval.

In pursuance of the powers conferred by the *Town and Country Planning Act 1961*, the Governor in Council on the 17th December, 1974, approved a Planning Scheme entitled the Seymour Planning Scheme, Amendment No. 12, 1974, in respect of the municipal district of the Shire of Seymour and such Planning Scheme comes into operation on the date this notice of approval is published in the *Government Gazette*.

A copy of the Planning Scheme as approved may be inspected free of charge during office hours at the office of the Town and Country Planning Board, 235 Queen Street, Melbourne; at the office of the Council of the Shire of Seymour, at Seymour, and when available, at the Office of Titles, Melbourne; and at the Central Plan Office of the Department of Crown Lands and Survey, Melbourne.

W. H. CRAIG, Secretary,
Town and Country Planning Board.

Town and Country Planning Act 1961.
SHIRE OF MORNINGTON PLANNING SCHEME 1959.
AMENDMENT No. 92, 1973.

Notice of Approval.

In pursuance of the powers conferred by the *Town and Country Planning Act 1961*, the Governor in Council on the 17th December, 1974, approved a Planning Scheme entitled the Shire of Mornington Planning Scheme 1959, Amendment No. 92, 1973, in respect of part of the municipal district of the Shire of Mornington and such Planning Scheme comes into operation on the date this notice of approval is published in the *Government Gazette*.

A copy of the Planning Scheme as approved may be inspected free of charge during office hours at the office of the Town and Country Planning Board, 235 Queen Street, Melbourne; at the office of the Council of the Shire of Mornington, at Mornington, and when available, at the Office of Titles, Melbourne; and at the Central Plan Office of the Department of Crown Lands and Survey, Melbourne.

W. H. CRAIG, Secretary,
Town and Country Planning Board.

Town and Country Planning Act 1961.
MAFFRA PLANNING SCHEME 1965.
AMENDMENT No. 6, 1973.

Notice of Approval.

In pursuance of the powers conferred by the *Town and Country Planning Act 1961*, the Governor in Council on the 17th December, 1974, approved a Planning Scheme entitled the Maffra Planning Scheme 1965, Amendment No. 6, 1973, in respect of part of the municipal district of the Shire of Maffra and such Planning Scheme comes into operation on the date this notice of approval is published in the *Government Gazette*.

A copy of the Planning Scheme as approved may be inspected free of charge during office hours at the office of the Town and Country Planning Board, 235 Queen Street, Melbourne; at the office of the Council of the Shire of Maffra, at Maffra, and when available, at the Office of Titles, Melbourne; and at the Central Plan Office of the Department of Crown Lands and Survey, Melbourne.

W. H. CRAIG, Secretary,
Town and Country Planning Board.

Town and Country Planning Act 1961.
TOWN OF KYABRAM PLANNING SCHEME 1963.
AMENDMENT No. 11, 1974.

Notice of Approval.

In pursuance of the powers conferred by the *Town and Country Planning Act 1961*, the Governor in Council on the 17th December, 1974, approved a Planning Scheme entitled the Town of Kyabram Planning Scheme 1963, Amendment No. 11, 1974, in respect of part of the municipal district of the Town of Kyabram and such Planning Scheme comes into operation on the date this notice of approval is published in the *Government Gazette*.

A copy of the Planning Scheme as approved may be inspected free of charge during office hours at the office of the Town and Country Planning Board, 235 Queen Street, Melbourne; at the office of the Council of the Town of Kyabram, at Kyabram, and when available, at the Office of Titles, Melbourne; and at the Central Plan Office of the Department of Crown Lands and Survey, Melbourne.

W. H. CRAIG, Secretary,
Town and Country Planning Board.

Town and Country Planning Act 1961.
SHIRE OF LILLYDALE PLANNING SCHEME.
REVOCATION No. 20.

Notice of Revocation.

In pursuance of the provisions of section 32 of the *Town and Country Planning Act 1961*, the Governor in Council on the 17th December, 1974, made an Order:—

- (i) revoking the Shire of Lillydale Planning Scheme in so far as it applies to part of Crown allotment 102, section 17, Parish of Monbulk in Glenview Road, Monbulk;
- (ii) providing that the said land may be used for the purposes of a Boy Scouts Camp or those uses permitted in the Rural Zone of the Shire of Lillydale Planning Scheme only and such use shall be subject to the grant of a permit by the Lillydale Shire Council and to any conditions it may include in a permit.

A copy of the Order may be inspected during office hours at the office of the Town and Country Planning Board, 235 Queen Street, Melbourne, and at the office of the Council of the Shire of Lillydale, at Lillydale.

W. H. CRAIG, Secretary,
Town and Country Planning Board.

Town and Country Planning Act 1961.
SHIRE OF WERRIBEE PLANNING SCHEME 1963.
REVOCATION No. 3.

Notice of Revocation.

In pursuance of the provisions of section 32 of the *Town and Country Planning Act 1961*, the Governor in Council on the 17th December, 1974, made an Order:—

- (i) revoking the Shire of Werribee Planning Scheme 1963 in so far as it applies to approximately 4.05 ha of land being lot 1 on lodged plan 68806 in the Parish of Cocoroc; and
- (ii) providing that—
 - (a) the land may be used or developed:
 - (i) for any use or development permitted in the Agricultural Zone; and
 - (ii) during the continuance of the business at present conducted upon the land, for the purpose of sales and repairs of motor trucks and trailers and purposes directly ancillary thereto; and
 - (b) any such use shall be permitted only subject to the grant of a permit by the Council of the Shire of Werribee and to any conditions it may include in a permit.

A copy of the Order may be inspected during office hours at the office of the Town and Country Planning Board, 235 Queen Street, Melbourne, and at the office of the Council of the Shire of Werribee, at Werribee.

W. H. CRAIG, Secretary,
Town and Country Planning Board.

Town and Country Planning Act 1961.
EILDON RESERVOIR PLANNING SCHEME 1959.

(SHIRE OF MANSFIELD.)
AMENDMENT No. 13, 1974.
Notice of Amendment.

In pursuance of the powers conferred by sub-section 6 of section 32 of the *Town and Country Planning Act 1961*, the Governor in Council, on the 20th December, 1974, amended the Eildon Reservoir Planning Scheme 1959 (Shire of Mansfield) to amend the provisions of the Rural and Rural Forest Zones in order to give Council control of subdivision, use and development of land which does not presently require a permit.

A copy of the amendment may be inspected during office hours at the office of the Town and Country Planning Board, 235 Queen Street, Melbourne; at the office of the Council of the Shire of Mansfield at Mansfield, and when available at the Office of Titles, Melbourne; and at the Central Plan Office of the Department of Crown Lands and Survey, Melbourne.

W. H. CRAIG, Secretary,
Town and Country Planning Board.

Town and Country Planning Act 1961.
SEYMOUR PLANNING SCHEME.

AMENDMENT No. 8.
Notice of Approval.

In pursuance of the powers conferred by the *Town and Country Planning Act 1961*, the Governor in Council on the 20th December, 1974, approved a Planning Scheme entitled the Seymour Planning Scheme, Amendment No. 8 in respect of part of the municipal district of the Shire of Seymour and such Planning Scheme comes into operation on the date this Notice of Approval is published in the *Government Gazette*.

A copy of the Planning Scheme as approved may be inspected, free of charge, during office hours at the office of the Town and Country Planning Board, 235 Queen Street, Melbourne; at the office of the Council of the Shire of Seymour at Seymour and when available, at the Office of Titles, Melbourne, and at the Central Plan Office of the Department of Crown Lands and Survey, Melbourne.

W. H. CRAIG, Secretary,
Town and Country Planning Board.

Town and Country Planning Act 1961.
GEELONG PLANNING SCHEME 1959.

(SHIRE OF CORIO.)
AMENDMENT No. 18, 1974.
Notice of Approval.

In pursuance of the powers conferred by the *Town and Country Planning Act 1961*, the Governor in Council on the 20th December, 1974, approved a Planning Scheme entitled the Geelong Planning Scheme 1959 Amendment No. 18, 1974 (Shire of Corio), in respect of part of the municipal district of the Shire of Corio and such Planning Scheme comes into operation on the date this Notice of Approval is published in the *Government Gazette*.

A copy of the Planning Scheme as approved may be inspected, free of charge, during office hours at the office of the Town and Country Planning Board, 235 Queen Street, Melbourne; at the office of the Council of the Shire of Corio at North Geelong and when available, at the Office of Titles, Melbourne, and at the Central Plan Office of the Department of Crown Lands and Survey, Melbourne.

W. H. CRAIG, Secretary,
Town and Country Planning Board.

Town and Country Planning Act 1961.
CITY OF BENDIGO PLANNING SCHEME 1962.
AMENDMENT No. 12, 1973, PART 1.

Notice of Approval.

In pursuance of the powers conferred by the *Town and Country Planning Act 1961*, the Governor in Council on the 20th December, 1974, approved a Planning Scheme entitled the City of Bendigo Planning Scheme 1962, Amendment No. 12, 1973, Part 1, in respect of part of the municipal district of the City of Bendigo and such Planning Scheme comes into operation on the date this Notice of Approval is published in the *Government Gazette*.

A copy of the Planning Scheme as approved may be inspected, free of charge, during office hours at the office of the Town and Country Planning Board, 235 Queen Street,

Melbourne; at the office of the Council of the City of Bendigo at Bendigo and when available, at the office of Titles, Melbourne, and at the Central Plan Office of the Department of Crown Lands and Survey, Melbourne.

W. H. CRAIG, Secretary,
Town and Country Planning Board.

Town and Country Planning Act 1961.
CITY OF KEILOR PLANNING SCHEME.
INTERIM DEVELOPMENT ORDER.

Notice of Approval.

In pursuance of the powers conferred by the *Town and Country Planning Act 1961*, the Governor in Council on the 20th day of December, 1974, approved the making of an Interim Development Order by the Keilor City Council for part of the municipal district of the City of Keilor.

The Interim Development Order provides that the use, subdivision or development of any land within the area described or the erection, construction or carrying out of any buildings, roads or other works thereon is prohibited except in accordance with the provisions of the Order.

A copy of the Interim Development Order and a map showing the area affected may be inspected, free of charge, at the office of the Council of the City of Keilor at Keilor, and at the office of the Town and Country Planning Board, 235 Queen Street, Melbourne.

W. H. CRAIG, Secretary,
Town and Country Planning Board.

Town and Country Planning Act 1961.
CITY OF HORSHAM PLANNING SCHEME,
REVOCATION No. 1.

Notice of Revocation.

In pursuance of the provisions of section 32 of the *Town and Country Planning Act 1961*, the Governor in Council on the 17th December, 1974, made an Order:—

- (i) revoking the City of Horsham Planning Scheme in so far as it applies to land being lot 15 on lodged plan 9738 in the Town and Parish of Horsham; and
- (ii) providing that—

- (a) the land may be used or developed:
 - (i) for any use or development permitted in the Residential 'A' Zone; and
 - (ii) for the purpose of housing of buses for the school bus service; and
- (b) any such use shall be permitted only subject to the grant of a permit by the Council of the City of Horsham and to any conditions it may include in a permit.

A copy of the Order may be inspected during office hours at the office of the Town and Country Planning Board, 235 Queen Street, Melbourne, and at the office of the Council of the City of Horsham, at Horsham.

W. H. CRAIG, Secretary,
Town and Country Planning Board.

Town and Country Planning Act 1961.
GEELONG PLANNING SCHEME 1959.

(CITY OF GEELONG WEST.)
AMENDMENT No. 12, 1973.

Notice of Approval.

In pursuance of the powers conferred by the *Town and Country Planning Act 1961*, the Governor in Council on the 17th December, 1974, approved a Planning Scheme entitled the Geelong Planning Scheme 1959, Amendment No. 12, 1973 (City of Geelong West), in respect of the municipal district of the City of Geelong West and such Planning Scheme comes into operation on the date this notice of approval is published in the *Government Gazette*.

A copy of the Planning Scheme as approved may be inspected free of charge during office hours at the office of the Town and Country Planning Board, 235 Queen Street, Melbourne; at the office of the Council of the City of Geelong West, at Geelong West, and when available, at the Office of Titles, Melbourne; and at the Central Plan Office of the Department of Crown Lands and Survey, Melbourne.

W. H. CRAIG, Secretary,
Town and Country Planning Board.

Town and Country Planning Act 1961.
CITY OF BENALLA PLANNING SCHEME.
NOTICE OF APPROVAL.

In pursuance of the powers conferred by the *Town and Country Planning Act 1961*, the Governor in Council on the 24th December, 1974, approved a planning scheme entitled the City of Benalla Planning Scheme, in respect of the municipal district of the City of Benalla and such planning scheme comes into operation on the date this notice of approval is published in the *Government Gazette*.

A copy of the planning scheme as approved may be inspected free of charge during office hours at the office of the Town and Country Planning Board, 235 Queen Street, Melbourne; at the office of the Council of the City of Benalla at Benalla, and when available, at the Office of Titles, Melbourne, and at the Central Plan Office of the Department of Crown Lands and Survey, Melbourne.

W. H. CRAIG, Secretary,
Town and Country Planning Board.

Town and Country Planning Act 1961.
CITY OF KNOX PLANNING SCHEME 1965.
AMENDMENT No. 132, 1974.

Notice of Approval.

In pursuance of the powers conferred by the *Town and Country Planning Act 1961*, the Governor in Council on the 17th December, 1974, approved a Planning Scheme entitled the City of Knox Planning Scheme 1965, Amendment No. 132, 1974, in respect of the municipal district of the City of Knox and such Planning Scheme comes into operation on the date this notice of approval is published in the *Government Gazette*.

A copy of the Planning Scheme as approved may be inspected free of charge during office hours at the office of the Town and Country Planning Board, 235 Queen Street, Melbourne; at the office of the Council of the City of Knox, at Knoxfield, and when available, at the Office of Titles, Melbourne; and at the Central Plan Office of the Department of Crown Lands and Survey, Melbourne.

W. H. CRAIG, Secretary,
Town and Country Planning Board.

Town and Country Planning Act 1961.
GEELONG PLANNING SCHEME 1959.
(SHIRE OF BARRABOOL.)

AMENDMENT No. 9, 1974.

Notice of Approval.

In pursuance of the powers conferred by the *Town and Country Planning Act 1961*, the Governor in Council on the 17th December, 1974, approved a Planning Scheme entitled the Geelong Planning Scheme 1959, Amendment No. 9, 1974 (Shire of Barrabool), in respect of part of the municipal district of the Shire of Barrabool and such Planning Scheme comes into operation on the date this notice of approval is published in the *Government Gazette*.

A copy of the Planning Scheme as approved may be inspected free of charge during office hours at the office of the Town and Country Planning Board, 235 Queen Street, Melbourne; at the office of the Council of the Shire of Barrabool, at Geelong, and when available, at the Office of Titles, Melbourne; and at the Central Plan Office of the Department of Crown Lands and Survey, Melbourne.

W. H. CRAIG, Secretary,
Town and Country Planning Board.

Town and Country Planning Act 1961.
SHIRE OF CORIO (LARA) PLANNING SCHEME 1961.
AMENDMENT No. 9, 1973.

Notice of Approval.

In pursuance of the powers conferred by the *Town and Country Planning Act 1961*, the Governor in Council on the 17th December, 1974, approved a Planning Scheme entitled the Shire of Corio (Lara) Planning Scheme 1961, Amendment No. 9, 1973, in respect of part of the municipal district of the Shire of Corio and such Planning Scheme comes into operation on the date this notice of approval is published in the *Government Gazette*.

A copy of the Planning Scheme as approved may be inspected free of charge during office hours at the office of the Town and Country Planning Board, 235 Queen Street, Melbourne; at the office of the Council of the Shire of Corio, at North Geelong, and when available, at the Office of Titles, Melbourne; and at the Central Plan Office of the Department of Crown Lands and Survey, Melbourne.

W. H. CRAIG, Secretary,
Town and Country Planning Board.

Town and Country Planning Act 1961.
BALLAARAT AND DISTRICT PLANNING SCHEME 1966.
(CITY OF BALLAARAT.)
AMENDMENT No. 10, 1974.

Notice of Approval.

In pursuance of the powers conferred by the *Town and Country Planning Act 1961*, the Governor in Council on the 17th December, 1974, approved a Planning Scheme entitled the Ballaarat and District Planning Scheme 1966, Amendment No. 10, 1974 (City of Ballaarat), in respect of part of the municipal district of the City of Ballaarat and such Planning Scheme comes into operation on the date this notice of approval is published in the *Government Gazette*.

A copy of the Planning Scheme as approved may be inspected free of charge during office hours at the office of the Town and Country Planning Board, 235 Queen Street, Melbourne; at the office of the Council of the City of Ballaarat, at Ballaarat, and when available, at the Office of Titles, Melbourne, and at the Central Plan Office of the Department of Crown Lands and Survey, Melbourne.

W. H. CRAIG, Secretary,
Town and Country Planning Board.

Town and Country Planning Act 1961.
SHIRE OF DAYLESFORD AND GLENLYON PLANNING SCHEME.

INTERIM DEVELOPMENT ORDER.

Notice of Approval.

In pursuance of the powers conferred by the *Town and Country Planning Act 1961*, the Governor in Council on the 17th day of December, 1974, approved the making of an Interim Development Order by the Council of the Shire of Daylesford and Glenlyon for the municipal district of the Shire of Daylesford and Glenlyon.

The Interim Development Order provides that the use, subdivision or development of any land within the area described or the erection, construction or carrying out of any buildings, roads or other works thereon is prohibited except in accordance with the provisions of the Order.

A copy of the Interim Development Order and a map showing the area affected may be inspected free of charge at the office of the Council of the Shire of Daylesford and Glenlyon, at Daylesford, and at the office of the Town and Country Planning Board, 235 Queen Street, Melbourne.

W. H. CRAIG, Secretary,
Town and Country Planning Board.

Town and Country Planning Act 1961.
LORNE PLANNING SCHEME.

(SHIRE OF WINCHELSEA.)

INTERIM DEVELOPMENT ORDER.

Notice of Approval.

In pursuance of the powers conferred by the *Town and Country Planning Act 1961*, the Governor in Council on the 20th day of December, 1974, approved the making of an Interim Development Order by the Town and Country Planning Board for part of the municipal district of the Shire of Winchelsea.

The Interim Development Order provides that the use, subdivision or development of any land within the area described or the erection, construction or carrying out of any buildings, roads or other works thereon is prohibited except in accordance with the provisions of the Order.

A copy of the Interim Development Order and a map showing the area affected may be inspected, free of charge, at the office of the Shire of Winchelsea at Winchelsea, and at the office of the Town and Country Planning Board, 235 Queen Street, Melbourne.

W. H. CRAIG, Secretary,
Town and Country Planning Board.

Stamps Act 1958.

NOTICE UNDER SECTION 40A.

Pursuant to Section 40A of the *Stamps Act 1958*, I hereby declare Australian Society of Accountants of 49 Exhibition Street, Melbourne to be an authorized person in relation to bills of exchange payable on demand drawn out of Victoria and received for the credit of the company.

R. J. HAMER,
Treasurer.

The Treasury,
Melbourne, 17th December, 1974.

Stamps Act 1958.
ANNUAL LICENCE.

NOTIFICATION PURSUANT TO SECTION 97.

I hereby notify that stamp duty has been paid for a licence under section 96 of the Stamps Act to carry on assurance and insurance business in Victoria from 1st January, 1975, to 31st December, 1975, by the following:—
CHIYODA FIRE AND MARINE INSURANCE COMPANY LIMITED.

R. M. PHIBBS,
Comptroller of Stamps.

Stamp Duties Office,
Melbourne, 18th December, 1974.

Stamps Act 1958.
STAMPS (EXEMPTIONS) REGULATIONS 1971.

NOTICE.

Pursuant to the provisions of the Stamps (Exemptions) Regulations 1971, I hereby declare—

BOSTON FINANCIAL LIMITED
to be for the purpose of subdivision (13A) of Division 3 of Part II. of the Stamps Act 1958, a dealer in the unofficial short-term money market.

R. M. PHIBBS,
Comptroller of Stamps.

Stamp Duties Office,
Melbourne, 8th January, 1975.

Cemeteries Act 1958.
SCALE OF FEES OF THE WANGARATTA PUBLIC CEMETERY.

In pursuance of the powers conferred upon them by the Cemeteries Act the trustees of the Wangaratta Public Cemetery hereby make the following scale of fees, which shall come into operation upon publication in the *Government Gazette* and from and after such publication every scale of fees heretofore made by the said trustees shall be and is hereby rescinded to the extent to which it conflicts with this scale.

Scale of Fees and Charges.

8 ft. x 4 ft.—General Area	\$50.00
10 ft. x 4 ft.—Lawn Area	\$100.00
8 ft. x 4 ft.—(external measurement) Vault area	\$50.00
6 ft. x 4 ft.—Children's Lawn Area (including sinking)	\$40.00
6 ft. x 3 ft.—Children's Lawn Area (including sinking)	\$30.00
5 ft. x 3 ft.—Children's Lawn Area (including sinking)	\$20.00
2 ft. 6 in. x 2 ft.—Children's Lawn Area (including sinking)	\$15.00
Own selection of land—General Area	\$20.00

Land for Public Graves.

Interment in grave without exclusive right—stillborn child	\$10.00
Interment in grave without exclusive right—Others	\$50.00
Number peg or label	\$2.00

Sinking Charges for Private Graves.

Sinking grave 5½ feet deep	\$60.00
Sinking grave 7 feet deep	\$70.00
Each additional foot	\$10.00
Sinking oversize grave (extra)	\$10.00
Sinking oversize grave for American type casket (extra)	\$10.00
Cancellation of order to sink (if commenced)	\$10.00
Vault preparation and sealing	\$20.00

Reopening Charges.

Reopening grave (no cover)	\$60.00
Reopening grave (with cover)	\$70.00
Reopening grave (American type casket)	\$80.00

Extra Charges.

Interment in private grave without due notice	\$10.00
Late fee (per half-hour or part thereof in excess of the first fifteen minutes)	\$5.00
Interments on Saturday, Sundays or Public Holidays (extra)	\$25.00

Miscellaneous Charges.

Certificate of Right of Burial	\$2.00
Inspection of Plan or Register	\$2.00
Annual maintenance (single grave)	\$10.00
Permission to erect a headstone or monument—General area	\$10.00

Plus an additional \$5.00 if flower containers (2) are to be supplied by Trustees	
—Lawn area (including supply of two flower containers by Trustees)	\$10.00
Permission to construct a brick grave or to erect any stone, kerb, brick, tile work or concrete	\$10.00
Grave renovations or additional inscription	\$10.00
Exhuming the remains of a body (when authorized)	\$200.00
Interment of ashes in a private grave	\$10.00
Removal of slab at owner's risk	\$10.00
Vaults—including land, sinking charges and construction—as arranged with the Engineering Department of the Wangaratta City Council	
Searching records and providing written information	\$5.00

E. D. EVANS, Trustee.
B. M. MILSOM, Trustee.
W. J. FINDLAY, Trustee.
J. W. ELWARD, Secretary.

Approved by the Governor in Council, 17th December, 1974.—TOM FORRISTAL, Clerk of the Executive Council.

Cemeteries Act 1958.
SCALE OF FEES OF THE WILLIAMSTOWN PUBLIC CEMETERY (THE MEMORIAL PARK).

In pursuance of the powers conferred upon them by the Cemeteries Act the trustees of the Williamstown Public Cemetery (the Memorial Park) hereby make the following scale of fees, which shall come into operation upon publication in the *Government Gazette*, and from and after such publication every scale of fees heretofore made by the said trustees shall be and is hereby rescinded to the extent to which it conflicts with this scale.

Cremation.

Week Days—Normal Fee	\$ 85
Concession Rates—	
Australian Ex-Service Personnel (with overseas service)	} 80
Pensioner (Invalid, Old Age, Widow)	
E. S. LOFT, Trustee. H. M. WHITTAKER, Trustee. S. H. ROBINSON, Trustee. C. W. SIDWAY, Manager and Secretary.	

Approved by the Governor in Council, 17th December, 1974.—TOM FORRISTAL, Clerk of the Executive Council.

Cemeteries Act 1958.
SCALE OF FEES OF THE UPPER YARRA PUBLIC CEMETERY.

In pursuance of the powers conferred upon them by the Cemeteries Act the trustees of the Upper Yarra Public Cemetery hereby make the following scale of fees which shall come into operation upon publication in the *Government Gazette*, and from and after such publication every scale of fees heretofore made by the said trustees shall be and is hereby rescinded to the extent to which it conflicts with this scale.

Private Graves.

Land, 2.44 m x 1.22 m	\$25.00
Own selection of land	\$5.00

Sinking Charges for Private Graves.

	Ordinary.	Oversize.
Sinking Grave 1.6 m deep	\$30.00	\$40.00
Sinking Grave 2.2 m deep	\$36.00	\$48.00
Sinking Grave 2.8 m deep	\$46.00	\$60.00

Reopening Charges.

Permit Fee	\$5.00
Reopening grave to 1.6 m (no cover)	\$30.00
Reopening grave to 1.6 m (with cover)	\$40.00

Miscellaneous Charges.

Permission to erect a headstone or monument	\$10.00
Exhuming the remains of a body (when authorized)	\$50.00
Interment of ashes in a private grave	\$10.00

E. F. COLVERSON, Trustee.
DAVID WALKER, Trustee.
V. A. MELBOURNE, Trustee.
M. A. THOMAS, Trustee.

Approved by the Governor in Council, 17th December, 1974.—TOM FORRISTAL, Clerk of the Executive Council.

Cemeteries Act 1958.
REGULATIONS OF THE WANGARATTA PUBLIC CEMETERY.

In pursuance of the powers conferred upon them by the *Cemeteries Act 1958* the trustees of the Wangaratta Public Cemetery hereby amend the Wangaratta Public Cemetery Regulations approved by the Governor in Council on 22nd day of June, 1971 and published in the *Government Gazette* on 7th day of July, 1971 as follows:—

1. In Regulation 19 for the expression "seven days" there shall be substituted the expression "three days".

E. D. EVANS, Trustee.
 B. M. MILSOM, Trustee.
 W. J. FINDLAY, Trustee.
 J. W. ELWARD, Secretary.

Approved by the Governor in Council, 17th December, 1974.—TOM FORRISTAL, Clerk of the Executive Council.

ROAD DEVIATION ORDER.—SHIRE OF COLAC.

In pursuance of the powers conferred by sections 522 and 526 of the *Local Government Act 1958*, the Council of the Shire of Colac doth hereby direct that the land in the Parish of Warrion shown hatched on the plan hereunder, which has been taken and acquired by it, shall be a public highway from and after the date of publication of this Order in the *Government Gazette*, and doth declare that such land shall be a public highway in lieu of the land in the said Parish shown cross-hatched on the said plan.

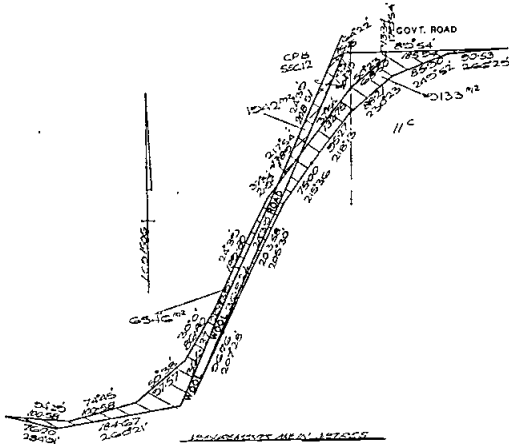

The corporate seal of the President, Councillors and Ratepayers of the Shire of Colac was hereto affixed this 18th day of November, 1974, in the presence of—

(SEAL) E. P. CARMODY, President.
 M. J. COBBLEDICK, Councillor.
 W. J. MAUNSELL, Secretary.

Confirmed by the Governor in Council, 24th December, 1974.—TOM FORRISTAL, Clerk of the Executive Council.

LOCAL GOVERNMENT DEPARTMENT.
ORDER CONFIRMED.—CITY OF SPRINGVALE.

The Minister of the Crown administering the *Local Government Act 1958*, on the 20th day of December, 1974 confirmed the Orders hereinafter referred to in pursuance of section 514 of the said Act namely:—

Two Orders of the Council of the City of Springvale made on the 7th October, 1974 directing the compulsory taking of the lands described hereunder for the purpose of the widening of an existing twelve foot road to provide access to a car parking area.

Firstly.—All that piece of land being part of the land described in Certificate of Title Volume 8407 Folio 960 commencing at a point being the north eastern corner of Lot 1 on Lodged Plan of Subdivision Number 47141 thence by lines bearing 180° 0' for six feet; 270° 0' for 4 feet 8½ inches; 290° 0' for 17 feet 6½ inches and 90° 0' for 21 feet 2½ inches to the point of commencement.

Secondly.—All that piece of land being part of the land described in Certificate of Title Volume 5038 Folio 409 commencing at a point being the south west corner of

the land described in the said Certificate of Title thence by lines bearing 360° 0' for 6 feet; 90° 0' for 72 feet; 110° 0' for 17 feet 6½ inches and 270° 0' for 158 feet 10 inches to the point of commencement.

A. J. HUNT,
 Minister for Local Government.

Local Government Department,
 Melbourne (74/8232).

ROAD DEVIATION ORDER.—SHIRE OF MORWELL.

Pursuant to the provisions of sections 522 and 526 of the *Local Government Act 1958* the Council of the Shire of Morwell hereby directs that the land in the Parish of Budgeree indicated by hatching on the diagram hereunder, which has been purchased taken or acquired by it, shall be a public highway on and from the date of publication of this order in the *Government Gazette* and declares that such land shall be a public highway in lieu of the land indicated by cross-hatching on the said diagram.

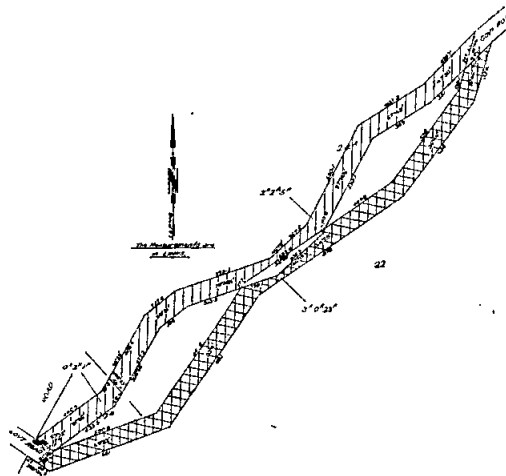

The common seal of the President, Councillors and Ratepayers of the Shire of Morwell was hereto affixed this 3rd day of June, 1965, in the presence of—

(SEAL) A. L. HARE, President.
 B. F. WALSH, Councillor.
 R. J. LORD, Secretary.

Confirmed by the Governor in Council, 24th December, 1974.—TOM FORRISTAL, Clerk of the Executive Council.

Milk Board Act 1958.
NOTICE PURSUANT TO SECTION 23 OF THE MILK BOARD ACT 1958.

After inquiry conducted pursuant to the provisions of the Milk Board Act, the Milk Board, by this notice, hereby further amends the notice published pursuant to section 23 of the said Act in the *Government Gazette* No. 104 of 6th December, 1972, as follows:—

To the amendment of the Second Schedule to the said notice as published in the *Government Gazette* No. 120 of 18th December, 1974, after the line reading "St. Kilda 2, 3, 8, 9 and 10", there shall be added the following:—

- "Brunswick 9 and 13.
- Collingwood 1, 2, 3, 4, 5, 6 and 7.
- Essendon 3, 5, 6, 7, 8, 9, 10, 11, 12 and 13.
- Fitzroy 1, 2, 3, 4, 5, 6 and 7.
- Melbourne, 1, 2A, 2B, 4, 5, 7, 8, 9, 10B, 14, 15A, 18 and 19.
- Northcote 6, 8, 9, 11.
- Richmond 1."

By order of the Milk Board.
 A. R. BEYNON,
 Secretary.

Health Act 1958.

VICTORIA—DEPARTMENT OF HEALTH.

NOTICE TO ATTEND FOR RADIOLOGICAL EXAMINATION.

To all persons aged twenty-one years and over enrolled or resident in the subdivisions specified hereunder in the State Electoral District of BALWYN.

Take notice that you are required to attend at a Department of Health X-ray Unit sited in the public street at or as near as possible to the main entrance to the premises specified in this notice, at any time between the hours specified on one of the days specified and during the period specified in respect of those premises, and thereat to submit yourself to radiological examination of the chest for the purpose of ascertaining whether you may be suffering from pulmonary tuberculosis. If you have had a Chest X-ray within the last twelve months and for this reason do not wish to be examined now, you should attend the unit as directed and submit particulars of the previous examination.

SPECIFIED SUBDIVISIONS, PREMISES, PERIOD, DAYS AND HOURS.

Subdivision.	Premises.	Period.	Days.	Hours.
Surrey Hills	W.E.B. Airconditioning, 2b Milne Road, Box Hill North	Tuesday, 28th January, 1975 to Friday, 31st January, 1975 (inclusive)	Each day during the period except Public Holidays	From 10 a.m. to 8.30 p.m.
	Squash Bowl Car Park, Dunloe Avenue, Mont Albert North	Tuesday, 28th January, 1975 to Friday, 31st January, 1975 (inclusive)	Each day during the period except Public Holidays	From 10 a.m. to 8.30 p.m.
	Parker's Pharmacy, 40 Hamilton Street, Mont Albert	Tuesday, 28th January, 1975 to Tuesday, 4th February, 1975 (inclusive)	Each day during the period except Saturday, Sunday and Public Holidays	From 10 a.m. to 8.30 p.m.
Greythorn	Black's Pharmacy, 283 Doncaster Road, Balwyn North	Monday, 3rd February, 1975 to Tuesday, 11th February, 1975 (inclusive)	Each day during the period except Saturday, Sunday and Public Holidays	From 10 a.m. to 8.30 p.m.
	Collins' Pharmacy, 400 Balwyn Road, Balwyn North	Monday, 3rd February, 1975 to Thursday, 6th February, 1975 (inclusive)	Each day during the period except Public Holidays	From 10 a.m. to 8.30 p.m.
	Golden Fleece Service Station, cnr. Belmore and Kalonga Roads, Balwyn	Wednesday, 5th February, 1975 to Monday, 10th February, 1975 (inclusive)	Each day during the period except Saturday, Sunday and Public Holidays	From 10 a.m. to 8.30 p.m.
Balwyn	Yooralla Fruit Market, 178 Belmore Road, Balwyn	Friday, 7th February, 1975 to Wednesday, 12th February, 1975 (inclusive)	Each day during the period except Saturday, Sunday and Public Holidays	From 10 a.m. to 8.30 p.m.
	Car Park, Heaths' Supermarket, cnr. Iramoo Street and Whitehorse Road, Balwyn	Tuesday, 11th February, 1975 to Monday, 17th February, 1975 (inclusive)	Each day during the period except Saturday, Sunday and Public Holidays	From 10 a.m. to 8.30 p.m.
	Car Park, cnr. Union and Whitehorse Roads, Balwyn	Thursday, 13th February, 1975 to Wednesday, February 19, 1975 (inclusive)	Each day during the period except Saturday, Sunday and Public Holidays	From 10 a.m. to 8.30 p.m.
Deepline	Tsaltas' Milk Bar, 8 Tivey Parade, Balwyn	Wednesday, 12th February, 1975 and Thursday, 13th February, 1975	Wednesday, 12th February, 1975 Thursday, 13th February, 1975	From 10 a.m. to 8.30 p.m. From 10 a.m. to 8.30 p.m.
	Caltex Service Station, cnr. Jersey Street and Whitehorse Road, Balwyn	Friday, 14th February, 1975 to Tuesday, 18th February, 1975 (inclusive)	Each day during the period except Saturday, Sunday and Public Holidays	From 10 a.m. to 8.30 p.m.
	1st Deepline Scout Hall, Whitehorse Road, Balwyn	Tuesday, 18th February, 1975 to Friday, 21st February, 1975 (inclusive)	Each day during the period except Public Holidays	From 10 a.m. to 8.30 p.m.
Surrey Hills West	Cnr. Croydon and Union Roads, Surrey Hills	Wednesday, 19th February, 1975 to Friday, 21st February, 1975 (inclusive)	Each day during the period except Public Holidays	From 10 a.m. to 8.30 p.m.
	Cnr. Rochester and Mont Albert Roads, Canterbury	Thursday, 20th February, 1975 Friday, 21st February, 1975	Thursday, 20th February, 1975 Friday, 21st February, 1975	From 10 a.m. to 8.30 p.m. From 10 a.m. to 8.30 p.m.

NOTE: Any person to whom this notice applies and who without reasonable excuse fails to comply with the requirements of the notice shall be guilty of an offence, and shall be liable to a penalty of not more than five hundred dollars.

Dated this Twelfth day of December, One thousand nine hundred and seventy-four.

W. J. STEVENSON, Chief Health Officer.

Social Welfare Act 1970.

POLICE GAOLS.

NOTICE.

Whereas it is provided in Part IV, Section 115 of the *Social Welfare Act 1970* that whenever it appears to the Director-General after consultation with the Chief Commissioner of Police to be necessary so to do the Director-General may recommend to the Minister that a lock-up is fit for the reception of prisoners sentenced to imprisonment for a term not exceeding the term the Director-General thinks fit and specifies in his recommendation:

And whereas it is further provided in the said Section that upon receiving any such recommendation the Minister may by notice published in the *Government Gazette* proclaim any police lock-up so recommended to be a "police gaol" for the reception of prisoners for any term up to the term specified but not exceeding in any case thirty days:

And whereas the Director-General, after consultation with the Chief Commissioner has recommended that the lock-ups specified in the Schedules to this Notice are fit for the reception of prisoners sentenced to imprisonment for terms not exceeding the terms of imprisonment specified hereunder in respect of each Schedule.

Now therefore, I the Minister for Social Welfare of the State of Victoria, in the Commonwealth of Australia, in pursuance of the powers conferred by the *Social Welfare Act 1970*, do by this Notice—

- (a) proclaim the lock-up referred to in the Second Schedule hereto to be a police gaol for the reception of prisoners sentenced to imprisonment for a term not exceeding two days; and
- (b) proclaim the lock-up referred to in the Third Schedule hereto to be a police gaol for the reception of prisoners sentenced to imprisonment for a term not exceeding three days;

SECOND SCHEDULE.

Police Lock-Up.	Police Station at which Police Lock-Up is Situated.	Location of Police Lock-Up on Police Station Premises.	Description of Police Lock-Up.	Crown Description.
Mooroolbark	Hull Road, Mooroolbark	Rear of Mooroolbark Police Station	Brick building 26' 6" x 20' 6" approx.	Parish of Mooroolbark, County of Evelyn, Crown Portion 12 V 2

THIRD SCHEDULE.

Police Lock-Up.	Police Station at which Police Lock-Up is Situated.	Location of Police Lock-Up on Police Station Premises.	Description of Police Lock-Up.	Crown Description.
Nunawading	Cnr. Maroondah Highway and Humphreys Avenue	Rear of ground floor of Nunawading Police Station	Brick building 82' x 82' approx.	Parish of Nunawading, County of Bourke, Part of Crown Portion 119

Social Welfare Department,
Melbourne, 23rd December, 1974.

VASEY HOUGHTON,
Minister for Social Welfare.

Social Welfare Act 1970.

POLICE GAOLS.

NOTICE.

Whereas it is provided in Part IV, section 115, of the *Social Welfare Act 1970* that whenever it appears to the Director-General after consultation with the Chief Commissioner of Police to be necessary so to do the Director-General may recommend to the Minister that a lock-up is fit for the reception of prisoners sentenced to imprisonment for a term not exceeding the term the Director-General thinks fit and specifies in his recommendation:

And whereas it is further provided in the said section that upon receiving any such recommendation the Minister may by notice published in the *Government Gazette* proclaim any police lock-up so recommended to be a "police gaol" for the reception of prisoners for any term up to the term specified but not exceeding in any case thirty days:

And whereas by a notice published in the *Government Gazette* of 21st January, 1970, certain police lock-ups were proclaimed to be police gaols for the reception of prisoners sentenced to imprisonment for a term not exceeding a specified period:

And whereas it is further provided in the said section 115 that the Minister may from time to time by notice in the *Government Gazette* revoke or vary any proclamation made under this section:

And whereas by notices published in the *Government Gazette* of 9th December, 1970; 23rd August, 1972; 1st August, 1973 and 13th February, 1974, the Minister did vary certain particulars of the afore-mentioned proclamation:

And whereas the Director-General after consultation with the Chief Commissioner has recommended that the aforementioned notice published in the *Government Gazette* of 21st January, 1970, and varied by the aforementioned notices published in the *Government Gazette* on 9th December, 1970; 23rd August, 1972; 1st August, 1973 and 13th February, 1974 be further varied:

Now therefore, I, the Minister for Social Welfare of the State of Victoria in the Commonwealth of Australia, in pursuance of the powers conferred by the *Social Welfare Act 1970*, do by this notice further vary the notice published in the *Government Gazette* on 21st January, 1970, and varied by the notices published in the *Government Gazette* on 9th December, 1970; 23rd August, 1972; 1st August, 1973 and 13th February, 1974 by—

1. In the First Schedule, in respect of the Police Lock-up at Axedale:
 - (a) Substituting the expression "Cnr. High and Mitchell Streets, Axedale" for the expression "William Street, Axedale";
 - (b) substituting the expression "Rear of Police Station Office (south side of building)" for the expression "South-east corner of Axedale Police Station residence";
 - (c) substituting the expression "Brick building 10' x 10' approx." for the expression "Wooden building 9'6" x 9'6" approx."; and
 - (d) substituting the expression "Township of Axedale, Parish of Axedale, County of Bendigo, Crown Allotment 1, Section 9" for the expression "Township of Axedale, Parish of Axedale, County of Bendigo, Crown Allotment 9, Section 12."
2. In the First Schedule, in respect of the Police Lock-up at Marysville:
 - (a) substituting the expression "Rear of Marysville Police Station" for the expression "South side of Marysville Police Station"; and
 - (b) substituting the expression "Brick building 10' x 10' approx." for the expression "Wooden building 10' x 10' approx."
3. In the First Schedule, in respect of the Police Lock-up at Rokewood:
 - (a) substituting the expression "Brick building 12' x 12' approx.", for the expression "Wooden building 10' x 10' approx."; and

- (b) substituting the expression "Township of Rokewood, Parish of Corindhap, County of Grenville, Crown Allotment 1b" for the expression "Township of Rokewood, Parish of Corindhap, County of Grenville, Section 8".
4. In the First Schedule, in respect of the Police Lock-up at Mitta Mitta:
- (a) substituting the expression "Brick building 10' x 10' approx." for the expression "Wooden building 9'9" x 9'9" approx."
5. In the Third Schedule, in respect of the Police Lock-up at Korumburra:
- (a) substituting the expression "East end of Korumburra Police Station" for the expression "Rear of Police Station Korumburra"; and
- (b) substituting the expression, "Brick building 30' x 17' approx." for the expression "Wooden building 10' x 10' approx."
6. In the Third Schedule in respect of the Police Lock-up at Maffra:
- (a) substituting the expression "Rear of Maffra Police Station" for the expression "North-east corner of Maffra Police Station"; and
- (b) substituting the expression "Brick building 18' x 17' approx." for the expression "wooden building 9' x 9' approx."
7. In the Third Schedule in respect of the Police Lock-up at Mortlake:
- (a) substituting the expression "South-west corner of Mortlake Police Station" for the expression "South-east corner of Mortlake Police Station rear of residence"; and
- (b) substituting the expression "Brick building 10' x 10' approx." for the expression "Wooden building 9' x 9' approx."

VASEY HOUGHTON,
Minister for Social Welfare.

Social Welfare Department,
Melbourne, 23rd December, 1974.

Co-operation Act 1958.

ASSUMPTION COLLEGE PARENTS & FRIENDS
CO-OPERATIVE SOCIETY LIMITED.

WAYBURNE PRE-SCHOOL CO-OPERATIVE LIMITED.

ST. LEONARDS COLLEGE CO-OPERATIVE SOCIETY
LIMITED.

NOTICE OF DISSOLUTION OF SOCIETIES.

Notice is hereby given that I have this day registered the dissolution of the above-named societies and cancelled their registration under the above-named Act.

Dated at Melbourne, this twenty-ninth day of November, 1974.

E. P. LIDDELL,
Deputy Registrar of Co-operative Societies.

Co-operation Act 1958.

CHANGE OF NAME OF A SOCIETY.

Notice is hereby given that MARYBOROUGH PARISH CO-OPERATIVE CREDIT SOCIETY LIMITED, which was incorporated as a Credit Society under the above-named Act, on the twenty-second day of November, 1961, has registered a change of its name and is now incorporated under the name of MARYBOROUGH SAVINGS AND CREDIT CO-OPERATIVE LIMITED under the said Act.

Dated at Melbourne, this thirteenth day of December, 1974.

E. P. LIDDELL,
Deputy Registrar of Co-operative Societies.

Co-operation Act 1958.

BURRAMINE IRRIGATORS CO-OPERATIVE SOCIETY
LIMITED.

Notice is hereby given in pursuance of section 78 (7) of the *Co-operation Act 1958* and section 308 (2) of the *Companies Act 1961* that, at the expiration of three months from the date hereof, the name of the aforementioned society will, unless cause is shown to the contrary, be struck off the register and the society will be dissolved.

Dated this thirteenth day of December, 1974.

E. P. LIDDELL,
Deputy Registrar.

Co-operation Act 1958.

NOTICE OF AMALGAMATION OF SOCIETIES.

Notice is hereby given that, pursuant to the provisions of the *Co-operation Act 1958*, Frankston Co-operative Credit Society Limited and Seaford-Pines Credit Union Co-operative Limited were amalgamated into one society under the name of Frankston District Savings Co-operative Credit Union Limited, on the 1st day of January, 1975.

Dated at Melbourne, this First day of January, 1975.

E. P. LIDDELL,
Acting Registrar of Co-operative Societies.

Co-operation Act 1958.

WATTLE PARK HIGH SCHOOL CO-OPERATIVE
LIMITED.

NOTICE OF DISSOLUTION OF SOCIETY.

Notice is hereby given that I have this day registered the dissolution of the abovenamed society and cancelled its registration under the abovenamed Act.

Dated at Melbourne this 18th day of December, 1974.

E. P. LIDDELL,
Deputy Registrar of Co-operative Societies.

Co-operation Act 1958.

BEAUMARIS SENIOR CITIZENS CO-OPERATIVE
LIMITED.

Notice is hereby given in pursuance of section 78 (7) of the *Co-operation Act 1958* and section 308 (2) of the *Companies Act 1961* that, at the expiration of three months from the date hereof, the name of the aforementioned society will, unless cause is shown to the contrary, be struck off the register and the society will be dissolved.

Dated this 15th day of December, 1974.

E. P. LIDDELL,
Deputy Registrar.

Co-operation Act 1958.

COLLINS CO-OPERATIVE BOOK SOCIETY LIMITED.

Notice is hereby given in pursuance of section 78 (7) of the *Co-operation Act 1958* and section 308 (2) of the *Companies Act 1961* that, at the expiration of three months from the date hereof, the name of the aforementioned society will, unless cause is shown to the contrary, be struck off the register and the society will be dissolved.

Dated this 19th day of December, 1974.

E. P. LIDDELL,
Deputy Registrar.

Co-operation Act 1958.

DROMANA PRIMARY SCHOOL CO-OPERATIVE
LIMITED.

Notice is hereby given in pursuance of section 78 (7) of the *Co-operation Act 1958* and section 308 (2) of the *Companies Act 1961* that, at the expiration of three months from the date hereof, the name of the aforementioned society will, unless cause is shown to the contrary, be struck off the register and the society will be dissolved.

Dated this 30th day of December, 1974.

E. P. LIDDELL,
Deputy Registrar of Co-operative Societies.

Co-operation Act 1958.

MOUNT EVELYN PRIMARY SCHOOL CO-OPERATIVE
LIMITED.

Notice is hereby given in pursuance of section 78 (7) of the *Co-operation Act 1958* and section 308 (2) of the *Companies Act 1961* that, at the expiration of three months from the date hereof, the name of the aforementioned society will, unless cause is shown to the contrary, be struck off the register and the society will be dissolved.

Dated this 19th day of December, 1974.

E. P. LIDDELL,
Deputy Registrar.

Co-operation Act 1958.

BENTLEIGH HIGH SCHOOL CO-OPERATIVE LIMITED.

NOTICE OF DISSOLUTION OF SOCIETY.

Notice is hereby given that I have this day registered the dissolution of the above-named society and cancelled its registration under the above-named Act.

Dated at Melbourne, this eleventh day of December, 1974.

E. P. LIDDELL,
Deputy Registrar of Co-operative Societies.

**Farm Produce Merchants and Commission Agents Act 1965
(No. 7274).**

**LIST OF NAMES AND ADDRESSES OF LICENCE
HOLDERS TO WHOM LICENCES HAVE BEEN
ISSUED DURING NOVEMBER, 1974.**

In accordance with the above Act, those issued with a Merchant's or Commission Agent's Licence have paid the prescribed fee to the Farm Produce Merchants and Commission Agents Guarantee Fund. All licences, unless earlier cancelled, shall continue in force until 30th June, 1975.

D. S. WISHART,
Director of Agriculture.

MERCHANTS.

Name; Principal Place of Business.

Borgia Brothers; Lonsdale Street, South Geelong, 3220.
Norstar Provedores; 335 Punt Road, Richmond, 3121.
Purdey, Frank; 9 Gillies Street, Rochester, 3561.
Zurcas Coolstore and Packing Company Pty. Ltd.; Benalla Road, Shepparton, 3630.

COMMISSION AGENT.

Arharidis, George; Melbourne Wholesale Fruit and Vegetable Market, Footscray Road, Footscray, 3011.

SECONDARY WHOLESALER.

Fairsave—A Division of Cohn's Industries Pty. Ltd.; Benalla Road, Shepparton, 3630.

Swine Compensation Act 1967 (No. 7614).

NOTICE UNDER SECTION 14.

APPROVED AGENT.

No. C.S.—12.

I hereby revoke the declaration made and published in the *Government Gazette* No. 102 of 4th December, 1968, of G. C. Norton & Co. Pty. Ltd., as an "approved agent" for the purposes of Part II. of the *Swine Compensation Act 1967*, with effect from 9th December, 1974.

Pursuant to the provisions of Regulation 81 of the *Stamps Regulations 1960*, I hereby state that the aforesaid revocation is being made at the request of the said G. C. Norton & Co. Pty. Ltd.

R. M. PHIBBS,
Comptroller of Stamps.

Stamp Duties Office,
Melbourne, 18th December, 1974.

Cattle Compensation Act 1967 (No. 7615).

NOTICE UNDER SECTION 14.

APPROVED AGENT.

No. C.S.—12.

I hereby revoke the declaration made and published in the *Government Gazette* No. 102 of 4th December, 1968, of G. C. Norton & Co. Pty. Ltd., as an "approved agent" for the purposes of Part II. of the *Cattle Compensation Act 1967*, with effect from 9th December, 1974.

Pursuant to the provisions of Regulation 81 of the *Stamps Regulations 1960*, I hereby state that the aforesaid revocation is being made at the request of the said G. C. Norton & Co. Pty. Ltd.

R. M. PHIBBS,
Comptroller of Stamps.

Stamp Duties Office,
Melbourne, 18th December, 1974.

RECREATION VEHICLES ACT 1973, SECTION 12 (3).

Notice is hereby given that, for the purpose of section 12 (3) of the *Recreation Vehicles Act 1973*, approval has been granted to the association listed below to organize and conduct official motor vehicle races in which recreation vehicles participate.

WAVERLEY MINI/MOTOR CYCLE CLUB.

R. JACKSON,
Chief Commissioner of Police.

Pounds Act 1958.

THIRD SCHEDULE

Table of Rates to be charged for the trespass of Cattle, their conveyance to the Pound where motor transport is used, and their sustenance while impounded, fixed by the Council of the City of Ringwood.

A. For Trespass.

Description of Cattle Trespassing.	Upon Tillage Land Enclosed by a Substantial Fence.	Upon Land other than Tillage Land Enclosed by a Substantial Fence.
	\$ c	\$ c
For every sheep	0.60	0.02
For every goat	4.00	1.00
For every pig	8.00	1.00
For every head of other cattle	20.00	1.00

	\$ c
In addition for the trespass of any entire horse	20.00
In addition for the trespass of any bull	20.00
In addition for the trespass of any ram	20.00

B. For Transport.

Description of Cattle.	Amount.
	\$ c
For every sheep	0.50
For any entire horse any bull or any ram	8.00
For every head of other cattle	4.00

C. For Sustenance.

Description of Cattle.	Amounts to be charged Daily for Sustenance While Impounded.
	\$ c
For every sheep	1.00
For every goat	2.00
For every pig	2.00
For every head of other cattle	2.00

By Order of the Council,
A. W. HALL,
Town Clerk.

Approved by the Governor in Council, 24th December, 1974.
—TOM FORRISTAL, Clerk of the Executive Council.

PUBLIC TRUSTEE ACT 1958 (No. 6350), SECTION 17.

I hereby give notice that on the 6th December, 1974, the Public Trustee filed elections to administer the following deceased persons' estates in accordance with section 17 of the *Public Trustee Act 1958*.

COOPER, GERTRUDE MAY, late of Queen Elizabeth Home, Ballarat, spinster, died 10th July, 1974.

JOHNSON, HAROLD JAMES, late of McKenzies Road, Roadside Delivery, Box 61, Neerim South, pensioner, died 25th July, 1974.

PRYSE, LOUISA DORIS, formerly of 93 Tennyson Street, Essendon, but late of Flat 36, 125 Pascoe Vale Road, Moonee Ponds, widow, died 7th October, 1974.

STONES, ADA, formerly of 1 Gordon Grove, Northcote, but late of Mont Park, spinster, died 12th July, 1974.

WARD, WILLIAM RICHARD, late of Gordon's Lane, South Morang, cleaning supplies salesman, died 21st August, 1974.

WASON, THOMAS, late of Playne Street, Heathcote, invalid pensioner, died 19th May, 1974.

I hereby give notice that on the 11th December, 1974, the Public Trustee filed elections to administer the following deceased persons' estates, in accordance with section 17 of the *Public Trustee Act 1958*.

CHEVALIER, VINCENT ANTHONY, late of 5 Melinga Crescent, Chadstone, military pensioner, died 6th October, 1974.

FETTES, CLARICE ANNE, formerly of 81 Park Street, South Yarra, but late of Ararat, widow, died 10th August, 1974.

ROSS, ELSIE MAY, also known as Elsie Ross, formerly of 1 Kernon Street, Moonee Ponds, but late of Bentleigh House Private Hospital, 193 Jasper Road, Bentleigh, widow, died 5th October, 1974.

SELLS, SARAH BEATRICE, formerly of Clyde, but late of Sampford Private Hospital, 508 Glen Eira Road, Caulfield, widow, died 24th September, 1974.

N. P. BRODY,
Public Trustee.

168 Exhibition Street, Melbourne, 3000, 18th December, 1974.

NOTICE.

Creditors, next of kin, and others having claims against the estate of any of the under-mentioned deceased persons are required to send particulars of their claims to the Public Trustee, 168 Exhibition Street, Melbourne, 3000, the personal representative, on or before the 10th March, 1975, after which date the Public Trustee may convey or distribute the assets, having regard only to the claims of which the Public Trustee then has notice:—

BASTIN, PATRICIA ISABEL, formerly of 144 Nell Street, Greensborough, but late of 2 McLennans Road, Plenty, married woman, died 10th October, 1974.

BEVERIDGE, ETHEL ELIZABETH, late of 47 Iffla Street, South Melbourne, married woman, died 29th September, 1974.

BOYD, NORMAN WILLIAM, late of Flat 6, 79 Park Street, Moonee Ponds, pensioner, died 15th or 16th September, 1974.

CAULFIELD, WILLIAM HENRY, late of 32 Alfred Street, Beaumaris, retired wood machinist, died 12th October, 1974.

CHEVALIER, VINCENT ANTHONY, late of 5 Melinga Crescent, Chadstone, military pensioner, died 6th October, 1974.

COOPER, GERTRUDE MAY, late of Queen Elizabeth Home, Ballarat, spinster, died 10th July, 1974.

DAVIS, ELIZABETH, late of 24 Gordon Street, Newport, widow, died 2nd February, 1971.

FETTES, CLARICE ANNE, formerly of 81 Park Street, South Yarra, but late of Ararat, widow, died 10th August, 1974.

HELLINGS, ELLEN ISABELLA, also known as Ellen Isobel Hellings, late of 14 Belmont Street, West Preston, widow, died 2nd August, 1974.

JOHNS, JACK, late of 47 Freeburgh Avenue, Mount Beauty, maintenance labourer, died 4th May, 1974.

JOHNSON, HAROLD JAMES, late of McKenzies Road, Roadside Delivery, Box 61, Neerim South, pensioner, died 25th July, 1974.

MOIR, WILLIAM, late of 13 Dixon Avenue, Croydon, retired draftsman, died 24th June, 1974.

MCCARTHY, WILFRED THOMAS, late of 27 Brown Avenue, Ascot Vale, retired train driver, died 2nd October, 1974.

O'SULLIVAN, MARY ELLEN, late of 34 Edinburgh Street, East Bentleigh, widow, died 6th October, 1974.

PRYSE, LOUISA DORIS, formerly of 93 Tennyson Street, Essendon, but late of Flat 36, 125 Pascoe Vale Road, Moonee Ponds, widow, died 7th October, 1974.

REEVE, MARY ELLEN, late of 37 Salisbury Street, Newport, widow, died 24th August, 1974.

ROBERTS, WILLIAM CARLOS DARBYSHIRE, formerly of 24 Bond Street, Ringwood, but late of 5 Merton Avenue, Elwood, retired farmer, died 26th October, 1974.

ROSS, ELSIE MAY, also known as Elsie Ross, formerly of 1 Kernon Street, Moonee Ponds, but late of Bentleigh House Private Hospital, 193 Jasper Road, Bentleigh, widow, died 5th October, 1974.

SELLS, SARAH BEATRICE, formerly of Clyde, but late of Sampford Private Hospital, 508 Glen Eira Road, Caulfield, widow, died 24th September, 1974.

STEWART, JOHN CUMMING, late of Kew, retired storeman, died 14th July, 1974.

STONES, ADA, formerly of 1 Gordon Grove, Northcote, but late of Mont Park, spinster, died 12th July, 1974.

UNDERDOWN, ETHEL FRANCES, formerly of Seaview Street, Newhaven, Phillip Island, but late of Kew, widow, died 11th September, 1974.

WARD, WILLIAM RICHARD, late of Gordon's Lane, South Morang, cleaning supplies salesman, died 21st August, 1974.

WASON, THOMAS, late of Playne Street, Heathcote, invalid pensioner, died 19th May, 1974.

N. P. BRODY,
Public Trustee.

Melbourne, 18th December, 1974.

PUBLIC TRUSTEE ACT 1958 (No. 6350), SECTION 17.

I hereby give notice that on the 11th December, 1974, the Public Trustee filed elections to administer the following deceased persons' estates, in accordance with section 17 of the *Public Trustee Act 1958*:—

ARTHUR, ALICE, late of 20 Law Street, Newborough, widow, died 23rd July, 1974.

CARTON, ARTHUR JOSEPH, late of Repatriation General Hospital, Heidelberg, cook, died 21st September, 1974.

DOBSON, WILLIAM, late of Beechworth, pensioner, died 15th March, 1974.

HILL, ALICE ANNIE, late of Ararat, spinster, died 29th July, 1974.

LATIMER, FRANCIS, late of "Mayflower", 7 Centre Road, East Brighton, artist, died 1st October, 1974.

I hereby give notice that on the 6th December, 1974, the Public Trustee filed elections to administer the following deceased persons' estates, in accordance with section 17 of the *Public Trustee Act 1958*:—

MIFSUD, EDWARD JOSEPH CARMEL, late of 53 Carlisle Street, St. Kilda, factory hand, died between 20th and 24th September, 1974.

PORTER, EDWARD CHARLES, late of 82 Canterbury Road, Middle Park, retired S.E.C. linesman, died 15th March, 1974.

SABESTON, HAROLD WILLIAM, late of 107 Ford Street, Ivanhoe, carpenter, died 13th October, 1974.

SALTER, CATHERINE VICTORIA, formerly of 16 Linsey Street, Coburg, but late of 4 Keith Street, Parkdale, widow, died 21st September, 1974.

N. P. BRODY,
Public Trustee.

168 Exhibition Street, Melbourne, 3000, 20th December, 1974.

NOTICE.

Creditors, next of kin and others having claims against the estate of any of the under-mentioned deceased persons are required to send particulars of their claims to the Public Trustee, 168 Exhibition Street, Melbourne, Vic. 3000, the personal representative, on or before the 14th March, 1975, after which date the Public Trustee may convey or distribute the assets, having regard only to the claims of which the Public Trustee then has notice:—

ARTHUR, ALICE, late of 20 Law Street, Newborough, widow, died 23rd July, 1974.

CARTON, ARTHUR JOSEPH, late of Repatriation General Hospital, Heidelberg, cook, died 21st September, 1974.

DOBSON, WILLIAM, late of Beechworth, pensioner, died 15th March, 1974.

HILL, ALICE ANNIE, late of Ararat, spinster, died 29th July, 1974.

LATIMER, FRANCIS, late of "Mayflower", 7 Centre Road, East Brighton, artist, died 1st October, 1974.

MALCOLM, FLORENCE IRENE, late of 22 Venice Street, Mentone, home duties, died 22nd August, 1974.

MIFSUD, EDWARD JOSEPH CARMEL, late of 53 Carlisle Street, St. Kilda, factory hand, died between 20th and 24th September, 1974.

PORTER, EDWARD CHARLES, late of 82 Canterbury Road, Middle Park, retired S.E.C. linesman, died 15th March, 1974.

SABESTON, HAROLD WILLIAM, late of 107 Ford Street, Ivanhoe, carpenter, died 13th October, 1974.

SALTER, CATHERINE VICTORIA, formerly of 16 Linsey Street, Coburg, but late of 4 Keith Street, Parkdale, widow, died 21st September, 1974.

N. P. BRODY,
Public Trustee.

Melbourne, 20th December, 1974.

NOTICE.

Creditors, next of kin and others having claims against the estate of any of the under-mentioned deceased persons are required to send particulars of their claims to the Public Trustee, 168 Exhibition Street, Melbourne, Vic. 3000, the personal representative, on or before the 24th March, 1975, after which date the Public Trustee may convey or distribute the assets, having regard only to the claims of which the Public Trustee then has notice:—

FRASER-LINDSAY, AGNES LOUISE MARY ANN, also known as Agnes Fraser-Lindsay, late of "Strathallan", Erskine Road, MacLeod, widow, died 22nd October, 1974.

FROUDE, WILLIAM AMBROSE, late of 25 Maryston Street, Yarraville, retired public servant, died 17th September, 1974.

GREEN, ARTHUR JOSEPH, late of 19 Harrow Street, Box Hill, retired foreman engineer, died 25th September, 1974.

GUILFOYLE, PATRICK, late of 196 Roberts Street, Yarraville, clerk, died 18th December, 1974.

MCCONNELL, ELIZABETH ANN, late of 14 Cremorne Street, Balwyn, spinster, died 22nd October, 1974.

URQUHART, EDITH, late of 62 Gallipoli Parade, Pascoe Vale, widow, died 14th October, 1974.

WALDRON, LESLIE BENSON, late of 20 Southernhay Street, Reservoir, retired public servant, died 21st September, 1974.

N. P. BRODY,
Public Trustee.

Melbourne, 31st December, 1974.

ERRATA NOTICE.

This notice is printed in lieu of that which appeared on page 4256 of the *Victoria Government Gazette*, No. 118. Referring to the Estates of Ieene Ruby Jackson and Olive Melva Myrtle Northby:—

JACKSON, ILEENE RUBY, also known as Ieene Jackson, late of 1 Govan Street, Footscray, married woman, died 19th September, 1974.

NORTHBY, OLIVE MELBA MYRTLE, also known as Olive Melva Northby, late of 29 Ross Street, Coburg, widow, died 12th October, 1974.

18th December, 1974.

N. P. BRODY,
Public Trustee.

STATE RIVERS AND WATER SUPPLY COMMISSION.

LICENCE TO DIVERT WATER PURSUANT TO THE PROVISIONS OF SECTION 204 OF THE WATER ACT (AS AMENDED).

The Schedule of Licence as detailed hereunder to divert water has been revoked by the Governor in Council.

SCHEDULE.

Licence No.	Term of Licence and Commencing Date.	Name and Address of Person to whom Licence is Granted.	Source of Supply.
1235	Fifteen years from 1.7.59 ..	Director of Agriculture of Melbourne	Blind Creek

Office of the State Rivers and Water Supply Commission,
Melbourne, 24th December, 1974.

G. W. LEWIS, Secretary,
State Rivers and Water Supply Commission.

STATE RIVERS AND WATER SUPPLY COMMISSION.

LICENCES TO DIVERT WATER PURSUANT TO THE PROVISIONS OF SECTION 204 OF THE WATER ACT (AS AMENDED).

The Schedule of Licences as detailed hereunder to divert water have been revoked by the Governor in Council.

SCHEDULE.

Licence No.	Term of Licence and Commencing Date.	Name and Address of Person to whom Licence is Granted.	Source of Supply.
3427	Four years from 1.7.72 ..	Geert Willem Raak of Pine Lodge	Broken River
1222	Four years from 1.7.73 ..	Robert Maxwell Colman of Nathalia	Wakiti Lagoon

Office of the State Rivers and Water Supply Commission,
Melbourne, 24th December, 1974.

G. W. LEWIS, Secretary,
State Rivers and Water Supply Commission.

STATE RIVERS AND WATER SUPPLY COMMISSION.

LICENCE TO DIVERT WATER PURSUANT TO THE PROVISIONS OF SECTION 204 OF THE WATER ACT (AS AMENDED).

The Schedule of Licence as detailed hereunder to divert water has been revoked by the Governor in Council.

SCHEDULE.

Licence No.	Term of Licence and Commencing Date.	Name and Address of Person to whom Licence is Granted.	Source of Supply.
3202	Four years from 1.7.73 ..	Giovanni Paolini and Pasqualino Paolini of Benalla ..	Broken Creek

Office of the State Rivers and Water Supply Commission,
Melbourne, 24th December, 1974.

G. W. LEWIS, Secretary,
State Rivers and Water Supply Commission.

WOODEND WATERWORKS TRUST.

RATING BY-LAW FOR THE PERIOD COMMENCING 1ST OCTOBER, 1974, AND ENDING 30TH SEPTEMBER, 1975.

The Woodend Waterworks Trust in pursuance and exercise of the powers conferred by the Water Acts doth hereby make a rate for the supply of water for domestic purposes of 8.5 cents in the dollar of the annual municipal valuation of lands and tenements liable to be rated within the Woodend Urban District.

Provided that in no case shall the amount of rate payable in respect of any tenement be less than Fourteen Dollars, and in respect of any land on which there is no buildings, less than Fourteen dollars.

Such rates are made and shall be levied upon the occupiers or owners of the same lands and tenements for the period commencing the First day of October, 1974 and ending the Thirtieth day of September, 1975 and shall be payable on the 8th day of January 1975 at the Office of the Trust.

Where persons liable to pay the Rate elect to pay such rate in instalments the first instalment shall be due 14 days after posting of the Demand for such Rate and the remaining instalments shall be due on 28th February, 31st May and 31st August, 1975.

The maximum quantity of water to be supplied in the period without further charge to any property rated by the Trust is hereby affixed at the quantity which at a charge of forty cents per 1,000 gallons would produce an amount equal to the amount of the rate levied on such property for the said period.

The Charge for water supplied by measure to any property rated by the Trust in excess of such maximum quantity computed as in the last preceding clause, is hereby fixed at forty cents per 1,000 gallons.

The Charge for water supplied by measure to any property not rated by the Trust is hereby fixed at forty cents per 1,000 gallons, and the minimum quantity of water to be charged for in cases where water is so supplied is hereby fixed at fifty thousand gallons.

The Charge for water supplied by measure shall be repayable on demand at the Office of the Trust.

Passed this 17th day of December, 1974.

(SEAL) G. KEATING, Commissioner.
GILBERT GORDON, Commissioner.
R. J. PEKIN, Secretary.

Approved, 24th December, 1974.—F. J. GRANTER, Minister of Water Supply.

PORTLAND WATERWORKS TRUST.

RATING BY-LAW FOR THE PERIOD
1ST OCTOBER, 1974, TO 30TH SEPTEMBER, 1975.

THE PORTLAND WATERWORKS TRUST in pursuance of and in exercise of the powers conferred by the Water Act 1958 and of any and every other power it thereunto enabling doth hereby make a By-law as follows:—

1. The Trust hereby makes and levies a rate in respect of all the lands and tenements within the Portland Urban District of 5.90 cents in the Dollar on the Nett Annual Value set out in the valuations at present in force of such lands and tenements for the purposes of the municipal rates of the Town of Portland which are hereby adopted as the valuation of such lands and tenements respectively.

2. Such rate shall be made and levied upon the occupiers and owners of such lands and tenements for the period commencing on the 1st day of October, 1974, and ending on the 30th day of September, 1975, and shall be payable on the 8th day of January, 1975, at the Office of the said Trust. Any person electing to pay such rate by four instalments shall pay the first instalment within fourteen days of the posting of the demand and the remaining instalments on or before the last days of February, May and August, 1975.

3. In no case shall the rate payable hereunder in respect of any land on which there is a building be less than Eighteen Dollars (\$18) or in respect of land on which there is no building be less than Twelve Dollars (\$12).

Dated this 17th day of December, 1974.

(SEAL) BARRY T. PAYNE, Chairman.
L. FELL, Secretary.

Approved, 24th December, 1974.—F. J. GRANTER, Minister of Water Supply.

No. 1.—12660/74.—2

PORTLAND WATERWORKS TRUST.

By-Law No. 12.

THE PORTLAND WATERWORKS TRUST in pursuance of and in exercise of the powers conferred by the Water Act 1958 and of any and every other power it thereunto enabling doth hereby make a By-Law as follows:—

1. By-Law No. 11 of the Portland Waterworks Trust is hereby revoked.

2. The meter or meters measuring the supply of water to any land or tenement shall be read as near as practicable to twelve months from the date that it was read previously and the quantity of water so measured as having been supplied during the period between any two successive such readings (hereinafter called "the meter year") shall be the basis of the calculating of charges payable under this By-Law provided always that where a meter has been installed on any land or tenement during the course of a meter year the quantity of water measured as having been supplied during the period between the date of such installation and the date of the reading shall be the basis of calculating such charges.

3. Subject as is hereinafter provided in respect of any land or tenement rated by the Trust—

(a) The maximum quantity of water to be supplied in any meter year without charge under this By-Law is hereby fixed as a quantity which if charged at the rate per thousand gallons for any meter year shown in clause 4 of this By-Law would give an amount equal to the amount of the rate payable in respect of the land or tenement for the financial year in which the said meter year ended.

(b) For all water supplied in any meter year in excess of the maximum quantity referred to in paragraph (a) of this clause the charge is hereby fixed in accordance with the appropriate rate shown in clause 4 of this By-Law.

4. The basis of charging for the supply of water in any meter year to any lands or tenements shall be as follows:—

(a) Shipping supplied by the Portland Harbor Trust—
50 cents per 1,000 gallons.

(b) Property outside of Trust District—
45 cents per 1,000 gallons.

(c) Bowling Clubs, Tennis Clubs, Golf Clubs—
First 80,000 gallons—40 cents per 1,000 gallons
80,001 gallons and over—15 cents per 1,000 gallons.

(d) Portland and District Hospital—
15 cents per 1,000 gallons.

(e) All other consumers—
First 80,000 gallons—40 cents per 1,000 gallons.
80,001-2,000,000 gallons—35 cents per 1,000 gallons.
2,000,001-5,000,000 gallons—20 cents per 1,000 gallons.
5,000,001 gallons and over—15 cents per 1,000 gallons.

5. The minimum charge for water supplied by measure to any property not rated by the Trust is hereby fixed at Eighteen Dollars (\$18) with consumption calculated in accordance with the appropriate rates set out in clause 4 of this By-Law.

6. The aforesaid charges shall be payable within seven days of demand upon the owner or occupier at the office of the Trust during normal business hours.

Dated this 17th day of December, 1974.

(SEAL) BARRY T. PAYNE, Chairman.
L. FELL, Secretary.

Approved, 24th December, 1974.—F. J. GRANTER, Minister of Water Supply.

MANSFIELD WATERWORKS TRUST.

RATING BY-LAW FOR 1975.

The Mansfield Waterworks Trust in pursuance and exercise of the powers conferred by the Water Act of 1958 and of any and every other power it thereunto enabling doth hereby make a By-Law as follows:—

(1) The Trust hereby makes and levies a rate in respect of all lands and tenements within the Mansfield Urban District of Ten cents in the dollar on the Net Annual Value set out in the Valuation at present in force of

such lands and tenements for the purposes of the Municipal rate of the Shire of Mansfield which is hereby adopted as the Valuation of such lands and tenements respectively.

(2) Such rate shall be made and levied upon the occupiers and owners of such lands and tenements for the year commencing on the 1st Day of January 1975 and shall be payable on the 1st Day of March 1975 at the office of the said Trust.

(3) In no case shall the amount of the rate payable in respect of any tenements (other than land on which there is no dwelling) be less than Twenty Five Dollars.

(4) In no case shall the amount of rate payable in respect of land on which there is no dwelling be less than fifteen dollars (\$15).

Dated this 28th day of November, 1974.

In witness whereof the common seal of the Trust was hereunto affixed, in the presence of—

(SEAL) C. J. BREEN, Chairman.
I. R. LEWELLYN, Member.
G. D. PAYNE, Secretary.

Approved, 12th December, 1974.—F. J. GRANTER, Minister of Water Supply.

TYERS AND GLENGARRY WATERWORKS TRUST.

RATING BY-LAW FOR YEAR 1975.

The Tyers and Glengarry Waterworks Trust, in pursuance and exercise of the powers conferred by the Water Act, doth hereby make a rate for the supply of water for domestic purposes of ten cents in the dollar on the net annual value of lands and tenements liable to be rated within the Tyers, Glengarry and Toongabbie Urban Districts.

1. Provided that in no case shall the amount of rate payable per annum in respect of any tenement (other than land upon which there is no building) be less than twenty-five dollars (\$25), and in respect of any land on which there is no building be less than five dollars (\$5).

2. Such rates are made and shall be levied upon the occupiers or owners of the said lands and tenements for the year commencing on the first day of January, 1975, and shall be made payable at the office of the said Trust on the Fifteenth day of March, 1975.

3. The maximum quantity of water to be supplied in any one year without further charge to any property rated by the Trust is hereby fixed at a quantity which, at a charge of twenty-five cents (25c) per 1,000 gallons, would produce an amount equal to the amount of the rate levied on such property for the said year.

4. The charge for water supplied by measure to any property rated by the Trust in excess of such maximum quantity, computed in the last preceding clause, is hereby fixed at twenty-five cents (25c) per 1,000 gallons.

5. The charge for water supplied by measure to any property not rated by the Trust will be fixed by special agreement with the Trust provided that in no case shall the amount payable be less than:—

For a property with not less than 40 acres, with a tenement thereon	\$75.00
For a property with not less than 40 acres, with no tenement thereon	\$45.00
For a property with not less than 10 acres, but not more than 40 acres, with a tenement thereon	\$45.00
For a property with not less than 10 acres, but not more than 40 acres, with no tenement thereon	\$25.00
For a property with less than 10 acres with a tenement thereon	\$25.00
For a property with less than 10 acres with no tenement thereon	\$15.00

The charge for water supplied by measure and by special agreement shall be payable on demand at the office of the said Trust.

Passed this 26th day of November, 1974.

(SEAL) K. McD. CHRISTENSEN, Chairman.
C. O. COLEMAN, Commissioner.
W. TEASDALE, Secretary.

Approved 12th December, 1974.—F. J. GRANTER, Minister of Water Supply.

MOE WATERWORKS TRUST.

By-Law No. 21.

The Moe Waterworks Trust in pursuance of and in exercise of the powers conferred by the Water Act 1958 and of any and every other power it thereunto enabling doth hereby make a By-Law as follows:—

1. The meter or meters measuring the supply of water to any land or tenement shall be read as near as practicable to twelve months from the date that it was read previously and the quantity of water so measured having been supplied during the period between any two successive such readings (hereinafter called "the meter year") shall be the basis of the calculating of charges payable under this By-Law provided always that where a meter has been installed on any land or tenement during the course of a meter year the quantity of water measured as having been supplied during the period between the date of such installation and the date of the reading shall be the basis of calculating such charges.

2. Subject as is hereinafter provided in respect of any land or tenement rated by the Trust:—

(a) The maximum quantity of water to be supplied in any meter year without charge is hereby fixed as a quantity which if charged at eight (8) cents per kilolitre for any meter year would give an amount equal to the amount of the rate payable in respect of the land or tenement for the financial year in which the said year ended.

(b) For all water supplied in any meter year in excess of the maximum quantity referred to in paragraph (a) of this clause the charge is hereby fixed at eight (8) cents per kilolitre for any meter year.

3. Subject as is hereinafter provided the charge for water supplied by measure to any property not rated by the Trust is hereby fixed at eight (8) cents per kilolitre, except in the case of special arrangements.

4. The minimum charge for water supplied by measure to any property not rated by the Trust is hereby fixed at four (4) dollars.

5. The aforesaid charges shall be payable within seven days of demand upon the owner or occupier at the office of the Trust during normal business hours.

6. The provisions of Clauses 3, 4 and 5 of this By-Law shall not apply to any land tenement or property with water by the Trust under a special agreement pursuant to section 215 of the Water Act 1958.

Passed this 16th day of December, 1974.

(SEAL) J. S. TABUTEAU, Chairman.
R. C. SHAW, Commissioner.
J. S. DWYER, Commissioner.
A. DEWAR, Secretary.

Approved, 24th December, 1974.—F. J. GRANTER, Minister of Water Supply.

MOE WATERWORKS TRUST.

RATING BY-LAW 1975.

By-Law No. 19.

The Moe Waterworks Trust in pursuance of and in exercise of the powers conferred by the Water Act 1958 and of any and every other power it thereunto enabling doth hereby make a By-Law as follows:—

1. The Trust hereby makes and levies a rate in respect of all the land and tenements within the Moe Urban District of four cents (4) cents in the dollar on the Net Annual Value set out in the valuation at present in force of such lands and tenements for the purposes of the Municipal rate of the City of Moe which is hereby adopted as the valuation of such lands and tenements respectively.

2. Such rate shall be made and levied upon the occupiers and owners of such lands and tenements for the year commencing on the 1st day of January 1975 and shall be payable on the 8th day of January 1975 at the office of the said Trust.

3. In no case shall the rate payable hereunder in respect of any land on which there is a building be less than thirty (30) dollars and in respect of land on which there is no building be less than fifteen (15) dollars.

Passed this 16th day of December, 1974.

(SEAL) J. S. TABUTEAU, Chairman.
E. SCOTT, Commissioner.
J. GILMOUR, Commissioner.
A. DEWAR, Secretary.

Approved, 24th December, 1974.—F. J. GRANTER, Minister of Water Supply.

MOE WATERWORKS TRUST.

BY-LAW NO. 20 FIXING CHARGES FOR WATER WITHIN THE TRUST'S DISTRICT EXCEPT WITHIN THE URBAN DISTRICT THEREIN.

The Moe Waterworks Trust in pursuance and exercise of the powers conferred by the Water Act 1958, doth hereby make a By-Law as follows:—

1. This By-Law shall apply to, and come into force on the 1st January, 1975, within the Moe Waterworks Trust District except within any Urban District therein.

2. Minimum annual charges for water supplied by measure from the works of the Trust, except in the case of special agreements with the Trust, shall be as set out in the following schedule. Such charges shall be payable on demand at the office of the Moe Waterworks Trust.

SCHEDULE.

Land on which there is a house.	Minimum Annual Charge.	Vacant Land.	Minimum Annual Charge.
	\$		\$
Up to 1 acre ..	35	Up to 40 acres ..	20
1 acre to 5 acres ..	45	40 acres to 100 acres ..	30
5 acres to 50 acres ..	65	100 acres to 160 acres ..	50
50 acres to 100 acres ..	95	160 acres to 220 acres ..	80
100 acres to 150 acres ..	115	220 acres to 280 acres ..	100
Exceeding 150 acres ..	135	Exceeding 280 acres ..	120
Extra House—Plus	\$27		

In addition a tapping charge will be made in compliance with charges made by regulation from time to time.

3. The maximum allowance for water to be supplied per annum in respect of the minimum annual charge shall in each case be the quantity which if charged at eight (8) cents per kilolitre would give an amount equal to such minimum annual charge, and for all water supplied in excess of such allowance the charge shall be eight (8) cents per kilolitre.

Passed this 16th day of December, 1974.

(SEAL) J. S. TABUTEAU, Chairman.
J. S. DWYER, Commissioner.
R. C. SHAW, Commissioner.
A. DEWAR, Secretary.

Approved, 24th December, 1974.—F. J. GRANTER, Minister of Water Supply.

BANNOCKBURN DISTRICT WATERWORKS TRUST.

BY-LAW NO. 14.

The Bannockburn District Waterworks Trust in pursuance of and in exercise of the powers conferred by the Water Act 1958 and of any and every other power it thereunto enabling doth hereby make a By-Law as follows:—

1. The meter or meters measuring the supply of water to any land or tenements shall be read as near as practicable to twelve months from the date that it was read previously and the quantity of water so measured as having been supplied during the period between any two successive such readings (hereinafter called the "meter year") shall be the basis of the calculating of charges payable under this By-Law provided always that where a meter has been installed on any land or tenement during the course of a meter year the quantity of water measured as having been supplied during the period between the date of such installation and the date of the reading shall be the basis of calculating such charges.

2. Subject as is hereinafter provided in respect of any land or tenement rated by the Trust:—

(a) The maximum quantity of water to be supplied in any meter year without charge is hereby fixed as a quantity which if charged at Sixty-one and a half cents per thousand gallons (13.5 cents per Kilolitre) for any meter year would give an amount equal to the amount of the rate payable in respect of the land or tenement for the financial year in which the said meter year ended.

(b) For all water supplied in any meter year in excess of the maximum quantity referred to in paragraph (a) of the clause the charge is hereby fixed at Sixty-one and a half cents per thousand gallons (13.5 cents per Kilolitre) for any meter year.

3. Subject as is hereinafter provided the charge for water supplied by measure to any property not rated by the Trust shall be as set out in the schedule below

Land on which there is a house or houses	Min. Annual Charge	Vacant land	Min. Annual Charge
Area not exceeding 20 acres	\$25	Area not exceeding 20 acres	\$10
Area exceeding 20 acres	\$50	Area exceeding 20 acres	\$25

4. The minimum charge for water supplied by measure to any property not rated by the Trust is hereby fixed at TEN Dollars.

5. The aforesaid charges shall be payable within fourteen days of demand upon the owner or occupier at the office of the Trust during normal business hours.

6. The provisions of Clauses 2, 3 and 4 of this By-Law shall not apply to any land, tenement or property supplied with water by the Trust under a special agreement pursuant to Section 215 of the Water Act 1958.

Passed this 5th day of December, 1974.

(SEAL) JAMES E. HARVEY, Chairman.
H. B. COOKE, Commissioner.
J. G. STEVENSON, Commissioner.
K. T. MIDDLETON, Secretary.

Approved, 17th December, 1974.—F. J. GRANTER, Minister of Water Supply.

BANNOCKBURN DISTRICT WATERWORKS TRUST.

By-Law No. 13.

The Bannockburn District Waterworks Trust in pursuance of and in exercise of the powers conferred by the Water Act 1958 and of any and every other power it thereunto enabling doth hereby make a By-Law as follows:—

1. The Trust hereby makes and levies a rate in respect of all the lands and tenements within the Meredith, Lethbridge, Bannockburn, Inverleigh and Teesdale Urban Districts of SEVENTEEN and ONE HALF Cents in the Dollar on the net annual value set out in the valuation at present in force of such lands and tenements for the purposes of the municipal rate of the Shire of Bannockburn and Shire of Leigh which is hereby adopted as the valuation of such lands and tenements respectively.

2. Such rate shall be made and levied upon the occupiers and owners of such lands and tenements for the year commencing on the 1st Day of January, 1975 and shall be payable on the 1st Day of March, 1975 at the office of the said Trust.

3. In no case shall the rate payable hereunder in respect of any land on which there is a building be less than THIRTY-ONE Dollars and in respect of land on which there is no building be less than NINE Dollars.

Passed this 5th Day of December, 1974.

(SEAL) JAMES E. HARVEY, Chairman.
H. B. COOKE, Commissioner.
J. G. STEVENSON, Commissioner.
K. T. MIDDLETON, Secretary.

Approved, 17th December, 1974.—F. J. GRANTER, Minister of Water Supply.

ALBERTON—PORT ALBERT WATERWORKS TRUST.

By-Law No. 13.

The Alberton—Port Albert Waterworks Trust in pursuance and exercise of the powers conferred by the Water Act 1958 and of any and every other power it thereunto enabling doth hereby make a By-Law as follows:

1. This By-Law shall have effect as from the commencement of the meter year ending in the financial year beginning 1st January 1975.

2. The meter or meters measuring the supply of water to any land or tenement shall be read as near as practicable to twelve months from the date of the previous reading thereof and the quantity of water measured as having been supplied during the period between any two successive such readings (hereinafter called "the Meter year") shall be the basis of the calculating of charges payable under this By-Law provided always that where a meter has been installed on any land or tenement during the course of a meter year the quantity of water measured as having been supplied during the period between the date of such installation and the date of the reading shall be the basis of calculating such charges.

3. Subject as is hereinafter provided in respect of any land or tenement rated by the Trust—

- (a) The maximum quantity of water supplied in any meter year without charge is hereby fixed as a quantity which if charged at 45 cents per thousand gallons for any meter year would give an amount equal to the amount of the rate payable in respect of the land or tenement for the financial year in which the said meter year ended;
- (b) For all water supplied in any meter year in excess of the maximum quantity referred to in paragraph (a) of this clause the charge is hereby fixed at 45 cents per thousand gallons for any meter year.

4. Subject as is hereinafter provided the charge for water supplied by measure to any property not rated by the Trust is hereby fixed at 45 cents per thousand gallons.

5. The minimum charge for water supplied by measure to any property not rated by the Trust is hereby fixed at 6 dollars.

6. The aforesaid charge shall be payable within seven days of demand upon the owner or occupier at the office of the Trust during normal business hours.

7. The provisions of clauses 3, 4 and 5 of this By-Law shall not apply to any land tenement or property supplied with water by the Trust under special agreement pursuant to Section 215 of the *Water Act 1958*.

8. This By-Law shall apply to the Alberton and Port Albert Urban Districts.

Passed this 19th day of November, 1974.

(SEAL) A. J. ROBERTSON, Chairman.
B. ROBERTS, Commissioner.
N. J. CHRISTENSEN, Secretary.

Approved, 17th December, 1974.—F. J. GRANTER, Minister of Water Supply.

SHIRE OF KANIVA WATERWORKS TRUST.

By-Law No. 3.

The Shire of Kaniva Waterworks Trust in pursuance of and in exercise of the powers conferred by the *Water Act 1958* and of any and every other power thereunto enabling it, doth hereby make a By-Law as follows:—

- (1) By-Laws Nos. 1 and 2 are hereby repealed.
- (2) The meter or meters measuring the supply of water to any land or tenement shall be read as near as practicable to twelve months from the date that it was previously read and the quantity of water so measured as having been supplied during the period between any two successive such readings (hereinafter called the "meter year"), shall be the basis for the calculation of charges payable under this By-Law provided always, that where a meter has been installed on any land or tenement during the course of a meter year, the quantity of water measured as having been supplied during the period between the date of such installation and the date of reading, shall be the basis for the calculation of such charges.

(3) Subject as is hereinafter provided in respect of any land or tenement within the Kaniva Urban District and rated by the Trust:—

- (a) The maximum quantity of water to be supplied in any meter year without charge is hereby fixed as a quantity which charged at Five and One Half cents per kilolitre for any meter year would give an amount equal to the amount of the rate payable in respect of such land or tenement for the financial year in which the said meter year ended provided that in no case shall the maximum quantity of water to be supplied in any meter year without charge in respect of any tenement be less than 450 kilolitres.

- (b) For all water supplied to any land or tenement within the Kaniva Urban District in any meter year in excess of the maximum quantity referred to in paragraph (a) of this clause, the charge is hereby fixed at Five and One Half cents per kilolitre for any meter year.

(4) Subject as is hereinafter provided in respect of any land or tenement within the Lillimur and Miram Urban Districts and rated by the Trust:—

- (a) The maximum quantity of water to be supplied in any meter year without charge is hereby fixed as a quantity which if charged at Seven and One Half cents per kilolitre for any meter year would give an amount equal to the amount of

the rate payable in respect of such land or tenement for the financial year in which the said meter year ended.

- (b) For all water supplied to any land or tenement within the Lillimur and Miram Urban Districts in any meter year in excess of the maximum quantity referred to in paragraph (a) of this clause, the charge is hereby fixed at Seven and One Half cents per kilolitre for any meter year.

(5) The charge for water supplied by measure to any water trough not rated by the Trust is hereby fixed at Five and One Half cents per kilolitre provided that the minimum amount payable in any meter year shall be five dollars.

(6) The provisions of Clauses 3, 4, and 5 of this By-Law shall not apply to any land, tenement or property supplied with water by the Trust under a special agreement pursuant to Section 215 of the *Water Act 1958*.

(7) The aforesaid charges shall be payable on the 10th day of December, following the end of the meter year by the owner or occupier at the office of the Trust during normal business hours.

By-Law passed this 17th day of September, 1974.

(SEAL) W. H. HICKS, Chairman.
G. J. WALKER, Secretary.

Approved, 24th December, 1974.—F. J. GRANTER, Minister of Water Supply.

MINES DEPARTMENT.

APPLICATIONS FOR MINING LEASES REFUSED.

No. 10; Ray A. Borchers, Stanley I. Lincoln, John C. Kennedy; 40 ha, Parish of Tarlarn.

No. 63; Duncan Robert McLean, Arthur Maxwell Hamilton; 280 ha, Parish of Taponga.

No. 221; Duncan Robert McLean, Arthur Maxwell Hamilton; 80 ha, Parish of Youarrabuk.

No. 264; Lionel John Duffy, Frederick Beatty Chalwell; 80 ha, Parish of Bright.

No. 265; Lionel John Duffy, Robert Clifford Ince; 80 ha, Parish of Bright.

MINING LEASE GRANTED.

No. 152; David John Dent; 4.3 ha, Parish of El Dorado.

MINING LEASES TRANSFERRED.

8377, Beechworth; from Ludbrooks Limited to Arthur Clifton Pelham Webb.

8378, Beechworth; from Ludbrooks Limited to Arthur Clifton Pelham Webb.

8386, Beechworth; from Ludbrooks Limited to Arthur Clifton Pelham Webb.

EXPLORATION LICENCE EXPIRED.

No. 147; Coopers Creek Mining and Exploration N.L.; 789 km², Counties of Tanjil and Wonnangatta.

APPLICATION FOR EXTRACTIVE INDUSTRY LICENCE DECLARED ABANDONED.

No. 664; Concrete Industries (Monier) Limited; 8 ha, Parish of Mordialloc.

APPLICATION FOR EXTRACTIVE INDUSTRY LICENCE REFUSED.

No. 696; Geelong Quarries Pty. Ltd.; 6.8 ha, Parish of Gheringhap.

J. C. M. BALFOUR,
Minister of Mines.

HOSPITALS AND CHARITIES ACT 1958, No. 6274.

It is hereby notified for general information that the Hospitals and Charities Commission has, under the provisions of section 50 of the above-mentioned Act, approved of the corporate name of Bairnsdale District Hospital being changed to—

"EAST GIPPSLAND HOSPITAL."

Dated at Melbourne this 30th day of December, 1974.

E. WILDER,
Chairman.

Transport Regulation Act.
TRANSPORT REGULATION BOARD.

HEARING OF APPLICATIONS.

Notice is hereby given that the following applications will be considered by the Transport Regulation Board on 28th January, 1975.

AJAX NETTLEFOLDS PTY. LTD., 484 Ballarat Road, Sunshine. Application for one commercial passenger vehicle with seating capacity for eleven persons to operate for the carriage of employees, free of charge, from the company's premises at 484 Ballarat Road, Sunshine, via the most direct route to Ajax Pump Works, Sunshine Road, Tottenham, then again via the most direct route to Ajax Nettlefolds Pty. Ltd. premises, 27 Burnley Street, Richmond.

TIME-TABLE:

Monday to Friday.

Depart Sunshine	7.30 a.m.
Depart Richmond	5.00 p.m.

DEVESON, L. V. (Mrs.), 5 Cooper Street, Essendon, 3040. Application for one commercial passenger vehicle with large seating capacity to operate as an additional Metropolitan Stage Omnibus under the same terms and conditions as existing licences held by the applicant.

LIVINGSTONE, C. E. & G. E. and CHANDLER, J. H. & E. N., 86 Shannon Street, Box Hill. Application for authority to operate licence M.O.594 for the carriage of school children only between the corner of Shannon and Elgar Roads, Box Hill, and the Donvale Christian School via Elgar and Canterbury Roads, Station Street, Eley and Middleborough Roads, Fultons, Hollands, Canterbury, Blackburn and Railway Roads, Chapel Street, Whitehorse, Surrey, Junction, Springvale, Hedge End and Newport Roads, Lemon Grove, Ashwood Drive, Springvale Road, Aranga Crescent, Darvall Street, Tunstall, Doncaster, Old Warrandyte and Tindals Roads to the school, under contract to the school.

MORRELL, W. J., Flat 1, Ski View Flats, Mount Buller. Application for one commercial passenger vehicle, Toyota Landervisor, with seating capacity for five persons to operate for the carriage of passengers on day tours from Mount Buller as follows: (i) Mt. Stirling—From Mt. Buller via Tip Track to Circuit Road to Stirling Track and Mt. Stirling. Fare adults \$5, children \$2.50. (ii) The Bluff—From Mt. Buller via Tip Track, Circuit Road, Bindaree Road, Sixteen Mile Road to Bluff Hut. Fare adult \$10, child \$5. (iii) Cobbler Lake—From Mt. Buller via Tip Track, Circuit Road, Speculation Road to Cobbler Lake. Fare adult \$10, child \$5.

MUSGROVE CHICKS (a division of Allied Mills) PTY. LTD., 24 Yarra Road, Croydon. Application for one commercial passenger vehicle with seating capacity for eight persons, to operate for the carriage of service staff and light equipment, free of charge, from the applicant's depot at Yarra Road, Croydon, to the farms of contract growers and customers, within an 80-km radius.

Applications for renewal of licences as shown by the persons listed hereunder to operate under the same terms and conditions:—

CLARINDA TRANSPORT PTY. LTD., 1037 Centre Road, South Oakleigh; M.O.81, M.O.414, M.O.451.

DEVESON, E. V., 5 Cooper Street, Essendon; M.O.14, M.O.288.

HUNTER, J., Main Street, Winchelsea; T.S.237, T.S.265.

JAENSCH, R. L. & K. M., Nyah West; T.S.683.

LAWLER, J. W. & M. E., 50 Fairview Avenue, Yarram; T.S.893.

MOLONEY, R. W., 21 Henty Street, Pakenham; C.T.227, C.T.339.

MORTIMER, F. P. & M. A., Kostadt Street, Nathalia; T.S.946.

SPENCER, L. A., Lake Charm; T.S.427.

TREWEEK, W. J., 2 Hood Street, Sunbury; T.S.374, T.S.655.

Notice of any objections should be forwarded to reach the Secretary of the Board not later than 22nd January, 1975.

Applicants are advised that it will not be necessary to appear on the hearing date specified, unless advised in writing by the Board.

A. V. C. COOK,
Secretary.

Corner Lygon and Princes Streets, Carlton, 3053,
Wednesday, 8th January, 1975.

Commercial Goods Vehicles Act.
TRANSPORT REGULATION BOARD.

HEARING OF APPLICATIONS.

Notice is hereby given that the following applications will be considered by the Transport Regulation Board on 21st January, 1975.

BATTY, A. C. (trading as A. B. Metal & General Merchants), 107 Gertrude Street, Geelong West, 3218. One commercial goods vehicle (L/C. 7.65 tonne) to operate: (a) Within a 40-km radius of the chief post office in the City of Geelong—general goods. (b) Within an 80-km radius of the chief post office in the City of Geelong in the course of business as "Marine Collector"—special wares, marine stores and old metals as designated in the *Marine Stores and Old Metals Act 1958*, No. 6303, Part (1), Section (3).

ADAMS, WILLIAM, METALS LTD., 691 Geelong Road, Brooklyn, 3011. One commercial goods vehicle (L/C. 0.75 tonne) to operate throughout the State of Victoria in the course of business as "General Engineers" for the purpose of servicing and maintaining machine tools and filtration plants—tools of trade, spare parts and materials, required for servicing machine tools and filtration plants in the field only.

AYWON PTY. LTD., 590 High Street, Thornbury, 3071. One commercial goods vehicle (L/C. 0.95 tonne) to operate: (a) Within a 40-km radius of the G.P.O., Melbourne, in the course of business as "Clothing Manufacturers"—own goods. (b) From own premises at Thornbury to own approved decentralized secondary industry premises at Wonthaggi (clothing)—raw materials, semi-processed garments, spare parts and machinery solely for use in the manufacturing processes of such industry. (c) From own premises at Wonthaggi to own premises at Thornbury—own manufactured goods and machinery for repair.

BABIC, O., Flat 1, 7 Dover Street, Flemington, 3031. One commercial goods vehicle (L/C. 9.35 tonne) to operate within an 80-km radius of the G.P.O., Melbourne, solely on behalf of Albion Reid Pty. Ltd.—premixed concrete in a specially constructed agitator vehicle.

BARKER, E. (trading as Barker Bros.), Yarra Junction, 3797. Application to vary the conditions of licence No. D.T.117/5 (L/C. 13.90 tonne) by adding to the existing conditions in paragraph (a) (ii) after "sawn timber" "but excluding operations west of a north/south line drawn through Sunshine". Also by adding to paragraph (c) after "new pallets" "but excluding operations west of a north/south line drawn through Sunshine".

BARTLETT, A. T., Adelaide Lead, via Maryborough, 3465. One commercial goods vehicle (L/C. 10.15 tonne) to operate: (a) Within a 40-km radius of Adelaide Lead—general goods. (b) From own premises at Adelaide Lead to consignees at Colac and Camperdown—wooden fencing posts.

BAXTER, J. G., Ocean Road, Anglesea, 3230. Two commercial goods vehicles (L/C. 7.25 tonne and 2.40 tonne) to operate: (a) Within a 40-km radius of the post office at Anglesea—own goods. (b) From places situated within a 16-km radius of the G.P.O., Melbourne, to own premises at Anglesea in the course of business as "Building and Hardware Supplier"—own goods.

NOTE.—Nothing contained in paragraph (b) shall be deemed to authorize any goods taken up within a 16-km radius of the G.P.O., Melbourne, to be set down at any point beyond own premises at Anglesea.

J. BENNETT NEWLYN PTY. LTD., Newlyn, 3364. Two commercial goods vehicles (L/C. 3.95 tonne and 1.00 tonne) to operate: (a) Within an 80-km radius of Newlyn in course of trade as "Builder, Irrigation Equipment Distributor and Boring Contractor"—own goods. (b) From Newlyn to Melbourne—own machinery for repair. (c) From Melbourne to Newlyn—aluminium and plastic irrigation pipes and associated fittings, bricks, own machinery having been repaired.

BORG, J., 50 Mulhall Drive, St. Albans, 3021. One commercial goods vehicle (L/C. 10.90 tonne) to operate within an 80-km radius of the G.P.O., Melbourne, solely on behalf of Albion Reid Pty. Ltd.—road-making plant, hot asphalt, quarry products and road-making materials excluding the carriage of lime and cement from places within a 13-km radius of Geelong.

- BRANCH, B. (trading as R. J. & B. Branch), 5 Curletts Road, Lara, 3212. One commercial goods vehicle (L/C. 12.40 tonne) to operate: (a) Within a 40-km radius of the post office at Lara—general goods, subject to the condition that no goods shall be carried whether by one stage or by more than one stage from any point within the said radius to any point within the said radius which is situated more than 50 km apart by the nearest and most practicable route. (b) From the premises of Spadings, Lara Lime Co. at Lara to the premises of Pivot Superphosphate Co. at Yarraville—bulk lime. (c) From the premises of Pivot Superphosphate Co. at Yarraville to places situated within that part of the area described in paragraph (a) above east of a north/south line drawn through the Township of Lara Lake—bulk and bagged superphosphate.
- BRENTNALL, D. S., Smith's Road, Bamawn, 3561. One commercial goods vehicle (L/C. 11.80 tonne) to operate: (a) Within a 40-km radius of Bamawn—general goods. (b) Within an 80-km radius of own premises at Bamawn in course of business as Primary Producer—own goods. (c) From points within the State of Victoria to own approved decentralized secondary industry at Bamawn (Stockfoods)—raw materials and goods used solely in the manufacturing processes of such industry. (d) From own approved decentralized secondary industry premises at Bamawn to points throughout the State of Victoria—manufactured articles from such industry.
- BRUNI & BISOGNI PTY. LTD., Broadway Street, Cobram, 3644. Five commercial goods vehicles (L/C. 0.75, 0.75, 0.75, 0.75 and 0.50 tonne) to operate: (a) Within an 80-km radius from the post office at Cobram in the course of business as "Building Contractors"—own goods. (b) Throughout the State of Victoria in the course of business as "Building Contractors"—own tools of trade and own equipment. (c) Within a 32-km radius from the site of any contract currently engaged upon—materials required for use in such contract. (d) From the metropolitan area as defined in the Transport Consolidated Regulations to own premises at Cobram being an approved decentralized secondary industry (joinery)—raw materials for use in the manufacturing processes of such industry. (e) From the aforesaid premises at Cobram to places throughout the State of Victoria—manufactured articles from the approved decentralized secondary industry.
- CHAPMAN, E. M., 1 Bendigo Crescent, Bendigo, 3550. One commercial goods vehicle (L/C. 5.10 tonne) to operate: (a) Within a 40-km radius of the chief post office in the City of Bendigo—general goods. (b) From Bendigo to the premises of Australian Paper Manufacturers Ltd. at Broadford—waste paper.
- D'AGOSTINO, V., High Street, Heathcote, 3606. One commercial goods vehicle (L/C. 7.05 tonne) to operate: (a) Within a 40-km radius of the post office at Heathcote—general goods. (b) From Heathcote to Melbourne in the course of business as "Wood Merchant"—firewood.
- DOWELL AUST. LTD., Numurkah Road, Shepparton, 3630. One commercial goods vehicle (L/C. 0.60 tonne) to operate within an 80-km radius of own branch premises at Shepparton in the course of business as aluminium window manufacturer—windows, doors and fittings.
- DUNNING, G. A. (trading as G. & D. Dunning), 78 Forest Road, Orbost, 3888. One commercial goods vehicle (L/C. 18.35 tonne) to operate: (a) Within that part of the State of Victoria east of the Snowy River—logs. (b) From places situated within the area specified in paragraph (a) above to sawmills at Newmerella and Waygara—logs. (c) From sawmills situated within the area specified in paragraph (a) above and/or from sawmills at Newmerella to—(i) The railway station at Orbost. (ii) Customers and/or building sites within a 40-km radius of the post office at Orbost—sawn timber. (d) Within a 40-km radius of the post office at Orbost—general goods. (e) From the Melbourne metropolitan area and towns *en route* to destinations within a 40-km radius of Orbost—roofing tiles, bricks, cement ex Traralgon, concrete products including concrete drainage pipes, earthenware pipes, fruit and vegetables, boats and boat trailers, petroleum products in small containers up to 58 litre capacity, glazed doors and windows, cement sheets and mouldings and accessories, plaster board, mouldings and fittings, cement garden ornaments, septic tanks, prefabricated hay sheds, and garages, scaffolding, building gear and equipment, new and second-hand furniture, motor cars, racking sticks, potatoes, onions, asbestos stormwater pipes and P.V.C. polythene pipes, roll-a-doors, shower bases, Strammit board, roof decking, fittings and brackets, roofing iron over 7 metres in length, steel trusses, aluminium irrigation pipes, repaired machinery, small bulldozers and tractors, milk vats, bulk petroleum products, prefabricated timber roof trusses, empty return containers, plaster moulds, agricultural pipes, timber strapping, sawmill equipment, groceries, livestock. (f) From sawmills within that part of the State of Victoria east of the Snowy River to the metropolitan areas and towns situated east of a north/south line drawn through Melbourne and south of an east/west line drawn through Melbourne—sawn timber. (g) From places within a 40-km radius of Orbost to the Melbourne metropolitan area and towns *en route*—sawmill machinery for repair, livestock, empty return containers, fruit and vegetables.
- HUTCHINSON, G. C. (trading as E.T.Y. Transport), 14 Deboos Street, Euroa, 3666. Two commercial goods vehicles (L/C. 0.70 and 8.25 tonne) to operate: (a) From the premises of Euroa Timber Yard Pty. Ltd. at Euroa to consignees situated within an 80-km radius from the post office at Euroa in the course of business as "Contract Carriers" solely on behalf of the said company—seasoned timber boards and mouldings. (b) Between the City of Shepparton and the Township of Euroa—general goods.
- EMERY, B., 16 Mawarra Avenue, West Rosebud, 3939. One commercial goods vehicle (L/C. 7.00 tonne) to operate within a 56-km radius of the premises of Hillview Quarries Pty. Ltd. at Dromana solely on behalf of the said company—screenings, sand, stone dust and quarry products.
- EVERLAST CONCRETE TANKS PTY. LTD., 48 Fallon Street, Albury, N.S.W. 2640. Application to vary the conditions of licences numbered D.A.58613/6 (L/C. 8.30 tonne), D.A.58613/8 (L/C. 3.25 tonne) by the addition of additional paragraph (c)—" (c) Within a 160-km radius from each of own plants at Bendigo and Ballarat (approved decentralized industries), and within a 112-km radius of own plant at Pakenham and to places situated east of a line drawn north and south through Pakenham—own prefabricated concrete tanks on a specially constructed vehicle with own lifting and winching equipment."
- EVERLAST CONCRETE TANKS PTY. LTD., 48 Fallon Street, Albury, N.S.W. 2640. Application to vary the conditions of licences numbered D.A.58613/1 (L/C. 7.50 tonne), D.A.58613/3 (L/C. 7.30 tonne), D.A.58613/5 (L/C. 7.45 tonne), D.A.58613/9 (L/C. 7.35 tonne), D.A.58613/10 (L/C. 5.65 tonne), D.A.58613/11 (L/C. 5.05 tonne), D.A.58613/12 (L/C. 6.70 tonne), D.A.58613/13 (L/C. 11.25 tonne), D.A.58613/15 (L/C. 7.50 tonne), D.A.58613/16 (L/C. 7.80 tonne), D.A.58613/17 (L/C. 6.05 tonne), D.A.58613/18 (L/C. 6.55 tonne), D.A.58613/19 (L/C. 7.10 tonne) by deleting paragraph (c) and adding in lieu as paragraph (c)—"Within a 160-km radius from each of own plants at Bendigo and Ballarat (approved decentralized industries), and within a 112-km radius of own plant at Pakenham and to places situated east of a line drawn north and south through Pakenham—own prefabricated concrete tanks on a specially constructed vehicle with own lifting and winching equipment."
- FARRAR, M., 14 Thompson Crescent, Bendigo, 3550. One commercial goods vehicle (L/C. 0.95 tonne) to operate from Melbourne to Maryborough, Inglewood, Bendigo, Shepparton and towns *en route* in the course of business as cake distributor—wedding cakes, birthday cakes, shortbreads and small quantities of block cakes.
- FLACK, N., Mill Street, Horsham, 3400. One commercial goods vehicle (L/C. 1.35 tonne) to operate: (a) Within a 40-km radius of the post office at Horsham—general goods. (b) Within an 80-km radius of the post office at Horsham as an agent on behalf of Esso Standard Oil (Aust.) Ltd.—petroleum products in bulk and in prescribed containers and empty return containers.
- FRASCA, J. & J., Myrrhee, 3732. One commercial goods vehicle (L/C. 12.80 tonne) to operate: (a) Throughout the State of Victoria—livestock. (b) Throughout the State of Victoria as a specially constructed bulk tanker, being a prescribed type of vehicle—petroleum products in bulk.
- GAS & FUEL CORPORATION OF VICTORIA, 171 Flinders Street, Melbourne, 3000. Four commercial goods vehicles (L/C. 0.85, 1.05, 0.95 and 0.95 tonne) to operate throughout the State of Victoria in the course of business as "Gas Distributors" for the purpose of servicing and maintaining own gas pipelines and gas distribution equipment—tools of trade, special servicing and testing equipment and materials incidental to on-site servicing.

- GENDORE PTY. LTD.**, South Gippsland Highway, Tooradin, 3980. Application to vary the conditions of licences numbered D.A.37142/8 (L/C. 1.30 tonne), D.A.37142/18 (L/C. 0.70 tonne), D.A.37142/21 (L/C. 0.70 tonne) by the addition of additional paragraph (c)—(c) Throughout the State of Victoria from own premises at Tooradin in the course of business as farm-machinery distributors for the purpose of displaying and demonstrating own machinery—farm machinery for display and demonstration only.
- GLOURY, P. H.**, Broadway, Dunolly, 3472. One commercial goods vehicle (L/C. 15.80 tonne) to operate: (a) Within a 40-km radius of Dunolly—general goods. (b) Throughout the State of Victoria—firewood. (c) From Dunolly to places within that part of the State of Victoria bounded by a north/south line drawn through the City of Port Fairy, and east/west line drawn through the City of Bendigo, and by a north/south line drawn through the Township of King Lake, but excluding any operations to or from the Melbourne metropolitan area—fencing posts.
- GRAVES, C. E. & D. E.**, 309 Melbourne Road, Corio, 3214. One commercial goods vehicle (L/C. 12.15 tonne) to operate: (a) Within a 40-km radius of the chief post office in the City of Geelong—general goods. (b) From the Townships of Fyansford, Anakie, and Maude and from the sand and gravel pits of Trans West Cement Haulage Pty. Ltd. in the You Yangs to places within a 16-km radius of the City of Ballarat—bulk lime, scoria, sand, screenings, gravel, crushed rock and clay. (c) Within that part of an 80-km radius of the G.P.O., Melbourne bounded on the east by a north/south line drawn through the Township of Lilydale and on the north by an east/west line drawn through the Township of Craigieburn for the carriage of the following dry bulk commodities, viz: lime, clay, sand, screenings, gravel, crushed rock, scoria, salt, muriate of potash, sulphate of ammonia, manufactured fertilizers, soda ash, sulphur, gypsum waste, overburden rubbish, aluminium dross, scrap metals and brown coal. (d) From Columbia Concrete Masonry Pty. Ltd. at Springvale to consignees within a 160-km radius therefrom—concrete masonry and on return journeys empty pallets and excess concrete masonry to the said plant provided that weight of each concrete block does not exceed 18 kg. (e) From the premises of Pivot Superphosphate Company at North Shore, Geelong, the premises of I.C.I. Australia Ltd. at Yarraville, the premises of Sulphates Chemical Company at Spotswood and the premises of Omega Chemicals Pty. Ltd. at Brooklyn to consignees throughout the State of Victoria—the following bulk liquid commodities, viz: alum, sulphuric acid and caustic soda.
- GRIFFIN, F. W.**, Britannia Creek Road, Wesburn, 3139. One commercial goods vehicle (L/C. 4.70 tonne) to operate within a 56-km radius of the depot of Melbourne and Metropolitan Board of Works at Mitcham and to and from points on the Mornington Peninsula and to and from the Upper Yarra Dam—tools, equipment, construction and repair materials when being carried between construction sites solely on behalf of the M.M.B.W.
- HACKETT, T.** (trading as T. & V. Hackett), 181 Main Street, Bairnsdale, 3875. Application to vary the conditions of licence No. D.A.67283 (L/C. 0.45 tonne) by the addition of paragraph (b)—(b) Within that part of the State of Victoria east of a north/south line drawn through Sale in the course of business as "Agent for Yamaha musical instruments"—electronic musical instruments.
- HAMPSHIRE, C. & SEACH, D. W.**, 45 James Street, Belmont, 3216. One commercial goods vehicle (L/C. 7.35 tonne) to operate: (a) Within a 40-km radius of the chief post office in the City of Geelong—general goods. (b) From the sawmill of C. R. & J. M. Hampshire & Sons Pty. Ltd. at Deans Marsh to consignees at Colac, Anglesea, Torquay, Barwon Heads, Ocean Grove, Point Lonsdale, Queenscliff, St. Leonards, Portarlington and within the Geelong Urban District (as defined in the *Transport Regulation Act 1958*)—sawn timber. (c) From the sawmill of C. R. & J. M. Hampshire & Sons Pty. Ltd. at Deans Marsh to the Nestle Company (Aust.) Ltd. at Dennington—dunnage timber.
- HARTNETT, B.**, 13 Glenelg Avenue, Corio, 3214. One commercial goods vehicle (L/C. 11.80 tonne) to operate: (a) Within a 40-km radius of the chief post office in the City of Geelong—general goods. (b) From the Townships of Fyansford, Anakie and Maude and from the sand and gravel pits of Trans West Cement Haulage Pty. Ltd. in the You Yangs to places within a 16-km radius of the City of Ballarat—bulk lime, scoria, sand, screenings, gravel, crushed rock and clay. (c) Within that part of an 80-km radius of the G.P.O., Melbourne bounded on the east by a north/south line drawn through the Township of Lilydale and on the north by an east/west line drawn through the Township of Craigieburn for the carriage of the following dry bulk commodities, viz: lime clay, sand, screenings, gravel, crushed rock, scoria, salt, muriate of potash, sulphate of ammonia, manufactured fertilizers, soda ash, sulphur, gypsum waste, overburden rubbish, aluminium dross, scrap metals and brown coal.
- HARWOOD, K. R.**, 284-286 Thompson's Road, North Geelong, 3215. One commercial goods vehicle (L/C. 6.60 tonne) to operate: (a) Within a 40-km radius of the chief post office in the City of Geelong in the course of business as "Petroleum Agents"—own goods. (b) From the premises of B.P. Australia Ltd. at Altona and Port Melbourne to own depot at North Geelong—bulk and drummed petrol, kerosine, distillate and oil and on the forward journey empty return containers.
- HELLA AUSTRALIA PTY. LTD.**, Southern Road, Mentone, 3194. One commercial goods vehicle (L/C. 6.30 tonne) to operate: (a) Within a 40-km radius of the G.P.O., Melbourne in course of business as "Automotive Lighting and Signalling Equipment Manufacturers"—own goods. (b) From own premises at Mentone to own premises at Seymour being an approved decentralized secondary industry (automotive instruments (electrical))—raw materials and machinery required for use in the manufacturing processes of such industry. (c) From own approved decentralized secondary industry at Seymour to places within a 40-km radius of the G.P.O., Melbourne—manufactured products from such industry and machinery for repair.
- HIGGINS, A. F.**, 9 Arden Avenue, Leopold, 3221. One commercial goods vehicle (L/C. 10.80 tonne) to operate: (a) Within a 40-km radius of the chief post office in the City of Geelong—general goods. (b) From the Townships of Fyansford, Anakie and Maude and from the sand and gravel pits of Trans West Cement Haulage Pty. Ltd. in the You Yangs to places within a 16-km radius of the City of Ballarat—bulk lime, scoria, sand, screenings, gravel, crushed rock and clay. (c) Within that part of an 80-km radius of the G.P.O., Melbourne bounded on the east by a north/south line drawn through the Township of Lilydale and on the north by an east/west line drawn through the Township of Craigieburn for the carriage of the following dry bulk commodities, viz: lime clay, sand, screenings, gravel, crushed rock, scoria, salt, muriate of potash, sulphate of ammonia, manufactured fertilizers, soda ash, sulphur, gypsum waste, overburden rubbish, aluminium dross, scrap metals and brown coal.
- JENNINGS, C. P.**, 41 Tennyson Street, Norlane, 3214. One commercial goods vehicle (L/C. 10.85 tonne) to operate: (a) Within a 40-km radius of the chief post office in the City of Geelong—general goods. (b) From the Townships of Fyansford, Anakie and Maude and from the sand and gravel pits of Trans West Cement Haulage Pty. Ltd. in the You Yangs to places within a 16-km radius of the City of Ballarat—bulk lime, scoria, sand, screenings, gravel, crushed rock and clay. (c) Within that part of an 80-km radius of the G.P.O., Melbourne bounded on the east by a north/south line drawn through the Township of Lilydale and on the north by an east/west line drawn through the Township of Craigieburn for the carriage of the following dry bulk commodities, viz: lime clay, sand, screenings, gravel, crushed rock, scoria, salt, muriate of potash, sulphate of ammonia, manufactured fertilizers, soda ash, sulphur, gypsum waste, overburden rubbish, aluminium dross, scrap metals and brown coal.
- KATSAROS, C.**, Timboon West, 3268. One commercial goods vehicle (L/C. 3.80 tonne) to operate: (a) Within an 80-km radius of own premises at Timboon West in course of business as Primary Producer—own goods. (b) Within a 180-km radius of own premises at Timboon West in course of business as scrap metal dealer—scrap metal.
- KEILAR, B. F.**, 3 Florence Street, Warrnambool, 3280. One commercial goods vehicle (L/C. 16.50 tonne) to operate: (a) Within a 40-km radius of the chief post office at Warrnambool—general goods. (b) Within a 16-km radius of the Township of Kororoit to Rosella and Farquhar, Ballarat, McCanns, Daylesford, Costa Packing, Shepparton and Melbourne Market—potatoes

and onions and empty return containers carried on the forward journey. (c) Within the area described in paragraph (a) above and from various within an area west of a north/south line drawn through Melbourne and south of an east/west line drawn through Donald—livestock. (d) Within an 80-km radius of the chief post office at Warrnambool—hay. (e) From Brick and Pipe Industries Ltd., situated at Northcote, Scoresby, Burwood and Clifton Brick Pty. Ltd. situated at Craigieburn and Brunswick to places within an 80-km radius of the chief post office at Warrnambool—bricks. (f) From Walkers Geelong to consignees within a 40-km radius of the chief post office at Warrnambool—Victor Plaster Board. (g) From Datsun situated at Braeside and Clayton to L. H. Faulkner Sales & Service, Warrnambool—new cars. (h) Within the Warrnambool division of the C.R.B. on behalf of the C.R.B.—concrete bridge piles, beams and sections. (i) From Vitclay, Ballarat to consignees within a 40-km radius of the chief post office at Warrnambool—earthenware pipes. (j) From Humes, Geelong to consignees within the Warrnambool area—concrete pipes, septic tanks. (k) Within an 80-km radius of Warrnambool, Hamilton, Horsham and Shepparton branches on behalf of Parkers Portable Concrete Tanks Pty. Ltd., a declared decentralized secondary industry—concrete water tanks. (l) From Pontings Sawmill at Portland and Heywood, Rowe's Sawmill at Heathmere and Porter's Sawmill at Ettrick to Ponting Bros.; Fotheringham Bros., and Hobsons Warrnambool—sawn timber. (m) From Warrnambool to Australian Paper Manufacturers, Melbourne—waste paper.

LAKES FOODRAMA PTY. LTD., Myer Street, Lakes Entrance, 3909. One commercial goods vehicle (L/C. 6-00 tonne) to operate: (a) Within a 40-km radius of Lakes Entrance in course of business as "Licensed Grocer and Mixed Business"—own goods. (b) Between Lakes Entrance and Melbourne markets—fresh fruit and vegetables and empty fruit boxes.

LEWIS, G. L., 25 High Street, Seymour, 3660. Two commercial goods vehicles (L/C. 17-45 and 12-50 tonne) to operate: (a) Within a 40-km radius of the post office at Seymour—general goods. (b) From Caltex Oil (Aust.) Ltd. depot at Spotswood to own depot at Seymour—petroleum products in drums and various small containers returning with empty drums. (c) From Chateau Tahbilk an approved decentralized secondary industry at Tahbilk to Melbourne bulk wine in hogshead and bottled wine to Van Cooth & Co. Pty. Ltd. (d) From Melbourne to Tahbilk new or second-hand bottles. (e) From Astra Engineering Pty. Ltd. Coburg to Seymour Auto Spares Pty. Ltd., Seymour an approved decentralized secondary industry and from Seymour Auto Spares Pty. Ltd. Seymour to Astra Engineering Pty. Ltd., Coburg—partly fabricated bulk bins. (f) From Melbourne to Mitchelton Vintners (Aust.) Ltd., a declared decentralized secondary industry at Mitchellstown new or secondhand bottles. (g) From manufacturing works to primary producers properties which are situated within 160 km from such works for use on such properties—superphosphate. (h) From Melbourne to Costain Aust. Ltd. at Seymour—fibrous plaster sheeting and fixing materials. (i) From consignors situated within a 40-km radius from the post office at Seymour to consignees situated within a 40-km radius from the G.P.O., Melbourne—firewood. (j) From consignors situated within a 40-km radius from the G.P.O., Melbourne to Seymour—bricks. (k) From C.S.I.R.O. "Sungarin" at Seymour to C.S.I.R.O. Werribee and Maribymong research farms—baled green hay and fresh cut lucerne. (l) From S.E.C. depot at Moreland to caravan park, Seymour—industrial briquettes. (m) From S.E.C. depot at Moreland to own premises at Seymour—briquettes in packs. (n) From Melbourne to McSwain's Seymour—glazed doors and windows and various size glass pieces. (o) From Shepparton to Victoria Dock, Melbourne—fresh fruit and vegetables in containers for export.

LOE, A. G. F. (trading as A. M. Loe & Co.), 13-15 Broomfield Street, Shepparton, 3630. One commercial goods vehicle (L/C. 16-25 tonne) to operate: (a) Within a 40-km radius of the post office at Shepparton—general goods. (b) Within a 80-km radius of own premises at Shepparton in the course of business as "Case Manufacturers"—own goods. (c) From the sawmills at Macedon, Harcourt, Mansfield, Ballarat and Baranduda to own premises at Shepparton in the course of business as "Case Manufacturers" (an approved decentralized industry)—case timber and case shooks. (d) From Cobram, Invergordon and Strathmerton areas to the S.P.C. Ltd. cannery at

Shepparton and to the Ardmora Fruit Products Co-op. Ltd. cannery at Mooropna—fresh fruit and empty cases for return. (e) From places within a 40-km radius of the G.P.O., Melbourne to own premises at Shepparton in the course of business as Case Manufacturer (an approved decentralized industry)—case timber, case shooks and nails. (f) From the terminal of Shell Co. of Australia Ltd. at Newport to Shell Co. of Australia Ltd. (agent) at Somers Avenue, Shepparton—petroleum products in prescribed containers. (g) From Shepparton to consignees in Melbourne—skins, hides and tallow, provided that not more than 10 x 200 litre drums of tallow are carried on any one journey. (h) From areas described in paragraph (c) to Melbourne metropolitan area—fresh fruit and returning with empty cases.

MAJOR BUILDING SERVICE PTY. LTD., 27 McArthurs Road, North Altona, 3025. One commercial goods vehicle (L/C. 0-85 tonne) to operate: (a) Throughout the State of Victoria in the course of business as "Maintenance Builders" on behalf of Caltex Oil (Australia) Pty. Ltd., Mobil Oil Australia Ltd., Total Australia Ltd. and Esso Standard Oil (Australia) Ltd. for the purpose of supervising own contracts—tools of trade and own plant and equipment. (b) Throughout the State of Victoria on behalf of Caltex Oil (Australia) Pty. Ltd., Mobil Oil (Australia) Ltd., Total Australia Ltd. and Esso Standard Oil (Australia) Ltd. for the purpose of repairing and erecting advertising signs—tools of trade and own plant and equipment together with advertising signs for erection.

MANGER & O'NEILL PTY. LTD., 99 Annesley Street, Echuca, 3625. One commercial goods vehicle (L/C. 6-25 tonne) to operate: (a) Within that part of the State of Victoria bounded by the cities, townships or towns (as the case may be) of Robinvale, St. Arnaud, Ballarat, Kilmore, Eildon, Myrtleford and Wodonga in the course of business as "Distributors"—potato chips, peanuts, canned fruit, fruit juices, fish, vegetables, jams, milk, jelly crystals, honey, pickles, coffee, tea, rice, flour, soft drinks, cordials, glassware, soups, sauces, straws, paperbags, cleaning chemicals and deodorants, disinfectants, insecticides, soap and soap powders, floor polishes and empty containers on return journeys to Echuca, provided that all commodities so carried shall originally have been consigned by rail to Echuca. (b) Within the State of Victoria—(i) To own factory at Echuca—goods and raw materials solely for use in that factory as an approved decentralized secondary industry in the manufacture and packaging of soft drinks and tomato products together with empty return containers for re-use. (ii) From such factory premises at Echuca—own manufactured articles and products of such decentralized industry.

MANNING, B. J., P.O. Box 16, Koondrook, 3580. One commercial goods vehicle (L/C. 0-45 tonne) to operate: (a) Within a 40-km radius of the post office at Koondrook—general goods. (b) Between and including the towns of Koondrook and Kerang—mails and parcels under contract to the P.M.G.'s department.

MARTINO, A., 67 Polwarth Street, Colac, 3250. One commercial goods vehicle (L/C. 6-90 tonne) to operate: (a) Within a 40-km radius of the post office in the City of Colac—general goods. (b) From Martino Bros. Sawmills at Barongarook to the City of Ballarat, and places situated within a 30-km radius of the chief post office in the City of Geelong—sawn timber.

MEMBREY, J. & N., PTY. LTD., Wells Road, Seaford South, 3201. One commercial goods vehicle (L/C. 13-20 tonne) to operate: (a) Within a 40-km radius of own premises at Seaford in the course of business as "Sand and Screenings Suppliers"—own goods. (b) From pits at Healesville to own premises at Seaford—own soil. (c) From pits at Bacchus Marsh to own premises at Seaford—own river pebbles and own river gravel. (d) From Werribee, Laverton, Bacchus Marsh and Rockbank areas to own premises at Seaford—own garden stone. (e) From Beveridge to own premises at Seaford—own scoria. (f) From pits at Nar-Nar-Goon to own premises at Seaford—own sand. (g) From Yea and Seymour to own premises at Seaford—own river pebbles.

This application replaces licence No. D.A.55566/3 currently held by the applicant.

MEMBREY, J. & N. PTY. LTD., Wells Road, Seaford South, 3201. One commercial goods vehicle (L/C. 12-60 tonne) to operate: (a) Within a 48-km radius of own premises at Seaford in the course of business as "Sand and Screenings Suppliers"—own goods. (b) From Healesville to own depot at Seaford—own mountain soil. (c) From Bacchus Marsh to own depot at Seaford—own river pebbles and river gravel.

(d) From Werribee, Laverton, Bacchus Marsh, and Rockbank areas to own premises at Seaford—own garden stone. (e) From Beveridge to own premises at Seaford—own scoria. (f) From Yea and Seymour to own premises at Seaford—own river pebbles.

This application replaces licence No. D.A.55566 currently held by the applicant.

MORROW, J. H., 5 Pinnacle Crescent, Bulleen, 3105. One commercial goods vehicle (L/C. 10.10 tonne) to operate from the premises of Castal Moulding Sand Pty. Ltd. at Oakleigh and Cranbourne to places within a 40-km radius of the G.P.O., Melbourne and to Geelong as an exclusive carrier solely on behalf of Castal Moulding Sand Pty. Ltd.—sand.

MURRELL, R. T. & V. M. (trading as Murrell Bros.), Foxhow Wayside Delivery, Berrybank, 3323. Two commercial goods vehicles (L/C. 16.55, 11.80 tonne) to operate: (a) Within a 40-km radius of the Township of Foxhow—general goods. (b) From or to the City of Geelong to or from properties owned by primary producers wholly within and/or fronting the boundaries of the area defined hereunder—farm produce and primary producers requisites and livestock. *Area referred to*—The area bounded on the west from the corner of Lower Darlington Road and Gnarpur Road as far as the Camperdown/Lismore Road via the road to the present boundary of the Camperdown/Foxhow Road to its junction with the Leslie Manor Road; on the east by the Leslie Manor Road and the shores of Lake Corangamite and thence via the Foxhow/Cundare Road and Cundare/Duverney Road to the junction of that road with the Lower Darlington Road and on the north by the Lower Darlington Road from its junction with the Cundare/Duverney Road to its junction with the Gnarpur Road. (c) Throughout the State of Victoria—livestock. (d) From places within a 32-km radius of the Township of Foxhow to Meggitt Ltd. at Footscray—bulk rape seed and bulk linseed. (e) From the premises of Pivot Superphosphate Company at North Shore, Geelong to places within a 32-km radius of Berrybank—superphosphate.

MCCALLUM, J. C., P.O. Box 59, Casterton, 3311. One commercial goods vehicle (L/C. 12.25 tonne) to operate: (a) Within a 40-km radius of the post office at Casterton—general goods. (b) From and to the depot of B.P. Australia Ltd. at Portland to and from applicants own premises at Casterton—petroleum products in prescribed types of containers and empty containers for return. (c) From the depot of B.P. Australia Ltd. at Hamilton to own premises at Casterton—heating oil. (d) From superphosphate works at Portland to consignees within a 160-km thereof—superphosphate. (e) For the carriage of wool to Portland but only when shorn within the areas specified hereunder. *Areas specified*—(i) The area south of the Glenelg Highway from Hamilton via Coleraine, Casterton and Ardno to the border of Victoria and South Australia. (ii) The area north of that section of highway referred to in paragraph (i) above as is not within a distance of 32 km of any railway station in Victoria. (iii) The area within an 80-km radius of the post office at Portland.

NOTE.—The provisions of the Transport Consolidated Regulations 1960 which requires that a "Waybill" or "Delivery Docket" showing the names of the consignor and consignee identified as such, a description of the goods received and the origin and destination of such goods has to be carried on the vehicle and produced by the driver on demand to an Inspector.

MCDONALD, G. J., 73 Wyong Street, East Keilor, 3042. One commercial goods vehicle (L/C. 11.65 tonne) to operate within a 56-km radius of the G.P.O. Melbourne on behalf of Pioneer Quarries (Victoria) Pty. Ltd.—sand, soil, screenings, premix and quarry products.

McGOWN, B. F., 227 Bulleen Road, Bulleen, 3105. One commercial goods vehicle (L/C. 11.00 tonne) to operate: (a) Within a 40-km radius of own premises at Bulleen in course of business as "Sand, Screening and Garden Supplies"—own goods. (b) From Yea to own premises at Bulleen—own river pebbles. (c) From Gilderoy and Toolangi to own premises at Bulleen—own mountain soil.

McKENZIE, M. R., 163 Mitchell Street, Bendigo, 3550. One commercial goods vehicle (L/C. 12.60 tonne) to operate: (a) Within a 40-km radius of the post office at Bendigo—general goods. (b) From pits at Axedale to Brunswick—clay.

McMAHON, B. T. (trading as J. McMahon & Sons), 491 Rynie Street, Geelong, 3220. One commercial goods vehicle (L/C. 8.70 tonne) to operate: (a) From the premises of Barastoc products at Kensington and/or

from own premises at Geelong to points within a 40-km radius from the chief post office in the City of Geelong and/or to the City of Colac in the course of business as "Produce Merchants"—bulk poultry and stock feed in a specially constructed bulk unit. (b) From the premises of Bunge (Australia) Pty. Ltd. an approved decentralized secondary industry at Ballarat to points within the area bounded on the west by a north/south line drawn through the Township of Lismore and on the north by an east/west line drawn through the Township of Meredith—bulk poultry and stock feed in a specially constructed bulk unit.

McMASTER, N., 1 Reid Street, Brown Hill, Ballarat, 3350. One commercial goods vehicle (L/C. 7.00 tonne) to operate: (a) Within a 40-km radius of the chief post office at Ballarat—general goods. (b) From Victorian Portland Cement at Waurm Ponds to own premises at Ballarat—bagged cement.

NOWELL, L. A. & R. J., 15 Kosciuszko Avenue, Corio, 3214. One commercial goods vehicle (L/C. 11.50 tonne) to operate: (a) Within a 40-km radius of the chief post office in the City of Geelong—general goods. (b) From the Townships of Fyansford, Anakie and Maude and from the sand and gravel pits of Trans West Cement Haulage Pty. Ltd. in the You Yangs to places within a 16-km radius of the City of Ballarat—bulk lime, scoria, sand, screenings, gravel, crushed rock and clay. (c) Within that part of an 80-km radius of the G.P.O., Melbourne, bounded on the east by a north/south line drawn through the Township of Lilydale and on the north by an east/west line drawn through the Township of Craigieburn for the carriage of the following dry bulk commodities, viz.: lime clay, sand, screenings, gravel, crushed rock, scoria, salt, muriate of potash, sulphate of ammonia, manufactured fertilizers, soda ash, sulphur, gypsum waste, overburden rubbish, aluminium dross, scrap metals and brown coal.

ORR, L. T., Bullarto R.S.D., Daylesford, 3461. One commercial goods vehicle (L/C. 11.80 tonne) to operate: (a) Throughout the State of Victoria—potatoes. (b) From the premises of Superphosphate Works in Melbourne and Geelong to consignees within a 16-km radius of Bullarto—superphosphate.

PANGRAZIO, D., 10 High Street, Heathcote, 3606. One commercial goods vehicle (L/C. 8.40 tonne) to operate: (a) Within a 40-km radius of own premises at Heathcote—general goods. (b) From Heathcote to Melbourne—firewood. (c) From Melbourne to own premises at Heathcote in the course of business as "Garage and Mixed Business Proprietor"—own goods.

PIONEER ASPHALTS PTY. LTD., P.O. Box 239, Clayton, 3168. One commercial goods vehicle (L/C. 3.80 tonne) to operate: (a) Throughout the State of Victoria in the course of business as "Road Construction Contractors"—own tools of trade and own road-making equipment. (b) Within a 32-km radius of any current contract site—materials for use on such contract and waste materials for disposal within the said area.

PRESSMASTA DRY CLEANERS PTY. LTD., 74 Scott Street, Warracknabeal, 3393. One commercial goods vehicle (L/C. 0.50 tonne) to operate: (a) Within an 80-km radius of own premises at Warracknabeal in course of business as "Dry Cleaner"—articles for dry cleaning or having been dry cleaned. (b) From Warracknabeal to the Townships of Watchem, Birchip, Beulah, Rainbow and Jeparit—newspapers and periodicals.

RICHARDSON, C., Great Ocean Road, Airey's Inlet, 3221. One commercial goods vehicle (L/C. 2.40 tonne) to operate: (a) Within an 80-km radius of the post office at Airey's Inlet in the course of business as a Timber Merchant—own goods. (b) From places within a 16-km radius of the general post office in the City of Melbourne to own premises at Airey's Inlet—own goods.

NOTE.—(i) The total combined load capacity of the vehicle as prime mover and of any trailer hauled in conjunction with the vehicle for the carriage of goods pursuant to the terms of this application shall not at any time exceed 6 tonnes. (ii) Nothing contained in paragraph (b) shall be deemed to authorize any goods taken up within a 16-km radius of the G.P.O., Melbourne, to be set down at any point beyond own premises at Airey's Inlet.

RIZAKIS, D., 43 Grenville Street, Prahran, 3181. One commercial goods vehicle (L/C. 12.55 tonne) to operate within a 56-km radius of the G.P.O., Melbourne, on behalf of Pioneer Quarries (Vic.) Pty. Ltd.—sand, soil, screenings, premix and quarry products.

SELL, A. C., 25 Kidman Avenue, Belmont, 3216. One commercial goods vehicle (L/C. 0.85 tonne) to operate within an 80-km radius of the chief post office in the City of Geelong in the course of business as a "Carpet and Vinyl Layer"—tools of trade and small quantities of carpet, vinyl and floor tiles for laying purposes only.

BARRY SHEALES HOLDEN PTY. LTD., 243 Main Street, Mornington, 3931. One commercial goods vehicle (L/C. 0.50 tonne and 1.00 tonne trailer) to operate: (a) Within an 80-km radius of own premises at Mornington in the course of business as "Motor Garage and New Car Distributor"—own goods. (b) Within an 80-km radius of own premises at Mornington on a specially constructed car-carrying trailer—wrecked and disabled motor cars being the property of own customers, provided that the said vehicle and trailer shall not be used to tow away any wrecked or damaged vehicle from the scene or area of collision or point of impact at which the damage was caused to any such vehicle and that all towing shall be confined to the subsequent disposal or repair of such vehicle after its initial towing to a garage by a properly authorized tow truck operator.

This application replaces licence No. D.A.35515/2 held in the name of C. R. Turner Motors Pty. Ltd.

TULLOCH PETROLEUM SERVICES PTY. LTD., 217 Blackburn Road, Mount Waverley, 3149. One commercial goods vehicle (L/C. 0.55 tonne) to operate throughout the State of Victoria for the purpose of servicing, maintaining and installing petroleum dispensing equipment—tools of trade, also spare parts for on-site servicing and installation together with petroleum dispensing equipment for installation.

RICHTER, B. R. (trading as Valdawn School Supplies), 179 View Street, Bendigo, 3550. One commercial goods vehicle (to be purchased approximately 1.25 tonne) to operate in the course of business as "School Stationery Supplies"—throughout that area bounded by and including the cities and townships of Wodonga, Mansfield, Eildon, Whittlesea, Bacchus Marsh, Cressy, Colac, Camperdown, Warrnambool, Ararat, Halls Gap, Warracknabeal, Hopetoun, Murrayville and Mildura—stationery supplies, school aids and equipment with the proviso that all goods are initially consigned by rail to Bendigo.

VAN EGMOND, J. T., 21 Orange Grove, Bayswater, 3153. One commercial goods vehicle (L/C. 11.70 tonne) to operate: (a) Within a 40-km radius of own premises at Bayswater in course of business as "Garden Supplies"—own goods. (b) From Beveridge to own yard at Bayswater—own scoria. (c) From Gisborne to own yard at Bayswater—own rock. (d) From Bacchus Marsh to own yard at Bayswater—own river pebbles. (e) From Garfield to own yard at Bayswater—own coarse sand. (f) From Werribee to own yard at Bayswater—own honeycomb rock.

WALKER, V. J., Mill Street, Horsham, 3400. One commercial goods vehicle (L/C. 6.55 tonne) to operate: (a) Within a 40-km radius of the post office at Horsham—general goods. (b) Within an 80-km radius of the post office at Horsham as an Agent on behalf of Esso Standard Oil (Aust.) Ltd.—petroleum products in bulk and in prescribed types of containers and also empty containers for return.

WESTERN, J. R. (trading as J. R. & E. E. Western Stores), 321 High Street, Nagambie, 3608. One commercial goods vehicle (L/C. 0.40 tonne and 0.30 tonne trailer) to operate: (a) Within an 80-km radius of own premises at Nagambie in the course of business as "Hardware and Gift Store Proprietor"—own goods. (b) From and to places situated within a 40-km radius of the G.P.O., Melbourne, to and from own premises at Nagambie—own urgently required goods and goods for return and/or for repair or having been repaired.

WHEATER, B. M. M. L., 545 Napier Street, White Hills, 3550. One commercial goods vehicle (L/C. 0.40 tonne) to operate: (a) Within a 40-km radius of Bendigo—general goods. (b) From Bendigo to Elmore, Redesdale, Heathcote, Kyneton, Malmsbury, Castlemaine, Maryborough, Goormong, Toolleen, Tara-dale, Chewton, Newstead, Elphinstone and places en route—newspapers on behalf of the Bendigo Advertiser.

WHITE, P., 3/333 Nepean Highway, Frankston, 3199. One commercial goods vehicle (L/C. 0.75 tonne) to operate throughout the State of Victoria in course of business as "Carpet and Linoleum Layer" solely on behalf of Andersons Pty. Ltd.—tools of trade and small quantities of carpet, linoleum and underlay for laying purposes only.

WILLIAMS, R. J. (trading as R. & D. Williams), R.S.D., Chetwynd via Casterton, 3311. One commercial goods vehicle (L/C. 6.45 tonne and 7.05 tonne trailer) to operate: (a) Within a 40-km radius of Chetwynd—general goods. (b) Within an 80-km radius of own premises at Chetwynd in the course of business as "Primary Producer"—own goods. (c) Within an 80-km radius of own premises at Chetwynd—livestock. (d) From Chetwynd to Portland and return—Golden Fleece petroleum products and empty returns. (e) From Superphosphate Works at Portland to consignees within a 160-km radius thereof—superphosphate. (f) For the carriage of wool to Portland but only when shorn within the areas specified hereunder. Areas Specified—(i) the area south of the Glenelg Highway from Hamilton via Coleraine, Casterton and Ardno to the border of Victoria and South Australia. (ii) The area north of that section of highway referred to in paragraph (i) above as is not within a distance of 32 road km of any railway station in Victoria. (iii) The area within an 80-km radius of the post office at Portland.

NOTE.—The provisions of the Transport Consolidated Regulations 1960 which required that a "Waybill" or "Delivery Docket" showing the names of the consignor and consignee identified as such, a description of the goods received and the origin and destination of such goods has to be carried on the vehicle and produced by the driver on demand to an Inspector.

TOW TRUCKS.

BECKETT, A. E., 310 Bluff Road, Sandringham, 3191. Application to vary the conditions of licence number D.A.46994 (L/C. 1.60 tonne) by deleting from the existing conditions "Within a 25-mile radius of the G.P.O., Melbourne" and adding in lieu "throughout the State of Victoria".

NALDER, G. W. (trading as Nalder's Garage), 2 Patrick Street, Stawell, 3380. Application to vary the conditions of licence number D.A.27941 (L/C. 2.30 tonne) by deleting from the existing conditions "Throughout the State of Victoria" and adding in lieu "Within an 80-km radius of the post office at Stawell".

RENEWALS.

Applications for renewal of licences as shown by persons listed hereunder to operate under the same terms and conditions from the expiry shown in each case.

ACKROYD, I. & N. S. DADSWELL, 8 Mont Street, Newtown, 3220; T.D.A.60683; 29th May, 1975; 1.60 tonne.

ANNETT, G. R. (trading as G. R. & B. F. Annett), Heathmere Wayside, via Portland, 3305; D.A.65113; 3rd May, 1975; 6.50 tonne and 4.45 tonne trailer.

BAIER, J., 801 Delaney Street, Albury, 2640; D.A.48938; 6th May, 1975; 7.30 tonne.

BLAKE, W. W., 24 Edward Street, Horsham, 3400; D.A.64550; 17th May, 1975; 3.70 tonne.

BORDIGNON, R., 2 Lucas Street, Wangaratta, 3677; D.A.64407; 9th March, 1975; 5.95 tonne.

BROWN, A. J., 21 Brentwood Avenue, Pascoe Vale, 3044; D.A.60670; 10th April, 1975; 6.25 tonne.

BRYANT, G. J., 17 Cresta Street, Leopold, 3221; D.A.64533; 26th April, 1975; 6.45 tonne.

ECLIPSE RADIO PTY. LTD. (trading as Canes), 168 Chester-ville Road, Moorabbin, 3189; D.A.55650/6; 26th April, 1975; 0.80 tonne.

COFFEY BROS., Southey Street, Inglewood, 3517; D.A.60680; 29th May, 1975; 6.80 tonne.

CONWAY, A. E., 34 Tennyson Street, Carrum, 3197; T.D.A.66714; 6th May, 1975; 6.75 tonne.

COOMBS, A. G. PTY. LTD., 26 Cochranes Road, Moorabbin, 3189; D.A.891; 28th January, 1975; 3.60 tonne.

COX, E. N., 38 Murphy Street, Bairnsdale, 3875; D.A.60740; 1st May, 1975; 3.95 tonne.

DALGETY AUST. LTD., 461 Bourke Street, Melbourne, 3000; D.A.46170/20; 29th April, 1975; 0.40 tonne.

DALGETY AUSTRALIA LTD., 461 Bourke Street, Melbourne, 3000; D.A.46170/28; 20th May, 1975; 0.40 tonne.

ELLIS, R. J. & B. C. (trading as J. T. Dixon & Sons), 125 Clarence Street, West Geelong, 3218; D.A.66084/1; 19th June, 1975; 0.65 tonne.

DONALD, G. A., 53 Nance Street, Noble Park, 3174; T.D.A.66070; 28th May, 1975; 2.00 tonne.

ELLIOT, A. & M. S., Bethanga, 3691; D.A.43561/2; 29th May, 1975; 8.00 tonne.

GAS & FUEL CORPORATION OF VICTORIA, 171 Flinders Street, Melbourne, 3000; D.A.49393/12; 3rd May, 1975; 0.70 tonne.

GAS & FUEL CORPORATION OF VICTORIA, 171 Flinders Street, Melbourne, 3000; D.A.49393/9; 26th April, 1975; 0.75 tonne; D.A.49393/10; 26th April, 1975; 0.75 tonne; D.A.49393/11; 26th April, 1975; 0.65 tonne.

GAS & FUEL CORPORATION OF VICTORIA, 171 Flinders Street, Melbourne, 3000; D.A.49393/51; 26th February, 1975; 2.10 tonne.

GENDORE PTY. LTD., South Gippsland Highway, Tooradin, 3980; D.A.37242/20; 29th March, 1975; 1.70 tonne and 1.00 tonne trailer.

GILL, F. W., 16 Desmond Street, Maidstone, 3012; D.A.62250; 26th April, 1975; 0.70 tonne.

GUILMARTIN, T. W. & M. L. (trading as "Guilmartins", 322 Lyttleton Terrace, Bendigo, 3550; D.A.1738/1; 30th May, 1975; 0.50 tonne.

HARRIS, H. R.; Simson Street, Carisbrook, 3464; D.A.37055; 25th May, 1975; 0.70 tonne.

HEPNER, R. G. (trading as A. M. Hepner & Sons), 73-77 Yarra Street, Geelong, 3220; D.A.55714/1; 17th April, 1975; 0.50 tonne.

HICKS, W. G. PTY. LTD., 562 City Road, South Melbourne, 3205; D.A.62469/3; 24th May, 1975; 3.45 tonne.

JOHNS, E. H. & CO. PTY. LTD., 120 King Street, Melbourne, 3000; D.A.46763/3; 17th May, 1975; 1.05 tonne.

JORDAN, R. A. PTY. LTD., 16 Levenswell Road, Moorabbin, 3189; D.A.44035/10; 22nd March, 1975; 0.65 tonne.

JUNCTION TRANSPORT CO. PTY. LTD., Grasmere Junction, 3282; D.A.35478/32; 7th June, 1975; 15.75 tonne.

JUNCTION TRANSPORT CO. PTY. LTD., Grasmere Junction, 3282; D.A.35478/33; 15th June, 1975; 18.50 tonne.

KLEEHAMMER CONTRACTING PTY. LTD., 1 Besley Street, Bruthen, 3885; D.T.258/2; 14th March, 1975; 15.80 tonne.

LOWE, L. G., Parker Street, Dunkeld, 3294; D.A.45986/2; 26th April, 1975; 3.55 tonne.

MALVERN STAR STORES, 168 Chesterville Road, Moorabbin, 3189; D.A.17246/14; 29th May, 1975; 0.75 tonne.

MALVERN STAR STORES, 168 Chesterville Road, Moorabbin, 3189; D.A.17246/9; 29th May, 1975; 0.80 tonne.

MAPLES PROPRIETARY LTD., 54-58 Deakin Avenue, Mildura, 3500; D.A.19270/2; 28th February, 1975; 1.85 tonne.

MASSEY HERBERT PTY. LTD., P.O. Box 63, Orbost, 3888; D.A.1906/5; 14th April, 1975; 1.35 tonne.

MCCLURE, J. E., 15 Plumridge Street, White Hills, 3550; D.A.60731; 16th May, 1975; 0.50 tonne.

MCINTOSH, N. G., 40 Apex Avenue, Moorabbin, 3189; D.A.49046; 6th May, 1975; 0.50 tonne.

OSBORNE, J. E., Main Road, Anakie, 3221; D.A.32657; 4th May, 1975; 6.85 tonne.

POLONI, G., 35 Irwin Street, Yarraville, 3013; D.A.64435; 9th March, 1975; 9.40 tonne.

PRIMAL CHEMICALS PTY. LTD., 26 Collins Street, Melbourne, 3000; D.A.26920/1; 26th April, 1975; 1.95 tonne.

ROBERTSON, D. & R. A., 42 Francis Street, Belmont, 3216; D.A.64582; 7th June, 1975; 3.95 tonne; D.A.64582/1; 7th June, 1975; 3.95 tonne.

ROBERTSON, J. T., 43 Pynsent Street, Horsham, 3400; T.D.A.61857; 20th May, 1975; 1.00 tonne.

REED, K., Bombala Street, Delegate, N.S.W. 2554; D.A.61556; 18th April, 1975; 1.00 tonne.

SCOWN & STANDEN PTY. LTD., P.O. Box 336, Swan Hill, 3585; D.A.55394/3; 1st May, 1975; 0.55 tonne.

STUART & HARRISON PTY. LTD., 31-33 Deakin Avenue, Mildura, 3500; D.A.46285/1; 17th April, 1975; 0.30 tonne.

TAYLOR, J. C. & SONS (AUST.) PTY. LTD., 108 Gheringhap Street, Geelong, 3220; D.A.36378; 22nd June, 1975; 5.00 tonne; D.A.36378/1; 22nd June, 1975; 3.00 tonne.

TOM THE CHEAP (VIC.) PTY. LTD., P.O. Box 60, Malvern, 3144; D.A.65111; 3rd May, 1975; 0.50 tonne.

WATERS, S. H. & CO. PTY. LTD., 160 Firebrace Street, Horsham, 3400; T.D.A.2247/10; 6th April, 1975; 1.35 tonne.

TOW TRUCKS.

BURNHAM, F. A., 10 Grange Road, Cheltenham, 3192; D.A.47319; 25th March, 1975; 2.55 tonne.

COLAC BODY & PANEL WORKS PTY. LTD., Corner Murray and Grant Streets, Colac, 3250; D.A.65339; 25th March, 1975; 4.85 tonne.

LANEWAY PANEL BEATING & SPRAY PAINTING WORKS, 370 Murray Street, Colac, 3250; D.A.48356; 22nd April, 1975; 2.80 tonne.

MIKES MOTOR BODY WORKS PTY. LTD., 120 Nicholson Street, East Brunswick, 3057; D.A.65449; 22nd May, 1975; 3.30 tonne.

PARR & SPENCER PTY. LTD., 238-240 Murray Street, Colac, 3250; D.A.44828/2; 19th June, 1975; 2.50 tonne.

SCHOTTNER, R., 32 Emily Street, Seymour, 3660; D.A.63617; 20th May, 1975; 1.75 tonne.

SMILEY, G. F., 375 Bayswater Road, Bayswater, 3153; D.A.67338; 18th February, 1975; 1.80 tonne.

VERBEEK, P. J. (trading as H. Verbeek & Sons), Broadway, Wycheproof, 3527; D.A.49078; 6th May, 1975; 3.90 tonne and 1.65 tonne trailer.

RENEWALS WITH VARIATION.

Applications made by the persons listed hereunder for renewal of the licences listed with variation of conditions in the manner set out opposite the names.

DALGETY AUSTRALIA LTD., 461 Bourke Street, Melbourne, 3000; D.A.46170/18; 29th April, 1975. Application to renew and vary the conditions of licence No. D.A.46170/18 (L/C. 0.50 tonne) by deleting "Edenhope" and adding in lieu "Hamilton".

MALVERN STAR STORES, 168 Chesterville Road, Moorabbin, 3189; D.A.17246/18; 29th May, 1975. Application to renew and vary the conditions of licence No. D.A.17246/18 (L/C. 0.70 tonne) by deleting from the existing conditions "Warragul" and adding in lieu "Ararat".

MALVERN STAR STORES, 168 Chesterville Road, Moorabbin, 3189; D.A.17246/23; 29th May, 1975. Application to renew and vary the conditions of licence No. D.A.17246/23 (L/C. 0.70 tonne) by deleting from the existing conditions "Maryborough" and adding in lieu "Mildura".

MALVERN STAR STORES, 168 Chesterville Road, Moorabbin, 3189; D.A.17246/10; 29th May, 1975. Application to renew and vary the conditions of licence No. D.A.17246/10 (L/C. 0.70 tonne) by deleting from the existing conditions "Warracknabeal" and adding in lieu "Kyabram".

MCQUALTER, A. J. H., Lake Rowan, 3727; D.A.20507; 2nd May, 1975. Application to renew and vary the conditions of licence No. D.A.20507 (L/C. 6.50 tonne) by deleting paragraph (c) and adding in lieu as paragraph (c) as follows—"(c) Within a 40-km radius of the post office at Lake Rowan—general goods." And also adding an additional paragraph (d) as follows—"(d) Within an 80-km radius from the post office at Lake Rowan in the course of business as "Primary Producer"—own goods."

THORNLEY, W. J., & CO. PTY. LTD., P.O. Box 483, Horsham, 3400; D.A.28166/6; 6th March, 1975. Application to renew and vary the conditions of licence No. D.A.28166/6 (L/C. 0.70 tonne) by deleting from paragraph (a) "Horsham" and adding in lieu "Hamilton".

WILSON, L. C., 95 Langford Parade, Paynesville, 3880; D.A.66269; 1st May, 1975. Application to renew and vary the conditions of licence No. D.A.66269 (L/C. 7.85 tonne), by deleting paragraph (a) and adding in lieu as paragraph (a)—"(a) Within a 40-km radius of the post office at Paynesville—general goods."

Notice of any objection should be forwarded to reach the Secretary of the Board not later than 15th January, 1975.

Applicants are advised that it will not be necessary to appear on the hearing date specified above, unless advised in writing by the Board.

H. SHEAHAN,
Acting Secretary.

Corner Lygon and Princes Streets, Carlton, 3053, Wednesday, 8th January, 1975.

CONTRACTS ACCEPTED.—(Series 1974-75.)

AMENDMENTS:

Item No.	Unit.	Rate.	Effective From.	Item No.	Unit.	Rate.	Effective From.
----------	-------	-------	-----------------	----------	-------	-------	-----------------

PROVISIONS 1974-75.

Gazette No. 62—13th June, 1974.

Schedule No. 1—Melbourne and Metropolitan District.

			\$		
Biscuits :					
Dry—per tin—					
1	Sao "Arnott" 3-lb. tin	1.67	} 9.12.74		
	Savoy "Brockoff"—5½-lb. tin	3.36			
	Thin Captain "Arnott"—5½-lb. tin	3.15			
	Thin Captain "Brockoff"—5½-lb. tin	3.15			
Sweet—per lb.—					
2	Marie	0.474*	} 6.12.74		
	Milk Arrowroot	0.474*			
	Nice	0.474*			
	Teddy Bear	0.474*			
	Assorted Creams	0.543*			
3	Sweet Assorted	0.489*			

* Note—minimum order :—per carton (non returnable).

21	Per 25 kg. bag	12.53	} 1.1.75		
25	" " "	12.53			
83	" " "	6.65			
177	Per gal.—Maize Oil	5.14	} 20.12.74		
	" "—Sunflower Oil	5.14			
418	Per tin	1.63	} 1.1.75		
419	" "	1.85			
420	" —1½-lb.	2.16			
427	Per 8 pkts.	19.20			

Schedule No. 18—Sub-Schedule No. 3.

2	Per doz.	18.80	} 23.12.74		
3	" "	18.80			
6	Per pkt.	0.47			
7	" "	0.47			
8	Per lb.—mild	0.65			
	" —mature	0.70			
14	" "	0.22			
16	Per bottle	0.73			
18	" "	0.73			
20	" "	1.90			
21	Per doz.	7.44			
23	Per pkt.—10 kg.	3.10			
31	Per doz.	20.28			
32	" "	20.28			
36	Per pkt.	0.46			
37	Per tin	17.20			
38	Per pkt.	3.90			
41	Per tin	0.94			
42	" "	0.27			
44	Per pkt.	0.27			
45	Per doz.	18.80			
48	Per jar	1.90			
50	Per doz.—500 gm.	2.04			
51	Per bottle	3.40			
52	" "	2.75			
53	Per doz.	17.95			
57	Each	0.51			
58	Per doz.	2.70			
60	Per tin	1.55			
65	Per doz.	4.80			

Schedule No. 18—Sub-Schedule No. 4.

Jams :—					
1	Apricot—per lb.	0.26	} 23.12.74		
	Apricot and Pine—per lb.	0.26			
	Marmalade—per doz.	16.32			
	Melon—per lb.	0.26			
	Melon and Lemon—per lb.	0.26			
	Peach—per lb.	0.26			
	Plum—per lb.	0.26			
	Plum—Dark—per lb.	0.26			
	Plum and Raspberry—per lb.	0.26			
	Quince—per lb.	0.26			

GENERAL STORES.

Gazette No. 75—31st July, 1974.

Schedule No. 48—Iron (Galvanized).

			\$		
2	" Custom Blue Orb" E.B.O./ 10.5 x 76 :—	0.69	} 23.12.74		
	Orders 450 sq. metres and over —per 10 sq. metres	28.40			
	Orders below 450 sq. metres—per 10 sq. metres	29.60			
	" Custom Orb" 0.49 :—				
	Orders 450 sq. metres and over —per 10 sq. metres	20.10			
	Orders below 450 sq. metres—per 10 sq. metres	21.20			

Schedule No. 64—Cleaning, Polishing and Toilet Requirements.

36	Per 10 gross' ctn.	13.70	11.12.74		
49	Per gal.	0.95	16.12.74		
50	Per ctn.—		} 1.1.75		
	—in lots 200 ctns	9.61			
	" " 100 "	10.04			
	" " 50 "	10.27			
	" " 10 "	10.48			
51	Per ctn.	11.25			
52	" —in lots 240 ctns.	10.98			
	—in lots 100 ctns.	11.39			
	—in lots 50 ctns.	11.59			
	—in lots 10 ctns.	11.80			

BUTTER AND CHEESE.

Gazette No. 100—9th October, 1974.

Schedule No. 26.

Butter :—					
15	Per cwt.	64.72	} 25.11.74		
	Per 56-lb.	32.36			
	Per 30-lb.	18.10			
Cheese :—					
1	Per lb.—40-lb. size—semi-matured	0.51			
2	Per lb.—40-lb. size—matured	0.54			
8	Per lb.—10-lb. size—semi-matured	0.52			
10	Per lb.—10-lb. size—matured	0.55			

TOOLS (GENERAL).

Gazette No. 30—9th April, 1974.

Schedule No. 52.

27	Each— $\frac{3}{8}$ "	0.48	} 10.12.74		
	" — $\frac{1}{2}$ "	0.50			
	" — $\frac{5}{8}$ "	0.61			
	" — $\frac{3}{4}$ "	0.78			
	" — $\frac{7}{8}$ "	0.90			
	" —1"	1.06			
	" —1"	0.85			
28	" —6" x $\frac{1}{4}$ " x $\frac{1}{4}$ "	1.04			
	" —7" x $\frac{1}{4}$ " x $\frac{1}{4}$ "	0.85			
29	" —6" x $\frac{1}{4}$ " x $\frac{1}{4}$ "	1.04			
	" —7" x $\frac{1}{4}$ " x $\frac{1}{4}$ "	0.85			
30	" —6" x $\frac{1}{4}$ " x $\frac{1}{4}$ "	1.04			
	" —7" x $\frac{1}{4}$ " x $\frac{1}{4}$ "	0.85			
46	Each	6.39	} 16.12.74		
47	" "	8.82			
48	P and N Price List No. 74				
	Std. items less 32½%				
	Asterisked items less 8%				
93	Each—2½" diam.	1.93			
157	Sidchrome Price List No. SL 2/75 less 37½%				
166	Each—8-oz.	1.68			
	" —12-oz.	2.15			
	" —16-oz.	2.53			
167	Sidchrome Price List No. SL 2/75 Less 37½%				
174	P. and N. Price List No. 74				
	Std. items less 32½%				
	Asterisked items less 8%				
272	Each	6.41			
302	" "	3.37			

AMENDMENTS—continued.

Item No.	Unit.	Rate.	Effective From.
MOTOR SPIRIT.			
<i>Gazette No. 24—27th March, 1974.</i>			
<i>Schedule No. 56.</i>			
		\$	
1A	Per gal.—metro.	0.4115	21.10.74
	" — " — "	0.4295	16.12.74
	" —country	0.4215	21.10.74
	" — " — "	0.4395	16.12.74
1B	" —metro.	0.3965	21.10.74
	" — " — "	0.4145	16.12.74
	" —country	0.4065	21.10.74
	" — " — "	0.4245	16.12.74
3A	" — " — "	0.431	} 16.12.74
3C	" — " — "	0.431	
3D	" —Golden Fleece	0.5015	
	" —Shell	0.5195	} 21.10.74
4A	" — " — "	0.517	
4C	" — " — "	0.463	
4D	" —Shell	0.463	
	" —Golden Fleece	0.556	} 16.12.74
	" — " — "	0.542	
5A	" —5 gal." drum	0.56	21.10.74
	" — " — "	0.6179	21.10.74
5B	" —44 gal." drum	0.6368	16.12.74
	" — " — "	0.4179	21.10.74
	" — " — "	0.4368	16.12.74
6	Per drum	1.744	} 16.12.74
7	Per gal.	0.241	
8	" — " — "	0.233	
9	Per ton	59.12	
10	" — " — "	57.92	

W. L. ROBERTSON, Secretary to the Tender Board, 7.1.1975

Country Fire Authority Act 1958.

FIRE DANGER PERIOD IN RESPECT OF SPECIFIED PARTS OF THE COUNTRY AREA OF VICTORIA.

Whereas by section 4 of the *Country Fire Authority Act 1958*, it is enacted that the Chief Secretary of Victoria, after consultation with the Minister of Forests, may from time to time by declaration published in the *Government Gazette* declare any period to be the fire danger period in respect of the country area of Victoria, or any specified part or parts thereof and, without affecting the generality of the foregoing, may declare different periods to be the fire danger period in respect of different parts of the said country area:

And whereas the Chief Secretary and the Minister of Forests have consulted accordingly:

Now therefore I, the Chief Secretary of Victoria, do hereby declare the period commencing at midnight on the 10th January, 1975, and ending at midnight on the 30th April, 1975, to be the fire danger period in respect of the parts of the country area of Victoria situated within the municipal districts or parts of municipal districts, being portions of the Thirteenth and Twenty-Sixth Fire Control Regions, specified in the Schedule hereunder:—

SCHEDULE No. 10.

Municipalities—

- City of Knox.
- Shires of Healesville, Sherbrooke, and Upper Yarra.
- Part Cities of Croynon, Doncaster and Templestowe (excluding those portions within the Metropolitan Fire District).
- Part Shire of Lillydale (excluding that portion within the Metropolitan Fire District).

J. F. ROSSITER,
Chief Secretary.

Chief Secretary's Office,
Melbourne, 7th January, 1975.

Country Fire Authority Act 1958.

FIRE DANGER PERIOD IN RESPECT OF SPECIFIED PARTS OF THE COUNTRY AREA OF VICTORIA.

Whereas by section 4 of the *Country Fire Authority Act 1958*, it is enacted that the Chief Secretary of Victoria, after consultation with the Minister of Forests, may from time to time by declaration published in the *Government Gazette* declare any period to be the fire danger period in respect of the country area of Victoria, or any specified

part or parts thereof and, without affecting the generality of the foregoing, may declare different periods to be the fire danger period in respect of different parts of the said country area:

And whereas the Chief Secretary and the Minister of Forests have consulted accordingly:

Now therefore I, the Chief Secretary of Victoria, do hereby declare the period commencing at midnight on the 12th January, 1975, and ending at midnight on the 30th April, 1975, to be the fire danger period in respect of the parts of the country area of Victoria situated within the municipal districts or parts of municipal districts, being portion of the Ninth Fire Control Region, specified in the Schedule hereunder:—

SCHEDULE No. 11.

Municipalities—

- City of Moe.
- Shires of Buln Buln, Korumburra, Mirboo, Narracan and Warragul.

J. F. ROSSITER,
Chief Secretary.

Chief Secretary's Office,
Melbourne, 7th January, 1975.

APPOINTMENTS AND RESIGNATIONS

APPOINTMENTS.

His Excellency the Governor of the State of Victoria, by and with the advice of the Executive Council thereof, has, by Orders made on the 17th day of December, 1974, been pleased to make the under-mentioned appointments, viz.:—

MINISTRY OF HEALTH.

Superintendent of Psychiatric Hospital, Mental Hospital and Training Centre.

JOHN MCLEOD GORDON GRIGOR, M.B., Ch.B., D.P.M., to be Superintendent, Psychiatric Hospital, Larundel, and Mental Hospital, Larundel, and Kingsbury Training Centre, pursuant to the provisions of section 26 (1) of the *Mental Health Act 1959*, from the 21st December, 1974, vice Dr. D. Barlow, on leave.

Psychiatrist Superintendent.

JOHN MCLEOD GORDON GRIGOR, M.B., Ch.B., D.P.M., to be Psychiatrist Superintendent, Mental Hygiene Branch, Department of Health, pursuant to the provisions of section 20 (3) of the *Mental Health Act 1959*, from the 19th January, 1975, vice Dr. D. Barlow, resigned.

Consultant Psychiatrist.

GRAHAM WILFRED MELLOP, M.B., Ch.B., D.P.M., to be Consultant Psychiatrist, Mental Hygiene Branch, Department of Health, pursuant to the provisions of section 20 (3) of the *Mental Health Act 1959*.

Trustee of Public Cemetery.

EDWARD STEPHEN RYBERG to be a Trustee of the Emerald Public Cemetery, vice W. Legg, deceased, pursuant to section 3 (1) of the *Cemeteries Act 1958*.

LAW DEPARTMENT.

Commissioners for Taking Declarations, &c.

- MICHAEL WINSTON BLYTH, care of Edward Waters and Sons, 30 Russell Street, Melbourne.
- RAYMOND ARTHUR BOWYER, care of P.M.G. Department, 152 Elizabeth Street, Melbourne.
- ALAN THOMAS CARTER, 13 Pultney Street, Dandenong.
- WILLIAM ARTHUR EDWARDS,
- REX HACKWILL,
- ANTHONY McEVOY,
- STUART HAROLD WALKER, and
- ANDREJS VOLDEMARS ZALUDKA, care of State Accident and Motor Car Insurance Offices, 480 Collins Street, Melbourne.
- LLOYD WILLIAM EMPSON, care of Quaker Products Aust. Ltd., Sunshine Road, West Footscray.
- CHRISTOPHER CHARLES GRAETZ, care of Statax Co-operative Credit Society Ltd., 350 Collins Street, Melbourne.
- VERNE FRANCIS JOHN HOOPER, Spring Gully, Fryers-town.
- RONALD CLIVE HUTCHENS, care of Liner Services Pty. Ltd., Terminal Depot, Appleton Dock, West Melbourne.
- STEVEN THEAN-ANN LEE, care of State College of Victoria—Rusden, Blackburn Road, Clayton.

JOANNES MULLER, care of Coleman, McClure and Wilby, Accountants, 367 Victoria Street, Abbotsford.

JOHN WILLIAM O'CONNOR, 463 Melbourne Road, Newport.

DONATO ROMANELLA, 66 Well Street, Middle Brighton, MALCOLM RONALD TALATI, care of A.G.C. (Advances) Ltd., 170 Queen Street, Melbourne.

HARRY MAURICE TEW, care of Office of the Public Service Board, 1 Treasury Place, Melbourne.

KEITH LEONARD WARFE, 52 Fifth Avenue, Chelsea Heights, and

HERBERT PETER WARREN, care of Alderdice Brass Founders Pty. Ltd., Henna Street, Warrnambool, to be Commissioners for taking Declarations and Affidavits under the Evidence Act 1958.

Justices of the Peace.

DONALD SYDNEY GILLARD, Spencer Street, Nar-Nar-Goon.

ALAN HECTOR FERGUS NICKOLS, 11 Amiens Street, Sutey Hills.

DOROTHY MURIEL RUTH REEKIE, 7 James Street, Belmont, and

KENNETH JACK SPUNNER, 11 Hakea Avenue, West Rosebud, to be Justices of the Peace for the State of Victoria.

MINES DEPARTMENT.

Acting Chairman of Board of Examiners for Engine Drivers.

RAYMOND STANLEY DAVEY, member of the Board of Examiners for Engine Drivers, to be Acting Chairman of the Board, vice Gilbert Hadden, resigned, in pursuance of the provisions of section 401 (1) of the Mines Act 1958.

DEPARTMENT OF WATER SUPPLY.

Waterworks Trusts Commissioners.

ROBERT GRAHAM JOHNSTONE to be a Commissioner of the Lismore and Derrinallum Waterworks Trust, to hold such position from the date hereof until the date of the next election of the Trust, to be held in 1976, subject to the provisions of the Water Act; and

NEVILLE THOMAS BROADBENT to be a Commissioner of the Beaufort Waterworks Trust, to hold such position from the date hereof until 30th October, 1976, subject to the provisions of the Water Act.

TOM FORRISTAL,
Clerk of the Executive Council.

At the Executive Council Chamber,
Melbourne, 17th December, 1974.

APPOINTMENTS.

His Excellency the Governor of the State of Victoria, by and with the advice of the Executive Council thereof, has, by Orders made on the 24th day of December, 1974, been pleased to make the under-mentioned appointments, viz.:

CHIEF SECRETARY'S DEPARTMENT.

Warden of Archaeological Area.

RONALD BELL CHIRNSIDE, pursuant to the provisions of the Archaeological and Aboriginal Relics Preservation Act 1972, to be a Warden in respect of an archaeological area being allotment 28, Parish of Wurdi Youyang, County of Grant.

CROWN LANDS AND SURVEY DEPARTMENT.

Managers of Common.

SAMUEL BENJAMIN WILDE,
ALAN CHARLES KENT,
HAROLD HENRY KENT, and
RONALD HENRY KENT,
to be Managers of the Moyston Common, for a period ending the 31st December, 1977, pursuant to the provisions of section 182 of the Land Act 1958.

MINISTRY OF HEALTH.

Members of Committees of Management of Hospitals.

CHARLES HENRY CLAMP to be Government appointee on the Committee of Management of The Queen Elizabeth Geriatric Centre;

ALFRED HOOTON to be Government appointee on the Committee of Management of the Warrnambool and District Base Hospital; and

ALAN PURVES BRUMLEY

to be Government appointee on the Committee of Management of the Korumburra District Hospital; re-appointed for periods of three years commencing the 15th January, 1975, pursuant to the provisions of sub-paragraph (ii) of paragraph (a) of the proviso to sub-section (1) of section 48 of the Hospitals and Charities Act 1958; and

WALTER GORDON WRIGHT

to be Government appointee on the Committee of Management of the Dandenong and District Hospital, re-appointed for a term of three years commencing the 4th January, 1975, pursuant to the provisions of sub-paragraph (ii) of paragraph (a) of the proviso to sub-section (1) of section 48 of the Hospitals and Charities Act 1958.

LAW DEPARTMENT.

Prothonotary of the Supreme Court (Acting).

BRYAN MAURICE HICKEY

to act as Prothonotary of the Supreme Court of Victoria, during the absence of P. S. Malbon, on recreation leave.

SOCIAL WELFARE DEPARTMENT.

Chaplain of Prison.

WILLIAM JOHN CAFFREY (Reverend Father), care of The Presbytery, Commercial Road, Morwell, to be Chaplain (part-time), Roman Catholic, H.M. Morwell River Reforestation Prison.

TOM FORRISTAL,

Clerk of the Executive Council.

At the Executive Council Chamber,
Melbourne, 24th December, 1974.

Education Act 1958.

APPOINTMENT OF MEMBERS OF TEACHERS REGISTRATION BOARDS.

His Excellency the Governor of the State of Victoria by and with the advice of the Executive Council thereof doth by Order made on the 24th day of December, 1974, pursuant to the powers conferred by the Education Act 1958, appoint the following persons to be members of teachers registration boards as shown:—

TREVOR STUART WAITE, to be a member of the Primary Teachers Registration Board, vice Donald Thomas Reeves.

ALAN WILLIAM MILL, to be a member of the Primary Teachers Registration Board, vice Bartley Robert Dinsmore.

JUDITH ELIZABETH THURLEY, to be a member of the Secondary Teachers Registration Board, vice Hugh Glynn Evans; and

MARGARET ELIZABETH BURNS, to be a member of the Technical Teachers Registration Board, vice Douglas van Reein Alkamade.

TOM FORRISTAL,

Clerk of the Executive Council.

At the Executive Council Chamber,
Melbourne, 24th December, 1974.

APPOINTMENT OF DEPUTY MINING REGISTRAR.

His Excellency the Governor of the State of Victoria, by and with the advice of the Executive Council thereof, doth by Order made on the 3rd day of December, 1974, appoint Ernest Alfred Jackman, to act as Deputy Mining Registrar, at Bendigo, for the Sandhurst Division of the Bendigo Mining District.

TOM FORRISTAL,

Clerk of the Executive Council.

At the Executive Council Chamber,
Melbourne, 3rd December, 1974.

Tobacco Leaf Industry Stabilization Act 1966.

APPOINTMENT OF MEMBERS OF THE TOBACCO QUOTA COMMITTEE.

In pursuance of the powers conferred upon me by section 6 of the Tobacco Leaf Industry Stabilization Act 1966, I Ian Winton Smith, Minister of Agriculture for the time being of the State of Victoria, after consultation with The Tobacco Leaf Marketing Board, hereby appoint the following persons, as members of the Tobacco Quota Committee for a period of three (3) years from and inclusive of the 1st January, 1975:—

DESMOND JOHN MCCORMACK,
ANGELO RIGONI, and
HAROLD ARTHUR WHITE,
who shall be representatives of tobacco producers.

IAN SMITH,
Minister of Agriculture.

23rd December, 1974.

Tobacco Leaf Industry Stabilization Act 1966.

APPOINTMENT OF CHAIRMAN OF THE TOBACCO QUOTA COMMITTEE.

In pursuance of the powers conferred upon me by section 6 of the Tobacco Leaf Industry Stabilization Act 1966, I Ian Winton Smith, Minister of Agriculture for the time being of the State of Victoria, hereby appoint HARRY GUY DARLING to be Chairman of the Tobacco Quota Committee from and inclusive of the 1st January, 1975.

IAN SMITH,
Minister of Agriculture.

23rd December, 1974.

Liquor Control Act 1968.

APPOINTMENT OF LICENSING INSPECTORS.

In accordance with the authority conferred upon me by sub-section (1) of Section 22 of the Liquor Control Act 1968, I, Reginald Jackson, Chief Commissioner of Police, hereby appoint the following Officers of Police as Licensing Inspectors for the Divisions of the Police Districts as shown:—

Division Number.	Police District.	Rank and Name.
2	Moonee Ponds ..	Inspector Frederick Maxwell Elliott (from 27.12.74 to 20.2.75).
5	Moonee Ponds ..	Inspector Leslie William Cannon (from 23.12.74 to 11.1.75).
2	Cheltenham ..	Inspector Laurence Gordon Taylor (from 19.12.74 to 18.1.75).
4	Sunshine ..	Inspector Thomas Owen Daly (from 17.12.74 to 25.1.75).

3.1.1975

R. JACKSON,
Chief Commissioner of Police.

REVOCAION OF APPOINTMENT OF COMMISSIONER FOR TAKING DECLARATIONS, ETC.

His Excellency the Governor of the State of Victoria by and with the advice of the Executive Council thereof doth by Order made on the 17th day of December, 1974, revoke the appointment of Peter Ernest Lowry as a Commissioner for taking Declarations and Affidavits under the Evidence Act 1958.

TOM FORRISTAL,
Clerk of the Executive Council.

At the Executive Council Chamber,
Melbourne, 17th December, 1974.

REVOCAION OF APPOINTMENT OF A BAILIFF OF CROWN LANDS.

His Excellency the Governor of the State of Victoria by and with the advice of the Executive Council thereof doth by Order made on the 24th day of December, 1974, pursuant to the provisions of section 30 (1) of the Land Act 1958, revoke the appointment of Basil Allan Rush as a bailiff of Crown lands, made by the Governor in Council on the 22nd September, 1970, and notified in the Government Gazette of 30th September, 1970.

TOM FORRISTAL,
Clerk of the Executive Council.

At the Executive Council Chamber,
Melbourne, 24th December, 1974.

RESIGNATIONS.

His Excellency the Governor of the State of Victoria, by and with the advice of the Executive Council thereof, has, by Order made on the 24th day of December, 1974, accepted the resignations of the persons named hereunder of the office mentioned, viz.:—

SOCIAL WELFARE DEPARTMENT.
Probation and Parole Officers.

SHELLEY HASSARD (Miss),
BARBARA SHAH (Mrs.), and
YVONNE MUTTON (Mrs.),
as Probation and Parole Officers, pursuant to the provisions of section 8 (2) of the Children's Court Act 1973, section 507 (1) of the Crimes Act 1958 and section 165 (1) and 189 (2) of the Social Welfare Act 1970 (as amended), from and inclusive of 30th October, 1974, 29th October, 1974, and 30th November, 1974, respectively.

TOM FORRISTAL,
Clerk of the Executive Council.

At the Executive Council Chamber,
Melbourne, 24th December, 1974.

RESIGNATIONS.

His Excellency the Governor of the State of Victoria, by and with the advice of the Executive Council thereof, has, by Orders made on the 17th day of December, 1974, accepted the resignations of the persons named hereunder of the offices mentioned, viz.:—

LAW DEPARTMENT.

Commissioners for Taking Declarations, &c.

JOHN LAMBERT BRANDL,
LILLIAN EVA BUCKMAN,
FRANZ DENK,
RAYMOND NOEL GERRING,
CESARE MARZOCCHI, and
ALLAN KENNETH WOODBERRY,
as Commissioners for taking Declarations and Affidavits under the Evidence Act 1958.

Justices of the Peace.

JAMES EDDIE, and
THOMAS LOFTUS TAYLOR
as Justices of the Peace for the State of Victoria.

TOM FORRISTAL,
Clerk of the Executive Council.

At the Executive Council Chamber,
Melbourne, 17th December, 1974.

ORDERS IN COUNCIL

STATE ELECTRICITY COMMISSION ACT 1958.

At the Executive Council Chamber, Melbourne, the
seventeenth day of December, 1974.

PRESENT:

His Excellency the Governor of Victoria.
Mr. Rossiter | Mr. Dunstan
Mr. Hunt | Mr. Houghton.

APPOINTMENT OF THE CHAIRMAN OF THE FALLS CREEK TOURIST AREA MANAGEMENT COMMITTEE.

Pursuant to the provisions of the State Electricity Commission Act 1958 and the Falls Creek Tourist Area Regulations 1971, His Excellency the Governor of the State of Victoria, by and with the advice of the Executive Council thereof doth by this Order appoint—

JOHN DOUGLAS SWANN
to be a Member and the Chairman of the Falls Creek Tourist Area Management Committee for a period of one year from and including the 1st day of January, 1975.

And the Honorable James Charles Murray Balfour, Her Majesty's Minister for Fuel and Power for the State of Victoria, shall give the necessary directions herein accordingly.

TOM FORRISTAL,
Clerk of the Executive Council.

GEELONG HARBOR TRUST ACT 1958.

At the Executive Council Chamber, Melbourne, the
seventeenth day of December, 1974.

PRESENT:

His Excellency the Governor of Victoria.
Mr. Rossiter | Mr. Dunstan
Mr. Hunt | Mr. Houghton.

APPOINTMENT OF A COMMISSIONER OF THE GEELONG HARBOR TRUST COMMISSIONERS.

In accordance with the provisions of the Geelong Harbor Trust Act 1958, His Excellency the Governor of the State of Victoria, by and with the advice of the Executive Council thereof, doth by this Order re-appoint GORDON DAVID MURRAY, a Commissioner of the Geelong Harbor Trust Commissioners for a period of three years ending 31st December, 1977.

And the Honorable Roberts Dunstan, Her Majesty's Minister of Public Works for the State of Victoria, shall give the necessary directions accordingly.

TOM FORRISTAL,
Clerk of the Executive Council.

COUNTRY ROADS BOARD.
Act No. 6229.

At the Executive Council Chamber, Melbourne, the
seventeenth day of December, 1974.

PRESENT:

His Excellency the Governor of Victoria.
Mr. Rossiter | Mr. Dunstan
Mr. Hunt | Mr. Houghton.

ORDER APPROVING OF LAND BEING ACQUIRED AND
ROADS, DEVIATIONS OR WIDENINGS BEING MADE
TOGETHER WITH ALL ANCILLARY WORKS
REQUIRED TO BE EXECUTED IN CONJUNCTION
THEREWITH.

His Excellency the Governor of the State of Victoria,
by and with the advice of the Executive Council thereof,
being satisfied that there are funds legally available for
acquiring the land, doth hereby approve the acquiring of
the land described in the Schedule hereunder and the
making of new roads and deviations from and widenings
of existing roads, together with all ancillary works required
to be executed in conjunction therewith, referred to in
the said Schedule.

SCHEDULE.
State Highways.

The land shown hatched on plan numbered G.P.13797
hereunder required for the widening of the Western
Highway in the Shire of Kaniva and making of the widen-
ing thereon.

STATE HIGHWAY
WESTERN HIGHWAY
SHIRE OF KANIVA
Lengths in metres

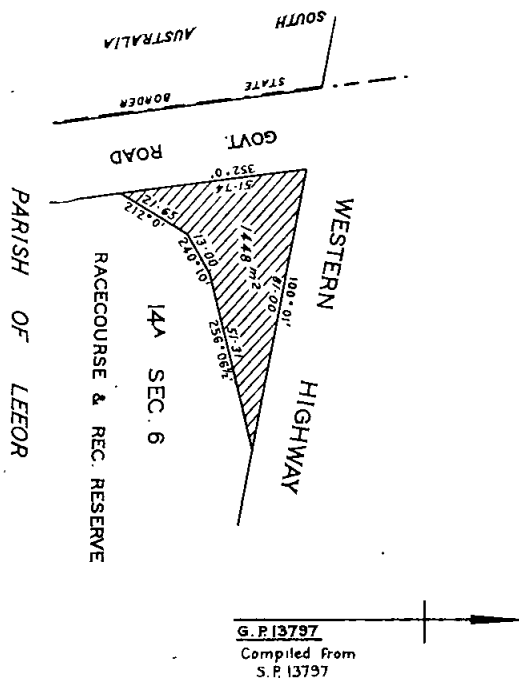

The land shown hatched on plan numbered G.P.13845
hereunder required for the widening of the Goulburn
Valley Highway in the Shire of Seymour and making of
the widening thereon.

STATE HIGHWAY
GOULBURN VALLEY HIGHWAY
SHIRE OF SEYMOUR
Lengths in metres

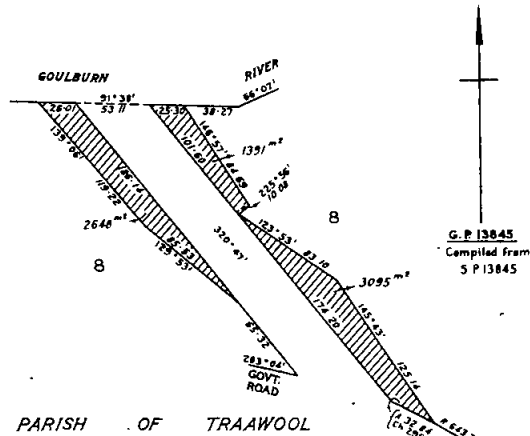

The land shown hatched on plans numbered G.P.13809A
and G.P.13809B hereunder required for the widening of
the Princes Highway in the Shire of Tambo and making
of the widening thereon.

STATE HIGHWAY
PRINCES HIGHWAY
SHIRE OF TAMBO
Lengths in Metres

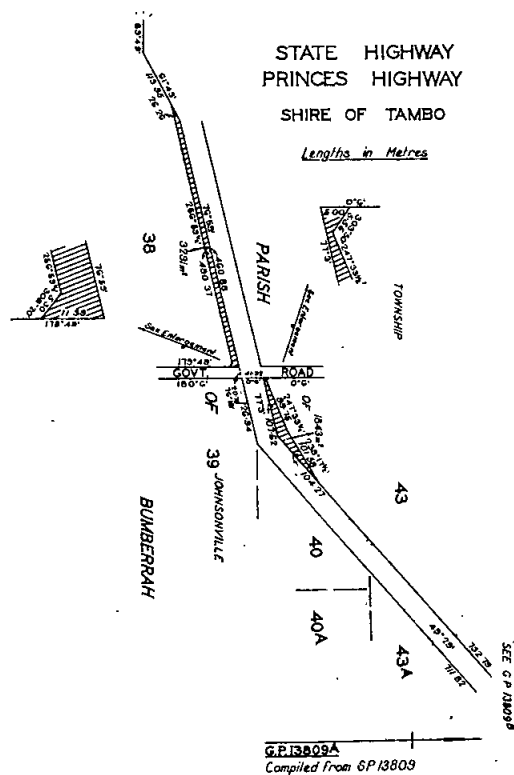

STATE HIGHWAY
PRINCES HIGHWAY

SHIRE OF TAMBO

Lengths in Metres

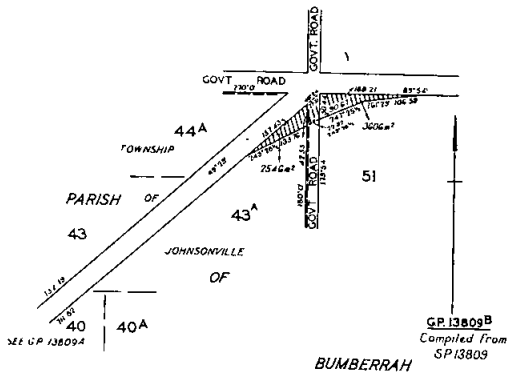

The land shown hatched on plan numbered G.P.13749B hereunder required for the widening of the Hume Highway in the City of Wangaratta and making of the widening thereon.

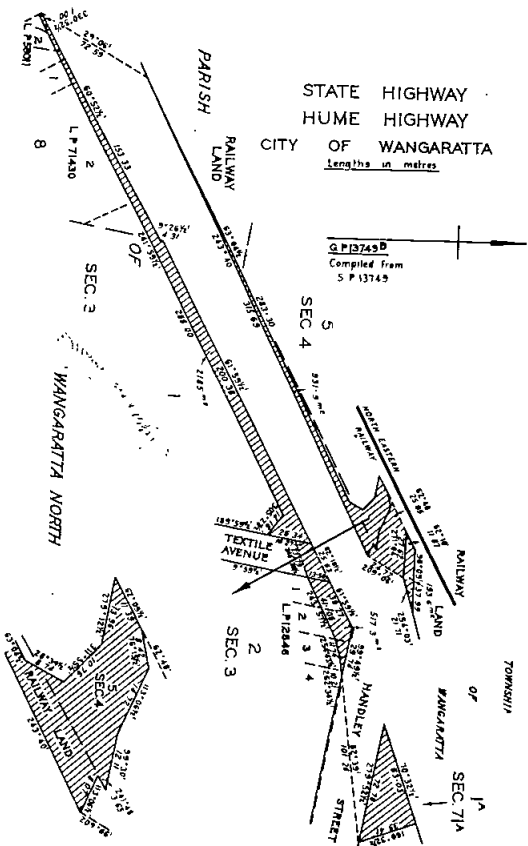

Main Road.

The land shown hatched on plan numbered G.P.13501 hereunder required for the widening of the Geelong-Portarlington Road in the Shire of Bellarine and making of the widening thereon.

No. 1.—12660/74.—3

MAIN ROAD
GEELONG—PORTARLINGTON ROAD

SHIRE OF BELLARINE

Lengths in Metres

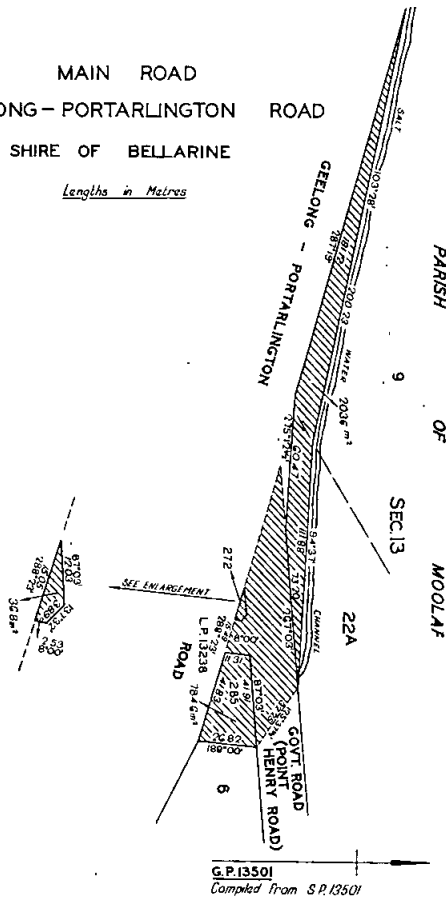

Unclassified Road.

The land shown hatched on plan numbered G.P.13749A hereunder required for the widening of a road in the City of Wangaratta and making of the widening thereon.

ROAD

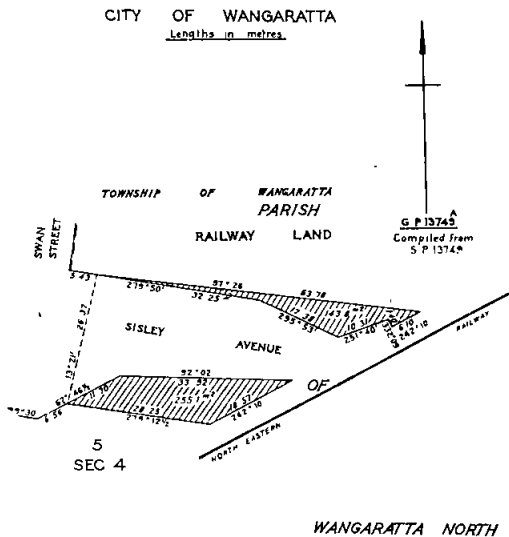

And the Honorable Edward Raymond Meagher, Her Majesty's Minister of Transport for the State of Victoria, shall give the necessary directions herein accordingly.

TOM FORRISTAL,
Clerk of the Executive Council.

Land Act 1958.

DEPARTMENT OF CROWN LANDS AND SURVEY.

At the Executive Council Chamber, Melbourne, the seventeenth day of December, 1974.

PRESENT:

His Excellency the Governor of Victoria.

Mr. Rossiter | Mr. Dunstan
Mr. Hunt | Mr. Houghton.

LANDS TEMPORARILY RESERVED AS SITES.

His Excellency the Governor of the State of Victoria, by and with the advice of the Executive Council thereof, doth hereby in pursuance of the provisions of section 14 of the Land Act 1958, reserve temporarily from sale, from being leased and from having a licence granted in respect thereof, and also except from occupation for mining purposes under any miner's right the lands hereinafter described, viz.:-

ASCOT.—Site for Public purposes (Public Recreation), 1600 square metres, more or less, being Crown allotment 48b, Parish of Ascot, County of Ripon as indicated by hatching on plan hereunder.—(A.69⁽²⁾) (Rs.9986).

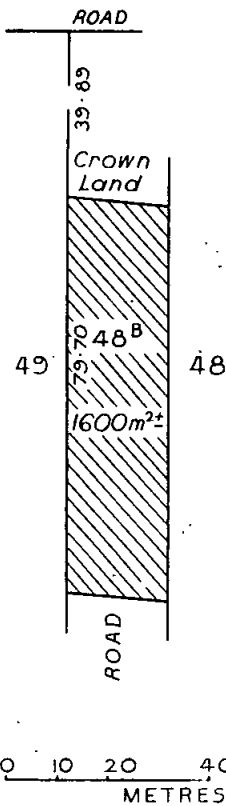

ASCOT.—Site for Public purposes (Educational purposes), 830 square metres, more or less, being Crown allotment 48A, Parish of Ascot, County of Ripon as indicated by hatching on plan hereunder.—(A.69⁽²⁾) (Rs.9987).

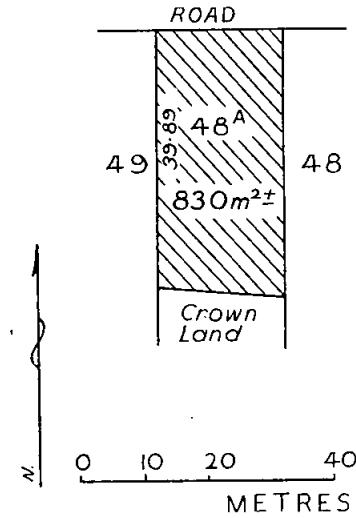

LYONS.—Site for Public purposes (Preservation of the Landscape), 22 hectares, more or less, being Crown allotment 10, section 8, Township of Lyons, Parish of Glenaulin, County of Normanby as indicated by hatching on plan hereunder.—(L.104⁽⁸⁾) (Rs.9985).

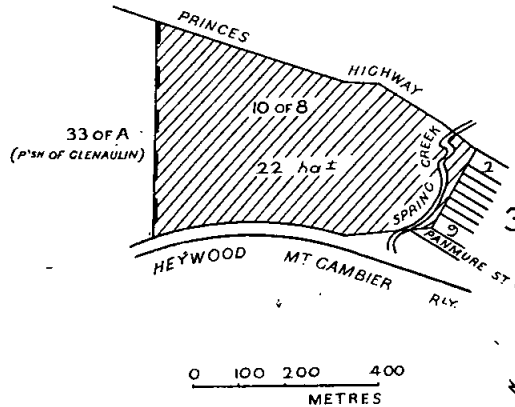

OLANGOLAH (BEECH FOREST).—Site for Public purposes (Departmental Residence), 607 square metres being Crown allotment 13Y, Parish of Olangolah, County of Polwarth as indicated by hatching on plan hereunder.—(O.24⁽⁵⁾) (Rs.10018).

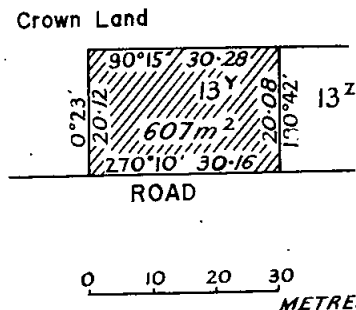

RUSHWORTH.—Site for Public Recreation purposes, 7700 square metres, more or less, being Crown allotment 4, section 29, Township of Rushworth, Parish of Moora, County of Rodney as indicated by hatching on plan hereunder.—(R.47⁽⁷⁾) (Rs.5952).

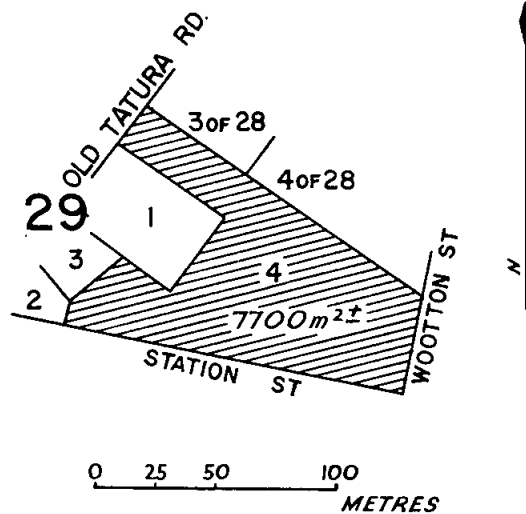

TRUGANINA.—Site for Public purposes (Police purposes), 847 square metres, being Crown allotment 4C, section A, Parish of Truganina, County of Bourke as indicated by hatching on plan hereunder.—(T.109⁽⁶⁾) (Rs.10021).

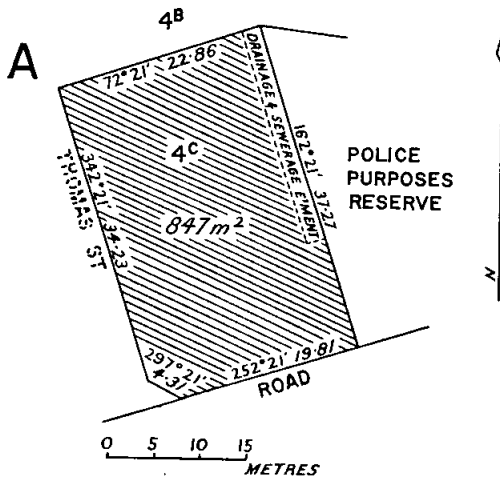

And the Honorable William Archibald Borthwick, Her Majesty's Minister of Lands for the State of Victoria, shall give the necessary directions herein accordingly.

TOM FORRISTAL,
Clerk of the Executive Council.

DEPARTMENT OF CROWN LANDS AND SURVEY.

At the Executive Council Chamber, Melbourne, the seventeenth day of December, 1974.

PRESENT:

His Excellency the Governor of Victoria.
Mr. Rossiter | Mr. Dunstan
Mr. Hunt | Mr. Houghton.

AMENDMENT OF BOUNDARIES OF LAND VESTED IN THE MELBOURNE AND METROPOLITAN BOARD OF WORKS.

His Excellency the Governor of the State of Victoria, by and with the advice of the Executive Council thereof, in pursuance of the provisions of Section 22A (4) (a)

of the Land Act 1958, hereby amends the metes and bounds of the land described in the Third Schedule of the Melbourne and Metropolitan Board of Works Act 1915 by the excision therefrom of the land containing 12 hectares, more or less, in the Parish of Nillumbik, County of Evelyn, as indicated by hatching on plan hereunder.—(C.93897).

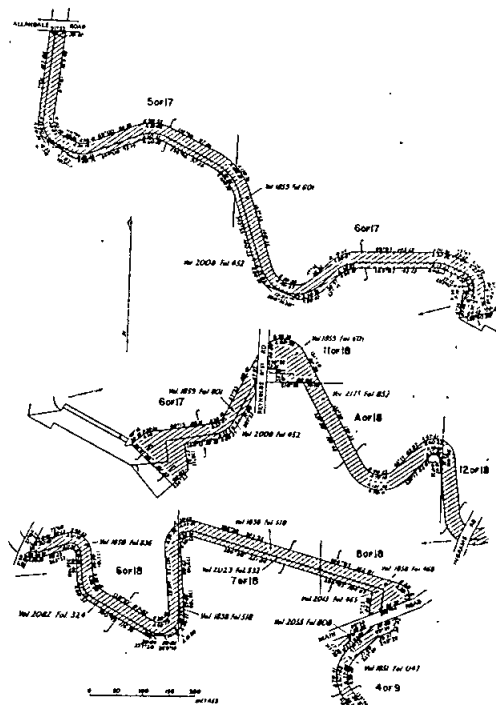

Total area of hatched portions 12 ha±

And the Honorable William Archibald Borthwick, Her Majesty's Minister of Lands for the State of Victoria, shall give the necessary directions herein accordingly.

TOM FORRISTAL,
Clerk of the Executive Council.

DEPARTMENT OF CROWN LANDS AND SURVEY.

At the Executive Council Chamber, Melbourne, the seventeenth day of December, 1974.

PRESENT:

His Excellency the Governor of Victoria.
Mr. Rossiter | Mr. Dunstan
Mr. Hunt | Mr. Houghton.

REVOCATION OF TEMPORARY RESERVATIONS OF LANDS BY ORDERS IN COUNCIL.

His Excellency the Governor of the State of Victoria, by and with the advice of the Executive Council thereof, in pursuance of the provisions of the Land Act 1958, hereby revokes the temporary reservations of lands by Orders in Council hereinafter described:—

MALDON (NUGGETTY).—The temporary reservation by Order in Council of the 30th April, 1910, of 8094 square metres (2 acres) of land in the Parish of Maldon as a site for a State School.—(M.449⁽¹⁶⁾) (C.60483).

MALDON (NUGGETTY).—The temporary reservation by Order in Council of the 13th May, 1914, of 4047 square metres (1 acre) of land in the Parish of Maldon as a site for a State School.—(M.449⁽¹⁶⁾) (C.60483).

WONGA WONGA SOUTH.—The temporary reservation by Order in Council of the 4th July, 1939, of 4275 square metres (1 acre 9 perches) of land in the Parish of Wonga Wonga South as a site for Public purposes.—(W.353⁽¹¹⁾) (Rs.4951).

GLENMONA (LAMPLOUGH).—The temporary reservation by Order in Council of the 5th May, 1896, of 2.023 hectares (5 acres) of land in the Parish of Glenmona as a site for Public Recreation so far only as portion containing 3067 square metres, as defined by description and hatching on plan published in the *Government Gazette* of 13th November, 1974.—(G.155^(s)) (Rs.4772).

HOLDEN (SUNBURY).—The temporary reservation by Order in Council of the 18th July, 1864 (see *Government Gazette*, 1864, page 1670) of 451.2 hectares (1115 acres, more or less) of land in the Parish of Holden as a site for Industrial School, revoked as to part by various Orders so far as the balance thereof containing 426.1 hectares (1052 acres 3 roods 28 perches, more or less) is concerned.—(H.99^(s)) (Rs.7215).

LAMPLOUGH.—The temporary reservation by Order in Council of the 13th February, 1865 (see *Government Gazette*, 1865, page 459) of 3966 square metres (3 roods 36 8/10 perches) of land in the Township of Lamplough as a site for Presbyterian Church purposes so far only as the portion containing 746 square metres as defined by description and hatching on plan published in the *Government Gazette* of 13th November, 1974.—(L.134^(s)) (Rs.10024).

WA-DE-LOCK.—The temporary reservation by Order in Council of the 19th March, 1894, of 46.72 hectares (115 acres 1 rood 31 perches) of land in the Parish of Wa-de-lock as a site for Public purposes, revoked as to part by various Orders so far only as the portion containing 17 hectares, more or less, as defined by description and hatching on plan published in the *Government Gazette* of 13th November, 1974.—(W.89^(1s)) (Rs.855).

And the Honorable William Archibald Borthwick, Her Majesty's Minister of Lands for the State of Victoria, shall give the necessary directions herein accordingly.

TOM FORRISTAL,
Clerk of the Executive Council.

LAND ACT 1958.

At the Executive Council Chamber, Melbourne, the seventeenth day of December, 1974.

PRESENT:
His Excellency the Governor of Victoria.
Mr. Rossiter | Mr. Dunstan
Mr. Hunt | Mr. Houghton.

UNUSED ROAD CLOSED.

In pursuance of the provisions of section 349 of the *Land Act* 1958, His Excellency the Governor of Victoria, by and with the advice of the Executive Council thereof, and the concurrence in writing of the Council of the municipality concerned doth hereby close the unused road referred to hereunder, viz.:—

Parish of Sandhurst, County of Bendigo being the road as indicated by hatching on plan hereunder.—(S.371^(4s)) (W.86290).

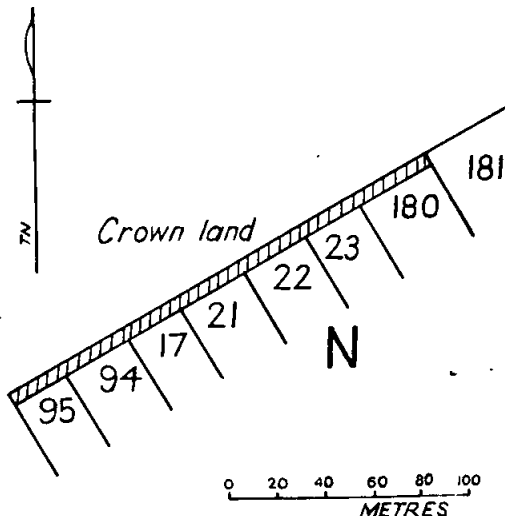

And the Honorable William Archibald Borthwick, Her Majesty's Minister of Lands for the State of Victoria, shall give the necessary directions herein accordingly.

TOM FORRISTAL,
Clerk of the Executive Council.

SUPERANNUATION ACT 1958.

At the Executive Council Chamber, Melbourne, the seventeenth day of December, 1974.

PRESENT:
His Excellency the Governor of Victoria.
Mr. Rossiter | Mr. Dunstan
Mr. Hunt | Mr. Houghton.

Pursuant to the powers conferred by the provisions of paragraph (ja) of sub-section (1) of section 3 of the *Superannuation Act* 1958, His Excellency the Governor of the State of Victoria, by and with the advice of the Executive Council thereof doth by this Order declare that the provisions of the *Superannuation Act* shall apply to DIANE JOY HENDERSON being an officer of the State College of Victoria at Coburg constituted pursuant to the provisions of the *Education Act* 1958 No. 6240.

And the Honorable Rupert James Hamer, Her Majesty's Treasurer for the State of Victoria, shall give the necessary directions herein accordingly.

TOM FORRISTAL,
Clerk of the Executive Council.

SUPERANNUATION ACT 1958.

At the Executive Council Chamber, Melbourne, the seventeenth day of December, 1974.

PRESENT:
His Excellency the Governor of Victoria.
Mr. Rossiter | Mr. Dunstan
Mr. Hunt | Mr. Houghton.

Pursuant to the powers conferred by the provisions of paragraph (ja) of sub-section (1) of section 3 of the *Superannuation Act* 1958, His Excellency the Governor of the State of Victoria, by and with the advice of the Executive Council thereof doth by this Order declare that the provisions of the *Superannuation Act* shall apply to:—

HORNE, ISABEL ANNIE,
SMITH, ROSS GIBSON
WESTBROOK, EMILY MURIEL, and
WILLIS, JOYCE,

being officers of the State College of Victoria, Rusden, constituted pursuant to the provisions of the *Education Act* 1958 No. 6240.

And the Honorable Rupert James Hamer, Her Majesty's Treasurer for the State of Victoria, shall give the necessary directions herein accordingly.

TOM FORRISTAL,
Clerk of the Executive Council.

SUPERANNUATION ACT 1958.

At the Executive Council Chamber, Melbourne, the seventeenth day of December, 1974.

PRESENT:
His Excellency the Governor of Victoria.
Mr. Rossiter | Mr. Dunstan
Mr. Hunt | Mr. Houghton.

Pursuant to the powers conferred by the provisions of paragraph (ja) of sub-section (1) of section 3 of the *Superannuation Act* 1958, His Excellency the Governor of the State of Victoria, by and with the advice of the Executive Council thereof doth by this Order declare that the provisions of the *Superannuation Act* shall apply to MARJORIE-DORE MARTIN being an officer of the State College of Victoria at Toorak constituted pursuant to the provisions of the *Education Act* 1958 No. 6240.

And the Honorable Rupert James Hamer, Her Majesty's Treasurer for the State of Victoria, shall give the necessary directions herein accordingly.

TOM FORRISTAL,
Clerk of the Executive Council.

LOCAL GOVERNMENT DEPARTMENT.

At the Executive Council Chamber, Melbourne, the
seventeenth day of December, 1974.

PRESENT:

His Excellency the Governor of Victoria.	
Mr. Rossiter	Mr. Dunstan
Mr. Hunt	Mr. Houghton.

ROAD DISCONTINUED.—SHIRE OF CORIO.

Whereas it is provided in section 528 (2) of the *Local Government Act 1958*, that where a road (whether or not a public highway but not being a road set out on land of the Crown) or any part thereof is not required for public use the Governor in Council on the request of the council of the Municipality in which such road is situated made not less than one month after publishing in a newspaper generally circulating in the district and posting to the registered proprietor (if any) of the land and the owners and occupiers (if any) of the lands abutting or immediately adjacent to the road notice of intention to make such request may by Order published in the *Government Gazette* direct that such road or part shall be discontinued and thereupon such road or part shall be discontinued accordingly.

And whereas the Council of the Shire of Corio has requested that the Governor in Council direct that a portion of Broлга Avenue, North Geelong, be discontinued and not less than one month previously has published in a newspaper generally circulating in the district and posted to the registered proprietor of the land in the portion of road and to the owners and occupiers of lands abutting or immediately adjacent to the portion of road notice of intention to make such request.

Now therefore, His Excellency the Governor of the State of Victoria, by and with the advice of the Executive Council thereof, hereby directs that the said portion of road, which is Broлга Avenue coloured brown on Plan of Subdivision No. 15572 shall be discontinued and that the land may be sold by the Council of the Shire of Corio by agreement.

And the Honorable Alan John Hunt, Her Majesty's Minister for Local Government for the State of Victoria, shall give the necessary directions herein accordingly.

TOM FORRISTAL,
Clerk of the Executive Council.

LOCAL GOVERNMENT DEPARTMENT.

At the Executive Council Chamber, Melbourne, the
seventeenth day of December, 1974.

PRESENT:

His Excellency the Governor of Victoria.	
Mr. Rossiter	Mr. Dunstan
Mr. Hunt	Mr. Houghton.

ROAD DISCONTINUED.—CITY OF SOUTH BARWON.

Whereas it is provided in section 528 (2) of the *Local Government Act 1958*, that where a road (whether or not a public highway but not being a road set out on land of the Crown) or any part thereof is not required for public use the Governor in Council on the request of the council of the municipality in which such road is situated made not less than one month after publishing in a newspaper generally circulating in the district and posting to the registered proprietor (if any) of the land and to the owners and occupiers (if any) of the lands abutting or immediately adjacent to the road notice of intention to make such request may by Order published in the *Government Gazette* direct that such road or part shall be discontinued and thereupon such road or part shall be discontinued accordingly.

And whereas the Council of the City of South Barwon has requested that the Governor in Council direct that a portion of Orkney Place, Belmont, be discontinued and not less than one month previously has published in a newspaper generally circulating in the district and posted to the registered proprietor of the land in the portion of road and to the owners and occupiers of lands abutting or immediately adjacent to the portion of road notice of intention to make such request.

Now therefore, His Excellency the Governor of the State of Victoria, by and with the advice of the Executive Council thereof, hereby directs:—

- that the said portion of road which is shown by hachure and cross-hachure on the diagram hereunder shall be discontinued;
- that notwithstanding such discontinuance the Geelong Waterworks and Sewerage Trust shall continue to have and possess the same right title power authority or interest in or in relation to the land shown cross-hatched on the said diagram as it had or possessed prior to such discontinuance with respect to or in connection with any drains or pipes laid or erected in on or over such land for the purposes of drainage or sewerage;
- and, that subject to any such right title power authority or interest, the land in the said portion of road may be sold by the Council of the City of South Barwon by agreement.

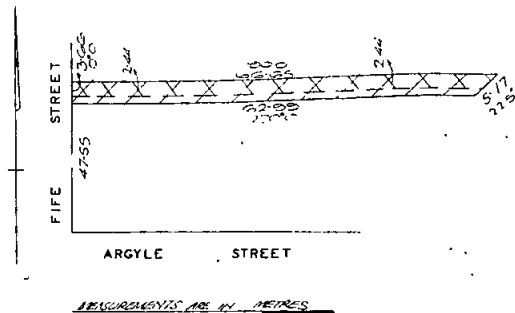

And the Honorable Alan John Hunt, Her Majesty's Minister for Local Government for the State of Victoria, shall give the necessary directions herein accordingly.

TOM FORRISTAL,
Clerk of the Executive Council.

LOCAL GOVERNMENT DEPARTMENT.

At the Executive Council Chamber, Melbourne, the
seventeenth day of December, 1974.

PRESENT:

His Excellency the Governor of Victoria.	
Mr. Rossiter	Mr. Dunstan
Mr. Hunt	Mr. Houghton.

VESTING OF A RESERVE IN THE KNOX CITY COUNCIL.

Whereas it is provided in section 569BA of the *Local Government Act 1958*, that where any map or plan has been lodged or deposited with the Registrar of Titles pursuant to section 97 of the *Transfer of Land Act 1958*, or any corresponding previous enactment (whether before or after the commencement of the *Local Government Act 1963*) and any allotment on that map or plan has been transferred the Governor in Council on the request of the council of the municipality may by Order published in the *Government Gazette* direct that the whole or any part of the land comprised in any reserve shown on that map or plan shall vest in the Council whereupon such land shall so vest freed and discharged from any mortgage charge lease or sub-lease.

And whereas the Council of the City of Knox has requested that a reserve shown on a plan of subdivision be vested in the Council and an allotment on the plan has been transferred.

Now therefore, His Excellency the Governor of the State of Victoria, by and with the advice of the Executive Council thereof, doth by this Order vest in the Council of the City of Knox the reserve for parking area coloured blue and green on Plan of Subdivision No. 52561 lodged in the Office of Titles.

And the Honorable Alan John Hunt, Her Majesty's Minister for Local Government for the State of Victoria, shall give the necessary directions herein accordingly.

TOM FORRISTAL,
Clerk of the Executive Council.

LOCAL GOVERNMENT DEPARTMENT.

At the Executive Council Chamber, Melbourne, the seventeenth day of December, 1974.

PRESENT:

His Excellency the Governor of Victoria.	
Mr. Rossiter	Mr. Dunstan
Mr. Hunt	Mr. Houghton.

VARIATION OF ORDER FIXING THE DATE FOR SUBSTITUTION OF SITE VALUE FOR UNIMPROVED CAPITAL VALUE GENERALLY—SHIRE OF KORUMBURRA.

Whereas it is provided by sub-section 2 of section 315A of the *Local Government Act 1958* that the Governor in Council may by Order or by successive Orders published in the *Government Gazette* fix the date when any reference in the said Act or the *Valuation of Land Act 1960* (however occurring) to unimproved capital value shall be construed as a reference to site value in respect of any rate payable thereon to the municipal council or councils specified in the Order, though remaining a reference to unimproved capital value in respect of any rate or tax payable thereon to any rating authority other than a municipality or in the making of a valuation therefor.

And whereas by Order published in the *Government Gazette* of the 15th May, 1974 at page 1677 the Governor in Council fixed the said date as the 1st October, 1975 for the council of any municipality not being a municipality in respect of which an order as aforesaid had previously been made.

And whereas it is provided by sub-section (3) of section 315A of the *Local Government Act 1958* that any Order made pursuant to sub-section (2) may in like manner be revoked amended or varied.

And whereas it is now expedient that the Order previously made be varied to provide that in the case of the Council of the Shire of Korumburra the expression "the 8th January, 1975" shall be substituted for the expression "the 1st October 1975".

Now therefore, His Excellency the Governor of the State of Victoria by and with the advice of the Executive Council thereof and in pursuance of the provisions of sub-section (3) of section 315A of the *Local Government Act 1958* hereby orders accordingly.

And the Honorable Alan John Hunt, Her Majesty's Minister for Local Government for the State of Victoria, shall give the necessary directions herein accordingly.

TOM FORRISTAL,
Clerk of the Executive Council.

BALLAN WATERWORKS TRUST.

At the Executive Council Chamber, Melbourne, the seventeenth day of December, 1974.

PRESENT:

His Excellency the Governor of Victoria.	
Mr. Rossiter	Mr. Dunstan
Mr. Hunt	Mr. Houghton.

EXTENT OF URBAN AND WATERWORKS DISTRICTS INCREASED.

Under the powers conferred by the Water Act and all other powers enabling him in that behalf, His Excellency the Governor of the State of Victoria, by and with the advice of the Executive Council of the said State, doth hereby declare, order and direct that the extent of the Urban and Waterworks Districts of the Ballan Waterworks Trust be increased by adding to the same the lands shown on plan approved by the Governor in Council by and with this Order and deposited in the office of the State Rivers and Water Supply Commission, Melbourne (Corres. 72/3559/29) and as on and from the date hereof, the extent of such Districts shall be and be deemed to be increased accordingly.

And the Honorable Frederick James Granter, Her Majesty's Minister of Water Supply for the State of Victoria, shall give the necessary directions herein accordingly.

TOM FORRISTAL,
Clerk of the Executive Council.

MOUNT BEAUTY WATERWORKS TRUST.

At the Executive Council Chamber, Melbourne, the seventeenth day of December, 1974.

PRESENT:

His Excellency the Governor of Victoria.	
Mr. Rossiter	Mr. Dunstan
Mr. Hunt	Mr. Houghton.

AMENDMENT OF ORDER.

Under the powers conferred by the Water Act and all other powers enabling him in that behalf, His Excellency the Governor of the State of Victoria, by and with the advice of the Executive Council of the said State, doth hereby amend as follows the Order in Council made on 6th November, 1974, diminishing the extent of the Rural District and increasing the extent of the Urban District of the Mount Beauty Waterworks Trust:—

Before the words "Rural District" there shall be inserted the words "Tawonga" and before the words "Urban District" there shall be inserted the word "Tawonga".

And the Honorable Frederick James Granter, Her Majesty's Minister of Water Supply for the State of Victoria, shall give the necessary directions herein accordingly.

TOM FORRISTAL,
Clerk of the Executive Council.

BENALLA WATERWORKS TRUST.

At the Executive Council Chamber, Melbourne, the seventeenth day of December, 1974.

PRESENT:

His Excellency the Governor of Victoria.	
Mr. Rossiter	Mr. Dunstan
Mr. Hunt	Mr. Houghton.

SALE OF LAND.

Under the powers conferred by the Water Act and all other powers enabling him in that behalf, His Excellency the Governor of the State of Victoria, by and with the advice of the Executive Council of the said State, doth hereby consent to the sale by the Benalla Waterworks Trust of the land shown by red colour on a plan approved by the Governor in Council and deposited in the office of the State Rivers and Water Supply Commission, Melbourne (Corr. No. 69/3432/146).

And the Honorable Frederick James Granter, Her Majesty's Minister of Water Supply for the State of Victoria, shall give the necessary directions herein accordingly.

TOM FORRISTAL,
Clerk of the Executive Council.

KYABRAM SEWERAGE AUTHORITY.

At the Executive Council Chamber, Melbourne, the seventeenth day of December, 1974.

PRESENT:

His Excellency the Governor of Victoria.	
Mr. Rossiter	Mr. Dunstan
Mr. Hunt	Mr. Houghton.

APPROVAL TO EXTENSION OF EFFLUENT DISPOSAL AREA AND ACQUISITION OF LAND.

Under the powers conferred by the Sewerage Districts Act and all other powers enabling him in that behalf, His Excellency the Governor of the State of Victoria, by and with the advice of the Executive Council of the said State, doth hereby declare, order and direct that the extent of the effluent disposal area of the Kyabram Sewerage Authority be increased and that approval be given to the acquisition by the said Authority of the necessary lands,

such extension and lands being shown on a plan approved by the Governor in Council by and with this Order and deposited in the office of the State Rivers and Water Supply Commission (Corr. 71/1203/57, 66).

And the Honorable Frederick James Granter, Her Majesty's Minister of Water Supply for the State of Victoria, shall give the necessary directions herein accordingly.

TOM FORRISTAL,
Clerk of the Executive Council.

FIRST MILDURA IRRIGATION TRUST.
MILDURA URBAN WATER TRUST.

At the Executive Council Chamber, Melbourne, the
seventeenth day of December, 1974.

PRESENT:

His Excellency the Governor of Victoria.
Mr. Rossiter | Mr. Dunstan
Mr. Hunt | Mr. Houghton.

SEVERANCE OF PORTION OF THE FIRST MILDURA
IRRIGATION TRUST DISTRICT AND ANNEXATION
TO THE MILDURA URBAN WATER TRUST DISTRICT.

Under the powers conferred by the Mildura Irrigation and Water Trusts Act and all other powers enabling him in that behalf, His Excellency the Governor of the State of Victoria, by and with the advice of the Executive Council of the said State, doth hereby declare, order and direct as follows:—

That as on and from the date hereof the lands comprised within the boundaries shaded red on the plans approved by the Governor in Council and deposited in the office of the State Rivers and Water Supply Commission, Melbourne (Corr. No. 59/2164/91A, 91B, 91c and 59/2164/92) shall be severed from the District of the First Mildura Irrigation Trust and annexed to the District of the Mildura Urban Water Trust.

And the Honorable Frederick James Granter, Her Majesty's Minister of Water Supply for the State of Victoria, shall give the necessary directions herein accordingly.

TOM FORRISTAL,
Clerk of the Executive Council.

MELBOURNE AND METROPOLITAN TRAMWAYS ACT
1958, No. 6311.

At the Executive Council Chamber, Melbourne, the
seventeenth day of December, 1974.

PRESENT:

His Excellency the Governor of Victoria.
Mr. Rossiter | Mr. Dunstan
Mr. Hunt | Mr. Houghton.

Whereas His Excellency the Governor of the State of Victoria by and with the advice of the Executive Council thereof has this day consented pursuant to the provisions of section 28 of the *Melbourne and Metropolitan Tramways Act 1958*, to the Melbourne and Metropolitan Tramways Board raising by way of a loan an amount not exceeding Five hundred thousand dollars (\$500,000); And whereas His Excellency the Governor in Council is satisfied that a sufficient proportion of the loan to be so raised will fall due and be repaid in each year during the currency of the proposed loan; Now therefore it is directed, pursuant to the provisions of section 28 (6) of the said Act, that it shall not be necessary to provide a sinking fund in connection with such loan.

And the Honorable Rupert James Hamer, Her Majesty's Treasurer for the State of Victoria, shall give the necessary directions herein accordingly.

TOM FORRISTAL,
Clerk of the Executive Council.

STATE COLLEGE OF VICTORIA ACT 1972.

At the Executive Council Chamber, Melbourne, the
twenty-fourth day of December, 1974.

PRESENT:

His Excellency the Governor of Victoria.
Mr. Hamer | Mr. Dickie
Mr. Meagher | Mr. Rossiter
Mr. Wilcox | Mr. Borthwick
Mr. Rafferty | Mr. Smith
Mr. Hunt | Mr. Scanlan
Mr. Houghton | Mr. Dixon.
Mr. Granter

CONSTITUTION OF COUNCIL TO MANAGE AND
CONTROL THE STATE COLLEGE OF VICTORIA—
INSTITUTE OF CATHOLIC EDUCATION.

Whereas sub-section (2) of section 31 of the *State College of Victoria Act 1972* provides that, where the governing body of an institution to which Division 5 of Part I of that Act applies makes an application in writing to the Minister for the incorporation of a council to manage and control the institution, the Governor in Council may on the recommendation of the Minister by Order published in the *Government Gazette* constitute a council by such name as is specified in the Order as a body corporate to manage and control the institution and exercise the several other powers set out in the said sub-section in relation to the council so constituted:

And whereas the State College of Victoria—Institute of Catholic Education (hereinafter called "the Institute") is an institution to which the said Division applies.

And whereas the governing body of the Institute has applied in writing to the Minister for the incorporation under the *State College of Victoria Act 1972* of a council to manage and control the Institute:

Now therefore His Excellency the Governor of the State of Victoria by and with the advice of the Executive Council thereof and on the recommendation of the Minister, doth by this Order provide as follows:—

CONSTITUTION OF COUNCIL.

1. There shall be a council to be known as the Council of the State College of Victoria—Institute of Catholic Education (hereinafter called "the Council") which shall be a body corporate to manage and control the Institute.

2. (1) The Council shall consist of not more than twenty-four members of whom—

- (a) one shall be a person appointed from time to time as occasion arises by the Roman Catholic Archbishop of Melbourne to be Chairman of the Institute;
- (b) one shall be the person who is for the time being the Vicar for Tertiary Education of the Roman Catholic Archdiocese of Melbourne or his nominee;
- (c) not more than three shall be appointed by the Governor in Council;
- (d) one shall be a person appointed by the Minister of Education;
- (e) one shall be the person who is for the time being the Director of the Victorian Catholic Education Office or his nominee;
- (f) one shall be a person appointed by the Victorian Commission for Catholic Education;
- (g) four shall be the persons who are for the time being the Principals of—
 - (i) Christ College, Oakleigh;
 - (ii) Mercy College, Ascot Vale;
 - (iii) Aquinas College, Ballarat; and
 - (iv) Christian Brothers Teachers College, Box Hill—

(hereinafter called "the colleges conducted by the Institute").

- (h) where there is an Academic Board (whether called by that or any other name) of the Institute one shall be a member of the Board appointed by the board from amongst its members who are members of the academic staff of the colleges conducted by the Institute;
- (i) in the case of each of the colleges conducted by the Institute, one shall be elected by the academic staff thereof from amongst their number in a manner determined by the Council;

(k) not more than four shall be persons having a special interest in education from time to time appointed by co-option by the Council; and

(l) two shall be students of the Institute elected annually in a manner determined by the Council of which—

(i) in the year 1975 and every second year thereafter—one shall be elected by the enrolled students of each of the colleges referred to in sub-paragraphs (i) and (iii) of paragraph (g) of sub-clause (1) of this clause from amongst their number; and

(ii) in the year 1976 and every second year thereafter—one shall be elected by the enrolled students of each of the colleges referred to in sub-paragraphs (ii) and (iv) of paragraph (g) of sub-clause (1) of this clause from amongst their number.

(2) A member appointed by the Governor in Council may be removed by the Governor in Council.

(3) Members of the Council (other than the members referred to in paragraphs (a), (b), (e), (g) and (l) of sub-clause (1) of this clause) shall be entitled to hold office for four years from the dates of their respective appointments and elections: Provided that, in the case only of the first appointments, not more than two of the members appointed pursuant to paragraph (c) of sub-clause (1) and not more than two of the members appointed pursuant to paragraph (k) of sub-clause (1) may be appointed to hold office for two years.

(4) A member of the Council shall be eligible to be re-appointed or re-elected (as the case may be) but a member (other than a member appointed pursuant to paragraph (d) of sub-clause (1) of this clause) shall not be elected or appointed for more than three successive terms unless he is appointed by co-option for a further term under paragraph (j) or paragraph (k) of sub-clause (1).

(5) If a member of the Council—

(a) resigns his office by writing under his hand directed to the Chairman;

(b) becomes of unsound mind or becomes a person whose person or estate is liable to be dealt with in any way under the law relating to mental health;

(c) becomes bankrupt;

(d) is convicted of any indictable offence;

(e) without special leave previously granted by the Council absents himself from four consecutive meetings of the Council;

(f) ceases to hold any qualifications required for his becoming or being a member of the Council;

(g) being a member appointed by the Governor in Council is removed from office; or

(h) dies—

his office shall become vacant so as to create a casual vacancy.

(6) A member appointed or elected to fill a casual vacancy shall be entitled to hold office for the unexpired portion of the original term of office only.

(7) A casual vacancy shall not be filled if it occurs within three months before the expiration of the term of office concerned.

(8) Where for any reason the Council appoints a person to be Acting Principal of a college conducted by the Institute, the person so appointed shall, while holding that office, be entitled to attend and vote at any meeting of the Council and for that purpose shall have the rights and privileges of the Principal.

(9) Notwithstanding anything to the contrary in the other provisions of this Order—

(a) a person who when this Order takes effect is a member of the unincorporate governing body of the Institute appointed or elected to serve for a fixed term and who does not become a member of the Council under sub-clause (1) of this clause shall, subject to the provisions other than paragraph (f) of sub-clause (5) of this clause, be a member of the Council for the unexpired portion of the term for which he was appointed or elected to be a member of the unincorporate governing body; and

(b) no such member shall be taken into account in determining the total number of persons who may under sub-clause (1) of this clause

become members of the Council, or the question of whether any person may under that sub-clause become a member in any particular capacity.

(10) Notwithstanding anything to the contrary in sub-clause (1) of this clause, the said Council shall be properly constituted where there is a deficiency in the number of members or of members of any class whether originally or as the result of the occurrence of a vacancy.

(11) A member of the staff of the Institute who is also a member of the Council shall withdraw from that part of any meeting at which applications are considered for appointment or promotion of a person to a post senior to that of his or the suspension, dismissal or retirement of a person holding such a post is considered.

(12) A member of the staff of the Institute who is also a member of the Council shall withdraw from that part of any meeting at which there is consideration of his promotion, suspension, dismissal or retirement.

(13) A student of the Institute who is also a member of the Council shall withdraw from that part of any meeting at which there is consideration of the appointment, promotion, suspension, dismissal or retirement of any member of the staff of the College.

PROCEEDINGS OF COUNCIL.

3. The following provisions shall apply to the Council of the Institute:—

(a) twelve members of the Council shall constitute a quorum at any meeting;

(b) at every meeting of the Council the Chairman or (in his absence) the Vice-Chairman shall preside, but if both be absent the members present shall elect a person to preside at the meeting; for the first four years the Vice-Chairman shall be the member appointed under paragraph (b) of sub-clause (1) of clause 2 but thereafter the Vice-Chairman shall be elected by the Council.

(c) the Council shall meet at least six times in each year;

(d) the decision of the majority of those present at any meeting of the Council shall be the decision of the Council;

(e) in the event of equality of votes on any question, the person presiding shall have a second or casting vote;

(f) the Council shall provide for the safe custody of the Seal, which shall only be used by authority of the Council, and every instrument to which the Seal is affixed shall be signed by two members of the Council and shall be countersigned by the Secretary (if any) of the Council or by some other person appointed by the Council for that purpose: Provided that the affixing of the Seal to all diplomas certificates and other awards shall be evidenced by their being signed by the Chairman and countersigned by the Principal only;

(g) any member who has a pecuniary interest whether directly or indirectly in any business of the Council or of any Committee thereof or in any joint committee of the Council and officers of the Institute shall declare the nature of his interest on every occasion when any business in which he has such interest is being considered, and no member shall be entitled to vote at any meeting of the Council or any Committee thereof or any such joint committee on any subject in which he has a direct pecuniary interest and if any such member does vote on any such subject his vote shall be disregarded.

POWERS OF COUNCIL.

4. The Council shall have power to—

(a) appoint from amongst the Principals of the colleges conducted by the Institute or remove a Principal of the Institute who shall be responsible to the Council for the conduct and management of the Institute except as regards any matter pertaining to a particular college conducted by the Institute and shall for all purposes be a member of the academic staff of the Institute;

(b) appoint or remove a Principal of each college conducted by the Institute on the recommendation of the Advisory Board thereof, who shall be responsible to the Council for the conduct and management of the college, and shall for all purposes be a member of the academic staff of the Institute;

- (c) from time to time determine the terms and conditions on which students of the Institute may be accepted and on which they and any other persons may attend classes or make use of any premises or equipment of the Institute;
- (d) employ members of the academic staff of the Institute on such terms and conditions as are for the time being fixed in respect of them by the Governor in Council on the recommendation of the Senate of the State College of Victoria;
- (e) employ members of the administrative technical and other staff of the Institute on such terms and conditions as are for the time being fixed in respect of them by the Senate of the State College of Victoria;
- (f) from time to time define the duties of members of the academic administrative technical and other staff of the Institute;
- (g) suspend or dismiss any member of the academic administrative technical or other staff of the Institute (but, in the case of dismissal of a member of the academic staff, only on a resolution of the Council passed by a majority consisting of not less than two-thirds of the total number of members of the Council);
- (h) charge fees in connexion with education provided, examinations held and any other services provided by the Institute;
- (i) from time to time hold examinations in the several subjects and courses offered by the Institute, and award diplomas certificates and other awards (except degrees) to students who reach the required standard in any subject or course;
- (j) grant scholarships on such terms and conditions as it thinks fit;
- (k) purchase take on lease or in exchange or hire, and sell mortgage lease or dispose of any real or personal property (which power to sell mortgage lease or dispose of property may, in the case of any real property for the purchase acquisition or development of which or the erection of any building on which any public moneys have been provided, be exercised only with the consent of the Senate of the State College of Victoria) and enter into agreements for the supply of services for the Institute;
- (l) engage architects and other professional advisers or experts in any field and enter into contracts for the erection of buildings, the making of improvements or alterations or the carrying out of repairs, on any land or buildings vested in or occupied or used by the Institute;
- (m) borrow on overdraft of current account at any bank, or raise money and secure the payment thereof or of any past debt or obligation of the Institute with interest and other charges by mortgage or charge or other security of upon or over the whole or any part of the property present or future of the Institute upon such terms and in such manner as the Council thinks fit or without any such security and purchase redeem or pay off any such security;
- (n) invest any moneys of the Institute not immediately required for its purposes in any securities which are authorized investments within the meaning of any law relating to trustees or, with the consent of the Senate of the State College of Victoria, in any other manner;
- (o) accept gifts of real or personal property to the Institute;
- (p) delegate, subject to such conditions as it thinks fit, any powers vested in the Council to any member or committee of members of the Council, any officer or committee of officers of the Institute, any joint committee of members of the Council of the Institute and officers of the Institute or the Advisory Board of any college conducted by the Institute;
- (q) do all such things as advance the interests of the staff and students of the Institute;
- (r) do all such things as may be required to be done in order to render the Institute eligible to receive grants under any law of the Commonwealth of Australia or of the State of Victoria which provides for the making of grants to educational institutions; and

- (s) do all such things as are necessarily incidental to the proper management and control of the Institute or the effective exercise of the powers conferred on the Council.

DUTIES OF COUNCIL.

5. The Council shall exercise the powers conferred on it by this Order in such a way as to further the objects of the Institute.

6. (1) The Council shall ensure in relation to each college conducted by the Institute that there is an Advisory Board to tender advice to the Council as regards matters particularly affecting the college.

(2) In exercising its powers in relation to any matter particularly affecting any college conducted by the Institute, the Council shall take into account any advice tendered to the Council in relation thereto by the Advisory Board of the College.

7. It shall be the duty of the Council to invite tenders by publishing an advertisement in a newspaper circulating generally throughout Victoria for the supply of any goods or services or the carrying out of any work the cost of which is estimated by the Council to exceed \$5,000 except in regard to the engagement of architects consultants and other professional advisers whose charges are normally made at rates fixed and published by professional or statutory bodies.

8. The Council shall cause minutes to be duly entered in books provided for that purpose—

- (a) of the names of the members present at each meeting of the Council of any committee thereof;
- (b) of all resolutions and proceedings at any meeting of the Council or any committee thereof; and
- (c) of all declarations made by any member of his pecuniary interest in any business of the Council or of any committee thereof.

And the Honorable Lindsay Hamilton Simpson Thompson, Her Majesty's Minister of Education for the State of Victoria, shall give the necessary directions herein accordingly.

TOM FORRISTAL,
Clerk of the Executive Council.

LOCAL GOVERNMENT DEPARTMENT.

At the Executive Council Chamber, Melbourne, the twenty-fourth day of December, 1974.

PRESENT:

His Excellency the Governor of Victoria.

Mr. Hamer	Mr. Dickie
Mr. Meagher	Mr. Rossiter
Mr. Wilcox	Mr. Borthwick
Mr. Rafferty	Mr. Smith
Mr. Hunt	Mr. Scanlan
Mr. Houghton	Mr. Dixon.
Mr. Granter	

ROAD DISCONTINUED.—CITY OF FOOTSCRAY.

Whereas it is provided in section 528 (2) of the *Local Government Act 1958*, that where a road (whether or not a public highway but not being a road set out on land of the Crown) or any part thereof is not required for public use the Governor in Council on the request of the council of the municipality in which such road is situated made not less than one month after publishing in a newspaper generally circulating in the district and posting to the registered proprietor (if any) of the land and the owners and occupiers (if any) of the lands abutting or immediately adjacent to the road notice of intention to make such request may by Order published in the *Government Gazette* direct that such road or part shall be discontinued and thereupon such road or part shall be discontinued accordingly.

And whereas the Council of the City of Footscray requested that the Governor in Council direct that portion of a road off Williamstown Road, Yarraville be discontinued and not less than one month previously has published in a newspaper generally circulating in the district and posted to the registered proprietor of the land in the portion of road and to the owners and occupiers of land abutting or immediately adjacent to the portion of road notice of intention to make such request.

Now therefore, His Excellency the Governor of the State of Victoria, by and with the advice of the Executive Council thereof, hereby directs that the said portion of the road

which is shown by hachure on the plan hereunder, shall be discontinued and that the land may be sold by the Council of the City of Footscray by agreement.

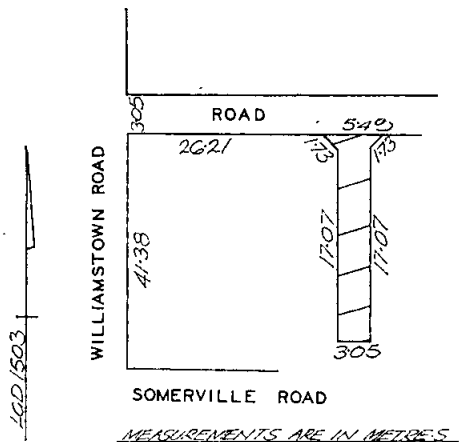

And the Honorable Alan John Hunt, Her Majesty's Minister for Local Government for the State of Victoria, shall give the necessary directions herein accordingly.

TOM FORRISTAL,
Clerk of the Executive Council.

LOCAL GOVERNMENT DEPARTMENT.

At the Executive Council Chamber, Melbourne, the twenty-fourth day of December, 1974.

PRESENT:

- | | |
|--|---------------|
| His Excellency the Governor of Victoria. | |
| Mr. Hamer | Mr. Dickie |
| Mr. Meagher | Mr. Rossiter |
| Mr. Wilcox | Mr. Borthwick |
| Mr. Rafferty | Mr. Smith |
| Mr. Hunt | Mr. Scanlan |
| Mr. Houghton | Mr. Dixon. |
| Mr. Granter | |

ROAD DISCONTINUED.—CITY OF PRESTON.

Whereas it is provided in section 528 (2) of the Local Government Act 1958, that where a road (whether or not a public highway but not being a road set out on land of the Crown) or any part thereof is not required for public use the Governor in Council on the request of the council of the municipality in which such road is situated made not less than one month after publishing in a newspaper generally circulating in the district and posting to the registered proprietor (if any) of the land and to the owners and occupiers (if any) of the lands abutting or immediately adjacent to the road notice of intention to make such request may by Order published in the Government Gazette direct that such road or part shall be discontinued and thereupon such road or part shall be discontinued accordingly.

And whereas the Council of the City of Preston requested that the Governor in Council direct that a road off Grandview Road, Preston be discontinued and not less than one month previously has published in a newspaper generally circulating in the district and posted to the registered proprietor of the land in the road and to the owners and occupiers of lands abutting or immediately adjacent to the road notice of intention to make such request.

Now therefore, His Excellency the Governor of the State of Victoria, by and with the advice of the Executive Council thereof, hereby directs:—

- that the said road which is shown by hachure on the plan hereunder shall be discontinued.
- that notwithstanding such discontinuance the Melbourne and Metropolitan Board of Works shall continue to have and possess the same right title power authority or interest in or in relation to the whole of the road shown on the said plan as it had or possessed prior to such discontinuance with respect to or in connection with any drains or pipes laid or erected in on or over such land for the purposes of drainage and sewerage.

- that subject to any such right title power authority or interest, the land in the said road may be sold by the Council of the City of Preston by agreement.

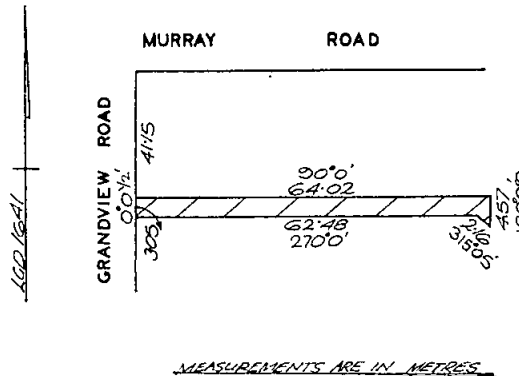

And the Honorable Alan John Hunt, Her Majesty's Minister for Local Government for the State of Victoria, shall give the necessary directions herein accordingly.

TOM FORRISTAL,
Clerk of the Executive Council.

LOCAL GOVERNMENT DEPARTMENT.

At the Executive Council Chamber, Melbourne, the twenty-fourth day of December, 1974.

PRESENT:

- | | |
|--|---------------|
| His Excellency the Governor of Victoria. | |
| Mr. Hamer | Mr. Dickie |
| Mr. Meagher | Mr. Rossiter |
| Mr. Wilcox | Mr. Borthwick |
| Mr. Rafferty | Mr. Smith |
| Mr. Hunt | Mr. Scanlan |
| Mr. Houghton | Mr. Dixon. |
| Mr. Granter | |

ROAD DISCONTINUED.—SHIRE OF WARRAGUL.

Whereas it is provided in section 528 (2) of the Local Government Act 1958, that where a road (whether or not a public highway but not being a road set out on land of the Crown) or any part thereof is not required for public use the Governor in Council on the request of the council of the municipality in which such road is situated made not less than one month after publishing in a newspaper generally circulating in the district and posting to the registered proprietor (if any) of the land and to the owners and occupiers (if any) of the lands abutting or immediately adjacent to the road notice of intention to make such request may by Order published in the Government Gazette direct that such road or part shall be discontinued and thereupon such road or part shall be discontinued accordingly.

And whereas the Council of the Shire of Warragul has requested that the Governor in Council direct that a portion of a road off Williams Street, Warragul be discontinued and not less than one month previously has published in a newspaper generally circulating in the district and posted to the registered proprietor of the land in the portion of road and to the owners and occupiers of lands abutting or immediately adjacent to the portion of road notice of intention to make such request.

Now therefore, His Excellency the Governor of the State of Victoria, by and with the advice of the Executive Council thereof, hereby directs:—

- that the said portion of road which is shown by hachure and cross hachure on the diagram hereunder shall be discontinued;
- that notwithstanding such discontinuance the Warragul Sewerage Authority shall continue to have and possess the same right title power authority or interest in or in relation to the land shown cross-hatched on the said diagram as it had or possessed prior to such discontinuance with respect to or in connection with any drains or pipes laid or erected in on or over such land for the purposes of drainage or sewerage.

(c) and, that subject to any such right title power authority or interest, the land in the said portion of road may be sold by the Council of the Shire of Warragul by agreement.

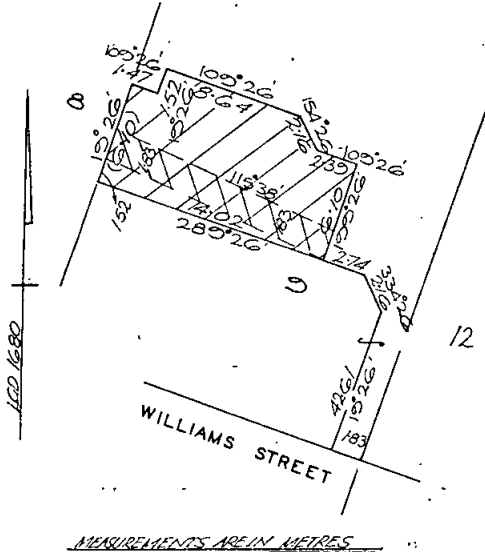

And the Honorable Alan John Hunt, Her Majesty's Minister for Local Government for the State of Victoria, shall give the necessary directions herein accordingly.

TOM FORRISTAL,
Clerk of the Executive Council.

LOCAL GOVERNMENT DEPARTMENT.

At the Executive Council Chamber, Melbourne, the twenty-fourth day of December, 1974.

PRESENT:

- | | |
|--|---------------|
| His Excellency the Governor of Victoria. | |
| Mr. Hamer | Mr. Dickie |
| Mr. Meagher | Mr. Rossiter |
| Mr. Wilcox | Mr. Borthwick |
| Mr. Rafferty | Mr. Smith |
| Mr. Hunt | Mr. Scanlan |
| Mr. Houghton | Mr. Dixon. |
| Mr. Granter | |

CONFIRMATION OF SEPARATE RATE.—CITY OF CAMBERWELL.

In pursuance of the provisions of section 287 of the Local Government Act 1958, His Excellency the Governor of the State of Victoria, by and with the advice of the Executive Council thereof, hereby confirms a separate rate made by the Council of the City of Camberwell on the 20th May, 1974, for the purpose of providing off-street parking facilities for use in connection with the Middle Camberwell Shopping Centre and that the amounts of the rate in the dollar to be made and levied on the Unimproved Capital Value of the properties respectively shall be as set out in Schedule "A" hereunder, subject to the variation that the property described in Schedule "B" shall not be subject to the rate.

SCHEDULE "A".

Properties to be Rated.	Amount of Rate in \$.
720-744 Riversdale Road, Camberwell	2-8352 cents
746 Riversdale Road, Camberwell	5-8162 cents
752 Riversdale Road, Camberwell	16-3269 cents
756 Riversdale Road, Camberwell	1-4176 cents
760 Riversdale Road, Camberwell	2-8352 cents
764-780 Riversdale Road, Camberwell	2-8352 cents
724 (Rear) Riversdale Road, Camberwell	2-8352 cents
2 Cooloongatta Road, Camberwell	5-8162 cents
717-729 Riversdale Road, Canterbury	1-4176 cents
785 Riversdale Road, Canterbury	0-7088 cents
745-763 Riversdale Road, Canterbury	1-4176 cents
1A Quantock Street, Canterbury	1-4176 cents
1A, 1 and 3 Hasset Avenue, Canterbury	1-4176 cents

SCHEDULE "B".

Property not to be subject to the rate.

748 Riversdale Road, Camberwell.

And the Honorable Alan John Hunt, Her Majesty's Minister for Local Government for the State of Victoria, shall give the necessary directions herein accordingly.

TOM FORRISTAL,
Clerk of the Executive Council.

SUPERANNUATION ACT 1958.

At the Executive Council Chamber, Melbourne, the twenty-fourth day of December, 1974.

PRESENT:

His Excellency the Governor of Victoria.

- | | |
|--------------|---------------|
| Mr. Hamer | Mr. Dickie |
| Mr. Meagher | Mr. Rossiter |
| Mr. Wilcox | Mr. Borthwick |
| Mr. Rafferty | Mr. Smith |
| Mr. Hunt | Mr. Scanlan |
| Mr. Houghton | Mr. Dixon. |
| Mr. Granter | |

Pursuant to the powers conferred by the provisions of paragraph (ja) of sub-section (1) of section 3 of the Superannuation Act 1958, His Excellency the Governor of the State of Victoria, by and with the advice of the Executive Council thereof doth by this Order declare that the provisions of the Superannuation Act shall apply to YULIE GREIG, being an officer of the State College of Victoria at Melbourne constituted pursuant to the provisions of the Education Act 1958 No. 6240.

And the Honorable Rupert James Hamer, Her Majesty's Treasurer for the State of Victoria, shall give the necessary directions herein accordingly.

TOM FORRISTAL,
Clerk of the Executive Council.

SUPERANNUATION ACT 1958.

At the Executive Council Chamber, Melbourne, the twenty-fourth day of December, 1974.

PRESENT:

His Excellency the Governor of Victoria.

- | | |
|--------------|---------------|
| Mr. Hamer | Mr. Dickie |
| Mr. Meagher | Mr. Rossiter |
| Mr. Wilcox | Mr. Borthwick |
| Mr. Rafferty | Mr. Smith |
| Mr. Hunt | Mr. Scanlan |
| Mr. Houghton | Mr. Dixon. |
| Mr. Granter | |

Pursuant to the powers conferred by the provisions of paragraph (ja) of sub-section (1) of section 3 of the Superannuation Act 1958, His Excellency the Governor of the State of Victoria, by and with the advice of the Executive Council thereof doth by this Order declare that the provisions of the Superannuation Act shall apply to:—

- VAN KALKEN, LAMBERT CHRISTOPHER,
- EVANS, JOHN ROBERT,
- DAVIS, KENNETH HAROLD,
- DEAN, RONALD MURRAY,
- REARDON, RAYMOND EDWARD,
- O'NEILL, GRAHAM LESLIE,
- FITZPATRICK, MARITA JESSIE,
- POTTS, LESLIE MARTIN,
- WALL, WALLACE PARKER,
- CAREY, DAVID LESLIE,
- ZIERSCH, WENDY,
- HANNA, PETER JOHN,
- ROBOTTOM, IAN MORRIS,
- MILLEN, NEVILLE THOMAS,
- SCRIVEN, BRUCE ROBERT,
- WETHERELL, DAVID FIELDING,
- WILLIAMS, IAN HORTON, and
- WHITE, NOEL GRANT.

being officers of the State College of Victoria at Geelong constituted pursuant to the provisions of the Education Act 1958 No. 6240.

And the Honorable Rupert James Hamer, Her Majesty's Treasurer for the State of Victoria, shall give the necessary directions herein accordingly.

TOM FORRISTAL,
Clerk of the Executive Council.

SUPERANNUATION ACT 1958.

At the Executive Council Chamber, Melbourne, the twenty-fourth day of December, 1974.

PRESENT:

His Excellency the Governor of Victoria.

Mr. Hamer	Mr. Dickie
Mr. Meagher	Mr. Rossiter
Mr. Wilcox	Mr. Borthwick
Mr. Rafferty	Mr. Smith
Mr. Hunt	Mr. Scanlan
Mr. Houghton	Mr. Dixon.
Mr. Granter	

Pursuant to the powers conferred by the provisions of paragraph (ja) of sub-section (1) of section 3 of the *Superannuation Act 1958*, His Excellency the Governor of the State of Victoria, by and with the advice of the Executive Council thereof doth by this Order declare that the provisions of the *Superannuation Act* shall apply to:—

BRASIER, JOHN,
O'BRIEN, DAVID, and
WARD, MALCOLM GEORGE,

being officers of the State College of Victoria at Bendigo constituted pursuant to the provisions of the *Education Act 1958 No. 6240*.

And the Honorable Rupert James Hamer, Her Majesty's Treasurer for the State of Victoria, shall give the necessary directions herein accordingly.

TOM FORRISTAL,
Clerk of the Executive Council.

SUPERANNUATION ACT 1958.

At the Executive Council Chamber, Melbourne, the twenty-fourth day of December, 1974.

PRESENT:

His Excellency the Governor of Victoria.

Mr. Hamer	Mr. Dickie
Mr. Meagher	Mr. Rossiter
Mr. Wilcox	Mr. Borthwick
Mr. Rafferty	Mr. Smith
Mr. Hunt	Mr. Scanlan
Mr. Houghton	Mr. Dixon.
Mr. Granter	

Pursuant to the powers conferred by the provisions of paragraph (ja) of sub-section (1) of section 3 of the *Superannuation Act 1958*, His Excellency the Governor of the State of Victoria, by and with the advice of the Executive Council thereof doth by this Order declare that the provisions of the *Superannuation Act* shall apply to:—

FRAMPTON, KEITH GEORGE,
HOSFORD, GEOFFREY THOMAS,
MOONEY, GAVIN JOHN, and
TURNER, DONALD ROBERT,

being officers of the State College of Victoria at Burwood constituted pursuant to the provisions of the *Education Act 1958 No. 6240*.

And the Honorable Rupert James Hamer, Her Majesty's Treasurer for the State of Victoria, shall give the necessary directions herein accordingly.

TOM FORRISTAL,
Clerk of the Executive Council.

SUPERANNUATION ACT 1958.

At the Executive Council Chamber, Melbourne, the twenty-fourth day of December, 1974.

PRESENT:

His Excellency the Governor of Victoria.

Mr. Hamer	Mr. Dickie
Mr. Meagher	Mr. Rossiter
Mr. Wilcox	Mr. Borthwick
Mr. Rafferty	Mr. Smith
Mr. Hunt	Mr. Scanlan
Mr. Houghton	Mr. Dixon.
Mr. Granter	

Pursuant to the powers conferred by the provisions of paragraph (ja) of sub-section (1) of section 3 of the *Superannuation Act 1958*, His Excellency the Governor of

the State of Victoria, by and with the advice of the Executive Council thereof doth by this Order declare that the provisions of the *Superannuation Act* shall apply to:—

ARKLEY, NORMAN CLYDE,
BOORD, WINSTON ALEXANDER, and
DE LA RUE, PETER PHILLIP,

being officers of the State College of Victoria, at Hawthorn constituted pursuant to the provisions of the *Education Act 1958 No. 6240*.

And the Honorable Rupert James Hamer, Her Majesty's Treasurer for the State of Victoria, shall give the necessary directions herein accordingly.

TOM FORRISTAL,
Clerk of the Executive Council.

SUPERANNUATION ACT 1958.

At the Executive Council Chamber, Melbourne, the twenty-fourth day of December, 1974.

PRESENT:

His Excellency the Governor of Victoria.

Mr. Hamer	Mr. Dickie
Mr. Meagher	Mr. Rossiter
Mr. Wilcox	Mr. Borthwick
Mr. Rafferty	Mr. Smith
Mr. Hunt	Mr. Scanlan.
Mr. Houghton	Mr. Dixon.
Mr. Granter	

Pursuant to the powers conferred by the provisions of paragraph (ja) of sub-section (1) of section 3 of the *Superannuation Act 1958*, His Excellency the Governor of the State of Victoria, by and with the advice of the Executive Council thereof doth by this Order declare that the provisions of the *Superannuation Act* shall apply to Raymond Kevin Watson, being an officer of the State College of Victoria at Ballarat constituted pursuant to the provisions of the *Education Act 1958 No. 6240*.

And the Honorable Rupert James Hamer, Her Majesty's Treasurer for the State of Victoria, shall give the necessary directions herein accordingly.

TOM FORRISTAL,
Clerk of the Executive Council.

SUPERANNUATION ACT 1958.

At the Executive Council Chamber, Melbourne, the twenty-fourth day of December, 1974.

PRESENT:

His Excellency the Governor of Victoria.

Mr. Hamer	Mr. Dickie
Mr. Meagher	Mr. Rossiter
Mr. Wilcox	Mr. Borthwick
Mr. Rafferty	Mr. Smith
Mr. Hunt	Mr. Scanlan
Mr. Houghton	Mr. Dixon.
Mr. Granter	

Pursuant to the powers conferred by the provisions of paragraph (ja) of sub-section (1) of section 3 of the *Superannuation Act 1958*, His Excellency the Governor of the State of Victoria, by and with the advice of the Executive Council thereof doth by this Order declare that the provisions of the *Superannuation Act* shall apply to—

JOHN MICHAEL ENRIGHT
MARGARET RANKIN OAG

being officers of the State College of Victoria, Rusden, constituted pursuant to the provisions of the *Education Act 1958 No. 6240*.

And the Honorable Rupert James Hamer, Her Majesty's Treasurer for the State of Victoria, shall give the necessary directions herein accordingly.

TOM FORRISTAL,
Clerk of the Executive Council.

SUPERANNUATION ACT 1958.

At the Executive Council Chamber, Melbourne, the twenty-fourth day of December, 1974.

PRESENT:

His Excellency the Governor of Victoria.	
Mr. Hamer	Mr. Dickie
Mr. Meagher	Mr. Rossiter
Mr. Wilcox	Mr. Borthwick
Mr. Rafferty	Mr. Smith
Mr. Hunt	Mr. Scanlan
Mr. Houghton	Mr. Dixon.
Mr. Granter	

Pursuant to the powers conferred by the provisions of paragraph (ja) of sub-section (1) of section 3 of the *Superannuation Act 1958*, His Excellency the Governor of the State of Victoria, by and with the advice of the Executive Council thereof doth by this Order declare that the provisions of the *Superannuation Act* shall apply to:—

BROWN, GARTH HOWARD,
SOMMERVILLE, BETTY DORICE,

being officers of the State College of Victoria at Coburg constituted pursuant to the provisions of the *Education Act 1958* No. 6240.

And the Honorable Rupert James Hamer, Her Majesty's Treasurer for the State of Victoria, shall give the necessary directions herein accordingly.

TOM FORRISTAL,
Clerk of the Executive Council.

SOIL CONSERVATION AND LAND UTILIZATION ACT 1958.

At the Executive Council Chamber, Melbourne, the twenty-fourth day of December, 1974.

PRESENT:

His Excellency the Governor of Victoria.	
Mr. Hamer	Mr. Dickie
Mr. Meagher	Mr. Rossiter
Mr. Wilcox	Mr. Borthwick
Mr. Rafferty	Mr. Smith
Mr. Hunt	Mr. Scanlan
Mr. Houghton	Mr. Dixon.
Mr. Granter	

DISTRICT ADVISORY COMMITTEE.—SOUTHERN WIMMERA SOIL CONSERVATION DISTRICT.

In pursuance of the powers conferred by section 15 of the *Soil Conservation and Land Utilization Act*, His Excellency the Governor of the State of Victoria by and with the advice of the Executive Council thereof doth hereby appoint the following persons to be members of the District Advisory Committee of the Southern Wimmera Soil Conservation District for a term of three years.

GERARD JOSEPH CRANAGE, being a person elected to represent grazing, agricultural and other relevant interests in the District.

ERIC ARNOLD ROSS, being a person elected to represent grazing, agricultural and other relevant interests in the District.

ALAN THOMAS HEARD, being a person elected to represent grazing, agricultural and other relevant interests in the District.

ARTHUR ROLLET GROSS, being a person elected to represent grazing, agricultural and other relevant interests in the District.

CHARLES LOELIGER, being a person elected to represent grazing, agricultural and other relevant interests in the District.

JOHN DAVID GILLESPIE, being the person representing the Forests Commission.

IAN RICHARD MCALPIN, being the person representing the Soil Conservation Authority.

And the Honorable William Archibald Borthwick, Her Majesty's Minister for Conservation for the State of Victoria, shall give the necessary directions herein accordingly.

TOM FORRISTAL,
Clerk of the Executive Council.

ROAD TRAFFIC ACT 1958.

At the Executive Council Chamber, Melbourne, the twenty-fourth day of December, 1974.

PRESENT:

His Excellency the Governor of Victoria.	
Mr. Hamer	Mr. Dickie
Mr. Meagher	Mr. Rossiter
Mr. Wilcox	Mr. Borthwick
Mr. Rafferty	Mr. Smith
Mr. Hunt	Mr. Scanlan
Mr. Houghton	Mr. Dixon.
Mr. Granter	

ORDER EXTENDING THE APPLICATION OF THE ROAD TRAFFIC ACT 1958 TO CERTAIN LAND UNDER THE CONTROL OF THE CITY OF BROADMEADOWS.

In pursuance of the powers conferred by the *Road Traffic Act 1958*, His Excellency the Governor of the State of Victoria in the Commonwealth of Australia, by and with the advice of the Executive Council of the said State, and at the request in writing of the Council of the City of Broadmeadows doth by this Order extend the provisions of the said Act to the following land under the control of the City of Broadmeadows:

All those pieces of land known as the Belair Avenue Car Park and Bus Terminal, Glenroy, commencing at a point on the south side of Belair Avenue 49.98 metres west of Pascoe Vale Road; thence 102.00 metres in a westerly direction; thence 52.41 metres in a southerly direction; thence 36.57 metres in an easterly direction; thence 48.15 metres in a southerly direction; thence 31.69 metres in an easterly direction; thence 41.14 metres in a northerly direction to the commencing point, as shown on the plan hereunder.

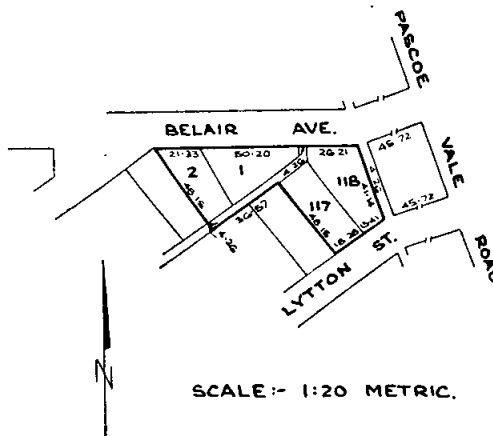

And the Honorable John Frederick Rossiter, Her Majesty's Chief Secretary for the State of Victoria, shall give the necessary directions herein accordingly.

TOM FORRISTAL,
Clerk of the Executive Council.

ROAD TRAFFIC ACT 1958.

At the Executive Council Chamber, Melbourne, the twenty-fourth day of December, 1974.

PRESENT:

His Excellency the Governor of Victoria.	
Mr. Hamer	Mr. Dickie
Mr. Meagher	Mr. Rossiter
Mr. Wilcox	Mr. Borthwick
Mr. Rafferty	Mr. Smith
Mr. Hunt	Mr. Scanlan
Mr. Houghton	Mr. Dixon.
Mr. Granter	

ORDER EXTENDING THE APPLICATION OF THE ROAD TRAFFIC ACT 1958 TO CERTAIN LAND UNDER THE CONTROL OF THE CITY OF COBURG.

In pursuance of the powers conferred by the *Road Traffic Act 1958*, His Excellency the Governor of the State of Victoria in the Commonwealth of Australia, by and

with the advice of the Executive Council of the said State, and at the request in writing of the Council of the City of Coburg doth by this Order extend the provisions of the said Act to the following land under the control of the City of Coburg:

Commencing at the north-east corner of Victoria Street and Waterfield Street proceed in a northerly direction on a bearing of 359 deg. 55 min. for a distance of 224 ft. 1 in.; thence in an easterly direction on a bearing of 89 deg. 12 min. for a distance of 101 ft. 3 in.; thence southerly on a bearing of 180 deg. 00 min. for a distance of 66 ft. 6 in.; thence easterly on a bearing of 89 deg. 32 min. for a distance of 23 ft. 9 in.; thence southerly on a bearing 359 deg. 55 min. for a distance of 66 ft.; thence westerly on a bearing of 89 deg. 32 min. for a distance of 8 ft. 4 in.; thence southerly on 0 deg. 28 min. for a distance of 91 ft. 3 in.; thence westerly on a bearing of 269 deg. 16 min. for a distance of 118 ft. 2 in. to the commencing point, as shown hatched on the plan hereunder.

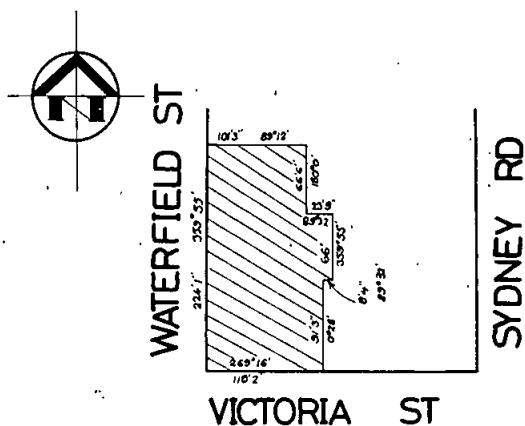

And the Honorable John Frederick Rossiter, Her Majesty's Chief Secretary for the State of Victoria, shall give the necessary directions herein accordingly.

TOM FORRISTAL,
Clerk of the Executive Council.

MELBOURNE UNDERGROUND RAIL LOOP ACT 1970,
No. 8023.

At the Executive Council Chamber, Melbourne, the twenty-fourth day of December, 1974.

PRESENT:

His Excellency the Governor of Victoria.

- | | |
|--------------|---------------|
| Mr. Hamer | Mr. Dickie |
| Mr. Meagher | Mr. Rossiter |
| Mr. Wilcox | Mr. Borthwick |
| Mr. Rafferty | Mr. Smith |
| Mr. Hunt | Mr. Scanlan |
| Mr. Houghton | Mr. Dixon. |
| Mr. Granter | |

Whereas His Excellency the Governor of the State of Victoria by and with the advice of the Executive Council thereof has this day consented pursuant to the provisions of the Melbourne Underground Rail Loop Act 1970 to the Melbourne Underground Rail Loop Authority raising by way of a loan the sum of Two million dollars (\$2,000,000); and whereas His Excellency the Governor in Council is satisfied that a sufficient proportion of the loan to be raised will fall due and be repaid in each year during the currency of the proposed loan; Now therefore it is directed pursuant to the provisions of section 16 (3) of the said Act, that it shall not be necessary to provide a sinking fund in connection with such loan.

And the Honorable Rupert James Hamer, Her Majesty's Treasurer for the State of Victoria, shall give the necessary directions herein accordingly.

TOM FORRISTAL,
Clerk of the Executive Council.

STATE ELECTRICITY COMMISSION ACT 1958, No. 6377.

At the Executive Council Chamber, Melbourne, the twenty-fourth day of December, 1974.

PRESENT:

His Excellency the Governor of Victoria.

- | | |
|--------------|---------------|
| Mr. Hamer | Mr. Dickie |
| Mr. Meagher | Mr. Rossiter |
| Mr. Wilcox | Mr. Borthwick |
| Mr. Rafferty | Mr. Smith |
| Mr. Hunt | Mr. Scanlan. |
| Mr. Houghton | Mr. Dixon. |
| Mr. Granter | |

Whereas His Excellency the Governor of the State of Victoria by and with the advice of the Executive Council thereof has this day consented pursuant to the provisions of the State Electricity Commission Act 1958 to the State Electricity Commission of Victoria raising by way of a loan the sum of Three hundred and six thousand two hundred dollars (\$306,200); and whereas the Governor in Council is satisfied that a sufficient proportion of the loan to be raised will fall due and be repaid in each year during the currency of the proposed loan; Now therefore it is directed pursuant to the provisions of section 91 (3) of the said Act, that it shall not be necessary to provide a sinking fund in connection with such loan.

And the Honorable Rupert James Hamer, Her Majesty's Treasurer for the State of Victoria, shall give the necessary directions herein accordingly.

TOM FORRISTAL,
Clerk of the Executive Council.

BALLAN WATERWORKS TRUST.

At the Executive Council Chamber, Melbourne, the twenty-fourth day of December, 1974.

PRESENT:

His Excellency the Governor of Victoria.

- | | |
|--------------|---------------|
| Mr. Hamer | Mr. Dickie |
| Mr. Meagher | Mr. Rossiter |
| Mr. Wilcox | Mr. Borthwick |
| Mr. Rafferty | Mr. Smith |
| Mr. Hunt | Mr. Scanlan |
| Mr. Houghton | Mr. Dixon. |
| Mr. Granter | |

APPROVAL OF SITE OF PIPELINE.

Under the powers conferred by the Water Act and all other powers enabling him in that behalf, His Excellency the Governor of the State of Victoria, by and with the advice of the Executive Council of the said State doth hereby approve a plan showing the proposed site for a new pipeline to be constructed by the Ballan Waterworks Trust, the said plan being deposited in the office of the State Rivers and Water Supply Commission, Melbourne.—(Corr. No. 72/3559/34).

And the Honorable Frederick James Granter, Her Majesty's Minister of Water Supply for the State of Victoria, shall give the necessary directions herein accordingly.

TOM FORRISTAL,
Clerk of the Executive Council.

TRAFALGAR WATERWORKS TRUST.

At the Executive Council Chamber, Melbourne, the twenty-fourth day of December, 1974.

PRESENT:

His Excellency the Governor of Victoria.

- | | |
|--------------|---------------|
| Mr. Hamer | Mr. Dickie |
| Mr. Meagher | Mr. Rossiter |
| Mr. Wilcox | Mr. Borthwick |
| Mr. Rafferty | Mr. Smith |
| Mr. Hunt | Mr. Scanlan. |
| Mr. Houghton | Mr. Dixon. |
| Mr. Granter | |

APPROVAL TO SITES OF BORE AND PIPELINE.

Under the powers conferred by the Water Act and all other powers enabling him in that behalf, His Excellency the Governor of the State of Victoria, by and with the

advice of the Executive Council of the said State, doth hereby approve the work comprising a Bore and Pipeline to be constructed by the Trafalgar Waterworks Trust on the lands shown on a plan deposited in the office of the State Rivers and Water Supply Commission, Melbourne.—(Corr. No. 59/1755/105).

And the Honorable Frederick James Granter, Her Majesty's Minister of Water Supply for the State of Victoria, shall give the necessary directions herein accordingly.

TOM FORRISTAL,
Clerk of the Executive Council.

KYNETON SHIRE WATERWORKS TRUST.

At the Executive Council Chamber, Melbourne, the twenty-fourth day of December, 1974.

PRESENT:

His Excellency the Governor of Victoria.

Mr. Hamer	Mr. Dickie
Mr. Meagher	Mr. Rossiter
Mr. Wilcox	Mr. Borthwick
Mr. Rafferty	Mr. Smith
Mr. Hunt	Mr. Scanlan
Mr. Houghton	Mr. Dixon.
Mr. Granter	

RURAL DISTRICT PROCLAIMED.

Under the powers conferred by the Water Act and all other powers enabling him in that behalf, His Excellency the Governor of the State of Victoria, by and with the advice of the Executive Council of the said State, doth hereby by Order proclaim that on and from the date hereof portions of the Waterworks District of the Kyneton Shire Waterworks Trust comprised within the areas shaded red on the plan approved by the Governor in Council by and with this Order and deposited in the office of the State Rivers and Water Supply Commission, Melbourne (Corr. No. 67/2928/119) shall be and become a Rural District for the purposes of and within the meaning of the said Act and shall be known as the West Kyneton Rural District and shall be under the jurisdiction of the Kyneton Shire Waterworks Trust.

And the Honorable Frederick James Granter, Her Majesty's Minister of Water Supply for the State of Victoria, shall give the necessary directions herein accordingly.

TOM FORRISTAL,
Clerk of the Executive Council.

DONALD WATERWORKS TRUST.

At the Executive Council Chamber, Melbourne, the twenty-fourth day of December, 1974.

PRESENT:

His Excellency the Governor of Victoria.

Mr. Hamer	Mr. Dickie
Mr. Meagher	Mr. Rossiter
Mr. Wilcox	Mr. Borthwick
Mr. Rafferty	Mr. Smith
Mr. Hunt	Mr. Scanlan
Mr. Houghton	Mr. Dixon.
Mr. Granter	

CONSENT TO BORROWING \$30,000.

Under the powers conferred by the Water Act and all other powers enabling him in that behalf, His Excellency the Governor of the State of Victoria, by and with the advice of the Executive Council of the said State, hereby consents to the Donald Waterworks Trust borrowing the sum of Thirty thousand dollars (\$30,000), to meet the cost of water supply works.

And the Honorable Frederick James Granter, Her Majesty's Minister of Water Supply for the State of Victoria, shall give the necessary directions herein accordingly.

TOM FORRISTAL,
Clerk of the Executive Council.

LAKES ENTRANCE WATERWORKS TRUST.

At the Executive Council Chamber, Melbourne, the twenty-fourth day of December, 1974.

PRESENT:

His Excellency the Governor of Victoria.

Mr. Hamer	Mr. Dickie
Mr. Meagher	Mr. Rossiter
Mr. Wilcox	Mr. Borthwick
Mr. Rafferty	Mr. Smith
Mr. Hunt	Mr. Scanlan
Mr. Houghton	Mr. Dixon.
Mr. Granter	

CONSENT TO BORROWING \$80,000.

Under the powers conferred by the Water Act and all other powers enabling him in that behalf, His Excellency the Governor of the State of Victoria, by and with the advice of the Executive Council of the said State, doth hereby consent to the Lakes Entrance Waterworks Trust borrowing the sum of Eighty thousand dollars (\$80,000) to meet the cost of water supply works.

And the Honorable Frederick James Granter, Her Majesty's Minister of Water Supply for the State of Victoria, shall give the necessary directions herein accordingly.

TOM FORRISTAL,
Clerk of the Executive Council.

PORTLAND WATERWORKS TRUST.

At the Executive Council Chamber, Melbourne, the twenty-fourth day of December, 1974.

PRESENT:

His Excellency the Governor of Victoria.

Mr. Hamer	Mr. Dickie
Mr. Meagher	Mr. Rossiter
Mr. Wilcox	Mr. Borthwick
Mr. Rafferty	Mr. Smith
Mr. Hunt	Mr. Scanlan
Mr. Houghton	Mr. Dixon.
Mr. Granter	

CONSENT TO BORROWING \$40,000.

Under the powers conferred by the Water Act and all other powers enabling him in that behalf, His Excellency the Governor of the State of Victoria, by and with the advice of the Executive Council of the said State, hereby consents to the Portland Waterworks Trust borrowing the sum of Forty thousand dollars (\$40,000) to meet the cost of water supply works.

And the Honorable Frederick James Granter, Her Majesty's Minister of Water Supply for the State of Victoria, shall give the necessary directions herein accordingly.

TOM FORRISTAL,
Clerk of the Executive Council.

CITY OF WARRNAMBOOL.

At the Executive Council Chamber, Melbourne, the twenty-fourth day of December, 1974.

PRESENT:

His Excellency the Governor of Victoria.

Mr. Hamer	Mr. Dickie
Mr. Meagher	Mr. Rossiter
Mr. Wilcox	Mr. Borthwick
Mr. Rafferty	Mr. Smith
Mr. Hunt	Mr. Scanlan.
Mr. Houghton	Mr. Dixon.
Mr. Granter	

CONSENT TO BORROWING \$50,000.

Under the powers conferred by the Water Act and all other powers enabling him in that behalf, His Excellency the Governor of the State of Victoria, by and with the

advice of the Executive Council of the said State, hereby consents to the City of Warrambool borrowing the sum of Fifty thousand dollars (\$50,000) to meet the cost of water supply works.

And the Honorable Frederick James Granter, Her Majesty's Minister of Water Supply for the State of Victoria, shall give the necessary directions herein accordingly.

TOM FORRISTAL,
Clerk of the Executive Council.

DROMANA ROSEBUD SEWERAGE AUTHORITY.

At the Executive Council Chamber, Melbourne, the twenty-fourth day of December, 1974.

PRESENT:

His Excellency the Governor of Victoria.

Mr. Hamer	Mr. Dickie
Mr. Meagher	Mr. Rossiter
Mr. Wilcox	Mr. Borthwick
Mr. Rafferty	Mr. Smith
Mr. Hunt	Mr. Scanlan
Mr. Houghton	Mr. Dixon.
Mr. Granter	

CONSENT TO BORROWING \$225,000.

Under the powers conferred by the Sewerage Districts Act and all other powers enabling him in that behalf, His Excellency the Governor of the State of Victoria, by and with the advice of the Executive Council of the said State, hereby consents to the Dromana Rosebud Sewerage Authority borrowing the sum of Two hundred and twenty-five thousand dollars (\$225,000) to meet the cost of sewerage works as set forth in the detailed statement bearing date 20th December, 1974.

And the Honorable Frederick James Granter, Her Majesty's Minister of Water Supply for the State of Victoria, shall give the necessary directions herein accordingly.

TOM FORRISTAL,
Clerk of the Executive Council.

SUNBURY SEWERAGE AUTHORITY.

At the Executive Council Chamber, Melbourne, the twenty-fourth day of December, 1974.

PRESENT:

His Excellency the Governor of Victoria.

Mr. Hamer	Mr. Dickie
Mr. Meagher	Mr. Rossiter
Mr. Wilcox	Mr. Borthwick
Mr. Rafferty	Mr. Smith
Mr. Hunt	Mr. Scanlan
Mr. Houghton	Mr. Dixon.
Mr. Granter	

EXTENSION OF SEWERAGE DISTRICT.

Under the powers conferred by the Sewerage Districts Act and all other powers enabling him in that behalf, His Excellency the Governor of the State of Victoria, by and with the advice of the Executive Council of the said State, doth hereby declare, order and direct that the extent of the Sewerage District of the Sunbury Sewerage Authority be increased by adding the lands as shown on the plan approved by the Governor in Council by and with this Order and deposited in the office of the State Rivers and Water Supply Commission, Melbourne (Corr. No. 65/1690/111) and as on and from the date hereof the extent of such District shall be deemed to be increased accordingly.

And the Honorable Frederick James Granter, Her Majesty's Minister of Water Supply for the State of Victoria, shall give the necessary directions herein accordingly.

TOM FORRISTAL,
Clerk of the Executive Council.

FRANKSTON SEWERAGE AUTHORITY.

At the Executive Council Chamber, Melbourne, the twenty-fourth day of December, 1974.

PRESENT:

His Excellency the Governor of Victoria.

Mr. Hamer	Mr. Dickie
Mr. Meagher	Mr. Rossiter
Mr. Wilcox	Mr. Borthwick
Mr. Rafferty	Mr. Smith
Mr. Hunt	Mr. Scanlan
Mr. Houghton	Mr. Dixon.
Mr. Granter	

CONSENT TO BORROWING \$200,000.

Under the powers conferred by the Sewerage Districts Act and all other powers enabling him in that behalf, His Excellency the Governor of the State of Victoria, by and with the advice of the Executive Council of the said State, hereby consents to the Frankston Sewerage Authority borrowing the sum of Two hundred thousand dollars (\$200,000) to meet the cost of sewerage works as set forth in the detailed statement bearing date 20th December, 1974.

And the Honorable Frederick James Granter, Her Majesty's Minister of Water Supply for the State of Victoria, shall give the necessary directions herein accordingly.

TOM FORRISTAL,
Clerk of the Executive Council.

ORBOST SEWERAGE AUTHORITY.

At the Executive Council Chamber, Melbourne, the twenty-fourth day of December, 1974.

PRESENT:

His Excellency the Governor of Victoria.

Mr. Hamer	Mr. Dickie
Mr. Meagher	Mr. Rossiter
Mr. Wilcox	Mr. Borthwick
Mr. Rafferty	Mr. Smith
Mr. Hunt	Mr. Scanlan
Mr. Houghton	Mr. Dixon.
Mr. Granter	

CONSENT TO BORROWING \$5,000.

Under the powers conferred by the Sewerage Districts Act and all other powers enabling him in that behalf, His Excellency the Governor of the State of Victoria, by and with the advice of the Executive Council of the said State, hereby consents to the Orbost Sewerage Authority borrowing the sum of Five thousand dollars (\$5,000) to meet the cost of sewerage works as set forth in the detailed statement bearing date 20th December, 1974.

And the Honorable Frederick James Granter, Her Majesty's Minister of Water Supply for the State of Victoria, shall give the necessary directions herein accordingly.

TOM FORRISTAL,
Clerk of the Executive Council.

WONTHAGGI SEWERAGE AUTHORITY.

At the Executive Council Chamber, Melbourne, the twenty-fourth day of December, 1974.

PRESENT:

His Excellency the Governor of Victoria.

Mr. Hamer	Mr. Dickie
Mr. Meagher	Mr. Rossiter
Mr. Wilcox	Mr. Borthwick
Mr. Rafferty	Mr. Smith
Mr. Hunt	Mr. Scanlan
Mr. Houghton	Mr. Dixon.
Mr. Granter	

CONSENT TO BORROWING \$50,000.

Under the powers conferred by the Sewerage Districts Act and all other powers enabling him in that behalf, His Excellency the Governor of the State of Victoria, by and

with the advice of the Executive Council of the said State, hereby consents to the Wonthaggi Sewerage Authority borrowing a sum of Fifty thousand dollars (\$50,000) to meet the cost of sewerage works as set forth in the detailed statement bearing date 20th December, 1974.

And the Honorable Frederick James Granter, Her Majesty's Minister of Water Supply for the State of Victoria, shall give the necessary directions herein accordingly.

TOM FORRISTAL,
Clerk of the Executive Council.

COBRAM SEWERAGE AUTHORITY.

At the Executive Council Chamber, Melbourne, the twenty-fourth day of December, 1974.

PRESENT:

His Excellency the Governor of Victoria.

Mr. Hamer	Mr. Dickie
Mr. Meagher	Mr. Rossiter
Mr. Wilcox	Mr. Borthwick
Mr. Rafferty	Mr. Smith
Mr. Hunt	Mr. Scanlan
Mr. Houghton	Mr. Dixon.
Mr. Granter	

EXTENT OF SEWERAGE DISTRICT INCREASED.

Under the powers conferred by the Sewerage Districts Act and all other powers enabling him in that behalf, His Excellency the Governor of the State of Victoria, by and with the advice of the Executive Council of the said State, doth hereby declare, order and direct that the extent of the Sewerage District of the Cobram Sewerage Authority be increased by adding thereto the lands shown coloured red on a plan approved by the Governor in Council, by and with this Order and deposited in the office of the State Rivers and Water Supply Commission, Melbourne (Corr. 74/3078/16), and as on and from the date hereof the extent of such District shall be deemed to be increased accordingly.

And the Honorable Frederick James Granter, Her Majesty's Minister of Water Supply for the State of Victoria, shall give the necessary directions herein accordingly.

TOM FORRISTAL,
Clerk of the Executive Council.

COLAC SEWERAGE AUTHORITY.

At the Executive Council Chamber, Melbourne, the twenty-fourth day of December, 1974.

PRESENT:

His Excellency the Governor of Victoria.

Mr. Hamer	Mr. Dickie
Mr. Meagher	Mr. Rossiter
Mr. Wilcox	Mr. Borthwick
Mr. Rafferty	Mr. Smith
Mr. Hunt	Mr. Scanlan
Mr. Houghton	Mr. Dixon.
Mr. Granter	

CONSENT TO BORROWING \$15,000.

Under the powers conferred by the Sewerage Districts Act and all other powers enabling him in that behalf, His Excellency the Governor of the State of Victoria, by and with the advice of the Executive Council of the said State, hereby consents to the Colac Sewerage Authority borrowing the sum of Fifteen thousand dollars (\$15,000) to meet the cost of sewerage works as set forth in the detailed statement bearing date 20th December, 1974.

And the Honorable Frederick James Granter, Her Majesty's Minister of Water Supply for the State of Victoria, shall give the necessary directions herein accordingly.

TOM FORRISTAL,
Clerk of the Executive Council.

GEELONG WATERWORKS AND SEWERAGE TRUST.

At the Executive Council Chamber, Melbourne, the twenty-fourth day of December, 1974.

PRESENT:

His Excellency the Governor of Victoria.	
Mr. Hamer	Mr. Dickie
Mr. Meagher	Mr. Rossiter
Mr. Wilcox	Mr. Borthwick
Mr. Rafferty	Mr. Smith
Mr. Hunt	Mr. Scanlan
Mr. Houghton	Mr. Dixon.
Mr. Granter	

APPROVAL TO COMPULSORY ACQUISITION OF LAND.

Under the powers conferred by the Geelong Waterworks and Sewerage Act 1958 and all other powers enabling him in that behalf, His Excellency the Governor of the State of Victoria, by and with the advice of the Executive Council of the said State, doth hereby approve of the Geelong Waterworks and Sewerage Trust compulsorily acquiring certain lands, for the site of pumping station and sewerage rising main, as shown by pink colour on the plan approved by the Governor in Council, by and with this Order and deposited in the office of the State Rivers and Water Supply Commission, Melbourne (Corr. No. 66/5019/87.)

And the Honorable Frederick James Granter, Her Majesty's Minister of Water Supply for the State of Victoria, shall give the necessary directions herein accordingly.

TOM FORRISTAL,
Clerk of the Executive Council.

LANDS DEPARTMENT NOTICES

APPROACHING LAND SALES.

Sale of Crown Land, in fee-simple, will be held at the under-mentioned places and dates, viz.:—

	No. of Gazette.
Lorne.—Saturday, 18th January, 1975 ..	118
Red Cliffs.—Wednesday, 29th January, 1975 ..	118

COMMITTEES OF MANAGEMENT OF RESERVES.

APPOINTMENTS.

Notice is hereby given that, in pursuance of section 221 of the Land Act 1958, the following appointments of Committees of Management of reserved Crown lands have been made by the Minister of Lands:—

PUBLIC PURPOSES RESERVE AT STAWELL.

The Corporation of the Town of Stawell as the Committee of Management of the land in the Parish of Stawell, shown colored red on plan S/22.10.74 attached to Lands Department correspondence No. Rs.2465.—(Rs.2465.)

PUBLIC PURPOSES (CAR PARK) RESERVE, PARISH OF WELSHPOOL.

The Corporation of the Shire of South Gippsland as a Committee of Management of the land being Crown allotment 35A, section B, Parish of Welshpool, temporarily reserved pursuant to Order in Council dated the 30th October, 1974, as a site for Public purposes (Car Park).—(Rs.4589.)

PUBLIC PURPOSES (BOAT RAMP), PARISH OF WELSHPOOL.

The Corporation of the Shire of South Gippsland as a Committee of Management of the land being Crown allotment 35B, section B, Parish of Welshpool, temporarily reserved pursuant to Order in Council dated the 30th October, 1974, as a site for Public purposes (Boat Ramp).—(Rs.4589.)

W. BORTHWICK,
Minister of Lands.

Department of Crown Lands and Survey,
Melbourne, 23rd December, 1974.

PROPOSED REVOCATIONS OF TEMPORARY RESERVATIONS OF LANDS BY ORDERS IN COUNCIL.

In pursuance of the provisions of the Land Act 1958, notice is hereby given that it is the intention of the Governor in Council to revoke the temporary reservations of lands by Orders in Council hereunder referred to viz.:

The following Notices were published 1° on the 11th December, 1974, pursuant to Orders of the 3rd December, 1974.

GEELONG (EAST GEELONG).—The temporary reservation by Order in Council of the 3rd August, 1954, of 759 square metres (30 perches) of land in the City of Geelong (called Parish of Corio in Order), as a site for a Public Hall is about to be revoked.—(G.25(w1) (Rs.7291).

GEELONG (EAST GEELONG).—The temporary reservation by Order in Council of the 1st September, 1970 of 101 square metres (4 perches) of land in the City of Geelong, as a site for Public purposes (Public Hall) is about to be revoked.—(G.25(w1) (Rs.7291).

DEUTGAM (WERRIBEE).—The temporary reservation by Order in Council of the 21st September, 1936, of 429.9 hectares (1062 acres 1 rood 20 perches) of land in the Parishes of Deutgam and Tarnet, as a site for an Experimental Farm is about to be revoked so far only as the portion in the Parish of Deutgam containing 4.247 hectares, indicated by hatching on plan hereunder, is concerned.—(D.42(6) (Rs.4620).

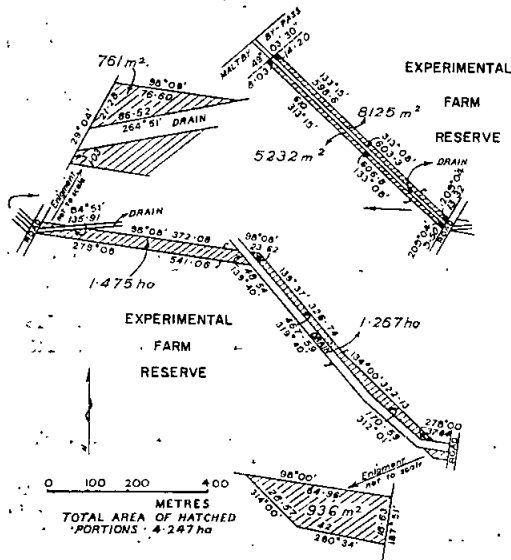

W. BORTHWICK, Minister of Lands.

PROPOSED REVOCATIONS OF TEMPORARY RESERVATIONS OF LANDS BY ORDERS IN COUNCIL.

In pursuance of the provisions of the Land Act 1958, notice is hereby given that it is the intention of the Governor in Council to revoke the temporary reservations of lands by Orders in Council hereunder referred to, viz.:

The following Notices were published 1° on the 8th January, 1975, pursuant to Orders of the 17th December, 1974.

JIKA JIKA (PRESTON).—The temporary reservation by Order in Council of 25th June, 1957, of 3.331 hectares (8 acres, 37 perches) of land in the Parish of Jika Jika, as a site for Mental Hygiene Authority purposes is about to be revoked.—(J.16(4) (Rs.7573).

JIKA JIKA (PRESTON).—The temporary reservation by Order in Council of the 27th August, 1968, of 683 square metres (27 perches) of land in the Parish of Jika Jika, as a site for Public purposes (Mental Health Authority) is about to be revoked.—(J.16(4) (Rs.7573).

JIKA JIKA (PRESTON).—The temporary reservation by Order in Council of the 8th July, 1969, of 531 square metres (21 perches) of land in the Parish of Jika Jika, as a site for Public purposes (Mental Health Authority) is about to be revoked.—(J.16(4) (Rs.7573).

EMERALD.—The temporary reservation by Order in Council of the 27th August, 1894 (see Government Gazette 1894 page 3528), of 4.424 hectares (10 acres 3 roods 29 perches) of land in the Township of Emerald, as a site for Public Recreation revoked as to part by various Orders is about to be revoked so far only as the portion containing 520 square metres, more or less, indicated by hatching on plan hereunder is concerned.—(E.110(4) (Rs.192).

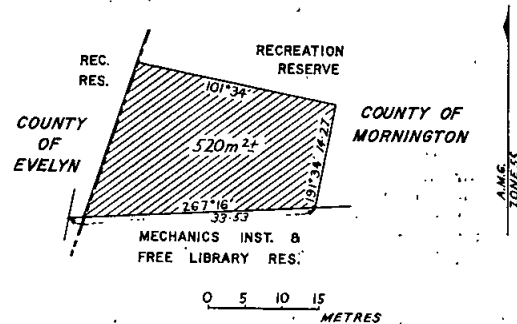

EMERALD.—The temporary reservation by Order in Council of the 4th March, 1958, of 2023 square metres (2 roods, more or less) of land in the Township of Emerald, as a site for Public Recreation is about to be revoked so far only as the portion containing 75 square metres, more or less, indicated by hatching on plan hereunder, is concerned.—(E.110(4) (Rs.192).

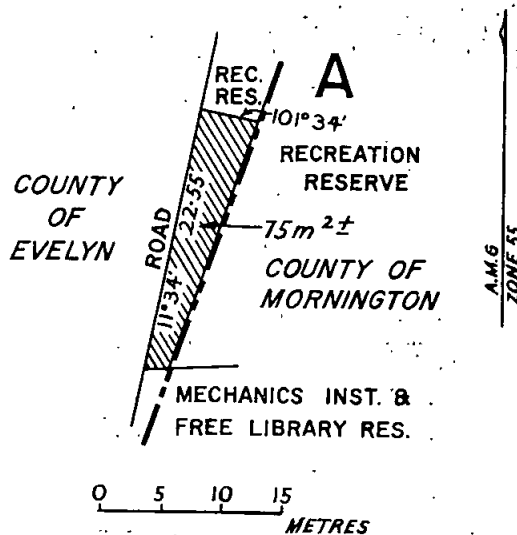

MAFFRA.—The temporary reservation by Order in Council of the 13th February, 1895 (see Government Gazette 1895 page 764), of 1.214 hectares (3 acres, more or less) of land in the Township of Maffra, as a site for Public purposes, revoked as to part by Order of the 5th May, 1942 is about to be revoked so far only as the portion containing 1600 square metres, more or less, indicated by hatching on plan hereunder, is concerned.—(M.89(4) (Rs.10029).

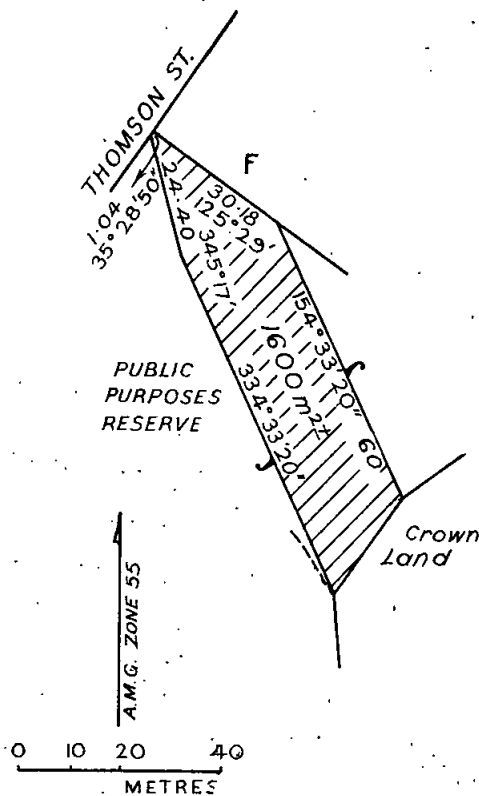

PENSHURST.—The temporary reservation by Order in Council of the 13th September, 1960, of 5.453 hectares (13 acres 1 rood 36 perches) of land in the Township of Peshurst, as a site for Public Park and Public Recreation is about to be revoked so far only as the portion containing 1.131 hectares indicated by hatching on plan hereunder, is concerned.—(P.29(4) (Rs.376).

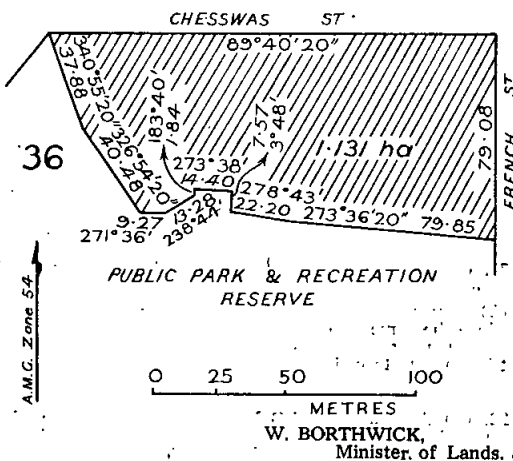

W. BORTHWICK,
Minister of Lands.

REGULATIONS FOR THE CARE, PROTECTION AND MANAGEMENT OF THE WEST PORT FORESHORE RESERVE, CITY OF PORT MELBOURNE.

Whereas by section 218 of the Land Act 1958 the Minister of Lands is empowered to make regulations as to any land which under the provisions of that Act or of any other Act relating to Crown lands has been reserved for any public purpose whatsoever and which has not been conveyed or vested in trustees, and

Whereas certain land in the City of Port Melbourne, Parish of Melbourne South, being Crown allotment 5, section 67A and known as the "West Port Foreshore

Reserve" hereinafter referred to as "the Reserve", has been temporarily reserved pursuant to Order in Council dated the 11th June, 1974, as a site for public recreation, and

Whereas such lands have not been conveyed to or vested in trustees, and

Whereas it is expedient that regulations for the care, protection and management of the Reserve and for other purposes connected therewith should be made:

Now therefore, I, William Archibald Borthwick, Her Majesty's Minister of Lands, in and for the State of Victoria, in pursuance of the powers aforesaid, do hereby make the following Regulations for or with respect to the Reserve.

The Reserve has been placed under the control of the Corporation of the City of Port Melbourne as the Committee of Management (hereinafter referred to as "the Committee") with power and authority to enforce the following regulations.

REGULATIONS.

Definitions.

1. In these Regulations unless inconsistent with the context or subject-matter—

"Act" means the Land Act 1958.

"Authorised Officer" means any person appointed, in writing, by the Committee as an authorised officer for the purpose of these Regulations and (except for the purpose of receipt of any fees or the grant, variation or revocation of any permit) also includes any member of the Police Force and any bailiff of Crown lands.

"Building" means any tent, marquee, stall, booth, shed, bathing box, boat shed, swing boat, merry-go-round, ocean wave, toilet block or other structure or erection.

"Committee" means the Committee of Management appointed pursuant to the Act to manage the Reserve.

"Firearms" includes any rifle, gun, pistol, air pistol, or like thing using, gas, cartridges, catapult, bow and arrow or cross bow and any other implement designed to discharge missiles capable of injuring or destroying animal life.

"Permit" includes any authority, approval, consent, permission, receipt, ticket or the like given, granted or issued under the Act or these Regulations.

"Person" means and includes a person, a group of persons, members of any Club, Society or any organisation or any member thereof and any firm or corporation (where the context so permits).

"Vehicle" includes any motor car, motor cycle, bicycle, cart, trailer, caravan; horse drawn vehicle, trailer and water craft.

For the purpose of these Regulations words purporting the singular number shall mean and include the plural and words purporting the masculine gender shall mean and include the feminine gender where the context requires or admits.

Behaviour.

2. No person shall—

(a) Enter or remain in the Reserve who may offend against decency as regards dress, language, or conduct;

(b) commit or create or knowingly permit or allow to continue any public or private nuisance or any annoyance to the public or any person lawfully in the Reserve whether such nuisance or annoyance takes place in a public or private building or other structure or in any enclosed or unenclosed space in the Reserve or do or suffer to be done any act which in the opinion of an authorised officer is or is likely to be to the annoyance or disturbance of any person using the Reserve;

(c) Except in an area set apart for the purpose, play any game in which a hard ball is used or engage in any game or sport likely to cause interference, disturbance or danger to other persons using the Reserve.

Shooting, &c.

3. No person shall in the Reserve except in accordance with a written permit have in his possession, carry or use any firearms, poison, trap or snare.

4. (a) Any person carrying or using any firearm, poison, trap or snare in the Reserve without a permit shall surrender the same on demand to any authorised officer who shall issue a receipt therefor.

(b) The person apparently entitled to any such article may collect it from the office of the Committee after completion of investigations and legal proceedings (if any) by the Committee or the Police in relation to any offence alleged against the person who surrendered the same.

Damage.

5. (a) No person, except with a permit issued by the Committee, shall in the Reserve, remove, cut, damage, displace, deface or interfere with any rock, timber, tree, shrub, plant, wild flower, or other vegetation or any sign, notice board, seat, table, gate, post, fence, bridge, building, structure or any other thing of the like nature to any of the foregoing.

(b) No person shall without a permit from the Committee, dig or remove from or take into the Reserve any gravel, stone, shell grit, sand, soil or loam.

Missiles.

6. No person shall roll or throw any stone or other substance or missile within the Reserve.

Camping.

7. No person shall camp in any part of the Reserve.

Refuse and Litter.

8. No person shall within the Reserve deposit or cause to be deposited (except in a receptacle provided for the purpose) any bottles, glass object, vessel or other container, broken glass, tins, waste paper, foodstuff, vegetable matter, offal or other refuse or litter.

Glass &c.

9. No person shall intentionally break any glass, bottle or other container within the Reserve and in the event of breaking any glass, bottle or other container shall immediately gather the pieces up and place them in a receptacle provided for refuse.

Dogs.

10. No person shall cause, suffer or permit any dog belonging to him or in his charge to be brought into or enter or remain in the Reserve unless such dog be and continue to be under proper control on a chain, cord or leash and unless such dog be effectively restrained from causing annoyance to any person and from damaging, or interfering in any way with the property of the Committee.

Animals Generally.

11. (a) Save as aforesaid, no person shall cause or suffer or knowingly permit any animal belonging to him or in his charge to be brought into or enter or remain in the Reserve without a permit.

(b) Any animal found in the Reserve contrary to these Regulations may be seized by an Authorised Officer and impounded or destroyed, and the owner or custodian thereof shall be liable to pay compensation for any damage done by such animal to the property of the Committee.

Enclosures.

12. No person except labourers and workmen employed in the Reserve shall enter any plots therein which may be set aside for plantations of young trees, shrubs or plants.

13. No person shall light a fire in the Reserve except at such places as may be set apart for that purpose by the Committee.

Fireworks.

14. No person shall throw or set fire to any fireworks within the Reserve.

Roadways, &c.

15. No person shall—

- (a) unless authorised by the Committee drive, ride, push, pull, place or leave any vehicle in or on the Reserve except in or upon such roadways or areas set aside for the purpose, and no person shall allow any vehicle to remain stationary in any position obstructing the lawful passage of others;
- (b) drive any vehicle in a manner dangerous to the public;
- (c) drive any vehicle so as to cause noise which is unreasonable in the circumstances.

Parking.

16. No person shall park any vehicle within the Reserve except—

- (a) In an area set apart for the purpose and clearly defined by signs; or
- (b) as and where directed or authorised by the Committee or an Authorised Officer;
- (c) upon payment of such fees (if any) as may be prescribed.

Recreation Vehicle.

17. No person shall drive or ride a recreational vehicle (as defined under the *Recreational Vehicles Act 1973*) in or on the Reserve.

Use of Facilities.

18. No person shall—

- (a) Use any kitchen, laundry, change room, shower, toilet or other convenience or facility or any part thereof in the Reserve, except for its proper purpose and upon payment of such fees (if any) as may be prescribed;
- (b) enter or use or permit any child under his care or control to enter or use any place, room, convenience or structure set apart for the use of the opposite sex; provided that this Regulation shall not apply to a child under the age of six years when accompanied by an adult of the opposite sex;
- (c) if above the age of fourteen years, use any swings or play equipment provided for children, or (save whilst in charge of a child under that age) enter any children's playground.

Boatsheds, &c.

19. (a) The Committee may set aside sites on the Reserve for bathing boxes, boatsheds and other buildings or structures.

(b) No person shall occupy any such site or erect or maintain any such structure without a written permit from the Committee.

(c) The Committee may at any time cancel the permit given in which case the bathing box, boatshed or other structure shall be removed and in the event of it not being removed by the person to whom the permit had been given for such occupation, the Committee may cause the bathing box, boatshed, or other structure to be removed from the Reserve.

(d) No bathing box, boatshed or similar structure shall be used at any time for residential purposes and in the event of the Committee being satisfied that such bathing box, boatshed, or similar structure is being used contrary to this Regulation, the permit may be cancelled.

Direction by Sign.

20. (a) The Committee may, by notices or signs established in such prominent position or positions as the case requires, prohibit or regulate any act, matter or thing within the Reserves or any part thereof.

(b) No person shall erect or remove any such notice or sign except with the authority of the Committee.

(c) No person shall disobey the directions indicated in any such notice or sign.

Permits.

21. (a) The holder of any permit shall observe and comply with all conditions thereof.

(b) Any person purporting to hold any permit shall produce the same on demand by an Authorised Officer and unless such permit is thereupon produced that person shall not be entitled to claim the benefit of any such permit.

Direction to Leave.

22. (a) Any Authorised Officer may direct a person who in his opinion offends any of these Regulations forthwith to leave the Reserve or any place herein.

(b) Every person who fails to comply forthwith with any such direction shall be guilty of an offence and may be removed from the Reserve or such place.

Giving of Name.

23. If, in the opinion of an Authorised Officer, any person has contravened or failed to comply with any provision of these Regulations, then such officer may demand and receive the name and address of such person and any person who when asked by such Officer refuses to furnish his name and address or who furnishes an incorrect name and address shall be deemed to have committed an offence.

Obstruction to Officers.

24. No person shall obstruct, hinder or interfere with an Authorised Officer or any employee of the Committee in the execution of his duty in the Reserve.

General.

25. No person shall in any part of the Reserve, except in accordance with and upon the terms of a permit, in writing, by the Committee—

- (a) Sell or offer for sale any article whatsoever;
- (b) give out, distribute, erect, leave, set up or display any handbills, placards, notices, pamphlets, books, papers, advertising matter or the like thing;
- (c) Occupy, use or enter any building, booth, shed, stand or structure unless the same is set aside for public use;
- (d) erect or place therein any building, booth, shed, or other structure;
- (e) solicit or collect money or orders for goods or services;
- (f) take part in or advertise any entertainment for gain;
- (g) preach, declaim, harangue or deliver any address of any kind or use any amplifier, public address system, loud hailer or similar device;
- (h) let for hire any article, device or thing;
- (i) take photographs for gain or commercial purposes;
- (j) ply any vehicle for hire or carry passengers for fee or reward;
- (k) conduct any school or provide any form of instruction for gain;
- (l) advertise for sale or trade or hire any article, device, service or thing.

26. Every person found to be under the influence of alcohol in the Reserve shall be guilty of an offence against these Regulations.

27. No person shall commit any nuisance or behave in a disorderly manner in the Reserve.

28. No person shall dress or undress or remove any part of his or her bathing costume in any part of the Reserve open to public view.

29. No person shall play any game or take part in any activity in or on any portion of the Reserve to the danger, inconvenience or annoyance of the public or any member of the public.

30. No club, association or person shall, without written authority of the Committee, hold any entertainment, performance, sports or ceremony in any part of the Reserve.

31. Any permits required to be issued by the Committee shall be issued by the Secretary of the Committee or other Authorised Officer of the Committee.

32. Every person granted permission to use the Reserve or part thereof or any structure therein shall make good any damage caused to the Reserve or structure or any other improvement therein during the period of the permissive occupancy granted by the permit.

33. No person shall spit or expectorate on the paths or on any structure or erection in the Reserve.

General Powers.

34. The Committee may—

- (a) Provide and maintain conveniences, facilities and amenities of any description in any part of the Reserve; or arrange for the provision and maintenance thereof and may from time to time determine or vary the conditions of entry or use thereof;
- (b) make such arrangements as it deems necessary or desirable for or in connexion with the proper and efficient management and operation of the Reserve or any portion thereof.

Permits.

35. (a) Any permit may be granted for such period and subject to such terms, conditions and fees consistent with these regulations as the Committee may from time to time determine either generally or in a particular case.

(b) No permit shall be transferable.

(c) Any permit (other than a permit granted by or pursuant to a document under seal) may be revoked or withdrawn.—(Rs.6000.)

Given under my hand, at Melbourne on the thirteenth day of December, 1974.

W. BORTHWICK,
Minister of Lands.

Every person who contravenes or fails to comply with these Regulations shall in accordance with the provisions of section 218 of the Land Act 1958 for each offence, be liable to a penalty of not more than Fifty Dollars, and every person who contravenes or fails to comply with any such regulations and who after he has been warned by any Bailiff of Crown lands or by any member of the police force, does not desist therefrom may be forthwith apprehended by such Bailiff or any member of the Police Force and taken before some justice to be dealt with according to law, and shall be liable to a penalty of not more than One Hundred Dollars, provided that every person who contravenes any regulation made under the said section for or with respect to prohibiting the depositing and leaving of any unwanted material or thing or rubbish of any kind on any land to which this section relates shall for each offence be liable to a penalty of not more than Two hundred dollars.

COMMON ABOUT TO BE DIMINISHED.

In pursuance of the provisions contained in the Land Act 1958, notice is hereby given that it is the intention of the Governor in Council to diminish the common hereinafter mentioned viz:—

The following Notice was published 1° on the 8th January, 1975, pursuant to Order of the 17th December, 1974.

The Ballarat West Town Common, proclaimed as such by the Governor in Council on the 28th January, 1861 (see Government Gazette 1861, page 256) is about to be diminished by the excision therefrom of the portion in the Parish of Dowling Forest containing 9.565 hectares indicated by hatching on plan hereunder.—(C.91998).

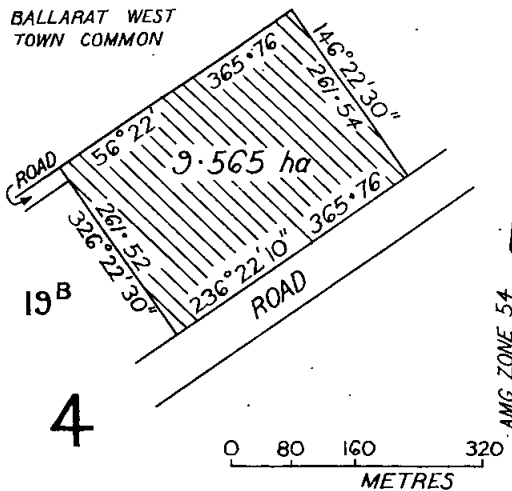

W. BORTHWICK,
Minister of Lands.

COMMON ABOUT TO BE DIMINISHED.

In pursuance of the provisions contained in the Land Act 1958, notice is hereby given that it is the intention of the Governor in Council to diminish the common hereinafter mentioned viz:—

The following Notice was published 1° on the 8th January, 1975, pursuant to Order of the 24th December, 1974.

The Moyston Common, proclaimed as such by the Governor in Council on the 5th March, 1889, is about to be diminished by the excision therefrom of all lands save and except the portions indicated by hatching on plan hereunder and containing 10.6 hectares, more or less.—(Rs.465.)

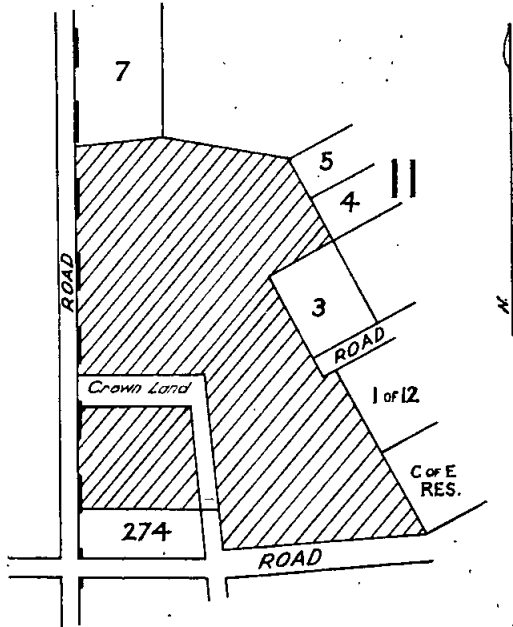

TOTAL AREA OF HATCHED PORTIONS 10.6 ha ±

W. BORTHWICK,
Minister of Lands.

PUBLIC SERVICE NOTICES

No. 255.

Public Service Act 1958, Section 39.

REGULATIONS.—PART IV.—SALARIES AND INCREMENTS.

The Public Service Board, in pursuance of the powers conferred by the Public Service Act 1958, hereby amends the Public Service (Public Service Board) Regulations as shown below :—

THIRD SCHEDULE.

PART B.

PROFESSIONAL DIVISION.

Scale of Rates of Annual Salaries.

HARBOUR MASTERS AND MARINE OFFICERS, DIVISION OF PORTS AND HARBOURS, PUBLIC WORKS DEPARTMENT.

The salary scale shown is deleted and the following salary scale is inserted in lieu thereof :—

Class.	Annual Salary of Each Subdivision of Each Class.		
	1.	2.	3.
	\$	\$	\$
M—1	11,813	11,983	12,154
M—2	12,267	12,552	12,888
M—3	13,108	13,329	..
M—4	13,549	13,881	14,156
M—5	15,665

This Regulation shall have effect from 8th December, 1974.

A. J. A. GARDNER, Chairman.
R. P. NOLAN, Acting Secretary.

Office of the Public Service Board,
Melbourne, 9th December, 1974.

No. 254.

Public Service Act 1958, Section 39.

REGULATIONS.—PART IV.—SALARIES AND INCREMENTS.

The Public Service Board, in pursuance of the powers conferred by the Public Service Act 1958, hereby amends the Public Service (Public Service Board) Regulations as shown below :—

THIRD SCHEDULE.

PART B.

PROFESSIONAL DIVISION.

Scale of Rates of Annual Salaries.

MANAGER, COOL STORES, DEPARTMENT OF AGRICULTURE.

The salary scale shown is deleted and the following salary scale is inserted in lieu thereof :—

Class.	Annual Salary.
	\$
MC-1	16,497

PUMPING STATION SUPERINTENDENTS, WATER SUPPLY DEPARTMENT.

The salary scale shown is deleted and the following salary scale is inserted in lieu thereof—

Class.	Annual Salary of Each Subdivision of Each Class.			
	1.	2.	3.	4.
	\$	\$	\$	\$
PU-1	11,586	11,870	12,154	12,438
PU-2	12,438	12,723	12,998	..
PU-3	13,549	13,991	14,302	14,728
PU-4	16,497

This Regulation shall have effect from 1st December, 1974.

A. J. A. GARDNER, Chairman.
R. P. NOLAN, Acting Secretary.

Office of the Public Service Board,
Melbourne, 9th December, 1974.

No. 249.

Public Service Act 1958, Section 39.

REGULATIONS.—PART IV.—SALARIES AND INCREMENTS.

The Public Service Board, in pursuance of the powers conferred by the Public Service Act 1958, hereby amends its Regulations as shown below :—

FOURTH SCHEDULE.

ADMINISTRATIVE DIVISION.

Amount of Salary Assigned to Offices in Class "A1".

Office.	Yearly Rate of salary.
	\$
PREMIER'S DEPARTMENT.	
Delete— Deputy Secretary	24,500
Add— Deputy Secretary	26,000

A. J. A. GARDNER, Chairman.
R. P. NOLAN, Acting Secretary.

Office of the Public Service Board,
Melbourne, 13th December, 1974.

No. 252.

PUBLIC SERVICE ACT 1958.

The Public Service Board, in pursuance of the powers conferred by the *Public Service Act 1958*, hereby amends the Public Service (Public Service Board) Regulations as follows:—

PART IV.—SALARIES AND INCREMENTS.
DIVISION IV.—TECHNICAL AND GENERAL DIVISION.
Regulation 119.

Immediately following paragraph (i) insert the following paragraph:—

“(j) Officers occupying the under-mentioned offices in the Maternal and Child Welfare Branch, Department of Health, may be granted the following annual increments:—

- Dental Therapist—one of \$356, one of \$336, one of \$356 and one of \$373.
- Tutor, Dental Therapist—one of \$381 and one of \$341.”

A. J. A. GARDNER, Chairman.
R. P. NOLAN, Acting Secretary.

Office of the Public Service Board,
Melbourne, 9th December, 1974.

No. 257.

PUBLIC SERVICE ACT 1958.

The Public Service Board, in pursuance of the powers conferred by the *Public Service Act 1958*, hereby amends the Public Service (Public Service Board) Regulations as follows:—

PART IV.—SALARIES AND INCREMENTS.
DIVISION IV.—TECHNICAL AND GENERAL DIVISION.
Regulation 119.

In sub-regulation (2), the amount “\$14,574” in the table of salaries is deleted and the amount “\$15,204” is inserted in lieu thereof.

Regulation 120.

DEPARTMENT OF AGRICULTURE.

In clause (ii) of paragraph (a) the expression “Grade 209” is deleted and the expression “Grade 211” is inserted in lieu thereof.

This Regulation shall have effect from 8th December, 1974.

A. J. A. GARDNER, Chairman.
R. P. NOLAN, Acting Secretary.

Office of the Public Service Board,
Melbourne, 16th December, 1974.

No. 256.

Public Service Act 1958, Section 39.

REGULATIONS.—PART IV.—SALARIES AND INCREMENTS.

The Public Service Board, in pursuance of the powers conferred by the *Public Service Act 1958*, hereby amends the Public Service (Public Service Board) Regulations as shown below:—

FIRST SCHEDULE.

PROFESSIONAL DIVISION.

Amount of Salary Assigned to Offices in “Special” Class.

Office.	Yearly Rate of salary.
	\$
<i>Delete the existing yearly rates of salary for the following offices and insert the rates shown hereunder in lieu thereof—</i>	
DEPARTMENT OF AGRICULTURE.	
Deputy Director of Agriculture	26,000
Assistant Director of Agriculture	24,500
Chief Biologist	23,200
Chief of Division of Agricultural Chemistry and Chief Chemist	23,200
Chief of Division of Agricultural Education	23,200
Chief of Division of Agriculture	23,200
Chief of Division of Animal Health	23,200
Chief of Division of Animal Industry	23,200
Chief of Division of Dairying	23,200
Chief of Division of Extension Services	23,200
Chief of Division of Horticulture	23,200
CHIEF SECRETARY'S DEPARTMENT.	
Government Statist and Actuary	24,500
Director, National Museum	22,000
Director, Science Museum	22,000
MINISTRY FOR CONSERVATION.	
Deputy Director of Conservation	24,500
Director of Fisheries and Wildlife	23,200
DEPARTMENT OF CROWN LANDS AND SURVEY.	
Surveyor-General	23,200
Director, Royal Botanic Gardens and Government Botanist	22,000
DEPARTMENT OF HEALTH.	
Chief Health Officer	29,700
Deputy Chief Health Officer	26,000
Government Medical Officer	26,000
Chief Health Education Officer	23,200
Medical Research Officer (Road Safety)	22,000

FIRST SCHEDULE—continued.

Office.	Yearly Rate of Salary.
	\$
General Health Branch.	
Assistant Chief Health Officer (Community Services)	24,500
Assistant Chief Health Officer (Public Health)	24,500
Chief Engineer	23,200
Chief Industrial Hygiene Officer	23,200
Health Officer (Venereal Diseases)	23,200
Senior District Health Officer	23,200
District Health Officer, Grade I	22,000
Industrial Hygiene Medical Officer, Grade I	22,000
Medical Officer, Poliomyelitis	22,000
Senior Medical Officer, Venereal Diseases Clinic	22,000
Supervising Medical Officer (Special Health Services)	22,000
Medical Superintendent, Prison Medical Service	22,000
Maternal and Child Welfare Branch.	
Director of Child Health (Dental)	23,200
Director of Child Health (Medical)	23,200
Director of Maternal, Infant and Pre-School Welfare	23,200
Senior Superintending Dental Officer	22,000
Superintending School Medical Inspector	22,000
Tuberculosis Branch.	
Deputy Director of Tuberculosis	23,200
Clinical Tuberculosis Officer	22,000
Medical Superintendent, Sanatoria	22,000
Radiologist, Mass X-ray Surveys	22,000
Supervisor of Mass X-ray Surveys	22,000
Tuberculosis Officer	22,000
MINISTRY OF HOUSING.	
Chief Technical Officer, Office of the Housing Commission	24,500
Chief Architect, Office of the Housing Commission	22,000
General Manager, Holmesglen Concrete House Factory, Office of the Housing Commission	22,000
LAW DEPARTMENT.	
Chief Parliamentary Counsel	29,700
Crown Solicitor	29,700
Registrar-General and Registrar of Titles	26,000
Assistant Crown Solicitor	23,200
Deputy Chief Parliamentary Counsel	23,200
Solicitor to the Commissioner for Corporate Affairs	23,200
Deputy Registrar and Chief Examiner of Titles	22,000
LOCAL GOVERNMENT DEPARTMENT.	
Valuer-General	22,000

FIRST SCHEDULE—continued.

Office.	Yearly Rate of Salary.
MINES DEPARTMENT.	
Director, Oil and Gas Division	23,200
Director of Geological Survey	23,200
Chief Inspector of Explosives, Gas Examiner and Chief Inspector of Inflammable Liquids* .. .	22,000
State Mining Engineer and Chief Mining Inspector	22,000
PREMIER'S DEPARTMENT.	
State Librarian, State Library, Ministry for the Arts	23,200
Director, National Gallery, Ministry for the Arts	22,000
PUBLIC WORKS DEPARTMENT.	
Director, Division of Building	26,000
Chief Architect	24,500
Director, Division of Ports and Harbours .. .	24,500
Chief Engineer, Division of Building	23,200
Deputy Chief Architect	23,200
SOCIAL WELFARE DEPARTMENT.	
Deputy Director-General of Social Welfare .. .	23,200
Director of Family Welfare	22,000
Director of Prisons	22,000
Director of Youth Welfare	22,000
STATE FORESTS DEPARTMENT.	
Chief of the Division of Forest Management .. .	22,000
Chief of the Division of Forest Operations .. .	22,000
TREASURY.	
Co-ordinator of Works	26,000
Comptroller of Stamps	24,500
Government Printer	24,500
WATER SUPPLY DEPARTMENT.	
Chief Engineer, Major Works	24,500
Chief Engineer, Rural Water Supplies	24,500
Chief Engineer, Town Water Supplies and Local Authorities	24,500
Chief Constructional Engineer	23,200
Chief Designing Engineer	23,200
Chief Mechanical Engineer	23,200

*An annual allowance to be determined by the Board shall be payable in respect of the duties of Gas Examiner.

THIRD SCHEDULE.

PART B.

PROFESSIONAL DIVISION.

Scale of Rates of Annual Salaries.

OFFICERS CLASSIFIED IN "SPECIAL" CLASS.

Class.	Annual Salary.	
	Minimum.	Maximum.
	\$	\$
Delete the existing salary scale and insert the following scale in lieu thereof—		
"SPECIAL"	22,000	29,700

This Regulation shall have effect from 8th December, 1974.

A. J. A. GARDNER, Chairman.
R. P. NOLAN, Acting Secretary.

Office of the Public Service Board,
Melbourne, 13th December, 1974.

No. 253.

Public Service Act 1958, Section 50.

REGULATIONS.—PART IV.—SALARIES AND INCREMENTS.

The Public Service Board, in pursuance of the powers conferred by the Public Service Act 1958, hereby amends its Regulations as shown below :—

SIXTH SCHEDULE.

TEMPORARY EMPLOYEES.

Designations of Positions and Rates of Salaries.

Department and Designation of Position.	Designation Code.	Yearly Rate of Salary.		Salary/Increment Code.
		Minimum.	Maximum.	
DEPARTMENT OF HEALTH.				
<i>Maternal and Child Welfare.</i>				
<i>Add—</i>				
Dental Therapist	6,355	7,776	AD
Tutor, Dental Therapist	8,112	8,834	AD

A. J. A. GARDNER, Chairman.
R. P. NOLAN, Acting Secretary.

Office of the Public Service Board,
Melbourne, 9th December, 1974.

No. 248.

Public Service Act 1958, Section 50.

REGULATIONS.—PART IV.—SALARIES AND INCREMENTS.

The Public Service Board, in pursuance of the powers conferred by the Public Service Act 1958, hereby amends the Public Service (Public Service Board) Regulations as shown below :—

SIXTH SCHEDULE.

TEMPORARY EMPLOYEES.

Designations of Positions and Rates of Salaries.

Department and Designation of Position.	Designation Code.	Yearly Rate of Salary.		Salary/Increment Code.
		Minimum.	Maximum.	
GENERAL.				
<i>Delete the existing yearly rates of salary for the following position and insert the rates shown hereunder in lieu thereof :—</i>				
Trainee Programmer	GA	7,760	9,069	CA

This Regulation shall have effect from 22nd September, 1974.

EIGHTH SCHEDULE.

TECHNICAL AND GENERAL DIVISION AND RELATED TEMPORARY POSITIONS.

Department and Office and/or Position.	Scale of Rates of Annual Salary with Incremental Stages.
MINISTRY OF HOUSING.	
<i>Office of the Housing Commission.</i>	
With effect from 22nd September, 1974—	
Delete— Accommodations Officer	\$6,600
Add— Accommodations Officer	\$6,600—\$6,789
With effect from 29th September, 1974—	
Delete— Accommodations Officer	\$6,761
Add— Accommodations Officer	\$6,761—\$6,950

A. J. A. GARDNER, Chairman.
L. R. BROWN, Secretary.

Office of the Public Service Board,
Melbourne, 2nd December, 1974.

No. 258.

Public Service Act 1958, Section 50.

REGULATIONS.—PART IV.—SALARIES AND INCREMENTS.

The Public Service Board, in pursuance of the powers conferred by the Public Service Act 1958, hereby amends its Regulations as shown below :—

THIRD SCHEDULE.

PART A.

ADMINISTRATIVE DIVISION.

Scales of Rates of Annual Salaries.

The salary scale shown is deleted and the following salary scale is inserted in lieu thereof—

Class.	Annual Salary of Each Subdivision of Each Class.									
	1.	2.	3.	4.	5.	6.	7.	8.	Mini-mum.	Maxi-mum.
	\$	\$	\$	\$	\$	\$	\$	\$	\$	\$
A1 ..									16,382	29,700
A ..	14,148	14,504	14,868
BI ..	12,516	12,879	13,241
B ..	11,162	11,449	11,735
C2 ..	9,942	10,228	10,507
CI ..	8,717	8,999	9,279
C ..	7,374	7,577	7,772	7,974
D ..	6,243	6,437	6,624	6,819	7,004	7,185	7,360	7,540
E ..	3,025	3,630	4,235	4,840	5,445	6,050

PART B.

PROFESSIONAL DIVISION.

Scale of Rates of Annual Salaries.

The salary scales shown are deleted and the following salary scales are inserted in lieu thereof—

CLERKS OF COURTS.

Class.	Annual Salary of Each Subdivision of Each Class.					
	1.	2.	3.	4.	5.	6.
	\$	\$	\$	\$	\$	\$
CC-1	7,440	7,871	8,146	8,367
CC-2	8,855	9,123	9,291	9,819	9,993	10,393
CC-3	10,904	11,302	11,530
CC-4	12,267	12,494	12,888
CC-5	13,439	13,991	14,624
CC-6	15,977
CC-7	17,337

EXECUTIVE ADVICE OFFICERS (DRAUGHTING), OFFICE OF TITLES, LAW DEPARTMENT.

Class.	Annual Salary of Each Subdivision of Each Class.		
	1.	2.	3.
	\$	\$	\$
EA-1	12,494	12,888
EA-2	16,289	..
EA-3	17,562	..

PROGRAMMERS/SYSTEMS ANALYSTS.

Class.	Annual Salary of Each Subdivision of Each Class.					
	1.	2.	3.	4.	5.	6.
	\$	\$	\$	\$	\$	\$
PS-1 ..	7,871	8,146	8,367	8,855	9,123	9,291
PS-2 ..	9,936	10,220	10,505
PS-3 ..	9,936	10,220	10,505	11,245
PS-4 ..	11,245	11,471	11,643
PS-5 ..	12,494	12,888	13,219

RESEARCH OFFICERS.

Class.	Annual Salary of Each Subdivision of Each Class.						
	1.	2.	3.	4.	5.	6.	7.
	\$	\$	\$	\$	\$	\$	\$
RO-1 ..	7,387	7,543	7,760	8,035	8,748	9,069	9,291
RO-2 ..	9,936	10,220	10,505
RO-3 ..	11,245	11,471	11,643
RO-4 ..	12,494	12,888	13,219
RO-5 ..	14,156	14,520	14,832

TECHNICAL OFFICER, PREMIER'S DEPARTMENT.

Class.	Annual Salary of Each Subdivision.		
	1.	2.	3.
	\$	\$	\$
TE-1 ..	11,302	11,471	11,756

WATER DISTRIBUTION OFFICERS, WATER SUPPLY DEPARTMENT.

Class.	Annual Salary of Each Subdivision of Each Class.			
	1.	2.	3.	4.
	\$	\$	\$	\$
WD-1 ..	10,677	10,904	11,358	12,098
WD-2 ..	14,374
WD-3 ..	15,248

FOURTH SCHEDULE.

ADMINISTRATIVE DIVISION.

Amount of Salary Assigned to Offices in Class "A1".

Office.	Yearly Rate of salary.
	\$

Delete the existing yearly rates of salary for the following offices and insert the rates shown hereunder in lieu thereof—

DEPARTMENT OF AGRICULTURE.

Assistant Director of Agriculture ..	22,000
Accountant ..	17,637
Secretary ..	17,637

CHIEF SECRETARY'S DEPARTMENT.

Deputy Under Secretary ..	24,500
Director of Administration, Office of the Chief Commissioner of Police ..	22,000
Assistant Under Secretary ..	18,887
Chief Electoral Officer ..	18,887
Deputy Insurance Commissioner ..	18,887
Officer in Charge, Motor Registration Branch ..	18,887
Manager, State Motor Car Insurance Office ..	17,637
Accountant, State Insurance Offices ..	16,382
Accountant, Chief Secretary's Office ..	16,382
Chief Registration Officer, Office of the Government Statist ..	16,382
Deputy Officer in Charge, Motor Registration Branch ..	16,382
Manager, State Accident Insurance Office ..	16,382
Officer in Charge, Electronic Data Processing Section, State Insurance Offices ..	16,382
Senior Executive Officer, Office of the Chief Commissioner of Police ..	16,382
Senior Executive Officer, Chief Secretary's Office ..	16,382

MINISTRY FOR CONSERVATION.

Secretary ..	17,637
--------------	--------

FOURTH SCHEDULE—continued.

Office.	Yearly Rate of salary.
	\$
DEPARTMENT OF CROWN LANDS AND SURVEY.	
Assistant Secretary	23,200
Superintendent of Occupation .. .	18,887
Accountant	17,637
Executive Officer	17,637
Superintendent of Crown Land Management .. .	17,637
EDUCATION DEPARTMENT.	
Secretary	24,500
Accountant	17,637
Assistant Secretary	17,637
Finance Officer	17,637
Officer in Charge, Stores Branch	17,637
DEPARTMENT OF HEALTH.	
Deputy Secretary	24,500
Secretary to the Mental Health Authority .. .	22,000
Accountant, Mental Hygiene Branch .. .	17,637
Assistant Secretary (Financial and Administration) .. .	17,637
Secretary, General Health Branch	17,637
Assistant Secretary to the Mental Health Authority .. .	17,637
Accountant	16,382
MINISTRY OF HOUSING.	
Registrar of Co-operative Housing Societies and Registrar of Co-operative Societies .. .	22,000
Secretary to the Housing Commission .. .	22,000
Chief Finance Officer, Office of the Housing Commission	18,887
Property Control Officer, Office of the Housing Commission	18,887
Accountant, Office of the Housing Commission .. .	17,637
Officer in Charge, Property and Allocations Division, Office of the Housing Commission	17,637
Accountant and Personnel Officer, Holmesglen Concrete House Factory, Office of the Housing Commission	16,382
Assistant Accountant, Office of the Housing Commission	16,382
Officer in Charge, Estate Management, Office of the Housing Commission	16,382
DEPARTMENT OF LABOUR AND INDUSTRY.	
Director of the Office of Industrial Relations Co-ordination (Public Employing Authorities) .. .	23,200
Deputy Secretary	23,200
Assistant Secretary	17,637
Chief Inspector of Factories and Shops .. .	17,637
Chief Industrial Officer	16,382
Deputy Director of the Office of Industrial Relations Co-ordination (Public Employing Authorities) .. .	16,382
Secretary, Apprenticeship Commission	16,382
LAW DEPARTMENT.	
Assistant Secretary	23,200
Commissioner for Corporate Affairs	23,200
Chief Investigation Officer, Corporate Affairs Office .. .	18,887
Deputy Commissioner for Corporate Affairs .. .	18,887
Assistant Public Trustee	17,637
Executive Officer (Planning), Office of Titles .. .	17,637
Officer in Charge, Criminal Branch, Crown Solicitor's Office	17,637
Prothonotary	17,637
Second Assistant Secretary	17,637
Senior Executive Advice Officer, Office of Titles .. .	17,637
Accountant	16,382
Accountant, Office of the Public Trustee	16,382
Executive Advice Officer, Office of Titles .. .	16,382
Registrar of Probates and Administrations .. .	16,382
Sheriff	16,382
LOCAL GOVERNMENT DEPARTMENT.	
Assistant Secretary	17,637
Senior Inspector of Municipal Administration .. .	16,382

FOURTH SCHEDULE—continued.

Office.	Yearly Rate of salary.
	\$
MINES DEPARTMENT.	
Assistant Secretary	17,637
PREMIER'S DEPARTMENT.	
Assistant Auditor-General	26,000
Chief Public Service Inspector, Office of the Public Service Board	26,000
Deputy Secretary	24,500
Assistant Chief Public Service Inspector, Office of the Public Service Board	22,000
Secretary to the Public Service Board	22,000
First Assistant Secretary	18,887
Officer in Charge, Electronic Data Processing Centre, Office of the Public Service Board	18,887
Senior Public Service Inspector, Office of the Public Service Board	18,887
Senior Public Service Inspector (Organization and Methods), Office of the Public Service Board .. .	18,887
Senior Auditor, Audit Office	18,887
Assistant Senior Auditor, Audit Office .. .	16,382
Chief Executive Officer, State Film Centre, Ministry for the Arts	16,382
Clerk of the Executive Council and Official Secretary to the Governor	16,382
Deputy Officer in Charge, Electronic Data Processing Centre, Office of the Public Service Board .. .	16,382
Deputy Secretary, Office of the Public Service Board .. .	16,382
Executive Officer, Recruitment and Staff Development, Office of the Public Service Board .. .	16,382
Second Assistant Secretary	16,382
Secretary, Council of Trustees of the National Gallery, Ministry for the Arts	16,382
Secretary, Office of the Agent-General	16,382
PUBLIC WORKS DEPARTMENT.	
Director, Division of Administration	23,200
Chief Finance Officer	18,887
Accountant	17,637
Chief Property Officer	17,637
Officer in Charge, Stores Branch	17,637
Assistant Accountant	16,382
SOCIAL WELFARE DEPARTMENT.	
Secretary	18,887
Accountant	17,637
DEPARTMENT OF STATE DEVELOPMENT.	
Director of Industrial Development	18,887
Assistant Secretary	17,637
STATE FORESTS DEPARTMENT.	
Secretary	22,000
Chief Finance Officer	18,887
Accountant	17,637
Assistant Secretary	17,637
TREASURY.	
Deputy Director of Finance	26,000
Assistant Director of Finance	24,500
Commissioner, Land Tax and Probate Duties .. .	24,500
Accountant to the Treasury	18,887
Budget Officer	18,887
Deputy Commissioner, Probate Duties	18,887
Deputy Comptroller of Stamps	18,887
Executive Officer, Treasury	18,887
Secretary and Accountant, Government Printing Office	17,637
Secretary to the Superannuation Board	17,637
Assistant Accountant to the Treasury	17,637
Deputy Commissioner, Land Tax (Administration) .. .	17,637
Deputy Comptroller of Stamps	17,637
Assistant Commissioner, Land Tax, Probate and Gift Duties	16,382
Assistant Commissioner, Probate Duties	16,382

FOURTH SCHEDULE.—continued.

Office.	Yearly Rate of Salary.
	\$
WATER SUPPLY DEPARTMENT.	
Secretary	22,000
Chief Finance Officer	18,887
Chief Accountant	17,637
Chief Estates Officer	17,637
Staff and Industrial Officer	17,637
Officer in Charge, Stores Branch	17,637
Assistant Chief Accountant	16,382
DEPARTMENT OF YOUTH, SPORT AND RECREATION.	
Director, Planning and Co-ordination	18,887
Executive Officer, Racing Division	16,382

SIXTH SCHEDULE.—continued.

Department and Designation of Position.	Designation Code.	Yearly Rate of Salary.		Salary/Increment Code.
		Minimum.	Maximum.	
		\$	\$	
MINISTRY OF HOUSING.				
Assistant, Engineering Supervision	8,791	9,394	AA
Estate Officer, Grade II.	GA	7,279	7,485	AA
Estate Officer, Grade I.	GA	6,805	7,047	AA
DEPARTMENT OF LABOUR AND INDUSTRY.				
Inspector of Boilers and Pressure Vessels	9,394	10,533	AA
Inspector of Lifts and Cranes	9,651	10,533	AA
LAW DEPARTMENT.				
Attendant, Coroner's Court	7,444	7,610	AA
LOCAL GOVERNMENT DEPARTMENT.				
<i>Weights and Measures.</i>				
Inspector	8,451	8,791	AA
Technical Equipment Officer	8,704	9,092	AA
Technical Equipment Officer, Assistant	7,124	7,444	AA
MINES DEPARTMENT.				
Driller, Grade IV.	8,324	8,579	AA
Driller, Grade III.	8,070	..
Driller, Grade II.	7,320	7,444	AA
Inspector of Mines and Quarries	11,714	13,060	AA
EXPLOSIVES AND GAS EXAMINING.				
Inspector of Explosives	7,124	7,692	AA
PUBLIC WORKS DEPARTMENT.				
<i>Ports and Harbours.</i>				
Marine Inspector	HB, HC, HD	7,735	8,153	AA
SOCIAL WELFARE DEPARTMENT.				
FAMILY WELFARE DIVISION.				
Activities Officer	GA	6,875	7,776	AA
Child Care Officer, Senior	GA, HI	7,124	7,320	AA
Cottage Mother	7,610	7,860	AA, AC
Superintendent, "The Gables"	GA	8,662	8,834	AA
Superintendent, "Iloura"	GA	8,662	8,834	AA
Superintendent, "Lady Dugan Home"	GA	8,662	8,834	AA
Superintendent, "Pirra"	GA	8,662	8,834	AA
Superintendent, "Sutton Grange"	GA	8,662	8,834	AA
Superintendent, Assistant, "Iloura"	GA	7,944	8,153	AA
Superintendent, Assistant, "Lady Dugan Home"	GA	7,944	8,153	AA
Superintendent, Assistant, "Pirra"	GA	7,944	8,153	AA
YOUTH WELFARE DIVISION.				
Hostel Supervisor, "Ivanhoe"	GA	7,361	7,860	AA, AC
Girls Hostel	7,650	8,579	AA
Trade Instructor	7,124	7,320	AA
Youth Officer, Senior	GA
REGIONAL SERVICES DIVISION.				
Attendance Officer	HM	6,828	7,485	AA
STATE FORESTS DEPARTMENT.				
Construction Overseer, Senior	8,493	9,092	AA
Foreman, Field Workshop	8,324	8,919	AA
Photographer and Projectionist	7,902	8,070	AA
Plant Inspector	8,919	9,092	AA
WATER SUPPLY DEPARTMENT.				
Inspector (Materials and Testing)	7,692	8,070	AA
Inspector, Works	7,944	8,324	AA
Inspector, Grade I.	7,279	7,444	AA
Mechanical Supervisor, Grade II.	8,153	8,324	AA

SIXTH SCHEDULE.

TEMPORARY EMPLOYEES.

Designations of Positions and Rates of Salaries.

Department and Designation of Position.	Designation Code.	Yearly Rate of Salary.		Salary/Increment Code.
		Minimum.	Maximum.	
		\$	\$	
<i>Delete the existing yearly rates of salary for the following positions and insert the rates shown hereunder in lieu thereof—</i>				
GENERAL.				
Photographer (Male), Grade II.	7,444	7,860	AA
Programmer	GA	11,245	11,643	CC
Programmer, Assistant	GA	9,936	11,245	CB
Survey Assistant, Grade III.	8,704	9,092	AA
Survey Assistant, Grade II.	7,692	8,070	AA
Trainee Programmer	GA	7,871	9,291	CA
DEPARTMENT OF AGRICULTURE.				
Animal Health Assistant	7,320	8,153	AA
Apiary Inspector	6,970	7,692	AA
Dairy Produce Inspector	8,962	9,479	AA
Dairy Projects Officer	8,962	9,479	AA
Dairy Supervisor	7,610	8,379	AA
Display Designer	GA	6,474	7,279	AA
Farm Produce Inspector	7,124	7,944	AA
Foreman, Government Cool Stores	7,361	7,650	AA
Herd Improvement Organizer	7,202	8,579	AA, AG
Horticultural Adviser	7,568	8,153	AA
Horticultural Inspector	7,124	8,153	AA
Orchard Inspector	7,320	7,692	AA
Overseer, Government Cool Stores	8,579	8,919	AA
Potato Inspector	7,124	7,944	AA
Tobacco Instructor, Assistant	7,009	7,944	AA
MILK BOARD.				
Inspector, Grade II.	7,610	8,579	AA
Inspector, Grade I.	7,202	7,610	AA
CHIEF SECRETARY'S DEPARTMENT.				
Boating Officer, Chief Secretary's Office	10,440	11,194	AA
Claims Investigator, State Insurance Offices	8,791	9,394	AA
Claims Investigator, Assistant, State Insurance Offices	7,202	7,610	AA
<i>Office of the Chief Commissioner of Police.</i>				
Instructor, Physical Training	7,650	8,579	AA
Licence Testing Officer, Senior	7,279	7,692	AA
DEPARTMENT OF CROWN LANDS AND SURVEY.				
Inspector of Land Settlement	7,610	8,579	AA
DEPARTMENT OF HEALTH.				
<i>General Health.</i>				
Plumbing Inspector, Plumbers and Gasfitters Board	7,735	8,324	AA
<i>Tuberculosis.</i>				
State Sanatoria	GY
Foreman	7,444	7,860	AA

EIGHTH SCHEDULE.
PROFESSIONAL DIVISION.

Class.	Annual Salary of Each Subdivision of Each Class.					
	1.	2.	3.	4.	5.	6.
	\$	\$	\$	\$	\$	\$

FRUIT PRESERVING EXPERT, DEPARTMENT OF AGRICULTURE.

The salary scale shown is deleted and the following salary scale in inserted in lieu thereof—

FP-1 ..	7,468	7,634	7,807	7,986	8,105	8,206
---------	-------	-------	-------	-------	-------	-------

TECHNICAL AND GENERAL DIVISION AND RELATED TEMPORARY POSITIONS.

Department and Office and/or Position.	Scale of Rates of Annual Salary with Incremental Stages.
<i>Delete the existing yearly rates of salary for the following positions and insert the rates shown hereunder in lieu thereof:—</i>	
SOCIAL WELFARE DEPARTMENT.	
<i>Youth Welfare Division.</i>	
Commercial Instructress, "Winlaton"	\$7,468—\$7,634—\$7,807—\$7,986—\$8,105—\$8,206
Trade Instructor, Dressmaking T	\$7,468—\$7,634—\$7,807—\$7,986—\$8,105—\$8,206
DEPARTMENT OF STATE DEVELOPMENT.	
<i>Division of Tourism.</i>	
Inquiry Clerk, Senior	\$7,665
Inquiry Clerk, Grade II.	\$7,254

SECOND SCHEDULE.

TECHNICAL AND GENERAL DIVISION.
GRADES AND SALARY SCALES.
PART A.

Grade Number.	Yearly Rate of Salary.
	\$
<i>Add—</i>	
348	14,637
349	14,700
350	14,763
351	14,826
352	14,889
353	14,952
354	15,015
355	15,078
356	15,141
357	15,204

This Regulation shall have effect from 8th December, 1974.

A. J. A. GARDNER, Chairman.
R. P. NOLAN, Acting Secretary.

Office of the Public Service Board,
Melbourne, 16th December, 1974.

No. 251.

Public Service Act 1958, Section 39.

REGULATIONS.—PART IV.—SALARIES AND INCREMENTS.

The Public Service Board, in pursuance of the powers conferred by the *Public Service Act 1958*, hereby amends the Public Service (Public Service Board) Regulations as shown below:—

THIRD SCHEDULE.

PART B.

PROFESSIONAL DIVISION.

Scale of Rates of Annual Salaries.

WATER DISTRIBUTION OFFICERS, WATER SUPPLY DEPARTMENT.

Class.	Annual Salary of Each Subdivision of Each Class.
	1.
	\$
<i>Delete—</i> WD-3	15,248

A. J. A. GARDNER, Chairman.

R. P. NOLAN, Acting Secretary.

Office of the Public Service Board,
Melbourne, 13th December, 1974.

No. 250.

Public Service Act 1958, Section 50.

REGULATIONS.—PART IV.—SALARIES AND INCREMENTS.

The Public Service Board, in pursuance of the powers conferred by the *Public Service Act 1958*, hereby amends its Regulations as shown below:—

SIXTH SCHEDULE.

TEMPORARY EMPLOYEES.

Designations of Positions and Rates of Salaries.

Department and Designation of Position.	Designation Code.	Yearly Rate of Salary.		Salary/Increment Code.
		Minimum.	Maximum.	
		\$	\$	
CHIEF SECRETARY'S DEPARTMENT.				
NATIONAL MUSEUM AND SCIENCE MUSEUM.				
<i>Delete—</i> Lavatory Attendant	GA	5,133	5,433	AA
<i>Add—</i> Lavatory Attendant	GA	5,599	5,905	AA

This Regulation shall have effect from 15th December, 1974.

A. J. A. GARDNER, Chairman.
R. P. NOLAN, Acting Secretary.

Office of the Public Service Board,
Melbourne, 13th December, 1974.

*Teaching Service Act 1958.*TEACHING SERVICE (TEACHERS TRIBUNAL) REGULATIONS.
AMENDMENT No. 306 (T.T.6).

The Teachers Tribunal, in pursuance of the powers conferred by the *Teaching Service Act 1958*, hereby amends Regulation 21 of the Teaching Service (Teachers Tribunal) Regulations as follows:—

Regulation 21.

Rescind Regulation 21 and substitute therefor the following new Regulation:—

Regulation 21.

RELATIVE NUMBERS OF POSITIONS FOR TEACHERS IN EACH CLASS OF THE TECHNICAL SCHOOLS DIVISION.

The relative numbers of positions for teachers in each class of the Technical Schools Division from the 1st January, 1975, shall be as follows:—

Class.	Numbers of Positions.
Principal	281
Senior Teacher	649
Assistant—Posts of Responsibility	1,459
Assistant	4,500

W. E. SAMPSON, Chairman.
A. F. LE CLERCQ, Secretary.

Office of the Teachers Tribunal,
Melbourne, 24th December, 1974.

*Teaching Service Act 1958.*TEACHING SERVICE — PRIMARY SCHOOLS DIVISION
(CLASSIFICATION, SALARIES, AND ALLOWANCES)
REGULATION.

AMENDMENT No. 298 (PRIM. C.S. & A.1).

The Teachers Tribunal, in pursuance of the powers conferred by the *Teaching Service Act 1958*, hereby amends the Teaching Service—Primary Schools Division (Classification, Salaries, and Allowances) Regulation as follows:—

In sub-clause 11 (d) for the amounts "\$1,000", "\$334", "\$570", and "\$290" substitute the amounts "\$1,500", "\$500", "\$1,200", and "\$1,200" respectively.

(To take effect from and including the 1st January, 1975.)

W. E. SAMPSON, Chairman.
A. F. LE CLERCQ, Secretary.

Office of the Teachers Tribunal,
Melbourne, 24th December, 1974.

*Teaching Service Act 1958.*TEACHING SERVICE (TEACHERS TRIBUNAL)
REGULATIONS.

AMENDMENT No. 301 (T.T.4).

The Teachers Tribunal, in pursuance of the powers conferred by the *Teaching Service Act 1958*, hereby amends Regulation 4 of the Teaching Service (Teachers Tribunal) Regulations as follows:—

Regulation 4.

1. In clause 1A for the expression "State-wide" substitute the expression "Regional".

2. In the second and third provisos to sub-clause 3 (a) for the expression "State-wide" where appearing substitute the expression "Regional".

(To take effect from and including the 1st January, 1975.)

W. E. SAMPSON, Chairman.
A. F. LE CLERCQ, Secretary.

Office of the Teachers Tribunal,
Melbourne, 24th December, 1974.

Teaching Service Act 1958.

TEACHING SERVICE—PRIMARY SCHOOLS DIVISION
(CLASSIFICATION, SALARIES, AND ALLOWANCES)
REGULATION.

AMENDMENT No. 302 (PRIM. C.S. & A.2).

The Teachers Tribunal, in pursuance of the powers conferred by the *Teaching Service Act 1958*, hereby amends the Teaching Service—Primary Schools Division (Classification, Salaries, and Allowances) Regulation as follows:—

1. In paragraph (ii) of sub-clause 13 (c) for the amount "\$3,536" substitute the amount "\$3,957".

2. Rescind paragraph (iii) of sub-clause 13 (c).

(To take effect from and including the 5th January, 1975.)

W. E. SAMPSON, Chairman.

A. F. LE CLERCQ, Secretary.

Office of the Teachers Tribunal,
Melbourne, 24th December, 1974.

Teaching Service Act 1958.

TEACHING SERVICE—SECONDARY SCHOOLS DIVISION
(CLASSIFICATION, SALARIES, AND ALLOWANCES)
REGULATION.

AMENDMENT No. 303 (SEC. C.S. & A.2).

The Teachers Tribunal, in pursuance of the powers conferred by the *Teaching Service Act 1958*, hereby amends the Teaching Service—Secondary Schools Division (Classification, Salaries, and Allowances) Regulation as follows:—

1. In paragraph (ii) of sub-clause 13 (c) for the amount "\$3,536" substitute the amount "\$3,957".

2. Rescind paragraph (iii) of sub-clause 13 (c).

(To take effect from and including the 5th January, 1975.)

W. E. SAMPSON, Chairman.

A. F. LE CLERCQ, Secretary.

Office of the Teachers Tribunal,
Melbourne, 24th December, 1974.

Teaching Service Act 1958.

TEACHING SERVICE—TECHNICAL SCHOOLS DIVISION
(CLASSIFICATION, SALARIES, AND ALLOWANCES)
REGULATION.

AMENDMENT No. 304 (TECH. C.S. & A.2).

The Teachers Tribunal, in pursuance of the powers conferred by the *Teaching Service Act 1958*, hereby amends the Teaching Service—Technical Schools Division (Classification, Salaries, and Allowances) Regulation as follows:—

1. In paragraph (ii) of sub-clause 13 (c) for the amount "\$3,536" substitute the amount "\$3,957".

2. Rescind paragraph (iii) of sub-clause 13 (c).

3. In sub-clause 13 (g) for the figure "2,247" substitute the figure "2,514".

(To take effect from and including the 5th January, 1975.)

W. E. SAMPSON, Chairman.

A. F. LE CLERCQ, Secretary.

Office of the Teachers Tribunal,
Melbourne, 24th December, 1974.

Teaching Service Act 1958.

TEACHING SERVICE (TEACHERS TRIBUNAL) REGULATIONS.

AMENDMENT No. 305 (T.T.5).

The Teachers Tribunal, in pursuance of the powers conferred by the *Teaching Service Act 1958*, hereby amends Regulation 19 of the Teaching Service (Teachers Tribunal) Regulations as follows:—

Regulation 19.

Rescind Regulation 19 and substitute therefor the following new Regulation:—

Regulation 19.

RELATIVE NUMBERS OF POSITIONS FOR TEACHERS IN EACH CLASS OF THE SECONDARY SCHOOLS DIVISION.

The relative numbers of positions for teachers in each class of the Secondary Schools Division from the 1st January, 1975, shall be as follows:—

Class.	Numbers of Positions.
Principal—Principals	285
Deputy Principals	214
	499
Senior Teacher	1,094
Assistant—Posts of Responsibility	2,324
Assistant	9,000

W. E. SAMPSON, Chairman.
A. F. LE CLERCQ, Secretary.

Office of the Teachers Tribunal,
Melbourne, 24th December, 1974.

*Teaching Service Act 1958.*TEACHING SERVICE — SECONDARY SCHOOLS DIVISION
(CLASSIFICATION, SALARIES, AND ALLOWANCES)
REGULATION.

AMENDMENT No. 299 (SEC. C.S. & A.1).

The Teachers Tribunal, in pursuance of the powers conferred by the *Teaching Service Act 1958*, hereby amends the Teaching Service—Secondary Schools Division (Classification, Salaries, and Allowances) Regulation as follows:—

Rescind sub-clause 11 (e) and substitute therefor the following new sub-clause:—

“(e) *Regional Relieving Assistants.*

Disability allowance at the rate of \$1,200.”

(To take effect from and including the 1st January, 1975.)

W. E. SAMPSON, Chairman.
A. F. LE CLERCQ, Secretary.

Office of the Teachers Tribunal,
Melbourne, 24th December, 1974.

*Teaching Service Act 1958.*TEACHING SERVICE — TECHNICAL SCHOOLS DIVISION
(CLASSIFICATION, SALARIES, AND ALLOWANCES)
REGULATION.

AMENDMENT No. 300 (TECH. C.S. & A.1).

The Teachers Tribunal, in pursuance of the powers conferred by the *Teaching Service Act 1958*, hereby amends the Teaching Service—Technical Schools Division (Classification, Salaries, and Allowances) Regulation as follows:—

Rescind sub-clause 11 (e) and substitute therefor the following new sub-clause:—

“(e) *Regional Relieving Assistants.*

Disability allowance at the rate of \$1,200.”

(To take effect from and including the 1st January, 1975.)

W. E. SAMPSON, Chairman.
A. F. LE CLERCQ, Secretary.

Office of the Teachers Tribunal,
Melbourne, 24th December, 1974.

PRIVATE ADVERTISEMENTS**CITY OF ARARAT.**

LOAN No. 84.

Notice of Intention to Borrow.

NOTICE is hereby given that the Council of the City of Ararat intends to borrow ONE HUNDRED AND FIFTY THOUSAND DOLLARS (\$150,000) secured by a charge over the General Rates of the Municipality by the grant of a Mortgage in accordance with the provisions of the Local Government Acts.

In connection therewith the following information is stated:—

- (a) The amount of the principal moneys which it is proposed to borrow is ONE HUNDRED AND FIFTY THOUSAND DOLLARS (\$150,000).
- (b) The maximum rate of interest that may be paid is 9.85 per centum per annum.
- (c) The times which the moneys borrowed are to be repayable are on the first day of September, 1975, and on the first days of March and September during the years 1976-1994 inclusive and on the first day of March, 1995; and that the place such moneys shall be repayable is at the Bank of New South Wales, Ararat Branch.
- (d) The purpose for which the Loan is to be applied is:—

Concrete fluming of the North Storm Channel between Grano Street and the Railway.

Seal Murphy Street and carry the construction through the Part private street section of Fay Street.

McLellan Street—continuous kerb and channel on the north side between King and Grano Streets along with necessary strip widening of the seal.

Banfield Street—between George Road and Brewster Road completion of the concrete kerb and channel and strip widening of the seal.

Taylor Street—reconstruction kerb to kerb to match new kerb on west and replace pitcher drain.

View Point Street—widen seal in that section which already has kerb and channel to final design.

Laidlaw Street and Port Fairy Road—improvements by underground pipe work to the drainage from Laidlaw Street across Port Fairy Road.

Gordon Street—between Barkly and Elizabeth Streets construction of concrete kerb and channel.

Moore Street between Princes and Gordon—construction of median kerbing to complete the design profile.

Princes Street—Construction of concrete footpath from Moore Street to Marx Crescent.

Carey Street—Full construction from Tobin Street to the Emu Park drainage line.

Temple Street—Surface central seal between Vincent and View Point Streets.

McGibbony Street—matching construction between Queen and King Street to that done in the first stage between King and Princes Streets.

Brewster Road—cost of City share of construction between Barkly and High Streets.

- (e) The manner in which the Loan is to be liquidated is by provision out of the Municipal Fund in each half-year during the currency of the Loan of the sum of \$8,652.13 which includes Principal and Interest.

The plans and specifications and estimate of the cost of the works and a statement showing the proposed expenditure of the moneys to be borrowed are open for inspection at the Municipal Offices (Engineer's Department) Ararat.

Dated this 6th day of January, 1975.

2795

J. I. GRENFELL, Town Clerk.

CITY OF BALLAARAT.

LOAN No. 46.

(Re-advertised).

Notice of Intention to Borrow the Sum of \$300,000 for Permanent Works and Undertakings.

Notice is hereby given that the Council of the City of Ballarat proposes to borrow the principal sum of three hundred thousand dollars (\$300,000), secured by a charge

over the general rates of the municipality, such sum to be raised by the grant of a mortgage, in accordance with the provisions of the Local Government Act 1958.

1. The maximum rate of interest that may be paid is 9.85 per centum per annum.

2. The purposes for which the loan is to be applied are:—

Multi-Storey Car Park—part cost.

3. The period of the loan shall be fifteen years.

4. The money borrowed shall be repayable by providing out of the municipal fund, 30 half-yearly instalments of \$19,348.90 each including principal and interest on the 10th day of August and on the 10th day of February during the currency of the loan. The first instalment shall be payable on the 10th day of August 1975.

Such moneys are to be repayable at the office of the Commercial Savings Bank of Australia Ltd., Staff Superannuation Fund, in Melbourne.

The plans and specifications and the estimate of the cost of the works and a statement showing the proposed expenditure of the moneys to be borrowed, are open for inspection at the Town Hall, Ballarat.

Dated 12th December, 1974.

2719

F. J. ROGERS, Town Clerk.

CITY OF BALLAARAT.

CHANGE OF STREET NAME.

Notice is given of change of name of streets known as MAIN STREET and GEELONG ROAD.

New Name.—MAIN ROAD from Victoria Street to Elsworth Street.

2714

F. J. ROGERS, Town Clerk.

Town and Country Planning Act 1961 (Twelfth Schedule).

CITY OF SOUTH BARWON.—CONNENWARRE PLANNING SCHEME 1964.

(CITY OF SOUTH BARWON 1974).

NOTICE THAT A PLANNING SCHEME HAS BEEN PREPARED AND IS AVAILABLE FOR INSPECTION.

Amendment No. 7.

Notice is hereby given that the City of South Barwon in pursuance of its powers under the Town and Country Planning Act 1961 has prepared a planning scheme for "Rezoning Lot 17 on the North side of Gilbert Street, Torquay from "New Minor Road" to "Commercial".

The purpose of the amendment is to revert a proposed minor road which was to be included in a now abandoned Off Street Parking Scheme to its original zoning of Commercial.

A copy of the scheme has been deposited at the City Offices, 33 Mt. Pleasant Road, Belmont. The Office of the Geelong Regional Planning Authority, 117 Myers Street, Geelong and at the office of the Town and Country Planning Board, 235 Queen Street, Melbourne, and will be open for inspection during office hours by any person free of charge.

Any persons affected by the planning scheme are required to set forth in writing all objections they may have addressed to the Town Clerk, City of South Barwon, 33 Mt. Pleasant Road, Belmont, 3216 on or before the 8th day of April, 1975 and to state whether they wish to be heard in respect of their objections.

18th December, 1974.

2673

H. W. S. JACKSON, Town Clerk.

Town and Country Planning Act 1961 (Twelfth Schedule).

CITY OF SOUTH BARWON.—GEELONG PLANNING SCHEME 1959.

NOTICE THAT A PLANNING SCHEME HAS BEEN PREPARED AND IS AVAILABLE FOR INSPECTION.

Amendment No. 47.

Notice is hereby given that the City of South Barwon in pursuance of its powers under the Town and Country Planning Act 1961 has prepared a planning scheme for

"Rezoning of that area bounded by Regent Street, Church Street, and Thomson Street in Belmont from Residential "A" to Commercial "B" for the purpose of extending the present High Street, Belmont Commercial area.

A copy of the scheme has been deposited at the City Offices, 33 Mount Pleasant Road, Belmont. The Office of the Geelong Regional Planning Authority, 76 Malop Street,

Geelong and the Office of the Town and Country Planning Board, 235 Queen Street, Melbourne, and will be open for inspection during office hours by any person free of charge.

Any persons affected by the planning scheme are required to set forth in writing all objections they may have, addressed to the Town Clerk, City of South Barwon, 33 Mount Pleasant Road, Belmont, 3216 on or before 8th February, 1975.

13th December, 1974.

2668

H. W. S. JACKSON, Town Clerk.

CITY OF BRIGHTON.

LOAN NO. 103.

Notice of Intention to Borrow the Sum of \$150,000 for Permanent Works and Undertakings.

NOTICE is hereby given that the Council of the City of Brighton proposes to borrow the principal sum of \$150,000 secured by a charge over the general rates of the municipality, such sum to be raised by the grant of a mortgage in accordance with the provisions of the Local Government Act 1958.

1. The maximum rate of interest that may be paid is 9.85 per cent per annum.

2. The purpose for which the loan is to be applied is: Reconstruction of Roads and Drainage—\$150,000.

3. The period of the loan shall be fifteen years.

4. The money borrowed shall be repayable by providing out of the municipal fund half-yearly instalments of approximately \$9,674.46 each including principal and interest on the 1st day of March and the 1st day of September during the currency of the loan. The first instalment shall be payable on the 1st day of September 1975.

5. Such moneys shall be repayable to the Commonwealth Trading Bank of Australia, 304 Bay Street, North Brighton.

The plans, and specifications and the estimate of the cost of the proposed works, and a statement showing the proposed expenditure of the moneys to be borrowed, are open for inspection at the office of the Council of the City of Brighton at Boxshall Street, Brighton.

18th December, 1974.

A. C. G. DE GARIS, Town Clerk.

Municipal Offices, Boxshall Street, Brighton, 3186. 2676

CITY OF CAMBERWELL.

VARIATION OF SEPARATE RATE.

Burwood Shopping Centre.

On 20th May, 1974, Council, pursuant to Section 280A of the Local Government Act, proposed a Separate Rate for the purpose of providing additional off-street parking facilities in connection with the Burwood Shopping Centre.

Pursuant to Section 288 of the said Act, it is hereby notified that Council, on 16th December, 1974 varied the rate by reducing the amounts in the dollar of the rate.

The amounts in the dollar of the rate as made are as follows:

Property.	Amount in the dollar which the rate is not to exceed.
Nos. 1337-1433, 1338-1346 and 1360-1432 Toorak Road, Burwood	.66 cents
No. 1350 Toorak Road, Burwood	.33 cents
Nos. 242-250 Warrigal Road, Burwood	.66 cents

2667

L. F. CHEFFERS, Chief Administrator.

CITY OF ECHUCA.

LOAN NO. 82.

Notice of Intention to Borrow.

NOTICE is hereby given that the Council of the City of Echuca intends to borrow Twenty-one thousand (\$21,000) dollars secured by a charge over the General Rates of the Municipality by the grant of a Mortgage in accordance with the provisions of the Local Government Act 1958 as amended.

In connection therewith the following information is stated:—

(a) The amount of the principal moneys which it is proposed to borrow is \$21,000.

(b) The maximum rate of interest that may be paid is 9.85 per centum per annum.

No. 1.—12660/74.—5

(c) The times at which the moneys borrowed are to be repayable are the Fifteenth day of August 1975, and the Fifteenth days of February and August during the years 1976 to 1994, and the Fifteenth day of February 1995, and the place where such moneys shall be repayable is the Bank of New South Wales, Echuca.

(d) The purpose for which the loan is to be applied is:—

Purchase of land, viz.: Crown Allotment 3, Section B, Parish of Echuca North.

(e) The manner in which the loan is to be liquidated is by the provision out of the municipal fund in each half year during the currency of the loan of the sum of \$1211.30 which includes principal and interest.

The plans and specifications and estimate of the cost of the works and a statement showing the proposed expenditure of the moneys to be borrowed are open for inspection at the Office of the Council of the City of Echuca at the corner of Hare and Heygarth Streets, Echuca.

2661.

K. F. MCCARTNEY, Town Clerk.

CITY OF GEELONG.

By-Law No. 161.

A By-Law of the City of Geelong made under the provisions of Section 6 of 6 Victoria No. 18 extended to the City of Geelong pursuant to Section 6 of 13 Victoria No. 40 for imposing the rates tolls rents and dues to be levied in the Cattle Market of the City.

In pursuance of the powers conferred by the above-mentioned Acts and every other power enabling it in that behalf it is hereby enacted by the Council of the City of Geelong as follows:—

1. By-Law No. 160 shall be and the same is hereby repealed.

2. The rates tolls and dues to be levied and paid in the Cattle Market of the City shall be as follows:—

(a) as set out hereunder in respect of any animal sold or exposed for sale in the Cattle Market:

any horse, mare, gelding, foal or head of neat cattle	55 cents
any pig	20 cents
any calf not more than 6 weeks old	15 cents
any sheep, lamb or goat	7 cents

(b) for any animal yarded in the cattle market per night 7 cents

3. Every company firm or person who conducts or arranges the sale by auction of any goods or cattle in any market provided by the Council shall pay the following rents:—

(i) on appointed market days	\$10
(ii) on days other than appointed market days	\$10

Resolution for passing this By-Law agreed to by the Council of the City of Geelong on the 26th of November, 1974.

Confirmed on the 17th day of December, 1974.

The common seal of the Mayor, Councillors and Citizens of the City of Geelong was affixed hereto, in the presence of—

(SEAL) H. G. VERRALL, Mayor.
T. J. T. NEAL, Town Clerk.

2670

CITY OF HAMILTON.

APPOINTMENT OF PROSECUTING OFFICER.

Notice is hereby given that the Council of the City of Hamilton has appointed Sergeant Russell Louis Bertram, No. 12215, as Prosecuting Officer in lieu of Sergeant Colin Edward Mooney, No. 10382, transferred.

2697

T. J. NEVILLE, Town Clerk.

CITY OF HORSHAM.

LOAN NO. 86.

Notice of Intention to Borrow the Sum of \$60,000 for Permanent Works and Undertakings.

NOTICE is hereby given that the Council of the City of Horsham intends to borrow the principal sum hereinafter mentioned on the credit of the municipal revenues of the Mayor, Councillors and Citizens of the City of Horsham by the grant of a mortgage in accordance with the provisions of the Local Government Acts.

1. The amount of the principal moneys which it is proposed to borrow is \$60,000.

2. The maximum rate of interest that may be paid is 9.85 per centum per annum.

3. The period of the loan shall be 20 years.

4. The moneys borrowed shall be repayable by providing out of the municipal fund 40 equal half-yearly instalments of approximately \$3,460.85 each including principal and interest on the 10th day of August and the 10th day of February during the currency of the loan. The first instalment to be paid on the 10th day of August, 1975.

5. Such moneys to be repayable at the Commercial Savings Bank of Australia Limited, 335 Collins Street, Melbourne, or at the Council's Bankers for the time being in the City of Melbourne.

6. The purposes for which the loan is to be applied:—

Basketball Stadium	\$7,500
Drainage	23,000
Footpath Construction	7,400
Council Contribution C.R.B. Works	22,100
	<u>\$60,000</u>

The plans, specifications and estimates for the costs of such works and the statement showing the proposed expenditure of the money to be borrowed are open for inspection at the office of the Council, Town Hall, Horsham, during Office Hours.

Dated 20th December, 1974.

2693

A. R. CONN, Town Clerk.

CITY OF KEILOR.

NOTICE OF CHANGING NAMES OF STREETS.

In accordance with the provisions of the *Local Government Act 1958*, the Council of the City of Keilor hereby gives notice that the said Council has made an order changing the name of part of the following street.

Old Name.—Arcade Square.

New Name.—West Gateway.

Location.—Extension of West Gateway to Norwood Drive.

2659

R. F. B. KELLY, Town Clerk.

CITY OF MALVERN.

BY-LAW NO. 153.

Notice is hereby given of the making of a by-law of the City of Malvern numbered 153 and known as the *Burning and Incinerator By-law*, for the purpose of preventing and extinguishing fires and suppressing nuisances.

A summary of the contents of the by-law is as follows:

- Clause 1—Short title and operative date.
- Clause 2—Repeal of portion of By-law No. 37 of the Shire of Malvern.
- Clause 3—Definitions of various terms.
- Clause 4—Restrictions on construction and use of incinerators.
- Clause 5—Prohibition and restrictions of lighting of fires in the open air in Residential Areas.
- Clause 6—Prohibition and restrictions of lighting of fires in the open generally.
- Clause 7—Restriction of lighting of fires during certain hours.
- Clause 8—Prohibition of burning materials likely to cause a nuisance.
- Clause 9—Penalties.
- Clause 10—Area of operation of by-law.

A copy of the said by-law is available for inspection free of charge during office hours at the office of the Council.

P. A. BIRRELL, Town Clerk.

City Hall, Malvern.

2717

Town and Country Planning Act 1961.

CITY OF MOE.—CITY OF MOE PLANNING SCHEME 1966.

NOTICE THAT A PLANNING SCHEME HAS BEEN PREPARED AND IS AVAILABLE FOR INSPECTION.

Amendment No. 40.

NOTICE IS HEREBY GIVEN that the City of Moe, in pursuance of its powers under the *Town and Country Planning Act 1961* has prepared a Planning Scheme for the following areas:

- (a) land on the south-west corner of the Princes By-Pass (Moe Section) and Two Mile Road

(b) land on the south-west corner of Law Street and Monash Road

(c) all of the lands presently zoned as Commercial "A" Zone along the north-west side of Monash Road (opposite Rutherglen Road)

(d) all of the land presently zoned as Commercial "A" Zone at the south end of Market Street, east side, at Purvis Lane

(e) all of the land presently zoned as Commercial "B" Zone within C.A. 5, Section F, Parish of Yarragon along the north side of Waterloo Road

(f) all of the V.R. Department land presently zoned as Commercial "A" Zone and part of the V.R. Department land presently zoned as Commercial "B" along the north side of Lloyd Street (opposite Fowler Street)

(g) all lands on the east side of Della Torre Road presently zoned as "Reserve for Public Purposes—Municipal Depot"

(h) land on the north-west corner of Della Torre Road and Moore Street

(i) land on the east side of Della Torre Road at Saviges Road corner

(j) setting out Bubb Street, full length, between Della Torre Road and Saxtons Drive

(k) lots 538 and 553, P.S. 50953 (land on the west side of King Street) and Lot 271, P.S. 54435 (land on the east side of Stirling Street).

A copy of the scheme may be inspected at the City Offices, Albert Street, Moe, and at the office of the Town and Country Planning Board, 235 Queen Street, Melbourne, and will be open for inspection during office hours by any person free of charge.

Any persons affected by the Planning Scheme are required to set forth in writing all objections they may have addressed to the Town Clerk, City of Moe, P.O. Box 189, Moe on or before April 8, 1975 and to state whether they wish to be heard in respect of their objections.

2695

R. J. PUGSLEY, Town Clerk.

CITY OF NORTHCOTE.

LOAN NO. 117.

Notice of Intention to Borrow the Sum of \$50,000 for Permanent Works and Undertakings.

Notice is hereby given that the Council of the City of Northcote proposes to borrow the principal sum of Fifty Thousand Dollars (\$50,000) secured by a charge over the general rates of the Municipality, such sum to be raised by the grant of a mortgage in accordance with the provisions of the *Local Government Act 1958*.

1. The maximum rate of interest that may be paid is 9.85 per cent per annum.

2. The purposes for which the loan is to be applied are:—

Making of roadway in Wingrove Street	\$25,000
Construction of a drain in Wales Street—Clarendon Street	\$25,000
	<u>\$50,000</u>

3. The period of the loan shall be fifteen (15) years.

4. The moneys borrowed shall be repayable by providing out of the Municipal Fund 30 half-yearly instalments of approximately \$3,224.82 each including principal and interest on the first day of March and the first day of September during the currency of the loan. The first instalment shall be payable on the first day of September, 1975.

5. Such moneys shall be repayable to the Commissioners of the State Savings Bank of Victoria at the office of the said Commissioners, corner Elizabeth and Bourke Streets, Melbourne.

The plans and specifications and the estimates of the cost of the proposed works and a statement showing the proposed expenditure of the moneys to be borrowed are open for inspection at the office of the Council of the CITY OF NORTHCOTE, High Street, Northcote.

Dated at Northcote, this 6th day of January, 1975.

2716

A. J. HILL, Town Clerk and City manager.

CITY OF PRAHRAN.

BY-LAW NO. 262.

A By-Law of the City of Prahran made under the provisions of the *Local Government Act 1958* and numbered 262 for the purpose of altering By-Law No. 210.

In pursuance of the powers conferred by the *Local Government Act 1958* and of any and every other power it thereunto enabling the Mayor Councillors and Citizens of the City of Prahran order as follows:—

1. From and after the coming into operation of this By-Law, By-Law No. 210 made and passed by the Council on the 23rd day of October, 1950 confirmed on the 20th day of November 1950 and approved by the Governor in Council on the 9th day of January 1951 is hereby altered as follows and to the extent that any part or parts thereof respectively which is or are inconsistent with or repugnant to this By-Law are hereby expressly repealed:—

- (i) Clause 91 to be amended by the substitution of the words "Five Dollars" in lieu of the words "One Pound" and "One Pound, Ten Shillings".
- (ii) The Second Schedule to be amended by the substitution of the words "Nine Metres" in lieu of the words "Thirty Feet" and the addition of the words "Rockley Road, East side from a point nine metres North of the building line of Toorak Road, extending to a point eighty-five metres North of the building line of Toorak Road."

Resolution for the making and passing this By-Law agreed to by the Council of the City of Prahran on the 14th day of October, 1974 and confirmed on the 11th day of November, 1974.

The common seal of the Mayor, Councillors and Citizens of the City of Prahran was hereunto affixed in the presence of—

(SEAL) C. J. BELL, Mayor.
F. T. FARRALL, Councillor.
JOHN A. LUCAS, Town Clerk.

Approved by the Governor in Council on the 10th day of December, 1974.—T. J. FORRISTAL, Clerk of the Executive Council. 2773

CITY OF RINGWOOD.

LOAN No. 114.

Notice of Intention to Borrow the Sum of \$200,000 for Permanent Works and Undertakings.

NOTICE is hereby given that the Council of the City of Ringwood proposes to borrow the sum of \$200,000 (Two hundred thousand dollars) secured by a charge over the General Rates of the Municipality such sum to be raised by the grant of a Mortgage in accordance with the provisions of the *Local Government Act 1958* for Permanent Works and Undertakings within the Municipality.

(a) That the maximum rate of interest that may be paid be 9.9% per annum.

(b) That the purposes for which the Loan is to be applied are:—

1. Council Contribution—C.R.B. Unclassified Roads		
Canterbury Road	\$11,000	
Wantirna Road	5,000	
Loughman Road	37,000	\$53,000
2. Bus-bays Bedford Road		1,500
3. Footbridge, Wantirna Road		1,500
4. Parks Gardens and Reserves		
Golf Course, second nine holes (part cost)		50,000
5. Buildings		
Ringwood East Pavilion Extn. (pt. cost)	18,000	
H. E. Parker Pavilion (part cost)	51,000	
Proclamation Park Pavilion (part cost)	25,000	94,000
		<u>\$200,000</u>

(c) The period of the Loan shall be nine (9) years.

(d) The monies borrowed shall be repayable by providing out of the Municipal Fund eighteen half-yearly instalments of approximately \$17,424.74 each including principal and interest on the 1st day of March and September in each year and the first instalment shall be payable on the 1st day of September 1974.

(e) Such monies shall be repayable at the Australia and New Zealand Savings Bank Limited, 394-396 Collins Street, Melbourne at the office of the said Bank.

The plans and specifications and an estimate of the cost of the proposed works are open for inspection at the office of the Council, Civic Centre, Ringwood, during office hours.

CITY OF SANDRINGHAM.

LOAN No. 115.

Notice of Intention to Borrow.

Notice is hereby given that the Council of the City of Sandringham intends to borrow Two Hundred and Twenty Eight Thousand dollars (\$228,000.00) secured by a charge over the General rates of the municipality by the grant of a Mortgage in accordance with the provisions of the *Local Government Acts*.

In connection therewith the following information is stated:—

(a) The amount of the principal moneys which it is proposed to borrow is \$228,000.00.

(b) The maximum rate of interest that may be paid is 9.85 per centum per annum.

(c) The times which the moneys borrowed are to be repayable are the 15th day of August, 1975 and the 15th days of February and August during the years 1976-1990 inclusive and that the place such moneys shall be repayable is at the National Bank Savings Bank, Ltd. Melbourne.

(d) The purpose for which the loan is to be applied is:—

(a) Road Works—(Linacre Road—Hampton Street to Railway) additional provision, Henry Street, Bayside Crescent, Karoola Street, Redevelopment Railway Square, Melrose Street, Traffic diversion, Beaumaris, C.R.B. Contribution, Orlando Street, (Linacre Road to Small Street), Exon Street, Hoyt Street, (Bolton Avenue south to right-of-way) Arcadia Street	\$60,600
(b) Improvements to Places of Public Resort and Recreation—Tulip Street Reserve, Banksia Reserve (additional Provision) Tennis Courts, Beach Oval, Banksia Reserve, Donald McDonald Oval (Additional Provision), Tulip Street/Spring Street Reserve, Balcombe Park Reserve (additional provision)	70,000
(c) Drainage works—Beach Road near Bayview Crescent, Haydens Road and Wattle Avenue, Beach Road, near Rennison Street, Griffiths Street/Cromer Road area, Flood relief drainage Beach Road near Bayview Crescent (additional provision), Jack Lane drain (additional provision), Upgrading Retreat Road drain, drainage improvement—Central Ward	47,300
(d) Traffic Signals—Bay/Bluff Roads, South Road/New Street	16,000
(e) Public Conveniences—Hampton Station bus terminal	10,000
(f) Off street car parks—rear of shops in Hampton Street, south of Willis Street, South Concourse, Beaumaris	8,300
(g) Olive Phillips Infant Welfare Centre	5,000
(h) New Street Level Crossing and Boom Barrier	6,000
(i) Extensions to Beaumaris Senior Citizens Clubrooms	4,800
	<u>\$228,000</u>

(e) The manner in which the Loan is to be liquidated is by provision out of the Municipal Fund in each half-year during the currency of the Loan of the sum of \$14,705.17 which includes Principal and Interest.

The plans and specifications and estimate of the cost of the works and a statement showing the proposed expenditure of the moneys to be borrowed are open for inspection at the Municipal Offices, Royal Avenue, Sandringham.

Dated this 17th day of December, 1974.

CITY OF TRARALGON.

LOAN No. 46.

Notice of Intention to Borrow.

NOTICE is hereby given that the Council of the City of Traralgon intends to borrow Fifty thousand dollars (\$50,000) secured by a charge over the General Rates of the Municipality by the grant of a mortgage in accordance with the provisions of the *Local Government Act*.

In connection herewith the following information is stated—

- (a) The amount of the principal moneys which it is proposed to borrow is \$50,000 (Fifty thousand dollars).
- (b) The maximum rate of interest that may be paid is 10.3 per centum per annum.
- (c) The money borrowed shall be repayable by ten (10) equal instalments of approximately \$6,522.48 each including principal and interest, payable on the Fifteenth day of August and February. The first instalment shall be payable on 15th August, 1975, and the final instalment on 15th February, 1980. Such moneys are repayable at the Australia and New Zealand Savings Bank Ltd., Franklin Street, Traralgon.
- (d) The period of the loan shall be five (5) years.
- (e) The purpose for which the loan is to be applied is—

- (i) \$35,000 — purchase of plant, motor vehicles and equipment,
- (ii) \$15,000—purchase of office equipment.

The plans and specifications and the estimate of cost of the proposed works and statement showing the proposed expenditure of the moneys borrowed are open for inspection at the office of the Council of the City of Traralgon, Kay Street, Traralgon.

Dated 20th December, 1974.

2663

K. J. SAUNDERS, Town Clerk.

CITY OF TRARALGON.

LOAN No. 47.

Notice of Intention to Borrow.

NOTICE is hereby given that the Council of the City of Traralgon intends to borrow One hundred thousand dollars (\$100,000) secured by a charge over the General Rates of the Municipality by the grant of a mortgage in accordance with the provisions of the Local Government Act.

In connection herewith the following information is stated—

- (a) The amount of the principal moneys which it is proposed to borrow is \$100,000 (One hundred thousand dollars).
- (b) The maximum rate of interest that may be paid is 9.85 per centum per annum.
- (c) The money borrowed shall be repayable by thirty (30) equal instalments of approximately \$6,449.63 each including principal and interest payable on the Fifteenth day of August and February. The first instalment shall be payable on 15th August, 1975 and the final instalment on 15th February, 1990. Such moneys are repayable at the Australia and New Zealand Savings Bank Ltd., Franklin Street, Traralgon.
- (d) The period of the loan shall be fifteen (15) years.
- (e) The purpose for which the loan is to be applied is—

- (i) \$80,000 — Decentralized industry assistance.
- (ii) \$20,000—Part cost construction Elderly Citizens Club extensions and Fire Brigade Demonstration Track.

The plans and specifications and the estimate of cost of the proposed works and statement showing the proposed expenditure of the moneys borrowed are open for inspection at the office of the Council of the City of Traralgon, Kay Street, Traralgon.

Dated 20th December, 1974.

2664

K. J. SAUNDERS, Town Clerk.

CITY OF TRARALGON.

LOAN No. 48.

Notice of Intention to Borrow.

NOTICE is hereby given that the Council of the City of Traralgon intends to borrow One hundred thousand dollars (\$100,000) secured by a charge over the General Rates of the Municipality by the grant of a mortgage in accordance with the provisions of the Local Government Act.

In connection herewith the following information is stated—

- (a) The amount of the principal moneys which it is proposed to borrow is \$100,000 (One hundred thousand dollars).

- (b) The maximum rate of interest that may be paid is 9.85 per centum per annum.

- (c) The money borrowed shall be repayable by twenty (20) equal instalments of approximately \$7,973.31 each including principal and interest, payable on the Fifteenth day of August and February. The first instalment shall be payable on 15th August, 1975, and the final instalment on 15th February, 1985. Such moneys are repayable at the Commonwealth Savings Bank of Australia, Franklin Street, Traralgon.

- (d) The period of the loan shall be ten (10) years.

- (e) The purpose for which the loan is to be applied is—

Part cost construction Yallambee Village for the Aged.

The plans and specifications and the estimate of cost of the proposed works and statement showing the proposed expenditure of the moneys borrowed are open for inspection at the office of the Council of the City of Traralgon, Kay Street, Traralgon.

Dated 20th March, 1974.

2665

K. J. SAUNDERS, Town Clerk.

CITY OF WANGARATTA.

LOAN No. 92.

Notice of Intention to Borrow the Sum of \$148,000 for Permanent Works and Undertakings.

Notice is hereby given that the City of Wangaratta proposes to borrow the principal sum of one hundred and forty eight thousand dollars (\$148,000) secured by a charge over the general rates of the municipality, such sum to be raised by the grant of a mortgage in accordance with the provisions of the Local Government Act 1958.

1. The maximum rate of interest that may be paid is 9.85 per cent per annum.
2. The purpose for which the loan is to be applied is for—

- (a) Drainage Work \$5,000
- (b) Erection of Sports Store \$5,000
- (c) Property Acquisitions \$138,000

3. The period of the loan shall be fifteen (15) years.
4. The monies borrowed shall be repayable by providing out of the Municipal Fund half yearly instalments of approximately \$9,545.45 each including principal and interest on the fifteenth day of August and the fifteenth day of February during the currency of the loan. The first instalment shall be repayable on the fifteenth day of August, 1975.

5. Such monies shall be repayable to the Bank of New South Wales Savings Bank Limited.

The plans, specifications and the estimate of the cost of the proposed works and a statement showing the proposed expenditure of the monies to be borrowed are open for inspection at the office of the Council of the City of Wangaratta, Ford Street, Wangaratta.

Dated 19th December, 1974.

2672

J. W. ELWARD, Town Clerk.

CITY OF WANGARATTA.

LOAN No. 91.

Notice of Intention to Borrow the Sum of \$50,000 for Permanent Works and Undertakings.

Notice is hereby given that the Council of the City of Wangaratta intends to borrow the sum of fifty thousand dollars (\$50,000) secured by a charge over the general rates of the municipality by the grant of a mortgage in accordance with the provisions of the Local Government Act 1958.

1. The amount of the principal monies which it is proposed to borrow is fifty thousand dollars.
2. The maximum rate of interest that may be paid is 10.3 per cent per annum.
3. The purpose for which the loan is to be applied is for the purchase of Plant.
4. The period of the loan shall be five (5) years.

5. The monies borrowed shall be repaid by providing out of the Municipal Fund ten (10) half yearly instalments of approximately \$6,522.48 each including principal and interest on the fifteenth day of August and the fifteenth day of February during the currency of the loan. The first instalment shall be payable on the fifteenth day of August, 1975.

6. Such monies shall be repayable to the Bank of New South Wales Savings Bank Limited.

Dated the 19th December, 1974.

2671 J. W. ELWARD, Town Clerk.

Dog Act 1970.

CITY OF WILLIAMSTOWN.

The Council of the City of Williamstown at its meeting on the 9th December, 1974, resolved under the provisions of the Dog Act Section 16 (3) (b) to order that the beach area at Williamstown between Victoria Street and Garden Street during the months of November to April inclusive to be a specified area where it will be an offence under the Dog Act, for the owner, of any dog found in such area during such period. Penalty \$50.00.

By Order of the Council.

2675 J. E. MORLEY, Town Clerk and Manager.

BOROUGH OF EAGLEHAWK.

PROCEEDINGS OF COUNCIL BY-LAW NO. 49.

Notice is hereby given that the Council of the Borough of Eaglehawk has made a By-Law numbered 49 under Section 197 (1) (i) of the *Local Government Act 1958* for the purpose of adopting a modified version of Part XI (Regulation of Proceedings of Council, Officers, etc.) of the Fifteenth Schedule of such Act.

A copy of the By-Law is open for inspection free of charge during office hours at the office of the Council, Town Hall, Eaglehawk.

The resolution for passing the By-Law was agreed to by the Council on 7th November 1974, and confirmed on 19th December 1974.

2662 A. J. SMARK, Town Clerk.

BOROUGH OF SEBASTOPOL.

Notice is hereby given that Geoffrey W. Whale of 202 Yarrowee St., Sebastopol has been appointed Pound Keeper for the Borough of Sebastopol; in place of Dini Tuender.

2785 HAROLD L. TEAGUE, Town Clerk.

SHIRE OF AVOCA.

Notice is hereby given that the Council of the Shire of Avoca has appointed Senior Constable Eric Frank Wines, No. 10940 as Prosecuting Officer in place of Senior Constable Walter Foy Scott, No. 9513, resigned.

18th December, 1974.

F. C. S. EDWARDS, Shire Secretary.

Shire Office, Avoca, Vic. 3467. 2698

SHIRE OF BANNOCKBURN.

CHANGE IN ROAD-NAME.

Notice is hereby given, that pursuant to the provisions of the *Local Government Act 1958*, the Council of the Shire of Bannockburn, doth order that the name of the road shall be changed at follows.

Old name. New name. Location referred to.

- (1) Woolbrook road, Hopes Plains Road. Running from Common Road, along the North Western boundary of lots 15 and 14 Parish of Carrah, to a Govt road on the Northern boundary of lot 14.

2694 A. F. HELYAR, Shire Secretary.

SHIRE OF GOULBURN.

LOAN NO. 20.

Notice of Intention to Borrow the Sum of \$15,000 for Permanent Works and Undertakings.

Notice is hereby given that the Council of the Shire of Goulburn intends to borrow the sum of Fifteen Thousand Dollars (\$15,000), secured by a charge over the general rates of the municipality, such sum to be raised by a grant of a mortgage in accordance with the provisions of the *Local Government Act 1958*.

1. The maximum rate of interest that may be paid is 9.85 per centum per annum.

2. The purpose for which the loan is to be applied is—

Land Purchase—Nagambie Senior Citizens Clubhouse Site and future municipal purposes	\$10,000
Recreation Land	\$ 5,000
	\$15,000

3. The period of the loan shall be fifteen (15) years.

4. The moneys borrowed shall be repayable by providing out of the municipal fund thirty (30) half-yearly instalments of approximately \$967.45 each, including principal and interest, on the 10th days of April and October. The first instalment shall be payable on 10th October, 1975 and the final instalment on 10th April, 1990.

5. Such moneys shall be repayable to the Commercial Bank of Australia Limited, Melbourne.

The plans and specifications and the estimate of the cost of the proposed works and a statement showing the proposed expenditure of moneys to be borrowed are open for inspection at the office of the Council of the Shire of Goulburn, High Street, Nagambie.

Dated 6th January, 1975.

2786 J. L. MITCHELL, Shire Secretary.

SHIRE OF HASTINGS.

NOTICE OF INTENTION TO TAKE LAND COMPULSORILY.

WHEREAS the Council of the Shire of Hastings deems it expedient to exercise its powers of taking compulsorily the following land situated at Salmon Street, Hastings, and being the land more particularly described hereunder:—

1. Lot 191 on Lodged Plan of Subdivision No. 2991, being part of Crown Portion 94, Parish of Tyabb, Certificate of Title Volume 2343, Folio 467.

2. Lots 192 and 193 on Lodged Plan of Subdivision No. 2991, being part of Crown Portion 94, Parish of Tyabb, Certificate of Title Volume 4211, Folio 113.

for the purpose of providing land for off-street parking areas.

AND WHEREAS the Council has caused to be prepared a map and other papers setting out the general description of the works or undertakings for which the land is proposed to be taken and the names of owners, reputed owners, lessees or reputed lessees, mortgagees and occupiers of the land so far as those names are known or can be ascertained by the Council.

Such map and other papers are deposited at the Municipal Offices, Marine Parade, Hastings, where they are and will remain open for inspection by all interested persons during office hours for a period of forty (40) clear days after publication of this notice in the *Government Gazette*.

All persons affected by the proposed work or undertaking are hereby called upon to set forth in writing addressed to the Shire Secretary, Shire of Hastings, within forty (40) clear days from publication of this Notice in the *Government Gazette*, all objections which they may have to the said works or undertaking.

Dated this 3rd day of January, 1975.

By Order of the Council of the Shire of Hastings,

L. A. WALKER, Shire Secretary.

Municipal Offices, Hastings, 3915. 2715

SHIRE OF LILLYDALE.

NOTICE OF COMPULSORY ACQUISITION.

WHEREAS the Council of the Shire of Lillydale deems it expedient to exercise its powers of taking compulsorily the land for a Public Purpose Reserve being part of Lot No. 51 on Plan of Subdivision No. 4315, being part of Crown Allotment 11A, Parish of Warrandyte commencing at a point 124.93 metres on a bearing of 169° 50' and a further 0.80 metres on a bearing of 173° 34' from the south west intersection of Launder Avenue and Old Yarra Road, Wonga Park and thence southerly on a bearing of 173° 34' for a distance of 41.94 metres and thence westerly on a bearing of 269° 18' for a distance of 131.06 metres and thence southerly on a bearing of 173° 34' for a distance of 30.48 metres and thence in a westerly direction on a bearing of 269° 18' for a distance of 229.73 metres and thence in a northerly direction on a bearing of 180° 00' for a distance of 191.25 metres and thence in an easterly direction on a bearing of 88° 28' for a distance of 204.89 metres and thence in a southerly direction on a bearing of 169° 50' for a distance of 124.93 metres and thence continuing in a southerly direction on a bearing of 173° 44' for a distance of 0.80 metres and thence to the point of commencement on a bearing of 88° 28' for a distance of

125.73 metres AND WHEREAS the Council has caused to be prepared maps and other papers setting out general description of the work or undertaking for which the land proposed to be taken and the names of the owners or reputed owners, lessees or reputed lessees, mortgagees and occupiers of that land so far as those names are known or can be ascertained by the Council AND WHEREAS the said maps and other papers are deposited at the Office of the said Council at Lilydale and are and shall be open for inspection by all persons interested at all reasonable hours for the space of forty clear days after the publication of this notice in the *Government Gazette*. NOW NOTICE IS HEREBY GIVEN to all persons affected by the proposed taking of the said land to set forth in writing addressed to the Council or the Shire Secretary within forty clear days of the publication of this notice in the *Government Gazette* all objections which they may have to the taking of the said land.

Dated this 18th day of December, 1974.

2657

F. O. KENT, Shire Secretary.

River Improvement Act 1958.

SHIRE OF METCALFE.

PROPOSED RIVER IMPROVEMENT DISTRICT.

NOTICE is hereby given that the Council of the Shire of Metcalfe has forwarded to the Minister of Water Supply an application for the constitution of a River Improvement District under the jurisdiction and control of a River Improvement Trust and comprising all of the Municipality of the Shire of Metcalfe.

Copies of the application and general plan and description of the proposed works have been deposited for inspection at the Offices of—

- (a) The Minister of Water Supply, State Rivers and Water Supply Commission, 590 Orrong Road, ARMADALE, 3143.
- (b) The Shire of Metcalfe, Metcalfe.

2658

J. R. DENNIS, Shire Secretary.

SHIRE OF SHEPPARTON.

(SPECIAL ORDER.)

LOAN NO. 92.

Notice of Intention to Borrow the Sum of \$250,000.

Notice is hereby given pursuant to Section 585 of the Local Government Act, that it is the intention of Council to borrow as follows:

- (1) The amount of principal money to be borrowed is \$250,000.
- (2) The rate of interest to be paid is 9.85 per cent per annum.
- (3) The moneys borrowed shall be repayable by providing out of the Municipal Fund half-yearly instalments of approximately \$14,420.22 each including principal and interest on the first day of August and on the first day of February during the currency of the loan. The first instalment payable shall be on the first day of August, 1975.
- (4) The purpose for which the loan proceeds are to be applied is the construction of private streets in the G. V. Kialla Estate.
- (5) The loan is to be secured by the issue of a Mortgage Deed pursuant to the provisions of the Local Government Act.

Notice is given that the above Special Order was passed at a meeting of the Council of the Shire of Shepparton held on Monday, 16th December, 1974.

Notice is further given that this Special Order will be presented for confirmation at a meeting of Council to be held on Monday, 20th January, 1975.

2705

J. W. REED, Shire Secretary.

SHIRE OF STAWELL.

ORDER DECLARING PUBLIC HIGHWAY.

In pursuance of the powers conferred by Section 522 of the *Local Government Act 1958*, the Council of the Shire of Stawell doth hereby order:—

That the land hereinafter described, which has been purchased by it, shall be a public highway, viz.:—

All that piece of land being part of Crown Allotment 67 and 80 Parish of Wirchilleba as described in Certificate of Title Volume 9042 Folio 660.

The common seal of the President, Councillors and Ratepayers of the Shire of Stawell was hereto affixed, this 3rd day of December, 1974, in the presence of—

(SEAL) C. J. HUTCHINGS, President.
J. WILLIAMS, Councillor.
V. C. NIELSEN, Secretary.

SHIRE OF TRARALGON.

BY-LAW NO. 61.

A By-law of the Shire of Traralgon made under Section 197 of the *Local Government Act 1958* and every other power it thereunto enabling and numbered 61 for:—

- (a) providing for the health of residents in the municipal district, and
- (b) prohibiting or regulating the placing of caravans on private property.

In pursuance of the powers conferred by the *Local Government Act 1958* and every other power in that behalf enabling it, the President, Councillors and Ratepayers of the Shire of Traralgon order as follows:—

1. In this By-law unless inconsistent with the context "Council" means the Council of the Shire of Traralgon. "Frontage" means the boundary line between private property and the street upon which such private property abuts and where such property abuts on more than one street then the boundary line between the said property and the street to which any building that may be erected thereon fronts. "Private Property" includes vacant land and a private street. "Private Street" has the same meaning as in the *Local Government Act 1958*. "Caravan" includes a covered van, a house on wheels, and any vehicle used or adapted for living quarters whether on wheels or not.

2. This By-law shall come into force and operation immediately after its publication in the *Government Gazette*.

3. This By-law shall apply to and have operation throughout the whole of the municipal district of the Shire of Traralgon.

4. A person shall not place or permit to be placed—

(a) More than one caravan on any private property in the one ownership or occupation.

(b) Any caravan on any private property in such a position that any part of the caravan is within a distance of eight (8) metres from the frontage to such property or is within a distance of one and one half (1.5) metres from any other boundary of the said property.

Provided however the Council may permit more than one caravan to be placed on any private property and within lesser distances from the frontage or other boundary of the said property upon application in writing by the owner or occupier of such property.

5. A person shall not occupy any caravan placed on any private property without the consent of the Council in writing.

6. (a) Every person applying to the Council for the placing of or for consent to occupy any caravan under this By-law shall make application in writing and supply all reasonable information required by the Council including the reasons for seeking such consent, the number, age and sex of the persons proposing to occupy the caravan, the size and location of the caravan and the sanitation facilities to be provided in respect thereof.

(b) The Council may grant or refuse its consent to any such application as it thinks fit.

6. (c) Should the Council give its consent then the permit issued thereon shall be for a period not exceeding six months and be conditional upon the number of persons to occupy a caravan not exceeding the number set out in the permit and upon proper sanitation facilities being provided to the satisfaction of the Health Inspector of the Council and being available at all times to the occupants of the caravan.

(d) Should such sanitation facilities cease to be available during the period of the permit and not be restored within twenty-four (24) hours after notice in writing has been given by the Health Inspector to the owner or occupier of the caravan or of the premises on which the caravan is placed then any permit granted hereunder shall at the expiration of the period of notice be immediately cancelled.

7. Any person guilty of a wilful act or default contrary to this By-law shall be guilty of an offence and shall be liable to a penalty of not less than ten dollars (\$10) or more than twenty dollars (\$20) and to a further penalty

of not more than ten dollars (\$10) for each day upon which such offence is continued after a conviction or order is made by any Court.

8. This By-law shall apply to and have force throughout the whole of the municipal district of the Shire of Traralgon except such areas as are registered with the Council as camping areas under the provisions of the Health Acts.

Resolution for making this By-law passed by the Council on the 5th day of September, 1974, and confirmed on the 3rd day of October, 1974.

In witness whereof the common seal of the President, Councillors and Ratepayers of the Shire of Traralgon was hereunto affixed, in the presence of—

(SEAL) H. J. SAUNDERS, Shire President.
J. D. BLACK, Councillor.
W. TEASDALE, Shire Secretary.

Approved by the Governor in Council on the 10th December, 1974.—T. FORRISTAL, Clerk of the Executive Council. 2660

SHIRE OF WANNON.

BY-LAW No. 42.

A By-Law of the Shire of Wannan made under Sections 197 and 198 of the *Local Government Act 1958* and numbered 42 for the purpose of—

- (a) Regulating the keeping of dogs within the boundaries of the Township of Coleraine.
- (b) Regulating the manner in which dogs may be kept.

A copy of the said By-Law is open for inspection free of charge, during office hours at the Office of the Council, Shire Office, Coleraine.

Resolution for passing of this By-Law agreed to by the Council on 8th July, 1974, and confirmed on 12th August, 1974.

E. L. WATSON, President.
A. K. KEALY, Councillor.
W. TEMPLETON, Councillor.
P. BALDWIN, Shire Secretary.

Approved by Governor in Council on 26th November, 1974. 2674

SHIRE OF WERRIBEE.

LOAN No. 91.

Notice of Intention to Borrow the Sum of \$100,000 for Permanent Works and Undertakings.

NOTICE is hereby given that the Council of the Shire of Werribee proposes to borrow the principal sum of One Hundred Thousand Dollars by the grant of a mortgage in accordance with the provisions of the *Local Government Act 1958*.

1. The maximum rate of interest that may be paid is 9.85% per annum.
2. The purpose for which the loan is to be applied is Part-Construction of Civic Centre Complex, Stage 1.
3. The period of the loan shall be twenty (20) years.
4. The moneys borrowed shall be repayable by providing out of the municipal fund half-yearly instalments of approximately \$5,768.09 each including principal and interest on the first day of March and the first day of September during the currency of the loan. The first instalment shall be payable on the first day of September, 1975.
5. Such moneys shall be repayable to The Commissioners of The State Savings Bank of Victoria at the office of the said Commissioners, corner Elizabeth and Bourke Streets, Melbourne.

The plans and specifications and the estimate of the cost of the proposed works and a statement showing the proposed expenditure of the moneys to be borrowed are open for inspection at the office of the Council of the Shire of Werribee at Watton Street, Werribee.

Dated 24th December, 1974.

2704

J. T. KERR, Shire Secretary.

THE BALLARAT WATER COMMISSIONERS.

Notice is hereby given to owners of tenements in the streets set out in the Schedule hereto and the private streets lanes courts and alleys opening thereto that the main pipes in the said streets being laid down the owners of all tenements situated as above are required to cause proper pipes and stopcocks to be laid so as to supply water within such tenements from the main pipe and the laying of all such pipes and stopcocks shall be completed

in accordance with ByLaw Number 17 of The Ballarat Water Commissioners on or before the First day of March, 1975.

Allenby Court, throughout.
Avoca Crescent, Alfredton, throughout.
Back Street, from Clayton Street northerly 60 metres.
Barrington Court, throughout.
Benson Close, Delacombe, throughout.
Bevtre Street, Sebastopol, from Alfred Street westerly 95 metres.
Boronia Grove, Wendouree West, from Marigold Street westerly 43 metres.
Boundary Road, Brown Hill, from Gracefield Road southerly 415 metres.
Caldwell Street, throughout.
Carinda Court, throughout.
Caroline Street, Alfredton, from Western Highway southerly 99 metres.
Cedar Avenue, Alfredton, from Cuthberts Road northerly 283 metres.
Clayton Street West, from Back Street westerly 28 metres.
Clematis Avenue, Wendouree West, from Marigold Street westerly 22 metres.
Clover Street, Wendouree West, from Grevillea Road southerly 251 metres.
Club Crescent, throughout.
Club Court, throughout.
Coronet Street, Wendouree, from Dowling Street westerly 463 metres.
Cromwell Street, Sebastopol, from 127 metres south of Kent Street southerly 76 metres.
Cuthberts Road, Alfredton, from Cedar Avenue westerly 21 metres.
Daylesford Road, Brown Hill, from 198 metres west of Hillview Road westerly 111 metres.
Draper Street, Nerrina, from Hillcrest Road northerly 78 metres.
Eddy Avenue, Mount Helen, from Moss Avenue, southerly 52 metres.
Edgewood Court, Delacombe, throughout.
Edwards Crescent, Wendouree, from 45 metres west of Grandview Grove westerly 24 metres.
Elm Street, Wendouree West, from Clover Street easterly 51 metres.
Gracefield Road, Brown Hill, from 154 metres south-east of Daylesford Road south-easterly 14 metres.
Grandison Avenue, from Highfield Avenue northerly 187 metres.
Grandview Grove, Wendouree, from 21 metres north of Marilyn Street to Marie Crescent.
Greenhalghs Road, Delacombe, from Sutton Street to Wiltshire Lane.
Gregory Street, from Sim Street easterly 78 metres.
Heales Street, from 80 metres south of Tress Street southerly 20 metres.
Hermitage Avenue, from Hocking Avenue southerly 274 metres.
Highfield Avenue, throughout.
Hillcrest Road, Nerrina, from George Street southerly 43 metres.
John Street, Wendouree, from 198 metres east of Marie Crescent easterly 49 metres.
Kalty Court, Sebastopol, throughout.
Kely Street, throughout.
Larter Street, from 199 metres south of Lal Lal Street southerly 222 metres.
Linton Court, Alfredton, throughout.
Luth Street, Sebastopol, throughout.
Lyon Street, Miners Rest, from 40 metres south of Clarke Street southerly 65 metres.
Mansfield Avenue, from 10 metres south of Glenvale Road southerly 165 metres.
Marie Crescent, Wendouree, from Grandview Grove westerly 112 metres.
Marie Crescent, Wendouree from Harrow Street southerly 41 metres.
Margaret Avenue, from Walker Street northerly 37 metres.
Marigold Street, Wendouree West, from Grevillea Road northerly 287 metres.
Marigold Street, Wendouree West, from 113 metres west of Wattle Avenue westerly 19 metres.
Meadow Court, Delacombe, throughout.
Meredith Court, Alfredton, throughout.
Moss Avenue, Mount Helen, from 235 metres west of Eddy Avenue westerly 164 metres.
Muraban Court, Delacombe, throughout.
McKee Street, from Gladstone Street northerly 101 metres.
Nerrina Road, from 249 metres east of Doodts Road easterly 41 metres.
Orion Street, Sebastopol, from 123 metres north of Sayle Street northerly 67 metres.
Paragon Court, Wendouree West, throughout.
Regent Drive, from 108 metres south of Kinnersley Avenue southerly 30 metres.

Robert Drive, from Simpson Street easterly 17 metres.
 Simpson Street, from Norman Street southerly 169 metres.
 Simpson Street, from Robert Drive northerly 36 metres.
 Simpson Street, from 79 metres south of Walker Street southerly 27 metres.
 Simpson Street, from 58 metres south of Landsborough Street southerly 33 metres.
 Spencer Street, Sebastopol, from Morgan Street northerly 101 metres.
 Spencer Street, Sebastopol, from Queen Street northerly 43 metres.
 Springs Road, Brown Hill, from 170 metres south of Benson Street southerly 62 metres.
 St. George's Court, Sebastopol, throughout.
 Vincent Court, Delacombe, throughout.
 Warratta Avenue, Delacombe, from 103 metres west of Mawarra Drive westerly 31 metres.
 Warreen Street, Sebastopol, from Nanta Court northerly 121 metres.
 Weemala Avenue, Delacombe, from Mawarra Avenue westerly 65 metres.
 Wiltshire Lane, Delacombe, from Greenhalghs Road to Glenelg Highway.
 Windsor Avenue, Alfredton, from 190 metres south of Western Highway southerly 204 metres.
 Winifred Street, from Kelly Street easterly 48 metres.
 Woolway Court, Delacombe, throughout.
 Yarana Drive, Mount Helen, from Nyora Grove to Shakespeare Avenue.
 Yew Street, Wendouree West, from Wattle Avenue westerly 147 metres.

CHAS. H. CLAMP, Secretary of The Ballarat Water Commissioners, 18th December, 1974. 2718

AXEDALE WATERWORKS TRUST.

Notice is hereby given that the Axedale Waterworks Trust on 3/12/74 passed a Rating By-Law for the year 1975. The By-Law may be inspected free of charge at the Trust's office, Axedale.

2761 J. A. ELVEY, Secretary.

COLAC WATERWORKS TRUST.

NOTICE OF MAKING BY-LAW No. 8—WATER SUPPLY SERVICES.

NOTICE is hereby given that the Colac Waterworks Trust has made By-law No. 8 which repeals By-law No. 3 made 25th August 1958 and relates to Water Supply Services, Licences, Connections, Materials, Meters, Fire Services, Misuse and Waste of Water, etc.

The By-law was approved by the Governor in Council on 11th December 1974.

A copy of the By-law is open for inspection free of charge at the office of the Trust, 2 Rae Street, Colac, 2703

E. J. ROBBINS, Secretary.

GEELONG WATERWORKS AND SEWERAGE TRUST.

Pursuant to Section 60 of the *Geelong Waterworks and Sewerage Act 1958* (No. 6263) the Trust has prepared plans to indicate the particulars of sewers and underground works, the construction of which the Trust intends to begin at a date, not less than one month after publication of the notice, in or adjacent to the following localities within the Drainage Area.

Merlin Crescent, Corio. Shire of Corio.

Fellmongers Road, Breakwater. City of Geelong.

NOTICE IS HEREBY GIVEN that the plans indicated above are open for inspection at the Trust's Offices, Ryrie Street, Geelong, between the hours of 9.00 a.m. and 5.00 p.m. from Monday to Friday (public holidays excepted) by the owners or occupiers of land or premises within the Drainage Area.

2720 B. C. HENSHAW, Secretary.

COLAC SEWERAGE AUTHORITY.

NOTICE OF MAKING BY-LAW No. 6.—HOUSE CONNECTION WORKS.

NOTICE is hereby given that the Colac Sewerage Authority has made By-Law No. 6 which repeals By-Law No. 2 made 30th July 1962 and relates to Consents, Licences, etc., also Levels, Dimensions, Construction, Maintenance, Ventilation and Cleansing of Sewers and other matters relating to House Connection Work.

The By-Law was approved by the Governor-in-Council on 10th December 1974.

A copy of the By-Law is open for inspection free of charge at the office of the Authority, 2 Rae Street, Colac.

2702 E. J. ROBBINS, Secretary.

NOTICE IS HEREBY GIVEN that WILLIAM HOLYMAN AND SONS PROPRIETARY LIMITED has applied for a lease pursuant to Sections 134 and 135 of the *Land Act 1958* for a term of 50 years in respect of Allotments 8A, 8B and 8C, Section 63B, City of Port Melbourne containing 9690 square metres as a site for use for general industrial purposes. 2721

Notice is hereby given that the Eaglehawk Branch of the Returned Sailors Soldiers and Airmen's Imperial League of Australia has applied for a lease, pursuant to section 134 of the *Land Act 1958*, for a term of 21 years in respect of allotment 13, section 22, at Eaglehawk, Parish of Sandhurst containing 2863.3 square metres (2 roods 33 6/10 perches) as a site for amusement and recreation.

Bendigo 01342/134.

2624

G. A. FIRTH, Secretary.

NOTICE OF INTENTION TO APPLY FOR A LICENCE TO DIVERT WATER AND CUT RACE (RE-ISSUE) FROM THE RIVER MURRAY, AT KARADOC, VICTORIA.

We hereby give notice that we intend to apply for a licence empowering us to divert water for a term of fifteen years to the extent of 207 megalitres per annum at a maximum rate of 5 megalitres per day of 24 hours for the irrigation of 23 hectares, being lot 11, on plan of subdivision No. 87592, being part of allotment 35, Parish of Karadoc, and to occupy certain Crown lands for works of diversion, and to cut a race thereon.

Any objection to such application must be forwarded in writing to reach the State Rivers and Water Supply Commission, Melbourne, before 7th February, 1975, being 30 days from the first publication of this notice.

TIMOTHY BOZINEKIS.
ANGELA BOZINEKIS.

P.O. Box 711, Red Cliffs, 3496.

2625

NOTICE OF INTENTION TO APPLY FOR A LICENCE TO DIVERT WATER AND CUT RACE FROM THE OVENS RIVER, AT BOWMAN'S FOREST.

I hereby give notice that I intend to apply for a Licence empowering me to divert water for a term of 4 years to the extent of 24 acre feet per annum at a maximum rate of 1 acre feet per day of 24 hours for the irrigation of 16 acres of hops being part of Allotment 310, Section 12, Parish of Murrumgee.

Any objection to such application must be forwarded in writing to reach the State Rivers and Water Supply Commission, Melbourne before 7th February, 1975, being thirty days from the first publication of this Notice.

KEITH WHITE.

Bowman's Forest.

2765

TAKE NOTICE that the partnership heretofore carried on by C. Simievic and H. Nankin known as *Ginan Fashions* at 12 Kingsway, Armadale was dissolved on the 31st day of December, 1974. 2762

NOTICE IS HEREBY GIVEN that the partnership heretofore subsisting between Arthur Elliott Pardew Farmer and John Turnbull Pardew Farmer both of Orbost carrying on a business as Graziers at Orbost under the style or firm name of A. H. Pardew & Sons has been dissolved from the 30th day of June, 1973.

Dated the 12th day of December, 1974.

MOSLEY & PALMER, solicitors, 139 Nicholson Street, Orbost. 2777

Notice is hereby given that the partnership heretofore subsisting between Glenice Boswell Stanistreet Mary McLroy Stanistreet Isobel Maud Horgan and Ronald Bruce Stanistreet carrying on business as Insurance Agents at Charing Cross Bendigo under the style or firm name of McColl Rankin and Stanistreet has been dissolved by mutual consent as from the Thirty-first day of December 1974 and in future the said business under the same firm name shall be carried on by the said Glenice Boswell Stanistreet at 136 Mollison Street Bendigo.

WATSON, JAMES & ROGERS, solicitors and agents for the parties. 2691

NOTICE is hereby given that the Partnership heretofore subsisting between the undersigned FRANC VRAVNIK, MARY VRAVNIK, ANTON MIKIKITS and HEIDI MIKIKITS carrying on engineering business at 28 Capella Crescent, East Moorabbin under the name and style of "Frankston Motor Body Works and Chassis Engineering" has been dissolved by mutual consent as from the 16th

day of December 1974. All debts due to and owing by the said late firm will be received and paid by ANTON MIKIKITS and HEIDI MIKIKITS who will continue to carry on the business at the same place.

Dated this 20th day of December, 1974.

FRANC VRAVNIK,
MARY VRAVNIK,
ANTON MIKIKITS,
HEIDI MIKIKITS.

2677

I, LEONARD CLINTON SHAW of 15 Simpson Street East Melbourne hereby give notice that on the 31st day of December 1974 I retire as a partner from the legal firm of Middletons who carry on the practice of solicitors at 457 Little Collins Street Melbourne.

As from the 1st January 1975 I shall be Consultant to the said firm.

2678

L. C. SHAW.

NOTICE IS HEREBY GIVEN that the partnership heretofore subsisting between DOUGLAS SCOTT of 33 Oakleigh Road, Glenhuntingly, Accountant, and BALWANT SINGH of 44 Weeden Drive, East Burwood, Accountant, carrying on business as Public Accountants and Auditors at and from 473 Glenhuntingly Road Elsternwick under the style of "SCOTT AND SINGH" has been dissolved as from the 30th day of September, 1974.

The said business has been continued since that date by the said BALWANT SINGH under the same style.

Dated the 19th day of December, 1974. 2627

Mr. John Wolf is retiring from partnership in the firm of Messrs. Tribe Strasser & Gorr, Solicitors of 576 St. Kilda Road, Melbourne as from the 24th December, 1974. The partnership will continue, the remaining partners being Messrs. Leon Gorr and Peter Strasser. 2628

Notice Is Hereby Given that the partnership formerly subsisting between Peter Gordon Morrison, Merrilyn Anne Morrison, Jack Sandford Lyons and Betty Lynne Lyons carrying on business as suppliers of pressure sensitive labels under the style or firm of "P. G. Morrison & Sons" has been dissolved as from the 30th day of June 1974. All debts due and owing by the said firm will be received and paid by the said Peter Gordon Morrison and Merrilyn Anne Morrison. 2629

Take notice that the partnership formerly conducted by Costa Iskandar Mansour and Paul Romito in the business known as "Piperno Pizza Restaurant" of High Street, Wodonga has been dissolved as from the 29th day of November, 1974.

Creditors having any claim against the partnership should send full particulars of such claim immediately to Potter, Trivett & Associates of 84 High Street, Wodonga.

Notice is also given that Costa Iskandar Mansour is no longer associated with any business conducted from the premises formerly occupied by the partnership.

POTTER, TRIVETT & ASSOCIATES, solicitors, 84 High Street, Wodonga. 2630

The partnership of BRAND TRANSPORT carried on at 22 McIndoe Parade Parkdale between KATHRYN GARDINER of 22 McIndoe Parade Parkdale and SANDRA JONES of 4 Latham Court Dandenong has been dissolved as from the 22nd September 1974 and this is notice to all concerned of such notification. 2698

The partnership of BRAND & JONES carried on between BRIAN MICHAEL BRAND of 22 McIndoe Parade Parkdale and DAVID RICHARD JONES of 4 Latham Court Dandenong has been dissolved as from the 22nd September 1974 and this is notice to all concerned of such notification. 2626

Pursuant to Section 41 of the Partnership Act 1958 notice is hereby given that the firm of Conzinc Holdings Alumina Sales ceased to carry on business as from the 9th January 1974 and that the partnership between Conzinc Riotinto of Australia Limited and C.R.A. Holdings Pty. Limited carrying on business under the firm name of Conzinc Holdings Alumina Sales has been dissolved as of the 17th December 1974.

R. J. KNOTT,
Secretary to the above Companies. 2725

NOTICE IS HEREBY GIVEN that the partnership heretofore subsisting between DAVID ARTHUR DAVIES and MAVIS MERLE DAVIES, and ALAN WILLIAM DAVIES and KAREN BERYL DAVIES carrying on business as Licensed Hotelkeepers' at the Royal Oak Hotel, Kilmore

under the style of D. A.; M.; A. W. and K. B. DAVIES has been dissolved as and from the date hereof. ALL debts due to and owing by the said firm will be received and paid respectively by DAVID ARTHUR DAVIES, MAVIS MERLE DAVIES and ALAN WILLIAM DAVIES who will continue to carry on the said business under their names.

Dated this 23rd day of December, 1974.

D. A. DAVIES,
M. M. DAVIES,
A. W. DAVIES.

2724

NOTICE IS HEREBY GIVEN that the partnership heretofore subsisting between JOHN KARAGIANNAKIS and PITSA KARAGIANNAKIS and CHRISTOS ATHANASOPOULOS and KATI ATHANASOPOULOS carrying on the business of a Snack Bar at the premises of 1966 Dandenong Road, North Clayton has been dissolved as from the 20th day of December One thousand nine hundred and seventy-four by the retirement of CHRISTOS ATHANASOPOULOS and KATI ATHANASOPOULOS from the said business. All debts due and owing to the said business will be received and paid respectively by JOHN KARAGIANNAKIS and PITSA KARAGIANNAKIS who will continue to carry on the said business.

Notice is hereby given that the partnership between EDWIN WATSON CHILVERS of 6 Talbot Street, Hampton, in the State of Victoria and GEOFFREY DAWSON of 235 Beach Road, Black Rock in the State of Victoria who carried on business at 258 Flinders Lane, Melbourne under the firm name Chilvers & Dawson has been dissolved as from the 20th day of December, 1974. 2723

The Companies Act 1961.—In the matter of BELGRAVE ELECTRICS PTY. LIMITED (in Voluntary Liquidation).—Members Winding Up.

Notice is hereby given that at the Extraordinary General meeting of Belgrave Electrics Pty. Limited duly convened and held at 76 Sandels Road, Tecoma in the State of Victoria on the 30th day of December 1974, the following Resolution was proposed and passed as a Special Resolution.

"That the Company be wound up voluntarily".

Dated this 31st day of December, 1974.

2742 K. J. RUSSELL, Liquidator.

Companies Act 1961.

UNITED PLASTICS PTY. LTD. (IN VOLUNTARY LIQUIDATION).

NOTICE is hereby given that at an Extraordinary General Meeting of Members of the abovenamed company held on 18th December, 1974, it was resolved that the company be wound up voluntarily and at a meeting of Creditors held on the same day it was resolved that for such purpose Lewis Luckins, Chartered Accountant of 423 Bourke Street, Melbourne, be appointed liquidator.

Notice is also given that after twenty-one days from this date I shall proceed to distribute the assets. All creditors who have any claim against the company should furnish particulars of same by that date, otherwise I shall proceed to distribute the assets without regard to their claim.

Dated this 24th day of December, 1974.

LEWIS LUCKINS, Liquidator.

Lewis Luckins & Co., chartered accountants, 423 Bourke Street, Melbourne, 3000. Telephone 67 6944. 2743

Companies Act 1961.

DREXEL CONTRACT FURNISHINGS PTY. LTD. (IN VOLUNTARY LIQUIDATION).

NOTICE is hereby given that at an Extraordinary General Meeting of Members of the abovenamed company held on 23rd December, 1974, it was resolved that the company be wound up voluntarily and at a meeting of Creditors held on the same day it was resolved that for such purpose Lewis Luckins, Chartered Accountant of 423 Bourke Street, Melbourne, be appointed liquidator.

Notice is also given that after twenty-one days from this date I shall proceed to distribute the assets. All creditors who have any claim against the company should furnish particulars of same by that date, otherwise I shall proceed to distribute the assets without regard to their claim.

Dated this 27th day of December, 1974.

LEWIS LUCKINS, Liquidator.

Lewis Luckins & Co., chartered accountants, 423 Bourke Street, Melbourne, 3000. Telephone 67 6944. 2744

Companies Act 1961.

JOHN H. ROWE INTERIORS PTY. LTD. (IN VOLUNTARY LIQUIDATION).

NOTICE is hereby given that at an Extraordinary General Meeting of Members of the abovenamed company held on 23rd December, 1974, it was resolved that the company be wound up voluntarily and at a meeting of Creditors held on the same day it was resolved that for such purpose Lewis Luckins, Chartered Accountant of 423 Bourke Street, Melbourne, be appointed liquidator.

Notice is also given that after twenty-one days from this date I shall proceed to distribute the assets. All creditors who have any claim against the company should furnish particulars of same by that date, otherwise I shall proceed to distribute the assets without regard to their claim.

Dated this 26th day of December, 1974.

LEWIS LUCKINS, Liquidator.

Lewis Luckins & Co., chartered accountants, 423 Bourke Street, Melbourne, 3000. Telephone 67 6944. 2745

Companies Act 1961.

DACA MANUFACTURING PTY. LTD. (IN VOLUNTARY LIQUIDATION).

NOTICE is hereby given that at an Extraordinary General Meeting of Members of the abovenamed company held on 24th December, 1974, it was resolved that the company be wound up voluntarily and at a meeting of Creditors held on the same day it was resolved that for such purpose Lewis Luckins, Chartered Accountant of 423 Bourke Street, Melbourne, be appointed liquidator.

Notice is also given that after twenty-one days from this date I shall proceed to distribute the assets. All creditors who have any claim against the company should furnish particulars of same by that date, otherwise I shall proceed to distribute the assets without regard to their claim.

Dated this 30th day of December, 1974.

LEWIS LUCKINS, Liquidator.

Lewis Luckins & Co., chartered accountants, 423 Bourke Street, Melbourne, 3000. Telephone 67 6944. 2746

In the matter of the *Companies Act 1961*; and in the matter of JEMEL PROPRIETARY LIMITED.

NOTICE IS HEREBY GIVEN that at an Extraordinary General Meeting of the Company held at 3 Stradbroke Avenue, Toorak, Victoria on Saturday the 21st day of December, 1974 the following Special Resolution was passed:

That the Company be and is hereby wound up voluntarily and that Mr. Keith Oscar Harris of the firm Blake & Riggall of 140 William Street, Melbourne be appointed Liquidator.

Dated this 24th day of December, 1974.

K. O. HARRIS, Liquidator.

Blake & Riggall, solicitors for the liquidator, 140 William Street, Melbourne. 2747

EVANS SPRINGS PTY. LTD. (IN VOLUNTARY LIQUIDATION).

Pursuant to Section 254 (1) of the *Companies Act 1961* the following Special Resolution was passed on 18th December, 1974 at a General Meeting of the Members—

"That the Company be wound up voluntarily under Section 254 (1) of the *Companies Act 1961* and that Herbert A. B. McWilliam of Touche Ross & Co., 440 Collins Street, Melbourne, be appointed liquidator for the purpose of such winding up."

Dated the 18th day of December, 1974.

2748 H. A. B. McWILLIAM, Liquidator.

Companies Act 1961.

E. HASSETT & SONS PROPRIETARY LIMITED (IN VOLUNTARY LIQUIDATION).

At an Extraordinary General Meeting of the abovenamed Company duly convened and held on 20th December, 1974 at 24 Whitehorse Road, Ringwood, Melbourne, the following Special Resolution was passed:

"That E. Hassett & Sons Proprietary Limited be placed in voluntary liquidation under Section 254 (1) of the *Companies Act 1961*, and that Alan Leigh Middleton of 11 Bank Place, Melbourne be appointed Liquidator."

Dated 20th December, 1974.

2647 A. L. MIDDLETON, Liquidator.

The Companies Act 1961.

In the matter of BILL DUNN PROPRIETARY LIMITED (in Liquidation)—(formerly MELBOURNE CARBON SPECIALISTS PTY. LTD.).

NOTICE IS HEREBY GIVEN that at an extraordinary General Meeting of the members of the abovenamed Company held on the 20th December 1974, it was resolved that the Company be wound up voluntarily and that MICHAEL WILLIAM ERNEST HOSKING be nominated as Liquidator for the purpose of such winding up and that at a meeting of Creditors held later on the same day my appointment as Liquidator was confirmed.

NOTICE is also given that persons having claims against the Company should lodge a proof of debt within 21 days at my office at Suite 3, 96 St. Kilda Road, St. Kilda.

Dated this 20th day of December, 1974.

MICHAEL W. E. HOSKING, Liquidator.

Michael W. E. Hosking, public accountant, 96 St. Kilda Road, St. Kilda, 3182. Phone 94 1932. 2749

In the Supreme Court of Victoria.—1974 Co. 8998.—In the matter of the *Companies Act 1961*; and in the matter of P.P. INTERNATIONAL SALES & CO. PTY. LTD.; and in the matter of a scheme proposed to be entered into as a Scheme of Arrangement under section 181 of the said Act between the company, its members and the secured creditor and the unsecured creditors.

NOTICE IS HEREBY GIVEN that by an Order dated the 16th day of December 1974 the Court has directed that the said Company should convene separate meetings of its members and unsecured creditors as defined in the said Scheme for the purpose of considering and if thought fit approving with or without modification the said Scheme as a Scheme of Arrangement proposed to be made between the company and its members secured creditor and unsecured creditors and that the meeting of the unsecured creditors of the said Company is to be held on the 29th day of January 1975 at the office of The Victorian Employers Federation, 151 Flinders Street, Melbourne 3000 at the hour of 10.30 in the forenoon.

A print of the said Scheme of Arrangement and an Explanatory Statement can be seen and proxy forms can be obtained upon request at the office of Thomas Dunn Maclean at Suite 3, 545 St. Kilda Road Melbourne on any week-day between the hours of 10 a.m. and 4 p.m. prior to the date of such meeting.

The said unsecured creditors of the said Company may attend such meeting and vote in person or by proxy provided all proxies given by the said creditors are deposited with the said Thomas Dunn Maclean at Suite 3, 545 St. Kilda Road, Melbourne no later than 12 noon on the day before the meeting.

The Court has appointed Thomas Dunn Maclean of Suite 3, 545 St. Kilda Road Melbourne in the State of Victoria, Accountant, to act as Chairman of the said meeting unless the meeting shall otherwise resolve and has directed that such Chairman report the results of the said meeting to the Court.

The above Scheme will be subject to the subsequent approval of the Court.

Dated the 18th day of December, 1974.

HAVYATT & STEWARD, 432 William Street, Melbourne. 2643

Companies Act 1961.—In the matter of PETER HANSEN PTY. LTD. (in Liquidation).

NOTICE is hereby given that at an Extraordinary General Meeting of the members of the abovenamed Company held on the 19th day of December, 1974 it was resolved that the Company be wound up voluntarily, and at a meeting of creditors held on the same day, pursuant to section 260, it was resolved that for such purpose, Thomas Dunn Maclean, of 545 St. Kilda Road, Melbourne, Accountant, be appointed Liquidator.

NOTICE is also given that after 21 days from this date I shall proceed to distribute the assets. All creditors having any claims against the Company should furnish particulars of same by that date, otherwise I shall proceed to distribute the assets without regard to their claim.

Dated this 19th day of December, 1974.

THOMAS DUNN MACLEAN, Liquidator.

T. D. Maclean & Company, Suite 3, 545 St. Kilda Road, Melbourne, Vic. 3004. 2644

Companies Act 1961.—In the matter of MIMOSA FROCKS PTY. LTD. (in Liquidation).

NOTICE is hereby given that at an Extraordinary General Meeting of the members of the abovenamed Company held on the 19th day of December, 1974 it was resolved that the Company be wound up voluntarily, and at a meeting of creditors held on the same day, pursuant to section 260, it was resolved that for such purpose, Thomas Dunn Maclean, of 545 St. Kilda Road, Melbourne, Accountant be appointed Liquidator.

NOTICE is also given that after 21 days from this date I shall proceed to distribute the assets. All creditors having any claims against the Company should furnish particulars of same by that date, otherwise I shall proceed to distribute the assets without regard to their claim.

Dated this 19th day of December, 1974.

THOMAS D. MACLEAN, Liquidator.

T. D. Maclean & Company, Suite 3, 545 St. Kilda Road, Melbourne, Vic. 3004. 2645

BUTLER HOUSE PTY. LTD.

At an Extraordinary General Meeting of the abovenamed Company duly convened and held at the office of H. Guest & Associates Pty. Ltd., 207B Balaclava Road, Caulfield on the 20th December, 1974 the following Resolution was duly passed as a Special Resolution:

(1) That the Company be wound up voluntarily.

(2) That Mr. John Durlacher, Public Accountant of 207B Balaclava Road, Caulfield be and is hereby appointed liquidator at a remuneration in accordance with the scale of fees laid down by the Australian Society of Accountants.

Dated this 20th day of December, 1974.

2646 J. DURLACHER, Liquidator.

LOCKERBIE INVESTMENTS PTY. LTD.

SPECIAL RESOLUTION TO WIND-UP PURSUANT TO SECTION 254 OF THE COMPANIES ACT 1961.

At an Extraordinary General Meeting of the abovenamed Company, duly convened and held at 38 Walsh Street, Melbourne on 19th December 1974, the following Resolution was passed as a Special Resolution—

“RESOLVED that in accordance with provisions of Section 254 of the *Companies Act 1961*, the Company be wound-up voluntarily.”

And at such last-mentioned Meeting Ronald Jessel Sicree of 38 Walsh Street, Melbourne, was appointed Liquidator for the purposes of winding-up.

2648 N. W. CURWOOD, Chairman.

E. S. LAWRENCE & CO. PTY. LTD.

SPECIAL RESOLUTION TO WIND-UP PURSUANT TO SECTION 254 OF THE COMPANIES ACT 1961.

At an Extraordinary General Meeting of the abovenamed Company, duly convened and held at 38 Walsh Street, Melbourne on 19th December 1974, the following Resolution was passed as a Special Resolution—

“RESOLVED that in accordance with provisions of Section 254 of the *Companies Act 1961*, the Company be wound-up voluntarily.”

And at such last-mentioned Meeting Ronald Jessel Sicree of 38 Walsh Street, Melbourne, was appointed Liquidator for the purposes of winding-up.

2649 N. W. CURWOOD, Chairman.

THRIFT STYLES PTY. LTD.

SPECIAL RESOLUTION TO WIND-UP PURSUANT TO SECTION 254 OF THE COMPANIES ACT 1961.

At an Extraordinary General Meeting of the abovenamed Company, duly convened and held at 38 Walsh Street, Melbourne on 19th December 1974, the following Resolution was passed as a Special Resolution—

“RESOLVED that in accordance with provisions of Section 254 of the *Companies Act 1961*, the Company be wound-up voluntarily.”

And at such last-mentioned Meeting Ronald Jessel Sicree of 38 Walsh Street, Melbourne, was appointed Liquidator for the purposes of winding-up.

2650 N. W. CURWOOD, Chairman.

In the matter of the *Companies Act 1961*; and in the matter of PRYOAK PTY. LIMITED (in Liquidation)—members voluntarily winding-up.

NOTICE is hereby given that a final meeting of members of the above named company being a redundant company will be held at the offices of Messrs. Fell &

Starkey, Level 26, Australia Square, Sydney on Wednesday 15th February, 1975 at 12 noon for the purpose of laying before the meeting an account showing how the winding up has been conducted and the property of the company has been disposed and of hearing any explanation that may be given by the liquidator and also of determining by ordinary resolution the manner in which the books, accounts and documents of the Company shall be disposed.

Dated at Sydney this 31st day of December, 1974.

2759 C. K. D. DICKINS, Liquidator.

In the Supreme Court of Victoria.—No. Co. 8961 of 1974.—In the matter of the *Companies Act 1961*; and in the matter of CARMEL SHOE CO. PTY. LTD.—Notice of Winding Up Order.

Winding up Order made: 17th day of December, 1974.

Name and Address of Liquidator: PHILLIP DOUGLAS GEORGE of 440 Collins Street, Melbourne.

BRAHAM & PIRANI, solicitors for the petitioner. 2651

COMPANIES ACT 1961.

At a general meeting of the members of Glamourline Homes (Vic.) Pty. Limited duly convened and held at the offices of Harari and Lowenstein, 39 Wellington Street, Windsor on the nineteenth day of December, 1974, the special resolution set out below was duly passed:

“That the company be placed into voluntary liquidation and that Mr. Raymond Harari be appointed to act as liquidator for the purpose of winding up the affairs and distributing the assets of the company.”

HARARI & LOWENSTEIN, accountants, 39-41 Wellington Street, Windsor, 3181. 2653

Companies Act 1961.—In the matter of BINATANG PROPRIETARY LIMITED (in Liquidation).—Members' Voluntary Winding Up.

NOTICE is hereby given that at an extraordinary Meeting of the Members of the abovenamed company held on the 27th of December 1974, it was resolved that the company be wound up voluntarily in accordance with the provisions of the *Companies Act 1961* relating to a Members Voluntary Winding Up and that BRENDAN JOHN O'CONNOR, Accountant, of Taylor O'Connor & Co., 562 St. Kilda Road, Melbourne, be appointed Liquidator.

NOTICE is also given that after twenty-one days from this date I shall proceed to distribute the assets. All creditors having any claim against the company should furnish particulars of same by that date, otherwise I shall proceed to distribute the assets without regard to their claim.

Dated this 30th day of December, 1974.

B. J. O'CONNOR, Liquidator.

Taylor, O'Connor & Co., 562 St. Kilda Road, Melbourne, 3004. 2654

In the matter of the *Companies Act 1961*; and in the matter of JORDAN AND MOSS (AUST.) PTY. LIMITED—members voluntarily winding-up.

NOTICE is hereby given that a final meeting of members of the above named company being a redundant company will be held at the offices of Messrs. Fell & Starkey, Level 26, Australia Square, Sydney on Wednesday 15th February, 1975 at 12 noon for the purpose of laying before the meeting an account showing how the winding up has been conducted and the property of the company has been disposed and of hearing any explanation that may be given by the liquidator and also of determining by ordinary resolution the manner in which the books, accounts and documents of the Company shall be disposed.

Dated at Sydney this 31st day of December, 1974.

2760 C. K. D. DICKINS, Liquidator.

The *Companies Act 1961.*—In the matter of BROOKLYN HIDE & SKIN PROCESSORS PROPRIETARY LIMITED (Receiver and Manager Appointed) (in Liquidation).

NOTICE is hereby given that a First and Final Dividend is intended to be declared in this matter. Creditors who have not proved their debts by the Thirty-First Day of January 1975 will be excluded from the dividend.

Dated this 19th day of December, 1974.

P. D. GEORGE, liquidator, 440 Collins Street, Melbourne.

2754

Companies Act 1961.

APEX FIRE DETECTION SYSTEMS (MANUFACTURING) PTY. LTD. (IN VOLUNTARY LIQUIDATION).

NOTICE OF FINAL MEETING, PURSUANT TO SECTION 272.

Notice is hereby given, pursuant to Section 272 of the Companies Act, that the Final General Meeting of members of the abovenamed company will be held at the offices of Fell & Starkey, Chartered Accountants, Stock Exchange House, 351 Collins Street, Melbourne on 10th February, 1975 at 10 a.m. for the purpose of having an account laid before it showing the manner in which the winding up has been conducted and the property of the company disposed of and hearing any explanation that may be given by the liquidator.

Dated this 20th day of December, 1974.

2764 L. N. JUPP, Liquidator.

Companies Act 1961.

APEX FIRE DETECTION SYSTEMS PTY. LTD. (IN LIQUIDATION).

NOTICE OF FINAL MEETING, PURSUANT TO SECTION 272.

Notice is hereby given, pursuant to Section 272 of the Companies Act, that the Final General Meeting of members of the abovenamed company will be held at the offices of Fell & Starkey, Chartered Accountants, Stock Exchange House, 351 Collins Street, Melbourne on 10th February, 1975 at 10 a.m. for the purpose of having an account laid before it showing the manner in which the winding up has been conducted and the property of the company disposed of and hearing any explanation that may be given by the liquidator.

Dated this 20th day of December, 1974.

2763 L. N. JUPP, Liquidator.

In the matter of the Companies Act 1961; and in the matter of L. J. CHANCE PTY. LTD. (in Voluntary Liquidation).

NOTICE OF FINAL MEETING OF MEMBERS PURSUANT TO SECTION 272.

Notice is hereby given in pursuance of Section 272 of the Companies Act 1961 that a General Meeting of the members of the Company will be held at the office of W. Marshall & Associates, Chartered Accountants of Suite 2, 162 Albert Road, South Melbourne on the 14th day of February, 1975 at 10.30 o'clock in the forenoon for the purpose of having an account laid before it showing the manner in which the winding up has been conducted and the property of the Company disposed of, and hearing any explanation that may be given by the Liquidator.

Dated this 2nd day of January, 1975.

2758 R. G. CAMERON, Liquidator.

The Companies Act 1961.

R. & N. DAVIS INVESTMENTS PTY. LTD. (IN LIQUIDATION).

NOTICE is hereby given that a First Dividend is intended to be declared in the above matter. Creditors who have not proved their debts by the 15th day of January, 1975 may be excluded from this Dividend.

Dated this 17th day of December, 1974.

G. O. HARRISON, Liquidator.

Hall & Rose, chartered accountants, 395 Collins Street, Melbourne, Victoria, 3000. 2687

The Companies Act 1961.

ODEON MUSIC HOUSE & CO. (VIC.) PTY. LTD. (IN LIQUIDATION).

NOTICE is hereby given that a First Dividend is intended to be declared in the above matter. Creditors who have not proved their debts by the 15th day of January, 1975 may be excluded from this Dividend.

Dated this 17th day of December, 1974.

G. O. HARRISON, Liquidator.

Hall & Rose, chartered accountants, 395 Collins Street, Melbourne, Victoria, 3000. 2688

The Companies Act 1961.—In the matter of COMTEK COMMUNICATIONS PTY. LTD. (in Liquidation).

NOTICE IS HEREBY GIVEN that at an extraordinary General Meeting of the members of the abovenamed Company held on the 23rd December, 1974, it was resolved that the Company be wound up voluntarily and that MICHAEL WILLIAM ERNEST HOSKING be nominated

as Liquidator for the purpose of such winding up and that at a meeting of Creditors held later on the same day my appointment as Liquidator was confirmed.

NOTICE is also given that persons having claims against the Company should lodge a proof of debt within 21 days at my office at: Suite 3, 96 St. Kilda Road, St. Kilda, 3182.

MICHAEL W. E. HOSKING, Liquidator.

Dated this 23rd day of December, 1974.

Michael W. E. Hosking, public accountant, 96 St. Kilda Road, St. Kilda, 3182. Phone: 94 1932. 2750

Companies Act 1961.

W. H. THORNTON & SONS PTY. LTD.

NOTICE is hereby given that at an Extraordinary General Meeting of members of the above named company held on the 16th December, 1974 it was resolved that the company be wound up voluntarily and that Mr. J. C. R. Sitlington of the firm of Officer & Smith Chartered Accountants 121 William Street, Melbourne be appointed Liquidator of the Company.

NOTICE is also given that after twenty-one days from this date I shall proceed to distribute the assets. All creditors having any claims against the Company should furnish particulars of same by that date, otherwise I shall proceed to distribute the assets without regard to their claim.

Dated this 8th day of January, 1975.

J. C. R. SITLINGTON, Liquidator.

Officer & Smith, chartered accountants, 121 William Street, Melbourne. 2751

The Companies Act 1961.—In the matter of JOHN FAUTLEY INDUSTRIES PTY. LTD. (Receiver and Manager Appointed).

NOTICE is hereby given that at an Extraordinary General Meeting of the Members of the above-named Company held on the 19th December, 1974 it was resolved that the Company be wound up voluntarily and at a meeting of creditors held on the same day pursuant to Section 260 it was resolved that for such purpose John Martin Walsh of 296 Little Lonsdale Street, Melbourne, Accountant, be appointed Liquidator.

NOTICE is also given that after twenty-one days from this date I shall proceed to distribute the assets. All creditors having any claim against the Company should furnish particulars of same by that date, otherwise I shall proceed to distribute the assets without regard to their claim.

Dated this 23rd day of December, 1974.

J. M. WALSH, Liquidator.

Kennedy Smail, 296 Little Lonsdale Street, Melbourne, 3000. 2752

The Companies Act 1961.—In the matter of TRAN SPAN ENGINEERING PTY. LTD.—Notice re Meeting of Creditors pursuant to Section 260.

NOTICE is hereby given that a Meeting of Creditors of the abovenamed Company will be held at the offices of Kennedy Smail 296 Little Lonsdale Street, Melbourne at 10.30 a.m. on the 14th day of January, 1975, the Company having convened a Meeting of its Members for the same day for the purpose of considering a Resolution that the Company be wound up voluntarily.

Dated this 23rd day of December, 1974.

2753 K. E. GILBEE, Director.

Companies Act 1961.

376 BOURKE STREET PTY. LTD. (IN VOLUNTARY LIQUIDATION).

NOTICE OF FINAL MEETING, PURSUANT TO SECTION 272.

Notice is hereby given, pursuant to section 272 of the Companies Act, that the Final General Meeting of members of the abovenamed company will be held at the offices of Fell & Starkey, Chartered Accountants, Stock Exchange House, 351 Collins Street, Melbourne on 10th February, 1975 at 10 a.m. for the purpose of having an account laid before it showing the manner in which the winding up has been conducted and the property of the company disposed of and hearing any explanation that may be given by the Liquidator.

Dated this 20th day of December, 1974.

2689 J. E. HOWARD, Liquidator.

The Companies Act 1961.

ALTIM SALES PROPRIETARY LIMITED.

Notice is hereby given that, at a General Meeting of the members of the above-named company held on Monday the 30th December 1974, it was resolved that the company be wound up voluntarily, and that Robert Alwyn Berry of 420 St. Kilda Road, Melbourne, be appointed liquidator for the purposes of winding up, with full power to exercise any power conferred by the Companies Act 1961, upon a liquidator in a members' voluntary winding up.

Dated this 30th day of December, 1974.

2692 G. F. SECCOMBE, Secretary.

RE: FEATHEROCK INDUSTRIES PTY. LTD. (UNDER OFFICIAL MANAGEMENT), 747 Geelong Road, Brooklyn.

NOTICE OF INTENTION TO DECLARE DIVIDEND.

NOTICE IS HEREBY GIVEN that a first dividend is intended to be declared in the above matter. Creditors who do not lodge Proof of Debt in the prescribed form by 24th January, 1975 will be excluded from this dividend.

Dated this 30th day of December, 1974.

D. J. COUGLE, Official Manager.

Bent & Cogle, Suite 18, 545 St. Kilda Road, Melbourne, 3004. 2701

Companies Act 1961, Section 254.

GARDEN PRIDE PTY. LIMITED.

Notice is hereby given that at a general meeting of members of the above-named company, held on the 20th day of December, 1974, the following resolution was passed as a special resolution:

"That the company be wound up voluntarily."

2707 R. HOLLIS, Secretary.

In the matter of the Companies Act 1961; and in the matter of—

PLOWRIGHT READY MIXED CONCRETE PROPRIETARY LIMITED.
SUPERMIX CONCRETE (BROOKLYN) PROPRIETARY LIMITED.
SUPERMIX CONCRETE (NORTHCOTE) PROPRIETARY LIMITED.
CESTER SAND PITS PROPRIETARY LIMITED.
ALPHA PLANT HIRE CO. PTY. LTD.
PARAMOUNT QUARRYING COMPANY PROPRIETARY LIMITED.

Notice is hereby given that at meetings of the members of the above companies held on the 20th December 1974 the following resolution was passed as a Special Resolution.

That the Company be wound up voluntarily and that Geoffrey Arthur Cohen of 330 Collins Street, Melbourne be and is hereby appointed liquidator for the purpose of such winding up.

2708 G. A. COHEN, Liquidator.

SOUTHERN ADVANCE PTY. LTD. (IN LIQUIDATION).

Notice is hereby given, pursuant to Section 272 of the Companies Act, that the affairs of the company have been fully wound up and that a final meeting of shareholders will be held at the offices of Coleman, McClure & Wilby, 367 Victoria St., Abbotsford, on Tuesday, 18th February, 1975, at 9 A.M. for the purpose of laying before it an account showing how the winding up has been conducted and the property of the company disposed of and giving any explanation thereof.

J. MULLER, Liquidator, care of Coleman, McClure & Wilby, 367 Victoria Street, Abbotsford. 2713

Companies Act 1961, as Amended, Section 272 (1).

HUME DRAPERS PTY. LTD. (IN VOL. LIQ.).

NOTICE TO MEMBERS.

Notice is hereby given that a General Meeting of the Company will be held at the Offices of A. N. Rooke, First Floor, 153 Upper Heidelberg Road, Ivanhoe, Victoria, at 12.30 p.m. on Wednesday, 5th February, 1975 to receive and adopt the Liquidator's Final Account. 2735

Companies Act 1961.—In the matter of BROMLEY BUILDERS PTY. LTD. (in Liquidation).

NOTICE is hereby given that at an extraordinary Meeting of the Members of the abovenamed Company held on the 17th December, 1974 it was resolved that the Company be wound up voluntarily and at a Meeting of Creditors held on the same day pursuant to Section 260, it was resolved that for such purpose EVERETT THOMSON BENT of Suite 18, 545 St. Kilda Road, Melbourne, Public Accountant, be appointed Liquidator.

NOTICE is also given that after twenty-one days from this date I shall proceed to distribute the assets. All creditors having any claims against the Company should

furnish particulars of same by that date, otherwise I shall proceed to distribute the assets without regard to their claim.

Dated this 17th day of December, 1974.

E. T. BENT, Liquidator.

Bent & Cogle, public accountants, 545 St. Kilda Road, Melbourne, 3004. 2656

The Companies Act 1961.

NOTICE OF FINAL MEETING OF SHAREHOLDERS OF GROUP WAREHOUSE LIMITED (IN LIQUIDATION).

NOTICE IS HEREBY GIVEN in pursuance of Section 272 of the Companies Act 1961 that a general meeting of the members of Group Warehouse Limited (In Liquidation) will be held at the offices of Messrs. J. S. Eastwood & Etherington, 450 Little Collins Street, Melbourne on Thursday the 20th day of February 1975 at 11.00 a.m. for the purpose of laying before the meeting an account showing how the winding up has been conducted and the property of the company has been disposed of and of giving any explanation of the account.

2739 M. J. SCOTT, Liquidator.

Companies Act 1961, Section 272 (2).

ALUMINIUM EXTRUSIONS PTY. LTD.
NONFERROUS EXTRUDERS PTY. LTD.
OGDEN INDUSTRIES SALES PTY. LTD.
N.K.S. (INVESTMENTS) PTY. LTD.
(ALL IN VOLUNTARY LIQUIDATION.)

NOTICE OF FINAL MEETINGS.

Notice is hereby given that pursuant to Section 272 of the Companies Act 1961, general meetings of the members of the abovenamed companies will be held at Messrs. Peat, Marwick, Mitchell & Co., 12th Floor, 447 Collins Street, Melbourne, on the 10th day of February 1975 beginning at 10.00 o'clock in the forenoon.

The purpose of the meetings is to lay accounts before them showing the manner in which the winding ups have been conducted and the property of the companies disposed of and of hearing any explanation that may be given by the Liquidator.

Dated this 5th day of January, 1975.

D. A. CRAWFORD, Liquidator.

Messrs. Peat, Marwick, Mitchell & Co., 447 Collins Street, Melbourne, 3000. 2740

Companies Act, Section 272.

MACROBERTSON (AUSTRALIA) LIMITED.

NOTICE OF FINAL MEETING.

Notice is hereby given that the final meeting of the members of MacRobertson (Australia) Limited will be held at the office of the liquidator, 8th Floor, A.M.P. Building, 86 Collins Street, Hobart on Wednesday the 5th day of February, 1975 at 11 o'clock in the forenoon for the purpose of laying before the meeting an account showing how the winding up has been conducted and the property of the Company disposed of and to give any explanation thereof.

2741 L. N. P. COX, Liquidator.

In the matter of CAMELOT PRESS PTY. LTD.—Notice of Winding-Up Order.

WINDING-UP ORDER made the 19th day of December 1974.

Name and address of Official Liquidator: Ronald Dennis Widdows, 703 South Road, Moorabbin.

L. T. FITZGERALD, Deputy Commissioner of Taxation of the Commonwealth of Australia. 2737

In the matter of CAMELOT MOTELS LIMITED.—Notice of Winding-Up Order.

WINDING-UP ORDER made the 19th day of December 1974.

Name and address of Official Liquidator, Richard Joseph O'Keefe, 162A High Street, Ashburton.

L. T. FITZGERALD, Deputy Commissioner of Taxation of the Commonwealth of Australia. 2738

In the matter of the Companies Act 1961; and in the matter of RIVARNO PTY. LTD.

WINDING-UP ORDER MADE 18TH DECEMBER 1974.

NAME AND ADDRESS OF LIQUIDATOR: JAMES POULTON of 447 Collins Street MELBOURNE.

WEIGALL & CROWTHER, solicitors for the petitioner. 2736

Companies Act 1961.—In the matter of MULTI PRODUCTS AUSTRALIA PROPRIETARY LIMITED (in Liquidation).

NOTICE is hereby given that at an extraordinary Meeting of the Members of the abovenamed Company held on the 19th December 1974, it was resolved that the Company be wound up voluntarily and at a Meeting of Creditors held on the same day pursuant to Section 260, it was resolved that for such purpose, BRENDAN JOHN O'CONNOR of Taylor O'Connor & Co., 562 St. Kilda Road, Melbourne be appointed Liquidator.

Notice is also given that after twenty-one days from this date I shall proceed to distribute the assets. All creditors having any claims against the Company should furnish particulars of same by that date, otherwise I shall proceed to distribute the assets without regard to their claims.

Dated this 23rd day of December, 1974.

B. J. O'CONNOR, Liquidator.

Taylor, O'Connor & Co., accountants, 562 St. Kilda Road, Melbourne, 3004. Telephone: 51 1388. 2655

In the matter of the *Companies Act 1961.*—In the matter of JOHN GREEN INVESTMENTS PROPRIETARY LIMITED (in Liquidation).

Notice is hereby given that at the Extraordinary General Meeting of John Green Investments Proprietary Limited duly convened and held at 18 Hargrave Street, East Sydney in the State of New South Wales on the 31st day of December 1974 the following Resolution was passed as a Special Resolution:—

"That the Company be wound up voluntarily and that Allan William Carlile of Messrs. Condon, Hamilton & Co., 234 Albert Road, South Melbourne be appointed Liquidator for the purpose of such winding up."

Dated this 6th day of January, 1975.

2766 A. W. CARLILE, Liquidator.

In the matter of the *Companies Act 1961;* and in the matter of 28 WOODLANDS AVENUE EAST KEW PROPRIETARY LIMITED.

Notice is hereby given that at a meeting of the members of 28 Woodlands Avenue East Kew Proprietary Limited held on the 20th day of December 1974 the following resolution was passed as a Special Resolution:—

That the Company be wound up voluntarily.

2778 HANS SCHILLER, Liquidator.

Companies Act 1961, Section 254 (2).

BOX HILL CHAMBERS PTY. LTD. (IN LIQUIDATION).

NOTICE OF RESOLUTION.

At an Extraordinary General Meeting of the Members of BOX HILL CHAMBERS PTY. LTD. duly convened and held at 155 Wellington Parade South, Jolimont, Victoria at 10.30 a.m. on 27th December, 1974 the Special Resolution set out below was duly passed:

"That the Company be wound up voluntarily as a members' voluntary winding up in accordance with the provisions of the *Companies Act 1961.* That Allan Nahum be and is hereby appointed Liquidator."

Notice is also given that after 21 days from this date we shall proceed to distribute the assets. All creditors having any claims against the Company should furnish particulars of same by that date, otherwise we shall proceed to distribute the assets without regard to their claim.

Dated this 30th day of December, 1974.

ALLAN NAHUM, Liquidator.

155 Wellington Parade South, Jolimont, Vic. 3002. 2779

Companies Act 1961, Section 254 (2).

BENDLEBY INVESTMENTS CO. PTY. LTD.

(IN LIQUIDATION).

NOTICE OF RESOLUTION.

At an Extraordinary General Meeting of the Members of BENDLEBY INVESTMENTS CO. PTY. LTD. duly convened and held at 155 Wellington Parade South, Jolimont, Victoria at 10.30 a.m. on 27th December 1974, the Special Resolution set out below was duly passed:

"That the Company be wound up voluntarily as a members' voluntary winding up in accordance with the provisions of the *Companies Act 1961.* That Allan Nahum be and is hereby appointed Liquidator."

Notice is also given that after 21 days from this date we shall proceed to distribute the assets. All creditors having any claims against the Company should furnish

particulars of same by that date, otherwise we shall proceed to distribute the assets without regard to their claim.

Dated this 30th day of December, 1974.

ALLAN NAHUM, Liquidator.

155 Wellington Parade South, Jolimont, Vic. 3002 2780

Companies Act 1961, Section 254 (2).

NUMBER 264 LITTLE COLLINS STREET PTY. LTD.

(IN LIQUIDATION).

NOTICE OF RESOLUTION.

At an Extraordinary General Meeting of the Members of Number 264 Little Collins Street Pty. Ltd. duly convened and held at 155 Wellington Parade South, Jolimont, Victoria at 10.30 a.m. on 27th December, 1974 the Special Resolution set out below was duly passed.

"That the Company be wound up voluntarily as a members' voluntary winding up in accordance with the provisions of the *Companies Act 1961.* That Allan Nahum be and is hereby appointed Liquidator."

Notice is also given that after 21 days from this date we shall proceed to distribute the assets. All creditors having any claims against the Company should furnish particulars of same by that date, otherwise we shall proceed to distribute the assets without regard to their claim.

Dated this 30th day of December, 1974.

ALLAN NAHUM, Liquidator.

155 Wellington Parade South, Jolimont, Vic. 3002. 2781

Companies Act 1961.

USELESS PTY. LIMITED.

At an Extraordinary General Meeting of USELESS PTY. LIMITED duly convened and held at 111 Lonsdale Street, Melbourne on the 31st day of December, 1974, at 10.00 a.m., the following resolution was duly passed as a Special Resolution:

"That the company be wound up voluntarily and that Mr. C. G. Roberts of 64 Airlie Street, South Yarra be and is hereby appointed Liquidator."

Dated this 31st day of December, 1974.

C. G. ROBERTS, Liquidator.

Messrs. Mann, Judd & Co., chartered accountants, 111 Lonsdale Street, Melbourne, Vic. 3000. 2782

Companies Act 1961.

MEDINDIE INVESTMENTS PTY. LIMITED.

At an Extraordinary General Meeting of MEDINDIE INVESTMENTS PTY. LIMITED duly convened and held at 12 Sherbourne Road, Medindie, South Australia on 30th December, 1974, at 10.30 a.m. the following resolution was duly passed as a Special Resolution:

"That the company be wound up voluntarily and that Mr. C. G. Roberts of 111 Lonsdale Street, Melbourne, be and is hereby appointed Liquidator."

Dated 7th January, 1975.

C. G. ROBERTS, Liquidator.

Messrs. Mann, Judd & Co., 111 Lonsdale Street, Melbourne, Vic. 3000. 2783

RAY GEOPHYSICS (AUSTRALIA) PTY. LTD.

At a General Meeting of the members of the abovenamed Company held at 140 William Street, Melbourne on the 30th day of December, 1974, the Special Resolution set out below was duly passed:

Resolved that the Company be wound up voluntarily and that Eric Maxwell Huggard and Brian Argent Waters of the firm of Touche Ross & Co. Chartered Accountants be appointed joint and several liquidators at a fee to be determined in accordance with the normal professional scale rates for the time occupied by the said Liquidators and/or their staff in carrying out their duties as Liquidators.

Dated this 7th day of January, 1975.

2794 B. BRETT, Secretary.

LYDHOLME PTY. LTD.

NOTICE CONVENING FINAL MEETING.

Notice is hereby given pursuant to Section 272 of the *Companies Act 1961* that a general meeting of members of the Company will be held at 450 Little Collins Street, Melbourne on Monday 10th February 1975 at 10 o'clock in the forenoon to receive the final account of the liquidator.

2789 NORMAN FRANK HENNING, Liquidator.

WINALEN INVESTMENTS PTY. LTD.
NOTICE CONVENING FINAL MEETING.

Notice is hereby given pursuant to Section 272 of the Companies Act 1961 that a general meeting of members of the Company will be held at 450 Little Collins Street, Melbourne on Monday 10th February 1975 at 10.30 o'clock in the forenoon to receive the final account of the liquidator.

2790 NORMAN FRANK HENNING, Liquidator.

LORON INVESTMENTS PTY. LTD.
NOTICE CONVENING FINAL MEETING.

Notice is hereby given pursuant to Section 272 of the Companies Act 1961 that a general meeting of members of the Company will be held at 450 Little Collins Street, Melbourne on Monday 10th February 1975 at 11 o'clock in the forenoon to receive the final account of the liquidator.

2791 NORMAN FRANK HENNING, Liquidator.

Companies Act 1961, Section 254 (2) (b).
FERNCROFT PTY. LTD.

TAKE NOTICE that at an Extraordinary General Meeting of the members of the abovenamed company held on the Twentieth day of November 1974 a Special Resolution was carried that the company be wound up voluntarily as a creditors' voluntary winding up. The liquidator appointed for the purposes of the winding up was Earnest Harding Niemann of the firm of Messrs. Hungerfords, 44 Market Street, Melbourne.

Dated the 6th day of January, 1975. 2792

Form 92.

Companies Act 1961 (as amended) Victoria, Section 272.
REGULATIONS 28 (2) (b) AND 46 (2).

NOTICE OF MEETING OF CREDITORS OR CONTRIBUTORIES—DALMUIR PROPRIETARY LIMITED.

Notice is hereby given that a meeting of the Contributors of Dalmuir Proprietary Limited will be held in the office of C. G. Landy & Company, 7th Floor, 37-41 Queen Street, Melbourne on Monday the 10th day of February, 1975 at 9.30 o'clock in the forenoon.

Agenda.

To lay before the meeting the Liquidators Account showing how the winding up of the Company has been conducted and the property of the Company has been disposed of.

Dated this 6th day of January, 1975.

2793 DONALD ALBERT CONABERE, Liquidator.

Creditors next of kin and others having claims in respect of the Will of ROBERT KOHN late of 93 Errol Street North Melbourne Mirror Manufacturer who died on the 29th day of November 1973 are requested to send particulars of their claims to the Executors EDWARD CURMI and JOHN MCINERNEY both care of the undermentioned Solicitor by the 19th day of March 1975 after which date they will distribute the assets having regard only as to the claims of which they then have notice.

EDWARD CURMI, of 440 Victoria Street, North Melbourne. 2635

MARGARET JANE URAND, late of 282 Warrigal Road, Burwood, in the State of Victoria, married woman, DECEASED.

CREDITORS next-of-kin and others having claims in respect of the estate of the deceased (who died on 10th May 1974) are required by The Equity Trustees Executors & Agency Company Limited of 472 Bourke Street Melbourne to send particulars to them by 8th March 1975 after which date the Trustees may convey or distribute the assets having regard only to the claims of which they then have notice. 2636

Creditors next of kin and others having claims in respect of the Will of DUGALD JOHN CAMPBELL late of 7 Mair Street Brighton Beach Retired who died on the 9th day of November 1974 are requested to send particulars of their claims to the Executrix WILIAMENA WEST care of the undermentioned Solicitor by the 19th day of March 1975 after which date she will distribute the assets having regard only as to the claims of which she then has notice.

JOHN STEWART, of 290 Racecourse Road, Newmarket. 2637

CREDITORS next of kin and others having claims against the estate of KEITH SCANLON late of Wurruk in the State of Victoria Retired deceased who died on the 19th day of August, 1974 are required by the Executors KEVIN THOMAS HOWARD Retired and JOSEPHINE HOWARD Married Woman both of Princes Street, Wurruk in the said State to send particulars of their claims to the said Executors care of J. CROFTON LEE & MOIR of 233 Raymond Street, Sale Solicitors by the 10th day of March, 1975 after which date they will distribute the assets of the said Estate having regard only to the claims of which they then have notice.

J. CROFTON LEE & MOIR, solicitors, 233 Raymond Street, Sale. 2638

CREDITORS next-of-kin and others having claims in respect of the Estate of AUDREY GWENNIS BERYL SMITH late of 21 Alexandra Street, East St. Kilda, Spinster deceased who died on the 29th day of October, 1974 ARE REQUESTED to send particulars of their claims to ROBIN EDWARD CLEMENTS the Executor of the Will of the said deceased in care of the undermentioned Solicitors by the 10th day of March, 1975 after which date the Executor will distribute the assets having regard only to the claims of which he has notice.

CLEMENTS, MOTT & BETT, solicitors, 253-255 Glenhuntly Road, Elsternwick. 2639

CREDITORS next-of-kin and others having claims in respect of the Estate of MARY ELIZABETH HENDEN late of No. 7 Trawalla Court, Croydon, Widow, deceased who died on the 30th July, 1974 ARE REQUESTED to send particulars of their claims to KENNETH JOHN CLEMENTS, the Executor of the Will of the said deceased in care of the undermentioned Solicitors by the 15th day of March, 1975 after which date the Executor will distribute the assets having regard only to the claims of which he has notice.

CLEMENTS, MOTT & BETT, solicitors, 253-255 Glenhuntly Road, Elsternwick. 2640

CREDITORS next-of-kin and others having claims in respect of the Estate of GEORGE ARTHUR BAXTER late of 69 Garnet Street, Brunswick, in the State of Victoria, Retired Carrier deceased, who died on the 10th September 1974, are to send particulars of their claims to the Executor NATIONAL TRUSTEES, EXECUTORS & AGENCY COMPANY OF AUSTRALASIA LIMITED of 95 Queen Street Melbourne by the 20th February 1975, after which date it will distribute the Assets having regard only to the claims of which it then has notice.

LE GRAND, RANDES, GAFFNEY & CO., 644 Sydney Road, Brunswick, solicitors for the applicant. 2641

CREDITORS NEXT OF KIN AND OTHERS having regard in respect of the Estate of JOHN MURRAY HARRISON late of "Langi" Metung Retired Deceased who died on 9th September 1974 and Probate of whose Will and Codicil was granted to ERNEST RICHARD HARRISSON of 46 Kitchener Street Auckland New Zealand Management Consultant and HAROLD MONTOLIEU HARRISSON of 21 Hawdon Street Wilston Queensland Retired Commercial Manager are to send particulars of their claims to the said Executors care of the below mentioned Solicitors by the 28th February 1975 after which date they will distribute the assets of the deceased having regard only to the claims of which they then have notice.

BRUCE LITTLETON & HACKFORD, solicitors, Traralgon. 2642

CREDITORS, Next-of-kin and others having claims in respect of the Estate of KAROLINE LOUISE ESTHER LEDITSCHKE, formerly of Vectis East but late of Glen Isla in the State of Victoria Farmer and Grazier deceased (who died on the 1st day of September 1973) are required to send their particulars of their claims to THE UNION FIDELITY TRUSTEE COMPANY OF AUSTRALIA LIMITED of 100 Exhibition Street, Melbourne in the said State by the 10th day of March 1975 after which date it will distribute the assets having regard only to the claims of which it then has notice.

STEWART F. BROWN & PROUDFOOT, solicitors, 74 Wilson Street, Horsham, solicitors for the applicant. 2679

CREDITORS next of kin and others having CLAIMS in respect of the ESTATE of HUGH GEORGE GRAY late of 153 Main Road Ferntree Gully Retired Packer deceased who died on the Third day of June 1973 intestate and Letters of Administration of whose estate have been granted to JESSIE AGNES SUTHERLAND of 1131 Burwood Highway Ferntree Gully Widow are required to

SEND PARTICULARS of their claims to the said Administratrix care of the undermentioned Solicitors by the Twenty-seventh day of February 1975 after which date she will distribute the assets having regard only to the claims of which she then has notice.

PEARCE & WEBSTER, solicitors, 430 Little Collins Street, Melbourne. 2680

CREDITORS next of kin and others having claims in respect of the Estate of Alan William Ferguson formerly of 65 Denmark Street Kew late of Inala Village 220 Middleborough Road, Blackburn South Retired bricklayer deceased who died on the Seventeenth day of July 1974 are to send particulars of their claims to The Trustees Executors and Agency Company Limited of 401 Collins Street Melbourne by the Tenth day of March 1975 after which date it will distribute the estate having regard only to the claims of which it then has notice.

DAVID THOMAS & FRENKEL, of 303 La Trobe Street, Melbourne, solicitors for the said company. 2681

CREDITORS next of kin and others having claims in respect of the Estate of Eulalie Merna Moore sometimes known as Merna Stewart late of 82 Palmerston Crescent South Melbourne Music Teacher deceased who died on the Twenty eighth day of July 1974 are to send particulars of their claims to The Trustees Executors and Agency Company Limited of 401 Collins Street Melbourne by the Tenth day of March 1975 after which date it will distribute the assets having regard only to the claims of which it then has notice.

DAVID THOMAS & FRENKEL, of 303 La Trobe Street, Melbourne, solicitors for the said company. 2682

CREDITORS next-of-kin and others having claims in respect of the Estate of Savo Maric late of 10 Cantala Avenue Rosanna Labourer who died on the 28th day of August 1974 are to send particulars of their claims to Stanisa Grijic care of R. P. BARRETT & SON Solicitors 472 Bourke Street Melbourne on or before the 12th March, 1975 after which date he will distribute the assets having regard only to the claims of which he then has notice.

R. P. BARRETT & SON, solicitors, 472 Bourke Street, Melbourne. 2683

Creditors, Next of Kin and Others having claims against the Estate of JOSHUA LYONS sometimes of 46 Stewartfield Crescent Broxton West Lothian Scotland but latterly of 18 Bunarong Drive Frankston Retired Gentleman Deceased who died on the 6th October 1973 are to send particulars of their claims to Robert William John Glendinning Shaw Solicitor and William Lyons the Executors of the Will of the said deceased care of the undermentioned Solicitors by the 9th March 1975 after which date the Executors will distribute the Estate having regard to the claims of which they then have notice.

R. WADHAM & DOIG, solicitors, 383 Flinders Lane, Melbourne. 2726

INA MARJORIE OGILBY, late of 47 Riversdale Road, Hawthorn, in the State of Victoria, widow, DECEASED.

CREDITORS next-of-kin and other having claims in respect of the estate of the above-named deceased who died on the 22nd day of May 1974 are required by the executor THE TRUSTEES EXECUTORS AND AGENCY COMPANY LIMITED of 401 Collins Street Melbourne in the said State to send particulars to the executor by the 10th day of March 1975 after which date the executor may convey or distribute the assets having regard only to the claims of which it then has notice.

DAVIES, CAMPBELL & PIESSE, solicitors, 401 Collins Street, Melbourne. 2727

GEORGE PERCIVAL KEECH, late of 52 Cascade Street, North Balwyn, in the State of Victoria, gentleman, DECEASED.

Creditors next-of-kin and others having claims in respect of the estate of the abovenamed deceased who died on the Fifteenth day of October One thousand nine hundred and Seventy-four are required by RONALD GEORGE KEECH of 19 Torney Street North Balwyn Medical Practitioner and VERA DORRAT ANGUS of 6 Maylands Avenue North Balwyn Married Woman the Executors of the Will of the said deceased to send particulars of their claims to the said Executors care of the undernamed Solicitors by the Fourteenth day of March One thousand nine hundred and Seventy-five after which date they will convey or distribute the assets having regard only to the claims of which they then have notice.

RUSSELL, KENNEDY & COOK, solicitors, 257 Collins Street, Melbourne. 2728

CREDITORS, next-of-kin and others having claims in respect of the estate of JAMES FREDERICK DIBBIN late of 20 Doncaster Road, North Balwyn, Company Director deceased who died on the First day of May 1974 are requested to send particulars of their claims to the executors GEORGE THOMAS RAMSAY WILBY, BRIAN JAMES DIBBIN and MARY MARGUERITE DIBBIN care of the undermentioned Solicitors by the Eleventh day of March 1975, after which date they will distribute the assets having regard only to the claims of which they then have notice.

MAHONY O'BRIEN & DUGGAN, solicitors, 85 Queen Street, Melbourne. 2732

CREDITORS Next-of-kin and others having claims in respect of the Estate of MARY SYLVIE DOWNIE late of 126 Balwyn Road, Balwyn Widow deceased who died between the 4th and 6th of October 1974 are requested to send particulars of their claims to the Executor GRAEME JOSEPH DOWNIE care of the undermentioned Solicitors on or before 10th March 1975 after which date he will distribute the assets having regard only to the claims of which he then has notice.

McKEAN & PARK, solicitors, 84 William Street, Melbourne. 2733

POLLY MARY BIER, late of Flat 2, 51 Spenser Street, St. Kilda, in the State of Victoria, home duties, DECEASED.

Creditors, Next-of-Kin and Others having claims in respect of the Estate of the abovenamed Deceased who died on the 24th day of April, 1974 are required by the Executrix of the Deceased's Will HANNAH SARAH THOMAS of 6 White Street, Windsor to send particulars to her by the 9th day of March 1975 AFTER which date the Executrix may convey or distribute the assets of the Estate having regard only to the claims of which she may have notice.

KEITH & IAN NESS, solicitors, 380 Collins Street, Melbourne. 2734

BLANCHE CLOAK, late of 13 Macarthur Street, Sale, married woman, DECEASED.

Creditors next-of-kin and others having claims in respect of the estate of the deceased who died on the 1st day of February, 1973 are required by the Executrix MARGARET ELIZA ANDREWS of 224 Raymond Street, Sale to send particulars to her solicitors Messrs. Warren, Graham & Murphy of 164-166 Raymond Street, Sale by the 6th day of March, 1975 after which date the Executrix may convey or distribute the assets having regard only to the claims of which she then has notice.

WARREN GRAHAM & MURPHY, solicitors, 164-166 Raymond Street, Sale. 2710

RICHARD VICCARS, formerly of Lal Lal, but late of 102 Ascot Street South, Ballarat, in the State of Victoria, T.P.I. pensioner, DECEASED, who died on the 5th October, 1974.

CREDITORS next of kin and all other persons having claims against the Estate of the said deceased are required by the Executor THE UNION-FIDELITY TRUSTEE COMPANY OF AUSTRALIA LIMITED of 100 Exhibition Street Melbourne to send detailed particulars of their claims in respect of the said property to the said Executor care of the said Company at 101 Lydiard Street North Ballarat on or before the 8th day of March, 1975 after which date it will proceed to distribute the said estate having regard only to the claims of which it then has notice.

Dated this 23rd day of December, 1974.

RAMSAY, GAUNT & FRASER, of 41 Lydiard Street South, Ballarat, solicitors for the executor. 2711

Creditors next-of-kin and others having claims in respect of the Estate of ARCHIBALD CURRIE MCGARRY late of Nyarrin Farmer and Grazier deceased who died on 27th July, 1974 are required to send particulars to the Executor THE UNION-FIDELITY TRUSTEE COMPANY OF AUSTRALIA LIMITED at its address 101 Lydiard Street North Ballarat by 15th March, 1975 after which date the said Company will distribute the assets having regard only to the claims of which it then has notice.

BAIRD, MCGREGOR & FOWLER, solicitors, Ballarat. 2712

ANDREW JOHN REGINALD BERRIE, late of 14 The Mews, Vermont, retired, DECEASED.

Creditors, next of kin and others having claims in respect of the estate of the deceased (who died on the 28th day of September, 1974), are required by the Executor NATIONAL TRUSTEES EXECUTORS AND AGENCY

COMPANY OF AUSTRALASIA LIMITED of 95 Queen Street, Melbourne to send particulars to them, on or before the 2nd day of March, 1975 after which date they will distribute the assets having regard only to the claims of which they then have notice.

R. P. BAYLOR & CO., solicitors, 1 Walkers Road, Nunawading, 3131. 2631

LOFTUS FRANCIS ST. CLAIR LLOYD (usually known as LOFTUS FRANCIS LLOYD), late of 18 Nelson Street, Ringwood, physiotherapist, DECEASED.

Creditors, next of kin and others having claims in respect of the estate of the deceased (who died on the 23rd day of September 1974) are required by THE PERPETUAL EXECUTORS AND TRUSTEES ASSOCIATION OF AUSTRALIA LIMITED of 50 Queen Street Melbourne to send particulars of their claims to the said Company by the 10th day of March 1975 after which date it will convey or distribute the assets, having regard only to the claims of which the Company then has notice.

D. R. JAMES, LL.M., solicitor, 145 Whitehorse Road, Ringwood. 2632

MYRTLE CHARLOTTE REICHMAN, late of Mortlake, widow, DECEASED.

Creditors next of kin and others having claims in respect of the estate of the abovenamed deceased (who died on the 2nd April 1973) are required by the surviving Executors Cyril Henry Edwards and Noel Edwards Reichman to send particulars to them, care of the undermentioned Solicitors by the 21st day of March 1975 after which date they may convey or distribute the assets, having regard only to the claims of which they shall then have had notice.

ARTHUR E. GEORGE & SONS, solicitors, 202 Manifold Street, Camperdown. 2633

WILLIAM THOMAS GREEN, late of 23 Magazine Street, Eaglehawk, retired engineer, DECEASED, intestate.

CREDITORS next of kin and others having claims against the estate of the abovenamed deceased are required by the Administrator thereof NATIONAL TRUSTEES EXECUTORS AND AGENCY COMPANY OF AUSTRALASIA LIMITED of 95 Queen Street, Melbourne and at 46 Queen Street, Bendigo to forward particulars thereof care of the said Company on or before the 1st day of March, 1975 after which date it will distribute the assets of the said estate having regard only to the claims of which it then has notice.

HYETT & HYETT, of 51 Bull Street, Bendigo, solicitors for the administrator. 2634

CREDITORS next-of-kin and others having claims in respect of the Estate of ANNIE EDITH FANNING formerly of 11 Flowerdale Road Glen Iris but late of 24 Burnley Street Frankston Widow deceased who died on the 22nd October 1974 are to send particulars of their claims to GEORGE JOSEPH FANNING and RICHARD CLAYTON MUIR in care of their Solicitors Middletons of 457 Little Collins Street Melbourne by the 12th March 1975 after which date they will distribute the assets having regard only to the claims of which they then have notice.

MIDDLETONS Solicitors 457 Little Collins Street, Melbourne. 2684

Creditors next of kin and others having claims in respect of the estate of Esther Wilson Campbell late of Hurlingham Private Hospital 68 Union Street Brighton in the State of Victoria Nursing Sister deceased who died on the 22nd October 1974 are to send the particulars of their claims to THE UNION-FIDELITY TRUSTEE COMPANY OF AUSTRALIA LIMITED of 100 Exhibition Street Melbourne in the said State by the 16th day of March 1975 after which date it will distribute the assets having regard only to the claims of which it then has notice.

MORRISON TEARE & PURNELL, Solicitors, 164 Flinders Street, Melbourne. 2685

ANNIE ROBERTSON late of Kingston Centre Warrigal Road Cheltenham Widow, DECEASED.

Creditors next of kin and others having claims in respect of the estate of the deceased who died on the 9th day of November 1974 are required by the executor GUY BEAUCHAMP SEWELL of 454 Collins Street Melbourne Solicitor to send particulars to him by the 17th day of March 1975 after which date the executor may convey or distribute the assets having regard only to the claims of which he then has notice.

Dated this 23rd day of December, 1974.

SEWELL & SEWELL, 454 Collins Street, Melbourne, Solicitors. 2686

CREDITORS next of kin and others having claims against the Estate of MATTHEW ALBERT JAMES NAYLOR late of 48 Albert Road Drouin Timber Worker who died on the 2nd February 1972 are requested to send particulars of their claims to Margaret Naylor of 48 Albert Road Drouin Widow the administratrix of the estate of the said deceased in care of the undersigned by the 15th March 1975 after which date she will distribute the assets having regard only to the claims of which she then shall have had notice.

M. DAVINE & CO. Solicitors, Warragul. 2699

CREDITORS NEXT OF KIN AND OTHERS having claims in respect of the Estate of FRANCIS CHARLES PERKINS late of Traralgon Retired Deceased who died on the 21st. September 1974 are to send particulars of their claims to THE UNION-FIDELITY TRUSTEE COMPANY OF AUSTRALIA LIMITED of 100 Exhibition Street Melbourne by the 15th. March 1975 after which date it will distribute the assets of the deceased having regard only to the claims of which it then has notice.

BRUCE LITTLETON & HACKFORD Solicitors, Traralgon. 2700

CREDITORS next of kin and all other persons having claims against the estate of WILLIAM JAMES LINEHAM Late of 2 Amberley Crescent Frankston Retired Farmer deceased are required by the Executors THE TRUSTEES EXECUTORS AND AGENCY COMPANY LIMITED of 401 Collins Street Melbourne and ELLEN MAY LINEHAM of 2 Amberley Crescent Frankston-Widow to send particulars of their claims to the said The Trustees Executors and Agency Company Limited by the 9th day of March 1975 after which date they will proceed to distribute the estate having regard only to the claims of which they then have notice.

JOHN D. MUSTOW & CO., solicitors, 131 Queen Street, Melbourne. 2729

CREDITORS next of kin and others having claim in respect of the Estate of RONALD STEWART ANSELL late of Flat 10, 39 Heller Street, West Brunswick in the State of Victoria Retired Sales Officer Deceased who died on the 19th day of August, 1974 are to send particulars of their claims to ROYSTON CAHIR, MARTIN & DILLON Solicitors of 17 Queen Street, Melbourne by the 10th March, 1975 after which date the Executor will distribute the assets of the Estate having regard only to claims to which he then has notice.

ROYSTON CAHIR, MARTIN & DILLON, solicitors of 17 Queen Street, Melbourne. 2730

Creditors next of kin and others having CLAIMS in respect of the estate of CONSTANCE HENRIETTA COX late of 15 St. George's Court Toorak in the State of Victoria Widow deceased who died on the 8th day of October 1974 are to send particulars of their claims to the executor of her Will namely THE EQUITY TRUSTEES EXECUTORS AND AGENCY COMPANY LIMITED of 472 Bourke Street Melbourne in the said State by the 1st day of April 1975 after which date the said executor will distribute the assets in the said estate having regard only to the claims at which it then has notice.

ARTHUR ROBINSON & CO., solicitors, 447 Collins Street, Melbourne. 2731

CREDITORS next of kin and others having claims in respect of the estate of LORNA MAY ANDREWS late of 4 Surrey Court Ivanhoe spinster deceased who died on the 25th day of June 1974 are required to send particulars of their claims to THE TRUSTEES EXECUTORS AND AGENCY COMPANY LIMITED of 401 Collins Street Melbourne by the 3rd day of April, 1975, after which date it will distribute the assets having regard only to the claims of which it then has notice.

LEACH & THOMSON, solicitors, 472 Bourke Street, Melbourne. 2769

CREDITORS next of kin and others having claims in respect of the Estate of KEITH VALENTINE GRAY late of 9 Lydford Road, Ferntree Gully in the State of Victoria formerly Foreman late Assistant Manager deceased who died on the 19th day of April, 1974 are to send particulars of their claims to THE TRUSTEES EXECUTORS AND AGENCY COMPANY LIMITED of 401 Collins Street, Melbourne by the 17th day of March, 1975 after which date it will distribute the assets having regard only to the claims of which it then has notice.

WILLIAM HARRISON & SON, solicitors of 11 Bank Place, Melbourne. 2768

CREDITORS next of kin and others having claims in respect of the estate of DENIS MURPHY late of Flat 2 No. 59 Riversdale Road Hawthorn in the State of Victoria gentleman deceased who died on the 25th day of November 1970 are required by the executor ERIC ALLAN MANSFIELD of 4 Market Street Essendon trustee officer to send particulars of their claims to him care of the undermentioned solicitors by the 3rd April 1975 after which date he will distribute the assets having regard only to the claims of which he then has notice.

LEACH & THOMSON, solicitors, 472 Bourke Street, Melbourne. 2770

ANNE DOUGLAS FERRIER, late of 67 Pilleau Street, Coleraine, in the State of Victoria, spinster, DECEASED.

CREDITORS next of kin and others having claims in respect of the Estate of the Deceased (who died on the 10th day of December, 1973) are required by the Executors of the Estate RONALD LOWENSTERN and ROBERT MAXWELL HUNTER both of Hamilton in the State of Victoria, Solicitors to send particulars to them care of the undermentioned Solicitors by the 24th day of February, 1975 after which date the Executors may convey or distribute the assets having regard to claims only of which they then have notice.

CAMERON & LOWENSTERN, solicitors, 62 Thompson Street, Hamilton. 2771

CREDITORS next of kin and other persons having claims against the estate of MURIEL IRENE COOK late of Chiltern in the State of Victoria Spinster deceased who died on the second day of September 1974 ARE REQUIRED to send particulars of their claims to the Executor THOMAS KEITH BURGIN of 23 Wavell Street Bentleigh Law Clerk by the 10th day of March 1975 after which date the Executor will distribute the assets having regard only for the claims of which he then has had notice.

JAMES P. OGGE & CO., solicitors, 165 Greville Street, Prahran. 2772

MYRA PEARL CROSS, late of 11 Laurel Grove, Blackburn, in the State of Victoria, spinster, DECEASED.

Creditors next-of-kin and others having claims in respect of the estate of the above-named deceased are to send particulars of their claims to THE EQUITY TRUSTEES EXECUTORS AND AGENCY COMPANY LIMITED and JOSEPH RICHARD LOVE the executors of the Will of the said deceased C/o the said The Equity Trustees Executors and Agency Company Limited 472 Bourke Street Melbourne by the 9th day of March 1975 after which date they will distribute the assets of the estate of the said deceased having regard only to the claims of which they then have notice.

HALL & WILCOX, solicitors, 20 Queen Street, Melbourne. 2787

Creditors next of kin and others having claims in respect of the estate of SALVATORE ARTURO PEPE (also known as SAM ARTHUR PEPE) late of 129 Greaves Street, Werribee in the State of Victoria Mechanic who died on the 14th day of May, 1974 are required by the Administratrix of his estate, namely GIUSEPPA PEPE of 129 Greaves Street, Werribee to send particulars of such claims to the said Administratrix care of the office of Lloyd P. Goode & Co., at 406 Lonsdale Street, Melbourne by the 27th day of March, 1975 after which date the said Administratrix will distribute the assets having regard only to the claims of which she then has notice.

LLOYD P. GOODE & CO., solicitors, 406 Lonsdale Street, Melbourne, 3000. 2788

Trustee Act 1958.

NOTICE TO CLAIMANTS.

Pursuant to the Trustee Act 1958, creditors next of kin and all other persons having claims in respect of the estate of any deceased person named below are required to send particulars to the legal personal representative or representatives at the addresses stated, after which date the representatives will distribute the assets, having regard only to the claims of which notice has been received:—

HARRY JAMES COX late of 176 Mason Street Newport Retired Engineer deceased, died on the 26th day of August 1974. Claims to the Executrix, Anne Bernadine Cox of 176 Mason Street Newport Widow by the 10th day of February, 1975.—John F. Carroll, LL.B., solicitor, 4 Paisley Street, Footscray. 2767

In the Supreme Court of the State of Victoria.

SALE BY THE SHERIFF.

ON FRIDAY the 14TH of FEBRUARY 1975 at 10.00 a.m. AT THE POLICE STATION FAWKNER (unless process be stayed or satisfied).

ALL the Estate and Interest (if any) of FRANK EVAN PARKER, engineer, of 1040-1042 Sydney Road, North Coburg as proprietor of an estate in fee simple in the land described in Certificate of Title Volume 4813 Folio 487 upon which is erected a weatherboard dwelling with garage known as No. 1040-1042 Sydney Road, North Coburg.

Registered Mortgage No. F.5376 and Caveat F.400389 affect the said estate and interest.

TERMS—CASH ONLY.

DOUGLAS S. HALL, Sheriff's Officer.

8th January, 1975.

2774

INSOLVENCY NOTICES

Bankruptcy Act 1966-73.

NOTICE TO CREDITORS.

Creditors of Robert Henry Atkins and Leonie Judith Atkins both of 5 Hawthory Road, Kilsyth, are advised that Mr & Mrs Atkins have executed a Deed of Arrangement under the Provisions of Part 10 of the Bankruptcy Act 1966-73 on the 20th day of December, 1974.

The Trustee is Mr Edward Peter Taylor of 67A Church Street, Brighton, 3186, and creditors are requested to lodge their Proof of Debts with the Trustee at their earliest.

2757

E. P. TAYLOR, Trustee.

BANKRUPTCY ACT 1966-73.

NOTICE TO CREDITORS.

Creditors of Graeme Leonard Clark and Ann Dorothy Clark both of 11 McNabb Street, Berwick, are advised that Mr. & Mrs. Clark have executed a Deed of Arrangement under the Provisions of Part 10 of the Bankruptcy Act 1966-73 on the 16th day of December, 1974.

The Trustee is Mr. Edward Peter Taylor of 67A Church Street, Brighton, 3186, and creditors are requested to lodge their Proof of Debts with the Trustee at their earliest.

2652

E. P. TAYLOR, Trustee.

IMPOUNDINGS

CRESWICK.—Impounded in Creswick Pound, by Ranger, on 31st December, 1974.

2 heifers (strawberry)

If not claimed and expenses paid, to be sold on Thursday, 23rd January, 1975, at 12 noon.

2756—\$3.85

J. McNICOL,

Poundkeeper.

KEILOR.—Impounded in Keilor Pound, by Council Ranger.

1 bay gelding, black points, star on forehead, white above near side front hoof, no visible brand
1 black and white bull, approximately 12 months old, no visible brand

If not claimed and expenses paid, to be sold on 23rd January, 1975.

2776—\$4.95

C. M. MISSEN,

Poundkeeper.

MALDON.—Impounded in Maldon Pound.

2 Hereford steers, no visible brands.

If not claimed and expenses paid, to be sold at noon on Thursday, 9th January, 1975.

2690—\$3.30

F. SHEPHERD,

Poundkeeper.

MT. MORIAC.—Impounded in Mt. Moriac Pound, from Henty Main Road, Moriac.

5 shorn sheep, no visible earmark or brands.

If not claimed and expenses paid, to be sold on Monday, 20th January, 1975 at the Geelong Saleyards.

2622—\$3.85

W. D. HUTTON,

Poundkeeper.

RINGWOOD.—Impounded in City of Ringwood Pound from Croydon area on 23rd December, 1974.

1 brown and white brindled bull
1 brown and white, brindled yearling, Hereford heifer, no visible brands
1 tan and white, Jersey heifer, small triangle with three holes in left ear

If not claimed and expenses paid, to be sold at 12 noon on Thursday 23rd January, 1975.

2709—\$6.05

B. W. RUTHERFORD,
Acting Poundkeeper.

TATURA.—Impounded in Tatura Pound, from Ardmona.
1 red Shorthorn bull, V in tip and V in bottom of right ear
1 red Shorthorn bull, no visible brand

If not claimed and expenses paid, to be sold on Thursday, 23rd January, 1975.

2775—\$4.40

J. H. MACTIER,
Poundkeeper.

TERANG.—Impounded in Terang Pound, from Framlingham-Terang Road.

1 black and white baldy cow with small red baldy calf.

If not claimed and expenses paid, to be sold on 3rd February, 1975.

2623—\$3.85

DORIS M. KIDD,
Poundkeeper.

Subordinate Legislation Act 1962.

NOTICE OF MAKING OF STATUTORY RULES.

In pursuance of the provisions of the *Subordinate Legislation Act 1962* and the Regulations made thereunder, notice is given of the making of the following statutory rules:—

No.	Act	Price.
1/1975.	Architects Act 1958. Architects Registration Board (Amendment No. 2) Regulations 1974	10c
2/1975.	River Improvement Act 1958. River Improvement Trusts' Regulations for the Election of Commissioners (Amendment) 1974	10c
3/1975.	Grain Elevators Act 1958. Grain Elevators Board By-Law (relating to the Conditions of Employment of Staff) No. 47R	10c
4/1975.	Films Act 1971. Films (Exemption of Exhibitors Amendment No. 1) Regulations 1974	10c
5/1975.	Agricultural Education Cadetships Act 1969. Agricultural Education Cadetships (Living Allowances) Regulations 1974	10c
6/1975.	Apprenticeship Act 1958. Apprenticeship (Carpentry and Joinery Trades) (Amendment) Regulations 1974	10c
7/1975.	Apprenticeship Act 1958. Apprenticeship (Dry Cleaning Trade) (Amendment) Regulations 1974	10c
8/1975.	Apprenticeship Act 1958. Apprenticeship (Garment Cutting Trade) (Amendment) Regulations 1974	10c
9/1975.	Apprenticeship Act 1958. Apprenticeship (Optical Trade) (Amendment) Regulations 1974	10c
10/1975.	Apprenticeship Act 1958. Apprenticeship (Plumbing Trades) (Amendment) Regulations 1974	10c
11/1975.	Apprenticeship Act 1958. Apprenticeship (Textile Mechanic Trade) (Amendment) Regulations 1974	10c
12/1975.	Milk and Dairy Supervision Act 1958. Milk and Dairy Supervision (Fees No. 3) Regulations 1974	10c
13/1975.	Firearms Act 1958. Firearms (Castlemaine Market Museum) Regulations 1974	10c
14/1975.	National Gallery of Victoria Act 1966. National Gallery of Victoria (Admission (Amendment) Regulations 1974	10c
15/1975.	Fisheries Act 1968. Fishing (General Amendment No. 3) Regulations 1974	10c
16/1975.	Boilers and Pressure Vessels Act 1970. Boilers and Pressure Vessels (General) Regulations 1974	40c
17/1975.	Melbourne Harbor Trust Act 1958 (No. 6312). Melbourne Harbor Trust (Wharfage and Tonnage Rates) Regulations No. 3/74	15c
18/1975.	Education Act 1958. Education Department (Amendment) Regulations 1974 (Amendment No. 32)	10c
19/1975.	Transport Regulation Act 1958. Transport Consolidated (Taxi Hiring Accounts) Regulations 1974	10c
20/1975.	Health Act 1958 (No. 6270). Lead Workers (Medical Examination) (Amendment) Regulations 1974	10c
21/1975.	State Electricity Commission Act 1958. State Electricity Commission (Licensing of Electrical Mechanics) Regulations 1974	30c
22/1975.	Liquor Control Act 1968. Liquor Control (Dartmouth Dam Canteen—Fees) Regulations 1974	10c
23/1975.	Liquor Control Act 1969. Liquor Control (Railways—Fees) Regulations 1974	10c
24/1975.	Social Welfare Act 1970. Social Welfare (Trainees' and Prisoners' Earnings) Regulations 1974	10c
25/1975.	Pay-roll Tax Act 1971. Pay-roll Tax (Further Amendment) Regulations 1974	20c
26/1975.	Estate Agents Act 1958. Order Consenting to the Making of Rules	10c
27/1975.	Legal Profession Practice Act 1958. Rules of the Council of Legal Education. Rules Relating to the Qualification and Admission of Candidates	10c
28/1975.	Legal Profession Practice Act 1958. Rules of the Council of Legal Education. Rules Relating to the Qualification and Admission of Candidates	10c
29/1975.	Workers Compensation Act 1958. Workers Compensation Board (Amendment No. 1) Regulations 1974	10c
30/1975.	Motor Car Act 1958. Motor Car (Application of Design Rules) Regulations 1974	10c
31/1975.	Magistrates' Courts Act 1971. Magistrates' Courts (Bailiffs) Rules 1974	10c
32/1975.	Justices Act 1958. Justices (Warrant of Distress) Rules 1974	10c
33/1975.	Magistrates' Courts Act 1971. Justices Act 1958. Magistrates' Courts (Further Amendment) Rules 1974	15c

Copies of these statutory rules may be purchased at the Sale of Publications Section of the Government Printing Office, located at 7A Parliament Place, Melbourne, 3002. If

ordered by mail, remittance should be addressed to "The Government Printer, Box 203, P.O., North Melbourne, 3051", and should include 11c extra for postage. If a credit account is held at this office, no remittance is required with the mail order.

The annual subscription rate for Statutory Rules (including Bound Volumes) is \$35, payable in advance. The subscription year commences on 1st January.

C. H. RIXON,
Government Printer.

THE "VICTORIA GOVERNMENT GAZETTE".

SUBSCRIPTIONS.—The subscription, including postage, is \$40 per annum, or \$20 per half year, payable in advance.

Subscriptions are required for whole months, and must cover at least a half year.

Single copies are 30 cents, posted 63 cents. Subscribers do not receive the Acts of Parliament with the GAZETTE.

GAZETTES are held in stock for five years only.

PRIVATE ADVERTISEMENTS.—The charge for insertion is 55 cents per line single column, and \$1.10 cents per line double column. The title forms one or more lines as a heading. On an average ten words make a line of single column. Every signature must likewise be counted as a line. The final words of a paragraph, though only portion of a line, must be counted as one line. Signatures (in particular) and proper names must be written very plainly in the text; ONE SIDE ONLY of each sheet of paper should be WRITTEN UPON. The charge for a full page is \$85.

All documents illegibly written will be returned unpublished, and where brands occur unprovided for by the ordinary letters of the alphabet, a worded explanatory description must be furnished.

PUBLICATION.—Unless otherwise advertised, the VICTORIA GOVERNMENT GAZETTE is published on WEDNESDAY EVENING in each week, and Notices for insertion will be received by the Government Printer at or before ONE p.m. at ordinary rates, and late advertisements between ONE p.m. and half-past THREE p.m. at double rates on the day preceding the day of publication.

PAYMENTS.—Unless the advertiser has a credit account, all payments are required in advance. Remittances should be made by cheque, postal order, or money order payable to "GOVERNMENT PRINTER".

ADDRESS.—All communications should be addressed to "The Government Printer, Box 203, P.O., North Melbourne, 3051."

PUBLICATION OF OFFICIAL MATTER.

Attention is invited to the following procedure in relation to the publication of official matter in the *Government Gazette*:—

Publication will be facilitated by the submission of carbon copies for the use of the Gazette Officer.

1. *Matter submitted to the Executive Council.*

Matter submitted to the Executive Council which requires gazettal will normally be published in the issue of the following week.

Where urgent gazettal is required, special arrangements should be made with the Gazette Officer, Room 9, first floor, Old Treasury Building.

2. *Other matter.*

(a) All other matter duly certified by a responsible officer for publication should be lodged with the Gazette Officer not later than half-past Nine a.m. on Tuesday.

(b) Lengthy or involved notices should be forwarded several days before publication.

(c) Proofs, which will be supplied only when specifically requested or at the direction of the Gazette Officer, should be returned promptly to avoid delay in publication.

(d) No additions or amendments to matter for publication will be accepted by telephone.

CONTENTS	PAGE
Appointments	29
Cemeteries—Scale of Fees	9
Contracts	28
Estates of Deceased Persons	14
Government Notices	2
Impoundings	82
Insolvency Notices	82
Lands	49
Mining	20
Notice to attend for Radiological Examination	11
Notice of Making Statutory Rules	83
Orders in Council—	
Acts—State Electricity Commission; Geelong Harbor Trust; Country Roads; Land; Superannuation; Local Government; Water; Sewerage Districts; Mildura Irrigation and Water Trusts; Melbourne and Metropolitan Tramways; State College of Victoria; Local Government; Superannuation; Soil Conservation and Land Utilization; Road Traffic; Melbourne Underground Rail Loop; State Electricity Commission; Water; Sewerage Districts; Geelong Waterworks and Sewerage.	31 et seq
Private Advertisements	64
Proclamations	2
Public Holiday—Australia Day	2
Public Service Notices	54
Regulations—	
Acts—Teaching Service	61
Resignations	31
State Rivers and Water Supply Commission	16
Transport Regulation Board—Public Hearings	21
Waterworks Trusts	17