



VICTORIA  
GOVERNMENT GAZETTE

Published by Authority

No. 58]

WEDNESDAY, JULY 9

[1975

PROCLAMATIONS

*Land Act 1958.*  
UNALIENATED CROWN LAND MADE AVAILABLE FOR  
LEASING FOR PLANTATION AREAS.

PROCLAMATION

By His Excellency the Governor of the State of Victoria and its Dependencies in the Commonwealth of Australia, &c., &c., &c.

In pursuance of the provisions of section 151b (1) of the *Land Act 1958*, I, the Governor of the State of Victoria, in the Commonwealth of Australia, by and with the advice of the Executive Council of the said State, do by this my Proclamation declare the unalienated Crown land in the Parish of Nagwarry, being allotments 95 and 95A and comprising 391.8 hectares (968 acres 23 perches), to be made available for leasing for the growing of forest trees of the "*Pinus Radiata*" species for commercial purposes.—(Z.29402).

Given under my Hand and the Seal of the State of Victoria aforesaid, at Melbourne, this first day of July, in the year of our Lord One thousand nine hundred and seventy-five, and in the twenty-fourth year of the reign of Her Majesty Queen Elizabeth II.

(L.S.) HENRY WINNEKE.

By His Excellency's Command,  
W. BORTHWICK,  
Minister of Lands.

GOD SAVE THE QUEEN !

PUBLIC HALF-HOLIDAYS.

PROCLAMATION

By His Excellency the Governor of the State of Victoria and its Dependencies in the Commonwealth of Australia, &c., &c., &c.

In pursuance of the provisions contained in Part III. of the *Public Service Act 1958*, I, the Governor of the State of Victoria, in the Commonwealth of Australia, by and

with the advice of the Executive Council of the said State, do by this my Proclamation appoint the days and dates hereunder mentioned to be observed as Public Half-Holidays at the places respectively specified, viz.:—

*Public Half-Holidays from the Hour of Twelve o'clock noon:—*

THURSDAY, THE 2ND OCTOBER, 1975, throughout the Shire of Wimmera.

WEDNESDAY, THE 15TH OCTOBER, 1975, in the North and Tyrrell Ridings, including the Township of Culgoa, in the Shire of Wycheproof.

WEDNESDAY, THE 22ND OCTOBER, 1975, in the South and Central Ridings, excluding the Township of Culgoa, in the Shire of Wycheproof.

Given under my Hand and the Seal of the State of Victoria aforesaid, at Melbourne, this first day of July, in the year of our Lord One thousand nine hundred and seventy-five, and in the twenty-fourth year of the reign of Her Majesty Elizabeth the Second, Queen of Australia.

(L.S.) HENRY WINNEKE.

By His Excellency's Command,  
J. F. ROSSITER,  
Chief Secretary.

GOD SAVE THE QUEEN !

*Apprenticeship Act 1958.*

REVOCATION OF THE WOOD TURNING TRADE AS AN  
APPRENTICESHIP TRADE.

PROCLAMATION

By His Excellency the Governor of the State of Victoria and its Dependencies in the Commonwealth of Australia, &c., &c., &c.

Whereas section 13 of the *Apprenticeship Act 1958* provides, *inter alia*, that after the Minister has taken into consideration any recommendation made by the Apprenticeship Commission the Governor in Council, for the purposes of the said Act, may from time to time by Proclamation proclaim any trades to be apprenticeship trades and that

the Governor in Council (whether with or without any recommendation of the said Commission) may by Proclamation at any time revoke amend or vary any such Proclamation:

And whereas the trade of Wood Turning, *inter alia*, was proclaimed to be an apprenticeship trade within the Metropolitan District on the 25th of March, 1952, and within the remainder of the State of Victoria on the 10th of March, 1965:

And whereas the Apprenticeship Commission of Victoria has recommended to the Minister that such Proclamations be revoked in so far as they relate to the trade of Wood Turning:

And whereas the Minister has taken the said recommendation into consideration:

Now therefore I, the Governor of the State of Victoria, in the Commonwealth of Australia, by and with the advice of the Executive Council of the said State, do by this my Proclamation revoke the aforesaid Proclamations in so far as they relate to the trade of Wood Turning.

Given under my Hand and the Seal of the State of Victoria aforesaid, at Melbourne, this first day of July, in the year of our Lord One thousand nine hundred and seventy-five, and in the twenty-fourth year of the reign of Her Majesty Queen Elizabeth the Second, by the Grace of God Queen of Australia and Her other Realms and Territories, Head of the Commonwealth.

(L.S.) HENRY WINNEKE.

By His Excellency's Command,  
J. A. RAFFERTY,  
Minister of Labour and Industry.  
GOD SAVE THE QUEEN!

## GOVERNMENT NOTICES

### MINISTRY OF FUEL AND POWER.

#### NOTICE.

*Pipelines Act 1967, No. 7541.*

#### APPLICATION FOR A PERMIT TO OWN AND USE A PIPELINE.

1. In accordance with the provisions of section 11 (1) of the *Pipelines Act 1967*, notice is given that an application has been received by me from the Gas and Fuel Corporation of Victoria for a permit to own and use a pipeline for the purpose of conveying liquefied petroleum gas from the Long Island Point Tank Farm to Hastings.

2. The proposed route of the pipeline is as follows—a steel pipeline 3.7 km long commencing at a junction with a pipeline owned by Esso Exploration and Production Australia Inc. and Hematite Petroleum Pty. Ltd. situated in the south-eastern corner of the Long Island Point Tank Farm owned jointly by these two companies and operated by Esso Australia Ltd. and located on Allot. 77, Parish of Tyabb; thence proceeding in a northerly direction within an existing easement and pipeway for a distance of approximately 920 metres through Lots 23, 24, 25, 26 and 27 of Allot. 77; thence within Lot 27 turning to continue in a westerly direction within the existing pipeway and easement for a distance of approximately 1100 metres through such lot and Lots 16 and 15, Allot. 77, across Jeremiah's Road and through Lots 10, 7, 6, 5, 4 and 3; thence within Lot 3 turning to continue in a northerly direction through such lot and land owned by the Shire of Hastings to Bayview Road, Hastings; thence crossing such road and the Tyabb-Long Island Point rail spur; thence re-entering the existing pipeway and easement to divert in a north-westerly direction through Allot. 69, Lot 2 of Allot. 80A, Lot 2 of Allot. 80, Lot 2 of Allot. 81 and Allot. 71, to the Frankston-Flinders Road; thence turning in a westerly direction and leaving the existing pipeway and easement to cross such road and the Frankston-Crib Point rail line at a point approximately 600 metres north of the junction of such rail line and the spur line to Long Island Point to enter Lot 82, Parish of Tyabb; thence, after passing through a valve station, re-entering the Victorian Railways' reserve containing the Frankston-Crib Point rail line to terminate and form a junction with the existing Crib Point to Dandenong liquefied petroleum gas pipeline owned and operated by the Gas and Fuel Corporation of Victoria.

Apart from crossing the Frankston-Flinders Road, the Frankston-Crib Point rail line and entering Lot 82, Parish of Tyabb, the pipeline would be laid wholly within an existing approved pipeway and existing easement across private land containing several other major transmission pipelines.

3. Plans of the proposed route of the pipeline may be inspected commencing Thursday, 3rd July, 1975, between the hours of 10.00 a.m. and 4.00 p.m. on Mondays to Fridays (excluding Public Holidays) at—

- (a) Ministry of Fuel and Power,  
15th floor, 171 Flinders Street, Melbourne.
- (b) Plan Room, Gas and Fuel Corporation of Victoria,  
8th floor, 171 Flinders Street, Melbourne.
- (c) Municipal Offices, Hastings.

Additional copies of plans are not available from the Ministry and detailed route plans can be seen only at the Gas and Fuel Corporation's Plan Room, 8th floor, 171 Flinders Street, Melbourne.

4. Any objections to the proposed route of the pipeline must be addressed to me and reach the Office of the Ministry no later than Friday, 15th August, 1975.

J. C. M. BALFOUR,  
Minister for Fuel and Power.

3rd July, 1975.

### MINISTRY OF FUEL AND POWER.

#### NOTICE.

*Pipelines Act 1967, No. 7541.*

#### APPLICATION FOR A PERMIT TO OWN AND USE A PIPELINE.

1. In accordance with the provisions of section 11 (1) of the *Pipelines Act 1967*, notice is given that an application has been received by me from Esso Exploration and Production Australia Inc. and Hematite Petroleum Pty. Ltd. for a permit to own and use a pipeline for the purpose of conveying liquefied petroleum gas within the partnership's Long Island Point installations.

2. The pipeline was laid several years ago as a line exempt from the provisions of the *Pipelines Act 1967*. However the line is now being modified, will be connected to a pipeline to be owned and operated by the Gas and Fuel Corporation of Victoria and is therefore now subject to the provisions of the *Pipelines Act 1967*. It is laid wholly within the installation area of the Long Island Point Fractionation Plant, the major pipe right-of-way and the Long Island Point Tank Farm, all owned jointly by Esso Exploration and Production Australia Inc. and Hematite Petroleum Pty. Ltd. and operated by Esso Australia Ltd.

3. The route of the pipeline is as follows—a steel pipe line 1.1 km in length commencing at a suction flange located in the pressure storage area in the north-east corner of the fractionation plant owned jointly by Esso Exploration and Production Australia Inc. and Hematite Petroleum Pty. Ltd. and operated by Esso Australia Ltd. at Long Island Point situated on Allot. 76, Parish of Tyabb and proceeding in a northerly direction through a transfer pump for approximately 25 metres; thence turning to continue in a westerly direction for a distance of 12 metres; thence reducing to a 75 mm nominal diameter pipeline and turning to continue in a northerly direction for a distance of approximately 70 metres to the boundary of A and B process areas; thence entering the Esso/BHP pipe right-of-way and turning to continue in a westerly direction within the pipeway through Allots. 76 and 77 for a distance of approximately 1025 metres to the pumping station area in the south-east corner of the Long Island Point Tank Farm owned by Esso Exploration and Production Australia Inc. and Hematite Petroleum Pty. Ltd. situated on Allot. 77, Parish of Tyabb; thence within such area increasing in diameter to 100 mm and proceeding for a further distance of approximately 30 metres to terminate at a junction of a pipeline owned by the Gas and Fuel Corporation of Victoria.

4. A plan of the route of the pipeline may be inspected commencing Thursday, 3rd July, 1975, between the hours of 10.00 a.m. and 4.00 p.m. on Mondays to Fridays (excluding Public Holidays) at—

- (a) Ministry of Fuel and Power,  
15th floor, 171 Flinders Street, Melbourne.
- (b) Municipal Offices, Hastings.

Additional copies of the plan are not available from the Ministry and further details may be obtained on application to the Superintendent, Long Island Point Fractionation Plant, Hastings.

5. Any objections to the route of the pipeline must be addressed to me and reach the Office of the Ministry no later than Friday, 15th August, 1975.

J. C. M. BALFOUR,  
Minister for Fuel and Power.

3rd July, 1975.

Transport Regulation Act.  
**TRANSPORT REGULATION BOARD.**  
 HEARING OF APPLICATIONS.

Notice is hereby given that the following applications will be considered by the Transport Regulation Board on 29th July, 1975.

**BORTHWICK, THOMAS AND SONS (AUST.) LTD.,** Box 150, Portland. Application for one commercial passenger vehicle with seating capacity for 11 persons to operate as follows: (a) For the carriage of the applicant's own employees to and from Portland, from and to various depots within a 32-km radius from the post office at Portland as required. (b) For the carriage of the applicant's own goods within an 80-km radius of the post office at Portland as required.

Applications for renewal of licences as shown by the persons listed hereunder to operate under the same terms and conditions:—

**THIESS BROTHERS PTY. LTD.,** Dartmouth Dam via Mitta Mitta, T.P.44.

**CLYNES BUS SERVICES PTY. LTD.,** 48 The Avenue, Ocean Grove; T.S.609; T.S.688; T.S.1385.

Notice of any objections should be forwarded to reach the Secretary of the Board not later than 23rd July, 1975.

Applicants are advised that it will not be necessary to appear on the hearing date specified, unless advised in writing by the Board.

A. V. C. COOK,  
 Secretary.

Corner Lygon and Princes Streets, Carlton, 3053,  
 Wednesday, 9th July, 1975.

Commercial Goods Vehicles Act.  
**TRANSPORT REGULATION BOARD.**  
 HEARING OF APPLICATIONS.

Notice is hereby given that the following applications will be considered by the Transport Regulation Board on 29th July, 1975.

**ABURROW, G. L.,** Flat 8, 2 Dundas Street, Thornbury, 3071. One commercial goods vehicle (L/C. 6.25 tonne) to operate within a 112-km radius of the premises of Brick and Pipe Industries Ltd. at Northcote solely on behalf of the said company—bricks.

**ADAMS, R. W.,** 3 Freeman Street, Castlemaine, 3450. One commercial goods vehicle (L/C. 0.75 tonne) to operate from the premises of C. W. & P. J. Barnes of Castlemaine an approved decentralized secondary industry (confectionery) solely on behalf of the said firm to points throughout the State of Victoria—manufactured products from such industry.

**ADAMS, WILLIAM, TRACTORS PTY. LTD.,** Nantilla Road, Clayton, 3168. Two commercial goods vehicles (L/C. 0.80 tonne each) to operate throughout the State of Victoria in the course of business as "Earthmoving Equipment Distributor" for the purpose of servicing and maintaining earthmoving and agricultural machinery—tools of trade, spare parts and associated servicing and maintenance materials incidental to on site servicing.

**BOILERS, ALFAREI, PTY. LTD.,** 259 Dundas Street, Preston, 3072. One commercial goods vehicle (L/C. 1.25 tonne) to operate throughout the State of Victoria in the course of business as "Boiler Manufacturers" for the purpose of servicing boilers—tools of trade, spare parts and materials incidental to on-site servicing.

**ATKINSON, G. J.,** 70 Latrobe Road, Morwell, 3840. Application to vary the conditions of licence No. T.D.A.67096 (L/C. 2.55 and 1.40 tonne trailer) by deleting paragraph (a) of the existing conditions and adding in lieu—"From the premises of Datsun Distribution Pty. Ltd. at Cheltenham and Clayton to the premises of Latrobe Valley Motors Pty. Ltd. at Morwell, V. & E. Motors Pty. Ltd. at Moe, Tokyo Motors Pty. Ltd. at Sale, Vin Rowe Pty. Ltd. at Warragul and Wights Datsun at Traralgon with a specially constructed car carrying trailer combination—"new Datsun Motor Vehicles" and also by adding additional paragraphs (e) and (f)—(e) From the premises of Australian Motor Industries Ltd. at Port Melbourne and Campbellfield to the premises of Colin Lucas Toyota at Sale with a specially constructed car carrying trailer combination—"new Toyota Motor Vehicles." (f) From the various dealerships mentioned in paragraphs (a), (b), (c) and (e) above to various motor car auctions and wholesalers—used motor vehicles.

**CALLINAN, N. J.,** 4 Scott Street, Cranbourne, 3977. One commercial goods vehicle (L/C. 8.00 and 6.00 tonne trailer) to operate from pits at Cranbourne to places within a 40-km radius of the G.P.O., Melbourne and to Geelong solely on behalf of R. Wright Sand Pty. Ltd.—moulding sand.

**COLLINS, R. & L.,** 410 Doncaster Road, Doncaster, 3108. One commercial goods vehicle (L/C. 0.70 tonne) to operate within an 80-km radius of own branch premises at Shepparton in the course of business as "Builders"—own goods.

**COLWELL, J. P.,** 87 Lowndes Street, Bendigo, 3550. Application to vary the conditions of licence No. D.A.67274 (L/C. 15.25 tonne) by adding an additional paragraph (c) "From Bendigo to Melbourne—broken glass".

**COVERDALE, E. H.,** P.O. Box 67, Bairnsdale, 3875. One commercial goods vehicle (L/C. 12.90 tonne) to operate: (a) Throughout the State of Victoria as a Bulk Petroleum Tanker—bulk petroleum. (b) Within that part of the State of Victoria east of a north/south line drawn through Werribee—livestock.

**CRAWFORD, I. J., & CO. PTY. LTD.,** Morwell, 3840. One commercial goods vehicle (L/C. 0.80 tonne) to operate within that part of the State of Victoria east of a line drawn north and south through the township of Berwick in the course of business as "Sporting Goods Industrial Equipment and Abrasives Wholesaler"—own goods.

NOTE.—(i) That all goods carried on the vehicle shall have been initially consigned by rail to Morwell. (ii) That freight records shall be furnished to the Board every three months showing details of all goods consigned by rail during such three months.

**DALTON, A. V.,** Wyndham Street, Drysdale, 3222. One commercial goods vehicle (L/C. 1.15 tonne) to operate: (a) Within an 80-km radius of the post office at Drysdale in the course of business as "Florist Supply Wholesaler"—own goods. (b) Throughout the State of Victoria in the course of business as "Florist Wholesaler"—floral ornaments for exhibition to prospective purchasers only with the ability to leave a sample in an emergency.

**TRANSDYER MANAGEMENT PTY. LTD.** (trading as Dyers Transport), 34-46 York Street, Sale, 3850. Application to vary the conditions of licences numbered D.A.43146/15-25 and D.A.43146/31 (L/C. 4.00, 1.50, 3.90, 15.40, 14.40, 22.05, 19.30, 21.15, 2.00, 1.05, 2.05 and 19.51 tonne) by adding an additional paragraph (e) "From and to places within a 40-km radius of the G.P.O., Melbourne to and from all places en route including the Hazelwood-Churchill area and the proposed Loy Yang complex on behalf of various consignees—goods carried under existing licences.

**EGLO ENGINEERING PTY. LTD.,** 237 Kororoit Creek Road, Williamstown, 3016. One commercial goods vehicle (L/C. 3.35 tonne) to operate: (a) Within an 80-km radius of own premises at Williamstown in course of business as "Mechanical Construction Engineers"—own goods. (b) From places described in paragraph (a) above to own approved decentralized secondary industry premises at Sale (Steel Fabrications)—raw materials required for use in the manufacturing processes of such industry. (c) From own approved decentralized secondary industry premises at Sale to places within an 80-km radius thereof and to places within an 80-km radius of the G.P.O., Melbourne—manufactured products from such industry.

**ELLIOT, B. R.** (trading as Rex Elliot's Tyre Service), 136 Bromley Road, Robinvale, 3549. One commercial goods vehicle (L/C. 0.70 tonne) to operate within a 100-km radius from the chief post office in the Township of Robinvale in the course of business as "Tyre Dealers"—tyres and tubes for repair or having been repaired, new tyres and tubes, batteries, motor car accessories and polythene piping.

**FREETH, W.,** 32 Ernest Street, Broadmeadows, 3044. One commercial goods vehicle (L/C. 7.00 tonne) to operate within an 11-km radius of the premises of Clifton Brick Holdings Ltd. at Brunswick solely on behalf of the said company—bricks.

**FULLWOOD, A. E. PTY. LTD.,** 54 Barry Street, Bayswater, 3153. Application to vary the condition of licence No. D.T.1580 (L/C. 9.60 tonne) by deleting "Vermont" from paragraph (a) and adding in lieu "Bayswater".

**HALL, K. S.,** Burn Street, Spring Gully, Bendigo, 3550. One commercial goods vehicle (L/C. 11.05 tonne) to operate within an 80-km radius of Bendigo in the course of business as "Earth-moving Contractor"—own goods of trade, own earth-moving machinery and own equipment.

- D'ESPOSITO, G.** (trading as Highway Motor Cycles), Old Macclesfield Road, Monbulk, 3793. One commercial goods vehicle (L/C. 0.55 tonne) to operate: (a) Within an 80-km radius of own premises at Ferntree Gully in course of business as "Motor Cycle Dealer"—own goods, also motor cycles for repair or for return after having been repaired. (b) Throughout the State of Victoria for the purpose of attending motor cycle racing meetings—own motor cycles for racing.
- HOLLANDS, I. D.** Benambra, 3900. One commercial goods vehicle (L/C. 0.75 tonne) to operate within an 80-km radius of Bairnsdale in the course of business as "Builder"—tools of trade and materials incidental to the completion of own contracts.
- HORMAN, T. W.**, 9 Nolan Drive, Epping, 3076. One commercial goods vehicle (L/C. 7.25 tonne) to operate within a 112-km radius of the premises of Clifton Brick Holdings Ltd. at Brunswick solely on behalf of the said company—bricks.
- KEATH, R. D.**, 41A Herbert Street, Middle Park, 3206. One commercial goods vehicle (L/C. 6.65 tonne) to operate within an 80-km radius of the G.P.O., Melbourne in course of business as "Earth-moving Contractor"—tools of trade, earth-moving plant and equipment and spare parts and materials incidental to servicing of earth-moving equipment.
- KENNEDY, P. J.**, 43 Lemart Street, Strathmore, 3041. Three commercial goods vehicles (L/C. 4.00, 3.95, and 3.95 tonne) to operate: (a) From the premises of City Abattoirs at Flemington to skin and hide stores within a 40-km radius of the G.P.O., Melbourne—green hides and green skins. (b) From the premises of Jacksons Corio Meat Packing (1965) Pty. Ltd. at Corio to skin and hide stores at Brooklyn, Braybrook and Footscray—green hides and green skins. (c) From the premises of J. C. Hutton Pty. Ltd. at Kyneton to hide and skin stores at Brooklyn, Braybrook and Footscray—green hides and green skins. (d) From Melbourne to own farm at Tylden and return in course of business as "Primary Producer"—own goods.
- LOWRY, K. W.**, 6 Valerie Street, Lalor, 3075. One commercial goods vehicle (L/C. 7.50 tonne) to operate: (a) Within an 80-km radius of each of the plants of Pioneer Asphalts Pty. Ltd. at Brooklyn, Epping, Clarinda and Dromana—hot asphalt solely on behalf of the said company. (b) Within a 40-km radius of each of the plants of Pioneer Asphalts Pty. Ltd. at Brooklyn, Epping, Clarinda and Dromana or within a 40-km radius of any contract site within the radii referred to in paragraph (a)—raw materials for the manufacture of asphalt.
- LUKE, K. G. GROUP INDUSTRIES LTD.**, 74 River Street, South Yarra, 3141. One commercial goods vehicle (L/C. 0.75 tonne) to operate throughout the State of Victoria in course of business as "Refrigeration and Air Conditioning Engineers" as a service vehicle for the purpose of servicing and repairing of Refrigeration and Air Conditioning Units—tools of trade, spare parts and equipment necessary to service and repair Refrigeration and Air Conditioning Equipment on-site.
- MEMBREY, J. & N. PTY. LTD.**, Lot 577, Wells Road, Seaford South, 3201. One commercial goods vehicle (L/C. 12.75 tonne) to operate: (a) Within a 40-km radius of own premises at Seaford in the course of business as "Sand and Soil, Screenings and Garden Supplies"—own goods. (b) From Healesville to own premises at Seaford—own mountain soil. (c) From Bacchus Marsh to own premises at Seaford—own river pebbles and river gravel. (d) From Werribee, Laverton, Bacchus Marsh and Rockbank areas to own premises at Seaford—own garden stone. (e) From Beveridge to own premises at Seaford—own scoria. (f) From Yea and Seymour to own premises at Seaford—own river pebbles.
- MITCHELTON VINTNERS (AUST.) PTY. LTD.**, Mitchellstown, 3608. One commercial goods vehicle (L/C. 0.55 tonne) to operate: (a) Within a 40-km radius of the post office at Mitchellstown in the course of business as Vintners—own goods. (b) From Wholesale Food Markets at Footscray to own premises at Mitchellstown in the course of business as Vintners and Restaurant Proprietor—fresh fruit and fresh vegetables (other than potatoes and onions) fresh meat, fresh fish, eggs, fresh milk and fresh cream.
- MONIER SERVICES PTY. LTD.**, Frankston Road, Dandenong, 3175. Application to vary the conditions of licences numbered D.A.65751, D.A.65751/1, D.A.65751/2, D.A.65751/3, D.A.65751/4 (L/C. 7.25, 9.95, 17.50, 12.50, 9.35 tonne) by adding an additional paragraph (f) "From Clayton to the premix concrete plant of Apex Quarries Ltd. at East Kilmore—own sand".
- CRAWFORD, I. J. PTY. LTD.** (trading as McMahon Wholesale), 109 George Street, Morwell, 3840. One commercial goods vehicle (L/C. 1.00 tonne) to operate within that part of the State of Victoria east of a line drawn north and south through the township of Berwick in the course of business as "Sporting Goods Industrial Equipment and Abrasives Wholesaler"—own goods.
- NOTE—(i) That all goods carried on the vehicle shall have been initially consigned by rail to Morwell. (ii) That freight records shall be furnished to the Board every three months showing details of all goods consigned by rail during such three months.
- MCPHERSON, J. J.** 93 Cramer Street, Warrnambool, 3280. Application to vary conditions of licence No. D.A.58047/4 (L/C. 12.00 tonne) by adding in lieu as paragraph (b)—(b) From Nestles Depot at Portland Wharf to Nestles Factory Dennington—coffee beans and by adding an additional paragraph (c)—(c) From Pivot Company Portland to Farms situated within a 20-km radius of the post office at Warrnambool—superphosphate.
- NICOL, R. A.**, 70 Nicol Street, Warrnambool, 3280. One commercial goods vehicle (L/C. 6.50 tonne) to operate from Melbourne to Warrnambool and places en route on a specially constructed car carrying unit—new and secondhand motor cars returning with secondhand motor cars to Melbourne and places en route.
- PROSCH TIMBER PTY. LTD.**, P.O. Box 42, Drouin, 3818. One commercial goods vehicle (L/C. 16.20 tonne) to operate: (a) From forest landings within a 48-km radius from the post office at Longwarry or from forest landings in the Morwell area to own sawmills at Longwarry and Drouin—logs. (b) From own sawmills at Longwarry to timber yards and building contract sites at Wonthaggi and Archie's Creek and to places within a 40-km radius of the post office situated at the corner of Bourke and Elizabeth Streets Melbourne and to places within a 48-km radius of the post office at Longwarry—own sawn timber. (c) From own sawmill at Longwarry to places within a 40-km radius of the post office at the corner of Bourke and Elizabeth Streets in the City of Melbourne and to places within a 48-km radius of the post office at Longwarry—own new pallets. (d) From school sites within a 64-km radius of the post office at Longwarry to own sawmills at Longwarry and Drouin—pine logs.
- ROBBINS, A. H. & D. E.**, Carlisle River, 3239. One commercial goods vehicle (L/C. 15.70 tonne) to operate: (a) Within a 40-km radius of the post office at Carlisle River—general goods. (b) From forest landings within an 80-km radius of Terang to Terang Sawmilling and Timber Company at Terang—logs. (c) From the premises of Terang Sawmilling and timber Company at Terang to places within an 80-km radius thereof—sawn timber.
- ROBERTS, A. J.**, 181 Kent Road, Hamilton, 3300. Application to vary the conditions of licence No. D.A.66510 (L/C. 6.90 tonne) by adding an additional paragraph (c) "From Hamilton to Casterton—uncrated cement sheets and uncrated gyprock board".
- ROBERTS, A. J.**, 181 Kent Road, Hamilton, 3300. Application to vary the conditions of licence No. D.A.66510/3 (L/C. 15.25 tonne) by deleting paragraph (c) and adding in lieu as paragraph (c)—(c) From places within a 40-km radius of the G.P.O. Melbourne to places within a 40-km radius of the post office at Hamilton and to Casterton—uncrated cement sheets and uncrated plaster sheets and uncrated gyprock board in less than rail wagon lots, glazed windows, glazed doors, new furniture as per T.R.B. new furniture list.
- ROBERTS, A. J.**, 181 Kent Road, Hamilton, 3300. Application to vary the conditions of licences numbered D.A.66510/1, D.A.66510/2 (L/C.'s 15.25, 15.05 tonne) by deleting paragraph (c) and adding in lieu as paragraph (c)—"From places within a 40-km radius of the G.P.O. Melbourne to places within a 40-km radius of the post office at Hamilton and to Casterton—uncrated cement sheets and uncrated plaster sheets and uncrated gyprock board in less than rail wagon lots, glazed windows, glazed doors, new furniture as per T.R.B. new furniture list" and by adding an additional paragraph—(f) Within an 80-km radius of the post office at Hamilton in the course of business as cement distributors—bagged cement".

- RAFFERTY, F. T. PTY. LTD.**, 2 Nicholas Street, Lilydale, 3140. Two commercial goods vehicles (L/C. 11.35, 12.60 tonne) to operate: (a) Within a 40-km radius of the G.P.O., Melbourne—general goods. (b) From wharves and railway stations within a 40-km radius of the G.P.O. Melbourne to building contract sites and timber yards within a 40-km radius of the G.P.O., Melbourne and to points on the Mornington Peninsula—sawn timber.
- SEDDON ATKINSON AUSTRALIA PTY. LTD.**, 1948 Princes Highway, Clayton, 3168. One commercial goods vehicle (L/C. 1.10 tonne) to operate throughout the State of Victoria in course of business as "Motor Vehicle Manufacturers" for the purpose of servicing and maintaining own manufactured vehicles—tools of trade also spare parts and materials required for such on site servicing and maintenance.
- T.R. SERVICES PTY. LTD.**, 19 Walkers Road, Nunawading, 3131. One commercial goods vehicle (L/C. 0.95 tonne) to operate throughout the State of Victoria in the course of business as "Suppliers and Installers of Air Tube Conveyor and Dictograph Intercommunicating Telephone Systems" for the purpose of servicing communication systems—tools of trade, also spare parts and materials required for the on-site servicing and maintenance of such systems.
- TOMLINSON, T. C.**, 20 Ramsdon Street, Clifton Hill, 3068. One commercial goods vehicle (L/C. 6.20 tonne) to operate within a 112-km radius of the premises of Clifton Brick Holding Ltd. at Brunswick on behalf of the said company—bricks.
- VAN POLEN BROS. PTY. LTD.**, Burwood Highway, Wantirna South, 3152. One commercial goods vehicle (L/C. 0.95 tonne) to operate throughout the State of Victoria in the course of business as "Drainage Contractors" for the purpose of supervising own drainage contracts—tools of trade, drainage equipment and a small quantity of material incidental to the repair or completion of a contract.
- WARRAGUL METALS PTY. LTD.**, 13 Phoenix Street, Warragul, 3820. Application to vary conditions of licence No. D.A.66358 (L/C. 8.00 tonne) by adding an additional paragraph—(c) Within a 40-km radius of any contract or demolition site, currently engaged upon—own tools of trade, own equipment, surplus materials and rubble".
- WHITE WAY SIGN & LIGHTING CO. LTD.**, 1-9 Cecil Street, South Melbourne, 3205. Two commercial goods vehicles (L/C. 0.95 tonne each) to operate throughout the State of Victoria in the course of business as "Electrical Sign Manufacturers" for the purpose of servicing and repairing signs—tools of trade, spare parts and materials incidental to on-site servicing and signs for repair or having been repaired.
- WILKINS, R. J.**, Stewart Road, Yinnar, 3869. One commercial goods vehicle (L/C. 9.10 tonne) to operate from the plants of Readymix Concrete Pty. Ltd. at Leongatha, Morwell, Sale and Yallourn to consignees situated within an 80-km radius from the particular plant—premixed concrete in a specially constructed agitator type vehicle solely on behalf of the said company.
- TOW TRUCKS.**
- COOK, G. L. & N. E.**, (trading as Timboon Motors) Timboon, 3268. Application to vary the conditions of licence No. D.A.46876 (L/C. 1.25 tonne) by deleting "175 miles" and adding in lieu "80 km".
- COULTER, O. W.**, (trading as Valley Auto Wreckers), 73 Latrobe Road, Morwell, 3840. One commercial goods vehicle (L/C. 4.00 tonne) to operate throughout that part of the State of Victoria situated east of a north/south line drawn through Warragul and south of an east/west line drawn through Omeo in the course of business as "Auto Wrecker"—wrecked or disabled motor vehicles carried on a specially constructed tipper tray vehicle and used secondhand spare parts dismantled from wrecked motor vehicles but excluding the ability to attend the scene of an accident.
- RENEWALS.**
- Applications for renewal of licences as shown by persons listed hereunder to operate under the same terms and conditions from the expiry shown in each case.
- ALLEN, R.**, Fishers Road, Drouin West, 3818; D.A.64729; 31st August, 1975; 7.25 tonne.
- ALSTERGREN PTY. LTD.**, Fireplace Road, Heyfield, 3858; D.A.29856/3; 22nd January, 1976; 0.85 tonne.
- COLVILLE, R. O.**, (trading as Barham Construction), 55 Edward Street, Shepparton, 3630; D.A.37342/1; 11th January, 1976; 3.95 tonne.
- BEAUREPAIRE TYRE SERVICE PTY. LTD.**, 689 Burke Road, Camberwell, 3124; D.A.629/38; 16th November, 1975; 0.60 tonne; D.A.629/39; 16th November, 1975; 0.85 tonne.
- BEAUREPAIRE TYRE SERVICE PTY. LTD.**, 689 Burke Road, Camberwell, 3124; D.A.629/40; 16th November, 1975; 1.00 tonne.
- BLENNER HASSETT, J. & L. C.**, 33 Koonwarra Road, Leongatha, 3953; D.A.60463/3; 20th November, 1975; 12.50 tonne.
- BOYLE, L. K.**, 8 Newton Crescent, Lalor, 3075; D.A.33930; 5th December, 1975; 2.50 tonne.
- BROWN, J. R.**, 40 Princes Highway, Warrnambool, 3280; D.A.741/4; 16th December, 1975; 0.30 tonne.
- BRUNT, R. J.**, 22 Raymond Street, Orbost, 3888; D.A.67353; 3rd May, 1975; 7.25 tonne.
- CAMPBELLS TRANSPORT (DROMANA) PTY. LTD.**, 905 Nepean Highway, Mornington, 3931; D.A.65150; 16th December, 1975; 12.80 tonne.
- COBURN, R. W.**, Murray Valley Highway, Nyah, 3594; D.A.64632/2; 20th December, 1975; 12.85 tonne.
- CORSER, JOHN, PTY. LTD.**, Princes Highway, Morwell, 3840; D.A.60935/3; 22nd January, 1976; 4.00 tonne.
- D'ALTEIRO, L.**, 80 Pakington Street, Kew, 3101; D.A.37634; 14th December, 1975; 3.60 tonne.
- DOWNES, R. E., PTY. LTD.**, Nar Nar Goon, 3812; D.A.27544/13; 13th December, 1975; 7.70 tonne.
- DOWNES, R. E., PTY. LTD.**, Nar Nar Goon, 3812; D.A.27544/11; 11th November, 1975; 12.00 tonne.
- DUNSTAN, A.**, LOGGING CO. PTY. LTD., 1 Tallangatta Road, Wodonga, 3690; D.A.1011/5; 6th December, 1975; 0.75 tonne.
- EBERSBERGER, A. E. & J.**, 37 McMillan Street, Morwell, 3840; D.T.1468; 8th November, 1975; 15.20 tonne.
- FERGUSON, F.**, WOOL CO. PTY. LTD., 80 McIvor Road, Bendigo, 3350; T.D.A.62018/1; 13th January, 1976; 3.65 tonne.
- FIRESTONE SALES PTY. LTD.**, 36 Malua Street, Reservoir, 3073; T.D.A.67298; 20th January, 1976; 0.75 tonne.
- FLEETWAYS TRANSPORT SERVICES LTD.**, Princes Highway, Doveton, 3177; D.A.48588/47; 7th June, 1975; 6.75 tonne and 10.30 tonne trailer.
- GENDORE PTY. LTD.**, South Gippsland Highway, Tooradin, 3980; D.A.37242/1; 21st December, 1975; 0.65 tonne.
- GIBSON CHEMICALS LTD.**, 350 Reserve Road, Cheltenham, 3192; D.A.40371/8; 22nd January, 1976; 0.70 tonne.
- GLEESON, S. M.**, Main Road, Neerim South, 3831; D.T.1236; 27th November, 1975; 10.40 tonne.
- LINGFIELD NOMINEES PTY. LTD.** (trading as Gouge Country Services) 480d Glenhuntly Road, Elsternwick, 3185; D.A.1177/2; 6th December, 1975; 1.125 tonne.
- GREENWAY PTY. LTD.**, Grant Road, Somerville, 3912; D.A.66062/7; 6th December, 1975; 9.55 tonne; D.A.66062/9; 6th December, 1975; 11.05 tonne.
- GRIEB, E.**, Box 761, Morwell, 3840; D.A.50558/5; 20th November, 1975; 9.10 tonne.
- GRUNDY, R. H.**, 9 Salisbury Street, Essendon North, 3040; T.D.A.66426; 29th October, 1975; 7.95 tonne.
- HAMS, W.**, Hills End via Moe, 3825; D.T.1084/1; 31st August, 1975; 13.35 tonne.
- JONAS, W. J.**, 46 Latrobe Road, Morwell, 3840; D.A.64824; 2nd November, 1975; 2.35 tonne and 2.00 tonne trailer.
- KANE, BRIAN JAMES**, 76 Gordon Street, North Wonthaggi, 3995; D.A.66942; 20th December, 1975; 10.35 tonne.
- KERTON, W. K.**, P.O. Box 266, Bairnsdale, 3875; D.A.62606/3; 15th November, 1975; 5.90 tonne.
- LARRAD, E. I.**, 1 Albert Street, Oakpark, 3046; T.D.A.66418; 29th October, 1975; 6.55 tonne and 3.40 tonne.
- LATROBE VALLEY WHOLESALE AGENCIES**, 54 Langford Street, Moe, 3840; D.A.36797; 16th November, 1975; 2.35 tonne.
- LEES SUPERMARKET COBDEN PTY. LTD.**, Cobden, 3266; D.A.64829; 20th December, 1975; 1.80 tonne.
- LEWIS, K. W.**, 113 High Street, Seymour, 3660; D.A.12270/3; 18th December, 1975; 8.05 tonne.
- LUCAS, K. J.**, 8 Tudgey Street, Wangaratta, 3677; D.A.62795/2; 20th December, 1975; 4.70 tonne.
- MARSHALL, R.** (trading as R. & K. F. Marshall & Son), Pte Bag 2, Neerim, 3821; D.A.18834/2; 18th October, 1975; 11.65 tonne.
- MILLER, D. J.**, 17 Moreton Crescent, Bundoora, 3083; D.A.61257; 18th December, 1975; 2.10 tonne.
- MOORES, A.**, Flat 4, 4 Stuart Street, Noble Park, 3174; T.D.A.57779/1; 9th June, 1975; 6.95 tonne and 1.45 tonne trailer.
- MURPHY, P. J. & J. L.**, Barrett Street, Timboon, 3268; D.A.60000/1; 20th December, 1975; 6.30 tonne.
- NELSON, R. F.**, Cobrico, Cobden, 3266; D.A.1712/1; 8th November, 1975; 6.80 tonne and 4.20 tonne trailer.

- NEVINSON, J. G., 43 Maple Street, Golden Square, 3550; D.A.65139; 6th December, 1975; 10.10 tonne.
- PEACOCK, J. M. & K. R. (trading as R. T. Peacock & Sons), 339 Elgar Road, Box Hill, 3128; D.A.1789/3; 14th December, 1975; 7.10 tonne.
- PEARCE, A. J. & LEE, P., 24 Sternberg Street, Bendigo, 3550; D.A.61301; 11th December, 1975; 0.50 tonne and 1.00 tonne trailer.
- PURCELL, K. A., Cliftons Road, Athlone, 3818; D.T.1466; 6th December, 1975; 8.00 tonne.
- PYKE, B., 52 Grayson Drive, Scoresby, 3179; D.A.61339; 18th December, 1975; 5.70 tonne.
- QUEEN'S BRIDGE MOTORS PTY. LTD., 359 Plummer Street, Port Melbourne, 3207; D.A.1783/43; 16th December, 1975; 0.70 tonne; D.A.1783/42; 15th December, 1975; 0.70 tonne.
- QUINN, A. T., 19 Edward Street, Essendon, 3040; D.A.64884; 29th November, 1975; 0.80 tonne.
- REPO AUTO PARTS (VIC.) PTY. LTD., 618 Elizabeth Street, Melbourne, 3000; D.A.1907/32; 20th January, 1976; 0.65 tonne.
- REYNOLDS, R. A., 36 New Station Street, Cressy, 3322; D.A.1909/6; 1st December, 1975; 7.75 tonne.
- REYNOLDS, R. A., 36 New Station Street, Cressy, 3322; D.A.1909/2; 1st December, 1975; 16.50 tonne.
- RUSSELL, E. A. C., 154 Burwood Highway, Upper Ferntree Gully, 3156; D.A.64699; 14th December, 1975; 4.75 tonne.
- SABATO, G., 533 Keilor Road, Niddrie, 3042; D.A.38268; 11th January, 1975; 6.80 tonne.
- SBISA, R. B., 15B, 114 Princes Highway, Dandenong, 3175; D.A.64820/1; 6th December, 1975; 11.20 tonne.
- SCAPIN, A., 10 Dickson Street, Wonthaggi, 3995; D.A.64940; 20th December, 1975; 3.05 tonne.
- SEARLE, W. E., PTY. LTD., 26 Coster Street, Alexandra, 3714; D.A.16878/1; 5th December, 1975; 3.10 tonne.
- SLATER, R. & SON, 40 Hart Street, Colac, 3250; D.A.48284/2; 7th October, 1975; 6.15 tonne.
- SOUTHCOTT HYDRAULICS (VIC.) PTY. LTD., 9 Bricker Street, Cheltenham, 3192; D.A.50849; 16th December, 1975; 0.55 tonne.
- BONNEY, C. W. (trading as Spider Pest Control), Goulburn Valley Highway, Kialla, 3630; D.A.64770/1; 8th November, 1975; 1.00 tonne.
- STAWELL TIMBER INDUSTRIES PTY. LTD., 1221d Howitt Street, Wendouree, 3355; D.A.13328/12; 22nd January, 1976; 12.50 tonne.
- STELZER, G., Edithvale Road, Keysborough, 3175; D.A.61327; 18th December, 1975; 10.25 tonne.
- SULTANA, A., 130 Service Road, Moe, 3825; D.A.64787; 8th November, 1975; 1.10 tonne.
- SUTHERLAND, A. P., PTY. LTD., 175 Sturt Street, South Melbourne, 3205; T.D.A.2800/4; 18th December, 1975; 0.70 tonne.
- SUTHERLAND, A. P., PTY. LTD., 175 Sturt Street, South Melbourne, 3205; D.A.2800/2; 18th December, 1975; 0.80 tonne.
- TYNAN, W. J., 6 Breed Street, Traralgon, 3844; D.A.28095/6; 13th December, 1975; 13.25 tonne.
- VEAL, J. D., 28 Hunter Street, Wonthaggi, 3995; D.A.65162/1; 31st November, 1975; 0.65 tonne.
- VICTORIAN OATGROWERS POOL AND MARKETING CO. LTD., 406 Lonsdale Street, Melbourne, 3000; D.A.37995/12; 20th December, 1975; 0.80 tonne.
- VOLVO AUST. PTY. LTD., Cherry Lane, Brooklyn, 3025; D.A.64780/2; 13th December, 1975; 0.65 tonne.
- WALTER, W. & SONS PTY. LTD., 40 Main Street, Willaura, 3291; D.A.64917; 17th January, 1976; 7.25 tonne and 4.30 tonne.
- WHITE WAY SIGN & LIGHTING CO. LTD.; 1-9 Cecil Street, South Melbourne, 3205; D.A.1713/18; 8th February, 1975; 0.95 tonne.
- WILLIAMS, J., 331 Lava Street, Warrnambool, 3280; T.D.A.66464; 14th January, 1976; 0.65 tonne.
- WILCOX, N. E., 57 Hunter Street, Euroa, 3666; D.A.64910; 6th December, 1975; 0.70 tonne.
- WINDY'S SALES & SERVICES PTY. LTD., Hume Highway, Euroa, 3666; D.A.50405; 20th January, 1976; 1.50 tonne and 3.20 tonne trailer.
- WRIGHT, WALTER H., PTY. LTD., Sudholz Street, West Melbourne, 3003; D.A.19947/2; 18th December, 1975; 15.24 tonne.
- YOUNGS READY MIX PTY. LTD., 182 High Street, Shepparton, 3630; D.A.35594/21; 27th January, 1976; 10.30 tonne; D.A.35594/23; 27th January, 1976; 10.30 tonne.
- B. & R. TOWING SERVICE PTY. LTD., 718 Malvern Road, Prahran, 3181; D.A.66128/2; 14th December, 1975; 2.85 tonne; D.A.66128/4; 14th December, 1975; 2.45 tonne.
- KERRIGAN, T. E. (trading as Kerrigans Motor Body Works), 311 Whitehorse Road, Balwyn, 3103; D.A.41847/3; 16th December, 1975; 1.75 tonne.
- LES RILEY PTY. LTD., 21 Bland Street, Yarram, 3971; D.A.65816; 27th November, 1975; 2.75 tonne.
- SERVIS PANEL WORKS PTY. LTD., 4-6 Levanswell Road, Moorabbin, 3189; D.A.67362/2; 17th December, 1975; 2.20 tonne.
- WARFE, A. N., Nepean Highway, Dromana, 3936; D.A.61139; 16th December, 1975; 1.85 tonne.

## RENEWAL WITH VARIATION.

Application made by the person listed hereunder for renewal of the licence listed with variation of conditions in the manner set out opposite the name.

CUTHBERTSON & RICHARDS SAWMILLS PTY. LTD., Payne Street, Bairnsdale, 3875; D.A.43930/2; 14th August, 1975. Application to renew and vary the conditions of licence No. D.A.43930/2 (L/C. 1.35 tonne) by adding an additional paragraph (b)—(b) between sawmills at Bendoc and Bairnsdale in the course of business as "Sawmillers"—own goods.

Notice of any objection should be forwarded to reach the Secretary of the Board not later than 23rd July, 1975.

Applicants are advised that it will not be necessary to appear on the hearing date specified above, unless advised in writing by the Board.

A. V. C. COOK,

Secretary.

Corner Lygon and Princes Streets, Carlton, 3053, Wednesday, 9th July, 1975.

## NOTICE TO MARINERS.

[No. 111 of 1975.]

## AUSTRALIA.—VICTORIA.

PORT PHILLIP.—DRILLING OPERATIONS IN PROGRESS.

Date: On or about 4th July, 1975.

Position: 30 metres south of Gellibrand Pile Light Lat. 37 deg. 53 min. S. Long. 144 deg. 55 min. E (approx.)

Details: A steel drilling barge, 20 x 10 metres anchored in the above position will be carrying out site investigation drilling works for a period of approximately 10 days.

The barge will display the shapes and lights required by the International Regulations for Preventing Collision at Sea.

Mariners are requested to proceed at slow speed when passing the barge.

Charts Affected: Aus. 155, Aus. 143.

A. J. WAGGLEN,

Port Officer.

Public Works Department,

Ports and Harbors Division,

168 Exhibition Street,

Melbourne, 3000, 1st July, 1975.

## NOTICE TO MARINERS.

[No. 107 of 1975.]

## AUSTRALIA.—VICTORIA.

CORNER INLET AND PORT ALBERT.—FAIRWAY BUOYS MISSING FROM STATIONS.

1. Corner Inlet Approach—No. 2 Buoy Lat. 38 deg. 51 min. S., Long. 146 deg. 36 min. E. (Approx.) is missing from station.

2. Port Albert Approach—Fairway buoy, red can Lat. 38 deg. 46 min. S., Long. 146 deg. 42 min. E. (approx.) has been reported 2 miles west of chartered position.

Charts Affected.—Aus. 801, Aus. 357.

A. J. WAGGLEN,

Port Officer.

Public Works Department,

Ports and Harbors Division,

168 Exhibition Street, Melbourne, Vic., 3000.

30th June, 1975.

## TOW TRUCK RENEWALS.

- ANKETELL, B., E. J., R. T. & G. B., & Y. S. LONCRANE (trading as Anketell Motors, 116 Main Street, Drouin, 3818; D.A.24560/3; 22nd December, 1975; 3.00 tonne.
- ARNOTT, H. W. (trading as Arnotts Motors), 88-90 Bridge Street, Benalla, 3672; D.A.67456; 14th January, 1976; 4.15 tonne.

## Private Agents Act 1966.

## NOTICE OF RECEIPT OF APPLICATIONS FOR LICENCES UNDER THE PROVISIONS OF THE PRIVATE AGENTS ACT 1966.

The Clerk(s) of the Magistrates' Court(s) as listed hereunder hereby give notice that applications, as under, have been lodged for hearing by the said Court(s) on the date(s) specified.

Any person desiring to object to any of such applications must—

- (a) lodge with the respective Clerk of the Magistrates' Court a notice in the prescribed form of his objection and of the grounds thereof;
- (b) cause a copy of such notice to be served personally or by post upon the applicant at least three days before the hearing of the application; and
- (c) send or deliver—
  - (i) where the objection is not made by the officer in charge of the police district in which the Court is situated—a copy of the notice to such officer; and
  - (ii) where the objection is not made by the Registrar or Deputy Registrar—a copy to the Registrar.

Full Name of Applicant or in the Case of a Firm or Corporation, of the Nominee.	Place of Abode of Applicant or Nominee.	Name of Firm or Corporation.	Address for Registration.	Type of Licence.	Date of Hearing of Application.
---	---	------------------------------	---------------------------	------------------	---------------------------------

## MAGISTRATES' COURT, FRANKSTON.

Britton, Ernest John	196 Austin Road, Seaford		196 Austin Road, Seaford	Inquiry Agent	14.7.75
----------------------	--------------------------	--	--------------------------	---------------	---------

Dated at Frankston this 23rd day of June, 1975.

J. BOUNDY, Clerk of the Magistrates' Court.

## MAGISTRATES' COURT, PORT MELBOURNE.

Baker, David George	242 Main Road, East St. Albans	Mayne Nickless Limited	94 York Street, South Melbourne	Watchman	5.8.75
Lucas, Ian Darryl	4 Lorimer Street, Melton	" " "	" " "	"	"
Parker, George Edward	42 Bayview Road, Glenroy	" " "	538 Williamstown Road, Port Melbourne	"	"
Naudi, Anthony Paul	2/112 East Esplanade, St. Albans	" " "	" " "	"	19.8.75

Dated at Port Melbourne this 30th day of June, 1975.

JOHN ARDLIE, Clerk of the Magistrates' Court.

## MAGISTRATES' COURT, GEELONG.

McAlpine, William Gary	12 Callendar Thompson Street	Geelong Armed and Security Service Co. Pty. Ltd.	55 The Esplanade North Shore	Watchman	14.7.75
Scholl, Doreen Margaret	27 Frys Road, Corio	" " "	" " "	Inquiry Agent	25.7.75
Scholl, Reginald	" " "	" " "	" " "	Inquiry Agent	"
Scholl, Anthony Paul	" " "	" " "	" " "	Watchman	16.7.75

Dated at Geelong this 30th day of June, 1975.

J. E. REILLY, Clerk of the Magistrates' Court.

## MAGISTRATES' COURT, BOX HILL.

Ericksen, Thomas Joseph Fabian	34 Edwards Street, Essendon	Internal Security Company Limited	8-12 Market Street, Box Hill	Inquiry Agent (Corporation)	1.8.75
" " " " "	" " "	" " "	" " "	Guard Agent (Corporation)	"

Dated at Box Hill this 1st day of July, 1975.

P. C. CLOTHIER, Clerk of the Magistrates' Court.

## MAGISTRATES' COURT, NORTHCOTE.

Reid, Dennis Norman John	3/7 Oak Flemington Street		257 Gooch Street, Thornbury	Process Server	29.7.75
" " " " "	" " "	" " "	" " "	Inquiry Agent	"

Dated at Northcote this 1st day of July, 1975.

PETER O'FARRELL, Clerk of the Magistrates' Court.

## MAGISTRATES' COURT, ELTHAM.

Swann, Derek Joseph	Lot 2 Haleys Gully Road, Hurstbridge		Lot 2 Haleys Gully Road, Hurstbridge	Guard	24.7.75
" " " " "	" " "	" " "	" " "	Inquiry Agent	"

Dated at Eltham this 1st day of July, 1975.

JOHN M. WALSH, Clerk of the Magistrates' Court.

## MAGISTRATES' COURT, OAKLEIGH.

Durkin, James Vincent	7 Avondale Grove, Mt. Waverley		P.O. Box 184, Mt. Waverley	Watchman	25.7.75
-----------------------	--------------------------------	--	----------------------------	----------	---------

Dated at Oakleigh this 2nd day of July, 1975.

A. J. JOHNSON, Clerk of the Magistrates' Court.

## MAGISTRATES' COURT, BROADMEADOWS.

Gray, Edward Francis	8 Martha Court, Craieburn		8 Martha Court, Craieburn	Guard Agent	24.7.75
----------------------	---------------------------	--	---------------------------	-------------	---------

Dated at Broadmeadows this 2nd day of July, 1975.

G. G. WILLIAMSON, Clerk of the Magistrates' Court.

## MAGISTRATES' COURT, FRANKSTON.

Holley, Wayne John	3/25 Fairway Street, Frankston		14 Scoble Street, Frankston	Inquiry Agent	22.7.75
" " " " "	" " "	" " "	" " "	Process Server	"

Dated at Frankston this 30th day of June, 1975.

J. BOUNDY, Clerk of the Magistrates' Court.

## PRIVATE AGENTS—continued.

Full Name of Applicant or in the Case of a Firm or Corporation, of the Nominee.	Place of Abode of Applicant or Nominee.	Name of Firm or Corporation.	Address for Registration.	Type of Licence.	Date of Hearing of Application.
MAGISTRATES' COURT, MELBOURNE.					
Belmont, Christopher John ..	11-19 Tiuna Grove, Elwood	Mayne Nickless Limited	94 York Street, South Melbourne	Watchman ..	13.6.75
Drury, Maurice William ..	East Bridge Hostel, Nunawading	" " "	" " "	" ..	"
Gannon, Michael John ..	35 Elliot Street, Mordialloc	" " "	" " "	" ..	"
Hinds, David John ..	20 St. Albans Road, Keilor	" " "	" " "	" ..	"
Knight, Michael John ..	1/67 Hammond Road, Dandenong	" " "	" " "	" ..	"
Norris, Gary Charles ..	2 Crellin Grove, Camberwell	" " "	" " "	" ..	"
Scodella, Tino Nienzio ..	43 Angus Street, Glenroy	" " "	" " "	" ..	"
Vernon, Terence Peter ..	142 Shield Street, Flemington	" " "	" " "	" ..	"
Wylde, Stewart ..	2/230 Queens Parade, Clifton Hill	" " "	" " "	" ..	"

Dated at Melbourne this 1st day of July, 1975.

G. L. WEBSTER, Clerk of the Magistrates' Court.

## MAGISTRATES' COURT, DROMANA.

Castles, Robert William ..	163 Sixth Avenue, Rosebud	J. A. Cull (trading as Southern Cross Security Services)	701 Nepean Highway, McCrae	Watchman ..	4.8.75
Evans, Stewart Malcolm ..	2 Catherine Street, McCrae	R. Platek (trading as Highland Security Service)	1/31 Blamey Street, Noble Park	" ..	"

Dated at Dromana this 3rd day of July, 1975.

B. DOBSON, Clerk of the Magistrates' Court.

## MAGISTRATES' COURT, BOX HILL.

Keck, Lynton John ..	10 Boronia Street, Surrey Hills	" " "	94 York Street, South Melbourne	Watchman ..	8.8.75
----------------------	---------------------------------	-------	---------------------------------	-------------	--------

Dated at Box Hill this 3rd day of July, 1975.

P. C. CLOTHIER, Clerk of the Magistrates' Court.

## MAGISTRATES' COURT, ELTHAM.

Pelling, Nicholas Berend ..	" Coori Bank " Yarra Glen Road, Kangaroo Ground	" " "	" Coori Bank " Yarra Glen Road, Kangaroo Ground	Inquiry Agent ..	24.7.75
-----------------------------	---	-------	---	------------------	---------

Dated at Eltham this 3rd day of July, 1975.

JOHN M. WALSH, Clerk of the Magistrates' Court.

## MAGISTRATES' COURT, PORT MELBOURNE.

Ashley, Ian Russell ..	4/52 Raleigh Street, Prahran	Mayne Nickless Limited	538 Williamstown Road, Port Melbourne	Watchman ..	19.8.75
Howes, Bruce John ..	12 Bellara Crescent, St. Albans	" " "	" " "	" ..	"
Jones, Raymond John ..	14 Nairn Street, Ashburton	" " "	" " "	" ..	"
Kirby, Frederick Stephen ..	14 Fairbank Avenue, Tullamarine	" " "	" " "	" ..	"
Symon, Robert Francis Blair ..	3/19 Horace Street, Malvern	" " "	" " "	" ..	"
Marks, Alick William ..	4/46 Swift Street, Thornbury	" " "	" " "	" ..	"

Dated at Port Melbourne this 4th day of July, 1975.

JOHN ARDLIE, Clerk of the Magistrates' Court.

## MAGISTRATES' COURT, SALE.

Kuizenga, Niesko ..	5 Rolland Court, Sale	" " "	8 Elston Court, Sale	Watchman ..	29.7.75
---------------------	-----------------------	-------	----------------------	-------------	---------

Dated at Sale this 3rd day of July, 1975.

M. W. GERKENS, Clerk of the Magistrates' Court.

## MAGISTRATES' COURT, COLLINGWOOD.

Kubilay, Mehmet ..	85 Graham Street, Sunshine	" " "	1 Southampton Crescent, Abbotsford	Watchman ..	24.7.75
--------------------	----------------------------	-------	------------------------------------	-------------	---------

Dated at Collingwood this 3rd day of July, 1975.

GRAHAM COLLINS, Clerk of the Magistrates' Court.



State Electricity Commission Acts.  
STATE ELECTRICITY COMMISSION OF VICTORIA.  
ELECTRICAL APPROVALS BOARD.

In accordance with the requirements of the Electrical Approvals Regulations—Proceedings of Electrical Approvals Board, the State Electricity Commission of Victoria hereby gives notice that the following appointments have been made pursuant to the provisions contained in section 51 of the State Electricity Commission Act 1958, and the said Regulations, viz.:

CHARLES FRANK BAKER as representing the workers in the electrical trade; and  
PHILIP JOHN MARKS as representing the interests of the fire underwriters  
to be members of the said Board to hold office until the 30th day of June, 1978.

Dated the 29th day of May, 1975.  
F. P. CHIPPERFIELD,  
Secretary.

COUNTRY ROADS BOARD.

RESOLUTIONS OF THE COUNTRY ROADS BOARD.

The Country Roads Board, in pursuance of the provisions of the Country Roads Act 1958, has passed Resolutions the dates whereof and the terms of which are scheduled hereunder:

SCHEDULE.

Main Roads.

Resolution dated the Ninth day of June, One thousand nine hundred and seventy-five, made pursuant to sections 21 and 58 of the Country Roads Act 1958, declaring the deviation from the Buninyong—Mt. Mercer Road in the Shire of Buninyong, as indicated by diagonal hatching on plans numbered G.P.12438 and G.P.12439 hereunder to be part of a main road within the meaning and for the purposes of the said Act, and also declaring that such deviation shall be in lieu of the existing road or part thereof indicated by cross hatching and horizontal hatching on plan numbered G.P.12439 which part indicated by cross hatching on the said plan shall be discontinued.

MAIN ROAD  
BUNINYONG — MT. MERCER ROAD  
SHIRE OF BUNINYONG  
Measurements in Links

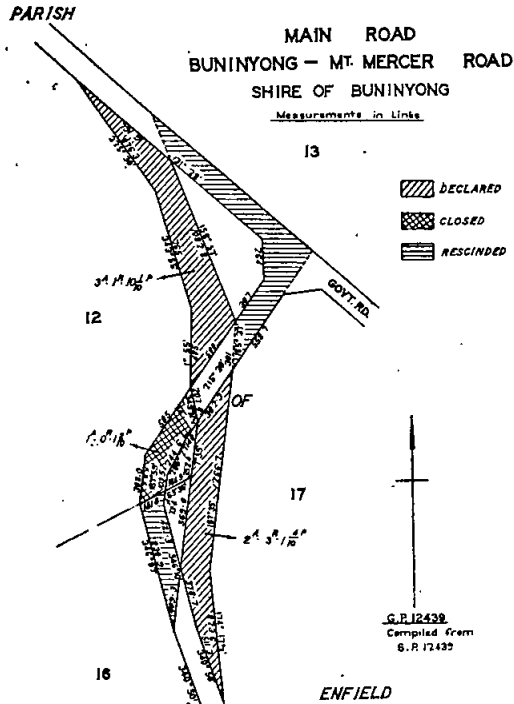
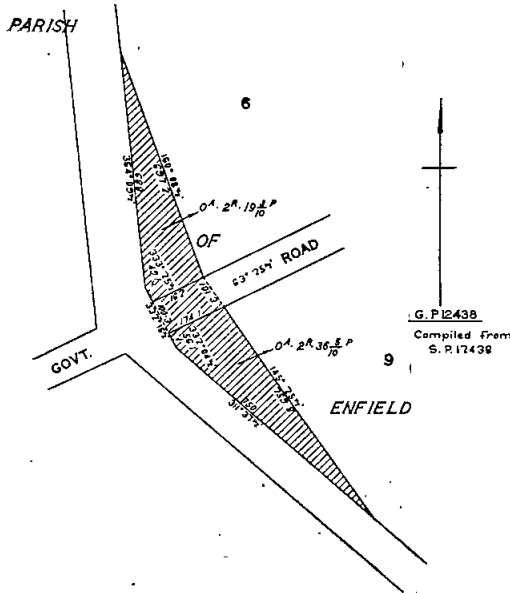

Resolution dated the Ninth day of June, One thousand nine hundred and seventy-five, made pursuant to section 21 of the Country Roads Act 1958, declaring the widening of Robinvale Road in the Shire of Swan Hill, as shown hatched on plan numbered G.P.13361 hereunder to be part of a main road within the meaning and for the purposes of the said Act.

MAIN ROAD  
ROBINVALE ROAD  
SHIRE OF SWAN HILL  
Measurements in Links

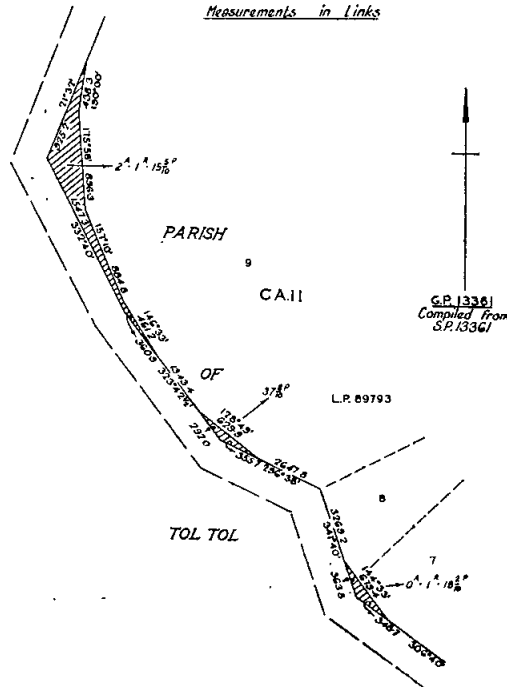

Resolution dated the Twenty-third day of June, One thousand nine hundred and seventy-five, made pursuant to sections 21 and 58 of the Country Roads Act 1958, declaring the deviation from the Ballan-Meredith Road in the Shire of Ballan, as indicated by diagonal hatching on plans numbered G.P.13410A and G.P.13410B hereunder to be part of a main road within the meaning and for the purposes of the said Act, and also declaring that such deviation shall be in lieu of the existing road or part thereof indicated by cross hatching on the said plans and that such part of the said existing road shall be discontinued.

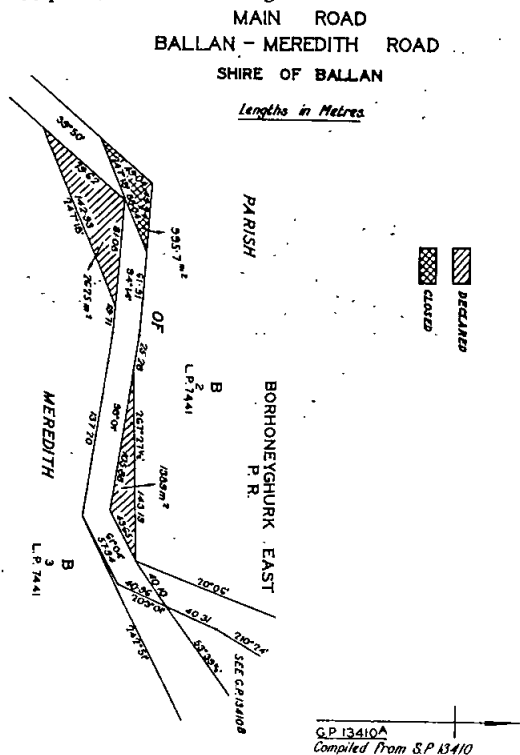

MAIN ROAD  
BALLAN - MEREDITH ROAD  
SHIRE OF BALLAN  
*Lengths in Metres*

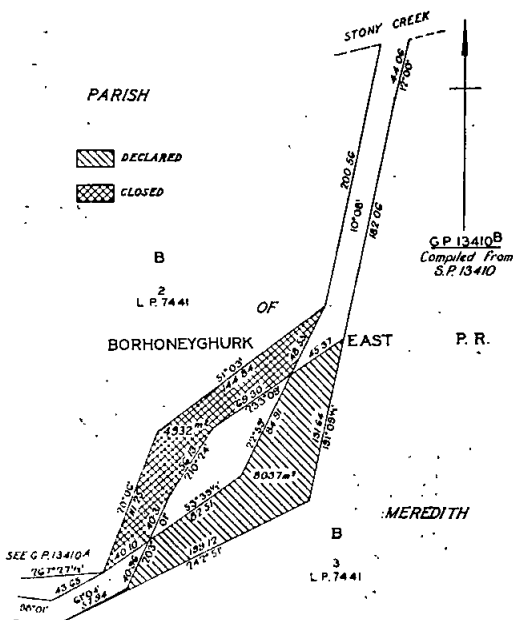

Resolution dated the Twenty-third day of June, One thousand nine hundred and seventy-five, made pursuant to section 21 of the Country Roads Act 1958, declaring the widening of the Pascoe Vale Road in the City of Broadmeadows, as shown hatched on plan numbered G.P.13006C hereunder to be part of a main road within the meaning and for the purposes of the said Act.

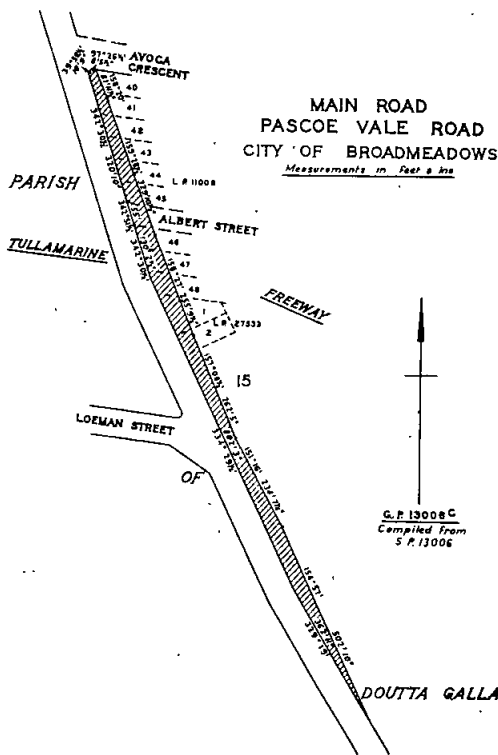

Resolution dated the Twenty-third day of June, One thousand nine hundred and seventy-five, made pursuant to section 21 of the Country Roads Act 1958, declaring the widening of Wellington Road in the City of Oakleigh, as shown hatched on plan number G.P.11803A hereunder to be part of a main road within the meaning and for the purposes of the said Act.

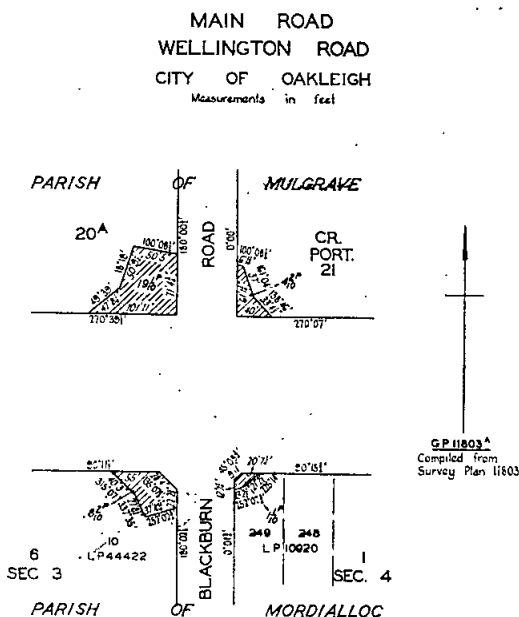

Freeway.

Resolution dated the Twenty-third day of June, One thousand nine hundred and seventy-five, made pursuant to sections 21 and 101 of the Country Roads Act 1958, declaring the road in the Cities of Broadmeadows, Coburg and Keilor, as shown hatched on plans numbered G.P.13005, G.P.13006A, G.P.13006B, G.P.10773A, G.P.10799A, G.P.10798A, G.P.13007, G.P.13340A, G.P.13340B, and G.P.13341 hereunder to be a freeway (Tullamarine Freeway) within the meaning and for the purposes of the said Act.

FREWAY  
TULLAMARINE FREEWAY  
CITY OF BROADMEADOWS  
*Measurements in feet & ins*

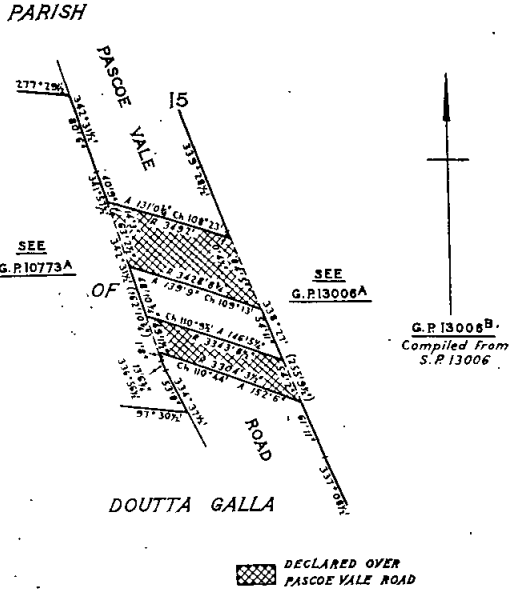
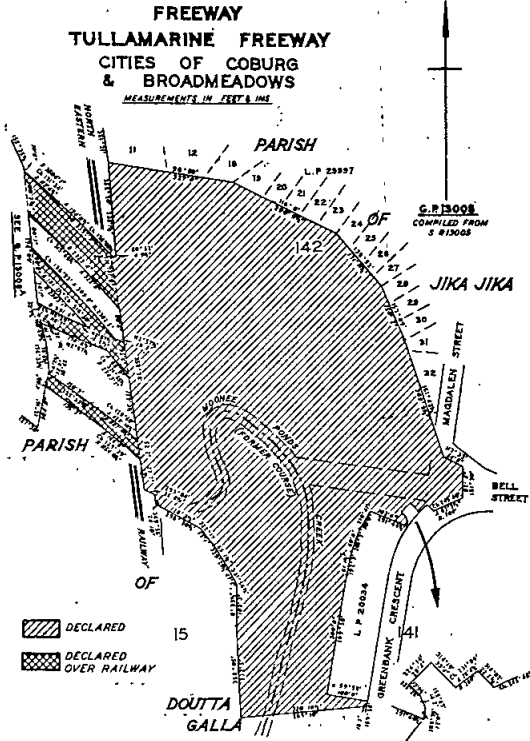

FREWAY  
TULLAMARINE FREEWAY  
CITIES OF COBURG & BROADMEADOWS  
*Measurements in feet & ins*

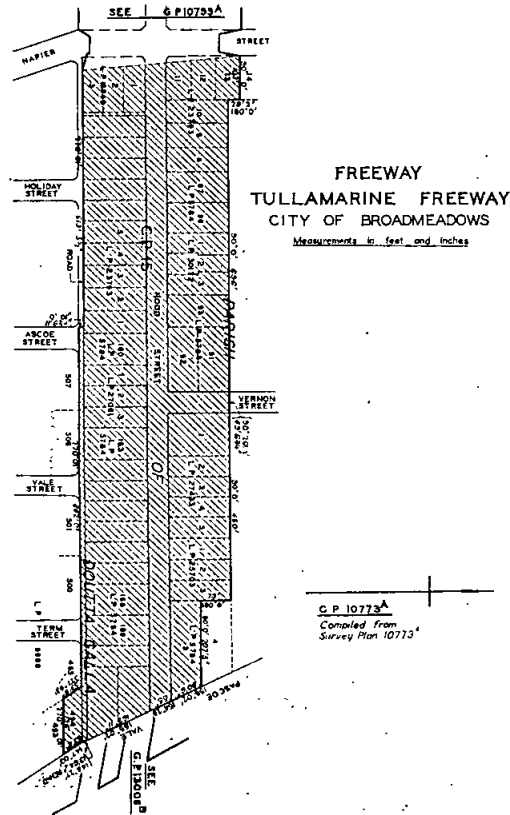
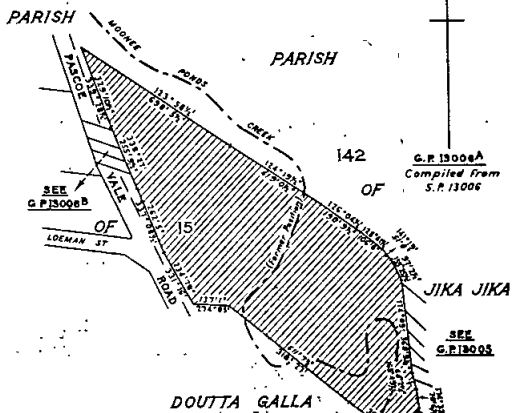

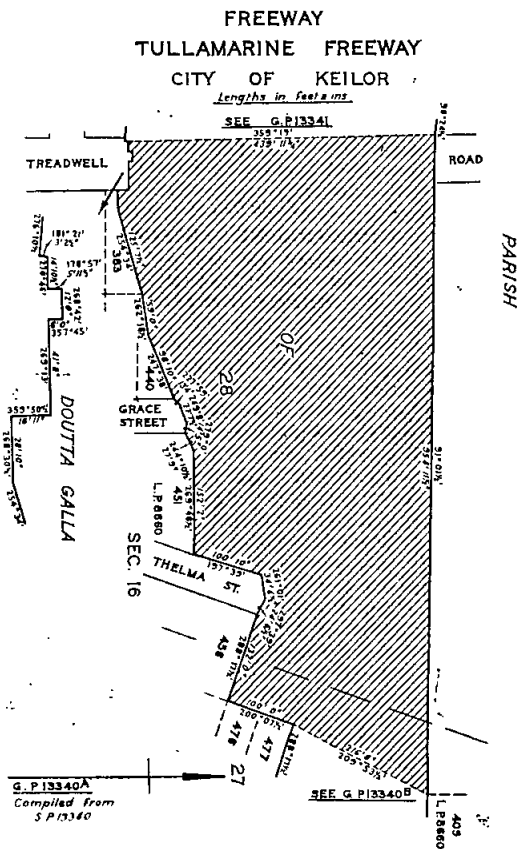
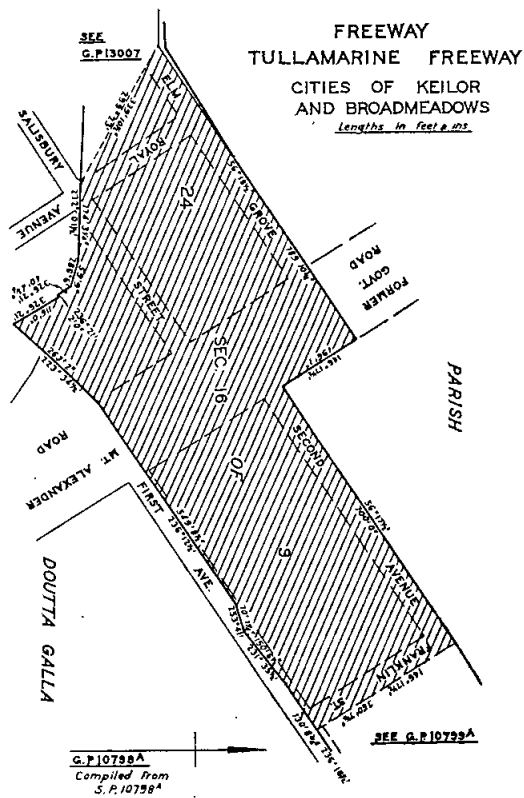
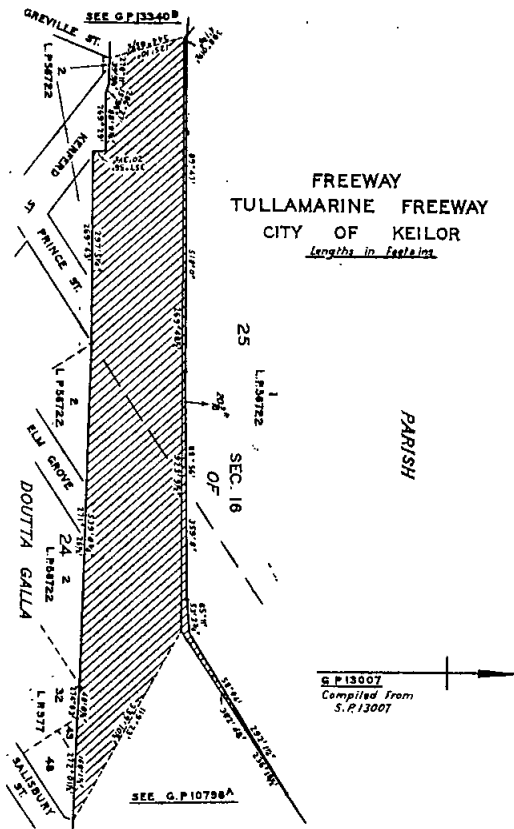
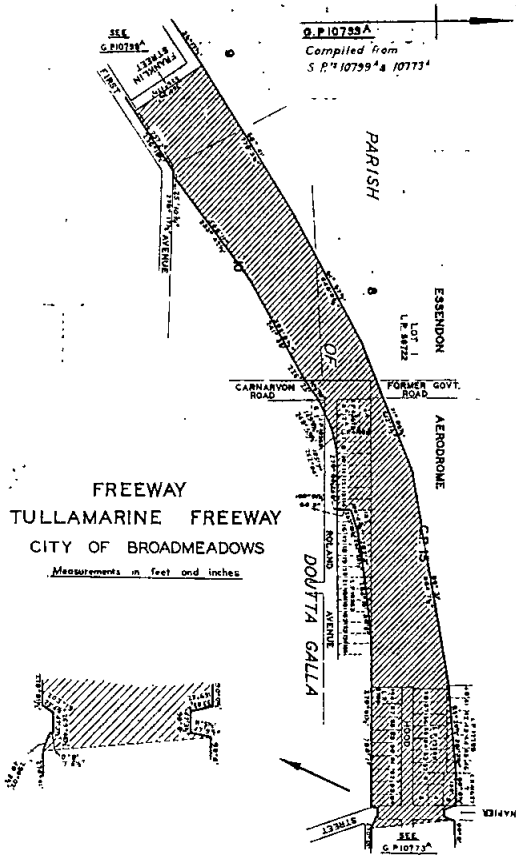

Unclassified Roads.

Resolution dated the Twenty-third day of June, One thousand nine hundred and seventy-five, made pursuant to sections 21 and 110 of the Country Roads Act 1958, declaring the road in the City of Broadmeadows as shown hatched on plan numbered G.P.10773b hereunder to be a road (Napier Street) within the meaning and for the purposes of the said Act.

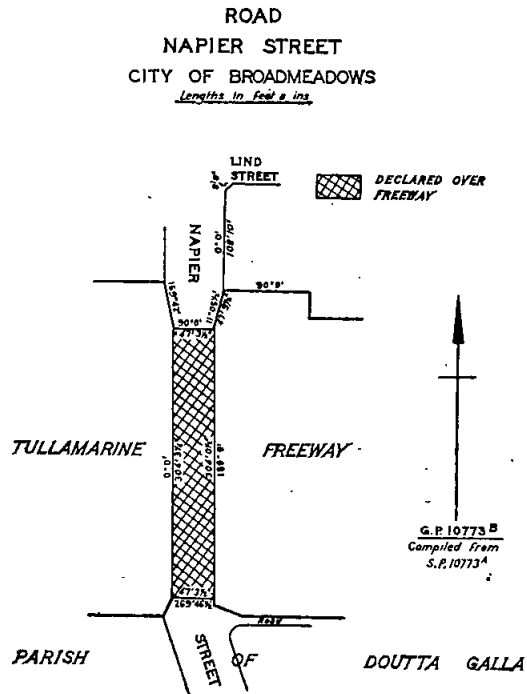
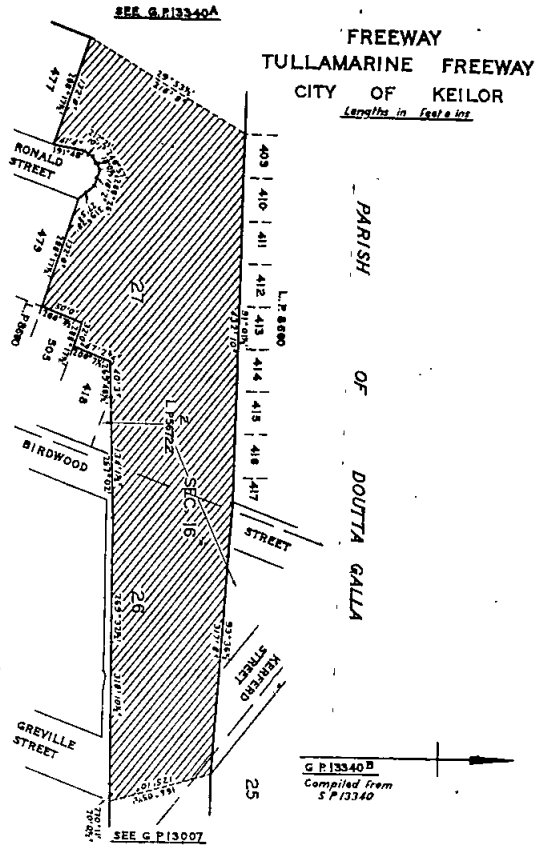

Resolution dated the Twenty-third day of June, One thousand nine hundred and seventy-five, made pursuant to sections 21 and 110 of the Country Roads Act 1958, declaring the widening of a road in the City of Broadmeadows, as shown hatched on plan numbered G.P.10773c hereunder to be part of a road within the meaning and for the purposes of the said Act.

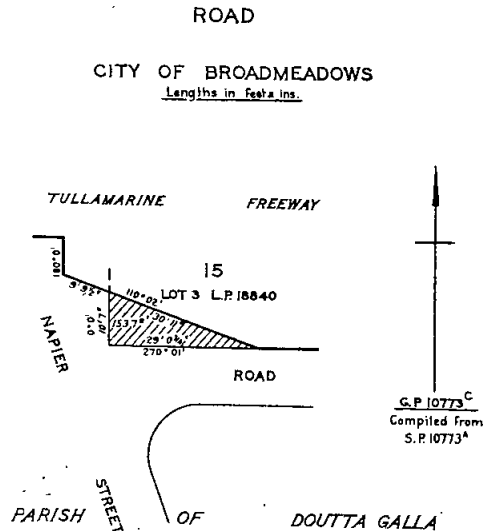
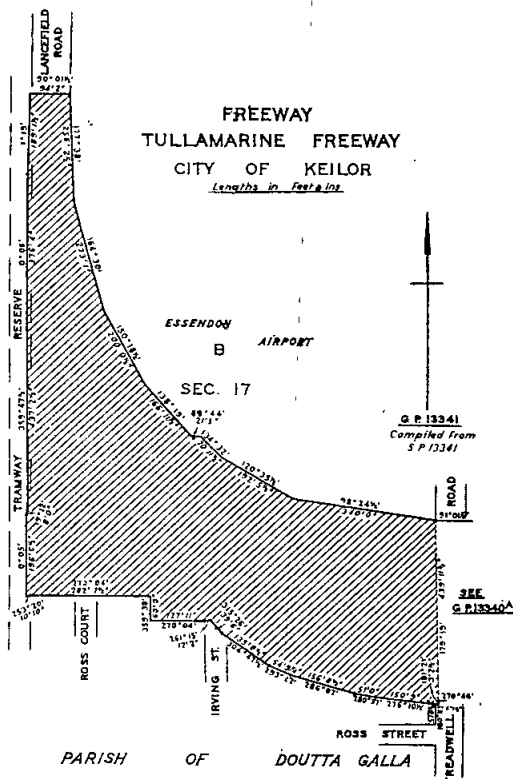

Resolution dated the Twenty-third day of June, One thousand nine hundred and seventy-five, made pursuant to sections 21 and 110 of the *Country Roads Act 1958*, declaring the widening of Carnarvon Road in the City of Broadmeadows, as shown hatched on plan numbered G.P.10799B hereunder to be part of a road within the meaning and for the purposes of the said Act.

Keilor, as shown hatched on plan numbered G.P.13340C hereunder to be part of a road within the meaning and for the purposes of the said Act.

ROAD  
CARNARVON ROAD  
CITY OF BROADMEADOWS  
Lengths in feet & ins.

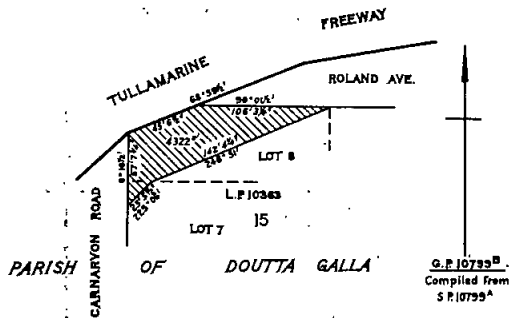

ROAD  
RONALD STREET  
CITY OF KEILOR  
Lengths in feet & ins.

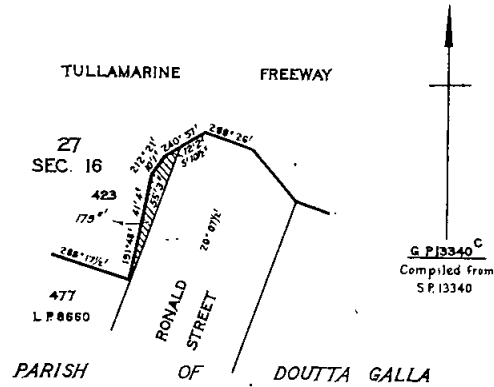

Resolution dated the Twenty-third day of June, One thousand nine hundred and seventy-five, made pursuant to sections 21 and 110 of the *Country Roads Act 1958*, declaring the road in the City of Coburg, as shown hatched on plan numbered G.P.13005A hereunder to be a road within the meaning and for the purposes of the said Act.

Resolution dated the Twenty-third day of June, One thousand nine hundred and seventy-five, made pursuant to sections 21 and 110 of the *Country Roads Act 1958*, declaring the widening of Thelma Street in the City of Keilor as shown hatched on plan numbered G.P.13340D hereunder to be part of a road within the meaning and for the purposes of the said Act.

ROAD  
CITY OF COBURG  
Lengths in feet & ins.

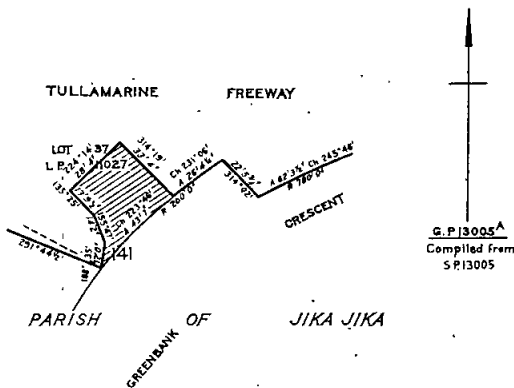

ROAD  
THELMA STREET  
CITY OF KEILOR  
Lengths in feet & ins.

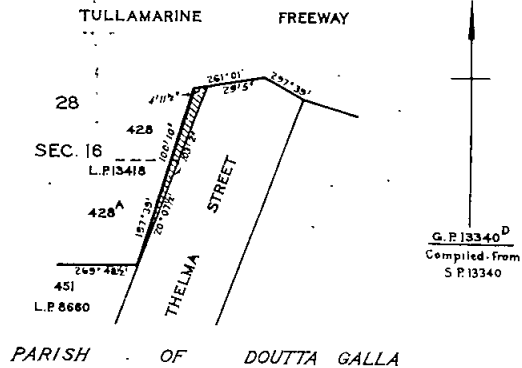

Resolution dated the Twenty-third day of June, One thousand nine hundred and seventy-five, made pursuant to sections 21 and 110 of the *Country Roads Act 1958*, declaring the widening of Ronald Street in the City of

Keilor, as shown hatched on plan numbered G.P.13340D hereunder to be part of a road within the meaning and for the purposes of the said Act.

declaring the road in the City of Keilor as shown hatched on plan numbered G.P.13340E hereunder to be a road within the meaning and for the purposes of the said Act.

Oakleigh, as shown hatched on plan numbered G.P.11803B hereunder to be part of road within the meaning and for the purposes of the said Act.

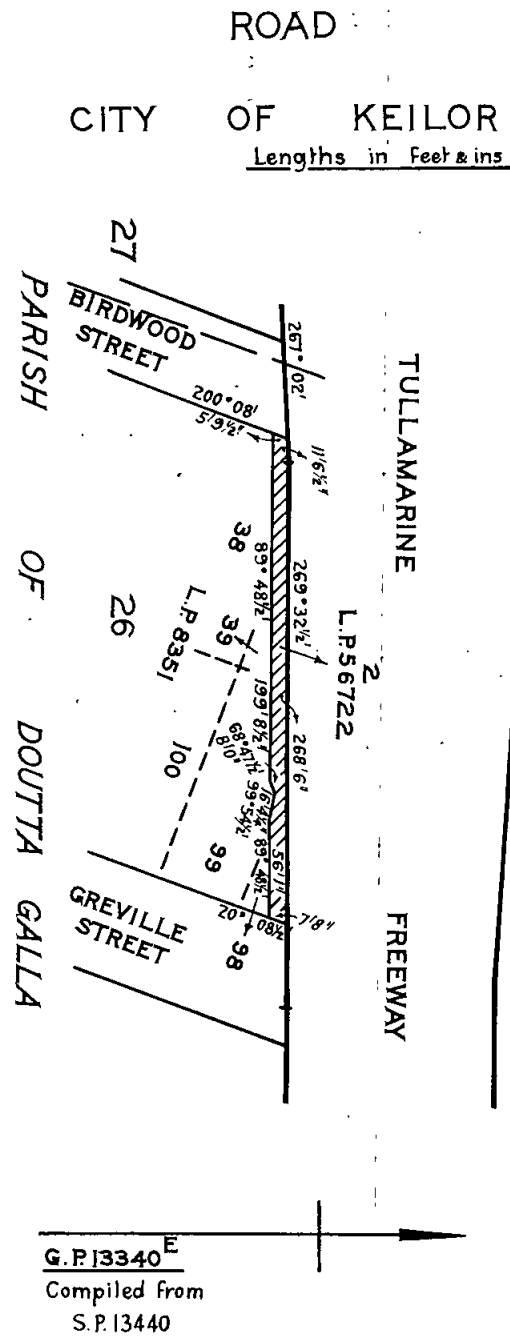

Resolution dated the Twenty-third day of June, One thousand nine hundred and seventy-five, made pursuant to sections 21 and 110 of the Country Roads Act 1958, declaring the widening of Blackburn Road in the City of

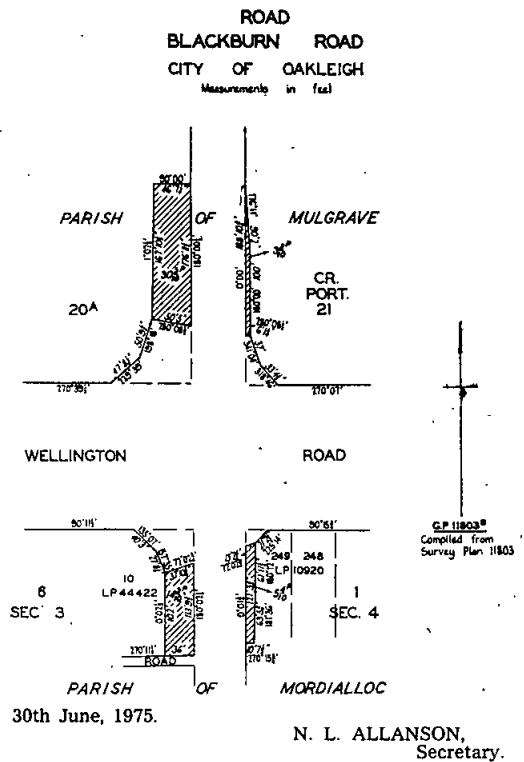

*Stamps Act 1958.*  
**ANNUAL LICENCE.**  
NOTIFICATION PURSUANT TO SECTION 97.  
I hereby notify that stamp duty has been paid for a licence under section 96 of the Stamps Act to carry on assurance and insurance business in Victoria from 1st January, 1975, to 31st December, 1975, by the following:—  
HUDIG LANGEVELDT PTY. LIMITED.  
R. M. PHIBBS,  
Comptroller of Stamps.  
Stamp Duties Office,  
Melbourne, 9th July, 1975.

*Stamps Act 1958.*  
**ANNUAL LICENCE.**  
NOTIFICATION PURSUANT TO SECTION 97.  
I hereby notify that stamp duty has been paid for a licence under section 96 of the Stamps Act to carry on assurance and insurance business in Victoria from 1st January, 1975, to 31st December, 1975, by the following:—  
FRIENDS PROVIDENT LIFE OFFICE.  
R. M. PHIBBS,  
Comptroller of Stamps.  
Stamp Duties Office,  
Melbourne, 9th July, 1975.

*Stamps Act 1958.*  
**ANNUAL LICENCE.**  
NOTIFICATION PURSUANT TO SECTION 97.  
I hereby notify that stamp duty has been paid for a licence under section 96 of the Stamps Act to carry on assurance and insurance business in Victoria from 12th March, 1975, to 31st December, 1975, by the following:—  
RICHARD OLIVER & Co. PTY. LTD.  
R. M. PHIBBS,  
Comptroller of Stamps.  
Stamp Duties Office,  
Melbourne, 9th July, 1975.

*Co-operation Act 1958.***CHANGE OF NAME OF A SOCIETY.**

Notice is hereby given that ST. COLUMBAS CO-OPERATIVE CREDIT SOCIETY LIMITED which was incorporated as a Credit Society under the above-named Act on the thirty-first day of January, 1962, has registered a change of its name and is now incorporated under the name of BALLARAT DISTRICT CO-OPERATIVE CREDIT SOCIETY LIMITED under the said Act.

Dated at Melbourne this twenty-fourth day of June, 1975.

N. F. CURRY,  
Acting Deputy Registrar of Co-operative Societies.

*Co-operation Act 1958.***CHANGE OF NAME OF A SOCIETY.**

Notice is hereby given that POSTAL INSTITUTE CREDIT CO-OPERATIVE LIMITED which was incorporated as a Credit Society under the above-named Act on the twenty-sixth day of February, 1971, has registered a change of its name and is now incorporated under the name of POST-TEL INSTITUTE CREDIT CO-OPERATIVE LIMITED under the said Act.

Dated at Melbourne this twenty-seventh day of June, 1975.

N. F. CURRY,  
Acting Deputy Registrar of Co-operative Societies.

*Co-operation Act 1958.***COATESVILLE SCHOOL CO-OPERATIVE COMMUNITY ADVANCEMENT SOCIETY LIMITED.**

Notice is hereby given in pursuance of section 78 (7) of the *Co-operation Act 1958* and section 308 (2) of the *Companies Act 1961* that, at the expiration of three months from the date hereof, the name of the aforementioned society will, unless cause is shown to the contrary, be struck off the register and the society will be dissolved.

Dated this 13th day of June, 1975.

N. F. CURRY,  
Acting Deputy Registrar.

*Co-operation Act 1958.***PARK ORCHARDS STATE SCHOOL CO-OPERATIVE LIMITED.**

Notice is hereby given in pursuance of section 78 (7) of the *Co-operation Act 1958* and section 308 (2) of the *Companies Act 1961* that, at the expiration of three months from the date hereof, the name of the aforementioned society will, unless cause is shown to the contrary, be struck off the register and the society will be dissolved.

Dated this 13th day of June, 1975.

N. F. CURRY,  
Acting Deputy Registrar.

*Co-operation Act 1958.***MANIFOLD HEIGHTS PRIMARY SCHOOL CO-OPERATIVE SOCIETY LIMITED.****NOTICE OF DISSOLUTION OF SOCIETY.**

Notice is hereby given that I have this day registered the dissolution of the above-named society and cancelled its registration under the above-named Act.

Dated at Melbourne this 25th day of June, 1975.

N. F. CURRY,  
Acting Deputy Registrar of Co-operative Societies.

**Cattle Compensation Act 1967 (No. 7615).****APPROVED AGENT.****NOTICE UNDER SECTION 14.**

No. C.S. 63.

I hereby revoke the declaration made and published in the *Government Gazette* No. 84 on 15th September, 1971, of Rendell Ackland & Co., as an "Approved Agent" for the purposes of Part II. of the *Cattle Compensation Act 1967* with effect from 1st January, 1975.

Pursuant to the provisions of regulation 81 of the Stamps Regulations 1960, I hereby state that the aforesaid revocation is being made at the request of the said Rendell, Ackland & Co.

R. M. PHIBBS,  
Comptroller of Stamps.

Stamp Duties Office,  
Melbourne, 2nd July, 1975.

**Cattle Compensation Act 1967 (No. 7615).****APPROVED AGENT.****NOTICE UNDER SECTION 14.**

I hereby declare B. A., J. A., and J. E. Watson trading as Bruce Watson & Co. (number C.S.83 in the register) being a person carrying on business as a stock and station agent to be an "Approved Agent" for the purposes of part II. of the *Cattle Compensation Act 1967* with effect from 1st March, 1975.

R. M. PHIBBS,  
Comptroller of Stamps.

Stamp Duties Office,  
Melbourne, 9th July, 1975.

**Cattle Compensation Act 1967 (No. 7615).****APPROVED AGENT.****NOTICE UNDER SECTION 14.**

I hereby declare M. L. Pitts, L. J. Larkin and E. T. Pineo trading as Mervyn L. Pitts & Co. Pty. Ltd. (No. C.S. 84 in the register), being a person carrying on business as a stock and station agent, to be an "Approved Agent" for the purposes of part II of the *Cattle Compensation Act 1967* with effect from Friday 1st August, 1975.

R. M. PHIBBS,  
Comptroller of Stamps.

Stamp Duties Office,  
Melbourne, 9th July, 1975.

**Swine Compensation Act 1967 (No. 7614).****APPROVED AGENT.****NOTICE UNDER SECTION 14.**

No. C.S. 63.

I hereby revoke the declaration made and published in the *Government Gazette* No. 84 on 15th September, 1971, of Rendell, Ackland & Co. as an "Approved Agent" for the purposes of Part II. of the *Swine Compensation Act 1967* with effect from 1st January, 1975.

Pursuant to the provisions of regulation 81 of the Stamps Regulations 1960, I hereby state that the aforesaid revocation is being made at the request of the said Rendell, Ackland & Co.

R. M. PHIBBS,  
Comptroller of Stamps.

Stamp Duties Office,  
Melbourne, 2nd July, 1975.

**Swine Compensation Act 1967 (No. 7614).****APPROVED AGENT.****NOTICE UNDER SECTION 14.**

I hereby declare M. L. Pitts, L. J. Larkin and E. T. Pineo trading as Mervyn L. Pitts & Co. Pty. Ltd. (No. C.S. 84 in the register), being a person carrying on business as a stock and station agent, to be an "Approved Agent" for the purposes of part II of the *Swine Compensation Act 1967* with effect from Friday, 1st August, 1975.

R. M. PHIBBS,  
Comptroller of Stamps.

Stamp Duties Office,  
Melbourne, 9th July, 1975.

**Swine Compensation Act 1967 (7614).****APPROVED AGENT.****NOTICE UNDER SECTION 14.**

I hereby declare B. A., J. A., and J. E. Watson trading as Bruce Watson & Co. (number C.S.83 in the register) being a person carrying on business as a stock and station agent for the purposes of part II. of the *Swine Compensation Act 1967* with effect from 1st March, 1975.

R. M. PHIBBS,  
Comptroller of Stamps.

Stamp Duties Office,  
Melbourne, 9th July, 1975.

*Survey Co-ordination Act 1958.***NOTICE OF PROPOSAL TO ASSIGN A NAME.**

Pursuant to the powers conferred under section 28 of the above Act, the Place Names Committee hereby gives notice of its intention to assign the following name:—

*Name.*—Lake Narracan.

*Location.*—The area of land in the Parishes of Tanjil East and Narracan which was flooded by the State Electricity Commission of Victoria and which is known and referred to as "Yallourn Storage Dam".



**Municipality.—Shire of Narracan.**

Any person who objects to the above proposal may give notice of objection in writing, stating the reasons therefor, to the Secretary of the Committee, not more than two (2) months following publication of this notice.

By order of the Committee,  
P. G. SEWELL,  
Secretary.

Office of the Place Names Committee,  
Department of Crown Lands and Survey,  
Melbourne, Vic. 3002.

**Survey Co-ordination Act 1958.****NOTICE OF PROPOSAL TO ASSIGN A NAME.**

Pursuant to the powers conferred under section 28 of the above Act, the Place Names Committee hereby gives notice of its intention to assign the following name:—

**Name.**—Yulong Park.

**Location.**—The reserve on the corner of Plenty Road and Bent Street, Bundoora, 3083.

**Municipality.**—Shire of Diamond Valley.

Any person who objects to the above proposal may give notice of objection in writing, stating the reasons therefor, to the Secretary of the Committee, not more than two (2) months following publication of this notice.

By order of the Committee,  
P. G. SEWELL,  
Secretary.

Office of the Place Names Committee,  
Department of Crown Lands and Survey,  
Melbourne, Vic. 3002.

**Survey Co-ordination Act 1958.****NOTICE OF PROPOSAL TO ASSIGN A NAME.**

Pursuant to the powers conferred under section 28 of the above Act, the Place Names Committee hereby gives notice of its intention to assign the following name:—

**Name.**—Highpoint West Post Office.

**Location.**—Rosamond Road, Maribyrnong.

**Municipality.**—City of Sunshine.

Any person who objects to the above proposal may give notice of objection in writing, stating the reasons therefor, to the Secretary of the Committee, not more than two (2) months following publication of this notice.

By order of the Committee,  
P. G. SEWELL,  
Secretary.

Office of the Place Names Committee,  
Department of Crown Lands and Survey,  
Melbourne, Vic. 3002.

**Police Offences Act 1958, No. 6337.****DIVISION 1A.—STATE ADVISORY BOARD ON PUBLICATIONS.**

Whereas I have considered reports made to me by the State Advisory Board on Publications under section 180(2) (a) of the Police Offences Act.

I, John Frederick Rossiter, Chief Secretary for Victoria, in pursuance of the powers vested in me by section 180H (1) of the Police Offences Act, hereby determine that the following publications prescribed by title in the schedule hereunder shall be classified as restricted publications for the purposes of the above-named Act.

**SCHEDULE OF PUBLICATIONS.**

Title.	Publisher.
"The Americans—Baby"	Angus and Robertson
Joy of Love	Not shown
Kings Cross Venus No. 52	Venus Publications
Kings Cross Whisper No. 203	Peter Dennison
New Giant Kake No. 1	Not shown
New Giant Kake No. 2	Not shown
New Giant Kake No. 3	Not shown
New Giant Kake No. 4	Not shown
Pleasure No. 119	Peter Dennison
Ribald No. 135	Bertram Horne and Co.
Rip Off No. 24	Star Publication
Ripe and Ready	Not shown
Searchlight No. 112	Searchlight Publication
Sexy Swingers No. 130	Peter Dennison.

J. F. ROSSITER,  
Chief Secretary.

Chief Secretary's Office,  
Melbourne, 8th July, 1975.

No. 58.—6100/75.—2

**TEACHING SERVICE ACT 1958, SECTION 73.****PUBLIC SERVICE ACT 1958, SECTION 55.**

Miss Annamaria Gabrielle Mei, Record No. 1108648, Assistant Class, Secondary Schools Division, Bacchus Marsh High School, Education Department, having been charged under the provisions of section 55 of the *Public Service Act 1958*, as extended and made applicable to members of the Teaching Service by section 73 of the *Teaching Service Act 1958*, with being absent without leave from the 3rd February, 1975, to the 16th April, 1975, and such charge having been referred, by direction of the Honorable the Minister of Education, to the Teachers Tribunal, the Tribunal after enquiry finds such charge proven and under the provisions of the section of the Act above cited, hereby dismisses the said Annamaria Gabrielle Mei from the Teaching Service as from and including the 1st July, 1975.

J. J. KENNEDY, Alternate Chairman.  
A. F. LE CLERCQ, Secretary.

Office of the Teachers Tribunal,  
Melbourne, 30th June, 1975.

**TEACHING SERVICE ACT 1958, SECTION 73.****PUBLIC SERVICE ACT 1958, SECTION 55.**

Mrs. Jennifer M. Deslandes, Record No. 1155255, Assistant Class, Secondary Schools Division, Brunswick Girls High School, Education Department, having been charged under the provisions of section 55 of the *Public Service Act 1958*, as extended and made applicable to members of the Teaching Service by section 73 of the *Teaching Service Act 1958*, with being absent without leave from the 5th October, 1973, to the 7th October, 1974, and such charge having been referred, by direction of the Honorable the Minister of Education, to the Teachers Tribunal, the Tribunal after enquiry finds such charge proven and under the provisions of the section of the Act above cited, hereby dismisses the said Jennifer M. Deslandes from the Teaching Service as from and including the 1st July, 1975.

J. J. KENNEDY, Alternate Chairman.  
A. F. LE CLERCQ, Secretary.

Office of the Teachers Tribunal,  
Melbourne, 30th June, 1975.

**Cemeteries Act 1958.****SCALE OF FEES OF THE EAGLEHAWK PUBLIC CEMETERY.**

In pursuance of the powers conferred upon them by the Cemeteries Act the trustees of the Eaglehawk Public Cemetery hereby make the following scale of fees, which shall come into operation upon publication in the *Government Gazette*, and from and after such publication every scale of fees heretofore made by the said trustees shall be and is hereby rescinded to the extent to which it conflicts with this scale.

**Monumental Section.**

Grave sites:	
Private ground .. .. .	\$130.00
Private ground in special position .. .. .	\$140.00
Sinking and reopening:	
Adult graves .. .. .	\$80.00
Child graves (under five years or stillborn) .. .. .	\$10.00
Monumental fees:	
Erection of new monument .. .. .	\$20.00
Alterations to existing monument .. .. .	\$10.00

**Lawn Section.**

First interment (including plaque, flower container and right to second interment) .. .. .	\$270.00
Second interment (including plaque) .. .. .	\$140.00

**Lawn Monumental Section.**

First interment (including right to second interment) .. .. .	\$300.00
Second interment .. .. .	\$80.00

**Extra Charges.—Lawn and Monumental.**

Interment on Saturdays and Public Holidays .. .. .	\$45.00
Interment where order is given after 3.45 p.m. on day previous to funeral .. .. .	\$20.00
Shaping grave to fit rectangular coffin .. .. .	\$25.00
Extra sinking charge per 0.3048 m .. .. .	\$20.00

**Memorial Wall.**

Niche (including plaque) .. .. .	\$55.00
Reserved niche (including plaque) .. .. .	\$65.00

*Memorial Rose (Tenure 25 years).*

Rose in special bed with positions for two bronze plaques:	
First interment (including plaque and right to second interment)	\$100.00
Second interment (including plaque)	\$75.00

*Other Charges.*

Interment of cremated remains in grave	\$25.00
Exhumation (when authorized by Department of Health)	\$200.00
Search of records	\$3.00

A. W. BULLOCK, Trustee.  
J. TAYLOR, Trustee.  
P. W. CLYMO, Trustee.

Approved by the Governor in Council, 1st July, 1975.—  
L. G. HOUSTON, Acting Clerk of the Executive Council.

*Lawn Cemetery (Undenominational).*

Land for lawn grave including first interment	\$175.00
Second interment in same grave	\$90.00

*Miscellaneous Charges.*

Burial of stillborn child	\$16.00
Sinking each additional 0.3 m past 1.8 m	\$12.00
Sinking grave for oversize casket (extra)	\$20.00
Sinking and re-opening grave inside fence, &c. (extra)	\$12.00
Removing and replacing ledgers or breaking through sealings	\$12.00
Interment of cremated ashes	\$8.00
Interment not in prescribed hours or on Saturdays or Public Holidays	\$40.00

T. E. DUNSTAN, Trustee.  
J. P. SHARRY, Trustee.  
A. W. UEBERGANG, Trustee.

Approved by the Governor in Council, 1st July, 1975.—  
L. G. HOUSTON, Acting Clerk of the Executive Council.

*Cemeteries Act 1958.***SCALE OF FEES OF THE ARARAT PUBLIC CEMETERY.**

In pursuance of the powers conferred upon them by the Cemeteries Act the trustees of the Ararat Public Cemetery hereby make the following scale of fees, which shall come into operation upon publication in the *Government Gazette*, and from and after such publication every scale of fees heretofore made by the said trustees shall be and is hereby rescinded to the extent to which it conflicts with this scale.

*Lawn Cemetery.*

Lawn grave 2.44 m x 1.22 m, including cost of first interment	\$150.00
Second and subsequent interments	\$70.00

*Monumental Section.*

Land 2.44 m x 1.22 m including cost of first interment	\$74.00
Second and subsequent interments	\$60.00

P. CASHAN, Trustee.  
R. L. ROLPH, Trustee.  
W. ERWIN, Trustee.

Approved by the Governor in Council, 1st July, 1975.—  
L. G. HOUSTON, Acting Clerk of the Executive Council.

*Cemeteries Act 1958.***SCALE OF FEES OF THE GRANTVILLE PUBLIC CEMETERY.**

In pursuance of the powers conferred upon them by the Cemeteries Act the trustees of the Grantville Public Cemetery hereby make the following scale of fees, which shall come into operation upon publication in the *Government Gazette*, and from and after such publication every scale of fees heretofore made by the said trustees shall be and is hereby rescinded to the extent to which it conflicts with this scale.

*Lawn Cemetery (Udenominational).*

Lawn grave 2.44 x 1.22 m	\$105.00
For each interment therein	\$52.00
Bronze plaque for each interment	\$55.00
Memorial wall niche and plaque	\$55.00

C. A. BLACKNEY, Trustee.  
M. WALKER, Trustee.  
A. GEORGE, Trustee.

Approved by the Governor in Council, 1st July, 1975.—  
L. G. HOUSTON, Acting Clerk of the Executive Council.

*Cemeteries Act 1958.***SCALE OF FEES OF THE HORSHAM PUBLIC CEMETERY.**

In pursuance of the powers conferred upon them by the Cemeteries Act the trustees of the Horsham Public Cemetery hereby make the following scale of fees, which shall come into operation upon publication in the *Government Gazette*, and from and after such publication every scale of fees heretofore made by the said trustees shall be and is hereby rescinded to the extent to which it conflicts with this scale.

*General Cemetery.*

Land for private grave 2.44 m x 1.22 m	\$60.00
Sinking grave—adult	\$60.00
Sinking grave—child	\$40.00

*Cemeteries Act 1958.***SCALE OF FEES OF THE CHELTENHAM PUBLIC CEMETERY.**

In pursuance of the powers conferred upon them by the Cemeteries Act the trustees of the Cheltenham Public Cemetery hereby make the following scale of fees, which shall come into operation upon publication in the *Government Gazette*, and from and after such publication every scale of fees heretofore made by the said trustees shall be and is hereby rescinded to the extent to which it conflicts with this scale.

*Lawn Area.*

	Total Cost.
Land, 8 ft. x 4 ft.	\$180
Sinking fee	\$95
Land, 8 ft. x 4 ft. (special positions and facing drive)	\$200
Sinking fee	\$95
Reopening fee	\$95

*Monumental Area.*

Land, 8 ft. x 4 ft.	\$180
Sinking fee	\$95
Land, 8 ft. x 4 ft. (special positions and facing drive)	\$200
Sinking fee	\$95
Reopening fee	\$95

*Additional Charges.*

Interment Saturday Morning	\$60
Interment Sunday Morning	\$70
Interment Public Holiday and/or Cemetery Employees Picnic	\$70
Interment of cremated remains	\$20
Fees for exhumation (when authorized)	\$250
Removal of concrete top for reopening grave	\$7
Removal of ledger for reopening grave	\$15

J. CAMPBELL, Trustee.  
J. O'KELLY, Trustee.  
C. L. SIMPSON, Trustee.  
L. A. THOMAS, Secretary.

Approved by the Governor in Council, 1st July, 1975.—  
L. G. HOUSTON, Acting Clerk of the Executive Council.

*Cemeteries Act 1958.***SCALE OF FEES OF THE CHILTERN PUBLIC CEMETERY.**

In pursuance of the powers conferred upon them by the Cemeteries Act the trustees of the Chiltern Public Cemetery hereby make the following scale of fees, which shall come into operation upon publication in the *Government Gazette*, and from and after such publication every scale of fees heretofore made by the said trustees shall be and is hereby rescinded to the extent to which it conflicts with this scale.

*Public Graves.*

Interment in grave without exclusive right—stillborn child	\$16.00
Interment in grave without exclusive right—others	\$32.00
Number peg or label	\$5.00

*Private Graves.*

Land, 2.44 m x 1.22 m .. .. .	\$60.00
Own selection of site (extra) .. .. .	\$17.00

*Sinking Charges for Private Graves.*

Sinking grave 1.83 m deep .. .. .	\$52.00
Each additional 0.3 m .. .. .	\$10.00
Sinking oversize grave (extra) .. .. .	\$20.00
Sinking oversize grave for American type casket (extra) .. .. .	\$20.00
Cancellation of order to sink (if commenced) .. .. .	\$10.00

*Reopening Charges.*

Reopening grave (no cover) .. .. .	\$45.00
Reopening grave (with cover or kerb) .. .. .	\$50.00

*Extra Charges.*

Interment not in the prescribed hours or on Saturdays, Sundays or Public Holidays .. .. .	\$20.00
Interment in private grave without due notice .. .. .	\$20.00
Late fee (per half-hour or part thereof in excess of first fifteen minutes) .. .. .	\$2.50

*Miscellaneous Charges.*

Interment fee .. .. .	\$16.00
Certificate of right of burial .. .. .	\$2.50
Number plate or brick .. .. .	\$5.00
Inspection of plan or register .. .. .	\$2.00
Annual maintenance (single grave) .. .. .	\$17.00
Permission to erect a headstone or monument—5 per cent. of cost, with a minimum of \$6.00.	
Permission to construct a brick grave or to erect any stone kerb, brick, tilework or concrete .. .. .	\$7.00
Grave renovations or additional inscription .. .. .	\$6.00
Exhuming the remains of a body (when authorized) .. .. .	\$70.00
Interment of ashes in a private grave .. .. .	\$16.00
Memorial wall niche and plaque .. .. .	\$50.00

W. W. McLEAN, Trustee.  
W. E. CARMODY, Trustee.  
J. G. BYRON, Trustee.

Approved by the Governor in Council, 1st July, 1975.—  
L. G. HOUSTON, Acting Clerk of the Executive Council.

*Cemeteries Act 1958.*  
**SCALE OF FEES OF THE PORT FAIRY PUBLIC CEMETERY.**

In pursuance of the powers conferred upon them by the Cemeteries Act the trustees of the Port Fairy Public Cemetery hereby make the following scale of fees, which shall come into operation upon publication in the *Government Gazette*, and from and after such publication every scale of fees heretofore made by the said trustees shall be and is hereby rescinded to the extent to which it conflicts with this scale.

Land, 2.44 m x 1.22 m .. .. .	\$54.00
Sinking a grave, 2.13 m for two burials .. .. .	\$36.00
Sinking a grave, 2.75 m for three burials .. .. .	\$45.00
Reopening a grave .. .. .	\$36.00
Certificate of right of burial .. .. .	\$3.00
Land in stillborn area .. .. .	\$12.00
Interment fee .. .. .	\$18.00
Digging or interment on Saturdays, Sundays or Public Holidays (extra) .. .. .	\$18.00
Sinking a grave for American casket to 2.13 m .. .. .	\$45.00
Sinking a grave for American casket to 2.75 m .. .. .	\$53.00
Sinking a grave without due notice (extra) .. .. .	\$18.00
Sinking a grave for stillborn casket .. .. .	\$15.00
Lawn maintenance charge on each interment .. .. .	\$25.00
Permission to erect a monument .. .. .	\$15.00
Permission to inscribe a headstone .. .. .	\$3.50
Permission to alter an existing monument or to replace a slab .. .. .	\$8.00
Removing a slab to permit interment .. .. .	\$12.00

K. PARKINSON, Trustee.  
T. DIGBY, Trustee.  
F. D. PEVITT, Trustee.

Approved by the Governor in Council, 1st July, 1975.—  
L. G. HOUSTON, Acting Clerk of the Executive Council.

*Cemeteries Act 1958.*  
**SCALE OF FEES OF THE TATYOON PUBLIC CEMETERY.**

In pursuance of the powers conferred upon them by the Cemeteries Act the trustees of the Tatyoon Public Cemetery hereby make the following scale of fees, which shall come into operation upon publication in the *Government*

*ment Gazette*, and from and after such publication every scale of fees heretofore made by the said trustees shall be and is hereby rescinded to the extent to which it conflicts with this scale.

Grave site, 2.44 m x 2.44 m .. .. .	\$50.00
Grave site, 2.44 m x 1.22 m .. .. .	\$25.00

K. JOYCE, Trustee.  
M. D. MARTIN, Trustee.  
C. A. SUTHERLAND, Trustee.  
A. M. PHILLIPS, Trustee.

Approved by the Governor in Council, 1st July, 1975.—  
L. G. HOUSTON, Acting Clerk of the Executive Council.

**OFFICE OF THE OMBUDSMAN.**

Applications are invited for the position on the staff of the Ombudsman of—

INVESTIGATION OFFICER.

Yearly Salary—\$21,600.

*Qualifications.*—To have experience in conducting investigations and to possess a suitable tertiary qualification.

Terms and conditions of employment will be similar to those applicable to officers of the State Public Service (attention is directed to sections 8 and 9 of the *Ombudsman Act 1973*).

Applications detailing age, qualifications and experience should be marked "Personal" and lodged with the Ombudsman, 406 Collins Street, Melbourne, 3000, by Tuesday, 22nd July, 1975.

**NOTICE OF FIXING NEW ALIGNMENTS OF HEIDELBERG-KINGLAKE ROAD IN THE SHIRE OF DIAMOND VALLEY.**

Notice is hereby given that the Country Roads Board under the powers conferred upon it by the *Country Roads Act 1958* (No. 6229) has fixed a new alignment for the south side of Heidelberg-Kinglake Road in the Shire of Diamond Valley as shown on Survey Plan Numbered 13790.

Copies of the said Survey Plan are lodged in the offices of the Country Roads Board, the municipality of the Shire of Eltham, the Registrar of Titles and the Registrar-General respectively, and may be inspected by any person without a fee at any time at which such offices are open for business.

The locality in which the alignment has been fixed is indicated on the plan hereunder—

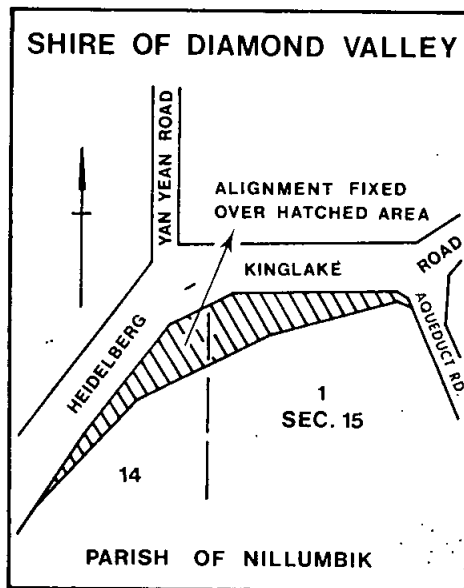

Dated 2nd July, 1975.

N. L. ALLANSON,  
Secretary.

Country Roads Board,  
60 Denmark Street, Kew.

**ROAD DEVIATION ORDER.—CITY OF PRESTON.**

In pursuance of the powers conferred by section 522 and 526 of the Local Government Act 1958, the Council of the City of Preston hereby directs that the land in the Parish of Jika Jika shown hatched on the plan hereunder shall be a public highway from and after the date of publication of this order in the *Government Gazette* and doth declare that such land shall be a public highway in lieu of the land in the parish shown cross hatched on the said plan.

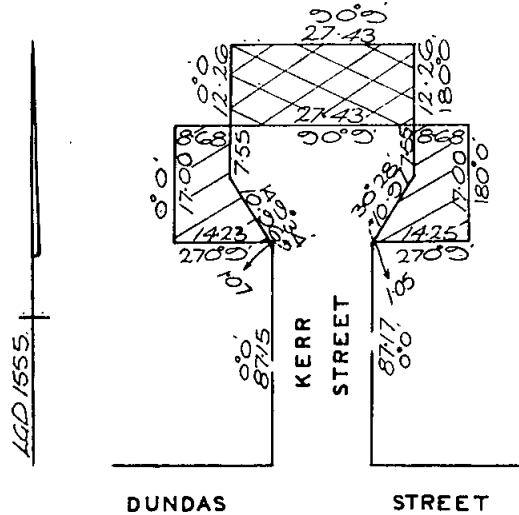

MEASUREMENTS ARE IN METRES

Dated the 10th day of February, 1975.

The common seal of the Mayor, Councillors and Citizens of the City of Preston was hereunto affixed in the presence of:—

- B. T. CONNOR, J.P., Mayor.
- (SEAL) A. H. CAPP, O.B.E., J.P., Councillor.
- J. C. DONATH, Town Clerk.

Confirmed by the Governor in Council, 3rd June, 1975.  
—TOM FORRISTAL, Clerk of the Executive Council.

Melbourne and Metropolitan  
BOARD OF WORKS.

GENERAL NOTICE.

The Melbourne and Metropolitan Board of Works having made provision for carrying off the sewage of each and every property which or any part of which is situate in the Sewerage Areas hereinafter described doth hereby declare that on and after the 14th day of July, 1975, each and every property so situate shall be deemed to be a seweraged property within the meaning of the *Melbourne and Metropolitan Board of Works Act 1958*.

The Sewerage Areas hereinbefore referred to are:—

*Sewerage Area No. 2838.*

*City of Knox.*—Commencing at the junction of Rachele Drive and Mountain Highway; thence westerly along Mountain Highway, northerly along the western boundaries of lots 19 Mountain Highway and 88 Tabilk Court, further northerly along Tabilk Court, easterly along portion of the northern boundary of lot 84 Tabilk Court, northerly along the western boundary of lot 83 Rachele Drive, easterly along Rachele Drive, northerly and easterly along the western and northern boundaries of a reserve to the north-western angle of lot 31 Rachele Drive, further easterly along the northern boundaries of lots 31 to 33 Rachele Drive, 42 to 44 Karen Court and 51 to 53 Dean Court, southerly along the eastern boundaries of lots 54 Dean Court and 56 Northam Road and a reserve, further southerly along the eastern boundaries of lots 74 to 76 Sullivan Court and 87 Mountain Highway, westerly along Mountain Highway to the commencing point.

*Sewerage Area No. 2839.*

*City of Heidelberg.*—Commencing at the junction of Ironbark Street and Jacaranda Place; thence westerly along Jacaranda Place and the southern boundary of lot 181

Jacaranda Place, northerly along the western boundaries of lots 181 and 180 Jacaranda Place and 178 and 177 Ironbark Street, north-westerly along the south-western boundary of lot 103 Rosemar Circuit, northerly along Rosemar Circuit; easterly along the northern boundary of lot 93 Rosemar Circuit, northerly along portion of the western boundary of lot 166 Oaktree Close, easterly along the northern boundaries of lots 166 to 164 Oaktree Close and 159 to 152 Northwood Drive, south-easterly along the north-eastern boundaries of lots 152 and 151 Northwood Drive, easterly along the northern boundaries of lots 150 Northwood Drive, 149 Protea Court and 140 Hendersons Road, southerly along Hendersons Road to the south-eastern angle of lot 144 Hendersons Road on the boundary of Sewerage Area No. 2453, generally south-westerly along the said area boundary to the commencing point.

*Sewerage Area No. 2840.*

*City of Altona.*—Commencing at a point in Slough Road 380 metres west of the western boundary of Maidstone Street; thence southerly by a line at right angles to Slough Road to a point 100 metres south of the southern boundary of Slough Road, westerly by a line to and along the southern boundaries of lots 19 to 15 Slough Road, northerly along the western boundary of the said lot 15, easterly along Slough Road, northerly along the western boundaries of lots 14 Slough Road and 12 to 9 Malton Court, easterly along the northern boundaries of lots 9 and 8 Malton Court, southerly along the eastern boundaries of lots 8 and 7 Malton Court, easterly along the northern boundaries of lots 23, 24 and 1 Slough Road to the north-eastern angle of the said lot 1, northerly by a line to a point on the production of the northern boundary of Ajax Road 486 metres west of the western boundary of Maidstone Street, further northerly by a line in continuation a distance of about 107 metres to the southern boundary of a railway reserve, easterly along the said reserve boundary and the northern boundary of lot 6 Ajax Road to the boundary of Sewerage Area No. 2415, generally southerly, westerly and southerly along the said area boundary to Slough Road, westerly along Slough Road to the commencing point.

*Sewerage Area No. 2841.*

*City of Waverley.*—Commencing at the south-western extremity of Harlingford Court; thence north-westerly along the south-western boundaries of lots 174 Harlingford Court and 173 Marykirk Drive, north-easterly along Marykirk Drive, south-easterly along the north-eastern boundary of lot 70 Marykirk Drive, north-easterly along portion of the north-western boundary of lot 75 Summerhill Avenue, southerly along the eastern boundaries of lots 75 and 76 Summerhill Avenue and 78 to 81 and 63 Haversham Avenue, easterly and southerly along the northern and eastern boundaries of lot 64 Haversham Avenue, south-westerly and north-westerly along the south-eastern and south-western boundaries of lot 127 Haversham Avenue, south-westerly along the south-eastern boundaries of lots 126 and 90 Garnett Road, north-westerly along the south-western boundaries of the said lot 90 and lots 135 to 142 Garnett Road, south-westerly along the south-eastern boundaries of lots 144 to 150 Harlingford Court, northerly along the western boundary of the said lot 150 to the commencing point.

*Sewerage Area No. 2842.*

*City of Sunshine.*—Commencing at the junction of Willis Street and Harris Street; thence westerly along the southern boundary of lot 1 Harris Street, northerly along the western boundaries of lots 1 to 6 Harris Street, easterly along the northern boundary of the said lot 6, southerly along Harris Street to the commencing point.

*Sewerage Area No. 2843.*

*City of Doncaster and Templestowe.*—Commencing at the junction of Rowan Street and Marsden Crescent; thence easterly, north-easterly and northerly along Marsden Crescent; generally easterly along the northern boundary of a municipal reserve to Hertford Road, northerly along Hertford Road, north-westerly along Jarma Cove and the south-western boundary of lot 65 Jarma Cove, north-easterly along the north-western boundary of lot 71 Leroy Place, northerly by a line to the south-western angle of lot 75 Leroy Place, north-westerly and easterly along the south-western and portion of the northern boundaries of the said lot 75, north-easterly along the north-western boundary of lot 78 Honni Mews, northerly by a line to the south-western angle of lot 83 Honni Mews, north-westerly and easterly along the south-western and northern boundaries of the said lot 83, southerly along Bareena Crescent, westerly along Leroy Place, southerly along the eastern boundary of lot 70 Leroy Place, easterly along portion of the northern boundary of lot 68 Bareena Crescent, southerly along Bareena Crescent to the northern angle of lot 52 Hertford Road, south-easterly, southerly

and north-westerly along the north-eastern, eastern and portion of the south-western boundaries of the said lot 52, southerly along the eastern boundaries of lots 51 and 50 Hertford Road, south-easterly by a line to the north-eastern angle of lot 43 Hertford Road, southerly along the eastern boundaries of lots 43 and 42 Hertford Road, south-westerly along the south-eastern boundary of the said lot 42, southerly along Hertford Road, south-westerly along Crellin Street, north-westerly along the south-western boundary of lot 60 Crellin Street to its western angle, westerly by a line to the eastern angle of lot 27 Marsden Crescent, south-westerly along the south-eastern boundary of the said lot 27, generally westerly along the southern boundaries of lots 26 and 25 Marsden Crescent, northerly along portion of the western boundary of the said lot 25, westerly along the southern boundary of lot 24 Rowan Street, north-easterly along Rowan Street to the commencing point.

*Sewerage Area No. 2844.*

*Shire of Cranbourne.*—Commencing at the junction of Somerville Road and South Gippsland Highway; thence northerly along South Gippsland Highway, easterly along the northern boundaries of lots 1 South Gippsland Highway and 3 to 10 Garnet Court, southerly along the eastern boundaries of lots 10 to 12 Garnet Court and a reserve, further southerly along the eastern boundaries of lots 9 and 10 Willis Close and 24 Somerville Road, westerly along Somerville Road to the commencing point.

*Sewerage Area No. 2845.*

*Shire of Whittlesea.*—Commencing at the junction of Midholm Court and Gardenia Road; thence northerly along Gardenia Road, easterly along the northern boundaries of lots 1 and 15 to 20 Ainwick Crescent and 24 to 26 Midholm Court and a line in continuation to Edgars Creek, generally south-westerly along the said creek to the production of the southern boundary of lot 46 Gardenia Road, westerly along the said production and lot boundary, northerly along Gardenia Road to the commencing point.

*Sewerage Area No. 2846.*

*City of Knox.*—Commencing at the junction of Dorset Road and Henry Street; thence westerly along Henry Street, north-westerly along Power Road, northerly along Catherine Street, westerly along Central Avenue, northerly along the western boundary of lot 5 Central Avenue, further northerly along Tunstall Avenue, westerly along Woodmason Road, northerly along the western boundary of lot 3 on Lodged Plan of Subdivision No. 7570 to the boundary of Sewerage Area No. 2799, easterly, north-easterly and easterly along the said area boundary to Dorset Road, southerly along Dorset Road, easterly along the northern boundary of lot 5 Dorset Road, northerly along portion of the western boundary of lot 3 Montclair Court, easterly along the northern boundaries of lots 4 and 5 Montclair Court and 2, an adjoining 2 and 3 Olive Grove, southerly along the eastern boundaries of the said lot 3 and lot 4 Olive Grove, westerly along Olive Grove, southerly along the eastern boundary of lot 40 Olive Grove, easterly along the northern boundaries of lots 16 and 18 Girdwood Road, southerly along the eastern boundary of the said lot 18, south-westerly along Girdwood Road, southerly along the eastern boundary of lot 17 Girdwood Road, easterly along the northern boundaries of lots 20 to 22 and 79 to 82 Elsie Street, south-westerly along Elsie Street, southerly along Rangeview Road, westerly along Oak Avenue, northerly along Dorset Road to the commencing point.

*Sewerage Area No. 2847.*

*City of Heidelberg.*—Commencing at the junction of Graham Road and Fran Crescent; thence north-easterly along Fran Crescent and the north-western boundary of lot 40 Fran Crescent, south-easterly along the north-eastern boundaries of lots 40 to 43 Fran Crescent, easterly along the northern boundaries of lots 43 to 46 Fran Crescent and 3 Banyule Road, southerly along the eastern boundary of the said lot 3, easterly along the northern boundary of lot 1 Banyule Road, north-easterly by a line to the north-western angle of lot 2 Banyule Road, easterly along the northern boundaries of the said lot 2 and lot 3 Banyule Road, southerly along the eastern boundary of the said lot 3, westerly and north-westerly along Banyule Road, northerly along Graham Road to the commencing point.

*Sewerage Area No. 2848.*

*City of Nunawading.*—Commencing at the junction of Hartland Road and Burwood Highway; thence easterly along Burwood Highway to a point about 232 metres east of the eastern boundary of Hartland Road, southerly and westerly along the eastern and southern boundaries of the Australian Road Research Board property to the south-eastern angle of lot 20 Hartland Road, further westerly along the southern boundaries of the said lot 20 and lot 19

Hartland Road, northerly along the western boundaries of lots 19 to 15 Hartland Road, easterly along the northern boundary of the said lot 15, northerly along Hartland Road, westerly along the southern boundary of lot 11 Hartland Road, northerly along the western boundaries of lots 11 and 10 Hartland Road, 7 and 6 Citrus Street and 1 Burwood Highway, easterly along Burwood Highway to the commencing point.

*Sewerage Area No. 2849.*

*City of Knox.*—Commencing at the junction of Harold Street and Alderford Drive on the boundary of Sewerage Area No. 2784; thence southerly, westerly and generally southerly following the said area boundary and the boundary of Sewerage Area No. 2744 to the south-eastern angle of lot 57 Davington Court, westerly along Davington Court, northerly along the western boundary of lot 55 Davington Court, westerly along the southern boundaries of lots 569 and 570 Carisbrooke Court, 586 Birchfield Crescent and 587 Crestdale Road, northerly along portion of the western boundary of the said lot 587, westerly and northerly along the southern and western boundaries of lot 456 Crestdale Road, westerly along Crestdale Road, northerly along the western boundary of lot 421 Crestdale Road, westerly along portion of the southern boundary of lot 419 Trentham Court, northerly along Trentham Court, north-easterly along the north-western boundary of lot 418 Trentham Court, easterly along the northern boundaries of the said lot 418 and lots 426 and 427 Saxon Avenue, 434 to 437 Elandra Court and 443 to 445 Balmain Court, further easterly by a line to the south-western angle of lot 32 Cameron Court, northerly along the western boundaries of lots 32 to 29 Cameron Court, 20 to 17 Jenkins Court and 1 Harold Street, easterly along Harold Street, northerly along the western boundary of lot 131 Harold Street, westerly and northerly along the southern and western boundaries of lot 132 Roehampton Avenue, north-easterly and northerly along Roehampton Avenue, westerly along the southern boundary of lot 142 Roehampton Avenue, northerly along the western boundaries of the said lot 142, lot 141 Roehampton Avenue and a reserve to the boundary of Sewerage Area No. 2742, generally easterly, southerly and generally south-easterly following the said area boundary and the boundary of Sewerage Area No. 2784 to the commencing point.

*Sewerage Area No. 2850.*

*City of Knox.*—Commencing at the junction of Harold Street and Cherrington Square; thence northerly along Cherrington Square, easterly along the northern boundary of lot 4 Cherrington Square and a line in continuation to Stud Road, southerly along Stud Road to the production of the southern boundary of lot 89 Harold Street, westerly along the said production and lot boundary, northerly along portion of the western boundary of the said lot 89, westerly and northerly along the southern and western boundaries of lot 88 Harold Street to the commencing point.

*Sewerage Area No. 2851.*

*City of Knox.*—Commencing at the junction of Michellan Court and Mountain Highway; thence westerly along Mountain Highway, northerly along the western boundary of lot 1 Mountain Highway to the south-eastern angle of lot 49 Cumberland Avenue, westerly along the southern boundary of the said lot 49, northerly along Cumberland Avenue, easterly along the northern boundaries of lots 62 Cumberland Avenue and 16 and 17 Michellan Court, southerly along the eastern boundaries of lots 17 to 27 Michellan Court and 28 Mountain Highway, westerly along Mountain Highway to the commencing point.

By order of the Board,

R. H. ENGLESMAN,  
Secretary.

625 Little Collins Street, Melbourne, 3001. 8th July, 1975.

HEYWOOD SEWERAGE AUTHORITY.

INCREASING THE LIMIT OF BANK OVERDRAFT.

His Excellency the Governor of the State of Victoria by and with the advice of the Executive Council thereof doth by Order made on the first day of July, 1975, increase the total amount of the sums which the Heywood Sewerage Authority may owe at any one time in respect of moneys borrowed by overdraft of the current account pursuant to the provisions of section 79 of the Sewerage Districts Act 1958, as fixed by the Governor in Council on 3rd April, 1973, at Two hundred thousand dollars (\$200,000) to Three hundred thousand dollars (\$300,000).

L. G. HOUSTON,  
Acting Clerk of the Executive Council.

At the Executive Council Chamber,  
Melbourne, 1st July, 1975.

## ROBINVALE SEWERAGE AUTHORITY.

## AUDIT OF ACCOUNTS.

## Fee Payable to Auditor.

His Excellency the Governor of the State of Victoria by and with the advice of the Executive Council thereof doth by Order made on the first day of July, 1975, and in pursuance of the provisions of the *Sewerage Districts Act 1958* (No. 6368) approve the payment to J. B. Fox Esquire, of the sum of One hundred and ten dollars (\$110) as remuneration for making an audit of the accounts of the Robinvale Sewerage Authority for the period from the constitution of the Authority to 30th September, 1973, he having been duly appointed by Order in Council made on 4th September, 1973, to make such audit.

L. G. HOUSTON,  
Acting Clerk of the Executive Council.

At the Executive Council Chamber,  
Melbourne, 1st July, 1975.

## UNDERBOOL WATERWORKS TRUST.

## RATING BY-LAW FOR 1975.

The Underbool Waterworks Trust, in pursuance of and in exercise of the powers conferred by the *Water Act 1958*, and of any and every other power it thereunto enabling doth hereby make a By-Law as follows:—

1. The Trust hereby makes and levies a rate in respect of all lands and Tenements within the Underbool Urban District of Seventeen Cents (17c) in the Dollar on the Net Annual Value set out in the valuation at present in force of such lands and tenements for the purposes of the municipal rates of the Shire of Walpeup which is hereby adopted as the valuation of such lands and tenements respectively.

2. Such rate shall be made and levied upon the occupiers and owners of such lands and tenements for the year commencing on the 1st day of January, 1975, and shall be payable on the 2nd day of June, 1975, at the Office of the said Trust, Ouyen.

3. In no case shall the rate payable hereunder in respect of any land on which there is a building be less than Fifteen Dollars (\$15.00) and in respect of land on which there is no building be less than Four Dollars (\$4).

4. Rates so levied may be paid by instalments, with the first instalment to be made prior to 30th June, 1975. Further instalments fall due on the 31st August, 31st October and 31st December respectively.

5. The maximum quantity of water supplied in any one year without further charge to any property rated by the Trust, is hereby fixed at the quantity which, at a charge of Twenty Cents per 1,000 gallons, would produce an amount equal to the amount levied upon such property for the said year.

6. The charge for water supplied by measure to any property rated by the Trust in excess of such maximum quantity computed as in the last preceding clause, is hereby fixed at Twenty Cents per 1,000 gallons.

7. The charge for water supplied by measure shall be payable on demand, at the Office of the Trust, Ouyen.

The foregoing By-Law was made on the 10th day of April and the common seal of the Underbool Waterworks Trust was affixed that day, in the presence of—

(SEAL) B. W. BROWN, Commissioner.  
A. A. KIMPTON, Commissioner.  
BARRY CROSS, Secretary.

Approved, 30th May, 1975.—F. J. GRANTER, Minister of Water Supply.

## MURRAYVILLE WATERWORKS TRUST.

## RATING BY-LAW FOR 1975.

The Murrayville Waterworks Trust in pursuance of and in exercise of the powers conferred by the *Water Act 1958*, doth hereby make a By-Law as follows:—

1. The Trust hereby makes and levies a rate in respect of all lands and tenements within the Murrayville Urban District of twelve and one half Cents (12½c) in the Dollar on the net annual value set out in the valuation at present in force of such lands and tenements for the purpose of the municipal rate of the Shire of Walpeup which is hereby adopted as the valuation of such lands and tenements respectively.

2. Such rate shall be made and levied upon the occupiers and owners of such lands and tenements for the year commencing on the 1st day of January, 1975 and shall be payable on the 2nd day of June, 1975, at the Office of the said Trust.

3. In no case shall the rate payable hereunder in respect of any land on which there is a building be less than Fourteen Dollars (\$14) and in respect of land on which there is no building be less than Four Dollars (\$4).

4. Rates so levied may be paid by instalments, with the first instalment to be made prior to 30th June, 1975. Further instalments fall due on the 31st October, 30th November and the 31st December respectively.

5. The maximum quantity of water to be supplied in any year without further charge to any property rated by the Trust is hereby fixed at the quantity which, at a charge of Twenty Cents (20c) per 1,000 gallons would produce an amount equal to the amount of rates levied on such property for the said year.

6. The charge for water supplied by measure to any property rated by the Trust in excess of such maximum quantity, computed as in the last preceding clause, is hereby fixed at Twenty Cents per 1,000 gallons.

The charge for water supplied by measure to any property not rated by the Trust and where no agreement exists, is hereby fixed at Twenty Cents per 1,000 gallons.

7. The charge for water supplied by measure shall be payable on demand at the Office of the Trust, Ouyen.

The foregoing By-Law was made on the 10th day of April, and the common seal of the Murrayville Waterworks Trust was affixed that day, in the presence of—

(SEAL) M. WILLERSDORF, Chairman.  
E. R. MENZEL, Commissioner.  
BARRY CROSS, Secretary.

Approved, 30th May, 1975.—F. J. GRANTER, Minister of Water Supply.

## PUBLIC TRUSTEE ACT 1958 (No. 6350), SECTION 17.

I hereby give notice that on the 9th June, 1975, the Public Trustee filed an election to administer the following deceased person's estate, in accordance with section 17 of the *Public Trustee Act 1958*:—

PLANT, GEORGE LESLIE, late of 47 Murray Street, Prahran, painter, died 7th April, 1975.

I hereby give notice that on the 12th June, 1975, the Public Trustee filed elections to administer the following deceased persons' estates, in accordance with section 17 of the *Public Trustee Act 1958*:—

JACQUES, DORIS, formerly of 62 Bridport Street, South Melbourne, but late of Surrey Hills Convalescent Hospital, 16 Florence Road, Surrey Hills, widow, died 11th March, 1975.

PERRIN, DESMOND IVAN, also known as Ivan Perrin, but late of 59 Powlett Street, East Melbourne, professional pianist, died 12th April, 1975.

SCOTT, JOSEPH ALICK, late of 7 Jack Street, Newport, retired car builder, died 3rd March, 1975.

SMITH, RONALD JAMES, late of 25 Nolan Street, Niddrie, Commonwealth public servant, died 28th November, 1974.

STAIR, ELSIE, formerly of 2 Talford Street, Doncaster East, but late of 67 Eley Road, Box Hill South, widow, died 26th April, 1975.

TREMLETT, JOHN EDWIN, late of care of Empire State Hotel, Inglewood, war pensioner, died 8th February, 1975.

I hereby give notice that on the 18th June, 1975, the Public Trustee filed elections to administer the following deceased persons' estates, in accordance with section 17 of the *Public Trustee Act 1958*:—

MCINTYRE, JOSEPH, late of 519 Spencer Street, Melbourne, retired carpenter, died 8th March, 1975.

QUINLAN, JOHN PATRICK, formerly of 87 Reynards Road, Coburg, but late of Greenvale Village for the Aged, Greenvale, retired Victorian Railway employee, died 19th December, 1974.

ROSENBERG, ABRAHAM ALBERT, late of Ballarat, pensioner, died 30th March, 1975.

SENIOR, AGNES JANE ISABELLA, formerly of 17 Buena Vista Drive, Montmorency, but late of Mont Park, widow, died 15th October, 1974.

TAYLOR, KATE PRATT, formerly of Flat 6, 112 Ormond Street, South Kensington, but late of "Ashleigh Lodge" Private Hospital, 58 Cochrane Street, North Brighton, widow, died 14th March, 1975.

N. P. BRODY,  
Public Trustee.

168 Exhibition Street, Melbourne, 3000, 2nd July, 1975.

## NOTICE.

Creditors, next of kin and others having claims against the estate of any of the under-mentioned deceased persons are required to send particulars of their claims to the Public Trustee, 168 Exhibition Street, Melbourne, Vic. 3000, the personal representative, on or before the 13th September, 1975, after which date the Public Trustee may convey or distribute the assets, having regard only to the claims of which the Public Trustee then has notice:—

ARMSTRONG, THOMAS ALPHONSUS, late of 90 Danks Street, Albert Park, retired printer, died 21st January, 1975.

BELL, RACHEL LILLIAN, formerly of 26 Moore Street, Elwood, but late of Kew, widow, died 27th March, 1975.

CONNOLLY, REBECCA ELIZABETH ELLEN, late of 65 Wright Street, McKinnon, widow, died 24th November, 1974.

DIXON, NIREE TESSIE, late of 30 Watt Street, South Kingsville, widow, died 16th April, 1975.

DONOVAN, ANN SYLVIA, late of 26 Bloomfield Road, Ascot Vale, widow, died 18th March, 1975.

ERSKINE, ALLISTER ROY, formerly of 177 Henry Street, Greensborough, but late of Adult Deaf Society Home, Lake Road, Blackburn, retired Commonwealth public servant, died 2nd May, 1975.

FAGAN, LUCY HANSENA, also known as (in the will called Lucy Fagan), formerly of 35 Carlyle Street, Maidstone, but late of Mont Park, widow, died 21st May, 1974.

FLYNN, ELFRIDA VICTORIA, late of 80 Park Street, Abbotsford, widow, died 4th January, 1975.

GAYNOR, ALFONSO JOSEPH, late of 281 Walsh Street, South Yarra, chauffeur, died 24th January, 1975.

GEORGE, ELIZABETH ANN, late of 34 Ilan Road, Abertridus, Glamorgan, Wales, widow, died 7th July, 1971.

HARRIS, MARGARET, formerly of 65 Haddington Road, Stoke, Plymouth, Devon, England, but late of 30 Findon Street, Nidderminster, England, widow, died 9th March, 1974.

HOLT, OLIVER PETER BERNARD, formerly of 98 Rupert Street, West Footscray, but late of 27 Dempster Street, Tottenham, retired machinist, died 5th March, 1975.

JACQUES, DORIS, formerly of 62 Bridport Street, South Melbourne, but late of Surrey Hills Convalescent Hospital, 16 Florence Road, Surrey Hills, widow, died 11th March, 1975.

LIVINGSTON, MARGARET ANN, formerly of 35 South Street, Ascot Vale, late of Glenburn Private Hospital, 21 Glenleith Avenue, North Geelong, widow, died 10th March, 1975.

MOGG, HERBERT FRANCIS, late of 10 Fenton Avenue, Kew, retired caterer, died 16th January, 1975.

MCCBRIDE, JAMES LEONARD LAMONT, formerly of Settlement Road, Bundoora, but late of 1 Brooks Crescent, Diamond Creek, retired bank officer, died 2nd April, 1975.

MCCARTHY, ANDREW JEREMIAH, also known as Andrew Jeremiah Brendan McCarthy and Andrew McCarthy, but late of 49 Alma Terrace, Newport, retired clerk, died 25th April, 1975.

MCINTYRE, JOSEPH, late of 519 Spencer Street, Melbourne, retired carpenter, died 8th March, 1975.

PERRIN, DESMOND IVAN, also known as Ivan Perrin, but late of 59 Powlett Street, East Melbourne, professional pianist, died 12th April, 1975.

PLANT, GEORGE LESLIE, late of 47 Murray Street, Prahran, painter, died 7th April, 1975.

QUINLAN, JOHN PATRICK, formerly of 87 Reynards Road, Coburg, but late of Greenvale Village for the Aged, Greenvale, retired Victorian Railway employee, died 19th December, 1974.

RAMWELL, MARY ADA, but late of 33 Kinkora Road, Hawthorn, widow, died 9th October, 1974.

RANDALL, EILEEN MARY, formerly of 125 Through Road, Burwood, but late of Flat 4, 1096 Burke Road, North Balwyn, widow, died 20th April, 1975.

ROSENBERG, ABRAHAM ALBERT, late of Ballarat, pensioner, died 30th March, 1975.

ROSS, RODNEY GRAEME, late of 188 Boundary Road, North Melbourne, labourer, died 6th March, 1974.

SCOTT, JOSEPH ALICK, late of 7 Jack Street, Newport, retired car builder, died 3rd March, 1975.

SENIOR, AGNES JANE ISABELLA, formerly of 17 Buena Vista Drive, Montmorency, but late of Mont Park, widow, died 15th October, 1974.

SMITH, RONALD JAMES, late of 25 Nolan Street, Niddrie, Commonwealth public servant, died 28th November, 1974.

STAIR, ELSIE, formerly of 2 Talford Street, Doncaster East, but late of 67 Eley Road, Box Hill South, widow, died 26th April, 1975.

TABOR, HAROLD JAMES, late of Kew, pensioner, died 2nd April, 1975.

TAYLOR, KATE PRATT, formerly of Flat 6, 112 Ormond Street, South Kensington, but late of "Ashleigh Lodge" Private Hospital, 58 Cochrane Street, North Brighton, widow, died 14th March, 1975.

TREMLETT, JOHN EDWIN, late of care of Empire State Hotel, Inglewood, war pensioner, died 8th February, 1975.

N. P. BRODY,  
Public Trustee.

Melbourne, 2nd July, 1975.

## MINES DEPARTMENT.

Subject to any necessary excisions &c., it is proposed to grant the following mining lease:—

No. 19; Eric Clifford Braumann, Charles Bruce Hope; 61 ha, Parish of Marong.

## APPLICATION FOR MINING LEASE DECLARED ABANDONED.

No. 166; Ivan Vincent Eames; 8.1 ha, Parish of Lal Lal.

## MINING LEASE GRANTED.

No. 70; John Lee Jones, Mancel Edward Dougherty, William James Kyte; 112 ha, Parish of Avoca.

## APPLICATION FOR EXPLORATION LICENCE REFUSED.

No. 513; Allminex; 396 km<sup>2</sup>, Counties of Anglesey and Wonnangatta.

## EXPLORATION LICENCE CANCELLED.

No. 491; Cominco Exploration Pty. Ltd.; 264 km<sup>2</sup>, County of Talbot.

## TAILINGS LICENCES EXPIRED.

3802, Tailings Licence; Country Roads Board; to remove tailings from the "Albion" tailings dump, Parish of Smythesdale.

3805, Tailings Licence; Country Roads Board; to remove tailings from the "Watson's Dredge" dump, Parish of Smythesdale.

3806, Tailings Licence; Country Roads Board; to remove tailings from the tailings dumps at Sago Hills, Parish of Cardigan.

## EXTRACTIVE INDUSTRY LICENCE EXPIRED.

No. 592; Henry Moore Taylor; 3.3 ha, Parish of Barramunga.

J. C. M. BALFOUR,  
Minister of Mines.

## MINES DEPARTMENT.

Subject to any necessary excisions, &c., it is proposed to grant the following mining leases:—

No. 216; Kilmore Mining Co. Pty. Limited; 5.9 ha, Parish of Korweinguboora.

No. 309; Noel Frederick Charles Wagner; 6.2 ha, Parish of Katyl.

No. 339; C.S.R. Limited; 3.8 ha, Parish of Goonegul.

## MINING LEASES TRANSFERRED.

9251, Castlemaine; from Frederick Arthur Clarke, Thomas Kevin Thompson, Noel Skinner and Castlemaine Engineering and Mining Co. Pty. Ltd. to Thomas Kevin Thompson, Noel Skinner and Castlemaine Engineering and Mining Co. Pty. Ltd.

8963, Mineral; from James Say to Vincent Berenguer.

9192, Mineral; from James Say to Vincent Berenguer.

## EXTRACTIVE INDUSTRY LICENCE GRANTED.

No. 663; Robert Andrew Hornbuckle; 11 ha, Parish of Korkuperrimul.

J. C. M. BALFOUR,  
Minister of Mines.

CONTRACTS ACCEPTED.—(Series 1974-75.)  
AMENDMENTS.

Item No.	Unit.	Rate.	Effective From.	Item No.	Unit.	Rate.	Effective From.
PROVISIONS.				PROVISIONS—continued.			
Gazette No. 49—June 18th, 1975.				Schedule No. 11.—School of Forestry, Creswick—continued			
Schedule No. 1—Provisions (Melbourne and Metropolitan District).				Schedule No. 14—Geelong District.			
		\$				\$	
214	Per tin	2.90	1.7.75	59	Per pkt.	0.37	} 1.7.75
Amendment to Gazette No. 49—18th June, 1975.				60	Per doz.	4.68	
216	Delete Brand Name "Quick Chips"			61	Per lb.	0.19	
311	Item No. 311 is not stated in Gazette. This item No. is:— Tinned—Asparagus Tips—10-oz. tins "Neil Fuller", per doz. (To be purchased from Terra (Self Service) Pty. Ltd.)	6.48		62	Per bag	7.50	
324	Per ctn.	14.44	} 1.7.75	63	Per lb.	0.19	
326	"	15.61		64	"	0.26	
Amendment to Gazette No. 49—18th June, 1975.				66	"	0.88	
336	Delete brand name "Grove"			67	Per doz.	11.40	
365	Per doz.	6.39	} 1.7.75	69	Per lb.	0.38	
366	Each ..	1.76		70	Per tin	0.37	
374	Per tin	2.87		71	"	0.35	
398	Per lb.	0.63		72	Per pint	0.12	
Schedule No. 6—Sub-Schedule No. 4—Ararat Mental Hospital.				Schedule No. 21—Sub-Schedule No. 4—Pleasant Creek Special School, Stawell.			
25	Per doz.	5.49	1.7.75	1	Per doz.	21.91	} 1.7.75
Schedule No. 7—Sub-Schedule No. 4—Ballarat Teachers' College.				16	"	5.51	
10	Per doz.	4.02	} 1.7.75	23A	Each ..	6.94	
44	"	8.90		24	Per ctn.	19.72	
52	"	5.37		29	Per doz.	20.60	
64	"	6.48		36	Each ..	3.33	
66	"	4.91		Schedule No. 29—Sub-Schedule No. 3—Won Wron Re-forestation Prison.			
67	"	4.79		2	Per lb.	1.80	} 1.7.75
68	"	4.79		3	Per tin	2.30	
69	"	4.79		4	Per lb.	0.74	
89	"	3.99		5	Each ..	0.57	
102	"	22.21		6	"	1.75	
116	"	21.15	8	"	5.00		
117	"	3.53	9	Per lb.	0.99		
Schedule No. 7—Sub-Schedule No. 5—Lakeside Hospital, Ballarat.				10	Each ..	0.90	
3	Per doz.	21.15	} 1.7.75	12	Per doz.	4.25	
9	"	4.02		13	Each ..	1.80	
27	"	4.91		14	Per doz.	0.89	
35	Per ctn.	19.34		15	Each ..	1.65	
36	"	16.30		16	"	0.75	
47	Per doz.	19.84		17	Each ..	1.65	
52	"	22.21		18	"	1.65	
Schedule No. 11—School of Forestry, Creswick.				20	Per lb.	1.60	
2	Per lb.	0.17	} 1.7.75	21	Each ..	1.90	
3	Each ..	0.51		22	"	1.90	
6	Per pkt.	0.16		24	"	1.90	
7	Per lb.	0.65		25	Per case	15.36	
8	Per doz.	5.80		26	"	22.20	
9	Per box	3.40		27	"	15.36	
10	Per lb.	1.04		29	Each ..	0.37	
11	Per doz.	16.20		32	Per 5-lb.	2.00	
13	"	10.08		34	Per lb.	0.45	
14	Per lb.	0.64		35	"	0.45	
15	Per doz.	3.84		36	Each ..	12.50	
16	"	3.80		37	"	24.00	
20	"	5.70		38	Per lb.	0.80	
21	"	3.84		39	Per doz.	8.40	
22	Per tin	0.96		40	Per lb.	1.55	
24	Per doz.	3.55		42	Per doz.	5.40	
25	Per bag	4.40		43	Each ..	2.15	
31	Per doz.	7.20		44	Per gal.	3.50	
33	"	4.20		46	"	4.50	
35	Per tin	22.00		47	Each ..	5.75	
37	Per doz.	1.68		48	"	1.70	
39	Per pkt.	0.28		49	Per lb.	0.85	
40	Per tin	2.15		50	"	1.70	
41	Per doz.	4.20		51	Each ..	1.75	
42	Per tin	0.99		53	Per lb.	0.26	
46	Per lb.	0.46		54	Each ..	1.60	
49	Per doz.	8.45	55	"	1.80		
50	Per lb.	0.26	PROVISIONS—BUTTER, AND CHEESE.				
51	"	0.19	Gazette No. 100—9th October, 1974.				
52	"	0.09	Butter—Schedule No. 26.				
54	Each ..	2.59	11	Per cwt.	70.84	2.6.75	
55	Per doz.	8.00					
56	Per pkt.	0.26					
58	Per can	1.70					



AMENDMENTS—continued.

Item No.	Unit.	Rate.	Effective From.	Item No.	Unit.	Rate.	Effective From.
<b>PROVISIONS—BUTTER.</b>				<b>TOOLS (GENERAL)—continued.</b>			
<i>Gazette No. 49—18th June, 1975.</i>				<i>Schedule No. 52—continued.</i>			
<i>Schedule No. 2.</i>				<i>Schedule No. 52—continued.</i>			
		\$				\$	
1	*Ruling market rate metropolitan	}	1.7.75	16	Each—12" x 1" x 0.050 x 14 pitch	1.11	} 17.6.75
2				28	" 14" x 1" .. .. .	1.23	
3				\$34.04 per 56-lb. box .. .. .	1.01		
4				\$19.00 per 30-lb. box .. .. .	1.25		
5				29	" 6" x 1/2" x 1/2" .. .. .	1.01	
11	Per cwt. .. .. .	70.84	30	" 7" x 1/2" x 1/2" .. .. .	1.25		
14	*Ruling market rate Metropolitan	}		146	Each .. .. .	1.01	} 10.6.75
15				222	Per pair .. .. .	9.49	
<b>PROVISIONS—CHEESE.</b>				<b>STATIONERY, GENERAL.</b>			
<i>Gazette No. 49—18th June, 1975.</i>				<i>Gazette No. 97—30th September, 1974.</i>			
<i>Schedule No. 3.</i>				<i>Schedule No. 69.</i>			
1	Rate per lb.			72	Per pan .. .. .	0.11	} 28.5.75
2	40-lb. size—			73	" .. .. .	0.11	
8	Semi matured .. .. .	0.57	} 1.7.75	75	" .. .. .	0.11	
10	Matured .. .. .	0.60					
	10 lb. size—			263	Delete per 100, substitute Per quire		
	Semi matured .. .. .	0.58					
	Matured .. .. .	0.61		264			
<b>GENERAL STORES.</b>				<b>OFFICE EQUIPMENT AND REQUISITES.</b>			
<i>Gazette No. 51—25th June, 1975.</i>				<i>Gazette No. 18—14th March, 1975.</i>			
<i>Schedule No. 3—Batteries (Lead Acid Cells).</i>				<i>Schedule No. 4.</i>			
Delete Brand Name "Exide"				6	Each .. .. .	50.60	15.4.75
<i>Schedule No. 25—Chemicals, etc.</i>				<b>MOTOR SPIRIT, KEROSENE, FUEL OILS AND LUBRICANTS.</b>			
4	Delete per gal., Substitute per 3 gal.			<i>Gazette No. 27—21st April, 1975.</i>			
33	Contract cancelled—Delete Lane Limited—Rural Division, Substitute—Apply Tender Board.			<i>Schedule No. 56.</i>			
41	Contract cancelled—Delete C.I.B.A.—GEIBY Australia Ltd., Substitute—Apply Tender Board.			16A	Per litre—Bulk .. .. .	0.269	} 26.6.75
					" 205 litre .. .. .	0.284	
					" 60 .. .. .	0.33	
					" 20 .. .. .	0.338	
					" 5 .. .. .	0.384	
				16B	" Bulk .. .. .	0.293	
					" 205 .. .. .	0.309	
					" 60 .. .. .	0.355	
					" 20 .. .. .	0.363	
					" 5 .. .. .	0.409	
				17	" Bulk .. .. .	0.295	
					" 205 .. .. .	0.311	
					" 60 .. .. .	0.357	
					" 20 .. .. .	0.365	
					" 5 .. .. .	0.411	
					" 205 .. .. .	0.403	
					" 60 .. .. .	0.449	
					" 20 .. .. .	0.457	
					" 5 .. .. .	0.503	
				19	" 205 .. .. .	1.118	
					" 60 .. .. .	1.164	
					" 20 .. .. .	1.172	
					" 5 .. .. .	1.218	
				20	" 205 .. .. .	0.28	
					" 60 .. .. .	0.326	
					" 20 .. .. .	0.334	
				21	" 205 .. .. .	0.246	
					" 60 .. .. .	0.292	
					" 20 .. .. .	0.30	
				22	" Bulk .. .. .	0.292	
					" 205 .. .. .	0.308	
					" 60 .. .. .	0.354	
					" 20 .. .. .	0.362	
					" 5 .. .. .	0.408	
				23	Per kg 180 kg .. .. .	0.414	
					" 55 .. .. .	0.474	
					" 20 .. .. .	0.474	
					" 2.5 .. .. .	0.542	
				24	" 180 .. .. .	0.41	
					" 55 .. .. .	0.47	
					" 20 .. .. .	0.538	
					" 2.5 .. .. .	0.712	
				25	" 0.5 .. .. .	0.5	
					" 180 .. .. .	0.56	
					" 55 .. .. .	0.56	
					" 20 .. .. .	0.628	
				26	" 2.5 .. .. .	0.43	
					" 180 .. .. .	0.49	
					" 20 .. .. .	0.414	
				27	" 180 .. .. .	0.474	
					" 55 .. .. .	0.474	
					" 20 .. .. .	0.474	
					" 2.5 .. .. .	0.542	
<b>Name and Address of Contractors etc.</b>				<b>TOOLS (GENERAL).</b>			
Australian Cotton Textile Industries Limited, Actil Avenue, Woodville Street, Woodville, S.A. 5011.				<i>Gazette No. 22—27th March, 1975.</i>			
<i>Schedule No. 52.</i>				<i>Schedule No. 52.</i>			
9	Each .. .. .	0.43	} 18.6.75				
15	Per doz.—10" x 18 .. .. .	1.04					
	" 10" x 24 .. .. .	1.04					
	" 10" x 32 .. .. .	1.04					
	" 12" x 18 .. .. .	1.11					
	" 12" x 24 .. .. .	1.11					
	" 12" x 32 .. .. .	1.11					

**CONTRACTS ACCEPTED.—(Series 1975-76.)****VICTORIAN RAILWAYS.**

1. Collection and Disposal of Rubbish during the period 1st February, 1975, to 31st January, 1977, at rates (Contract No. 64117).—Industrial Waste Collection (a Division of Brambles Holdings Limited). 2. Ten year Maintenance Painting of the Metalwork of Railway Bridges on the Glen Waverley Line, for the amount of \$41,349.90 (Contract No. 64116).—Miles Industrial Painting Services Pty. Limited. 3. Manufacture, Supply, Delivery and Erection of two (2) No. 8-tonne Electric Travelling Gantry Cranes and Removal of two (2) No. existing 8-ton Gantry Cranes at Dynon Goods Depot, at rates (Contract No. 64022).—Hydromecrane Pty. Ltd. (Receiver and Manager Appointed). 4. Construction of Steel and Concrete Railway Bridge at 8M 7C for Third Track at Oakleigh Road, Ormond, at rates (Contract No. 64017).—Prentice Bros. and Minson Proprietary Limited.

By Order of the Victorian Railways Board.  
C. W. MILLER, Secretary. 7.7.75.

**APPOINTMENTS AND RESIGNATIONS****APPOINTMENTS.**

His Excellency the Governor of the State of Victoria, by and with the advice of the Executive Council thereof, has, by Orders made on the 1st day of July, 1975, been pleased to make the under-mentioned appointments, viz.:

**EDUCATION DEPARTMENT.***Members of Council of Adult Education.*

PETER PINSON, nominated by the Trustees of the National Gallery of Victoria, vice Gordon Andrew Thomson, and

CECILIA JOSEPHINE FALKLAND, representing the Country Women's Association, being an association, department or organization interested in adult education, vice Mary Margaret Chattaway,

to be members of the Council of Adult Education in pursuance of the powers conferred by the *Education Act 1958*, for the term ending on 30th April, 1977.

*Members of the Council of Monash University.*

SANDFORD SAUL NEVILLE, O.B.E., vice Kenneth Paget Palmer, for the period ending 2nd July, 1977,

VICTOR EDWARD JENNINGS for a four year term commencing on 3rd July, 1975, and

JOHN WIDDIS LESLIE for a four year term commencing on 3rd July, 1975,

to be members of the Council of Monash University for the periods shown pursuant to the *Monash University Act 1958*.

**MINISTRY OF HEALTH.***Members of Committees of Management of Hospitals.*

ANDREW WITOLD RUTKOWSKI, F.A.S.A., F.C.I.S., A.I.M.A., A.A.I.M.,

to be Government Appointee on the Committee of Management of the Wodonga District Hospital for a further period of three years commencing 30th July, 1975, pursuant to the provisions of sub-paragraph (ii) of paragraph (a) of the proviso to sub-section (1) of section 48 of the *Hospitals and Charities Act 1958*; and

ALEXANDER FOXCROFT BOTTOMLEY, O.B.E., J.P., to be the Government Appointee on the Committee of Management of the Hampton Hospital for a further period of three years commencing the 9th July, 1975, pursuant to the provisions of sub-paragraph (ii) of paragraph (a) of section 48 of the *Hospitals and Charities Act 1958*.

*Consultant Psychiatrist.*

MERLYN ELIZABETH ROSS, M.B., B.S. (Melb. 1963), D.P.M. (Melb. 1968),

to be Consultant Psychiatrist, Mental Hygiene Branch, Department of Health, pursuant to the provisions of sub-section 3 of section 20 of the *Mental Health Act 1959*.

**LAW DEPARTMENT.***Justices of the Peace.*

JAMES WILLIAM BOXSHALL, 31 Longfellow Avenue, Mooroolbark,

IVY MAY NELSON, 21 Prefect Street, Wendouree,

BARRY JOHN WARD, care of Municipal Offices, Station Street, Chelsea, and

GEORGE HENRY SELKRIK, care of Allambie Reception Centre, 70 Elgar Road, Burwood,

to be Justices of the Peace for the State of Victoria.

*Commissioners for Taking Declarations, &c.*

ALEXANDER JEFFERSON HAYMES, care of Health Insurance Commission, 16 Armstrong Street, Ballarat,

JOHN GARY McNABB, care of Health Insurance Commission, 349 Bell Street, Preston,

GRAHAM JOHN OLIVER, care of Health Insurance Commission, "Medibank Cash Payment Centre", "The Hub", McRae Street, Dandenong,

COLIN FRANCIS TURNER, care of Health Insurance Commission, 75 Nicholson Street, Footscray,

KEITH WELSFORD WINTER, care of Health Insurance Commission, 379 Collins Street, Melbourne,

MICHAEL THORNTON BOWDITCH, care of Health Insurance Commission, 123 Lonsdale Street, Melbourne,

JOHN JOSEPH CARROLL, care of Health Insurance Commission, 171 Moorabool Street, Geelong,

JOSEPH LESLIE CURTIS, care of Health Insurance Commission, 25 Koornang Road, Carnegie,

BRIAN PATRICK DRISCOLL, care of Health Insurance Commission, Box Hill Cash Payments Centre, Shop 28, Level 4, Whitehorse Plaza, 29 Ellingworth Parade, Box Hill,

VIVA JOHN ALEKNA, 7 Fitzgibbon Crescent, Caulfield,

PETER EVAN LEWIS CRIBB, 41 Alameda Drive, Sale,

JOHN BERRYMAN KIFT, 27 Good Govers Street, Mitcham,

JAMES REX MORTON, care of The National Mutual Life Association of Australasia Ltd., 447 Collins Street, Melbourne, and

ANDREW GORDON MATHERS and

DONALD HOUSTON STALLARD, care of Department of Labour and Industry, 160 Queen Street, Melbourne,

to be Commissioners for taking Declarations and Affidavits under the *Evidence Act 1958*.

**SOCIAL WELFARE DEPARTMENT.***Stipendiary Probation Officers.*

BERNARD JOHN CHATLEY,  
WILLIAM STANLEY ROPER,  
MARGARET YVONNE SHELTON (Miss),  
MELVILLE ALLAN BALDWIN,  
DAMIEN COSGRIFF,  
JOHN DERKSEN,  
SHANE MULDOON,  
JOHN HOLDEN,  
SANDRA KOWALSKI, and  
DEBRA WADDINGHAM,

to be Stipendiary Probation Officers for every Children's Court, Stipendiary Probation Officers and Stipendiary Parole Officers and Stipendiary Youth Parole Officers respectively, pursuant to the provisions of section 8 (2) of the *Children's Court Act 1973*, section 507 (1) of the *Crimes Act 1958* and sections 165 (1) and 189 (2) of the *Social Welfare Act 1970* (as amended).

**DEPARTMENT OF WATER SUPPLY.***Waterworks Trust Commissioner.*

LEONARD HENRY CALLENDAR

to be a Commissioner of the Bruthen Waterworks Trust, to hold such position for a period of four years from the date hereof, subject to the provisions of the *Water Act*.

*River Improvement Trust Commissioner.*

LEONARD EDGAR ALLAN

to be a Commissioner of the Ovens River Improvement Trust, to hold such position for a period of four years from the date hereof, subject to the provisions of the *River Improvement Act*.

L. G. HOUSTON,

Acting Clerk of the Executive Council.

At the Executive Council Chamber,  
Melbourne, 1st July, 1975.

**MARINE ACT 1958.****APPOINTMENT OF ASSESSORS FOR COURTS OF MARINE INQUIRY.**

His Excellency the Governor of the State of Victoria, by and with the advice of the Executive Council thereof, doth by Order made on the 1st day of July, 1975, appoint the following persons to be Assessors for Courts of Marine Inquiry, pursuant to the provisions of section 178 of the *Marine Act 1958*, for the twelve months ending 30th June, 1976:—

**COURTS OF MARINE INQUIRY.—ASSESSORS.***Class 1.—Masters.*

ROBERT STEPHENSON ALLEN,  
SAMUEL JAMES BENSON,

DOUGLAS JOHN McDONALD,  
FRANK EDWIN PEELE, and  
ALAN ALFRED COOPER PHILIP.

**Class 2.—Engineers.**

ALFRED STANLEY DERRICK CLARKE,  
JOHN HENRY MICHELL,  
DEREK NORMAN MOORE, and  
JOHN CHARLES ROBERT SUNDERCOMBE.

**Class 3.—Pilots and Exempt Masters.**

SAMUEL JAMES BENSON,  
DOUGLAS JOHN McDONALD,  
FRANK EDWIN PEELE, and  
ALAN ALFRED COOPER PHILIP.

**Class 4.—Scientific.**

ARTHUR MAURICE CLARK, and  
JOHN CHARLES ROBERT SUNDERCOMBE.  
L. G. HOUSTON,  
Acting Clerk of the Executive Council.

At the Executive Council Chamber,  
Melbourne, 1st July, 1975.

**RESIGNATIONS.**

His Excellency the Governor of the State of Victoria, by and with the advice of the Executive Council thereof, has, by Orders made on the 1st day of July, 1975, accepted the resignations of the persons named hereunder of the offices mentioned, viz.:—

**LAW DEPARTMENT.**

*Commissioners for Taking Declarations, &c.*

Laurie James Blair,  
James William Boxshall,  
Edward Amiens Briggs,  
Barry Raymond Burckhardt,  
Murray George Freestun-Neville,  
Kevin John Kirby,  
Lachlan John Jenkin,  
Ivy May Nelson,  
John Roland Stanley, and  
Barry John Ward,  
as Commissioners for taking Declarations and Affidavits under the Evidence Act 1958.

**SOCIAL WELFARE DEPARTMENT.**

*Honorary Probation Officers.*

John Wilson Blackie,  
Laura Lillian Cameron (Mrs.),  
John Edward Joseph Carson,  
Peter Joseph Connors (Rev.),  
Barbara Joan Hester (Miss),  
Margaret F. Howes (Mrs.),  
Eric William Mitchell,  
Thomas Maxwell O'Connor (Rev.),  
David Campbell (Rev.), and  
Robert Geoffrey Taylor,  
as Honorary Probation Officers, pursuant to the provisions of section 507 (2) of the Crimes Act 1958, and section 9 of the Children's Court Act 1973.

L. G. HOUSTON,  
Acting Clerk of the Executive Council.

At the Executive Council Chamber,  
Melbourne, 1st July, 1975.

**APPRENTICESHIP COMMISSION.**

**RESIGNATION.**

His Excellency the Governor of the State of Victoria, by and with the advice of the Executive Council thereof, doth by Order made on the 1st day of July, 1975, accept the resignation of Frank Albert Hansen, as a Member of the Apprenticeship Commission of Victoria, representing employers.

L. G. HOUSTON,  
Acting Clerk of the Executive Council.

At the Executive Council Chamber,  
Melbourne, 1st July, 1975.

**ORDERS IN COUNCIL**

**SOIL CONSERVATION AND LAND UTILIZATION ACT.**

At the Executive Council Chamber, Melbourne, the  
twenty-fourth day of June, 1975.

**PRESENT:**

His Excellency the Governor of Victoria.  
Mr. Byrne | Mr. Rossiter  
Mr. Scanlan | Mr. Granter.

**DISTRICT ADVISORY COMMITTEE.—WESTERN  
MALLEE SOIL CONSERVATION AUTHORITY.**

Whereas a vacancy exists on the Western Mallee Soil Conservation District Advisory Committee due to the transfer of Trevor Ernest Telford, being the person elected to represent the Department of Agriculture, now, therefore I, the Governor of the State of Victoria, by and with the advice of the Executive Council thereof, and in pursuance of the provisions of section 15 of the Soil Conservation and Land Utilization Act do hereby remove the said Trevor Ernest Telford from office and appoint the following person to such vacancy for a period up to and including the 19th day of June, 1976:—

John Bernard Griffiths, being the person appointed to represent the Department of Agriculture.

And the Honorable William Archibald Borthwick, Her Majesty's Minister for Conservation for the State of Victoria, shall give the necessary directions herein accordingly.

L. G. HOUSTON,  
Acting Clerk of the Executive Council.

**SOIL CONSERVATION AND LAND UTILIZATION ACT.**

At the Executive Council Chamber, Melbourne, the  
twenty-fourth day of June, 1975.

**PRESENT:**

His Excellency the Governor of Victoria.  
Mr. Byrne | Mr. Rossiter  
Mr. Scanlan | Mr. Granter.

**DISTRICT ADVISORY COMMITTEE.—LOWER  
GOULBURN SOIL CONSERVATION DISTRICT.**

Whereas a vacancy exists on the Lower Goulburn Soil Conservation District Advisory Committee due to the retirement of William Samuel Yates, being the person elected to represent the Department of Crown Lands and Survey, now, therefore I, the Governor of the State of Victoria, by and with the advice of the Executive Council thereof, and in pursuance of the provisions of section 15 of the Soil Conservation and Land Utilization Act do hereby remove the said William Samuel Yates from office and appoint the following person to such vacancy for a period up to and including the 26th day of July, 1975:—

Robert Godfrey Niggl, being the person appointed to represent the Forests Commission.

And the Honorable William Archibald Borthwick, Her Majesty's Minister for Conservation for the State of Victoria, shall give the necessary directions herein accordingly.

L. G. HOUSTON,  
Acting Clerk of the Executive Council.

**LAND ACT 1958.**

At the Executive Council Chamber, Melbourne, the  
first day of July, 1975.

**PRESENT:**

His Excellency the Governor of Victoria.  
Mr. Balfour | Mr. Borthwick.

**PERMANENT RESERVATION OF LAND AS A SITE FOR  
THE VICTORIAN ARTS CENTRE.**

His Excellency the Governor of the State of Victoria, by and with the advice of the Executive Council thereof, pursuant to the provisions of sections 14 and 21 of the Land Act 1958, hereby reserves permanently from sale,

from being leased and from having a licence granted in respect thereof, and also except from occupation for mining purposes under any miner's right the lands herein after described:

MELBOURNE.—Site for the Victorian Arts Centre, 6602 square metres, being Crown allotment 3C, City of Melbourne, Parish of Melbourne South, County of Bourke, as defined by the description and hatching on plan published in the *Government Gazette* of 4th June, 1975, on page 1947.—(M.333<sup>(31)</sup>) (Rs.5546).

And the Honorable William Archibald Borthwick, Her Majesty's Minister of Lands for the State of Victoria, shall give the necessary directions herein accordingly.

L. G. HOUSTON,  
Acting Clerk of the Executive Council.

LAND ACT 1958.

At the Executive Council Chamber, Melbourne, the first day of July, 1975.

PRESENT:

His Excellency the Governor of Victoria.  
Mr. Balfour | Mr. Borthwick.

UNUSED ROAD CLOSED.

In pursuance of the provisions of section 349 of the *Land Act 1958*, His Excellency the Governor of Victoria, by and with the advice of the Executive Council thereof and the concurrence in writing of the Council of the municipality concerned doth hereby close the unused road referred to hereunder, viz.:

Parish of Jamieson, County of Wonnangatta being the road indicated by hatching on plan hereunder.—(J.22<sup>(6)</sup>) (C.101304).

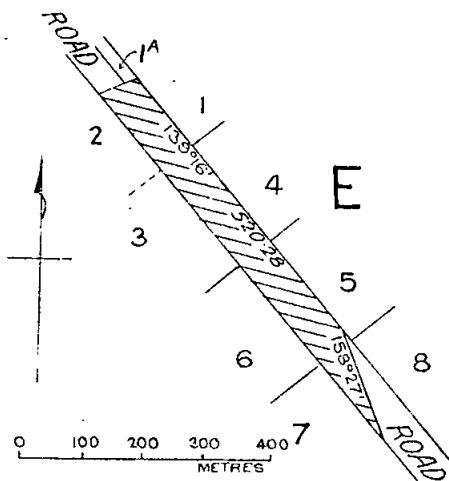

And the Honorable William Archibald Borthwick, Her Majesty's Minister of Lands for the State of Victoria, shall give the necessary directions herein accordingly.

L. G. HOUSTON,  
Acting Clerk of the Executive Council.

Land Act 1958.

DEPARTMENT OF CROWN LANDS AND SURVEY.

At the Executive Council Chamber, Melbourne, the first day of July, 1975.

PRESENT:

His Excellency the Governor of Victoria.  
Mr. Balfour | Mr. Borthwick.

LANDS TEMPORARILY RESERVED AS SITES.

His Excellency the Governor of the State of Victoria, by and with the advice of the Executive Council thereof, doth hereby in pursuance of the provisions of section 14

of the *Land Act 1958*, reserve temporarily from sale, from being leased and from having a licence granted in respect thereof, and also except from occupation for mining purposes under any miner's right the lands hereinafter described, viz.:

FRANKSTON.—Site for Public Recreation purposes 946 square metres, being Crown allotment 3, section 14, Township of Frankston, Parish of Frankston, County of Mornington as indicated by hatching on plan hereunder.—(F.86<sup>(4)</sup>) (Rs.4823).

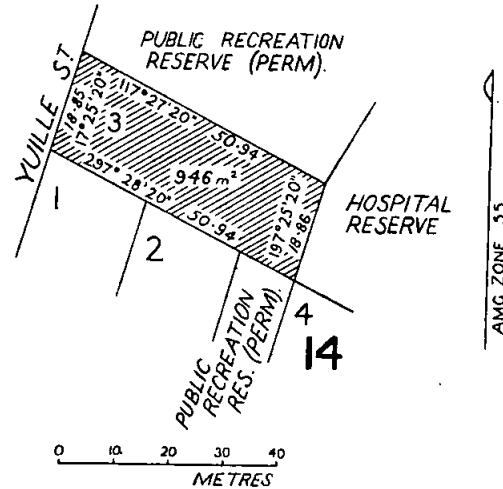

GEMBROOK (COCKATOO).—Site for Public Recreation purposes 4 hectares, more or less, being Crown allotment 64A, Parish of Gembrook, County of Evelyn as indicated by hatching on plan hereunder.—(G.206<sup>(14)</sup>) (Rs.10063).

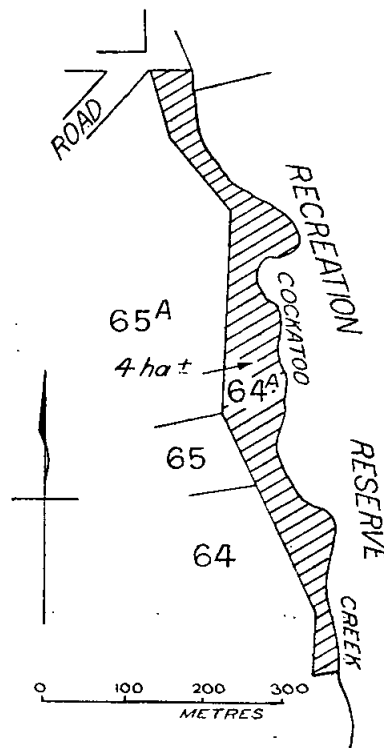

And the Honorable William Archibald Borthwick, Her Majesty's Minister of Lands for the State of Victoria, shall give the necessary directions herein accordingly.

L. G. HOUSTON,  
Acting Clerk of the Executive Council.

## LAND ACT 1958.

At the Executive Council Chamber, Melbourne, the first day of July, 1975.

## PRESENT:

His Excellency the Governor of Victoria.  
Mr. Balfour | Mr. Borthwick.

## TEMPORARY RESERVATION OF SITE FOR AN ADDITIONAL PURPOSE.

His Excellency the Governor of the State of Victoria, by and with the advice of the Executive Council thereof, pursuant to the provisions of section 14 of the Land Act 1958, hereby reserves temporarily for the additional purpose of Public Purposes (Preservation of Fauna) the Crown land in the Township of Edenhope, Parish of Edenhope, County of Lowan, comprising 3.971 hectares (9 acres 3 roods 10 perches, more or less), being the site temporarily reserved for Public Purposes (Preservation of Flora) by Order in Council of the 26th September, 1972, and as was notified in the Government Gazette dated the 4th October, 1972.—(Rs.9669.)

And the Honorable William Archibald Borthwick, Her Majesty's Minister of Lands for the State of Victoria, shall give the necessary directions herein accordingly.

L. G. HOUSTON,  
Acting Clerk of the Executive Council.

## HURSTBRIDGE WATERWORKS TRUST.

At the Executive Council Chamber, Melbourne, the first day of July, 1975.

## PRESENT:

His Excellency the Governor of Victoria.  
Mr. Balfour | Mr. Borthwick.

## EXTENT OF URBAN DISTRICT DIMINISHED.

Under the powers conferred by the Water Act and all other powers enabling him in that behalf, His Excellency the Governor of the State of Victoria, by and with the advice of the Executive Council of the said State, doth hereby declare, order and direct that the extent of the Kangaroo Ground Urban District of the Hurstbridge Waterworks Trust be diminished by excising from the same the lands comprised within the area shown in green hatching on the accompanying plan approved by the Governor in Council and deposited in the office of the State Rivers and Water Supply Commission, Melbourne (Corr. No. 74/5057/18) and as on and from the date hereof, the extent of such District shall be deemed to be diminished accordingly.

And the Honorable Frederick James Granter, Her Majesty's Minister of Water Supply for the State of Victoria, shall give the necessary directions herein accordingly.

L. G. HOUSTON,  
Acting Clerk of the Executive Council.

## Water Act 1958.

## STATE RIVERS AND WATER SUPPLY COMMISSION.

At the Executive Council Chamber, Melbourne, the first day of July, 1975.

## PRESENT:

His Excellency the Governor of Victoria.  
Mr. Balfour | Mr. Borthwick.

## LAKE HUME (SHIRE OF WODONGA) RECREATIONAL AREA.—BOUNDARIES VARIED.

Under the powers conferred by the Water Act 1958 and all other powers enabling him in that behalf, His Excellency the Governor of the State of Victoria, with the advice of the Executive Council of the said State, on the recommendation of the State Rivers and Water Supply Commission, doth hereby declare, order and direct that the boundaries of the Lake Hume (Shire of Wodonga) Recreational Area be varied by adding to the said Area the lands shown by blue colour on a plan numbered 6125A approved by the Governor in Council and lodged in the Plan Room

of the State Rivers and Water Supply Commission, at 590 Orrong Road, Armadale, and as on and from the date hereof, the boundaries of such Area shall be so varied.

And the Honorable Frederick James Granter, Her Majesty's Minister of Water Supply for the State of Victoria, shall give the necessary directions herein accordingly.

L. G. HOUSTON,  
Acting Clerk of the Executive Council.

FIRST MILDURA IRRIGATION TRUST.  
MILDURA URBAN WATER TRUST.

At the Executive Council Chamber, Melbourne, the first day of July, 1975.

## PRESENT:

His Excellency the Governor of Victoria.  
Mr. Balfour | Mr. Borthwick.

## SEVERANCE OF PORTION OF THE FIRST MILDURA IRRIGATION TRUST DISTRICT AND ANNEXATION TO THE MILDURA URBAN WATER TRUST DISTRICT.

Under the powers conferred by the Mildura Irrigation and Water Trusts Act and all other powers enabling him in that behalf, His Excellency the Governor of the State of Victoria, by and with the advice of the Executive Council of the said State, doth hereby declare, order and direct as follows:—

That as on and from the date hereof, the lands comprised within the area shaded red on the plan approved by the Governor in Council and deposited in the office of the State Rivers and Water Supply Commission, Melbourne (Corr. No. 53/2164/99) shall be severed from the District of the First Mildura Irrigation Trust and annexed to the District of the Mildura Urban Water Trust.

And the Honorable Frederick James Granter, Her Majesty's Minister of Water Supply for the State of Victoria, shall give the necessary directions herein accordingly.

L. G. HOUSTON,  
Acting Clerk of the Executive Council.

## METROPOLITAN FIRE BRIGADES ACT.

At the Executive Council Chamber, Melbourne, the first day of July, 1975.

## PRESENT:

His Excellency the Governor of Victoria.  
Mr. Balfour | Mr. Borthwick.

## CONSENT TO THE BORROWING OF FIVE HUNDRED THOUSAND DOLLARS BY THE METROPOLITAN FIRE BRIGADES BOARD.

Whereas by section 46 of the Metropolitan Fire Brigades Act 1958, it is enacted that the Metropolitan Fire Brigades Board, with the consent of the Governor in Council may from time to time borrow such moneys as the Board deems necessary in order to enable the Board to carry out and perform the powers, authorities, and duties vested in or conferred or imposed upon the Board by the said Act:

And whereas the Metropolitan Fire Brigades Board deems it necessary to borrow the sum of five hundred thousand dollars for the purposes aforesaid:

Now, therefore, His Excellency the Governor of the State of Victoria, in the Commonwealth of Australia, by and with the advice of the Executive Council of the said State, and in pursuance of the powers conferred by the said section 46 of the Metropolitan Fire Brigades Act 1958 and all other powers him thereunto enabling, doth by this Order consent to the borrowing by the Metropolitan Fire Brigades Board of the sum of Five hundred thousand dollars for a period of ten years, to be liquidated by half-yearly repayments on the principal sum, with interest at the rate of Nine dollars and ninety cents per centum per annum.

And the Honorable John Frederick Rossiter, Her Majesty's Chief Secretary for the State of Victoria, shall give the necessary directions herein accordingly.

L. G. HOUSTON,  
Acting Clerk of the Executive Council.

## APPRENTICESHIP ACT 1958.

At the Executive Council Chamber, Melbourne, the first day of July, 1975.

## PRESENT:

His Excellency the Governor of Victoria.  
Mr. Balfour | Mr. Borthwick.

## APPOINTMENT OF A MEMBER OF THE APPRENTICESHIP COMMISSION OF VICTORIA.

In pursuance of the powers conferred by section 7 of the *Apprenticeship Act 1958*, and all other powers him thereunto enabling, His Excellency the Governor of the State of Victoria, by and with the advice of the Executive Council thereof, doth by this Order appoint Donald Cockram, who was nominated by the Victorian Employers' Federation, as a member of the Apprenticeship Commission of Victoria, representing employers, for the remainder of a term ending on the 31st August, 1977.

And the Honorable Joseph Anstice Rafferty, Her Majesty's Minister of Labour and Industry for the State of Victoria, shall give the necessary directions herein accordingly.

L. G. HOUSTON,  
Acting Clerk of the Executive Council.

## STATE SAVINGS BANK ACT 1958, No. 6379.

At the Executive Council Chamber, Melbourne, the first day of July, 1975.

## PRESENT:

His Excellency the Governor of Victoria.  
Mr. Balfour | Mr. Borthwick.

In accordance with the provisions of subsection (6) of section 8 of the *State Savings Bank Act 1958*, His Excellency the Governor of the State of Victoria by and with the advice of the Executive Council thereof doth by this Order appoint

JAMES ARNOLD HANCOCK, O.B.E., B.Com., F.C.A., a Commissioner of the State Savings Bank of Victoria for a period of seven years.

And the Honorable Rupert James Hamer, Her Majesty's Treasurer for the State of Victoria, shall give the necessary directions herein accordingly.

L. G. HOUSTON,  
Acting Clerk of the Executive Council.

## MELBOURNE AND METROPOLITAN TRAMWAYS ACT 1958, No. 6311.

At the Executive Council Chamber, Melbourne, the first day of July, 1975.

## PRESENT:

His Excellency the Governor of Victoria.  
Mr. Balfour | Mr. Borthwick.

Whereas His Excellency the Governor of the State of Victoria by and with the advice of the Executive Council thereof has this day consented pursuant to the provisions of section 28 of the *Melbourne and Metropolitan Tramways Act 1958*, to the Melbourne and Metropolitan Tramways Board raising by way of a loan an amount not exceeding Two hundred and fifty thousand dollars (\$250,000); and whereas His Excellency the Governor in Council is satisfied that a sufficient proportion of the loan to be so raised will fall due and be repaid in each year during the currency of the proposed loan; now therefore it is directed, pursuant to the provisions of section 28 (6) of the said Act, that it shall not be necessary to provide a sinking fund in connection with such loan.

And the Honorable Rupert James Hamer, Her Majesty's Treasurer for the State of Victoria, shall give the necessary directions herein accordingly.

L. G. HOUSTON,  
Acting Clerk of the Executive Council.

## MELBOURNE UNDERGROUND RAIL LOOP ACT 1970, No. 8023.

At the Executive Council Chamber, Melbourne, the first day of July, 1975.

## PRESENT:

His Excellency the Governor of Victoria.  
Mr. Balfour | Mr. Borthwick.

Whereas His Excellency the Governor of the State of Victoria by and with the advice of the Executive Council thereof has this day consented pursuant to the provisions of the *Melbourne Underground Rail Loop Act 1970* to the Melbourne Underground Rail Loop Authority raising by way of a loan the sum of Three hundred and fifty thousand dollars (\$350,000); and whereas His Excellency the Governor in Council is satisfied that a sufficient proportion of the loan to be raised will fall due and be repaid in each year during the currency of the proposed loan; now therefore it is directed, pursuant to the provisions of section 16 (3) of the said Act that it shall not be necessary to provide a sinking fund in connection with such loan.

And the Honorable Rupert James Hamer, Her Majesty's Treasurer for the State of Victoria, shall give the necessary directions herein accordingly.

L. G. HOUSTON,  
Acting Clerk of the Executive Council.

## SUPERANNUATION ACT 1958.

At the Executive Council Chamber, Melbourne, the first day of July, 1975.

## PRESENT:

His Excellency the Governor of Victoria.  
Mr. Balfour | Mr. Borthwick.

Pursuant to the powers conferred by the provisions of paragraph (ja) of sub-section (1) of section 3 of the *Superannuation Act 1958*, His Excellency the Governor of the State of Victoria, by and with the advice of the Executive Council thereof, doth by this Order declare that the provisions of the Superannuation Act shall apply to the officers named in the schedule set out hereunder.

## SCHEDULE.

FORD, JAMES DAVID GEORGE, State College of Victoria, at Bendigo.  
HEALEY, LEIGH GREGORY, State College of Victoria, at Bendigo.  
BRADY, JOHN LEONARD, State College of Victoria, at Coburg.  
COMTE, MARTIN MILTON, State College of Victoria, at Coburg.  
AUSTIN, DOROTHY MARGARET, State College of Victoria, at Frankston.  
CHAMBERLIN, JULIA CLARE, State College of Victoria, Institute of Catholic Education.  
DAWSON, PETER JAMES, State College of Victoria, Institute of Catholic Education.  
EGGLESTON, IAN FREDERICK, State College of Victoria, Institute of Catholic Education.  
HUGHES, CATHERINE ELIZABETH, State College of Victoria, Institute of Catholic Education.  
LOKE, YEEN THENG, State College of Victoria, Institute of Catholic Education.  
POLLOCK, MARGARET LILIAN, State College of Victoria, Institute of Catholic Education.  
WALSH, DIANE PATRICIA, State College of Victoria, Institute of Catholic Education.  
HARRIS, MARGARET MARY, State College of Victoria, at Melbourne.  
PITTS, SUSAN ELIZABETH, State College of Victoria, at Melbourne.  
RED, COLIN HENRY, State College of Victoria, at Melbourne.  
WALKER, VALERIE JOAN, State College of Victoria, at Melbourne.

And the Honorable Rupert James Hamer, Her Majesty's Treasurer for the State of Victoria, shall give the necessary directions herein accordingly.

L. G. HOUSTON,  
Acting Clerk of the Executive Council.

## Swan Hill Pioneer Settlement Act 1974.

## ORDER CONSTITUTING AND ESTABLISHING THE SWAN HILL PIONEER SETTLEMENT AUTHORITY.

At the Executive Council Chamber, Melbourne, the eighth day of July, 1975.

## PRESENT:

His Excellency the Governor of Victoria.

Mr. Wilcox  
Mr. Houghton

Mr. Rafferty.

Pursuant to the powers conferred by the Swan Hill Pioneer Settlement Act 1974 and all other powers him thereunto enabling, His Excellency the Governor of the State of Victoria, in the Commonwealth of Australia, by and with the advice of the Executive Council of the said State and upon the recommendation of the Minister, doth by this Order constitute and establish the Swan Hill Pioneer Settlement Authority (that is to say)—

(1) The following persons are hereby appointed to be directors of the Swan Hill Pioneer Settlement Authority for a period of three years commencing on the 2nd day of July, 1975—

(a) Robert Alan Quin of 3 Wallace Street, Swan Hill; Peter Joseph Livingston of 8 Donnington Street, Swan Hill; John William Kellock of Lalbert Road, Swan Hill; Norman Hudson Dowling of 429 Campbell Street, Swan Hill; Arthur Herman Feldtmann of 22 Naretha Street, Swan Hill; being the nominees of the Council of the City of Swan Hill.

(b) Brett Samuel Wilgriss Freeman of 483 Campbell Street, Swan Hill; Herbert Raymond Dowell of 1 Tobruk Street, Swan Hill; Ian Rosslyn Martin of 20 Gregg Street, Swan Hill; being the nominees of the life members and subscribers for the time being of the Swan Hill Pioneer Settlement; and the following persons are hereby appointed to be Directors of the Swan Hill Pioneer Settlement Authority for a period of one year commencing on the 2nd day of July, 1975.

(c) Barry Cameron McOrist of 13 Pleasant Road, Bulleen; John Desmond Lauritz of 33 Gray Street, Swan Hill.

(2) The Directors aforementioned shall hold their first meeting at 7.30 p.m. on the 15th day of July, 1975, aboard the Paddle Steamer Gem lying within the environs of the Swan Hill Pioneer Settlement.

(3) The area of the Settlement shall be that portion of the Township of Swan Hill, Parish of Castle Donnington, County of Tatchera, shown hatched on the plan hereunder.

(4) Pursuant to section 28 of the said Act, the Minister may grant or lend to the Authority for the purposes of the said Act, but such grant or loan shall not any one time exceed in the aggregate \$100,000.

(5) The Authority may borrow moneys by way of overdraft, but the aggregate of such borrowing shall not exceed at any one time the sum of \$175,000.

(6) The undertakings, facilities works equipment plant and machinery, which are the property of the said Authority at the time of making of this Order, are those set out in the second schedule hereunder.

(7) If it is necessary to wind up the Authority such winding up shall be initiated by the Governor in Council upon the recommendation of the Minister and after consideration of a report by the Council of the City of Swan Hill and shall be in accordance with the provisions of Part X. of the Companies Act 1961.

(8) The liabilities incurred by the said Authority upon the coming into operation of the said Act shall be those set out in the second schedule hereunder.

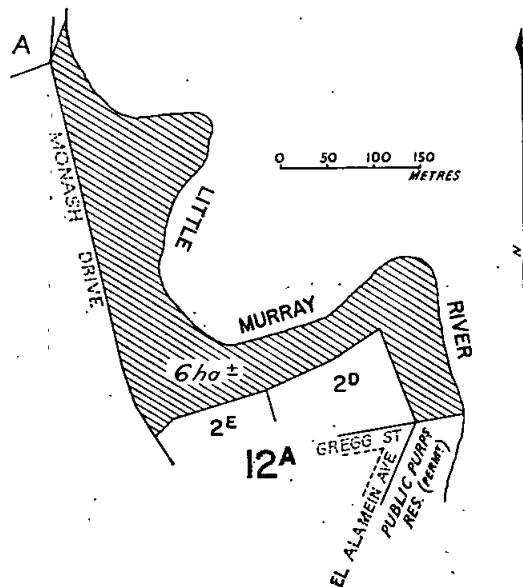

SECOND SCHEDULE.  
SWAN HILL PIONEER SETTLEMENT.

*Balance Sheet September 30, 1974.*

## ASSETS

*Current Assets*

	\$	\$	\$	\$
Change and Petty Cash .. .. .	..	..	1,020.00	..
Bank—Advance Account .. .. .	..	..	200.00	..
Loan Funds Unexpended .. .. .	..	..	3,301.77	..
Debtors .. .. .	..	..	22,788.26	..
Stocks at Cost .. .. .	..	..	57,146.34	..
			84,456.37	

*Fixed Assets*

	<i>Site</i>	<i>Cost</i>	<i>Depreciation Provision</i>	<i>Net</i>
Paddlesteamer "Gem" .. .. .	..	138,517.15	..	138,517.15
Grounds (Crown Land) .. .. .	..	148,083.15	..	148,083.15
Environment Park .. .. .	..	5,635.99	..	5,635.99
Exhibits .. .. .	..	184,594.65	..	184,594.65
Exhibits (Buildings) .. .. .	..	169,876.51	..	169,876.51
Barge "Vega" .. .. .	..	30,776.76	..	30,776.76
Sound and Light .. .. .	..	35,965.22	..	35,965.22
Buildings .. .. .	..	69,254.36	13,759.36	55,495.00
		782,703.79	13,759.36	768,944.43

*Plant, Equipment, Fittings*

Sound and Light .. .. .	9,518.70	4,605.70	4,913.00
Maintenance and Restoration .. .. .	9,541.87	3,825.87	5,716.00
Sundry .. .. .	8,501.91	3,785.91	4,716.00
Damper .. .. .	8,793.25	4,805.25	3,988.00
Printing .. .. .	1,259.90	374.90	885.00
Office .. .. .	3,342.92	1,359.92	1,983.00
Motor Vehicles .. .. .	3,574.47	1,306.47	2,268.00
	14,533.02	20,064.02	24,469.00

*Hostel*

Land and Buildings .. .. .	65,320.17	5,884.17	59,436.00
Plant and Fittings .. .. .	4,925.03	1,548.03	3,377.00
Bedding, Crockery, Cutlery .. .. .	6,967.38	..	6,967.38
	77,212.58	7,432.20	69,780.38

*Other*

Film "Yesterday" .. .. .	13,406.61	7,947.61	5,459.00
House and Land Gray Street .. .. .	10,619.88	..	10,619.88
Art Gallery Paintings .. .. .	4,990.00	..	4,990.00
	29,016.49	7,947.61	21,068.88
	933,465.88	49,203.19	884,262.69

884,262.69

968,719.06

## LIABILITIES

*Current Liabilities*

Bank—Current Account .. .. .	140,487.93
Trade Creditors .. .. .	15,879.01
Accrued Expenses .. .. .	16,903.71

*Deferred Liabilities*

Unemployment Relief Fund .. .. .	16,000.00
Roy Grounds Bequest .. .. .	7,500.00
Loans—City of Swan Hill .. .. .	132,340.54
Loan—State Government .. .. .	100,000.00
—Mortgage .. .. .	4,403.94
	260,244.48

433,515.13

535,203.93

And the Honorable Murray Byrne, Her Majesty's Minister for State Development and Decentralization for the State of Victoria, shall give the necessary directions herein accordingly.

L. G. HOUSTON,  
Acting Clerk of the Executive Council.



## CRANBOURNE SEWERAGE AUTHORITY.

At the Executive Council Chamber, Melbourne, the eighth day of July, 1975.

## PRESENT:

His Excellency the Governor of Victoria.	
Mr. Wilcox	Mr. Rafferty.
Mr. Houghton	

## CONSENT TO BORROWING \$75,000.

Under the powers conferred by the Sewerage Districts Act and all other powers enabling him in that behalf, His Excellency the Governor of the State of Victoria, by and with the advice of the Executive Council of the said State, hereby consents to the Cranbourne Sewerage Authority borrowing the sum of Seventy-five thousand dollars (\$75,000) to meet the cost of sewerage works as set forth in the detailed statement bearing date 3rd July, 1975.

And the Honorable Frederick James Granter, Her Majesty's Minister of Water Supply for the State of Victoria, shall give the necessary directions herein accordingly.

L. G. HOUSTON,  
Acting Clerk of the Executive Council.

## FRANKSTON SEWERAGE AUTHORITY.

At the Executive Council Chamber, Melbourne, the eighth day of July, 1975.

## PRESENT:

His Excellency the Governor of Victoria.	
Mr. Wilcox	Mr. Rafferty.
Mr. Houghton	

## CONSENT TO BORROWING \$50,000.

Under the powers conferred by the Sewerage Districts Act and all other powers enabling him in that behalf, His Excellency the Governor of the State of Victoria, by and with the advice of the Executive Council of the said State, hereby consents to the Frankston Sewerage Authority borrowing the sum of Fifty thousand dollars (\$50,000), to meet the cost of sewerage works as set forth in the detailed statement bearing date 3rd July, 1975.

And the Honorable Frederick James Granter, Her Majesty's Minister of Water Supply for the State of Victoria, shall give the necessary directions herein accordingly.

L. G. HOUSTON,  
Acting Clerk of the Executive Council.

## LAKES ENTRANCE SEWERAGE AUTHORITY.

At the Executive Council Chamber, Melbourne, the eighth day of July, 1975.

## PRESENT:

His Excellency the Governor of Victoria.	
Mr. Wilcox	Mr. Rafferty.
Mr. Houghton	

## CONSENT TO BORROWING \$100,000.

Under the powers conferred by the Sewerage Districts Act and all other powers enabling him in that behalf, His Excellency the Governor of the State of Victoria, by and with the advice of the Executive Council of the said State, hereby consents to the Lakes Entrance Sewerage Authority borrowing the sum of One hundred thousand dollars (\$100,000) to meet the cost of sewerage works as set forth in the detailed statement bearing date 3rd July, 1975.

And the Honorable Frederick James Granter, Her Majesty's Minister of Water Supply for the State of Victoria, shall give the necessary directions herein accordingly.

L. G. HOUSTON,  
Acting Clerk of the Executive Council.

## FRANKSTON SEWERAGE AUTHORITY.

At the Executive Council Chamber, Melbourne, the eighth day of July, 1975.

## PRESENT:

His Excellency the Governor of Victoria.	
Mr. Wilcox	Mr. Rafferty.
Mr. Houghton	

## CONSENT TO BORROWING \$250,000.

Under the powers conferred by the Sewerage Districts Act and all other powers enabling him in that behalf, His Excellency the Governor of the State of Victoria, by and with the advice of the Executive Council of the said State, hereby consents to the Frankston Sewerage Authority borrowing the sum of Two hundred and fifty thousand dollars (\$250,000) to meet the cost of sewerage works as set forth in the detailed statement bearing date 3rd July, 1975.

And the Honorable Frederick James Granter, Her Majesty's Minister of Water Supply for the State of Victoria, shall give the necessary directions herein accordingly.

L. G. HOUSTON,  
Acting Clerk of the Executive Council.

## ANGLESEA SEWERAGE AUTHORITY.

At the Executive Council Chamber, Melbourne, the eighth day of July, 1975.

## PRESENT:

His Excellency the Governor of Victoria.	
Mr. Wilcox	Mr. Rafferty.
Mr. Houghton	

## CONSENT TO BORROWING \$100,000.

Under the powers conferred by the Sewerage Districts Act and all other powers enabling him in that behalf, His Excellency the Governor of the State of Victoria, by and with the advice of the Executive Council of the said State, hereby consents to the Anglesea Sewerage Authority borrowing the sum of One hundred thousand dollars (\$100,000) to meet the cost of sewerage works as set forth in the detailed statement bearing date 3rd July, 1975.

And the Honorable Frederick James Granter, Her Majesty's Minister of Water Supply for the State of Victoria, shall give the necessary directions herein accordingly.

L. G. HOUSTON,  
Acting Clerk of the Executive Council.

## PAKENHAM SEWERAGE AUTHORITY.

At the Executive Council Chamber, Melbourne, the eighth day of July, 1975.

## PRESENT:

His Excellency the Governor of Victoria.	
Mr. Wilcox	Mr. Rafferty.
Mr. Houghton	

## CONSENT TO BORROWING \$75,000.

Under the powers conferred by the Sewerage Districts Act and all other powers enabling him in that behalf, His Excellency the Governor of the State of Victoria, by and with the advice of the Executive Council of the said State, hereby consents to the Pakenham Sewerage Authority borrowing the sum of Seventy-five thousand dollars (\$75,000) to meet the cost of sewerage works as set forth in the detailed statement bearing date 3rd July, 1975.

And the Honorable Frederick James Granter, Her Majesty's Minister of Water Supply for the State of Victoria, shall give the necessary directions herein accordingly.

L. G. HOUSTON,  
Acting Clerk of the Executive Council.

**PORT FAIRY SEWERAGE AUTHORITY.**

At the Executive Council Chamber, Melbourne, the eighth day of July, 1975.

PRESENT:

His Excellency the Governor of Victoria,  
Mr. Wilcox | Mr. Rafferty.  
Mr. Houghton

**CONSENT TO BORROWING \$20,000.**

Under the powers conferred by the Sewerage Districts Act and all other powers enabling him in that behalf, His Excellency the Governor of the State of Victoria, by and with the advice of the Executive Council of the said State, hereby consents to the Port Fairy Sewerage Authority borrowing the sum of Twenty thousand dollars (\$20,000) to meet the cost of sewerage works as set forth in the detailed statement bearing date 3rd July, 1975.

And the Honorable Frederick James Granter, Her Majesty's Minister of Water Supply for the State of Victoria, shall give the necessary directions herein accordingly.

L. G. HOUSTON,  
Acting Clerk of the Executive Council.

**CRANBOURNE SEWERAGE AUTHORITY.**

At the Executive Council Chamber, Melbourne, the eighth day of July, 1975.

PRESENT:

His Excellency the Governor of Victoria,  
Mr. Wilcox | Mr. Rafferty.  
Mr. Houghton

**CONSENT TO BORROWING \$50,000.**

Under the powers conferred by the Sewerage Districts Act and all other powers enabling him in that behalf, His Excellency the Governor of the State of Victoria, by and with the advice of the Executive Council of the said State, hereby consents to the Cranbourne Sewerage Authority borrowing the sum of Fifty thousand dollars (\$50,000), to meet the cost of sewerage works as set forth in the detailed statement bearing date 3rd July, 1975.

And the Honorable Frederick James Granter, Her Majesty's Minister of Water Supply for the State of Victoria, shall give the necessary directions herein accordingly.

L. G. HOUSTON,  
Acting Clerk of the Executive Council.

**WARRAGUL WATERWORKS TRUST.**

At the Executive Council Chamber, Melbourne, the eighth day of July, 1975.

PRESENT:

His Excellency the Governor of Victoria,  
Mr. Wilcox | Mr. Rafferty.  
Mr. Houghton

**CONSENT TO BORROWING \$50,000.**

Under the powers conferred by the Water Act and all other powers enabling him in that behalf, His Excellency the Governor of the State of Victoria, by and with the advice of the Executive Council of the said State, hereby consents to the Warragul Waterworks Trust borrowing three separate amounts of Twenty thousand dollars (\$20,000), Fifteen thousand dollars (\$15,000) and Fifteen thousand dollars (\$15,000), totalling Fifty thousand dollars (\$50,000), to meet the cost of water supply works.

And the Honorable Frederick James Granter, Her Majesty's Minister of Water Supply for the State of Victoria, shall give the necessary directions herein accordingly.

L. G. HOUSTON,  
Acting Clerk of the Executive Council.

**MELTON WATERWORKS TRUST.**

At the Executive Council Chamber, Melbourne, the eighth day of July, 1975.

PRESENT:

His Excellency the Governor of Victoria,  
Mr. Wilcox | Mr. Rafferty.  
Mr. Houghton

**CONSENT TO BORROWING \$100,000.**

Under the powers conferred by the Water Act and all other powers enabling him in that behalf, His Excellency the Governor of the State of Victoria, by and with the advice of the Executive Council of the said State, doth hereby consent to the Melton Waterworks Trust borrowing the sum of One hundred thousand dollars (\$100,000) to meet the cost of water supply works.

And the Honorable Frederick James Granter, Her Majesty's Minister of Water Supply for the State of Victoria, shall give the necessary directions herein accordingly.

L. G. HOUSTON,  
Acting Clerk of the Executive Council.

**LEONGATHA WATERWORKS TRUST.**

At the Executive Council Chamber, Melbourne, the eighth day of July, 1975.

PRESENT:

His Excellency the Governor of Victoria,  
Mr. Wilcox | Mr. Rafferty.  
Mr. Houghton

**CONSENT TO BORROWING \$35,000.**

Under the powers conferred by the Water Act and all other powers enabling him in that behalf, His Excellency the Governor of the State of Victoria, by and with the advice of the Executive Council of the said State, hereby consents to the Leongatha Waterworks Trust borrowing the sum of Thirty-five thousand dollars (\$35,000) to meet the cost of water supply works.

And the Honorable Frederick James Granter, Her Majesty's Minister of Water Supply for the State of Victoria, shall give the necessary directions herein accordingly.

L. G. HOUSTON,  
Acting Clerk of the Executive Council.

**PORT FAIRY WATERWORKS TRUST.**

At the Executive Council Chamber, Melbourne, the eighth day of July, 1975.

PRESENT:

His Excellency the Governor of Victoria,  
Mr. Wilcox | Mr. Rafferty.  
Mr. Houghton

**CONSENT TO BORROWING \$30,000.**

Under the powers conferred by the Water Act and all other powers enabling him in that behalf, His Excellency the Governor of the State of Victoria, by and with the advice of the Executive Council of the said State, doth hereby consent to the Port Fairy Waterworks Trust borrowing the sum of Thirty thousand dollars (\$30,000) to meet the cost of water supply works.

And the Honorable Frederick James Granter, Her Majesty's Minister of Water Supply for the State of Victoria, shall give the necessary directions herein accordingly.

L. G. HOUSTON,  
Acting Clerk of the Executive Council.

**LANDS DEPARTMENT NOTICES**

**APPROACHING LAND SALES.**

Sale of Crown Land, in fee-simple, will be held at the under-mentioned places and dates, viz:—

	No. of Gazette.
Bendigo.—Wednesday, 16th July, 1975	44
Beulah.—Tuesday, 22nd July, 1975	48
Broadford.—Wednesday, 30th July, 1975	48
Thorpdale.—Wednesday, 13th August, 1975	58

**SALE OF CROWN LAND BY AUCTION.**

The land will be offered for sale in fee-simple, and subject to the provisions of the Land Act and Regulations thereunder.

The upset price is the sum at which bidding will start, and no bid below that sum can be accepted. The highest bidder at or above that sum shall be the purchaser, subject to signature of contract and any necessary payment.

**TERMS:—**

A deposit of at least 12½% of the purchase price must be paid at the sale, either in cash or by cheque.

The residue is payable in half-yearly instalments, in accordance with the following scale, or may be paid off at any earlier time.

- Over \$40, and not exceeding \$100, 8 instalments.
- Over \$100, and not exceeding \$200, 10 instalments.
- Over \$200, and not exceeding \$400, 12 instalments.
- Over \$400, and not exceeding \$600, 14 instalments.
- Over \$600, and not exceeding \$800, 16 instalments.
- Over \$800, and not exceeding \$1,000, 18 instalments.
- Over \$1,000, 20 instalments.

Interest at the rate of 7% per annum is payable with all payments of residue, and is computed for each instalment from the date of sale to the date of such payment. Additional interest is charged if any instalment is not paid on or before the due date.

If paid off within 30 days of sale, no interest is payable.

**FEES, ETC.:**

Also payable at the sale, in addition to the deposit, are the survey fee and, if applicable, the valuation of improvements (if purchaser be not the owner thereof).

Payable with balance of purchase money—

Crown Grant fee—\$10.00.

Assurance Fund contribution.—One cent in every Five dollars or part thereof of purchase price. (This is a fund established to guarantee the validity of freehold titles.)

Transfer of interest prior to completion of payment may be allowed on payment of \$5 fee and subject to stamp duty.

If unable to attend personally, a prospective purchaser may arrange for another person to bid as his agent.

Attention is drawn to section 95, Land Act 1958, which provides that the purchaser shall be deemed to be the owner for the purposes of other Acts; also to an amendment to the Local Government Act providing for Government roads, in certain circumstances, to be declared "private streets", thus making the purchaser liable to contribute to the cost of street construction.

W. BORTHWICK,

Minister of Lands.

Office of Crown Lands and Survey,  
Melbourne, 9th July, 1975.

**THORPDALE.**—Sale (No. 12194) of Crown Land in fee-simple, by auction, will be held at the THORPDALE MECHANICS INSTITUTE, THORPDALE, on WEDNESDAY the 13TH day of AUGUST, 1975, at HALF-PAST ELEVEN o'clock a.m. To be conducted by P. COGLAN, Land Officer, Melbourne.

Lot 1.

**PARISH OF MOE.**

Abutting the north side of MacDonalds Track about 40 metres (2 chains) west of the Mirboo North-Thorpdale Road.

Upset price \$250.00 the lot. Survey fee \$70.00.

Area 2018 square metres (2 roods). Allotment 1 Section B<sup>2</sup>.—(G.76451.)

**PROPOSED REVOCATIONS OF TEMPORARY RESERVATIONS OF LANDS BY ORDERS IN COUNCIL.**

In pursuance of the provisions of the Land Act 1958, notice is hereby given that it is the intention of the Governor in Council to revoke the temporary reservations of lands by Orders in Council hereunder referred to, viz.:

The following Notices were published 1<sup>o</sup> on the 25th June, 1975, pursuant to Orders of the 18th June, 1975.

**TERRAPPEE (LAKE MARMAL).**—The temporary reservation by Order in Council of the 9th September, 1940, of 1.214 hectares (3 acres) of land in the Parish of Terrappee as a site for State School is about to be revoked.—(T.253<sup>(2)</sup>) (Rs.4860).

**HORSHAM.**—The temporary reservation by Order in Council of the 2nd March, 1965, of 3.409 hectares (8 acres 1 rood 28 perches) of land in the Township of Horsham as a site for Public Recreation, revoked as to part by various Orders, is about to be revoked so far only as the portion containing 8455 square metres, more or less, indicated by hatching on plan hereunder, is concerned.—(H.91<sup>(3)</sup>) (Rs.4656).

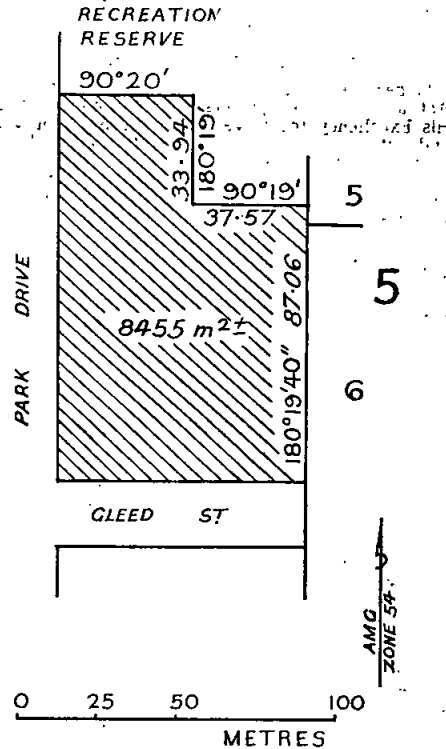

**GREENSBOROUGH.**—The temporary reservation as a site for Public Purposes and the withholding from sale, leasing and licensing by Order in Council of the 7th September, 1879, of 7158 square metres (1 acre 3 roods 3 perches) of land in the Parish of Greensborough are about to be revoked so far only as the portion containing 3486 square metres, indicated by hatching on plan hereunder, is concerned.—(G.179<sup>(7)</sup>) (Rs.2976).

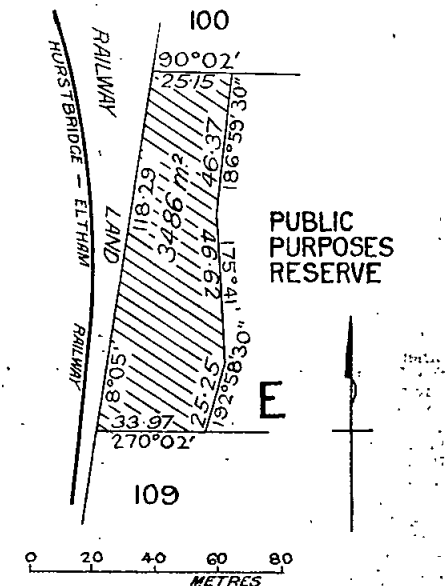

W. BORTHWICK,  
Minister of Lands.

**PROPOSED REVOCATIONS OF TEMPORARY RESERVATIONS OF LANDS BY ORDERS IN COUNCIL.**

In pursuance of the provisions of the Land Act 1958, notice is hereby given that it is the intention of the Governor in Council to revoke the temporary reservations of lands by Orders in Council hereunder referred to viz.:-

The following Notices were published 1° on the 2nd July, 1975, pursuant to Orders of the 24th June, 1975.

**KORUMBURRA (STRZELECKI).**—The temporary reservation by Order in Council of the 11th April, 1972, of 3971 square metres (3 rood 37 perches, more or less) of land in the Parish of Korumburra as a site for Public Purposes (State School Forest Plantation) is about to be revoked.—(K.172<sup>(10)</sup>) (Rs.9570).

**ANGLESEA.**—The temporary reservation by Order in Council of the 26th February, 1917, of 29.95 hectares (74 acres, more or less) of land in the Township of Anglesea as a site for Public Recreation, revoked as to part by various Orders is about to be revoked so far only as the portion containing 1.947 hectares, indicated by hatching on plan hereunder is concerned.—(A.183<sup>(8)</sup>) (Rs.1527).

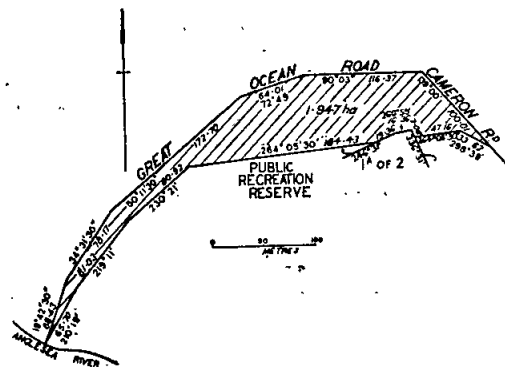

W. BORTHWICK,  
Minister of Lands.

**REGULATIONS FOR THE CARE, PROTECTION AND MANAGEMENT OF THE "PUBLIC PURPOSES (PENAL MUSEUM), CITY OF MELBOURNE".**

I, William Archibald Borthwick, Her Majesty's Minister of Lands in and for the State of Victoria, in pursuance of the powers conferred on me by section 218 of the Land Act 1958, do hereby make the following Regulations for or with respect to the land in the Parish of Melbourne North, City of Melbourne, temporarily reserved pursuant to Order in Council dated the 7th December, 1971, as a site for Public purposes (Penal Museum) which shall, hereinafter be referred to as the "Reserve".

The reserve has been placed under the control of the National Trust of Australia (Victoria) (hereinafter referred to as the "Committee") with power and authority to enforce the following regulations.

**REGULATIONS.**

1. The Reserve shall be open to the public on such days and at such times as shall, from time to time, be determined by the Committee.
2. No person or persons shall enter or remain in the Reserve without having first paid such fees as may be prescribed and deemed reasonable by the Committee from time to time.
3. No person shall interfere with, move, damage or destroy any shrub, tree, plant, grass, flowers or any property, or enter on any flower bed or borders, or light fires within the Reserve.
4. No person shall climb on any portion of any building, balustrade, or property in the Reserve, or jump over any fence or hedge thereon.
5. No person shall cut names on, or in any way damage or injure any of the buildings, gates, fences, seats, or trees in the Reserve, or stick bills thereon; nor leave or deposit any glass, paper or rubbish; nor roll or throw stones or any missiles of any kind therein.
6. No person except on lawful occasions, may enter any enclosed area or building, garage, or shed, or any other structure within the Reserve.

7. No person shall enter or remain in the Reserve who may offend against decency as regards dress, language, or conduct.

8. No person shall remain within the Reserve, or on any property therein, when lawfully directed to leave the same by any bailiff of Crown Lands, or member of the Police Force or authorized officer of the Committee.

9. No person shall hawk or sell, or offer for sale, within the Reserve, any goods, fruit, or merchandise or anything, or solicit or gather money therein without the authority in writing, of the Committee.

10. No person shall give out, or distribute, any handbills, placards, notices, advertisements, books, pamphlets or papers in the Reserve, other than those duly authorised by the Committee, nor litter the Reserve by scattering or throwing down handbills, placards, notices, advertisements, books, pamphlets or papers.

11. No person shall take part in any public entertainment of any sort in the Reserve without the permission, in writing, of the Committee.

12. No person shall bring into the Reserve any dog unless securely held by chain, cord or leash.

13. No person shall bring in or allow to remain in the Reserve any horse, cow, sheep, goat, pig or any other animal.

14. No person shall spit or expectorate on the paths or seats or any wall, structure, or property within the Reserve.—(Rs.9452).

Given under my hand, at Melbourne, on the second day of July, 1975.

W. BORTHWICK,  
Minister of Lands.

Every person who contravenes or fails to comply with these Regulations shall, in accordance with the provisions of section 218 of the Land Act 1958, for each offence be liable to a penalty of not more than Fifty dollars, and every person who contravenes or fails to comply with any such Regulations, and who, after he has been warned by any bailiff of Crown lands or by any member of the Police Force, does not desist therefrom may be forthwith apprehended by such bailiff or member of the Police Force and taken before some justice to be dealt with according to law and shall be liable to a penalty of not more than One hundred dollars, provided that every person who contravenes any regulation made under the said section for or with respect to prohibiting the depositing and leaving of any unwanted material or thing or rubbish of any kind on any land to which this section relates shall for each offence be liable to a penalty of not more than Two hundred dollars.

**REGULATIONS FOR THE CARE, PROTECTION AND MANAGEMENT OF THE "MEREDITH RECREATION RESERVE".**

I, William Archibald Borthwick, Her Majesty's Minister of Lands in and for the State of Victoria, in pursuance of the powers conferred on me by section 218 of the Land Act 1958, do hereby make the following Regulations for or with respect to the land in the Township of Meredith temporarily reserved pursuant to Order in Council dated the 19th June, 1883, as a site for Cricket and other purposes of Public Recreation (hereinafter referred to as "the Reserve").

The Reserve has, pursuant to the provisions of section 221 of the Land Act 1958, been placed under the control of a Committee of Management (hereinafter referred to as "the Committee"), with power and authority to enforce the following Regulations:—

These Regulations are made in lieu of those made on the 21st February, 1888, by the Board of Land and Works.

**REGULATIONS.**

1. The Reserve shall be open to the public at all times free of charge, except on such days as the Reserve may be set apart for public entertainment, fêtes or sports on any of which occasions a fee as may be determined by the Committee from time to time may be charged and taken for the admission of every adult to the Reserve.
2. Any person, club, association or other combined body of persons desiring to use the Reserve may do so subject to the payment of such fees and the observance of such conditions as may be determined by the Committee from time to time.
3. No person shall—
  - (a) enter or remain in the Reserve who may offend against decency as regards, dress, language or conduct or behave in a disorderly, unseemly or offensive manner or create or take part in any disturbance;

- (b) carry, use or discharge any firearm, air rifle or other lethal weapon in the Reserve;
- (c) disturb, interfere with or destroy any animal or bird, or its lair or nest in the Reserve;
- (d) climb or jump over the gates or fences in or around the Reserve, stick bills thereon, or cut names on or in any way damage or injure any of the buildings, gates, fences, seats, trees, shrubs or flowers nor leave or deposit any glass, paper or rubbish therein except in receptacles provided for the purposes.

4. No person shall unless authorized in writing by the Committee—

- (a) cut, dig, move or displace any trees or plants in the Reserve;
- (b) remove any earth, sand, stone, marl or gravel from the Reserve;
- (c) light or cause to be lit any fires in the Reserve;
- (d) erect any booth or other structure, nor offer for sale or hire any article or commodity within the Reserve or within any structure thereon;
- (e) put or allow to remain in the Reserve any sheep, cattle, horses, goats, pigs or any other animals;
- (f) break glass, deposit or leave any bottles, glass, paper, fruit, peel, litter or rubbish or refuse of any kind except in receptacles provided for the purpose by the Committee.
- (g) bring into the Reserve any dog unless such dog is and continues to be at all times controlled by a chain or leash and any dog found in the Reserve except as herein provided may be seized and disposed of by the Committee.

Given under my hand, at Melbourne, on the second day of July, 1975.

W. BORTHWICK,  
Minister of Lands.

Every person who contravenes or fails to comply with these Regulations shall, in accordance with the provisions of section 218 of the Land Act 1958, for each offence be liable to a penalty of not more than Fifty dollars, and every person who contravenes or fails to comply with any such Regulations, and who, after he has been warned by any bailiff of Crown lands or by any member of the Police Force, does not desist therefrom may be forthwith apprehended by such bailiff or member of the Police Force and taken before some justice to be dealt with according to law and shall be liable to a penalty of not more than One hundred dollars, provided that every person who contravenes any regulation made under the said section for or with respect to prohibiting the depositing and leaving of any unwanted material or thing or rubbish of any kind on any land to which this section relates shall for each offence be liable to a penalty of not more than Two hundred dollars.

## TENDERS

### PUBLIC WORKS DEPARTMENT

Tenders will be received at Public Works Department, 2 Treasury Place, Melbourne, until TWO p.m. on dates shown and for purposes mentioned hereunder.

Particulars and tender forms available at Contracts Office, Room 27, Ground Floor, No. 2, Treasury Place, and at places indicated in brackets hereunder.

Abbreviations in brackets mean:—W.O.—Inspector of Works Office; P.S.—Police Station; C.S.—Consolidated School; H.E.S.—Higher Elementary School; H.S.—High School; Pr.S.—Primary School; T.S.—Technical School.

Tenders to be submitted on the Department's printed Tender Form and will not be received by telephone. All tenders must be on a "Firm Tender" basis. The lowest or any tender will not necessarily be accepted.

Address tenders to the Minister of Public Works, and endorse the envelope containing the tender "Tender for \_\_\_\_\_, closing Tuesday,

Hand delivered tenders to be placed in the Tender Box of the Public Works Department, located on the wall of the centre entrance foyer, Ground Floor, 2 Treasury Place, Melbourne.

No preliminary deposit is required with any tender, but successful tenderer will be required to pay a deposit for any accepted tender of \$10,000 or over.

Tuesday, 15th July, 1975.

#### Building, Electrical and Mechanical Works.

FRANKSTON.—Provision of additional cell accommodation, Police Station.

LARUNDEL.—Electrical services, remodelling, Ward 2, Mental Hospital.

NHILL.—Electrical services, alterations and additions, Pr.S.2411 (W.O., Horsham.)

NHILL.—Mechanical services, alterations and additions, Pr.S.2411 (W.O., Horsham.)

OAKLEIGH.—Provision of garage facilities, Technical School. (Re-advertised.) (W.O., Dandenong.)

PASCOE VALE SOUTH.—External repairs and painting, Pr.S.4704. (Re-advertised.)

#### Site Works.

COBDEN.—Site works, Pr.S.864 (W.O., Camperdown, Warrnambool.)

CORIO.—Site works, Technical School. (W.O., Geelong.)

#### Miscellaneous.

COORIEMUNGLE.—Construction of sewerage treatment plant, Prison Farm. (W.O., Camperdown.)

Tuesday, 22nd July, 1975.

#### Building, Electrical and Mechanical Works.

LONGERENONG.—Mechanical services, erection of new Library, Agricultural College. (W.O., Horsham and Bendigo.)

#### Site Works.

BROADMEADOWS.—Site works, Technical School.

CRAIGIEBURN.—Site works, Primary School 4770.

#### Miscellaneous.

FERNTREE GULLY.—Maintenance cleaning 11th August, 1975–10th August, 1978, Court House.

HAWTHORN.—Maintenance cleaning 15th July, 1975–14th July, 1978, Road Safety and Traffic Authority, 801 Glenferrie Road.

MALVERN.—Maintenance cleaning, 11th August, 1975–10th August, 1978, Court House, Glenferrie Road.

MELBOURNE.—Maintenance cleaning, 1st August, 1975–30th July, 1978, State Laboratories, 5 Parliament Place.

PORT MELBOURNE.—Maintenance cleaning 21st July, 1975–20th July, 1978, Marine Laboratories, Salmon Street.

PRESTON.—Maintenance cleaning 11th August, 1975–10th August, 1978, Court House, Roseberry Avenue.

RINGWOOD.—Maintenance cleaning 4th August, 1975–3rd August, 1978, Social Welfare Offices, 291 Whitehorse Road.

Tuesday, 29th July, 1975.

#### Building, Electrical and Mechanical Works.

FRANKSTON.—Conversion of premises, Motor Registration and Licence Testing Station, 126 Dandenong Road.

WARRNAMBOOL.—Electrical installation, alterations and additions, Pr.S.1743. (W.O., Warrnambool and Hamilton.)

#### Site Works.

DONCASTER.—Site works, High School.

HAWKESDALE.—Site works, High School. (W.O., Warrnambool.)

NUNAWADING.—Site works, High School.

#### Miscellaneous.

PORT MELBOURNE.—Maintenance cleaning 18th August, 1975, to 17th August, 1978, Court House, Bay Street.

SOUTH MELBOURNE.—Maintenance cleaning 11th August, 1975, to 10th August, 1978, Court House, Bank Street.

J. F. ROSSITER,  
Acting Minister for Public Works.

Public Works Department,  
Melbourne, 7th July, 1975.

STATE TENDER BOARD.  
TENDERS FOR THE SERVICE 1975-77.  
General Stores.

Tenders will be received until Eight thirty a.m. on Friday, 1st August, 1975, from persons willing to supply the under-mentioned articles in such quantities as may be ordered by the Victorian Government during the period commencing 1st October, 1975.

Schedule No. 66.—Tyres and Tubes, Pneumatic.

Full particulars may be obtained from the Secretary to the Tender Board, by whom also any information will be afforded to persons tendering.

Tenders enclosed in the envelope provided, must be deposited in the tender-box at the Tender Board Offices, 3rd Floor, 49 Spring Street, Melbourne, 3000, or, if sent by post, postage must be prepaid and the tenders addressed to the Chairman of the Tender Board, Tender Board Offices, 49 Spring Street, Melbourne, 3000, which office they must reach not later than by first post on the date of closing of tenders.

W. L. ROBERTSON,  
Secretary to the Tender Board.

STATE TENDER BOARD.  
TENDERS FOR THE SERVICE 1975-77.  
General Stores.

Tenders will be received until Eight thirty a.m. on Friday, 25th July, 1975, from persons willing to supply the under-mentioned articles in such quantities as may be ordered by the Victorian Government from 1st August, 1975, to 30th June, 1976.

Schedule No. 25.—Chemicals, &c.

Item No. 33.—2,4,5—Trichlorophenoxyacetic acid only in an ester form.

Item No. 41.—Amitrol T. (3-amino-1,2,4 triazole) and ammonium thiocyanate in equal proportions.

Full particulars may be obtained from the Secretary to the Tender Board, by whom also any information will be afforded to persons tendering.

Tenders enclosed in the envelope provided, must be deposited in the tender-box at the Tender Board Offices, 3rd Floor, 49 Spring Street, Melbourne, 3000, or, if sent by post, postage must be prepaid and the tenders addressed to the Chairman of the Tender Board, Tender Board Offices, 49 Spring Street, Melbourne, 3000, which office they must reach not later than by first post on the date of closing of tenders.

W. L. ROBERTSON,  
Secretary to the Tender Board.

**PUBLIC SERVICE NOTICES**

EXAMINATION FOR LICENCE AS SHORTHAND WRITER.

It is hereby notified that the undermentioned persons passed the examination, held on 28th June, 1975, for Licence as Shorthand Writers under the Evidence Act:—

BARKER, M. R.,  
CARR, PAULINE,  
CASONATO, VALL,  
FOLEY, SHARRON D.,  
FOWLER, TREVOR,  
HARE, WENDY A.,  
JAEGER, CAROLYN,  
KEELAN, L. F.,  
MCKINNON, MARGARET,  
MANNAS, CARINA,  
MENADUE, CAROLYN,  
PAGLIARO, MARI.

By Order,

L. R. BROWN,  
Secretary.

Office of the Public Service Board,  
Melbourne, 1st July, 1975.

APPOINTMENT OF A DEPUTY TO A MEMBER OF THE PUBLIC SERVICE BOARD.

Whereas in the manner prescribed by the Regulations and at an election held in conjunction with the election of Kevin John Tutty, the public service representative on the Public Service Board, EDWIN JOHN BENNETT was elected to be his deputy in the case of his suspension, illness or absence:

And whereas the said Kevin John Tutty will be absent from meetings of the Board on the 7th and the 8th July 1975:

Now therefore, at the request of the said Kevin John Tutty and in pursuance of the powers conferred by section 15(2A) of the Public Service Act 1958, I do hereby appoint the said Edwin John Bennett to be the deputy of Kevin John Tutty on the abovementioned days.

Given under my hand at Melbourne, this fourth day of July, 1975.

A. J. A. GARDNER, Chairman.

No. 442.

PUBLIC SERVICE ACT 1958.

The Public Service Board, in pursuance of the powers conferred by the Public Service Act 1958, hereby amends the Public Service (Public Service Board) Regulations as follows—

PART V.—ALLOWANCES.

DIVISION IV.—SHIFT DUTY AND ROSTERED TIME OF ORDINARY DUTY PERFORMED BY OFFICERS DURING WEEK-ENDS OR ON PUBLIC HOLIDAYS.

DEPARTMENT OF HEALTH—MENTAL HYGIENE BRANCH.  
Regulation 170.

In this Regulation the amounts "\$1.50" and "\$2.90" are deleted and the amounts "\$2.10" and "\$4.20" are inserted in lieu thereof respectively.

A. J. A. GARDNER, Chairman.  
L. R. BROWN, Secretary.

Office of the Public Service Board,  
Melbourne, 25th June, 1975.

No. 445.

PUBLIC SERVICE ACT 1958.

The Public Service Board, in pursuance of the powers conferred by the Public Service Act 1958, hereby amends the Public Service (Public Service Board) Regulations as follows:—

PART IV.—SALARIES AND INCREMENTS.

DIVISION IV.—TECHNICAL AND GENERAL DIVISION.

Regulation 119.

In paragraph (d) of sub-regulation (3) the expression "two annual increments of \$206, two annual increments of \$210 and one annual increment of \$212" is deleted and the expression "four annual increments of \$210 and one annual increment of \$214" is inserted in lieu thereof.

In paragraph (e) of sub-regulation (3) the expression "two annual increments of \$303 and one annual increment of \$304" is deleted and the expression "two annual increments of \$331 and one annual increment of \$332" is inserted in lieu thereof.

PART V.—ALLOWANCES.

DIVISION I.—ALLOWANCES FOR QUALIFICATIONS OR EFFICIENCY.

TECHNICAL AND GENERAL DIVISION.

Department of Health.

Regulation 149.

The amount "\$106" is deleted and the amount "\$200" is inserted in lieu thereof.

DIVISION IV.—SHIFT DUTY AND ROSTERED TIME OF ORDINARY DUTY PERFORMED BY OFFICERS DURING WEEK-ENDS OR ON PUBLIC HOLIDAYS.

Department of Health.—Mental Hygiene Branch.

Regulation 169.

In sub-regulation (1) the existing scale of annual rates of allowances is deleted and the following scale is inserted in lieu thereof—

	Yearly Rate of Allowance.
	\$
" Student Nurse—	
1st year	788
2nd year	815
3rd and subsequent years	843
Staff Nurse	988

Ward Nurse—	
1st. year	1,015
2nd year	1,060
3rd year	1,104
4th and subsequent years	1,149
Deputy Charge Nurse	1,220
Charge Nurse	1,316
Assistant Head Nurse	1,469

This Regulation shall have effect from 6th July, 1975.

A. J. A. GARDNER, Chairman.  
L. R. BROWN, Secretary.

Office of the Public Service Board,  
Melbourne, 30th June, 1975.

No. 441.

Public Service Act 1958, Sections 39 and 50.

REGULATIONS.—PART IV.—SALARIES AND INCREMENTS.

The Public Service Board, in pursuance of the powers conferred by the Public Service Act 1958, hereby amends the Public Service (Public Service Board) Regulations as shown below:—

FOURTH SCHEDULE.

PART B.

TECHNICAL AND GENERAL DIVISION AND TEMPORARY EMPLOYEES.

Grades.	Yearly Salary.		Salary/ Increment Code.	Title of Office and Position.	Title Code.
	Minimum.	Maximum.			
	\$	\$			
DEPARTMENT OF HEALTH.					
Tuberculosis.					
State Sanatoria.					
Delete— 181-196	6,953	7,380	AA	Mechanic	

This Regulation shall have effect from 22nd June, 1975.

A. J. A. GARDNER, Chairman.  
L. R. BROWN, Secretary.

Office of the Public Service Board,  
Melbourne, 23rd June, 1975.

No. 444.

Public Service Act 1958, Sections 39 and 50.

REGULATIONS.—PART IV.—SALARIES AND INCREMENTS.

The Public Service Board, in pursuance of the powers conferred by the Public Service Act 1958, hereby amends the Public Service (Public Service Board) Regulations as shown below:—

FOURTH SCHEDULE.

PART B.

TECHNICAL AND GENERAL DIVISION AND TEMPORARY EMPLOYEES

Grades.	Yearly Salary.		Salary/ Increment Code.	Title of Office and Position.	Title Code.
	Minimum.	Maximum.			
	\$	\$			
EDUCATION DEPARTMENT.					
Schools.					
Delete— 184-191	7,050	7,196	AA	Typist, Grade II.	
Add— 185-191	7,050	7,196	AA	Typist, Grade II.	
DEPARTMENT OF STATE DEVELOPMENT.					
Division of Tourism.					
Delete— 182-184	6,975	7,754	AA	Inquiry Clerk, Grade I.—Adult	
Add— 182-205	6,975	7,754	AA	Inquiry Clerk, Grade I.—Adult	

This Regulation shall have effect from 22nd June, 1975.

A. J. A. GARDNER, Chairman.  
L. R. BROWN, Secretary.

Office of the Public Service Board,  
Melbourne, 30th June, 1975.

No. 446.

Public Service Act 1958, Sections 39 and 50.

REGULATIONS.—PART IV.—SALARIES AND INCREMENTS.

The Public Service Board, in pursuance of the powers conferred by the Public Service Act 1958, hereby amends the Public Service (Public Service Board) Regulations as shown below:—

FIFTH SCHEDULE.

TECHNICAL AND GENERAL DIVISION.

DEPARTMENT OF HEALTH.

MENTAL HYGIENE.

Grades and Salary Scales.

PART A.

Grade.	Yearly Rate of Salary at Each Age in Years.				
	Under 17.	17.	18.	19.	20.
	\$	\$	\$	\$	\$
Delete— J-7	..	..	..	..	4,847(a)
Add— J-7	..	..	..	..	5,221(a)

PART B.

DEPARTMENT OF HEALTH.

MENTAL HYGIENE.

TECHNICAL AND GENERAL DIVISION AND TEMPORARY EMPLOYEES

Classifications of Offices and Positions and Rates of Salaries.

Delete the existing grades and yearly rates of salary for the following offices and/or positions and insert the grades and rates shown hereunder in lieu thereof—

Grades.	Yearly Salary.		Salary/ Increment Code.	Title of Office and Position.	Title Code.
	Minimum.	Maximum.			
	\$	\$			
Nursing Staff.					
302	..	12,351	AC	Assistant to the Nursing Adviser	..
234	..	9,063	..	Clinical Instructor, Grade I.	..
250	..	9,775	..	Clinical Instructor, Grade II.	..
317	..	13,160	AC	Director of Nursing, Assistant	..
317	..	13,160	AC	Director of Nursing, Grade I.	..
329	..	13,923	AC	Director of Nursing, Grade II.	..
352	..	15,425	AC	Director of Nursing, Grade III.	..
250	..	9,775	..	Nurse, Charge	..
234	..	9,063	..	Nurse, Deputy Charge	..
317	..	13,160	AC	Nurse, Head	..
274	..	10,912	..	Nurse, Head, Assistant	..
329	..	13,923	AC	Nurse, Principal	..
195	..	7,340	..	Nurse, Staff	..
136-153	5,850	6,265	AD	Nurse, Student	..
274	..	10,912	..	Nurse, Supervisory	..
200-222A	7,541	8,535	AD	Nurse, Ward	..
337	..	15,751	AC	Nursing Adviser (Mental Health)	..
309	..	12,728	AC	Nursing Education Officer, Grade I.	..
319	..	13,268	AC	Nursing Education Officer, Grade II.	..
323	..	13,530	AC	Nursing Education Officer, Senior	..
134-177	5,801	6,855	AD	Training Assistant, Sandhurst Boys' Centre	..
317	..	13,160	AC	Training Supervisor, Sandhurst Boys' Centre	..
301	..	12,297	AC	Tutor	..
134-177	5,801	6,855	AD	Ward Assistant—Adult	..
1-7	..	..	..	Ward Assistant—Junior	GC, GF

This Regulation shall have effect from 6th July, 1975.

A. J. A. GARDNER, Chairman.  
L. R. BROWN, Secretary.

Office of the Public Service Board,  
Melbourne, 30th June, 1975.

No. 443.

Public Service Act 1958, Sections 39 and 50.

REGULATIONS.—PART IV.—SALARIES AND INCREMENTS.

The Public Service Board, in pursuance of the powers conferred by the Public Service Act 1958, hereby amends the Public Service (Public Service Board) Regulations as shown below:—

FOURTH SCHEDULE.

PART A.

TECHNICAL AND GENERAL DIVISION.

Grades and Salary Scales.

JUNIOR GRADES.

Grade.	Yearly Rate of Salary at Each Age in Years.				
	Under 17.	17.	18.	19.	20.
	\$	\$	\$	\$	\$
Delete— J-37	2,912	3,411	3,996	4,559	5,227
Add— J-37	3,118	3,660	4,286	4,891	5,600

PART B.

TECHNICAL AND GENERAL DIVISION AND TEMPORARY EMPLOYEES.

Grades.	Yearly Salary.		Salary/ Increment Code.	Title of Office and Position.	Title Code.
	Minimum.	Maximum.			
	\$	\$			
DEPARTMENT OF AGRICULTURE.					
Delete— 171-187	6,707	7,100	AA	Cook .. ..	..
<i>Dookie Agricultural College.</i>					
Delete— 140-153	6,707	7,100	AA	Cook .. ..	..
140-153	5,947	6,265	AA	Cook Assistant ..	..
<i>Longerenong Agricultural College.</i>					
Delete— 171-187	6,707	7,100	AA	Cook .. ..	..
<i>Mallee Research Station, Walpeup.</i>					
Delete— 137-149	5,874	6,166	AA	Housekeeper-Caterer ..	..
CHIEF SECRETARY'S DEPARTMENT.					
<i>Office of the Chief Commissioner of Police.</i>					
Delete— 162-175	6,484	6,805	AA	Cook, Police .. ..	..
DEPARTMENT OF HEALTH.					
<i>Alcoholics and Drug Dependent Persons Services.</i>					
Delete— 148-161	6,142	6,460	AA	Cook, Grade I. ..	..
176-192	6,831	7,221	AA	Cook, Grade II. ..	..
192-201	7,221	7,584	AA	Cook, Grade III. ..	..
131-144	5,728	6,045	AA	General Reliever ..	..
<i>General Health.</i>					
Delete 148-161	6,142	6,460	AA	Cook (Exotic .. ..	..
<i>Tuberculosis.</i>					
<i>State Sanatoria.</i>					
Delete— 192-201	7,221	7,584	AA	Cook .. ..	..
162-175	6,484	6,805	AA	Cook .. ..	..
148-161	6,142	6,460	AA	Cook, Assistant ..	..
SOCIAL WELFARE DEPARTMENT.					
<i>Family Welfare Division.</i>					
Delete— 131-144	5,728	6,045	AA	Cook, Grade I. ..	..
140-153	5,947	6,265	AA	Cook, Grade II. ..	..
146-160	6,094	6,435	AA	Cook, Grade III. ..	..
171-187	6,707	7,100	AA	Cook, Grade IV. ..	..
131-144	5,728	6,045	AA, AG	General Reliever— Adult .. ..	..
J-37	..	..	..	General Reliever— Junior .. ..	HR

PART B.—continued.

Grades.	Yearly Salary.		Salary/ Increment Code.	Title of Office and Position.	Title Code.
	Minimum.	Maximum.			
	\$	\$			
<i>Youth Welfare Division.</i>					
Delete— 137-149	5,874	6,166	AA	Cook, Western .. ..	..
<i>Suburbs Youth Welfare Service.</i>					
146-160	6,094	6,435	AA, AC	Cook, "Sunshine" ..	..
137-149	5,874	6,166	AA	Cook, Brunswick ..	..
<i>Intervention Unit.</i>					
131-144	5,728	6,045	AA	Cook, Grade I. ..	..
140-153	5,947	6,265	AA	Cook, Grade II. ..	..
146-160	6,094	6,435	AA	Cook, Grade III. ..	..
171-187	6,707	7,100	AA	Cook, Grade IV. ..	..
131-144	5,728	6,045	AA, AG	General Reliever— Adult .. ..	..
J-37	..	..	..	General Reliever— Junior .. ..	HR
<i>General.</i>					
Add— 148-161	6,142	6,460	AA	Cook, Grade I. ..	..
162-175	6,484	6,805	AA	Cook, Grade IA. ..	..
176-192	6,831	7,221	AA	Cook, Grade II. ..	..
182-196	6,975	7,380	AA	Cook, Grade IIIA. ..	..
192-201	7,221	7,584	AA	Cook, Grade III. ..	..
148-161	6,142	6,460	AA, AG	General Reliever— Adult .. ..	..
J-37	..	..	..	General Reliever— Junior .. ..	HR
DEPARTMENT OF AGRICULTURE.					
<i>Mallee Research Station, Walpeup.</i>					
Add— 176-192	6,831	7,221	AA	Housekeeper- Caterer .. ..	..
SOCIAL WELFARE DEPARTMENT.					
<i>Youth Welfare Division.</i>					
Add— 182-196	6,975	7,380	AA, AC	Cook, "Sunshine" ..	..

This Regulation shall have effect from 22nd June, 1975.

A. J. A. GARDNER, Chairman.

L. R. BROWN, Secretary.

Office of the Public Service Board,  
Melbourne, 20th June, 1975.

No. 448.

Public Service Act 1958, Sections 39 and 50.

REGULATIONS.—PART IV.—SALARIES AND INCREMENTS.

The Public Service Board, in pursuance of the powers conferred by the Public Service Act 1958, hereby amends the Public Service (Public Service Board) Regulations as shown below:—

FIFTH SCHEDULE.

PART B.

DEPARTMENT OF HEALTH—MENTAL HYGIENE.

TECHNICAL AND GENERAL DIVISION AND TEMPORARY EMPLOYEES  
Classifications of Offices and Positions and Rates of Salaries.

Grades.	Yearly Salary.		Salary/ Increment Code.	Title of Office and Position.	Title Code.
	Minimum.	Maximum.			
	\$	\$			
<i>Nursing Staff.</i>					
Delete— 117-134	5,386	5,801	AD	Nurse, Student— Adult .. ..	..
J-7	..	..	..	Nurse, Student— Junior .. ..	GC
115-132	5,341	5,753	AD, AE	Training Assistant, Sandhurst Boys' Centre .. ..	AC
115-132	5,341	5,753	AD, AE	Ward Assistant— Adult .. ..	..
J-7	..	..	..	Ward Assistant— Junior .. ..	GC, GF
Add— 117-134	5,386	5,801	AD	Nurse, Student ..	..
115-158	5,341	6,385	AD	Training Assistant, Sandhurst Boys' Centre .. ..	..
115-158	5,341	6,385	AD	Ward Assistant— Adult .. ..	..
J-7	..	..	..	Ward Assistant— Junior .. ..	GC, GF

This Regulation shall have effect from 22nd June, 1975.

A. J. A. GARDNER, Chairman.

L. R. BROWN, Secretary.

Office of the Public Service Board,  
Melbourne, 25th June, 1975.



No. 447.

**PUBLIC SERVICE ACT 1958.**

The Public Service Board, in pursuance of the powers conferred by the *Public Service Act 1958*, hereby amends the Public Service (Public Service Board) Regulations as follows:—

**PART IV.—SALARIES AND INCREMENTS.**  
**DIVISION IV.—TECHNICAL AND GENERAL DIVISION.**  
*Regulation 119.*

In paragraph (c) of sub-regulation (3) the word "Adults" is deleted and the word "Officers" is inserted in lieu thereof.

In paragraph (d) of sub-regulation (3) the expression "two annual increments of \$206" is deleted and the expression "two annual increments of \$206, two annual increments of \$210 and one annual increment of \$212" is inserted in lieu thereof.

*Regulation 120.*

Clause (i) of paragraph (b) is deleted.

Clause (ii) of paragraph (b) is re-numbered Clause (i).

**PART V.—ALLOWANCES.**

**DIVISION I.—ALLOWANCES FOR QUALIFICATIONS OR EFFICIENCY.**  
**TECHNICAL AND GENERAL DIVISION.**

*Department of Health.*

*Regulation 147.*

This Regulation is revoked.

**DIVISION IV.—SHIFT DUTY AND ROSTERED TIME OF ORDINARY DUTY PERFORMED BY OFFICERS DURING WEEK-ENDS OR ON PUBLIC HOLIDAYS.**

**DEPARTMENT OF HEALTH—MENTAL HYGIENE BRANCH.**

*Regulation 169.*

In the scale of allowances in sub-regulation (i)—

	<i>Yearly Rate of Allowance.</i>
	\$
<i>Delete—</i>	
Student Nurse	
Junior	653
Adult—1st year	725
2nd year	753
3rd and subsequent years	781
<i>Add—</i>	
Student Nurse—	
1st year	725
2nd year	753
3rd and subsequent years	781.

*This Regulation shall have effect from 22nd June, 1975.*

A. J. A. GARDNER, Chairman.  
L. R. BROWN, Secretary.

Office of the Public Service Board,  
Melbourne, 25th June, 1975.

**PRIVATE ADVERTISEMENTS**

**CITY OF DONCASTER AND TEMPLESTOWE.**

**By-Law No. 61.**

A By-Law of the City of Doncaster and Templestowe made under the provisions of the *Local Government Act 1958* and numbered 61 for:—

- (1) Prohibiting or minimizing noises in any public highway;
- (2) Suppressing nuisances;
- (3) Controlling and regulating the use of premises with a view to preventing objectionable noises at unreasonable times.
- (4) Repealing By-Law numbers 38 and 39 of the City of Doncaster and Templestowe.

In pursuance of the powers conferred by the *Local Government Act 1958* and of every other power it thereunto enabling, the Mayor, Councillors and Citizens of the City of Doncaster and Templestowe order as follows:—

1. By-Law numbers 38 and 39 of the City of Doncaster and Templestowe are hereby repealed.
2. No person upon any street, road or footway shall without the written consent of the Council—
  - (a) Sound or play upon any musical or noise instrument, or

- (b) Sound, play, control, operate or use any loud-speaker, amplifier, microphone, wireless receiving set, or broadcasting set or any other device capable of being used for making or amplifying sound or noise, or
- (c) Shout, sing or harangue.

3. Any person applying for such written consent from the Council pursuant to Clause 2 hereof shall—

- (a) Make application in writing to the Council;
- (b) State the purpose for which Council consent is sought;
- (c) State what musical or other instrument it is proposed shall be used;
- (d) State the place date and time at which such musical or other instrument is proposed to be used.
- (e) Supply such other information as the Council requires.

4. No person shall cause or permit or suffer to exist on any premises owned or occupied by him or of which he is in charge any noise materially interfering with the reasonable comfort (having regard to the time at which such noise is caused permitted or suffered to exist) of any person in any adjacent premises.

5. No person shall use or cause to be used or suffer to be used any premises so that there emanates therefrom any noise materially interfering with the reasonable comfort (having regard to the time at which such noise emanates) of any person in any adjacent premises.

6. For the purposes of Clauses 4 and 5 hereof noises arising from the use of any premises and emanating from such premises shall not be deemed to unduly disturb a person unless he shall have objected to such noises in writing to the Council.

7. Where any premises have been used in such a way as to make an objectionable noise at an unreasonable time an Officer duly appointed under this By-Law may—

- (a) Make enquiries of the occupier or person apparently in charge of such premises and the source of the said objectionable noise; and
- (b) At the direction of the Council serve a notice in writing upon the occupier of the said premises or any person who has caused or permitted or suffered the said premises to be used in such a way as to make the said objectionable noise, specifying—
  - (i) the address and general use of the said premises;
  - (ii) the apparent source of the said objectionable noise;
  - (iii) that the person to whom the said notice is addressed is required not to cause or permit to suffer the said premises to be used in such a way as to make the said objectionable noise at the times stated in the said notice.

8. Any person who—

- (a) fails or refuses to answer any such enquiries or makes any false answers to such enquiries; or
- (b) fails to comply with the provisions of any such notice;

shall be guilty of an offence against this By-Law.

9. Any person who is guilty of a wilful act or default contrary to the provisions of this By-Law shall be liable to a penalty of not less than \$10.00 nor more than \$100.00 for each and every offence and any person who is guilty of a continuing offence shall be liable to a penalty of not more than \$10.00 for each day on which an offence against this By-Law is continued after a conviction or order by any court.

10. This By-Law shall apply to and have operation through the whole of the Municipal District of the City of Doncaster and Templestowe.

The resolution for passing this By-Law was agreed to by the Council at a meeting on the 7th April, 1975, and confirmed by the Council on the 26th May, 1975.

The corporate seal of the Mayor, Councillors and citizens of the City of Doncaster and Templestowe was hereunto affixed, in the presence of—

(SEAL) I. R. MARSDEN, Mayor.  
R. D. WHITE, Councillor.  
J. W. THOMSON, Town Clerk.

Approved by the Governor in Council on the 24th day of June, 1975.—L. G. HOUSTON, Acting Clerk of the Executive Council.

**Town and Country Planning Act 1961 (Twelfth Schedule).**  
**SHIRE OF ALBERTON COASTAL PLANNING SCHEME,**  
 1962.

NOTICE THAT A PLANNING SCHEME HAS BEEN PREPARED AND IS AVAILABLE FOR INSPECTION.

Amendment No. 5, 1975.

Notice is hereby given that the Shire of Alberton in pursuance of its powers under the *Town and Country Planning Act 1961*, has prepared a Planning Scheme for the purpose of:

Re-zoning land bordered by Rodgers, Cyril, Lawrence and Station Streets, Yarram, from Residential zone to Industrial "B" zone.

A copy of the scheme has been deposited at the Shire Office, Yarram and at the Office of the Town and Country Planning Board, 235 Queen Street, Melbourne, and will be open for inspection during office hours by any person free of charge.

Any persons affected by the Planning Scheme are required to set forth in writing all objections they may have, addressed to:

Shire Secretary,  
 Shire of Alberton,  
 Shire Office,  
 YARRAM, 3971,

on or before the 9th day of August, 1975, and state whether they wish to be heard in respect of their objections.

27th June, 1975.

6096

D. CARTLEDGE, Shire Secretary.

**SHIRE OF BULN BULN.**

LOAN No. 70.

*Notice of Intention to Borrow the Sum of \$65,000 for Permanent Works and Undertakings.*

Notice is hereby given that the Council of the Shire of Buln Buln proposes to borrow the principal sum of \$65,000 secured by a charge over the general rates of the municipality, such sum to be raised by the grant of a mortgage in accordance with the provisions of the *Local Government Act 1958*.

1. The maximum rate of interest that may be paid is 9.5 per cent per annum.

2. The purpose for which the loan is to be applied is assistance to a decentralised industry pursuant to Part XLA of the *Local Government Act 1958*.

3. The period of the loan shall be four years.

4. The moneys borrowed shall be repayable by providing out of the municipal fund seven half-yearly instalments of approximately \$5,105.78 each including principal and interest on the first day of March and the first day of September during the currency of the loan, and one instalment of \$51,004.49 on the first day of September, 1979. The first instalment shall be payable on the first day of March 1976.

5. Such moneys shall be repayable to the Australian Mutual Provident Society, 535 Bourke Street, Melbourne.

The plans and specifications and the estimate of the cost of the proposed works and a statement showing the proposed expenditure of the moneys to be borrowed are open for inspection at the office of the Council of the Shire of Buln Buln, at Drouin.

Dated 9th July, 1975.

6104

K. A. PRETTY, Shire Secretary.

**SHIRE OF COBRAM.**

Notice is hereby given that the Council of the Shire of Cobram in compliance with the provisions of the *Local Government Act* has prepared and approved of a report accompanied by plans and maps for the compulsory acquisition of the south west corner of Crown Allotment 92 Parish of Cobram County of Moira having a frontage of 402.37 metres to Campbell Road and 352 metres to McIntyre Road for the establishment of a pit to extract red sand for road construction and maintenance works, kerb and channel construction, underground drainage schemes, lawn top dressing and garden use and filling.

The said report, plans and maps are deposited at the Shire Office, Cobram and are open for inspection during normal office hours.

Persons affected by the proposed taking of the land are to submit written objections, if any, to the Shire Secretary, Shire Office, Cobram within 40 clear days from the date of the publication of this notice.

6103.

R. T. CUTTS, Shire Secretary.

**SHIRE OF FLINDERS.**

Notice is hereby given that pursuant to the provisions of the *Local Government Act 1958* the Council of the Shire of Flinders has ordered that the name of the following streets be changed as set out hereunder.

Old Name.—Fern Road.

New Name.—Heath Road.

Location.—Lots, 172, 222, 223, 259, 260, 283, 284, 290, on lodged plan 21130.

Old Name.—Dahlia Street.

New Name.—Iris Street.

Location.—Lots 288, 289 on lodged plan 21130.

6092

S. WILLIAMS, Shire Secretary.

**SHIRE OF MYRTLEFORD.**

LOAN No. 24.

*Notice of Intention to Borrow the Sum of \$12,000.*

Notice is hereby given that the Council of the Shire of Myrtleford proposes to borrow the principal sum of \$12,000 secured by a charge over the general rates of the Municipality, such sum to be raised by the grant of a Mortgage in accordance with the provisions of the *Local Government Act 1958*.

1. The maximum rate of interest that may be paid is 9.9 per cent per annum.

2. The purpose for which the loan is to be applied is to finance provisions of power to an industrial estate by means of a fully refundable deposit to the State Electricity Commission of Victoria.

3. The period of the loan shall be ten years.

4. The moneys borrowed shall be repayable by providing out of the Municipal Fund, half-yearly instalments of approximately \$958.83 each, including principal and interest, on the fifteenth days of March and September, during the currency of the loan. The first instalment shall be payable on the Fifteenth day of March 1976.

5. Such moneys shall be repayable to the Australia and New Zealand Savings Bank Limited, Melbourne.

The plans and specifications and the estimate of the cost of the proposed works and a statement showing the proposed expenditure of the moneys to be borrowed are open for inspection at the office of the Council of the Shire of Myrtleford, at Myrtleford.

6173

K. S. LANE, Shire Secretary.

**SHIRE OF MYRTLEFORD.**

LOAN No. 25.

*Notice of Intention to Borrow the Sum of \$25,000.*

Notice is hereby given that the Council of the Shire of Myrtleford proposes to borrow the principal sum of \$25,000 secured by a charge over the general rates of the Municipality, such sum to be raised by a grant of a Mortgage in accordance with the provisions of the *Local Government Act 1958*.

1. The maximum rate of interest that may be paid is 9.9 per cent per annum.

2. The purpose for which the loan is to be applied is to finance the purchase and development of land for Industrial development.

3. The period of the loan shall be ten years.

4. The moneys borrowed shall be repayable by providing out of the Municipal Fund, half-yearly instalments of approximately \$1,997.57 each, including principal and interest, on the fifteenth days of March and September during the currency of the loan. The first instalment shall be payable on the Fifteenth day of March 1976.

5. Such moneys shall be repayable to the Australia and New Zealand Savings Bank Limited, Melbourne.

The plans and specifications and the estimate of the cost of the proposed works and a statement showing the proposed expenditure of the moneys to be borrowed are open for inspection at the office of the Council of the Shire of Myrtleford, at Myrtleford.

6174

K. S. LANE, Shire Secretary.

**SHIRE OF WOORAYL.**

ORDER PURSUANT TO SECTION 522 OF THE LOCAL GOVERNMENT ACT.

Pursuant to the provisions of section 522 of the *Local Government Act* the Council of the Shire of Woorayl hereby directs that the land in the Parish of Meeniyah indicated by hatching on the plan hereunder which has

been purchased taken or acquired by it shall be a Public Highway on and from the date of publication of this Order in the Government Gazette.

In witness hereof the common seal of the President, Councillors and Ratepayers of the Shire of Wooraui was affixed, pursuant to a Resolution of the Council this 13th day of June, 1975, in the presence of—

(SEAL) A. R. ASHENDEN, Councillor.  
L. J. TAYLOR, Councillor.  
R. G. STANLEY, Shire Secretary.

6091

KYNETON SHIRE WATERWORKS TRUST.

TYLDEN URBAN DISTRICT.

Schedule 8A.

Notice to the owners of tenements in the area described in the Schedule to this notice.

Main pipes having been laid down for the supply of water to the area shown in the Schedule to this notice in such places as are marked on a plan available for inspection at the offices of the Kyneton Shire Waterworks Trust at the Shire Office, Kyneton, the owners of all tenements in the said area are hereby required on or before the 1st day of August 1975 next to cause a proper pipe and stop-cocks to be laid so as to supply water within such tenements from the nearest main pipe.

SCHEDULE.

Tylden Urban District.

Clowes Street, Tylden Woodend Road Section 1 Part Section 10, Clayton Street, Trentham Road. 6187

KYNETON SEWERAGE AUTHORITY.

By-Law No. 3.

House Drainage Plans.

Notice is hereby given that By-Law No. 3 was approved by the Governor in Council on the 3rd June, 1975.

The purpose of the By-Law is to fix charges for and regulate the provision of house drainage plans by the Authority and it will operate as from the 9th July, 1975.

A copy of the By-Law is available for inspection free of charge at the Authority's office at the Shire Hall, Mollison St., Kyneton.

6188

S. G. PORTER, Secretary.

Notice is hereby given that DUNLOP AUSTRALIA LIMITED has applied for a lease pursuant to Sections 134 and 135 of the Land Act 1958 for a term of 30 years in respect of Allotments 3, 4, 12, 13 and 14 Section 104 City of South Melbourne containing 1.9231 hectares as a site for general industrial purposes. 5776

Notice is hereby given that the East Geelong Community Youth Club has applied for a lease under Section 134 of the Land Act 1958 for a term of 21 years in respect of a site in Wood Street, City of Geelong for the purpose of amusement and recreation. 5731

Notice is hereby given that Reed Paper Products Limited has applied for a lease pursuant to sections 134 and 135 of the Land Act 1958 for a term of 10 years in respect of allotment 9 section B City of South Melbourne containing 4072 square metres as a site for Commercial and Industrial purposes. 6059

NOTICE OF INTENTION TO APPLY FOR A LICENCE TO DIVERT WATER FROM THE BROKEN RIVER AT BENALLA.

I hereby give notice that I intend to apply for a Licence empowering me to divert water for a term of 4 years to the extent of 144 megalitres per annum at a maximum rate of 5 megalitres per day of 24 hours for the irrigation of 24 hectares of lucerne and pasture, being part of Allotment 4A, 4B, 5A, 5B, 7A, 7B, 8B, Parish of Goomalibee.

Any objection to such application must be forwarded in writing to reach the State Rivers and Water Supply Commission, Melbourne, before 8th August, 1975, being thirty days from the first publication of this Notice.

G. P. H. WILSON.

Box 319, Benalla. 6055

NOTICE is hereby given that the partnership heretofore subsisting between Ernest James Marriott and John Charles Marriott carrying on the business of cattle grazing at Clyde and Lyndhurst in the State of Victoria under the style of firm of "E. J. & J. C. Marriott" has been dissolved as from the 30th day of June, 1975.

Dated the 27th day of June, 1975.

6182

E. J. & J. C. MARRIOTT.

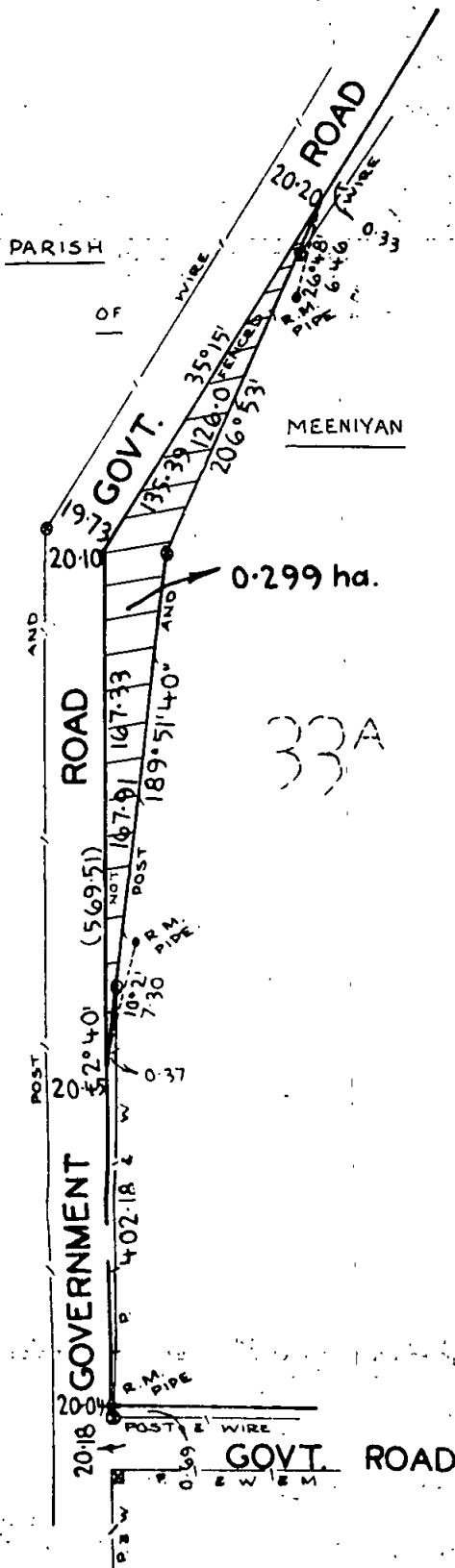

NOTICE IS HEREBY GIVEN that the Partnership heretofore subsisting between EDGAR STANLEY BROAD and GRAEME EDGAR BROAD, carrying on business of Farmers at Durham Ox in the State of Victoria under the style or firm name of "E. S. & G. E. BROAD", has been dissolved as from the 30th day of June, 1975.

Dated the 1st day of July, 1975.

R. H. SCHLEIGER & ASSOCIATES, 290 Williamson Street, Bendigo, solicitors for Edgar Stanley Broad and Graeme Edgar Broad. 6168

TAKE NOTICE that the partnership "F. G. & A. J. Hill" heretofore subsisting between FRANK GRENVELL HILL of Stonehaven Farmer and ANTHONY JOHN HILL of Stonehaven Farmer, has been dissolved by mutual consent, as from the 30th June 1975.

Dated the 1st day of July 1975.

F. G. HILL.  
A. J. HILL.

Wighton & McDonald, solicitors, 89 Myers Street, Geelong. 6183

TAKE NOTICE that the Partnership heretofore carried on by HILTON JAMES CLARKE and REGINALD FRANCIS McVILLY as a Bicycle Shop under the name of REG. McVILLY CYCLES at 221 Hawthorn Road, South Caulfield, was dissolved on the 31st day of May 1975. REGINALD FRANCIS McVILLY will carry on the said business and all debts due by or to the late Partnership will be received or paid by him at the said place of business.

Dated the 30th June, 1975.

R. F. McVILLY.  
H. J. CLARKE.

6205

Notice is hereby given that Colin Stubbs retired from the partnership of Ian Potter & Co. on 30th June 1975. The partnership is being continued by the remaining partners as from 1st July 1975 under the name of Potter Partners. 6057

TAKE NOTICE that the partnership previously existing between Isobel Irma Madden and Desmond Howard Madden in the business known as "Izzy's Gearbox" has been dissolved. Isobel Irma Madden will continue as sole proprietor of the said business. 6056

NOTICE IS HEREBY GIVEN that the partnership heretofore subsisting between KATHLEEN ANNE WHELLER (formerly known as Kathleen Anne Watt) of 7 Dundee Street Warragul in the State of Victoria and GEOFFREY ALLAN LEUNIG (formerly of 1 Mary Street Warragul) but now of 33 Clifford Street Warragul in the said State carrying on business as Opticians at 4 Smith Street Warragul and at Albert Street Moe under the style or firm of "G. M. Watt" has been dissolved as from the 30th day of June, 1975.

Dated the 30th day of June, 1975.

6058 KATHLEEN ANNE WHELLER.

Notice is hereby given that Lindsay James Yeo retired from the partnership subsisting between himself and Vernon Keith Reynolds and Bruce Peşcod and Douglas Ewart Tonkin and Leslie Philip Smart and John Desmond Byrne and Allen Douglas Killey and Robert Lindsay Yeo and Peter John Siggins and Graeme Walter Briggs practising as Chartered Accountants under the firm name of Marquand & Co. at 51 Queen Street, Melbourne, on the 30th day of JUNE, 1975.

Dated the 7th day of July, 1975.

6107

NOTICE IS HEREBY GIVEN that the partnership heretofore subsisting between TERESA PAPAACHARIA, ARTHUR KIRLIS and DIMITRIOS KIRLIS carrying on the business of New and Used Car Sales under the registered business names of CLEOPATRA CAR SALES and JAMESFORD MOTORS on the premises situate at and known as 101-105 Burgundy Street, Heidelberg in the State of Victoria has been dissolved as from the 1st day of July, 1975 by the retirement of the said ARTHUR KIRLIS and DIMITRIOS KIRLIS from that partnership. All debts due and owing by the business shall be received and paid respectively by TERESA PAPAACHARIA who will continue to carry on the said business in the said business name at the said premises.

D. C. CARLI, FURLETTI & SCOTT, solicitors, of 52 Pelham Street, Carlton, 3053. 6139

NOTICE IS HEREBY GIVEN that the partnership heretofore subsisting between GIOVANNI FERRARO and CLAUDIO DALL'OSTE carrying on the business of ceramic under the name of ITAL CERAMIC on the premises situate at and known as 117 McEwan Road, West Heidelberg in the State of Victoria has been dissolved as from the 8th day of June, 1975 by the retirement of the said Giovanni Ferraro from that partnership.

Creditors should communicate with D. C. Carli, Furletti & Scott, of 52 Pelham Street, Carlton. Tel.: 347 4166.

6140

Notice is hereby given that the partnership heretofore subsisting between GORDON PETER BRIGGS and ARTHUR JOANNES LUNEMAN carrying on business as Tenants Agency at 179 Barkley Street, St. Kilda in the State of Victoria under the style or firm of "Rent-a-Place" has been dissolved by mutual consent as from the 2nd day of May, 1975 and that the business will continue to be carried on by Arthur Joannes Luneman only.

NEVILLE & CO., solicitors, 1401 Malvern Road, Malvern. 6105

Notice is hereby given that the partnership heretofore subsisting between the undersigned DENIS HAIG BULLOCK, GERTRUDE MARY BULLOCK, JAMES ALEXANDER LAPSLEY and MARGARET LAPSLEY carrying on business as engineers and blacksmiths at 519 Melbourne Road Newport under the name of G. F. LOFT & SONS has been dissolved by mutual consent as from the 30th day of June 1975.

All debts due to and owing by the said late firm will be received and paid by the said James Alexander Lapsley and Margaret Lapsley who will continue to carry on the business at the same place.

Dated at Newport the 30th day of June, 1975.

D. H. BULLOCK.  
G. M. BULLOCK.  
JAMES LAPSLEY.  
M. LAPSLEY.

Witness.—A. W. MAYER.

6106

MIRAMA PROPRIETARY LIMITED (IN LIQUIDATION).

NOTICE CONVENING FINAL MEETING PURSUANT TO SECTION 272 OF THE COMPANIES ACT 1961.

NOTICE is hereby given in pursuance of Section 272 of the Companies Act 1961, that a General Meeting of the members of the abovenamed Company will be held in the office of the Liquidator, 24 Taylors Lane, Rowville on Monday 11th August, 1975, at two o'clock in the afternoon, for the purpose of having an account laid before them showing the manner in which the winding up has been conducted and the property of the Company disposed of and of hearing any explanation that may be given by the Liquidator.

Dated the 2nd day of July, 1975.

6130 JOHN C. BRIEN, Liquidator.

The Companies Act 1961.

MILK INDUSTRIES TYRE SERVICE LTD. (IN VOLUNTARY LIQUIDATION).

NOTICE OF FINAL MEETING.

NOTICE is hereby given that, pursuant to Section 272 of the Companies Act 1961, a Final Meeting of the members of the abovenamed company will be held at the office of the Liquidator, 1 Little Collins Street, Melbourne on the 6th August, 1975 at 10.30 a.m. for the purpose of presenting the Liquidator's account of the winding up.

Dated this 3rd day of July, 1975.

R. R. CROZIER, Liquidator.

Wallace, McMullin & Partners, chartered accountants, 3rd Floor, 1 Little Collins Street, Melbourne, Vic. 3000. 6131

VIKING TIMBER AND JOINERY CO. PTY. LTD. (IN VOLUNTARY LIQUIDATION).

Notice is hereby given that a general meeting of the Company will be held at the offices of Robertson Darling & Wolfenden, 535 Bourke Street, Melbourne on the 8th day of August, 1975, at 12 o'clock noon, to receive an account showing how the winding up has been conducted and the property of the Company disposed of.

Dated this 27th day of June, 1975.

6132 D. K. LINLEY, Liquidator.

**VARMAN PTY. LTD. (IN VOLUNTARY LIQUIDATION).**

Notice is hereby given that a general meeting of the Company will be held at the offices of Robertson Darling & Wolfenden, 535 Bourke Street, Melbourne, on the 8th day of August, 1975, at 12.30 p.m. to receive an account showing how the winding up has been conducted and the property of the company disposed of.

Dated this 27th day of June, 1975.

6133 D. K. LINLEY, Liquidator.

The Companies Act 1961.—Rule 99 and Regulation 56.—in the matter of G. R. WILLS (BUILDERS) PTY. LTD. (in Liquidation).

TAKE NOTICE that the Liquidator of the abovenamed Company has fixed Thursday the 17th day of July, 1975 as the day on or before which creditors of the company are to prove their debts or claims and to establish any title they may have to priority under section 292 or be excluded from the benefit of any distribution made before such debts are proved or as the case may be from objecting to such distribution.

Dated this 3rd day of July, 1975.

JOHN MARTIN WALSH, Liquidator.

Kennedy Smal, 296 Little Lonsdale Street, Melbourne, 6134

**Companies Act 1961.****TIQUA INVESTMENTS PTY. LTD. (IN VOLUNTARY LIQUIDATION).**

Notice is hereby given that at an Extraordinary General Meeting of Shareholders of the abovementioned Company held on the 26th day of June, 1975 the following Resolutions were passed—

**Special Resolution.**

It was resolved that the Company be wound up voluntarily.

**Ordinary Resolutions.**

It was resolved—

1. That Hassia Schwarz of Unit 6, No. 15 Denbigh Road Armadale and Oshri Schwarz of 51 Coolibah Street Doncaster be appointed liquidators for the purpose of the winding up.
2. That the said Hassia Schwarz alone exercise the powers mentioned in Section 236 (2) (f) of the Companies Act 1961.

HASSIA SCHWARZ and OSHRI SCHWARZ, the appointed liquidators, Unit 6, No. 15 Denbigh Road, Armadale. 6135

**Companies Act 1961.****OSMAR INVESTMENTS PROPRIETARY LIMITED (IN VOLUNTARY LIQUIDATION).**

Notice is hereby given that at an Extraordinary General Meeting of Shareholders of the abovementioned Company held on the 26th day of June, 1975 the following Resolutions were passed—

**Special Resolution.**

It was resolved that the Company be wound up voluntarily.

**Ordinary Resolutions.**

It was resolved—

1. That Hassia Schwarz of Unit 6, No. 15 Denbigh Road Armadale and Oshri Schwarz of 51 Coolibah Street Doncaster be appointed liquidators for the purpose of the winding up.
2. That the said Hassia Schwarz alone exercise the powers mentioned in Section 236 (2) (f) of the Companies Act 1961.

HASSIA SCHWARZ and OSHRI SCHWARZ, the appointed liquidators, Unit 6, No. 15 Denbigh Road, Armadale. 6136

**Companies Act 1961, Section 272.****STONEHENGE CELLARS PTY. LTD. (IN LIQUIDATION).****NOTICE OF FINAL MEETING OF MEMBERS.**

Notice is hereby given that the final meeting of Members of the abovenamed Company shall be held on Monday 11th August, 1975 at 2.30 p.m. at the offices of Max Gee & Co., 325 Warrigal Road, Burwood, 3125.

**Agenda.**

1. Presentation by the Liquidator of an account showing how the winding up has been conducted and the property of the Company has been disposed of, and to give any explanation of the account.

**2. The meeting to consider the following resolution:**

“That immediately after the dissolution of the Company the Liquidator may destroy the books and papers of the Company pursuant to Section 284 of the Act.”

Dated this 9th day of July, 1975.

M. G. GEE, Liquidator.

Max Gee & Co., 325 Warrigal Road, Burwood, Victoria, 3125. Telephone 288 5109. 6171

**Companies Act 1961, Section 272.****BELVIEW COURT PTY. LTD. (IN VOLUNTARY LIQUIDATION):****NOTICE OF FINAL MEETING OF MEMBERS.**

Notice is hereby given, pursuant to section 272 of the Companies Act 1961, that a General meeting of the members of the abovenamed company will be held in the offices of Kutner, Lederer & Co., 31 Horne Street, Elsternwick on Friday, 15th day of August, 1975, for the purposes of having an account laid before them, showing the manner in which the winding up has been conducted and the property of the company disposed of and of hearing any explanations that may be given by the Liquidator.

Dated this 7th day of July, 1975.

EDDIE KUTNER, Liquidator.

Kutner, Lederer & Co., chartered accountants, 31 Horne Street, Elsternwick. 6172

The Companies Act 1961 (as amended).—In the matter of HOWELL PASTORAL COMPANY PTY. LTD. (in Members Voluntary Liquidation).

NOTICE is hereby given that at our Extraordinary General Meeting of Members of the abovenamed Company held on the fourth day of July 1975 it was resolved that the Company be wound up voluntarily and that BRUCE EDWARD FORDHAM, Chartered Accountant, be appointed Liquidator.

Dated this fourth day of July, 1975.

S. W. HOWELL, Director.

Bruce Fordham & Co., chartered accountants, 521 Toorak Road, Toorak, 3142. 6137

**The Companies Act 1961.****BURLEIGH HEADS DRIVE-IN THEATRE INVESTMENTS PTY. LTD. (IN VOLUNTARY LIQUIDATION).****SOUTH COAST (QUEENSLAND) DRIVE-IN INVESTMENTS PTY. LTD. (IN VOLUNTARY LIQUIDATION).**

NOTICE CONVENING FINAL MEETING OF MEMBERS, Pursuant to Section 272, notice is hereby given pursuant to Section 272 of the Companies Act 1961 that a General Meeting of the members of the abovenamed Companies will be held in the Office of S. L. Williams & Co., 1st Floor, 486 Nepean Highway, Frankston on Monday the eleventh day of August, 1975 at 10.00 AM for the purpose of having an account laid before them showing the manner in which the winding up has been conducted and the property of the company disposed of and of hearing any explanations that may be given by the Liquidator.

Dated this 1st day of July, 1975.

6170

S. L. WILLIAMS, Liquidator.

In the Supreme Court of Victoria.—1975 No. Co. 9091.—

In the matter of Part X. of the Companies Act 1961; and in the matter of PROJECT & DEVELOPMENT CORPORATION PROPRIETARY LIMITED.

NOTICE IS HEREBY GIVEN that a Petition for the Winding Up of the abovenamed Company by the Supreme Court was on the 19th day of June, 1975 presented by K. POPPER & ASSOCIATES PTY. LIMITED AND THAT the said Petition is directed to be heard before the Court sitting at the Fourteenth Court Law Courts, William Street, Melbourne on the 8th day of August, 1975 at the hour of 10.30 o'clock in the forenoon AND ANY Creditor or Contributory of the said Company desiring to support or oppose the making of an Order on the said Petition may appear at the time of hearing by himself or his Counsel for that purpose, and a copy of the Petition will be furnished to any Creditor or Contributory of the said Company requesting the same by the undersigned on payment of the regulated charge for the same.

THE PETITIONER'S ADDRESS IS 622 St. Kilda Road, Melbourne.

THE PETITIONER'S SOLICITORS are Messrs. Sackville, Wilks & Co. of 100 Collins Street, Melbourne.

SACKVILLE, WILKS & CO., solicitors for the petitioner.

NOTE.—Any person who intends to appear at the hearing of the said petition must serve on or send by post to the abovenamed solicitors, notice in writing of his intention so to do. The notice must state the name and address of the person, or, if a firm, the name and address of the firm and must be signed by the person, or firm, or his or their solicitors (if any) and must be served, or if posted, must be sent by post in sufficient time to reach the abovenamed not later than 4.00 o'clock in the afternoon of the 7th of August, 1975. 6157

The Companies Act 1961.

F. & H. HOBSON PROPRIETARY LIMITED (IN VOLUNTARY LIQUIDATION).

NOTICE CONVENING FINAL MEETING OF MEMBERS, PURSUANT TO SECTION 272.

Notice is hereby given, in pursuance of section 272 of the Companies Act 1961, that a General Meeting of the members of the above-named Company will be held at the office of I. T. McIVOR, 3rd floor, 472 Bourke Street, Melbourne on Tuesday, 19th August 1975 at 12 o'clock noon, for the purpose of having an account laid before them showing the manner in which the winding up has been conducted and the property of the company disposed of, and hearing any explanation that may be given by the liquidator.

Dated this 4th day of July, 1975.

6181 I. T. McIVOR, Liquidator.

The Companies Act 1961.

WINMAN PROPRIETARY LIMITED (MEMBERS' VOLUNTARY LIQUIDATION).

NOTICE OF FINAL MEETING OF MEMBERS PURSUANT TO SECTION 272.

Notice is hereby given that in pursuance of Section 272 of the Companies Act 1961 that a meeting of the members of the above named Company will be held on the 19th day of August, 1975 at 157 Moorabool Street, Geelong at 11.00 a.m. for the purpose of having an account laid before them showing the manner in which the winding up has been conducted and the property of the company disposed of and of hearing any explanation which may be given by the Liquidator.

Dated this 7th day of July, 1975.

6184 CEDRIC L. CARR, Liquidator, 157 Moorabool Street, Geelong, 3220.

The Companies Act 1961.—In the matter of CONN BROTHERS PTY. LTD. (in Voluntary Liquidation) and AGCO HUCKSON PTY. LTD. (in Voluntary Liquidation).—Members' Winding Up.

Notice is hereby given that at an extraordinary general meeting of each of the abovenamed companies duly convened and held at 10th Floor, 44 Market Street, Melbourne, Victoria, on 7th July 1975, the following resolution was proposed and passed as a special resolution by each of the companies named:

"That the Company be wound up voluntarily and that Eric James Ramsay of 44 Market Street, Melbourne, Victoria, be appointed Liquidator for the purpose of such winding up and that he be authorised to draw as remuneration for his services as Liquidator his normal hourly charges in respect thereto."

Dated 7th July, 1975.

6138 J. BORTHWICK, Director.

Companies Act 1961, Section 254.

GARDEN CREDITS PTY. LTD.

Notice is hereby given that at an Extraordinary General Meeting of the members of the abovenamed company held on 30th June 1975 the following resolution was passed as a Special Resolution:—

"That this company be wound up as a members' voluntary liquidation and that Robert Arthur Waters of 470 Bourke Street, Melbourne be appointed liquidator."

6154 R. A. WATERS, Liquidator.

The Companies Act 1961.

J. E. GODING PTY. LTD. (IN LIQUIDATION).

NOTICE CONVENING FINAL MEETING OF MEMBERS, PURSUANT TO SECTION 272.

NOTICE is hereby given in pursuance of Section 272 of the Companies Act 1961 that a Meeting of the Members of the abovenamed Company will be held on the 12th day of August, 1975 at the offices of Hall & Rose, 395 Collins Street, Melbourne, at 10.30 a.m. for the purpose of having

an account laid before them showing the manner in which the winding up has been conducted and the property of the Company disposed of and of hearing any explanations that may be given by the Liquidator.

Dated this 9th day of July, 1975.

G. O. HARRISON, Liquidator.

Hall & Rose, chartered accountants, 395 Collins Street, Melbourne, Vic. 3000. 6158

Companies Act 1961, Section 272 (2).

GEORGE H. CURTIS & SONS PTY. LTD.

NOTICE is hereby given that the final meeting of the shareholders of the company will be held at the offices of the Liquidator on Monday, 11th August, 1975, at 10.00 a.m. for the purpose of having an account laid before it showing how the winding up of the company has been conducted and the property of the company has been disposed of and to pass a resolution to destroy the company's books and papers pursuant to Section 284 (3) (b) of the Act.

Dated 2nd July, 1975.

W. A. BROWNE, liquidator, 24 Jeffcott Street, Melbourne, Vic., 3003. 6159

The Companies Act 1961.

J. W. DODDS PROPRIETARY LIMITED (IN VOLUNTARY LIQUIDATION).

PURSUANT TO SECTIONS 254 AND 258.

At an Extraordinary General Meeting of the Shareholders of J. W. DODDS Proprietary Limited convened and held at 461 Bourke Street, Melbourne on the 30th June, 1975, the following Special Resolution was duly passed:—

"That the Company be wound up voluntarily in accordance with the Companies Act 1961, and that James Collier Benzie and John Arthur Hargreaves, Chartered Accountants of 461 Bourke Street, Melbourne, be appointed joint and several liquidators of the Company at a fee to be calculated in accordance with the rates recommended by the Institute of Chartered Accountants in Australia."

30th June, 1975.

6129 J. GOAD, Secretary.

Companies Act 1961, Section 254.

J. HOLMES STEVEDORING PTY. LTD.

Notice is hereby given that at an Extraordinary General Meeting of the members of the abovenamed company held on 30th June 1975 the following resolution was passed as a Special Resolution:—

"That this company be wound up as a members' voluntary liquidation and that Robert Arthur Waters of 470 Bourke Street, Melbourne be appointed liquidator."

6155 R. A. WATERS, Liquidator.

Companies Act 1961.

ARARAT BUTTER & FREEZING COMPANY LIMITED (IN LIQUIDATION).

Notice is hereby given that pursuant to Section 272 of the Companies Act 1961, the final meeting of the members and creditors of the Ararat Butter and Freezing Co. will be held at 486 Sydney Road, Coburg on the fifth day of August 1975 at 11 a.m., for the purpose of laying before the meeting the account of the winding up and any explanation thereof.

Dated this 30th day of June, 1975.

J. D. CURTAIN, Liquidator.

Curtain & Nunan, chartered accountants, 486 Sydney Road, Coburg. 6066

Companies Act 1961.—In the matter of THORNBURY SELECTED MEATS PROPRIETARY LIMITED (in Liquidation).—Notice Convening Final Meeting of Members, Pursuant to Section 272.

NOTICE is hereby given pursuant to Section 272 of the Companies Act 1961, that a General Meeting of members of the abovenamed company will be held at the offices of Taylor O'Connor & Co., 562 St. Kilda Road, Melbourne on Friday 8th August, 1975 at 2.00 p.m. for the purpose of having an account laid before them showing the manner in which the winding-up has been conducted and the property of the company disposed of and of hearing any explanations that may be given by the Liquidator.

Dated this 1st day of July, 1975.

B. K. TAYLOR, Liquidator.

Taylor O'Connor & Co., 562 St. Kilda Road, Melbourne, 3004. 6090

In the Supreme Court of Victoria.—1974 No. Co. 8980.—  
In the matter of the Companies Act 1961; and in the  
matter of R. A. WARREN INDUSTRIES PTY. LTD.—Notice  
of Winding Up Order.

WINDING UP ORDER made 19th June 1975.

NAME AND ADDRESS OF LIQUIDATOR: PETER  
WILLIAM HARVEY, 447 Collins Street, Melbourne.

ALAN R. NEAVES, Crown Solicitor for the Common-  
wealth and Solicitor for the Petitioner. 6122

Companies Act 1961, Section 254 (2).

BEN LEDI HOLDINGS PTY. LTD. (IN LIQUIDATION).

NOTICE OF RESOLUTION.

At an Extraordinary General Meeting of the members  
of Ben Ledi Holdings Pty. Ltd. duly convened and held at  
46 Charles Street, Kew at 9.00 a.m. on the 30th June, 1975,  
the Special Resolution set out below was duly passed.

"That the company be wound up voluntarily as a  
Members' Voluntary Winding Up in accordance with the  
provisions of the Companies Act 1961. That Norman  
Patrick Tyrrell be and is hereby appointed Liquidator."

Notice is also given that after 21 days from this date  
we shall proceed to distribute the assets. All creditors  
having any claims against the company should furnish partic-  
ulars of same by that date, otherwise we shall proceed  
to distribute the assets without regard to their claim.

Dated this 2nd day of July, 1975.

N. P. TYRRELL, liquidator, 305 La Trobe Street, Mel-  
bourne, Vic., 3000. 6063

Companies Act 1961, Section 254 (2).

MALCOLM WALKER & COMPANY PROPRIETARY  
LIMITED (IN LIQUIDATION).

NOTICE OF RESOLUTION.

At an Extraordinary General Meeting of the Members  
of Malcolm Walker & Company Proprietary Limited duly  
convened and held at the residence of M. C. A. Walker,  
Surrey Road, Warburton at 8.15 p.m. on the 30th June,  
1975, the Special Resolution set out below was duly  
passed.

"That the company be wound up voluntarily as a  
Members' Voluntary Winding Up in accordance with the  
provisions of the Companies Act 1961. That Norman  
Patrick Tyrrell be and is hereby appointed Liquidator."

Notice is also given that after 21 days from this date  
we shall proceed to distribute the assets. All creditors  
having any claims against the company should furnish partic-  
ulars of same by that date, otherwise we shall proceed  
to distribute the assets without regard to their claim.

Dated this 2nd day of July, 1975.

N. P. TYRRELL, liquidator, 305 La Trobe Street, Mel-  
bourne, Vic., 3000. 6064

Companies Act 1961, Section 254 (2).

BADGER CREEK MILLS PTY. LTD. (IN LIQUIDATION).

NOTICE OF RESOLUTION.

At an Extraordinary General Meeting of the Members  
of Badger Creek Mills Pty. Ltd. duly convened and held  
at the residence of M. C. A. Walker, Surrey Road, War-  
burton at 8.00 p.m. on the 30th June, 1975, the Special  
Resolution set out below was duly passed.

"That the company be wound up voluntarily as a  
Members' Voluntary Winding Up in accordance with the  
provisions of the Companies Act 1961. That Norman  
Patrick Tyrrell be and is hereby appointed Liquidator."

Notice is also given that after 21 days from this date  
we shall proceed to distribute the assets. All creditors  
having any claims against the company should furnish partic-  
ulars of same by that date, otherwise we shall proceed  
to distribute the assets without regard to their claim.

Dated this 2nd day of July, 1975.

N. P. TYRRELL, liquidator, 305 La Trobe Street, Mel-  
bourne, Vic., 3000. 6065

Companies Act 1961, Section 254.

SHEFFIELD DRAINAGE PTY. LTD.

Notice is hereby given that at an Extraordinary General  
Meeting of the members of the abovenamed Company held  
on 26th June 1975 the following resolution was passed  
as a Special Resolution:—

"That this company be wound up as a members'  
voluntary liquidation and that Robert Panter Orr of 470  
Bourke Street, Melbourne be appointed liquidator."

6156

R. P. ORR, Liquidator.

Companies Act 1961.

BELLS COMMERCIAL PTY. LIMITED. (IN VOLUNTARY  
LIQUIDATION.)

PURSUANT TO SECTION 254 (2).

Notice is hereby given that at an Extraordinary  
General Meeting of the abovenamed Company, duly  
convened and held at 25 Ely Street, Wangaratta on the  
30th June, 1975 the following Resolution was proposed and  
passed as a Special Resolution—

"That the company be wound up voluntarily and that  
Alexander Luxmoore Macgeorge be appointed as  
Liquidator."

Dated this 30th June, 1975.

6067 A. L. MACGEORGE, Liquidator.

In the Supreme Court of Victoria.—1974 No. Co. 8979.—  
In the matter of the Companies Act 1961; and in the  
matter of WARREN AND MACMAHON BUILDERS PTY. LTD.—  
Notice of Winding Up Order.

WINDING UP ORDER made 19th June 1975.

NAME AND ADDRESS OF LIQUIDATOR: ROGER  
DOUGLAS EVANS, 351 Collins Street, Melbourne.

ALAN R. NEAVES, Crown Solicitor for the Common-  
wealth and Solicitor for the Petitioner. 6123

Companies Act 1961, Section 272.

N. S. ECKERSLEY PROPRIETARY LIMITED (IN  
LIQUIDATION).

NOTICE OF FINAL MEETING OF CONTRIBUTORIES.

NOTICE IS HEREBY GIVEN that a meeting of the con-  
tributories of N. S. Eckersley Proprietary Limited (in  
Liquidation) will be held at the office of Fell & Starkey,  
351 Collins Street, Melbourne on the 11th day of August,  
1975 at 10.00 a.m.

Agenda.

To lay before the meeting the Liquidator's account  
showing how the winding up has been conducted and the  
property of the Company has been disposed of, and to  
give any explanation of the account which may be  
required.

Dated this 2nd day of July, 1975.

6062 ROGER D. EVANS, Liquidator.

Companies Act 1961–1974, Section 254 (2) (b).

FITWEAR (CASTERTON) PTY. LIMITED.

MEMBERS' VOLUNTARY WINDING UP.

NOTICE is hereby given that at the Extraordinary  
General Meeting of the above-named company duly con-  
vened and held at North Carlton on the 27th day of June  
1975, the following resolution was proposed and passed  
as a Special Resolution—

"That the company be wound up voluntarily and that  
Geoffrey Arthur COHEN of 330 Collins Street, Melbourne,  
be hereby appointed liquidator for the purpose of such  
winding up."

Dated this 3rd day of July, 1975.

6068

Companies Act 1961–1974, Section 254 (2) (b).

R. J. DYMOND WEAVING CO. PROPRIETARY LIMITED.

MEMBERS' VOLUNTARY WINDING UP.

NOTICE is hereby given that at the Extraordinary  
General Meeting of the above-named company duly con-  
vened and held at Collingwood on the 25th day of June  
1975, the following resolution was proposed and passed  
as a Special Resolution—

"That the company be wound up voluntarily and that  
Geoffrey Arthur COHEN of 330 Collins Street, Melbourne,  
be hereby appointed liquidator for the purpose of such  
winding up."

Dated this 3rd day of July, 1975. 6069

Companies Act 1961, Section 254.

G. R. I. HOLDINGS PTY. LTD.

Notice is hereby given that at an extraordinary general  
meeting of the members of the abovenamed company held  
on 30th June 1975 the following resolution was passed as  
a special resolution:—

"That this company be wound up as a members'  
voluntary liquidation and that Stanley Michael Mitchell  
of 6 Gullsway Frankston be and is hereby appointed  
liquidator."

6089

S. M. MITCHELL, Liquidator.

Companies Act 1961–1974, Section 254 (2) (b).  
LEE AND DAY PROPRIETARY LIMITED.

MEMBERS' VOLUNTARY WINDING UP.

NOTICE is hereby given that at the Extraordinary General Meeting of the above-named company duly convened and held at Collingwood on the 25th day of June 1975, the following resolution was proposed and passed as a Special Resolution—

"That the company be wound up voluntarily and that Geoffrey Arthur COHEN of 330 Collins Street, Melbourne, be hereby appointed liquidator for the purpose of such winding up."

Dated this 3rd day of July, 1975. 6070

Companies Act 1961–1974, Section 254 (2) (b).  
LEATHERCOL PROPRIETARY LIMITED.

MEMBERS' VOLUNTARY WINDING UP.

NOTICE is hereby given that at the Extraordinary General Meeting of the above-named company duly convened and held at Collingwood on the 25th day of June 1975, the following resolution was proposed and passed as a Special Resolution—

"That the company be wound up voluntarily and that Geoffrey Arthur COHEN of 330 Collins Street, Melbourne, be hereby appointed liquidator for the purpose of such winding up."

Dated this 3rd day of July, 1975. 6071

Companies Act 1961–1974, Section 254 (2) (b).  
FITWEAR MILLS PTY. LIMITED.

MEMBERS' VOLUNTARY WINDING UP.

NOTICE is hereby given that at the Extraordinary General Meeting of the above-named company duly convened and held at North Carlton on the 27th day of June 1975, the following resolution was proposed and passed as a Special Resolution—

"That the company be wound up voluntarily and that Geoffrey Arthur COHEN of 330 Collins Street, Melbourne, be hereby appointed liquidator for the purpose of such winding up."

Dated this 3rd day of July, 1975. 6072

Companies Act 1961–1974, Section 254 (2) (b).  
MASRA DYERS PTY. LIMITED.

MEMBERS' VOLUNTARY WINDING UP.

NOTICE is hereby given that at the Extraordinary General Meeting of the above-named company duly convened and held at North Carlton on the 27th day of June 1975, the following resolution was proposed and passed as a Special Resolution—

"That the company be wound up voluntarily and that Geoffrey Arthur COHEN of 330 Collins Street, Melbourne, be hereby appointed liquidator for the purpose of such winding up."

Dated this 3rd day of July, 1975. 6073

Companies Act 1961–1974, Section 254 (2) (b).  
FITWEAR (ADMINISTRATION) PTY. LIMITED.

MEMBERS' VOLUNTARY WINDING UP.

NOTICE is hereby given that at the Extraordinary General Meeting of the above-named company duly convened and held at North Carlton on the 27th day of June 1975, the following resolution was proposed and passed as a Special Resolution—

"That the company be wound up voluntarily and that Geoffrey Arthur COHEN of 330 Collins Street, Melbourne, be hereby appointed liquidator for the purpose of such winding up."

Dated this 3rd day of July, 1975. 6074

Companies Act 1961–1974, Section 254 (2) (b).  
FITWEAR (MANAGEMENT SERVICES) PTY. LIMITED.

MEMBERS' VOLUNTARY WINDING UP.

NOTICE is hereby given that at the Extraordinary General Meeting of the above-named company duly convened and held at North Carlton on the 27th day of June 1975, the following resolution was proposed and passed as a Special Resolution—

"That the company be wound up voluntarily and that Geoffrey Arthur COHEN of 330 Collins Street, Melbourne, be hereby appointed liquidator for the purpose of such winding up."

Dated this 3rd day of July, 1975. 6075

Companies Act 1961–1974, Section 254 (2) (b).

FITWEAR (HOSIERY) PTY. LIMITED.

MEMBERS' VOLUNTARY WINDING UP.

NOTICE is hereby given that at the Extraordinary General Meeting of the above-named company duly convened and held at North Carlton on the 27th day of June 1975, the following resolution was proposed and passed as a Special Resolution—

"That the company be wound up voluntarily and that Geoffrey Arthur COHEN of 330 Collins Street, Melbourne, be hereby appointed liquidator for the purpose of such winding up."

Dated this 3rd day of July, 1975. 6076

Companies Act 1961–1974, Section 254 (2) (b).

FITWEAR (WAREHOUSE) PTY. LIMITED.

MEMBERS' VOLUNTARY WINDING UP.

NOTICE is hereby given that at the Extraordinary General Meeting of the above-named company duly convened and held at North Carlton on the 27th day of June 1975, the following resolution was proposed and passed as a Special Resolution—

"That the company be wound up voluntarily and that Geoffrey Arthur COHEN of 330 Collins Street, Melbourne, be hereby appointed liquidator for the purpose of such winding up."

Dated this 3rd day of July, 1975. 6077

Companies Act 1961–1974, Section 254 (2) (b).

FITWEAR (FINISHING) PTY. LIMITED.

MEMBERS' VOLUNTARY WINDING UP.

NOTICE is hereby given that at the Extraordinary General Meeting of the above-named company duly convened and held at North Carlton on the 27th day of June 1975, the following resolution was proposed and passed as a Special Resolution—

"That the company be wound up voluntarily and that Geoffrey Arthur COHEN of 330 Collins Street, Melbourne, be hereby appointed liquidator for the purpose of such winding up."

Dated this 3rd day of July, 1975. 6078

Companies Act 1961–1974, Section 254 (2) (b).

FITWEAR (VIC.) PTY. LIMITED.

MEMBERS' VOLUNTARY WINDING UP.

NOTICE is hereby given that at the Extraordinary General Meeting of the above-named company duly convened and held at North Carlton on the 27th day of June 1975, the following resolution was proposed and passed as a Special Resolution—

"That the company be wound up voluntarily and that Geoffrey Arthur COHEN of 330 Collins Street, Melbourne, be hereby appointed liquidator for the purpose of such winding up."

Dated this 3rd day of July, 1975. 6079

Companies Act 1961–1974, Section 254 (2) (b).

FITWEAR (TRADING) PTY. LIMITED.

MEMBERS' VOLUNTARY WINDING UP.

NOTICE is hereby given that at the Extraordinary General Meeting of the above-named company duly convened and held at North Carlton on the 27th day of June 1975, the following resolution was proposed and passed as a Special Resolution—

"That the company be wound up voluntarily and that Geoffrey Arthur COHEN of 330 Collins Street, Melbourne, be hereby appointed liquidator for the purpose of such winding up."

Dated this 3rd day of July, 1975. 6080

Companies Act 1961–1974, Section 254 (2) (b).

FITWEAR (KNITWEAR) PTY. LIMITED.

MEMBERS' VOLUNTARY WINDING UP.

NOTICE is hereby given that at the Extraordinary General Meeting of the above-named company duly convened and held at North Carlton on the 27th day of June 1975, the following resolution was proposed and passed as a Special Resolution—

"That the company be wound up voluntarily and that Geoffrey Arthur COHEN of 330 Collins Street, Melbourne, be hereby appointed liquidator for the purpose of such winding up."

Dated this 3rd day of July, 1975. 6081



Unclaimed Moneys Act 1962.

Register of Unclaimed Moneys held by the—

Name of Owner on Books and Last Known Address.	Total Amount Due to Owner.	Description of Unclaimed Moneys.	Date when Amount first became Payable
<b>THE BROKEN HILL PROPRIETARY COMPANY LIMITED.</b>			
Electro Industries Pty. Ltd., c/o E. Turner, 152 Balwyn Road, Balwyn	109.20	Dividend .. .. .	30.5.73
Allen, Sheila Gleeson (Miss), 5 Sandy Bay Road, Clontarf, N.S.W.	16.97	" .. .. .	"
Pyramul, Myee Jane Allison (Miss), 57 Ethel Street, Balgowlah, N.S.W.	13.80	" .. .. .	"
Anderson, Anne (Mrs.), Waterford, No. 6 R.D., Ashburton, N.Z.	10.15	" .. .. .	"
Anderson, Florence Henderson (Mrs.), 14/1 Domain Park, 193 Domain Road, South Yarra	66.00	" .. .. .	"
Angino, Francis, c/o Myer L. Orlov, 85 Devonshire Street, Boston, Massachusetts, U.S.A.	28.99	" .. .. .	"
Archbold, Arnold W., 7 Woonona Parade, Woonona, N.S.W.	12.00	" .. .. .	"
A. S. Wyness Holdings Ltd., P.O. Box 9431, Wellington, N.Z.	15.95	" .. .. .	"
Auld, Donald, 133 Bergen Court, Ridgewood, New Jersey, U.S.A.	34.54	" .. .. .	"
Avery, Margaret I. (Mrs.), c/o Brightfields Farm Ltd., Rural Delivery No. 8, Palmerston North, N.Z.	13.84	" .. .. .	"
Bagshawe, John, Tuesnood Grange, Bethersden, Kent, U.K.	12.76	" .. .. .	"
Baile, Greta L. (Mrs.), 24 Wattleton Road, Beaconsfield, Bucks., U.K.	32.39	" .. .. .	"
Bailey, Margaret (Miss), 24 Agamemnon Road, London, N.W.6, U.K.	47.61	" .. .. .	"
Bailey, James W., 12 Sturgess Avenue, Harbord, N.S.W.	60.31	" .. .. .	"
Bain, Claude William, 17 Marywil Crescent, Takapuna, Auckland, 9, N.Z.	45.68	" .. .. .	"
Bainbridge, Agatha (Mrs.), 106 Bowen Crescent, North Carlton	38.75	" .. .. .	"
Baker, Robin Gai (Mrs.), 64 Wentworth Road, Vaucluse, N.S.W.	21.00	" .. .. .	"
Baldwin, Robert John, 231 Forest Road, Arncliffe, N.S.W.	18.14	" .. .. .	"
Bancroft, Catherine C. E. (Miss), The Grange, Ballyragget, Co. Kilkenny, Eire	15.85	" .. .. .	"
Banta, Robert Le Roy, 19 Macarthur Lane, Stamford, Conn. 06902, U.S.A.	15.95	" .. .. .	"
Barcham, John D. (Dr.), c/o Bank of N.S.W., 14 Kingsway, London, W.C.2, England	159.00	" .. .. .	"
Barclay, Robert James, Peacock Hotel, Baslow, Bakewell, Derbyshire, U.K.	37.09	" .. .. .	"
Barclays Rhodesian Nominees (Private) Limited, P.O. Box 790, Salisbury, Rhodesia	19.78	" .. .. .	"
Barnes, William Peter W. and Mary Veronica (Mrs.), 6 Park Village, West London, N.W.1, U.K.	24.65	" .. .. .	"
Battle, John Llewellyn (Dr.), The Marshes, Coleford, Glos., U.K.	15.24	" .. .. .	"
Bayer, Martin H. and Peck, David A., Roman House, Wood Street, London, E.C.2, U.K.	15.42	" .. .. .	"
Bell, Robert Moore, Ngahere, R.D.1, Waipawa, Hawkes Bay, N.Z.	11.07	" .. .. .	"
Bertelsen, Ole Peder, 3 Victoria Laan, Wassenaar, Z.H., The Netherlands	40.04	" .. .. .	"
B.G.K. Nominees Pty. Ltd., c/o 222 Albert Road, South Melbourne	77.50	" .. .. .	"
Bickell, Roderick, 12 Burnley Street, Newmarket, Qld.	15.00	" .. .. .	"
Bilbie, Patricia A. (Miss), c/o Mrs. Patricia A. Plumbley, Flat 3, Little Glencoe Street, The Range, Rockhampton, Qld.	14.71	" .. .. .	"
Black, Anna Ruth (Mrs.), and Charles, 813 Agathon Drive, Evansville, Indiana, 47712, U.S.A.	14.50	" .. .. .	"
Blackadder, Margaret Rose (Miss), c/o 22 Hole Road, Mosman, N.S.W.	122.24	" .. .. .	"
Blake, Dennis John, N.T.A. Centre, Gove Bag 36, Darwin, N.T.	16.51	" .. .. .	"
Blake, Wayne Robert G., 29 Rakeiora Grove, Korokoro, N.Z.	12.13	" .. .. .	"
Bogle, Archibald H. (estate of), c/o A. G. Little, P.O. Box 2043, Wellington, N.Z.	302.64	" .. .. .	"
Bond, Margaret N. (Miss), Visiting Teacher, Porirua East School, Porirua, N.Z.	18.56	" .. .. .	"
Raeburn, Donald Bookless, Quarterbridge Road, Douglas, Isle of Man	15.95	" .. .. .	"
Bottoms, Diana Salisbury (Mrs.), Tynrhos, Llanrhystyd, Cardiganshire, U.K.	25.75	" .. .. .	"
Braga, Antonio Maria (Dr.), 37 Cambrai Avenue, Engadine, N.S.W.	10.15	" .. .. .	"
Breen, Mary J. (Mrs.), 9 Campbell Street, Camperdown	19.43	" .. .. .	"
Briggs, Violet B. (estate of), c/o F. C. Petrie and Son, 375 George Street, Sydney, N.S.W.	12.00	" .. .. .	"
Brock, Lawrence G. (Dr.), Pine Ridge, Stanley Avenue, Wirral, Merseyside, L63 5QF, U.K.	38.28	" .. .. .	"
Broeker, Bernard D., 701 East Third Street, Bethlehem, Pennsylvania, 18017, U.S.A.	26.49	" .. .. .	"
Brogan, Roy Francis and Dalton, David Paul, 6 Green Street, Cremorne, N.S.W.	10.80	" .. .. .	"
Brown, Aubrey Arthur and Wooffindin Thomas, c/o Aubrey A. Brown and Co., P.O. Box 110, Wyong, N.S.W.	17.50	" .. .. .	"
Brown, John Richard H., Green Lodge, The Severals, Newmarket, Suffolk, U.K.	30.45	" .. .. .	"
Browne, Ian Malkin, 52 William Street, Roseville, N.S.W.	17.05	" .. .. .	"
Browning, Thomas I., c/o National Prov. Bank Ltd., 1 Alphington Street, Exeter, Devon, U.K.	50.90	" .. .. .	"
Bubbins, Charles Stanley, 50A Nile Street, Mayfield, N.S.W.	33.00	" .. .. .	"
Buckley, Thomas, Rockchapel, Co. Cork, Eire	29.67	" .. .. .	"
Burke, Thomas, Grange, Sligo, Eire	53.24	" .. .. .	"
Burke, David McDuff, 12 Pursers Cross Road, London, S.W.6, U.K.	10.81	" .. .. .	"
Burn, Judith Anne (Mrs.), 1 Lisgar Road, Hornsby, N.S.W.	17.40	" .. .. .	"
Burnham, Conlan Bill, 269 Aberdeen Avenue, Hamilton 12, Ontario, Canada	10.25	" .. .. .	"
Burns, Marie Therese D. (Mrs.), 336 Aberdeen Road, Gisborne, N.Z.	15.24	" .. .. .	"
Buttanshaw, Margaret (Mrs.), The Glen, Kill-of-the-Grange, Co. Dublin, Eire	16.97	" .. .. .	"

## Unclaimed Moneys Act 1962.

## Register of Unclaimed Moneys held by the—

Name of Owner on Books and Last Known Address.	Total Amount Due to Owner.	Description of Unclaimed Moneys.	Date when Amount first became Payable.
5			
THE BROKEN HILL PROPRIETARY COMPANY LIMITED—continued.			
Callender, Jack C., c/o Commonwealth Banking Corp., Gunnedah, N.S.W.	13.80	Dividend .. .. .	30.5.73
Campbell, George A., 188 Main Road, Ballarat	71.11	" .. .. .	"
Campbell, Patricia Rosaline (Mrs.), and Wood, James Roland T., 25 Longfield Street, Cabramatta, N.S.W.	83.24	" .. .. .	"
Campbell, William Thomas, Kirby Farm, Braddan, Isle of Man	14.33	" .. .. .	"
Cant, David, Apartment 71, Race View Apartments, 46 Stubbs Road, Hong Kong	16.74	" .. .. .	"
Cartland, John Basil, Jeremy Brian and Jill Elizabeth (Miss), 172 Dyke Road, Brighton 5, Sussex, U.K.	143.91	" .. .. .	"
Cavanagh, Nan Jean (estate of), c/o Perry Wylie Pope and Page, P.O. Box 3246, Wellington, N.Z.	10.15	" .. .. .	"
Cerny, Thelma Margaret (Mrs.), 63 Gueudecourt Avenue, Earlwood, N.S.W.	37.51	" .. .. .	"
Chadwick, Emery Lynn (Miss), 1/26 Queenscliff Road, Queenscliff, N.S.W.	12.00	" .. .. .	"
Chambers, Marguerite S. (Mrs.), 9 Wiston Gardens, Double Bay, N.S.W.	13.20	" .. .. .	"
Chandler, John Richard, Wechylstone, Speldhurst, Tunbridge Wells, Kent, U.K.	12.76	" .. .. .	"
Chapman, Ross, Redoubt Road, Papatoetoe, Auckland, N.Z.	15.24	" .. .. .	"
Chappell, Lawrence Frederick and Judith Emily (Mrs.), 2 Bapaume Road, Mosman, N.S.W.	14.50	" .. .. .	"
Charlesby, Arthur, Apartamentos Andalucia 2, Los Boliches, Malaga, Spain	25.51	" .. .. .	"
Charleton, Eileen (estate of), c/o G. S. Berrigan, 213 Park Street, South Melbourne	18.29	" .. .. .	"
Chaytor, Anthony D. C., Marshlands, Blenheim, R.D.3, N.Z.	76.12	" .. .. .	"
Chaytor, John L. C., Marshlands, R.D.3, Blenheim, N.Z.	230.26	" .. .. .	"
Chisholm, Robert Martin, P.O. Box 233, Broadway, N.S.W.	34.51	" .. .. .	"
Christie, Heather Mary (Mrs.), 171 B. Barrenjoey Road, Newport, N.S.W.	17.05	" .. .. .	"
Clark, Eileen Joan (Mrs.), 7 Parthenia Street, Boondall Heights, Qld.	13.20	" .. .. .	"
Clarke, Noel G., Flat 6, Erin Lea, Yorton Court, Elsternwick	63.31	" .. .. .	"
Cohen, Lillian Mary (Mrs.), 5A Selwood Street, East Hawthorn	18.00	" .. .. .	"
Colborne, Thomas Frank (estate of), c/o Sylvester and Mackett, Castle House, Trowbridge, Wilts, U.K.	16.97	" .. .. .	"
Coley, John, Heathfield, Sandy Lane Church, Brampton, Northampton, N.N.6, 8A.X., U.K.	15.24	" .. .. .	"
Collins, Augustus J. (estate of), c/o John Cain and Peter Lamers, P.O. Box 133, Preston	24.03	" .. .. .	"
Commonwealth Securities Ltd., c/o P. J. Bunting, Annesborough, Craigavon, Co. Armagh, Northern Ireland	1,863.64	" .. .. .	"
Computer Resources Pty. Ltd., Superannuation Fund, 32 Atchison Street, St. Leonards, N.S.W.	33.00	" .. .. .	"
Cook, Hunter Louthier R., 195 Noble Street, Newtown	13.80	" .. .. .	"
Coombs, Ruby R. (Miss) and Harniman, William R., c/o Local and District Criminal Courts Department, 301 King William Street, Adelaide, S.A.	280.00	" .. .. .	"
Cope, Kenneth C., c/o Comdr. Innes Hamilton, 10 Haymarket, London, S.W.1, U.K.	16.06	" .. .. .	"
Copeland, William R. and Paynter, John C., c/o J. C. Paynter, 10 Martin Place, Sydney, N.S.W.	57.04	" .. .. .	"
Cosgrove, Betty (Miss), 126 Page Street, Middle Park	17.05	" .. .. .	"
Cote Investments Ltd., 5 Fitzalan Road, Cardiff, U.K.	14.50	" .. .. .	"
Coty, Georgette (Mrs.), 20 Birriga Road, Bellevue Hill, N.S.W.	66.00	" .. .. .	"
Couchman, Robert John, c/o Bank of New South Wales, Napier, N.Z.	24.36	" .. .. .	"
Coventry, John Philip C. and Esther E. G. (Mrs.), c/o United Transport (Malawi) Limited, P.O. Box 176, Blantyre, Malawi	16.97	" .. .. .	"
Cowan, Duncan John, P.O. Box 12398, Penrose, Auckland, N.Z.	15.95	" .. .. .	"
Cowlshaw, John Abbott Cowlshaw, Carol Mary (Mrs.), 139 Middle Harbour Road, East Lindfield, N.S.W.	36.27	" .. .. .	"
Cox, David I., 9 Berkswell Close, Four Oaks, Sutton Coldfield, Warks, U.K.	91.33	" .. .. .	"
Crabb, Elizabeth Anne (Miss), 5/66 Roslyn Gardens, Elizabeth Bay, N.S.W.	24.00	" .. .. .	"
Craske, Margaret M. (Miss), 6/14 Godfrey Terrace, Leabrook, S.A.	20.77	" .. .. .	"
Crick, Joan Mary (Mrs.), 33 Glenfern Road, Howick, Auckland, N.Z.	15.95	" .. .. .	"
Cronmire, Amy Maud Hill (Mrs.), 3 Venner Road, Sydenham, S.E.26, U.K.	18.56	" .. .. .	"
Crosthwaite, Gillian D. (Mrs.), 18 Ormonde Avenue, Netherlee, Glasgow, U.K.	15.42	" .. .. .	"
Cullen, Walter and Conway, Charles, c/o Clark Doge and Co. Incorp., 61 Wall Street, New York, 10005 U.S.A.	29.00	" .. .. .	"
Cunin, Jean Michel, c/o Compagnie Generale De Geophysique, 26/28 Manning Street, South Brisbane, Qld.	30.69	" .. .. .	"
Cunningham, Peter, P.O. Box 402, Coffs Harbour, N.S.W.	18.14	" .. .. .	"
Cussins, Manny and Muriel (Mrs.), c/o Cobden Board and Co., Fountain House, Broomgrove Road, Sheffield 10, U.K.	170.81	" .. .. .	"
Cuthbert, Caroline J. B. (Mrs.), Old Ballikinrain, Balfour by Glasgow, U.K.	22.33	" .. .. .	"
Daly, Anne Cecilia McKee (Mrs.), 33 Trees Road, Mount Merriion, Co. Dublin, Eire	15.21	" .. .. .	"
Damman, Lloyd, c/o O. G. Damman, 551 Orrong Road, Armadale	36.43	" .. .. .	"

## Unclaimed Moneys Act 1962.

## Register of Unclaimed Moneys held by the—

Name of Owner on Books and Last Known Address.	Total Amount Due to Owner.	Description of Unclaimed Moneys.	Date when Amount first became Payable
S			
THE BROKEN HILL PROPRIETARY COMPANY LIMITED—continued.			
De Meeu, Comte Camille A., Dargentieville, Chateau De Et A Linsmeau, Par Racour, Brabant, Belgium	13.96	Dividend	30.5.73
Davidson, Thelma (Mrs.), P.O. Box 244, Chatswood, N.S.W.	16.97	"	"
Davies, Frances Dorothy (Dr.), P.O. Box 628, Whangarei, N.Z.	213.30	"	"
Davies, John Norman, 3 Warwick Avenue, Coventry, U.K.	28.99	"	"
Davis, Anthony A., c/o A. A. Davis Herniman and Co., P.O. Box 86, Katoomba, N.S.W.	18.14	"	"
Davis, Anthony A., P.O. Box 77, Katoomba, N.S.W.	20.77	"	"
Davis, Anthony A., 72 Katoomba Street, Katoomba, N.S.W.	109.43	"	"
Dawson, Arthur J., 19 Agnes Street, Torwood, Qld.	51.04	"	"
Dean, Agnes (Mrs.), 60 St. Chads Road, Chester, Cheshire, U.K.	15.42	"	"
Dean, Francis Joseph, 60 St. Chads Road, Chester, Cheshire, U.K.	30.97	"	"
Dean, Ian R. and Gweneth M. (Mrs.), 7 Hutchinson Street, Mt. Barker, S.A.	33.91	"	"
De Banville, Henri (estate of), c/o Midland Bank Ltd., Overseas Branch, P.O. Box 181, 60 Gracechurch Street, London, E.C.3., P3B.N., U.K.	51.33	"	"
Delaney, Michael Beverley, c/o Barclays Bank Limited, Abbey House, Victoria Street, London, S.W.1 U.K.	48.58	"	"
De Robeck, Denis Caroline Iris (The Baroness), Gowran Grange, Naas, Co. Kildare, Eire	19.14	"	"
Dickie, John G., Hayes, Waverley, N.Z.	12.76	"	"
Dickson, Robert Hamish, 9 Clevedon Gardens, Glasgow, W.2, U.K.	12.18	"	"
Dixon, Margaret Lesley (Miss), 111 Cheam Road, Sutton, Surrey, U.K.	16.21	"	"
Dixon, Gray Michael, Elworthy, Timothy C. (Sqrn. Ldr.) and Anthony, Arthur, 12 Station Road, Reading, Berks., U.K.	27.68	"	"
Dodds-Parker, Peter Douglas, c/o First National City Bank, 17 Bruton Street, London, W.1, U.K.	59.23	"	"
Doe, Russell Malloch, 2203 Green Acres Drive, Visalia, California, U.S.A.	30.45	"	"
Dollond, Jack J. (Dr.), 260A Shirland Road, London, W.9, U.K.	203.43	"	"
Dollond, Jack (Dr.), 260A Shirland Road, London, W.9, U.K.	74.46	"	"
Donaldson, Maitland G., P.O. Box 444, West Perth, W.A.	22.63	"	"
Donohoe, Eileen Elizabeth (Miss), c/o Mrs. Eileen E. Rawlence, c/o G. M. Cole, 60-66 Hunter Street, Sydney, N.S.W.	15.95	"	"
Downey, Gordon L., P.O. Box 211, Bendigo	11.89	"	"
Drew, John Graham, 14 Eaton Place, London, S.W.1, U.K.	41.52	"	"
Dunlop, Gertrude Clemes (Dr.), 6 Florence Street, Strathfield, N.S.W.	38.29	"	"
Dutriez, Paul Emile, 40 Rue D'enghien, Paris 10, France	41.13	"	"
Eagleton, Edward S., 4/1 Ralston Street, Lane Cove, N.S.W.	73.20	"	"
Early, Lawrence C., Hororata, Canterbury, N.Z.	22.43	"	"
Eastwell, Geoffrey John, 2 Blackwell, Darlington, Co. Durham, U.K.	20.48	"	"
Edwards, Helen (Mrs.), Flat 2, 37 Wilton Crescent, London, S.W.1, U.K.	27.41	"	"
Elason, Charles and Dorothy (M/s.), 2445 Cortland Drive, Upper St. Clair, Pennsylvania, 15241, U.S.A.	15.24	"	"
Ellery, Douglas, P.O. Box 4161, Christchurch, N.Z.	12.26	"	"
Ellson, Douglas and Elizabeth (M/s.), 1207 East Wylie Street, Bloomington, Indiana, U.S.A.	16.10	"	"
Embley, Norman Perrin, 27 Oravel Street, North Balwyn	12.18	"	"
Emms, Glynis Mary (Mrs.), Thornton Road, Mount Eliza	12.09	"	"
Ennis, Betty (Mrs.), c/o J. M. Croker, 33 Elstree Avenue, Mount Lawley, W.A.	111.65	"	"
Evans, Ronald C., c/o The Chartered Bank, Seremban, Negri Sembilan, Malaysia	19.53	"	"
Evatt, Susan Frances (Mrs.), 51 Finlay Road, Warrabee, N.S.W.	21.75	"	"
Fairbairns, John Joshua, 149 Waldegrave Road, Teddington, Middlesex, U.K.	15.24	"	"
Falk, James Edward, 6 Yarravale Road, Kew	14.50	"	"
Falkner, Beatrice A. (Mrs.), 6/21 Manning Road, Double Bay, N.S.W.	110.40	"	"
Farkas, Jonathan, 24 Central Park South, New York, N.Y., U.S.A.	26.35	"	"
Faul, Ida J. (Mrs.), 69 Clencairn Avenue, East Brighton	11.47	"	"
Fawckner, Dorothy Marion (Mrs.), Bonnie Downs, Corfield, Qld.	132.00	"	"
Ferguson, Richard, 30 North Circular Road, Lisburn, Co. Antrim, U.K.	23.06	"	"
Fisher, Graham Godfrey W., 8 Aroona Court, West Essendon	15.95	"	"
Fitzgerald, Sean, 23 Garnet Street, Gore, N.Z.	18.27	"	"
Flanagan, James (estate of), c/o Odonnell, Creswell and Cudby, P.O. Box 447, Wellington, N.Z.	55.64	"	"
Fleming, Percival James, 213 Jeffries Street, Rockhampton, Qld.	17.05	"	"
Foote, Kenneth J. R. (estate of), c/o Short Punch and Grotorix, P.O. Box 559, Southport, Qld.	31.00	"	"
Footner, Geoffrey Marsh, c/o Binder, Hamlyn, Singleton, Fabian, Carolyn House, Dingwall Road, Croydon, C.R.9, 2P.L., U.K.	10.54	"	"
Formby, David John, 77 The Esplanade, Balmoral Beach, N.S.W.	25.89	"	"
Fraser, Barbara (Mrs.), 37 John Miller Street, Ryde, N.S.W.	13.80	"	"
Fraser, Kathleen Joan (Mrs.), P.O. Box 139, North Quay, Qld.	19.80	"	"
Freeman, Anthony Marriot, Ross Marriot and Simon Marriot, Doleswood, Burgate, Fordingbridge, Hants., U.K.	15.24	"	"
Freer Investments Private Ltd., P.O. Box 358, Salisbury, Southern Rhodesia	46.40	"	"
Frost, Peter and Barnes, Jack F., c/o 17 Smith Street, Parramatta, N.S.W.	17.11	"	"
Fuller, Ian Ross, Rugby, Goondiwindi, Qld.	34.08	"	"
Fung, Frederick, c/o 83 Bindy Street, Forest Hill	15.50	"	"
Furley, Brian Paget, 47 Liverpool Road, Burwood, N.S.W.	39.37	"	"

## Unclaimed Moneys Act 1962.

## Register of Unclaimed Moneys held by the—

Name of Owner on Books and Last Known Address.	Total Amount Due to Owner.	Description of Unclaimed Moneys.	Date when Amount first became Payable
§			
THE BROKEN HILL PROPRIETARY COMPANY LIMITED—continued.			
Furst, Johanna (Mrs.), 2/11A The Avenue, Randwick, N.S.W.	16.59	Dividend	30.5.73
Furst, Peter John, c/o 2/11A The Avenue, Randwick, N.S.W.	18.76	"	"
Gaffney, Delia E. (Miss), 37 Lislee Road, Maryborough, Cork, Eire	11.94	"	"
Gajdik, Milos, c/o R. A. Beston, 48 New North Rocks Road, North Rocks, N.S.W.	10.23	"	"
Gale, Walter and Margai et (Mrs.) 9 The Crescent, Chatswood, N.S.W.	10.23	"	"
Gallagher, Michael, P.O. Box 77, Kieta, P.N.G.	66.00	"	"
Gardner, Nigel H., 82 Rue Saint Louis, En L'ile, Paris 4E., France	11.67	"	"
Garnett, Grace E. (Mrs.), c/o The Hongkong and Shanghai Banking Corporation, 9 Gracechurch Street, London, E.C.3, U.K.	15.95	"	"
Gee, Clement M., 9 Hampden Avenue, Wahroonga, N.S.W.	85.26	"	"
Gee, George C. M. (estate of), c/o A. E. Whatmore, G. C. Gee and Co., 20 Bridge Street, Sydney, N.S.W.	556.45	"	"
Gerszt, John Maxwell, c/o T. Hardwick, 84 Chapel Street, St. Kilda	23.25	"	"
Gethin-Jones, Thomas A. L. (Dr.), c/o Bank of New Zealand, P.O. Box 644, Whangarei, N.Z.	218.92	"	"
Gibson, Mary M. (M/s.), 31 De Witt Street, Battery Point, Hobart, Tas.	44.39	"	"
Gilder, Mary (Mrs.), 1/240 Domain Road, South Yarra	16.97	"	"
Glaven Nominees Limited, Northgate House, 20/24 Moorgate, London, E.C.2, U.K.	47.24	"	"
Glover, Eileen May (Mrs.), c/o The Public Trust Office, 168 Exhibition Street, Melbourne	300.63	"	"
Goddard, Gwendoline Vera (Mrs.), 5 Beaufort Road, London, W.5, U.K.	91.33	"	"
Goodall, Donald G. W., No. 2, R.D. Mossburn, Southland, N.Z.	70.62	"	"
Goodwin, Clare (Mrs.), c/o Bank of N.S.W., Balmain, N.S.W.	14.50	"	"
Gordon, Alan, c/o A.N.Z. Banking Group Ltd., Kingsford, N.S.W.	31.00	"	"
Gordon, Betty (Mrs.), 3 Walworth Avenue, Caulfield	18.14	"	"
Gordon, Margaret Anne (Mrs.), The Coach House, Bardowie Castle, Bardowie, Milngavie, Glasgow, U.K.	45.68	"	"
Gotlieb, Alan J., 57A Chaytor Street, Karori, Wellington, N.Z.	45.95	"	"
Goudes, Nick, 526 Anzac Parade, Kingsford, N.S.W.	21.00	"	"
Gould, Phyllis M. (Mrs.), 305 East Street, Rockhampton, Qld.	10.39	"	"
Graves, Bruce, 3548 Dupont Avenue South, Apartment 103, Minneapolis, Minnesota, 55408, U.S.A.	14.50	"	"
Gray, James Allan, 57 Duthie Street, Wellington, N.Z.	34.61	"	"
Green, Arnold, 4 Wilberforce Street, Wellington, N.Z.	30.97	"	"
Green, Joan Alice (Mrs.), Newlands, Arne Road Ridge, Wareham, Dorset, U.K.	10.15	"	"
Greenwood, Anthea (Miss), The Barton, Patricxbourne, Canterbury, Kent, U.K.	42.62	"	"
Grenville, Stephen Alexander, Department of External Affairs, Canberra, A.C.T.	29.76	"	"
Gundry, John H. B., c/o Bank of N.S.W., Head Office, 341 George Street, Sydney, N.S.W.	68.20	"	"
Gunn, Donald Malcolm and Balnaves, Peter, c/o D. M. Gunn, 3 Geary Place, Athelstone, S.A.	13.20	"	"
Gyles, Peter William, 54 Tutanekei Street, Paraparaumu, N.Z.	51.91	"	"
Hall, Peter Arthur, Hong Kong Land Investment Agency, 1st Floor, Gloucester Building, Hong Kong	11.94	"	"
Halls, Eileen Margaret (Mrs.), c/o J. R. Halls, c/o Bank of N.S.W., 9-15 Sackville Street, London, W.1, U.K.	14.50	"	"
Halsall, David Wilson, 56 West Street, Southport, Lancashire, U.K.	170.81	"	"
Hamilton, Robert, c/o Laidlaw and Co., 25 Broad Street, New York, U.S.A.	28.99	"	"
Hankey, Donald R. A. (The Hon.), 3 Pembridge Crescent, London, W.11, U.K.	17.00	"	"
Hann, Cecil, c/o Post Office, Hahndorf, S.A.	18.14	"	"
Hanson, David, Department of Education, Pago Pago, American Samoa	15.95	"	"
Hapted, Percival E., 6 Roxwell House, Valley Hill, Loughton, Essex, U.K.	32.39	"	"
Harding, George Frederick, 1 Marlborough Street, Herne Hill	74.71	"	"
Harding, Richard S., 64 Ridgway Place, London, S.W.19, U.K.	153.70	"	"
Hargreaves, Judith Anne (Mrs.), c/o William and Glyn's Bank Ltd., 67 Lombard Street, London, E.C.3P. 3D.L., U.K.	79.75	"	"
Harley, Roy Ernest and Bevan, Dorothy Lilian (Mrs.), 25 Duneva Avenue, West Pymble, N.S.W.	34.80	"	"
Harris, Harry F. J., 759 Nepean Highway, Rosebud	20.46	"	"
Harris, Neil Gregory, 7 Ruzac Street, Campbelltown, N.S.W.	15.50	"	"
Harrison, Christopher B., 33 Burdeshett Avenue, Richmond, Surrey, U.K.	14.40	"	"
Harrold, Alfred, Trennant, Tavistock Road, Wisbech, Cambs., U.K.	10.15	"	"
Hart, Helen Barbara (Mrs.), P.O. Box 2060, Konedobu, T.P.N.G.	11.89	"	"
Harwood, Meryl Lilian (Mrs.), 96 Motuhara Road, Plimmerton, N.Z.	33.87	"	"
Hatter, Frances (Mrs.), c/o Messrs. Michael Kramer and Co., 137 Regent Street, London, W.1R, 8B.U., U.K.	59.74	"	"
Hauger, Eugene, 79 Rue De Bale, Mulhouse, Haut Rhin, France	19.29	"	"
Haynes, Bernard John, 54 South Park, Sevenoaks, Kent, U.K.	14.50	"	"
Heath, Joyce Wilma (Mrs.), Koorana, Private Bag No. 4, Heywood	100.13	"	"
Leueen, Anne (Miss), Heathcote-Drummond-Willoughby, c/o Royal Bank of Canada, 685 West Hastings Street, Vancouver 2, B.C., Canada	23.93	"	"
Heiman, David L., 18 Thomas Street, Worcester, Massachusetts, U.S.A.	15.95	"	"
Helme, Florence Jane (Mrs.), Mayfield, Victoria Park, Manchester, U.K.	11.63	"	"

## Unclaimed Moneys Act 1962.

## Register of Unclaimed Moneys held by the—

Name of Owner on Books and Last Known Address.	Total Amount Due to Owner.	Description of Unclaimed Moneys.	Date when Amount first became Payable.
S			
THE BROKEN HILL PROPRIETARY COMPANY LIMITED—continued.			
Richard, Henry Majtherthon, Lord Hindlip, Vern Leaze, Calne, Wilts., U.K.	91.33	Dividend .. .. .	30.5.73
Herman, Jean Desmond (Mrs.), Rua Senador Vergueiro, 207 Apartment 410, Rio De Janeiro, Z.C.01, Brazil	13.20	" .. .. .	"
Hiatt, Dora (Mrs.), and White, Stuart, 2 Rosemont Avenue, Woollahra, N.S.W.	34.08	" .. .. .	"
Hickok, Sanford D., Tempe Wick Road, Morristown, New Jersey, 07960, U.S.A.	30.45	" .. .. .	"
Hill, Francis Pahl (estate of), c/o Hill Lee and Scott, P.O. Box 13004, Christchurch, N.Z.	17.66	" .. .. .	"
Hine, Richard, c/o Department Geology, James Cook University, Townsville, Qld.	15.50	" .. .. .	"
Hoare, Jocelyn R. (Mrs.), Hasketts Road, Yaldhurst, Christchurch, N.Z.	21.75	" .. .. .	"
Hodder, Richard Tarn, 156 Piccotts End, Hemel Hempstead, Herts., U.K.	16.97	" .. .. .	"
Hodge, Agnes Alexandra E. (Mrs.), 6 Barncroft Road, Berkhamsted, Herts., U.K.	29.00	" .. .. .	"
Hogan, Eldon J., 1050 Malvern Road, Armadale	2,594.24	" .. .. .	"
Hokansson, Ulla Marianne (Mrs.) and Holger, Gustav, c/o J. R. Rosenberg MacPhillamy Cummins and Gibson, A.N.Z. Bank Building, Hobart Place, Canberra City, A.C.T.	204.00	" .. .. .	"
Holdsworth, Paul H. (estate of), c/o Harold Smith and Dallison, P.O. Box 118, Christchurch, N.Z.	37.93	" .. .. .	"
Holt, Nicholas Macd. F., 16 Millicent Avenue, Toorak	18.14	" .. .. .	"
Holyer, Sheila Ann (Mrs.), 14 Domaine Des Alluets, Rue Montaine 78, Chambourly, France	17.75	" .. .. .	"
Hone, Anthony and Morton, John Douglas, 47-49 Rye Lane, Peckham, London, S.E.15, U.K.	56.19	" .. .. .	"
Hopkin, Mary (Miss), c/o Bryce Hammer and Co., 23 Albemarle Street, London, W.1, U.K.	202.90	" .. .. .	"
Hopkins, Judith Mary (M/s.), Wormbete, Winchelsea	385.64	" .. .. .	"
Hornberger, Ronald, Apartment 113, 1505 Sunnyvale, Austin, Texas, 78741, U.S.A.	91.33	" .. .. .	"
Hoskins, Charles Thomas, 362 Annadale Street, Annadale, N.S.W.	33.00	" .. .. .	"
Houghton, Arthur H. (estate of), c/o MacDiarmid Mears and Gray, P.O. Box 13, Hamilton, N.Z.	32.02	" .. .. .	"
Houghton, Neville W., 330 Gallaghers Road, Glen Waverley	19.43	" .. .. .	"
Houghton, Stephen Noel, 47 Cotswold Close, Singapore 13	65.88	" .. .. .	"
Hughes, Dorothea Florence (Mrs.), 12 Chelsea Street, Wellington, N.Z.	16.06	" .. .. .	"
Hughes, John Dixon, 77 Bulkara Road, Bellevue Hill, N.S.W.	18.14	" .. .. .	"
Hughston, Walter Raymond, 15 Broxbourne Street, Westmead, N.S.W.	58.28	" .. .. .	"
Hunt, Francis Milton, c/o Dow Chemical Australia Pty. Ltd., P.O. Box 384, North Sydney, N.S.W.	17.05	" .. .. .	"
Hunt, Janet E. (Mrs.), 6 Harkin Avenue, Mentone	18.14	" .. .. .	"
Hunter, Margaret Hannah Mary (estate of), c/o Gardner and Croft, 2 Castle Street, Canterbury, C.T.1, 2Q.H., U.K.	30.45	" .. .. .	"
Hutton, Margaret A. (Miss), Geelong Grammar School, Corio	264.00	" .. .. .	"
Huxley, Margaret (Miss), c/o Mrs. A. C. Farrant, 1/63 Darling Point Road, Darling Point, N.S.W.	13.20	" .. .. .	"
Iles, Austin Arthur, c/o Lowe Bingham and Matthews, Princes Building, 22nd Floor, Hong Kong	22.48	" .. .. .	"
Ilina Investments Pty. Limited, c/o Mrs. J. Melville, 42 Bulkara Road, Bellevue Hill, N.S.W.	17.05	" .. .. .	"
Irving, Michael E., 185 East 85th Street, New York, New York State, U.S.A.	51.19	" .. .. .	"
Ives, Elizabeth Catherine (Miss), c/o Mrs. Elizabeth C. Dooley, 7/10 Orpington Street, Ashfield, N.S.W.	13.64	" .. .. .	"
Iwi, Esther (Mrs.), 5 Meadway, London, N.W.11, U.K.	16.06	" .. .. .	"
Jack, Thomas N. E. (estate of), c/o Asher Old and Jones, 5 Bligh Street, Sydney, N.S.W.	10.23	" .. .. .	"
Jackson, Harold, 2101 Parkside Avenue, Hillsborough, California, U.S.A.	60.89	" .. .. .	"
Jacobsen, Elizabeth M. (Mrs.), 15 Hibble Street, West Ryde, N.S.W.	20.00	" .. .. .	"
Jaeger, Frederick W. (Jnr.), c/o Merrill Lynch Pierce Fenner and Smith, 70 Pine Street, New York, New York, 10005 U.S.A.	16.97	" .. .. .	"
James, Paul Meyer, P.O. Box 607, Alexandria, Virginia, 22313 U.S.A.	15.24	" .. .. .	"
Jardine, Pamela Anne (Mrs.), 158 Riverview Road, Clareville, N.S.W.	35.00	" .. .. .	"
Jarrell, John A., 1 Hitchingpost Road, West Lafayette, Indiana, U.S.A.	37.93	" .. .. .	"
Jarrell, Marjorie J. (Mrs.), 1 Hitchingpost Road, West Lafayette, Indiana, U.S.A.	30.45	" .. .. .	"
J. D. Secretarial Service Pty. Ltd., 2 Fetherstone Street, Bankstown, N.S.W.	15.95	" .. .. .	"
Jenner, Jocelyn (Mrs.), 25 Holland Avenue, Cheam, Surrey, S.M.2 6H.W., U.K.	32.92	" .. .. .	"
Jermano, Frances (Miss), 38 Meridian Street, Depew, New York, U.S.A.	15.24	" .. .. .	"
Jessop, John Walter H., 33 Parsley Road, Vacluse, N.S.W.	21.46	" .. .. .	"
Johnstone, Michele (Miss), 57A Sydney Street, Willoughby, N.S.W.	51.48	" .. .. .	"
Jones, Helen C. (Miss), 7 Shirley Road, Roseville, N.S.W.	14.79	" .. .. .	"
Jones, John Ernest, Grove Farm, Condover, Shrewsbury, Salop, U.K.	32.39	" .. .. .	"
Jones, Susie Katherine (estate of), c/o Teece Hodgson and Ward, 280 George Street, Sydney, N.S.W.	16.68	" .. .. .	"

## Unclaimed Moneys Act 1962.

## Register of Unclaimed Moneys held by the—

Name of Owner on Books and Last Known Address.	Total Amount Due to Owner.	Description of Unclaimed Moneys.	Date when Amount first became Payable.
5			
THE BROKEN HILL PROPRIETARY COMPANY LIMITED—continued.			
Jose, Donald, Sandy Lane, Redlynch, Salisbury, Wiltshire, U.K.	19.66	Dividend .. .. .	30.5.73
Joseph, Michael Kennedy and David Peter, 5 Stack Street, Herne Bay, Auckland, N.Z.	45.97	" .. .. .	"
Joy, Henry, 25 Victoria Place, Stirling, U.K.	14.50	" .. .. .	"
Kalb, Bernard, c/o CBS News, 2020 M. Street, N.W. Washington, D.C., U.S.A.	30.97	" .. .. .	"
Kalb, Bernard and Phyllis (Mrs.), c/o CBS News, 2020 M. Street, N.W. Washington, D.C., U.S.A.	15.42	" .. .. .	"
Keane, Robert Mortimer, c/o Mrs. S. M. Bennett, P.O. Box 258, Coonabarabran, N.S.W.	26.40	" .. .. .	"
Kearney, Kevin David N., Broomacre, Chobham Woking, Surrey, U.K.	15.95	" .. .. .	"
Keen, Irene Rose (Mrs.), 68 Thomson Street, Invercargill, Southland, N.Z.	15.24	" .. .. .	"
Kegley, Paul, 654 Gilman Street, Palo Alto, California, 94301 U.S.A.	13.18	" .. .. .	"
Kell, James Robert, 30 Mudies Road, St. Ives, N.S.W.	15.50	" .. .. .	"
Kelley, Jennifer Margaret H. (Mrs.), Little Stannalls, Bittell Road, Alvechurch, Worcs., U.K.	14.50	" .. .. .	"
Kellow, Henry Edward (Dr.), 169 Boundary Street, East Roseville, N.S.W.	492.44	" .. .. .	"
Kendall, Peggy E. (Mrs.) and Raymond J., P.O. Box 23—083 Papatotoe, N.Z.	21.75	" .. .. .	"
Kenyon, Frederick, 5 Willawa Street, Balgowlah, N.S.W.	12.31	" .. .. .	"
Kewell, Emmanuel (estate of), c/o Charles Lucas and Marshall, Newbury, Berks., U.K.	157.50	" .. .. .	"
Kinabatangan Development Co. Limited, P.O. Box 887, Sandakan, Sabah East, Malaysia	10.85	" .. .. .	"
Kindig, Paul E., 455 Old Post Road, Fairfield, Conn. 06430 U.S.A.	14.50	" .. .. .	"
King, David W., 2 Madeira Street, Sylvania, N.S.W.	17.40	" .. .. .	"
King, Diane Lesley (Miss), c/o Mrs. Diane Clarke, 48 Belmore Terrace, Woodville Park, S.A.	14.36	" .. .. .	"
King, Edward Kenneth, Stedall, Henry S. O. P. and Marcus, B. P., 21A Northampton Square, London, E.C.1, U.K.	19.24	" .. .. .	"
King, James Leopold, 7 Belmont Road, Glen Waverley	12.76	" .. .. .	"
King, Thomas R. R. c/o P. A. Mooney and Co., Kenlis Place, Kells, Co. Meath, Eire	10.65	" .. .. .	"
King, William F., Kingsacre, Kikhill Road, Newton Mearns, Renfrewshire, U.K.	16.06	" .. .. .	"
Kleinmann, Gary, 2 Brockley Close, Stanmore, Middlesex, U.K.	16.06	" .. .. .	"
Kneen, Peter Walder, 8 Stayner Street, Beaumaris	14.11	" .. .. .	"
Knight, Wilfred C. and Eileen M. C. (Mrs.) and Gotelee, Allan A., White Lodge, Westerfield, Ipswich, Suffolk, U.K.	14.68	" .. .. .	"
Knowles, Edward Athol, 14 Scenic Drive, Titirangi, Auckland, N.Z.	36.89	" .. .. .	"
Koedam, Joan M. (Mrs.), c/o Ellison Hewison and Whitehead, 379 Collins Street, Melbourne	23.93	" .. .. .	"
Kornhauser, Mark, 27 Balaclava Road, East St. Kilda	19.80	" .. .. .	"
Kwai/Yung, Ko. (Mrs.), c/o W. H. Bennett, Inland Revenue Department, Central Government Office, Hong Kong	29.67	" .. .. .	"
Kwok, Frank W., 38 Roxburgh Street, Mount Victoria, Wellington 1, N.Z.	16.06	" .. .. .	"
Lacey, Herbert William R. and Denman, June Margaret (Mrs.) and Wells, Brian Lewis, Mayfield, Woodvill Road, Leatherhead, Surrey, U.K.	15.55	" .. .. .	"
Lai, So Chun (Mrs.), P.O. Box 416, Tawua, Sabah, East Malaysia	23.87	" .. .. .	"
Lamb, Irene E. (Miss), 1/17 Grange Road, Mt. Eden, Auckland 3, N.Z.	17.26	" .. .. .	"
Lambert, Alexander, 28 Nicholson Street, Chatswood, N.S.W.	31.00	" .. .. .	"
Lamont, Elizabeth Ann (Miss), Byeways, Brocklamont, Ballymana Co., Antrim, U.K.	11.07	" .. .. .	"
Landy, John Michael, c/o C. G. Landy and Co., G.P.O. Box 968G, Melbourne	10.15	" .. .. .	"
Langley, Cyril William, c/o T. L. Kingston Pty. Ltd., 48 Egan Street, Richmond	76.73	" .. .. .	"
Larkin, Patricia Jeoune (Mrs.), 3 Sirius Place, Red Hill, A.C.T.	15.50	" .. .. .	"
Larmap Pty. Limited, c/o J. A. Weeks, P.O. Box 9, Maitland, N.S.W.	14.50	" .. .. .	"
Lawrence, Patricia Nellie (Mrs.), Rockthorpe, Cressy, Tas.	29.00	" .. .. .	"
Laws, Michael James, c/o B.P. Singapore Limited, Box 2814, Singapore	25.52	" .. .. .	"
Lawson, James M., 9 Bridge Street, Torbay, N.Z.	18.56	" .. .. .	"
Lawton, Frank H. (estate of), P.O. Box 42, Gisborne, N.Z.	428.88	" .. .. .	"
Lean, James Hugh John, c/o George Augers, 93 Wigmore Street, London, W.1, U.K.	31.90	" .. .. .	"
Le Bourgeois, Henry, 7 Rue De Chilon, Havre, France	10.65	" .. .. .	"
Leger, Hugh St. (estate of), c/o Jermyn and Moloney, 7 Georges Quay, Cork, Eire	322.96	" .. .. .	"
Leigh, Noel Patricia (Dr.), c/o National Westminster Bank Ltd., Chancery Lane, Holborn Branch, 332 High Holborn, London, W.C.1, U.K.	30.97	" .. .. .	"
Leigh-Wood, Charles, 73 McCarrs Creek Road, Church Point, N.S.W.	15.95	" .. .. .	"
Leighton, Richard and Easdale Hamish, Flat 26, 52/56 Pont Street, London, S.W.1, U.K.	204.89	" .. .. .	"
Leonard, Edward G. (Dr.), and Nellie, Mrs., 47 Chiltern Drive, Singapore 13	32.39	" .. .. .	"
Lester, Kenneth John, 18 Roosevelt Avenue, Canvey Island, Essex, SS8 9EE, U.K.	15.24	" .. .. .	"
Leung, Lionel T., 18 Weetalibah Road, Northbridge, N.S.W.	27.28	" .. .. .	"
Lim, Elaine (Mrs.), c/o J. Ballas and Co., Pte. 5th Floor, Straits Trading Building, 9 Battery Road, Singapore 1	15.95	" .. .. .	"

## Unclaimed Moneys Act 1962.

## Register of Unclaimed Moneys held by the—

Name of Owner on Books and Last Known Address.	Total Amount Due to Owner.	Description of Unclaimed Moneys.	Date when Amount first became Payable
5			
THE BROKEN HILL PROPRIETARY COMPANY LIMITED—continued.			
Lim, Merrito, P.O. Box 2212, Manila, Philippines	102.37	Dividend	30.5.73
Linfoot, John Sebastian, 7 Sherlock Road, Cambridge, U.K.	17.84	"	"
Ling, Beng H., c/o Kong Ming Bank Ltd., P.O. Box 451, Sabu, Sarawak	13.96	"	"
Ling, Sadie Alma Shirlow (Mrs.), 14 Mysotis Street, Bowral, N.S.W.	506.75	"	"
Lipman, Ismelda (Miss), 9/2 Berry Street, North Essendon	10.85	"	"
Little, Archibald, Patons Road, Hope, Nelson, N.Z.	30.45	"	"
Little, John Reginald, 86 Westerloe Avenue, Rochester, New York, 14620 U.S.A.	15.95	"	"
Livingstone, David Forsythe, No. 2 A/C., 2047 Malvern Road, East Malvern	35.11	"	"
Lloyds Bank Limited, Executor and Trustee Department, 105292 A/C., 18 High Street, Southampton, U.K.	47.85	"	"
Logan, Phyllis B. (Mrs.), Ford Street, Beechworth	12.00	"	"
Lopez, Josephine (M/s.), 189 Harrington Lane, Sydney, N.S.W.	10.39	"	"
Lord, Eileen Mary (Mrs.), 20 Mansion Road, Bellevue Hill, N.S.W.	212.50	"	"
Lord, Lionel Robert H., 94 Grafton Street, Woollahra, N.S.W.	33.00	"	"
Lough, John C., 49 Manning Road, Double Bay, N.S.W.	95.11	"	"
Loughnan, Kenneth F. M., c/o Lloyds Bank Limited, 147 High Street, Guildford, Surrey, U.K.	28.79	"	"
Lovatt, Colin, 112 Stannycliffe Lane, Middleton, Nr. Manchester, U.K.	13.84	"	"
Lowe, Charles Crawford W., 22 Argyle Street, St. Kilda	13.51	"	"
Lutton, Don W., 41 Kinnerton Street, Chermiside West, Qld.	34.26	"	"
Lyell, Gwenda Mary (Mrs.), 34 Hilton Street, Beaumaris	13.64	"	"
Lyne, Anthony, P.O. Box 77, Rose Bay, N.S.W.	18.14	"	"
MacDonald, Frances Anne (M/s.), Tuki Tuki Road, R.D.2, Hastings, N.Z.	28.99	"	"
MacFarlane, Lynette (Mrs.), 45 Cullen Street, Strathgordon, Tas.	34.10	"	"
MacGibbon, Audrey D. (Mrs.), The Paddock, Thetford, Norfolk, U.K.	18.27	"	"
MacLachlan, Ian (Dr.), 60 Wilga Street, Fairfield, N.S.W.	13.20	"	"
MacQueen, David B., 15 Gilmour Street, Paisley, U.K.	127.04	"	"
Madsen, Carl T., P.O. Box 1093, Tacoma, Washington 98401, U.S.A.	14.50	"	"
Maher, Peter John, 9/99 Thames Street, Box Hill	13.95	"	"
Malcolm, Jillian (Mrs.), c/o W. Farquharson, 109 Charlotte Crescent, Hastings, N.Z.	11.17	"	"
Mallett, Jane Jarrell (Mrs.), 1 Hitching Post Road, West Lafayette, Indiana, U.S.A.	15.24	"	"
Malouf, Rastom D. (address unknown)	12.60	"	"
Maltby, David Frederick, Bargate Farm, Drayton Parslow, Bletchley, Bucks, U.K.	59.23	"	"
Mann, Beryl Frances (Miss); c/o Mrs. Mireille Golding, 4/40 Washington Street, Toorak	70.00	"	"
Manning, Robert N., Maple Hill, 605 Greenbank Road, Wilmington, Delaware, 19808 U.S.A.	32.39	"	"
Mansfield, Jeune Rose (Mrs.), 26 Athlone Road, Glendowie, Auckland, N.Z.	10.81	"	"
Mansfield, John A. B., 26 Athlone Road, Glendowie, Auckland, N.Z.	29.92	"	"
Marcel, Joseph, St. Brieuc, Cotes Du Nord, France	57.80	"	"
Marchant, Millicent A. (estate of), c/o George A. Raves and Poole, 109 Pitt Street, Sydney, N.S.W.	47.85	"	"
Markus, Horst W., c/o National Bank of Australasia, Macquarie Street, Parramatta, N.S.W.	16.51	"	"
Marshall, Boyd Ewen, 19 Willis Street, Wellington, N.Z.	17.69	"	"
Marson, Auriol M. (Mrs.), c/o Barclays Bank Ltd., Saxmundham, Suffolk, U.K.	20.03	"	"
Martelli, Otho Leeson and Peter Leeson, P.O. Box 5794, Auckland, N.Z.	14.50	"	"
Martin, Bruce Alexander, P.O. Box 945, Cairns, Qld.	14.50	"	"
Martin, David J. (Commdr.), 20 O'Connell Street, Sydney, N.S.W.	26.40	"	"
Martin Investments Ltd., c/o Desmond Williams, New Zealand House, London, U.K.	37.09	"	"
Martin, Margaret Sheila (Mrs.), 14 Brompton Square, London, S.W.3, U.K.	15.24	"	"
Maskell, Harold John, 5/27 Billyard Avenue, Elizabeth Bay, N.S.W.	270.60	"	"
Mason Anderson Limited (In Trust for Mason Anderson Superannuation Welfare Fund), P.O. Box 19543, Woolston, Christchurch, N.Z.	13.18	"	"
Mason, Edward James Hurdie, 3/11 The Avenue, Sneyd Park, Bristol 9, U.K.	11.21	"	"
Masuda, Takeo, 1-8-18 Minami-Ogikubo, Suginam-Ku, Tokyo, Japan	32.39	"	"
Mathew, Robert Knox, 11 Markham Street, London, S.W.3, U.K.	33.21	"	"
Matthews, Stanley (Sir.), c/o Broadway Chambers, 50 Broad Street, Hanley, Stoke-on-Trent, Staffs., U.K.	15.42	"	"
May, Vera A. (M/s.), 247 Royal Road, Massey, Auckland 8, N.Z.	42.91	"	"
McCarthy, Clive F., 2/21A Bondi Road, Bondi Junction, N.S.W.	15.00	"	"
McCormick, Kathleen (estate of), c/o Maurice M. Flynn, Vulcan Buildings, Cnr. Queen Street and Vulcan Lane, Auckland C.1, N.Z.	19.11	"	"
McCredie, Hilda Mary (estate of), c/o Alderdice and Clarke, P.O. Box 298, Chatswood, N.S.W.	19.11	"	"
McCullagh, David Charles, Pt. Halloran Road, Victoria Point, Qld.	52.50	"	"
McCullagh, Jennifer Anne (Mrs.), O'Halloran Road, Victoria Point, Qld.	17.05	"	"
McCullagh, Jennifer Anne (Mrs.), O'Halloran Road, Victoria Point, Qld.	38.75	"	"
McDonald, F. James, 1233 Vaughn Road, Bloomfield Hills, Michigan 48013, U.S.A.	13.84	"	"
McDowell, Margaret Russell (Mrs.), Grange Marches, Whitechurch, Dublin 14, Eire	33.47	"	"
McGovern, Francis O., Box R.W.107, Ridgeway, Lusaka, Zambia	24.36	"	"
McGregor, Douglas William, 41 Ashley Gardens, London, S.W.1, U.K.	17.13	"	"

## Unclaimed Moneys Act 1962.

## Register of Unclaimed Moneys held by the—

Name of Owner on Books and Last Known Address.	Total Amount Due to Owner.	Description of Unclaimed Money.	Date when Amount first became Payable.
§			
THE BROKEN HILL PROPRIETARY COMPANY LIMITED— <i>continued.</i>			
McGregor, John Middleton, P.O. Box 314, Bundaberg, Qld.	33.00	Dividend .. .. .	30.5.73
McKhubay, Christine (Mrs.), Flat 2, 40 Glen Street, Hawthorn	89.59	" .. .. .	"
McKinnon, Mairi Caroline W. (estate of), c/o Anderson Banks and Co., 4/6 Stevenson Street, Oban, Argyll, PA34 5NB, U.K.	77.61	" .. .. .	"
McLaren, John D., 359 Pigdon Street, Carlton	20.77	" .. .. .	"
McLaren, Shirley M. (M/s.), 359 Pigdon Street, Carlton	52.08	" .. .. .	"
McLenaghin, Hector E., 28 Awarua Street, Ngaio, Wellington, N.Z.	53.07	" .. .. .	"
McLennan, Donald Bruce, 101 Luginsland, Old Peak Road, Hong Kong	50.70	" .. .. .	"
McMahon, Elizabeth (Mrs.), North Circular Road, Limerick, Eire	25.52	" .. .. .	"
McMicking, Germain N. and Jean H. (Mrs.), Manus, Goondiwindi, Qld.	40.20	" .. .. .	"
McNicoll, Jean M. (Mrs.), 75 Kambala Road, Bellevue Hill, N.S.W.	44.80	" .. .. .	"
McRae, Shona Mary (Mrs.), 24 Prillisick Crescent, Ngaio, Wellington, N.Z.	10.15	" .. .. .	"
McWhirter, Ronald Bruce, 7/31 Dauphin Street, Highgate Hill, Qld.	11.78	" .. .. .	"
Meffan, Norman I., c/o Butterfield and Swire, P.O. Box 1, Hong Kong	36.40	" .. .. .	"
Mellor, Johnalyn E. L. (Miss), c/o Bank of N.S.W., Overseas Department, 306 Pacific Highway, Crows Nest, N.S.W.	68.15	" .. .. .	"
Melzer, Leo (estate of), 9/66 Roslyn Gardens, Elizabeth Bay, N.S.W.	10.23	" .. .. .	"
Merlan Investments Pty. Ltd., 474 Victoria Street, West Brunswick	44.40	" .. .. .	"
Metz, Horst, Lot 62 Carlisle Road, Hallam	11.94	" .. .. .	"
Miller, John Sanders; Baggaley, Philip Major; Tooke, Brian and Russell, Norman Harvey, City-Gate House, Finsbury Square, London, E.C.2, U.K.	153.70	" .. .. .	"
Millet, Adele (Mme.), 38 Rue De La Republique, St. Mandé, Seine, France	17.00	" .. .. .	"
Millner, Frances Elaine C. (Mrs.), Greenhead, East Curthwaite, Nr. Dalston, U.K.	63.94	" .. .. .	"
Milne, Beverly Jocelyn (Mrs.), c/o J. V. A. Reid, Tawera Longbush, Masterton, N.Z.	22.48	" .. .. .	"
Minehan, Beverley Patricia (Mrs.), 509 Blaxland Road, Eastwood, N.S.W.	13.20	" .. .. .	"
Moginie, Vera Constance (Miss), 668 Remuera Road, Auckland 5, N.Z.	13.32	" .. .. .	"
Molyneux, Wendy J. (Miss), 5/8 Gillies Street, Wollstonecraft, N.S.W.	12.04	" .. .. .	"
Moore, Daisy Shanklin (Mrs.) and Maze, Jean P. Etienne, c/o 63 High Street, Lymington, Hants., U.K.	28.99	" .. .. .	"
Moore, Richard Cromwell, Officers Mess, R.A.A.F. Base Williamtown, N.S.W.	16.51	" .. .. .	"
Moreton, John Richard, c/o Barclays Bank Limited, 69 Market Place, Swaffham, Norfolk, U.K.	14.11	" .. .. .	"
Morrey, John, 52 Bruce Street, Toorak	72.85	" .. .. .	"
Morris, Mary (Miss), The Retreat, No. 8 Kalang Road, Eleanora Heights, Narrabeen, N.S.W.	28.37	" .. .. .	"
Morrison, Archibald Horne and Anne Cairns (Mrs.), 17 Foy Street, Euroa	15.50	" .. .. .	"
Morro, Wytton R., 22a Fowlers Road, Glen Osmond, S.A.	17.55	" .. .. .	"
Morter, Alice D. (Miss), c/o H. W. Morter, 3/10 Walsh Street, Carnegie	135.72	" .. .. .	"
Morter, Annie L. (Miss), c/o H. W. Morter, 3/10 Walsh Street, Carnegie	155.15	" .. .. .	"
Muir, Rowland Huntly, Billingbear House, Binfield, Berks., U.K.	15.95	" .. .. .	"
Muircroft, Charles and Erica Elizabeth (Mrs.), P.O. Box 36, Wittenoom, W.A.	12.00	" .. .. .	"
Mumford, Peter Graham, P.O. Box 14, Port Vincent, S.A.	70.91	" .. .. .	"
Murphy, Cecilia M. (M/s.), 59 Redmyre Road, Strathfield, N.S.W.	36.43	" .. .. .	"
Murray, Jane E. (Mrs.), c/o Queensland Arts Council, 33 Queen Street, Brisbane, Qld.	36.43	" .. .. .	"
Murray, Peter I., 363 East 76th Street, Apartment 10J, New York, 10021, New York, U.S.A.	44.15	" .. .. .	"
Murray-Leach, Roger, Flat 1, Athaneum Hall, Vale of Health, Hampstead, London, N.W.3, U.K.	65.23	" .. .. .	"
Mustoe, Brian Henry, 154 Waldegrave, Kingswood, Basildon, Essex, U.K.	15.24	" .. .. .	"
Myers, Richard, 20 Beach Road, Onerari, Whangarei, N.Z.	39.53	" .. .. .	"
Myers, Richard and Vivien B. (Mrs.), 20 Beach Road, Onerari, Whangarei, N.Z.	15.42	" .. .. .	"
Napier, William Ian, P.O. Box 13, Lamu, Kenya, East Africa	36.89	" .. .. .	"
National Westminster Bank Limited, H887558 A/c., 63 Piccadilly London, W1V 0AJ, U.K.	18.27	" .. .. .	"
Nelligar, Madeline Camille (Mrs.), 2568 Five Point Circle, Trantwood Shores, Virginia Beach, Virginia, U.S.A.	29.78	" .. .. .	"
Nelson, Hanns (Dr.), 49 Marine Parade, Herne Bay, Auckland 2, N.Z.	155.21	" .. .. .	"
Nelson, Roy J., 1152 Fairlawn Court No. 1, Walnut Creek, California, 94529, U.S.A.	14.50	" .. .. .	"
Neville, Annette L. (estate of), c/o Richardson Chubb and Co., 52 High West Street, Dorchester, Dorset DT1 1UT, U.K.	337.93	" .. .. .	"
Newell, Antony Stuart, 120 Vodanovich Road, Te Atatu, N.Z.	39.53	" .. .. .	"
Newland, Ben Totham J. (Dr.), 128 Childers Street, North Adelaide, S.A.	69.31	" .. .. .	"
Noah, Arthur William, 21 Wellington Terrace, Harrow, Middlesex, U.K.	16.61	" .. .. .	"
Nordland, Tore (Dr.), 11 Braeside Street, Wahroonga, N.S.W.	44.23	" .. .. .	"
Nunnerley, Priscilla Alice (Miss), High Down, Cokes Lane, Chalfont St. Giles, Bucks., U.K.	13.18	" .. .. .	"
Oakley, Major Michael O., c/o Williams Glyn and Co., Kirkland House, Whitehall, S.W.1, U.K.	60.89	" .. .. .	"



## Unclaimed Moneys Act 1962.

## Register of Unclaimed Moneys held by the—

Name of Owner on Books and Last Known Address.	Total Amount Due to Owner.	Description of Unclaimed Moneys.	Date when Amount first became Payable.
§			
THE BROKEN HILL PROPRIETARY COMPANY LIMITED—continued.			
O'Brien, Paul Joseph, 33A Kings Road, Vaucluse, N.S.W. . . . .	11.94	Dividend . . . . .	30.5.73
O'Brien, William J. (estate of), c/o Cullinane and Cullinane, P.O. Box 37, Manchester Square, Fielding, N.Z. . . . .	32.39	" . . . . .	"
O'Connor, Claude William, 14 Myall Road, Waratah, N.S.W. . . . .	11.17	" . . . . .	"
O'Keeffe, Andrew Ellis, c/o Mrs. M. Pirola, 1 Kyora Drive, Kew East	16.51	" . . . . .	"
Ong, Kiat W. (Mrs.), 8 Jalan Telok Batu, Sepuch Off Jalan Klang, Kuala Lumpur, Malaysia . . . . .	14.71	" . . . . .	"
Palmer, Ellen (Mrs.), Norman M. and Neville H. W., Rosery Lodge, Molesworth Road, Stoke, Devonport, S. Devon, U.K. . . . .	17.40	" . . . . .	"
Patente, William Henry M., Monte San Michele, Capri, Italy . . . . .	55.83	" . . . . .	"
Park, Beryl M. (Miss), c/o The Manager, Commonwealth Trading Bank of Australia, Royal Prince Alfred Hospital Branch, Missenden Road, Camperdown, N.S.W. . . . .	14.00	" . . . . .	"
Parker, Jonathan Frederic, c/o Lloyds Bank Limited, Saffron Walden, Essex, U.K. . . . .	36.24	" . . . . .	"
Parsons, Lionel (address unknown) . . . . .	11.63	" . . . . .	"
Partacoona Investments Limited, Avonmore, Southdown Road, Shawford, Winchester, Hants., U.K. . . . .	31.90	" . . . . .	"
Partridge, Jack Herbert, Kerr, Alexander Ross and Munro, Stuart Charles, c/o Alliance Holdings Ltd., 19-31 Pitt Street, Sydney, N.S.W. . . . .	423.50	" . . . . .	"
Patel, Arvindbhai S., P.O. Box 500, Nakuru, Kenya . . . . .	29.67	" . . . . .	"
Patterson, Joan C. (estate of), c/o Cannan and Peterson, G.P.O. Box 407, Brisbane, Qld. . . . .	21.60	" . . . . .	"
Paull, Carmel R. (Miss), 32a Freeman Road, Kuala Lumpur, Malaysia . . . . .	19.10	" . . . . .	"
Payne, Timothy R., P.O. Box 41, Orford, Tas. . . . .	10.39	" . . . . .	"
Pearson, Colin Frank and Della-Marta, Michael Vincent, 3 Bishop Street, Morley, W.A. . . . .	12.40	" . . . . .	"
Pegg, Veronica F. (Miss), 64 Muston Street, Mosman, N.S.W. . . . .	10.39	" . . . . .	"
Pelham, Eric T., 7 Birch Lane, London, E.C.3, U.K. . . . .	204.25	" . . . . .	"
Pelham, Richard J., The Old Rectory, Spaldwick, Huntingdon, U.K. . . . .	17.45	" . . . . .	"
Petty, Julie (Mrs.), 29 Glenmore Road, Paddington, N.S.W. . . . .	16.28	" . . . . .	"
Phillips, Sandra Mary L. (Mrs.), 2 St. Martins Row, Upton Grey, Basingstoke, Hants., U.K. . . . .	55.35	" . . . . .	"
Phillipson, John Burton D., 38 Birmingham Street, Springvale . . . . .	17.05	" . . . . .	"
Pinder-Wilson, Ralph H., 18 Earls Terrace, London, W.8, U.K. . . . .	24.36	" . . . . .	"
Pitcher, Eril E. T. (Miss), 62 Arabella Street, Longueville, N.S.W. . . . .	10.39	" . . . . .	"
Pitt, Frank J. K., Glen Dhu, Ouse, Tas. . . . .	10.13	" . . . . .	"
Pivac, Milosh, 2 Cullinane Avenue, Feilding, N.Z. . . . .	93.02	" . . . . .	"
Playdon, Geoffrey and Diane (Mrs.), c/o 8 Fifth Avenue, Eastwood, N.S.W. . . . .	23.70	" . . . . .	"
Pocock, Avis Diana (Mrs.), 34 Oxford Court, Ramsey, New Jersey 07446, U.S.A. . . . .	21.32	" . . . . .	"
Pong, Gloria (Mrs.), c/o Hong Kong Pty. Ltd., 42 Campbell Street, Sydney, N.S.W. . . . .	15.95	" . . . . .	"
Potts, Heather J. (Ms), Box 9, Quairading, W.A. . . . .	16.51	" . . . . .	"
Pratley, Brian Vincent, 4/11 Dumaresq Road, Rose Bay, N.S.W. . . . .	16.51	" . . . . .	"
Pratt, Arthur R. (estate of), c/o Cozens-Hardy and Jewson, Castle Chambers, Opie Street, Norwich Nor 35E., U.K. . . . .	81.10	" . . . . .	"
Prawer, David Moszek, 38a Landsdowne Road, East St. Kilda . . . . .	15.50	" . . . . .	"
Prebble, Patricia Elsie (Mrs.), 35 Crichton Terrace, Christchurch, N.Z. . . . .	30.45	" . . . . .	"
Prentice, Herbert V. (estate of), c/o C. R. V. and S. H. Prentice, 64 Lucretia Avenue, Longueville, N.S.W. . . . .	57.35	" . . . . .	"
Priggen, Vivien Gloria (Mrs.), Keys, 7 Latchmoor Avenue, Gerrards Cross, Bucks., U.K. . . . .	10.81	" . . . . .	"
Pritchard, Hefin Wyn, Llwyn Onn, Penygroes, Caernarvon, U.K. . . . .	11.60	" . . . . .	"
Proverbs, Cuthbert Lawrence, 33 Johnstone Street, Greenock, Renfrewshire, U.K. . . . .	45.68	" . . . . .	"
Pyne, John Charles and Patricia (Mrs.), 15 Scott Street, Narrabundah, A.C.T. . . . .	33.00	" . . . . .	"
Quinton, Harold Victor, P.O. Box E102, St. James, N.S.W. . . . .	79.75	" . . . . .	"
Randall, Robert Charles and Diana Elizabeth (Mrs.), c/o Barclays Bank Ltd., 54A Theobolds Road, London, W.C.1, U.K. . . . .	30.45	" . . . . .	"
Rawlins, Ruth (Mrs.), 6 Heaton Drive, Edgbaston, Birmingham, 15, U.K. . . . .	28.99	" . . . . .	"
Rawstorne, Joanna (Miss), 70 Bannockburn Road, Pymble, N.S.W. . . . .	11.16	" . . . . .	"
Ray, Alfred C., 1230 Brace Road, Cherry Hill, New Jersey, 08034, U.S.A. . . . .	30.45	" . . . . .	"
Reay, Constance H. (Miss), 291 Willis Street, Wellington, N.Z. . . . .	35.45	" . . . . .	"
Reid, Victor Norman, and Valda June (Mrs.), 111 Albatross Avenue, Mermaid Beach, Qld. . . . .	15.50	" . . . . .	"
Reus, Jan Rudolph, c/o Security Department, Bank of N.S.W., King and George Streets, Sydney, N.S.W. . . . .	55.49	" . . . . .	"
Richards, Henry T., 9 Narrabri Street, Brighton, Qld. . . . .	110.71	" . . . . .	"
Richards, Maxwell Andrew, 324 Williamstown Road, Garden City . . . . .	19.43	" . . . . .	"
Riches, James P. R. (Dr.), c/o Hunter Boucaut and Ashton, G.P.O. Box 165c, Adelaide, S.A. . . . .	14.00	" . . . . .	"
Robertazzi, Alexandra (Mrs.), 2045 East 14 Street, Brooklyn, N.Y., 11229, U.S.A. . . . .	61.93	" . . . . .	"
Robertson, Ian, 143 Frenchs Forest Road, Frenchs Forest, N.S.W. . . . .	30.54	" . . . . .	"
Robinson, Gerald Peter, c/o A.N.Z. Banking Group Limited, Martin Place and George Street, Sydney, N.S.W. . . . .	10.88	" . . . . .	"
Robinson, Ian K. (Dr.), 167 Grandview Grove, Macleod West . . . . .	17.40	" . . . . .	"
Robinson, John Phillip, Trustee Estate, Hayward, c/o Roblnson Curwood and Small, 141 Elizabeth Street, Sydney, N.S.W. . . . .	305.11	" . . . . .	"

## Unclaimed Moneys Act 1962.

## Register of Unclaimed Moneys held by the—

Name of Owner on Books and Last Known Address.	Total Amount Due to Owner.	Description of Unclaimed Moneys.	Date when Amount first became Payable.
\$			
THE BROKEN HILL PROPRIETARY COMPANY LIMITED— <i>continued.</i>			
Robinson, Philip Napier, and Anna (Mrs.), B, A/C, Brook House, Castle Combe, Chippenham, Wilts., U.K.	29.00	Dividend .. .. .	30.5.73
Robinson, Philip Napier, and Anna (Mrs.), X, A/C, Brook House, Castle Combe, Chippenham, Wilts., U.K.	21.75	" .. .. .	"
Robinson, Philip Napier and Michael Victor, B, A/C, Brook House, Castle Combe, Chippenham, Wilts., U.K.	27.55	" .. .. .	"
Rogers, Kenneth, 125 Gooseberry Road, Gooseberry Hill, W.A.	18.14	" .. .. .	"
Rolfe, Lorna Elizabeth (Mrs.), 103 Park Drive, Parkville ..	137.64	" .. .. .	"
Ronan, Glenyce Marianne (Mrs.), P.O. Box 63, Aldgate, S.A.	24.75	" .. .. .	"
Roper, Geoffrey V., c/o R. F. Long and Co., 193 William Street, Perth, W.A.	66.00	" .. .. .	"
Roper, Rita (Miss), G.P.O. Box 1131, South Townsville, Qld.	113.11	" .. .. .	"
Roser, Caryl Robin (Miss), and Hans-Jorg, Frederick, 40 Officer Crescent, Ainslie, A.C.T.	30.00	" .. .. .	"
Ross, June (Mrs.), P.O. Box 540, Biloela, Qld.	34.10	" .. .. .	"
Roughton, Dennis Rhodes and Latham, Arthur James, c/o Reid Clarke and Co., 52 King Street, Sydney, N.S.W.	79.52	" .. .. .	"
Routledge, Wade S., 25 Risely Street, Applescross, W.A.	57.91	" .. .. .	"
Roy, Hugh, P.O. Box N7899, Nassau, Bahamas	88.73	" .. .. .	"
Russell, Charles Edward, 76 Rawson Street, Punchbowl, N.S.W.	29.00	" .. .. .	"
Russell, Raymond E., c/o Staff Mess, Mt. Isa Mines Ltd., Mt. Isa, Qld.	23.11	" .. .. .	"
Ryan, Desmond R., 6/347 Lake Street, Cairns, Qld.	18.14	" .. .. .	"
Ryan, Kathleen (Ms), 9 Menzies Street, Sumner, Christchurch, N.Z.	30.45	" .. .. .	"
Saacke, Charles, 104c Heritage Hill Road, New Canaan, Connecticut, 06840, U.S.A.	14.50	" .. .. .	"
Sainsbury, Murray Jack, 8 Yates Avenue, Mt. Keira, N.S.W.	31.00	" .. .. .	"
Salkeld, John G., 4 Lamont Road, London, S.W.10, U.K.	13.57	" .. .. .	"
Saunders, Donald Robinson, 3740 North 53rd Avenue, Hollywood, Florida 33021, U.S.A.	86.80	" .. .. .	"
Saunders, Phillip C. H., 8 Allamanda Street, Fairfield, Qld.	13.20	" .. .. .	"
Schaffer, Alwine (Mrs.), c/o Mrs. Boese, Manor House Boarding Establishment, Bewdley, Worcs., U.K.	50.37	" .. .. .	"
Scheele, Lawrence Dennis, Garema Arcade, Canberra City, A.C.T.	66.00	" .. .. .	"
Serpell, Geoffrey R. T. (Dr.), 12 Wimba Avenue, Kew	18.29	" .. .. .	"
Servaes, Michael M., Hubert C., William R. and Patricia (Mrs.), 385 Sefton House, Exchange Bldgs., Liverpool, 2, U.K.	63.88	" .. .. .	"
Setu, Ami C. (Ms), P.O. Box 62, Emerald, Qld.	41.76	" .. .. .	"
Shambrook, Delia N. (Miss), 8 Bracken Drive, Chigwell, Essex, U.K.	14.50	" .. .. .	"
Sharp, David T., P.O. Box 20069, Glen Eden, Auckland, N.Z.	23.25	" .. .. .	"
Shaw, Margaret E. (Mrs.), 12 Banks Avenue, North Turramurra, N.S.W.	61.63	" .. .. .	"
Sherbrooke, Rupert St. Vincent (Adml.) and Digby, Edward Henry Kenelm Lord (Capt. The Rt. Hon.), Oxton Lodge, Newark., Notts., U.K.	119.63	" .. .. .	"
Shersby, Hazzard Kenneth and Gardner, Anne (Mrs.), 120 Cope Hill, London, S.W.20, ONL., U.K.	15.42	" .. .. .	"
Shipp, Herbert, 69 Cotswold Road, Chipping, Sodbury, Bristol, U.K.	30.45	" .. .. .	"
Simmonds, Aileen M. (M/s.), 140 Mt. Korong Road, Eaglehawk	23.11	" .. .. .	"
Simpson, Alexander, c/o Post Office, Arapuni, Waikato, N.Z.	73.52	" .. .. .	"
Simson, Roberta (Miss), c/o R. P. Simson, Boonery Park, Corlewis, N.S.W.	700.00	" .. .. .	"
Sisson, Gladys M. (M/s.), Eulalie, Gunnedah, N.S.W.	29.14	" .. .. .	"
Sixty-five South Washington Street Inc., 65 South Washington Street, Rochester, New York 14608, U.S.A.	12.18	" .. .. .	"
Smart, Archibald (estate of), c/o The Public Curator, G.P.O. Box 1449, Brisbane, Qld.	17.69	" .. .. .	"
Smellie, Jennifer Sydney (Mrs.), Ravensbourne, Rossett, Nr. Wrexham, Denbighshire, U.K.	21.75	" .. .. .	"
Smith, Barry Lee, Gulf Air Operations, P.O. Box 138, Bahrain, Arabian Gulf	10.85	" .. .. .	"
Smith, David Lancelot M., 14 Waterloo Street, Queanbeyan, N.S.W.	14.50	" .. .. .	"
Smith, Denis Norman, 11 Marshall Street, New Lambton Heights, N.S.W.	36.43	" .. .. .	"
Smith, Irene (Mrs.), Clydesdale Bank Ltd., 31 St. James Street, London W.1, U.K.	30.97	" .. .. .	"
Smith, Raymond F. K., P.O. Box No. 121, Manuka, P.O., A.C.T.	37.51	" .. .. .	"
Smith, Vincent, P.O. Box 92, North Hobart, Tas.	80.71	" .. .. .	"
Snitcher, Carl E., 1 Culross Street, London, W.1, U.K.	23.54	" .. .. .	"
Sobey, Leslie William, 26 Trafalgar Street, Belmore, N.S.W.	56.40	" .. .. .	"
Sparkes, George Michael, Paddock Wood, East Knoyle, Salisbury, Wilts., U.K.	28.86	" .. .. .	"
Speed, Nathalie C. (Mrs.), 3 Rose Avenue, South Perth, W.A.	36.43	" .. .. .	"
Springer, Josephine M. C. (Miss), 19 Douglass Street, Geelong West ..	12.26	" .. .. .	"
Spry, William Michael, and Anne Patricia (Mrs.), c/o J. S. Eastwood and Etherington, 450 Little Collins Street, Melbourne	25.58	" .. .. .	"
Stanford, Bruce A., 7/95 West Street, Balgowlah, N.S.W.	31.16	" .. .. .	"
Starnes, Joyce Edith (Mrs.), 6 Shelly Street, Tumut, N.S.W.	34.10	" .. .. .	"
Steidl, Robert G. W., 29 Rivermead Court, Hurlingham, London, S.W.1	19.24	" .. .. .	"
Stenmark, Patricia Anne (Mrs.), 3 Torrington Road, Strathfield, N.S.W.	12.91	" .. .. .	"
Stephens, Brian W. H., 170 The White House, Albany Street, London, N.W.1, U.K.	27.68	" .. .. .	"
Stephenson, Martha D. (Mrs.), Box 10333, Greenville, South Carolina, U.S.A.	14.50	" .. .. .	"
Stevenson, Christina Jane (Miss), 157 Mugdock Road, Milngavie, Glasgow, U.K.	60.89	" .. .. .	"

Unclaimed Moneys Act 1962.

Register of Unclaimed Moneys held by the—

Name of Owner on Books and Last Known Address.	Total Amount Due to Owner.	Description of Unclaimed Moneys.	Date when Amount first became Payable.
<b>5</b>			
<b>THE BROKEN HILL PROPRIETARY COMPANY LIMITED—continued.</b>			
Stiel, Joram, 11 Abbotsford Road, Homebush, N.S.W. . . . .	22.17	Dividend . . . . .	30.5.73
Stoop, Michael, Old Cottage, Hare Hatch, Twyford, Berks, U.K. . . . .	27.68	" . . . . .	"
Story, David C., 495 South Road, Moorabbin . . . . .	10.30	" . . . . .	"
Stuart, Christina (Mrs.), c/o Radio Hong Kong, 6th Floor, Sutherland House, Hong Kong . . . . .	28.66	" . . . . .	"
Stuart, Gay Cicely (Miss), c/o Dept. of Foreign Affairs, Canberra, A.C.T. . . . .	85.25	" . . . . .	"
Sutherland, Josceline F. (Miss), 6 Fulham Avenue, South Yarra . . . . .	12.40	" . . . . .	"
Swales, Isabel A. (Miss), 2 Bridge Street, Uralla, N.S.W. . . . .	887.58	" . . . . .	"
Swinbourne, Robyn A. (Miss), 219 Church Street, Middle Brighton . . . . .	20.15	" . . . . .	"
Swinfield, Raymond, 51 Newstead Way, Somerset Road, London, S.W.19, U.K. . . . .	15.24	" . . . . .	"
Tangye, James A., c/o Lloyds Bank Limited, 19 Comberton Hill, Kidderminster, Worcester, U.K. . . . .	12.18	" . . . . .	"
Taylor, Fiona Margaret (Miss), 4 Pindari Avenue, St. Ives, N.S.W. . . . .	49.51	" . . . . .	"
Taylor, Kathleen (Mrs.), 27 Coventry Road, Homebush, N.S.W. . . . .	16.51	" . . . . .	"
Taylor, Ruth Esther (Mrs.), 16 Harrison Street, Box Hill North . . . . .	16.51	" . . . . .	"
Teare, Elizabeth K. (Miss), c/o Isle of Man Bank Ltd., Castletown, Isle of Man . . . . .	11.94	" . . . . .	"
Testoni, Francis Joseph, 9 Challis Street, Randwick, N.S.W. . . . .	13.64	" . . . . .	"
Thompson, Richard Henry, 78 Iluka Road, Palm Beach, N.S.W. . . . .	31.00	" . . . . .	"
Thompson, Rosemary I. (Mrs.), 78 Iluka Road, Palm Beach, N.S.W. . . . .	56.58	" . . . . .	"
Throsby, Peter Wentworth, G.P.O. Box 290, Sydney, N.S.W. . . . .	40.20	" . . . . .	"
Tomi, Janet (Miss), c/o Dept. of Foreign Affairs, Canberra, A.C.T. . . . .	14.36	" . . . . .	"
Townsend, David C. H., Garth End, Wolviston, Billingham, Co Durham U.K. . . . .	23.98	" . . . . .	"
Trenchard-Smith, Brian, 41 Epping Drive, Frenchs Forest, N.S.W. . . . .	21.00	" . . . . .	"
Tucker, Gaye W. (Dr.), 120 Cambridge Terrace, Malvern, S.A. . . . .	13.48	" . . . . .	"
Turnbull, Elizabeth Maude (Mrs.), 23 Whitehall Road, Toronto 5, Canada . . . . .	35.82	" . . . . .	"
Vautier, Ray (estate of), c/o V. Benson, 160 Castlereagh Street, Sydney, N.S.W. . . . .	24.34	" . . . . .	"
Ventura, Dorothy Evelyn (Mrs.), 14332 Martha Street, Van Nuys, California, U.S.A. . . . .	27.68	" . . . . .	"
V. K. Investments Pty. Ltd., c/o Mrs. V. Keach, Bluegong, Cressy, Tas. . . . .	17.05	" . . . . .	"
Vuytsteke-Janssens, Monique (Mrs.), Kortrijkse, Steenweg 391, Ghent, Belgium . . . . .	33.47	" . . . . .	"
Wade, Ralf Emerson, 28536 Murietta Road, Sun City, Arizona 92381, U.S.A. . . . .	30.45	" . . . . .	"
Wake, Alice Ruth (Mrs.), 6 York Street, Levin, N.Z. . . . .	39.01	" . . . . .	"
Wake, Geoffrey Oswald, 6 York Street, Levin, N.Z. . . . .	39.01	" . . . . .	"
Walker, Roland Robert, P.O. Box 1782, Rabaul, T.P.N.G. . . . .	33.00	" . . . . .	"
Wallace, Lance Arthur, 468 Greenhill Road, Hazelwood Park, S.A. . . . .	36.98	" . . . . .	"
Wallace-Smith, Jennifer M. (Mrs.), Brooklyn, Tumbarumba Road, Wagga Wagga, N.S.W. . . . .	19.87	" . . . . .	"
Walpole-Brown, Stella S. (Miss), Halford Manor, nr. Shipston-on-Stour, Warwickshire, U.K. . . . .	44.66	" . . . . .	"
Walter, Patricia (Mrs.), 10 Onslow Street, Timaru, N.Z. . . . .	39.53	" . . . . .	"
The Wanganui Herald Newspaper, Co. Limited, P.O. Box 435, Wanganui, N.Z. . . . .	372.51	" . . . . .	"
Ward, Frederick George, P.O. Box 7071, Wellington South, N.Z. . . . .	28.99	" . . . . .	"
Watson, Gillian Margaret, (Miss) 138 Kooyong Road, Toorak . . . . .	10.85	" . . . . .	"
Watson, Thomas Oswald, 2 Edward Street, Guildford, N.S.W. . . . .	15.95	" . . . . .	"
Webb, Sam, c/o Webb Distributors (Aust.) Pty. Ltd., 106-114 Bouverie Street, Carlton . . . . .	35.19	" . . . . .	"
Webster, Stephen, Ragbir Street, St. Augustine, Trinidad. . . . .	14.71	" . . . . .	"
Weil, Warren, 30 Clarke Place, Bronx, New York, U.S.A. . . . .	15.24	" . . . . .	"
Weinmann, Georges Edouard (Mrs.), 16 Rue De La Fauvette, Epernay, France . . . . .	28.66	" . . . . .	"
Weldon, Anthony, Rathdonnell House, Trentagh County, Donegal, Eire . . . . .	25.51	" . . . . .	"
Welstead, Edward Henry, Manor House, East Chaldon, Dorchester, Dorset, U.K. . . . .	31.38	" . . . . .	"
Wendouree Investments Pty. Ltd., 44 McPherson Street, Cunderdin, W.A. . . . .	30.31	" . . . . .	"
Wheless, Kenneth Gordon, 5 Tulip Drive, Apartment 2S, Fords, New Jersey, U.S.A. . . . .	28.99	" . . . . .	"
Wheen, Natalie Kathleen (Miss), 19 Drayton Gardens, London, S.W.10, U.K. . . . .	15.95	" . . . . .	"
White, Hazel Elsie (estate of), Southern Cross Hotel, 93 Oxide Street, Broken Hill, N.S.W. . . . .	10.39	" . . . . .	"
White, Kathleen Norma (Mrs.), 52 Potter Street, Black Rock . . . . .	11.16	" . . . . .	"
White, Lionel Kelvin, c/o Sunview Terrace Motel, P.O. Box 160, Wanaka, Central Otago, N.Z. . . . .	18.56	" . . . . .	"
White, William David, 151 Tillans Street, Otumdetai, Tanranga, N.Z. . . . .	59.23	" . . . . .	"
Whiting, Francis Hugh and Kingsbury, Neville Oliver, 110 Livingstone Street, West End, Townsville, Qld. . . . .	15.00	" . . . . .	"
Whitter, Margaret A. (Mrs.), Trustee for J. B. Turnbull Trust, 36 Walpole Street, Bentley, W.A. . . . .	63.80	" . . . . .	"
Whitte, Edward William, P.O. Box 237, Proserpine, Qld. . . . .	15.95	" . . . . .	"
Wilbur-Ham, Brian Lincoln, 3 Balfour Street, Toorak . . . . .	49.80	" . . . . .	"
Wilcox, Thomas Lindsay, 97 Elgin Street, Carlton . . . . .	141.91	" . . . . .	"
Wilkie, Ralph P., 33 Cherry Street, Warrabee, N.S.W. . . . .	10.51	" . . . . .	"
Wilkinson, Charles Gordon, 19 Tamar Street, Annerley, Qld. . . . .	16.51	" . . . . .	"
Wilkinson, David Norman, 142 Mountain View Road, North Balwyn . . . . .	30.00	" . . . . .	"

Unclaimed Moneys Act 1962.

Register of Unclaimed Moneys held by the—

Name of Owner on Books and Last Known Address.	Total Amount Due to Owner.	Description of Unclaimed Moneys.	Date when Amount first became Payable.
5			
THE BROKEN HILL PROPRIETARY COMPANY LIMITED— <i>continued.</i>			
Williams, Christine Isabel (Mrs.), 7 Swallow Street, Slade Point via Mackay, Qld.	35.00	Dividend .. .. .	30.5.73
Williams, John Edward C. (Lt.Cmdr.), c/o Ian Potter and Co., P.O. Box 174, Canberra City, A.C.T.	31.47	" .. .. .	"
Williams, Penelope A. (Miss), 60 Berresford Road, Rose Bay, N.S.W.	18.14	" .. .. .	"
Wilson, James Leonard, 9 Moya Crescent, Kingsgrove, N.S.W. ..	18.13	" .. .. .	"
Wilson, Valerie (Miss), 9 Mysore Street, Ngaio, Wellington, N.Z. ..	25.47	" .. .. .	"
Winstone, Geoffrey Bruce, 37 Claude Road, Epsom, Auckland 3, N.Z.	28.99	" .. .. .	"
Wirth, Franz, 48 Benaud Crescent, Warilla, N.S.W. .. .. .	15.95	" .. .. .	"
Wong, George, 38 Reid Road, South Dunedin, N.Z. .. .. .	27.41	" .. .. .	"
Woodham, Georgina Ann (Mrs.), 11 Tiromoana Road, Raumai, South Wellington, N.Z.	26.68	" .. .. .	"
Woods, John Patrick H., 13 Artie Street, Fairfield, N.S.W. .. ..	60.40	" .. .. .	"
Woods, Timothy Kieran, 2 Geraldine Street, Cottesloe, W.A. ..	15.50	" .. .. .	"
Woolley, Ian B. H., Findon, Southill Lane, Eastcote, Pinner, Middlesex, U.K.	15.95	" .. .. .	"
Wright, Lian Hugh (Dr.), 100 Arney Road, Remuera, Auckland 5, N.Z.	13.18	" .. .. .	"
Wright, Reginald Charles, 95 Elizabeth Street, Hobart, Tas. ..	85.25	" .. .. .	"
Wright-Nooth, Frances (Mrs.), 17/22 Plunketts Road, The Peak, Hong Kong	14.71	" .. .. .	"
Zoltak, Jacob and Lanseu, Rache, c/o R. Lansell, 49 Exhibition Street, Melbourne	23.87	" .. .. .	"
Clinton-Baker, William Lewis and Anne R. L. (Mrs.), Tupurupuru, Longbush Road, 4 Masterton, N.Z.	200.00	" .. .. .	"
Dillon, Doreen M. (Miss), P.O. Box 2348, Wellington, N.Z.	100.00	" .. .. .	"
Lance, Mary Osborn (estate of), c/o Treadwell Gordon and Co., P.O. Box 16, Wanganui, N.Z.	100.00	" .. .. .	"
Thorogood, Victoria Maud (Mrs.), " Senga ", Rectory Lane, Leybourne, West Mailing, Kent, U.K.	25.10	" .. .. .	"

4847

FORD MOTOR COMPANY OF AUSTRALIA LIMITED.

Sunberg, St. Kilda, Travelodge .. .. .	13.43	Wages .. .. .	—6.73
Spour, G., (address unknown) .. .. .	14.06	" .. .. .	—7.73
Sayhoune, (address unknown) .. .. .	13.41	" .. .. .	—8.73
Sancar, 5 Lake Grove, Coburg .. .. .	13.93	" .. .. .	—3.73
Sahin, I., 10 Donald Street, Brunswick .. .. .	11.00	" .. .. .	—7.73
Seehan, (address unknown) .. .. .	84.91	" .. .. .	—1.73
Siro, 45 Waratah Avenue, Tullamarine .. .. .	16.93	" .. .. .	—11.73
Saleh, 77 Shamrock Street, West Brunswick .. .. .	129.87	" .. .. .	—1.73
Sleiman, 38 Rowe Street, North Fitzroy .. .. .	256.95	" .. .. .	"
Szoke, J., 60 West Street, Glenroy .. .. .	62.97	" .. .. .	"
Saul, H., Northside Caravan Park, Campbellfield .. .. .	155.61	" .. .. .	"
Schembri, R., 65 Lydia Avenue, Campbellfield .. .. .	261.03	" .. .. .	"
Sallehi, G., 1 Fay Street, Fawkner .. .. .	150.00	" .. .. .	—8.73
Sobah, A., 1 Brockenshire Street, Clifton Hill .. .. .	91.85	" .. .. .	—8.73
Spasevski, B., 282 Bell Street, Preston .. .. .	12.59	" .. .. .	—7.73
Tah, H. (address unknown) .. .. .	79.96	" .. .. .	—3.73
Tektas, 18 Cliff Street, Brunswick .. .. .	34.00	" .. .. .	—4.73
Tsaguisidis, C. (address unknown) .. .. .	44.86	" .. .. .	"
Thurlow, D., 40 Barkly Street, Box Hill .. .. .	40.00	" .. .. .	"
Tzaferis, S., 29 Blair Street, Coburg .. .. .	48.58	" .. .. .	—12.73
Tomic, 38/108 Elizabeth Street, North Richmond .. .. .	125.41	" .. .. .	—1.73
Taylor, (address unknown) .. .. .	36.03	" .. .. .	"
Ulanos, (address unknown) .. .. .	11.46	" .. .. .	—3.73
Ulver (address unknown) .. .. .	243.92	" .. .. .	—1.73
Umay, 182/120 Racecourse Road, Flemington .. .. .	244.50	" .. .. .	"
Umireuk, (address unknown) .. .. .	207.84	" .. .. .	"
Ulusan, 201 Power Street, Richmond .. .. .	13.61	" .. .. .	—7.73
Velouski, Midway Hostel, Marybyrnong .. .. .	11.46	" .. .. .	—3.73
Vassiliadis, S., 203 Albion Street, East Brunswick .. .. .	32.24	" .. .. .	"
Volceviski, 3 Abbot Grove, Clifton Hill .. .. .	71.98	" .. .. .	—1.73
Watkinson, W., 44 Yoringa Road, Norlane .. .. .	243.12	" .. .. .	"
Woods, (address unknown) .. .. .	63.22	" .. .. .	"
Wood, W. (address unknown) .. .. .	194.00	" .. .. .	"
Younal, Y., 643 Lygon Street, Brunswick .. .. .	31.09	" .. .. .	—4.73
Zikovic, S., c/o Midway Hostel .. .. .	12.90	" .. .. .	—5.73
Ziya, (address unknown) .. .. .	215.30	" .. .. .	—1.73
Zois, 2 Waranga Road, Broadmeadows .. .. .	12.08	" .. .. .	—5.73
Anderson, J., 15 Grubb Road, Wellington .. .. .	119.50	" .. .. .	—4.73
Windt, B., 108 Thompson Street, Norlane .. .. .	227.80	" .. .. .	"
Carter, B., 12 Weller Street, Geelong West .. .. .	74.12	" .. .. .	"
Lekkas, V., 128 High Street, Belmont .. .. .	35.15	" .. .. .	—6.73
Kojcic, M., 15 Coleman Avenue, Norlane .. .. .	21.42	" .. .. .	—7.73
Novakovic, 120 Station Street, Port Melbourne .. .. .	11.62	" .. .. .	—3.73
Nosal, S., 47 Munro Street, Coburg .. .. .	25.07	" .. .. .	"
Nour Eddine, A., 92 Deakon Street, Brunswick .. .. .	35.02	" .. .. .	—5.73
Onal, O. (address unknown) .. .. .	264.17	" .. .. .	—1.73
Ozkan, 5/378 Albert Street, Brunswick .. .. .	91.15	" .. .. .	"
O'Neil, 34 Darebin Drive, Thomastown .. .. .	102.19	" .. .. .	"
Ozturk, N. (address unknown) .. .. .	13.20	" .. .. .	—6.73
Petekanos, S. (address unknown) .. .. .	10.00	" .. .. .	—3.73
Pukaj, R. (address unknown) .. .. .	11.00	" .. .. .	"

Unclaimed Moneys Act 1962.

Register of Unclaimed Moneys held by the—

Name of Owner on Books and Last Known Address.	Total Amount Due to Owner.	Description of Unclaimed Moneys.	Date when Amount first became Payable.
5			
FORD MOTOR COMPANY OF AUSTRALIA LIMITED—continued.			
Pavlovic, M. (address unknown) .. .. .	24.31	Wages .. .. .	—4.73
Petrou, M. (address unknown) .. .. .	12.62	" .. .. .	" .. .. .
Popovic, D., 21 Brunswick Street, Fitzroy .. .. .	11.81	" .. .. .	—5.73
Popovic, M., 197 Holland Court, Kensington .. .. .	12.59	" .. .. .	—6.73
Pecini, N. (address unknown) .. .. .	12.18	" .. .. .	" .. .. .
Paunovic, S., 16 Shores Road, Coburg .. .. .	45.00	" .. .. .	—9.73
Pavlidis, E., 26 Bent Street, Northcote .. .. .	38.69	" .. .. .	—10.73
Pizzo, C., 70 Morell Street, Glenroy .. .. .	15.69	" .. .. .	—11.73
Piskopas, J., 4 Huntly Street, Moonee Ponds .. .. .	17.75	" .. .. .	—12.73
Polygogopoulos, 1 Bessel Court, Jacana .. .. .	75.53	" .. .. .	—12.73
Pizzo, 70 Morell Street, Glenroy .. .. .	83.09	" .. .. .	" .. .. .
Papadomanolakis, (address unknown) .. .. .	125.41	" .. .. .	" .. .. .
Payne, U., 533 Barry Road, Broadmeadows .. .. .	13.70	" .. .. .	—8.73
Paleka, 10/58 Chesnut Street, Richmond .. .. .	12.59	" .. .. .	" .. .. .
Papadopoulos, A., 15 Hattan Grove, Coburg .. .. .	35.96	" .. .. .	" .. .. .
Poiatkesin, 306/100 Altona Street, Kensington .. .. .	12.84	" .. .. .	—7.73
Pouklis, N., 4/288 Langrege Street, Abbotsford .. .. .	12.59	" .. .. .	" .. .. .
Querico, P., 197 Weston Street, Brunswick .. .. .	97.00	" .. .. .	—8.73
Rapa, M., 6 Winchester Street, Moonee Ponds .. .. .	12.90	" .. .. .	—3.73
Rossittos, S., 29 Lydia Avenue, Campbellfield .. .. .	11.46	" .. .. .	—4.73
Racardi, 189 Gordon Street, West Coburg .. .. .	13.24	" .. .. .	—6.73
Rey, J., 100 Spring Street, Port Melbourne .. .. .	13.15	" .. .. .	" .. .. .
Rowlands, 22 Nash Street, Brunswick .. .. .	12.25	" .. .. .	" .. .. .
Randocevie, (address unknown) .. .. .	15.00	" .. .. .	—11.73
Rippon, 1 Congram Street, Broadmeadows .. .. .	19.40	" .. .. .	—12.73
Smith, K., 63 Glen Street, Glenroy .. .. .	66.78	" .. .. .	" .. .. .
Szkoda, P., 15 Thomas Street, Thomastown .. .. .	24.10	" .. .. .	—3.73
Smith, J., 12 Stanhope Street, Broadmeadows .. .. .	15.73	" .. .. .	" .. .. .
Schlosser, 71 Wilcox Street, Preston .. .. .	18.13	" .. .. .	" .. .. .
Salone, S., (address unknown) .. .. .	45.00	" .. .. .	" .. .. .
Saratin, (address unknown) .. .. .	47.73	" .. .. .	" .. .. .
Sadku, Sadik, 63 Brunswick Street, Fitzroy .. .. .	10.26	" .. .. .	" .. .. .
Sertel, A., 38 Mayfield Street, Coburg .. .. .	71.07	" .. .. .	—4.73
Horvath, J., 18 Little Page Street, Albert Park .. .. .	106.64	" .. .. .	—10.73
Horvat, A., 10 Derby Street, Moonee Ponds .. .. .	114.14	" .. .. .	" .. .. .
Halkias, C., 22 Lahinch Street, Broadmeadows .. .. .	17.18	" .. .. .	—11.73
Haynes, (address unknown) .. .. .	16.31	" .. .. .	" .. .. .
Hajdari, S., 71 Bridge Street, Northcote .. .. .	18.00	" .. .. .	" .. .. .
Halkias, C., 22 Lahinch Street, Broadmeadows .. .. .	139.00	" .. .. .	—12.73
Harrison, A., 759 Sydney Road, Coburg .. .. .	231.10	" .. .. .	—12.73
Hashim, H., 177 Moreland Road, Coburg .. .. .	14.17	" .. .. .	—2.74
Kolas, (address unknown) .. .. .	29.00	" .. .. .	—3.73
Kozam, 165-167 Gipps Street, Collingwood .. .. .	11.07	" .. .. .	—4.73
Khallil, M., 56 Ramsden Street, Clifton Hill .. .. .	12.59	" .. .. .	—6.73
Karsu, Y., (address unknown) .. .. .	10.37	" .. .. .	" .. .. .
Khoury, J., 4 Bakers Parade, North Coburg .. .. .	13.15	" .. .. .	" .. .. .
Kouroumalos, 20 Parker Street, Pascoe Vale .. .. .	37.88	" .. .. .	—12.73
Kuza, A. (address unknown) .. .. .	60.00	" .. .. .	—8.73
Kasios, S. (address unknown) .. .. .	123.08	" .. .. .	—12.73
Kassir (address unknown) .. .. .	246.88	" .. .. .	" .. .. .
Kaloudis, C., 21 Grai Grossie Avenue, Coburg .. .. .	25.21	" .. .. .	—7.73
Kanidiadis, 25 Munro Street, Coburg .. .. .	42.95	" .. .. .	" .. .. .
Law, F., 1780 Sydney Road, Campbellfield .. .. .	37.43	" .. .. .	—3.73
Lisle, A., 36 Pitt Street, Fawkner .. .. .	13.66	" .. .. .	—7.73
Lazar, 9 Ilsa Avenue, Glenroy .. .. .	134.39	" .. .. .	—7.73
Lyttleton, 45 Andrews Avenue, Reservoir .. .. .	84.31	" .. .. .	" .. .. .
Lasslett (address unknown) .. .. .	23.84	" .. .. .	—7.73
Milankovski, M., 299 Grove Street, Fitzroy .. .. .	24.50	" .. .. .	" .. .. .
Mananelli, C. (address unknown) .. .. .	12.19	" .. .. .	—4.73
Mahlis, J., 28 Leonard Avenue, Glenroy .. .. .	88.31	" .. .. .	—3.73
Massid, K. (address unknown) .. .. .	25.96	" .. .. .	" .. .. .
McShonag, 13/37 Dalgety Street, St. Kilda .. .. .	59.39	" .. .. .	—4.73
Motica, 9/4 Smith Street, Richmond .. .. .	13.04	" .. .. .	—3.73
Mammone, F., 6/79 Dawson Street, West Brunswick .. .. .	34.38	" .. .. .	—5.73
Meiselbach, A., 74 Arthur Street, Fairfield .. .. .	33.03	" .. .. .	—4.73
Margiolakis, E., 68 Hunter Street, West Brunswick .. .. .	17.13	" .. .. .	—5.73
Matic, A. (address unknown) .. .. .	19.26	" .. .. .	" .. .. .
Mangiafico, 4 Mutton Street, Fawkner .. .. .	56.99	" .. .. .	" .. .. .
Mustafa, S. (address unknown) .. .. .	11.36	" .. .. .	—6.73
Monori, 2/60 Buckley Street, Essendon .. .. .	77.16	" .. .. .	—12.73
Moyes, L., 47 Kitchener Street, Broadmeadows .. .. .	229.89	" .. .. .	" .. .. .
Manlio, A., 32 Burnell Street, Brunswick .. .. .	253.84	" .. .. .	" .. .. .
Malek (address unknown) .. .. .	98.32	" .. .. .	" .. .. .
Moumajar (address unknown) .. .. .	153.50	" .. .. .	" .. .. .
Milevski, 26 Ambon Street, Preston .. .. .	223.24	" .. .. .	" .. .. .
Asyestas, J., 54 Robb Street, Essendon .. .. .	54.92	" .. .. .	—3.73
Armiriois, G., 3 Queen Street, Essendon .. .. .	11.73	" .. .. .	—4.73
Akavcot, H. (address unknown) .. .. .	44.00	" .. .. .	—3.73
Ayuaz, M., c/o Broadmeadows Hostel .. .. .	48.70	" .. .. .	—4.73
Akbalik, E., 2 Sheffield Street, Coburg .. .. .	50.22	" .. .. .	—5.73
Ali, M., 35 Lonsdale Street, Fawkner .. .. .	10.59	" .. .. .	—6.73
Akyol, B., 46 Glenlyon Road, Brunswick .. .. .	13.66	" .. .. .	" .. .. .
Agaliotis (address unknown) .. .. .	114.94	" .. .. .	—10.73
Aziret (address unknown) .. .. .	26.17	" .. .. .	—12.73
Ammendola, A., 19 Dally Street, Clifton Hill .. .. .	36.18	" .. .. .	" .. .. .
Allen, 6 Lockley Street, Glenroy .. .. .	16.31	" .. .. .	" .. .. .

## Unclaimed Moneys Act 1962.

## Register of Unclaimed Moneys held by the—

Name of Owner on Books and Last Known Address.	Total Amount Due to Owner.	Description of Unclaimed Moneys.	Date when Amount first became Payable.
S			
FORD MOTOR COMPANY OF AUSTRALIA LIMITED—continued.			
Arena, 89 Holmes Road, Moonee Ponds .. .. .	103.58	Wages .. .. .	— .73
Alkan, c/o Broadmeadows Hostel .. .. .	236.36	" .. .. .	" .. .
Ammendola, 19 Dally Street, Clifton Hill .. .. .	34.36	" .. .. .	— .73
Asik, K., c/o Broadmeadows Hostel .. .. .	90.32	" .. .. .	— 8.73
Baran, F., 1/125 Holden Street, North Fitzroy .. .. .	25.80	" .. .. .	" .. .
Bratina, M. (address unknown) .. .. .	14.73	" .. .. .	— 3.73
Berry, D., 200 Albion Street, Brunswick .. .. .	16.14	" .. .. .	" .. .
Bafkopoulos, D., 8 O'Grady Street, Brunswick .. .. .	20.34	" .. .. .	— 4.73
Brooks, C., 234 Widford Street, Broadmeadows .. .. .	63.84	" .. .. .	" .. .
Burrows, E., 187 Paper Road, Airport West .. .. .	35.43	" .. .. .	— 5.73
Bueti, R., 79 Garnett Street, Brunswick .. .. .	12.59	" .. .. .	— 6.73
Belegris, T., 2 Hope Street, Brunswick .. .. .	12.59	" .. .. .	" .. .
Bottari, S., 3/30 Tennyson Street, Elwood .. .. .	11.38	" .. .. .	" .. .
Boieri, E., 20 Lindsay Street, Coburg .. .. .	19.01	" .. .. .	— 7.73
Brooks, C., 234 Widford Street, Broadmeadows .. .. .	866.59	" .. .. .	— 5.73
Beri (address unknown) .. .. .	10.09	" .. .. .	— 10.73
Bademoelu, A. (address unknown) .. .. .	34.36	" .. .. .	— 12.73
Brkic, M., 68 Gore Street, Fitzroy .. .. .	55.33	" .. .. .	— 7.73
Barden, I., 74/240 Wellington Street, Collingwood .. .. .	12.59	" .. .. .	" .. .
Brigante, R., 28 Morrell Street, Glenroy .. .. .	12.95	" .. .. .	— 6.73
Cigdem, 25 Lonark Street, East Brunswick .. .. .	12.90	" .. .. .	— 3.73
Connuli, D., 32 Oakland Street, Maribyrnong .. .. .	13.00	" .. .. .	— 4.73
Cargirn, N. (address unknown) .. .. .	55.42	" .. .. .	" .. .
Cuarkovic, B. (address unknown) .. .. .	46.26	" .. .. .	" .. .
Coccivea, S., 38 Milton Street, Ascot Vale .. .. .	35.75	" .. .. .	— 5.73
Cuitkovic, R., 142/12 Holland Court, Flemington .. .. .	44.51	" .. .. .	" .. .
Cetin, S., 220 Buckley Street, Brunswick .. .. .	10.18	" .. .. .	— 6.73
Condis, 630 Drummond Street, North Carlton .. .. .	59.20	" .. .. .	" .. .
Contanzaro (address unknown) .. .. .	62.00	" .. .. .	— 5.73
Cooke, R., 46/38 Main Street, Diamond Creek .. .. .	240.00	" .. .. .	— 10.73
Cifti, M., 123 Middle Street, Glenroy .. .. .	18.00	" .. .. .	" .. .
Cmallis (address unknown) .. .. .	86.48	" .. .. .	— .73
Christodouloupoulos, 32 Kendall Street, Coburg .. .. .	86.15	" .. .. .	" .. .
Cilia, G., 19 Winn Grove, Fawkner .. .. .	25.39	" .. .. .	— 7.73
Durson, M. (address unknown) .. .. .	13.52	" .. .. .	— 5.73
Duke, A. (address unknown) .. .. .	67.65	" .. .. .	" .. .
Dauoodian-Rezaie, 51 McKilwraith Street, North Fitzroy .. .. .	13.95	" .. .. .	— 6.73
Dawia, 127 McKilwraith Street, North Fitzroy .. .. .	63.92	" .. .. .	— 8.73
Dum, 293 Napier Street, Fitzroy .. .. .	65.00	" .. .. .	— 5.73
Dogangum, 58 Moore Street, Coburg .. .. .	121.39	" .. .. .	— .73
Doger, M., 29 Sydney Road, Coburg .. .. .	30.00	" .. .. .	— 8.73
Durson (address unknown) .. .. .	67.42	" .. .. .	— 5.73
Dogan, H., 245 Victoria Street, Brunswick .. .. .	31.88	" .. .. .	— 10.73
Donmez, A. (address unknown) .. .. .	121.67	" .. .. .	— 11.73
Diamandis, P., 8/17 Hopetown Avenue, West Brunswick .. .. .	19.35	" .. .. .	— 12.73
Diaz, S., 48 Charles Street, Northcote .. .. .	147.27	" .. .. .	— .73
Esel, A., 220 Barkly Street, Brunswick .. .. .	23.00	" .. .. .	— 4.73
Erogau, R., 17 Michael Avenue, St. Albans .. .. .	65.03	" .. .. .	" .. .
Evans, 9/65 Bayswater Road, Kensington .. .. .	12.42	" .. .. .	" .. .
El Sayed, M. (address unknown) .. .. .	66.05	" .. .. .	— 7.73
El-Roubi, A., 6/1655 Sydney Road, Campbellfield .. .. .	17.75	" .. .. .	— 12.73
Efthimiadis, 14 Beckwith Street, Coburg .. .. .	230.76	" .. .. .	— .73
Elzner, I., 32/120 Racecourse Road, Flemington .. .. .	80.36	" .. .. .	— 8.73
Falcone, 30 Ethel Street, Brunswick .. .. .	12.52	" .. .. .	" .. .
Foundoulakis, J. (address unknown) .. .. .	67.70	" .. .. .	— 5.73
Fotiadis, I., 38 Belfast Road, Brunswick .. .. .	13.86	" .. .. .	— 6.73
Franklin, B., 60 Hilton Street, Glenroy .. .. .	21.34	" .. .. .	— 11.73
Fell, 6/8 Bristol Parade, Pascoe Vale .. .. .	135.04	" .. .. .	— 12.73
Gonullo, F., 27 Bruce Street, West Coburg .. .. .	96.06	" .. .. .	— 5.73
Glogavac, 3 Dolphin Court, Gladstone Park .. .. .	25.25	" .. .. .	— .73
Giagozoglou, H., 51 Mayne Street, West Brunswick .. .. .	19.00	" .. .. .	— 11.73
Gorgen, E., c/o Broadmeadows Hostel .. .. .	51.54	" .. .. .	— 12.73
Guclukol, 99 Barrow Street, Coburg .. .. .	242.78	" .. .. .	— .73
Geci (address unknown) .. .. .	116.28	" .. .. .	" .. .
Geng, c/o Broadmeadows Hostel .. .. .	14.28	" .. .. .	— 5.73
Grganovic, I., 13/510 Lygon Street, Carlton .. .. .	18.70	" .. .. .	— 8.73
Ibrahim, 2/1 Fernot Street, Glenroy .. .. .	23.00	" .. .. .	" .. .
Isaac, S., 37 Hanover Street, Brunswick .. .. .	117.96	" .. .. .	— .73
Isakoundouras (address unknown) .. .. .	9.00	" .. .. .	" .. .
Jeffrey, P. (address unknown) .. .. .	80.00	" .. .. .	— .72
Hanninigan, M. (address unknown) .. .. .	36.19	" .. .. .	— 4.73
Henry, K. (address unknown) .. .. .	43.07	" .. .. .	" .. .
Hale, M., 543 Grimshaw Street, Bundoora .. .. .	24.90	" .. .. .	" .. .
Kandera, P., 14 Tornburn Street, Bell Park .. .. .	92.70	" .. .. .	— 7.73
Golanovski, K., 46 Marshall Street, Chilwell .. .. .	42.53	" .. .. .	" .. .
Seiler E., P.O. Box 33, Balmoral .. .. .	75.08	" .. .. .	— 9.73
Oster, H., 39 Northshore Road, Norlane .. .. .	20.70	" .. .. .	— 11.73
Gomes, R., 17 Spring Street, Geelong West .. .. .	21.70	" .. .. .	— 10.73
Gill, M., 6 Aberdeen Street, Geelong West .. .. .	19.17	" .. .. .	— 2.74
Marshall, D., 69 Balliang Street, South Geelong .. .. .	139.93	" .. .. .	— 11.73
Taylor, R. L., Barwon River Caravan Park, Geelong .. .. .	42.73	" .. .. .	— 1.74
DeKovsemaker, J. B., 6 Taroonga Court, Norlane .. .. .	64.41	" .. .. .	" .. .
Prosic, J., 71 Aberdeen Court, Norlane .. .. .	21.37	" .. .. .	— 12.73
Christou, A., 4 Ann Street, Geelong West .. .. .	36.84	" .. .. .	— 5.73
Payne, B., 25 Glenleith Avenue, Geelong West .. .. .	14.10	" .. .. .	— 6.73

## Unclaimed Moneys Act 1962.

## Register of Unclaimed Moneys held by the—

Name of Owner on Books and Last Known Address.	Total Amount Due to Owner.	Description of Unclaimed Moneys.	Date when Amount first became Payable.
§			
FORD MOTOR COMPANY OF AUSTRALIA LIMITED—continued.			
Ricarj, J., Norlane Hostel, Norlane .. .. .	160.33	Wages .. .. .	—7.73
Anticevc, J., 52 Walgott Street, North Geelong .. .. .	26.65	" .. .. .	" .. .. .
Stevens, B. S., 9 Arkins Street, Pt. Lonsdale .. .. .	24.68	" .. .. .	—4.73
Karatas, O., Flat 3, 3 Fyans Street, South Geelong .. .. .	9.69	" .. .. .	—1.73
Platek, W., 582 Thompsons Road, North Geelong .. .. .	29.03	" .. .. .	—3.73
Hunt, H., 54 McDougall Street, West Geelong .. .. .	12.10	" .. .. .	" .. .. .
Bozionelos, J., c/o Argo Nauplian Society .. .. .	1,500.00	Deposit .. .. .	—8.73
Adams, G. R. (address unknown) .. .. .	20.22	Wages .. .. .	—4.74
Sharina, A. (address unknown) .. .. .	87.97	" .. .. .	" .. .. .
5090			
BOUGAINVILLE COPPER LIMITED.			
Andersen, H. (Mrs.), P.O. Box 179, George Town, Tasmania .. .. .	61.20	Dividend .. .. .	23.11.73
Ash, M. E. M. S. (Mrs.), 4 Marathon Avenue, Darling Point, N.S.W. .. .. .	98.94	" .. .. .	" .. .. .
Austin R. P., 1 Francis Street, Bedford Park, S.A. .. .. .	20.40	" .. .. .	" .. .. .
Combond Pty. Ltd., 11 Bath Road, Burwood .. .. .	20.40	" .. .. .	" .. .. .
Conway, J., 24 Victory Parade, Toronto, N.S.W. .. .. .	10.20	" .. .. .	" .. .. .
Cressie, A. M. (Miss), P.O. Box 21, Dampier, W.A. .. .. .	20.40	" .. .. .	" .. .. .
Falconer, P. D., 41 View Street, Mont Albert .. .. .	20.40	" .. .. .	" .. .. .
Hans, T. O. W., c/o C. R. A., 295 Hay Street, Kalgoorlie, W.A. .. .. .	35.70	" .. .. .	" .. .. .
Harju, A., 28 Swinden Street, Downer, N.S.W. .. .. .	20.40	" .. .. .	" .. .. .
Hatchman, L. J., Post Office, Weipa, Q'ld. .. .. .	11.73	" .. .. .	" .. .. .
Henderson, G. S. (Dr.), c/o Mrs. E. J. Dalgarno, 11 Milton Street, Heathmont .. .. .	20.40	" .. .. .	" .. .. .
Hill, E. R. (Mrs.), 1 Short Street, Mudgee, N.S.W. .. .. .	24.82	" .. .. .	" .. .. .
Hohnen, G. J., 44 View Street, Peppermint Grove, W.A. .. .. .	13.34	" .. .. .	" .. .. .
Hopcroft, R. S., House 224, Karratha, W.A. .. .. .	15.30	" .. .. .	" .. .. .
Hulme, J. M. (estate of), G.P.O. Box 1590, c/o W. A. Astridge, Sydney, New South Wales .. .. .	15.30	" .. .. .	" .. .. .
Hylton, J., P.O. Box 240, Broken Hill, N.S.W. .. .. .	39.52	" .. .. .	" .. .. .
Kinvest, Pty. Ltd., 281A Edgecliffe Road, Woollahra, N.S.W. .. .. .	10.20	" .. .. .	" .. .. .
Lambert, C. A. (Mrs.), 271 Pingandy Crescent, Dampier, W.A. .. .. .	10.20	" .. .. .	" .. .. .
Mathers, R. G., P.O. Box 163, Tom Price, W.A. .. .. .	35.70	" .. .. .	" .. .. .
McMahon, L. K. (Mrs.), Flat D9, Hill Road, Dampier, W.A. .. .. .	20.40	" .. .. .	" .. .. .
Medling, L. M. (Mrs.), 65 Hamersley Road, Subiaco, W.A. .. .. .	20.40	" .. .. .	" .. .. .
Merlo, K. G., c/o Hamersley Iron Pty. Ltd., Dampier, W.A. .. .. .	35.70	" .. .. .	" .. .. .
Murray, M. F. and Murray G. A. (M/s.), The Kings School, Parramatta, New South Wales .. .. .	11.81	" .. .. .	" .. .. .
Peachy, P. R., 11 Water Street, Southport, Q'ld. .. .. .	10.20	" .. .. .	" .. .. .
Pozzebon, L. E. (Mrs.), 12 Mary Street, George Town, Tasmania .. .. .	11.73	" .. .. .	" .. .. .
Stack, J. F. and Stack, M. J. (Mrs.), P.O. Box 176, Tennant Creek, N.T. .. .. .	20.40	" .. .. .	" .. .. .
Stewart, C. M. (Mrs.), c/o C.B.A. Ltd., Post Office, Currie, King Island, Tasmania .. .. .	15.30	" .. .. .	" .. .. .
Street, B. A. (Mrs.), 104 Murchison Crescent, Dampier, W.A. .. .. .	76.50	" .. .. .	" .. .. .
Tymms, M. M. (Mrs.), C3/120 Arden Street, North Melbourne .. .. .	51.00	" .. .. .	" .. .. .
Watson, I. R., 70 Onslow Street, Rose Bay, N.S.W. .. .. .	20.40	" .. .. .	" .. .. .
Wellington, M. J. (Mrs.), 9 Church Street, Highgate, S.A. .. .. .	20.40	" .. .. .	" .. .. .
Williams, C. I. (Mrs.), Swallow Street, Slade Point, Q'ld. .. .. .	14.02	" .. .. .	" .. .. .
Williams, E. R., 22 Salisbury Street, Subiaco, W.A. .. .. .	30.60	" .. .. .	" .. .. .
Williams, L. M. (Mrs.), 137 Balmoral Road, Port Pirie, S.A. .. .. .	11.81	" .. .. .	" .. .. .
Williamson, R. J., 57 Whaleback Avenue, Paraburdoo, W.A. .. .. .	35.70	" .. .. .	" .. .. .
Woolams, F. W., 4/144A High Street, North Sydney, N.S.W. .. .. .	10.20	" .. .. .	" .. .. .
Woosnam, M. F. and Woosnam, L. J. (Mrs.), 221 Frangipani Street, Tom Price, W.A. .. .. .	35.70	" .. .. .	" .. .. .
Wright, D., c/o C.E.S., Paraburdoo, W.A. .. .. .	35.70	" .. .. .	" .. .. .
Bee, L. C., P.O. Box 10, Kuantan, Malaysia .. .. .	10.20	" .. .. .	" .. .. .
Gardner, G. L. (Mrs.), 1528 Willingdon Avenue, N. Burnaby, BC, V5C 5HB, Canada .. .. .	306.00	" .. .. .	" .. .. .
Schmiegelow, G. J. (Mrs.), 4 Barton House, Barton Close, Sidmouth, South Devon, EX10 8nl., U.K. .. .. .	12.24	" .. .. .	" .. .. .
Stanley, I. M. (Mrs.) and Patel, Y. V. (Mrs.), 12 Binjai Walk, Singapore, 21, Singapore .. .. .	12.83	" .. .. .	" .. .. .
Chaytor, J. L. C., Marshlands, R.D.3, Blenheim, N.Z. .. .. .	13.60	" .. .. .	" .. .. .
Mathieson, J. (Mrs.), 64 Paremata Crescent, Paremata, N.Z. .. .. .	10.20	" .. .. .	" .. .. .
Waddilove, J., 19 Haunui Road, Pukerua Bay, Wellington, N.Z. .. .. .	20.74	" .. .. .	" .. .. .
Sammon, J. R., 1724 E. St. Jude Court, Peoria Heights, Ill., 61614 .. .. .	10.20	" .. .. .	" .. .. .
U.K. Register.		£ U.K.	
Anderson, M. R. (Dr.), 37 Church Wood Avenue, Far Headingley, Leeds, 16 .. .. .	5.15	" .. .. .	" .. .. .
Anton, P. J., Wynn Cottage, Wribbenhall, Bewdley, Worcestershire .. .. .	8.23	" .. .. .	" .. .. .
Buckfield, P. (Mrs.), 38 Southview Road, Hockley, Essex .. .. .	5.02	" .. .. .	" .. .. .
Cargin, M. A., The White Cottage, Crampshaw Lane, Ashtead, Surrey .. .. .	51.47	" .. .. .	" .. .. .
Cash, G. (Mrs.), 35 Portman Square, George Street, London, W.1 .. .. .	14.07	" .. .. .	" .. .. .
C.B. Nominees Limited, 30 St. Vincent Place, Glasgow .. .. .	15.44	" .. .. .	" .. .. .
Charlton, P. (Mrs.), Deerland, Bosley, Macclesfield, Cheshire .. .. .	18.53	" .. .. .	" .. .. .
Coats, J. C., 68 Broadoak Road, Ashton-Under-Lyne, Lancashire .. .. .	38.60	" .. .. .	" .. .. .
Curzon, J., Lockington Hall, Derby .. .. .	123.52	" .. .. .	" .. .. .
Dodd, P., c/o National Westminster Bank Ltd., 249 Regent Street, London, W.1 .. .. .	18.53	" .. .. .	" .. .. .
Duff, S. E., Treelands, Aylmerton, Norwich, Norfolk .. .. .	11.45	" .. .. .	" .. .. .
Etherington, E. M. M. (Mrs.), Little Folby Grove Road, Hind Head, Surrey .. .. .	51.47	" .. .. .	" .. .. .

## Unclaimed Moneys Act 1962.

## Register of Unclaimed Moneys held by the—

Name of Owner on Books and Last Known Address.	Total Amount Due to Owner.	Description of Unclaimed Moneys.	Date when Amount first became Payable.
§			
BOUGAINVILLE COPPER LIMITED— <i>continued.</i>			
Felton H. J., Foxhall Cottage, Kelshall, Hertshire .. .. .	7.38	Dividend .. .. .	23.11.73
Firebrace, A. G., 3/5 Royal Avenue, London, S.W.3 .. .. .	10.68	" .. .. .	"
Fleming, E. E. (Mrs.), 6 Holbein Mews, London, S.W.1 .. .. .	7.04	" .. .. .	"
Geddes, L. S., 51 Silverknowes Hill, Edinburgh, EH4, 5HD .. .. .	12.87	" .. .. .	"
Groves, J. J. D. (Lt. Col.) and MacNaghten, c/o Lloyds Bank Ltd., 6 Pall Mall, London, S.W.1 .. .. .	28.22	" .. .. .	"
Grut, D. R. (Mrs.), Sycamore End, Oak Lane, Sevenoaks, Kent .. .. .	15.44	" .. .. .	"
Hanscomb, J. M. (estate of), (address unknown) .. .. .	25.73	" .. .. .	"
Hart, M. C., 11 Glebe Road, Dorking, Surrey .. .. .	10.30	" .. .. .	"
Hodgson, W. D. J., c/o National Westminster Bank Ltd., 1 Royal Exchange Arcade, Manchester, 2 .. .. .	6.17	" .. .. .	"
Mainwaing-Holt, F. (Mrs.), Towers Flat, Castle Road, Scarborough, Yorkshire YO11, 1HY .. .. .	7.04	" .. .. .	"
Ingram, F. M. (Mrs.), The Grange, Benenden, Granbrook, Kent .. .. .	14.07	" .. .. .	"
Kilpatrick, J. S., 4 Princes Gate Mews, London, S.W.7 .. .. .	5.53	" .. .. .	"
Lloyd, B. C. J., Kentings, 80 Brattle Wood, Sevenoaks, Kent .. .. .	25.73	" .. .. .	"
MacGill, A. G., Glen Almond, Bowes Rigg, Stewarton, Ayrshire .. .. .	9.65	" .. .. .	"
Massey Ferguson Holdings Pension Ltd., Trust Mai, 33 Davies Street, London, W.1 .. .. .	7.76	" .. .. .	"
Menzies, I., Buxton and Armitage, Cannon Hall, Cannon Place, Hampstead, London, N.W.3 .. .. .	35.30	" .. .. .	"
Meyerhoff, R., 4 Cambridge Gate, Regents Park, London, N.W.1 .. .. .	15.87	" .. .. .	"
Mitchell, S. I. (Mrs.), 21 St. Josephs Road, Guilford, Surrey .. .. .	5.15	" .. .. .	"
Monckton, G. H., 197 The Fairway, Ruislip, Middlesex .. .. .	19.64	" .. .. .	"
Palmer, R. H. (Lt. Col.), Peasmore Manor, Newbury, Berkshire .. .. .	23.03	" .. .. .	"
Perrott, D. H., 31 Wolverton Avenue, Kingston-on-Thames, Surrey .. .. .	5.15	" .. .. .	"
Pettigrew, K. (Miss), Merse End, Rockcliffs, Dalbeattie, Kircudleright- shire .. .. .	10.30	" .. .. .	"
Rennie, R. (Mrs.), 41 Falcon Gardens, Edinburgh .. .. .	14.58	" .. .. .	"
Reynolds, R. N., Hillcote, Weston Lane, West Kirby, Cheshire .. .. .	51.47	" .. .. .	"
Richards, E. D. (Mrs.), 41 Westcliffs Road, Birkdale, Southport, Lancashire .. .. .	116.00	" .. .. .	"
Schmiegelow, G. J. (Mrs.), 3 Park Court, Church Road, Haywards Heath, Sussex .. .. .	5.02	" .. .. .	"
Smith, F. B. (Mrs.), 321 The Drive, Ilford, Essex .. .. .	11.75	" .. .. .	"
Smyth, N. W. and Heyman, c/o Markbys, Moor House, London Wall, London, E.C.2. .. .. .	20.59	" .. .. .	"
Spurrer, M. C., 25 Thomas Court, Victoria Avenue, East Molesley, Surrey .. .. .	10.30	" .. .. .	"
Strachan, F. A., Craigend, Westfield, Newcastle-Upon-Tyne 3 .. .. .	51.47	" .. .. .	"
Vale, F. M. (Miss), 92 Palmerston Road, Buckhurst Hill, Essex .. .. .	25.73	" .. .. .	"
West, G., Springfield, The Cast, Lasswade, Midlothian, EH18, 1EB .. .. .	18.45	" .. .. .	"
Wilkinson, M. V. K. (Mrs.), c/o Barclays Bank Ltd., 137 Brompton Road, London, S.W.3. .. .. .	21.11	" .. .. .	"
Zuckerman, J. A. V. R. (Lady), The Shooting Box, Burnsham Thorpe, Kings Lynn, Norfolk 4870 .. .. .	77.20	" .. .. .	"
N.K.S. HOLDINGS LIMITED.			
Campbell, George A., 188 Main Road, Ballarat .. .. .	89.10	Dividend .. .. .	6.4.73
Clark, Ronald E., 29 Latham Crescent, Dandenong .. .. .	15.60	" .. .. .	"
Fry, Alfred D., 6/94 Ewart Street, Dulwich Hill, N.S.W. .. .. .	13.00	" .. .. .	"
Wilbur-Ham, Brian L. (Dr.), 1 Balfour Street, Toorak .. .. .	765.94	" .. .. .	22.10.73
A.P.M. FIBERCRAFT PTY. LTD.			
Scott, R. T., 5 Greville Street, Reservoir .. .. .	25.00	Wages .. .. .	7.4.73
INDUSTRIAL ENGINEERING LIMITED.			
Gazzard, Henry, 66 Anzac Avenue, Collaroy, N.S.W. .. .. .	25.00	Dividend .. .. .	24.11.73
Gibbs, Kaye B., The Crescent, Crafers, S.A. .. .. .	393.75	" .. .. .	31.5.72
Mann, Emily F., Unit 7, 52 Orrong Road, Elsternwick .. .. .	20.00	" .. .. .	28.11.72
Glen, Jean F. (estate of), c/o M. G. Cone (Mrs.), 14 Nott Street, East Malvern .. .. .	12.70	" .. .. .	28.11.73
Alexander, Judith A. S., 322 Huntingdale Road, Mt. Waverley .. .. .	600.00	Repayment of Principal .. .. .	31.12.73
" .. .. .	144.00	Interest .. .. .	30.6.71
Burns, Ailsa (Mrs.), 42 John Street, Woollahra, N.S.W. .. .. .	24.00	" .. .. .	30.6.73
Kennett, Frederick T. (Mrs.), 199 Glen Iris Road, Glen Iris .. .. .	80.00	" .. .. .	30.6.73
Thompson, Kaye M. (Mrs.), 20 Ainslie Parade, Carlingford, N.S.W. .. .. .	16.00	" .. .. .	31.12.73
JOHNS CONSOLIDATED LIMITED.			
Ford, Archibald, 27 Montana Parade, Croydon .. .. .	75.00	Dividend .. .. .	28.11.73
Ford, Elizabeth S. G. (Mrs.), 27 Montana Parade, Croydon .. .. .	31.25	" .. .. .	"
Leigh, Robert F. L., 35 Oakhill Road, Mt. Waverley .. .. .	16.60	" .. .. .	"
Slink, Greta (Mrs.), 16 Culshaw Avenue, Clayton .. .. .	10.00	" .. .. .	"
Walter, John L., 5 Upper Shene Street, Newtown .. .. .	33.35	" .. .. .	"



Unclaimed Moneys Act 1962.

Register of Unclaimed Moneys held by the—

Name of Owner on Books and Last Known Address.	Total Amount Due to Owner.	Description of Unclaimed Moneys.	Date when Amount first became Payable.
<b>§</b>			
<b>BUNNY INDUSTRIES LIMITED.</b>			
Breedon, William H., 46 Stewart Street, Ormond	46.88	Dividend	30.4.73
Saint, Dudley T., c/o Immigration Department, Suva, Fiji	21.00	"	26.11.73
Slattery, Keith, Dudley Avenue, Moorabbin	15.00	"	30.4.73
Genovese, Frank J., c/o Wesfarmers Taxation Section, 560 Wellington Street, Perth	17.50	"	26.11.73
McAuley, John W. and Marie T. (Mrs.), 112 Ross Street, Bairnsdale 5136	70.00	"	"
<b>OLEX CABLES PTY. LTD.</b>			
Attard, John, 94 Ireland Street, West Melbourne	19.20	Wages	9.6.73
Agius, Paul, 63 Railway Street, Altona	26.60	"	14.7.73
Allan, Cherry Dale, 1 Evans Crescent, Laverton	72.50	"	30.6.73
Amaro, Toao Gouveia, 49 Newell Street, Footscray	14.20	"	3.11.73
Azzopardi, Lina, 18 Nottingham Street, North Sunshine	31.60	"	20.1.74
Barun, Lucy, 21 Hamilton Street, Seddon	13.70	"	17.3.73
Bouquhoric, Dragica, 33 Maxweld Street, Ardeer	13.50	"	31.3.73
Bazin, Lynette, 65 Devonshire Street, West Footscray	11.50	"	14.7.73
Bellato, Maria, 21 Tuppal Place, East Keilor	14.00	"	15.9.73
Brokenbrow, Leslie Douglas, 90 Heaths Road, Werribee	19.30	"	22.9.73
Burns, James, Flat 1, 39 Mary Street, Hawthorn	19.60	"	10.2.74
Corak, Stefica, 2/3 Emily Street, St. Albans	13.20	"	8.9.73
Cockburn, Denise, Lot 2, Calder Highway, Macedon	15.20	"	27.10.73
Cook, Colleen Maree, Calder Highway, Macedon	15.20	"	"
D'Aquimo, Frank, Unit 16, 28 Suffolk Road, North Sunshine	17.30	"	17.3.73
Deak, Frank, 133 Sunshine Road, Tottenham	54.60	"	22.12.73
Friggieri, Sam, 117/76 Canning Street, North Melbourne	15.10	"	29.9.73
Grima, Maryanne, 23 Vincent Avenue, St. Albans	26.60	"	20.1.74
Gulaboski, Lube, 33 Pilgram Street, Footscray	16.40	"	24.2.74
Heffernan, Molly Margaret, 91 Ashley Street, Braybrook	11.50	"	14.7.73
Higginbottom, Kevin Edward, 48 Nicholson Street, Footscray	23.40	"	17.11.73
Hazistarvou, Christopher, 42 Davey Street, West Sunshine	32.60	"	24.2.74
Idanhou, Philipos, 694 High Street, Reservoir	32.50	"	22.12.73
Jackson, Leslie John, Flat 20, 7 Eldridge Street, Footscray	45.20	"	13.1.74
Johnson, Diane Elaine, 3A Whitehall Street, Footscray	47.00	"	24.2.74
Koljanin, Ljubica, 24 Elizabeth Street, St. Albans	40.60	"	28.7.73
King, Carol Anne, 4/84 South Road, Braybrook	28.40	"	3.11.73
Kisler, Peter, 10 Marnoo Street, Sunshine	13.80	"	22.12.73
Naylor, Geoffrey, 163 Somerville Road, Footscray	18.00	"	6.10.73
Nelson, Gary James, 9 Thomson Street, Footscray	54.50	"	10.11.73
Osman, Salih, 137 Charles Street, Footscray	37.70	"	21.7.73
Omerovic, Mehmed, 8 Medway Street, Footscray	43.60	"	20.1.74
Perris, Seva, 28 Raymond Street, West Sunshine	12.90	"	8.9.73
Picone, Lynette Maree, Lot 164 Fairbairn Road, Sunshine	35.60	"	4.8.73
Reynolds, John, 636 Barkly Street, West Footscray	26.40	"	20.1.74
Stefanovic, Dobrila, 5 Cannon Street, Sunshine	12.00	"	12.5.73
Stojanova, Savka, Midway Hostel, Maribyrnong	40.10	"	17.11.73
Saville, Jeffrey, 37 Bishop Street, West Footscray	14.20	"	24.2.74
Tsetsinas, Theodosia, 28 Raymond Street West Sunshine	12.90	"	8.9.73
Valentic, Ivan, 24 Davies Street, Moonee Ponds	39.20	"	20.1.74
Vassallo, Lina, 28 Vincent Avenue, St. Albans	26.60	"	20.1.74
Wilson, Stanley, 7 Burns Avenue, St. Albans	10.00	"	15.9.73
Wade, John Ray, 14 Baird Street, Maidstone	13.10	"	20.10.73
Zivkovic, Ivan, 41 Cowper Street, Footscray	43.90	"	29.9.73
<b>5137</b>			
<b>THE EGG AND EGG PULP MARKETING BOARD.</b>			
Attard, R. and Felini, A., 204 Biggs Street, St. Albans	16.80	Cheque	8.3.73
Condello, A., Warrandyte Road, North Ringwood	29.69	"	22.3.73
Craig, D. G. and M. E., Perryman Street, Pearcedale	21.97	"	"
Chelsea Cake Kitchen, Nepean Highway, Chelsea	44.73	"	24.5.73
Macreadie, C. C. (Mrs), Box 23, Rosedale	76.48	"	8.9.73
Storey, A. and Sons, Hoppers Lane, Werribee South	65.81	Purchases	19.2.72
Williams, B. M. J. and O. R., George Street, Dimboola	12.85	"	1.4.72
Pherson, R. J. and J. D., Newton Avenue, Baxter	45.79	"	15.4.72
Qualiza, P. F., Pearcedale Road, Cranbourne South	73.47	"	"
Freemantle, R. H. and L. L., Woodstock West	33.78	"	10.5.72
Douglas Poultry, Box 15, Werrimull	51.36	"	"
Borelli, A. J., 9 Coombs Avenue, Huntingdale	12.85	"	3.5.73
Freemantle, R. H. and L. L., Woodstock West	57.20	"	"
Gould, Jack and Sons, Charlton Road, Wedderburn	194.64	"	"
Dear, S. G. (Mrs.), Box 87, Quambatook	85.42	"	"
Mannes, W. J., Strathfieldsaye	26.49	"	"
McLean, Charles A., Kilmarnock	14.66	"	2.3.74
<b>5770</b>			
<b>PRITCHARD STEAM POWER PTY. LTD.</b>			
Tilley, William John, 44 Hunter Street, Sydney	80.00	Dividend	16.1.73
Guinea Truck Sales Pty. Ltd., Goroka, New Guinea	50.00	"	"
Breen, Joseph (deceased), c/o T. J. Purcell and Co., 66 King Street, Sydney	20.00	"	"
<b>5771</b>			

## Unclaimed Moneys Act 1962.

## Register of Unclaimed Moneys held by the—

Name of Owner on Books and Last Known Address.	Total Amount Due to Owner.	Description of Unclaimed Moneys.	Date when Amount first became Payable.
\$			
<b>THE MYER EMPORIUM LIMITED.</b>			
Smythe, Betty M. F. (Miss), 19 Arthur Street, Plympton Park, S.A.	11.55	Interest .. .. .	31.3.73 ..
Fyffe, Richard G., 7/9 High Street, Camberwell .. .. .	12.00	" .. .. .	" .. .. .
Gibson, Ella C. (Mrs.), 26 Sutherland Road, Armadale .. .. .	80.00	" .. .. .	" .. .. .
Maitland-Jacoby, Sarah (Mrs.), 11 Longmore Street, West St. Kilda	160.00	" .. .. .	" .. .. .
Boldner, Bruce W., 1/19 Mitford Street, St. Kilda .. .. .	16.88	" .. .. .	31.5.73 ..
MacIntosh, Mabel, 10 Stafford Grove, Heathpool, S.A. .. .. .	13.50	" .. .. .	" .. .. .
Rollason, Robert C., c/o Office of the Public Trustee, 256-262 Flinders Street, Melbourne	10.13	" .. .. .	" .. .. .
Paterson, May E. (Miss), 10 Bogota Avenue, Neutral Bay, N.S.W.	10.13	" .. .. .	" .. .. .
Stephen, Laura M. (Mrs.), Waratah House, Terraloug Street, Kiama, N.S.W.	16.88	" .. .. .	" .. .. .
Winter-Cooke, Mary E. (deceased), c/o The Trustees Executors and Agency Co. Ltd., P.O. Box 389D, Melbourne	35.00	" .. .. .	" .. .. .
Coy, Belinda T. (Miss), 8 Khartoum Street, Caulfield North .. .. .	14.00	" .. .. .	" .. .. .
Brooke, Etha E. (Mrs.), P.O. Box 28, Kingston on Murray, S.A. .. .. .	21.00	" .. .. .	" .. .. .
Cohen, Leslie, 31 Queen Street, Melbourne .. .. .	90.00	" .. .. .	" .. .. .
Freadman, Estella, (Mrs.), 1/20 Lisson Grove, Hawthorn .. .. .	45.00	" .. .. .	" .. .. .
Savage, George, 23 Laughlin Avenue, Nunawading .. .. .	45.00	" .. .. .	" .. .. .
Challis, Gwendoline L. (M/s.), 91 Amalfi Drive, Isle of Capri, Surfers Paradise, Qld.	90.00	" .. .. .	" .. .. .
MacIntosh, Mabel, 10 Stafford Grove, Heathpool, S.A. .. .. .	18.00	" .. .. .	" .. .. .
Dunn, Venetia (Miss), 93 East Avenue, Allenby Gardens, S.A. .. .. .	18.00	" .. .. .	1.10.73 ..
Smythe, Betty M. P. (Miss), 19 Arthur Street, Plympton Park, S.A. .. .. .	11.55	" .. .. .	" .. .. .
Gibson, Ella C. (Mrs.), 26 Sutherland Road, Armadale .. .. .	80.00	" .. .. .	" .. .. .
Neil, Irma R., 1/6 Ipswich, Toowoomba, Qld. .. .. .	20.00	" .. .. .	" .. .. .
Kennedy, Catherine, 9 Sturt Road, Brighton, S.A. .. .. .	120.00	" .. .. .	" .. .. .
Miller, Lorna E. (Mrs.), 10 Vincent Street, Glen Iris .. .. .	47.25	" .. .. .	30.11.73 ..
Giovanetta, Barbara L. (Miss), c/o Miss, L. J Hewitt, 13 Pine Street, Bendigo	22.50	Dividend .. .. .	24.1.74 ..
Hogan, Eldon J., 1050 Malvern Road, Armadale .. .. .	72.00	" .. .. .	" .. .. .
McDonald, Eileen M., (Mrs.) 13 Pine Street, Bendigo .. .. .	18.00	" .. .. .	" .. .. .
Nicholls, Avonia R., 7/260 Wattletree Road, Malvern .. .. .	18.00	" .. .. .	" .. .. .
Nicholls, Avonia R., 7/260 Wattletree Road, Malvern .. .. .	18.50	" .. .. .	19.7.73 ..
Rumble, William H., 25 Meading Avenue, Balwyn .. .. .	13.50	Interest .. .. .	30.11.73 ..
Eldred, Beatrice A. (deceased), c/o Hunt and Hunt, Box 4132, G.P.O., Sydney, N.S.W.	33.75	" .. .. .	" .. .. .
Paterson, May E. (Miss), 10 Bogota Avenue, Neutral Bay, N.S.W.	10.13	" .. .. .	" .. .. .
Stephen, Laura M. (Mrs.), Waratah House, Terraloug Street, Kiama, N.S.W.	16.88	" .. .. .	" .. .. .
Eastgate, Edward L., 244 Highgate, Roslyn, Dunedin, N.Z. .. .. .	33.42	" .. .. .	" .. .. .
Coy, Belinda T. (Miss), 8 Khartoum Street, Caulfield North .. .. .	14.00	" .. .. .	" .. .. .
Lockbow Pty. Ltd., c/o Mrs. D. V. Kinlock, 49 Clayfield Street, Qld.	105.00	" .. .. .	" .. .. .
Fern, Micheal W. G., Englebool, Balmoral .. .. .	10.50	" .. .. .	" .. .. .
Savage, George (deceased), c/o Norman Shankly and Hamilton, 406 Lonsdale Street, Melbourne	45.00	" .. .. .	" .. .. .
Whitten, Winifred I. (Mrs.), 11 Cosham Street, Brighton .. .. .	18.00	" .. .. .	" .. .. .
Smith, Doris (Mrs.), "Whit-Hame", 10 Bangella Street, Warrawee, N.S.W.	58.50	" .. .. .	" .. .. .
Frith, Willia E., 53 Jennifer Street, Charlestown, N.S.W. .. .. .	46.25	" .. .. .	" .. .. .
5772			
<b>SOUTH BRITISH UNITED LIFE ASSURANCE CO. LTD.</b>			
Lewis, J. P., 25 Mayflower Close, Mangere East, Auckland, N.Z. .. .. .	20.40	Maturity Claim .. .. .	—.—.—
5368			
<b>MARCHANTS DRINKS PTY. LTD.</b>			
Von Czupinski, K., 34 Stackdale Avenue, Clayton .. .. .	15.87	Wages .. .. .	" .. .. .
Humphries, G., 5 Coocil Street, South Oakliegh .. .. .	12.47	" .. .. .	" .. .. .
Farrell, P., 27 Strathmore Street, McKinnon .. .. .	12.50	" .. .. .	" .. .. .
Grostate, A., 3 Belle Vista Road, North Caulfield .. .. .	28.16	" .. .. .	" .. .. .
Sweaney, A. J., 7 Fox Court, Dandenong South .. .. .	18.60	" .. .. .	" .. .. .
Rosewall, R., c/o 52 Foster Street, Dandenong .. .. .	52.31	" .. .. .	" .. .. .
Murk, S., 24 Colin Road, Clayton .. .. .	20.28	" .. .. .	" .. .. .
Matthews, W. J., 3 Judas Court, Doveton .. .. .	27.85	" .. .. .	" .. .. .
5369			
<b>AUSTRALIAN NEWSPRINT MILLS HOLDINGS LIMITED.</b>			
Grievson, Ana L. M., 11 Zara Road, Willoughby, N.S.W. .. .. .	100.00	Dividend .. .. .	3.11.71 ..
Francis, Gwendolen R., 8 Sheridan Park Avenue, Florid, S.A. .. .. .	140.00	" .. .. .	15.5.72 ..
Guthrie, Jean Douglass, 6 Scott's Place, Berwick-On-Tweed, England	17.85	" .. .. .	31.10.73 ..
5370			
<b>H. J. HEINZ COMPANY AUSTRALIA LTD.</b>			
Shutt, M., c/o Caravan Park, Rowville .. .. .	21.00	Wages .. .. .	—,3.73 ..
Tubicki, E., 10/14 Allen Street, Noble Park .. .. .	12.30	" .. .. .	—,5.73 ..
Gull, H., 102 Brancourt Avenue, Yagoona, N.S.W. .. .. .	30.30	" .. .. .	—,6.73 ..
Foster, M. K., 18 Campbell Road, Dandenong .. .. .	14.60	" .. .. .	—,2.74 ..
5371			
<b>RHEEM AUSTRALIA LIMITED.</b>			
Hack, Percy, J., G.P.O. Box 277, Sydney, N.S.W. .. .. .	11.24	Dividend .. .. .	4.5.73 ..
5373			

Unclaimed Moneys Act 1962.

Register of Unclaimed Moneys held by the—

Name of Owner on Books and Last Known Address.	Total Amount Due to Owner.	Description of Unclaimed Moneys.	Date when Amount first became Payable.
5			
EPICURE CONTINENTAL FOOD CO. PTY. LTD.			
Blakeley, M., 42 Waratah Avenue, Glenhuntly .. .. .	13.29	Wages .. .. .	—3.73
McDonald, P., 8 Scotch Parade, Chelsea .. .. .	20.29	" .. .. .	" .. .. .
Selman, W., 24 Morris Street, Parkdale .. .. .	23.20	" .. .. .	—4.73
Jonas, G., 2 Murphy Street, South Clayton .. .. .	16.27	" .. .. .	—5.73
Stefanon, J., 13 Monash Crescent, Westall .. .. .	16.79	" .. .. .	" .. .. .
Pollard, P., 4/3 Hume Road, South Springvale .. .. .	23.48	" .. .. .	—6.73
Virlander, S., 20 Delacombe Court, Cheltenham .. .. .	29.45	" .. .. .	—7.73
Murdoch, G., 12 Corio Avenue, Frankston .. .. .	20.00	" .. .. .	" .. .. .
Fonte, P., 5 Venile Street, Mentone .. .. .	32.45	" .. .. .	—11.73
Thomas, J., 8 Lucas Street, East Brighton .. .. .	14.60	" .. .. .	" .. .. .
Dorward, R., 30 Perkers Road, Parkdale .. .. .	16.56	" .. .. .	" .. .. .
Cook, E., 9 Embankment Grove, Chelsea .. .. .	20.15	" .. .. .	" .. .. .
Virgo, D., 90 Latrobe Street, Mentone .. .. .	19.74	" .. .. .	" .. .. .
Norton, J., 982 North Road, East Bentleigh .. .. .	14.15	" .. .. .	—12.73
Timmons, S., 10 St. Cuthberts Avenue, Dingley .. .. .	51.77	" .. .. .	—1.74
Hegemeller, H., 37 Schulz Street, East Bentleigh .. .. .	33.54	" .. .. .	" .. .. .
Halley-Frame, E., 173 Linacre Road, Hampton .. .. .	19.62	" .. .. .	" .. .. .
Grech, G., 2/46 Rosanna Street, Murrumbena .. .. .	13.59	" .. .. .	—2.74

5372

MURRAY GOULBURN CO-OPERATIVE. CO. LIMITED.

Bennett, Kenneth James and Dawn Lorraine, Murrabit West .. .. .	23.75	Dividend .. .. .	1.4.73
Chalmers, Margaret May, 6 Gatehouse Street, Parkville .. .. .	28.35	" .. .. .	" .. .. .
Chivers, J., (estate of) (address unknown) .. .. .	10.00	" .. .. .	" .. .. .
Francavilla, Angelo (address unknown) .. .. .	40.65	" .. .. .	" .. .. .
French, John Bryson, R.D. Kyvalley, via Tongala .. .. .	37.25	" .. .. .	" .. .. .
Kortum Bros., Cobram .. .. .	10.00	" .. .. .	" .. .. .
Lyle, Emily and Lily, Nathalia .. .. .	16.50	" .. .. .	" .. .. .
Mont, Ann L., 17 Bonview Road, Malvern .. .. .	20.00	" .. .. .	" .. .. .
Oulton, Robert John and Julianne (address unknown) .. .. .	16.80	" .. .. .	" .. .. .
Pyle, Ethel May, Mirboo .. .. .	31.20	" .. .. .	" .. .. .
Pyle, Frederick Henry (estate of), c/o Mrs. Ethel M. Pyle, Mirboo .. .. .	13.20	" .. .. .	" .. .. .
Walker, Leslie D., Hillside .. .. .	20.20	" .. .. .	" .. .. .
Richards, H. G. (estate of), c/o T. T. O'Brien, 276 Clayton Road, Clayton .. .. .	10.35	" .. .. .	" .. .. .
Edwards, T. P. and K. M., Bundalaguah .. .. .	13.40	" .. .. .	" .. .. .
Allan, J. B., Bag 3, Leongatha .. .. .	36.85	" .. .. .	1.10.73
Bowler, P. O'R., Ruby .. .. .	21.90	" .. .. .	" .. .. .
Buckland, G. T., Walkerville, via Fish Creek .. .. .	10.50	" .. .. .	" .. .. .
Cole, D. J., 14 Vernal Avenue, Mitcham .. .. .	17.50	" .. .. .	" .. .. .
Petersen, W. C. and P., Hoddle, via Fish Creek .. .. .	13.85	" .. .. .	" .. .. .
Rigby, M. W., 79 Waverley Road, East Malvern .. .. .	17.50	" .. .. .	" .. .. .
Eagle, E. W. and M. I., Buffalo .. .. .	22.60	" .. .. .	" .. .. .
Evans, I. G., 13 Shellcott's Road, Korumburra .. .. .	23.75	" .. .. .	" .. .. .
Gow, D., Kongwak .. .. .	70.00	" .. .. .	" .. .. .
Hayes, P. R., Woodleigh .. .. .	35.70	" .. .. .	" .. .. .
McLeish, D. H., Lardners Track, Drouin East .. .. .	28.90	" .. .. .	" .. .. .
Rayner, W. G., 219 Mount Street, North Albury .. .. .	10.00	" .. .. .	" .. .. .
Coates, I. L., Hillside .. .. .	20.00	" .. .. .	" .. .. .
Barry, E. (estate of), Gelliondale .. .. .	51.90	" .. .. .	" .. .. .
Moore, R. D., 15 Jacka Street, North Balwyn .. .. .	13.60	" .. .. .	" .. .. .
Nicol, E. M., Box 68, Yarram .. .. .	50.00	" .. .. .	" .. .. .
Trewin, A. J., R. S. and D. E., Box 136, Orbest .. .. .	10.20	" .. .. .	" .. .. .
Garner, F. G. (estate of), Cobains, via Sale .. .. .	16.60	" .. .. .	" .. .. .
Poole, T. (estate of), 439 Mont Albert Road, Mont Albert .. .. .	10.20	" .. .. .	" .. .. .
Garry, E. P., D. P. and F. G., Almurta .. .. .	25.75	" .. .. .	" .. .. .
Ruddell, S. E., Sea View, Glen Forbes .. .. .	10.70	" .. .. .	" .. .. .
Kingswell, C. E. (estate of), c/o 42 Palmerston Street, Sale .. .. .	21.20	" .. .. .	" .. .. .
McMahon, J. P., 11 Hagelthorne Street, Wonthaggi .. .. .	10.50	" .. .. .	" .. .. .
Croft, R. T., Nullawarre .. .. .	45.00	" .. .. .	" .. .. .
Davies, R. A., 37 Shakespeare Street, Hamilton .. .. .	37.50	" .. .. .	" .. .. .
Horneman, M. L., 117 Wellington Street, Deniliquin, N.S.W. .. .. .	10.00	" .. .. .	" .. .. .
Patterson, G. R., Warrock, Casterton .. .. .	14.90	" .. .. .	" .. .. .
Pearson, T., Box 2, Macarthur .. .. .	13.10	" .. .. .	" .. .. .
Roth, E. V., Ensay .. .. .	50.00	" .. .. .	" .. .. .
Smith, G. C., Mepunga West .. .. .	15.00	" .. .. .	" .. .. .
Stanyer, J. C., Box 3, Barouga, N.S.W. .. .. .	10.00	" .. .. .	" .. .. .
Stonehouse, C. C. M., P.B. 17, Terang .. .. .	15.00	" .. .. .	" .. .. .
Trewin, L. E. (estate of), Strathallan .. .. .	15.30	" .. .. .	" .. .. .
Willis, J. C., P.O. Box 481, Hamilton .. .. .	57.50	" .. .. .	" .. .. .
Coleman, P. G., Maffra .. .. .	31.50	" .. .. .	" .. .. .
Barry, E. (estate of), Gelliondale .. .. .	50.00	" .. .. .	" .. .. .
O'Leary, E., R. D., Cobram .. .. .	10.00	" .. .. .	" .. .. .
O'Leary, R. J., R. D., Cobram .. .. .	10.00	" .. .. .	" .. .. .
Abbott, L. E., Fish Point, Swan Hill .. .. .	40.00	" .. .. .	" .. .. .
Milne, H. and G., Finley .. .. .	12.55	" .. .. .	" .. .. .
Addinsall, C. O. and Ross, G. D., Private Bag, Macarthur .. .. .	10.55	" .. .. .	" .. .. .
Atkinson, R. L., P. B., Swan Hill .. .. .	29.55	" .. .. .	" .. .. .
Batten, A., V. and J. K., Mailors Flat .. .. .	15.65	" .. .. .	" .. .. .
Beavis, P. G., Box 209, Heywood .. .. .	10.90	" .. .. .	" .. .. .
Clover, L. E., Wallacedale .. .. .	24.05	" .. .. .	" .. .. .
Grey, M. S., Gringegalgon, via Coleraine .. .. .	16.05	" .. .. .	" .. .. .
McKeown, L. J. and D. M., Block 46, R.D., Cobram .. .. .	35.30	" .. .. .	" .. .. .
McPherson, J. T., Katamatite .. .. .	15.00	" .. .. .	" .. .. .

Unclaimed Moneys Act 1962.

Register of Unclaimed Moneys held by the—

Name of Owner on Books and Last Known Address.	Total Amount Due to Owner.	Description of Unclaimed Moneys.	Date when Amount first became Payable.
\$			
MURRAY GOULBURN CO-OPERATIVE CO. LIMITED—continued.			
Stephens, S. E., P.O. Box 34, Mirboo North .. .. .	14.75	Dividend .. .. .	1.10.73
Bishop, V. M. (estate of), c/o D. T. Hann, Lockington .. .. .	29.45	" .. .. .	" .. .. .
Fawcett, H. B., P. Bag 13, Pyramid Hill .. .. .	50.00	" .. .. .	" .. .. .
Bonney, A., Nambrook, via Rosedale .. .. .	19.40	" .. .. .	" .. .. .
Tilburg, K. (Jnr.) (address unknown) .. .. .	20.00	Sales of shares .. .. .	23.11.73
Name and address unknown .. .. .	32.38	Interest on share moneys .. .. .	10.73
Sheather, M. G. (address unknown) .. .. .	67.00	Sales of shares .. .. .	1.4.74

5377

PILKINGTON ACT OPERATIONS PTY. LTD.

Cox, Paul Anthony, Flat 8, 34 Fraser Street, Herne Hill .. .. .	16.87	Wages .. .. .	19.2.74
Hibberd, H., 3 Cecil Street, Frankston .. .. .	43.26	Bonus .. .. .	28.1.73
Bratic, M., 10 Firman Street, Springvale .. .. .	17.30	" .. .. .	11.2.73
Agnello, J., 14 Waratah Avenue, Dandenong .. .. .	15.09	" .. .. .	21.5.73
Kerrison, R., c/o Victorio Motta, Manks Road, Koo-Wee-Rup .. .. .	37.41	Pay and Bonus .. .. .	28.5.73
Hogg, R., c/o 44 Loch Road, Wooranna Park .. .. .	22.23	Bonus .. .. .	" .. .. .
Holda, E., 23 Hilton Street, Dandenong .. .. .	17.79	" .. .. .	24.12.72
White, I., 9 Greenhaw Court, Mt. Martha .. .. .	27.94	Wages and Bonus .. .. .	22.10.73
Ton, H., Flat 3, 16 Stud Road, Dandenong .. .. .	19.71	Bonus .. .. .	10.10.73
Heazelwood, A., 1 Karri Court, Pines East, Frankston .. .. .	82.46	Pay and Bonus .. .. .	2.7.73
Marshall, G., 234 Seaford Road, Seaford .. .. .	20.60	Bonus .. .. .	16.7.73
Unwin, C., Flat 3, 53 Hammond Road, Dandenong .. .. .	15.67	" .. .. .	6.8.73
Newman, R., 63 Armata Crescent, Frankston .. .. .	145.58	" .. .. .	19.11.73
Alievski, A., 3 Sunset Grove, Dandenong .. .. .	28.00	" .. .. .	19.12.73
Muir, K., Kingston Lodge, Carrum Downs .. .. .	22.56	Wages .. .. .	14.11.73
Peterson, G., Kingston Lodge, Carrum Downs .. .. .	22.56	" .. .. .	" .. .. .
Newman, R., 63 Armata Crescent, Frankston .. .. .	20.60	Bonus .. .. .	21.11.73
Faivre, R., Caravan Park, Skye Road, Frankston .. .. .	32.40	" .. .. .	28.11.73

5378

In the Supreme Court of Victoria.—In the matter of the Companies Act 1961; and in the matter of KIDRON PTY. LTD.

Notice is hereby given that a petition for the winding up of the abovenamed company was on the 18th day of June 1975 presented to the said Court by Kimberley Charles Smith of 21 Clive Street East Brighton in the State of Victoria, a creditor of the company, and that the said Petition is directed to be heard before the Court sitting at Melbourne at the hour of 10.30 o'clock in the forenoon on the 6th day of August 1975; and any creditor or contributory of the said company desirous to support or oppose the making of an order on the said Petition may appear at the hearing by himself or his Counsel for that purpose; and a copy of the Petition will be furnished to any creditor or contributory of the said company requiring the same by the undersigned on payment of the registered charge for the same.

The Petitioner's address is 21 Clive Street, East Brighton.

The Petitioner's solicitors were Messrs. L. M. Schetzer & Associates of 288 Brunswick Street, Fitzroy, but are now Gary Goldstein & Co., of 164 Upper Heidelberg Road, Ivanhoe.

NOTE.—Any person who intends to appear on the hearing of the said Petition must serve on or send by post to the abovenamed solicitors notice in writing of his intention to do so. The notice must state the name and address of the person, or, if a firm, the name of the firm and must be signed by the person or firm or his or their solicitor and must be served, or if posted, must be sent by post in sufficient time to reach the abovenamed not later than four o'clock in the afternoon of the 5th day of August 1975 the day previous to the day appointed for the hearing of the Petition.

GARY GOLDSTEIN & CO., solicitors for the Petitioner.  
6082

Companies Act 1961.

R. C. OLSEN PTY. LTD.

At an Extraordinary General Meeting of the above company duly convened and held at 6 Mills Street, Hampton on 10th day of June 1975, the following resolution was duly passed.

"The Company go into voluntary liquidation."

6083

W. T. NEVILLE, Liquidator.

THE COMPANIES ACT 1961.

Notice is hereby given that the partnership heretofore subsisting between Nicola Ciavarella and Michele Ciavarella both of 8 Bates Avenue, Thomastown and carrying on business in partnership under the style or name of Bundoora Fibrous Plaster at 26 Settlement Road, Bundoora has been dissolved as from the 30th day of June, 1975.

6084

The Companies Act 1961.—In the matter of AMESBURY INVESTMENTS PTY. LIMITED (in Voluntary Liquidation).—Members' Winding Up.

Notice is hereby given that at the Extraordinary General Meeting of Amesbury Investments Pty. Limited duly convened and held at 461 Bourke Street, Melbourne in the State of Victoria on the 30th day of June 1975, the following Resolution was proposed and passed as a Special Resolution.

"That the company be wound up voluntarily."

Dated this 1st day of July, 1975.

J. L. MAFFEY, Liquidator.

Messrs. Coopers & Lybrand, chartered accountants, 461 Bourke Street, Melbourne, Victoria. 6088

In the Supreme Court of Victoria.—No. Co.9046 of 1974.—In the matter of the Companies Act 1961; and in the matter of SQUASHWAY PTY. LTD.—Advertisement of Petition.

Notice is hereby given that a Petition for the winding up of the abovenamed Company by the Supreme Court was presented on the 6th day of June 1975 and that the said Petition is directed to be heard before the Court sitting at Melbourne at the hour of 10.30 on the 18th day of July 1975 and any creditor or contributory of the said Company desiring to support or oppose the making of an Order on the said Petition may appear at the time of hearing by himself or his counsel for that purpose and a copy of the Petition will be furnished to any creditor or contributory of the said Company requiring the same by the undersigned on payment of the regulated charge for the same. The Petitioner's address is 464 Lower Heidelberg Road, Heidelberg in the said State. The Petitioner's Solicitors are Messrs. Braham & Pirani of 521 Toorak Road, Toorak in the State of Victoria.

BRAHAM & PIRANI, solicitors for the Petitioner, 521 Toorak Road, Toorak. 6085

The Companies Act 1961.—In the matter of HMP PROPERTIES PTY. LIMITED (in Voluntary Liquidation).—Members Winding Up.

Notice is hereby given that at the Extraordinary General Meeting of Hmp Properties Pty. Limited duly convened and held at 461 Bourke Street, Melbourne in the State of Victoria on the 30th day of June, 1975, the following Resolution was proposed and passed as a Special Resolution.

“That the company be wound up voluntarily.”

Dated this 1st day of July, 1975.

J. L. MAFFEY, Liquidator.

Messrs. Coopers & Lybrand, chartered accountants, 461 Bourke Street, Melbourne, Victoria. 6087

In the matter of the Companies Act; and in the matter of CHRIS ALLEN PROPRIETARY LIMITED.

Notice is hereby given that at an extraordinary general meeting of the above named company duly convened and held at 1 Derby Street, Pascoe Vale at 5.00 p.m. on Monday, 30th June 1975 the following Special Resolution was duly passed:

“That the Company be wound up voluntarily and that Barry Reginald Waters be appointed liquidator for the purpose of such winding up.”

Dated the 30th day of June, 1975.

6086 BARRY REGINALD WATERS, Chairman.

The Companies Act 1961.—In the matter of TRIO-TEX TEXTILE PRINTERS & DESIGNERS PTY. LTD. (in Voluntary Liquidation).

NOTICE is hereby given that at an Extraordinary Meeting of the Members of the abovenamed Company held on Tuesday, the 1st day of July, 1975 it was resolved that the Company be wound up voluntarily and at a Meeting of Creditors held on Wednesday, the 2nd day of July, 1975 it was resolved that for such purpose GEOFFREY ORMOND HARRISON, Chartered Accountant, be appointed Liquidator.

Notice is also given that after 21 days from this date I shall proceed to distribute the assets. All creditors having any claim against the Company should furnish particulars of same by that date, otherwise I shall proceed to distribute the assets without regard to their claim.

Dated this 4th day of July, 1975.

G. O. HARRISON, Liquidator.

Hall & Rose, chartered accountants, 395 Collins Street, Melbourne, Vic. 3000. 6160

Companies Act 1961.—In the matter of I. F. MAYES INVESTMENTS PTY. LIMITED.

At an Extraordinary General Meeting of the abovenamed Company, duly convened and held at 351 Collins Street, Melbourne, on the 30th June 1975, the following resolution was duly passed as a special resolution:—

“That the company be wound up voluntarily.”

And at such meeting Russell William Daff, Chartered Accountant of 351 Collins Street, Melbourne, was appointed Liquidator for the purposes of the winding up.

Dated this 30th day of June, 1975.

6161 R. W. DAFF, Liquidator.

Companies Act 1961.—In the matter of C. D. MAYES INVESTMENTS PTY. LIMITED.

At an Extraordinary General Meeting of the abovenamed Company, duly convened and held at 351 Collins Street, Melbourne, on the 30th June 1975, the following resolution was duly passed as a special resolution:—

“That the company be wound up voluntarily.”

And at such meeting Russell William Daff, Chartered Accountant of 351 Collins Street, Melbourne, was appointed Liquidator for the purposes of the winding up.

Dated this 30th day of June, 1975.

6162 R. W. DAFF, Liquidator.

KILWINNING PTY. LIMITED (IN VOLUNTARY LIQUIDATION).

Notice is hereby given that a general meeting of the company will be held at the office of Robertson, Darling & Wolfenden, 19th Floor, 535 Bourke Street, Melbourne, on Monday, the 11th day of August, 1975, at 12 o'clock noon, to receive an account showing how the winding up has been conducted and the property of the company disposed of.

Dated this 3rd day of July, 1975.

6204 H. W. McCUTCHEON, Liquidator.

Companies Act 1961.—In the matter of BEXLEY SECURITIES PTY. LIMITED.

At an extraordinary general meeting of the abovenamed company, duly convened and held at 356 Collins Street, Melbourne on the 30th June, 1975 the following resolution was duly passed as a special resolution:—

“That the company be wound up voluntarily.”

And at such meeting, Roger Douglas Evans, Chartered Accountant of 351 Collins Street, Melbourne was appointed liquidator for the purposes of the winding up.

Dated this 30th day of June, 1975.

6163 R. D. EVANS, Liquidator.

Companies Act 1961.—In the matter of FINANCIAL SYSTEMS, OVERSEAS PTY. LIMITED.

At an extraordinary general meeting of the abovenamed company, duly convened and held at 356 Collins Street, Melbourne on the 30th day of June, 1975 the following resolution was duly passed as a special resolution—

“That the company be wound up voluntarily.”

And at such meeting, Roger Douglas Evans, Chartered Accountant of 351 Collins Street, Melbourne was appointed liquidator for the purposes of the winding up.

Dated this 30th day of June, 1975.

6164 R. D. EVANS, Liquidator.

The Companies Act 1961.

N. S. F. HEDDITCH & SON PTY. LTD.  
(IN VOLUNTARY LIQUIDATION).

NOTICE is hereby given pursuant to Section 272 that the final meeting to receive the Liquidator's accounts will be held at my office on Friday, 8th August, 1975 at 4 p.m.

G. O. HARRISON, Liquidator.

Hall & Rose, chartered accountants, 395 Collins Street, Melbourne, Vic 3000. 6165

Companies Act 1961, Section 272 (2).

MAYFORD PTY. LTD. (IN VOLUNTARY LIQUIDATION).

Notice is hereby given that the final meeting of the shareholders of the company will be held at the offices of the Liquidator on Wednesday, 13th August, 1975, at 11 a.m. for the purpose of having an account laid before it showing how the winding up of the company has been conducted and the property of the company has been disposed of and to pass a resolution to destroy the company's books and papers pursuant to Section 284 (3) (b) of the Act.

W. R. WARRY, liquidator, 12th Floor, 351 Collins Street, Melbourne. 6166

The Companies Act 1961.—In the matter of TRANSPAC SUSPENSIONS PTY. LIMITED.

NOTICE is hereby given that at the Extraordinary General Meeting of Transpac Suspensions Pty. Limited duly convened and held at 570 Geelong Road, Brooklyn, in the State of Victoria on the 30th day of June, 1975, the following Resolution was proposed and passed as a Special Resolution.

“That the company be wound up voluntarily.”

Dated this 30th day of June, 1975.

6167 J. L. MAFFEY, Liquidator.

The Companies Act 1961.—In the matter of PROTECTIVE CASTINGS (S.A.) PTY. LIMITED (in Voluntary Liquidation).—Members Winding Up.

Notice is hereby given that at an Extraordinary General Meeting of Protective Coatings (S.A.) Pty. Limited duly convened and held at 437 St. Kilda Road, Melbourne in the State of Victoria, on the 27th day of June, 1975, the following resolution was proposed and passed as a Special Resolution.

“That the company be wound up voluntarily.”

Dated this 27th day of June, 1975.

6201 B. W. LITHGOW, Liquidator.

In the Supreme Court of Victoria.—1975 Co. No. 9082.—In the matter of the Companies Act 1961; and in the matter of OUTBACK PRODUCE PTY. LIMITED.

Notice is hereby given that a Petition for the winding up of the abovenamed Company by the Supreme Court was on the 5th day of June, 1975 presented by LINDSAY JAMES YEO, ROBERT LINDSAY YEO, VERNON KEITH REYNOLDS, DOUGLAS EWART TONKIN, BRUCE PESCOD, ALLEN DOUGLAS KILLEY, LESLIE PHILIP SMART, JOHN DESMOND BYRNE, GRAEME WALTER BRIGGS AND PETER JOHN SIGGINS all of 51 Queen

Street, Melbourne in the State of Victoria and that the said Petition is directed to be heard before the Court sitting at Melbourne at the hour of 10.30 a.m. on Wednesday the 23rd day of July, 1975 at the Practice Court and any creditor or contributory of the said company desiring to support or oppose the making of an order on the said petition may appear at the time of hearing by himself or his Counsel for that purpose; and a copy of the Petition will be furnished to any creditor or contributory of the said company requiring the same by the undersigned on payment of the regulated charge for the same. The Petitioner's address is 51 Queen Street, Melbourne in the State of Victoria. The Petitioners' Solicitors are Cohen, Thompson Bolger & Co., of 400 Lonsdale Street, Melbourne.

COHEN, THOMPSON, BOLGER & CO., solicitors for the Petitioners.

NOTE.—Any person who intends to appear on the hearing of the said Petition must serve on or send by post to the abovenamed Cohen, Thompson, Bolger & Co. notice in writing of the intention so to do. The notice must state the name and address of the person, or if a firm the name and address of the firm and must be signed by the person or firm or his or their Solicitor (if any) and must be served or if posted; must be sent by post in sufficient time to reach the abovenamed not later than four o'clock in the afternoon on the 22nd day of July, 1975. 6194

The Companies Act 1961.

SUPA CAMPA PROPRIETARY LIMITED (IN LIQUIDATION).

NOTICE CONVENING FINAL MEETING OF MEMBERS AND CREDITORS, PURSUANT TO SECTION 272.

Notice is hereby given pursuant to Section 272 of the Companies Act 1961, that a General Meeting of the members and creditors of the abovenamed company will be held in the offices of Kennedy Smail, 296-304 Little Lonsdale Street, Melbourne, on Wednesday the Sixth day of August, 1975, at 10.30 a.m. for the purpose of having an account laid before them showing the manner in which the winding up has been conducted and the property of the company disposed of and of hearing any explanations that may be given by the Liquidator.

Dated this 7th day of July, 1975.

ROBERT EASTAUGH RAMSAY, Liquidator.

Kennedy Smail, 296-304 Little Lonsdale Street, Melbourne, 3000. 6198

Companies Act 1961; as amended section 254 (2).—In the matter of CORDOVA PTY. LTD. (in Liquidation).

NOTICE IS HEREBY GIVEN that at an Extraordinary General Meeting of the above named Company held on the 30th day of June, 1975 the following special resolution was passed:

"That the company be wound up voluntarily and that Michael Ashley Coppins be appointed Liquidator for the purpose of such winding up."

Dated this 7th day of July, 1975.

MICHAEL A. COPPINS, Liquidator.

Wilson, Bishop, Bowes & Craig, 271 William Street, Melbourne, 3000. 6192

LEETON MARKETING PTY. LTD. (IN VOLUNTARY LIQUIDATION).

NOTICE OF FINAL MEETING IN VOLUNTARY WINDING UP.

TAKE NOTICE that the affairs of the above-named Company are now fully wound up and that in pursuance of Section 272 (1) of the Companies Act 1961 a General Meeting of the Company will be held at 1184 Malvern Road, Malvern, on the 12th day of August 1975, at 10 o'clock in the forenoon for the purpose of laying before it an account showing how the winding up has been conducted and the property of the Company disposed of and giving any explanation thereof.

Dated the 7th day of July, 1975.

6199 GEOFFREY E. LEVINGSTON, Liquidator.

In the Supreme Court of Victoria.—1975 Co. No. 9098.—In the matter of the Companies Act 1961; and in the matter of J. D. BARRY (CONSTRUCTIONS) PTY. LTD.

Notice is hereby given that a Petition for the winding up of the abovenamed company by the Supreme Court was on the 27th day of June, 1975 presented by Pioneer Concrete (Vic) Pty. Ltd. and that the said Petition is directed to be heard before the Court sitting at the Fourteenth Court, Law Courts, William Street, Melbourne at the hour of 10.30 o'clock in the forenoon on the 15th day of August, 1975 and any creditor or contributory of

the said company desiring to support or oppose the making of an Order on the said Petition may appear at the time of hearing by himself or his Counsel for the purpose; and a copy of the said Petition will be furnished to any creditor or contributory of the said company requiring the same by the undersigned on payment of the regulated charge for the same.

The Petitioner's official address is 87 High Street, Prahran.

The Petitioner's Solicitors are Messrs. Cornwall Stodart & Co. of 380 Lonsdale Street, Melbourne.

CORNWALL STODART & CO.

NOTE.—Any person who intends to appear on the hearing of the said Petition must serve on or send by post to the abovenamed Cornwall Stodart & Co., notice in writing of his intention so to do. The notice must state the name and address of the person, or, if a firm, the name and address of the firm, and must be signed by the person or firm, or his or their Solicitor (if any), and must be served or, if posted, must be sent by post in sufficient time to reach the abovenamed not later than 4.00 o'clock in the afternoon on the 14th day of August, 1975. 6124

Companies Act 1961, Section 254 (2).

AZRIEL INVESTMENTS PROPRIETARY LIMITED (IN LIQUIDATION).

NOTICE OF RESOLUTION.

At an extraordinary general meeting of the members of Azriel Investments Proprietary Limited duly convened and held at 1 Palmerston Crescent, South Melbourne on the 27th June, 1975, the special resolution set out below was duly passed.

"THAT the company be wound up voluntarily as a members' voluntary winding up in accordance with the provisions of the Companies Act 1961."

"THAT Kevin James Browne be and is hereby appointed liquidator."

Notice is also given that after twenty-one days from this date, I shall proceed to distribute the assets. All creditors having any claims against the company should furnish particulars of same by that date, otherwise, I shall proceed to distribute the assets without regard to their claim.

Dated this 3rd day of July, 1975.

K. J. BROWNE, Liquidator.

Bentley, Wheeler, Cartledge & Co., chartered accountants, 1 Palmerston Crescent, South Melbourne, Vic. 3205. 6125

CLOVELLY COURT PTY. LTD.

By Special Resolution dated 30th June, 1975 it was resolved that the company be wound up voluntarily and that Mr. R. A. Seymour of 6th Floor, 350 Latrobe Street, Melbourne, be appointed Liquidator. 6126

Companies Act 1961, Section 272 (1).

DURACRETE PROPRIETARY LIMITED.

NOTICE OF FINAL MEETING.

TAKE NOTICE that the affairs of the above-named Company are now fully wound up and that in pursuance of Section 272 (1) of the Companies Act 1961 a general meeting of the Company will be held at 9th Floor, 461 Bourke Street, Melbourne on the first day of September, 1975 at 10.00 o'clock in the forenoon for the purpose of laying before it an account showing how the winding-up has been conducted and the property of the Company disposed of and giving any explanation thereof.

Dated the 1st day of July, 1975.

J. C. BENZIES, Liquidator.

Wilson Danby & Giddy, 9th Floor, 461 Bourke Street, Melbourne, Vic. 3000. 6128

The Companies Act 1961.—In the matter of CORNISH & QUINTON PTY. LIMITED (in Voluntary Liquidation).—Members Winding Up.

Notice is hereby given that at an Extraordinary General Meeting of Members of Cornish & Quinton Pty. Limited duly convened and held at 2 Cambridge Street, Box Hill, in the State of Victoria, on the 27th day of June, 1975 the following resolution was proposed and passed as a Special Resolution—

"That the Company be wound up voluntarily in accordance with the provisions of the Act relating to a members' voluntary winding up."

Dated this 27th day of June, 1975.

6202

D. J. NEILSON, Liquidator.

*Companies Act 1961.***ZORA (KEW) PTY. LTD.**

At an Extraordinary General Meeting of the abovenamed company duly convened and held at 4th floor, 18 Queen Street, Melbourne on 27th June 1975 the following resolution was duly passed as a Special Resolution;

“that the Company be wound up voluntarily”

and at that meeting, David H. England, Chartered Accountant, of 3 Ithaca Road Frankston, Vic., was appointed liquidator for the purpose of winding up.

Dated 27th June, 1975.

6127

L. G. BOWES, Secretary.

**TAYLOR'S FRESH FOODS PTY. LTD. (IN VOLUNTARY LIQUIDATION).**

NOTICE CONVENING FINAL MEETING PURSUANT TO SECTION 272 OF THE COMPANIES ACT 1961.

Pursuant to Section 272 of the *Companies Act, 1961* a General Meeting of members of the above-mentioned company will be held at the office of the liquidator, 13th floor, 257 Collins Street, Melbourne on Tuesday the 12th day of August, 1975 at 9.15 a.m. for the purpose of having an account laid before them showing the manner in which the winding up has been conducted and the property of the company disposed of, and of hearing any explanations that may be given by the liquidator.

Dated this 1st day of July, 1975.

6203

N. A. ROGERS, Liquidator.

*Companies Act 1961.***MARINAS PTY. LIMITED (IN LIQUIDATION).**

NOTICE CONVENING FINAL MEETING OF MEMBERS, PURSUANT TO SECTION 272 (1).

NOTICE IS HEREBY GIVEN that the Final Meeting of Members of the above named Company will be held at 10th Floor, 271 William Street, Melbourne on Monday, August 11th, 1975 at 10.15 a.m. for the purpose of laying before the meeting an account showing how the winding up has been conducted and the property of the Company disposed of and giving any explanation thereof.

Dated this 7th day of July, 1975.

J. B. HUTCHINS, Liquidator.

Wilson, Bishop, Bowes & Craig, 271 William Street, Melbourne, 3000. 6191

*Companies Act 1961.***SHIRE HOLDINGS PTY. LIMITED (IN LIQUIDATION).**

NOTICE CONVENING FINAL MEETING OF MEMBERS, PURSUANT TO SECTION 272 (1).

NOTICE IS HEREBY GIVEN that the Final Meeting of Members of the above named Company will be held at 10th Floor, 271 William Street, Melbourne on Monday, August 11th, 1975 at 10.00 a.m. for the purpose of laying before the meeting an account showing how the winding up has been conducted and the property of the Company disposed of and giving any explanation thereof.

Dated this 7th day of July, 1975.

J. B. HUTCHINS, Liquidator.

Wilson, Bishop, Bowes & Craig, 271 William Street, Melbourne, 3000. 6193

*Companies Act 1961.***TPT INVESTMENTS PTY. LIMITED (IN LIQUIDATION).**

NOTICE CONVENING FINAL MEETING OF MEMBERS PURSUANT TO SECTION 272 (1).

NOTICE IS HEREBY GIVEN that the Final Meeting of Members of the above named Company will be held at 10th Floor, 271 William Street, Melbourne on Monday, August 11th, 1975 at 10.30 a.m. for the purpose of laying before the meeting an account showing how the winding up has been conducted and the property of the Company disposed of and giving any explanation thereof.

Dated this 7th day of July, 1975.

J. B. HUTCHINS, Liquidator.

Wilson, Bishop, Bowes & Craig, 271 William Street, Melbourne, 3000. 6190

In the Supreme Court of Victoria.—1975 No. C.9094.—In the matter of the *Companies Act 1961*; and in the matter of B. & W. PALLETS PTY. LTD.

NOTICE IS HEREBY GIVEN that a Petition for the winding-up of the abovenamed Company by the Supreme Court was on the 19th day of June 1975 presented by

SAMUEL SHOSTAK; AND THAT the said Petition is directed to be heard before the Court sitting at the Fourteenth Court, Law Courts, William Street Melbourne on the 6th day of August 1975 at the hour of 10.30 o'clock in the forenoon; and any creditor or contributory of the said Company desiring to support or oppose the making of an Order on the said Petition may appear at the time of hearing by himself or his Counsel for the purpose; and a copy of the Petition will be furnished to any creditor or contributory of the said Company requiring the same by the undersigned on payment of the regulated charge for the same.

THE PETITIONER'S ADDRESS is 5 Nareeb Court, Toorak.

THE PETITIONER'S SOLICITORS are Messrs. Yelland, Shuster & Jonas of 21 Swanston Street Melbourne, 3000.

Yelland, Shuster & Jonas, solicitors for the Petitioner.

NOTE.—Any person who intends to appear on the hearing of the said Petition must serve on or send by post to the abovenamed Solicitors, notice in writing of his intention so to do. The notice must state the name and address of the person, or, if a firm, the name and address of the firm and must be signed by the person or firm, or his or their Solicitor (if any) and must be served, or if posted, must be sent by post in sufficient time to reach the abovenamed not later than 4 o'clock in the afternoon of the 5th day of August 1975. 6200

CREDITORS next of kin and others having claims in respect of the estate of SUSANNAH PHYLLIS WEBB late of "Beesnest Cottage" Redbourn St. Albans Hertfordshire England married woman deceased intestate who died on the 17th day of October 1974 are required to send particulars of their claims to THE EQUITY TRUSTEES EXECUTORS AND AGENCY COMPANY LIMITED of 472 Bourke Street Melbourne by the 18th day of September 1975 after which date it will distribute the assets having regard only to the claims of which it then has notice.

LEACH & THOMSON, solicitors, 472 Bourke Street, Melbourne. 6177

CREDITORS, next of kin and others having claims in respect of the estate of STELLA EMILY SETTEN TOWELL late of 52 Edmond Street Parkdale Widow deceased (who died on the 30th day of December 1974) are to send particulars of their claims to The Union-Fidelity Trustee Company of Australia Limited, 100 Exhibition Street, Melbourne, by 7th October 1975, after which date it will distribute the assets having regard only to the claims of which it then has notice.

IVAN L. McDONALD, solicitor, 136 Balcombe Road, Mentone. 6178

WILLIAM JAMES MARSHALL, late of 18 Irvine Street, Pascoe Vale, confectioner, DECEASED.

CREDITORS next of kin and others having claims in respect of the estate of the deceased who died on 13th April 1975 are required by the personal representative MAVIS IRENE ORCHARD of 85 Durham Road Kilsyth married woman to send particulars to her by the 15th day of September 1975 after which date the personal representative may convey or distribute the assets having regard only to the claims of which she then has notice.

LEACH & THOMSON, solicitors, 472 Bourke Street, Melbourne. 6179

ALL PERSONS having claims against the estate of RONALD PATERSON CURSON late of 30 Arranmore Avenue Black Rock in the State of Victoria Retired deceased who died on the 23rd day of August 1974 and probate of whose will was granted by the Supreme Court of the said State on the 9th day of January 1975 to JOHN COOKE of 128 Exhibition Street Melbourne in the said State Solicitor, are required to send particulars in writing of such claims to the said JOHN COOKE C/- Cooke & Cussen 128 Exhibition Street Melbourne on or before the 15th day of September 1975 after which date the said JOHN COOKE will proceed to distribute the assets of RONALD PATERSON CURSON deceased which shall have come to his hands amongst the persons entitled thereto, having regard only to the claims of which he shall then have had notice.

COOKE & CUSSEN, solicitors, 128 Exhibition Street, Melbourne. 6189

All persons having claims against the Estate of THOMAS MADDOCKS late of Marine Hotel, Adelphi Road, Paignton, Torbay, Devon, England, Chartered Accountant deceased who died on the 28th day of November 1968 and

Probate of whose Will was on the 10th day of February 1969 granted by the High Court of Justice District Probate Registry Exeter to ROBERT ANTHONY LETCHER of the Manor Office Victoria Street Paignton aforesaid Solicitor PHILIP HUNTON THOMAS of 80 Windsor Road Torquay Torbay aforesaid Chartered Accountant and GILBERT CHARLES KITCHENER DREW of 48 Winner Hill Road Paignton aforesaid Certified Accountant and application to the Supreme Court of Victoria (Probate Jurisdiction) by The Perpetual Executors & Trustees Association of Australia Limited to seal such Probate having been granted on the 3rd day of July 1975 are hereby required to send particulars of such claims to The Perpetual Executors & Trustees Association of Australia Limited at its Registered Office at 50 Queen Street Melbourne on or before 10th September 1975 after which date the said Company will proceed to transfer, convey or distribute the said Estate to or among the persons entitled thereto having regard only to the claims of which it shall then have had notice and will not be liable for the assets so transferred, conveyed or distributed to any persons of whose claim it shall not then have had notice.

BEST, HOOPER, RINTOUL & SHALLARD, 377 Little Collins Street, Melbourne, solicitors for the applicant.

6195

CREDITORS next of kin and others having CLAIMS in respect of the Estate of JOHN FRANCIS HANRAHAN late of St. Georges Road Northcote Retired Deceased who died on the 16th May 1975 are requested to send particulars of the claims to the Executor MARTIN JOSEPH HANRAHAN c/- M. Mornane 118 Queen Street Melbourne Solicitor by the 12th September 1975 after which date he will distribute the assets having regard only to the claims of which he shall then have had notice.

M. MORNANE, solicitor, 118 Queen Street, Melbourne.

6197

#### Trustee Act 1958.

#### NOTICE TO CLAIMANTS.

Pursuant to the Trustee Act 1958, creditors next of kin and all other persons having claims in respect of the estate of any deceased person named below are required to send particulars to the legal personal representative or representatives at the addresses stated, after which date the representatives will distribute the assets, having regard only to the claims of which notice has been received:—

JOSEPH OWEN MURPHY late of 85 Hudson Road Spotswood Gentleman deceased died on the First day of February 1971. Claims to the Executor, NATIONAL TRUSTEES EXECUTORS AND AGENCY COMPANY OF AUSTRALASIA LIMITED of 95 Queen Street Melbourne by the 12th day of September 1975. JOHN F. CARROLL, LL.B., Solicitor, 4 Paisley Street, Footscray. 6180

JAMES LOCK, late of 55 Glenora Avenue, East Coburg, greengrocer, DECEASED.

CREDITORS, next-of-kin and others having claims in respect of the Estate of the deceased who died on the 25th day of August, 1974 are requested to send particulars of their claims to the Executor ILSE LOCK C/- the undersigned Solicitor by the 10th September 1975 after which date the said Executor will proceed to distribute the Estate having regard only to the claims of which she then has notice.

MARJORY C. COATES, 422 Collins Street, Melbourne 3000. 6108

DANIEL NORMAN CHAPPELL, late of 182 The Esplanade, Middle Brighton, gentleman, DECEASED.

Creditors next-of-kin and others having claims in respect of the estate of the said deceased who died on the 29th day of March 1975 are required by The Equity Trustees Executors and Agency Company Limited of 472 Bourke Street Melbourne the Executor to whom Probate of the deceased's Will was granted to send particulars of their claims to the said Company by the 30th day of August 1975 after which date the Company will convey or distribute the assets having regard only to the claims of which it then has notice.

ALAN WAINWRIGHT & CO., solicitors, 397 Little Collins Street, Melbourne. 6111

CREDITORS, next-of-kin and others having claims against the estate of CHARLES EDMUND BEISSEL late of 14 Lansell Road Toorak Printer deceased who died on the 26th day of May 1975 are required by NATIONAL TRUSTEES EXECUTORS AND AGENCY COMPANY OF AUSTRALASIA LIMITED of 95 Queen Street Melbourne

to send to it particulars of their claims by the 17th day of September 1975 after which date the said Company will distribute the assets having regard only to claims of which it then has noted.

A. G. ALLAWAY & SON, solicitors, 386 Flinders Lane, Melbourne. 6109

CREDITORS next-of-kin and other persons having claims against the estate of FRANCIS MAXWELL COLLENS late of 18 Thornbury Crescent, East Malvern, Merchant, deceased, who died on the 16th September, 1974, are required to send particulars of their claims to the Executrix JUNE LESLEY COLLENS c/- Messrs. Morton Watson and Young, 1st floor, 406 Lonsdale Street, Melbourne, by the 11th day of September 1975, after which date the Executrix will distribute the assets having regard only for the claims of which she then has had notice.

OSWALD BURT & CO., solicitors, of 389 Lonsdale Street, Melbourne, 3000. 6110

CREDITORS next of kin and others having CLAIMS in respect of the Estate of PETER NORMAN PENTREATH late of 19 Marriage Road Brighton Gentleman deceased who died the 19th May 1975 are requested to send particulars of the claims to the Executor MICHAEL JOSEPH MORNANE c/- M. Mornane 118 Queen Street Melbourne Solicitor by the 12th September 1975 after which date he will distribute the assets having regard only to the claims of which he shall then have had notice.

M. MORNANE, solicitor, 118 Queen Street, Melbourne.

6196

CLIFFORD CYRIL JOHN SAMSON, late of 40 Norman Street, Wendouree, railwayman, DECEASED.

Creditors next of kin and others having claims in respect of the estate of the deceased who died on the 22nd day of March 1975 are required by the Trustee Arthur John Robinson of 104 Lydiard Street South Ballarat Solicitor to send particulars of their claims to him by the 11th day of September 1975 after which date the Administrator may convey or distribute the assets having regard only to the claims of which he then has notice.

D. & A. ARONSON, solicitors, of 104 Lydiard Street, South Ballarat. 6098

CREDITORS next of kin and others having claims against the Estate of MAY EDNA THISTLETHWAITE late of Colbrook in the State of Victoria Married Woman deceased who died on the 15th day of May, 1974 are requested to send particulars of their claims to the Executors THE UNION-FIDELITY TRUSTEE COMPANY OF AUSTRALIA LIMITED and ROBERT JAMES THISTLETHWAITE such claims to be forwarded to C/- The Union Fidelity Trustee Company of Australia Limited of 101 Lydiard Street North, Ballarat by the 9th day of September, 1975 after which date the said Executors will distribute the assets having regard only to the claims of which it then has notice.

NEVETT, GLENN & COUTTS, solicitors, 205 Dana Street, Ballarat. 6099

Creditors next of kin and others having claims in respect of the estate of WILLIAM RUDOLPH WESTPHALEN late of 58 Cumberland Road Pascoe Vale in the State of Victoria Gentleman deceased who died on the fourteenth day of February 1975 are to send particulars of their claims to his Executor NATIONAL TRUSTEES EXECUTORS AND AGENCY COMPANY OF AUSTRALASIA LIMITED 95 Queen Street Melbourne by the 17th day of September, 1975 after which date it will distribute the assets having regard to the claims of which it then has notice.

PETER J. WALSH, solicitor, 95 Queen Street, Melbourne:

6121

HARRISON THOMAS ALMOND, formerly of Ancona, but late of 4 Crosbie Road, Murrumbeena, retired grazier, DECEASED.

Creditors, next-of-kin and others having claims in respect of the deceased who died on the twelfth day of February 1975 are required by his Trustees DAISY MAY ALMOND of 4 Crosbie Road Murrumbeena Widow and DAVID LESLIE JACKSON of Moyston via Ararat Farmer to SEND PARTICULARS to them care of the undermentioned firm of Solicitors by the Eighteenth day of September 1975 after which date the Trustees may convey and distribute the assets having regard only to the claims of which they then have notice.

MAL RYAN, JACKSON & GLEN, 9 High Street, Mansfield, solicitors for the trustees. 6101



ROY STEDWELL, late of 10 Amery Street, Ashburton, in the State of Victoria, clerk, DECEASED.

CREDITORS next of kin and others having claims in respect of the estate of the deceased who died on the 14th day of April 1975 are required by VERONICA VIOLET STEDWELL widow of 10 Amery Street Ashburton and PETER ADRIAN STEDWELL accountant of 65 Maywood Road Pearceedale the executors of the will of the said deceased to send particulars to their Solicitor Peter G. Norden of Warburton Highway Woori Yallock by the 18th day of September 1975 after which date the said VERONICA VIOLET STEDWELL and PETER ADRIAN STEDWELL may convey or distribute the assets, having regard only to the claims of which they then have notice.

Dated the 9th day of July, 1975.

PETER G. NORDEN, solicitor, Warburton Highway, Woori Yallock. 6102

MARIA ELIZABETH CONFEGGI, late of 87 Cardigan Road, Mooroolbark, in the State of Victoria, retired nursing sister, DECEASED.

CREDITORS, next of kin, and others having claims in respect of the estate of the abovenamed deceased who died on the 16th day of February, 1975 are required by National Trustees Executors and Agency Company of Australasia Limited of 95 Queen Street Melbourne, the executor of the will of the said deceased to send particulars to it by the 18th day of September 1975 after which date the said National Trustees Executors and Agency Company of Australasia Limited may convey or distribute the assets, having regard only to the claims of which it then has notice.

Dated the 9th day of July, 1975.

PETER G. NORDEN, solicitor, Warburton Highway, Woori Yallock. 6060

CREDITORS next of kin and others having claims in respect of the estate of ROBERT IVAN COLE late of Traralgon Pensioner deceased, who died on 10th May 1975, are required to send particulars thereof to the executor Graeme Edward Morley care of the undersigned by 15th September, 1975, after which date he may distribute the assets having regard only to the claims of which he then has notice.

C. H. FORD, LL.M., solicitor, 47-49 Princes Street, Traralgon. 6100

CREDITORS next of kin and others having claims in respect of the estate of HORACE EDNEY BECK late of 47 Deans Marsh Road Lorne Gentleman deceased who died on the 14th day of January 1975 are required by CHARLES VICKERS-WILLIS and ROY LINDSAY BOCKHOLT the Executors of the Will of the deceased to send to them c/- the undermentioned Solicitors particulars thereof on or before the 9th September 1975 after which date they will distribute the assets having regard only to the claims of which they shall then have notice.

WIGHTON & McDONALD, solicitors, 89 Myers Street, Geelong. 6061

KATHLEEN RUSSELL VARLEY, formerly of 5 Fowler Street, Box Hill South, but late of Ashwood Private Hospital, 95-107 High Street Road, Ashwood, in the State of Victoria, retired telephonist, DECEASED.

Creditors, next of kin and others having claims in respect of the Estate of the Deceased (who died on the 2nd day of March, 1975) are required by GEOFFREY FRANCIS DAWSON of 84 William Street, Melbourne, the Executor to whom Probate of the Will of the Deceased has been granted to send particulars of their claims to him by the 10th day of September, 1975, after which date he will convey or distribute the assets having regard only to the claims of which he then has notice.

Dated the 9th day of July, 1975.

F. R. E. DAWSON & SON, 84 William Street, Melbourne. 6141

CREDITORS next of kin and others having claims in respect of the estate of DORIS VERONIQUE O'CONNOR late of 2 Woodmason Road, Boronia in the State of Victoria Widow deceased who died on the 25th day of January, 1975 are requested to send particulars of their claims to ANTHONY DAVID COOKE of 406 Lonsdale Street, Melbourne Solicitor by the 9th day of September, 1975 after which date the Executor will distribute the assets having regard only to the claims of which he then has notice.

PROUDFOOT, HORTON & COOKE, solicitors of 406 Lonsdale Street, Melbourne. 6142

KATHERINE MARY LADD, late of 31 Beveridge Street, Swan Hill in the State of Victoria, widow, DECEASED.

Creditors next-of-kin and other persons having CLAIMS against the Estate of the said Deceased who died on the 3rd day of June 1975 ARE REQUIRED to send particulars of same to the Executrix JOYCE FRANCES STOKER in care of the undersigned on or before the 5th day of September 1975 after which date she will distribute the assets having regard only to the claims of which she then has notice.

DELANY & DWYER, barristers and solicitors, 201 Campbell Street, Swan Hill. 6143

FLORENCE ELIZABETH BLACK, late of 6 Smythe Avenue, Mont Albert, in the State of Victoria, widow, DECEASED.

CREDITORS, next of kin and others having claims in respect of the estate of the said deceased who died on the 19th December 1974 are required by the executor THE TRUSTEES EXECUTORS AND AGENCY COMPANY LIMITED of 401 Collins Street Melbourne to send particulars of their claims to the said Company on or before the 3rd September 1975 after which date it will convey or distribute the assets having regard only to the claims of which the Company then has notice.

WISEWOULDS, solicitors, 1211A Toorak Road, Burwood, 6125. 6144

WILLIAM STANLEY GALE, late of Kerang, in the State of Victoria, retired farmer, DECEASED.

CREDITORS next-of-kin and all other persons having claims against the Estate of the said Deceased are required by AUDREY MAY NEWTON of 40 Henshall Road Strathmore in the said State Married Woman the sole executrix of the Estate of the said Deceased to send particulars of such claims to them in care of the undermentioned Solicitors on or before the twenty ninth day of August 1975 after which date they will distribute the assets having regard only to the claims of which they then have notice.

BASILE & CO., barristers and solicitors, 46 Wellington Street, Kerang. 6145

THOMAS ALEXANDER WALLIS FURPHEY, late of Unit 2, 54 Weybridge Street, Surrey Hills, merchant, DECEASED.

Creditors next of kin and others having claims in respect of the estate of the deceased who died on the 30th day of December, 1974 are required by THE EQUITY TRUSTEES EXECUTORS AND AGENCY COMPANY LIMITED of 472 Bourke Street, Melbourne to send particulars of their claims to the said Company by the Tenth day of September, 1975 after which date it will convey or distribute the assets having had regard only to the claims of which the Company then had notice.

CORR & CORR, solicitors, 290 La Trobe Street, Melbourne. 6146

MARY CORAL GERTRUDE SCHIFFERLE, late of Nyah West, in the State of Victoria, orchardist, DECEASED.

Creditors next-of-kin and other persons having CLAIMS against the Estate of the said deceased who died on the 28th day of February 1975 ARE REQUIRED to send particulars of same to the Executors LEO THOMAS SCHIFFERLE, KEVIN JAMES SCHIFFERLE and PATRICIA CHISHOLM in care of the undersigned on or before the 4th day of September, 1975 after which date they will distribute the assets having regard only to the claims of which they then have notice.

DELANY & DWYER, barristers and solicitors, 201 Campbell Street, Swan Hill. 6147

FRANCIS RAPHAEL KENNEDY, late of 142 Stradbroke Avenue, Swan Hill, in the State of Victoria, retired farmer, DECEASED.

Creditors next-of-kin and other persons having CLAIMS against the Estate of the said deceased who died on the 2nd day of May 1975 ARE REQUIRED to send particulars of same to the Executrix EMILY MARY KENNEDY in care of the undersigned on or before the 4th day of September 1975 after which date she will distribute the assets having regard only to the claims of which she then has notice.

DELANY & DWYER, barristers and solicitors, 201 Campbell Street, Swan Hill. 6148

DOROTHY ELIZABETH HAUSER, late of St. Leon Private Hospital, 31 Thanet Street, Malvern, widow, DECEASED.

Creditors, next of kin and others having claims in respect of the estate of the deceased who died on the Twenty-seventh day of March One thousand nine hundred and Seventy-five are required by the Trustee GEOFFREY

BOLITHO HAUSER of 32 Sherwood Road, Mount Waverley, Company Director to send particulars to him care of the undersigned by the 10th September 1975 after which date the Trustee may convey or distribute the assets having regard only to the claims of which he then has notice.

WHITING & BYRNE, 440 Collins Street, Melbourne. 6206

THOMAS PETER AGOSTA, late of Murrawee, in the State of Victoria, shop assistant, DECEASED.

Creditors next-of-kin and other persons having CLAIMS against the Estate of the said deceased who died on the 18th day of March 1975 ARE REQUIRED to send particulars of same to the Administrator LUIGI AGOSTA in care of the undersigned on or before the 4th day of September 1975 after which date he will distribute the assets having regard only to the claims of which he then has notice.

DELANY & DWYER, barristers and solicitors, 201 Campbell Street, Swan Hill. 6149

ALAN DUNCAN TWIGG, formerly of Berriwillock, in the State of Victoria, contractor, but late of 76 Murlong Street, Swan Hill, in the said State, contractor and farmer, DECEASED.

Creditors next-of-kin and other persons having CLAIMS against the Estate of the said deceased who died on the 27th day of August 1974 ARE REQUIRED to send particulars of same to the Executors UNA LOUISE TWIGG and KENNETH RALPH SUTTON in care of the undersigned on or before the 4th day of September 1975 after which date they will distribute the assets having regard only to the claims of which they then have notice.

DELANY & DWYER, barristers and solicitors, 201 Campbell Street, Swan Hill. 6150

ALLAN ELLIS NALDER, late of Lalbert, in the State of Victoria, farmer, DECEASED.

Creditors next-of-kin and other persons having CLAIMS against the Estate of the said deceased who died on the 20th day of November 1974 ARE REQUIRED to send particulars of same to the Executrix BERTHA LINDA NALDER in care of the undersigned on or before the 4th day of September 1975 after which date she will distribute the assets having regard only to the claims of which she then has notice.

DELANY & DWYER, barristers and solicitors, 201 Campbell Street, Swan Hill. 6151

MICHELANGELO PICCOLO, late of Woorinen, in the State of Victoria, farmer, DECEASED.

Creditors next-of-kin and other persons having CLAIMS against the Estate of the said deceased who died on the 29th day of October 1973 ARE REQUIRED to send particulars of same to the Executor GIUSEPPE PICCOLO in care of the undersigned on or before the 4th day of September 1975 after which date he will distribute the assets having regard only to the claims of which he then has notice.

DELANY & DWYER, barristers and solicitors, 201 Campbell Street, Swan Hill. 6152

CREDITORS, NEXT OF KIN AND OTHERS having claims in respect of the Estate of CLARA MAY EASTAUGH late of 12 Glyndon Road, Camberwell Widow deceased who died on the 7th day of June, 1974 are required by the executors KENNETH GEOFFREY EASTAUGH of 25 Mahratta Avenue, Wairoonga, Bank Official and MAVIS JOAN TASSICKER of 119 Heaslip Street, Mangerton Wollongong Married Woman both in the State of New South Wales to send particulars to them care of the Solicitors mentioned hereunder by the 20th day of September, 1975 after which date they will distribute the assets of the said deceased having regard only to the claims of which they then have Notice.

HEFFEY & BUTLER, solicitors, 258 Little Bourke Street, Melbourne. 6153

Creditors, next of kin and others having claims against the estate of RITA SHOESMITH formerly of Maritana Avenue, Reservoir but late of 29 Boneo Road, Rosebud Married Woman deceased TAKE NOTICE that the Executor ARTHUR LAWRENCE SHOESMITH of 16 Beatty Street, Reservoir, Contractor whose address for service is C/o David Bullard of 380 Lonsdale Street, Melbourne will distribute the assets of the estate fourteen days after the publication of this notice taking into account only those claims of which he then has notice. 6165

CREDITORS next-of-kin and others having claims in respect of the Estate of BEVERLEY BEAUMONT formerly of 14 Scheele Street Surrey Hills but late of Khan-coban Station Corryong Widow deceased who died on 9th April 1975 are required to send particulars of such claims to NATIONAL TRUSTEES EXECUTORS AND AGENCY COMPANY OF AUSTRALASIA LIMITED at its registered office at 95 Queen Street Melbourne by the 16th September 1975 after which date it will distribute the assets having regard only to the claims of which it then has notice.

DOYLE & KERR, solicitors, 450 Little Collins Street, Melbourne. 6176

ROBERT ARTHUR BURT, late of 15 Haig Avenue, Coburg, retired railway employee, DECEASED.

CREDITORS next of kin and others having claims against the estate of the said deceased who died on 28th August 1974 are to send particulars of their claims to BERNARD GORE BRETT c/- Blake & Riggall 140 William Street Melbourne by the 16th September 1975 after which date he will distribute the assets having regard only to the claims of which he then has notice.

BLAKE & RIGGALL, solicitors, 140 William Street, Melbourne. 6120

STANLEY PHILIP FUSSELL, late of Nhill, in the State of Victoria, labourer, DECEASED.

Creditors' next-of-kin and others having claims in respect of the estate of the deceased who died on the Twenty-fourth day of September One thousand nine hundred and seventy-four are required by the trustee Vera May Graham of 26 Blair Street Lutana in the State of Tasmania Married Woman to send particulars to her care of the undersigned by the Fifteenth day of September One thousand nine hundred and seventy-five after which date the trustee may convey or distribute the assets having regard only to the claims of which she then has notice.

Dated the 1st day of July, 1975.

TURNER & HOBDAV, 30 Victoria Street, Nhill, solicitors for the said trustee. 6113

CLARIS CARTER, formerly of 20 Grandview Road, Glen Iris, but late of Kiverton Park Private Hospital, 16 Wills Street, Glen Iris, widow.

CREDITORS, next of kin, and others having claims in respect of the estate of the deceased, who died on the 8th day of January 1975 are required by the trustees Harry McEwin Scambler of 29 Berkeley Street, Hawthorn and David Stuart Murray of 120 Collins Street, Melbourne to send particulars to them at 120 Collins Street, Melbourne by the 5th day of September 1975 after which date the trustees may convey or distribute the assets, having regard only to the claims of which they then have notice.

WM. MURRAY & SON, solicitors, 120 Collins Street, Melbourne. 6114

Creditors next of kin and others having claims against the Estate of HARRIET MARGARET NAUMANN MCHATTIE late of "Broughton Hall" 2 Berwick Street Camberwell in the State of Victoria Widow deceased who died on the 24th day of November 1974 are requested to send particulars of their claims to RHODA MARGARET JARVIE of 17 Rowena Road Chadstone in the said State Widow care of the below mentioned Solicitors by the 12th day of September 1975 after which date she will distribute the assets having regard only to the claims of which she then has notice.

PURVES & PURVES, solicitors, 121 William Street, Melbourne. 6117

CREDITORS next of kin and others having claims in respect of the Estate of ALICE MAY JONES late of "Jullynn" Sea Breeze Avenue, Ferny Creek in the State of Victoria Married Woman deceased who died on the 3rd day of April 1975 are required by the Executors of the Will, namely VELMA EDNA MONTAGUE of 7 Maneroo Place, Cooma North in the State of New South Wales Married Woman and ALAN RAYMOND JONES formerly of Mt. Morton Road, South Belgrave in the State of Victoria but now of 15 Powell Street, Mt. Gambier in the said State Wood Machinist to send particulars of such claims to the said Executors care of the office of Lloyd P. Goode & Co., at 406 Lonsdale Street, Melbourne by the 9th day of September 1975 after which date the said Executors will distribute the assets having regard only to the claims of which they then have notice.

LLOYD P. GOODE & CO., solicitors, 406 Lonsdale Street, Melbourne, 3000. 6118

CREDITORS next of kin and others having claims in respect of the Estate of DAVID REDVERS WALKER late of 211 Heaths Road, Werribee in the State of Victoria but formerly of 2 Ashmore Road, Weeke, Winchester, Hampshire, England, Technical Manager deceased who died on the 19th day of November 1974 are required by the Executrix of the Will, namely SYLVIA SELWYN WALKER of 211 Heaths Road, Werribee in the said State Widow to send particulars of such claims to the said Executrix care of the office of Lloyd P. Goode & Co., at 406 Lonsdale Street, Melbourne by the 9th day of September 1975 after which date the said Executrix will distribute the assets having regard only to the claims of which she then has notice.

LLOYD P. GOODE & CO., solicitors, 406 Lonsdale Street, Melbourne, 3000. 6115

EDITH MARY BRAY, late of 15 Dunlop Avenue, Kew, widow, DECEASED.

CREDITORS next of kin and others having claims against the estate of the said deceased who died on 18th February 1975 are to send particulars of their claims to KATHARINE STANSFIELD ROBERSON Married Woman and JOHN LUDDINGTON ROBERSON Retired Wool Buyer C/- Blake & Riggall 140 William Street Melbourne by the 16th September 1975 after which date they will distribute the assets having regard only to the claims of which they then have notice.

BLAKE & RIGGALL, solicitors, 140 William Street, Melbourne. 6118

JOSEPH LYON, late of 6 Dougherty Road, Rosanna, school teacher, DECEASED.

CREDITORS next of kin and others having claims against the estate of the said deceased who died on 3rd March 1975 are to send particulars of their claims to JEAN HESELTINE LYON C/- Blake & Riggall 140 William Street Melbourne by the 16th September 1975 after which date she will distribute the assets having regard only to the claims of which she then has notice.

BLAKE & RIGGALL, solicitors, 140 William Street, Melbourne. 6119

ELLA KATHLEEN ABERTON, late of 18A Park Road, Surrey Hills, married woman, DECEASED.

Creditors, next of kin and others having claims in respect of the estate of the deceased, who died on the 8th day of December, 1974 are required by THE TRUSTEES, EXECUTORS AND AGENCY COMPANY LIMITED of 401 Collins Street, Melbourne to send particulars of their claims to the said Company by the 12th day of September, 1975, after which date it will convey or distribute the assets, having regard only to the claims of which the Company then has notice.

RODDA, BALLARD & VROLAND, solicitors, 695 Burke Road, Camberwell. 6112

In the Supreme Court of the State of Victoria.  
SALE BY THE SHERIFF.

ON FRIDAY the 15TH of AUGUST 1975 at 11.00 a.m. AT THE POLICE STATION EPPING (unless process be stayed or satisfied).

ALL the Estate and Interest (if any) of MICHELANGELO GERACE, shop proprietor, 549A Barkley Street, Footscray as joint proprietor with VANNA CARMELINA GERACE, married woman of an estate in fee simple in the land described in Certificate of Title Volume 8925 Folio 584 which is a vacant block of land situate 563' 4" north of Memorial Avenue known as Lot 22 High Street Epping. Registered Mortgage No. F.199915 affects the said estate and interest.

TERMS—CASH ONLY.

KEITH R. MARTIN, Sheriff's Officer.  
9th July, 1975. 6207

In the Supreme Court of the State of Victoria.  
SALE BY THE SHERIFF.

ON FRIDAY the 15TH of AUGUST 1975 at 10.00 a.m. AT THE POLICE STATION DONCASTER (unless process be stayed or satisfied).

ALL the Estate and Interest (if any) of SERGIO BIANCHI, garage mechanic, and KITTY BIANCHI, (shown on Certificate of Title as KETTI BIANCHI,) married

woman, both of 20 Esther Street, Templestowe as proprietors of an estate in fee simple in the land described in Certificate of Title Volume 8299 Folio 754 upon which is erected a brick dwelling known as No. 20 Esther Street Templestowe.

Registered Mortgage No. B.437356 and D.645766 affect the said estate and interest.

TERMS—CASH ONLY.

H. BUETTNER, Sheriff's Officer.  
9th July, 1975. 6208

## IMPOUNDINGS

FOSTER.—Impounded in Foster Pound.

On Monday, 23rd June, 1975, from Longstaff Road.

1 black baldy heifer, notch in right ear

On Tuesday, 24th June, 1975, from Midland Highway, Woorarra East.

1 Friesian bull

On Monday, 30th June, 1975, from Fish Creek—Foster Road.

1 blue roan cow.

If not claimed and expenses paid, to be sold on or after 24th July, 1975.

A. G. JONES,  
Poundkeeper.

6097—\$7.15

KYNETON.—Impounded in Kyneton Pound on the 3rd July, 1975 from the Black Hill area.

1 Poll Dorset ram, tag 37, Right ear, crossways.

If not claimed and expenses paid to be sold on the 17th July, 1975.

C. H. RIORDAN,  
Poundkeeper.

6185—\$3.85

KYNETON.—Impounded in Kyneton Pound on the 7th July, 1975 from the View Point area.

1 Hereford cross steer, approximately 18 months

If not claimed and expenses paid to be sold on the 10th July, 1975.

C. H. RIORDAN,  
Poundkeeper.

6186—\$3.85

TATURA.—Impounded in Tatura Pound from the Mooroopna area.

1 Hereford heifer, no visible brand

1 Guernsey cow, no visible brand

If not claimed and expenses paid, to be sold on Thursday, 24th July, 1975.

J. H. MACTIER,  
Poundkeeper.

6175—\$4.40

TRAFALGAR.—Impounded in Trafalgar Pound Nos. 37 to 42, from Yallourn North

6 Friesian heifers, no visible brand, notch out of top side of right ears

If not claimed and expenses paid, shall be sold at Trafalgar saleyards, 9th July, 1975.

V. KAYE,  
Poundkeeper.

6209—\$4.40

YINNAR.—Impounded in Yinnar Pound.

1 Jersey cow, heifer calf at foot, no visible brand

1 Jersey cow, horns; no visible brand, notch top left ear

1 black and white cow, horns

1 black heifer, 18 months

1 black heifer, 12 months

1 brindle steer, short horns.

If not claimed and expenses paid, will be sold Yinnar Yards, 16th July, 1975.

J. HEESOM,  
Poundkeeper.

6054—\$6.05

*Subordinate Legislation Act 1962.*

**NOTICE OF MAKING OF STATUTORY RULES.**

In pursuance of the provisions of the *Subordinate Legislation Act 1962* and the Regulations made thereunder, notice is given of the making of the following statutory rules:—

No.		Price.
	<i>Melbourne Harbor Trust Act 1958</i> (No. 6312).	
190/1975.	Melbourne Harbor Trust (Wharfage and Tonnage Rates) Regulations No. 4/75	15c
	<i>Portland Harbor Trust Act 1958.</i>	
191/1975.	Portland Harbor Trust Commissioners (Amendment No. 4) Staff Regulations	-10c
	<i>Metropolitan Fire Brigades Act 1958.</i>	
192/1975.	Metropolitan Fire Brigades (Loan No. 24) Regulations 1975	10c
	<i>Motor Car Act 1958.</i>	
193/1975.	Motor Car (Sale of Authorized Log Books) Regulations 1975	10c
	<i>Motor Boating Act 1961.</i>	
194/1975.	Motor Boating (General—Amendment No. 1) Regulations 1975	10c
	<i>Motor Car Act 1958.</i>	
195/1975.	Motor Car (Preliminary Breath Test) Regulations 1975	10c
	<i>Police Regulation Act 1958.</i>	
196/1975.	Police (Authorized Strength No. 7) Regulations 1975	10c
	<i>Status of Children Act 1974.</i>	
197/1975.	Status of Children (Fees) Regulations 1975	10c
	<i>Forests Act 1958 (No. 6254).</i>	
198/1975.	Forests (Baw Baw Alpine Reserve) (Amendment) Regulations 1975	10c
	<i>Forests Act 1958 (No. 6254).</i>	
199/1975.	Forests (Mt. Buller Alpine Reserve) (Amendment) Regulations 1975	10c
	<i>Education Act 1958.</i>	
200/1975.	Education Department (Amendment) Regulations 1975 (Amendment No. 35)	10c

Copies of these statutory rules may be purchased at the Sale of Publications Section of the Government Printing Office, located at 7A Parliament Place, Melbourne, 3002. If ordered by mail, remittance should be addressed to "The Government Printer, Box 203, P.O., North Melbourne, 3051", and should include 11c extra for postage. If a credit account is held at this office, no remittance is required with the mail order.

The annual subscription rate for Statutory Rules (including Bound Volumes) is \$35, payable in advance. The subscription year commences on 1st January.

C. H. RIXON,  
Government Printer.

**STATE ACTS, 1974**

Copies of the following Acts of Parliament of Victoria may be obtained at the Government Printing Office, Sale of Publications Branch, off Parliament-place, Melbourne, phone 63 0321, extension 6181, or from any accredited agent, at the price set opposite to each (these prices do not include postage).

The annual subscription for State Acts 1974 is \$15 payable in advance.

Bound Volumes of State Acts are also available on a subscription basis of \$21 per annum.

No.		Price.
8532.	Veterinary Research Institute (Consequential Amendment)	\$0.10
8533.	Stock (Artificial Breeding) (Amendment)	\$0.10
8534.	Carriers and Innkeepers (Licences)	\$0.10
8535.	Bittern Land	\$0.10
8536.	Labour and Industry	\$0.10
8537.	Public Lands and Works (Amendment)	\$0.10
8538.	Land Tax (Amendment)	\$0.10

STATE ACTS, 1974—continued.

No.		Price.
8539.	Superannuation (Railway Service)	\$0.10
8540.	Consumer Protection (Unordered Goods and Services Amendment)	\$0.10
8541.	Morwell and Mirboo Railway Removal	\$0.10
8542.	Bread Industry (Amendment)	\$0.10
8543.	Co-operative Housing Societies (Amendment)	\$0.10
8544.	Lotteries Gaming and Betting (Amendment)	\$0.10
8545.	Supply (No. 1, 1974-75)	\$0.15
8546.	Melbourne Cricket Club	\$0.15
8547.	Home Finance (Amendment)	\$0.10
8548.	Swan Hill Pioneer Settlement	\$0.30
8549.	Ministry of Transport (Transport Fund)	\$0.10
8550.	Youth, Sport and Recreation (Amendment)	\$0.10
8551.	Stamps (Bills of Exchange)	\$0.10
8552.	Gas and Fuel Corporation (Powers)	\$0.20
8553.	Registration of Births Deaths and Marriages	\$0.10
8554.	Meat Inspection Services	\$0.10
8555.	Sewerage Districts (Interest Subsidies)	\$0.10
8556.	Printers and Newspapers (Amendment)	\$0.10
8557.	Local Government (Amendment)	\$0.30
8558.	Decentralized Industry (Housing) (Amendment)	\$0.10
8559.	Teaching Service (Conditions of Service)	\$0.10
8560.	Environment Protection (Amendment)	\$0.10
8561.	Motor Car (Further Amendment)	\$0.15
8562.	Victorian Civil Ambulance Service	\$0.10
8563.	Forests (Wood Pulp Agreement)	\$0.40
8564.	Local Government (House Builders Liability Amendment)	\$0.20
8565.	Companies (Interstate Corporate Affairs Commission)	\$0.60
8566.	Racing (Amendment)	\$0.10
8567.	Appropriation (1973-74, No. 2)	\$0.10
8568.	Public Servants Ethical Conduct (Joint Select Committee)	\$0.10
8569.	Historic Buildings	\$0.30
8570.	Appropriation (1973-74, No. 3)	\$0.10
8571.	Supply (No. 2, 1974-75)	\$0.10
8572.	Victorian Inland Meat Authority	\$0.10
8573.	Metropolitan Bridges Highways and Fore-shores	\$0.30
8574.	Melbourne and Metropolitan Board of Works (Rates)	\$0.10
8575.	Wheat Marketing	\$0.10
8576.	Mildura Irrigation and Water Trusts (Amendment)	\$0.10
8577.	The Alfred Nicholas Memorial Gardens	\$0.10
8578.	Bonnie Doon (Public Hall) Land	\$0.10
8579.	Carlton Land (University Women's College)	\$0.10
8580.	Newmarket Sheep Sales	\$0.10
8581.	Tattersall Consultations (Soccer Football Pools)	\$0.15
8582.	Geelong Land	\$0.10
8583.	Melbourne (Alexandra Gardens) Land	\$0.10
8584.	Terang Mechanics Institute and Free Library Trust	\$0.10
8585.	Pay-roll Tax (Rate)	\$0.10
8586.	Co-operative Housing Societies	\$0.10
8587.	Forests (Amendment)	\$0.15
8588.	Dental Alumni Research Foundation	\$0.10
8589.	Pesticides (Amendment)	\$0.10
8590.	Dried Fruits (Amendment)	\$0.10
8591.	Road Safety (Educational)	\$0.10
8592.	Commonwealth Places (Administration of Laws)	\$0.10
8593.	Pharmacists	\$0.40
8594.	Payroll Tax	\$0.20
8595.	Stamps (Bills of Exchange) (Amendment)	\$0.10
8596.	Motor Car (Fees)	\$0.10
8597.	Business Franchise (Tobacco)	\$0.20
8598.	Liquor Control (Fees)	\$0.10
8599.	Zoological Gardens (Amendment)	\$0.10
8600.	Local Government (Amendment No. 2)	\$0.10
8601.	Revocation and Excision of Crown Reservations	\$0.15
8602.	Status of Children	\$0.20
8603.	Racing (Further Amendment)	\$0.15
8604.	Fertilizers	\$0.40
8605.	Appropriation (1974-75, No. 1)	\$2.20
8606.	Aboriginal Affairs (Transfer of Functions)	\$0.15
8607.	Victorian Institute of Marine Sciences	\$0.20
8608.	Ministry of Transport (Consultative Committees)	\$0.15
8609.	Milk Board (Delivery Charges)	\$0.10
8610.	Deakin University	\$0.30
8611.	Country Roads (Salaries and Contributions)	\$0.10
8612.	Farm Produce Merchants and Commission Agents (Amendment)	\$0.10
8613.	Municipalities Assistance (Amendment)	\$0.10
8614.	Country Fire Authority (Amendment)	\$0.10
8615.	Justices (Theft Offences)	\$0.10

STATE ACTS, 1974—continued.		Price.
No.		
8616.	Chiropodists (Additional Training of Applicants)	\$0.10
8617.	Friendly Societies (Benefits)	\$0.10
8618.	Labour and Industry (Amendment)	\$0.10
8619.	Melbourne and Metropolitan Tramways (Amendment)	\$0.10
8620.	Housing (Commonwealth State Supplemental Agreement)	\$0.10
8621.	Land Tax	\$0.15
8622.	Marine Stores and Old Metals (Beverage Cans)	\$0.10
8623.	West Gate Bridge Authority	\$0.10
8624.	Stamps (Credit and Rental Business)	\$0.10
8625.	County Court (Chief Judge)	\$0.10
8626.	Victorian Public Offices Corporation	\$0.15
8627.	Harbors and Navigable Waters Control	\$0.20
8628.	Electoral Provinces and Districts	\$0.20
8629.	Water Supply Works and Services	\$0.30
8630.	Consumer Affairs	\$0.15
8631.	Wheat Industry Stabilization	\$0.30
8632.	Educational Grants (Continuation)	\$0.10
8633.	Small Claims Tribunals (Amendment)	\$0.10
8634.	Cemeteries (Pioneer Memorial Parks)	\$0.10
8635.	Public Works and Services	\$0.15
8636.	State Forests Works and Services	\$0.10
8637.	Local Government (Shire of Bacchus Marsh)	\$0.10
8638.	Melbourne University (Amendment)	\$0.20
8639.	Sewerage Districts (Amendment)	\$0.10
8640.	River Improvement (Minimum Rate)	\$0.10
8641.	Groundwater (Amendment)	\$0.10
8642.	Health (Contraceptives)	\$0.30
8643.	Pounds (Amendment)	\$0.10
8644.	Railway Works and Services	\$0.10
8645.	Local Government (Municipal Employees Long Service Leave)	\$0.15
8646.	Latrobe Valley (Amendment)	\$0.10
8647.	Extractive Industries (Amendment)	\$0.10
8648.	Housing (Amendment)	\$0.15
8649.	Valuation of Land (Amendment)	\$0.15
8650.	Melbourne and Metropolitan Board of Works (Amendment)	\$0.20
8651.	Ombudsman (Exemption)	\$0.10
8652.	Land (Amendment)	\$0.10
8653.	Wodonga Area Land Acquisition (Amendment)	\$0.10
8654.	Cattle and Swine Compensation (Amendment)	\$0.10
8655.	Milk and Dairy Supervision (Amendment)	\$0.15
8656.	Public Service	\$0.60
8657.	Motor Car	\$0.15
8658.	Education (Teacher Registration)	\$0.15
8659.	Education (Work Experience)	\$0.10
8660.	Local Government (Municipal Abattoirs)	\$0.10
8661.	Cluster Titles	\$0.50
8662.	Motor Boating (Amendment)	\$0.30

C. H. RIXON,  
Government Printer.

ACTS REPRINTED IN ACCORDANCE WITH THE AMENDMENTS INCORPORATION ACT 1958 (No. 6422), AND FOR SALE AT THE SALE OF PUBLICATIONS BRANCH OF THE GOVERNMENT PRINTING OFFICE, MACARTHUR-STREET, MELBOURNE, 3002.  
(These prices do not include postage.)

No.		Price.
6189.	Acts Interpretation (Fourth Reprint—Incorporating amendments up to No. 8305)	\$0.35
6191.	Administration and Probate (Fourth Reprint—Incorporating amendments up to No. 7874)	\$0.75
6194.	Agricultural Colleges (First Reprint—Incorporating amendments up to No. 7302)	\$0.15
6198.	Anzac Day (First Reprint—Incorporating amendments up to No. 8344)	\$0.15
7117.	Appeal Costs Fund Act 1964 (Second Reprint—Incorporating amendments up to No. 7488)	\$0.35
6199.	Apprenticeship (Second Reprint—Incorporating amendments up to No. 7869)	\$0.40
6201.	Architects (First Reprint—Incorporating amendments up to No. 8077)	\$0.30
6203.	Audit (First Reprint—Incorporating amendments up to No. 7377)	\$0.35
6208.	Benefit Associations (First Reprint—Incorporating amendments up to No. 6961)	\$0.45
8004.	Boiler and Pressure Vessels Act 1970 (First Reprint—Incorporating amendments up to No. 8389)	\$0.45
6529.	Bread Industry Act 1959 (First Reprint—Incorporating amendments up to No. 7728)	\$0.30

No.		Price.
6973.	Building Contracts (Deposits) Act 1962 (First Reprint—Incorporating amendments from No. 7315)	\$0.10
6210.	Building Society (Third Reprint—Incorporating amendments up to No. 8405)	\$0.65
6213.	Cancer (First Reprint—Incorporating amendments up to No. 7455)	\$0.35
6214.	Carriers and Innkeepers (Second Reprint—Incorporating amendments up to No. 8534)	\$0.20
6217.	Cemeteries (First Reprint—Incorporating amendments up to No. 7672)	\$0.30
6220.	Clean Air (Second Reprint—Incorporating amendments up to No. 8196)	\$0.15
6221.	Coal Mines (First Reprint—Incorporating amendments up to No. 7628)	\$1.05
6222.	Commercial Goods Vehicles Act 1958 (Third Reprint)—Incorporating amendments up to Act No. 8525	\$0.55
6223.	Commonwealth Arrangements (First Reprint—Incorporating amendments from No. 7809)	\$0.10
6839.	Companies (Fifth Reprint—Incorporating amendments up to No. 8594)	\$5.95
8276.	Consumer Protection Act 1972 (Second Reprint)—Incorporating amendments up to Act No. 8540	\$0.75
6224.	The Constitution Act Amendment (First Reprint—Incorporating amendments up to No. 8086)	\$3.05
6225.	Co-operation Act (Third Reprint—Incorporating amendments up to No. 8339)	\$0.85
6226.	Co-operative Housing Societies (Second Reprint—Incorporating amendments up to No. 7575)	\$0.53
6227.	Coroners Act 1958. Reprint (No. 2) incorporating amendments up to Act No. 8184	\$0.35
6228.	Country Fire Authority (Second Reprint—Incorporating Amendments up to No. 7476)	\$0.50
6229.	Country Roads (Fourth Reprint—Incorporating amendments up to Act No. 8573)	\$1.05
6230.	County Court (Second Reprint—Incorporating amendments up to No. 8132)	\$0.65
6231.	Crimes (Fourth Reprint—Incorporating amendments up to Act No. 8338)	\$2.75
6232.	Crown Proceedings (First Reprint—Incorporating amendments up to No. 7900)	\$0.30
6233.	Dairy Products (First Reprint—Incorporating amendments up to No. 7945)	\$0.20
7060.	Dandenong Valley Authority Act 1963 (First Reprint—Incorporating amendments up to No. 7523)	\$0.35
6235.	Dietitians Registration (First Reprint—Incorporating amendments up to No. 6886)	\$0.20
4989.	Discharged Servicemen's Preference Act 1943. (Second Reprint—Incorporating amendments up to No. 7991)	\$0.20
6815.	Disposal of Uncollected Goods Act 1961 (First Reprint—Incorporating amendments up to No. 7181)	\$0.15
6237.	Drainage Areas (First Reprint—Incorporating amendments up to No. 7276)	\$0.35
6238.	Drainage of Land (First Reprint—Incorporating amendments up to No. 7876)	\$0.15
6239.	Dried Fruits Act 1968 (First Reprint—Incorporating amendments up to No. 7337)	\$0.25
6240.	Education (First Reprint—Incorporating amendments up to No. 7533)	\$0.45
6241.	Electric Light and Power (First Reprint—Incorporating amendments up to No. 7315)	\$0.30
6242.	Employers and Employés (Incorporating amendments up to No. 6740)	\$0.18
8056.	Environment Protection Act 1970 (Second Reprint—Incorporating amendments up to No. 8560)	\$0.55
6245.	Estate Agents (Fourth Reprint—Incorporating amendments up to No. 8181)	\$0.85
6246.	Evidence (Fourth Reprint—Incorporating amendments up to No. 8228)	\$1.05
7499.	Extractive Industries Act 1966. (Second Reprint)—Incorporating amendments up to No. 7951)	\$0.40
6250.	Fertilizers (Incorporating amendments up to No. 7142)	\$0.25
6468.	Filled Milk (First Reprint—Incorporating amendments up to No. 6886)	\$0.15
6251.	Firearms (Fourth Reprint—Incorporating amendments up to No. 8288)	\$0.75
6916.	Foreign Judgments Act 1962 (First Reprint—Incorporating amendments made by No. 7332)	\$0.15

ACTS REPRINTED IN ACCORDANCE WITH THE AMENDMENTS INCORPORATION ACT 1958 (No. 6422)—*continued*.

6585. Forests (Pulpwood Agreement) (Incorporating amendments up to No. 6886) ..	\$0.15
6254. Forests (First Reprint—Incorporating amendments up to No. 7356) ..	\$0.60
6255. Friendly Societies (First Reprint—Incorporating amendments up to No. 7554) ..	\$0.60
6256. Fruit and Vegetables (First Reprint—Incorporating amendments up to No. 6944) ..	\$0.30
3258. Game (First Reprint—Incorporating amendments up to No. 7389) ..	\$0.30
3260. Gas and Fuel Corporation (First Reprint—Incorporating amendments up to No. 7422) ..	\$0.70
6262. Geelong Harbor Trust (First Reprint—Incorporating amendments up to No. 7547) ..	\$0.45
6263. Geelong Waterworks and Sewerage (First Reprint—Incorporating amendments up to No. 7547) ..	\$0.75
8176. Gift Duty Act 1971 (First Reprint—Incorporating amendments from No. 8202) ..	\$0.55
6265. Goods Act 1958 (Sixth Reprint—Incorporating amendments up to Act No. 8455) ..	\$0.45
6266. Grain Elevators (First Reprint—Incorporating amendments up to No. 7486) ..	\$0.35
7849. Groundwater (First Reprint—Incorporating amendments up to No. 8153) ..	\$0.45
6267. Hairdressers Registration (First Reprint—Incorporating amendments up to Act No. 7659) ..	\$0.30
6269. Hawkers and Pedlars Act 1958 (Second Reprint—Incorporating amendments up to Act No. 8247) ..	\$0.30
6270. Health Act (Third Reprint—Incorporating amendments up to No. 8506) ..	\$3.25
6531. Hire Purchase Act 1959 (Second Reprint—Incorporating amendments from Act No. 8232) ..	\$0.55
6933. Home Finance Act 1962 (First Reprint—Incorporating amendments up to No. 7363) ..	\$0.25
6274. Hospitals and Charities (Second Reprint—Incorporating amendments up to No. 7455) ..	\$0.50
6275. Housing (Second Reprint—Incorporating amendments up to No. 8052) ..	\$1.65
6276. Imprisonment of Fraudulent Debtors (First Reprint—Incorporating amendments up to No. 7876) ..	\$0.35
6277. Industrial and Provident Societies (First Reprint—Incorporating amendments up to No. 7547) ..	\$0.35
6279. Instruments (Fourth Reprint—Incorporating amendments up to No. 7941) ..	\$0.75
6280. Judicial Proceedings Reports (First Reprint—Incorporating amendments up to No. 7596) ..	\$0.15
7651. Juries (First Reprint—Incorporating amendments up to No. 8170) ..	\$0.55
6282. Justices Act 1958 (Fourth Reprint—Incorporating amendments up to No. 8338) ..	\$2.35
6283. Labour and Industry Act 1958 (Sixth Reprint—Incorporating amendments up to Act No. 8642) ..	\$1.50
6284. Land Act 1959 (Second Reprint—Incorporating amendments up to No. 8243) ..	\$3.15
6534. Land Settlement Act 1959 (First Reprint—Incorporating amendments up to No. 7328) ..	\$0.30
6288. Land Surveyors (First Reprint—Incorporating amendments up to Act No. 7065) ..	\$0.30
6289. Land Tax (Second Reprint—Incorporating amendments up to No. 7466) ..	\$0.40
6285. Landlord and Tenant (Fourth Reprint—Incorporating amendments up to No. 8208) ..	\$1.15
6286. Lands Compensation (Second Reprint—Incorporating amendments up to No. 8432) ..	\$0.45
6290. Latrobe Valley (First Reprint—Incorporating amendments up to No. 7332) ..	\$0.35
6291. Legal Profession Practice Act (Third Reprint—Incorporating amendments up to No. 8259) ..	\$1.15
6292. Libraries (First Reprint—Incorporating amendments up to No. 7364) ..	\$0.15
6295. Limitation of Actions (Third Reprint—Incorporating amendments up to No. 8300) ..	\$0.35
7695. Liquor Control Act 1958 (Third Reprint—Incorporating amendments up to No. 8598) ..	\$1.35
7145. Litter Act 1964 (First Reprint—Incorporating amendments up to No. 7608) ..	\$0.15
6298. Local Authorities Superannuation (Second Reprint—Incorporating amendments up to No. 7161) ..	\$0.40
6299. Local Government (New Parts I. and II.—Incorporating amendments up to No. 8380 of 1972) ..	\$0.60

ACTS REPRINTED IN ACCORDANCE WITH THE AMENDMENTS INCORPORATION ACT 1958 (No. 6422)—*continued*.

No.	Price.
6299. Local Government. New Parts III. to IX.—(Incorporating amendments up to No. 8557) ..	\$1.70
6299. Local Government New Parts X.—XI. (Incorporating amendments up to No. 8405) ..	\$0.80
6299. Local Government New Parts XII.—XIX. (Incorporating amendments up to No. 8380) ..	\$2.65
6299. Local Government New Parts XX.—XXIX. (Incorporating amendments up to No. 8445 and S.R. 186/73) ..	\$2.90
6299. Local Government Act (New Divisions 1 and 2 to Part XLIX.—Incorporating amendments up to No. 8564) ..	\$0.60
7289. Maintenance (First Reprint—Incorporating amendments up to No. 8036) ..	\$1.05
6301. Margarine (First Reprint—Incorporating amendments up to No. 7714) ..	\$0.18
6302. Marine (Incorporating amendments up to No. 7350) ..	\$0.72
6303. Marine Stores and Old Metals (First Reprint—Incorporating amendments up to No. 7876) ..	\$0.35
6304. Marketing of Primary Products (First Reprint—Incorporating amendments up to No. 7491) ..	\$0.45
6305. Markets (First Reprint—Incorporating amendments up to No. 7705) ..	\$0.20
6306. Marriage (First Reprint—Incorporating amendments up to No. 6959) ..	\$0.25
6307. Masseurs (First Reprint—Incorporating amendments up to No. 7566) ..	\$0.20
6309. Medical (Second Reprint—Incorporating amendments up to No. 7408) ..	\$0.40
6310. Melbourne and Metropolitan Board of Works (Fourth Reprint—Incorporating amendments up to No. 8650) ..	\$1.95
6311. Melbourne and Metropolitan Tramways (First Reprint—Incorporating amendments up to No. 7622) ..	\$0.70
6312. Melbourne Harbor Trust (First Reprint—Incorporating amendments up to No. 7356) ..	\$0.48
6405. Melbourne University (First Reprint—Incorporating amendments up to No. 7871) ..	\$0.40
6605. Mental Health (Incorporating amendments up to No. 7135) ..	\$0.45
6315. Metropolitan Fire Brigades (Second Reprint—Incorporating amendments up to No. 8165) ..	\$0.65
6316. Mildura Irrigation and Water Trusts (First Reprint—Incorporating amendments up to No. 7448) ..	\$0.75
6317. Milk and Dairy Supervision (Incorporating amendments up to No. 6964) ..	\$0.40
6318. Milk Board (Incorporating amendments up to No. 7093) ..	\$0.22
6319. Milk Pasteurization (First Reprint—Incorporating amendments up to No. 7480) ..	\$0.18
6320. Mines (Second Reprint—Incorporating amendments up to No. 7876) ..	\$1.25
6184. Monash University (First Reprint—Incorporating amendments up to No. 7533) ..	\$0.30
6324. Money Lenders (Fourth Reprint—Incorporating amendments up to No. 8490) ..	\$0.55
6325. Motor Car Act 1958 (Fifth Reprint—Incorporating amendments up to No. 8657) ..	\$2.25
6713. National Fitness Council of Victoria Act 1960 (First Reprint—Incorporating amendments up to No. 8344) ..	\$0.20
6705. Navigable Waters (Oil Pollution) Act 1960. (First Reprint—Incorporating amendments up to No. 7890) ..	\$0.30
6328. Nurses (Second Reprint—Incorporating amendments up to No. 7375) ..	\$0.45
6329. Opticians Registration (First Reprint—Incorporating amendments up to No. 7409) ..	\$0.30
6330. Partnership (Second Reprint—Incorporating amendments up to No. 7315) ..	\$0.35
6331. Patriotic Funds (First Reprint—Incorporating amendments up to No. 7338) ..	\$0.25
6332. Pawnbrokers (First Reprint—Incorporating amendments up to No. 7876) ..	\$0.35
7417. Pensions Supplementation (First Reprint—Incorporating amendments up to No. 8475) ..	\$0.20
6257. Pesticides Act 1968 (First Reprint—Incorporating amendments up to No. 7595) ..	\$0.15
6334. Petroleum (First Reprint—Incorporating amendments up to No. 7876) ..	\$0.65
6889. Poisons Act 1962 (Third Reprint—Incorporating amendments up to No. 8424) ..	\$0.85

ACTS REPRINTED IN ACCORDANCE WITH THE AMENDMENTS—  
INCORPORATION ACT 1958 (No. 6422)—*continued.*

No.	Price.
6337. Police Offences Act 1958 ( <i>Third Reprint</i> — Incorporating amendments up to No. 8433)	\$0.45
6338. Police Regulation ( <i>Second Reprint</i> — Incorporating amendments up to No. 8179)	\$0.95
6340. Portland Harbor Trust ( <i>First Reprint</i> — Incorporating amendments up to No. 7475)	\$0.35
6341. Pounds ( <i>First Reprint</i> — Incorporating amendments up to No. 7315)	\$0.25
7498. Port Phillip Authority Act 1966 ( <i>First Reprint</i> — Incorporating amendments from No. 8081)	\$0.15
6342. Printers and Newspapers ( <i>First Reprint</i> — Incorporating amendments up to No. 7876)	\$0.15
7494. Private Agents Act 1966 ( <i>First Reprint</i> — Incorporating amendments in No. 7646)	\$0.35
6344. Property Law ( <i>Third Reprint</i> — Incorporating amendments up to No. 8181)	\$1.95
6345. Public Account ( <i>First Reprint</i> — Incorporating amendments up to No. 8012)	\$0.20
6346. Public Authorities Marks ( <i>First Reprint</i> — Incorporating amendments from No. 7315)	\$0.10
6350. Public Trustee ( <i>Incorporating amendments</i> up to No. 6961)	\$0.35
6353. Racing ( <i>Third Reprint</i> — Incorporating amendments up to No. 8080)	\$1.45
6355. Railways ( <i>First Reprint</i> — Incorporating amendments up to No. 7475)	\$0.75
6564. Registration of Births Deaths and Marriages Act 1959 ( <i>First Reprint</i> — Incorporating amendments up to No. 7332)	\$0.25
6358. River Improvement Act ( <i>First Reprint</i> — Incorporating amendments up to No. 8342)	\$0.55
2596. River Murray Waters Act 1915 ( <i>First Reprint</i> — Incorporating amendments up to No. 7061)	\$0.35
6360. Rural Finance ( <i>First Reprint</i> — Incorporating amendments up to No. 7328)	\$0.15
6846. Rural Finance and Settlement Commission Act 1961 ( <i>First Reprint</i> — Incorporating amendments up to No. 7332)	\$0.30
6917. Sale of Human Blood Act 1962 ( <i>First Reprint</i> — Incorporating amendments from No. 7332)	\$0.10
6975. Sale of Land Act 1962 ( <i>Second Reprint</i> — Incorporating amendments up to No. 7898)	\$0.35
6363. Second-hand Dealers ( <i>First Reprint</i> — Incorporating amendments up to No. 7529)	\$0.25
7962. Securities Industry Act 1970 ( <i>First Reprint</i> — Incorporating amendments made by Act No. 8059)	\$0.65
6367. Settled Land ( <i>Second Reprint</i> — Incorporating amendments up to No. 7065)	\$0.50
6368. Sewerage Districts ( <i>Second Reprint</i> — Incorporating amendments up to No. 7547)	\$0.75
6369. Shearers Accommodation ( <i>First Reprint</i> — Incorporating amendments up to No. 7876)	\$0.35
6809. Sheep Owners Protection Act 1961 ( <i>Second Reprint</i> — Incorporating amendments up to No. 8179)	\$0.20
6372. Soil Conservation and Land Utilization Act ( <i>Third Reprint</i> — Incorporating amendments up to No. 8432)	\$0.45
6373. Soldier Settlement ( <i>First Reprint</i> — Incorporating amendments up to No. 7328)	\$0.42
6375. Stamps Act 1958 ( <i>Sixth Reprint</i> — Incorporating amendments up to Act No. 8624)	\$2.15
6377. State Electricity Commission ( <i>Second Reprint</i> — Incorporating amendments up to No. 7421)	\$0.65
6378. State Relief Committee ( <i>First Reprint</i> — Incorporating amendments from No. 6886)	\$0.10
6379. State Savings Bank Act 1958 ( <i>Third Reprint</i> — Incorporating amendments up to Act No. 8519)	\$0.95
6380. Statistics ( <i>First Reprint</i> — Incorporating amendments up to No. 6961)	\$0.15
6383. Stock Foods ( <i>First Reprint</i> — Incorporating amendments up to No. 7607)	\$0.28
6384. Stock Medicines ( <i>First Reprint</i> — Incorporating amendments up to No. 7726)	\$0.20
7551. Strata Titles Act 1967 ( <i>Second Reprint</i> — Incorporating amendments up to No. 8149)	\$0.65
6886. Subordinate Legislation Act 1962 ( <i>Second Reprint</i> — Incorporating amendments up to No. 8127)	\$0.15

ACTS REPRINTED IN ACCORDANCE WITH THE AMENDMENTS—  
INCORPORATION ACT 1958 (No. 6422)—*continued.*

No.	Price.
7405. Summary Offences Act 1966 ( <i>Second Reprint</i> — Incorporating amendments up to Act No. 8276)	\$0.55
7634. Sunday Entertainment ( <i>First Reprint</i> — Incorporating amendments up to No. 8173)	\$0.15
6386. Superannuation ( <i>Second Reprint</i> — Incorporating amendments up to No. 7910)	\$0.75
6387. Supreme Court ( <i>First Reprint</i> — Incorporating amendments up to No. 7522)	\$0.75
6388. Survey Co-ordination ( <i>First Reprint</i> — Incorporating amendments up to Act No. 8107)	\$0.35
6390. Tattersall Consultations ( <i>First Reprint</i> — Incorporating amendments up to No. 8289)	\$0.15
6391. Teaching Service ( <i>First Reprint</i> — Incorporating amendments up to No. 7536)	\$0.35
6849. Town and Country Planning Act 1961 ( <i>Fourth Reprint</i> — Incorporating amendments up to No. 8380)	\$1.15
6401. Trustee ( <i>Third Reprint</i> — Incorporating amendments up to No. 7833)	\$0.85
6402. Trustee Companies ( <i>First Reprint</i> — Incorporating amendments up to No. 7858)	\$0.35
7223. Tomato Processing Industry (Uniform Agree- ment) Act 1964 ( <i>First Reprint</i> — Incorporating amendments up to No. 7342)	\$0.15
6397. Trade Unions ( <i>First Reprint</i> — Incorporating amendments up to No. 6839)	\$0.20
6399. Transfer of Land Act ( <i>Fourth Reprint</i> — Incorporating amendments up to No. 8181)	\$1.15
6400. Transport Regulation Act ( <i>Second Reprint</i> — Incorporating amendments up to Act 8549)	\$0.45
6879. Unclaimed Moneys Act 1962 ( <i>Second Reprint</i> — Incorporating amendments up to Act No. 8448)	\$0.20
7095. Underseas Mineral Resources Act 1963 ( <i>First Reprint</i> — Incorporating amendments from No. 7591)	\$0.10
6653. Valuation of Land Act 1960 ( <i>Third Reprint</i> — Incorporating amendments up to No. 8432)	\$0.55
6407. Vegetation and Vine Diseases ( <i>First Reprint</i> — Incorporating amendments up to No. 7423)	\$0.30
6409. Vermin & Noxious Weeds ( <i>First Reprint</i> — Incorporating amendments up to No. 7463)	\$0.35
6410. Veterinary Surgeons ( <i>First Reprint</i> — Incorporating amendments up to No. 7343)	\$0.15
6411. Victorian Inland Meat Authority ( <i>First Reprint</i> — Incorporating amendments up to No. 8000)	\$0.30
7291. Victoria Institute of Colleges Act 1965 ( <i>First Reprint</i> — Incorporating amendments up to No. 7644)	\$0.25
6412. Warehousemen's Liens ( <i>First Reprint</i> — Incorporating amendments up to No. 7876)	\$0.15
6413. Water ( <i>Second Reprint</i> — Incorporating amendments up to No. 7590)	\$1.95
6414. Weights and Measures ( <i>Third Reprint</i> — Incorporating amendments up to No. 8068)	\$1.05
6415. Wild Flowers and Native Plants Protection ( <i>First Reprint</i> — Incorporating amendments up to No. 6976)	\$0.15
6416. Wills ( <i>First Reprint</i> — Incorporating amendments up to No. 7238)	\$0.25
6417. Wire Netting ( <i>First Reprint</i> — Incorporating amendments up to No. 7876)	\$0.45
6419. Workers Compensation ( <i>Sixth Reprint</i> — Incorporating amendments up to No. 8417)	\$1.05
6420. Wrongs ( <i>First Reprint</i> — Incorporating amendments up to No. 8330)	\$0.35
8344. Youth, Sport and Recreation Act 1972 ( <i>First Reprint</i> — Incorporating amendments up to Act No. 8550)	\$0.35

C. H. RIXON,  
Government Printer.

## FIRST NOTIFICATION OF REPRINT.

7629. Lifts and Cranes Act 1967 ( <i>First Reprint</i> — Incorporating amendments up to No. 8320)	\$0.30
6202. Auction Sales Act 1958 ( <i>First Reprint</i> — Incorporating amendments up to Act No. 8490)	\$0.35
7733. Fences ( <i>First Reprint</i> — Incorporating amendments from No. 7876)	\$0.35



**THE "VICTORIA GOVERNMENT GAZETTE".**

**SUBSCRIPTIONS.**—The subscription, including postage, is \$40 per annum, or \$20 per half year, payable in advance.

Subscriptions are required for whole months, and must cover at least a half year.

Single copies are 30 cents, posted 63 cents. Subscribers do not receive the Acts of Parliament with the GAZETTE.

GAZETTES are held in stock for five years only.

**PRIVATE ADVERTISEMENTS.**—The charge for insertion is 55 cents per line single column, and \$1.10 cents per line double column. The title forms one or more lines as a heading. On an average ten words make a line of single column. Every signature must likewise be counted as a line. The final words of a paragraph, though only portion of a line, must be counted as one line. Signatures (in particular) and proper names must be written very plainly in the text; ONE SIDE ONLY of each sheet of paper should be WRITTEN UPON. The charge for a full page is \$85.

All documents illegibly written will be returned unpublished, and where brands occur unprovided for by the ordinary letters of the alphabet, a worded explanatory description must be furnished.

**PUBLICATION.**—Unless otherwise advertised, the VICTORIA GOVERNMENT GAZETTE is published on WEDNESDAY EVENING in each week, and Notices for insertion will be received by the Government Printer at or before ONE p.m. at ordinary rates, and late advertisements between ONE p.m. and half-past THREE p.m. at double rates on the day preceding the day of publication.

**PAYMENTS.**—Unless the advertiser has a credit account, all payments are required in advance. Remittances should be made by cheque, postal order, or money order payable to "GOVERNMENT PRINTER".

**ADDRESS.**—All communications should be addressed to "The Government Printer, Box 203, P.O., North Melbourne, 3051."

**AGENTS FOR THE "VICTORIA GOVERNMENT GAZETTE".**

The following have been appointed agents to receive Advertisements and Subscriptions for the Victoria Government Gazette:—

- ARMSTRONG'S AGENCY, 217 Queen-street, Melbourne, Victoria 3000.
- ARNALL & JACKSON, 390 Barkly-street, Brunswick, Victoria 3056.
- BAIRNSDALE AUTHORIZED NEWSAGENCY, 132 Main-street, Bairnsdale, Victoria 3875.
- BICKNELL, M. J., Authorized Newsagent, 196 Timor-street, Warrnambool, Victoria 3280.
- BLANE'S AUTHORIZED NEWSAGENTS, 162 Murray-street, Colac, Victoria 3250.
- CARTER, R. G., ADVERTISING SERVICE PTY. LTD., Suite 24, 65 Queens-road, Melbourne, Victoria 3004.
- DAVIES, G. & M. V., 112 Gray-street, Hamilton, Victoria 3300.
- DAVIS, WM. (MILDURA) PTY. LTD., 126 Eighth-street, Mildura, Victoria 3500.
- DIXON'S NEWSAGENCY, 89 Firebrace-street, Horsham, Victoria 3400.
- EDGAR'S AUTHORIZED NEWSAGENCY, 45 Bridge-street, Benalla, Victoria 3672.
- FRANKS, H., & CO., 184 Ryrie-street, Geelong, Victoria 3220.
- GATLEY, A. & J., 250 Lonsdale-street, Dandenong, Victoria 3175.
- GORDON & GOTCH AUSTRALASIA LTD., 434 St. Kilda-road, Melbourne, Victoria 3004.
- GULLAN'S NEWSAGENCY, 88 Bridge-street, Ballarat, Victoria 3350.
- HAMPTON, A. C., 243 Mitchell-street, Bendigo, Victoria 3550.

- HARSTON, PARTRIDGE & CO. PTY. LTD., 455 Little Collins-street, Melbourne, Victoria 3000.
- KYNETON GUARDIAN PTY. LTD., P.O. Box 18, Kyneton Victoria 3444.
- LIVINGSTON'S SHEPPARTON NEWSAGENCY, 246 Wyndham-street, Shepparton, Victoria 3630.
- THE MERCANTILE EXCHANGE, 34 Queen-street, Melbourne, Victoria 3000.
- MCGILL'S AUTHORIZED NEWSAGENCY, 183-5 Elizabeth-street, Melbourne, Victoria 3000.
- POWNEY'S AUTHORIZED NEWSAGENCY, 293 Hargreaves-street, Bendigo, Victoria 3550.
- PURDIE, J., & CO., 138 Moorabool-street, Geelong, Victoria 3220.
- SALE AUTHORIZED NEWSAGENCY, 142 Raymond-street, Sale, Victoria 3850.
- SKINNER'S AUTHORIZED NEWSAGENCY, 49-51 Franklin-street, Traralgon, Victoria 3844.
- STEVENSON, A. C. & M., NEWSAGENTS, 132 Henty-street, Casterton, Victoria 3311.
- VANCE'S AUTHORIZED NEWSAGENCY, 83 Murray-street, Wangaratta 3677.
- VERNONS OF RICHMOND, 162 Bridge-road, Richmond, Victoria 3121.
- VIEW POINT AUTHORIZED NEWSAGENCY, 4 View-Point, Bendigo, Victoria 3550.

A copy of the Gazette is filed at each place for public reference.

<b>CONTENTS</b>	<b>PAGE</b>
Acts of Parliament on Sale at the Government Printing Office .. .. .	2574
Appointments .. .. .	2524
Cemeteries—Scale of Fees .. .. .	2515
Contracts .. .. .	2522
Country Roads Board .. .. .	2507
Estates of Deceased Persons .. .. .	2520
Government Notices .. .. .	2500
Impoundings .. .. .	2573
Lands .. .. .	2532
Melbourne and Metropolitan Board of Works—Notice .. .. .	2518
Mining .. .. .	2521
Notices to Mariners .. .. .	2504
Notice of Making of Statutory Rules .. .. .	2574
Orders in Council—	
Acts—Soil Conservation and Land Utilization; Land; Water; Mildura Irrigation and Water Trusts; Metropolitan Fire Brigades; Apprenticeship; State Savings Bank; Melbourne and Metropolitan Tramways; Melbourne Underground Rail Loop; Superannuation; Swan Hill Pioneer Settlement; Sewerage Districts; Water.	2525 et seq
Private Advertisements .. .. .	2539
Proclamations .. .. .	2499
Public Half-Holidays .. .. .	2499
Public Service Notices .. .. .	2536
Resignations .. .. .	2525
Tenders .. .. .	2535
Transport Regulation Board—Public Hearings .. .. .	2501
Waterworks Trusts .. .. .	2520