

[1387]



VICTORIA GOVERNMENT GAZETTE

Published by Authority

No. 48]

WEDNESDAY, MAY 19

[1976

PROCLAMATIONS

BANK HALF-HOLIDAY.

PROCLAMATION

By His Excellency the Governor of the State of Victoria and its Dependencies in the Commonwealth of Australia, &c., &c., &c.

In pursuance of the provisions of the *Bank Holidays Act 1958, I*, the Governor of the State of Victoria, in the Commonwealth of Australia, do by this my Proclamation appoint the day and date named hereunder a special day to be observed as a Bank Half-Holiday at the place mentioned, that is to say:—

Bank Half-Holiday from the Hour of Eleven a.m.:—

FRIDAY, THE 28TH MAY, 1976, at Coleraine.

Given under my Hand and the Seal of the State of Victoria aforesaid, at Melbourne, this eleventh day of May, in the year of our Lord One thousand nine hundred and seventy-six and in the twenty-fifth year of the reign of Her Majesty Elizabeth the Second, Queen of Australia.

(L.s.) HENRY WINNEKE.

By His Excellency's Command.

VANCE DICKIE,
Chief Secretary.

GOD SAVE THE QUEEN!

PUBLIC HALF-HOLIDAY.

PROCLAMATION

By His Excellency the Governor of the State of Victoria and its Dependencies in the Commonwealth of Australia, &c., &c., &c.

In pursuance of the provisions contained in Part VI of the *Public Service Act 1974, I*, the Governor of the State of Victoria, in the Commonwealth of Australia, by and with the advice of the Executive Council of the said State, do by this my Proclamation appoint the day and date hereunder mentioned to be observed as a Public Half-Holiday at the place specified, viz:—

Public Half-Holiday from the Hour of Twelve o'clock noon:—

FRIDAY, THE 28TH MAY, 1976, throughout the Coleraine Riding of the Shire of Wannon.

Given under my Hand and the Seal of the State of Victoria aforesaid, at Melbourne, this eleventh day of May, in the year of our Lord One thousand nine hundred and seventy-six and in the twenty-fifth year of the reign of Her Majesty Elizabeth the Second, Queen of Australia.

(L.s.) HENRY WINNEKE.

By His Excellency's Command.

VANCE DICKIE,
Chief Secretary.

GOD SAVE THE QUEEN!

Metropolitan Fire Brigades Act 1958.

METROPOLITAN FIRE BRIGADES BOARD.—
ENLARGEMENT OF FIRE DISTRICT.

PROCLAMATION

By His Excellency the Governor of the State of Victoria and its Dependencies in the Commonwealth of Australia, &c., &c., &c.

Whereas by the *Metropolitan Fire Brigades Act 1958* it is amongst other things enacted that, on the request of the Council of any municipal district and on receiving a certificate from the Metropolitan Fire Brigades Board that it is necessary or desirable so to do, the Governor in Council may by Proclamation published in the *Government Gazette* declare that that municipal district, or a specified part thereof, shall be added to and shall form part of the Metropolitan Fire District:

And whereas the council of the municipal district of the City of Keilor has requested that a further portion of the municipal district of the City of Keilor be included within the Metropolitan Fire District:

And whereas a certificate has been received from the Metropolitan Fire Brigades Board that it is desirable so to do:

Now therefore I, The Governor of the State of Victoria, in the Commonwealth of Australia, by and with the advice of the Executive Council of the said State, and in pursuance of the provisions of Section 5 (1) of the said Act, do by this my Proclamation declare that the portions of

the municipal district of the City of Keilor enclosed within the boundaries set forth hereunder shall from the nineteenth day of May, 1976, be added to and form part of the Metropolitan Fire District, viz:—

Area.

Commencing at the junction of Kororoit Creek and Main Road West; generally northerly by the boundary of the City of Keilor to its junction with Taylors Road; easterly by that road to the Melbourne-Bendigo Railway line; north westerly by that railway line to its intersection with the Keilor-Melton Road; south easterly by that road to the Calder Highway; north westerly by that Highway for approximately 753 metres to an unnamed Government road; easterly and northerly by that road to the Maribyrnong River; generally easterly and southerly by that River to its junction with the existing boundary of the Metropolitan Fire District; thence generally southerly and westerly by that boundary to the point of commencement.

Given under my Hand and the Seal of the State of Victoria aforesaid, at Melbourne, this eighteenth day of May, in the year of our Lord One thousand nine hundred and seventy-six and in the twenty-fifth year of the reign of Her Majesty Elizabeth the Second, Queen of Australia.

(L.S.) HENRY WINNEKE.

By His Excellency's Command,

VANCE DICKIE,
Chief Secretary.

GOD SAVE THE QUEEN!

Land Act 1958.

MALDON SHIRE COMMON DIMINISHED.

PROCLAMATION

By His Excellency the Governor of the State of Victoria and its Dependencies in the Commonwealth of Australia, &c., &c., &c.

I, the Governor of the State of Victoria in the Commonwealth of Australia, by and with the advice of the Executive Council of the said State, pursuant to Section 184 of the Land Act 1958, do hereby diminish the Maldon Shire Common, proclaimed as such on the 2nd April, 1889, by the excision therefrom of allotment 46 of section 6A in the Township of Maldon, containing 8777 square metres. —(Rs.353.)

Given under my Hand and the Seal of the State of Victoria aforesaid, at Melbourne, this eleventh day of May, in the year of our Lord One thousand nine hundred and seventy-six and in the twenty-fifth year of the reign of Her Majesty Queen Elizabeth the Second, Queen of Australia.

(L.S.) HENRY WINNEKE.

By His Excellency's Command,

W. BORTHWICK,
Minister of Lands.

GOD SAVE THE QUEEN!

Land Act 1958.

MALDON SHIRE COMMON DIMINISHED.

PROCLAMATION

By His Excellency the Governor of the State of Victoria and its Dependencies in the Commonwealth of Australia, &c., &c., &c.

I, the Governor of the State of Victoria in the Commonwealth of Australia, by and with the advice of the Executive Council of the said State, pursuant to Section 184 of the Land Act 1958, do hereby diminish the Maldon Shire Common, proclaimed as such on the 2nd April, 1889, by the excision therefrom of allotment 8c of Section 11c in the Township of Maldon, containing 3351 square metres. —(Rs.353.)

Given under my Hand and the Seal of the State of Victoria aforesaid, at Melbourne, this eleventh day of May, in the year of our Lord One thousand nine hundred and seventy-six and in the twenty-fifth year of the reign of Her Majesty Queen Elizabeth the Second, Queen of Australia.

(L.S.) HENRY WINNEKE.

By His Excellency's Command,

W. BORTHWICK,
Minister of Lands.

GOD SAVE THE QUEEN!

Land Act 1958.

THE COROP AGRICULTURAL AREA TEMPORARY COMMON ABOLISHED.

PROCLAMATION

By His Excellency the Governor of the State of Victoria and its Dependencies in the Commonwealth of Australia, &c., &c., &c.

I, the Governor of the State of Victoria in the Commonwealth of Australia, by and with the advice of the Executive Council of the said State, pursuant to Section 184 of the Land Act 1958, do hereby abolish the Corop Agricultural Area Temporary Common, proclaimed as such on the 5th November, 1866.—(C.82897.)

Given under my Hand and the Seal of the State of Victoria aforesaid, at Melbourne, this eleventh day of May, in the year of our Lord One thousand nine hundred and seventy-six and in the twenty-fifth year of the reign of Her Majesty Queen Elizabeth the Second, Queen of Australia.

(L.S.) HENRY WINNEKE.

By His Excellency's Command,

W. BORTHWICK,
Minister of Lands.

GOD SAVE THE QUEEN!

SOCIAL WELFARE (AMENDMENT) ACT 1973, No. 8426.

DATE OF COMING INTO OPERATION.

PROCLAMATION

By His Excellency the Governor of the State of Victoria and its Dependencies in the Commonwealth of Australia, &c., &c., &c.

Whereas by an Act of Parliament of the State of Victoria passed in the twenty-second year of the reign of Her Majesty Queen Elizabeth II, Queen of Australia, entitled the Social Welfare (Amendment) Act 1973—No. 8426—it is amongst other things enacted that the several provisions of the said Act shall come into operation on the day or respective days to be fixed by proclamation or successive proclamations of the Governor in Council published in the Government Gazette.

Now, therefore I, the Governor of the State of Victoria in the Commonwealth of Australia, by and with the advice of the Executive Council of the said State, do by this my proclamation fix Monday the seventh day of June One thousand nine hundred and seventy-six as the day on which Sections 2; 3; 4; 5; 6 and 9 of the said Social Welfare (Amendment) Act 1973—No. 8426—shall come into operation.

Given under my Hand and the Seal of the State of Victoria aforesaid, at Melbourne, this eighteenth day of May, in the year of our Lord One thousand nine hundred and seventy-six and in the twenty-fifth year of the reign of Her Majesty, Elizabeth the Second, Queen of Australia.

(L.S.) HENRY WINNEKE.

By His Excellency's Command,

BRIAN DIXON,
Minister for Social Welfare.

GOD SAVE THE QUEEN!

ACTS OF PARLIAMENT.

PROCLAMATION

By His Excellency the Governor of the State of Victoria and its Dependencies in the Commonwealth of Australia, &c., &c., &c.

I, the Governor of the State of Victoria, in the Commonwealth of Australia, do hereby declare that I have this day assented, in Her Majesty's name, to the Bills passed by the Parliament of the said State, the titles whereof are hereunder set forth, together with the short titles, that is to say:—

No. 8835. "An Act to amend the Bees Act 1971 and for other purposes." (Bees (Amendment) Act 1976.)

No. 8836. "An Act to facilitate the Transfer of Officers of the Australian Tractor Testing Station at Werribee employed by the University of Melbourne to employment in the Public Service." (Australian Tractor Testing Station Act 1976.)

No. 8837. "An Act to amend the Liquefied Gases Act 1968 and for other purposes." (Liquefied Gases (Amendment) Act 1976.)

No. 8838. "An Act to amend the *Business Franchise (Tobacco) Act 1974* with respect to Wholesale Tobacco Merchants' Licences and for other purposes." (*Business Franchise (Tobacco) Act 1976*.)

Given under by Hand and the Seal of the State of Victoria aforesaid, at Melbourne, this eighteenth day of May, in the year of our Lord One thousand nine hundred and seventy-six and in the twenty-fifth year of the reign of Her Majesty Queen Elizabeth II.

(L.S.) HENRY WINNEKE.
By His Excellency's Command.

R. J. HAMER,
Premier.

GOD SAVE THE QUEEN!

NOTE.—Act Nos. 8835, 8836, 8837 and 8838 shall come into operation on the day of Royal Assent i.e. 18th May, 1976.

Survey Co-ordination Act 1958.
PROCLAIMED SURVEY AREA (No. 33).

PROCLAMATION

By His Excellency the Governor of the State of Victoria and its Dependencies in the Commonwealth of Australia, &c., &c., &c.

In pursuance of the provisions of Section 12 (2) (b) of the *Survey Co-ordination Act 1958*, I, the Governor of the State of Victoria, in the Commonwealth of Australia, by and with the advice of the Executive Council of the said State, do by this my Proclamation, proclaim 1060 hectares, more or less, of land being part of the Township of Wonthaggi, Parish of Wonthaggi, County of Mornington, and part of the Parish of Wonthaggi, County of Mornington, as indicated by hatching on the plan hereunder, to be a "Proclaimed Survey area" for the purposes of the *Survey Co-ordination Act 1958*.—(COS.3214.)

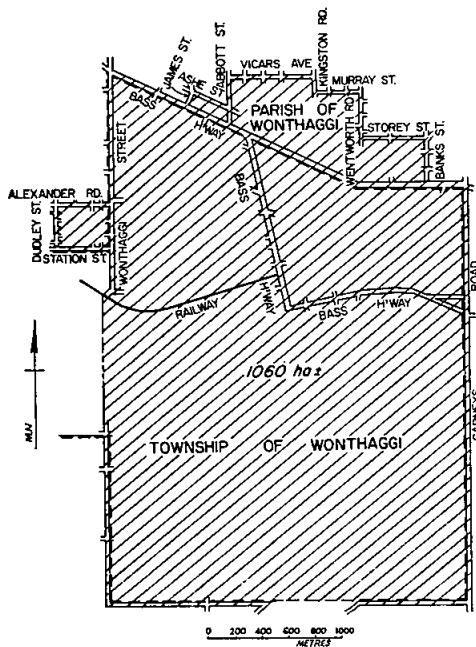

Given under my Hand and the Seal of the State of Victoria aforesaid, at Melbourne, this eleventh day of May, in the year of our Lord One thousand nine hundred and seventy-six and in the twenty-fifth year of the reign of Her Majesty Queen Elizabeth the Second, Queen of Australia.

(L.S.) HENRY WINNEKE.
By His Excellency's Command,

W. BORTHWICK,
Minister of Lands.

GOD SAVE THE QUEEN!

GOVERNMENT NOTICES

PUBLIC HOLIDAY.—QUEEN'S BIRTHDAY.

It is hereby notified that on—
MONDAY, THE 14TH JUNE, 1976,
the Public Offices will be closed, such day having been appointed by the *Public Service Act 1974*, to be observed as a holiday in the Public Offices throughout the State of Victoria.

This notice relates only to the closing of the State Public Offices. All inquiries regarding the holiday in other offices and in shops and industry should be directed to the Industrial Information Service of the Department of Labour and Industry, 35 Spring Street, Melbourne, 3000. (Telephone 63 0321).

VANCE DICKIE,
Chief Secretary.

Chief Secretary's Office,
Melbourne, 17th May, 1976.

Stamps Act 1958.
ANNUAL LICENCES.

NOTIFICATIONS PURSUANT TO SECTION 97.

I hereby notify that stamp duty has been paid for licences under section 96 of the *Stamps Act* to carry on assurance and insurance business in Victoria during the year ending 31st December, 1976, by the following:—

- A.C.I. Insurances Proprietary Limited.
- A.F.G. Insurances Limited.
- A.G.C. (Insurances) Ltd.
- A.I.A. Insurance Limited Incorporating.
- A.I.A. Insurance Syndicate.
- A.M.P. Fire and General Insurance Company Limited.
- A.P.A. Fire and General Insurance Company Limited.
- A.P.A. Life Assurance Ltd.
- Accident Insurance Mutual Limited.
- Riunione Adriatica Di Sicurita, trading as Adriatic Insurance Coy.
- Aetna Life of Australia and New Zealand Limited.
- Ajax Insurance Company Limited.
- Albion Insurance Company Limited.
- American Home Assurance Company.
- American International Assurance Co. Ltd.
- American Life Insurance Company.
- American Re-insurance Company.
- Ansvar Insurance Company Limited.
- Associated General Contractors Insurance Company Limited.
- Associated Group Insurance Limited.
- Associated National Insurance Company Limited.
- Australian Associated Motor Insurers Ltd.
- Australian Casualty Company Limited.
- Australian Community Insurance Co. Ltd.
- Australian Equitable Insurance Company Limited.
- Australian General Insurance Company Limited.
- Australian & International Insurances Ltd.
- Australian Marine Underwriting Agency Proprietary Limited.
- Australian Mortgage Insurance Corporation Limited.
- Australian Motor Traders Insurance Limited.
- Australian Mutual Provident Society.
- Australian Natives' Association Insurance Company Limited.
- Australian Reinsurance Company Limited.
- B. T. Insurance Proprietary Limited.
- Baillieu Bowring (Professional Indemnity) Pty. Ltd.
- Baillieu Bowring (Reinsurances) Pty. Ltd.
- Baillieu Bowring (Vic.) Pty. Ltd.
- Bain Dawes Southern Pty. Ltd.
- Baltica-Skandinavia Insurance Company Limited.
- Bankers and Traders' Insurance Company Limited.
- Bland Payne Australia Limited.
- Bland Payne Australia Reinsurance P/L.
- Boral Insurance and Fund Management Ltd.
- British Medical Insurance Company of Victoria Limited.
- British Protection Insurance Company Proprietary Limited.
- Business Mens Assurance Company of Australia Limited.
- C.E. Heath Underwriting Agencies Pty. Limited.
- C.E. Heath Underwriting & Insurance (Australia) Pty. Ltd.
- C.E. Heath Underwriting (Australia) Pty. Ltd.
- C.M.L. Fire and General Insurance Company Limited.
- Car Owners Mutual Insurance Company Limited.
- Catholic Church Insurances Limited.
- Cayzer Steel Bowater Pty. Ltd.
- Century Insurance Company Limited.
- Chamber of Manufactures Insurance Limited.
- Chiyoda Fire and Marine Insurance Company Limited.
- City Mutual General Insurance Limited.
- The Closer Settlement Fire Insurance Fund of the Department of Crown Lands and Survey.

Colonial Mutual Fire Insurance Company Limited.
 Colonial Mutual Life Assurance Society Limited.
 Combined Insurance Company of America.
 Commercial and Industrial Insurance Limited.
 Commercial Union Assurance Company of Australia Limited.
 Commissioners of the State Savings Bank of Victoria.
 Connecticut General Insurance Company Limited.
 Consolidated Insurances of Australia Limited.
 Co-operative Insurance Company of Australia Limited.
 Copenhagen Reinsurance Company (Aust.) Limited.
 Cornhill Insurance Company Limited.
 Cumis Insurance Society Inc.
 Cyril Stanley Pty. Ltd.
 Dominion Insurance Company of Australia Limited.
 Ecclesiastical Property Insurance Company Proprietary Limited.
 Edward Lumley (Brokers) Limited.
 Edward Lumley and Sons (N.S.W.) Pty. Ltd.
 Edward Lumley and Sons (Vic.) Proprietary Limited.
 F.A.I. Insurances Ltd.
 F M Insurance Company Limited.
 Farmers and Graziers Co-operative Company Limited.
 Farmers' and Settlers' Co-operative Insurance Company of Australia Limited.
 Federation Insurance Limited.
 Fire and All Risks Insurance Company Limited.
 Forsikringsaktieselskapet Vesta (Vesta Insurance Company).
 Friends Provident Life Office.
 G.R.E. Insurance Ltd.
 General Accident Fire and Life Assurance Corporation Limited.
 Gibbs Bright Insurance Group.
 Gilman Weller Australia Pty. Ltd.
 Godfrey Orton Insurances Pty. Ltd.
 Guardall Insurance Co. Pty. Ltd.
 Guild Insurance Company Limited.
 H. G. Poland (Australia) Proprietary Limited.
 H. J. Heinz Company Australia Limited.
 Hallmark General Insurance Co. Ltd.
 Hanover Insurance Company.
 Hartford Fire Insurance Company.
 Hematite Insurances Pty. Ltd.
 Hogg Robinson C.C.L. Pty. Ltd.
 Home Owners Insurances Pty. Ltd.
 Housing Commission Victoria.
 Hudig Langeveldt Pty. Limited.
 I.C. Insurance Australia Limited.
 Insurance Commissioner (State Accident Insurance Office and State Motor Car Insurance Office).
 Insurance Company of North America.
 Insurance Corporation of Ireland Limited.
 Interstate Steamship Insurance Company Proprietary Limited.
 Invincible Life and General Insurance Company Limited.
 J. H. Minet and Company (ANZ) Proprietary Limited.
 Jardine Turnbull (Insurances) Pty. Ltd.
 John Forsaith (Aust.) Pty. Ltd.
 Legal and General Assurance Society Limited.
 Leslie, Godwin & Garroway Pty. Limited.
 Lombard Insurance Company Limited.
 London and Overseas Insurance Company Limited.
 L Union Des Assurances De Paris.
 M.L.C. Fire and General Insurance Company Proprietary Limited.
 Manchester Unity Fire Insurance Company of Victoria Limited.
 Manor Insurances (Australasia) Ltd.
 Manufacturers Mutual Insurance Limited.
 Marine Hull and Liability Insurance Company Proprietary Limited.
 Marsh and McLennan Proprietary Limited.
 Mercantile and General Re-insurance Company of Australia Limited.
 Mercantile Mutual Insurance Company Limited.
 Monarch Insurance Company Limited.
 Mortgage Guaranty Insurance Corporation of Australia Limited.
 Munich Reinsurance Company of Australia Limited.
 Mutual Life & Citizens' Assurance Company Limited.
 National and General Insurance Company Limited.
 National Employers' Mutual General Insurance Association Limited.
 National Insurance Company of New Zealand Limited.
 National Mutual Casualty Insurances Limited.
 National Mutual Fire Insurance Company Limited.
 New Reinsurance Company.
 New Zealand Insurance Company Limited.
 New Zealand Victoria Life Limited.
 Nippon Fire and Marine Insurance Company Limited.
 Norwich Union Fire Insurance Society Limited.
 Oak Insurance Ltd.
 Orion Insurance Company Limited.
 Overseas Shipping Insurance Company Proprietary Limited.

Pan Australian Insurance Proprietary Limited.
 Phoenix Assurance Company of Australia Ltd.
 Phoenix Life Assurance Company of Australia Ltd.
 Provincial Insurance Company Limited.
 Prudential Assurance Company Limited.
 Q.B.E. Insurance Limited.
 R.A.C.V. Insurance Pty. Ltd.
 R. H. Tolley and Gardner Pty. Ltd.
 Reinsurance Company of Australasia Limited.
 Richard Oliver & Co. Pty. Ltd.
 Royal Insurance Company Limited.
 Rural Finance and Settlement Commission.
 Sapphire Insurance Co. Pty. Ltd.
 Sea Insurance Company Limited.
 Security and General Insurance Company Limited.
 Security Life Assurances Limited.
 Sedgwick Forbes Leslie Pty. Ltd.
 Seven Provinces Insurance Co. Ltd.
 Sirius Insurance Company Limited.
 Skandia Insurance Company Limited.
 Societe Commerciale De Reassurance
 South Australian Insurance Company Limited.
 South British Insurance Company Limited.
 South British United Life Assurance Co. Ltd.
 Southern Pacific Insurance Company Limited.
 Southern Star General Insurance Company Proprietary Limited.
 Sphere Drake Underwriting (Australia) Limited.
 Sphere Insurance Company Limited.
 Stanley Taylor and Company.
 State Government Insurance Office (Queensland).
 Steeves Agnew (Australia) Pty. Ltd.
 Stenhouse, Scott, North Australia Limited.
 Sten-Re Australia Limited.
 Stewart Wrightson (Vic.) Pty. Ltd.
 Stromark Australia Insurances Limited.
 Sumitomo Marine & Fire Insurance Co. Ltd.
 Sun Alliance Insurance Limited.
 Surrey Insurance Company Limited.
 Swann Insurance Limited.
 Swiss Reinsurance Company.
 Switzerland General Insurance Company Limited.
 T. & G. Fire and General Insurance Company Limited.
 T & G Mutual Life Society Limited.
 T. P. Clark and Chapman Proprietary Limited.
 T. P. Clark and Chapman (Reinsurances) P/L.
 Taisho Marine and Fire Insurance Company Limited.
 Thompson Graham (Australia) Pty. Ltd.
 Tokio Marine and Fire Insurance Company Limited.
 Trade Indemnity Company Limited.
 Traders Prudent Insurance Company Limited.
 Trans-Pacific Insurance Company Aust. Ltd.
 Transport Industries Insurance Company Proprietary Limited.
 Union Assurance Society of Australia Limited.
 United Insurance Company Limited.
 V.A.C.C. Insurance Company Ltd.
 Vanguard Insurance Company Limited.
 Victor Aghion & Sons Pty. Ltd.
 Victoria Insurance Company Limited.
 Victorian Wheatgrowers Corporation Limited trading as Wheatgrowers and General Insurance Company.
 Vigilant Insurance Company.
 Victory Reinsurance Company of Australia Limited.
 Waltons Insurance Company Limited.
 Western Australian Insurance Company (Canberra) Limited.
 Willis Faber Johnson and Higgins Vic. Pty. Ltd.
 Yasuda Fire and Marine Insurance Company Limited.
 R. M. PHIBBS,
 Comptroller of Stamps.

Stamp Duties Office,
 Melbourne, 19th May, 1976.

ERRATUM.

In Victorian *Government Gazette* No. 46 dated the 5th May, 1976, page No. 1275 under the heading Melbourne and Metropolitan Board of Works, Helene Court, Briar Street and Sycamore Crescent were incorrectly shown under Doncaster and Templestowe. The notice should have read:

Knox.

Helene Court, from Briar Street, south-westwards 150 metres.

Briar Street, from Helene Court, south-eastwards 91 metres.

Helene Court, from Sycamore Crescent, south-westwards 160 metres.

Sycamore Crescent, from 80 metres south of Currawa Drive, further south-eastwards 105 metres.

Transport Regulation Act.
TRANSPORT REGULATION BOARD.

HEARING OF APPLICATIONS.

Notice is hereby given that the following applications will be considered by the Transport Regulation Board on 8th June, 1976.

DOYLE, P., 118 Vaughan Street, Shepparton. Application to license one commercial passenger vehicle with seating capacity for 48 persons, to be purchased, to operate as an additional stage omnibus under the same terms and conditions as existing C.O. licences held by the applicant.

VENTURA MOTORS PTY. LTD., 1037 Centre Road, South Oakleigh. Application for variation of M.O. licence conditions on route 736 (Blackburn Railway Station—Morack Road) to delete service from the corner of Taunton Road and Arthur Street via Arthur Street, Christa Avenue and Blackburn Street to K-Mart Shopping Centre and instead to operate via Taunton Road to normal route along Burwood Highway.

Application for renewal of licence as shown by the person listed hereunder to operate under the same terms and conditions:—

TRENGROVE, L. J., Waterloo via Broadford; T.S.792.

Notice of any objection should be forwarded to reach the Secretary of the Board not later than 2nd June, 1976.

Applicants are advised that it will not be necessary to appear on the hearing date specified, unless advised in writing by the Board.

A. V. C. COOK,
Secretary.

Corner Lygon and Princes Streets, Carlton, 3053,
Wednesday, 19th May, 1976.

Commercial Goods Vehicles Act.
TRANSPORT REGULATION BOARD.

HEARING OF APPLICATIONS.

Notice is hereby given that the following applications will be considered by the Transport Regulation Board on 8th June, 1976.

WILLIAMSON, R. T. (trading as Alexandra Freighters), 124 Grant Street, Alexandra, 3714. One commercial goods vehicle (L/C. 11.50 tonne) to operate: (a) Within a 40-km radius of the post office at Alexandra—general goods. (b) From forest landings situated within an 80-km radius from the post office at Alexandra to sawmills at Alexandra, Mansfield and Strathbogie—sawmill logs.

A.R.C. ENGINEERING PTY. LTD., 528 Ballarat Road, Sunshine, 3020. One commercial goods vehicle (L/C. 11.40 tonne) to operate within an 80-km radius of own premises at Sunshine in the course of business as "Reinforcing Manufacturers and Engineers"—own reinforcing mesh and reinforcing rod.

BIVIA PTY. LTD., 16 Blaxland Avenue, Thomastown, 3074. One commercial goods vehicle (L/C. 0.75 tonne) to operate throughout the State of Victoria in the course of business as "Motor Vehicle Distributors" for the purpose of servicing and repairing vehicles—tools of trade, spare parts and materials incidental to on-site servicing only.

CHASEMORE EXCAVATIONS PTY. LTD., 253 Whitehorse Road, Blackburn, 3130. One commercial goods vehicle (L/C. 10.30 tonne) to operate: (a) Throughout the State of Victoria in the course of business as "Road Construction Contractors"—own tools of trade and own equipment. (b) Within a 40-km radius of any current contract site or from the railway station nearest thereto—materials required for use on such contract.

COOMBS, A. G., GROUP PTY. LTD., 26 Cochranes Road, Moorabbin, 3189. One commercial goods vehicle (L/C. 0.70 tonne) to operate throughout the State of Victoria in the course of business as "Heating Engineers" for the purpose of supervising the installation and servicing of air conditioning and heating systems—tools of trade, spare parts and materials incidental to on-site servicing.

DAVIES, E. J., 55 Park Road, Maryborough, 3465. One commercial goods vehicle (L/C. 12.25 tonne) to operate: (a) Within a 40-km radius of the post office at Maryborough—general goods. (b) From Maryborough to places within that part of the State of Victoria west of a north/south line drawn through Maryborough and Winchelsea, south of an east/west line drawn through Maryborough and Stawell and east of a north/south line drawn through Horsham and Port Fairy—wooden fencing posts and droppers. (c) From Maryborough to the Melbourne metropolitan area (as defined in the

Transport Regulation Act 1958)—firewood. (d) From places within a 32-km radius of Melbourne, Ballarat, Trentham and Warrnambool to Maryborough, Mildura and Dandenong—fresh vegetables excluding the carriage of potatoes and onions. (e) Within an 80-km radius of Maryborough—road-making materials and plant. (f) From Maryborough to Stramit Board at Bendigo—baled straw.

DICKSON, T. J., 51 Federal Street, Rainbow, 3424. One commercial goods vehicle (L/C. 2.00 and 1.90 tonne trailer) to operate within that part of the State of Victoria west of a north/south line drawn through the City of Ballarat in the course of business as "Brick-layer"—tools of trade, equipment and a small quantity of materials incidental to the completion of a contract.

DIMITRIU, G., 27 Kathleen Street, Morwell, 3840. One commercial goods vehicle (L/C. 7.60 tonne) to operate from forest and private landings situated within a 10-km radius of the post office at Jindivick to A.P.M. Ltd., Maryvale—pulpwood.

ENSIGN SERVICES (VIC.) PTY. LTD., 24 Leinster Grove, Northcote, 3070. One commercial goods vehicle (L/C. 1.10 tonne) to operate: Clause I (a) Within an 80-km radius from the post office situated at the corner of Bourke and Elizabeth Streets in the City of Melbourne in the course of business as "Industrial Dry Cleaners"—goods to be cleaned or having been cleaned, samples of cleaning materials and industrial garments also cleaning equipment for hire. (b) From and to own premises at Northcote to and from clients at Ballarat, Maryborough, Castlemaine, Bendigo and Kyneton, servicing the aforementioned places on a weekly round trip—goods to be cleaned, or having been cleaned, samples of cleaning materials, industrial garments and cleaning equipment for hire. Clause II. From and to own premises at Northcote to and from clients at the township of Bairnsdale via the Princes Highway and returning via the South Gippsland Highway and servicing places en route in the course of business as "Garment Rental and Cleaning Service"—own industrial garments for cleaning or having been cleaned, dusting and wiper cloths and roller towels for toilet cabinet services.

GORDIJN, G., 16 Fernlea Street, Traralgon, 3844. One commercial goods vehicle (L/C. 10.50 tonne) to operate within an 80-km radius of the post office at Traralgon on behalf of Concrete Industries Ltd. at Traralgon—bricks.

HARLAND, N. J., Prince Street, Gisborne, 3437. One commercial goods vehicle (L/C. 6.10 tonne) to operate: (a) Within a 13-km radius of own premises at Gisborne in the course of business as "Produce Merchant and Petroleum Agent"—own goods, petroleum products and empty return containers. (b) From places within an 8-km radius of the G.P.O., Melbourne, to own premises at Gisborne and return in course of business as "Produce Merchant and Petroleum Agent"—own goods, petroleum products and empty return containers.

HARRIS, D. E., 45 King Street, Ballarat, 3350. One commercial goods vehicle (L/C. 3.90 tonne) to operate: (a) From the premises of Coronet Caravans Pty. Ltd. at Ballarat to points throughout the State of Victoria on behalf of the said company—new caravans. (b) From Melbourne and Bendigo to Ballarat Camping Centre at Ballarat—caravans and campervans.

HARVEY, J. E., Evans Road, Lovely Banks, 3221. One commercial goods vehicle (L/C. 3.95 tonne) to operate from Melbourne to Warrnambool via Geelong, Camperdown and Terang, serving places en route—Sun newspapers.

HEMINGWAY, LEO, & PICKETT PTY. LTD., 330 Sydney Road, Brunswick, 3056. One commercial goods vehicle (L/C. 1.05 tonne) to operate within an 80-km radius of own branch premises at Mildura in the course of business as "Cigarette and Tobacco Merchants"—own goods.

JELLY, T. S., Dooen, 3378. One commercial goods vehicle (L/C. 12.50 tonne) to operate: (a) Within a 136-km radius of the post office at Dimboola and/or 128-km of the post office at Linga (Horsham Division of the Country Roads Board)—plant the property of a contractor and required for use in connection with the construction or maintenance of some specific, existing or proposed road, street, footpath, bridge, wharf, pier, weir or channel. (b) Within a 32-km radius from site of construction or maintenance work performed pursuant to paragraph (a) above, or from the railway station nearest thereto—metal, stones, screenings, ashes, gravel, sand and earth and any other materials required for such work. (c) Within a 40-km radius of the post office at Horsham—general goods.

JONES, W. A., 31 Ashwood Drive, Ashwood, 3147. One commercial goods vehicle (L/C. 7.90 tonne) to operate within an 80-km radius of Brick and Pipe Industries premises at Oakleigh, solely on behalf of the said company—bricks.

KEATHSON PTY. LTD., 21 Brock Street, Thomastown, 3074. One commercial goods vehicle (L/C. 6.15 tonne) to operate: (a) Within a 40-km radius of own premises at Thomastown in the course of business as "Earth-moving Contractor"—own goods. (b) Throughout the State of Victoria for the purpose of moving equipment from site to site—own tools of trade, own earth-moving plant, own equipment and own spare parts for on-site servicing. (c) Within a 40-km radius of any contract site currently engaged upon or from the nearest railway station thereto—materials for use on such contract.

KEATHSON PTY. LTD., 21 Brock Street, Thomastown, 3074. One commercial goods vehicle (L/C. 5.95 tonne) to operate throughout the State of Victoria in the course of business as "Earthmoving Contractors" for the purpose of servicing own plant equipment on-site—tools of trade, special servicing equipment, spare parts, water and up to a maximum of 2 x 200 litre drums of fuel, oil or grease for on-site servicing.

LANTERI, N. (trading as N. & R. Lanteri), 176 Wallace Street, Bairnsdale, 3875. Application to vary the conditions of licence number D.A.67677 (L/C. 3.95 tonne) by adding an additional paragraph "From 7X Beverages Pty. Ltd. Morwell to own premises at Bairnsdale—bottled aerated waters, returning with empty return containers.

LEISURE & ALLIED INDUSTRIES PTY. LTD., 122 Lydiard Street North, Ballarat, 3350. One commercial goods vehicle (L/C. 0.75 and 1.00 tonne trailer) to operate throughout the State of Victoria in the course of business as "Amusement and Vending Machine Operator" for the purpose of siting and servicing of coin operated amusement or vending machines—machines on lease for siting or repair or having been repaired, tools of trade and materials incidental to on-site servicing.

MAJOR, A. B. (trading as Majors Goroke), Railway Street, Goroke, 3411. One commercial goods vehicle (L/C. 3.75 tonne) to operate: (a) Within a 40-km radius of the post office at Goroke—general goods. (b) From and to "A" Class Mobil Depot at Horsham to and from places as defined in paragraph (a) above—petroleum products for delivery and empty containers for return. (c) From Horsham Railway Station to Goroke and return, serving places *en route* whilst under contract to the Victorian Railways Board—general goods.

MT. BEAUTY TIMBERS PTY. LTD., Embankment Drive, Mt. Beauty, 3699. One commercial goods vehicle (L/C. 10.85 tonne) to operate: (a) From forest landings within an 80-km radius of own sawmill at Glen Creek to own sawmills at Glen Creek and Mt. Beauty—logs. (b) From own sawmills at Glen Creek and Mt. Beauty to places within an 80-km radius of own sawmill at Glen Creek—sawn timber.

MCPHERSON, K., 15 King Street, Myrtleford, 3737. Application to vary the conditions of licence D.A.66917 by deleting the existing conditions and adding in lieu—(a) Within an 80-km radius of the post office at Myrtleford—plant the property of a contractor and required by him for use in connection with the construction or maintenance of some specific, existing or proposed road, street, footpath, bridge, pier, wharf, weir or channel and also the following materials, viz—metal, stones, screenings, ashes, gravel, sand and earth. (b) Within a 32-km radius from the site of any construction or maintenance work performed pursuant to paragraph (a) above, or from the railway station nearest thereto—any other materials required for such work. (c) Within a 40-km radius of the post office at Myrtleford—general goods.

PRIOR, L. & J. E., Hyland Way, Willung South, 3844. One commercial goods vehicle (L/C. 3.20 tonne) to operate throughout the State of Victoria in the course of business as "Marine Collector"—marine goods as designated in the *Marine Stores and Old Metals Act 1958*, No. 6303, but excluding the carriage of any such goods to wharves, docks or ships for shipment or export purposes provided that the combined load capacity of the vehicle and any trailer attached thereto does not exceed 6.00 tonnes.

REED, B. (trading as B. & J. A. Reed), Corner Symonds and Kronk Streets, Golden Square, Bendigo, 3555. One commercial goods vehicle (L/C. 9.80 tonne) to operate within an 80-km radius of Pioneer Concrete (Victoria) Pty. Ltd. at Bendigo solely on behalf of the said company—premixed concrete in a specially constructed agitator vehicle.

SCOTT, P., Southern Park Road, Newlyn, 3364. One commercial goods vehicle (L/C. 0.40 tonne) to operate from Horsham to Australian Postal Commission Mail Centre at Ballarat via Stawell, Ararat, Maryborough and Creswick on Saturdays under the terms of contract number M.S.I.1980—mail under contract to the Australian Postal Commission.

BRAMBLES HOLDINGS LTD. (trading as Southern Plant Hire Co.), 1846 Princes Highway, Clayton, 3168. One commercial goods vehicle (L/C. 1.05 tonne) to operate: (a) Within a 40-km radius of own premises at Clayton in the course of business as "Earthmoving Contractors, Civil Engineers and Plant Hire Contractors"—own goods. (b) Throughout the State of Victoria in the course of business as "Earthmoving Contractors, Civil Engineers, Crane and Plant Hire Contractors"—tools of trade and spare parts incidental to the servicing and maintenance of own plant and equipment. (c) Within a 40-km radius of the G.P.O. in the City of Melbourne—goods or plant on behalf of other contractors.

TRIFFETT, E. A., Benalla City Caravan Park, Benalla, 3672. One commercial goods vehicle (L/C. 7.95 tonne) to operate: (a) Within a 144-km radius of the post office at Wangaratta (Benalla Division of the Country Roads Board)—plant the property of a contractor and required by him for use in connection with the construction or maintenance of some specific, existing or proposed road, street, footpath, bridge, pier, wharf, weir or channel. (b) Within a 32-km radius of the site of any construction or maintenance work referred to in paragraph (a) above or from the railway station nearest thereto—metal, stones, screenings, ashes, gravel, sand, earth and any other materials required for such work.

TUNNECLIFFE, T. H., 23 Briggs Street, Box Hill North, 3129. One commercial goods vehicle (L/C. 0.75 tonne) to operate throughout the State of Victoria in the course of business as "Pest Control Contractor"—tools of trade, spraying equipment and a small quantity of concentrated spraying chemicals.

WARBURTON, A. (trading as A. & E. A. Warburton & Co.), Woolsthorpe, 3279. Application to vary the conditions of licence number D.A.65943/1 by adding an additional paragraph (e) "From places within a 40-km radius of Maryborough and Navarre, to places within a 40-km radius of Woolsthorpe—firewood and fencing posts.

WEHL, C. (trading as Wehl & Naylor), P.O. Box 42, Stawell, 3380. One commercial goods vehicle (L/C. 14.85 tonne) to operate: (a) Within a 32-km radius from the post office at Stawell—general goods. (b) From the Country Roads Board crusher and pits at Hall's Gap to places situated within an 80-km radius from the chief post office in the City of Horsham—gravel and screenings.

RENEWALS.

Applications for renewal of licences as shown by persons listed hereunder to operate under the same terms and conditions from the expiry shown in each case.

AUSTRALIAN MOTOR INDUSTRIES LTD., 155 Bertie Street, Port Melbourne, 3207; D.A.36696/13; 10th July, 1976; 0.50 tonne.

BALLANTYNE, K. L., PTY. LTD., 295 Grant Street, South Melbourne, 3204; D.A.65182/1; 24th July, 1976; 5.90 tonne.

7 X BEVERAGES (CENTRAL) PTY. LTD., 88 Burns Street, Maryborough, 3465; T.D.A.63354/23; 27th March, 1976; 1.00 tonne.

DAVIS BROS. (VIC.) PTY. LTD., McPherson Street, Casterton, 3311; D.A.37026/2; 22nd March, 1976; 1.00 tonne.

FURMAN, S., 55 Aileen Grove, South Caulfield, 3162; D.A.52530; 16th June, 1976; 1.75 tonne.

DIVERSE PRODUCTS LTD. (trading as Grampian Beverages), Stawell Road, Horsham; D.A.65160/3; 3rd July, 1976; 0.70 tonne.

GREENWAYS REFRIGERATED TRANSPORT PTY. LTD., Grant Road, Somerville, 3912; D.A.66062/10; 29th July, 1976; 8.65 tonne.

MCCOSH, R. J., Mailors Flat, 3282; D.A.26911; 9th July, 1976; 7.70 tonne.

MOORE, D. H., 5 Scott Crescent, Mildura, 3500; T.D.A.50951/2; 1st July, 1976; 0.75 tonne.

NANDAPI, G., 46 Bourke Street, Bulleen, 3105; D.A.61843; 11th June, 1976; 12.60 tonne.

QUEEN'S BRIDGE MOTORS PTY. LTD., 359 Plummer Street, Port Melbourne, 3207; D.A.1783/22; 20th June, 1976; 0.75 tonne.

OVENS VALLEY PETROLEUM PRODUCTS PTY. LTD., Standish Street, Myrtleford, 3737; T.D.A.64527/1; 17th July, 1976; 7.75 tonne.
 SANDERS, C. V., Conness Street, Chiltern, 3683; D.A.39627; 25th July, 1976; 4.80 tonne.
 SMITH, S. J., 23 Rooks Road, Nunawading, 3131; D.A.52627; 7th July, 1976; 0.90 tonne.
 SOUTHERN PENINSULA TRANSPORT SERVICE PTY. LTD., 1403 Nepean Highway, Rosebud, 3939; D.A.2075; 16th July, 1976; 7.00 tonne.

TOW TRUCK.

MAVROMATAKIS, S., 31 Butler Street, Richmond, 3121; D.A.62825/2; 26th June, 1976; 3.40 tonne.

Notice of any objection should be forwarded to reach the Secretary of the Board not later than 2nd June, 1976.

Applicants are advised that it will not be necessary to appear on the hearing date specified above, unless advised in writing by the Board.

A. V. C. COOK,
Secretary.

Corner Lygon and Princes Streets, Carlton, 3053,
Wednesday, 19th May, 1976.

Co-operation Act 1958.

CHANGE OF NAME OF A SOCIETY.

Notice is hereby given that The Ballarat Education Centre Co-operative Society Limited which was incorporated as a Community Advancement Society under the above named Act on the twelfth day of November, 1974, has registered a change of its name and is now incorporated under the name of Ballarat Community Education Centre Co-operative Society Limited under the said Act.

Dated at Melbourne this 29th day of April, 1976.

N. F. CURRY,
Acting Deputy Registrar of Co-operative Societies.

Co-operation Act 1958.

CROYDON HIGH SCHOOL CO-OPERATIVE
ADVANCEMENT SOCIETY LIMITED.
BRIGHTON SCHOOL (No. 1542) CO-OPERATIVE
SOCIETY LIMITED.
PASCOE VALE GIRLS SECONDARY SCHOOL
CO-OPERATIVE LIMITED.

NOTICE OF DISSOLUTION OF SOCIETIES.

Notice is hereby given that I have this day registered the dissolution of the abovenamed societies and cancelled their registration under the abovenamed Act.

Dated at Melbourne this 24th day of April, 1976.

N. F. CURRY,
Acting Deputy Registrar of Co-operative Societies.

Co-operation Act 1958.

KYNETON PRIMARY SCHOOL CO-OPERATIVE LIMITED.
RADIO CONTROLLED SERVICES CO-OPERATIVE
LIMITED.

NOTICE OF DISSOLUTION OF SOCIETIES.

Notice is hereby given that I have this day registered the dissolution of the abovenamed societies and cancelled their registration under the abovenamed Act.

Dated at Melbourne this 22nd day of April, 1976.

N. F. CURRY,
Acting Deputy Registrar of Co-operative Societies.

Co-operation Act 1958.

MOORABBIN STATE SCHOOL CO-OPERATIVE LIMITED.
ASCOT VALE WEST PRIMARY SCHOOL CO-OPERATIVE
LIMITED.

Notice is hereby given in pursuance of section 78 (7) of the Co-operation Act 1958 and section 308 (2) of the Companies Act 1961 that, at the expiration of three months from the date hereof, the names of the aforementioned societies will, unless cause is shown to the contrary, be struck off the register and the societies will be dissolved.

Dated this 6th day of May, 1976.

N. F. CURRY,
Acting Deputy Registrar of Co-operative Societies.

Co-operation Act 1958.

MORDIALLOC BOWLING CLUB CO-OPERATIVE
LIMITED.

Notice is hereby given in pursuance of section 78 (7) of the Co-operation Act 1958 and section 308 (2) of the Companies Act 1961 that, at the expiration of three months from the date hereof, the name of the aforementioned society will, unless cause is shown to the contrary, be struck off the register and the society will be dissolved.

Dated this 3rd day of May, 1976.

N. F. CURRY,
Acting Deputy Registrar.

Co-operation Act 1958.

SOMERVILLE BOWLING CLUB CO-OPERATIVE
LIMITED.

Notice is hereby given in pursuance of section 78 (7) of the Co-operation Act 1958 and section 308 (2) of the Companies Act 1961 that, at the expiration of three months from the date hereof, the name of the aforementioned society will, unless cause is shown to the contrary, be struck off the register and the society will be dissolved.

Dated this 7th day of May, 1976.

N. F. CURRY,
Acting Deputy Registrar of Co-operative Societies.

Co-operation Act 1958.

ELWOOD HIGH SCHOOL CO-OPERATIVE LIMITED.
NOTICE OF DISSOLUTION OF SOCIETY.

Notice is hereby given that I have this day registered the dissolution of the abovenamed society and cancelled its registration under the abovenamed Act.

Dated at Melbourne this 6th day of May, 1976.

N. F. CURRY,
Acting Deputy Registrar of Co-operative Societies.

Co-operation Act 1958.

HEALESVILLE PRIMARY SCHOOL CO-OPERATIVE
LIMITED.

Notice is hereby given in pursuance of section 78 (7) of the Co-operation Act 1958 and section 308 (2) of the Companies Act 1961 that, at the expiration of three months from the date hereof, the name of the aforementioned society will, unless cause is shown to the contrary, be struck off the register and the society will be dissolved.

Dated this 30th day of April, 1976.

N. F. CURRY,
Acting Deputy Registrar.

SUMMONING OFFICER.

Under section 5 of the Education Act 1958, I hereby appoint:—

JOAN PATTERSON,
to summons parents within the State of Victoria.

BRIAN DIXON,
Minister for Social Welfare.

10th May, 1976.

LAW DEPARTMENT.

County Court Act 1958.

COUNTY COURT SITTINGS 1976.

Notice is hereby given that the Sittings of the County Court appointed to commence at Kerang on Tuesday the 27th day of July 1976 have been cancelled.

10th May, 1976.

D. P. WHELAN,
Chief Judge of the County Court of Victoria.

LAW DEPARTMENT.

County Court Act 1958.

COUNTY COURT SITTINGS 1976.

Notice is hereby given that Criminal matters listed for the Sittings of the County Court appointed to commence at Ballarat on Thursday the 15th day of July 1976 will be held at Ararat commencing at 10 a.m. on Thursday the 15th day of July 1976.

11th May, 1976.

D. P. WHELAN,
Chief Judge of the County Court.

Private Agents Act 1966.

NOTICE OF RECEIPT OF APPLICATIONS FOR LICENCES UNDER THE PROVISIONS OF THE PRIVATE AGENTS ACT 1966.

The Clerk(s) of the Magistrates' Court(s) as listed hereunder hereby give notice that applications, as under, have been lodged for hearing by the said Court(s) on the day(s) specified.

Any person desiring to object to any of such applications must—

- (a) lodge with the respective Clerk of the Magistrates' Court a notice in the prescribed form of his objection and of the grounds thereof;
- (b) cause a copy of such notice to be served personally or by post upon the applicant at least three days before the hearing of the application; and
- (c) send or deliver—
 - (i) where the objection is not made by the officer in charge of the police district in which the Court is situated—a copy of the notice to such officer; and
 - (ii) where the objection is not made by the Registrar or Deputy Registrar—a copy to the Registrar.

Full Name of Applicant or in the Case of a Firm or Corporation, of the Nominee.	Place of Abode of Applicant or Nominee.	Name of Firm or Corporation	Address for Registration.	Type of Licence.	Date of Hearing of Application.
---------------------------------------------------------------------------------	-----------------------------------------	-----------------------------	---------------------------	------------------	---------------------------------

MAGISTRATES' COURT, PORT MELBOURNE.

Carpenter, Donald ..	11 Sanick Court, East Bentleigh	Mayne Nickless Ltd.	538 Williamstown Road, Port Melbourne	Watchman ..	8.6.76
Daoud, Nâgui Yousséf ..	2/15 Mitchell Street, St. Kilda	" " "	" " "	" ..	25.5.76

Dated at Port Melbourne this 4th day of May, 1976.

J. ARDLIE, Clerk of the Magistrates' Court.

MAGISTRATES' COURT, HEIDELBERG.

Blackwood, Phillip Charles ..	14/9 Devonshire Road, Watsonia	Mobile Securities Vic.	179 Mountain View Parade, Macleod	Watchman ..	28.5.76
-------------------------------	--------------------------------	------------------------	-----------------------------------	-------------	---------

Dated at Heidelberg this 5th day of May, 1976.

G. G. WILLIAMSON, Clerk of the Magistrates' Court.

MAGISTRATES' COURT, MOONEE PONDS.

Egan, Thomas Leslie ..	4/4 Prospect Street, Glenroy	Watchman ..	1.6.76
------------------------	------------------------------	---------	---------	-------------	--------

Dated at Moonee Ponds this 10th day of May, 1976.

G. J. CONDON, Clerk of the Magistrates' Court.

MAGISTRATES' COURT, WODONGA.

Strong, Peter James ..	889 Howe Place, Albury	192 High Street, Wodonga	Process Server ..	1.6.76
------------------------	------------------------	---------	--------------------------	-------------------	--------

Dated at Wodonga this 6th day of May, 1976.

L. P. BYRNE, Clerk of the Magistrates' Court.

MAGISTRATES' COURT, OAKLEIGH.

Frew, Leslie Henry ..	2/84 Argyle Avenue, Chelsea	Mayne Nickless Ltd.	72 Atkinson Street, Oakleigh	Provisional Watchman	4.6.76
-----------------------	-----------------------------	---------------------	------------------------------	----------------------	--------

Dated at Oakleigh this 7th day of May, 1976.

D. LYNCH, Clerk of the Magistrates' Court.

MAGISTRATES' COURT, MILDURA.

Hill, Robin Leslie ..	62 7th Street, Mildura	62 7th Street, Mildura	Guard Agent ..	26.5.76
-----------------------	------------------------	---------	------------------------	----------------	---------

Dated at Mildura this 4th day of May, 1976.

G. SCHMIDT, Clerk of the Magistrates' Court.

MAGISTRATES' COURT, PRAHRAN.

Buckland, Peter ..	51/99 Spring Street, Melbourne	Transearch Commercial Investigators (Vic.) Pty. Ltd.	566 St. Kilda Road, Melbourne	Application to change Nominee of Corporation	28.5.76
--------------------	--------------------------------	------------------------------------------------------	-------------------------------	----------------------------------------------	---------

Dated at Prahran this 7th day of May, 1976.

K. McDONALD, Clerk of the Magistrates' Court.

MAGISTRATES' COURT, OAKLEIGH.

Broadbent, David Henry Victor	36 Highclere Avenue, Mt. Waverley	23 Avondale Grove, Mt. Waverley	Watchman ..	4.6.76
-------------------------------	-----------------------------------	---------	---------------------------------	-------------	--------

Dated at Oakleigh this 10th day of May, 1976.

P. PATTISON, Clerk of the Magistrates' Court.

MAGISTRATES' COURT, CHELTENHAM.

Nowland, John William ..	41 Swinden Avenue, Cheltenham	41 Swinden Avenue, Cheltenham	Process Server (Individual)	25.5.76
--------------------------	-------------------------------	---------	-------------------------------	-----------------------------	---------

Dated at Cheltenham this 3rd day of May, 1976.

J. T. FERGUSON, Clerk of the Magistrates' Court.

MAGISTRATES' COURT, DANDENONG.

Jenkinson, Bruce ..	21 Putt Grove, Noble Park	83 Clow Street, Dandenong	Guard Agent ..	1.6.76
---------------------	---------------------------	---------	---------------------------	----------------	--------

Dated at Dandenong this 10th day of May, 1976.

M. CONNOLLY, Clerk of the Magistrates' Court.

PRIVATE AGENTS—continued.

Full Name of Applicant or in the Case of a Firm or Corporation, of the Nominee.	Place of Abode of Applicant or Nominee.	Name of Firm or Corporation.	Address for Registration.	Type of Licence.	Date of Hearing of Application
MAGISTRATES' COURT, MELBOURNE.					
Carty, James Hugh ..	7 Currong Street, Mooroolbark	Wormald International Security	340 Abbotsford Street, North Melbourne	Watchman ..	16.6.76
Childs, Stanley Hubert ..	30 Lahinch Street, Broadmeadows	" " "	" " "	" ..	"
Dalton, Francis Raymond ..	B.P. Caravan Park, Werribee South	" " "	" " "	" ..	"
Hogan, Reginald Ronnié ..	87 Sussex Street, Coburg	" " "	" " "	" ..	"
Janschitz, Otto ..	3 Wandsworth Avenue, Deer Park	" " "	" " "	" ..	"
Judd, Norman Frederick ..	2 Neal Court, North Altona	" " "	" " "	" ..	"
Mason, Rodney James ..	69 Wales Street, West Footscray	" " "	" " "	" ..	"
Mills, Robert Thomas ..	3/901 Toorak Road, East Camberwell	" " "	" " "	" ..	"
Pollica, Bruce Wilson ..	4/14 Caringa Street, Pascoe Vale	" " "	" " "	" ..	"
Savage, Keith Geoffrey Kenneth	70 Martin Street, Belgrave	" " "	" " "	" ..	"
Stefanetti, Andrew Peter ..	5/79 Maribyrnong Road, Ascot Vale	" " "	" " "	" ..	"
Walton, Terry William ..	1 Heswell Court, Wantirna	" " "	" " "	" ..	"
Mitchell, George Henry ..	174 Railway Crescent, Dallas	Brambles Ltd. Brinks	Cnr. Arden and Lothian Streets, North Melbourne	" ..	"

Dated at Melbourne this 10th day of May, 1976.

L. W. HUSSEY, Clerk of the Magistrates' Court.

MAGISTRATES' COURT, PORT MELBOURNE.

O'Connor, Clifford Francis Gerald	19 Fernhill Road, Sandringham	Mayne Nickless Ltd.	538 Williamstown Road, Port Melbourne	Watchman ..	3.6.76
Clayton, Brian George ..	1 Torlice Avenue, Nunawading	" " "	" " "	" ..	"

Dated at Port Melbourne this 11th day of May, 1976.

J. ARDLIE, Clerk of the Magistrates' Court.

MAGISTRATES' COURT, SPRINGVALE.

Hamilton, Maxwell John ..	23 Woodward Street, Springvale	Mayne Nickless Ltd.	Cnr. Fairview and Joyce Streets, Springvale	Watchman ..	3.6.76
Gaffke, Ian ..	4/1768 Dandenong Road, Clayton	Southern Star Security Services	21 Clarke Road, Springvale	" ..	"

Dated at Springvale this 12th day of May, 1976.

J. B. DENNIS, Clerk of the Magistrates' Court.

MAGISTRATES' COURT, OAKLEIGH.

Kajtar, William ..	325 Corrigan Road, Noble Park	" " "	72 Atkinson Street, Oakleigh	Watchman ..	4.6.76
--------------------	-------------------------------	-------	------------------------------	-------------	--------

Dated at Oakleigh this 12th day of May, 1976.

P. PATTISON, Clerk of the Magistrates' Court.

MAGISTRATES' COURT, DANDENONG.

Clarke, Laurence George ..	4 Page Court, Dandenong	" " "	4 Spruce Court, Narre Warren	Commercial Sub-Agents	4.6.76
----------------------------	-------------------------	-------	------------------------------	-----------------------	--------

Dated at Dandenong this 13th day of May, 1976.

M. CONNOLLY, Clerk of the Magistrates' Court.

MAGISTRATES' COURT, BOX HILL.

Snape, William Stanley ..	7 Prior Road, Noble Park	Mayne Nickless Ltd.	203 Elgar Road, Box Hill	Watchman ..	10.6.76
---------------------------	--------------------------	---------------------	--------------------------	-------------	---------

Dated at Box Hill this 13th day of May, 1976.

J. WILKINSON, Clerk of the Magistrates' Court.

MAGISTRATES' COURT, PORT MELBOURNE.

Charylo, Richard Grant ..	11 Virgillia Street, North Blackburn	Mayne Nickless Ltd.	538 Williamstown Road, Port Melbourne	Watchman ..	8.6.76
Withers, Warren Leicester ..	63 Warranga Crescent, Broadmeadows	" " "	" " "	" ..	"

Dated at Port Melbourne this 14th day of May, 1976.

J. ARDLIE, Clerk of the Magistrates' Court.

MAGISTRATES' COURT, MELBOURNE.

Tolliday, Gary David ..	52 Borva Drive, East Keilor	Commercial and General Acceptance Limited	461 Bourke Street, Melbourne	Process Server ..	30.6.76
-------------------------	-----------------------------	-------------------------------------------	------------------------------	-------------------	---------

Dated at Melbourne this 13th day of May, 1976.

L. W. HUSSEY, Clerk of the Magistrates' Court.

Police Regulation Act 1958.

POLICE FORCE OF VICTORIA.

DETERMINATION No. 255 OF THE POLICE SERVICE BOARD.

The Police Service Board, in pursuance of the powers in that behalf conferred by the *Police Regulation Act 1958*, hereby makes the following Determination (that is to say):—

1. The Determination No. 179 of the Police Service Board of 14th December, 1971, and published in the *Government Gazette* of 25th January, 1972, as amended, is hereby further amended as follows:—

In paragraph 63 under the heading "Kilometre Rates for Use of Private Motor Vehicles", by deleting sub-paragraphs (a), (b), (c), and (d) and substituting therefor the following sub-paragraphs:—

Kilometres Rates—
'B' Pass.

"(a) For members who are issued with the 'B' Pass by the Victorian Government Motor Transport Committee authorizing the holder to obtain supplies of petrol and oil at Government rates—

For the first 8,000 kilometres in a financial year. A kilometre.	Distance over 8,000 kilometres in a financial year. A kilometre.
c	c

Motor cars—

17 h.p. and over	17.3	8.3
under 17 h.p.	12.9	5.2
Motor cycles with side-cars	6.4	2.6
Motor cycles	5.5	2.2

—without
'B' Pass.

(b) For members who are not issued with the 'B' Pass referred to in sub-paragraph (a):—

For the first 8,000 kilometres in a financial year. A kilometre.	Distance over 8,000 kilometres in a financial year. A kilometre.
c	c

Motor cars—

17 h.p. and over	17.7	9.3
under 17 h.p.	13.1	6.0
Motor cycles with side-cars	6.6	3.1
Motor cycles	5.7	2.5

(c) In addition to the allowances prescribed in sub-paragraph (b) hereof, members—

(i) who are not issued with the 'B' Pass referred to in sub-paragraph (a); and

(ii) who do not exceed in any one financial year the maximum number of kilometres set out hereunder, shall be paid at the end of the financial year an additional amount calculated at the appropriate following rate:—

For the first 800 kilometres in a financial year. A kilometre.	Exceeding 800 kilometres but not exceeding 2,400 kilometres in a financial year. A kilometre.
c	c

Motor cars—

17 h.p. and over	7.6	2.9
under 17 h.p.	5.4	1.7

—bicycles.

(d) For bicycles—at the rate of 1.9c per kilometre irrespective of distance."

2. This Determination shall come into operation on and from the 9th May, 1976.

Dated the 10th day of May, 1976.

N. A. VICKERY,
A Judge of the County Court of Victoria,
Chairman and Member of the Police Service Board.

J. G. BROWN,
Member of the Police Service Board.

G. DAVIDSON,
Member of the Police Service Board.

Police Regulation Act 1958.

POLICE FORCE OF VICTORIA.

DETERMINATION No. 254 OF THE POLICE SERVICE BOARD.

The Police Service Board, in pursuance of the powers in that behalf conferred by the *Police Regulation Act 1958*, hereby makes the following Determination (that is to say):—

1. The Determination No. 179 of the Police Service Board of 14th December, 1971, and published in the *Government Gazette* of 25th January, 1972, as amended, is hereby further amended as follows:—

In Sub-Division I. of Division III., under the heading "Allowances for the Performance of Special Duties", and under the sub-heading "Services Department", by inserting after paragraph 11, sub-paragraph (c), the following new sub-paragraph:—

"Communications Engineering Division.

(cA) (i) There shall be paid to the Officer or Sub-Officer in Charge, and being an 'Experienced Engineer' as defined in the Professional Engineers Award 1964 of the Commonwealth Conciliation and Arbitration Commission, an allowance (inclusive of any other Special Duties Allowance) equivalent to the amount by which the salary determined by the said award for 'Experienced Engineer' as defined in the said award, or as hereafter varied by an applicable award of the said Commission, exceeds the salary and allowances, except the allowance for uniform prescribed or hereafter to be prescribed for the rank of such officer or sub-officer by a Determination of the Police Service Board.

(ii) There shall be paid to the Officer in Charge who is not an 'Experienced Engineer' within the meaning of part (i), sub-paragraph (cA) of this paragraph an allowance (inclusive of any other Special Duties Allowance) at the rate of \$3.15 per day."

2. This Determination shall come into operation on and from the 6th day of April, 1976.

Dated this 6th day of May, 1976.

N. A. VICKERY,
A Judge of the County Court of Victoria,
Chairman and Member of the Police Service Board.

J. G. BROWN,
Member of the Police Service Board.

G. DAVIDSON,
Member of the Police Service Board.

Police Regulation Act 1958.

POLICE FORCE OF VICTORIA.

DETERMINATION NO. 256 OF THE POLICE SERVICE BOARD.

The Police Service Board, in pursuance of the powers in that behalf conferred by the *Police Regulation Act 1958*, hereby makes the following Determination (that is to say):—

1. The Determination No. 179 of the Police Service Board of 14th December, 1971, and published in the *Government Gazette* of 25th January, 1972, as amended, is hereby further amended as follows:—

In Sub-Division VIII. of Division III., under the heading "Travelling and Incidental Expenses":—

- (a) (i) In paragraph 42, sub-paragraph 5, clause (a), by deleting the amount "\$6.04" and substituting therefor the amount "\$6.50".
- (ii) In paragraph 42, sub-paragraph 5, clause (b), by deleting the amount "\$7.94" and substituting therefor the amount "\$8.55".
- (b) In paragraph 44, by deleting the amount "\$1.15" and substituting therefor the amount "\$1.25".
- (c) In paragraph 47, sub-paragraph 4, clause (c), by deleting the amount "\$1.00" and substituting therefor the amount "\$1.10".

2. This Determination shall come into operation on and from the 9th May, 1976.

Dated this 10th day of May, 1976.

N. A. VICKERY,
A Judge of the County Court of Victoria,
Chairman and Member of the Police Service Board.

J. G. BROWN,
Member of the Police Service Board.

G. DAVIDSON,
Member of the Police Service Board.

Police Offences Act 1958, No. 6337.
DIVISION 1A.—STATE ADVISORY BOARD ON PUBLICATIONS.

Whereas I have considered reports made to me by the State Advisory Board on Publications under section 180B (2) (a) of the Police Offences Act.

I, Vance Oakley Dickie, Chief Secretary for Victoria, in pursuance of the power vested in me by section 180H (1) of the Police Offences Act hereby determine that the following publications prescribed by title in the schedule hereunder shall be classified as restricted publications for the purposes of the abovenamed Act.

Title.	Publisher.
Searchlight Nos. 155 & 156	Searchlight Publications.
Sensation No. 1	Color Climax Corporation
Sexy Swingers Nos. 168 & 169	Interpersonal Holdings Pty. Ltd.
Sexy Views Vol. 1 No. 2	Not Shown.
Smut Vol. 4 No. 55	Bad Seed Inc.
Sun Lovers No. 2	Not Shown.

VANCE DICKIE,
Chief Secretary.

Chief Secretary's Office,
Melbourne, 12th May, 1976.

SCHEDULE OF PUBLICATIONS.

Title.	Publisher.
Australian Guys Nos. 81 & 82	Private Book and Magazine Co.
Belong To Me Vol. 1 No. 4	Not Shown.
Cocksure No. 62	Interpersonal Holdings Pty. Ltd.
Dirty No. 7	Not Shown.
Erotic Encounters Vol. 1 No. 2	Not Shown.
Hardcore Quarterly Vol. 1 No. 1	Not Shown.
Homo Action No. 6	Jens & Peter Theander
Kings Cross Whisper No. 217	Interpersonal Holdings Pty. Ltd.
Pleasure No. 139	Interpersonal Holdings Pty. Ltd.
Screw Nos. 191 & 192	Private Book and Magazine Co.

BEALIBA WATERWORKS TRUST.

WATER CHARGES BY-LAW 1976.

The Bealiba Waterworks Trust in pursuance and exercise of the powers conferred by the *Water Act 1958* and of any and every other power it thereunto enabling doth hereby make a By-Law as follows:—

- (1) The maximum quantity of water to be supplied in any one year without further charge to properties rated by the Trust is hereby fixed at the quantity which at a charge of 6.6 cents per kilolitre (30 cents per 1,000 gallons) would give an amount equal to the amount of rate levied on such property for the year.
- (2) The charge for water supplied by measure to any property rated by the Trust in excess of such maximum quantity computed as in the last preceding clause, is hereby fixed at 6.6 cents per kilolitre. (30 cents per 1,000 gals.)

- (3) The charge for water supplied to any property not rated by the Trust is hereby fixed at 6.6 cents per kilolitre (30 cents per 1,000 gallons) provided always that the minimum charge shall be 25 dollars.
- (4) The charge for water supplied by measure shall be payable on demand at the Office of the Trust.

Passed this 18th day of March, 1976.

The seal of the Bealiba Waterworks Trust was hereunto affixed, in the presence of—

(SEAL) S. H. WHITEHEAD, Chairman.
K. JARDINE, Commissioner.
A. J. KENNEDY, Secretary.

Approved, 28th April, 1976.—F. J. GRANTER, Minister of Water Supply.

WALLAN WATERWORKS TRUST.

INCREASING THE LIMIT OF BANK OVERDRAFT.

His Excellency the Governor of the State of Victoria, by and with the advice of the Executive Council thereof, doth by Order made on the 11th day of May, 1976, increase the total amount of the sums which the Wallan Waterworks Trust may owe at any one time in respect of moneys borrowed by overdraft of current account pursuant to the provisions of section 288 of the Water Act 1958, fixed by the Governor in Council on 18th February, 1975, at Forty thousand dollars (\$40,000) to One hundred thousand dollars (\$100,000).

TOM FORRISTAL,
Clerk of the Executive Council.

At the Executive Council Chamber,
Melbourne, 11th May, 1976.

SHIRE OF UPPER MURRAY RIVER IMPROVEMENT TRUST.

INCREASING THE LIMIT OF BANK OVERDRAFT.

His Excellency the Governor of the State of Victoria, by and with the advice of the Executive Council thereof, doth by Order made on the 11th day of May, 1976, increase the total amount of the sums which the Shire of Upper Murray River Improvement Trust may owe at any one time in respect of moneys borrowed by overdraft of current account pursuant to the provisions of section 42A of the River Improvement Act fixed by the Governor in Council on 12th August, 1975, at Twenty thousand dollars (\$20,000) to Forty thousand dollars (\$40,000).

TOM FORRISTAL,
Clerk of the Executive Council.

At the Executive Council Chamber,
Melbourne, 11th May, 1976.

LAKES ENTRANCE SEWERAGE AUTHORITY.

AUDIT OF ACCOUNTS. Fee Payable to Auditor.

His Excellency the Governor of the State of Victoria, by and with the advice of the Executive Council thereof, doth by Order made on the 11th day of May, 1976, and in pursuance of the provisions of the Sewerage Districts Act 1958 (No. 6368), approve of the payment to M. P. Ball, Esquire, of the sum of Two hundred and fifty dollars (\$250) as remuneration for making an audit of the accounts of the Lakes Entrance Sewerage Authority for the period from the date of constitution to 31st December, 1975, he having been duly appointed by Order made on 13th January, 1976, to make such audit.

TOM FORRISTAL,
Clerk of the Executive Council.

At the Executive Council Chamber,
Melbourne, 11th May, 1976.

RAINBOW SEWERAGE AUTHORITY.

FIXING THE LIMIT OF BANK OVERDRAFT.

His Excellency the Governor of the State of Victoria, by and with the advice of the Executive Council thereof, doth by Order made on the 11th day of May, 1976, fix the total amount of the sums which the Rainbow Sewerage Authority may owe at any one time in respect of moneys borrowed by overdraft of current account pursuant to the provisions of sections 78 and 79A of the

Sewerage Districts Act 1958, at Ten thousand dollars (\$10,000) and Thirty thousand dollars (\$30,000) respectively.

TOM FORRISTAL,
Clerk of the Executive Council.

At the Executive Council Chamber,
Melbourne, 11th May, 1976.

WONTHAGGI SEWERAGE AUTHORITY.

AUDIT OF ACCOUNTS. Fee Payable to Auditor.

His Excellency the Governor of the State of Victoria, by and with the advice of the Executive Council thereof, doth by Order made on the 11th day of May, 1976, and in pursuance of the provisions of the Sewerage Districts Act 1958 (No. 6368), approve of the payment to E. A. Faulkner, Esquire, of the sum of Two hundred and thirty-five dollars (\$235.00) as remuneration for making an audit of the accounts of the Wonthaggi Sewerage Authority for the year ended 30th September, 1974, he having been duly appointed by Order made on 1st October, 1974, to make such audit.

TOM FORRISTAL,
Clerk of the Executive Council.

At the Executive Council Chamber,
Melbourne, 11th May, 1976.

YEA SEWERAGE AUTHORITY.

AUDIT OF ACCOUNTS. Fee Payable to Auditor.

His Excellency the Governor of the State of Victoria, by and with the advice of the Executive Council thereof, doth by Order made on the 11th day of May, 1976, and in pursuance of the provisions of the Sewerage Districts Act 1958 (No. 6368), approve of the payment to C. G. Condon of the sum of One hundred and fifty dollars (\$150) as remuneration for making an audit of the accounts of the Yea Sewerage Authority for the period from the date of constitution to 31st December, 1975, he having been duly appointed to make such audit by Order made 13th January, 1976.

TOM FORRISTAL,
Clerk of the Executive Council.

At the Executive Council Chamber,
Melbourne, 11th May, 1976.

LONGWARRY DRAINAGE TRUST.

INCREASING THE LIMIT OF BANK OVERDRAFT.

His Excellency the Governor of the State of Victoria, by and with the advice of the Executive Council thereof, doth by Order made on the 18th day of May, 1976, increase the total amount of the sums which the Longwarry Drainage Trust may owe at any one time in respect of moneys borrowed by overdraft of current account pursuant to the provisions of section 42A of the River Improvement Act 1958, fixed by the Governor in Council on 24th July, 1968, at Twelve thousand dollars (\$12,000) to Forty-two thousand dollars (\$42,000).

TOM FORRISTAL,
Clerk of the Executive Council.

At the Executive Council Chamber,
Melbourne, 18th May, 1976.

DRAINAGE AREAS ACT.

SPECIAL MAINTENANCE CHARGE MADE BY THE COUNCIL OF THE SHIRE OF MINHAMITE IN RESPECT OF THE NORTHERN EUMERALLA DRAINAGE AREA.

Notice is hereby given that on the 11th day of May, 1976, in accordance with the provisions of section 36 of the Drainage Areas Act 1958, the Governor in Council approved of the estimate of the cost of proposed maintenance works in the Northern Eumeralla Drainage Area submitted by the Council of the Shire of Minhamite and of the making by the Council of Special Maintenance Charge on properties within the said Drainage Area, for the year ending 30th September, 1976.

TOM FORRISTAL,
Clerk of the Executive Council.

DRAINAGE AREAS ACT.

SPECIAL MAINTENANCE CHARGE MADE BY THE COUNCIL OF THE SHIRE OF MINHAMITE IN RESPECT OF THE MOYNE DRAINAGE AREA.

Notice is hereby given that on the 11th day of May, 1976, in accordance with the provisions of section 36 of the Drainage Areas Act 1958, the Governor in Council

approved of the estimate of the cost of proposed maintenance works in the Moyne Drainage Area submitted by the Council of the Shire of Minhamite and of the making by the Council of Special Maintenance Charge on properties within the said Drainage Area, for the year ending 30th September, 1976.

TOM FORRISTAL,
Clerk of the Executive Council.

DRAINAGE AREAS ACT.

SPECIAL MAINTENANCE CHARGE MADE BY THE COUNCIL OF THE SHIRE OF MINHAMITE IN RESPECT OF THE EUMERALLA DRAINAGE AREA.

Notice is hereby given that on the 11th day of May, 1976, in accordance with the provisions of section 36 of the Drainage Areas Act 1958, the Governor in Council approved of the estimate of the cost of proposed maintenance works in the Eumeralla Drainage Area submitted by the Council of the Shire of Minhamite and of the making by the Council of Special Maintenance Charge on properties within the said Drainage Area, for the year ending 30th September, 1976.

TOM FORRISTAL,
Clerk of the Executive Council.

SHIRE OF KYNETON.—ROAD DEVIATION.

Pursuant to the provisions of sections 522 and 526 of the Local Government Act 1958, the Council of the Shire of Kyneton hereby directs that the land in the Parish of Trentham indicated by hatching on the diagram hereunder which has been purchased, taken or acquired by it shall be a public highway on and from the date of publication of this order in the Government Gazette and declares that such land shall be a public highway in lieu of the land indicated by cross-hatching on the said diagram.

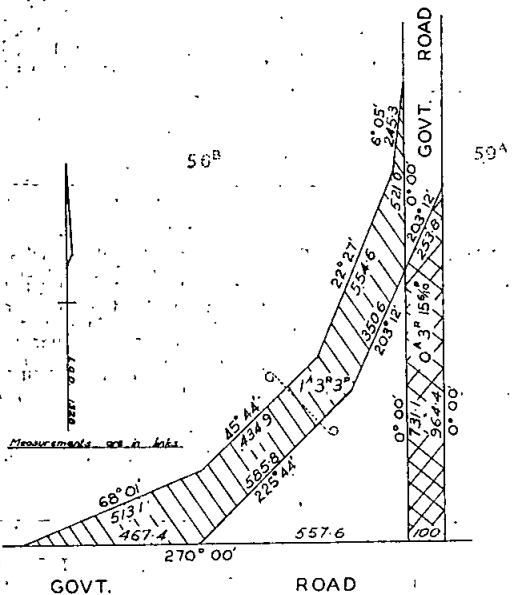

The common seal of the President, Councillors and Ratepayers of the Shire of Kyneton was hereunto affixed, the 8th day of May, 1974, in the presence of—

(SEAL) J. DONOVAN, President.
R. M. HOOPPELL, Councillor.
S. G. PORTER, Secretary.

Confirmed by the Governor in Council, 11th May, 1976.
—TOM FORRISTAL, Clerk of the Executive Council.

SHIRE OF WYCHEPROOF.
ROAD DEVIATION ORDER.

In pursuance of the powers conferred by sections 522 and 526 of the Local Government Act 1958, the Council of the Shire of Wycheproof hereby directs that the land in the Parish of Nullawil, indicated by hatching on the diagram which has been purchased, taken or acquired by it,

shall be a public highway on and from the date of publication of this Order in the Government Gazette and declares that such land shall be a public highway in lieu of the land indicated by cross-hatching on the said diagram.

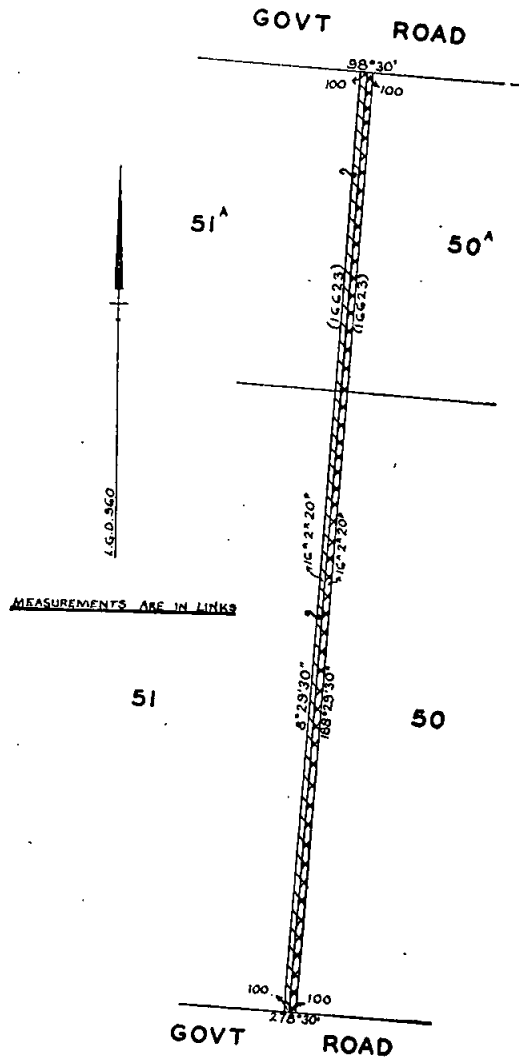

The common seal of the President, Councillors and Ratepayers of the Shire of Wycheproof was hereunto affixed, this 14th day of August, 1972—

(SEAL) D. H. DIBBY, Shire President.
R. H. NEWELL, Councillor.
G. K. DRYDEN, Shire Secretary.

Confirmed by the Governor in Council, 13th April, 1976.
—TOM FORRISTAL, Clerk of the Executive Council.

Business Franchise (Tobacco) Act 1974.
WHOLESALE TOBACCO MERCHANT'S LICENCE.

I hereby notify that a Wholesale Tobacco Merchant's Licence under the Business Franchise (Tobacco) Act 1974 for the year ending 31st December 1976, has been issued to the following:

R. & A.W. CO. PTY. LTD.
R. M. PHIBBS,
Commissioner of Business Franchises.

Melbourne and Metropolitan
BOARD OF WORKS.

GENERAL NOTICE.

The Melbourne and Metropolitan Board of Works having made provision for carrying off the sewage of each and every property which or any part of which is situate in the Sewerage Areas hereinafter described doth hereby declare that on and after the 24th day of May, 1976, each and every property so situate shall be deemed to be a sewered property within the meaning of the *Melbourne and Metropolitan Board of Works Act 1958*.

The Sewerage Areas hereinbefore referred to are:—

Sewerage Area No. 3023.

City of Waverley.—Commencing at the junction of Suemar Street and Knell Street; thence northerly along Knell Street, easterly along Hansworth Street, northerly along Merrill Street, north-easterly along the north-western boundary of lot 16 Merrill Street, easterly along the northern boundaries of the said lot 16 and lot 202 Zita Street, southerly along Albany Drive, easterly along Hansworth Street, southerly along Withers Avenue, westerly along Police Road to the boundary of Sewerage Area No. 2250 at a point about 165 metres west of the western boundary of Albany Drive, northerly, westerly, northerly and westerly along the said area boundary to the commencing point.

Sewerage Area No. 3024.

City of Altona.—Commencing at the junction of Civic Parade and McIntyre Drive; thence northerly, north-easterly, northerly and north-westerly along McIntyre Drive, north-easterly along the north-western boundary of lot 418 McIntyre Drive, south-easterly along the north-eastern boundaries of lots 418 to 420, 444 to 449, 481 and 482 and 1 to 9 McIntyre Drive, easterly along the northern boundaries of the said lot 9 and lot 587 McIntyre Drive, southerly along the eastern boundaries of lots 587 to 606 and 647 to 652 McIntyre Drive, further southerly by a line to and along the eastern boundary of lot 1 McIntyre Drive, easterly and southerly along the northern and eastern boundaries of lot 32 Civic Parade, westerly along Civic Parade to the commencing point.

Sewerage Area No. 3025.

Cities of Doncaster and Templestowe and Nunawading.—Commencing at the northern end of Oxford Street on the boundary of Sewerage Area No. 2249; thence southerly, westerly, northerly, and westerly along the said area boundary to the junction of the southern part of Astelot Drive and Springvale Road, northerly along Springvale Road, easterly and northerly along Solson Place, further northerly and easterly along the western and northern boundaries of lot 10 Solson Place, further easterly along the northern boundary of lot 1 Mitcham Road, south-easterly along Mitcham Road, north-easterly along the north-western boundary of lot 12 Mitcham Road, south-easterly along the north-eastern boundaries of lots 12 and 11 Mitcham Road, further south-easterly by a line to and along the north-eastern boundaries of lots 10 to 4 Mitcham Road, easterly along the northern boundaries of lots 4 to 1 Mitcham Road, south-easterly by a line to and along Hollygreen Close and the north-eastern boundary of lot 15 Hollygreen Close, southerly along the eastern boundary of the said lot 15, south-easterly along Mitcham Road to the boundary of Sewerage Area No. 2249, generally south-westerly along the said area boundary to the commencing point.

Sewerage Area No. 3026.

City of Doncaster and Templestowe.—Commencing at the junction of Tunstall Road and Lynne Street on the boundary of Sewerage Area No. 2185; thence easterly, generally northerly, easterly, northerly and generally easterly along the said area boundary to Mitcham Road, south-easterly along Mitcham Road, southerly along Springvale Road to the boundary of Sewerage Area No. 2246, westerly, southerly and westerly along the said area boundary to the eastern extremity of Argyle Street, further westerly along Argyle Street, northerly along Braham Street, westerly along Roy Street, northerly along Tunstall Road to the commencing point.

Sewerage Area No. 3027.

Shire of Whittlesea.—Commencing at the junction of Howard Street and Cooper Street; thence westerly along Cooper Street, northerly along the western boundaries of lots 4 Cooper Street and 1 Wedge Street, westerly along Wedge Street, north-easterly and northerly along High Street, easterly along Houston Street, south-easterly along Campbell Street, north-easterly along Rufus Street to Darebin Creek, generally southerly along the said creek to the northern boundary of a railway reserve, westerly

along the said boundary to the junction of Davisson Street and Cooper Street, further westerly along Cooper Street to the commencing point.

Sewerage Area No. 3028.

City of Doncaster and Templestowe.—Commencing at the junction of Latrobe Street and Grant Olson Avenue; thence southerly along Grant Olson Avenue, westerly along Bourke Street, northerly along the western boundaries of lots 28 to 22 Cameo Court and 1 Latrobe Street, easterly along Latrobe Street to the commencing point.

Sewerage Area No. 3029.

City of Ringwood.—Commencing at a point in Poynton Avenue about 35 metres south-east of the south-eastern boundary of Loughnan Road; thence north-easterly along the north-western boundary of lot 1 Poynton Avenue, southerly along the eastern boundaries of lots 1 to 4 Poynton Avenue, south-westerly by a line to the junction of the eastern and southern boundaries of Poynton Avenue, northerly and north-westerly along Poynton Avenue to the commencing point.

Sewerage Area No. 3030.

Shire of Werribee.—Commencing at the junction of Cambridge Crescent and Iluka Drive; thence easterly and south-easterly along Iluka Drive, north-easterly along the north-western boundary of lot 235 Iluka Drive, easterly along the northern boundaries of the said lot 235 and lot 234 Iluka Drive, further easterly by a line to and along the northern boundaries of lots 117 to 115 Elaroo Court and 113 Cambridge Crescent, south-easterly by a line to the north-western angle of lot 112 Cambridge Crescent, easterly along the northern boundaries of the said lot 112 and lots 101 to 98 Terrigal Court and 82 Walls Road, southerly along Walls Road, westerly along the southern boundaries of lots 497 and 496 Charinga Drive, 494 and 480 Juka Court and 478 and 127 Charinga Drive, further westerly by a line to and along the southern boundaries of lots 139 to 144 Cambridge Crescent, 145 Wallara Road, 147 to 163 Cambridge Crescent, 239 Yaltara Drive, 240 and 241 Kiandra Way and 289 McGrath Road, northerly along McGrath Road, easterly along the northern boundaries of lots 266 McGrath Road and 265 Cambridge Crescent, southerly along Cambridge Crescent to the commencing point.

Sewerage Area No. 3031.

City of Sunshine.—Commencing at the junction of James Street and Ridgeway Parade; thence easterly along Ridgeway Parade, southerly along Frank Street, south-easterly along Whitsides Avenue and Evelyn Crescent, easterly along the northern boundary of lot 785 Evelyn Crescent, southerly along the eastern boundaries of lots 785, 784, 6 and 766 to 764 Evelyn Crescent and 761 Glengala Road, westerly along Glengala Road, southerly along the eastern boundaries of lots 1135 Glengala Road and 1125 Murray Street, westerly along Murray Street, northerly along Alexander Street, easterly along Glengala Road, northerly and north-easterly along Lorna Crescent, further north-easterly along Whitsides Avenue, northerly along James Street to the commencing point.

Sewerage Area No. 3032.

City of Knox.—Commencing at a point in Burwood Highway about 56 metres south-east of the south-eastern boundary of Austin Street; thence north-easterly and south-easterly along the north-western and north-eastern boundaries of lot 3 Burwood Highway, north-easterly along portion of the north-western boundary of lot 2 Burwood Highway, northerly along the western boundary of lot 2 Winwood Drive, easterly along Winwood Drive, southerly along the eastern boundary of the said lot 2 Winwood Drive to the north-eastern boundary of Burwood Highway, south-westerly by a line to and along the south-eastern boundary of lot 1 Burwood Highway, northerly along the western boundaries of the said lot 1 and lot 2 Burwood Highway, north-easterly along the north-western boundary of the said lot 2, south-easterly along Burwood Highway a distance of about 20 metres to the commencing point.

Sewerage Area No. 3033.

City of Nunawading.—Commencing at the junction of Caroben Avenue and Morack Road; thence southerly along Morack Road, westerly along the southern boundaries of lots 92 Morack Road, 103 to 105 Carramar Court and 114 to 116 Myuna Court and a line in continuation to the south-eastern angle of lot 66 Phillip Street, further westerly along the southern boundaries of the said lot 66 and lots 60 to 54 Glenora Drive, northerly along the western boundary of the said lot 54, further northerly by a line to and along the western boundaries of lots 53 to 49 Bellbird Crescent, westerly along portion of the southern

boundary of lot 48 Bellbird Crescent, northerly along the western boundaries of lots 48 to 40 Bellbird Crescent, south-easterly along the north-eastern boundary of the said lot 40 Bellbird Crescent, easterly along Bellbird Crescent, southerly along Phillip Street, easterly along Caroben Avenue to the commencing point.

Sewerage Area No. 3034.

Shire of Whittlesea.—Commencing at the junction of Currajong Street and Heath Street on the boundary of Sewerage Area No. 2382; thence westerly, southerly and generally westerly along the said boundary to a point in Station Street about 33 metres south of the southern boundary of Heath Street, northerly along Station Street to the boundary of Sewerage Area No. 2382, easterly and southerly along the said area boundary to the commencing point.

Sewerage Area No. 3035.

City of Knox.—Commencing at the junction of Stewart Street and Albert Avenue; thence southerly along Albert Avenue, westerly along the southern boundaries of lots 23 Albert Avenue and 18 to 2 Stewart Street, northerly along the western boundary of the said lot 2, easterly along Stewart Street to the commencing point.

Sewerage Area No. 3036.

City of Doncaster and Templestowe.—Commencing at the intersection of Thompsons Road and Koonung Creek; thence generally north-westerly along the said creek to Bulleen Road, northerly along Bulleen Road, easterly along the northern boundaries of lots 1 and 2 on Lodged Plan of Subdivision No. 45733 to the boundary of Sewerage Area No. 2379, southerly and south-easterly along the said area boundary to Thompsons Road, south-westerly along Thompsons Road to the commencing point.

By Order of the Board,
R. H. ENGELSMAN,
Secretary.

625 Little Collins Street, Melbourne, 3001, 18th May, 1976.

NOTICE TO MARINERS.
[No. 18t of 1976.]

AUSTRALIA—VICTORIA.
WESTERNPORT.

Current Meter Buoys Established.

- Positions.—(a) Lat. 38 deg. 20·9 min. S. Long. 145 deg. 30·3 min. E.
(b) Lat. 38 deg. 20·7 min. S. Long. 145 deg. 30·5 min. E.
(c) Lat. 38 deg. 20·5 min. S. Long. 145 deg. 30·8 min. E.

(In vicinity of Sandy Point, French Island).

Details.—Current meters supported by red and white drum buoys are being temporarily established in the above positions.

Chart Temporarily Affected.—AUS. 149Y.
A. J. WAGGLEN,
Port Officer.

Public Works Department,
Ports and Harbors Division,
168 Exhibition Street,
Melbourne, 3000, 10th May, 1976.

Survey Co-ordination Act 1958.

NOTICE OF PROPOSAL TO ASSIGN A NAME.

Pursuant to the powers conferred under section 28 of the above Act, the Place Names Committee hereby gives notice of its intention to assign the following name:

Name.—Row Camping Reserve.

Municipality.—Shire of Warrnambool.

Location.—Land situated in the Township of Peterborough and temporarily reserved as a site for Tourists Camp purposes by Order in Council of 25th March, 1947.

Any person who objects to the above proposal may give notice of objection, in writing, stating the reasons therefor, to the Secretary of the Committee not more than two (2) months following publication of this notice.

By Order of the Committee,
P. G. SEWELL,
Secretary.

Office of the Place Names Committee,
Department of Crown Lands and Survey,
Melbourne, Vic. 3002.

Survey Co-ordination Act 1958.

NOTICE OF PROPOSAL TO ALTER A NAME.

Pursuant to the powers conferred under section 28 of the above Act, the Place Names Committee hereby gives notice of its intention to alter the name of the mountain mentioned hereunder:—

Municipality.—Shire of Upper Murray.

Location.—The mountain shown on the Tallangatta map sheet (No. SJ55-03; Scale 1 : 250,000) at south latitude 36 deg. 10 min. east longitude 147 deg. 52 min.

Present Name.—Mount Mitta Mitta.

Proposed Name.—Mount Mittamatite.

Any person who objects to the above proposal may give notice of objection, in writing, stating the reasons therefor, to the Secretary of the Committee not more than two (2) months following publication of this notice.

By Order of the Committee,
P. G. SEWELL,
Secretary.

Office of the Place Names Committee,
Department of Crown Lands and Survey,
Melbourne, 3002.

Cemeteries Act 1958.

SCALE OF FEES OF THE TARRAWINGEE PUBLIC CEMETERY.

In pursuance of the powers conferred upon them by the Cemeteries Act, the trustees of the Tarrawingee Public Cemetery hereby make the following scale of fees, which shall come into operation upon publication in the *Government Gazette*, and from and after such publication every scale of fees heretofore made by the said trustees shall be and is hereby rescinded to the extent to which it conflicts with this scale.

<i>Private Graves.</i>	
Land, 2·44 m x 1·22 m	\$12·00
<i>Extra Charges.</i>	
Interment fee in private grave—adults	\$10·00
Interment fee in private grave—child under fourteen years	\$6·00
<i>Miscellaneous Charges.</i>	
Permission to construct a brick grave or to erect any stone kerb, brick tilework or concrete	\$6·00
Exhuming the remains of a body (when authorized)	\$20·00
Interment of ashes in a private grave	\$6·00
Permission to erect a headstone or monument	\$6·00
Permission to add to any monument or additional lettering	\$3·00
J. R. KAY, Trustee. F. V. KEOGH, Trustee. W. G. BENNETT, Trustee.	

Approved by the Governor in Council, 11th May, 1976.—
TOM FORRISTAL, Clerk of the Executive Council.

Cemeteries Act 1958.

SCALE OF FEES OF THE RYE PUBLIC CEMETERY.

In pursuance of the powers conferred upon them by the Cemeteries Act, the trustees of the Rye Public Cemetery hereby make the following scale of fees, which shall come into operation upon publication in the *Government Gazette*, and from and after such publication every scale of fees heretofore made by the said trustees shall be and is hereby rescinded to the extent to which it conflicts with this scale.

<i>Private Graves—Ordinary Section.</i>	
Land, 2·44 m x 1·22 m	\$50·00
Reopening fee (no cover)	\$30·00
Reopening fee (with cover or kerb slab)	\$40·00
Sinking grave 2·13 m	\$35·00
<i>Lawn Section.</i>	
Sinking grave 2·13 m	\$35·00
W. A. GOODREM, Trustee. R. E. PITCHER, Trustee. J. W. HAYLBERT, Trustee. G. M. JARMAN, Trustee.	

Approved by the Governor in Council, 11th May, 1976.—
TOM FORRISTAL, Clerk of the Executive Council.

Cemeteries Act 1958.

SCALE OF FEES OF THE MELBOURNE GENERAL CEMETERY.

In pursuance of the powers conferred upon them by the Cemeteries Act, the trustees of the Melbourne General Cemetery hereby make the following scale of fees, which shall come into operation upon publication in the *Government Gazette*, and from and after such publication every scale of fees heretofore made by the said trustees shall be and is hereby rescinded to the extent to which it conflicts with this scale.

<i>Private Graves.</i>	
Land, 8 ft. x 4 ft. (special positions)	\$200.00
Land, 8 ft. x 4 ft. (where available)	\$165.00
<i>Sinking Charges.</i>	
Sinking grave 7 feet deep	\$115.00
Sinking grave 8 feet deep	\$120.00
Sinking grave 9½ feet deep	\$130.00
Reopening any grave	\$115.00
Sinking grave to standard length 6 ft. 9 in. but wider than 2 ft. 3 in. at shoulder (extra) ..	\$30.00
Sinking grave to standard width 2 ft. 3 in. but longer than 6 ft. 9 in. (extra)	\$30.00
American casket (oblong) (all sizes)	\$45.00

<i>Interment Charges Extra.</i>	
Interment Saturday morning	\$100.00
Interment Sunday morning (when permitted) ..	\$130.00
Interment Public Holiday or on Cemetery Employees' Picnic Day	\$100.00
Interment of stillborn child (public grave) ..	\$5.00
Interment of stillborn child (private grave) ..	\$40.00
Interment of cremated remains (in grave) ..	\$40.00

<i>Extra Charges.</i>	
Fee for exhumation (when authorized)	\$260.00
Search of records (up to five years)	\$5.00
Search of records (up to 25 years)	\$30.00
Concrete vault for two (2) interments (land inclusive)	\$750.00
Annual maintenance (single grave)	\$20.00
Annual maintenance (double grave)	\$25.00
Annual maintenance (treble grave)	\$30.00

F. P. WILLIAMS, Trustee.
MOSS J. DAVIS, Trustee.
I. H. LYALL, Trustee.
L. NORMAN LEY, Trustee.
M. S. BRENNAN, Secretary.

Approved by the Governor in Council, 11th May, 1976.—TOM FORRISTAL, Clerk of the Executive Council.

Cemeteries Act 1958.

SCALE OF FEES OF THE GEELONG WESTERN PUBLIC CEMETERY.

In pursuance of the powers conferred upon them by the Cemeteries Act, the trustees of the Geelong Western Public Cemetery hereby make the following scale of fees, which shall come into operation upon publication in the *Government Gazette*, and from and after such publication every scale of fees heretofore made by the said trustees shall be and is hereby rescinded to the extent to which it conflicts with this scale.

<i>General Section.</i>	
Land, 1.2 m x 2.4 m	\$120.00
Sinking, any depth to 2.3 m	\$125.00
Reopening any grave	\$125.00
Sunday and holidays (when permissible) (extra) ..	\$40.00
Saturday mornings (extra)	\$40.00
Saturday mornings—late fee—after 11.30 a.m. (extra)	\$25.00
<i>Lawn Section.</i>	
Land, 1.2 m x 2.4 m	\$150.00
First interment	\$125.00
Second interment (final interment)	\$125.00
Small graves (children only)	\$60.00
Interment stillborn child (unmarked)	\$20.00
Sunday and holidays (when permissible) (extra) ..	\$40.00
Saturday mornings (extra)	\$40.00
Saturday mornings—late fee—after 11.30 a.m. (extra)	\$25.00

R. W. REID, Trustee.
ERIC J. LYONS, Trustee.
IAN F. APTEID, Trustee.

Approved by the Governor in Council, 11th May, 1976.—TOM FORRISTAL, Clerk of the Executive Council.

Cemeteries Act 1958.

SCALE OF FEES OF THE KERANG PUBLIC CEMETERY.

In pursuance of the powers conferred upon them by the Cemeteries Act, the trustees of the Kerang Public Cemetery hereby make the following scale of fees, which shall come into operation upon publication in the *Government Gazette*, and from and after such publication every scale of fees heretofore made by the said trustees shall be and is hereby rescinded to the extent to which it conflicts with this scale.

<i>Lawn Cemetery (Undenominational).</i>	
Lawn grave 2.44 x 1.22 m	\$130.00
For each interment therein	\$65.00
Bronze plaque for each interment	\$55.00
Exhuming the remains of a body when authorised ..	\$80.00
Flower container supplied by trust	\$30.00
Memorial wall niche and plaque	\$70.00

W. DUNSTAN, Trustee.
J. B. MESSER, Trustee.
H. W. JORGENSON, Trustee.

Approved by the Governor in Council, 11th May, 1976.—TOM FORRISTAL, Clerk of the Executive Council.

Cemeteries Act 1958.

SCALE OF FEES OF THE COROP PUBLIC CEMETERY.

In pursuance of the powers conferred upon them by the Cemeteries Act 1958, the trustees of the Corop Public Cemetery hereby make the following scale of fees, which shall come into operation upon publication in the *Government Gazette*, and from and after such publication every scale of fees heretofore made by the said trustees shall be and is hereby rescinded:—

<i>Public Graves.</i>	
Interment in grave without exclusive right—stillborn child	\$12.00
Interment in grave without exclusive right—others	\$24.00
Number peg or label	\$5.00

<i>Private Graves.</i>	
Land, 2.44 m x 1.22 m	\$34.00
Own selection of land (extra)	\$8.00

<i>Sinking Charges for Private Graves.</i>	
Sinking grave 1.83 m deep	\$52.00
Each additional 0.3 m	\$10.00
Sinking oversize grave (extra)	\$20.00
Cancellation of order to sink (if commenced) ..	\$10.00

<i>Reopening Charges.</i>	
Reopening grave (no cover)	\$45.00
Reopening grave (with cover)	\$50.00

<i>Extra Charges.</i>	
Interment outside prescribed hours, or on Saturdays, Sundays or Public Holidays	\$18.00
Interment in a private grave without due notice ..	\$18.00

<i>Miscellaneous.</i>	
Interment fee	\$16.00
Certificate of right of burial	\$2.50
Number plate or brick	\$5.00

Permission to erect a headstone or monument—5 per cent. of cost with a minimum of \$6.	
Permission to construct a brick grave or to erect any stone kerb, brick tile-work or concrete ..	\$7.00
Exhuming the remains of a body (when authorized)	\$70.00
Interment of ashes in a private grave	\$16.00
Memorial wall niche and plaque	\$50.00

Made this 16th day of March, 1976.

W. AYSON, Trustee.
R. E. HICKSON, Trustee.
G. BUZZA, Trustee.
T. H. LARKINS, Secretary.

Approved by the Governor in Council, 11th May, 1976.—TOM FORRISTAL, Clerk of the Executive Council.

Cemeteries Act 1958.

SCALE OF FEES OF THE LISMORE PUBLIC CEMETERY.

In pursuance of the powers conferred upon them by the *Cemeteries Act*, the trustees of the Lismore Public Cemetery hereby make the following scale of fees, which shall come into operation upon publication in the *Government Gazette*, and from and after such publication every scale of fees heretofore made by the said trustees shall be and is hereby rescinded to the extent to which it conflicts with this scale.

Sinking Charges for Private Graves.

Sinking grave 1.83 m deep	\$40.00
Each additional .3 m	\$10.00

J. E. BAKER, Trustee.
C. J. BUSTARD, Trustee.
J. E. GRILLS, Trustee.

Approved by the Governor in Council, 11th May, 1976.—
TOM FORRISTAL, Clerk of the Executive Council.

Town and Country Planning Act 1961.
CITY OF COLAC PLANNING SCHEME.

AMENDMENT No. 9, 1975.

Notice of Approval.

In pursuance of the powers conferred by the *Town and Country Planning Act 1961*, the Governor in Council on the 11th May, 1976, approved a planning scheme entitled the City of Colac Planning Scheme, 1963, Amendment No. 9, 1975 in respect of part of the municipal district of the City of Colac and such planning scheme comes into operation on the date this Notice of Approval is published in the *Government Gazette*.

A copy of the planning scheme as approved may be inspected, free of charge, during office hours at the office of the Town and Country Planning Board, 235 Queen Street, Melbourne, at the office of the Council of the City of Colac at Colac, and when available, at the Office of Titles, Melbourne, and at the Central Plan Office of the Department of Crown Lands and Survey, Melbourne.

W. H. CRAIG, Secretary,
Town and Country Planning Board.

Town and Country Planning Act 1961.
CITY OF KNOX PLANNING SCHEME 1965.

AMENDMENT No. 149, 1975.

Notice of Approval.

In pursuance of the powers conferred by the *Town and Country Planning Act 1961*, the Governor in Council on the 11th May, 1976, approved a planning scheme entitled the City of Knox Planning Scheme 1965, Amendment No. 149, 1975, in respect of part of the municipal district of the City of Knox and such planning scheme comes into operation on the date this Notice of Approval is published in the *Government Gazette*.

A copy of the planning scheme as approved may be inspected, free of charge, during office hours at the office of the Town and Country Planning Board, 235 Queen Street, Melbourne, at the office of the Council of the City of Knox at Knoxfield, and when available, at the Office of Titles, Melbourne, and at the Central Plan Office of the Department of Crown Lands and Survey, Melbourne.

W. H. CRAIG, Secretary,
Town and Country Planning Board.

Town and Country Planning Act 1961.
CITY OF KNOX PLANNING SCHEME 1965.

AMENDMENT No. 134, 1974.

Notice of Approval.

In pursuance of the powers conferred by the *Town and Country Planning Act 1961*, the Governor in Council on the 11th May, 1976, approved a planning scheme entitled the City of Knox Planning Scheme 1965, Amendment No. 134, 1974 in respect of part of the municipal district of the City of Knox and such planning scheme comes into operation on the date this Notice of Approval is published in the *Government Gazette*.

A copy of the planning scheme as approved may be inspected, free of charge, during office hours at the office of the Town and Country Planning Board, 235 Queen Street, Melbourne, at the office of the Council of the City of Knox at Knoxfield, and when available, at the Office of Titles, Melbourne, and at the Central Plan Office of the Department of Crown Lands and Survey, Melbourne.

W. H. CRAIG, Secretary,
Town and Country Planning Board.

Town and Country Planning Act 1961.
CITY OF KNOX PLANNING SCHEME 1965.

AMENDMENT No. 140, 1975.

Notice of Approval.

In pursuance of the powers conferred by the *Town and Country Planning Act 1961*, the Governor in Council on the 11th May, 1976, approved a planning scheme entitled the City of Knox Planning Scheme 1965, Amendment No. 140, 1975, in respect of part of the municipal district of the City of Knox and such planning scheme comes into operation on the date this Notice of Approval is published in the *Government Gazette*.

A copy of the planning scheme as approved may be inspected, free of charge, during office hours at the office of the Town and Country Planning Board, 235 Queen Street, Melbourne, at the office of the Council of the City of Knox at Knoxfield, and when available, at the Office of Titles, Melbourne, and at the Central Plan Office of the Department of Crown Lands and Survey, Melbourne.

W. H. CRAIG, Secretary,
Town and Country Planning Board.

Town and Country Planning Act 1961.
BOROUGH OF PORT FAIRY PLANNING SCHEME.

AMENDMENT No. 2, 1976.

Notice of Amendment.

In pursuance of the powers conferred by sub-section 6 of section 32 of the *Town and Country Planning Act 1961*, the Governor in Council, on the 11th May, 1976 amended the Borough of Port Fairy Planning Scheme to relax the contiguous ownership clause and setback provisions in the Agricultural Zone as it applies to approximately two hectares of land adjoining the Princes Highway.

A copy of the amendment may be inspected during office hours at the office of the Town and Country Planning Board, 235 Queen Street, Melbourne, at the office of the Council of the Borough of Port Fairy at Port Fairy and when available at the Office of Titles, Melbourne and at the Central Plan Office of the Department of Crown Lands and Survey, Melbourne.

W. H. CRAIG, Secretary,
Town and Country Planning Board.

Town and Country Planning Act 1961.
GEELONG REGIONAL PLANNING SCHEME.

INTERIM DEVELOPMENT ORDER.

AMENDMENT No. 1.

Notice of Amendment.

In pursuance of the powers conferred by section 26 of the *Town and Country Planning Act 1961*, the Governor in Council on the 18th May, 1976, amended the Geelong Regional Planning Scheme Interim Development Order to enable Councils acting under powers delegated from the Geelong Regional Planning Authority to permit the erection of a house in any Rural Zone on an allotment comprising a tenement of not more than five allotments without the approval of the Geelong Regional Planning Authority.

A copy of the amendment may be inspected during office hours at the office of the Town and Country Planning Board, 235 Queen Street, Melbourne and at the office of the Geelong Regional Planning Authority at 117 Myers Street, Geelong.

W. H. CRAIG, Secretary,
Town and Country Planning Board.

Town and Country Planning Act 1961.
SHIRE OF BACCHUS MARSH PLANNING SCHEME.

REVOCATION No. 1.

Notice of Revocation.

In pursuance of the provisions of Section 32 of the *Town and Country Planning Act 1961* the Governor in Council on the 11th May, 1976, made an Order:—

- (i) Revoking the Shire of Bacchus Marsh Planning Scheme in so far as it applies to part of Crown Allotments 22 and 23, Parish of Merrimu, more particularly described in Certificate of Title Volume 8603, Folio 207; and
- (ii) providing that:—

- (a) The land may be used only for those purposes permissible in the Rural 'A' Zone or Rural 'B' Zone in the Shire of Bacchus Marsh Planning Scheme;

(b) The land may be subdivided into no more than two allotments; and

(c) Any such use or development is permitted only subject to the grant of a permit by the Council of the Shire of Bacchus Marsh.

A copy of the Order may be inspected during office hours at the office of the Town and Country Planning Board, 235 Queen Street, Melbourne; and at the office of the Council of the Shire of Bacchus Marsh at Bacchus Marsh.

W. H. CRAIG, Secretary,
Town and Country Planning Board.

Town and Country Planning Act 1961.
SHIRE OF GORDON PLANNING SCHEME.

INTERIM DEVELOPMENT ORDER.

Notice of Approval.

In pursuance of the powers conferred by the *Town and Country Planning Act 1961*, the Governor in Council on the 11th day of May, 1976, approved an Interim Development Order made by the Gordon Shire Council for the whole of the municipal district of the Shire of Gordon.

The Interim Development Order provides that the use, subdivision or development of any land within the area described or the erection, construction or carrying out of any buildings, roads or other works thereon is prohibited except in accordance with the provisions of the Order.

A copy of the Interim Development Order and a map showing the area affected may be inspected, free of charge, at the office of the Council of the Shire of Gordon at Boort, and at the office of the Town and Country Planning Board, 235 Queen Street, Melbourne.

W. H. CRAIG, Secretary,
Town and Country Planning Board.

Town and Country Planning Act 1961.
SHIRE OF PAKENHAM PLANNING SCHEME.

INTERIM DEVELOPMENT ORDER 1974.

AMENDMENT NO. 4, 1975.

Notice of Amendment.

In pursuance of the powers conferred by section 26 of the *Town and Country Planning Act 1961*, the Governor in Council on the 18th May, 1976, amended the Shire of Pakenham Planning Scheme Interim Development Order 1974 to include new uses and to rectify anomalies in the Special Conservation "A" and "B", Agricultural "A" and Special Agricultural "B" Zones.

A copy of the amendment may be inspected during office hours at the office of the Town and Country Planning Board, 235 Queen Street, Melbourne and at the office of the Council of the Shire of Pakenham at Pakenham.

W. H. CRAIG, Secretary,
Town and Country Planning Board.

Town and Country Planning Act 1961.
SHIRE OF PAKENHAM PLANNING SCHEME.

INTERIM DEVELOPMENT ORDER 1974.

AMENDMENT NO. 5, 1975.

Notice of Amendment.

In pursuance of the powers conferred by Section 26 of the *Town and Country Planning Act 1961*, the Governor in Council on the 11th May, 1976 amended the Shire of Pakenham Planning Scheme Interim Development Order 1974 to introduce a Country Residential 'B' Zone and to rezone an area of land adjacent to the township of Gembrook to the new zone.

A copy of the amendment may be inspected during office hours at the office of the Town and Country Planning Board, 235 Queen Street, Melbourne and at the office of the Council of the Shire of Pakenham at Pakenham.

W. H. CRAIG, Secretary,
Town and Country Planning Board.

Town and Country Planning Act 1961.
PORTLAND PLANNING SCHEME 1957 (SHIRE OF PORTLAND).

AMENDMENT NO. 13, PART 1.

Notice of Approval.

In pursuance of the powers conferred by the *Town and Country Planning Act 1961*, the Governor in Council on the 11th May, 1976, approved a planning scheme entitled the Portland Planning Scheme 1957, Amendment No. 13,

Part 1 (Shire of Portland) in respect of part of the municipal district of the Shire of Portland and such planning scheme comes into operation on the date this Notice of approval is published in the *Government Gazette*.

A copy of the planning scheme as approved may be inspected, free of charge, during office hours at the office of the Town and Country Planning Board, 235 Queen Street, Melbourne, at the office of the Council of the Shire of Portland at Heywood and when available, at the Office of Titles, Melbourne, and at the Central Plan Office of the Department of Crown Lands and Survey, Melbourne.

W. H. CRAIG, Secretary,
Town and Country Planning Board.

MINES DEPARTMENT.

MINING LEASE DECLARED VOID.

No. 123; Albert Booth Clarke; 6.9 ha, Parish of Kooroon.

R. G. WHITING,

Acting Secretary for Mines.

PUBLIC TRUSTEE ACT 1958 (No. 6350), SECTION 17.

I hereby give notice that on the 28th April, 1976 the Public Trustee filed elections to administer the following deceased persons' estates in accordance with section 17 of the *Public Trustee Act 1958*.

ENDERLIN, GEORGE, late of Broadbeach Nursing Home, Broadbeach, Queensland, retired, died 6th May, 1975.

HAZLE, ROBERT WILLIAM, formerly of 4 Jasmine Court, Frankston, but late of 63 Wimborne Avenue, Mount Eliza, office manager, died 28th December, 1975.

KISHANDER, JAMES ALFRED, formerly of 87 Mortimore Street, Moorabbin, but late of 34 Elder Street, Clayton, public servant, died 23rd February, 1976.

RICHARDSON, KATHERINE MARY, late of Flat 1, 26 Grey Street, East Melbourne, secretary, died 18th February, 1976.

I hereby give notice that on the 30th April, 1976 the Public Trustee filed elections to administer the following deceased persons' estates in accordance with section 17 of the *Public Trustee Act 1958*.

LEWIS, LEWIS FREDERICK, late of Eighth Street, Parkdale, cabinet maker, died 10th June, 1936.

LYONS, MAISIE MARGARET, also known as Lyons, Maisie Margaret, late of Flat 1, 249 Beaconsfield Parade, Middle Park, widow, died 18th February, 1976.

SCOLLON, JAMES PATRICK, formerly of 1 Gaynor Court, Malvern, but late of 146 Patterson Road, Moorabbin, public servant, died 5th January, 1976.

N. P. BRODY,
Public Trustee.

168 Exhibition Street, Melbourne, 3000, 11th May, 1976.

NOTICE.

Creditors, next of kin, and others having claims against the estate of any of the under-mentioned deceased persons are required to send particulars of their claims to the Public Trustee, 168 Exhibition Street, Melbourne, Vic. 3000, the personal representative, on or before the 18th July, 1976 after which date the Public Trustee may convey or distribute the assets having regard only to the claims of which the Public Trustee then has notice:—

CRAIG, CHARLES, HUTTON, late of 15 Vasey Street, Bentleigh East, retired salesman, died 13th February, 1976.

ENDERLIN, GEORGE, late of Broadbeach Nursing Home, Broadbeach, Queensland, retired, died 6th May, 1975.

FARRELL, HUBERT CHARLES, formerly of 31 Beach Street, Frankston, but late of Flat 6, 89 Westbury Street, St. Kilda, retired storeman and packer, died 2nd July, 1975.

HAZLE, ROBERT WILLIAM, formerly of 4 Jasmine Court, Frankston, but late of 63 Wimborne Avenue, Mount Eliza, office manager, died 28th December, 1975.

KISHANDER, JAMES ALFRED, formerly of 87 Mortimore Street, Moorabbin, but late of 34 Elder Street, Clayton, public servant, died 23rd February, 1976.

LAV, MARIE ANNETTE, late of Gillies Street, Wendouree, spinster, died 17th June, 1975.

LERMER, BERTHA, also known as Berta Lermer, formerly of Flat 32, 366 Beaconsfield Parade, St. Kilda but late of Montefiore Homes for the Aged, 619 St. Kilda Road, Melbourne, widow, died 17th February, 1976.

LEWIS, LEWIS FREDERICK, late of Eighth Street, Parkdale, cabinet maker, died 10th June, 1936.

LOWE, EDWARD MAURICE, late of 34 Roderick Street, East Doncaster, turner and fitter, died 24th November, 1975.

LYONS, MAISIE MARGARET, also known as Lyons, Maisie Margaret, late of Flat 1, 249 Beaconsfield Parade, Middle Park, widow, died 18th February, 1976.

MULLEN, JAMES PATRICK, also known as Mullen, James, late of 4 Schackell Street, West Coburg, gentleman, died 24th February, 1976.

McMANNIS, FRANCIS FITZGERALD, late of Victoria Hotel, Beaconsfield Parade, Albert Park, clerk, died 14th January, 1976.

NEILSON, JOHN HOWARD, late of 34 Shelly Street, Richmond, pensioner, died 12th February, 1976.

RADZIMIRSKI, JAN, late of 43 Thompson Street, Ormond, electrical foreman, died 11th January, 1976.

RICHARDSON, KATHERINE MARY, late of Flat 1, 26 Grey Street, East Melbourne, secretary, died 18th February, 1976.

ROFFEY, LOUISE, late of 96 Queenscliff Road, Newcomb, Geelong, married woman, died 13th January, 1974.

SCOLLON, JAMES PATRICK, formerly of 1 Gaynor Court, Malvern, but late of 146 Patterson Road, Moorabbin, public servant, died 5th January, 1976.

SCOTT, WILLIAM ARTHUR, late of 23 McLean Avenue, Bentleigh, retired sales representative, died 29th November, 1975.

SMITH, CATHERINE, late of 2 Walstab Street, Brighton Beach, widow, died 31st January, 1976.

SOLOMON, CATHERINE MARY ELLEN, late of 15 Clarence Street, Geelong West, married woman, died 7th November, 1975.

WARREN, ETHEL KATHLEEN, late of 6 Wendora Street, Strathmore, married woman, died 3rd March, 1976.

N. P. BRODY,
Public Trustee.

Melbourne, 11th May, 1976.

CONTRACTS ACCEPTED.—(Series 1975-76.)

SOIL CONSERVATION AUTHORITY.

CONTRACT No. 37604.

Earthworks at the Cairn Curran Project.—Wabco 122 bulldozer, \$20.00 per hour.—N. Smith, Redbank.

VICTORIAN RAILWAYS.

44. Supply and delivery and installation of two (2) Data Capture Systems, at rates (Contract No. 64143).—Computer Manufacturers (Australia) Pty. Ltd. 45. Manufacture, supply and delivery of 1500V 2000KW Silicon Diode Rectifier Assemblies and Associated Protection Relays, at rates (Contract No. 64148).—Westinghouse Brake and Signal Co. (Aust.) Pty. Ltd.

By Order of the Victorian Railways Board,
C. W. MILLER, Secretary. 17.5.76.

CONTRACTS ACCEPTED.—(Series 1975-76.)

AMENDMENTS.

Sched. No.	Item No.	Description.	Unit of measurement.	New Rate.	Contractor.	Effective Date.
		General Stores.		\$		
		<i>Gazette No. 51—25th June, 1975.</i>				
		<i>Protective Clothing.</i>				
26	14	Amendment to <i>Gazette No. 30—17th March 1976</i> :— Coats—Sac, White Drill with epaulettes	each	6.18	Crown White Coats	15.2.76
		Motor Spirit.				
		<i>Gazette No. 29—15th March, 1976.</i>				
		Amendment to <i>Gazette No. 46—5th May, 1976</i> :—				
56	32	Heating Oil—into tanks	per litre	0.0702	Caltex Oil (Aust.) Pty. Ltd. ..	15.4.76

W. L. ROBERTSON, Secretary to the Tender Board.

APPOINTMENTS AND RESIGNATIONS

APPOINTMENTS.

His Excellency the Governor of the State of Victoria, by and with the advice of the Executive Council thereof, has, by Orders made on the 11th day of May, 1976, been pleased to make the under-mentioned appointments, viz.:—

DEPARTMENT OF HEALTH.

Superintendents of Mental Hospitals.

ALEXANDER SARAH, M.B., B.S., D.P.M. to be Superintendent, Warrnambool Mental Hospital, pursuant to the provisions of section 26 (1) of the *Mental Health Act 1959*, for the period 10th May, 1976, to the 16th May, 1976, vice Dr. G. Jensen, on annual leave; and

JENNIFER ANN BARRON, M.B., D.P.M., M.A.N.Z.C.P. to be Superintendent, Beechworth Mental Hospital, pursuant to the provisions of section 26 (1) of the *Mental Health Act 1959*, for the period from 5th April, 1976, to the 11th April, 1976, vice Dr. E. Darby, on annual leave.

Trustees of Public Cemeteries.

ERIC ALAN FOX to be a Trustee of the Yarck Public Cemetery, vice E. T. Fox, deceased;

JEAN MAVIS FARLEY to be an additional Trustee of the San Remo Public Cemetery; and

GEORGE GEOFFREY ALFORD,
FRANCIS XAVIER MOLLOY, and
WILLIAM ROBSON CORBETT,
to be Trustees of the Skipton Public Cemetery, vice D. J. Daly, A. McDonald, and W. G. Smith, all deceased, pursuant to section 3 (1) of the *Cemeteries Act 1958*.

LAW DEPARTMENT.

Justices of the Peace.

GRAHAM JOHN BENSON, 20 Hazelwood Road, Morwell,
DORIS CHARLOTTE CONLEY, 11 Richmond Street,
Hadfield,
FRANCIS ROSS SMITH, Elmhurst, and
ALICE JEAN WASHUSEN, "Kanangra", Gruyere Road,
Gruyere,
to be Justices of the Peace for the State of Victoria.

Commissioners for Taking Declarations, &c.

BARRY MARTIN BAGULEY, 332A Main Road East, St. Albans,
KENNETH GEORGE COLLINS, 1/58 Park Street,
Wendouree,
BRUCE RENFREE DINGLE, 44 Market Street, Melbourne,
KEITH ALLAN FRYER, 44 Market Street, Melbourne,
ROBERT THOMAS GRONDMAN, 2-50 Murray Road, Preston,

JOHN THOMAS HARKIN, "Callista", Cowwarr,
MICHAEL ALLAN HARRISON, State Public Offices, Benalla
West,

HILARY EVERARD VERNON METZELING, 272 Collins Street,
Melbourne,

BRIAN FRANCIS OSBORNE, 350 Collins Street, Melbourne,
JOSEPH GEORGE PICONE, 272 Collins Street, Melbourne,
and

MARGARET JOAN POPE, 22 Langhorne Street, Dandenong,
to be Commissioners for taking Declarations and Affidavits
under the Evidence Act 1958.

Deputy Prothonotaries.

ROBERT JOHN CUTHILL, Clerk of Courts, and
to be Deputy Prothonotary at Geelong, vice J. Reilly, on
recreation leave; and

RICHARD JOHN CANNING, Clerk of Courts,
to be Deputy Prothonotary at Bairnsdale.

Assistant Collector of Maintenance.

BARRY JOHN BOLTON, Clerk of Courts,
to be an Assistant Collector of Maintenance, pursuant to
section 69 (1) of the Maintenance Act 1965, vice N.
Raicevic, transferred.

PUBLIC WORKS DEPARTMENT.

Wharf Manager.

Sergeant ALFRED CLYDE EASTAUGH, No. 11493
to be Wharf Manager at Mallacoota, Gypsy Point and
Sydenham Inlet to carry out that portion of Part II. of the
Marine Act 1958, which relates to the management of
Public Wharfs and to be an officer under section 19 of
such Act to levy and collect wharfage rates thereat, at a
remuneration of \$80.00 per annum, vice Sergeant Alexander
Bruce Robinson, No. 12184, transferred.

DEPARTMENT OF WATER SUPPLY.

Waterworks Trust Commissioners.

JAMES ASHLEY
to be a Commissioner of the Goornong Waterworks Trust
to hold such position for a period from the date hereof,
until 11th December, 1977, subject to the provisions of
the Water Act;

WILLIAM CHARLES WELSH
to be a Commissioner of the Morwell Waterworks Trust
to hold such position for a period of four years from the
date hereof, subject to the provisions of the Water Act;

RONALD HENRY COSTIN
to be a Commissioner of the Noojee Waterworks Trust to
hold such position for a period of four years from the date
hereof, subject to the provisions of the Water Act; and

WILLIAM EDWARD HEYWOOD, and
THOMAS GORDON WILKINSON,
to be Commissioners of the Seymour Waterworks Trust to
hold such position for a period of four years from the date
hereof, subject to the provisions of the Water Act.

TOM FORRISTAL,
Clerk of the Executive Council.

At the Executive Council Chamber,
Melbourne, 11th May, 1976.

**APPOINTMENT OF CHIEF INSPECTOR OF STOCK AND
CHIEF VETERINARY INSPECTOR.**

The Public Service Board by Certificate No. 4690, appoints
BRYAN H. RUSHFORD, Chief Veterinary Officer, First Division
as Chief Veterinary Inspector and Chief Inspector of Stock,
pursuant to the provisions of the following Acts, *Bees Act*
1971, *Cattle Breeding Act 1958*, *Cattle Compensation Act*
1967, *Horse Breeding Act 1958*, *Milk and Dairy Supervision*
Act 1958, *Shearers Accommodation Act 1958*, *Stock (Artificial*
Breeding) Act 1962, *Stock Diseases Act 1968*, *Stock*
Medicines Act 1958 and *Swine Compensation Act 1967*,
without additional salary, as from and inclusive of 4th
February, 1976.

R. O. KEFFORD,
Acting Director of Agriculture.

Vermin and Noxious Weeds Act 1958.

**APPOINTMENT OF SUPERINTENDENT OF VERMIN AND
NOXIOUS WEEDS DESTRUCTION.**

It is hereby notified that the Public Service Board in
exercise of its powers has appointed the under-mentioned
person as Superintendent under the provisions of section 4
of the *Vermin and Noxious Weeds Act 1958*, without
additional salary, with effect from 6th May, 1976:

ALLAN FERGUSON HUNTER.

C. E. MIDDLETON,
Secretary for Lands.
Melbourne, 14th May, 1976.

Liquor Control Act 1968.

APPOINTMENT OF LICENSING INSPECTORS.

In accordance with the authority conferred upon me by
sub-section (1) of Section 22 of the *Liquor Control Act 1968*, I,
Reginald Jackson, Chief Commissioner of Police, hereby appoint
the following Officers of Police as Licensing Inspectors for the
Divisions of the Police Districts as shown:—

Division Number.	Police District.	Rank and Name.
2	Melbourne ..	Inspector Charles Herbert Petty (from 9.5.76 to 29.5.76)
2	Sunshine ..	Inspector Mervyn Henry Goltz (vice Chief Inspector T. E. Young)

R. JACKSON,
13.5.1976. Chief Commissioner of Police.

RESIGNATIONS.

His Excellency the Governor of the State of Victoria,
by and with the advice of the Executive Council thereof,
has, by Order made on the 11th day of May, 1976, accepted
the resignations of the persons named hereunder of the
office mentioned, viz.:—

LAW DEPARTMENT.

Justices of the Peace.

ALBERT ROY HARDWIDGE,
EDMUND JOSEPH KELLIHER,
FREDERICK ARTHUR MARRIOTT, and
JOSEPH JAMES NEWTON O'BRIEN,
as Justices of the Peace for the State of Victoria.

Commissioners for Taking Declarations, &c.

GRAHAM JOHN BENSON,
IAN GORDON BOGLE,
ROBERT LANCASTER FULTON,
NORMAN GROVE,
HENRY JOHN JAMES,
CYRIL FREDERICK KEMISH,
JOHN GEORGE MCKINLEY,
DANIEL LAURENCE MONAGHAN, and
ALFRED JAMES SEARLE,
as Commissioners for taking Declarations and
Affidavits under the Evidence Act 1958.

TOM FORRISTAL,
Clerk of the Executive Council.

At the Executive Council Chamber,
Melbourne, 11th May, 1976.

ORDERS IN COUNCIL

STATE RIVERS AND WATER SUPPLY COMMISSION.

At the Executive Council Chamber, Melbourne, the
fourth day of May, 1976.

PRESENT:

His Excellency the Governor of Victoria.
Mr. Dickie | Mr. Balfour.
Mr. Dunstan |

**HEATHCOTE SEWERAGE AUTHORITY.—SEWERAGE
DISTRICT PROCLAIMED AND AUTHORITY
CONSTITUTED.**

Under the powers conferred by the Sewerage Districts
Act and all other powers enabling him in that behalf, His
Excellency the Governor of Victoria, by and with the advice
of the Executive Council thereof, doth hereby approve of
the construction of works for the sewerage of Heathcote
as set out in the description and general plan accompanying
the application of the Shire of McIvor for the proclamation
of a Sewerage District and for the constitution of a Sewerage
Authority to carry out the said works for the sewerage
of Heathcote in accordance with the provisions of the
said Act and doth hereby appoint as follows:—

1. That a Sewerage Authority is hereby constituted and
its corporate name shall be Heathcote Sewerage Authority.
2. That the members of the said Sewerage Authority
shall comprise the Councillors for the time being of the
Shire of McIvor.

3. That the lands within the boundary shown in red colour on the plan accompanying this Order are hereby proclaimed to be the Sewerage District (to be known as the Heathcote Sewerage District) of the said Sewerage Authority; such District being wholly within the Shire of McIvor:

4. That the principal works to be constructed or carried out by the said Sewerage Authority shall consist of reticulation sewers, pumping stations, rising main outfall sewer and treatment works.

5. That the estimated cost of carrying out the proposed works is six hundred and sixteen thousand dollars (\$616,000).

6. That the lands outside the Sewerage District to be acquired for the treatment works are as shown in brown colour on the plan accompanying this Order.

The location of the said rising main and treatment works and the boundary of the said Sewerage District are shown on the plan approved by the Governor in Council by and with this Order and deposited in the office of the State Rivers and Water Supply Commission, Melbourne (Corr. No. 64/77/25).

And the Honorable Frederick James Granter, Her Majesty's Minister of Water Supply for the State of Victoria, shall give the necessary directions herein accordingly.

TOM FORRISTAL,
Clerk of the Executive Council.

COUNTRY ROADS BOARD.
Act No. 6229.

At the Executive Council Chamber, Melbourne, the
eleventh day of May, 1976.

PRESENT:

His Excellency the Governor of Victoria,
Mr. Hunt | Mr. Rafferty
Mr. Houghton | Mr. Crozier.

ORDER APPROVING OF LAND BEING ACQUIRED AND ROADS, DEVIATIONS OR WIDENINGS BEING MADE TOGETHER WITH ALL ANCILLARY WORKS REQUIRED TO BE EXECUTED IN CONJUNCTION THEREWITH.

His Excellency the Governor of the State of Victoria, by and with the advice of the Executive Council thereof, being satisfied that there are funds legally available for acquiring the land, doth hereby approve the acquiring of the land described in the schedule hereunder and the making of new roads and deviations from and widenings of existing roads, together with all ancillary works required to be executed in conjunction therewith, referred to in the said schedule.

SCHEDULE.
State Highway.

The land shown hatched on plan numbered G.P.13922B hereunder required for the widening of the Burwood Highway in the City of Knox and making of the widening thereon.

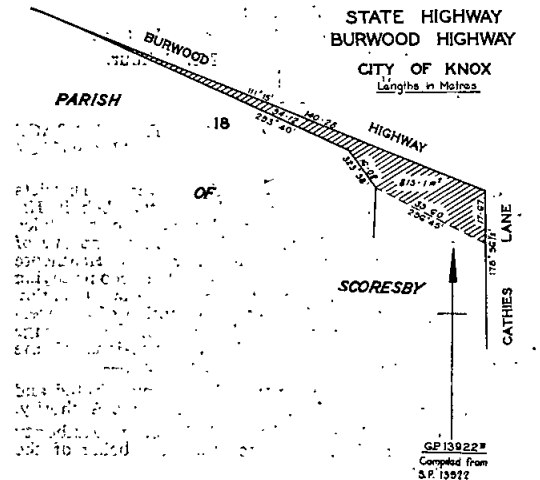

The land shown hatched on plans numbered G.P.13891A, G.P.13891B, G.P.13891C, G.P.13891D and G.P.13892A hereunder required for the deviation from Walhalla Road in the Shire of Narracan and making of the deviation thereon.

MAIN ROAD
WALHALLA ROAD
SHIRE OF NARRACAN
Lengths in Metres

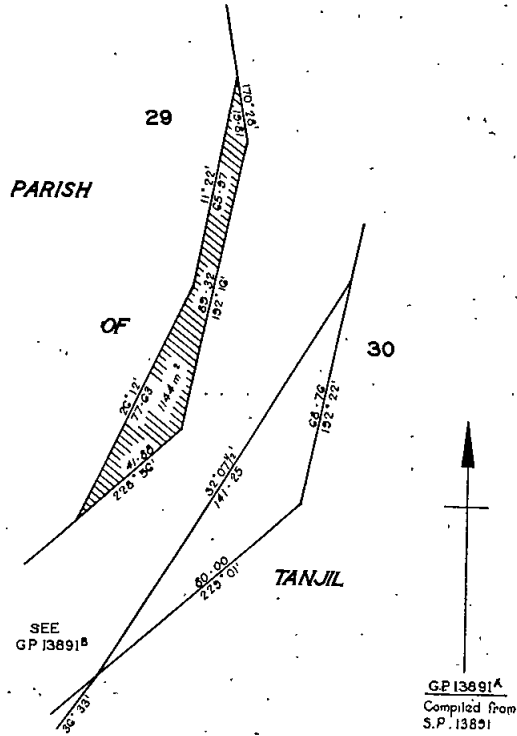

MAIN ROAD
WALHALLA ROAD
SHIRE OF NARRACAN
Lengths in Metres

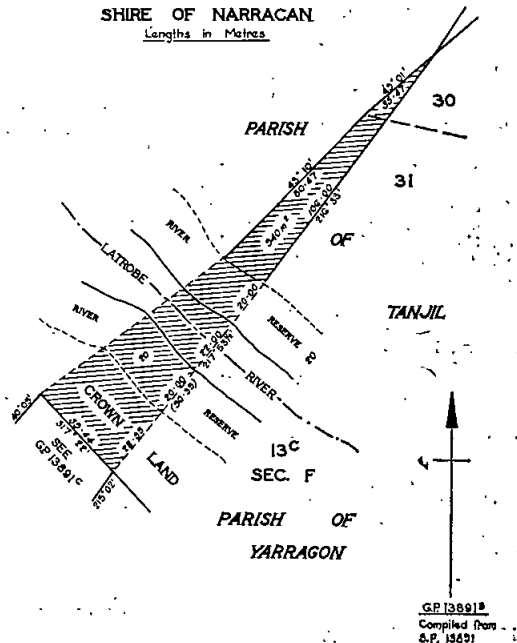

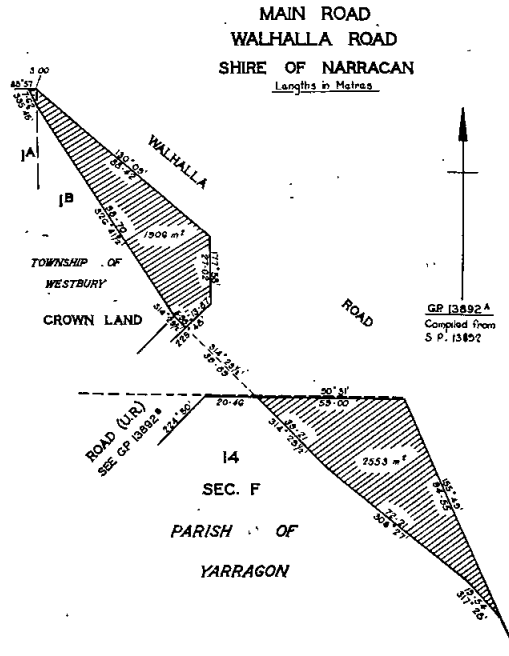
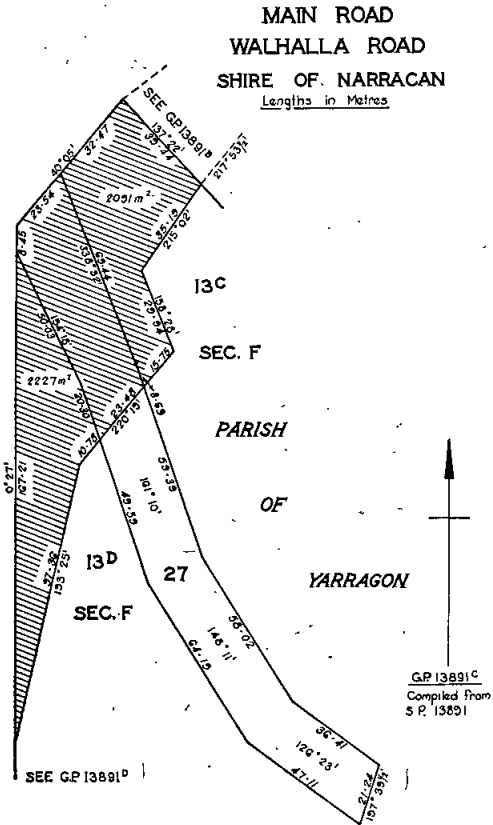

Freeway.

The land shown hatched on plan numbered G.P.13922A hereunder required for the making of a new freeway (Scoresby Freeway) in the City of Knox.

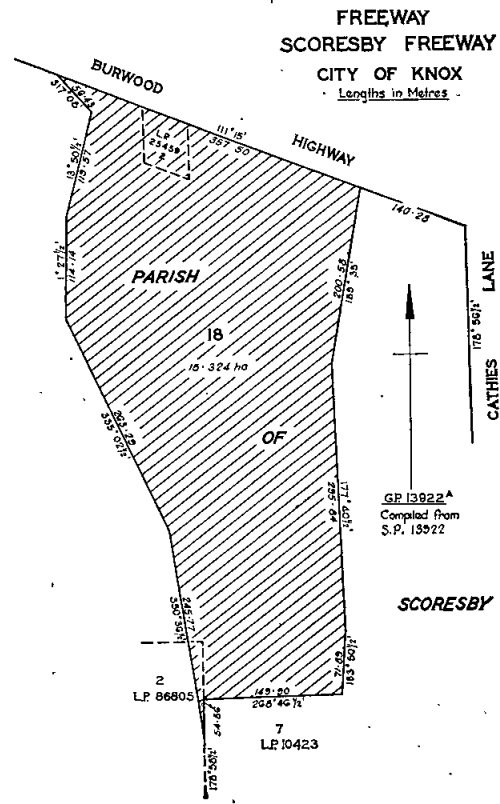
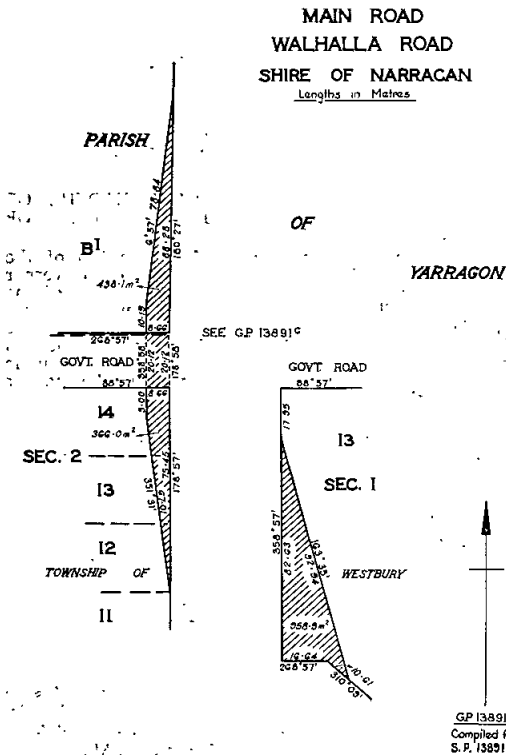

Unclassified Roads.

The land shown hatched on plan numbered G.P.13922c hereunder required for the widening of Cathies Lane in the City of Knox and making of the widening thereon.

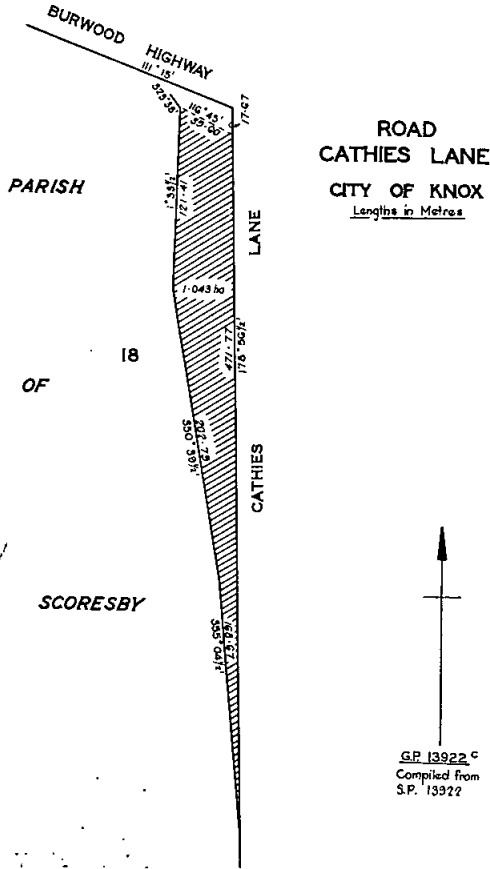

The land shown hatched on plans numbered G.P.13892b and G.P.13892c hereunder required for the deviation from a road in the Shire of Narracan and making of the deviation thereon.

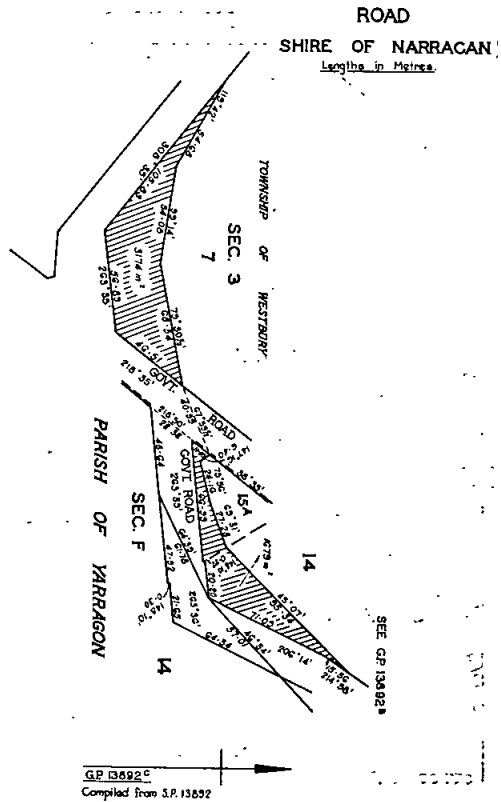
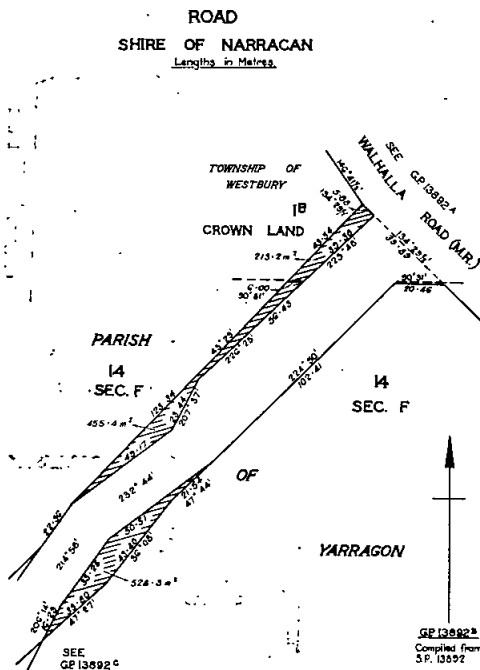

And the Honorable Joseph Anstice Rafferty, Her Majesty's Minister of Transport for the State of Victoria, shall give the necessary directions herein accordingly.

TOM FORRISTAL,
Clerk of the Executive Council.

LOCAL GOVERNMENT DEPARTMENT.

At the Executive Council Chamber, Melbourne, the eleventh day of May, 1976.

PRESENT:

His Excellency the Governor of Victoria.
Mr. Hunt | Mr. Rafferty
Mr. Houghton | Mr. Crozier.

FIXATION AND DECLARATION OF BREADTHS OF CARRIAGEWAY AND FOOTWAYS.—CITY OF WARRNAMBOOL.

In pursuance of the provisions of section 520 of the Local Government Act 1958, His Excellency the Governor of the State of Victoria, by and with the advice of the Executive Council thereof, and in compliance with a request of the Council of the City of Warrnambool, hereby fixes and declares the breadths of the carriageway and footways of portion of Caramut Road, Warrnambool being a public highway as shown on the plan hereunder, in the manner indicated on the said plan.

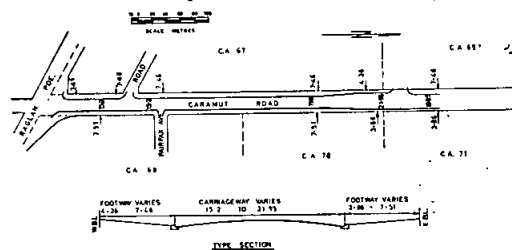

And the Honorable Alan John Hunt, Her Majesty's Minister for Local Government for the State of Victoria, shall give the necessary directions herein accordingly.

TOM FORRISTAL,
Clerk of the Executive Council.

LOCAL GOVERNMENT DEPARTMENT.

At the Executive Council Chamber, Melbourne, the eleventh day of May, 1976.

PRESENT:

His Excellency the Governor of Victoria.
 Mr. Hunt | Mr. Rafferty
 Mr. Houghton | Mr. Crozier.

ROAD DISCONTINUED.—CITY OF WILLIAMSTOWN.

Whereas it is provided in section 528 (2) of the *Local Government Act 1958*, that where a road (whether or not a public highway but not being a road set out on land of the Crown) or any part thereof is not required for public use the Governor in Council on the request of the council of the municipality in which such road is situated made not less than one month after publishing in a newspaper generally circulating in the district and posting to the registered proprietor (if any) of the land and the owners and occupiers (if any) of the lands abutting or immediately adjacent to the road notice of intention to make such request may by Order published in the *Government Gazette* direct that such road or part shall be discontinued and thereupon such road or part, shall be discontinued accordingly.

And whereas the Council of the City of Williamstown has requested that the Governor in Council direct that a road between Schutt and Steele Streets, Newport be discontinued and not less than one month previously has published in a newspaper generally circulating in the district and posted to the registered proprietor of the land in the road and to the owners and occupiers of lands abutting or immediately adjacent to the said road notice of intention to make such request.

Now therefore, His Excellency the Governor of the State of Victoria, by and with the advice of the Executive Council thereof, hereby directs:—

- (a) that the said road which is shown by hachure on the plan hereunder shall be discontinued;
- (b) that notwithstanding such discontinuance the Melbourne and Metropolitan Board of Works shall continue to have and possess the same right title power authority or interest in or in relation to the whole of the land shown by hachure on the said plan as it had or possessed prior to such discontinuance with respect to or in connection with any drains or pipes laid or erected in on or over such lands for the purpose of drainage or sewerage; and
- (c) that subject to any such right title power authority or interest, the land in the said road may be sold by the Council of the City of Williamstown by agreement.

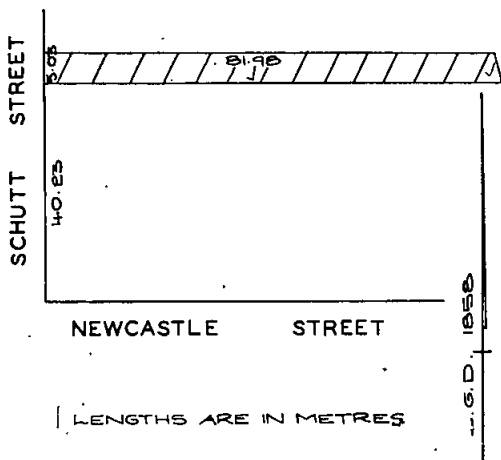

And the Honorable Alan John Hunt, Her Majesty's Minister for Local Government for the State of Victoria, shall give the necessary directions herein accordingly.

TOM FORRISTAL,
 Clerk of the Executive Council.

LOCAL GOVERNMENT DEPARTMENT.

At the Executive Council Chamber, Melbourne, the eleventh day of May, 1976.

PRESENT:

His Excellency the Governor of Victoria.
 Mr. Hunt | Mr. Rafferty
 Mr. Houghton | Mr. Crozier.

ROAD DISCONTINUED.—CITY OF PRAHRAN.

Whereas it is provided in section 528 (2) of the *Local Government Act 1958*, that where a road (whether or not a public highway but not being a road set out on land of the Crown) or any part thereof is not required for public use, the Governor in Council on the request of the council of the municipality in which such road is situated made not less than one month after publishing in a newspaper generally circulating in the district and posting to the registered proprietor (if any) of the land and the owners and occupiers (if any) of lands abutting or immediately adjacent to the road notice of intention to make such request may by Order published in the *Government Gazette* direct that such road or part shall be discontinued and thereupon such road or part shall be discontinued accordingly:

And whereas the Council of the City of Prahran has requested that the Governor in Council direct that a road between Perth Street and Nottingham Street, Prahran being the land coloured brown on Plan of Subdivision No. 30622 lodged in the Office of Titles shall be discontinued and not less than one month previously has published in a newspaper generally circulating in the district and posted to the registered proprietor of the land in the road and to the owners and occupiers of land abutting or immediately adjacent to the road notice of intention to make such request:

Now therefore, His Excellency the Governor of the State of Victoria, by and with the advice of the Executive Council thereof, hereby directs:—

- (a) that the said road shall be discontinued;
- (b) that notwithstanding such discontinuance the City of Prahran shall continue to have and possess the same right title power authority or interest in or in relation to the land in the said road it had or possessed prior to such discontinuance with respect to or in connection with any drains or pipes laid or erected in on or over such land for the purposes of drainage;
- (c) and, that subject to any such right title power authority or interest, the land in the said road may be sold by the Council of the City of Prahran by agreement.

And the Honorable Alan John Hunt, Her Majesty's Minister for Local Government for the State of Victoria, shall give the necessary directions herein accordingly.

TOM FORRISTAL,
 Clerk of the Executive Council.

Land Act 1958.
 DEPARTMENT OF CROWN LANDS AND SURVEY.

At the Executive Council Chamber, Melbourne, the eleventh day of May, 1976.

PRESENT:

His Excellency the Governor of Victoria.
 Mr. Hunt | Mr. Rafferty
 Mr. Houghton | Mr. Crozier.

LANDS TEMPORARILY RESERVED AS SITES.

His Excellency the Governor of the State of Victoria, by and with the advice of the Executive Council thereof, doth hereby in pursuance of the provisions of section 14 of the *Land Act 1958*, reserve temporarily from sale, from being leased and from having a licence granted in respect thereof, and also except from occupation for mining purposes under any miner's right the lands hereinafter described, viz.:—

BUMBANG.—Site for Water Supply purposes, 1.267 hectares, being Crown allotment 24A, section B, Parish of Bumbang, County of Karkaroc as indicated by hatching on plan hereunder.—(B.660⁽¹⁰⁾) (Rs.10126).

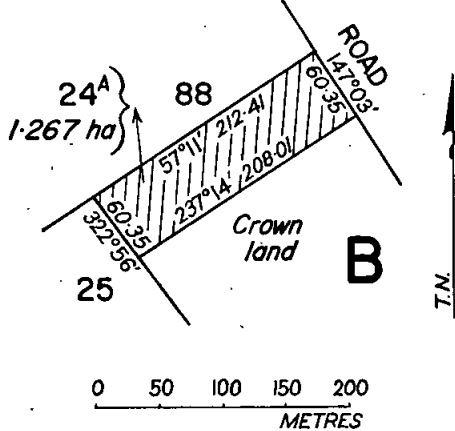

DROUIN.—Site for Public purposes (Police purposes), 2586 square metres, being Crown allotment 31A, section 1, Township of Drouin, Parish of Drouin West, County of Buln Buln as indicated by hatching on plan hereunder.—(D.173⁽¹³⁾) (Rs.10188).

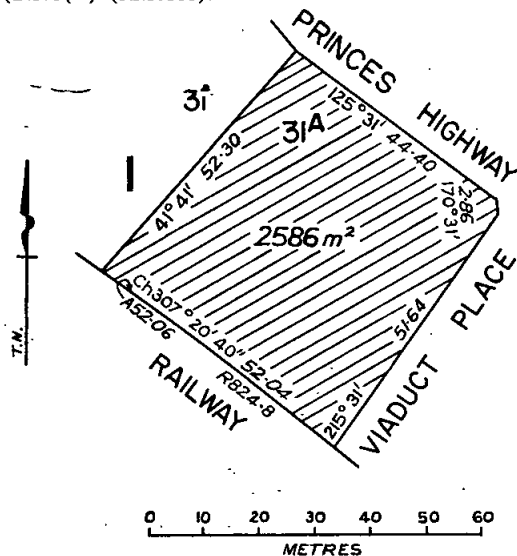

NEEREMAN.—Site for Public purposes (Supply of Gravel), 7430 square metres, being Crown allotment 4E, section 16, Parish of Neereman, County of Talbot as indicated by hatching on plan hereunder.—(N.43⁽⁴⁾) (Rs.10144).

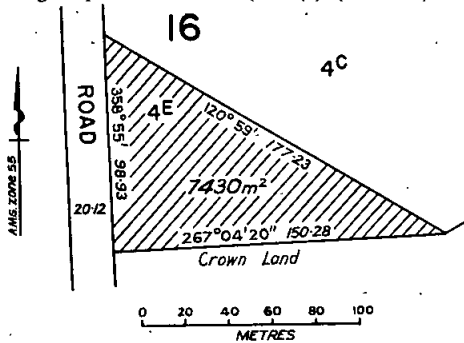

And the Honorable William Archibald Borthwick, Her Majesty's Minister of Lands for the State of Victoria, shall give the necessary directions herein accordingly.

TOM FORRISTAL,
Clerk of the Executive Council.

LAND ACT 1958.

At the Executive Council Chamber, Melbourne, the eleventh day of May, 1976.

PRESENT:

His Excellency the Governor of Victoria.
Mr. Hunt | Mr. Rafferty
Mr. Houghton | Mr. Crozier

UNUSED ROAD CLOSED.

In pursuance of the provisions of section 349 of the Land Act 1958, His Excellency the Governor of Victoria, by and with the advice of the Executive Council thereof, and the concurrence in writing of the Council of the municipality concerned doth hereby close the unused road referred to hereunder, viz:—

Township of Stawell, Parish of Stawell, County of Borung, being the road indicated by hatching on plan hereunder.—(S.329⁽¹³⁾) (M.61115).

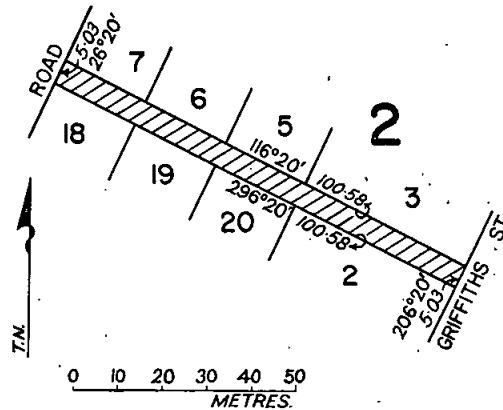

And the Honorable William Archibald Borthwick, Her Majesty's Minister of Lands for the State of Victoria, shall give the necessary directions herein accordingly.

TOM FORRISTAL,
Clerk of the Executive Council.

LABOUR AND INDUSTRY ACT 1958.

At the Executive Council Chamber, Melbourne, the eleventh day of May, 1976.

PRESENT:

His Excellency the Governor of Victoria.
Mr. Hunt | Mr. Rafferty
Mr. Houghton | Mr. Crozier

BUTCHERS BOARD.—NUMBER OF MEMBERS INCREASED.

Whereas, by Order in Council of the 3rd day of August, 1942, published in the Victoria Government Gazette, No. 254, dated 5th August, 1942, it was directed that the membership of Shops Board No. 3 (Butchers) should consist of six members and a Chairman:

And whereas by Order in Council of the 30th day of September, 1969, published in the Victoria Government Gazette No. 91, dated 8th October, 1969, the short title of Shops Board No. 3 (Butchers), was altered so that the said Shops Board No. 3 (Butchers) was for all purposes thereafter to be described as the Butchers Board.

Now therefore, in pursuance of the powers conferred by section 22 of the Labour and Industry Act 1958, and all other powers him thereunto enabling, His Excellency the Governor of the State of Victoria, by and with the advice of the Executive Council thereof, doth hereby vary the Order made on the 3rd day of August, 1942, and published in the Victoria Government Gazette No. 254, dated 5th August, 1942, in so far as it directed that the Wages Board now described as the Butchers Board should consist of

six members and a Chairman, and doth hereby specify that the said Butchers Board shall consist of eight members and a Chairman.

And the Honorable Robert Roy Cameron Maclellan, Her Majesty's Minister of Labour and Industry for the State of Victoria, shall give the necessary directions herein accordingly.

TOM FORRISTAL,
Clerk of the Executive Council.

LABOUR AND INDUSTRY ACT 1958.

At the Executive Council Chamber, Melbourne, the eleventh day of May, 1976.

PRESENT:

His Excellency the Governor of Victoria.	
Mr. Hunt	Mr. Rafferty
Mr. Houghton	Mr. Crozier.

EXTENSION OF POWERS OF THE HOSPITAL MEDICAL ANCILLARY SERVICES BOARD.

In pursuance of the powers conferred by section 20 of the *Labour and Industry Act 1958*, and all other powers him hereunto enabling, His Excellency the Governor of the State of Victoria, by and with the advice of the Executive Council thereof, doth hereby extend the powers of the Hospital Medical Ancillary Services Board so that in substitution for the powers heretofore conferred on the said Hospital Medical Ancillary Services Board it shall be appointed for the occupations of medical laboratory technician or technologist, physiotherapist, dietitian, radiographer, radiotherapy technician, hospital librarian, occupational therapist, orthoptist, speech therapist, medical photographer, medical illustrator, chiropodist and nucleographer (including trainees in any of these occupations) in or in connexion with any hospital or benevolent home, community health centre, society or association registered pursuant to the *Hospital and Charities Act 1958*, or the Cancer Institute constituted under the *Cancer Act 1958*.

And the Honorable Robert Roy Cameron Maclellan, Her Majesty's Minister of Labour and Industry for the State of Victoria, shall give the necessary directions herein accordingly.

TOM FORRISTAL,
Clerk of the Executive Council.

MELBOURNE AND METROPOLITAN BOARD OF WORKS ACT 1958.

At the Executive Council Chamber, Melbourne, the eleventh day of May, 1976.

PRESENT:

His Excellency the Governor of Victoria.	
Mr. Hunt	Mr. Rafferty
Mr. Houghton	Mr. Crozier.

VARIATION OF ORDER.

In pursuance of the powers conferred by the *Melbourne and Metropolitan Board of Works Act 1958*, His Excellency the Governor of the State of Victoria, by and with the advice of the Executive Council thereof, doth hereby vary the Order in Council made on the 8th day of December, 1970, and published in the *Victoria Government Gazette*, dated 16th December, 1970, including in the Metropolis for sewerage purposes parts of the City of Springvale and the Shires of Cranbourne and Berwick, (hereinafter called "the said Order"), by excluding the area of land described hereunder from the Second Part Firstly of the Schedule to the said Order.

All that land being part of Crown allotments A and B, section 54 and part of Crown allotment 53, Parish of Dandenong, County of Bourke, bounded by a line commencing at a point on the southern alignment of Cheltenham Road, east of Dingley By-pass Road, shown in C.R.B. Plan S.P.8016 and proceeding generally westerly for a distance of 439 ft. 2½ ins. to the eastern alignment of the aforesaid Dingley By-pass Road; thence generally southerly and easterly along the eastern and northern alignments of Dingley By-pass Road and a line in continuation across Perry Road and further eastwards along the

aforesaid northern alignment to the western alignment of Chandler Road; thence northerly along the last mentioned alignment to the southern alignment of Cheltenham Road aforesaid; thence westerly along the last-mentioned alignment to the point of commencement.

And the Honorable Frederick James Granter, Her Majesty's Minister of Water Supply for the State of Victoria, shall give the necessary directions herein accordingly.

TOM FORRISTAL,
Clerk of the Executive Council.

MELBOURNE AND METROPOLITAN TRAMWAYS ACT 1958, No. 6311.

At the Executive Council Chamber, Melbourne, the eleventh day of May, 1976.

PRESENT:

His Excellency the Governor of Victoria.	
Mr. Hunt	Mr. Rafferty
Mr. Houghton	Mr. Crozier.

Whereas His Excellency the Governor of the State of Victoria, by and with the advice of the Executive Council thereof, has this day consented pursuant to the provisions of section 28 of the *Melbourne and Metropolitan Tramways Act 1958*, to the Melbourne and Metropolitan Tramways Board raising by way of a loan an amount not exceeding One million dollars (\$1,000,000): And whereas His Excellency the Governor in Council is satisfied that a sufficient proportion of the loan to be so raised will fall due and be repaid in each year during the currency of the proposed loan: Now therefore it is directed, pursuant to the provisions of section 28 (6) of the said Act, that it shall not be necessary to provide a sinking fund in connection with such loan.

And the Honorable Rupert James Hamer, Her Majesty's Treasurer for the State of Victoria, shall give the necessary directions herein accordingly.

TOM FORRISTAL,
Clerk of the Executive Council.

FRUIT AND VEGETABLES ACT 1958.

At the Executive Council Chamber, Melbourne, the eleventh day of May, 1976.

PRESENT:

His Excellency the Governor of Victoria.	
Mr. Hunt	Mr. Rafferty
Mr. Houghton	Mr. Crozier.

In pursuance of the powers conferred by section 48 of the *Fruit and Vegetables Act 1958*, His Excellency the Governor of the State of Victoria, by and with the advice of the Executive Council thereof, doth hereby authorize Henry Gunther Schneider who is an Inspector under the said Act, to take proceedings in respect of offences against Part II. of the said Act or the Regulations thereunder.

And the Honorable Ian Winton Smith, Her Majesty's Minister of Agriculture for the State of Victoria, shall give the necessary directions herein accordingly.

TOM FORRISTAL,
Clerk of the Executive Council.

SPRINGVALE AND NOBLE PARK SEWERAGE AUTHORITY.

At the Executive Council Chamber, Melbourne, the eleventh day of May, 1976.

PRESENT:

His Excellency the Governor of Victoria.	
Mr. Hunt	Mr. Rafferty
Mr. Houghton	Mr. Crozier.

EXTENT OF SEWERAGE DISTRICT INCREASED.

Under the powers conferred by the Sewerage Districts Act and all other powers enabling him in that behalf, His Excellency the Governor of the State of Victoria, by and with the advice of the Executive Council of the said State, doth hereby declare, order and direct that the extent of the Sewerage District of the Springvale and Noble Park Sewerage Authority be increased by adding thereto the land as shown by red colour on the plan approved by the

Governor in Council, by and with this Order and deposited in the office of the State Rivers and Water Supply Commission, Melbourne (Corr. No. 73/2950/53) and as on and from the date hereof the extent of such District shall be and be deemed to be increased accordingly.

And the Honorable Frederick James Granter, Her Majesty's Minister of Water Supply for the State of Victoria, shall give the necessary directions herein accordingly.

TOM FORRISTAL,
Clerk of the Executive Council.

ARCHAEOLOGICAL AND ABORIGINAL RELICS
PRESERVATION ACT 1972.

At the Executive Council Chamber, Melbourne, the
eleventh day of May, 1976.

PRESENT:

His Excellency the Governor of Victoria.
Mr. Hunt | Mr. Rafferty
Mr. Houghton | Mr. Crozier.

APPOINTMENT OF ACTING PROTECTOR OF RELICS.

In pursuance of the provisions of the *Archaeological and Aboriginal Relics Preservation Act 1972*, His Excellency the Governor of the State of Victoria, by and with the advice of the Executive Council thereof, doth by this Order appoint ALFRED DUNBAVIN BUTCHER, to be Acting Protector of Relics, during the absence on sick leave of John McNally, Protector of Relics.

And the Honorable William Archibald Borthwick, Her Majesty's Minister for Conservation for the State of Victoria, shall give the necessary directions herein accordingly.

TOM FORRISTAL,
Clerk of the Executive Council.

SUPERANNUATION ACT 1958.

At the Executive Council Chamber, Melbourne, the
eleventh day of May, 1976.

PRESENT:

His Excellency the Governor of Victoria.
Mr. Hunt | Mr. Rafferty
Mr. Houghton | Mr. Crozier.

Pursuant to the powers conferred by the provisions of paragraph (ja) of sub-section (1) of section 3 of the *Superannuation Act 1958*, His Excellency the Governor of the State of Victoria, by and with the advice of the Executive Council thereof, doth by this Order declare that the provisions of the *Superannuation Act* shall apply to the officers named in the schedule set out hereunder.

SCHEDULE.

BLUNDEN, Ralph Kenneth, State College of Victoria,
at Hawthorn.

BROKENSHIRE, Lancelot Stanley, Liquor Control
Commission.

And the Honorable Rupert James Hamer, Her Majesty's Treasurer for the State of Victoria, shall give the necessary directions herein accordingly.

TOM FORRISTAL,
Clerk of the Executive Council.

LAKES ENTRANCE WATERWORKS TRUST.

At the Executive Council Chamber, Melbourne, the
eighteenth day of May, 1976.

PRESENT:

His Excellency the Governor of Victoria.
Mr. Dixon | Mr. Hayes.

CONSENT TO BORROWING \$50,000.

Under the powers conferred by the Water Act and all other powers enabling him in that behalf, His Excellency the Governor of the State of Victoria, by and with the

advice of the Executive Council of the said State, hereby consents to the Lakes Entrance Waterworks Trust borrowing the sum of Fifty thousand dollars (\$50,000) for the purpose of water supply works.

And the Honorable Frederick James Granter, Her Majesty's Minister of Water Supply for the State of Victoria, shall give the necessary directions herein accordingly.

TOM FORRISTAL,
Clerk of the Executive Council.

PORTLAND WATERWORKS TRUST.

At the Executive Council Chamber, Melbourne, the
eighteenth day of May, 1976.

PRESENT:

His Excellency the Governor of Victoria.
Mr. Dixon | Mr. Hayes.

CONSENT TO BORROWING \$20,000.

Under the powers conferred by the Water Act and all other powers enabling him in that behalf, His Excellency the Governor of the State of Victoria, by and with the advice of the Executive Council of the said State, hereby consents to the Portland Waterworks Trust borrowing the sum of Twenty thousand dollars (\$20,000) to meet the cost of water supply works.

And the Honorable Frederick James Granter, Her Majesty's Minister of Water Supply for the State of Victoria, shall give the necessary directions herein accordingly.

TOM FORRISTAL,
Clerk of the Executive Council.

WOORI YALLOCK-LAUNCHING PLACE WATERWORKS
TRUST.

At the Executive Council Chamber, Melbourne, the
eighteenth day of May, 1976.

PRESENT:

His Excellency the Governor of Victoria.
Mr. Dixon | Mr. Hayes.

CONSENT TO BORROWING \$39,000.

Under the powers conferred by the Water Act and all other powers enabling him in that behalf, His Excellency the Governor of the State of Victoria, by and with the advice of the Executive Council of the said State, hereby consents to the Woori Yallock-Launching Place Waterworks Trust borrowing the sum of Thirty-nine thousand dollars (\$39,000) to meet the cost of water supply works.

And the Honorable Frederick James Granter, Her Majesty's Minister of Water Supply for the State of Victoria, shall give the necessary directions herein accordingly.

TOM FORRISTAL,
Clerk of the Executive Council.

MELTON SEWERAGE AUTHORITY.

At the Executive Council Chamber, Melbourne, the
eighteenth day of May, 1976.

PRESENT:

His Excellency the Governor of Victoria.
Mr. Dixon | Mr. Hayes.

CONSENT TO BORROWING \$250,000.

Under the powers conferred by the Sewerage Districts Act and all other powers enabling him in that behalf, His Excellency the Governor of the State of Victoria, by and with the advice of the Executive Council of the said State,

hereby consents to the Melton Sewerage Authority borrowing the sum of Two hundred and fifty thousand dollars (\$250,000) to meet the cost of sewerage works as set forth in the detailed statement bearing date 13th May, 1976.

And the Honorable Frederick James Granter, Her Majesty's Minister of Water Supply for the State of Victoria, shall give the necessary directions herein accordingly.

TOM FORRISTAL,
Clerk of the Executive Council.

MOOROPNA SEWERAGE AUTHORITY.

At the Executive Council Chamber, Melbourne, the
eighteenth day of May, 1976.

PRESENT:

His Excellency the Governor of Victoria.
Mr. Dixon | Mr. Hayes.

CONSENT TO BORROWING \$50,000.

Under the powers conferred by the Sewerage Districts Act and all other powers enabling him in that behalf, His Excellency the Governor of the State of Victoria, by and with the advice of the Executive Council of the said State, hereby consents to the Mooropna Sewerage Authority borrowing the sum of Fifty thousand dollars (\$50,000) to meet the cost of sewerage works as set forth in the detailed statement bearing date 13th May, 1976.

And the Honorable Frederick James Granter, Her Majesty's Minister of Water Supply for the State of Victoria, shall give the necessary directions herein accordingly.

TOM FORRISTAL,
Clerk of the Executive Council.

COAL MINES ACT 1958.

At the Executive Council Chamber, Melbourne, the
eighteenth day of May, 1976.

PRESENT:

His Excellency the Governor of Victoria.
Mr. Dixon | Mr. Hayes.

CHANGES IN RATES OF PENSIONS PAYABLE UNDER PART III. OF COAL MINES ACT 1958.

Whereas it is provided in section 110 of the Coal Mines Act 1958, that whenever rates of Commonwealth pensions are increased, rates of pensions payable under Part III. of the Coal Mines Act 1958, shall be increased and that whenever rates of pensions are increased by the operation of that provision the Governor in Council may, by Order published in the *Government Gazette*, declare those rates to be the rates payable under the said Part.

And whereas rates of Commonwealth pensions have been increased as from 13th May, 1976.

Now therefore, I, the Governor of the State of Victoria, by and with the advice of the Executive Council thereof, do by this Order declare the rates of pension shown hereunder to be the rates of pension payable under the several provisions of the said Part.

\$46.50, section 104;
\$46.50, section 105;
\$30.00, paragraphs (a) and (c) of section 106;
\$7.00, paragraph (b) of section 106;
\$45.50, sub-sections (1) and (1A) of section 107.

And the Honorable James Charles Murray Balfour, Her Majesty's Minister of Mines for the State of Victoria, shall give the necessary directions herein accordingly.

TOM FORRISTAL,
Clerk of the Executive Council.

METROPOLITAN FIRE BRIGADES ACT 1958.

At the Executive Council Chamber, Melbourne, the
eighteenth day of May, 1976.

PRESENT:

His Excellency the Governor of Victoria.
Mr. Dixon | Mr. Hayes.

CONSENT TO THE BORROWING OF FIVE HUNDRED THOUSAND DOLLARS BY THE METROPOLITAN FIRE BRIGADES BOARD.

Whereas by section 46 of the *Metropolitan Fire Brigades Act 1958*, it is enacted that the Metropolitan Fire Brigades Board, with the consent of the Governor in Council may from time to time borrow such moneys as the Board deems necessary in order to enable the Board to carry out and perform the powers, authorities, and duties vested in or conferred or imposed upon the Board by the said Act:

And whereas the Metropolitan Fire Brigades Board deems it necessary to borrow the sum of five hundred thousand dollars for the purposes aforesaid:

Now therefore, His Excellency the Governor of the State of Victoria, in the Commonwealth of Australia, by and with the advice of the Executive Council of the said State, and in pursuance of the powers conferred by the said section 46 of the *Metropolitan Fire Brigades Act 1958* and all other powers him thereunto enabling, doth by this Order consent to the borrowing by the Metropolitan Fire Brigades Board of the sum of Five hundred thousand dollars for a period of ten years, to be liquidated by half-yearly repayments on the principal sum, with interest at the rate of Ten dollars and fifty cents per centum per annum.

And the Honorable Vance Oakley Dickie, Her Majesty's Chief Secretary for the State of Victoria, shall give the necessary directions herein accordingly.

TOM FORRISTAL,
Clerk of the Executive Council.

LANDS DEPARTMENT NOTICES

APPROACHING LAND SALES.

Sale of Crown Land, in fee-simple, will be held at the under-mentioned places and dates, viz:—

	No. of Gazette.
Ballarat.—Wednesday, 7th July, 1976 46

COMMITTEES OF MANAGEMENT OF RESERVES. APPOINTMENTS.

Notice is hereby given that, in pursuance of section 221 of the *Land Act 1958*, the following appointments of Committees of Management of reserved Crown lands have been made by the Minister of Lands:—

CERTAIN LAND IN THE PARISH OF BULLEEN RESERVED FOR NATIONAL PARKS SERVICE PURPOSES; FORMERLY PART OF WESTERFOLDS ESTATE.

The National Parks Advisory Council as a Committee of Management of the land in the Parish of Bulleen, temporarily reserved by Order in-Council, dated the 13th April, 1976, as a site for Public purposes (purposes of the National Parks Service).—(Corres. No. Rs.10148.)

CERTAIN LAND IN THE TOWNSHIP OF DONALD RESERVED FOR PUBLIC RECREATION.

The Corporation of the Shire of Donald as a Committee of Management of the land in the Township of Donald, Parish of Banyenong, temporarily reserved by Order in Council, dated the 1st April, 1976, as a site for Public Recreation.—(Corres. No. Rs.10114.)

W. BORTHWICK,
Minister of Lands.

Department of Crown Lands and Survey,
Melbourne, 12th May, 1976.

PROPOSED REVOCATION OF TEMPORARY RESERVATION OF LAND BY ORDERS IN COUNCIL.

In pursuance of the provisions of the Land Act 1958, notice is hereby given that it is the intention of the Governor in Council to revoke the temporary reservation of land by Orders in Council hereunder referred to, viz.:

The following Notice was published 1° on the 12th May 1976, pursuant to Orders of the 4th May, 1976.

KEELBUNDORA.—The temporary reservation by Order in Council of the 11th January, 1943, of 184.7 hectares (456 acres 1 rood 32 perches) of land in the Parish of Keelbundora as a site for Mental Hospital purposes, revoked as to part by various Orders, is about to be revoked so far only as the portion containing 17.95 hectares indicated by hatching on plan hereunder is concerned.—(K.25⁽⁵⁾) (Rs.5380).

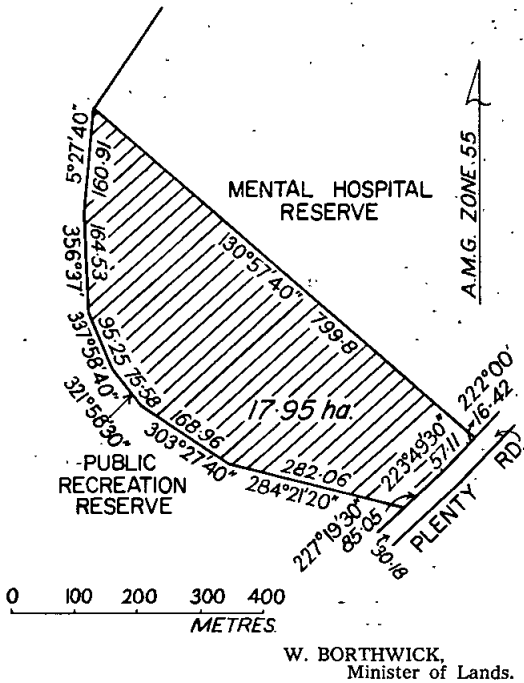

DEUTGAM AND TARNEIT.—The temporary reservation by Order in Council of the 21st September, 1936, of 429.9 hectares (1062 acres, 1 rood, 20 perches) of land in the Parishes of Deutgam and Tarneit as a site for an Experimental Farm, revoked as to part by Order of the 21st January, 1975, is about to be revoked so far only as the portions containing 41.84 hectares indicated by hatching on plan hereunder, are concerned.—(D.42⁽⁶⁾ and T.24⁽⁸⁾) (Rs.4620).

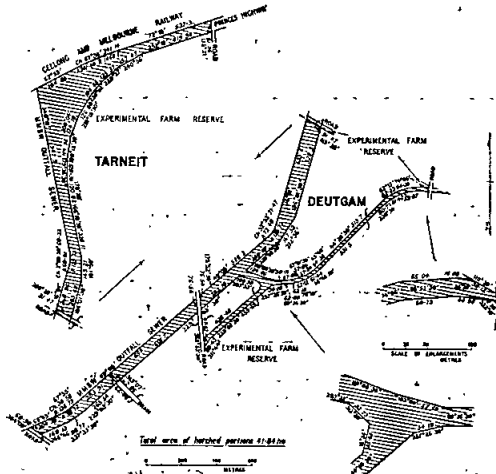

CORIO (BELMONT).—The temporary reservation by Order in Council of the 26th August, 1901, of 3.232 hectares (7 acres, 3 roods, 38 perches) of land in the Parish of Corio as a site for a Public Park is about to be revoked so far only as the portions containing 1.038 hectares indicated by hatching on plan hereunder are concerned.—(OPC.272⁽⁶⁾) (Rs.1466).

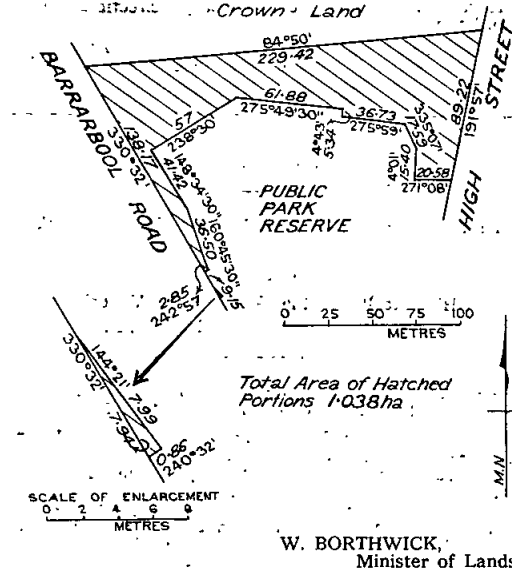

PROPOSED REVOCATIONS OF TEMPORARY RESERVATIONS OF LANDS BY ORDERS IN COUNCIL.

In pursuance of the provisions of the Land Act 1958, notice is hereby given that it is the intention of the Governor in Council to revoke the temporary reservations of lands by Orders in Council hereunder referred to viz.:

The following Notices were published 1° on the 19th May, 1976, pursuant to Orders of the 11th May, 1976.

WONTHAGGI.—The temporary reservation by Order in Council of the 21st December, 1971, of 7.993 hectares (19 acres 3 roods) of land in the Township of Wonthaggi as a site for Public Recreation (Swimming Pool) is about to be revoked so far only as the portion containing 2091 square metres indicated by hatching on plan hereunder, is concerned.—(W.345⁽¹⁶⁾) (Rs.9574).

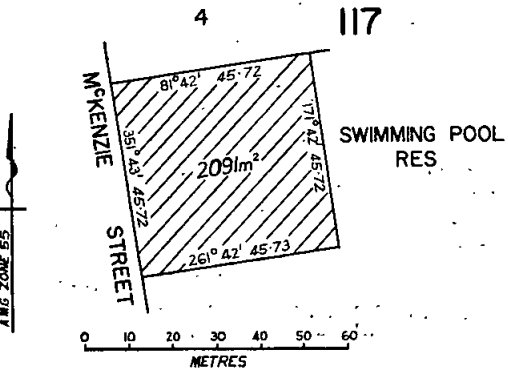

LOCAL LAND BOARDS.

In pursuance of the provisions of section 34 of the Land Act 1958, notice is hereby given that a public hearing at the following place and time will be conducted by the person mentioned, being duly appointed in that behalf.

Place of Meeting of Local Land Board.	Time of Meeting.	Members of Local Land Board.
Leongatha—Former Municipal Hall, Michael Place	10 a.m., Friday, 4th June, 1976	A. L. Renshaw N. J. Cahill H. J. Macdonald

W. BORTHWICK,
Minister of Lands.
Department of Crown Lands and Survey,
Melbourne, 14th May, 1976.

Education Act 1958.

TECHNICAL TEACHERS REGISTRATION BOARD
REGULATIONS 1975.

In pursuance of the powers conferred by the *Education Act 1958* and all other powers it thereunto enabling the Technical Teachers Registration Board doth hereby make the following Regulations:—

1. These Regulations may be cited as the Technical Teachers Registration Board Regulations 1975.

2. The Technical Teachers Registration Board Regulations 1975 made on thirty-first day of January 1975 shall be revoked.

3. In these Regulations unless inconsistent with the context or subject-matter—

“ACT” means the *Education Act 1958*.

“APPROVED” means—

(i) in the case of any Victorian qualifications approved by the Board;

(ii) in the case of any qualification obtained interstate or overseas, approved by the Board after equivalence determination to Victorian qualifications has been made by the Teacher Registration Council.

“BOARD” means the Technical Teachers Registration Board.

“DIVISION” means the Technical Schools Division.

“REGISTER” means the register of Technical Teachers kept pursuant to the Act.

“TERTIARY STUDY” means study at post Form VI. level or approved equivalent.

“INDUSTRIAL EXPERIENCE” means—

(a) In the case of applicants possessing an approved diploma:

(i) Until 1st January 1981 being engaged in an occupation of a non-teaching nature of at least two years' duration for men and at least one year's duration for women following completion or partial completion of an approved qualification.

(ii) After 1st January 1981 being engaged in an occupation of a non-teaching nature of at least two years' duration for men and women following completion or partial completion of an approved qualification.

(b) In the case of applicants possessing an approved certificate course or equivalent, being engaged for six years in an occupation associated with the course following completion or partial completion of the course.

(c) In the case of applicants possessing an approved apprenticeship or technician course, being engaged in an occupation for which the course provides relevant training for a period of five years following completion of the course.

4. Any person appointed by the Teachers Tribunal to the classified roll of State School Teachers in the Division in the period from 1st July 1972 to 30th June 1973, both dates inclusive, shall be registered as a teacher in the Division and his name shall be entered in the Register accordingly.

5. Any person employed as a teacher in the Division in the period from 1st July 1972 to 30th June 1973, both dates inclusive, who—

(a) was qualified under the Regulations made by the Teachers Tribunal under the *Teaching Service Act 1958* for the time being in force for permanent appointment to the Division;

or

(b) has successfully completed an approved course of teacher training and successfully completed the first year of an approved course of tertiary study—
shall be registered as a teacher in the Division upon application to the Board on the form prescribed by the Board.

Provided that Regulation 5 (a) shall only be applicable to persons so qualified as at 30th June 1973.

6. Any person desiring to become a registered teacher or a provisionally registered teacher in the Division and who is not otherwise registered pursuant to the Act or the Regulations shall:

- (a) make application to the Board on the form prescribed by the Board;
- (b) be deemed to have made such application on inclusion of his name and qualifications on an appropriate list provided by the State College of Victoria, Hawthorn, on commencement or completion of an approved teacher training course.
- (c) be deemed to have made application on inclusion of his name and qualifications on an appropriate list of secondary exit students provided by a constituent college of the State College of Victoria, or an approved Victorian University, and whose name also appears on an appropriate list provided by the Director of Technical Education of those persons who have been assigned to teach in the Technical Schools Division.

7. The Board shall grant registration to an applicant who—

(1) has successfully completed—

(a) an approved degree together with an approved course of teacher training;

or

(b) the Trained Technical Teacher's Certificate awarded under Regulation XXXIII. (o) of the Education Department Regulations 1962;

or

(c) the Trained Trade Instructor's Certificate awarded under Regulation XXXIII. (p) of the Victorian Education Department Regulations 1962; the course for which was commenced prior to 1st January 1975;

or

(d) the Trained Trade Instructor's Certificate awarded under Regulation XXXIII. (p) of the Education Department Regulations 1962 and—

(i) an approved Trade Technician Course;

or

(ii) approved studies at or above Form V. Secondary Level;

or

(iii) approved equivalent studies;

or

(e) the Trained Technician Instructor's Certificate awarded under Regulation XXXIII. (q) of the Education Department Regulations 1962;

or

(f) an approved course of teacher training and at least one of the following:—

(i) an approved Diploma of Music together with approved industrial experience;

(ii) an approved Diploma of Physical Education;

- (iii) the requirements for the Registration Certificate of the Library Association of Australia together with approved industrial experience;
 - (iv) corporate membership of an approved professional institution secured through approved studies, together with five years of approved industrial experience;
 - (v) the licentiateship, or its equivalent, of an approved examining body in the practising art of instrumental or vocal music, speech or drama together with five years of approved experience in the relevant field;
 - (vi) an approved certificate course from an approved technical college or other approved institution and six years of approved industrial experience.
- (2) has successfully completed at an approved Victorian educational institution or institutions an approved course of teacher training and an approved diploma awarded by a college of advanced education or other approved institution and has approved industrial experience;
 - (3) has successfully completed an approved Higher Diploma of Teaching (Secondary), or its equivalent, at a College affiliated with the State College of Victoria. Provided that where the major academic content of the course is in Art and Crafts or Domestic Arts, that applicants will also require approved industrial experience;
 - (4) has successfully completed the Trained Secondary Teacher's Certificate (Art and Craft or Domestic Arts) which was commenced prior to 1st January 1969 through a course of three years' duration following Matriculation, or its equivalent, and approved industrial experience or an approved fourth year of study;
 - (5) was provisionally registered prior to 1st January 1975 and who required only industrial experience for registration on the completion of the equivalent of five years full time teaching in a State Technical School;
 - (6) has obtained any qualification or qualifications approved as equivalent to the requirements of paragraphs (a), (b), (c), (d), (e) or (f) of Regulation 7 sub-regulations (1), (2), (3) or (4).
8. The Board shall grant provisional registration—
- (1) to any applicant who—
 - (a) has successfully completed an approved course of teacher training together with two years of approved tertiary study and where appropriate, approved industrial experience;
 - or
 - (b) is undertaking an approved course of teacher training the successful completion of which will entitle him to registration;
 - or
 - (c) has successfully completed the associateship, or its equivalent, of an approved examining body in the practising art of instrumental or vocal music, speech and drama, together with five years of approved experience in the relevant field and an approved course of teacher training;
 - or

(d) has successfully completed the Trained Trade Instructor's Certificate which was commenced after 1st January 1975 and awarded under Regulation XXXIII. (P) of the Education Department Regulations 1962;

or

(e) is the holder of a Technical Studentship or Student Instructions and whose name and qualifications are provided on an appropriate list by the State College of Victoria, Hawthorn, and is currently undergoing approved teacher training;

(2) in special circumstances to an applicant whom the Board is satisfied possesses competence in a particular field gained through long professional or industrial experience.

Provided however that any registration granted pursuant to this provision shall be limited to the particular field of experience.

9. Notwithstanding anything in these Regulations the Board may, on receipt of an application on the prescribed form, renew the provisional registration of any teacher subject to any conditions the Board thinks fit.

10. The Board may grant provisional registration to an applicant, not otherwise registerable, who has served formerly in the Technical Division for a period of not less than two years and who at the time of such service held qualifications equivalent to those required for permanent appointment by the then operative regulations of the Teacher Tribunal.

The foregoing Regulations were approved by the Board on the twenty-second day of October, 1975, as witnessed by the signatures of the members of the Board present.

(L.S.)	H. C. GILHAM, Vice Chairman.
(L.S.)	E. N. SCHONFELDER, Member.
(L.S.)	P. E. CAMIER, Member.
(L.S.)	K. W. MASSON, Member.
(L.S.)	M. E. BURNS, Member.

TENDERS

PUBLIC WORKS DEPARTMENT

Tenders will be received at Public Works Department, 2 Treasury Place, Melbourne, until TWO p.m. on dates shown for purposes mentioned hereunder.

Particulars and tender forms available at Contracts Office, Room 27, Ground Floor, No. 2, Treasury Place, and at Inspector of Works Office if indicated by W.O. Tenders must be on a "Firm Tender" basis. The lowest or any tender will not necessarily be accepted.

Address tenders to the Minister of Public Works, and endorse the envelope "Tender for". Hand delivered tenders to be placed in the Tender Box of the Public Works Department, Main Entrance Foyer, Ground Floor, 2 Treasury Place, Melbourne.

No preliminary deposit is required with any tender, but successful tenderer will be required to pay a deposit for any accepted tender of \$10,000 or over.

Tuesday, 1st June, 1976.

Building, Electrical and Mechanical Works.

FRANKSTON FOREST.—Internal and External Repairs and Painting, Primary School 4872.

MITCHAM.—Alterations to Existing Building for Health Clinic.

WODONGA.—Interior and Exterior Renovations, Adult Education Centre (Old High School). (W.O., Wangaratta.)

WODONGA.—Electrical Services relevant to Interior and Exterior Renovations, Adult Education Centre. (W.O., Wangaratta.)

Site Works.

MOOROOLBARK NORTH.—Siteworks, Primary School 5011.

Miscellaneous.

MELBOURNE.—Maintenance Cleaning, 1st August, 1976–31st July, 1979, Coroner's Court, Flinders Street Extension.

Various.—Supply of Kitchen Equipment, Schools and Other Government Buildings.

Various.—Supply of Domestic Equipment, Schools and Other Government Buildings.

Tuesday, 8th June, 1976.

Building, Electrical and Mechanical Works.

GLENORMISTON.—Erection of new Seminar room and Conference facilities, Agricultural College. (W.O., Horsham.)

HUNTINGDALE.—External and internal renovations, High School.

SPRINGVALE.—External repairs and painting, Primary School 3507. (W.O., Dandenong.)

WANTIRNA.—Internal and external repairs and painting, Primary School 3152.

WAVERLEY.—Repairs and painting, High School.

WESTALL.—External and internal renovations and painting, High School.

Site Works.

MILDURA.—Site works (Car Park and General), Special Education Unit. (W.O., Mildura.)

RINGWOOD NORTH.—Site works, Primary School, 4120.

Miscellaneous.

MELBOURNE.—Supply and installation of PABX telephone system, Public Offices (Forest Commission), 601 Bourke Street.

ROBERTS DUNSTAN,
Minister for Public Works.

Public Works Department,
Melbourne, 18th May, 1976.

TENDERS FOR THE SERVICE 1976-77.**GENERAL STORES.**

Tenders will be received until Eight thirty a.m. on Friday, 11th June, 1976, from persons willing to supply the under-mentioned machines in such quantities as may be ordered by the Victorian Government during the periods commencing 1st September, 1976.

Schedule No.

2. Exercise Books and Requisites, Education Department (1 year)—1st September, 1976 to 31st August, 1977.
73. Dictation Equipment (1 year)—1st September, 1976 to 31st August, 1977.
76. Adding/Listing Machines (11 months)—1st September, 1976 to 31st July, 1977.

Full particulars may be obtained from the Secretary to the Tender Board, by whom also any information will be afforded to persons tendering.

Tenders enclosed in the envelope provided, must be deposited in the tender-box at the Tender Board Offices, 3rd Floor, 49 Spring Street, Melbourne, 3000, or, if sent by post, postage must be pre-paid and the tenders addressed to the Chairman of the Tender Board, Tender Board Offices, 49 Spring Street, Melbourne, 3000, which office they must reach not later than by first post on the date of closing of tenders.

W. L. ROBERTSON,
Secretary to the Tender Board.

PRIVATE ADVERTISEMENTS**CITY OF BENDIGO.****By-Law No. 113.**

A By-Law of the City of Bendigo made under the provisions of the *Local Government Act 1958* and the *Uniform Building Regulations, Victoria*, and numbered 113 for the purpose of:—

- (a) Repealing portions of By-Laws Nos. 66 and 101, and
- (b) Adopting the minimum dimensions as set out in Columns 2 and 3 of Table 804 of the *Uniform Building Regulations, Victoria* and prescribing areas throughout the Municipal District in which such dimensions shall apply.

In pursuance of the powers conferred by the *Local Government Act* and the *Uniform Building Regulations, Victoria* and of any and every other power it thereunto enabling the Mayor, Councillors and Citizens of the City of Bendigo order as follows:—

1. Clause 2 and the Second Schedule of By-Law No. 66 is hereby repealed.
2. Clause 3 of By-Law No. 101 is hereby repealed and the following substituted in lieu thereof:
3. (i) The minimum width of frontage, minimum depth and minimum area of site in respect of sites for Buildings of Class I Occupancy (House), and the minimum width of frontage, minimum depth, minimum area of site and minimum open space at ground level per flat in respect of sites for Buildings of Class II Occupancy (Flats) as specified in Column 2 of Table 804 of the *Uniform Building Regulations, Victoria* are hereby adopted and made applicable throughout that portion of the Municipal District of the City of Bendigo set out and described in the Second Schedule hereto.
- (ii) The minimum width of frontage, minimum depth and minimum area of site in respect of sites for Buildings of Class I Occupancy (House), and the minimum width of frontage, minimum depth, minimum area of site and

minimum open space at ground level per flat in respect of sites for Buildings of Class II Occupancy (Flats) as specified in Column 3 of Table 804 of the *Uniform Building Regulations, Victoria* are hereby adopted and made applicable throughout the whole of the Municipal District of the City of Bendigo, save for that area set out and described in the Second Schedule hereto.

SECOND SCHEDULE.

Being all land within the following boundaries together with all land within the following boundaries having frontage to or principal access to the streets forming the boundary of the said area:—

Commencing at a point where the Bendigo-Swan Hill Railway Line meets the north end of Bannister Street,
Thence south-west along Bannister Street to Nolan Street,
Thence north-west along Nolan Street to Lobb Street,
Thence south-west along Lobb Street to Bayne Street,
Thence north-west along Bayne Street to Prouses Road,
Thence north-east along Prouses Road to Swan Street,
Thence north-west along Swan Street to Kookaburra Avenue,
Thence south-west along Kookaburra Avenue to Holmes Road,
Thence north-west along Holmes Road to Havilah Road,
Thence south-west along Havilah Road to Eaglehawk Road,
Thence south along Eaglehawk Road to Marong Road,
Thence south-west along Marong Road to Lily Street,
Thence south along Lily Street to Barnard Street,
Thence south-west along Barnard Street to Maple Street,
Thence south along Maple Street to McKenzie Street West,
Thence south-west along McKenzie Street West to Oak Street,
Thence south along Bendigo Creek to Elm Street,
Thence south-east along Elm Street to McLachlan Street,
Thence north-east along McLachlan Street to Oak Street,
Thence south-east along Oak-Hattam Streets to Allingham Street,
Thence north-east along Allingham Street to McDougall Road,
Thence north-east along Breen Street (continuation of Allingham Street) to Russell Street,
Thence south-east along Russell Street to Houston Street,
Thence east along Houston Street to Somerville Street,
Thence north along Somerville Street to Nish Street,
Thence east along Nish Street to Neale Street,
Thence north along Neale Street to Condon Street,
Thence east along Condon Street to City Boundary Line,
Thence north along City Boundary Line to Lansell Street,
Thence west along Lansell Street to Railway Line,
Thence north along Railway Line to Bendigo-Swan Hill Railway Line,
Thence north-west along Bendigo-Swan Hill Railway Line to commencing point at Bannister Street.

Resolution for passing this By-Law agreed to by the Council on the 19th day of January, 1976 and confirmed on the 16th day of February, 1976.

The common seal of the Mayor, Councillors and Citizens of the City of Bendigo was hereto affixed the 19th day of March, 1976.

(SEAL)

R. L. CAMPBELL, Mayor.
D. R. DENNIS, Councillor.
A. J. WATTS, Town Clerk.

Approved by the Governor in Council, 27th April 1976.—
TOM FORRISTAL, Clerk of the Executive Council. 1654

CITY OF BOX HILL.**LOAN No. 265.****Notice of Intention to Borrow.**

Notice is hereby given that the Council of the City of Box Hill intends to borrow the sum of seventy five thousand dollars (\$75,000) secured by a charge over the general rates of the municipality by the grant of a mortgage in accordance with the provisions of the *Local Government Act 1958*.

In connection therewith the following information is stated—

1. The amount of principal monies which it is proposed to borrow is Seventy Five Thousand Dollars—\$75,000.

2. The maximum rate of interest that may be paid is 10.5 per centum per annum.
3. The purpose for which the loan is to be applied is—
Swimming pool complex—Surrey Park—\$75,000.
4. The loan is to be liquidated over a period of 10 years by 20 half yearly instalments of \$6,146.42 each covering principal and interest on the 31st day of the month of December and the 30th day of June in each year during the currency of the loan, the first instalment shall be payable on the 31st December, 1976.
5. Such monies shall be repayable to the Mutual Life and Citizens' Assurance Company Limited—Collins and Elizabeth Streets, Melbourne.

The plans and specifications and the estimate of the cost of the proposed works and a statement showing the proposed expenditure of the monies to be borrowed are open for inspection at the office of the Council of the City of Box Hill at the Town Hall, Box Hill.

1590 I. G. PORT, Town Clerk.

CITY OF BROADMEADOWS.

LOAN NO. 88.

Notice of Intention to Borrow the Sum of \$100,000 for Permanent Works and Undertakings.

Notice is hereby given that the Council of the City of Broadmeadows proposes to borrow the principal sum of \$100,000 secured by a charge over the general rates of the Municipality, such sum to be raised by the grant of a mortgage in accordance with the provisions of the *Local Government Act 1958*.

(1) The maximum rate of interest that may be paid is 10.5 per centum per annum.

(2) The purposes for which the loan is to be applied are:—

(a) Reconstruction of Piper Street	\$40,000
(b) Reconstruction of Uplands Road	30,000
(c) Reconstruction of Chapman Avenue (part provision)	20,000
(d) Coolaroo Multi-purpose Hall (part provision)	10,000
	\$100,000

(3) The period of the Loan shall be fifteen (15) years.

(4) The monies borrowed shall be repayable by providing out of the Municipal Fund half-yearly instalments of approximately \$6,691.69 each including principal and interest on the first day of January and the first day of July during the currency of the loan. The first instalment shall be payable on the first day of January 1977.

(5) Such moneys shall be repayable to the Commonwealth Savings Bank of Australia, Glenroy, or such other place or places as the Bank from time to time requires.

The plans and specifications and the estimate of the cost of the proposed works and a statement showing the proposed expenditure of the monies to be borrowed are open for inspection at the Municipal Offices, Pascoe Vale Road, Broadmeadows.

1566 BRUCE D. MCGREGOR, Town Clerk.

CITY OF BROADMEADOWS.

ORDER CHANGING NAME OF STREET.

Notice is hereby given that at a meeting of the Council of the City of Broadmeadows held on 2nd April 1973 the said Council, in pursuance of the provisions of the *Local Government Act 1958* did make an Order changing the name of the street set out hereunder:—

Old Name.—Talbot Street.

New Name.—Talbot Road.

Location.—From Wallace Crescent to Moonee Ponds Creek, Strathmore.

1593 BRUCE D. MCGREGOR, Town Clerk.

CITY OF DANDENONG.

LOAN NO. 79.

Notice of Intention to Borrow the Sum of \$500,000 for Permanent Works and Undertakings.

Notice is hereby given that the Council of the City of Dandenong proposes to borrow the principal sum of Five hundred thousand dollars secured by a charge over the general rates of the municipality, such sum to be raised by the grant of a mortgage in accordance with the provisions of the *Local Government Act 1958*.

1. The maximum rate of interest that may be paid is 10.5 per cent. per annum.

2. The purposes for which the loan is to be applied are:—

1. Completion of W. G. Wright Complex (swimming pool, etc., Mills Reserve)	\$450,000
2. Extension to Municipal Offices	50,000
	\$500,000

3. The period of the loan shall be fifteen years.

4. The moneys borrowed shall be repayable by providing out of the municipal fund 30 half-yearly instalments of approximately \$33,458.47 each, including principal and interest on the 10th day of January and the 10th day of July, during the currency of the loan. The first instalment shall be payable on the 10th day of January, 1977.

5. Such moneys shall be repayable at the Commercial Savings Bank of Australia Limited, Head Office, Melbourne, or at such other places as the lender may direct.

The plans and specifications and the estimate of the cost of the proposed works and a statement showing the proposed expenditure of the moneys to be borrowed are open for inspection at the office of the Council of the City of Dandenong, at 39 Clow Street, Dandenong.

1564 C. A. ELLIOTT, Town Clerk.

Town and Country Planning Act 1961 (Twelfth Schedule).

CITY OF KNOX PLANNING SCHEME 1965.

NOTICE THAT A PLANNING SCHEME HAS BEEN PREPARED AND IS AVAILABLE FOR INSPECTION.

Amendment No. 162, 1976.

Notice is hereby given that the Council of the City of Knox in pursuance of its powers under the *Town and Country Planning Act 1961*, has prepared a Planning Scheme for portions of the City of Knox for the purpose of amending the Principal Scheme by amending the Planning Scheme Ordinance, with respect to the provisions of the Commercial General, Commercial Local and Commercial Industrial Zones, to the effect that Commercial Development be permitted in these Zones subject to the grant of a Permit and to any conditions imposed thereby.

A copy of the Scheme has been deposited at the Office of the City of Knox, Civic Centre, 511 Burwood Highway, Knoxfield, and at the Office of the Town and Country Planning Board, 5th Floor, 235 Queen Street, Melbourne, and will be open for inspection during office hours by any person free of charge.

Any persons affected by the Planning Scheme are required to set forth in writing all objections they may have, addressed to the Town Clerk, City of Knox, Civic Centre, Knoxfield, on or before the 19th day of June 1976, and to state whether they wish to be heard in respect of their objections.

1574 T. J. NEVILLE, Town Clerk.

CITY OF MELBOURNE.

NOTICE OF APPLICATION FOR LEASE UNDER SECTION 134 OF LAND ACT 1958.

Notice is hereby given that the Corporation of the City of Melbourne has applied for a lease pursuant to section 134 of the *Land Act 1958* over an area of 3.928 hectares in the Parish of Doutta Galla, being the area in Footscray Road, West Melbourne, in the City of Melbourne, known as the Roy Schintler Recreation Reserve. The lease applied for is for the purpose of amusement and recreation and for a term of 21 years.

1577 F. H. ROGAN, Town Clerk.

Town and Country Planning Act 1961 (Twelfth Schedule).

CITY OF MILDURA PLANNING SCHEME.

NOTICE THAT A PLANNING SCHEME HAS BEEN PREPARED AND IS AVAILABLE FOR INSPECTION.

Amendment No. 18, 1976.

Notice is hereby given that the Mildura City Council in pursuance of its powers under the *Town and Country Planning Act 1961* has prepared a Planning Scheme to re-zone the following land:—

The southern corner of Eighth Street and Orange Avenue, being lots 21-25 and known as 43-45 Orange Avenue, of dimensions 50.32 m by 47.24 m, to Commercial 'C'.

A copy of the Scheme has been deposited at the offices of the Mildura City Council, Deakin Avenue, Mildura, and at the office of the Town and Country Planning Board, 235 Queen Street, Melbourne, and will be open for inspection during office hours by any person free of charge.

Any persons affected by the Planning Scheme are required to set forth in writing all objections they may have addressed to the Town Clerk, City of Mildura, Civic Buildings, Deakin Avenue, Mildura, on or before 19th June 1976, and to state whether they wish to be heard in respect of their objections.

22nd April, 1976.

1575

W. J. DOWNIE, Town Clerk.

Town and Country Planning Act 1961 (Twelfth Schedule).
CITY OF MILDURA PLANNING SCHEME.

NOTICE THAT A PLANNING SCHEME HAS BEEN PREPARED AND IS AVAILABLE FOR INSPECTION.

Amendment No. 17, 1976.

Notice is hereby given that the Mildura City Council in pursuance of its powers under the *Town and Country Planning Act 1961* has prepared a Planning Scheme to re-zone the following land:—

The north corner of Fourteenth Street and Walnut Avenue, of dimension 8·634 ha, and being described as lot 2 of LP 69534, and lots 13-14 and part of lots 4-5 section 16, block E of LP 2496, being part of CP 2, to Residential 'A' and to zone an area of land 370·5 metres north-east of the corner of Walnut Avenue and Fourteenth Street within the above description of land, having an area of 2,087 sq.m., to Commercial 'D'.

A copy of the Scheme has been deposited at the offices of the Mildura City Council, Deakin Avenue, Mildura, and at the office of the Town and Country Planning Board, 235 Queen Street, Melbourne, and will be open for inspection during office hours by any person free of charge.

Any persons affected by the Planning Scheme are required to set forth in writing all objections they may have addressed to the Town Clerk, City of Mildura, Civic Buildings, Deakin Avenue, Mildura, on or before the Nineteenth day of June, 1976, and to state whether they wish to be heard in respect of their objections.

29th April, 1976.

1576

D. B. GROSS, Acting Town Clerk.

CITY OF RICHMOND.

LOAN No. 62.

Notice of Intention to Borrow the Sum of \$700,000 for Permanent Works and Undertakings.

Notice is hereby given that the Council of the City of Richmond proposes to borrow the sum of \$700,000 (Seven Hundred Thousand dollars) on the credit of the Municipal Revenues of the Mayor, Councillors and Citizens of the said City, such sum to be raised by the grant of a mortgage in accordance with the provisions of the *Local Government Act 1958*.

1. The amount of the principal moneys which it is proposed to borrow is \$700,000 (Seven hundred thousand dollars).

2. The maximum rate of interest that may be paid is 10·50 per cent. per annum.

3. The period of the loan shall be fifteen years.

4. The times which the moneys borrowed are repayable are on the 1st day of January and the 1st day of July during the years 1977-1991 inclusive and the place such moneys shall be repayable is at the Commonwealth Savings Bank of Australia or at the Council's Bankers for the time being in Melbourne.

5. The purpose for which the loan is to be applied is for:

Kerb & Channelling & drainage works	\$200,000
Library Construction	\$234,000
Reconstruction of Bridge Road	\$266,000

6. The manner in which the Loan is to be liquidated is by provision out of the Municipal Fund in each half year during the currency of the Loan of the sum of \$46,841·85 (Forty-six thousand eight hundred and forty-one dollars and eighty five cents) which includes principal and interest. The first instalment shall be payable on the 1st day of January, 1977.

7. The plans and specifications and estimate of the cost of the proposed works and a statement showing the proposed expenditure of the moneys to be borrowed are open for inspection at the Municipal Offices.

Dated the 13th day of May, 1976.

1568

C. C. EYRES, Town Clerk.

CITY OF RINGWOOD.

Notice of Intention to Borrow the Sum of \$118,000 for Permanent Works and Undertakings.

Notice is hereby given that the Council of the City of Ringwood proposes to borrow the sum of \$118,000 (One hundred and eighteen thousand dollars) secured by a charge over the General Rates of the Municipality such sum to be raised by the grant of a Mortgage in accordance with the provisions of the *Local Government Act 1958* for Permanent Works and Undertakings within the Municipality.

(a) That the maximum rate of interest that may be paid be 10·5 per centum per annum.

(b) That the purposes for which the Loan is to be applied are:—

1. Council's contribution	
Main Drain through Tip Extension	\$16,000
2. Completion and development of two playing areas Wonga Road Tip site	16,500
3. Retarding basin—Greenwood Park	5,500
4. Ringwood Golf Course—to complete	80,000
	<u>\$118,000</u>

(c) That the period of the Loan shall be fifteen (15) years.

(d) That the monies borrowed shall be repayable by providing out of the Municipal Fund thirty half-yearly instalments of approximately \$7,113·79 each including principal and interest on the 30th day of June and December in each year and the first instalment shall be payable on the 30th December 1976.

(d) Such monies shall be repayable to the Australia and New Zealand Savings Bank Limited, 394-396 Collins Street, Melbourne at the office of the said Bank.

The plans and specification and an estimate of the cost of the proposed works are open for inspection at the office of the Council, Civic Centre, Ringwood, during office hours.

1565

A. W. HALL, Town Clerk.

CITY OF WANGARATTA.

LOAN No. 97.

Notice of Intention to Borrow the Sum of \$220,000 for Permanent Works and Undertakings.

Notice is hereby given that the City of Wangaratta proposes to borrow the principal sum of \$220,000 (Two hundred and twenty thousand dollars), secured by a charge over the general rates of the municipality, such sum to be raised by the grant of a mortgage in accordance with the provisions of the *Local Government Act 1958*.

1. The maximum rate of interest that may be paid is 10·5 per centum per annum.

2. The purpose to which the loan is to be applied is:—

(a) Depot—Plant Shelter Extension, Stage 3	\$2,000
(b) Private Street Construction	10,000
(c) Wangaratta City Ladies Bowling Club Clubhouse (Part Payment)	6,000
(d) Construction of new James Tilson Kindergarten and Infant Welfare Centre	40,000
(e) Year 2 of Programmed Works—	
Footpath Construction	13,000
Kerb and Channel Construction	26,000
Drainage in Association with Kerb and Channel	23,000
(f) C.R.B. Council Contribution	30,000
(g) Development new refuse disposal system	70,000
	<u>\$220,000</u>

3. The period of the loan shall be fifteen (15) years.

4. The moneys borrowed shall be repayable by providing out of the municipal fund half-yearly instalments of approximately \$14,721·73 each, including principal and interest, on the thirtieth day of December and the thirtieth day of June, during the currency of the loan. The first instalment shall be repayable on the thirtieth of December, 1976.

5. Such moneys shall be repayable to the Bank of New South Wales Savings Bank Limited, Murphy Street, Wangaratta, or any place or places as the Bank from time to time may require.

The plans, specifications and the estimate of the cost of the proposed works and a statement showing the proposed expenditure of the moneys to be borrowed are open for inspection at the office of the Council of the City of Wangaratta, Ford Street, Wangaratta during office hours.

Dated 14th May, 1976.

1588

J. W. ELWARD, Town Clerk.

CITY OF WANGARATTA.

LOAN No. 98.

Notice of Intention to Borrow the Sum of \$100,000 for Permanent Works and Undertakings.

Notice is hereby given that the City of Wangaratta proposes to borrow the principal sum of \$100,000 (One hundred thousand dollars), secured by a charge over the general rates of the municipality, such sum to be raised by the grant of a mortgage in accordance with the provisions of the Local Government Act 1958.

1. The maximum rate of interest that may be paid is 9.8 per centum per annum.

2. The purpose to which the loan is to be applied is:—

Plant Purchases—In Conjunction with New Refuse Disposal System—\$100,000.

3. The period of the loan shall be 5 (five) years.

4. The moneys borrowed shall be repayable by providing out of the municipal fund half-yearly instalments of approximately \$12,887.63 each, including principal and interest, on the thirtieth day of December and the thirtieth day of June, during the currency of the loan. The first instalment shall be repayable on the thirtieth of December, 1976.

5. Such moneys shall be repayable to the Bank of New South Wales Savings Bank Limited, Murphy Street, Wangaratta, or any place or places as the Bank from time to time may require.

Dated 14th May, 1976.

1589

J. W. ELWARD, Town Clerk.

TOWN OF KYABRAM.

PROSECUTING OFFICER.

Notice is hereby given that the Council of the Town of Kyabram has appointed Snr. Sgt. N. W. Cameron, No. 12026, as Prosecuting Officer for the Municipality, in lieu of Snr. Sgt. R. O. Stanfield, No. 10849 transferred.

1569

E. T. CORNISH, Town Clerk.

SHIRE OF BANNOCKBURN.

LOAN No. 13.

Notice is hereby given that the Council of the Shire of Bannockburn proposes to borrow the sum of Sixty five thousand five hundred dollars (\$65,500.00) secured by a charge over the general rates of the municipality by the grant of a mortgage in accordance with the provisions of the Local Government Act 1958 as amended. The following information is provided in relation to the proposal:

1. The amount of principal moneys proposed to be borrowed is sixty five thousand five hundred dollars (\$65,500.00).

2. The purposes for which the loan is to be applied are:

(a) Purchase of land \$2,000.00.

(b) Road and street construction \$13,500.00.

(c) Purchase of plant \$50,000.00.

3. The maximum rate of interest that may be paid is 10.5 per cent per annum.

4. The period of the loan shall be ten (10) years.

5. The moneys borrowed shall be repayable by providing out of the municipal fund twenty (20) half-yearly instalments of \$5,367.87 each, including principal and interest, on the 10th day of January and the 10th day of July, during the currency of the loan. The first instalment shall be payable on the 10th day of January 1977.

6. Such moneys shall be repayable at the office of the Commercial Savings Bank of Australia Ltd., High Street, Bannockburn.

The plans and specifications and estimates of the cost of the works and a statement showing the proposed expenditure of the moneys to be borrowed, are open for inspection at the Municipal Offices, High Street, Bannockburn, 3331.

1591

A. J. MACDONALD, Shire Secretary.

SHIRE OF BELLARINE.

LOAN No. 71.

Notice of Intention to Borrow the Sum of \$75,000 for Permanent Works and Undertakings.

Notice is hereby given that the Council of the Shire of Bellarine proposes to borrow the principal sum of Seventy-five thousand dollars secured by a charge over the general rates of the municipality, such sum to be raised by the grant of a mortgage in accordance with the provisions of the Local Government Act 1958.

1. The maximum rate of interest that may be paid is 10.5 per centum per annum.

2. The purposes for which the loan is to be applied are as follows:—

Part cost of construction Drysdale Senior Citizens' Club	\$35,000
Part cost of development St. Leonards Recreation Reserve	<u>\$40,000</u>
	\$75,000

3. The period of the loan shall be ten years.

4. The moneys borrowed shall be repayable by providing out of the municipal fund half-yearly instalments of approximately \$6,146.42 each including principal and interest on the thirtieth day of June and the thirty-first day of December during the currency of the loan. The first instalment shall be payable on the thirty-first day of December, 1976.

5. Such moneys shall be repayable to the M.L.C. Assurance Company Limited, Melbourne.

The plans and specifications and the estimate of the cost of the proposed works and a statement showing the proposed expenditure of the moneys to be borrowed are open for inspection at the office of the Council of the Shire of Bellarine at Drysdale.

12th May, 1976.

1567

H. A. WILLIAMS, Shire Secretary.

SHIRE OF HUNTLY.

NOTICE OF NAMING OF ROADS.

Notice is hereby given that the Council of the Shire of Huntly has allocated the following street names—

1. That the Government Road commencing at Boronia Road and thence south-westerly along Crown allotment 24 Parish of Huntly and continuing to Grevillea Road be named Lavenia Road.

2. That the Government Road commencing at the Midland Highway in the Township of Huntly; thence north-westerly northerly of Crown allotment 280; thence past the School Reserve and Recreation Reserve to Government Road and also continuing south-easterly from the Midland Highway and past the Pound Reserve to Government Road on the Township Boundary be named Gungurru Road.

1570

ALAN K. LEE, Shire Secretary.

Town and Country Planning Act 1961.

MAFFRA PLANNING SCHEME 1965.

NOTICE THAT A PLANNING SCHEME HAS BEEN PREPARED AND IS AVAILABLE FOR INSPECTION.

Amendment No. 14, 1976.

Notice is hereby given that the Shire of Maffra in pursuance with its powers under the Town and Country Planning Act 1961, has resolved to amend the Maffra Planning Scheme 1965, by rezoning an area of land east of Landy Street, being part of Crown Allotment 1c, Parish of Wa-de-lock from Rural to Reserve for Municipal Purposes to be developed for use as a Shire Depot complex and to re-zone land bounded by Powerscourt, Morrison, Landy and Davis Streets, Maffra from Rural to Residential Purposes.

A copy of the Scheme has been deposited at the Office of the Shire of Maffra, Johnson Street, Maffra and at the Office of the Town and Country Planning Board, 235 Queen Street, Melbourne, and will be open for inspection during office hours by any person free of charge.

Any persons effected by the Planning Scheme are required to set forth in writing all objections they have addressed to the Shire Secretary, Shire Office, Maffra on or before the 19th August, 1976, and to state whether they wish to be heard in respect of their objections.

19th May, 1976.

1592

J. RENNICK, Municipal Clerk.

Town and Country Planning Act 1961 (Twelfth Schedule).

SHIRE OF WARRAGUL PLANNING SCHEME.

NOTICE THAT A PLANNING SCHEME HAS BEEN PREPARED
AND IS AVAILABLE FOR INSPECTION.

Amendment No. 17, 1972.

INTERIM DEVELOPMENT ORDER.

Amendment No. 1, 1976.

Notice is hereby given that the Shire of Warragul in pursuance of its powers under the *Town and Country Planning Act 1961* has prepared a Planning Scheme for the whole of the Shire of Warragul with the exception of that portion indicated by the grey border on the Warragul Planning Scheme 1954 map for the purpose controlling the establishment of Dog Boarding and Breeding Kennels within the Interim Development Order.

A copy of the scheme has been deposited at Shire Office, Civic Place, Warragul and at the office of the Town and Country Planning Board, 235 Queen Street, Melbourne, and will be open for inspection during office hours by any person free of charge.

Any persons affected by the Planning Scheme are required to set forth in writing all objections they may have, addressed to Shire Secretary, Shire of Warragul, Civic Place, Warragul on or before the 19th day of June 1976 and to state whether they wish to be heard in respect of their objections.

1573

D. McADIE, Municipal Clerk.

Town and Country Planning Act 1961 (Twelfth Schedule).

SHIRE OF WARRAGUL PLANNING SCHEME, 1954.

NOTICE THAT A PLANNING SCHEME HAS BEEN PREPARED
AND IS AVAILABLE FOR INSPECTION.

Amendment No. 23, 1976.

Notice is hereby given that the Shire of Warragul in pursuance of its powers under the *Town and Country Planning Act 1961* has prepared a Planning Scheme for all that area within the grey border of the Warragul Planning Scheme 1954 for the purpose of controlling the establishment of Dog Boarding and Breeding Kennels within the Agricultural Zone of the Planning Scheme.

A copy of the scheme has been deposited at Shire Office, Civic Place, Warragul and at the office of the Town and Country Planning Board, 235 Queen Street, Melbourne, and will be open for inspection during office hours by any person free of charge.

Any persons affected by the Planning Scheme are required to set forth in writing all objections they may have, addressed to Shire Secretary, Shire of Warragul, Civic Place, Warragul on or before the 19th day of June 1976 and to state whether they wish to be heard in respect of their objections.

1572

D. McADIE, Municipal Clerk.

CRANBOURNE SEWERAGE AUTHORITY.

GENERAL NOTICE.

The Cranbourne Sewerage Authority having made provision for carrying of sewage from each and every property, which or any part of which is within the sewerage areas hereinafter described, doth hereby declare that on and after the 31st day of March, 1976 each and every property which or any part of which is within the said sewerage areas shall be deemed to be a sewerage property within the meaning of the *Sewerage Districts Act 1958*. The boundary of the sewerage areas hereinbefore referred to are:—

Description—Area No. 11.

Comprising Lots 35 and 36 L.P.34556 Circle Drive, Cranbourne.

Description—Area No. 12.

Comprising Lot 112 L.P.89619 Raymond Avenue and Lot 1 L.P.99657 Lorraine Avenue, Langwarrin.

By Order of the Cranbourne Sewerage Authority,
5th May, 1976.

1571

W. B. CAMPBELL, Chairman.
T. VICKERMAN, Secretary.

INVERLOCH SEWERAGE AUTHORITY.

Notice is hereby given that the above Authority intends to construct a Treatment and Outfall Sewer Works on part of Crown allotment 63, Parish of Kirrak, and an associated Rising Main between Inverloch and the Treatment Works, in accordance with plans and specifications which are available for inspection at the Authority's Office, Reilly Street, Inverloch, during office hours.

1498

I. M. SYMINGTON, Secretary.

EXECUTION OF DEEDS UNDER PART X.

25/76—Re Francesco & Vicki Aronica of 2/47 Mitchell Street, Northcote, trading as Masquerade Modes at 301 Smith Street, Fitzroy.

Deed of Assignment; 10th May, 1976.

G. O. HARRISON, Trustee.

Hall & Rose, chartered accountants, 395 Collins Street,
Melbourne. 1595

Notice is hereby given that T.B. Transport Pty. Ltd. has applied for a lease pursuant to sections 134 and 135 of the *Land Act 1958* for a term of ten (10) years in respect of allotment 16, section 104, City of South Melbourne containing 2732 square metres as a site for timber storage.

1540

Notice is hereby given that International Harvester Australia Limited has applied for a lease pursuant to sections 134 and 135 of the *Land Act 1958* for a term of fifty years in respect of allotment 10, section 59, City of Port Melbourne containing 2.8783 hectares as a site for general industrial purposes.

1541

Take notice that I John Barnes of 15 North Street, Ardeer will not be responsible for any debts incurred in my name without my written consent.

1655

Notice is hereby given that the partnership heretofore subsisting between us the undersigned Cecil Harold Farmers and Ian Harold Farmers carrying on business as farmers and graziers at Nhill in Victoria under the style or firm of "C. H. Farmers & Son" has been dissolved by mutual consent as from the 1st day of May 1976 and that all debts due and owing by the said late firm will be received and paid for by the said Cecil Harold Farmers.

Dated the 29th day of April, 1976.

1545

C. H. FARMERS.
I. H. FARMERS.

Notice is hereby given that the partnership heretofore subsisting between Paul Thomas Cover of 5 Melrose Avenue, Highton, carpenter of the one part and Jeffrey Robert Parker of 1 Thornbury Lane, Highton, carpenter of the other part carrying on business as contract carpenters and builders at 5 Melrose Avenue, Highton under the style or firm of P. T. Cover and J. R. Parker has been dissolved as from the 31st day of March, 1976.

Dated the 2nd day of April, 1976.

1546

PAUL THOMAS COVER.
JEFFREY ROBERT PARKER.

The partnership of Mr. J. A. Watts, Flat 1, 14 Bowe Street, Shepparton and Mrs. N. Kimmond, 27 Bradford Road, Shepparton, in Goulburn Valley Sewing Centres, 96 High Street, Shepparton, has been dissolved as at 30th April, 1976.

The business of Goulburn Valley Sewing Centres is being continued, with Mrs. N. Kimmond as sole proprietor. 1547

Notice is hereby given that the partnership heretofore subsisting between Robert Alan Jones and Sandra Fay Jones both of 15 Hickford Street, Reservoir and Reginald Charles Salter and Phyllis Jean Salter both of 4 Frank Street, Doncaster carrying on business as Milk Vendors has been dissolved as from the 2nd day of January, 1976, by the retirement of Phyllis Jean Salter from the said business shall be received and paid respectively by Robert day of January, 1976. All debts due and owing by the said business shall be received and paid respectively by Robert Alan Jones and Sandra Fay Jones who will continue to carry on the said business.

McGRATH & COLMAN, solicitors, of 2A Cheddar Road,
Reservoir. 1594

COSMIC INVESTMENTS PTY. LTD.

At an Extraordinary General Meeting of the abovenamed company duly convened and held at the office of H. & H. Guest & Associates Pty. Ltd., 207B Balaclava Road, Caulfield on the 12th May, 1976 the following Resolution was duly passed as a Special Resolution:

(1) That the company be wound up voluntarily.

(2) That Mr. John Durlacher, public accountant of 207B Balaclava Road, Caulfield be and is hereby appointed liquidator of the company.

Dated this 12th day of May, 1976.

1556

J. DURLACHER, Liquidator.

In the matter of the *Companies Act 1961* and in the matter of the following companies:—

PRESTON MOTORS (FOOTSCRAY) WHOLESALE PTY. LTD. (in Liquidation).

PRESTON MOTORS (COMMERCIAL SALES) PTY. LTD. (in Liquidation).

PRESTON MOTORS (MALVERN) PTY. LTD. (in Liquidation).

G. V. CLARKE (WHOLESALE) PTY. LTD. (in Liquidation).

PRESTON MOTORS (MORNINGTON) PTY. LTD. (in Liquidation).
Notice of Final Meeting of Members, Pursuant to Section 272.

Notice is hereby given in pursuance of section 272 of the *Companies Act 1961* that a General Meeting of the members of each of the above companies will be held at the office of Messrs. Coopers & Lybrand, 461 Bourke Street, Melbourne, on the 21st day of June, 1976, at 10.00 o'clock in the forenoon for the purpose of having an account laid before it showing the manner in which the winding up was conducted and the property of the company disposed of, and hearing any explanation that may be given by the liquidator.

Dated this 11th day of May, 1976.

1557 D. C. CHRISTENSEN, Liquidator.

In the matter of the *Companies Act 1961*; and in the matter of THE SOUTHERN CROSS ASSURANCE COMPANY (AUSTRALIA) LIMITED (in Voluntary Liquidation).—Notice of Final Meeting of Members, Pursuant to Section 272.

Notice is hereby given in pursuance of section 272 of the *Companies Act 1961* that a General Meeting of the members of the company will be held at the office of Messrs. Coopers & Lybrand, 461 Bourke Street, Melbourne, on the 21st day of June 1976, at 10.00 o'clock in the forenoon for the purpose of having an account laid before it showing the manner in which the winding up has been conducted and the property of the company disposed of, and hearing any explanation that may be given by the liquidator.

Dated this 13th day of May, 1976.

1558 R. W. BETTS, Liquidator.

In the matter of the *Companies Act 1961*; and in the matter of PEDIGREE DOLLS (AUST.) PTY. LIMITED (in Voluntary Liquidation) and RADCOATES PTY. LIMITED (in Voluntary Liquidation).—Notice of Final Meeting of Members, Pursuant to Section 272.

Notice is hereby given in pursuance of section 272 of the *Companies Act 1961* that a General Meeting of the members of each of the above companies will be held at the office of Messrs. Coopers & Lybrand, 461 Bourke Street, Melbourne, on the 21st day of June, 1976, at 10.00 o'clock in the forenoon for the purpose of having an account laid before it showing the manner in which the winding up has been conducted and the property of the company disposed of, and hearing any explanation that may be given by the liquidator.

Dated this 12th day of May, 1976.

1559 R. W. BETTS, Liquidator.

The *Companies Act 1961*.—In the matter of WILLOUGHBY CATERING SERVICE PTY. LTD.

At an Extraordinary General Meeting of the members of Willoughby Catering Service Pty. Ltd., duly convened and held at the Continental (Coves) Pty. Ltd. 5-6 The Esplanade, Cowes, Phillip Island, Vic. 3922, on Wednesday the 12th day of May, 1976, the following Special Resolution was duly passed:—

"That the company be and is hereby wound up voluntarily pursuant to the provisions of subdivision (2) of Division 3 Part X of the *Companies Act 1961* and that for the purpose of such winding up Adrian Douglas Cran of 16 Panorama Avenue, Lower Plenty, Vic., be appointed liquidator."

Notice is hereby given that after twenty-one days from this date I shall proceed to distribute the assets. All creditors having any claims against the company should furnish particulars of same by that date, otherwise I shall proceed to distribute the assets without regard to their claim.

Dated this 12th day of May, 1976.

A. D. CRAN, Liquidator.
16 Panorama Avenue, Lower Plenty, Vic., 3093. 1560

Companies Act 1961, Section 254 (2) (b).

RHUM PROPRIETARY LIMITED.

At a General Meeting of the Members of Rhum Proprietary Limited duly convened and held at the registered office, first floor, cnr. Scott and Thomas Streets, Dandenong on Monday, 26th April, 1976 the following Resolutions were duly passed as Special Resolutions:—

1. That the company be wound up voluntarily and that Trevor Burton Huttley be hereby appointed liquidator for the purpose of such winding up.

2. That pursuant to section 269 of the *Companies Act 1961* the liquidator be and is hereby authorised to exercise any of the powers given by paragraphs (b) (c) and (d) of section 236 of the *Companies Act 1961* to a liquidator in a winding up by the Court.

Dated this 4th day of May, 1976.

T. B. HUTTLEY, liquidator, 406 Lonsdale Street, Melbourne. 1561

Companies Act 1961.—In the matter of BINATANG PROPRIETARY LIMITED (in Liquidation).—Notice Convening Final Meeting of Members, Pursuant to Section 272.

Notice is hereby given pursuant to section 272 of the *Companies Act 1961*, that a General Meeting of members of the abovenamed company will be held at the offices of Taylor O'Connor & Co., 562 St. Kilda Road, Melbourne on Thursday 24th June, 1976 at 9.00 a.m. for the purpose of having an account laid before them showing the manner in which the winding-up has been conducted and the property of the company disposed of and of hearing any explanations that may be given by the liquidator.

Dated this 13th day of May, 1976.

B. J. O'CONNOR, Liquidator.

Taylor O'Connor & Co., 562 St. Kilda Road, Melbourne, 3004. 1562

Companies Act 1961.—In the matter of HOG INDUSTRIES PROPRIETARY LIMITED.—Notice Re Meeting of Creditors, Pursuant Section 260.

Notice is hereby given that a Meeting of Creditors of the abovenamed company will be held at the Meeting Room, Taylor O'Connor & Co., 562 St. Kilda Road, Melbourne on Thursday 3rd June, 1976 at 11.00 a.m. the company having convened a Meeting of its Members for the same day for the purpose of considering a Resolution that the company be wound up voluntarily.

Dated this 13th day of May, 1976.

P. A. HUBBARD, Director.

Taylor O'Connor & Co., 562 St. Kilda Road, Melbourne, 3004. 1563

The *Companies Act 1961*, Rule 99 and Regulation 56.—In the matter of RIALTO HOMES (CREDITS) PTY. LTD. (in Liquidation).

Take notice that the liquidator of the abovenamed company has fixed Friday, the 4th day of June, 1976 as the day on or before which creditors of the company are to prove their debts or claims and to establish any title they may have to priority under section 292 or be excluded from the benefit of a first and final dividend made before such debts are proved or as the case may be from objecting to such dividend.

Dated this 14th day of May, 1976.

EDWARD RONALD SMAIL, Liquidator.

Wallace McMullin & Smail, 499 St. Kilda Road, Melbourne 3004. 1630

Companies Act.—In the matter of WODONGA BORDER TRANSPORT PROPRIETARY LIMITED (in Voluntary Liquidation).—Members' Winding Up.

Notice is hereby given that pursuant to section 272 of the above Act the final General Meeting of the members of the company for the purpose of receiving the liquidator's account showing how the winding up has been conducted and how the property of the company has been disposed of, will be held at the office of Grant & Co. 108 Queen Street, Melbourne in the State of Victoria, on Wednesday the 16th day of June 1976 at 2.00 p.m.

Dated this 10th day of May, 1976.

E. H. NIEMANN, Liquidator.

Grant & Co., solicitors, 108 Queen Street, Melbourne, 3000. 1631

In the matter of the *Companies Act 1961*; and in the matter of H.E.B. HOLDINGS PTY. LTD. (in Liquidation).

Notice is hereby given that pursuant to section 272 of the *Companies Act 1961*, the Final Meeting of the members and creditors of the company will be held at 37 Queen Street, Melbourne, on the 29th day of June, 1976, at 11.30 a.m. for the purpose of laying before the meeting the account of the winding up and any explanation thereof.

Dated this 12th day of May, 1976.

1634

R. S. JAMES, Liquidator.

Companies Act 1961, Section 254.

BELLBROOK PROPRIETARY LIMITED.

Notice is hereby given that at an Extraordinary General Meeting of members of the abovenamed company held on 6th May, 1976, the following resolution was passed as a Special Resolution:—

“That this company be wound up as a members' voluntary liquidation and that Marjorie Blanche Stevens of 470 Bourke Street, Melbourne, be appointed liquidator.”

Dated this 13th day of May, 1976.

MARJORIE B. STEVENS, Liquidator.

Orr, Martin & Waters, chartered accountants, 470 Bourke Street, Melbourne, 3000. Telephone No. 67 6085. 1632

The *Companies Act 1961*.

C. J. McLENNAN & CO. PTY. LTD.

NOTICE OF VOLUNTARY LIQUIDATION.

At an extraordinary general meeting of C. J. McLennan & Co. Pty. Ltd., held at 443 Plenty Road Preston on the 30th day of April, 1976 the following special resolution was passed.

That the necessary action be taken for the voluntary winding up of the company.

1586

P. D. GILBERT, Liquidator.

The *Companies Act 1961*.

C.J. CONSTRUCTION CO. PTY. LTD.

NOTICE OF VOLUNTARY LIQUIDATION.

At an extraordinary general meeting of C.J. Construction Co. Pty. Ltd. held at 443 Plenty Road Preston on the 30th day of April, 1976 the following special resolution was passed.

That the necessary action be taken for the voluntary winding up of the company.

1587

P. D. GILBERT, Liquidator.

In the Supreme Court of Victoria.—1976 Co. 9328.—In the matter of the *Companies Act 1961*; and in the matter of TOWART DISTRIBUTION CO. PTY. LIMITED.

Notice is hereby given that a petition for the winding up of the abovenamed company by the Supreme Court was on the 29th day of April 1976 presented by Leo Thomas FitzGerald, Deputy Commissioner of Taxation of the Commonwealth of Australia and that the said petition is directed to be heard before the Court sitting at the Fourteenth Court, Law Courts, William Street, Melbourne at the hour of 10.30 o'clock in the forenoon on the 15th day of June 1976 and any creditor or contributory of the said company desiring to support or oppose the making of an order on the said petition may appear at the time of hearing by himself or his Counsel for the purpose; and a copy of the said petition will be furnished to any creditor or contributory of the said company requiring the same by the undersigned on payment of the regulated charge for the same.

The petitioner's official address is 350 Collins Street, Melbourne.

The petitioner's solicitor is Alan R. Neaves, Crown Solicitor for the Commonwealth of 99 Queen Street, Melbourne.

ALAN R. NEAVES.

NOTE.—Any person who intends to appear on the hearing of the said petition must serve on or send by post to the abovenamed Alan R. Neaves, notice in writing of his intention so to do. The notice must state the name and address of the person, or, if a firm, the name and address of the firm, and must be signed by the person or firm, or his, or their solicitor (if any), and must be served or, if posted, must be sent by post in sufficient time to reach the abovenamed not later than 4 o'clock in the afternoon of the 14th day of June 1976. 1617

In the Supreme Court of Victoria.—1976 Co. 9330.—In the matter of the *Companies Act 1961*; and in the matter of REGAL PUBLICATIONS PTY. LIMITED.

Notice is hereby given that a petition for the winding up of the abovenamed company by the Supreme Court was on the 29th day of April 1976 presented by Leo Thomas FitzGerald, Deputy Commissioner of Taxation of the Commonwealth of Australia and that the said petition is directed to be heard before the Court sitting at the Fourteenth Court, Law Courts, William Street, Melbourne at the hour of 10.30 o'clock in the forenoon on the 15th day of June 1976 and any creditor or contributory of the said company desiring to support or oppose the making of an order on the said petition may appear at the time of hearing by himself or his Counsel for the purpose; and a copy of the said petition will be furnished to any creditor or contributory of the said company requiring the same by the undersigned on payment of the regulated charge for the same.

The petitioner's official address is 350 Collins Street, Melbourne.

The petitioner's solicitor is Alan R. Neaves, Crown Solicitor for the Commonwealth of 99 Queen Street, Melbourne.

ALAN R. NEAVES.

NOTE.—Any person who intends to appear on the hearing of the said petition must serve on or send by post to the abovenamed Alan R. Neaves, notice in writing of his intention so to do. The notice must state the name and address of the person, or, if a firm, the name and address of the firm, and must be signed by the person or firm, or his, or their solicitor (if any), and must be served or, if posted, must be sent by post in sufficient time to reach the abovenamed not later than 4 o'clock in the afternoon of the 14th day of June 1976. 1618

In the Supreme Court of Victoria.—1976 Co. 9329.—In the matter of the *Companies Act 1961*; and in the matter of NEWTON COMICS (AUST.) PTY. LTD.

Notice is hereby given that a petition for the winding up of the abovenamed company by the Supreme Court was on the 29th day of April 1976 presented by Leo Thomas FitzGerald, Deputy Commissioner of Taxation of the Commonwealth of Australia and that the said petition is directed to be heard before the Court sitting at the Fourteenth Court, Law Courts, William Street, Melbourne at the hour of 10.30 o'clock in the forenoon on the 15th day of June 1976 and any creditor or contributory of the said company desiring to support or oppose the making of an order on the said petition may appear at the time of hearing by himself or his Counsel for the purpose; and a copy of the said petition will be furnished to any creditor or contributory of the said company requiring the same by the undersigned on payment of the regulated charge for the same.

The petitioner's official address is 350 Collins Street, Melbourne.

The petitioner's solicitor is Alan R. Neaves, Crown Solicitor for the Commonwealth of 99 Queen Street, Melbourne.

ALAN R. NEAVES.

NOTE.—Any person who intends to appear on the hearing of the said petition must serve on or send by post to the abovenamed Alan R. Neaves, notice in writing of his intention so to do. The notice must state the name and address of the person, or, if a firm, the name and address of the firm, and must be signed by the person or firm, or his, or their solicitor (if any), and must be served or, if posted, must be sent by post in sufficient time to reach the abovenamed not later than 4 o'clock in the afternoon of the 14th day of June 1976. 1619

In the Supreme Court of Victoria.—1976 Co. 9331.—In the matter of the *Companies Act 1961*; and in the matter of OPTIMUS HOLDINGS PTY. LIMITED.

Notice is hereby given that a petition for the winding up of the abovenamed company by the Supreme Court was on the 29th day of April 1976 presented by Leo Thomas FitzGerald, Deputy Commissioner of Taxation of the Commonwealth of Australia and that the said petition is directed to be heard before the Court sitting at the Fourteenth Court, Law Courts, William Street, Melbourne at the hour of 10.30 o'clock in the forenoon on the 15th day of June 1976 and any creditor or contributory of the said company desiring to support or oppose the making of an order on the said petition may appear at the time of hearing by himself or his Counsel for the purpose; and a copy of

the said petition will be furnished to any creditor or contributory of the said company requiring the same by the undersigned on payment of the regulated charge for the same.

The petitioner's official address is 350 Collins Street, Melbourne.

The petitioner's solicitor is Alan R. Neaves, Crown Solicitor for the Commonwealth of 99 Queen Street, Melbourne.

ALAN R. NEAVES.

NOTE.—Any person who intends to appear on the hearing of the said petition must serve on or send by post to the abovenamed Alan R. Neaves, notice in writing of his intention so to do. The notice must state the name and address of the person, or, if a firm, the name and address of the firm, and must be signed by the person or firm, or his, or their solicitor (if any), and must be served or, if posted, must be sent by post in sufficient time to reach the abovenamed not later than 4 o'clock in the afternoon of the 14th day of June 1976. 1620

In the Supreme Court of Victoria.—1976 Co. 9336.—In the matter of the *Companies Act 1961*; and in the matter of ALERA CO. PTY. LTD.

Notice is hereby given that a petition for the winding up of the abovenamed company by the Supreme Court was on the 4th day of May 1976 presented by Leo Thomas FitzGerald, Deputy Commissioner of Taxation of the Commonwealth of Australia and that the said petition is directed to be heard before the Court sitting at the Fourteenth Court, Law Courts, William Street, Melbourne at the hour of 10.30 o'clock in the forenoon on the 15th day of June 1976 and any creditor or contributory of the said company desiring to support or oppose the making of an order on the said petition may appear at the time of hearing by himself or his Counsel for the purpose; and a copy of the said petition will be furnished to any creditor or contributory of the said company requiring the same by the undersigned on payment of the regulated charge for the same.

The petitioner's official address is 350 Collins Street, Melbourne.

The petitioner's solicitor is Alan R. Neaves, Crown Solicitor for the Commonwealth of 99 Queen Street, Melbourne.

ALAN R. NEAVES.

NOTE.—Any person who intends to appear on the hearing of the said petition must serve on or send by post to the abovenamed Alan R. Neaves, notice in writing of his intention so to do. The notice must state the name and address of the person, or, if a firm, the name and address of the firm, and must be signed by the person or firm, or his, or their solicitor (if any), and must be served or, if posted, must be sent by post in sufficient time to reach the abovenamed not later than 4 o'clock in the afternoon of the 14th day of June 1976. 1621

Companies Act 1971.

OLAVOT PROPRIETARY LIMITED.

NOTICE OF MEETING.

Section 206. (3) (4).

Notice is hereby given of a Meeting of Creditors of Olavot Proprietary Limited to be held at the Institute of Chartered Accountants Meeting Room, 140 Queen Street, Melbourne on the 31st day of May, 1976, at 11.00 a.m. for the purpose of considering and if thought fit, passing the following resolution:—

"That the Company be wound up voluntarily."

"That paragraph (c) of section 277A (1) shall not apply to the winding up of the company."

1585

E. P. TAYLOR, Official Manager.

LINDFIELD PROPRIETARY LIMITED.

Notice is hereby given, pursuant to section 254 (2) (b) of the *Companies Act 1961*, that at an Extraordinary General Meeting of members of Lindfield Proprietary Limited, duly convened and held at 106 Elizabeth Street, Melbourne on Monday the 10th day of May, 1976, the special resolution set out below was duly passed—

That the company be wound up voluntarily and that Bruce Etherington of 1st Floor, 450 Little Collins Street, Melbourne, chartered accountant, be and is hereby appointed as liquidator for the purposes of such winding up.

Dated this 10th day of May, 1976.

1629

B. ETHERINGTON, Liquidator.

COMPANIES ACT 1961, SECTION 254.

Notice is hereby given that at an Extraordinary General Meeting of Delphic Stores Pty. Limited held on the 2nd day of April 1976 it was resolved as a special resolution that the said Delphic Stores Pty. Limited be wound up voluntarily.

ELLISON, HEWISON & WHITEHEAD, 379 Collins Street, Melbourne, solicitors for the company. 1633

Companies Act 1961, as Amended.—Section 260 (1).—In the matter of VERACITY AUDIO PROPRIETARY LIMITED.—Notice of Meeting of Creditors.

Notice is hereby given that pursuant to section 260 (1) of the *Companies Act 1961*, as amended, a meeting of creditors of Veracity Audio Proprietary Limited will be held at 10th Floor, 271 William Street, Melbourne on the 27th day of May, 1976 at 10.30 a.m. the company having convened a meeting of its members for the same day for the purpose of considering a special resolution that the company be wound up voluntarily.

Dated this 19th day of May, 1976.

GUDRUN ASHCROFT, Secretary.

Wilson, Bishop, Bowes & Craig, chartered accountants, 271 William Street, Melbourne, 3000, telephone 67 7372.

1604

The *Companies Act 1961.*

THE FLASH STUDIO PTY. LIMITED (IN LIQUIDATION).

NOTICE CONVENING FINAL MEETING OF MEMBERS AND CREDITORS PURSUANT TO SECTION 272.

Notice is hereby given in pursuance of section 272 of the *Companies Act 1961* that a Meeting of the Members and Creditors of the abovenamed Company will be held on the 11th day of June, 1976, at the offices of The Institute of Chartered Accountants, 140 Queen Street, Melbourne at 10.00 a.m. for the purpose of having an account laid before them showing the manner in which the winding up has been conducted and the property of the company disposed of and of hearing any explanations that may be given by the liquidators.

Dated this 10th day of May, 1976.

J. P. GRANT AND D. L. NICHOLL, joint liquidators, 3rd Floor, 470 Bourke Street, Melbourne. 1616

The *Companies Act 1961.*—In the matter of STARQUEEN HATCHERY PTY. LIMITED (in Liquidation).—Members' Winding Up.—Notice of Final Meeting of Members.

Notice is hereby given that pursuant to section 272 of the *Companies Act 1961*, a final meeting of the abovenamed company will be held at the offices of Parkhill, Lithgow & Gibson, chartered accountants, 8th Floor, 500 Collins Street, Melbourne on the 18th June, 1976, at 10.00 a.m. for the purpose of laying before the meeting an account showing how the winding up has been conducted, and how the assets have been disposed of.

Dated this 14th day of May, 1976.

1625

J. D. ADAMS, Liquidator.

Companies Act 1961.

BOOLA ENTERPRISES PROPRIETARY LIMITED (IN VOLUNTARY LIQUIDATION).

Notice is hereby given that in pursuance of section 272 of the *Companies Act 1961* a General Meeting of the company will be held at the offices of Morton, Watson & Young, chartered accountants, 1st Floor, 406 Lonsdale Street, Melbourne, on Friday, 25th June, 1976, at 4 p.m. for the purpose of receiving the liquidator's final account of the winding-up of the company.

Dated this 14th day of May, 1976.

1626

C. T. YOUNG, Liquidator.

The *Companies Act 1961.*—In the matter of VISION INDUSTRIES PTY. LTD. (in Liquidation).

Notice is hereby given pursuant to section 272 (1) of the *Companies Act 1961* that a meeting of the company and the creditors of the company will be held at the office of Scree, Nixon, Watt & Co., 10th Floor, 257 Collins Street, Melbourne, on Monday, the 21st day of June 1976, at 10.00 o'clock in the forenoon for the purpose of having an account laid before it, showing the manner in which the winding up has been conducted and the property of the company disposed of, and of hearing any explanation that may be given by the liquidator.

Dated this 13th day of May, 1976.

R. J. SICREE, Liquidator, 38 Walsh Street, Melbourne.

1648

Companies Act 1961.

HOME PRIDE BAKERIES (KILSYTH) PTY. LTD.
HOME PRIDE FOODS PTY. LTD.
HOME PRIDE BAKERY (CASTLEMAINE) PTY. LTD.
HOME PRIDE BAKERY (EUROA) PTY. LTD.
CRANBOURNE BAKERIES PTY. LTD.
CHERRY'S BAKERY PTY. LTD.
ROSEBUD BAKERY PTY. LTD.
WONTHAGGI BAKERY PTY. LTD.

MEMBERS' VOLUNTARY WINDING UP SECTION 254.

The following special resolution was duly passed by the Meetings of above named companies held on the 5th day of May 1976.

"That the company would be wound up as a members' voluntary liquidation and that Warick Allen Leeming be appointed liquidator."

WARICK ALLEN LEEMING, Liquidator.

Duesbury, Johnston & Marks, 446 Collins Street, Melbourne, Vic., 3000. 1635

In the Supreme Court of Victoria.—1976 No. Co. 9311.—
In the matter of the *Companies Act 1961*; and in the matter of C. C. & B. J. MCADAM PROPRIETARY LIMITED.

Notice is hereby given that a petition for the winding up of the abovenamed company by the Supreme Court was on the 6th day of April 1976 presented by Provincial Traders Proprietary Limited and that the said petition is directed to be heard before the Court sitting at Law Courts William Street Melbourne at the hour of 10.30 o'clock in the forenoon on Friday the 18th day of June 1976 and any creditor or contributory of the said company desiring to support or oppose the making of an order on the said petition may appear at the time of hearing by himself or his counsel for that purpose; and a copy of the petition will be furnished to any creditor or contributory of the said company requiring the same by the undersigned on payment of the regulated charge for the same.

The petitioner's registered office is situated at Murarrie Road, Murarrie, Brisbane in the State of Queensland.

The petitioner's solicitors are Messrs. Blake & Riggall of 140 William Street, Melbourne in the State of Victoria.

BLAKE & RIGGALL.

NOTE.—Any person who intends to appear on the hearing of the said Petition must serve on or send by post to the abovenamed Messrs. Blake & Riggall notice in writing of his intention to do so. The Notice must state the name and address of the person, or, if a firm, the name and address of the firm, and must be signed by the person or firm, or his or their solicitor (if any), and must be served, or, if posted, must be sent by post in sufficient time to reach the abovenamed not later than Four o'clock in the afternoon of the 17th day of June, 1976. 1627

In the Supreme Court of Victoria.—1976 No. Co. 9345.—
In the matter of the *Companies Act 1961*; and in the matter of BRUMER INVESTMENTS PROPRIETARY LIMITED.

Notice is hereby given that a petition for the winding up of the abovenamed company by the Supreme Court was on the 12th day of May 1976 presented by Maurice Brumer. And that the said Petition is directed to be heard before the Court sitting at the Fourteenth Court, Law Courts, William Street, Melbourne on the 23rd day of June 1976 at the hour of 10.30 o'clock in the forenoon; and any creditor or contributory of the said company desiring to support or oppose the making of an Order on the said Petition may appear at the time of hearing by himself or his Counsel for that purpose; and a copy of the Petition will be furnished to any creditor or contributory of the said company requiring the same by the undersigned on payment of the regulated charge for the same.

The petitioner's address is 58 Blamey Street, East Bentleigh.

The petitioner's solicitors are Alan Wainwright & Co., of 397 Little Collins Street, Melbourne.

ALAN WAINWRIGHT & CO.

NOTE.—Any person who intends to appear on the hearing of the said Petition must serve on or send by post to the abovenamed solicitors, notice in writing of his intention so to do. The notice must state the name and address of the person, or, if a firm, the name and address of the firm, and must be signed by the person or firm, or his or their solicitor (if any) and must be served, or, if posted, must be sent by post in sufficient time to reach the abovenamed not later than 4 o'clock in the afternoon of the 22nd day of June, 1976. 1628

The *Companies Act 1961*.—In the matter of BALMORAL TEXTILES (N.S.W.) PTY. LTD. (in Liquidation).

Notice is hereby given pursuant to section 272 (1) of the *Companies Act 1961* that a meeting of the company and the creditors of the company will be held at the office of Sicree, Nixon, Watt & Co., 10th Floor, 257 Collins Street, Melbourne, on Monday, the 21st day of June 1976, at 10.45 o'clock in the forenoon for the purpose of having an account laid before it, showing the manner in which the winding up has been conducted and the property of the company disposed of, and of hearing any explanation that may be given by the liquidator.

Dated this 13th day of May, 1976.

R. J. SICREE, Liquidator, 38 Walsh Street, Melbourne. 1651

The *Companies Act 1961*.—In the matter of BALMORAL TEXTILES (AUST.) PTY. LTD. (in Liquidation).

Notice is hereby given pursuant to section 272 (1) of the *Companies Act 1961* that a meeting of the company and the creditors of the company will be held at the office of Sicree, Nixon, Watt & Co., 10th Floor, 257 Collins Street, Melbourne, on Monday, the 21st day of June 1976, at 11.00 o'clock in the forenoon for the purpose of having an account laid before it, showing the manner in which the winding up has been conducted and the property of the company disposed of, and of hearing any explanation that may be given by the liquidator.

Dated this 13th day of May, 1976.

R. J. SICREE, Liquidator, 38 Walsh Street, Melbourne. 1652

The Companies Act 1961.

J. W. M. & J. M. PORTER INVESTMENTS PTY. LTD.

Notice is hereby given pursuant to section 254 (2) (b) of the *Companies Act 1961* that at a duly convened meeting of the members of J. W. M. & J. M. Porter Investments Pty. Ltd. held on 14th May, 1975 the following resolution was passed as a Special Resolution:—

"That the company be wound up voluntarily, and that Eric Ronald Markham of the firm of Markham, Crane & Associates, public accountants, of 33 Melrose Street, Sandringham be and is hereby appointed liquidator.

1653

E. R. MARKHAM, Liquidator.

In the matter of MOOLPA PASTORAL CO. (in Liquidation); and in the matter of the *Companies Act 1961*.

Notice is hereby given that at a meeting of the members of Moolpa Pastoral Co. Pty. Limited held on 3 May 1976 the following resolutions were passed as special resolutions:

"That the company be wound up voluntarily."

"That the liquidator may divide among the contributories in specie any part of the assets of the company."

"That Messrs. Gavin John Hosking and Peter William Harvey be appointed to act jointly and severally as liquidator for the purpose of the winding-up."

GAVIN JOHN HOSKING, Liquidator.

PETER WILLIAM HARVEY, Liquidator.

Care of Price Waterhouse & Co., 8th Floor, National Mutual Centre, 447 Collins Street, Melbourne, Vic., 3000.

1655

Form 46.

Companies Act 1961, Section 140 (7).

COPY OF MINUTE BY REPRESENTATIVE OF HOLDING COMPANY RELATING TO PROCEEDINGS OF SUBSIDIARY COMPANY.

JAY-CEE POTATO CHIPS PTY. LIMITED.

To the Registrar of Companies.

On the twenty ninth day of April 1976 the minute of Jay-Cee Potato Chips Pty. Limited set out below was signed by Richard Charles Crebbin, the representative of Marrickville Holdings Limited authorised pursuant to subsection (3) of section 140 of the *Companies Act 1961*.

Resolved as a Special Resolution.

"That the company be wound up voluntarily and that Mr. Robert R. Smith of Messrs. O. W. Parkinson & Son, chartered accountants, 450 Little Collins Street, Melbourne be and is hereby appointed the liquidator for the purpose of such winding up."

Dated this 29th day of April, 1976.

R. C. CREBBIN, Director of Marrickville Holdings Limited. 1648

The Companies Act 1961.—In the matter of VLADOFF PTY. LIMITED.—Notice Re Meeting of Creditors, Pursuant to Section 260.

Notice is hereby given that a meeting of Creditors of the abovenamed company will be held at the Alibond Room, 7th Floor, V.A.C.C. Building, 464 St. Kilda Road, Melbourne at 11.00 a.m. on the 28th day of May, 1976, the company having convened a meeting of its members for the same day for the purpose of considering a Resolution that the company be wound up voluntarily.

Dated this 14th day of May, 1976.

1636

N. ZAKRYSZKA, Director.

In the Supreme Court of Victoria.—1976 Co. 9337.—In the matter of the Companies Act 1961; and in the matter of SUNRAYSA SHEARING COMPANY PROPRIETARY LIMITED.

Notice is hereby given that a petition for the winding up of the abovenamed company by the Supreme Court was on the 4th day of May 1976 presented by Leo Thomas FitzGerald, Deputy Commissioner of Taxation of the Commonwealth of Australia and that the said petition is directed to be heard before the Court sitting at the Fourteenth Court, Law Courts, William Street, Melbourne at the hour of 10.30 o'clock in the forenoon on the 15th day of June 1976 and any creditor or contributory of the said company desiring to support or oppose the making of an order on the said petition may appear at the time of hearing by himself or his Counsel for the purpose; and a copy of the said petition will be furnished to any creditor or contributory of the said company requiring the same by the undersigned on payment of the regulated charge for the same.

The petitioner's official address is 350 Collins Street, Melbourne.

The petitioner's solicitor is Alan R. Neaves, Crown Solicitor for the Commonwealth of 99 Queen Street, Melbourne.

ALAN R. NEAVES.

NOTE.—Any person who intends to appear on the hearing of the said petition must serve on or send by post to the abovenamed Alan R. Neaves, notice in writing of his intention so to do. The notice must state the name and address of the person, or, if a firm, the name and address of the firm, and must be signed by the person or firm, or his, or their solicitor (if any), and must be served or, if posted, must be sent by post in sufficient time to reach the abovenamed not later than 4 o'clock in the afternoon of the 14th day of June 1976.

1622

In the Supreme Court of Victoria.—1976 Co. 9335.—In the matter of the Companies Act 1961; and in the matter of JOHN HYSLOP REALTY PTY. LIMITED.

Notice is hereby given that a petition for the winding up of the abovenamed company by the Supreme Court was on the 4th day of May 1976 presented by Leo Thomas FitzGerald, Deputy Commissioner of Taxation of the Commonwealth of Australia and that the said petition is directed to be heard before the Court sitting at the Fourteenth Court, Law Courts, William Street, Melbourne at the hour of 10.30 o'clock in the forenoon on the 15th day of June 1976 and any creditor or contributory of the said company desiring to support or oppose the making of an order on the said petition may appear at the time of hearing by himself or his Counsel for the purpose; and a copy of the said petition will be furnished to any creditor or contributory of the said company requiring the same by the undersigned on payment of the regulated charge for the same.

The petitioner's official address is 350 Collins Street, Melbourne.

The petitioner's solicitor is Alan R. Neaves, Crown Solicitor for the Commonwealth of 99 Queen Street, Melbourne.

ALAN R. NEAVES.

NOTE.—Any person who intends to appear on the hearing of the said petition must serve on or send by post to the abovenamed Alan R. Neaves, notice in writing of his intention so to do. The notice must state the name and address of the person, or, if a firm, the name and address of the firm, and must be signed by the person or firm, or his, or their solicitor (if any), and must be served or, if posted, must be sent by post in sufficient time to reach the abovenamed not later than 4 o'clock in the afternoon of the 14th day of June 1976.

1623

In the Supreme Court of Victoria.—1976 Co. 9334.—In the matter of the Companies Act 1961; and in the matter of CARBUL 4 PTY. LTD.

Notice is hereby given that a petition for the winding up of the abovenamed company by the Supreme Court was on the 4th day of May 1976 presented by Leo Thomas FitzGerald, Deputy Commissioner of Taxation of the Commonwealth of Australia and that the said petition is directed to be heard before the Court sitting at the Fourteenth Court, Law Courts, William Street, Melbourne at the hour of 10.30 o'clock in the forenoon on the 15th day of June 1976 and any creditor or contributory of the said company desiring to support or oppose the making of an order on the said petition may appear at the time of hearing by himself or his Counsel for the purpose; and a copy of the said petition will be furnished to any creditor or contributory of the said company requiring the same by the undersigned on payment of the regulated charge for the same.

The petitioner's official address is 350 Collins Street, Melbourne.

The petitioner's solicitor is Alan R. Neaves, Crown Solicitor for the Commonwealth of 99 Queen Street, Melbourne.

ALAN R. NEAVES.

NOTE.—Any person who intends to appear on the hearing of the said petition must serve on or send by post to the abovenamed Alan R. Neaves, notice in writing of his intention so to do. The notice must state the name and address of the person, or, if a firm, the name and address of the firm, and must be signed by the person or firm, or his, or their solicitor (if any), and must be served or, if posted, must be sent by post in sufficient time to reach the abovenamed not later than 4 o'clock in the afternoon of the 14th day of June 1976.

1624

The Companies Act 1961.—In the matter of BALMORAL TEXTILES (QLD.) PTY. LTD. (in Liquidation).

Notice is hereby given pursuant to section 272 (1) of the Companies Act 1961 that a meeting of the company and the creditors of the company will be held at the office of Scree, Nixon, Watt & Co., 10th Floor, 257 Collins Street, Melbourne, on Monday, the 21st day of June 1976, at 10.15 o'clock in the forenoon for the purpose of having an account laid before it, showing the manner in which the winding up has been conducted and the property of the company disposed of, and of hearing any explanation that may be given by the liquidator.

Dated this 13th day of May, 1976.

R. J. SICREE, Liquidator, 38 Walsh Street, Melbourne.

1649

In the matter of WINBAR PTY. LIMITED (in Liquidation); and in the matter of the Companies Act 1961.

Notice is hereby given that at a meeting of the members of Winbar Pty. Limited held on 3 May 1976 the following resolutions were passed as special resolutions:

"That the company be wound up voluntarily."

"That the liquidator may divide among the contributories in specie any part of the assets of the company."

"That Messrs. Gavin John Hosking and Peter William Harvey be appointed to act jointly and severally as liquidator for the purpose of the winding-up."

GAVIN JOHN HOSKING, Liquidator.

PETER WILLIAM HARVEY, Liquidator.

Care of Price Waterhouse & Co., 8th Floor, National Mutual Centre, 447 Collins Street, Melbourne, Vic., 3000.

1666

The Companies Act 1961.—In the matter of BALMORAL TEXTILES (VIC.) PTY. LTD. (in Liquidation).

Notice is hereby given pursuant to section 272 (1) of the Companies Act 1961 that a meeting of the company and the creditors of the company will be held at the office of Scree, Nixon, Watt & Co., 10th Floor, 257 Collins Street, Melbourne, on Monday, the 21st day of June 1976, at 10.30 o'clock in the forenoon for the purpose of having an account laid before it, showing the manner in which the winding up has been conducted and the property of the company disposed of, and of hearing any explanation that may be given by the liquidator.

Dated this 13th day of May, 1976.

R. J. SICREE, Liquidator, 38 Walsh Street, Melbourne.

1650

The Companies Act 1961.

TOMKINS HOLDINGS PTY. LTD. (IN LIQUIDATION).

NOTICE CONVENING FINAL MEETING OF MEMBERS AND CREDITORS, PURSUANT TO SECTION 272.

Notice is hereby given pursuant to section 272 of the Companies Act 1961, that a general meeting of the members and creditors of the abovenamed company will be held on the 21st day of June, 1976, at 10.30 o'clock in the forenoon at the office of Neville Bird, Davies & Co., chartered accountants, 289 Flinders Lane, Melbourne.

Agenda.

1. To lay before the meeting an account showing the manner in which the winding up has been conducted and the property of the company disposed of and of hearing any explanation that may be given by the liquidator.

2. To consider and if thought fit, pass a special resolution that all the books and papers of the company and of the liquidator shall be destroyed after three months of the holding of the final meeting or upon dissolution of the company whichever shall last occur.

Dated this 19th day of May, 1976.

NEVILLE BIRD, Liquidator.

Neville Bird, Davies & Co., chartered accountants, 289 Flinders Lane, Melbourne, 3000. Telephone 63 2874. 1662

The Companies Act 1961.

LITCHFIELD INVESTMENTS PTY. LTD. (IN VOLUNTARY LIQUIDATION).

Notice is hereby given, pursuant to section 272 of the Companies Act, that the affairs of the company have been fully wound up and that a final meeting of members will be held at 5 Yarravale Road, Kew on 23rd June, 1976 at 8 p.m. for the purpose of laying before it an account showing how the winding up has been conducted and the property of the company has been disposed of and giving any explanation thereof.

Dated this 14th day of May, 1976.

J. F. G. DARBY, Liquidator.

Molomby & Molomby, 459 Collins Street, Melbourne, 3000. 1663

The Companies Act 1961.

PORT PHILLIP MARINE PROPRIETARY LIMITED (IN LIQUIDATION).

NOTICE CONVENING FINAL MEETING OF MEMBERS AND CREDITORS PURSUANT TO SECTION 272.

Notice is hereby given pursuant to section 272 of the Companies Act 1961, that a General Meeting of the members and creditors of the abovenamed company will be held in the offices of Wallace, McMullin & Small, 499 St. Kilda Road, Melbourne, 3004, on Wednesday the sixteenth day of June, 1976, at 11 a.m., for the purpose of having an account laid before them showing the manner in which the winding up has been conducted and the property of the company disposed of and of hearing any explanations that may be given by the liquidator.

Dated this 13th day of May, 1976.

1657 EDWARD RONALD SMAIL, Liquidator.

Companies Act 1961.—In the matter of PRADSTAFF PTY. LTD. (in Liquidation).—Notice of Meeting of Creditors, Pursuant to Section 261 (5).

Notice is hereby given that a meeting of the creditors of the abovenamed company will be held pursuant to section 261 (5) of the Companies Act to appoint a liquidator of the company following the vacancy caused by the death of the former liquidator Mr. Lewis Luckins. The meeting will be held at the office of Lewis Luckins & Co. 6th Floor, 423 Bourke Street, Melbourne, on Wednesday, 26th May, 1976, at 2.15 p.m.

Dated this 18th day of May, 1976.

P. J. MANN,
WATERS, GRANT & CO.

Lewis Luckins & Co., 423 Bourke Street, Melbourne, 3000, telephone 67 6944. 1658

Companies Act 1961.—In the matter of NOBLE MOTEL PTY. LTD. (in Liquidation).—Notice of Meeting of Contributors, Pursuant to Section 258 (3).

Notice is hereby given that a meeting of the contributors of the abovenamed company will be held pursuant to section 258 (3) of the Companies Act to appoint a liquidator of the company following the vacancy caused by

the death of the former liquidator Mr. Lewis Luckins. The meeting will be held at the office of Lewis Luckins & Co. 6th Floor, 423 Bourke Street, Melbourne, on Wednesday, 26th May, 1976, at 3.45 p.m.

Dated this 18th day of May, 1976.

LIEUT.-GENERAL R. BIERWIRTH.

Lewis Luckins & Co., 6th Floor, 423 Bourke Street, Melbourne, 3000, telephone 67 6944. 1659

Companies Act 1961.

NEULYNE ENGINEERING PTY. LTD. (IN LIQUIDATION).

NOTICE OF INTENTION TO DECLARE A FIRST DIVIDEND.

Notice is hereby given that as liquidator of the abovenamed company I Leslie Philip Smart, chartered accountant of Marquand & Co., 51 Queen Street, Melbourne, 3000, intend to declare a First Dividend in this matter.

Creditors must prove their debts by 4th June, 1976.

Dated at Melbourne this 14th day of May, 1976.

1660

L. P. SMART, Liquidator.

Companies Act 1961.—In the matter of APEX HEATING PTY. LTD.—Notice Re Meeting of Creditors, Pursuant to Section 260.

Notice is hereby given that a meeting of creditors of the abovenamed company will be held at the Board Room, Institute of Chartered Accountants, 140 Queen Street, Melbourne, at 10.30 a.m. on the 16th day of June 1976 the company having convened a meeting of its members for the same day for the purpose of considering a Resolution that the company be wound up voluntarily.

Dated this 19th day of May, 1976.

N. D. OGDEN, Director.

Neville Bird, Davies & Co., chartered accountants, 289 Flinders Lane, Melbourne, telephone 63 2874. 1661

Companies Act 1961.

E. V. DEE PTY. LTD. (IN LIQUIDATION).

MEMBERS' VOLUNTARY WINDING UP, SECTION 254.

Notice is hereby given that pursuant to S.272 of the Companies Act 1961, the final meeting of members of the above named company will be held at 446 Collins Street, Melbourne on 28th of June 1976 for the purpose of receiving the liquidator's account and his report upon the winding up.

Dated this 18th day of May, 1976.

1664

K. F. COURTNEY, Liquidator.

ERNEST BIDDINGTON, late of 102 Ascot Street South, Ballarat, retired engineer, DECEASED.

Creditors, next of kin and others having claims in respect of the estate of the deceased who died on the 15th day of December 1975 are required to send particulars of their claims to The Union-Fidelity Trustee Company of Australia Limited to its registered office at 101 Lydiard Street North, Ballarat by the 31st day of July 1976 after which date it may convey or distribute the assets having regard only to the claims of which it then has notice.

D. & A. ARONSON, solicitors, of 104 Lydiard Street South, Ballarat. 1583

Creditors, next-of-kin and others having claims against the estate of John Francis Carroll late of 7 Sunnyside Avenue Camberwell in the State of Victoria solicitor deceased who died on the fourth day of June 1975 are to send particulars of their claims to the executors, Marjorie Elsie Carroll, Patricia Mary Carroll and John Andrew Carroll, care of the undersigned solicitor before the 31st day of July 1976 after which date the executors will distribute the assets of the estate having regard only to the claims of which they then have notice.

JOHN F. CARROLL, solicitor, 95 Queen Street, Melbourne. 1596

ELIZABETH ELLEN DAWSON, formerly of Fisheries Road, Clyde, in the State of Victoria, but late of 190 Forest Road, Boronia in the said State, widow, DECEASED.

Creditors, next of kin and others having claims in respect of the estate of the abovenamed deceased who died on the seventh day of March, 1976 are required by The Perpetual Executors and Trustees Association of Australia Limited of 50 Queen Street, Melbourne, to send particulars of their claims to the said company by the twenty-seventh day of July, 1976 after which date it will convey or distribute the assets, having regard only to the claims of which the company then has notice.

READ & READ, solicitors, 422 Collins Street, Melbourne. 1597

RE MURIEL LUISE GWYTHYR, late of 1 Bruce Street, Box Hill, in the State of Victoria, widow, DECEASED, who died on the 21st day of December, 1975.

Creditors next of kin and all persons having claims against the estate of the above-named are required by the executors of the will William James Gwyther of 76 Manchester Road Mooroolbark in the said State computer centre manager and Roy Davison Birdsey of 166A Ryrie Street Geelong in the said State solicitor to send particulars to them care of the under-mentioned solicitors on or before the twenty-eighth day of July 1976 after which date they will distribute the assets having regard only to the claims of which they then have notice.

BIRDSEY, DEDMAN & BARTLETT, solicitors, of 166A Ryrie Street, Geelong. 1548

CHARLOTTE ELIZABETH SUTTON, late of 20 Donnington Street, Swan Hill, in the State of Victoria, widow, DECEASED.

Creditors, next of kin, and others having claims in respect of the estate of the deceased (who died on the 13th day of January, 1976) are required by the Executors, Clarence Herbert Sutton of 109 Chapple Street, Wodonga, John Joseph Sutton of 125 Queen Street, Bendigo, and Leslie Arthur Luke of Swan Hill, to send particulars to them care of the undersigned by the 27th day of July, 1976, after which date the Executors may convey or distribute the assets, having regard only to the claims of which they then shall have notice.

HAYES (ALEC M.) & MCINERNEY, solicitors, 148 Campbell Street, Swan Hill. 1549

Creditors next of kin and others having claims against the estate of Ruby May Jane Williams formerly of 1328 High Street, Malvern late of Parkview Private Hospital, 82 Burke Road, East Malvern in the State of Victoria, widow, deceased, who died on the 18th day of September, 1975 are required by William Patrick Melville of 224 Glenferrie Road, Malvern aforesaid, solicitor, the executor of the will of the said deceased, to send particulars of their claims to the said executor care of the undermentioned solicitors by the 19th day of July, 1976, after which date the executor will convey or distribute the estate of the said deceased having regard only to the claims of which he then has notice.

MELVILLE & MELVILLE, solicitors, of 224 Glenferrie Road, Malvern. 1550

ERIC JAMES LOWE, late of Ultima in the State of Victoria, postmaster, DECEASED (who died on 1st March, 1976).

Creditors next-of-kin and all other persons having claims against the estate of the deceased are required by the executrix of the will, Elsa Maree Lowe, to send particulars to her care of the undersigned on or before the 14th day of July 1976 after which date she will distribute the assets having regard only to the claims of which she then has notice.

GARDEN & GREEN, solicitors, 4 McCallum Street, Swan Hill. 1551

ETHEL MARY PEACE, late of Cohuna, in the State of Victoria, widow, DECEASED.

Creditors next of kin and all other persons having claims against the estate of the said deceased are required by Regina Ethel McKinnon married woman of Pyramid Hill in the said State the administratrix of the estate of the said deceased to send particulars of such claims to her in care of the undermentioned solicitors on or before the tenth day of July 1976 after which date they will distribute the assets having regard only to the claims of which they then have notice.

BASILE & CO., solicitors, 46 Wellington Street, Kerang. 1598

Creditors, next-of-kin and others having claims in respect of the estate of Maud Graham late of Flat 42, 18 Cochrane Street, North Brighton, widow deceased who died on the 4th December, 1975 are required by the executor, John Hampden Crutch, manager of The Equity Trustees' Executors and Agency Company Limited of 472 Bourke Street, Melbourne to send particulars of their claims to him care of the undermentioned solicitors by the 22nd July, 1976 after which date they will convey or deal with the assets having regard only to the claims of which they then have notice.

PETER C. NEIL, of 49 Drummond Street, Carlton. 1599

BRIDGET PHILOMENA O'SHEA, late of 48 Reeve Street, Sale, in the State of Victoria, home duties, DECEASED.

Creditors, next-of-kin and others having claims in respect of the estate of Bridget Philomena O'Shea late of 48 Reeve Street, Sale in the State of Victoria home duties deceased, who died on the sixth day of May One thousand nine hundred and sixty-seven are required to send particulars of their claims to The Union-Fidelity Trustee Company of Australia Limited of 100 Exhibition Street, Melbourne by the first day of August One thousand nine hundred and seventy-six after which date it will distribute the assets having regard only to the claims of which it then has notice.

Dated the 19th day of May, 1976.

KEVIN J. ALLMAN, solicitor, 195-7 Raymond Street, Sale, 3850. 1581

SARAH PRUDEN, late of 6 Riverview Terrace, Hamilton, Brisbane, in the State of Queensland, married woman, DECEASED.

Creditors, next-of-kin and others having claims in respect of the estate of Saarah Pruden late of 6 Riverview Terrace, Hamilton, Brisbane in the State of Queensland married woman deceased, who died on the second day of November One thousand nine hundred and seventy-four are required to send particulars of their claims to The Union-Fidelity Trustee Company of Australia Limited of 100 Exhibition Street, Melbourne by the first day of August One thousand nine hundred and seventy-six after which date it will distribute the assets having regard only to the claims of which it then has notice.

Dated the 19th day of May, 1976.

KEVIN J. ALLMAN, solicitor, 195-7 Raymond Street, Sale, 3850. 1582

Creditors next-of-kin and others having claims in respect of the estate of Richard George Ernest McCan late of 32 Parkview Road, Alphington gentleman deceased who died on the 12th day of February, 1976 and Probate of whose Will has been granted to The Trustees Executors and Agency Company Limited of 401 Collins Street, Melbourne are required to send particulars of their claims to the said executor by the 19th day of July, 1976 after which date it will distribute the assets having regard only to the claims of which it then has notice.

H. L. YUNCKEN & YUNCKEN, solicitors, 443 Little Collins Street, Melbourne, 3000. 1600

Creditors next of kin and others having claims in respect of the estate of Annie Elizabeth O'Connor late of 33 Clyde Street East Kew in the State of Victoria, widow deceased who died on the 17th day of January, 1976 are required to send particulars of their claims to the executor National Trustees Executors and Agency Company of Australasia Limited of 95 Queen Street Melbourne in the State of Victoria by the 22nd day of July, 1976 after which date the executor will distribute the assets having regard only to the claims of which it then has notice.

BERNARD, NOLAN & CO., and MAHONY, O'BRIEN & DUGGAN, solicitors, 9th Floor, 85 Queen Street, Melbourne. 1601

All persons having claims against the estate of Victoria Louise Duke formerly of 1047 Norman Street Wendouree in the State of Victoria married woman late of 17 Royal Avenue Bendigo in the said State widow deceased Probate of whose Will has been applied for by The Union-Fidelity Trustee Company of Australia Limited of 100 Exhibition Street Melbourne the executor appointed by the said Will are hereby required to send particulars thereof in writing to the said company at its office at 101 Lydiard Street North Ballarat before the 29th day of July 1976 after which date the said company will proceed to distribute the assets of the said deceased having regard only to the claims of which it shall then have had notice and the said company will not be liable for the assets so distributed or any part thereof to any person of whose claim it shall not then have had notice.

R. G. DOBSON & CO., of 52 Lydiard Street, Ballarat, solicitors for the said company. 1580

After fourteen clear days application will be made to the Supreme Court that letters of administration of the estate of Luigi Rangan late of 733 Point Nepean Road, Brighton in the State of Victoria, pensioner, deceased, who died intestate on the 21st day of June 1975 be granted to Lucia Clelia Rangan of 250 Arthur Street, Fairfield in the said State, widow of the said deceased.

D. C. CARLI, FURLETTI & SCOTT, barristers and solicitors, 53 Pelham Street, Carlton, 3053. 1602

AGNES ANNIE BIRD, late of 11 Reynolds Parade, Pascoe Vale South, in the State of Victoria, widow, DECEASED.

Creditors next of kin and all others having claims in respect of the estate of Agnes Annie Bird late of 11 Reynolds Parade, Pascoe Vale South widow, deceased who died on the 24th day of November, 1975 are required by the executor Mervyn Downie Parry Bird of 11 Reynolds Parade, Pascoe Vale South to send particulars of their claims to him in the care of the undermentioned solicitor prior to the 2nd day of August, 1976 after which date he will distribute the assets having regard only to the claims of which he then has notice.

M. F. HUGHES, LL.B., solicitor, 300 Barkly Street, Brunswick. 1578

ALAN DOUGLAS KEFFORD, late of 333 Doncaster Road, North Balwyn, in the State of Victoria, cartage contractor, DECEASED.

Creditors next of kin and all others having claims in respect of the estate of Alan Douglas Kefford late of 333 Doncaster Road, North Balwyn cartage contractor deceased who died on the 31st day of May, 1975 are required by Douglas Kefford of South Gippsland Highway, Lyndhurst cartage contractor and Rae Parker of 14 Savoy Court, West Pennant Hills in the State of New South Wales married woman to send particulars of their claims to them in the care of the undermentioned solicitor prior to the 2nd day of August, 1976 after which date they will distribute the assets having regard only to the claims of which they then have notice.

M. F. HUGHES, LL.B., solicitor, 300 Barkly Street, Brunswick. 1579

Creditors, next of kin and others having claims in respect of the estate of Iris Wing Shing late of 2 Kelvin-side Street North Balwyn in Victoria housewife deceased (who died on the Second day of April 1974) are required to send particulars of their claims to National Trustees Executors and Agency Company of Australasia Limited of 95 Queen Street Melbourne in Victoria by the Twenty-first day of July 1976, after which date the said company will distribute the assets having regard only to the claims of which it then has notice.

GILLOTT MOIR & WINNEKE, solicitors, of 500 Collins Street, Melbourne. 1613

DAVID GILD, formerly of Main Street, Garfield, but late of Unit 2, 9 Kinane Street, East Brighton, medical practitioner, DECEASED.

Creditors, next of kin and others having claims in respect of the estate of the deceased who died on the 23rd day of December 1975 are required by the executor The Union-Fidelity Trustee Company of Australia Limited of 100 Exhibition Street Melbourne to send particulars to it at its above stated address by the 23rd day of July 1976 after which date the executor may convey or distribute the assets having regard only to the claims of which it then has notice.

Dated the 19th day of May, 1976.

MADDEN, BUTLER, ELDER & GRAHAM, solicitors, 500 Collins Street, Melbourne. 1614

ALICE BEATRICE KELLY, late of 28 Myrtle Grove, Reservoir, widow, DECEASED.

Creditors, next-of-kin and others having claims in respect of the estate of the deceased who died on the 9th day of March, 1976, are requested to send particulars of their claims to the executor George Henry Firth C/- the undersigned solicitor by the 20th July, 1976, after which date the said executor will proceed to distribute the estate having regard only to the claims of which he then has notice.

MARJORY C. COATES, 422 Collins Street, Melbourne, 3000. 1605

Creditors next of kin and others having claims against the estate of Keith Rutherford Reilly late of 3 Holmby Road, Cheltenham in the State of Victoria, clerk, deceased who died on the 25th day of April, 1974, are requested to send particulars of their claims to Hope Rutherford Reilly of 178 Balwyn Road Balwyn in the said State and Alan Roy Argyle of 29 Sea Parade, Mentone in the said State, care of the below mentioned solicitors by the 22nd day of July, 1976, after which date they will distribute the assets having regard only to the claims of which they then have notice.

PURVES & PURVES, solicitors, of 121 William Street, Melbourne. 1607

Creditors next of kin and others having claims against the estate of Helena Hope Canney late of "Peebles", 6 Briarong Avenue, Frankston in the State of Victoria, spinster deceased who died on the fifteenth February, 1976 are requested by the executor of the will of the said deceased The Equity Trustees Executors and Agency Company Limited of 472 Bourke Street, Melbourne in the said State to send particulars of their claims to the said executor on or before July 26th, 1976 after which date the executor will distribute the assets having regard only to the claims of which it shall then have had notice.

ELLISON, HEWISON AND WHITEHEAD, solicitors, 379 Collins Street, Melbourne, 3000. Tel: 62 2911. 1615

Creditors next of kin and other persons having claims against the estate of Robert Henry Carrick late of Blind Hostel 1 Donald Street Prahran retired deceased who died on the sixteenth day of September 1975 are required to send particulars of their claims to the executor Maurice John McKernan in care of the undermentioned solicitors by the twenty-first day of July 1976 after which date the executor will distribute the assets having regard only to the claims of which he then has had notice.

JAMES P. OGGE & CO., solicitors, 165 Greville Street, Prahran. 1637

Creditors next of kin and other persons having claims against the estate of Ellen Roda Goebly formerly of Boronia and Healesville but late of Elanora Home and Hospital 7 Mair Street Brighton Beach widow deceased who died on the fifth day of February 1976 are required to send particulars of their claims to the executor National Trustees Executors and Agency Company of Australasia Limited of 95 Queen Street Melbourne by the twenty-first day of July 1976 after which date the executor will distribute the assets having regard only for the claims of which it then has had notice.

JAMES P. OGGE & CO., solicitors, 165 Greville Street, Prahran. 1638

Creditors next of kin and other persons having claims against the estate of Ruby Frances Percy late of 26 Oakleigh Crescent Ormond widow deceased who died on the eighteenth day of March, 1976 are required to send particulars of their claims to the executors Walter George Saunders and John Percival Pick in care of the undermentioned solicitors by the twenty-first day of July 1976 after which date the executors will distribute the assets having regard only for the claims of which they then have had notice.

JAMES P. OGGE & CO., solicitors, 165 Greville Street, Prahran. 1639

IAN HENRY FRANCIS HIGHTT, late of "Greenlands", Healesville.

Creditors, next of kin, and others having claims in respect of the estate of the deceased, who died on 1st July, 1975, are required by the trustee, Kathleen Moore Hightt, of "Greenlands", Healesville to send particulars to her care of the undersigned by the 21st day of July, 1976, after which date she may convey or distribute the assets, having regard only to the claims of which she then has notice.

WHITING & BYRNE, 440 Collins Street, Melbourne.

1640

Creditors next of kin and others having claims in respect of the estate of Sidney John Riley late of Kingston Centre Warrigal Road Cheltenham gentleman deceased who died on 27th March 1976 are to send particulars of their claims to The Union-Fidelity Trustee Company of Australia Limited, 100 Exhibition Street Melbourne by 3rd August 1976 after which date it will distribute the assets having regard only to the claims of which it then has notice.

IVAN L. McDONALD, solicitor, 136 Balcombe Road, Mentone. 1642

EDWARD GRAEME ROBERTSON, late of 9 Landen Place, Toorak, medical practitioner, DECEASED.

Creditors next of kin and others having claims in respect of the estate of the deceased who died on the 25th December 1975 are required by the personal representatives Joan Robertson of 9 Landen Place Toorak home duties Denis Graeme Robertson of 15 Ellesmere Road Windsor medical practitioner and George Herbert O'Dell Crowther of 459 Little Collins Street Melbourne solicitor to send particulars to them by the 21st July 1976 after which date the personal representatives may convey or distribute the assets having regard only to the claims of which they then have notice.

WEIGALL & CROWTHER, solicitors for the personal representatives. 1656

CREDITORS next of kin and others having claims in respect of the estate of Oskars Podzins late of 14 Maude Street, Box Hill, machinist, deceased (who died on the 20th day of June, 1975) are requested to send particulars of their claims to the executor of the estate, Eriks Podzins, care of the undermentioned solicitor, by 31st August, 1976, after which date he will convey and distribute the assets having regard only to the claims of which he has then notice.

E. T. BRENNERS, solicitor, of 114 Princess Street, Kew.
1603

Creditors, next of kin, and others having claims in respect of the estate of Jack Wing Shing late of 2 Kelvinside Street, North Balwyn in Victoria, architect, deceased (who died on the second day of April, 1974) are required to send particulars of their claims to National Trustees Executors and Agency Company of Australasia Limited of 95 Queen Street, Melbourne in Victoria, by the twenty-first day of July, 1976, after which date the said company will distribute the assets having regard only to the claims of which it then has notice.

GILLOTT MOIR & WINNEKE, solicitors, of 500 Collins Street, Melbourne.
1606

Creditors next-of-kin and others having claims in respect of the estate of Elizabeth Ann McKinnon late of 43 Exhibition Street, McKinnon, widow, deceased (who died on the 6th of April, 1976, are requested to send particulars of their claims to the executor, Arthur Leslie Park care of the undermentioned solicitors, on or before 21st of July, 1976, after which date he will distribute the assets having regard only to the claims of which he then has notice.

McKEAN & PARK, solicitors, 450 Little Collins Street, Melbourne.
1608

Creditors next-of-kin and others having claims in respect of the estate of Moskos John Kryzis (in the will called Kryzis John Moskos) late of 19 Queensbury Street, Carlton, retired, deceased, who died on the 1st of May, 1976, are requested to send particulars of their claims to the executrix, Erasmia Moores, care of the undermentioned solicitors on or before 21st of July, 1976, after which date she will distribute the assets having regard only to the claims of which she then has notice.

McKEAN & PARK, solicitors, 450 Little Collins Street, Melbourne.
1609

JESSIE MARIA ISABEL WALTERS, late of 32 Monomeath Avenue, Canterbury, married woman, DECEASED.

Creditors, next-of-kin and others having claims in respect of the estate of the deceased who died on 21st January, 1976, are required by National Trustees Executors and Agency Company of Australasia Limited of 95 Queen Street, Melbourne, the applicant for a grant of letters of administration of the estate of the said deceased with the will annexed to send particulars to it by the 21st day of July, 1976, after which that company may convey or distribute the assets having regard only to the claims of which it then has notice.

Dated this 11th day of May, 1976.

ARTHUR PHILLIPS & JUST, solicitors, 472 Bourke Street, Melbourne.
1610

FRANCES JEAN LACHMUND, late of Flat 4, 50 Locksley Road, Ivanhoe, widow, DECEASED.

Creditors next-of-kin and others having claims in respect of the estate of the deceased who died on the 5th day of July, 1975, are requested to send particulars of their claims to the executor, Peter Allan Lachmund, C/- the under-signed solicitor by the 20th July, 1976, after which date the said executor will proceed to distribute the estate having regard only to the claims of which he then has notice.

MARJORY C. COATES, solicitor, 422 Collins Street, Melbourne.
1611

Creditors next of kin and others having claims against the estate of Merle May Tuohy late of "Green Glades", The Crescent, Sassafras in the State of Victoria, art gallery director, deceased, who died on the 27th day of October, 1975, are requested to send particulars of their claims to Morven Bond of 121 William Street, Melbourne in the said State, solicitor, care of the below mentioned solicitors by the 22nd day of July, 1976, after which date he will distribute the assets having regard only to the claims of which he then has notice.

PURVES & PURVES, solicitors, of 121 William Street, Melbourne.
1612

WILLIAM FRASER LANG, late of Marnoo, agent,
DECEASED.

Creditors, next of kin and others having claims in respect of the estate of the deceased who died on the 18th day of March, 1976 are required by the Union-Fidelity Trustee Company of Australia Limited of 100 Exhibition Street, Melbourne to send particulars to it by the 1st day of August, 1976 after which date the Union-Fidelity Trustee Company of Australia Limited may convey or distribute the assets having regard only to the claims of which it then has notice.

Dated the 14th day of May, 1976.

1552

BERTIE EDISON PAYNTER, late of Ellinbank, retired farmer, DECEASED.

Creditors next of kin and others having claims in respect to the estate of the deceased who died on the 14th day of April 1975 are required by the trustees Clarice Thelma Paynter and Claude William Harris to send particulars of their claims to them care of the undersigned solicitors by the 23rd day of July 1976 after which date the trustees may convey or distribute the assets having regard only to the claims of which they then have notice.

GRAY FRIEND & LONG, solicitors, Warragul.

1553

Creditors, next of kin and others having claims in respect of the estate of Joseph Allan Waddell late of 44 Harrison Street East Brunswick in the State of Victoria bus driver deceased who died on the 3rd day of August 1975 are required by the executrix of the estate Violet May Waddell of 44 Harrison Street East Brunswick in the said State formerly married woman but now widow to send particulars to N. C. Gay & Co., solicitors of 136 Sydney Road, Brunswick by the 20th day of July 1976 after which date the said executrix may distribute the assets having regard only to claims of which she then has notice.

N. C. GAY & CO., solicitors, 136 Sydney Road, Brunswick.
1554

Creditors, next of kin and others having claims in respect of the estate of Harold Percival Waddell (therein described as Percy Harold Waddell) late of 210 Blyth Street Brunswick in the State of Victoria gentleman deceased who died on the 12th day of May 1971 are required by the executor of the estate Terence Allan Waddell formerly of 5 Nola Court Bundoora in the State of Victoria but now of 11 Tilba Street Essendon in the said State branch manager to send particulars to N. C. Gay & Co., solicitors of 136 Sydney Road, Brunswick by the 20th day of July 1976 after which date the said executor may distribute the assets having regard only to claims of which he then has notice.

N. C. GAY & CO., solicitors, 136 Sydney Road, Brunswick.
1555

Trustee Act 1958.

NOTICE TO CLAIMANTS.

Pursuant to the Trustee Act 1958, creditors next of kin and all other persons having claims in respect of the estate of any deceased person named below are required to send particulars to the legal personal representative or representatives at the addresses stated, after which date the representatives will distribute the assets, having regard only to the claims of which notice has been received:—

John Patrick McMahon, late of Junction Hotel, Hall Street Newport retired gentleman deceased, died on the 28th day of February 1976.—Claims to the executrix Carmel Hamilton of 40 Finnis Crescent Narrabundah A.C.T. by the 21st July, 1976. John F. Carroll, LL.B., solicitor, 4 Paisley Street, Footscray.
1643

Edith Gwen Coram, late of 11 Grevillia Court, Frankston married woman deceased, died on the 29th day of December 1975.—Claims to the executor Harold Clifford Roy Coram of 11 Grevillia Court Frankston by the 21st July, 1976. John F. Carroll, LL.B., solicitor, 4 Paisley Street Footscray.
1644

Joseph Robert Roy Horkings, late of 20 Wingara Avenue East Keilor retired contractor deceased, died on the 14th day of November 1975.—Claims to the executrix Marjorie Jean Collas of 37 Jindabyne Avenue Jordanville by the 28th day of July, 1976. John F. Carroll, LL.B., solicitor, 4 Paisley Street, Footscray.
1645

In the Supreme Court of the State of Victoria.

SALE BY THE SHERIFF.

On Friday the 25th of June 1976 at 11.00 a.m. at the Police Station Thomastown (unless process be stayed or satisfied).

All the estate and interest (if any) of Angela Apidopoulos, married woman, of 513 Napier Street, North Fitzroy as proprietor of an estate in fee simple in the land described in certificate of title volume 8705 folio 833 upon which is erected a triple fronted two storey brick home with a solid brick double garage and a further brick building behind the garage which appears to be a second residence. The upper floor of the building has not yet been plastered, known as No. 26 Kenna Drive, Lalor.

Registered mortgage No. F.960394 affects the said estate and interest.

Terms—Cash only.

KEITH R. MARTIN, Sheriff's Officer.

19th May, 1976. 1641

IMPOUNDINGS

BROADMEADOWS.—Impounded in Tullamarine Pound, found on 5th May, 1976, on the Hume Highway, at Somerton.

4 mixed steers

If not claimed and expenses paid, to be sold at 12 noon on 27th May, 1976.

1543—\$4.40 G. LEATHAM, Poundkeeper.

KNOX.—Impounded at City of Knox Pound, Ferntree Gully.

1 Friesian heifer
1 Friesian steer
6 Hereford steers

If not claimed and expenses paid, to be sold by auction on 2nd June, 1976.

1542—\$4.40 J. WILLIAMS, Poundkeeper.

KYNETON.—Impounded at Kyneton Pound on the 11th May, 1976, from the Trentham town area.

2 Hereford crossbred cows
1 Jersey crossbred cow
2 calves

If not claimed and expenses paid, to be sold on 2nd June, 1976.

1544—\$4.95 C. H. RIORDAN, Poundkeeper.

Subordinate Legislation Act 1962.

NOTICE OF MAKING OF STATUTORY RULES.

In pursuance of the provisions of the *Subordinate Legislation Act 1962* and the Regulations made thereunder, notice is given of the making of the following statutory rules:—

No. *Social Welfare Act 1970* (as amended). Price.
109/1976. *Social Welfare (Attendance Centre) Regulations 1976* 20c

Workers Compensation Act 1958.
110/1976. *Workers Compensation Board (Amendment No. 1) Regulations 1976* 10c

Melbourne and Metropolitan Board of Works Act 1958.
111/1976. *By-law No. 137: Sick Leave Regulations 1976* 10c

Copies of these statutory rules may be purchased at the Sale of Publications Section of the Government Printing Office, located at 7A Parliament Place, Melbourne, 3002. If ordered by mail, remittance should be addressed to "The Government Printer, Box 203, P.O., North Melbourne, 3051", and should include 20c extra for postage.

The annual subscription rates for Statutory Rules for the year commencing 1st January, 1976, payable in advance, are as follows:—

Statutory Rules (other than Public Service Determinations)	\$45.00
Public Service Determinations	\$20.00

C. H. RIXON, Government Printer.

STATE ACTS, 1973

Copies of the following Acts of the Parliament of Victoria may be obtained at the Government Printing Office, Sale of Publications Branch, 7A Parliament-place, Melbourne, phone 63 0321, extension 6181, or from any accredited agent, at the price set opposite to each (these prices do not include postage).

Postage costs must be added to your remittance when ordering by mail as follows:—

Act Price.	Postage Cost.
10c-40c	20c
45c-70c	30c
75c-\$1.70	40c
\$1.75-\$4.00	60c
Above \$4.00	86c

Bound Volumes of 1973 State Acts are also available at a cost of \$17.50.

No.	Price.
8385. The Constitution Act Amendment (Qualifications)	\$0.10
8386. Hungarian Reformed Church of Australia (Victoria District) Incorporation	\$0.20
8387. Melbourne Family Care Organization	\$0.10
8388. Gas and Fuel Corporation (Colonial Gas Holdings Limited)	\$0.10
8389. Boilers and Pressure Vessels	\$0.10
8390. State Electricity Commission (Yallourn Council)	\$0.10
8391. Home Finance (Amendment)	\$0.10
8392. Zoological Gardens (Amendment)	\$0.10
8393. Melba Trust Fund	\$0.10
8394. Hospitals and Charities (Guarantee)	\$0.10
8395. Water (Amendment)	\$0.15
8396. Geelong Harbor Trust (Lands)	\$0.10
8397. Latrobe Valley (Amendment)	\$0.10
8398. Maryborough Land	\$0.10
8399. The Constitution Act Amendment (Presiding Officers)	\$0.10
8400. Constitutional Convention (Alternate Members)	\$0.10
8401. Ballarat (Sovereign Hill) Land	\$0.15
8402. Taxation Appeals (Commencement)	\$0.10
8403. Patriotic Funds (Amendment)	\$0.10
8404. Abattoir and Meat Inspection	\$0.40
8405. Valuation of Land (Valuers)	\$0.20
8406. Egg Industry Stabilization	\$0.40
8407. Recreation Vehicles	\$0.15
8408. Motor Car Traders	\$0.50
8409. Decentralized Industry (Housing)	\$0.15
8410. Crimes (Amendment)	\$0.10
8411. Cattle Compensation	\$0.10
8412. Victorian Inland Meat Authority (Amendment)	\$0.10
8413. Bendigo Aerodrome	\$0.10
8414. Ombudsman	\$0.30
8415. Public Service (Amendment)	\$0.10
8416. Coal Mines (Pensions Increase)	\$0.10
8417. Workers Compensation	\$0.10
8418. Public Records	\$0.20
8419. Joint Select Committee (Osteopathy, Chiropractic and Naturography)	\$0.10
8420. Marketing of Primary Products (Citrus Fruit)	\$0.10
8421. Barley Marketing (Amendment)	\$0.10
8422. Margarine	\$0.10
8423. Metric Conversion	\$0.10
8424. Medical Practitioners (Amendment)	\$0.15
8425. Crimes (Theft)	\$0.30
8426. Social Welfare (Amendment)	\$0.20
8427. Magistrates' Courts (Jurisdiction)	\$0.60
8428. Victorian Development Corporation	\$0.40
8429. Motor Accidents	\$0.80
8430. Motor Car (Amendment)	\$0.15
8431. Teaching Service	\$0.10
8432. Lands Compensation	\$0.15
8433. Police Offences (Publications)	\$0.15
8434. The Constitution Act Amendment (Responsible Ministers)	\$0.10
8435. Supply (July to October)	\$0.10
8436. Supply (Supplementary Estimates)	\$0.10
8437. Joint Select Committee (Meat Industry)	\$0.10
8438. Joint Select Committee (Road Safety)	\$0.10
8439. Joint Select Committee (Osteopathy, Chiropractic and Naturography) Amendment	\$0.10
8440. Public Works Committee	\$0.10
8441. The Constitution Act Amendment (Qualifications Joint Select Committee)	\$0.10
8442. Ministry of Consumers Affairs	\$0.10
8443. Ministry for Planning	\$0.10

STATE ACTS, 1973—continued.		Price.
No.		
8444.	Volunteer Civil Defence Workers Compensation (Amendment)	\$0.10
8445.	Local Government (Rates)	\$0.10
8446.	Hospitals Superannuation (Amendment)	\$0.10
8447.	Public Works Committee (Attendance Fees)	\$0.10
8448.	Unclaimed Moneys	\$0.10
8449.	Appropriation	\$1.90
8450.	Racing (Amendment)	\$0.10
8451.	Ministry for the Arts (Amendment)	\$0.10
8452.	Local Authorities Superannuation (Amendment)	\$0.10
8453.	Sewerage Districts (Amendment)	\$0.10
8454.	Money Lenders (Advertisements)	\$0.15
8455.	Tomato Processing Industry (Uniform Agreement)	\$0.20
8456.	Poisons (Fees)	\$0.10
8457.	Camperdown (Public Park) Land	\$0.10
8458.	Maidstone Land	\$0.10
8459.	Labour and Industry (Amendment)	\$0.10
8460.	Hairdressers Registration (Amendment)	\$0.10
8461.	Land (Metric Conversion)	\$0.30
8462.	Co-operative Housing Societies (Amendment)	\$0.10
8463.	Rosebud Institutions	\$0.10
8464.	Gas and Fuel Corporation (Amalgamations)	\$0.15
8465.	Stamps	\$0.20
8466.	Estate Agents (Fees)	\$0.10
8467.	Auction Sales (Licence Fees)	\$0.10
8468.	Motor Car (Fees)	\$0.10
8469.	Mines (Fees)	\$0.10
8470.	The Constitution Act Amendment (Executive Council)	\$0.10
8471.	State Forests Works and Services	\$0.10
8472.	Entertainments Tax	\$0.10
8473.	State College of Victoria (Staff)	\$0.10
8474.	Decentralized Industry (Land Tax Rebates) Incentive Payments	\$0.10
8475.	Pensions Supplementation	\$0.10
8476.	Metropolitan Fire Brigades (Amendment)	\$0.10
8477.	Children's Court	\$0.60
8478.	Country Fire Authority	\$0.10
8479.	Housing (Commonwealth State Agreement)	\$0.20
8480.	Probate Duty (Amendment)	\$0.15
8481.	Judges Salaries and Allowances	\$0.10
8482.	Pay-roll Tax (Amendment)	\$0.10
8483.	Land Reform	\$0.15
8484.	Flemington Land	\$0.10
8485.	Educational Lands	\$0.10
8486.	Small Claims Tribunals	\$0.20
8487.	Police Regulation (Amendment)	\$0.10
8488.	Consumer Protection	\$0.20
8489.	Country Roads (Amendment)	\$0.10
8490.	Attorney-General and Chief Secretary (Additional Functions)	\$0.10
8491.	Revocation and Excision of Crown Reservations	\$0.15
8492.	Land	\$0.10
8493.	Social Welfare	\$0.40
8494.	Monash University (Amendment)	\$0.15
8495.	Educational Grants	\$0.10
8496.	Victoria Institute of Colleges (Amendment)	\$0.10
8497.	Boilers and Pressure Vessels (Amendment)	\$0.10
8498.	Water Supply (Works) and Services	\$0.30
8499.	Youth, Sport and Recreation (State School Premises)	\$0.10
8500.	Melbourne Underground Rail Loop (Amendment)	\$0.10
8501.	Health (Special Accommodation Houses)	\$0.10
8502.	St. Kilda (Ormond Restaurant) Land	\$0.10
8503.	Racing (Further Amendment)	\$0.10
8504.	Social Welfare (Financial)	\$0.10
8505.	Education (Handicapped Children)	\$0.15
8506.	Health (Fluoridation)	\$0.10
8507.	Victorian Development Corporation (Amendment)	\$0.10
8508.	Housing (Sale of Land)	\$0.10
8509.	Weights and Measures (Amendment)	\$0.15
8510.	Hospitals and Charities (Amendment)	\$0.10
8511.	Hospitals and Charities (Institutions and Benevolent Societies)	\$0.10
8512.	Wheat Industry Stabilization (Amendment)	\$0.15
8513.	Audit (Appointment)	\$0.10
8514.	Swan Hill (Railways) Land	\$0.10
8515.	Water (Further Amendment)	\$0.10
8516.	Mines (Amendment)	\$0.15
8517.	Public Works and Services	\$0.15
8518.	Wodonga Area Land Acquisition	\$0.10
8519.	State Savings Bank (Amendment)	\$0.10
8520.	Albury-Wodonga Agreement	\$0.40
8521.	Melbourne Family Care Organization (Amendment)	\$0.10
8522.	Railway Works and Services	\$0.10

STATE ACTS, 1973—continued.		Price.
No.		
8523.	Teaching Service (Professional Appointees)	\$0.10
8524.	Development Areas	\$0.10
8525.	Road Transport	\$0.20
8526.	Municipalities Assistance	\$0.10
8527.	Land Tax	\$0.20
8528.	Abattoirs and Meat Inspection (Commencement)	\$0.10
8529.	Local Government (House Builders' Liability)	\$0.30
8530.	Parliamentary Salaries and Allowances	\$0.20
8531.	Local Government (Subdivision of Land)	\$0.70

C. H. RIXON,
Government Printer

STATE ACTS, 1974

Copies of the following Acts of the Parliament of Victoria may be obtained at the Government Printing Office, Sale of Publications Branch, 7A Parliament-place, Melbourne, phone 63 0321, extension 6181, or from any accredited agent, at the price set opposite to each (these prices do not include postage).

Postage costs must be added to your remittance when ordering by mail as follows:—

Act Price.	Postage Cost.
10c-40c	20c
45c-70c	30c
75c-\$1.70	40c
\$1.75-\$4.00	60c
Above \$4.00	86c

Bound Volumes of 1974 State Acts are also available at a cost of \$21.

No.		Price.
8532.	Veterinary Research Institute (Consequential Amendment)	\$0.10
8533.	Stock (Artificial Breeding) (Amendment)	\$0.10
8534.	Carriers and Innkeepers (Licences)	\$0.10
8535.	Bittern Land	\$0.10
8536.	Labour and Industry	\$0.10
8537.	Public Lands and Works (Amendment)	\$0.10
8538.	Land Tax (Amendment)	\$0.10
8539.	Superannuation (Railway Service)	\$0.10
8540.	Consumer Protection (Unordered Goods and Services Amendment)	\$0.10
8541.	Morwell and Mirboo Railway Removal	\$0.10
8542.	Bread Industry (Amendment)	\$0.10
8543.	Co-operative Housing Societies (Amendment)	\$0.10
8544.	Lotteries Gaming and Betting (Amendment)	\$0.10
8545.	Supply (No. 1, 1974-75)	\$0.15
8546.	Melbourne Cricket Club	\$0.15
8547.	Home Finance (Amendment)	\$0.10
8548.	Swan Hill Pioneer Settlement	\$0.30
8549.	Ministry of Transport (Transport Fund)	\$0.10
8550.	Youth, Sport and Recreation (Amendment)	\$0.10
8551.	Stamps (Bills of Exchange)	\$0.10
8552.	Gas and Fuel Corporation (Powers)	\$0.20
8553.	Registration of Births Deaths and Marriages	\$0.10
8554.	Meat Inspection Services	\$0.10
8555.	Sewerage Districts (Interest Subsidies)	\$0.10
8556.	Printers and Newspapers (Amendment)	\$0.10
8557.	Local Government (Amendment)	\$0.30
8558.	Decentralized Industry (Housing) (Amendment)	\$0.10
8559.	Teaching Service (Conditions of Service)	\$0.10
8560.	Environment Protection (Amendment)	\$0.10
8561.	Motor Car (Further Amendment)	\$0.15
8562.	Victorian Civil Ambulance Service	\$0.10
8563.	Forests (Wood Pulp Agreement)	\$0.40
8564.	Local Government (House Builders Liability Amendment)	\$0.20
8565.	Companies (Interstate Corporate Affairs Commission)	\$0.60
8566.	Racing (Amendment)	\$0.10
8567.	Appropriation (1973-74, No. 2)	\$0.10
8568.	Public Servants Ethical Conduct (Joint Select Committee)	\$0.10
8569.	Historic Buildings	\$0.30
8570.	Appropriation (1973-74, No. 3)	\$0.10
8571.	Supply (No. 2, 1974-75)	\$0.10
8572.	Victorian Inland Meat Authority	\$0.10
8573.	Metropolitan Bridges Highways and Fore-shores	\$0.30
8574.	Melbourne and Metropolitan Board of Works (Rates)	\$0.10
8575.	Wheat Marketing	\$0.10
8576.	Mildura Irrigation and Water Trusts (Amendment)	\$0.10
8577.	The Alfred Nicholas Memorial Gardens	\$0.10
8578.	Bonnie Doon (Public Hall) Land	\$0.10

STATE ACTS, 1974—continued.

No.	Price.
8579. Carlton Land (University Women's College)	\$0.10
8580. Newmarket Sheep Sales	\$0.10
8581. Tattersall Consultations (Soccer Football Pools)	\$0.15
8582. Geelong Land	\$0.10
8583. Melbourne (Alexandra Gardens) Land	\$0.10
8584. Terang Mechanics Institute and Free Library Trust	\$0.10
8585. Pay-roll Tax (Rate)	\$0.10
8586. Co-operative Housing Societies	\$0.10
8587. Forests (Amendment)	\$0.15
8588. Dental Alumni Research Foundation	\$0.10
8589. Pesticides (Amendment)	\$0.10
8590. Dried Fruits (Amendment)	\$0.10
8591. Road Safety (Educational)	\$0.10
8592. Commonwealth Places (Administration of Laws)	\$0.10
8593. Pharmacists	\$0.40
8594. Payroll Tax	\$0.20
8595. Stamps (Bills of Exchange) (Amendment)	\$0.10
8596. Motor Car (Fees)	\$0.10
8597. Business Franchise (Tobacco)	\$0.20
8598. Liquor Control (Fees)	\$0.10
8599. Zoological Gardens (Amendment)	\$0.10
8600. Local Government (Amendment No. 2)	\$0.10
8601. Revocation and Excision of Crown Reservations	\$0.15
8602. Status of Children	\$0.20
8603. Racing (Further Amendment)	\$0.15
8604. Fertilizers	\$0.40
8605. Appropriation (1974-75, No. 1)	\$2.20
8606. Aboriginal Affairs (Transfer of Functions)	\$0.15
8607. Victorian Institute of Marine Sciences	\$0.20
8608. Ministry of Transport (Consultative Committees)	\$0.15
8609. Milk Board (Delivery Charges)	\$0.10
8610. Deakin University	\$0.30
8611. Country Roads (Salaries and Contributions)	\$0.10
8612. Farm Produce Merchants and Commission Agents (Amendment)	\$0.10
8613. Municipalities Assistance (Amendment)	\$0.10
8614. Country Fire Authority (Amendment)	\$0.10
8615. Justices (Theft Offences)	\$0.10
8616. Chiroprodists (Additional Training of Applicants)	\$0.10
8617. Friendly Societies (Benefits)	\$0.10
8618. Labour and Industry (Amendment)	\$0.10
8619. Melbourne and Metropolitan Tramways (Amendment)	\$0.10
8620. Housing (Commonwealth State Supplemental Agreement)	\$0.10
8621. Land Tax	\$0.15
8622. Marine Stores and Old Metals (Beverage Cans)	\$0.10
8623. West Gate Bridge Authority	\$0.10
8624. Stamps (Credit and Rental Business)	\$0.10
8625. County Court (Chief Judge)	\$0.10
8626. Victorian Public Offices Corporation	\$0.15
8627. Harbors and Navigable Waters Control	\$0.20
8628. Electoral Provinces and Districts	\$0.20
8629. Water Supply Works and Services	\$0.30
8630. Consumer Affairs	\$0.15
8631. Wheat Industry Stabilization	\$0.30
8632. Educational Grants (Continuation)	\$0.10
8633. Small Claims Tribunals (Amendment)	\$0.10
8634. Cemeteries (Pioneer Memorial Parks)	\$0.10
8635. Public Works and Services	\$0.15
8636. State Forests Works and Services	\$0.10
8637. Local Government (Shire of Bacchus Marsh)	\$0.10
8638. Melbourne University (Amendment)	\$0.20
8639. Sewerage Districts (Amendment)	\$0.10
8640. River Improvement (Minimum Rate)	\$0.10
8641. Groundwater (Amendment)	\$0.10
8642. Health (Contraceptives)	\$0.30
8643. Pounds (Amendment)	\$0.10
8644. Railway Works and Services	\$0.10
8645. Local Government (Municipal Employees Long Service Leave)	\$0.15
8646. Latrobe Valley (Amendment)	\$0.10
8647. Extractive Industries (Amendment)	\$0.10
8648. Housing (Amendment)	\$0.15
8649. Valuation of Land (Amendment)	\$0.15
8650. Melbourne and Metropolitan Board of Works (Amendment)	\$0.20
8651. Ombudsman (Exemption)	\$0.10
8652. Land (Amendment)	\$0.10
8653. Wodonga Area Land Acquisition (Amendment)	\$0.10
8654. Cattle and Swine Compensation (Amendment)	\$0.10
8655. Milk and Dairy Supervision (Amendment)	\$0.15
8656. Public Service	\$0.60

STATE ACTS, 1974—continued.

No.	Price.
8657. Motor Car	\$0.15
8658. Education (Teacher Registration)	\$0.15
8659. Education (Work Experience)	\$0.10
8660. Local Government (Municipal Abattoirs)	\$0.10
8661. Cluster Titles	\$0.50
8662. Motor Boating (Amendment)	\$0.30

C. H. RIXON,
Government Printer.

STATE ACTS, 1975

Copies of the following Acts of the Parliament of Victoria may be obtained at the Government Printing Office, Sale of Publications Branch, 7A Parliament Place, Melbourne, phone 63 0321, extension 6181, or from any accredited agent, at the price set opposite to each (these prices do not include postage).

Postage costs must be added to your remittance when ordering by mail as follows:—

Act Price.	Postage Cost.
10c-40c	20c
45c-70c	30c
75c-\$1.70	40c
\$1.75-\$4.00	60c
Above \$4.00	86c

Bound Volumes of 1974 State Acts are also available at a cost of \$21.

No.	Price.
8663. Parliamentary Salaries and Superannuation (Amendment)	\$0.15
8664. Dog (Amendment)	\$0.10
8665. State College of Victoria (Borrowing Powers)	\$0.10
8666. Scaffolding (Amendment)	\$0.10
8667. Marine (Amendment)	\$0.10
8668. Methodist Church of Australasia Superannumerary Ministers and Ministers' Widows Fund	\$0.10
8669. Motor Accidents	\$0.10
8670. Pensioners' Rates Remission	\$0.10
8671. Geelong Harbor Trust Lands	\$0.15
8672. Railways (Amendment)	\$0.15
8673. Labour and Industry (Industrial Appeals Court)	\$0.10
8674. Health (Proprietary Medicines Advisory Committee)	\$0.10
8675. William E. Dorling Scholarship Fund	\$0.10
8676. Transport Regulation (Licence Fees)	\$0.10
8677. Juries (Amendment)	\$0.10
8678. Northcote Trust Fund	\$0.15
8679. Crimes (Capital Offences)	\$0.10
8680. Judges Salaries and Allowances	\$0.10
8681. Stock Foods	\$0.10
8682. Heathcote Railway Removal	\$0.15
8683. Home Finance (Amendment)	\$0.10
8684. Building Societies (Special Advances)	\$0.10
8685. Melbourne (Snowden Gardens) Land	\$0.10
8686. Thornbury Lands	\$0.15
8687. Parliamentary Salaries and Superannuation	\$0.10
8688. Water (Amendment)	\$0.30
8689. Veterinary Surgeons (Amendment)	\$0.10
8690. Racing	\$0.10
8691. Teaching Service (Assistant Professional Appointees)	\$0.10
8692. Public Service (Transitional Provisions)	\$0.10
8693. Building Industry Long Service Leave	\$0.40
8694. Fisheries	\$0.30
8695. Local Government (City of Ringwood)	\$0.10
8696. Hairdressers Legislation (Amendment)	\$0.10
8697. Professional Boxing Control	\$0.15
8698. Trustee Companies (Commission)	\$0.10
8699. Wildlife	\$0.50
8700. Transport Regulation (Private Omnibuses)	\$0.10
8701. Social Welfare (Amendment)	\$0.20
8702. National Parks	\$0.50
8703. Carlton (Recreation Ground) Land	\$0.10
8704. Broiler Chicken Industry	\$0.15
8705. Stock Diseases (Amendment)	\$0.10
8706. Industrial Training	\$0.50
8707. Town and Country Planning (Amendment)	\$0.10
8708. Dandenong Valley Authority (Amendment)	\$0.10
8709. Stock (Artificial Breeding) (Amendment)	\$0.10
8710. Victoria Institute of Colleges (Amendment)	\$0.10
8711. Latrobe Valley (Amendment)	\$0.10

STATE ACTS, 1975—continued.

No.	Price.
8712. Geelong Waterworks and Sewerage (Powers)	\$0 10
8713. Housing (Movable Units)	\$0 10
8714. Cattle Compensation (Amendment)	\$0 10
8715. Stock Medicines (Amendment)	\$0 10
8716. Town and Country Planning (Outdoor Advertising)	\$0 30
8717. Superannuation	\$0 50
8718. Magistrates' Courts (Amendment)	\$0 15
8719. Gas and Fuel Corporation	\$0 10
8720. Margarine	\$0 30
8721. Teaching Service (Special Duty Allowances)	\$0 10
8722. Police Regulation (Pensions)	\$0 20
8723. Marine (Further Amendment)	\$0 30
8724. Ports and Harbors	\$0 15
8725. Tomato Processing Industry (Uniform Agreement) (Amendment)	\$0 15
8726. Grain Elevators (Amendment)	\$0 10
8727. State Insurance Office	\$0 30
8728. Supply (1975-76, No. 1)	\$0 15
8729. Water Resources	\$0 15
8730. Parliamentary Officers	\$0 15
8731. Magistrates (Summary Proceedings)	\$1 50
8732. Liquor Control (Amendment)	\$0 30
8733. Workers Compensation (Amendment)	\$0 30
8734. Small Claims Tribunals (Amendment)	\$0 10
8735. Eltham Land	\$0 10
8736. Frankston Land	\$0 10
8737. Melbourne Cricket Ground (Amendment)	\$0 10
8738. South Melbourne Land	\$0 10
8739. Racing (Totalizator)	\$0 10
8740. Land Settlement (Amendment)	\$0 10
8741. Rural Finance (Amendment)	\$0 10
8742. Water Resources (Amendment)	\$0 10
8743. Nurses (Amendment)	\$0 10
8744. Lifts and Cranes (Amendment)	\$0 10
8745. Police Regulation (Amendment)	\$0 10
8746. Business Franchise (Tobacco)	\$0 10
8747. Stamps	\$0 10
8748. Forests (Softwood Holdings Agreement)	\$0 20
8749. Harbors and Navigable Waters Protection	\$0 30
8750. Constitution	\$0 50
8751. Decentralized Industries Incentive Payments (Amendment)	\$0 10
8752. Courts Administration	\$0 10
8753. Metropolitan Fire Brigades (Borrowing Powers)	\$0 10
8754. Medical Practitioners (Fees)	\$0 10
8755. Lotteries Gaming and Betting (Amendment)	\$0 10
8756. Health (Fees)	\$0 10
8757. Coal Creek Historical Park	\$0 30
8758. Melbourne Harbor Trust (Long Service Leave) (Amendment)	\$0 10
8759. Police Regulation (Long Service Leave)	\$0 10
8760. Metropolitan Fire Brigades (Long Service Leave)	\$0 10
8761. Liquor Control (Chairmen)	\$0 10
8762. Bendigo (Dai Gum San Village) Land	\$0 10
8763. Land	\$0 10
8764. Wodonga Area Land Acquisition (Amendment)	\$0 10
8765. Road Traffic (Amendment)	\$0 20
8766. Education (Work Experience) (Amendment)	\$0 10
8767. Agricultural Colleges (Amendment)	\$0 20
8768. Education (Administration)	\$0 10
8769. Inflammable Liquids (Amendment)	\$0 10
8770. Land Tax	\$0 10
8771. Superannuation (Amendment)	\$0 10
8772. Patriotic Funds (Amendment)	\$0 10
8773. Horse Breeding (Repeal)	\$0 10
8774. Milk and Dairy Supervision (Amendment)	\$0 10
8775. Stock Diseases (Further Amendment)	\$0 10
8776. Racing (Mid-week Racing)	\$0 20
8777. State Forests Works and Services	\$0 10
8778. Legal Profession Practice	\$0 10
8779. Public Works and Services	\$0 20
8780. Appropriation (1975-76, No. 1)	\$3 10
8781. Local Government (Amendment)	\$0 80
8782. Zoological Gardens (Amendment)	\$0 20
8783. Education (Volunteer Workers Compensation)	\$0 10
8784. State Development (Amendment)	\$0 10
8785. Pay-roll Tax	\$0 50
8786. Co-operative Housing Societies (Amendment)	\$0 10
8787. Companies	\$1 50
8788. Securities Industry	\$1 50
8789. Teaching Service (Amendment)	\$0 20
8790. Educational Grants (Continuation)	\$0 10
8791. Coal Mines (Pensions Increase)	\$0 10
8792. Motor Car (Penalties)	\$0 20
8793. State Co-ordination Council	\$0 20
8794. Pensioners' Water and Sewerage Rates Remission	\$0 30
8795. Revocation and Excision of Crown Reservations	\$0 10

STATE ACTS, 1975—continued.

No.	Price.
8796. Ports and Harbors (Penalties)	\$0 20
8797. State Electricity Commission (Amendment)	\$0 10
8798. The Constitution Act Amendment (Conjoint Elections)	\$0 10
8799. Education (School Councils)	\$0 20
8800. Optometrists	\$0 30
8801. Railways (Amendment)	\$0 10
8802. Scaffolding (Amendment)	\$0 10
8803. Transport Works and Services	\$0 10
8804. Workers Compensation (Surcharge Payments)	\$0 10
8805. Mines (Amendment)	\$0 30
8806. Public Service	\$0 10
8807. State Electricity Commission (Tramways)	\$0 10
8808. Dental Technicians (Amendment)	\$0 10
8809. Melbourne Underground Rail Loop (Amendment)	\$0 10
8810. Motor Car (Child Seat Restraints)	\$0 10
8811. Drainage of Land	\$0 80
8812. Railways (Participation in Pipeline Operation)	\$0 10
8813. Country Fire Authority (Constitution)	\$0 10
8814. Labour and Industry (Wages Board Determinations)	\$0 10
8815. West Moorabool Water Board (Amendment)	\$0 10
8816. Navigable Waters (Oil Pollution) (Amendment)	\$0 10
8817. Valuation of Land (Amendment)	\$0 10
8818. Town and Country Planning (Further Amendment)	\$0 10
8819. Local Authorities Superannuation (Pensions)	\$0 40
8820. La Trobe University (Amendment)	\$0 10
8821. Social Welfare (Amendment)	\$0 10
8822. Geelong Regional Authority	\$0 60
8823. Environment Protection (Noise Control)	\$0 30
8824. Consumer Affairs (Amendment)	\$0 10
8825. Water Supply Works and Services	\$0 40

ACTS REPRINTED IN ACCORDANCE WITH THE AMENDMENTS INCORPORATION ACT 1958 (No. 6422), AND FOR SALE AT THE SALE OF PUBLICATIONS BRANCH OF THE GOVERNMENT PRINTING OFFICE, 7A PARLIAMENT PLACE, MELBOURNE, 3002. Postage costs must be added to your remittance when ordering by mail as follows:—

Act Price.	Postage Cost.
10c-40c	20c
45c-70c	30c
75c-\$1.70	40c
\$1.75-\$4.00	60c
Above \$4.00	86c

No.	Price.
6189. Acts Interpretation (Fourth Reprint—Incorporating amendments up to No. 8305)	\$0 35
6191. Administration and Probate (Fourth Reprint—Incorporating amendments up to No. 7874)	\$0 75
6194. Agricultural Colleges (First Reprint—Incorporating amendments up to No. 7302)	\$0 15
6198. Anzac Day (First Reprint—Incorporating amendments up to No. 8344)	\$0 15
7117. Appeal Costs Fund Act 1964 (Second Reprint—Incorporating amendments up to No. 7488)	\$0 35
6199. Apprenticeship (Second Reprint—Incorporating amendments up to No. 7869)	\$0 40
6201. Architects (First Reprint—Incorporating amendments up to No. 8077)	\$0 30
6202. Auction Sales Act 1958 (First Reprint—Incorporating amendments up to Act No. 8490)	\$0 75
6203. Audit (First Reprint—Incorporating amendments up to No. 7377)	\$0 35
6208. Benefit Associations (First Reprint—Incorporating amendments up to No. 6961)	\$0 45
8004. Boiler and Pressure Vessels Act 1970 (First Reprint—Incorporating amendments up to No. 8389)	\$0 45
6529. Bread Industry Act 1959 (First Reprint—Incorporating amendments up to No. 7728)	\$0 30
6973. Building Contracts (Deposits) Act 1962 (First Reprint—Incorporating amendments from No. 7315)	\$0 10
6210. Building Society (Third Reprint—Incorporating amendments up to No. 8405)	\$0 65
6213. Cancer (First Reprint—Incorporating amendments up to No. 7455)	\$0 35

ACTS REPRINTED IN ACCORDANCE WITH THE AMENDMENTS
INCORPORATION ACT 1958 (No. 6422)—*continued.*

No.	Price.
6214. Carriers and Innkeepers (<i>Second Reprint</i> —Incorporating amendments up to No. 8534)	\$0.20
6217. Cemeteries (<i>First Reprint</i> —Incorporating amendments up to No. 7672)	\$0.30
6220. Clean Air Act 1958 (<i>Third Reprint</i> —Incorporating amendments up to Act No. 8324)	\$0.15
6221. Coal Mines (<i>First Reprint</i> —Incorporating amendments up to No. 7628)	\$1.05
6222. Commercial Goods Vehicles Act 1958 (<i>Third Reprint</i> —Incorporating amendments up to Act No. 8525)	\$0.55
6223. Commonwealth Arrangements (<i>First Reprint</i> —Incorporating amendments from No. 7809)	\$0.10
6839. Companies (<i>Fifth Reprint</i> —Incorporating amendments up to No. 8594)	\$5.95
8276. Consumer Protection Act 1972 (<i>Second Reprint</i> —Incorporating amendments up to Act No. 8540)	\$0.75
6224. The Constitution Act Amendment (<i>First Reprint</i> —Incorporating amendments up to No. 8086)	\$3.05
6225. Co-operation Act (<i>Third Reprint</i> —Incorporating amendments up to No. 8339)	\$0.85
6226. Co-operative Housing Societies (<i>Second Reprint</i> —Incorporating amendments up to No. 7575)	\$0.53
6227. Coroners Act 1958, Reprint (No. 2) incorporating amendments up to Act No. 8184	\$0.35
6228. Country Fire Authority (<i>Second Reprint</i> —Incorporating Amendments up to No. 7476)	\$0.50
6229. Country Roads (<i>Fourth Reprint</i> —Incorporating amendments up to Act No. 8573)	\$1.05
6230. County Court (<i>Second Reprint</i> —Incorporating amendments up to No. 8132)	\$0.65
6231. Crimes (<i>Fourth Reprint</i> —Incorporating amendments up to Act No. 8338)	\$2.75
6232. Crown Proceedings (<i>First Reprint</i> —Incorporating amendments up to No. 7900)	\$0.30
6233. Dairy Products (<i>First Reprint</i> —Incorporating amendments up to No. 7945)	\$0.20
7060. Dandenong Valley Authority Act 1963 (<i>First Reprint</i> —Incorporating amendments up to No. 7523)	\$0.35
6235. Dietitians Registration (<i>First Reprint</i> —Incorporating amendments up to No. 6886)	\$0.20
4989. Discharged Servicemen's Preference Act 1943. (<i>Second Reprint</i> —Incorporating amendments up to No. 7991)	\$0.20
6815. Disposal of Uncollected Goods Act 1961 (<i>First Reprint</i> —Incorporating amendments up to No. 7181)	\$0.15
6237. Drainage Areas (<i>First Reprint</i> —Incorporating amendments up to No. 7276)	\$0.35
6238. Drainage of Land (<i>First Reprint</i> —Incorporating amendments up to No. 7876)	\$0.15
6239. Dried Fruits Act 1968 (<i>First Reprint</i> —Incorporating amendments up to No. 7337)	\$0.25
6240. Education Act (<i>Second Reprint</i> —Incorporating amendments up to No. 8659)	\$0.95
6241. Electric Light and Power (<i>First Reprint</i> —Incorporating amendments up to No. 7315)	\$0.30
6242. Employers and Employees (Incorporating amendments up to No. 6740)	\$0.18
8056. Environment Protection Act 1970 (<i>Second Reprint</i> —Incorporating amendments up to No. 8560)	\$0.55
6245. Estate Agents—(<i>Fifth reprint</i> —Incorporating amendments up to Act No. 8490)	\$0.85
6246. Evidence (<i>Fourth Reprint</i> —Incorporating amendments up to No. 8228)	\$1.05
7499. Extractive Industries Act 1966 (<i>Third Reprint</i> —Incorporating amendments up to Act No. 8647)	\$0.45
7733. Fences (<i>First Reprint</i> —Incorporating amendments from No. 7876)	\$0.35
6250. Fertilizers (Incorporating amendments up to No. 7142)	\$0.25
6468. Filled Milk (<i>First Reprint</i> —Incorporating amendments up to No. 6886)	\$0.15
6251. Firearms (<i>Fourth Reprint</i> —Incorporating amendments up to No. 8288)	\$0.75
6916. Foreign Judgments Act 1962 (<i>First Reprint</i> including amendments made by No. 7332)	\$0.15
6585. Forests (Pulpwood Agreement) (Incorporating amendments up to No. 6886)	\$0.15

ACTS REPRINTED IN ACCORDANCE WITH THE AMENDMENTS
INCORPORATION ACT 1958 (No. 6422)—*continued.*

No.	Price.
6254. Forests (<i>First Reprint</i> —Incorporating amendments up to No. 7356)	\$0.60
6255. Friendly Societies (<i>First Reprint</i> —Incorporating amendments up to No. 7554)	\$0.60
6256. Fruit and Vegetables (<i>First Reprint</i> —Incorporating amendments up to No. 6944)	\$0.30
6258. Game (<i>First Reprint</i> —Incorporating amendments up to No. 7389)	\$0.30
6260. Gas and Fuel Corporation (<i>First Reprint</i> —Incorporating amendments up to No. 7422)	\$0.70
6262. Geelong Harbor Trust (<i>First Reprint</i> —Incorporating amendments up to No. 7547)	\$0.45
6263. Geelong Waterworks and Sewerage (<i>First Reprint</i> —Incorporating amendments up to No. 7547)	\$0.75
8176. Gift Duty Act 1971 (<i>First Reprint</i> —Incorporating amendments from No. 8202)	\$0.55
6265. Goods Act 1958 (<i>Sixth Reprint</i> —Incorporating amendments up to Act No. 8455)	\$0.45
6266. Grain Elevators (<i>First Reprint</i> —Incorporating amendments up to No. 7486)	\$0.35
7849. Groundwater (<i>First Reprint</i> —Incorporating amendments up to No. 8153)	\$0.45
6267. Hairdressers Registration (<i>First Reprint</i> —Incorporating amendments up to Act No. 7659)	\$0.30
6269. Hawkers and Pedlers Act 1958 (<i>Second Reprint</i> —Incorporating amendments up to Act No. 8247)	\$0.30
6270. Health Act (<i>Third Reprint</i> —Incorporating amendments up to No. 8506)	\$3.25
6531. Hire Purchase Act 1959 (<i>Second Reprint</i> —Incorporating amendments from Act No. 8232)	\$0.55
6933. Home Finance Act 1962 (<i>First Reprint</i> —Incorporating amendments up to No. 7363)	\$0.25
6274. Hospitals and Charities (<i>Second Reprint</i> —Incorporating amendments up to No. 7455)	\$0.50
6275. Housing (<i>Second Reprint</i> —Incorporating amendments up to No. 8052)	\$1.65
6276. Imprisonment of Fraudulent Debtors (<i>First Reprint</i> —Incorporating amendments up to No. 7876)	\$0.35
6277. Industrial and Provident Societies (<i>First Reprint</i> —Incorporating amendments up to No. 7547)	\$0.35
6279. Instruments (<i>Fourth Reprint</i> —Incorporating amendments up to No. 7941)	\$0.75
6280. Judicial Proceedings Reports (<i>First Reprint</i> —Incorporating amendments up to No. 7596)	\$0.15
7651. Juries (<i>First Reprint</i> —Incorporating amendments up to No. 8170)	\$0.55
6282. Justices Act 1958 (<i>Fourth Reprint</i> —Incorporating amendments up to No. 8338)	\$2.35
6283. Labour and Industry Act 1958 (<i>Sixth Reprint</i> —Incorporating amendments up to Act No. 8642)	\$1.50
6284. Land Act 1959 (<i>Second Reprint</i> —Incorporating amendments up to No. 8243)	\$3.15
6534. Land Settlement Act 1959 (<i>First Reprint</i> —Incorporating amendments up to No. 7328)	\$0.30
6288. Land Surveyors (<i>First Reprint</i> —Incorporating amendments up to Act No. 7065)	\$0.30
6289. Land Tax (<i>Second Reprint</i> —Incorporating amendments up to No. 7466)	\$0.40
6285. Landlord and Tenant (<i>Fourth Reprint</i> —Incorporating amendments up to No. 8208)	\$1.15
6286. Lands Compensation (<i>Second Reprint</i> —Incorporating amendments up to No. 8432)	\$0.45
6290. Latrobe Valley (<i>First Reprint</i> —Incorporating amendments up to No. 7332)	\$0.35
6291. Legal Profession Practice Act (<i>Fourth Reprint</i> —Incorporating amendments up to No. 8778)	\$1.45
6292. Libraries (<i>First Reprint</i> —Incorporating amendments up to No. 7364)	\$0.15
7629. Lifts and Cranes Act 1967 (<i>First Reprint</i> —Incorporating amendments up to No. 8320)	\$0.30
6295. Limitation of Actions (<i>Third Reprint</i> —Incorporating amendments up to No. 8300)	\$0.35
7695. Liquor Control Act 1958 (<i>Third Reprint</i> —Incorporating amendments up to No. 8598)	\$1.35
7145. Litter Act 1964 (<i>Second Reprint</i> —Incorporating amendments up to No. 8702)	\$0.20
6298. Local Authorities Superannuation (<i>Second Reprint</i> —Incorporating amendments up to No. 7161)	\$0.40

ACTS REPRINTED IN ACCORDANCE WITH THE AMENDMENTS INCORPORATION ACT 1958. (No. 6422)—*continued*.

No.	Price.
6299. Local Government (Third Reprint—Incorporating amendments up to No. 8781)	\$10.90
7289. Maintenance (First Reprint—Incorporating amendments up to No. 8036)	\$1.05
6301. Margarine (First Reprint—Incorporating amendments up to No. 7714)	\$0.18
6302. Marine (Incorporating amendments up to No. 7350)	\$0.72
6303. Marine Stores and Old Metals (First Reprint—Incorporating amendments up to No. 7876)	\$0.35
6304. Marketing of Primary Products (First Reprint—Incorporating amendments up to No. 7491)	\$0.45
6305. Markets (First Reprint—Incorporating amendments up to No. 7705)	\$0.20
6306. Marriage (First Reprint—Incorporating amendments up to No. 6959)	\$0.25
6307. Masseurs (First Reprint—Incorporating amendments up to No. 7566)	\$0.20
6309. Medical (Second Reprint—Incorporating amendments up to No. 7408)	\$0.40
6310. Melbourne and Metropolitan Board of Works (Fourth Reprint—Incorporating amendments up to No. 8650)	\$1.95
6311. Melbourne and Metropolitan Tramways (First Reprint—Incorporating amendments up to No. 7622)	\$0.70
6312. Melbourne Harbor Trust. (First Reprint—Incorporating amendments up to No. 7356)	\$0.48
6405. Melbourne University (First Reprint—Incorporating amendments up to No. 7871)	\$0.40
6605. Mental Health (Second Reprint—Incorporating amendments up to Act No. 8679)	\$0.75
6315. Metropolitan Fire Brigades (Second Reprint—Incorporating amendments up to No. 8165)	\$0.65
6316. Mildura Irrigation and Water Trusts (First Reprint—Incorporating amendments up to No. 7448)	\$0.75
6317. Milk and Dairy Supervision (Second Reprint—Incorporating amendments up to Act No. 8655)	\$0.85
6318. Milk Board (Incorporating amendments up to No. 7093)	\$0.22
6319. Milk Pasteurization (First Reprint—Incorporating amendments up to No. 7480)	\$0.18
6320. Mines (Second Reprint—Incorporating amendments up to No. 7876)	\$1.25
6184. Monash University (First Reprint—Incorporating amendments up to No. 7533)	\$0.30
6324. Money-Lenders (Fourth Reprint—Incorporating amendments up to No. 8490)	\$0.55
6832. Motor Boating Act 1961 (Third Reprint—Incorporating amendment up to No. 8662)	\$0.55
6325. Motor Car Act 1958 (Fifth Reprint—Incorporating amendments up to No. 8657)	\$2.25
6713. National Fitness Council of Victoria Act 1960 (First Reprint—Incorporating amendments up to No. 8344)	\$0.20
6705. Navigable Waters (Oil Pollution) Act 1960 (First Reprint—Incorporating amendments up to No. 7890)	\$0.30
6328. Nurses Act (Third Reprint—Incorporating amendments up to Act No. 8743)	\$0.65
6329. Opticians Registration (First Reprint—Incorporating amendments up to No. 7409)	\$0.30
6330. Partnership (Second Reprint—Incorporating amendments up to No. 7315)	\$0.35
6331. Patriotic Funds (First Reprint—Incorporating amendments up to No. 7338)	\$0.25
6332. Pawnbrokers Act 1958 (Second Reprint—Incorporating amendments up to Act No. 8181)	\$0.35
7417. Pensions Supplementation (First Reprint—Incorporating amendments up to No. 8475)	\$0.20
6257. Pesticides Act 1958 (Second Reprint—Incorporating amendments up to Act No. 8589)	\$0.35
6334. Petroleum (First Reprint—Incorporating amendments up to No. 7876)	\$0.65
6889. Poisons Act 1962 (Third Reprint—Incorporating amendments up to No. 8424)	\$0.85
6337. Police Offences Act 1958 (Third Reprint—Incorporating amendments up to No. 8433)	\$0.45

ACTS REPRINTED IN ACCORDANCE WITH THE AMENDMENTS INCORPORATION ACT 1958 (No. 6422)—*continued*.

No.	Price.
6388. Police Regulation (Third Reprint—Incorporating amendments up to No. 8722)	\$0.95
6340. Portland Harbor Trust (First Reprint—Incorporating amendments up to No. 7475)	\$0.35
6341. Pounds (First Reprint—Incorporating amendments up to No. 7315)	\$0.25
7498. Port Phillip Authority Act 1966 (First Reprint—Incorporating amendments from No. 8081)	\$0.15
6342. Printers and Newspapers (First Reprint—Incorporating amendments up to No. 7876)	\$0.15
7494. Private Agents Act 1966 (Second Reprint—Incorporating amendments up to Act No. 8427)	\$0.45
6344. Property Law (Third Reprint—Incorporating amendments up to No. 8181)	\$1.95
6345. Public Account (First Reprint—Incorporating amendments up to No. 8012)	\$0.20
6346. Public Authorities Marks (First Reprint—Incorporating amendments from No. 7315)	\$0.10
6350. Public Trustee (Incorporating amendments up to No. 6961)	\$0.35
6353. Racing (Fourth Reprint—Incorporating amendments up to No. 8690)	\$1.55
6355. Railways (First Reprint—Incorporating amendments up to No. 7475)	\$0.75
6564. Registration of Births Deaths and Marriages Act 1959 (First Reprint—Incorporating amendments up to No. 7332)	\$0.25
6358. River Improvement Act (First Reprint—Incorporating amendments up to No. 8342)	\$0.55
2596. River Murray Waters Act 1915 (First Reprint—Incorporating amendments up to No. 7061)	\$0.35
3360. Rural Finance (First Reprint—Incorporating amendments up to No. 7328)	\$0.15
6846. Rural Finance and Settlement Commission Act 1961 (First Reprint—Incorporating amendments up to No. 7332)	\$0.30
6917. Sale of Human Blood Act 1962 (First Reprint—Incorporating amendments from No. 7332)	\$0.10
6975. Sale of Land Act 1962 (Second Reprint—Incorporating amendments up to No. 7898)	\$0.35
8146. Scaffolding Act 1971 (Second Reprint—Incorporating amendments up to Act No. 8666)	\$0.35
6363. Second-hand Dealers (First Reprint—Incorporating amendments up to No. 7529)	\$0.25
7962. Securities Industry Act 1970 (First Reprint—Incorporating amendments made by Act No. 8059)	\$0.65
6367. Settled Land (Second Reprint—Incorporating amendments up to No. 7065)	\$0.50
6368. Sewerage Districts (Second Reprint—Incorporating amendments up to No. 7547)	\$0.75
6369. Shearers Accommodation (First Reprint—Incorporating amendments up to No. 7876)	\$0.35
6809. Sheep Owners Protection Act 1961 (Third Reprint—Incorporating amendments up to Act No. 8247)	\$0.20
6372. Soil Conservation and Land Utilization Act (Third Reprint—Incorporating amendments up to No. 8432)	\$0.45
6373. Soldier Settlement (First Reprint—Incorporating amendments up to No. 7328)	\$0.42
6375. Stamps Act 1958 (Sixth Reprint—Incorporating amendments up to Act No. 8624)	\$2.15
6377. State Electricity Commission (Second Reprint—Incorporating amendments up to No. 7421)	\$0.65
6378. State Relief Committee (First Reprint—Incorporating amendments from No. 6886)	\$0.10
6379. State Savings Bank Act 1958 (Third Reprint—Incorporating amendments up to Act No. 8519)	\$0.95
6380. Statistics (First Reprint—Incorporating amendments up to No. 6961)	\$0.15
6383. Stock Foods (First Reprint—Incorporating amendments up to No. 7607)	\$0.28
6384. Stock Medicines (First Reprint—Incorporating amendments up to No. 7726)	\$0.20
7551. Strata Titles Act 1967. (Third Reprint—Incorporating amendments up to Act No. 8661)	\$0.65
6886. Subordinate Legislation Act 1962 (Second Reprint—Incorporating amendments up to No. 8127)	\$0.15

ACTS REPRINTED IN ACCORDANCE WITH THE AMENDMENTS
INCORPORATION ACT 1958 (No. 6422)—*continued.*

No.	Price.
7405. Summary Offences Act 1966 (<i>Second Reprint</i>)—Incorporating amendments up to Act No. 8276	\$0.55
7634. Sunday Entertainment (<i>First Reprint</i>)—Incorporating amendments up to No. 8173	\$0.15
6386. Superannuation (<i>Third Reprint</i>)—Incorporating amendments up to No. 8717	\$1.35
6387. Supreme Court (<i>First Reprint</i>)—Incorporating amendments up to No. 7522	\$0.75
6388. Survey Co-ordination (<i>First Reprint</i>)—Incorporating amendments up to Act No. 8107	\$0.35
6390. Tattersall Consultations (<i>First Reprint</i>)—Incorporating amendments up to No. 8289	\$0.15
6391. Teaching Service (<i>Second Reprint</i>)—Incorporating amendments up to No. 8691	\$0.55
6849. Town and Country Planning Act 1961 (<i>Fifth Reprint</i>)—Incorporating amendments up to No. 8716	\$1.25
6401. Trustee (<i>Third Reprint</i>)—Incorporating amendments up to No. 7833	\$0.85
6402. Trustee Companies (<i>First Reprint</i>)—Incorporating amendments up to No. 7858	\$0.35
7223. Tomato Processing Industry (Uniform Agreement) Act 1964 (<i>First Reprint</i>)—Incorporating amendments up to No. 7342	\$0.15
6397. Trade Unions (<i>First Reprint</i>)—Incorporating amendments up to No. 6839	\$0.20
6399. Transfer of Land (<i>Fifth Reprint</i>)—Incorporating amendments up to No. 8531	\$1.15
6400. Transport Regulation Act (<i>Second Reprint</i>)—Incorporating amendments up to Act 8549	\$0.45
6879. Unclaimed Moneys Act 1962 (<i>Second Reprint</i>)—Incorporating amendments up to Act No. 8448	\$0.20
7095. Underseas Mineral Resources Act 1963 (<i>First Reprint</i>)—Incorporating amendments from No. 7591	\$0.10
6653. Valuation of Land Act 1960 (<i>Third Reprint</i>)—Incorporating amendments up to No. 8432	\$0.55
6407. Vegetation and Vine Diseases (<i>First Reprint</i>)—Incorporating amendments up to No. 7423	\$0.30
6409. Vermin & Noxious Weeds (<i>First Reprint</i>)—Incorporating amendments up to No. 7463	\$0.35
6410. Veterinary Surgeons (<i>First Reprint</i>)—Incorporating amendments up to No. 7343	\$0.15
6411. Victorian Inland Meat Authority (<i>First Reprint</i>)—Incorporating amendments up to No. 8000	\$0.30
7291. Victoria Institute of Colleges Act 1965 (<i>First Reprint</i>)—Incorporating amendments up to No. 7644	\$0.25
6412. Warehousemen's Liens (<i>First Reprint</i>)—Incorporating amendments up to No. 7876	\$0.15
6413. Water (<i>Third Reprint</i>)—Incorporating amendments up to No. 8729	\$3.45
6414. Weights and Measures (<i>Third Reprint</i>)—Incorporating amendments up to No. 8068	\$1.05
6415. Wild Flowers and Native Plants Protection (<i>First Reprint</i>)—Incorporating amendments up to No. 6976	\$0.15
6416. Wills (<i>First Reprint</i>)—Incorporating amendments up to No. 7238	\$0.25
6417. Wire Netting (<i>First Reprint</i>)—Incorporating amendments up to No. 7876	\$0.45
6419. Workers Compensation (<i>Sixth Reprint</i>)—Incorporating amendments up to No. 8417	\$1.05
6420. Wrongs (<i>First Reprint</i>)—Incorporating amendments up to No. 8330	\$0.35
8344. Youth, Sport and Recreation Act 1972 (<i>First Reprint</i>)—Incorporating amendments up to Act No. 8550	\$0.35

FIRST NOTIFICATION OF REPRINT.

No.	Price.
7723. Parliamentary Salaries and Superannuation Act 1968 (<i>First Reprint</i>)—Incorporating amendments up to Act No. 8687	\$0.35
7919. Legal Aid Act 1969 (<i>First Reprint</i>)—Incorporating amendments up to Act No. 8427	\$0.30

C. H. RIXON,
Government Printer.

PUBLICATION OF OFFICIAL MATTER.

Attention is invited to the following procedure in relation to the publication of official matter in the *Government Gazette*:—

Publication will be facilitated by the submission of carbon copies for the use of the Gazette Officer.

1. *Matter submitted to the Executive Council.*

Matter submitted to the Executive Council which requires gazettal will normally be published in the issue of the following week.

Where urgent gazettal is required, special arrangements should be made with the Gazette Officer, Room 14, first floor, Old Treasury Building.

2. *Other matter.*

(a) All other matter duly certified by a responsible officer for publication should be lodged with the Gazette Officer not later than half-past Nine a.m. on Tuesday.

(b) Lengthy or involved notices should be forwarded several days before publication.

(c) Proofs, which will be supplied only when specifically requested or at the direction of the Gazette Officer, should be returned promptly to avoid delay in publication.

(d) No additions or amendments to matters for publication will be accepted by telephone.

THE "VICTORIA GOVERNMENT GAZETTE".

SUBSCRIPTIONS.—The subscription, including postage, is \$46 per annum, or \$23 per half year, payable in advance.

Subscriptions are required for whole months, and must cover at least a half year.

Subscribers do not receive the Acts of Parliament with the GAZETTE.

GAZETTES are held in stock for five years only. Single copies posted may be obtained for 70 cents.

PRIVATE ADVERTISEMENTS.—The charge for insertion is 55 cents per line single column, and \$1.10 cents per line double column. The title forms one or more lines as a heading. On an average ten words make a line of single column. Every signature must likewise be counted as a line. The final words of a paragraph, though only portion of a line, must be counted as one line. Signatures (in particular) and proper names must be written very plainly in the text; ONE SIDE ONLY of each sheet of paper should be WRITTEN UPON. The charge for a full page is \$85.

All documents illegibly written will be returned unpublished, and where brands occur unprovided for by the ordinary letters of the alphabet, a worded explanatory description must be furnished.

PUBLICATION.—A VICTORIA GOVERNMENT GAZETTE is published every WEDNESDAY EVENING, unless advertised otherwise. ADVERTISEMENTS for insertion will be received by the Government Printer not later than the day preceding publication—at ordinary rates at or before ONE p.m. and at double rates between ONE p.m. and half-past THREE p.m.

PAYMENTS.—Unless the advertiser has a credit account, all payments are required in advance. Remittances should be made by cheque, postal order, or money order payable to "GOVERNMENT PRINTER".

ADDRESS.—All communications should be addressed to "The Government Printer, Box 203, P.O., North Melbourne, 3051."

AGENTS FOR THE "VICTORIA GOVERNMENT GAZETTE".

The following have been appointed agents to receive Advertisements and Subscriptions for the *Victoria Government Gazette*:—

ARMSTRONG'S AGENCY, 217 Queen Street, Melbourne, Victoria 3000.

ARNALL & JACKSON, 390 Barkly Street, Brunswick, Victoria 3056.

BAIRNSDALE AUTHORISED NEWSAGENCY, 132 Main Street, Bairnsdale, Victoria 3875.

BLANE'S AUTHORIZED NEWSAGENTS, 162 Murray Street, Colac, Victoria 3250.

CARTER, R. G., ADVERTISING SERVICE PTY. LTD., Suite 11, 285 Carlisle Street, Balaclava, Victoria 3183.

DAVIES, G. & M. V., 112 Gray Street, Hamilton, Victoria 3300
 DAVIS, WM. (MILDURA) PTY. LTD., 126 Eighth Street, Mildura, Victoria 3500.
 DIXON'S NEWSAGENCY, 89 Firebrace Street, Horsham, Victoria 3400.
 EDGAR'S AUTHORIZED NEWSAGENCY, 45 Bridge Street, Benalla, Victoria 3672.
 FRANKS, H., & CO., 184 Ryrie Street, Geelong, Victoria 3220.
 GATLEY, A. & J., 250 Lonsdale Street, Dandenong, Victoria 3175.
 GORDON & GOTCH AUSTRALASIA LTD., 434 St. Kilda Road, Melbourne, Victoria 3004.
 GULLAN'S NEWSAGENCY, 88 Bridge Street, Ballarat, Victoria, 3350.
 HAMPTON, A. C., 243 Mitchell Street, Bendigo, Victoria, 3550.
 HARSTON, PARTRIDGE & CO. PTY. LTD., 455 Little Collins Street, Melbourne, Victoria 3000.
 KYNETON GUARDIAN PTY. LTD., P.O. Box 18, Kyneton, Victoria 3444.
 LIVINGSTON'S SHEPPARTON NEWSAGENCY, 246 Wyndham Street, Shepparton, Victoria 3630.
 THE MERCANTILE EXCHANGE, 34 Queen Street, Melbourne, Victoria 3000.
 MCGILL'S AUTHORIZED NEWSAGENCY, 183-5 Elizabeth Street, Melbourne, Victoria 3000.
 POWNEY'S AUTHORIZED NEWSAGENCY, 293 Hargreaves Street, Bendigo, Victoria 3550.
 PURDIE, J., & CO., 138 Moorabool Street, Geelong, Victoria 3220.
 SALE AUTHORIZED NEWSAGENCY, 142 Raymond Street, Sale, Victoria 3850.
 SKINNER'S AUTHORIZED NEWSAGENCY, 49-51 Franklin Street, Traralgon, Victoria 3844.
 STEVENSON, A. C. & M., NEWSAGENTS, 132 Henty Street, Casterton, Victoria 3311.
 VANCE'S AUTHORIZED NEWSAGENCY, 83 Murray Street, Wangaratta 3677.
 VERNONS OF RICHMOND, 162 Bridge Road, Richmond, Victoria 3121.
 VIEW POINT AUTHORIZED NEWSAGENCY, 4 View-Point, Bendigo, Victoria 3550.

A copy of the Gazette is filed at each place for public reference.

Form 7.

Companies Act 1961, Section 21 (2), Sections 26 (1), (2) and 146 (1), Section 28 (9), Section 146 (1), Section 254 (2). Company No. 70974.

ASTERISK PROPRIETARY LIMITED.

NOTICE OF RESOLUTION.

At a general meeting of the members of Asterisk Proprietary Limited duly convened and held at 33 Sherringham Drive, Glen Waverley on the tenth day of May, 1976, the special resolution set out below was duly passed.

"That the company be wound up voluntarily."

"That Edward Peter Taylor be appointed liquidator of the company."

Dated this 10th day of May, 1976.

1647

B. CARROLL, Director.

Form 7.
 Companies Act 1961, Section 21 (2), Sections 26 (1), (2) and 146 (1), Section 28 (9), Section 146 (1) and Section 254 (2). Company No. 44746.

BELLCOLOUR PRINTING PROPRIETARY LIMITED.

NOTICE OF RESOLUTION.

At a general meeting of the members of Bellcolour Printing Proprietary Limited duly convened and held at 432 Waverley Road, East Malvern on the 13th day of May, 1976, the special resolution set out below was duly passed.

"That the company be wound up voluntarily."

"That Edward Peter Taylor of 583 Hampton Street, Hampton, 3188, registered liquidator be appointed liquidator of the company."

"That paragraph (c) of section 277A (1) shall not apply to the winding up of Bellcolour Printing Proprietary Limited."

Dated this 13th day of May, 1976.

1584

G. F. BELLMAINE, Director.

CONTENTS

PAGE

Acts of Parliament	1388
Acts of Parliament on Sale at the Government Printing Office	1435
Appointments	1406
Bank Half-Holiday	1387
Cemeteries—Scale of Fees	1402
Companies Act	1442
Contracts	1406
Courts	1393
Estates of Deceased Persons	1405
Government Notices	1389
Impoundings	1435
Lands	1415
Melbourne and Metropolitan Board of Works—Notice	1401
Mining	1405
Notice to Mariners	1402
Notice of Making of Statutory Rules	1435
Orders in Council—	
Acts—Sewerage Districts; Country Roads Board; Local Government; Land; Labour and Industry; Melbourne and Metropolitan Board of Works; Melbourne and Metropolitan Tramways; Fruit and Vegetables; Sewerage Districts; Archaeological and Aboriginal Relics; Preservation; Superannuation; Water; Sewerage Districts; Coal Mines; Metropolitan Fire Brigades.	1407 et seq
Private Advertisements	1421
Proclamations	1387
Public Half-Holiday	1387
Public Holiday	1389
Regulations—	
Act—Education	1417
Resignations	1407
Tenders	1420
Transport Regulation Board—Public Hearings	1391
Waterworks Trusts	1398