



VICTORIA GOVERNMENT GAZETTE

Published by Authority

No. 70]

WEDNESDAY, JULY 21

[1976

PROCLAMATION

Summary Offences Act 1966.

APPLICATION OF PROVISIONS OF SECTION 50A OF THE SUMMARY OFFENCES ACT 1966 TO THE SHIRE OF ARARAT.

PROCLAMATION

By His Excellency the Governor of the State of Victoria and its Dependencies in the Commonwealth of Australia, &c., &c., &c.

In pursuance of the powers conferred by the *Summary Offences Act 1966*, I, the Governor of the State of Victoria, in the Commonwealth of Australia, by and with the advice of the Executive Council of the said State and on the application of the Council of the Shire of Ararat do by this my Proclamation declare the municipal district of the Shire of Ararat to be a district to which Section 50A of the *Summary Offences Act 1966* applies.

Given under my Hand and the Seal of the State of Victoria aforesaid, at Melbourne, this thirteenth day of July, in the year of our Lord One thousand nine hundred and seventy-six and in the twenty-fifth year of the reign of Her Majesty, Elizabeth the Second Queen of Australia.

(L.S.) HENRY WINNEKE.

By His Excellency's Command,
VANCE DICKIE,
Chief Secretary.

GOD SAVE THE QUEEN!

GOVERNMENT NOTICES

Co-operation Act 1958.

BROWN HILL KINDERGARTEN CO-OPERATIVE LIMITED.

Notice is hereby given in pursuance of section 78 (7) of the *Co-operation Act 1958* and section 308 (2) of the *Companies Act 1961* that, at the expiration of three months from the date hereof, the name of the aforementioned society will, unless cause is shown to the contrary, be struck off the register and the society will be dissolved.

Dated this 22nd day of June, 1976.

E. P. LIDDELL,
Deputy Registrar.

Co-operative Housing Societies Act 1958.

CAXTON CO-OPERATIVE HOUSING SOCIETY LIMITED.

NOTICE OF DISSOLUTION OF SOCIETY.

Notice is hereby given that I have this day registered the dissolution of the above-named society and cancelled its registration under the above-named Act.

Dated at Melbourne, this 5th day of July, 1976.

E. P. LIDDELL,
Acting Registrar of Co-operative Housing Societies.

Victoria.

ACT 391.—SECOND SCHEDULE.

A Statement of Trusts having been submitted by the head or authorized representative of the denomination known as The Methodist Church of Australasia in Victoria under the provisions of the "Act to provide for the Abolition of State Aid to Religion", for allowance by the Governor, the same was allowed by him on the 13th day of July, 1976, and the following is the form in which such statement of trusts has been allowed.

STATEMENT OF TRUSTS.

Description of Land.—Site set apart for Wesleyan Church purposes, 8197 square metres, Township of Ballan, Parish of Ballan, County of Grant, being Crown allotment 5A, section 6; commencing at the south-western angle of Crown allotment 5, section 6; bounded thence by Steiglitz Street bearing 260 deg. 00 min. 89.12 metres, by the eastern boundary of Crown allotment 13, section 3, Parish of Gorong, bearing 0 deg. 00 min. 101.79 metres, by Inglis Street bearing 80 deg. 00 min. 74.03 metres; and thence by the western boundary of Crown allotment 5, section 6, Township of Ballan, bearing 170 deg. 00 min. 100.58 metres to the point of commencement.—(C.101289.)

Name of Trustees.—The Methodist Church (Victoria) Property Trust.

Powers of Disposition.—Such powers of disposition including powers of sale, lease or mortgage as are given to the Trust by the Methodist Church (Victoria) Property Trust Act being Act No. 8007 of 1970.

Purposes to which Proceeds of Disposition are to be Applied.—To such Methodist Church purposes as shall be approved by the Property Committee of the Annual Conference of the Methodist Church of Australasia in Victoria.

As witness the Hand of the Governor of the State of Victoria, this 13th day of July, 1976.

HENRY WINNEKE,
Governor of the State of Victoria.

Transport Regulation Act.
TRANSPORT REGULATION BOARD.

HEARING OF APPLICATIONS.

Notice is hereby given that the following applications will be considered by the Transport Regulation Board on 10th August, 1976.

KENNEDY, K. T. & J. P., Hastings. Applications by the holder of six C.T. licences and two C.H. licences (including one temporary C.H. licence) operating from Hastings and Crib Point, for issue of a country hire car licence in lieu of licence C.T.200 and in respect of a Ford Galaxie Ltd. with seating capacity for five persons, to operate from Hastings.

NOTE.—This application is made subject to cancellation of licence C.T.200 and temporary C.H. licence held in the name of the applicant.

SPICER, W. A., Toora. Application to license a five seating capacity vehicle as a country hire car to operate from an address at Toora subject to the cancellation of existing licences C.H.14 and C.H.15 held in the names A. E. & K. B. Holland.

TRANS OTWAY LTD., Geelong. Application to license a forty-five seat coach to operate as follows: (a) As an additional C.O. licensed vehicle, under the same terms and conditions as existing licences. (b) Charter from the Geelong Urban District.

NOTE.—This application replaces an application for an additional U.O. licence, which appeared in the *Government Gazette* dated 30th June, 1976.

RENEWALS.

Applications for renewal of licences as shown by the persons listed hereunder to operate under the same terms and conditions—

PAPOULDIS, P., Brunswick; M.T.4863.

REBLCO PTY. LTD., Preston; T.P.205.

Notice of any objections should be forwarded to reach the Secretary of the Board not later than 4th August, 1976.

Applicants are advised that it will not be necessary to appear on the hearing date specified, unless advised in writing by the Board.

A. V. C. COOK,
Secretary.

Corner Lygon and Princes' Streets, Carlton, 3053,
Wednesday, 21st July, 1976.

Commercial Goods Vehicles Act.
TRANSPORT REGULATION BOARD.

HEARING OF APPLICATIONS.

Notice is hereby given that the following applications will be considered by the Transport Regulation Board on 10th August, 1976.

ANSETT TRANSPORT INDUSTRIES (OPERATIONS) PTY. LTD., 89 High Street, Bendigo, 3550. One commercial goods vehicle (L/C. 1.00 tonne) to operate within an 80-km radius of the premises of J. Sist & Co. Pty. Ltd. an associate company, earth-moving contractors for the purpose of servicing earth-moving equipment and plant—tools of trade, spare parts and materials incidental to on-site servicing in the field only.

CANANZI HYDRO-PNEUMATICS PTY. LTD., Rear of 192 Edwards Street, Reservoir, 3073. One commercial goods vehicle (L/C. 1.95 tonne) to operate throughout the State of Victoria in the course of business as "Hydraulic and General Engineers" for the purpose of servicing and installing hydraulic equipment—tools of trade, spare parts, hydraulic components and equipment for specialised installation and materials incidental to on-site servicing.

CAPP, W. G., 11 Boston Road, Bundoora, 3083. One commercial goods vehicle (L/C. 1.00 tonne) to operate: (a) Within an 80-km radius of the G.P.O., Melbourne in the course of business as "Automotive Parts Wholesaler"—own goods. (b) Throughout the State of Victoria for the purpose of displaying automotive parts and booking orders—automotive parts and automotive accessories for display purposes only, excluding the ability to make a delivery under paragraph (b).

CASTLEHOW, R. E., 46 Harold Street, Ascot Vale, 3032. One commercial goods vehicle (L/C. 4.85 tonne) to operate within an 80-km radius of the G.P.O., Melbourne, solely on behalf of Cadbury Schweppes Pty. Ltd.—aerated waters and empty return containers.

CLARK KING & CO. PTY. LTD., 33-37 Walsh Street, West Melbourne, 3003. One commercial goods vehicle (L/C. 17.45 tonne) to operate: (a) Within an 80-km radius from the post office at the corner of Bourke and Elizabeth Streets in the City of Melbourne in the course of business as "Stockfeed Manufacturers" in specially constructed bulk tanker unit—own stockfeed in bulk. (b) From own premises at North Melbourne to Morwell in specially constructed bulk vehicle—own stockfeed in bulk.

CLARIDGE, W. L., 69 Holdsworth Road, Eaglehawk, 3556. One commercial goods vehicle (L/C. 19.40 tonne) to operate within a 160-km radius of the chief post office in the City of Bendigo in the course of business as "House Removers"—houses, sheds and out-buildings for removal and subsequent re-erection also tools of trade, equipment and materials incidental to the re-erection of the said building being moved.

COBRAM FURNISHING CO. PTY. LTD., 20-34 Sydney Street, Cobram, 3644. One commercial goods vehicle (L/C. 3.05 tonne) to operate: (a) Within an 80-km radius of the post office at Cobram in the course of business as "Furniture and Homewares Retailer"—own goods. (b) From agents and manufacturers in the Melbourne metropolitan area to own premises at Cobram—new furniture as per new furniture list.

COLGATE, R. E. (P.O. Box 198), Apsley Road, Edenhope, 3318. One commercial goods vehicle (L/C. 13.10 tonne) to operate general goods within an area bounded as follows: (a) On the west by the Victorian/South Australian border. (b) On the north by the road running from Horsham, via Natimuk and Goroke to the border of South Australia *en route* to Frances S.A. (c) On the east by the road running from Horsham, via Noradjuha, Jalumba, Kanagulk and Balmoral to Hamilton. (d) On the south by the road running from Hamilton via Coleraine and Casterton to the border of South Australia *en route* to Penola S.A.

NOTE.—This application replaces licence No. D.A.868/1 previously held in the name of E. R. Colgate.

DOWELL AUSTRALIA LTD., Box 102, Preston, 3072. Two commercial goods vehicles (L/C. 0.75 tonne each) to operate throughout the State of Victoria in the course of business as "Window and Door Manufacturers" for the purpose of servicing and installing glazed windows and doors—tools of trade, spare parts, glazed windows and doors for installation and materials incidental thereto.

TRANS DYER MANAGEMENT PTY. LTD (trading as Dyers Transport), 34-46 York Street, Sale, 3850. Application to vary the conditions of licence numbers D.A.43146/15 to D.A.43146/24, D.A.43146/31, D.A.43146/33, D.A.43146/34, D.A.43146/35 by adding to the existing conditions paragraphs (k) and (l)—(k) From the premises of Coles New World depots situated within a 40-km radius of the G.P.O. Melbourne to Coles New World Retail Stores situated at Warragul, Moe, Morwell, Traralgon and Sale—frozen goods, groceries and allied products. (l) From Coles New World Retail Stores situated at Warragul, Moe, Morwell, Traralgon and Sale to Coles New World Storage Depots situated within a 40 km radius of the G.P.O. Melbourne—empty return containers, empty return pallets &c.

BELL, J. A. & E. J. (trading as E. J. & J. A. Timber Transport), 22 Ailsa Street, Mansfield, 3722. Application to vary the conditions of licence No. D.T.1670 by deleting "Benalla" and adding in lieu "Jamieson".

LINFORD, D. R. (trading as Elmore Chemicals), 64 Railway Place, (Northern Highway) Elmore, 3558. One commercial goods vehicle (L/C. 3.97 tonne) to operate: (a) Within a 40-km radius of the railway station at Elmore—general goods. (b) From points throughout the State of Victoria to own premises at Elmore being an approved decentralized secondary industry (chemicals) at Elmore—raw materials and goods used solely in the manufacturing processes of such industry. (c) From own premises at Elmore being an approved decentralized secondary industry (chemicals) to points throughout the State of Victoria—manufactured articles and products from the said industry.

GARDENER, J. F. & L. H., 4 McIlraith Court, Croydon; 3136. One commercial goods vehicle (L/C. 9.58 tonne) to operate within an 80-km radius of the G.P.O. Melbourne on behalf of Albion Reid Pty. Ltd.—premixed concrete in a specially constructed agitator vehicle.

GRANT, J. A., P.O. Box 680 (Midland Highway Jeeralang Junction), Morwell, 3840. One commercial goods vehicle (L/C. 16.50 tonne) to operate: (a) Within an 80-km radius of the post office at Morwell—plant

- the property of a contractor and required by him for use in connection with the construction or maintenance of some specific, existing or proposed road, street, footpath, bridge, pier, wharf, weir or channel and also the following materials—viz: metal, stones, screenings, ashes, gravel, sand and earth. (b) Within a 32-km radius from the site of any construction or maintenance work performed pursuant to paragraph (a) above, or from the railway station nearest thereto—any other materials required for such work. (c) Within a 40-km radius of the post office at Morwell—general goods.
- GUARDIAN STEEL INDUSTRIES PTY. LTD.**, 2137 Dandenong Road, Clayton, 3168. One commercial goods vehicle (L/C. 0.80 tonne) to operate: (a) Within an 80-km radius of own premises at Clayton in the course of business as "Steel Garage Manufacturers"—own goods. (b) Throughout the State of Victoria—own tools of trade and equipment. (c) Within a 40-km radius of any current contract site or from the railway station nearest thereto any materials required for use on such contract.
- HUNTER, W. B., PTY. LTD.**, Meninya Street, Moama, N.S.W., 2739. Six commercial goods vehicles (L/C. 19.30, 19.30, 19.60, 19.60, 19.60 tonne) to operate throughout the State of Victoria—general goods:
- JOHNS & WAYGOOD LTD.**, Corner City Road and Cecil Street, South Melbourne, 3205. One commercial goods vehicle (L/C. 0.85 tonne) to operate: (a) Within an 80-km radius of own premises at South Melbourne in the course of business as "Structural Engineers"—own goods. (b) Between own premises at South Melbourne and own site office at Yallourn W power station and within a 40-km radius thereof for the purpose of supervising own contract—tools of trade, spare parts, materials incidental to servicing and urgent replacement small structural components.
- KENYON, C. W.**, 34 Wellington Street, Kerang, 3579. Two commercial goods vehicles (L/C. 0.75 and 2.50 tonne trailer and 0.75 tonne) to operate within a 160-km radius from own premises at Kerang in course of business as "Motor Vehicle and Agricultural Equipment Dealer" for the purpose of servicing: farm machinery, tractors and motor vehicles—tools of trade and spare parts incidental thereto.
- KEOGH, P., PTY. LTD.**, 371 Francis Street, Yarraville, 3013. One commercial goods vehicle (L/C. 0.60 tonne) to operate throughout the State of Victoria in the course of business as "Erection Engineers and Contractors" for the purposes of servicing own equipment and supervising own contracts—tools of trade, spare parts, erection gear, equipment and materials incidental to servicing.
- KEOGH, P., PTY. LTD.**, 371 Francis Street, Yarraville, 3013. Two commercial goods vehicles (L/C. 17.25 and 17.05 tonne) to operate: (a) Within a 40-km radius from the post office at the corner of Bourke and Elizabeth Streets, Melbourne—general goods. (b) Throughout the State of Victoria in the course of business as "Erection Engineers and Contractors"—tools of trade, erection equipment, machinery and materials incidental thereto with sufficient fuel, oil and grease to operate machinery on site but subject to the condition that the total aggregate weight of all materials carried on the vehicle at any one time shall not exceed one tonne. (c) Within a 32-km radius from the site of any contract upon which the applicant is currently engaged or to such site from the railway station nearest thereto—materials for use in such contract.
- HEYWOOD, BRUCE ALFRED** (trading as Maryvale Sand & Trading Supply), 30 George Street, Morwell, 3840. One commercial goods vehicle (L/C. 8.45 tonne) to operate: (a) Within a 40-km radius of Morwell—general goods. (b) Within an 80-km radius of own premises at Morwell in the course of business as "Sand and Gravel Supply"—sand and gravel. (c) Within a 50-km radius of Glenco Lime at Dutton—agricultural lime.
- MORGAN, A.**, 1 Townsend Street, Churchill, 3842. One commercial goods vehicle (L/C. 11.50 tonne) to operate: (a) From points throughout the State of Victoria to the premises of Seven X Beverages Pty. Ltd. at Morwell being an approved decentralized secondary industry (aerated waters) solely on behalf of the said company—goods and raw materials for use solely in the manufacturing process of such industry. (b) From the premises of Seven X Beverages Pty. Ltd. at Morwell to points throughout the State of Victoria—manufactured articles or products from such industry.
- NAPIER, B. F.**, Harrow, 3317. One commercial goods vehicle (L/C. 3.00 tonne) to operate: (a) Within a 40-km radius of the post office at Harrow—general goods. (b) Within an 80-km radius of the post office at Harrow in the course of business as "Marine Collectors"—marine stores and old metals as defined in the *Marine Stores and Old Metals Act 1958*, No. 6303, Part 1, Section 3.
- NORTH POINT CARAVANS PTY. LTD.**, 1515–1521 Sydney Road, Campbellfield, 3061. One commercial goods vehicle (L/C. 0.70 tonne) to operate throughout the State of Victoria in the course of business as "Caravan Dealer and Distributor" for the purpose of towing caravans—own caravans and caravans having been traded.
- PANOFF, A.**, 28 Wells Road, Frankston, 3199. One commercial goods vehicle (L/C. 9.75 tonne) to operate: (a) Within a 40-km radius of own premises at Frankston in the course of business as "Soil, Screening and Garden Supply"—own goods. (b) From pits at Tynong to own premises at Frankston—own sand. (c) From Bacchus Marsh and Yea to own premises at Frankston—own river pebbles.
- PEACOCK & SMITH PTY. LTD.**, Foch Street, North Shore, 3214. One commercial goods vehicle (L/C. 1.60 tonne) to operate within an 80-km radius of own branch premises at North Shore, Geelong in the course of business as "Marine and Industrial Engineers"—tools of trade, spare parts and materials required for on-site servicing of marine and industrial equipment and marine and industrial equipment for repair or having been repaired.
- PRIDHAM, W. (AUST.) PTY. LTD.**, 11 Evans Street, Braybrook, 3019. One commercial goods vehicle (L/C. 11.75 tonne) to operate: (a) Within an 80-km radius from own premises at Braybrook in the course of business as "Meat Meal, Tallow and Casing Manufacturers"—own goods (other than restricted goods which may be specified by notice in the *Government Gazette*: from time to time). (b) Throughout the State of Victoria for collection from country abattoirs, butchers and killing centres for return to own premises at Braybrook—offal, bones, animal runners and waste materials, excluding tallow. (c) Within an 80-km radius of own premises at Braybrook in the course of business as "Meatmeal, Tallow and Casing Manufacturers"—for collection from butchers and abattoirs—meatmeal, tallow and semi-processed tallow and protein meal.
- RAND, D. B.**, Lot 52, Cranbourne Road, Langwarrin, 3910. One commercial goods vehicle (L/C. 11.75 tonne) to operate within an 80-km radius from the premises of Wall Truss Pty. Ltd. at Dandenong as an "Installation Contractor" solely on behalf of the said company—but excluding operations to the City of Geelong—prefabricated timber roof trusses, prefabricated wall frames and erection equipment.
- SCHILKE, WALTER**, 6 Lantana Court, Wantirna, 3152. One commercial goods vehicle (L/C. 13.60 tonne) to operate: (a) Within a 40-km radius of own premises at Wantirna in the course of business as "Soil, screening and Garden Supply"—own goods. (b) From Seymour and Yea to own premises at Wantirna—own river pebbles. (c) From Pirron Yallock, Bacchus Marsh and Rockbank to own premises at Wantirna—own rock. (d) From Toolangi to own premises at Wantirna—own mountain soil.
- SILLFY NOMINEES PTY. LTD.**, 7 Market Court, Reservoir, 3073. One commercial goods vehicle (L/C. 0.70 tonne) to operate within an 80-km radius of own branch premises at Mansfield and to Shepparton in the course of business as "Electrical Contractors and Service" for the purpose of servicing and installing electrical equipment—tools of trade, spare parts, electrical appliances for specialised installation and materials incidental to on-site servicing.
- TOTALIZATOR AGENCY BOARD**, 2 Queens Road, Melbourne, 3004. One commercial goods vehicle (L/C. 0.75 tonne) to operate throughout the State of Victoria in the course of business as "Totalizator Agency" for the purpose of servicing and maintenance of Ticket Issuing Machines—tools of trade, spare parts, and materials incidental to on-site servicing.
- TROTTER, D. J. & C. C.**, P.O. Box 7, Warracknabeal, 3393. Two commercial goods vehicles (L/C. 2.65 and 5.95 tonne) to operate: (a) Within an 80-km radius of the Mobil Oil Australia Pty. Ltd. depot at Warracknabeal as a Petroleum Agent—petroleum products in prescribed types of containers and empty return containers. (b) Within an 80-km radius of the Mobil

Oil Australia Pty. Ltd. depot at Warracknabeal—bulk petroleum tanks for installation on properties within the said radius.

HOLLAND, J. G. (trading as Warrnambool Bowl), 153 Timor Street, Warrnambool, 3280. One commercial goods vehicle (L/C, 0.85 tonne) to operate throughout the State of Victoria in course of business as Amusement Equipment Hirer—own equipment for hire and for return after having been hired.

WHYTE, K. R., 30 Hopetoun Road, Warrnambool, 3280. One commercial goods vehicle (L/C, 8.00 tonne) to operate: (a) Within an 80-km radius of the chief post office in the City of Warrnambool in the course of business as "Plumber and Drainage Contractor"—own goods. (b) Within that part of the State of Victoria bounded on the east by a north/south line drawn through the City of Geelong and bounded on the north by an east/west line drawn through the City of Horsham—own tools of trade and own equipment incidental to own contracts.

TOW TRUCK.

PARKLANE PANELS PTY. LTD., Park Lane, Box 32, Romsey, 3434. One commercial goods vehicle (to be constructed approximately 3.00 tonne) to operate within an 80-km radius of own premises at Romsey as a "Tow Truck" for the purpose of towing wrecked or disabled vehicles—wrecked or disabled vehicles—tools of trade, spare parts and materials incidental to the repair of disabled motor vehicles.

RENEWALS.

Applications for renewal of licences as shown by persons listed hereunder to operate under the same terms and conditions from the expiry shown in each case.

AKENIS, E., 35 Sharp Street, Newtown, 3220; D.A.50768/1; 30th September, 1976; 7.40 tonne.
 BARKER, R. S., 2-10 St. Andrews Avenue, Bendigo, 3550; D.A.62076; 29th October, 1976; 1.50 tonne.
 BARKLA, G. J., 6 Lanoma Court, Mulgrave, 3170; D.A.53325; 26th October, 1976; 4.70 tonne.
 BAGLIN, I. W., 2 Sussex Street, Blackburn, 3130; D.A.62271; 29th October, 1976; 0.50 tonne.
 BROADBENT, H. A., 324 Centre Road, Bentleigh, 3204; D.A.62217/1; 14th October, 1976; 7.85 tonne.
 BROADBENT, H. A., 324 Centre Road, Bentleigh, 3204; D.A.62217/2; 14th October, 1976; 8.05 tonne.
 BROWN, J. R., 158-162 Princes Highway, Warrnambool, 3280; D.A.741/10; 21st August, 1976; 13.60 tonne.
 CECIL, G. L., Drouin Road, Poowong, 3988; D.A.53504; 5th October, 1976; 6.80 tonne.
 CLARK, W. G., 145 Victoria Street, Kerang, 3579; D.A.65641; 23rd October, 1976; 0.55 tonne.
 THE COBDEN & DISTRICT CO-OPERATIVE PIONEER CHEESE & BUTTER FACTORY CO. LTD., 229 Curdie Street, Cobden, 3266; D.A.61181/25; 29th October, 1976; 0.75 tonne.
 COLGATE, R. E., Box 198, P.O., Edenhope, 3318; D.A.66736; 6th September, 1976; 12.40 tonne.
 CONCRETE TESTING PTY. LTD., 33 Cremorne Street, Richmond, 3121; D.A.62194; 30th September, 1976; 0.80 tonne.
 CONCRETE TESTING PTY. LTD., 33 Cremorne Street, Richmond, 3121; D.A.62194/1; 30th September, 1976; 1.00 tonne.
 COOK, E. G. L., Waterloo Road, Trafalgar, 3824; D.A.887/5; 22nd September, 1976; 11.30 tonne.
 COOMBS, A. G., GROUP PTY. LTD., 26 Cochranes Road, Moorabbin, 3189; D.A.891/7; 5th October, 1976; 0.75 tonne.
 COOMBS, A. G., GROUP PTY. LTD., 26 Cochranes Road, Moorabbin, 3189; D.A.891/34; 9th October, 1976; 0.75 tonne; D.A.891/35; 9th October, 1976; 0.75 tonne.
 CORDERY, K. L., Pryor's Road, Drouin, 3818; T.D.A.33539/4; 24th September, 1976; 8.05 tonne and 3.40 tonne trailer).
 COWLAND, J. W., 12 Mines Road, East Ringwood, 3135; D.A.65597; 9th October, 1976; 0.65 tonne.
 CURTIN, V. T. (trading as Vern Curtin Motors), 86 Graham Street, Wonthaggi, 3995; T.D.A.67848; 15th September, 1976; 0.50 tonne.
 DALTON, D. P., Whorouly, via Wangaratta, 3677; D.A.40639/1; 24th October, 1976; 7.15 tonne.
 DALTON, D. P., Whorouly, via Wangaratta, 3677; D.A.40639; 24th October, 1976; 6.65 tonne.
 DEVLIN, A. G., 20 McKenzie Street, Alexandra, 3714; D.A.62191/1; 23rd October, 1976; 0.75 tonne.
 ENSIGN SERVICES (VIC.) PTY. LTD., 109 Archer Street, Shepparton, 3630; D.A.1046/14; 16th October, 1976; 3.35 tonne.

ENSGN SERVICES (VIC.) PTY. LTD., 24 Leinster Grove) Northcote, 3070; D.A.1046/15; 16th October, 1976; 3.30 tonne.

ESSO AUSTRALIA LTD., 42 Raymond Street, Sale, 3850; D.A.60640/17; 16th October, 1976; 0.70 tonne; D.A.60640/20; 16th October, 1976; 0.70 tonne.

ESSO AUSTRALIA LTD., 42 Raymond Street, Sale, 3850; D.A.60640/15; 16th October, 1976; 0.70 tonne; D.A.60640/16; 16th October, 1976; 0.70 tonne.

FITZROY SAND & GARDEN SUPPLIES PTY. LTD., 13A Alfred Crescent, North Fitzroy, 3068; D.A.65170/2; 4th September, 1976; 7.70 tonne.

FYFE, K. F., Box 179, Sale, 3850; D.A.61293/1; 29th October, 1976; 9.20 tonne.

DIVERSE PRODUCTS LTD. (trading as Grampian Beverages), Stawell Road, Horsham, 3400; D.A.65160/2; 28th February, 1976; 0.60 tonne.

GREY, S. C., 112 Salisbury Street, Orbost, 3888; D.T.1510; 5th September, 1976; 18.60 tonne.

GOODALL, H., & SON PTY. LTD., Dunlop Street, Mortlake, 3272; D.A.1171/6; 29th October, 1976; 0.35 tonne.

HOWELL, L. A., 21 Cheshunt Avenue, Morwell, 3840; D.A.62144; 30th September, 1976; 6.60 tonne.

HUTCHINSON, ROBERT, LTD., Hartington Street, Glenroy, 3046; T.D.A.27836/63; 9th October, 1976; 8.15 tonne.

HUTCHINSON, ROBERT, LTD., Hartington Street, Glenroy, 3046; T.D.A.27836/66; 7th October, 1976; 11.65 tonne.

HUTCHINSON, ROBERT, LTD., Hartington Street, Glenroy, 3046; T.D.A.27836/67; 21st October, 1976; 6.65 tonne.

JEFFREY, J., & SONS PTY. LTD., Princes Highway, Morwell, 3840; D.A.32735/33; 30th September, 1976; 10.60 tonne.

LEURY, D. P., 13 Daley Street, Pascoe Vale, 3044; D.A.61095/1; 30th September, 1976; 11.60 tonne.

LYLE, R. B. & I., 21 Crook Street, Bacchus Marsh, 3340; D.A.62161/1; 13th September, 1976; 12.80 tonne.

MALLEYS CONSUMER SERVICES PTY. LTD., corner Cameron & Allen Streets, Moreland, 3058; D.A.67058; 30th October, 1976; 0.75 tonne.

MANDEL, N., 54 Spray Street, Elwood, 3184; D.A.53586; 19th October, 1976; 9.95 tonne.

MENDELSON, N. R., Lot 26, Scottsangle Road, Wattle Glen, 3096; D.A.62223; 14th October, 1976; 6.15 and 5.00 tonne trailer.

MIDLAND BRICK CO. PTY. LTD., P.O. Box 663, Shepparton, 3630; D.A.45839/4; 30th September, 1976; 1.10 tonne.

MOBILCO LIMITED, 410 Whitehorse Road, Mitcham, 3132; D.A.48327/11; 5th October, 1976; 1.00 tonne.

MORWELL TYRE SERVICE PTY. LTD., 8 Collins Street, Morwell, 3840; D.A.62030; 19th August, 1976; 0.85 tonne.

MORWELL TYRE SERVICE PTY. LTD., 8 Collins Street, Morwell, 3840; D.A.62030/2; 19th August, 1976; 0.80 tonne.

NEWMAN, G. W., 35 Fernhill Road, Mt. Evelyn, 3796; D.A.62255; 29th October, 1976; 11.60 tonne.

PHILLIPS, R. J., 2A Bruce Street, West Coburg, 3058; D.A.53274/2; 31st August, 1976; 2.25 tonne.

PHILLIPS, M. E. (trading as R. J. Phillips), 2A Bruce Street, West Coburg, 3058; D.A.53274/1; 31st August, 1976; 3.00 tonne.

PIONEER QUARRIES (VIC.) PTY. LTD., 87 High Street, Prahran, 3181; D.A.64073/3; 31st July, 1976; 17.21 tonne.

PUMP, H. O., 13 Hazelwood Road, Traralgon, 3844. D.A.62023; 12th August, 1976; 0.30 tonne.

RAWLINGS, D. P., Swiftscreek, 3896; D.A.65712; 5th October, 1976; 4.80 tonne.

RAYMOND, G. N., TIMBER PTY. LTD., Greens Road, Dandenong, 3175; D.T.1068/3; 16th September, 1976; 6.90 tonne.

RAYMOND, G. N., TIMBER PTY. LTD., Greens Road, Dandenong, 3175; D.T.1068/7; 4th September, 1976; 6.85 tonne.

ROBUR TEA CO. PTY. LTD., 28 Clarendon Street, South Melbourne, 3205; D.A.1940; 25th August, 1976; 1.05 tonne.

SAVORY, R. W. & P., 18 Farmer's Lane, Orbost, 3888; T.T.D.1606; 29th September, 1976; 20.00 tonne.

SELKIRK FREIGHT LINES PTY. LTD., 630 Howitt Street, Ballarat, 3350; D.A.11450/10; 5th October, 1976; 10.90 and 9.80 tonne trailer.

SENIOR G. J. R. (trading as Senior Paper Supplies), 20 Jersey Road, Bayswater, 3153; T.D.A.57279/1; 9th March, 1976; 3.30 tonne.

SEVEN X BEVERAGES PTY. LTD., 16-20 First Avenue, Sunshine, 3020; T.D.A.63354/8; 6th July, 1976; 3.65 tonne.

SIGMA CO. LTD., 1408 Centre Road, Clayton, 3168; D.A.2435/3; 29th October, 1976; 0.80 tonne.

SMITH, W. F., 17 Michael Place, Box 265, Leongatha, 3953; D.A.44523/2; 21st September, 1976; 6.35 tonne.

SURE TRANSPORT PTY. LTD., P.O. Box 350 Warragul, 3820; D.A.64478/6; 18th September, 1976; 11.40 tonne.

VENN, J., 41 Vickery Street, Alexandra, 3714; T.D.A.62823; 5th October, 1976; 5.85 tonne.

WHITFIELD, T. W. & M. D., 116 The Fairway, Kingsbury, 3083; D.A.65546; 11th September, 1976; 8.60 tonne.

WILLIAMS, G. W., ELECTRONICS PTY. LTD., 248 Lonsdale Street, Dandenong, 3175; D.A.66515; 24th September, 1976; 1.30 tonne.

WILSON, B. J. (trading as Wilson & Sheridan), 22 McCann Crescent, Kerang, 3579; D.A.47105/1; 19th August, 1976; 0.40 tonne.

WILSON, A. E., 86 Mine Road, Korumburra, 3950; D.A.63758/2; 28th August, 1976; 1.10 tonne.

DYKE, S. W., Mirboo North, 3871; D.A.52949; 10th August, 1976; 3.60 tonne.

TOW TRUCKS.

BARTON, J., 208 Main Street, Box 82 P.O., Bacchus Marsh, 3340; D.A.53716; 5th October, 1976; 3.10 tonne.

CUSACK MOTORS, Barker Street, Castlemaine, 3450; D.A.46078/1; 30th September, 1976; 2.95 tonne.

MELBOURNE TOWING SERVICE PTY. LTD., 169 City Road, South Melbourne, 3205; D.A.2816/19; 26th October, 1976; 2.65 tonne.

MODERN TOWING & SALVAGE PTY. LTD., 380 Barkly Street, Footscray, 3011; D.A.28588/1; 1st October, 1976; 3.00 tonne.

PURECO PTY. LTD., 88 Moore Street, Moe, 3825; D.A.61846; 30th September, 1976; 3.35 tonne.

RENEWALS WITH VARIATION.

Applications made by the persons listed hereunder for renewal of the licences listed with variation of conditions in the manner set out opposite the name.

BAULCH, B. S. (trading as Baulch Electric Fencing), Private Bag 35, Hawkesdale, 3287; D.A.65603; 9th October, 1976. Applications to renew and vary the conditions of licence No. D.A.65603 (L/C. 1.75 tonne) by deleting existing paragraph (a) and adding in lieu as paragraph (a) "Throughout the State of Victoria in the course of business as "Fencing Contractor"—tools of trade and materials incidental to own contract, maximum weight not to exceed 0.25 tonnes providing these goods are railed to Warrnambool Station initially".

KENNEDY, G. T. (trading as G. T. & S. M. Kennedy), Station Road, Bruthen, 3885; T.T.D.1600; 6th August, 1976. Application to renew and vary the conditions of licence No. T.T.D.1600 (L/C. 17.35 tonne) by deleting existing conditions and adding in lieu—"From forest landings situated within a radius of 80-km of Bairnsdale Post Office to sawmills operated by S. M. Collins Pty. Ltd. at Bairnsdale and Stratford, to Trimview Timber Mills at Swifts Creek and sawmills at Bruthen—sawmill logs".

BIELBY, G. A. (trading as Wendouree Confectionery Wholesalers), 28 Lake Street, Wendouree, 3355; D.A.61497/1; 29th October, 1976. Application to renew and vary the conditions of licence No. D.A.61497/1 by adding to paragraph (b) the words "Landsborough and Towns en route via Ararat".

Notice of any objection should be forwarded to reach the Secretary of the Board not later than 4th August, 1976.

Applicants are advised that it will not be necessary to appear on the hearing date specified above, unless advised in writing by the Board.

A. V. C. COOK,
Secretary.

Corner Lygon and Princes Streets, Carlton, 3053,
21st July, 1976.

LOCAL GOVERNMENT DEPARTMENT.

ORDER CONFIRMED.—SHIRE OF DIAMOND VALLEY.

The Minister of the Crown administering the Local Government Act 1958, on the 16th day of July, 1976, confirmed the Order hereinafter referred to in pursuance of section 514 of the said Act namely:

An Order of the Council of the Shire of Diamond Valley made on the 31st May, 1976 directing the compulsory taking of the land described hereunder for the purpose of providing a road reserve.

1. All that piece of land being part of lot 1 on Plan of Subdivision No. 83107 lodged in the Office of Titles and commencing at the north-west corner of the said lot 1 and bounded; thence by a line bearing 90 deg. 22 min. for a distance of 9.14 metres; thence bearing 180 deg. 22 min. for a distance of 20.73 metres; thence bearing 153 deg. 46 min. 12 sec. for a distance of 21.81 metres; thence bearing 127 deg. 10 min. 24 sec. for a distance of 143.89 metres; thence bearing 180 deg. 22 min. for a distance of 24.38 metres; thence bearing 282 deg. 52 min. for a distance of 125.17 metres; thence bearing 321 deg. 37 min. for a

distance of 19.01 metres; thence bearing 0 deg. 22 min. for a distance of 108.89 metres back to the point of commencement.

2. All those pieces of land being part of lots 1 and 3 on Plan of Subdivision No. 52011 lodged in the Office of Titles and—

(a) commencing at the north-west corner of the said lot 1 and bounded; thence by a line bearing 90 deg. 8 min. for a distance of 10.67 metres; thence bearing 180 deg. 39 min. for a distance of 30.52 metres; thence bearing 270 deg. 22 min. for a distance of 9.14 metres; thence bearing 0 deg. 22 min. for a distance of 30.48 metres back to the point of commencement.

(b) commencing at the north-west corner of the said lot 3 and bounded; thence by a line bearing 90 deg. 22 min. for a distance of 9.14 metres; thence bearing 180 deg. 22 min. for a distance of 30.48 metres; thence bearing 270 deg. 22 min. for a distance of 9.14 metres; thence bearing 0 deg. 22 min. for a distance of 30.48 metres back to the point of commencement.

3. All that piece of land being part of lot 2 on Plan of Subdivision No. 52011 lodged in the Office of Titles and commencing at the north-west corner of the said lot 2 and bounded; thence by a line bearing 90 deg. 22 min. for a distance of 9.14 metres; thence bearing 180 deg. 22 min. for a distance of 30.48 metres; thence bearing 270 deg. 22 min. for a distance of 9.14 metres; thence bearing 0 deg. 22 min. for a distance of 30.48 metres back to the point of commencement.

4. All that piece of land being part of lot 4 on Plan of Subdivision No. 52011 lodged in the Office of Titles and commencing at the north-west corner of the said lot 4 and bounded; thence by a line bearing 90 deg. 22 min. for a distance of 9.14 metres; thence bearing 180 deg. 22 min. for a distance of 30.48 metres; thence bearing 270 deg. 22 min. for a distance of 9.14 metres; thence bearing 0 deg. 22 min. for a distance of 30.48 metres back to the point of commencement.

5. All that piece of land being part of lot 5 on Plan of Subdivision No. 52011 lodged in the Office of Titles and commencing at the north-west corner of the said lot 5 and bounded; thence by a line bearing 90 deg. 22 min. for a distance of 9.14 metres; thence bearing 180 deg. 22 min. for a distance of 30.48 metres; thence bearing 270 deg. 22 min. for a distance of 9.14 metres; thence bearing 0 deg. 22 min. for a distance of 30.48 metres back to the point of commencement.

A. J. HUNT,

Minister for Local Government.

Local Government Department,
Melbourne (76/3454).

Stamps Act 1958.

ANNUAL LICENCE.

I hereby notify that stamp duty has been paid for a licence under section 96 of the Stamps Act to carry on assurance and insurance business in Victoria in respect of the year ending 31st December, 1976, by the following:—

B. CHALMERS LEASK UNDERWRITING AGENCIES PTY. LTD.
R. M. PHIBBS,
Comptroller of Stamps.

Stamp Duties Office,
Melbourne, 21st July, 1976.

Stamps Act 1958.

ANNUAL LICENCE.

I hereby notify that stamp duty has been paid for a licence under section 96 of the Stamps Act to carry on assurance and insurance business in Victoria in respect of the period 1st February, 1976 to 31st December, 1976, by the following:—

HARLOCK & AUGUSTINE PTY. LTD.

R. M. PHIBBS,
Comptroller of Stamps.

Stamp Duties Office,
Melbourne, 21st July, 1976.

CORRIGENDUM.

In Victoria Government Gazette, No. 68, dated 7th July, 1976, page 2115 under the heading "Melbourne Metropolitan Board of Works, Sewerage Area No. 3063" in line 9, substitute the word "eastern" with "western".

Soil Conservation and Land Utilization Act 1958.

NOTICE IN RESPECT OF CHANGE IN LAND USE IN A SPECIFIED PART OF THE ROSSLYNNE RESERVOIR (RIDDELL CREEK) WATER SUPPLY CATCHMENT.

(PROCLAIMED 14TH SEPTEMBER, 1971, VICTORIA GOVERNMENT GAZETTE No. 87, DATED 22ND SEPTEMBER, 1971.)

Notice is hereby given that the Soil Conservation Authority in pursuance of its powers under the Soil Conservation and Land Utilization Act 1958, as amended, has specified the changes in land use which may not be made without the prior approval of the Authority, within the specified part of the Rosslynne Reservoir (Riddell Creek) Water Supply Catchment as defined on Authority Plan No. S382 hereunder, the original of which is lodged at the Head Office of the Soil Conservation Authority at 378 Cotham Road, Kew.

The changes in land use which may not be made without the prior approval of the Soil Conservation Authority are:—

- (1) The construction of a house, the construction of, or addition to, buildings from which are produced waste discharges.

(NOTE.—The following two aspects will be given special consideration in any application for approval:—

 - (i) The location and suitability of sites for the disposal of liquid waste;
 - (ii) The hazard associated with any earthworks involved in site preparation.)
- (2) The clearing or burning of forest or scrub land.
- (3) The construction of tracks, roads, or dams, the commencement of earthworks associated with building sites or for any other purpose.
- (4) The establishment of any intensive animal housing or any other operations which will produce waste discharges.
- (5) The subdivision of any existing allotment of land.

Rosslynne Reservoir (Riddell Creek) Water Supply Catchment

PLAN S 382.

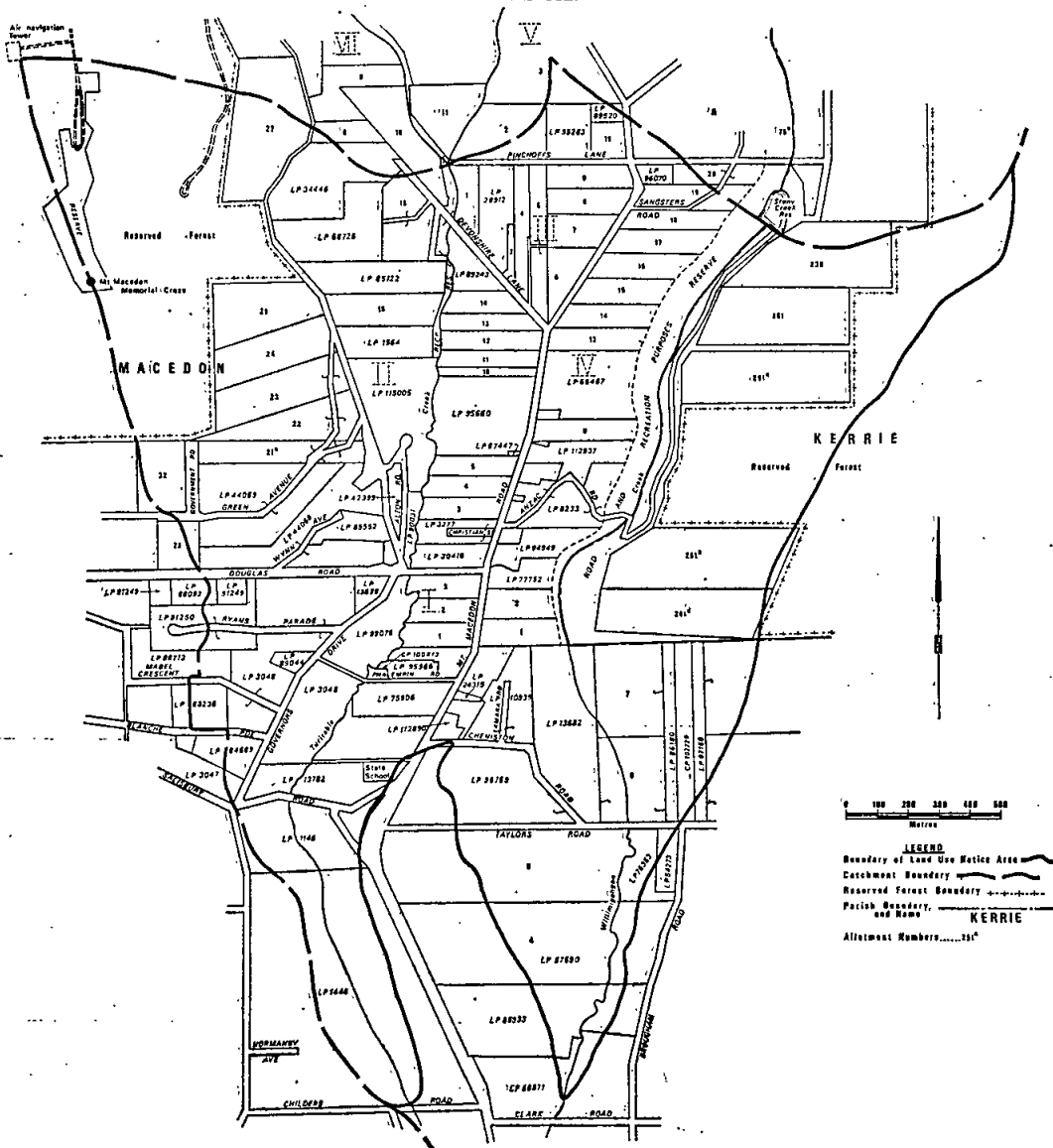

Health Act 1958.

VICTORIA—DEPARTMENT OF HEALTH.

NOTICE TO ATTEND FOR RADIOLOGICAL EXAMINATION.

To all persons aged thirty-five years and over enrolled or resident in the subdivisions specified hereunder in the State Electoral District of SANDRINGHAM.

Take notice that you are required to attend at a Department of Health X-ray Unit sited in the public street at or as near as possible to the main entrance to the premises specified in this notice, at any time between the hours specified on one of the days specified and during the period specified in respect of those premises, and thereat to submit yourself to radiological examination of the chest for the purpose of ascertaining whether you may be suffering from pulmonary tuberculosis. If you have had a Chest X-ray within the last twelve months and for this reason do not wish to be examined now, you should attend the unit as directed and submit particulars of the previous examination.

SPECIFIED SUBDIVISIONS, PREMISES, PERIODS, DAYS AND HOURS.

Subdivision.	Premises.	Period.	Days.	Hours.
Moorabbin West	Maytime Beauty Saloon, 332B South Road, Moorabbin	Monday, 2nd August, 1976 to Wednesday 4th August, 1976 (inclusive)	Each day during the period except Public Holidays	From 10 a.m. to 8.30 p.m.
	Corner Widdop Crescent and Keith Street, Moorabbin	Monday, 2nd August, 1976 to Wednesday, 4th August, 1976 (inclusive)	Each day during the period except Public Holidays	From 10 a.m. to 8.30 p.m.
	Lloyd's Milk Bar, 19 Spring Road, Highett	Friday, 13th August, 1976 to Tuesday, 17th August, 1976 (inclusive)	Each day during the period except Saturday, Sunday and Public Holidays	From 10 a.m. to 8.30 p.m.
	Jenny Leon's Beauty Saloon, 493 Highett Road, Highett	Friday, 13th August, 1976 to Thursday, 19th August, 1976 (inclusive)	Each day during the period except Saturday, Sunday and Public Holidays	From 10 a.m. to 8.30 p.m.
	Corner Sterling Avenue and Tibroekney Street, Highett	Wednesday, 18th August, 1976	Wednesday, 18th August, 1976	From 10 a.m. to 8.30 p.m.
Hampton	Triangle Gardens, Corner Linacre Road and Hampton Street, Hampton	Thursday, 5th August, 1976 and Friday 6th August, 1976	Thursday, 5th August, 1976 Friday, 6th August, 1976	From 10 a.m. to 8.30 p.m. From 10 a.m. to 8.30 p.m.
	Corner Sargood Street and Linacre Road, Hampton	Thursday, 5th August, 1976 to Monday, 9th August, 1976 (inclusive)	Each day during the period except Saturday, Sunday and Public Holidays	From 10 a.m. to 8.30 p.m.
Sandringham	Memorial Hall, Waltham Street, Sandringham	Monday, 9th August, 1976 to Thursday, 12th August, (inclusive)	Each day during the period except Public Holidays	From 10 a.m. to 8.30 p.m.
	John Batman Gardens, Corner Bay Road and Waverley Street, Sandringham	Tuesday, 10th August, 1976 to Thursday, 12th August, 1976 (inclusive)	Each day during the period except Public Holidays	From 10 a.m. to 8.30 p.m.
	Corner Bluff Road and Royal Avenue, Sandringham	Thursday, 19th August, 1976 to Monday, 23rd August, 1976 (inclusive)	Each day during the period except Saturday, Sunday and Public Holidays	From 10 a.m. to 8.30 p.m.
	McLennan's Milk Bar, Corner Arkaringa Crescent and Bluff Road, Black Rock	Friday, 27th August, 1976 to Tuesday, 31st August, 1976 (inclusive)	Each day during the period except Saturday, Sunday and Public Holidays	From 10 a.m. to 8.30 p.m.
Cheltenham West	Park Road Hardware, 21 Park Road, Cheltenham	Friday, 20th August, 1976 and Monday, 23rd August, 1976	Friday, 20th August, 1976 Monday, 23rd August, 1976	From 10 a.m. to 8.30 p.m. From 10 a.m. to 8.30 p.m.
	Opportunity Shop, 31 Station Road, Cheltenham	Tuesday, 24th August, 1976 to Thursday, 26th August, 1976 (inclusive)	Each day during the period except Public Holidays	From 10 a.m. to 8.30 p.m.
	The Oval Cake Shop, 174 Weatherall Road, Cheltenham	Tuesday, 24th August, 1976 to Thursday, 26th August, 1976 (inclusive)	Each day during the period except Public Holidays	From 10 a.m. to 8.30 p.m.
	Wilson's Milk Bar, 100 Charman Road, Mentone	Friday, 27th August, 1976 to Tuesday, 31st August, 1976 (inclusive)	Each day during the period except Saturday, Sunday and Public Holidays	From 10 a.m. to 8.30 p.m.

NOTE: Any person to whom this notice applies and who without reasonable excuse fails to comply with the requirements of the notice shall be guilty of an offence, and shall be liable to a penalty of not more than five hundred dollars.

Dated this Third day of June, One thousand nine hundred and seventy-six.

B. P. McCLOSKEY, Chief Health Officer.

Health Act 1958.

VICTORIA—DEPARTMENT OF HEALTH.

NOTICE TO ATTEND FOR RADIOLOGICAL EXAMINATION.

To all persons aged thirty-five years and over enrolled or resident in the subdivisions specified hereunder in the State Electoral District of GIPPSLAND SOUTH.

Take notice that you are required to attend at a Department of Health X-ray Unit sited in the public street at or as near as possible to the main entrance to the premises specified in this notice, at any time between the hours specified on one of the days specified and during the period specified in respect of those premises, and thereat to submit yourself to radiological examination of the chest for the purpose of ascertaining whether you may be suffering from pulmonary tuberculosis. If you have had a Chest X-ray within the last twelve months and for this reason do not wish to be examined now, you should attend the unit as directed and submit particulars of the previous examination.

SPECIFIED SUBDIVISIONS, PREMISES, PERIODS, DAYS AND HOURS.

Subdivision.	Premises.	Period.	Days.	Hours.
Yarram ..	C.B.C. Bank, Yarram Street, Yarram	Monday, 2nd August, 1976 to Friday, 6th August, 1976 (inclusive)	Monday, 2nd August, 1976. All other days during the period except Public Holidays	From 2 p.m. to 6 p.m. and 7.30 p.m. to 9 p.m. From 10 a.m. to 6 p.m. and 7.30 p.m. to 9 p.m.
	Post Office Store, Woodside	Tuesday, 3rd August, 1976	Tuesday, 3rd August, 1976	From 11 a.m. to 6 p.m. and 7.30 p.m. to 9 p.m.
	St. Joseph's Church, Port Albert	Wednesday, 4th August, 1976	Wednesday, 4th August, 1976	From 11 a.m. to 6 p.m. and 7.30 p.m. to 9 p.m.
	Public Hall, Alberton	Thursday, 5th August, 1976	Thursday, 5th August, 1976	From 11 a.m. to 6 p.m. and 7.30 p.m. to 9 p.m.
Foster ..	Post Office, Port Welshpool	Friday, 6th August, 1976	Friday, 6th August, 1976	From 11 a.m. to 6 p.m. and 7.30 p.m. to 9 p.m.
	Tibball's Garage, Welshpool	Monday, 9th August, 1976	Monday, 9th August, 1976	From 11 a.m. to 6 p.m. and 7.30 p.m. to 9 p.m.
	Transfield Hostel, Barry's Beach	Tuesday, 10th August, 1976	Tuesday, 10th August, 1976	From 11 a.m. to 6 p.m. and 7.30 p.m. to 9 p.m.
	Public Hall, Toora ..	Tuesday, 10th August, 1976	Tuesday, 10th August, 1976	From 11 a.m. to 6 p.m. and 7.30 p.m. to 9 p.m.
	Memorial Hall, Foster	Wednesday, 11th August, 1976 to Friday, 13th August, 1976 (inclusive)	Wednesday, 11th August, 1976 All other days during the period except Public Holidays	From 11 a.m. to 6 p.m. and 7.30 p.m. to 9 p.m. From 10 a.m. to 6 p.m. and 7.30 p.m. to 9 p.m.
	Car Park, Opposite Public Hall, Fish Creek	Wednesday, 11th August, 1976	Wednesday, 11th August, 1976	From 11 a.m. to 6 p.m. and 7.30 p.m. to 9 p.m.
	Public Hall, Dumbalk ..	Thursday, 12th August, 1976	Thursday, 12th August, 1976	From 11 a.m. to 6 p.m. and 7.30 p.m. to 9 p.m.
Leongatha ..	National Bank, McCartin Street, Leongatha	Friday, 13th August, 1976 to Friday, 20th August, 1976 (inclusive)	Friday, 13th August, 1976 All other days during the period except Saturday, Sunday and Public Holidays	From 2 p.m. to 6 p.m. and 7.30 p.m. to 9 p.m. From 10 a.m. to 6 p.m. and 7.30 p.m. to 9 p.m.
	Mechanics' Institute, Meeniyan	Monday, 16th August, 1976 and Tuesday, 17th August, 1976	Monday, 16th August, 1976 Tuesday, 17th August, 1976	From 2 p.m. to 6 p.m. and 7.30 p.m. to 9 p.m. From 10 a.m. to 6 p.m. and 7.30 p.m. to 9 p.m.
	Mechanics' Institute, Inverloch	Wednesday, 18th August, 1976 to Friday, 20th August, 1976 (inclusive)	Wednesday, 18th August, 1976 All other days during the period except Public Holidays	From 11 a.m. to 6 p.m. and 7.30 p.m. to 9 p.m. From 10 a.m. to 6 p.m. and 7.30 p.m. to 9 p.m.

NOTE : Any person to whom this notice applies and who without reasonable excuse fails to comply with the requirements of the notice shall be guilty of an offence, and shall be liable to a penalty of not more than five hundred dollars.

Dated this Third day of June, One thousand nine hundred and seventy-six.

B. P. MCCLOSKEY, Chief Health Officer.

Town and Country Planning Act 1961.
CITY OF BENALLA PLANNING SCHEME.

AMENDMENT No. 9, 1976.

Notice of Amendment.

In pursuance of the powers conferred by sub-section 6 of section 32 of the *Town and Country Planning Act 1961*, the Governor in Council, on the 13th July, 1976, amended the City of Benalla Planning Scheme to include provision for the control of cluster development.

A copy of the amendment may be inspected during office hours at the office of the Town and Country Planning Board, 235 Queen Street, Melbourne, at the office of the Council of the City of Benalla at Benalla, and when available at the Office of Titles, Melbourne and at the Central Plan Office of the Department of Crown Lands and Survey, Melbourne.

W. H. CRAIG, Secretary,
Town and Country Planning Board.

Town and Country Planning Act 1961.
CITY OF KNOX PLANNING SCHEME 1965.

REVOCATION No. 17.

In pursuance of the provisions of section 32 of the *Town and Country Planning Act 1961* the Governor in Council on the 13th July, 1976, made an Order:—

- (i) Revoking the City of Knox Planning Scheme in so far as it applies to lot 3, lodged plan 52221, Allora Avenue, Ferntree, Gully, and
- (ii) Providing that the land may only be used or developed for: (a) those purposes permitted within the Rural "A" Zone of the City of Knox Planning Scheme and subject to the provisions of that planning scheme, and (b) the purposes of one only additional house. Any such use or development is permitted only subject to the grant of a permit by the Council of the City of Knox.

A copy of the Order may be inspected during office hours at the office of the Town and Country Planning Board, 235 Queen Street, Melbourne, and at the office of the Council of the City of Knox, at Knoxfield.

W. H. CRAIG, Secretary,
Town and Country Planning Board.

Town and Country Planning Act 1961.
MELBOURNE METROPOLITAN PLANNING SCHEME.
AMENDMENT No. 49, PART 2.

Notice of Approval.

In pursuance of the powers conferred by the *Town and Country Planning Act 1961*, the Governor in Council on the 13th July, 1976, approved a planning scheme entitled the Melbourne Metropolitan Planning Scheme, Amendment No. 49, Part 2 and such planning scheme comes into operation on the date this Notice of Approval is published in the *Government Gazette*.

A copy of the planning scheme as approved may be inspected free of charge, during office hours at the office of the Town and Country Planning Board, 235 Queen Street, Melbourne, at the office of the Melbourne and Metropolitan Board of Works at 625 Little Collins Street, Melbourne, and when available, at the Office of Titles, Melbourne, and at the Central Plan Office of the Department of Crown Lands and Survey, Melbourne.

W. H. CRAIG, Secretary,
Town and Country Planning Board.

Town and Country Planning Act 1961.
SHIRE OF SHERBROOKE PLANNING SCHEME 1965.

AMENDMENT No. 93, 1975.

Notice of Approval.

In pursuance of the powers conferred by the *Town and Country Planning Act 1961*, the Governor in Council on the 13th July, 1976, approved a planning scheme entitled the Shire of Sherbrooke Planning Scheme 1965, Amendment No. 93—1975 in respect of part of the municipal district of the Shire of Sherbrooke and such planning scheme comes into operation on the date this Notice of Approval is published in the *Government Gazette*.

A copy of the planning scheme as approved may be inspected, free of charge, during office hours at the office of the Town and Country Planning Board, 235 Queen Street, Melbourne, at the office of the Council of the Shire of Sherbrooke at Upwey, and when available, at the Office of Titles, Melbourne, and at the Central Plan Office of the Department of Crown Lands and Survey, Melbourne.

W. H. CRAIG, Secretary,
Town and Country Planning Board.

NORTH-EASTERN REGIONAL LIBRARY SERVICE.
NOTICE OF APPROVAL OF AGREEMENT.

The agreement made between the Mayor, Councillors and Citizens of the City of Wangaratta, the President, Councillors and Ratepayers of the Shires of Bright, Myrtleford, Wangaratta, Yarrowonga and the United Shire of Beechworth for the provision of a joint library service in the municipal districts of the said municipalities was approved by the Governor in Council pursuant to the provisions of section 799 of the *Local Government Act 1958* on the 13th day of July, 1976.

TOM FORRISTAL,
Clerk of the Executive Council.

LAKES ENTRANCE SEWERAGE AUTHORITY.
INCREASING LIMIT OF BANK OVERDRAFT.

His Excellency the Governor of the State of Victoria by and with the advice of the Executive Council thereof doth by Order made on the 13th day of July, 1976, increase the total amount of the sums which the Lakes Entrance Sewerage Authority may owe at any one time in respect of moneys borrowed by overdraft of current account pursuant to the provisions of section 79 of the *Sewerage Districts Act* fixed by the Governor in Council on 2nd March, 1976, at Four hundred and fifty thousand dollars (\$450,000), to Six hundred thousand dollars (\$600,000).

TOM FORRISTAL,
Clerk of the Executive Council.

At the Executive Council Chamber,
Melbourne, 13th July, 1976.

SEYMOUR WATERWORKS TRUST.
INCREASING LIMIT OF BANK OVERDRAFT.

His Excellency the Governor of the State of Victoria by and with the advice of the Executive Council thereof doth by Order made on the 13th day of July, 1976, increase the total amount of the sums which the Seymour Waterworks Trust may owe at any one time in respect of moneys borrowed by overdraft of current account pursuant to the provisions of section 286 of the *Water Act 1958*, fixed by the Governor in Council on 2nd November, 1966 at Fifty thousand dollars (\$50,000), to One hundred thousand dollars (\$100,000).

TOM FORRISTAL,
Clerk of the Executive Council.

At the Executive Council Chamber,
Melbourne, 13th July, 1976.

GOORAMBAT WATERWORKS TRUST.

The maximum quantity of water to be supplied in any one year without further notice on any property rated by the Trust is hereby fixed at the quantity which, at a charge of 18.0 cents per kilolitre, would produce an amount equal to the amount of the rate levied on such property for the said year.

The charge for the water supplied by measure to any property rated by the Trust in excess of such maximum quantity, computed as in the last preceding clause is hereby fixed at 18.0 cents per kilolitre.

The charge for water supplied by measure shall be payable on demand at the office of the said Trust.

Passed by Resolution on this 23rd day of February, 1976.

(SEAL) C. W. COOPER,
L. J. SAUNDERS,
M. R. SAUNDERS.

Approved, 18th June, 1976.—F. J. GRANTER, Minister of Water Supply.

PENTAL ISLAND RIVER IMPROVEMENT TRUST.
BY-LAW No. 18.

The Pental Island River Improvement Trust, in pursuance and exercise of the powers conferred by the *River Improvement Act 1958*, doth hereby make the By-law following:—

1. The following rate to be called the Pental Island River Improvement District River Improvement Rate is hereby made and shall be levied upon the occupiers or owners of all the properties within the Pental Island River Improvement District which are rateable in the municipality, the rate of three cents in the dollar on the net annual municipal value of such properties. Provided that the sum of ten cents shall be the minimum amount of rate in respect of any property liable to be rated in the said district.

2. Such rate is made and shall be levied for the period beginning with the 1st day of January, 1975 and ending with the 31st day of December, 1975, and shall be payable on the 1st July, 1975, at the office of the Pental Island River Improvement Trust, at Swan Hill.

3. Such person or persons as the Pental Island River Improvement Trust may from time to time appoint for that purpose is or are hereby authorized to demand, receive, collect and recover the said rate.

The foregoing By-law was made by the Pental Island River Improvement Trust on the 18th day of February, 1975, and the common seal of the said Trust was hereunto affixed on the 23rd day of May, 1975, in the presence of—

(SEAL) K. JAMES, Chairman,
R. BURNS, Secretary.

Approved by the Governor in Council, 6th July, 1976.—
F. J. GRANTER, Minister of Water Supply.

STATE RIVERS AND WATER SUPPLY COMMISSION.

LICENCES TO DIVERT WATER AND CUT RACES PURSUANT TO THE PROVISIONS OF SECTION 204 OF THE WATER ACT 1958 (AS AMENDED).

The Governor in Council has approved of the granting by the State Rivers and Water Supply Commission of licences as detailed hereunder for the term of years from the date specified in each case to the persons named in the following Schedule :—

SCHEDULE.

Licence No.	Term of Licence and Commencing Date.	Name and Address of Person to whom Licence is to be Granted.	Source of Supply.	Area Authorized to be Irrigated	Volume of Water Authorized to be Diverted	Annual Fee.
				Per Annum.	Per Annum.	
				hectares	megalitres	\$
644	Fifteen years from 1.7.75	Denis Raymond Kelly of Swan Hill	River Murray ..	102.8	617	802.10
1169	Fifteen years from 1.7.75	Keith Leslie James of Swan Hill	River Murray ..	41.1	247	321.10
1170	Fifteen years from 1.7.75	Clifford Thomas James of Swan Hill	River Murray ..	41.1	247	321.10
1508	Fifteen years from 1.7.75	R. E. Baker of Murchison ..	Goulburn River ..	7.3	44	57.20
1614/810	Fifteen years from 1.7.72	Golden Acres Pty. Ltd. of Red Cliffs	River Murray ..	27.2	245	294.00
2292	Fifteen years from 1.7.75	Christina Magnusson of Nathalia	Goulburn River ..	30.8	185	240.50
3132	Fifteen years from 1.7.75	Mervyn Jack Cupper of Merbein	River Murray ..	14.5	130	136.50
3201	Fifteen years from 1.7.75	Mona Isabel Paul of Mildura ..	River Murray ..	0.6	5.6	23.50
3205	Fifteen years from 1.7.75	Emmanuel Cullias and Maria Cullias of Robinvale	River Murray ..	16.1	145	132.25
3223	Fifteen years from 1.7.75	George Marshall Burrowes and Pamela Mary Burrowes of Whitfield	King River ..	9.5	43	55.90
3237	Fifteen years from 1.7.75	Gordon Edward Bechaz of Wangaratta	King River ..	0.8	37	19.50
3288	Fifteen years from 1.7.75	Rocco Primerano and Scarfo Primerano of Cheshunt	King River ..	13.3	60	78.00
3296	Fifteen years from 1.7.75	Iannis Myriallakis Georgios Myriallakis, Katina Myriallakis and Elfthera Myriallakis of Robinvale	River Murray ..	24.6	222	233.10
3304	Fifteen years from 1.7.75	Nicola Motta and Marianina Motta of King Valley	King River ..	28.8	130	169.00
3330	Fifteen years from 1.7.75	F. and G. Brown of Barmah ..	River Murray ..	0.8	2.2	13.00
3408	Fifteen years from 1.7.75	Francesco Ciccone and Bruno Primerano of Cheshunt	King River ..	28.8	130	169.00
3425	Four years from 1.7.75	Massimo Perri of Mt. Beauty ..	King River ..	16.4	74	96.20
3695	Four years from 1.7.75	Estate of K. Henderson of Eltham	Lake Mulwala ..	6.1	37	48.10
3711	Nine years from 1.7.76	Gordon Munro Kruss and Lynne Maree Kruss of Echuca	River Murray ..	3.3	20	29.60
3713	Fifteen years from 1.7.75	Bernard Thomas Gehrig of Barnawartha	River Murray ..	30.8	185	240.50
3715	Fifteen years from 1.7.76	Brymay Forests Pty. Ltd. of Yarrawonga	River Murray ..	203	1523	2254.04
3717	Ten years from 1.7.76	S. Nicholl of Eddington ..	Loddon River ..	1.7	10	22.20

Office of the State Rivers and Water Supply Commission,
Melbourne 13th July, 1976.G. W. LEWIS, Secretary,
State Rivers and Water Supply Commission.

STATE RIVERS AND WATER SUPPLY COMMISSION.

LICENCES TO DIVERT WATER PURSUANT TO THE PROVISIONS OF SECTION 204 OF THE WATER ACT 1958 (AS AMENDED).

The Governor in Council has approved of the granting by the State Rivers and Water Supply Commission of the licences as detailed hereunder for the term of years from the dates specified to the persons named in the following Schedule :—

SCHEDULE.

Licence No.	Term of Licence and Commencing Date.	Name and Address of Person to whom Licence is to be Granted.	Source of Supply.	Area Authorized to be Irrigated	Volume of Water Authorized to be Diverted	Annual Fee.
				Per Annum.	Per Annum.	
				hectares	megalitres	\$
1527	Two years from 1.7.75	K. J. and P. M. Mullins of Eddington	Tullaroop Creek ..	8.3	50	65.00
1579	Fifteen years from 1.7.75	Basilios Kaklios of Werribee ..	Werribee River ..	3.3	10.1	19.50
1580	Fifteen years from 1.7.75	Noel Williamson of Carisbrook	Tullaroop Creek ..	16.5	99	128.70
3208	Four years from 1.7.75	Norman Geoffrey Murrell of Wangaratta	King River ..	16.4	74	96.20
3227	Fifteen years from 1.7.75	Giuseppe Motta and Palmira Motta of Cheshunt	King River ..	12.3	56	72.80
3251	Fifteen years from 1.7.75	Luigi Groppo and Francesca Groppo of Cheshunt	King River ..	14.4	64	84.50
3635	Fifteen years from 1.7.75	Benalla City Council of Benalla	Broken River ..	10.8	63	40.95
3706	Fifteen years from 1.7.74	Rex Kenneth Ebert of Myrtlebank	Thompson River ..	12.3	74	77.70
3708	Fifteen years from 1.7.74	Gregory John Grundy of Riverslea	Thompson River ..	20	120	126.00
3714	Fifteen years from 1.7.76	Brymay Forests Pty. Ltd. of Yarrawonga	River Murray ..	145.6	1110	1642.80

Office of the State Rivers and Water Supply Commission,
Melbourne, 13th July, 1976.G. W. LEWIS, Secretary,
State Rivers and Water Supply Commission.

Private Agents Act 1966.

NOTICE OF RECEIPT OF APPLICATIONS FOR LICENCES UNDER THE PROVISIONS OF THE PRIVATE AGENTS ACT 1966.

The Clerk(s) of the Magistrates' Court(s) as listed hereunder hereby give notice that applications, as under, have been lodged for hearing by the said Court(s) on the day(s) specified.

Any person desiring to object to any of such applications must—

- (a) lodge with the respective Clerk of the Magistrates' Court a notice in the prescribed form of his objection and of the grounds thereof;
- (b) cause a copy of such notice to be served personally or by post upon the applicant at least three days before the hearing of the application; and
- (c) send or deliver—
 - (i) where the objection is not made by the officer in charge of the police district in which the Court is situated—a copy of the notice to such officer; and
 - (ii) where the objection is not made by the Registrar or Deputy Registrar—a copy to the Registrar.

Full Name of Applicant or in the Case of a Firm or Corporation, of the Nominee.	Place of Abode of Applicant or Nominee.	Name of Firm or Corporation.	Address for Registration.	Type of Licence.	Date of Hearing of Application.
---	---	------------------------------	---------------------------	------------------	---------------------------------

MAGISTRATES' COURT, PRAHRAN.

Brown, Barry Marshall ..	2 Sang Ringwood Court,	Suite 17, 562 St. Kilda Road, Melbourne	Guard Agent ..	2.8.76
--------------------------	------------------------	---------	---	----------------	--------

Dated at Prahran this 12th day of July 1976.

G. A. SHARKEY, Clerk of the Magistrates' Court.

MAGISTRATES' COURT, SOUTH MELBOURNE.

Djordjevic, Peter ..	24 Beverley Crescent, Blackburn	Mayne Nickless Limited	94 York Street, South Melbourne	Watchman ..	9.8.76
Wotton, Clive Russell ..	1 Yelta Court, Coolaroo	" " "	" " "	" ..	"

Dated at South Melbourne this 12th day of July, 1976.

P. CONNOLLY, Clerk of the Magistrates' Court.

MAGISTRATES' COURT, HAWTHORN.

Owen, Francis William ..	8 Highfield Avenue, South Blackburn	Armagard	769 Glenferrie Road, Hawthorn	Watchman	12.8.76
--------------------------	-------------------------------------	----------	-------------------------------	----------	---------

Dated at Hawthorn this 7th day of July, 1976.

W. E. BYRNE, Clerk of the Magistrates' Court.

MAGISTRATES' COURT, PRESTON.

Craig, Helen Joan ..	4/43 Spring Street, Preston	" Wabel "	4/43 Spring Street, Preston	Watchman ..	10.8.76
Craig, Brian John ..	" " "	" " "	" " "	Inquiry Agent ..	"

Dated at Preston this 12th day of July, 1976.

L. GERKENS, Clerk of the Magistrates' Court.

MAGISTRATES' COURT, ELSTERNWICK.

Dunlevie, Peter Raymond ..	62A Elster Avenue, Gardenvale	Concise Electronics Patrols Locks and Watching	62A Elster Avenue, Gardenvale	Guard Agent ..	3.8.76
----------------------------	-------------------------------	--	-------------------------------	----------------	--------

Dated at Elsternwick this 13th day of July, 1976.

M. O'CONNOR, Clerk of the Magistrates' Court.

MAGISTRATES' COURT, COBURG.

Swallow, Rodney Malcolm ..	19 Byrne Crescent, Watsonia	88 Bakers Road, North Coburg	Watchman ..	5.8.76
----------------------------	-----------------------------	---------	------------------------------	-------------	--------

Dated at Coburg this 13th day of July, 1976.

C. LANE, Clerk of the Magistrates' Court.

MAGISTRATES' COURT, WODONGA.

Peters, Robert John ..	6 Athens Street, Wodonga	M.S.S. ..	1 Tallangatta Road, Wodonga	Watchman	3.8.76
Draper, Kevin Raymond ..	RMB 2007 Leneva via Wodonga	Armaguard ..	23A High Street, Wodonga	" ..	"
Nash, Brian Maxwell ..	123 Boronia Street, North Albury	Metropolitan Security Services	1 Tallangatta Road, Wodonga	" ..	"

Dated at Wodonga this 13th day of July, 1976.

L. P. BYRNE, Clerk of the Magistrates' Court.

MAGISTRATES' COURT, BERWICK.

Webster, Ian Charles ..	1 Craig Court, Cheltenham	4 Spruce Court, Narre Warren	Commercial Sub-Agent	3.8.76
-------------------------	---------------------------	---------	------------------------------	----------------------	--------

Dated at Berwick this 13th day of July, 1976.

A. MCCORMACK, Clerk of the Magistrates' Court.

MAGISTRATES' COURT, BAIRNSDALE

Lania, John Richard ..	5 Dreverman Street, Bairnsdale	Bairnsdale Security Service	68 Main Street, Bairnsdale	Watchman ..	5.8.76
------------------------	--------------------------------	-----------------------------	----------------------------	-------------	--------

Dated at Bairnsdale this 13th day of July, 1976.

R. J. CANNING, Clerk of the Magistrates' Court.

MAGISTRATES' COURT, MELBOURNE.

Ellis, Edward Samuel Thomas	1 Valetta Street, Malvern	Mayne Nickless Limited	94 York Street, South Melbourne	Watchman ..	18.8.76
-----------------------------	---------------------------	------------------------	---------------------------------	-------------	---------

Dated at Melbourne this 12th day of July, 1976.

L. W. HUSSEY, Clerk of the Magistrates' Court.

PRIVATE AGENTS—continued.

Full Name of Applicant or in the Case of a Firm or Corporation, of the Nominee.	Place of Abode of Applicant or Nominee.	Name of Firm or Corporation	Address for Registration.	Type of Licence.	Date of Hearing of Application.
MAGISTRATES' COURT, MELBOURNE.					
Arena, Angelo	7 Wiltshire Road, Gladstone Park	Armaguard Mayne Nickless Limited	699 Queensberry Street, North Melbourne	Watchman ..	25.8.76
Whittaker, Laurence Keith ..	24 Heyington Avenue, Thomastown	24 Heyington Avenue, Thomastown	Inquiry Agent ..	25.8.76
Dated at Melbourne this 14th day of July, 1976.					
L. W. HUSSEY, Clerk of the Magistrates' Court.					
MAGISTRATES' COURT, BOX HILL.					
Karasek, Bevin Roy	Anderson Creek Road, Doncaster East	94 York Street, South Melbourne	Watchman ..	17.8.76
Dated at Box Hill this 12th day of July, 1976.					
L. GOULD, Clerk of the Magistrates' Court.					

Police Offences Act 1958, No. 6337.
DIVISION 1A.—STATE ADVISORY BOARD ON PUBLICATIONS.
 Whereas I have considered reports made to me by the State Advisory Board on Publications under section 180(2) (a) of the Police Offences Act.
 I, Vance Oakley Dickie, Chief Secretary of Victoria, in pursuance of the power vested in me by section 180(1) of the Police Offences Act hereby determine that the following publications prescribed by title in the schedule hereunder shall be classified as restricted publications for the purposes of the abovenamed Act.

SCHEDULE OF PUBLICATIONS.

Title.	Publisher.
Australian Guys Nos. 89, 90 & 91	Private Book and Magazine Co.
Cocksure No. 67	Interpersonal Holdings Pty. Ltd.
Dirty No. 9	Western Colour Print
Four And More	Orion Press
Gay No. 24	Not shown
Hard Core No. 32	Interpersonal Holdings Pty. Ltd.
It Takes Three	Orion Press
New Cunts Nos. 3, 4, 5, 7, & 8	Jens and Peter Theander
Nookie No. 1	Western Colour Print
Ribald Nos. 186-189 (inclusive)	Ribald Publications
Screw Nos. 199, 200 & 201	Private Book and Magazine Co.
Searchlight Nos. 165 & 166	Searchlight Publications
Sex Delight Nos. 10 & 11	Silwa Film
Sex Intim Nos. 22, 23, 26 & 33	Silwa Film
Sex Orgies	Not shown
Sexy Swingers No. 179	Interpersonal Holdings Pty. Ltd.
Sweet Shocking Charlotte	Orion Press
The English Housemaid	Orion Press
3 Virgins and 2 Boys	Not shown

VANCE DICKIE,
 Chief Secretary.

Chief Secretary's Office,
 Melbourne, 19th July, 1976.

Motor Car Act 1958, Section 41.
AUTHORIZED INSURER.
 I, Vance Oakley Dickie, Her Majesty's Chief Secretary for the State of Victoria, in pursuance of the powers conferred by section 41 of the Motor Car Act 1958, do hereby grant approval to the Insurance Commissioner, appointed under the State Insurance Office Act 1975 as an authorized insurer for the purposes of Division 1 of Part V. of the Motor Car Act 1958, from the date of operation of the said State Insurance Office Act 1975.

VANCE DICKIE,
 Chief Secretary.

Chief Secretary's Office,
 Melbourne, 14th July, 1976.

MINES DEPARTMENT.

Subject to any necessary excisions, &c., it is proposed to grant the following mining lease:—
 No. 371; William James Bond; 6.5 ha, Parish of Banu Bonyit.

MINING LEASE GRANTED.

5642, Gippsland; Namdalg Nominees Proprietary Limited; 30 ha, Parishes of Bundowra and Tanjil.

TERM OF EXPLORATION LICENCE EXTENDED, WITH AREA REDUCED.

No. 483; Western Mining Corporation Limited; reduced from 264 km² to 198 km² comprising Graticular Blocks Nos. 435, 507 and 508, Melbourne Map Sheet.

APPLICATIONS FOR TAILINGS LICENCES DECLARED ABANDONED.

3948, Tailings Licence; Lone Star Exploration N.L.; to treat tailings, Parishes of Glenalbyn and Salisbury West.
 3955, Tailings Licence; Lone Star Exploration N.L.; to treat and remove tailings, Parish of Maldon.

APPLICATION FOR TAILINGS LICENCE REFUSED.

4008, Tailings Licence; Gerald Roger Gill; to remove tailings from dumps situated at Bell Topper Hill, Parish of Drummond.

SEARCH LICENCES EXPIRED.

No. 1156; Goldbent Holdings Proprietary Limited; 743 ha, Parish of Glenaulin.
 No. 1158; Goldbent Holdings Proprietary Limited; 395 ha, Parish of Drik Drik.

J. C. M. BALFOUR,
 Minister of Mines.

CONTRACTS ACCEPTED.—(Series 1976-77.)
VICTORIAN RAILWAYS.
 3. Internal and external cleaning of the Spencer Street rail terminal for a period of 4 years, for the amount of \$600,564.00 (Contract No. 64223).—A. L. Dee & Sons Cleaning Service. 4. Design, supply, delivery and installation of an Automatic Halon Suppression and Fire Detection system in the new signal box building Spencer Street, for the amount of \$20,491.00 (Contract No. 64212).—Wormald International (Aust.) Pty. Ltd. 5. Cleaning glass at Electrical Testing Depot Workshops "A" and Electronics Annexe, Spencer Street and at the Yard Foreman's Office building at north end of No. 1 Platform Spencer Street, for the amount of \$4,532.00 (Contract No. 64237).—Utility Cleaning Co. (Vic.) Pty. Ltd. 6. Fabrication, drilling, placing, grouting and stressing of sixteen (16) No., prestressed tie-backs for temporary works with M.U.R.L. Connections, for the amount of \$10,800.00 (Contract No. 64177).—V.S.L. Prestressing (Aust.) Pty. Ltd.
 By Order of the Victorian Railways Board,
 C. W. MILLER, Secretary. 19.7.76.

CONTRACTS ACCEPTED.—(Series 1975-76.)
AMENDMENTS.

Sched. No.	Item No.	Description.	Unit of measurement.	New Rate.	Contractor.	Effective Date.
		Provisions.		\$		
		<i>Gazette No. 54—3rd June, 1976.</i>				
1		<i>Provisions—Melbourne and Metropolitan District.</i>				
	31	Semolina, 67 kg. bags "K.M.M." ..	per bag	14.20	Terra Self Service Pty. Ltd. ...	5.7.76
	44	Custard Powder, 4.5 kg. "Parsons" ..	each	..	Cancel contract with Terra Self Service Pty. Ltd.	5.7.76
	44	Custard Powder, 5 kg. bags "Havelock" ..	per bag	2.38	Composite Buyers Pty. Ltd. ..	5.7.76
		Minimum order 8 bags ..	per ctn.	13.72		
	89	Apricot halves, stoned, No. 10 cans ..	"	8.14	Terra Self Service Pty. Ltd. ..	5.7.76
	97	Peaches, sliced, 425 g. tins ..	"	13.34		
	98	" " 825 g. " ..	"	8.14		
	99	Pears, 425 g. " ..	"	13.34		
	100	" " 825 g. " ..	"	9.20		
	101	Solid Pack Apple, No. 10 cans, "IXL" or "SPC" ..	per doz.	9.10	Unigate Australia Pty. Ltd. ..	18.6.76
	108	Honey, 750 g. jars ..	per ctn.	18.00		
	109	" " 6 x 3 kg. tin ..	per jar	2.16		
	122	Mayonnaise, 2 kg. jar "Heinz" ..	each	3.82	Terra Self Service Pty. Ltd. ..	5.7.76
	143	Salt, bulk, cooking, 50 kg. ..	"	3.82		
	144	" " fine, 50 kg. ..	per doz.	6.14		
	146	Sauce, 600 ml. bottle ..	per bag	4.29		
	151	Sugar, white, 2 kg. packs of 8 ..	per ctn.	2.72	Luke Wright Industries Pty. Ltd.	
	67	Amendment to Gazette : Slices, "Chiko" 24 x 2-oz. per ctn. Minimum order one carton ..				
2		<i>Groceries—Melbourne and Metropolitan District.</i>				
	1	Baking powder, 375 g. pkt. "Excelsior" ..	per doz.	10.90	Terra Self Service Pty. Ltd. ..	5.7.76
		Biscuits—				
	4	Dry, Salada, 1.36 kg., "Brockoff" ..	each	2.14		
	5	Sweet, milk arrowroot, 6½-lb. ..	"	3.72		
	6	Sweet, assorted, 3.5 kg. ..	"	5.12		
	7	Boiled sweets, 6.5 kg. ctn. ..	per ctn.	6.88		
		Breakfast cereals—				
	9	Popped Rice, 375 g. pkt. ..	per doz.	7.32		
	10	" Corn Flakes", 500 g. pkt. ..	"	8.06		
	12	" Weetbix", 750 g. ..	"	8.56		
	14	All bran, 375 g. ..	"	5.14		
	15	Cake containers, paper, 120's ..	"	2.50		
	16	Cake mix, 5 kg. bags ..	per bag	3.76		
	17	" " 25 kg. bags ..	"	15.24		
		Powdered Mousses—				
	18	Chocolate, 5 kg. ..	"	6.41		
	19	Strawberry, 5 kg. ..	"	6.52		
	20	Lemon, 5 kg. ..	"	6.52		
	21	Pudding Mix, 5 kg. bags ..	"	7.65		
	22	Sponge Mix, 10 kg. bags ..	"	6.11		
	23	" " 5 kg. bags ..	"	3.72		
	24	Self saucing sponge pudding mix— Lemon/Butterscotch, 5 kg. bag ..	"	5.84		
		Chocolate, 5 kg. bag ..	"	7.48		
	33	Grated Cheese, 1.5 kg. ..	per bag	5.71		
		Coffee, bulk brewing—				
	34	2 cup bags ..	per ctn.	49.58		
	35	4 pint bags ..	"	47.34		
		Essence, bottles—				
	36	250 ml. ..	per doz.	4.90		
	37	500 ml. ..	"	9.04		
	38	5 litre ..	each	6.20		
	39	Coffee, Instant, 100 g. tins ..	per doz.	11.56		
	40	" " 150 g. jars ..	"	15.68		
	46	Custard Powder, 500 g. pkts. ..	"	4.48		
	53	Parisian, 26-oz. ..	"	8.12		
	63	Gherkin Spread Jars, 2 litre ..	each	3.52		
	64	Peanut Butter, 12-oz. ..	per doz.	9.28		
	78	Cornflour, 4.5 kg. ..	each	2.52		
	86	Grapefruit juice, No. 10 cans ..	per ctn.	13.03		
	87	Orange juice, 825 ml. tins ..	"	6.66		
	88	" " No. 10 cans ..	"	10.18		
	89	Pineapple juice, 852 ml. tins ..	"	8.12		
	90	" " No. 10 cans ..	"	5.98		
	91	Tomato juice, 852 ml. tins ..	"	5.42		
	92	" " No. 10 cans ..	"	7.80		
	94	Apricot halves—stoned, No. 10 cans ..	"	14.53		
	95	Peaches, sliced, 30-oz. cans ..	"	14.12		
	96	" " No. 10 cans ..	"	13.65		
	97	Pear halves, 30-oz. cans ..	"	14.12		
	98	" " No. 10 cans ..	"	13.65		
	102	Two fruits, 30-oz. tins ..	"	14.12		
	103	" " No. 10 cans ..	"	13.65		

AMENDMENTS.—continued.

Sched. No.	Item No.	Description.	Unit of measurement.	New Rate.	Contractor.	Effective Date.	
		Provisions—continued.			\$		
		<i>Groceries—Melbourne and Metropolitan District—continued.</i>					
	105	Peaches, sliced—150-oz. tins	per ctn.	8.60	} Terra Self Service Pty. Ltd.	5.7.76	
	106	Pears, 15-oz. tins	"	8.60			
	109	Peaches, No. 10 cans	"	15.60			
	114	Beef Booster, 1½-lb. tins	per tin	3.36			
	115	Chicken Booster, 1½-lb. tins	"	2.81			
	116	Mushroom Booster, 650 g. tins	"	3.58			
	117	Tomato concentrate Booster, 1-kg.	"	7.04			
	129	Junket tabs. 12 tabs. per pack	per doz.	3.50			
	135	Mayonnaise, 2 kg. jars	each	2.27			
	138	Sausages and vegetables, 425 g. tins	per doz.	5.54			
	141	Monosodium glutamate, 650 g. tins	"	33.00			
	147	Sunflower cooking oil, 4 litre	per tin	5.82			
	153	Pickles, mustard, 2.27 litre jar	per jar	1.84			
	154	Salt—fine bulk, 50 kg. bag	per bag	3.82			
	155	" table, 500 g.	per doz.	2.60			
	163	Tomato sauce, 4.5 litre	each	3.59			
	164	Worcestershire sauce, 19-oz.	per doz.	6.34			
	165	" " 4.5 litre	each	2.12			
	169	Bay leaves, 500 g. pkts.	per 500 g.	1.21			
	179	White sugar, 1 kg. bags x 15	per parcel	4.05			
	181	Asparagus tips, 340 g. tin	per doz.	7.54			
	183	Baked Beans, No. 10 can	per ctn.	12.06			
	184	Beetroot, 450 g. tins	per doz.	2.88			
	185	" No. 10 cans	per ctn.	8.53			
	186	Gherkins, sweet, 170 g.	per doz.	5.66			
	188	Mushrooms, No. 10 cans	per ctn.	22.55			
	189	Sweet Corn, cream style, 16-oz. tins	per doz.	4.02			
	193	Vinegar, 750 ml. bottles	"	3.16			
4		<i>Butter.</i>					
	2	Melbourne District—Butter, prints	per ctn.	23.31	} Amalgamated Co-operative Market-ers (Aust.) Ltd.	19.7.76	
	4	Mont Park District— Butter, prints 500 g.	"	23.31			
	5	" " 250 g.	"	23.31			
		Discount unchanged.					
		General Stores.					
		<i>Gazette No. 58—10th June, 1976.</i>					
37		<i>Electrical Goods.</i>					
	52	Urn, 2 gal. capacity "Birko" 2G	each	63.30	Birko Electric (Sales) Pty. Ltd. ..	1.7.76	
64		<i>Cleaning and Polishing Requirements.</i>					
	31	Buckets, galvanized— 9 litres	each	2.70	} B. and R. Domestic Homewares Pty. Ltd.	1.7.76	
	32	" " —18 litres	"	4.54			
		Rubbish Bins, heavy duty galvanized—			} B. and R. Domestic Homewares Pty. Ltd.	1.7.76	
	35	No. 3	each	6.60			
	36	No. 4	"	7.82			
	37	No. 5	"	11.62			
56		Motor Spirit.					
		<i>Gazette No. 29—15th March, 1976.</i>					
	31	Bunker fuel	per tonne	66.28	B.P. Australia Ltd.	1.7.76	
		<i>Distribution Outlets—Country Areas :</i>					
		<i>Kilmore :</i>					
		Delete Esso—G. R. Saunders, Lancefield Road.					
		Substitute :					
		G. and M. Allan, B.P. Parkview Service Station, Hume Highway, Kilmore :					
		Super	per litre	15.63			
		Standard	"	14.92			
		<i>St Arnaud :</i>					
		Shell—N. J. and P. J. Hando					
		Delete—21 George Street,					
		Substitute : 22 Millett Street.					

NOTICE.

Creditors, next of kin and others having claims against the estate of any of the under-mentioned deceased persons are required to send particulars of their claims to the Public Trustee, 168 Exhibition Street, Melbourne, Vic. 3000; the personal representative, on or before the 27th September, 1976, after which date the Public Trustee may convey or distribute the assets having regard only to the claims of which the Public Trustee then has notice.

AMERY, EDWARD JAMES, late of 34 Middle Street, Ascot Vale, retired labourer, died 29th November, 1975.

BEGG, PETER, late of 295 Grimshaw Street, Watsonia, retired fireman, died 13th April, 1976.

BLANEY, ALLEN FRED, in the will called A. Blaney and also known as Alan Frederick Blaney and Allan Blaney, late of 5 Ellt Crescent, Noble Park, retired seaman, died 24th May, 1975.

BOURKE, GENEVIEVE MCKINNEY, late of 453 Clarke Street, Northcote, widow, died 7th May, 1976.

HAY, PETER RICHARD, late of 23 Bay Street, Southport, Queensland, retired painter, died 29th October, 1975.

JONES, MALCOLM RICHARDSON, late of 52 King Street, Essendon, retired accountant, died 6th December, 1975.

KANE, KATHLEEN EDITH, late of 15 McDonald Street, Mordialloc, married woman, died 9th April, 1976.

KLINE, JOHN WILLIAM, formerly of 20 Dods Street, Brunswick, but late of Bundoora, retired postal worker, died 3rd December, 1975.

LORIMER, QUEENIE AMY CLARIBEL, late of Unit 4, 37 Belgrave Road, East Malvern, spinster, died 22nd March, 1976.

MAXEY, JEANETTE IVY, also known as Maxey, Jeanette, late of 3 Pallett Street, North Coburg, widow, died 24th March, 1976.

MCNICOL, WILLIAM DONALD, also known as McNicol, Donald William, late of 10 Maroona Road, Glenhuntly, retired labourer, died 16th March, 1976.

PETLEY, ETHEL, late of 16 Heathfield Grove, Montrose, widow, died 8th April, 1976.

POOK, GEORGE, late of 28 Hackett Street, Pascoe Vale South, pensioner, died 14th January, 1976.

ROBERTS, WILLIAM GEORGE, late of 12 Leonard Street, Moorabbin, retired, died 26th April, 1976.

SIED, JAMES FRANCIS, also known as James Francis Seid and James Francis Dugdale, late of 598 Canning Street, North Carlton, invalid pensioner, died between 1st and 31st December, 1975.

WOUFFE, MURIEL JOYCE, late of 119 Liberty Parade, West Heidelberg, widow, died 9th February, 1976.

ZAUNER, FRANZ, late of Seabeach Parade, North Shore, engineer, died 6th April, 1976.

N. P. BRODY,
Public Trustee.

Melbourne, 13th July, 1976.

APPOINTMENTS AND RESIGNATIONS

APPOINTMENTS.

His Excellency the Governor of the State of Victoria, by and with the advice of the Executive Council thereof, has, by Orders made on the 13th day of July, 1976, been pleased to make the under-mentioned appointments, viz.:

MINISTRY OF HEALTH.

Member of Committee of Management, Mount Royal.

Professor-elect DEREK MELVILLE PRINSLEY, M.B., B.S., M.D. (Dunelm), F.R.C.P. (Edin.)
to be University Nominee on Committee of Management of Mount Royal for a period of three years pursuant to the provisions of section 48 (1) (c) of the Hospitals and Charities Act 1958.

LAW DEPARTMENT.

Justices of the Peace.

SAVVAS DAVID, 7 Daley Street, West Sunshine,
JAMES JOSEPH DURMAN, 240 Victoria Parade, East Melbourne, and
FREDERICK ALFRED PEARSON, 25 Holyrood Street, Hampton,
to be Justices of the Peace for the State of Victoria.

Commissioners for Taking Declarations, &c.

PATRICK JOHN ABBOTT, 221 Burwood Highway, Burwood,
ROBERT GEORGE ALLAN, 109-111 Sturt Street, South Melbourne,
PERCY BORG, 50 Rutland Road, Box Hill,
GEORGE WILLIAM JOHN JENKINS, 260 Dorset Road, Boronia,
MICHAEL KAMINSKYJ, 57 Pakington Street, Geelong West,
AREND JAN KARMAN, 9 Aitken Street, Sunbury,
ALEXANDER RONALD KENNEDY, 293 Swanston Street, Melbourne,
ANTHONY EDWARD WATSON, 109 Sturt Street, South Melbourne, and
WILLIAM HARRY WHITFORD, Burwood Highway, Upper Ferntree Gully,
to be Commissioners for taking Declarations and Affidavits under the Evidence Act 1958.

PUBLIC WORKS DEPARTMENT.

Wharf Managers.

Sergeant IVAN MAURICE WHYTE, No. 14131,
to be Wharf Manager at Port Welshpool-Port Franklin to carry out that portion of Part II. of the Marine Act 1958, which relates to the management of Public Wharfs and to be an officer under section 19 of such Act to levy and collect wharfage rates thereat, at a remuneration of \$100.00 per annum, vice Sergeant Derek Stuart Robinson, No. 14242, transferred;

Sergeant ROBERT ALAN KILNER, No. 13895,
to be Wharf Manager at Half Moon Bay to carry out that portion of Part II. of the Marine Act 1958 which relates to the management of Public Wharfs, and to be an officer under section 19 of such Act to levy and collect wharfage rates thereat at a remuneration of \$50.00 per annum, vice Sergeant Francis Peter Lyons, No. 12848, transferred; and

Senior Sergeant WILLIAM JOHN STEWART, No. 13113,
to be Wharf Manager at Bairnsdale and Paynesville to carry out that portion of Part II. of the Marine Act 1958, which relates to the management of Public Wharfs and to be an officer under section 19 of such Act to levy and collect wharfage rates thereat, at a remuneration of \$100.00 per annum, vice Senior Sergeant Frank Irwin Morgan, No. 10610, retired.

DEPARTMENT OF WATER SUPPLY.

Waterworks Trust Commissioners.

PERCY BOWEN MARTIN
to be a Commissioner of the Toora Waterworks Trust, to hold such position for a period of four years from the date hereof, subject to the provisions of the Water Act.

ALLAN WESTON
to be a Commissioner of the Foster Waterworks Trust, to hold such position for a period of four years from the date hereof, subject to the provisions of the Water Act.

TOM FORRISTAL,
Clerk of the Executive Council.

At the Executive Council Chamber,
Melbourne, 13th July, 1976.

Forests Act 1958.

APPOINTMENT OF COMMITTEE OF MANAGEMENT OF ST. GEORGE'S LAKE SCENIC RESERVE.

Whereas by section 50 of the Forests Act 1958 (No. 6254), it is provided that the Minister of Forests may, on the recommendation of the Forests Commission, appoint any number of persons, not less than three, to be a committee of management of any land forming part of any reserved forest, such land being set aside and declared to be a scenic reserve, and may remove any of those persons: Now therefore, I, Frederick James Granter, Her Majesty's Minister of Forests for the State of Victoria, on the recommendation of the Forests Commission, do hereby appoint—

ALEXANDER THOMAS EVANS, M.P.,
JOHN ALEXANDER SELWYN GEDDES,
WILLIAM HENRY ROFE,
EDWIN JAMES SEMMENS,
ALAN ROBERT EDDY,
KENNETH JAMES RUSSELL,
ANDREW ALEXANDER ALLAN,
JOHN RAYMOND CHANNON, and
RODNEY WILLIAM HANDMER,

as members of the Committee of Management until the 30th day of June, 1979, of the land forming part of the reserved forest in the Parish of Creswick, County of Talbot,

described in the accompanying Schedule, and known as "St. George's Lake Scenic Reserve".

SCHEDULE ABOVE REFERRED TO.

Parish of Creswick, County of Talbot, 26.71 hectares, more or less, being the area shown by pink colour on the plan marked 60/67 over 18.3.63 on file of correspondence No. 72/2288 of the Forests Department.

Dated at Melbourne the 12th day of July, 1976.

F. J. GRANTER,
Minister of Forests.

Forests Act 1958.

APPOINTMENT OF COMMITTEE OF MANAGEMENT OF CRESWICK KOALA PARK.

Whereas by section 50 of the Forests Act 1958 (No. 6254), it is provided that the Minister of Forests may, on the recommendation of the Forests Commission, appoint any number of persons, not less than three, to be a committee of management of any land forming part of any reserved forest, such land being set aside and declared to be a koala park and may remove any of those persons: Now therefore, I, Frederick James Granter, Her Majesty's Minister of Forests for the State of Victoria, on the recommendation of the Forests Commission, do hereby appoint—

- ALEXANDER THOMAS EVANS, M.P.,
- JOHN ALEXANDER SELWYN GEDDES,
- WILLIAM HENRY ROFE,
- EDWIN JAMES SEMMENS,
- ALAN ROBERT EDDY,
- JOHN CLEMENTS,
- KENNETH JAMES RUSSELL,
- ANDREW ALEXANDER ALLAN,
- JOHN RAYMOND CHANNON, and
- RODNEY WILLIAM HANDMER,

as members of the Committee of Management until the 30th day of June, 1979, of the land forming part of the reserved forest in the Parish of Creswick, County of Talbot, described in the accompanying Schedule, and known as "Creswick Koala Park".

SCHEDULE ABOVE REFERRED TO.

Parish of Creswick, County of Talbot, 9.3 hectares, more or less, being the area shown by pink colour on plan marked A.41/746 over 15.7.42 on file of correspondence No. 74/2828 of the Forests Department.

Dated at Melbourne the 12th day of July, 1976.

F. J. GRANTER,
Minister of Forests.

Vermin and Noxious Weeds Act 1958.

APPOINTMENT OF INSPECTOR.

It is hereby notified that the Public Service Board in exercise of its powers has appointed the under-mentioned person as an Inspector under the provisions of section 4 of the Vermin and Noxious Weeds Act 1958, without additional salary:

- KENNETH GEORGE COLLINS
- C. E. MIDDLETON,
Secretary for Lands.

Melbourne, 15th July, 1976.

Liquor Control Act 1968.

APPOINTMENT OF LICENSING INSPECTORS.

In accordance with the authority conferred upon me by sub-section (1) of Section 22 of the Liquor Control Act 1968, I, Reginald Jackson, Chief Commissioner of Police, hereby appoint the following Officers of Police as Licensing Inspectors for the Divisions of the Police Districts as shown:—

Division Number	Police District.	Rank and Name.
4	Maroondah	Inspector Roy Edward Lauder East (from 5.7.76 to 26.7.76).
1	Sunshine	Superintendent Thomas Weymouth Williams (vice Superintendent S. W. Hanlon, Q.P.M.).
1	Westernport	Chief Inspector Alfred Francis Irwin (vice Superintendent G. F. Marchesi).

15.7.1976

R. JACKSON,
Chief Commissioner of Police.

RESIGNATIONS.

His Excellency the Governor of the State of Victoria, by and with the advice of the Executive Council thereof, has, by Order made on the 13th day of July, 1976, accepted the resignations of the persons named hereunder of the office mentioned, viz:—

LAW DEPARTMENT.

Justices of the Peace.

GABRIEL ALEXANDER PIERRE CONSIDINE, and
GERARD MAJELLA THOMAS O'BRIEN,
as Justices of the Peace for the State of Victoria.

Commissioners for Taking Declarations, &c.

SAM DAVID,
ERIC JOHN HARLE,
GEORGE DUNCAN JARVE,
KEITH HUDSPETH PATERSON,
HARRY STANSFIELD, and
REGINALD STEPHEN TABERNER,

as Commissioners for taking Declarations and Affidavits under the Evidence Act 1958.

TOM FORRISTAL,
Clerk of the Executive Council.

At the Executive Council Chamber,
Melbourne, 13th July, 1976.

ORDERS IN COUNCIL

DEPARTMENT OF CROWN LANDS AND SURVEY.

At the Executive Council Chamber, Melbourne, the thirteenth day of July, 1976.

PRESENT:

His Excellency the Governor of Victoria.
Mr. Houghton | Mr. Crozier.
Mr. Haddon Storey

UNUSED ROADS CLOSED.

In pursuance of the provisions of section 349 of the Land Act 1958, His Excellency the Governor of the State of Victoria, by and with the advice of the Executive Council thereof, and the concurrence in writing of the Council of the municipality concerned, doth hereby close the unused roads referred to hereunder, viz:—

Township of Ventnor, Parish of Phillip Island, County of Mornington, being the roads indicated by hatching on plan hereunder.—(V.10(1) (C.101023).

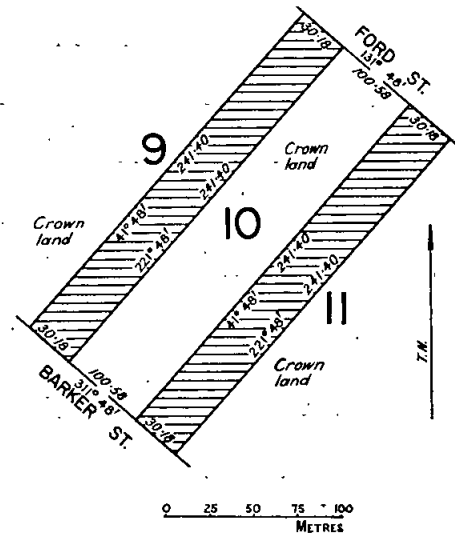

And the Honorable William Archibald Borthwick, Her Majesty's Minister of Lands for the State of Victoria, shall give the necessary directions herein accordingly.

TOM FORRISTAL,
Clerk of the Executive Council.

Land Act 1958.

DEPARTMENT OF CROWN LANDS AND SURVEY.

At the Executive Council Chamber, Melbourne, the thirteenth day of July, 1976.

PRESENT:

His Excellency the Governor of Victoria.

Mr. Houghton | Mr. Crozier.
Mr. Haddon Storey |

LANDS TEMPORARILY RESERVED AS SITES.

His Excellency the Governor of the State of Victoria, by and with the advice of the Executive Council thereof, doth hereby in pursuance of the provisions of section 14 of the Land Act 1958, reserve temporarily from sale, from being leased and from having a licence granted in respect thereof, and also except from occupation for mining purposes under any miner's right the lands hereinafter described, viz.:

FRANKSTON.—Site for Public Recreation, 6029 square metres, being Crown allotment 6U, section 6, Parish of Frankston, County of Mornington, as indicated by hatching on plan hereunder.—(F.87⁽⁵⁾) (Rs.3545).

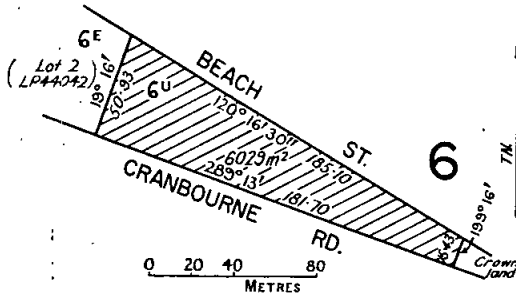

KEELBUNDORA (GREENSBOROUGH).—Site for Public purposes (Mental Health Authority purposes) 809 square metres, being Crown allotment 18B, Parish of Keelbundora, County of Bourke, as indicated by hatching on plan hereunder.—(K.25⁽⁵⁾) (Rs.10158).

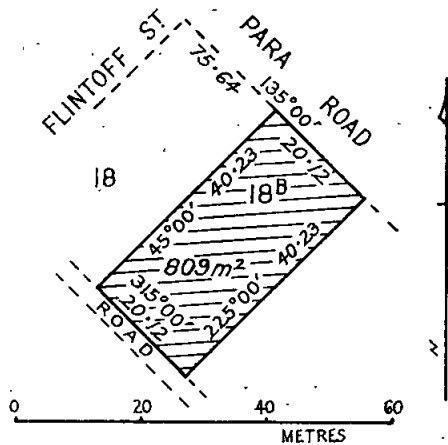

NARRACAN (NEWBOROUGH).—Site for Water Supply purposes 1694 square metres, being Crown allotment 6J, K Parish of Narracan, County of Buln Buln, as indicated by hatching on plan hereunder.—(N.129⁽¹²⁾) (Rs.7085).

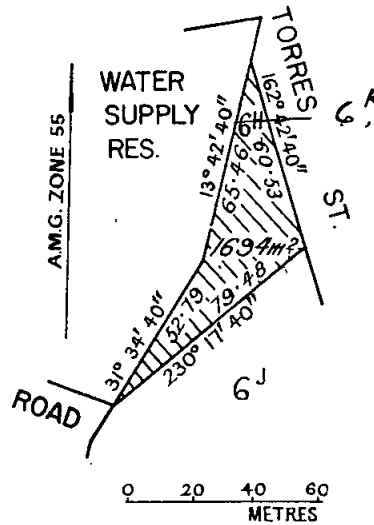

SOUTH MELBOURNE (MIDDLE PARK).—Site for Public purposes (Mental Health Authority purposes), 3451 square metres, being Crown allotment 23A, section 43R, City of South Melbourne, Parish of Melbourne South, County of Bourke as indicated by hatching on plan hereunder.—(M.333⁽²⁸⁾) (Rs.10157).

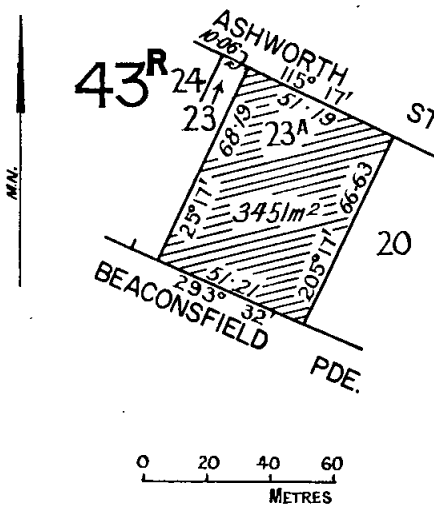

And the Honorable William Archibald Borthwick, Her Majesty's Minister of Lands for the State of Victoria, shall give the necessary directions herein accordingly.

TOM FORRISTAL,
Clerk of the Executive Council.

LOCAL GOVERNMENT DEPARTMENT

At the Executive Council Chamber, Melbourne, the
thirteenth day of July, 1976.

PRESENT:

His Excellency the Governor of Victoria.
Mr. Houghton | Mr. Crozier.
Mr. Haddon Storey

CONSENT TO VARIATION OF USE OF PORTION OF RESERVE BY THE FRANKSTON CITY COUNCIL.

Whereas the Council of the City of Frankston is the registered proprietor of certain land being the Public Resort and Recreation Reserve on Plan of Subdivision No. 112401 lodged in the Office of Titles and the said Council is now of the opinion that portion of the land is no longer required for the purposes for which it was reserved and has requested that consent be given, pursuant to section 569BA of the Local Government Act 1958, to the use of the said portion of land for the purposes of a site for a Pre-School and Infant Welfare Centre.

And whereas the said Council:

- (a) has published in a newspaper generally circulating in the municipal district a notice describing the land and the proposal for the altered use thereof and stating that at the next ordinary meeting of the Council after the expiration of forty days after publication of the notice the Council would consider any objection to the proposal; and
- (b) there being no registered mortgagee chargee or lessee has posted a similar notice upon the land in question.

And whereas no objection to the proposal has been received.

Now therefore, the Governor of the State of Victoria, by and with the advice of the Executive Council thereof, doth hereby consent to the use of the land in that portion of the Public Resort and Recreation Reserve on Plan of Subdivision No. 112401 lodged in the Office of Titles shown by hachure on the plan hereunder for the purposes of a site for a Pre-School and Infant Welfare Centre.

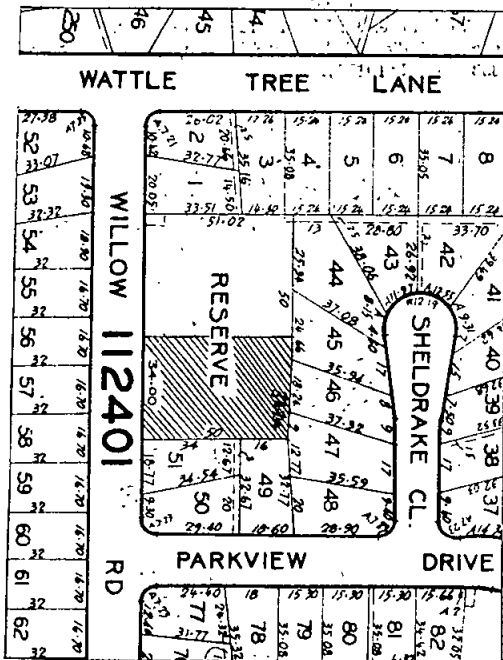

And the Honorable Alan John Hunt, Her Majesty's Minister for Local Government for the State of Victoria, shall give the necessary directions herein accordingly.

TOM FORRISTAL,
Clerk of the Executive Council.

LOCAL GOVERNMENT DEPARTMENT.

At the Executive Council Chamber, Melbourne, the
thirteenth day of July, 1976.

PRESENT:

His Excellency the Governor of Victoria.
Mr. Houghton | Mr. Crozier.
Mr. Haddon Storey

PART OF ROAD DISCONTINUED.—CITY OF PRAHRAN.

Whereas it is provided in section 528 (2) of the Local Government Act 1958, that where a road (whether or not a public highway but not being a road set out on land of the Crown) or any part thereof is not required for public use, the Governor in Council on the request of the Council of the municipality in which such road is situated made not less than one month after publishing in a newspaper generally circulating in the district and posting to the registered proprietor (if any) of the land and the owners and occupiers (if any) of lands abutting or immediately adjacent to the road notice of intention to make such request may by Order published in the Government Gazette direct that such road or part shall be discontinued and thereupon such road or part shall be discontinued accordingly.

And whereas the Council of the City of Prahran has requested that the Governor in Council direct that a part of a road off Chatsworth Road, Prahran be discontinued and not less than one month previously has published in a newspaper generally circulating in the district and posted to the registered proprietor of the land in the road and to the owners and occupiers of the lands abutting or immediately adjacent to the road notice of intention to make such request.

Now therefore, His Excellency the Governor of the State of Victoria, by and with the advice of the Executive Council thereof, hereby directs that the said road which is shown by hachure on the plan hereunder shall be discontinued and that the said road which is shown by hachure on the plan hereunder shall be discontinued and that the land may be sold by the Council of the City of Prahran by agreement.

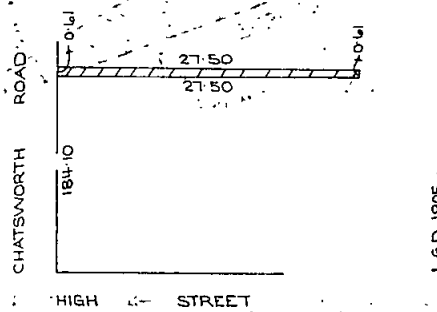

LENGTHS ARE IN METRES.

And the Honorable Alan John Hunt, Her Majesty's Minister for Local Government for the State of Victoria, shall give the necessary directions herein accordingly.

TOM FORRISTAL,
Clerk of the Executive Council.

LOCAL GOVERNMENT DEPARTMENT.

At the Executive Council Chamber, Melbourne, the
thirteenth day of July, 1976.

PRESENT:

His Excellency the Governor of Victoria.
Mr. Houghton | Mr. Crozier.
Mr. Haddon Storey

CONSENT TO VARIATION OF USE OF PART OF A RESERVE BY THE WAVERLEY CITY COUNCIL.

Whereas certain land being the Reserve for Municipal purposes on Plan of Subdivision No. 98125 was transferred to the Council of the City of Waverley pursuant to the provisions of section 569a (8A) (ii) (a) of the Local

LOCAL GOVERNMENT DEPARTMENT.

At the Executive Council Chamber, Melbourne, the
thirteenth day of July, 1976.

PRESENT:

His Excellency the Governor of Victoria.
Mr. Houghton | Mr. Crozier.
Mr. Haddon Storey

PART OF ROAD DISCONTINUED.—SHIRE OF MORWELL.

Whereas it is provided in section 528 (2) of the *Local Government Act 1958*, that where a road (whether or not a public highway but not being a road set out on land of the Crown) or any part thereof is not required for public use, the Governor in Council on the request of the Council of the municipality in which such road is situated made not less than one month after publishing in a newspaper generally circulating in the district and posting to the registered proprietor (if any) of the land and the owners and occupiers (if any) of lands abutting or immediately adjacent to the road notice of intention to make such request may by Order published in the *Government Gazette* direct that such road or part shall be discontinued and thereupon such road or part shall be discontinued accordingly.

And whereas the Council of the Shire of Morwell has requested that a part of Marretts Road in the Parish of Narracan be discontinued and not less than one month previously has published in a newspaper generally circulating in the district and posted to the registered proprietor of the land in the road and to the owners and occupiers of the lands abutting or immediately adjacent to the said road notice of intention to make such request.

Now therefore, His Excellency the Governor of the State of Victoria, by and with the advice of the Executive Council thereof, hereby directs that the said part of road, which is shown by hachure on the plan hereunder, shall be discontinued and that, the land in the said part of road may be sold by the Council of the Shire of Morwell by agreement.

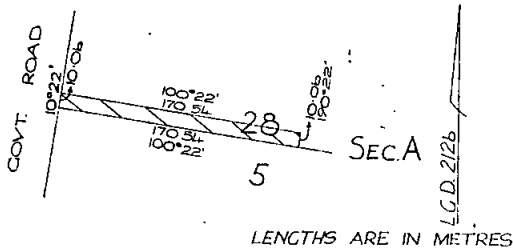

And the Honorable Alan John Hunt, Her Majesty's Minister for Local Government for the State of Victoria, shall give the necessary directions herein accordingly.
TOM FORRISTAL,
Clerk of the Executive Council.

COUNTRY ROADS BOARD.
Act No. 6229.

At the Executive Council Chamber, Melbourne, the
thirteenth day of July, 1976.

PRESENT:

His Excellency the Governor of Victoria.
Mr. Houghton | Mr. Crozier.
Mr. Haddon Storey

ORDER APPROVING OF LAND BEING ACQUIRED AND ROADS, DEVIATIONS OR WIDENINGS BEING MADE TOGETHER WITH ALL ANCILLARY WORKS REQUIRED TO BE EXECUTED IN CONJUNCTION THEREWITH.

His Excellency the Governor of the State of Victoria, by and with the advice of the Executive Council thereof, being satisfied that there are funds legally available for acquiring the land, doth hereby approve the acquiring of the land described in the schedule hereunder and the

making of new roads and deviations from and widenings of existing roads, together with all ancillary works required to be executed in conjunction therewith, referred to in the said Schedule.

SCHEDULE.

State Highway.

The land shown hatched on plans numbered G.P.14012A, G.P.14012B and G.P.14013 hereunder required for the deviation from the Bonang Highway in the Shire of Orbost and making of the deviation thereon.

STATE HIGHWAY
BONANG HIGHWAY
SHIRE OF ORBOST
Lengths in metres.

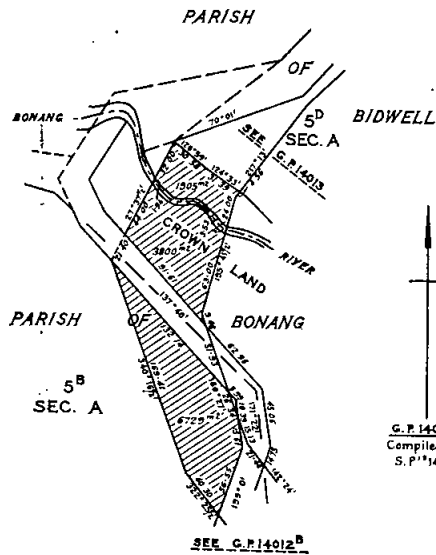

STATE HIGHWAY
BONANG HIGHWAY
SHIRE OF ORBOST
Lengths in metres.

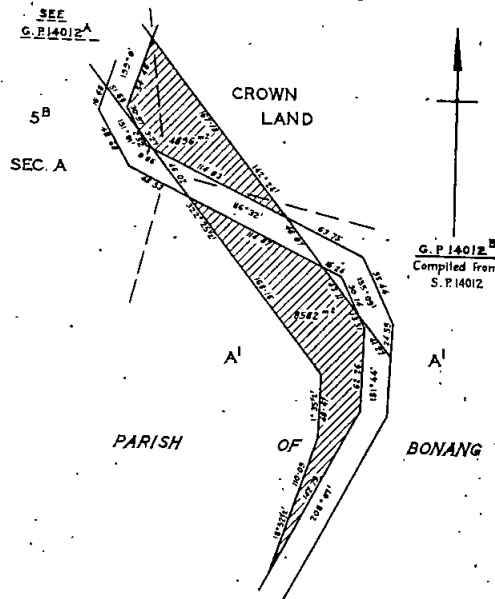

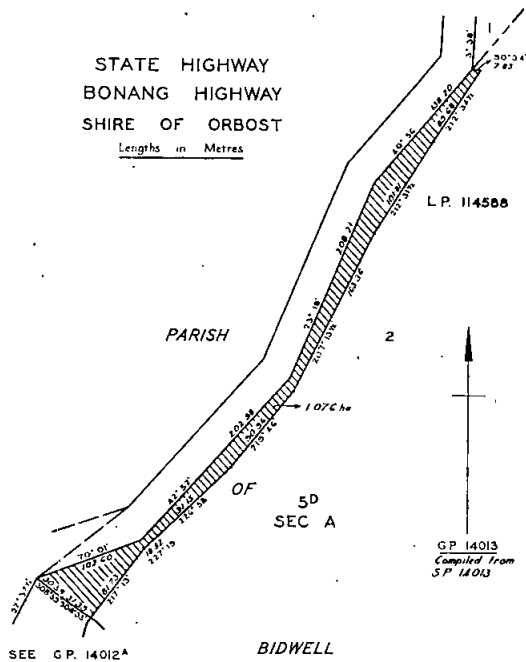

Unclassified Road.
The land shown hatched on plan numbered G.P.14227 hereunder required for the making of a new road in the Shire of Ballan.

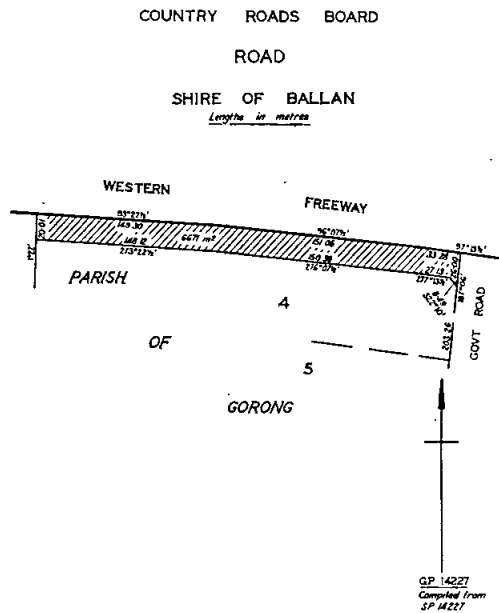

Main Road.
The land shown hatched on plan numbered G.P.13062b hereunder required for the deviation from the Wandiligong Road in the Shire of Bright and making of the deviation thereon.

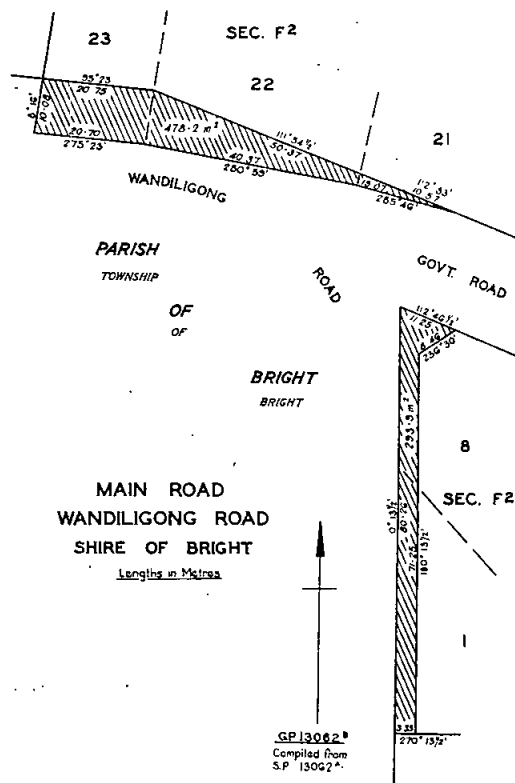

And the Honorable Joseph Anstice Rafferty, Her Majesty's Minister of Transport for the State of Victoria, shall give the necessary directions herein accordingly.

TOM FORRISTAL,
Clerk of the Executive Council.

COUNTRY ROADS BOARD.
Act No. 6229.

At the Executive Council Chamber, Melbourne, the thirteenth day of July, 1976.

PRESENT:

His Excellency the Governor of Victoria.
Mr. Houghton | Mr. Crozier.
Mr. Haddon Storey

ORDER APPROVING OF LAND BEING ACQUIRED AND ROADS, DEVIATIONS OR WIDENINGS BEING MADE TOGETHER WITH ALL ANCILLARY WORKS REQUIRED TO BE EXECUTED IN CONJUNCTION THEREWITH.

His Excellency the Governor of the State of Victoria, by and with the advice of the Executive Council thereof, being satisfied that there are funds legally available for acquiring the land described in the schedule hereunder and the making of new roads and deviations from and widenings of existing roads, together with all ancillary works required to be executed in conjunction therewith, referred to in the said schedule.

SCHEDULE.

Main Road.

The land shown hatched on plans numbered G.P.14031a and G.P.14031b hereunder required for the widening of the Boolarra-Foster road in the Shire of South Gippsland and making of the widening thereon.

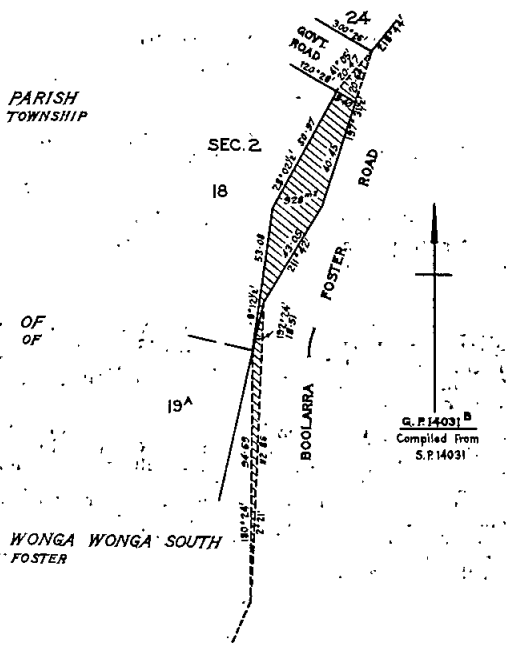
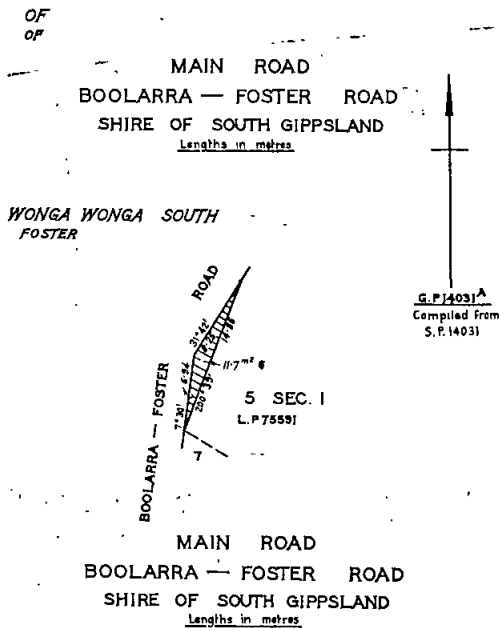
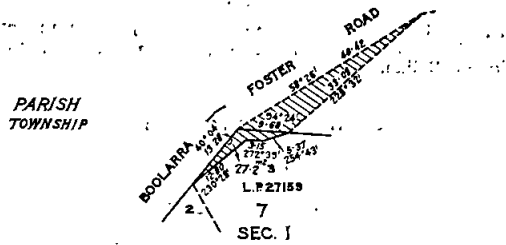

And the Honorable Joseph Anstice Rafferty, Her Majesty's Minister of Transport for the State of Victoria, shall give the necessary directions herein accordingly.

TOM FORRISTAL,
Clerk of the Executive Council.

OCEAN GROVE SEWERAGE AUTHORITY.

At the Executive Council Chamber, Melbourne, the thirteenth day of July, 1976.

PRESENT:

His Excellency the Governor of Victoria.
Mr. Houghton | Mr. Crozier.
Mr. Haddon Storey

EXTENT OF SEWERAGE DISTRICT DIMINISHED.—
AMENDMENT OF ORDER IN COUNCIL CONSTITUTING THE OCEAN GROVE SEWERAGE AUTHORITY.

Under the powers conferred by the Sewerage Districts Act and all other powers enabling him in that behalf, His Excellency the Governor of the State of Victoria by and with the advice of the Executive Council of the said State, doth hereby—

- (a) declare, order and direct that the extent of the Sewerage District of the Ocean Grove Sewerage Authority be diminished by excising from the same the areas shown by green colour on a plan approved by the Governor in Council and deposited in the office of the State Rivers and Water Supply Commission, Melbourne (Corr. No. 74/3096/42), and as on and from the date hereof the extent of such District shall be and be deemed to be diminished accordingly; and
- (b) amends the Order in Council constituting the Ocean Grove Sewerage Authority, made on 30th August, 1966, by deleting clause (b) and substituting therefor the expression "(b) that the Members of the said Sewerage Authority shall comprise three Councillors for the time being of the Bellarine Riding of the Shire of Bellarine, and three other persons appointed by the Governor in Council."

And the Honorable Frederick James Granter, Her Majesty's Minister of Water Supply for the State of Victoria, shall give the necessary directions herein accordingly.

TOM FORRISTAL,
Clerk of the Executive Council.

Water Act 1958.
STATE RIVERS AND WATER SUPPLY COMMISSION.

At the Executive Council Chamber, Melbourne, the thirteenth day of July, 1976.

PRESENT:

His Excellency the Governor of Victoria.
Mr. Houghton | Mr. Crozier.
Mr. Haddon Storey

GOULBURN-MURRAY IRRIGATION DISTRICT—
DISTRICT EXTENDED COHUNA IRRIGATION AREA.—BOUNDARIES VARIED.

Under the powers conferred by the Water Act 1958 and all other powers enabling him in that behalf, His Excellency the Governor of the State of Victoria, with the advice of the Executive Council of the said State, on the recommendation of the State Rivers and Water Supply Commission, doth hereby declare, order and direct that the Goulburn-Murray Irrigation District be extended and the boundaries of the Cohuna Irrigation Area be varied by adding to the said District and Area the lands shown by blue colour on a plan approved by the Governor in Council and deposited in the office of the State Rivers and Water Supply Commission at 590 Orrong Road, Armadale (Corr. Nos. 66/3982, 72/1612, 72/1622, 72/1624 and 74/2685) and as on and from the 1st day of August, 1976, such District shall be deemed to be so extended and the boundaries of such Area shall be so varied.

And the Honorable Frederick James Granter, Her Majesty's Minister of Water Supply for the State of Victoria, shall give the necessary directions herein accordingly.

TOM FORRISTAL,
Clerk of the Executive Council.

Water Act 1958.
STATE RIVERS AND WATER SUPPLY COMMISSION.

At the Executive Council Chamber, Melbourne, the
thirteenth day of July, 1976.

PRESENT:

His Excellency the Governor of Victoria.
Mr. Houghton | Mr. Crozier.
Mr. Haddon Storey

WERRIBEE IRRIGATION DISTRICT.—PORTION
EXCISED.

Under the powers conferred by the Water Act 1958 and all other powers enabling him in that behalf, His Excellency the Governor of the State of Victoria, with the advice of the Executive Council of the said State, on the recommendation of the State Rivers and Water Supply Commission, doth hereby declare, order and direct that there shall be excised from the Werribee Irrigation District that portion of the same shown by green colour on a plan approved by the Governor in Council and deposited in the office of the State Rivers and Water Supply Commission, at 590 Orrong Road, Armadale (Corr. No. 73/566) and as on and from the 31st day of July, 1976, such portion shall be deemed to be excised accordingly.

And the Honorable Frederick James Granter, Her Majesty's Minister of Water Supply for the State of Victoria, shall give the necessary directions herein accordingly.

TOM FORRISTAL,
Clerk of the Executive Council.

Water Act 1958.
STATE RIVERS AND WATER SUPPLY COMMISSION.

At the Executive Council Chamber, Melbourne, the
thirteenth day of July, 1976.

PRESENT:

His Excellency the Governor of Victoria.
Mr. Houghton | Mr. Crozier.
Mr. Haddon Storey

BACCHUS MARSH IRRIGATION DISTRICT.—PORTION
EXCISED.

Under the powers conferred by the Water Act 1958 and all other powers enabling him in that behalf, His Excellency the Governor of the State of Victoria, with the advice of the Executive Council of the said State, on the recommendation of the State Rivers and Water Supply Commission, doth hereby declare, order and direct that there shall be excised from the Bacchus Marsh Irrigation District that portion of the same shown by green colour on a plan approved by the Governor in Council and deposited in the Office of the State Rivers and Water Supply Commission at 590 Orrong Road, Armadale (Corr. No. 71/1640) and as on and from the 31st day of July, 1976, such portion shall be deemed to be excised accordingly.

And the Honorable Frederick James Granter, Her Majesty's Minister of Water Supply for the State of Victoria, shall give the necessary directions herein accordingly.

TOM FORRISTAL,
Clerk of the Executive Council.

WATER ACT 1958.

At the Executive Council Chamber, Melbourne, the
thirteenth day of July, 1976.

PRESENT:

His Excellency the Governor of Victoria.
Mr. Houghton | Mr. Crozier.
Mr. Haddon Storey

BACCHUS MARSH WATER SUPPLY DISTRICT.—
LOCAL GOVERNING BODY, BACCHUS MARSH SHIRE
COUNCIL.—AREA OF DISTRICT INCREASED.

Under the powers conferred by the Water Act 1958 and all other powers enabling him in that behalf, His Excellency the Governor of the State of Victoria, with the

advice of the Executive Council of the said State, doth hereby declare, order and direct that the area of the Bacchus Marsh Water Supply District, under the control of the Bacchus Marsh Shire Council, as a local governing body, be increased by adding thereto the land shown by blue colour on a plan approved by the Governor in Council and deposited in the office of the State Rivers and Water Supply Commission, at 590 Orrong Road, Armadale (Corr. No. 71/1640) and as on and from the 1st day of August, 1976, the area of such District shall be deemed to be so increased.

And the Honorable Frederick James Granter, Her Majesty's Minister of Water Supply for the State of Victoria, shall give the necessary directions herein accordingly.

TOM FORRISTAL,
Clerk of the Executive Council.

SUPERANNUATION ACT 1958.

At the Executive Council Chamber, Melbourne, the
thirteenth day of July, 1976.

PRESENT:

His Excellency the Governor of Victoria.
Mr. Houghton | Mr. Crozier.
Mr. Haddon Storey

Pursuant to the powers conferred by the provisions of paragraph (ja) of sub-section (1) of section 3 of the Superannuation Act 1958, His Excellency the Governor of the State of Victoria, by and with the advice of the Executive Council thereof doth by this Order declare that the provisions of the Superannuation Act shall apply to the officers named in the schedule set out hereunder.

SCHEDULE.

SCOTTON, JUNE, State College of Victoria, at Melbourne.
KNOL, FREERK, State College of Victoria, Rusden.
SHEPHERD, FAY, State College of Victoria, Institute of
Early Childhood Development.
BROWN, ELIZABETH HELEN, Lincoln Institute.
HETHERINGTON, ROBERT JOHN, Victorian Development
Corporation.

And the Honorable Rupert James Hamer, Her Majesty's Treasurer for the State of Victoria, shall give the necessary directions herein accordingly.

TOM FORRISTAL,
Clerk of the Executive Council.

APOLLO BAY SEWERAGE AUTHORITY.

At the Executive Council Chamber, Melbourne, the
twentieth day of July, 1976.

PRESENT:

His Excellency the Governor of Victoria.
Mr. Hunt | Mr. Smith.
Mr. Maclellan

CONSENT TO BORROWING \$50,000.

Under the powers conferred by the Sewerage Districts Act and all other powers enabling him in that behalf, His Excellency the Governor of the State of Victoria, by and with the advice of the Executive Council of the said State, hereby consents to the Apollo Bay Sewerage Authority borrowing the sum of Fifty thousand dollars (\$50,000) to meet the cost of sewerage works as set forth in the detailed statement bearing date 15th July, 1976.

And the Honorable Frederick James Granter, Her Majesty's Minister of Water Supply for the State of Victoria, shall give the necessary directions herein accordingly.

TOM FORRISTAL,
Clerk of the Executive Council.

DROUIN SEWERAGE AUTHORITY.

At the Executive Council Chamber, Melbourne, the twentieth day of July, 1976.

PRESENT:

His Excellency the Governor of Victoria.
Mr. Hunt | Mr. Smith
Mr. Maclellan

CONSENT TO BORROWING \$20,000.

Under the powers conferred by the Sewerage Districts Act and all other powers enabling him in that behalf, His Excellency the Governor of the State of Victoria, by and with the advice of the Executive Council of the said State, hereby consents to the Drouin Sewerage Authority borrowing the sum of Twenty thousand dollars (\$20,000) to meet the cost of sewerage works as set forth in the detailed statement bearing date 15th July, 1976.

And the Honorable Frederick James Granter, Her Majesty's Minister of Water Supply for the State of Victoria, shall give the necessary directions herein accordingly.

TOM FORRISTAL,
Clerk of the Executive Council.

SHEPPARTON SEWERAGE AUTHORITY.

At the Executive Council Chamber, Melbourne, the twentieth day of July, 1976.

PRESENT:

His Excellency the Governor of Victoria.
Mr. Hunt | Mr. Smith
Mr. Maclellan

CONSENT TO BORROWING \$90,000.

Under the powers conferred by the Sewerage Districts Act and all other powers enabling him in that behalf, His Excellency the Governor of the State of Victoria, by and with the advice of the Executive Council of the said State, hereby consents to the Shepparton Sewerage Authority borrowing the sum of Ninety thousand dollars (\$90,000) to meet the cost of sewerage works as set forth in the detailed statement bearing date 15th July, 1976.

And the Honorable Frederick James Granter, Her Majesty's Minister of Water Supply for the State of Victoria, shall give the necessary directions herein accordingly.

TOM FORRISTAL,
Clerk of the Executive Council.

HASTINGS SEWERAGE AUTHORITY.

At the Executive Council Chamber, Melbourne, the twentieth day of July, 1976.

PRESENT:

His Excellency the Governor of Victoria.
Mr. Hunt | Mr. Smith
Mr. Maclellan

CONSENT TO BORROWING \$50,000.

Under the powers conferred by the Sewerage Districts Act and all other powers enabling him in that behalf, His Excellency the Governor of the State of Victoria, by and with the advice of the Executive Council of the said State, hereby consents to the Hastings Sewerage Authority borrowing the sum of Fifty thousand dollars (\$50,000) to meet the cost of sewerage works as set forth in the detailed statement bearing date 15th July, 1976.

And the Honorable Frederick James Granter, Her Majesty's Minister of Water Supply for the State of Victoria, shall give the necessary directions herein accordingly.

TOM FORRISTAL,
Clerk of the Executive Council.

TATURA SEWERAGE AUTHORITY.

At the Executive Council Chamber, Melbourne, the twentieth day of July, 1976.

PRESENT:

His Excellency the Governor of Victoria.
Mr. Hunt | Mr. Smith
Mr. Maclellan

CONSENT TO BORROWING \$50,000.

Under the powers conferred by the Sewerage Districts Act and all other powers enabling him in that behalf, His Excellency the Governor of the State of Victoria, by and with the advice of the Executive Council of the said State, hereby consents to the Tatura Sewerage Authority borrowing the sum of Fifty thousand dollars (\$50,000) to meet the cost of sewerage works as set forth in the detailed statement bearing date 15th July, 1976.

And the Honorable Frederick James Granter, Her Majesty's Minister of Water Supply for the State of Victoria, shall give the necessary directions herein accordingly.

TOM FORRISTAL,
Clerk of the Executive Council.

MOOROOPNA SEWERAGE AUTHORITY.

At the Executive Council Chamber, Melbourne, the twentieth day of July, 1976.

PRESENT:

His Excellency the Governor of Victoria.
Mr. Hunt | Mr. Smith
Mr. Maclellan

CONSENT TO BORROWING \$20,000.

Under the powers conferred by the Sewerage Districts Act and all other powers enabling him in that behalf, His Excellency the Governor of the State of Victoria, by and with the advice of the Executive Council of the said State, hereby consents to the Mooroopna Sewerage Authority borrowing the sum of Twenty thousand dollars (\$20,000) for sewerage reticulation extensions.

And the Honorable Frederick James Granter, Her Majesty's Minister of Water Supply for the State of Victoria, shall give the necessary directions herein accordingly.

TOM FORRISTAL,
Clerk of the Executive Council.

MELTON WATERWORKS TRUST.

At the Executive Council Chamber, Melbourne, the twentieth day of July, 1976.

PRESENT:

His Excellency the Governor of Victoria.
Mr. Hunt | Mr. Smith
Mr. Maclellan

CONSENT TO BORROWING \$50,000.

Under the powers conferred by the Water Act and all other powers enabling him in that behalf, His Excellency the Governor of the State of Victoria, by and with the advice of the Executive Council of the said State, hereby consents to the Melton Waterworks Trust borrowing the sum of Fifty thousand dollars (\$50,000) to meet the cost of water supply works.

And the Honorable Frederick James Granter, Her Majesty's Minister of Water Supply for the State of Victoria, shall give the necessary directions herein accordingly.

TOM FORRISTAL,
Clerk of the Executive Council.

Water Act 1958.

STATE RIVERS AND WATER SUPPLY COMMISSION.

At the Executive Council Chamber, Melbourne, the twentieth day of July, 1976.

PRESENT:

His Excellency the Governor of Victoria.	
Mr. Hunt	Mr. Smith
Mr. Maclellan	

OTWAY RURAL DISTRICT.—AREA OF DISTRICT INCREASED.

Under the powers conferred by the *Water Act 1958* and all other powers enabling him in that behalf, His Excellency the Governor of the State of Victoria, with the advice of the Executive Council of the said State, on the recommendation of the State Rivers and Water Supply Commission, doth hereby declare, order and direct that the area of the Otway Rural District be increased by adding to the same the lands shown by blue colour on a plan approved by the Governor in Council and deposited in the office of the State Rivers and Water Supply Commission, at 590 Orrong Road, Armadale (Corr. No. 73/511) and as on and from the 1st day of August, 1976, the area of such District shall be deemed to be so increased.

And the Honorable Frederick James Granter, Her Majesty's Minister of Water Supply for the State of Victoria, shall give the necessary directions herein accordingly.

TOM FORRISTAL,
Clerk of the Executive Council.

Water Act 1958.

STATE RIVERS AND WATER SUPPLY COMMISSION.

At the Executive Council Chamber, Melbourne, the twentieth day of July, 1976.

PRESENT:

His Excellency the Governor of Victoria.	
Mr. Hunt	Mr. Smith
Mr. Maclellan	

WEST LODDON WATERWORKS DISTRICT.—PORTION EXCISED.

Under the powers conferred by the *Water Act 1958* and all other powers enabling him in that behalf, His Excellency the Governor of the State of Victoria, with the advice of the Executive Council of the said State, on the recommendation of the State Rivers and Water Supply Commission, doth hereby declare, order and direct that there shall be excised from the West Loddon Waterworks District that portion of the same shown by green colour on a plan approved by the Governor in Council and deposited in the office of the State Rivers and Water Supply Commission at 590 Orrong Road, Armadale (Corr. No. 70/1671) and as on and from the 31st day of July, 1976, such portion shall be deemed to be excised accordingly.

And the Honorable Frederick James Granter, Her Majesty's Minister of Water Supply for the State of Victoria, shall give the necessary directions herein accordingly.

TOM FORRISTAL,
Clerk of the Executive Council.

Water Act 1958.

STATE RIVERS AND WATER SUPPLY COMMISSION.

At the Executive Council Chamber, Melbourne, the twentieth day of July, 1976.

PRESENT:

His Excellency the Governor of Victoria.	
Mr. Hunt	Mr. Smith
Mr. Maclellan	

GOULBURN—MURRAY IRRIGATION DISTRICT—DISTRICT EXTENDED.—BOORT IRRIGATION AREA—BOUNDARIES VARIED.

Under the powers conferred by the *Water Act 1958* and all other powers enabling him in that behalf, His Excellency the Governor of the State of Victoria, with the advice of

the Executive Council of the said State, on the recommendation of the State Rivers and Water Supply Commission, doth hereby declare, order and direct that the Goulburn—Murray Irrigation District be extended and the boundaries of the Boort Irrigation Area be varied by adding to the said district and area the land shown by blue colour on a plan approved by the Governor in Council and deposited in the office of the State Rivers and Water Supply Commission, at 590 Orrong Road, Armadale (Corr. No. 70/1671) and as on and from the 1st day of August, 1976, such district shall be deemed to be so extended and the boundaries of such area shall be so varied.

And the Honorable Frederick James Granter, Her Majesty's Minister of Water Supply for the State of Victoria, shall give the necessary directions herein accordingly.

TOM FORRISTAL,
Clerk of the Executive Council.

Water Act 1958.

STATE RIVERS AND WATER SUPPLY COMMISSION.

At the Executive Council Chamber, Melbourne, the twentieth day of July, 1976.

PRESENT:

His Excellency the Governor of Victoria.	
Mr. Hunt	Mr. Smith
Mr. Maclellan	

GOULBURN—MURRAY IRRIGATION DISTRICT—COHUNA IRRIGATION AREA—BOUNDARIES VARIED.

Under the powers conferred by the *Water Act 1958* and all other powers enabling him in that behalf, His Excellency the Governor of the State of Victoria, with the advice of the Executive Council of the said State, on the recommendation of the State Rivers and Water Supply Commission, doth hereby declare, order and direct that as on and from the 1st day of August, 1976, the boundaries of the Cohuna Irrigation Area of the Goulburn—Murray Irrigation District shall be varied by adding to the said area the land shown by blue colour on a plan approved by the Governor in Council, and deposited in the office of the State Rivers and Water Supply Commission, at 590 Orrong Road Armadale (Corr. No. 76/1441).

And the Honorable Frederick James Granter, Her Majesty's Minister of Water Supply for the State of Victoria, shall give the necessary directions herein accordingly.

TOM FORRISTAL,
Clerk of the Executive Council.

Water Act 1958.

STATE RIVERS AND WATER SUPPLY COMMISSION.

At the Executive Council Chamber, Melbourne, the twentieth day of July, 1976.

PRESENT:

His Excellency the Governor of Victoria.	
Mr. Hunt	Mr. Smith
Mr. Maclellan	

GOULBURN—MURRAY IRRIGATION DISTRICT—KERANG IRRIGATION AREA—BOUNDARIES VARIED.

Under the powers conferred by the *Water Act 1958* and all other powers enabling him in that behalf, His Excellency the Governor of the State of Victoria, with the advice of the Executive Council of the said State, on the recommendation of the State Rivers and Water Supply Commission, doth hereby declare, order and direct that as on and from the 31st day of July, 1976, the boundaries of the Kerang Irrigation Area of the Goulburn—Murray Irrigation District shall be varied by excising from the said area the land shown by green colour on a plan approved by the Governor in Council, and deposited in the Office of the State Rivers and Water Supply Commission at 590 Orrong Road, Armadale (Corr. No. 76/1441).

And the Honorable Frederick James Granter, Her Majesty's Minister of Water Supply for the State of Victoria, shall give the necessary directions herein accordingly.

TOM FORRISTAL,
Clerk of the Executive Council.

Water Act 1958.
STATE RIVERS AND WATER SUPPLY COMMISSION.

*At the Executive Council Chamber, Melbourne, the
twentieth day of July, 1976.*

PRESENT:
His Excellency the Governor of Victoria.
Mr. Hunt | Mr. Smith.
Mr. Maclellan

**DERRINAL RECREATIONAL AREA—BOUNDARIES
VARIED.**

Under the powers conferred by the Water Act 1958 and all other powers enabling him in that behalf, His Excellency the Governor of the State of Victoria, with the advice of the Executive Council of the said State, on the recommendation of the State Rivers and Water Supply Commission, doth hereby declare, order and direct that the boundaries of the Derrinal Recreational Area be varied by excising from the said area the land shown by green colour on a plan numbered 6128A approved by the Governor in Council and lodged in the Plan Room of the State Rivers and Water Supply Commission, at 590 Orrong Road, Armadale, and as on and from the date hereof, the boundaries of such area shall be so varied.

And the Honorable Frederick James Granter, Her Majesty's Minister of Water Supply for the State of Victoria, shall give the necessary directions herein accordingly.

TOM FORRISTAL,
Clerk of the Executive Council.

Audit Act 1958, No. 6203.
PUBLIC ACCOUNTS AND STORES REGULATIONS 1958.
PART V.—STORES AND TRANSPORT.—CLAUSE 96 (1).

*At the Executive Council Chamber, Melbourne, the
twentieth day of July, 1976.*

PRESENT:
His Excellency the Governor of Victoria.
Mr. Hunt | Mr. Smith
Mr. Maclellan

Whereas pursuant to the provisions of Clause 96 (1) of the Public Accounts and Stores Regulations 1958, the Treasurer for the State of Victoria, hereby nominates JOHN THOMAS MINTER, Officer in Charge, Stores Branch, Education Department, for appointment by the Governor in Council as a Member of the Tender Board, vice V. L. Smith, resigned: Now therefore, His Excellency the Governor of the State of Victoria, by and with the advice of the Executive Council thereof, doth hereby appoint the said John Thomas Minter, a Member of the Tender Board.

And the Honorable Rupert James Hamer, Her Majesty's Treasurer for the State of Victoria, shall give the necessary directions herein accordingly.

TOM FORRISTAL,
Clerk of the Executive Council.

**CONSTITUTION ACT AMENDMENT ACT 1958 AND
PARLIAMETARY CONTRIBUTORY SUPERANNUATION
ACT 1962.**

*At the Executive Council Chamber, Melbourne, the
twentieth day of July, 1976.*

PRESENT:
His Excellency the Governor of Victoria.
Mr. Hunt | Mr. Smith
Mr. Maclellan

Whereas pursuant to the provisions of sub-section (4) of section 37 of the Constitution Act Amendment Act 1958 and sub-section (5) of section 2 of the Parliamentary Contributory Superannuation Act 1962, the Governor in Council shall by order published in the Government Gazette within 31 days after the 30th June in each year declare the amount that in his opinion having regard to any awards of the Commonwealth Conciliation and Arbitration Commission is the amount by which the minimum wage has been increased between the 1st day of December, 1968 and the 30th day of June then last past; now therefore, His Excellency the Governor of the State of Victoria, by and with the advice of the Executive Council thereof, doth by this Order

declare that \$56.75 is the amount by which the minimum wage has been increased between 1st day of December, 1968 and the 30th day of June, 1976.

And the Honorable Rupert James Hamer, Her Majesty's Premier for the State of Victoria, shall give the necessary directions herein accordingly.

TOM FORRISTAL,
Clerk of the Executive Council.

LANDS DEPARTMENT NOTICES

APPROACHING LAND SALES.

Sale of Crown Land, in fee-simple, will be held at the under-mentioned places and dates, viz:—

	No. of Gazette.
Wonthaggi.—Wednesday, 8th September, 1976	70
Rochford.—Saturday, 28th August, 1976	70

SALE OF CROWN LAND BY AUCTION.

The land will be offered for sale in fee-simple, and subject to the provisions of the Land Act and Regulations thereunder.

The upset price is the sum at which bidding will start, and no bid below that sum can be accepted. The highest bidder at or above that sum shall be the purchaser, subject to signature of contract and any necessary payment.

TERMS:
A deposit of at least 12½% of the purchase price must be paid at the sale, either in cash or by cheque.

The residue is payable in half-yearly instalments, in accordance with the following scale, or may be paid off at any earlier time.

Over \$40, and not exceeding \$100,	8 instalments.
Over \$100, and not exceeding \$200,	10 instalments.
Over \$200, and not exceeding \$400,	12 instalments.
Over \$400, and not exceeding \$600,	14 instalments.
Over \$600, and not exceeding \$800,	16 instalments.
Over \$800, and not exceeding \$1,000,	18 instalments.
Over \$1,000,	20 instalments.

Interest at the rate of 9% per annum is payable with all payments of residue, and is computed for each instalment from the date of sale to the date of such payment. Additional interest is charged if any instalment is not paid on or before the due date.

If paid off within 30 days of sale, no interest is payable.

FEES, ETC.:
Also payable at the sale, in addition to the deposit, are the survey fee and, if applicable, the valuation of improvements (if purchaser be not the owner thereof).

Payable with balance of purchase money—
Crown Grant fee—\$15.00.

Assurance Fund contribution.—One cent in every Five dollars or part thereof of purchase price. (This is a fund established to guarantee the validity of freehold titles.)

Transfer of interest prior to completion of payment may be allowed on payment of \$10 fee and subject to stamp duty.

If unable to attend personally, a prospective purchaser may arrange for another person to bid as his agent.

Attention is drawn to section 95, Land Act 1958, which provides that the purchaser shall be deemed to be the owner for the purposes of other Acts; also to an amendment to the Local Government Act providing for Government roads, in certain circumstances, to be declared "private streets", thus making the purchaser liable to contribute to the cost of street construction.

W. BORTHWICK,
Minister of Lands.

Office of Crown Lands and Survey,
Melbourne, 21st July, 1976.

WONTHAGGI.—Sale (No. 12212) of Crown land in fee-simple by auction, will be held at the COURT HOUSE, WONTHAGGI, on WEDNESDAY, the 8th SEPTEMBER, 1976, at HALF PAST ELEVEN o'clock a.m. To be conducted by P. K. COGHLAN, Land Officer, Melbourne.

TOWNSHIP OF WONTHAGGI. PARISH OF WONTHAGGI.
Lot 1.
Fronting the west side of a Government Road 60 metres south of White Road.

Upset price \$1,250.00 the lot. Survey fee \$90.00.
Area 3,207 square metres (3 roods 7 perches), allotment 4E of section 117.

Special Condition.—Sale of the above lot is subject to a condition requiring that the purchaser shall erect improvements thereon to the minimum value of \$12,000 within two years from the date of the sale. No transfer of interest will be approved before building covenant is completed.

NOTE.—The Government Road fronting this allotment has been declared a "private street".—(G.75337.)

Lot 2.

Fronting the west side of a Government Road about 80 metres south of White Road.

Upset price \$1,250.00 the lot. Survey fee \$90.00.

Area 3,026 square metres (3 roods), allotment 4H of section 117.

Special Condition.—Sale of the above lot is subject to a condition requiring that the purchaser shall erect improvements thereon to the minimum value of \$12,000.00 within two years from the date of the sale. No transfer of interest will be approved before building covenant is completed.

NOTE.—The Government Road fronting this allotment has been declared a "private street".—(G.75337.)

SALE OF FREEHOLD LAND BY AUCTION.

ROCHFORD.—A sale of Freehold land by auction, for and on behalf of the Minister of Education, will be held on the site of the former ROCHFORD PRIMARY SCHOOL, ROCHFORD on SATURDAY, the 28th day of AUGUST, 1976, at ONE o'clock p.m. To be conducted by P. COGHLAN, Land Officer, Melbourne.

Conditions.—A deposit of at least 10% of purchase price must be paid at the sale and the balance within sixty days. Purchaser to arrange for and bear costs of conveyance of ownership.

Office of Crown Lands and Survey,
Melbourne, 21st July, 1976.

Lot 1.

PARISH OF ROCHFORD.

Being the former Rochford Primary School (No. 540) and residence fronting the Lancefield-Woodend Road 3.2 kilometres west of Lancefield.

Area 8092 square metres (2 acres), being part of Crown Portion 24B and more particularly being the land conveyed in Memorial 282 Book 268.—(W.92632.)

PROPOSED REVOCATION OF TEMPORARY RESERVATION OF LAND BY ORDER IN COUNCIL.

In pursuance of the provisions of the Land Act 1958, notice is hereby given that it is the intention of the Governor in Council to revoke the temporary reservation of land by Order in Council hereunder referred to, viz.:

The following Notice was published 1° on the 1st July, 1976, pursuant to an Order of the 22nd June, 1976.

WYELANGTA.—The temporary reservation by Order in Council of the 18th March, 1912, of 8979 square metres (2 acres 35 perches) of land in the Township of Wyelangta as a site for Watering Purposes is about to be revoked, so far only as the portion containing 4324 square metres indicated by hatching on plan hereunder is concerned.—(W.358⁽⁸⁾) (C.61197).

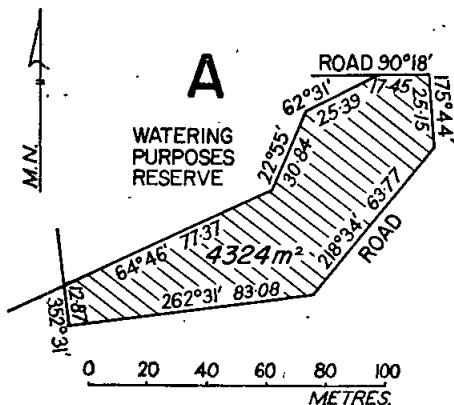

W. BORTHWICK,
Minister of Lands.

PROPOSED REVOCATIONS OF TEMPORARY RESERVATIONS OF LANDS BY ORDERS IN COUNCIL.

In pursuance of the provisions of the Land Act 1958, notice is hereby given that it is the intention of the Governor in Council to revoke the temporary reservations of lands by Orders in Council hereunder referred to, viz.:

The following Notices were published 1° on the 14th July, 1976, pursuant to Orders of the 6th July, 1974.

YEA.—The temporary reservation by Order in Council of the 16th April, 1937, of 1,351 square metres (1 rood 13 4/10 perches) of land in the Township of Yea as a site for Public Gardens is about to be revoked so far only as the portion containing 183 square metres indicated by hatching on plan hereunder, is concerned.—(Y.56⁽³⁾) (Rs.4668).

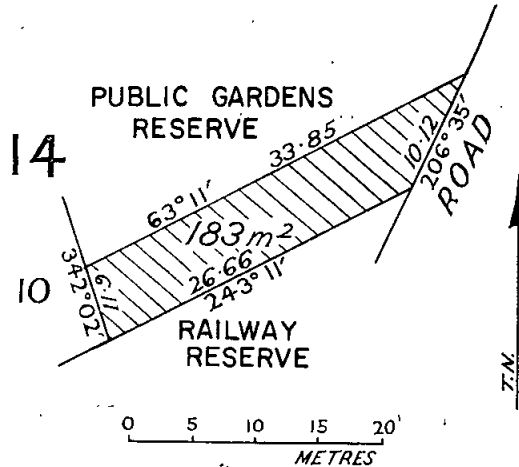

NARRACAN.—The temporary reservation by Order in Council of the 21st April, 1953 of 6703 square metres (1 acre 2 roods 25 perches) of land in the Parish of Narracan as a site for Water Supply purposes is about to be revoked so far only as the portion containing 54.1 square metres, indicated by hatching on plan hereunder, is concerned.—(N.129⁽¹²⁾) (Rs.7085).

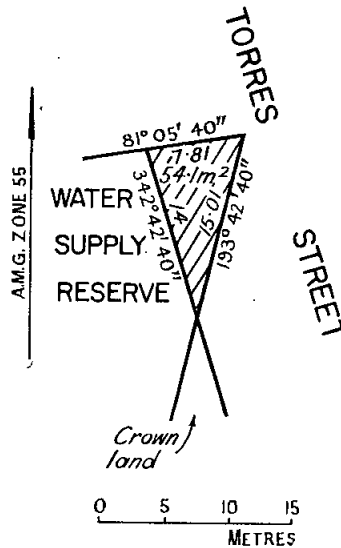

THORNTON.—The temporary reservation by Order in Council of the 25th March, 1947, of 40.47 hectares (100 acres) of land in the Parish of Thornton as a site for Trout Hatchery purposes is about to be revoked.—(T.180(A²)) (Rs.5940).

THORNTON.—The temporary reservation by Order in Council of the 29th September 1953 of 9.626 hectares (23 acres 3 roods 6 perches) of land in the Parish of Thornton as a site for Trout Hatchery purposes is about to be revoked.—(T.180(A³)) (Rs.5940).

W. BORTHWICK,
Minister of Lands.

PROPOSED REVOCATIONS OF TEMPORARY RESERVATIONS OF LANDS BY ORDERS IN COUNCIL.

In pursuance of the provisions of the *Land Act 1958*, notice is hereby given that it is the intention of the Governor in Council to revoke the temporary reservations of lands by Orders in Council hereunder referred to, viz.:—

The following Notices were published 1° on the 21st July, 1976, pursuant to Orders of the 13th July, 1976.

LEOR (SERVICETON).—The temporary reservation by Order in Council of the 9th November, 1914, of 40.78 hectares (100 acres 3 roods 4 perches) of land in the Parish of Leor as a site for a Racecourse and other purposes of Public Recreation is about to be revoked so far only as the portion containing 1448 square metres indicated by hatching on plan hereunder, is concerned.—(L.160⁽¹⁾) (Rs.317).

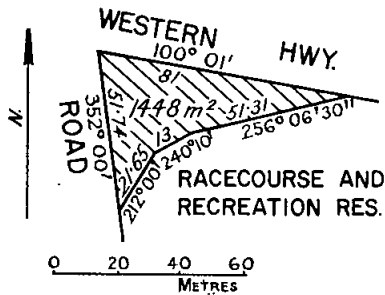

MONBULK (OLINDA).—The temporary reservation by Order in Council of the 16th July, 1957, of 1.214 hectares (3 acres, more or less) of land in the Parish of Monbulk as a site for Public Recreation is about to be revoked so far only as the portion containing 497 square metres indicated by hatching on plan hereunder, is concerned.—(M.555⁽¹³⁾) (Rs.984).

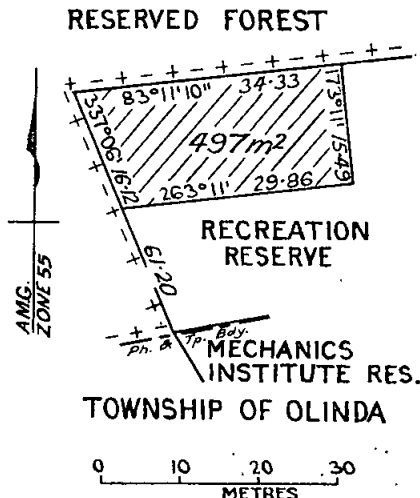

W. BORTHWICK,
Minister of Lands.

PROPOSED REVOCATION OF TEMPORARY RESERVATION OF LAND BY ORDER IN COUNCIL.

In pursuance of the provisions of the *Land Act 1958*, notice is hereby given that it is the intention of the Governor in Council to revoke the temporary reservation of land by Orders in Council hereunder referred to, viz.:—

The following Notice was published 1° on the 7th July, 1976, pursuant to an Order of the 29th June, 1976.

LEONGATHA.—The temporary reservation by Order in Council of the 5th August, 1889, of 8094 square metres (2 acres) of land in the Township of Leongatha as a site for a State School is about to be revoked so far only as the portion containing 2529 square metres indicated by hatching on plan hereunder, is concerned.—(L.167⁽⁶⁾) (C.100942).

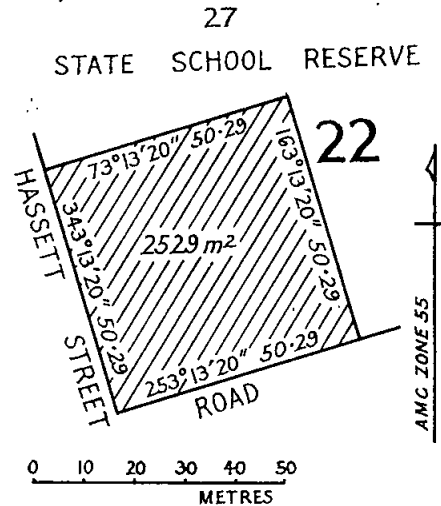

W. BORTHWICK,
Minister of Lands.

COMMITTEES OF MANAGEMENT OF RESERVES.

APPOINTMENTS.

Notice is hereby given that, in pursuance of section 221 of the *Land Act 1958*, the following appointments of Committees of Management of reserved Crown lands have been made by the Acting Minister of Lands:—

CERTAIN LAND IN THE PARISH OF GEMBROOK, RESERVED FOR PUBLIC RECREATION.

The Corporation of the Shire of Sherbrooke as the Committee of Management of the land in the Parish of Gembrook temporarily reserved by Order in Council dated the 1st July, 1975, as a site for Public Recreation purposes.—(Corres. No. Rs.10063.)

THE "MALLACOOTA INLET, NATIONAL PARK."

The National Parks Advisory Council as the Committee of Management of the land in the Parish of Wau Wauka West deemed to be permanently reserved as a site for a National Park as is indicated by blue colour on plan marked "W/3.9.74" attached to Lands Department. Correspondence No. Rs.1176.

J. C. M. BALFOUR,
Acting Minister of Lands.

Department of Crown Lands and Survey,
Melbourne, 16th July, 1976.

COMMON ABOUT TO BE DIMINISHED.

In pursuance of the provisions contained in the *Land Act 1958*, notice is hereby given that it is the intention of the Governor in Council to diminish the common hereinafter mentioned, viz.:—

The following Notice was published 1° on the 23rd June, 1976, pursuant to Order of the 16th June, 1976.

The Mortlake United Town and Farmers' Common, proclaimed as such by the Governor in Council on the 7th March, 1864 and the 22nd May, 1871, is about to be diminished by the excision therefrom of Crown allotment 7A in the Parish of Connemara containing 3.915 hectares.—(C.70656.)

W. BORTHWICK,
Minister of Lands.

LICENCES UNDER THE LAND ACT SURRENDERED.

Notice is hereby given that the surrender of the licences referred to in the Schedule hereunder have been accepted with the view of a Crown grant issuing in respect of each case.

Corres. No.	Name.	Section of Land Act under which licensed.	Locality.	Area.		Purchase Price.
				A.	R. P.	
1452/86 (Ballarat)	S. J. Field ..	86	Allotment 11, section M, Parish of Glenmona	20	0 0	40.00
1454/86 (Ballarat)	B. A. Field ..	86	Allotment 6, section M, Parish of Glenmona	19	3 15	40.00

Department of Crown Lands and Survey,
Melbourne, 16th July, 1976.

JIM BALFOUR,
Acting Minister of Lands.

Teaching Service Act 1958.

TEACHING SERVICE—PRIMARY SCHOOLS DIVISION
(CLASSIFICATION, SALARIES, AND ALLOWANCES)
REGULATION.

AMENDMENT No. 373 (PRIM. C.S. & A.4).

The Teachers Tribunal, in pursuance of the powers conferred by the *Teaching Service Act 1958*, hereby amends the Teaching Service—Primary Schools Division (Classification, Salaries, and Allowances) Regulation as follows:—

In paragraph (ii) of sub-clause 13 (c) for the amount “\$4,841” substitute the amount “\$4,987”.

(To take effect from and including the 14th July, 1976.)

W. E. SAMPSON, Chairman.
A. F. LE CLERCQ, Secretary.

Office of the Teachers Tribunal,
Melbourne, 14th July, 1976.

Teaching Service Act 1958.

TEACHING SERVICE (TEACHERS TRIBUNAL)
REGULATIONS.

AMENDMENT No. 372 (T.T. 34).

The Teachers Tribunal, in pursuance of the powers conferred by the *Teaching Service Act 1958*, hereby amends Regulation 1 of the Teaching Service (Teachers Tribunal) Regulations as follows:—

REGULATION 1.

In sub-clause 20 (a) after the expression “household furniture and personal effects” insert the expression “including the cost of comprehensive insurance cover for such furniture and effects whilst in transit, up to a maximum cover of \$5,000”.

W. E. SAMPSON, Chairman.
A. F. LE CLERCQ, Secretary.

Office of the Teachers Tribunal,
Melbourne, 27th April, 1976.

Teaching Service Act 1958.

TEACHING SERVICE—SECONDARY SCHOOLS DIVISION
(CLASSIFICATION, SALARIES, AND ALLOWANCES)
REGULATION.

AMENDMENT No. 374 (SEC. C.S. & A.4).

The Teachers Tribunal, in pursuance of the powers conferred by the *Teaching Service Act 1958*, hereby amends the Teaching Service—Secondary Schools Division (Classification, Salaries, and Allowances) Regulation as follows:—

In paragraph (ii) of sub-clause 13 (c) for the amount “\$4,841” substitute the amount “\$4,987”.

(To take effect from and including the 14th July, 1976.)

W. E. SAMPSON, Chairman.
A. F. LE CLERCQ, Secretary.

Office of the Teachers Tribunal,
Melbourne, 14th July, 1976.

*Teaching Service Act 1958.*TEACHING SERVICE.—TECHNICAL SCHOOLS DIVISION
(CLASSIFICATION, SALARIES, AND ALLOWANCES)
REGULATION.

AMENDMENT NO. 375 (TECH. C.S. & A.5).

The Teachers Tribunal, in pursuance of the powers conferred by the *Teaching Service Act 1958*, hereby amends the Teaching Service—Technical Schools Division (Classification, Salaries, and Allowances) Regulation as follows:—

1. In paragraph (ii) of sub-clause 13 (c) for the amount "\$4,841" substitute the amount "\$4,987".

2. In sub-clause 13 (g) for the figure "3,075" substitute the figure "3,168".

(To take effect from and including the 14th July, 1976.)

W. E. SAMPSON, Chairman.

A. F. LE CLERCQ, Secretary.

Office of the Teachers Tribunal,
Melbourne, 14th July, 1976.

TENDERS

PUBLIC WORKS DEPARTMENT

Tenders will be received at Public Works Department, 2 Treasury Place, Melbourne, until TWO p.m. on dates shown for purposes mentioned hereunder.

Particulars and tender forms available at Contracts Office, Room 27, Ground Floor, No. 2, Treasury Place, and at Inspector of Works Office if indicated by W.O. Tenders must be on a "Firm Tender" basis. The lowest or any tender will not necessarily be accepted.

Address tenders to the Minister of Public Works, and endorse the envelope "Tender for Hand delivered tenders to be placed in the Tender Box of the Public Works Department, Main Entrance Foyer, Ground Floor, 2 Treasury Place, Melbourne.

No preliminary deposit is required with any tender, but successful tenderer will be required to pay a deposit for any accepted tender of \$10,000 or over.

Tuesday, 3rd August, 1976.

Building, Electrical, Mechanical Works.

BENDIGO.—Mechanical services to Glasshouse and Head House, Regional Centre. (W.O., Bendigo.)

HORSHAM.—Glasshouse air conditioning, Wheat Research Institute. (W.O., Horsham and Ballarat.)

KEW.—Internal and external repairs and painting, High School.

MALVERN.—Supply and installation of P.A.B.X. system. Clinic.

TIMBOON.—External and internal painting and renovations. (W.O., Camperdown.)

Site Works.

SCORESBY.—Siteworks. Horticultural Research Station.

Tuesday, 10th August, 1976.

Building, Electrical, Mechanical Works.

GOLDEN SQUARE.—Erection of art/craft, staff and library improvements &c., Primary School 5110. (W.O., Bendigo.)

GOLDEN SQUARE.—Electrical services—art/craft, staff and library improvements &c., Primary School 5110. (W.O., Bendigo.)

GOLDEN SQUARE.—Mechanical services—art/craft, staff and library improvements &c., Primary School 5110. (W.O., Bendigo.)

HAMILTON.—Renovations to leased property—46 Gray Street, Primary School 295. (W.O., Hamilton.) Re-advertised.

STANHOPE.—Internal and external renovations, Primary School 3937. (W.O., Bendigo.)

TECOMA.—Electrical services—art/craft centre, library, 3 classrooms, staff improvements and covered way, Primary School 3356.

TECOMA.—Mechanical services—art/craft centre, library, 3 classrooms, staff improvements and covered way, Primary School 3356.

Site Works.

TEMPLESTOWE VALLEY.—Site works, Primary School 4985.

Miscellaneous.

NUMURKAH.—Connection to Town sewerage, High School. (W.O., Shepparton.)

ROBERTS DUNSTAN,
Minister for Public Works.

Public Works Department,
Melbourne, 20th July, 1976.

PRIVATE ADVERTISEMENTS

Town and Country Planning Act 1961.

CITY OF BALLAARAT.—BALLAARAT AND DISTRICT PLANNING SCHEME 1966.

NOTICE THAT A PLANNING SCHEME HAS BEEN PREPARED AND IS AVAILABLE FOR INSPECTION.

Amendment No. 25, 1976.

Notice is hereby given that the City of Ballarat in pursuance of its powers under the *Town and Country Planning Act 1961* has prepared a Planning Scheme for the following area:—

That portion of land being allotment 1 of L.P. 118671 on the south west corner of Norman and Doveton Streets, being part of Crown allotment 3 of section E, Township of Ballarat North, Parish of Ballaarat, County of Grenville from Residential A to Commercial B.

A copy of the scheme has been deposited at the Town Hall, Ballaarat and at the office of the Town and Country Planning Board, 235 Queen Street, Melbourne, and will be open for inspection during office hours by any person, free of charge.

Any persons affected by the planning scheme are required to set forth in writing, all objections they may have, addressed to the Town Clerk, City of Ballaarat, Municipal Offices, Ballaarat on or before the 21st day of August, 1976 and to state whether they wish to be heard in respect of their objections.

16th July, 1976.

2744

I. C. SMITH, Acting Town Clerk.

CITY OF CHELSEA.

NOTICE OF CHANGE IN STREET NAME.

Notice is hereby given that in pursuance of powers conferred by the Local Government Act 1958, the Council of the City of Chelsea at a meeting held on 23rd February, 1976 resolved to make the following street name change:

Old name.—Collins Avenue, Chelsea.

New name.—Collins Court, Chelsea.

Location.—Whole of street from intersection with Hughes Avenue, Chelsea.

Municipal Offices,
Station Street, Chelsea.

2745

B. J. WARD, Town Clerk.

CITY OF WAVERLEY.

NOTICE OF INTENTION TO TAKE LAND COMPULSORILY.

Whereas the Council of the City of Waverley deems it expedient to exercise its power of taking compulsorily the land described hereunder for the work or undertaking of taking land to be used by the Council for the purpose of providing a place of public resort and recreation and whereas the Council has caused to be prepared a map and other papers setting out the general description of the work or undertaking for which the land proposed to be taken is to be used the description of the land proposed to be taken and the names of the owners or reputed owners lessees or reputed lessees mortgagees and occupiers of that land so far as those names are known to or can be ascertained by the Council and whereas the said map and other papers are deposited at the office of the said Council at Glen Waverley and are and shall be open for inspection by all persons interested at all reasonable hours for the space of forty clear days after the publication of this notice in the Government Gazette now notice is hereby given to all persons affected by the proposed taking of the said land to set forth in writing addressed to the Council or the Town Clerk within forty clear days of the publication of this notice in the Government Gazette all objections which they may have to the taking of the said land.

THE LAND REFERRED TO.

All that parcel of land being Lot 46 on lodged plan 70950 being part of Crown Portion 73 in the Parish of Mulgrave, County of Bourke and being the land described in Certificate of Title Volume 8594 Folio 380, and shown hatched on the plan attached hereto.

PART CROWN ALLOTMENT 73

PARISH OF MULGRAVE

COUNTY OF BOURKE

SCALE- 1:50

CORUNNA COURT

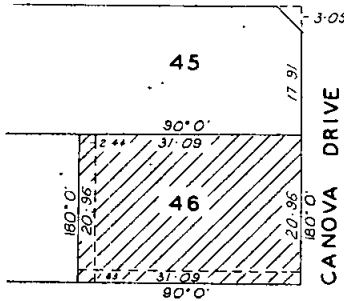

The land to be acquired is shown hatched.

Dated the 13th day of July, 1976.

By order of the Council.

2764

F. S. BALES, Town Clerk.

CITY OF WAVERLEY.

NOTICE OF INTENTION TO TAKE LAND COMPULSORILY.

Whereas the Council of the City of Waverley deems it expedient to exercise its power of taking compulsorily the land described hereunder for the work or undertaking of taking land to be used by the Council for the purpose of providing a place of public resort and recreation and whereas the Council has caused to be prepared a map and other papers setting out the general description of the work or undertaking for which the land proposed to be taken is to be used the description of the land proposed to be taken and the names of the owners or reputed owners lessees or reputed lessees mortgagees and occupiers of that land so far as those names are known to or can be ascertained by the Council and whereas the said map and other papers are deposited at the office of the said Council at Glen Waverley and are and shall be open for inspection by all persons interested at all reasonable hours for the space of forty clear days after the publication of this notice in the Government Gazette now notice is hereby given to all persons affected by the proposed taking of the said land to set forth in writing addressed to the Council or the Town Clerk within forty clear days of the publication of this notice in the Government Gazette all objections which they may have to the taking of the said land.

THE LAND REFERRED TO.

All that parcel of land being Lots 69 and 70 on lodged plan 55278 being part of Crown Portion 26 in the Parish of Mulgrave, County of Bourke and being the land described in Certificate of Title Volume 8399 Folio 146, and shown hatched on the plan attached hereto.

PART CROWN ALLOTMENT 26

PARISH OF MULGRAVE

COUNTY OF BOURKE

SCALE- 1:50

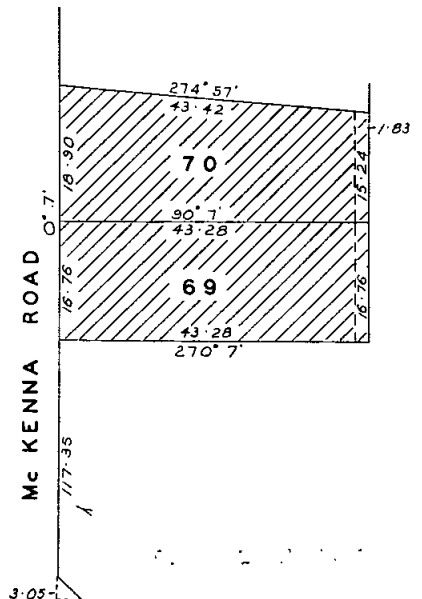

HAMPSHIRE ROAD

The land to be acquired is shown hatched.

Dated the 13th day of July, 1976.

By order of the Council.

2765

F. S. BALES, Town Clerk.

CITY OF WAVERLEY.

NOTICE OF INTENTION TO TAKE LAND COMPULSORILY.

Whereas the Council of the City of Waverley deems it expedient to exercise its power of taking compulsorily the land described hereunder for the work or undertaking of taking land to be used by the Council for the purpose of providing a place of public resort and recreation and whereas the Council has caused to be prepared a map and other papers setting out the general description of the work or undertaking for which the land proposed to be taken is to be used the description of the land proposed to be taken and the names of the owners or reputed owners lessees or reputed lessees mortgagees and occupiers of that land so far as those names are known to or can be ascertained by the Council and whereas the said map and other papers are deposited at the office of the said Council at Glen Waverley and are and shall be open for inspection by all persons interested at all reasonable hours for the space of forty clear days after the publication of this notice in the Government Gazette now notice is hereby given to all persons affected by the proposed taking of the said land to set forth in writing addressed to the Council or the Town Clerk within forty clear days of the publication of this notice in the Government Gazette all objections which they may have to the taking of the said land.

THE LAND REFERRED TO.

All that parcel of land being Lot 17 on lodged plan 76773 being part of Crown Portion 110 in the Parish of Mulgrave, County of Bourke and being the land described in Certificate of Title Volume 8676 Folio 354, and shown hatched on the plan attached hereto.

PART CROWN ALLOTMENT 110

PARISH OF MULGRAVE

COUNTY OF BOURKE

SCALE:- 1 : 50

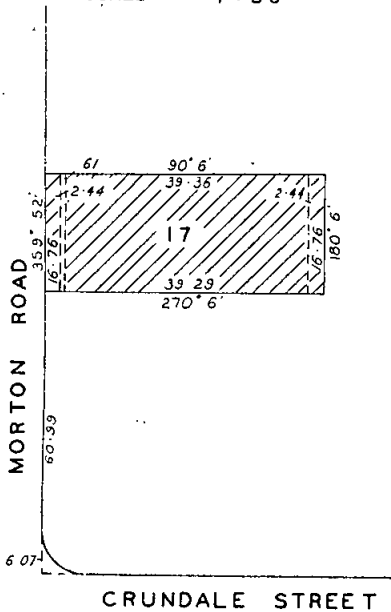

The land to be acquired is shown hatched.

Dated the 13th day of July, 1976.

By order of the Council.

2766 F. S. BALES, Town Clerk.

CITY OF WAVERLEY.

NOTICE OF INTENTION TO TAKE LAND COMPULSORILY.

Whereas the Council of the City of Waverley deems it expedient to exercise its power of taking compulsorily the land described hereunder for the work or undertaking of taking land to be used by the Council for the purpose of providing a place of public resort and recreation and whereas the Council has caused to be prepared a map and other papers setting out the general description of the work or undertaking for which the land proposed to be taken is to be used the description of the land proposed to be taken and the names of the owners or reputed owners lessees or reputed lessees mortgagees and occupiers of that land so far as those names are known to or can be ascertained by the Council and whereas the said map and other papers are deposited at the office of the said Council at Glen Waverley and are and shall be open for inspection by all persons interested at all reasonable hours for the space of forty clear days after the publication of this notice in the Government Gazette now notice is hereby given to all persons affected by the proposed taking of the said land to set forth in writing addressed to the Council or the Town Clerk within forty clear days of the publication of this notice in the Government Gazette all objections which they may have to the taking of the said land.

THE LAND REFERRED TO.

All that parcel of land being Lot 105 on lodged plan 78432 being part of Crown Portion 110 in the Parish of Mulgrave, County of Bourke and being the land described in Certificate of Title Volume 8688 Folio 260, and shown hatched on the plan attached hereto.

PART CROWN ALLOTMENT 110

PARISH OF MULGRAVE

COUNTY OF BOURKE

SCALE:- 1 : 50

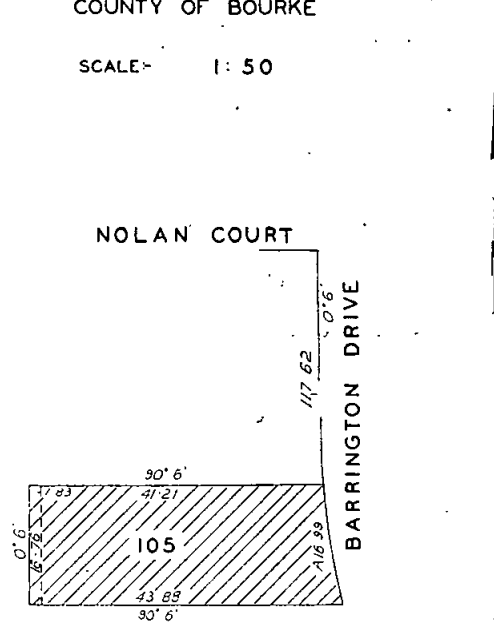

The land to be acquired is shown hatched.

Dated the 13th day of July, 1976.

By order of the Council.

2767 F. S. BALES, Town Clerk.

SHIRE OF ELTHAM:
PROSECUTING OFFICER.

Notice is hereby given that Senior Sergeant Robert Henry Crisfield, No. 10854, has been appointed Prosecuting Officer for the Shire of Eltham, in lieu of Senior Sergeant John Stuart Bateman, No. 12305.

2746 W. R. FEATHERSTON, Chief Administrator.

Town and Country Planning Act 1961 (Twelfth Schedule).
SHIRE OF FLINDERS PLANNING SCHEME 1962.

NOTICE THAT A PLANNING SCHEME HAS BEEN PREPARED AND IS AVAILABLE FOR INSPECTION.

Amendment No. 86, 1976.

Notice is hereby given that the Shire of Flinders, in pursuance of its powers under the *Town and Country Planning Act 1961*, has prepared a Planning Scheme for the purpose of amending the ordinance provision to allow for establishment of car parking areas subject to consent in the Residential 'A' and Residential 'B' zones.

A copy of the scheme has been deposited at the office of the responsible authority, Municipal Offices, Boneo Road, Rosebud, and at the Office of the Town and Country Planning Board, 235 Queen Street, Melbourne, and will be open for inspection during office hours by any person free of charge.

Any persons affected by the planning scheme are required to set forth in writing all objections they may have addressed to:

The Shire Secretary, Shire of Flinders, Municipal Offices, Boneo Road, Rosebud, 3439 on or before the 21st August 1976 and state whether they wish to be heard in respect of these objections.

14th July, 1976.

2747 S. WILLIAMS, Shire Secretary.

Town and Country Planning Act 1961 (Twelfth Schedule).
SHIRE OF FLINDERS PLANNING SCHEME 1962.

NOTICE THAT A PLANNING SCHEME HAS BEEN PREPARED AND IS AVAILABLE FOR INSPECTION.

Amendment No. 88, 1976.

Notice is hereby given that the Shire of Flinders, in pursuance of its powers under the *Town and Country Planning Act 1961*, has prepared a Planning Scheme for the purpose of—

- (a) Deleting the existing ordinance provision for "Block of Flats" in the Residential 'B' zone of the planning scheme;
- (b) Rezoning an area at Mount Martha between Ellerina Road and Tassells Creek from Residential 'B' zone to special residential zone.

A copy of the scheme has been deposited at the office of the responsible authority, Municipal Offices, Boneo Road, Rosebud, and at the Office of the Town and Country Planning Board, 235 Queen Street, Melbourne, and will be open for inspection during office hours by any person free of charge.

Any persons affected by the planning scheme are required to set forth in writing all objections they may have addressed to:

The Shire Secretary, Shire of Flinders, Municipal Offices, Boneo Road, Rosebud, 3439 on or before the 21st August 1976 and state whether they wish to be heard in respect of these objections.

14th July, 1976.

2748 S. WILLIAMS, Shire Secretary.

SHIRE OF KILMORE.

LOAN No. 48.

Notice of Intention to Borrow the Sum of \$60,000 for Permanent Works and Undertakings.

Notice is hereby given that the Shire of Kilmore intends after one month to proceed to borrow the principal sum of \$60,000 secured by a charge over the general rates of the municipality, such sum to be raised by the grant of a mortgage in accordance with provisions of the *Local Government Act, 1958*.

1. The maximum rate of interest that may be paid is 10.5% per annum.

2. Purpose for which the loan is to be applied is part development of the Shire's Industrial Estate.

3. Period of the loan shall be 20 years.

No. 70.—6290/76.—3

4. The money borrowed shall be repayable by providing out of the municipal fund forty half-yearly instalments of \$3,617.18 including principal and interest on the thirty-first of July and thirty-first of January during the currency of the loan. The first instalment shall be payable on the thirty-first day of January, 1977.

5. The money borrowed is to be repaid at the office of the C.B.C. Savings Bank Limited, Melbourne.

6. Plans of the proposed development are available for inspection at the Shire Offices, 16 Sydney Street, Kilmore.
2749 J. A. ELVEY, Shire Secretary.

SHIRE OF KILMORE PLANNING SCHEME AMENDMENT
No. 9/1976.

NOTICE THAT A PLANNING SCHEME HAS BEEN PREPARED AND IS AVAILABLE FOR INSPECTION.

Notice is hereby given that the Shire of Kilmore in pursuance of its powers under the *Town and Country Planning Act 1961* has prepared a Planning Scheme for Lots 13-36 of L.P. 7012, in Heathcote Junction for the purpose of rezoning Village Zone.

A copy of the scheme has been deposited at the office of the Shire of Kilmore, 16 Sydney Street, Kilmore and at the office of the Town and Country Planning Board, 5th Floor, 235 Queen Street, Melbourne, and will be open for inspection during office hours by any person free of charge.

Any persons affected by the Planning Scheme are required to set forth in writing all objections they may have addressed to the Secretary, Shire of Kilmore, 16 Sydney Street, Kilmore, on or before the 21st day of August, 1976, and to state whether they wish to be heard in respect of their objections.

21st July, 1976.

2750 J. A. ELVEY, Shire Secretary.

SHIRE OF KILMORE PLANNING SCHEME AMENDMENT
No. 10/1976.

NOTICE THAT A PLANNING SCHEME HAS BEEN PREPARED AND IS AVAILABLE FOR INSPECTION.

Notice is hereby given that the Shire of Kilmore in pursuance of its powers under the *Town and Country Planning Act 1961* has prepared a Planning Scheme for Lots 16-21; 38-43; 48-53 and 62-70 of L.P. 7005, in Heathcote Junction for the purpose of rezoning Village Zone.

A copy of the scheme has been deposited at the office of the Shire of Kilmore, 16 Sydney Street, Kilmore and at the office of the Town and Country Planning Board, 5th Floor, 235 Queen Street, Melbourne, and will be open for inspection during office hours by any person free of charge.

Any persons affected by the Planning Scheme are required to set forth in writing all objections they may have addressed to the Secretary, Shire of Kilmore, 16 Sydney Street, Kilmore, on or before the 21st day of August, 1976, and to state whether they wish to be heard in respect of their objections.

21st July, 1976.

2751 J. A. ELVEY, Shire Secretary.

SHIRE OF KILMORE PLANNING SCHEME AMENDMENT
No. 11/1976.

NOTICE THAT A PLANNING SCHEME HAS BEEN PREPARED AND IS AVAILABLE FOR INSPECTION.

Notice is hereby given that the Shire of Kilmore in pursuance of its powers under the *Town and Country Planning Act 1961* has prepared a Planning Scheme for part of Crown allotments 13, 14 and 15 of section 16 in the Township of Wallan for the purpose of rezoning Commercial Zone.

A copy of the scheme has been deposited at the office of the Shire of Kilmore, 16 Sydney Street, Kilmore and at the office of the Town and Country Planning Board, 5th Floor, 235 Queen Street, Melbourne, and will be open for inspection during office hours by any person free of charge. Any persons affected by the Planning Scheme are required to set forth in writing all objections they may have addressed to the Secretary, Shire of Kilmore, 16 Sydney Street, Kilmore, on or before the 21st day of August, 1976, and to state whether they wish to be heard in respect of their objections.

21st July, 1976.

2752 J. A. ELVEY, Shire Secretary.

SHIRE OF KILMORE PLANNING SCHEME AMENDMENT No. 12/1976.

NOTICE THAT A PLANNING SCHEME HAS BEEN PREPARED AND IS AVAILABLE FOR INSPECTION.

Notice is hereby given that the Shire of Kilmore in pursuance of its powers under the Town and Country Planning Act 1961 has prepared a Planning Scheme for the area bounded by Sydney, Mitchell, Melbourne and Brisbane Streets, in the Township of Kilmore for the purpose of rezoning Village Zone.

A copy of the scheme has been deposited at the office of the Shire of Kilmore, 16 Sydney Street, Kilmore and at the office of the Town and Country Planning Board, 5th Floor, 235 Queen Street, Melbourne, and will be open for inspection during office hours by any person free of charge. Any persons affected by the Planning Scheme are required to set forth in writing all objections they may have addressed to the Secretary, Shire of Kilmore, 16 Sydney Street, Kilmore, on or before the 21st day of August, 1976, and to state whether they wish to be heard in respect of their objections.

21st July, 1976.

2753

J. A. ELVEY, Shire Secretary.

SHIRE OF KYNETON.

BYLAW No. 62.

A Bylaw of the Shire of Kyneton made under the provisions of the Local Government Act 1958 and numbered 62 for the purpose of rescinding Bylaws No. 54 and 60 which prohibit the erection of verandahs other than cantilever and require the removal of verandahs not conforming to the provisions of these Bylaws.

In pursuance of the powers conferred by the Local Government Acts and every other power enabling it in that behalf, the President, Councillors and Ratepayers of the Shire of Kyneton order as follows:

1. Bylaw No. 54 and Bylaw No. 60 are hereby repealed.

The resolution for passing this Bylaw was agreed to by the Council of the Shire of Kyneton on the 21st January 1976 and confirmed at a meeting of Council held on the 11th February 1976.

The common seal of the President, Councillors and Ratepayers of the Shire of Kyneton was hereto

affixed this 11th day of February, 1976, in pursuance of a Resolution of the Council and in the presence of:—

W. R. HANSON, President; W. C. E. GOODMAN, Councillor; D. A. INDIAN, Acting Secretary.

Approved by the Governor in Council, 1st June, 1976.—TOM FORRISTAL, Clerk of the Executive Council. 2754

SHIRE OF MALDON, PROSECUTING OFFICER.

Notice is hereby given that Senior Constable REX PETER MULDOON, No. 14862, has been appointed as Prosecuting Officer for the Shire of Maldon, in the place of Senior Constable W. A. Thompson, No. 13329, transferred.

2755 ALAN SKILBECK, Acting Shire Secretary.

SHIRE OF MORNINGTON.

ORDER CHANGING NAME OF STREET.

Notice is hereby given that the Council of the Shire of Mornington, at a meeting held on the 12th July 1976, made an Order pursuant to section 535 (4) of the Local Government Act 1958 (as amended), changing the name of the street set out hereunder:—

Old Name.—Johns Road (part only).

New Name.—Kuranga Court.

Location.—All that part of the existing section of Johns Road off Coral Road, Mornington.

2758

D. G. COLLINGS, Shire Secretary.

SHIRE OF MORNINGTON.

ORDER CHANGING NAME OF STREET.

Notice is hereby given that the Council of the Shire of Mornington, at a meeting held on the 12th July 1976, made an Order pursuant to the provisions of the Local Government Act 1958 (as amended), to name the existing unnamed laneway between lot Nos. 512 and 513, L.P. No. 10717, Ranelagh Drive, Mount Eliza as follows:—

Petticoat Lane.

2759

D. G. COLLINGS, Shire Secretary.

SHIRE OF RIPON.

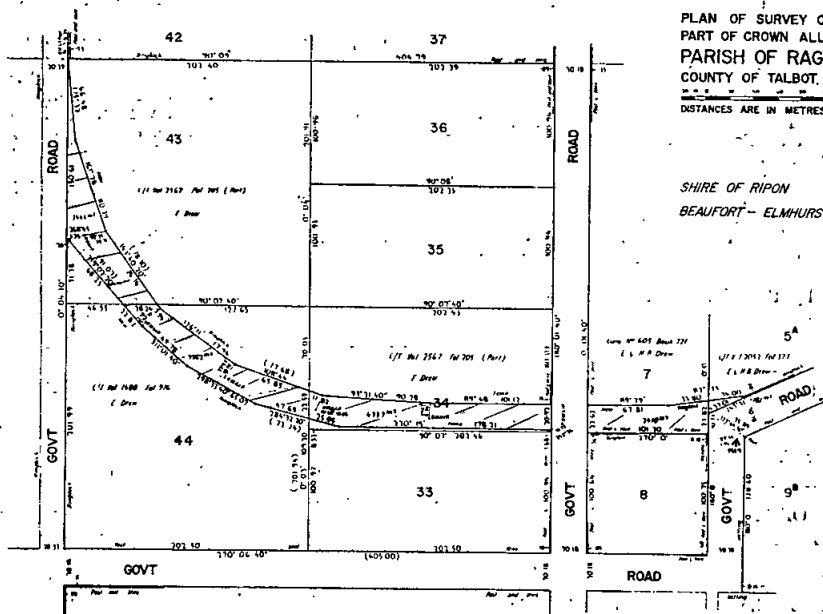

PLAN OF SURVEY OF PART OF CROWN ALLOTMENTS 67, 34, 43 & 44 PARISH OF RAGLAN WEST COUNTY OF TALBOT.

DISTANCES ARE IN METRES

SHIRE OF RIPON BEAUFORT—ELMHURST ROAD.

I G. Bishop and A A. Jeffreys 33 Lyndell Street South Ballarat Ref 3 B 1888

Pursuant to the provisions of section 522 of the Local Government Act the Council of the Shire of Ripon hereby directs that the land in the Parish of Raglan West indicated by hatching on the diagram above which has been purchased, acquired, or taken by it shall be a Public Highway on and from the date of publication of this Order in the Government Gazette.

The common seal of the President, Councillors and Ratepayers of the Shire of Ripon was hereto affixed, pursuant to a resolution of the Council, this 9th day of July, 1976, in the presence of—

(SEAL)

B. A. WILKINSON, Shire President; H. V. MARTIN, Councillor; F. W. GLARE, Shire Secretary.

2760

SHIRE OF OTWAY.

REVOCATION OF APPOINTMENT OF PLACE AS A POUND.

Notice is hereby given that the Council of the Shire of Otway has revoked the appointment of part Crown Allotment 19c, Parish of Barwongemong a pound for the purposes of the Pounds Act 1958.

Appointment of Place as a Pound.

Notice is hereby given that the Council of the Shire of Otway has appointed Lot 1, L.P.5673, Lavers Hill as a pound for the purposes of the Pounds Act 1958.

2845 T. R. RICHARDSON, Shire Secretary.

Town and Country Planning Act 1961 (Twelfth Schedule).

SHIRE OF SEYMOUR.—SHIRE OF SEYMOUR PLANNING SCHEME.

NOTICE THAT A PLANNING SCHEME HAS BEEN PREPARED AND IS AVAILABLE FOR INSPECTION.

Amendment No. 4, 1976.

Notice is hereby given that the Shire of Seymour in pursuance of its powers under the *Town and Country Planning Act 1961* has prepared an amending Planning Scheme for the purpose of:

Permitting and regulating small area subdivisions within the rural zone of the Shire of Seymour Planning Scheme.

A copy of the Scheme has been deposited at the Shire Office, Seymour and at the office of the Town and Country Planning Board, 235 Queen Street, Melbourne and will be open for inspection during office hours by any person free of charge.

Any persons affected by the Planning Scheme are required to set forth in writing all objections they may have, addressed to the Shire Secretary, Shire Office, Seymour on or before the 21st August 1976 and to state whether they wish to be heard in respect of their objections.

Dated the 9th day of July, 1976.

2761 G. G. McWHINNEY, Municipal Clerk.

SHIRE OF UPPER MURRAY.

PROSECUTING OFFICER.

Notice is hereby given that the Council of the Shire of Upper Murray has appointed Sergeant K. C. RICHARDS, No. 13226, as prosecuting officer for the municipality, in lieu of Sergeant L. J. O'Hagan, No. 11734, transferred.

2762 J. H. WALKER, Shire Secretary.

SHIRE OF WARRAGUL.

LOAN No. 118.

Notice of Intention to Borrow.

Notice is hereby given that the Council of the Shire of Warragul intends to borrow Twenty two thousand, three hundred dollars (\$22,300) secured by a grant of a mortgage in accordance with the provisions of the *Local Government Act 1958*.

1. The maximum rate of interest that may be paid is 10.5 per cent.

2. The purposes for which the loan is to be applied is as follows:—

Construction works Geoff Watt Memorial Track.

3. The period of the loan shall be 10 years, Notional repayment term of 15 years.

4. The moneys borrowed shall be repayable by providing out of the municipal fund half yearly instalments of approximately \$1,492.25 which includes principal and interest on the 1st day of March, and September, during the currency of the loan and a final payment of \$12,876.32. The first instalment shall be payable on the 1st day of March 1977.

5. Such moneys shall be repayable to the Australia and New Zealand Savings Bank Limited, Warragul.

6. The plans of specifications and the estimate of the cost of the proposed works and a statement showing the proposed expenditure of the moneys to be borrowed are open for inspection at the office of the Council, at Civic Place, Warragul.

2768 D. McADIE, Shire Secretary.

SHIRE OF WARRAGUL.

LOAN No. 119.

Notice of Intention to Borrow.

Notice is hereby given that the Council of the Shire of Warragul proposes to borrow the principal sum of Four Thousand dollars (\$4,000) secured by a grant of a mortgage in accordance with the provisions of the *Local Government Act 1958*.

1. The maximum rate of interest that may be paid is 9.8 per cent.

2. The purposes for which the loan is to be applied is—
Construction of Clubhouse—Lillico Tennis Club.

3. The period of the loan shall be five years.

4. The moneys borrowed shall be repayable by providing out of the Municipal fund half yearly instalments of approximately \$515.51 each including principal and interest on the first day of March and September during the currency of the loan. The first instalment shall be payable on the first day of March 1977.

5. Such moneys shall be repayable to the Australian and New Zealand Savings Bank Limited, Warragul.

6. The plans and specifications and estimates of the cost of the work and a statement showing the proposed expenditure of the money to be borrowed are open for inspection at the office of the Council, Civic Place, Warragul.

2769

D. McADIE, Shire Secretary.

Town and Country Planning Act 1961.

SHIRE OF YACKANDANDAH PLANNING SCHEME.

NOTICE THAT AN AMENDMENT HAS BEEN PREPARED AND IS AVAILABLE FOR INSPECTION.

Rural Area Interim Development Order.

Notice is hereby given that the Council of the Shire of Yackandandah in pursuance of its power under the *Town and Country Planning Act 1961* has prepared an amended Interim Development Order for all that land within the municipal district of the Yackandandah Shire, excepting those covered by the Yackandandah, Kiewa and Tangambalanga Township Planning Schemes and the Albury-Wodonga (Victoria) Planning Scheme Interim Development Order for the purpose of prohibiting, restricting or otherwise controlling the use, subdivision and development of land for certain purposes and the erection, construction or carrying out of buildings or works within the area covered.

A copy of the order has been deposited at the Shire Office, High Street, Yackandandah and at the office of the Town and Country Planning Board, 235 Queen Street, Melbourne, and will be open for inspection during office hours by any person free of charge.

Any persons affected by the Order are requested to set forth in writing, all objections they may have, addressed to the Shire Secretary, Yackandandah Shire Council, P.O. Box 75, Yackandandah, 3749 on or before the 21st August 1976 and to state whether they wish to be heard in respect of these objections.

13th July, 1976.

2743

T. FORBES, Shire Secretary.

AIREYS INLET WATERWORKS TRUST.

BY-LAW No. 1.

Meeting Procedure By-Law.

Notice is given that the Aireys Inlet Waterworks Trust has now made By-Law No. 1.

Title.

Standing Orders for regulating and appointing the place and hour of meetings of the Waterworks Trust, and providing for the management and conduct of business thereat.

Summary of Contents.

Clause 1	Extent of By-Law
Clause 2	Place and Hour of Meeting
Clause 3	Revocation of Resolutions
Clause 4-44	Management and Conduct of Business at Meeting
Clause 45	Signing of Cheques
Clause 46-47	Appointment of Permanent Office and fixing of salaries
Clause 48	Commissioners not to be Surety
Clause 49	Contracts
Clause 50	Plans etc. for public works
Clause 51	Secretary—Expending of Moneys between Meetings
Clause 52	Addresses to the Governor
Clause 53	Suspension of Regulations
Clause 54	Penalties
Clause 55	Affixing of Seal

A copy of the By-Law is open for inspection, free of charge, at the offices of the Trust at 441 Moorabool Street, South Geelong and the Anglesea Sewerage Authority, Community Centre, McMillan Street, Anglesea, during normal office hours.

2742

G. L. PEARCE, Secretary.

Water Acts.

PROPOSED CARAMUT WATERWORKS TRUST.

Notice is hereby given that the Warrnambool Shire Council has made application to the Honorable the Minister of Water Supply for the constitution of a Waterworks Trust, and for the proclamation of a Waterworks District, Urban and Rural Districts, and for the construction, maintenance and continuance of Water Supply Works within that district under the provisions of the Water Acts.

A general plan and description of the proposed works have been submitted with the application, and copies of same may be seen at the Post Office, Caramut, Shire Office, Warrnambool and Shire Office, Penshurst.

Dated at Warrnambool the 6th day of July, 1976.

2606

ALAN J. BOWES, Secretary.

Notice is hereby given that the A.P.M. Wood Products Pty. Ltd. has applied for a lease pursuant to Section 134 of the Land Act 1958 for a term of 25 years in respect of allotment 2, section B, allotment 7A section C, allotment 7 section D, allotments 1A and 7 section E, allotments three and five section F, and allotment one section G township of Powelltown containing 7.5 hectares approx. as a site for sawmilling activities. 2364

Notice is hereby given that the Murray Valley Aboriginal Co-operative Limited has applied for a lease for 21 years pursuant to section 134 of the Land Act 1958 in respect of an area of approximately 0.45 hectares of land known as the former Manatunga Aboriginal Settlement Reserve in the Parish of Bumbang. 2721

Notice is hereby given that Newport Oil Refinery Pty. Ltd. has applied for a lease pursuant to section 134 of the Land Act 1958 for a term of 20 years in respect of allotments 30 and 31A section 7 at Spotswood Parish of Cut-Paw-Paw and containing 1.7553 hectares as a site for General Industrial purposes. 2719

E.M.B. INSTRUMENT SERVICE,

546 Malvern Road, East Prahran.

Notice is given that as from 1st December 1975 Peter Clark of 41 Hillcrest Avenue Gladesville Sydney New South Wales has sold the above business to Alfred Norman Heaton formerly of 7 Lotus Court Wantirna Victoria and now of 96 Stud Road Wantirna in the said State and that as from the above date the said Alfred Norman Heaton is solely responsible for payment of all debts outstanding (if any) of the said business and is solely entitled to receipt of all amounts which may be due to the said business as from the said date.

THOMAS BURKE, solicitor, 152 Wattletree Road, Malvern. 2735

Victoria.

ACT 391.—FIRST SCHEDULE.

I, Donald Murray Macrae, authorized representative of the denomination known as the Presbyterian Church of Victoria with the consent of the Presbyterian Church of Victoria Trusts Corporation, trustees of the land described in the subjoined statement of trusts, and of Stanley John Cooper being the person entitled to minister in or occupy a building or buildings upon the said land, hereby apply to the Governor of the State of Victoria for leave to dispose of the said land by the means and for the purposes mentioned in the said statement of trusts, and I hereby certify that the said land was permanently reserved by Order in Council on the Twenty-first day of February, 1870, for the purpose of Presbyterian Church Reserve. That the only trustees of the said land resident in the State of Victoria are:—the Presbyterian Church of Victoria Trusts Corporation: That the only buildings upon the said land are nil: And that the only person entitled to minister in or occupy the same is the above-named Stanley John Cooper.

Signature of authorized representative—Donald Murray Macrae. We consent to this application—

N. J. McColl, Trustee, W. M. Hodges, Trustee, A. R. Gillespie, Treasurer of the Presbyterian Church of Victoria and Financial Secretary.

Attested by.—Ian D. Mackinnon, Law Agent.

Signature of person entitled to minister in or occupy building or buildings—S. J. Cooper.

STATEMENT OF TRUSTS.

Description of Land.—4047 sq. metres, Parish of Waddallah, County of Grant, being allotment 21A. Commencing at the south-western angle of allotment 22A; bounded

thence by that allotment and allotment 22 bearing 92 deg. 27 min. 100.58 metres; by allotment 21 bearing 182 deg. 27 min. 50.29 metres and 272 deg. 27 min. 60.35 metres; and thence by the Midland Highway bearing 323 deg. 57 min. 64.27 metres to the point of commencement.

Names of Trustees.—The Presbyterian Church of Victoria Trusts Corporation.

Powers of Disposition.—With the consent of the General Assembly of "The Presbyterian Church of Victoria", to mortgage, sell, lease, exchange and transfer, and grant easements over the said land, or any part or parts thereof, and subject to such powers and the exercise thereof, to hold the said land, or so much thereof as may from time to time remain vested in the said trustees, upon such trusts for the said Presbyterian Church of Victoria, and for such purposes, and with and subject to such powers, and provisions as are contained in the document enrolled by the Registrar-General of the State of Victoria, pursuant to the provisions of the Presbyterian Trusts Act 1890, and styled "The Presbyterian Church of Victoria Model Trust Deed for Church and Manse site".

Purposes to which Proceeds of Disposition are to be Applied.—To pay the money coming to the hands of such trustees by virtue of any such power of disposition to the Treasurer for the time being of the Presbyterian Church of Victoria, to be by him applied first in payment of all incidental costs, next in payment to the said Presbyterian Church of Victoria, of all deductions heretofore or hereafter to be authorized, by the General Assembly of the said Church and as to the residue, for such purposes as the said Assembly has heretofore authorized or may hereafter authorize. 2716

Lynnette Louise Seeley hereby publicly notifies the dissolution of the partnership between Lynnette Louise Seeley and Kenneth Alan Seeley, trading as Cormorant Place Constructions at 4 Cormorant Place, Dingley.

Dated the 1st day of June, 1976.

KEITH & IAN NESS, solicitors, 44 Market Street, Melbourne. 2806

Ian Andrew Ness hereby publicly notifies the dissolution of the partnership between Keith Adamson Ness, Ian Andrew Ness and Geoffrey Rees Gronow formerly trading as Keith A. Ness & Son of 380 Collins Street, Melbourne.

Dated the 14th day of July, 1976.

2805

Notice is hereby given that the partnership heretofore subsisting between Valerie Pascuzzi and Anita Pettehoffer carrying on business as clothing manufacturers at Factory 1, Lot 4 Barry Street, Bayswater in the State of Victoria under the firm of Unicorn Fashions has been dissolved as from the 17th day of June, 1976, so far as concerns the said Valerie Pascuzzi who retires from the said firm.

2789

Notice is hereby given that the Partnership heretofore subsisting between Platt Nominees Pty. Ltd., Piek Nominees Pty. Ltd., Gordon Nominees Pty. Ltd., Donjen Nominees Pty. Ltd., George John Schimmel and Marilyn Gertrude Schimmel carrying on business as Phoenix Press at 359 Little Lonsdale Street, Melbourne has been dissolved by reason of George John Schimmel and Marilyn Gertrude Schimmel purchasing the said business as at the 23rd day of May, 1976. 2807

Notice is hereby given that the partnership heretofore subsisting between Brian Douglas Roberts of 102 MacPherson Street North Carlton Film Producer and Jonathan Peter Hepworth Cecil of 62 Carlton Street Carlton Art Gallery Proprietor carrying on business of a modern print gallery under the style or firm of "Impression Modern Print Gallery" has been dissolved as from the 31st day of May 1976 and the said business shall continue to be carried on by the said Jonathan Peter Hepworth Cecil.

Dated the 14th day of July, 1976.

BRIAN D. ROBERTS.
J. P. H. CECIL.

2839

Notice is hereby given that the partnership heretofore subsisting between Edward Lambert John, Dennis Sutton and Michael Nodzio as manufacturers of fibreglass products at 31 Frankston Road Dandenong under the firm name of "Specialty Finance" has been dissolved by mutual consent as from the 26th November 1975.

MICHAEL NODZIO.

McCracken & McCracken, 414 Collins Street, Melbourne.

2838

Notice is hereby given that on the 30th June 1976 Helen Lucas retired from the partnership carrying on business under the name of Chaperon of Melbourne at 305 Lygon Street, East Brunswick. The partnership will be continued under the firm name of Chaperon of Melbourne by Donald George Lucas and George Lucas.

Dated the 14th July, 1976.

2808

HELEN LUCAS.

Notice is hereby given that the partnership heretofore subsisting between the undersigned William Robert Maurice Treble and William Maurice Treble carrying on business as Orchardists at Shepparton under the name of W. R. M. Treble and W. M. Treble has been dissolved by mutual consent as from the 31st day of December 1976. All debts due to and owing by the said late firm will be received and paid by William Maurice Treble who will continue to carry on the business at the same place.

Dated at Shepparton, the 14th day of July, 1976.

W. R. M. TREBLE.
W. M. TREBLE.

Witness.—A. P. SOFRA.

ABERNETHY, TOWERS & DOWD, solicitors, Shepparton. 2717

Notice is hereby given that the partnership heretofore subsisting between Barry John Allatt and Sally Anne Allatt both of 40 Hibiscus Avenue, Cheltenham, in the State of Victoria and Harold James Riley and Lorna Irene Riley both of 50 Park Road, Cheltenham in the said State carrying on business as Furniture Manufacturers at 15 Advantage Road, Highett under the style or firm of Riley and Allatt has been dissolved as from the 7th of June 1976 so far as concerns the said Harold James Riley and Lorna Irene Riley who retire from the said firm.

Dated the 5th day of July, 1976.

Signed by the said BARRY JOHN ALLATT and SALLY ANNE ALLATT in the presence of F. R. SCULLY, Justice of the Peace.

Signed by the said HAROLD JAMES RILEY and LORNA IRENE RILEY in the presence of DAVID BLACKBURN, Justice of the Peace. 2718

Notice is hereby given that the partnership heretofore subsisting between John Patrick Spadaccini, Maria Lea Lapenta and Rocco Lapenta carrying on business as Horticulturists at Cardoso under the style or firm of "J. P. Spadaccini and M. L. & R. Lapenta" has been dissolved as from the 30th day of June, 1976.

ROCCO LAPENTA, by his solicitors and agents, Duck, Crothers & Co., 75 Deakin Avenue, Mildura. 2736

Notice is hereby given that the partnership heretofore subsisting between Robert Francis Rawlinson and Edward Charles Rawlinson carrying on business as Crane Hire Operators at Peninsula Avenue Rye under the name of Rawlinson Brothers has been dissolved as from the 30th day of June, 1976.

Dated the 15th day of July, 1976.

2740 ROBERT FRANCIS RAWLINSON.

Companies Act 1961.—In the matter of BAZZA'S SHIRT SHOP PTY. LTD. (in Liquidation).—Formerly trading as "T-Shirt City" "Payless Photos" & "Photogenesis".

Notice is hereby given that Mr. D. J. Cogle has this day been appointed liquidator of the above company pursuant to the provisions of the Companies Act relating to a Creditors' Voluntary Winding Up.

Dated this 13th day of July, 1976.

D. J. COUGLE, Liquidator.

Bent & Cogle, public accountants, Suite 18, 545 St. Kilda Road, Melbourne, Vic. 3004. 2720

Companies Act 1961.—CANNBERRA HOTEL BALLARAT PROPRIETARY LIMITED (in Voluntary Liquidation).

Notice is hereby given that the Final Meeting of the members of Canberra Hotel Ballarat Proprietary Limited (in Voluntary Liquidation) will be held at 331 Main Street, Lilydale on 25th August, 1976 at 2 p.m. for the purpose of having an account laid before it showing how the winding up of the company has been conducted and the property of the company has been disposed of and to pass a resolution to destroy the company's books and papers pursuant to section 284 (3) (b) of the Companies Act.

Dated this 12th day of July, 1976.

2722 J. A. DOBRIGH, Liquidator.

Companies Act 1961, Section 291.

Companies Regulations.

SUPREME COURT (COMPANIES) RULES 1962.

Rule 99.

PERICLES CONSTRUCTIONS (TASMANIA) PTY. LTD. (IN LIQUIDATION).

Notice is hereby given that the creditors of Pericles Constructions (Tasmania) Pty. Ltd., (in liquidation) are required to furnish to the liquidator a proof of debt form in accordance with Form 75 of the Companies Regulations by Friday, 13th August, 1976. Any creditor claiming title to priority pursuant to section 292 of the Companies Act 1961 should serve notice in writing on the liquidator, such notice should accompany the said proof of debt form.

Any creditor not proving their claim by the above date will be excluded from the benefit of any distribution.

Dated this 15th day of July, 1976.

M. J. O'KEEFFE, Official Liquidator.

M. J. O'Keeffe & Co., accountants, 164 High Street, Ashburton, 3147. 2820

Companies Act 1961, Section 291.

Companies Regulations.

SUPREME COURT (COMPANIES) RULES 1962.

Rule 99.

FAIRLINE FURNITURE (SALES) PTY. LTD. (IN LIQUIDATION).

Notice is hereby given that the creditors of Fairline Furniture (Sales) Pty. Ltd. (in liquidation), are required to furnish to the liquidator a proof of debt form in accordance with Form 75 of the Companies Regulations by Friday, 13th August, 1976. Any creditor claiming title to priority pursuant to section 292 of the Companies Act 1961 should serve notice in writing on the liquidator, such notice should accompany the said proof of debt form.

Any creditor not proving their claim by the above date will be excluded from the benefit of any distribution.

Dated this 15th day of July, 1976.

M. J. O'KEEFFE, Official Liquidator.

M. J. O'Keeffe & Co., accountants, 164 High Street, Ashburton, 3147. 2821

Companies Act 1961.

VELCRETE TRANSPORT PTY. LTD. (IN LIQUIDATION).

DISPLAY FINANCE PTY. LTD. (IN LIQUIDATION).

SECOND SOUTHERN OPERATIONS PTY. LTD. (IN LIQUIDATION).

THIRD SOUTHERN OPERATIONS PTY. LTD. (IN LIQUIDATION).

FOURTH SOUTHERN OPERATIONS PTY. LTD. (IN LIQUIDATION).

NOTICE CONVENING FINAL MEETINGS OF MEMBERS, PURSUANT TO SECTION 272 (1).

Notice is hereby given that the Final Meetings of members of the abovenamed companies will be held at 447 Collins Street Melbourne on Friday, 20 August 1976 at 10.00 a.m. for the purpose of laying before the meetings an account showing how the winding up has been conducted and the property of the companies disposed of and giving any explanation thereof.

Dated this 19th day of July, 1976.

P. W. HARVEY, Liquidator.

Price Waterhouse & Co., chartered accountants, 447 Collins Street, Melbourne. 2840

Companies Act 1961, Section 272 (2).

SPACE INVESTMENTS PROPRIETARY LIMITED (IN VOLUNTARY LIQUIDATION).

NOTICE OF FINAL MEETING.

Notice is hereby given that pursuant to section 272 of the Companies Act 1961 a general meeting of the members of Space Investments Proprietary Limited will be held in the Conference Room of Messrs. Duesbury Johnston & Marks, 6th Floor, 446 Collins Street, Melbourne 3000 at 10 a.m. on 23rd August 1976 for the purpose of laying before the meeting an account showing how the winding up has been conducted and the property of the company disposed of and giving any explanation thereof.

Dated this 20th day of July, 1976.

A. I. SINCLAIR, Liquidator.

Duesbury Johnston & Marks, 446 Collins Street, Melbourne, 3000. 2841

Companies Act 1961 (As Amended), Section 254.—In the matter of J. DOYLE PTY. LTD. (in Voluntary Liquidation).

Notice is hereby given that at an Extraordinary General Meeting of the company on 12th July, 1976 the following special resolution was passed.

"That the company be wound-up voluntarily and that Mr. Bryan James Waters, chartered accountant, of 235 Lonsdale Street, Dandenong be appointed liquidator."

B. J. WATERS, liquidator, 235 Lonsdale Street, Dandenong.

2723

In the matter of the *Companies Act 1961*; and in the matter of BURGUNDY ESTATES PTY. LTD. (in Voluntary Liquidation).

Notice is hereby given that a General Meeting of the above named company will be held at 788 High Street, Thornbury, at 2.00 o'clock in the afternoon of Friday the 27th day of August, 1976, for the purpose of laying before the meeting the liquidator's account of receipts and payments and statement of how the winding up has been conducted and how the property of the company has been disposed of.

Dated this 19th day of July, 1976.

J. A. TARRAN, Liquidator, 788 High Street, Thornbury.

2724

The *Companies Act 1961*.

STANDARD STOCK SERVICE CO. PTY. LIMITED (IN LIQUIDATION).

Notice is hereby given that at an Extraordinary General Meeting of the members of the above-named company held on the 9th July, 1976, it was resolved that the company be wound up voluntarily and that Peter William Hebard of 2 Station Street, Moorabbin, be appointed liquidator.

P. W. HEBARD, Liquidator.

Hebard & Gunning, chartered accountants, 2 Station Street, Moorabbin, 3189.

2725

In the matter of the *Companies Act 1961*; and in the matter of JACKSON & SPRING (MELBOURNE) PTY. LIMITED. Notice to Creditors.

Notice is hereby given that, in accordance with section 260 (1) of the *Companies Act 1961*, a meeting of the creditors of the abovenamed company will be held at the offices of Coopers & Lybrand, 20th Level, Norwich House, 6 O'Connell Street, Sydney on 30th July, 1976 at 10.05 in the forenoon, for the purpose of considering the company's affairs and determining that section 277 (A) (1A) (b) of the *Companies Act 1961* should not apply to the winding up of the company. The company has already convened an Extraordinary General Meeting of its members to be held at the offices of Coopers & Lybrand, 20th Level, Norwich House, 6 O'Connell Street, Sydney on 30th July, 1976 at 10.00 in the forenoon for the purpose of considering and, if thought fit, passing as a special resolution the resolution following that is to say:

"That the company be wound up voluntarily."

An ordinary resolution will be submitted to the meeting for nomination of a person to be liquidator of the company for the purpose of the winding up.

Dated this 7th day of July, 1976.

By order of the Board,

J. LE NOBLE, Director.

Care of Coopers & Lybrand, chartered accountants, 6 O'Connell Street, Sydney, N.S.W., 2000.

2737

Companies Act 1961.

COBHAM CONSTRUCTIONS PTY. LTD. (IN LIQUIDATION).

Notice is hereby given that at an Extraordinary General Meeting of members of the above named company held on the 15th day of July, 1976 it was resolved that the company be wound up voluntarily and it was resolved for that purpose Murray Bruce Crabb, chartered accountant, of 1015 Burke Road, Camberwell, be appointed liquidator.

Notice is also given that after twenty-one days from this date I shall proceed to distribute the assets. All creditors who have any claim against the company should furnish particulars of their claims by that date, otherwise I shall proceed to distribute the assets without regard to their claim.

Dated this 16th day of July, 1976.

M. B. CRABB, Liquidator.

Shepherd & Partners, chartered accountants, 1015 Burke Road, Camberwell, 3124. Telephone 82 7129.

2738

Companies Act 1961, Section 272 (2).

KINGWOOD CHAMBERS PROPRIETARY LIMITED (MEMBERS' VOLUNTARY WINDING UP).

NOTICE OF FINAL MEETING AND DISSOLUTION.

Notice is hereby given that a general meeting of the members of Kingwood Chambers Proprietary Limited will be held at 155 Wellington Parade South, Jolimont on the 18th August, 1976 at 10.00 a.m. for the purpose of laying before the meeting an account showing how the winding up has been conducted and the property of the company has been disposed of and of giving any explanation of the account and also of determining by extraordinary resolution the manner in which the books, accounts and documents of the company and of the liquidator thereof shall be disposed of.

Dated this 16th day of July, 1976.

2739

ALLAN NAHUM, Liquidator.

WAVERLEY (AMALGAMATED) CO-OPERATIVE HOUSING SOCIETY LIMITED (IN LIQUIDATION).

Take notice that the affairs of the above-named Society are now fully wound up and that in pursuance of section 272 (1) of the *Companies Act 1961* and of the *Co-operative Housing Societies Act 1958*, a general meeting of the Society will be held at Room 109, V.R. Institute, 223 Flinders Street, Melbourne, on Tuesday the 24th August, 1976, for the purpose of:

(i) laying before it an account showing how the winding up has been conducted and the property of the Society disposed of and giving any explanations thereof; and

(ii) passing a resolution that the books and papers of the said Society and of the liquidator relevant to the officers of the Society be destroyed after a period of twelve months from the date of the meeting.

Dated the 21st day of July, 1976.

2741

V. E. BURNS, Liquidator.

Companies Act 1961.—In the matter of VERONICA TEXTILES PROPRIETARY LIMITED.—Notice of Meeting of Creditors, Pursuant to Section 260:

Notice is hereby given that a meeting of creditors of the abovenamed company will be held at the office of Lewis Luckins & Co. 6th Floor, 423 Bourke Street, Melbourne, on Wednesday, 28th July, 1976, at 3 p.m. the company having convened an extraordinary general meeting of its members for the same day for the purpose of considering a Special Resolution that the company be wound up voluntarily.

Dated this 20th day of July, 1976.

A. C. WRAY, Director.

Lewis Luckins & Co., 423 Bourke Street, Melbourne, 3000. Telephone 67 6944.

2809

Companies Act 1961.—In the matter of ORBIT INDUSTRIES PTY. LTD.—Notice of Meeting of Creditors, Pursuant to Section 260.

Notice is hereby given that a meeting of creditors of the abovenamed company will be held at the office of Lewis Luckins & Co. 6th Floor, 423 Bourke Street, Melbourne, on Tuesday, 27th July, 1976, at 11 a.m. the company having convened an extraordinary general meeting of its members for the same day for the purpose of considering a Special Resolution that the company be wound up voluntarily.

Dated this 15th day of July, 1976.

P. S. HERTZ, Director.

Lewis Luckins & Co., 423 Bourke Street, Melbourne, 3000. Telephone 67 6944.

2810

Companies Act 1961.—In the matter of W. & N. HOLDINGS PTY. LTD.—Notice of Meeting of Creditors, Pursuant to Section 260.

Notice is hereby given that a meeting of creditors of the abovenamed company will be held at the office of Lewis Luckins & Co. 6th Floor, 423 Bourke Street, Melbourne, on Thursday, 22nd July, 1976, at 11 a.m. the company having convened an extraordinary general meeting of its members for the same day for the purpose of considering a Special Resolution that the company be wound up voluntarily.

Dated this 14th day of July, 1976.

W. L. HOPPER, Director.

Lewis Luckins & Co., 423 Bourke Street, Melbourne, 3000. Telephone 67 6944.

2811

Unclaimed Moneys Act 1962.

Register of Unclaimed Moneys held by the—

Name of Owner on Books and Last Known Address.	Total Amount Due to Owner.	Description of Unclaimed Moneys.	Date when Amount first became Payable.
§			
CUMING SMITH AND COMPANY LIMITED.			
Dalton, Allan W., 13 Clare Street, Sylvania, N.S.W.	41.25	Dividend	27.3.74
Goodsir, Mary E., c/o The Trustees Executors and Agency Co. Ltd., 1 Bligh Street, Sydney, N.S.W.	206.25	„	25.9.74
Dalton, Allan W., 13 Clare Street, Sylvania, N.S.W.	41.25	„	„
Noss, Elizabeth G., 7 Glencoe Road, Woollahra, N.S.W.	41.25	„	„
2701			
DILLINGHAM CONSTRUCTIONS PTY. LTD.			
Knight, J., 140/112 Elizabeth Street, Richmond	89.00	Wages	14.8.74
2579			

Companies Act 1961.—Rule 99 and Regulation 56.—In the matter of R. E. EWING PTY. LTD. (in Liquidation).

Take notice that the Liquidator of the abovenamed Company has fixed Thursday the 5th day of August, 1976 as the day on or before which creditors of the company are to prove their debts or claims and to establish any title they may have to priority under section 292 or be excluded from the benefit of a first and final dividend made before such debts are proved or as the case may be from objecting to such dividend.

Dated this 15th day of July, 1976.

ROBERT EASTAUGH RAMSAY, Liquidator.

Wallace McMullin & Small, 499 St. Kilda Road, Melbourne, 3004. 2812

In the matter of JACQUES MCASKELL ADVERTISING VICTORIA PTY. LIMITED (in Liquidation); and in the matter of the *Companies Act 1961*.

At a special general meeting of the members of the abovenamed company, duly convened and held at 145 La Trobe Street, Melbourne on the 2nd day of March, 1976, the special resolution set out below and signed by me for the purposes of identification was duly passed:

“That it has been proved to the satisfaction of this meeting that the company cannot, by reason of its liabilities, continue its business, and that it is advisable to wind up the same, and accordingly that the company be wound up voluntarily.” Mr. John Edward Walker, F.C.A., of Walker Garrity & Co., chartered accountants was appointed liquidator of the company for the purposes of the winding up, by resolution of the members and of the creditors dated 2nd March, 1976.

Dated this 14th day of May, 1976.

D. JACKSON, C/- Walker Garrity & Co., 109 Pitt Street, Sydney. 2823

Companies Act 1961.

BETH'S INTERIORS PTY. LTD. (IN LIQUIDATION).

NOTICE OF MEETING.

Notice is hereby given that the final Meeting of Creditors and Members of Beth's Interiors Pty. Ltd. (In Liquidation) will be held at the Institute of Chartered Accountants on Friday the 27th day of August, 1976 at 11.00 a.m.

BUSINESS.

To receive the final report of the Liquidation on the winding up.

2772 E. P. TAYLOR, Liquidator.

Companies Act 1961, Section 272.

GOLDSTEIN ENGINEERING PTY. LTD. (IN LIQUIDATION).

NOTICE OF MEETING.

Notice is hereby given that the final Meeting of Creditors and Members of Goldstein Engineering Proprietary Limited (In Liquidation) will be held at the Institute of Chartered Accountants on Friday the 27th day of August at 10.00 a.m.

BUSINESS.

To receive the final report of the Liquidation on the winding up.

2773 E. P. TAYLOR, Liquidator.

In the matter of the *Companies Act, 1961*, as amended, and in the matter of JACQUES MCASKELL ADVERTISING VICTORIA PTY. LIMITED (in Liquidation).—Notice to Creditors.

Notice is hereby given that all persons having any claim against the above company as at the fourth day of May, 1976 are required to send their names and addresses and particulars of their debts or claims to Mr. John Edward Walker, liquidator of the said company at his office C/- Walker Garrity & Co., 1st floor, 109 Pitt Street, Sydney, and if so required by notice in writing by the said liquidator are required personally or by their solicitor to come in and prove their said debts or claims at such time and place as shall be specified in such notices: or in default thereof they will be excluded from the benefits of any distribution made before such debts or claims are so lodged or proved.

Dated this 14th day of July, 1976.

JOHN EDWARD WALKER, liquidator, C/- Walker Garrity & Co., 1st Floor, 109 Pitt Street, Sydney, 2000. 2822

Companies Act 1961, Section 272.

GEORGE SOUTHAM & CO. PTY. LTD. (IN LIQUIDATION).

Notice is hereby given that a meeting of members and creditors of the above company will be held in the Board Room of the Institute of Chartered Accountants in Australia, 140 Queen Street, Melbourne, on Friday, 20 August, 1976, at 10 a.m.

The purpose of this meeting is to consider the liquidator's account and to hear any explanations which may be requested.

P. D. GEORGE, Liquidator.

Arthur Young & Company, 440 Collins Street, Melbourne, 3000. 2843

Companies Act 1961, Section 272.

SOUTHAM ENGINEERING PTY. LTD. (IN LIQUIDATION).

Notice is hereby given that a meeting of members and creditors of the above company will be held in the Board Room of the Institute of Chartered Accountants in Australia, 140 Queen Street, Melbourne, on Friday, 20 August, 1976, at 11 a.m.

The purpose of this meeting is to consider the liquidator's account and to hear any explanations which may be requested.

P. D. GEORGE, Liquidator.

Arthur Young & Company, 440 Collins Street, Melbourne, 3000. 2844

The *Companies Act 1961.*—In the matter of LOBRON PTY. LIMITED, formerly Lohning Brothers Pty. Ltd.—Notice Re meeting of Creditors, Pursuant to Section 260.

Notice is hereby given that a meeting of creditors of the abovenamed company will be held at the Varcoe Room, 7th Floor, V.A.C.C. Building, 464 St. Kilda Road, Melbourne on the 29th day of July, 1976, the company having convened a meeting of its members for the same day for the purpose of considering a Resolution that the company be wound up voluntarily.

Dated this 16th day of July, 1976.

2770 K. W. LOHNING, Director.

The Companies Act 1961.—Notice of Meeting of Members, Pursuant to Section 272.—In the Matter of BERWICK HEIGHTS PROPRIETARY LIMITED, MANCHESTER ESTATES PROPRIETARY LIMITED, PERRY HOUSE PROPRIETARY LIMITED.

Notice is hereby given that pursuant to section 272 of the Companies Act 1961, the final meeting of members of the abovenamed companies will be held at the offices of Messrs. Bentley, Wheeler, Cartledge & Co., 1 Palmerston Crescent, South Melbourne, on Monday 23rd August, 1976, at 9.15 o'clock in the forenoon for the purpose of laying before the meeting the liquidator's final account and report and giving any explanation thereof.

Dated this 20th day of July, 1976.

K. J. BROWNE, Liquidator.

Bentley, Wheeler, Cartledge & Co., chartered accountants, 1 Palmerston Crescent, South Melbourne, Vic., 3205. 2842

Companies Act 1961.

GLASTRON BOAT CO. (AUSTRALIA) PTY. LTD.

NOTICE OF MEETING.

Notice is hereby given of a Meeting of Creditors and Members of Glastron Boat Co. (Australia) Pty. Ltd. to be held at the Institute of Chartered Accountants, 9th Floor, 149 Queen Street, Melbourne on Friday the 30th day of July, 1976 at 10.00 a.m. for the purpose of considering and if thought fit, passing the following resolution:

"That the Company be wound up voluntarily."

"That paragraph 277A 1A (B) of the Companies Act 1961 shall not apply to the winding up."

H. N. CARROLL, Director.

Care of E. P. Taylor, 583 Hampton Street, Hampton, 3188. Phone 598 7077. 2774

Companies Act 1961.

VOLERO (NON LINE) PTY. LTD.

NOTICE OF MEETING.

Notice is hereby given of a Meeting of Creditors and Members of Volero (Non Line) Pty. Ltd. to be held at the Institute of Chartered Accountants, 9th Floor, 140 Queen Street, Melbourne on Friday the 30th day of July, 1976 at 10.30 a.m. for the purpose of considering and if thought fit, passing the following resolution:

"That the Company be wound up voluntarily."

"That paragraph 277A 1A (B) of the Companies Act 1961 shall not apply to the winding up."

H. N. CARROLL, Director.

Care of E. P. Taylor, 583 Hampton Street, Hampton, 3188. Phone 598 7077. 2775

Companies Act 1961.

VOLERO BOAT CO. PTY. LTD.

NOTICE OF MEETING.

Notice is hereby given of a Meeting of Creditors and Members of Volero Boat Co. Pty. Ltd. to be held at the Institute of Chartered Accountants, 9th Floor, 140 Queen Street, Melbourne on Friday the 30th day of July, 1976 at 11.00 a.m. for the purpose of considering and if thought fit, passing the following resolution:

"That the Company be wound up voluntarily."

"That paragraph 277A 1A (B) of the Companies Act 1961 shall not apply to the winding up."

H. N. CARROLL, Director.

Care of E. P. Taylor, 583 Hampton Street, Hampton, 3188. Phone 598 7077. 2776

Companies Act 1961.

VOLERO (ASSEMBLY) PTY. LTD.

NOTICE OF MEETING.

Notice is hereby given of a Meeting of Creditors and Members of Volero (Assembly) Pty. Ltd. to be held at the Institute of Chartered Accountants, 9th Floor, 140 Queen Street, Melbourne on Friday the 30th day of July, 1976 at 11.30 a.m. for the purpose of considering and if thought fit, passing the following resolution:

"That the Company be wound up voluntarily."

"That paragraph 277A 1A (B) of the Companies Act 1961 shall not apply to the winding up."

H. N. CARROLL, Director.

Care of E. P. Taylor, 583 Hampton Street, Hampton, 3188. Phone 598 7077. 2777

MORDULINE CONSTRUCTIONS PROPRIETARY LIMITED (IN VOLUNTARY LIQUIDATION).

A first and final dividend is intended to be declared in the above company.

If the persons claiming to be creditors have not proved their debts and admitted by the Liquidator by the 23rd day of July 1976 they will be excluded from this dividend.

Dated this 26th day of July, 1976.

2787

H. CHAN, Liquidator.

Companies Act 1961.

ASSOCIATED TAXI SERVICES PTY. LTD.

NOTICE Re MEETING OF CREDITORS, PURSUANT TO SECTION 260.

Notice is hereby given that a meeting of creditors of the abovenamed company will be held at Room 515, 5th Floor, Shell House, 163 William Street, Melbourne on Monday, 2nd August, 1976 at 2.30 p.m., the company having convened a meeting of its members for the same day, for the purpose of considering a Resolution that the company be wound up voluntarily.

Dated this 19th day of July, 1976.

2788

B. NEWPORT, Secretary.

Companies Act 1961.—In the Supreme Court of Victoria.—1976 Co. No. 9400.—In the matter of the Companies Act 1961; and in the matter of D. & T. L. BUNNING PROPRIETARY LIMITED.

Notice is hereby given that a petition for the winding up of the above-named company by the Supreme Court was on the Thirtieth day of June, 1976, presented by Frank Velardo and Paul Velardo. And that the said petition is directed to be heard before the Court sitting at Melbourne at the hour of 10.30 on the 17th day of August, 1976; and any creditor or contributory of the said company desiring to support or oppose the making of an order on the said petition may appear at the time of hearing by himself or his counsel for that purpose; and a copy of the petition will be furnished to any creditor or contributory of the said company requiring the same by the undersigned on payment of the regulated charge for the same.

The Petitioners' addresses are Frank Velardo of 57 Chapman Street, Sunshine and Paul Velardo of 10 Whitty Street, Sunshine.

The Petitioners' solicitor is G. W. Legge, of 332A Main Road East, St. Albans, 3021.

G. W. LEGGE.

NOTE.—Any person who intends to appear on the hearing of the said petition must serve on or send by post to the above named G. W. Legge notice in writing of his intention so to do. The notice must state the name and address of the person or if a firm, the name and address of the firm, and must be signed by the person or firm, or his or their Solicitor (if any), and must be served, or, if posted, must be sent by post in sufficient time to reach the above named not later than four o'clock in the afternoon of the 16th of August, 1976. 2771

FRANK PILKINGTON BRETT, late of "Gooliga", Tilba Tilba Road, via Narooma, in the State of New South Wales, retired grazier, DECEASED.

Creditors next of kin and others having claims against the estate of the said deceased who died on 26th January 1976 are to send particulars of their claims to Bernard Gore Brett C/- Blake & Riggall solicitors 140 William Street Melbourne by the 30th day of September 1976 after which date they will distribute the assets having regard only to the claims of which they then have notice.

BLAKE & RIGGALL, solicitors, 140 William Street, Melbourne. 2830

REINE DESIREE FINCH, formerly of "Ockwella" Bruarong Crescent, Frankston, late of 24 Markham Square, London, in England, widow, DECEASED.

Creditors next of kin and others having claims against the estate of the said deceased who died on 14th August 1973 are to send particulars of their claims to Bernard Gore Brett C/- Blake & Riggall solicitors 140 William Street Melbourne by the 30th day of September 1976 after which date he will distribute the assets having regard only to the claims of which he then has notice.

BLAKE & RIGGALL, solicitors, 140 William Street, Melbourne. 2831

ARCHIBALD GORDON MITCHELL, late of 3 Blue Haze, Avenue, Seaford, in the County of Sussex, England, retired, DECEASED.

Creditors next of kin and others having claims against the estate of the said deceased who died on 19th August 1975 are to send particulars of their claims to Charles Percy Abbott C/- Blake & Riggall solicitors 140 William Street Melbourne by the 30th day of September 1976 after which date he will distribute the assets having regard only to the claims of which he then has notice.

BLAKE & RIGGALL, solicitors, 140 William Street, Melbourne. 2832

NORMAN COTTAM GADSDEN, formerly of Flat 8, 16 Marnie Street, South Yarra, in the State of Victoria, but late of 99 Spring Street, Melbourne in the said State, company director, DECEASED.

Creditors next-of-kin and others having claims in respect of the estate of the abovenamed deceased who died on the 27th day of May 1973 are required by the executors, Elizabeth Bluebell Marjorie Gadsden (in the will called Elizabeth Gadsden) of 99 Spring Street Melbourne in the State of Victoria widow, Graham William Brasch of 13 Kyeamba Grove Toorak in the said State sales manager and Brian Elliston Adams of 447 Collins Street Melbourne in the said State chartered accountant, to send particulars to the executors (addressed to the said Brian Elliston Adams care of Messrs. Price Waterhouse and Co., 447 Collins Street Melbourne aforesaid) by the 30th day of September 1976 after which date the executors may convey and distribute the assets having regard only to the claims of which they then have notice.

DAVIES, CAMPBELL & PIESSE, solicitors, 401 Collins Street, Melbourne, 3000. 2833

MARY SKUJE, late of Flat 13, 289 Barkly Street St. Kilda, widow, DECEASED.

Creditors next of kin and others having claims in respect of the estate of the abovenamed deceased who died on the nineteenth day of November 1975 are required by Tamara Frese of 10 Rolls Street Coburg widow and Ian Fraser Bult of 257 Collins Street Melbourne solicitor the executors of the will and codicil of the said deceased to send particulars of their claims to the executors care of the undernamed solicitors by the twenty-fourth day of September 1976 after which date the said executors will convey or distribute the assets having regard only to the claims of which they then have notice.

RUSSELL, KENNEDY & COOK, solicitors, 257 Collins Street, Melbourne. 2834

JOHN MORLEY, late of 98 Dendy Street, Brighton, in the State of Victoria, gentleman, DECEASED.

Creditors, next-of-kin and others having claims in respect of the estate of the abovenamed deceased who died on the 2nd March, 1976 are required by the executor Ian Andrew Ness of 44 Market Street, Melbourne to send particulars to him by the 30th September, 1976 after which date the executor intends to convey or distribute the assets of the estate having regard only to the claims of which he may have notice.

KEITH & IAN NESS, solicitors, 44 Market Street, Melbourne. 2835

GERTRUDE MARY DELLOW, late of 5 Kingsley Road, Reservoir, textile worker, DECEASED.

Creditors, next of kin and others having claims in respect of the estate of the deceased (who died on the 20th May 1976) are required by The Perpetual Executors and Trustees Association of Australia Limited of 50 Queen Street Melbourne to send particulars of their claims to the said company by the 20th September 1976 after which date it will convey or distribute the assets having regard only to the claims of which the company then has notice.

FREDERICK OWEN & ASSOCIATES, solicitors, 450 Little Collins Street, Melbourne. 2836

Creditors next of kin and others having claims in respect of the estate of Theodora Jean Campbell-Walker late of 35 Kalimna Drive Mornington spinster deceased who died on the 21st day of August, 1973 are required by the executor the Union Fidelity Trustee Company of Australia Limited of 100 Exhibition Street, Melbourne to send particulars of their claim to the executor care of the undernamed solicitors by the 24th day of September, 1976 after which date it will distribute the assets having regard only to the claim of which it then has notice.

FREDERICK OWEN & ASSOCIATES, solicitors, 222 Blackburn Road, Syndal, 3149. 2837

Creditors next-of-kin and others having claims against the estate of Ivan Franklin Stebbins late of 94 Durham Road, Surrey Hills, hardware merchant, deceased, who died on the 5th day of March 1975 are required by the executors Jane Eleanor Stebbins of 94 Durham Road, Surrey Hills, widow and Russell James Stebbins of 2 Ivy Court, Mount Waverley, retailer to send particulars to the undermentioned solicitors by the 23rd day of September, 1976 after which date they will distribute the assets having regard only to the claims to which they then have notice.

BRUSEY & CO., solicitors, 406 Lonsdale Street, Melbourne, 3000. 2702

Creditors next of kin, and others having claims in respect of the estate of Daphne Margaret Watt late of 16 Barloa Road, Mont Albert in the State of Victoria married woman deceased are required by the trustee The Equity Trustees Executors and Agency Company Limited of 472 Bourke Street, Melbourne in the said State to send particulars thereof to its solicitors Messrs. Aughterson Giblett & Williams of 156 Maroondah Highway, Ringwood in the said state by the 30th day of August, 1976 after which date the Trustee may convey or distribute the assets having regard only to the claims of which it then has notice.

AUGHTERSON, GIBLETT & WILLIAMS, barristers & solicitors, of 156 Maroondah Highway, Ringwood, 3134, Victoria. 2703

GEORGE McCARTNEY ABBOTT, late of 101 Market Road, Werribee, in the State of Victoria, retired driver, DECEASED, who died on the 2nd day of July, 1976.

Creditors next-of-kin and other persons having claims against the estate of the said deceased are requested by the executor Reginald Henry Coker to send particulars of their claims to the undermentioned solicitors on or before the 20th day of September 1976 after which date they will distribute the assets having regard only to the claims of which they then have notice.

GERALD E. DELANY & CO., barristers & solicitors, 185 William Street, Melbourne. 2704

Creditors next of kin and others having claims in the estate of Harry William Edwards late of 23 Indi Avenue, Red Cliffs second-hand car dealer deceased intestate who died on the 29th day of April, 1976 are to send particulars of their claims to the administratrix Margaret June Edwards care of the undersigned by the 30th September, 1976, after which date she will distribute the assets having regard only to the claims of which she then has notice.

DUCK, CROTHERS & CO., solicitors, of 75 Deakin Avenue, Mildura. 2705

ARTHUR CAMPBELL HEIGHWAY, late of 471 Campbell Street, Swan Hill, in the State of Victoria, retired orchardist, DECEASED (who died on the 23rd May, 1976).

Creditors next-of-kin and all other persons having claims against the estate of the deceased are required by the executor of the will Thomas Bridson Green to send particulars to him care of the undersigned on or before the 7th day of October, 1976 after which date he will distribute the assets having regard only to the claims of which he then has notice.

GARDEN & GREEN, solicitors, 4 McCallum Street, Swan Hill. 2706

ROBERT EMMETT RYAN, late of 29 Glengyle Street, East Coburg, retired, DECEASED.

Creditors, next of kin and others having claims in respect of the estate of the deceased who died 5th October, 1968 are required by the personal representatives National Trustees Executors and Agency Company of Australasia Limited of 95 Queen Street, Melbourne to send particulars to it by the 30th day of September, 1976 after which day the personal representatives may convey or distribute the assets, having regard only to the claims of which it then has notice.

WILFRID J. OSBORNE & OSBORNE, solicitors, Seymour. 2707

MARY ELIZABETH HALL, late of 96 Brougham Street, Bendigo, widow, DECEASED.

Creditors next of kin and others having claims against the estate of the abovenamed deceased are required by the executor thereof National Trustees Executors and Agency Company of Australasia Limited of 95 Queen Street, Melbourne and at 46 Queen Street, Bendigo to

forward particulars thereof care of the said company on or before the 24th day of September, 1976 after which date it will distribute the assets of the above said estate having regard only to the claims of which it then has notice.

Dated this 20th day of July, 1976.

ERIC C. COHEN, Victoria Chambers, Pall Mall, Bendigo, solicitors for the executor. 2708

KATHLEEN DOREEN JONES, late of 34 Carpenter Street, Bendigo, widow, DECEASED.

Creditors next of kin and others having claims against the estate of the abovenamed deceased are required by the executor thereof Desmond James Fitt of Condon Street, Bendigo, contractor to forward particulars thereof to him care of the undermentioned solicitor on or before the 24th day of September, 1976 after which date he will distribute the assets of the said estate having regard only to the claims of which he then has notice.

Dated this 20th day of July, 1976.

ERIC C. COHEN, Victoria Chambers, Pall Mall, Bendigo, solicitor for the executor. 2709

HENRIETTA WEBB DAW, formerly of Deniliquin, in the State of New South Wales, married woman, but late of 76 Bradford Road, Safety Beach, widow, DECEASED.

Creditors, next-of-kin and others having claims in respect of the deceased who died on the second day of April 1976 are required by her trustee Thomas James Fawcett of Sale retired accountant to send particulars to him care of the under-mentioned firm of solicitors by the twenty-third day of September 1976 after which date the trustee may convey and distribute the assets having regard only to the claims of which he then has notice.

MAL. RYAN, JACKSON & GLEN, 9 High Street, Mansfield, solicitors for the trustee. 2710

LORNA JEAN MAXWELL, late of 552 Inverness Avenue, The Basin, widow, DECEASED.

Creditors next-of-kin and others having claims in respect of the deceased who died on the twenty-fifth day of November 1974 are required by her trustee William Maxwell of Bonnie Doon contractor to send particulars to him care of the undermentioned firm of solicitors by the twenty-fourth day of September 1976 after which date the trustee may convey and distribute the assets having regard only to the claims of which he then has notice.

MAL. RYAN, JACKSON & GLEN, 9 High Street, Mansfield, solicitors for the trustee. 2711

ALLAN MAXWELL, late of 552 Inverness Avenue, The Basin, bricklayer, DECEASED.

Creditors next-of-kin and others having claims in respect of the deceased who died on the third day of April 1974 are required by his Trustee William Maxwell of Bonnie Doon contractor to send particulars to him care of the undermentioned firm of solicitors by the twenty-fourth day of September 1976 after which date the trustee may convey and distribute the assets having regard only to the claims of which he then has notice.

MAL. RYAN, JACKSON & GLEN, 9 High Street, Mansfield, solicitors for the trustee. 2712

PETER COMERFORD, late of Barwite, farmer, DECEASED.

Creditors next-of-kin and others having claims in respect of the deceased who died on the twenty-sixth day of March 1976 are required by his trustees Edward Francis Comerford and Patrick Comerford both of Barwite graziers to send particulars to them care of the undermentioned firm of solicitors by the twenty-fourth day of September 1976 after which date the trustees may convey and distribute the assets having regard only to the claims of which they then have notice.

MAL. RYAN, JACKSON & GLEN, 9 High Street, Mansfield, solicitors for the trustees. 2713

MARGARET MARY O'HALLORAN, late of Mansfield, widow, DECEASED.

Creditors next-of-kin and others having claims in respect of the deceased who died on the second day of April 1976 are required by her trustees Florence Vincent O'Halloran and John Patrick O'Halloran both of Mansfield graziers to send particulars to them care of the under-mentioned firm of solicitors by the twenty-fourth day of September 1976 after which date the trustees may convey and distribute the assets having regard only to the claims of which they then have notice.

MAL. RYAN, JACKSON & GLEN, 9 High Street, Mansfield, solicitors for the trustees. 2714

VIVIAN MARY BOWLER, formerly of 32 Brooke Street, Camperdown, but late of "Karana", 55 Walpole Street, Kew, in the State of Victoria, retired hospital matron.

Creditors, next-of-kin and others having claims in respect of the estate of the deceased, who died on the 23rd day of April 1976 and probate of whose will was granted by the Supreme Court of Victoria on the 6th day of July 1976 to John James Francis and Marjorie McLaren the executors named in the said Will, are to send particulars of their claims to the said executors at their addresses at the undermentioned solicitors by the 28th day of September 1976 after which date they will convey or distribute the assets having regard only to the claims of which they then have notice.

ALECK SACKS & SON, solicitors, of 341 Drummond Street, Carlton. 2715

CREDITORS next-of-kin and others having claims in respect of the estate of Robert Russell late of Trafalgar in the State of Victoria, farmer deceased, who died on the 29th day of March One thousand nine hundred and seventy-six are to send the particulars of their claims to the executor Ronald Robert Russell C/- the undermentioned solicitors prior to the 1st day of October One thousand nine hundred and seventy-six after which date the said executor will distribute the assets of the deceased having regard only to the claims of which he shall have notice.

KEVIN DAVINE & SONS, solicitors, Contingent Street, Trafalgar. 2726

ETHEL CLARA GLOVER, late of The Esplanade, Geelong West, in the State of Victoria, widow, DECEASED.

Creditors, next of kin, and others having claims in respect of the estate of the deceased who died on the twenty seventh day of February One thousand nine hundred and seventy five are required by the executor Hubert Percy Bowman of 43 Yarra Street Geelong in the said State solicitor to send particulars to him c/- the undermentioned solicitors by the 20th day of September 1976 after which date he may convey or distribute the assets having regard only to the claims of which he then has notice.

BOWMAN & KNÓX, solicitors, 43 Yarra Street, Geelong. 2727

Creditors, next-of-kin and others having claims against the estate of Louis Von Harten late of Hyde Park, Creswick in the State of Victoria retired farmer deceased who died on the 10th day of April 1976 are requested to send particulars of their claims to the executor The Union-Fidelity Trustee Company of Australia Limited of 101 Lydiard Street North Ballarat by the 15th day of October 1976 after which date the said executor will distribute the assets having regard only to the claims of which it then has notice.

NEVETT GLENN & COUTTS, solicitors, 2nd Floor, "Arrandale House", Bath Lane, Ballarat. 2728

Creditors next of kin and others having claims in respect of the estate of Allan Bernard Fox late of 435 Main Road Ballarat deceased who died on 3rd March 1976 are required to send particulars of their claims to the executor The Union-Fidelity Trustee Company of Australia Limited at its address 101 Lydiard Street North Ballarat by 22nd September 1976 after which date the said company will distribute the assets having regard only to the claims of which it then has notice.

BAIRD & MCGREGOR, solicitors, 2 Lydiard Street South, Ballarat. 2729

MARION JANE MALLEY, formerly of 44 Darebin Road, Northcote, but late of The Queen Elizabeth Geriatric Centre, 102 Ascot Street South, Ballarat, widow, DECEASED.

Creditors, next of kin and others having claims in respect of the estate of the deceased (who died on the 6th day of September, 1975) are required to send particulars of their claims to National Trustees Executors and Agency Company of Australasia Limited of 95 Queen Street, Melbourne before the 22nd day of September, 1976 after which date it will distribute the assets having regard only to the claims of which it then has notice.

F. P. & M. J. WALSH, solicitors, 452 High Street, Northcote. 2734

Creditors, next of kin and others having claims in respect of the estate of Rex White deceased late of 32 Milton Street, Nunawading in the State of Victoria Judges Associate deceased who died on the 19th October, 1975 are required by the executrix of the estate Joy Winifred White of 32 Milton Street, Nunawading in the said State, widow, send particulars to Kempson & Gay, solicitors of Suite 6, 79 Mahoney's Road, Forest Hill by the 21st day of September, 1976 after which date the said executrix may distribute the estate having regard only to claims of which she then has notice.

KEMPSON & GAY, solicitors, Suite 6, 79 Mahoney's Road, Forest Hill, Vic. 2731

Creditors, next-of-kin and others having claims against the estate of William Alexander Lugton (also known as William Alexander Grevis Lugton) late of "Weronia" Hilton Road, Ferny Creek retired deceased, who died on the 15th day of November, 1975, are required by the executors to send particulars of their claim to The Union-Fidelity Trustee Company of Australia Limited of 100 Exhibition Street, Melbourne, before the 25th day of September, 1976, after which date the executors will distribute the estate having regard only to the claims of which the said company then has notice.

ROMUALD J. MARTIN, solicitor, 100 Exhibition Street, Melbourne, 3000. 2732

Creditors next of kin and others having claims in respect of the estate of Mary Bennett Sleight late of Unit 2, Number 149 Church Street, Brighton in the State of Victoria, widow, who died on the 11th day of December 1975 are to send particulars of their claims to the executors Stanley Bruce Livingstone of 16 Florizel Street Burwood, and Richard Grenville Amherst Gamble of 250 Kooyong Road, Toorak, care of the undermentioned solicitors by the 23rd day of September 1976 after which date the said executors will distribute the assets having regard only to the claims of which they then have notice.

SEDDON & WITT, solicitors, of 406 Collins Street, Melbourne. 2733

Creditors, next of kin and others having claims against the estate of Valerie Mary Nickless late of 22 Burnell Street West Brunswick in the State of Victoria widow deceased who died on the 30th day of May 1975 are required to send particulars of the claims to the executor, Brian Stanley Nickless care of the undermentioned solicitors by 24th September, 1976 after which date he will distribute the estate of the said deceased having regard only to the claims of which he then has notice.

HOWELL & GARDINER, solicitors, 346 High Street, Preston. 2730

WILLIAM GEORGE BUNN, late of 2 Burcote Street, Blackburn North, in the State of Victoria, gentleman, DECEASED.

Creditors next of kin and others having claims in respect of the estate of the deceased (who died on the tenth day of February 1976) are required by the executors Bruce Charles Bunn of 39 St. James Village, James Street, Dandenong in the State of Victoria production planning manager and Gary George David Batson of 77 Chancellor Drive Mulgrave in the said State sales manager to send particulars to them in care of the undersigned by the first day of October 1976 after which date the executors may convey or distribute the assets having regard only to the claims of which they then have notice.

Dated the 14th day of July, 1976.

P. H. PIPPEY & SON, 1 Watts Street, Box Hill, solicitors for the executors. 2778

LOTTY WOOKEY, formerly of 15 Webster Street, Burwood, and of 27 Summerhill Road, Glen Iris, but late of 10 Highton Grove Balwyn, widow, DECEASED.

Creditors next of kin and others having claims in respect of the estate of the deceased who died on the 20th day of February 1976 are required by the personal representative Ernest Edward Sedman of 10 Highton Grove Balwyn retired buying controller to send particulars to him care of the undermentioned solicitors by the first day of October 1976 after which date the personal representative may convey or distribute the assets having regard only to the claims of which he then has notice.

HEFFEY & BUTLER, solicitors, 258 Little Bourke Street, Melbourne. 2779

LESLIE DAVID TYNAN, formerly of Wakool in the State of New South Wales, but late of 12 Shank Street, Warracknabeal, in the State of Victoria, retired licenced victualler, DECEASED.

Creditors next-of-kin and all persons having claims against the estate of the said deceased are required by Albert Edward Lyon of 56 Forest Street, Barham in the State of New South Wales labourer the sole executor of the estate of the said deceased to send particulars of such claims to him in care of the undermentioned solicitors on or before the 9th day of September, 1976 after which date they will distribute the assets having regard only to the claims of which they then have notice.

WILLAN & MCKENZIE, solicitors, Cohuna. 2780

RUBY HENSHAW, late of 68 Fisher Street, East Malvern, widow, DECEASED.

Creditors next of kin and other persons having claims against the estate of the said deceased who died on the 8th day of April, 1976 are required to send particulars thereof to the executors Ralph Kenneth James Henshaw and Victor George Henshaw care of the undersigned on or before the 30th day of September, 1976 after which date the executors will distribute the assets having regard only to the claims of which they then have notice.

HEFFEY & BUTLER, solicitors, 258 Little Bourke Street, Melbourne. 2781

Pursuant to the provisions of the Trustee Act 1958 creditors next-of-kin and all other persons having claims in respect of the estate of Alice Victoria Ruby Irvine late of 101 Oakleigh Road Carnegie in the State of Victoria widow who died on the 4th April 1976 are required to send particulars of their claims to the executor The Union-Fidelity Trustee Company of Australia Limited of 100 Exhibition Street Melbourne by the 29th day of September 1976 after which date the executor will distribute the assets having regard only to the claims of which it shall then have had notice.

MADDOCK, LONIE & CHISHOLM, solicitors, 60 Market Street, Melbourne. 2782

Creditors next-of-kin and others having claims in respect of the estate of Zambica De George late of 13 Somerset Drive North Dandenong widow deceased who died on the 25th day of January 1976 and probate of whose will has been granted to Dennis De George of 5 Tarwin Court Dandenong university tutor are required to send particulars of their claims to the said executor care of the undermentioned solicitors by the 20th day of September 1976 after which date he will distribute the assets having regard only to the claims of which he then has notice.

H. L. YUNCKEN & YUNCKEN, solicitors, 443 Little Collins Street, Melbourne, 3000. 2783

Creditors next-of-kin and others having claims in respect of the estate of Margaret Isobel Tweedley late of Flat 1, 202 Pascoe Vale Road Essendon widow deceased who died on the 22nd day of February 1976 and probate of whose will and codicil has been granted to Frank William Wheatley of 73 Hedderwick Street Essendon real estate agent are required to send particulars of their claims to the said executor care of the undermentioned solicitors by the 20th day of September 1976 after which date he will distribute the assets having regard only to the claims of which he then has notice.

H. L. YUNCKEN & YUNCKEN, solicitors, 443 Little Collins Street, Melbourne, 3000. 2784

FRANCIS JOHANAS RASSMUSSEN, late of 41 Washington Street, Toorak, in the State of Victoria, retired insurance executive, DECEASED.

Creditors, next of kin and others having claims in respect of the estate of the abovenamed deceased, who died on the eleventh day of January One thousand nine hundred and seventy-six are required by the personal representative The Union-Fidelity Trustee Company of Australia Limited of 100 Exhibition Street Melbourne in the said State to send particulars to it care of Messrs. Oakley Thompson & Co., of 105 King Street, Melbourne in the said State, solicitors, by the first day of October 1976, after which date the said personal representative may convey or distribute the assets, having regard only to the claims of which it then has notice.

MESSRS. OAKLEY THOMPSON & CO., solicitors, of 105 King Street, Melbourne. 62 7881. 2813

Creditors, next-of-kin and others having claims in respect of the estate of Rabe Alice Bannan late of 1 Vision Street, Chadstone clerk deceased who died on the 5th May, 1976 are required to send particulars of their claims to the executors Gary Paul Bannan and Peter Nicholas Bannan care of the under-mentioned solicitors by the 22nd day of September, 1976 after which date they will distribute the assets having regard only to the claims of which they then have notice.

ROYSTON, CAHIR & MARTIN, solicitors, 17 Queen Street, Melbourne. 2802

Creditors, next-of-kin and others having claims in respect of the estate of Harold Arthur Villinger late of 35 Dawson Street, Tullamarine taxi proprietor deceased who died on the 12th April, 1976 are required to send particulars of their claims to the executrix Valerie Dawn Villinger care of the undermentioned solicitors by the 22nd day of September 1976, after which date she will distribute the assets having regard only to the claims of which she then has notice.

ROYSTON, CAHIR & MARTIN, solicitors, 17 Queen Street, Melbourne. 2803

Creditors, next-of-kin and others having claims in respect of the estate of Ada Mary Fenwick late of 20 West Street, Preston widow deceased who died on the 11th May, 1976 are required to send particulars of their claims to the executor Colin Henry Sullivan care of the undermentioned solicitors by the 22nd day of September 1976 after which date he will distribute the assets having regard only to the claims of which he then has notice.

ROYSTON, CAHIR & MARTIN, solicitors, 17 Queen Street, Melbourne. 2804

Creditors next-of-kin and others having claims in respect of the estate of Sidney Geal late of 124 Blackburn Road Blackburn retired deceased who died on the 16th day of February 1976 and probate of whose will has been granted to Alma Rose Geal of 124 Blackburn Road Blackburn widow are required to send particulars of their claims to the said executrix care of the undermentioned solicitors by the 20th day of September 1976 after which date she will distribute the assets having regard only to the claims of which she then has notice.

H. L. YUNCKEN & YUNCKEN, solicitors, 443 Little Collins Street, Melbourne, 3000. 2785

PATRICK JOHN RYAN, late of Chinkapook, Victoria, farmer, DECEASED.

Creditors, next-of-kin and others having claims in respect of the estate of the deceased, who died 23rd June 1975, are required by the trustees of his estate, namely Herbert Robert Alexander Mackay of Chinkapook 3546 farmer, and Kevin Peter Curran of Robinvale, Victoria, 3549, farmer, to send particulars to them by 20th October 1976, care of the undersigned solicitors; after which date they the said trustees may convey or distribute the assets having regard only to the claims of which they shall then have had notice.

Dated this 17th July, 1976.

H. R. BLAIR & BLAIR, P.O. Box 24, Manangatang, 3546, solicitors for the trustees. 2814

WALTER GRAHAM WALTERS, late of Manangatang, Victoria, retired farmer, DECEASED.

Creditors, next-of-kin and others having claims in respect of the estate of the deceased, who died 2nd September 1975, are required by the trustee of his estate, namely Eric Henry Walters of P.O. Box 244, Irymple, Victoria, 3498 to send particulars to him by 20th October 1976 after which date he the said trustee may convey or distribute the assets having regard only to the claims of which he shall then have had notice.

Dated this 17th July, 1976.

H. R. BLAIR & BLAIR, P.O. Box 24, Manangatang, 3546, solicitors for the trustees. 2815

MARY LILIAN PATCHELL (also known as Mary Patchell), formerly of Numurkah, and late of Wheatley House, Wheatley Road, McKinnon, spinster, DECEASED.

Creditors, next of kin and other persons having claims against the estate of deceased who died on the 14th May, 1976, are required by Sydney William Everitt Stife of Numurkah, solicitor, the executor and trustee of the will of deceased to send particulars to him at his address Melville Street, Numurkah, by the 30th day of September, 1976, after which date he may convey or distribute the assets having regard only to the claims of which he then has notice. 2824

PERCY JOHN MOTT, formerly of 19 Cox Street, Hamilton, but late of 30 Mt. Napier Road, Hamilton, in the State of Victoria, baker, DECEASED.

Creditors next of kin and others having claims in respect of the estate of the deceased (who died on the 18th day of March, 1976) are required by the administrator of the estate Leslie John Mott, of 13 Leopold Avenue, Hamilton, municipal supervisor to send particulars to him care of the under mentioned solicitors by the 26th day of September, 1976 after which date the administrator may convey or distribute the assets having regard to the claims only of which he then has notice.

MESSRS. CAMERON & LOWENSTERN, solicitors, 62 Thompson Street, Hamilton, 3300. 2825

EILEEN ELIZABETH ELLIOTT, late of 31 Balmoral Avenue, Pascoe Vale South, widow, DECEASED.

Creditors next of kin and others having claims in respect of the estate of the deceased who died on the 2nd April 1976 are required to send particulars of their claims to The Equity Trustees Executors and Agency Company Limited of 472 Bourke Street Melbourne by the 21st day of September 1976 after which date it will distribute the assets having regard only to the claims of which it then has notice.

LEACH & THOMSON, solicitors, 472 Bourke Street, Melbourne. 2826

LESLIE NORMAN JAMES SHELL, late of 53 Kinsale Street, Reservoir, cartage contractor, DECEASED.

Creditors next of kin and others having claims against the estate of the said deceased who died on 16th September 1975 are to send particulars of their claims to Frederick Arthur Illingworth care of Blake & Riggall solicitors 140 William Street, Melbourne by the 30th day of September 1976 after which date he will distribute the assets having regard only to the claims of which he then has notice.

BLAKE & RIGGALL, solicitors, 140 William Street, Melbourne. 2827

PATRICIA GREGG SEARLE, late of 129 Presidents Avenue, Ocean Grove, spinster, DECEASED.

Creditors next of kin and others having claims against the estate of the said deceased who died on 18th March 1976 are to send particulars of their claims to Miss Marion Dora Parkes and Mr. David John Morrison care of Blake & Riggall solicitors 140 William Street Melbourne by the 30th day of September 1976 after which date they will distribute the assets having regard only to the claims of which they then have notice.

BLAKE & RIGGALL, solicitors, 140 William Street, Melbourne. 2828

FRANK HOBILL COLE, late of 31 Rockley Road, South Yarra, gentleman, DECEASED.

Creditors next of kin and others having claims against the estate of the said deceased who died on 15th May 1975 are to send particulars of their claims to Bernard Gore Brett, Robert Molesworth Hobill Cole, Wilfred John Rehfish and Letitia Molesworth Hobill Shelton care of Blake & Riggall solicitors 140 William Street Melbourne by the 30th day of September 1976 after which date they will distribute the assets having regard only to the claims of which they then have notice.

BLAKE & RIGGALL, solicitors, 140 William Street, Melbourne. 2829

Creditors next-of-kin and others having claims in respect of the estate of May Read late of 10 Wolseley Crescent Blackburn widow deceased who died on the 30th day of November 1975 and probate of whose will has been granted to Raymond Frederick Read of 49 Railway Road Blackburn manager and Francis Walter Appleby of Gran-tulla Road Kallista market gardener are required to send particulars of their claims to the said executors care of the undermentioned solicitors by the 20th day of September 1976 after which date they will distribute the assets having regard only to the claims of which they then have notice.

H. L. YUNCKEN & YUNCKEN, solicitors, 443 Little Collins Street, Melbourne, 3000. 2786

IVY MABEL HARDING, late of 13 Noble Street, Anglesea, in the State of Victoria, married woman, DECEASED.

Creditors next of kin and others having claims in respect of the estate of the deceased who died on the 2nd April, 1972 are required by the executor David Malcolm Harding of 384 Gilbert Road West Preston hardware merchant to send particulars to the undermentioned firm by 30th September 1976 after which date the said executor may convey or distribute the assets having regard only to the claims of which notice has by then been given.

SETON, WILLIAMS & SMYTH, solicitors, 954 Main Road, Eltham. 2790

JOSEPH FRANCIS TREACY, late of 16 Coolgardie Avenue, East Malvern, in the State of Victoria, law clerk, DECEASED.

Creditors next of kin and others having claims in respect of the estate of the deceased who died on the 22nd February, 1974 are required by the executors Brian Joseph Treacy of 16 Coolgardie Avenue East Malvern and Terrence Francis Treacy of Inglewood to send particulars to the undermentioned firm by 30th September 1976 after which date the said executors may convey or distribute the assets having regard only to the claims of which notice has by then been given.

SETON, WILLIAMS & SMYTH, solicitors, 954 Main Road, Eltham. 2791

GWENNETH MAY HOFFMANN, late of 1 Saturn Street, North Balwyn, in the State of Victoria, widow, DECEASED.

Creditors next of kin and others having claims in respect of the estate of the deceased who died on the 4th August, 1975 are required by the executrix Constance Agnes Cooper of 30 Lister Street East Kew married woman to send particulars to the undermentioned firm by 30th September 1976 after which date the said executrix may convey or distribute the assets having regard only to the claims of which notice has by then been given.

SETON, WILLIAMS & SMYTH, solicitors, 954 Main Road, Eltham. 2792

Creditors next of kin and others having claims in respect of the estate of Nora Catherine Levy late of 10 Franklin Street, Moorabbin widow deceased who died on the 10th day of April, 1976 are requested to send particulars of their claims to the executor Tasman Southwell care of the undermentioned solicitors by the 8th day of October, 1976 after which date he will distribute the assets having regard only to the claims of which he then has notice.

LLOYD P. GOODE & CO., solicitors, 406 Lonsdale Street, Melbourne, 3000. 2793

Creditors next of kin and others having claims in respect of the estate of James Laurence Ryan (also known as Laurie Hall), late of Unit 2, 22 Broadway Bonbeach, retired deceased who died on the 21st day of May, 1976 are requested to send particulars of their claims to the administrator Mary Isabel Loch care of the undermentioned solicitors by the 8th day of October, 1976 after which date she will distribute the assets having regard only to the claims of which she then has notice.

LLOYD P. GOODE & CO., solicitors, 406 Lonsdale Street, Melbourne, 3000. 2794

Creditors next of kin and others having claims in respect of the estate of Olga Patricia Oliver late of 43 Francis Street, Blackburn widow deceased who died on the 6th day of November, 1975 are required to send particulars of their claims to the administrator Michael Stuart Inglis care of the undermentioned solicitors by the 8th day of October, 1976 after which date he will distribute the assets having regard only to the claims of which he then has notice.

LLOYD P. GOODE & CO., solicitors, 406 Lonsdale Street, Melbourne, 3000. 2795

Creditors next of kin and others having claims in respect of the estate of Monica Anne White late of 101 James Street, Templestowe, married woman deceased who died on the 15th day of February, 1976 are required to send particulars of their claims to the administrator Walter Hugh White care of the undermentioned solicitors by the 8th day of October, 1976 after which date he will distribute the assets having regard only to the claims of which he then has notice.

LLOYD P. GOODE & CO., solicitors, 406 Lonsdale Street, Melbourne, 3000. 2796

Creditors next of kin and all other persons having claims in respect of the estate of Saul Zacharin late of 2 Burns Street Elwood in the State of Victoria company director deceased who died on the 20th day of November 1975 are required to send particulars of their claims to the executors Robert Fyfe Zacharin and Richard Fyfe Zacharin care of undermentioned solicitors by the 23rd day of September 1976 after which date they may convey and distribute the assets having regard only to the claims of which they may then have notice.

MICHAEL J. MEEHAN & CO., solicitors, 513 Toorak Road, Toorak. 2797

Creditors next of kin and others having claims in respect of the estate of William Francis Miller late of 54 Liverpool Road Kilsyth formerly employee of Melbourne Metropolitan Board of Works, but late retired, now deceased, who died on the 11th day of June, 1976, are to send particulars of their claims to The Union-Fidelity Trustee Company of Australia Limited of 100 Exhibition Street Melbourne by the 22nd day of September, 1976, after which date it will distribute the assets having regard only to the claims of which it then has notice.

D. R. JAMES LL.M., solicitor, 145 Whitehorse Road, Ringwood. 2798

AUDREY DERMER, late of Flat 43, 390 Toorak Road, South Yarra, married woman.

Creditors, next of kin and others having claims in respect of the estate of the deceased (who died on the 18th day of February 1976) are required by The Perpetual Executors and Trustees Association of Australia Limited of 50 Queen Street, Melbourne, to send particulars of their claims to the said company by the 23rd day of September 1976 after which date it will convey or distribute the assets, having regard only to the claims of which the company then has notice.

BEST, HOOPER, RINTOUL & SHALLARD, solicitors, 400 Little Collins Street, Melbourne. 2799

Creditors, next-of-kin and others having claims in respect of the estate of Donald Townsend Campbell late of 50 Murrumbeena Crescent Hughesdale, company director deceased who died on the 10th June 1975 are to send particulars of their claims to Mary Veronica Campbell and Alan William Northey the executors of the will of the said deceased care of R. Wadham & Doig of 383 Flinders Lane Melbourne 3000 by the 15th September 1976 after which date the executors will distribute the assets having regard only to the claims of which they then have notice.

R. WADHAM & DOIG, solicitors, of 383 Flinders Lane, Melbourne. 2800

Creditors, next-of-kin and others having claims in respect of the estate of Kenneth Souter, late of 16 Roberts Street Essendon temporary teacher deceased who died on the 5th April 1976 are to send particulars of their claims to The Union-Fidelity Trustee Company of Australia Limited of 100 Exhibition Street Melbourne by the 15th September 1976 after which date the said company will distribute the assets having regard only to the claims of which it then has notice.

R. WADHAM & DOIG, solicitors, of 383 Flinders Lane, Melbourne. 2801

In the Supreme Court of the State of Victoria.
SALE BY THE SHERIFF.

On Friday the 27th of August 1976 at 3.00 p.m. at the Police Station Richmond (unless process be stayed or satisfied).

All the estate and interest (if any) of S. Skoufis (shown on Certificate of Title as Peter Skoufis) pastry cook, of 2 Portland Street, Richmond as joint proprietor with Antigoni Skoufis, married woman of an estate in fee simple in the land described in Certificate of Title Volume 3930 Folio 918 upon which is erected a dwelling house known as No. 2 Portland Street Richmond.

Registered Mortgage No. E.804350 affects the said estate and interest.

Terms—Cash Only.

2816 H. BUETTNER, Sheriff's Officer.

In the Supreme Court of the State of Victoria.

SALE BY THE SHERIFF.

On Friday the 27th of August 1976 at 10.30 a.m. at the Police Station Sunshine (unless process be stayed or satisfied).

All the estate and interest (if any) of Joan Rasmussen (shown on Certificate of Title as Joan Doris Rasmussen), saleswoman, of 4 Elsum Avenue, Deer Park as proprietor of an estate in fee simple in the land described in Certificate of Title Volume 8915 Folio 144 upon which is erected a dwelling house known as No. 4 Elsum Avenue Deer Park.

Registered Mortgage Nos. F.743871 and F.767103 affect the said estate and interest.

Terms—Cash Only.

2817 KEITH R. MARTIN, Sheriff's Officer.

In the Supreme Court of the State of Victoria.

SALE BY THE SHERIFF.

On Friday the 3rd of September 1976 at 10.30 a.m. at the Police Station Cranbourne (unless process be stayed or satisfied).

All the estate and interest (if any) of L. Gray, (shown on Certificate of Title as Lyndsay William Gray), driver of Lot 57 Circle Drive, Cranbourne as joint proprietor with Valerie Ann Gray, married woman of an estate in fee simple in the land described in Certificate of Title Volume 8962 Folio 082 upon which is erected a detached dwelling known as Lot 57 Circle Drive Cranbourne. Registered Mortgage No. F.439246 and Caveat F.218499 affect the said estate and interest.

Terms—Cash Only.

2818 H. BUETTNER, Sheriff's Officer.

In the Supreme Court of the State of Victoria.

SALE BY THE SHERIFF.

On Friday the 3rd of September 1976 at 10.30 a.m. at the Police Station Frankston (unless process be stayed or satisfied).

All the estate and interest (if any) of R. A. F. Haigh, architect (shown on Certificate of Title as Ralph Alfred Fenwick Haigh) of 11 Marcus Road, Frankston and Z. M. Haigh, married woman (shown on Certificate of Title as Zelma May Haigh) of 27 Meerlu Street, Frankston as joint proprietors of an estate in fee simple in the land described in Certificate of Title Volume 8209 Folio 967 upon which is erected a dwelling house known as No. 11 Marcus Road Frankston.

Registered Mortgage Nos. E.709380, F.650146 and Caveat F. 683412 affect the said estate and interest.

Terms—Cash Only.

2819 DOUGLAS S. HALL, Sheriff's Officer.

IMPOUNDINGS

BUSHFIELD.—Impounded in Bushfield Pound.

1 black steer, white on forehead and back legs

If not claimed and expenses paid, to be sold on 27th July, 1976.

L. M. BARBER,
Poundkeeper.

2763—\$3.30

HEALESVILLE.—Impounded at Healesville Pound from Yarra View Road, Yarra Glen.

2 Short Horn cross heifers, no visible brands

1 Jersey cross heifer, no visible brands

If not claimed and expenses paid, will be sold by Public Auction at 12 noon on Thursday, 5th August, 1976.

E. PULLEN,
Poundkeeper.

2847—\$4.40

MELTON.—Impounded in Melton Pound, on 14th July, 1976.

1 black and white heifer

1 black heifer

1 red and white bull

2 Grey and white bulls

2 brown and white cows

1 black and white steer

If not claimed and expenses paid, to be sold at the Melton Pound, on 6th August, 1976, at 12 noon.

M. B. WATSON,
Shire Secretary, Chief Executive Officer.

2756—\$6.60

MELTON.—Impounded in Melton Pound.

On 5th July, 1976:

2 rams, no visible brand

On 6th July, 1976:

1 red steer, no visible brand

1 roan heifer, no visible brand

If not claimed and expenses paid, to be sold at the Melton Pound, on 6th August, 1976, at 12 noon.

M. B. WATSON,
Shire Secretary, Chief Executive Officer.

2757—\$5.50

Subordinate Legislation Act 1962.

NOTICE OF MAKING OF STATUTORY RULES.

In pursuance of the provisions of the *Subordinate Legislation Act 1962* and the Regulations made thereunder, notice is given of the making of the following statutory rules:—

No.	Price.
164/1976. Magistrates' (Alibi Evidence) Rules 1976	20c
<i>Crimes Act 1958.</i>	
165/1976. Crimes (Alibi Evidence) Regulations 1976	10c
<i>Motor Car Act 1958.</i>	
166/1976. Motor Car (Application of Design Rules) Regulations 1976	10c
167/1976. Regulations Governing the Expenditure of Commissions and Boards, of Inquiry (Amendment No. 2) 1976	10c
<i>Poisons Act 1962 (No. 6889).</i>	
168/1976. Special Poisons (Ovulatory Stimulant) Regulations 1976	10c
<i>Boilers and Pressure Vessels Act 1970.</i>	
169/1976. Boilers and Pressure Vessels (Steam Engine Drivers and Boiler Attendants) (Amendment) Regulations 1976	10c
<i>Industrial Training Act 1975.</i>	
170/1976. Industrial Training (Apprenticeship) (General) (Amendment No. 2) Regulations 1976	10c
<i>Labour and Industry Act 1958.</i>	
171/1976. Labour and Industry (Wages Boards) (Amendment) Regulations 1976	10c
<i>Legal Profession Practice Act 1958.</i>	
172/1976. Rules of the Council of Legal Education 1976 (Amendment No. 1)	10c
<i>State Savings Bank Act 1958.</i>	
173/1976. State Savings Bank (Interest Rates Amendment No. 3) General Orders 1976	10c
<i>Public Service Act 1974.</i>	
174/1976. Public Service Regulations	10c
<i>Public Service Act 1974.</i>	
175/1976. Public Service Regulations	10c
<i>Railways Act 1958.</i>	
176/1976. By law (Increased Charges) Amendments	10c
<i>Public Service Act 1974.</i>	
PSD79/1976. Public Service Determinations	10c
PSD80/1976. Public Service Determinations	10c
PSD81/1976. Public Service Determinations	10c
PSD82/1976. Public Service Determinations	10c
PSD83/1976. Public Service Determinations	10c
PSD84/1976. Public Service Determinations	10c
PSD85/1976. Public Service Determinations	10c
PSD86/1976. Public Service Determinations	10c

Copies of these statutory rules may be purchased at the Sale of Publications Section of the Government Printing Office, located at 7A Parliament Place, Melbourne, 3002. If ordered by mail, remittance should be addressed to "The Government Printer, Box 203, P.O., North Melbourne, 3051", and should include 20c extra for postage.

The annual subscription rates for Statutory Rules for the year commencing 1st January, 1976, payable in advance, are as follows:—

Statutory Rules (other than Public Service Determinations)	\$45.00
Public Service Determinations	\$20.00

C. H. RIXON,
Government Printer.

STATE ACTS, 1975

Copies of the following Acts of the Parliament of Victoria may be obtained at the Government Printing Office, Sale of Publications Branch, 7A Parliament Place, Melbourne, phone. 63 0321, extension 6181, or from any accredited agent, at the price set opposite to each (these prices do not include postage).

Postage costs must be added to your remittance when ordering by mail as follows:—

Act Price.	Postage Cost.
10c-40c	20c
45c-70c	30c
75c-\$1.70	40c
\$1.75-\$4.00	60c
Above \$4.00	86c

Bound Volumes of 1974 State Acts are also available at a cost of \$21.

No.	PRICE.
8663. Parliamentary Salaries and Superannuation (Amendment)	\$0.15
8664. Dog (Amendment)	\$0.10
8665. State College of Victoria (Borrowing Powers)	\$0.10
8666. Scaffolding (Amendment)	\$0.10
8667. Marine (Amendment)	\$0.10
8668. Methodist Church of Australasia Superannumerary Ministers and Ministers' Widows Fund	\$0.10
8669. Motor Accidents	\$0.10
8670. Pensioners' Rates. Remission	\$0.10
8671. Geelong Harbor Trust Lands	\$0.15
8672. Railways (Amendment)	\$0.15
8673. Labour and Industry (Industrial Appeals Court)	\$0.10
8674. Health (Proprietary Medicines Advisory Committee)	\$0.10
8675. William E. Dorling Scholarship Fund	\$0.10
8676. Transport Regulation (Licence Fees)	\$0.10
8677. Juries (Amendment)	\$0.10
8678. Northcote Trust Fund	\$0.15
8679. Crimes (Capital Offences)	\$0.10
8680. Judges Salaries and Allowances	\$0.10
8681. Stock Foods	\$0.10
8682. Heathcote Railway Removal	\$0.15
8683. Home Finance (Amendment)	\$0.10
8684. Building Societies (Special Advances)	\$0.10
8685. Melbourne (Snowden Gardens) Land	\$0.10
8686. Thornbury Lands	\$0.15
8687. Parliamentary Salaries and Superannuation	\$0.10
8688. Water (Amendment)	\$0.30
8689. Veterinary Surgeons (Amendment)	\$0.10
8690. Racing	\$0.10
8691. Teaching Service (Assistant Professional Appointees)	\$0.10
8692. Public Service (Transitional Provisions)	\$0.10
8693. Building Industry Long Service Leave	\$0.40
8694. Fisheries	\$0.30
8695. Local Government (City of Ringwood)	\$0.10
8696. Hairdressers Legislation (Amendment)	\$0.10
8697. Professional Boxing Control	\$0.15
8698. Trustee Companies (Commission)	\$0.10
8699. Wildlife	\$0.50
8700. Transport Regulation (Private Omnibuses)	\$0.10
8701. Social Welfare (Amendment)	\$0.20
8702. National Parks	\$0.50
8703. Carlton (Recreation Ground) Land	\$0.10
8704. Broiler Chicken Industry	\$0.15
8705. Stock Diseases (Amendment)	\$0.10
8706. Industrial Training	\$0.50
8707. Town and Country Planning (Amendment)	\$0.10
8708. Dandenong Valley Authority (Amendment)	\$0.10
8709. Stock (Artificial Breeding) (Amendment)	\$0.10
8710. Victoria Institute of Colleges (Amendment)	\$0.10
8711. Latrobe Valley (Amendment)	\$0.10
8712. Geelong Waterworks and Sewerage (Powers)	\$0.10
8713. Housing (Movable Units)	\$0.10
8714. Cattle Compensation (Amendment)	\$0.10
8715. Stock Medicines (Amendment)	\$0.10
8716. Town and Country Planning (Outdoor Advertising)	\$0.30
8717. Superannuation	\$0.50
8718. Magistrates' Courts (Amendment)	\$0.15
8719. Gas and Fuel Corporation	\$0.10
8720. Margarine	\$0.30
8721. Teaching Service (Special Duty Allowances)	\$0.10
8722. Police Regulation (Pensions)	\$0.20
8723. Marine (Further Amendment)	\$0.30
8724. Ports and Harbors	\$0.15
8725. Tomato Processing Industry (Uniform Agreement) (Amendment)	\$0.15
8726. Grain Elevators (Amendment)	\$0.10
8727. State Insurance Office	\$0.30

STATE ACTS, 1975—continued.

No.	Price.
8728. Supply (1975-76, No. 1)	\$0.15
8729. Water Resources	\$0.15
8730. Parliamentary Officers	\$0.15
8731. Magistrates (Summary Proceedings)	\$1.50
8732. Liquor Control (Amendment)	\$0.30
8733. Workers Compensation (Amendment)	\$0.30
8734. Small Claims Tribunals (Amendment)	\$0.10
8735. Eltham Land	\$0.10
8736. Frankston Land	\$0.10
8737. Melbourne Cricket Ground (Amendment)	\$0.10
8738. South Melbourne Land	\$0.10
8739. Racing (Totalizator)	\$0.10
8740. Land Settlement (Amendment)	\$0.10
8741. Rural Finance (Amendment)	\$0.10
8742. Water Resources (Amendment)	\$0.10
8743. Nurses (Amendment)	\$0.10
8744. Lifts and Cranes (Amendment)	\$0.10
8745. Police Regulation (Amendment)	\$0.10
8746. Business Franchise (Tobacco)	\$0.10
8747. Stamps	\$0.10
8748. Forests (Softwood Holdings Agreement)	\$0.20
8749. Harbors and Navigable Waters Protection	\$0.30
8750. Constitution	\$0.50
8751. Decentralized Industries Incentive Payments (Amendment)	\$0.10
8752. Courts Administration	\$0.10
8753. Metropolitan Fire Brigades (Borrowing Powers)	\$0.10
8754. Medical Practitioners (Fees)	\$0.10
8755. Lotteries Gaming and Betting (Amendment)	\$0.10
8756. Health (Fees)	\$0.10
8757. Coal Creek Historical Park	\$0.30
8758. Melbourne Harbor Trust (Long Service Leave) (Amendment)	\$0.10
8759. Police Regulation (Long Service Leave)	\$0.10
8760. Metropolitan Fire Brigades (Long Service Leave)	\$0.10
8761. Liquor Control (Chairmen)	\$0.10
8762. Bendigo (Dai Gum San Village) Land	\$0.10
8763. Land	\$0.10
8764. Wodonga Area Land Acquisition (Amendment)	\$0.10
8765. Road Traffic (Amendment)	\$0.20
8766. Education (Work Experience) (Amendment)	\$0.10
8767. Agricultural Colleges (Amendment)	\$0.20
8768. Education (Administration)	\$0.10
8769. Inflammable Liquids (Amendment)	\$0.10
8770. Land Tax	\$0.10
8771. Superannuation (Amendment)	\$0.10
8772. Patriotic Funds (Amendment)	\$0.10
8773. Horse Breeding (Repeal)	\$0.10
8774. Milk and Dairy Supervision (Amendment)	\$0.10
8775. Stock Diseases (Further Amendment)	\$0.10
8776. Racing (Mid-week Racing)	\$0.20
8777. State Forests Works and Services	\$0.10
8778. Legal Profession Practice	\$0.10
8779. Public Works and Services	\$0.20
8780. Appropriation (1975-76, No. 1)	\$3.10
8781. Local Government (Amendment)	\$0.80
8782. Zoological Gardens (Amendment)	\$0.20
8783. Education (Volunteer Workers Compensation)	\$0.10
8784. State Development (Amendment)	\$0.10
8785. Pay-roll Tax	\$0.50
8786. Co-operative Housing Societies (Amendment)	\$0.10
8787. Companies	\$1.50
8788. Securities Industry	\$1.50
8789. Teaching Service (Amendment)	\$0.20
8790. Educational Grants (Continuation)	\$0.10
8791. Coal Mines (Pensions Increase)	\$0.10
8792. Motor Car (Penalties)	\$0.20
8793. State Co-ordination Council	\$0.20
8794. Pensioners' Water and Sewerage Rates Remission	\$0.30
8795. Revocation and Excision of Crown Reservations	\$0.10
8796. Ports and Harbors (Penalties)	\$0.20
8797. State Electricity Commission (Amendment)	\$0.10
8798. The Constitution Act Amendment (Conjoint Elections)	\$0.10
8799. Education (School Councils)	\$0.20
8800. Optometrists	\$0.30
8801. Railways (Amendment)	\$0.10
8802. Scaffolding (Amendment)	\$0.10
8803. Transport Works and Services	\$0.10
8804. Workers Compensation (Surcharge Payments)	\$0.10
8805. Mines (Amendment)	\$0.30
8806. Public Service	\$0.10
8807. State Electricity Commission (Tramways)	\$0.10
8808. Dental Technicians (Amendment)	\$0.10
8809. Melbourne Underground Rail Loop (Amendment)	\$0.10

STATE ACTS, 1975—continued.

No.	Price.
8810. Motor Car (Child Seat Restraints)	\$0.10
8811. Drainage of Land	\$0.80
8812. Railways (Participation in Pipeline Operation)	\$0.10
8813. Country Fire Authority (Constitution)	\$0.10
8814. Labour and Industry (Wages Board Determinations)	\$0.10
8815. West Moorabool Water Board (Amendment)	\$0.10
8816. Navigable Waters (Oil Pollution) (Amendment)	\$0.10
8817. Valuation of Land (Amendment)	\$0.10
8818. Town and Country Planning (Further Amendment)	\$0.10
8819. Local Authorities Superannuation (Pensions)	\$0.40
8820. La Trobe University (Amendment)	\$0.10
8821. Social Welfare (Amendment)	\$0.10
8822. Geelong Regional Authority	\$0.60
8823. Environment Protection (Noise Control)	\$0.30
8824. Consumer Affairs (Amendment)	\$0.10
8825. Water Supply Works and Services	\$0.40

STATE ACTS, 1976

Copies of the following Acts of the Parliament of Victoria may be obtained at the Government Printing Office, Sale of Publications Branch, 7A Parliament Place, Melbourne, phone 63 0321, extension 6181, or from any accredited agent, at the price set opposite to each (these prices do not include postage).

Postage costs must be added to your remittance when ordering by mail as follows:—

Act Price.	Postage Cost.
10c-40c	20c
45c-70c	30c
75c-\$1.70	40c
\$1.75-\$4.00	60c
Above \$4.00	86c

Bound Volumes of 1974 State Acts are also available at a cost of \$21.

No.	PRICE.
8826. Public Servants Ethical Conduct (Joint Select Committee)	\$0.10
8827. Committees (Membership)	\$0.10
8828. Joint Select Committee (Meat Industry)	\$0.10
8829. Joint Select Committee (Road Safety)	\$0.10
8830. Latrobe Valley (Manager's Qualifications)	\$0.10
8831. Ministry for the Arts (Transfer of Administration)	\$0.10
8832. Bendigo College of Advanced Education	\$0.10
8833. Ballarat College of Advanced Education	\$0.20
8834. Constitution (Responsible Ministers)	\$0.10
8835. Bees (Amendment)	\$0.10
8836. Australian Tractor Testing Station	\$0.10
8837. Liquefied Gases (Amendment)	\$0.30
8838. Business Franchise (Tobacco)	\$0.30
8839. Land (Surrender of Lands)	\$0.10
8840. Dandenong (Shepley Oval) Land	\$0.10
8841. Railways (Participation in Pipeline Operations Payments)	\$0.10
8842. Tattersall Consultations (Soccer Football Pools)	\$0.10
8843. Commonwealth and States Financial Agreement	\$0.30
8844. Trustee Companies (Union-Fidelity) Amendment	\$0.10
8845. Supply (1976-77, No. 1)	\$0.20
8846. National Gallery of Victoria (Development Collection)	\$0.10

STATE ACTS, 1976—continued.

No.	Price.
8847. Revocation and Excision of Crown Reservations	\$0.20
8848. Pesticides (Amendment)	\$0.10
8849. Architects (Amendment)	\$0.10
8850. Gippsland Folk Museum	\$0.40
8851. Joint Select Committee (Conservation of Energy Resources)	\$0.10
8852. Tomato Processing Industry	\$0.50
8853. Judges Salaries	\$0.10
8854. Small Business Development Corporation	\$0.20
8855. Home Finance (Loans and Guarantees)	\$0.10
8856. Teaching Service (Professional Appointments)	\$0.10
8857. Friendly Societies (Amendment)	\$0.10
8858. Public Works and Services (Further Expenditure)	\$0.10
8859. Sewerage Districts (Amendment)	\$0.20
8860. Mildura College Lands (Schools Fund)	\$0.10
8861. Dandenong Valley Authority (Amendment)	\$0.10
8862. Second-hand Dealers (Charity Collectors)	\$0.30
8863. Mental Health (Amendment)	\$0.10
8864. Victorian Film Corporation	\$0.20
8865. Motor Car (Breath Testing Stations)	\$0.10
8866. Education (Minister of Special Education)	\$0.10
8867. Deakin University (Amendment)	\$0.10
8868. Public Service (Long Service Leave)	\$0.10
8869. Victorian Development Corporation	\$0.10
8870. Crimes	\$0.30
8871. Weights and Measures (Amendment)	\$0.30
8872. Wild Flowers and Native Plants Protection (Amendment)	\$0.10
8873. Ministry of Transport (Amendment)	\$0.10
8874. Abattoir and Meat Inspection (Amendment)	\$0.30
8875. Local Government (Rates) Amendment	\$0.20

CONTENTS

PAGE

Acts of Parliament on Sale at the Government Printing Office	2249
Appointments	2217
Contracts	2214
Estates of Deceased Persons	2217
Government Notices	2203
Impoundings	2248
Lands	2228
Mining	2214
Notice to attend for Radiological Examination	2209
Notice of Making of Statutory Rules	2248
Orders in Council—	
Acts—Land; Local Government; Country Roads Board; Sewerage Districts; Water; Superannuation; Sewerage Districts; Water; Audit; Constitution Act Amendment and Parliamentary Contributory Superannuation.	2218 et seq
Private Advertisements	2232
Proclamation	2203
Regulations—	
Acts—Teaching Service	2231
Resignations	2218
State Rivers and Water Supply Commission	2212
Tenders	2232
Transport Regulation Board—Public Hearings	2204