



# VICTORIA GOVERNMENT GAZETTE

Published by Authority

No. 681

WEDNESDAY, AUGUST 10

[1977

## GOVERNMENT NOTICES

### NOTICE TO MARINERS [No. 16 (T) OF 1977]

#### AUSTRALIA—VICTORIA PORT PHILLIP

##### Information about Wave Measuring Buoys

1. "Waverider" buoys have been permanently withdrawn as follows:—

Position.—(a) Lat. 38 deg. 0.8 min. S., Long. 145 deg. 05.8 min. E.

(b) Lat. 38 deg. 07 min. S., Long. 144 deg. 52 min. E.

Former Notice: No. 31 (T) of 1976 is cancelled.

2. "Waverider" buoy will be established as follows:—

Date.—On or about 15th August, 1977.

Position.—Lat. 38 deg. 00.6 min. S., Long. 144 deg. 42.7 min. E. (approx. 2½ miles South East of Werribee).

3. "Waverider" buoy will be established as follows:—

Date.—On or about 15th August, 1977.

Position.—Lat. 38 deg. 07.4 min. S., Long. 144 deg. 50.7 min. E. (approx. 5 miles West of Prince George Light).

Description.—Spherical shaped buoys 0.8 metre diameter, painted red and yellow vertical stripes, each surmounted by a 2 metre whip aerial and showing a group flashing white light, 3 flashes every 20 seconds. A spar buoy, painted red, with radar reflective properties will be situated close to the "Waverider" buoy in (3) above.

Abridged Description.—Gp. Fl (3) 20 sec.

Charts Affected.—(2) Aus. 143, Aus. 155, Aus. 157.

(3) Aus. 143.

A. J. WAGGLEN,  
Port Officer

Public Works Department,  
Ports and Harbors Division,  
168 Exhibition Street,  
Melbourne, Vic. 3000, 2nd August, 1977.

### Adoption of Children Act 1964 CHANGE OF NAME OF PRIVATE ADOPTION AGENCY

Whereas pursuant to section 19 of the *Adoption of Children Act 1964*, the Child Care Service of the Methodist and Presbyterian Churches was approved as a private adoption agency on 6th August, 1974, and notice thereof was published in the *Government Gazette*, dated 14th August, 1974.

And whereas, upon the merger of the Congregational, Methodist and Presbyterian Churches on 22nd June, 1977, to form the Uniting Church in Australia, the said agency changed its name to the Child Care Service of the Uniting Church.

Now, therefore, I, Brian James Dixon, Her Majesty's Minister for Social Welfare in the State of Victoria, do give notice that the said agency has for the purpose of approval as a private adoption agency, as on and from 22nd June, 1977, become known as the Child Care Service of the Uniting Church.

Dated at Melbourne this 28th day of July, 1977

BRIAN DIXON,  
Minister for Social Welfare

### PLENTY-YARRAMBAT WATERWORKS TRUST

#### INCREASING THE LIMIT OF BANK OVERDRAFT

His Excellency the Governor of the State of Victoria by and with the advice of the Executive Council thereof by Order made on the 2nd day of August, 1977, increase the total amount of the sums which the Plenty-Yarrambat Waterworks Trust may owe at any one time in respect of moneys borrowed by overdraft of current account pursuant to the provisions of section 286 of the *Water Act 1958*, fixed by the Governor in Council on 30th October, 1973, at Six thousand dollars (\$6,000) to One hundred thousand dollars (\$100,000).

L. G. HOUSTON,  
Acting Clerk of the Executive Council

At the Executive Council Chamber,  
Melbourne, 2nd August, 1977

*Local Government Act 1958*

**NOTICE OF CONFIRMATION OF AN ORDER OF THE COUNCIL OF THE CITY OF COLLINGWOOD ADOPTING A PROPOSAL FOR THE CLOSURE OF A STREET TO THROUGH TRAFFIC**

Pursuant to the provisions of section 539c of the *Local Government Act 1958*, the Governor in Council, on the 2nd day of August, 1977, confirmed an Order of the Council of the City of Collingwood made on 29th November, 1976, adopting a proposal for the closure of Page Street, Clifton Hill, to through traffic by the erection of a barrier at the location shown on the plan hereunder.

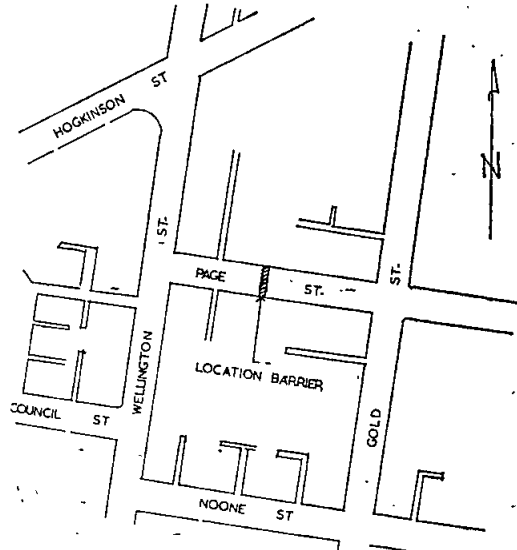

L. G. HOUSTON,  
Acting Clerk of the Executive Council  
At the Executive Council Chamber,  
Melbourne, 2nd August, 1977

**LOCAL GOVERNMENT DEPARTMENT  
ORDER CONFIRMED—CITY OF CAMBERWELL**

The Minister of the Crown administering the *Local Government Act 1958*, on the 28th day of July, 1977, confirmed the Order hereinafter referred to in pursuance of section 514 of the said Act, namely:

An Order of the Council of the City of Camberwell made on the 1st March, 1976, directing the compulsory taking of the land described hereunder for recreation purposes:

All that piece of land being part of the land described in Certificate of Title Volume 1916 Folio 136 commencing at the north-west corner of Myrtle Road and Matlock Street thence by a line in a westerly direction on a bearing of 270 deg. 0 min. for a distance of 11.89 metres; thence in a north-westerly direction on a bearing of 324 deg. 05 min. for a distance of 18.82 metres; thence in a north-westerly direction on a bearing of 329 deg. 05 min. for a distance of 35.53 metres; thence in a north-westerly direction on a bearing of 337 deg. 36 min. for a distance of 16.48 metres; thence in a north-westerly direction on a bearing of 329 deg. 58 min. for a distance of 17.6 metres; thence in a north-westerly direction on a bearing of 335 deg. 29 min. for a distance of 16.71 metres; thence in a north-westerly direction on a bearing of 323 deg. 24 min. 30 sec. for a distance of 18.97 metres; thence in a north-westerly direction on a bearing of 300

deg. 21 min. for a distance of 30.15 metres; thence in a north-westerly direction on a bearing of 347 deg. 16 min. for a distance of 35.81 metres; thence in south-easterly direction along the western alignment of Myrtle Road as shown on Plan of Subdivision No. 1519 to the point of commencement.

A. J. HUNT,  
Minister for Local Government

Local Government Department,  
Melbourne (76/2645)

**LOCAL GOVERNMENT DEPARTMENT  
ORDER CONFIRMED—CITY OF CAULFIELD**

The Minister of the Crown administering the *Local Government Act 1958*, on the 28th day of July, 1977, confirmed an Order hereinafter referred to in pursuance of the provisions of section 514 of the said Act namely:—

An Order of the Council of the City of Caulfield made on 28th June, 1977, directing the compulsory taking of the land described in Certificate of Title Volume 3834, Folio 730, for the purpose of providing a children's playground and access road.

A. J. HUNT,  
Minister for Local Government

Local Government Department,  
Melbourne (77/3486)

*Local Government Act 1958*

**NOTICE OF CONFIRMATION OF AN ORDER OF THE COUNCIL OF THE CITY OF COLLINGWOOD ADOPTING A PROPOSAL FOR THE CLOSURE OF STREET OR ROAD TO THROUGH TRAFFIC**

Pursuant to the provisions of section 539c of the *Local Government Act 1958*, the Governor in Council, on the 2nd day of August, 1977, confirmed an Order of the Council of the City of Collingwood made on 29th November, 1976, adopting a proposal for the closure of Mollison Street, Abbotsford, to through traffic by the erection of a barrier at the location shown on the plan hereunder.

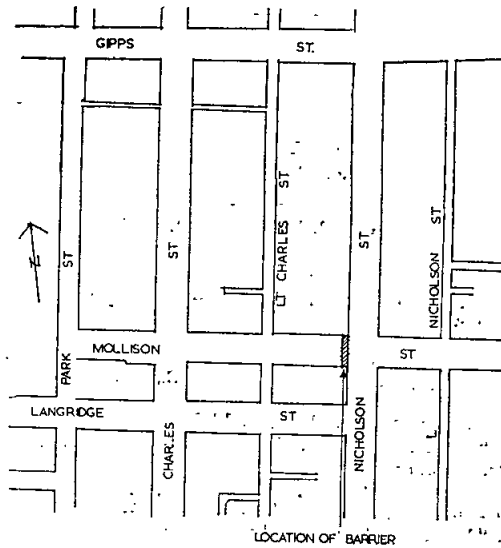

L. G. HOUSTON,  
Acting Clerk of the Executive Council  
At the Executive Council Chamber,  
Melbourne, 2nd August, 1977

**SITTINGS OF THE SUPREME COURT FOR THE HEARING OF CRIMINAL TRIALS  
IN MELBOURNE FOR THE YEAR 1978**

The Judges of the Supreme Court have appointed that the Sittings of the said Supreme Court for the hearing of Criminal Trials in Melbourne shall, during the year 1978, be held on the days and dates indicated in the Schedule following, that is to say:—

SCHEDULE

February	March	April	May	June	July	August	September	October	November	December
Wed. 1	Wed. 1	Mon. 3	Mon. 1	Thurs. 1	Mon. 17	Tues. 1	Fri. 1	Mon. 2	Wed. 1	Fri. 1

Dated the 3rd day of August, 1977

P. S. MALBON,  
Prothonotary of the Supreme Court

Transport Regulation Act  
TRANSPORT REGULATION BOARD  
HEARING OF APPLICATIONS

Notice is hereby given that the following applications will be considered by the Transport Regulation Board on 23rd August, 1977.

Application by the under-mentioned persons each for the issue of a country taxi cab licence to operate in Zone Z under radio control from the depot of D. & D. Cyma Taxis Ltd. Dandenong.

ARNDT, J. H., Hampton Park.  
BARNES, A. G. L., Hampton Park.  
BLAHO, F., Noble Park.  
BOICOS, A., Cheltenham.  
BROWN, G. G., Noble Park.  
CHAPMAN, J. E., Endeavour Hills.  
CHAPMAN, V. M., Endeavour Hills.  
CLEGG, K. P., Windsor.  
CLEMENTS, R. D., Mordialloc.  
COCHRANE, J. R., Carrum.  
ESCOTT, E. J., Dandenong.  
GALANIS, P., South Clayton.  
GIANNIAS, P., East Hawthorn.  
GRANT, V., North Dandenong.  
HALL, H. A., Dandenong.  
HAYRES, J. R., Noble Park.  
IKIN, R. B., South Belgrave.  
JOHNSON, G. J., Ashwood.  
JONES, A. H., Doveton.  
LONG, P. F., South Clayton.  
MARINACCI, M., Elsternwick.  
REICHEL, P., Moonee Ponds.  
SCRIVENS, R. W., Dandenong.  
SEARLE, G. W., Dandenong.  
SIKAND, J. B., Elsternwick.  
SLADE, E. R., Doveton.  
TAIT, R. J., Dandenong.  
THORNTON, C. E., Doveton.  
WARWICK, R. D. P., Hampton Park.  
WHALEN, N. D., Clayton.  
WINGATE, I. L., Upwey.

Notice of any objections should be forwarded to reach the Secretary of the Board not later than 17th August, 1977.

Applicants are advised that it will not be necessary to appear on the hearing date specified, unless advised in writing by the Board.

H. SHEAHAN, Secretary

Corner Lygon and Princes Streets, Carlton, Wednesday,  
10th August, 1977

Transport Regulation Act  
TRANSPORT REGULATION BOARD  
HEARING OF APPLICATIONS

Notice is hereby given that the following applications will be considered by the Transport Regulation Board on 30th August, 1977.

BLAND, C. P. & L. L., Goroke. Application for one commercial passenger vehicle with seating capacity for 18 persons, to be purchased, to operate as follows: (a) As a country stage omnibus between Goroke and Horsham via Natimuk with the ability to carry newspapers, parcels and general goods.

TIME-TABLE

Depart Goroke 9.30 a.m. Arrive Horsham 11.00 a.m.  
Depart Horsham 2.00 p.m. Arrive Goroke 3.15 p.m.

Fares.—To be determined.

(b) Under contract to the Education Department on the Nurcoung-Goroke school service. (c) To undertake charter hirings from Goroke.

B. M. WALKER'S BUS SERVICE PTY. LTD., Bendigo. Application to license one commercial passenger vehicle with seating capacity for 27 persons, to be purchased, to operate as follows: (a) As an urban omnibus under the same terms and conditions as existing U.O. licences held by the company. (b) To undertake charter hirings from Bendigo.

EASTERN GROUP TAXIS CO-OPERATIVE LTD. and BLACK CABS CO-OPERATIVE SOCIETY LTD., McKinnon. Application to extend the metropolitan taxi Pick up and Meter Fare area to include the area bounded by Wellington Road, Jacksons Road, Police Road, Browns Road, Princes Highway, Corrigan Road, Chapel Road, Pillars

Road, Springvale Road, Centre Dandenong Road, Old Dandenong Road, Boundary Road, Heatherton Road, Westall Road, Railway Line, Kouchi Road, McNaughton Road, Princes Highway and Garden Road to Wellington Road.

GREYDA NOMINEES PTY. LTD., Dandenong. Application for variation of Permit No. 4648, which authorizes various school services, to operate an additional service on a separate and distinct fare basis between Narre Warren North and Haileybury College, Keysborough via the following route: Commencing at the corner of Jaques Road and Hallam-Belgrave Road via Hallam-Belgrave Road, Narre Warren North Main Street, a Beckett Road, Harkaway Road, Brisbane Street, Manuka Road, Princes Highway to Beaconsfield (Wood Street) then via Princes Highway, Foster Street, Dandenong Station, Foster Street, Bennett Street, Cheltenham Road and Springvale Road to Haileybury College, Keysborough. Returning via Springvale Road, Cheltenham Road, Bennett Street, Foster Street, Dandenong Station, Foster Street, Robinson Street, Walker Street, Princes Highway then as morning route reversed.

TIME-TABLE

Depart cnr. of Jacques Road and Belgrave Road at 7.30 a.m.

Depart Haileybury College, Keysborough at 3.50 p.m.

Fares.—To be determined.

BENNETT, J. V., M. E., G. V. & M. J., Charlton. Application to license one commercial passenger vehicle with large seating capacity to be purchased to operate: (a) Half day, day and extended tours from Swan Hill, to be specified, as and when required. (b) To undertake charter hirings from Swan Hill.

HOYS ROADLINES PTY. LTD., Wangaratta. Application for variation of all T.S. and T.O. licence conditions to include the ability to operate a service for the carriage of school children between Benalla and Galen Catholic College in Wangaratta.

Timetable.—To be determined.

Fares.—To be determined.

LOFTHOUSE, P. G., Glen Waverley. Application for the issue of a metropolitan taxicab licence to operate from the depot of Yellow Cabs of Australia Pty. Ltd. and fitted with two-way radio, subject to the cancellation of existing suburban taxi licence No. S.T.49.

MARTYR, H. J., PTY. LTD., Warburton. Application to license one commercial passenger vehicle with seating capacity for 37 persons to operate between Dalry Road and Woori Yallock Primary School for carriage of school children only, under contract to the Education Department.

NOTE.—This application is subject to the cancellation of licence C.O.423 at present held in the name of the applicant.

ROULSTON, R. J., Casterton. Application to license one commercial passenger vehicle with seating capacity for 18 persons to operate between Byjuke and Casterton for the carriage of school children only, under contract to the Education Department.

Application for renewal of licences as shown by the persons listed hereunder to operate under the same terms and conditions:—

BARTA, T., East Hawthorn; S.T.5912.  
BELL, B. F., Yarraville; S.T.5493.  
CHAPMAN, H. L., Altona; S.T.5832.  
CHRISTOPOULOS, G., Bulleen; S.T.5076.  
CLARKE, N. L., Burwood; S.T.6016.  
COLLINS, W. J., Moorabbin; S.T.7510.  
CONNELLAN, K. G., Clayton; S.T.7602.  
COWELL, J. F., West Preston; M.T.2668.  
DIXSON, J. F., Mitcham; M.T.2562.  
DONATO, N., Hartwell; S.T.5532.  
GREEN, N., Caulfield; S.T.5043.  
KALLINICOS, J., Prahran; M.T.4218.  
KANTZAVELOS, V., Coburg; M.T.4242.  
KIRK, H. A., Glen Waverley; S.T.5039.  
KOUTSOHIMITROPOULOS, A., West Sunshine; S.T.5722.  
KRAIF, A., North Geelong; S.V.45.  
LOFTHOUSE, P. G., Glen Waverley; S.T.6057.  
LUPONE, O., Glenroy; M.T.4630, M.T.4314.  
MONCRIEFF, C. W., McKinnon; S.T.5046.  
MCKENNA, B. D., Burwood; M.T.5434.  
NORRIS, C. T., East Bentleigh; S.T.7606.  
PAPLOS, A., Camberwell; M.T.4369.

ROMIOPOULOS, V., Footscray; M.T.5048.  
SARRINIKOLAOU, G., Broadmeadows; M.T.5055.  
SORBELLO, S., Hampton; S.T.7612.  
TZOUVELIS, N., Rowville; S.T.5471;  
VIOLA, A., Glenroy; S.T.5653.  
XYNOS, G., Armadale; S.T.5993.

Application for the issue of a metropolitan taxi cab licence to operate from the depot of Yellow Cabs of Australia Pty. Ltd. and fitted with two-way radio subject to cancellation of the licences shown.

DARAXOGLU, A., Glen Waverley; S.T.7595.  
BEASLEY, A. A., Carnegie; S.T.5302, S.T.5237.  
BEASLEY, S. C., Carnegie; S.T.5238, S.T.5062.

In *Government Gazette* dated 1st June, 1977, there was an error in the first two applications and the third applicant was omitted.

Notice of the objections should be forwarded to reach the Secretary of the Board not later than 24th August, 1977.

Applicants are advised that it will not be necessary to appear on the hearing date specified, unless advised in writing by the Board.

H. SHEAHAN, Secretary

Corner Lygon and Princes Streets, Carlton, Wednesday, 10th August, 1977

Commercial Goods Vehicles Act  
TRANSPORT REGULATION BOARD  
HEARING OF APPLICATIONS

Notice is hereby given that the following applications will be considered by the Transport Regulation Board on 30th August, 1977.

BAKER PERKINS PTY. LTD., 110 Union Street, Brunswick, 3056. One commercial goods vehicle (L/C. 0.75 tonne) to operate throughout the State of Victoria in the course of business as "Refrigeration and Air Conditioning Engineers"—unrated refrigerators and air conditioning units for installation, for repair or having been repaired, tools of trade and materials incidental to the installation, servicing and maintenance of such equipment.

BECKER, P. M., 17 Swan Street, Bairnsdale, 3875. One commercial goods vehicle (L/C. 0.75 tonne) to operate throughout that part of the State of Victoria east of a north/south line drawn through Rosedale and south of an east/west line drawn through Omeo in the course of business as "Pest Control Agent"—tools of trade and materials incidental to the completion of own contracts.

NOTE.—All chemicals and pesticides to be initially consigned by rail to Bairnsdale.

BRIESE, D. A., 95 Aphrasia Street, Newtown, 3220. One commercial goods vehicle (L/C. 1.20 tonne) to operate: (a) Within an 80-km radius from the Chief Post Office in the City of Geelong in the course of business as "Petrol Pump Fitters"—own goods and plumbing equipment for repair or having been repaired. (b) Throughout the State of Victoria for the purpose of installing petrol pumps and tanks solely on behalf of B.P. Australia Ltd.—tools of trade and materials incidental to own contracts.

FAULKNER GLEESON SALES PTY. LTD., 1101 Raglan Parade, Warrnambool, 3280. One commercial goods vehicle (L/C. 1.20 tonne) to operate within a 112-km radius of own premises at Warrnambool in the course of business as "Garage Proprietors" for the purposes of demonstrating and servicing agricultural machinery and motor vehicles—tools of trade, spare parts and materials incidental thereto.

FREITAG, R., 167 Corio Street, Shepparton, 3630. One commercial goods vehicle (L/C. 1.15 tonne) to operate throughout the State of Victoria in the course of business as "Electrical Retailer and Serviceman" and "Public Address Equipment Hire"—public address equipment for hire, tools of trade, spare parts for on site servicing and electrical and sound equipment for specialized installation.

NOTE.—New appliances and equipment are not to be carried from places within a 40-km radius of G.P.O. Melbourne.

HAYWARD, G. W., Burrumbeet, 3352. Application to vary the conditions of licence number D.A.67588/1 (L/C. 15.92 tonne) by adding an additional paragraph—"Solely on behalf of A. W. Hancock & Co. Pty. Ltd.

from places situated within a 16-km radius of Carranballac, Darlington, Woomdoo, Navarre and Rokewood to Portland, Geelong and Melbourne—bulk oats.

LAMBRINIDIS, C., 86 Fergie Street, North Fitzroy, 3068. One commercial goods vehicle (L/C. 10.50 tonne) to operate: (a) Within a 40-km radius of the G.P.O. Melbourne solely on behalf of Pioneer Quarries (Vic.) Pty. Ltd.—sand, soil, screenings and quarry products. (b) Within an 80-km radius of the premises of Pioneer Asphalts Pty. Ltd. at Epping on behalf of the said company—hot asphalt.

MARTIN, E. S. & R. L. PTY. LTD., 31 Franklin Street, Traralgon, 3844. One commercial goods vehicle (L/C. 1.00 tonne and 1.50 tonne trailer) to operate: (a) Within an 80-km radius of own premises at Traralgon in the course of business as "Furniture Retailer"—new and secondhand furniture having been sold at the said premises or initially consigned by rail to Traralgon. (b) From places within a 40-km radius of the G.P.O. Melbourne to own premises at Traralgon in the course of business as "Furniture Retailer"—items of new furniture and furnishings as per T.R.B. new furniture schedule. (c) From places within a 40-km radius of the G.P.O. Melbourne to own premises at Traralgon in the course of business as "Furniture Retailer"—secondhand household furniture.

MASON, W. D. PTY. LTD., 25 Queen Street, Bendigo, 3550. One commercial goods vehicle (L/C. 1.20 tonne) to operate within that part of the State of Victoria bounded by a straight line drawn through and joining the townships of Swan Hill and Sea Lake then to the City of Horsham then to Ararat and the townships of Kyneton, Seymour and to Wodonga in the course of business as "Glass Merchants"—tools of trade, plate glass for fitting and installation and scaffolding incidental to own contracts.

MOLE, C. G., 57 Scott Street, Ouyen, 3490. One commercial goods vehicle (L/C. 19.89 tonne) to operate: (a) Within a 40-km radius of the Post Office at Ouyen—general goods. (b) Within an 80-km radius of the Saleyards at Ouyen—livestock. (c) Within an 80-km radius of own premises at Ouyen in course of business as "Primary Producer"—own goods. (d) Throughout that part of the State of Victoria north of a line drawn due east and west through Wycheproof and west of a line drawn due north and south through Swan Hill on behalf of the State Rivers and Water Supply Commission—plant and equipment the property of the said commission for removal from site to site. (e) Within a 100-km radius of the Post Office at Ouyen on behalf of the Victorian Railways Board—plant and equipment the property of the said Board.

MORDIALLOC FIBROUS PLASTER PTY. LTD., 9 Lamana Street, Mordialloc, 3195. One commercial goods vehicle (L/C. 2.75 tonne) to operate: (a) Within a 40-km radius of own premises at Mordialloc in course of business as "Fibrous Plaster Manufacturers"—own goods. (b) Throughout the State of Victoria in the course of business as "Plaster Craftsmen" for the purpose of installing plaster board—plaster sheet, uncrated plaster board, associated mouldings and accessories required to fit such plaster board and mouldings.

PAUL, J. A., Midlands Highway, Epsom, 3551. One commercial goods vehicle (L/C. 5.98 tonne) to operate: (a) Within an 80-km radius from the post office at Bendigo—plant the property of a contractor and required by him for use in connection with the construction or maintenance of some specific, existing or proposed road, street, footpath, bridge, pier, wharf, weir or channel and also the following materials, viz.: metal, stones, screenings, ashes, gravel, sand and earth. (b) Within a 32-km radius from the site of any construction or maintenance work performed, pursuant to paragraph (a) above, or from the railway station nearest thereto—any other materials required for such work. (c) Within a 40-km radius of the chief post office at Bendigo—general goods.

PENDERGAST, A. J., 30 Guthrie Street, Shepparton, 3630. Two commercial goods vehicles (L/C. 3.15 and 3.80 tonne) to operate from Melbourne to Swan Hill and Cohuna, via Kilmore or Kyneton, Echuca, Kerang and towns en route for the carriage of Sun Newspapers but excluding the ability to service places between Melbourne and Bendigo.

SCHADE'S FREIGHT SERVICES PTY. LTD., P.O. Box 499, Bendigo, 3550. Application to vary the conditions of licence No. D.A.69247 (L/C. 1.35 tonne) by adding an additional paragraph (c)—"From Melbourne to Bendigo—Sunday newspapers on behalf of the Melbourne Observer, Sydney Sunday Mirror, Sydney Sunday Press—Herald, Sydney Sunday Telegraph and Sunday Press".

**SNAITH, L.**, Steiglitz Street, Ballan, 3342. One commercial goods vehicle (L/C. 2.90 tonne) to operate: (a) Within a 32-km radius from the Mt. Wallace Exchange—general goods. (b) From and to places situated within a 16-km radius from the Exchange aforesaid to and from places situated within the limits of the City of Geelong—general goods. (c) From and to places situated within the radius as defined in paragraph (a) above and to and from places situated within an 80-km radius from the Mt. Wallace Exchange—household furniture being the property or personal effects of a householder or of a member of his family when such goods are being moved—(i) from residence to residence; (ii) from residence for storage or sale; (iii) from storage to residence; (iv) from a vendor to the residence of the purchaser. (d) From and to places situated within the radius as defined in paragraph (a) above and to and from places situated within an 80-km radius from the Mt. Wallace Exchange—livestock. (e) From and to places situated within a 16-km radius from the Mt. Wallace Exchange to and from the City of Melbourne, via the Townships of Bacchus Marsh or Lara—general goods.

**NOTE.**—No goods shall be carried from or to any point within the Metropolitan area (as defined in the Transport Regulation Act 1958) to or from any point within the Geelong urban district (as defined in the Transport Regulation Act 1958) or to or from any point within the Ballarat urban district (as defined in Transport Regulation Act 1958) by any route whatsoever.

**STOCKDALE, A. P.**, 19 Church Street, Leongatha, 3953. One commercial goods vehicle (L/C. 6.10 tonne) to operate: (a) Between places situated within a 40-km radius of the post office, situated at the corner of Bourke and Elizabeth Streets in the City of Melbourne and places situated within a 40-km radius of the post office at Leongatha—items of new furniture and household equipment as per T.R.B. new furniture schedule. (b) Throughout the State of Victoria for the carriage of household furniture, being furniture or personal effects of a householder or a member of his family when being moved from residence to residence; from residence for storage or sale; from storage to residence; from a vendor to the residence of the purchaser.

**TAIG NOMINEES PTY. LTD.**, 278 High Street, Shepparton, 3630. One commercial goods vehicle (L/C. 3.20 and 7.90 tonne trailer) to operate within an 80-km radius of the post office at Shepparton in course of business as "Motor Dealer, Agricultural Machinery Agent and Garage Proprietor"—own goods.

**TAYLOR, A. G.**, 85 Liebig Street, Warrnambool, 3280. One commercial goods vehicle (L/C. 1.75 tonne) to operate: (a) Within an 80-km radius of own premises at Warrnambool in the course of business as "Disposal Store Retailer"—own goods. (b) Between own stores situated at Warrnambool, Casterton and Hamilton in course of business as "Disposal Store Retailer"—own goods.

**TEMBY, R. A.**, 1 Barlow Street, Noble Park, 3174. One commercial goods vehicle (L/C. 6.70 tonne) to operate: (a) Within a 40-km radius of the G.P.O., Melbourne solely on behalf of Aberfeldie Quarries and Sand Supply Pty. Ltd.—sand, soil, screenings and quarry products. (b) From Bacchus Marsh to places within a 40-km radius of the G.P.O., Melbourne on behalf of the said company—sand, river pebbles and gravel. (c) From Cranbourne, Pearcevale and Devon Meadows to places within a 40-km radius of the G.P.O., Melbourne on behalf of the said company—sand and soil.

**VENNELL, R. J.**, Christine Street, Millgrove, 3139. One commercial goods vehicle (L/C. 6.40 tonne) to operate: (a) From forest landings at Matlock and Big River to Sawmills at Warburton and Croydon—logs. (b) From Tuckman's Sawmill at Warburton to timber yards and building contractors situated within a 40-km radius of the post office situated at the corner of Bourke and Elizabeth Streets, Melbourne, provided they are located within an 80-km radius of Warburton—sawn timber. (c) From Warburton to the State Electricity Commission Pole Treatment Works at Brooklyn—S.E.C. Poles.

**WALKER, B. J.**, Mt. Bute, via Lismore, 3324. One commercial goods vehicle (L/C. 20.00 tonne) to operate: (a) Within a 40-km radius of the post office at Mt. Bute—general goods. (b) Within an 80-km radius of the post office at Mt. Bute in the course of business as "Earth-moving Contractor"—own earth-moving equipment, tools of trade and sufficient fuel to operate own equipment on own contracts.

**ZVER, J.**, 17 Anderson Street, Wodonga, 3690. One commercial goods vehicle (L/C. 17.40 tonne) to operate: (a) Within a 40-km radius of the post office at Wodonga—general goods. (b) Within a 112-km radius of Bocrete Pty. Ltd. at Wodonga—concrete products.

#### RENEWALS

Applications for renewal of licences as shown by persons listed hereunder to operate under the same terms and conditions from the expiry shown in each case.

**SEITER, A. R.**, Knox Street, Numurkah, 3636; D.A.63066; 8th September, 1977; 0.65 tonne; D.A.63066/2; 8th September, 1977; 1.10 and 1.95 tonne trailer.

#### TOW TRUCKS

**DUNSTONE, R. J.** (trading as Lake Boga Auto Service), Murray Valley Highway, Lake Boga, 3584; D.A.66196; 10th September, 1977; 3.10 tonne.

**MELBOURNE TOWING SERVICE PTY. LTD.**, 169 City Road, South Melbourne, 3205; D.A.28169/13; 21st August, 1977; 3.70 tonne; D.A.28169/14; 28th August, 1977; 1.45 tonne; D.A.28169/15; 21st August, 1977; 3.80 tonne.

Notice of any objection should be forwarded to reach the Secretary of the Board not later than 24th August, 1977.

Applicants are advised that it will not be necessary to appear on the hearing date specified above, unless advised in writing by the Board.

H. SHEAHAN, Secretary

Corner Lygon and Princes Streets, Carlton, Vic. 3053, Wednesday, 10th August, 1977

#### MINES DEPARTMENT

##### MINING LEASES GRANTED

No. 338; John Irvine Dufty, Judith Ann Dufty; 13 ha, Parish of Banu Bonyit.

No. 453; Robert William Bennett, Wendy Jean Bennett; 4.5 ha, Parish of Bourka.

##### EXPLORATION LICENCE GRANTED

No. 619; Northern Mining Corporation No. Liability; 594 km<sup>2</sup>, County of Bogong.

##### TERM OF EXPLORATION LICENCE EXTENDED

No. 553; ICI Australia Limited; 264 km<sup>2</sup>, County of Moira.

##### APPLICATION FOR EXTRACTIVE INDUSTRY LICENCE DECLARED ABANDONED

No. 819; Woodyhill Extractive Industries Proprietary Limited; 46 ha, Parish of Kalkallo.

##### APPLICATION FOR EXTRACTIVE INDUSTRY LICENCE REFUSED

No. 936; Vernon McCallum, Glynis McCallum; 46 ha, Parish of Digby.

J. C. M. BALFOUR,  
Minister of Mines

#### CORRIGENDA

The Notice on page 2531 of *Government Gazette* No. 66 of 3rd August 1977, which advised the decision of the Minister of Lands to assign the name Bunguan Reserve in the Shire of Hastings, the heading of which should be corrected to read:

Notice of Assignment of a Name

The Notice on page 2531 of *Government Gazette* No. 66 of 3rd August 1977, which advised the decision of the Minister of Lands to change the name Clifton Park to Jack Tripovich Reserve in the City of Essendon, the heading of which should be corrected to read:

Notice of Alteration of a Name

By Order of the Committee,

M. W. COOKE, Secretary

Office of the Place Names Committee,  
Department of Crown Lands and Survey,  
Melbourne, Vic. 3002

Police Offences Act 1958, No. 6337

## DIVISION 1A—STATE ADVISORY BOARD ON PUBLICATIONS

Whereas I have considered reports made to me by the State Advisory Board on Publications under section 180D (2) (a) of the Police Offences Act:

I, William Archibald Borthwick, Acting Chief Secretary for the State of Victoria, in pursuance of the power vested in me by section 180H (1) of the Police Offences Act hereby determine that the following publications prescribed by title in the Schedule hereunder shall be classified as restricted publications for the purpose of the abovenamed Act.

## SCHEDULE OF PUBLICATIONS

Title	Distributor	Title	Distributor
Accord Vol. 1 Nos. 2 and 5	Magazine Imports Pty. Ltd.	Fetch The Cane Vol. 1, No. 1	Magazine Imports Pty. Ltd.
All Man—February, March, 1975	Magazine Imports Pty. Ltd.	Follow-Up Vol. 1 Nos. 4-9 (inclusive)	Magazine Imports Pty. Ltd.
All Man—April, June—November (inclusive) 1976	Magazine Imports Pty. Ltd.	Frenzy Vol. 2 No. 1	Pervada Fleur Pty. Ltd.
All The Way	Magazine Imports Pty. Ltd.	Frivol Magazin Nos. 3-7 (inclusive)	Magazine Imports Pty. Ltd.
Alpha Nos. 7, 8, 9 and 10	Magazine Imports Pty. Ltd.	Gay Guide—New 1975-76	Magazine Imports Pty. Ltd.
Alphabet of Pain (A-O)	Magazine Imports Pty. Ltd.	H & E International Monthly—July-October (inclusive) 1976	Magazine Imports Pty. Ltd.
Bang Vol. 1 No. 3	Magazine Imports Pty. Ltd.	Harem No. 6	Magazine Imports Pty. Ltd.
Bang Vol. 2 No. 2	Magazine Imports Pty. Ltd.	Heat	Magazine Imports Pty. Ltd.
Black Passion No. 1	Magazine Imports Pty. Ltd.	Heat Vol. 3 Nos. 2, 7-11 (inclusive)	Magazine Imports Pty. Ltd.
Blade No. 6	Magazine Imports Pty. Ltd.	Heat Vol. 4 Nos. 1, 2, 3, 4, 6 and 7	Magazine Imports Pty. Ltd.
Blockbusters Nos. 9 and 10	Magazine Imports Pty. Ltd.	Her Japanese Torturers	Pervada Fleur Pty. Ltd.
Block Busters Vol. 2 No. 3	Magazine Imports Pty. Ltd.	Him Exclusive Nos. 2, 3, 5 and 6	Magazine Imports Pty. Ltd.
Bona Vol. 1 No. 1	Magazine Imports Pty. Ltd.	Homo Action No. 7	Magazine Imports Pty. Ltd.
Brentwood No. 1	Pervada Fleur Pty. Ltd.	Hot Line	Magazine Imports Pty. Ltd.
Buttocks and Breasts	Magazine Imports Pty. Ltd.	Hot Line No. 1	Magazine Imports Pty. Ltd.
Call Girl	Magazine Imports Pty. Ltd.	How To Be A Better Lover Vol. 1 No. 10	Magazine Imports Pty. Ltd.
Cinema X Vol. 7 Nos. 8 and 9	Magazine Imports Pty. Ltd.	How To Be A Sexpert Vol. 1 No. 7	Magazine Imports Pty. Ltd.
Climax Nos. 7, 9, 10, 12-16 (inclusive)	Magazine Imports Pty. Ltd.	How To Give A Blue Film Party Vol. 1 No. 8	Magazine Imports Pty. Ltd.
Climax Vol. 2 Nos. 3-7 (inclusive)	Magazine Imports Pty. Ltd.	Impact Vol. 1 Nos. 1 and 3	Magazine Imports Pty. Ltd.
Climax—Special Quarterly Edition—Nos. 3 and 4	Magazine Imports Pty. Ltd.	Incognito—Naked Youth	Magazine Imports Pty. Ltd.
Club Magazin No. 4	Magazine Imports Pty. Ltd.	Incognito—Playguy Nos. 4, 6 and 7	Magazine Imports Pty. Ltd.
Cockade Nos. 14, 15 and 16	Magazine Imports Pty. Ltd.	Incognito—Young Studs	Magazine Imports Pty. Ltd.
Curious—June 1973	Magazine Imports Pty. Ltd.	In Depth	Magazine Imports Pty. Ltd.
Curious Nos. 43, 44 and 46	Magazine Imports Pty. Ltd.	In Depth Vol. 2 Nos. 8, 9, 11 and 12	Magazine Imports Pty. Ltd.
Curious Vol. 2 Nos. 1-6 (inclusive)	Magazine Imports Pty. Ltd.	In Depth Vol. 3 Nos. 1, 2, 3, 6, 10, 11 and 12	Magazine Imports Pty. Ltd.
Debonair—February, March, April, 1975	Magazine Imports Pty. Ltd.	In Depth Vol. 4 Nos. 1, 2 and 6	Magazine Imports Pty. Ltd.
Debonair—September, November, December, 1975	Magazine Imports Pty. Ltd.	International One Vol. 1 Nos. 1, 2 and 3	Magazine Imports Pty. Ltd.
Debonair—January, February, 1976	Magazine Imports Pty. Ltd.	In Touch Vol. 1 Nos. 6, 7, 9 and 10	Magazine Imports Pty. Ltd.
Debonair—April, May, June, August, 1976	Magazine Imports Pty. Ltd.	In Touch Vol. 2 No. 3	Magazine Imports Pty. Ltd.
Debonair—September—December (inclusive) 1976	Magazine Imports Pty. Ltd.	Just Us No. 2	Magazine Imports Pty. Ltd.
Down On The Ranch	Pervada Fleur Pty. Ltd.	Legs, Boobs, Lingerie Vol. 2 No. 2	Magazine Imports Pty. Ltd.
Eros No. 2	Magazine Imports Pty. Ltd.	Love-In Vol. 1 Nos. 9-12 (inclusive)	Magazine Imports Pty. Ltd.
Eros Vol. 2 Nos. 1, 2 and 3	Magazine Imports Pty. Ltd.	Love-In Vol. 2 Nos. 1 and 2	Magazine Imports Pty. Ltd.
Exciting Cinema Vol. 1 Nos. 7 and 11	Magazine Imports Pty. Ltd.	Love-In Vol. 3 Nos. 1-7 (inclusive)	Magazine Imports Pty. Ltd.
Exciting Cinema Vol. 2 Nos. 3, 4, 5, 6	Magazine Imports Pty. Ltd.	Love In Action	Pervada Fleur Pty. Ltd.
Exciting Cinema Vol. 2 Nos. 8-12 (inclusive)	Magazine Imports Pty. Ltd.	Madame Vol. 1 No. 2	Magazine Imports Pty. Ltd.
Experience Vol. 1 Nos. 1 and 2	Magazine Imports Pty. Ltd.	Man's Delight—Fall Quarterly 1975	Magazine Imports Pty. Ltd.
Experience Vol. 2 Nos. 2, 3, 5, 6, 7 and 10	Magazine Imports Pty. Ltd.	Man's Delight—February, April, 1975	Magazine Imports Pty. Ltd.
Experience Vol. 3 No. 3	Magazine Imports Pty. Ltd.	Man's Delight—August—December (inclusive) 1975	Magazine Imports Pty. Ltd.
Experience Vol. 4 No. 11	Magazine Imports Pty. Ltd.	Man's Delight—March, April, 1976	Magazine Imports Pty. Ltd.
Exposure Vol. 1 Nos. 1-4 (inclusive)	Magazine Imports Pty. Ltd.	Man's Delight—June—November (inclusive)	Magazine Imports Pty. Ltd.
Exposure Vol. 2 Nos. 1 and 2	Magazine Imports Pty. Ltd.	Mini Special Nos. 5-8 (inclusive) and 11	Magazine Imports Pty. Ltd.
		Naked Teens Vol. 1 No. 2	Magazine Imports Pty. Ltd.
		Nazi Capturers	Pervada Fleur Pty. Ltd.
		New Direction Vol. 3 Nos. 9 and 12	Magazine Imports Pty. Ltd.
		New Direction Vol. 4 Nos. 2, 3, 4, 6-12 (inclusive)	Magazine Imports Pty. Ltd.
		New Direction Vol. 5 No. 1	Magazine Imports Pty. Ltd.
		Nympho No. 8	Melbourne Wholesale News-agency Pty. Ltd.
		Open Vol. 3 Nos. 1-10 (inclusive)	Magazine Imports Pty. Ltd.
		Open Vol. 4 Nos. 1-9 (inclusive)	Magazine Imports Pty. Ltd.

Title	Distributor
Parade Vol. 2 Nos. 5, 6 and 7	Magazine Imports Pty. Ltd.
Park Lane Nos. 2-5 (inclusive)	Magazine Imports Pty. Ltd.
Pentact International Vol. 4 No. 4	Magazine Imports Pty. Ltd.
Playmates Nos. 8, 9 and 12	Magazine Imports Pty. Ltd.
Pleasure No. 169	Pervada Fleur Pty. Ltd.
Private Nos. 9, 13, 17, 20, 21 and 22	Magazine Imports Pty. Ltd.
Private Girl Nos. 2, 3, 4, 5, 7 and 8	Magazine Imports Pty. Ltd.
Private International Nos. 5 and 6	Magazine Imports Pty. Ltd.
Private View Nos. 1-4 (inclusive)	Magazine Imports Pty. Ltd.
Probe Vol. 2 Nos. 1, 4-7 (inclusive)	Magazine Imports Pty. Ltd.
Probe Vol. 2 Nos. 9-12 (inclusive)	Magazine Imports Pty. Ltd.
Probe Vol. 3 Nos. 1-10 (inclusive)	Magazine Imports Pty. Ltd.
Pussy Cat Vol. 1	Melbourne Wholesale News-agency Pty. Ltd.
Relate No. 7	Magazine Imports Pty. Ltd.
Saucy Nos. 2 and 3	Magazine Imports Pty. Ltd.
Search Vol. 2 Nos. 1 and 3	Magazine Imports Pty. Ltd.
Searchlight No. 219	Melbourne Wholesale News-agency Pty. Ltd.
Sex Fantasy Vol. 2 No. 11	Magazine Imports Pty. Ltd.
Sexgames Vol. 1 Nos. 4, 5, and 6	Magazine Imports Pty. Ltd.
Sex Mad Vol. 1 No. 1	Magazine Imports Pty. Ltd.
Sexpert Vol. 2 Nos. 2-6 (inclusive)	Magazine Imports Pty. Ltd.
Sex Studies—Book 1	Magazine Imports Pty. Ltd.
Sexuality Vol. 1 Nos. 3, 4 and 9	Magazine Imports Pty. Ltd.
Sexus Vol. 1 Nos. 1-11 (inclusive)	Magazine Imports Pty. Ltd.
Sexy And Silent	Magazine Imports Pty. Ltd.
Sexy Swingers No. 224	Pervada Fleur Pty. Ltd.
Special Search Vol. 2 Nos. 1, 2 and 5	Magazine Imports Pty. Ltd.
Sugar And Spice And Everything Nice No. 1	Magazine Imports Pty. Ltd.
Super Sexpert Vol. 1 Nos. 2 and 6	Magazine Imports Pty. Ltd.
Swap Vol. 6 No. 2	Magazine Imports Pty. Ltd.
Teenage Lesbian	Magazine Imports Pty. Ltd.
The Adventures Of Fanny Fondle	Magazine Imports Pty. Ltd.
The Age Of Perversion	Magazine Imports Pty. Ltd.
The Doggie Farm	Pervada Fleur Pty. Ltd.
The How To Guide To Oral Sex Vol. 1 No. 11	Magazine Imports Pty. Ltd.
The Wild Cats Vol. 6 No. 2	Magazine Imports Pty. Ltd.
Topper—March, April, June, July, 1975	Magazine Imports Pty. Ltd.
Topper—October, December, 1975	Magazine Imports Pty. Ltd.
Topper—January—June (inclusive) 1976	Magazine Imports Pty. Ltd.
Topper—August, October, 1976	Magazine Imports Pty. Ltd.
Turn On No. 1	Magazine Imports Pty. Ltd.
Vibrations Vol. 1 Nos. 1-6 (inclusive)	Magazine Imports Pty. Ltd.
Weekend Sex Nos. 6, 7, 8, 14 and 16	Magazine Imports Pty. Ltd.
Whitehouse Nos. 1-6 (inclusive)	Magazine Imports Pty. Ltd.
X-Films	Magazine Imports Pty. Ltd.
"X" Films Vol. 3 Nos. 6, 8, 9, 10 and 11	Magazine Imports Pty. Ltd.
X-Films Vol. 4 No. 12	Magazine Imports Pty. Ltd.
X-Films Vol. 5 No. 1	Magazine Imports Pty. Ltd.

W. BORTHWICK,  
Acting Chief Secretary

Chief Secretary's Office,  
Melbourne, 4th August, 1977

## Motor Car Act 1958

## EXEMPTIONS FROM FITTING OF SEAT BELTS

By notice published in the *Victoria Government Gazette* of 15th September, 1976, certain motor cars were exempted from being fitted with seat belts pursuant to sections 31A and 31AA of the *Motor Car Act 1958*.

In pursuance of the powers conferred on me by sections 31A (5) and 31AA (3) of the *Motor Car Act 1958*, I hereby revoke that notice in relation to such exemptions and substitute in its stead the following:—

- |                      |                          |
|----------------------|--------------------------|
| (i) Asphalt Spreader | Line Marking Machine     |
| Auto Header          | Mini Paver               |
| Back Actor           | Motorised Wheel Chair    |
| Back-end Loader      | Mower                    |
| Back Hoe             | Overhead Loader          |
| Bean Harvester       | Pavement Roller          |
| Bottom Dump Truck    | Paver                    |
| Bucket Loader        | Paymower                 |
| Bulldozer            | Power Buggy              |
| Bullgrader           | Power Grader             |
| Bulldozer Shovel     | Rear Blade               |
| Carry Lift Platform  | Rear-end Loader          |
| Coal Loader          | Ripper                   |
| Concrete Dumper      | Road Grader              |
| Combine              | Road Heater-Planer       |
| Combine Harvester    | Road Packer              |
| Crawler Trencher     | Road Paver               |
| Digger               | Road Roller              |
| Ditcher              | Road Sweeper             |
| Dozer Shovel         | Rock Ripper              |
| Dragline Excavator   | Rotary Mower             |
| Dragline Shovel      | Scarifier                |
| Drain Digger         | Scoop                    |
| Dumper               | Scoopmobile              |
| Duopactor            | Scraper Dozer            |
| Earth Ditcher        | Self-propelled Windrower |
| Earth Scoop          | Service Ditcher          |
| Excavator            | Shovel Loader            |
| Footpath Roller      | Skid                     |
| Fork Lift            | Skidder                  |
| Fork Loader          | Side Loader              |
| Front-end Loader     | Sprayer                  |
| Golf Buggy           | Stone Loader             |
| Golf Car             | Street Sweeper           |
| Grader               | Sweeper Loader           |
| Grain Combine        | Towmotor                 |
| Grass Cutter         | Tractor                  |
| Harvester            | Tractor-Loader           |
| Hauler               | Tractor-Shovel           |
| Hay Baler            | Trailer Crane            |
| Header               | Trench Digger            |
| Invalid Chair        | Trencher                 |
| Invalid Runabout     | Trench Hoe               |
| Lawn Roller          | Wheel Log Loader         |
| Lawn Sulky           |                          |
- (ii) Soft top motor cars having private, station wagon or utility types of bodies; and
- (iii) Motor cars manufactured prior to 1st July, 1977, and having a gross vehicle weight exceeding 4.5 tonnes.

3rd August, 1977

S. I. MILLER,  
Chief Commissioner of Police

*Police Regulation Act 1958, Section 122*  
SALE OF UNCLAIMED MOTOR VEHICLE

An owner is required for a 1965 model grey and white Holden station wagon, ex-registered No. JFL-961, engine No. 179F51998.

The vehicle came into the possession of Police on the 19th April, 1977, and if not claimed will be sold by public auction at the Broadmeadows Police Station, Cnr. Widford Road and Freda Street, Broadmeadows, at 11.00 a.m., on Monday, the 19th September, 1977.

S. I. MILLER,  
Chief Commissioner of Police

*Education Act 1958*

NOTICE OF MAKING OF AN ORDER UNDER SECTION 13 (4) OF THE ACT

Pursuant to section 13 of the *Education Act 1958* I hereby give notice that an Order was made on 9th August, 1977, under sub-section (4) of section 13 of the said Act amending certain provisions relating to the membership of the Council of the Ballarat Girls High School.

L. H. S. THOMPSON,  
Minister of Education

Education Department,  
Melbourne, 3rd August, 1977

Private Agents Act 1966

NOTICE OF RECEIPT OF APPLICATIONS FOR LICENCES UNDER THE PROVISIONS OF THE PRIVATE AGENTS ACT 1966

The Clerk(s) of the Magistrates' Court(s) as listed hereunder hereby give notice that applications, as under, have been lodged for hearing by the said Court(s) on the date(s) specified.

Any person desiring to object to any of such applications must—

- (a) lodge with the respective Clerk of the Magistrates' Court a notice in the prescribed form of his objection and of the grounds thereof;
- (b) cause a copy of such notice to be served personally or by post upon the applicant at least three days before the hearing of the application; and
- (c) send or deliver—
  - (i) where the objection is not made by the officer in charge of the police district in which the Court is situated—a copy of the notice to such officer; and
  - (ii) where the objection is not made by the Registrar or Deputy Registrar—a copy to the Registrar.

Full Name of Applicant or in the Case of a Firm or Corporation, of the Nominee	Place of Abode of Applicant or Nominee	Name of Firm or Corporation	Address for Registration	Type of Licence	Date of Hearing of Application
MAGISTRATES' COURT, FOOTSCRAY					
Feddersen, David Ian	492 Barkers Road, Hawthorn		2 Coode Road, West Melbourne	Watchman	26.8.77
Dated at Footscray this 1st day of August, 1977					
R. BRUGGEMANN, Clerk of the Magistrates' Court					
MAGISTRATES' COURT, PORT MELBOURNE					
Martin, Anthony Alan	21 Lilian Parade, Ringwood		538 Williamstown Road, Port Melbourne	Watchman	13.9.77
Dated at Port Melbourne this 2nd day of August, 1977					
R. J. MCHUGH, Clerk of the Magistrates' Court					
MAGISTRATES' COURT, HAMILTON					
Burgess, Denzil John	Martin Street, Dunkeld		Martin Street, Dunkeld	Guard Agent	25.8.77
Burgess, Denzil John	" " "		" " "	Watchman	"
Dated at Hamilton this 1st day of August, 1977					
J. B. RIES, Clerk of the Magistrates' Court					
MAGISTRATES' COURT, SOUTH MELBOURNE					
Gregory, John Henry	24 Patterson Street, Middle Park		24 Patterson Street, Middle Park	Process Server	30.8.77
Gregory, John Henry	" " "		" " "	Inquiry Agent	"
Dated at South Melbourne this 2nd day of August, 1977					
F. BENNETT, Clerk of the Magistrates' Court					
MAGISTRATES' COURT, MILDURA					
Gregson, Robert George	Block 544c Nealie Street, Red Cliffs		Block 544c Nealie Street, Red Cliffs	Process Server	31.8.77
Dated at Mildura this 1st day of August, 1977					
G. SCHMIDT, Clerk of the Magistrates' Court					
MAGISTRATES' COURT, WANGARATTA					
Marsh, George William	Bartley Street, Moyhu		Bartley Street, Moyhu	Watchman	9.9.77
Dated at Wangaratta this 3rd day of August, 1977					
J. G. DENAHY, Clerk of the Magistrates' Court					
MAGISTRATES' COURT, SUNBURY					
White, Charles William	Lot 9 Fenton Hill Road, Clarkefield		Lot 9, Fenton Hill Road, Clarkefield	Process Server	30.8.77
Dated at Sunbury this 3rd day of August, 1977					
L. F. HANDLEY, Clerk of the Magistrates' Court					
MAGISTRATES' COURT, RINGWOOD					
Allingham, Clifford	Lot 44, Brysons Road, Wonga Park		Lot 44, Brysons Road, Wonga Park	Guard Agent	2.9.77
Dated at Ringwood this 3rd day of August, 1977					
L. T. GOULD, Clerk of the Magistrates' Court					
MAGISTRATES' COURT, MARYBOROUGH					
Bilton, Arthur Matthew	3 Sydney Avenue, Maryborough		3 Sydney Avenue, Maryborough	Guard Agent	25.8.77
Dated at Maryborough this 4th day of August, 1977					
R. A. ISON, Clerk of the Magistrates' Court					



**CONTRACTS ACCEPTED—(Series 1977-78)**  
**AMENDMENTS**

Sched. No.	Item No.	Description	Unit of Measurement	New Rate	Contractor	Effective Date
		<b>General Stores</b>		\$		
		<i>Gazette No. 56—1st July, 1977</i>				
1/01		<i>Antiseptics, Disinfectants, Deodorants and Insecticides</i>				
		Delete Items 9 and 11, purchase under Items 10 and 12.				5.7.77
1/10		<i>Industrial Gases (In Cylinders)</i>				
		<i>Gazette No. 64—27th July, 1977</i>				
		Amendment to cylinder rental charges D, DS should read \$1.20.			The Commonwealth Industrial Gases Ltd.	
1/14		<i>Protective Clothing, Uniforms and Safety Equipment, etc.</i>				
	46	Helmets, protective, peaked type ..	each	3.80	Protector Safety Products Pty. Ltd. 1245 Sydney Road, Fawkner	1.7.77
	47	Inserts .. .. .	"	1.56		
	48	Straps, chin .. .. .	"	0.52		
1/64		<b>Stationery, General</b>				
		<i>Gazette No. 73—27th August, 1975</i>				
	145	Supply of stapling machines, contract cancelled			Michael A. Dortheimer Pty. Ltd. (Micador) ..	6.7.77
1/64	189	Supply of punches for files, contract cancelled			William Lewis Pty. Ltd. ..	12.7.77
2/01		<i>Provisions—Melbourne and Metropolitan District</i>				
		<i>Amendment to Gazette No. 64—27th July, 1977</i>				
	27	This should read 25 kg bags, not 15 kg bags				

W. L. ROBERTSON, Secretary to the Tender Board

**CONTRACTS ACCEPTED—(Series 1977-78)**  
**PUBLIC WORKS**

475. Essendon Airport, maintenance cleaning 1st July, 1977, to 30th June, 1980, Police Air Wing, \$1,820.00, per annum—Berkeley Cleaning Co. Pty. Ltd.

476. Gowrie Park, site works, multi-purpose hall-art/craft room, Primary School No. 4806, \$38,253.30—Bentleigh Road Constructions Pty. Ltd.

477. Balwyn, mechanical services, alterations and additions, St. Gabriel's Assessment Centre, \$41,300.00.—Bruce Sheet Metal Service.

478. Overport, internal and external repairs and painting, Primary School No. 4780, \$33,850.00—Custom Brick Co. Pty. Ltd.

479. Harrisfield, external repairs and painting, Primary School No. 4730, \$13,481.00.—C. Krstev.

480. Hopetoun, resiting of a Bristol unit, High School, \$15,500.00.—C. T. Friebe & D. R. Manning.

481. Various, rates for mechanical services to additions to standard Primary Schools within a 50-km radius of G.P.O., Melbourne, at rates—Chadstone Air Conditioning Services Pty. Ltd.

428. Swan Hill, external and part internal repairs and painting, Primary School No. 1142, \$16,554.00.—Cosmopolitan Painters & Decorators.

483. Collingwood, design, supply and installation of automatic fire sprinkler system and associated works, Mid-Level College, \$116,420.00.—Deluge Fire Protection Services (Vic.) Pty. Ltd.

484. Albion, electrical installation, rewire, Primary School No. 4265, \$15,950.00—D. J. & J. L. Suttie.

485. Newborough, mechanical services, alterations and extensions, High School, \$18,980.00—Ekon Industries Pty. Ltd.

486. French Island, mechanical services, conversion to holiday camp, former Penal Settlement, Stage 2, \$12,653.00—F.I.M.S. Heating.

487. Thornbury, external and internal renovations, Primary School No. 3889, \$52,350.00—John Toth.

488. Moe, re-roofing of corridors, High School, \$21,890.00—J. H. & R. L. Kendall.

489. Ballarat North, erection of three class-rooms, covered way and reposition class-room blocks 1 and 2, Primary School No. 4690, \$124,417.00.—H. A. & F. J. Graefe.

490. Swan Hill North, external repairs and painting and part internal repairs and painting, Primary School No. 4743, \$15,765.00—K. J. Haboltd & Son.

491. Apollo Bay, connection to sewer, Consolidated School, \$29,966.00.—K. H. Plumbing & Air Conditioning.

492. Mildura South, erection of new school wing and staff improvements, Primary School No. 4389, \$596,744.50—K. G. Renwick Holdings Pty. Ltd.

493. Hallam, ground improvements, special grant toward cost of provision of multi-purpose courts and asphalt areas, High School, \$24,789.23—Kenneth Worley.

494. Highvale, erection of blocks E, G, and J, High School, \$1,337,939.00—Lewis Constructions Co. Pty. Ltd.

495. Footscray, maintenance cleaning, 27th June, 1977, to 30th June, 1980, Social Welfare Regional Office, corner Paisley and Albert Streets, \$4,827.64, per annum—M. T. Cleaning Service.

496. Torquay, provision of canteen and covered play area, Primary School No. 3368, \$33,998.00.—Millford Builders Pty. Ltd.

497. Morwell, site works, Primary School No. 4680, \$33,810.00—Narambi Nominees Pty. Ltd.

498. Melbourne, maintenance cleaning, 11th July, 1977, to 30th June, 1980, Youth Sport and Recreation, 1st Floor, Swan Street, \$3,032.00, per annum—K. & M. Treble.

499. Northcote, electrical services, staff and administration improvements and improvements to learning areas, Primary School No. 1401, \$17,325.00—M. & K. M. Read.

500. Donald, internal and external repairs and painting, Primary School No. 1465, \$35,225.00—Onley's Holdings Pty. Ltd.

501. Lilydale, connection to sewer, Technical School, \$39,790.00—P. Adams.

502. Moorabbin West, installation of fire service, Primary School No. 4643, \$13,999.00—P. Adams.

503. Northcote, provision of staff and administration improvements and improvements to learning areas, Primary School No. 1401, \$69,626.00—Peter Brom Constructions.

504. Newborough, electrical services, alterations and extensions, High School, \$14,994.00.—Traraigon Electrical Services Pty. Ltd.

505. Whittlesea, erection of Stage 1, Technical-High School, \$1,285,923.00—Robert Salzer Constructions Pty. Ltd.

506. Ballarat, electrical services, fitting out works, Audio Visual Education Centre, \$16,389.00—T. J. Couatts Pty. Ltd.

507. Mitcham, internal and external repairs and painting, Primary School No. 2904, \$21,346.00—Rudi Memed Painting Service.

508. Howman's Gap, construction of recreation room camp, \$26,619.00—Roy O. Tobias.

509. Ballarat, fitting out works, Audio Visual Education Centre, \$40,993.70—S. J. Weir Pty. Ltd.

510. Wonthaggi, connection of buildings to sewer, Police Station and Residence, \$13,786.00—W. S. Purvis & Co.

511. Newborough, alterations and extensions, High School, \$247,604.00—W. G. Campbell Constructions Pty. Ltd.

512. South Yarra, repairs to roof of main building, Melbourne Boys' High School, \$29,695.00—Wilbey Services Pty. Ltd.

513. Various, rates for electrical services to additions to standard Primary Schools within a 50-km radius of G.P.O. Melbourne, at rates—W. T. Waterfall and Sons Pty. Ltd.

514. French Island, conversion to holiday camp, stage 2, former Penal Settlement, \$74,877.00—W. S. Purvis & Co.

D. J. LITTLE, Director-General. 2.8.77

#### CONTRACTS ACCEPTED—(Series 1977-78)

##### PUBLIC WORKS

515. Seymour, maintenance cleaning—from 14th July, 1977 to 13th July, 1980, Court House, \$3,780.00 per annum.—B. Bakes.

516. Melbourne, provision of air sampling system and associated equipment, E.P.A. Laboratory, 3rd Floor, 5 Parliament Place, \$10,815.00.—Barry Burke.

517. Box Hill, internal and external renovations and painting. High School, \$43,000.00.—E. Cotter.

518. Horsham, mechanical services for the alterations and additions to existing Lands Department, Depot/Workshop, \$18,496.00.—F. A. Watts.

519. Beechworth, external and part internal renovations and painting. Primary School No. 1560, \$16,040.00.—F. & D. Jensen Constructions.

520. Werribee, connection to sewer, Sewerage Plant Operators Training Centre. State Research Farm, \$27,687.00.—Glenroy Plumbing Service Pty. Ltd.

521. Ballarat, electrical services, internal and external renovations. Old Police Station, \$12,184.00.—Henderson-Lette & Co.

522. Bendigo, external and internal repairs and painting. High School, \$94,530.00.—John W. Henderson Builders Pty. Ltd.

523. Boort, external and internal renovations. High School, \$25,570.00.—K. J. Haboldt & Son.

524. Cockatoo, internal and external repairs and painting. Primary School No. 3535, \$16,990.00.—McDermott & Mether.

525. Sunshine West, siteworks. High School, \$128,827.00.—Paviors Nominees Pty. Ltd.

526. Rochester, reblocking and structural repairs, detached classroom block. High School, \$17,840.00.—P. K. & H. C. Hauke.

527. Broadmeadows, erection of small animal breeding building. "Attwood" Veterinary Research Station, \$63,275.00.—R. Osinski Building Co. Pty. Ltd.

528. Chatham, external and part internal repairs and painting. Primary School No. 4314, \$28,324.00.—Rudi Memed Painting Service.

D. J. LITTLE, Director-General. 8.8.77

#### CONTRACTS ACCEPTED—(Series 1976-77)

##### STATE RIVERS AND WATER SUPPLY COMMISSION

1214. Construction of SN4 type brick veneer residence at Murrabit, \$40,157.—T. J. & W. P. Laursen.

Sealed by Commission, 4th January, 1977

1215. Repair and remodelling of residence at Lake Buffalo, \$12,191.—Crisp & Taylor Pty. Ltd.

Sealed by Commission, 7th February, 1977

1216. Construction of SN4 type brick veneer residence at Lemnos, \$39,591.—Codner Bros. Pty. Ltd.

1217. Construction of SN4 type brick veneer residence at Cobram, \$37,661.—Codner Bros. Pty. Ltd.

1218. Construction of SN4 type brick veneer residence at Tatura, \$36,169.—Codner Bros. Pty. Ltd.

1219. Construction of SN4 type brick veneer residence at Kialla, \$38,355.—Codner Bros. Pty. Ltd.

1220. Construction of SN4 type brick veneer residence at Merrigum, \$38,753.—D. W. Warde.

Sealed by Commission, 7th March, 1977

1221. Construction of 2 SN4 type brick veneer residences at Lockington, \$71,440.—Peter Ives & Staff.

1222. Supply, delivery and erection of wire mesh fencing, storage tank, Upper Beaconsfield, \$6,226.—F. J. Brent Pty. Ltd.

Sealed by Commission, 28th March, 1977

1223. Construction of earthen storage at Sea Lake, \$36,938.—Twiggs Earthmoving Pty. Ltd.

1224. Construction of SN4 type brick veneer residence at Nathalia, \$38,108.—Codner Bros. Pty. Ltd.

1225. Construction of SN4 type brick veneer residence at Murchison, \$37,741.—G. L. & D. C. Marshall.

Sealed by Commission, 4th April, 1977

1226. Construction of SN4 type brick veneer residence at Rochester, \$37,394.—Peter Ives & Staff.

1227. Construction of SN4 type brick veneer residence at Boort, \$38,728.—Viscount Homes Pty. Ltd.

Sealed by Commission, 13th April, 1977

1228. Repair of head office building at Armadale, \$96,425.—Building Plastics (Melb.) Pty. Ltd.

1229. Construction of steel storage tank, Upper Beaconsfield, \$90,300.—V. G. Saunders Pty. Ltd.

1230. Construction of SN4 type brick veneer residence at Dingee, \$43,195.—Hansa-Prefab.

Sealed by Commission, 9th May, 1977

1231. Construction of 2 SN4 type brick veneer residences at Calivil, \$86,086.—Campaspe Constructions.

1232. Construction of SN4 type brick veneer residence at Yarrowalla, \$43,742.—K. F. Weinert.

Sealed by Commission, 23rd May, 1977

1233. Supply, delivery and erection of chain wire mesh fencing, at Tyabb storage site, \$40,480—Cyclone K. M. Products Pty. Ltd.

1234. Supply, delivery and erection of chain wire mesh fencing, Spring Gully Reservoir, Bendigo, \$18,488—T. C. Minster.

Sealed by Commission, 6th May, 1977

G. W. LEWIS, Secretary,  
State Rivers and Water Supply Commission

#### ORDERS IN COUNCIL—(Series 1977-78)

##### PUBLIC WORKS

His Excellency the Governor of the State of Victoria, by and with the advice of the Executive Council thereof doth by Order made on the 2nd day of August, 1977, approve of the acceptance by the Minister of Public Works of the undermentioned offers without public tenders being invited, viz.:

Offer of A. V. Pupedis & Associates, for professional services, New Gym & Canteen, Syndal Technical School, for the sum of nineteen thousand dollars (\$19,000.00)—(P.N.58366P).

Offer of Barry Burke, for provision of air sampling system and associated equipment, E.P.A. Laboratory, 5 Parliament Place, Melbourne, for the sum of Ten thousand eight hundred and fifteen dollars (\$10,815.00)—(C.18511B).

Offer of Commonwealth Industrial Gases Ltd., for installation of room isolating valves at Various Technical Schools throughout the Frankston Regional Directorate, for the sum of Eleven thousand four hundred and sixty dollars (\$11,460.00)—(E.V.17132).

Payment of the sum of Twelve thousand one hundred and eighty-four dollars (\$12,184.00), to Henderson-Lette & Co., for electrical services, internal and external renovations, Old Police Station, Ballarat—(W.69032A).

Payment to A. Priestley the sum of Twenty-seven thousand eight hundred dollars (\$27,800.00), for dredging operations at Patterson River—(P4H.134043u).

Offer of L. M. Ericsson Pty. Ltd., for the supply and installation of P.A.B.X., Education Department, Nauru House, for the sum of One hundred and forty-eight thousand six hundred and forty-seven dollars (\$148,647.00)—(C.185225).

Offer of Jennings Industries Ltd., for supply of a relocatable toilet building for the proposed Parkes Corner School, Upper Thomson Dam Project, for the sum of Twenty-three thousand dollars (\$23,000.00)—(B.G.161365).

Offer of Mervyn James Greed, for various fitting-out works at the Early Childhood Development Complex, Warrnambool, for the sum of Ten thousand four hundred and seventy-one dollars twenty-five cents (\$10,471.25)—(P.5813).

Offer of Kevin Borland & Associates Pty. Ltd., for professional services, conversion of Olympic Pool, Melbourne, for the sum of Ninety thousand dollars (\$90,000.00)—(P.C.186117P).

L. G. HOUSTON,  
Acting Clerk of the Executive Council

At the Executive Council Chamber,  
Melbourne, 2nd August, 1977

#### Metropolitan Fire Brigades Superannuation Act 1976 METROPOLITAN FIRE BRIGADES SUPERANNUATION (BOARD ELECTION) REGULATIONS 1977

Pursuant to the provisions of the Metropolitan Fire Brigades Superannuation (Board Election) Regulations 1977 I declare that at the election conducted by me on Wednesday, the 3rd August, 1977—

THOMAS HENRY TROTMAN  
was duly elected as representative of contributors for appointment as Member of the Metropolitan Fire Brigades Superannuation Board in accordance with sub-section (3) of section 3 of the Metropolitan Fire Brigades Superannuation Act 1976; and

RODNEY SINCLAIR KNOWLES  
was duly elected to act as the Deputy of the said Member in accordance with sub-section (10) of section 3 of the Metropolitan Fire Brigades Superannuation Act 1976.

J. MCKANE, Returning Officer  
State Electoral Office,  
Melbourne, 4th August, 1977

#### TEACHING SERVICE ACT 1958, SECTION 73 PUBLIC SERVICE ACT 1958, SECTION 60

It is hereby notified that, following an inquiry conducted under the provisions of section 60 of the Public Service Act 1958 as in force before the commencement of the Public Service Act 1974 and made applicable to members of the Teaching Service by section 73 of the Teaching Service Act 1958 into the fitness capacity and efficiency of Ivan Alexander Hartzberg, Teacher, Record No. 741770, Assistant Class, Primary Schools Division, Education Department, to discharge the duties of his office, the Teachers Tribunal has approved of the retirement of the said Ivan Alexander Hartzberg on the ground of ill health with effect from and including the 2nd August, 1977.

W. E. SAMPSON, Chairman  
A. F. LE CLERCQ, Secretary  
Office of the Teachers Tribunal,  
Melbourne, 1st August, 1977

#### Co-operative Housing Societies Act 1958

ALTONA (No. 2) CO-OPERATIVE HOUSING SOCIETY LIMITED

A.N.A. CO-OPERATIVE HOUSING SOCIETY (No. 2) LIMITED

BATMAN CO-OPERATIVE HOUSING SOCIETY LIMITED  
VACCINSCOL No. 1 CO-OPERATIVE HOUSING SOCIETY LIMITED

WAVERLEY (AMALGAMATED) CO-OPERATIVE HOUSING SOCIETY LIMITED

#### NOTICE OF DISSOLUTION OF SOCIETIES

Notice is hereby given that I have this day registered the dissolution of the above-named societies and cancelled their registration under the above-named Act.

Dated at Melbourne, this 27th day of July, 1977

E. P. LIDDELL, Deputy Registrar

#### Co-operation Act 1958

##### NOTICE OF AMALGAMATION OF SOCIETIES

Notice is hereby given that, pursuant to the provisions of the Co-operation Act 1958, Bulleen Co-operative Credit Society Limited and Doncaster & Templestowe Credit Co-operative Limited were amalgamated into one society under the name of Doncaster & Templestowe Credit Co-operative Limited on the first day of August, 1977.

Dated at Melbourne, this 1st day of August, 1977

J. W. JUNGWIRTH,  
Registrar of Co-operative Societies

#### PUBLIC TRUSTEE ACT 1958 (No. 6350), SECTION 17

I hereby give notice that on the 26th July, 1977, the Public Trustee filed elections to administer the following deceased persons' estates in accordance with section 17 of the Public Trustee Act 1958.

BELL, IRENE, late of Kew, pensioner, died 20th February, 1977.

COLLINS, NORMA GRACE, late of 215 Nicholson Street, Carlton, home duties, died 5th March, 1977.

GRACE, AGNES, also known as Grace, Agnes Nora, late of 7/18 York Street, Mont Albert, spinster, died 27th May, 1977.

HICKEY, EILEEN CLARE, late of 27 Fraser Street, Richmond, married woman, died 6th April, 1977.

MITCHELL, RACHAEL, late of Ballarat, widow, died 23rd February, 1977.

MULLENGER, ROBERT CHARLES, formerly of 34 Howitt Street, Northcote, but late of Mont Park, pensioner, died 3rd March, 1977.

ROSS, ANNIE DOUGLAS, late of 3 Bellett Street, Camberwell, retired saleslady, died 10th April, 1975.

TRAINOR, THOMAS MICHAEL, late of Mont Park, retired labourer, died 17th March, 1977.

WARREN, ARTHUR EDWARD EWART, late of Mont Park, retired electrician, died 19th May, 1977.

N. P. BRODY,  
Public Trustee

168 Exhibition Street, Melbourne, 3rd August, 1977

#### NOTICE

Creditors, next of kin, and others having claims against the estate of any of the under-mentioned deceased persons are required to send particulars of their claims to the Public Trustee, 168 Exhibition Street, Melbourne, Vic. 3000, the personal representative, on or before the 19th October,

1977, after which date the Public Trustee may convey or distribute the assets having regard only to the claims of which the Public Trustee then has notice:—

BACKHOLER, ETHEL, formerly of Flat 2, 1A Keats Street, Sandringham, but late of 49 Bay Road, Sandringham, widow, died 15th September, 1976.

BALLARD, MARGARET, formerly of 73 Cobden Street, South Melbourne, but late of Kew, widow, died 17th February, 1977.

BELL, IRENE, late of Kew, pensioner, died 20th February, 1977.

COLLINS, NORMA GRACE, late of 215 Nicholson Street, Carlton, home duties, died 5th March, 1977.

CREES, ROY JOSEPH, late of F3/16 Thackeray Street, Elwood, meat inspector, died 30th April, 1977.

CRENNAN, ELLEN AGNES, formerly of 30 Park Street, Moonee Ponds, but late of Caritas Christi Hospice, Kew, widow, died 16th March, 1977.

CROWE, WILLIAM FREDERICK, late of 1 Wallace Avenue, Murrumbidgee, retired bank officer, died 3rd May, 1977.

GRACE, AGNES, also known as Grace, Agnes Nora, late of 7/18 York Street, Mont Albert, spinster, died 27th May, 1977.

HAGGER, ALBERT EDWARD, formerly of S.S. "Australis", but late of 25 Torino Street, St. Albans, retired, died 6th September, 1976.

HICKEY, EILEEN CLARE, late of 27 Fraser Street, Richmond, married woman, died 6th April, 1977.

HICKFORD, WILFRED WYATT, formerly of 371 Montague Street, Albert Park, but late of 63 Bunny Road, Clayton, retired clerk, died 18th April, 1966.

HILL, ARTHUR HENRY, late of 7 Durrant Street, Brighton, glass merchant, died 23rd April, 1977.

INGRAM, EMMA DOROTHY, formerly of 28 Mercil Road, Alphington, but late of 227 Gillies Street, Fairfield, widow, died 19th May, 1977.

JACKSON, ALICE, late of 29 Houston Avenue, Strathmore, married woman, died 23rd May, 1977.

JACOBSEN, BERNARD FREDERICK, late of Sandhurst Rest Home, 638 Inkerman Road, Caulfield, pensioner, died 8th May, 1977.

KELLY, ELIZABETH, late of Portrick Geagh, Ballinasloe, County Galway, Ireland, married woman, died 9th May, 1973.

KIDD, OLIVE MAY, late of 8 Mt. Pleasant Grove, Armadale, spinster, died 10th May, 1977.

KIDD, WILLIAM JAMES, late of 8 Mt. Pleasant Grove, Armadale, retired storeman, died 10th May, 1977.

KIMBER, ELLENOR, late of 6 Brace Street, Camberwell, widow, died 10th May, 1977.

KULPINSKI, WLADYSLAW, late of 243 Elizabeth Street, Coburg, electrical fitter, died 20th August, 1976.

LINDSAY, GWENDOLYNE ALICE, also known as Gwendolynne Alice Lindsay and Gwendoline Alice Lindsay, formerly of 34 Kintore Crescent, Box Hill, but late of 59 Churchill Avenue, Braybrook, married woman, died 24th April, 1977.

LYCETT, MARGARET, late of 52 Hedderwick Street, Essendon, married woman, died 30th May, 1977.

MCBAIN, ALISON JEAN, late of Flat 8/647 Inkerman Road, North Caulfield, home duties, died 25th April, 1977.

MINTERN, ARTHUR WILLIAM, late of 98 St. Andrew's Street, North Brighton, retired postal sorter, died 10th August, 1976.

MITCHELL, RACHAEL, late of Ballarat, widow, died 23rd February, 1977.

MULLENGER, ROBERT CHARLES, formerly of 34 Howitt Street, Northcote, but late of Mont Park, pensioner, died 3rd March, 1977.

ROOTSEY, IVOR, late of 50 Para Road, Montmorency, retired railway employee, died 4th June, 1977.

ROSS, ANNIE DOUGLAS, late of 3 Bellett Street, Camberwell, retired saleslady, died 10th April, 1975.

RYAN, FRANCIS JOSEPH, late of 124 Easey Street, Collingwood, retired mail officer, died 5th May, 1977.

TRAINOR, THOMAS MICHAEL, late of Mont Park, retired labourer, died 17th March, 1977.

WARREN, ARTHUR EDWARD EWART, late of Mont Park, retired electrician, died 19th May, 1977.

WATTON, VIOLET, late of 24 River Street, Newport, widow, died 27th April, 1977.

WHITE, ROY, late of 1303 Heatherton Road, Noble Park, pensioner, died 12th April, 1977.

N. P. BRODY,  
Public Trustee

Melbourne, 3rd August, 1977

Town and Country Planning Act 1961  
SHIRE OF PAKENHAM PLANNING SCHEME

INTERIM DEVELOPMENT ORDER 1974

AMENDMENT No. 16, 1976

Notice of Amendment

In pursuance of the powers conferred by section 26 of the *Town and Country Planning Act 1961*, the Governor in Council on the 2nd day of August, 1977, amended the Shire of Pakenham Planning Scheme Interim Development Order 1974 to rezone four areas of land as follows:

- (i) Approximately 7.0 hectares of land having a frontage to the Beaconsfield-Emerald Road and Montuna Grove, Upper Beaconsfield, from Special Landscape Zone to Country Residential "B" Zone;
- (ii) Approximately 1.6 hectares of land having a frontage to the Nar Nar Goon-Longwarry Road, Garfield, from Agricultural "A" Zone to Township "B" Zone;
- (iii) Approximately 0.8 hectares of land situated on the north-west corner of the Garfield North Road and Wright Road Garfield North, from Special Conservation "B" Zone to Restricted Use Zone, (camping ground); and
- (iv) Approximately 2.0 hectares of land having a frontage to Tynong Road, Tynong, from Highway Zone to Township "B" Zone, and to amend the ordinance in the following manner:—

(i) make "Guest House" a consent use in the Special Conservation "A" Zone, the Special Conservation "B" Zone and the Special Landscape Zone by amendment, in each case, Column 2 of the appropriate Table; and

(ii) introduce a new sub-clause, sub-clause 7 (c)—to give the Responsible Authority power to permit subdivision for the purpose of "minor adjustments to or relocating a common boundary line between existing allotments of land where it is satisfied that such subdivision will not result in any loss of amenity to the area nor in any detrimental effect on the future planning of the area".

A copy of the amendment may be inspected during office hours at the office of the Town and Country Planning Board, 235 Queen Street, Melbourne, and at the office of the Council of the Shire of Pakenham at Pakenham.

W. H. CRAIG, Secretary,  
Town and Country Planning Board

Town and Country Planning Act 1961  
SHIRE OF SHERBROOKE PLANNING SCHEME 1965

AMENDMENT No. 105, 1977

Notice of Amendment

In pursuance of the powers conferred by sub-section 6 of section 32 of the *Town and Country Planning Act 1961*, the Governor in Council, on the 2nd day of August, 1977, amended the Shire of Sherbrooke Planning Scheme 1965 to amend the ordinance to introduce a clause providing for agreements with owners.

A copy of the amendment may be inspected during office hours at the office of the Town and Country Planning Board, 235 Queen Street, Melbourne, and at the office of the Council of the Shire of Sherbrooke at Upwey, and when available at the Office of Titles, Melbourne, and at the Central Plan Office of the Department of Crown Lands and Survey, Melbourne.

W. H. CRAIG, Secretary,  
Town and Country Planning Board

Town and Country Planning Act 1961  
SHIRE OF YACKANDANDAH PLANNING SCHEME

(TOWNSHIP OF YACKANDANDAH)

AMENDMENT No. 6

INTERIM DEVELOPMENT ORDER

PERIPHERAL AREA

Notice of Approval

In pursuance of the powers conferred by the *Town and Country Planning Act 1961*, the Governor in Council on the 2nd day of August, 1977, approved an Interim Development Order made by the Yackandandah Shire Council for that part of the municipal district of the Township of Yackandandah covering the area of the

Peripheral Towns Study. The Interim Development Order provides that the use, subdivision or development of any land within the area described or the erection, construction or carrying out of any buildings, roads or other works thereon is prohibited except in accordance with the provisions of the Order.

A copy of the Interim Development Order and a map showing the area affected may be inspected, free of charge, at the office of the Council of the Shire of Yackandandah at Yackandandah, and at the office of the Town and Country Planning Board, 235 Queen Street, Melbourne.

W. H. CRAIG, Secretary,  
Town and Country Planning Board

---

*Town and Country Planning Act 1961*  
OVENS-UPPER MURRAY PLANNING SCHEME  
INTERIM DEVELOPMENT ORDER 1975  
REVOCATION No. 4  
*Notice of Revocation*

In pursuance of the powers conferred by section 26 of the *Town and Country Planning Act 1961*, the Governor in Council on the 2nd day of August, 1977, revoked the Ovens-Upper Murray Planning Scheme Interim Development Order 1975 in respect of that portion of the Shire of Yackandandah to be covered by the proposed Amendment No. 6 to the Shire of Yackandandah Planning Scheme (Township of Yackandandah) and more particularly described on the map annexed to the said Order.

A copy of the revocation may be inspected during office hours at the office of the Town and Country Planning Board, 235 Queen Street, Melbourne, and at the office of the Council of the Shire of Yackandandah at Yackandandah.

W. H. CRAIG, Secretary,  
Town and Country Planning Board

---

*Town and Country Planning Act 1961*  
MELBOURNE METROPOLITAN PLANNING SCHEME  
AMENDMENT No. 79  
*Notice of Amendment*

In pursuance of the powers conferred by sub-section 6 of section 32 of the *Town and Country Planning Act 1961*, the Governor in Council, on the 2nd day of August, 1977, amended the Melbourne Metropolitan Planning Scheme to reserve approximately 1.6 hectares of land near Cleveland Avenue Lower Plenty for Existing Public Purposes No. 1 (Commonwealth Government).

A copy of the amendment may be inspected during office hours at the office of the Town and Country Planning Board, 235 Queen Street, Melbourne, and at the office of the Melbourne and Metropolitan Board of Works at 625 Little Collins Street, Melbourne, and when available at the Office of Titles, Melbourne, and at the Central Plan Office of the Department of Crown Lands and Survey, Melbourne.

W. H. CRAIG, Secretary,  
Town and Country Planning Board

---

*Town and Country Planning Act 1961*  
OVENS UPPER MURRAY PLANNING SCHEME  
INTERIM DEVELOPMENT ORDER 1975  
AMENDMENT No. 20  
*Notice of Amendment*

In pursuance of the powers conferred by section 26 of the *Town and Country Planning Act 1961*, the Governor in Council on the 2nd day of August, 1977, amended the Ovens Upper Murray Planning Scheme Interim Development Order 1975 to enable the erection of a house on land described in Certificate of Title Volume 8673 Folio 251 being part of Crown allotment 4, section 29, Parish of Baranduda.

A copy of the amendment may be inspected during office hours at the office of the Town and Country Planning Board, 235 Queen Street, Melbourne, and at the office of the Council of the Rural City of Wodonga at Wodonga.

W. H. CRAIG, Secretary,  
Town and Country Planning Board

*Town and Country Planning Act 1961*  
SEYMOUR PLANNING SCHEME  
AMENDMENT No. 28  
*Notice of Approval*

In pursuance of the powers conferred by the *Town and Country Planning Act 1961*, the Governor in Council on the 2nd day of August, 1977, approved a planning scheme entitled the Seymour Planning Scheme, Amendment No. 28, in respect of the municipal district of the Shire of Seymour and such planning scheme comes into operation on the date this Notice of Approval is published in the *Government Gazette*.

A copy of the planning scheme as approved may be inspected, free of charge, during office hours at the office of the Town and Country Planning Board, 235 Queen Street, Melbourne, at the office of the Council of the Shire of Seymour at Seymour, and when available, at the Office of Titles, Melbourne, and at the Central Plan Office of the Department of Crown Lands and Survey, Melbourne.

W. H. CRAIG, Secretary,  
Town and Country Planning Board

---

*Town and Country Planning Act 1961*  
NOTICE OF ORDER UNDER SECTION 32 (5)

In pursuance of the provisions of section 32 of the *Town and Country Planning Act 1961*, the Governor in Council on the 2nd day of August, 1977, made an Order under section 32 (5) with respect to the use and development of an area of land situated on lot 6, lodged plan 97476 in Grant Street, Bacchus Marsh.

A copy of the Order may be inspected during office hours at the office of the Town and Country Planning Board, 235 Queen Street, Melbourne, and at the office of the Council of the Shire of Bacchus Marsh at Bacchus Marsh.

W. H. CRAIG, Secretary,  
Town and Country Planning Board

---

*Town and Country Planning Act 1961*  
SHIRE OF YACKANDANDAH PLANNING SCHEME 1965  
(TOWNSHIP OF YACKANDANDAH)  
REVOCATION No. 3  
*Notice of Revocation*

In pursuance of the provisions of section 32 of the *Town and Country Planning Act 1961*, the Governor in Council on the 2nd day of August, 1977, made an Order revoking the Shire of Yackandandah Planning Scheme 1965 (Township of Yackandandah) in so far as it applies to all that part of the Township of Yackandandah covering the area of the peripheral towns study, and more particularly described on the maps annexed to the said Order.

A copy of the Order may be inspected during office hours at the office of the Town and Country Planning Board, 235 Queen Street, Melbourne, and at the office of the Council of the Shire of Yackandandah at Yackandandah.

W. H. CRAIG, Secretary,  
Town and Country Planning Board

---

*Town and Country Planning Act 1961*  
SHIRE OF BACCHUS MARSH PLANNING SCHEME  
REVOCATION No. 4  
*Notice of Revocation*

In pursuance of the provisions of section 32 of the *Town and Country Planning Act 1961*, the Governor in Council on the 2nd day of August, 1977, made an Order revoking the Shire of Bacchus Marsh Planning Scheme in so far as it applies to lot 6, lodged plan 97476, Grant Street, Bacchus Marsh.

A copy of the Order may be inspected during office hours at the office of the Town and Country Planning Board, 235 Queen Street, Melbourne, and at the office of the Council of the Shire of Bacchus Marsh at Bacchus Marsh.

W. H. CRAIG, Secretary,  
Town and Country Planning Board

*Town and Country Planning Act 1961*  
SHIRE OF FLINDERS PLANNING SCHEME 1962  
AMENDMENT No. 86, 1976

*Notice of Approval*

In pursuance of the powers conferred by the *Town and Country Planning Act 1961*, the Governor in Council on the 2nd day of August, 1977, approved a planning scheme entitled the Shire of Flinders Planning Scheme 1962, Amendment No. 86, 1976, in respect of part of the municipal district of the Shire of Flinders and such planning scheme comes into operation on the date this Notice of Approval is published in the *Government Gazette*.

A copy of the planning scheme as approved may be inspected, free of charge, during office hours at the office of the Town and Country Planning Board, 235 Queen Street, Melbourne; at the office of the Council of the Shire of Flinders at Rosebud, and when available at the Office of Titles, Melbourne, and at the Central Plan Office of the Department of Crown Lands and Survey, Melbourne.

W. H. CRAIG, Secretary,  
Town and Country Planning Board

*Town and Country Planning Act 1961*  
SHIRE OF WANGARATTA PLANNING SCHEME  
INTERIM DEVELOPMENT ORDER  
AMENDMENT No. 8

*Notice of Amendment*

In pursuance of the powers conferred by section 26 of the *Town and Country Planning Act 1961*, the Governor in Council on the 2nd day of August, 1977, amended the Shire of Wangaratta Planning Scheme Interim Development Order to rezone a portion of the Warby Ranges within the Shire of Wangaratta to Conservation zone and Escarpment zone.

A copy of the amendment may be inspected during office hours at the office of the Town and Country Planning Board, 235 Queen Street, Melbourne, and at the office of the Council of the Shire of Wangaratta at Wangaratta.

W. H. CRAIG, Secretary,  
Town and Country Planning Board

*Town and Country Planning Act 1961*  
SHIRE OF SHERBROOKE PLANNING SCHEME 1965  
AMENDMENT No. 107, 1977

*Notice of Amendment*

In pursuance of the powers conferred by sub-section 6 of section 32 of the *Town and Country Planning Act 1961*, the Governor in Council, on the 2nd day of August, 1977, amended the Shire of Sherbrooke Planning Scheme to amend the planning scheme ordinance to introduce the use Afforestation (Exotic Species) into Zones 12 (Rural) and 13 (Rural Forest).

A copy of the amendment may be inspected during office hours at the office of the Town and Country Planning Board, 235 Queen Street, Melbourne, and at the office of the Council of the Shire of Sherbrooke at Upwey, and when available at the Office of Titles, Melbourne, and at the Central Plan Office of the Department of Crown Lands and Survey, Melbourne.

W. H. CRAIG, Secretary,  
Town and Country Planning Board

*Survey Co-ordination Act 1958*  
NOTICE OF PROPOSAL TO ASSIGN A NAME

Pursuant to the powers conferred under section 28 of the above Act, the Place Names Committee hereby gives notice of its intention to assign the following name:—

*Name*—Pennington Reserve.

*Municipality*—Shire of Huntly.

*Location*—Area of land being Crown Land facing two Government Roads surrounded by Crown Allotment 24A in the Township of Huntly.

Any person who objects to the above proposal may give notice of objection in writing, stating the reasons therefore, to the Secretary of the Committee, not more than two (2) months following publication of this notice.

By order of the Committee,  
M. W. COOKE, Secretary

Office of the Place Names Committee,  
Department of Crown Lands and Survey,  
Melbourne, Vic. 3002

*Survey Co-ordination Act 1958*

NOTICE OF PROPOSAL TO ASSIGN A NAME

Pursuant to the powers conferred under section 28 of the above Act, the Place Names Committee hereby gives notice of its intention to assign the following name:—

*Name*—Cohuna Pony Club Reserve.

*Municipality*—Shire of Cohuna.

*Location*—Latitude 35 degrees 48 minutes 45 seconds south; Longitude 144 degrees 12 minutes 43 seconds east.

Any person who objects to the above proposal may give notice of objection in writing, stating the reasons therefore, to the Secretary of the Committee, not more than two (2) months following publication of this notice.

By order of the Committee,  
M. W. COOKE, Secretary

Office of the Place Names Committee,  
Department of Crown Lands and Survey,  
Melbourne, Vic. 3002

*Survey Co-ordination Act 1958*

NOTICE OF PROPOSAL TO ASSIGN A NAME

Pursuant to the powers conferred under section 28 of the above Act, the Place Names Committee hereby gives notice of its intention to assign the following name:—

*Name*—J. L. Jordan Reserve.

*Municipality*—Borough of Queenscliffe.

*Location*—Latitude 38 degrees 16 minutes south; Longitude 138 degrees 40 minutes east.

Any person who objects to the above proposal may give notice of objection in writing, stating the reasons therefore, to the Secretary of the Committee, not more than two (2) months following publication of this notice.

By order of the Committee,  
M. W. COOKE, Secretary

Office of the Place Names Committee,  
Department of Crown Lands and Survey,  
Melbourne, Vic. 3002

*Survey Co-ordination Act 1958*

NOTICE OF ASSIGNMENT OF NAMES

Pursuant to the powers conferred under section 29 of the above Act, the Place Names Committee hereby gives notice of the assignment of the following names in the City of Brunswick.

*Name*—Allard Park.

*Location*—Donald Street, Brunswick.

*Name*—Appleby Reserve.

*Location*—Rose Street, Brunswick.

*Name*—Balfe Park.

*Location*—John Street, East Brunswick.

*Name*—Brunswick Park.

*Location*—Victoria Street, Brunswick.

*Name*—Denzil Don Reserve.

*Location*—Hunter Street, West Brunswick.

*Name*—Dunstan Reserve.

*Location*—McCull Street, West Brunswick.

*Name*—Fleming Park.

*Location*—Albert Street, East Brunswick.

*Name*—Fisher Reserve.

*Location*—Glenlyon Road, Brunswick.

*Name*—Hudson Reserve.

*Location*—Passfield Street, West Brunswick.

*Name*—Jacobs Reserve.

*Location*—Melville Road, West Brunswick.

*Name*—Methven Park.

*Location*—Methven Street, East Brunswick.

*Name*—Reaburn Reserve.

*Location*—Corner Victoria and Pearson Streets, West Brunswick.

*Name*—Sheils Reserve.

*Location*—Duggan Street, West Brunswick.

*Name*—Temple Park.

*Location*—Gray Street, Brunswick.

*Name*—Warr Park.

*Location*—De Carle Street, Brunswick.

*Name*—Wylie Reserve.

*Location*—Corner South Daly and Union Streets, West Brunswick.

By order of the Committee,  
M. W. COOKE, Secretary

Office of the Place Names Committee,  
Department of Crown Lands and Survey,  
Melbourne, Vic. 3002

## Survey Co-ordination Act 1958

## NOTICE OF PROPOSAL TO ASSIGN A NAME

Pursuant to the powers conferred under section 28 of the above Act, the Place Names Committee hereby gives notice of its intention to assign the following name:—

*Name*—Little Lake Boort.

*Municipality*—Shire of Gordon.

*Location*—Latitude 36 degrees 7 minutes 30 seconds south; Longitude 143 degrees 43 minutes 30 seconds east.

Any person who objects to the above proposal may give notice of objection in writing, stating the reasons therefore, to the Secretary of the Committee, not more than two (2) months following publication of this notice.

By order of the Committee,  
M. W. COOKE, Secretary  
Office of the Place Names Committee,  
Department of Crown Lands and Survey,  
Melbourne, Vic. 3002

## Survey Co-ordination Act 1958

## NOTICE OF PROPOSAL TO ALTER A NAME

Pursuant to the powers conferred under section 28 of the above Act, the Place Names Committee hereby gives notice of its intention to alter the following name:—

*Municipality*—Shire of Ballarat.

*Present Name*—Ballarat Primary School No. 4936.

*Proposed Name*—Forest Street Primary School.

Any person who objects to the above proposal may give notice of objection in writing, stating the reasons therefore, to the Secretary of the Committee, not more than two (2) months following publication of this notice.

By order of the Committee,  
M. W. COOKE, Secretary  
Office of the Place Names Committee,  
Department of Crown Lands and Survey,  
Melbourne, Vic. 3002

## Survey Co-ordination Act 1958

## NOTICE OF PROPOSAL TO ASSIGN A NAME

Pursuant to the powers conferred under section 28 of the above Act, the Place Names Committee hereby gives notice of its intention to assign the following name:—

*Name*—Altona Gate Shopping Centre.

*Municipality*—City of Altona.

*Location*—South-west corner of Duosa and Miller Roads, Altona North.

Any person who objects to the above proposal may give notice of objection in writing, stating the reasons therefore, to the Secretary of the Committee, not more than two (2) months following publication of this notice.

By order of the Committee,  
M. W. COOKE, Secretary  
Office of the Place Names Committee,  
Department of Crown Lands and Survey,  
Melbourne, Vic. 3002

## Survey Co-ordination Act 1958

## NOTICE OF PROPOSAL TO ASSIGN A NAME

Pursuant to the powers conferred under section 28 of the above Act, the Place Names Committee hereby gives notice of its intention to assign the following name:—

*Name*—Charles Green Reserve.

*Municipality*—City of Berwick.

*Location*—James Cook Drive, Endeavour Hills.

Any person who objects to the above proposal may give notice of objection in writing, stating the reasons therefore, to the Secretary of the Committee, not more than two (2) months following publication of this notice.

By order of the Committee,  
M. W. COOKE, Secretary  
Office of the Place Names Committee,  
Department of Crown Lands and Survey,  
Melbourne, Vic. 3002

## Survey Co-ordination Act 1958

## NOTICE OF PROPOSAL TO ASSIGN A NAME

Pursuant to the powers conferred under section 28 of the above Act, the Place Names Committee hereby gives notice of its intention to assign the following name:—

*Name*—James Cook Reserve.

*Municipality*—City of Berwick.

*Location*—James Cook Drive, Endeavour Hills.

Any person who objects to the above proposal may give notice of objection in writing, stating the reasons therefore, to the Secretary of the Committee, not more than two (2) months following publication of this notice.

By order of the Committee,  
M. W. COOKE, Secretary  
Office of the Place Names Committee,  
Department of Crown Lands and Survey,  
Melbourne, Vic. 3002

## Survey Co-ordination Act 1958

## NOTICE OF PROPOSAL TO ASSIGN A NAME

Pursuant to the powers conferred under section 28 of the above Act, the Place Names Committee hereby gives notice of its intention to assign the following name:—

*Name*—Breslow Primary School.

*Municipality*—City of Doncaster and Templestowe.

*Location*—Burlleigh Drive, Templestowe.

Any person who objects to the above proposal may give notice of objection in writing, stating the reasons therefore, to the Secretary of the Committee, not more than two (2) months following publication of this notice.

By order of the Committee,  
M. W. COOKE, Secretary  
Office of the Place Names Committee,  
Department of Crown Lands and Survey,  
Melbourne, Vic. 3002

## Survey Co-ordination Act 1958

## NOTICE OF PROPOSAL TO ASSIGN A NAME

Pursuant to the powers conferred under section 28 of the above Act, the Place Names Committee hereby gives notice of its intention to assign the following name:—

*Name*—Ronald E. Gray Reserve.

*Municipality*—City of Nunawading.

*Location*—9 Springvale Road, Nunawading.

Any person who objects to the above proposal may give notice of objection in writing, stating the reasons therefore, to the Secretary of the Committee, not more than two (2) months following publication of this notice.

By order of the Committee,  
M. W. COOKE, Secretary  
Office of the Place Names Committee,  
Department of Crown Lands and Survey,  
Melbourne, Vic. 3002

## Survey Co-ordination Act 1958

## NOTICE OF PROPOSAL TO ASSIGN A NAME

Pursuant to the powers conferred under section 28 of the above Act, the Place Names Committee hereby gives notice of its intention to assign the following name:—

*Name*—Bramblefield Reserve.

*Municipality*—Shire of Hastings.

*Location*—Latitude 38 degrees 12 minutes south; Longitude 145 degrees 9 minutes east.

Any person who objects to the above proposal may give notice of objection in writing, stating the reasons therefore, to the Secretary of the Committee, not more than two (2) months following publication of this notice.

By order of the Committee,  
M. W. COOKE, Secretary  
Office of the Place Names Committee,  
Department of Crown Lands and Survey,  
Melbourne, Vic. 3002

**APPOINTMENTS AND RESIGNATIONS****APPOINTMENTS**

His Excellency the Governor of the State of Victoria, by and with the advice of the Executive Council thereof, has, by Orders made on the 2nd day of August, 1977, been pleased to make the under-mentioned appointments, viz.:

**DEPARTMENT OF CROWN LANDS AND SURVEY***Members of the Surveyors Board*

FREDERICK HAY EDWARDS, M.Surv., L.S., M.I.S. Aust., a nominee of the Minister,  
FRANCIS EDWARD CULLIVER, L.S., F.I.S. Aust., on the nomination of the Minister from a panel of names submitted by the Institution of Surveyors, Victoria,  
RAYMOND ROBERT SMITH, L.S., F.I.S. Aust., on the nomination of the Minister from a panel of names submitted by the Institution of Surveyors, Victoria, and  
GEOFFREY HOWARD VERNON THOMSON, B.Surv. (Melb.), L.S., M.I.S. Aust., as nominee of the Minister, to be members of the Surveyors Board for a period of two (2) years from the 2nd August, 1977, to the 1st August, 1979, pursuant to the provisions of section 4 of the *Land Surveyors Act 1958*.

*Bailiffs of Crown Lands*

IAN FRANCIS HARRIS, an officer of the Department of Crown Lands and Survey, to be a bailiff of Crown lands, without additional salary, in respect of all Crown lands situated within the State of Victoria, and with authority to discharge and exercise all the duties and powers of bailiffs;  
LAWRENCE JAMES NEWELL, S.B.St.J., Q.P.M., E.D., J.P., Deputy Commissioner of Police, to be a bailiff of Crown lands, without salary, in respect of all Crown lands situated in the State of Victoria, and with authority to discharge and exercise all the duties and powers of bailiffs; and  
ROBERT WILLIAM BASSETT, Building Inspector for the Council of the Shire of Tambo, to be a bailiff of Crown lands, without salary, in respect of all Crown lands situated within the Municipality of the Shire of Tambo, and with authority to discharge and exercise all the duties and powers of bailiffs, pursuant to the provisions of section 30 of the *Land Act 1958*.

**DEPARTMENT OF HEALTH***Deputy Chairman of the Dental Technicians Licensing Committee*

PATRICK JOSEPH MCCORMACK to be Deputy Chairman of the Dental Technicians Licensing Committee, pursuant to the provisions of sub-section 9 of section 3 of the *Dental Technicians Act 1972*, for the remainder of the period ending the 7th May, 1981.

*Member of the Hairdressers Registration Board*

PETER WILLIAM FISHER to be a member of the Hairdressers Registration Board, pursuant to the provisions of section 5 (2) (ba) of the *Hairdressers Registration Act 1958*, for the remainder of the period ending the 3rd December, 1978, vice P. J. McCormack, resigned.

*Deputy Superintendent of a Psychiatric Centre*

JASHAVANT SHIVAL PARMAR, M.B., B.S. (Bombay), D.P.M., M.A.N.Z.C.P., to be Deputy Superintendent of the Dandenong Psychiatric Centre, pursuant to the provisions of section 26 (1) of the *Mental Health Act 1959*, vice Dr. M. G. Jayasundera whilst acting as Psychiatrist Superintendent.

*Superintendent of a Training Centre*

DENYS BERRANGE BRINK, M.B., B.Ch., to be Superintendent of Janefield Training Centre, pursuant to the provisions of section 26 (1) of the *Mental Health Act 1959*.

*Trustees of a Public Cemetery*

FRANCIS MICHAEL EDSAL to be a Trustee of the Bellarine Public Cemetery, vice J. Henderson, Deceased;  
LYNETTE ELLEN BAKER to be a Trustee of the Manangatang Public Cemetery, vice B. P. Curran, resigned;

KEVIN PATRICK O'ROURKE to be an additional Trustee of the Yarragon Public Cemetery; and  
NICI SOLOHUB to be a Trustee of the Yarragon Public Cemetery, vice J. A. Tulloch, resigned.

**LAW DEPARTMENT***Justices of the Peace*

EVAN DOUGLAS EVANS, 33 Swan Street, Wangaratta,  
WILLIAM KEVIN KIMBERLEY, Black Hill Road, Kyneton,  
WILLIAM VINCENT O'CONNOR, 34 Mollison Street, Kyneton,  
WILLIAM EWEN SHAW, 55 Ocean Beach Road, Sorrento, and  
MYFANWY MAY TOMSETT, Parliament House, Spring Street, Melbourne, to be Justices of the Peace for the State of Victoria.

*Commissioners for Taking Declarations, &c.*

LESTER CHARLES ANDERSON, 1066 Mt. Alexander Road, North Essendon,  
LAURENCE BARNETT BARRIE, 684 Centre Road, East Bentleigh,  
OWEN CHARLES BROWN, 626 High Street, Thornbury,  
DOMINIC JOSEPH CALABRO, 2 Crossley Street, Melbourne,  
DOUGLAS GEORGE CROMARTY, 55 Elizabeth Street, Melbourne,  
ROGER ALAN EUSTACE, Greens Road, Dandenong,  
GRAHAM RICHARD FOWLES, R.A.C.T. Centre, Sergeants Mess, Puckapunyal,  
IVAN ALFRED FROST, 168 Exhibition Street, Melbourne,  
LESLIE GADOR, 5 Broadlea Crescent, Viewbank,  
CHESTER MURRAY ROBIN GRAY, 217 Glen Eira Road, East St. Kilda,  
ROBIN ALAN HALE, 12 Reichelt Avenue, Montmorency,  
RODNEY DERECK HALSTEAD,  
ALBERT CHARLES MARR, and  
ERNEST RICHARD TOLSON, 151 Flinders Street, Melbourne,  
ROBERT GEORGE LAMBELL, 83-85 Gellibrand Street, Colac,  
JILL LINDA LAUX, 662 Blackburn Road, North Clayton,  
DEREK LIVESLEY, 310 Ferntree Gully Road, Clayton,  
KENNETH STANLEY LUCAS, 100 Wyndham Street, Shepparton,  
WAYNE PETER McDONALD, 25 Devonshire Road, Sunshine,  
DAVID PERCIVAL MEE, 108 Lonsdale Street, Melbourne,  
JOHN PAUL MEEUWSEN, 10 Belair Avenue, Glenroy,  
JAMES FERGUSON MURRAY, 678 High Street, Reservoir,  
RAYMOND JOHN NICHOLLS, 117-119 Hotham Street, Traralgon,  
GRAEME RUSSELL, 662 Blackburn Road, North Clayton,  
COLIN DENNIS STEVENS, 12 Pascoe Vale Road, Moonee Ponds,  
WILLIAM TONER, 179 Queen Street, Melbourne,  
KENNETH VANDERMOLEN, 23 Cricklewood Avenue, Frankston,  
NORMAN JAMES WEST, 37 Murlong Street, Swan Hill,  
JOHN STANLEY WOOD, 384 Gilbert Road, West Preston, and  
LAURENCE DOUGLAS WRATHALL, 20 Melbourne Street, Ringwood, to be Commissioners for taking Declarations and Affidavits under the *Evidence Act 1958*.

*Assistant Registrar of the County Court*

LINDSAY EMMETT ANDERSON, Clerk of Courts, to be Assistant Registrar at Portland for the County Courts at Hamilton and Warnambool, vice E. Emerson, on recreation leave.

**SOCIAL WELFARE DEPARTMENT***Honorary Probation Officers*

PETER WHELDON BAKER, 29 Queen Street, Lalor,  
GARRY ERNEST BARNES, 8 Archibald Street, Pascoe Vale,  
GEORGE CHRISTOPHER COX, Bridge Inn Lane, Wollert,  
ALEC GEORGE CUNNINGHAM, care of 24 Newman Street, Thornbury,  
ELIZABETH DOWE (Miss), Flat 4, 2 Howson Street, Brunswick,  
GORDON JOSEPH GEBBIE (Rev.), St. Damian's Presbytery, Settlement Road, Bundoora,



MARY PAULINE KIRBY (Rev.), C.F.W.B., 62 McKillop Street, Geelong,  
 JANINA DOROTHY LACHOWICZ (Miss), 14 Leura Avenue, Rosanna,  
 IVAN CEDRIC THESSELL, 7 Rasheda Street, Watsonia,  
 DONALD WILTSHIRE PLANT, 25 Gladwyn Avenue, East Bentleigh,  
 COLIN ROBERT RISSTROM, 11 Wiluna Court, Briar Hill,  
 JUSTINE MARIE VAUGHAN (Miss), 13 Cleve Grove, Heidelberg,  
 TREVOR NORMAN WILLIAMS, 20 Beard Street, Eltham East, and  
 BARRY JAMES WITHERS, 180 High Street, Broadford, to be Honorary Probation Officers for all adult and Children's Courts in Victoria, pursuant to the provisions of section 507 (2) of the *Crimes Act 1958* and section 9 of the *Children's Court Act 1973*.

L. G. HOUSTON,  
 Acting Clerk of the Executive Council  
 At the Executive Council Chamber,  
 Melbourne, 2nd August, 1977.

*Stock Diseases Act 1968*  
 APPOINTMENT OF INSPECTORS

The Public Service Board by certificate dated the 12th July, 1977 appoints the undermentioned Animal Health Officers, Class "AO-1", Second Division as Inspectors of Stock, under Part I, Section 5, of the *Stock Diseases Act 1968*, without additional salary—  
 ARCHER, JOHN H.  
 NICHOLLS, RAYMOND J.  
 WATT, GERALD F.  
 KEYS, RICHARD G.  
 LAMBELL, ROBERT G.

D. S. WISHART,  
 Director-General of Agriculture

FARM PRODUCE MERCHANTS AND COMMISSION AGENTS ACT 1965

The Public Service Board in Certificate No. 6948 dated the 20th July, 1977 appointed John V. Fanning as an Inspector in accordance with the provisions of Section 4 of the *Farm Produce Merchants and Commission Agents Act 1965*, without additional salary.

D. S. WISHART,  
 Director-General of Agriculture

SUMMONING OFFICER

Under Section 5 of the *Education Act 1958*, I hereby appoint—

BRIAN MICHAEL FRANCIS DILLON,  
 to summon parents within the State of Victoria.

Dated 1st August, 1977

BRIAN DIXON,  
 Minister for Social Welfare

*Liquor Control Act 1968*

APPOINTMENT OF LICENSING INSPECTOR

In accordance with the authority conferred upon me by sub-section (1) of section 22 of the *Liquor Control Act 1968*, I, Sinclair Imrie Miller, Chief Commissioner of Police, hereby appoint the following Officer of Police as a Licensing Inspector for the Divisions of the Police Districts as shown :—

Division Number	Police District	Rank and Name
3	Sunshine	Inspector Max Bruce ( <i>vice</i> Chief Inspector J. T. Root)

4.8.1977

No. 68—7450/77—2

S. I. MILLER,  
 Chief Commissioner of Police

REVOCATION OF APPOINTMENTS

His Excellency the Governor of the State of Victoria, by and with the advice of the Executive Council thereof, has, by Orders made on the 2nd day of August, 1977, revoked the appointments of the persons named hereunder to the offices mentioned, viz.:—

DEPARTMENT OF CROWN LANDS AND SURVEY

*Bailiff of Crown Lands*

RONALD MAYNE BRAYBROOK  
 as a bailiff of Crown lands, pursuant to the provisions of section 30 of the *Land Act 1958*, made by the Governor in Council on the 2nd February, 1977, and notified in the *Government Gazette* of the 9th February, 1977, on page 353.

SOCIAL WELFARE DEPARTMENT

*Honorary Probation Officers*

LYNETTE JOY CADDY (Mrs.),  
 HARMAN MULDER, and  
 RICHARD JAMES TREMBATH,  
 as Honorary Probation Officers pursuant to the provisions of section 507 (2) of the *Crimes Act 1958* and section 9 of the *Children's Court Act 1973* for all Adult and Children's Courts in Victoria.

L. G. HOUSTON,  
 Acting Clerk of the Executive Council  
 At the Executive Council Chamber,  
 Melbourne, 2nd August, 1977

RESIGNATIONS

His Excellency the Governor of the State of Victoria, by and with the advice of the Executive Council thereof, has, by Orders made on the 2nd day of August, 1977, accepted the resignations of the persons named hereunder of the offices mentioned, viz.:—

SOCIAL WELFARE DEPARTMENT

*Probation and Parole Officer*

NILLA MAGNABOSCO  
 as a Probation and Parole Officer, pursuant to the provisions of section 8 (2) of the *Children's Court Act 1973*, section 507 (1) of the *Crimes Act 1958* and section 165 (1) and 189 (2) of the *Social Welfare Act 1970* (as amended).

*Honorary Probation Officers*

MARGARET KATHLEEN CALDICOTT (Mrs.), 5 Hoadley Avenue, Frankston,  
 SUSAN CURWOOD (Mrs.), 2 Patricia Street, East Keilor,  
 JOHN FRANCIS CURWOOD, 2 Patricia Street, East Keilor,  
 NOEL FRANK HALL, 15 Chaley Street, Burwood,  
 ALAN WALTER MCEVOY, 20 Beresford Street, Mount Albert,  
 PATRICK JAMES MURPHY, 25 Cope Street, Coburg,  
 IAN LIVINGSTONE TREYVAUD, Lawson Street, Spring Gully,  
 ANNE WILLIAMS (Mrs.), 27 Gleneagles Road, Mount Osmond, S.A., and  
 MARIAN GWENDA WILSON (Mrs.), 7 Percy Street, Noble Park,  
 as Honorary Probation Officers pursuant to the provisions of section 507 (2) of the *Crimes Act 1958* and section 9 of the *Children's Court Act 1973*.

L. G. HOUSTON,  
 Acting Clerk of the Executive Council  
 At the Executive Council Chamber,  
 Melbourne, 2nd August, 1977

DEPARTMENT OF CROWN LANDS AND SURVEY

RESIGNATION

His Excellency the Governor of the State of Victoria, by and with the advice of the Executive Council thereof, doth by Order made on the 2nd day of August, 1977, accept the resignation of Alan Crocker Pittard, O.B.E., as Chairman of the Ballarat West Town Common Managers, and rescind his appointment as a Manager of the said Ballarat West Town Common—(C.91998).

L. G. HOUSTON,  
 Acting Clerk of the Executive Council  
 At the Executive Council Chamber,  
 Melbourne, 2nd August, 1977

**ORDERS IN COUNCIL**

**LOCAL GOVERNMENT DEPARTMENT**

At the Executive Council Chamber, Melbourne, the second day of August, 1977

PRESENT:

His Excellency the Governor of Victoria  
 Mr. Dunstan | Mr. Houghton  
 Mr. Maclellan |

**BOUNDARY OF THE SHIRE OF HAMPDEN SET FORTH AND DECLARED**

Pursuant to the provisions of section 12 (2) of the Local Government Act 1958, His Excellency the Governor of the State of Victoria, by and with the advice of the Executive Council thereof, hereby sets forth and declares the boundary described hereunder as the boundary of the Shire of Hampden.

SHIRE OF HAMPDEN  
 (Enlarged and Re-defined)  
 Previous Gazettal 1954-3495

Commencing at a point on Mount Emu Creek, being portion of the boundary between the Counties of Hampden and Heytesbury, at the north-eastern angle of allotment 21c, Parish of Laang; thence generally south-westerly by that creek to the road forming the south-western boundary of subdivision 1a of allotment 13b, Township of Garvoc; thence north-westerly and northerly by that road to the Princes Highway; thence north-easterly by that highway to the western boundary of the Parish of Terang; thence northerly by that boundary to the southern shore of Lake Keilambete; thence westerly, northerly and easterly by the southern, western and northern shores of that lake to the eastern boundary of allotment 1, section 1, Parish of Keilambete; thence northerly by that boundary and northerly and easterly by the western and northern boundaries of the Parish of Glenormiston to Mount Emu Creek; thence generally northerly, generally easterly and generally north-easterly by that creek to the western boundary of the Township of Skipton; thence northerly by that boundary and easterly by the northern boundary of the said township to Mount Emu Creek aforesaid; thence north-easterly by that creek to the eastern boundary of the County of Hampden; thence southerly by that boundary to the northern boundary of the Parish of Poliah North; thence easterly by that boundary and the northern boundary of the Parish of Wilgul North to the Woody Yaloak River; thence generally southerly by that river and generally south-westerly and westerly by the southern margin of Salt Lakes and Junction Creek to Lake Corangamite; thence generally south-westerly and generally north-westerly by the eastern and western margins of that lake to the boundary between the Counties of Hampden and Heytesbury; and thence westerly by that boundary to the point of commencement. Excluding the municipal district of the Town of Camperdown. (Area of Shire enlarged to 2621 square kilometres.)

And the Honorable Alan John Hunt, Her Majesty's Minister for Local Government for the State of Victoria, shall give the necessary directions herein accordingly.

L. G. HOUSTON,  
 Acting Clerk of the Executive Council

**LOCAL GOVERNMENT DEPARTMENT**

At the Executive Council Chamber, Melbourne, the second day of August, 1977

PRESENT:

His Excellency the Governor of Victoria  
 Mr. Dunstan | Mr. Houghton  
 Mr. Maclellan |

**PART OF A ROAD DISCONTINUED—CITY OF SPRINGVALE**

Whereas it is provided in section 528 (2) of the Local Government Act 1958, that where a road (whether or not a public highway but not being a road set out on land of the Crown) or any part thereof is not required for public use, the Governor in Council on the request of the council of the municipality in which such road is situated made not less than one month after publishing in

a newspaper generally circulating in the district and posting to the registered proprietor (if any) of the land and the owners and occupiers (if any) of lands abutting or immediately adjacent to the road, notice of intention to make such request may by Order published in the Government Gazette direct that such road or part shall be discontinued and thereupon such road or part shall be discontinued accordingly.

And whereas the Council of the City of Springvale has requested that the Governor in Council direct that part of a road off Douglas Street, Noble Park, be discontinued and not less than one month previously has published in a newspaper generally circulating in the district and posted to the registered proprietor of the land in the part of a road and to the owners and occupiers of the land abutting or immediately adjacent to the said part of a road notice of intention to make such request.

Now therefore, His Excellency the Governor of the State of Victoria, by and with the advice of the Executive Council thereof, hereby directs:

- (a) that the part of the said road which is shown by hachure on the plan hereunder shall be discontinued;
- (b) that notwithstanding such discontinuance the Council of the City of Springvale shall continue to have and possess the same right title power, authority or interest in or in relation to the whole of the land shown by hachure on the said plan as it had or possessed prior to such discontinuance with respect to or in connection with any drains or pipes laid or erected in on or over such lands for drainage purposes;
- (c) that notwithstanding such discontinuance the Springvale and Noble Park Sewerage Authority shall continue to have and possess the same right title power authority or interest in or in relation to the whole of the land shown by hachure on the said plan as it had or possessed prior to such discontinuance with respect to or in connection with any drains or pipes laid or erected in on or over such lands for sewerage purposes; and
- (d) that subject to any such right title power authority or interest, the land in the said road shall be retained by the Council of the City of Springvale for municipal purposes.

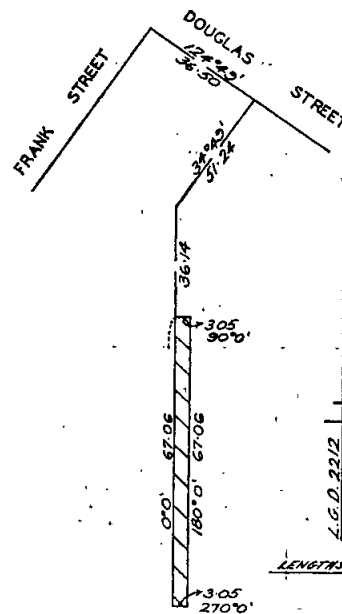

And the Honorable Alan John Hunt, Her Majesty's Minister for Local Government for the State of Victoria, shall give the necessary directions herein accordingly.

L. G. HOUSTON,  
 Acting Clerk of the Executive Council

LOCAL GOVERNMENT DEPARTMENT

At the Executive Council Chamber, Melbourne, the second day of August, 1977

PRESENT:

His Excellency the Governor of Victoria  
 Mr. Dunstan | Mr. Houghton  
 Mr. Maclellan

BOUNDARY OF THE SHIRE OF RIPON SET FORTH AND DECLARED

Pursuant to the provisions of section 12 (2) of the Local Government Act 1958, His Excellency the Governor of the State of Victoria, by and with the advice of the Executive Council thereof, hereby sets forth and declares the boundary described hereunder as the boundary of the Shire of Ripon.

SHIRE OF RIPON

(Reduced and Re-Defined)

(Previous Gazette 1890-4013)

Commencing at the junction of Burrumbeet Creek with Lake Burrumbeet; thence south-easterly by the said creek to a point in line with the eastern boundary of allotment 4, section B, Parish of Haddon; thence southerly by a line, the eastern boundary of the said allotment and a road to the south-eastern angle of allotment 17c, section 14A, Parish of Carngham; thence southerly by a direct line to the north-eastern angle of allotment 2, section 15A, Parish of Smythesdale; thence further southerly by the road forming the eastern boundary of that allotment to the northern boundary of allotment 8; thence westerly by that boundary and southerly by the road forming the western boundary of the said allotment to the northern boundary of allotment 1, section 32B, Parish of Carngham; thence north-westerly and westerly by that boundary and southerly by the western boundary of the said allotment to the northern boundary of the Parish of Scarsdale; thence westerly by that boundary to the north-eastern boundary of allotment 1A, section B, Parish of Argyle; thence south-easterly by that boundary and south-westerly by the south-eastern boundary of the said allotment to the eastern boundary of allotment 2A; thence southerly and westerly by the eastern and southern boundaries of that allotment to the road forming the eastern boundary of allotment 2B; thence southerly by that road to the southern boundary of the said allotment; thence westerly by that boundary and southerly, and westerly by the eastern and southern boundaries of allotment 2c to the south-western angle of the said allotment; thence due west (magnetic) by a direct line to the eastern boundary of the Parish of Mortchup; thence southerly and south-easterly by that boundary and westerly, north-easterly and westerly by the southern boundary of the said parish to the road forming the western boundary of allotment 7, section 13; thence northerly by that road to the road forming the northern boundary of allotment 6A, section 12; thence westerly by that road to Mount Emu Creek; thence generally south-westerly by that creek to the northern boundary of the Township of Skipton; thence westerly by that boundary and southerly by the western boundary of the said township to Mount Emu Creek aforesaid; thence generally south-westerly and generally westerly by that creek to the southern boundary of the Parish of Caraballuc North; thence further westerly by that boundary to the road from Nerrin Nerrin to Streatham; thence north-easterly and northerly by that road and further northerly and north-easterly by the Eurambeen-Streatham Road to the northern boundary of allotment 9A, section 12, Parish of Moallaack; thence westerly by that boundary to the western boundary of allotment 5B; thence northerly by that boundary and the western boundary of allotment 5A to the road forming the southern boundary of allotment 8AA, section 13; thence westerly by that road to the western boundary of the said allotment; thence northerly by that boundary and further northerly by a road to the north-eastern angle of allotment 85A, Parish of Woodnaggerak; thence northerly by a direct line to the south-western angle of allotment 76, Parish of Shirley and further northerly by the road forming the western boundary of the said allotment to Fiery Creek; thence easterly by Fiery Creek to its junction with Middle Creek; thence generally north-easterly by Middle Creek to the Western Highway; thence north-westerly by that highway to the road forming the eastern boundary of allotment 15, section 6, Parish of Buangor; thence north-easterly and northerly by that road to the road forming the northern boundary of allotment 20; thence north-westerly by that road and north-easterly and westerly by the roads forming the eastern and northern boundaries of allotment 46 to the road forming the eastern boundary of allotment 44; thence northerly by that road and north-westerly by the road

forming the north-eastern boundary of allotment 61B to the northern boundary of the County of Ripon; thence north-easterly by that boundary to the western boundary of allotment 48B; thence northerly, easterly and southerly by the western, northern and eastern boundaries of that allotment and easterly by the northern boundary of the County of Ripon aforesaid; thence generally north-easterly and generally easterly by that boundary to the western boundary of allotment 8A, section D, Parish of Langi-kal-kal; thence southerly by that boundary, a line, the western boundaries of former allotments 8A and 9, a line and further southerly, westerly and southerly by the western boundary of former allotment 9, section 63A, Parish of Raglan to the road forming the southern boundary of the said allotment; thence easterly, northerly and easterly by that road and further easterly by the northern boundary of allotment 4 to the eastern boundary of the said allotment; thence south-easterly by that boundary and the eastern boundaries of allotments 4A and 4B to the road forming the southern boundary of the latter allotment; thence easterly by that road to the Trawalla Creek; thence generally south-easterly and generally north-easterly by that creek to the southern boundary of allotment 1, section D, Parish of Langi-kal-kal; thence south-easterly by that boundary, south-westerly, south-easterly and north-easterly by the western, southern and eastern boundaries of allotment 2D and south-easterly by the southern boundary of allotment 2c to the road forming the western boundary of allotment 3; thence south-westerly by that road to its junction with the road from Chute to Waterloo; thence generally southerly by that road to the Trawalla Creek aforesaid; thence generally south-easterly by that creek and Mount Emu Creek aforesaid to the Western Highway aforesaid; thence south-easterly by that highway to the road forming the western boundary of suburban allotment 11, Parish of Brewster; thence southerly by that road to the southern boundary of the said allotment; thence easterly and north-easterly by that boundary to the most southern angle of suburban allotment 10; and thence south-easterly by a direct line crossing Lake Burrumbeet to the point of commencement.

(Area of Shire reduced by 245 hectares to 1531 square kilometres.)

And the Honorable Alan John Hunt, Her Majesty's Minister for Local Government for the State of Victoria, shall give the necessary directions herein accordingly.

L. G. HOUSTON,  
 Acting Clerk of the Executive Council

LOCAL GOVERNMENT DEPARTMENT

At the Executive Council Chamber, Melbourne, the second day of August, 1977

PRESENT:

His Excellency the Governor of Victoria  
 Mr. Dunstan | Mr. Houghton  
 Mr. Maclellan

PART OF ROAD DISCONTINUED—CITY OF ESSENDON

Whereas, it is provided in section 528 (2) of the Local Government Act 1958; that where a road (whether or not a public highway but not being a road set out on land of the Crown) or any part thereof is not required for public use the Governor in Council on the request of the Council of the municipality in which such road is situated made not less than one month after publishing in a newspaper generally circulating in the district and posting to the registered proprietor, (if any) of the land and the owners and occupiers (if any) of the lands abutting or immediately adjacent to the road notice of intention to make such request may by Order published in the Government Gazette direct that such a road or part thereof shall be discontinued and thereupon such road or part thereof shall be discontinued accordingly.

And whereas the Council of the City of Essendon has requested that the Governor in Council direct that part of a road off Lawson Street, Essendon be discontinued and not less than one month previously has published in a newspaper generally circulating in the district and posted to the registered proprietor of the land in the part of a road and to the owners and occupiers of lands abutting or immediately adjacent to the said part of a road notice of intention to make such request.

Now therefore, His Excellency the Governor of the State of Victoria, by and with the advice of the Executive Council thereof, hereby directs—

- (a) that the said part of a road, which is shown by hachure on the plan hereunder, shall be discontinued;
- (b) that notwithstanding such discontinuance the Melbourne and Metropolitan Board of Works shall continue to have and possess the same right title power authority or interest in or in relation to the whole of the land shown by hachure on the said plan as it had or possessed prior to such discontinuance with respect to or in connection with any drains or pipes laid or erected in on or over such land for the purposes of drainage or sewerage; and
- (c) that, subject to any such right title power authority or interest the land in the said road may be sold by the Council of the City of Essendon by agreement.

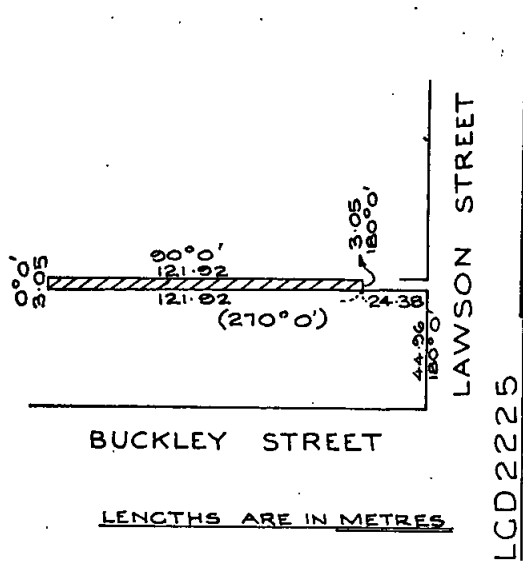

And the Honorable Alan John Hunt, Her Majesty's Minister for Local Government for the State of Victoria, shall give the necessary directions herein accordingly.

L. G. HOUSTON,  
Acting Clerk of the Executive Council

LOCAL GOVERNMENT DEPARTMENT

At the Executive Council Chamber, Melbourne, the second day of August, 1977

PRESENT:

His Excellency the Governor of Victoria  
Mr. Dunstan | Mr. Houghton  
Mr. Maclellan

PART OF ROAD DISCONTINUED—CITY OF FITZROY

Whereas it is provided in section 528 (2) of the Local Government Act 1958, that where a road (whether or not a public highway but not being a road set out on land of the Crown) or any part thereof is not required for public use the Governor in Council on the request of the Council of the municipality in which such a road is situated made not less than one month after publishing in a newspaper generally circulating in the district and posting to the registered proprietor (if any) of the land and the owners and occupiers (if any) of the lands abutting or immediately adjacent to the road notice of intention to make such request may by Order in the Government Gazette direct that such road or part thereof shall be discontinued and thereupon such road or part thereof shall be discontinued accordingly.

And whereas the Council of the City of Fitzroy has requested that the Governor in Council direct that part of a road off Nicholson Street, Fitzroy, be discontinued and

not less than one month previously has published in a newspaper generally circulating in the district and posted to the owners and occupiers of the lands abutting or immediately adjacent to the said part of a road notice of intention to make such request.

And whereas there is no registered proprietor to whom notice of intention may be posted.

Now therefore, His Excellency the Governor of the State of Victoria, by and with the advice of the Executive Council thereof, hereby directs—

- (a) that the said part of a road, which is shown by hachure on the plan hereunder, shall be discontinued;
- (b) that notwithstanding such discontinuance the Melbourne and Metropolitan Board of Works shall continue to have and possess the same right title power authority or interest in or in relation to the whole of the land shown by hachure on the said plan as it had or possessed prior to such discontinuance with respect to or in connection with any drains or pipes laid or erected in on or over such land for the purposes of drainage or sewerage; and
- (c) that, subject to any such right title power authority or interest, the land in the said part of a road may be sold by the Council of the City of Fitzroy by agreement.

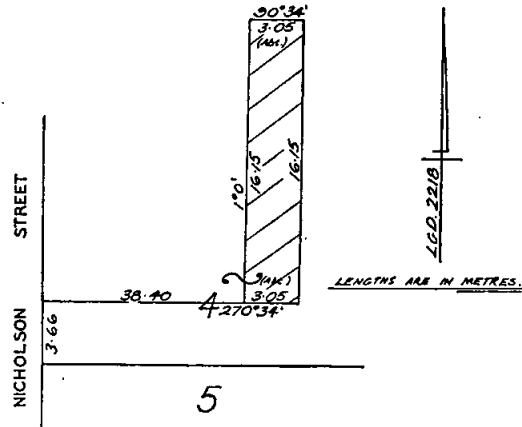

And the Honorable Alan John Hunt, Her Majesty's Minister for Local Government for the State of Victoria, shall give the necessary directions herein accordingly.

L. G. HOUSTON,  
Acting Clerk of the Executive Council

MELBOURNE UNDERGROUND RAIL LOOP ACT 1970,  
No. 8023

At the Executive Council Chamber, Melbourne, the second day of August, 1977

PRESENT:

His Excellency the Governor of Victoria  
Mr. Dunstan | Mr. Houghton  
Mr. Maclellan

Whereas His Excellency the Governor of the State of Victoria by and with the advice of the Executive Council thereof has this day consented pursuant to the provisions of the Melbourne Underground Rail Loop Act 1970 to the Melbourne Underground Rail Loop Authority raising by way of a loan the sum of One million dollars (\$1,000,000); and whereas His Excellency the Governor in Council is satisfied that a sufficient proportion of the loan to be raised will fall due and be repaid in each year during the currency of the proposed loan; now therefore it is directed pursuant to the provisions of section 16 (3) of the said Act, that it shall not be necessary to provide a sinking fund in connection with such loan.

And the Honorable Rupert James Hamer, Her Majesty's Treasurer for the State of Victoria, shall give the necessary directions herein accordingly.

L. G. HOUSTON,  
Acting Clerk of the Executive Council

COUNTRY ROADS BOARD  
Act No. 6229

At the Executive Council Chamber, Melbourne, the second day of August, 1977

PRESENT:

His Excellency the Governor of Victoria  
Mr. Dunstan | Mr. Houghton  
Mr. Maclellan

ORDER APPROVING OF LAND BEING ACQUIRED AND ROADS, DEVIATIONS OR WIDENINGS BEING MADE TOGETHER WITH ALL ANCILLARY WORKS REQUIRED TO BE EXECUTED IN CONJUNCTION THEREWITH

His Excellency the Governor of the State of Victoria, by and with the advice of the Executive Council thereof, being satisfied that there are funds legally available for acquiring the land, doth hereby approve the acquiring of the land described in the schedule hereunder and the making of new roads and deviations from and widenings of existing roads, together with all ancillary works required to be executed in conjunction therewith, referred to in the said schedule.

SCHEDULE  
State Highways

The land shown hatched on plan numbered G.P.14462 hereunder required for the widening of the Princes Highway in the Shire of Buln Buln and making of the widening thereon.

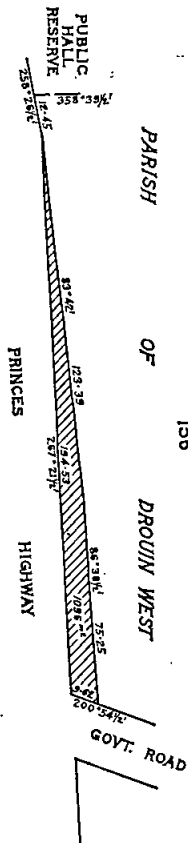

STATE HIGHWAY  
PRINCES HIGHWAY  
SHIRE OF BULN BULN  
Lengths in metres

G.P.14462  
Compiled from  
SP.14462

The land shown hatched on plan numbered G.P.14283 hereunder required for the widening of the Bellarine Highway in the City of Geelong and making of the widening thereon.

STATE HIGHWAY  
BELLARINE HIGHWAY  
CITY OF GEELONG  
Lengths in metres

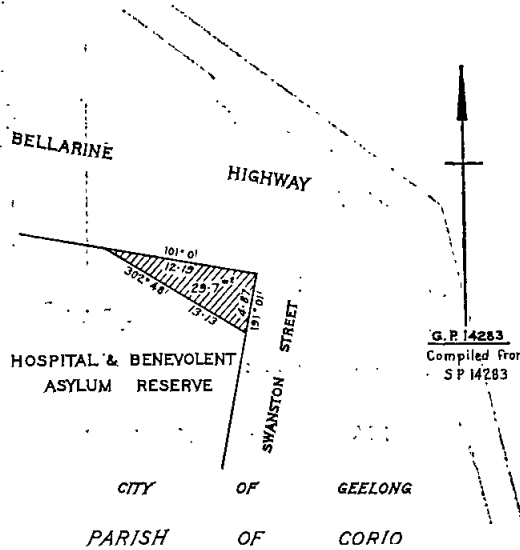

G.P.14283  
Compiled from  
SP.14283

Main Road

The land shown hatched on plans numbered G.P.14442A and G.P.14442B hereunder required for the deviation from Willowgrove Road in the Shire of Narracan and making of the deviation thereon.

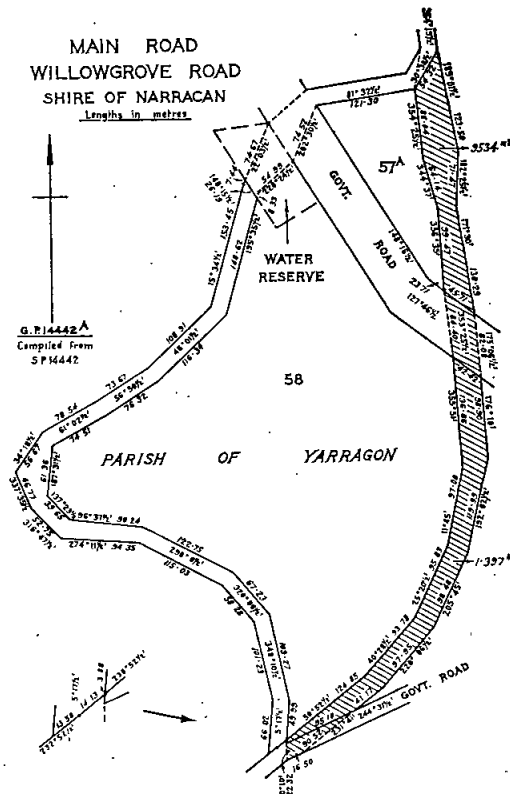

G.P.14442A  
Compiled from  
SP.14442

MAIN ROAD  
WILLOWGROVE ROAD  
SHIRE OF NARRACAN

Lengths in metres

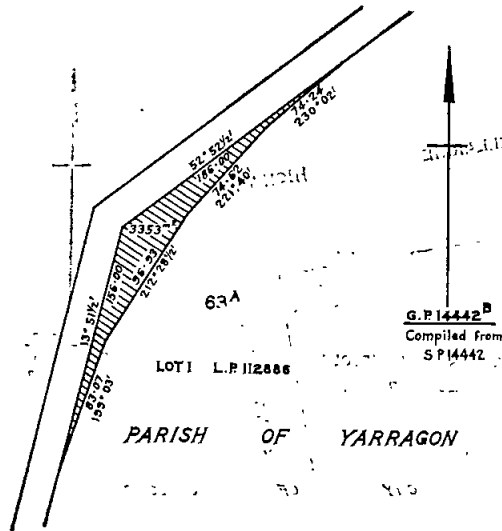

tion of the Housing Commission doth by this order declare the streets more particularly delineated and shown hatched on the plan hereunder to be absolutely dedicated to the public as Public Highways within the meaning of any law now or hereafter in force and that the Council of the Municipality in which the streets are situate shall hereafter be liable for all cost of any maintenance, repair, alteration or reconstruction thereof.

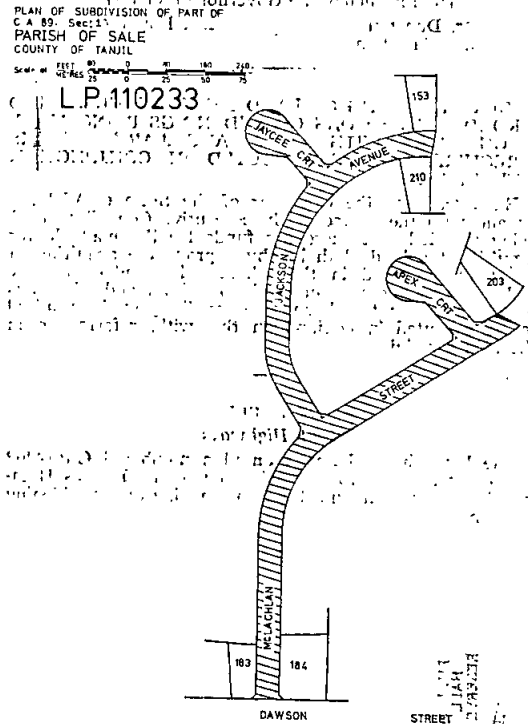

And the Honorable Joseph Anstice Rafferty, Her Majesty's Minister of Transport for the State of Victoria, shall give the necessary directions herein accordingly.  
L. G. HOUSTON,  
Acting Clerk of the Executive Council

And the Honorable Geoffrey Phillip Hayes, Her Majesty's Minister of Housing for the State of Victoria, shall give the necessary directions herein accordingly.  
L. G. HOUSTON,  
Acting Clerk of the Executive Council

HOUSING ACT 1958

At the Executive Council Chamber, Melbourne, the second day of August, 1977

PRESENT:

His Excellency the Governor of Victoria  
Mr. Dunstan | Mr. Houghton  
Mr. Maclellan

HOUSING ACT 1958

At the Executive Council Chamber, Melbourne, the second day of August, 1977

PRESENT:

His Excellency the Governor of Victoria  
Mr. Dunstan | Mr. Houghton  
Mr. Maclellan

DECLARATION OF PRIVATE STREETS AS PUBLIC HIGHWAYS WITHIN THE CITY OF SALE

Whereas pursuant to section 107 of the Housing Act 1958 it is among other things enacted that where works have been carried out in accordance with an agreement for the full construction of any roads, pavements, culverts or drains made pursuant to the provisions of the said section 107 such roads, pavements, culverts or drains shall be under the care and management of the Municipality which shall be liable for the cost of any maintenance, repair, alteration or reconstruction thereof, and the Governor in Council may by order published in the Government Gazette declare any road so constructed to be a public highway.

And whereas by Order dated the 6th June 1973, the Governor in Council consented to an agreement between the Housing Commission and the City of Sale regarding street and drainage construction in McLachlan Street, Apex Court, Jackson Avenue and Jaycee Court in the Newnhams Estate situate in the municipality of the City of Sale and the carrying-out of the works enumerated in the said Agreement.

And whereas the works of road pavements, culvert and drainage construction have now been carried out in accordance with the said agreement between the Housing Commission and the City of Sale.

Now therefore His Excellency the Governor of the State of Victoria by and with the advice of the Executive Council of the said State and in pursuance of the powers conferred by section 107 of the Housing Act and upon recommenda-

DECLARATION OF PRIVATE STREETS AS PUBLIC HIGHWAYS WITHIN THE CITY OF BROADMEADOWS

Whereas pursuant to section 107 of the Housing Act 1958 it is among other things enacted that where works have been carried out in accordance with an agreement for the full construction of any roads, pavements, culverts or drains made pursuant to the provisions of the said section 107 such roads, pavements, culverts or drains shall be under the care and management of the Municipality which shall be liable for the cost of any maintenance, repair, alteration or reconstruction thereof and the Governor in Council may by order published in the Government Gazette declare any road so constructed to be a public highway.

And whereas by Order dated the 30th November, 1976, the Governor in Council consented to an agreement between the Housing Commission and the City of Broadmeadows regarding street and drainage construction in Dimboola Road, Erinbank Crescent, Miram Court, Yarrck Court, Dobies Court, Toonan Court, Haven Court, Ninda Court, Alvie

Court and Nyora Court in the Broadmeadows "J" Estate situate in the municipality of the City of Broadmeadows and the carrying out of the works enumerated in the said Agreement.

And whereas the works of road pavements, culvert and drainage construction have now been carried out in accordance with the said agreement between the Housing Commission and the City of Broadmeadows.

Now therefore His Excellency the Governor of the State of Victoria by and with the advice of the Executive Council of the said State and in pursuance of the powers conferred by section 107 of the Housing Act and upon recommendation of the Housing Commission doth by this order declare the streets more particularly delineated and shown hatched on the plans hereunder to be absolutely dedicated to the public as Public Highways within the meaning of any law now or hereafter in force and that the Council of the Municipality in which the streets are situate shall hereafter be liable for all cost of any maintenance, repair, alteration or reconstruction thereof.

PART OF CROWN PORTION 10 & 14  
PARISH OF WILL WILL ROOK  
COUNTY OF BOURKE

Scale of Metres 0 20 40 80  
L.P. 118263

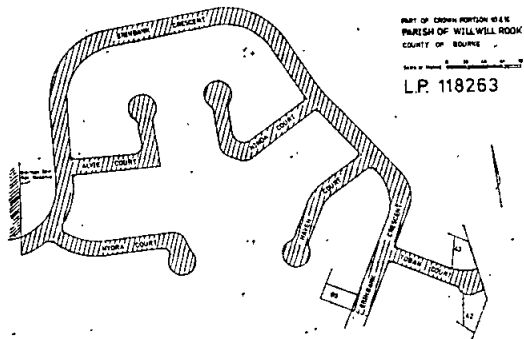
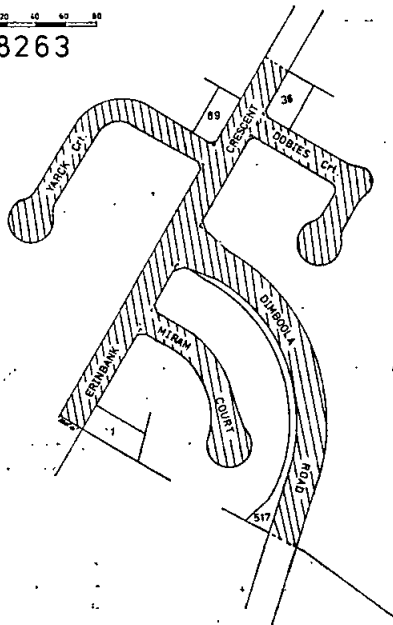

And the Honorable Geoffrey Phillip Hayes, Her Majesty's Minister of Housing for the State of Victoria, shall give the necessary directions herein accordingly.

L. G. HOUSTON,  
Acting Clerk of the Executive Council

HOUSING ACT 1958

At the Executive Council Chamber, Melbourne, the second day of August, 1977

PRESENT:

His Excellency the Governor of Victoria  
Mr. Dunstan | Mr. Houghton  
Mr. Maclellan |

DECLARATION OF PRIVATE STREETS AS PUBLIC HIGHWAYS WITHIN THE CITY OF HEIDELBERG

Whereas pursuant to section 107 of the Housing Act 1958 it is among other things enacted that where works have been carried out in accordance with an agreement for the full construction of any roads, pavements, culverts or drains made pursuant to the provisions of the said section 107 such roads, pavements, culverts or drains shall be under the care and management of the Municipality which shall be liable for the cost of any maintenance, repair, alteration or reconstruction thereof and the Governor in Council may by order published in the *Government Gazette* declare any road so constructed to be a public highway.

And whereas by Order dated the 6th May 1975, the Governor in Council consented to an agreement between the Housing Commission and the City of Heidelberg regarding street and drainage construction in Broadford Crescent, Glenmore Street, Highview Crescent, Thornton Street and Ardmore Court, in the Macleod-Dunvegan Estate situate in the municipality of the City of Heidelberg and the carrying out of the works enumerated in the said Agreement.

And whereas the works of road pavements, culvert and drainage construction have now been carried out in accordance with the said agreement between the Housing Commission and the City of Heidelberg.

Now therefore His Excellency the Governor of the State of Victoria by and with the advice of the Executive Council of the said State and in pursuance of the powers conferred by section 107 of the Housing Act and upon recommendation of the Housing Commission doth by this order declare the streets more particularly delineated and shown hatched on the plans hereunder to be absolutely dedicated to the public as Public Highways within the meaning of any law now or hereafter in force and that the Council of the Municipality in which the streets are situate shall hereafter be liable for all cost of any maintenance, repair, alteration or reconstruction thereof.

PART OF CROWN PORTION 9  
PARISH OF KEELBUNDORA  
COUNTY OF BOURKE

Scale of Metres 0 20 40 80  
L.P. 118400

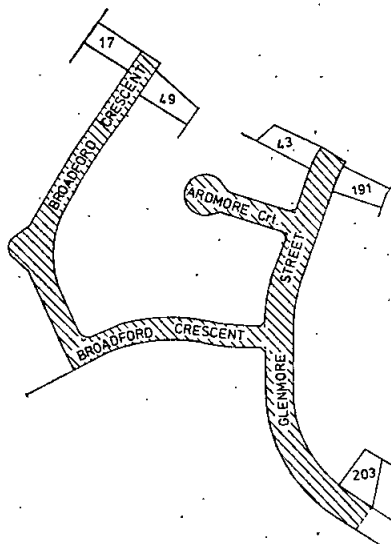

PART OF CROWN PORTION 9  
PARISH OF KEELBUNDORA  
COUNTY OF BOURKE  
SCALE 1" = 40 FEET

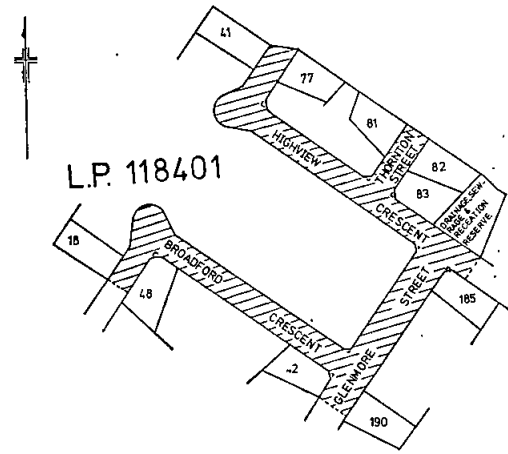

Municipality in which the streets are situate shall hereafter be liable for all cost of any maintenance, repair, alteration or reconstruction thereof.

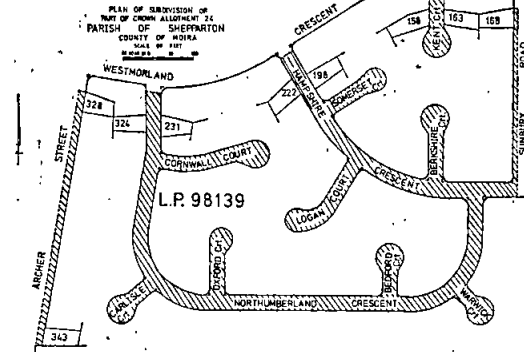

And the Honorable Geoffrey Phillip Hayes, Her Majesty's Minister of Housing for the State of Victoria, shall give the necessary directions herein accordingly.

L. G. HOUSTON,  
Acting Clerk of the Executive Council

And the Honorable Geoffrey Phillip Hayes, Her Majesty's Minister of Housing for the State of Victoria, shall give the necessary directions herein accordingly.

L. G. HOUSTON,  
Acting Clerk of the Executive Council

HOUSING ACT 1958

At the Executive Council Chamber, Melbourne, the second day of August, 1977

PRESENT:

His Excellency the Governor of Victoria  
Mr. Dunstan                      Mr. Houghton  
Mr. Maclellan

DECLARATION OF PRIVATE STREETS AS PUBLIC HIGHWAYS WITHIN THE CITY OF SHEPPARTON

Whereas pursuant to section 107 of the *Housing Act 1958* it is among other things enacted that where works have been carried out in accordance with an agreement for the full construction of any roads, pavements, culverts or drains made pursuant to the provisions of the said section 107 such roads, pavements, culverts or drains shall be under the care and management of the Municipality which shall be liable for the cost of any maintenance, repair, alteration or reconstruction thereof and the Governor in Council may by order published in the *Government Gazette* declare any road so constructed to be a public highway.

And whereas by Order dated the 9th May 1972, the Governor in Council consented to an agreement between the Housing Commission and the City of Shepparton regarding street and drainage construction in Northumberland Crescent, Carlisle Court, Warwick Court, Hampshire Crescent, Somerset Court, Berkshire Court, Kent Court, Sunbury Road, Bedford Court, Logan Court (formally London Court), Oxford Court, Cornwall Court and Archer Street in the Logans Estate situate in the municipality of the City of Shepparton and the carrying out of the works enumerated in the said Agreement.

And whereas the works of road pavements, culvert and drainage construction have now been carried out in accordance with the said agreement between the Housing Commission and the City of Shepparton.

Now therefore His Excellency the Governor of the State of Victoria by and with the advice of the Executive Council of the said State and in pursuance of the powers conferred by section 107 of the *Housing Act* and upon recommendation of the Housing Commission doth by this order declare the streets more particularly delineated and shown hatched on the plan hereunder to be absolutely dedicated to the public as Public Highways within the meaning of any law now or hereafter in force and that the Council of the

INDUSTRIAL TRAINING ACT 1975

At the Executive Council Chamber, Melbourne, the second day of August, 1977

PRESENT:

His Excellency the Governor of Victoria  
Mr. Dunstan                      Mr. Houghton  
Mr. Maclellan

APPOINTMENT OF MEMBERS OF THE INDUSTRIAL TRAINING COMMISSION OF VICTORIA

In pursuance of the powers conferred by section 7 of the *Industrial Training Act 1975*, and all other powers him thereunto enabling, His Excellency the Governor of the State of Victoria, by and with the advice of the Executive Council thereof, doth by this Order make the undermentioned appointments to the Industrial Training Commission of Victoria for a term of three years commencing on the 1st September, 1977—

- WILLIAM NORMAN ROEBUCK being an officer of the Education Department nominated by the Minister of Education, as Deputy President;
- ROBERT WILLIAM GOTTS, and
- THEODORE JOHN COUTTS, as members representing employers and who were nominated by the Victorian Chamber of Manufactures;
- DONALD COCKRAM as a member representing employers and who was nominated by the Victorian Employers' Federation;
- STANLEY FRANKLIN NEWMAN as a member representing employers and who was nominated by the Victorian Branch of the Metal Trades Industry Association of Australia; and
- FRANCIS HENRY BOSWELL, STANLEY BITMEAD, BERNARD THOMAS DALY, and KEVIN THOMAS DAVIES, as members representing employees and who were nominated by the Victorian Trades Hall Council.

And the Honorable Robert Roy Cameron Maclellan, Her Majesty's Minister of Labour and Industry for the State of Victoria, shall give the necessary directions herein accordingly.

L. G. HOUSTON,  
Acting Clerk of the Executive Council



ENVIRONMENT PROTECTION ACT 1970

At the Executive Council Chamber, Melbourne, the second day of August, 1977

PRESENT:

His Excellency the Governor of Victoria  
 Mr. Dunstan | Mr. Houghton  
 Mr. Maclellan

APPOINTMENT OF A MEMBER OF THE ENVIRONMENT PROTECTION COUNCIL

In pursuance of the provisions of section 7 (1) of the Environment Protection Act 1970, and all the powers him thereunto enabling His Excellency the Governor of the State of Victoria, by and with the advice of the Executive Council thereof, doth by this Order appoint BRUCE ROBERT WILSON, being a municipal councillor nominated by the Minister for Local Government from a panel of names of five municipal councillors submitted by the Municipal Association of Victoria, to be a member of the Environment Protection Council during the period 2nd August, 1977, to 30th June, 1980.

And the Honorable William Archibald Borthwick, Her Majesty's Minister for Conservation for the State of Victoria, shall give the necessary directions herein accordingly.

L. G. HOUSTON,  
 Acting Clerk of the Executive Council

SUPERANNUATION ACT 1958

At the Executive Council Chamber, Melbourne, the second day of August, 1977

PRESENT:

His Excellency the Governor of Victoria  
 Mr. Dunstan | Mr. Houghton  
 Mr. Maclellan

Pursuant to the powers conferred by the provisions of paragraph (ja) of sub-section (1) of section 3 of the Superannuation Act 1958, His Excellency the Governor of the State of Victoria, by and with the advice of the Executive Council thereof doth by this Order declare that the provisions of the Superannuation Act shall apply to the officers named in the schedule set out hereunder.

SCHEDULE

- HEAVENOR, LELIA DIANE, Bendigo College of Advanced Education
- MCLEAN, THOMAS JOHN HENRY, Bendigo College of Advanced Education
- LANGFORD, GRAEME STUART, Caulfield Institute of Technology
- MASSARO, VINCENT, Lincoln Institute
- THOMAS, EIRLYS MARY, Prahran College of Advanced Education
- LYNCH, FRANCIS JOSEPH, Warrnambool Institute of Advanced Education
- OW YONG, OI LIN, Warrnambool Institute of Advanced Education

And the Honorable Rupert James Hamer, Her Majesty's Treasurer for the State of Victoria, shall give the necessary directions herein accordingly.

L. G. HOUSTON,  
 Acting Clerk of the Executive Council

SUPERANNUATION ACT 1958

At the Executive Council Chamber, Melbourne, the second day of August, 1977

PRESENT:

His Excellency the Governor of Victoria  
 Mr. Dunstan | Mr. Houghton  
 Mr. Maclellan

Pursuant to the powers conferred by the provisions of paragraph (ja) of sub-section (1) of section 3 of the Superannuation Act 1958, His Excellency the Governor of the State of Victoria, by and with the advice of the

Executive Council thereof doth by this Order declare that the provisions of the Superannuation Act shall apply to COLIN WILLIAM NODEN, an officer of the State College of Victoria at Hawthorn, as from and inclusive of 9th August, 1977.

And the Honorable Rupert James Hamer, Her Majesty's Treasurer for the State of Victoria, shall give the necessary directions herein accordingly.

L. G. HOUSTON,  
 Acting Clerk of the Executive Council

ROAD TRAFFIC ACT 1958

At the Executive Council Chamber, Melbourne, the second day of August, 1977

PRESENT:

His Excellency the Governor of Victoria  
 Mr. Dunstan | Mr. Houghton  
 Mr. Maclellan

In pursuance of the powers conferred by the Road Traffic Act 1958, His Excellency the Governor of the State of Victoria, in the Commonwealth of Australia, by and with the advice of the Executive Council of the said State, and at the request in writing of the Council of the City of Keilor, doth by this Order extend the provisions of the said Act to an area of land under the control of the City of Keilor situated off Taylors Road, St. Albans, as shown by hachure on the plan hereunder.

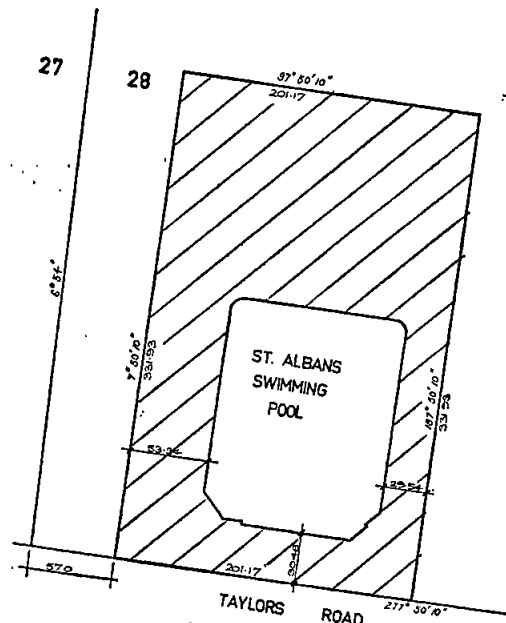

PART OF CROWN ALLOTMENT 28  
 SECTION B  
 PARISH OF MARIBYRNONG  
 COUNTY OF BOURKE

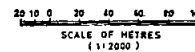

And the Honorable Vance Oakley Dickie, Her Majesty's Chief Secretary for the State of Victoria, shall give the necessary directions herein accordingly.

L. G. HOUSTON,  
 Acting Clerk of the Executive Council

## STAMPS ACT 1958, No. 6375

At the Executive Council Chamber, Melbourne, the second day of August, 1977

## PRESENT:

His Excellency the Governor of Victoria  
Mr. Dunstan | Mr. Houghton  
Mr. Maclellan

His Excellency the Governor of the State of Victoria by and with the advice of the Executive Council thereof, doth by this Order made pursuant to section 131c of the Stamps Act 1958, No. 6375, revoke the declaration made on 2nd April, 1968, and published in the *Government Gazette* of 3rd April, 1968, declaring certain persons to be "approved vendors" for the purposes of subdivision (14) of Division 3 of Part II. of the *Stamps Act 1958* in so far as the said declaration refers to the under-mentioned person:—

241. WARBURTON FRANKI INDUSTRIES (MELBOURNE) PTY. LTD.

And the Honorable Rupert James Hamer, Her Majesty's Treasurer for the State of Victoria, shall give the necessary directions herein accordingly.

L. G. HOUSTON,  
Acting Clerk of the Executive Council

## DANDENONG VALLEY AUTHORITY

At the Executive Council Chamber, Melbourne, the second day of August, 1977

## PRESENT:

His Excellency the Governor of Victoria  
Mr. Dunstan | Mr. Houghton  
Mr. Maclellan

Under the powers conferred by the *Dandenong Valley* enabling him in that behalf, His Excellency the Governor Authority Act 1963, as amended by the *Dandenong Valley Authority (Cardinia Creek) Act 1977*, and all other powers of the State of Victoria, by and with the advice of the Executive Council of the said State doth hereby order and direct as follows:—

That the map defining the boundaries of the District of the Dandenong Valley Authority shall be revised so as to include within the boundaries of the District those lands within the catchment of the Cardinia Creek as shown on plans numbered A103, A104, A105, A106, A107, A108, A109 and A110, approved by the Governor in Council and deposited in the office of the State Rivers and Water Supply Commission, Melbourne.

And the Honorable Frederick James Granter, Her Majesty's Minister of Water Supply for the State of Victoria, shall give the necessary directions herein accordingly.

L. G. HOUSTON,  
Acting Clerk of the Executive Council

## WATER RESOURCES ACT

At the Executive Council Chamber, Melbourne, the second day of August, 1977

## PRESENT:

His Excellency the Governor of Victoria  
Mr. Dunstan | Mr. Houghton  
Mr. Maclellan

## APPOINTMENT OF A MEMBER OF THE WATER RESOURCES COUNCIL

In exercise of the powers conferred on him by the Water Resources Act, His Excellency the Governor of the State of Victoria, by and with the advice of the Executive Council thereof, hereby appoints **RAYMOND WALLACE WHITESIDE** to be the Member of the Water Resources

Council representing the Waterworks Trusts Association of Victoria, for a term commencing on the 3rd day of August, 1977, and ending on the 30th day of November, 1978, both dates inclusive.

And the Honorable Frederick James Granter, Her Majesty's Minister of Water Supply for the State of Victoria, shall give the necessary directions herein accordingly.

L. G. HOUSTON,  
Acting Clerk of the Executive Council

FIRST MILDURA IRRIGATION TRUST  
MILDURA URBAN WATER TRUST

At the Executive Council Chamber, Melbourne, the second day of August, 1977

## PRESENT:

His Excellency the Governor of Victoria  
Mr. Dunstan | Mr. Houghton  
Mr. Maclellan

## SEVERENCE OF PORTION OF THE FIRST MILDURA IRRIGATION TRUST DISTRICT AND ANNEXATION TO THE MILDURA URBAN WATER TRUST DISTRICT

Under the powers conferred by the *Mildura Irrigation and Water Trusts Act* and all other powers enabling him in that behalf, His Excellency the Governor of the State of Victoria, by and with the advice of the Executive Council of the said State, doth hereby declare, order and direct that as on and from the date hereof the lands shown by red colour on the plans marked "A" and "B" approved by the Governor in Council and deposited in the office of the State Rivers and Water Supply Commission, Melbourne (Corr. No. 59/2164/124) shall be severed from the District of the First Mildura Irrigation Trust and annexed to the District of the Mildura Urban Water Trust.

And the Honorable Frederick James Granter, Her Majesty's Minister of Water Supply for the State of Victoria, shall give the necessary directions herein accordingly.

L. G. HOUSTON,  
Acting Clerk of the Executive Council

## MILDURA SEWERAGE AUTHORITY

At the Executive Council Chamber, Melbourne, the second day of August, 1977

## PRESENT:

His Excellency the Governor of Victoria  
Mr. Dunstan | Mr. Houghton  
Mr. Maclellan

## APPROVAL OF SITE FOR EXTENSION OF TREATMENT WORKS AND ACQUISITION OF LAND

Under the powers conferred by the *Sewerage Districts Act* and all other powers enabling him in that behalf, His Excellency the Governor of the State of Victoria, by and with the advice of the Executive Council of the said State, doth hereby approve of the site for the extension of the treatment works and the acquisition of the land required for the site by the Mildura Sewerage Authority being the land shown by red colour on the plan approved by the Governor in Council by and with this Order and deposited in the office of the State Rivers and Water Supply Commission, Melbourne (Corr. No. 73/1019/102).

And the Honorable Frederick James Granter, Her Majesty's Minister of Water Supply for the State of Victoria, shall give the necessary directions herein accordingly.

L. G. HOUSTON,  
Acting Clerk of the Executive Council

**LANDS DEPARTMENT NOTICES**

**APPROACHING LAND SALES**

Sale of Crown Land, in fee-simple, will be held at the under-mentioned places and dates, viz.:—

	No. of Gazette
Ouyen.—Friday, 9th September, 1977	68

**SALE OF CROWN LAND BY AUCTION**

The land will be offered for sale in fee-simple, and subject to the provisions of the Land Act and Regulations thereunder.

The upset price is the sum at which bidding will start, and no bid below that sum can be accepted. The highest bidder at or above that sum shall be the purchaser, subject to signature of contract and any necessary payment.

**TERMS:—**

A deposit of at least 12½% of the purchase price must be paid at the sale, either in cash or by cheque.

The residue is payable in half-yearly instalments, in accordance with the following scale, or may be paid off at any earlier time.

Over \$40, and not exceeding \$100,	8 instalments.
Over \$100, and not exceeding \$200,	10 instalments.
Over \$200, and not exceeding \$400,	12 instalments.
Over \$400, and not exceeding \$600,	14 instalments.
Over \$600, and not exceeding \$800,	16 instalments.
Over \$800, and not exceeding \$1,000,	18 instalments.
Over \$1,000,	20 instalments.

Interest at the rate of 9% per annum is payable with all payments of residue, and is computed for each instalment from the date of sale to the date of such payment. Additional interest is charged if any instalment is not paid on or before the due date.

If paid off within 30 days of sale, no interest is payable.

**FEES, ETC.:**

Also payable at the sale, in addition to the deposit, are the survey fee and, if applicable, the valuation of improvements (if purchaser be not the owner thereof).

Payable with balance of purchase money—

Crown Grant fee—\$18.00.

Assurance Fund contribution.—One cent in every Five dollars or part thereof of purchase price. (This is a fund established to guarantee the validity of freehold titles.)

Transfer of interest prior to completion of payment may be allowed on payment of \$12 fee and subject to stamp duty.

If unable to attend personally, a prospective purchaser may arrange for another person to bid as his agent.

Attention is drawn to section 95, Land Act 1958, which provides that the purchaser shall be deemed to be the owner for the purposes of other Acts; also to an amendment to the Local Government Act providing for Government roads, in certain circumstances, to be declared "private streets", thus making the purchaser liable to contribute to the cost of street construction.

W. BORTHWICK,  
Minister of Lands

Office of Crown Lands and Survey,  
Melbourne, 10th August, 1977

**OUYEN.**—Sale (No. 12240) of Crown Land in fee simple, by auction, will be held at the Land Inspectors Office, Mitchell Street, OUYEN, on Friday, the 9th day of September, 1977, at TWO o'clock P.M. To be conducted by P. Richardson, Land Officer, Red Cliffs.

Lot 1.

PARISH OF OUYEN

Fronting the south-east side of Nihill Street, Ouyen.  
Upset price \$1700.00 the lot. Survey fee \$120.00

Area 32 perches (809 square metres). Allotment 21 of Section 1. Subject to drainage easement 10 links (2.01 metres) wide (L5—236).

**PROPOSED REVOCATIONS OF TEMPORARY RESERVATIONS OF LANDS BY ORDERS IN COUNCIL**

In pursuance of the provisions of the Land Act 1958, notice is hereby given that it is the intention of the Governor in Council to revoke the temporary reservations of lands by Orders in Council hereunder referred to, viz.:—

The following Notices were published 1° on the 3rd August, 1977, pursuant to Orders of the 27th July, 1977

**WILBY.**—The temporary reservation as a site for Public purposes (State School) and the withholding from sale, leasing and licensing by Order in Council of the 14th February, 1882, of 8094 square metres of land being part of section 4, Township of Wilby (Town of Pelluebla in Order), revoked as to part by Order of the 19th February, 1974, are about to be revoked so far as the balance thereof containing 7981 square metres, is concerned.—(P.145(°) (Rs.9330).

**MILDURA.**—The temporary reservation by Order in Council of the 16th October, 1956, of 809 square metres of land being part of section 60, block D, Parish of Mildura as a site for Government Buildings, is about to be revoked.—(M.533(°) (Rs.7492).

**BALLARAT EAST.**—The temporary reservation by Order in Council of the 8th December, 1931, of 15.93 hectares of land in the Township of Ballarat East (City of Ballarat in Order) as a site for Public purposes (Tree Planting), and the temporary reservation by Order in Council of the 6th August, 1934, of the same land for the additional purpose of Public Recreation are about to be revoked, so far only as the portion containing 1352 square metres indicated by hatching on plan hereunder, is concerned.—(B.128(°) (Rs.4159).

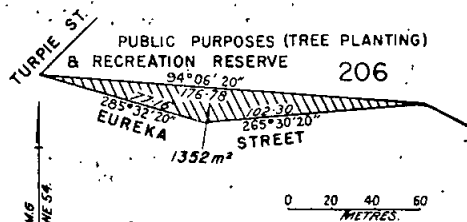

W. BORTHWICK,  
Minister of Lands

**PROPOSED PERMANENT RESERVATION OF LAND AS A SITE**

In pursuance of sections 14 and 21 of the Land Act 1958, notice is hereby given that it is the intention of the Governor in Council to reserve permanently from sale, from being leased and from having a licence granted in respect thereof and also except from occupation for mining purposes under any miners right, the lands hereinafter described:—

The following Notices were published 1° on the 20th July, 1977, pursuant to Orders of the 12th July, 1977

**NUNAWADING (BOX HILL SOUTH).**—Land proposed to be permanently reserved as a site for a Public Park and for Public Recreation, 3.178 hectares, more or less, being Crown allotment 22b, Parish of Nunawading, County of Bourke as indicated by hatching on plan hereunder.—(N.79(°) (Rs.10352.)

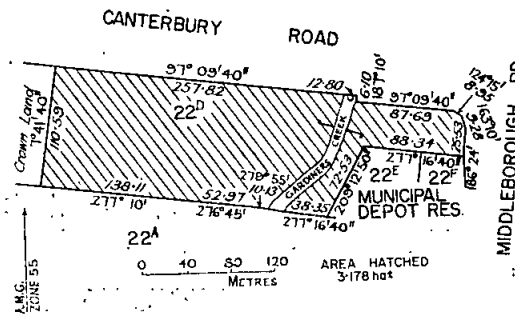

**NUNAWADING (BOX HILL).**—Land proposed to be permanently reserved as a site for a Public Park and for Public Recreation, 6223 square metres, being Crown allotment 26A, Parish of Nunawading, County of Bourke as indicated by hatching on plan hereunder.—(N.79(?) (Rs.10352.)

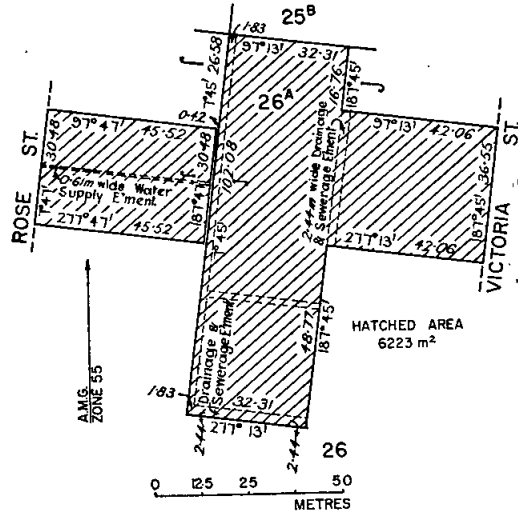

**JIM BALFOUR,**  
Acting Minister of Lands

**PROPOSED REVOCATION OF TEMPORARY RESERVATION OF LAND BY ORDER IN COUNCIL**

In pursuance of the provisions of the *Land Act 1958*, notice is hereby given that it is the intention of the Governor in Council to revoke the temporary reservation of land by Orders in Council hereunder referred to, viz.:—

The following Notice was published 1° on the 27th July, 1977, pursuant to an Order of the 19th July, 1977

**MERBEIN.**—The temporary reservation by Order in Council of 5th October, 1936, of 11.98 hectares of land being Crown allotment 8, section B, Parish of Merbein, as a site for Drainage purposes is about to be revoked.—(M.572(?) (Rs.4624.)

**JIM BALFOUR,**  
Acting Minister of Lands

**COMMITTEE OF MANAGEMENT OF THE "PHILLIP ISLAND PUBLIC PURPOSES RESERVE"**

In pursuance of section 221 of the *Land Act 1958* I hereby appoint the Corporation of the Shire of Phillip Island as the Committee of Management of the land in the Township of Newhaven, Parish of Phillip Island temporarily reserved by Order in Council dated the 27th July, 1976, as a site for Public purposes—(Corres. No. Rs.5133).

**W. A. BORTHWICK,**  
Minister of Lands

Department of Crown Lands and Survey,  
Melbourne, 3rd August, 1977

**PROPOSED REVOCATION OF TEMPORARY RESERVATION OF LAND BY ORDER IN COUNCIL**

In pursuance of the provisions of the *Land Act 1958*, notice is hereby given that it is the intention of the Governor in Council to revoke the temporary reservation of land by Orders in Council hereunder referred to, viz.:—

The following Notice was published 1° on the 10th August, 1977, pursuant to an Order of the 2nd August, 1977

**BINGINWARRI.**—The temporary reservation by Order in Council of the 9th May, 1906, of 2504 square metres of land adjoining Crown allotment 65K, Parish of Binginwarri as a site for a Public Hall, is about to be revoked.—(B.707(12) (Rs.1448).

**W. BORTHWICK,**  
Minister of Lands

**REGULATION FOR THE CARE, PROTECTION AND MANAGEMENT OF THE "COWES AND PHILLIP ISLAND FORESHORE AND OTHER RESERVES"**

Whereas by section 218 of the *Land Act 1958*, the Minister of Lands is empowered to make Regulations as to any land which under the provisions of that Act or of any other Act relating to Crown lands has been reserved for any public purpose whatsoever and which has not been conveyed to or vested in trustees: And whereas the reserved Crown lands in the Parish of Phillip Island, as are indicated by red colour on plan marked "P/24.1.47" attached to Lands Department correspondence No. Rs.5133, were reserved by various Orders in Council and by notices in the *Government Gazettes*: And whereas the Crown land in the said Parish, as is indicated by pink colour on plan marked "P/6.3.57" attached to the aforesaid correspondence, was temporarily reserved as a site for Public purposes by Order in Council dated 30th April, 1957 (vide *Government Gazette* of the 8th May, 1957): And whereas certain land in the said Parish and Township of Newhaven was temporarily reserved as a site for Public purposes by Order in Council dated the 2nd October, 1973 (vide *Government Gazette* of the 10th October, 1973): And whereas such lands (hereinafter called the "Reserves" or the "Parks") have not been conveyed to or vested in trustees but have been placed under the control of a Committee of Management (hereinafter referred to as the "Committee") pursuant to the provisions of section 221 of the *Land Act 1958*: And whereas Regulations for the care, protection and management of the Crown land shown by red colour on plan marked "P/24.1.47" mentioned aforesaid were made on 22nd April, 1947 (vide *Government Gazette* of the 30th April, 1947): And whereas such Regulations were applied to the Crown land indicated by pink colour on plan marked "P/6.3.57" mentioned aforesaid on the 2nd July, 1957 (vide *Government Gazette* of the 10th July, 1957): And whereas additional Regulations were made for the Crown lands described on the plans mentioned aforesaid on the 3rd October, 1962 (vide *Government Gazette* of the 10th October, 1962): And whereas all the Regulations mentioned aforesaid were applied to the Crown land reserved by Order in Council dated the 2nd October, 1973 on the 28th June, 1974 (vide *Government Gazette* of the 3rd July, 1974): And whereas it is expedient that an additional Regulation be made: Now therefore I, William Archibald Borthwick, Her Majesty's Minister of Lands in and for the State of Victoria, in pursuance of the powers aforesaid, do hereby make an additional Regulation to the aforesaid Regulations for or with respect to the Parks or Reserves as follows:—

The additional Regulation shall read:—

50. No person shall use in any part of the Parks or Reserves a beach umbrella or similar device for providing shade or protection unless it shall be securely anchored—

- (a) by means of a disc of weatherproof plywood at least 30 centimetres in diameter fitted over the shaft immediately above the tip and the disc buried in the sand to a depth of at least 30 centimetres, or
- (b) by means of a bag filled with at least 2 kilograms dry weight of sand securely tied to the shaft at sand level, or
- (c) by and other means approved by the Committee —(Rs.5144).

Given under my hand, at Melbourne, on the 3rd day of August, 1977.

**W. BORTHWICK,**  
Minister of Lands

Every person who contravenes or fails to comply with this Regulation shall, in accordance with the provisions of section 218 of the *Land Act 1958*, for each offence be liable to a penalty of not more than Fifty dollars, and every person who contravenes or fails to comply with any such Regulation, and who, after he has been warned by any bailiff or Crown lands or by any member of the Police Force, does not desist therefrom may be forthwith apprehended by such bailiff or member of the Police Force and taken before some justice to be dealt with according to law and shall be liable to a penalty of not more than One hundred dollars, provided that every person who contravenes any Regulation made under the said section for or with respect to prohibiting the depositing and leaving of any unwanted material or thing or rubbish of any kind on any land to which such Regulation relates shall for each offence be liable to a penalty of not more than Two hundred dollars.

REGULATIONS FOR THE CARE, PROTECTION AND MANAGEMENT OF CERTAIN LAND IN THE PARISH OF BALLARAT RESERVED FOR RECREATION AND PUBLIC PURPOSES AND KNOWN AS THE "SOVEREIGN HILL RESERVE"

Whereas by section 218 of the *Land Act 1958* the Minister of Lands is empowered to make Regulations as to any land which under the provisions of that Act or of any other Act relating to Crown lands has been reserved for any public purpose whatsoever and which has not been conveyed to or vested in trustees: And whereas certain Crown lands in the Parish of Ballarat were reserved as stipulated in the Schedule hereunder: And whereas such lands (hereinafter called the "Reserve") have not been conveyed to or vested in trustees but have been placed under the control of a Committee of Management pursuant to section 221 of the *Land Act 1958*: And whereas it is expedient that Regulations for the care, protection and management of the Reserve and for other purposes connected therewith should be made: Now therefore I, William Archibald Borthwick, Her Majesty's Minister of Lands in and for the State of Victoria, in pursuance of the powers aforesaid, do hereby make the following Regulations for or with respect to the Reserve:—

SCHEDULE

1. (a) The land deemed to be permanently reserved for Recreation and Public Purposes by virtue of section 4 of the *Ballarat (Sovereign Hill) Land Act 1970*, No. 7955, and as is shown by black hatching on the plan in the Schedule to such Act.

(b) The remaining portion of the lands deemed to be permanently reserved for Recreation and Public Purposes by virtue of section 3 of the *Ballarat (Sovereign Hill) Land Act 1973*, No. 8401, and as is shown by black hatching on the plans in Parts A and B in the Schedule to such Act.

(1) Definitions—

"Committee" means the Corporation of the City of Ballarat, duly appointed as the Committee of Management pursuant to section 221 of the *Land Act 1958*.

"Authorized Officer" means any employee or employees of the Ballarat Historical Park Association nominated by such Association and authorized by the Committee.

"Registered Office" means the Cottage of the Executive Director of the Ballarat Historical Park Association located at 39-41 Maggie Street, Ballarat, or such other office as is so designated from time to time.

"Dam" or "creek" means any dam or creek within the "Sovereign Hill Reserve".

(2) The Reserve shall be open to the public on such days and hours as determined by the Committee which shall also determine the charge or charges, if any, for admission.

(3) No person shall enter or remain in the Reserve who in the opinion of the Committee or its authorized officer may offend against decency as regards dress, language or conduct.

(4) No person shall affix, print, post, paint, cut or mark any advertisement, sign, picture, bill, placard, notice, words, letters and figures to or upon any wall or fence in or enclosing the Reserve, or to or upon any tree, building, barrier, railing, seat, structure, erection, flagging or path in the Reserve without the consent of the Committee or its authorized officer.

(5) No person shall climb on or over any of the buildings, gates or fences in the Reserve or in any manner deface, damage or interfere with any building, fence, gate, seat, bridge, culvert, rotunda, step, stairway, electrical fitting and equipment, water pipe, water tap, drain, drainage pipe, erection, enclosure, structure, post, fitting, tree, shrub or flower in the Reserve.

(6) No person shall damage or interfere with the works of the dam in the Reserve.

(7) No person shall enter any plot or enclosure set aside as a plantation for trees, flowers, plants or shrubs.

(8) No person shall damage or unlawfully remove or interfere with the works around any dam, tank or creek, nor shall any person dig or cut away any embankment, road or earthwork or any part thereof in the Reserve.

(9) No person shall unlawfully remove, damage or interfere with any emergency apparatus, fire-hose or any structure, erection or fitting used for the housing or holding of such hose or apparatus.

(10) No person shall use any privately owned canoe, boat or other water craft in the Reserve unless authorized by the Committee or its authorized officer.

(11) No person unless authorized by the Committee or its authorized officer shall enter upon any building, erection or enclosure set aside by the Committee or its authorized officer as a restricted area.

(12) No male person shall enter or use any place, room or building set apart for the use of females, and no female person shall enter or use any place, room or building set apart for the use of males. The provisions of this Regulation shall not apply to male persons under the age of seven years.

(13) No person shall disturb or destroy any bird, water fowl or any other fauna in the Reserve without the permission, in writing, of the Committee or its authorized officer first obtained.

(14) No person shall bring into the Reserve any dog unless led by a chain or cord. Should any dog led by a chain or cord annoy any person or disturb any bird, water fowl or any other fauna in the Reserve, the person in charge of such dog shall, at the request of the Committee or its authorized officer or any member of the Police Force, immediately remove such dog from the Reserve and shall not permit such dog to again enter the Reserve without the permission, in writing, of the Committee or its authorized officer first obtained.

(15) No person in charge of any dog shall allow such dog to enter any dam, tank or creek.

(16) All dogs, except as hereinbefore provided, and all goats, pigs and poultry found trespassing in the Reserve shall be liable to be destroyed.

(17) No person shall bring into or use or carry in the Reserve any firearm, catapult or other weapon or device of any description capable of being used to kill any bird, water fowl or any other fauna in the Reserve without the permission, in writing, of the Committee or its authorized officer.

(18) No person shall light any fire in the Reserve except in the fireplaces and barbecues provided for the purpose unless authorized by the Committee or its authorized officer.

(19) No person shall fish, swim, wade or boat in any pool or pond enclosed for the purpose of holding exhibition fish or the growing of water lilies without the permission, in writing, of the Committee or its authorized officer first obtained.

(20) No person shall leave or deposit any glass, paper or rubbish in the Reserve except in receptacles provided for the purpose, or roll or throw stones, sticks or missiles of any kind therein, or throw, deposit or place any bottle, glass, stone, stick or other foreign matter in the Reserve except as hereinbefore provided.

(21) No person shall put in the Reserve any cattle, horses, sheep, goats, pigs or other animals or permit the same to enter without the permission, in writing, of the Committee or its authorized officer first obtained, and any moneys received by the Committee or its authorized officer for agistment shall be expended in the maintenance and improvement of the Reserve and an account thereof shall be furnished annually to the Secretary for Lands.

(22) The Committee shall have full power and authority to impound any cattle found trespassing on the Reserve (with all power incidental to that status) within the meaning of any law for the time being in force relating to the impounding of cattle. For the purpose of this clause "cattle" shall mean cattle as defined by the *Pounds Act 1958*.

(23) No person shall camp in the Reserve, nor erect therein any building, tent, booth or other structure without the permission, in writing, of the Committee or its authorized officer first obtained.

(24) No person shall take part in any public entertainment of any kind in the Reserve without the permission, in writing, of the Committee or its authorized officer first obtained.

(25) No person shall play a musical instrument, tape recorder, radio or amplifier within the Reserve without the permission, in writing, of the Committee or its authorized officer first obtained.

(26) No person shall spit or expectorate on the paths or on any structure in the Reserve.

(27) No person shall bet in any part of the Reserve.

(28) No person shall play, practise or engage in any organized sport, including swimming, tennis, football, cricket, foot racing or any other like game except in portions of the Reserve which may from time to time

be set apart for the purpose and subject to such terms and conditions as the Committee or its authorized officer may determine.

(29) No person shall obstruct, disturb, interrupt or annoy any officer or employee of the Committee in the proper execution of his work and duty.

(30) No person shall ride any cycle within the Reserve or bring into the Reserve any motor car, horse, carriage, cart or other vehicle without the written authority of the Committee or its authorized officer (which authority shall state the conditions of the admission of such motor car, horse, carriage, cart or other vehicle) and then only in such part or parts of the Reserve as may be set apart by the Committee or its authorized officer. This Regulation shall not apply to emergency vehicles and those necessary for essential maintenance.

(31) The Committee may charge and collect a parking fee for each motor car, horse carriage, cart or other vehicle entering or remaining in any area designated for parking. The Committee or its authorized officer shall have the power to designate any such parking area and any access route in the Reserve.

(32) Persons occupying or hiring any site, stand, building, erection or enclosure on the occasions of any fêtes, games, sports or holiday amusements may be required to deposit a sum which the Committee may at any time determine by way of guarantee that due care shall be taken of such site, stand, building, erection or enclosure, and such Committee, in its absolute discretion, may make good any damage or loss sustained by such site, stand, building erection or enclosure or anything contained therein during such occupancy or hiring and deduct the cost of making good such loss or damage from the sum of money deposited by way of guarantee. All persons so occupying or hiring shall abide by these Regulations and by any lawful order given by the Committee or its authorized officer.

(33) No person shall preach, declaim, harangue or deliver any address of any kind to members of the public or assemble with any other person or persons for the purpose of hearing any public address within the Reserve without the permission, in writing, of the Committee or its authorized officer.

(34) Any person, in any part of the Reserve or in any building, structure or erection for the time being thereon, committing any of the following Acts shall be guilty of an offence against these Regulations:—

- (a) Being under the influence of intoxicating liquor;
- (b) Without the consent of the Committee or its authorized officer, crossing or trespassing on any playing ground or course during any sports or during practice by any person or member of any sports club for the time being occupying the Reserve or any portion thereof;
- (c) Improperly interfering with or interrupting any sports or holiday amusements or any practices thereat;
- (d) Obtaining admission to any part of the Reserve when not entitled to such admission under these Regulations.

(35) Any person, club or society having obtained permission of the Committee or its authorized officer to use any dressing room, pavilion or other structure in the Reserve shall maintain and/or leave the same in a clean and tidy condition. No water tap or shower shall be left running, nor shall any room or enclosure be left unlocked after use.

(36) No person shall force open any locked gate or door to any enclosure, room or building in the Reserve, nor shall any person use any key to open any lock on such gate or door unless authorized so to do by the Committee or its authorized officer.

(37) Any person receiving any key or keys for the unlocking of any door or gate in the Reserve from any member, employee or officer of the Committee shall return such key or keys in good order and condition to the Registered Office before sunset of the day on which the key or keys are received; unless otherwise allowed or directed by the Committee or its authorized officer.

(38) Admission to the Reserve by payment of a fee does not of itself confer on a person a right to take photographs either still or moving for any purpose whatsoever. However, no restriction shall be placed on a person taking photographs either still or moving which are not used for gain or profit so long as an acknowledgment is given that the photographs were taken at Sovereign Hill, Ballarat.

The Committee or its authorized officer shall have the right to refuse admission to any person who is not prepared to comply with any reasonable request about the taking of photographs, or, who having been admitted to the Reserve, refuses to follow the reasonable instructions of the Committee or its authorized officer about taking photographs. Upon payment of a fee determined by the Committee, a person may be granted approval, under certain specified conditions, to take photographs which photographs are to be used for gain or profit. In this Regulation the use of the term "photographs" shall also be deemed to include moving film, video tape, television films and similar methods of recording visually.

(39) No person shall hawk or sell or offer for sale within the Reserve any goods, fruit, merchandise or anything else whatsoever or solicit or gather money therein without the permission, in writing, of the Committee, or its authorized officer first obtained.

(40) The foregoing Regulations shall not restrict any servants, agents or workmen of the Committee or of the Ballarat Historical Park Association in the proper execution of their duty or work in or on the Reserve.—(Rs.3775.)

Given under my hand at Melbourne on the 3rd day of August, 1977.

W. BORTHWICK,  
Minister of Lands

Every person who contravenes or fails to comply with these Regulations shall, in accordance with the provisions of section 218 of the *Land Act 1958*, for each offence be liable to a penalty of not more than Fifty dollars, and every person who contravenes or fails to comply with any such Regulations, and who, after he has been warned by any bailiff of Crown lands or by any member of the Police Force, does not desist therefrom may be forthwith apprehended by such bailiff or member of the Police Force and taken before some justice to be dealt with according to law and shall be liable to a penalty of not more than One hundred dollars, provided that every person who contravenes any Regulation made under the said section for or with respect to prohibiting the depositing and leaving of any unwanted material or thing or rubbish of any kind on any land to which such Regulation relates shall for each offence be liable to a penalty of not more than Two hundred dollars.

#### BUCHAN, CAVES RESERVES

##### CHARGES AND VISITING TIMES

In accordance with Regulations 10 and 40 of the Regulations for the care, protection and management of the Buchan Caves Reserves made by me on 1st December, 1976 I, William Archibald Borthwick, Her Majesty's Minister of Lands in and for the State of Victoria, do hereby specify that:—

1. The times for inspection and scale of charges which shall be made and taken for the admission of each person to the caves respectively indicated shall be as follows:—

Visiting times at 10.30 a.m. and 2.30 p.m. and such times between those times as may be decided by the Supervisor having regard to the number of persons who desire to inspect the caves.

Cave	Scale of Charges
Fairy	\$1.30
Royal	\$1.30

Provided, however, that the sum of thirty (30) cents shall be charged and taken for the admission of any person not over the age of fourteen (14) years.

2. The charges for camping shall be as follows:—

Up to three (3) persons per night	\$2.00
Each additional person per night	\$0.70
Additional charge for powered site per night	\$1.00

3. The fee for the entry to and use of any area set aside for the parking of motor vehicles, bicycles or the tethering of horses shall be Twenty (20) cents per day per motor vehicle, bicycle or horse.

Given under my hand, at Melbourne, on the 3rd day of August, 1977.

W. A. BORTHWICK,  
Minister of Lands

(These charges replace those notified in the *Government Gazette* No. 99 of 8th December, 1976.)

**TENDERS**

**PUBLIC WORKS DEPARTMENT**

Tenders are invited for the purposes indicated hereunder and will be received at 2 Treasury Place, Melbourne, 3002, until TWO p.m. on dates shown.

Tenders must be addressed to the Minister of Public Works with the envelope endorsed "Tender for".

Hand delivered tenders must be placed in the Department's tender box in the foyer, Ground Floor, 2 Treasury Place, Melbourne.

Tender documents are available from the Contracts Office, Room 27, 2 Treasury Place, Melbourne and, where indicated, at offices of Inspectors of Works.

**Tuesday, 23rd August, 1977**

**Building, Electrical and Mechanical Works**

**BENDIGO.**—Portable Regional Education Centre—Office Complex, Regional Education Centre. (W.O., Bendigo.)

**BENNETTSWOOD.**—Internal and external renovations and painting, Primary School No. 4693.

**DONCASTER PARK.**—External and part internal renovations and painting, Primary School No. 4861.

**GLADESVILLE.**—Exterior and part interior repairs and painting, Primary School No. 5066.

**GLENDAL.**—Internal and external repairs and painting, Primary School No. 5010.

**KYABRAM.**—Provision of Art/Craft Centre, Primary School No. 4866. (W.O., Shepparton and Bendigo.)

**OAKLEIGH.**—Fire Alarm Installation, Technical School.

**SHEPPARTON.**—Exterior and part interior repairs and painting and alteration to form staff toilets, Primary School No. 4657. (W.O., Shepparton and Benalla.)

**TEMPLESTOWE HEIGHTS.**—External renovations and painting, Primary School No. 5004.

**MELBOURNE.**—Supply of 120 No. 5 Module Primary and 25 No. 5 Module Post Primary Relocatable Classroom Buildings, Relocatable Buildings. (W.O., Geelong, Benalla, Ballarat, Horsham, Wangaratta and Traralgon.)

**Miscellaneous**

**PORT MELBOURNE.**—Amended specification, supply of 2,000 Coir Mats, P.W.D. Storeyard.

**Tuesday, 30th August, 1977**

**Building, Electrical and Mechanical Works**

**BENA.**—External and internal repairs and painting, Primary School No. 3062. (W.O., Korumburra and Warragul.)

**MOORABBIN.**—Partitioning of existing building (first floor), C.G. & C.S. Centre.

**GREENSBOROUGH.**—Partitioning of existing building (first floor), C.G. & C.S. Centre.

**SUNSHINE WEST.**—External and internal repairs and painting, High School.

**TRARALGON.**—Steam and condensate pipework replacement, Mental Hospital. (W.O., Traralgon and Warragul.)

**MELBOURNE.**—Supply of 51 No. Special Relocatable Classroom Buildings and Administration Units, Relocatable Buildings. (W.O., Geelong, Benalla, Ballarat, Horsham, Wangaratta and Traralgon.)

**Tuesday, 6th September, 1977**

**Building, Electrical and Mechanical Works**

**DOOKIE.**—Renewal of rising main, Agricultural College. (W.O., Shepparton.)

**ROBERTS DUNSTAN,**  
Minister of Public Works

Public Works Department,  
Melbourne, 3002, 9th August, 1977

**PRIVATE ADVERTISEMENTS**

**CITY OF BALLAARAT**

LOAN No. 63

*Notice of Intention to Borrow the Sum of \$25,200 for Permanent Works and Undertakings*

Notice is hereby given that the Council of the City of Ballaarat proposes to borrow the principal sum of Twenty-Five Thousand Two Hundred dollars (\$25,200), secured by

a charge over the general rates of the municipality, such sum to be raised by the grant of a mortgage, in accordance with the provisions of the Local Government Act 1958.

1. The maximum rate of interest that may be paid is 10.9 per centum per annum.

2. The purpose for which the loan is to be applied is Town Hall Development and Eureka Park Glasshouse.

3. The period of the loan shall be ten years.

4. The money borrowed shall be repayable by providing out of the municipal fund, 20 half-yearly instalments of \$2,099.98 each including principal and interest on the 10th day of September and on the 10th day of April during the currency of the loan. The first instalment shall be payable on the 10th day of April 1978.

Such moneys are to be repayable at the office of the Commercial Bank of Australia Limited, Melbourne.

The plans and specifications and the estimate of the cost of the works and a statement showing the proposed expenditure of the moneys to be borrowed, are open for inspection at the Town Hall Ballarat.

Dated 4th August, 1977

9686

I. C. SMITH, Town Clerk

**CITY OF BALLAARAT**

LOAN No. 64

*Notice of Intention to Borrow the Sum of \$64,500 for Permanent Works and Undertakings*

Notice is hereby given that the Council of the City of Ballaarat proposes to borrow the principal sum of sixty-four thousand, five hundred dollars (\$64,500) secured by a charge over the general rates of the municipality, such sum to be raised by the grant of a mortgage, in accordance with the provisions of the Local Government Act 1958.

1. The maximum rate of interest that may be paid is 10.8 per centum per annum.

2. The purpose for which the loan is to be applied is Purchase of Plant.

3. The period of the loan shall be seven years.

4. The money borrowed shall be repayable by providing out of the municipal fund 14 half-yearly instalments of \$6,683.75 each including principal and interest on the 10th day of September and on the 10th day of April during the currency of the loan. The first instalment shall be payable on the 10th day of April 1978.

Such moneys are to be repayable at the office of the Commercial Bank of Australia Limited in Melbourne.

The plans and specifications and the estimate of the cost of the works and a statement showing the proposed expenditure of the moneys to be borrowed, are open for inspection at the Town Hall Ballarat.

Dated 4th August, 1977

9687

I. C. SMITH, Town Clerk

**CITY OF BERWICK**

LOAN No. 31

*Notice of Intention to Borrow the Sum of \$250,000 for Permanent Works and Undertakings*

Notice is hereby given that the Council of the City of Berwick proposes to borrow the principal sum of two hundred and fifty thousand dollars, secured by a charge over the general rates of the Municipality, such sum to be raised by the grant of a mortgage in accordance with the provisions of the Local Government Act 1958.

1. The maximum rate of interest that may be paid is 11 per centum per annum.

2. The purpose for which the loan is to be applied—

Part Cost of Municipal Offices and Council Chambers.

3. The period of the loan shall be twenty years.

4. The moneys borrowed shall be repayable by providing out of the municipal fund, forty half-yearly instalments of approximately \$15,580.09, each including principal and interest, on the first day of October and first day of April during the currency of the loan. The first instalment shall be payable on the first day of April, 1978.

5. Such moneys shall be repayable to the Local Authorities Superannuation Board, "Rigby House", 15 Queens Road, Melbourne, or such other place, or places, as the Board from time to time may determine.

Plans and specifications and the estimate of the cost of the proposed works and a statement showing the proposed expenditure of the moneys to be borrowed are open for inspection at the City Offices, Hallam.

Dated this 10th day of August, 1977

9688

P. J. NORTHEAST, Town Clerk

CITY OF DANDENONG

Pursuant to the provisions of Section 522 of the Local Government Act 1958 the Council of the City of Dandenong hereby directs that the lands being part of Lot 16 on Plan of Subdivision No. 51950 shown by hatchure on Plan Reference No. M/74/670 annexed hereto and being part of Lot 17 on Plan of Subdivision No. 70375 shown by hatchure on Plan Reference No. M/73/552 also annexed hereto which has been purchased taken or acquired by it shall be a Public Highway on and from the date of publication of this Order in the Government Gazette.

DECLARATION AS A PUBLIC HIGHWAY OF PART OF LOT 16 L.P.51950, PART OF CROWN PORTION 27 PARISH OF DANDENONG, COUNTY OF BOURKE  
SCALE: 1 : 500

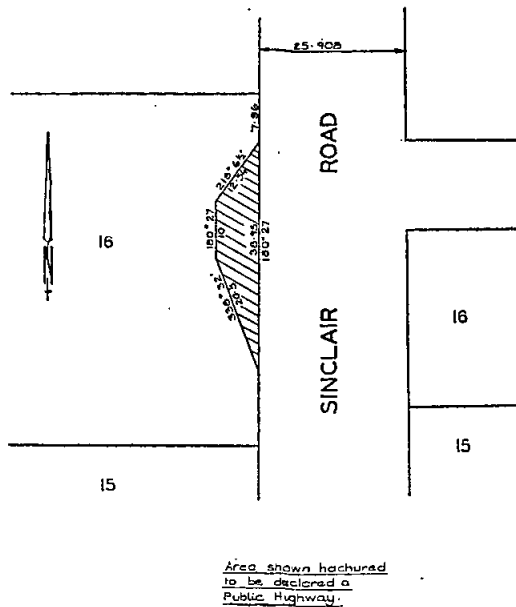

PLAN OF CREATION OF ROAD IN LIEU OF SECTION OF ROAD TO BE DISCONTINUED AND NOT REQUIRED FOR A PUBLIC HIGHWAY  
PART LOT 17 L.P.70375, BEING PART C.A.28A, PARISH OF DANDENONG, COUNTY OF BOURKE  
SCALE: 1" = 200'

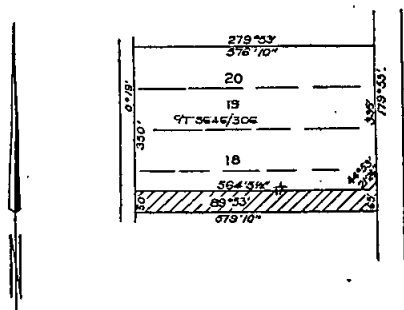

Dated the 27th day of July, 1977

The common seal of the Mayor, Councillors and Citizens of the City of Dandenong was hereto affixed in the presence of—

R. J. REED, Councillor  
M. G. JARVIS, Councillor  
C. A. ELLIOTT, Town Clerk

9685

CITY OF DONCASTER AND TEMPLESTOWE

Whereas the Council of the City of Doncaster and Templestowe deems it expedient to exercise its power of taking compulsorily the land delineated and hatched on the map at the foot hereof for the widening of that portion of the unnamed 15' road shown on plan of subdivision No. 13075 running between Manningham Road and the southern boundary of Certificate of Title Volume 9042 Folio 420 and commonly known as Balwyn Road pursuant to the provisions of the Local Government Act 1958 and acquiring the said land for that purpose and whereas the Council has caused to be prepared a map and other papers setting out the general description of the work or undertaking for which the land proposed to be taken is to be used the description of the land proposed to be taken and the names of the owners or reputed owners lessees or reputed lessees mortgagees and occupiers of that land so far as those names are known to or can be ascertained by the Council and whereas the said map and other papers are deposited at the office of the said Council at Doncaster and are and shall be open for inspection by all persons interested at all reasonable hours for the space of forty clear days after the publication of this notice in the Government Gazette now notice is hereby given to all persons affected by the proposed taking of the said land to set forth in writing addressed to the Council or the Town Clerk within forty clear days of the publication of this notice in the Government Gazette all objections which they may have to the taking of the said land.

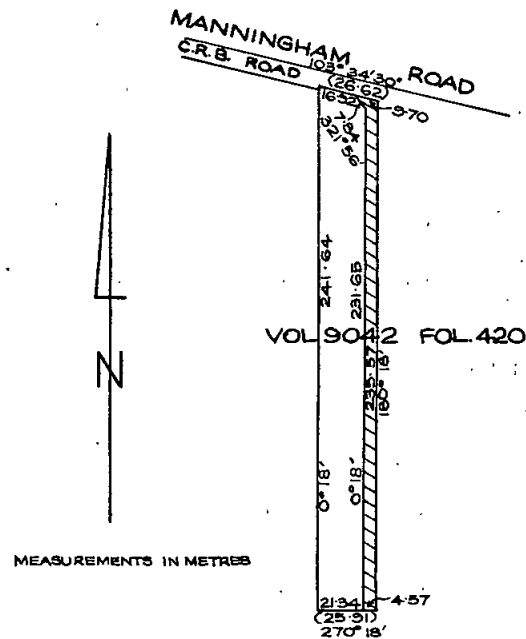

9689

By Order,  
J. W. THOMSON, Town Clerk

CITY OF ESSENDON

By-Law No. 190

Notice is hereby given in accordance with Section 208 (a) (ii) of the Local Government Act 1958, as amended, that the Council of the City of Essendon has made a By-Law entitled "Vacant Land By-Law"—By-Law No. 190 for the purpose of regulating the fencing of vacant land within the City of Essendon.

A copy of this By-Law is open for inspection free of charge during office hours at the Essendon Civic Centre, Cnr. Pascoe Vale Road and Kellaway Avenue, Moonee Ponds.

3rd August, 1977

9712

J. P. SCOTT, Town Clerk



CITY OF KNOX  
LOAN No. 171

Notice of Intention to Borrow the Sum of \$250,000.00 for Permanent Works and Undertakings

Notice is hereby given that the Council of the City of Knox in pursuance of powers conferred by the Local Governments Acts, intends to borrow the sum of \$250,000.00 secured by a charge over the general rates of the Municipality, such sum to be raised by the grant of a mortgage, in accordance with the said Acts and states:—

- (a) The amount of principal moneys it is proposed to borrow is \$250,000.00.
- (b) The maximum rate of interest that may be paid is 11.0 per cent. per annum.
- (c) The period of the loan will be twenty years and the time or times at which the moneys borrowed are to be repayable is on 1st day of April and the 1st day of October each year during the currency of the loan commencing on the 1st day of April, 1978, until the final payment on the 1st day of October, 1997.
- (d) The purpose for which the loan is to be applied is for permanent works and undertakings, viz.:— Council Contribution to C.R.B. Works.
- (e) The loan is to be liquidated by half yearly payments of approximately \$15,580.09 including principal and interest, payable out of the Municipal fund.
- (f) The place of repayment will be:—  
Local Authorities Superannuation Board,  
Rigby House,  
15 Queens Road,  
Melbourne, 3004.

Plans and specifications and an estimate of the cost of such works and undertakings, and a statement showing the proposed expenditure of the money to be borrowed, are open for inspection by ratepayers, during office hours, at the City Offices, Knoxfield, for one month after publication of this Notice.

Dated at Knoxfield this 3rd day of August, 1977  
9692 T. J. NEVILLE, Town Clerk

Town and Country Planning Act 1961 (Twelfth Schedule)  
CITY OF KNOX PLANNING SCHEME, 1965

NOTICE THAT A PLANNING SCHEME HAS BEEN PREPARED AND IS AVAILABLE FOR INSPECTION  
Amendment No. 180, 1977

Notice is hereby given that the Council of the City of Knox in pursuance of its powers under the Town and Country Planning Act, 1961, has prepared a Planning Scheme for portions of the City of Knox for the purpose of amending the Principal Scheme by amending the provisions of Clause 17 of Planning Scheme Ordinance to permit the creation of "battle axe" allotments in new residential subdivisions in Residential Development Zones, subject to compliance with conditions under which such allotments may be approved.

A copy of the Scheme has been deposited at the Office of the City of Knox, Civic Centre, 511 Burwood Highway, Knoxfield, and at the Office of the Town and Country Planning Board, 5th Floor, 235 Queen Street, Melbourne, and will be open for inspection during office hours by any person free of charge.

Any persons affected by the Planning Scheme are required to set forth in writing all objections they may have, addressed to the Town Clerk, City of Knox, Civic Centre, Knoxfield, on or before the 10th day of September, 1977, and to state whether they wish to be heard in respect of their objections:

9715 T. J. NEVILLE, Town Clerk

Town and Country Planning Act 1961 (Twelfth Schedule)  
CITY OF KNOX PLANNING SCHEME, 1965

NOTICE THAT A PLANNING SCHEME HAS BEEN PREPARED AND IS AVAILABLE FOR INSPECTION  
Amendment No. 181, 1977

Notice is hereby given that the Council of the City of Knox in pursuance of its powers under the Town and Country Planning Act 1961, has prepared a Planning Scheme for portions of the City of Knox for the purpose of amending the Principal Scheme by rezoning from Special Uses B (Church and Religious Organization) to Residential Development Zone, land described as the south-east corner

of the Seminary of Christ the Priest's land and bounded by the proposed road linkage connecting Bewsell Avenue and Orson Street. The land is specifically described as part of CA.10 being part of Lot 2 on L.P.86662, Scoresby, Parish of Scoresby.

A copy of the Scheme has been deposited at the Office of the City of Knox, Civic Centre, 511 Burwood Highway, Knoxfield, and at the Office of the Town and Country Planning Board, 5th Floor, 235 Queen Street, Melbourne, and will be open for inspection during office hours by any person free of charge.

Any persons affected by the Planning Scheme are required to set forth in writing all objections they may have, addressed to the Town Clerk, City of Knox, Civic Centre, Knoxfield, on or before the 10th day of September, 1977, and to state whether they wish to be heard in respect of their objections.

9714 T. J. NEVILLE, Town Clerk

CITY OF MOE  
LOAN No. 65

Notice of Intention to Borrow the Sum of \$50,000 for Permanent Works and Undertakings

Notice is hereby given that the Council of the City of Moe proposes to borrow the principal sum of \$50,000 secured by a charge over the general rates of the municipality, such sum to be raised by the grant of a mortgage in accordance with the Local Government Act 1958.

1. The maximum rate of interest that may be paid is 10.9 per centum per annum.

2. The purposes to which the loan is to be applied are:

Roads, streets and drains construction, maintenance and improvement	\$38,160
Council properties purchase, maintenance and improvement	11,840
	\$50,000

3. The period of the loan shall be ten (10) years.

4. The moneys borrowed shall be repayable by providing out of the municipal fund, twenty (20) equal half-yearly instalments of approximately \$4,166.63 each, including principal and interest, in each March and September during the currency of the loan. The first instalment shall be payable on 23rd March, 1978.

5. Such moneys shall be payable to the Australian Mutual Provident Society, 535 Bourke Street, Melbourne or at such other place as the Society may require.

The details and the estimate of the cost of the proposed expenditure, and a statement showing the proposed expenditure of the moneys to be borrowed, are open for inspection at the City Offices, Albert Street, Moe during office hours.

9693 R. J. PUGSLEY, Town Clerk

CITY OF NORTHCOTE  
BYLAW No. 191

A Bylaw of the City of Northcote made under Section 197 and Part XXXV. of the Local Government Act 1958 and numbered 191 for repealing Bylaw 188 and amending Bylaw No. 162.

In pursuance of the powers conferred by the Local Government Act 1958 and of any and every other power it thereunto enabling, the Mayor, Councillors and Citizens of the City of Northcote order as follows:

(1) Bylaw No. 188 of the City of Northcote shall be repealed.

(2) Bylaw No. 162 of the City of Northcote shall be amended by substituting for the schedule thereto the following schedule:

Schedule

- (a) For each adult person per one round of the golf course (nine holes) \$1.00
- (b) For each adult person per two rounds of the golf course (eighteen holes) \$1.60
- (c) For each person under the age of 16 years per one round of the golf course (nine holes) 55c
- (d) For each person under the age of 16 years per two rounds of the golf course (eighteen holes) 80c

The fees specified in (c) and (d) above shall apply to an adult person producing a pensioner's concession card.

Resolution for passing this Bylaw agreed to by the Council of the City of Northcote on the first day of March 1977, and confirmed on the fourth day of April 1977.

The corporate seal of the Mayor, Councillors and Citizens of the City of Northcote was hereunto affixed in the presence of:

(SEAL) O. W. A. BEECH, Mayor  
J. HAMILTON, Councillor  
A. J. HILL, Town Clerk

Approved by the Governor in Council on the 19th July, 1977.—TOM FORRISTAL, Clerk of the Executive Council. 9695

No. 2413

## CITY OF NUNAWADING

## LOAN No. 144

*Notice of Intention to Borrow the Sum of \$600,000 for Permanent Works and Undertakings*

Notice is hereby given that the Council of the City of Nunawading proposes to borrow the principal sum of Six Hundred Thousand Dollars (\$600,000) secured by a charge over the general rates of the municipality, such sum to be raised by the grant of a mortgage in accordance with the provisions of the *Local Government Act 1958*.

1. The maximum rate of interest that may be paid is 11 per centum per annum.
2. The purpose for which the loan is to be applied is the acquisition of open space.
3. The period of the loan shall be 15 years.
4. The moneys borrowed shall be repayable by providing out of the municipal fund thirty half-yearly instalments of \$41,283.23 each including principal and interest on the twenty-eighth day of March and the twenty-eighth day of September during the currency of the loan. The first instalment shall be payable on the twenty-eighth day of March 1978.
5. Such moneys shall be repayable at the Commonwealth Savings Bank of Australia, Nunawading, or such other place or places as the lender may from time to time direct.

The plans and specifications and the estimate of the cost of the proposed works and a statement showing the proposed expenditure of the moneys to be borrowed are open for inspection at the office of the Council of the City of Nunawading, Whitehorse Road, Nunawading.

9696

E. J. JANE, Town Clerk

## TOWN OF PORTLAND

## LOAN No. 127

*Notice of Intention to Borrow the Sum of \$80,000 for Permanent Works and Undertakings*

Notice is hereby given that the Council of the Town of Portland proposes to borrow the principal sum of \$80,000 secured by a charge over the general rates of the Municipality, such sum to be raised by the grant of a mortgage in accordance with the provisions of the *Local Government Act 1958*.

1. The maximum rate of interest that may be paid is 10.90% per annum.
2. The purpose for which the loan is to be acquired is:—  
Off-street car parking development, block bounded by Percy, Tyers, Hurd, and Henty Streets—\$80,000
3. The period of the loan shall be ten years.
4. The moneys borrowed shall be repayable by providing out of the Municipal Fund half yearly 20 instalments of \$6,666.60, each including principal and interest, on the 21st day of March and the 21st day of September during the currency of the loan. The first instalment shall be payable on the 21st day of March, 1978.
5. Such moneys shall be repayable to the Australia and New Zealand Banking Group, at the Office of the Bank, Percy Street, Portland.

The plans and specifications and the estimate of the proposed works and a statement showing the proposed expenditure of the moneys to be borrowed are open for inspection at the Office of the Council of the Town of Portland at Gawler Street, Portland.

Dated this 9th day of August, 1977

9716

B. T. CRAGO, Town Clerk

## BOROUGH OF KERANG

## PROSECUTING OFFICER

Notice is hereby given that the Council of the Borough of Kerang has appointed Sergeant Edmund Robert Capstick, No. 12840, as Prosecuting Officer in place of Sergeant Ken Billman transferred.

Dated 3rd August, 1977

9691

G. H. TATE, Town Clerk

## SHIRE OF COBRAM

## BY-LAW No. 29

Notice is hereby given in accordance with Section 207 (a) (ii) of the *Local Government Act 1958* as amended that the Council of the Shire of Cobram has made a By-Law No. 29 for the purpose of regulating and controlling the Cobram Corporation Saleyards and for fixing fees payable in respect of saleyards within the Municipality but not under the control of the Council of the Shire of Cobram. A copy of this By-Law is open for inspection free of charge during office hours at the office of the Council at 44 Station Street, Cobram.

Dated 10th August, 1977

9711

R. T. CUTTS, Shire Secretary

## SHIRE OF HUNTLY

## NOTICE OF NAMING OF ROADS

Notice is hereby given that the Council of the Shire of Huntly has allocated the following street names.

1. That the Government Road commencing at Fairway Drive between Section 4 of the Township of Ascot and Crown Allotment 367 of the Parish of Sandhurst thence northeasterly thence northwesterly to Taylor Street be named Cedar Drive.

2. That the Government Road commencing at Fairway Drive between Section 3 and Section 4 of the Township of Ascot thence northeasterly to Crown Allotment 2 of Section 3 of the Township of Ascot be named Ash Court.

9690

A. K. LEE, Shire Secretary

## SHIRE OF LILLYDALE

## ERRATUM

## LOAN No. 156

*Notice of Intention to Borrow the Sum of \$50,000 for Permanent Works and Undertakings*

Council's advertisement for Loan No. 156 dated 13th July, 1977 including the following:

The purpose for which the loan is to be applied is:

Traffic Signals (junction of Maroondah Highway and Anderson Street)	\$28,000
Road Construction (Manchester Road between Fiveways and Railway) part cost	\$22,000
	<u>\$50,000</u>

Notice is now given that the purpose for which the loan is to be applied is amended as follows:

Road Construction (Manchester Road between Fiveways and Railway) part cost	\$30,000
Road Construction Buildings—South Riding (Kalorama Reserve, Hansen Park, Cambridge Road Reserve and Swansea Road Reserve) part cost	\$20,000
	<u>\$50,000</u>

9713

K. D. WILSON, Shire Secretary

## SHIRE OF ROMSEY

## LOAN No. 47

*Notice of Intention to Borrow the Sum of \$50,000.00 for Permanent Works and Undertakings*

Notice is hereby given that the Council of the Shire of Romsey proposes to borrow the principal sum of \$50,000.00 secured by a charge over the general rates of the municipality, such sum to be raised by the grant of a mortgage in accordance with the provisions of the *Local Government Act 1958*.

1. The maximum rate of interest that may be paid is 11 (eleven) per cent. per annum.
2. The purpose for which the loan is to be applied is Extensions to Shire Offices.
3. The period of the loan shall be 20 years.

4. The moneys borrowed shall be repayable by providing out of the municipal fund half-yearly instalments of approximately \$3,116.02 each including principal and interest on the first day of October and the first day of April during the currency of the loan. The first instalment shall be payable on the first day of April 1978.

5. Such moneys shall be repayable to the Commissioners of The State Savings Bank of Victoria at the office of the said Commissioners, 233 Collins Street, Melbourne.

The plans and specifications and the estimate of the cost of the proposed works and a statement showing the proposed expenditure of the moneys to be borrowed are open for inspection at the office of the Council of the Shire of Romsey, at Shire Offices, Romsey, 3434.

9697

BRIAN F. CARNE, Shire Secretary

## SHIRE OF STRATHFIELDSAYE

LOAN No. 24

## Notice of Intention to Borrow the Sum of \$25,000 for Purchase of Plant

Notice is hereby given that the Council of the Shire of Strathfieldsaye proposes to borrow the principal sum of twenty-five thousand dollars, secured by a charge over the general rate of the Municipality, such sum to be raised by the grant of a mortgage in accordance with the provisions of the Local Government Act 1958.

1. The maximum rate of interest that may be paid is 10.6 per cent. per annum.

2. The purpose of which the loan is to be applied is:—

Purchase of Plant—

- (a) Sedan
- (b) Utility
- (c) Tip Truck

3. The period of the loan shall be five years.

4. The moneys borrowed shall be repayable by providing out of the Municipal fund 10 half yearly instalments of approximately \$3,284.95 each, including principal and interest, on the 10th April, and 10th October during the currency of the loan. The first instalment shall be payable on the 10th April, 1978.

5. Such moneys shall be repayable to the C.B.C. Savings Bank Ltd., Melbourne.

The Plans and Specifications and the estimate of the cost of the proposed expenditure of the moneys to be borrowed are open for inspection at the Office of the Council of the Shire of Strathfieldsaye, at the Council Chambers, Condon Street, Kennington.

Dated 29th July, 1977

MARGARET BRENNAN, Shire Secretary  
Council Chambers, Condon Street, Kennington, 3550  
9698

## Town and Country Planning Act 1961

## SHIRE OF WANNON PLANNING SCHEME INTERIM DEVELOPMENT ORDER

NOTICE THAT AN AMENDMENT HAS BEEN PREPARED AND IS AVAILABLE FOR INSPECTION

## Amendment No. 2

Notice is hereby given that the Shire of Wannon in pursuance of its powers under the Shire of Wannon Planning Scheme Interim Development Order has prepared an Amendment for the Shire of Wannon for:—

- (1) Crown Allotment 17 and Parts 16 and 21, section 2, Parish of Coleraine, for the purpose of re-zoning the land from "Rural Highway" to "Reserved Industrial".
- (2) Crown Allotments 18 and 19, section 2, Parish of Coleraine, for the purpose of re-zoning the land from "Rural" to "Reserved Industrial".

A copy of the Scheme has been deposited at the Town and Country Planning Board, 235 Queen Street, Melbourne, and the Shire Office, 71 Whyte Street, Coleraine, and will be open for inspection during office hours by any person free of charge.

Any persons affected by the amendment are required to set forth in writing all objections they may have, addressed to the Shire Secretary, Shire of Wannon, Coleraine, on or before the 10th day of September, 1977, and the state whether they wish to be heard in respect of their objections.

Dated 29th July, 1977

9699

G. J. WALLIS, Shire Secretary

## SHIRE OF WARRAGUL

LOAN No. 129

## Notice of Intention to Borrow the Sum of \$28,000 for Permanent Works and Undertakings

Notice is hereby given that the Council of the Shire of Warragul intends to borrow Twenty-eight Thousand dollars (\$28,000) secured by a charge over the general rates of the municipality by the grant of a mortgage in accordance with the provisions of the Local Government Act.

1. The maximum rate of interest that may be paid is 10.9%.

2. The purpose for which the loan is to be applied is as follows:—

Purchase of House—Civic Centre.

3. The period of the loan shall be ten (10) years.

4. The moneys borrowed shall be repayable by providing out of the municipal fund half yearly instalments of approximately \$2,333.31 each including principal and interest on the 15th day of March and the 15th day of September in each year during the currency of the loan. The first instalment shall be payable on the 15th day of March 1978.

5. Such moneys shall be repayable to the Bank of New South Wales Savings Bank Limited, Warragul.

The plans and specifications and the estimate of cost of the works and a statement showing the proposed expenditure of the moneys to be borrowed, are open for inspection at the Municipal Offices, Warragul.

Dated this 26th day of July 1977

9700

D. McADIE, Shire Secretary

## SHIRE OF WARRAGUL

LOAN No. 130

## Notice of Intention to Borrow the Sum of \$50,000, for Permanent Works and Undertakings

Notice is hereby given that the Council of the Shire of Warragul intends to borrow the sum of Fifty Thousand Dollars (\$50,000) secured by a charge over the general rates of the municipality by the grant of a mortgage in accordance with the provisions of the Local Government Act.

1. The maximum rate of interest that may be paid is 10.9%.

2. The purpose for which the loan is to be applied is as follows:—

Part construction—Western Oval.

3. The period of the loan shall be ten (10) years.

4. The moneys borrowed shall be repayable by providing out of the municipal fund half yearly instalments of approximately \$4,166.63 each including principal and interest on the 15th day of March and the 15th day of September in each year during the currency of the loan. The first instalment shall be payable on the 15th day of March 1978.

5. Such moneys shall be repayable to the Bank of New South Wales Savings Bank Limited, Warragul.

The plans and specifications and the estimate of cost of the works and a statement showing the proposed expenditure of the moneys to be borrowed, are open for inspection at the Municipal Offices, Warragul.

Dated this 26th day of July 1977

9701

D. McADIE, Shire Secretary

## SHIRE OF WARRAGUL

LOAN No. 131

## Notice of Intention to Borrow the Sum of \$94,000 for Permanent Works and Undertakings

Notice is hereby given that the Council of the Shire of Warragul intends to borrow Ninety-four Thousand Dollars (\$94,000) secured by a charge over the general rates of the municipality by the grant of a mortgage in accordance with the provisions of the Local Government Act.

1. The maximum rate of interest that may be paid is 10.9%.

2. The purpose for which the loan is to be applied is as follows:—

C.R.B. Contribution	38,500
Council contribution, Hope Street	15,500
Council contribution, Normanby Street	25,050
Saleyards Improvements	11,300
Purchase Building, State Emergency Service	3,650
	<hr/>
	\$94,000

3. The period of the loan shall be ten (10) years.
4. The moneys borrowed shall be repayable by providing out of the municipal fund half yearly instalments of approximately \$7,833.26 each including principal and interest on the 15th day of March and the 15th day of September in each year during the currency of the loan. The first instalment shall be payable on the 15th day of March 1978.
5. Such moneys shall be repayable to the Australian and New Zealand Savings Bank Limited, Warragul.

The plans and specifications and the estimate of cost of the works and a statement showing the proposed expenditure of the moneys to be borrowed, are open for inspection at the Municipal Offices, Warragul.

Dated this 26th day of July 1977  
9702 D. MCADIE, Shire Secretary

## SHIRE OF WARRAGUL

LOAN No. 132

*Notice of Intention to Borrow the Sum of \$188,000 for Permanent Works and Undertakings*

Notice is hereby given that the Council of the Shire of Warragul intends to borrow One Hundred and Eighty-eight Thousand Dollars (\$188,000) secured by a charge over the land and buildings Part of Lot 15 of LP 113240 Pearse Street, Warragul by the grant of a mortgage, in accordance with the provisions of the Local Government Act as amended.

In connection therewith the following information is stated:—

- The amount of the principal moneys which it is proposed to borrow is \$188,000.
- The maximum rate of interest that may be paid is 11% per annum.
- The period of the loan shall be 15 years.
- The moneys borrowed shall be repayable by providing out of the municipal fund half yearly instalments of \$12,935.42 each including principal and interest on the 1st day of April and 1st day of October during the currency of the loan the first instalment shall be payable on the first day of April 1978.
- The purpose for which the loan is to be applied:—  
Construction of an industrial building and associated works under Part XLa of the Local Government Act 1958 as amended.
- Such moneys shall be repayable to the Gas and Fuel Corporation Superannuation Fund, 171 Flinders Street, Melbourne.

The plans and specifications and the estimate of cost of the works and a statement showing the proposed expenditure are open for inspection at the offices of the Council of the Shire of Warragul.

9703 D. MCADIE, Shire Secretary.

## PRESBYTERIAN TRUSTS ACT 1890

I, William Arnold Loftus, Moderator for the time being of the General Assembly of the Presbyterian Church of Victoria, hereby certify that the said General Assembly did, on the Fifteenth day of July, 1977, pursuant to section 25 of the *Presbyterian Trusts Act 1890*, make the following alterations to the rules hitherto made by it, under the said Act:—

1. Rules 2 and 3 were repealed, and in lieu thereof the following rules were made:—

"2 (1). On and after the Fifteenth day of July, 1977, the number of members of the Corporation shall be eight.

"(2). On and after the Fifteenth day of July, 1977, the members of the Corporation shall be the person holding the office of Clerk of the General Assembly for the time being and the persons holding the offices of first, second, third, fourth, fifth, sixth and seventh elected member respectively, of the Board of Investment and Finance of the General Assembly for the time being, and after the said Fifteenth day of July, 1977, no person shall continue to be a member of the Corporation—

- pursuant to any resolution of the General Assembly made prior to the First day of July, 1977, or,
- after he has ceased to be a member of the said Board of Investment and Finance.

"3. The fact that the membership of the Corporation has for any reason fallen below eight shall not invalidate any action proceeding or resolution of the Corporation so long as a quorum was present at any meeting at which such action or proceeding took place or resolution was adopted."

2. Rules 6 and 7 were repealed, and in lieu thereof the following rules were made:—

"6. The seal of the Corporation shall be kept in the custody of the office manager appointed pursuant to the regulations made by the General Assembly inent the Board of Investment and Finance, and there shall be two keys to the seal, one of which shall be kept by the chairman of the said Board, and the other by the office manager; and the seal shall be affixed to documents only in pursuance of a resolution of the Corporation, or of a committee appointed by the Corporation from the trustees, with authority to act either generally or specially in the matter, of which committee three trustees shall form a quorum, and the affixing thereof shall be verified by two of the trustees, a law officer of the Church, and the said office manager, provided that if the affixing of the seal shall be duly verified as hereinbefore provided, such verification shall be sufficient evidence that the affixing thereof was duly authorised by a resolution of the Corporation.

"7. A reference in these rules to the holder of any office shall be deemed to include any person duly appointed in an acting or temporary capacity to perform the duties of that office."

9734 W. A. LOFTUS, Moderator

DROMANA-ROSEBUD SEWERAGE AUTHORITY—  
GENERAL NOTICE  
SEWERED AREA No. 5

The above-mentioned Sewerage Authority, having made provision for carrying off the sewage from each and every property which or any part of which is within the sewerage area hereinafter described hereby declare that on and after the 1st day of August 1977 each and every property which or any part of which is within the said sewerage area shall be a seweraged property within the meaning of the *Sewerage District Act 1958*.

The boundaries of the Sewerage area hereinafter referred to are:

Commencing at the intersection of Eighth Avenue and Nepean Highway, then generally north easterly, then southerly along the boundary of Sewerage Area No. 3; then further southerly along the boundary of Sewerage Area No. 4 then westerly and northerly along the boundary of Sewerage Area No. 1 to the point of commencement.

By Order of the said Sewerage Authority,

9751 JOHN K. BUCHANAN, Chairman  
S. WILLIAMS, Secretary

DROMANA-ROSEBUD SEWERAGE AUTHORITY—  
GENERAL NOTICE  
SEWERED AREA No. 6

The above-mentioned Sewerage Authority having made provision for carrying off the sewage from each and every property which or any part of which is within the sewerage area hereinafter described hereby declare that on and after the 1st day of August 1977 each and every property which or any part of which is within the said sewerage area shall be a seweraged property within the meaning of the *Sewerage District Act 1958*.

The boundaries of the Sewerage area hereinafter referred to are:

Commencing at the intersection of Ocean Street and Eastbourne Road then west along Eastbourne Road to the north east corner of No. 131 Eastbourne Road then south and west along the southern boundaries of Nos. 131 and 133 Eastbourne Road to Besgrove Street, then north to Eastbourne Road; west along Eastbourne Road to Sixth Avenue, north along Sixth Avenue to along the boundary of Sewerage Area No. 1 to the point of commencement.

By Order of the said Sewerage Authority,

9752 JOHN K. BUCHANAN, Chairman  
S. WILLIAMS, Secretary

## MOOROPNA SEWERAGE AUTHORITY

The abovementioned Sewerage Authority, having made provision for carrying off the sewage from each and every property which, or any part of which, is within the Sewerage Area hereinafter described, doth hereby declare that on and after the 1st August, 1977 each and every property which is within the said Sewerage Area shall be deemed to be a seweraged property within the meaning of the *Sewerage Districts Act*.

The Sewerage Area hereinafter referred to is:—

Sewerage Area No. 23.

All those pieces of land being Lots 1 to 4 inclusive, Lots 7 to 16 inclusive and Lots 21 to 47 inclusive on Lodged Plan of Subdivision No. 81194, Lots 49 to 58 inclusive on

Lodged Plan of Subdivision No. 88090, Lot 65 on Lodged Plan of Subdivision No. 89780, Lots 69, 74, 76, 77 and Lots 80 to 89 inclusive on Lodged Plan of Subdivision No. 90854, Lots 101 to 132 inclusive, being part of Crown Allotment 25A, Parish of Toolamba.

Streets concerned in this area being Lenne Street, Howe Street, Stanley Street, Sun Court, Brook Court, Albert Street, Rosstrata Crescent.

By Order of the Mooroopna Sewerage Authority  
9694 R. F. FORSTER, Secretary

#### PORTLAND SEWERAGE AUTHORITY

Notice is hereby given that the Authority intends to construct sewers to serve properties in Tamora Crescent, Regia Court, Coramba Court, Derril Road, Childers Street, Braemar Street, Prospect Court, Nelson Park, Wiltshire Court, Shirva Drive, Edgar Street, Carlisle Court, Stornaway Court and King Street, as shown on plans which are available for inspection by owners and occupiers of land within the Sewerage District at the Authority's Office, Gawler Street, Portland, during office hours.

9717 B. T. CRAGO, Secretary

#### WODONGA SEWERAGE AUTHORITY

##### GENERAL NOTICE

The Wodonga Sewerage Authority having made provisions for carrying off the sewerage from each and every property which or any part of which is within the sewerage areas hereinafter described doth hereby declare that on or after Wednesday 17th August, 1977, each and every property which or any part of which is within the said sewerage area shall be deemed to be a seweraged property within the meaning of the Sewerage Districts Act 1958.

The boundaries of the Sewerage Areas hereinbefore referred to are:—

*Sewerage Area No. 81* (Parkland Estate Stages 8 and 9)

All the lands contained within Crown Allotment 1, 2, and 3 of Section M2, together with all the lands contained within Crown Allotment 1 of Section 13, of the Parish of Wodonga, County of Bogong.

*Sewerage Area No. 82* (Willow Park Estate)

All the lands contained within Lots A, B and C of Lodged Plan No. 116811, Sheet 2 of 2.

*Sewerage Area No. 83* (Willow Park Estate)

All the lands contained within Lots 128 to 141 inclusive, Lots 147 to 157 inclusive and Lot 188 of Lodged Plan No. 120206 Sheet 3 of 3.

*Sewerage Area No. 84* (Hion View Estate)

All the lands contained within Crown Allotment 1 of Section 11 of Parish of Wodonga, County of Bogong.

*Sewerage Area No. 85* (DeKerilleau Estate)

All the lands contained within the western part of Lot M being 3.2ha and Lot J being 16.80ha of Lodged Plan No. 118732, together with all the lands contained within Lot P of Lodged Plan No. 118731.

*Sewerage Area No. 86* (Land east of Kendall Street)

All lands contained within Crown Allotments 1 to 6 inclusive of Section A9, Parish of Wodonga, County of Bogong.

*Sewerage Area No. 87* (Kendall Park Industrial Estate)

All the lands contained within Lot 12 of Lodged Plan No. 120855.

*Sewerage Area No. 88* (North West Industrial Estate)

All the lands contained within Lots 2-6 inclusive of Lodged Plan No. 121169.

*Sewerage Area No. 89* (Murray Brae and A.W.D.C. Land)

All the land contained within Crown Allotments 7, 8 and 12 of Section 15, Parish of Wodonga, County of Bogong.

*Sewerage Area No. 90* (H.C.V. Estate, West of Melrose Drive.)

All the lands contained within Crown Allotments 2c, 3a, 3b and 4 Section 14, Parish of Wodonga, County of Bogong.

*Sewerage Area No. 91* (Wilkinson Drive)

All the lands contained within Crown Allotment 1, Section H, Parish of Wodonga, County of Bogong.

By Order of the Wodonga Sewerage Authority,  
9704 H. W. DRAPER, Chairman  
A. W. RUTKOWSKI, Secretary

#### SEWERAGE DISTRICTS ACT

##### PROPOSED SEWERAGE AUTHORITY

Notice is hereby given that the Council of the Shire of Broadford has made application to the Honorable the Minister of Water Supply for the constitution of a Sewerage Authority and for the Proclamation of a Sewerage District at Broadford and for the construction, maintenance and continuance of sewerage works within that District under the provisions of the Sewerage Districts Act.

A general plan and description of the proposed works have been submitted with the application and copies of same may be seen at Shire Office, 113 High Street, Broadford.

Dated at Broadford the 25th day of July, 1977  
9539 G. J. TINDLE, Shire Secretary

#### FREDERICK OWEN & ASSOCIATES

##### CHANGE OF PARTNERSHIP

The present partners of Frederick Owen & Associates, Messrs. F. O. Owen, J. F. X. Dillon, W. M. Carroll and D. O. Owen announce that they dissolved their partnership with Mr. Frederick David Bailey on July 19, 1977.

The law practice continues to be carried on by the present partners under the same firm name at the same address—450 Little Collins Street, Melbourne. 3000. 9748

The partners of Davies and Collison, patent attorneys, of 1 Little Collins Street, Melbourne, announce that Geoffrey Miles Mansfield has retired from the partnership but for the time being will continue to act as a consultant to the firm. Gregory Joseph Noonan and Geoffrey Charles Pryor have joined Kenneth Norman Rimington, Desmond James Ryan, Keith Leslie, John Michael Slattery and Terence Guy Corbett as continuing partners of the firm. 9718

Notice is hereby given that the partnership heretofore subsisting between the undersigned Diane Elizabeth Price and George Chryssafis carrying on business as hairdressers at 114 Bridge Road, Richmond under the name of Smiles has been dissolved by mutual consent as from the 10th day of July 1977. All debts and liabilities incurred after the 10th July 1977 by the said late firm shall be received and paid by Diane Elizabeth Price who will continue to carry on business at the same place.

9705 D. E. PRICE  
G. CHRYSsafis

Notice is hereby given that the partnership heretofore subsisting between Leigh James Spence of 50 Moubay Street Albert Park and Colleen Patricia Bowden of 44 Broadway Camberwell carrying on business at 173 Toorak Road, South Yarra under the style or firm name of Basically Black and at 133 Puckle Street Moonee Ponds under the style or firm name of Midnight Mary has been dissolved as from the 12th February 1977 so far as concerns the said Leigh James Spence who retired from the said firms.

The said Colleen Patricia Bowden shall continue the said businesses under the said names of Basically Black and Midnight Mary.

Michael Taussig, LL.B., barrister and solicitor, 56 Dudley Street, West Melbourne 3003 9675

Take notice that the partnership comprising Joseph Lew, Jerry Lew, Paul Lew and Ching Sze Lew trading under the business name of the Wing Hing Restaurant was dissolved as from the 9th May, 1977. 9720

Notice is hereby given that the partnership heretofore subsisting between Graham Noel Thomas of 44-48 Whitehorse Road, Balwyn and Barbara Anna Thomas of 141 Balwyn Road, Balwyn carrying on business as stationers under the style or firm of Megara Office Supplies at 44-48 Whitehorse Road, Balwyn has been dissolved by mutual consent with effect from the 30th day of November, 1976 and that the said Graham Noel Thomas will continue to conduct the said business as a sole proprietor.

SACKVILLE, WILKS & CO., solicitors, 100 Collins Street, Melbourne 9721

In the Supreme Court of Victoria—1977 No. 1583—  
Between: AUSTRALIA AND NEW ZEALAND BANKING GROUP  
LIMITED, Plaintiff, and ALBERTO MARROCCO, Defendant

Notice is hereby given that an action has been commenced in this Court by the abovenamed Plaintiff against the abovenamed Defendant for certain moneys due and interest in respect thereof being moneys due under an Instrument of Guarantee dated 6th March, 1973 in respect of moneys lent to George and Mary Cipolla by the Plaintiff and Interest thereon and the Writ of Foreign Attachment has been issued directed to Messrs. Davies and Vodicka of 154 Commercial Road, Yarram in the State of Victoria and Dominic and Charles Puccio both of Buckley's Island Road, Yarram in the State of Victoria, for the purpose of attaching in the hands of the said Messrs. Davies and Vodicka, Dominic Puccio and Charles Puccio, all and singular the lands and other hereditaments moneys and chattels bills bonds and other property of whatsoever nature in the custody or under the control of the said Messrs. Davies and Vodicka, Dominic Puccio and Charles Puccio at the time of the service of the said Writ belonging to the abovenamed Alberto Marrocco, or to or in which such Defendant shall at the time be legally or equitably entitled or otherwise beneficially interested (and whether solely or jointly with any person or persons) and all debts of every kind then due by the said Messrs. Davies and Vodicka, Charles Puccio and Dominic Puccio to such Defendant although the same or part thereof may be payable only at a future day and if at any time before final judgment in this action the said Alberto Marrocco or any person on his behalf will give the security required by law the said Alberto Marrocco upon entering an Appearance and upon giving notice thereof to the Plaintiff may apply to the Court and have the said Judgment dissolved.

Dated this 2nd day of August, in the year of Our Lord One thousand nine hundred and seventy-seven

WISEWOLDS of 459 Little Collins Street, Melbourne,  
solicitors for the plaintiff 9729

*Companies Act 1961.* Kincaid and Associates Pty. Ltd., an Exempt Private Company whose Registered Office is situated at 67 Longview Rd., North Balwyn, Victoria

Notice is hereby given that at a General Meeting of the Members of the above named Company it was resolved that the Company be wound-up voluntarily and that John d'A. Kincaid be appointed Liquidator. Notice is also given that after 21 days from this date I shall proceed to distribute the assets. All Creditors having claims against the Company should furnish particulars of the same by that date otherwise I shall proceed to distribute the assets without regard to their claim.

Dated this 9th day of August 1977

JOHN d'A. KINCAID, Liquidator, 67 Longview Rd.  
North Balwyn 3104 9672

In the Supreme Court of Victoria—1977 Co. 9790—  
In the matter of the *Companies Act 1961*; and in the matter of P. R. NEVILLE & ASSOCIATES PTY. LTD.

Notice is hereby given that a Petition for the winding up of the abovenamed Company by the Supreme Court was presented on the 27th day of June 1977 and that the said Petition is directed to be heard before the Court sitting at Melbourne at the hour of 10.30 a.m. on Friday the 19th day of August 1977 and any creditor or contributory of the said company desiring to support or oppose the making of an Order on the said Petition may appear at the time of hearing by himself or his counsel for that purpose and a copy of the Petition will be furnished to any creditor or contributory of the said company requiring the same by the undersigned on payment of the regulated charge for the same.

The petitioner's address is 29 The Mall, South Croydon in the said State.

The Petitioner's solicitors are Messrs. Braham & Pirani of 521 Toorak Road, Toorak in the said State.

BRAHAM & PIRANI

NOTE:—Any person who intends to appear on the hearing of the said petition must serve on or send by post to the abovenamed Braham & Pirani, notice in writing of his intention so to do. The notice must state the name and address of the person, or, if a firm, the name and address of the firm, and must be signed by the person or firm, or his, or their solicitor (if any), and must be served or, if posted, must be sent by post in sufficient time to reach the abovenamed not later than 4 o'clock in the afternoon of the 18th day of August 1977. 9719

In the matter of the *Companies Act 1961*; and in the matter of W. A. & K. HARDWARE PTY. LTD. (in Liquidation).

Notice is hereby given that pursuant to Section 272 of the *Companies Act 1961*, the final meeting of the members and creditors of the Company will be held at Marquand & Co., 51 Queen Street, Melbourne on the sixth day of September, 1977 at 10.30 a.m. for the purpose of laying before the meeting the account and any explanation thereof.

Dated this 27th day of July, 1977

9735 D. E. TONKIN, Liquidator

In the matter of the *Companies Act 1961* and in the matter of BERANTO LODGE (COMPANY LIMITED BY GUARANTEE)

Notice is hereby given that at a meeting of the members of Beranto Lodge held on 29th July, 1977 the following resolution was passed as a Special Resolution:—

That the Company be wound up voluntarily and that Messrs. Douglas Ewart Tonkin and Leslie Philip Smart, Chartered Accountants, of Marquand & Co., 51, Queen Street, Melbourne, 3000 be and are hereby appointed liquidators to act jointly or severally for the purpose of such winding up, with the right to distribute assets in specie.

9736

D. E. TONKIN, Liquidator

In the matter of the *Companies Act 1961*; and in the matter of LIPSA PTY. LTD. (in Liquidation)—Notice of Final Meeting of Members. Pursuant to Section 272

Notice is hereby given in pursuance of Section 272 of the *Companies Act 1961* that a General Meeting of members of the Company will be held at the office of Messrs. Coopers & Lybrand, 461 Bourke Street, Melbourne on the 15th day of September 1977, at 10.00 o'clock in the forenoon for the purpose of having an account laid before it showing the manner in which the winding up has been conducted and the property of the company disposed of, and hearing any explanation that may be given by the liquidator.

Dated this 5th day of August, 1977

K. J. RUSSELL, Liquidator

Messrs. Coppers & Lybrand, 461 Bourke Street, Melbourne, Vic. 3000 9749

The *Companies Act 1961*—In the matter of MONTY BENNETT MOTORS (SALES) PROPRIETARY LIMITED—Notice Re Meeting of Creditors, Pursuant to Section 260

Notice is hereby given that a Meeting of Creditors of the above-named Company will be held at 27 Tahara Street, Hamlyn Heights, Geelong, at 11 a.m. on Friday, 19th August, 1977, the Company having convened a Meeting of its Members for the same day for the purpose of considering a Resolution that the Company be wound up voluntarily.

Dated this 9th day of August, 1977

9750 W. M. BENNETT, Director

*Companies Act 1961*

RE: JOHN RAYNIS MANAGEMENT PTY. LTD. (IN LIQUIDATION)

NOTICE CONVENING FINAL MEETING OF MEMBERS AND CREDITORS, PURSUANT TO SECTION 272

Notice is hereby given that a General Meeting of members and creditors of the abovenamed company will be held at the offices of Brendon O'Connor & Co., 562 St. Kilda Road, Melbourne on Monday the 12th September, 1977 at 11.00 a.m. for the purpose of having an account laid before them showing the manner in which the winding up has been conducted and the property of the company disposed of and of hearing any explanations that may be given by the Liquidator.

Dated this 8th day of August, 1977

B. J. O'CONNOR, Liquidator

Brendan O'Connor & Co., accountants, 562 St. Kilda Road, Melbourne, Vic. 3004. Telephone: 529 4722 9741

REALSTAR PTY. LIMITED (IN VOLUNTARY LIQUIDATION)  
NOTICE CONVENING FINAL MEETING

Notice is hereby given, in pursuance of section 272 of the *Companies Act 1961*, that the final general meeting of members of the abovenamed company will be held on the 1st floor, 15-19 Bent Street, Sydney at 10.00 a.m. on 5th September, 1977 for the purpose of having an account laid before them showing the manner in which the winding up has been conducted and the property of the company has been disposed of.

Dated this 1st day of August, 1977

9682

R. J. STEEL, Liquidator

## Unclaimed Moneys Act 1962

Register of Unclaimed Moneys held by the—

Name of Owner on Books and Last Known Address	Total Amount Due to Owner	Description of Unclaimed Moneys	Date when Amount first became Payable
\$			
APEX QUARRIES LIMITED			
Russell, Bryan B., 9 Aruma Court, Burwood	21.00	Dividend .. .. .	30.4.75
Salvaris, Helen (Miss), c/o 89 Riverside Avenue, South Melbourne	60.00	" .. .. .	"
Young, Patricia F. (Mrs), 7 Menzies Street, Box Hill	30.00	" .. .. .	"
Ziegler, Mary E. (Mrs), Flat 2, 24 Cherrytree Rise, Knoxfield	30.00	" .. .. .	"
Black, Elizabeth H. (Mrs), 76 Tyne Street, Box Hill	54.00	" .. .. .	"
Bacash, Michael, 3 Berkeley Court, Kew	12.00	" .. .. .	3.11.75
Bonwick, Georgina E. (Mrs), Moppett Street, Hay, N.S.W.	12.00	" .. .. .	"
Bortolussi, Benjamin, 257 Heidelberg Road, Fairfield	24.00	" .. .. .	"
Midgley, Mary A. (Mrs), c/o E. J. Douney, 400 Lonsdale Street, Melbourne	12.00	" .. .. .	"
Milner, Greta R. C. (Mrs), 323 Riversdale Road, Hawthorn	18.00	" .. .. .	"

## Companies Act 1961—In the matter of PREMIER CONSOLIDATED INDUSTRIES PTY. LTD. (in Liquidation)

Notice is hereby given that at an extraordinary Meeting of the Members of the abovenamed Company held on the 2nd August, 1977 it was resolved that the Company be wound up voluntarily and at a Meeting of Creditors held on the same day pursuant to Section 260, it was resolved that for such purpose Everett Thomson Bent of Suite 18, 545 St. Kilda Road, Melbourne, Public Accountant, be appointed Liquidator.

Notice is also given that after twenty-one days from this date I shall proceed to distribute the assets. All creditors having any claims against the Company should furnish particulars of same by that date, otherwise I shall proceed to distribute the assets without regard to their claim.

Dated this 2nd day of August, 1977

E. T. BENT, Liquidator

Bent &amp; Cogle, public accountants, Suite 18, 545 St. Kilda Road, Melbourne, 3004 9677

## Companies Act 1961—In the matter of JEANS INSTITUTE PTY. LTD. (in Liquidation)

Notice is hereby given that at an extraordinary Meeting of the Members of the abovenamed Company held on the 4th August, 1977, it was resolved that the Company be wound up voluntarily and at a Meeting of Creditors held on the same day pursuant to Section 260, it was resolved that for such purpose Everett Thomson Bent of Suite 18, 545 St. Kilda Road, Melbourne, Public Accountant, be appointed Liquidator.

Notice is also given that after twenty-one days from this date I shall proceed to distribute the assets. All creditors having any claims against the Company should furnish particulars of same by that date, otherwise I shall proceed to distribute the assets without regard to their claim.

Dated this 4th day of August, 1977

E. T. BENT, Liquidator

Bent &amp; Cogle, public accountants, Suite 18, 545 St. Kilda Road, Melbourne, 3004 9709

## COBURG NO. 2 CO-OPERATIVE HOUSING SOCIETY LIMITED (IN LIQUIDATION)

Take notice that the affairs of the above-named Society are now fully wound up and that in pursuance of Section 272 (1) of the Companies Act 1961 and of the Co-operative Housing Societies Act 1958, a General Meeting of the Society will be held at 131 Bell Street, Coburg on Wednesday, the 14th September, 1977 at 5.45 p.m. for the purposes of—

- (i) laying before it an account showing how the winding up has been conducted and the property of the Society disposed of and giving any explanations thereof; and
- (ii) passing a resolution that the books and papers of the said Society and of the Liquidator relevant to the affairs of the Society be destroyed after a period of twelve months from the date of the meeting.

Dated at Coburg, this 9th day of August, 1977

9678

H. CHALMERS, Liquidator

## Companies Act 1961, Section 291

## CALYPSO HOLDINGS PTY. LTD. (IN LIQUIDATION)

Companies Regulations

SUPREME COURT (COMPANIES) RULES 1962

Rule 99

Notice is hereby given that the creditors of Calypso Holdings Pty. Ltd. (in Liquidation) are required to furnish to the liquidator a proof of debt form in accordance with Form 75 of the Companies Regulations by Friday 9th September, 1977. Any creditor claiming title to priority pursuant to section 292 of the Companies Act 1961 should serve notice in writing on the liquidator, such notice should accompany the said proof of debt form.

Any creditor not proving their claim by the above date will be excluded from the benefit of any distribution.

Dated this 2nd day of August, 1977

M. J. O'KEEFFE, Official Liquidator.

M. J. O'Keefe &amp; Co., accountants, 66 High Street, Glen Iris, 3146 9681

## In the matter of the Companies Act 1961; and in the matter of GEORGE CATERING PTY. LTD.

Notice is hereby given that at an extraordinary general meeting of the abovenamed company duly convened and held at noon on the 31st day of July, 1977 the following special resolution was duly passed, viz:

"That the company be wound up voluntarily."

Dated the 31st day of July, 1977

9710

G. CHIN QUAN, Chairman

## Companies Act 1961—In the matter of NEWLANDS CARAVANS PTY. LTD., 38-40 Plateau Road, Reservoir, 3073

Notice is hereby given that at an extraordinary Meeting of the Members of the abovenamed Company held on the 3rd August, 1977 it was resolved that the Company be wound up voluntarily and at a Meeting of Creditors held on the same day pursuant to Section 260, it was resolved that for such purpose Mr. D. J. Cogle, of Suite 18, 545 St. Kilda Road, Melbourne, was appointed Liquidator.

Notice is also given that after twenty-one days from this date I shall proceed to distribute the assets. All creditors having any claims against the Company should furnish particulars of same by that date, otherwise I shall proceed to distribute the assets without regard to their claim.

Dated this 3rd day of August, 1977

D. J. COUGLE, Liquidator

Bent &amp; Cogle, public accountants, Suite 18, 545 St. Kilda Road, Melbourne, Vic. 3004 9676

## In the Supreme Court at Melbourne—1977 No. Co. 9728—In the matter of the Companies Act 1961; and in the matter of DEMEX PLANT HIRE PTY. LTD.; and in the matter of a Petition dated 18th day of April, 1977—Notice of Winding-up Order

In the matter of Demex Plant Hire Proprietary Limited Winding up Order made the 27th day of July, 1977

Liquidator: Mr. Ian MacKinnon of 562 St. Kilda Road, Melbourne 3004

A. B. NATALI, solicitor for the petitioner 9680

## BOURBON PTY. LTD.

## RESOLUTION FOR VOLUNTARY WINDING UP COMPANY

Reg. Office 5/111 Rattray Road, Montmorency

Special Resolution passed 2/8/1977: That the Company be wound up voluntarily and that Mr. H. Heseltine of 5/111 Rattray Road Montmorency be appointed Liquidator.

H. HESELTINE, Liquidator

The Companies Act 1961—In the matter of LUBELL NOMINEES PTY. LTD.—Notice Re Meeting of Creditors Pursuant to Section 260

Notice is hereby given that a Meeting of Creditors of the abovenamed company will be held at the Meeting Room, Amateur Sports Club, 14, McKillop Street, Melbourne at 10.30 a.m. on the 11th day of August, 1977, the company having convened a Meeting of its Members for the same day for the purpose of considering a Resolution that the Company be wound up voluntarily.

Dated this 1st day of August, 1977

S. CATANESE, Director

R. D. WIDDOWS, 703 South Road, Moorabbin 9683

In the Supreme Court of Victoria—1977 Co. 9804—In the matter of the Companies Act 1961; and in the matter of ALPINE PLUMBING AND CENTRAL HEATING PTY. LIMITED—Notice of Winding Up Order

Winding-Up Order: Made 2nd August 1977.

Name and Address of Liquidator: M. J. O'Keefe of 66 High Street, Glen Iris.

ALAN R. NEAVES,  
Crown Solicitor for the Commonwealth and  
Solicitor for the Petitioner

9762

In the Supreme Court of Victoria—1977 No. Co. 9843—In the matter of the Companies Act 1961; and in the matter of VICTORIAN BEARING SUPPLIES PROPRIETARY LIMITED

Notice is hereby given that a Petition for the winding up of the abovenamed Company by the Supreme Court was on the 3rd day of August, 1977 presented by Marie Joan Fitzgerald, Barbara Warrenner and Bonnie Annie Harper and that the said Petition is directed to be heard before the Court sitting at Law Courts, Melbourne, on Tuesday, the 27th day of September, 1977 at the hour of 10.30 o'clock in the forenoon; and any creditor or contributory of the said Company desiring to support or oppose the making of an order on the said Petition may appear at the time of hearing by himself or his Counsel for that purpose; and a copy of the Petition may appear at the time of hearing by himself or his Counsel for that purpose; and a copy of the Petition will be furnished to any creditor or contributory of the said Company requiring the same by the undersigned on payment of the regulated charge for the same.

The Petitioner Marie Joan Fitzgerald's Address is: 4 Laura Street, Boronia Park, New South Wales.

The Petitioner Barbara Warrenner's Address is: Lot 1, Sixth Road, Berkshire Park, New South Wales.

The Petitioner Bonnie Annie Harper's Address is: 19 Webb Street, Riverwood, New South Wales.

The Petitioners' Solicitors are: Messrs. Rogers & Gaylard of 51 Queen Street, Melbourne, Victoria.

ROGERS &amp; GAYLARD, solicitors for the petitioners.

NOTE.—Any person who intends to appear on the hearing of the said petition must serve on or send by post to the abovenamed Solicitors, notice in writing of his intention so to do. The notice must state the name and address of the person, or, if a firm, the name and address of the firm and must be signed by the person or firm, or his or their Solicitor (if any) and must be served, or if posted must be sent by post in sufficient time to reach the abovenamed not later than 4 o'clock in the afternoon of the 23rd day of September, 1977.

9763

In the matter of I. S. TRANSPORT PTY. LTD.—Winding-up Order made the 21st day of July, 1977—Notice of Winding-up Order

Name and Address of Liquidator—James Manson Poulton, 447 Collins Street, Melbourne.

THOMAS H. BELL, solicitor for the petitioner 9755

The Companies Act 1961.—In the matter of U. NEED. US. PTY. LTD.—Notices Re Meeting of Creditors, Pursuant to Section 260

Notice is hereby given that a Meeting of Creditors of the above-named Company will be held at the offices of Wallace McMullin & Small, in the Meeting Room, 3rd Floor, 499 St. Kilda Road, Melbourne on the 25th day of August, 1977, at 11.00 a.m., the Company having convened a Meeting of its Members for the same day for the purpose of considering a Resolution that the Company be wound up voluntarily.

Dated this 10th day of August, 1977

J. M. O'CONNELL, Director

Wallace McMullin &amp; Small, chartered accountants 9757

Companies Act 1961, As Amended, Section 254 (2)—In the matter of PRAHRAN TELEGRAPH & PRINTING CO. PTY. LTD. (in Liquidation)

Notice is hereby given that at an Extraordinary General Meeting of the abovenamed Company held on the 5th day of August 1977 the following special resolution was passed.

"That the Company be wound up voluntarily and that Michael A. Coppins and J. B. Hutchins be appointed Joint and Several Liquidators for the purpose of such winding up."

Notice is also given that after 21 days from this date we shall proceed to distribute the assets of the Company. All creditors having any claims against the Company should furnish particulars of such claims to the undersigned by that date, otherwise we shall proceed to distribute the assets without regard to their claim.

M. A. COPPINS, Liquidator

J. B. HUTCHINS, Liquidator

Wilson, Bishop, Bowes &amp; Craig, 271 William Street, Melbourne 9754

The Companies Act 1961—In the matter of LINSWAY BARGAIN CENTRE PTY. LTD. (in Voluntary Liquidation)

Notice is hereby given that at an Extraordinary Meeting of the Members of the above-named Company held on the 29th day of July, 1977 it was resolved that the Company be wound up voluntarily and that for such purpose Mr. David Wynne Jones of 1 Yarra Street, South Yarra be appointed Liquidator.

Notice is also given that after twenty-one days from this date I shall proceed to distribute the assets all creditors having any claim against the company shall furnish particulars of same by that date, otherwise I shall proceed to distribute the assets without regard to their claim.

Dated this 29th day of July, 1977

DAVID WYNNE JONES, Liquidator

B. M. COOK &amp; CO., chartered accountants, 1 Yarra Street, South Yarra, 3141 9747

In the Supreme Court of Victoria—1977 No. Co. 9837—In the matter of the Companies Act 1961; and in the matter of EDWARD PHILLIP MOTORS PTY. LTD.

Notice is hereby given that a Petition for the winding up of the abovenamed Company by the Supreme Court was on the 1st day of August, 1977 presented by the said Company and that the said Petition is directed to be heard before the Court sitting at the Thirteenth Court Law Courts William Street, Melbourne on the 6th day of September, 1977 at 10.30 o'clock in the forenoon and any Creditor or contributory of the said Company desiring to support or oppose the making of an Order on the said Petition may appear at the time of hearing by himself or his Counsel for that purpose; and a copy of the Petition will be furnished to any Creditor or contributory of the said Company requiring the same by the undersigned on payment of the regulated charge for the same.

The Petitioner's address is 2nd Floor, 153 Wellington Parade South, East Melbourne.

The Petitioner's Solicitors are Messrs. Phillips, Fox & Masel of 461 Bourke Street, Melbourne.

NOTE.—Any person who intends to appear on the hearing of the said Petition must serve on or send by post to the abovenamed Solicitors notice in writing of his intention to do so. The notice must state the name and address of the person, or, if a firm the name and address of the firm and must be signed by the person or firm, or his or their solicitors (if any) and must be served, or if posted must be sent by post in sufficient time to reach the abovenamed not later than 4.00 o'clock in the afternoon of Monday, 5th September, 1977.

9746



**The Companies Act 1961—In the matter of ADEY & BROWN (SALES) PTY. LTD. (in Liquidation)**

Notice is hereby given that at an extraordinary General Meeting of the members of the abovenamed Company held on the 4th August, 1977, it was resolved that the Company be wound up voluntarily and that Michael William Ernest Hosking, be nominated as Liquidator for the purpose of such winding-up and that at a meeting of Creditors held later on the same day my appointment as Liquidator was confirmed.

Notice is also given that persons having claims against the Company should lodge a proof of debt within 21 days at my office at: 312 Bay Street, Port Melbourne.

MICHAEL W. E. HOSKING, Liquidator

Dated this 4th day of August, 1977

Hosking, Dyer & Co., public accountants, 312 Bay Street, Port Melbourne, 3207. Phone 645 2444 9737

**The Companies Act 1961—In the matter of CLARKSON CARAVAN CENTRE PTY. LTD. (in Liquidation)**

Notice is hereby given that at an extraordinary General Meeting of the members of the abovenamed Company held on the 3rd August, 1977, it was resolved that the Company be wound up voluntarily and that Michael William Ernest Hosking be nominated as Liquidator for the purpose of such winding-up and that at a meeting of Creditors held later on the same day my appointment as Liquidator was confirmed.

Notice is also given that persons having claims against the Company should lodge a proof of debt within 21 days at my office at: 312 Bay Street, Port Melbourne.

MICHAEL W. E. HOSKING, Liquidator

Dated this 3rd day of August, 1977

Hosking, Dyer & Co., public accountants, 312 Bay Street, Port Melbourne, 3207. Phone 645 2444 9738

**The Companies Act 1961****WARBURTON FRANKI (MELBOURNE) PTY. LTD. (IN MEMBERS' VOLUNTARY LIQUIDATION)**

Notice is hereby given that an Extraordinary General Meeting of Members of the abovenamed Company held on the 1st August, 1977 it was resolved that the Company be wound up voluntarily and that Geoffrey Ormond Harrison and Robert Molesworth Hobill Cole of 10th Floor, 440 Collins Street, Melbourne, be appointed Liquidators.

Notice is also given that after 14 days from this date we shall proceed to distribute the assets. All creditors having any claims against the Company should furnish particulars of their claims by that date, otherwise we shall proceed to distribute the assets without regard to their claim.

G. O. HARRISON & R. M. H. COLE,  
Joint Liquidators

G. O. Harrison, chartered accountant, 10th Floor, 440 Collins Street, Melbourne, 3000 9739

**Companies Act 1961****J. A. WALLACE HOLDINGS PTY. LTD. (IN VOLUNTARY LIQUIDATION)**

Notice is hereby given that at an Extraordinary General Meeting of the members of the abovenamed Company held on the 1st day of August, 1977 it was resolved that the Company be wound up voluntarily and that Mr. Geoffrey Ormond Harrison be appointed Liquidator.

Notice is also given that after 30 days from this date I shall proceed to distribute the assets. All creditors having any claims against the Company should furnish particulars of same by that date otherwise I shall proceed to distribute the assets without regard to their claim.

Dated this 8th day of August, 1977

G. O. HARRISON, liquidator, 440 Collins Street, Melbourne 9760

**In the Supreme Court of Victoria—1977 Co. 9803—In the matter of the Companies Act 1961; and in the matter of DI-LYN PTY. LIMITED—Notice of Winding-up Order**

Winding-up Order: Made 2nd August 1977

Name and Address of Liquidator: Douglas Oldfield of 351 Collins Street, Melbourne

ALAN R. NEAVES, Crown Solicitor for the Commonwealth and Solicitor for the Petitioner 9761

**In the Supreme Court of Victoria—In the matter of the Companies Act 1961; and in the matter of WILLIAM LING (Vic.) PROPRIETARY LIMITED—Notice of Creditors Meeting**

Notice is hereby given that pursuant to Section 260 (1) of the Companies Act 1961 a meeting of creditors of William Ling (Vic.) Proprietary Limited will be held at The Institute of Chartered Accountants in Australia, 9th Floor, 140 Queen Street, Melbourne on Thursday the Twenty-fifth day of August, 1977 at 10.30 a.m. for the purpose of considering the Company's affairs, the Company having convened an extraordinary general meeting of its members to be held on the same day for the purpose of considering and if thought fit passing a special resolution to wind-up the Company voluntarily and to nominate Messrs. J. P. Grant and D. L. Nicholl, Chartered Accountants, of Dulhunty, Grant & Co., Third Floor, 470 Bourke Street, Melbourne as Liquidators for the purpose of the winding-up.

Dated this 2nd day of August, 1977

9740 A. MACLEOD, Director

**Companies Act 1961****BOOBULA LAND CO. PTY. LTD. (IN VOLUNTARY LIQUIDATION)**

Notice is hereby given that at an Extraordinary General Meeting of the members of the abovenamed Company held on the 1st day of August, 1977 it was resolved that the Company be wound up voluntarily and that Mr. Geoffrey Ormond Harrison be appointed Liquidator.

Notice is also given that after 30 days from this date I shall proceed to distribute the assets. All creditors having any claims against the Company should furnish particulars of same by that date otherwise I shall proceed to distribute the assets without regard to their claim.

Dated this 8th day of August, 1977

G. O. HARRISON, liquidator, 440 Collins Street, Melbourne 9759

**Companies Act 1961, Section 254 (2) (b)****VICTORIAN CEILING SUPPLIES PTY. LTD.**

Notice is hereby given that at an Extraordinary General Meeting of the members of the abovenamed company held on the 1st day of August, 1977 it was resolved that the company be wound up voluntarily and that James Manson Poulton and David Alexander Crawford of Messrs. Peat, Marwick, Mitchell & Co., 447 Collins Street, Melbourne be appointed Joint and Several Liquidators.

Notice is also given that after 21 days from this date we shall proceed to distribute the assets. All creditors having any claims against the company should furnish particulars of same by that date, otherwise we shall proceed to distribute the assets without regard to their claim.

Dated this 8th day of August, 1977

J. M. POULTON and D. A. CRAWFORD,  
Joint and Several Liquidators

Peat, Marwick, Mitchell & Co., 447 Collins Street, Melbourne, 3000, Vic. 9758

**ALEXANDER BROWN, late of Colbinabbin, farmer; DECEASED**

Creditors next of kin and others having claims in respect of the estate of the abovenamed deceased who died on the Seventh day of February 1977 are required by the executors Alan Ronald Brown Farmer and Rhonda Rae Brown Married Woman both of Colbinabbin to send particulars of their claims to them care of the undermentioned Solicitors by the Twenty-first day of October 1977 after which date the said executors may convey or distribute the assets having regard only to the claims of which they then have notice.

WATSON, JAMES & ROGERS, solicitors, 61 Bull Street, Bendigo 9673

Creditors next of kin and others having claims in respect of the estate of Robert Whipp late of Nanneella Farmer deceased who died on the Twenty-first day of October 1976 are to send particulars of their claims to the National Trustees Executors and Agency Company of Australasia Limited of 46 Queen Street, Bendigo by the Seventeenth day of October 1977 after which date it will distribute the assets having regard to the claims of which it then has notice.

WATSON, JAMES & ROGERS, solicitors, 61 Bull Street, Bendigo 9674

Creditors next of kin and others having claims against the Estate of Margaret Ellen Pekin formerly of 18 Valetta Street, Malvern in the State of Victoria late of "Amber House" 633 Riversdale Road, Camberwell in the said State, Widow, deceased who died on the 30th day of April 1977 are required by Edward Pekin of 28 Campbell Street, Camperdown in the said State, Gentleman, one of the Executors of the Estate of the said deceased to send particulars of their Claims to the said Executor care of the undermentioned solicitors by the 12th day of October, 1977 after which date the Executor will convey or distribute the estate of the said deceased having regard only to the claims of which he then has notice.

MELVILLE & MELVILLE, solicitors, 224 Glenferrie Road, Malvern 9708

HENRY ERNEST HARVEY, late of Grace McKellar House, Ballarat Road, North Geelong, grazier, DECEASED

Creditors next of kin and others having claims in respect of the estate of the deceased who died on the 23rd day of June 1976 are required by the personal representatives James Frederick Richmond of 1 Barrabool Road Belmont Farmer and John Welford Stubbs and Niel Lindsay Davidson both of 27 Malop Street Geelong Solicitors to send particulars to them care of the undermentioned Solicitors by the 31st day of October 1977 after which date the personal representatives may convey or distribute the assets having regard only to the claims of which they then have notice.

WHYTE JUST & MOORE, solicitors, 27, Malop Street, Geelong 9707

Creditors next of kin and others having claims in respect of the estate of Keith Hume Fraser late of "Five Oaks" Main Road Olinda Company Director deceased intestate who died on the 31st day of October 1976 and Letters of Administration of whose estate have been granted to Valerie Eileen Fraser of "Five Oaks" Main Road Olinda Widow of the said deceased are required to send particulars of their claims to the said Administratrix care of the undermentioned Solicitors by the 14th day of October 1977 after which date she will distribute the assets having regard only to the claims of which she then has notice.

PEARCE & WEBSTER, solicitors, 430 Little Collins Street, Melbourne 9727

SAMUEL CONSTANTINE PEARMAN READ, late of "Ameroo", Garden Hill Road, Launching Place, in the State of Victoria, retired, DECEASED

Creditors, next of kin and others having claims in respect of the estate of the abovenamed deceased who died on the 10th day of August 1976 are required by his Executrix Kathleen Louise Read to send particulars of their claims to care of the undermentioned Solicitors by the 10th day of October 1977 after which date she will convey and distribute the assets of the estate having regard only to the claims of which she then has notice and will not be liable for the assets so conveyed and distributed to any persons of whose claim she shall not then have notice of.

PAVEYS, solicitors, 390 Lonsdale Street, Melbourne, 3000 9728

Creditors next of kin and others having claim in respect of the Estate of Herbert White late of 5 Grandview Avenue Burwood in the State of Victoria Retired Trustee Officer deceased who died on the 5th day of March 1977 are to send particulars of their claims to the Executor The Equity Trustees Executors and Agency Company Limited of 472 Bourke Street Melbourne by the 17th day of October 1977 after which date it will distribute the assets having regard only to the claims of which it then has notice.

ELLISON HEWISON AND WHITEHEAD, solicitors, 379 Collins Street, Melbourne. Telephone 62 2911 9730

Creditors next of kin and others having claims in respect of the estate of Helen Lilian Attock formerly of Flat 1, 307 Riversdale Road, Hawthorn East but late of St. Josephs Home, Little Sisters of the Poor, St. Georges Road, Northcote, widow who died on the 22nd August 1976 are to send particulars of their claims to the Executor Bernard William Gaynor Solicitor c/o of the undersigned by the 17th October 1977 after which date he will commence to distribute the assets of the estate having regard only to the claims of which he then has notice.

RENNICK & GAYNOR, solicitors, 427 Riversdale Road, Hawthorn East, 3123 9731

LENA FOORMAN, (also known as Lena E. Foorman), late of 308 North Sycamore Avenue, Los Angeles, California, in the United States of America, widow, DECEASED

Creditors, next-of-kin, and others having claims in respect of the estate of the deceased, who died on 26th July 1974, are required by the personal representative The Equity Trustees Executors and Agency Company Limited of 472 Bourke Street Melbourne, a duly constituted Attorney under Power of Vivien Sherman of 999 Green Street Apartment No. 1704 San Francisco California in the United States of America the executrix named in the deceased's Will, to send particulars to it by 18th October 1977 after which date the personal representative may convey or distribute the assets, having regard only to the claims of which it then has notice.

ARTHUR ROBINSON & CO., solicitors, 447 Collins Street, Melbourne 9732

RAE BERRY (also known as Rae L. Berry), late of 999 Green Street, Apartment No. 1702, San Francisco, California, in the United States of America, widow, DECEASED

Creditors, next-of-kin, and others having claims in respect of the estate of the deceased, who died on 3rd December 1975, are required by the personal representative The Equity Trustees Executors and Agency Company Limited of 472 Bourke Street Melbourne, a duly constituted Attorney under Power of Vivien Sherman of 999 Green Street Apartment No. 1704 San Francisco California aforesaid the executrix named in the deceased's Will, to send particulars to it by 18th October 1977 after which date the personal representative may convey or distribute the assets, having regard only to the claims of which it then has notice.

ARTHUR ROBINSON & CO., solicitors, 447 Collins Street, Melbourne 9733

In the Will of GILES STEPHEN FITZMAURICE DIGBY, late of 28 Holland Park, London England, gentleman, DECEASED

Creditors next of kin and others having claims in respect of the Estate of the abovenamed deceased (who died on the 12th day of January, 1976) are required by the Executors Stephen Francis Thomas Lavie Robinson and Peter Richard Hamilton Dixon both of 10 Little College Street, Westminster, London, England to send particulars of their claims to them care of the undermentioned solicitors by the 12th day of October, 1977 after which date they will distribute the assets having regard only to the claims of which they then have notice.

AITKEN, WALKER & STRACHAN, solicitors, of 114 William Street, Melbourne, Vic. 3000 9665

MARTHA BRAIN, late of 246 Middleborough Road, Blackburn South, widow, DECEASED

Creditors next of kin and others having claims in respect of the estate of the deceased who died on the 6th day of April 1977 are required by the Trustees John Henry Brain and Peter McLaren Brain to send particulars of their claims to them care of the undersigned Solicitors by the 16th day of October 1977 after which date the Trustees may convey or distribute the assets having regard only to the claims of which they then have notice.

GRAY, FRIEND & LONG, solicitors, Warragul 9666

TREVOR JAMES CLEAVER, late of Neerim South, labourer, DECEASED

Creditors next of kin and others having claims in respect of the estate of the deceased who died on the 3rd day of October 1975 are required by the Trustee The Trustees Executors and Agency Company Limited to send particulars of their claims to it care of the undersigned Solicitors by the 16th day of October 1977 after which date the Trustee may convey or distribute the assets having regard only to the claims of which it then has notice.

GRAY, FRIEND & LONG, solicitors, Warragul 9667

FREDERICK JAMES HINTON, late of 13 O'Dowd's Road, Warragul, retired, DECEASED

Creditors next of kin and others having claims in respect of the estate of the deceased who died on the 26th day of March 1977 are required by the Trustee Thomas James Hinton to send particulars of their claims to him care of the undersigned Solicitors by the 16th day of October 1977 after which date the Trustee may convey or distribute the assets having regard only to the claims of which he then has notice.

GRAY, FRIEND & LONG, solicitors, Warragul 9668

FLORENCE MAY MANLEY, late of Landsborough Road, Warragul, widow, DECEASED

Creditors next of kin and others having claims in respect to the estate of the deceased who died on the 26th day of July 1976 are required by the Trustees Frederick Stanley Manley, Clifford James Manley and Eileen Mavis George to send particulars of their claims to them care of the undersigned Solicitors by the 15th day of October 1977 after which date the Trustees may convey or distribute the assets having regard only to the claims of which they then have notice.

GRAY, FRIEND & LONG, solicitors, Warragul 9669

SARAH MINNIE MURRAY, late of "Bonnie Doon", Coleraine Road, Hamilton, widow, DECEASED

Creditors next-of-kin and others having claims in respect of the Estate of the abovenamed who died on the 6th June, 1977 are required by the Executor of the Will The Union-Fidelity Trustee Company of Australia Limited of 100 Exhibition Street Melbourne to send particulars of their claims to the said Company at its address at 73 Thompson Street Hamilton by the Fifteenth day of September, 1977 after which date they will distribute the assets having regard only to the claims of which they then have notice.

MELVILLE, ORTON & LEWIS, solicitors, 66 Thompson Street, Hamilton 9670

AGNES KERR ROWE, late of Unit 1, 11 Hampden Street, Mornington, widow, DECEASED

Creditors next of kin and others having claims in respect of the estate of the deceased who died on the 29th day of March 1977 are required by the Perpetual Executors and Trustees Association of Australia Limited of 50 Queen Street, Melbourne and Maisie Agnes Harris of 9 Maxwell Grove Warrambool Married Woman the applicant for a grant of administration to send particulars of their claims to the said applicants in the care of the said company by the 30th day of September 1977 after which date they will convey or distribute the assets having regard only to the claims of which they then have notice. 9671

GILBERT ARTHUR BURNETT, formerly of Koondrook, in the State of Victoria, but late of Barham, in the State of New South Wales, farmer, DECEASED

Creditors next-of-kin and all other persons having claims against the Estate of the said Deceased are required by Ella Louise Burnett Widow and Arthur George Burnett labourer both of 45 Murray Street, Barham aforesaid the Executors of the Estate of the said Deceased to send particulars of such claims to them in care of the under-mentioned Solicitors on or before the 30th day of September, 1977 after which date they will distribute the assets having regard only to the claims of which they then have notice.

BASILE & CO., barristers and solicitors, 46 Wellington Street, Kerang 9722

ELIZABETH OVERTON, late of 29 Firdale Avenue, Tamboerskloof Cape Town, Cape of Good Hope, South Africa, married woman, DECEASED

Creditors, next of kin, and other having claims in respect of the estate of the deceased, who died on the 10th May, 1975 are required by the trustee Aubrey Galway Schrader to send particulars to him care of the undersigned by the Twelfth day of October 1977 after which date the trustee may convey or distribute the assets, having regard only to the claims of which he then has notice.

WHITING & BYRNE, solicitors of 440 Collins Street, Melbourne 9742

Creditors next of kin and others having claims in respect of the estate of Phyllis Joy Arklay, late of 169 Bell Street, Coburg Married Woman who died on the 1st day of January, 1977 are required by the executor Richard James Seeley, Manager of 71 Nungerner Street, Balwyn to send particulars of their claim to him care of the under-mentioned solicitor by the 6th October, 1977 after which date the said executor will distribute the assets of the deceased having regard only to the claim which he then shall have notice.

GLOVER, THWAITES & ASSOCIATES, solicitors, 657 Doncaster Road, Doncaster, 3108 9745

Creditors, next of kin and others having claims in respect of the estate of Constance Eleanor Poiner late of 69 Kennedy Street, Hamilton Widow deceased who died on the 7th June, 1977 are requested to send particulars of their claims to the executors Arthur Leslie Park and Francis Kathleen Hewett care of the undermentioned solicitors on or before 12th October 1977 after which date they will distribute the assets having regard only to the claims of which they then have notice.

Messrs. MCKEAN & PARK, solicitors, 450 Little Collins Street, Melbourne 9756

VITTORIO CANGIA, late of 1 Glenara Court, Bundoora, in the State of Victoria, retired storeman, DECEASED, Intestate

Creditors, next of kin and others having claims in respect of the Estate of the deceased (who died on the 25th day of April, 1977) are required by Maria Cangia of 1 Glenara Court, Bundoora, the Administratrix to whom letters of administration of the estate of the deceased have been granted to send particulars of their claims to her care of Messrs. F. R. E. Dawson & Son, 114 William Street, Melbourne, by the 12th day of October, 1977, after which date she will convey or distribute the assets having regard only to the claims of which she then has notice.

Dated the 10th day of August, 1977

F. R. E. DAWSON & SON, 114 William Street, Melbourne 9753

PHOEBE ETHEL TAYLOR, late of 58 Bedford Street, Niddrie, widow, DECEASED

Creditors, next of kin and others having claims in respect of the estate of the Deceased, who died on the 8th day of December, 1976, are required by Iris Rebecca Martha Oldaker of 58 Bedford Street, Niddrie Married Woman, the Executrix of the Will of the Deceased, to send particulars to her at the office of the undermentioned Solicitors by the 17th day of October, 1977, after which date the said Executrix may convey or distribute the assets having regard only to the claims of which it then has notice.

F. J. CORDER & CO., solicitors, 258 Little Bourke Street, Melbourne 9723

Creditors, next-of-kin and others having claims against the estate of Julie Doyle Hayes formerly of Flat 5, 9 The Grange East Malvern and late of Joycedale Private Hospital 9 Latham Street Ivanhoe in the State of Victoria Widow deceased (who died on the 15th day of March 1977) are to send particulars of their claims to the Executor National Trustees Executors and Agency Company of Australasia Limited at its registered office 95 Queen Street Melbourne in the said State before the 21st day of October 1977 after which date it will distribute the assets of the estate having regard only to the claims of which it then has notice.

JOHN F. CARROLL, solicitor, 95 Queen Street, Melbourne 9724

AGNES LILLIAN ENGLAND, late of 23 Hibiscus Road, Blackburn North, widow

Creditors next of kin and others having claims in respect of the Estate of the deceased who died on 14th March, 1977 are required by the National Trustees Executors and Agency Company of Australasia Limited of 95 Queen Street Melbourne to send particulars of their claims to the said Company by the 8th September after which date it will convey or distribute the assets having regard only to the claims of which the Company then has notice.

ARTHUR SECOMB & CO., solicitors, 339 William Street, West Melbourne 9725

Creditors next of kin and others having claims against the estate of Edith Brenda Clements formerly of 40 Dundas Place Albert Park in the State of Victoria but late of Unit 3, 16 Moushall Avenue Niddrie in the said State Widow deceased who died on the 12th day of March, 1977 are requested to send particulars of their claims to the Executor The Equity Trustees Executors and Agency Company Limited of 472 Bourke Street Melbourne by the 7th day of September, 1977 after which date the Executor will distribute the assets having regard only to the claims of which it then has notice.

COOKE & CUSSEN, solicitors, of 128 Exhibition Street, Melbourne 9726

**Trustee Act 1958  
NOTICE TO CLAIMANTS**

Pursuant to the *Trustee Act 1958*, creditors next of kin and all other persons having claims in respect of the estate of any deceased person named below are required to send particulars to the legal personal representative or representatives at the addresses stated, after which date the representatives will distribute the assets, having regard only to the claims of which notice has been received:—

Walter Andrew Milne, late of 41 Anderson Street Newport Retired Railway Employee deceased intestate, died on the First day of June 1972. Claims to the Administrator Leith Robert Milne of 41 Anderson Street Newport by the 12th day of October, 1977—JOHN F. CARROLL, LL.B., solicitor, 4 Paisley Street, Footscray 9743

Ethel Lena Prytherch, late of 2 Birmingham Street Spotswood Widow deceased, died on the 27th day of May 1977. Claims to the Administrator Peter John Prytherch of 2 Birmingham Street Spotswood by the 12th day of October 1977—JOHN F. CARROLL, LL.B., solicitor, 4 Paisley Street, Footscray 9744

**IMPOUNDING**

KYNETON—Impounded at Kyneton Pound on 26th July, 1977 from Lauriston Town area.

1 Poll shorthorn cow

If not claimed and expenses paid, will be sold on 18th August, 1977.

9684—\$3.85

C. H. RIORDAN,  
Poundkeeper.

*Subordinate Legislation Act 1962*

**NOTICE OF MAKING OF STATUTORY RULES**

In pursuance of the provisions of the *Subordinate Legislation Act 1962* and the Regulations made thereunder, notice is given of the making of the following statutory rules:—

No.	Grain Elevators Act 1958	Price
182/1977.	Grain Elevators Board By-Law (Relating to the Conditions of Employment of Staff) No. 47AG	10c
<i>Health Act 1959</i>		
183/1977.	Mental Health (Medical Positions and Salaries No. 3) Regulations 1977	10c
<i>Industrial Training Act 1975</i>		
184/1977.	Industrial Training (Building Trades Pre-Apprenticeship) Regulations 1977	10c
<i>Health Act 1958</i>		
185/1977.	Registration (Health Acts) (Fees) Regulations 1977	10c
<i>Public Service Act 1974</i>		
PSD71/1977.	Public Service Determinations	10c
PSD72/1977.	Public Service Determinations	10c
PSD73/1977.	Public Service Determinations	10c
PSD74/1977.	Public Service Determinations	10c
PSD75/1977.	Public Service Determinations	10c

Copies of these statutory rules may be purchased at the Sale of Publications Section of the Government Printing Office, located at 7A Parliament Place, Melbourne, 3002. If ordered by mail, remittance should be addressed to "The Government Printer, Box 203, P.O., North Melbourne, 3051", and should include 20c extra for postage.

The annual subscription rates for Statutory Rules for the year commencing 1st January, 1976, payable in advance, are as follows:—

Statutory Rules (other than Public Service Determinations)	\$45.00
Public Service Determinations	\$20.00

F. D. ATKINSON,  
Government Printer

**STATE ACTS, 1977**

Copies of the following Acts of the Parliament of Victoria may be obtained at the Government Printing Office, Sale of Publications Branch, 7A Parliament Place, Melbourne, phone 651 2754 or 651 2759, or from any accredited agent, at the price set opposite to each (these prices do not include postage).

Postage costs must be added to your remittance when ordering by mail as follows:—

Act Price.	Postage Cost.
10c-40c	20c
45c-70c	30c
75c-\$1.70	40c
\$1.75-\$4.00	60c
Above \$4.00	86c

No.	PRICE.
8969. Small Claims Tribunals (Amendment)	\$0.10
8970. Local Government (Rate Relief)	\$0.10
8971. State Electricity Commission (Financial Accommodation)	\$0.10
8972. Geelong (Kardinia Park) Land	\$0.10
8973. Revocation and Excision of Crown Reservations	\$0.30
8974. Agricultural Authorities (Members Insurance)	\$0.10
8975. Racing (Tabella Totalizators)	\$0.30
8976. Fuel Emergency	\$0.20
8977. Australia and New Zealand Banking Group	\$0.20
8978. Co-operative Housing Societies (Leasehold Securities)	\$0.10
8979. Geelong Waterworks and Sewerage (Amendment)	\$0.20
8980. Yooralla Society of Victoria	\$0.10
8981. Melbourne Underground Rail Loop (Amendment)	\$0.20
8982. Tattersall Consultations (Gold Lottery Consultations)	\$0.10
8983. Public Service (Government Offices)	\$0.10
8853. Judges Salaries	\$0.10
8854. Small Business Development Corporation	\$0.20
8855. Home Finance (Loans and Guarantees)	\$0.10
8856. Teaching Service (Professional Appointments)	\$0.10
8857. Friendly Societies (Amendment)	\$0.10
8858. Public Works and Services (Further Expenditure)	\$0.10
8859. Sewerage Districts (Amendment)	\$0.20
8860. Mildura College Lands (Schools Fund)	\$0.10
8861. Dandenong Valley Authority (Amendment)	\$0.10
8862. Second-hand Dealers (Charity Collectors)	\$0.30
8863. Mental Health (Amendment)	\$0.10
8864. Victorian Film Corporation	\$0.20
8865. Motor Car (Breath Testing Stations)	\$0.10
8866. Education (Minister of Special Education)	\$0.10
8867. Deakin University (Amendment)	\$0.10
8868. Public Service (Long Service Leave)	\$0.10
8869. Victorian Development Corporation	\$0.10
8870. Crimes	\$0.30
8871. Weights and Measures (Amendment)	\$0.30
8872. Wild Flowers and Native Plants Protection (Amendment)	\$0.10
8873. Ministry of Transport (Amendment)	\$0.10
8874. Abattoir and Meat Inspection (Amendment)	\$0.30
8875. Local Government (Rates) Amendment	\$0.20
8876. Cluster Titles (Amendment)	\$0.10
8877. Parliamentary Allowances	\$0.10
8878. Liquor Control (Exhibition Buildings)	\$0.10
8879. Waterworks Trusts Association of Victoria (Financial Year)	\$0.10
8880. Provincial Sewerage Authorities Association of Victoria (Financial Year)	\$0.10
8881. Crown Reservations (Revocations and Excisions)	\$0.30
8882. Co-operative Housing Societies (Amendment)	\$0.10
8883. County Court (Amendment)	\$0.10
8884. Ombudsman (Municipalities)	\$0.10
8885. Racing (Amendment)	\$0.10
8886. Home Finance (Amendment)	\$0.10
8887. Victoria Grants Commission	\$0.20
8888. Local Government (City of Sunshine)	\$0.10
8889. Gordon Technical College	\$0.20
8890. Water (Amendment)	\$0.20
8891. Nar Nar Goon Land Exchange	\$0.10
8892. Forests (Advances)	\$0.10
8893. Pensioners' Rates Remission	\$0.40
8894. State Electricity Commission (Loy Yang Power Station)	\$0.10
8895. Appropriation (1976-77, No. 1)	\$3.10
8896. Vital State Projects	\$0.20
8897. Barley Marketing (Amendment)	\$0.10
8898. Labour and Industry (Amendment)	\$0.10

STATE ACTS, 1976—continued.

No.	Price
8899. Lands Compensation (Amendment)	\$0.10
8900. Dentists (Amendment)	\$0.30
8901. Educational Institutions (Guarantees)	\$0.10
8902. Appeal Costs Fund (Amendment)	\$0.10
8903. Co-operation (Amendment)	\$0.20
8904. Victorian Institute of Secondary Education	\$0.20
8905. Water Supply Works and Services	\$0.40
8906. Health (Fees)	\$0.10
8907. Cemeteries (Amendment)	\$0.10
8908. State Forests Works and Services	\$0.10
8909. Gold Buyers (Repeal)	\$0.10
8910. Melbourne and Metropolitan Tramways (East Burwood Tramway)	\$0.10
8911. Box Hill Land	\$0.20
8912. Liquor Control (Orderly Marketing)	\$0.10
8913. Melbourne Underground Rail Loop (Financial Contributions)	\$0.10
8914. Companies (Fees)	\$0.10
8915. Employers and Employés (Repeal)	\$0.10
8916. Gas and Fuel Corporation (Borrowing Powers)	\$0.10
8917. Teacher Housing (Amendment)	\$0.10
8918. Education (Special Developmental Schools)	\$0.10
8919. Coal Mines (Pensions)	\$0.10
8920. Mines	\$0.10
8921. Northcote Children's Home	\$0.10
8922. Victoria Racing Club (Borrowings)	\$0.10
8923. Taxation Appeals (Amendment)	\$0.10
8924. Marine (Amendment)	\$0.30
8925. Hospitals Superannuation (Amendment)	\$0.50
8926. Ports and Harbours	\$0.20
8927. Building Industry Long Service Leave (Amendment)	\$0.20
8928. Public Works and Services	\$0.20
8929. Public Service (Amendment)	\$0.10
8930. Educational Grants (Continuation)	\$0.10
8931. Transport Works and Services	\$0.10
8932. Housing (Amendment)	\$0.20
8933. Country Fire Authority (Amendment)	\$0.10
8984. Anglican Church of Australia Constitution (Amendment)	\$0.20
8985. Portland Harbor Trust (Financial)	\$0.10
8986. Epworth Hospital (Guarantee)	\$0.10
8987. Mildura College Lands (Mildura Schools Fund)	\$0.10
8988. Lotteries Gaming and Betting (Raffles and Bingo)	\$0.40
8989. Racing (Amendment)	\$0.10
8990. Land Surveyors (Surveyors Board)	\$0.10
8991. Railways (Participation in Pipelines)	\$0.10
8992. Melbourne and Metropolitan Tramways (Borrowing Powers)	\$0.10
8993. Melbourne Wholesale Fruit and Vegetable Market Trust	\$0.80
8994. Geelong Grammar Schools Amalgamations	\$0.50
8995. Melton Land	\$0.10
8996. Land (Surrender of Lands)	\$0.10
8997. Shepparton Abattoirs (Amendment)	\$0.10
8998. Magistrates' Courts (Commitment)	\$0.10
8999. Melbourne and Geelong Corporations (Regent Theatre Buildings)	\$0.10
9000. Dental Technicians (Amendment)	\$0.10
9001. Motor Car (Breath Testing Stations) (Amendment)	\$0.10
9002. Marriage (Amendment)	\$0.10
9003. Public Contracts (Amendment)	\$0.10
9004. Victorian Dairy Industry Authority	\$0.60
9005. Public Service (Director-General of Agriculture)	\$0.20
9006. Local Authorities Superannuation (Contributions)	\$0.20
9007. County Court (Amendment)	\$0.10
9008. Bail	\$0.60
9009. Supply (1977-78, No. 1)	\$0.20
9010. Grain Elevators (Amendment)	\$0.30
9011. State Electricity Commission (Newport Power Station)	\$0.10
9012. Police Offences (Child Pornography)	\$0.10
9013. Milk Board (Milk Vendors)	\$0.20
9014. Dandenong Valley Authority (Cardinia Creek)	\$0.20
9015. Motor Car (Amendment)	\$0.50
9016. State Library and National Museum Buildings Committee	\$0.20
9017. Superannuation Benefits	\$0.20
9018. Social Welfare (Administration)	\$0.20
9019. Statute Law Revision	\$0.70
9020. Emerald Tourist Railway	\$0.50
9021. The Uniting Church in Australia	\$0.60
9022. Local Government (Amendment)	\$0.60
9023. Health Commission	\$1.10
9024. Geelong Regional Commission	\$0.60
9025. Equal Opportunity	\$0.60

ACTS REPRINTED IN ACCORDANCE WITH THE AMENDMENTS INCORPORATION ACT 1958; (No. 6422), AND FOR SALE AT THE SALE OF PUBLICATIONS BRANCH OF THE GOVERNMENT PRINTING OFFICE, 7A PARLIAMENT PLACE, MELBOURNE, 3002

Postage costs must be added to your remittance when ordering by mail as follows:—

Act Price	Postage Cost
10c-40c	20c
45c-70c	30c
75c-\$1.70	40c
\$1.75-\$4.00	60c
Above \$4.00	86c

No.	Price
6189. Acts Interpretation (Fourth Reprint—Incorporating amendments up to No. 8305)	\$0.35
6191. Administration and Probate (Fourth Reprint—Incorporating amendments up to No. 7874)	\$0.75
7147. Adoption of Children (First Reprint—Incorporating amendments up to Act No. 8602)	\$0.75
6194. Agricultural Colleges (First Reprint—Incorporating amendments up to No. 7302)	\$0.15
6198. Anzac Day (First Reprint—Incorporating amendments up to No. 8344)	\$0.15
7117. Appeal Costs Fund Act 1964 (Second Reprint—Incorporating amendments up to No. 7488)	\$0.35
6201. Architects (First Reprint—Incorporating amendments up to No. 8077)	\$0.30
6202. Auction Sales (First Reprint—Incorporating amendments up to No. 8490)	\$0.35
6203. Audit (First Reprint—Incorporating amendments up to No. 7377)	\$0.35
6208. Benefit Associations (First Reprint—Incorporating amendments up to No. 6961)	\$0.65
8004. Boiler and Pressure Vessels Act 1970 (First Reprint—Incorporating amendments up to No. 8389)	\$0.45
6529. Bread Industry Act 1959 (First Reprint—Incorporating amendments up to No. 7728)	\$0.30
6973. Building Contracts (Deposits) Act 1962 (First Reprint—Incorporating amendments from No. 7315)	\$0.10
6210. Building Societies (Third Reprint—Incorporating amendments up to No. 8405)	\$0.65
6213. Cancer (First Reprint—Incorporating amendments up to No. 7455)	\$0.35
6214. Carriers and Innkeepers (Second Reprint—Incorporating amendments up to No. 8534)	\$0.20
6215. Cattle Breeding (First Reprint—Incorporating amendments up to No. 6886)	\$0.10
6217. Cemeteries (First Reprint—Incorporating amendments up to No. 7672)	\$0.30
6220. Clean Air (Third Reprint—Incorporating amendments up to No. 8324)	\$0.15
6221. Coal Mines (First Reprint—Incorporating amendments up to No. 7628)	\$1.05
6222. Commercial Goods Vehicles (Third Reprint—Incorporating amendments up to No. 8525)	\$0.55
6223. Commonwealth Arrangements (First Reprint—Incorporating amendments from No. 7809)	\$0.10
6839. Companies (Sixth Reprint—Incorporating amendments up to No. 8788)	\$7.90
8276. Consumer Affairs Act 1972 (Third Reprint—Incorporating amendments up to No. 8824)	\$1.15
8750. Constitution Act 1975, The (First Reprint—Incorporating amendments up to No. 8951)	\$0.85
6224. Constitution Act Amendment, The (First Reprint—Incorporating amendments up to No. 8086)	\$3.05
6225. Co-operation Act (Third Reprint—Incorporating amendments up to No. 8339)	\$0.85
6226. Co-operative Housing Societies (Second Reprint—Incorporating amendments up to No. 7575)	\$0.53
6227. Coroners (Second Reprint—Incorporating amendments up to No. 8184)	\$0.35
6228. Country Fire Authority (Third Reprint—Incorporating amendments up to No. 8813)	\$1.25
6229. Country Roads (Fourth Reprint—Incorporating amendments up to No. 8573)	\$1.05
6230. County Court (Third Reprint—Incorporating amendments up to No. 8625)	\$0.65
6231. Crimes (Fifth Reprint—Incorporating amendments up to No. 8679)	\$2.35
6232. Crown Proceedings (Second Reprint—Incorporating amendments up to No. 8731)	\$0.40
6233. Dairy Products (First Reprint—Incorporating amendments up to No. 7945)	\$0.30

ACTS REPRINTED IN ACCORDANCE WITH THE AMENDMENTS  
INCORPORATION ACT 1958 (No. 6422)—continued

No.	Price
7060. Dandenong Valley Authority Act 1963 ( <i>First Reprint</i> —Incorporating amendments up to No. 7523)	\$0.35
6235. Dietitians Registration ( <i>First Reprint</i> —Incorporating amendments up to No. 6886)	\$0.20
4989. Discharged Servicemen's Preference Act 1943 ( <i>Second Reprint</i> —Incorporating amendments up to No. 7991)	\$0.20
6815. Disposal of Uncollected Goods Act 1961 ( <i>Second Reprint</i> —Incorporating amendments up to No. 8246)	\$0.30
8079. Dog Act 1970 ( <i>First Reprint</i> —Incorporating amendments up to No. 8664)	\$0.30
6237. Drainage Areas ( <i>First Reprint</i> —Incorporating amendments up to No. 7276)	\$0.35
6239. Dried Fruits Act 1968 ( <i>First Reprint</i> —Incorporating amendments up to No. 7337)	\$0.25
6240. Education Act ( <i>Second Reprint</i> —Incorporating amendments up to No. 8659)	\$0.95
6241. Electric Light and Power ( <i>First Reprint</i> —Incorporating amendments up to No. 7315)	\$0.30
8056. Environment Protection Act 1970 ( <i>Second Reprint</i> —Incorporating amendments up to No. 8560)	\$0.55
6244. Essential Services ( <i>First Reprint</i> —Incorporating amendments up to No. 8353)	\$0.20
6245. Estate Agents—( <i>Fifth Reprint</i> —Incorporating amendments up to No. 8490)	\$0.85
6246. Evidence ( <i>Fourth Reprint</i> —Incorporating amendments up to No. 8228)	\$1.05
7499. Extractive Industries Act 1966 ( <i>Third Reprint</i> —Incorporating amendments up to No. 8647)	\$0.45
7733. Fences ( <i>First Reprint</i> —Incorporating amendments up to No. 7876)	\$0.55
6468. Filled Milk ( <i>First Reprint</i> —Incorporating amendments up to No. 6886)	\$0.15
6251. Firearms ( <i>Fifth Reprint</i> —Incorporating amendments up to No. 8427)	\$1.05
7780. Fisheries Act 1968 ( <i>First Reprint</i> —Incorporating amendments up to No. 8694)	\$1.05
6916. Foreign Judgments Act 1962 ( <i>First Reprint</i> including amendments made by No. 7332)	\$0.15
6585. Forests (Pulpwood Agreement) (Incorporating amendments up to No. 6886)	\$0.15
6254. Forests ( <i>Second Reprint</i> —Incorporating amendments up to No. 8702)	\$1.35
6255. Friendly Societies ( <i>First Reprint</i> —Incorporating amendments up to No. 7554)	\$0.60
6256. Fruit and Vegetables ( <i>First Reprint</i> —Incorporating amendments up to No. 6944)	\$0.30
6260. Gas and Fuel Corporation ( <i>First Reprint</i> —Incorporating amendments up to No. 7422)	\$0.70
6262. Geelong Harbor Trust ( <i>First Reprint</i> —Incorporating amendments up to No. 7547)	\$0.45
6263. Geelong Waterworks and Sewerage ( <i>First Reprint</i> —Incorporating amendments, up to No. 7547)	\$0.75
8176. Gift Duty Act 1971 ( <i>First Reprint</i> —Incorporating amendments from No. 8202)	\$0.55
6265. Goods ( <i>Sixth Reprint</i> —Incorporating amendments up to No. 8425)	\$0.45
6266. Grain Elevators ( <i>First Reprint</i> —Incorporating amendments up to No. 7486)	\$0.35
7849. Groundwater ( <i>First Reprint</i> —Incorporating amendments up to No. 8153)	\$0.45
6267. Hairdressers Registration ( <i>First Reprint</i> —Incorporating amendments up to No. 7659)	\$0.30
6269. Hawkers and Pedlars ( <i>Second Reprint</i> —Incorporating amendments up to No. 8247)	\$0.40
6270. Health ( <i>Third Reprint</i> —Incorporating amendments up to No. 8506)	\$3.25
6531. Hire Purchase Act 1959 ( <i>Second Reprint</i> —Incorporating amendments from No. 8232)	\$0.55
6933. Home Finance Act 1962 ( <i>First Reprint</i> —Incorporating amendments up to No. 7363)	\$0.25
6274. Hospitals and Charities ( <i>Second Reprint</i> —Incorporating amendments up to No. 7455)	\$0.50
6275. Housing ( <i>Third Reprint</i> —Incorporating amendments up to No. 8713)	\$2.40
6276. Imprisonment of Fraudulent Debtors ( <i>First Reprint</i> —Incorporating amendments up to No. 7876)	\$0.35
6277. Industrial and Provident Societies ( <i>First Reprint</i> —Incorporating amendments up to No. 7547)	\$0.35
6279. Instruments ( <i>Fifth Reprint</i> —Incorporating amendments up to No. 8565)	\$0.75

ACTS REPRINTED IN ACCORDANCE WITH THE AMENDMENTS  
INCORPORATION ACT 1958 (No. 6422)—continued

No.	Price
6280. Judicial Proceedings Reports ( <i>First Reprint</i> —Incorporating amendments up to No. 7596)	\$0.15
7651. Juries ( <i>First Reprint</i> —Incorporating amendments up to No. 8170)	\$0.55
6283. Labour and Industry ( <i>Sixth Reprint</i> —Incorporating amendments up to No. 8642)	\$1.50
6284. Land ( <i>Third Reprint</i> —Incorporating amendments up to No. 8702)	\$3.25
6534. Land Settlement Act 1959 ( <i>First Reprint</i> —Incorporating amendments up to No. 7328)	\$0.30
6288. Land Surveyors ( <i>First Reprint</i> —Incorporating amendments up to No. 7065)	\$0.30
6289. Land Tax ( <i>Second Reprint</i> —Incorporating amendments up to No. 7466)	\$0.40
6285. Landlord and Tenant ( <i>Fourth Reprint</i> —Incorporating amendments up to No. 8208)	\$1.15
6286. Lands Compensation Act ( <i>Third Reprint</i> —Incorporating amendments up to No. 8599)	\$0.45
6290. Latrobe Valley ( <i>First Reprint</i> —Incorporating amendments up to No. 7332)	\$0.35
7919. Legal Aid—( <i>First Reprint</i> —Incorporating amendments up to No. 8427)	\$0.30
6291. Legal Profession Practice Act ( <i>Fourth Reprint</i> —Incorporating amendments up to No. 8778)	\$1.45
6292. Libraries ( <i>First Reprint</i> —Incorporating amendments up to No. 7364)	\$0.15
7629. Lifts and Cranes Act 1967 ( <i>First Reprint</i> —Incorporating amendments up to No. 8320)	\$0.30
6295. Limitation of Actions ( <i>Third Reprint</i> —Incorporating amendments up to No. 8300)	\$0.35
7695. Liquor Control Act 1958 ( <i>Third Reprint</i> —Incorporating amendments up to No. 8598)	\$1.35
7145. Litter Act 1964 ( <i>Second Reprint</i> —Incorporating amendments up to No. 8702)	\$0.20
6298. Local Authorities Superannuation ( <i>Second Reprint</i> —Incorporating amendments up to No. 7161)	\$0.40
6299. Local Government ( <i>Third Reprint</i> —Incorporating amendments up to No. 8781)	\$10.90
7429. Lotteries Gaming and Betting—( <i>First Reprint</i> —Incorporating amendments up to No. 8581)	\$0.75
8184. Magistrates' Courts ( <i>First Reprint</i> —Incorporating amendments up to No. 8718)	\$0.75
7289. Maintenance ( <i>First Reprint</i> —Incorporating amendments up to No. 8036)	\$1.05
6302. Marine (Incorporating amendments up to No. 7350)	\$0.72
6303. Marine Stores and Old Metals ( <i>First Reprint</i> —Incorporating amendments up to No. 7876)	\$0.35
6304. Marketing of Primary Products ( <i>First Reprint</i> —Incorporating amendments up to No. 7491)	\$0.45
6305. Markets Act ( <i>Second Reprint</i> —Incorporating amendments up to No. 8247)	\$0.30
6306. Marriage ( <i>Second Reprint</i> —Incorporating amendments up to No. 8602)	\$0.45
6307. Masseurs ( <i>First Reprint</i> —Incorporating amendments up to No. 7566)	\$0.20
6309. Medical Act 1958 ( <i>Third Reprint</i> —Incorporating amendments up to No. 8593)	\$0.45
8061. Medical Practitioners ( <i>First Reprint</i> —Incorporating amendments up to No. 8754)	\$0.75
6310. Melbourne and Metropolitan Board of Works ( <i>Fourth Reprint</i> —Incorporating amendments up to No. 8650)	\$1.95
6311. Melbourne and Metropolitan Tramways ( <i>First Reprint</i> —Incorporating amendments up to No. 7622)	\$0.70
6312. Melbourne Harbor Trust ( <i>Second Reprint</i> —Incorporating amendments up to No. 8796)	\$1.35
6405. Melbourne University ( <i>First Reprint</i> —Incorporating amendments up to No. 7871)	\$0.40
6605. Mental Health ( <i>Second Reprint</i> —Incorporating amendments up to No. 8679)	\$0.75
6315. Metropolitan Fire Brigades ( <i>Second Reprint</i> —Incorporating amendments up to No. 8165)	\$0.65
6316. Mildura Irrigation and Water Trusts ( <i>First Reprint</i> —Incorporating amendments up to No. 7448)	\$0.75
6317. Milk and Dairy Supervision ( <i>Second Reprint</i> —Incorporating amendments up to No. 8655)	\$0.85
6318. Milk Board (Incorporating amendments up to No. 7093)	\$0.22

ACTS REPRINTED IN ACCORDANCE WITH THE AMENDMENTS  
INCORPORATION ACT 1958 (No. 6422)—*continued*

No.	Price
6319. Milk Pasteurization ( <i>First Reprint</i> —Incorporating amendments up to No. 7480)	\$0.18
6320. Mines ( <i>Second Reprint</i> —Incorporating amendments up to No. 7876)	\$1.25
6184. Monash University ( <i>First Reprint</i> —Incorporating amendments up to No. 7533)	\$0.30
6324. Money Lenders ( <i>Fourth Reprint</i> —Incorporating amendments up to No. 8490)	\$0.55
6832. Motor Boating Act 1961 ( <i>Third Reprint</i> —Incorporating amendment up to No. 8662)	\$0.55
6325. Motor Car Act 1958 ( <i>Fifth Reprint</i> —Incorporating amendments up to No. 8657)	\$2.25
6713. National Fitness Council of Victoria Act 1960 ( <i>First Reprint</i> —Incorporating amendments up to No. 8344)	\$0.20
6705. Navigable Waters (Oil Pollution) Act 1960. ( <i>First Reprint</i> —Incorporating amendments up to No. 7890)	\$0.30
6328. Nurses Act ( <i>Third Reprint</i> —Incorporating amendments up to No. 8743)	\$0.65
8414. Ombudsman Act 1973. ( <i>First Reprint</i> —Incorporating amendments up to No. 8884)	\$0.45
6329. Optometrists Registration ( <i>First Reprint</i> —Incorporating amendments up to No. 7409)	\$0.30
7723. Parliamentary Salaries and Superannuation ( <i>First Reprint</i> —Incorporating amendments up to No. 8687)	\$0.35
6330. Partnership ( <i>Second Reprint</i> —Incorporating amendments up to No. 7315)	\$0.35
6331. Patriotic Funds ( <i>First Reprint</i> —Incorporating amendments up to No. 7338)	\$0.25
6332. Pawnbrokers Act 1958 ( <i>Second Reprint</i> —Incorporating amendments up to No. 8181)	\$0.35
7417. Pensions Supplementation ( <i>First Reprint</i> —Incorporating amendments up to No. 8475)	\$0.20
6257. Pesticides Act 1958 ( <i>Second Reprint</i> —Incorporating amendments up to No. 8589)	\$0.35
6335. Petrol Pumps ( <i>Second Reprint</i> —Incorporating amendments up to No. 7315)	\$0.15
6334. Petroleum ( <i>First Reprint</i> —Incorporating amendments up to No. 7876)	\$0.65
6889. Poisons Act 1962 ( <i>Fourth Reprint</i> —Incorporating amendments up to No. 8456)	\$0.95
6337. Police Offences Act 1958 ( <i>Third Reprint</i> —Incorporating amendments up to No. 8433)	\$0.45
6388. Police Regulation ( <i>Third Reprint</i> —Incorporating amendments up to No. 8722)	\$0.95
6340. Portland Harbor Trust ( <i>First Reprint</i> —Incorporating amendments up to No. 7475)	\$0.35
7498. Port Phillip Authority Act 1966 ( <i>Second Reprint</i> —Incorporating amendments from No. 8081)	\$0.15
6341. Pounds ( <i>First Reprint</i> —Incorporating amendments up to No. 7315)	\$0.25
6342. Printers and Newspapers ( <i>First Reprint</i> —Incorporating amendments up to No. 7876)	\$0.15
7494. Private Agents Act 1966 ( <i>Second Reprint</i> —Incorporating amendments up to No. 8427)	\$0.45
6344. Property Law ( <i>Third Reprint</i> —Incorporating amendments up to No. 8181)	\$1.95
6345. Public Account ( <i>First Reprint</i> —Incorporating amendments up to No. 8012)	\$0.20
6346. Public Authorities Marks ( <i>First Reprint</i> —Incorporating amendments from No. 7315)	\$0.10
8656. Public Service ( <i>First Reprint</i> —Incorporating amendments up to No. 8806)	\$0.95
6350. Public Trustee Act 1958 ( <i>Second Reprint</i> —Incorporating amendments up to No. 8125)	\$1.05
6353. Racing ( <i>Fourth Reprint</i> —Incorporating amendments up to No. 8690)	\$1.55
6355. Railways ( <i>First Reprint</i> —Incorporating amendments up to No. 7475)	\$0.75
6564. Registration of Births Deaths and Marriages Act 1959 ( <i>First Reprint</i> —Incorporating amendments up to No. 7332)	\$0.25
6358. River Improvements Act ( <i>Second Reprint</i> —Incorporating amendments up to No. 8967)	\$0.85
2596. River Murray Waters Act 1915 ( <i>First Reprint</i> —Incorporating amendments up to No. 7061)	\$0.35
6359. Road Traffic ( <i>Fourth Reprint</i> —Incorporating amendments up to No. 8353)	\$0.35
6360. Rural Finance ( <i>First Reprint</i> —Incorporating amendments up to No. 7328)	\$0.15

ACTS REPRINTED IN ACCORDANCE WITH THE AMENDMENTS  
INCORPORATION ACT 1958 (No. 6422)—*continued*

No.	Price
6846. Rural Finance and Settlement Commission Act 1961 ( <i>First Reprint</i> —Incorporating amendments up to No. 7332)	\$0.30
6917. Sale of Human Blood Act 1962 ( <i>First Reprint</i> —Incorporating amendments from No. 7332)	\$0.10
6975. Sale of Land Act 1962 ( <i>Second Reprint</i> —Incorporating amendments up to No. 7898)	\$0.35
8146. Scaffolding Act 1971 ( <i>Second Reprint</i> —Incorporating amendments up to No. 8666)	\$0.35
6363. Second-hand Dealers ( <i>First Reprint</i> —Incorporating amendments up to No. 7529)	\$0.25
6367. Settled Land ( <i>Second Reprint</i> —Incorporating amendments up to No. 7065)	\$0.85
6368. Sewerage Districts ( <i>Second Reprint</i> —Incorporating amendments up to No. 7547)	\$0.75
6369. Shearers Accommodation ( <i>First Reprint</i> —Incorporating amendments up to No. 7876)	\$0.35
6809. Sheep Owners Protection Act 1961 ( <i>Third Reprint</i> —Incorporating amendments up to No. 8247)	\$0.20
8089. Social Welfare Act 1970 ( <i>First Reprint</i> —Incorporating amendments up to No. 8821)	\$1.90
6372. Soil Conservation and Land Utilization Act ( <i>Third Reprint</i> —Incorporating amendments up to No. 8432)	\$0.45
6373. Soldier Settlement ( <i>First Reprint</i> —Incorporating amendments up to No. 7328)	\$0.42
6375. Stamps Act 1958 ( <i>Sixth Reprint</i> —Incorporating amendments up to No. 8624)	\$2.15
6377. State Electricity Commission ( <i>Second Reprint</i> —Incorporating amendments up to No. 7421)	\$0.65
6378. State Relief Committee ( <i>First Reprint</i> —Incorporating amendments from No. 6886)	\$0.10
6379. State Savings Bank Act 1958 ( <i>Third Reprint</i> —Incorporating amendments up to No. 8519)	\$0.95
6380. Statistics ( <i>First Reprint</i> —Incorporating amendments up to No. 6961)	\$0.15
6877. Stock (Artificial Breeding) Act 1962 ( <i>First Reprint</i> —Incorporating amendments up to No. 8709)	\$0.30
6383. Stock Foods ( <i>First Reprint</i> —Incorporating amendments up to No. 7607)	\$0.28
6384. Stock Medicines ( <i>First Reprint</i> —Incorporating amendments up to No. 7726)	\$0.20
7551. Strata Titles Act 1967 ( <i>Third Reprint</i> —Incorporating amendments up to No. 8661)	\$0.65
6886. Subordinate Legislation Act 1962 ( <i>Second Reprint</i> —Incorporating amendments up to No. 8127)	\$0.15
7405. Summary Offences Act 1966 ( <i>Second Reprint</i> —Incorporating amendments up to No. 8276)	\$0.55
7634. Sunday Entertainment ( <i>First Reprint</i> —Incorporating amendments up to No. 8173)	\$0.15
6386. Superannuation ( <i>Third Reprint</i> —Incorporating amendments up to No. 8717)	\$1.35
6387. Supreme Court ( <i>First Reprint</i> —Incorporating amendments up to No. 7522)	\$0.75
6388. Survey Co-ordination ( <i>First Reprint</i> —Incorporating amendments up to No. 8107)	\$0.35
6390. Tattersall Consultations ( <i>First Reprint</i> —Incorporating amendments up to No. 8289)	\$0.15
6391. Teaching Service ( <i>Second Reprint</i> —Incorporating amendments up to No. 8691)	\$0.55
6393. Theatres ( <i>First Reprint</i> —Incorporating amendments up to No. 8161)	\$0.15
6849. Town and Country Planning Act 1961 ( <i>Fifth Reprint</i> —Incorporating amendments up to No. 8716)	\$1.25
6397. Trade Unions ( <i>Second Reprint</i> —Incorporating amendments up to No. 8181)	\$0.20
6399. Transfer of Land ( <i>Fifth Reprint</i> —Incorporating amendments up to No. 8531)	\$1.15
6400. Transport Regulation Act ( <i>Second Reprint</i> —Incorporating amendments up to No. 8549)	\$0.45
6401. Trustee ( <i>Third Reprint</i> —Incorporating amendments up to No. 7833)	\$0.85
6402. Trustee Companies ( <i>First Reprint</i> —Incorporating amendments up to No. 7858)	\$0.35
6879. Unclaimed Moneys Act 1962 ( <i>Second Reprint</i> —Incorporating amendments up to No. 8448)	\$0.20
7095. Underseas Mineral Resources Act 1963 ( <i>First Reprint</i> —Incorporating amendments from No. 7591)	\$0.10

ACTS REPRINTED, IN ACCORDANCE WITH THE AMENDMENTS, INCORPORATION ACT 1958, (No. 6422)—continued

No.	Price
6653. Valuation of Land Act 1960 (Fourth Reprint—Incorporating amendments up to No. 8817)	\$0.85
6407. Vegetation and Vine Diseases (First Reprint—Incorporating amendments up to No. 7423)	\$0.30
6409. Vermin & Noxious Weeds (First Reprint—Incorporating amendments up to No. 7463)	\$0.35
6410. Veterinary Surgeons (First Reprint—Incorporating amendments up to No. 7343)	\$0.15
7291. Victoria Institute of Colleges Act 1965 (Second Reprint—Incorporating amendments up to No. 8710)	\$0.65
6412. Warehousemen's Liens (First Reprint—Incorporating amendments up to No. 7876)	\$0.15
6413. Water (Third Reprint—Incorporating amendments up to No. 8729)	\$3.45
6414. Weights and Measures (Third Reprint—Incorporating amendments up to No. 8068)	\$1.05
6415. Wild Flowers and Native Plants Protection (First Reprint—Incorporating amendments up to No. 6976)	\$0.15
6416. Wills (Second Reprint—Incorporating amendments up to No. 7238)	\$0.25
6417. Wire Netting (First Reprint—Incorporating amendments up to No. 7876)	\$0.65
6419. Workers' Compensation Act (Seventh Reprint—Incorporating amendments up to No. 8804)	\$1.45
6420. Wrongs Act (Second Reprint—Incorporating amendments up to No. 8915)	\$0.45
8344. Youth, Sport and Recreation Act, 1972 (First Reprint—Incorporating amendments up to No. 8550)	\$0.35

GATLEY, A. & J., 250 Lonsdale Street, Dandenong, Victoria 3175.
GORDON & GOTCH AUSTRALASIA LTD., 25-37 Huntingdale Road, Burwood, Victoria 3125.
GULLAN'S NEWSAGENCY, 88 Bridge Street, Ballarat, Victoria 3350.
HAMPTON, A. C., 243 Mitchell Street, Bendigo, Victoria, 3550.
HARSTON, PARTRIDGE & CO. PTY. LTD., 455 Little Collins Street, Melbourne, Victoria 3000.
KYNETON GUARDIAN PTY. LTD., P.O. Box 18, Kyneton, Victoria 3444.
LOVELL'S SHEPPARTON NEWSAGENCY, 246 Wyndham Street, Shepparton, Victoria 3630.
THE MERCANTILE EXCHANGE, 34 Queen Street, Melbourne, Victoria 3000.
MCGILL'S AUTHORIZED NEWSAGENCY, 183-5 Elizabeth Street, Melbourne, Victoria 3000.
MCNAUGHTON, P. R. & L. A., 112-114 Gray Street, Hamilton, Victoria 3300.
POWNEY'S AUTHORIZED NEWSAGENCY, 293 Hargreaves Street, Bendigo, Victoria 3550.
PURDIE, J., & CO., 138 Moorabool Street, Geelong, Victoria 3220.
SALE AUTHORIZED NEWSAGENCY, 142 Raymond Street, Sale, Victoria 3850.
SKINNER'S AUTHORIZED NEWSAGENCY, 49-51 Franklin Street, Traralgon, Victoria 3844.
VANCE'S AUTHORIZED NEWSAGENCY, 83 Murray Street, Wangaratta 3677.
VERNONS OF RICHMOND, 162 Bridge Road, Richmond, Victoria 3121.
VIEW POINT AUTHORIZED NEWSAGENCY, 4 View Point, Bendigo, Victoria 3550.

A copy of the Gazette is filed at each place for public reference.

NOTIFICATION OF FIRST REPRINT

No.	Price
8477. Children's Court Act, 1973 (First Reprint—Incorporating amendments up to No. 8731)	\$0.95

F. D. ATKINSON,  
Government Printer.

AGENTS FOR THE "VICTORIA GOVERNMENT GAZETTE."

The following have been appointed agents to receive Advertisements and Subscriptions for the Victoria Government Gazette:—

- ARMSTRONG'S AGENCY, 217 Queen Street, Melbourne, Victoria 3000.
- ARNALL, & JACKSON, 390 Barkly Street, Brunswick, Victoria 3056.
- BAIRNSDALE AUTHORIZED NEWSAGENCY, 132 Main Street, Bairnsdale, Victoria 3875.
- BENALLA AUTHORIZED NEWSAGENCY, 45 Bridge Street, Benalla, Victoria 3672.
- BLANE'S AUTHORIZED NEWSAGENTS, 162 Murray Street, Colac, Victoria 3250.
- CARTER, R. G., ADVERTISING SERVICE PTY. LTD., Suite 11, 285 Carlisle Street, Balaclava, Victoria 3183.
- DAVIS, WM. (MILDURA) PTY. LTD., 126 Eighth Street, Mildura, Victoria 3500.
- DIXON'S NEWSAGENCY, 89 Firebrace Street, Horsham, Victoria 3400.
- FAROE, S. W. & E. P., 79 Henty Street, Casterton, Victoria 3311.
- FRANKS, H., & CO., 184 Ryre Street, Geelong, Victoria 3220.

CONTENTS

	PAGE
Acts of Parliament on Sale at the Government Printing Office	2610
Appointments	2582
Contracts	2575
Courts	2568
Estates of Deceased Persons	2577
Government Notices	2567
Impounding	2610
Lands	2593
Mining	2571
Notice to Mariners	2567
Notice of Making of Statutory Rules	2610
Orders in Council—	
Acts—Local Government; Melbourne Underground Rail Loop; Country Roads Board; Housing; Industrial Training; Environment Protection; Superannuation; Road Traffic; Stamps; Dandenong Valley Authority; Water Resources; Mildura Irrigation and Water Trusts; Sewerage Districts.	2584 et seq.
Police Sale	2573
Private Advertisements	2597
Resignations	2583
Tenders	2957
Transport Regulation Board—Public Hearings	2569
Waterworks Trust	2567