

{3949}

PUBLISHED BY AUTHORITY



# Victoria Government Gazette

No. 104—Wednesday, 19 December 1979

## PUBLICATION OF THE "VICTORIA GOVERNMENT GAZETTE"

### Christmas and New Year Holidays

Because of the Christmas and New Year Holidays, the last issue of the Victoria Government Gazette for 1979 will be published on **Wednesday, 19 December 1979**, except if special circumstances shall require otherwise.

All official matter for publication therein should be lodged with the Gazette Officer, (Telephone 651 1287), not later than 9.30 a.m. on Tuesday, 18 December 1979.

The next Gazette, the first for 1980, will be published on Friday, 4 January 1980, and thereafter on each Wednesday, as usual.

**F. D. ATKINSON**  
Government Printer

## PROCLAMATIONS

### ACTS OF PARLIAMENT

#### PROCLAMATION

By His Excellency the Governor of the State of Victoria and its Dependencies in the Commonwealth of Australia, &c., &c., &c.

I, the Governor of the State of Victoria, in the Commonwealth of Australia, do hereby declare that I have this day assented, in Her Majesty's name, to the Bills passed by the Parliament of the said State, the titles whereof are hereunder set forth, together with the short titles, that is to say:—

- No. 9315. "An Act to make provision with respect to the Operation and Validity of Certain Planning Schemes, to amend the *Town and Country Planning Act 1961* and for other purposes." (*Town and Country Planning (Planning Schemes) Act 1979.*)
- No. 9316. "An Act to amend the *Victorian Government Travel Authority Act 1977* to make Provision with respect to the Reconstitution of the Authority and for other purposes." (*Victorian Government Travel Authority (Reconstitution) Act 1979.*)
- No. 9317. "An Act to amend the *Stamps Act 1958.*" (*Stamps (Amendment) Act 1979.*)
- No. 9318. "An Act to amend the *Motor Car Act 1958* with respect to the Amount of Registration Fees and certain other Fees payable under that Act, to amend the *Stamps Act 1958*, and for other purposes." (*Motor Car (Fees) Act 1979.*)
- No. 9319. "An Act to make Provision with respect to the Commissions deducted from *Trifecta Totalizators* the Borrowing Powers of the Totalizator Agency Board and for other purposes." (*Racing (Financial Provisions) Act 1979.*)
- No. 9320. "An Act to establish an Urban Land Authority to make Provision with respect to the Functions and Powers of the Authority and for other purposes." (*Urban Land Authority Act 1979.*)
- No. 9321. "An Act to authorize Expenditure on Public Works and Services and for other purposes." (*Public Works and Services Act 1979.*)
- No. 9322. "An Act to amend the *Second-hand Dealers Act 1958.*" (*Second-hand Dealers (Closing Hours) Act 1979.*)
- No. 9323. "An Act to amend the *Crimes Act 1958.*" (*Crimes (Amendment) Act 1979.*)

Given under my Hand and the Seal of the State of Victoria aforesaid, at Melbourne, this eighteenth day of December, in the year of our Lord One thousand nine hundred and seventy-nine and in the twenty-eighth year of the reign of Her Majesty Queen Elizabeth II.

(L.S.)

HENRY WINNEKE

By His Excellency's Command

R. J. HAMER  
Premier

GOD SAVE THE QUEEN!

No. 9315 shall come into operation on the day it receives the Royal Assent.

No. 9316 shall come into operation on the day on which it receives the Royal Assent.

No. 9317 several provisions of this Act shall come into operation on a day or the respective days to be fixed by proclamation or the successive proclamations.

No. 9318 several provisions of this Act, except paragraph (d) of section 3, shall come into operation on 1 January 1980. Paragraph (d) of section 3 shall be deemed to have come into operation on 1 November 1978.

No. 9319 shall come into operation on the day on which it receives the Royal Assent.

No. 9320 shall come into operation on a date to be fixed by proclamation.

No. 9321 shall come into operation on the day it receives the Royal Assent.

No. 9322 shall come into operation on a day to be fixed by proclamation.

No. 9323 shall come into operation on a day to be fixed by proclamation.

### ACTS OF PARLIAMENT

#### PROCLAMATION

By His Excellency the Governor of the State of Victoria and its Dependencies in the Commonwealth of Australia, &c., &c., &c.

I, the Governor of the State of Victoria, in the Commonwealth of Australia, do hereby declare that I have this day assented, in Her Majesty's name, to the Bills passed by the Parliament of the said State, the titles whereof are hereunder set forth, together with the short titles, that is to say:—

- No. 9324. "An Act to amend the *Transfer of Land Act 1958* and for other purposes." (*Transfer of Land (Amendment) Act 1979.*)
- No. 9325. "An Act to amend the *Melbourne College of Divinity Act 1910* and for other purposes." (*Melbourne College of Divinity Act 1979.*)
- No. 9326. "An Act to amend the *Transport Regulation Act 1958* and for other purposes." (*Transport Regulation (Car Pools) Act 1979.*)
- No. 9327. "An Act to amend the *Fisheries Act 1968.*" (*Fisheries (Amendment) Act 1979.*)
- No. 9328. "An Act to amend the *Egg Industry Stabilization Act 1973.*" (*Egg Stabilization (Amendment) Act 1979.*)
- No. 9329. "An Act to amend the *Local Authorities Superannuation Act 1958* and for other purposes." (*Local Authorities Superannuation Act 1979.*)
- No. 9330. "An Act to amend the *Latrobe Valley Act 1958.*" (*Latrobe Valley (Amendment) Act 1979.*)
- No. 9331. "An Act to authorize the Sale and Disposal of liquor at the Melbourne Food and Wine Festival, to amend the *Liquor Control Act 1968* and for other purposes." (*Liquor Control (Amendment) Act 1979.*)

Given under my Hand and the Seal of the State of Victoria aforesaid, at Melbourne, this eighteenth day of December, in the year of our Lord One thousand nine hundred and seventy-nine and in the twenty-eighth year of the reign of Her Majesty Queen Elizabeth II.

(L.S.)

HENRY WINNEKE

By His Excellency's Command

R. J. HAMER  
Premier

GOD SAVE THE QUEEN!

No. 9324 several provisions of this Act shall come into operation on a day or the respective days to be fixed by proclamation.

No. 9325 shall come into operation on the day on which it receives the Royal Assent.

No. 9326 shall come into operation on the day on which it receives the Royal Assent.

No. 9327 shall come into operation on the day on which it receives the Royal Assent.

No. 9328 shall come into operation on the day on which it receives the Royal Assent.

No. 9329 shall come into operation on the day on which it receives the Royal Assent.

No. 9330 shall come into operation on the day on which it receives the Royal Assent.

No. 9331 shall come into operation on the day on which it receives the Royal Assent.

## ACTS OF PARLIAMENT

## PROCLAMATION

By His Excellency the Governor of the State of Victoria and its Dependencies in the Commonwealth of Australia, &c., &c., &c.

I, the Governor of the State of Victoria, in the Commonwealth of Australia, do hereby declare that I have this day assented, in Her Majesty's name, to the Bills passed by the Parliament of the said State, the titles whereof are hereunder set forth, together with the short titles, that is to say:—

- No. 9332. "An Act to amend the *Motor Accidents Act 1973* with respect to Compensation for Deprivation or Impairment of Earning Capacity, and for other purposes." (*Motor Accidents (Amendment) Act 1979*.)
- No. 9333. "An Act to establish a Young Farmers' Finance Council and to amend the *Rural Finance Act 1958*." (*Young Farmers' Finance Council Act 1979*.)
- No. 9334. "An Act to amend the *Probate Duty Act 1962*, and for other purposes." (*Probate Duty Act 1979*.)
- No. 9335. "An Act to amend the *Railways Act 1958* with respect to the Membership and Procedure of the Victorian Railways Board, and for other purposes." (*Railways (Board) Act 1979*.)
- No. 9336. "An Act to amend the *Ministry of Transport Act 1958* to create the Position of Deputy Director of Transport and for other purposes." (*Ministry of Transport (Amendment) Act 1979*.)
- No. 9337. "An Act to reconstitute the membership of the Victorian Abattoir and Meat Inspection Authority, and for other purposes." (*Abattoir and Meat Inspection (Amendment) Act 1979*.)
- No. 9338. "An Act to amend the *Public Service Act 1974* and for other purposes." (*Public Service (Amendment) Act 1979*.)

Given under my Hand and the Seal of the State of Victoria aforesaid, at Melbourne, this eighteenth day of December, in the year of our Lord One thousand nine hundred and seventy-nine, and in the twenty-eighth year of the reign of Her Majesty Queen Elizabeth II.

(L.S.)

HENRY WINNEKE

By His Excellency's Command

R. J. HAMER  
Premier

GOD SAVE THE QUEEN!

No. 9332—Shall come into operation on the day on which it receives the Royal Assent.

No. 9333—Shall come into operation on the day on which it receives the Royal Assent.

No. 9334—Shall come into operation on 1 January 1980.

No. 9335—Shall come into operation on a day to be fixed by proclamation.

No. 9336—Shall come into operation on the day on which it receives the Royal Assent.

No. 9337—Shall come into operation on the day on which it receives the Royal Assent.

No. 9338—Shall come into operation on the day on which it receives the Royal Assent.

## ACTS OF PARLIAMENT

## PROCLAMATION

By His Excellency the Governor of the State of Victoria and its Dependencies in the Commonwealth of Australia, &c., &c., &c.

I, the Governor of the State of Victoria, in the Commonwealth of Australia, do hereby declare that I have this day assented, in Her Majesty's name, to the Bills passed by the

Parliament of the said State, the titles whereof are hereunder set forth, together with the short titles, that is to say:—

- No. 9339. "An Act to amend the *Trustee Companies Act 1958* with respect to the Power of Directors of Trustee Companies to refuse to register Transfer of Shares, to limit the Power of Subsidiaries of Trustee Companies to act as Estate Agents, and for other purposes." (*Trustee Companies (Amendment) Act 1979*.)
- No. 9340. "An Act to amend the *Vermin and Noxious Weeds Act 1958* and for other purposes." (*Vermin and Noxious Weeds (Amendment) Act 1979*.)

Given under my Hand and the Seal of the State of Victoria aforesaid, at Melbourne, this eighteenth day of December, in the year of our Lord One thousand nine hundred and seventy-nine, and in the twenty-eighth year of the reign of Her Majesty Queen Elizabeth II.

(L.S.)

HENRY WINNEKE

By His Excellency's Command

R. J. HAMER  
Premier

GOD SAVE THE QUEEN!

No. 9339—Several provisions of this Act shall come into operation on a day or on the respective days to be fixed by proclamation.

No. 9340—Shall come into operation on a day to be fixed by proclamation.

Vermin and Noxious Weeds Act 1958  
PROCLAMATION AMENDED

## PROCLAMATION

By His Excellency the Governor of the State of Victoria and its Dependencies in the Commonwealth of Australia, &c., &c., &c.

Whereas pursuant to the provisions of section 3 (1) of the *Vermin and Noxious Weeds Act 1958*, Rabbits, Hares, Foxes, Dingoes, Wild Dogs, Dogs Run Wild, Pigs Run Wild, Wombats, Sparrows and Starlings were declared to be vermin throughout the State of Victoria for the purposes of the said Act, by Proclamation dated 17 July 1973 (see *Government Gazette* of 25 July 1973, page 2654).

And whereas the said Proclamation dated 17 July 1973 was revoked as to part by Proclamation dated 23 August 1977 (see *Government Gazette* of 31 August 1977, page 2774) so far only as it related to Wombats in respect of only the area of the State described therein.

Now, therefore, I, the Governor of the State of Victoria, in the Commonwealth of Australia, by and with the advice of the Executive Council of the said State, pursuant to the provisions of section 3 (2) (c) of the said Act, do by this Proclamation amend the Proclamation of 17 July 1973 by substituting for the expression "Dingoes, Wild Dogs" the expression "Dingoes and their hybrids (except for recognized canine breeds such as the Australian Cattle Dog (Queensland Heeler) and the Australian Kelpie, Feral Dogs".

Given under my Hand and the Seal of the State of Victoria aforesaid, at Melbourne, this eleventh day of December, in the year of our Lord One thousand nine hundred and seventy-nine, and in the twenty-eighth year of the reign of Her Majesty Elizabeth the Second, Queen of Australia.

(L.S.)

HENRY WINNEKE

By His Excellency's Command

W. V. HOUGHTON  
Minister of Lands

GOD SAVE THE QUEEN!

Soil Conservation and Land Utilization Act 1958  
 Land Conservation Act 1970  
**BALLARAT WATER SUPPLY CATCHMENTS**

**PROCLAMATION**

By His Excellency the Governor of the State of Victoria and its Dependencies in the Commonwealth of Australia, &c., &c., &c.

I, the Governor of the State of Victoria, in the Commonwealth of Australia, by and with the advice of the Executive Council of the said State and having considered a recommendation of the Land Conservation Council in pursuance of the provisions contained in section 22 (1) of the Soil Conservation and Land Utilization Act 1958 (No. 6372) and section 5 (1) (b) of the Land Conservation Act 1970 (No. 8008) do by this Proclamation define the water supply catchment area to be known as the Ballarat Water Supply Catchments.

The areas proclaimed are, the natural catchments to the Moorabool Reservoir, Beales Reservoir, Kirks Reservoir, Gong Gong Reservoir, and White Swan Reservoir; the catchment to the aqueduct linking Pincotts Reservoir and Beales Reservoir not included in the previous statement and the catchment to the point of diversion of Clarkes Creek to the White Swan Reservoir.

The use of land within these catchments is subject to specification by notice or by determination made by the Soil Conservation Authority, acting under the provision of sections 22 (2) and 23 (1) (a), (b) and (c) of the Soil Conservation and Land Utilization Act 1958, as amended.

The area described is indicated on Plan No. S-765 hereunder, the original of which is lodged at Head Office of the Soil Conservation Authority, 378 Cotham Road, Kew, 3101.

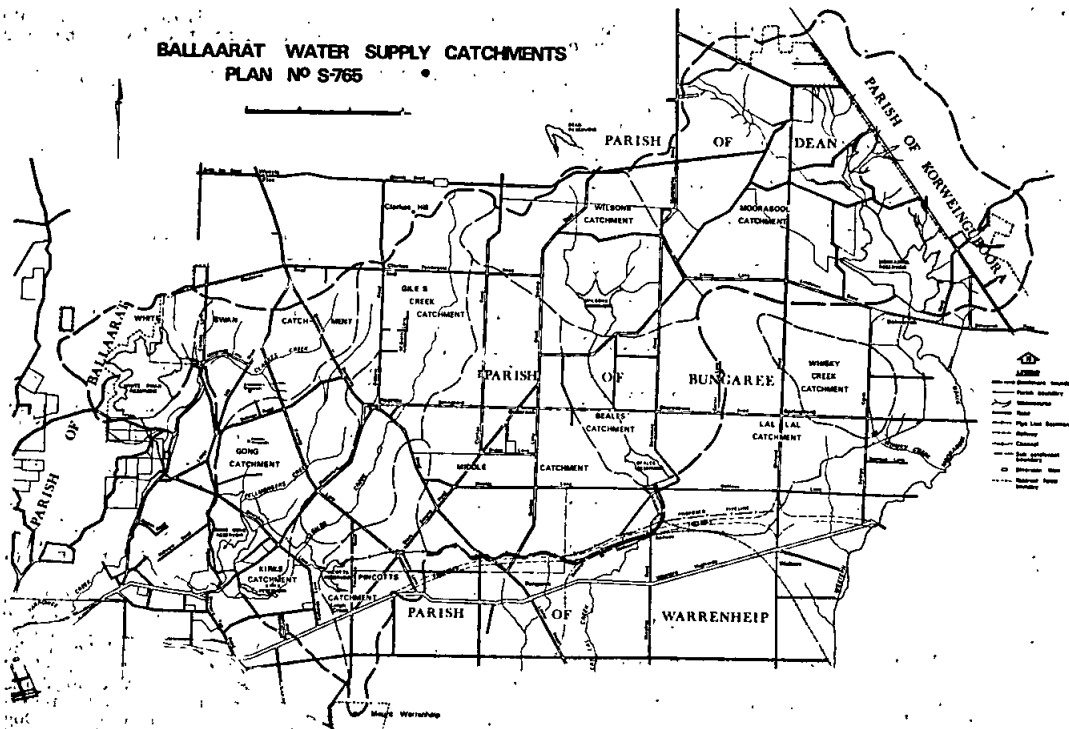

Given under my Hand and the Seal of the State of Victoria aforesaid, at Melbourne, this eleventh day of December, in the Year of our Lord One thousand nine hundred and seventy-nine, and in the twenty-eighth year of the reign of Her Majesty Queen Elizabeth II.

(L.S.)

HENRY WINNEKE

By His Excellency's Command

W. V. HOUGHTON  
 Minister for Conservation

GOD SAVE THE QUEEN!

Soil Conservation and Land Utilization Act 1958  
 Land Conservation Act 1970  
**TANJIL RIVER WATER SUPPLY CATCHMENT**

**PROCLAMATION**

By His Excellency the Governor of the State of Victoria and its Dependencies in the Commonwealth of Australia, &c., &c., &c.

I, the Governor of the State of Victoria, in the Commonwealth of Australia, by and with the advice of the Executive Council of the said State and having considered a recommendation of the Land Conservation Council in pursuance of the provisions contained in section 22 (1) a the *Soil Conservation and Land Utilization Act 1958* (No. 6372) and section 5 (1) (b) of the *Land Conservation Act 1970* (No. 8008) do by this Proclamation define the water supply catchment area to be known as the Tanjil River Water Supply Catchment.

The area proclaimed is the catchment to the proposed offtake weir to be constructed by the Moe Waterworks Trust on Crown land adjacent to Crown allotment 34 in the Parish of Tanjil.

The use of land within this catchment is subject to specification by notice or by determination made by the Soil Conservation Authority, acting under the provisions of sections 22 (2) and 23 (1) (a), (b) and (c) of the *Soil Conservation and Land Utilization Act 1958*, as amended.

The area described is indicated on Plan No. S-753 hereunder, the original of which is lodged at Head Office of the Soil Conservation Authority, 378 Cotham Road, Kew, 3101.

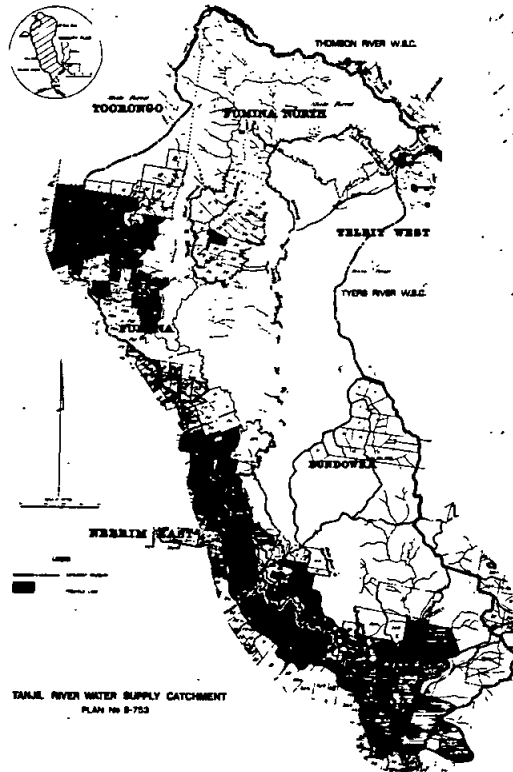

Given under my Hand and the Seal of the State of Victoria aforesaid, at Melbourne, this eleventh day of December, in the Year of our Lord One thousand nine hundred and seventy-nine, and in the twenty-eighth year of the reign of Her Majesty Queen Elizabeth II.

(L.S.)

By His Excellency's Command  
 HENRY WINNEKE  
 W. V. HOUGHTON  
 Minister for Conservation

GOD SAVE THE QUEEN!

Land Act 1958  
ROAD PROCLAIMED

PROCLAMATION

By His Excellency the Governor of the State of Victoria and its Dependencies in the Commonwealth of Australia, &c., &c., &c.

I, the Governor of the State of Victoria, in the Commonwealth of Australia, by and with the advice of the Executive Council of the said State, pursuant to the provisions of section 25 (3) (c) of the Land Act 1958, do hereby proclaim as road the Crown land hereinafter described, viz.:

Parish of Carboor being the land indicated by hatching on plan hereunder—(L.8-313).

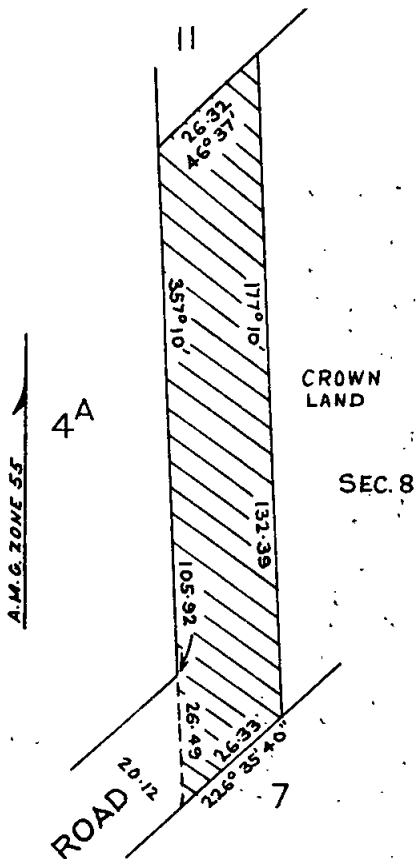

Given under my Hand and the Seal of the State of Victoria aforesaid, at Melbourne, this eleventh day of December, in the year of our Lord One thousand nine hundred and seventy-nine, and in the twenty-eighth year of the reign of Her Majesty Elizabeth the Second, Queen of Australia.

(L.S.) HENRY WINNEKE

By His Excellency's Command

A. R. WOOD  
Acting Minister of Lands

GOD SAVE THE QUEEN!

Land Act 1958  
ROAD PROCLAIMED

PROCLAMATION

By His Excellency the Governor of the State of Victoria and its Dependencies in the Commonwealth of Australia, &c., &c., &c.

I, the Governor of the State of Victoria, in the Commonwealth of Australia, by and with the advice of the Executive Council of the said State, pursuant to the provisions of section 25 (3) (c) of the Land Act 1958, do hereby proclaim as road the Crown land hereinafter described, viz.:

Parish of Sandhurst being the land indicated by hatching on plan hereunder—(S.371 (48) (L.6-805)).

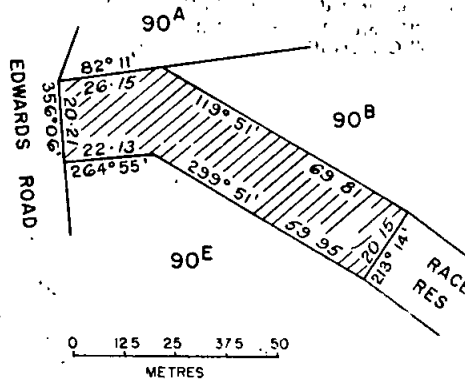

Given under my Hand and the Seal of the State of Victoria aforesaid, at Melbourne, this eleventh day of December, in the year of our Lord One thousand nine hundred and seventy-nine, and in the twenty-eighth year of the reign of Her Majesty Elizabeth the Second, Queen of Australia.

(L.S.) HENRY WINNEKE

By His Excellency's Command

W. V. HOUGHTON  
Minister of Lands

GOD SAVE THE QUEEN!

Land Act 1958  
ROAD PROCLAIMED

PROCLAMATION

By His Excellency the Governor of the State of Victoria and its Dependencies in the Commonwealth of Australia, &c., &c., &c.

I, the Governor of the State of Victoria, in the Commonwealth of Australia, by and with the advice of the Executive Council of the said State, pursuant to the provisions of section 25 (3) (c) of the Land Act 1958, do hereby proclaim as road the Crown land hereinafter described, viz.:

Parish of Kergunyah being the land indicated by hatching on plan hereunder—(2863) (L.8-1320).

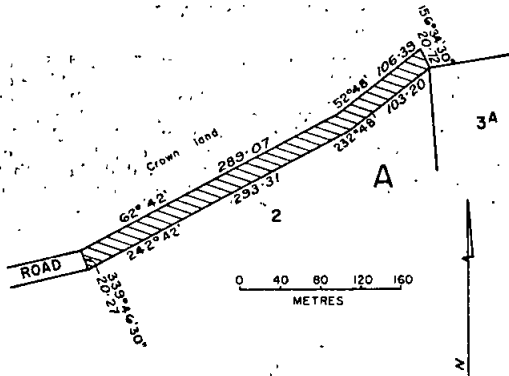

Given under my Hand and the Seal of the State of Victoria aforesaid, at Melbourne, this eleventh day of December, in the year of our Lord One thousand nine hundred and seventy-nine, and in the twenty-eighth year of the reign of Her Majesty Elizabeth the Second, Queen of Australia.

(L.S.) HENRY WINNEKE

By His Excellency's Command

W. V. HOUGHTON  
Minister of Lands

GOD SAVE THE QUEEN!

Health Act 1958  
DECLARATION OF OFFENSIVE TRADES

PROCLAMATION

By His Excellency the Governor of the State of Victoria and its Dependencies in the Commonwealth of Australia, &c., &c., &c.

By virtue of the powers conferred by section 94 of the Health Act 1958 (No. 6270), I the Governor of the State of Victoria, in the Commonwealth of Australia, by and with the advice of the Executive Council of the said State do by this my Proclamation amend the Proclamation dated 4 November 1940 and entitled "Amendment of a Proclamation relating to the trades usually carried on in connexion with the reception and disposal of night-soil and refuse and rubbish added to the list of offensive trades" by deleting paragraph 2 thereof.

Given under my Hand and the Seal of the State of Victoria aforesaid, at Melbourne, this eleventh day of December, in the year of our Lord One thousand nine hundred and seventy-nine, and in the twenty-eighth year of the reign of Her Majesty Queen Elizabeth II.

(L.S.) HENRY WINNEKE

By His Excellency's Command

W. BORTHWICK  
Minister of Health

GOD SAVE THE QUEEN!

STAMPS (AMENDMENT) ACT 1979, No. 9317  
DATE OF COMING INTO OPERATION

PROCLAMATION

By His Excellency the Governor of the State of Victoria and its Dependencies in the Commonwealth of Australia, &c., &c., &c.

Whereas by an Act of Parliament of the State of Victoria passed in the twenty-eighth year of the reign of Her Majesty Elizabeth the Second, Queen of Australia, entitled the Stamps (Amendment) Act 1979, it is amongst other things enacted that the several provisions of the said Act shall come into operation on a day or the respective days

to be fixed by Proclamation or the successive Proclamations of the Governor in Council published in the Government Gazette.

Now therefore, I, the Governor of the State of Victoria, by and with the advice of the Executive Council of the said State, do by this my Proclamation fix Wednesday 19 December 1979, as the day on which the provisions of the Stamps (Amendment) Act 1979, other than Section 2, shall come into operation, and fix Tuesday 1 January 1980 as the day on which Section 2 of the said Act shall come into operation.

Given under my Hand and the Seal of the State of Victoria aforesaid, at Melbourne, this eighteenth day of December, in the year of our Lord One thousand nine hundred and seventy-nine, and in the twenty-eighth year of the reign of Her Majesty Elizabeth the Second, Queen of Australia.

(L.S.) HENRY WINNEKE

By His Excellency's Command

L. H. S. THOMPSON  
Treasurer

GOD SAVE THE QUEEN!

GOVERNMENT NOTICES

CHRISTMAS AND NEW YEAR HOLIDAYS

It is hereby notified that on—  
MONDAY, 24 DECEMBER 1979,  
TUESDAY, 25 DECEMBER 1979,  
WEDNESDAY, 26 DECEMBER 1979,  
MONDAY, 31 DECEMBER 1979, and  
TUESDAY, 1 JANUARY 1980,

the Public Offices will be closed, such days having been appointed by the Public Service Act 1974 to be observed as holidays into the Public Offices throughout the State of Victoria.

This notice relates only to the closing of the State Public Offices. All inquiries regarding holidays in other offices and in shops and industry should be directed to the Department of Labour and Industry, Industrial Information Service, 35 Spring Street, Melbourne (telephone 651 3991).

R. J. HAMER  
Premier

Premier's Office  
Melbourne, 3000, 10 December 1979

LOCAL GOVERNMENT DEPARTMENT  
ORDER CONFIRMED—SHIRE OF GRENVILLE

The Minister of the Crown administering the Local Government Act 1958, on 12 December 1979 confirmed the Order hereinafter referred to in pursuance of section 514 of the said Act namely:

An order of the Council of the Shire of Grenville made on 1 November 1979 directing the compulsory taking of certain land being all of the land described in Crown Grant Book 226 Memo 919 for the purpose of providing a place of public resort and recreation.

D. G. CROZIER  
Minister for Local Government

Local Government Department  
Melbourne (79/3003)

SHIRE OF KOWREE  
ROAD DEVIATION ORDER

Pursuant to the provisions of sections 522 and 526 of the Local Government Act 1958 the Council of the Shire of Kowree hereby directs that the land in the Parish of Harrow indicated by hatching on the diagram hereunder which has been purchased taken or acquired by it, shall be a public highway on and from the date of publication of this Order in the Government Gazette and declares that such land shall be a public highway in lieu of the land indicated by cross hatching on the said diagram.

SHIRE OF ROSEDALE  
ROAD DEVIATION ORDER

Pursuant to the provisions of section 522 and 526 of the Local Government Act 1958 the Council of the Shire of Rosedale hereby directs that the land in the Parish of Willung indicated by hatching on the diagram hereunder which has been purchased taken or acquired by it, shall be a public highway on and from the date of publication of this Order in the Government Gazette and declares that such land shall be a public highway in lieu of the land indicated by cross hatching on the said diagram.

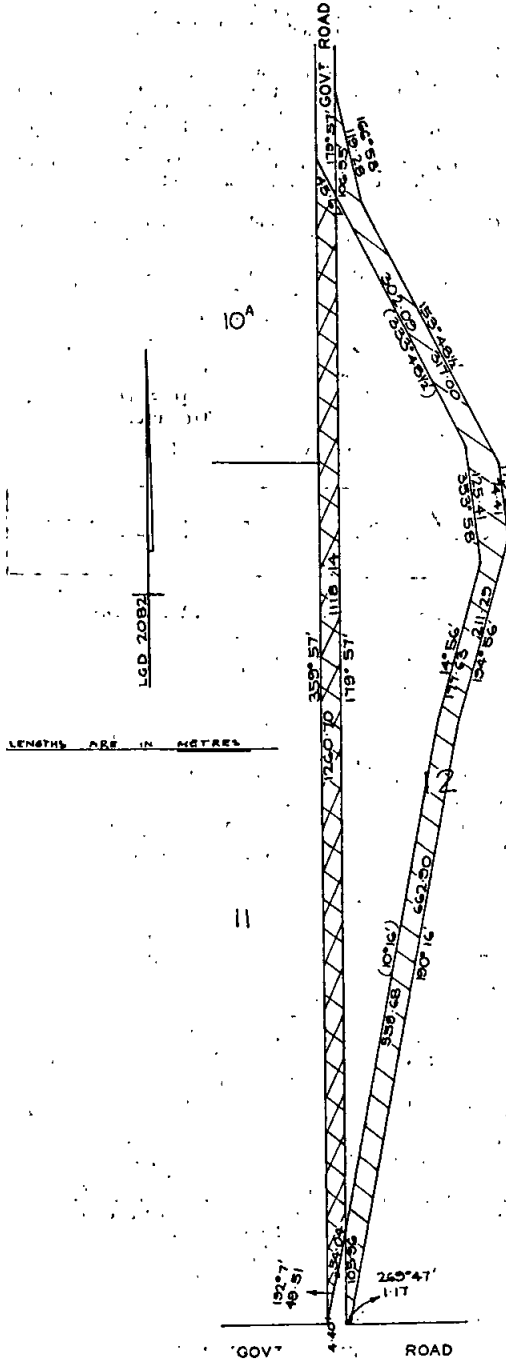

The common seal of the President, Councillors and Ratepayers of the Shire of Kowree was hereunto affixed, 1 November 1979—

(SEAL) J. L. JENKINS, President  
W. T. ROBINSON, Councillor  
H. L. TEAGUE, Secretary

Confirmed by the Governor in Council, 11 December 1979  
—TOM FORRISTAL, Clerk of the Executive Council

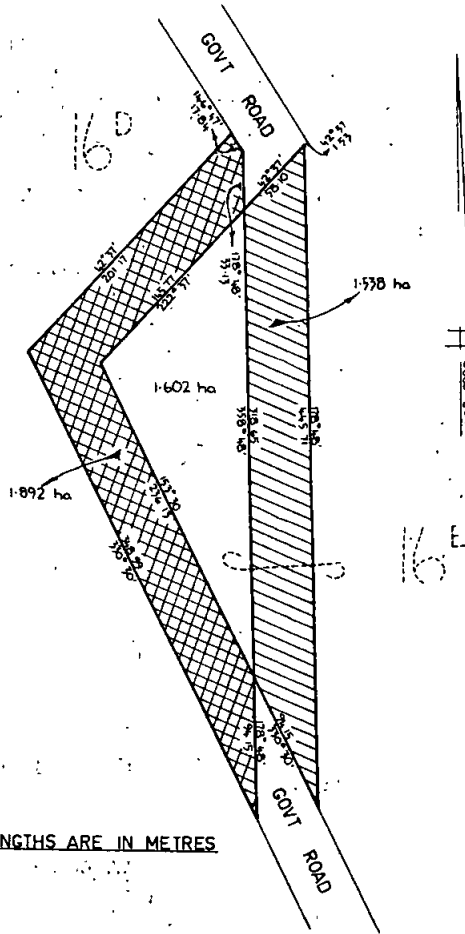

LENGTHS ARE IN METRES

The common seal of the President, Councillors and Ratepayers of the Shire of Rosedale was hereunto affixed, 20 August 1979—

(SEAL) R. E. HUG, Shire President  
T. W. WALLACE, Councillor  
J. L. MITCHELL, Shire Secretary

Confirmed by the Governor in Council, 11 December 1979  
—TOM FORRISTAL, Clerk of the Executive Council



Local Government Act 1958

NOTICE OF CONFIRMATION OF AN ORDER OF THE COUNCIL OF THE CITY OF MELBOURNE ADOPTING A PROPOSAL FOR THE CLOSURE OF A STREET TO THROUGH TRAFFIC

Pursuant to the provisions of section 539c of the Local Government Act 1958, the Governor in Council on 11 December 1979 confirmed an Order of the Council of the City of Melbourne made on 30 October 1978 adopting a proposal for the closure of Lytton Street at its intersection with Swanston Street, Carlton, to through traffic by the erection of a barrier at the location shown on the plan hereunder.

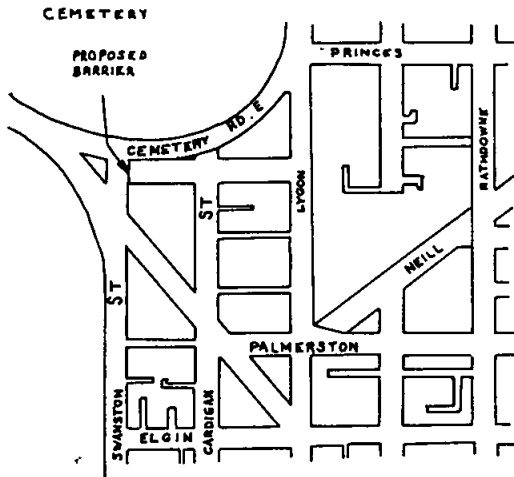

TOM FORRISTAL  
Clerk of the Executive Council

At the Executive Council Chamber  
Melbourne, 11 December 1979

Local Government Act 1958

NOTICE OF CONFIRMATION WITH MODIFICATION OF AN ORDER OF THE COUNCIL OF THE SHIRE OF BULLA ADOPTING A PROPOSAL FOR THE CLOSURE OF STREETS OR ROADS TO THROUGH TRAFFIC EAST OF THE RAILWAY LINE AT SUNBURY

Pursuant to the provisions of section 539c of the Local Government Act 1958, the Governor in Council on 11 December 1979 confirmed with modification an Order of the Council of the Shire of Bulla made on 4 September 1978 adopting a proposal for the closure of Terence, Harker, Timins and Powlett Streets, Sunbury, to through traffic by the erection of barriers at the locations shown on the plan hereunder, with the modification to Council's Order being that a barrier in Station Street at its junction with the eastern boundary of Jackson Street be deleted from the proposal.

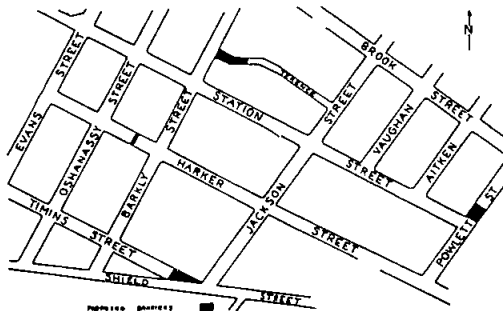

TOM FORRISTAL  
Clerk of the Executive Council

At the Executive Council Chamber  
Melbourne, 11 December 1979

Local Government Act 1958

NOTICE OF CONFIRMATION WITH MODIFICATION OF AN ORDER OF THE COUNCIL OF THE SHIRE OF BULLA ADOPTING A PROPOSAL FOR THE CLOSURE OF STREETS OR ROADS TO THROUGH TRAFFIC WEST OF THE RAILWAY AT SUNBURY

Pursuant to the provisions of section 539c of the Local Government Act 1958, the Governor in Council on 11 December 1979 confirmed with modification an Order of the Council of the Shire of Bulla made on 7 August 1978 adopting a proposal for the closure of Cornish, Darbyshire, Ligar and Pasley Streets, Sunbury, to through traffic by the erection of barriers at the locations shown on the plan hereunder, with the modification to Council's Order being that a barrier in Pasley Street at its junction with the western boundary of Neill Street be deleted from the proposal.

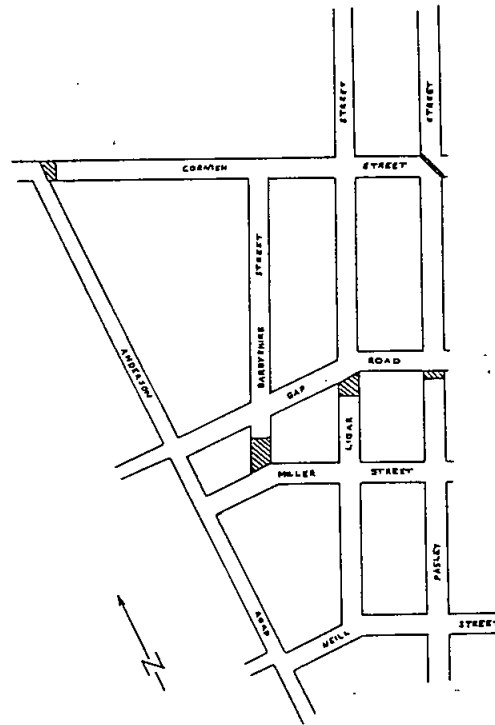

TOM FORRISTAL  
Clerk of the Executive Council

At the Executive Council Chamber  
Melbourne, 11 December 1979

LOCAL GOVERNMENT DEPARTMENT

ORDER CONFIRMED—SHIRE OF WINCHELSEA

The Minister of the Crown administering the Local Government Act 1958, on 5 December 1979 confirmed the Order hereinafter referred to in pursuance of section 514 of the said Act namely:

An Order of the Council of the Shire of Winchelsea made on 10 October 1979 directing the compulsory taking of certain land being all of the land described in Certificate of Title Volume 5049 Folio 622 for the purpose of providing a place of public resort and recreation.

D. G. CROZIER  
Minister for Local Government

Local Government Department  
Melbourne (79/2768)

Local Government Act 1958

NOTICE OF CONFIRMATION OF AN ORDER OF THE COUNCIL OF THE SHIRE OF KILMORE ADOPTING A PROPOSAL FOR THE CLOSURE OF A STREET TO THROUGH TRAFFIC

Pursuant to the provisions of section 539c of the Local Government Act 1958, the Governor in Council on 11 December 1979 confirmed an Order of the Council of the Shire of Kilmore made on 7 March 1979 adopting a proposal for the closure of Mill Street at its intersection with Sydney Street, Kilmore, to through traffic by the erection of a barrier at the location shown on the plan hereunder.

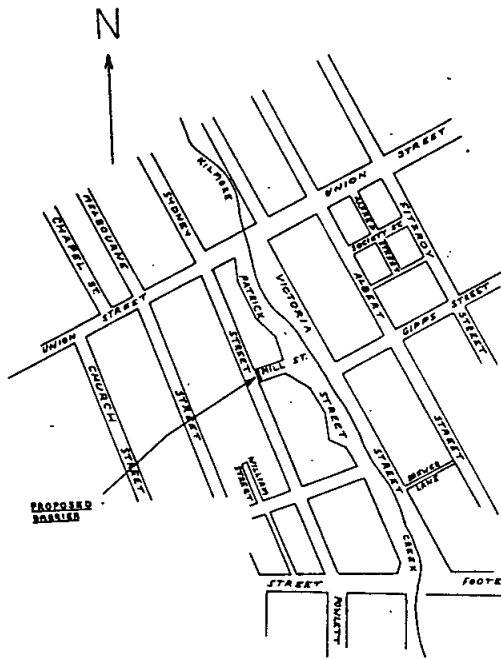

TOM FORRISTAL  
Clerk of the Executive Council  
At the Executive Council Chamber  
Melbourne, 11 December 1979

SHIRE OF KOWREE  
ROAD DEVIATION ORDER

Pursuant to the provisions of sections 522 and 526 of the Local Government Act 1958 the Council of the Shire of Kowree hereby directs that the land in the Parish of Durong indicated by hatching on the diagram hereunder which has been purchased taken or acquired by it, shall be a public highway on and from the date of publication of this Order in the Government Gazette and declares that such land shall be a public highway in lieu of the land indicated by cross hatching on the said diagram.

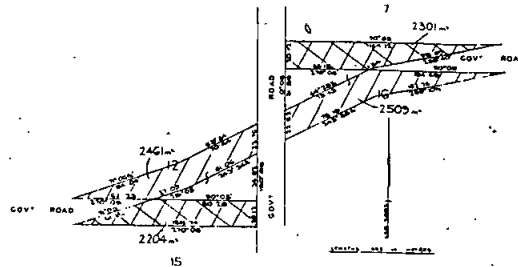

The common seal of the President, Councillors and Ratepayers of the Shire of Kowree was hereunto affixed, 1 November 1979—

(SEAL) J. L. JENKINS, President  
W. T. ROBINSON, Councillor  
H. L. TEAGUE, Secretary

Confirmed by the Governor in Council, 11 December 1979  
—TOM FORRISTAL, Clerk of the Executive Council

LOCAL GOVERNMENT DEPARTMENT  
ORDER CONFIRMED—SHIRE OF HEALESVILLE

The Minister of the Crown administering the Local Government Act 1958, on 5 December 1979 confirmed the Order hereinafter referred to in pursuance of section 514 of the said Act namely:

An Order of the Council of the Shire of Healesville made on 25 September 1979 directing the compulsory taking of a drainage easement over part of the land described in Certificate of Title Volume 6846 Folio 107 and shown by hatching on the plan hereunder.

CREATION OF EASEMENT PLAN  
PART OF C.A.4A SECTION 3  
PARISH OF GRACEDALE  
COUNTY OF EVELYN  
SCALE OF METRES 1:500

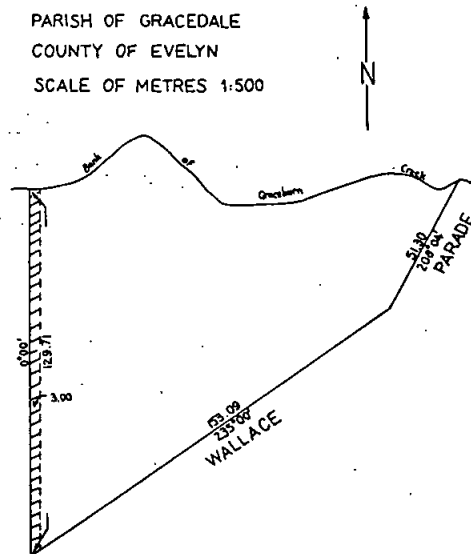

D. G. CROZIER  
Minister for Local Government

Local Government Department  
Melbourne (79/2741)

COUNTRY ROADS BOARD

RESOLUTIONS OF THE COUNTRY ROADS BOARD

The Country Roads Board, in pursuance of the provisions of the Country Roads Act 1958, has passed Resolutions the dates whereof and the terms of which are scheduled hereunder:

SCHEDULE  
Freeways

Resolution dated the Seventeenth day of December One thousand nine hundred and seventy-nine, made pursuant to sections 21 and 101 of the Country Roads Act 1958 declaring the road in the Shires of Goulburn and Seymour as shown hatched on plans numbered G.P.14007b, G.P.14007c, G.P.14008a, G.P.14008b, G.P.14009a, G.P.14009c, G.P.14217 and G.P.14218a hereunder to be a freeway (Hume Freeway) within the meaning and for the purposes of the said Act.

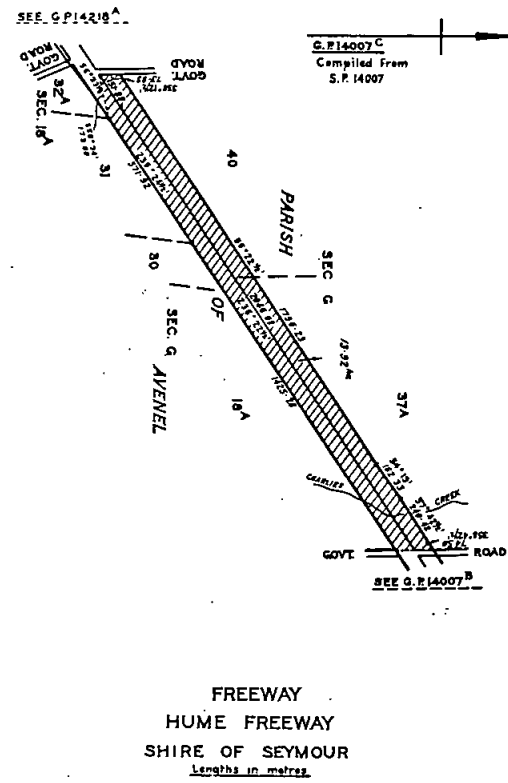
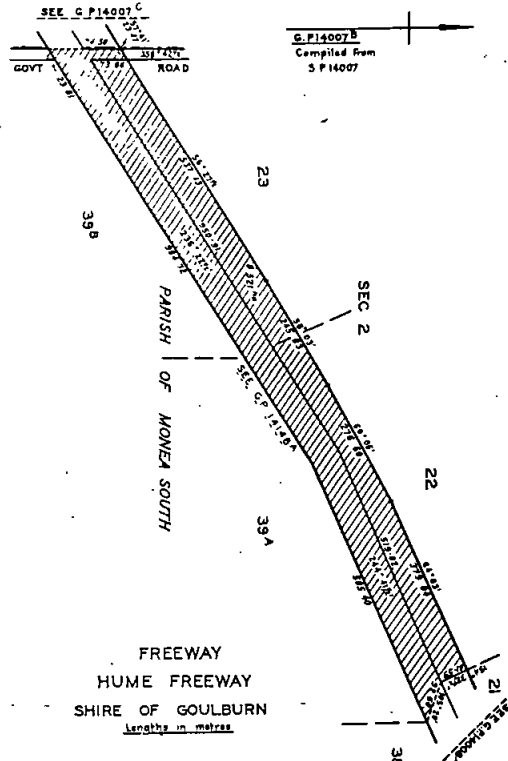
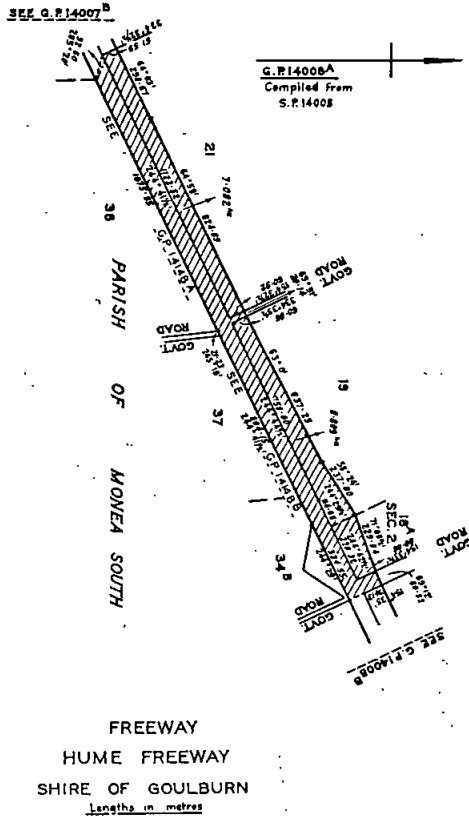

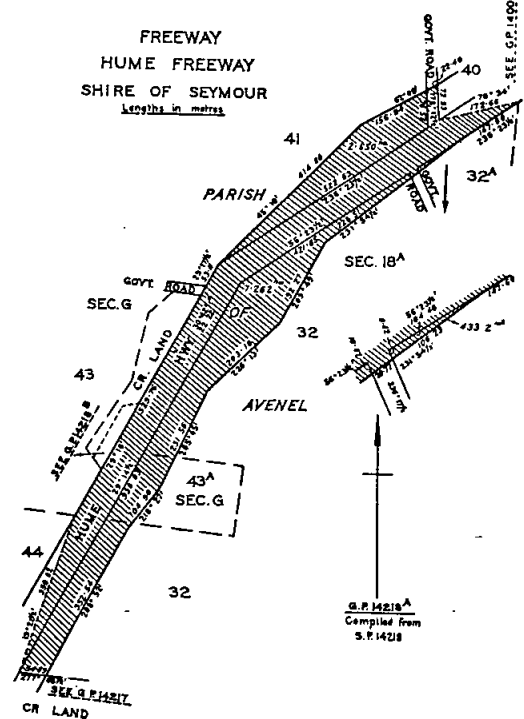
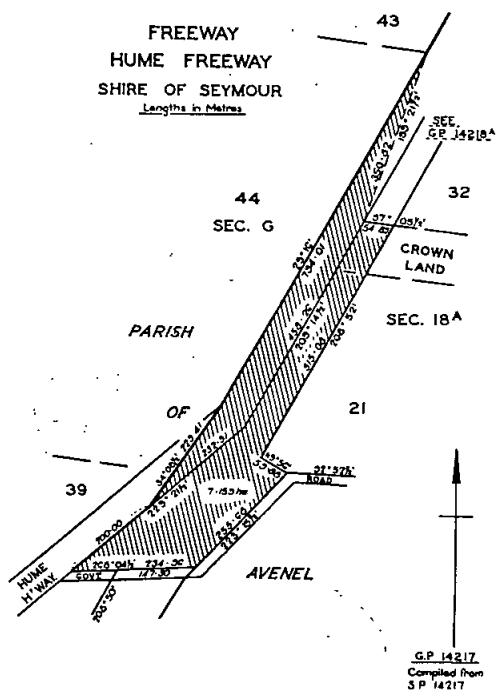
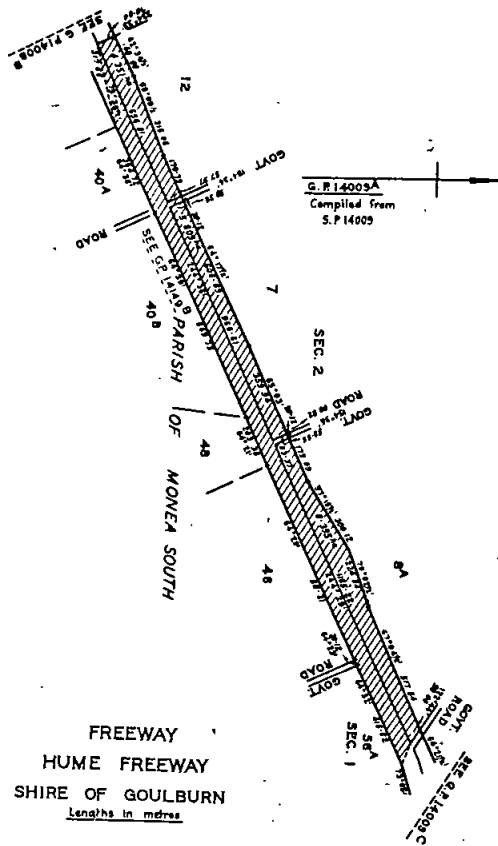
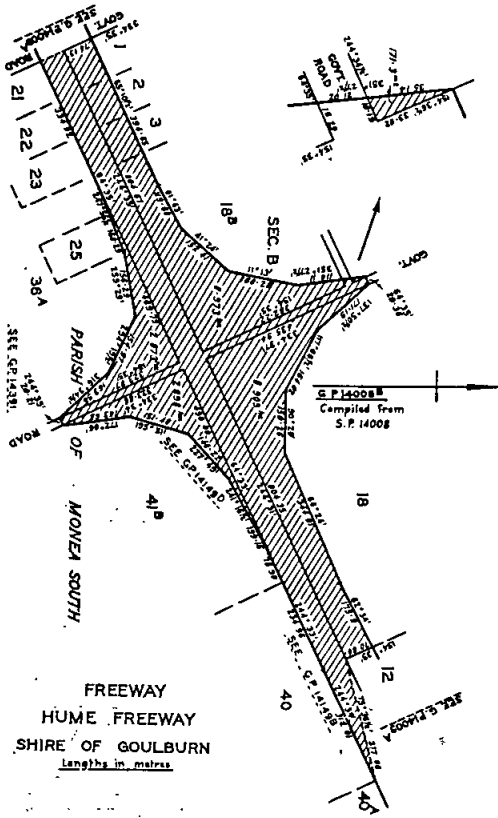

Resolution dated the Seventeenth day of December One thousand nine hundred and seventy-nine, made pursuant to sections 21 and 101 of the *Country Roads Act 1958* declaring the road in the City of Keilor as shown hatched on plan numbered G.P.14073 hereunder to be a freeway (Tullamarine Freeway) within the meaning and for the purposes of the said Act.

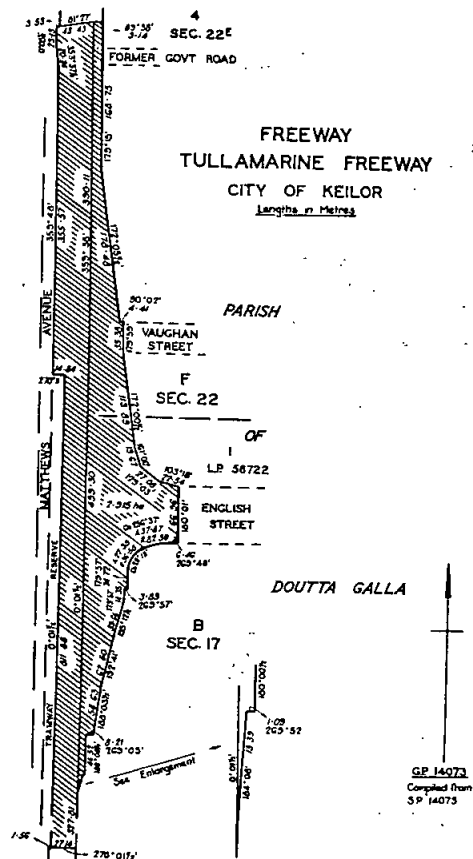
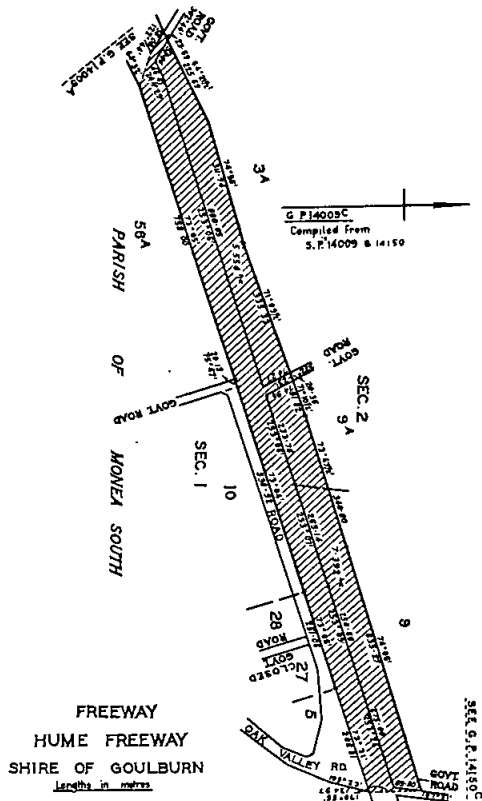

*Unclassified roads*

Resolution dated the Seventeenth day of December One thousand nine hundred and seventy-nine, made pursuant to sections 21 and 110 of the Country Roads Act 1958 declaring the road in the Shire of Goulburn as shown hatched on plans numbered G.P.14148A, G.P.14148B, G.P.14149B and G.P.14149D hereunder to be a road within the meaning and for the purposes of the said Act.

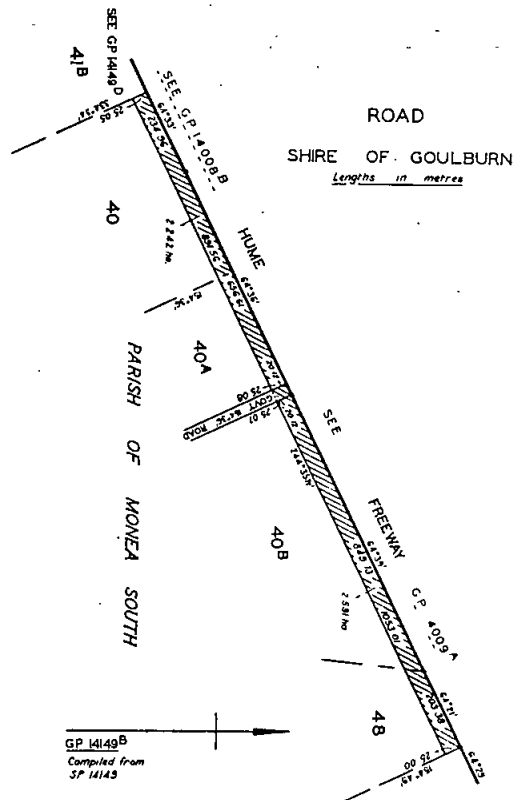
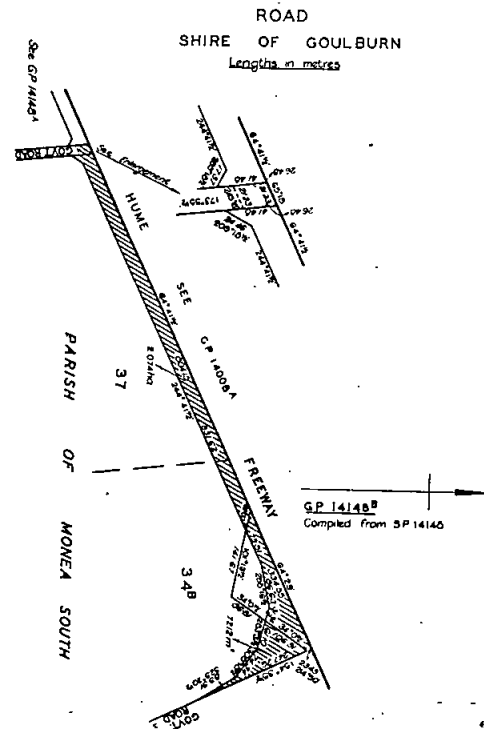
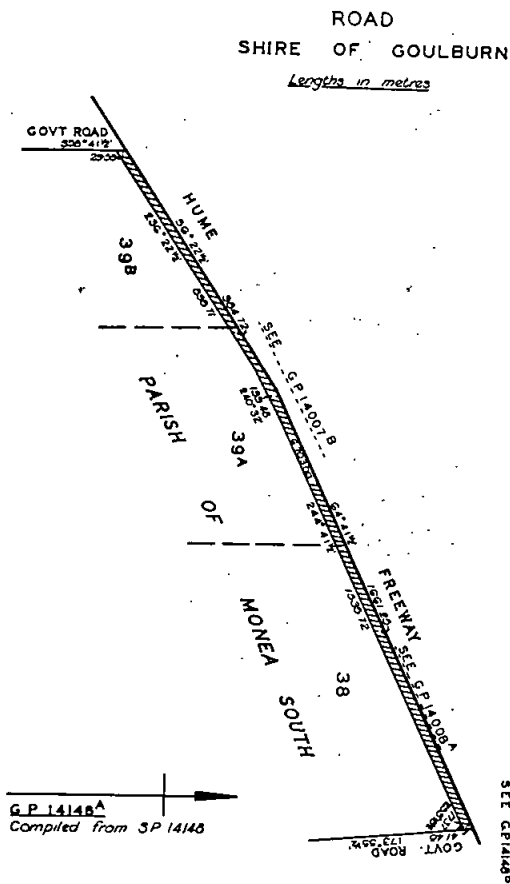

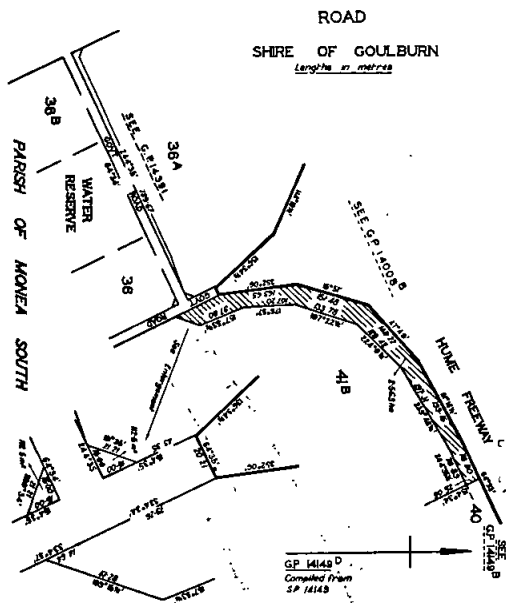

Resolution dated the Seventeenth day of December One thousand nine hundred and seventy-nine, made pursuant to sections 21 and 110 of the *Country Roads Act 1958* declaring the road in the Shire of Goulburn as shown hatched on plan numbered G.P.14150c hereunder to be a road (Oxenburys Road) within the meaning and for the purposes of the said Act.

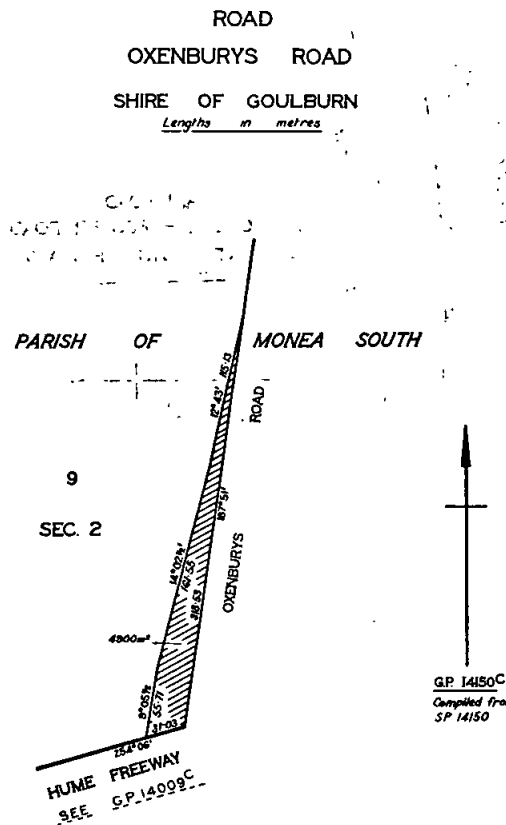

Resolution dated the Seventeenth day of December One thousand nine hundred and seventy-nine, made pursuant to sections 21 and 110 of the *Country Roads Act 1958* declaring the road in the Shire of Goulburn as shown hatched on plan numbered G.P.14529 hereunder to be a road (Wikman-Ackers Access Road) within the meaning and for the purposes of the said Act.

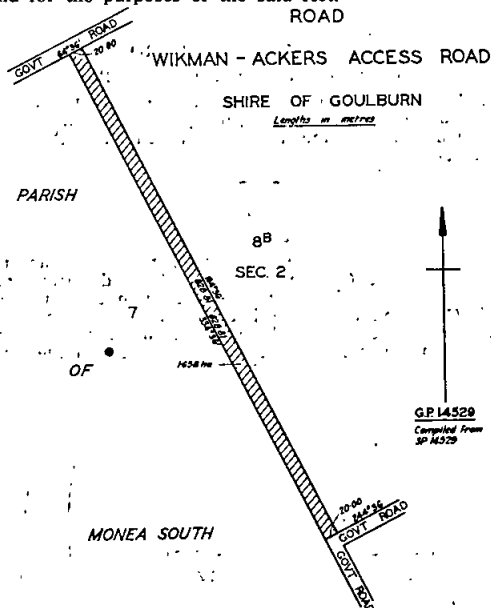

Resolution dated the Seventeenth day of December One thousand nine hundred and seventy-nine, made pursuant to sections 21 and 110 of the *Country Roads Act 1958* declaring the road in the Shire of Goulburn as shown hatched on plan numbered G.P.14391 hereunder to be a road within the meaning and for the purposes of the said Act.

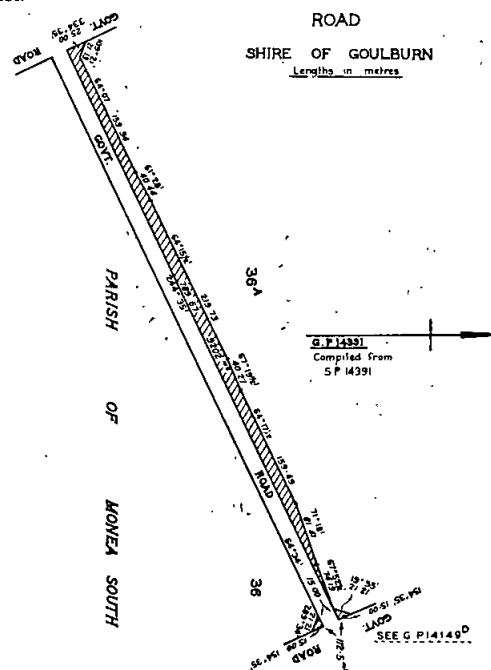

17 December 1979

G. K. COX, Secretary

COUNTRY ROADS BOARD

RESOLUTIONS OF THE COUNTRY ROADS BOARD

The Country Roads Board, in pursuance of the provisions of the *Country Roads Act 1958*, has passed Resolutions the dates whereof and the terms of which are scheduled hereunder:

SCHEDULE

Main Road

Resolution dated 26 November 1979, made pursuant to section 21 of the *Country Roads Act 1958*, declaring the widening of the Fish Creek-Foster Road in the Shire of South Gippsland as shown hatched on plans numbered G.P.14925A and G.P.14925B hereunder to be part of a main road within the meaning and for the purposes of the said Act.

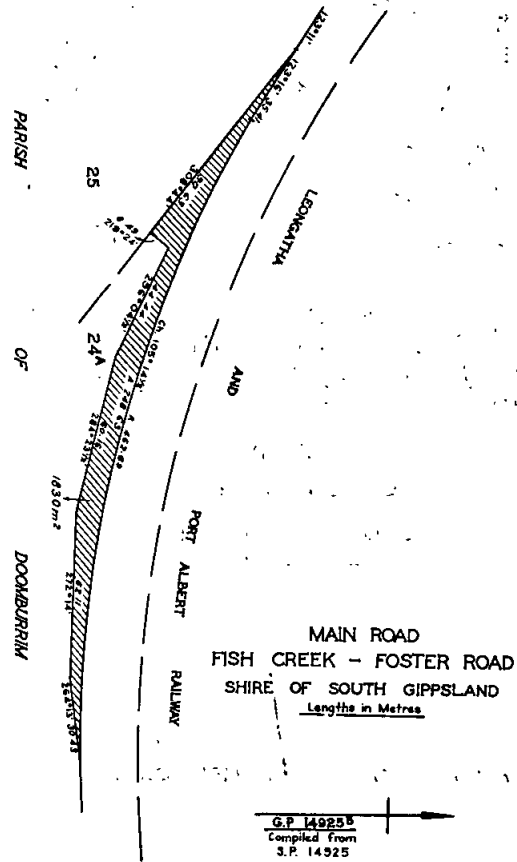
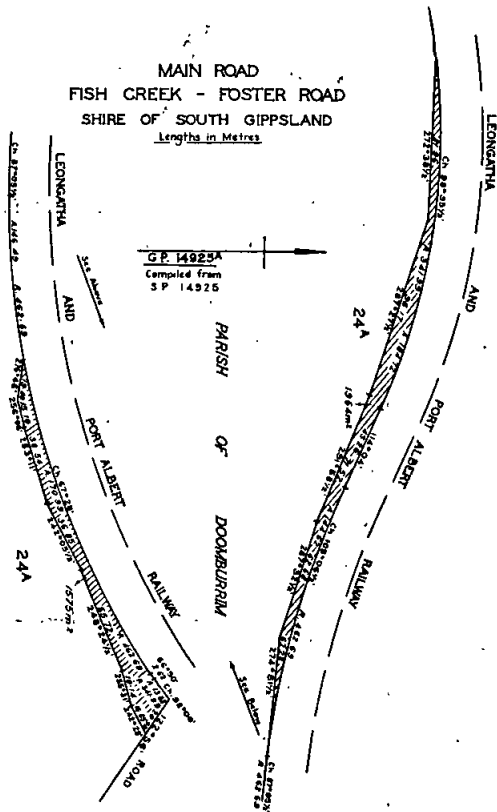



**State Highway**

Resolution dated 3 December 1979, made pursuant to sections 21, 58 and 74 of the *Country Roads Act 1958*, declaring the deviation from the Henty Highway in the Shire of Karkaroc as indicated by diagonal hatching on plan numbered G.P.9824A hereunder to be part of a State Highway within the meaning and for the purposes of the said Act, and also declaring that such deviation shall be in lieu of the existing road or part thereof indicated by cross hatching on the said plan.

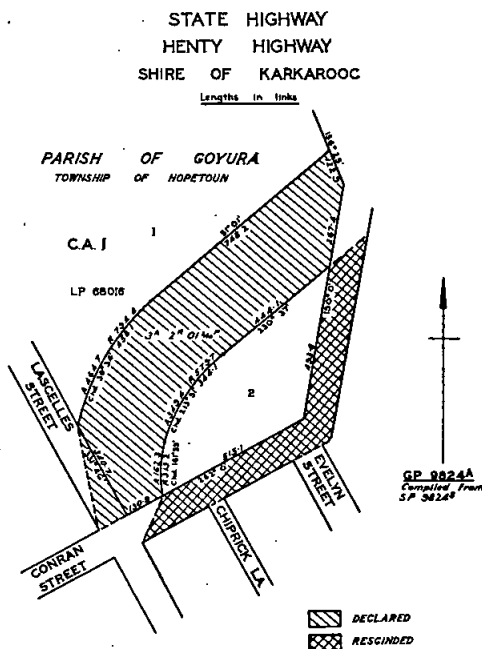

NOTE—This resolution is in lieu of the resolution passed by the Board on 21 June 1971 and published in the *Government Gazette* of 14 July 1971 on page 2375 (i.e. plan numbered G.P.9824).

**Main Road**

Resolution dated 3 December 1979, made pursuant to section 21 of the *Country Roads Act 1958*, declaring the widening of the Doncaster-Mitcham Road in the City of Doncaster and Templestowe as shown hatched on plan numbered G.P.14682C hereunder to be part of a main road within the meaning and for the purposes of the said Act.

**MAIN ROAD  
DONCASTER—MITCHAM ROAD  
CITY OF DONCASTER  
& TEMPLESTOWE**  
Lengths in metres

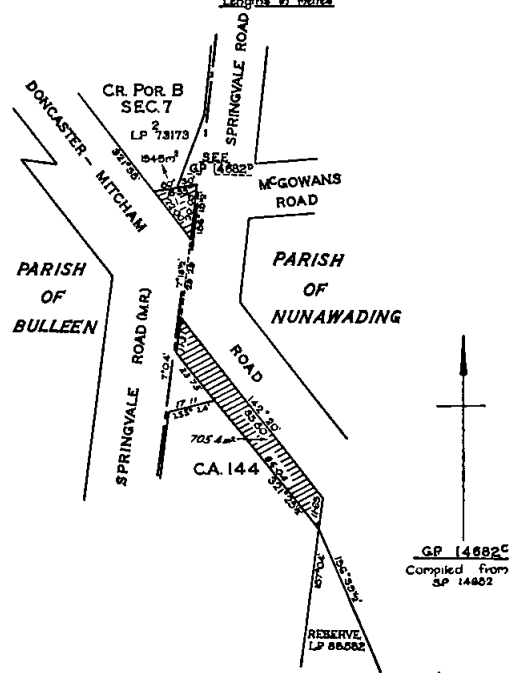

**Unclassified Road**

Resolution dated 3 December 1979, made pursuant to sections 21 and 110 of the *Country Roads Act 1958*, declaring the widening of Springvale Road in the City of Doncaster and Templestowe as shown hatched on plan numbered G.P.14682D hereunder to be part of a road within the meaning and for the purposes of the said Act.

**ROAD  
SPRINGVALE ROAD  
CITY OF DONCASTER AND TEMPLESTOWE**  
Lengths in metres

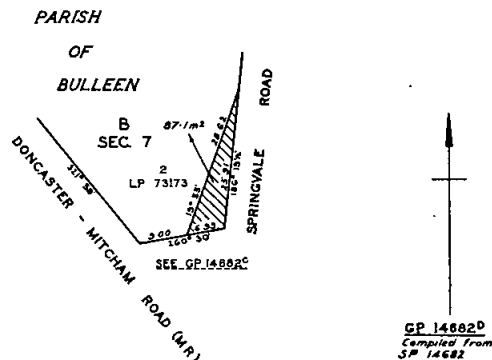

Transport Regulation Act  
TRANSPORT REGULATION BOARD

## HEARING OF APPLICATIONS

Notice is hereby given that the following applications will be considered by the Transport Regulation Board on 22 January 1980.

BRITTON, C., Derrinallum. Application for renewal of licences T.S.318 and T.S.489 expiring 31 January 1980 under the same terms and conditions.

TERLICH, J. F., Granya. Application for renewal of licence T.S.574 expiring 2 May 1980, under the same terms and conditions.

READ & BRACK PTY. LTD., Benalla. Application to licence one commercial passenger vehicle with large seating capacity, to be purchased, to operate on a service between Benalla and Yarrawonga under contract to the Victorian Railways Board.

TIME-TABLES AND FARES—As determined by T.R.B.

SHAVE BUS SERVICES PTY. LTD., Mt. Waverley. Application for variation of M.O. licence conditions on Route 623 (Glen Waverley—St. Kilda) to delete that part of route between Booran Road and Glen Eira Road along Neerim Road and Kambrook Road and instead to operate via Booran Road to normal route.

PEARCE, R. O., Bethanga. Application to license one commercial passenger vehicle with seating capacity for seventeen (17) persons to operate as follows: (a) In substitution for, but not in addition to, existing T.S. licences in the name of the applicant. (b) Under charter conditions from within a 2-km radius of the Bethanga Post Office.

TOWN OF ST. ARNAUD, St. Arnaud. Application for variation of conditions of licence S.V.106 which authorizes the carriage of elderly citizens within the Township of St. Arnaud to include the ability to operate for the carriage of long term geriatric patients of the St. Arnaud Hospital on tours within an 80-km radius of St. Arnaud.

Fare—30c.

KASTORIA BUS LINES PTY. LTD., Airport West. Application for renewal of licences M.O.87, M.O.298, M.O.407, M.O.408 and M.O.697, all expiring 31 December 1979 under the same terms and conditions.

NOTE—The above licences are in the course of transfer from E. V. Deyeson.

NORTHERN COACHLINES PTY. LTD., Melbourne. Application for renewal of licence M.C.38 expiring 2 April 1980 under the same terms and conditions.

MORGAN, T. J., Foster. Application for renewal of licences T.S.295, T.S.297, T.S.296, T.S.298, T.S.299 and T.S.300 all expiring 31 January 1980, under the same terms and conditions.

WILSON, T. & D., Bass. Application for renewal of licence T.S.175 expiring 9 May 1980, under the same terms and conditions.

TREZISE, J. A., Kinglake. Application to licence one commercial passenger vehicle with seating capacity for 39 persons to operate two stage services as follows: (a) Between Kinglake and the Chirnside Park Shopping Centre via Mt. Slide, Yarra Glen and Lilydale with pick up and set down rights restricted to that part of the route between Kinglake and Mt. Slide. (b) Between Kinglake and Eltham Shopping Centre via Mt. Slide, Yarra Glen, Christmas Hills and Kangaroo Ground with pick up and set down rights restricted to that part of the route between Kinglake and Mt. Slide and at Christmas Hills.

## TIME-TABLE

Route (a) Friday only. Depart Kinglake 6.00 p.m. Arrive Chirnside Park 7.00 p.m. Depart Chirnside Park 9.10 p.m. Arrive Kinglake 10.10 p.m.

Route (b)—Saturday only. Depart Kinglake 8.40 a.m. Arrive Christmas Hills 9.30 a.m. Arrive Eltham 10.00 a.m. Depart Eltham 12.10 p.m. Arrive Christmas Hills 12.40 p.m. Arrive Kinglake 1.30 p.m.

Fares:	Adult Single
Route (a)	
Kinglake to Chirnside Park	\$1.70
Route (b)	
Kinglake to Eltham	\$2.10
Christmas Hills to Eltham	\$0.80
(Children and Pensioners half adult fare).	

NOTE—No charter rights are sought in this application.

VENTURA MOTORS PTY. LTD., South Oakleigh. Application to license one commercial passenger vehicle with large seating capacity, to operate as a metropolitan special service omnibus.

WINNELL, R. J., North Carlton. Application for renewal of licence M.T.5163 expiring 24 May 1980, under the same terms and conditions.

Notice of any objections should be forwarded to reach the Secretary of the Board not later than 16 January 1979.

Applicants are advised that it will not be necessary to appear on the hearing date specified, unless advised in writing by the Board.

C. J. V. SMITH, Secretary

Corner Lygon and Princes Streets, Carlton, 3053, Wednesday, 19 December 1979

Commercial Goods Vehicles Act  
TRANSPORT REGULATION BOARD

## HEARING OF APPLICATIONS

Notice is hereby given that the following applications will be considered by the Transport Regulation Board on 15 January 1980.

BEAUREPAIRE TYRE SERVICE PTY. LTD., 689 Burke Road, Camberwell, 3124. One commercial goods vehicle (L/C. 0.80 tonne) to operate within an 80-km radius from own branch premises at Portland in the course of business as "Tyre Retreaders and Distributors"—tyres and tubes for sale and delivery, used tyres for repair or retreading or having been repaired or retreaded, batteries, oil and motor car accessories.

BOMBARDIERI, R. J., 39 Downington Street, Swan Hill, 3585. One commercial goods vehicle (L/C. 14.45 tonne) to operate throughout the State of Victoria, in the course of business as "House Removalist" as a specially constructed house removal float—houses, sheds and outbuildings for removal from site to site together with tools of trade and house moving equipment incidental thereto.

BONNEY'S PEST CONTROL PTY. LTD., 77 Lime Avenue, Mildura, 3500. One commercial goods vehicle (L/C. 1.15 tonne) to operate within a 150-km radius of the G.P.O. Melbourne in the course of business as "Pest Exterminators"—tools of trade, equipment and materials incidental to the completion of own contracts.

BRITTAIN, W. H., 10 Hampden Street, Terang, 3270. Application to vary the conditions of licence No. D.A.61825/2 by deleting existing paragraph (b) and adding in lieu—(b) Within that part of the State of Victoria west of a north/south line drawn through Dandenong in a specially constructed bulk tanker—petroleum products in bulk.

BURNS, V., Snake Valley, 3351. One commercial goods vehicle (L/C. 20.00 tonne) to operate throughout the State of Victoria in the course of business as "House Remover"—houses, sheds and out-houses for removal and re-erection together with tools of trade, removal equipment and materials incidental thereto.

CADBURY SCHWEPES PTY. LTD., 636 St. Kilda Road, Melbourne, 3001. Application to vary the conditions of licences numbered D.A.65903/1, D.A.65903/2, D.A.65903/3, D.A.65903/4, D.A.65903/5, D.A.65903/6, D.A.65903/7, D.A.65903/8, D.A.65903/9, D.A.65903/10, D.A.65903/11, D.A.65903/12, D.A.65903/15, D.A.65903/37, D.A.65903/39 by deleting "Highett" from the existing conditions and adding in lieu "Tullamarine".

- CARTER, G. R.**, 10 Flowerdale Road, Moorabbin, 3189. One commercial goods vehicle (L/C. 10.70 tonne) to operate throughout the State of Victoria in the course of business as "Frozen Food Carrier" as a specially constructed refrigerated vehicle for the purpose of servicing retail stores—frozen and chilled fruit juice in plastic and waxed containers, frozen processed vegetables, cream, special soft cheese, yoghurt, dripping and lard, frozen pies, frozen prepared meals, butter and margarine.
- NOTE—Butter and margarine are only to be carried from Melbourne as a mixed load when being carried with other frozen foods under refrigeration for distribution to retail stores and provided that the combined weight of butter and margarine carried does not exceed 3000 kilograms on any one load.
- CLELANDS COLD STORES PTY. LTD.**, 548 Clayton Road, Clayton, 3168. One commercial goods vehicle (L/C. 10.02 tonne) to operate throughout the State of Victoria in the course of business as "Frozen Food Carrier" as a specially constructed refrigerated vehicle for the purpose of servicing retail stores—frozen poultry, frozen fish, frozen and fresh meat, ice-cream, frozen and chilled fruit juice in plastic and waxed containers, frozen processed vegetables, cream, special soft cheese, yoghurt, dripping and lard.
- COCHRANE, B. D.**, 198 Clayton Road, Clayton, 3168. One commercial goods vehicle (L/C. 6.80 tonne) to operate within a radius of 112-km of the premises of Evans Brothers (Bricks) Pty. Ltd. at Scoresby—bricks solely on behalf of the said company.
- COWLAND, R. B.**, Penshurst Road, Macarthur, 3286. One commercial goods vehicle (L/C. 16.40 tonne) to operate within an 80-km radius of the Post Office at Macarthur in the course of business as "Earthmoving Contractors"—own earthmoving plant and equipment.
- HEYFIELD SAWMILLERS LOGGING CO. PTY. LTD.**, 14 Licola Road, Heyfield, 3858. One commercial goods vehicle (L/C. 6.10 tonne) to operate within an 80-km radius from own premises at Heyfield in the course of business as "Sawmillers and Logging Contractors"—tools of trade, equipment and materials incidental to the maintenance of roads for which the company is responsible.
- HONETIC PTY. LTD.**, P.O. Box 1108, Shepparton, 3630. One commercial goods vehicle (L/C. 15.00 tonne) to operate: (a) Within an 80-km radius of own premises at Kyabram and Shepparton in the course of business as "Motor Wreckers"—own goods. (b) Throughout the State of Victoria—wrecked or disabled vehicles for carriage to own wrecking yards at Kyabram and Shepparton from the garage premises or other places where purchased in the course of business as "Auto Wrecker" but excluding the right to carry or tow any disabled or wrecked vehicles from the scene or area of any accident or collision where such vehicle was wrecked, disabled or damaged and subject to the conditions that all towing or carrying of wrecked motor vehicles shall be confined solely to the subsequent carrying of any wrecked vehicle after its initial towing to a garage by a properly authorized tow truck.
- LARTER, R. J.**, 31 Pearson Street, Heyfield, 3858. Application to vary the conditions of licence No. D.T.1659 by deleting the existing conditions and adding in lieu—From forest landings within that part of an 80-km radius of the post office at Licola which is situated north of Licola to Sawmills at Heyfield—mill logs.
- MANSFIELD, R. G.**, 55 Crusoe Road, Kangaroo Flat, 3555. One commercial goods vehicle (L/C. 7.00 tonne) to operate: (a) From points throughout the State of Victoria to the premises of Everlast Concrete Tanks Holdings Pty. Ltd. solely on behalf of the said company, an approved decentralized secondary industry (portable water tanks) at Bendigo—raw materials and goods used solely in the manufacturing processes of such industry. (b) From the premises of Everlast Concrete Tanks Holdings Pty. Ltd. at Bendigo, being an approved decentralized secondary industry (portable water tanks) solely on behalf of the said company to points throughout the State of Victoria—manufactured articles and products from the said industry.
- MARTINS, F. W.**, 46 Marne Stret, Kerang, 3579. One commercial goods vehicle (L/C. 0.40 tonne) to operate from and to Kerang to and from Boort under the terms of the contract entered into between Australian Postal Commission and the applicant—mail on behalf of the said commission.
- MILLAR, A. W.**, 44 Greenwood Parade, Leongatha, 3953. One commercial goods vehicle (L/C. 6.70 tonne) to operate: (a) Within an 80-km radius of Leongatha in the course of business as "Roadmaking Contractor"—plant the property of a contractor and required by him for use in connection with the construction or maintenance of some specific, existing or proposed road, street, footpath, bridge, pier, wharf, weir or channel and also the following materials, viz.: metal, stones, screenings, ashes, gravel, sand and earth. (b) Within a 32-km radius of the site of any construction or maintenance work performed pursuant to paragraph (a) above or from the railway station nearest thereto—any other materials required for such work. (c) Within a 40-km radius of Leongatha—general goods. (d) Within an 80-km radius of the post office at Leongatha in the course of business as "Tree Trimming Contractor"—own equipment including the ability to dispose of the waste material.
- MURRAY, M. E.**, 58 Dooen Road, Horsham, 3400. One commercial goods vehicle (L/C. 13.25 tonne) to operate: (a) Within a 135-km radius of the post office at Dimboola and/or 128-km of the post office at Linga (Horsham Division of the Country Roads Board)—plant the property of a contractor and required for use in connection with the construction or maintenance of some specific, existing or proposed road, street, footpath, bridge, wharf, pier, weir or channel. (b) Within a 40-km radius from the site of construction or maintenance work performed pursuant to paragraph (a) above, or from the railway station nearest thereto—metal, stones, screenings, ashes, gravel, sand and earth and any other materials required for such work.
- MCLAUGHLIN, K. D.**, Railway Lot 12, Murray Valley, Highway, Lake Boga, 3585. Application to vary the conditions of licences numbered D.A.70055 and D.A.70055/1 by deleting from the existing conditions—"Within that part of the State of Victoria north of an east/west line drawn through Ballarat" and adding in lieu—within the State of Victoria but excluding operations to or from places within a 40-km radius of G.P.O. Melbourne".
- L. & B. M. NEAVE (TRARALGON) PTY. LTD.**, P.O. Box 364, Traralgon, 3844. Application to vary the conditions of licences numbered D.A.44081/3 and D.A.44081/5 by deleting the existing conditions and adding in lieu—Solely on behalf of Rocla Concrete Pipes Ltd. at Traralgon an approved decentralized secondary industry (pipe manufacture)—(i) From places within an 80-km radius of the G.P.O. Melbourne to such premises at Traralgon—raw materials required for use in the manufacturing processes of such industry. (ii) From such premises at Traralgon to places situated throughout the State of Victoria—finished products from such industry. (iii) Between the companies own branch premises at Springvale and Traralgon—manufactured machinery and equipment the property of the said company. (iv) From places within a 40-km radius of the G.P.O. Melbourne for delivery to places situated within a 112-km radius of the companies Traralgon premises—manufactured concrete products, excluding large concrete beams or slabs.
- NIKOLAOU, A.**, 11 Osmont Street, Armadale, 3143. One commercial goods vehicle (L/C. 14.95 tonne) to operate within an 80-km radius of the G.P.O. Melbourne on behalf of Boral Resources (Vic.) Pty. Ltd.—roadmaking plant, hot asphalt, premix and roadmaking materials excluding the carriage of cement and lime from places within a 13-km radius of Geelong.
- RODGER, G. T.**, 78 Simpson Street, Warrnambool, 3280. One commercial goods vehicle (L/C. 16.23 tonne) to operate within an 80-km radius of the post offices at Warrnambool and Elliminyt respectively in the course of business as "Plumbing, Drainage, Excavation and Road Contractors"—tools of trade, own plant and equipment and materials incidental to completion of own contracts.

- ST. LEON NOMINEES PTY. LTD., 815 Nepean Highway, Brighton East, 3187. One commercial goods vehicle (L/C. 1.15 tonne) to operate throughout the State of Victoria in the course of business as "Air Conditioning Engineers"—tools of trade, own equipment and spare parts incidental to the completion of own contracts.
- SANNAZZARO, M., 10 Duband Street, East Burwood, 3151. One commercial goods vehicle (L/C. 1.30 tonne) to operate throughout the State of Victoria in the course of business as "Frozen Food Distributor" in a specially constructed refrigerated vehicle—frozen and fresh meat, frozen poultry and fruit juice in plastic and waxed containers.
- W. L. SIDES & SON PTY. LTD., P.O. Box 228, Clayton, 3168. Two commercial goods vehicles (L/C. 1.35 and 1.15 tonne) to operate: (a) Throughout the State of Victoria in the course of business as "Boring Contractors"—tools of trade and boring equipment incidental to own contracts. (b) Within a 32-km radius of the site of any contract in the course of business specified above or to any such site from the railway station nearest thereto—materials for use on such contract.
- STEPHENS, J. L., 71 Seaview Avenue, Safety Beach, 3936. One commercial goods vehicle (L/C. 7.95 tonne) to operate: (a) Within an 80-km radius of own premises at Dromana in the course of business as "Drainage Contractor"—own tools of trade, own earthmoving equipment, own sand, own screenings, and own pipes. (b) From Yea and Pyalong to own premises at Dromana—own river gravel. (c) Throughout the State of Victoria—own tools of trade and own earthmoving equipment. (d) Within a 40-km radius of any contract currently engaged upon—materials for use in such contract.
- K. J. WICKHAM PTY. LTD., 44 Aquila Street, North Balwyn, 3104. One commercial goods vehicle (L/C. 0.75 tonne) to operate throughout the State of Victoria in the course of business as "Convention Consultant" for the purpose of arranging and preparing documentation for conventions—own display equipment and documents for direct delivery to convention centres.
- WILKIE, B. M., 30 Old Sale Road, Moe, 3825. One commercial goods vehicle (L/C. 10.50 tonne) to operate within an 80-km radius of the post office at Moe as a "Water Tanker" for the purpose of spray road construction projects and supplying water for domestic use.
- WILSON, D. L., P.O. Box 63, Doveton, 3177. One commercial goods vehicle (L/C. 11.20 tonne) to operate throughout the State of Victoria in the course of business as "House Remover" on a specially constructed house moving float—houses, sheds, outbuildings and classrooms for removal also tools of trade and house removing equipment.
- TOW TRUCK**
- TURNER, L. E., Western Highway, Buangor, 3375. One commercial goods vehicle (to be purchased) to operate throughout the State of Victoria as a Class 4 Heavy Duty Tow Truck having a Gross Train Weight of at least 25 000 kg tandem rear axles and power operated crane with a minimum capacity of 5000 kg for the purposes of lifting and carrying and/or towing wrecked or disabled motor vehicles—wrecked or disabled motor vehicles and spare parts incidental to the repair of disabled motor vehicles on site only.
- RENEWALS**
- Applications for renewal of licences as shown by persons listed hereunder to operate under the same terms and conditions from the expiry shown in each case.
- ARTHURS DAIRY PTY. LTD., 146 Beach Street, Frankston, 3199; D.A.53996/8; 4 March 1980; 4.55 tonne.
- BASS, R. B., 3 Regal Court, Montmorency, 3094; D.A.68275; 5 February 1980; 1.05 tonne.
- BROWN, T. A., 9 Romsey Street, Noble Park, 3174; D.A.36578/1; 17 August 1979; 6.05 tonne.
- CADBURY SCHWEPPE'S PTY. LTD., 636 St Kilda Road, Melbourne, 3004; D.A.65903/8; 28 March 1980; 7.27 tonne; D.A.65903/7; 28 March 1980; 7.32 tonne.
- CADBURY SCHWEPPE'S PTY. LTD., Yarrowee Street, Sebastopol, 3356; D.A.65903/44; 11 April 1980; 7.05 tonne.
- CARLTON & UNITED BREWERIES LTD., 16 Bouverie Street, Carlton, 3053; D.A.808/54; 14 March 1980; 7.60 tonne; D.A.808/55; 14 March 1980; 7.75 tonne; D.A.808/56; 14 March 1980; 7.50 tonne.
- COOK, E. G. L., Waterloo Road, Trafalgar, 3824; D.A.887/1; 28 March 1980; 6.20 tonne.
- DERITE MORWELL PTY. LTD., Commercial Road, Morwell, 3840; D.A.974/9; 4 March 1980; 5.10 tonne; D.A.974/10; 4 March 1980; 3.30 tonne.
- DEVESON, R. A., 4 Parklands Avenue, Briar Hill, 3088; D.A.68335; 18 March 1980; 7.90 tonne.
- EVANS, A. J., Lot 12, Pearcedale Road, South Cranbourne, 3977; D.A.61207/1; 4 March 1980; 5.95 tonne and 5.35 tonne trailer.
- FEGLIN, M., & SONS NOMINEES PTY. LTD., Station Street, Nunawading, 3131; D.A.1066/23; 18 September 1979; 6.90 tonne.
- FIELD AIR (BALLARAT) PTY. LTD., Municipal Airport, Ballarat, 3350; D.A.50493/20; 25 March 1980; Mobile Crane.
- FIELD AIR (COLAC) PTY. LTD., Municipal Airport, Ballarat, 3350; D.A.50493/15; 8 March 1980; 0.55 tonne; D.A.50493/14; 8 March 1980; 1.10 tonne; D.A.50493/18; 8 March 1980; 0.80 tonne; D.A.50493/17; 8 March 1980; 0.80 tonne.
- FLEETWAYS TRANSPORT PTY. LTD., 61 Bertie Street, Port Melbourne, 3207; D.A.48588/43; 27 March 1980; 4.35 tonne.
- FORD MOTOR CO. OF AUST. LTD., 1735 Sydney Road, Campbellfield, 3061; D.A.42814/24; 25 March 1980; 15.80 tonne.
- PAT GLEESON MOTORS (WARRNAMBOOL) PTY. LTD., 1101 Raglan Parade, Warrnambool, 3280; D.A.68917/1; 31 January 1980; 5.70 tonne.
- GOODEY, D. M., 9 O'Keefe Street, Wangaratta, 3677; D.A.68321; 8 March 1980; 10.45 tonne.
- GRAHAM, A. J., P.O. Box 67, Frankston, 3199; D.A.65908/1; 18 March 1980; 10.45 tonne.
- GRAZCOS CO-OPERATIVE LTD., 500 Collins Street, Melbourne, 3000; D.A.25161/8; 16 December 1979; 0.75 tonne.
- GRAZCOS CO-OPERATIVE LTD., 500 Collins Street, Melbourne, 3000; D.A.25161/9; 16 December 1979; 0.50 and 1.00 tonne trailer.
- GREEN, L. H., Rix Avenue, Cobden, 3266; D.A.68190; 11 January 1980; 5.40 tonne.
- HARMAN BROS. PTY. LTD., 314 Sturt Street, Ballarat, 3350; D.A.1249; 27 March 1980; 0.50 tonne.
- HEYFIELD SAWMILLERS LOGGING CO. PTY. LTD., Licola Road, Heyfield, 3858; D.T.1228/1; 6 March 1980; 6.85 tonne.
- HIBBERD, K. W., 38 Alfred Street, Sebastopol, 3356; D.A.65367/2; 8 March 1980; 1.95 tonne.
- HODGINS, G. A., 320 Frankston-Flinders Road, Somerville, 3912; D.A.70190; 28 March 1980; 3.90 tonne.
- HODGSON, C., Yarra Glen Road, Healesville, 3777; D.A.68979; 12 February 1980; 8.00 tonne.
- JAVA INDUSTRIES PTY. LTD., P.O. Box 158, Bulleen, 3105; D.A.66884/2; 14 March 1980; 3.30 tonne.
- LEISURE & ALLIED INDUSTRIES (1973) PTY. LTD., 202 Gillies Street, Ballarat, 3350; D.A.64946/9; 19 February 1980; 4.00 tonne.
- LEY, G. H., 9 Burchett Street, Penshurst, 3289; D.A.12848/8; 18 March 1980; 18.86 tonne.
- MAWSON, E. B., & SONS PTY. LTD., 141 King George Street, Cohuna, 3568; D.A.30119/55; 6 March 1980; 8.20 and 11.15 tonne trailer.
- MORAN, V., 119A Harold Street, Thornbury, 3021; D.A.48414/1; 23 March 1980; 6.65 tonne.
- TED NEILLS MOTORS PTY. LTD., Princes Highway, Warragul, 3820; D.A.61001/1; 26 March 1980; 2.95 and 2.10 tonne trailer.
- NELSON TOBACCO CO. PTY. LTD., 2 Moller Street, Shepparton, 3630; D.A.67753/9; 28 February 1980; 2.40 tonne.
- NELSON, M. J., 9 Haslem Street, Kyabram, 3620; D.A.67729/2; 11 January 1980; 4.10 tonne.
- O'BRIEN, N. & J. O., NOMINEES PTY. LTD., 55 Parker Road, Airport West, 3342; D.A.68277; 5 February 1980; 2.70 tonne.
- OSTLER, M., 551 High Street, Epping, 3076; D.A.68331/1; 25 March 1980; 18.30 tonne.

R. & F. DRILLING CO. PTY. LTD., 7 Earlwood Drive, Mulgrave, 3170; D.A.65785/2; 8 March 1980; 2.65 tonne; D.A.65785/3; 8 March 1980; 2.80 tonne.

REED PAPER PRODUCTS LTD., 2 Queen Street, Swan Hill, 3585; D.A.65971; 22 February 1980; 1.10 tonne.

RISELEY, K. P., 28 Yarragon Road, Leongatha, 3953; D.A.67776; 12 January 1980; 21.42 tonne; D.A.67776/3; 12 January 1980; 10.90 tonne.

SHELTON, R. P., Darraweit Guim, 3654; D.A.60806/1; 4 March 1980; 6.60 and 2.80 tonne trailer.

PETER STOITSE TRANSPORT PTY. LTD., P.O. Box 2, Welshpool, 3966; D.A.63134/8; 22 March 1980; 14.95 tonne; D.A.63134/9; 22 March 1980; 20.00 tonne; D.A.63134/10; 22 March 1980; 19.50 tonne; D.A.63134/11; 22 March 1980; 6.45 tonne; D.A.63134/12; 22 March 1980; 7.25 tonne; D.A.63134/13; 22 March 1980; 18.80 tonne.

SUTER, A. F., 20 Russell Street, Mount Evelyn, 3796; D.A.68046; 9 October 1979; 6.35 tonne.

TAYLOR, J. E., 19 Main Street, Foster, 3960; D.A.67122; 27 March 1980; 1.10 and 1.85 tonne trailer.

TERRY, G. R., care of Eldorado P.O., 3746; D.A.61586; 4 March 1980; 11.70 tonne.

TWINNESS DISTRIBUTORS PTY. LTD., McDonald Road, Brooklyn, 3425; D.A.64148/10; 27 March 1980; 3.85 tonne.

WESTINGHOUSE BRAKE & SIGNAL CO. (AUST.) PTY. LTD., Stephenson Street, Spotswood, 3015; D.A.68082/2; 18 March 1980; 2.05 tonne.

WILLIAMS THE SHOEMAN PTY. LTD., 578-584 Swanston Street, Carlton, 3053; D.A.38703; 21 March 1980; 0.30 tonne.

WOODS, T. H., 13 Heysen Drive, Sunbury, 3429; D.A.51507; 23 March 1980; 4.55 tonne.

## TOW TRUCK RENEWALS

GARDINER TOWING SERVICE PTY. LTD., 718 Malvern Road, Prahran, 3181; D.A.66372/6; 14 December 1979; 2.40 tonne; D.A.66372/8; 14 December 1979; 2.65 tonne.

HARDIE, D. M., 44-46 Bellarine Highway, Queenscliff, 3225; D.A.64930; 28 February 1980; 2.60 tonne.

JASMASAN NOMINEES PTY. LTD., 20 French Street, North Coburg, 3056; D.A.70280; 3 February 1980; 2.20 tonne.

YOUNG, S. J., Beauchamp Street, Kyneton, 3444; D.A.68223; 10 March 1980; 2.40 tonne.

Notice of any objection should be forwarded to reach the Secretary of the Board not later than 4 January 1980.

Applicants are advised that it will not be necessary to appear on the hearing date specified above, unless advised in writing by the Board.

C. J. V. SMITH, Secretary

Corner Lygon and Princes Streets, Carlton, 3053, Wednesday, 19 December 1979

## NOTICE TO MARINERS

[No. 51 of 1979]

## AUSTRALIA—VICTORIA

## PORT PHILLIP

## Fort West Beacon

Date—On or about 20 December 1979.

Previous Notice—No. 37 (P) of 1979 is superseded.

Details—The Fort West Beacon in position 232.6 degrees distant 213 metres from the Queenscliff High Lighthouse, Lat. 38 deg. 16.4 min. S., Long. 144 deg. 39.7 min. E. (approximately) has been replaced by a new beacon structure in position 232 deg. 39 min. distant 329 metres from the Queenscliff High Lighthouse.

The new Fort West Beacon is 8.0 metres high with a white daymark 5 metres high and 2.5 metres wide on the upper south western face of the structure.

A directional isophase light flashing two seconds has been established on the structure at a height of 19.0 metres above high water showing red from 058 deg. 42 min. to 052 deg. 42 min. thence white to 048 deg. 42 min. The red light is visible 10 miles and white light visible 12 miles.

The directional light has been established solely for the use of Pilot launches voyaging to and from ships for the purpose of embarking and disembarking pilots.

Mariners are reminded of the caution on page 188 of *Sailing Directions*, Victoria, 1970.

Abridged Description—Dir. Iso. R.W. 2s. 19m. 10M. 12M. Chart Affected—AUS 143 (Plan).

Publication Affected—*Sailing Directions*, Victoria, 1970 pages 163, 188 and 597.

A. J. WAGGLEN  
Port Officer

Public Works Department  
Ports and Harbors Division  
168 Exhibition Street  
Melbourne, 3000, 7 December 1979

## NOTICE TO MARINERS

[No. 50 of 1979]

## AUSTRALIA—VICTORIA

## PORT PHILLIP

## Spoil Ground Buoy Relocated

Date—On or about 19 December 1979.

Former Notice—No. 38 (T) of 1979 is cancelled.

Details—Spoil Ground light buoy will be re-located to a position 186.2 deg. distant 8.26 miles from Time Ball Tower light (Lat. 37 deg. 52.1 min. S., Long. 144 deg. 54.6 min. E. approximately).

The buoy is coloured yellow with black identification letters "S.G." on opposite sides. The buoy will show a flashing yellow light every five seconds. Flash  $\frac{1}{2}$  second, eclipse  $4\frac{1}{2}$  seconds.

Spoil must not be dumped northward nor within 350 metres of the buoy nor eastward of a line bearing 180 deg. from the buoy.

Abridged Description—F1. Y. 5s.

Charts Affected—AUS 143, AUS 155.

Publication Affected—*Sailing Directions*, Victoria, 1970 pages 291 and 629.

A. J. WAGGLEN  
Port Officer

Public Works Department  
Ports and Harbors Division  
168 Exhibition Street  
Melbourne, 3000, 7 December 1979

## NOTICE TO MARINERS

[No. 52T of 1979]

## AUSTRALIA—VICTORIA

## WESTERNPORT

## Temporary Light Established

A quick flashing yellow light will be exhibited from Westernport Yacht Club, Balnarring, Lat. 38 deg. 23 min. 33 sec. S., Long. 145 deg. 07 min. 36 sec. E until 19 April 1980.

Chart Temporarily Affected—AUS 156.

A. J. WAGGLEN  
Port Officer

Public Works Department  
Ports and Harbors Division  
168 Exhibition Street  
Melbourne, 3000, 10 December 1979

## Private Agents Act 1966

## NOTICE OF RECEIPT OF APPLICATIONS FOR LICENCES UNDER THE PROVISIONS OF THE PRIVATE AGENTS ACT 1966

The Clerk(s) of the Magistrates' Court(s) as listed hereunder hereby give notice that applications, as under, have been lodged for hearing by the said Court(s) on the date(s) specified.

Any person desiring to object to any of such applications must—

- (a) lodge with the respective Clerk of the Magistrates' Court a notice in the prescribed form of his objection and of the grounds thereof;
- (b) cause a copy of such notice to be served personally or by post upon the applicant at least three days before the hearing of the application; and
- (c) send or deliver—
  - (i) where the objection is not made by the officer in charge of the police district in which the Court is situated—a copy of the notice to such officer; and
  - (ii) where the objection is not made by the Registrar or Deputy Registrar—a copy to the Registrar.

Full Name of Applicant*	Place of Abode of Applicant or Nominee	Name of Firm or Corporation	Address for Registration	Type of Licence	Date of Hearing
<b>MAGISTRATES' COURT, ELTHAM</b>					
Vinar, Eric Richard	23 McKellar St, Watsonia	Mobile Watching (Aust.) Pty. Ltd.	173A Glenferrie Rd, Malvern	Inquiry Agent	21.1.80
" " "	" "	" "	" "	Guard Agent	"
Dated at Eltham 7 December 1979 G. P. BALE, Clerk of the Magistrates' Court					
<b>MAGISTRATES' COURT, HAWTHORN</b>					
Bird, Christopher Harry	12 Bakers Rd, North Dandenong	Armaguard Hawthorn	390 St Kilda Rd, South Melbourne	Watchman	4.1.80
Quirk, Gary Russell	14 Haldane St, Beaumaris	" "	842 High St, East Kew	Inquiry Agent	"
Gribble Management Service Pty. Ltd.	51 Robinson Rd, Hawthorn	Gribble Management Pty. Ltd.	7th Floor, 446 Collins St, Melbourne	Corporation Process Server	"
Dated at Hawthorn 7 December 1979 G. CABRAL, Clerk of the Magistrates' Court					
<b>MAGISTRATES' COURT, MELBOURNE</b>					
Howell, Nicholas Henry	2/5 Violen St, Bayswater	Transurety Limited	Cnr Arden and Lothian Sts, North Melbourne	Watchman	15.1.80
Heath, Michael Allin	8 Wendover Ave, Bayswater North	" "	" "	"	"
McQueen, Robert John	5/46 Whitehall St, Footscray	" "	" "	"	"
O'Conner, Paul Vincent	22 Lagnicourt St, Hampton	" "	" "	"	"
Showler, Arthur James	20 Cradle Rd, Diggers Rest	" "	" "	"	"
Salton, Richard Allan	25 Empress Rd, Surrey Hills	Armaguard Mayne Nickless Ltd.	699 Queensberry St, North Melbourne	Watchman	16.1.80
Gleeson, Anthony Wayne	31 Victoria Rd, Sydenham	Wormald International Security	340 Abbotsford St, North Melbourne	Inquiry Agent	"
Sandford, Stanley Joseph	2A Merrilands Rd, Reservoir	Armaguard Mayne Nickless Ltd.	699 Queensberry St, North Melbourne	" "	"
O'Donnell, Gerard Francis	5 Hawker St, Ivanhoe	Transurety Limited	Cnr Arden and Lothian Sts, North Melbourne	" "	"
Cainer, Robert Henry	14 Crusader Cres, Glen Waverley	" "	" "	" "	"
Mobbs, Richard Kenneth	32 Summit Rd, Frankston	Armaguard Mayne Nickless Ltd.	699 Queensberry St, North Melbourne	" "	"
Deal-Wills, Daryl Charles	3/51 Foam St, Elwood	" "	" "	" "	"
Anderson, William Arthur Frederick	98 St Hellier St, West Heidelberg	Transurety Limited	Cnr Arden and Lothian Sts, North Melbourne	" "	"
Dated at Melbourne 7 December 1979 M. J. QUIRK, Clerk of the Magistrates' Court					
<b>MAGISTRATES' COURT, BALLARAT</b>					
Marriner, Stephen John	29 Loveneer Gve Ballarat	Ballarat Security Services	423 Cobden St, Ballarat	Watchman	3.1.80
Dated at Ballarat 7 December 1979 D. CROFT, Clerk of the Magistrates' Court					

\* Or in the case of a firm or corporation, of the Nominee

## PRIVATE AGENTS—continued

Full Name of Applicant*	Place of Abode of Applicant or Nominee	Name of Firm or Corporation	Address for Registration	Type of Licence	Date of Hearing
<b>MAGISTRATES' COURT, FERNTREE GULLY</b>					
Tassoni, Umberto Natale	4 Quarry Rd, Upper Ferntree Gully		4 Quarry Rd, Upper Ferntree Gully	Inquiry Agent	28.12.79
" " "	" " "		" " "	Guard Agent Process Server	"
Dated at Ferntree Gully 6 December 1979 BRIAN DOBSON, Clerk of the Magistrates' Court					
<b>MAGISTRATES' COURT, PRAHRAN</b>					
Bednarz, Robert	47 Amblecote Cres, Mulgrave		14/65 Queen St, Melbourne	Commercial Sub Agent	18.1.80
Holmes, Gerard Francis	56 Aquila St, South Yarra		72 River St, South Yarra	Process Server	"
Lake, Kenneth	38 Kyora Pde, North Balwyn		72 River St, South Yarra	Process Server	"
Dated at Prahran 11 December 1979 H. F. ADAMS, Clerk of the Magistrates' Court					
<b>MAGISTRATES' COURT, WODONGA</b>					
Houting, Roulef Barry	61 London Rd, Wodonga		94 York St, South Melbourne	Watchman	8.1.80
Dated at Wodonga 11 December 1979 P. MALONEY, Clerk of the Magistrates' Court					
<b>MAGISTRATES' COURT, WODONGA</b>					
Lennane, Robert Lindsay	3 Nicole Cres, Wodonga		23 Huon St, Wodonga	Watchman	8.1.80
Dated at Wodonga 10 December 1979 P. MALONEY, Clerk of the Magistrates' Court					
<b>MAGISTRATES' COURT, BALLARAT</b>					
Duncan, James Ernest	305 Lyons St South, Ballarat	Wormald International Security	305 Lyons St South, Ballarat	Watchman	3.1.80
Dated at Ballarat 10 December 1979 D. L. CROFT, Clerk of the Magistrates' Court					
<b>MAGISTRATES' COURT, PRESTON</b>					
Vanderwerf, Peter Cornelius	10 Hawking St, Preston		10 Hawking St, Preston	Guard Agent	14.1.80
Dated at Preston 7 December 1979 J. C. TOBIN, Clerk of the Magistrates' Court					
<b>MAGISTRATES' COURT, LAKES ENTRANCE</b>					
Bird, Kevin John	66 Roadknight St, Lakes Entrance	Lakes Entrance Security Service	2 Fish St, Lakes Entrance	Watchman	16.1.8
Dated at Lakes Entrance 13 December 1979 T. A. GRANT, Clerk of the Magistrates' Court					
<b>MAGISTRATES' COURT, ST KILDA</b>					
Bradbury, Ian Russell	3/46 Foam St, Elwood	Braddan Investigations and Security	3/46 Foam St, Elwood	Process Server (Firm)	9.1.80
Bradbury, Ian Russell	" "	" "	" "	Guard Agent (Firm)	"
Bradbury, Ian Russell	" "	" "	" "	Inquiry Agent (Firm)	"
Kolitsch, Stefan Paul Peter	2/90 Hotham St, East St Kilda	All Purpose Investigations Detection	2/90 Hotham St, East St Kilda	Process Server (Firm)	"
Dated at St Kilda 12 December 1979 D. B. EWART, Clerk of the Magistrates' Court					

\* Or in the case of a firm or corporation, of the Nominee

## PRIVATE AGENTS—continued

Full Name of Applicant*	Place of Abode of Applicant or Nominee	Name of Firm or Corporation	Address for Registration	Type of Licence	Date of Hearing
-------------------------	--	-----------------------------	--------------------------	-----------------	-----------------

## MAGISTRATES' COURT, WANGARATTA

Creek, Martin Walter	2 Raymond St, Wangaratta		2 Raymond St, Wangaratta	Inquiry Agent	7.1.80
----------------------	-----------------------------	--	-----------------------------	---------------	--------

Dated at Wangaratta 13 December 1979  
L. WINTON-SMITH, Clerk of the Magistrates' Court

## MAGISTRATES' COURT, CHELSEA

Stretch, Paul	59 Edithvale Rd, Edithvale		59 Edithvale Rd, Edithvale	Process Server (Individual)	14.1.80
McLoughlin, Kerry	4 Brentwood St, Moorabbin		25 Golden Ave, Chelsea	Watchman	"
Shakeshaft, Anthony	2 East Boundary Rd, East Bentleigh		" "	"	"

Dated at Chelsea 12 December 1979  
W. A. WARD, Clerk of the Magistrates' Court

\* Or in the case of a firm or corporation, of the Nominee

## MAGISTRATES' COURTS ACT 1971

## DAY AND HOURS APPOINTED IN LIEU

His Excellency the Governor of the State of Victoria by and with the advice of the Executive Council thereof has by Order made on 14 December 1979, and pursuant to the provisions of section 4 of the *Magistrates' Courts Act 1971*, appointed the days and hours contained in the schedule below, public holidays excepted, for the holding of Magistrates' Courts at the places named in such schedule in lieu of the days and hours heretofore appointed—to take effect as from 1 January 1980.

Place	SCHEDULE Days and Hours	Place	Days and Hours
BOORT	Friday, 11 January 1980, at 10 a.m. and every alternate Friday thereafter at 10 a.m.	NUMURKAH	Every Thursday and every Friday at 10 a.m.
CARLTON	Every Tuesday and Thursday at 10 a.m.	RED CLIFFS	Tuesday, 15 January 1980, at 2 p.m. and every fourth Tuesday thereafter at 2 p.m.
CHARLTON	Thursday, 17 January 1980, at 10 a.m. and every fourth Thursday thereafter at 10 a.m.	RUSHWORTH	Every Tuesday and every Wednesday at 10 a.m.
COHUNA	Every Monday at 10 a.m. and Tuesday, 15 January 1980, at 10 a.m. and every alternate Tuesday thereafter at 10 a.m.	SEA LAKE	Thursday, 17 January 1980, at 10 a.m. and every fourth Thursday thereafter at 10 a.m.
COWES	Every Monday and every Wednesday at 10 a.m.	SEYMOUR	Every Monday, Wednesday and Friday at 10 a.m.
CRANBOURNE	Every Monday and every Wednesday at 10 a.m.	TATURA	Wednesday, 9 January 1980, at 10 a.m. and every alternate Wednesday thereafter at 10 a.m.
DONALD	Tuesday, 29 January 1980, at 10 a.m. and every fourth Tuesday thereafter at 10 a.m.	WINCHELSEA	Thursday, 31 January 1980, at 10 a.m. and every eighth Thursday thereafter at 10 a.m.
HOPETOUN	Tuesday, 29 January 1980, and every fourth Tuesday thereafter at 10 a.m.	WYCHEPROOF	Thursday, 3 January 1980, at 10 a.m. and every fourth Thursday thereafter at 10 a.m.
LAKES ENTRANCE	Every Wednesday at 10 a.m.		TOM FORRISTAL Clerk of the Executive Council
LANCEFIELD	Friday, 8 February 1980, at 10 a.m. and every eighth Friday thereafter at 10 a.m.		At the Executive Council Chamber, Melbourne, 14 December 1979
MORNINGTON	Every Thursday at 10 a.m. and Friday, 4 January 1980, at 10 a.m. and every alternate Friday thereafter at 10 a.m.		

## Magistrates' Courts Act 1971

## CLOSURE OF COURT AT HAWTHORN

His Excellency the Governor of the State of Victoria, by and with the advice of the Executive Council thereof, has by Order made on 14 December 1979, pursuant to the provisions of section 5 of the *Magistrates' Courts Act 1971*, revoked the appointment of Hawthorn as a place for holding a Magistrates' Court and directs that such court be closed from and after 31 December 1979, and that the books and other records of the said Court and of the Clerk thereof be delivered to the Clerk of the Magistrates' Court at Prahran.

TOM FORRISTAL

Clerk of the Executive Council

At the Executive Council Chamber  
Melbourne, 14 December 1979



Magistrates' Courts Rules 1976

SELECTION BY A LAW OFFICER OF THE PLACES AND DAYS AND HOURS FOR HOLDING COURTS TO EXERCISE THE SPECIAL JURISDICTION

I, the undersigned, HADDON STOREY, a Law Officer of the State of Victoria, in pursuance of the powers conferred upon me by Rule 5 of the Magistrates' Courts Rules 1976, do hereby select for the year 1980, from the places appointed by the Governor in Council for holding Magistrates' Courts, the places named in the Schedule as places for holding Magistrates' Courts consisting of a Stipendiary Magistrate sitting alone to exercise the special jurisdiction.

And I do hereby further select for the year 1980, from the days and hours appointed by the Governor in Council for holding Magistrates' Courts at the places named in the Schedule, the days and hours set forth in the Schedule opposite the respective names of the places so named as the days and hours for holding at those places Magistrates' Courts as aforesaid to exercise the special jurisdiction.

Dated at Melbourne 17 December 1979

HADDON STOREY  
Attorney-General

SCHEDULE

Courts, Days and Hours for the Hearing of Special Complaints During 1980

Court	Day	Hour	January	February	March	April	May	June	July	August	September	October	November	December
ALEXANDRA	Fri.	10 a.m.	4, 18	1, 15, 29	28	11	9, 23	6, 20	4, 18	1, 15, 29	12, 26	10, 24	7, 21	5, 19
APOLLO BAY	Tues.	10 a.m.	22	19	18	15	13	10	8	5	2, 30	28	25	23
ARARAT	Tues.	10 a.m.	Every	Tuesday	except	Public H	olidays							
BACCHUS MARSH	Thur.	10 a.m.	Every	Thursday	except	Public H	olidays							
BAIRNSDALE	Thur.	10 a.m.	Every	Thursday	except	Public H	olidays							
BALLAN	Thur.	10 a.m.	4, 18	1, 15, 29	28	11	9, 23	6, 20	4, 18	1, 15, 29	12, 26	10, 24	7, 21	5, 19
BALLARAT	Mon.	10 a.m.	Every	Monday	and	Tuesday	and	Wednesday	and	Thursday	except	Public H	olidays	
BEAUFORT	Tues.	10 a.m.	11	8	7	3	2, 30	27	25	22	19	17	14	12
BEECHWORTH	Fri.	10 a.m.	10	7	6	3	1, 29	26	24	21	18	16	13	11
BENALLA	Tues.	10 a.m.	Every	Tuesday	except	Public H	olidays							
BENDIGO	Wed.	10 a.m.	9, 23	6, 20	5, 19	2, 16, 30	14, 28	11, 25	9, 23	6, 20	3, 17	1, 15, 29	12, 26	10, 24
BERWICK	Mon.	10 a.m.	Every	Monday	except	Public H	olidays							
BIRCHIP	Wed.	10 a.m.	Every	Wednesday	except	Public H	olidays							
BOORT	Thur.	10 a.m.	3, 17, 31	14, 28	13, 27	10, 24	18, 22	5, 19	3, 17, 31	14, 28	11	9, 23	6, 20	4, 18
BOX HILL	Fri.	10 a.m.	Every	Friday	except	Public H	oliday							
BRIGHT	Tues.	10 a.m.	15, 29	12, 26	11, 25	22	16, 20	3, 17	1, 15, 29	12, 26	9, 23	7, 21	18	2, 12, 30
BRIGHTON	Tues.	10 a.m.	8	5	4	1, 29	27	24	22	19	16	14	11	9
BROADMEADOWS	Fri.	10 a.m.	11	8	7	3	2, 30	27	25	22	19	17	14	12
BRUNSWICK	Mon.	10 a.m.	Every	Monday	and	Thursday	except	Public H	olidays					
CAMBERWELL	Wed.	10 a.m.	Every	Wednesday	and	Thursday	except	Public H	olidays					
CAMPERDOWN	Thur.	10 a.m.	10	7	6	3	1, 29	26	24	21	18	16	13	11
CARLTON	Tues.	10 a.m.	Every	Tuesday	and	Thursday	except	Public H	olidays					
CASTLEMAINE	Fri.	10 a.m.	25	22	21	8	23	20	1, 29	26	24	21	19	
CHARLTON	Thur.	10 a.m.	3, 17, 31	14, 28	10, 24	8, 22	5, 19	3, 17, 31	14, 28	11, 25	9, 23	6, 20	4, 18	
CHELSEA	Thur.	10 a.m.	17	14	13	10	8	5	3, 31	28	25	23	20	
CHELTENHAM	Mon.	10 a.m.	Every	Monday	except	Public H	olidays							
CLUNES	Tues.	10 a.m.	Every	Tuesday	and	Thursday	and	Friday	except	Public H	olidays			
COBRAM	Wed.	10 a.m.	11	8	7	3	2, 30	27	25	22	19	17	14	12
COBURG	Fri.	10 a.m.	16, 30	13, 27	12, 26	9, 23	7, 21	4, 18	2, 16, 30	13, 27	10, 24	8, 22	5, 19	3, 17, 31
COHUNA	Thur.	10 a.m.	Every	Thursday	except	Public H	olidays							
COLAC	Tues.	10 a.m.	15, 29	12, 26	11, 25	22	16, 20	3, 17	1, 15, 29	12, 26	9, 23	7, 21	4, 18	2, 16, 30
COLLINGWOOD	Fri.	10 a.m.	11, 18, 25	8, 15, 22	17, 21	11, 18	2, 9, 16, 30	6, 27	4, 11, 25	1, 8, 22, 29	5, 19, 26	3, 17, 24, 31	14, 21, 28	12, 19
CORRYONG	Tues.	10 a.m.	Every	Tuesday	except	Public H	olidays							
COWES	Thur.	10 a.m.	24	21	20	17	15	12	10	7	4	2, 30	27	24
CRANBOURNE	Wed.	10 a.m.	9, 23	6, 20	5, 19	2, 16, 30	14, 28	11, 25	9, 23	6, 20	3, 17	1, 15, 29	12, 26	10, 24
DANDENONG	Mon.	10 a.m.	Every	Monday	except	Public H	olidays							
DAYLESFORD	Thur.	10 a.m.	3, 17, 31	7, 21	6, 20	13, 17	1, 15, 29	5, 19	3, 17, 31	7, 21	4, 18	2, 16, 30	6, 20	4, 18
DIMBOOLA	Fri.	10 a.m.	Every	Friday	except	Public H	olidays							
DONALD	Fri.	10 a.m.	4, 18	1, 15, 29	28	11	9, 23	6, 20	4, 18	1, 15, 29	12, 26	10, 24	7, 21	5, 19
DROMANA	Fri.	10 a.m.	18	15	14	11	9, 23	6, 20	4, 18	1, 15, 29	12, 26	10, 24	7, 21	5, 19
DUNOLLY	Tues.	10 a.m.	29	25	25	20	15	11	8	5	3, 31	28	25	21
ECHUCA	Mon.	10 a.m.	25	22	21	18	16	11	8	5	3, 31	28	25	21
EDENHOPE	Tues.	10 a.m.	Every	Tuesday	except	Public H	olidays							
ELMORE	Fri.	10 a.m.	11	8	7	3	2, 30	27	25	22	19	17	14	12
ELSTERNWICK	Fri.	10 a.m.	25	22	21	18	16	11	8	5	3, 31	28	25	21
ELTHAM	Tues.	10 a.m.	Every	Tuesday	and	Thursday	except	Public H	olidays					
EUROA	Thur.	10 a.m.	10, 24	7, 21	6, 20	3, 17	1, 15, 29	12, 26	10, 24	7, 21	4, 18	2, 16, 30	13, 27	11
FERN TREE GULLY	Mon.	10 a.m.	Every	Monday	except	Public H	olidays							
FITZROY	Wed.	10 a.m.	Every	Wednesday	and	Friday	except	Public H	olidays					
FOOTSCRAY	Fri.	10 a.m.	11, 25	8, 22, 29	28	11	9, 23, 30	27	11, 25	8, 22, 29	12, 26	10, 24, 31	14, 28	12
FÖSTER	Fri.	10 a.m.	16	13	12	9	7	4	2, 30	27	24	22	19	17
FRANKSTON	Mon.	10 a.m.	Every	Monday	except	Public H	olidays							
	Wed.	10 a.m.	9, 23, 30	13, 27	12, 26	9, 23, 30	14, 28	11, 25	9, 23, 30	13, 27	10, 24	8, 22, 29	12, 26	10, 24, 31

Courts, Days and Hours for the Hearing of Special Complaints During 1980—continued

Court	Day	Hour	January	February	March	April	May	June	July	August	September	October	November	December	
GEELONG	Tues.	10 a.m.	Every	Tuesday	Wednesday	Thursday	Friday	except	Public	Holidays					
	Wed.	10 a.m.													
	Thur.	10 a.m.													
HAMILTON	Thur.	10 a.m.	Every	Thursday	except	Public	Holidays								
	HASTINGS	Wed.													10 a.m.
	HEALESVILLE	Wed.													2, 16, 30
HEATHCOTE	Wed.	10 a.m.	Every	Monday	and	Friday	except	Public	Holidays						
	HEIDELBERG	Fri.													10 a.m.
	HOPETOUN	Mon.													10 a.m.
HORSHAM	Tues.	10 a.m.	Every	Tuesday	Wednesday	Thursday	Friday	except	Public	Holidays					
	INGLEWOOD	Tues.													10 a.m.
	JEPARIT	Thur.													10 a.m.
KANIVA	Tues.	10 a.m.	Every	Tuesday	Wednesday	Thursday	Friday	except	Public	Holidays					
	KERANG	Fri.													10 a.m.
	KILMORE	Thur.													10 a.m.
KORUMBURRA	Tues.	10 a.m.	Every	Tuesday	Wednesday	Thursday	Friday	except	Public	Holidays					
	KYABRAM	Thur.													10 a.m.
	KYNETON	Thur.													10 a.m.
LAKES ENTRANCE	Wed.	10 a.m.	Every	Tuesday	Wednesday	Thursday	Friday	except	Public	Holidays					
	LANG LANG	Wed.													10 a.m.
	LEONGATHA	Wed.													10 a.m.
LILYDALE	Thur.	10 a.m.	Every	Tuesday	Wednesday	Thursday	Friday	except	Public	Holidays					
	LISMORE	Tues.													10 a.m.
	LORNE	Tues.													10 a.m.
MAFFRA	Thur.	10 a.m.	Every	Tuesday	Wednesday	Thursday	Friday	except	Public	Holidays					
	MANSFIELD	Thur.													10 a.m.
	MARYBOROUGH	Thur.													10 a.m.
MELBOURNE	Mon.	10 a.m.	Every	Monday	Tuesday	Wednesday	Thursday	Friday	except	Public	Holidays				
	MELTON	Tues.													10 a.m.
	MILDURA	Mon.													10 a.m.
MIRBOO NORTH	Tues.	10 a.m.	Every	Tuesday	Wednesday	Thursday	Friday	except	Public	Holidays					
	MITTA MITTA	Tues.													10 a.m.
	MOE	Wed.													10 a.m.
MOONEE PONDS	Mon.	10 a.m.	Every	Monday	Tuesday	Wednesday	Thursday	Friday	except	Public	Holidays				
	MORDIALLOC	Wed.													10 a.m.
	MORNINGTON	Fri.													10 a.m.
MORTLAKE	Thur.	10 a.m.	Every	Tuesday	Wednesday	Thursday	Friday	except	Public	Holidays					
	MORWELL	Tues.													10 a.m.
	MYRTLEFORD	Wed.													10 a.m.
NATHALIA	Thur.	10 a.m.	Every	Tuesday	Wednesday	Thursday	Friday	except	Public	Holidays					
	NHILL	Thur.													10 a.m.
	NUMURKAH	Fri.													10 a.m.
OAKLEIGH	Tues.	10 a.m.	Every	Tuesday	Wednesday	Thursday	Friday	except	Public	Holidays					
	OMEO	Fri.													10 a.m.
	ORBOST	Wed.													10.30 a.m.
OUYEN	Thur.	10 a.m.	Every	Tuesday	Wednesday	Thursday	Friday	except	Public	Holidays					
	PAKENHAM	Thur.													10 a.m.
	PORT FAIRY	Fri.													10 a.m.
PORTLAND	Wed.	10 a.m.	Every	Tuesday	Wednesday	Thursday	Friday	except	Public	Holidays					
	PRAHRAN	Mon.													10 a.m.
	PRESTON	Tues.													10 a.m.
PYRAMID HILL	Thur.	10 a.m.	Every	Tuesday	Wednesday	Thursday	Friday	except	Public	Holidays					
	QUEENSLIFF	Tues.													10 a.m.
	RAINBOW	Fri.													10 a.m.
RED CLIFFS	Thur.	10 a.m.	Every	Tuesday	Wednesday	Thursday	Friday	except	Public	Holidays					
	RINGWOOD	Tues.													10 a.m.
	ROBINVALE	Thur.													10 a.m.
ROCHESTER	Wed.	10 a.m.	Every	Tuesday	Wednesday	Thursday	Friday	except	Public	Holidays					
	RUSHWORTH	Wed.													10 a.m.
	RUTHERGLEN	Thur.													10 a.m.
ST. ARNAUD	Thur.	10 a.m.	Every	Tuesday	Wednesday	Thursday	Friday	except	Public	Holidays					
	SALE	Tues.													10 a.m.
	SEA LAKE	Thur.													10 a.m.
SEYMOUR	Mon.	10 a.m.	Every	Monday	Tuesday	Wednesday	Thursday	Friday	except	Public	Holidays				
	SHEPPARTON	Wed.													10 a.m.
	SORRENTO	Fri.													10 a.m.
SOUTH MELBOURNE	Thur.	10 a.m.	Every	Tuesday	Wednesday	Thursday	Friday	except	Public	Holidays					
	SPRINGVALE	Wed.													10 a.m.
	STAWELL	Fri.													10 a.m.
SUNBURY	Tues.	10 a.m.	Every	Tuesday	Wednesday	Thursday	Friday	except	Public	Holidays					
	SUNSHINE	Fri.													10 a.m.
	SWAN HILL	Wed.													10 a.m.
TALLANGATTA	Wed.	10 a.m.	Every	Tuesday	Wednesday	Thursday	Friday	except	Public	Holidays					
	TATURA	Wed.													10 a.m.
	TERANG	Fri.													10 a.m.
TRARALGON	Mon.	10 a.m.	Every	Monday	Tuesday	Wednesday	Thursday	Friday	except	Public	Holidays				

Courts, Days and Hours for the Hearing of Special Complaints During 1980—continued

Court	Day	Hour	January	February	March	April	May	June	July	August	September	October	November	December
WALWA	Wed.	11 a.m.		20	21	16		11		6		1	26	
WANGARATTA	Fri.	10 a.m.	25	22	18	16		27	25	22	19	17	14	12
WARBURTON	Wed.	10 a.m.	9, 23	13, 27	12, 26	9, 23	14, 28	11, 25	9, 23	13, 27	10, 24	8, 22	12, 26	10, 24
WARRACKNABEAL	Thur.	10 a.m.	17	14	13	10	8	5	3, 31	28	25	23	20	18
WARRAGUL	Fri.	10 a.m.	Every	Monday	except Public	Friday except Public	Monday and Tuesday except Public	Friday except Public	Monday and Tuesday except Public	Friday except Public	Monday and Tuesday except Public	Friday except Public	Monday and Tuesday except Public	Friday except Public
WARRNAMBOOL	Mon.	10 a.m.	Every	Monday	except Public	Friday except Public	Monday and Tuesday except Public	Friday except Public	Monday and Tuesday except Public	Friday except Public	Monday and Tuesday except Public	Friday except Public	Monday and Tuesday except Public	Friday except Public
WERRIBEE	Tues.	10 a.m.	Every	Monday	except Public	Friday except Public	Monday and Tuesday except Public	Friday except Public	Monday and Tuesday except Public	Friday except Public	Monday and Tuesday except Public	Friday except Public	Monday and Tuesday except Public	Friday except Public
WHITTLESEA	Mon.	10 a.m.	Every	Monday	except Public	Friday except Public	Monday and Tuesday except Public	Friday except Public	Monday and Tuesday except Public	Friday except Public	Monday and Tuesday except Public	Friday except Public	Monday and Tuesday except Public	Friday except Public
WILLIAMSTOWN	Wed.	10 a.m.	9, 23	13, 27	12, 26	9, 23	14, 28	11, 25	9, 23	13, 27	10, 24	8, 22	12, 26	10, 24
WINCHELSEA	Thur.	10 a.m.	25	22	21	18	16			8	5	3, 31		
WODONGA	Tues.	10 a.m.	Every	Tuesday	except Public	Friday except Public	Monday and Tuesday except Public	Friday except Public	Monday and Tuesday except Public	Friday except Public	Monday and Tuesday except Public	Friday except Public	Monday and Tuesday except Public	Friday except Public
WONTHAGGI	Thur.	10 a.m.	31	13	27	22	7	4	17	7	11	22	6	17
WYCHEPROOF	Wed.	10 a.m.	16	13	12	9	22	2	30	2	24	11	19	4
YARRAM	Tues.	10 a.m.	8, 22	5, 19	4, 18	1, 15, 29	13, 27	10, 24	8, 22	5, 19	2, 16, 30	14, 28	11, 25	9, 23
YARRAWONGA	Thur.	10 a.m.	3, 31	28	27	24	22	19	17	14	11	9	6	4
YEA	Fri.	10 a.m.	4	1, 29	28	23	20	18	15	12	10	7	5	5
	Fri.	10 a.m.	11	8	7	2, 30	27	25	22	19	17	14	12	12
	Fri.	10 a.m.	11	8	7	2, 30	27	25	22	19	17	14	12	12

DEPARTMENT OF MINERALS AND ENERGY.  
Subject to any necessary excisions, etc., it is proposed to grant the following Mining Lease:—  
No. 629; Allan Clement Preston, George Broadbear, Eric James Pitt; 32.3 ha, Parish of Tullyvea.

APPLICATION FOR MINING LEASE DECLARED ABANDONED  
No. 532; Donald Anthony Plecas; 239 ha, Parish of Redcastle.

TERM OF EXPLORATION LICENCE EXTENDED  
No. 625; Castlemaine Engineering and Mining Co. Pty. Ltd.; 198 km<sup>2</sup>, County of Talbot.

APPLICATIONS FOR SEARCH LICENCES REFUSED  
No. 1379; Lionel Michael Gross; 40 ha, Parish of Dorchapel.  
No. 1381; Lionel Michael Gross; 40 ha, Parish of Gungarlan.  
No. 1382; Richard Charles Fawcett; 40 ha, Parish of Gowar.  
No. 1449; Arthur Edgar Martin, Collin James Martin; 20 ha, Parish of Kurting.  
No. 1547; Anthony Gross; 40 ha, Parish of Enoch's Point.  
No. 1549; Anthony Gross; 40 ha, Parish of Enoch's Point.  
No. 1550; Anthony Gross; 40 ha, Parish of Enoch's Point.

APPLICATION FOR TAILINGS LICENCE REFUSED  
No. 4178; Arthur Frederick Campbell; to treat tailings, Parish of Fryers.

TAILINGS LICENCES GRANTED  
No. 4363; Shire of Marong; to remove tailings from the "Moon and Catherine Sand Dump" situated at Eaglehawk.  
No. 4364; Shire of Marong; to remove tailings from "Lightning Hill Main Shaft Mullock Dump" situated at Eaglehawk.  
No. 4365; Shire of Marong; to remove tailings from the "Prince of Wales Mullock Heap" situated at Bendigo.  
No. 4378; Roger Wilfréd James; to remove tailings from the "Moon and Catherine Sand Dump" situated at Eaglehawk.  
No. 4379; McKenzie Roland Elvey; to remove tailings from the "Moon and Catherine Sand Dump" situated at Eaglehawk.

No. 4402; P. J. Clarke, G. P. Clarke; to remove tailings from the "Catherine Reef South Shaft" situated at Eaglehawk.

No. 4417; Shire of Bet Bet; to remove tailings from the "Yorkshire Mine Workings" situated in the Parish of Tarnagulla.

No. 4431; Maurice Edward Williams, Dorothy Jean Williams; to remove tailings from the "Pearl Mine Dump" situated in the Parish of Dunolly.

APPLICATIONS FOR EXTRACTIVE INDUSTRY LICENCES DECLARED ABANDONED  
No. 1075; Bryan Edward John Sparrow; 2.8 ha, Parish of Ardonachie.  
No. 1076; Ian John McNaughton, Roger Norman McInnes, Marjorie Helen McInnes; 260 ha, Parish of Glencoe.

EXTRACTIVE INDUSTRY LICENCE GRANTED  
No. 804-1; Pioneer Concrete (Vic.) Pty. Ltd.; 2.3 ha, Parish of Mordialloc.  
J. C. M. BALFOUR,  
Minister for Minerals and Energy

CORRIGENDUM  
In Victoria Government Gazette, No. 102, dated 12 December 1979, page 3893, under the heading "Pipelines Act 1967, No. 7541, Application for a permit to own and use a pipeline" the date appearing in paragraph 4 should read Friday, 18 January 1980.

Labour and Industry Act 1958  
CERTIFICATE OF EXEMPTION UNDER SECTION 104 (5)  
In pursuance of the powers conferred on me by section 104 of the Labour and Industry Act 1958, I hereby issue to—  
Austral Bakeries Pty. Ltd.  
this certificate exempting it and any person carting or delivering bread on its behalf from the operation of subsection (4) of the aforesaid section 104, subject to the following condition that this certificate shall apply only to the carting and delivery of bread from Bendigo to Daylesford and Malmsbury.  
Dated at Melbourne, 7 November 1979,  
J. H. RAMSAY  
Minister of Labour and Industry.

## PUBLIC SERVICE ACT 1974

The following is a list of Public Holidays (Whole and Half Days) proclaimed for the year 1979 in municipalities NOT included in the Fifth Schedule to the *Public Service Act 1974*.

<i>Municipality</i>	<i>Day and Date</i>	<i>Whole Day or Half-holiday</i>
Arapiles, Shire of	Tuesday, 28 August	Half-holiday
Ararat, City of	Friday, 30 November	Half-holiday
Ballan, Shire of	Monday, 19 March	Half-holiday
Ballaarat, City of	Wednesday, 21 November	Whole Day
Ballaarat, Shire of	Wednesday, 21 November	Whole Day
Benalla, City of	Monday, 8 October	Half-holiday
Bendigo, City of	Tuesday, 6 November	Whole Day
Bendigo, City of	Wednesday, 14 November	Half-holiday
Birchip, Shire of	Monday, 15 October	Half-holiday
Bungaree, Shire of	Wednesday, 21 November	Whole Day
Camperdown, Town of	Monday, 19 March	Half-holiday
Colac, City of	Wednesday, 31 January	Half-holiday
Colac, Shire of	Wednesday, 31 January	Half-holiday
Cranbourne, Shire of	Wednesday, 10 October	Half-holiday
Dimboola, Shire of— (North Riding)	Tuesday, 16 October	Half-holiday
(Centre Riding)	Wednesday, 17 October	Half-holiday
Donald, Shire of— (Townships of Donald, Corack and Litchfield)	Tuesday, 6 November	Whole Day
Dundas, Shire of	Wednesday, 4 April	Half-holiday
Dundas, Shire of	Tuesday, 13 November	Half-holiday
Dunmunkle, Shire of— (West Riding)	Friday, 20 July	Half-holiday
(West Riding)	Friday, 5 October	Half-holiday
(North Riding)	Tuesday, 9 October	Half-holiday
(East Riding)	Wednesday, 10 October	Half-holiday
Eaglehawk, Borough of	Tuesday, 6 November	Whole Day
Eaglehawk, Borough of	Wednesday, 14 November	Half-holiday
Echuca, City of	Friday, 19 October	Half-holiday
Geelong, City of	Wednesday, 24 October	Half-holiday
Hamilton, City of	Wednesday, 4 April	Half-holiday
Healesville, Shire of	Wednesday, 26 September	Whole Day
Horsham, City of	Thursday, 4 October	Half-holiday
Huntly, Shire of (West and South Ridings)	Wednesday, 10 October	Whole Day
	Wednesday, 14 November	Half-holiday
Karkarook, Shire of	Tuesday, 23 October	Whole Day
Kerang, Borough of	Tuesday, 9 October	Half-holiday
Kerang, Shire of	Tuesday, 9 October	Half-holiday
Kilmore, Shire of	Wednesday, 19 September	Half-holiday
Kilmore, Shire of (Wallan Riding)	Monday, 29 October	Half-holiday
Koroit, Borough of	Monday, 24 September	Whole Day
Korong, Shire of— (Township of Wedderburn)	Thursday, 3 May	Half-holiday
Kyneton, Shire of	Tuesday, 6 November	Half-holiday
	Wednesday, 7 November	Whole Day
Lowan, Shire of	Thursday, 18 October	Whole Day
McIvor, Shire of	Tuesday, 6 November	Whole Day
Marong, Shire of	Wednesday, 14 November	Half-holiday
Maryborough, City of	Tuesday, 10 July	Half-holiday
Mirboo, Shire of	Saturday, 3 February	Whole Day
Myrtleford, Shire of	Saturday, 27 October	Whole Day
Nathalia, Shire of	Saturday, 6 October	Whole Day
Newham and Woodend, Shire of	Thursday, 22 March	Whole Day
Newham and Woodend, Shire of	Monday, 24 September	Whole Day
Numurkah, Shire of	Wednesday, 24 October	Half-holiday
Phillip Island, Shire of— Pyalong, Shire of	Monday, 24 September	Whole Day
	Friday, 21 September	Whole Day
Queenscliffe, Borough of	Tuesday, 6 November	Whole Day
Sale, City of	Thursday, 15 March	Half-holiday
Sale, City of	Thursday, 1 March	Half-holiday
Seymour, Shire of	Wednesday, 12 September	Half-holiday
Shepparton, City of	Friday, 12 October	Whole Day
Shepparton, Shire of	Friday, 12 October	Whole Day
South Gippsland, Shire of	Saturday, 24 February	Whole Day
Strathfieldsaye, Shire of	Wednesday, 14 November	Half-holiday
Tullaroop, Shire of	Tuesday, 10 July	Half-holiday

## PUBLIC SERVICE ACT 1974—continued

Municipality	Day and Date	Whole Day or Half-holiday
Walpeup, Shire of— (East from township of Linga)	Tuesday, 6 November	Whole Day
Walpeup, Shire of— (West from township of Linga)	Wednesday, 10 October	Whole Day
Wannon, Shire of	Friday, 25 May	Half-holiday
Waranga, Shire of— (Western Riding)	Wednesday, 10 October	Half-holiday
(Township of Corop)	Wednesday, 10 October	Half-holiday
Warracknabeal, Shire of	Friday, 16 March	Half-holiday
Warracknabeal, Shire of	Thursday, 11 October	Whole Day
Warrambool, City of	Thursday, 3 May	Half-holiday
Wimmera, Shire of— (North Riding)	Thursday, 4 October	Half-holiday
Thursday, 11 October	Thursday, 11 October	Half-holiday
Wycheproof, Shire of— (North and Tyrell Ridings including township of Culgoa)	Wednesday, 17 October	Half-holiday
(South and Central Ridings excluding township of Culgoa)	Wednesday, 24 October	Half-holiday
Yea, Shire of	Tuesday, 11 December	Half-holiday

In addition, Monday 24 September was appointed as a Public Holiday in the Shires of Bacchus Marsh, Gisborne and Romsey in lieu of Melbourne Showday.

13 December 1979

K. D. GREEN

Secretary, Department of the Premier

## PUBLIC TRUSTEE ACT 1958, SECTION 17

I hereby give notice that on 30 November 1979, the Public Trustee filed elections to administer the following deceased person's estate in accordance with section 17 of the Public Trustee Act 1958.

MOODY, WALTER ALFRED, late of Flat 2, 42 Cecil Street, Fitzroy, pensioner, found deceased on 14 July 1979.

I hereby give notice that on 10 December 1979, the Public Trustee filed elections to administer the following deceased persons' estates in accordance with section 17 of the Public Trustee Act 1958.

CURTAIN, ROY MAURICE, late of St. Ronan's Private Nursing Home, 51 Adelaide Street, Armadale, retired proof reader, died 13 August 1979.

WILSON-MORRIS, DONALD STEWART, late of 43 Mary Street, Hawthorn, pensioner, died 2 August 1979.

WILSON, GEORGE LESLIE, late of 117 Kananook Avenue, Seaford, retired, died 16 June 1979.

I hereby give notice that on 12 December 1979, the Public Trustee filed elections to administer the following deceased persons' estates in accordance with section 17 of the Public Trustee Act 1958.

BATTYE, PERCIVAL THOMAS, formerly of 26 Rotherwood Street, Richmond, but late of 2 Maidstone Street, Ringwood, retired railway employee, died 8 August 1979.

CHICK, DOROTHY ANN, formerly of 199 Clausen Street, North Fitzroy, but late of 32 Kangerong Road, Box Hill, widow, died 12 May 1979.

FAIRALL, VICKI MAREE, late of Flat 4, 76 Orrong Road, Elsternwick, pensioner, died 26 September 1979.

LEWIS, HARRIET, formerly of Flat 16, 3 Browning Walk, South Yarra, but late of Harcourt Rest Home, 300 High Street, Windsor, widow, died 26 September 1979.

RAINEY, EILEEN MARGARET, in the Will called Eileen Rainey, late of Lincoln Parade, Aspendale, widow, died 14 December 1979.

SHARP, CHARLES HERBERT, late of Ballarat, retired hotel employee, died 27 September 1979.

P. T. SPENCER  
Public Trustee

168 Exhibition Street, Melbourne, 3000  
18 December 1979

Creditors, next of kin and others having claims against the estate of any of the under-mentioned deceased persons are required to send particulars of their claims to the Public Trustee, 168 Exhibition Street, Melbourne, Vic. 3000, the personal representative, on or before 5 March 1980 after which date the Public Trustee may convey or distribute the assets having regard only to the claims of which the Public Trustee then has notice.

BARANAUSKAS, ANTANAS ALBINAS, late of Flat 4, 16 Law Street, Newborough, pensioner; died 28 June 1979.

BATTYE, PERCIVAL THOMAS, formerly of 26 Rotherwood Street, Richmond, but late of 2 Maidstone Street, Ringwood, retired railway employee, died 8 August 1979.

BURNS, MAY ELLEN, also known as Burns, Eleanor May, formerly of 74 Fitzroy Street, Fitzroy, but late of Eagle-mont Private Nursing Home, 25 Thoresby Grove, Ivanhoe, widow, died 17 August 1979.

CHICK, DOROTHY ANN, formerly of 199 Clausen Street, North Fitzroy, but late of 32 Kangerong Road, Box Hill, widow, died 12 May 1979.

CURTAIN, ROY MAURICE, late of St. Ronan's Private Nursing Home, 51 Adelaide Street, Armadale, retired proof reader, died 13 August 1979.

FAIRALL, VICKI MAREE, late of Flat 4, 76 Orrong Road, Elsternwick, pensioner, died 26 September 1979.

LEWIS, HARRIET, formerly of Flat 16, 3 Browning Walk, South Yarra, but late of Harcourt Rest Home, 300 High Street, Windsor, widow, died 26 September 1979.

MOODY, WALTER ALFRED, late of Flat 2, 42 Cecil Street, Fitzroy, pensioner, found deceased on 14 July 1979.

WILSON-MORRIS, DONALD STEWART, late of 43 Mary Street, Hawthorn, pensioner, died 2 August 1979.

RAINEY, EILEEN MARGARET, in the Will called Eileen Rainey, late of 43 Lincoln Parade, Aspendale, widow, died 14 December 1979.

SHARP, CHARLES HERBERT, late of Ballarat, retired hotel employee, died 27 September 1979.

WILSON, GEORGE LESLIE, late of 117 Kananook Avenue, Seaford, retired, died 16 June 1979.

Melbourne, 17 December 1979

P. T. SPENCER  
Public Trustee

## PUBLIC TRUSTEE ACT 1958, SECTION 17

I hereby give notice that on 30 November 1979, the Public Trustee filed Elections to Administer the following deceased persons' estates in accordance with section 17 of the Public Trustee Act 1958.

BLACK, JOSEPH FRANCIS JOHN, late of 108 Athol Street, Moonee Ponds, retired railway employee, died 16 October 1979.

COATES, WINIFRED FANNY, also known as Winifred Coates, formerly of 57 Hawksburn Road, South Yarra, but late of Flat 11, 134 Jasper Road, Bentleigh, spinster, died 15 August 1979.

ELVY, LESLIE REGINALD, late of Queen Elizabeth Geriatric Centre, Ballarat, pensioner, died 19 July 1979.

HORVATH, PAUL, also known as Pal Horvath, late of Corpus Christi, lot 21 Mickleham Road, Greenvale, retired, died 6 July 1979.

KIELY, CECILIA, late of 73 Beavers Road, Northcote, home duties, died 9 May 1949.

MASON, EDITH IRENE, formerly of 130 Lebanon Street, Strathmore, but late of 38 Strelton Avenue, Strathmore, widow, died 30 July 1979.

MITCHELSON, FLORENCE ELIZABETH, formerly of 90 Reid Crescent, Wonthaggi, but late of Wonthaggi and District Hospital, Wonthaggi, widow, died 4 September 1978.

NOLAN, GEORGE ANTHONY, formerly of 26 Canterbury Road, Albert Park, but late of 21 Greig Street, Albert Park, retired motor tester, died 30 August 1979.

OLIPHANT, WILLIAM, late of 1 Dalveen Road, West Ivanhoe, retired painter, died 18 October 1979.

ROU, ERIC, also known as Eric Brown, late of 33 Hotham Street, Seddon, retired supervisor, died 28 August 1977.

SHERLOCK, WILLIAM HENRY, late of Flat 201, 351 Barkly Street, Brunswick, pensioner, died 11 September 1979.

WALKER, DULCIE, formerly of Willaura, but late of Carnsworth Garoopna Nursing Home, 18 Barry Street, Kew, pensioner, died 30 August 1979.

I hereby give notice that on 10 December 1979, the Public Trustee filed Elections to Administer the following deceased persons' estates in accordance with section 17 of the Public Trustee Act 1958.

BARTLETT, GEORGE HERBERT, late of Ararat, wood cutter, died 25 September 1979.

BROWN, JOHN JOSEPH, late of 20 Sutherland Avenue, Shepparton, retired labourer, died 13 June 1979.

CLEARY, REBECCA MINNIE, formerly of 25 Pitt Street, Fawkner, but late of 50 Ballard Avenue, North Coburg, widow, died 30 September 1979.

SMYTH, OLIVE MARY, formerly of 8, 49 Churchill Avenue, Ascot Vale, but late of 8, 31 St. Georges Road, Elsternwick, widow, died 22 September 1979.

WALKER, MABEL VERONICA, formerly of Parker Street, Dunkeld, but late of Ballarat, widow, died 1 August 1979.

WITEK, WALTER, late of After Care Hospital, 45 Victoria Parade, Collingwood, retired seaman, died 12 October 1979.

P. T. SPENCER  
Public Trustee

168 Exhibition Street, Melbourne, 3000  
12 December 1979

Creditors, next of kin, and others having claims against the estate of any of the under-mentioned deceased persons are required to send particulars of their claims to the Public Trustee, 168 Exhibition Street, Melbourne, Vic. 3000, the personal representative, on or before 28 February 1980, after which date the Public Trustee may convey or distribute the assets having regard only to the claims of which the Public Trustee then has notice.

BARTLETT, GEORGE HERBERT, late of Ararat, wood cutter, died 25 September 1979.

BLACK, JOSEPH FRANCIS JOHN, late of 108 Athol Street, Moonee Ponds, retired railway employee, died 16 October 1979.

BROWN, JOHN JOSEPH, late of 20 Sutherland Avenue, Shepparton, retired labourer, died 13 June 1979.

CHIVELL, VIOLET MAY (formerly Violet May Singleton), late of 7 Bourke Street, Footscray, married woman, died 26 September 1979.

CLEARY, REBECCA MINNIE, formerly of 25 Pitt Street, Fawkner, but late of 50 Ballard Avenue, North Coburg, widow, died 30 September 1979.

COATES, WINIFRED FANNY, also known as Winifred Coates, formerly of 57 Hawksburn Road, South Yarra, but late of Flat 11, 134 Jasper Road, Bentleigh, spinster, died 15 August 1979.

ELVY, LESLIE REGINALD, late of Queen Elizabeth Geriatric Centre, Ballarat, pensioner, died 19 July 1979.

HANCOCK, LESLIE JAMES, formerly of 7 Welwyn Avenue, Brighton, but late of Bundoora, retired labourer, died 25 August 1979.

HORVATH, PAUL, also known as Pal Horvath, late of Corpus Christi, lot 21, Mickleham Road, Greenvale, retired, died 6 July 1979.

JOHNSON, JANET AMELIA, formerly of 12 Avondale Street, Hampton, but late of Ashleigh Lodge Private Hospital, 58 Cochrane Street, North Brighton, widow, died 9 June 1979.

KHAN, ISMAIL, late of Punjab, Pakistan, occupation not known, died 1 June 1952.

KIELY, CECILIA, late of 73 Beavers Road, Northcote, home duties, died 9 May 1949.

MCCOOK, JOHN ARCHIBALD, late of Auckland, New Zealand, retired gardener, died 1 May 1979.

MCCRACKEN, DAVID, late of 14 Southey Street, Blackburn, public servant, died 4 September 1979.

MALLEY, HAROLD EDWARD, late of 12 Portland Street, Coburg, retired railway employee, died 13 August 1979.

MASON, EDITH IRENE, formerly of 130 Lebanon Street, Strathmore, but late of 38 Strelton Avenue, Strathmore, widow, died 30 July 1979.

MASON, JOHN SHARP, late of 19 Waiora Parade, West Footscray, retired boiler attendant, died 9 October 1979.

MILLARD, HORACE YEOMAN, also known as Horace Millard, late of Traralgon, retired plant operator, died 17 June 1979.

MITCHELSON, FLORENCE ELIZABETH, formerly of 90 Reid Crescent, Wonthaggi, but late of Wonthaggi and District Hospital, Wonthaggi, widow, died 4 September 1978.

NOLAN, GEORGE ANTHONY, formerly of 26 Canterbury Road, Albert Park, but late of 21 Greig Street, Albert Park, retired motor tester, died 30 August 1979.

OLIPHANT, WILLIAM, late of 1 Dalveen Road, West Ivanhoe, retired painter, died 18 October 1979.

OLIVER, GEORGE, also known as George Arthur Oliver, late of Sunbury, gentleman, died 23 March 1979.

RIAL, CECIL WILLIAM, late of 2A Rix Street, Glen Iris, retired bank officer, died 10 September 1979.

ROU, ERIC, also known as Eric Brown, late of 33 Hotham Street, Seddon, retired supervisor, died 28 August 1977.

SEWELL, MARY JANE, late of "Cremorne", 54 Lydia Street, Brunswick, widow, died 18 October 1979.

SHERLOCK, WILLIAM HENRY, late of Flat 201, 351 Barkly Street, Brunswick, pensioner, died 11 September 1979.

SMYTH, OLIVE MARY, formerly of 8, 49 Churchill Avenue, Ascot Vale, but late of 8, 31 St. Georges Road, Elsternwick, widow, died 22 September 1979.

STEWART, DONALD LAIDLAW, formerly of 71 Glen Iris Road, Glen Iris, but late of Kinross Private Hospital, 9-11 Broughton Road, Surrey Hills, gentleman, died 9 July 1979.

TAYLOR, HENRY LAWRENCE, late of 1 Beaumont Street, Vermont, retired, died 6 September 1979.

TOOHEY, DANIEL WILLIAM, late of 356 Station Street, North Carlton, retired railway employee, died 10 September 1979.

WALKER, DULCIE, formerly of Willaura, but late of Carnsworth Garoopna Nursing Home, 18 Barry Street, Kew, pensioner, died 30 August 1979.

WALKER, MABEL VERONICA, formerly of Parker Street, Dunkeld, but late of Ballarat, widow, died 1 August 1979.

WALLER, ERNEST ALFRED, late of 307 William Street, Huron, Ohio, U.S.A., signmaker, died 5 April 1976.

WITEK, WALTER, late of After Care Hospital, 45 Victoria Parade, Collingwood, retired seaman, died 12 October 1979.

Melbourne, 12 December 1979

P. T. SPENCER  
Public Trustee

**Country Fire Authority Act 1958**  
**FIRE DANGER PERIOD IN RESPECT OF SPECIFIED PARTS OF THE COUNTRY AREA OF VICTORIA**

Whereas by section 4 of the *Country Fire Authority Act 1958* it is enacted that the Minister for Police and Emergency Services of Victoria after consultation with the Minister of Forests, may from time to time by declaration published in the *Government Gazette* declare any period to be the fire danger period in respect of the country area of Victoria, or any specified part or parts thereof and, without affecting the generality of the foregoing, may declare different periods to be the fire danger period in respect of different parts of the said country area:

And whereas the Minister for Police and Emergency Services and the Minister of Forests have consulted accordingly:

Now therefore, I, the Minister for Police and Emergency Services of Victoria, do hereby declare the period commencing at midnight on 23 December 1979 and ending at midnight on 30 April 1980 to be the fire danger period in respect of the parts of the country area of Victoria situated within the municipal districts or parts of municipal districts, specified in the Schedule hereunder:—

**SCHEDULE**

- City of Keilor (those portions not included in the Metropolitan Fire District).
- City of Hamilton.
- City of Berwick.
- City of Moe.
- City of Chelsea.
- City of Dandenong.
- City of Springvale (those portions not included in the Metropolitan Fire District).
- City of Frankston (those portions not included in the 8th Fire Control Region).
- City of Knox (those portions not included in the 13th Fire Control Region).
- Town of Portland.
- Shire of Glenelg.
- Shire of Portland.
- Shire of Wannon.
- Shire of Dundas.
- Part Shire of Mortlake (those portions north of the Hamilton Highway excluding the Township of Mortlake).
- Shire of Mount Rouse.
- Shire of Pakenham.
- Shire of Cranbourne.
- Shire of Buln Buln.
- Shire of Korumburra.
- Shire of Mirboo.
- Shire of Narracan.
- Part Shire of South Gippsland (those portions south of the Fish Creek-Walkerville Road, Fish Creek-Waratah Road, Foster-Waratah Road, Promontory Road and Pattersons Road).
- Shire of Warragul.
- Shire of Woorayl.
- Shire of Gisborne.
- Shire of Kowree.
- Shire of Werribee (those portions not included in the Metropolitan Fire District).
- Shire of Bulla (those portions not included in the Metropolitan Fire District).
- Shire of Newham and Woodend.
- Shire of Romsey.
- Shire of Melton.
- Part Shire of Mornington (those portions not included in the 8th Fire Control Region):

L. H. S. THOMPSON  
 Minister for Police and Emergency Services  
 Ministry for Police and Emergency Services  
 Melbourne, 18 December 1979

**Country Fire Authority Act 1958**  
**FIRE DANGER PERIOD IN RESPECT OF SPECIFIED PARTS OF THE COUNTRY AREA OF VICTORIA**

Whereas by section 4 of the *Country Fire Authority Act 1958* it is enacted that the Minister for Police and Emergency Services of Victoria after consultation with

the Minister of Forests, may from time to time by declaration published in the *Government Gazette* declare any period to be the fire danger period in respect of the country area of Victoria, or any specified part or parts thereof and, without affecting the generality of the foregoing, may declare different periods to be the fire danger period in respect of different parts of the said country area:

And whereas the Minister for Police and Emergency Services and the Minister of Forests have consulted accordingly:

Now therefore, I, the Minister for Police and Emergency Services of Victoria, do hereby declare the period commencing at midnight on 21 December 1979, and ending at midnight on 30 April 1980 to be the fire danger period in respect of the parts of the country area of Victoria situated within the municipal districts or parts of municipal districts, specified in the Schedule hereunder:—

**SCHEDULE**

- City of Ballarat.
- City of Geelong.
- City of Geelong West.
- City of Newtown.
- City of Colac.
- City of South Barwon.
- City of Croydon (those portions not included in the Metropolitan Fire District).
- City of Doncaster and Templestowe (those portions not included in the Metropolitan Fire District).
- City of Knox (those portions not included in the 26th Fire Control Region).
- City of Maryborough.
- City of Wangaratta.
- Town of Camperdown.
- Borough of Sebastopol.
- Borough of Queenscliffe.
- Borough of Wonthaggi.
- Shire of Grenville.
- Shire of Ballarat.
- Shire of Bungaree.
- Shire of Buninyong.
- Shire of Barrabool.
- Shire of Bellarine.
- Shire of Corio.
- Shire of Colac.
- Shire of Hampden.
- Shire of Heytesbury.
- Shire of Otway.
- Shire of Bannockburn.
- Part Shire of Arapiles (those portions south of the Rifle Butts Road and the Clear Lake-Duffholm Road).
- Shire of Leigh.
- Shire of Winchelsea.
- Shire of Bass.
- Shire of Flinders.
- Shire of Phillip Island.
- Shire of Alexandra.
- Shire of Broadford.
- Shire of McIvor.
- Shire of Pyalong.
- Shire of Kilmore.
- Shire of Healesville.
- Shire of Sherbrooke.
- Shire of Upper Yarra.
- Shire of Eltham (those portions not included in the Metropolitan Fire District).
- Shire of Lillydale (those portions not included in the Metropolitan Fire District).
- Shire of Ballan.
- Shire of Creswick.
- Shire of Daylesford and Glenlyon.
- Shire of Kyneton.
- Shire of Newstead.
- Shire of Talbot and Clunes.
- Shire of Tullaroop.
- Shire of Rippon.
- Shire of Oxley.
- Shire of Rutherglen.
- Shire of Wangaratta.
- French Island.

L. H. S. THOMPSON  
 Minister for Police and Emergency Services  
 Ministry for Police and Emergency Services  
 Melbourne, 18 December 1979

## Country Fire Authority Act 1958

## FIRE DANGER PERIOD IN RESPECT OF SPECIFIED PARTS OF THE COUNTRY AREA OF VICTORIA

Whereas by section 4 of the *Country Fire Authority Act 1958* it is enacted that the Minister for Police and Emergency Services of Victoria after consultation with the Minister of Forests, may from time to time by declaration published in the *Government Gazette* declare any period to be the fire danger period in respect of the country area of Victoria, or any specified part or parts thereof and, without affecting the generality of the foregoing, may declare different periods to be the fire danger period in respect of different parts of the said country area:

And whereas the Minister for Police and Emergency Services and the Minister of Forests have consulted accordingly:

Now therefore, I, the Minister for Police and Emergency Services of Victoria, do hereby declare the period commencing at midnight on 30 December 1979 and ending at midnight on 30 April 1980 to be the fire danger period in respect of the parts of the country area of Victoria situated within the municipal districts or parts of municipal districts, specified in the Schedule hereunder:—

## SCHEDULE

Part City of Frankston (those portions not included in the 26th Fire Control Region).

Shire of Hastings.

Part Shire of Mornington (those portions not included in the 26th Fire Control Region).

L. H. S. THOMPSON

Minister for Police and Emergency Services

Ministry for Police and Emergency Services  
Melbourne, 18 December 1979

## Country Fire Authority Act 1958

## FIRE DANGER PERIOD IN RESPECT OF SPECIFIED PARTS OF THE COUNTRY AREA OF VICTORIA

Whereas by section 4 of the *Country Fire Authority Act 1958* it is enacted that the Minister for Police and Emergency Services of Victoria after consultation with the Minister of Forests, may from time to time by declaration published in the *Government Gazette* declare any period to be the fire danger period in respect of the country area of Victoria, or any specified part or parts thereof and, without affecting the generality of the foregoing, may declare different periods to be the fire danger period in respect of different parts of the said country area:

And whereas the Minister for Police and Emergency Services and the Minister of Forests have consulted accordingly:

Now therefore, I, the Minister for Police and Emergency Services of Victoria, do hereby declare the period commencing at midnight on 6 January 1980 and ending at midnight on 30 April 1980 to be the fire danger period in respect of the parts of the country area of Victoria situated within the municipal districts or parts of municipal districts, specified in the Schedule hereunder:—

## SCHEDULE

Part Shire of South Gippsland (those portions north of the Fish Creek-Walkerville Road, Fish Creek-Waratah Road, Foster-Waratah Road, Promontory Road and Pattersons Road).

L. H. S. THOMPSON

Minister for Police and Emergency Services

Ministry for Police and Emergency Services  
Melbourne, 18 December 1979

## Country Fire Authority Act 1958

## FIRE DANGER PERIOD IN RESPECT OF SPECIFIED PARTS OF THE COUNTRY AREA OF VICTORIA

Whereas by section 4 of the *Country Fire Authority Act 1958* it is enacted that the Minister for Police and Emergency Services of Victoria after consultation with the Minister of Forests, may from time to time by declaration published in the *Government Gazette* declare any period to be the fire danger period in respect of the country area of Victoria, or any specified part or parts thereof and, without affecting the generality of the foregoing, may declare different periods to be the fire danger period in respect of different parts of the said country area:

And whereas the Minister for Police and Emergency Services and the Minister of Forests have consulted accordingly:

Now therefore, I, the Minister for Police and Emergency Services of Victoria, do hereby declare the period commencing at midnight on 4 January 1980 and ending at midnight on 30 April 1980 to be the fire danger period in respect of the parts of the country area of Victoria situated within the municipal districts or parts of municipal districts, specified in the Schedule hereunder:—

## SCHEDULE

City of Warrnambool.

Borough of Koroit.

Borough of Port Fairy.

Shire of Belfast.

Shire of Warrnambool.

Part Shire of Mortlake (those portions south of the Hamilton Highway and including the Township of Mortlake).

Shire of Minhamite.

L. H. S. THOMPSON

Minister for Police and Emergency Services

Ministry for Police and Emergency Services  
Melbourne, 18 December 1979

## Police Offences Act 1958, No. 6337

## DIVISION 1A—STATE CLASSIFICATION OF PUBLICATIONS BOARD

Take note that the State Classification of Publications Board has classified the following publications in accordance with the provisions of section 180H (1) of the *Police Offences Act 1958*.

Each publication shall be subject to the following restrictions:

- it shall not be offered for sale, sold, delivered, exhibited or displayed to any person under the age of 18 years;
- it shall not be made available for inspection or perusal to any person under the age of 18 years;
- it shall not be exhibited or displayed in any place to which persons under the age of 18 years have access or so that it is visible from any such place;
- it shall not be advertised in any manner whatsoever.

## SCHEDULE OF PUBLICATIONS

Title	Distributor
Advisor—April 1977	
An Afternoon With Karen	Western Colour Print
Beautiful Man	
Begging For It!	Melbourne Wholesale News-agency Pty. Ltd.
Best Of Men Only No. 5	Venus Enterprises Pty. Ltd.
Black Velvet	
Bloody Virgin	Western Colour Print
Cie' Lavie' No. 1	Wathen Wholesale Pty. Ltd.
Close Family	Melbourne Wholesale News-agency Pty. Ltd.
Color Climax No. 102	Western Colour Print
Color Climax Playing Cards	Claredale Holdings Pty. Ltd.
Dream No. 1	Western Colour Print



Title	Distributor
Explosion No. 6	Claredale Holdings Pty. Ltd.
Flying Hooker, The Vol. 4 No. 4	Venus Enterprises Pty. Ltd.
French Fluffs Vol. 4 No. 4	Venus Enterprises Pty. Ltd.
Him Book, The	Venus Enterprises Pty. Ltd.
Homosexual Sexuality Vol. 1	Venus Enterprises Pty. Ltd.
Hot And Horny Jockstraps	Western Colour Print
Human Digest—January 1980	Gordon & Gotch (A'sia) Ltd.
John Holmes' Massage! No. 1	Claredale Holdings Pty. Ltd.
Lancer No. 2—Hazard & Co.	Wathen Wholesale Pty. Ltd.
Lesbian Love No. 4	Claredale Holdings Pty. Ltd.
Letting Hubby Watch	Melbourne Wholesale Newsagency Pty. Ltd.
Live Joke Book No. 11	Western Colour Print
Love Baby	Melbourne Wholesale Newsagency Pty. Ltd.
Lovin' Mom	Melbourne Wholesale Newsagency Pty. Ltd.
Male Erotica	
Mankind No. 2	
Men Only Vol. 43 No. 8	Venus Enterprises Pty. Ltd.
Men Only Vol. 45 No. 1	Gordon & Gotch (A'sia) Ltd.
Mistress Of Fellatio	Venus Enterprises Pty. Ltd.
New Cunts No. 17	Wathen Wholesale Pty. Ltd.
Overtime Orgy	Western Colour Print
Pillow Talk—November 1979	Gordon & Gotch (A'sia) Ltd.
Popular Cartoons—January 1980	Gordon & Gotch (A'sia) Ltd.
Popular Jokes—February 1980	Gordon & Gotch (A'sia) Ltd.
Pornoboy Nos. 20 and 22	Claredale Holdings Pty. Ltd.
Private Pleasures	Western Colour Print
Pussy Pugs Vol. 1 No. 1	Venus Enterprises Pty. Ltd.
Quartet No. 1	Wathen Wholesale Pty. Ltd.
Real Love Secrets—January, 1980	Gordon & Gotch (A'sia) Ltd.
Rodox—Special Magazine Nos. 1 and 2	Claredale Holdings Pty. Ltd.
Rounder Vol. 1 No. 3	Venus Enterprises Pty. Ltd.
Satyr June—July 1979 Vol. 1 No. 1	Venus Enterprises Pty. Ltd.
Scott Vol. 4 No. 3	Western Colour Print
Selecta No. 18	Claredale Holdings Pty. Ltd.
Sex Blast! Cartoons 1	Gordon & Gotch (A'sia) Ltd.
Sexciting Cartoons	Gordon & Gotch (A'sia) Ltd.
Sexology—December 1979	Gordon & Gotch (A'sia) Ltd.
Sexperiment Cartoons	Gordon & Gotch (A'sia) Ltd.
Sex Prescription	Western Colour Print
Sexual Capers	Western Colour Print
Sexultimate Cartoons	Gordon & Gotch (A'sia) Ltd.
Sexy Boobs	
Sexy Girls Nos. 27, 28 and 29	Claredale Holdings Pty. Ltd.
Sir Bizzarr No. 20	Claredale Holdings Pty. Ltd.
Swedish Orgasm	Western Colour Print
Swedish Seduction	Western Colour Print
Target Calendar—1980	Wathen Wholesale Pty. Ltd.
Teenage Nudist No. 21	
Tramp No. 3	
Triples No. 2	Western Colour Print
Voyeur Nos. 3, 4 and 6	
Wet And Wild Bizzare Tastes	Western Colour Print
What A Drag	Venus Enterprises Pty. Ltd.

J. SMITH, Secretary  
 State Classification of Publications Board  
 No. 104—15420/79—3

MOTOR CAR ACT, 1958, SECTION 19 (1d)

Notice is hereby given that, for the purpose of Section 19 (1d) of the Motor Car Act 1958, approval has been granted to the association listed below to organise and conduct official rallies for classic and historic motor cars:—

VAUXHALL OWNERS CLUB OF AUSTRALIA.

S. I. MILLER  
 Chief Commissioner

AUCTION SALES ACT 1958

EXTENSION OF TIME FOR PAYMENT OF FEES FOR AUCTIONEER'S LICENCES

His Excellency the Governor of the State of Victoria by and with the advice of the Executive Council thereof has by Order made on 11 December 1979, pursuant to the provisions of section 16 of the Auction Sales Act 1958, extended the time for making the payment of fees for Auctioneer's Licences granted at the General Meeting of Justices held on the fourth Tuesday in November 1979 for the licensing of Auctioneers to and inclusive of Tuesday 8 January 1980.

TOM FORRISTAL  
 Clerk of the Executive Council

At the Executive Council Chamber  
 Melbourne, 11 December 1979

CONTRACTS ACCEPTED—(Series 1979-80)

AMENDMENTS

Schedule Number	Item Number	Old Rate	New Rate	Effective Date
			\$ \$	
<i>Protective Clothing, Uniforms and Safety Equipment</i>				
1/14	33	9.50*†	10.20*†	29.11.79
	38	9.50*†	10.20*†	
* Less 2½%, 30 days.				
† \$3 surcharge orders below \$50.				
<i>Crockery, Cutlery and Kitchenware</i>				
1/29	38	1.20	1.30	15.11.79
	39	1.34	1.53	
	40	0.33	0.34	
<i>Provisions—Melbourne and Metropolitan</i>				
2/01	105	20.82	26.40	1.1.80
	151	4.48	4.60	
<i>Groceries—Melbourne and Metropolitan</i>				
2/02	1	5.86	3.06*	1.1.80
	11	10.20	10.28†	
	108	5.19	4.10†	5.12.79
	134	20.82	26.40	1.1.80
	146	11.30	11.99	
	169	8.15	8.48	
	205	2.98	3.17§	
	233	9.40	9.91	
* 125 g., rate per ½ doz.				
† Rate per 10.				
‡ 375 g., rate per ½ doz.				
§ 300 ml., rate per ½ doz.				
280 g., rate per doz.				
<i>Provisions—Creswick School of Forestry</i>				
2/12 (2)	1	0.72*	3.848†	5.12.79
	2	0.37	3.971	
* per 2 litre.				
† per litre.				
<i>Provisions—Geelong District</i>				
2/13 (2)	1	3.307	3.614	1.11.79
	2	3.637	3.971	

P. J. MAHNEY, Acting Secretary to the Tender Board

**CONTRACTS ACCEPTED—(Series 1979-80)****PUBLIC WORKS**

His Excellency the Governor of the State of Victoria by and with the advice of the Executive Council thereof has by Orders made on 11 December 1979, approved of the acceptance by the Minister of Public Works of the under-mentioned offers without public tenders being invited, viz.:

Offer of Duncan & Russell (Vic.) Pty. Ltd. for dredging of Mordialloc Creek for the sum of eighteen thousand seven hundred and fifty dollars (\$18 750.00)—(P.H.13403n).

Offer of R. D. Cooke Pty. Ltd. for hydraulic services (Relocatable Complex), Wheeler's Hill High School for the sum of thirty-three thousand three hundred and ninety dollars (\$33 390.00)—(N.204198H).

Offer of Strathtex Constructions Pty. Ltd. for site works (Relocatable Complex), Wheeler's Hill High School for the sum of seventy-five thousand one hundred and eighty dollars (\$75 180.00)—(N.204918c).

Offer of Tulmel Plumbing and Drainage Pty. Ltd. for hydraulic services (Relocatable Complex), Wantirna High School for the sum of thirty-four thousand seven hundred and fifty-eight dollars (\$34 758.00)—(N.204920H).

Offer of Hewlett-Packard Australia Pty. Ltd. for supply of small boat survey system, Ports and Harbors Division, Queenscliff, for the sum of thirteen thousand nine hundred and seventy dollars (\$13 970.00)—(P.&H.99604).

Offer of Telecom Australia for provision of four (4) Customphones, Public Works Department (Regions), for the sum of seventeen thousand six hundred and two dollars ninety-seven cents (\$17 602.97)—(C.22904).

Offer of Crabtree-Middows for installation of Solna Web Offset Press, Government Printing Office, North Melbourne for the sum of fifty-three thousand three hundred and seventy dollars, (\$53 370.00)—(C.190357x).

Offer of A.C.P. Roofing for removal of slate and battens and re-roofing with concrete shingle tiles, Ararat Primary School No. 800 for the sum of twenty thousand one hundred and seventy-eight dollars (\$20 178.00)—(C.G./W.72734).

**TOM FORRISTAL**

Clerk of the Executive Council

At the Executive Council Chamber  
Melbourne, 11 December 1979

**CONTRACTS ACCEPTED—(Series 1979-80)****SOIL CONSERVATION AUTHORITY**

CONTRACT No. 48001

Aerial Topdressing—Puckapunyal, Super Spread Aviation Australia, Cartage \$8.80/tonne, Aerial Application \$14.50/tonne.

**P. G. FERN**  
Acting Secretary

**Co-operative Housing Societies Act 1958****NOTICE OF AMALGAMATION OF SOCIETIES**

Notice is hereby given that, pursuant to the provisions of the Co-operative Housing Societies Act 1958, Hospital Employees (No. 1) Co-operative Housing Society Limited and Hospital Employees (No. 3) Co-operative Housing Society Limited were amalgamated into one society under the name of Hospital Employees (No. 4) Co-operative Housing Society Limited on 1 December 1979.

Dated at Melbourne 1 December 1979

**J. W. JUNGWIRTH**  
Registrar

**Co-operation Act 1958****CHANGE OF NAME OF A SOCIETY**

Notice is hereby given that Australian Telecom Employees' Recreational and Development Co-operative Limited which was incorporated as a Community Settlement Society under the abovenamed Act on 27 July 1979, has registered a change of its name and is now incorporated under the name of Telstar Co-operative Limited under the said Act.

Dated at Melbourne 10 December 1979

**J. W. BLACKMAN**  
Acting Deputy Registrar

**Melbourne and Metropolitan Board of Works Act 1958****MELBOURNE AND METROPOLITAN BOARD OF WORKS****NOTICE DECLARING CERTAIN SEWERAGE WORKS AT WEST MELBOURNE TO VEST IN THE BOARD**

In pursuance of the powers conferred by section 135A of the Melbourne and Metropolitan Board of Works Act 1958, Melbourne and Metropolitan Board of Works doth by this Notice declare that the certain sewerage works described in the Schedule hereunder shall vest in the Board and such sewerage works shall thereupon be vested in the Board for all the purposes of the said Act.

**SCHEDULE**

Sewerage pumping station No. 1 in the south-west corner of Crown allotment 14 (section 1a) and pumping station No. 2 on the eastern boundary of Crown allotment 14 (section 1A) together with the sewerage rising main commencing at pumping station No. 1 and travelling westwards to and within the eastern boundary of Crown allotment 17 (section 1A); thence northward along and within the eastern boundaries of Crown allotments 17 (section 1A), 16 (section 1A) and 14 (section 1A); thence generally westwards along and within the northern boundaries of Crown allotments 14 (section 1A), 13A (section 1A), 11 (section 1A) and 8b (section 1A) to and across Sims Street; thence northwards along the western boundary of Sims Street and eastwards across Sims Street to the Board's existing Sims Street Branch Sewer approximately 180 metres north of the northern boundary of Crown allotment 8b (section 1A) together with a rising main travelling from its junction with the above described rising main in the northwest corner of Crown allotment 11 (section 1A) southward along and within the western boundaries of Crown allotments 11 (section 1A) and 10A (section 1A) to a point ten metres south of the northern boundary of Crown allotment 10A (section 1A).

Dated 17 December 1979

**O. T. W. COSGRIFF, Secretary**

**Urban Renewal Act 1970****SHIRE OF BULN BULN (NEERIM SOUTH)****URBAN RENEWAL PROPOSAL****Housing Commission, Victoria**

The objects of the proposal are:—

- to solve problems associated with earlier forms of subdivision;
- improve road conditions and drainage;
- to utilize vacant land; and
- to provide renovation loans.

A copy of the proposal may be inspected during office hours in the Shire Offices, 33 Young Street, Drouin, at the office of the Town and Country Planning Board, 235 Queen Street, Melbourne, and at the office of the Neighbourhood Redevelopment Division, Ministry of Housing, 10th Floor, 250 Elizabeth Street, Melbourne.

All persons affected by the renewal proposal, who object to any matter contained in the proposal or who wish to make any submission with respect to the proposal, must set forth in writing to the Neighbourhood Redevelopment Division, Ministry of Housing, G.P.O. Box 1670N, Melbourne, 3001, by 19 March 1980, all objections which they may have or submissions which they may wish to make in respect to the proposal and state whether they wish to be heard in respect of their objections and submissions.

**N. GREEN, Manager**  
Administration

Cemeteries Act 1958

SCALE OF FEES OF THE NECROPOLIS SPRINGVALE

(Incorporating The Necropolis Springvale, St. Kilda General Cemetery and Melbourne General Cemetery.)

In pursuance of the powers conferred upon them by the Cemeteries Act 1958 the Trustees of The Necropolis Springvale, hereby make the following Scale of Fees which shall come into operation on and from 1 January 1980 and on and from such date, any Scale of Fees previously made by the Trustees shall be and is hereby rescinded to the extent to which it conflicts with the said following scale:

ALL FEES MUST BE PAID IN FULL BEFORE A LOCATION CAN BE ALLOCATED OR PLAQUE ORDERED:

1. Cremation fees:
- (i) Weekdays—Adult 180.00
  - (ii) Weekdays—Child under 5 years of age 110.00
  - (iii) Weekdays—Australian Ex-Service (with Overseas Service) 175.00
  - (iv) Weekdays—Pensioner\* (Invalid or Old Age or Widow) 245.00
- \*Provided that Proof of Entitlement is produced at the time of the Funeral.
- (v) Saturday Mornings or Public Holidays 245.00

2. Cremation Deed 180.00

3. Establishment of New Memorials—Cremation Memorial Gardens.

NOTE—(i) As all gardens are established, some types of memorial may not be available.

(ii) All fees include the cost of maintaining the memorial for the full period of tenure, which is 25 years from the date of purchase.

(iii) Memorials reserved for future use are subject to the tenure period of 25 years from date of purchase, on or after 1 January 1976.

(iv) A flower container cannot be installed later without re-ordering a complete new plaque, with the exception of a container for a wall niche.

- (A) Family Memorials, providing for additional plaques to be installed within the period of tenure.

	Appropriate Plaque Size	No. of Positions	\$
1. Memorial Tree:			
Individual Location	Large	Six	600.00
2. Memorial Shrub:			
Individual Location	Large	Four	450.00
Shrub in Garden Bed	Large	Two	360.00
Shrub in Garden Bed	Small	Four	360.00
3. Memorial Rose:			
Individual Location	Large	Four	600.00
Rose in Garden Bed	Large	Two	450.00
Rose in Garden Bed	Small	Four	450.00
(B) Memorials providing for one plaque per location.			
NOTE—Adjacent positions may be reserved.			
4. Memorial Rose Garden Position	Large	One	200.00
5. Memorial Shrub Garden Position	Large	One	150.00
6. Memorial Wall Niche			
General Area	Small	One	40.00
Special Location	Small	One	75.00
7. Memorial Columbarium Niches:			
(plus cost of urn and inscription). Urns: Vase, Scroll, Cenotaph.			
8. Special Family Memorials:			
Types on application—			
Fee Range: \$750.00 up to \$6000.00 (plus cost of selected plaque).			
Actual charge to be determined by Trustees within the prescribed range.			

	Appropriate Plaque Size	No. of Positions	\$
9. Fee for Placement of an Additional Plaque at a Memorial Location Established up to 31 December 1966 (includes plaque as appropriate to the Memorial Type and Area)			75.00

(C) Cremation Memorials Available in the Jewish Memorial Garden—Springvale:

Tenure period for memorials, established or reserved, is 25 years.

1. Memorial Tree	Large	Six	600.00
2. Memorial Shrub	Large	Four	450.00
3. Memorial Rose in Garden Bed	Large	Two	450.00
4. Memorial Shrub in Garden Bed	Large	Two	360.00
5. Memorial Shrub Garden Position	Large	One	150.00
6. Memorial Rose Garden Position	Large	One	200.00
7. Memorial Wall Niche	Small	One	75.00

(D) Cremation Memorials Available in the F. D. Michaelis Memorial Garden—St. Kilda Cemetery.

1. Memorial Tree	Large	Six	600.00
2. Memorial Shrub	Large	Four	450.00
3. Memorial Rose Garden Position	Small	One	200.00
4. Memorial Wall Niche	Small	One	75.00

(E) Flower Containers—Cremation Memorial Gardens.

(a) Wall Niche	16.00
(b) Small Rectangular (95 mm x 45 mm)	16.00
(c) Large Rectangular (170 mm x 50 mm)	20.00
(d) Vase for Columbarium Niches	10.00

(F) Plaques—Cremation Memorial Gardens.

(a) Small Bronze (4 lines of inscription 140 mm x 100 mm)	35.00
(b) Small Bronze (with inbuilt rectangular 95 mm x 45 mm Flower Container)	50.00
(c) Large Bronze (10 lines of inscription 280 mm x 230 mm)	85.00
(d) Large Bronze (with inbuilt rectangular 95 mm x 45 mm flower container)	85.00
(e) Large Bronze (with round flower container)	85.00
(f) Variation to an inscription or reconditioning of plaque.	
Removal and relocation charge of \$50.00 plus actual quoted cost from Engraving Company.	

(G) Photograph of a plaque or memorial Polaroid print 8 cm x 8 cm each

(H) Administration Fees:

(a) Collection of cremated remains from Office (48 hours notice required)	25.00
(b) Postage of cremated remains within Australia	35.00
(c) Postage of cremated remains overseas by Seamail	35.00
(d) Postage of cremated remains overseas by Airmail	45.00

<p>(I) <b>Transfer/Cancellation Fees:</b></p> <p>(a) Transfer—Relocation of a plaque within The Necropolis, plus charge for past maintenance (see below) 25.00</p> <p>(b) Cancellation charge if cancelling an allocated or reserved memorial location cremation deed, certificate of Right of Burial and/or 25.00</p> <p>(c) Maintenance fee.</p> <p>Refunds due in respect of cancelled memorials or reserved locations are subject to a fee for maintenance based on elapsed years of tenure.</p> <p style="text-align: center;"><b>SCALE OF FEES—CEMETERY</b></p> <p><b>1. Fee for Right of Burial—</b></p> <p>(a) Lawn, area—Non-denominational bronze plaque memorials only—</p> <p>(i) Springvale 2.44 m x 1.22 m (two interments) 260.00</p> <p>(ii) St. Kilda 2.44 m x 1.22 m (when available) (two interments) 260.00</p> <p>(b) Denominational area—</p> <p>(i) Approved monumental work or bronze plaque 2.44 m x 1.22 m (Two interments) 260.00</p> <p>(ii) St. Kilda General Cemetery 2.44 m x 1.22 m (when available) 260.00</p> <p>(iii) Melbourne General Cemetery 2.44 m x 1.22 m (when available) 260.00</p> <p>(c) Monumental Lawn area—</p> <p>Approved monumental work or bronze plaque—</p> <p>Type (A) 3.66 m x 3.66 m (six interments) 1080.00</p> <p>Type (B) 2.44 m x 3.66 m (four interments) 720.00</p> <p>Type (C) 1.22 m x 3.66 m (two interments) 360.00</p> <p>(d) Jewish Denominational areas—</p> <p>(i) Right of Burial within the Memorial Garden Section 2.44 m x 1.22 m—</p> <p>(a) Lawn area with headstone in rose garden setting 725.00</p> <p>(b) Lawn area with headstone 575.00</p> <p>(c) Lawn area with standard bronze plaque 395.00</p> <p>(ii) General Area—Outside the Memorial Section 2.44 m x 1.22 m—Monumental Work permitted 300.00</p> <p><b>2. Internment Fee—</b></p> <p>(a) (i) Weekdays 225.00</p> <p>(ii) Child under 5 years (including still-born) 165.00</p> <p>(iii) Saturday mornings or Public Holidays 270.00</p> <p>(b) Internment Fee Public Area—</p> <p>Child under 5 years of age, including still-born 40.00</p> <p>All others 115.00</p> <p><b>3. Exhumation Fee—</b></p> <p>A minimum period of two years after burial must elapse 370.00</p> <p><b>4. Vaults—Pre Cast Concrete Vaults—supply and installation only 650.00</b></p> <p><b>Cemetery Plaques—</b></p> <p>(i) Special dual decorative design to commemorate one or two persons with the same surname. Includes first attachment and inbuilt flower container (560 mm x 280 mm) 175.00</p>	<p>\$</p> <p>\$</p> <p>35.00</p> <p>125.00</p> <p>105.00</p> <p>105.00</p> <p><b>Internment of Cremated Remains—</b></p> <p>Written authority from the holder of the Right of Burial required 50.00</p> <p>Issue of Duplicate Certificate of Right of Burial 8.00</p> <p><b>Monumental Permit Fee—</b></p> <p>Administration Fee for each Right of Burial to issue permit—</p> <p>(a) For an additional inscription on headstone 25.00</p> <p>(b) Additional or renovation of a monument including additional inscription 50.00</p> <p>(c) New or additional monumental work 75.00</p> <p><b>Jewish Memorial Headstone Inscriptions—</b></p> <p>Lettering (per letter) 1.05</p> <p>Star of David of Menorah 9.00</p> <p><b>Other Services—</b></p> <p>Scatter at Sea 50.00</p> <p>Use of Chapel—Memorial Service only 50.00</p> <p>The common seal of the Trustees of The Necropolis, Springvale was hereto affixed on the authority of a resolution of Trustees on 30 October 1979 and in the presence of:</p> <p>(SEAL) R. T. M. PRESCOTT, Trustee</p> <p>A. C. DOWNARD, Trustee</p> <p>M. A. R. SYNNOT, Trustee</p> <p>I. L. MOUNTFORD, General Manager</p> <p>Approved by the Governor in Council, 4 December 1979</p> <p>—TOM FORRISTAL, Clerk of the Executive Council</p> <hr/> <p style="text-align: center;"><b>Cemeteries Act 1958</b></p> <p style="text-align: center;"><b>SCALE OF FEES OF THE PORTLAND PUBLIC CEMETERY</b></p> <p>In pursuance of the powers conferred upon them by the Cemeteries Act, the trustees of the Portland Public Cemetery hereby make the following scale of fees, which shall come into operation upon publication in the <i>Government Gazette</i>, and from and after such publication every scale of fees heretofore made by the said trustees shall be and is hereby rescinded to the extent to which it conflicts with this scale.</p> <p style="text-align: center;"><b>Private Graves</b></p> <p style="text-align: right;">\$</p> <p>Land, 2.44 m x 1.22 m 100.00</p> <p>Land, 2.44 m x 2.44 m 200.00</p> <p>Sinking grave to 1.83 m 72.00</p> <p>Sinking grave to 2.13 m 82.00</p> <p>Reopening grave 65.00</p> <p>Burials on Saturdays or Public Holidays (extra) 30.00</p> <p>Burials without due notice (extra) 30.00</p> <p>Internment of child under twelve years 30.00</p> <p style="text-align: right;">L. P. HUNT, Trustee</p> <p style="text-align: right;">L. J. KEMPTON, Trustee</p> <p style="text-align: right;">J. W. PITTS, Trustee</p> <p>Approved by the Governor in Council, 11 December 1979</p> <p>—TOM FORRISTAL, Clerk of the Executive Council</p>
--	--

## Cemeteries Act 1958

## MT. DUNEED PUBLIC CEMETERY

In pursuance of the powers conferred upon them by the Cemeteries Act 1958, the trustees of the Mt. Duneed Public Cemetery hereby make the following rules and regulations, which shall come into operation upon publication in the *Government Gazette*, and from and after such publication every Rule and Regulation previously made by the said trustees shall be and is hereby rescinded to the extent to which it conflicts with these Rules and Regulations.

1. All fees and charges shall be paid to the trustees when orders are given or before the ground or vault is opened.

2. Orders for interment are to be given either to the secretary or the trust's representative at least ten working hours prior to the time appointed for the funeral.

3. Any person desiring a brick grave or vault shall make or cause to be made an application for authorisation of such work to be carried out, and will be required to construct them under the direction of the trustees; and in case interment is to be made in any private grave or vault the consent in writing of the party entitled thereto must be left with the order.

4. Any person desiring to erect any memorial or other erection within the cemetery or to kerb land in respect of which he is the holder of an exclusive right of burial shall make or cause to be made an application for authorisation of such work to be carried out.

5. No such work referred to in Clauses 3 and 4 hereof shall be performed until and unless written approval has been given by the trustees and all fees and charges paid.

6. Any person desiring to reopen a grave or a vault for the purpose of an interment shall, not less than ten working hours prior to the time fixed for each interment, remove or cause to be removed the head and foot stones, kerbing slabs, and/or monuments necessary to permit such interment, and shall immediately after the interment duly and properly replace these, or cause them to be replaced in the conditions in all respects (subject to the approval of the trustees) in which the same were prior to removal.

7. The time fixed for the funeral shall be the time when the procession is to be at the cemetery, and the same must be punctually observed. Unless otherwise ordered and authorised the usual hours fixed for the performance of funerals will be from 9.30 a.m. to 3.30 p.m. Monday to Friday.

8. A person shall not—

- (a) affix any poster (bill), or stencil mark to any tree, seat, gate, post, fence, wall, pillar, railing, kerbing or memorial erection in the cemetery or its approaches;
- (b) cut, break, remove or deface any of the statuary, trees, shrubs, plants, seats, gates, posts, fences, or erections in the cemetery;
- (c) write upon any of the statuary, trees, shrubs, plants, seats, gates, posts, fences, or erection in the cemetery;
- (d) cut, pluck, gather, take or injure any of the plants, flowers, or fruit in the cemetery;
- (e) interfere with or injure any of the grass plots, trees, shrubs, flowers, vases, labels, birds, animals, or other property in the cemetery;
- (f) do any injury or damage to any road or pathway in the cemetery;
- (g) remove or interfere in any way with or injure any article whatsoever attached to the land or built or placed on or in any grave or burying place or land in the cemetery;
- (h) climb any of the trees or shrubs in the cemetery or climb or jump over any of the seats or fences therein or stand or lie on any of the seats therein;
- (i) behave in an improper or offensive manner, or use bad language, or commit any act of indecency within the cemetery;

- (j) drive or cause to be driven any motor vehicle within the cemetery at a speed in excess of 10 kilometres per hour;
- (k) except an employee directed so to do by the trustees, ride or drive any animal or vehicle except on the defined main road of the cemetery.
- (l) carry on within the cemetery any trade, business or calling, or promote or advertise the same by any means whatsoever;
- (m) in the employ of the trustees within the cemetery shall interfere in or suggest the engagement of any monumental mason or sculptor, stone cutters, or others, to erect or repair monuments or to do any other work in the cemetery;
- (n) distribute any handbill, card, circular, or advertisement in the cemetery;
- (o) disturb any funeral service at any grave;
- (p) cause or permit or suffer any animal to trespass or stray or be at large within the cemetery;
- (q) do any work near a grave where a burial service is being performed;
- (r) carry firearms, pea rifles, or other offensive weapons within the cemetery.

9. The cemetery will be open to the public daily from sunrise to sunset.

10. The secretary, or other proper officer duly appointed by the trustees as referred to in these Rules and Regulations, means the person for the time being employed by the trustees as the secretary or other officer in charge of the cemetery and such person shall, subject to the trustees, exercise a general supervision and control over all matters pertaining to the cemetery, and to the carrying out and enforcement of these Rules and Regulations, and subject to the provisions of the Cemeteries Act, the direction of such person shall in all such matters, and for all purposes, be presumed to be and to have been at the direction of the trustees.

## SCHEDULE 1

Date of Order

No.

CERTIFICATE OF RIGHT OF BURIAL IN  
MT. DUNEED PUBLIC CEMETERY

On the application of

(hereinafter referred to as the "Applicant") and upon payment of the sum of \$ \_\_\_\_\_ having been made, the Trustees of the Mt. Duneed Public Cemetery in terms of, and as authorized by the Act of Parliament of Victoria, Cemeteries Act 6217 of 1958, have agreed to grant, and do hereby grant, unto the said Applicant permission to dig or make a grave on the piece of ground \_\_\_\_\_ long \_\_\_\_\_ broad lying within the portion of the said Cemetery appropriated for burials and marked \_\_\_\_\_ Allotment No. \_\_\_\_\_ on the map or plan of the said Cemetery, kept by the said Trustees.

And it is hereby declared that the said Applicant shall be entitled to have the grave reserved by the Trust according to the terms of this permission, for the sole and separate use of the said applicant or her/his (or their) legal representatives for a period of twenty-five years, or if a burial should take place within that time, forever, provided, and it is hereby declared that this grant is made subject to the terms and conditions following viz.:

Firstly, that the said piece of ground shall be kept and used by the said Applicant or her/his representative solely as a burying place and that no other use shall be made thereof;

Secondly, that no enclosing wall, fence, building, monument, or tombstone shall be erected or placed on the said piece of ground other than such as allowed by the Trustees from time to time;

Thirdly, that the said Applicant, or her/his legal representative shall, in the use of the said piece of ground and access thereto be subject to such Rules, Regulations and By-Laws as the Trustees of the said Cemetery may from time to time make and shall not be entitled

to exercise the right to bury or inter therein except on payment of such charges as shall from time to time be established by the said Trustees; and

Fourthly, the Trustees shall not be entitled to maintain any headstone or memorial erected over the grave.

Given under the hands of the said Trustees, this  
19

Signed in the presence of

Trustees, of Mt. Duneed Public Cemetery

Secretary

A copy of the Rules and Regulations of the Mt. Duneed Cemetery may be inspected free of charge at the Office of the Secretary.

W. A. LUGG, Trustee  
R. W. PETTIT, Trustee  
H. J. KENT-HUGHES, Trustee  
H. W. HAIR, Secretary

Approved by the Governor in Council, 11 December 1979—TOM FORRISTAL, Clerk of the Executive Council

Cemeteries Act 1958

SCALE OF FEES OF THE TERANG PUBLIC CEMETERY

In pursuance of the powers conferred upon them by the Cemeteries Act, the trustees of the Terang Public Cemetery hereby make the following scale of fees, which shall come into operation upon publication in the *Government Gazette*, and from and after such publication every scale of fees heretofore made by the said trustees shall be and is hereby rescinded to the extent to which it conflicts with this scale.

Lawn Section (Undenominational)

	\$
Lawn grave 2.44 m x 1.2 m	180.00
For each interment therein	100.00
Bronze plaque for each interment	160.00
Headstone and flower container	40.00
Memorial wall niche and plaque	85.00
Ashes interred in rose garden (including plaque)	80.00
Exhuming the remains of a body (when authorized)	150.00
Interment outside prescribed hours or on Saturdays, Sundays or Public Holidays (extra)	40.00

Private Graves

Land 2.44 m x 1.22 m	100.00
Sinking grave, 1.83 m deep	100.00
Sinking oversize grave	140.00
Reopen grave (no cover)	80.00
Reopen grave (with cover or kerb)	95.00

Public Graves

Interment in grave without exclusive right—still-born child	50.00
Interment in grave without exclusive right—others	100.00
Permission to erect a headstone or monument—single grave	20.00
double grave	35.00

B. MILROY, Trustee  
A. G. LOCK, Trustee  
T. GREEN, Trustee

Approved by the Governor in Council, 11 December 1979—TOM FORRISTAL, Clerk of the Executive Council

Water Act 1958

STATE RIVERS AND WATER SUPPLY COMMISSION  
CULGOA URBAN DISTRICT

Notice to owners of tenements in the undermentioned streets in the Culgoa Urban District and the private streets, lanes, courts and alleys opening thereto:

Kaniera Street, from Watchupga Road northerly to unnamed street.

Unnamed Street, from Kaniera Street to a point opposite State school about 55 metres westerly.

The main pipe in the said streets being laid down, the owners of all tenements situated as above are hereby required, on or before 1 February next, to cause proper pipes and stop cocks to be laid, so as to supply water within such tenements from the main pipe.

Armadale, 12 December 1979

R. BIRD, Secretary  
State Rivers and Water Supply Commission

Water Act 1958

STATE RIVERS AND WATER SUPPLY COMMISSION  
SEA LAKE URBAN DISTRICT

Notice to owners of tenements in the undermentioned streets in the Sea Lake Urban District and the private streets, lanes, courts and alleys opening thereto:

Gallagher Street, from end of existing main (opposite Lot 4) to Best Street about 120 metres southerly.

Hamilton Street, from end of existing main (opposite Lot 70) to unnamed street about 20 metres westerly.

Hannou Street, from end of existing main (opposite Lot 112) to a point opposite Lot 111 about 20 metres easterly.

Mudge Street, from end of existing main (opposite Lot 26) to a point opposite Lot 27 about 8 metres southerly.

Unnamed Street, from Hamilton Street to a point opposite the site of a sewerage pumphouse on Lot 24a about 60 metres southerly.

Wilkinson Street, from Sutcliffe Street to a point opposite Lot 2 about 70 metres easterly.

The main pipe in the said streets being laid down, the owners of all tenements situated as above are hereby required, on or before 1 February next, to cause proper pipes and stop cocks to be laid, so as to supply water within such tenements from the main pipe.

Armadale, 12 December 1979

R. BIRD, Secretary  
State Rivers and Water Supply Commission

Water Act 1958

STATE RIVERS AND WATER SUPPLY COMMISSION  
WYCHEPROOF URBAN DISTRICT

Notice to owners of tenements in the undermentioned streets in the Wycheproof Urban District and the private streets, lanes, courts and alleys opening thereto:

Broadway, from southern end of Showgrounds to southern end of Golf Club about 481 metres northerly.

The main pipe in the said streets being laid down, the owners of all tenements situated as above are hereby required, on or before 1 February next, to cause proper pipes and stop cocks to be laid, so as to supply water within such tenements from the main pipe.

Armadale, 12 December 1979

R. BIRD, Secretary  
State Rivers and Water Supply Commission

Water Act 1958

STATE RIVERS AND WATER SUPPLY COMMISSION  
WOOMELANG URBAN DISTRICT

Notice to owners of tenements in the undermentioned streets in the Woomelang Urban District and the private streets, lanes, courts and alleys opening thereto:

Myall Street, from end of existing main (opposite Lot 12, L.P.6284) to a point opposite Lot 11 about 16 metres northerly.

The main pipe in the said streets being laid down, the owners of all tenements situated as above are hereby required, on or before 1 February next, to cause proper pipes and stop cocks to be laid, so as to supply water within such tenements from the main pipe.

Armadale, 12 December 1979

R. BIRD, Secretary  
State Rivers and Water Supply Commission

## Water Act 1958

STATE RIVERS AND WATER SUPPLY COMMISSION  
COLIBAN URBAN DISTRICT

Notice to owners of tenements in the undermentioned streets in the Coliban Urban District and the private streets, lanes, courts and alleys opening thereto:—

## BENDIGO

Carpenter Street, from Hallam Street to a point opposite C.A.231, Parish of Sandhurst about 431 metres northerly.

Dudley Street, from end of existing main (opposite Lot 39) to a point opposite Lot 28 L.P.25099, about 25 metres easterly.

## Heyington Place

Holland Street, from end of existing main (opposite Lot 8) to a point opposite Lot 5 L.P.125765 about 82 metres northerly.

## Kooyong Close

Marnies Road, from end of existing main (opposite Lot 2) to a point opposite Lot 2, L.P.125232 about 270 metres southerly.

## Nerang Court

Rohs Road, from end of existing main (opposite Lot 3, L.P.25914) to a point opposite Lot 7 about 303 metres northerly.

## CASTLEMAINE

Diamond Gully Road, from end of existing main (opposite part C.A. 1A, Section F, Parish of Castlemaine) to a point opposite Lot 2, L.P.81615 about 29 metres southerly.

## EAGLEHAWK

Brazier Street, from end of existing main (opposite Lot 5) to a point opposite Lot 1, L.P.128887 about 31 metres north-easterly.

## Bundala Court

Coakes Street, from Sailors Gully Road to a point opposite Lot 1 about 8 metres northerly from Bundala Court.  
Gill Avenue, from end of existing main (opposite Lot 1, L.P.123313) to a point opposite Lot 13, about 265 metres easterly.

Unnamed alley between Gill Avenue and Nelson Street.

## ELPHINSTONE

Wright Street, from end of existing main (opposite Lot 1) to a point opposite Lot 2 about 58 metres northerly.

## GOLDEN SQUARE

Adam Street, from a point opposite C.A.206A, Parish of Sandhurst to a point opposite C.A.22, Parish of Sandhurst about 171 metres southerly.

Ash Street, from Pantion Street to McLachlan Street.

## Mayo Court

McLachlan Street, from Ash Street to Elm Street.

## HUNTLY

Burgoyne Street (north side only), from unnamed Government Road west of Cemetery to a point opposite lot 6 about 180 metres south-easterly.

Egans Road, from end of existing main (opposite Lot 1) to a point opposite Lot 22 L.P.129730 about 506 metres northerly.

## Grevillia Road

Sawmill Road, from Midland Highway to a point opposite C.A.1b, Section 18, Township of Huntly about 141 metres westerly.

## Shirley Court

Strickland Street (east side only), from end of existing main (opposite C.A.8, Section 2, Parish of Sandhurst) to a point opposite C.A.7, Section 2, Parish of Sandhurst about 29 metres north-easterly.

Viola Road (a) from end of existing main (opposite Lot 8) to a point opposite Lot 4 about 174 metres westerly; (b) (north side only) from end of existing main (opposite Lot 4) to a point opposite Lot 6 about 69 metres westerly.

## KANGAROO FLAT

Browning Street, from Aspinall Street to a point opposite Lot 2 about 143 metres south-easterly.

Collins Street, from Ramsay Court to a point opposite Lot 17 about 179 metres north easterly.

John Street, from Aspinall Street to a point opposite Lot 18, L.P.125523 about 310 metres south-easterly.

Shelton Road, from end of existing main (opposite C.A.158A, Parish of Mandurang) to a point opposite C.A.81E, Section D, Parish of Mandurang about 18 metres south-easterly.

## MAIDEN GULLY

Calder Highway, from Schumakers Lane to Monsants Lane.

Carolyn Way (north side only), from Monsants Lane to a point opposite Lot 9, L.P.129060 about 433 metres westerly.

Monsants Lane (west side only), from Calder Highway to Carolyn Way.

## MARONG

Cathcart Street, from end of existing main (opposite Lot 4, Section 2, Parish of Marong) to a point opposite Lot 10 about 94 metres northerly.

Marong-Myers Flat Road, from Calder Highway to a point opposite C.A.13, Township of Marong about 92 metres north-easterly.

## WHITE HILLS

Andrew Street, from Heinz Street to a point opposite C.A.2, Section 16b, Parish of Sandhurst about 118 metres northerly.

The main pipe in the said streets being laid down, the owners of all tenements situated as above are hereby required, on or before 1 February next, to cause proper pipes and stop cocks to be laid, so as to supply water within such tenements from the main pipe.

Armadale, 12 December 1979

R. BIRD, Secretary  
State Rivers and Water Supply Commission

## Water Act 1958

STATE RIVERS AND WATER SUPPLY COMMISSION  
BIRCHIP URBAN DISTRICT

Notice to owners of tenements in the undermentioned streets in the Birchip Urban District and the private streets, lanes, courts and alleys opening thereto:

Cumming Avenue, from end of existing main (opposite Lot 6) to a point opposite Lot 5 about 15 metres northerly.

## Johnson Street

(a) from end of existing main (opposite Lot 2) to a point opposite Lot 4 about 96 metres southerly from Campbell Street.

(b) from end of existing main (opposite Lot 5) to Watson Street about 162 metres northerly.

The main pipe in the said streets being laid down, the owners of all tenements situated as above are hereby required, on or before 1 February next, to cause proper pipes and stop cocks to be laid, so as to supply water within such tenements from the main pipe.

Armadale, 12 December 1979

R. BIRD, Secretary  
State Rivers and Water Supply Commission

## STATE RIVERS AND WATER SUPPLY COMMISSION

## LICENCE TO DIVERT WATER

Pursuant to the Provisions of Section 204 of the Water Act 1958 (as amended)

His Excellency the Governor of the State of Victoria by and with the advice of the Executive Council thereof has by Order made on 11 December 1979, pursuant to the provisions of section 204 of the Water Act 1958 approved the inclusion as a condition of each licence set out in the schedule hereunder the condition set forth therein and where of the licensees have signified their consent in writing.

## SCHEDULE

## Part A—Additional Condition

10. The Commission may without notice cancel this licence if—

- (d) The licensee, its or his or their executors, administrators or assigns cease to be or fail to become financial members of the Wakiti Irrigators Society Ltd.

Part B—Licences authorising diversion from Wakiti Lagoon in which condition is to be inserted.

No.	Name	Entitlement ha LM
1261	Boal, J. W. and M. D.	24.6 148
1241	Broom, A.	24.6 148
1248	Broom, H. J. R.	24.6 148
1247	Broom, R.	24.6 148
1236	Broom, W. A.	24.6 148
1827	Colman, L. G.	24.6 148
1223	Colman, L. P.	24.6 148
1229	Shilling, E. F.	24.6 148
3605	Colman, R. M.	24.6 148
1234	McCormack, E. and H.	24.6 148
1231	Golding, R. C.	24.6 148
1227	Golding, R. C.	24.6 148
1260	Colman, R. and M.	24.6 148
1259	Railton, J. and C.	24.6 148
1258	Oxley, G. J. and B. J.	24.6 148
1228	Spencer, H. B. and H. I.	24.6 148
1283	Taylor, C. H.	24.6 148
1290	Taylor, W. T.	24.6 148

## TOM FORRISTAL

Clerk of the Executive Council

At the Executive Council Chamber  
Melbourne, 11 December 1979

## Water Act 1958

STATE RIVERS AND WATER SUPPLY COMMISSION  
COLIBAN URBAN DISTRICT

Notice to owners of tenements in the undermentioned streets in the Coliban Urban District and the private streets, lanes, courts and alleys opening thereto:

## Castlemaine

Diamond Gully Road, from end of existing main (opposite part C.A. 1A, Section F, Parish of Castlemaine) to a point opposite Lot 2, L.P.81615 about 29 metres southerly.

The main pipe in the said streets being laid down, the owners of all tenements situated as above are hereby required, on or before 1 February next, to cause proper pipes and stop cocks to be laid, so as to supply water within such tenements from the main pipe.

Armadale, 12 December 1979—

R. BIRD, Secretary  
State Rivers and Water Supply Commission

## Water Act 1958

STATE RIVERS AND WATER SUPPLY COMMISSION  
TALLYGAROPNA URBAN DISTRICT

Notice to owners of tenements in the undermentioned streets in the Tallygaroopna Urban District and the private streets, lanes, courts and alleys opening thereto:

Church Street, from Fowler Street to Smith Street.

Smith Street, from Church Street to a point opposite Lot 9 about 55 metres northerly.

The main pipe in the said streets being laid down, the owners of all tenements situated as above are hereby required, on or before 1 February next, to cause proper pipes and stop cocks to be laid, so as to supply water within such tenements from the main pipe.

Armadale, 12 December 1979

R. BIRD, Secretary  
State Rivers and Water Supply Commission

## ENGINEER OF WATER SUPPLY EXAMINATION 1979

The under-mentioned candidates have passed examinations conducted by the Board of Examiners of Water Supply, Victoria, and on payment of the prescribed fee may obtain certificates of qualification.

D. J. Blackmore  
T. J. Court  
R. H. Edwards  
A. W. Fischer  
D. W. Flett  
I. L. Johnson  
J. B. Keary  
I. G. Kitchenn  
J. A. Leckie  
K. R. Melvani  
G. L. Quarrell  
D. G. Rickerby  
J. H. Rose  
L. J. Ryan  
G. C. Scott  
J. A. Simpson  
N. W. Tappe  
P. F. Toll  
G. K. Turner  
R. G. Wealands

12 December 1979

N. L. GRIFFIN, Secretary, Board of Examiners, State Rivers and Water Supply Commission, Armadale

## KYNETON SHIRE WATERWORKS TRUST

## BY-LAW NO. 33

The Kyneton Shire Waterworks Trust in pursuance of and in exercise of the powers conferred by the Water Act 1958 and of any and every other power it thereunto enabling doth hereby make a By-law as follows:—

1. By-law 32 passed by the Trust on 7 December 1977 is hereby repealed.

The common seal of the Kyneton Shire Waterworks Trust is hereto affixed 20 December 1978 in the presence of—

(SEAL) T. G. DRIDAN, Chairman  
N. JENKINS, Commissioner  
M. M. HAMILTON, Commissioner  
S. G. PORTER, Secretary

Approved, 10 December 1979—F. J. GRANTER, Minister of Water Supply

DROMANA—ROSEBUD SEWERAGE AUTHORITY  
FIXING THE LIMIT OF BANK OVERDRAFT

His Excellency the Governor of the State of Victoria by and with the advice of the Executive Council thereof has by Order made on 18 December 1979, fixed the total amount of the sums which the Dromana—Rosebud Sewerage Authority may owe at any time in respect of moneys



borrowed by overdraft of current account pursuant to the provisions of section 78 of the *Sewerage Districts Act 1958*, at One hundred and sixty thousand dollars (\$160 000).

TOM FORRISTAL  
Clerk of the Executive Council

At the Executive Council Chamber  
Melbourne, 18 December 1979

#### YATCHAW DRAINAGE TRUST

##### BY-LAW No. 29

The Yatchaw Drainage Trust, in pursuance and exercise of the powers conferred by the *River Improvement Act 1958*, doth hereby make the by-law following:

1. The following rate to be called the "Yatchaw Drainage District Drainage Rate" is hereby made and shall be levied upon the occupiers or owners of properties within the Yatchaw Drainage District, which are Rateable to any municipality. A rate of two and eight tenths (2·8) cents per dollar on the Net Annual Municipal Value of all rateable properties within the first division, provided that the sum of two dollars shall be the minimum amount of the rate in respect of any property liable to be rated in the said District. In respect of properties in the second division no rates shall be levied.

2. Such rate is made and shall be levied for the period beginning with 1 January 1980, and ending with 31 December 1980, and shall be payable on 1 January 1980, at the office of the Yatchaw Drainage Trust, Hamilton, Victoria.

3. Such persons or person as the Yatchaw Drainage Trust may from time to time appoint for that purpose, shall be and is or are hereby authorized to demand, receive, collect and recover the said rate.

The foregoing By-law was made by the Yatchaw Drainage Trust on 26 November 1979, and the common seal of the said Trust hereunto affixed, on 26 November 1979, in the presence of—

(SEAL) EDGAR A. NAGORCKA, Chairman  
A. E. MENZEL, Commissioner  
G. N. JOSEPH, Secretary

Approved, 3 December 1979—F. J. GRANTER, Minister of Water Supply

#### LONGWARRY DRAINAGE TRUST

##### RATING BY-LAW No. 17, 1980

The Longwarry Drainage Trust, in pursuance and exercise of the powers conferred by the *River Improvement Act 1958*, doth hereby make the By-law following:—

1. The following rates to be called "Longwarry Drainage District Drainage Rate", are hereby made, and shall be levied upon the occupiers or owners of all properties within the Longwarry Drainage District, which are rateable to any municipality:—

A rate of two cents (2c) in the Dollar on the net annual municipal value of all properties in the First Division being those properties uncoloured on the plan of the Longwarry Drainage District approved by the Governor in Council, and lodged at the office of the State Rivers and Water Supply Commission at Melbourne.

A rate of one cent (1c) in the Dollar on the net annual municipal value of all properties in the Second Division, being those properties shown coloured green on the said plan.

Provided that the sum of Four Dollars (\$4.00) shall be the minimum amount of rate in respect of any property liable to be rated in the First and Second Divisions of the said District.

2. Such rates are made and shall be levied for the year beginning with 1 January 1980 and ending with 31 December 1980 and shall be payable on 29 February 1980 at the office of the Longwarry Drainage Trust at Drouin.

3. Such person or persons as the Longwarry Drainage Trust may from time to time appoint for the purpose shall be and is or are hereby authorized to demand, receive, collect and recover the said rate.

The foregoing By-law was made by the Longwarry Drainage Trust on 22 November 1979, and the common seal of the said Trust was hereunto affixed, 22 November 1979, in the presence of—

(SEAL) M. K. ANDERSON, Chairman  
P. E. EACOTT, Commissioner  
K. A. PRETTY, Secretary

Approved, 3 December 1979—F. J. GRANTER, Minister of Water Supply

#### CANN RIVER IMPROVEMENT TRUST

##### BY-LAW No. 17

The Cann River Improvement Trust, in pursuance and exercise of the powers conferred by the *River Improvement Act 1958*, and subsequent amendments thereof, doth hereby make the By-law following:—

1. The following rate, to be called the "Cann River Improvement District River Improvement Rate", is hereby made and shall be levied upon the occupiers or owners of all the properties within the Cann River Improvement District which are rateable to any municipality, a rate of .141 of one cent in the \$1 on the municipal site value of such properties. Provided that the sum of Two dollars shall be the minimum amount of rate in respect of any property liable to be rated in the said District.

2. Such rate is made and shall be levied for the year beginning with 1 January 1980, and ending with 31 December 1980, and shall be payable on 30 April 1980, at the office of the Cann River Improvement Trust, Noorinbee.

3. Such person or persons as the Cann River Improvement Trust may from time to time appoint for that purpose shall be or is or are hereby authorised to demand, receive, collect and recover the said rate.

The foregoing By-law was made by the Cann River Improvement Trust on 13 November 1979, and the common seal of the said Trust was hereunto affixed, on 13 November 1979—

(SEAL) R. G. WALKER, Chairman  
B. B. ROBERTSON, Commissioner  
D. S. BROOME, Secretary

Approved, 3 December 1979—F. J. GRANTER, Minister of Water Supply

#### Forests Act 1958, No. 6254

##### DECLARATION OF PROHIBITED PERIOD

In pursuance of the powers conferred by section 3 of the *Forests Act 1958*, I, Frederick James Granter, Her Majesty's Minister of Forests in the State of Victoria, hereby declare a Prohibited Period in respect of any fire protected area (other than State Forest, National Park or Protected Public Land) at the times, dates and in the municipalities specified in the Schedule hereunder.

##### SCHEDULE 1

The Prohibited Period shall commence at midnight between 21 and 22 December 1979 and end between 13 April and 1 May 1980 in the municipalities shown hereunder:

The Shires of—  
Ripon  
Romsey  
Winchelsea  
13 December 1979

F. J. GRANTER  
Minister of Forests

*Town and Country Planning Act 1961*  
CITY OF CROYDON PLANNING SCHEME 1961  
AMENDMENT No. 82

*Notice of Approval*

In pursuance of the powers conferred by the *Town and Country Planning Act 1961*, the Governor in Council on 11 December 1979, approved a planning scheme entitled the City of Croydon Planning Scheme 1961, Amendment No. 82, in respect of part of the municipal district of the City of Croydon and such planning scheme comes into operation on the date this Notice of Approval is published in the *Government Gazette*.

A copy of the planning scheme as approved may be inspected, free of charge, during office hours at the office of the Town and Country Planning Board, 235 Queen Street, Melbourne, at the office of the Council of the City of Croydon at Croydon, and when available, at the Office of Titles, Melbourne, and at the Central Plan Office of the Department of Crown Lands and Survey, Melbourne.

W. H. CRAIG, Secretary  
Town and Country Planning Board

*Town and Country Planning Act 1961*  
CITY OF CROYDON PLANNING SCHEME 1961  
AMENDMENT No. 85

*Notice of Approval*

In pursuance of the powers conferred by the *Town and Country Planning Act 1961*, the Governor in Council on 11 December 1979, approved a planning scheme entitled the City of Croydon Planning Scheme 1961, Amendment No. 85, in respect of part of the municipal district of the City of Croydon and such planning scheme comes into operation on the date this Notice of Approval is published in the *Government Gazette*.

A copy of the planning scheme as approved may be inspected, free of charge, during office hours, at the office of the Town and Country Planning Board, 235 Queen Street, Melbourne, at the office of the Council of the City of Croydon at Croydon, and when available, at the Office of Titles, Melbourne, and at the Central Plan Office of the Department of Crown Lands and Survey, Melbourne.

W. H. CRAIG, Secretary  
Town and Country Planning Board

*Town and Country Planning Act 1961*  
GEELONG REGIONAL INTERIM DEVELOPMENT  
ORDER

AMENDMENT No. 22

*Notice of Amendment*

In pursuance of the powers conferred by section 26 of the *Town and Country Planning Act 1961*, the Governor in Council on 11 December 1979 amended the Geelong Regional Interim Development Order to include 131 hectares of land between Portarlington and St. Leonards in a Proposed Public Purposes 4 Reservation (Water Works and Sewerage Trust) to enable the establishment of a sewerage treatment plant and irrigation sit by the Portarlington Sewerage Authority.

A copy of the amendment may be inspected during office hours at the office of the Town and Country Planning Board, 235 Queen Street, Melbourne, and at the office of the Geelong Regional Commission at the Geelong Public Offices on the corner of Little Malop and Fenwick Streets, Geelong.

W. H. CRAIG, Secretary  
Town and Country Planning Board

*Town and Country Planning Act 1961*  
CITY OF KNOX PLANNING SCHEME 1965  
AMENDMENT No. 205, 1979

*Notice of Approval*

In pursuance of the powers conferred by the *Town and Country Planning Act 1961*, the Governor in Council on 18 December 1979 approved a planning scheme entitled the City of Knox Planning Scheme 1965, Amendment No. 205, 1979, in respect of part of the municipal district

of the City of Knox and such planning scheme comes into operation on the date this Notice of Approval is published in the *Government Gazette*.

A copy of the planning scheme as approved may be inspected, free of charge, during office hours at the office of the Town and Country Planning Board, 235 Queen Street, Melbourne, at the office of the Council of the City of Knox at Knoxfield, and when available, at the Office of Titles, Melbourne, and at the Central Plan Office of the Department of Crown Lands and Survey, Melbourne.

W. H. CRAIG, Secretary  
Town and Country Planning Board

*Town and Country Planning Act 1961*  
CITY OF KNOX PLANNING SCHEME 1965  
AMENDMENT No. 206, 1979

*Notice of Approval*

In pursuance of the powers conferred by the *Town and Country Planning Act 1961*, the Governor in Council on 11 December 1979, approved a planning scheme entitled the City of Knox Planning Scheme 1965, Amendment No. 206, 1979, in respect of part of the municipal district of the City of Knox and such planning scheme comes into operation on the date this Notice of Approval is published in the *Government Gazette*.

A copy of the planning scheme as approved may be inspected, free of charge, during office hours at the office of the Town and Country Planning Board, 235 Queen Street, Melbourne, at the office of the Council of the City of Knox at Knoxfield, and when available, at the Office of Titles, Melbourne, and at the Central Plan Office of the Department of Crown Lands and Survey, Melbourne.

W. H. CRAIG, Secretary  
Town and Country Planning Board

*Town and Country Planning Act 1961*  
CITY OF KNOX PLANNING SCHEME 1965  
AMENDMENT No. 206A, 1979

*Notice of Amendment*

In pursuance of the powers conferred by sub-section 6 of section 32 of the *Town and Country Planning Act 1961*, the Governor in Council on 11 December 1979 amended the City of Knox Planning Scheme 1965 to rezone the rear portion of lots 1 and 4, lodged plan 131168 from General Industrial to Garden Industrial.

A copy of the amendment may be inspected during office hours at the office of the Town and Country Planning Board, 235 Queen Street, Melbourne, at the office of the Council of the City of Knox at Knoxfield, and when available, at the Office of Titles, Melbourne, and at the Central Plan Office of the Department of Crown Lands and Survey, Melbourne.

W. H. CRAIG, Secretary  
Town and Country Planning Board

*Town and Country Planning Act 1961*  
MELBOURNE METROPOLITAN PLANNING SCHEME  
AMENDMENT No. 90, PART 1c

*Notice of Approval*

In pursuance of the powers conferred by the *Town and Country Planning Act 1961*, the Governor in Council on 18 December 1979 approved a planning scheme entitled the Melbourne Metropolitan Planning Scheme, Amendment No. 90, Part 1c, in respect of part of the municipal district of the City of Northcote and such planning scheme comes into operation on the date this Notice of Approval is published in the *Government Gazette*.

A copy of the planning scheme as approved may be inspected, free of charge, during office hours at the office of the Town and Country Planning Board, 235 Queen Street, Melbourne, at the office of the Melbourne and Metropolitan Board of Works at 625 Little Collins Street, Melbourne, and when available, at the Office of Titles, Melbourne, and at the Central Plan Office of the Department of Crown Lands and Survey, Melbourne.

W. H. CRAIG, Secretary  
Town and Country Planning Board

Town and Country Planning Act 1961  
MELBOURNE METROPOLITAN PLANNING SCHEME  
AMENDMENT No. 110, PART 3

*Notice of Approval*

In pursuance of the powers conferred by the *Town and Country Planning Act 1961*, the Governor in Council on 11 December 1979 approved a planning scheme entitled the Melbourne Metropolitan Planning Scheme, Amendment No. 110, Part 3, in respect of parts of the municipal districts of the Cities of Oakleigh and Doncaster and Templestowe and such planning schemes come into operation on the date this Notice of Approval is published in the *Government Gazette*.

A copy of the planning schemes as approved may be inspected, free of charge, during office hours at the office of the Town and Country Planning Board, 235 Queen Street, Melbourne, at the office of the Melbourne and Metropolitan Board of Works at 625 Little Collins Street, Melbourne, and when available, at the Office of Titles, Melbourne, and at the Central Plan Office of the Department of Crown Lands and Survey, Melbourne.

W. H. CRAIG, Secretary  
Town and Country Planning Board

Town and Country Planning Act 1961  
MELBOURNE METROPOLITAN PLANNING SCHEME  
AMENDMENT No. 136  
*Notice of Amendment*

In pursuance of the powers conferred by sub-section 6 of section 32 of the *Town and Country Planning Act 1961*, the Governor in Council, on 18 December 1979 amended the Melbourne Metropolitan Planning Scheme in respect to clause 24 (3) (b) of the Ordinance which relates to control over heights of buildings in the Special Use Zone No. 8—Shrine Locality.

A copy of the amendment may be inspected during office hours at the office of the Town and Country Planning Board, 235 Queen Street, Melbourne, at the office of the Melbourne and Metropolitan Board of Works at 625 Little Collins Street, Melbourne, and when available, at the Office of Titles, Melbourne, and at the Central Plan Office of the Department of Crown Lands and Survey, Melbourne.

W. H. CRAIG, Secretary  
Town and Country Planning Board

Town and Country Planning Act 1961  
OVENS-UPPER MURRAY PLANNING SCHEME  
INTERIM DEVELOPMENT ORDER 1975  
AMENDMENT No. 41  
*Notice of Amendment*

In pursuance of the powers conferred by section 26 of the *Town and Country Planning Act 1961*, the Governor in Council on 18 December 1979 amended the Ovens-Upper Murray Planning Scheme Interim Development Order 1975 to enable the erection of one house on each of Crown Allotments 4 and 8, section 3, Parish of Tallandoon.

A copy of the amendment may be inspected during office hours at the office of the Town and Country Planning Board, 235 Queen Street, Melbourne, and at the office of the Council of the Shire of Tallangatta at Tallangatta.

W. H. CRAIG, Secretary  
Town and Country Planning Board

Town and Country Planning Act 1961  
SEYMOUR PLANNING SCHEME  
AMENDMENT No. 48

*Notice of Approval*

In pursuance of the powers conferred by the *Town and Country Planning Act 1961*, the Governor in Council on 11 December 1979, approved a planning scheme entitled the Seymour Planning Scheme, Amendment No. 48, in respect of part of the municipal district of the Shire of

Seymour and such planning scheme comes into operation on the date this Notice of Approval is published in the *Government Gazette*.

A copy of the planning scheme as approved may be inspected, free of charge, during office hours, at the office of the Town and Country Planning Board, 235 Queen Street, Melbourne, at the office of the Council at the Shire of Seymour at Seymour, and when available, at the Office of Titles, Melbourne, and at the Central Plan Office of the Department of Crown Lands and Survey, Melbourne.

W. H. CRAIG, Secretary  
Town and Country Planning Board

Town and Country Planning Act 1961  
SOUTH WESTERN COASTAL PLANNING SCHEME  
(SHIRE OF OTWAY)

INTERIM DEVELOPMENT ORDER  
*Notice of Revocation*

In pursuance of the powers conferred by section 26 of the *Town and Country Planning Act 1961*, the Governor in Council on 18 December 1979 revoked the South Western Coastal Planning Scheme (Shire of Otway) Interim Development Order.

A copy of the revocation may be inspected during office hours at the office of the Town and Country Planning Board, 235 Queen Street, Melbourne, and at the office of the Council of the Shire of Otway at Beech Forest.

W. H. CRAIG, Secretary  
Town and Country Planning Board

Town and Country Planning Act 1961  
WARRAGUL PLANNING SCHEME 1954  
AMENDMENT No. 31, 1977

*Notice of Approval*

In pursuance of the powers conferred by the *Town and Country Planning Act 1961*, the Governor in Council on 11 December 1979 approved a planning scheme entitled the Warragul Planning Scheme 1954, Amendment No. 31, 1977, in respect of part of the municipal district of the Shire of Warragul and such planning scheme comes into operation on the date this Notice of Approval is published in the *Government Gazette*.

A copy of the planning scheme as approved may be inspected, free of charge, during office hours at the office of the Town and Country Planning Board, 235 Queen Street, Melbourne, at the office of the Council of the Shire of Warragul at Warragul, and when available, at the Office of Titles, Melbourne, and at the Central Plan Office of the Department of Crown Lands and Survey, Melbourne.

W. H. CRAIG, Secretary  
Town and Country Planning Board

Town and Country Planning Act 1961  
SHIRE OF BALLARAT  
INTERIM DEVELOPMENT ORDER  
*Notice of Approval*

In pursuance of the powers conferred by the *Town and Country Planning Act 1961*, the Governor in Council on 18 December 1979 approved the making of an Interim Development Order by the Ballarat Shire Council for that part of the municipal district of the Shire of Ballarat not covered by the approved Ballarat and District Planning Scheme.

The Interim Development Order provides that the use, subdivision or development of any land within the area described or the erection, construction or carrying out of any buildings, roads or other works thereon is prohibited except in accordance with the provisions of the Order.

A copy of the Interim Development Order and a map showing the area affected may be inspected, free of charge, at the office of the Council of the Shire of Ballarat at Ballarat and at the office of the Town and Country Planning Board, 235 Queen Street, Melbourne.

W. H. CRAIG, Secretary  
Town and Country Planning Board

*Town and Country Planning Act 1961*  
**SHIRE OF BUNGAREE PLANNING SCHEME**  
 INTERIM DEVELOPMENT ORDER  
 AMENDMENT No. 4

*Notice of Amendment*

In pursuance of the powers conferred by section 26 of the *Town and Country Planning Act 1961*, the Governor in Council on 11 December 1979 amended the Shire of Bungaree Planning Scheme Interim Development Order to rezone an area of land on the Midland Highway from Rural Highway to Rural.

A copy of the amendment may be inspected during office hours at the office of the Town and Country Planning Board, 235 Queen Street, Melbourne, and at the office of the Council of the Shire of Bungaree at Leigh Creek.

W. H. CRAIG, Secretary  
 Town and Country Planning Board

*Town and Country Planning Act 1961*  
**SHIRE OF KILMORE PLANNING SCHEME**  
 AMENDMENT No. 40, 1979

*Notice of Amendment*

In pursuance of the powers conferred by sub-section 6 of section 32 of the *Town and Country Planning Act 1961*, the Governor in Council, on 11 December 1979 amended the Shire of Kilmore Planning Scheme to reserve approximately 10 hectares of land, presently zoned part Residential A and reserved part Public Open Space and Part Minor Road, for Public Purposes 2—Civic Centre.

A copy of the amendment may be inspected during office hours at the office of the Town and Country Planning Board, 235 Queen Street, Melbourne, at the office of the Council of the Shire of Kilmore at Kilmore, and when available, at the Office of Titles, Melbourne, and at the Central Plan Office of the Department of Crown Lands and Survey, Melbourne.

W. H. CRAIG, Secretary  
 Town and Country Planning Board

*Town and Country Planning Act 1961*  
**SHIRE OF LILLYDALE PLANNING SCHEME 1958**  
 REVOCATION No. 33

*Notice of Revocation*

In pursuance of the provisions of section 32 of the *Town and Country Planning Act 1961* the Governor in Council on 18 December 1979, made an Order:—

- (i) revoking the Shire of Lillydale Planning Scheme in so far as it applies to lot 1 on lodged plan 120339 and lot 105 on lodged plan 9302, being approximately 1.2 hectares of land at the Crescent, Mt. Evelyn, and
- (ii) providing that the land so revoked may be used or developed only as if:
  - (a) it were land to which the Shire of Lillydale Planning Scheme applies; and
  - (b) it were land within the Residential "G" Zone; and
  - (c) notwithstanding the provisions of Clause 7 of the said Planning Scheme it were permissible subject to the grant of a permit and in accordance with any conditions attached by the Responsible Authority to use and develop the land for the purposes of a Residential Building.

A copy of the Order may be inspected during office hours at the office of the Town and Country Planning Board, 235 Queen Street, Melbourne, and at the office of the Council of the Shire of Lillydale at Lillydale.

W. H. CRAIG, Secretary  
 Town and Country Planning Board

*Town and Country Planning Act 1961*  
**SHIRE OF MYRTLEFORD (MYRTLEFORD TOWNSHIP)**  
 PLANNING SCHEME 1966

AMENDMENT No. 6

*Notice of Approval*

In pursuance of the powers conferred by the *Town and Country Planning Act 1961*, the Governor in Council on 11 December 1979, approved a planning scheme entitled the Shire of Myrtleford (Myrtleford Township) Planning Scheme 1966, Amendment No. 6, in respect of part of the municipal district of the Shire of Myrtleford and such planning scheme comes into operation on the date this Notice of Approval is published in the *Government Gazette*.

A copy of the planning scheme as approved may be inspected, free of charge, during office hours at the office of the Town and Country Planning Board, 235 Queen Street, Melbourne, at the office of the Council of the Shire of Myrtleford at Myrtleford, and when available, at the Office of Titles, Melbourne, and at the Central Plan Office of the Department of Crown Lands and Survey, Melbourne.

W. H. CRAIG, Secretary  
 Town and Country Planning Board

*Town and Country Planning Act 1961*  
**SHIRE OF NARRACAN PLANNING SCHEME**

INTERIM DEVELOPMENT ORDER

AMENDMENT No. 13

*Notice of Amendment*

In pursuance of the powers conferred by section 26 of the *Town and Country Planning Act 1961*, the Governor in Council on 11 December 1979 amended the Shire of Narracan Interim Development Order to enable the erection of houses on each of Crown Allotments 1, 2 and 2a, section A, Parish of Neerim East.

A copy of the amendment may be inspected during office hours at the office of the Town and Country Planning Board, 235 Queen Street, Melbourne, and at the office of the Council of the Shire of Narracan at Trafalgar.

W. H. CRAIG, Secretary  
 Town and Country Planning Board

*Town and Country Planning Act 1961*  
**SHIRE OF NEWHAM AND WOODEND PLANNING SCHEME**

AMENDMENT No. 1, 1978

*Notice of Approval*

In pursuance of the powers conferred by the *Town and Country Planning Act 1961*, the Governor in Council on 11 December 1979 approved a planning scheme entitled the Shire of Newham and Woodend Planning Scheme, Amendment No. 1, 1978, in respect of part of the municipal district of the Shire of Newham and Woodend and such planning scheme comes into operation on the date this Notice of Approval is published in the *Government Gazette*.

A copy of the planning scheme as approved may be inspected, free of charge, during office hours at the office of the Town and Country Planning Board, 235 Queen Street, Melbourne, at the office of the Council of the Shire of Newham and Woodend at Woodend, and when available, at the Office of Titles, Melbourne, and at the Central Plan Office of the Department of Crown Lands and Survey, Melbourne.

W. H. CRAIG, Secretary  
 Town and Country Planning Board

*Town and Country Planning Act 1961*  
**SHIRE OF OTWAY COASTAL AREAS**

INTERIM DEVELOPMENT ORDER

*Notice of Approval*

In pursuance of the powers conferred by the *Town and Country Planning Act 1961*, the Governor in Council on 18 December 1979 approved the making of an Interim Development Order by the Otway Shire Council for that

part of the municipal district of the Shire of Otway covered by the South Western Coastal Planning Scheme (Shire of Otway) Interim Development Order being administered by the Town and Country Planning Board.

The Interim Development Order provided that the use, subdivision or development of any land within the area described or the erection, construction or carrying out of any buildings, roads or other works thereon is prohibited except in accordance with the provisions of the Order.

A copy of the Interim Development Order and a map showing the area affected may be inspected, free of charge, at the office of the Council of the Shire of Otway at Beech Forest, and at the office of the Town and Country Planning Board, 235 Queen Street, Melbourne.

W. H. CRAIG, Secretary  
Town and Country Planning Board

*Town and Country Planning Act 1961*  
**SHIRE OF SEYMOUR PLANNING SCHEME**

INTERIM DEVELOPMENT ORDER

AMENDMENT NO. 11

*Notice of Amendment*

In pursuance of the powers conferred by section 26 of the *Town and Country Planning Act 1961*, the Governor in Council on 11 December 1979 amended the Shire of Seymour Interim Development Order to include modifications to clauses 1 and 2.

A copy of the amendment may be inspected during office hours at the office of the Town and Country Planning Board, 235 Queen Street, Melbourne, and at the office of the Council of the Shire of Seymour, Shire Hall, Seymour.

W. H. CRAIG, Secretary  
Town and Country Planning Board

*Town and Country Planning Act 1961*  
**SHIRE OF UPPER YARRA PLANNING SCHEME**

INTERIM DEVELOPMENT ORDER

AMENDMENT NO. 52

*Notice of Amendment*

In pursuance of the powers conferred by section 26 of the *Town and Country Planning Act 1961*, the Governor in Council on 11 December 1979 amended the Shire of Upper Yarra Planning Scheme Interim Development Order to permit the erection of a house on the combined areas of Crown Allotments 54, 55, 56 and 57, Township of Yellingbo, Parish of Woori Yallock on the Healesville-Koo Wee Rup Road.

A copy of the amendment may be inspected during office hours at the office of the Town and Country Planning Board, 235 Queen Street, Melbourne, and at the office of the Council of the Shire of Upper Yarra at Yarra Junction.

W. H. CRAIG, Secretary  
Town and Country Planning Board

*Town and Country Planning Act 1961*  
**SHIRE OF UPPER YARRA PLANNING SCHEME**

INTERIM DEVELOPMENT ORDER

AMENDMENT NO. 53

*Notice of Amendment*

In pursuance of the powers conferred by section 26 of the *Town and Country Planning Act 1961*, the Governor in Council on 11 December 1979 amended the Shire of Upper Yarra Planning Scheme Interim Development Order to enable the erection of a house on each of lots 59 to 64 (inclusive), lodged plan 14006 in Yarra Junction-Noojee Road, Gladysdale.

A copy of the amendment may be inspected during office hours at the office of the Town and Country Planning Board, 235 Queen Street, Melbourne, and at the office of the Council of the Shire of Upper Yarra at Yarra Junction.

W. H. CRAIG, Secretary  
Town and Country Planning Board

**APPOINTMENTS AND  
RESIGNATIONS**

**APPOINTMENTS**

His Excellency the Governor of the State of Victoria, by and with the advice of the Executive Council thereof, has, by Orders made on 11 December 1979, been pleased to make the under-mentioned appointments, viz.:

HEALTH COMMISSION OF VICTORIA

*Trustees of Public Cemeteries*

LIONEL PAVEY  
to be a Trustee of the Kyneton General Cemetery, vice S. Gilmore, resigned,

ALPHONSUS BYRNE LOVE  
to be an additional Trustee of the Maddingley Public Cemetery,

GORDON PEARCE  
to be a Trustee of the Murrayville Public Cemetery, vice H. G. Pearce, deceased, pursuant to section 3 (1) of the *Cemeteries Act 1958*.

LAW DEPARTMENT

*Commissioners for Taking Declarations, &c.*

NORAH ELIZABETH CAMPBELL, 301 Dana Street, Ballarat;

MICHAEL JOHN CARRATELLI, 160 Queen Street, Melbourne,

WILLIAM GEOFFREY DAVIES, 60 Market Street, Melbourne,

MERVIN REX DE SILVA and  
WILLIAM ROBERT HARWOOD,  
Springvale Road, Glen Waverley,

TONY CHERIAN JACOB, 500 Bourke Street, Melbourne,  
TREVOR MAXWELL JAMES, 440 Collins Street, Melbourne,  
GARY STUART JOHNSTON, 187 Settlement Road, Bundoora,

MICHAEL JOSEPH KEOWN, 801 Glenferrie Road, Hawthorn,

GRAHAM LASKY, 390 St. Kilda Road, Melbourne,  
STUART JAMES MCGEE, 459 Little Collins Street, Melbourne,

FRANK MATHER, 1082 Nepean Highway, Highett,  
MAURICE MAXWELL ROGERS MAWER, corner Collins and  
Swanston Streets, Melbourne,

ARTHUR NALIS, 265 Chandler Road, Noble Park,  
MICHAEL JOHN SHORT, 67 Spencer Street, Melbourne, and  
ADAM TRUMBLE, 538 Collins Street, Melbourne,

to be Commissioners for taking Declarations and Affidavits under the *Evidence Act 1958*.

*Assistant Registrar of County Court*

PAUL JOSEPH CRONIN, Clerk of Courts,  
to be Assistant Registrar at Castlemaine for the County Courts at Ballarat and Bendigo, vice P. Crawford, on recreation leave.

TOM FORRISTAL

Clerk of the Executive Council

At the Executive Council Chamber  
Melbourne, 11 December 1979

EDUCATION DEPARTMENT

APPOINTMENT

*Member of the Technical Teachers Registration Board*

His Excellency the Governor of the State of Victoria by and with the advice of the Executive Council thereof has by Order made on 11 December 1979, been pleased to appoint Ms MARJORIE HEATHER WINSOME BROADBENT, duly elected Deputy Member, to be a member of the Technical Teachers Registration Board, vice Mrs Margaret Elizabeth Burns from 1 January 1980, pursuant to the powers conferred by the *Education Act 1958*.

TOM FORRISTAL

Clerk of the Executive Council

At the Executive Council Chamber  
Melbourne, 11 December 1979

**MENTAL HEALTH ACT 1959, SECTION 26**

Notice is hereby given that the following appointment has been made pursuant to section 26 of the *Mental Health Act 1959*.

JOSEPH PAUL PETER BENINCASA, Manager, Shepparton Psychiatric Hospital from 28 December 1979 to 18 January 1980, vice J. L. Freeman, on leave.

G. TREVAKS, Chairman  
Health Commission of Victoria

*Liquor Control Act 1968***APPOINTMENT OF LICENSING INSPECTORS**

In accordance with the authority conferred upon me by Section 6 of the *Police Regulation Act 1958*, I, John Ronald George Salisbury, Deputy Commissioner of Police, do hereby appoint under sub-section (1) of Section 22 of the *Liquor Control Act 1968*, the following Officers of Police as Licensing Inspectors for the Divisions of the Police Districts as shown:

Division Number	Police District	Rank and Name
3	Avondale Heights	Inspector John Edward Shanahan (from 30.12.79 to 19.1.80)
1	Cheltenham	Superintendent Richard Carlile Knight (vice Chief Superintendent I. M. Adams, Q.P.M.)
1	Cheltenham	Inspector Ian Andrew Smyth (from 23.12.79 to 12.1.80)
1	Prahran	Superintendent Edward Caddle (vice Chief Superintendent L. K. Plattfuss, Q.P.M., V.A.)
13.12.1979 J. R. G. SALISBURY Deputy Commissioner (Administration)		

**REVOCATION OF APPOINTMENT**

LAW DEPARTMENT  
*Justices of the Peace*

His Excellency the Governor of the State of Victoria by and with the advice of the Executive Council thereof has by Order made on 11 December 1979, revoked the appointment of VICTOR GEORGE ALFRED BROOKER as a Justice of the Peace for the State of Victoria.

TOM FORRISTAL  
Clerk of the Executive Council

At the Executive Council Chamber  
Melbourne, 11 December 1979

**RESIGNATIONS**

His Excellency the Governor of the State of Victoria, by and with the advice of the Executive Council thereof, has, by Orders made on 11 December 1979 accepted the resignations of the persons named hereunder of the offices mentioned, viz.:

**HEALTH COMMISSION OF VICTORIA**

*Member of the Medical Board of Victoria*

JOHN GAVIN JOHNSON, M.B., B.S., F.R.A.C.P. (Hon.), as a member of the Medical Board of Victoria from 31 December 1979.

LAW DEPARTMENT  
*Justices of the Peace*

GEORGE GARNET FIELDING, and  
RAYMOND WILLIAM WALSH  
as Justices of the Peace for the State of Victoria.  
*Commissioners for Taking Declarations, &c.*

FRANK ASHFORTH,  
DONALD GREGORY BEVAN,  
WILLIAM JOHN DUNCAN,  
GWYNNE MARY ELLETT,  
RONALD ARTHUR ELLETT,  
EDWARD JAMES GILLESPIE, and  
WILLIAM ALAN THOMPSON,  
as Commissioners for taking Declarations and Affidavits under the *Evidence Act 1958*.

TOM FORRISTAL  
Clerk of the Executive Council

At the Executive Council Chamber  
Melbourne, 11 December 1979

**ORDERS IN COUNCIL****HOSPITALS AND CHARITIES ACT 1958**

At the Executive Council Chamber, Melbourne, the  
eleventh day of December, 1979

PRESENT:

His Excellency the Governor of Victoria  
Mr Houghton | Mr Ramsay  
Mr Austin

Whereas by sub-section (4) of section 5 of the *Hospitals and Charities Act 1958*, it is amongst other things enacted that the Governor in Council may by order published in the *Government Gazette* amend or vary the Fourth Schedule to the *Hospitals and Charities Act 1958*.

Now therefore His Excellency the Governor of the State of Victoria, in the Commonwealth of Australia, by and with the advice of the Executive Council of the said State, does by this order amend the said Fourth Schedule in the manner following:—

By adding the name of the municipality of—  
Frankston.

And the Honorable William Archibald Borthwick, Her Majesty's Minister of Health for the State of Victoria, shall give the necessary directions herein accordingly.

TOM FORRISTAL  
Clerk of the Executive Council

**SUPERANNUATION ACT 1958**

At the Executive Council Chamber, Melbourne, the  
eleventh day of December, 1979

PRESENT:

His Excellency the Governor of Victoria  
Mr Houghton | Mr Ramsay  
Mr Austin

Pursuant to the powers conferred by the provisions of paragraph (jd) of sub-section (1) of section 3 of the *Superannuation Act 1958*, His Excellency the Governor of the State of Victoria, by and with the advice of the Executive Council thereof doth by this Order declare that the provisions of the *Superannuation Act* shall apply to the officers named in the schedule hereunder.

**SCHEDULE**

COCHRANE, ROBERT JOHN, Motor Accidents Board.  
DIXON, JOANNE SUSAN, Motor Accidents Board.  
GRILLI, CYNTHIA LIVIANA, Motor Accidents Board.  
MCCLURE, PENNY ANNE, Motor Accidents Board.  
ROSE, JOHN THOMAS, Motor Accidents Board.  
PALMER, SALLY ANN, Victorian Institute of Secondary Education.  
GUTHRIE, JAMES ERNEST, Warrnambool Institute of Advanced Education.

And the Honorable Lindsay Hamilton Simpson Thompson, Her Majesty's Treasurer for the State of Victoria, shall give the necessary directions herein accordingly.

TOM FORRISTAL  
Clerk of the Executive Council

## LOCAL GOVERNMENT ACT 1958

At the Executive Council Chamber, Melbourne, the  
eleventh day of December, 1979

PRESENT:

His Excellency the Governor of Victoria  
Mr Houghton | Mr Ramsay  
Mr Austin |

ALTERATION OF TIME FOR CLOSING POLL AT  
MUNICIPAL ELECTIONS—SHIRE OF BRIGHT

His Excellency the Governor of the State of Victoria, by and with the advice of the Executive Council thereof, in pursuance of the powers conferred by section 134 of the *Local Government Act 1958*, and in compliance with the prayer of a petition presented by the Council of the Shire of Bright declares that the hour for closing the poll at municipal elections for the said Shire shall be six o'clock in the afternoon.

And the Honorable Digby Glen Crozier, Her Majesty's Minister for Local Government for the State of Victoria, shall give the necessary directions herein accordingly.

TOM FORRISTAL  
Clerk of the Executive Council

## LOCAL GOVERNMENT ACT 1958

At the Executive Council Chamber, Melbourne, the  
eleventh day of December, 1979

PRESENT:

His Excellency the Governor of Victoria  
Mr Houghton | Mr Ramsay  
Mr Austin |

## ROAD DISCONTINUED—SHIRE OF SHERBROOKE

Whereas it is provided in section 528 (2) of the *Local Government Act 1958*, that where a road (whether or not a public highway but not being a road set out on land of the Crown) or any part thereof is not required for public use the Governor in Council on the request of the council of the municipality in which such road is situated made not less than one month after publishing in a newspaper generally circulating in the district and posting to the registered proprietor (if any) of the land and the owners and occupiers (if any) of lands abutting or immediately adjacent to the road notice of intention to make such a request may by Order published in the *Government Gazette* direct that such a road or part shall be discontinued and thereupon such road or part shall be discontinued accordingly.

And whereas the Council of the Shire of Sherbrooke has requested that the Governor in Council direct that a road between Orana and Gilmore Courts, Belgrave, be discontinued and not less than one month previously has published in a newspaper generally circulating in the district and posted to the registered proprietor of the land in the road and to the owners and occupiers of lands abutting or immediately adjacent to the road notice of intention to make such a request.

Now therefore, His Excellency the Governor of the State of Victoria, by and with the advice of the Executive Council thereof, hereby directs:

- that the said road which is shown by hatching, hatching marked "A" and cross hatching on the plan hereunder, shall be discontinued;
- that notwithstanding such discontinuance the Melbourne and Metropolitan Board of Works shall continue to have and possess the same right title power authority or interest in or in relation to the whole of the land shown by hatching marked "A" on the said plan as it had or possessed prior to such discontinuance with respect to or in connection with any drains or pipes laid or erected in on or over such land for the purposes of drainage or sewerage;

- that notwithstanding such discontinuance the State Electricity Commission shall continue to have and possess the same right title power authority or interest in or in relation to the whole of the land shown by hatching marked "A" and cross-hatching on the said plan as it had or possessed prior to such discontinuance with respect to or in connection with any wires or cables laid or erected in on or over such land for the purposes of electricity supply;
- that notwithstanding such discontinuance Telecom Australia shall continue to have and possess the same right title power authority or interest in or in relation to the whole of the land shown by hatching marked "A" and cross-hatching on the said plan as it had or possessed prior to such discontinuance with respect to or in connection with any apparatus wires or cables laid or erected in on or over such land for the purposes of communications; and
- that, subject to any such right title power authority or interest the land in the said road shall be retained by the Council of the Shire of Sherbrooke for municipal purposes;

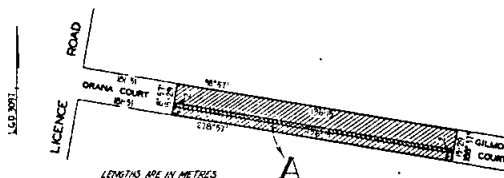

And the Honorable Digby Glen Crozier, Her Majesty's Minister for Local Government for the State of Victoria, shall give the necessary directions herein accordingly.

TOM FORRISTAL  
Clerk of the Executive Council

## LOCAL GOVERNMENT DEPARTMENT

At the Executive Council Chamber, Melbourne, the  
eleventh day of December, 1979

PRESENT:

His Excellency the Governor of Victoria  
Mr Houghton | Mr Ramsay  
Mr Austin |

CONFIRMATION OF SEPARATE RATE—CITY OF  
BOX HILL

In pursuance of the provisions of section 287 of the *Local Government Act 1958*, His Excellency the Governor of the State of Victoria, by and with the advice of the Executive Council thereof, hereby confirms a separate rate of zero point six five two seven (0.6527) cents in the dollar on the site value on the properties described in the Schedule hereunder which rate was made by the Council of the City of Box Hill on 9 October 1978 for the purpose of providing off street parking facilities for use in connection with the Hamilton Street, Mont Albert Shopping Centre.

## SCHEDULES OF PROPERTIES TO BE RATED

- Hamilton Street, Nos. 1, 1A, 1B, 1C, 1D, 1E, 1F, 3, 5, 7, 9, 11, 13-15, 17-19, 46-48, 44, 42, 40, 38, 36, 34, 32, 30, 24-26, 22, 18-20, 14, 12, 10, 8, 6, 4 and 2.
- Mont Albert Road, Nos. 377-379, 369 and 358.
- Churchill Street, Nos. 14A, 12, 10, 8, 6, 4 and 2.

And the Honorable Digby Glen Crozier, Her Majesty's Minister for Local Government for the State of Victoria, shall give the necessary directions herein accordingly.

TOM FORRISTAL  
Clerk of the Executive Council

LOCAL GOVERNMENT ACT 1958

At the Executive Council Chamber, Melbourne, the eleventh day of December, 1979

PRESENT:

His Excellency the Governor of Victoria  
 Mr Houghton                      Mr Ramsay  
 Mr Austin

MAKING OF A TREE RESERVE—CITY OF BALLAARAT

His Excellency the Governor of the State of Victoria, by and with the advice of the Executive Council thereof, in pursuance of the provisions of section 557 of the Local Government Act 1958 and in compliance with a request by the Council of the City of Ballarat, hereby directs that the land shown by hatching on the plan hereunder, being part of Vale Street, between Leopold Street and Napier Avenue, Ballarat, be a Tree Reserve.

any corresponding previous enactment (whether before or after the commencement of the Local Government Act 1963) and any allotment on that map or plan has been transferred the Governor in Council on the request of the Council of the municipality may by Order published in the Government Gazette direct that the whole or any part of the land comprised in any reserve shown on that map or plan shall vest in the council whereupon such land shall so vest freed and discharged from any mortgage charge lease or sub-lease.

And whereas the Council of the City of Caulfield has requested that a reserve shown on a plan of subdivision be vested in the Council and allotments on the plan have been transferred.

Now therefore, His Excellency the Governor of the State of Victoria, by and with the advice of the Executive Council thereof, by this Order vests in the Council of the City of Caulfield the Drainage Reserve on Plan of Sub-division No. 3183 shown by hatching and cross-hatching on the plan hereunder.

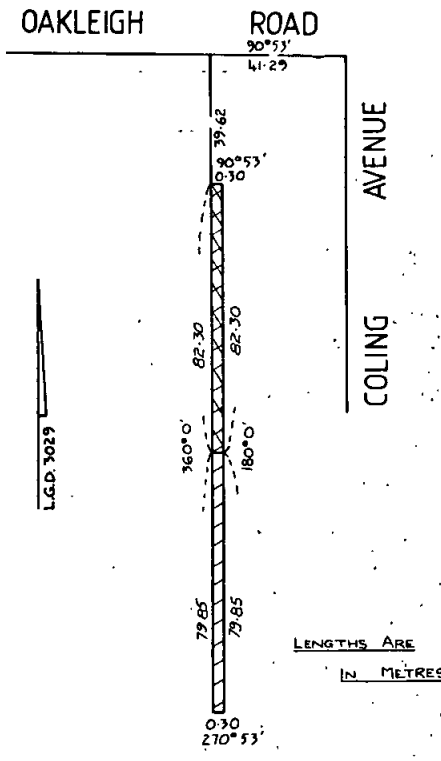
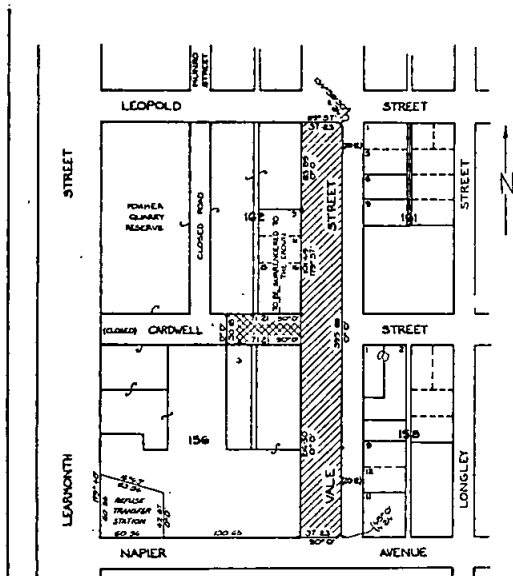

And the Honorable Digby Glen Crozier, Her Majesty's Minister for Local Government for the State of Victoria, shall give the necessary directions herein accordingly.

TOM FORRISTAL  
 Clerk of the Executive Council

LOCAL GOVERNMENT ACT 1958

At the Executive Council Chamber, Melbourne, the eleventh day of December, 1979

PRESENT:

His Excellency the Governor of Victoria  
 Mr Houghton                      Mr Ramsay  
 Mr Austin

VESTING OF RESERVE IN THE CAULFIELD CITY COUNCIL

Whereas it is provided by section 569BA of the Local Government Act 1958, that where any map or plan has been lodged or deposited with the Registrar of Titles pursuant to section 97 of the Transfer of Land Act 1958, or

And the Honorable Digby Glen Crozier, Her Majesty's Minister for Local Government for the State of Victoria, shall give the necessary directions herein accordingly.

TOM FORRISTAL  
 Clerk of the Executive Council



COUNTRY ROADS ACT 1958

Act No. 6229

At the Executive Council Chamber, Melbourne, the eleventh day of December, 1979

PRESENT:

His Excellency the Governor of Victoria  
Mr Houghton | Mr Ramsay  
Mr Austin

ORDER CONFIRMING RESOLUTIONS OF THE COUNTRY ROADS BOARD

His Excellency the Governor of the State of Victoria, by and with the advice of the Executive Council thereof, doth hereby, in pursuance of the provisions of the Country Roads Act 1958, confirm the resolutions of the Country Roads Board, the dates whereof and the terms of which are scheduled hereunder:

SCHEDULE

State Highways

Resolution dated the Twentieth day of November, One thousand nine hundred and seventy-nine, made pursuant to section 70 of the Country Roads Act 1958 rescinding the resolution passed by the Country Roads Board on the Nineteenth day of January, One thousand nine hundred and twenty-five, and confirmed by an Order in Council published in the Government Gazette of the Eleventh day of February, One thousand nine hundred and twenty-five, on page 570 declaring the highway to be a State Highway (Omeo Highway) in the Shire of Omeo, so far as it relates to the part of the said State highway indicated by cross hatching on plan numbered G.P.1313T1 hereunder.

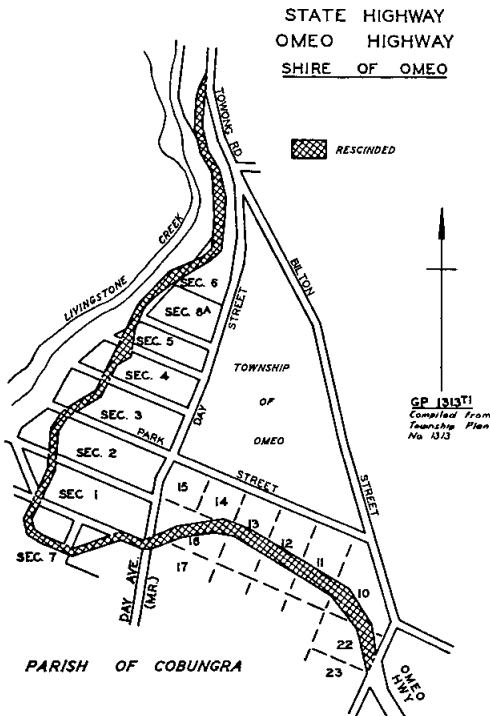

Resolution dated the Twentieth day of November, One thousand nine hundred and seventy-nine, made pursuant to section 70 of the Country Roads Act 1958 declaring the highway in the Shire of Omeo as shown hatched on plan numbered G.P.1313T2 hereunder to be a State highway (Omeo Highway) within the meaning and for the purposes of the said Act.

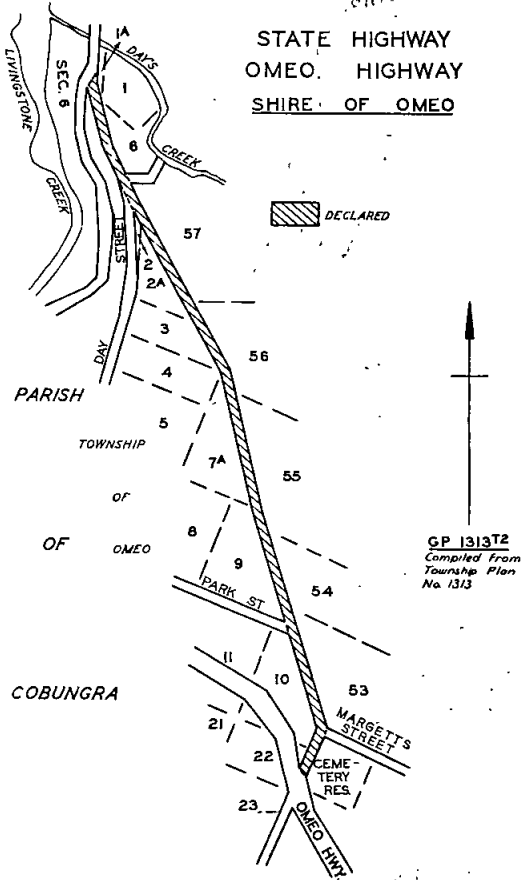

COUNTRY ROADS BOARD

Act No. 6229

At the Executive Council Chamber, Melbourne, the eleventh day of December, 1979

PRESENT:

His Excellency the Governor of Victoria
Mr Houghton
Mr Austin
Mr Ramsay

ORDER APPROVING OF LAND BEING ACQUIRED AND ROADS, DEVIATIONS OR WIDENINGS BEING MADE TOGETHER WITH ALL ANCILLARY WORKS REQUIRED TO BE EXECUTED IN CONJUNCTION THEREWITH

His Excellency the Governor of the State of Victoria, by and with the advice of the Executive Council thereof, being satisfied that there are funds legally available for acquiring the land, doth hereby approve the acquiring of the land described in the schedule hereunder and the making of new roads and deviations from and widenings of existing roads, together with all ancillary works required to be executed in conjunction therewith, referred to in the said schedule.

SCHEDULE

State Highway

The land shown hatched on plans numbered G.P.14947b and 14948 hereunder required for the widening of the McIvor Highway in the Shire of Strathfieldsaye and making of the widening thereon.

STATE HIGHWAY
MCIVOR HIGHWAY
SHIRE OF STRATHFIELDSAYE
Lengths in metres

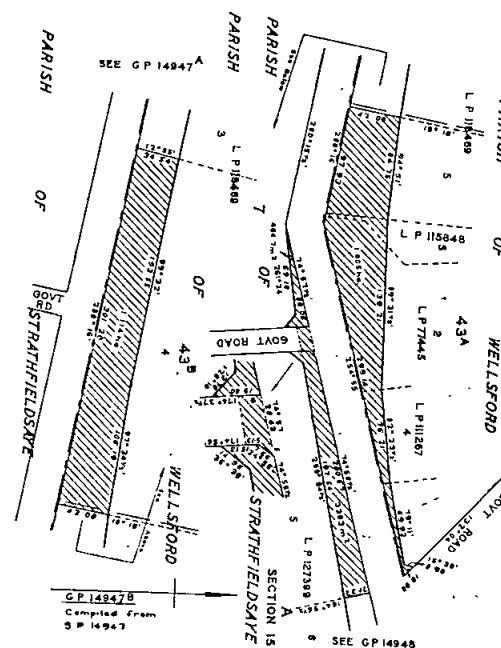

Main Road
Resolution dated the Twentieth day of November, One thousand nine hundred and seventy-nine, made pursuant to section 18 of the Country Roads Act 1958 declaring the highway in the Shire of Omeo as shown hatched on plan numbered G.P.1313T3 hereunder to be a main road (Day Avenue) within the meaning and for the purposes of the said Act.
MAIN ROAD
DAY AVENUE
SHIRE OF OMEO

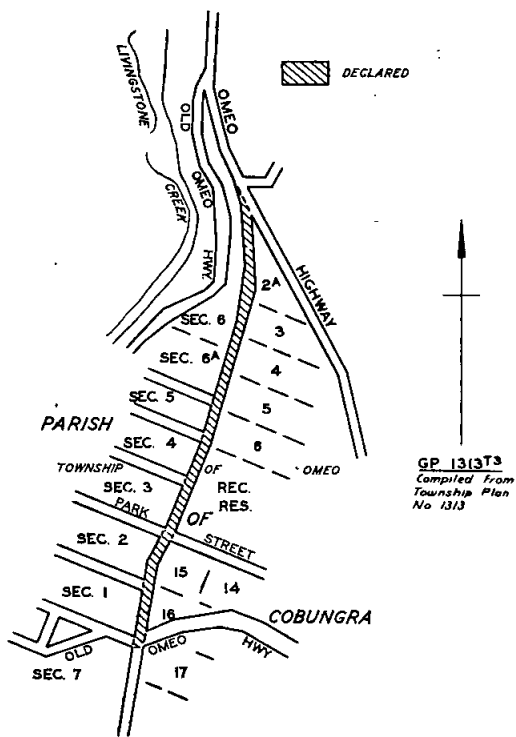

And the Honorable Robert Roy Cameron Maclellan, Her Majesty's Minister of Transport for the State of Victoria, shall give the necessary directions herein accordingly.

TOM FORRISTAL
Clerk of the Executive Council

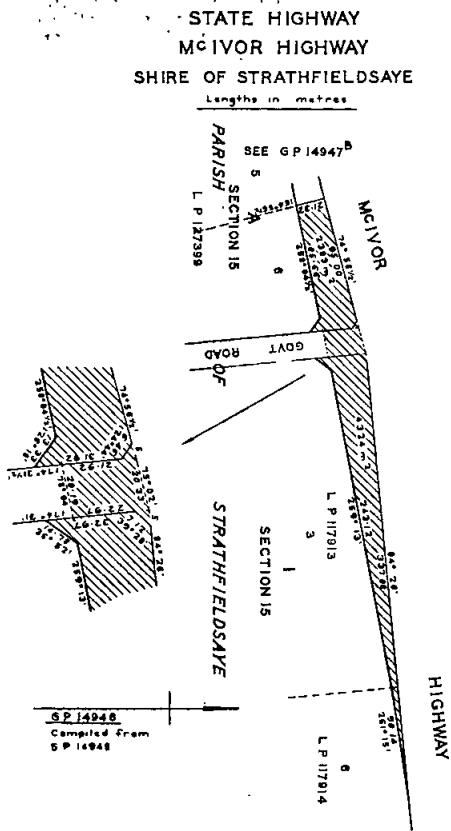

**Main Roads**

The land shown hatched on plan numbered G.P.15103 hereunder required for the widening of Tarra Valley Road in the Shire of Alberton and making of the widening thereon.

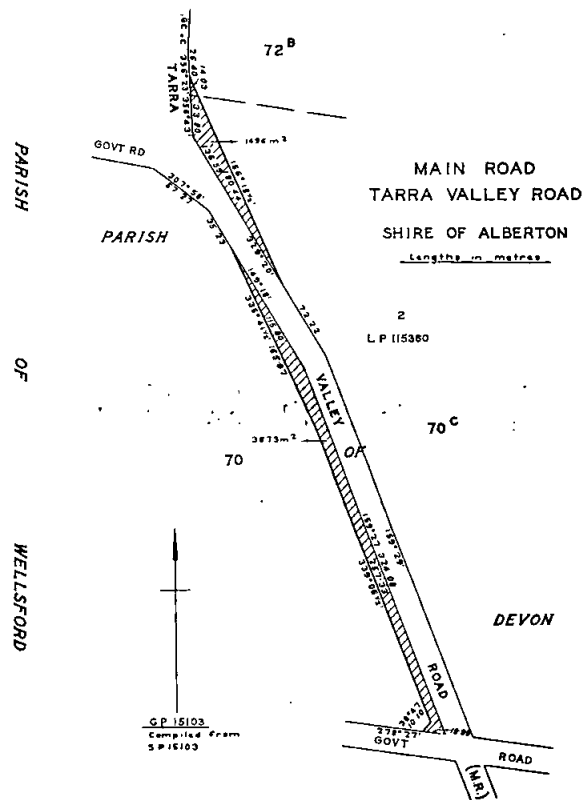

The land shown hatched on plan numbered G.P.15098A hereunder required for the widening of Ferntree Gully Road in the City of Waverley and making of the widening thereon.

MAIN ROAD  
 FERNTREE GULLY ROAD  
 CITY OF WAVERLEY  
 Lengths in metres

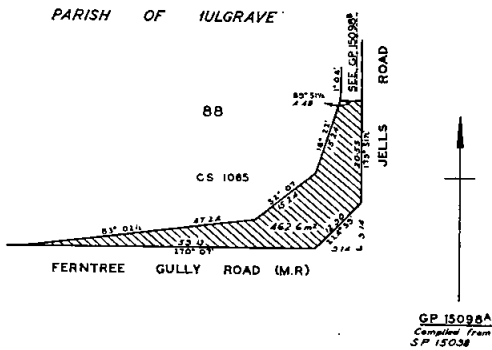

The land shown hatched on plans numbered G.P.15108A and G.P.15108B hereunder required for the deviation from the Carrajung-Woodside Road in the Shire of Alberton and making of the deviation thereon.

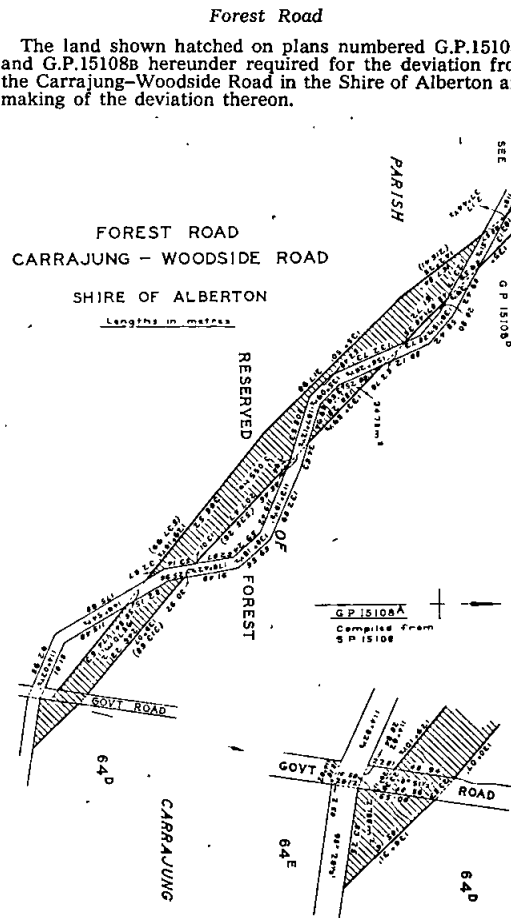

The land shown hatched on plan numbered G.P.15098B hereunder required for the widening of Jells Road in the City of Waverley and making of the widening thereon.

UNCLASSIFIED ROAD  
 JELLS ROAD  
 CITY OF WAVERLEY  
 Lengths in metres

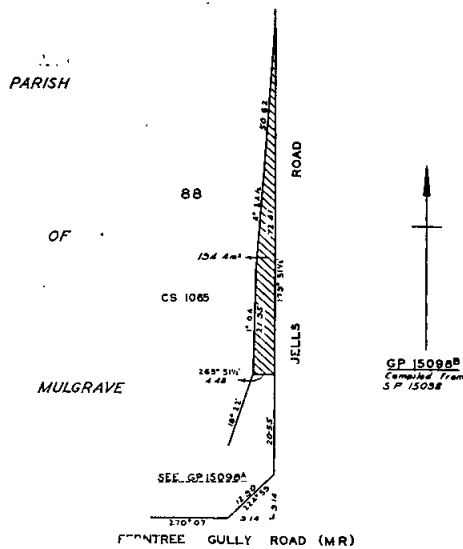

Ancillary Works

The land shown hatched on plan numbered G.P.15040 hereunder required for ancillary works required to be executed in conjunction with the improvement of Irrewillipe Road in the Shire of Colac.

ANCILLARY WORKS  
(IRREWILLIPE ROAD)

SHIRE OF COLAC

Lengths in metres

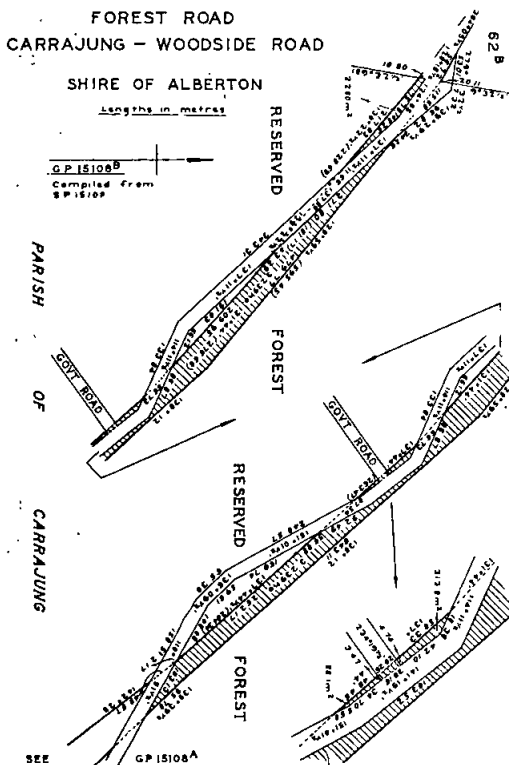
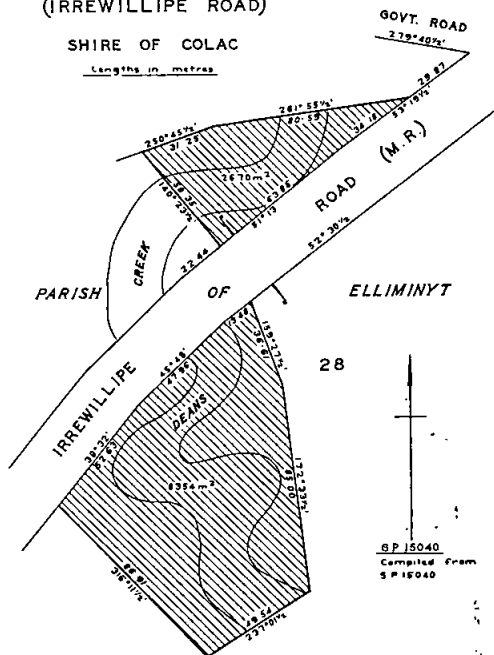

And the Honorable Robert Roy Cameron Maclellan, Her Majesty's Minister for the State of Victoria, shall give the necessary directions herein accordingly.

TOM FORRISTAL  
Clerk of the Executive Council

HOUSING ACT 1958

At the Executive Council Chamber, Melbourne, the eleventh day of December, 1979

PRESENT:

His Excellency the Governor of Victoria  
Mr Houghton | Mr Ramsay  
Mr Austin

DECLARATION OF PRIVATE STREETS AS PUBLIC HIGHWAYS WITHIN THE BOROUGH OF KOROI

Whereas pursuant to section 107 of the Housing Act 1958 it is among other things enacted that where works have been carried out in accordance with an agreement for the full construction of any roads, pavements, culverts or drains made pursuant to the provisions of the said section 107 such roads, pavements, culverts or drains shall be under the care and management of the Municipality which shall be liable for the cost of any maintenance, repair, alteration or reconstruction thereof and the Governor in Council may by order published in the Government Gazette declare any road so constructed to be a public highway.

And whereas by Order dated 23 March 1976 the Governor in Council consented to an agreement between the Housing Commission and the Borough of Koroit regarding street and drainage construction in Sturt Street and Jongebloed Court in the Koroit Estate situate in the municipality of the Borough of Koroit and the carrying out of the works enumerated in the said Agreement.

And whereas the works of road pavements, culvert and drainage construction have now been carried out in accordance with the said Agreement between the Housing Commission and the Borough of Koroit.

Now therefore His Excellency the Governor of the State of Victoria by and with the advice of the Executive Council of the said State and in pursuance of the powers conferred by section 107 of the Housing Act and upon recommendation of the Housing Commission doth by this order declare the streets more particularly delineated and shown hatched on the plan hereunder to be absolutely dedicated to the public as Public Highways within the meaning of any law now or hereafter in force and that the Council of the Municipality in which the streets are situate shall hereafter be liable for all cost of any maintenance, repair, alteration or reconstruction thereof.

Part of Crown Allotment 19  
Parish of KOROIT  
County of VILLIERS  
16 8 0 20 40 60  
Length in Metres.

L.P. 126882

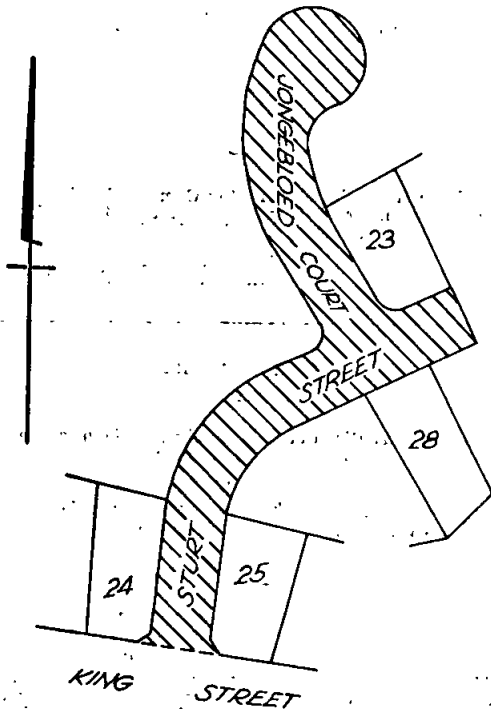

And the Honorable Brian James Dixon, Her Majesty's Minister of Housing for the State of Victoria, shall give the necessary directions herein accordingly.

TOM FORRISTAL  
Clerk of the Executive Council

HOUSING ACT 1958

At the Executive Council Chamber, Melbourne, the eleventh day of December, 1979

PRESENT:

His Excellency the Governor of Victoria  
Mr Houghton | Mr Ramsay  
Mr Austin |

DECLARATION OF PRIVATE STREETS AS PUBLIC HIGHWAYS WITHIN THE SHIRE OF WERRIBEE

Whereas pursuant to section 107 of the Housing Act 1958 it is among other things enacted that where works have been carried out in accordance with an agreement for the full construction of any roads, pavements, culverts or drains made pursuant to the provisions of the said section 107 such roads, pavements, culverts or drains shall be under the care and management of the Municipality which shall be liable for the cost of any maintenance, repair, alteration or reconstruction thereof and the Governor in Council may by order published in the Government Gazette declare any road so constructed to be a public highway.

And whereas by Order dated 10 April 1979 the Governor in Council consented to an agreement between the Housing Commission and the Shire of Werribee regarding street and drainage construction in Newbury Street, Nightingale Drive, Jago Court, Kookaburra Avenue, Dobell Crescent, Kramer Street, Dove Court, Giles Court, Darvall Court, Troy Court and Sibley Street in the Werribee "B" Estate situate in the municipality of the Shire of Werribee and the carrying out of the works enumerated in the said Agreement.

And whereas the works of road pavements, culvert and drainage construction have now been carried out in accordance with the said Agreement between the Housing Commission and the Shire of Werribee.

Now therefore His Excellency the Governor of the State of Victoria by and with the advice of the Executive Council of the said State and in pursuance of the powers conferred by section 107 of the Housing Act and upon recommendation of the Housing Commission doth by this order declare the streets more particularly delineated and shown hatched on the plans hereunder to be absolutely dedicated to the public as Public Highways within the meaning of any law now or hereafter in force and that the Council of the Municipality in which the streets are situate shall hereafter be liable for all cost of any maintenance, repair, alteration or reconstruction thereof.

CROWN ALLOTMENTS A B C D

PART OF CROWN ALLOTMENTS F G & H

SECTION 2

PARISH OF TARNEIT

COUNTY OF BOURKE

L P 128791

Scale 20 40 60  
Lengths are in Metres

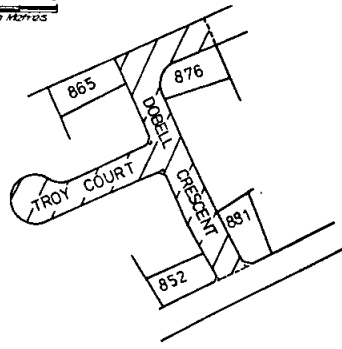

CROWN ALLOTMENTS A.B.C.D  
PART OF CROWN ALLOTMENTS F.G.&H.

SECTION 2  
PARISH OF TARNEIT  
COUNTY OF BOURKE

L.P. 128792

Scale: 0 10 20 30 40 50 60  
Lengths are in Metres

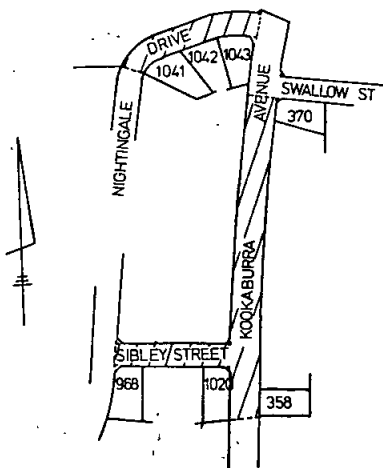

CROWN ALLOTMENTS A.B.C.D &  
PART OF CROWN ALLOTMENTS F.G.&H.

SECTION 2  
PARISH OF TARNEIT  
COUNTY OF BOURKE

L.P. 128789

Scale: 0 10 20 30 40 50 60  
Lengths are in Metres

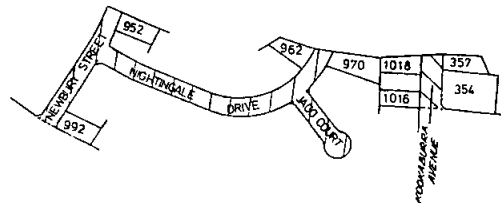

And the Honorable Brian James Dixon, Her Majesty's  
Minister of Housing for the State of Victoria, shall give  
the necessary directions herein accordingly.

TOM FORRISTAL  
Clerk of the Executive Council

HOUSING ACT 1958

At the Executive Council Chamber, Melbourne, the  
eleventh day of December, 1979

PRESENT:

His Excellency the Governor of Victoria  
Mr Houghton | Mr Ramsay  
Mr Austin |

DECLARATION OF PRIVATE STREETS AS PUBLIC  
HIGHWAYS WITHIN THE CITY OF SUNSHINE

Whereas pursuant to section 107 of the *Housing Act* 1958 it is among other things enacted that where works have been carried out in accordance with an agreement for the full construction of any roads, pavements, culverts or drains made pursuant to the provisions of the said section 107 such roads, pavements, culverts or drains shall be under the care and management of the Municipality which shall be liable for the cost of any maintenance, repair, alteration or reconstruction thereof and the Governor in Council may by order published in the *Government Gazette* declare any road so constructed to be a public highway.

And whereas by Order dated 11 July 1978 the Governor in Council consented to an agreement between the Housing Commission and the City of Sunshine regarding street and drainage construction in Warrington Crescent, Livingston Street, Craigavon Court, Antrim Court, Columbia Court, Bracknell Place and a portion of Tamar Drive in the Deer Park-Westerngate Estate Stages 4C1, 4C2 and 5 situate in the municipality of the City of Sunshine and the carrying out of the works enumerated in the said Agreement.

And whereas the works of road pavements, culvert and drainage construction have now been carried out in accordance with the said Agreement between the Housing Commission and the City of Sunshine.

Now therefore His Excellency the Governor of the State of Victoria by and with the advice of the Executive Council of the said State and in pursuance of the powers conferred by section 107 of the *Housing Act* and upon recommendation of the Housing Commission doth by this order declare the streets more particularly delineated and shown hatched on the plans hereunder to be absolutely dedicated to the public as Public Highways within the meaning of any law now or hereafter in force and that the Council of the

CROWN ALLOTMENTS A,B,C,D  
AND PART OF CROWN ALLOTMENTS F,G & H

SECTION 2  
PARISH OF TARNEIT  
COUNTY OF BOURKE

L.P. 128790

Scale: 0 10 20 30 40 50 60  
Lengths are in Metres

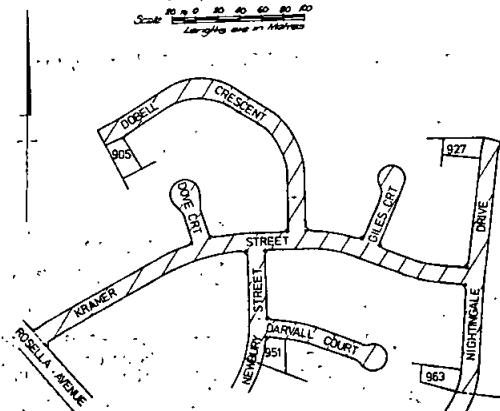

Municipality in which the streets are situate shall hereafter be liable for all cost of any maintenance, repair, alteration or reconstruction thereof.

PART OF CROWN ALLOTMENT 45A  
PARISH OF MARIBYRNONG  
COUNTY OF BOURKE  
L.P. 126683

Scale: 0 5 10 15 20 25 30 35 40  
LENGTHS ARE IN METRES

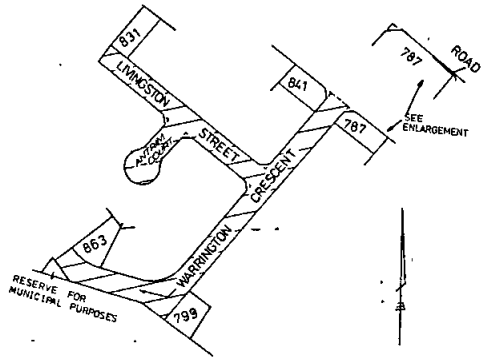

PART OF CROWN ALLOTMENT 45A  
PARISH OF MARIBYRNONG  
COUNTY OF BOURKE  
L.P. 126682

Scale: 0 5 10 15 20 25 30 35 40  
LENGTHS ARE IN METRES

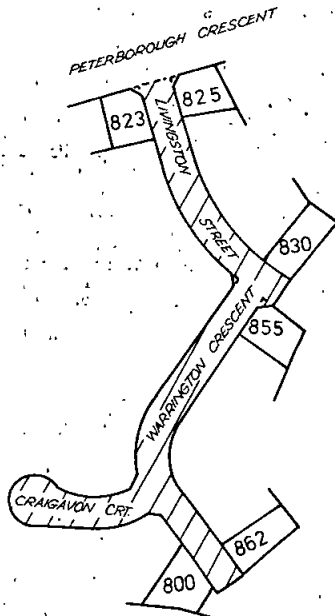

PART OF CROWN ALLOTMENTS 42A & 45A  
PARISH OF MARIBYRNONG  
COUNTY OF BOURKE

L.P. 126850

Scale: 0 5 10 15 20 25 30 35 40  
LENGTHS ARE IN METRES

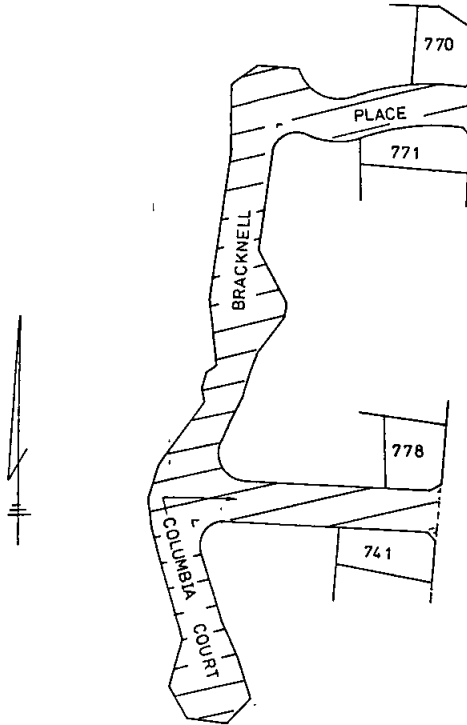

And the Honorable Brian James Dixon, Her Majesty's Minister of Housing for the State of Victoria, shall give the necessary directions herein accordingly.

TOM FORRISTAL  
Clerk of the Executive Council

HOUSING ACT 1958

At the Executive Council Chamber, Melbourne, the eleventh day of December, 1979

PRESENT:

His Excellency the Governor of Victoria  
Mr Houghton  
Mr Austin  
Mr Ramsay

DECLARATION OF PRIVATE STREETS AS PUBLIC HIGHWAYS WITHIN THE SHIRE OF WERRIBEE

Whereas pursuant to section 107 of the Housing Act 1958 it is among other things enacted that where works have been carried out in accordance with an agreement for the full construction of any roads, pavements, culverts or drains made pursuant to the provisions of the said section 107 such roads, pavements, culverts or drains shall be under the care and management of the Municipality which shall be liable for the cost of any maintenance, repair, alteration or reconstruction thereof and the Governor



in Council may by order published in the *Government Gazette* declare any road so constructed to be a public highway.

And whereas by Order dated 8 November 1978 the Governor in Council consented to an agreement between the Housing Commission and the Shire of Werribee regarding street and drainage construction in Kookaburra Avenue, Swallow Street, Boyd Court, Redpath Court, Sherrin Court, Owen Court, Upton Court, Malleehen Street and Olsen Court in the Werribee "B" Estate situate in the municipality of the Shire of Werribee and the carrying out of the works enumerated in the said Agreement.

And whereas the works of road pavements, culvert and drainage construction have now been carried out in accordance with the said Agreement between the Housing Commission and the Shire of Werribee.

Now therefore His Excellency the Governor of the State of Victoria by and with the advice of the Executive Council of the said State and in pursuance of the powers conferred by section 107 of the Housing Act and upon recommendation of the Housing Commission doth by this order declare the streets more particularly delineated and shown hatched on the plan hereunder to be absolutely dedicated to the public as Public Highways within the meaning of any law now or hereafter in force and that the Council of the Municipality in which the streets are situate shall hereafter be liable for all cost of any maintenance, repair, alteration or reconstruction thereof.

CROWN ALLOTMENTS A B C D  
PART OF CROWN ALLOTMENTS FG & H  
SECTION 2  
PARISH OF TARNEIT  
COUNTY OF BOURKE  
L PS 128793 & 4

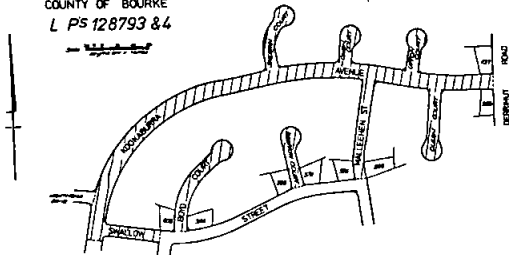

And the Honorable Brian James Dixon, Her Majesty's Minister of Housing for the State of Victoria, shall give the necessary directions herein accordingly.

TOM FORRISTAL  
Clerk of the Executive Council

#### TEACHER HOUSING ACT 1970

At the Executive Council Chamber, Melbourne, the  
eleventh day of December, 1979

PRESENT:

His Excellency the Governor of Victoria  
Mr Houghton | Mr Ramsay  
Mr Austin

In pursuance of the provisions of section 5 of the *Teacher Housing Act 1970*, No. 8062, His Excellency the Governor of the State of Victoria, by and with the advice of the Executive Council thereof, doth by this Order appoint Bernard Joseph Leonard as a Member and Chairman of the Teacher Housing Authority from and inclusive of 11 December 1979.

And the Honorable Brian James Dixon, Her Majesty's Minister of Housing for the State of Victoria, shall give the necessary directions herein accordingly.

TOM FORRISTAL  
Clerk of the Executive Council

#### TEACHER HOUSING ACT 1970

At the Executive Council Chamber, Melbourne, the  
eleventh day of December, 1979

PRESENT:

His Excellency the Governor of Victoria  
Mr Houghton | Mr Ramsay  
Mr Austin

In pursuance of the provisions of section 8 of the *Teacher Housing Act 1970*, No. 8062, His Excellency the Governor of the State of Victoria, by and with the advice of the Executive Council thereof, doth by this Order remove from office Alan Adair Ashman as a Member and Chairman of the Teacher Housing Authority, from and inclusive of 11 December 1979.

And the Honorable Brian James Dixon, Her Majesty's Minister of Housing for the State of Victoria, shall give the necessary directions herein accordingly.

TOM FORRISTAL  
Clerk of the Executive Council

#### ROYAL COMMISSION INTO CERTAIN HOUSING COMMISSION LAND PURCHASES AND OTHER MATTERS

At the Executive Council Chamber, Melbourne, the  
eleventh day of December, 1979

PRESENT:

His Excellency the Governor of Victoria  
Mr Houghton | Mr Ramsay  
Mr Austin

#### ORDER AUTHORIZING MAXIMUM EXPENDITURE OF ROYAL COMMISSION

His Excellency the Governor of the State of Victoria, in the Commonwealth of Australia, by and with the advice of the Executive Council of the said State and in pursuance of the powers conferred by Regulation 39 of the Public Accounts and Stores Regulations 1958, and all other powers him thereunto enabling, hereby authorizes a maximum expenditure of the sum of Six hundred and twenty-two thousand dollars (\$622 000) by the Royal Commission to inquire into and report upon certain matters relating to the land purchased by the Housing Commission and to the valuation of land purchased by the Government or its instrumentalities being an addition of Three hundred and thirty-seven thousand dollars (\$337 000) to the amount authorized by His Excellency the Governor in Council on 10 July 1979.

And the Honorable Haddon Storey, Her Majesty's Attorney-General for the State of Victoria, shall give the necessary directions herein accordingly.

TOM FORRISTAL  
Clerk of the Executive Council

#### ROYAL COMMISSION INTO CERTAIN HOUSING COMMISSION LAND PURCHASES AND OTHER MATTERS

At the Executive Council Chamber, Melbourne, the  
eleventh day of December, 1979

PRESENT:

His Excellency the Governor of Victoria  
Mr Houghton | Mr Ramsay  
Mr Austin

Whereas:

1. By Order made on 20 June 1979, and published in the *Government Gazette* on 20 June 1979, The Honorable Sir SYDNEY FROST, Q.C., LL.M., and ALFRED JAMES ELLWOOD Esquire, LL.M., were appointed a Royal Commission to

inquire into and report upon certain matters relating to land purchased by the Housing Commission and to the valuation of land purchased by the Government or its instrumentalities and were directed, with as little delay as possible and by 31 December 1979, at the latest, to report under their hand their opinion resulting from the inquiry.

2. It is expedient to extend the latest date upon which the said Sir Sydney Frost and Alfred James Ellwood shall report as aforesaid.

Now therefore, His Excellency the Governor of the State of Victoria, in the Commonwealth of Australia, by and with the advice of the Executive Council of the said State, doth by this Order extend the said Order made on 20 June, 1979, by substituting for the expression "31 December 1979" the expression "31 May 1980".

And the Honorable Haddon Storey, Her Majesty's Attorney-General for the State of Victoria, shall give the necessary directions herein accordingly.

TOM FORRISTAL  
Clerk of the Executive Council

STATE ELECTRICITY COMMISSION ACT 1958, No. 6377

At the Executive Council Chamber, Melbourne, the  
eleventh day of December, 1979

PRESENT:

His Excellency the Governor of Victoria  
Mr Houghton | Mr Ramsay  
Mr Austin

Whereas His Excellency the Governor of the State of Victoria by and with the advice of the Executive Council thereof has this day consented pursuant to the provisions of the State Electricity Commission Act 1958 to the State Electricity Commission of Victoria raising by way of a loan the sum of One million dollars (\$1 000 000); And whereas the Governor in Council is satisfied that a sufficient proportion of the loan to be raised will fall due and be repaid in each year during the currency of the proposed loan; Now therefore it is directed pursuant to the provisions of section 91 (3) of the said Act, that it shall not be necessary to provide a sinking fund in connection with such loan.

And the Honorable Lindsay Hamilton Simpson Thompson, Her Majesty's Treasurer for the State of Victoria, shall give the necessary directions herein accordingly.

TOM FORRISTAL  
Clerk of the Executive Council

STATE ELECTRICITY COMMISSION ACT 1958, No. 6377

At the Executive Council Chamber, Melbourne, the  
eleventh day of December, 1979

PRESENT:

His Excellency the Governor of Victoria  
Mr Houghton | Mr Ramsay  
Mr Austin

Whereas His Excellency the Governor of the State of Victoria by and with the advice of the Executive Council thereof has this day consented pursuant to the provisions of the State Electricity Commission Act 1958 to the State Electricity Commission of Victoria raising by way of a loan the sum of Twenty-five thousand dollars (\$25 000); and whereas the Governor in Council is satisfied that a sufficient proportion of the loan to be raised will fall due and be repaid in each year during the currency of the proposed

loan; Now therefore it is directed pursuant to the provisions of section 91 (3) of the said Act, that it shall not be necessary to provide a sinking fund in connection with such loan.

And the Honorable Lindsay Hamilton Simpson Thompson, Her Majesty's Treasurer for the State of Victoria, shall give the necessary directions herein accordingly.

TOM FORRISTAL  
Clerk of the Executive Council

STATE ELECTRICITY COMMISSION ACT 1958, No. 6377

At the Executive Council Chamber, Melbourne, the  
eleventh day of December, 1979

PRESENT:

His Excellency the Governor of Victoria  
Mr Houghton | Mr Ramsay  
Mr Austin

Whereas His Excellency the Governor of the State of Victoria by and with the advice of the Executive Council thereof has this day consented pursuant to the provisions of the State Electricity Commission Act 1958 to the State Electricity Commission of Victoria raising by way of a loan the sum of Thirty-nine thousand dollars (\$39 000); And whereas the Governor in Council is satisfied that a sufficient proportion of the loan to be raised will fall due and be repaid in each year during the currency of the proposed loan; Now therefore it is directed pursuant to the provisions of section 91 (3) of the said Act, that it shall not be necessary to provide a sinking fund in connection with such loan.

And the Honorable Lindsay Hamilton Simpson Thompson, Her Majesty's Treasurer for the State of Victoria, shall give the necessary directions herein accordingly.

TOM FORRISTAL  
Clerk of the Executive Council

STATE ELECTRICITY COMMISSION ACT 1958, No. 6377

At the Executive Council Chamber, Melbourne, the  
eleventh day of December, 1979

PRESENT:

His Excellency the Governor of Victoria  
Mr Houghton | Mr Ramsay  
Mr Austin

Whereas His Excellency the Governor of the State of Victoria by and with the advice of the Executive Council thereof has this day consented pursuant to the provisions of the State Electricity Commission Act 1958 to the State Electricity Commission of Victoria raising by way of a loan the sum of Sixty-four thousand dollars (\$64 000); And whereas the Governor in Council is satisfied that a sufficient proportion of the loan to be raised will fall due and be repaid in each year during the currency of the proposed loan; Now therefore it is directed pursuant to the provisions of section 91 (3) of the said Act, that it shall not be necessary to provide a sinking fund in connection with such loan.

And the Honorable Lindsay Hamilton Simpson Thompson, Her Majesty's Treasurer for the State of Victoria, shall give the necessary directions herein accordingly.

TOM FORRISTAL  
Clerk of the Executive Council

ROAD TRAFFIC ACT 1958

At the Executive Council Chamber, Melbourne, the eleventh day of December, 1979

PRESENT:

His Excellency the Governor of Victoria  
Mr Houghton | Mr Ramsay  
Mr Austin

In pursuance of the powers conferred by the Road Traffic Act 1958, His Excellency the Governor of the State of Victoria, in the Commonwealth of Australia, by and with the advice of the Executive Council of the said State, and at the request in writing of the Council of the City of Wangaratta doth by this Order extend the provisions of the said Act to the land under the control of the City of Wangaratta as shown by cross-hatching on the plan hereunder.

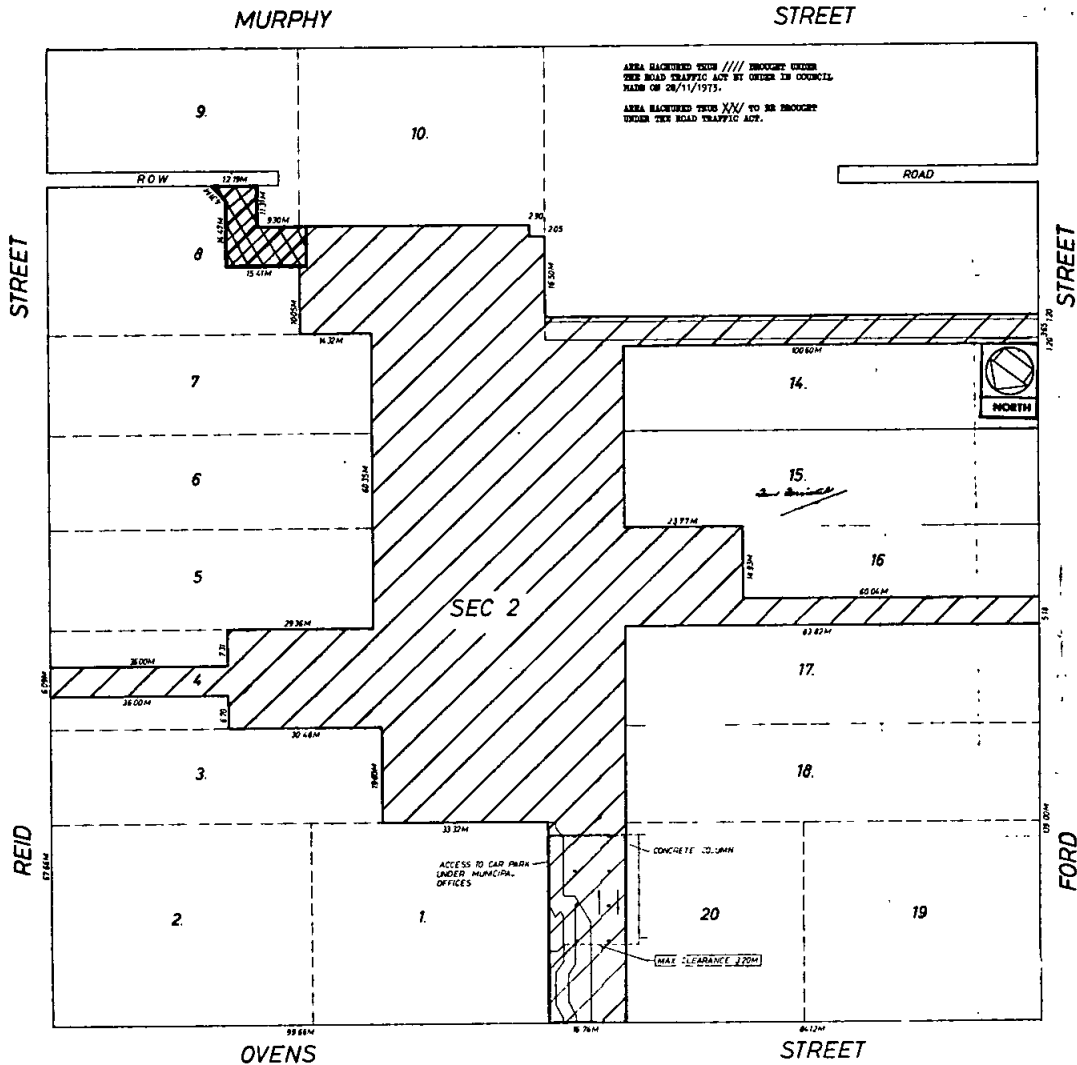

And the Honorable Lindsay Hamilton Simpson Thompson, Her Majesty's Minister for Police and Emergency Services for the State of Victoria, shall give the necessary directions herein accordingly.

TOM FORRISTAL  
Clerk of the Executive Council

ROAD TRAFFIC ACT 1958

At the Executive Council Chamber, Melbourne, the eleventh day of December, 1979

PRESENT:

His Excellency the Governor of Victoria  
Mr Houghton | Mr Ramsay  
Mr Austin

In pursuance of the powers conferred by the Road Traffic Act 1958, His Excellency the Governor of the State of Victoria, in the Commonwealth of Australia, by and with the advice of the Executive Council of the said State, and at the request in writing of the Council of the Rural City of Wodonga, doth by this Order extend the provisions of the said Act to the land under the control of the Rural City of Wodonga, shown by hatching on the plan hereunder.

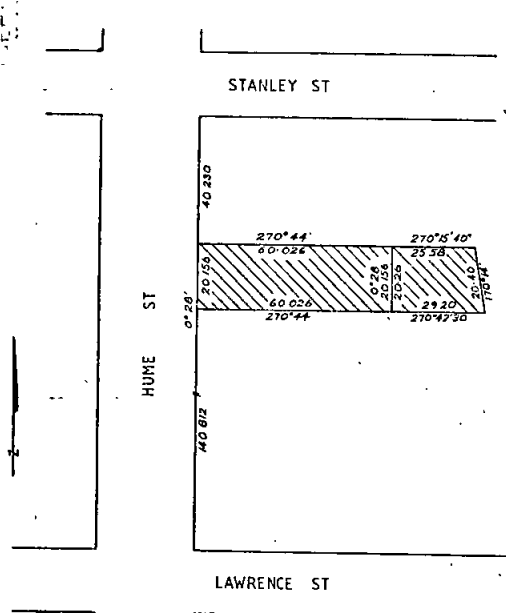

RURAL CITY OF WODONGA  
OFF STREET PARKING

Area hatched thus  to be brought under the road traffic regulations.

And the Honorable Lindsay Hamilton Simpson Thompson, Her Majesty's Minister for Police and Emergency Services for the State of Victoria, shall give the necessary directions herein accordingly.

TOM FORRISTAL  
Clerk of the Executive Council

ROAD TRAFFIC ACT 1958

At the Executive Council Chamber, Melbourne, the eleventh day of December, 1979

PRESENT:

His Excellency the Governor of Victoria  
Mr Houghton | Mr Ramsay  
Mr Austin

In pursuance of the powers conferred by the Road Traffic Act 1958, His Excellency the Governor of the State of Victoria, in the Commonwealth of Australia, by and with the advice of the Executive Council of the said State, and at the request in writing of the Council of the City of Ringwood, doth by this Order extend the provisions of the said Act to the land under the control of the City of Ringwood shown by hatching on the plan hereunder.

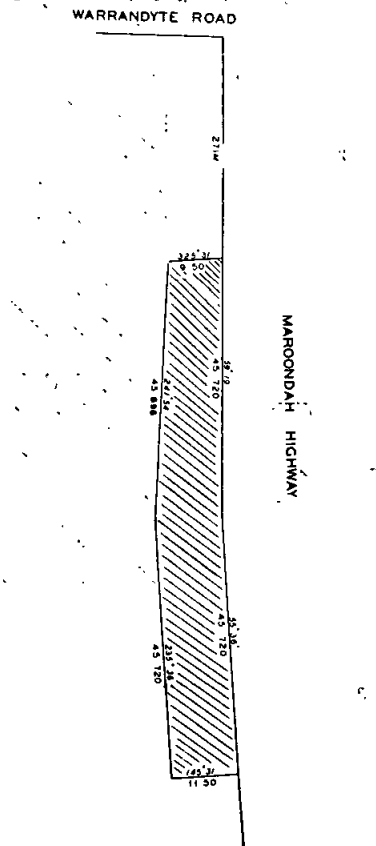

And the Honorable Lindsay Hamilton Simpson Thompson, Her Majesty's Minister for Police and Emergency Services for the State of Victoria, shall give the necessary directions herein accordingly.

TOM FORRISTAL  
Clerk of the Executive Council

ROAD TRAFFIC ACT 1958

At the Executive Council Chamber, Melbourne, the eleventh day of December, 1979

PRESENT:

His Excellency the Governor of Victoria  
 Mr Houghton Mr Ramsay  
 Mr Austin

In pursuance of the powers conferred by the Road Traffic Act 1958, His Excellency the Governor of the State of Victoria, in the Commonwealth of Australia, by and with the advice of the Executive Council of the said State and at the request in writing of the Council of the Shire of Cranbourne, doth by this Order extend the provisions of the said Act to the land under the control of the Shire of Cranbourne shown by hatching on the plan hereunder.

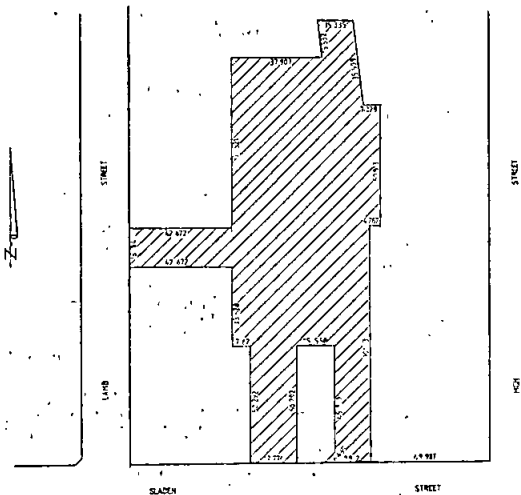

PART OF CROWN ALLOTMENT 5  
 TOWNSHIP OF CRANBOURNE  
 COUNTY OF MORNINGTON  
 1:1000  
 Application of the provisions of the Road Traffic Act 1958 to land shown hatching

And the Honorable Lindsay Hamilton Simpson Thompson, Her Majesty's Minister for Police and Emergency Services for the State of Victoria, shall give the necessary directions herein accordingly.

TOM FORRISTAL  
 Clerk of the Executive Council

LAND ACT 1958

At the Executive Council Chamber, Melbourne, the eleventh day of December, 1979

PRESENT:

His Excellency the Governor of Victoria  
 Mr Houghton Mr Ramsay  
 Mr Austin

UNUSED ROADS CLOSED

His Excellency the Governor of the State of Victoria, in the Commonwealth of Australia, by and with the advice of the Executive Council of the said State, pursuant to the provisions of section 349 of the Land Act 1958, and with the concurrence in writing of the council of the municipality concerned and that of any adjoining land owners, doth hereby close the unused roads hereinafter described, viz.:

Municipal District of the City of Ararat, Township of Ararat being the road indicated by hatching on plan hereunder—(A.148(9) (L.3-1263).

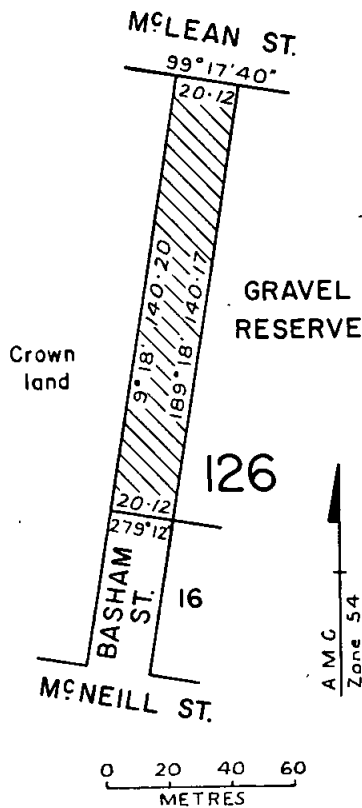

Municipal District of the Shire of Daylesford and Glenlyon, Township of Daylesford West being the road indicated by hatching on plan hereunder—(D.13(?) (10/137A).

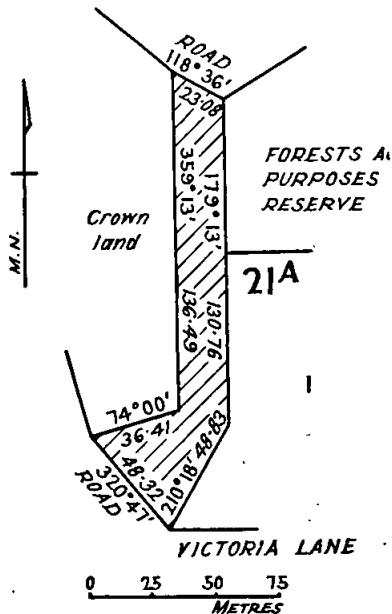

Municipal District of the City of Echuca—Township of Echuca being the road indicated by hatching on plan hereunder—(E.3<sup>(1)</sup>) (W.67468).

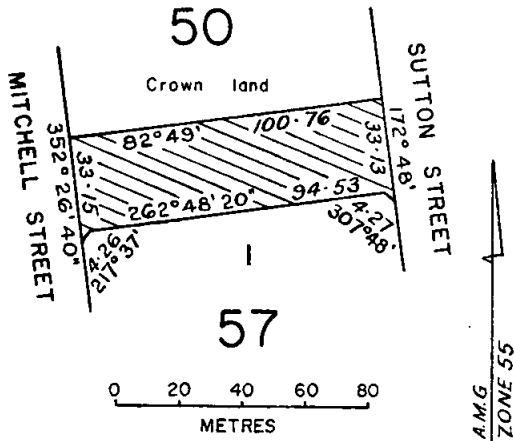

the Crown lands in the Parish of Glenelg temporarily reserved for Public purposes (National Parks Act purposes) by Order in Council of 24 July 1979 (see Government Gazette of 1 August 1979)—(G.191<sup>(\*)</sup>) (Rs.10637).

And the Honorable William Vasey Houghton, Her Majesty's Minister of Lands for the State of Victoria, shall give the necessary directions herein accordingly.

TOM FORRISTAL  
Clerk of the Executive Council

CROWN LAND (RESERVES) ACT 1978

At the Executive Council Chamber, Melbourne, the eleventh day of December, 1979

PRESENT:

His Excellency the Governor of Victoria  
Mr Houghton | Mr Ramsay  
Mr Austin

CROWN LANDS TEMPORARILY RESERVED

His Excellency the Governor of the State of Victoria, in the Commonwealth of Australia, by and with the advice of the Executive Council of the said State, pursuant to the provisions of sections 4 and 7 of the Crown Land (Reserves) Act 1978, and being of the opinion that the Crown lands concerned are required for the public purposes respectively mentioned, doth hereby temporarily reserve and also except from occupation for mining purposes under any miner's right the Crown lands hereinafter described, viz.:

OLANGOLAH—For Departmental Depot, 4620 square metres, being Crown allotment 13 x 4, Parish of Olangolah, as shown on Certified Plan No. 104301 lodged in the Central Plan Office—(Rs.11081).

ST. ARNAUD—For Health Commission purposes, 1763 square metres, being Crown allotment 4A, section M1, Township of St. Arnaud, Parish of St. Arnaud, as indicated by hatching on plan hereunder—(S.206<sup>(11)</sup>) (Rs.10846).

Municipal District of the Shire of Otway, Parish of Yaughter being the road indicated by hatching on plan hereunder—(Y.115<sup>(1)</sup>) (G.76125).

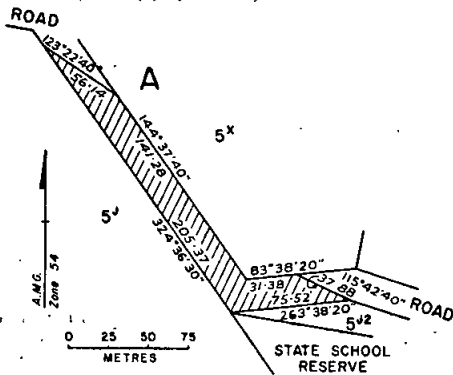

And the Honorable William Vasey Houghton, Her Majesty's Minister of Lands for the State of Victoria, shall give the necessary directions herein accordingly.

TOM FORRISTAL  
Clerk of the Executive Council

CROWN LAND (RESERVES) ACT 1978

At the Executive Council Chamber, Melbourne, the eleventh day of December, 1979

PRESENT:

His Excellency the Governor of Victoria  
Mr Houghton | Mr Ramsay  
Mr Austin

CERTAIN RESERVED CROWN LANDS IN THE PARISH OF GLENELG PLACED UNDER THE CONTROL AND MANAGEMENT OF THE DIRECTOR OF NATIONAL PARKS

His Excellency the Governor of the State of Victoria, in the Commonwealth of Australia, by and with the advice of the Executive Council of the said State, pursuant to the provisions of section 18 (1) of the Crown Land (Reserves) Act 1978, and with the concurrence of the Minister for Conservation, doth hereby place under the control and management of the Director of National Parks,

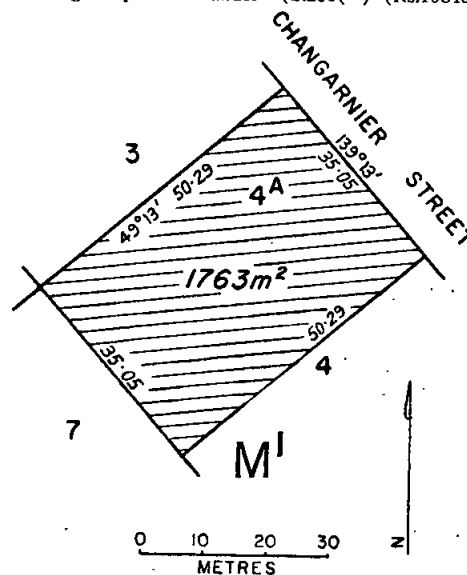

WONTHAGGI—For Infant Welfare and Kindergarten, 2156 square metres, being Crown allotment 2, section 9A, Township of Wonthaggi, Parish of Wonthaggi, as shown on Certified Plan No. 103721 lodged in the Central Plan Office—(Rs.11089).

YALOK—For Soil Conservation Authority purposes, 222.3 hectares, being Crown allotment 8, section 2, Parish of Yalok, as indicated by hatching on plan hereunder—(Y.112(2)) (Rs.10715).

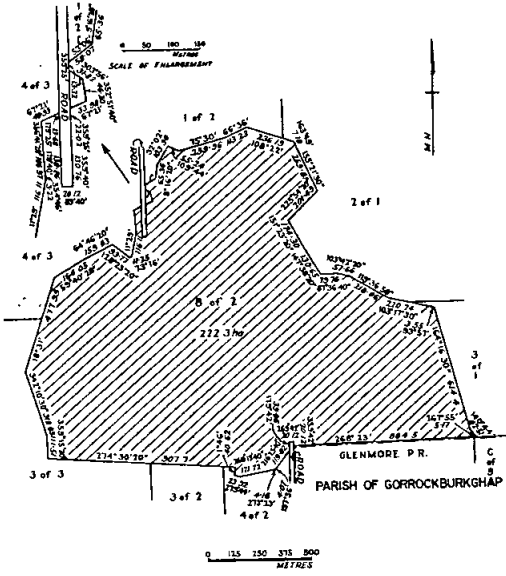

And the Honorable William Vasey Houghton, Her Majesty's Minister of Lands for the State of Victoria, shall give the necessary directions herein accordingly.

TOM FORRISTAL  
Clerk of the Executive Council

CROWN LAND (RESERVES) ACT 1978

At the Executive Council Chamber, Melbourne, the eleventh day of December, 1979

PRESENT:

His Excellency the Governor of Victoria  
Mr Houghton | Mr Ramsay  
Mr Austin

REVOCATION OF TEMPORARY RESERVATIONS OF LANDS BY ORDERS IN COUNCIL

His Excellency the Governor of the State of Victoria, in the Commonwealth of Australia, by and with the advice of the Executive Council of the said State, pursuant to the provisions of section 10 of the Crown Land (Reserves) Act 1978, doth hereby revoke the temporary reservations of lands by Orders in Council hereinafter described, viz.:

HAMILTON—The temporary reservation by Order in Council of 6 October 1953 of 6.070 hectares of land in the Township of Hamilton as a site for Public Recreation, so far only as the portion thereof containing 2981 square metres, as defined by description and hatching on plan published in the Government Gazette of 14 November 1979, is concerned—(H.45(3)) (Rs.102).

WOOMELANG—The temporary reservation by Order in Council of 18 February 1908 of 1.214 hectares of land in the Township of Woomelang (Parish of Cronomby in Order) as a site for a State School, so far only as the portion thereof containing 900 square metres, as shown on Certified Plan No. 104271 lodged in the Central Plan Office, is concerned—(Rs.6645).

And the Honorable William Vasey Houghton, Her Majesty's Minister of Lands for the State of Victoria, shall give the necessary directions herein accordingly.

TOM FORRISTAL  
Clerk of the Executive Council

CROWN LAND (RESERVES) ACT 1978

At the Executive Council Chamber, Melbourne, the eleventh day of December, 1979

PRESENT:

His Excellency the Governor of Victoria  
Mr Houghton | Mr Ramsay  
Mr Austin

CROWN LANDS TEMPORARILY RESERVED

His Excellency the Governor of the State of Victoria, in the Commonwealth of Australia, by and with the advice of the Executive Council of the said State, pursuant to the provisions of sections 4 and 7 of the Crown Land (Reserves) Act 1978, and being of the opinion that the Crown lands concerned are required for the purposes respectively mentioned, doth hereby temporarily reserve and also except from occupation for mining purposes under any miner's right the Crown lands hereinafter described, viz.:

DIMBOOLA—For State School purposes, 5257 square metres, being Crown allotment 148A, Parish of Dimboola, as shown on Certified Plan No. 102554 lodged in the Central Plan Office—(D.150(2)) (Rs.10734).

KEELBUNDORA—For State School purposes, 7.881 hectares, being Crown allotment 10f, Parish of Keelbundora, as shown on Certified Plan No. 104244 lodged in the Central Plan Office—(K.25(2)) (Rs.7832).

NORTHWOOD—For Conservation of an Area of Natural Interest, 18.11 hectares, being Crown allotment 38b, section A, Parish of Northwood, as indicated by hatching on plan hereunder—(N.100(A2)) (Rs.10884).

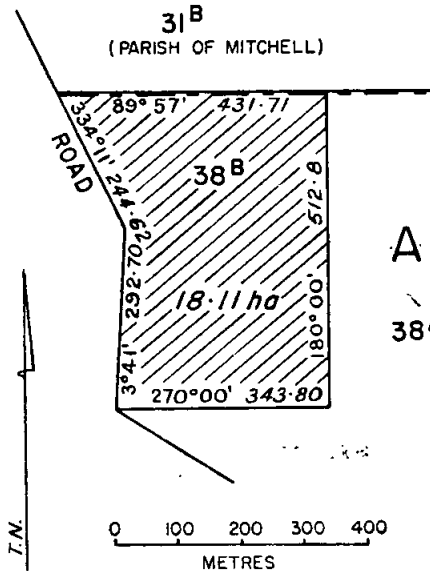

And the Honorable William Vasey Houghton, Her Majesty's Minister of Lands for the State of Victoria, shall give the necessary directions herein accordingly.

TOM FORRISTAL  
Clerk of the Executive Council

HEALTH ACT 1958

At the Executive Council Chamber, Melbourne, the  
eleventh day of December, 1979

PRESENT:

His Excellency the Governor of Victoria  
Mr Houghton | Mr Ramsay  
Mr Austin |

PROHIBITION OF SPREADING OF NIGHT-SOIL IN CERTAIN AREAS IN THE MUNICIPALITY OF  
THE SHIRE OF BASS

Whereas it is provided therein that sub-section (1) of section 52 of the Health Act 1958 shall apply to any such Shire or part thereof as the Governor in Council by Order, on the recommendation of the Health Commission of Victoria, directs.

Now therefore His Excellency the Governor of the State of Victoria, in the Commonwealth of Australia, by and with the advice of the Executive Council of the said State and on the recommendation of the Health Commission of Victoria doth by this Order direct that no person shall place, deposit or spread or cause, permit or suffer to be placed, deposited or spread any night-soil (whether mixed with other substances or not) or any liquid mixture of night-soil in or on any of the parts of the municipal district of the Shire of Bass shown hatched on the plan hereunder.

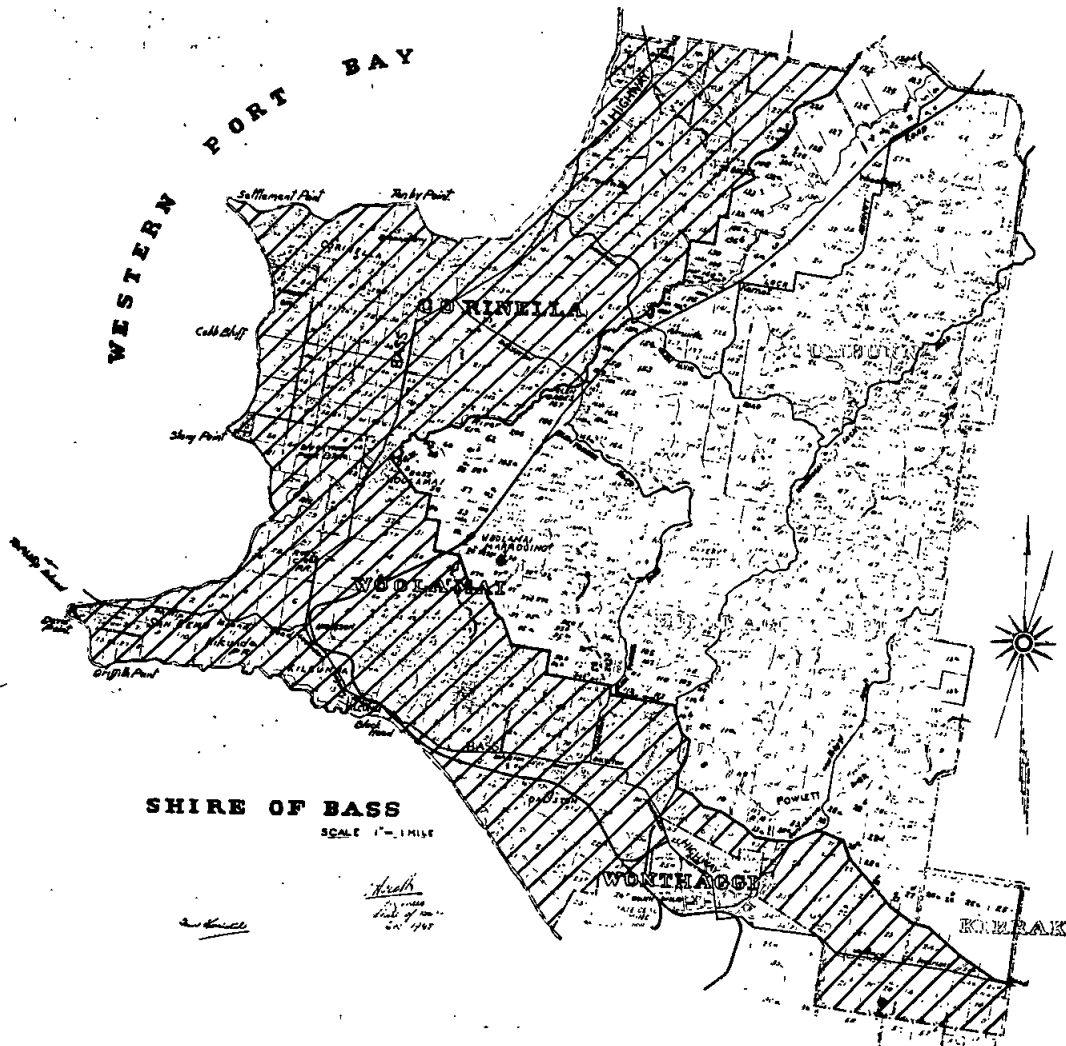

And the Honorable William Archibald Borthwick Her Majesty's Minister of Health for the State of Victoria, shall give the necessary directions herein accordingly

TOM FORRISTAL  
Clerk of the Executive Council



## Water Act 1958

## STATE RIVERS AND WATER SUPPLY COMMISSION

At the Executive Council Chamber, Melbourne, the  
eleventh day of December, 1979

## PRESENT:

His Excellency the Governor of Victoria  
Mr Houghton | Mr Ramsay  
Mr Austin

UPPER BEACONSFIELD URBAN DISTRICT—AREA OF  
DISTRICT INCREASED

Under the powers conferred by the *Water Act 1958* and all other powers enabling him in that behalf, His Excellency the Governor of the State of Victoria, with the advice of the Executive Council of the said State, on the recommendation of the State Rivers and Water Supply Commission, doth hereby declare, order and direct that the area of the Upper Beaconsfield Urban District be increased by adding to the same the lands shown by blue colour on a plan approved by the Governor in Council and deposited in the office of the State Rivers and Water Supply Commission at 590 Orrong Road, Armadale (Corr. No. 77/1872), and as on and from 1 January 1980 the area of such District shall be deemed to be so increased.

And the Honorable Frederick James Granter, Her Majesty's Minister of Water Supply for the State of Victoria, shall give the necessary directions herein accordingly.

TOM FORRISTAL  
Clerk of the Executive Council

## THE BALLARAT WATER COMMISSIONERS

At the Executive Council Chamber, Melbourne, the  
eleventh day of December, 1979

## PRESENT:

His Excellency the Governor of Victoria  
Mr Houghton | Mr Ramsay  
Mr Austin

## SALE OF LAND

His Excellency the Governor of the State of Victoria, by and with the advice of the Executive Council thereof, doth hereby under the provisions of the *Water Act*, approve of the sale by The Ballarat Water Commissioners of part of Crown Allotment 6, section 2, Township of Nerrena, Parish of Ballarat, being the whole of the land comprised in Certificate of Title Volume 8727, Folio 091, shown by red colour on the plan deposited in the office of the State Rivers and Water Supply Commission, Melbourne (Corr. No. 79/2122/2), provided always that if a sale is not made at the auction at the reserve price set by The Ballarat Water Commissioners the said land may subsequently be sold by private treaty in which case any Contract of Sale made shall be subject to the consent of the Governor in Council being given.

And the Honorable Frederick James Granter, Her Majesty's Minister of Water Supply for the State of Victoria, shall give the necessary directions herein accordingly.

TOM FORRISTAL  
Clerk of the Executive Council

## WATER ACT 1958

At the Executive Council Chamber, Melbourne, the  
eleventh day of December, 1979

## PRESENT:

His Excellency the Governor of Victoria  
Mr Houghton | Mr Ramsay  
Mr Austin

MORNINGTON PENINSULA WATERWORKS DISTRICT  
—DISTRICT EXTENDED

Under the powers conferred by the *Water Act 1958* and all other powers enabling him in that behalf, His Excellency the Governor of the State of Victoria, with the advice of the Executive Council of the said State, on the recommendation of the State Rivers and Water Supply Commission doth hereby declare, order, and direct that the Mornington Peninsula Waterworks District be extended by adding to the same the land shown by blue colour on a plan approved by the Governor in Council and deposited in the office of the State Rivers and Water Supply Commission, at 590 Orrong Road, Armadale (Corr. No. 77/1872), and as on and from 1 January 1980 such District shall be deemed to be so extended.

And the Honorable Frederick James Granter, Her Majesty's Minister of Water Supply for the State of Victoria, shall give the necessary directions herein accordingly.

TOM FORRISTAL  
Clerk of the Executive Council

## WINCHELSEA SEWERAGE AUTHORITY

At the Executive Council Chamber, Melbourne, the  
eleventh day of December, 1979

## PRESENT:

His Excellency the Governor of Victoria  
Mr Houghton | Mr Ramsay  
Mr Austin

APPROVAL OF COMPULSORY ACQUISITION OF LAND  
AND EXTENSION OF TREATMENT WORKS SITE AND  
EXTENT OF SEWERAGE DISTRICT INCREASED

Under the powers conferred by the *Sewerage Districts Act* and all other powers enabling him in that behalf, His Excellency the Governor of the State of Victoria, by and with the advice of the Executive Council of the said State, doth hereby—

- (a) approve of the extension of the treatment works site as shown by green border on a plan approved by the Governor in Council and deposited in the office of the State Rivers and Water Supply Commission, Melbourne (Corr. No. 67/1647/95);
- (b) approve of the compulsory acquisition of the land required for the treatment works site as shown by brown and green borders on the said plan; and
- (c) declare, order and direct that the extent of the Sewerage District of the Winchelsea Sewerage Authority be increased by adding thereto the areas shown by red border on the said plan and as on and from the date hereof the extent of such District shall be and be deemed to be increased accordingly.

And the Honorable Frederick James Granter, Her Majesty's Minister of Water Supply for the State of Victoria, shall give the necessary directions herein accordingly.

TOM FORRISTAL  
Clerk of the Executive Council

## WORKERS COMPENSATION ACT 1958

At the Executive Council Chamber, Melbourne, the  
twelfth day of December, 1979

PRESENT:

His Excellency the Governor of Victoria  
Mr Houghton | Mr Ramsay  
Mr Austin

## APPROVAL OF INSURERS

In pursuance of the powers conferred by section 72 of the *Workers Compensation Act 1958*, and all other powers him thereunto enabling, His Excellency the Governor of the State of Victoria, by and with the advice of the Executive Council thereof, doth by this Order approve the undermentioned Companies as "Insurers" for the purposes of the said section until 30 June 1980:

A.G.C. (Insurances) Limited  
Albion Insurance Company Limited  
Ansva Australia Insurance Ltd.  
Australian Eagle Insurance Company Limited  
C.G.A. Fire and Accident Insurance Co. Limited  
The City Mutual General Insurance Limited  
Cornhill Insurance Company Limited  
Farmers and Settlers Co-operative Insurance Company of Australia Limited  
C. E. Heath Underwriting and Insurance (Australia) Pty. Ltd.  
Legal and General Insurance of Australia Limited  
L'Union des Assurances de Paris  
The M.L.C. Fire and General Insurance Company Pty. Limited  
National and General Insurance Company Limited  
Norwich Winterthur Insurance (Australia) Limited  
Provincial Insurance Company Limited  
The Prudential Assurance Company Limited  
Royal Insurance Australia Limited  
Sun Alliance Insurance Limited  
Switzerland General Insurance Company Limited  
T. & G. Fire and General Insurance Company Limited.

And the Honorable James Halford Ramsay, Her Majesty's Minister of Labour and Industry for the State of Victoria, shall give the necessary directions herein accordingly.

TOM FORRISTAL  
Clerk of the Executive Council

## WORKERS COMPENSATION ACT 1958

At the Executive Council Chamber, Melbourne, the  
twelfth day of December, 1979

PRESENT:

His Excellency the Governor of Victoria  
Mr Houghton | Mr Ramsay  
Mr Austin

## APPROVAL OF INSURERS

In pursuance of the powers conferred by section 72 of the *Workers Compensation Act 1958*, and all other powers him thereunto enabling, His Excellency the Governor of the State of Victoria, by and with the advice of the Executive Council thereof, doth by this Order approve the undermentioned Companies as "Insurers" for the purposes of the said section until 31 March 1980:

Accident Insurance Mutual Limited  
A.F.G. Insurances Limited  
A.M.P. Fire and General Insurance Company Limited  
Associated National Insurance Company Limited  
Australian Natives' Association Insurance Company Limited  
British Protection Insurance Company Pty. Limited  
Catholic Church Insurances Limited  
Chamber of Manufactures Insurances Limited  
C.M.L. Fire and General Insurance Company Limited

Commercial Union Assurance Company of Australia Limited  
The Co-operative Insurance Company of Australia Limited  
FAI Insurances Limited  
The Federation Insurance Limited  
Fire and All Risks Insurance Company Limited  
Greater Pacific General Insurance Limited  
The Guild Insurance Co. Limited  
Interstate Steamship Insurance Co. Pty. Ltd.  
Mercantile Mutual Insurance Company Limited  
The New Zealand Insurance Company Limited  
The Nippon Fire & Marine Insurance Company Limited  
Overseas Shipping Insurance Company Pty. Ltd.  
Palmdale Insurance Limited  
Phoenix Assurance Company of Australia Ltd.  
QBE Insurance Limited  
Security and General Insurance Company Limited  
South British United Insurance Group  
Taisho Marine and Fire Assurance Co. Ltd.  
Traders Prudent Insurance Company Limited  
Union Assurance Society of Australia Limited  
V.A.C.C. Insurance Co. Limited  
Vanguard Insurance Company Limited  
Victoria Racing Club  
The Western Australian Insurance Company (Canberra) Limited.

And the Honorable James Halford Ramsay, Her Majesty's Minister of Labour and Industry for the State of Victoria, shall give the necessary directions herein accordingly.

TOM FORRISTAL  
Clerk of the Executive Council

ROYAL COMMISSION INTO CERTAIN HOUSING  
COMMISSION LAND PURCHASES AND OTHER  
MATTERS

At the Executive Council Chamber, Melbourne, the  
fourteenth day of December, 1979

PRESENT:

His Excellency the Governor of Victoria  
Mr Haddon Storey | Mr Dixon

Whereas:

1. By Order made on 20 June 1979, and published in the *Government Gazette* on 20 June 1979, The Honorable Sir Sydney Frost, Q.C., LL.M., and Alfred James Ellwood Esquire, LL.M., were appointed a Royal Commission to inquire into and report upon certain matters relating to land purchased by the Housing Commission and to the valuation of land purchased by the Government or its instrumentalities and were directed, with as little delay as possible and by 31 December 1979, at the latest, to report under their hand their opinion resulting from the inquiry.

2. By Order made on 11 December 1979 the latest date upon which the said Sir Sydney Frost and Alfred James Ellwood shall report as aforesaid was extended from 31 December 1979 to 31 May 1980.

3. It is expedient that the said Sir Sydney Frost and Alfred James Ellwood shall inquire into and report upon certain other matters.

Now therefore, His Excellency the Governor of the State of Victoria, in the Commonwealth of Australia, by and with the advice of the Executive Council of the said State, by this Order directs that the matters into which the said Sir Sydney Frost and Alfred James Ellwood have been directed to inquire into and report upon should be extended to include the following matters namely:—

4. The circumstances in which the Housing Commission entered into:

(a) A Contract of Sale dated 6 April 1979 for the sale to Damian Buildings Proprietary Limited of the whole of the land described in Certificate of Title Volume 8898 Folio 925;

(b) A Contract of Sale dated 4 April 1979 for the sale to R. & M. Cardigan Developments Proprietary Limited of the whole of the land described in Certificate of Title Volume 8786 Folio 756 including in each case the means by which and the circumstances in which the amount of the consideration for the sale of the said land and the special conditions included in the Contract of Sale were determined, and in particular:

- (i) Whether, in each case, the consideration for such sale and the terms and conditions thereof were fair and reasonable and appropriate in the circumstances;
- (ii) Whether there was dishonesty, impropriety, malfeasance or negligence on the part of any person in relation to the sale of such land or in arriving at the consideration for the sale of such land or in the determination of the terms and conditions upon which the land was sold.

And the Honorable Haddon Storey, Her Majesty's Attorney-General for the State of Victoria, shall give the necessary directions herein accordingly.

TOM FORRISTAL  
Clerk of the Executive Council

#### PATRIOTIC FUNDS ACT 1958

At the Executive Council Chamber, Melbourne, the eighteenth day of December, 1979

PRESENT:

His Excellency the Governor of Victoria	
Mr Crozier	Mr Balfour
Mr Wood	

#### APPOINTMENT OF MEMBERS FOR THE PATRIOTIC FUNDS COUNCIL OF VICTORIA

In pursuance of the provisions of the *Patriotic Funds Act 1958* (No. 6331), His Excellency the Governor of the State of Victoria, by and with the advice of the Executive Council thereof, doth by this Order—

1. Appoint the undermentioned persons to be members of the Patriotic Funds Council of Victoria for a period of three years as from and including 22 December 1979:—

The Right Honorable the Lord Mayor of Melbourne, for the time being.

ARTHUR GRAHAME TAYLOR, F.C.A., being a representative nominated by the Chairman of the Australian Red Cross Society (Victorian Division), for the time being.

SIR WILLIAM JOHN JUNGWIRTH, C.M.G.  
BRIGADIER SIR WILLIAM HENRY HALL, K.B.E., D.S.O., E.D., A.F.A.I.M., M.P.S.O., (London).

LYLE JACK BYRNE, M.B.E., LL.B.

JOHN ERNEST COOPER, A.C.I.S., A.A.S.A.

COLONEL EDNA NELL DOIG, R.R.D., F.N.M., F.C.N.A.

COUNCILLOR CHARLES ARTHUR GREGORY, A.A.S.A., J.P.  
CUTHBERT OSWALD HARRY.

LESLIE JOHN HYAMS.

GEORGE PEARCE MACKENZIE, O.B.E., LL.B.

NOEL LANCETER RAWSON, F.E.T.I.

ALLAN GORDON ROBERTSON, O.B.E., B.E.

2. Appoint Cuthbert Oswald Harry to be Chairman of the said Council and Arthur Grahame Taylor to be Vice-Chairman of the said Council.

And the Honorable Haddon Storey, Her Majesty's Attorney-General for the State of Victoria, shall give the necessary directions herein accordingly.

TOM FORRISTAL  
Clerk of the Executive Council

#### LOCAL GOVERNMENT ACT 1958

At the Executive Council Chamber, Melbourne, the eighteenth day of December, 1979

PRESENT:

His Excellency the Governor of Victoria.	
Mr Crozier	Mr Balfour
Mr Wood	

#### CONFIRMATION OF SEPARATE RATE—CITY OF KEILOR

In pursuance of the provisions of section 287 of the *Local Government Act 1958*, His Excellency the Governor of the State of Victoria, by and with the advice of the Executive Council thereof, hereby confirms a separate rate of four point eight (4.8) cents in the dollar on the site value of the properties known as Nos. 161, 163, 165, 167, 169, 171, 173, 175, 177, 179, 181, 183, 185, 187, 189, 191, 193, 195, 197, 199, 201 and 203 Sunshine Avenue Kealba, which rate was made by the Council of the City of Keilor on 2 October 1979 for the purpose of the construction or road pavement, kerb and channel, drainage and footpath for the whole of Sunshine Avenue western service road between Errington Road and Norman Street, Kealba.

And the Honorable Digby Glen Crozier, Her Majesty's Minister for Local Government for the State of Victoria, shall give the necessary directions herein accordingly.

TOM FORRISTAL  
Clerk of the Executive Council

#### LIQUOR CONTROL ACT 1968

At the Executive Council Chamber, Melbourne, the eighteenth day of December, 1979

PRESENT:

His Excellency the Governor of Victoria	
Mr Crozier	Mr Balfour
Mr Wood	

#### APPOINTMENT OF DEPUTY JUDICIAL MEMBER AND DEPUTY CHAIRMAN OF THE LIQUOR CONTROL COMMISSION

Whereas sub-section (6) of section 7 of the *Liquor Control Act 1968* provides, *inter alia*, that if a member of the Liquor Control Commission is unable to act as a member, the Governor in Council may appoint an eligible person to act as deputy for such member while he is unable to act:

And whereas John Richard Campton a judicial member and Chairman of the Commission is unable to act as a member during the period from 20 December 1979 to 21 December 1979, both dates inclusive:

Now therefore, in pursuance of the powers conferred by the said sub-section, His Excellency the Governor of the State of Victoria, by and with the advice of the Executive Council thereof, doth by this Order appoint—

ALISTAIR NICHOLSON, a person qualified to be appointed a Judge of the County Court—  
to be a deputy judicial member and Deputy Chairman of the Commission during the said period from 20 December 1979 to 21 December 1979, both dates inclusive.

And the Honorable James Halford Ramsay, Her Majesty's Minister of Labour and Industry for the State of Victoria, shall give the necessary directions herein accordingly.

TOM FORRISTAL  
Clerk of the Executive Council

## SUPERANNUATION ACT 1958, No. 6386

At the Executive Council Chamber, Melbourne, the  
eighteenth day of December, 1979

## PRESENT:

His Excellency the Governor of Victoria  
Mr Crozier | Mr Balfour  
Mr Wood

Whereas the State Superannuation Board has granted leave of absence to John Charles Finemore, Q.C., LLB., a Member of the State Superannuation Board for the period 2 January 1980 to 29 January 1980: Now therefore in accordance with the provisions of section 52 of the Superannuation Act 1958, His Excellency the Governor of Victoria, acting by and with the advice of the Executive Council thereof, doth by this Order appoint John Daniel Cameron, a Deputy to act for the said John Charles Finemore as a Member of the State Superannuation Board during the absence of the said John Charles Finemore during the period 2 January 1980 to 29 January 1980.

And the Honorable Lindsay Hamilton Simpson Thompson, Her Majesty's Treasurer for the State of Victoria, shall give the necessary directions herein accordingly.

TOM FORRISTAL  
Clerk of the Executive Council

## SUPERANNUATION ACT 1958, No. 6386

At the Executive Council Chamber, Melbourne, the  
eighteenth day of December, 1979

## PRESENT:

His Excellency the Governor of Victoria  
Mr Crozier | Mr Balfour  
Mr Wood

Whereas the State Superannuation Board has granted leave of absence to John Miles Ryder, F.I.A., a member of the State Superannuation Board for the period 9 January 1980 to 24 January 1980: Now therefore in accordance with the provisions of section 52 of the Superannuation Act 1958, His Excellency the Governor of Victoria, acting by and with the advice of the Executive Council thereof doth by this Order appoint Carl James Stevenson, B.Sc., F.I.A. a Deputy to act for the said John Miles Ryder as a Member of the State Superannuation Board, during the absence of the said John Miles Ryder during the period 9 January 1980 to 24 January 1980.

And the Honorable Lindsay Hamilton Simpson Thompson, Her Majesty's Treasurer for the State of Victoria, shall give the necessary directions herein accordingly.

TOM FORRISTAL  
Clerk of the Executive Council

## ST. ARNAUD WATERWORKS TRUST

At the Executive Council Chamber, Melbourne, the  
eighteenth day of December, 1979

## PRESENT:

His Excellency the Governor of Victoria  
Mr Crozier | Mr Balfour  
Mr Wood

## CONSENT TO BORROWING \$150 000

Under the powers conferred by the Water Act and all other powers enabling him in that behalf, His Excellency the Governor of the State of Victoria, by and with the

advice of the Executive Council of the said State, hereby consents to the St. Arnaud Waterworks Trust borrowing the sum of One hundred and fifty thousand dollars (\$150 000) to meet the cost of water supply works.

And the Honorable Frederick James Granter, Her Majesty's Minister of Water Supply for the State of Victoria, shall give the necessary directions herein accordingly.

TOM FORRISTAL  
Clerk of the Executive Council

## GEELONG WATERWORKS AND SEWERAGE TRUST

At the Executive Council Chamber, Melbourne, the  
eighteenth day of December, 1979

## PRESENT:

His Excellency the Governor of Victoria  
Mr Crozier | Mr Balfour  
Mr Wood

## CONSENT TO BORROWING \$500 000

Under the powers conferred by the Geelong Waterworks and Sewerage Act and all other powers enabling him in that behalf, His Excellency the Governor of the State of Victoria, by and with the advice of the Executive Council of the said State, hereby consents to the Geelong Waterworks and Sewerage Trust borrowing the sum of Five hundred thousand dollars (\$500 000) to meet the cost of sewerage works.

And the Honorable Frederick James Granter, Her Majesty's Minister of Water Supply for the State of Victoria, shall give the necessary directions herein accordingly.

TOM FORRISTAL  
Clerk of the Executive Council

## FRANKSTON SEWERAGE AUTHORITY

At the Executive Council Chamber, Melbourne, the  
eighteenth day of December, 1979

## PRESENT:

His Excellency the Governor of Victoria  
Mr Crozier | Mr Balfour  
Mr Wood

## CONSENT TO BORROWING \$50 000

Under the powers conferred by the Sewerage Districts Act and all other powers enabling him in that behalf, His Excellency the Governor of the State of Victoria, by and with the advice of the Executive Council of the said State, hereby consents to the Frankston Sewerage Authority borrowing the sum of Fifty thousand dollars for the conversion of loan No. 111.

And the Honorable Frederick James Granter, Her Majesty's Minister of Water Supply for the State of Victoria, shall give the necessary directions herein accordingly.

TOM FORRISTAL  
Clerk of the Executive Council

## WARRNAMBOOL SEWERAGE AUTHORITY

At the Executive Council Chamber, Melbourne, the  
eighteenth day of December, 1979

## PRESENT:

His Excellency the Governor of Victoria  
Mr Crozier Mr Balfour  
Mr Wood

## CONSENT TO BORROWING \$100 000

Under the powers conferred by the Sewerage Districts Act and all other powers enabling him in that behalf, His Excellency the Governor of the State of Victoria, by and with the advice of the Executive Council of the said State, hereby consents to the Warrnambool Sewerage Authority borrowing the sum of One hundred thousand dollars (\$100 000) to meet the cost of unsubsidised sewerage works.

And the Honorable Frederick James Granter, Her Majesty's Minister of Water Supply for the State of Victoria, shall give the necessary directions herein accordingly.

TOM FORRISTAL  
Clerk of the Executive Council

## WINCHELSEA SEWERAGE AUTHORITY

At the Executive Council Chamber, Melbourne, the  
eighteenth day of December, 1979.

## PRESENT:

His Excellency the Governor of Victoria  
eighteenth day of December, 1979  
Mr Crozier Mr Balfour  
Mr Wood

## CONSENT TO BORROWING \$100 000

Under the powers conferred by the Sewerage Districts Act and all other powers enabling him in that behalf, His Excellency the Governor of the State of Victoria, by and with the advice of the Executive Council of the said State hereby consents to the Winchelsea Sewerage Authority borrowing the sum of One hundred thousand dollars (\$100 000) to meet the cost of sewerage works as set forth in the detailed statement bearing date 12 December 1979.

And the Honorable Frederick James Granter, Her Majesty's Minister of Water Supply for the State of Victoria, shall give the necessary directions herein accordingly.

TOM FORRISTAL  
Clerk of the Executive Council

LANDS DEPARTMENT  
NOTICES

## APPROACHING LAND SALES

Sale of Crown Land, in fee-simple, will be held at the under-mentioned places and dates, viz:—

Ormond—Wednesday, 13 February 1980

No. of  
Gazette  
100

REGULATION IN RESPECT OF CERTAIN RESERVES  
AROUND THE COAST OF VICTORIA

I, William Vasey Houghton, Her Majesty's Minister of Lands in and for the State of Victoria, in pursuance of the powers conferred on me by Section 13 of the Crown Land (Reserves) Act 1978, do hereby make the following Regulation in respect of the Crown Lands around the coast of the said State and described in the Schedule hereto which before the making of this Regulation have been reserved for Public Purposes pursuant to Section 4 of the said Act or corresponding previous enactment.

## REGULATION

"Notwithstanding the provisions of any Regulation for the time being in force for the control and use of any motor cars, motor cycles or any other vehicles on such lands, the respective Committees of Management may authorise the emergency use of any vehicle required for the saving of lives on the beach or in the sea."

## SCHEDULE

The Crown Lands described in notifications in Government Gazettes of—

Year	Page	Locality
1878	2584	Woolamai Beach
1879	2045	Lakes Entrance
1879	2045	Cape Paterson
1879	2045	Portland
1879	2045	Venus Bay
1879	2045	Kennet River
1879	2045	Wye River
1879	2045	Seaspray
1879	2045	Fairhaven
1879	2045	Woodside
1879	2045	Apollo Bay
1880	2661	Ocean Grove
1880	2661	Point Lonsdale
1880	2661	13th Beach, Barwon Heads
1880	2661	Bancoora
1880	2661	Torquay
1880	2661	Jan Juc
1880	2661	Anglesea
1917	2732	Lorne
1920	184	Point Leo
1939	3764	Waratah
1942	1226	Lorne
1948	7572	Warrnambool
1955	775	Lakes Entrance
1960	3242	Fairhaven
1972	2993	Ocean Grove

Given under my hand at Melbourne on 14 December 1979

W. V. HOUGHTON  
Minister of Lands

REGULATIONS TO AMEND FURTHER THE REGULATIONS (No. 180) FOR THE CARE, PROTECTION AND MANAGEMENT OF CARLTON, FITZROY AND FLAGSTAFF GARDENS; ALEXANDRA, FAWKNER, FLEMINGTON AND KENSINGTON, FLINDERS, PRINCES AND YARRA PARKS; POWLETT RESERVE; AND ARGYLE, CURTAIN, DARLING, LINCOLN, MACARTHUR, MURCHISON AND UNIVERSITY SQUARES IN THE CITY OF MELBOURNE, AND NUMBERED 188

In pursuance of the powers conferred by section 13 of the Crown Land (Reserves) Act 1978, the Minister of Lands and the Corporation of the City of Melbourne as Trustees of the above-named lands hereby make the following Regulations:

1. (1) These Regulations may be cited as the City of Melbourne Parks and Gardens (General) (Amendment No. 3) Regulations 1979.

(2) In these Regulations, the City of Melbourne Parks and Gardens (General) Regulations 1959, Regulations No. 180, as approved by the Governor in Council on 22 September 1959, and as amended by the City of Melbourne Parks and Gardens (General) (Amendment No. 1) Regulations 1971, Regulations No. 186, and the City of Melbourne Parks and Gardens (General) (Amendment No. 2) Regulations 1975, Regulations No. 187, as approved by the

Governor in Council on 3 August 1971, and 23 September 1975, respectively, are referred to as the Principal Regulations.

2. In Regulation 34 of the Principal Regulations for the expression "fifty cents (\$0.50)" there shall be substituted the expression "eighty cents (\$0.80)".

Given under my hand at Melbourne on 16 November 1979 (C.64311).

W. V. HOUGHTON  
Minister of Lands

The common seal of the Lord Mayor, Councillors and Citizens of the City of Melbourne was hereto affixed, on 7 September 1979—

(SEAL) R. A. BERNARDI  
Lord Mayor  
J. REILLY  
Acting Chief Executive Officer and Town Clerk

The Governor in Council certifies that he is satisfied that there are special reasons justifying these Regulations and approves these Regulations.

TOM FORRISTAL  
Clerk of the Executive Council

At the Executive Council Chamber  
Melbourne, 21 November 1979

**PROPOSED REVOCATION OF TEMPORARY RESERVATIONS OF LANDS BY ORDERS IN COUNCIL**

In pursuance of the provisions of Section 10 of the Crown Land (Reserves) Act 1978, notice is hereby given that it is the intention of the Governor in Council to revoke the temporary reservations of lands by Orders in Council hereunder referred to, viz.:

**NORTHCOTE**—The temporary reservation by Order in Council of 2 February 1977 of 3671 square metres of land in the City of Northcote, Parish of Jika Jika, being Crown allotment 9, section U, as a site for Public Purposes (Municipal Depot)—(N.71 (E<sup>1</sup>)) (Rs.10227).

**SANDHURST**—The temporary reservation by Order in Council of 13 August 1946 of 110 hectares, more or less, of land in the Parish of Sandhurst as a site for the Growth of Timber for the purpose of manufacture or production of eucalyptus oil, revoked as to part by various Orders, so far only as the portion thereof containing 7553 square metres, as indicated by hatching on plan hereunder, is concerned—(S.371(44)) (Rs.5844).

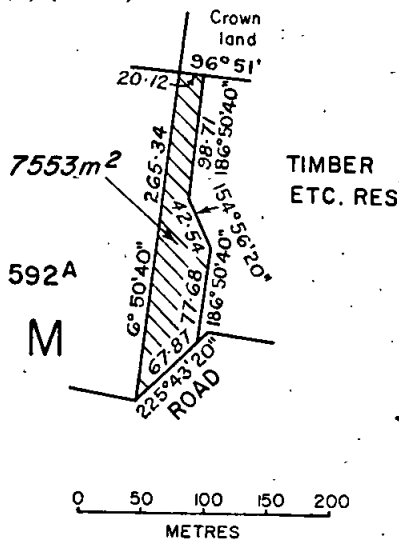

W. V. HOUGHTON  
Minister of Lands

**PRIVATE ADVERTISEMENTS**

CITY OF BENALLA.  
LOAN No. 48

*Notice of Intention to Borrow*

Notice is hereby given that the Council of the City of Benalla intends to borrow One hundred and twenty thousand dollars (\$120 000) secured over the general rates of the municipality by the grant of a mortgage in accordance with the provisions of the Local Government Act.

In connection therewith, the following information is stated:

- (a) The amount of the principal moneys which it is proposed to borrow \$120 000 (One hundred and twenty thousand dollars).
- (b) The maximum rate of interest that may be paid is 10.8 per centum per annum.
- (c) The times which the moneys borrowed are to be repayable are 1 March and 1 September during the currency of the loan, and that the place such moneys shall be repayable is at the State Insurance Office, 480 Collins Street, Melbourne, or such other place and places the Lender from time to time may require.
- (d) The purpose of the loan will be for private street construction in Coish Avenue, Second Avenue and Third Avenue.
- (e) The manner in which the loan is to be liquidated is by the provision out of the municipal fund of a Sinking Fund created by investments per annum, pursuant to the provisions of Section 428A of the Local Government Act 1958.
- (f) The loan will be for a period of 10 (ten) years with the balance owing at the end of 10 years repayable in a lump sum.

The plans and specifications and estimate of the cost of the works, and a statement showing the proposed expenditure of the moneys to be borrowed are open for inspection at the Civic Centre, Benalla.

4194 L. A. HEMLEY, Town Clerk

CITY OF BENDIGO  
LOAN No. 101

*Notice of Intention to Borrow the Sum of \$100 000 for Permanent Works and Undertakings*

Notice is hereby given that the Council of the City of Bendigo proposes to borrow the principal sum of \$100 000 secured by a charge over the general rates of the Municipality, such sum to be raised by the grant of a Mortgage Loan in accordance with the provisions of the Local Government Act 1958.

1. The maximum rate of interest that may be paid is 10.8% per annum.
2. The purpose for which the Loan is to be applied is:

Road Construction—	\$
Council proportion CRB Funds—	
Wood St. IT Asphalt Extn.	12 500
Bridge St./Chapel St.—Land Acquisition	
221 and 223 Bridge St. being Crown Allotment 12, 12A, 13 and 13A Section 55C Parish of Sandhurst	18 000
Saleyards Drainage (Balance)	22 000
Drainage—	
Lily Street—High St. to Mackenzie St.	10 000
Minor Works—	
Napoleon Crescent Reconstruction—	
Napier St. to Hamelin St.	22 000
Miscellaneous—	
Dean Street (Retaining walls) batter stabilization	5 500
Parks and Recreation—	
Lake Weeroona Pavilion (Total Estimated cost \$114 000)	10 000
	<b>100 000</b>

3. The period of the Loan shall be fifteen (15) years.

4. The moneys borrowed shall be repayable by providing out of the Municipal Fund thirty (30) half-yearly instalments of principal and interest of \$6804.72 on 30 March and September during the currency of the loan. The first repayment shall be payable on 30 September 1980.

5. Such moneys shall be repayable at the T. & G. Mutual Life Society Limited, cnr. Collins and Russell Streets, Melbourne.

The plans and specifications and an estimate of the cost of the proposed works and a statement showing the proposed expenditure of the money to be borrowed are open for inspection at the Municipal Offices, Lyttleton Terrace, Bendigo during office hours.

4276

C. K. BEAMISH, Town Clerk

## CITY OF BENDIGO

## LOAN No. 102

*Notice of Intention to Borrow the Sum of \$50 000 for Permanent Works and Undertakings*

Notice is hereby given that the Council of the City of Bendigo proposes to borrow the principal sum of \$50 000 secured by a charge over the general rates of the Municipality, such sum to be raised by the grant of a Mortgage Loan in accordance with the provisions of the *Local Government Act 1958*.

1. The maximum rate of interest that may be paid is 10.8% per annum.

2. The purpose for which the Loan is to be applied is:

Parks and Recreation—	\$
Installation of Watering System—	
Bendigo Sports Centre	16 000
Construction of Staff Facilities—	
Rosalind Park	20 000
Coolinda Park Development (balance)	8 500
Purchase of Playground Equipment (sundry Reserves)	5 500
	<u>50 000</u>

3. The period of the Loan shall be fifteen (15) years.

4. The moneys borrowed shall be repayable by providing out of the Municipal Fund thirty (30) half-yearly instalments of principal and interest of \$3402.36 on 5 February and July during the currency of the Loan, the first repayment shall be payable on 5 July 1980.

5. Such moneys shall be repayable at the Commonwealth Savings Bank of Australia, cnr. Elizabeth and Flinders Streets, Melbourne.

The plans and specifications and an estimate of the cost of the proposed works and a statement showing the proposed expenditure of the money to be borrowed are open for inspection at the Municipal Offices, Lyttleton Terrace, Bendigo, during office hours.

4277

C. K. BEAMISH, Town Clerk

## CITY OF BRUNSWICK

## By-Law No. 206

A By-Law of the City of Brunswick made under the provisions of section 197 of the *Local Government Act 1958* and numbered 206 for the purposes of preventing and extinguishing fires and suppressing nuisances.

In pursuance of the powers conferred by the *Local Government Act* and of any and every power it thereunto enabling the Mayor, Councillors and Citizens of the City of Brunswick Order as follows:

1. In this By-Law:

"Authorised Officer" means and includes the Town Clerk of the City of Brunswick and any Officer of the Council for the time being authorized by it in that behalf.

"Council" means the Council of the City of Brunswick.

"Incinerator" means and includes a structure or device (not enclosed in a building) which is designed or capable of being used for the purpose of burning any matter, material or substance and which is not required to be licenced under the provisions of the *Environment Protection Act 1970*.

2. Subject to paragraph 5 of this By-Law a person shall not except with the prior written consent of an authorised officer and in accordance with any conditions set out in such consent light or allow to remain alight any fire in the open or on any land in a residential area other than in a properly constructed incinerator which complies with all the requirements of paragraphs 3 and 4 of this By-Law.

3. A person shall not use any incinerator unless such incinerator is constructed of brick, stone, concrete, cement, metal or other material approved by the Council or an authorised officer, or any combination of such materials and unless such incinerator is fitted with a lid and spark arrester and is so constructed and maintained as to prevent the emission of sparks or the spread of fire.

4. A person shall not use any incinerator or keep or allow to be kept any incinerator in which it is proposed to burn any material or substance on any land or premises unless such incinerator is distant:

- At least 3.66 metres from the nearest point of any dwelling whether on the same or adjoining land;
- At least 15.24 metres from the boundary of any street or road (other than a side street or road) to which the land has a frontage;
- At least 1.22 metres from the boundary of any side street or road to which the land has an abuttal;
- At least 1.22 metres from the boundary of any adjoining allotment of land.

5. The provisions of paragraph 2 of this By-Law do not apply to the lighting of any fire in the open air within a residential area if it complies with all the following conditions:

- the material, matter or substance to be burnt occupies a space not exceeding one cubic metre, and
- whilst such a fire remains alight the material, matter or substance being burnt occupies a space not exceeding one cubic metre at all times, and
- such a fire is supervised by an adult person from the time it is lit until the time it is completely extinguished, and
- adequate means such as a hose of adequate length attached to a tap giving sufficient pressure shall at all times be readily available for extinguishing the fire, and
- the ground within three metres from any material, matter or substance being burnt is free from all inflammable material and vegetation except for growing vegetation not exceeding 15 centimetres in height, and
- the space about the material, matter or substance being burnt and the space above all the ground within three metres of such material, matter or substance is free from all vegetation and inflammable material, and
- no more than one fire of any kind referred to in sub-paragraphs (a) to (f) inclusive of this paragraph shall be permitted at any one time on any premises.

6. When any person obtains the written consent of any authorised officer pursuant to paragraph 2 hereof to light a fire in the open he shall give at least 24 hours written notice of his intention to light such fire to the Officer in Charge of the Metropolitan Fire Brigade Station at Brunswick.

7. A fire permitted by this By-Law shall not be lit before the hour of 8 o'clock in the morning and any such fire shall be completely extinguished before the hour of 8 o'clock in the afternoon of the same day provided however where such person has obtained the prior written consent of an authorised officer such fire may be lit or extinguished at such other time as may be specified in such written consent.

8. A person shall not burn any matter, material or substance in any incinerator unless such matter, material or substance is household or garden rubbish.

9. A person shall not on any premises owned or occupied by him burn or allow to be burnt any material, matter or substance in such manner or to such an extent as may cause such quantities of smoke fumes or ash to be emitted from such premises as to cause a nuisance to any person upon any other land or upon any public highway.

10. Notwithstanding the provisions of paragraphs 3 and 4 of this By-Law an incinerator may be constructed appurtenant to flats or apartments subject to the design and location being approved by the Municipal Building Surveyor and the design incorporating a chimney conforming to the provisions of clause 2311 of the Uniform Building Regulations.

11. Any person or corporation who is guilty of any wilful act or default contrary to any of the provisions of this By-Law shall be liable upon conviction to a penalty of not less than \$10.00 nor more than \$100.00 and any person guilty of a continuing offence against this By-Law after a conviction or order by any Court shall be liable to a penalty of not more than \$10.00 for each day on which an offence against this By-Law is continued.

12. By-Law No. 204 of the City of Brunswick is hereby repealed.

13. This By-Law shall apply to and have operation throughout the whole of the municipal district of the City of Brunswick.

Resolution for passing this By-Law was agreed to on 17 September 1979, and confirmed on 15 October 1979.

In witness whereof the common seal of the Mayor, Councillors and Citizens of the City of Brunswick was hereto affixed, 13 December 1979, in the presence of—

(SEAL) H. S. V. JURY, Councillor  
F. G. WALKER, Councillor  
K. D. WILSON, Town Clerk  
4146

CITY OF DONCASTER AND TEMPLESTOWE  
LOAN No. 231

Notice of Intention to Borrow the Sum of \$200 000 for Permanent Works and Undertakings

Notice is hereby given that the Council of the City of Doncaster and Templestowe propose to borrow the principal sum of Two hundred thousand dollars (\$200 000) secured by a charge over the general rates of the municipality, such sum to be raised by the grant of a mortgage in accordance with the provisions of the Local Government Act 1958.

1. The maximum rate of interest that will be paid is 10.8 per cent per annum.

2. The purpose for which the loan is to be applied is:—

	\$
East Doncaster High School (Joint Use)	85 000
Tennis Courts	60 000
Springvale Road Deviation—Connection to Reynolds Road	33 000
Drainage Improvements	9 000
Park Orchards Tennis Club	13 000
Donvale Tennis Courts	200 000

3. The period of the loan shall be 10 years.

4. The moneys borrowed shall be repayable by providing out of the municipal fund 20 half-yearly instalments of \$16 597.29 including principal and interest on 15 August and 15 February during the currency of the loan. The first instalment shall be payable on 15 August 1980.

5. Such moneys shall be repayable at the Australia and New Zealand Savings Bank Limited, 686 Doncaster Road, Doncaster.

The plans and specifications and the estimate of the cost of the proposed works and a statement showing the proposed expenditure of the moneys to be borrowed are open for inspection at the office of the Council of the City of Doncaster and Templestowe at the Municipal Offices, Doncaster Road, Doncaster.

4195 G. J. MORTON, Town Clerk

CITY OF ECHUCA  
LOAN No. 106

Notice of Intention to Borrow

Notice is hereby given that the Council of the City of Echuca intends to borrow Ninety thousand dollars (\$90 000), secured by a charge over the general rates of the municipality by the grant of a mortgage in accordance with the provisions of the Local Government Act 1958:—

In accordance therewith the following information is stated:—

- (a) The amount of the principal moneys which it is proposed to borrow is, \$90 000.
- (b) The maximum rate of interest that may be paid is 10.8 per centum per annum.
- (c) The period of the loan shall be fifteen years.
- (d) The moneys borrowed shall be repayable by providing out of the Municipal Fund half-yearly instalments of approximately \$6124.25 each including principal and interest on 31 January and 31 July during the currency of the loan. The first instalment shall be payable on 31 July 1980.
- (e) The purposes for which the loan is to be applied are:—

	\$
(1) Construction of Public Conveniences—Victoria Park Oval	15 000
(2) Municipal Saleyards Improvements—Liveweight Selling facilities	50 000
(3) Improvements at Echuca Aerodrome (part cost)	10 000
(4) Drainage Construction—Annesley and Minor Streets	15 000
	90 000

(f) Such moneys shall be repayable at the Bank of New South Wales, Echuca.

The plans and specifications and estimates of the cost of the works and a statement showing the proposed expenditure of the moneys to be borrowed are open for inspection at the office of the Council of the City of Echuca at the corner of Hare and Heygarth Streets, Echuca. 4205

K. F. McCARTNEY, Town Clerk

CITY OF FRANKSTON  
LOAN No. 195

Notice of Intention to Borrow

Notice is hereby given that the Council of the City of Frankston intends to borrow the principal sum of \$50 000 secured by a charge over the general rates of the municipality by the grant of a mortgage in accordance with the provisions of the Local Government Act 1958.

In connection therewith the following information is stated:—

- (a) The amount of the principal moneys which it is proposed to borrow is fifty thousand dollars.
- (b) The maximum rate of interest that may be paid is 10.8 per centum per annum.
- (c) The times which the moneys borrowed are to be repayable are 23 June and January during the years 1980–1990 inclusive and that the place such moneys shall be repayable is at the Bank of New South Wales, Nepean Highway, Frankston.
- (d) The purpose for which the loan is to be applied is for drainage works and purchase of plant.
- (e) The manner in which the loan is to be liquidated is by provision out of the Municipal Fund in each half-year during the currency of the loan of the sum of \$4149.32 which includes principal and interest.

The plans and specifications and estimate of the cost of the works and a statement showing the proposed expenditure of the moneys to be borrowed are open for inspection at the Civic Centre, Davey Street, Frankston.

A. H. BUTLER, Town Clerk  
Civic Centre, Frankston 4148



## CITY OF GEELONG

Notice is hereby given that at a meeting held on 30 October 1979 the Council of the City of Geelong resolved to change the following street name:

*Old Name*—La Trobe Terrace between Melbourne Road (Princes Highway) and The Esplanade.

*New Name*—The Esplanade South.

T. J. T. NEAL, Town Clerk and Chief Administrative Officer 3879

## CITY OF HAMILTON

## LOAN No. 108

*Notice of Intention to Borrow the Sum of \$473 000 for Permanent Works and Undertakings*

Notice is hereby given that the Council of the City of Hamilton proposes to borrow the principal sum of \$473 000 secured by a charge over the general rates of the Municipality, such sum to be raised by the grant of a mortgage in accordance with the provisions of the *Local Government Act 1958*.

1. The maximum rate of interest that may be paid is 10.8 per centum per annum.

2. The purpose for which the loan is to be applied is:—

	\$
Lake Hamilton Redevelopment Industrial Estate	70 000
Partial Peck Street Construction	6 800
Landscape of Reserve	1 700
Pedrina Park—	
Seal Car Park	2 500
Landscaping	500
Kerb and Channel	15 000
Hamilton Showgrounds—	
Relocate Y.F. Building	1 000
Dog Facilities	4 500
S.E.S. Accommodation	10 000
P. and A. Storage Facilities	5 000
Land Acquisition—	
Lake Hamilton	9 000
Mechanics Institute	21 000
Municipal Depot Aggregate Bins, George Kennedy Oval	3 000
Pavilion Materials	16 000
Retaining Wall	1 000
Earthworks	500
Sprinklers	500
Botanic Gardens Zoo, Redevelopment	9 000
Mitchell Park—Landscape development	1 500
Flinders/Dinwoodie Street Reserve—Landscape and site works	800
Ray Middleton Reserve—Landscaping	1 200
Hamilton Airport Terminal Construction (part)	20 000
Hamilton Recreation Reserve—	
Resurface Cycle Track	7 000
C.R.B. Works—Council contribution—	
Coleraine Road	85 000
Road Reconstruction—	
McLuckies Lane: Hot Mix	5 200
Ballarat Road: Service Road	6 000
Rippon Road: Final Seal	2 400
Lawson Street	5 000
George Street/Riley Street: Reconstruction and Final Seal	20 600
Cross Street/Mannett Street/Rowntree Street: Final Seal	6 000
Kerb and Channel—Half Cost—	
Coleraine Road	2 400
Riley Street/George Street	6 000
Ballarat Road	4 900
Clarendon Street	2 000
Mill Road (Balance)	100
Kenny Street	2 000
Kennedy Street	1 400
Horner Street	2 000

	\$
Footpath Construction—Half Cost—	
Coleraine Road	9 500
George Street	400
Mt. Baimbridge Road	2 400
Stephen Street	9 450
Milton Street	4 650
Ballarat Road	1 500
Lawson Street	1 000
Scoresby Street	2 600
Private Street Construction—	
Chamberlain Court	58 000
National Cafe R.O.W.	8 000
Bennett Farmers R.O.W.	7 000
Drainage Works—	
Coleraine Road	2 400
Mt. Baimbridge Road	7 600
	473 000

3. The period of the loan shall be ten (10) years.

4. The moneys borrowed shall be repayable by providing out of the Municipal Fund nineteen (19) half-yearly instalments of \$29 091.26 each including principal and interest on 29 July and 29 January during the currency of the loan with a final instalment of \$379 645.72 on 29 January 1990. The first instalment shall be payable on 29 July 1980.

5. Such moneys shall be repayable at the Commercial Banking Company of Sydney Savings Bank Limited at 257 Collins Street, Melbourne.

The plans and specifications and estimates of the cost of the works and a statement showing the proposed expenditure of the moneys to be borrowed are open for inspection at the Office of the Council of the City of Hamilton, Brown Street, Hamilton, 3300.

4130

R. J. WORLAND, Town Clerk

## CITY OF HAMILTON

## LOAN No. 109

*Notice of Intention to Borrow the Sum of \$40 000 for Permanent Works and Undertakings*

Notice is hereby given that the Council of the City of Hamilton proposes to borrow the principal sum of \$40 000 secured by a charge over the general rate of the Municipality such sum to be raised by the grant of a mortgage in accordance with the provisions of the *Local Government Act 1958*.

1. The maximum rate of interest that may be paid is 10.7 per centum per annum.

2. The purposes for which the loan is to be applied is for plant replacement purchases.

3. The period of the loan shall be eight (8) years.

4. The moneys borrowed shall be repayable by providing out of the Municipal fund sixteen (16) half-yearly instalments of \$3783.31 each including principal and interest on 29 July and 29 January during the currency of the loan. The first instalment shall be payable on 29 July 1980.

5. Such moneys shall be repayable at the Commercial Banking Company of Sydney Savings Bank Limited of 257 Collins Street, Melbourne.

The plans and specifications and the estimate of the cost of the proposed works and a statement showing the proposed expenditure of the moneys to be borrowed are open for inspection at the Office of the Council of the City of Hamilton, Brown Street, Hamilton.

4131

R. J. WORLAND, Town Clerk

## CITY OF MOORABBIN

## LOAN No. 202

*Notice of Intention to Borrow the Sum of \$400 000 for Permanent Works and Undertakings*

Notice is hereby given that the Council of the City of Moorabbin proposes to borrow the principal sum of Four Hundred Thousand dollars (\$400 000) secured by a charge over the general rates of the Municipality, such sum to be raised by the grant of a mortgage in accordance with the provisions of the *Local Government Act 1958*.

1. The maximum rate of interest that may be paid is 10.8% per annum.

2. The purposes for which the loan is to be applied are—

	\$
(1) Land purchase commitments (part cost)	100 000
(2) C.A.R. Works—Council contribution (part cost)	50 000
(3) Bentleigh Recreation Reserve—Treatment of east side embankment and improve water reticulation	15 000
(4) Centre Dandenong Road Land—Tree planting, water reticulation, clearing scrub, fencing draining, earthworks (part cost)	100 000
(5) Keys Road Reserve—Complete surface of second oval and provide water reticulation	15 000
(6) Golf Course—Additional AG Drains, tree planting, car park and redevelopment of some greens (part cost)	20 000
(7) King George VI Reserve—Development of garden areas and balance of tree planting	22 000
(8) Municipal Depot—Extensions and improvements (part cost)	68 000
(9) Highett Reserve—Landscaping, car park area, and paving adjacent to pavilion	10 000
	400 000

3. The period of the loan shall be 10 years.

4. The moneys borrowed shall be repayable by providing out of the Municipal Fund, twenty half-yearly instalments of approximately \$33 194.58 each including principal and interest on 1 February and August, during the currency of the loan. The first instalment shall be payable on 1 August 1980.

5. Such moneys shall be repayable to the Commonwealth Savings Bank of Australia, Elizabeth/Flinders Street, Melbourne, or at such other place as the Bank may require.

The plans and specifications and the estimates of the costs of the proposed works and a statement showing the proposed expenditure of the moneys to be borrowed are open for inspection at the offices of the Council of the City of Moorabbin, 977 Nepean Highway, Moorabbin, 3189.

Dated 17 December 1979

4324 JAMES W. WATERS, Town Clerk

#### CITY OF MOORABBIN

##### NOTICE OF MAKING BY-LAW NO. 302

##### Hawkers and Peddlers By-Law

The Council of the City of Moorabbin by resolution made 9 July 1979 and confirmed 20 August 1979, has made a By-Law numbered 302 for the purposes of—

- (a) Repealing By-Law 276 made by the City of Moorabbin, notice of the making of which was published in the *Government Gazette* issue 33 of 19 April 1968.
- (b) Prescribing the limits whether as to time or place within which persons holding a Metropolitan Hawkers Licence may sell or offer or expose for sale any articles specified in their licences in any street, road, or public place within the municipal district of the City of Moorabbin.

Such By-Law was approved by the Governor in Council on 27 November 1979 and becomes effective on the day after this notice is published in the *Victoria Government Gazette*—viz. 20 December 1979.

A copy of the By-Law has been deposited at the office of the Council, 977 Nepean Highway, Moorabbin, and may be inspected by any person interested (free of charge) during office hours.

4275 JAMES W. WATERS, Town Clerk

#### Town and Country Planning Act (Twelfth Schedule) CITY OF SALE PLANNING SCHEME 1975 NOTICE THAT A PLANNING SCHEME HAS BEEN PREPARED AND IS AVAILABLE FOR INSPECTION Amendment No. 6

Notice is hereby given that the City of Sale has prepared a planning scheme for Raglan Street north side west corner of McCole Street for the purpose of rezoning land from Local Commercial to Residential.

A copy of the scheme has been deposited at the offices of the City of Sale, Macalister Street, Sale, and at the office of the Town and Country Planning Board, 235 Queen Street, Melbourne. The scheme may be inspected at either place during office hours by any person free of charge.

Any persons feeling they may be detrimentally affected by the amending planning scheme are required to submit in writing, all objections they have, addressed to the Town Clerk, City of Sale, City Council Chamber, Macalister Street, Sale, 3850, on or before 19 January 1980 and to state whether they wish to be heard in respect of their objections.

4203 J. L. LOW, Town Clerk

#### Town and Country Planning Act (Twelfth Schedule) CITY OF SALE PLANNING SCHEME 1975 NOTICE THAT A PLANNING SCHEME HAS BEEN PREPARED AND IS AVAILABLE FOR INSPECTION Amendment No. 7

Notice is hereby given that the City of Sale has prepared a planning scheme for Princes Highway, Wurruk, north side between Otway and Fisk Streets for the purpose of rezoning the land from Residential Low Density B to Highway Commercial.

A copy of the scheme has been deposited at the offices of the City of Sale, Macalister Street, Sale, and at the office of the Town and Country Planning Board, 235 Queen Street, Melbourne. The scheme may be inspected at either place during office hours by any person free of charge.

Any person feeling they may be detrimentally affected by the amending planning scheme are required to submit in writing, all objections they have, addressed to the Town Clerk, City of Sale, City Council Chamber, Macalister Street, Sale, 3850, on or before 19 January, 1980 and to state whether they wish to be heard in respect of their objections.

4204 J. L. LOW, Town Clerk

#### CITY OF SHEPPARTON

##### LOAN NO. 99

##### Notice of Intention to Borrow the Sum of \$270 000 for Permanent Works and Undertakings

Notice is hereby given that the Council of the City of Shepparton proposes to borrow the sum of \$270 000, secured by a charge over the general rates of the municipality, such sum to be raised by the grant of a mortgage in accordance with the provisions of the *Local Government Act 1958*.

1. The Principal amount to be borrowed is \$270 000.
2. The maximum rate of interest to be paid is 10.8 per centum per annum.
3. The times at which the moneys borrowed are to be repayable are:

The thirtieth day of July; and

The thirtieth day of January; during the years 1980 to 1995.

4. The moneys shall be repayable to the Commonwealth Savings Bank of Australia, Melbourne.

5. The purposes for which the loan is to be applied are—

	\$
<i>The Making of Roads and Streets:</i>	
Central Area Streets	35 100
<i>Main Drainage:</i>	
Newton Street Pumping Station	70 000
<i>Public Conveniences:</i>	
Fraser Street Toilet block (incorporating baby changing and feeding facilities)	47 800
<i>Places of Public Resort and Recreation:</i>	
Installation of automatic watering system at Shepparton Lawn Tennis Club	10 000
Construction of pavilion at The John McEwen Reserve (part cost)	78 100
<i>Elderly Persons' Housing:</i>	
Purchase of land	29 000
	270 000

6. The loan shall be liquidated by the provision, out of the Municipal Fund, of thirty half-yearly instalments of \$18 372.77, including principal and interest. The first instalment shall be payable on 30 July 1980, and the final instalment on 30 January 1995.

7. The plans, specifications and estimate of the cost of the proposed works, and a statement showing the proposed expenditure of the moneys to be borrowed, are open for inspection at the office of the Council, Civic Centre, Welsford Street, Shepparton, during office hours.  
4210 P. M. SMITH, Town Clerk

## CITY OF SHEPPARTON

LOAN NO. 100

*Notice of Intention to Borrow the Sum of \$30 000 for Permanent Works and Undertakings*

Notice is hereby given that the Council of the City of Shepparton proposes to borrow the sum of \$30 000, secured by a charge over the general rates of the municipality, such sum to be raised by the grant of a mortgage in accordance with the provisions of the *Local Government Act 1958*.

- The principal amount to be borrowed is \$30 000.
- The maximum rate of interest to be paid is 10.7 per centum per annum.
- The times at which the moneys borrowed are to be repayable are:  
The thirtieth day of July; and  
The thirtieth day of January;  
during the years 1980 to 1986.
- The moneys shall be repayable to the Commonwealth Savings Bank of Australia, Melbourne.

5. The purpose for which the loan is to be applied is—  
Purchase of Equipment—Mobile Library (part cost).

6. The loan shall be liquidated by the provision, out of the Municipal Fund, of twelve half-yearly instalments of \$3451.90 including principal and interest. The first instalment shall be payable on 30 July 1980, and the final instalment on 30 January 1986.

7. The plans, specifications and estimate of the cost of the proposed work, and a statement showing the proposed expenditure of the moneys to be borrowed, are open for inspection at the office of the Council, Civic Centre, Welsford Street, Shepparton, during office hours.  
4211 P. M. SMITH, Town Clerk

## CITY OF ST. KILDA

LOAN NO. 46

*Notice of Intention to Borrow the Sum of \$214 500 for Permanent Works and Undertakings*

Notice is hereby given that the Council of the City of St. Kilda intends to borrow the principal sum hereinafter mentioned on the credit of the general rates of the Mayor, Councillors, and Citizens of the City of St. Kilda by the grant of a mortgage in accordance with the provisions of the *Local Government Acts*, and notice is hereby further given that—

- (a) the amount of the principal sum which it is proposed to borrow is \$214 500,

(b) the maximum rate of interest that may be paid is 10.7 per centum per annum,

(c) the moneys borrowed and interest thereon are to be repayable by 10 half-yearly instalments, each of \$28 253 approximately, on 10 August and 10 February, in each year, and the place at which such moneys are to be repayable is The Commercial Bank of Australia Limited, Melbourne, or at the St. Kilda Office of the Council's Bankers for the time being. The first instalment shall be payable on 10 August 1980,

(d) the purpose for which the loan is to be applied is:—

	\$	\$
1. Traffic Signals:		
Hotham Street (School Crossing)	7 000	
Marine Parade (Acland Street)	15 000	22 000
2. C.R.B. Road Works:		
Main Roads	34 400	
Council Proportion of Works	34 100	68 500
3. Plant and Equipment:		
Footpath Flusher/Lane-way Sweeper	20 000	
Replace 5 Suzuki Collectors	25 000	
Replace 4 Leyland Tip-pers	36 000	
Replace Compressor	9 000	
Large Mower	17 000	107 000
4. Parks and Gardens Project:		
Ormond Esplanade Fencing (Elwood Bowling Club)	17 000	
	214 500	

(e) the loan to be liquidated by appropriation out of the municipal fund,

(f) the plans, specifications and estimate for the cost of such works, and the statement showing the proposed expenditure of the money to be borrowed, are open for inspection at the office of the Council, Town Hall, St. Kilda, during office hours.

Dated 14 December 1979

4149

W. A. SISSON, Town Clerk

## CITY OF ST. KILDA

LOAN NO. 47

*Notice of Intention to Borrow the Sum of \$385 500 for Permanent Works and Undertakings*

Notice is hereby given that the Council of the City of St. Kilda intends to borrow the principal sum hereinafter mentioned on the credit of the general rates of the Mayor, Councillors, and Citizens of the City of St. Kilda by the grant of a mortgage in accordance with the provisions of the *Local Government Acts*, and notice is hereby further given that—

- (a) the amount of the principal sum which it is proposed to borrow is \$385 500,
- (b) the maximum rate of interest that may be paid is 10.8 per centum per annum,
- (c) the moneys borrowed and interest thereon are to be repayable by 20 half-yearly instalments, each of \$31 991 approximately, on 10 August and 10 February, in each year, and the place at which such moneys are to be repayable is The Commercial Bank of Australia Limited, Melbourne, or at the St. Kilda Office of the Council's Bankers for the time being. The first instalment shall be payable on 10 August 1980,

(d) the purpose for which the loan is to be applied is:—

	\$	\$
1. Refuse Transfer Station		40 000
2. Drainage Works:		
John/Byron Streets	17 000	
Chusan Street Outfall		
Drain	25 000	
Herbert/Mitford Streets	12 500	
Westbury/Inkerman Streets	40 000	
Dispersal Drain—Elwood		
Beach	6 000	
Palm Court	7 000	
	107 500	
3. Road Closures:		
Church Square	11 000	
Dalgety Street Precinct	28 500	
	39 500	
4. Property Purchase:		
Carlisle/Chapel Streets	108 500	
5. General Footpath Maintenance	55 000	
6. St. Kilda Baths Demolition	35 000	
	385 500	

(e) the loan to be liquidated by appropriation out of the municipal fund,

(f) the plans, specifications and estimate for the cost of such works, and the statement showing the proposed expenditure of the money to be borrowed, are open for inspection at the office of the Council, Town Hall, St. Kilda, during office hours.

Dated 14 December 1979

4150

W. A. SISSON, Town Clerk

a distance of 1.33 metres and thence by a line bearing 272 deg. 50 min. a distance of 1.145 metres back to the commencing point.

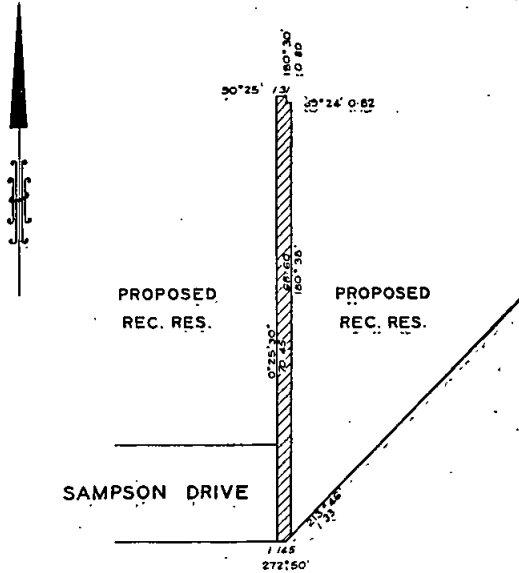

Area shown hatched to be compulsorily acquired

4191

By order of the Council  
COLIN J. BOCK, Town Clerk

CITY OF WAVERLEY

NOTICE OF INTENTION TO TAKE LAND COMPULSORILY

Whereas the Council of the City of Waverley deems it expedient to exercise its power of taking compulsorily the land described hereunder for the work or undertaking of taking land to be used by the Council for the purpose of providing a place of public resort and recreation and whereas the Council has caused to be prepared a map and other papers setting out the general description of the work or undertaking for which the land proposed to be taken is to be used the description of the land proposed to be taken and the names of the owners or reputed owners lessees or reputed lessees mortgagees or occupiers of that land so far as those names are known to or can be ascertained by the Council (in this case the land is a hiatus existing between Titles and there are no known owners or reputed owners lessees or reputed lessees mortgagees or occupiers of the subject land so far as can be ascertained by the Council) and whereas the said map and other papers are deposited at the office of the said Council at Glen Waverley and are and shall be open for inspection by all persons interested at all reasonable hours for the space of forty clear days after the publication of this notice in the *Government Gazette* now notice is hereby given to all persons affected by the proposed taking of the said land to set forth in writing addressed to the Council or the Town Clerk within forty clear days of the publication of this notice in the *Government Gazette* all objections which they may have to the taking of the said land.

THE LAND REFERRED TO

All that piece or parcel of land being part of Crown Portion 29, Parish of Mulgrave, County of Bourke, containing 140 square metres or thereabouts, bounded by lines commencing at a point at the southern end of the eastern boundary of Sampson Drive as delineated in Plan of Subdivision No. 67190 and bounded on the west by a line being part of the eastern boundary of the said plan of subdivision bearing 0 deg. 25 min. 30 sec. a distance of 70.45 metres, thence by a line bearing 90 deg. 25 min. a distance of 1.31 metres, thence by a line bearing 180 deg. 30 min. a distance of 0.82 metres, thence by a line bearing the western boundary of Lot 66 on Plan of Subdivision No. 70284 bearing 180 deg. 38 min. a distance of 68.60 metres, thence by a line bearing 213 deg. 46 min.

CITY OF WAVERLEY

By-Law No. 112

Procedures of Council By-Law

A By-Law of the City of Waverley made under section 197 of the *Local Government Act 1958* (as amended) and numbered 112 for adopting certain provisions of the 15th Schedule of the said Act and carrying out certain purposes provided for in the said Schedule.

In pursuance of the powers conferred by the *Local Government Act 1958* (as amended) and of any and every other power it thereunto enabling the Mayor, Councillors and Citizens of the City of Waverley orders as follows:

1. This By-Law shall be known as the proceedings of Council By-Law.

2. By-Laws numbers 92 and 109 relating to proceedings of the Council are hereby repealed.

3. Such of the clauses of the 15th Schedule of the *Local Government Act 1958* (as amended) entitled "Regulation of proceedings of Council", as are set out hereunder are hereby adopted, namely:

- Clauses 1-25 both inclusive
- 27-29 both inclusive
- 31-35 both inclusive
- 38-51 both inclusive.

4. Right of Reply—The mover of every original proposition at any Council meeting but not of any amendment shall (if he has not spoken on any amendment proposed to such original proposition) have a right of reply to be exercised at the conclusion of the debate (including debate on any such amendment) but save as aforesaid no Councillor shall be allowed to speak more than once on the same question unless permission be given to explain or unless the purpose of calling the attention of the Chair to a point of order. For the purposes of this Clause, a proposition shall be deemed to be an original proposition even although any amendment thereto has been carried.

5. Speaking Twice—No Councillor shall speak a second time on the same motion, except where entitled to reply or in explanation when he has been misrepresented or misunderstood, or as provided for in Clause 25.

6. Points of Order—The Mayor or other Chairman when called upon to decide on points of order or practice shall state the provision rule or practice which he deems applicable to the case without discussing or commenting on the same and his decision as to order or explanation in each case shall be final unless a Councillor moves that the Chairman's decision be disagreed with. Any such motion shall, if carried by a majority be acted upon instead of the decision made by the Chairman.

7. This By-Law shall apply to and have operating throughout the whole of the municipal district.

Resolution for passing this By-Law agreed to by the Council of the City of Waverley on 20 November 1979 and confirmed on 11 December 1979.

The common seal of the Mayor, Councillors and Citizens of the City of Waverley was hereunto affixed in the presence of—

(SEAL) G. B. FRECKER, Mayor  
D. C. McINTOSH, Councillor  
C. J. BOCK, Town Clerk

4279

## TOWN OF BAIRNSDALE

LOAN No. 39

*Notice of Intention to Borrow the Sum of \$120 000 for Permanent Works and Undertakings*

Notice is hereby given that the Council of the Town of Bairnsdale proposes to borrow the principal sum of one hundred and twenty thousand dollars secured by a charge over the general rates of the municipality, such sum to be raised by the grant of a mortgage in accordance with the provisions of the *Local Government Act 1958*.

1. The maximum rate of interest that may be paid is 10.8% per annum.

2. The purpose for which the loan is to be applied is for—

1. Road Construction and associated drainage works.
- |                        |        |
|------------------------|--------|
|                        | \$     |
| (a) Pyke Street (part) | 39 000 |
| (b) Greene Street      | 46 000 |
| (c) Pope Street        | 22 000 |

## 2. Drainage Construction.

- |                          |         |
|--------------------------|---------|
| (a) Forge Creek Road     | 3 500   |
| (b) Bosworth Road (part) | 9 500   |
|                          | 120 000 |

3. The period of the loan shall be ten years.

4. The moneys borrowed shall be repayable by providing out of the Municipal Fund nineteen half-yearly instalments of \$3165.67 each including principal and interest on 1 February and 1 August, during the currency of the loan, and the balance of the principal and interest owing shall be payable on 1 February 1990. The first instalment shall be payable on 1 August 1980.

5. Such moneys shall be payable to the Australian and New Zealand Savings Bank Limited, 134 Main Street, Bairnsdale.

Specifications and the estimate of the cost of the proposed expenditure of the moneys to be borrowed are open for inspection at the office of the Council of the Town of Bairnsdale, during office hours.

4132 G. G. McWHINNEY, Town Clerk

## TOWN OF STAWELL

LOAN No. 68

*Notice of Intention to Borrow the Sum of \$90 000 for Permanent Works and Undertakings*

Notice is hereby given that the Council of the Town of Stawell, in pursuance of the powers conferred by the *Local Government Acts*, intends to borrow the sum of \$90 000 secured by a charge over the general rates of the Municipality, such sum to be raised by the grant of a mortgage in accordance with the said Acts and states:—

- (a) That maximum rate of interest that may be paid is 10.8% per annum.
- (b) The period of the loan shall be 20 years.

(c) The purpose for which the loan is to be applied is part cost of Stawell Municipal Library.

(d) The monies borrowed shall be repayable by providing out of the Municipal Fund nineteen half-yearly instalments of \$5535.34, each including principal, and interest, on 1 August and 1 February during the period of the loan. The first instalment shall be payable on 1 August 1980.

(e) The place of repayment will be at the office of the State Savings Bank of Victoria, 101 Main Street, Stawell or at such other place as the Bank may require.

Plans and specifications and estimates of such works and undertakings and a statement showing the proposed expenditure of the money to be borrowed are available for inspection at the Town Hall, Main Street, Stawell during office hours.

4212

D. H. HUTTON, Town Clerk

*Town and Country Planning Act 1961 (Twelfth Schedule)*

## TOWN OF STAWELL PLANNING SCHEME 1963

NOTICE THAT A PLANNING SCHEME HAS BEEN PREPARED AND IS AVAILABLE FOR INSPECTION

Amendment No. 18, 1979

Notice is hereby given that the Council of the Town of Stawell, in pursuance of its powers under the *Town and Country Planning Act 1961*, has prepared a planning scheme for the following purpose:

To rezone Crown Allotments 1, 1A, 2 and 3, section 140A, Parish of Stawell from Rural to Rural Residential.

A copy of the Scheme has been deposited at the Town Hall, Main Street, Stawell and the Office of the Town and Country Planning Board, 235 Queen Street, Melbourne and will be open for inspection to any person free of charge during office hours.

Any persons affected by the planning scheme are required to set forth in writing to the Town Clerk, Town of Stawell, Town Hall, Stawell, 3380, all objections they may have on or before 19 January 1980 and to state whether they wish to be heard in respect of their objections.

4213

D. H. HUTTON, Town Clerk

## BOROUGH OF QUEENSCLIFFE

CHANGE OF STREET NAME

Notice is hereby given that the Council of the Borough of Queenscliffe pursuant to the provisions of section 535 of the *Local Government Act 1958* did resolve at a meeting held on 27 November 1979, to re-name the following street in Point Lonsdale:

Old Name: Sara Street

New Name: Bezzant Close

Location: Off Ann Street, Point Lonsdale.

4145

R. T. FORBES, Town Clerk

## SHIRE OF ARARAT

LOAN No. 11

*Notice of Intention to Borrow the Sum of \$25 000 for Permanent Works and Undertakings*

Notice is hereby given that the Council of the Shire of Ararat proposes to borrow the principal sum of Twenty-five thousand dollars secured by a charge over the General Rates of the municipality, such sum to be raised by the grant of a mortgage with the provisions of the *Local Government Act 1958*.

The maximum rate of interest that may be paid is 10.7 per centum per annum.

The purpose for which the loan is to be applied is alteration and additions to the Shire Hall, Ararat.

The period of the loan shall be five years.

The moneys borrowed shall be repayable by providing out of the Municipal Fund half-yearly instalments of approximately \$3292.87 each including principal and interest on 5 April and 5 October during the currency of the loan. The first instalment shall be payable on 5 October 1980.

Such moneys shall be repayable to the C.B.C. Savings Bank Limited, Melbourne.

The plans and specifications and estimate of the cost of the proposed works and a statement showing the proposed expenditure of the moneys to be borrowed, are open for inspection at the office of the Council, Shire Hall, Barkly Street, Ararat.

4196

L. M. CONSTABLE, Shire Secretary

*Town and Country Planning Act 1961 (Twelfth Schedule)*  
SHIRE OF BALLARAT—BALLAARAT AND DISTRICT  
PLANNING SCHEME

NOTICE THAT A PLANNING SCHEME HAS BEEN PREPARED AND IS AVAILABLE FOR INSPECTION

Amendment No. 8, 1980

Notice is hereby given that the Shire of Ballarat in pursuance of its powers under the *Town and Country Planning Act 1961* has prepared a planning scheme known as Amendment No. 8, 1980 for all the area covered by the Ballarat and District Planning Scheme 1966 (Shire of Ballarat).

A copy of the scheme has been deposited at Shire Offices, Gillies Street, Wendouree, and at the office of the Town and Country Planning Board, 235 Queen Street, Melbourne, and will be open for inspection during office hours by any person free of charge. Any persons affected by the Planning Scheme are required to set forth in writing all objections and/or any submission which they wish to make with respect to the scheme, addressed to the Shire Secretary, Shire of Ballarat, Gillies Street, Wendouree, 3355, on or before 31 March 1980, and to state whether they wish to be heard in respect of such objection or submission.

4281

J. W. KELLOCK, Shire Secretary

## UNITED SHIRE OF BEECHWORTH

LOAN No. 31

*Notice of Intention to Borrow the Sum of \$50 000 for Permanent Works and Undertakings*

Notice is hereby given that the Council of the United Shire of Beechworth intends to borrow the principal sum of Fifty thousand dollars (\$50 000) secured by a charge over the General Rates of the Municipality, such sum to be raised by the grant of a mortgage in accordance with the provisions of the *Local Government Act 1958*.

1. The maximum rate of interest that may be paid is 10·8 per cent per annum.

2. Such moneys shall be repayable at Bank of New South Wales, Beechworth.

3. The loan is to be liquidated by providing out of the municipal fund 20 half-yearly instalments of \$4149.32 each including principal and interest on 4 September and 4 April during the currency of the loan. The first instalment shall be payable on 4 September 1980.

4. The purposes for which the loan is to be applied are:—

	\$
Road Construction—	
Atkinson Road	10 000
Williams Street	30 000
Various Unclassified Roads	10 000
	50 000

5. The period of the loan shall be 10 years.

The plans, specifications, estimate of the cost of the proposed works and a statement showing the proposed expenditure of the moneys to be borrowed are open for inspection at the Municipal Offices, Beechworth.

Dated 17 December 1979

4280

G. T. GRAY, Shire Secretary

## SHIRE OF CORIO

LOAN No. 130

*Notice of Intention to Borrow the Sum of \$100 000 for Permanent Works and Undertakings*

Notice is hereby given that the Council of the Shire of Corio proposes to borrow the principal sum of \$100 000 secured by a charge over the general rates of the municipality, such sum to be raised by the grant of a mortgage in accordance with the provisions of the *Local Government Act 1958*.

1. The maximum rate of interest that may be paid is 10·8 per cent. per annum.

2. The purpose for which the loan is to be applied is—  
Building and Recreation—

	\$
Norlane Pool	90 000
Corio Athletic Stadium	10 000
	100 000

3. The period of the loan shall be ten years.

4. The moneys borrowed shall be repayable by providing out of the municipal fund half-yearly instalments of approximately \$8298.64 each including principal and interest on 22 August and 22 February during the currency of the loan. The first instalment shall be payable on 22 August 1980.

5. Such moneys shall be repayable to Australian Mutual Provident Society at the office of the said Society, 535 Bourke Street, Melbourne.

The plans and specifications and the estimate of the cost of the proposed works and a statement showing the proposed expenditure of the moneys to be borrowed are open for inspection at the office of the Council of the Shire of Corio at Osborne House, Swinburne Street, North Geelong, 3215.

4206

R. P. METCALF, Shire Secretary

## SHIRE OF CRANBOURNE

LOAN No. 89

*Notice of Intention to Borrow*

Notice is hereby given that the Council of the Shire of Cranbourne proposes to borrow the principal sum of \$42 000 secured by a charge over the general rates of the Municipality, such sum to be raised by the grant of a mortgage in accordance with the provisions of the *Local Government Act 1958* (as amended).

1. The maximum rate of interest that may be paid is 10·8 per cent per annum.

2. The purposes for which the loan is to be applied are as follows:—

Heavy Duty Grader (part cost)—\$42 000

3. The period of the loan shall be 10 years, the moneys borrowed shall be repayable by providing out of the Municipal Fund 20 half yearly instalments of \$3 485.43, including principal and interest on 1 February and 1 August, during the currency of the loan. The first instalment shall be payable on 1 August 1980.

4. Such moneys shall be repayable to the National Bank of Australasia Ltd., 271-285 Collins Street, Melbourne, or such other place or places as the Bank from time to time may require.

The plans and specifications and the estimate of the cost of the proposed works and statement showing the proposed expenditure of moneys to be borrowed are open for inspection at the office of the Council of the Shire of Cranbourne.

Dated 17 December 1979

4207

T. VICKERMAN, Shire Secretary

## SHIRE OF CRANBOURNE

## LOAN No. 90

## Notice of Intention to Borrow

Notice is hereby given that the Council of the Shire of Cranbourne proposes to borrow the principal sum of \$158 000 secured by a charge over the general rates of the Municipality, such sum to be raised by the grant of a mortgage in accordance with the provisions of the *Local Government Act 1958* (as amended).

1. The maximum rate of interest that may be paid is 10.8 per cent per annum.
2. The purposes for which the loan is to be applied are as follows:—

	\$
Road construction Russell Street, Cranbourne (part cost)	9 000
Road construction Lyall Street, Cranbourne (part cost)	34 900
Purchase Civic Centre Site (part cost)	34 900
Recreation Reserve building works—	
Cranbourne Betting Ring Enclosure	18 200
Cranbourne Multi-purpose pavilion	50 000
Walter Street Private Street Scheme (Council contribution)	11 000
	158 000

3. The period of the loan shall be 20 years, the moneys borrowed shall be repayable by providing out of the Municipal Fund 40 half yearly instalments of \$9717.59, including principal and interest on 1 February and 1 August, during the currency of the loan. The first instalment shall be payable on 1 August 1980.

4. Such moneys shall be repayable to the National Bank of Australasia Ltd., 271-285 Collins Street, Melbourne, or such other place or places as the Bank from time to time may require.

The plans and specifications and the estimate of the cost of the proposed works and statement showing the proposed expenditure of moneys to be borrowed are open for inspection at the office of the Council of the Shire of Cranbourne.

Dated 17 December 1979

4208 T. VICKERMAN, Shire Secretary

## SHIRE OF FLINDERS

## NOTICE OF ROAD NAME CHANGE

Notice is hereby given that in pursuance of the powers conferred by the *Local Government Act 1958* the Council of the Shire of Flinders at a meeting held on 28 November 1979 resolved to make the following road name change—

Old Name—Road.

New Name—Arranga Street.

Location—Rosebud on Lodged Plan 126920 being the southern boundaries of lots one and two, and northern boundaries of lots three and four.

Change of name to take effect on acceptance of plan at Office of Titles.

4209 G. W. WHITE, Shire Secretary

## SHIRE OF GRENVILLE

## By-Law No. 26

Notice is hereby given that the Council of the Shire of Grenville has made a By-Law under the provisions of the *Local Government Act 1958* for the purpose of limiting the number of dogs to be kept on any property in portion of the Delacombe Riding. The area concerned is that which is bounded by Latrobe Street, Wiltshire Lane, Sutton Street and the Glenelg Highway.

No person shall keep or permit to be kept on any property more than two dogs over the age of six months without the consent of the Council. Such By-Law No. 26 was approved by the Governor in Council on 27 November 1979 and shall come into operation on 19 December 1979.

A copy of the By-Law is open for inspection free of charge during office hours at the Municipal Office, Shire Hall, Linton.

4133 I. OLDFHAM, Shire Secretary

## SHIRE OF HASTINGS

## LOAN No. 84

## Notice of Intention to Borrow the Sum of \$40 000 for Permanent Works and Undertakings

Notice is hereby given that the Council of the Shire of Hastings proposes to borrow the principal sum of \$40 000, secured by a charge over the general rates of the Municipality, such sum to be raised by the grant of a mortgage in accordance with the provisions of the *Local Government Act 1958*.

1. The maximum rate of interest that may be paid is 10.8% per annum.
2. The purpose for which the loan is to be applied is for:

(i) Establishment Costs—Municipal Library, 37-41 Victoria Street, Hastings. (Internal Works and Provision of Equipment.)

3. The period of the Loan shall be 15 years.

4. The moneys borrowed shall be repayable by providing out of the Municipal Fund 30 half-yearly instalments of \$2721.89 each, including principal and interest on 6 February and 6 August during the currency of the loan. The first instalment to be repayable on 6 August 1979.

5. Such moneys shall be repayable to the National Bank of Australasia Ltd., High Street, Hastings.

6. The plans and specifications and the estimate of the cost of the abovementioned works and a Statement showing the proposed expenditure of the moneys to be borrowed are open for inspection at the Office of the Shire of Hastings, Marine Parade, Hastings.

Dated 11 December 1979.

Municipal Offices, Hastings, 3915

4192 W. R. FEATHERSTON, Shire Secretary

## Town and Country Planning Act 1961

## SHIRE OF NEWSTEAD PLANNING SCHEME 1980

NOTICE THAT A PLANNING SCHEME HAS BEEN PREPARED AND IS AVAILABLE FOR INSPECTION

## Interim Development Order

Notice is hereby given that the Shire of Newstead, in pursuance of its powers under the *Town and Country Planning Act 1961*, has prepared a Planning Scheme for that Part of the Municipal District of the Shire of Newstead, which is not included in the Lake Cairn Curran Planning Scheme, for the purposes of:—

(a) Incorporating a Rural Residential Zone.

(b) Incorporating a Rural Highway Zone.

(c) Making slight alterations to existing Urban Zone boundaries and conditions for development.

(d) Making provision for cluster subdivisions under the *Cluster Titles Act 1974*.

A copy of the scheme has been deposited at the Office of the Council of the Shire of Newstead, Lyons Street, Newstead, and at the office of the Town and Country Planning Board, 235 Queen Street, Melbourne, and will be open for inspection there during office hours, by any person free of charge.

Any persons affected by the planning scheme are required to set forth, in writing, all objections they may have, addressed to the Shire Secretary, Shire of Newstead, P.O. Box 3, Newstead, on or before 19 January 1980, and to state whether they wish to be heard in respect of their objections.

4147 DAVID R. BROAD, Shire Secretary

## Town and Country Planning Act 1961

## SHIRE OF PAKENHAM

## INTERIM DEVELOPMENT ORDER 1974

## Amendment No. 30, 1979

Notice is hereby given that the Council of the Shire of Pakenham pursuant to its powers under the *Town and Country Planning Act 1961* has made and adopted an Interim Development Order known as the Shire of Paken-

ham Interim Development Order—Amendment No. 30, 1979, which amends the Shire of Pakenham Interim Development Order 1974 as follows:—

1. By rezoning land being lot 2, Plan of Subdivision No. 79491, Parish of Nar Nar Goon and having frontage to Army Road, Pakenham, from Highway Zone to Country Township Zone.

2. In Column 2 of Sub-Clause (ii), Table of Uses to Clause 5 (0) after the words Consulting Rooms (4) there shall be inserted the words "Drive-in-Cinema (4a)".

3. By rezoning land being Lot 3 Plan of Subdivision No. 129705, Parish of Nar Nar Goon situated at the corner of Army Road and Princes Highway, Pakenham, from Township B Zone to Restricted Use Zone (Drive-in-Cinema) (4a).

A copy of the Shire of Pakenham Interim Development Order—Amendment No. 30 has been deposited at the office of the Town and Country Planning Board, 5th Floor, 235 Queen Street, Melbourne, and at the office of the Shire of Pakenham, Main Street, Pakenham, and may be inspected during office hours by any persons free of charge.

Any persons affected by the Shire of Pakenham Interim Development Order 1974—Amendment No. 30, 1979, are required to set forth in writing to the Shire Secretary, Shire of Pakenham, Main Street, Pakenham, all objections they may have on or before 19 January 1980 and to state whether they wish to be heard in respect of their objections.

4282

B. J. WALLIS, Shire Secretary

SHIRE OF PORTLAND

LOAN No. 41

*Notice of Intention to Borrow the Sum of \$60 000 for Permanent Works and Undertakings*

Notice is hereby given that the Council of the Shire of Portland proposes to borrow the principal sum of \$60 000 secured by a charge over the general rates of the municipality, such sum to be raised by the grant of a mortgage in accordance with the provisions of the *Local Government Act 1958*, as amended.

1. Maximum rate of interest that may be paid is 10.8 per centum per annum.

2. The period of the loan shall be fifteen (15) years.

3. The moneys borrowed shall be repayable by providing out of the Municipal Fund twenty-nine half-yearly instalments of \$3384.22 each including principal and interest and a final instalment of the outstanding principal. Principal and interest shall be payable on 24 January and 24 July each year during the currency of the loan. The first instalment shall be payable on 24 January 1980.

4. Such moneys shall be repayable at the Commercial Bank of Australia Limited, Heywood.

5. The purpose for which the loan is to be applied is for the construction of a Library in Heywood.

The plans and specifications and estimate of the cost of the works and a statement showing the proposed expenditure of the money to be borrowed are open for inspection at the Shire Office, 77 Edgar Street, Heywood, during normal office hours.

4193

P. K. SHANAHAN, Shire Secretary

SHIRE OF PORTLAND

LOAN No. 42

*Notice of Intention to Borrow the Sum of \$27 440 for Permanent Work and Undertakings*

Notice is hereby given that the Council of the Shire of Portland intends to borrow the sum of Twenty-seven thousand four hundred and forty dollars (\$27 440) secured by a charge over the general rate of the Municipality by the grant of a mortgage in accordance with the provisions of the *Local Government Act 1958*.

1. The maximum rate of interest that may be paid is ten point seven per cent. per annum (10.7 per cent.).

2. The period of the Loan shall be 8 years.

3. The moneys borrowed shall be repayable by providing out of the municipal fund sixteen (16) half-yearly instalments of \$2595.35 each including principal and interest on 24 January and 10 July during the currency of the loan. The first instalment shall be payable on 24 January 1980.

4. Such moneys shall be repayable at the Commercial Bank of Australia Ltd., Heywood.

5. Purpose for which the loan is to be applied is part purchase of a motor grader, \$27 440.

A statement showing the proposed expenditure of the moneys to be borrowed is open for inspection at the Shire office, 77 Edgar Street, Heywood, during the normal office hours.

4325

P. K. SHANAHAN, Shire Secretary

SHIRE OF PORTLAND

LOAN No. 43

*Notice of Intention to Borrow the Sum of \$118 600 for Permanent Works and Undertakings*

Notice is hereby given that the Council of the Shire of Portland intends to borrow the sum of One hundred and eighteen thousand six hundred dollars (\$118 600) secured by a charge over the general rates of the Municipality by the grant of a mortgage in accordance with the provisions of the *Local Government Act 1958*.

1. The maximum rate of interest that may be paid is ten point eight per cent. per annum (10.8 per cent.).

2. The period of the loan shall be fifteen (15) years.

3. The moneys borrowed shall be repayable by providing out of the municipal funds twenty-nine half-yearly instalments of \$6689.47 each including principal and interest and a final instalment of the outstanding principal and interest. Principal and interest shall be payable on 24 January and 24 July each year during the currency of the loan. The first instalment shall be payable on 24 January 1980.

4. Such moneys shall be repayable at the Commercial Bank of Australia Ltd., Heywood.

5. The purpose for which the loan is to be applied is—

1. Bridge construction—

	\$	\$
(a) Branxholme—Byaduk No. 1	18 000	
(b) Glares bridge and road-work	22 000	
(c) Branxholme—Byaduk No. 2	2 000	
(d) Jennings Bridge	8 000	
	50 000	

2. Footpaths, Kerb and Channel (Owen and Cameron Street, Heywood) (Council's contribution) 16 000

3. Rubbish Tips—

(a) Branxholme	10 100	
(b) Myamyn	4 800	
(c) Narrawong	18 700	
(d) Wallacedale	8 000	
	41 600	

4. Shire Office Extensions 11 000

118 600

A statement showing the proposed expenditure of the money to be borrowed is open for inspection at the Shire office, 77 Edgar Street, Heywood, during normal office hours.

4326

P. K. SHANAHAN, Shire Secretary

SHIRE OF WHITTLESEA

LOAN No. G. 59

*Notice of Intention to Borrow the Sum of \$100 000 for Permanent Works and Undertakings*

Notice is hereby given that the Council of the Shire of Whittlesea proposes to borrow the principal sum of \$100 000 secured by a charge over the general rates of the Municipality, such sum to be raised by the grant of a mortgage in accordance with the provisions of the *Local Government Act 1958*.



1. The maximum rate of interest that may be paid is 10·8 per cent. per annum.

2. The purposes for which the loan is to be applied are:—

	\$
(a) Lalor Bowling Club extensions	80 000
(b) Roadworks—Forest Street, North of Laurel Street (Additional Funds)	14 000
Glenburnie Road, Culvert at Barbers Creek and Seventh Avenue (Additional Funds)	6 000
	100 000

3. The period of the loan shall be fifteen years.

4. The moneys borrowed shall be repayable by providing out of the Municipal Fund half-yearly instalments of \$6804.73 each including principal and interest on 10 February and 10 August, during the currency of the loan. The first instalment shall be payable on 10 August 1980.

5. Such moneys shall be repayable to the Commercial Savings Bank of Australia Limited, Melbourne.

The plans and specifications and estimate of the cost of the proposed works and a statement showing the proposed expenditure of the moneys to be borrowed are open for inspection at the Office of the Council of the Shire of Whittlesea at High Street, Epping.

4143

L. G. ESMONDE, Shire Secretary

## SHIRE OF WHITTLESEA

## LOAN No. G. 60

*Notice of Intention to Borrow the Sum of \$100 000 for Permanent Works and Undertakings*

Notice is hereby given that the Council of the Shire of Whittlesea proposes to borrow the principal sum of \$100 000 secured by a charge over the general rates of the Municipality, such sum to be raised by the grant of a mortgage in accordance with the provisions of the *Local Government Act 1958*.

1. The maximum rate of interest that may be paid is 10·8 per cent. per annum.

2. The purposes for which the loan is to be applied are:—

	\$
(a) Pavilion, Huskisson Avenue Reserve (to complete)	14 000
(b) Pre-School Centre, Kingsway Drive, Lalor West (to complete)	25 000
(c) Elderly Citizens Club Building, May Road, Lalor (to complete)	45 000
(d) Toilet Block, Yan Yean Reserve (to complete)	3 000
(e) Construction of Clarks Road, west of Wallan Road (to commence)	13 000
	100 000

3. The period of the Loan shall be ten (10) years and the money borrowed is to be repaid in full at the expiration of the Loan on 15 February 1990.

4. The Loan is to be liquidated by the establishment of a Sinking Fund pursuant to section 428A (1) of the *Local Government Act 1958* with a yearly appropriation of \$7950.46 payable from the Municipal Fund.

5. Such money shall be repayable to the Insurance Commissioner, State Insurance Office, 480 Collins Street, Melbourne.

The plans and specifications and an estimate of the proposed works and a statement showing the proposed expenditure of money to be borrowed are open for inspection at the Office of the Council of the Shire of Whittlesea at High Street, Epping.

4144

L. G. ESMONDE, Shire Secretary

## SHIRE OF WYCHEPROOF

## LOAN No. 74

*Notice of Intention to Borrow the Sum of \$25 000 for Permanent Works and Undertakings*

Notice is hereby given that the Council of the Shire of Wycheproof proposes to borrow the principal sum of \$25 000, secured by a charge over the general rates of the municipality, such sum to be raised by the grant of a mortgage in accordance with the provisions of the *Local Government Act 1958*.

1. The maximum rate of interest that may be paid is 10·8 per cent. per annum.

2. The purpose for which the loan is to be applied is for Depot redevelopment.

3. The period of the loan shall be 10 years.

4. The moneys borrowed shall be payable by providing out of the municipal fund, half-yearly instalments of approximately \$2074.66 each including principal and interest on 17 March and 17 September during the currency of the loan. The first instalment shall be payable on 17 September 1980.

5. Such moneys shall be repayable to the Commercial Bank of Australia Limited.

The plans and specifications and the estimate of cost of the Depot redevelopment and a statement showing the proposed expenditure of the moneys to be borrowed are open for inspection at the office of the Council of the Shire of Wycheproof at 367 Broadway, Wycheproof, Shire Office, Wycheproof, 17 December 1979

4278

G. R. DRYDEN, Shire Secretary

## GEELONG WATERWORKS AND SEWERAGE TRUST

The abovementioned Trust having made provision for carrying off the sewage from each and every property which or any part of which is within the sewerage area hereinafter described doth hereby declare that on or after 1 January 1980 each and every property which or any part of which is within the said sewerage area shall be deemed and taken to be seweraged property within the meaning of the said *Geelong Waterworks and Sewerage Act 1958*.

## SEWERAGE AREA No. 733

*Shire of Corio, Parish of Moorpanyal, County of Grant*

Commencing at a point being the south-west corner of the intersection of Nicholson Crescent and Hastie Avenue, North Geelong, the said point being also on the boundary of Sewerage Area No. 730, thence south-westerly and westerly along the south-east and south sides of Hastie Avenue to the prolongation of the south-western boundary of allotment No. 11 Nicholson Crescent, thence north-westerly across Hastie Avenue and continuing north-westerly along the south-western boundary of the said allotment No. 11 to the north-west corner of the said allotment No. 11, thence north-westerly, westerly and northerly along the south-western, southern and western boundaries of allotments Nos. 12 to 17 inclusive Nicholson Crescent to the north-west corner of the said allotment No. 17, thence north-easterly along the north-west boundary of the said allotment No. 17 to the north-east corner of the said allotment No. 17, which is also on the south-west side of Nicholson Crescent, thence south-easterly along the south-west side of Nicholson Crescent and crossing Nicholson Crescent to the point of commencement.

## SEWERAGE AREA No. 734

*City of South Barwon, Parish of Corio, County of Grant*

Commencing at a point being the north-west corner of the intersection of Bailey and Osborne Streets, East Belmont, the said point being also on the boundary of Sewerage Area No. 627, thence southerly across Osborne Street and continuing southerly along the west side of Bailey Street to the boundary of Sewerage Area No. 732, thence westerly and northerly following the boundaries of Sewerage Areas Nos. 732, 709 and 626 to the south-east corner of the intersection of Francis and Osborne Streets, thence northerly across Osborne Street to the north-east corner of the intersection of Francis and Osborne Streets, thence easterly along the north side of Osborne Street to the point of commencement.

## SEWERAGE AREA No. 735.

*City of South Barwon, Parish of Conewarre, County of Grant*

Commencing at a point being the south-west corner of the intersection of Grove and Mornane Road, Marshall, thence south-easterly and southerly along the south-west and west side of Mornane Road and crossing Tamala Avenue and Marshall Town Road on a straight line to the south side of Marshall Town Road, thence westerly along the south side of Marshall Town Road and crossing Drews Road and Geelong-Colac Railway (Victorian Railways Reserve) to the point being 185 metres west from the south-west corner of the intersection of Marshall Town Road and Drews Roads, thence north-easterly by a line bearing 16 degrees 54 minutes across Marshall Town Road and continuing north-easterly for a distance of 57 metres, thence south-easterly by a line bearing 107 degrees to the north-west side of Station Road, thence north-easterly along the north-west side of Station Road to the south-west corner of the intersection of Station and Grove Roads, thence easterly along the south side of Grove Road and crossing Station Road, Geelong-Colac Railway (Victorian Railway Reserve), Plantation Reserve and Drews Road to the point of commencement.

## SEWERAGE AREA No. 736

*City of Newtown, Parish of Moorpanyal, County of Grant*

Commencing at a point being the north-east corner of allotment No. 12 Whyte Court, Newtown, the said point being also on the boundaries of Sewerage Areas Nos. 189 and 683, thence south-easterly along the eastern boundaries of allotments Nos. 12 to 10 inclusive Whyte Court and allotment No. 1 Queens Park Road and crossing Queens Park Road on a straight line to the south side of Queens Park Road, thence westerly along the south side of Queens Park Road for a distance of 196 metres, thence southerly by a line bearing 180 degrees 42 minutes and crossing Queens Road to the boundary of Sewerage Area No. 506, thence north-westerly and westerly following the boundary of Sewerage Area No. 506 and crossing Heathfield Court to the prolongation of the western boundary of allotment No. 63 Louis Court, thence northerly across Queens Park Road and continuing northerly along the western boundary of the said allotment No. 63 to the south-west corner of allotment No. 62 Louis Court, thence northerly and north-westerly along the western and south-western boundaries of allotments Nos. 62 to 56 inclusive Louis Court to the north-west corner of allotment No. 55 Louis Court, thence easterly along the northern boundaries of allotments Nos. 55 and 54 Louis Court and along the north side of Access Road to the boundary of Sewerage Area No. 254, thence easterly, north-easterly, south-easterly and easterly following the boundaries of Sewerage Areas Nos. 254 and 189 and crossing Melville Avenue to the point of commencement.

## SEWERAGE AREA No. 737

*Shire of Corio, Parish of Moorpanyal, County of Grant*

Commencing at a point being the south-west corner of the intersection of Walchs Road and Seabeach Parade, North Shore, the said point being also on the boundary of Sewerage Area No. 368, thence northerly across Walchs Road and continuing northerly along the west side of Seabeach Parade to the prolongation of the north side of Madden Avenue, thence westerly by a line bearing 278 degrees to the south-east side of Victorian Railways Reserve (Geelong-Melbourne Railway), thence north-easterly along the south-east side of the Victorian Railways Reserve and crossing St. Georges Road to a point being 400 metres north-easterly from the north side of St. Georges Road, thence south-easterly by a line bearing 120 degrees to the north-west side of Lowe Street, thence south-westerly along the north-west side of Lowe Street, to the north-west corner of the intersection of Lowe Street and St. Georges Road, thence easterly across Lowe Street to the north-east corner of the intersection of Lowe Street and St. Georges Road, thence south-westerly across St. Georges Road and continuing south-westerly and southerly along the south-east and east sides of Seabeach Parade and crossing Greta and Baron Streets to the north-east corner of the intersection of Seabeach Parade and Madden Avenue, thence easterly along the

north side of Madden Avenue and crossing Lesley Street to the south-west corner of allotment No. 62 Madden Avenue, thence northerly along the western boundary of the said allotment No. 62 to the southern boundary of allotment No. 106 Baron Street, thence westerly along the southern boundary of the said allotment No. 106 to the south-west corner of the said allotment No. 106, thence northerly along the western boundary of the said allotment No. 106 to the south side of Baron Street, thence north-westerly across Baron Street to the south-west corner of allotment No. 107 Baron Street, thence northerly along the western boundaries of the said allotment No. 107 and allotment No. 147 The Esplanade to the south side of Greta Street, thence easterly along the south side of Greta Street to the south-west corner of the intersection of Greta Street and The Esplanade, thence south-easterly along the south-west side of The Esplanade and crossing Baron Street to the south-east corner of allotment No. 61 The Esplanade, thence south-westerly along the south-eastern boundary of the said allotment No. 61 to the north-eastern boundary of allotment No. 106 Baron Street, thence south-easterly along the north-eastern boundaries of the said allotment No. 106 and allotment No. 62 Madden Avenue to the north-west corner of allotment No. 55 The Esplanade, thence north-easterly along the north-western boundary of the said allotment No. 55 to the south-west side of The Esplanade thence south-easterly and southerly along the south-west and west sides of The Esplanade and crossing Madden Avenue and Walchs Road to the south-west corner of the intersection of The Esplanade and Walchs Road, thence westerly along the south side of Walchs Road to the boundary of Sewerage Area No. 276, thence westerly following the boundaries of Sewerage Area Nos. 276 and 368 and crossing Seabeach Parade to the point of commencement.

## SEWERAGE AREA No. 738

*Shire of Bellarine, Parish of Moolap, County of Grant*

Commencing at a point being the south-east corner of allotment No. 35 Ellstone Avenue, Whittington, the said point being also on the boundary of Sewerage Area No. 656, thence westerly along the southern boundaries of allotments Nos. 35 to 45 inclusive Ellstone Avenue to the south-west corner of the said allotment No. 45 thence northerly along the western boundary of the said allotment No. 45 to the prolongation of the southern boundary of allotment No. 50 Buckingham Street, thence westerly across Buckingham Street and continuing westerly along the southern boundary of the said allotment No. 50 to the south-west corner of the said allotment No. 50, thence northerly along the western boundaries of allotments Nos. 50 and 49 Buckingham Street to the boundary of Sewerage Area No. 609, thence easterly, northerly, easterly, southerly, easterly, south-easterly and southerly following the boundaries of Sewerage Areas Nos. 609 and 656 and crossing Buckingham Street and Ellstone Avenue to the point of commencement.

Signed under seal of the Geelong Waterworks and Sewerage Trust, 12 December 1979

4151

R. W. WHITESIDE, Chairman  
B. C. HENSHAW, Secretary

## GEELONG WATERWORKS AND SEWERAGE TRUST

Pursuant to section 60 of the *Geelong Waterworks and Sewerage Act 1958* (No. 6263) the Trust has prepared plans to indicate the particulars of sewers and underground works, the construction of which the Trust intends to begin, at a date not less than one month after publication of the notices, in or adjacent to the following localities within the Drainage Area.

Rodney Road and Morgan Street, North Geelong, Shire of Corio

Notice is hereby given that the plans indicated are open for public inspection at the Trust's Offices, 61-67 Ryre Street, Geelong, between the hours of 9.00 a.m. and 5.00 p.m. from Monday to Friday (public holidays excepted) by the owners or occupiers of land or premises within the Drainage Area.

4217

B. C. HENSHAW, Secretary

## ALEXANDRA SEWERAGE AUTHORITY

## By-Law No. 4

Notice is hereby given that the Alexandra Sewerage Authority have made a By-Law relating to consents, licences and other matters relating to house connection work.

A copy of the By-Law is open for inspection at the offices of the Alexandra Sewerage Authority during normal business hours.

The By-Law was approved by the Governor in Council at the Executive Council Meeting held on 20 November 1979.

4214 G. I. WALSHE, Secretary to the Authority

## ALEXANDRA SEWERAGE AUTHORITY

## By-Law No. 3

Notice is hereby given that the Alexandra Sewerage Authority have made a By-Law for the purpose of increasing the fees and charges relating to house connection plans drawn up and supervised by the Authority.

A copy of the By-Law is open for inspection at the offices of the Alexandra Sewerage Authority during normal business hours.

The By-Law was approved by the Governor in Council at the Executive Council Meeting held on 20 November 1979.

4215 G. I. WALSHE, Secretary to the Authority

## THE BALLARAT SEWERAGE AUTHORITY

Pursuant to section 119 (2) of the *Sewerage Districts Act 1958* (No. 6368), notice is hereby given of the intention to construct sewers to provide for properties situated in the vicinity of the following streets:

*Shire of Ballarat*—Elaine Avenue, Alfredton, North Western Highway, Regina Street, Wendouree more particularly as shown on maps which are open for inspection at this office between the hours of 8.45 a.m. and 4.30 p.m., Monday to Friday, inclusive.

11 December, 1979

B. E. LEACH, Secretary  
Water and Sewerage Offices Ballarat 4198

## FRANKSTON SEWERAGE AUTHORITY

## COMMENCEMENT OF WORKS

Notice is hereby given that the Authority intends to construct sewers in the general vicinity of Brunel Road, Pascal Road and Stephenson Road, Seaford.

Details of the proposed works are available for inspection at the office of the Authority, Civic Centre Annexe, 34 Davey Street, Frankston during office hours.

A. H. BUTLER, Secretary  
Civic Centre Annexe, Frankston, 3199 4283

## KORUMBURRA SEWERAGE AUTHORITY

## GENERAL NOTICE

The abovementioned Sewerage Authority having made provision for carrying off the sewage from each and every property which or any part of which is within the sewerage areas hereinafter described doth hereby declare that on and after 1 January 1980 each and every property which or any part of which is within the said sewerage areas shall be deemed to be a seweraged property within the meaning of the *Sewerage Districts Act 1958*.

The Sewerage Areas hereinbefore referred to are:—

*Sewerage Area No. 16*—Comprising Lots 1, 2, 3 and 4 being Part C/A 90—Jumbunna Road.

*Sewerage Area No. 17*—Comprising Lots 3 and 4 being Part C/A 90—Hawkins Street.

*Sewerage Area No. 18*—Comprising Allotment 21, Section D Riflebutt's Road.

*Sewerage Area No. 19*—Comprising Allotment 5, Section M Mine Road.

*Sewerage Area No. 20*—Comprising Lots 3, 5, 6, 23, 25, 26, 27, 28, 29 being Part C/A 89—Industrial Estate. (Part only.)

By order of the said Sewerage Authority  
M. V. MOSKOS, Chairman  
C. J. PATERSON, Secretary/Manager.

4216

## LILYDALE SEWERAGE AUTHORITY

## GENERAL NOTICE

The above-mentioned Sewerage Authority having made provision for carrying off the sewage from each and every property which or any part of which is within the sewerage area hereinafter described doth hereby declare that on and after 1 January 1980 each and every property which or any part of which is within the said sewerage area shall be deemed to be a seweraged property within the meaning of the *Sewerage Districts Act 1958*.

The boundaries of the sewerage area hereinbefore referred to are:

*Declared Area No. 97*

Comprising Lots 189 and 190 on Plan of Subdivision No. 68218 Parish of Yering County of Evelyn situated in Circle Ridge, Chirnside Park, lots 231 to 233 inclusive on Plan of Subdivision No. 69542 Parish of Yering County of Evelyn situated in Chirnside Drive, Chirnside Park and lots 2136 and 2137 on Plan of Subdivision No. 95407 Parish of Yering County of Evelyn situated in Carole Avenue, Chirnside Park.

The plans are available for inspection during normal working hours at the Office of the Authority, rear of ground floor, 7-9 John Street, Lilydale.

By order of the said Sewerage Authority  
A. J. LILLIE, Chairman  
W. L. HALSE, Secretary

4197

Notice is hereby given that Ampol Petroleum (Vic.) Pty. Ltd. has applied for a lease pursuant to section 134 of the *Land Act 1958* for a term of 14 years in respect of Allotment 15 Section 1A Parish of Doutta Galla City of Melbourne containing 1.5859 hectares as a site for Transportation Purposes. 4153

Notice is hereby given that Avin Plating Pty. Ltd. has applied for a lease pursuant to section 135 of the *Land Act 1958* for a term of 15 years in respect of Allotment 18, Section D Parish of Melbourne South City of South Melbourne containing 1821 square metres as a site for Commercial and Industrial Purposes. 4154

Notice is hereby given that Avin Plating Pty. Ltd. has applied for a lease pursuant to section 135 of the *Land Act 1958* for a term of 15 years in respect of Allotments 7A and Part 8A Section D Parish of Melbourne South City of South Melbourne containing 1576 square metres as a site for Commercial and Industrial Purposes. 4155

Notice is hereby given that Avin Plating Pty. Ltd. has applied for a lease pursuant to section 135 of the *Land Act 1958* for a term of 15 years in respect of Allotments 7 and 8 Section 101A Parish of Melbourne South City of South Melbourne containing 982 square metres as a site for Commercial and Industrial Purposes. 4156

Mr Paul K. Cooper, LL.B., commenced practice on a part-time basis as a Solicitor on 17 December 1979 at 95A Simpson Street, East Melbourne. Telephone 419 5482.

4142

APPLICATION FOR DISPOSAL OF LAND PURSUANT  
TO AN ACT TO PROVIDE FOR THE ABOLITION OF  
STATE AID TO RELIGION

ACT 391: FIRST SCHEDULE

1. The Right Reverend Maxwell McNee Thomas of Wangaratta in the State of Victoria, Bishop of the Church of England Diocese of Wangaratta head or authorised representative of the Denomination known as The Church of England in the Diocese of Wangaratta in Victoria with the consent of The Church of England Trusts Corporation for the Diocese of Wangaratta of Wangaratta aforesaid which is entitled to be registered as the Trustee of the land described in the subjoined Statement of Trusts hereby applies to the Governor of the State of Victoria for leave to dispose of the said land by means and for the purposes mentioned in the said Statement of Trusts and I hereby certify that the said land was promised or reserved as a site for the Church of England purposes on 20 February One thousand Eight hundred and sixty-five.

2. That the Church of England Trusts Corporation for the Diocese of Wangaratta is entitled to be registered as the only Trustee of the said land.

3. There are no buildings erected upon the said land.

4. The only person entitled to minister or occupy same is the incumbent for the Parish of Mansfield namely the Reverend Edwin Thomas John Richardson, St. Johns Rectory, Mansfield.

Dated 22 May 1979

Signed sealed and delivered by the said The Right Reverend Maxwell McNee Thomas in Victoria in the presence of SHIRLEY A. CAMERON.

MAXWELL McNEE THOMAS

The common seal of The Church of England Trusts Corporation for the Diocese of Wangaratta was hereunto affixed by authority of the Trustees—

(SEAL) M. M. THOMAS, Corporation Trustee  
D. L. THAWLEY, Corporation Trustee  
M. NELSON, Corporation Trustee

STATEMENT OF TRUST

Description of the land—3598 square metres Parish of Lauraville County of Wonnangatta being Crown allotment 4A section 12. Commencing at at point bearing 136 deg. 34 min. 20-12 metres from the southern angle of allotment 2 section 12; bounded thence by lines bearing 46 deg. 34 min. 70-41 metres and 136 deg. 34 min. 32-39 metres thence by a road bearing 197 deg. 00 min. 66-39 metres and thence by lines bearing 257 deg. 26 min. 14-89 metres and 316 deg. 34 min. 57-53 metres to the point of commencement.

Name of Trustee—The Church of England Trusts Corporation for the Diocese of Wangaratta of Wangaratta aforesaid.

Power of Disposition—Power to sell lease mortgage or exchange all or any part of such land subject to the approval of the Bishop of Wangaratta for the time being or during the absence of the Bishop from the Diocese or the vacancy of the See to the approval of the person for the time being administering the affairs thereof. The land until otherwise disposed of to be held for the purpose for which it was granted or reserved by the Crown.

Purposes to which Proceeds of Disposition are to be Applied—To such purposes of the Church of England as may be agreed upon by—

- (1) The Bishop or during his absence from his See or during the vacancy thereof by the person or persons for the time being administering the affairs of the Diocese.
- (2) The Trustees of the Church of England Trusts Corporation for the Diocese of Wangaratta.
- (3) The Minister entitled to occupy the aforesaid land.

Messrs MAL. RYAN, JACKSON & GLEN of 9 High Street, Mansfield, solicitors for the applicant 4200

Notice is hereby given that the partnership subsisting between Thomas Hugh Henry, John Henry Briggs and Philip Hugh Henry carrying on business as H. & B. Haulage has been dissolved as from 6 September 1979. 4135

Notice is hereby given that the partnership heretofore subsisting between Michele Martino and Venerand Martino carrying on a business as Retail Butchers at 444 Sydney Road, Brunswick in the State of Victoria under the firm of M. & F. Butchers has been dissolved as from 1 July 1979 so far as concerns the said Venerand Martino who retires from the said firm. All debts due to and owing by the said firm will be received and paid respectively by Michele Martino who will continue to carry on the said business under the firm of M. & F. Butchers.

Dated 28 November 1979

4136

MICHELE MARTINO  
VENERAND MARTINO

Notice is hereby given that the partnership heretofore subsisting between Leonardus Adrianus Schoormans and Maretje Schoormans carrying on a brick laying business at 2 Lugarno Court, Noble Park in the State of Victoria has been dissolved as and from 30 June 1979.

Dated 7 December 1979

NEWMAN, SHEEDY & BOUGHTON, solicitors for  
Maretje Schoormans. 4165

Take notice that the partnership previously carried on between Graham Frederic Hobson and Ian James Marshall at 25 Curran Street, Traralgon under the name of A. & S. Controls has now been dissolved. 4242

Notice is hereby given that the partnership heretofore subsisting between us the undersigned Ivy Pearl Walker, Gregory John Walker and Bernard James Walker of the Peter Lalor Hotel at Ballarat carrying on business as Hotelkeepers at the Peter Lalor Hotel at Ballarat under the style or firm of "I. P., G. J. and B. J. Walker" being dissolved by mutual consent as from 30 June 1978 so far as concerns the said Bernard James Walker who retired from the said firm.

Dated 14 December 1979

Signed by the said Ivy Pearl Walker in the presence of:  
T. J. Byrne.

Signed by the said Gregory John Walker in the presence of:  
T. J. Byrne.

Signed by the said Bernard James Walker in the presence of:  
T. J. Byrne. 4273

Notice is hereby given that the partnership between Steven Robert Rivette and Cathryn Elizabeth Barton and Andrew Ronald Barton carrying on business at 130 Commercial Road, Morwell, under the name Freedom Stores (Morwell) will be dissolved on 31 December 1979. 4327

Companies Act 1961

J. C. BROWNHILL & SONS PTY. LTD. (IN VOLUNTARY  
LIQUIDATION)

MEMBERS' VOLUNTARY WINDING UP

Notice is hereby given that pursuant to section 272 (2) of the Companies Act 1961 a general meeting of the Shareholders of the above Company will be held at the offices of Day, Neilson, Jenkins & Johns, 199-203 Moorabool Street, Geelong on Wednesday, 16 January 1980 at 4.30 p.m. for the purpose of having accounts laid before them showing the manner in which the Winding Up has been conducted and the property of the Company disposed of and of hearing any explanation that may be given by the Liquidator.

Dated 10 December 1979

RUSSELL PEAKE, Liquidator

Day, Neilson, Jenkins & Johns, chartered accountants,  
199-203 Moorabool Street, Geelong, 3220 4126

P. & L. COLLINS PROPRIETARY LIMITED

At a special meeting held at Warrnambool it was resolved that the Company be wound up voluntarily and that J. J. Purcell of 67-69 Kepler Street, Warrnambool be appointed liquidator at a fee to be arranged. 4137

THIRD HAMILTON INDUSTRIES PTY. LIMITED (IN  
VOLUNTARY LIQUIDATION)

Notice is hereby given that at an Extraordinary General Meeting of Members of the abovenamed Companies duly convened and held at 10th Floor, 15 Young Street, Sydney on 8 November 1979, the following Special Resolution was duly passed.

Special Resolution

"That the Company be wound up voluntarily"

MESSRS BRUCE HENRY SMITH AND KEVIN RICHARD SHIRLAW of 20th Floor, 68 Pitt Street, Sydney have been appointed liquidators for the purposes of the winding up.

4127

Companies Act 1961, Section 252 (2)  
GIVI CELLARS PROPRIETARY LIMITED (IN  
LIQUIDATION)

NOTICE OF RESOLUTION

At an extraordinary general meeting of the members of Givi Cellars Proprietary Limited duly convened and held at 16 Neave Street Hawthorn East on 7 December 1979 the Special Resolution set out below was duly passed:

"That the Company be wound-up voluntarily as a Members' Voluntary Winding-Up in accordance with the provisions of the Companies Act 1961 as amended, and that Percy Raymond Jackson of 16 Neave Street Hawthorn East be and is hereby appointed Liquidator of the Company."

Notice is also given that after 21 days from this date I shall proceed to distribute the assets. All creditors having any claims against the Company should furnish particulars of same by that date, otherwise I shall proceed to distribute the assets without regard to their claim.

Dated 7 December 1979

P. R. JACKSON, Liquidator

Address: 16 Neave Street, Hawthorn East, 3123. Phone  
82 3835 4128

In the Supreme Court of Victoria—1979 No. Co. 11122—  
In the matter of the Companies Act 1961; and in the matter of NOELEEN KING PROPRIETARY LIMITED—Notice of Appointment of Provisional Liquidator

Notice is hereby given that the Supreme Court of Victoria has by Order made 6 December 1979 appointed Geoffrey Ormond Harrison of the firm of Messrs. Touche Ross & Co. of 11th Floor, 440 Collins Street, Melbourne to be provisional liquidator of Noeleen King Proprietary Limited until the hearing and determination of the Petition herein or until further Order.

WHITING & BYRNE, solicitors, of 440 Collins Street, Melbourne 4129

The Companies Act 1961—In the matter of SWINTONS SEEDS PROPRIETARY LIMITED (in Liquidation)

Notice is hereby given that pursuant to section 272 of the Companies Act 1961, a Final Meeting of members of the above Company will be held at the offices of Coffey & Co., 67-69 Kepler Street, Warrnambool, on Wednesday, 23 January, 1980 at 10 a.m.

Dated 10 December 1979

4138

In the matter of the Companies Act 1961; and in the matter of D. S. AITKEN PTY. LTD.

Notice is hereby given that at a meeting of the members of D. S. Aitken Pty. Ltd., on 7 December 1979 the following resolution was passed as a Special Resolution—

That the Company be wound up voluntarily and that Mr Eric Hamilton Carter, Chartered Accountant of 113 Swanston Street Melbourne be and is hereby appointed liquidator for the purpose of such winding up.

4139

E. H. CARTER, Liquidator

KYABRAM AND DISTRICT (No. 5) CO-OPERATIVE  
HOUSING SOCIETY LIMITED (IN LIQUIDATION)

SPECIAL RESOLUTION

Passed 3 December 1979

At a special general meeting of the above-named Society duly convened and held at Kyabram on 3 December 1979 at 8.00 p.m., the subjoined special resolution was duly passed:—

That the Society, having successfully completed its objectives forty-six (46) months ahead of its expected term, be wound up voluntarily, and that Mr R. A. Brown of Echuca be appointed Liquidator for the purposes of the winding up.

L. J. SLATTERY, Chairman of Meeting  
R. A. BROWN, Secretary

4140

In the matter of the Co-operative Housing Societies Act, 1958 and the Companies Act 1961; and in the matter of KYABRAM AND DISTRICT (NO. 5) CO-OPERATIVE HOUSING SOCIETY LIMITED (IN LIQUIDATION)

Notice is hereby given that all persons having any claim against the above Society are required on or before 28 December 1979 to send their names and addresses and particulars of their debts or claims to Mr R. A. Brown, Kyabram, the Liquidator of the said Society at his office and if so required by notice in writing from the said liquidator are personally, or by their Solicitors, to come in and prove their said debts or claims at such time and place as shall be specified in such notice: or, in default thereof, they shall be excluded from the benefit of any distribution made before such debts or claims are so lodged and proved.

Dated at Kyabram, 7 December 1979

4141 R. A. BROWN, Liquidator

The Companies Act 1961, Section 254

M. G. DYKE & SONS PTY. LIMITED (IN VOLUNTARY  
LIQUIDATION)

SPECIAL RESOLUTION TO WIND UP

At an Extraordinary General Meeting of the abovenamed Company duly convened and held at 824 Elizabeth Street, Waterloo, Sydney on 4 December 1979 the following resolution was passed as a Special Resolution:

"That the company be wound up voluntarily."

At the abovementioned meeting Peter James Ralph of 5th Floor, 499 St. Kilda Road, Melbourne was appointed Liquidator for the purpose of the winding up.

Dated 4 December 1979

4166

P. J. RALPH, Liquidator

Companies Act 1961

DYASONS (MILDURA) PTY. LIMITED

NOTICE OF RESOLUTION

Notice is hereby given that at an extraordinary general meeting of members of the abovenamed Company held on 10 December 1979 it was resolved that the Company be wound up voluntarily and that Mr J. D. Rodger Chartered Accountant of 50 Bridge Street Sydney be appointed to act as liquidator for the purpose of such winding up.

Notice is also given that after 21 days from this date we shall proceed to distribute the assets of the Company. All creditors who have any claim against the Company should furnish particulars of same by that date, otherwise we shall proceed to distribute the assets without regard to their claim.

Dated 19 December 1979

J. D. RODGER, Liquidator

Price Waterhouse & Co., 50 Bridge Street, Sydney, 2000.  
Telephone: 238 1533 4167

## Unclaimed Moneys Act 1962

## Register of Unclaimed Moneys held by the—

Name of Owner on Books and Last Known Address	Total Amount Due to Owner	Description of Unclaimed Money	Date when Amount first became Payable
5			
WOOLWORTHS (VICTORIA) LIMITED			
Dyersden, D., 26 Harmon Ave, St Albans	12.59	Wages	—11.77
Wilkinson, R., 65 Reeve St., Sale	110.65	"	"
Cassar, J., 56 Toy St., St Albans	13.77	"	—12.77
Cassar, C., 56 Toy St., St Albans	17.00	"	"
Thornton, M., 774 Sunbeam St, Pascoe Vale	15.69	"	"
Mitchell, C., 58 Widdop Cres, Moorabbin	18.12	"	"
Johnstone, 273 Koornang St, Carnegie	34.73	"	"
Frazer, B., 11 Mandowie Cres, Croydon	14.16	"	"
Parker, M., 29 Curtain Rd, Hurstbridge	67.61	"	"
Hannah, S., 8 Kandra St, North Dandenong	14.53	"	"
Lang, G., 4 Vickers St, Sebastopol	36.69	"	"
Avard, L., 1 Williams St, Mentone	36.72	"	"
Johnson, 4 Danene Cr, South Vermont	12.68	"	"
Moloney, S., 48 Regent Ave, Springvale	29.42	"	"
Dainton, D., 48 Balaclava Rd, Shepparton	21.09	"	"
McInerney, S., 519 Balcombe Rd, Blackrock	53.12	"	—1.78
Kohlenberg, P., 5 Porter St, Hampton	60.05	"	"
Tandy, D., 23 Cobham St, Cheltenham	18.58	"	"
Wilson, J., Nineteenth St, Cardross, Mildura	14.48	"	"
Berton, D., 17 Oppy Cres, Hoppers Crossing	10.46	"	"
Brennan, Julie, 3/36 The Glen, Ferntree Gully	45.08	"	—3.78
Gibb, Lee-Anne, 14 Odessa St, St Kilda	18.42	"	"
Conway, Leonie, 20 Cowper St, Sandringham	57.55	"	"
Barker, Deidrie, 4/25 Nepean Hwy, Elsternwick	39.27	"	"
Johansson, Donna, 2/18 Vale St, St Kilda	12.90	"	—4.78
Green, Tracey, Fiveways Caravan Park, Braeside	32.07	"	"
McGrath, Robyn, 140 High St, Ashwood	43.01	"	"
Box, C., 33 Hampstead Dr, Hoppers Crossing	24.00	"	—5.78
Fuchs, 14 Alfred St, Upper Ferntree Gully	29.46	"	"
Bird, Michael, 12A/55 Jackson St, St Kilda	23.26	"	—7.78
Johnson, Paula, 133 Canterbury Rd, Middle Park	16.23	"	"
Hassell, Anthony, 10 Cosdown Cl, Gladstone Park	11.97	"	—8.78
Schwals, Andrew, 30 Lee Ave, Springvale	49.93	"	"
Cape, Russell, 16 Rosalie Ave, Cranbourne	31.19	"	"
Dunkerton, Rodney, 790 Heatherton Rd, Springvale	97.82	"	"
Jack, Barbara, 5 Henry St, Box Hill	29.99	"	—9.78
Beswick, C., 308 York St, Sale	15.34	"	—10.78
Noble, M., 83 Power Rd, Boronia	21.39	"	"
Collins, A., 76 Bonnie View Rd, North Croydon	42.64	"	"
Powell, P., 8/5 Garnet St, Sunshine	27.52	"	"
Koops, R., 3F Jumping Creek Rd, Warrandyte	106.34	"	"
Rogers, M. E., 16 Marshall St, Maryborough	27.58	"	"
4009			
CAULFIELD INSTITUTE OF TECHNOLOGY			
Sanson, D., 66 Tranmere Ave, Carnegie	39.80	Salary	31.12.77
Roberts, A., 46 Chapman St, Macleod	47.10	"	20.5.78
Hutchinson, M., 24 Wallingford St, Cheltenham	15.00	"	26.8.78
Burns, T., c/o Pram Factory, 325 Drummond St, Carlton	27.80	"	"
Vary, M., 5/8 Hughenden St, East St Kilda	52.30	"	18.11.78.
Wright, R., 14/12 Rosedale Ave, Glenhuntly	30.00	"	8.3.78
Harrison, J., 56 Iona St, Black Rock	16.20	"	23.9.78
McKee, P., 1 Woolcock Ave, Kew	70.00	Book Allowance	—7.78
Middleton, W. A., 10 Wilson St, Highett	70.00	"	"
Mills, J. F., 3 Leigh St, Huntingdale	70.00	"	"
4152			

The Companies Act 1961, Section 254  
**CHUBB ALARMS (VIC.) PTY. LIMITED (IN VOLUNTARY LIQUIDATION)**

SPECIAL RESOLUTION TO WIND UP

At an Extraordinary General Meeting of the abovenamed Company duly convened and held at 824 Elizabeth Street, Waterloo, Sydney on 4 December 1979 the following resolution was passed as a Special Resolution:

"That the Company be wound up voluntarily."

At the abovementioned meeting Roger Douglas Evans, of 17 Raglan Street, South Melbourne, Victoria, was appointed Liquidator for the purpose of the winding up.

Dated 4 December 1979.

4168

R. D. EVANS, Liquidator

Re: M. G. DYKE PTY. LIMITED (IN LIQUIDATION)  
 NOTICE INVITING PROOF OF DEBT OR CLAIM

The creditors of the abovenamed Company are required on or before 27 December 1979, to prove their debts or claims and to establish any title they may have to priority by delivering or sending through the post to the liquidator at the undermentioned address an affidavit verifying their respective debts or claims. In default they will be excluded from the benefit of any distribution made before such debts or claims are proved or such priority is established and from objecting to any such distribution.

Form of proof may be obtained from the undersigned.

Dated 3 December 1979

R. J. RALPH, Liquidator, 5th Floor, 499 St. Kilda Road, Melbourne

4169

**Re: CHUBB ALARMS (VIC.) PTY. LIMITED**  
**NOTICE INVITING PROOF OF DEBT OR CLAIM**

The creditors of the abovenamed Company are required on or before 27 December 1979 to prove their debts or claims and to establish any title they may have to priority by delivering or sending through the post to the liquidator at the undermentioned address an affidavit verifying their respective debts or claims. In default they will be excluded from the benefit of any distribution made before such debts or claims are proved or such priority is established and from objecting to any such distribution.

Form of proof may be obtained from the undersigned.  
 Dated 3 December 1979

R. D. EVANS, Liquidator, 17 Raglan Street, South Melbourne, Victoria 3205 4170

**The Companies Act 1961**  
**H. CRANE HAULAGE PTY. LTD.**

Notice is hereby given that at an Extraordinary General Meeting of the members of the abovenamed Company held on 12 December 1979, it was resolved that the Company be wound up voluntarily and at a meeting of creditors held on the same day, pursuant to section 260, it was resolved that for such purpose, Thomas Dunn Maclean of 260 Auburn Road, Hawthorn, be appointed Liquidator.

Notice is also given that after twenty-one (21) days from this date I shall proceed to distribute the assets. All creditors having any claims against the Company should furnish particulars of same by that date otherwise I shall proceed to distribute the assets without regard to their claims.

Dated this 12 December 1979

THOMAS DUNN MACLEAN, Liquidator

Maclean & Patterson, chartered accountants, 260 Auburn Road, Hawthorn, 3122. Telephone: 818 0577 4171

**In the matter of the Co-operative Housing Societies Act 1958, and the Companies Act 1961; and in the matter of SOUTHERN CO-OPERATIVE HOUSING SOCIETY LIMITED (in Liquidation)—Notice to Creditors**

Notice is hereby given that all persons having any claim against the above Society are required on or before 31 January 1980 to send their names and addresses and particulars of their debts or claims to Clive Thornton White the liquidator of the said Society, at his office 381-383 Bay Street, North Brighton, and if so required by notice in writing from the said liquidator are personally, or by their solicitors, to come in and prove their said debts or claims at such time and place as shall be specified in such notice; or, in default thereof, they shall be excluded from the benefit of any distribution made before such debts or claims are so lodged or proved.

Dated at Brighton this 12 December 1979

4172 C. T. WHITE, Liquidator

**SOUTHERN CO-OPERATIVE HOUSING SOCIETY LIMITED (IN LIQUIDATION)**  
**SPECIAL RESOLUTION**

At a special general meeting of the abovenamed society duly convened and held at 381-383 Bay Street, North Brighton, on 11 December 1979 at 5.30 p.m. the subjoined special resolution was duly passed:—

"That the society having successfully completed its objectives more than eighteen (18) months ahead of its expected term be wound up voluntarily, and that Clive Thornton White, Secretary of 381-383 Bay Street, North Brighton, be appointed liquidator for the purpose of the winding up."

Dated 12 December 1979

4173 R. W. CARRUTHERS, Chairman of Meeting  
 C. T. WHITE, Secretary

**In the Supreme Court of Victoria—1979 Co. No. 11110—**  
**In the matter of the Companies Act 1961; and in the matter of a Petition for the winding up of SUBURBAN PLUMBING SERVICES PTY. LTD.**

Notice is hereby given that a Petition for the winding up of Suburban Plumbing Services Pty. Ltd. by the Supreme Court was on 27 November 1979 presented by John

McIlwraith Industries Ltd. and that the said Petition is directed to be heard before the Court sitting at the Practice Court, Law Courts, William Street, Melbourne, at the hour of 10.30 o'clock in the fore-noon on 7 February 1980 and any creditor or contributory of the said Company desiring to support or oppose the making of an Order on the said Petition may appear at the time of hearing by himself or his Counsel for that purpose and a copy of the Petition will be furnished to any creditor or contributory of the said Company requiring the same by the undersigned upon payment of the regulated charge for the same. The Petitioner's address is 34 York Street, Richmond in the State of Victoria. The Petitioner's Solicitor is Mr Stanley Levine of the firm of Bristols, of 269 Carlisle Street, Balaclava.

STANLEY LEVINE

**NOTE—**Any person who intends to appear on the hearing of the said Petition must serve on or send by post to the abovenamed Stanley Levine of the firm of Bristols, notice in writing of his intention so to do. The Notice must state the name and address of the person, or, if a firm, the name and address of the firm, and must be signed by the person or firm, or his or their Solicitor, and must be served, or, if posted, must be sent by post in sufficient time to reach the abovenamed not later than four o'clock in the afternoon of 6 February 1980. 4174

**HAIG MILLS PTY. LIMITED (IN VOLUNTARY LIQUIDATION)**  
**SPECIAL RESOLUTION TO WIND UP**

At an Extraordinary General Meeting of the above named company duly convened and held at 645 Toorak Road Toorak, on 11 December 1979 the following resolution was passed as a special resolution "That the Company be wound up voluntarily". At the above mentioned meeting, H. C. Haig of 645 Toorak Road Toorak was appointed liquidator for the purpose of the winding up. Notice is also given that after 30 days from this date I shall proceed to distribute the assets. All creditors having any claim against the Company should furnish particulars of same by that date, otherwise I shall proceed to distribute the assets without regard to their claim.

Dated 12 December 1979

4175 H. C. HAIG, Liquidator

**In the matter of the Companies Act 1961; and in the matter of BREWQUIP MILLING INDUSTRIES PROPRIETARY LIMITED (in Voluntary Liquidation)**

Notice is hereby given that at an extraordinary general meeting of members of the abovementioned Company duly convened and held at 24-34 Clarke Street, South Melbourne on 13 December 1979, the Special Resolution in the words set out below was duly passed:

"That in accordance with the provisions of Section 254 of the Companies Act 1961, the Company be wound up voluntarily."

and at the meeting, A. J. Beckwith and T. L. Phillips of Messrs A. H. G. Clarke & Co., 1st Floor, 460 Bourke Street, Melbourne, were appointed joint and several liquidators.

Dated 13 December 1979

4176 J. A. RATCLIFFE, Chairman

**In the matter of the Companies Act 1961; and in the matter of BREWQUIP PROPRIETARY LIMITED (in Voluntary Liquidation)**

Notice is hereby given that at an extraordinary general meeting of members of the abovementioned Company duly convened and held at 24-34 Clarke Street, South Melbourne on 13 December 1979, the Special Resolution in the words set out below was duly passed:

"That in accordance with the provisions of Section 254 of the Companies Act 1961, the Company be wound up voluntarily."

and at the meeting, A. J. Beckwith and T. L. Phillips of Messrs A. H. G. Clarke and Co., 1st Floor, 460 Bourke Street, Melbourne, were appointed joint and several liquidators.

Dated 13 December 1979

4177 J. A. RATCLIFFE, Chairman

**SANLEELOR INVESTMENT COMPANY PTY. LTD.**  
NOTICE OF VOLUNTARY LIQUIDATION

At an Extraordinary General Meeting of Sanleelor Investment Company Pty. Ltd., held at 3/19 Beddele Avenue, East Brighton, Victoria on 12 December 1979, the following resolutions were passed:

1. That the Company be wound up voluntarily.
2. That Mr P. A. Juno, of 30 Selwyn Avenue, Elwood, be appointed liquidator for the purpose of winding up the Company.

4178 P. A. JUNO, F.A.S.A., Liquidator

purpose of having an account laid before them showing the manner in which the winding up has been conducted and the property disposed of, and of hearing any explanation that may be given by the liquidator.

Dated 15 December 1979

4183 G. E. GOLDSMITH, Liquidator

Companies Act, Section 272

**DREVER NORTHERN DISTRIBUTORS PTY. LTD. (IN VOLUNTARY LIQUIDATION)**

Notice is hereby given that a General Meeting of the above company will be held at Suite 10, 596 St. Kilda Road, Melbourne on 16 January 1980 at 10 a.m. for the purpose of having an account laid before them showing the manner in which the winding up has been conducted and the property disposed of, and of hearing any explanation that may be given by the liquidator.

Dated 15 December 1979.

4184 G. E. GOLDSMITH, Liquidator

Form 7  
Companies Act 1961, Section 21 (2), Sections 26 (1), (2) and 146 (1), Section 28 (9), Section 146 (1), Section 254 (2)

Company No. 70612

**L. B. & A. M. HARRIS PROPRIETARY LIMITED**

NOTICE OF RESOLUTION

To the Commissioner for Corporate Affairs

At a general meeting of the members of L. B. & A. M. Harris Proprietary Limited duly convened and held at 45 Lesley Avenue Caboolture Queensland on 10 December 1979, the special resolution set out below was duly passed.

It was resolved that the Company be wound up voluntarily and that Donald William Currie of 81 Elizabeth Street, Edenhope, Victoria be and is now appointed liquidator of the Company.

Dated 10 December 1979

4179 L. B. HARRIS, Director

In the matter of the Companies Act 1961; and in the matter of THE DOMINION INSURANCE COMPANY OF AUSTRALIA LIMITED

At an Extraordinary General Meeting of the Dominion Insurance Company of Australia Limited duly convened and held at 34-36 Hunter Street, Sydney on 12 December 1979 the following Special Resolution was duly passed:

"That the Company be wound up voluntarily and that Mr B. P. McMahon F.C.A. be appointed Liquidator for the purpose of such winding up."

Dated 12 December 1979

By order of the Board

J. N. GOULD, Chairman

McMahon Vincent & Co., Level 35, M.L.C. Tower, 19 Martin Place, Sydney, N.S.W., 2000 4185

Companies Act, Section 272  
**DREVER SMALLGOODS SUPPLIERS PTY. LTD. (IN VOLUNTARY LIQUIDATION)**

Notice is hereby given that a General Meeting of the above company will be held at Suite 10, 596 St. Kilda Road, Melbourne on 16 January 1980 at 10 a.m. for the purpose of having an account laid before them showing the manner in which the winding up has been conducted and the property disposed of, and of hearing any explanation that may be given by the liquidator.

Dated 15 December 1979

4180 G. E. GOLDSMITH, Liquidator

In the matter of the Companies Act; and in the matter of WISA HOTELS PTY. LIMITED (in Liquidation)—Members' Voluntary Winding Up

Notice is hereby given that a final meeting of members of the abovenamed company will be held at the offices of Messrs Hungerfords, 167 Macquarie Street, Sydney on Tuesday, 22 January 1980 at 9.30 a.m. for the purposes of receiving the Liquidator's account and his report upon the winding-up.

Dated 19 December 1979

G. F. WARHURST, Liquidator, 10th Floor, 167 Macquarie Street, Sydney, 2000 4186

Companies Act, Section 272  
**DREVER DISTRIBUTORS PTY. LTD. (IN VOLUNTARY LIQUIDATION)**

Notice is hereby given that a General Meeting of the above company will be held at Suite 10, 596 St. Kilda Road, Melbourne on 16 January 1980 at 10 a.m. for the purpose of having an account laid before them showing the manner in which the winding up has been conducted and the property disposed of, and of hearing any explanation that may be given by the liquidator.

Dated 15 December 1979

4181 G. E. GOLDSMITH, Liquidator

Companies Act 1961, Section 254 (2) (b)  
**MIRASOL PROPRIETARY LIMITED (IN VOLUNTARY LIQUIDATION)**

Notice is hereby given that at an Extraordinary General Meeting of the members of the above named company held on 12 December the following Special Resolution was passed—

"That the company be voluntarily wound up and that Solomon Segal, of 189 Kooyong Road, Toorak, be appointed Liquidator.

4187

S. SEGAL, Liquidator

Companies Act, Section 272  
**DREVER SOUTHERN DISTRIBUTORS PTY. LTD. (IN VOLUNTARY LIQUIDATION)**

Notice is hereby given that a General Meeting of the above company will be held at Suite 10, 596 St. Kilda Road, Melbourne on 16 January 1980 at 10 a.m. for the purpose of having an account laid before them showing the manner in which the winding up has been conducted and the property disposed of, and of hearing any explanation that may be given by the liquidator.

Dated 15 December 1979.

4182 G. E. GOLDSMITH, Liquidator

**EWERS & WINSTANLEY PTY. LTD. (IN VOLUNTARY LIQUIDATION)**

NOTICE CONVENING FINAL MEETING

Notice is hereby given pursuant to Section 272 (2) of the Victorian Companies Act 1961 that a general meeting of members of the above Company will be held in the Offices of Alexander & Spencer, 88 Boronia Road, Boronia on Monday, 21 January 1980 commencing at 10.00 a.m. for the purpose of having an account laid before them showing the manner in which the winding up has been conducted and the property of the company disposed of, and of hearing any explanations that may be given by the Liquidator.

Dated 12 December 1979

4188 C. B. SLOWO, Liquidator

Companies Act, Section 272  
**DREVER EASTERN DISTRIBUTORS PTY. LTD. (IN VOLUNTARY LIQUIDATION)**

Notice is hereby given that a General Meeting of the above company will be held at Suite 10, 596 St. Kilda Road, Melbourne on 16 January 1980 at 10 a.m. for the



In the Supreme Court of Victoria—1979 Co. 11026—In the matter of the *Companies Act 1961*; and in the matter of *MESONA ENTERPRISES PTY. LIMITED—Order for Winding Up by the Court 29 November 1979*

Upon the Petition of Gunston Pty. Ltd. on 9 October 1979 preferred unto the Court, and upon hearing Miss L. Krejus of Counsel for the Petitioner there being no appearance for Mesona Enterprises Pty. Limited and upon reading the said Petition, an Affidavit of Richard Gunston filed and dated 9 October 1979 verifying the said Petition, an Affidavit of A. G. Moore dated 21 November 1979, the *Government Gazette* of 24 August 1979, the *Age Newspaper* 19 October 1979 each containing an advertisement of the said Petition this Court doth order:—

1. That the said Company be wound up by the Court under the provisions of the *Companies Act 1961*.
2. That Everett Thomson Bent be appointed liquidator for the purposes of the said winding up.
3. That the Bank in which the Liquidator is to open a Trust Account is the National Bank of Australasia at 570 St. Kilda Road, Melbourne.

NOTES—It will be the duty of such of the persons as are liable to make out or concur in making out a Statement of Affairs as the Liquidator may require to attend on him at such time and place as he may appoint and to give him all information he may require.

4189

JUDGE

In the Supreme Court of Victoria—1979 Co. 11129—In the matter of the *Companies Act 1961*; and in the matter of *MERKANI NOMINEES PTY. LTD.*

Notice is hereby given that a petition for the winding up of the abovenamed Company by the Supreme Court was on 11 December 1979 presented by Rogers Seller and Myhill Pty. Ltd. and that the said petition is directed to be heard before the Court sitting at the Law Courts William Street Melbourne on 6 March 1980 at the hour of 10.30 o'clock in the forenoon and any creditor or contributory of the said Company desiring to support or oppose the making of an Order on the said petition may appear at the time of hearing by himself or his Counsel for that purpose and a copy of the petition will be furnished to any creditor or contributory of the said Company requiring the same by the undersigned on payment of the regulated charge for the same.

The Petitioner's address is 27 City Road, South Melbourne.

The Petitioner's solicitors are Messrs Leach & Thomson of 472 Bourke Street, Melbourne, 3000.

LEACH & THOMSON, solicitors for the petitioner

NOTE—Any person who intends to appear on the hearing of the said petition must serve on or send by post to the abovenamed solicitors notice in writing of his intention to do so. The notice must state the name and address of the person, or, if a firm, the name and address of the firm and must be signed by the person or firm or his or their solicitor (if any) and must be served, or if posted, must be sent by post in sufficient time to reach the abovenamed not later than 4 o'clock in the afternoon of 5 March 1980.

4190

Re: KEITH JOSHUA MURPHY

14A Dreadnought Street, Sandringham

NOTICE OF ACCEPTANCE OF COMPOSITION AND NOTICE OF FIRST DIVIDEND

Notice is hereby given that the Composition of the abovenamed Debtor has been accepted by a Special Resolution of creditors. The Trustee named in the Composition is Mt E. T. Bent of Suite 18, 545 St. Kilda Road, Melbourne.

Notice is also given that a first dividend is intended to be declared. Creditors who do not prove by 11 January 1980 will be excluded.

Dated 12 December 1979

E. T. BENT, Trustee

Bent & Cogle, public accountants, Suite 18, 545 St. Kilda Road, Melbourne, Vic. 3004 4199

The *Companies Act 1961*, Section 254  
METZKE INDUSTRIES PTY. LTD.

At an extraordinary General Meeting of the abovenamed company duly convened and held at 89 Type Street, Richmond on 14 December 1979 the following resolution was passed as a Special Resolution:—

“That the Company be wound up voluntarily.”

4201 K. W. G. WATSON, Liquidator

The *Companies Act 1961*, Section 254  
ANIMAL SERVICES PTY. LTD.

At an extraordinary General Meeting of the abovenamed company duly convened and held at Razorback Road, Flinders on 14 December 1979 the following resolution was passed as a Special Resolution:—

“That the Company be wound up voluntarily.”

4202 R. P. KERR, Liquidator

COLORCRAFT PRINTERS PTY. LIMITED (IN VOLUNTARY LIQUIDATION)

NOTICE OF FINAL MEETING

Notice is hereby given that pursuant to Section 272 of the *Companies Act 1961* the final meeting of the members of the Company will be held at the office of Sicree, Nixon, Watt & Co., 257 Collins Street, Melbourne on Thursday 31 January 1980, at 9.45 a.m. for the purpose of having an account laid before them showing the manner in which the winding up has been conducted and hearing any explanations that may be given by the liquidator.

Dated 10 December 1979

N. W. CURWOOD, Liquidator

Sicree, Nixon, Watt & Co., 257 Collins Street, Melbourne 4243

In the matter of the *Companies Act 1961*; and in the matter of *MASTERMAN INVESTMENTS PTY. LTD.* (in Voluntary Liquidation)

Notice is hereby given that at an Extraordinary General Meeting of members of the abovementioned Company duly convened and held at 460 Bourke Street, Melbourne on 14 December 1979, the Special Resolution in the words set out below was duly passed:—

“That in accordance with the provisions of Section 254 of the *Companies Act 1961*, the Company be wound up voluntarily and that the division and transfer by a liquidator of the whole or any part of the assets of the Company upon liquidation to or among members *in specie* or kind be and is hereby sanctioned.”

And at the meeting Trevor Laurence Phillips and Adrian Joseph Beckwith of Messrs. A. H. G. Clarke & Co., 460 Bourke Street, Melbourne, were appointed liquidators to act jointly and severally for the purpose of such winding up.

Notice is also given that I shall proceed to distribute the assets after 31 January 1980. All creditors should prove their debts by that date otherwise I shall proceed to distribute the assets without regard to their claim.

A. J. BECKWITH, Liquidator

A. H. G. Clarke & Co., chartered accountants, 460 Bourke Street, Melbourne, 3000 4244

In the matter of the *Companies Act 1961*; and in the matter of No. 4 *STUDLEY AVENUE PTY. LTD.* (in Voluntary Liquidation)

Notice is hereby given that pursuant to Section 272 of the *Companies Act 1961*, the final meeting of the members and creditors of the Company will be held at Flat 2, 4 Studley Avenue, Kew, on 22 January 1980, at 8 o'clock in the evening, for the purpose of laying before the meeting the account of the winding up and any explanation thereof.

Dated 10 December 1979

N. E. WEST, Liquidator

No. 4 *STUDLEY AVENUE PTY. LTD.*  
(in Voluntary Liquidation)

Maddock, Lonie & Chisholm, solicitors, 60 Market Street, Melbourne 4246

In the matter of HIPWORTH HEATING & AIRCONDITIONING PTY. LTD.—Notice of Winding Up Order

Winding Up Order made 13 December 1979.

Name and Address of Liquidator: Geoffrey Ormond Harrison, Touche Ross & Co., 440 Collins Street, Melbourne.  
CORNWALL STODART & CO., solicitors for petitioner  
4245

purpose of laying before the Meeting an account showing how the winding up has been conducted and the property of the Company has been disposed of and giving any explanation thereof.

Dated 18 December 1979

G. O. HARRISON, Liquidator

Touche Ross & Co., chartered accountants, 440 Collins Street, Melbourne, 3000 4251

Companies Act 1961—In the matter of AFAM PTY. LTD.

At an Extraordinary General Meeting of the above-named Company, duly convened and held at the offices of Ernst & Whinney, Chartered Accountants, 351 Collins Street, Melbourne, on 14 December 1979, the following resolution was duly passed as a Special Resolution:

"That the Company be wound up voluntarily."

And at such meeting, Anthony William Adena, Chartered Accountant of 351 Collins Street, Melbourne, was appointed Liquidator for the purposes of the winding up.

Dated 14 December 1979

4247

A. W. ADENA, Liquidator

In the matter of the Companies Act 1961—Notice of Final Meeting

Notice is hereby given that pursuant to section 272 of the Act, the final meetings of Members and Creditors of the Companies listed below will be held at 312 Bay Street, Port Melbourne on 10 January 1980 at the times listed below for the purpose of the Liquidator laying before the meeting an account of the winding up and the giving of any explanation thereof.

TOOLCRAFT PTY. LTD., 10.00 a.m.

BINGHAM-SWIFT AUSTRALIA PTY. LTD., 10.15 a.m.

Dated 7 December 1979

MICHAEL W. E. HOSKING, Liquidator.

Hosking, Dyer and Co., public accountants, 312 Bay Street, Port Melbourne, 3207. Telephone: 645 2444 4252

TWO-O-ONE SPRING ST. PTY. LTD. (IN VOLUNTARY LIQUIDATION)

NOTICE OF MEETING

Notice is hereby given that the liquidator's final Meeting of Two-O-One Spring St. Pty. Ltd. (in Voluntary Liquidation) for the purpose of considering the Liquidator's statement as to how the liquidation has been conducted, and the Company's assets disposed of, and such other matters as permitted by law, will be held at the office of John H. Donegan & Co., 390 Lonsdale Street, Melbourne on 25 January 1980 at 9.00 a.m.

4248

JOHN H. DONEGAN, Liquidator

Companies Act 1961—In the matter of KLONIS ENTERPRISES PTY. LTD. (in Liquidation); and in the matter of the Companies Act 1961—Notice of Final Meeting of the company and the creditors

Notice is hereby given that pursuant to section 272 of the Companies Act 1961 a final meeting of the company and the creditors will be held at 11 o'clock in the forenoon on Friday, 25 January 1980 at the office of Baumanis & Brennan, Solicitors, Suite B, 11th Floor, 406 Lonsdale Street, Melbourne for the purpose of laying before it an account showing how the winding up has been conducted and the property of the company has been disposed of and giving any explanations required.

J. A. COAKLEY, Liquidator

Dated 13 December 1979

477A Nepean Highway, Frankston 3199

4253

Companies Act 1961, Section 272 (2)  
EPHOS PROPRIETARY LIMITED (IN VOLUNTARY LIQUIDATION)

At an extraordinary general meeting of the members of Ephos Pty. Ltd. duly convened and held at the office of Hosking Quinn & Partners, 422 Collins Street, Melbourne on 10 December 1979 the resolution set out below was duly passed.

(1) That the Company be wound up voluntarily.

(2) That Charles Campbell Rivington of 422 Collins Street, Melbourne be and is hereby appointed liquidator for the purposes of such winding up.

4249

C. C. RIVINGTON, Liquidator

Companies Act 1961, Section 272

136 ALMA ROAD PROPRIETARY LIMITED (IN VOLUNTARY LIQUIDATION)

NOTICE OF FINAL MEETING OF SHAREHOLDERS

Notice is hereby given that a General Meeting of the Members of 136 Alma Road Proprietary Limited (in Voluntary Liquidation) will be held at 1st Floor, 695 Burke Road, Camberwell on 21 January 1980 at 4 o'clock in the afternoon for the purpose of laying before the meeting an account showing how the winding up has been conducted and the property of the Company has been disposed of and of giving any explanation of the account.

Dated 13 December 1979

4254 FREDERICK HECTOR BATHURST, Liquidator

The Companies Act 1961

BOYLAND HOLDINGS PTY. LTD. (IN LIQUIDATION)  
NOTICE CONVENING FINAL MEETING OF THE COMPANY,  
PURSUANT TO SECTION 272 (1)

Notice is hereby given that the Final Meeting of Members of the abovenamed Company will be held at the offices of Touche Ross and Co., 12th Floor, 440 Collins Street, Melbourne on 20 January 1980 at 10.00 a.m. for the purpose of laying before the Meeting an account showing how the winding up has been conducted and the property of the Company has been disposed of and giving any explanation thereof.

Dated 18 December 1979

G. O. HARRISON, Liquidator

Touche Ross & Co., chartered accountants, 440 Collins Street, Melbourne, 3000 4250

Companies Act 1961

H. R. BLACK RETAIL PTY. LTD. (IN LIQUIDATION)

Notice is hereby given that at an extraordinary general meeting of the members of the abovenamed company held on Friday 30 November 1979 it was resolved that the company be wound up voluntarily and at a meeting of creditors held later the same day it was resolved that for such purpose Victor Raymond Dye of 536 Whitehorse Road Mitcham be appointed liquidator.

Notice is also given that after twenty one days from this date I shall proceed to distribute the assets of the Company. All creditors who have any claim against the Company should furnish particulars of the same by that date, otherwise I shall proceed to distribute the assets without regard to their claim.

Dated 4 December 1979

V. R. DYE, Liquidator

V. R. Dye & Co., chartered accountants, 536 Whitehorse Road, Mitcham 3132 4255

The Companies Act 1961

HOME LODGE INVESTMENTS PTY. LTD. (IN LIQUIDATION)  
NOTICE CONVENING FINAL MEETING OF THE COMPANY,  
PURSUANT TO SECTION 272 (1)

Notice is hereby given that the Final Meeting of Members of the abovenamed Company will be held at the offices of Touche Ross and Co., 12th Floor, 440 Collins Street, Melbourne on 20 January 1980 at 10.30 a.m. for the

## Companies Act 1961

## C. W. &amp; E. N. LINDNER &amp; SONS (VIC.) PTY. LTD. (IN LIQUIDATION)

Notice is hereby given that at an extraordinary general meeting of the members of the abovenamed company held on Monday 26 November 1979 it was resolved that the company be wound up voluntarily and at a meeting of creditors held later the same day it was resolved that for such purpose Victor Raymond Dye of 536 Whitehorse Road Mitcham be appointed liquidator.

Notice is also given that after twenty one days from this date I shall proceed to distribute the assets of the Company. All creditors who have any claim against the Company should furnish particulars of the same by that date, otherwise I shall proceed to distribute the assets without regard to their claim.

Dated 4 December 1979

V. R. DYE, Liquidator

V. R. Dye &amp; Co., chartered accountants, 536 Whitehorse Road, Mitcham 3132 4256

## Companies Act 1961

## MARGARET CURTAYNE PTY. LTD. (IN LIQUIDATION)

Notice is hereby given that at an extraordinary general meeting of the members of the abovenamed company held on Friday 7 December 1979 it was resolved that the company be wound up voluntarily and at a meeting of creditors held later the same day it was resolved that for such purpose Victor Raymond Dye of 536 Whitehorse Road Mitcham be appointed liquidator.

Notice is also given that after twenty one days from this date I shall proceed to distribute the assets of the Company. All creditors who have any claim against the Company should furnish particulars of the same by that date, otherwise I shall proceed to distribute the assets without regard to their claim.

Dated 10 December 1979

V. R. DYE, Liquidator

V. R. Dye &amp; Co., chartered accountants, 536 Whitehorse Road, Mitcham 3132 4257

## Companies Act 1961—In the matter of GUILDHOUSE PROPRIETARY LIMITED (in Liquidation)—Notice of Voluntary Winding Up

At an Extraordinary General Meeting of Guildhouse Proprietary Limited (in Liquidation), duly convened and held at 379 Collins Street, Melbourne, Victoria on 10 December 1979 the following resolution was passed as a Special Resolution:—

"That the Company be wound up voluntarily and Lewis Charles Sumpter of 3 Belmont Close, Glen Iris be appointed Liquidator."

Dated 10 December 1979

4258 L. C. SUMPTER, Liquidator

## Companies Act 1961, Section 260

## CREAM NOMINEES PTY. LTD.

## NOTICE OF MEETING OF CREDITORS

Notice is hereby given that a meeting of Creditors of Cream Nominees Pty. Ltd. will be held at the Board Room, Accountants' House, 49 Exhibition Street, Melbourne on Thursday 20 December 1979 at 10.00 a.m. the Company having convened a meeting of its members for the same day for the purpose of considering a Resolution that the Company be wound up voluntarily.

Dated 11 December 1979

J. R. COATH, Director

Hosking, Dyer and Co., public accountants, 312 Bay Street, Port Melbourne 3207. Telephone: 645 2444 4259

## The Companies Act 1961—In the matter of FOREST LODGE HOLDINGS PTY. LTD. (in Liquidation)—Members' Winding Up

Notice is hereby given that at the Extraordinary General Meeting of Forest Lodge Holdings Pty. Ltd. duly convened and held at Suite 904, 450 Little Collins Street, Melbourne

in the State of Victoria on 6 December 1979, the following Resolution was proposed and passed as a Special Resolution.

"That the company be wound up voluntarily."

Dated 10 December 1979

K. J. RUSSELL, Liquidator

Messrs Coopers &amp; Lybrand, chartered accountants, 461 Bourke Street, Melbourne, Vic. 3000 4260

## Companies Act 1961

## VIDEO-TAPE CENTRE PTY. LTD. (IN VOLUNTARY LIQUIDATION)

Notice is hereby given in accordance with Section 254 (b) that at an Extraordinary General Meeting of the members of Video-Tape Centre Pty. Ltd. held on 11 December 1979 it was resolved that the company be wound up voluntarily and that John Lachlan Charles McInnes be appointed as liquidator for the purposes of the winding up.

Dated 12 December 1979

J. L. C. McINNES, Liquidator

J. L. C. McInnes, chartered accountant, 12 Wellington Parade, East Melbourne. 3002 4261

## NORTHERN TUBULAR STEEL PROPRIETARY LIMITED

## NOTICE OF VOLUNTARY LIQUIDATION

At an Extraordinary General Meeting of Northern Tubular Steel Proprietary Limited held at 18 McHenry Street, East St. Kilda on 12 December 1979 the following resolutions were passed as Special Resolutions:

1. That the Company be wound up voluntarily.
2. That Mr Robert James Grimm of 76 Union Street, East Brighton be and is hereby appointed Liquidator of the Company.
3. That the Liquidator may distribute *in specie* or kind amongst the members of the Company in accordance with their respective rights and interest therein the whole or any part of the assets of the Company he shall think fit.

ROBERT JAMES GRIMM, liquidator, 76 Union Street, East Brighton 3187 4262

## Companies Act 1961

## PRESTON TELEVISION SERVICE PTY. LTD. (IN LIQUIDATION)

Notice is hereby given that at an extraordinary general meeting of the members of the abovenamed company held on Friday 14 December 1979 it was resolved that the company be wound up voluntarily and at a meeting of creditors held later the same day it was resolved that for such purpose Victor Raymond Dye of 536 Whitehorse Road Mitcham be appointed liquidator.

Notice is also given that after 21 days from this date I shall proceed to distribute the assets of the Company. All creditors who have any claim against the Company should furnish particulars of the same by that date, otherwise I shall proceed to distribute the assets without regard to their claim.

Dated 17 December 1979

V. R. DYE, Liquidator

V. R. Dye &amp; Co., chartered accountants, 536 Whitehorse Road, Mitcham, 3132 4263

## In the matter of the Companies Act 1961; and in the matter of N. F. DAVIES PTY. LIMITED

Notice is hereby given that at an Extraordinary General Meeting of the abovenamed company duly convened and held at 5 Berkeley Court, Kew, on 13 December 1979 the following special resolution was duly passed:—

"That the company be wound-up voluntarily and that John Stuart Walker, Chartered Accountant of 500 Collins Street, Melbourne, be appointed Liquidator for the purpose of such winding-up."

Dated 14 December 1979

4265

N. F. DAVIES, Chairman

*Companies Act 1961*  
**CONCEPT BUILDING SUPPLIES PTY. LTD. (IN LIQUIDATION)**

Notice is hereby given that at an extraordinary general meeting of the members of the abovenamed company held on Friday 14 December 1979 it was resolved that the company be wound up voluntarily and at a meeting of creditors held later the same day it was resolved that for such purpose Victor Raymond Dye of 536 Whitehorse Road Mitcham be appointed liquidator.

Notice is also given that after 21 days from this date I shall proceed to distribute the assets of the Company. All creditors who have any claim against the Company should furnish particulars of the same by that date, otherwise I shall proceed to distribute the assets without regard to their claim.

Dated 17 December 1979

V. R. DYE, Liquidator

V. R. Dye & Co., chartered accountants, 536 Whitehorse Road, Mitcham, 3132 4264

*Companies Act 1961*

**YSAPAR PTY. LTD. (IN LIQUIDATION)**

**ELDDAP PTY. LTD. (IN LIQUIDATION)**

Notice is hereby given that at an extraordinary general meetings of the members of the abovenamed companies held on 7 December 1979 it was resolved that the companies be wound up voluntarily and that for such purpose George Walter Long Chartered Accountant of 536 Whitehorse Road, Mitcham be appointed liquidator.

Notice is also given that after 21 days from this date I shall proceed to distribute the assets of the companies. All creditors who have any claim against the companies should furnish particulars of same by that date, otherwise I shall proceed to distribute the assets without regard to their respective claim.

Dated 7 December 1979

G. W. LONG, Liquidator

V. R. Dye & Co., chartered accountants, 536 Whitehorse Road, Mitcham 3132 4266

*Companies Act 1961, Section 260*

**GLENRICH ADVERTISING PTY. LTD.**

**NOTICE OF MEETING OF CREDITORS**

Notice is hereby given that a meeting of Creditors of Glenrich Advertising Pty. Ltd. will be held at the Board Room, Accountants' House, 49 Exhibition Street, Melbourne on Thursday 20 December 1979 at 11.00 o'clock in the forenoon, the Company having convened a meeting of its members for the same day for the purpose of considering a Resolution that the Company be wound up voluntarily.

Dated 11 December 1979

J. R. COATH, Director

Hosking, Dyer and Co., public accountants, 312 Bay Street, Port Melbourne, 3207. Telephone: 645 2444 4267

The *Companies Act 1961*—In the matter of D.M.F. STAR HOMES PROPRIETARY LIMITED—Notice of Appointment of Provisional Liquidator

Order for appointment of an official Liquidator as Provisional Liquidator made 7 December 1979.

Name and address of Provisional Liquidator: Anthony George Hodgson, C/- Messrs Ferrier, Hodgson, Green & Co., Chartered Accountants, 459 Collins Street, Melbourne, 3000.

MESSRS MADGWICKS, solicitors for the petitioner 4268

In the Supreme Court of Victoria—No. Co. 11127 of 1979—In the matter of the *Companies Act 1961*; and in the matter of EMKO ENGINEERING PTY. LTD.

Notice is hereby given that a petition for the winding up of the abovenamed company by the Supreme Court was on 10 December 1979 presented by Pitstock Pty. Ltd. And the said Petition is directed to be heard before the Court sitting at Melbourne at the hour of 10.30 o'clock in the

forenoon on Thursday 21 February 1980 and any creditor or contributory of the said company desiring to support or oppose the making of an order on the said Petition may appear at the time of hearing by himself or his Counsel for that purpose and a copy of the Petition will be furnished to any creditor or contributory of the said company requiring the same by the undersigned on payment of the regulated charge for the same.

The Petitioner's address is 44 Market Street, Sydney in the State of New South Wales and the Petitioner's solicitor is Philip E. Fox, 351 Collins Street, Melbourne in the State of Victoria.

PHILIP E. FOX

NOTE—Any person who intends to appear on the hearing of the Petition must serve on or send by post to the abovenamed Philip E. Fox notice in writing of his intentions so to do. The notice must state the name and address of the person or if a firm the name and address of the firm and must be signed by the person or firm or his or their solicitor (if any) and must be served or if posted must be sent by post in sufficient time to reach the abovenamed not later than 4 o'clock in the afternoon of Wednesday, 20 February 1980, the day before the day appointed for the hearing of the Petition. 4269

In the matter of the *Companies Act 1961*; and in the matter of TUDOR INVESTMENTS PROPRIETARY LIMITED—Notice Pursuant to Section 254 (2) of the *Companies Act 1961*

Notice is hereby given that an Extraordinary General Meeting of Members of the above Company duly convened and held at "Glencairn", Mt. Macedon on 17 December 1979 in the forenoon the following resolution was passed, viz:

"1. That Tudor Investments Proprietary Limited being solvent be wound up voluntarily; and

2. That Mr Emile Rochman, Accountant of the firm of Rezak & Associates, Accountants, 3rd Floor, 390 St. Kilda Road, Melbourne, be appointed liquidator for the purpose of such winding up and that the liquidator's remuneration be calculated on a time basis."

Dated 17 December 1979

4274

F. B. F. RATTEN, Chairman

In the matter of the *Companies Act 1961*; and in the matter of CHAH SINGH PTY. LIMITED

Notice is hereby given that a Petition has been presented at the Supreme Court for confirming resolution of the above company reducing its capital from \$300 000.00 to \$111 377.85. By Order made 13 December 1979 it has been directed that the provisions of Sub-Section (2) of Section 64 of the *Companies Act 1961* shall not apply. Dated 13 December 1979.

NORMAN SHEEHAN, Solicitor for the company, 3rd Floor, 377 Little Collins Street, Melbourne, 3000 4284

In the matter of the *Companies Act 1961*; and in the matter of CHAH SINGH PASTORAL PTY. LIMITED

Notice is hereby given that a Petition has been presented at the Supreme Court for confirming resolution of the above company reducing its capital from \$100 000.00 to \$4 732.73. By Order made 13 December 1979 it has been directed that the provisions of Sub-Section (2) of Section 64 of the *Companies Act 1961* shall not apply. Dated 13 December 1979.

NORMAN SHEEHAN, solicitor for the company, 3rd Floor, 377 Little Collins Street, Melbourne, 3000 4285

*Companies Act 1961*

**DRUMHELLER INVESTMENTS PTY. LTD. (IN VOLUNTARY LIQUIDATION)**

Notice is hereby given at the Extraordinary General Meeting of the above mentioned Company held on 11 December 1979 the following Special Resolutions were passed:—

1. "That the Company be placed in Voluntary Liquidation."

2. "That Mr Lawrence Neville O'Rourke of 28 Winston Drive, Doncaster be appointed liquidator of the Company." 4286

L. N. O'ROURKE, Secretary

Form 92

## Companies Regulations

Regulations 28 (2) (b) and 46 (2)

H. A. WOOD &amp; CO. (MELTON) PTY. LIMITED

## NOTICE OF MEETING OF CONTRIBUTORIES

Notice is hereby given that a meeting of the contributories of H. A. Wood & Co. (Melton) Pty. Limited will be held at 55 High Street, Melton, on 4 February 1980 at 10.00 o'clock in the forenoon.

## Agenda

To receive an explanation of the winding-up of the company.

Dated 30 November 1979

4287

G. S. KNOTT, Liquidator

At an Extraordinary General Meeting of the members of Global Marine Australasia Pty. Ltd. held on 12 December 1979 the Special Resolutions set out below were duly passed:

That the business of Global Marine Australasia Pty. Ltd. be voluntarily wound up and dissolved.

That John Leonard Maffey of 461 Bourke Street, Melbourne, Australia be and hereby is appointed as Liquidator for purposes of such winding up and dissolution.

That the Liquidator have full authority to proceed with the winding up of the Company and that he be authorised to divide all or such part of the surplus assets of the Company as he shall think fit in specie amongst the members of the Company.

BLAKE & RIGGALL, solicitors, B.H.P. House, 140 William Street, Melbourne, Victoria 3000 4288

## The Companies Act 1961

## DEFCHIE PROPRIETARY LIMITED

Notice is hereby given that a General Meeting of the Members of the abovenamed Company held on Monday, 10 December 1979, it was resolved that the Company be wound up voluntarily, and that Robert Alwyn Berry of 499 St. Kilda Road, Melbourne, be appointed Liquidator for the purposes of winding up with full power to exercise any power conferred by the Companies Act 1961, upon a Liquidator in a members' voluntary winding-up.

Dated this 10 December 1979

4289

WARREN LYALL BULLEY, Secretary

## Companies Act 1961, Section 254 (2)

## CLEFAM PROPRIETARY LIMITED (IN LIQUIDATION)

## NOTICE OF VOLUNTARY LIQUIDATION

At an Extraordinary General Meeting of Clefam Proprietary Limited (in Liquidation) duly convened and held at 4 Lenne Court, Camberwell, on 13 December 1979, the following resolution was passed as a Special Resolution.

"That the Company be wound up voluntarily as a members' voluntary winding up in accordance with the provisions of the Companies Act 1961, and that the liquidator may distribute the assets amongst the members in specie if he so desires."

Dated this 13 December 1979

4290

A. R. CLEFAM, Liquidator

## Companies Act 1961, Pursuant to Section 254 (2) (b)

## TAYCO CONCRETE PRODUCTS PTY. LTD.

Notice is hereby given that at an Extraordinary General Meeting of Members of the abovenamed Company duly convened and held at 16-20 Rooks Road, Nunawading on Monday, 17 December 1979, the following resolution was passed as a Special Resolution:—

"That the Company be wound up voluntarily" and at such last mentioned meeting Robert Wells Vance, 7th Level, 459 Collins Street, Melbourne, was appointed liquidator for the purposes of the winding up.

Dated at Melbourne 17 December 1979

4291

R. W. VANCE, Liquidator

## Companies Act 1961, Pursuant to Section 254 (2) (b)

## TAYCO CONCRETE PIPE COMPANY PTY. LTD.

Notice is hereby given that at an Extraordinary General Meeting of Members of the abovenamed Company duly convened and held at 16-20 Rooks Road, Nunawading on Monday, 17 December 1979, the following resolution was passed as a Special Resolution:—

"That the Company be wound up voluntarily" and at such last mentioned meeting Robert Wells Vance, 7th Level, 459 Collins Street, Melbourne, was appointed liquidator for the purposes of the winding up.

Dated at Melbourne 17 December 1979

4292

R. W. VANCE, Liquidator

## The Companies Act 1961—In the matter of STONBAY PTY. LTD.

Notice is hereby given that at an Extraordinary General Meeting of Members of the abovenamed Company held on 4 December 1979, it was resolved that the Company be wound up voluntarily, as a members' voluntary winding-up pursuant to the provisions of subdivision 2 of division 3 of Part X of the Companies Act 1961, and it was further resolved that for such purpose, Mr Alan Murray Horsburgh, Chartered Accountant, of 499 St. Kilda Road, Melbourne, be appointed Liquidator.

Notice is also given that after 21 days from this date we shall proceed to distribute the assets. Any creditors having any claims against the Company should furnish particulars of same by that date, otherwise we shall proceed to distribute the assets without regard to their claim.

Dated this 12 December 1979

A. M. HORSBURGH, Liquidator

Wallace, McMullin & Small, chartered accountants, 499 St. Kilda Road, Melbourne, Vic. 3004 4293

## Companies Act 1961, Section 254 (2) (b)

## B. &amp; H. FURNISHINGS PTY. LTD.

## (IN VOLUNTARY LIQUIDATION)

Notice is hereby given that at an Extraordinary General Meeting of the members of the abovenamed Company held on 17 December 1979, it was resolved that the company be wound up voluntarily and that Messrs. Michael Ashley Coppins and John Barry Hutchins of Wilson Bishop Bowes & Craig, 271 William Street, Melbourne, be appointed joint and several liquidators for the purpose of winding up at a meeting of creditors held later on the same day the appointment of Messrs Coppins and Hutchins as Liquidators was confirmed.

Notice is also given that after 21 days from this date, we shall proceed to distribute the assets. All creditors having any claims against the company should furnish particulars of same by that date, otherwise we shall proceed to distribute the assets without regard to their claims.

Dated 17 December 1979

M. A. COPPINS & J. B. HUTCHINS, Joint and Several Liquidators, care of Wilson Bishop Bowes & Craig, 271 William Street, Melbourne, 3000 4294

## The Companies Act 1961—In the matters of FOLETCO LTD. and AGSTAL LTD.—Members Winding Up

Notice is hereby given that at Extraordinary General Meetings of the above companies duly convened and held at 204 Sydney Road, Brunswick in the State of Victoria on 17 December 1979 it was resolved that the companies be wound up voluntarily.

Dated 17 December 1979

A. N. BIRD, Liquidator

A. N. Bird, chartered accountant, 3 Bowen Crescent, Melbourne, Vic.; 3004 4295

## NEYSTEP PROPRIETARY LIMITED

The above Company was placed in Voluntary Liquidation by a Resolution of Members at an Extraordinary General Meeting held on 14 December 1979.

I. E. DAVEY, liquidator, corner Scott and Thomas Streets, Dandenong, 3175 4296

**R. L. GEDYE PROPRIETARY LIMITED**

The above Company was placed in Voluntary Liquidation by a Resolution of Members at an Extraordinary General Meeting held on 14 December 1979 at 12 noon.

I. E. DAVEY, F.C.A., liquidator, 406 Lonsdale Street, Melbourne, 3000 4297

**DERICK PROPRIETARY LIMITED**

The above Company was placed in Voluntary Liquidation by a Resolution of Members at an Extraordinary General Meeting held on 14 December 1979.

I. E. DAVEY, liquidator, corner Scott and Thomas Streets, Dandenong, 3175 4298

*Companies Act 1961*

Companies Regulations, Regulation 26 (2) (b)

GREENGLASS PTY. LTD.

AND

C.M. GREENGLASS & CO. PTY. LTD.

AND

LEIGH DENTAL SUPPLIES PTY. LTD.

(ALL IN VOLUNTARY LIQUIDATION)

## NOTICE OF MEETINGS

Notice is hereby given that meetings of the members of Greenglass Pty. Ltd., C.M. Greenglass & Co. Pty. Ltd., and Leigh Dental Supplies Pty. Ltd. (all in Liquidation) will be held at the offices of Wilson, Bishop, Bowes & Craig, 11th Floor, 271 William Street, Melbourne, on 10 January 1980 at 10.00 a.m., 10.15 a.m. and 10.30 a.m. respectively, for the purpose of receiving an account of the Liquidator's acts and dealings and the conduct of the windings up for the year ended 11 December 1979.

Dated 17 December 1979

A. T. TUDOR, Liquidator

Care of Wilson, Bishop, Bowes and Craig, 271 William Street, Melbourne 4299

*Companies Act 1961, Section 272 (2)*

TRADITIONAL HOLDINGS PTY. LTD. (IN LIQUIDATION)

## NOTICE OF FINAL MEETING

Notice is hereby given that pursuant to section 272 of the Companies Act 1961, a general meeting of members of Traditional Holdings Pty. Ltd. will be held at Messrs Duesbury Johnston & Marks, 19th Floor, 114 William Street, Melbourne, 3000, on 23 January 1980, at 10.00 a.m.

The purpose of the meeting is to lay accounts before it, showing the manner in which the winding up has been conducted and the property of the company disposed of, and of hearing any explanation that may be given by the liquidator.

Dated 17 December 1979

R. P. GAY, Liquidator

Duesbury Johnston & Marks, 114 William Street, Melbourne, Vic., 3000 4300

*Companies Act 1961, Section 272 (2)*

EVERAY PTY. LTD. (IN LIQUIDATION)

## NOTICE OF FINAL MEETING

Notice is hereby given that pursuant to section 272 of the Companies Act 1961, a general meeting of members of Everay Pty. Ltd. will be held at Messrs Duesbury Johnston & Marks, 19th Floor, 114 William Street, Melbourne 3000, on 23 January 1980, at 11.00 a.m.

The purpose of the meeting is to lay accounts before it, showing the manner in which the winding up has been conducted and the property of the company disposed of, and of hearing any explanation that may be given by the liquidator.

Dated 17 December 1979

R. P. GAY, Liquidator

Duesbury Johnston & Marks, 114 William Street, Melbourne, Vic., 3000 4301

*Companies Act 1961, Section 272*

LOW FAMILY PTY. LTD. (IN LIQUIDATION)

## NOTICE OF FINAL MEETING OF MEMBERS

Notice is hereby given that a meeting of the members of Low Family Pty. Limited (in Liquidation) will be held at the offices of Ernst and Whinney, 351 Collins Street, Melbourne, on 22 January 1980 at 9.00 a.m.

## Agenda

To lay before the meeting the Liquidator's account showing how the winding up has been conducted and the property of the company has been disposed of, and to give any explanation of the account which may be required.

Dated 19 December 1979

4302

D. O. OLDFIELD, Liquidator

*Companies Act 1961, Section 272*

NIDDRIE LICENSED SUPERMARKET PTY. LTD. (IN LIQUIDATION)

## NOTICE OF FINAL MEETING OF MEMBERS AND CREDITORS

Notice is hereby given that pursuant to section 272 of the Companies Act 1961, the final meeting of the members and creditors of the company will be held at the offices of Marquand & Co., 1st Floor, 51 Queen Street, Melbourne on Friday, 25 January 1980 at 11.00 a.m. for the purpose of laying before the meeting an account showing how the winding up has been conducted and the property has been disposed of and giving any explanation thereof.

Dated 18 December 1979

D. E. TONKIN, Liquidator

Marquand & Co., chartered accountants, 51 Queen Street, Melbourne 4303

*Companies Act 1961*—In the matter of MILLBANK INVESTMENT FUND (AUSTRALIA) INCORPORATED (in Liquidation)  
—Notice of Meeting

Notice is hereby given that pursuant to section 272 of the Companies Act, the final meeting of the members of the above named company will be held at 14th Floor, 447 Collins Street, Melbourne, at 10.00 a.m. on 23 January 1980 for the purpose of having an account laid before it showing the manner in which the winding up has been conducted and the property of the company disposed of and hearing any explanation that may be given by the liquidator.

Dated 12 December 1979

P. W. HARVEY, Liquidator

Price Waterhouse & Co., 447 Collins Street, Melbourne 3000 4304

*Companies Act 1961*—In the matter of DUOVEST AUSTRALIA LIMITED (in Liquidation)—Notice of Meeting

Notice is hereby given that pursuant to section 272 of the Companies Act, the final meeting of the members of the above named company will be held at 14th Floor, 447 Collins Street, Melbourne at 10.30 a.m. on 23 January 1980 for the purpose of having an account laid before it showing the manner in which the winding up has been conducted and the property of the company disposed of and hearing any explanation that may be given by the liquidator.

Dated 12 December 1979

P. W. HARVEY, Liquidator

Price Waterhouse & Co., 447 Collins Street, Melbourne 3000 4305

In the Supreme Court of Victoria—1979 No. Co. 11125—  
In the matter of the Companies Act 1961; and in the matter of D.M.F. STAR HOMES PTY. LIMITED; and in the matter of a Petition dated 7 December 1979—Advertisement of Petition

Notice is hereby given that a Petition for the winding up of the abovenamed company by the Supreme Court was on 7 December 1979 presented by D.M.F. Star Homes Pty. Limited and that the said Petition is directed to be heard before the Court sitting at the Law Courts, Lonsdale Street, Melbourne at the hour of 10.30 o'clock in the forenoon on 14 February 1980 and any creditor or contributory of the

said company desiring to support or oppose the making of an order on the said Petition may appear at the time of the hearing by himself or his counsel for that purpose; and a copy of the Petition will be furnished to any creditor or contributory of the said company requiring the same by the undersigned on payment of the regulated charge for the same.

The Petitioner's address is 7th Floor, 128 Exhibition Street, Melbourne, Victoria.

The Petitioner's Solicitors are Messrs Madgwicks of 440 Collins Street, Melbourne, Victoria.

Messrs MADGWICKS, solicitors for the petitioner

NOTE—Any person who intends to appear on the hearing of the said Petition must serve on or send by post to the abovenamed solicitors notice in writing of his intention so to do. The notice must state the name and address of the person, or if a firm, the name and address of the firm, must be signed by the person or firm, or his or their Solicitor (if any), and must be served, or if posted, must be sent by post in sufficient time to reach the abovenamed not later than four o'clock in the afternoon of 13 November 1979. 4306

ALGAR PTY. LTD.  
NOTICE TO CREDITORS

Creditors of the abovenamed Company are required on or before 31 January 1980, to send in their names and address with particulars of their debts or claims to Mr C. S. Wight and Mr A. N. Broome of Arthur Young & Co., 500 Bourke Street, Melbourne, the Liquidators of the said Company, and, if so required by notice in writing from the said Liquidators, shall formally prove their said debts or claims by affidavit or in default thereof they will be excluded from the benefit of and from objecting to any distribution made before such debts or claims are proved. Dated 17 December 1979

4323

A. N. BROOME, Liquidator  
C. S. WIGHT, Liquidator

Creditors next of kin and others having claims in respect of the estate of Olive Myrtle Birkett late of 102 Ascot Street, South Ballarat deceased who died on 28 June 1979 are required to send particulars of their claims to the Executor The Union-Fidelity Trustee Company of Australia Limited at its address 101 Lydiard Street North Ballarat by 20 February 1980 after which date the said Company will distribute the assets having regard only to the claims of which it then has notice.

BAIRD & MCGREGOR, solicitors, 9 Lydiard Street, Ballarat 4123

KARL DZENIS, late of 14 High Street, Moe, in the State of Victoria, loco driver, DECEASED

Creditors, next of kin and others having claims in respect of the Estate of the deceased who died on 11 May 1979 are required by the Executors Francis Xavier O'Halloran and Arthur John Francis Davis both of Trafalgar Solicitors to send particulars to Messrs F. X. O'Halloran, Davis & Co., Solicitors of Kirk Street Moe by 18 February 1980 after which date the Executors may convey or distribute the assets having regard only to the claims of which they then have notice.

Dated 11 December 1979

F. X. O'HALLORAN, DAVIS & CO., solicitors, Moe 4124

ANGUS WILFRED NICHOLSON, late of 140 Beaconsfield Parade, Northcote in the State of Victoria, public servant, DECEASED

Creditors, next of kin and all other persons having claims against the Estate of the Deceased are required by National Trustees Executors and Agency Company of Australasia Limited, of 95 Queen Street, Melbourne in the State of Victoria, the Executor of the Estate of the said Deceased to send particulars of such claims to it at care of the undermentioned Solicitors on or before 19 February 1980 after which date it will distribute the assets having regard only to the claims of which it then has notice.

LYNCH & MacDONALD, FLOOD & PERMEZEL, solicitors of 360 Collins Street, Melbourne. 4134

WILLIAM HENRY PETERS, formerly of Lake Boga, in the State of Victoria, but late of 27 Pascoe Street, Swan Hill, in the said State, retired farmer, DECEASED (who died on 12 October 1979)

Creditors next-of-kin and all other persons having claims against the Estate of the deceased are required by the Executrices of the Will, Tryphenia Harriett Peters and Elaine Dawn Thornett, to send particulars to them care of the undersigned on or before 21 February 1980 after which date they will distribute the assets having regard only to the claims of which they then have notice.

GARDEN & GREEN, solicitors, 4 McCallum Street, Swan Hill 4157

ELIZABETH MARY DOBBINS, late of 247 Westgarth Street, Northcote, widow, DECEASED

Creditors, next-of-kin and others having claims in respect of the deceased who died on 27 September 1979 are required by the Union Fidelity Trustee Company of Australia Ltd. of 100 Exhibition Street, Melbourne and Donald Mathew Miles of 34 Titcher Road, Noble Park, Supervisor, the applicants for a grant of Probate to send particulars of their claims to the said applicants in the care of the said Company by 26 February 1980 after which date they will convey or distribute the assets having regard only to the claims of which they then have notice.

F. R. MONOTTI & CO., solicitors, of 13 Scott Street, Dandenong 4158

EDITH ELLEN GLADYS WATERS, late of Strathaven Rest Home, 47 Warrigal Road, Mentone, widow, DECEASED

Creditors next of kin and others having claims in respect of the estate of the deceased who died on 18 August 1979 are required by the personal representatives Emma May Turnley and Thelma Daniel to send particulars to them care of the undersigned solicitors by 19 February 1980 after which date the personal representatives may convey or distribute the assets, having regard only to the claims of which they then have notice.

VERA FOWLER & CO., solicitors, 1 Evandale Road, Malvern, 3144 4159

BERNARD SMEE, late of 32 Nelson Road, South Melbourne, pensioner, DECEASED

Creditors next of kin and others having claims in respect of the estate of the deceased who died on 31 January 1975 are required by the personal representative Violet Adelaide Skewes to send particulars to her care of the undersigned solicitors by 19 February 1980 after which date the personal representative may convey or distribute the assets, having regard only to the claims of which she then has notice.

VERA FOWLER & CO., solicitors, 1 Evandale Road, Malvern, 3144 4160

Creditors next of kin and others having claims in respect of the Estate of Edith Robotham late of 47 Victoria Street Sebastopol Married Woman deceased who died on 12 August 1979 are required by the Executor The Union Fidelity Trustee Company of Australia of 100 Exhibition Street Melbourne to send particulars of their claim to it by 24 March 1980 after which date the said executor will distribute the assets of the deceased having regard only to the claims of which it then shall have notice.

B. J. WILLIAMS, LL.B., solicitor, 1 Ellesmere Parade, Rosanna 4161

MABEL DOREEN SUTHERLAND, formerly of 7 McKillop Street, East Geelong, but late of Grace McKellar House, Ballarat Road, North Geelong, in the State of Victoria, home duties, DECEASED

Creditors, next of kin, and others having claims in respect of the Estate of the abovenamed deceased who died on 14 September 1978 are required by the Executor Graeme James Richmond of 125 Fitzroy Street St. Kilda Hotel Keeper to send particulars to him C/- the undermentioned Solicitors by 21 February 1980 after which date he may convey or distribute the assets having regard only to the claims of which he then has notice.

BOWMAN & KNOX, solicitors, 43 Yarra Street, Geelong 4162

BARBARA LYALL TRUMPY, late of Unit 2, 20 Male Street Brighton, widow, DECEASED

Creditors next of kin and others having claims in respect of the estate of the deceased who died on 5 October 1979 are required by The Perpetual Executors and Trustees Association of Australia Limited of 50 Queen Street Melbourne and George Edward Fulford of 106 Kooyong Road Malvern Accountant the applicants for a grant of administration to send particulars of their claims to the said applicants in the care of the said company by 12 February 1980 after which date they will convey or distribute the assets having regard only to the claims of which they then have notice.

BALLARDS, solicitors, 695 Burke Road, Camberwell  
4163

Creditors next of kin and all persons having claims against the estate of Ruby Violet Nelson late of 52 Norwood Street Caulfield Widow deceased are required by the Executrix Betty Rosina Elliott of 81 Talbot Crescent Kooyong Librarian to send particulars of their claims to her care of the undersigned by 21 February 1980 after which date she will distribute the estate having regard only to the claims of which she then has notice.

JOHN D. MUSTOW & CO., solicitors, of 401 Collins Street, Melbourne  
4218

Creditors next of kin and others having claims in respect of the Estate of Ruth Margaret Paddle late of "Daiseyburn" Seymour, Gentlewoman Deceased are requested to send particulars of their claims to the Administrator Neil William Paddle care of the undermentioned Solicitors on or before 20 February 1980 after which date he will then distribute the assets having regard only to the claims of which he then has notice.

McKEAN & PARK, solicitors, of 450 Little Collins Street, Melbourne  
4219

Creditors next of kin and others having claims in respect of the Estate of Magnus Tulloch Laird Late of 7 Coolomon Close, Wantirna South in the State of Victoria Retired deceased who died on 24 October 1979 are requested to send particulars of their claims to the Executor The Union-Fidelity Trustee Company of Australia Limited of 100 Exhibition Street, Melbourne by 25 February 1980 at which time it will distribute the assets having regard only to the claims of which it then has notice.

Creditors next of kin and others having claims in respect of the Estate of Anna Rhoda Louisa Bouchier late of Unit 18, Camden Court, 8 Freeman Street, Caulfield, Retired Schoolteacher deceased are to send particulars of their claims to The Union-Fidelity Trustee Company of Australia Limited of 100 Exhibition Street, Melbourne by 20 February 1980 after which date the company will distribute the assets having regard to the claims of which it then has notice.

R. WADHAM & DOIG, solicitors, of 383 Flinders Lane, Melbourne  
4222

NORMAN HARTLEY, late of Gonn Crossing, in the State of Victoria, driver, DECEASED, intestate

Creditors next of kin and all other persons having claims against the Estate of the said Deceased are required by Glenna Annetta Hartley of Gonn Crossing aforesaid Widow the Administratrix of the Estate of the said Deceased to send particulars of such claims to her in care of the undermentioned solicitors on or before 14 February 1980 after which date she will distribute the assets having regard only to the claims of which she then has notice.

BASILE & CO., barristers and solicitors, 46 Wellington Street, Kerang  
4224

MONICA MAY WILSON, late of 21 Curtin Avenue, Lalor, pensioner, DECEASED who died on 4 October, 1979

Creditors next of kin and others having claims in respect of the Estate of the deceased are required by Maree Janice Pitman of 24 Waratah Drive, Lower Templestowe, Home Duties, and Carol Ann Fitt of 21 Sydney Crescent, Lalor Married Woman to send particulars of

their claims to them care of the undermentioned, by 20 February 1980 after which date they may convey or distribute the assets, having regard only to the claims of which they then have notice.

READ & READ, solicitors, of 422 Collins Street, Melbourne  
4223

Creditors next of kin and others having claims against the Estate of the undermentioned persons, are required to send particulars thereof to The Union Fidelity Trustee Company of Australia Limited, of 100 Exhibition Street, Melbourne on or before 31 March, 1980. Otherwise they may be excluded when the assets are being distributed.

Dated 13 December 1979

Ismy Laura Theresa Keane, Unit 1, 21 Hazel Street, South Camberwell, widow, Deceased 21 September 1979  
4221

DONALD ERIC WEISS, late of Royal Australian Air Force Base, East Sale, air force cook, DECEASED

Creditors next of kin and others having claims in respect of the Estate of the abovenamed Deceased who died on 31 March 1978 are required by the Executor Gordon William Weiss of 33 Flaxton Street, Acacia Ridge, Brisbane, Queensland, television technician, to send particulars of their claims care of the undermentioned solicitors by 17 March 1980 after which date he will distribute the assets having regard only to the claims of which he then has notice.

HENDERSON & BALL, solicitors, of 825 Burke Road, Camberwell  
4225

Creditors next of kin and others having claims in respect of the estate of Winifred Rose Forrer late of 64 Devon Drive East Doncaster Widow Deceased who died on 29 September 1978 are required to send particulars of such claims to National Trustees Executors and Agency Company of Australasia Limited at its registered office at 95 Queen Street Melbourne before 29 February 1980 after which date it will distribute the assets having regard only to the claims of which it then has notice.

DOYLE & KERR, solicitors, 450 Little Collins Street, Melbourne  
4226

Pursuant to the provisions of the Trustee Act 1958 creditors next of kin and all other persons having claims in respect of the Estate of Mary Ann Besanko (known as Dorothy Besanko) late of 39 Wheeler Street, Ormond in the State of Victoria Widow Deceased who died on 7 August 1979 are required to send particulars of their claims to the Executor Donald Lyston Chisholm of 60 Market Street, Melbourne in the said State, solicitor, by 20 February 1980 after which date the Executor will distribute the assets having regard only to the claims of which he shall then have had notice.

MADDOCK, LONIE & CHISHOLM, solicitors, 60 Market Street, Melbourne  
4227

Creditors next of kin and others having claims against the Estate of Frederick Arthur Smith late of 66 Dunne Street, Kingsbury, Retired Fitter deceased who died on 7 June 1979 are required by Dorothy Alice Smith and Frederick Walter Smith the Executrix and Executor respectively of his Will to send particulars of their claims to them care of the undermentioned solicitors before 3 March 1980 after which date they will distribute the assets having regard only to the claims of which they then have notice.

PEARCE & WEBSTER, solicitors, 430 Little Collins Street, Melbourne  
4228

KARL WALDEMAR HEINCKE, late of 1 Meadowbank Court, St. Albans in the State of Victoria, motor mechanic, DECEASED

Creditors next of kin and other persons having claims against the Estate of the said deceased who died on 2 September 1978 are required to send particulars of same to the Administratrix Ruth Heincke in care of the undersigned on or before 14 February 1980 after which date she will distribute the assets having regard only to the claims of which she then has notice.

DWYER & BENNETT, barristers and solicitors, 201 Campbell Street, Swan Hill  
4229



Creditors next of kin and others having claims in respect of the Estate of Helen Melba Patterson late of Flat 10, 12 Walsh Street, South Yarra, Gentlewoman, deceased, who died on 1 October 1979 are required by the Executors The Trustees Executors and Agency Company Limited of 401 Collins Street, Melbourne, to send particulars of their claims to the said Trustee Company by 25 February 1980 after which date it will distribute the assets having regard only to the claims of which it then has notice.

MESSRS H. L. YUNCKEN & YUNCKEN, solicitors, 443 Little Collins Street, Melbourne 3000 4230

Creditors next of kin and others having claims against the estate of Eric Harold Payne Mulcahy formerly of 2 Cricklewood Avenue, Frankston but late of 28 Olive Street, East Malvern in the State of Victoria, Retired Clerk, deceased who died on 10 October 1979 are requested to send particulars of their claims to The Trustees, Executors and Agency Company Limited of 401 Collins Street, Melbourne in the said State by 19 February 1980 after which date the Company will distribute the assets having regard only to the claims of which it shall then have notice.

THOMAS, FRENKEL & BERKOVITCH, solicitors, of 303 Latrobe Street, Melbourne 4231

Creditors next of kin and others having claims in respect of the Estate of Oliver John Horler formerly of 85 Marine Terrace Burnie in the State of Tasmania but late of 126 Roberts Street Essendon in the State of Victoria Retired deceased who died on 9 August 1979 are to send particulars of their claims to Arthur Raymond Sloman of 11 Lovell Street East Hawthorn on or before 20 February 1980 after which date he will distribute the assets having regard only to the claims of which he then has notice.

R. P. BARRETT & SON, solicitors, 472 Bourke Street, Melbourne, 3000 4232

FRANCIS XAVIER GEORGE GUY, late of 6 Grantully Road, Mount Evelyn, gentleman, DECEASED

Creditors next of kin and others having claims in respect of the estate of the deceased who died on 8 October 1979 are required by The Perpetual Executors and Trustees Association of Australia Limited of 50 Queen Street, Melbourne, to send particulars of their claims to the said Company by 20 February 1980 after which date it will convey or distribute the assets, having regard only to the claims of which the Company then has notice.

CORR & CORR, solicitors, 290 La Trobe Street, Melbourne 4233

REGINALD CHARLES GRAFHAM, late of 31 Barcelona Street, Box Hill, in the State of Victoria, office worker, DECEASED

Creditors, next of kin and others having claims in the estate of the deceased who died on 4 August 1979 are required by Harland Thomas Gardiner of Thompson Road, Carrum Downs in the said State Farmer the executor to whom Probate of the Will of the said deceased was granted to send particulars to him in care of the undersigned by 29 February 1980 after which date the executor may convey or distribute the assets having regard only to the claims of which he then has notice.

Dated 17 December 1979

P. H. PIPEY & SON, 1 Watts Street, Box Hill, solicitors for the executor 4234

ETHEL MARY LINDSAY, late of 28 Linton Avenue, Lower Templestowe, widow, DECEASED

Creditors next of kin and others having claims against the estate of the above-named deceased (who died on 7 September 1979) are required to present particulars of their claims to the executor National Trustees Executors and Agency Company of Australasia Limited of 95 Queen Street, Melbourne by 21 February 1980 after which date the executor may convey or distribute having only regard to the claims of which it then has notice.

RIVERS DICKINSON STIRLING & MUNZ, solicitors, 51 Queen Street, Melbourne 4236

No. 104—15420/79—7

HAROLD CLYDE FLETCHER, late of Unit 1, 114 Leeds Road, Mount Waverley, in the State of Victoria, retired bank officer, DECEASED

Creditors next of kin and others having claims in respect of the estate of the deceased (who died on 28 August 1979) are required by the Administrator The Equity Trustees Executors and Agency Company Limited of 472 Bourke Street Melbourne in the said State to send particulars to it in care of the undersigned by 29 February 1980 after which date the Administrator may convey or distribute the assets having regard only to the claims of which it then has notice.

Dated 17 December 1979

P. H. PIPEY & SON, 1 Watts Street, Box Hill, solicitors for the administrator 4235

ARCHIBALD CHASE BROWNE, late of 15 Heard Avenue, Plenty, in the State of Victoria, retired electrician, DECEASED

Creditors next of kin and others having claims in respect of the estate of deceased, who died on 10 September 1979, are required by the personal representative John Mathew Browne of 9 Riddell Parade, Elsternwick in the State of Victoria, to send particulars to him by 29 February 1980 after which date the personal representative may convey or distribute the estate, having regard only to the claims of which he then has notice.

Dated 19 December 1979

BEST HOOPER RINTOUL & SHALLARD, solicitors, 400 Little Collins Street, Melbourne 4237

Creditors next of kin and other persons having claims against the estate of James Walter Curtis late of Windsor Hall Rest Home 8 The Avenue Windsor Retired deceased who died on 5 July 1979 are required to send particulars of their claims to the Executors in care of the undermentioned solicitors by 21 February 1980 after which date the Executors will distribute the assets having regard only for the claims of which they then have had notice.

JAMES P. OGG & CO. AND E. K. O'DONNELL, solicitors, 165 Greville Street, Prahran 4238

In the will of LESLIE JAMES AUSTIN, late of 35 The Esplanade, Torquay, retired manager, DECEASED

Creditors next of kin and others having claims in respect of the Estate of the said deceased who died on the 10 August 1977 are required by the Executrix of the Will of the deceased, Patricia June Curry of 10 Evelyn Street, Manifold Heights, Geelong Married Woman to send particulars to her care of the undermentioned solicitors by the 31 March 1980 after which date the said Executrix may convey or distribute the assets having regard only to the claims of which they then have notice.

INGPEN & BENT, solicitors, 54 Malop Street, Geelong 4239

BOHDAN STEFANIW, late of 19 Elliott Street, Cheltenham, in the State of Victoria, public servant, DECEASED

Creditors, next of kin and all other persons having claims against the estate of the deceased are required by the Executor The Equity Trustees Executors and Agency Company Limited of 472 Bourke Street, Melbourne to send particulars to it at the above address on or before 20 February 1980 after which date it will distribute the assets having regard only to the claims of which it then has notice.

LANDER AND ROGERS, solicitors, 140 Queen Street, Melbourne 4240

Creditors next-of-kin and others have claims in respect of the Estate of Winifred Agnes Caulfield late of Unit 2, 7 Camperdown Street, East Brighton, Widow, deceased, who died on 16 February, 1979 are requested to send particulars of their claims to David Roy Conly of 3 Fellows Street, Oakleigh, the Executor of the Will of the said deceased, in care of the undermentioned Solicitors by 1 March, 1980 after which date the Executor will distribute the assets having regard only to the claims of which he then has notice.

CLEMENTS, MOTT & BETT, solicitors, 253-257 Glenhuntly Road, Elsternwick 4241

Creditors next of kin and others having claims in respect of the Estate of Laura Ethel Williams formerly of Albert Street Geelong West but late of 45-95 Ballarat Road North Geelong who died on 7 June 1979 are required to send particulars of their claims to the Administrator The Union-Fidelity Trustee Company of Australia Ltd. at its address 101 Lydiard Street North Ballarat by 29 February 1980 after which date the said Company will distribute the assets having regard only to the claims of which it then has notice.

4270

Creditors next of kin and others having claims in respect of the Estate of Denis John McGrath late of 264 Racecourse Road Newmarket Radio Engineer deceased Intestate who died on 9 October, 1979 are requested to send particulars of their claims to the Administratrix Edith Catherine Isobel McGrath care of the undermentioned Solicitor by 27 February, 1980 after which date she will distribute the assets having regard only as to the claims of which she then has notice.

JOHN STEWART, 290 Racecourse Road, Newmarket  
4271

Creditors next of kin and others having claims against the estate of Martin Albert Stuckey late of 7 Stooke Street West Yarraville, Retired, deceased who died on 11 July 1979 are required by the Executor William George Stuckey of "Colombo Court" 54 Acland Street St. Kilda, Retired, to send particulars of such claims to him at the office of the undersigned Solicitors on or before 19 February 1980 after which date he will distribute the assets having regard only to the claims of which he shall then have had notice.

ARCHER SHULMAN AND CO., solicitors, 140 Queen Street, Melbourne  
4272

Creditors next of kin and others having claims in respect of the Estate of Ethel Daisy Hillier late of La La Avenue Warburton, Widow deceased are to send particulars of their claims to The Union-Fidelity Trustee Company of Australia Limited of 100 Exhibition Street Melbourne by 20 February 1980 after which date the Company will distribute the assets having regard to the claims of which it then has notice.

R. WADHAM & DOIG, solicitors, of 383 Flinders Lane, Melbourne  
4307

Creditors next of kin and others having claims in respect of the Estate of Norman Edmund Leister late of "Aimeo" Caraar Creek Lane Mornington, Gentleman deceased are to send particulars of their claims to the Executors of the said Estate care of the undermentioned Solicitors by 20 February 1980 after which date the Executors will distribute the assets having regard to the claims of which they have notice.

R. WADHAM & DOIG, solicitors, of 383 Flinders Lane, Melbourne  
4308

LILLIAN ESTHER DAUNT, late temporarily residing at Narracoorte, South Australia, widow, DECEASED

Creditors next of kin and others having claims against the Estate of the said deceased who died on 17 July 1979 are to send particulars of their claims to Christopher David Turnbull C/- Messrs. Blake & Riggall Solicitors 140 William Street Melbourne by 21 February 1980 after which date he will distribute the assets having regard only to the claims of which he then has notice.

BLAKE & RIGGALL, solicitors, 140 William Street, Melbourne  
4309

Creditors next of kin and others having claims in respect of the estate of John Joseph Costella late of 16 Rockingham Street, Kew in the State of Victoria Hospital Administrator deceased who died on 9 October, 1979 are required by the Executor National Trustees Executors and Agency Company of Australasia Limited of 95 Queen Street, Melbourne in the said State to send particulars of their claims to the said Company by 11 March, 1980 after which date it will convey or distribute the assets, having regard only to the claims of which the Company then has notice.

HODGSON & FINLAYSON, of 505 Little Collins Street, Melbourne, solicitors for the estate  
4310

Creditors next of kin and others having claims in respect to the estate of Stella May Kathleen Milte late of 1 Royal Avenue, Sandringham, Home Duties deceased who died on 18 July, 1979 are required to send particulars of their claims to National Trustees Executors and Agency Company of Australasia Limited of 95 Queen Street, Melbourne the Executor appointed by the deceased's Will by 29 February, 1980 after which date it will distribute the assets having regard only to the claims of which it then has notice.

G. R. HERBERT & CO., solicitors, 612-614 Balcombe Road, Black Rock  
4311

LORNA CONSTANCE DEBENHAM, late of Lynn Private Hospital, 11 Elgin Avenue, Armadale, widow, DECEASED

Creditors next of kin and others having claims in respect of the estate of the deceased who died on 27 February, 1979 are required by The Union-Fidelity Trustee Company of Australia Limited of 100 Exhibition Street, Melbourne, Michael Debenham of 5A Edward Street, Toorak, Design Engineer and David Christopher Debenham of 10 Mile Road, Tarwin Lower, Farmer the applicants for a grant of administration to send particulars of their claims to the said applicants in the care of the said Company by 20 February, 1980 after which date they will convey or distribute the assets having regard only to the claims of which they then have notice.

HEDDERWICK, FOOKES & ALSTON, 121 William Street, Melbourne  
4312

CONSTANCE MURIEL LAVINIA ANDREWARTHA, late of 137 The Esplanade, Elwood, widow, DECEASED

Creditors, next of kin, and others having claims in respect of the estate of the deceased, who died on 20 September, 1979 are required by her executors, Robert William Andrewartha of 77 Woodlands Street, North Essendon, Printer and Stanley Richard Tytler of Ringins Road, Drouin South, Retired Farmer to send particulars to them by 20 February, 1980 after which date they may convey or distribute the assets, having regard only to the claims of which they then have notice.

HEDDERWICK, FOOKES & ALSTON, 121 William Street, Melbourne  
4313

#### Trustee Act 1958

#### NOTICE TO CLAIMANTS

Pursuant to the Trustee Act 1958, creditors next of kin and all other persons having claims in respect of the estate of any deceased person named below are required to send particulars to the legal personal representative or representatives at the addresses stated, after which date the representatives will distribute the assets, having regard only to the claims of which notice has been received:—

Ivy Fisher late of 4 James Street Footscray Pensioner deceased, who died on 5 December 1979. Claims to the Executor Henry Charles Howard Wolegde of 15 Herbert Street Footscray by 9 February 1980—JOHN F. CARROLL, LL.B., solicitor, 4 Paisley Street, Footscray  
4164

#### In the Supreme Court of the State of Victoria SALE BY THE SHERIFF

On Friday, 8 February 1980 at 11.30 a.m. at the Police Station, Red Cliffs (unless process be stayed or satisfied).

All the Estate and Interest (if any) of Sidney John Robertson, Horticulturist, of Block 265, Sunny Cliffs, as proprietor of an estate in fee simple in the land described in Crown Grant Volume 7443 Folio 565 upon which is erected a weatherboard dwelling and sheds known as Block 265, Sunny Cliffs and is located approximately half-mile along the turn off road to Kings Billabong from the Calder Highway near Red Cliffs.

Registered Mortgages Nos. G.745280 and H.26751 affect the said estate and interest.

Terms—Cash only  
4314

G. L. WHITE, Sheriff's Officer

In the Supreme Court of the State of Victoria  
SALE BY THE SHERIFF

On Friday, 8 February 1980 at 10.30 a.m. at the Police Station, Melton (unless process be stayed or satisfied).

All the Estate and Interest (if any) of David Paul Eyers, salesman, of 36 Essex Drive, Melton, as joint proprietor with Judith Anne Eyers married woman, of an estate in fee simple in the land described in Certificate of Title Volume 8368 Folio 242 upon which is erected a brick veneer dwelling known as No. 36 Essex Drive, Melton.

Registered Mortgage No. F.641198 affects the said estate and interest.

Terms—Cash only  
4315 KEITH R. MARTIN, Sheriff's Officer

In the Supreme Court of the State of Victoria  
SALE BY THE SHERIFF

On Friday, 1 February 1980 at 10.30 a.m. at the Police Station, Preston (unless process be stayed or satisfied).

All the Estate and Interest (if any) of George Gridic also known as Jure Gridic (shown on Certificate of Title as Jure Gridic) cabinet maker of 1 Fitzroy Street, West Preston, as proprietor of an estate in fee simple in the land described in Certificate of Title Volume 6913 Folio 510 upon which is erected a weatherboard dwelling known as No. 1 Fitzroy Street, West Preston.

Terms—Cash only  
4316 KEITH R. MARTIN, Sheriff's Officer

In the Supreme Court of the State of Victoria  
SALE BY THE SHERIFF

On Friday, 1 February 1980 at 12.30 p.m. at the Police Station, Melton (unless process be stayed or satisfied).

All the Estate and Interest (if any) of Paul Micallef, farmer of Mount Cottrell Road, Rockbank, as joint proprietor with Renie Micallef, married woman, of an estate in fee simple in the land described in Certificate of Title Volume 8515 Folio 722, which is a vacant block of land known as Lot 2 Mount Cottrell Road, Rockbank.

Registered Mortgage No. G.395047 and Caveat H.359789 affect the said estate and interest.

Terms—Cash only  
4317 KEITH R. MARTIN, Sheriff's Officer

In the Supreme Court of the State of Victoria  
SALE BY THE SHERIFF

On Friday, 8 February 1980 at 10.30 a.m. at the Police Station, Kew (unless process be stayed or satisfied).

All the Estate and Interest (if any) of Evengelos Orfanakos, shown on Certificate of Title as Evangelos Orfanakos, machine operator, and Aspasia Orfanakos, married woman, both of 47 Strathalbyn Street, Kew, as joint proprietor of an estate in fee simple in the land described in Certificate of Title Volume 2145 Folio 810 upon which is erected a brick dwelling known as No. 47 Strathalbyn Street, Kew.

Registered Mortgage No. H.524923 and Caveat H.567325 affects the said estate and interest.

Terms—Cash only  
4318 H. BUETTNER, Sheriff's Officer

In the Supreme Court of the State of Victoria  
SALE BY THE SHERIFF

On Friday, 8 February 1980 at 10.30 a.m. at the Boronia Police Station (unless process be stayed or satisfied).

All the Estate and Interest (if any) of Vittoria Guida, concreter, of 192 Scoresby Road, Boronia, as joint proprietor with Maria Guida, factory worker, of an estate in fee simple in the land described in Certificate of Title, Volume 9120 Folio 483 upon which is erected a weather-board dwelling known as No. 192 Scoresby Road, Boronia.

Registered Mortgages Nos. G.213853 and H.300046 and Caveat H.603990 affect the said estate and interest.

Terms—Cash only  
4319 H. BUETTNER, Sheriff's Officer

In the Supreme Court of the State of Victoria  
SALE BY THE SHERIFF

On Friday, 8 February 1980 at 12 noon at the Mount Evelyn Police Station (unless process be stayed or satisfied).

All the Estate and Interest (if any) of Geoff Harris, shown on Certificate of Title as Geoffrey Alan Harris, truck driver, of 6 Olinda Road, Mount Evelyn as joint proprietor with Shirley Elaine Harris, married woman, of an estate in fee simple in the land described in Certificate of Title Volume 7665 Folio 010 upon which is erected a dwelling known as No. 6 Olinda Road, Mount Evelyn.

Registered Mortgages Nos. F.240100, F.240101 and Caveats G.891300, H.288179, H.782070, and H.784181 affect the said estate and interest.

Terms—Cash only  
4320 H. BUETTNER, Sheriff's Officer

In the Supreme Court of the State of Victoria  
SALE BY THE SHERIFF

On Wednesday, 23 January 1980 at 10.30 a.m. at the Police Station, Oakleigh (unless process be stayed or satisfied).

All the Estate and Interest (if any) of Maria Immacolata Salvatore, married woman, of 365 Manningham Road, Doncaster, as joint proprietor with Pasquale Salvatore, builder, of 365 Manningham Road, Doncaster, of an estate in fee simple in the land described in Certificate of Title Volume 8845 Folio 844 upon which is erected a brick factory and warehouse known as No. 79 Atherton Road, Oakleigh.

Registered Mortgage No. H.559381 affects the said estate and interest.

Terms—Cash only  
4321 H. BUETTNER, Sheriff's Officer

In the Supreme Court of the State of Victoria  
SALE BY THE SHERIFF

On Friday, 8 February 1980 at 11.00 a.m. at the Police Station, Boronia (unless process be stayed or satisfied).

All the Estate and Interest (if any) of I. D. Mallett and V. J. Mallett, shown on Certificate of Title as Ian Douglas Mallett, contractor and Viki Josephine Mallett, married woman both of 32 Pine Crescent, Boronia, as joint proprietors of an estate in fee simple in the land described in Certificate of Title Volume 7417 Folio 260 upon which is erected a dwelling house known as No. 32 Pine Crescent, Boronia.

Registered Mortgage No. G.60767 and Caveats G.473993 and G.782636 affect the said estate and interest.

Terms—Cash only  
4322 H. BUETTNER, Sheriff's Officer

**NOTICE OF MAKING OF  
STATUTORY RULES**

In pursuance of the provisions of the *Subordinate Legislation Act 1962* and the Regulations made thereunder, notice is given of the making of the following statutory rules:—

No.	Lifts and Cranes Act 1967	Price
452/1979	Cranes (Amendment) Regulations 1979	60c
	<i>Road Traffic Act 1958</i>	
453/1979	Road Traffic (Miscellaneous Amendments) Regulations 1979	10c
	<i>Industrial Training Act 1975</i>	
454/1979	Industrial Training (Printing Trades Apprenticeship) (Amendment) Regulations 1979	20c

No.	Forests Act 1958	Price
455/1979	Forests (Baw Baw Alpine Reserve) (Amendment) Regulations 1979	10c
<i>Films Act 1971</i>		
456/1979	Films (Lions Club of Cohuna Exemption) Regulations 1979	10c
<i>Country Fire Authority Act 1958</i>		
457/1979	Country Fire Authority (Loan No. 115) (Amendment) Regulations 1979	10c
<i>Public Service Act 1974</i>		
458/1979	Public Service Amendment Regulations (No. 12) 1979	10c
<i>Public Service Act 1974</i>		
459/1979	Public Service Amendment Regulations (No. 13) 1979	10c
<i>Public Service Act 1974</i>		
460/1979	Public Service Amendment Regulations (No. 14) 1979	10c
<i>Public Service Act 1979</i>		
PSD100/1979	Public Service Amendment Determinations (No. 100) 1979	20c
PSD101/1979	Public Service Amendment Determinations (No. 101) 1979	20c
PSD102/1979	Public Service Amendment Determinations (No. 102) 1979	20c
PSD103/1979	Public Service Amendment Determinations (No. 103) 1979	10c
PSD104/1979	Public Service Amendment Determinations (No. 104) 1979	10c
PSD105/1979	Public Service Amendment Determinations (No. 105) 1979	10c
PSD106/1979	Public Service Amendment Determinations (No. 106) 1979	10c
PSD107/1979	Public Service Amendment Determinations (No. 107) 1979	10c
PSD108/1979	Public Service Amendment Determinations (No. 108) 1979	10c
PSD109/1979	Public Service Amendment Determinations (No. 109) 1979	10c
PSD110/1979	Public Service Amendment Determinations (No. 110) 1979	10c
PSD111/1979	Public Service Amendment Determinations (No. 111) 1979	10c
PSD112/1979	Public Service Amendment Determinations (No. 112) 1979	10c

Copies of these statutory rules when printed may be purchased at the Sale of Publications Section of the Government Printing Office, located at 7A Parliament Place, Melbourne, 3002. If ordered by mail, remittance should be addressed to "The Government Printer, Box 203, P.O., North Melbourne, 3051", and should include 25c extra for postage.

The annual subscription rates for Statutory Rules for the year commencing 1 January 1980, payable in advance, are as follows:—

*Statutory Rules (other than Public Service Determinations), Pamphlet copies only	\$36.00
Public Service Determinations	\$25.00

\*The Bound Volume of Statutory Rules is not included in the subscription rate.

F. D. ATKINSON  
Government Printer

ACTS REPRINTED IN ACCORDANCE WITH THE AMENDMENTS INCORPORATION ACT 1958 (No. 6422), AND FOR SALE AS STOCKS ARE AVAILABLE AT THE SALE OF PUBLICATIONS BRANCH OF THE GOVERNMENT PRINTING OFFICE, 7A PARLIAMENT PLACE, MELBOURNE, 3002

Postage costs must be added to your remittance when ordering by mail as follows:—

Act Price	Postage Cost
10c-40c	25c
45c-70c	35c
75c-\$1.70	45c
\$1.75c-\$4.00	70c
Above \$4.00	\$1.15

No.	Price
8404. Abattoir and Meat Inspector (First Reprint—Incorporating amendments up to No. 9005)	\$0.85
6189. Acts Interpretation (Fourth Reprint—Incorporating amendments up to No. 8305)	\$0.35
6191. Administration and Probate Act 1958 (Fifth Reprint—Incorporating amendments up to No. 9075)	\$1.05
7147. Adoption of Children (First Reprint—Incorporating amendments up to Act No. 8602)	\$0.75
6194. Agricultural Colleges (First Reprint—Incorporating amendments up to No. 7302)	\$0.15
7772. Alcoholic and Drug-Dependent Persons Act 1968 (First Reprint—Incorporating amendments up to Act No. 9023)	\$0.60
6198. Anzac Day (First Reprint—Incorporating amendments up to No. 8344)	\$0.15
7117. Appeal Costs Fund Act 1964 (Second Reprint—Incorporating amendments up to No. 8145)	\$0.35
8273. Archaeological and Aboriginal Preservation Act 1972 (First Reprint—Incorporating amendments up to Act No. 9019)	\$0.30
6201. Architects (First Reprint—Incorporating amendments up to No. 8077)	\$0.30
6202. Auction Sales (First Reprint—Incorporating amendments up to No. 8490)	\$0.35
6203. Audit (First Reprint—Incorporating amendments up to No. 7377)	\$0.35
9008. Bail Act 1977 (First Reprint—Incorporating amendments up to Act No. 9158)	\$0.70
6206. Barley Marketing (First Reprint—Incorporating amendments up to No. 9005)	\$0.30
6208. Benefit Associations (First Reprint—Incorporating amendments up to No. 6961)	\$0.65
8004. Boilers and Pressure Vessels Act 1970 (Second Reprint—Incorporating amendments up to Act No. 9019)	\$0.65
6529. Bread Industry Act 1959 (Second Reprint—Incorporating amendments up to Act No. 8542)	\$0.20
6973. Building Contracts (Deposits) Act 1962 (First Reprint—Incorporating amendments from No. 7315)	\$0.10
8693. Building Industry Long Service Leave (First Reprint—Incorporating Amendments up to No. 9122)	\$0.85
6213. Cancer Act 1958 (Second Reprint—Incorporating amendments up to No. 9023)	\$1.10
6214. Carriers and Innkeepers (Second Reprint—Incorporating amendments up to No. 8534)	\$0.20
6215. Cattle Breeding (First Reprint—Incorporating amendments up to No. 6886)	\$0.10
6217. Cemeteries Act 1958 (Second Reprint—Incorporating amendments up to Act No. 9052)	\$0.90
8477. Children's Court Act 1973 (First Reprint—Incorporating amendments up to No. 8731)	\$0.95
6220. Clean Air (Third Reprint—Incorporating amendments up to No. 8324)	\$0.15
8661. Cluster Titles Act 1974 (First Reprint—Incorporating amendments up to Act No. 9128)	\$0.85
6221. Coal Mines (Second Reprint—Incorporating amendments up to No. 8953)	\$2.15
6222. Commercial Goods Vehicles (Third Reprint—Incorporating amendments up to No. 8525)	\$0.55
6223. Commonwealth Arrangements (First Reprint—Incorporating amendments from No. 7809)	\$0.10

ACTS REPRINTED IN ACCORDANCE WITH THE AMENDMENTS  
INCORPORATED ACT 1958 (No. 6422)—*continued*

No.	Price
6839. Companies (Sixth Reprint—Incorporating amendments up to No. 8788) . . . . .	\$7.90
8750. Constitution Act 1975 (Third Reprint—Incorporating amendments up to Act No. 9251) . . . . .	\$1.30
8276. Consumer Affairs Act 1972 (Third Reprint—Incorporating amendments up to No. 8824) . . . . .	\$1.15
6225. Co-operation Act 1958 (Fourth Reprint—Incorporating amendments up to Act No. 9136) . . . . .	\$1.60
6226. Co-operative Housing Societies (Second Reprint—Incorporating amendments up to No. 7575) . . . . .	\$0.53
6227. Coroners (Second Reprint—Incorporating amendments up to No. 8184) . . . . .	\$0.35
6228. Country Fire Authority (Third Reprint—Incorporating amendments up to No. 8813) . . . . .	\$1.25
6229. Country Roads Act 1958 (Fifth Reprint—Incorporating amendments up to No. 9212) . . . . .	\$2.00
6230. County Court (Fourth Reprint—Incorporating amendments up to No. 9075) . . . . .	\$0.95
6231. Crimes Act 1958 (Sixth Reprint—Incorporating amendments up to Act No. 9073) . . . . .	\$3.15
6232. Crown Proceedings (Second Reprint—Incorporating amendments up to No. 8731) . . . . .	\$0.40
7060. Dandenong Valley Authority Act 1963 (Second Reprint—Incorporating amendments up to Act No. 9172) . . . . .	\$1.20
8383. Decentralized Industry Incentive Payments (First Reprint—Incorporating Amendments up to No. 8751) . . . . .	\$0.20
6235. Dietitians Registration (First Reprint—Incorporating amendments up to No. 6886) . . . . .	\$0.20
4989. Discharged Servicemen's Preference Act 1943 (Second Reprint—Incorporating amendments up to No. 7991) . . . . .	\$0.20
6815. Disposal of Uncollected Goods Act 1961 (Second Reprint—Incorporating amendments up to No. 8246) . . . . .	\$0.30
8079. Dog Act 1970 (First Reprint—Incorporating amendments up to No. 8664) . . . . .	\$0.30
6237. Drainage Areas Act 1958 (Second Reprint—Incorporating amendments up to Act No. 8811) . . . . .	\$0.75
6239. Dried Fruits Act 1968 (First Reprint—Incorporating amendments up to No. 7337) . . . . .	\$0.25
6240. Education Act 1958 (Third Reprint—Incorporating amendments up to Act No. 9248) . . . . .	\$1.50
6241. Electric Light and Power (First Reprint—Incorporating amendments up to No. 7315) . . . . .	\$0.30
8056. Environment Protection Act 1970 (Third Reprint—Incorporating amendments up to Act No. 9098) . . . . .	\$0.95
6244. Essential Services (First Reprint—Incorporating amendments up to No. 8353) . . . . .	\$0.20
6245. Estate Agents—(Fifth Reprint—Incorporating amendments up to No. 8490) . . . . .	\$0.85
6246. Evidence (Fifth Reprint—Incorporating amendments up to No. 9019) . . . . .	\$1.35
6715. Explosives Act 1960 (First Reprint—Incorporating amendments up to Act No. 8920) . . . . .	\$0.85
7499. Extractive Industries Act 1966 (Third Reprint—Incorporating amendments up to No. 8647) . . . . .	\$0.45
7733. Fences Act 1968 (Second Reprint—Incorporating amendments up to Act No. 9019) . . . . .	\$0.70
6468. Filled Milk (First Reprint—Incorporating amendments up to No. 6886) . . . . .	\$0.15
6251. Firearms (Fifth Reprint—Incorporating amendments up to No. 8427) . . . . .	\$1.05
7780. Fisheries Act 1968 (First Reprint—Incorporating amendments up to No. 8694) . . . . .	\$1.05
6916. Foreign Judgments Act 1962 (First Reprint including amendments made by No. 7332) . . . . .	\$0.15
6585. Forests (Pulpwood Agreement) (Incorporating amendments up to No. 6886) . . . . .	\$0.15
6254. Forests (Second Reprint—Incorporating amendments up to No. 8702) . . . . .	\$1.35
6255. Friendly Societies (First Reprint—Incorporating amendments up to No. 7554) . . . . .	\$0.60
6256. Fruit and Vegetables (First Reprint—Incorporating amendments up to No. 6944) . . . . .	\$0.30

ACTS REPRINTED IN ACCORDANCE WITH THE AMENDMENTS  
INCORPORATION ACT 1958 (No. 6422)—*continued*

No.	Price
6260. Gas and Fuel Corporation (First Reprint—Incorporating amendments up to No. 7422) . . . . .	\$0.70
6262. Geelong Harbor Trust (First Reprint—Incorporating amendments up to No. 7547) . . . . .	\$0.45
6263. Geelong Waterworks and Sewerage (First Reprint—Incorporating amendments up to No. 7547) . . . . .	\$0.75
8176. Gift Duty Act 1971 (First Reprint—Incorporating amendments from No. 8202) . . . . .	\$0.55
6265. Goods (Sixth Reprint—Incorporating amendments up to No. 8425) . . . . .	\$0.75
6266. Grain Elevators (First Reprint—Incorporating amendments up to No. 7486) . . . . .	\$0.35
7849. Groundwater (Second Reprint—Incorporating amendments up to No. 9019) . . . . .	\$0.75
6267. Hairdressers Registration (First Reprint—Incorporating amendments up to No. 7659) . . . . .	\$0.30
6269. Hawkers and Pedlers (Second Reprint—Incorporating amendments up to No. 8247) . . . . .	\$0.40
6270. Health (Third Reprint—Incorporating amendments up to No. 8506) . . . . .	\$3.25
6531. Hire Purchase Act 1959 (Second Reprint—Incorporating amendments from No. 8232) . . . . .	\$0.85
6933. Home Finance Act 1962 (First Reprint—Incorporating amendments up to No. 7363) . . . . .	\$0.25
6274. Hospitals and Charities (Second Reprint—Incorporating amendments up to No. 7455) . . . . .	\$0.50
6275. Housing (Third Reprint—Incorporating amendments up to No. 8713) . . . . .	\$2.40
3270. Imperial Acts Application (First Reprint—Incorporating Amendments up to No. 8037) . . . . .	\$1.30
6276. Imprisonment of Fraudulent Debtors (Second Reprint—Incorporating amendments up to No. 8731) . . . . .	\$0.55
6277. Industrial and Provident Societies (First Reprint—Incorporating amendments up to No. 7547) . . . . .	\$0.35
6279. Instruments (Fifth Reprint—Incorporating amendments up to No. 8565) . . . . .	\$0.75
6280. Judicial Proceedings Reports (First Reprint—Incorporating amendments up to No. 7596) . . . . .	\$0.20
7651. Juries (First Reprint—Incorporating amendments up to No. 8170) . . . . .	\$0.55
6283. Labour and Industry Act 1958 (Seventh Reprint—Incorporating amendments up to Act No. 9163) . . . . .	\$1.90
6284. Land (Third Reprint—Incorporating amendments up to No. 8702) . . . . .	\$3.25
6534. Land Settlement Act 1959 (First Reprint—Incorporating amendments up to No. 7328) . . . . .	\$0.30
6288. Land Surveyors (First Reprint—Incorporating amendments up to No. 7065) . . . . .	\$0.30
6289. Land Tax Act 1958 (Third Reprint—Incorporating amendments up to Act No. 9190) . . . . .	\$1.40
6285. Landlord and Tenant (Fourth Reprint—Incorporating amendments up to No. 8208) . . . . .	\$1.90
6286. Lands Compensation Act (Third Reprint—Incorporating amendments up to No. 8899) . . . . .	\$0.45
6290. Latrobe Valley (First Reprint—Incorporating amendments up to No. 7332) . . . . .	\$0.35
7919. Legal Aid—(First Reprint—Incorporating amendments up to No. 8427) . . . . .	\$0.30
6291. Legal Profession Practice Act (Fourth Reprint—Incorporating amendments up to No. 8778) . . . . .	\$1.45
6292. Libraries (First Reprint—Incorporating amendments up to No. 7364) . . . . .	\$0.15
7629. Lifts and Cranes Act 1967 (First Reprint—Incorporating amendments up to No. 8320) . . . . .	\$0.30
6295. Limitation of Actions (Third Reprint—Incorporating amendments up to No. 8300) . . . . .	\$0.55
7695. Liquor Control Act 1958 (Third Reprint—Incorporating amendments up to No. 8598) . . . . .	\$1.70
7145. Litter Act 1964 (Second Reprint—Incorporating amendments up to No. 8702) . . . . .	\$0.20
6298. Local Authorities Superannuation (Second Reprint—Incorporating amendments up to No. 7161) . . . . .	\$0.40

ACTS REPRINTED IN ACCORDANCE WITH THE AMENDMENTS  
INCORPORATING ACT 1958 (No. 6422)—*continued*

No.	Price
6479. Local Government Department Act 1958 (First Reprint—Incorporating amendments up to Act No. 8656)	\$0.10
6299. Local Government (Third Reprint—Incorporating amendments up to No. 8781)	\$10.90
7429. Lotteries Gaming and Betting Act 1966 (Second Reprint—Incorporating amendments up to No. 9075)	\$1.20
8184. Magistrates' Courts (First Reprint—Incorporating amendments up to No. 8718)	\$0.75
7289. Maintenance (Second Reprint—Incorporating amendments up to No. 9019)	\$1.35
6302. Marine (First Reprint—Incorporating amendments up to No. 7350)	\$0.72
6303. Marine Stores and Old Metals Act 1958 (Second Reprint—Incorporating amendments up to Act No. 8622)	\$0.65
6304. Marketing of Primary Products (First Reprint—Incorporating amendments up to No. 7491)	\$0.45
6305. Markets Act (Second Reprint—Incorporating amendments up to No. 8247)	\$0.30
6306. Marriage (Second Reprint—Incorporating amendments up to No. 8602)	\$0.45
6309. Medical Act 1958 (Third Reprint—Incorporating amendments up to No. 8593)	\$0.45
8061. Medical Practitioner (First Reprint—Incorporating amendments up to No. 8754)	\$0.75
6310. Melbourne and Metropolitan Board of Works (Fourth Reprint—Incorporating amendments up to No. 8650)	\$1.95
6311. Melbourne and Metropolitan Tramways Act 1958 (Second Reprint—Incorporating amendments up to Act No. 8992)	\$1.45
6312. Melbourne Harbor Trust (Second Reprint—Incorporating amendments up to No. 8796)	\$1.35
6605. Mental Health (Second Reprint—Incorporating amendments up to No. 8679)	\$0.75
6315. Metropolitan Fire Brigades (Third Reprint—Incorporating amendments up to No. 9019)	\$0.95
6316. Mildura Irrigation and Water Trusts (First Reprint—Incorporating amendments up to No. 7448)	\$0.75
6317. Milk and Dairy Supervision (Second Reprint—Incorporating amendments up to No. 8655)	\$0.85
6318. Milk Board (Incorporating amendments up to No. 7093)	\$0.22
6319. Milk Pasteurization (First Reprint—Incorporating amendments up to No. 7480)	\$0.20
6320. Mines Act 1958 (Third Reprint—Incorporating amendments up to Act No. 8953)	\$2.60
6184. Monash University (First Reprint—Incorporating amendments up to No. 7533)	\$0.30
6324. Money Lenders (Fourth Reprint—Incorporating amendments up to No. 8490)	\$0.55
8429. Motor Accidents Act 1973 (First Reprint—Incorporating amendment up to No. 8669)	\$1.15
6832. Motor Boating Act 1961 (Third Reprint—Incorporating amendment up to No. 8662)	\$0.55
6325. Motor Car Act 1958 (Fifth Reprint—Incorporating amendments up to No. 8657)	\$2.25
6713. National Fitness Council of Victoria Act 1960 (First Reprint—Incorporating amendments up to No. 8344)	\$0.20
6705. Navigable Waters (Oil Pollution) Act 1960 (Second Reprint—Incorporating amendments up to No. 8816)	\$0.65
6328. Nurses Act 1958 (Fourth Reprint—Incorporating amendments up to Act No. 9059)	\$1.00
8414. Ombudsman Act 1973 (First Reprint—Incorporating amendments up to No. 8884)	\$0.45
6329. Optometrists Registration Act 1958 (Second Reprint—Incorporating amendments up to Act No. 8800)	\$0.70
7723. Parliamentary Salaries and Superannuation (First Reprint—Incorporating amendments up to No. 8687)	\$0.35
6330. Partnership (Second Reprint—Incorporating amendments up to No. 7315)	\$0.45

ACTS REPRINTED IN ACCORDANCE WITH THE AMENDMENTS  
INCORPORATING ACT 1958 (No. 6422)—*continued*

No.	Price
6331. Patriotic Funds (First Reprint—Incorporating amendments up to No. 7338)	\$0.25
6332. Pawmbrokers Act 1958 (Second Reprint—Incorporating amendments up to No. 8181)	\$0.35
8154. Pay-Roll Tax Act 1971 (First Reprint—Incorporating amendments up to No. 9059)	\$1.15
7417. Pensions Supplementation (First Reprint—Incorporating amendments up to No. 8475)	\$0.20
6257. Pesticides Act 1958 (Second Reprint—Incorporating amendments up to No. 8589)	\$0.35
6335. Petrol Pumps (Second Reprint—Incorporating amendments up to No. 7315)	\$0.15
6889. Poisons Act 1962 (Fourth Reprint—Incorporating amendments up to No. 8456)	\$0.95
6337. Police Offences Act 1958 (Third Reprint—Incorporating amendments up to No. 8433)	\$0.45
6388. Police Regulation (Third Reprint—Incorporating amendments up to No. 8722)	\$0.95
6340. Portland Harbor Trust Act 1958 (Second Reprint—Incorporating amendments up to Act No. 9204)	\$1.10
7498. Port Phillip Authority Act 1966 (Second Reprint—Incorporating amendments from No. 8081)	\$0.20
6341. Pounds Act 1958 (Second Reprint—Incorporating amendments up to Act No. 9168)	\$0.60
6342. Printers and Newspapers (Second Reprint—Incorporating amendments up to No. 8556)	\$0.30
7494. Private Agents Act 1966 (Second Reprint—Incorporating amendments up to No. 8427)	\$0.45
6890. Probate Duty Act 1962. (Fourth Reprint)—Incorporating amendments up to Act No. 9019	\$1.15
6344. Property Law (Third Reprint—Incorporating amendments up to No. 8181)	\$1.95
7432. Protection of Animals (First Reprint—Incorporating Amendments Up to No. 9019)	\$0.40
6345. Public Account (First Reprint—Incorporating amendments up to No. 8012)	\$0.20
6346. Public Authorities Marks (First Reprint—Incorporating amendments from No. 7315)	\$0.10
8656. Public Service Act 1974 (Second Reprint—Incorporating amendments up to Act No. 9248)	\$1.40
6350. Public Trustee Act 1958 (Second Reprint—Incorporating amendments up to No. 8125)	\$1.05
6353. Racing (Fourth Reprint—Incorporating amendments up to No. 8690)	\$1.55
6355. Railways Act 1958 (Second Reprint—Incorporating amendments up to Act No. 9142)	\$1.55
6564. Registration of Births Deaths and Marriages Act 1959 (Second Reprint—Incorporating amendments up to Act No. 8602)	\$0.70
6357. Religious Successory and Charitable Trusts Act 1958 (First Reprint—Incorporating amendments made by Act No. 7315)	\$0.75
6358. River Improvements Act (Second Reprint—Incorporating amendments up to No. 8967)	\$0.85
2596. River Murray Waters Act 1915 (First Reprint—Incorporating amendments up to No. 7228)	\$0.35
6359. Road Traffic (Fourth Reprint—Incorporating amendments up to No. 8353)	\$0.35
6360. Rural Finance (First Reprint—Incorporating amendments up to No. 7328)	\$0.15
6846. Rural Finance and Settlement Commission Act 1961 (First Reprint—Incorporating amendments up to No. 7332)	\$0.30
6917. Sale of Human Blood Act 1962 (First Reprint—Incorporating amendments from No. 7332)	\$0.10
6975. Sale of Land Act 1962 (Third Reprint—Incorporating amendments up to No. 8861)	\$0.55
8146. Scaffolding Act 1971 (Second Reprint—Incorporating amendments up to No. 8666)	\$0.35

ACTS REPRINTED IN ACCORDANCE WITH THE AMENDMENTS  
INCORPORATION ACT 1958 (NO. 6422)—continued

No.	Price
6363. Second-hand Dealers (First Reprint—Incorporating amendments up to No. 7529)	\$0.25
6367. Settled Land Act 1958 (Third Reprint—Incorporating amendments up to Act No. 9075)	\$1.50
6368. Sewerage Districts Act 1958 (Third Reprint—Incorporating amendments up to Act No. 9139)	\$1.90
6809. Sheep Owners Protection Act 1961 (Third Reprint—Incorporating amendments up to No. 8247)	\$0.20
8089. Social Welfare Act 1970 (First Reprint—Incorporating amendments up to No. 8821)	\$1.90
6372. Soil Conservation and Land Utilization Act (Third Reprint—incorporating amendments up to No. 8432)	\$0.45
6373. Soldier Settlement (First Reprint—Incorporating amendments up to No. 7328)	\$0.42
6375. Stamps Act 1958 (Sixth Reprint—Incorporating amendments up to No. 8624)	\$2.15
6376. State Development Committee Act 1958 (First Reprint—Incorporating amendments up to No. 8827)	\$0.30
6377. State Electricity Commission Act 1958 (Third Reprint—incorporating amendments up to Act No. 9121)	\$1.35
6378. State Relief Committee (First Reprint—Incorporating amendments from No. 6886)	\$0.10
6379. State Savings Bank Act 1958 (Third Reprint—Incorporating amendments up to No. 8519)	\$0.95
6380. Statistics (First Reprint—Incorporating amendments up to No. 6961)	\$0.20
6877. Stock (Artificial Breeding) Act 1962 (First Reprint—Incorporating amendments up to No. 8709)	\$0.30
6383. Stock Foods (First Reprint—Incorporating amendments up to No. 7607)	\$0.28
6384. Stock Medicines Act 1958 (Second Reprint—Incorporating amendments up to No. 9005)	\$0.50
7551. Strata Titles Act 1967 (Third Reprint—Incorporating amendments up to No. 8661)	\$1.00
6886. Subordinate Legislation Act 1962 (Second Reprint—Incorporating amendments up to No. 8127)	\$0.15
7405. Summary Offences Act 1966 (Second Reprint—Incorporating amendments up to No. 8276)	\$0.55
7634. Sunday Entertainment (First Reprint—Incorporating amendments up to No. 8173)	\$0.15
6386. Superannuation Act 1958 (Fourth Reprint—Incorporating amendments up to No. 9125)	\$1.70
6387. Supreme Court (Second Reprint—Incorporating amendments up to No. 8951)	\$1.35
6388. Survey Co-ordination (First Reprint—Incorporating amendments up to No. 8107)	\$0.35
6390. Tattersall Consultations (Second Reprint—Incorporating amendments up to No. 8982)	\$0.30
8274. Taxation Appeals Act 1972 (First Reprint—Incorporating amendments up to Act No. 9045)	\$0.55
6391. Teaching Service (Second Reprint—Incorporating amendments up to No. 8691)	\$0.55
6393. Theatres (First Reprint—Incorporating amendments up to No. 8161)	\$0.15
6224. The Constitution Act Amendment Act 1959 (Second Reprint—Incorporating amendment up to No. 9216)	\$3.00
6405. The Melbourne University Act 1958 (Second Reprint—Incorporating amendments up to Act No. 9123)	\$0.85
6334. The Petroleum Act 1958 (Second Reprint—Incorporating amendments up to Act No. 9212)	\$1.30
6402. The Trustee Companies Act 1958 (Second Reprint—Incorporating amendments up to Act No. 9075)	\$0.55
6849. Town and Country Planning Act 1961 (Fifth Reprint—Incorporating amendments up to No. 8716)	\$1.25

ACTS REPRINTED IN ACCORDANCE WITH THE AMENDMENTS  
INCORPORATION ACT 1958 (NO. 6422)—continued

No.	Price
6397. Trade Unions (Second Reprint—Incorporating amendments up to No. 8181)	\$0.20
6399. Transfer of Land (Fifth Reprint—Incorporating amendments up to No. 8531)	\$1.15
6400. Transport Regulation Act (Third Reprint—Incorporating amendments up to No. 8700)	\$0.75
6401. Trustee Act 1958 (Fourth Reprint—incorporating amendments up to Act No. 9075)	\$1.15
6879. Unclaimed Moneys Act 1962 (Second Reprint—Incorporating amendments up to No. 8448)	\$0.20
7095. Underseas Mineral Resources Act 1963 (First Reprint—Incorporating amendments from No. 7591)	\$0.10
6653. Valuation of Land Act 1960 (Fourth Reprint—Incorporating amendments up to No. 8817)	\$0.85
6407. Vegetation and Vine Diseases (First Reprint—Incorporating amendments up to No. 7423)	\$0.30
6408. Venereal Diseases (First Reprint—Incorporating amendments made by Act No. 6886)	\$0.55
6409. Vermin & Noxious Weeds (First Reprint—Incorporating amendments up to No. 7463)	\$0.35
6410. Veterinary Surgeons (First Reprint—Incorporating amendments up to No. 7343)	\$0.15
7291. Victoria Institute of Colleges Act 1965 (Second Reprint—Incorporating amendments up to No. 8710)	\$0.65
6412. Warehousemen's Liens (First Reprint—Incorporating amendments up to No. 7876)	\$0.15
6413. Water (Third Reprint—Incorporating amendments up to No. 8729)	\$3.45
6414. Weights and Measures Act 1958 (Fourth Reprint—Incorporating amendments up to Act No. 9019)	\$1.90
6415. Wild Flowers and Native Plants Protection (First Reprint—Incorporating amendments up to No. 6976)	\$0.15
6416. Wills Act 1958 (Second Reprint—Incorporating amendments up to Act No. 9075)	\$0.60
6417. Wire Netting (Second Reprint—Incorporating amendments up to No. 7876)	\$0.65
6419. Workers Compensation Act (Seventh Reprint—Incorporating amendments up to No. 8804)	\$1.45
6420. Wrongs Act 1958. (Third Reprint—Incorporating amendments up to Act No. 9153)	\$0.60
8344. Youth, Sport and Recreation Act 1972 (First Reprint—Incorporating amendments up to No. 8550)	\$0.35

F. D. ATKINSON  
Government Printer

## PUBLICATION OF OFFICIAL MATTER

Attention is invited to the following procedure in relation to the publication of official matter in the *Government Gazette*:—

Publication will be facilitated by the submission of carbon copies for the use of the *Gazette Officer*.

## 1. Matter submitted to the Executive Council

Matter submitted to the Executive Council which requires gazettal will normally be published in the issue of the following week.

Where urgent gazettal is required, special arrangements should be made with the *Gazette Officer*, Room 15, first floor, Old Treasury Building.

## 2. Other matter

(a) All other matter duly certified by a responsible officer for publication should be lodged with the *Gazette Officer* not later than half-past Nine a.m. on Tuesday.

(b) Lengthy or involved notices should be forwarded several days before publication.

(c) Proofs, which will be supplied only when specifically requested or at the direction of the Gazette Officer, should be returned promptly to avoid delay in publication.

(d) No additions or amendments to matters for publication will be accepted by telephone.

LOVELL'S SHEPPARTON NEWSAGENCY, 246 Wyndham Street, Shepparton, Victoria 3630.

THE MERCANTILE EXCHANGE, 15 Queen Street, Melbourne, Victoria 3000.

MCDONALD'S NEWSAGENCY, 88 Bridge Street, Ballarat, Victoria 3350.

MCGILL'S AUTHORIZED NEWSAGENCY, 183-5 Elizabeth Street, Melbourne, Victoria 3000.

MCGILL'S AUTHORIZED NEWSAGENCY, 183-5 Elizabeth Street, Melbourne, Victoria 3000.

MCGILL'S AUTHORIZED NEWSAGENCY, 183-5 Elizabeth Street, Melbourne, Victoria 3000.

POWNEY'S AUTHORIZED NEWSAGENCY, 293 Hargreaves Street, Bendigo, Victoria 3550.

PURDIE, J., & CO., 138 Moorabool Street, Geelong, Victoria 3220.

SALE AUTHORIZED NEWSAGENCY 292-294 Raymond Street, Sale, Victoria 3850.

VERNONS OF RICHMOND, 261 Bridge Road, Richmond, Victoria 3121.

VIEW POINT AUTHORIZED NEWSAGENCY, 4 View-Point, Bendigo, Victoria 3550.

**THE "VICTORIA GOVERNMENT GAZETTE"**

PUBLICATION—A VICTORIA GOVERNMENT GAZETTE is published every WEDNESDAY EVENING unless advertised otherwise.

SUBSCRIPTIONS—The Subscription, including postage, is \$62 per annum, or \$31 per half year, payable in advance. Subscriptions are required for whole months, but must cover at least a half-year.

PRIVATE ADVERTISEMENTS—Advertisements will be received by the Government Printer not later than the day preceding publication—at ordinary rates at or before ONE p.m. and at double rates between ONE p.m. and HALF PAST THREE p.m. The charge for ADVERTISEMENTS is 78 cents per line single column and \$1.56 per line double column. The charge for a full page is \$118. The title forms one or more lines as a heading. On an average ten words make a line of single column. Every signature must likewise be counted as a line. The final words of a paragraph though only portion of a line, must be counted as one line. Signatures (in particular) and proper names must be written very clearly in the text; ONE SIDE ONLY of each sheet of paper should be written upon.

All documents NOT CLEARLY PREPARED will be returned unpublished. Where brands occur, not provided for by the ordinary letters of the alphabet, a written explanatory description also must be furnished.

PAYMENTS—Unless the advertiser has a Credit Account, all payments are required in advance. Remittances should be made by cheque, postal order or money order, payable to "GOVERNMENT PRINTER".

CORRESPONDENCE—All correspondence should be addressed to "The Victorian Government Printer, P.O. Box 203, North Melbourne, 3051".

**AGENTS FOR THE "VICTORIA GOVERNMENT GAZETTE"**

The following have been appointed agents to receive Advertisements and Subscriptions for the Victoria Government Gazette:—

ARMSTRONG'S AGENCY, 217 Queen Street, Melbourne, Victoria 3000.

ARNALL & JACKSON, 390 Barkly Street, Brunswick, Victoria 3056

BAIRNSDALE AUTHORIZED NEWSAGENCY, 132 Main Street, Bairnsdale, Victoria 3875.

BENALLA AUTHORIZED NEWSAGENCY, 45 Bridge Street, Benalla, Victoria 3672.

BLANE'S AUTHORIZED NEWSAGENTS, 162 Murray Street, Colac, Victoria 3250.

CARTER, R. G., ADVERTISING SERVICE PTY. LTD., 129 Church Street, Hawthorn, Victoria 3122.

DAVIS, WM. (MILDURA) PTY. LTD., 126 Eighth Street, Mildura, Victoria 3500.

FAROE, S. W. & E. P., 79 Henty Street, Casterton, Victoria 3311.

FRANKS, H., & CO., 184 Ryrie Street, Geelong, Victoria 3220.

GORDON & GOTCH AUSTRALASIA LTD., 25-37 Huntingdale Road, Burwood, Victoria 3125.

HARSTON, PARTRIDGE & CO. PTY. LTD., 455 Little Collins Street, Melbourne, Victoria 3000.

KYNETON GUARDIAN PTY. LTD., P.O. Box 18, Kyneton, Victoria 3444.

LONSDALE NEWSAGENCY, 250 Lonsdale Street, Danedong, Victoria 3175.

**CONTENTS**

	Page
Acts of Parliament	3950
Acts of Parliament on Sale at the Government Printing Office	4048
Appointments	3993
Auction Sales Act	3981
Cemeteries—Scale of Fees	3983
Christmas and New Year Holidays	3955
Contracts	3981
Country Roads Board	3959
Courts	3972
Estates of Deceased Persons	3977
Government Notices	3955
Lands	4017
Melbourne and Metropolitan Board of Works—Notice	3982
Minerals and Energy	3975
Notice to Mariners	3969
Notice of Making of Statutory Rules	4047
Orders in Council—	
Acts—Hospitals and Charities; Superannuation; Local Government; Country Roads Board; Housing; Teacher Housing; Royal Commission; State Electricity Commission; Road Traffic; Land; Crown Land (Reserves); Health; Water; Sewerage Districts; Workers Compensation; Royal Commission; Patriotic Funds; Local Government; Liquor Control; Superannuation; Water; Geelong Waterworks and Sewerage; Sewerage District.	3994 et seq
Private Advertisements	4018
Proclamations	3950
Public Holidays	3976
Resignations	3994
State Rivers and Water Supply Commission	3986
Transport Regulation Board—Public Hearings	3966
Waterworks Trust	3988