



VICTORIA GOVERNMENT GAZETTE

Published by Authority

No. 3]

FRIDAY, JANUARY 5

[1979

Governor's Office,
Melbourne,
3rd January, 1979

The Queen has been graciously pleased to signify Her Majesty's intention of conferring the following Honours, Decorations and Awards in the New Year's Honours, 1979.

KNIGHTS BACHELOR

The Honourable Mr. Justice George Hermann Lush.
Mr. Oscar Gwynne Meyer, O.B.E., E.D.

COMMANDER OF THE CIVIL DIVISION OF THE MOST EXCELLENT ORDER OF THE BRITISH EMPIRE (C.B.E.)

Mr. Henry Krongold.

OFFICERS OF THE CIVIL DIVISION OF THE MOST EXCELLENT ORDER OF THE BRITISH EMPIRE (O.B.E.)

The Honourable Archibald Keith Bradbury.
Mr. Ralph Leyton Cooper
Mr. Reginald Harry Ebbott.
Dr. Keith Thomas Henry Farrer.
Dr. Leo John Murphy.
Mr. Francis James Sheehan.
Miss Nellie Louise Stephenson.
Mr. Ivan Wade.
Miss Carmen Winter.

COMPANION OF THE IMPERIAL SERVICE ORDER (I.S.O.)

Mr. Arthur John Alliance Gardner.

MEMBERS OF THE CIVIL DIVISION OF THE MOST EXCELLENT ORDER OF THE BRITISH EMPIRE (M.B.E.)

Dr. William Henry Beischer.
Mrs. Norma Jean Buckland.
Mr. Harry Dench.
Mr. Silvester Augustine Doyle.
Councillor Thomas Allan Drechsler.
Mr. Roydon Beresford Mactier Gerrand.
Reverend Canon Leslie Guy Harmer.
Councillor Kenneth Humphrey Harrison.
Dr. Alister Ashworth Hinchley.

Mr. Kenneth Irvine James Hodgson.
Councillor Leslie James Howarth.
Miss Ruby May Ivison.
Mrs. Gwendolyn Marjorie Nisbet.
Mr. Henri Schubert
Councillor Jessie Margaret Scott.
Mr. Lloyd Cecil Worland.

THE BRITISH EMPIRE MEDAL (B.E.M.)

Mrs. Kathleen May Foster Andrews.
Miss Florence Mary Bennett.
Mrs. Vera Florence Bennett.
Mrs. Grace Elizabeth Berglund.
Mrs. Charlotte Helena Campbell.
Mr. John Joseph Cornall.
Mrs. Mavis Mary Crawford.
Mr. Francis John Doolan.
Mrs. Margaret Jean Ellwood.
Mr. Stanley Edgar Fostineo.
Mr. Sidney Walter Goldfinch.
Mr. Christopher Sidney Johnston.
Mrs. Mary Jean Kerr.
Miss Annie Christina Kettle.
Mr. Jack Oliver Leary.
Mrs. Hilda Mayes.
Mr. Allan James Monaghan.
Mrs. Mary Morton.
Mr. John Patrick Noonan.
Mrs. Dorothy Margaret Paul.
Mr. Jack Douglas Verity.
Mrs. Dorothy Waight.
Mrs. Edna Mavis Wells.
Mr. John Russell Wheeler.

THE QUEEN'S POLICE MEDAL (Q.P.M.)

Superintendent Percival Noah Dennis Ball.
Inspector William John Brand.
Senior Sergeant Arthur Oswald Hann.
Senior Sergeant Colin Robert Hodder.
Chief Superintendent Robert John Martin.
Chief Superintendent Ludwig Keith Plattfuss, V.A.

TOM FORRISTAL,
Official Secretary to the Governor

GOVERNMENT NOTICES

**SHIRE OF BASS
ROAD DEVIATION ORDER**

Pursuant to the powers conferred by section 522 and 526 of the *Local Government Act 1958*, the Council of the Shire of Bass does hereby direct that the land in the Parish of Kirrak, County of Buln Buln, shown on the plan attached and shown hatched, which has been taken, purchased, or acquired by it, shall be a Public Highway from and after the date of the publication of this Order in the *Government Gazette*, and does declare that such land shall be a public highway in lieu of the land in the said parish shown cross hatched on the said plan.

Local Government Act 1958

NOTICE OF CONFIRMATION OF AN ORDER OF THE COUNCIL OF THE SHIRE OF FLINDERS ADOPTING A PROPOSAL FOR THE CLOSURE OF THE STREET OR ROAD TO THROUGH TRAFFIC

Pursuant to the provisions of section 539c of the *Local Government Act 1958*, the Governor in Council, on the 19th day of December, 1978 confirmed an Order of the Council of the Shire of Flinders made on March 1, 1978 adopting a proposal for the closure of Pamela and Norma Avenues, Rye on the western sides of their intersection with Centre Drive and the closure of Albert Avenue, Rye on the eastern side of its intersection with Centre Drive to through traffic by the erection of barriers at the locations shown on the plan hereunder.

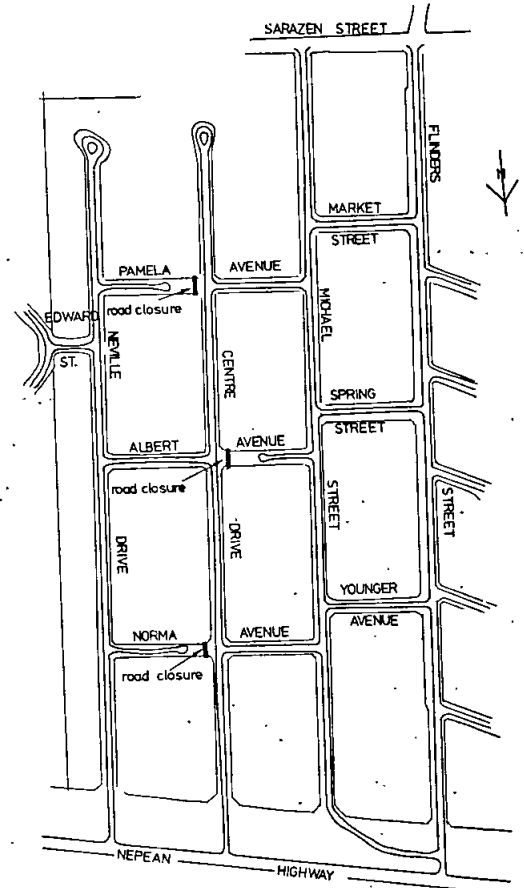
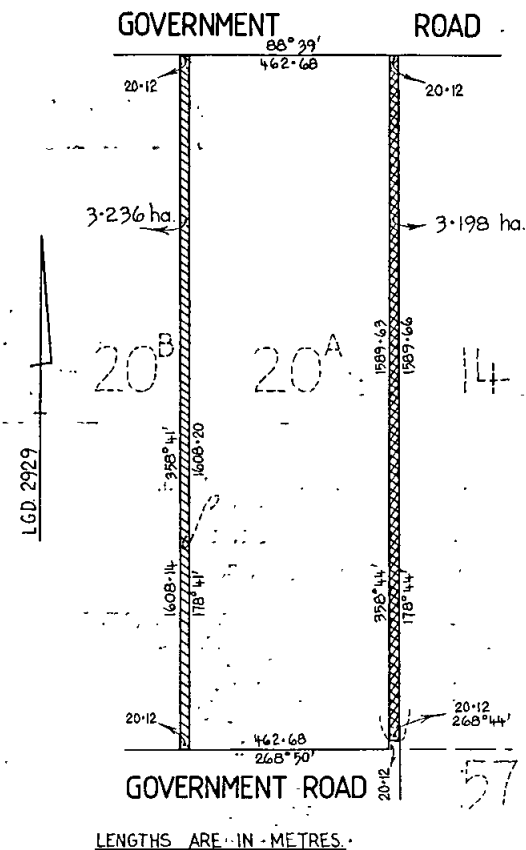

The common seal of the President, Councillors and Ratepayers of the Shire of Bass was hereunto affixed, this 12th day of June, 1978, in the presence of—

(SEAL) K. J. McRAE, President
D. R. McRAE, Councillor
G. J. HARLAND, Shire Secretary

Confirmed by the Governor in Council, 18th July, 1978—
TOM FORRISTAL, Clerk of the Executive Council

Note.—This notice is published in lieu of the notice appearing in *Government Gazette*, No. 66, dated 25th July, 1978, on page 2433.

TOM FORRISTAL,
Clerk of the Executive Council

Local Government Act 1958

NOTICE OF CONFIRMATION OF AN ORDER OF THE COUNCIL OF THE CITY OF PRESTON ADOPTING A PROPOSAL FOR THE CLOSURE OF STREET OR ROAD TO THROUGH TRAFFIC

Pursuant to the provisions of section 539c of the Local Government Act 1958, the Governor in Council, on the 19th day of December, 1978 confirmed an Order of the Council of the City of Preston made on May 15, 1978 adopting a proposal for the closure of Gray Street, Preston to through traffic by the erection of barriers at the locations shown on the plan hereunder.

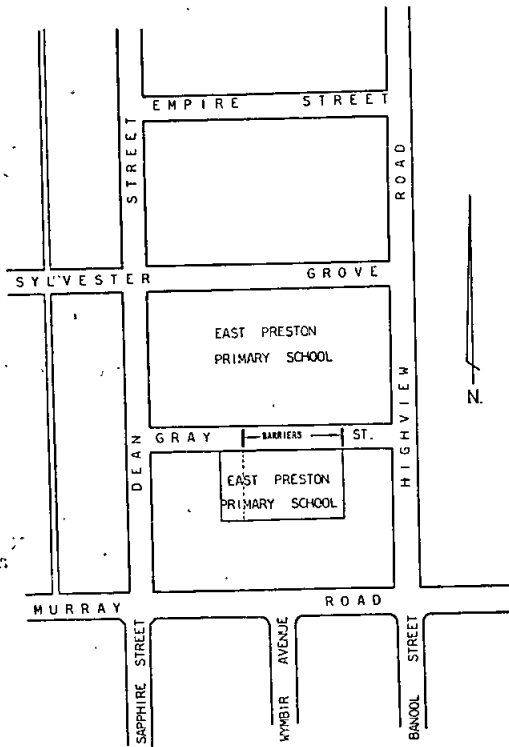

TOM FORRISTAL,
Clerk of the Executive Council

Equal Opportunity Act 1977

EXEMPTION REQUEST No. 12 OF 1978

On 15th December, 1978, the Equal Opportunity Board granted to the Victoria Police, exemptions from the provisions of the Equal Opportunity Act 1977 in the following circumstances:

- (a) An exemption for two years from 15th December, 1978, to permit the Women's Police Division to be staffed with women only.
- (b) An exemption for two years from 15th December, 1978, to permit Police Stations having the strength of only one member to be staffed with men only.
- (c) An exemption for two years from 15th December, 1978, to permit country Police Stations with a Sergeant in Charge to be staffed with men only.
- (d) An exemption for three years from 15th December, 1978, to permit the Prison Liaison Section to be staffed with men only.
- (e) An exemption for three years from 15th December, 1978, to permit the sex of a person to be taken into account in selection of staff in the Police Welfare Section so that there is always at least one person of each sex in that section.
- (f) An exemption for three years from 15th December, 1978, to permit the employment of men only in the ranks of Senior Sergeant, Sergeant, Senior Constable and Constable in the Government House and Shrine of Remembrance Group.

DEIDRE FITZGERALD, Chairman
JOAN WOFFINDEN, Board Member
DON ROSS, Board Member

NOTICE TO MARINERS
[No. 52T of 1978]

AUSTRALIA—VICTORIA
PORT OF GIPPSLAND
Lakes Light Extinguished

The flashing green light on Lakes Entrance Eastern Pier Head, Lat. 37 deg. 53 min. S., Long. 147 deg. 58 min. E. (approx.) is temporarily extinguished and has been replaced by a fixed green light.

Further notice will issue.

D. P. BARKLEY,
Deputy Port Officer

Public Works Department,
Ports and Harbors Division,
168 Exhibition Street,
Melbourne, 3000, 20th December, 1978

NOTICE TO MARINERS
[No. 53T of 1978]

AUSTRALIA—VICTORIA
CORNER INLET

Temporary Mooring Buoy Established

Date—On or about 3 January, 1979.

Reference Position—Mt. Singapore, Lat. 38 deg. 47 min. S., Long. 146 deg. 26.6 min. E. (approx.).

A yellow cylindrical shaped mooring buoy will be laid 0.17 degrees distant 0.65 mile from reference position.

The mooring buoy will be used by vessels operating from Corner Inlet in connection with Bass Strait oil and gas production.

D. P. BARKLEY,
Deputy Port Officer

Public Works Department,
Ports and Harbors Division,
168 Exhibition Street,
Melbourne, 3000, 20th December, 1978

NOTICE TO MARINERS
[No. 54 OF 1978]

AUSTRALIA—VICTORIA
PORT PHILLIP

Reef Buoy Established

A green conical buoy has been established bearing 307 deg. distant 4,037 m (2.18 miles) from Mordialloc Pier light (Lat. 38 deg. 01 min. S., Long. 145 deg. 05 min. E., approx.). This buoy marks the South Western extremity of the shoal area off Houndstooth Reef.

Charts Affected—AUS 155, AUS 143, AUS 143y.

Publication Affected—Sailing Directions Victoria, 1970, page 286.

D. P. BARKLEY,
Deputy Port Officer

Public Works Department,
Ports and Harbors Division,
168 Exhibition Street,
Melbourne 3000, 21st December, 1978

NOTICE TO MARINERS
[No. 55T of 1978]

AUSTRALIA—VICTORIA
WESTERNPORT

Temporary Light Established

A quick flashing yellow light will be exhibited from Westernport Yacht Club, Balnarring, Lat. 38 deg. 23 min. 33 sec. S, Long. 145 deg. 07 min. 36 sec. E until 21st April, 1979.

Chart Temporarily Affected—AUS 156

D. P. BARKLEY,
Deputy Port Officer

Public Works Department,
Ports and Harbors Division,
168 Exhibition Street,
Melbourne, 3000, 28th December, 1978

Commercial Goods Vehicles Act
TRANSPORT REGULATION BOARD

HEARING OF APPLICATIONS

Notice is hereby given that the following applications will be considered by the Transport Regulation Board on 23rd January, 1979.

- BEER, M. G., Lancefield Road, Sunbury, 3429. Application to vary the conditions of licence No. D.A.67204 by deleting the existing paragraph (b) and adding in lieu—"From Geelong to own premises at Sunbury in course of business as 'Superphosphate Agent'"—Superphosphate.
- BEER, M. G., Lancefield Road, Sunbury, 3429. Application to vary the conditions of licence No. D.A.67204/1 by deleting from paragraph (b) "Heathcote" and adding in lieu "Maryborough" and by deleting from paragraph (c) "80-km" and adding in lieu "100-km".
- CLARK, G. N., 5 Gardena Street, Horsham, 3400. Application to vary the conditions of licence No. D.A.69851 (L/C. 0.50 and 0.30 tonne trailer) by deleting from paragraph (b) "160-km radius of Horsham" and adding in lieu "that part of the State of Victoria west of a straight line drawn from Melbourne to Bright and thence to Wodonga".
- COOK, R. J., Neerim East Road, Neerim South, 3831. One commercial goods vehicle (L/C. 10.30 tonne) to operate from motor car distributors within a 40-km radius of the G.P.O. Melbourne to motor car dealers *en route* to Bairnsdale and in the South Gippsland area on a specially constructed car carrying unit—new motor cars excluding tractors and on return journeys secondhand motor cars.
- A. G. COOMBS GROUP PTY. LTD., 26 Cochranes Road, Moorabbin, 3189. One commercial goods vehicle (L/C. 0.75 tonne) to operate throughout the State of Victoria in the course of business as "Heating and Air Conditioning Engineers" for the purpose of servicing heating and air conditioning equipment—tools of trade, spare parts and materials incidental to on-site servicing.
- CROUCH, E. K., 36 High Street, Beaufort, 3373. Application to vary the conditions of licence No. D.A.57218/2 by deleting the existing paragraph (a).
- DAMPIER MINING COMPANY LTD., 140 William Street, Melbourne, 3000. One commercial goods vehicle (L/C. 0.70 tonne) to operate throughout the State of Victoria in the course of business as "Exploration Contractors" for the purpose of collecting mineral samples for testing—tools of trade, spare parts, own drilling equipment and mineral samples for testing purposes only.
- GANGE, J., Box 63, Red Cliffs, 3496. One commercial goods vehicle (L/C. 1.00 tonne) to operate: (a) Within a 40-km radius of the post office at Red Cliffs—general goods. (b) From the VicRail Freight Centre at Mildura to Carwarp and Hattah and servicing places *en route*, whilst under contract to the Victorian Railways Board—general goods on behalf of such Board.
- GEELONG QUARRIES PTY. LTD., Hamilton Highway, Fyansford 3220. Three commercial goods vehicles (L/C. 7.85, 9.85 and 10.82 tonne) to operate within a 80-km radius of the chief post office in the City of Geelong—own premixed concrete in a specially constructed agitator vehicle.
- GOWER, T., 29 McMillan Avenue, Anglesea, 3230. One commercial goods vehicle (L/C. 1.20 tonne) to operate: (a) Within a 40-km radius of the post office at Anglesea—own goods, rubbish and refuse. (b) From places situate within a 40-km radius of the G.P.O. Melbourne to own premises at Anglesea in the course of business as "Joiner, House Renovator and Plant and Shrub Supplier"—own goods.
- NOTE—Nothing contained in paragraph (b) shall be deemed to authorise any goods taken up within a 40-km radius of the G.P.O. Melbourne to set down at any point beyond own premises at Anglesea.
- GREBE PTY. LTD., Lot 4, Albert Street, Warrnambool, 3280. Application to vary the conditions of licence Nos D.A.69322 and D.A.69322/2 by deleting the existing paragraph (c) and adding in lieu—(c) Within that part of the State of Victoria west of a north/south line drawn through Ballarat and south of an east/west line drawn through Warracknabeal in the course of business as "Aerated Water Manufacturers"—an approved decentralized secondary industry at Warrnambool—own manufactured aerated waters and empty return containers. (d) From places within a 40-km radius of G.P.O. Melbourne to own approved decentralized secondary industry premises at Warrnambool—raw materials required for use in the manufacturing processes of such industry.
- HEEPS, N. J., Mitchell Street, Ouyen, 3490. One commercial goods vehicle (L/C. 9.37 tonne) to operate: (a) Within a 40-km radius of the post office at Ouyen—general goods. (b) From the VicRail Freight Centre at Ouyen to the South Australian border at Pinnaroo and return, servicing all towns *en route* whilst under contract to the Victorian Railways Board—general goods on behalf of such Board.
- RICHARD HUNT NOMINEES PTY. LTD., 75 Balaclava Road, Caulfield, 3161. One commercial goods vehicle (L/C. 5.35 and 3.45 tonne trailer) to operate: (a) Within a 40-km radius of own branch premises at Tooradin in the course of business as "Building Contractors"—own goods. (b) Within an 80-km radius of own premises at Tooradin—own plant and equipment.
- KUSTER, H. M., 26 Marriott Street, Parkdale, 3194. One commercial goods vehicle (L/C. 11.65 tonne) to operate throughout the State of Victoria in the course of business as "Frozen Food Carrier" as a specially constructed refrigerated vehicle for the purpose of servicing retail stores—frozen poultry, frozen fish, frozen and fresh meat, ice-cream, frozen and chilled fruit juice in plastic and waxed containers, frozen processed vegetables, cream, special soft cheese, yoghurt, dripping and lard, frozen pies, frozen prepared meals, butter and margarine.
- NOTE—Butter and margarine is only to be carried from Melbourne as a mixed load when being carried with other frozen foods under refrigeration for distribution to retail stores and provided that the combined weight of butter and margarine carried does not exceed 3000 kilograms on any one load.
- NEWTON, R. J. K., Flat 1, 18 Hopetoun Avenue, Morwell, 3840. One commercial goods vehicle (L/C. 5.95 tonne) to operate between the Morwell Mail Centre and places situated *en route* between Warragul, Korumburra and Yarram under contract to the Australian Postal Commission as per the terms of the Contract No. M.S.F.1998—mails on behalf of the said commission.
- PERRI, A., 93 Halsey Road, Airport West, 3042. One commercial goods vehicle (L/C. 7.80 tonne) to operate within an 80-km radius of the G.P.O. Melbourne on behalf of Boral Resources Vic. Pty. Ltd.—road-making plant, hot asphalt, premix and road-making materials but excluding the carriage of cement and lime from places within a 13-km radius of the chief post office in the City of Geelong.
- PORTER, J. S., 17 Owen Street, Heywood, 3304. One commercial goods vehicle (L/C. 11.20 tonne) to operate: (a) Within a 120-km radius of the post office at Peshurst (Warrnambool Division of the Country Roads Board)—plant the property of a contractor and required for use in connection with the construction or maintenance of some specific, existing or proposed road, street, footpath, bridge, wharf, pier, weir or channel. (b) Within a 32-km radius from site of construction or maintenance work performed pursuant to paragraph (a) above—metal, stones, screenings, ashes, gravel, sand, earth and any other materials required for such work.
- KEN RATTEN PTY. LTD., 6 Padua Court, Vermont, 3133. Two commercial goods vehicles (L/C. 12.45 tonne each) to operate throughout the State of Victoria as a specially constructed low loader in the course of business as "House Remover"—tools of trade, equipment, houses, sheds, outbuildings and classrooms.
- SCOTT, A. F., 7 Shelley Street, West Heidelberg, 3081. One commercial goods vehicle (L/C. 6.70 tonne) to operate within a 112-km radius of the premises of Brick and Pipe Industries Ltd. at Craigieburn solely on behalf of the said company—bricks.
- SIMPSON, I. M., Station Street, Alexandra, 3714. One commercial goods vehicle (L/C. 13.00 tonne) to operate: (a) Within a 40-km radius from the post office at Alexandra—general goods. (b) From and to the B.P. Australia Ltd. depot at Seymour to and from own depot at Alexandra—petroleum products in prescribed types of containers and empty return containers.
- SUNTESTER (AUSTRALIA) PTY. LTD., 3 Raglan Street, South Melbourne, 3205. One commercial goods vehicle (L/C. 1.15 tonne) to operate: (a) Within an 80-km radius of own premises at South Melbourne in the course of business as "Automotive and Engine Test Equipment

Engineers"—own goods. (b) Throughout all of Victoria for the purpose of servicing and installation of Automotive Testing Equipment—tools of trade, spare parts and equipment required for the specialized installation of Automotive Equipment.

TOWNSON & MERCER PTY. LTD., 17 Pickering Road, Mulgrave, 3170. One commercial goods vehicle (L/C. 1.10 tonne) to operate throughout the State of Victoria in the course of business as "Engineers" for the purposes of servicing and installing specialized hydraulic and electronic equipment—tools of trade, spare parts incidental to on-site servicing and electronic equipment for specialized installation.

TRANS WEST HAULAGE PTY. LTD., 202 Station Street, Norlane, 3214. Application to vary the conditions of licences numbered D.A.65323/119, D.A.65323/112, D.A.65323/125, D.A.65323/109, D.A.65323/124, D.A.65323/123, D.A.65323/127, D.A.33968/63, D.A.33968/64, D.A.33968/65 and D.A.33968/67 by adding additional paragraphs: (1) Within a 40-km radius of own branch premises at Morwell—general goods. (2) From lime pits at Merrimans Creek to the premises of Gippsland Cement and Lime Company Pty. Ltd. at Traralgon—bulk lime stone.

WIFFEN, L., 39 Princess Street, Drysdale, 3222. One commercial goods vehicle (L/C. 11.55 tonne) to operate within an 80-km radius of the chief post office in the City of Geelong solely on behalf of Geelong Quarries Pty. Ltd.—premixed concrete in a specially constructed agitator vehicle.

WOOLLARD, P. J. Patchewollock, 3491. One commercial goods vehicle (L/C. 10.33 tonne) to operate: (a) Within a 40-km radius of the post office at Patchewollock—general goods. (b) From the VicRail Freight Centre at Ouyen to Sea Lake via Mittyack and Nandaly and return to Patchewollock and servicing towns en route whilst under contract to the Victorian Railways Board—general goods on behalf of such board. (c) From the VicRail Freight Centre at Ouyen to Woomelang and return to Patchewollock via Speed whilst under contract to the Victorian Railways Board—general goods on behalf of such Board.

TOW TRUCKS

HARRIS, G. T. & L. I., King Street, Yarra Glen, 3775. Application to vary the conditions of licence No. D.A.64190 by deleting from the existing conditions "80-km radius of Yarra Glen" and adding in lieu "Throughout the State of Victoria."

STONE, D. W., 768 Mountain Highway, Bayswater, 3153. Application to vary the conditions of licence No. D.A.70095 by deleting from the existing conditions "32-km of Ferntree Gully" and adding in lieu "Throughout the State of Victoria".

RENEWALS

Applications for renewal of licences as shown by persons listed hereunder to operate under the same terms and conditions from the expiry shown in each case.

BARTRAM, D. C., 30 Somerville Street, Bendigo, 3550; D.A.67018/1; 3rd March, 1979; 4.00 tonne; D.A.67018/2; 3rd March, 1979; 4.00 tonne; D.A.67018/4; 3rd March, 1979; 3.95 tonne.

BIDDLE, A. E., 105 Collingwood Street, Apollo Bay, 3233; D.A.67497; 13th March, 1979; 1.35 tonne.

BRUNI & BISOGNI PTY. LTD., Broadway Street, Cobram, 3644; D.A.63299/11; 29th March, 1979; 0.75 tonne.

CHASEMORE, K. R., 253 Whitehorse Road, Blackburn, 3130; D.A.61808/3; 13th February, 1979; 11.15 tonne; D.A.61808/4; 13th February, 1979; 6.05 tonne.

COLLINS, S. M. PTY. LTD., 10-26 Collins Street, Bairnsdale, 3875; D.A.65088; 15th February, 1979; 2.40 tonne; D.A.65088/2; 15th February, 1979; 0.70 tonne.

CUMMINS, I. J., 2 Callow Street, Ballarat, 3350; D.A.34945/1; 3rd November, 1978; 0.70 tonne.

DALE, C. W., Elizabeth Street, Castlemaine, 3450; T.D.A.61056; 12th December, 1978; 0.75 and 1.00 tonne trailer.

DAVERN, T. N., 21 Olive Grove, Boronia, 3155; D.A.67499; 6th March, 1979; 9.95 tonne.

DENNIS BROS. DELIVERIES PTY. LTD., 295 Grant Street, South Melbourne, 3205; D.A.48450/6; 12th March, 1979; 1.15 tonne.

ENSGN SERVICES (VIC.) PTY. LTD., 24 Leinster Grove, Northcote, 3070; D.A.1046/9; 6th March, 1979; 3.30 tonne.

FITZPATRICK, P. J., 16 Victoria Street, Numurkah, 3636; D.A.62761/1; 10th August, 1978; 6.40 tonne.

FOARDS FREEHOLDS PTY. LTD., 25 Wangaratta Street, Richmond, 3121; D.A.41240/6; 1st March, 1979; 0.50 tonne.

FOSTER, K. A., Lot 2, Mountain Crescent, Mt. Evelyn, 3796; D.A.67484; 6th March, 1979; 6.55 tonne.

GREENWAYS REFRIGERATED TRANSPORT PTY. LTD., Grant Road, Somerville, 3912; D.A.66062/6; 20th November, 1978; 6.60 tonne.

ROBERT HUTCHINSON LTD., Hartington Street, Glenroy, 3046; T.D.A.27836/50; 9th November, 1978; 10.10 tonne.

INGLIS, N., Gisborne Road, Bacchus Marsh, 3340; D.A.65092; 22nd February, 1979; 8.90 tonne.

KMON, W. L., 23 Nigel Crescent, Tullamarine, 3043; D.A.67234; 1st December, 1978; 10.80 tonne.

LEY, G. H., Burchett Street, Penshurst, 3289; D.A.12848/7; 2nd February, 1979; 11.75 tonne.

JIM MORRIS AMUSEMENTS PTY. LTD., 23 Rigby Street, Carum, 3197; D.A.63726/1; 1st March, 1979; 1.65 tonne.

PETERSVILLE LTD., 254-294 Wellington Road, Mulgrave, 3170; D.A.1813/36; 12th March, 1979; 3.60 tonne; D.A.1813/38; 25th March, 1979; 4.05 tonne; D.A.1813/89; 25th March, 1979; 3.60 tonne; D.A.1813/91; 23rd March, 1979; 6.05 tonne; D.A.1813/117; 1st March, 1979; 3.90 tonne; D.A.1813/118; 1st March, 1979; 3.85 tonne; D.A.1813/119; 1st March, 1979; 3.85 tonne; D.A.1813/139; 7th March, 1979; 3.50 tonne; D.A.1813/227; 9th March, 1979; 3.80 tonne.

PIONEER REFRIGERATION PTY. LTD., 178 Normanby Road, South Melbourne, 3205; D.A.65337/9; 2nd March, 1979; 1.10 tonne.

RAE, K. V., 72 Vincent Street, Daylesford, 3460; D.A.65504; 20th January, 1976; 0.75 tonne.

SHAW, J. V., 2 Worsley Avenue, Clayton, 3169; D.A.67454; 20th February, 1979; 8.60 tonne.

W. L. SIDES & SON PTY. LTD., 168 Wellington Road, Clayton, 3168; D.A. 28601/38; 22nd February, 1979; 1.20 tonne; D.A.28601/39; 22nd February, 1979; 0.95 tonne.

G. H. TURNER BROS PTY. LTD., 40 Westminster Street, Oakleigh, 3166; D.A.64461; 29th March, 1979; 2.95 tonne; D.A.64461/1; 29th March, 1979; 1.70 tonne; D.A.64461/2; 29th March, 1979; 1.80 tonne.

J. & R. TYNER PTY. LTD., 114 William Street, Melbourne, 3000; D.A.65005/1; 13th March, 1979; 8.10 tonne.

SHARTON, J. W., Lot 13, Fiona Drive, Cranbourne South, 3977; D.A.65083; 22nd February, 1979; 7.40 tonne.

J. H. WISEMAN & SONS PTY. LTD., 69 Gipps Street, Collingwood, 3066; D.A.37454/3; 25th March, 1979; 0.50 tonne.

TOW TRUCKS

BURNHAM, F. A., 63 Grange Road, Cheltenham, 3192; D.A.47319; 25th March, 1979; 2.55 tonne.

HEAVER, D. K. & T. D., 9 Henty Street, Portland, 3305; D.A.68545/1; 21st September, 1978; 2.4 tonne.

INTERNATIONAL WELDING & PANEL BEATING TECH. CO., 47 Henderson Road, Clayton North, 3168; D.A.61122; 14th November, 1978; 1.65 tonne.

KANEN, J. H., Clancy Road, Mt. Evelyn, 3796; D.A.66018; 14th December, 1978; 3.80 tonne.

MURNANE, J. M., 73-75 Collingwood Street, Apollo Bay, 3233; D.A.70059; 6th November, 1978; 3.40 tonne.

O'TOOLE, R. L., Murray Valley Highway, Cohuna, 3568; D.A.66985; 14th October, 1978; 1.75 tonne.

SEGAL, E. & M., 1A Park Street, Elsternwick, 3185; D.A.44817/1; 10th December, 1978; 1.80 tonne.

Notice of any objection should be forwarded to reach the Secretary of the Board not later than 17th January, 1979.

Applicants are advised that it will not be necessary to appear on the hearing date specified above, unless advised in writing by the Board.

C. J. V. SMITH, Secretary

Corner Lygon and Princes Street, Carlton, 3053, Friday 5th January, 1979.

Private Agents Act 1966

NOTICE OF RECEIPT OF APPLICATIONS FOR LICENCES UNDER THE PROVISIONS OF THE PRIVATE AGENTS ACT 1966

The Clerk(s) of the Magistrates' Court(s) as listed hereunder hereby give notice that applications, as under, have been lodged for hearing by the said Court(s) on the date(s) specified.

Any person desiring to object to any of such applications must—

- (a) lodge with the respective Clerk of the Magistrates' Court a notice in the prescribed form of his objection and of the grounds thereof;
- (b) cause a copy of such notice to be served personally or by post upon the applicant at least three days before the hearing of the application; and
- (c) send or deliver—
 - (i) where the objection is not made by the officer in charge of the police district in which the Court is situated—a copy of the notice to such officer; and
 - (ii) where the objection is not made by the Registrar or Deputy Registrar—a copy to the Registrar.

Full Name of Applicant or in the case of a Firm or Corporation, of the Nominee	Place of Abode of Applicant or Nominee	Name of Firm or Corporation	Address for Registration	Type of Licence	Date of Hearing of Application
--	--	-----------------------------	--------------------------	-----------------	--------------------------------

MAGISTRATES' COURT, BENDIGO

Smith, Stanley Rowland	98 Havelin Street West, Bendigo	Bendigo Investments Limited	Abel Street, Bendigo	Watchman	8.1.79
------------------------	---------------------------------	-----------------------------	----------------------	----------	--------

Dated at Bendigo this 13th day of December, 1978

R. N. HOLLIS, Clerk of the Magistrates' Court

MAGISTRATES' COURT, BOX HILL

Sass, Wolfgang Harri	52 Nathan Street, Ferntree Gully	Mayne Nickless Ltd.	203 Elgar Road, Box Hill	Watchman	16.1.79
----------------------	----------------------------------	---------------------	--------------------------	----------	---------

Dated at Box Hill this 14th day of December, 1978

S. R. McMILLAN, Clerk of the Magistrates' Court

MAGISTRATES' COURT, BROADMEADOWS

Campbell, John	111 Major Fawcner Road		3/20 West Street, Glenroy	Watchman	15.1.79
----------------	------------------------	--	---------------------------	----------	---------

Dated at Broadmeadows this 18th day of December, 1978

R. R. WILSON, Clerk of the Magistrates' Court

MAGISTRATES' COURT, CHELTENHAM

Nikitakos, Nick	5/6 Aster Highett Court		94 York Street, South Melbourne	Watchman	26.1.79
-----------------	-------------------------	--	---------------------------------	----------	---------

Dated at Cheltenham this 15th day of December, 1978

H. McINNES, Clerk of the Magistrates' Court

MAGISTRATES' COURT, CHELTENHAM

Shaw, Robert Anthony	12 Rosebud Avenue, Moorabbin		12 Rosebud Avenue, Moorabbin	Process Server	2.2.79
"	"	"	"	Inquiry Agent	"

Dated at Cheltenham this 18th day of December, 1978

H. McINNES, Clerk of the Magistrates' Court

MAGISTRATES' COURT, COBURG

Coleman, John Garry	28 Bicknell Court, Broadmeadows		16 Clifton Grove, Coburg	Watchman	15.1.79
Court, Garry	Burke Street, Woodend		94 York Street, South Melbourne	"	3.1.79
Wilson, Glenn	99 Tennyson Street, Essendon		4 Heath Street, Pascoe Vale	"	24.1.79

Dated at Coburg this 15th day of December, 1978

J. F. ISAACS, Clerk of the Magistrates' Court

MAGISTRATES' COURT, COBURG

Honey, Karen Julie	27 Rutland Niddrie Street		4 Heath Street, Pascoe Vale	Process Server	24.1.79
--------------------	---------------------------	--	-----------------------------	----------------	---------

Dated at Coburg this 21st day of December, 1978

J. F. ISAACS, Clerk of the Magistrates' Court

MAGISTRATES' COURT, FERNTREE GULLY

Boyse, William Thomas	31 Colby Drive, Belgrave Heights		31 Colby Drive, Belgrave Heights	Process Server	10.1.79
Walker, Susan Jane	39 "Harley" Street, Knoxfield		39 "Harley" Street, Knoxfield	Guard Agent	"
"	"	"	"	Process Server	"
Walker, Craig Norman	"	C. and S. Service	"	Inquiry Agent	"
"	"	"	"	Process Server (Firm)	"
"	"	"	"	Inquiry Agent (Firm)	"

Dated at Ferntree Gully this 12th day of December, 1978

B. DOBSON, Clerk of the Magistrates' Court

PRIVATE AGENTS—continued

Full Name of Applicant or in the Case of a Firm or Corporation, of the Nominee	Place of Abode of Applicant or Nominee	Name of Firm or Corporation	Address for Registration	Type of Licence	Date of Hearing of Application
MAGISTRATES' COURT, FRANKSTON					
Jansen, Willy	108 Walkers Road, Mount Eliza	Protective Engineering	108 Walkers Road, Mount Eliza	Guard Agent	9.1.79
Dated at Frankston this 14th day of December, 1978			P. M. PATTISON, Clerk of the Magistrates' Court		
MAGISTRATES' COURT, GEELONG					
Campbell, Ronald R.	39 Mervyn Street, Newtown	Armaguard	50 Autumn Street, Geelong West	Watchman	15.1.79
Dated at Geelong this 18th day of December, 1978			R. J. CUTHILL, Clerk of the Magistrates' Court		
MAGISTRATES' COURT, GEELONG					
Zielinski, Zygmunt Martin	80 Ernest Street, Bell Post Hill	Trading as an Individual under the name of Z. M. Zielinski, Process Server	15 Melbourne Road, Drumcondra	Process Server	17.1.79
Dated at Geelong this 21st day of December, 1978			R. J. CUTHILL, Clerk of the Magistrates' Court		
MAGISTRATES' COURT, HEIDELBERG					
Threlfall, Geoffrey	11 El Reno Crescent, Airport West		179 Mountainview Parade, Macleod	Watchman	15.2.79
Dated at Heidelberg this 19th day of December, 1978			M. TIPPETT, Clerk of the Magistrates' Court		
MAGISTRATES' COURT, MELBOURNE					
Davidson, K.	24 Margorie Avenue, Sunbury	Armaguard	94 York Street, South Melbourne	Watchman	31.1.79
Dated at Melbourne this 19th day of December, 1978			M. J. QUIRK, Clerk of the Magistrates' Court		
MAGISTRATES' COURT, MOONEE PONDS					
Loccoli, Joseph Alfred	4 Riverview Street, Avondale Heights	The New Security Co.	4 Riverview Street, Avondale Heights	Guard Agent	9.12.79
Dated at Moonee Ponds this 19th day of December, 1978			M. F. MOLONEY, Clerk of the Magistrates' Court		
MAGISTRATES' COURT, MORWELL					
Harris, Raymond Russell	74 Latrobe Road, Morwell		27 Barkers Crescent, Traralgon	Watchman	12.1.79
Dated at Morwell this 18th day of December, 1978			J. WILKINSON, Clerk of the Magistrates' Court		
MAGISTRATES' COURT, PRAHRAN					
Robertson, Stewart McLeod	8 Bruton Court, Bundoora	Mayne Nickless Ltd.	94 York Street, South Melbourne	Watchman	17.1.79
Dated at Prahran this 13th day of December, 1978			A. R. ELLIS, Clerk of the Magistrates' Court		
MAGISTRATES' COURT, PRAHRAN					
Campbell, Clifford	2/20 Selwyn Street, Elwood	Mayne Nickless Ltd.	94 York Street, South Melbourne	Watchman	18.1.79
Carter, Robert Christian	9 Barry Street, Watsonia	" " "	" " "	" " "	" " "
Smith, Raymond Edward	17/174 Toorak Road, South Yarra	Security Pacific	1/765 Punt Road, South Yarra	" " "	" " "
Johannsen, Christian	2 Turner Street, Westmeadows	Mayne Nickless Ltd.	94 York Street, South Melbourne	" " "	" " "
Bentley, Harry Cole	4 Opal Court, East Bentleigh	" " "	4 Opal Court, East Bentleigh	Inquiry Agent	22.1.79
Smith, Raymond Edward	17/174 Toorak Road, South Yarra	" " "	1/765 Punt Road, South Yarra	" " "	" " "
Dated at Prahran this 18th day of December, 1978			A. R. ELLIS, Clerk of the Magistrates' Court		
MAGISTRATES' COURT, PRAHRAN					
Cuddihy, Anthony	16 Stewart Drive, Werribee	Mayne Nickless Ltd.	94 York Street, South Melbourne	Watchman	25.1.79
Reynolds, John	33 Hartington Street, Glenroy	" " "	" " "	" " "	" " "
Dated at Prahran this 19th day of December, 1978			A. R. ELLIS, Clerk of the Magistrates' Court		

PRIVATE AGENTS—continued

Full Name of Applicant or in the case of a Firm or Corporation, of the Nominee	Place of Abode of Applicant or Nominee	Name of Firm or Corporation	Address for Registration	Type of Licence	Date of Hearing of Application
MAGISTRATES' COURT, PRAHRAN					
Warburton, William Gordon ..	54 Beresford Road, Lilydale	Mayne Nickless Ltd.	94 York Street, South Melbourne	Watchman	.. 25.1.79
Sheppard, Malcolm ..	4 Beverley Street, St. Albans	" " "	" " "	"	"
Dated at Prahran this 19th day of December, 1978					
A. R. ELLIS, Clerk of the Magistrates' Court					
MAGISTRATES' COURT, PRAHRAN					
Roberts, Terrence James ..	15 Monterey Boulevard, Frankston	" " "	94 York Street, South Melbourne	Watchman	.. 26.1.79
Dated at Prahran this 20th day of December, 1978					
A. R. ELLIS, Clerk of the Magistrates' Court					
MAGISTRATES' COURT, PRESTON					
Uket, Osman ..	23 Pinetree Crescent, Lalor	" " "	23 Pinetree Crescent, Lalor	Process Server	.. 15.1.79
" " ..	" " "	" " "	" " "	Guard Agent	"
Dated at Preston this 18th day of December, 1978					
J. TOBIN, Clerk of the Magistrates' Court					
MAGISTRATES' COURT, PORT MELBOURNE					
Jones, Raymond Cyril ..	Lot 39, Springs Road, Clayton South	Fleet-x-press Security and Watching Co. Pty. Ltd.	61 Bertie Street, Port Melbourne	Watchman	.. 25.1.79
Reid, Robert Henry ..	3 Claremont Crescent, Keysborough	" " "	" " "	"	"
Dated at Port Melbourne this 15th day of December, 1978					
R. J. McHUGH, Clerk of the Magistrates' Court					
MAGISTRATES' COURT, SOUTH MELBOURNE					
Knox, Mandy Leigh ..	"Dunvegan", Heathcote Junction via Wandong	T.N.T. Group 4 Total Security Pty. Ltd.	" " "	Watchman	.. 9.1.79
Dated at South Melbourne this 13th day of December, 1978					
J. T. FERGUSON, Clerk of the Magistrates' Court					
MAGISTRATES' COURT, ST. KILDA					
Paul, Wilfred Ivan ..	12 Lonsdale Street, Moorabbin	International Private Agency	197 Inkerman Street, St. Kilda	Guard Agent (Firm)	24.1.79
" " ..	" " "	" " "	" " "	Guard Agent	"
Dated at St. Kilda this 20th day of December, 1978					
P. ADDICOAT, Clerk of the Magistrates' Court					
MAGISTRATES' COURT, SUNBURY					
Bromley, John Roderick ..	16 Simpson Street, Sunbury	N.I.C. Instrument Co.	Mathews Avenue, Airport West	Guard Agent	.. 16.1.79
Dated at Sunbury this 19th day of December, 1978					
L. F. HANDLEY, Clerk of the Magistrates' Court					
MAGISTRATES' COURT, SUNSHINE					
King, Graeme ..	11 Sussex Street, Yarraville	R. J. Kirwan Security Services	10a Williamson Road, Maribyrnong	Watchman	.. 31.1.79
Dated at Sunshine this 20th day of December, 1978					
B. J. STOCKS, Clerk of the Magistrates' Court					
MAGISTRATES' COURT, TRARALGON					
Brown, Adolphe John ..	43 Loch Park Road, Traralgon	" " "	A.M.P. Building, Hotham Street, Traralgon	Guard Agent	.. 8.1.79
Brown, Adolphe John ..	" " "	Magnum Armed Security	" " "	Guard Agent (Firm)	"
Dated at Traralgon this 15th day of December, 1978					
K. G. McMAHON, Clerk of the Magistrates' Court					
MAGISTRATES' COURT, MORWELL					
Hughan, Anthony Wayne ..	Pages Road, Yinnar South	" " "	27 Barkers Crescent, Traralgon	Watchman	.. 12.1.79
Dated at Morwell this 21st day of December, 1978					
J. WILKINSON, Clerk of the Magistrates' Court					

PRIVATE AGENTS—continued

Full Name of Applicant or in the case of a Firm or Corporation, of the Nominee	Place of Abode of Applicant or Nominee	Name of Firm or Corporation	Address for Registration	Type of Licence	Date of Hearing of Application
MAGISTRATES' COURT, PRAHRAN					
Black, Andrew Arnold	.. 56 Kanooka Grove, Clayton 94 York Street, South Melbourne	Watchman	.. 26.1.79
Dated at Prahran this 21st day of December, 1978			A. R. ELLIS, Clerk of the Magistrates' Court		
MAGISTRATES' COURT, PRAHRAN					
Bolger, James Morris	.. 5A Elm Grove, Richmond	Mayne Nickless Ltd.	28 Stephenson Street, Richmond	Watchman	.. 25.1.79
Dated at Prahran this 22nd day of December, 1978			A. R. ELLIS, Clerk of the Magistrates' Court		
MAGISTRATES' COURT, PORT MELBOURNE					
Arendt, Gabriel Derrymore	.. 7 Sproul Street, North Sunshine	Mayne Nickless Ltd.	836 Lorimer Street, Port Melbourne	Watchman	.. 1.2.79
Dated at Port Melbourne this 22nd day of December, 1978			R. J. MCHUGH, Clerk of the Magistrates' Court		

Social Welfare Act 1970

POLICE GAOLS

NOTICE

Whereas it is provided in Part IV, Section 115 of the *Social Welfare Act 1970* that whenever it appears to the Director-General after consultation with the Chief Commissioner of Police to be necessary so to do the Director-General may recommend to the Minister that a lock-up is fit for the reception of prisoners sentenced to imprisonment for a term not exceeding the term the Director-General thinks fit and specifies in his recommendation :

And whereas it is further provided in the said Section that upon receiving any such recommendation the Minister may by notice published in the *Government Gazette* proclaim any Police lock-up so recommended to be a " Police Gaol " for the reception of prisoners for any term up to the term specified but not exceeding in any case thirty days :

And whereas by a notice published in the *Government Gazette* of 21st January 1970 ; certain Police lock-ups were proclaimed to the Police Gaols for the reception of prisoners sentenced to imprisonment for a term not exceeding a specified period :

And whereas it is further provided in the said Section 115 that the Minister may from time to time by notice in the *Government Gazette* revoke or vary any proclamation made under this Section :

And whereas by notices published in the *Government Gazette* of 9th December 1970 ; 23rd August 1972 ; 1st August 1973 ; 13th February 1974 ; 8th January 1975 ; and 5th April 1978, the Minister did vary certain particulars of the afore-mentioned Proclamation :

And whereas the Director-General after consultation with the Chief Commissioner has recommended that the afore-mentioned notice published in the *Government Gazette* of 21st January 1970, and varied by the afore-mentioned notices published in the *Government Gazette* on 9th December 1970 ; 23rd August 1972 ; 1st August 1973 ; 13th February 1974 ; 8th January 1975 and 5th April 1978, be further varied :

Now therefore I, the Minister for Social Welfare of the State of Victoria in the Commonwealth of Australia, in pursuance of the powers conferred by the *Social Welfare Act 1970*, do by this notice further vary the notice published in the *Government Gazette* on 21st January 1970, and varied by the notices published in the *Government Gazette* on 9th December 1970 ; 23rd August 1972 ; 1st August 1973 ; 13th February 1974 ; 8th January 1975 and 5th April 1978, by—

- (1) In the First Schedule thereto—deleting all reference to the City Watch House Russell Street Melbourne.
- (2) In the Third Schedule thereto immediately following the heading " Third Schedule " insert the following expression—

Police Lock-up	Police Station at which Police Lock-up is situated	Location of Police Lock-up on Police Station Premises	Description of Police Lock-up	Crown Description
City Watch House	Russell Melbourne	Street On West side of Russell Street between La Trobe and Victoria Streets, Melbourne opposite Russell Street Police Station and adjoining the Melbourne Magistrates' Court on the North side	Brick building 53.4 m x 31 m approximately excluding the first floor level	City of Melbourne, Parish of Melbourne North, County of Bourke. The remaining portion of the site temporarily reserved for Court House and Police purposes by Order in Council of 10th April 1951 (<i>Government Gazette</i> 18th April 1951, page 2807)

BRIAN DIXON,
Minister for Social Welfare

Social Welfare Department,
Melbourne, 19th December, 1978

Police Regulation Act 1958

POLICE FORCE OF VICTORIA

DETERMINATION NO. 304 OF THE POLICE SERVICE BOARD

The Police Service Board, in pursuance of the powers in that behalf conferred by the *Police Regulation Act 1958*, hereby makes the following Determination (that is to say):—

1. The Determination No. 179 of the Police Service Board of 14th December, 1971, and published in the *Government Gazette* of 25th January, 1972, as amended, is hereby further amended as follows:—

(a) In paragraph 7—

By deleting sub-paragraphs (a), (b) and (c), and substituting therefor the following sub-paragraphs:—

“(a) Officers

Salaries— Officers.	Rank	Salary per Annum
		\$
	Commander	26,801
	Chief Superintendent	24,465
	Superintendent	22,862
	Chief Inspector	20,727
	Inspector	20,170

(b) Sub-Officers

—Sub-Officers.	Rank	Salary per Annum
		\$
	Senior Sergeant	15,659
	Sergeant	13,862

(c) Senior Constables and Constables

—Senior Constables and Constables.	Rank	Salary per Annum
		\$
	Senior Constable—	
	During twelfth year of service and after	12,280
	During eleventh, tenth, ninth, eighth and seventh years of service	12,022
	During sixth and fifth years of service	11,875
	During fourth and third years of service	11,723
	During second and first years of service	11,571
	Constable—	
	During seventh year of service and after	11,094
	During sixth and fifth years of service	10,960
	During fourth and third years of service	10,709
	During second year of service	10,329
	During first year of service	10,063

- (b) By deleting paragraph 8 and substituting therefor the following paragraph:—

“8. The salaries to be paid to members designated in this paragraph shall be in accordance with the following scale:—

SCALE OF ANNUAL SALARIES
Police Cadets

	Salary per Annum \$	Salaries —Police Cadets.
Single Cadet at sixteen years ..	4,763	
Single Cadet at seventeen years ..	5,711	
Single Cadet at eighteen years ..	6,642	
Married Cadet at any age before joining Recruit Training Squad ..	7,023	
Cadet on joining Recruit Training Squad ..	8,353	
Married Cadet on joining Recruit Training Squad ..	8,734	
Married Cadet with totally dependant spouse and/or child ..	7,356	

- (c) In paragraphs 9-14 inclusive, by deleting, wherever occurring, the rates shown in table 'A', and substituting therefor, wherever occurring, the corresponding new rates shown in table 'B'—

TABLE 'A' (Present Rates)	TABLE 'B' (Corresponding New Rates)
\$	\$
0.27	0.28
0.32	0.33
0.50	0.52
0.55	0.57
0.60	0.62
0.65	0.68
0.68	0.71
0.70	0.73
0.76	0.79
0.82	0.85
0.87	0.90
0.92	0.96
0.97	1.01
1.03	1.07
1.04	1.08
1.09	1.13
1.14	1.19
1.20	1.25
1.25	1.30
1.30	1.35
1.35	1.40
1.37	1.42
1.42	1.48
1.47	1.53
1.52	1.58
1.57	1.63
1.63	1.70
1.68	1.75
1.74	1.81
1.77	1.84
1.79	1.86
1.85	1.92
1.91	1.99
2.07	2.15
2.12	2.20
2.17	2.26
2.33	2.42
2.39	2.49
2.51	2.61
2.56	2.66

\$	\$
2.66	2.77
2.71	2.82
3.16	3.29
3.21	3.34
3.75	3.90
4.47	4.65

(d) By deleting paragraph 26, under the heading "Compensatory Allowance-Rate" and substituting therefor following the paragraph:—

"Such allowance shall be at the following rates:—

Rate.	Rank	Annual Allowance \$
	Senior Sergeant	1,566
	Sergeant	1,386
	Senior Constable—	
	During twelfth year of service and after	1,228
	During eleventh, tenth, ninth, eighth and seventh years of service	1,202
	During sixth and fifth years of service	1,188
	During fourth and third years of service	1,172
	During second and first years of service	1,157
	Constable—	
	During seventh year of service and after	1,109
	During sixth and fifth years of service	1,096
	During fourth and third years of service	1,071
	During second year of service	1,033
	During first year of service	1,006"

(e) In paragraph 27, under the heading "Compensatory Allowance—Night Shift", by deleting the amounts "\$6.79" and "\$3.39" and substituting therefor the amounts "\$7.06" and "\$3.53" respectively.

(f) In paragraph 33, under the heading "Overtime—Detective", by deleting the amounts "\$1,419" and "\$1,144" and substituting therefor the amounts "\$1,476" and "\$1,189" respectively.

(g) In paragraph 34, sub-paragraph (1), under the heading "Overtime—one-man Stations", by deleting the amount "\$915.00" and substituting therefor the amount "\$951.00".

2. This Determination shall come into operation on and from the 17th day of December, 1978.

Dated the 18th day of December, 1978

N. A. VICKERY,
A Judge of the County Court of Victoria,
Chairman and Member of the Police
Service Board

G. DAVIDSON,
Member of the Police Service Board

B. J. HARDING,
Member of the Police Service Board

Police Regulation Act 1958

POLICE FORCE OF VICTORIA

DETERMINATION NO. 305 OF THE POLICE SERVICE BOARD

The Police Service Board, in pursuance of the powers in that behalf conferred by the *Police Regulation Act 1958*, hereby makes the following Determination (that is to say):—

1. The Determination No. 179 of the Police Service Board of 14th December, 1971, and published in the *Government Gazette* of 25th January, 1972, as amended, is hereby further amended as follows:—

In the Third Schedule, by deleting the Appendix, and substituting therefor the following:—

APPENDIX

DAILY RATES OF ALLOWANCES FOR PERSONAL EXPENSES OF MEMBERS TRAVELLING ABROAD

Type "A"—Rate is all inclusive.

Type "B"—Rate is cost of accommodation plus the amount specified for meals and incidentals.

Type "C"—Rate is cost of accommodation and meals plus the amount specified for incidentals.

Country	Currency	Type	Rate
Algeria	A. Dinars	B	169.50
Arab Republic of Egypt	L.E.	B	15
Argentina	\$U.S.	B	18.75
Austria	A. Schillings	B	600
Bahrain	B. Dinars	B	13.50
Bangladesh—			
Dakka	Takas	A	790
Elsewhere	Takas	B	263
Belgium	B. Francs	A	3,060
Brazil—Brasilia	\$U.S.	B	25.50
Sao Paulo	\$U.S.	B	31.50
Rio de Janeiro	\$U.S.	B	28
Britain	£Sterling	B	17.50
British Solomon Islands Protectorate—			
Honiara	SA.	A	37
Elsewhere	SA	C	5
Burma	Kyats	A	152
Canada	\$Can.	B	33
Caribbean Area	\$U.S.	B	27
Chile	\$U.S.	B	32
China, People's Republic of	P.B.Y.	B	22
Cyprus	£C.	A	19
Denmark	D. Krona	A	536
Fiji	\$F.	A	39.10
Finland	F. Marks	A	338
France	F. Francs	B	180
Germany, Democratic Republic of	M.D.N.	B	71
Germany, Federal Republic of	F.R.G. Deutschmarks	A	188
Ghana	New Cedis	A	140
Greece	Drachmae	B	1,010
Hong Kong	\$H.K.	B	134
India	Rupees	B	195
Indonesia	Rupiahs	A	25,300
Iran	Rials	A	5,430
Iraq	I. Dinars	A	15.50
Ireland	£Irish	A	30.60
Israel	\$U.S.	B	40
Italy	Lire	B	26,000
Jamaica	\$J.	B	28.50
Japan	Yen	B	12,700
Jordan	J. Dinars	A	23
Kenya (1 April—15 December)	K. Shillings	A	455
Kenya (16 December—31 March)	K. Shillings	A	475
Korea, Republic of	Won	A	33,300
Laos	\$U.S.	A	31.70
Lebanon	L.L.	B	94
Libya	L.D.	B	7.90
Luxembourg	B.F.	A	2,440
Malaysia—Kuala Lumpur	\$M	A	121
Penang	\$M	A	105
Malta	£M.	A	12.60
Mauritius	Rupees	A	255
Mexico	\$Mex.	A	1,025
Nauru, Republic of	\$A.	A	39.50
Netherlands	N. Florins	A	201
New Caledonia	C.F.P. Francs	B	2,900
New Hebrides	N.H. Francs	A	4,000
New Zealand	\$N.Z.	A	45
Nigeria	£N.	A	40
Norway	N. Krona	A	458

Country	Currency	Type	Rate
Pakistan—			
Karachi	P.Rs.	A	660
Elsewhere	P.Rs.	A	540
Papua New Guinea—			
Port Moresby	Kina	A	45
Elsewhere	Kina	B	19
Elsewhere	Kina	B*	15.50
Paraguay	\$U.S.	B	22
Peru	\$U.S.	B	22
Philippines	Pesos	A	400
Poland	Zloties	B*	596
Portugal	Escudos	A	1,360
Saudi Arabia	S. Riyals	B	163
Singapore	\$S.	A	137
South Africa	Rand	A	33
Spain	Pesetas	A	2,700
Sri Lanka—			
Colombo	\$A	A	40
Elsewhere	Rupees **	B	118
Sudan	Lsd.	C	4.50
Sweden	S. Krona	A	433
Switzerland	S. Francs	B	86
Syria	S. Pound (L.S.)	A	307
Tanzania	T. Shillings	A	320
Thailand	Baht	A	1,123
Tonga—			
Nuku'alofa	\$T.	A	30
Elsewhere	\$T.	C	3.50
Trinidad and Tobago	\$T.T.	A	142
Turkey	T. Liras	A	1,620
Union of Soviet Socialist Republics	Roubles	B	18.20
United States of America—			
Washington and New York	\$U.S.	B	37.50
Elsewhere	\$U.S.	B	33.50
Uruguay	\$U.S.	B	15.75
Venezuela	\$U.S.	B	31.50
Vietnam, Socialist Republic of	Dongs	B	36
Western Samoa	\$W.S.	A	39
Yugoslavia	New Dinars	A	795
Other Countries	\$A	C	5.50

* Rate is cost of accommodation and breakfast plus the amount specified for lunch, dinner and incidentals.

** Members are to receive the \$A. equivalent converted at the tourist exchange rate.

2. This Determination shall come into operation on and from the 17th day of December, 1978.

Dated this 18th day of December, 1978

N. A. VICKERY,
A Judge of the County Court of Victoria,
Chairman and Member of the Police
Service Board

G. DAVIDSON,
Member of the Police Service Board.

B. J. HARDING,
Member of the Police Service Board

In the Supreme Court of Victoria—1978 No. M.13438—
In the matter of the *Lotteries Gaming and Betting Act* 1966; and in the matter of an application by Ernest William Cartwright to have the house or place situate at first floor, 128-130 Franklin Street, Melbourne, in the State of Victoria declared to be a common gaming house or place

Take notice that on Tuesday, the 19th day of December 1978, His Honour Mr. Justice Fullagar Ordered that the house or place situate at so much of the first floor of 128-130 Franklin Street, Melbourne as is depicted on the plan being exhibit marked "A1" to the affidavit of Ernest William Cartwright sworn on the 14th day of December 1978 be declared to be a common gaming house or place.

The abovementioned affidavit and plan are filed in Supreme Court file numbered M.13438 and can be inspected at the office of the Prothonotary, Law Courts, William Street, Melbourne.

ERNEST WILLIAM CARTWRIGHT,
Inspector of Police

Police Regulation Act 1958, Section 122
SALE OF UNCLAIMED AND CONFISCATED PROPERTY
An auction of unclaimed and confiscated property held by Police will be conducted at the auction rooms of J. W. Styles & Son Pty. Ltd., 280 Spencer Street, Melbourne, at 11 a.m., on 8th February, 1979.

S. I. MILLER,
Chief Commissioner

COUNTRY FIRE AUTHORITY ACT
PERMISSION TO HOLD FIRE BRIGADE DEMONSTRATIONS
In pursuance of the provisions of Section 103 of the *Country Fire Authority Act* 1958, the Country Fire Authority has granted permission for the holding of fire brigade demonstrations as under:—

Rural Fire Brigades
At Geelong on Sunday, 25th March, 1979.
At Colbinabbin on Sunday, 25th March, 1979.

L. T. D'ARCY,
Secretary

18th December, 1978

*Country Fire Authority Act 1958***FIRE DANGER PERIOD IN RESPECT OF SPECIFIED PARTS OF THE COUNTRY AREA OF VICTORIA**

Whereas by section 4 of the *Country Fire Authority Act 1958* it is enacted that the Chief Secretary of Victoria, after consultation with the Minister of Forests, may from time to time by declaration published in the *Government Gazette* declare any period to be the fire danger period in respect of the country area of Victoria, or any specified part or parts thereof and, without affecting the generality of the foregoing, may declare different periods to be the fire danger period in respect of different parts of the said country area:

And whereas the Chief Secretary and the Minister of Forests have consulted accordingly:

Now therefore I, the Chief Secretary of Victoria, do hereby declare the period commencing at midnight on the fifth day of January, 1979 and ending at midnight on the thirtieth day of April, 1979 to be the fire danger period in respect of the parts of the country area of Victoria situated within the municipal districts or parts of municipal districts, being parts of the Eighth and Twenty-sixth Fire Control Regions specified in the Schedule hereunder:—

SCHEDULE No. 17
Municipalities

City of Berwick.

Part City of Knox (those portions not included in the Thirteenth Fire Control Region).

Part Shire of Mornington (those portions not included in the Eighth Fire Control Region).

J. A. RAFFERTY, Chief Secretary

Chief Secretary's Office,

Melbourne, 4th January, 1979

*Country Fire Authority Act 1958***FIRE DANGER PERIOD IN RESPECT OF SPECIFIED PARTS OF THE COUNTRY AREA OF VICTORIA**

Whereas by section 4 of the *Country Fire Authority Act 1958* it is enacted that the Chief Secretary of Victoria, after consultation with the Minister of Forests, may from time to time by declaration published in the *Government Gazette* declare any period to be the fire danger period in respect of the country area of Victoria, or any specified part or parts thereof and, without affecting the generality of the foregoing, may declare different periods to be the fire danger period in respect of different parts of the said country area:

And whereas the Chief Secretary and the Minister of Forests have consulted accordingly:

Now therefore I, the Chief Secretary of Victoria, do hereby declare the period commencing at midnight on the seventh day of January, 1979 and ending at midnight on the thirtieth day of April, 1979 to be the fire danger period in respect of the parts of the country area of Victoria situated within the municipal districts or parts of municipal districts, being part of the Fifth Fire Control Region specified in the Schedule hereunder:—

SCHEDULE No. 18
Municipalities

City of Hamilton,
Shire of Dundas.

J. A. RAFFERTY, Chief Secretary

Chief Secretary's Office,

Melbourne, 4th January, 1979

*Hospital and Charities Act 1958***PETITION TO INCORPORATE ST. ALBANS COMMUNITY HEALTH AND RESOURCES CENTRE**

It is notified in accordance with the provisions of sections 46 and 64 of the *Hospitals and Charities Act 1958*, that the Health Commission of Victoria has received a petition signed by twenty-five contributors to an organisation known as St. Albans Community Health and Resources Centre praying that the organisation be incorporated as a Benevolent Society under the provisions of the said Act.

The organisation will have for its objects:

- (a) To manage and maintain a Community Health and Resources Centre in St. Albans which will provide facilities for family physicians, specialists, nurses, physiotherapists, occupational therapists, social workers, psychiatric nurses and other medical and/or para-medical personnel as are required.

(b) To provide facilities for diagnosis and treatment of illness and for provision of preventive health services for all persons including those in necessitous circumstances.

(c) To purchase or acquire any real and/or personal property and other buildings to be used for the above purpose.

(d) To do all such other things as are incidental or conducive to the attainment of the above objects.

If a counter petition signed by an equal or greater number of contributors is not lodged with the aforesaid Commission at 555 Collins Street, Melbourne, within one calendar month of publication of this notice, the Governor in Council may, by Order pursuant to the *Hospitals and Charities Act 1958*, declare the contributors for the time being to St. Albans Community Health and Resources Centre to be a body corporate by the name set forth in such Order.

19th December, 1978

W. V. HOUGHTON,
Minister of Health

Health Commission of Victoria,
Melbourne

Co-operation Act 1958

NEWBOROUGH BOWLING CO-OPERATIVE LIMITED
B.B.F. TAXI CO-OPERATIVE SOCIETY LIMITED
WATSONIA PRIMARY SCHOOL CO-OPERATIVE LIMITED

KERRIMUIR STATE SCHOOL CO-OPERATIVE LIMITED
DEER PARK STATE SCHOOL CO-OPERATIVE LIMITED
THE WORKS CO-OPERATIVE LIMITED
NORTH EASTERN HERD IMPROVEMENT CO-OPERATIVE LIMITED
THE MARSH A.B. CO-OPERATIVE LIMITED
UPPER FERNTREE GULLY STATE SCHOOL CO-OPERATIVE SOCIETY LIMITED
KYABRAM TROTTERING TRAINERS CO-OPERATIVE LIMITED

NOTICE OF DISSOLUTION OF SOCIETIES

Notice is hereby given that I have this day registered the dissolution of the abovenamed societies and cancelled their registration under the abovenamed Act:

Dated at Melbourne this 18th day of December, 1978

E. P. LIDDELL,
Deputy Registrar

Co-operation Act 1958

MALVERN TOORONGA CHILD CARE CO-OPERATIVE LIMITED
ST. ALBANS NORTH PRIMARY SCHOOL CO-OPERATIVE LIMITED
SPRINGVALE HIGH SCHOOL CO-OPERATIVE LIMITED
DAVEY STREET FRANKSTON S.S. CO-OPERATIVE LIMITED

BRIAR HILL PRE-SCHOOL CO-OPERATIVE LIMITED
MOUNT WAVERLEY H.S. CO-OPERATIVE LIMITED
TALINGA HOME BUYERS CO-OPERATIVE NO. 1 LIMITED
STUDFIELD STATE SCHOOL CO-OPERATIVE LIMITED

Notice is hereby given in pursuance of section 78 (7) of the *Co-operation Act 1958* and section 308 (2) of the *Companies Act 1961* that, at the expiration of three months from the date hereof, the names of the aforementioned societies will, unless cause is shown to the contrary, be struck off the register and the societies will be dissolved.

Dated this 19th day of December, 1978

E. P. LIDDELL
Deputy Registrar

Co-operation Act 1958

CHECKER CABS CO-OPERATIVE TRADING SOCIETY LIMITED
ST. LEONARDS YACHT CLUB CO-OPERATIVE SOCIETY LIMITED

NOTICE OF DISSOLUTION OF SOCIETIES

Notice is hereby given that I have this day registered the dissolution of the abovenamed societies and cancelled their registration under the abovenamed Act.

Dated at Melbourne this 24th day of December, 1978

E. P. LIDDELL
Deputy Registrar

STATE RIVERS AND WATER SUPPLY COMMISSION

LICENCES TO DIVERT WATER AND CUT RACES PURSUANT TO THE PROVISIONS OF SECTION 204 OF THE WATER ACT 1958.
(AS AMENDED)

The Governor in Council has approved of the granting by the State Rivers and Water Supply Commission of licences as detailed hereunder for the term of years from the date specified in each case to the persons named in the following Schedule :—

SCHEDULE

Licence No.	Terms of Licence and Commencing Date	Name and Address of Persons to whom Licence is to be Granted	Source of Supply	Area Authorized to be Irrigated Per Annum	Volume of Water Authorized to be Diverted Per Annum	Annual Fee
				hectares	megalitres	
437	Fifteen years from 1.7.78..	Allan James Branson of Piangil..	River Murray ..	27.4	247	335.92
1593	Fifteen years from 1.7.77..	Reginald William Freemantle and Marjorie Joyce Freemantle of Eddington	Tullaroop Creek ..	50.8	305	512.76
1819	Fifteen years from 1.7.78..	V. J. and E. M. Tobin and Co. Pty. Ltd. of Wodonga	Kiewa River ..	10.3	62	84.32
1824	Fifteen years from 1.7.78..	Dino Mario Rigoni of Mt. Beauty	Kiewa River ..	10.3	62	84.32
3371	Fifteen years from 1.7.77..	Feiglin Brothers of Nunawading	River Murray ..	164.4	1,480	1,760.00
3525	Fifteen years from 1.7.77..	Lucipel Produce Pty. Ltd. of Melbourne	River Murray ..	56.1	506	607.20
3543	Fifteen years from 1.7.77..	L. G. and B. McEwan of Nangiloc	River Murray ..	61.6	556	667.20
3551	Fifteen years from 1.7.75..	Georgios and Kitja Giannoukas of Robinvale	River Murray ..	24.6	222	266.40
3554	Fifteen years from 1.7.78..	George Maxwell Madeley and Agnes Madeley of Benjeroop	River Murray ..	4.3	26	43.68
3582	Fifteen years from 1.7.78..	William Henry Cramp and Dulcie Evelyn Cramp of Robinvale	River Murray ..	1.2	11.1	30.60
3590	Fifteen years from 1.7.78..	John F. Edey of Red Cliffs	River Murray ..	8.5	77	104.72
3692	Fifteen years from 1.7.78..	Neville James Byron and Evelyn Jean Byron of Mildura	River Murray ..	40.5	365	496.40
3766	Eleven years from 1.7.77..	Aldo Michelini and Fabio Michalini of Buffalo River	Buffalo River ..	4.6	21	31.08
3771	Four years from 1.7.77 ..	Lindsay Vineyards Pty. Ltd. of Burnside S.A.	River Murray ..	164.4	1,480	2,012.80
3781	Four years from 1.7.77 ..	Currawa Irrigation Syndicate of Goorambat	Broken River ..	107	642	950.16
3784	Four years from 1.7.77 ..	Sunnycliff Producers of Irymple	River Murray ..	54.7	493	591.60
3795	Ten years from 1.7.78 ..	C. J. and M. G. Milne of Myrtleford	Buffalo River ..	8	36	63.48

Office of the State Rivers and Water Supply Commission,
Melbourne, 19th December, 1978R. BIRD, Secretary,
State Rivers and Water Supply Commission

STATE RIVERS AND WATER SUPPLY COMMISSION

LICENCE TO DIVERT WATER PURSUANT TO THE PROVISIONS OF SECTION 204 OF THE WATER ACT 1958 (AS AMENDED)

The Governor in Council has approved of the granting by the State Rivers and Water Supply Commission of the licence as detailed hereunder for the term of years from the date specified to the person named in the following Schedule :—

SCHEDULE

Licence No.	Term of Licence and Commencing Date	Name and Address of Person to whom Licence is to be Granted	Source of Supply	Area Authorized to be Irrigated Per Annum	Volume of Water Authorized to be Diverted Per Annum	Annual Fee
				hectares	megalitres	
3800	Four years from 1.7.78 ..	John William Ginnivan	Broken River ..	24	144	241.92

Office of the State Rivers and Water Supply Commission,
Melbourne, 19th December, 1978R. BIRD, Secretary,
State Rivers and Water Supply Commission

Education Act 1958

NOTICE OF MAKING OF AN ORDER UNDER SECTION 13 (1) OF THE ACT

Pursuant to section 13 of the Education Act 1958 I hereby give notice that an Order of the Governor in Council was made on 12th December 1978, under sub-section (1) of section 13 in relation to Berwick High School.

L. H. S. THOMPSON,
Minister of EducationEducation Department,
Melbourne, 14th December, 1978

Education Act 1958

NOTICE OF MAKING OF AN ORDER UNDER SECTION 13 (4) OF THE ACT

Pursuant to Section 13 of the Education Act 1958 I hereby give notice that an Order of the Governor in Council was made on 19 December 1978 under sub-section (4) of section 13 of the said Act extending the term of office of the current members of the Emily McPherson College Council from 31 December 1978 to 30 June 1979.

L. H. S. THOMPSON,
Minister of EducationEducation Department,
Melbourne, 19th December, 1978

Pounds Act 1958

Table of Rates to be charged for the Trespass of Cattle, and their sustenance while impounded fixed by the Council of the Shire of Oxley.

A. For Trespass

Description of Cattle Trespassing	Upon tillage land enclosed by a substantial fence	Upon land other than tillage land enclosed by a substantial fence
	\$	\$
For every sheep	0.50	0.10
For every goat	3.00	3.00
For every pig	3.00	3.00
For every head of other cattle ..	3.00	3.00
\$		
In addition for the trespass of any entire horse ..	20.00	
In addition for the trespass of any bull ..	20.00	
In addition for the trespass of any ram ..	20.00	

B. For Sustenance

Description of Cattle	Amounts to be charged daily for sustenance while impounded
	\$
For every sheep	0.10
For every goat	0.50
For every pig	0.50
For every head of other cattle ..	1.00

NOTE.—Section 10A of the *Pounds Act 1958* provides—where a person impounding cattle conveys them to the pound by motor transport there shall be payable as a transport rate the expenses reasonably incurred by him in so conveying them to the Pound.

By order of the Council,
E. F. Van Leeuwen
Shire Secretary

Approved by the Governor in Council, 19th December, 1978
—TOM FORRISTAL, Clerk of the Executive Council.

Pounds Act 1958

Table of Rates to be charged for the Trespass of Cattle, and their sustenance while impounded fixed by the Council of the City of Broadmeadows.

A. For Trespass

Description of Cattle Trespassing	Upon tillage land enclosed by a substantial fence	Upon land other than tillage land enclosed by a substantial fence
	\$	\$
For every sheep	0.10	0.10
For every goat	3.00	3.00
For every pig	3.00	3.00
For every head of other cattle ..	3.00	3.00
\$		
In addition for the trespass of any entire horse ..	20.00	
In addition for the trespass of any bull ..	20.00	
In addition for the trespass of any ram ..	20.00	

B. For Sustenance

Description of Cattle	Amounts to be charged daily for sustenance while impounded
	\$
For every sheep	1.00
For every goat	2.00
For every pig	2.00
For every head of other cattle ..	2.00

NOTE.—Section 10A of the *Pounds Act 1958* provides—where a person impounding cattle conveys them to the pound by motor transport there shall be payable as a transport rate the expenses reasonably incurred by him in so conveying them to the Pound.

By order of the Council

Approved by the Governor in Council, 19th December, 1978
—TOM FORRISTAL, Clerk of the Executive Council.

PUBLIC TRUSTEE ACT 1958 (No. 6350), SECTION 17

I hereby give notice that on the 19th December, 1978, the Public Trustee file elections to administer the following persons' estates in accordance with section 17 of the Public Trustee Act 1958.

BARNES, MARGARET MARY, late of 11 Carlisle Avenue, East St. Kilda, spinster, died 21st October, 1978.

DAVE, ANDREW, late of 54 Mills Street, Albert Park, retired fitter and turner, died 11th October, 1978.

GOATES, PATRICK, late of 14 Francis Street, Werribee, retired engine driver, died 21st August, 1978.

JAMIESON, STELLA, late of Flat 4, 24 Jackson Street, St. Kilda, secretary, died 5th January, 1978.

ROTHQUE, JUDITH ISOBEL MABEL, also known as Isobel Mabel Stanton, late of 21 Denmark Street, Kew, home duties, died 15th August, 1978.

SMITH, KENNETH, late of 16 Ludwell Crescent, East Bentleigh, manager, died 4th October, 1978.

STAMFORD, REGINALD, formerly of 39 Croydon Road, Surrey Hills, but late of Unit 8, 74 Croydon Road, Surrey Hills, retired factory hand, died 7th September, 1978.

TAPPENDEN, CYRIL FREDERICK, formerly of Flat 6, 76 Railway Road, Carnegie, but late of 6 Forest Court, Gladstone Park, Tullamarine, Draughtsman, died 7th June, 1978.

TOURON, GASTON JULES ERNEST, late of 22 Orange Grove, North Essendon, foreman, died 6th May, 1978.

N. P. BRODY,
Public Trustee

168 Exhibition Street, Melbourne, 3000, 27th December, 1978

Creditors, next of kin, and others having claims against the estate of any of the under-mentioned deceased persons are required to send particulars of their claims to the Public Trustee, 168 Exhibition Street, Melbourne, Vic. 3000, the personal representative, on or before the 11th March, 1979, after which date the Public Trustee may convey or distribute the assets having regard only to the claims of which the Public Trustee then has notice:—

BINDLOSS, GLADYS MAY, late of 88 O'Grady Street, Clifton Hill, widow, died 30th September, 1978.

BLUMENFELD, TINA, late of Flat 10, 24 Kingsley Street, Elwood, retired housemaid, died 26th June, 1978.

COXON, DOROTHY GERTRUDE, also known as Dorothy Coxon, late of 291 Bluff Road, Sandringham, trained nurse, died 7th September, 1978.

DERBYSHIRE, MURIEL DAPHNE, also known as Muriel Derbyshire, late of 1 Adelaide Street, McKinnon, widow, died 12th October, 1978.

HEGNEY, WILLIAM MARTYN, also known as William Martin Hagney, late of 28 Murdo Road, Clayton North, retired painter and sign writer, died 6th September, 1978.

LAING, ELSIE MAY, late of Mont Park, widow, died 2nd August, 1978.

LEONARD, THOMAS, late of 11 Pretoria Street, Deepdene, retired public servant, died 6th August, 1978.

LOUCH, LILY OLIVE, late of 75 Moonya Road, Murrumbena, married woman, died 21st September, 1978.

MCKEOWN, JOHN GEORGE, late of Bridge Street, Trentham, retired shearer, died 8th September, 1978.

MCNALLY, JOSEPH PATRICK, also known as Joseph McNally, formerly of 204 Roden Street, West Melbourne, but late of 151 Keele Street, Collingwood, retired engineer, died 18th October, 1978.

O'FLYNN, BRIAN IGNATIUS, formerly of 36 Herbert Street, Northcote, but late of 3 Haig Street, Reservoir, Control Officer, died 30th July, 1978.

MAGEE-ORR, HUGH, late of 2 Glenbrook Avenue, North Clayton, retired carpenter, died 11th June, 1978.

PAGE, CHARLES JOHN, late of 52 Byron Street, Elwood, public servant, died 13th April, 1975.

PRESARI, RIRIERI, late of Warrnambool, prospector, died 21st December, 1977.

RAPSON, GORDON JAMES, late of 12 Liardet Street, Port Melbourne, retired storeman, died 16th September, 1978.

ROGERS, REGINALD WALTER, late of Kingston Centre, Warrigal Road, Cheltenham, retired, died 26th January, 1977.

SHEPHERDSON, KEITH, formerly of 46 Langs Road, Ascot Vale, but late of 44 Jarvis Avenue, Croydon, retired clerk, died 15th October, 1978.

SLATER, MILLICENT EVELINE MARY, late of Flat 3, 319 Riversdale Road, Hawthorn, widow, died 25th August, 1978.

WALKER, HAROLD CYRIL, late of 32 Chatsworth Road, Prahran, retired tramway employee, died 16th October, 1978.

WILLIS, HARRY GEORGE, late of 10 Flemington Street, Flemington, pensioner, died 14th October, 1978.

Melbourne, 20th December, 1978

N. P. BRODY,
Public Trustee

PUBLIC TRUSTEE ACT 1958, SECTION 17

I hereby give notice that on the 17th November, 1978, the Public Trustee filed elections to administer the following deceased persons' estates in accordance with section 17 of the Public Trustee Act 1958.

BAZLEY, CAROLINE, late of 105 Charles Street, Fitzroy, married woman, died 11th April, 1943.

HUNTING, ALICE, late of Beechworth, pensioner, died 16th August, 1978.

BURNS, CLAUDE EDWARD, late of Flat 4, 33 Rathmines Street, Fairfield, pensioner, died 17th September, 1978.

COLLINS, FRANCIS HENRY, late of Flat 3, 43 Spenser Street, St. Kilda, foreman, died 17th June, 1978.

FANNING, ERIC, late of Kew, pensioner, died 3rd September, 1978.

HEMING, KATHERINE EMMA, late of Flat 7, 37 Stafford Street, Abbotsford, pensioner, died 3rd August, 1978.

MACKEY, ANGUS, late of 82 Maribymong Road, Moonee Ponds, pensioner, died 11th September, 1978.

RAFTER, MARIE ANTOINETTE, late of Mount Eliza Geriatric Centre, Jacksons Road, Mount Eliza, widow, died 22nd July, 1978.

VOLUNTA, PAUL, late of 683 Park Street, Brunswick, pensioner, died on or about the 22nd December, 1977.

WEBSTER, MARY ELIZABETH ADA, formerly of 32 Bass Street, Box Hill, but late of "Mount Calm", 173 Prospect Hill Road, Canterbury, widow, died 8th September, 1978.

WOOLLEY, DENESE HEATHER, late of Flat 5, 73 Riversdale Road, Hawthorn, receptionist, died 5th November, 1975.

N. P. BRODY,
Public Trustee

168 Exhibition Street, Melbourne, 3000, 21st December, 1978

Creditors, next of kin, and others having claims against the estate of any of the under-mentioned deceased persons are required to send particulars of their claims to the Public Trustee, 168 Exhibition Street, Melbourne, Vic. 3000, the personal representative, on or before the 18th March, 1979, after which date the Public Trustee may convey or distribute the assets having regard only to the claims of which the Public Trustee then has notice.

BARNES, MARGARET MARY, late of 11 Carlisle Avenue, East St. Kilda, spinster, died 21st October, 1978.

DAVIE, ANDREW, late of 54 Mills Street, Albert Park, retired fitter and turner, died 11th October, 1978.

DOUGLAS, ALEXANDER STANLEY McNAUGHTON, also known as Stanley Douglas, formerly of 37 Queens Parade, Burwood, but late of Unit 3/9 Glencairn Avenue, Burwood, retired bank manager, died 2nd September, 1978.

DWAN, ANNIE LOUISE ALICE, late of 48 Droop Street, Footscray, widow, died 16th September, 1978.

GNATEK, JAN, late of 45 Napier Street, Fitzroy, electrician, died 12th September, 1978.

GOATES, PATRICK, late of 14 Francis Street, Werribee, retired engine driver, died 21st August, 1978.

JAMIESON, STELLA, late of Flat 4, 24 Jackson Street, St. Kilda, secretary, died 5th January, 1978.

JOBSON, BASIL BAKER, late of 2 Norma Avenue, South Oakleigh, retired public servant, died 25th September, 1978.

JONES, HILDA MABEL, also known as (In the Will called Mabel Hilda Jones) formerly of "Mountjoy" Guest Lodge, Ridge Road, Kalorama, but late of "Kulki" Private Hospital, 14 The Grove, Moreland, widow, died 8th May, 1978.

MILLINGTON, EDMUND RICHARD, formerly of 4 Elder Parade, Essendon, but late of Kew, motor mechanic, died 20th July, 1978.

MYLREA, FRANK RADCLIFFE, late of 40 Monteith Place, Durban North, South Africa, accountant, died 15th August, 1978.

NOLAN, LORNA ALICE, late of 52 Third Street, Parkdale, married woman, died 28th May, 1978.

PIPE, ANNE, late of 21 Norwood Street, Flemington, widow, died 3rd September, 1978.

PITT, SUSANNAH MAY, late of Flat 1, 14 Woorigoleen Road, Toorak, retired school teacher, died between 26th September, 1978, and 11th October, 1978.

REYNOLDS, THOMAS ANDREW, formerly of Central Mens Residence, 214 Arden Street, North Melbourne, late of "Beach House", 81 Nepean Highway, Seaford, retired, died 22nd October, 1978.

ROTHQUE, JUDITH ISOBEL MABEL, also known as Isobel Mabel Stanton, late of 21 Denmark Street, Kew, home duties, died 15th August, 1978.

SMITH, KENNETH, late of 16 Ludwell Crescent, East Bentleigh, manager, died 4th October, 1978.

STAMFORD, REGINALD, formerly of 39 Croydon Road, Surrey Hills, but late of Unit 8, 74 Croydon Road, Surrey Hills, retired factory hand, died 7th September, 1978.

SWAN, ELSIE JANE, formerly of 3/20 Denmark Hill Road, Hawthorn East, but late of Inala Village, Middleborough Road, Blackburn South, widow, died 3rd October, 1978.

TAPPENDEN, CYRIL FREDERICK, formerly of Flat 6, 76 Railway Road, Carnegie, but late of 6 Forest Court, Gladstone Park, Tullamarine, Draughtsman, died 7th June, 1978.

THOMAS, RUTH ELISABETH, late of 18 Raleigh Street, Thornbury, married woman, died 21st September, 1978.

TODD, HARRIET SALOME, late of 30 Thomson Street, Essendon, married woman, died 17th October, 1978.

TOURON, GASTON JULES ERNEST, late of 22 Orange Grove, North Essendon, foreman, died 6th May, 1978.

TUCK, EVELYN, late of Elgar Private Hospital, 366 Elgar Road, Box Hill, pensioner, died 27th April, 1978.

WALLACE, ANNIE ETHEL, late of Unit 2, 145 Park Road, Cheltenham, widow, died 12th October, 1978.

Melbourne, 27th December, 1978

N. P. BRODY,
Public Trustee

PUBLIC TRUSTEE ACT 1958, SECTION 17

I hereby give notice that on the 13th December 1978, the Public Trustee filed elections to administer the following deceased persons' estates in accordance with section 17 of the Public Trustee Act 1958.

BLUMENFELD, TINA, late of Flat 10, 24 Kingsley Street, Elwood, retired housemaid, died 26th June, 1978.

LOUCH, LILY OLIVE, late of 75 Moonya Road, Murrumbidgee, married woman, died 21st September, 1978.

MCNALLY, JOSEPH PATRICK, also known as Joseph McNally, formerly of 204 Roden Street, West Melbourne, but late of 151 Keele Street, Collingwood, retired engineer, died 18th October, 1978.

O'FLYNN, BRIAN IGNATIUS, formerly of 36 Herbert Street, Northcote, but late of 3 Haig Street, Reservoir, Control Officer, died 30th July, 1978.

PAGE, CHARLES JOHN, late of 52 Byron Street, Elwood, public servant, died 13th April, 1975.

PRESARI, RIRIERI, late of Warrnambool, prospector, died 21st December, 1977.

ROGERS, REGINALD WALTER, late of Kingston Centre, Warrigal Road, Cheltenham, retired, died 26th January, 1977.

WILLIS, HARRY GEORGE, late of 10 Flemington Street, Flemington, pensioner, died 14th October, 1978.

N. P. BRODY,
Public Trustee

168 Exhibition Street, Melbourne, 3000, 20th December, 1978

CONTRACTS ACCEPTED—(Series 1978-79)
AMENDMENTS

Sched. No.	Item No.	Description	Unit of Measurement	New Rate	Contractor	Effective Date
				\$		
		General Stores				
		<i>Gazette No. 51—19th June, 1978</i>				
1/04		<i>Cleaning and Polishing Requirements</i>				
	33	Buckets, Mop wringing	each	10.60*	Delete :—Janitor's Supply Pty. Ltd. Substitute :—Janitor's Supply, A Div. of Ogden Industries Pty. Ltd., A Div. of N.K.S. (Holdings) Ltd. (Vic.)	11.12.78
		*Rates less 2½% Settlement Discount, 30 days.				
		<i>Gazette No. 74—1st September, 1977</i>				
		<i>Electrical Goods</i>				
1/05	31	Fans, Wall/Desk, 16 inch	each	Reg. 109	Delete :—G.E.C.—A.E.I. (Aust.) Pty. Ltd.,—Domestic Appliance Division Substitute :—Purchase (Regulation 109)	11.12.78
	32	12 inch	"	Reg. 109		
	64	General Electrical Accessories ; "Clipsal", "H.P.M." and "Ring-Grip"	"	Trade Lists Oct. 1978 Less 21%	Telcon Australia Pty. Ltd. .. .	12.12.78
		<i>Gazette No. 51—19th June, 1978</i>				
		<i>Paints and Painters' Sundries</i>				
1/13	14	G.P.C.—P-12/3—4 litres	per tin	8.84	Berger Paints Victoria Pty. Ltd.	27.12.78
	37	G.P.C.—P-41—4 litres	"	6.52		
	38	1 litre	"	2.08		
		<i>Gazette No. 84—12th October, 1977</i>				
		<i>Liquid Petroleum Gas</i>				
1/52		L.P. Gas in 45kg cylinders	per cyl.	13.72	Gas and Fuel Corporation of Victoria, L.P. Gas Division	11.12.78
		L.P. Gas—Bulk—				
		within 85 km from G.P.O.	per tonne	158.30		
		86—170 km from G.P.O.	"	164.21		
		171—255 km from G.P.O.	"	181.99		
		256—425 km from G.P.O.	"	192.80		
		Over 425 km from G.P.O.	"	212.44		
		<i>Gazette No. 19—4th April, 1977</i>				
		<i>Tools (General)</i>				
1/56	49	Cutters, Bolt, No. 918, "Record"	each	15.91	Industrial Hardware Pty. Ltd.	1.12.78
	51	Pipe, No. 2, "Record"	"	17.19		
	69	Gauges, Cutting, "Marples" No. 2083	"	2.66	Delete : A. J. Calder Substitute :—Apply Tender Board A. J. Calder*	14.12.78
	202	Handsaws, 650 mm	"	..		
	338	Slashers, Handled, "Spear and Jackson" No. 4636	"	15.57	A. J. Calder*	14.12.78
	428	Padlocks, "Lockwood" No. 245	"	5.54	Industrial Hardware Pty. Ltd.	6.12.78
	429	No. 234	"	4.27		
	430	No. 234B	"	4.58		
	431	No. 225	"	1.82		
		*Rates less 1½% Settlement Discount, 30 days				
		\$1.00 Delivery Charge on orders less than \$35.00.				
		<i>Gazette No. 81—4th October, 1977</i>				
		<i>Stationery, General</i>				
1/64	3	Bands, Elastic, 0½	per doz. boxes	2.82	General Stationers Pty. Ltd. .. .	7.12.78
	4	00½	"	2.82		
	5	000½	"	2.82		
	6	0000½	"	2.82		
	9	1" x 1/16" x 1/32"	"	2.82		
	10	1½" x 1/16" x 1/32"	"	2.82		
	11	2" x 1/16" x 1/32"	"	2.82		
	12	3" x 1/16" x 1/32"	"	2.82		

AMENDMENTS—continued

Sched. No.	Item No.	Description	Units of Measurement	New Rate	Contractor	Effective Date
		Provisions		\$		
		Gazette No. 40—18th May, 1978				
2/01		Provisions—Melbourne and Metropolitan District				
	48A	Eggs—Large (60g)	per 15 doz.	17.62	} Marsh Dairy Products Pty. Ltd.	18.12.78
	48B	Small (50g)	per "	14.56		
	93	Prunes, A10 cans	per ctn. (6)	16.16	} Composite Buyers Ltd.	1.1.79
	124	Evaporated Milk, 410g	per doz.	3.56		
	155B	Toppings in 375 ml containers	"	4.98		
2/02		Groceries—Melbourne and Metropolitan District				
	2	Beverages, Instant, Chocolate, 500g	per doz.	11.74	} Composite Buyers Ltd.	1.1.79
	3	Strawberry, 500g	"	11.74		
	9	"Rice Bubbles", 375g	"	8.38		
	11	"Weeties", 750g	"	11.36	} Composite Buyers Ltd.	11.12.78
	13	"Provita", Delete :—750g Substitute :—500g	"	6.88		
	42	Coffee, Instant, 100g	"	18.48	} Composite Buyers Ltd.	1.1.79
	43	150g	"	29.88		
	59	Essences, Vanilla, 200 ml	"	12.20		
	71	Tomato Paste, 700g	"	14.24		
	106	Prunes, No. 10 cans	per case (6)	16.16		
	146	Evaporated Milk, 410 ml	per doz.	3.56		
	147A	Monosodium Glutamate, 650g	each	3.20		
2/14		Provisions—Agricultural College, Glenorniston Sub-Schedule No. 1				
	1	Bread, Fine wheaten, first quality	per 100kg	46.06	} J. and J. Hoedemaekers	6.12.78
	2	Wrapped and sliced, first quality	"	51.94		
	4	Flour, First quality, 67kg bags	per bag	15.17		

J. M. PAWSON, Secretary to the Tender Board

SCHEDULE NO. 1/74
DUPLICATORS—ELECTRIC

CONTRACT FROM 1ST JANUARY 1979 TO 31ST DECEMBER, 1979

1978/779—Roneo Vickers, A Division of Vickers Sales Pty. Ltd., 93-103 Clarendon Street, South Melbourne
All items to be purchased through Officer In Charge, Stores Branch, Education Department.
The "Conditions of Contract for General Stores" shall apply to all contracts for this supply.

Item No.	Description of Articles	Unit of Measurement	Rate	Name of Contractor
	Duplicators—Electric—		\$	
1	Ink Style, medium volume model, "Roneo Vickers" Model 475E	each	503.00	} Roneo Vickers Purchase (Regulation 109)
2	Ink Style, heavy duty model, "Roneo Vickers" Model 865E	"	718.00	
3	Spirit Style	"		

Approved—R. J. HAMER, Treasurer—20.12.78.

CONTRACTS ACCEPTED—(Series 1978-79)

PUBLIC WORKS

756. Melbourne, fit out and adaptation of office accommodation, 24 and 25 Queens Road, \$65,000.00—Dalbon Constructions.

757. South Melbourne, provision of hot water service and ventilation to Science Rooms, MacRobertson Girls' High School, \$15,855.00—Aquaduct Mechanical Services.

758. Traralgon, external repairs and painting, Hobsons Park Hospital, \$23,285.00—B. A. Dye.

759. Merrilands, internal and external repairs and painting, Primary School No. 4826, \$34,990.00—Balkan Painters & Decorators.

760. Upwey, extensions to sewage treatment plant, High and Primary Schools, \$22,000.00—Bayswater Septic Tanks Pty. Ltd.

761. Heidelberg West, exterior and interior renovations and conversion of class-rooms to staff room, administration, library, art and craft, Primary School No. 4267, \$59,621.00—D. P. & B. Cullen.

762. Various, construction of various Dental Therapy slabs, Northern Metropolitan Area Primary Schools, \$42,311.00—E. Osinski Building Co. Pty. Ltd.

763. Daylesford, heating of theatre, gymnasium complex, Technical School, \$26,694.00—G. Stone & Sons (Vic.) Pty. Ltd.

764. Stawell, replacement of flooring to multi-purpose hall, High School, \$18,076.00—H. A. & P. J. Graefe.

765. Donald, installation of fire services and renewal of water supply, Primary School No. 1465, \$13,557.73—H. J. Hardingham & Son.

766. Morwell, re-roofing of older wings, Primary School No. 2136, \$22,200.82—I. & N. Stiglic.

767. Myrtleford, exterior and part interior renovations, Consolidated School, \$24,530.00—J. Toth.

768. Mirboo North, repairs to subsided floor, High School, \$13,400.00—L. W. & A. L. Gathercole.

769. Coburg, demolition of fire damaged roof and erection of new steel truss roof "B" Division Chapel, Pentridge Prison, \$43,990.00—Macalam Builders Pty. Ltd.

770. Kew, erection of new T.A.F.E. Office, High School, \$27,580.00—N. & J. Rawlings.

771. Traralgon, internal and external renovations, Cooina Hill Day Training Centre, \$10,100.00—North Melbourne Painting Service.

772. East Melbourne, cleaning of Public Offices, 250 Victoria Parade, period 11th December, 1978 to 30th November, 1981—\$21,051.22 per annum—Peter Mazzeo Contract Cleaning.

773. Eltham, connection to M.M.B.W. sewer, Police Station and Residence, \$10,070.00—Prall's Plumbing Installations.

774. Shepparton, erection of covered way and locker accommodation, external repairs and painting and part internal painting, High School, \$77,762.00—R. A. Bourke Proprietary as Trustee.

775. Sushine, new school, supply and installation of language laboratory equipment, Technical School, \$24,205.00—Rank Industries Australia Pty. Ltd.

776. Sunbury, site works, High School, \$103,950.00—Strathtex Pty. Ltd.

777. St. James, internal and external renovations, Police Station and Residence, \$19,348.00—Wolf's Painting Service.

778. Banyule, construction of a new library/drama complex, High School, \$729,090.00—W. O. Longmuir Pty. Ltd.

G. WILLIAMS, Director-General. 18.12.78

CONTRACTS ACCEPTED—(Series 1978-79)

PUBLIC WORKS

His Excellency the Governor of the State of Victoria by and with the advice of the Executive Council thereof has by Orders made on the 19th day of December, 1978, approved of the acceptance by the Minister of Public Works of the undermentioned offers without public tenders being invited, viz.:

Offer of Duncan & Russell (Vic.) Pty. Ltd. for dredging approach to boat haven and facilities, Mordialloc Creek, for the sum of twenty-one thousand seven hundred and fifty dollars (\$21,750.00)—(PH.134043n).

Offer of P.R. Electrics Pty. Ltd. for electrical services, Mentone Primary School 2950, for the sum of ten thousand seven hundred and fifteen dollars twenty-five cents (\$10,715.25)—(E.11973A).

Offer of Christie Electrical Services Pty. Ltd. for electrical services to relocatables Cranbourne West Primary School 3977, for the sum of twenty thousand eight hundred and fourteen dollars (\$20,814.00)—(E.19322A).

Offer of P.A. Electrics Pty. Ltd. for electrical services to relocatables, Tooradin Primary School No. 1503, for the sum of seventeen thousand two hundred dollars (\$17,200.00)—(E.19287A).

Offer of Christie Electrical Services Pty. Ltd. for electrical services to relocatables, Kunyung Primary School No. 3930, for the sum of twenty-three thousand four hundred and thirty-five dollars (\$23,435.00)—(E.19325A).

Offer of W.P.L. Industries Pty. Ltd. for supply delivery and erection of 2 No. relocatable modular buildings, Yellingbo and Mallacoota, Fisheries & Wildlife Department, Ministry of Conservation, for the sum of twenty-two thousand dollars (\$22,000.00)—(BG.161673).

Offer of Romberg & Boyd Pty. Ltd. for consultant services (Architectural), Cranbourne Police Station, for the sum of twenty thousand dollars (\$20,000.00)—(E.18528P).

Offer of Bera Furniture Pty. Ltd. for supply of Special furniture, Richmond Technical College, for the sum of twelve thousand five hundred and sixty-three dollars (\$12,563.00)—(S.245201).

Offer of M. & K. M. Read Electrical Service for electrical services to relocatables, Seaford Park Primary School, for the sum of ten thousand six hundred dollars (\$10,600.00)—(E.19324A).

Offer of J. & B. Ranking Pty. Ltd. for electrical services, Keysborough Park Primary School No. 3172, for the sum of fifteen thousand four hundred and twelve dollars (\$15,412.00)—(E.19323A).

Offer of Gray & Wood for provision of sawdust extraction system, Glenroy Technical School for the sum of ten thousand eight hundred and seventy dollars (\$10,870.00)—(C.188660).

Offer of M. & K. M. Read Electrical Service for electrical services to relocatables, Patterson Lakes Primary School No. 3197 for the sum of twelve thousand nine hundred dollars (\$12,900.00)—(E.19288A).

Offer of B. & K. M. Read Electrical Service for electrical services, Noble Park North Primary School No. 3675, for the sum of eleven thousand seven hundred of fifty dollars (\$11,750.00)—(E.19320A).

TOM FORRISTAL,

Clerk of the Executive Council

At the Executive Council Chamber,
Melbourne, 19th December, 1978

COMPANIES ACT 1961

Notice is hereby given in pursuance of Section 308 (2) and 308 (3) of the Companies Act 1961 that at the expiration of three months from the date hereof the names of the following Companies will, unless cause is shown to the contrary, be struck off the Register and the said Companies will be dissolved.

Dated this 14th day of December, 1978

E. B. MITCHAM,

Deputy Commissioner for Corporate Affairs

Corporate Affairs Office,
Melbourne

COMPANIES ABOVE REFERRED TO

Name of Company	Number of Registration
J. T. Hamilton Pty. Ltd.	C20258F
Pizzey (Victoria) Pty. Ltd.	C23268G
Australian Ceramic Society Pty. Ltd.	C25640V
Makad Holdings Pty. Ltd.	C39084B
Rubanit Roofing & Paper Products Pty. Ltd.	C48068H
Laurie Larson Advertising (Holdings) Pty. Ltd.	C50562Y
Carlytex (Queensland) Pty. Ltd.	C5199P
Melbourne Taxi Trucks Pty. Ltd.	C55396U
John Munroe Pty. Ltd.	C57326L
Northern Victoria Electroplating Pty. Ltd.	C57412E
Helanca Parade Pty. Ltd.	C57533U
Meyer & Co. Pty. Ltd.	C57702T
Painter Weathershield Company Pty. Ltd.	C57935V
Norge Village (Camberwell) Pty. Ltd.	C58163P
Hook Signs Pty. Ltd.	C59954P
Vancorp (Victoria) Pty. Ltd.	C60263W
Aimms Pty. Ltd.	C63334S
Hozig (Victoria) Pty. Ltd.	C63617H
E.L. & E.K. Builders Pty. Ltd.	C64490R
Maritamo Robe St. Pty. Ltd.	C68058D
P. A. King Pty. Ltd.	C68129B
Twentieth Century Engineering Service Co. Pty. Ltd.	C69059N
G.F.T. Services Pty. Ltd.	C72150H
Thyssen Australia Pty. Ltd.	C72360X
Z-Brick (Aust.) Pty. Ltd.	C74277A
Jack Jeffrey Pty. Ltd.	C75770V
Elfman Pty. Ltd.	C82428U
A.P.C. Plumbing Service Pty. Ltd.	C83618J
P.F. & F.L.M. Kaye (Administration) Pty. Ltd.	C83923T
Midwest Holdings Pty. Ltd.	C85574E
Paved Pty. Ltd.	C86539K
I. & B. Properties Pty. Ltd.	C86570D
Renewals & Constructions Pty. Ltd.	C90546Y

Name of Company	Number of Registration	Name of Company	Number of Registration
Fred Pyke Pty. Ltd.	C96385U	Peter Godson Motors Pty. Ltd.	C51314H
First Woolmaine Pty. Ltd.	C97471V	Brandon Park Meats Pty. Ltd.	C51383D
Twenty-First Woolmaine Pty. Ltd.	C97491B	N. C. Oliver (Moorabbin) Pty. Ltd.	C52325W
Twenty-Second Woolmaine Pty. Ltd.	C97492D	N. C. Oliver (Preston) Pty. Ltd.	C52326Y
Twenty-Third Woolmaine Pty. Ltd.	C97493F	Sure Health Foods Pty. Ltd.	C52576A
Twenty-Fourth Woolmaine Pty. Ltd.	C97494H	Melbourne Indent Co. Pty. Ltd.	C52730K
Twenty-Fifth Woolmaine Pty. Ltd.	C97495K	Rezzo Pty. Ltd.	C53134U
Twenty-Sixth Woolmaine Pty. Ltd.	C97496M	N. C. Oliver (Coburg) Pty. Ltd.	C53495G
Twenty-Seventh Woolmaine Pty. Ltd.	C97527X	Twenty-Three Degraeves Street Pty. Ltd.	C53589T
Twenty-Eighth Woolmaine Pty. Ltd.	C97528Z	N. C. Oliver (Toorak) Pty. Ltd.	C53685P
Twenty-Ninth Woolmaine Pty. Ltd.	C97529B	Peter G. Hartley Pty. Ltd.	C55099J
Thirtieth Woolmaine Pty. Ltd.	C97530K	Chromatic Specialities Pty. Ltd.	C55532B
Thirty-First Woolmaine Pty. Ltd.	C97531M	Giuliano Bros. & Co. Pty. Ltd.	C56897F
Thirty-Second Woolmaine Pty. Ltd.	C97532P	H. W. Templeton & Co. Pty. Ltd.	C57171F
Forty-First Woolmaine Pty. Ltd.	C97541R	H.C. Constructions Pty. Ltd.	C59165B
Forty-Second Woolmaine Pty. Ltd.	C97542T	Option Brokers Association Ltd.	C60743S
Forty-Third Woolmaine Pty. Ltd.	C97543V	P. X. Danald Pty. Ltd.	C61104F
Forty-Fourth Woolmaine Pty. Ltd.	C97544X	G. G. M. Vance & Co. Pty. Ltd.	C61783M
Forty-Fifth Woolmaine Pty. Ltd.	C97545Z	H. & D. Shipston Pty. Ltd.	C61787W
Forty-Sixth Woolmaine Pty. Ltd.	C97546B	Holroyd Holdings Pty. Ltd.	C63089C
Forty-Seventh Woolmaine Pty. Ltd.	C97547D	H.C.M.S. Pty. Ltd.	C64587H
Forty-Eighth Woolmaine Pty. Ltd.	C97548F	S. A. Bell Ltd.	C64961K
Forty-Ninth Woolmaine Pty. Ltd.	C97549H	Clives Menswear Pty. Ltd.	C65174J
Fiftieth Woolmaine Pty. Ltd.	C97550S	International Gas & Power Engineers Pty. Ltd.	C65394B
Mt. Buller Holdings Pty. Ltd.	C98379P	General Loans & Mortgages Finance Co. Pty. Ltd.	C65496L
Franks & Heikel Sewage Treatment Plant Pty. Ltd.	C100670G	G.L.S. Nominees Pty. Ltd.	C67814T
Medical Contacts Pty. Ltd.	C100817N	Pakit International (Australia) Pty. Ltd.	C69153F
Moolaroo Nominees Pty. Ltd.	C105779V	Z & D Holdings Pty. Ltd.	C69805G
Beemore Auto Wholesale Supplies Pty. Ltd.	C107333M	Glen Kiah Pty. Ltd.	C70428S
Greensleeves Manufacturing Pty. Ltd.	C107642E	John McClure Pty. Ltd.	C70784U
Sportmark Pty. Ltd.	C111456X	Gwarra Pty. Ltd.	C71268B
Dynasty Fashions (Victoria) Pty. Ltd.	C112280R	Maloro Investments Pty. Ltd.	C72483R
T.S.I. Holdings Pty. Ltd.	C112816N	I. & P. McKenzie Pty. Ltd.	C72921U
Ferro Marine Constructions Pty. Ltd.	C118468H	Raknoon Pty. Ltd.	C74577S
Hughes Meaney & Associates Pty. Ltd.	C119123A	Taan Pty. Ltd.	C74713Z
J. Roper and Associates Pty. Ltd.	C120684T	Girlpower Pty. Ltd.	C74736M
Metro Flight Academy Pty. Ltd.	C121956L	Wykeham Holdings Pty. Ltd.	C78220Z
Inter Company Airlines Pty. Ltd.	C122159G	Peter Godson Used Cars Pty. Ltd.	C78501L
Leverington Nominees Pty. Ltd.	C122349P	Penguin Motels Pty. Ltd.	C78628N
B. and B. Mercolee Pty. Ltd.	C123859C	Lakeliner Industries Pty. Ltd.	C79262Z
Multi-Sales Pty. Ltd.	C123953V	John Britain Homes Pty. Ltd.	C79883R
Guinevere Pty. Ltd.	C125855J	Bushy Park Vineyard (Wantirna) Pty. Ltd.	C81666F
Seville Property Holdings Pty. Ltd.	C126378C	Lamborn's Bus Services Pty. Ltd.	C81742W
		Peter Thompson Homes Pty. Ltd.	C82410Y
		Platypus Car Wash (Preston) Pty. Ltd.	C82863T
		L.C. and L.M. Investments Pty. Ltd.	C82911C
		Workload Temporaries Pty. Ltd.	C82977K
		Abinger Investments Pty. Ltd.	C83586X
		Byng Pty. Ltd.	C83587Z
		Second G.P.I. Services Pty. Ltd.	C84568C
		Third G.P.I. Services Pty. Ltd.	C84569E
		Fourth G.P.I. Services Pty. Ltd.	C84570N
		Fifth G.P.I. Services Pty. Ltd.	C84571R
		Sixth G.P.I. Services Pty. Ltd.	C84572T
		Seventh G.P.I. Services Pty. Ltd.	C84573V
		Ninth G.P.I. Services Pty. Ltd.	C84574X
		Eighth G.P.I. Services Pty. Ltd.	C84575Z
		Tenth G.P.I. Services Pty. Ltd.	C84576B
		Eleventh G.P.I. Services Pty. Ltd.	C84577D
		Twelfth G.P.I. Services Pty. Ltd.	C84578F
		V.J. Motor Products Pty. Ltd.	C84942E
		Thirteenth G.P.I. Services Pty. Ltd.	C85555A
		Fourteenth G.P.I. Services Pty. Ltd.	C85556C
		Fifteenth G.P.I. Services Pty. Ltd.	C85557E
		Herkel Pty. Ltd.	C85619B
		D. & O. Investments Pty. Ltd.	C86196B
		H.G. & B.M. Pty. Ltd.	C87341T
		Eildon Outboard Service Pty. Ltd.	C87967V
		Glenariff Pty. Ltd.	C88037U
		Athabaska Nominees Pty. Ltd.	C88266M
		O.R.C. Pty. Ltd.	C89019Z
		Australian Mercantile & Accident Insurance Brokers Pty. Ltd.	C89285Z
		Four Bells International Pty. Ltd.	C89331E
		H.Q.P. Pty. Ltd.	C89441N
		Mauritius-Australia Trading Company Pty. Ltd.	C89505P
		Colinem Nominees Pty. Ltd.	C89689E
		A.I.M. Minerals Prospecting Pty. Ltd.	C90458A
		Multi-Purpose Loans Pty. Ltd.	C90750Z
		Union Loans Pty. Ltd.	C90751B
		Third Lloyds, Burns & Associates Pty. Ltd.	C91130T
		Second Lloyds, Burns & Associates Pty. Ltd.	C91131V
		A. Lekkas Transport Pty. Ltd.	C91529F
		International Pools Pty. Ltd.	C92047N
		Expedite International Pty. Ltd.	C92133G
		Fifth Lloyds, Burns & Associates Pty. Ltd.	C92626M
		Quindalup Village Pty. Ltd.	C92687J
		Fine Fabric Dyers Pty. Ltd.	C92750P
		Adey & Brown Nominees Pty. Ltd.	C95606D
		Dubitante Pty. Ltd.	C96275K
		J. P. M. Appleby Projects Pty. Ltd.	C97049F

COMPANIES ACT 1961

Notice is hereby given that in pursuance of section 308 (4) of the Companies Act 1961 the names of the Companies referred to below have been struck off the Register and on publication of this Notice in the Government Gazette the said Companies will be dissolved.

Dated this 15th day of December, 1978

E. B. MITCHAM,

Deputy Commissioner for Corporate Affairs

Corporate Affairs Office,
Melbourne

COMPANIES ABOVE REFERRED TO

Name of Company	Number of Registration
Satupulo No Liability	M9451M
Eganstown Gold Mines No Liability	M10523F
Beret Manufacturers Pty. Ltd.	C18259G
G. Rawson Pty. Ltd.	C21508N
Carbul 4. Pty. Ltd.	C25387G
Parker Toy Distributors Pty. Ltd.	C31064J
J. G. Downes Pty. Ltd.	C31996X
Sunset Milk Coolers Pty. Ltd.	C32705M
Huntingtower Constructions Pty. Ltd.	C35364F
Valley Poultry Pty. Ltd.	C36076E
Melbourne Printers Pty. Ltd.	C36764K
Easson's Bakery Pty. Ltd.	C38122A
Bartlett & Launder Pty. Ltd.	C39142P
Treffield Estates Pty. Ltd.	C40010N
Contract Information Services Pty. Ltd.	C41238F
Milga Estates Pty. Ltd.	C41554V
A. S. Salmon Pty. Ltd.	C42162E
Sussport Holdings Pty. Ltd.	C43025A
Daljon Pty. Ltd.	C46809U
N. C. Oliver (Prahlan) Pty. Ltd.	C47173Y
L. C. Tucker's Motors Pty. Ltd.	C48026R
G. G. S. Annuities Pty. Ltd.	C48217A
L.P. Investments Pty. Ltd.	C48336K
Hunter Featherston Pty. Ltd.	C48675M
Careys (Hampton) Pty. Ltd.	C48745H
Hat Corporation Pty. Ltd.	C48858Y
Finance House Developments Pty. Ltd.	C49407R
Sandown Park Motor Sport Pty. Ltd.	C51291X

Name of Company	Number of Registration
Horsfall Investments Pty. Ltd.	C97104M
Bestly Pty. Ltd.	C97221T
Medivest Co. Pty. Ltd.	C97524R
Acrylic Design Pty. Ltd.	C97602K
Ornum Pastoral & Investments Pty. Ltd.	C97663G
Jessamine Investments Pty. Ltd.	C97941M
C. A. E. Constructions Pty. Ltd.	C98075P
Beverage Custom Packers Pty. Ltd.	C98709N
Mount Alsop Pty. Ltd.	C99121C
Nhill Gemini Fashions Pty. Ltd.	C100179Z
Universal Units (Properties and Estates) Ltd.	C100381W
Planweld Pty. Ltd.	C100422J
C. A. Price Constructions Pty. Ltd.	C100493J
M. L. Price Constructions Pty. Ltd.	C100757W
Springford Electrics Pty. Ltd.	C102164A
Beaumont Treatment Plants Pty. Ltd.	C103484F
Quell Investments Pty. Ltd.	C104146N
Sturdee Constructions Pty. Ltd.	C106072Z
Chemical Fertilizers (Australia) Pty. Ltd.	C106338R
Galaxy Floors Pty. Ltd.	C106778A
B.S. Home Garden Service Pty. Ltd.	C107082K
Brook Falkiner Ltd.	C107774Z
Regis Pty. Ltd.	C108380E
Ingman Nominees Pty. Ltd.	C108435E
E.R.M. Computer Services Pty. Ltd.	C108963M
Langhorne Street Market Pty. Ltd.	C109265L
Acropol Carpets Pty. Ltd.	C109672E
Mulara Pty. Ltd.	C110810K
Frael Nominees Pty. Ltd.	C111210K
D. & H. Munro Nominees Pty. Ltd.	C114501Y
McKenzie & Arnel Pty. Ltd.	C120998W
Abbotts Langley Pty. Ltd.	C124882E
Pigall's Pty. Ltd.	C125755D
Centro Espanol De Victoria	C128171S
Eastway Oriental Food Distributor Pty. Ltd.	C137813U

Labour and Industry Act 1958

ORDER OF EXEMPTION UNDER SECTION 80c

Whereas pursuant to section 80c of the *Labour and Industry Act 1958* as amended by the *Labour and Industry (Further Amendment) Act 1969* the Shire of Healesville has applied to the Minister for an order exempting certain shopkeepers of shops in its municipal district from being required to close and keep closed their shops in accordance with Part VI. of the said Act:

And whereas I have considered the report of the Minister of Tourism obtained in accordance with the provisions of sub-section (4) of section 80c of the said Act:

Now therefore I, James Halford Ramsay, Her Majesty's Minister of Labour and Industry in the State of Victoria, do pursuant to the aforesaid section 80c of the *Labour and Industry Act 1958* make this order granting exemption to—

G. W. White and G. K. Seyffer,
321 Maroondah Highway, Healesville

in the Shire of Healesville from being required to close and keep closed their shop on

Saturdays between the hours of 1 p.m. and 6 p.m.:
Sundays and public holidays between the hours of 10 a.m. and 6 p.m.

provided that such exemption shall not apply to Good Friday or Anzac Day.

Dated at Melbourne this 21st day of December, 1978.

J. H. RAMSAY,
Minister of Labour and Industry

APPOINTMENTS AND RESIGNATIONS

APPOINTMENTS

His Excellency the Governor of the State of Victoria, by and with the advice of the Executive Council thereof, has, by Orders made on the 19th day of December, 1978, been pleased to make the under-mentioned appointments, viz.:

CHIEF SECRETARY'S DEPARTMENT

Returning Officer

COLIN FRANCIS ELIOTT
to be Returning Officer for the Electoral District of South Barwon, vice K. N. Guyett, resigned.

DEPARTMENT OF HEALTH

Members of Victorian Nursing Council

NORMA BRYAN

to be a Member of the Victorian Nursing Council pursuant to provisions of section 4 of the *Nurses Act 1958* for the remainder of the period ending 28th September, 1980, vice M. Evans, resigned.

DORIS EGGE

to be a Member of the Victorian Nursing Council pursuant to the provisions of section 4 of the *Nurses Act 1958* for the remainder of the period ending 28th September, 1980.

GABRIEL MARY WATSON

to be a Member of the Victorian Nursing Council pursuant to the provisions of section 4 of the *Nurses Act 1958* for the remainder of the period ending 28th September, 1980.

JOYCE NIXON

to be a Member of the Victorian Nursing Council pursuant to the provisions of section 4 of the *Nurses Act 1958* for the remainder of the period ending 28th September, 1980.

BERTRAM PAYNE McCLOSKEY, M.D., F.R.A.C.P., D.P.H., F.A.C.M.A., M.I.H.E.,

to be a Member of the Victorian Nursing Council pursuant to the provisions of section 4 of the *Nurses Act 1958* for the remainder of the period ending 28th September, 1980.

Acting Chairman of Health Commission

JAMES ANTHONY RYAN, D.P.A., LL.B.,

to be Acting Chairman, Health Commission of Victoria pursuant to the provisions of section 17 (1) of the *Health Commission Act 1977* for the period 25th December, 1978, to the 14th January, 1979, vice Dr. G. Trevaks, on recreation leave.

Deputy Psychiatrists Superintendents

ROSSLYN BYERS ROBINSON, M.B., B.S., D.P.M.,
to be Deputy Psychiatrist Superintendent, Traralgon Psychiatric and Mental Hospital, pursuant to the provisions of section 26 (1) of the *Mental Health Act 1959*, vice Dr. C. R. Vasudevan, transferred.

TERRENCE MARK HARDIKER, M.B., Ch.B., D.P.M.,
to be Deputy Psychiatrist Superintendent, Dandenong Psychiatric Centre, pursuant to the provisions of section 26 (1) of the *Mental Health Act 1959* from 15th December, 1978, to 11th February, 1979, vice Dr. J. S. Parmar, on leave and relieving duties.

Psychiatrist Superintendents

HENRY CHARLES BETHUNE, M.B., Ch.B., D.P.M.,
M.R.A.N.Z.C.P.,
to be Psychiatrist Superintendent, Beechworth Mental Hospital, Psychiatric Hospital and Training Centre, pursuant to the provisions of section 26 (1) of the *Mental Health Act 1959* from 15th January, 1979, to 28th January, 1979, vice Dr. J. Mason, on leave.

JASHAVANT SHIVAL PARMAR, M.B., B.S., D.P.M.,
M.R.A.N.Z.C.P.,
to be Psychiatrist Superintendent, Beechworth Mental Hospital, Psychiatric Hospital and Training Centre, appointed pursuant to the provisions of section 26 (1) of the *Mental Health Act 1959* from 29th January, 1979, to 11th February, 1979, vice Dr. J. Mason, on leave.

RANJIT NIHAL WIJESURIYA, M.B., B.S., D.P.M.,
M.R.C.Psych., M.R.A.N.Z.C.P.,
to be Psychiatrist Superintendent, Beechworth Mental Hospital, Psychiatric Hospital and Training Centre, pursuant to the provisions of section 26 (1) of the *Mental Health Act 1959* from 12th February, 1979, to 18th February, 1979, vice Dr. J. Mason, on leave.

DINESH CHANDRA PAREKH, M.B., B.S., D.P.M.,
M.R.A.N.Z.C.P.,
to be Psychiatrist Superintendent, Beechworth Mental Hospital, Psychiatric Hospital and Training Centre, pursuant to the provisions of section 26 (1) of the *Mental Health Act 1959* from 19th February, 1979, to 25th February, 1979, vice Dr. J. Mason, on leave.

LOISE MARY LOUISE LUCAS, M.B., B.S., D.P.M.,
M.R.C.Psych.,
to be Psychiatrist Superintendent, Beechworth Mental Hospital, Psychiatric Hospital and Training Centre, pursuant to the provisions of section 26 (1) of the *Mental Health Act 1959* from 26th February, 1979, to 2nd March, 1979, vice Dr. J. Mason, on leave.

LAW DEPARTMENT

Justices of the Peace

KENNETH RAYMOND BUCHANAN, Lot 1, Yea Road, Humevale,
KENNETH JOHN CAMERON, 88 Young Street, Frankston,

ROBERT RUSSELL COOPER, 5 Cambridge Crescent, White Hills,
 ALLAN JOSEPH COUPER, 15 William Street, Melbourne,
 JOHN GREGORY EDWARDS, 18 Hakea Street, Bendigo,
 BERNARD DANIEL MCKEE, 31 Monmouth Street, Newport West, and
 NORMAN WILLIAM CHARLIE PASCOE, 14 Bess Court, Dandenong,
 to be Justices of the Peace for the State of Victoria.

Commissioners for Taking Declarations, &c.

BERNARD LEO BOND, 214 Brunswick Street, Fitzroy,
 THOMAS ROBERT BOYD, 10 Haldane Street, Carrum,
 NORMAN GEORGE BUNN, and
 TREVOR FRANCIS WALKER,
 555 Collins Street, Melbourne,
 ALAN WILLIAM CALDWELL, 54 Edwards Street, Reservoir,
 LOUIS CHAN, 150 Lonsdale Street, Melbourne,
 JEFFREY ALAN GARFIELD, Duncans Road, Werribee,
 DOUGLAS KENNETH HYSLOP, Wodonga,
 RONALD STANLEY JOYCE, 30 Merricks Close, Ferntree Gully,
 MARGARET LILLIAN MCCARTHY, 9 Seville Court, St. Albans,
 RONALD GRAEME McDONALD, 19 Neville Street, St. Keilor,
 GEORGE ALEXANDER MCKINNON, Lot 10, Wellington Road, Clematis,
 ALLAN KEITH MATHERS, Main Road, Launching Place,
 ALECK MILLER, 3 Andrew Place, Bundoora,
 MARIAN JOHN TED PARAWA, 20 Hertford Road, Sunshine,
 ROBERT WILLIAM POPPINS, Reynolds Road, East Doncaster,
 TREVOR MAXWELL POWELL, 257 Chapel Street, Prahran,
 WILLIAM JOHN RYAN, 11 Civic Place, Ringwood,
 MEHMET MUSTAFA SABAN, 198 Glenroy Road, Glenroy,
 GEOFFREY RONALD SHIELDS, 304 Lorimer Street, Port Melbourne, and
 ARTHUR JOHN WILSON, 350 Camberwell Road, Camberwell,
 to be Commissioners for taking Declarations and Affidavits under the Evidence Act 1958.

Assistant Registrars of County Court

VAUGHAN VINCENT KELLY, Clerk of Courts,
 to be Assistant Registrar at Traralgon for the County Court at Morwell, vice K. McMahan, on recreation leave.

STEPHEN CHARLES WEBSTER, Clerk of Courts,
 to be Assistant Registrar at Castlemaine for the County Courts at Ballarat and Bendigo, vice P. Crawford, on recreation leave.

Assistant Collector of Maintenance

SIMON PAUL GILBERT BRYANT, Clerk of Courts,
 to be an Assistant Collector of Maintenance pursuant to section 69 (1) of the Maintenance Act 1965, vice S. Mackie, transferred.

PUBLIC WORKS DEPARTMENT

Wharf Manager

Senior Sergeant ADRIAN CASSIDY, No. 11314,
 to be Wharf Manager at Warrnambool, to carry out that portion of Part II. of the Marine Act 1958, which relates to the management of Public Wharfs and to be an officer under section 19 of such Act to levy and collect wharfage rates thereat, vice Senior Sergeant Richard Albert Greinke, No. 11266, retired.

TOM FORRISTAL,

Clerk of the Executive Council

At the Executive Council Chamber,
 Melbourne, 19th December, 1978

Racing Act 1958

APPOINTMENT OF CHAIRMAN OF RACECOURSES LICENCES BOARD

His Excellency the Governor of Victoria, by and with the advice of the Executive Council thereof, doth by Order made on the 19th day of December, 1978, and pursuant to the provisions of section 34 (2) (a) of the Racing Act 1958, appoint BERT ANDREW KEDDIE, to be Chairman of the Racecourses Licences Board for a period of three years from 1st January, 1979.

TOM FORRISTAL,

Clerk of the Executive Council

At the Executive Council Chamber,
 Melbourne, 19th December, 1978

Racing Act 1958

RACECOURSES LICENCES BOARD

In pursuance of the powers conferred upon me by the Racing Act 1958, I, Brian Dixon, the Minister for Youth, Sport and Recreation of the State of Victoria, do hereby appoint the under-mentioned persons to be members of the Racecourses Licences Board, for a period of three years commencing 1st January, 1979:—

- (1) PHILLIP JOHN RUPERT STEELE, Chairman of the Victoria Racing Club, pursuant to the provisions of section 34 (2) (b) of the said Act;
- (2) WILLIAM NASH LIENHOP, pursuant to the provisions of section 34 (2) (c) of the said Act, as a person representing in my opinion the interests of racing clubs having racecourses within the race-meetings districts;
- (3) ROBERT GRAEME COCHRAN, Chairman of the Trotting Control Board pursuant to the provisions of section 34 (3) (i) of the said Act;
- (4) FRANK RYAN, pursuant to the provisions of section 34 (3) (ii) of the said Act, as a person representing in my opinion the interests of trotting clubs having racecourses within the race-meetings districts.

BRIAN DIXON,

Minister for Youth, Sport and Recreation

Department of Youth, Sport and Recreation,
 Melbourne, 19th December, 1978

MENTAL HEALTH ACT 1959, SECTION 26

Notice is hereby given that the following appointment has been made pursuant to section 26 of the Mental Health Act 1959.

JOHN LAURENCE FREEMAN, Manager, Shepparton Psychiatric Hospital from 29th December, 1978, to 23rd February, 1979, vice A. A. Norman, on leave.

G. TREVAKS, Chairman,
 Health Commission of Victoria

21st December, 1978

MENTAL HEALTH ACT 1959, SECTION 26

Notice is hereby given that the following appointment has been made pursuant to section 26 of the Mental Health Act 1959.

PETER RICHARD CLAPP, Deputy Manager, Plenty Psychiatric and Mental Hospitals, as from 1st January, 1979, vice P. Mezaks, promoted.

G. TREVAKS, Chairman,
 Health Commission of Victoria

21st December, 1978

MENTAL HEALTH ACT 1959, SECTION 26

Notice is hereby given that the following appointment has been made pursuant to section 26 of the Mental Health Act 1959.

CHARLES CHRISTESEN, Deputy Manager, Sunbury Training Centre, vice I. Arnell, promoted.

G. TREVAKS, Chairman,
 Health Commission of Victoria

21st December, 1978

Liquor Control Act 1968

APPOINTMENT OF LICENSING INSPECTORS

In accordance with the authority conferred upon me by Section 6 of the Police Regulation Act 1958, I, Aubrey William Conn, Deputy Commissioner of Police, do hereby appoint under sub-section (1) of Section 22 of the Liquor Control Act 1968, the following Officers of Police as Licensing Inspectors for the Divisions of the Police Districts as shown:—

<i>Division Number</i>	<i>Police District</i>	<i>Rank and Name</i>
1	Cheltenham ..	Inspector Kenneth John McDonald (from 17.12.78 to 6.1.79)
1	Maroondah ..	Inspector Kevin Neville Hastings (from 17.12.78 to 5.2.79)

21.12.1978

A. W. CONN,
 Deputy Commissioner

Liquor Control Act 1968

APPOINTMENT OF LICENSING INSPECTORS

In accordance with the authority conferred upon me by Section 6 of the *Police Regulation Act 1958*, I, Aubrey William Conn, Deputy Commissioner of Police, do hereby appoint under sub-section (1) of Section 22 of the *Liquor Control Act 1968*, the following Officers of Police as Licensing Inspectors for the Divisions of the Police Districts as shown:—

Division Number	Police District	Rank and Name
3	Heidelberg	Inspector Brian Richard Hegarty (from 14.1.79 to 3.2.79)
1	Melbourne Ports	Inspector Kenneth Martin Olsen (from 10.12.78 to 6.1.79)
		A. W. CONN, Deputy Commissioner
28.12.1978		

RESIGNATIONS

His Excellency the Governor of the State of Victoria, by and with the advice of the Executive Council thereof, has, by Order made on the 18th day of November, 1975, accepted the resignations of the persons named hereunder of the office mentioned, viz.:—

HEALTH DEPARTMENT

Administrative Member of the Mental Health Authority

WILFRED JOHN WOODS, A.A.S.A.,
as Administrative Members, Mental Health Authority, to date from and inclusive of 8th December, 1978.

LAW DEPARTMENT

Justices of the Peace

CLEMENT JAMES INGRAM and
ALLAN GEORGE NORTON
as Justices of the Peace for the State of Victoria.

Commissioners for Taking Declarations, &c.

DONALD ARTHUR BAINES,
WILLIAM FREDERICK COLBORNE,
KENNETH RAYMOND CROSS,
HAROLD EDWARD FRICKER,
DOUGLAS FRANK KISSICK,
BERNARD D. MCKEE, and
ALEXANDER NICHOLAS MOON,
as Commissioners for taking Declarations and Affidavits under the Evidence Act 1958.

TOM FORRISTAL,
Clerk of the Executive Council

At the Executive Council Chamber,
Melbourne, 19th December, 1978

ORDERS IN COUNCIL

LOCAL GOVERNMENT DEPARTMENT

At the Executive Council Chamber, Melbourne, the
nineteenth day of December, 1978

PRESENT:

His Excellency the Governor of Victoria
Mr. Smith | Mr. Maclellan
Mr. Hayes | Mr. Ramsay

ROAD DISCONTINUED—SHIRE OF KORUMBURRA

Whereas it is provided in section 528 (2) of the *Local Government Act 1958*, that where a road (whether or not a public highway but not being a road set out on land of the Crown) or any part thereof is not required for public use the Governor in Council on the request of the council of the municipality in which such road is situated made not less than one month after publishing in a newspaper generally circulating in the district and posting to the registered proprietor (if any) of the land and the owners and occupiers (if any) of lands abutting or immediately adjacent to the road notice of intention to make such a request may by Order published in the *Government Gazette* direct that such a road or part shall be discontinued and thereupon such road or part shall be discontinued accordingly.

And whereas the Council of the Shire of Korumburra has requested that the Governor in Council direct that part of Hyman Street, Korumburra, be discontinued and not less than one month previously has published in a newspaper generally circulating in the district and posted to the registered proprietor of the land in the road and to the owners and occupiers of lands abutting or immediately adjacent to the road notice of intention to make such a request.

Now therefore, His Excellency the Governor of the State of Victoria, by and with the advice of the Executive Council thereof, hereby directs:

- (a) that the said part of a road which is shown by hatching and cross-hatching on the plan hereunder, shall be discontinued;
- (b) that notwithstanding such discontinuance the Korumburra Waterworks Trust shall continue to have and possess the same right title power authority or interest in or in relation to the whole of the land shown by cross-hatching on the said plan as it had or possessed prior to such discontinuance with respect to or in connection with any pipes laid or erected in on or over such land for the purposes of water supply;
- (c) that notwithstanding such discontinuance the Korumburra Sewerage Authority shall continue to have and possess the same right title power authority and interest in or in relation to the whole of the land shown by cross-hatching on the said plan as it had or possessed prior to such discontinuance with respect to or in connection with any drains or pipes laid or erected in on or over such land and for the purposes of drainage or sewerage; and
- (d) that, subject to any such right title power authority or interest in the said part of the road shall be sold by the Council of the Shire of Korumburra by public auction.

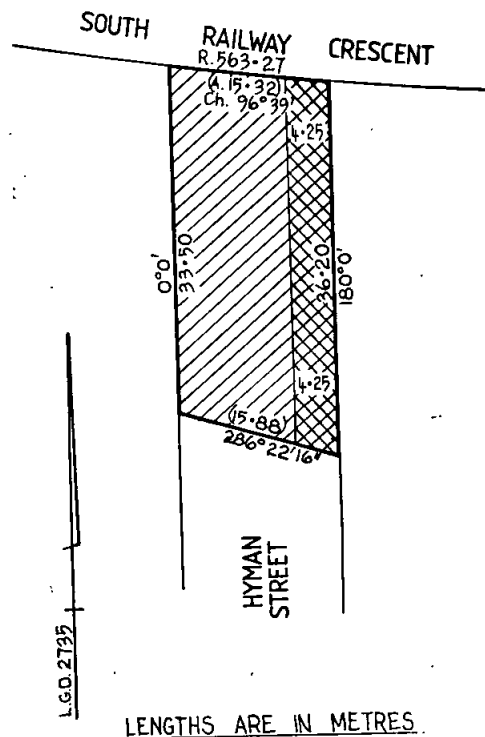

And the Honorable Alan John Hunt, Her Majesty's Minister for Local Government for the State of Victoria, shall give the necessary directions herein accordingly.

TOM FORRISTAL,
Clerk of the Executive Council

LOCAL GOVERNMENT DEPARTMENT

At the Executive Council Chamber, Melbourne, the nineteenth day of December, 1978

PRESENT:

His Excellency the Governor of Victoria	
Mr. Smith	Mr. Maclellan
Mr. Hayes	Mr. Ramsay

PART OF A ROAD DISCONTINUED—CITY OF BOX HILL

Whereas it is provided in section 528 (2) of the *Local Government Act 1958*, that where a road (whether or not a public highway but not being a road set out on land of the Crown) or any part thereof is not required for public use the Governor in Council on the request of the council of the municipality in which such road is situated made not less than one month after publishing in a newspaper generally circulating in the district and posting to the registered proprietor (if any) or the land and the owners and occupiers (if any) of lands abutting or immediately adjacent to the road notice of intention to make such a request may by Order published in the *Government Gazette* direct that such a road or part shall be discontinued and thereupon such road or part shall be discontinued accordingly.

And whereas the Council of the City of Box Hill has requested that the Governor in Council direct that part of a road between Station Street and Riversdale Road, Box Hill, be discontinued and not less than one month previously has published in a newspaper generally circulating in the district and posted to the registered proprietor of the land in the road and to the owners and occupiers of lands abutting or immediately adjacent to the road notice of intention to make such a request.

Now therefore, His Excellency the Governor of the State of Victoria, by and with the advice of the Executive Council thereof, hereby directs:—

- (a) that the said road which is shown by hatching and cross-hatching on the plan hereunder shall be discontinued;
- (b) that notwithstanding such discontinuance the Melbourne and Metropolitan Board of Works shall continue to have and possess the same right title power authority or interest in or in relation to the whole of the land shown by cross-hatching on the said plan as it had or possessed prior to such discontinuance with respect to or in connection with any drains or pipes laid or erected in on or over such land for drainage or sewerage purposes; and
- (c) that subject to any such right title power authority or interest, the land in the said road shall be retained by the Council of the City of Box Hill for municipal purposes.

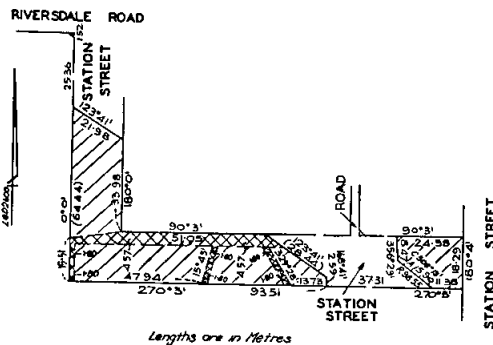

And the Honorable Alan John Hunt, Her Majesty's Minister for Local Government for the State of Victoria, shall give the necessary directions herein accordingly.

TOM FORRISTAL,
Clerk of the Executive Council

LOCAL GOVERNMENT DEPARTMENT

At the Executive Council Chamber, Melbourne, the nineteenth day of December, 1978

PRESENT:

His Excellency the Governor of Victoria	
Mr. Smith	Mr. Maclellan
Mr. Hayes	Mr. Ramsay

ROAD DISCONTINUED—CITY OF SPRINGVALE

Whereas it is provided in section 528 (2) of the *Local Government Act 1958*, that where a road (whether or not a public highway but not being a road set out on land of the Crown) or any part thereof is not required for public use the Governor in Council on the request of the council of the municipality in which such a road is situated made not less than one month after publishing in a newspaper generally circulating in the district and posting to the registered proprietor (if any) of the land and the owners and occupiers (if any) of lands abutting or immediately adjacent to the road notice of intention to make such a request may by Order published in the *Government Gazette* direct that such road or part shall be discontinued and thereupon such road or part shall be discontinued accordingly;

And whereas the Council of the City of Springvale has requested that the Governor in Council direct that Genesta Court, Noble Park be discontinued and not less than one month previously has published in a newspaper generally circulating in the district and posted to the registered proprietor of the land in the road and to the owners and occupiers of lands abutting or immediately adjacent to the road notice of intention to make such a request.

Now therefore, His Excellency the Governor of the State of Victoria, by and with the advice of the Executive Council thereof, hereby directs:

- (a) that the said road, which is shown by hatching and cross hatching on the plan hereunder, shall be discontinued;
- (b) that notwithstanding such discontinuance the Springvale and Noble Park Sewerage Authority shall continue to have and possess the same right title power authority or interest in or in relation to the whole of the land shown by cross hatching on the said plan as it had or possessed prior to such discontinuance with respect to or in connection with any drains or pipes laid or erected in on or over such lands for the purposes of drainage or sewerage; and
- (c) that, subject to any such right title power authority or interest, the land in the said road may be sold by the Council of the City of Springvale by agreement.

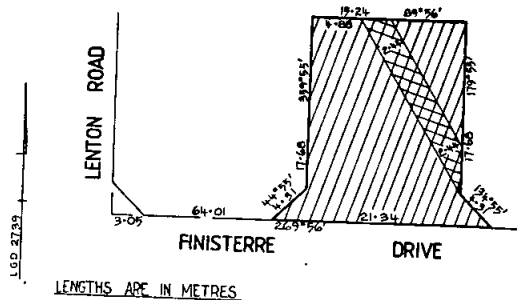

LENGTHS ARE IN METRES

And the Honorable Alan John Hunt, Her Majesty's Minister for Local Government for the State of Victoria, shall give the necessary directions herein accordingly.

TOM FORRISTAL,
Clerk of the Executive Council

LOCAL GOVERNMENT DEPARTMENT

At the Executive Council Chamber, Melbourne, the nineteenth day of December, 1978

PRESENT:

His Excellency the Governor of Victoria
 Mr. Smith | Mr. Maclellan
 Mr. Hayes | Mr. Ramsay

ROAD DISCONTINUED—CITY OF KNOX

Whereas it is provided in section 528 (2) of the Local Government Act 1958, that where a road (whether or not a public highway but not being a road set out on land of the Crown) or any part thereof is not required for public use the Governor in Council on the request of the council of the municipality in which such road is situated made not less than one month after publishing in a newspaper generally circulating in the district and posting to the registered proprietor (if any) of the land and the owners and occupiers (if any) of lands abutting or immediately adjacent to the road notice of intention to make such a request may by Order published in the Government Gazette direct that such road or part shall be discontinued and thereupon such road or part shall be discontinued accordingly;

And whereas the Council of the City of Knox has requested that the Governor in Council direct that part of a road at the rear of Station Street, Bayswater be discontinued and not less than one month previously has published in a newspaper generally circulating in the district and posted to the registered proprietor of the land in the road and to the owners and occupiers of lands abutting or immediately adjacent to the road notice of intention to make such a request;

Now therefore, His Excellency the Governor of the State of Victoria, by and with the advice of the Executive Council thereof, hereby directs that part of the said road, which is shown by hatching on the diagram hereunder, shall be discontinued and that the land may be sold by the Council of the City of Knox by agreement.

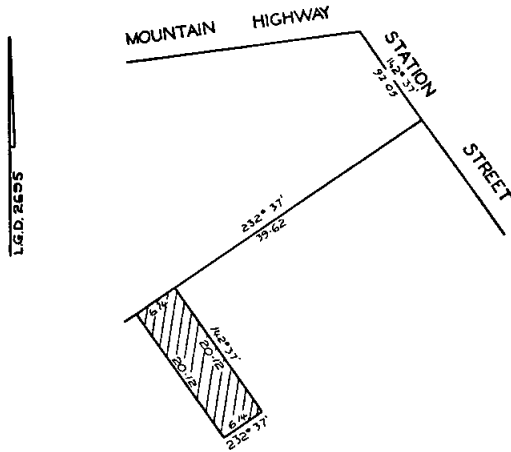

And the Honorable Alan John Hunt, Her Majesty's Minister for Local Government for the State of Victoria, shall give the necessary directions herein accordingly.

TOM FORRISTAL,
 Clerk of the Executive Council

LOCAL GOVERNMENT DEPARTMENT

At the Executive Council Chamber, Melbourne, the nineteenth day of December, 1978

PRESENT:

His Excellency the Governor of Victoria
 Mr. Smith | Mr. Maclellan
 Mr. Hayes | Mr. Ramsay

ROADS DISCONTINUED—CITY OF GEELONG

Whereas it is provided in section 528 (2) of the Local Government Act 1958, that where a road (whether or not a public highway but not being a road set out on land

of the Crown) or any part thereof is not required for public use the Governor in Council on the request of the council of the municipality in which such road is situated made not less than one month after publishing in a newspaper generally circulating in the district and posting to the registered proprietor (if any) of the land and the owners and occupiers (if any) of lands abutting or immediately adjacent to the road notice of intention to make such a request may by Order published in the Government Gazette direct that such a road or part shall be discontinued and thereupon such road or part shall be discontinued accordingly;

And whereas the Council of the City of Geelong has requested that the Governor in Council direct that a road and parts of roads off Holman Street, Breakwater be discontinued and not less than one month previously has published in a newspaper generally circulating in the district and posted to the registered proprietors of the land in the roads and to the owners and occupiers of lands abutting or immediately adjacent to the roads notice of intention to make such a request;

Now therefore, His Excellency the Governor of the State of Victoria, by and with the advice of the Executive Council thereof, hereby directs that the said road and parts of roads which are shown by hatching and cross-hatching on the plans hereunder, shall be discontinued and the land in the said road and parts of roads shown by hatching on the said plans may be sold by the Council of the City of Geelong by agreement and the land shown by cross-hatching shall be retained by the said Council for municipal purposes.

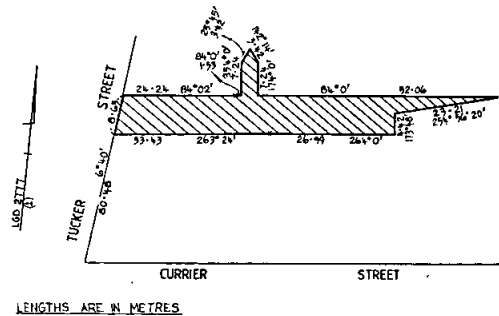

LENGTHS ARE IN METRES

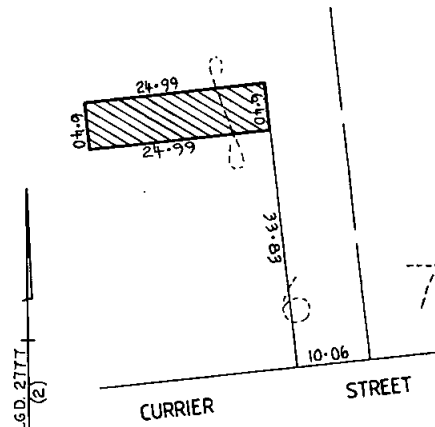

LENGTHS ARE IN METRES

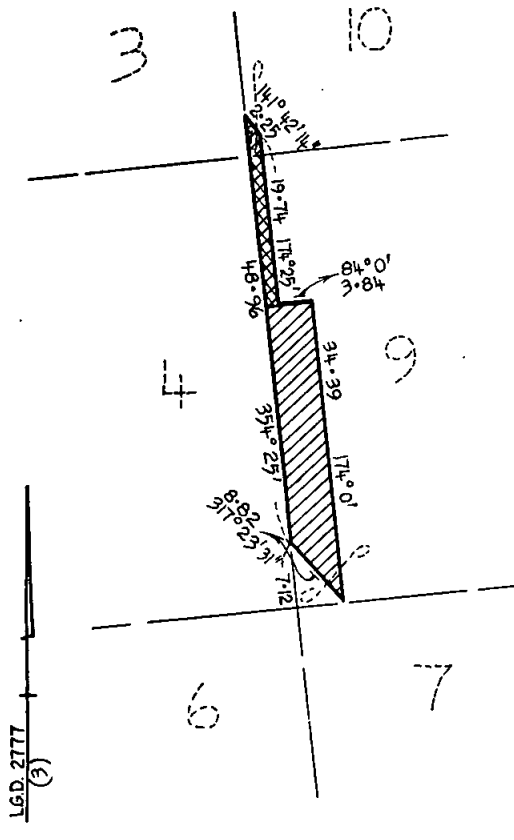

LENGTHS ARE IN METRES.

And the Honorable Alan John Hunt, Her Majesty's Minister for Local Government for the State of Victoria, shall give the necessary directions herein accordingly.

TOM FORRISTAL
Clerk of the Executive Council

LOCAL GOVERNMENT DEPARTMENT

At the Executive Council Chamber, Melbourne, the nineteenth day of December, 1978

PRESENT:

His Excellency the Governor of Victoria
Mr. Smith | Mr. Maclellan
Mr. Hayes | Mr. Ramsay

ROADS DISCONTINUED—CITY OF SPRINGVALE

Whereas it is provided in section 528 (2) of the *Local Government Act 1958* that where a road (whether or not a public highway but not being a road set out on land of the Crown) or any part thereof is not required for public use, the Governor in Council on the request of the council of the municipality in which such road is situated made not less than one month after publishing in a newspaper generally circulating in the district and posting to the registered proprietor (if any) of the land and the owners and occupiers (if any) of lands abutting or immediately adjacent to the road notice of intention to make such a request may by Order published in the *Government Gazette* direct that such road or part shall be discontinued and thereupon such road or part shall be discontinued accordingly.

And whereas the Council of the City of Springvale has requested that the Governor in Council direct that roads off Moncur Avenue, Springvale, be discontinued and not less than one month previously has published in a newspaper generally circulating in the district and posted to the registered proprietor of the land in the roads and to the owners and occupiers of the lands abutting or immediately adjacent to the roads notice of intention to make such a request.

Now therefore, His Excellency the Governor of the State of Victoria, by and with the advice of the Executive Council thereof, hereby directs:—

- (a) that the said roads which are shown by hatching and cross-hatching on the plan hereunder, shall be discontinued;
- (b) that notwithstanding such discontinuance the Springvale and Noble Park Sewerage Authority shall continue to have and possess the same right title power authority or interest in or in relation to the whole of the land shown by cross hatching on the said plan as it had or possessed prior to such discontinuance with respect to or in connection with any drains or pipes laid or erected in on or over such lands for the purposes of drainage or sewerage; and
- (c) that, subject to any such right title power authority or interest the land in the said part of road may be sold by the Council of the City of Springvale by agreement.

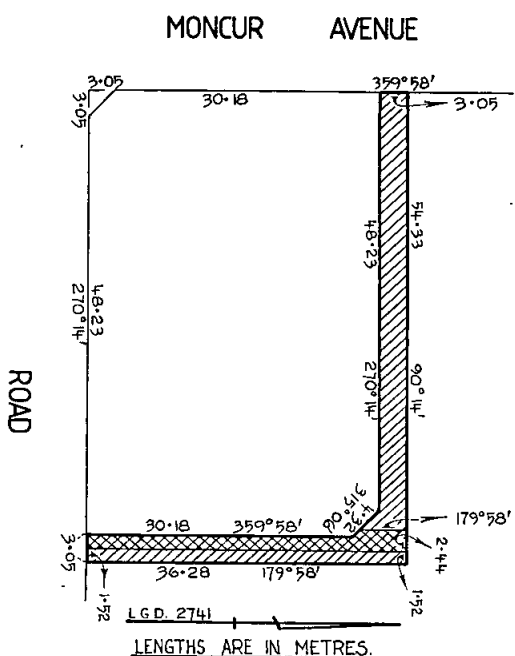
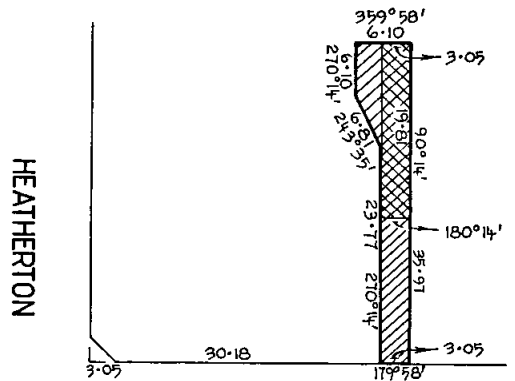

LENGTHS ARE IN METRES.

And the Honorable Alan John Hunt, Her Majesty's Minister for Local Government for the State of Victoria, shall give the necessary directions herein accordingly.

TOM FORRISTAL
Clerk of the Executive Council

LOCAL GOVERNMENT ACT 1958

At the Executive Council Chamber, Melbourne, the nineteenth day of December, 1978

PRESENT:

His Excellency the Governor of Victoria	
Mr. Smith	Mr. Maclellan
Mr. Hayes	Mr. Ramsay

DECLARATION OF THE WESTERN REFUSE DISPOSAL REGION

Whereas it is provided by section 812A of the Local Government Act 1958 that the Governor in Council may from time to time by Order published in the Government Gazette declare any two or more municipal districts to be a refuse disposal region.

Now therefore His Excellency the Governor of the State of Victoria, by and with the advice of the Executive Council thereof, hereby declares the municipal districts of the Cities of Altona, Collingwood, Essendon, Fitzroy, Footscray, Keilor, Melbourne, Port Melbourne, Richmond, South Melbourne, Sunshine and Williamstown and the Shires of Melton and Werribee to be a refuse disposal region under the name of the Western Refuse Disposal Region.

And the Honorable Alan John Hunt, Her Majesty's Minister for Local Government for the State of Victoria, shall give the necessary directions herein accordingly.

TOM FORRISTAL,
Clerk of the Executive Council

LOCAL GOVERNMENT DEPARTMENT

At the Executive Council Chamber, Melbourne, the nineteenth day of December, 1978

PRESENT:

His Excellency the Governor of Victoria	
Mr. Smith	Mr. Maclellan
Mr. Hayes	Mr. Ramsay

ROAD DISCONTINUED—CITY OF NUNAWADING

Whereas it is provided in section 528 (2) of the Local Government Act 1958, that where a road (whether or not a public highway but not being a road set out on land of the Crown) or any part thereof is not required for public use, the Governor in Council on the request of the council of the municipality in which such road is situated made not less than one month after publishing in a newspaper generally circulating in the district and posting to the registered proprietor (if any) of the land and the owners and occupiers (if any) of the lands abutting or immediately adjacent to the road notice of intention to make such a request may by Order published in the Government Gazette direct that such a road or part thereof shall be discontinued and thereupon such road or part thereof shall be discontinued accordingly.

And whereas the Council of the City of Nunawading has requested that the Governor in Council direct that a road between Linlithgow Street and Hopetoun Street, Nunawading be discontinued and not less than one month previously has published in a newspaper generally circulating in the district and posted to the registered proprietors of the land in the road and to the owners and occupiers of lands abutting or immediately adjacent to the said road notice of intention to make such request.

Now therefore, His Excellency the Governor of the State of Victoria, by and with the advice of the Executive Council thereof, hereby directs:—

- (a) that the said road which is shown by hatching and cross-hatching on the plan hereunder shall be discontinued;
- (b) that notwithstanding such discontinuance the Melbourne and Metropolitan Board of Works shall continue to have and possess the same right title power authority or interest in or in relation to the whole of the land shown by cross-hatching on the said plan as it had or possessed prior to such discontinuance with

respect to or in connection with any drains or pipes laid or erected in on or over such land for the purposes of drainage or sewerage;

- (c) that notwithstanding such discontinuance the Council of the City of Nunawading shall continue to have and possess the same right title power authority or interest in or in relation to the whole of the land shown by hatching and cross-hatching on the said plan as it had or possessed prior to such discontinuance with respect to or in connection with any drains or pipes laid or erected in on or over such land for the purposes of drainage; and
- (d) that, subject to any such right title power authority or interest the land in the said road may be sold by the City of Nunawading by agreement.

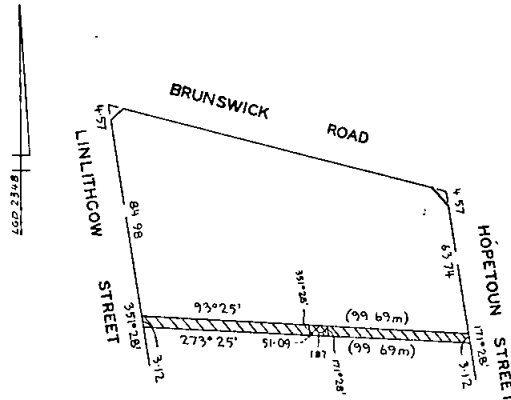

LENGTHS ARE IN METRES

And the Honorable Alan John Hunt, Her Majesty's Minister for Local Government for the State of Victoria, shall give the necessary directions herein accordingly.

TOM FORRISTAL,
Clerk of the Executive Council

LOCAL GOVERNMENT DEPARTMENT

At the Executive Council Chamber, Melbourne, the nineteenth day of December, 1978

PRESENT:

His Excellency the Governor of Victoria	
Mr. Smith	Mr. Maclellan
Mr. Hayes	Mr. Ramsay

ROAD DISCONTINUED—SHIRE OF CORIO

Whereas it is provided in section 528 (2) of the Local Government Act 1958, that where a road (whether or not a public highway but not being a road set out on land of the Crown) or any part thereof is not required for public use the Governor in Council on the request of the council of the municipality in which such road is situated made not less than one month after publishing in a newspaper generally circulating in the district and posting to the registered proprietor (if any) of the land and the owners and occupiers (if any) of lands abutting or immediately adjacent to the road notice of intention to make such a request may by Order published in the Government Gazette direct that such a road or part shall be discontinued and thereupon such road or part shall be discontinued accordingly;

And whereas the Council of the Shire of Corio has requested that the Governor in Council direct that a road off Plantation Road, Corio be discontinued and not less than one month previously has published in a newspaper generally circulating in the district and posted to the

registered proprietor of the land in the road and to the owners and occupiers of lands abutting or immediately adjacent to the road notice of intention to make such a request;

Now therefore, His Excellency the Governor of the State of Victoria, by and with the advice of the Executive Council thereof, hereby directs:

- (a) that the said road which is shown by hatching and cross-hatching on the plan hereunder, shall be discontinued;
- (b) that notwithstanding such discontinuance the State Electricity Commission shall continue to have and possess the same right title power authority or interest in or in relation to the whole of the land shown by cross-hatching on the said plan as it had or possessed prior to such discontinuance with respect to or in connection with any wires or cables laid or erected in on or over such land for the purposes of electricity supply; and
- (c) that, subject to any such right title power authority or interest the land in the said road may be sold by the Council of the Shire of Corio by agreement;

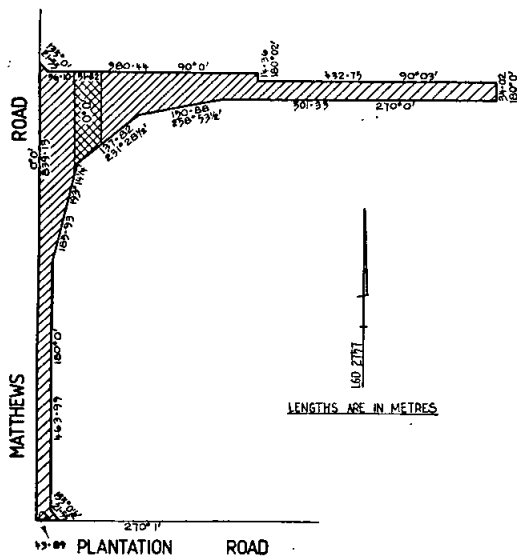

And the Honorable Alan John Hunt, Her Majesty's Minister for Local Government for the State of Victoria, shall give the necessary directions herein accordingly.

TOM FORRISTAL,
Clerk of the Executive Council

LOCAL GOVERNMENT DEPARTMENT

At the Executive Council Chamber, Melbourne, the nineteenth day of December, 1978

PRESENT:
His Excellency the Governor of Victoria
Mr. Smith | Mr. Maclellan
Mr. Hayes | Mr. Ramsay

ROAD RETAINED—CITY OF CROYDON

Whereas it is provided by paragraph (baa) of subsection (2) of section 528 of the *Local Government Act 1958*, that where pursuant to an Order made by the Governor in Council under the provisions of this section or any corresponding previous enactment as in force before the commencement of the *Local Government (Amendment) Act 1962* any road or part of a road was discontinued and the land and soil thereof vested in the municipality, then if the said land has not been

sold the Governor in Council may by a further Order published in the *Government Gazette* direct that the land shall be retained by the municipality for municipal purposes.

And whereas by an Order made under the said subsection and published in the *Government Gazette* of 23rd August, 1978, that the part of a road indicated by hatching on the plan annexed hereto was discontinued.

Now therefore, His Excellency the Governor of the State of Victoria by and with the advice of the Executive Council thereof, hereby directs that the land in the said part of a road shall be retained by the Council of the City of Croydon for municipal purposes.

And the Honorable Alan John Hunt, Her Majesty's Minister for Local Government for the State of Victoria, shall give the necessary directions herein accordingly.

TOM FORRISTAL,
Clerk of the Executive Council

LOCAL GOVERNMENT ACT 1958

At the Executive Council Chamber, Melbourne, the nineteenth day of December, 1978

PRESENT:
His Excellency the Governor of Victoria
Mr. Smith | Mr. Maclellan
Mr. Hayes | Mr. Ramsay

DECLARATION OF THE EASTERN REFUSE DISPOSAL REGION

Whereas it is provided by section 812A of the *Local Government Act 1958* that the Governor in Council may from time to time by Order published in the *Government Gazette* declare any two or more municipal districts to be a refuse disposal region.

Now therefore His Excellency the Governor of the State of Victoria, by and with the advice of the Executive Council thereof, hereby declares the municipal districts of the Cities of Berwick, Croydon, Dandenong, Knox, Nunawading and Ringwood and the Shires of Healesville, Lillydale, Pakenham and Sherbrooke to be a refuse disposal region under the name of the Eastern Refuse Disposal Region.

And the Honorable Alan John Hunt, Her Majesty's Minister for Local Government for the State of Victoria, shall give the necessary directions herein accordingly.

TOM FORRISTAL,
Clerk of the Executive Council

LOCAL GOVERNMENT DEPARTMENT

At the Executive Council Chamber, Melbourne, the nineteenth day of December, 1978

PRESENT:
His Excellency the Governor of Victoria
Mr. Smith | Mr. Maclellan
Mr. Hayes | Mr. Ramsay

ALTERATION OF TIME FOR CLOSING POLL AT MUNICIPAL ELECTIONS—SHIRE OF TRARALGON

His Excellency the Governor of the State of Victoria, by and with the advice of the Executive Council thereof, in pursuance of the powers conferred by section 134 of the *Local Government Act 1958*, and in compliance with the prayer of a petition presented by the Council of the Shire of Traralgon declares that the hour for closing the poll at municipal elections for the said Shire shall be eight o'clock in the afternoon.

And the Honorable Alan John Hunt, Her Majesty's Minister for Local Government for the State of Victoria, shall give the necessary directions herein accordingly.

TOM FORRISTAL,
Clerk of the Executive Council

COUNTRY ROADS BOARD
Act No. 6229

At the Executive Council Chamber, Melbourne, the
nineteenth day of December, 1978

PRESENT:

His Excellency the Governor of Victoria
Mr. Smith | Mr. Maclellan
Mr. Hayes | Mr. Ramsay

ORDER APPROVING OF LAND BEING ACQUIRED AND
ROADS, DEVIATIONS OR WIDENINGS BEING MADE
TOGETHER WITH ALL ANCILLARY WORKS
REQUIRED TO BE EXECUTED IN CONJUNCTION
THEREWITH

His Excellency the Governor of the State of Victoria,
by and with the advice of the Executive Council thereof,
being satisfied that there are funds legally available for
acquiring the land, doth hereby approve the acquiring of
the land described in the schedule hereunder and the
making of new roads and deviations from and widenings
of existing roads, together with all ancillary works required
to be executed in conjunction therewith, referred to in
the said schedule.

SCHEDULE
Main Roads

The land shown hatched on plan numbered G.P.14821
hereunder required for the widening of the Baxter-Tooradin
Road in the Shire of Cranbourne and making of the
widening thereon.

The land shown hatched on plan numbered G.P.14808
hereunder required for the widening of the Foster North-
Mirboo South Road in the Shire of South Gippsland
and making of the widening thereon.

MAIN ROAD
FOSTER NORTH - MIRBOO SOUTH ROAD
SHIRE OF SOUTH GIPPSLAND
Lengths in metres

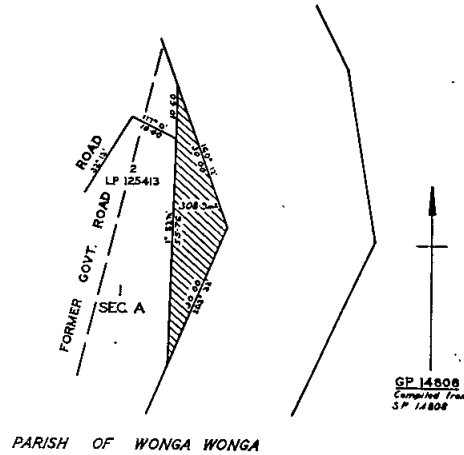

The land shown hatched on plan numbered G.P.14751
hereunder required for the widening of the Talgarno Road
in the Shire of Tallangatta and making of the widening
thereon.

MAIN ROAD
TALGARNO ROAD
SHIRE OF TALLANGATTA
Lengths in metres

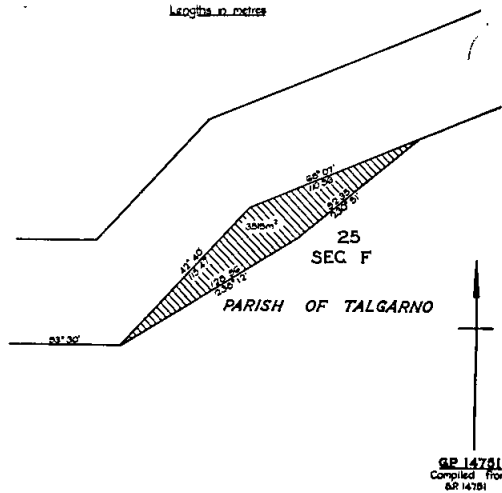

MAIN ROAD
BAXTER-TOORADIN ROAD
SHIRE OF CRANBOURNE
Lengths are in metres

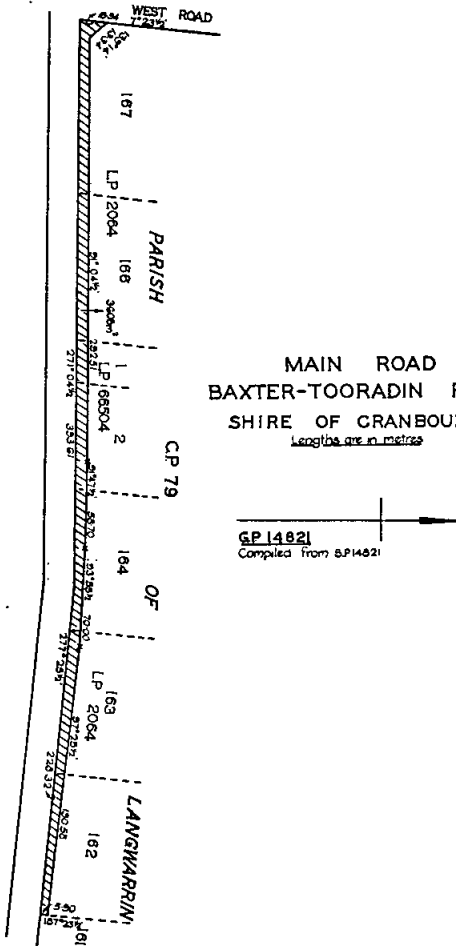

And the Honorable Robert Roy Cameron Maclellan, Her
Majesty's Minister of Transport for the State of Victoria
shall give the necessary directions herein accordingly.

TOM FORRISTAL,
Clerk of the Executive Council

COUNTRY ROADS BOARD
Act No. 6229

At the Executive Council Chamber, Melbourne, the
nineteenth day of December, 1978

PRESENT:
His Excellency the Governor of Victoria
Mr. Smith | Mr. Maclellan
Mr. Hayes | Mr. Ramsay

ORDER APPROVING OF LAND BEING ACQUIRED AND
ROADS, DEVIATIONS OR WIDENINGS BEING MADE
TOGETHER WITH ALL ANCILLARY WORKS
REQUIRED TO BE EXECUTED IN CONJUNCTION
THEREWITH

His Excellency the Governor of the State of Victoria,
by and with the advice of the Executive Council thereof,
being satisfied that there are funds legally available for
acquiring the land, doth hereby approve the acquiring of
the land described in the schedule hereunder and the
making of new roads and deviations from and widenings
of existing roads, together with all ancillary works required
to be executed in conjunction therewith, referred to in
the said schedule.

SCHEDULE
State Highway

The land shown hatched on plan numbered G.P.14849
hereunder required for the widening of the Midland High-
way in the Shire of Buninyong and making of the widening
thereon.

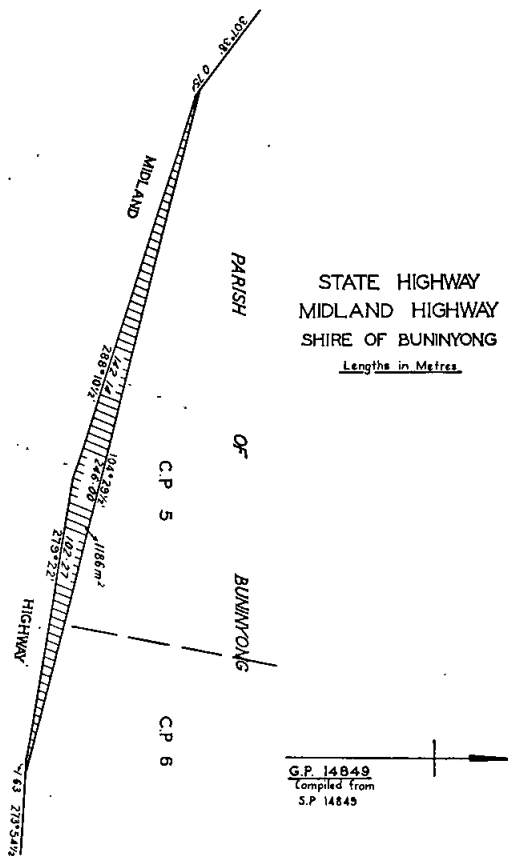

And the Honorable Robert Roy Cameron Maclellan, Her
Majesty's Minister of Transport for the State of Victoria
shall give the necessary directions herein accordingly.

TOM FORRISTAL,
Clerk of the Executive Council

HOUSING ACT 1958

At the Executive Council Chamber, Melbourne, the
nineteenth day of December, 1978

PRESENT:
His Excellency the Governor of Victoria
Mr. Smith | Mr. Maclellan
Mr. Hayes | Mr. Ramsay

DECLARATION OF PRIVATE STREETS AS PUBLIC
HIGHWAYS WITHIN THE CITY OF KEILOR

Whereas pursuant to section 107 of the *Housing Act*
1958 it is among other things enacted that where works
have been carried out in accordance with an agreement
for the full construction of any roads, pavements, culverts
or drains made pursuant to the provisions of the said
section 107 such roads, pavements, culverts or drains
shall be under the care and management of the muni-
cipality which shall be liable for the cost of any main-
tenance, repair, alteration or reconstruction thereof and
the Governor in Council may by Order published in the
Government Gazette declare any road so constructed to
be a public highway.

And whereas by Order dated the 10th May, 1977, the
Governor in Council consented to an agreement between
the Housing Commission and the City of Keilor regarding
street and drainage construction in Carbine Way, Hispano
Drive, Packard Street, Rodney Drive, Alfa Court, Bianchi
Court, Lotis Court, Bean Court, Germain Court, Taylors
Road and Buick Court in the Pecatru Estate situate in the
municipality of the City of Keilor and the carrying out of
the works enumerated in the said agreement.

And whereas the works of road pavements, culvert and
drainage construction have now been carried out in
accordance with the said agreement between the Housing
Commission and the City of Keilor.

Now therefore His Excellency the Governor of the
State of Victoria by and with the advice of the Executive
Council of the said State and in pursuance of the powers
conferred by section 107 of the *Housing Act* and upon
recommendation of the Housing Commission doth by this
Order declare the streets more particularly delineated and
shown hatched on the plan hereunder to be absolutely
dedicated to the public as Public Highways within the
meaning of any law now or hereafter in force and that
the Council of the Municipality in which the streets
are situate shall hereafter be liable for all cost of any
maintenance, repair, alteration or reconstruction thereof.

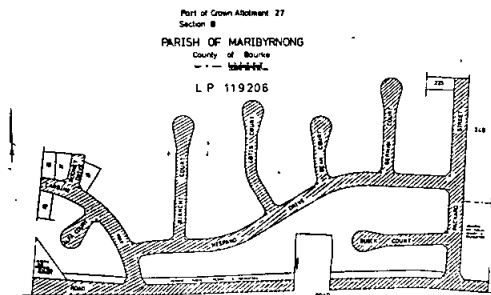

And the Honorable Geoffrey Phillip Hayes, Her
Majesty's Minister of Housing for the State of Victoria,
shall give the necessary directions herein accordingly.

TOM FORRISTAL,
Clerk of the Executive Council

HOUSING ACT 1958

At the Executive Council Chamber, Melbourne, the
nineteenth day of December, 1978

PRESENT:
His Excellency the Governor of Victoria
Mr. Smith | Mr. Maclellan
Mr. Hayes | Mr. Ramsay

DECLARATION OF PRIVATE STREETS AS PUBLIC
HIGHWAYS WITHIN THE CITY OF KEILOR

Whereas pursuant to section 107 of the *Housing Act*
1958 it is among other things enacted that where works
have been carried out in accordance with an agreement

for the full construction of any roads, pavements, culverts or drains made pursuant to the provisions of the said section 107 such roads, pavements, culverts or drains shall be under the care and management of the municipality which shall be liable for the cost of any maintenance, repair, alteration or reconstruction thereof and the Governor in Council may by Order published in the *Government Gazette* declare any road so constructed to be a public highway.

And whereas by Order dated the 10th May, 1977, the Governor in Council consented to an agreement between the Housing Commission and the City of Keilor regarding street and drainage construction in Daimler Avenue, Rodney Drive, Talbot Close and Buggatti Court in the Pecatru Estate situate in the municipality of the City of Keilor and the carrying out of the works enumerated in the said agreement.

And whereas the works of road pavements, culvert and drainage construction have now been carried out in accordance with the said agreement between the Housing Commission and the City of Keilor.

Now therefore His Excellency the Governor of the State of Victoria by and with the advice of the Executive Council of the said State and in pursuance of the powers conferred by section 107 of the Housing Act and upon recommendation of the Housing Commission doth by this Order declare the streets more particularly delineated and shown hatched on the plan hereunder to be absolutely dedicated to the public as Public Highways within the meaning of any law now or hereafter in force and that the Council of the Municipality in which the streets are situate shall hereafter be liable for all cost of any maintenance, repair, alteration or reconstruction thereof.

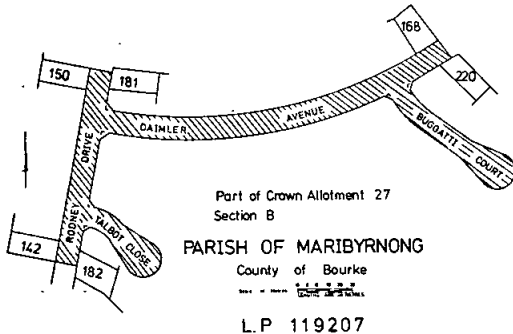

And the Honorable Geoffrey Phillip Hayes, Her Majesty's Minister of Housing for the State of Victoria, shall give the necessary directions herein accordingly.

TOM FORRISTAL,
Clerk of the Executive Council

HOUSING ACT 1958

At the Executive Council Chamber, Melbourne, the nineteenth day of December, 1978

PRESENT:

His Excellency the Governor of Victoria	
Mr. Smith	Mr. Maclellan
Mr. Hayes	Mr. Ramsay

DECLARATION OF PRIVATE STREETS AS PUBLIC HIGHWAYS WITHIN THE CITY OF KEILOR

Whereas pursuant to section 107 of the *Housing Act 1958* it is among other things enacted that where works have been carried out in accordance with an agreement for the full construction of any roads, pavements, culverts or drains made pursuant to the provisions of the said section 107 such roads, pavements, culverts or drains shall be under the care and management of the municipality which shall be liable for the cost of any maintenance, repair, alteration or reconstruction thereof and the Governor in Council may by Order published in the *Government Gazette* declare any road so constructed to be a public highway.

And whereas by Order dated the 10th May, 1977, the Governor in Council consented to an agreement between the Housing Commission and the City of Keilor regarding

street and drainage construction in Hotchkiss Way, Rodney Drive, Packard Street, Thornhill Drive, Itala Court, Lago Close, Metz Place, Daimler Avenue and Belmont Avenue in the Pecatru Estate situate in the municipality of the City of Keilor and the carrying out of the works enumerated in the said agreement.

And whereas the works of road pavements, culvert and drainage construction have now been carried out in accordance with the said agreement between the Housing Commission and the City of Keilor.

Now therefore His Excellency the Governor of the State of Victoria by and with the advice of the Executive Council of the said State and in pursuance of the powers conferred by section 107 of the Housing Act and upon recommendation of the Housing Commission doth by this Order declare the streets more particularly delineated and shown hatched on the plan hereunder to be absolutely dedicated to the public as Public Highways within the meaning of any law now or hereafter in force and that the Council of the Municipality in which the streets are situate shall hereafter be liable for all cost of any maintenance, repair, alteration or reconstruction thereof.

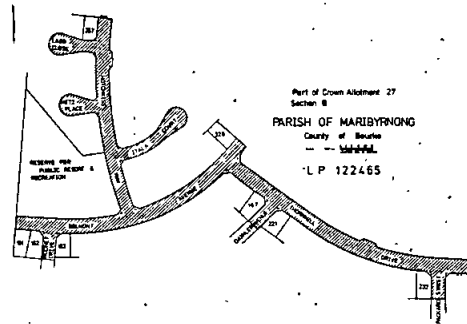

And the Honorable Geoffrey Phillip Hayes, Her Majesty's Minister of Housing for the State of Victoria, shall give the necessary directions herein accordingly.

TOM FORRISTAL,
Clerk of the Executive Council

HOSPITALS AND CHARITIES ACT 1958

At the Executive Council Chamber, Melbourne, the nineteenth day of December, 1978

PRESENT:

His Excellency the Governor of Victoria	
Mr. Smith	Mr. Maclellan
Mr. Hayes	Mr. Ramsay

EXTENSION OF THE OBJECTS OR PURPOSES OF MARYBOROUGH AND DISTRICT HOSPITAL

Whereas Maryborough and District Hospital is an incorporated institution within the meaning of the *Hospitals and Charities Act 1958*; and whereas the Committee of Management of the said institution has agreed that the objects or purposes of the said institution should be extended; and whereas the Health Commission of Victoria after enquiry has recommended that the objects or purposes should be extended; now therefore His Excellency the Governor of the State of Victoria, by and with the advice of the Executive Council of the said State, and by virtue of the powers conferred on him by section 52 of the *Hospitals and Charities Act 1958*, and all other powers enabling him in that behalf, hereby extends the objects or purposes of Maryborough and District Hospital by adding the following:

"(e) To participate in General Nursing Education by providing clinical experience for students on secondment from the Northern District School of Nursing."

And the Honorable William Vasey Houghton, Her Majesty's Minister of Health for the State of Victoria, shall give the necessary directions herein accordingly.

TOM FORRISTAL,
Clerk of the Executive Council

LAND ACT 1958

At the Executive Council Chamber, Melbourne, the nineteenth day of December, 1978

PRESENT:

His Excellency the Governor of Victoria	
Mr. Smith	Mr. Maclellan
Mr. Hayes	Mr. Ramsay

REVOCATION OF TEMPORARY RESERVATIONS OF LANDS BY ORDERS IN COUNCIL

His Excellency the Governor of the State of Victoria, in the Commonwealth of Australia, by and with the advice of the Executive Council of the said State, pursuant to the provisions of the Land Act 1958, hereby revokes the temporary reservations of lands by Orders in Council hereinafter described, viz.:

MIA MIA—The temporary reservation by Order in Council of the 18th October, 1966, of 1.082 hectares of land in the Township of Mia Mia, Parish of Spring Plains, as a site for Public Recreation, so far only as regards the portion thereof containing 162 square metres as shown on Certified Plan No. 103414 lodged in the Central Plan Office—(M.110(?) (Rs.3365).

SERPENTINE—The temporary reservation by Order in Council of the 24th July, 1865, of 2,023 square metres of land in the Township of Serpentine (at Janiember East in Order) as a site for Presbyterian Church purposes, so far only as regards the portion thereof containing 405 square metres, as defined by description and hatching on plan published in the Government Gazette of the 22nd November, 1978, is concerned—(J.20(?) (C.9514).

SERPENTINE—The temporary reservation by Order in Council of the 12th June, 1865, of 4,047 square metres of land in the Township of Serpentine as a site for Presbyterian Church purposes, so far only as regards the portion thereof containing 1,619 square metres, as defined by description and hatching on plan published in the Government Gazette of the 22nd November, 1978, is concerned—(J.20(?) (C.9514).

And the Honorable William Archibald Borthwick, Her Majesty's Minister of Lands for the State of Victoria, shall give the necessary directions herein accordingly.

TOM FORRISTAL,
Clerk of the Executive Council

SUPERANNUATION ACT 1958

At the Executive Council Chamber, Melbourne, the nineteenth day of December, 1978

PRESENT:

His Excellency the Governor of Victoria	
Mr. Smith	Mr. Maclellan
Mr. Hayes	Mr. Ramsay

Pursuant to the powers conferred by the provisions of paragraph (ja) of subsection (1) of section 3 of the Superannuation Act 1958, His Excellency the Governor of the State of Victoria, by and with the advice of the Executive Council thereof doth by this Order declare that the provisions of the Superannuation Act shall apply to the officers named in the schedule set out hereunder.

SCHEDULE

JEAN ELIZABETH BROWN,	The Victorian College of the Arts
ALISON HARTLEY FRASER,	The Victorian College of the Arts
BRENDAN HENNESSY,	The Victorian College of the Arts
JEANETTE MARY McLEAN,	The Victorian College of the Arts

And the Honorable Rupert James Hamer, Her Majesty's Treasurer for the State of Victoria, shall give the necessary directions herein accordingly.

TOM FORRISTAL,
Clerk of the Executive Council

ROAD TRAFFIC ACT

At the Executive Council Chamber, Melbourne, the nineteenth day of December, 1978

PRESENT:

His Excellency the Governor of Victoria	
Mr. Smith	Mr. Maclellan
Mr. Hayes	Mr. Ramsay

In pursuance of the powers conferred by the Road Traffic Act 1958, His Excellency the Governor of the State of Victoria, in the Commonwealth of Australia, by and with the advice of the Executive Council of the said State, and at the request of the Port Officer in Victoria, doth by this Order extend the provisions of the said Act to the premises being the wharves, jetties and piers under the control of the said Port Officer in Victoria specified in the schedule hereunder:—

SCHEDULE

Port Fairy Wharf	Rye Jetty
Warrnambool Wharf	Sorrento Pier
Port Campbell Jetty	Portsea Pier
Apollo Bay Wharf	Flinders Jetty
Lorne Jetty	Stony Point Jetty
Barwon Heads Jetty	Hastings Jetty
Queenscliff Pier	Cowes Jetty
St. Leonards Jetty	Rhyll Jetty
Portarlington Pier	Newhaven Jetty
Altona Jetty	San Remo Jetty
St. Kilda Pier	Inverloch Jetty
Middle Brighton Pier	Welshpool Pier
Sandringham Jetty	Welshpool Jetty
Black Rock Jetty	Port Albert Wharf
Mordialloc Jetty	Paynesville Wharf
Seaford Jetty	Metung Jetty
Frankston Jetty	Lakes Entrance Post Office Jetty
Mornington Jetty	Lakes Entrance Eastern Wharf
Dromana Pier	
Rosebud Jetty	

And the Honorable Joseph Anstice Rafferty, Her Majesty's Chief Secretary for the State of Victoria, shall give the necessary directions herein accordingly.

TOM FORRISTAL,
Clerk of the Executive Council

HISTORIC BUILDINGS ACT 1974 (No. 8569)

At the Executive Council Chamber, Melbourne, the nineteenth day of December, 1978

PRESENT:

His Excellency the Governor of Victoria	
Mr. Smith	Mr. Maclellan
Mr. Hayes	Mr. Ramsay

AMENDMENT OF REGISTER OF HISTORIC BUILDINGS

Whereas it is provided by Section 3 of the Historic Buildings Act 1974 that the Governor in Council, on the recommendation of the Minister, may by notice published in the Government Gazette amend the Register of Historic Buildings established under the said Act—

- by adding any specified building;
- by removing any specified building; or
- by altering any item.

And whereas the Minister has recommended that the Register be amended.

Now therefore His Excellency the Governor of the State of Victoria, by and with the advice of the Executive Council thereof, doth hereby amend the Register of Historic Buildings in the manner and to the extent shown as follows: by adding—

"HISTORIC BUILDING No. 436

Salvation Army Temple, 65-73 Bourke Street, Melbourne (to the extent of the facade to Bourke Street and the Temple Hall including the balconies)."

And the Honorable Alan John Hunt, Her Majesty's Minister for Planning for the State of Victoria, shall give the necessary directions herein accordingly.

TOM FORRISTAL,
Clerk of the Executive Council

HISTORIC BUILDINGS ACT 1974 (No. 8569)

At the Executive Council Chamber, Melbourne, the nineteenth day of December, 1978

PRESENT:

His Excellency the Governor of Victoria	
Mr. Smith	Mr. Maclellan
Mr. Hayes	Mr. Ramsay

AMENDMENT OF REGISTER OF HISTORIC BUILDINGS

Whereas it is provided by Section 3 of the *Historic Buildings Act 1974* that the Governor in Council, on the recommendation of the Minister, may by notice published in the *Government Gazette* amend the Register of Historic Buildings established under the said Act—

- (a) by adding any specified building;
- (b) by removing any specified building; or
- (c) by altering any item.

And whereas the Minister has recommended that the Register be amended.

Now therefore His Excellency the Governor of the State of Victoria, by and with the advice of the Executive Council thereof, doth hereby amend the Register of Historic Buildings in the manner and to the extent shown as follows: by amending—

"Historic Building No. 354 10 John Street, Beechworth"
to
"Historic Building No. 354, Building, 10 John Street, Beechworth (to the extent of the house, and area of land within the red perimeter defined on the plan approved with this Order), Part Crown allotment 4, Section T2, Township of Beechworth, Parish of Bogong".

And the Honorable Alan John Hunt, Her Majesty's Minister for Planning for the State of Victoria, shall give the necessary directions herein accordingly.

TOM FORRISTAL,
Clerk of the Executive Council

HISTORIC BUILDINGS ACT 1974 (No. 8569)

At the Executive Council Chamber, Melbourne, the nineteenth day of December, 1978

PRESENT:

His Excellency the Governor of Victoria	
Mr. Smith	Mr. Maclellan
Mr. Hayes	Mr. Ramsay

AMENDMENT OF REGISTER OF HISTORIC BUILDINGS

Whereas it is provided by Section 3 of the *Historic Buildings Act 1974* that the Governor in Council, on the recommendation of the Minister, may by notice published in the *Government Gazette* amend the Register of Historic Buildings established under the said Act—

- (a) by adding any specified building;
- (b) by removing any specified building; or
- (c) by altering any item.

And whereas the Minister has recommended that the Register be amended.

Now therefore His Excellency the Governor of the State of Victoria, by and with the advice of the Executive Council thereof, doth hereby amend the Register of Historic Buildings in the manner and to the extent shown as follows: by adding—

HISTORIC BUILDING NO. 442

Sum-Kum Lee, 112-114 Little Bourke Street, Melbourne, (to the extent of the total external fabric of the building).

And the Honorable Alan John Hunt, Her Majesty's Minister for Planning for the State of Victoria, shall give the necessary directions herein accordingly.

TOM FORRISTAL,
Clerk of the Executive Council

NATIONAL PARKS ACT 1975

At the Executive Council Chamber, Melbourne, the nineteenth day of December, 1978

PRESENT:

His Excellency the Governor of Victoria	
Mr. Smith	Mr. Maclellan
Mr. Hayes	Mr. Ramsay

In pursuance of the powers conferred by the provisions of Sections 10 and 13 of the *National Parks Act 1975*, His Excellency the Governor of the State of Victoria by and with the advice of the Executive Council thereof doth by this Order appoint ROBERT WILLIAM RITCHIE, nominated by the Minister from a panel of not less than three names submitted by the Municipal Association of Victoria within the meaning of the *Municipal Association Act 1907*, to be a member of the National Parks Advisory Council for the period ending 4th December, 1981.

And the Honorable William Archibald Borthwick, Her Majesty's Minister for Conservation for the State of Victoria, shall give the necessary directions herein accordingly.

TOM FORRISTAL,
Clerk of the Executive Council

FISHERIES ACT 1968

At the Executive Council Chamber, Melbourne, the nineteenth day of December, 1978

PRESENT:

His Excellency the Governor of Victoria	
Mr. Smith	Mr. Maclellan
Mr. Hayes	Mr. Ramsay

APPOINTMENT OF HONORARY INSPECTOR OF FISHERIES

Pursuant to Section 6 of the *Fisheries Act 1968* and all other powers him thereunto enabling, His Excellency the Governor of the State of Victoria, by and with the advice of the Executive Council thereof, and upon the recommendation of the Minister for Conservation, doth by this Order appoint—

ALAN CLARK
to be an Honorary Inspector of Fisheries.

And the Honorable William Archibald Borthwick, Her Majesty's Minister for Conservation for the State of Victoria, shall give the necessary directions herein accordingly.

TOM FORRISTAL,
Clerk of the Executive Council

STATE ELECTRICITY COMMISSION ACT 1958,
No. 6377

At the Executive Council Chamber, Melbourne, the nineteenth day of December, 1978

PRESENT:

His Excellency the Governor of Victoria	
Mr. Smith	Mr. Maclellan
Mr. Hayes	Mr. Ramsay

Whereas His Excellency the Governor of the State of Victoria by and with the advice of the Executive Council thereof this day consented pursuant to the provisions of the *State Electricity Commission Act 1958* to the State Electricity Commission of Victoria raising by way of a

loan the sum of Seventy thousand dollars (\$70,000); and whereas the Governor in Council is satisfied that a sufficient proportion of the loan to be raised will fall due and be repaid in each year during the currency of the proposed loan; now therefore it is directed pursuant to the provisions of section 91 (3) of the said Act, that it shall not be necessary to provide a sinking fund in connection with such loan.

And the Honorable Rupert James Hamer, Her Majesty's Treasurer for the State of Victoria, shall give the necessary directions herein accordingly.

TOM FORRISTAL,
Clerk of the Executive Council

STATE ELECTRICITY COMMISSION ACT 1958,
No. 6377

At the Executive Council Chamber, Melbourne, the nineteenth day of December, 1978

PRESENT:

His Excellency the Governor of Victoria
Mr. Smith Mr. Maclellan
Mr. Hayes Mr. Ramsay

Whereas His Excellency the Governor of the State of Victoria by and with the advice of the Executive Council thereof has this day consented pursuant to the provisions of the State Electricity Commission Act 1958 to the State Electricity Commission of Victoria raising by way of a loan the sum of Forty thousand dollars (\$40,000); and whereas the Governor in Council is satisfied that a sufficient proportion of the loan to be raised will fall due and be repaid in each year during the currency of the proposed loan; now therefore it is directed pursuant to the provisions of section 91 (3) of the said Act, that it shall not be necessary to provide a sinking fund in connection with such loan.

And the Honorable Rupert James Hamer, Her Majesty's Treasurer for the State of Victoria, shall give the necessary directions herein accordingly.

TOM FORRISTAL,
Clerk of the Executive Council

WILDLIFE ACT 1975

At the Executive Council Chamber, Melbourne, the nineteenth day of December, 1978

PRESENT:

His Excellency the Governor of Victoria
Mr. Smith Mr. Maclellan
Mr. Hayes Mr. Ramsay

APPOINTMENT OF HONORARY WILDLIFE OFFICER

Pursuant to Section 9 of the Wildlife Act 1968 and all other powers him thereunto enabling, His Excellency the Governor of the State of Victoria, by and with the advice of the Executive Council thereof, and upon the recommendation of the Minister for Conservation, doth by this Order appoint—

ALAN CLARK, being an officer in the Public Service of the State of Victoria,
to be an Honorary Wildlife Officer.

And the Honorable William Archibald Borthwick, Her Majesty's Minister for Conservation for the State of Victoria, shall give the necessary directions herein accordingly.

TOM FORRISTAL,
Clerk of the Executive Council

LANDS DEPARTMENT NOTICES

APPROACHING LAND SALES

Sale of Crown Land, in fee-simple, will be held at the under-mentioned places and dates, viz.:-

	No. of Gazette
Ouyen—Friday, 26th January, 1979	107
Underbool—Friday, 26th January, 1979	107
Underbool—Friday, 26th January, 1979	113

PROPOSED REVOCATIONS OF TEMPORARY RESERVATIONS OF LANDS BY ORDERS IN COUNCIL

In pursuance of the provisions of the Land Act 1958, notice is hereby given that it is the intention of the Governor in Council to revoke the temporary reservations of lands by Orders in Council hereunder referred to viz.:-
The following Notices were published 1° on the 13th December, 1978, pursuant to Orders of the 5th December, 1978

KEELBUNDORA—The temporary reservation by Order in Council of the 26th October, 1965, of 195.9 hectares of land in the Parish of Keelbundora, as a site for Public Purposes (La Trobe University purposes) is about to be revoked—(K.25°) (Rs.8751).

KEELBUNDORA—The temporary reservation by Orders in Council of the 25th March, 1975, of 101.2 hectares, more or less, of land in the Parish of Keelbundora as a site for Public Purposes (Mental Health purposes), is about to be revoked so far only as the portion containing 18.46 hectares indicated by hatching on plan hereunder, is concerned—(K.25°) (Rs.1436).

MENTAL HEALTH
PURP\$ RES.

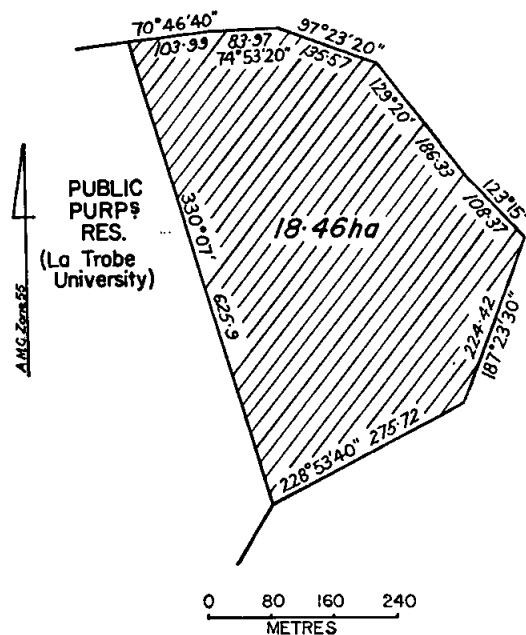

NUNAWADING—The temporary reservation as a site for a Cemetery and the withholding from sale, leasing and licensing by Order in Council of the 27th March, 1876, of 9106 square metres of land in the Parish of Nunawading,

so far only as the portion containing 3184 square metres, indicated by hatching on plan hereunder, is concerned—(N.79(1) (Rs.4455).

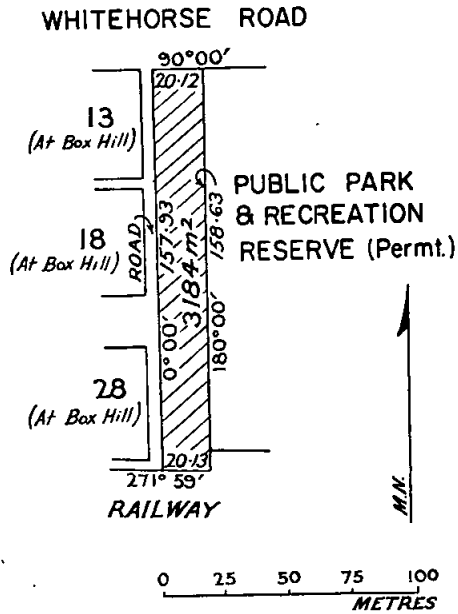

WEEAPROINAH—The temporary reservation by Order in Council of the 5th December, 1938, of 564.1 hectares of land in the Parish of Weeaprounah, as a site for Water Supply purposes, is about to be revoked, so far only as the portion containing 1143 square metres, indicated by hatching on plan hereunder, is concerned—(W.361(2) (Rs.4834).

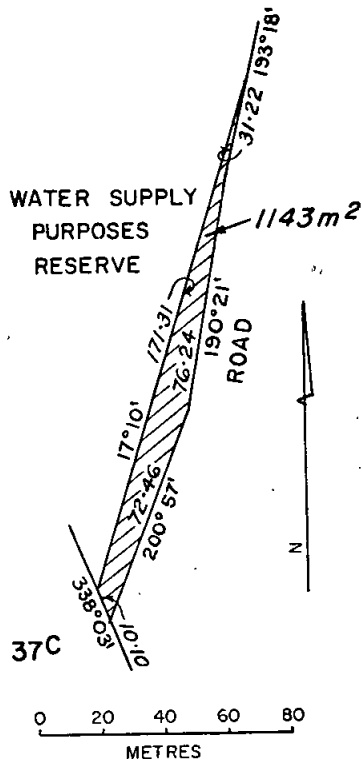

W. BORTHWICK,
Minister of Lands

PROPOSED PERMANENT RESERVATIONS OF LAND AS A SITE

In pursuance of the provisions of the Land Act 1958, notice is hereby given that it is the intention of the Governor in Council to permanently reserve as a site, and also except from occupation for mining purposes under any miner's right, the land hereunder referred to:—

The following Notice was published 1° on the 6th December, 1978, pursuant to an Order of the 28th November, 1978

MAGEPPA (BENIAGH SWAMP)—Land proposed to be permanently reserved as a site for Public Purposes (Management of Wildlife), 215.4 hectares, being Crown allotment 19, Parish of Mageppa, County of Follett, as indicated by hatching on plan hereunder—(M.460(A*) (Rs.10491).

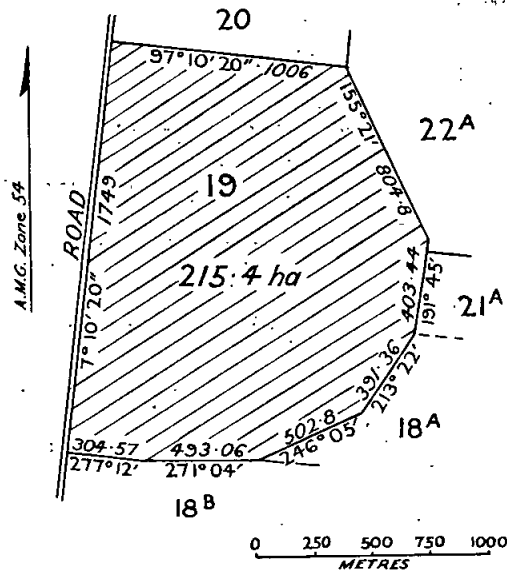

W. BORTHWICK,
Minister of Lands

COMMITTEES OF MANAGEMENT OF RESERVES

APPOINTMENTS

Notice is hereby given that, in pursuance of section 221 of the Land Act 1958, the following appointments of Committees of Management of reserved Crown Lands have been made by the Minister of Lands, viz.:—

CERTAIN LAND IN THE PARISH OF BALLARAT RESERVED FOR WATER SUPPLY PURPOSES

The Ballarat Water Commissioners as a Committee of Management of the land in the Township of Nerrina, Parish of Ballarat, temporarily reserved by Order in Council dated the 24th October, 1978, as a site for Water Supply Purposes—(Corres. No. Rs.10454).

CERTAIN LAND IN THE CITY OF GEELONG RESERVED AS A SITE FOR PUBLIC PURPOSES (PERFORMING ARTS)

The Geelong and District Cultural Institute as a Committee of Management of the land in the City of Geelong, Parish of Corio, permanently reserved by Order in Council dated the 17th October, 1978, as a site for Public Purposes (Performing Arts)—(Corres. No. Rs.10620).

W. BORTHWICK,
Minister of Lands

Department of Crown Lands and Survey,
Melbourne, 20th December, 1978

REGULATIONS FOR THE CARE, PROTECTION, AND
MANAGEMENT OF CERTAIN LAND IN THE PARISH
OF ROSEDALE RESERVED FOR PUBLIC PURPOSES
(PRESERVATION OF NATIVE FLORA)

Whereas by section 218 of the *Land Act 1958* the Minister of Lands is empowered to make Regulations as to any land which under the provisions of that Act or of any other Act relating to Crown lands has been reserved for any public purpose whatsoever and which has not been conveyed to or vested in trustees: And whereas certain Crown land in the Parish of Rosedale was temporarily reserved as a site for Public Purposes (Preservation of Native Flora) by Order in Council dated the 10th January, 1978 (*vide Government Gazette* of the 18th January, 1978): And whereas such land (hereinafter called the "Reserve") has not been conveyed to or vested in trustees: And whereas it is expedient that Regulations for the care, protection, and management of the Reserve and for other purposes connected therewith should be made: Now therefore I, William Archibald Borthwick, Her Majesty's Minister of Lands in and for the State of Victoria, in pursuance of the powers aforesaid, do hereby make the following Regulations for or with respect to the Reserve:—

REGULATIONS

1. The Reserve shall be open to the public at all times free of charge.
2. No person shall—
 - (a) enter or remain in the Reserve who may offend against decency as regards dress, language or conduct or who may behave in a disorderly, unseemly or offensive manner, or create or take part in any disturbance;
 - (b) carry, use or discharge any firearm, air-rifle or any other weapon in the Reserve;
 - (c) disturb, interfere with or destroy any animal or bird or its lair or nest in the Reserve;
 - (d) interfere with, mark, cut names on or in any way damage or injure any of the buildings, gates, fences, barriers, seats, signs or any other improvements in the Reserve;
 - (e) interfere with, mark, cut names on or in any way damage, injure or disturb any tree, shrub, plant or other vegetation or any sand, stone, gravel, rock or any other earth in the Reserve;
 - (f) remove any sand, soil, gravel or rock from the Reserve;
 - (g) pick leaves, bark or flowers from any vegetation in the Reserve;
- (h) leave or deposit any glass, bottle, tin, can, waste paper, refuse or any other rubbish except in receptacles provided for the purpose in the Reserve;
- (i) erect any building, tent, booth or other structure in the Reserve, nor sell or offer for sale or hire any article or any other commodity whatsoever therein or within any structure thereon;
- (j) light or cause to be lit any fire in the Reserve except in any properly constructed fireplace provided for the purpose;
- (k) drive any motorized vehicle off any formed road or parking area provided in the Reserve or in contravention of any authorized sign therein;
- (l) put or allow to remain in the Reserve any sheep, horses, cattle, pigs or other animals except as hereinafter provided;
- (m) organize or take part in any public entertainment, game or sport in the Reserve.

3. No dog shall be in the Reserve unless such dog is and continues to be at all times controlled by a chain, cord or leash and any dog found wandering at large in the Reserve may be seized and delivered to the proper officer of the municipality concerned by any Bailiff of Crown lands or destroyed by such Bailiff—(Rs.10415).

Given under my hand, at Melbourne, on the 20th day of December, 1978.

W. BORTHWICK,
Minister of Lands

Every person who contravenes or fails to comply with these Regulations shall, in accordance with the provisions of section 218 of the *Land Act 1958*, for each offence be liable to a penalty of not more than fifty dollars, and every person who contravenes or fails to comply with any such Regulations, and who, after he has been warned by any bailiff of Crown lands or by any member of the Police Force, does not desist therefrom may be forthwith apprehended by such bailiff or member of the Police Force and taken before some justice to be dealt with according to law and shall be liable to a penalty of not more than One hundred dollars; provided that every person who contravenes any Regulation made under the said section for or with respect to prohibiting the depositing and leaving of any unwanted material or thing or rubbish of any kind on any land to which such Regulation relates shall for each offence be liable to a penalty of not more than two hundred dollars.

Teaching Service Act 1958

TEACHING SERVICE—TECHNICAL SCHOOLS DIVISION
(CLASSIFICATION, SALARIES, AND ALLOWANCES)
REGULATION

AMENDMENT No. 475 (TECH. C.S. & A.5)

The Teachers Tribunal, in pursuance of the powers conferred by the *Teaching Service Act 1958*, hereby amends the Teaching Service—Technical Schools Division (Classification, Salaries, and Allowances) Regulation as follows:—

In paragraph (i) of sub-clause 4 (a) after the expression "Melbourne School of Hairdressing;" insert the expression "Sunnyside College of Technical and Further Education;".

(To take effect from and including the 1st January, 1979)

J. J. KENNEDY, Alternate Chairman
A. F. LE CLERCQ, Secretary

Office of the Teachers Tribunal,
Melbourne, 22nd December, 1978

Teaching Service Act 1958
TEACHING SERVICE (TEACHERS TRIBUNAL)
REGULATIONS

AMENDMENT No. 473 (T.T. 64)

The Teachers Tribunal, in pursuance of the powers conferred by the *Teaching Service Act 1958*, hereby amends Regulation 19 of the Teaching Service (Teachers Tribunal) Regulations as follows:—

Regulation 19

Rescind Regulation 19 and substitute therefor the following new Regulation:—

Regulation 19

RELATIVE NUMBERS OF POSITIONS FOR TEACHERS IN EACH CLASS
OF THE SECONDARY SCHOOLS DIVISION

The relative numbers of positions for teachers in each class of the Secondary Schools Division from the 1st January, 1979, shall be as follows:—

<i>Class</i>	<i>Numbers of Positions</i>
Principal—	
Principals	298
Deputy Principals	235
	533
Senior Teacher	1,383
Assistant—Posts of Responsibility	2,584
Assistant	11,781

J. J. KENNEDY, Alternate Chairman
A. F. LE CLERCQ, Secretary

Office of the Teachers Tribunal,
Melbourne, 22nd December, 1978

Teaching Service Act 1958
TEACHING SERVICE (TEACHERS TRIBUNAL)
REGULATIONS

AMENDMENT No. 474 (T.T. 65)

The Teachers Tribunal, in pursuance of the powers conferred by the *Teaching Service Act 1958*, hereby amends Regulation 21 of the Teaching Service (Teachers Tribunal) Regulations as follows:—

Regulation 21

Rescind Regulation 21 and substitute therefor the following Regulation:—

Regulation 21

RELATIVE NUMBERS OF POSITIONS FOR TEACHERS IN EACH CLASS
OF THE TECHNICAL SCHOOLS DIVISION

The relative numbers of positions for teachers in each class of the Technical Schools Division from the 1st January, 1979, shall be as follows:—

<i>Class</i>	<i>Numbers of Positions</i>
Principal	318
Senior Teacher	897
Assistant—Posts of Responsibility	1,664
Assistant	6,669

J. J. KENNEDY, Alternate Chairman
A. F. LE CLERCQ, Secretary

Office of the Teachers Tribunal,
Melbourne, 22nd December, 1978

PRIVATE ADVERTISEMENTS

CITY OF ARARAT

By-Law No. 130

Notice is hereby given that in pursuance of the powers conferred by Section 197 of the *Local Government Act 1958*, the Council of the City of Ararat has made a By-Law numbered 130 for the purpose of regulating the proceedings of Council meetings, Committee meetings and for other purposes and also for repealing By-Law No. 53.

The resolution for the By-Law was agreed to on the 13th day of November 1978, and confirmed on the 18th day of December 1978.

A copy of the By-Law is open for inspection during office hours at the Municipal Offices, Vincent Street, Ararat.

97

J. I. GRENFELL, Town Clerk

CITY OF ECHUCA

LOAN No. 101

Notice of Intention to Borrow

Notice is hereby given that the Council of the City of Echuca intends to borrow Fifty Thousand dollars (\$50,000), secured by a charge over the general rates of the municipality by the grant of a mortgage in accordance with the provisions of the *Local Government Act 1958*, as amended.

In connection therewith the following information is stated:—

- (a) The amount of the principal moneys which it is proposed to borrow is \$50,000;
- (b) The maximum rate of interest that may be paid is 9.3 per centum per annum;
- (c) The period of the loan shall be fifteen years.
- (d) The moneys borrowed shall be repayable by providing out of the Municipal Fund half yearly instalments of \$3,123.97 each including principal and interest on the sixteenth day of February and the sixteenth day of August during the currency of the loan. The first instalment shall be payable on the sixteenth day of August, 1979.
- (e) The purpose for which the loan is to be applied:—

Part cost of the erection of an Industrial Building and associated works under Part XLA of the *Local Government Act 1958*.

- (f) Such moneys shall be repayable to the Bank of New South Wales, Echuca.

The plans and specifications and estimate of the cost of the works and a statement showing the proposed expenditure of the moneys to be borrowed are open for inspection at the office of the Council of the City of Echuca at the corner of Hare and Heygarth Streets, Echuca.

96

K. F. McCARTNEY, Town Clerk

CITY OF HAMILTON

By-Law No. 106

A By-Law of the City of Hamilton made under the provisions of section 197 of the *Local Government Act 1958* and numbered 106 for the purpose of prohibiting and regulating the placing of caravans on private property.

Pursuant to the powers conferred by the *Local Government Act 1958* as amended and of any and every other power it thereunto enabling the Mayor, Councillors and Citizens of the City of Hamilton order as follows:—

PART 1—DEFINITIONS

Definitions

In this By-Law unless inconsistent with the context or subject matter—

Authorised Officer means an Officer authorised in writing by the Council.

Caravan—includes any object, structure, vehicle or conveyance having the general characteristics of a caravan, a house on wheels, a covered van and any vehicle used and adapted for living purposes, whether the wheels or axles thereof have been removed or not and whether it is resting directly on the ground or is placed on blocks or other support

and any structure, awning, annex, verandah, lean-to, carport or any enclosed or partly enclosed area used or capable of being used in conjunction with or appurtenant to a caravan.

Council—means the Council of the City of Hamilton.

Occupy—includes residing or living in any caravan for the purposes of entertainment, sleeping, resting, cooking, eating or for any other similar use whether permanent or temporary.

PART 2—CAMPING ON PRIVATE PROPERTIES

1. No person without the written consent of Council and when such consent is given otherwise than in accordance with any condition or conditions imposed by the Council shall place or permit or suffer to be placed—

- (a) more than one Caravan on any private property;
- (b) any Caravan upon any private property in such a position that any part of such Caravan is within a distance of six metres from the frontage of such property, or is within a distance of two metres from any other boundary thereof except where any Caravan is located within a permanent building or structure on the said private property.

2. That proceeding Clause 1 shall not apply to the commercial display of Caravans for lease, sale or hire.

3. (a) Subject to part (b) hereof no person shall occupy any Caravan parked on any private property where a dwelling has been erected without the consent in writing of the Council under the hand of the Municipal Clerk.

(b) Nothing in this clause shall prevent the occupier of any private property placing thereon one Caravan for the use of a member of his household or a temporary visitor to sleep in the same for a total period not exceeding twenty-eight (28) days in any period of one (1) year provided that always that proper sanitary facilities to the satisfaction of the Health Inspector or authorised officer of the Council shall at all times be available on the land for the use of such member or visitor.

4. No person shall occupy any Caravan parked on any vacant land without the consent in writing of the Council under the hand of the Municipal Clerk.

5. The consent of the Council under the preceding clauses shall be subject to the following conditions—

1. The occupation shall be for a period not exceeding six (6) months; and

2. Proper sanitation facilities to the satisfaction of the Health Inspector or authorised officer of the Council being at all times available on the land for the use of the occupant. In the event of such sanitation facilities at any time ceasing to be so available then any permit granted under sub-clause (a) of clause 7 shall be immediately cancelled on service to the holder of such permit a notice under the signature of the Health Inspector or authorised officer of Council that such facilities have ceased to be available.

6. Every person applying for such consent shall make application in writing to the Council and supply such information as the Council may require.

7. (a) That Council may grant or refuse its consent to the application as it sees fit; and

(b) That consent may be granted subject to such further or additional conditions as the Council thinks proper including a condition that a specified matter or thing be done to the satisfaction of the Council.

8. This By-Law shall not apply to camping and caravan parks which have been approved by the Council.

PART 3—ENFORCEMENT OF BY-LAW

9. Any notice of permit given by the Council under this By-Law may be given under the hand of the Town Clerk, Health Inspector or authorised officer of the Council.

10. Any wilful action or default contrary to this By-Law shall constitute an offence against the By-Law and any person guilty of such an offence shall be liable to a penalty of not more than \$100 and in the case of continuing offence shall be liable to a penalty of not more than \$10 for each day on which the offence against the By-Law is continued after a conviction or order by any court.

11. This By-Law shall have operations throughout the whole of the municipal district of the City of Hamilton.

Resolution for passing this By-Law agreed to by the Council of the City of Hamilton on 25th May, 1978, and confirmed on the 22nd June, 1978.

The seal of the Mayor, Councillors and Citizens of the City of Hamilton was affixed hereto, this 22nd day of June, 1978—

(SEAL) J. J. SOULSBY, Mayor
L. J. WRAITH, Councillor
R. J. WORLAND, Town Clerk

Approved by the Governor in Council, 5th December, 1978—TOM FORRISTAL, Clerk of the Executive Council
106

CITY OF HAMILTON

LOAN No. 105

Notice of Intention to Borrow the Sum of \$40,000 for Permanent Works and Undertakings

Notice is hereby given that the Council of the City of Hamilton proposes to borrow the principal sum of \$40,000 secured by a charge over the General Rate for the Municipality by the grant of a Mortgage in accordance with the provisions of *Local Government Act 1958*.

(I) The amount of principal monies to be borrowed is \$40,000.

(II) The maximum rate of interest that may be applied is 9.30 per centum per annum.

(III) The purpose for which the loan monies are to be applied is redevelopment and extensions for the Hamilton Municipal Saleyards.

(IV) The period of the loan shall be Twenty Years.

(V) The monies borrowed shall be repayable by providing out of the Municipal Fund half-yearly instalments of \$2,220.48 each including principal and interest on the 9th day of February and the 9th day of August during the currency of the loan. The first instalment shall be payable on the 9th day of August 1979.

(VI) Such monies shall be payable to the Commercial Banking Company of Sydney Savings Bank Limited, 257 Collins Street, Melbourne.

The plans and specifications and the estimate of the cost of the proposed works and a statement showing the proposed expenditure of the monies to be borrowed are open for inspection at the office of the Council of the City of Hamilton, Brown Street, Hamilton.

Dated this 11th day of December, 1978
103 R. J. WORLAND, Town Clerk

Town and Country Planning Act 1961

CITY OF HORSHAM PLANNING SCHEME

NOTICE THAT A PLANNING SCHEME HAS BEEN PREPARED AND IS AVAILABLE FOR INSPECTION

Amendment No. 46, 1978

Notice is hereby given that the Council of the City of Horsham, in pursuance of its powers under the *Town and Country Planning Act 1961*, has prepared a planning scheme to amend the City of Horsham Planning Scheme Ordinance by adding a clause and table to introduce a new Service Business "A" Zone, and to rezone from Rural "A" to the proposed Service Business "A" Zone that part of the Municipal District of the City of Horsham bounded by Dooen Road, Pepper Tree Lane and Channel Reserve shown enclosed within a black border on the Planning Scheme map.

A copy of the Scheme has been deposited at the Office of the Council of the City of Horsham, Wilson Street, Horsham and at the Office of the Town and Country Planning Board, 235 Queen Street, Melbourne, and will be open for inspection thereat during Office Hours by any person free of charge.

Any persons affected by the Planning Scheme are required to set forth in writing, all objections they may have addressed to the Town Clerk, City of Horsham, Post Office Box 511, Horsham, on or before the 5th day of February, 1979, and to state whether they wish to be heard in respect of their objections.

94 A. R. CONN, Town Clerk

Town and Country Planning Act 1961

CITY OF HORSHAM PLANNING SCHEME

NOTICE THAT A PLANNING SCHEME HAS BEEN PREPARED AND IS AVAILABLE FOR INSPECTION

Amendment No. 47, 1978

Notice is hereby given that the Council of the City of Horsham, in pursuance of its powers under the *Town and Country Planning Act 1961*, has prepared a planning scheme to rezone from Residential "B" to Commercial "C" and Car Parking those parts of the Municipal District of the City of Horsham bounded by Darlot, Baillie, Wallis and Glead Streets and Delville, Darlot, Glead Streets and Park Drive shown enclosed within the black border on the Planning Scheme map.

A copy of the Scheme has been deposited at the Office of the Council of the City of Horsham, Wilson Street, Horsham, and at the Office of the Town and Country Planning Board, 235 Queen Street, Melbourne, and will be open for inspection thereat during office hours by any person free of charge.

Any persons effected by the Planning Scheme are required to set forth in writing, all objections they may have addressed to the Town Clerk, City of Horsham, Post Office Box 511, Horsham, on or before the 5th day of April, 1979, and to state whether they wish to be heard in respect of their objections.

93

A. R. CONN, Town Clerk

Town and Country Planning Act 1961

CITY OF HORSHAM PLANNING SCHEME

NOTICE THAT A PLANNING SCHEME HAS BEEN PREPARED AND IS AVAILABLE FOR INSPECTION

Amendment No. 48, 1978

Notice is hereby given that the Council of the City of Horsham, in pursuance of its powers under the *Town and Country Planning Act 1961*, has prepared a planning scheme to rezone from proposed minor road widening to Commercial "C" that part of the Municipal District of the City of Horsham bounded by Firebrace, Pynsent, and Urquhart Streets and Roberts Avenue, shown enclosed within the black border on the Planning Scheme map.

A copy of the Scheme has been deposited at the office of the Council of the City of Horsham, Wilson Street, Horsham, and at the Office of the Town and Country Planning Board, 235 Queen Street, Melbourne, and will be open for inspection thereat during office hours by any person free of charge.

Any persons affected by the Planning Scheme are required to set forth in writing all objections they may have addressed to the Town Clerk, City of Horsham, Post Office Box 511, Horsham, on or before the 5th day of April, 1979, and to state whether they wish to be heard in respect of their objections.

91

A. R. CONN, Town Clerk

CITY OF HORSHAM

LOAN No. 97

Notice of Intention to Borrow the Sum of \$75,000 for Permanent Works and Undertakings

Notice is hereby given that the Council of the City of Horsham intends to borrow the principal sum hereinafter mentioned by the grant of a Mortgage secured by a charge over the general rates of the municipality in accordance with the provisions of the *Local Government Act 1958*.

1. The amount of the principal moneys which it is proposed to borrow is \$75,000.

2. The maximum rate of interest that may be paid is 9.3 per centum per annum.

3. The period of the loan shall be 15 years.

4. The moneys borrowed shall be repayable by providing out of the municipal fund 30 equal half yearly instalments of approximately \$4,685.95 each including principal and interest on the 1st day of March and the 1st day of September each year during the currency of the loan. The first instalment shall be payable on the 1st day of September, 1979.

5. Such moneys shall be repayable to the Commercial Savings Bank of Australia Limited, 335 Collins Street, Melbourne, or at the Council's Bankers for the time being in the City of Melbourne.

6. The purpose for which the loan is to be applied:—

Drainage Construction	\$10,000
Council contribution C.R.B. Works	36,000
Kerb and Channel Construction	20,000
Road Construction	9,000
	<hr/>
	\$75,000

The plans, specifications and estimates for the costs of such works and the statement showing the proposed expenditure of the money to be borrowed are open for inspection at the Office of the Council, Town Hall, Horsham, during office hours.

Dated this 22nd day of December, 1978.

92

A. R. CONN, Town Clerk

CITY OF MARYBOROUGH

LOAN No. 58

Notice of Intention to Borrow

Notice is hereby given that the Council of the City of Maryborough intends to borrow the sum of Thirty thousand dollars (\$30,000) secured by a charge over the General Rates of the municipality by grant of a mortgage in accordance with the provisions of the *Local Government Act 1958*.

1. The maximum rate of interest that may be paid is 9.2 per cent per annum.

2. The purpose for which the loan is to be applied is:—

Part cost of purchase of plant and equipment viz:—
Street Flusher, Bitumen Heater Sprayer and Utility Trucks.

3. The period of the loan shall be 15 years.

4. The moneys borrowed shall be repayable by providing out of the municipal fund 14 half yearly instalments of approximately \$2,954 each including principal and interest on the 16th day of August and the 16th day of February each year during the currency of the loan. The first instalment shall be payable on the 16th day of August, 1978.

5. Such moneys shall be payable to the Commonwealth Savings Bank of Australia in Melbourne.

The plans and specifications and estimate of cost of the proposed works and a statement showing the proposed expenditure of money to be borrowed are open for inspection at the office of the Council, Neill Street, Maryborough.

Dated the 21st day of December, 1978

99

E. S. MOORE, Town Clerk

In pursuance of the powers conferred by the *Local Government Act 1958*, the Mayor Councillors and rate-payers of the City of Mordialloc order as follows:

1. This Bylaw may be known as the Sale of Goods Bylaw.

2. Bylaw No. 68 is hereby repealed.

3. No person shall, on and from the 1st day of December, 1978, without the previous consent, in writing of the Council:

(i) erect or use on any land within the Mordialloc Municipal District any tent or other temporary structure or building for the sale of goods therefrom.

(ii) sell any goods from such tent structure or building.

4. No person shall, without the previous consent, in writing, of the Council, sell any goods from any stall, motor car, cart, truck, barrow or any other vehicle, box, basket, crate, bag or other receptacles standing or placed on vacant land (not being Crown Land, or land under the care and management of the City of Mordialloc, or a public place within the meaning of section three of the *Summary Offences Act 1966*) or land which is not ordinarily occupied by the seller of the goods.

5. No person shall, without the previous consent, in writing, of the Council, sell any goods from any stall, motor car, cart, truck, barrow, box, basket, crate, bag or other vehicle or receptacle standing or placed on any street road or public place within the Mordialloc Municipal District.

6. Every person who shall be guilty of an offence against any of the provisions of this Bylaw shall be liable for every first offence to a penalty of Fifty dollars and for every subsequent offence to a penalty of One hundred dollars. In the event of any offence being continued after a conviction or order imposed or made on or against such person by a Court such person shall be liable to a further penalty of Ten dollars for each day the offence is continued.

7. This Bylaw shall apply to and have operation throughout the whole of the Municipal District.

A Resolution adopting the foregoing Bylaw was passed by the Council of the City of Mordialloc on the 27th day of November, 1978, and confirmed on the 18th day of December, 1978.

The common seal of the Mayor, Councillors and Citizens of the City of Mordialloc was hereunto affixed, in the presence of—

DAVID K. TINDAL, Mayor

F. J. FINN, Councillor

D. H. CORBEN, Town Clerk

(SEAL)

100

CITY OF MORDIALLOC

BYLAW No. 162

A Bylaw of the City of Mordialloc made under Section 197 of the *Local Government Act 1958* for:

(a) Prohibiting on from and after a date specified in the by-law or regulating—

(i) the erection or use on any land within the municipal district or within any area set forth in the by-law within the municipal district of tents or other temporary structures or buildings for the sale of goods therein or therefrom; and

(ii) the sale of goods in or from such tents structures or buildings; and

(b) Prohibiting or regulating the sale of goods from stalls motor cars carts trucks barrows or any vehicles boxes baskets crates bags or other receptacles standing or placed on vacant land (not being Crown land, or land under the care and management of the municipality, or a public place within the meaning of section three of the *Summary Offences Act 1966*) or land which is not ordinarily occupied by the seller of the goods within any area set forth in the by-law within the municipal district.

(c) Prohibiting or regulating the sale of goods from stalls motor cars carts trucks barrows boxes baskets crates bags or other vehicles or receptacles standing or placed on any street road or public place within any area within any municipal district set forth in the by-law.

CITY OF SWAN HILL

LOAN No. 78

Notice of Intention to Borrow the Sum of \$10,000 for the Erection of Buildings of a Decentralized Industry

Notice is hereby given that the Council of the City of Swan Hill proposes to borrow the principal sum of ten thousand dollars (\$10,000) secured by a charge over the general rates of the municipality, such sum to be raised by the grant of a mortgage in accordance with the provisions of the *Local Government Act 1958*.

1. The maximum rate of interest that may be paid is 9.2 per centum per annum.

2. The purposes for which the loan is to be applied is to assist the establishment of a decentralized secondary industry by the erection of a building on Council's Industrial Estate.

3. The period of the loan shall be five (5) years.

4. The moneys borrowed shall be repayable by providing out of the municipal fund half yearly instalments of approximately \$1,270.01 each including principal and interest on the 19th day of February and August during the currency of the loan. The first instalment shall be payable on the nineteenth day of August, 1979.

5. Such moneys shall be payable to the Bank of New South Wales, 223 Campbell Street, Swan Hill. The plans the specifications and the estimates of the cost of the proposed expenditure of the moneys borrowed are open for inspection at the office of the Council of the City of Swan Hill, Town Hall, Swan Hill.

Dated this 21st day of December, 1978

87

G. J. MENNIE, Town Clerk

CITY OF TRARALGON

LOAN No. 71

Notice of Intention to Borrow

Notice is hereby given that the Council of the City of Traralgon intends to borrow One hundred thousand dollars (\$100,000) secured by a charge over the General Rates of the Municipality by the grant of a mortgage in accordance with the provisions of the Local Government Act.

In connection herewith the following information is stated:

- (a) The amount of principal moneys to be borrowed is One hundred thousand dollars (\$100,000).
- (b) The maximum rate of interest to be paid is 9.2 per centum per annum.
- (c) The money borrowed shall be repayable by ten (10) equal instalments of approximately \$12,700.10 each including principal and interest payable on the first days of March and September. The first instalment shall be payable on the first day of September, 1979, and the final instalment on the first day of March, 1984. Such moneys shall be repayable at the Commonwealth Savings Bank of Australia, Traralgon.
- (d) The period of the loan shall be five (5) years.
- (e) The purpose for which the loan is to be applied is: Purchase of Plant.

89

G. A. COCKRAM, Town Clerk

CITY OF TRARALGON

LOAN No. 72

Notice of Intention to Borrow

Notice is hereby given that the Council of the City of Traralgon intends to borrow One hundred thousand dollars (\$100,000) secured by a charge over the General Rates of the Municipality by the grant of a mortgage in accordance with the provisions of the Local Government Act.

In connection herewith the following information is stated:

- (a) The amount of principal moneys to be borrowed is One hundred thousand dollars (\$100,000).
- (b) The maximum rate of interest to be paid is 9.3 per centum per annum.
- (c) The money borrowed shall be repayable by twenty (20) equal instalments of approximately \$7,787.86 each including principal and interest payable on the first days of March and September. The first instalment shall be payable on the first day of September, 1979, and the final instalment on the first day of March, 1989. Such moneys shall be repayable at the Commonwealth Savings Bank of Australia, Traralgon.
- (d) The period of the loan shall be ten (10) years.
- (e) The purpose for which the loan is to be applied is: Roadworks.

90

G. A. COCKRAM, Town Clerk

SHIRE OF ARARAT

By-Law No. 33

Notice is hereby given that the Council of the Shire of Ararat has made a By-Law under the provisions of the Local Government Act for the Purpose of regulating the proceedings of Council and Committee Meetings conducted by the Council of the Shire of Ararat and for other purposes and for the purpose of repealing By-law No. 18. A copy of the By-law is open for inspection, free of charge, during office hours at the Shire Hall, Barkly Street, Ararat.

104

L. M. CONSTABLE, Shire Secretary

SHIRE OF BARRABOOL

Notice of Intention to Borrow the Sum of \$100,000 for Permanent Works and Undertakings

Notice is hereby given that the Council of the Shire of Barrabool proposed to borrow the principal sum of \$100,000 secured by a charge over the general rates of the municipality, such sum to be raised by the grant of a mortgage in accordance with the provisions of the Local Government Act 1958.

1. The maximum rate of interest that may be paid is 9.4 per centum per annum.

2. The purposes for which the loan is to be applied are:

Acquisition of Plant	\$40,000
Council Roads and Streets Reseal Program	11,500
Preparation of Plans and Specifications Ceres	
Bridge Replacement	3,500
Kerb and Channel Works Duffields Road	19,500
Hall Renovations Freshwater Creek	5,500
Development Recreation Facilities	20,000
	\$100,000

3. The period of the loan shall be five (5) years.

4. The monies borrowed shall be repayable by providing out of the Municipal Fund half-yearly instalments of principal and interest of approximately \$7,200 with a final instalment in the fifth year of approximately \$31,142. The first instalment shall be repayable on 1st July, 1979.

5. That such monies shall be repayable to the Insurance Commissioner, State Insurance Office, 480 Collins Street, Melbourne, 3001.

The plans and specifications of the estimate of the cost of the proposed works and a statement showing the proposed expenditure of the monies to be borrowed are open for inspection at the office of the Council of the Shire of Barrabool, 441 Moorabool Street, South Geelong, during office hours.

105

M. W. HAIR, Shire Secretary

SHIRE OF BULLA

LOAN No. 86

Notice of Intention to Borrow the Sum of \$60,000

Notice is hereby given that the Council of the Shire of Bulla propose to borrow the sum of \$60,000 on the credit of the Municipal Revenues of the President, Councillors and Ratepayers of the Shire of Bulla, such sum to be raised by the grant of a Mortgage in accordance with the provisions of the Local Government Act 1958.

1. The maximum rate of interest that may be paid is 9.3% per annum.
2. The purpose for which the loan is to be applied is:

Towards completion of the Craigieburn Swimming Pool and Community Complex	\$50,000
Development of the Eric Boardman Reserve, Sunbury	10,000
	\$60,000
3. The period of the loan shall be 20 years.
4. The moneys borrowed shall be repayable by 40 half yearly instalments of principal and interest of \$3,330.72; first instalment being payable on the 1st September, 1979.
5. Such moneys shall be repayable at the State Savings Bank of Victoria, 233 Collins Street, Melbourne.

Plans, specifications and estimate of the cost of the work, and a statement showing the proposed expenditure of the moneys to be borrowed, are open for inspection at the Municipal Offices, Sunbury.

102

JOHN M. KELLY, Shire Secretary

SHIRE OF BULN BULN

By-Law No. 95

A By-law of the Shire of Buln Buln, made under Section 197 of the Local Government Act 1958, and numbered 95 for the purpose of amending By-law No. 39 and for prescribing the manner of keeping and affixing the Common Seal of the Shire.

In pursuance of the powers conferred by the Local Government Act 1958, and of every other power it thereunto enabling, the President Councillors and Ratepayers of the Shire of Buln Buln orders as follows:—

1. By-law No. 39 shall be and is hereby amended by inserting therein immediately following the table in Clause 106 thereof, the following expression and Clause:—

“SEAL:

107. (a) The common seal of the Shire shall be kept in safe custody by the municipal clerk and shall not be affixed to any document except by authority of the Council.

(b) The affixing of the seal shall be witnessed by—

(i) the Chairman of the Shire and any other Councillor or, in the absence of the Chairman, by two Councillors; and

(ii) the municipal clerk or some other officer authorised by the Council to act in the absence of the municipal clerk.”

2. This By-law shall apply to and have operation throughout the whole of the municipal district of the Shire of Buln Buln.

Resolution for passing this By-law agreed to by the Council of the Shire of Buln Buln on the 20th day of November, 1978, and confirmed the 18th day of December, 1978.

The common seal of the President, Councillors and Ratepayers of the Shire of Buln Buln was hereto affixed, in the presence of—

(SEAL) JOHN E. DELZOPPO, Shire President
I. M. STOLL, Councillor
K. A. PRETTY, Shire Secretary

85

SHIRE OF COLAC

By Law No. 132

Meeting Procedure By-Law

Notice is hereby given that the Council of the Shire of Colac has made a By-Law under the provisions of the Local Government Act 1958 (as amended), entitled "Meeting Procedure By-Law" for the purpose of regulating the proceedings of the Council and Committee meetings conducted by the Council of the Shire of Colac.

A copy of the By-Law is open for inspection, free of charge, during office hours at the Shire Hall, Murray Street, Colac.

162 W. J. MAUNSELL, Shire Secretary

SHIRE OF DUNMUNKLE

By-Law No. 43

Notice is hereby given that in pursuance of the powers conferred by Section 197 of the Local Government Act 1958, the Council of the Shire of Dunmunkle has made a by-law numbered 43 for the purpose of regulating the proceedings at meetings of the Council and at meetings of committees of the Council.

The resolution for the By-law was agreed to on the 28th day of November 1978, and confirmed on the 19th day of December 1978.

A copy of the By-law is open for inspection during office hours at the Municipal Offices, Cromie Street, Rupanyup.

84 E. N. WIDDICOMBE, Shire Secretary

SHIRE OF ELTHAM

By-Law No. 68

Incinerators and Barbecues By-Law

A By-Law of the Shire of Eltham made under Section 197 of the Local Government Act 1958 and numbered 68 for—

- (a) preventing and extinguishing fires; and
- (b) suppressing nuisances.

In pursuance of the powers conferred by the Local Government Act 1958, the President Councillors and Ratepayers of the Shire of Eltham order as follows:—

1. This By-law shall be known as the Incinerators and Barbecues By-law.

2. In this By-law unless inconsistent with the context or subject matter—

"Approved" means approved in writing under the hand of an authorised officer.

"Authorised Officer" means the Municipal Clerk of the Shire of Eltham and includes any other officer of the Council for the time being authorised by the Council in that behalf.

"Barbecue" includes any structure, receptacle, fire-place or container used or intended to be used for the cooking of meat or other edible matter by the combustion of any solid or liquid or gaseous fuel not being housed inside a building.

"Council" means the President Councillors and Ratepayers of the Shire of Eltham.

"Incinerator" includes any structure receptacle fire-place or container constructed to form a combustion chamber and used or intended to be used for the purpose of burning any rubbish waste or inflammable material whatsoever not being housed inside a building but does not include a barbecue.

"Municipal District" means the municipal district of the Shire of Eltham.

"Rural Property" means any parcel of land having an area of not less than 2 hectares and upon which is erected not more than one dwelling for each 2 hectares of the total area of the parcel of land.

3. A person shall not burn or cause or allow to be burned any matter material or substance whatsoever on any land or premises within the municipal district (not being a rural property) otherwise than in—

- (a) a properly constructed fireplace housed inside a building; or
- (b) an incinerator or barbecue constructed erected or installed in accordance with the provisions of this By-law.

without the prior written consent of an authorised officer.

4. A person shall not burn or cause or allow to be burned on any land or premises within the municipal district owned or occupied by him any matter material or substance whatsoever so as to cause a nuisance to any person by the emission of smoke fumes ash grit soot or smell.

5. A person shall not use or permit or allow to be used on any land or premises within the municipal district (not being a rural property) any incinerator or barbecue within a distance of 3 metres from—

- (a) the boundary between the land or premises upon which the said incinerator or barbecue is erected constructed or installed and any adjoining land or premises; or
- the alignment of any street or road;

without the prior written consent of an authorised officer.

6. A person shall not construct or erect or install or use or permit or allow to be used on any land or premises within the municipal district (not being a rural property)—

- (a) any incinerator unless—
 - (i) the combustion chamber is constructed of brick stone concrete steel or a combination of the aforesaid materials or other approved non-combustible materials; and
 - (ii) it is fabricated mortared together or loosely assembled; and
 - (iii) it is fitted with a lid or doors or both and a spark arrestor fixed in such a manner as to prevent the emission of sparks or burning materials or the spread of fire therefrom; or
- (b) any barbecue unless—
 - (i) it is constructed of metal brick concrete rock or a combination of the aforesaid materials or other approved non-combustible materials; and
 - (ii) it is fabricated mortared together or loosely assembled; and
 - (iii) it is used for no purpose other than the cooking of meat or other edible matter;

without the prior written consent of an authorised officer.

7. (a) A person shall not light or cause or permit or allow to be lit a fire in an incinerator on any land or premises within the municipal district otherwise than between the hours of 10.00 a.m. and 6.00 p.m. and shall cause any fire so lit to be extinguished prior to 6.00 p.m. on the day on which it is lit.

(b) Notwithstanding anything hereinbefore contained a person shall not during any proclaimed fire danger period light or cause or permit or allow to be lit a fire in an incinerator on any land or premises within the municipal district and not being within the area described in the Schedule hereto otherwise than between the hours of 6.00 p.m. on any day and 6.00 a.m. on the immediately succeeding day, and shall cause any fire so lit to be extinguished prior to 6.00 a.m. on the aforesaid succeeding day.

8. Any person guilty of any wilful act or default contrary to this By-law shall be liable to a penalty of not more than \$10.00 for each day on which such offence is continued after a conviction or order is made by any Court.

9. Save as herein otherwise provided this By-law shall apply to and have operation throughout the whole of the municipal district of the Shire of Eltham.

SCHEDULE

All that area within the municipal district bounded by a line commencing at the point of Reynolds Road and the Yarra River, thence northerly by Reynolds Road to Eltham-Yarra Glen Road, thence westerly to Coleman Crescent, thence westerly to the Diamond Creek, thence

generally westerly by the Shire boundary to the Plenty River, thence southerly by the Plenty River to the junction of the Yarra River, thence generally easterly by the Yarra River to the commencing point.

Resolution for passing this By-law agreed to by the Council of the Shire of Eltham on the 13th day of November, 1978, and confirmed on the 18th day of December, 1978.

Dated this 18th day of December, 1978

The corporate seal of the President Councillors and Ratepayers of the Shire of Eltham was hereunto affixed, in the presence of—

174 (SEAL) R. K. MARSHALL, President
D. A. NEIL, Councillor
R. M. WALKER, Shire Secretary

SHIRE OF GISBORNE

BY LAW NO. 42

Notice is hereby given in accordance with section 207 of the *Local Government Act 1958* that the Council of the Shire of Gisborne has made By Law No. 42 for the purpose of repealing By Law No. 17 and Regulating the proceedings at Meetings of the Council and the Committees of the Council.

The resolution for passing this By Law was agreed to by the Council of the Shire of Gisborne on the 20th day of November, 1978 and confirmed on the 18th day of December, 1978.

A copy of the By Law may be inspected free of charge during office hours at the Office of the Council, Hamilton Street, Gisborne.

234 T. H. LARKINS, Shire Secretary

SHIRE OF KOWREE

LOAN NO. 31

Notice of Intention to Borrow the Sum of \$40,000 for Permanent Works and Undertakings

Notice is hereby given that the Council of the Shire of Kowree proposes to borrow the principal sum of \$40,000 secured by a charge over the general rates of the municipality, such sum to be raised by the grant of a mortgage in accordance with the provisions of the *Local Government Act 1958*.

1. The maximum rate of interest that may be paid is 9.2 per cent. per annum.

2. The purpose for which the loan is to be applied is part payment for the purchase of the following items of plant:—

5 m ² truck	\$20,575
Patrol truck	10,520
Tractor	13,646

3. The period of the loan shall be five years.

4. The moneys borrowed shall be repayable by providing out of the municipal fund half-yearly instalments of approximately \$5080.04 each including principal and interest on the first day of April and the first day of October during the currency of the loan. The first instalment shall be payable on the first day of October, 1979.

5. Such moneys shall be repayable to The Commissioners of The State Savings Bank of Victoria at the office of the said Commissioners, 233 Collins Street, Melbourne.

The plans and specifications and the estimate of the cost of the proposed works and a statement showing the proposed expenditure of the moneys to be borrowed are open for inspection at the office of the Council of the Shire of Kowree, at Edenhope, Victoria.

107 H. L. TEAGUE, Shire Secretary

Sewerage District Act 1958

SHIRE OF MILDURA SEWERAGE AUTHORITY

RED CLIFFS DISTRICT—GENERAL NOTICE

The abovementioned Sewerage Authority having made provision for the carrying off the sewage from each and every property which or any part of which is within the sewerage area hereinafter described doth hereby declare that on and after the publication of this notice, each and every property which or which part of which is

within the said sewerage area shall be deemed to be a seweraged property within the meaning of the *Sewerage District Act 1958*. The description of the area hereinbefore referred to is as follows:—

Crown Allotment No's.—220D, 220E, 220F, 220G, 220H, 220J, 220K, 220L, 220M, 220N, 220P, 220Q, 220R, 220S, 220T, 220U, 220V, 220W, 220X, 220Y, as shown on Department of Crown Lands and Survey certified plan No. 70287, Section B, Parish of Mildura, County of Karkaroc.

Crown Allotment No's.—222B, 222C, 222D, 222E, 222F, 222G, 222H, 222J, 222K, as shown on Department of Crown Lands and Survey certified plan No. 101998, Section B, Parish of Mildura, County of Karkaroc.

The lots hereinbefore referred to are generally situate between Doubah and Richardson Avenues and Richardson Avenue and Snowy Avenue adjacent and to the eastern side of the Calder Highway, Red Cliffs, Victoria.

By order of the Shire of Mildura Sewerage Authority,

95 R. STIRRAT, Chairman
J. W. HARTMANN, Acting Secretary

SHIRE OF MORTLAKE

BY-LAW NO. 34

A By-law of the Shire of Mortlake, made under the *Local Government Act* and the *Uniform Building Regulations, Victoria*, and numbered 34 for determining, applying, dispensing with, or regulating such matters or things as are left to be determined, applied, dispensed with or regulated by the Council of the said Shire of Mortlake, under the *Uniform Building Regulations, Victoria*.

In pursuance of the powers conferred by the *Local Government Act* and the *Uniform Building Regulations, Victoria*, and every other power it thereunto enabling, the President, Councillors and Ratepayers of the Shire of Mortlake order as follows:—

1. By-law No. 23 is hereby repealed.
2. By-law No. 28 is hereby repealed.
3. Unless otherwise provided, this by-law shall apply to and have operation throughout the whole of the municipal district.

Brick Areas

4. The areas set out and described in the First Schedule hereto are hereby prescribed as brick areas, and no person shall in any such area construct or cause to be constructed any building, the external walls of which are of material other than brick, stone or concrete.

Minimum Area, Depth, Width of Frontage, and Distance From Boundaries

5. The minimum area, depth, width of frontage, and distance of outer walls from street alignment and boundaries in Column 3 of Table 804 of the *Uniform Building Regulations, Victoria*, (hereinafter called the *Regulations*) are hereby adopted as the minimum area, depth, width of frontage and distance of outer walls from street alignment and boundaries of land on which a building shall be constructed.

Rear Access

6. In the case of a building on any land forming part of a subdivision approved by the Council and lodged with the Office of Titles prior to the date of commencement of the *Regulations*, the requirements of Clause 813 of the *Regulations* are hereby dispensed with.

Sites Below Minimum Requirement

7. Notwithstanding anything contained in the *Regulations*, any person may:—

- (a) Construct a building of Class I. Occupancy on land having a lesser area, depth, or width of frontage or at a lesser distance from the boundaries than those specified in Column 3 of Table 804 of the *Regulations*; or
- (b) Construct a building of Class III, V, VI, VII, or VIII. Occupancy, or a building to which a building of Class IV. Occupancy is attached on land having an area, depth, or width of frontage less than that prescribed in Clause 809 of the *Regulations*—in any case where on the date of commencement of the *Regulations* such land existed as a separate allotment and has not since been reduced in area, or is shown on any plan of subdivision approved by the Council and lodged in the Office of Titles.

Rural Outbuildings

8. Any outbuildings to be constructed of steel and/or timber and not being greater in area than 60 m² and to be situated on any property not within the Township of Mortlake and used for the purpose of primary production and not used for habitation and described in the Second Schedule hereto are hereby exempted from the requirements of the Regulations.

Post and Wire Fences

9. Any post and wire fence which is constructed on any property used for the purpose of primary production is hereby exempted from the requirements of the Regulations.

FIRST SCHEDULE

Allotments 1, 8, 9, 10, section III., allotments 9 and 10, section II., allotments 8 and 9, section IV. and allotment 9, section V. and that portion to a depth of 250 links from Dunlop Street of allotments 5, 6 and 7, section V., allotments 5, 6 and 7, section IV., allotments 2, 3, 4, 5, 6, and 7, section III., allotments 2, 3, 4, 5, 6, and 7, section II., Township of Mortlake, Parish of Mortlake, County of Hampden.

SECOND SCHEDULE

Rural outbuildings used for the following purposes:

- (a) Machinery storage
- (b) Hay storage
- (c) Shearing
- (d) Dairying
- (e) Cattle and sheep yarding
- (f) Poultry production

Resolution for passing this By-law numbered 34 agreed to by the Council of the Shire of Mortlake on the 16th day of May, 1978, and confirmed on the 20th day of June, 1978.

The common seal of the President, Councillors and Ratepayers of the Shire of Mortlake was hereto affixed, in the presence of—

(SEAL) ALEX BRAMICH, Shire President
F. SEIVER, JNR., Councillor
K. E. LIEBOLD, Shire Secretary

Approved by the Governor in Council, 5th December, 1978—TOM FORRISTAL, Clerk of the Executive Council

101

SHIRE OF SOUTH GIPPSLAND

LOAN No. 44, \$50,000

Notice of Intention to Borrow the Sum of \$50,000 for Permanent Works and Undertakings

Notice is hereby given that the Shire of South Gippsland intends to borrow the principal sum of fifty thousand dollars (\$50,000) secured by a charge over the general rates of the municipality, such sum to be raised by the grant of a mortgage in accordance with the provisions of the *Local Government Act 1958*.

1. The maximum rate of interest that may be paid is 9.3 per centum per annum.

2. The purpose for which the loan is to be applied is—

- (i) Assembly Hall, Foster and District High School \$35,000
- (ii) Toora Recreation Reserve local contribution \$12,500
- (iii) Purchase of Plant \$2,500

\$50,000

3. The period of the loan shall be fifteen (15) years.

4. The moneys borrowed shall be repayable by providing out of the municipal fund 30-half-yearly equal instalments of approximately \$3,123.97 each, including principal and interest, on the first day of August and the first day of February during the currency of the loan. The first instalment shall be payable on the first day of August, 1979.

5. Such moneys shall be repayable to the Australia & New Zealand Banking Group Limited, Foster, and the plans and specifications and estimated cost of the proposed works and a statement showing the proposed expenditure of the moneys to be borrowed, is open for inspection at the office of the Council of the Shire of South Gippsland, 14-18 Pioneer Street, Foster, 3960.

176

H. R. LOMAX, Shire Secretary

SHIRE OF SOUTH GIPPSLAND
DECLARATION OF LAND AS PUBLIC HIGHWAY

Harding-Lawson Road

Pursuant to the provisions of Section 522 of the *Local Government Act 1958*, the Council of the Shire of South Gippsland hereby directs that the land in the Parish of Doomburrin indicated by hatching on the diagram annexed hereto which has been purchased, taken or acquired by it, shall be a Public Highway on and from the date of the publication of this Order in the *Government Gazette*.

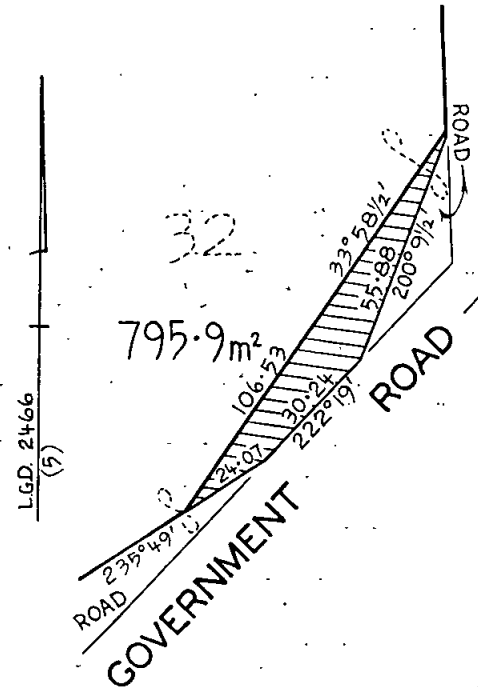

LENGTHS ARE IN METRES.

The common seal of the President, Councillors and Ratepayers of the Shire of South Gippsland was hereto affixed, this 13th day of April, 1978, in the presence of—

(SEAL) W. E. COOK, Shire President
A. J. SYMMONS, Councillor
H. R. LOMAX, Shire Secretary

175

SHIRE OF TRARALGON

LOAN No. 58

Notice of Intention to Borrow the Sum of \$150,000 for Permanent Works and Undertakings

Notice is hereby given that the Council of the Shire of Traralgon proposes to borrow the principal sum of One hundred and fifty thousand dollars (\$150,000) secured by a charge over the general rates of the municipality such sum to be raised by the grant of a mortgage in accordance with the provisions of the *Local Government Act 1958*.

1. The maximum rate of interest that may be paid is 9.3%.

2. The purpose for which the loan is to be applied is roads construction associated with Loy Yang project development.

3. The period of the Loan shall be ten (10) years.

4. The manner in which the Loan is to be liquidated is by the provision out of the Municipal Fund in each half year during the currency of the Loan the sum of \$11,681.79 approximately which includes principal and interest.

5. Such moneys shall be repayable to the A.N.Z. Banking Group Limited, Melbourne, or such other place as the Bank from time to time may require.

The plans, specifications and estimate of the cost of the works and a statement showing the proposed expenditure of the moneys to be borrowed are open for inspection at the Municipal Offices, Kay Street, Traralgon.

Dated this 22nd day of December, 1978

88

W. TEASDALE, Shire Secretary

SHIRE OF WARRACKNABEAL

NAMING OF ROAD

Notice is hereby given that in pursuance of the powers confirmed by section 535 of the Local Government Act, the Shire of Warracknabeal at a meeting held on Friday, 15th December, 1978 did resolve to name the road adjacent to allotments 91, 92 and 93 Parish of Yellangip in the Shire of Warracknabeal.

Name: Johns' Road.

86

JOSEPH B. NEAL, Shire Secretary

SHIRE OF WINCHELSEA

BY-LAW No. 64

A By-law of the Shire of Winchelsea made under section 197 (1) (i) of the Local Government Act 1928 and numbered 64 for adoption of the Fifteenth Schedule.

In pursuance of the powers conferred by the Local Government Act 1928, the President, Councillors and Ratepayers of the Shire of Winchelsea order as follows:

1. That all of the provisions of the Fifteenth Schedule of the Local Government Act 1958, as amended by the Local Government (Miscellaneous Provisions) Act 1978, intitled "Regulations of Proceedings of Council" are hereby adopted.

2. That By-laws No. 36 and No. 48 of the Shire of Winchelsea are hereby repealed.

Resolution for passing this By-law was agreed to by the Council the 13th day of September, 1978, and confirmed on the 11th day of October, 1978.

The common seal of the President, Councillors and Ratepayers of the Shire of Winchelsea was hereto affixed, in the presence of—

(SEAL) E. D. BEAUREPAIRE, President
L. A. HINTON, Councillor
W. K. MATHISON, Shire Secretary

98

YEA WATERWORKS TRUST

BY-LAW No. 13

Water Supply Services

Notice is hereby given that the Yea Waterworks Trust in pursuance and exercise of the powers conferred by the Water Act, Section 330, has made a By-law for the Licencing of Plumbers; the Execution of Works of Water Supply; Private Extensions; Connections to Main Pipes and Aqueducts; Repairs; Materials; Meters; Fire Services; General; Misuse and Waste of Water; and Penalties.

A copy of the By-law is available for inspection by any person without charge during office hours, at the office of the Trust, Civic Centre, Yea.

166

F. F. BERKERY, Trust Secretary

GEELONG WATERWORKS AND SEWERAGE TRUST

Pursuant to section 60 of the Geelong Waterworks and Sewerage Act 1958 (No. 6263), the Trust has prepared plans to indicate the particulars of sewers and underground works, the construction of which the Trust intends to begin at a date, not less than one month after publication of the notices, in or adjacent to the following localities within the Drainage Area.

Thomson and Jillong (ex-Church) Street, City of South Barwon.

Notice is hereby given that the plans indicated are open for public inspection at the Trust's Offices, 61-67 Ryrie Street, Geelong, between the hours of 9.00 a.m. and 5.00 p.m. from Monday to Friday (public holidays excepted) by the owners or occupiers of land or premises within the drainage area.

165

B. C. HENSHAW, Secretary

DROMANA-ROSEBUD SEWERAGE AUTHORITY

GENERAL NOTICE

The abovementioned Sewerage Authority having made provision for carrying off the sewage from each and every property which or any part of which is within the sewerage area hereinafter described doth hereby declare that on and after the 1st day of January, 1979 each and every property which or any part of which is within the said sewerage area shall be deemed to be a seweraged property within the meaning of the Sewerage Districts Act 1958.

The boundaries of the sewerage area hereinbefore referred to are:—

Declared Area No. 14

Commencing at the intersection of Adams Avenue and Mark Street on the boundary of Declared Area No. 12, proceed east along Mark Street, then south along Kennington Road and west along Keogh Street to the north-east corner of No. 21 Keogh Street, south then north-west along the rear boundaries of this allotment, then westerly along the southern boundary of No. 26 Kooringa to Kooringa Court. South along Kooringa Court, then further south along the eastern boundaries of No. 10 Kooringa Court, No's 14 to 20 Carcoola Court and No. 62 Wootton Street, across Wootton Street, then further south along the rear boundaries of No's 79 to 93 Leon Avenue to the Mornington Peninsula Freeway boundary. South-west along this boundary to meet the boundary of the present Declared Sewerage Area, then generally north along this boundary to the point of commencement.

Declared Area No. 15

Commencing at the intersection of First Avenue and Eastbourne Road on the boundary of Declared Area No. 2, proceed east along Eastbourne Road, then south along the eastern boundaries of No. 141 Eastbourne Road and No. 6 Harridge Street to the boundary of Declared Area No. 10, then generally south and west along this boundary to the south-east corner of No. 29 Dunstone Drive, then generally west along the southern boundaries of No's 29 and 31 Dunstone Drive and No. 1 Dullard Street, then north to Dunstone Drive, west to Hinton Street, south to Besgrove Street and west along Besgrove Street to the boundary of the present Declared Sewerage Area, then generally north along this boundary to the point of commencement.

By order of the said Sewerage Authority,

163

J. K. BUCHANAN, Chairman
J. O. WILLIAMS, Secretary

LILYDALE SEWERAGE AUTHORITY

CONSTRUCTION OF SEWERS, LILYDALE

The Lilydale Sewerage Authority gives notice that it intends to construct sewers in the area detailed below.

A plan showing details of the proposed works may be inspected by any persons during office hours 8.30 a.m. to 6.15 p.m. Thursday and 8.30 a.m. to 5.00 p.m. all other weekdays at the Authority office, 197 Main Street, Lilydale.

The proposed alignment of the sewer is as follows:— Commencing in the footpath at the south-east corner of Lot 95 Bronwyn Street, Coldstream, extending 53 metres northwards to the Shire of Lilydale land.

161

J. O. PUGSLEY, Acting Secretary

TORQUAY SEWERAGE AUTHORITY

GENERAL NOTICE

The abovementioned Sewerage Authority having made provision for carrying off the sewage from each and every property which or any part of which is within the sewerage areas hereinafter described doth declare that on and after the 1st day of October, 1978, each and every property which or any part of which is within the said sewerage areas shall be deemed to be a seweraged property within the meaning of the Sewerage Districts Act 1958.

The sewerage area hereinafter referred to shall be known as Sewerage Area No. 7.

The boundaries of the sewerage area hereinafter referred to are:

The area being those properties as follows:

(1) L.P. 125759, 45 Lots, Nos. 31 to 75.

Extension of Dunketh Avenue

Tathra Court

Weron Court

(2) L.P. 124269, 91 Lots, Nos. 1 to 10; 32 to 80;

87 to 100; 147 to 158; 164 to 169A.

Extension of Sandhurst Crescent

Extension of Ocean Boulevard

Extension of Cantala Drive

Iuka Court

Watersun Road

Riviera Drive

Broadbeach Road

(3) L.P. 125445, 33 Lots, Nos. 1 to 33.

Extension of Fischer Street

Highlander Street

Aquilla Avenue

The boundaries of the said sewerage area are delineated on the plans which may be inspected at the branch office of the Authority, 12 Price Street, Torquay, and also at the Head Office at 441 Moorabool Street, South Geelong.

By order of the said Sewerage Authority,

164

R. W. PETTITT, Chairman
M. W. HAIR, Secretary

Notice is hereby given that Sandringham Yacht Club has applied for a lease pursuant to section 134 of the Land Act 1958 for a term of 21 years in respect of Allotment 21A Parish of Moorabbin, City of Sandringham containing 3.919 hectares as a site for sport and recreation and amenities connected therewith, including the erection of buildings. 9617

Notice is hereby given that BP Australia Limited has applied for a lease pursuant to Section 134 of the Land Act 1958 for a term of 20 years in respect of Allotment 28 Section 7 Parish of Cut-Paw-Paw. 51

Take notice that as from the 22nd December 1978 the mixed business and sub-newsagency being carried on at 50a Heatherhill Road, Frankston by G. J. & P. M. Alderson and N. G. & E. J. Gibbons will be carried on by G. J. & P. M. Alderson only, N. G. & E. J. Gibbons having retired from the business on that date. 123

NOTICE OF INTENTION TO APPLY FOR A LICENCE TO DIVERT WATER AND CUT RACE FROM THE KING RIVER, AT OXLEY

We hereby give notice that we intend to apply for a Licence empowering us to divert water for a term of 4 years for the purpose of irrigating grape vines on 9 hectares being part of Allotment 3 Section 4 Parish of Oxley, and to occupy certain Crown Lands for works of diversion, and to cut a race thereon.

Any objection to such application must be forwarded in writing to reach the State Rivers and Water Supply Commission, Melbourne before 11th January being thirty days from the first publication of this Notice.

J. M. GEHRIG
E. E. GEHRIG

McKeone Vines, Oxley, Vic. 3678 108

Notice is hereby given that the partnership heretofore subsisting between Norman Stanley Olsen and Eileen Lorraine Olsen carrying on business as Share Farmers at Lathams Road, Carrum Downs has been dissolved as from the 25th day of September, 1978.

Dated this 25th day of September, 1978

171 EILEEN LORRAINE OLSEN

Notice is hereby given that the Partnership heretofore subsisting between Emil Nemirovsky and Karl Jorgenson cabinet makers of 23 Regent Street Prahran under the style and firm of Unique Kitchens has been dissolved as from the 31st day of December, 1978.

SERGE STRAIT & ASSOCIATES, solicitors and agents for the said Emil Nemirovsky 122

Notice is hereby given that the partnership heretofore subsisting between Ena Margaret Carroll and Shirley Elaine Kudeviita carrying on business as Wallpaper Retailers at 564 Hampton Street, Hampton under the style or firm of "Shirley's Wallpapers" has been dissolved by mutual consent as from the 5th day of November 1978 the said Ena Margaret Carroll having retired from the said firm.

124 SHIRLEY ELAINE KUDEVIIITA
ENA MARGARET CARROLL

Notice is hereby given that the Partnership heretofore subsisting between Herbert Edward Minney of 6 Roma Court, Lower Templestowe and Pierre Korassandjian of 74 High Street, Glen Iris Restaurateurs carrying on business of restaurateurs at 107 Acland Street, St. Kilda under the style or firm name of Pierre's Fishermans Catch has been dissolved by mutual consent as from the 4th of July 1978. All debts due and owing by the said firm will be received and paid by Pierre Korassandjian who will continue to carry on the said business under the said business name.

Dated the 11th day of December, 1978

Signed by the said Herbert Edward Minney in Victoria in the presence of—J. M. LUKE

Signed by the said Pierre Korassandjian in Victoria in the presence of—JOHN LEDERER

125 H. E. MINNEY
PIERRE KORASSANDJIAN

Notice is hereby given that the Partnership heretofore subsisting between Gerrit Pieteron and John Pieteron carrying on business as Sheet Metal Workers at 6 Factory 5 Walker Street, Braeside, under the style or firm of P. B. Precision Sheet Metal has been dissolved as and from the 5th day of October, 1978.

Dated the 22nd day of December, 1978

F. R. MONOTTI & CO., as solicitors and agents for the said Gerrit Pieteron 126

Notice is hereby given that the Partnership heretofore subsisting between Douglas William Morris, John Roger Morris and Patricia Anne Morris carrying on business as Farmers at Woori Yallock Road, Cockatoo has been dissolved as from the 1st day of December 1978.

Dated the 1st day of December, 1978

DOUGLAS WILLIAM MORRIS
JOHN ROGER MORRIS
PATRICIA ANNE MORRIS

F. R. Monotti & Co., solicitors, 13 Scott Street, Dandenong 127

G. M. FAST AND M. J. FARNWORTH—PARTNERSHIP NOTICE OF DISSOLUTION

Notice is hereby given that the partnership heretofore subsisting between Michael John Farnworth and Georges Michel Fast carrying on the business of dental practice at 511 Whitehorse Road, Mitcham under the style or firm name of "G. M. Fast and M. J. Farnworth" has been dissolved as from the 8th day of December 1978 so far as concerned the said Georges Michel Fast who retires from the said firm.

MEERKIN & APEL, solicitors 128

Notice is hereby given that the partnership heretofore subsisting between David Brendan Guiney and John William Lodge carrying on business as Consulting Land Surveyors at 1761 Ferntree Gully Road Ferntree Gully under the name of Guiney & Lodge has been dissolved by mutual consent as from the 1st day of October 1978. The business will be continued by the said David Brendan Guiney at the same address. 129

Notice is hereby given that Partnership heretofore subsisting between Brian Jon Hall and Patrick Evrard Eijsvogel carrying on business as Geelong Cash Systems at 197 Shannon Avenue has been dissolved as from the 22nd day of December, 1978 so far as the said Patrick Evrard Eijsvogel who retires from the said firm.

130 BRIAN JON HALL
PATRICK EVRARD EIJSVOGEL

The Companies Act 1961
JAYSELTEX NOMINEES PTY. LTD.
MOSPIL PTY. LTD.
GELSOL PTY. LTD.
A.L.Z. INVESTMENTS PTY. LTD.
RAGON HOLDINGS PTY. LTD.
THERIS FASHIONS PTY. LTD.
SIXTH RAMBORA PTY. LTD.
BERGRAM PTY. LTD.
WALPOLE HOLDINGS PTY. LTD.
MERMELSTEIN & SPRINGS BUILDERS PTY. LTD.

Notice is hereby given that at extraordinary general meetings of the members of the abovenamed companies held on 21st December, 1978, it was resolved that the companies be wound up voluntarily and that for such purpose, Richard H. Judson, Chartered Accountant, care of Ferrier Hodgson Green & Co., 459 Collins Street, Melbourne, 3000, be appointed Liquidator.

Notice is also given that after twenty-one days from this date, I shall proceed to distribute the assets of the companies. All creditors who have any claim against the companies should furnish particulars of same by that date, otherwise I shall proceed to distribute the assets without regard to their respective claim.

Dated this 27th day of December, 1978

69 R. H. JUDSON, Liquidator

The Companies Act 1961

WINDMOORE MANTLES PTY. LTD.
 THIRD ELAM PTY. LTD.
 SECOND REBBIT PTY. LTD.
 NORTHING INVESTMENTS PTY. LTD.
 S. GLASS & CO. PTY. LTD.
 MOUNTAIN REACH DEVELOPMENT PTY. LTD.
 NESTOR FASHIONS PTY. LTD.
 THERIS MANUFACTURERS PTY. LTD.
 T.H.L. INVESTMENTS PTY. LTD.
 MECKERING TRADING PTY. LTD.

Notice is hereby given that at extraordinary general meetings of the members of the abovenamed companies held on 21st December, 1978, it was resolved that the companies be wound up voluntarily and that for such purpose, Richard H. Judson, Chartered Accountant, care of Ferrier Hodgson Green & Co., 459 Collins Street, Melbourne, 3000, be appointed Liquidator.

Notice is also given that after twenty-one days from this date, I shall proceed to distribute the assets of the companies. All creditors who have any claim against the companies should furnish particulars of same by that date, otherwise I shall proceed to distribute the assets without regard to their respective claim.

Dated this 27th day of December, 1978

70

R. H. JUDSON, Liquidator

The Companies Act 1961

DEMPI PTY. LTD.
 ROMAY PTY. LTD.
 K. & M. DEVELOPMENT CORPORATION PTY. LTD.
 STARLINE INDUSTRIES PTY. LTD.
 WILLDUCK PTY. LTD.
 PORTLA PTY. LTD.
 BRANTFORD MANSIONS PTY. LTD.
 WINDEMERE CONSTRUCTIONS PTY. LTD.
 PRESTON TIMBER CO. PTY. LTD.
 SEVENTH RAMBORA PTY. LTD.

Notice is hereby given that at extraordinary general meetings of the members of the abovenamed companies held on 21st December, 1978, it was resolved that the companies be wound up voluntarily and that for such purpose, Richard H. Judson, Chartered Accountant, care of Ferrier Hodgson Green & Co., 459 Collins Street, Melbourne, 3000, be appointed Liquidator.

Notice is also given that after twenty-one days from this date, I shall proceed to distribute the assets of the companies. All creditors who have any claim against the companies should furnish particulars of same by that date, otherwise I shall proceed to distribute the assets without regard to their respective claim.

Dated this 27th day of December, 1978

73

R. H. JUDSON, Liquidator

The Companies Act 1961

FRANK BOURNE PTY. LTD.
 INTERGOLD FABRICS PTY. LTD.
 GREEN PINES PTY. LTD.
 FRANK HAUSER & CO. PTY. LTD.
 J.H.E. HOMES PTY. LTD.
 MAGNET SHOE (DISTRIBUTORS) PTY. LTD.
 MAGNET SHOE (SERVICES) PTY. LTD.
 LINTRIM PTY. LTD.
 DRESSKNIT FABRICS PTY. LTD.
 DOUBLE JERSEY FABRICS PTY. LTD.

Notice is hereby given that at extraordinary general meetings of the members of the abovenamed companies held on 21st December, 1978, it was resolved that the companies be wound up voluntarily and that for such purpose, Richard H. Judson, Chartered Accountant, care of Ferrier Hodgson Green & Co., 459 Collins Street, Melbourne, 3000, be appointed Liquidator.

Notice is also given that after twenty-one days from this date, I shall proceed to distribute the assets of the companies. All creditors who have any claim against the companies should furnish particulars of same by that date, otherwise I shall proceed to distribute the assets without regard to their respective claim.

Dated this 27th day of December, 1978

71

R. H. JUDSON, Liquidator

The Companies Act 1961

NEWPORT FUNCIONS FREEHOLD PTY. LTD.
 ADPEARL PTY. LTD.
 FOURTH KALAMANDER PTY. LTD.

Notice is hereby given that at extraordinary general meetings of the members of the abovenamed companies held on 21st December, 1978, it was resolved that the companies be wound up voluntarily and that for such purpose, Richard H. Judson, Chartered Accountant, care of Ferrier Hodgson Green & Co., 459 Collins Street, Melbourne, 3000, be appointed Liquidator.

Notice is also given that after twenty-one days from this date, I shall proceed to distribute the assets of the companies. All creditors who have any claim against the companies should furnish particulars of same by that date, otherwise I shall proceed to distribute the assets without regard to their respective claim.

Dated this 27th day of December, 1978

74

R. H. JUDSON, Liquidator

Form 92

The Companies Act 1961, Section 272 (1)

Companies Regulation

ELLIVERG INVESTMENTS PTY. LTD (IN LIQUIDATION)

NOTICE OF MEETING OF CREDITORS AND CONTRIBUTORS.

Notice is hereby given that a final meeting of the creditors and contributories of Elliverg Investments Pty. Ltd. (in Liquidation) will be held at the office of Orr, Martin & Waters, 3rd Floor, 470 Bourke Street, Melbourne, on Tuesday, 23rd January, 1979, at 10.00 o'clock in the forenoon, to receive the liquidator's account of his acts and dealings and of the conduct of the winding up and of hearing any explanations thereof.

Dated this 22nd day of December, 1978

ROBERT A. WATERS, Liquidator

Orr, Martin & Waters, chartered accountants, 470 Bourke Street, Melbourne, 3000. Telephone 67 6085 68

Companies Act 1961—In the matter of SPEER BROS. PTY. LTD. (in Liquidation)

Notice is hereby given that at an Extraordinary General Meeting of the members of the above Company held on Thursday, the 21st December, 1978 the following resolution was passed as a Special Resolution:—

"That Speer Bros. Pty. Ltd. be wound up voluntarily and that Peter Charles Watmuff, Chartered Accountant of 4th Floor, 691 Burke Road, Camberwell, be appointed Liquidator for the purpose of winding up the affairs of the Company with the power to distribute the assets in specie, amongst its members."

Dated this 21st day of December, 1978

P. C. WATMUFF, Liquidator

Garnham & Hinsley, chartered accountants, 4th Floor, 691 Burke Road, Camberwell 75

The Companies Act 1961

DRAFTING ASSISTANTS STRUCTURAL (VIC.) PTY. LTD.
 DRAFTING ASSISTANTS MECHANICAL (VIC.) PTY. LTD.
 OCEAN GROVE ESTATES PTY. LTD.
 S. & S. D. MAGGIO PTY. LTD.
 CUNNAMULLA TRADING PTY. LTD.
 THERIS FABRICS PTY. LTD.
 JAYWINSELL PTY. LTD.
 JONDE CONSTRUCTIONS PTY. LTD.
 ATID INVESTMENTS PTY. LTD.
 JAYSELFAB PTY. LTD.

Notice is hereby given that at extraordinary general meetings of the members of the abovenamed companies held on 21st December, 1978, it was resolved that the companies be wound up voluntarily and that for such purpose, Richard H. Judson, Chartered Accountant, care of Ferrier Hodgson Green & Co., 459 Collins Street, Melbourne, 3000, be appointed Liquidator.

Notice is also given that after twenty-one days from this date, I shall proceed to distribute the assets of the companies. All creditors who have any claim against the companies should furnish particulars of same by that date, otherwise I shall proceed to distribute the assets without regard to their respective claim.

Dated this 27th day of December, 1978

72

R. H. JUDSON, Liquidator

Companies Act 1961—In the matter of K. & M. CLARK HOLDINGS PTY. LTD. (in Liquidation)

Notice is hereby given that at an Extraordinary General Meeting of the members of the above Company held on Thursday, the 21st December, 1978 the following resolution was passed as a Special Resolution:—

"That K. & M. Clark Holdings Pty. Ltd. be wound up voluntarily and that Peter Charles Watmuff, Chartered Accountant of 4th Floor, 691 Burke Road, Camberwell, be appointed Liquidator for the purpose of winding up the affairs of the Company with the power to distribute the assets *in specie*, amongst its members."

Dated this 21st day of December, 1978

P. C. WATMUFF, Liquidator

Garnham & Hinsley, chartered accountants, 4th Floor,
691 Burke Road, Camberwell 76

Companies Act 1961—In the matter of LEON FINANCE CO. PTY. LTD. (in Liquidation)

Notice is hereby given that at an Extraordinary General Meeting of the members of the above Company held on Thursday, the 21st December, 1978 the following resolution was passed as a Special Resolution:—

"That Leon Finance Co. Pty. Ltd. be wound up voluntarily and that Peter Charles Watmuff, Chartered Accountant of 4th Floor, 691 Burke Road, Camberwell, be appointed Liquidator for the purpose of winding up the affairs of the Company with the power to distribute the assets, *in specie*, amongst its members."

Dated this 21st day of December, 1978

P. C. WATMUFF, Liquidator

Garnham & Hinsley, chartered accountants, 4th Floor,
691 Burke Road, Camberwell 77

The Companies Act 1961

ALOHA PTY. LTD. (IN LIQUIDATION)

Notice is hereby given that an extraordinary general meeting of the above named company held on Wednesday, 20th December, 1978 it was resolved that the company be wound up voluntarily and at a meeting of creditors held later the same day it was resolved that for such purpose Desmond John Hinsley of 4th Floor, 691 Burke Road, Camberwell, be appointed liquidator.

Notice is also given that after twenty-one days from this date I shall proceed to distribute the assets of the company. All creditors who have any claim against the company should furnish particulars of the same by that date, otherwise I shall proceed to distribute the assets without regard to their claim.

Dated this 21st day of December, 1978

78 D. J. HINSLEY, Liquidator

The Companies Act 1961

C. CARLTON FINANCE CO. PTY. LTD. (IN LIQUIDATION)

Notice is hereby given that an extraordinary general meeting of the members of the above named company held on Wednesday, 20th December, 1978, it was resolved that the company be wound up voluntarily and at a meeting of creditors held later the same day it was resolved that for such purpose Desmond John Hinsley of 4th Floor, 691 Burke Road, Camberwell, be appointed Liquidator.

Notice is also given that after twenty-one days from this date I shall proceed to distribute the assets of the company. All creditors who have any claim against the company should furnish particulars of the same by that date, otherwise I shall proceed to distribute the assets without regard to their claim.

Dated this 21st day of December, 1978

79 D. J. HINSLEY, Liquidator

RE: T.R.W. LAND HOLDINGS PTY. LIMITED (IN LIQUIDATION)

The creditors of the abovenamed company are required on or before the tenth day of January 1979, to prove their debts or claims and to establish any title they may have to priority by delivering or sending through the post to the liquidator at the undermentioned address an affidavit verifying their respective debts or claims. In default they will be excluded from the benefit of any distribution made before such debts or claims are proved or such priority is established and from objecting to any such distribution.

Form of proof may be obtained from the undersigned.

Dated this 18th day of December, 1978

M. G. CHAPMAN, Liquidator, 351 Collins Street, Melbourne 81

DONRUS PTY. LIMITED, LARKE L. T. KENNETT (VIC.) PTY. LTD., SIXTY-EIGHT STURT STREET PTY. LTD., MOTORBAR PROPRIETARY LIMITED, LNC (SERVICES) PTY. LIMITED

The Creditors of the abovenamed Company are required on or before the 29th day of January, 1979, to prove their debts or claims by delivering or sending through the post to the Liquidator at the undermentioned address an affidavit verifying their respective debts or claims. In default they will be excluded from the benefit of and from objecting to any distribution made before such debts and claims are proved. Forms of proofs may be obtained from the undersigned.

Dated this 15th day of December, 1978

NEAL FRANCIS STEVENS, Liquidator

Care of Arthur Young & Company, 35th Floor, 80
Bridge Street, Sydney 80

In the matter of the Companies Act 1961; and in the matter of T.R.W. LAND HOLDINGS PTY. LIMITED (in Liquidation)

Notice is hereby given pursuant to section 254 (2) of the Companies Act 1961 that an Extraordinary General Meeting of T.R.W. Land Holdings Pty. Limited held on the eighteenth day of December, 1978 the following Resolutions were duly passed:—

Special Resolution:

"That the Company be wound up voluntarily."

Ordinary Resolution:

"That Maxwell Geoffrey Chapman be and is hereby nominated Liquidator of the Company for the purposes of such winding up."

82

L. J. TORPY, Secretary

DORUS PTY. LIMITED
LARKE L. T. KENNETT (VIC.) PTY. LTD.
SIXTY-EIGHT STURT STREET PTY. LTD.
MOTORBAR PROPRIETARY LIMITED
LNC (SERVICES) PTY. LIMITED

The following Special Resolution was passed at an Extraordinary General Meeting of the Members of the abovenamed Company, held on the 15th December, 1978.

"That the Company be wound up voluntarily and that Neal Francis Stevens Chartered Accountant be appointed Liquidator for the purpose of the winding up."

Dated the 15th day of December, 1978

83

NEAL FRANCIS STEVENS

In the matter of the Companies Act 1961; and in the matter of COLONSAY ESTATES PTY. LTD.

Notice is hereby given that at a meeting of creditors of the above named Company, duly convened and held at 3.00 p.m. on 4th day of December, 1978, the following Resolution was passed—

"That the Company be wound up as a Creditors' Voluntary Liquidation."

Mr. B. M. Dunlop of 2nd Floor, 553 Kiewa Street, Albury, was appointed Liquidator of the Company.

Dated this 4th day of December, 1978

121

B. M. DUNLOP, Liquidator

In the matter of the Companies Act 1961; and in the matter of WINTERFOLD SPINNING MILLS PTY. LTD.

Notice is hereby given that at a meeting of the members of Winterfold Spinning Mills Pty. Ltd. on the 22nd day of December 1978 the following resolution was passed as a Special Resolution:

"That the Company be wound up voluntarily and that Kent Frederick Kay and John Charles Ward, both of 361 Nepean Highway, Mordialloc, be and are hereby appointed liquidators to act jointly or severally for the purpose of such winding up."

K. F. KAY, Liquidator

131

J. C. WARD, Liquidator

SNOCK PTY. LIMITED (IN VOLUNTARY LIQUIDATION)

NOTICE OF RESOLUTION

Notice is hereby given that at an extraordinary general meeting of the abovenamed company duly convened and held on Monday, 18th December, 1978, the following resolution was passed as a special resolution—

"That the company be wound up voluntarily."

Dated this 20th day of December, 1978

134

P. J. GORMLEY, Director

The Companies Act 1961

EAST AFRICAN COFFEE PLANTATIONS LIMITED

Notice is hereby given that upon a petition presented to the Supreme Court of Victoria on 7th December, 1978 by East African Coffee Plantations Limited, the said Court did on 18th December, 1978 confirm a special resolution passed by the said Company in general meeting to reduce the issued capital of the Company from \$1,620,000 divided into 1,620,000 ordinary stock units of \$1.00 each fully paid up to \$1,296,000 divided into 1,620,000 ordinary stock units of 80c each fully paid up by repaying to the holders of ordinary stock units the sum of 20c per ordinary stock unit, being capital which is in excess of the needs of the Company, and that by force of a further conditional resolution for subdivision passed by the said Company in general meeting the unissued capital of the Company will upon the Order of the said Court taking effect be \$380,000 divided into 475,000 ordinary shares of 80c each.

And take further notice that upon the 22nd day of December, 1978 an office copy of the said Order of the Supreme Court of Victoria confirming the said reduction of capital was registered by the Commissioner for Corporate Affairs.

Dated the 22nd day of December, 1978

PHILLIPS, FOX & MASEL, solicitors, 461 Bourke Street, Melbourne, 3000 132

GUNS & AMMUNITION PTY. LTD. (IN VOLUNTARY LIQUIDATION)

SPECIAL RESOLUTION TO WIND UP

At an Extraordinary General Meeting of the abovenamed Company duly convened and held at 117 Waverley Road, East Malvern, on the 13th day of December, 1978 the following Resolution was passed as a Special Resolution—

"That the Company be wound up voluntarily."

At the abovementioned Meeting, Harry George Wadge of 23 Waverley Road, East Malvern, was appointed Liquidator for the purpose of winding up.

Notice is also given that after 28 days from this date I shall proceed to distribute the Assets. All Creditors having any claim against the Company should furnish particulars of same by that date, otherwise I shall proceed to distribute the Assets without regard to their claim.

Dated this 15th day of December, 1978

133 HARRY G. WADGE, Liquidator

In the matter of the Companies Act 1961; and in the matter of—

EXPLASTICS INSULATIONS PTY. LTD.
COMMONWEALTH FLOOR PTY. LTD.
OLYFIN PTY. LTD.

OLYMPIC GENERAL PRODUCTS (QLD) PTY. LTD.

Notice is hereby given that at an Extraordinary General Meeting of each of the abovenamed companies duly convened and held at 393 Swanston Street, Melbourne, Victoria, the following Special Resolution was duly passed:

"That the Company be wound up voluntarily."

At the same meeting of each of the abovenamed companies Phillip Douglas George, Chartered Accountant of 21st Floor, 500 Bourke Street, Melbourne was appointed Liquidator of each of the Companies respectively leave having been given by the Supreme Court of Victoria on 7th December, 1978 for him to consent to be appointed as Liquidator of each of the abovenamed companies and if so appointed to act as Liquidator of each or any of the abovenamed companies.

Dated this 22nd day of December, 1978

R. J. SAMPSON, LL.B., 6th Floor, 393 Swanston Street, Melbourne, Vic. 3000. Phone No. 347 7322 135

In the matter of the Companies Act 1961; and in the matter of FALCON INVESTMENTS PTY. LTD.

Notice is hereby given that at a meeting of the members of Falcon Investments Pty. Ltd. held on the 14th December, 1978 the following resolution was passed as a special resolution—

"That the company be wound up voluntarily and that Mr. Gregory John McCluskey be appointed liquidator for the purpose of such winding up."

GREGORY JOHN McCLUSKEY, Liquidator

Care of Chaundy & Henry, 126 Wellington Parade, East Melbourne 3002 136

SKAGWAY INVESTMENTS PTY. LIMITED

MEMBERS' VOLUNTARY WINDING UP

Notice is hereby given that at an Extraordinary General Meeting of the members of the above Company held on 22nd December 1978 it was resolved that the company be wound up voluntarily and that Mr. N. W. Curwood be appointed liquidator of the Company.

Notice is also given that after 21 days from this date I shall proceed to distribute the assets. All creditors having any claims against the company should furnish particulars of such claim by that date, otherwise I shall proceed to distribute the assets without regard to their claim.

Dated this 22nd day of December, 1978

N. W. CURWOOD, Liquidator
Sicree, Nixon, Watt & Co., 257 Collins Street, Melbourne 137

ROMONA INVESTMENTS PTY. LIMITED

MEMBERS' VOLUNTARY WINDING UP

Notice is hereby given that at an Extraordinary General Meeting of the members of the above Company held on 21st December 1978 it was resolved that the company be wound up voluntarily and that Mr. N. W. Curwood be appointed liquidator of the Company.

Notice is also given that after 21 days from this date I shall proceed to distribute the assets. All creditors having any claims against the company should furnish particulars of such claim by that date, otherwise I shall proceed to distribute the assets without regard to their claim.

Dated this 22nd day of December, 1978

N. W. CURWOOD, Liquidator
Sicree, Nixon, Watt & Co., 257 Collins Street, Melbourne 138

BEACHSIDE ACCOMMODATION PTY. LIMITED

MEMBERS' VOLUNTARY WINDING UP

Notice is hereby given that at an Extraordinary General Meeting of the members of the above Company held on 22nd December, 1978 it was resolved that the company be wound up voluntarily and that Mr. N. W. Curwood be appointed liquidator of the company and that he be authorised to divide among the members in specie or kind all or any part of the assets of the company.

Notice is also given that after 21 days from this date I shall proceed to distribute the assets. All creditors having any claims against the company should furnish particulars of such claim by that date, otherwise I shall proceed to distribute the assets without regard to their claim.

Dated this 22nd day of December, 1978

N. W. CURWOOD, Liquidator
Sicree, Nixon, Watt & Co., 257 Collins Street, Melbourne 139

S.A.R. CO-OPERATIVE LIMITED (IN VOLUNTARY LIQUIDATION)

SPECIAL RESOLUTION

Passed 12th December, 1978

At a special general meeting of the abovenamed society duly convened and held at 973 Whitehorse Road, Box Hill on the twelfth day of December 1978 at 11 a.m. the subjoined special resolution was duly passed:—

The Society having successfully completed its objectives be wound up voluntarily, and that Alexander William Price of 973 Whitehorse Road, Box Hill, be appointed liquidator for the purposes of the winding up.

S. DORLING, Chairman of Meeting
A. W. PRICE, Secretary 141

EMPLOYEE BENEFIT PLANS AUSTRALIA PROPRIETARY LIMITED (IN VOLUNTARY LIQUIDATION)

At an Extraordinary General Meeting of Shareholders of the above company held at 43 Agnes Street, East Melbourne, on the 19th day of December, 1978, the following Special Resolution was duly passed:—

"That the company be wound up voluntarily, and that J. D. Cullen be appointed liquidator."

Dated this 19th day of December, 1978

J. D. CULLEN & ASSOCIATES, 563 Highett Road, Highett, Victoria, 3190 147

Company No. 58711—Companies Act 1961—In the matter of GUILDFORD FASHIONS PTY. LTD. (in Voluntary Liquidation)

Notice is hereby given that at an Extraordinary General Meeting of the members of the abovenamed Company held on the 21st December, 1978 it was resolved that the Company be wound up voluntarily and that Peter Charles Phillips and Eric Stanwell Field of W. Marshall & Associates of Suite 2, 162 Albert Road, South Melbourne, Chartered Accountants be appointed Liquidators.

Notice is also given that after twenty-one days from this date we shall proceed to distribute the assets. All creditors having any claims against the Company should furnish particulars of same by that date otherwise we shall proceed to distribute the assets without regard to their claim.

Dated this 21st day of December, 1978

146 PETER C. PHILLIPS, Liquidator
ERIC S. FIELD, Liquidator

The Companies Act 1961—In the matter of WILLIAM LEVERTON PTY. LTD.

Pursuant to section 254 (2) (b) of the Companies Act 1961 notice is hereby given that at an Extraordinary General Meeting of the company duly convened and held on December 22, 1978 the following Resolution was passed as a Special Resolution:—

"That the company be wound up voluntarily."

and at such meeting James Stanley Phillips, of 133 Abbotsford Street, North Melbourne, Chartered Accountant, was appointed liquidator for the purposes of the winding up.

Dated this 22nd day of December, 1978

148 G. S. HYETT, Director

The Companies Act 1961

A. & I. WALKER HOLDINGS PTY. LTD. (IN MEMBERS' VOLUNTARY LIQUIDATION)

At a Meeting of Members of the above Company on the 30th day of November, 1978, the following Special Resolution was duly passed:—

Resolved that the Company be wound up voluntarily and that John Alan Niven, Chartered Accountant, of Suite "A", 3rd Floor, 406 Lonsdale Street, Melbourne, be hereby appointed liquidator for the purposes of winding up the Company and that the assets of the Company be distributed between its Members.

J. A. NIVEN, Liquidator

T. J. Whittle and Company, chartered accountants, Suite "A", 3rd Floor, 406 Lonsdale Street, Melbourne 149

In the matter of the Companies Act; and in the matter of ARIGNA PROPERTIES PROPRIETARY LIMITED

Notice is hereby given that at an extraordinary general meeting of the abovenamed company duly convened and held at 224 Queen Street, Melbourne at 12.00 noon, on the 20th day of December, 1978, the following special resolution was duly passed:

"That the company be wound up voluntarily, and that Donald McCance Gibson of 1 Coles Arcade, Evans Street, Sunbury be appointed liquidator for the purposes of such winding up, and that the remuneration of Donald McCance Gibson be fixed at \$500 for his services in the winding up of the company and be in addition to his costs charges and expenses as Solicitor.

That the said liquidator be and he is hereby authorised pursuant to Section 270 to transfer to Sulnit Proprietary Limited any real estate owned by Arigna Properties Proprietary Limited."

Dated this 20th day of December, 1978

140 D. McC. GIBSON, Liquidator

TENTH FLOOR INVESTMENTS PTY. LIMITED (IN LIQUIDATION)

Notice is hereby given that the following resolution was passed on 22 December 1978 as a special resolution:—

"That the company be wound up voluntarily."

Notice is also given that after 21 days from this date, I will proceed to distribute the assets. All creditors having any claims against the company should furnish particulars of same by that date, otherwise I shall proceed to distribute the assets without regard to their claim.

Dated this 22nd day of December, 1978

C. S. WIGHT, Liquidator
Arthur Young & Company, 500 Bourke Street, Melbourne 143
3000

Companies Act 1961—in the matter of BEL-AIR CARPETS PTY. LTD. (in Liquidation)

Notice is hereby given that at an extraordinary Meeting of the Members of the abovenamed Company held on the 21st December, 1978, it was resolved that the Company be wound up voluntarily and at a Meeting of Creditors held on the same day pursuant to Section 260 it was resolved that for such purpose Mr. D. J. Cogle of Suite 18, 545 St. Kilda Road, Melbourne, Public Accountant, be appointed Liquidator.

Notice is also given that after twenty-one days from this date I shall proceed to distribute the assets. All creditors having any claim against the Company should furnish particulars of same by that date, otherwise I shall proceed to distribute the assets without regard to their claim.

Dated this 21st day of December, 1978

D. J. COUGLE, Liquidator
Bent & Cogle, public accountants, Suite 18, 545 St. Kilda Road, Melbourne 3004 142

A.N.A. CO-OPERATIVE HOUSING SOCIETY (No. 4) LIMITED (IN LIQUIDATION)

SPECIAL RESOLUTION

Passed on the 14th December, 1978

At a Special General Meeting of the abovenamed society duly convened and held at the 9th floor, 114 Albert Road, Melbourne on the 14th of December, 1978, at 3.30 p.m. the subjoined special resolution was duly passed:—

1. That the Society have successfully completed its objectives twenty (20) months ahead of its expected term be wound up voluntarily, and that Thomas Raymond Davey of 4 Ashby Court, North Balwyn be appointed liquidator for the purposes of winding up.

T. R. DAVEY, Chairman of Meeting
A. J. BUSSEY, Secretary

144

In the matter of the Co-operative Housing Societies Act 1958; and the Companies Act 1967; and in the matter of A.N.A. CO-OPERATIVE HOUSING SOCIETY (No. 4) LIMITED (in Liquidation)—Notice to Creditors

Notice is hereby given that all persons having any claim against the above society are required on or before the 26th of January, 1979, to send their names and addresses and particulars of their debts or claims to Thomas Raymond Davey, the liquidator of the said society at his office (28 Elizabeth Street, Melbourne) and if so required by notice in writing from the said Liquidator are personally, or by their solicitors, to come in and prove their said debts or claims at such time, and place as shall be specified in such notice; or, in default thereof, they shall be excluded from the benefit of any distribution made before such debts or claims are so lodged or proved.

Dated at Melbourne this 21st day of December, 1978

145 T. R. DAVEY, Liquidator

KY-ALBION PROPRIETARY LIMITED

At a special meeting held at Warrambool it was resolved that the Company be wound up voluntarily and that J. J. Purcell of 67-69 Kepler Street, Warrambool be appointed liquidator at a fee to be arranged.

150 CLAIRE E. SAVAGE, Director

In the matter of the Companies Act 1961; and in the matter of RED ROSE LINGERIE PTY. LTD.—Notice Pursuant to Section 254 (2) of the Companies Act 1961

Notice is hereby given that an Extraordinary General Meeting of Members of the Company duly convened and held at 2 Adelaide Street, Richmond on the 19th day of December, 1978 in the forenoon the following resolution was passed, viz:

1. That Red Rose Lingerie Pty. Ltd. being solvent be wound up voluntarily, and

2. That John Rezak, Accountant of the firm of Rezak & Associates, Accountants, 3rd Floor, 390 St. Kilda Road, Melbourne, be appointed liquidator for the purpose of such winding up and that the liquidator's remuneration be calculated on a time basis.

Dated this 19th day of December, 1978

151 MAURICE TAUMAN, Chairman

Companies Act 1961—In the matter of SOUTH ASCOT PTY. LTD. (in Liquidation)

Notice is hereby given that at an extraordinary Meeting of the Members of the abovenamed Company held on the 18th December 1978, it was resolved that the Company be wound up voluntarily and at a Meeting of Creditors held on the same day pursuant to Section 260 it was resolved that for such purpose Mr. D. J. Cogle of Suite 18, 545 St. Kilda Road, Melbourne, Public Accountant, be appointed Liquidator.

Notice is also given that after twenty one days from this date I shall proceed to distribute the assets. All creditors having any claims against the Company should furnish particulars of same by that date, otherwise I shall proceed to distribute the assets without regard to their claim.

Dated this 18th day of December, 1978

D. J. COUGLE, Liquidator

Bent & Cogle, public accountants, Suite 18, 545 St. Kilda Road, Melbourne 3004 152

Companies Act 1961—In the matter of CRANBOURNE TILES PTY. LTD., of 26 Cedar Street, Langwarrin—Notice Re Meeting of Creditors, Pursuant to Section 260

Notice is hereby given that a Meeting of Creditors of the abovenamed Company will be held at Suite 18, 545 St. Kilda Road, Melbourne on Friday, 26th January, 1979 at 10.30 a.m., the Company having convened a Meeting of its Members for the same day for the purpose of considering a Resolution that the Company be wound up voluntarily.

Dated this 19th day of December, 1978

B. R. REED, Director

Bent & Cogle, public accountants, Suite 18, 545 St. Kilda Road, Melbourne 3004 153

S. MELTON PROPRIETARY LIMITED (IN VOLUNTARY LIQUIDATION)

At an Extraordinary General Meeting of the abovenamed Company, duly convened and held at 88 Bignell Road, East Bentleigh on 18th day of December, 1978 the following resolutions were duly passed:—

That the Company be wound up voluntarily and that Jacob Stainmagen of 14 Fitzroy Street, St. Kilda be appointed liquidator for the purposes of such winding up.

Dated this 18th day of December, 1978

154 JACOB STAINMAGEN, Liquidator

Companies Act 1961—1975, Section 272**70 PARK STREET PTY. LTD.****NOTICE OF FINAL MEETING AND DISSOLUTION****Members' Voluntary Winding Up**

The affairs of 70 Park Street Pty. Ltd. having been fully wound up, Notice is hereby given of a General Meeting of the Company to be held at 10.30 a.m. on Monday, 22nd January, 1979, in the Office of Thomas Miles & Co., 7th floor, Commonwealth Bank Building, King George Square, Adelaide Street, Brisbane.

Business

(1) To lay before the meeting the account showing how the winding up has been conducted and the property of the Company disposed of, and to give any explanation thereof.

(2) To resolve whether or not the books and records of the Company may be destroyed after a period of three months from the date of the meeting.

Brisbane, 15th December, 1978

155 G. L. MILES, Liquidator
D. W. IMBER, Liquidator

In the matter of the Co-operative Housing Societies Act 1958; and in the matter of KARDINIA (No. 3) CO-OPERATIVE HOUSING SOCIETY LIMITED (in Liquidation)

At a Special General Meeting of the above-named Society duly convened and held at the Registered Office, "Whitehall Manor", 42 Aberdeen Street, Geelong West on Monday, 16th October, 1978 the subjoined special resolution was duly passed:—

"That the Society having successfully completed its objectives fifty-seven months ahead of its expected term be wound up voluntarily, and that Brian Geoffrey Thom of 42 Aberdeen Street, Geelong West, be appointed Liquidator for the purposes of the winding up."

Dated this 17th day of October, 1978

156 L. G. OLNEY, Chairman of Meeting
B. G. THOM, Secretary

The Companies Act 1961—In the matter of R. J. MOORE TRANSPORT SERVICES PROPRIETARY LIMITED—Notice of Appointment of Provisional Liquidator

Order for appointment of an Official Liquidator as Provisional Liquidator made the 15th day of December, 1978.

Name and Address of Provisional Liquidator:—Dennis John Cogle of Bent & Cogle, 545 St. Kilda Road, Melbourne, 3000, Victoria.

HEDDERWICKS, FOOKES & ALSTON, 121 William Street, Melbourne, 3000, Agents for Riordan & Riordan, 95 Welsford Street, Shepparton, 3630, solicitors for the petitioners. 157

Companies Act 1961, Section 272**CENTRE PANEL BEATING PTY. LTD. (IN LIQUIDATION)****NOTICE OF FINAL MEETING OF MEMBERS AND CREDITORS**

Notice is hereby given that the final meeting of members and creditors of the abovenamed Company shall be held on Wednesday, 7th February, 1979 at 2.00 p.m. at the offices of Max Gee & Co., corner Grant and Pilmer Streets, Bacchus Marsh, 3340.

Agenda

1. Presentation by the Liquidator of an account showing how the winding up has been conducted and the property of the Company has been disposed of and to give any explanation of the account.

2. The meeting to consider the following resolution: "That immediately after the dissolution of the Company the Liquidator may destroy the books and papers of the Company pursuant to section 284 of the Act."

Dated this 5th day of January, 1979

D. S. SCOTT, Liquidator

Max Gee & Co., corner Grant and Pilmer Streets, Bacchus Marsh, 3340. Telephone (053) 673664. 158

CHOTA WALLAH INVESTMENTS PTY. LTD. (IN VOLUNTARY LIQUIDATION)**SPECIAL RESOLUTION TO WIND UP**

At an extraordinary general meeting of the abovenamed Company, duly convened and held at 116 High Street, Hastings on the 19th day of December, 1978, the following Resolution was passed as a Special Resolution:

"That the company be wound up voluntarily."

At the abovementioned meeting Janice Everist was appointed Liquidator for the purpose of the winding up.

"Notice is also given that after twenty-one days from this date, I shall proceed to distribute the assets. All creditors having any claim against the Company should furnish particulars of same by that date, otherwise I shall proceed to distribute the assets without regard to their claim."

Dated this 20th day of December, 1978

JANICE EVERIST, Liquidator, 116 High Street, Hastings. 159

The Companies Act 1961—In the matter of BLUE LINE FREIGHTERS PTY. LTD.—Notice of Appointment of Provisional Liquidator

Order for appointment of an Official Liquidator as Provisional Liquidator made the 15th day of December, 1978.

Name and Address of Provisional Liquidator:—Dennis John Cogle of Bent & Cogle, 545 St. Kilda Road, Melbourne, 3000, Victoria.

HEDDERWICKS, FOOKES & ALSTON, 121 William Street, Melbourne, 3000, Agents for Riordan & Riordan, 95 Welsford Street, Shepparton, 3630, solicitors for the petitioners. 167

Companies Act 1961**RE E. F. ZARB PTY. LIMITED**

Notice is hereby given that at a general meeting of the members of E. F. Zarb Pty. Limited duly convened and held at 3 Juan Street, Alexandra Headlands, Queensland, on the 27th day of December, 1978.

The special resolution set out below was duly passed.

"That the company be wound up voluntarily."

Dated this 28th day of December, 1978

172 N. L. HOCKING, Secretary

In the matter of CHOTA WALLAH INVESTMENTS PTY. LTD. (IN LIQUIDATION)—and in the matter of the Companies Act 1961—Notice Inviting Proof of Debt of Claim

The Creditors of the abovenamed company are required on or before the twenty-third day of January, 1979, to prove their debts or claims and to establish any title they may have to priority by delivering or sending through the post to the Liquidator at the undermentioned address an affidavit verifying their respective debts of claims. In default they will be excluded from the benefit of any distribution made before such debts or claims are proved or such priority is established and from objecting to any such distribution. Form of proof may be obtained from the Liquidator at the address shown below.

Dated this 20th day of December, 1978

JANICE EVERIST, Liquidator
Care of Weber, Crawford & Co., 116 High Street,
Hastings, Vic., 3915. 160

Companies Act 1961, Section 254 (2) (b)
KAYSILK INVESTMENTS PROPRIETARY LIMITED

At a General Meeting of the Members of Kaysilk Investments Proprietary Limited duly convened and held at the offices of Morton, Watson & Young, First Floor, Corner Scott & Thomas Streets, Dandenong on the Twenty-second day of December, 1978 the following Resolutions were duly passed as Special Resolutions—

1. That the Company be wound up voluntarily and that Ian Elwood Davey be hereby appointed Liquidator for the purpose of such winding up.

2. That pursuant to section 269 of the Companies Act 1961 the Liquidator be and is hereby authorised to exercise any of the powers given by paragraphs (b) (c) and (d) of section 236 of the Companies Act 1961 to a Liquidator in a winding up by the Court.

Dated this 22nd day of December, 1978

I. E. DAVEY, Liquidator, corner Scott and Thomas Streets, Dandenong 173

Companies Act 1961, Section 260 (3)
THE CARPET FACTORY PTY. LTD.

NOTICE OF MEETING OF CREDITORS

Notice is hereby given that a meeting of creditors of Carpet Factory Pty. Ltd., will be held at the Board Room, Institute of Chartered Accountants in Australia, 140 Queen Street, Melbourne on Wednesday the Seventeenth day of January, 1979 at 3.00 p.m., the company having convened a meeting of its members for the same day for the purpose of considering a resolution that the company be wound up voluntarily.

Dated this 20th day of December, 1978

R. A. GILBERT, Director
V. R. Dye & Co., chartered accountants, 536 Whitehorse Road, Mitcham 177

The Companies Act 1961
LUCAS RECYCLERS OF AUSTRALASIA LIMITED
At an Extraordinary General Meeting of the Shareholders of Lucas Recyclers of Australasia Limited, convened and held at 407 City Road, South Melbourne, on 22nd December, 1978, the following Special Resolution was duly passed—

"That the Company be wound up voluntarily in accordance with the Companies Act 1961, and that Eric Edwin Haines, Chartered Accountant, of 343 Little Collins Street, Melbourne, be appointed liquidator of the Company."

22nd December, 1978

182 J. T. M. MURRAY, Director

Companies Act 1961, Section 254 (2)
ERICO ENGINEERING PTY. LTD. (FORMERLY CABUS ENGINEERING PTY. LTD.)

Notice is hereby given that at an extraordinary Meeting of the Members of the abovenamed company duly convened and held on the 15th day of December, 1978, it was resolved that the Company be wound up voluntarily and at a meeting of Creditors held on the same day pursuant to section 260, it was resolved that for such purpose Mr. M. G. Chapman, of 351 Collins Street, Melbourne, be appointed Liquidator.

"Notice is also given that after twenty one days from this date, I shall proceed to distribute the assets. All creditors having any claim against the Company should furnish particulars of same by that date, otherwise I shall proceed to distribute the assets without regard to their claim."

Dated this 15th day of December, 1978

M. G. CHAPMAN, Liquidator, 351 Collins Street, Melbourne, Vic., 3000 183

Companies Act 1961, Section 254 (2)
CABUS ERICO PTY. LTD.

Notice is hereby given that at an extraordinary Meeting of the Members of the abovenamed company duly convened and held on the 15th day of December, 1978, it was resolved that the Company be wound up voluntarily and at a meeting of Creditors held on the same day pursuant to section 260, it was resolved that for such purpose Mr. M. G. Chapman, of 351 Collins Street, Melbourne, be appointed Liquidator.

"Notice is also given that after twenty one days from this date, I shall proceed to distribute the assets. All creditors having any claim against the Company should furnish particulars of same by that date, otherwise I shall proceed to distribute the assets without regard to their claim."

Dated this 15th day of December, 1978

M. G. CHAPMAN, Liquidator, 351 Collins Street, Melbourne, Vic., 3000 184

Companies Act 1961
READY MIXED CONCRETE (VICTORIA) PTY. LTD.

Notice is hereby given in accordance with section 254 (2) (b) that at an Extraordinary General Meeting of the members of the abovenamed company held on 18th December, 1978 it was resolved that the company be wound up voluntarily and that John Lachlan Charles McInnes be appointed as liquidator for the purposes of the winding up.

Dated this 22nd day of December, 1978

J. L. C. McINNES, Liquidator
J. L. C. McInnes, chartered accountant, 12 Wellington Parade, East Melbourne, 3002 185

The Companies Act 1961
AUSTRALIAN BASE METALS N.L.
MEMBERS' WINDING UP

Notice is hereby given that at an extraordinary general meeting of the above company, duly convened and held at 10th Floor, 44 Market Street, Melbourne, Victoria, on 11th December 1978, the following resolution was proposed and passed as a special resolution:

"That the Company be wound up voluntarily and that Eric James Ramsay of 44 Market Street, Melbourne, Victoria, be appointed Liquidator for the purpose of such winding up and that he be authorised to draw as remuneration for his services as Liquidator his normal hourly charges in respect thereto."

11th December, 1978

186 A. K. JAMISON, Secretary

The Companies Act 1961, Regulation 54
S.E. & E.B. PTY. LTD. (IN LIQUIDATION) (formerly Stock Clearing Centre Pty. Ltd.)

Notice is hereby given that a first and final dividend is about to be declared in the abovementioned liquidation.

Creditors who have not proved their debts by 15 January 1979 will be excluded from the dividend.

Dated this 18th day of December, 1978

V. R. DYE, Liquidator
V. R. Dye & Co., chartered accountants, 535 Whitehorse Road, Mitcham 187

Companies Act 1961
SOUTH EAST PROPERTY DEVELOPMENT PTY. LTD.

Notice is hereby given in accordance with Section 254 (2) (b) that at an Extraordinary General Meeting of the Members of the above named company held on 13th December 1978 it was resolved that the company be wound up voluntarily and that John Lachlan Charles McInnes be appointed as liquidator for the purposes of the winding up.

Dated this 19th day of December, 1978

J. L. C. McINNES, Liquidator
J. L. C. McInnes, chartered accountant, 12 Wellington Parade, East Melbourne, 3002 189

The Companies Act 1961
NILKERIE PTY. LTD.
MEMBERS' WINDING UP

Notice is hereby given that at an extraordinary general meeting of the above company, duly convened and held at 10th Floor, 44 Market Street, Melbourne, Victoria, on 15 December 1978, the following resolution was proposed and passed as a special resolution:

"That the Company be wound up voluntarily and that Eric James Ramsay of 44 Market Street, Melbourne, Victoria, be appointed Liquidator for the purpose of such winding up and that he be authorised to draw as remuneration for his services as Liquidator his normal hourly charges in respect thereto."

15th December, 1978

188

S. BATTISTI, Director

Companies Act 1961, Section 272 (2)

GEVON TRADING PTY. LTD. (IN LIQUIDATION)

Notice is hereby given that pursuant to Section 272 of the Companies Act 1961 a general meeting of the members and creditors of Gevon Trading Pty. Ltd. (in Liquidation) will be held at the offices of Peat, Marwick, Mitchell & Co., 16th Floor, 500 Bourke Street, Melbourne on Thursday the eighth day of February 1979 at 10.15 o'clock in the forenoon.

The purpose of the meeting is to lay accounts before it showing the manner in which the winding up has been conducted and the property of the company disposed of and of hearing any explanation that may be given by the Liquidator.

Dated this 20th day of December, 1978

190

D. A. CRAWFORD, Liquidator

Companies Act 1961, Section 272 (2)

GEVON TIMBER SALES PTY. LTD. (IN LIQUIDATION)

Notice is hereby given that pursuant to Section 272 of the Companies Act 1961 a general meeting of the members and creditors of Gevon Timber Sales Pty. Ltd. (in Liquidation) will be held at the offices of Peat, Marwick, Mitchell & Co., 16th Floor, 500 Bourke Street, Melbourne, on Thursday the eighth day of February 1979 at 10.30 o'clock in the forenoon.

The purpose of the meeting is to lay accounts before it showing the manner in which the winding up has been conducted and the property of the company disposed of and of hearing any explanation that may be given by the Liquidator.

Dated this 20th day of December, 1978

191

D. A. CRAWFORD, Liquidator

Companies Act 1961, Section 272 (2)

GEVON PLUMBING SUPPLIES PTY. LTD. (IN LIQUIDATION)

Notice is hereby given that pursuant to Section 272 of the Companies Act 1961 a general meeting of the members and creditors of Gevon Plumbing Supplies Pty. Ltd. (in Liquidation) will be held at the offices of Peat, Marwick, Mitchell & Co., 16th Floor, 500 Bourke Street, Melbourne on Thursday the eighth day of February 1979 at 10.45 o'clock in the forenoon.

The purpose of the meeting is to lay accounts before it showing the manner in which the winding up has been conducted and the property of the company disposed of and of hearing any explanation that may be given by the Liquidator.

Dated this 20th day of December, 1978

192

D. A. CRAWFORD, Liquidator

The Companies Act 1961

T.T. PROPERTIES (BRUNSWICK) PTY. LTD. (IN LIQUIDATION)

NOTICE CONVENING FINAL MEETING OF THE COMPANY,
PURSUANT TO SECTION 272 (1)

Notice is hereby given that the Final Meeting of Members of the abovenamed Company will be held on the 40th Floor of the MLC Centre, Martin Place, Sydney, on the 31st day of January, 1979 at 9.30 a.m. for the purpose of laying

before the Meeting an account showing how the winding up has been conducted and the property of the Company has been disposed of and giving any explanation thereof.

Dated this 19th day of December, 1978

A. R. M. MACINTOSH AND D. A. CRAWFORD, Joint and Several Liquidators

Peat, Marwick, Mitchell & Co., chartered accountants,
Tower Building, Australia Square, Sydney, 2000 193

The Companies Act 1961

T.T. PROPERTIES (PRESTON) PTY. LTD. (IN LIQUIDATION)

NOTICE CONVENING FINAL MEETING OF THE COMPANY,
PURSUANT TO SECTION 272 (1)

Notice is hereby given that the Final Meeting of Members of the abovenamed Company will be held on the 40th Floor of the MLC Centre, Martin Place, Sydney, on the 31st day of January, 1979 at 9.35 a.m. for the purpose of laying before the Meeting an account showing how the winding up has been conducted and the property of the Company has been disposed of and giving any explanation thereof.

Dated this 19th day of December, 1978

A. R. M. MACINTOSH AND D. A. CRAWFORD, Joint and Several Liquidators

Peat, Marwick, Mitchell & Co., chartered accountants,
Tower Building, Australia Square, Sydney, 2000 194

The Companies Act 1961

ALLIED BAKERIES DISTRIBUTORS (MELBOURNE) PTY. LTD. (IN LIQUIDATION)

NOTICE CONVENING FINAL MEETING OF THE COMPANY,
PURSUANT TO SECTION 272 (1)

Notice is hereby given that the Final Meeting of Members of the abovenamed Company will be held on the 40th Floor of the MLC Centre, Martin Place, Sydney, on the 31st day of January, 1979 at 9.40 a.m. for the purpose of laying before the Meeting an account showing how the winding up has been conducted and the property of the Company has been disposed of and giving any explanation thereof.

Dated this 19th day of December, 1978

A. R. M. MACINTOSH AND D. A. CRAWFORD, Joint and Several Liquidators

Peat, Marwick, Mitchell and Co., chartered accountants,
Tower Building, Australia Square, Sydney, 2000 195

The Companies Act 1961

T.T. PROPERTIES (DANDENONG) PTY. LTD. (IN LIQUIDATION)

NOTICE CONVENING FINAL MEETING OF THE COMPANY,
PURSUANT TO SECTION 272 (1)

Notice is hereby given that the Final Meeting of Members of the abovenamed Company will be held on the 40th Floor of the MLC Centre, Martin Place, Sydney, on the 31st day of January, 1979 at 9.45 a.m. for the purpose of laying before the Meeting an account showing how the winding up has been conducted and the property of the Company has been disposed of and giving any explanation thereof.

Dated this 19th day of December, 1978

A. R. M. MACINTOSH AND D. A. CRAWFORD, Joint and Several Liquidators

Peat, Marwick, Mitchell and Co., chartered accountants,
Tower Building Australia Square, Sydney, 2000 196

The Companies Act 1961

TIP TOP PROPERTIES (OAKLEIGH) PTY. LTD. (IN LIQUIDATION)

NOTICE CONVENING FINAL MEETING OF THE COMPANY,
PURSUANT TO SECTION 272 (1)

Notice is hereby given that the Final Meeting of Members of the abovenamed Company will be held on the 40th Floor of the MLC Centre, Martin Place, Sydney, on the 31st day of January, 1979 at 9.50 a.m. for the purpose of laying before the Meeting an account showing how the winding up has been conducted and the property of the Company has been disposed of and giving any explanation thereof.

Dated this 19th day of December, 1978

A. R. M. MACINTOSH AND D. A. CRAWFORD, Joint and Several Liquidators

Peat, Marwick, Mitchell and Co., chartered accountants,
Tower Building, Australia Square, Sydney, 2000 197

The Companies Act 1961

T.T. PROPERTIES (VERMONT) PTY. LTD. (IN LIQUIDATION)

NOTICE CONVENING FINAL MEETING OF THE COMPANY, PURSUANT TO SECTION 272 (1)

Notice is hereby given that the Final Meeting of Members of the abovenamed Company will be held on the 40th Floor of the MLC Centre, Martin Place, Sydney, on the 31st day of January, 1979 at 9.55 a.m. for the purpose of laying before the Meeting an account showing how the winding up has been conducted and the property of the Company has been disposed of and giving any explanation thereof.

Dated this 19th day of December, 1978

A. R. M. MACINTOSH AND D. A. CRAWFORD, Joint and Several Liquidators

Peat, Marwick, Mitchell and Co., chartered accountants, Tower Building, Australia Square, Sydney, 2000 198

The Companies Act 1961

M.B. PROPERTIES PTY. LTD. (IN LIQUIDATION)

NOTICE CONVENING FINAL MEETING OF THE COMPANY, PURSUANT TO SECTION 272 (1)

Notice is hereby given that the Final Meeting of Members of the abovenamed Company will be held on the 40th Floor of the MLC Centre, Martin Place, Sydney, on the 31st day of January, 1979 at 10.00 a.m. for the purpose of laying before the Meeting an account showing how the winding up has been conducted and the property of the Company has been disposed of and giving any explanation thereof.

Dated this 19th day of December, 1978

A. R. M. MACINTOSH AND D. A. CRAWFORD, Joint and Several Liquidators

Peat, Marwick, Mitchell and Co., chartered accountants, Tower Building, Australia Square, Sydney, 2000 199

The Companies Act 1961

CRANMOOR DISTRIBUTORS PTY. LTD. (IN LIQUIDATION)

NOTICE CONVENING FINAL MEETING OF THE COMPANY, PURSUANT TO SECTION 272 (1)

Notice is hereby given that the Final Meeting of Members of the abovenamed Company will be held on the 40th Floor of the MLC Centre, Martin Place, Sydney, on the 31st day of January, 1979 at 10.05 a.m. for the purpose of laying before the Meeting an account showing how the winding up has been conducted and the property of the Company has been disposed of and giving any explanation thereof.

Dated this 19th day of December, 1978

A. R. M. MACINTOSH AND D. A. CRAWFORD, Joint and Several Liquidators

Peat, Marwick, Mitchell and Co., chartered accountants, Tower Building, Australia Square, Sydney, 2000 200

The Companies Act 1961

N.B.L. PROPERTIES (VIC.) PTY. LTD. (IN LIQUIDATION)

NOTICE CONVENING FINAL MEETING OF THE COMPANY, PURSUANT TO SECTION 272 (1)

Notice is hereby given that the Final Meeting of Members of the abovenamed Company will be held on the 40th Floor of the MLC Centre, Martin Place, Sydney, on the 31st day of January, 1979 at 10.10 a.m. for the purpose of laying before the Meeting an account showing how the winding up has been conducted and the property of the Company has been disposed of and giving any explanation thereof.

Dated this 19th day of December, 1978

A. R. M. MACINTOSH AND D. A. CRAWFORD, Joint and Several Liquidators

Peat, Marwick, Mitchell and Co., chartered accountants, Tower Building, Australia Square, Sydney, 2000 201

The Companies Act 1961

N.B. LOVE POULTRY (VIC.) PTY. LTD. (IN LIQUIDATION)

NOTICE CONVENING FINAL MEETING OF THE COMPANY, PURSUANT TO SECTION 272 (1)

Notice is hereby given that the Final Meeting of Members of the abovenamed Company will be held on the 40th Floor of the MLC Centre, Martin Place, Sydney, on the 31st day of January, 1979 at 10.15 a.m. for the purpose of

laying before the Meeting an account showing how the winding up has been conducted and the property of the Company has been disposed of and giving any explanation thereof.

Dated this 19th day of December, 1978

A. R. M. MACINTOSH AND D. A. CRAWFORD, Joint and Several Liquidators

Peat, Marwick, Mitchell and Co., chartered accountants, Tower Building, Australia Square, Sydney, 2000 202

Companies Act 1961

SEHLBACH & WHITING (AUSTRALIA) PTY. LTD. (IN VOLUNTARY LIQUIDATION)

At an Extraordinary General Meeting of Sehlbach & Whiting (Australia) Pty. Ltd. duly convened and held at 367 Collins Street, on 21st December, 1978, the following resolutions were duly passed as Special Resolutions:

(a) That the company be wound-up voluntarily.

(b) That, Peter Roger Manuell of Hancock & Offner having consented to act, be and is hereby appointed liquidator.

Dated this 21st day of December, 1978

203 P. R. MANUELL, Liquidator

Companies Act 1961, Section 272

Notice of final meeting of ADDISON BALLANTYNE PTY. LTD. (in Liquidation)

Notice is hereby given that a meeting of the abovenamed company will be held in the offices of Fell & Starkey, 18th Floor, 351 Collins Street, Melbourne, on 26th January, 1979 at 10.00 a.m. in the forenoon.

Agenda

To lay before the meeting the liquidator's account showing how the winding up has been conducted and the property of the company has been disposed of and to give any explanation of the account which may be required.

Dated this 27th day of December, 1978 204

The Companies Act 1961

WORLD COLOURVISION PTY. LTD.

PURSUANT TO SECTION 260 OF THE COMPANIES ACT 1961

Notice is hereby given that a Meeting of Creditors of World Colourvision Pty. Ltd. will be held at the offices of Touche Ross & Co., Chartered Accountants, 440 Collins Street, Melbourne on Tuesday, 23rd January, 1979 at 3.00 p.m. for the purposes of considering the Company's affairs, the Company having convened an Extraordinary General Meeting of its Members to be held on Tuesday, 23rd January, 1979 at 2.30 p.m. and for the purpose of considering and if thought fit passing a Special Resolution that the Company be wound up voluntarily.

Dated this 27th day of December, 1978

205 G. J. BOORER, Director

The Companies Act 1961

PALATIAL POOLS PTY. LTD.

PURSUANT TO SECTION 260 OF THE COMPANIES ACT 1961

Notice is hereby given that a Meeting of Creditors of Palatial Pools Pty. Ltd. will be held at the offices of Touche Ross & Co., Chartered Accountants, 440 Collins Street, Melbourne on Thursday, 25th January, 1979 at 3.00 p.m. for the purposes of considering the Company's affairs, the Company having convened an Extraordinary General Meeting of its Members to be held on Thursday, 25th January, 1979 at 2.30 p.m. and for the purpose of considering and if thought fit passing a Special Resolution that the Company be wound up voluntarily.

Dated this 27th day of December, 1978

206 G. J. BOORER, Director

Companies Act 1961—In the matter of ASTRONETICS PTY. LTD. (in Liquidation)

Notice is hereby given that at an Extraordinary Meeting of the members of the abovenamed company held on 27th December, 1978 it was resolved that the company be wound up voluntarily and at a Meeting of Creditors held on the same day pursuant to Section 260, it was resolved that Messrs. Douglas Ewart Tonkin and Leslie Philip Smart of 51 Queen Street, Melbourne, be appointed liquidators to act jointly or severally for the purpose of such winding up.

Dated this 27th day of December, 1978

L. P. SMART, Liquidator

Marquand & Co., chartered accountants, 51 Queen Street, Melbourne, 3000 207

Companies Act 1961—In the matter of—
HEATHS SERVICE STATION PTY. LTD. (IN LIQUIDATION)
WOODFORD MOTORS PTY. LTD. (IN LIQUIDATION)
GLENBARRY MOTORS PTY. LTD. (IN LIQUIDATION)

Notice is hereby given that at Extraordinary Meetings of the members of the abovenamed companies held on the 22nd December, 1978 it was resolved that the companies be wound up voluntarily and that Messrs. Robert Lindsay Yeo and Barry Lorne Jenner of Marquand & Co., 51 Queen Street, Melbourne, be appointed joint and several liquidators for the purpose of such windings up.

Dated this 22nd day of December, 1978
 208 R. L. YEO, Liquidator

The Companies Act 1961
RON NORTH DISCOUNT SALES PTY. LTD.
PURSUANT TO SECTION 260 OF THE COMPANIES ACT 1961

Notice is hereby given that a meeting of Creditors of Ron North Discount Sales Pty. Ltd., will be held at the City Mutual Meeting Room, 18th Floor, 459 Collins Street, Melbourne on Monday the 8th day of January, 1979 at 10.30 a.m. for the purpose of considering the Company's affairs, the Company having convened an Extraordinary General Meeting of its Members to be held on Monday the 8th day of January, 1979 and for the purpose of considering and if thought fit passing a Special Resolution that the Company be wound up voluntarily.

Dated this 29th day of December, 1978

R. J. NORTH, Director
 Ferrier Hodgson Green & Co., chartered accountants,
 459 Collins Street, Melbourne, 3000 218

The Companies Act 1961
TRICOIN PROPRIETARY LIMITED (IN VOLUNTARY LIQUIDATION)

At an Extraordinary General Meeting of the Shareholders of Tricoin Proprietary Limited convened and held at 74 Scotsburn Avenue, Huntingdale on 29th December, 1978, the following Special Resolution was duly passed—

"That the Company be wound up voluntarily in accordance with the Companies Act 1961, and that James Collier Benzie and John Arthur Hargreaves, Chartered Accountants, of 9th Floor, 461 Bourke Street, Melbourne, be appointed joint and several liquidators of the Company."

29th December, 1978

220 J. R. SCARFE, Director

Companies Act 1961—In the matter of D. & L. PTY. LTD. (in Voluntary Liquidation)—Members' Winding Up

Notice is hereby given that at an extraordinary general meeting of D. & L. Pty. Ltd. duly convened and held at the registered office of the Company on the 28th December, 1978, the following resolution was proposed and passed as a special resolution:—

"That the Company be wound up voluntarily."

It was also resolved by ordinary resolution that Arnold Geoffrey Saffer be appointed liquidator.

Dated this 29th day of December, 1978

221 A. G. SAFFER, Liquidator

Companies Act 1961—In the matter of RENTNEZ LABORATORIES PTY. LTD. (in Voluntary Liquidation)—Members' Winding Up

Notice is hereby given that at an extraordinary general meeting of Rentnez Laboratories Pty. Ltd. duly convened and held at the registered office of the Company on the 28th December, 1978, the following resolution was proposed and passed as a special resolution:—

"That the Company be wound up voluntarily."

It was also resolved by ordinary resolution that Arnold Geoffrey Saffer be appointed liquidator.

Dated this 29th day of December, 1978

222 A. G. SAFFER, Liquidator

The Companies Act 1961—In the matter of SEFA NOMINEES PTY. LTD. (in Voluntary Liquidation)

Notice is hereby given that at an adjourned Extraordinary Meeting of Members of the abovenamed Company held on Friday, the 22nd day of December, 1978 it was resolved that the Company be wound up voluntarily and at a Meeting of Creditors held on Thursday, the 21st day of December, 1978 it was resolved that for such purpose Anthony George Hodgson of Ferrier Hodgson Green & Co., Chartered Accountants be appointed Liquidator.

Notice is also given that after 21 days from this date I shall proceed to distribute the assets. All Creditors having any claim against the Company should furnish particulars of same by that date, otherwise I shall proceed to distribute the assets without regard to their claim.

Dated this 27th day of December, 1978

A. G. HODGSON, Liquidator
 Ferrier Hodgson Green & Co., chartered accountants, 459
 Collins Street, Melbourne, 3000 219

Companies Act 1961—In the matter of SULAN INVESTMENTS PTY. LTD. (in Voluntary Liquidation)—Members' Winding Up

Notice is hereby given that at an extraordinary general meeting of Sulan Investments Pty. Ltd. duly convened and held at the registered office of the Company on the 28th December, 1978, the following resolution was proposed and passed as a special resolution:—

"That the Company be wound up voluntarily."

It was also resolved by ordinary resolution that Arnold Geoffrey Saffer be appointed liquidator.

Dated this 29th day of December, 1978

223 A. G. SAFFER, Liquidator

KNOCKHOLT PTY. LTD.

Pursuant to Section 254 (2) of the Companies Act 1961

Notice is hereby given that at an extraordinary general meeting of members of the above Company, held on the 11th day of December, 1978 the following resolutions were passed—

1. That the Company be wound up voluntarily.

2. That William Francis Krammer, Chartered Accountant from Fox, Krammer & Wollington, 118 Queen Street, Melbourne be appointed Liquidator.

Dated this 11th day of December, 1978 225

Companies Act 1961, Section 254

DARITON PTY. LTD.
 HUTLEY ENTERPRISES PTY. LTD.
 ERLERE BEDDING PTY. LTD.
 LOWY JEWELLERY PTY. LTD.
 D. W. & E. D. JORDAN PTY. LTD.
 MARSIA PTY. LTD.
 SIMON FREEDMAN PTY. LTD.
 SHOEHOLD PTY. LTD.
 PATTERSONS SHOES PTY. LTD.
 JLM HOLDINGS PTY. LTD.
 J. & L. MORTON PTY. LTD.
 ST. ANDREWS VIEWS PTY. LTD.
 ST. ANDREWS RIVERS PTY. LTD.
 ST. ANDREWS FINANCE PTY. LTD.
 ST. ANDREWS ESTATES PTY. LTD.
 ST. ANDREWS CREDITS PTY. LTD.
 GREENACRES INVESTMENTS PTY. LTD.
 S.S.W.Z INVESTMENTS PTY. LTD.
 S.S.F.Z INVESTMENTS PTY. LTD.
 S.S.D.Z INVESTMENTS PTY. LTD.
 A.F.C.Z INVESTMENTS PTY. LTD.
 G.F.C.Z INVESTMENTS PTY. LTD.
 P.A.C.Z INVESTMENTS PTY. LTD.
 N.O.R.Z INVESTMENTS PTY. LTD.
 M.X.B.Z INVESTMENTS PTY. LTD.
 H.I.H.Z INVESTMENTS PTY. LTD.

Notice is hereby given that each of the above companies held an Extraordinary General Meeting of its members on 28th December, 1978 and that at each Meeting the following Special Resolution was passed—

"That the company be wound up voluntarily."

MURRAY DEWAR, Liquidator, 17 Landcox Street, East Brighton, Victoria, 3187 226

Companies Act 1961—In the matter of LAGONA NOMINEES PTY. LTD., 20-22 Little Bourke Street, Melbourne—Notice Re Meeting of Creditors, Pursuant to Section 260

Notice is hereby given that a Meeting of Creditors of the abovenamed Company will be held at Suite 18, 545 St. Kilda Road, Melbourne, On Thursday, 1st February, 1979, At 10.30 a.m. the Company having convened a Meeting of its Members for the same day for the purpose of considering a special Resolution that the Company be wound up voluntarily.

Dated this 29th day of December, 1978

D. RYAN, Director
 BENT & COUGLE, public accountants, Suite 18, 545
 St. Kilda Road, Melbourne, Vic., 3004 227

Companies Act 1961—In the matter of **CORSAGE NOMINEES PRY. LTD.**, trading as "Bourke Inn", 20-22 Little Bourke Street, Melbourne—Notice Re Meeting of Creditors, Pursuant to Section 260

Notice is hereby given that a Meeting of Creditors of the abovenamed Company will be held at Suite 18, 545 St. Kilda Road, Melbourne, On Thursday, 1st February, 1978 At 11.30 a.m. the Company having convened a Meeting of its Members for the same day for the purpose of considering a special Resolution that the Company be wound up voluntarily.

Dated this 29th day of December, 1978

D. RYAN, Director

BENT & COUGLE, public accountants, Suite 18, 545 St. Kilda Road, Melbourne, Vic., 3004 228

Companies Act 1961—In the matter of **DELPHIC REALTY PTY. LTD.**—Notice Re Meeting of Members, Pursuant to Section 260

Notice is hereby given that a meeting of Members of the abovenamed company will be held at the offices of T. D. Maclean & Company, 2nd Floor, 60 Albert Road, South Melbourne, at 9.30 a.m. in the forenoon on the 26th day of January, 1979, to consider a resolution that the company be wound up voluntarily and that Mr. Thomas Dunn Maclean, a person qualified under the terms of the *Companies Act 1961* and having consented in writing to his appointment, be appointed Liquidator of the Company.

Dated this 20th day of December, 1978

229 LAWRENCE DARRELL, Director

Companies Act 1961—In the matter of **LAROLY PTY. LTD.**, trading as Mullers Mens Wear—Notice Re Meeting of Creditors, Pursuant to Section 260

Notice is hereby given that a meeting of creditors of the abovenamed company will be held at the Fitzgerald Room, Accountants' House, 49 Exhibition Street, Melbourne, on Thursday the 18th of January, 1979 at 11.00 a.m. the company having convened a meeting of its members for the same day for the purpose of considering a Resolution that the company be wound up voluntarily.

Dated this 29th day of December, 1978

B. K. TAYLOR & CO., accountants, 576 St. Kilda Road, Melbourne, Vic., 3004 230

Companies Act 1961
EDGEWOOD PTY. LTD.

NOTICE PURSUANT TO SECTION 254 (2)

Notice is hereby given that at an Extraordinary General Meeting of the members of the above Company, duly convened and held on the 27th day of December, 1978, the following Special Resolution was duly passed:

"That the Company be wound up voluntarily under Section 254 (1) of the *Companies Act 1961* and that Malcolm Henry James Taylor be and the same is hereby appointed Liquidator for the purposes of such winding up."

Dated this 27th day of December, 1978

JOSE APPLETON, Secretary

Green, Taylor & Greenall, chartered accountants, 35 McLachan Street, Horsham, Vic., 3400 231

Companies Act 1961

MORNINGTON ELECTRICAL SERVICES PTY. LTD.
NOTICE OF MEETING OF CREDITORS

Notice is hereby given that a Meeting of the Creditors of Mornington Electrical Services Pty. Ltd. will be held at the meeting room of the Institute of Chartered Accountants in Australia, 9th Floor, 140 Queen Street, Melbourne on the 22nd day of January, 1979 at 10.00 o'clock in the forenoon.

Agenda

The Meeting convened pursuant to section 260 (1) of the *Companies Act 1961* for the purposes of considering the position of the company's affairs, the company having convened an Extraordinary General Meeting of its members to be held on the same day for the purpose of considering and if deemed expedient passing an extraordinary resolution to wind up the company voluntarily and to nominate James Scott Romanis, Chartered Accountant, 23rd Floor, 500 Collins Street, Melbourne as Liquidator for the purpose of winding up.

No person will be entitled to vote as a creditor at the meeting unless he has lodged with the Chairman of the Meeting a Proof of Debt which he claims to be due to him by the Company:

Dated this 3rd day of January, 1979

By order of the Board,

232

K. C. CANT, Director

Companies Act 1961

NIDDRIE LICENSED SUPERMARKET PTY. LTD.

RECEIVERS AND MANAGERS APPOINTED

Notice of Meeting of Creditors to Consider Winding Up Resolution

Notice is hereby given that pursuant to section 260 of the *Companies Act 1961*, a meeting of creditors of Niddrie Licensed Supermarket Pty. Ltd. (Receivers and Managers Appointed) will be held at the offices of Marquand & Co., 1st Floor, 51 Queen Street, Melbourne on Friday, 12th January, 1979 a 11.30 a.m. for the purpose of considering the position of the Company's Affairs, the Company having convened an Extraordinary General Meeting of its Members for the same day for the purpose of considering and if deemed expedient, passing a Special Resolution to wind up the Company voluntarily and to nominate Douglas Ewart Tonkin and Vernon Keith Reynolds, Chartered Accountants of Marquand & Co., 51 Queen Street, Melbourne, 3000 as liquidators to act jointly and severally for the purpose of the winding up.

Dated this 3rd January, 1979

233

A. SPARANO, Director

Creditors, Next-of-Kin and Others having claims in respect of the Estate of John Andrew Rankin late of Corop Shop Proprietor deceased who died on the 22nd day of September, 1978 are to send particulars of their claims to the Executrix Una Dorothy Rankin of Flat 4, 3 Towers Street, Bendigo by the 3rd day of March, 1979 after which date she will distribute the assets having regard only to the claims of which she then has notice.

EVERY & EVERY, solicitors, V.P.C. Building, Bull Street, Bendigo 52

Creditors, Next-of-Kin and Others having claims in respect of the Estate of Edna Jane Cook late of 1 Manallack Street, Golden Square Widow deceased who died on the 19th day of April, 1978 are to send particulars of their claims to the Executor Harold Edgar Every of V.P.C. Building, Bull Street, Bendigo by the 3rd day of March, 1979 after which date he will distribute the assets having regard only to the claims of which he then has notice.

EVERY & EVERY, solicitors, V.P.C. Building, Bull Street, Bendigo 53

Creditors, Next-of-Kin and Others having claims in respect of the Estate of Douglas Harry Lace late of 5 Bray Street, Bendigo Car & Waggon Builder deceased who died on the 29th day of October, 1978 are to send particulars of their claims to the Executrix Sybil Amy Lace of 5 Bray Street, Bendigo by the 3rd day of March, 1979 after which date she will distribute the assets having regard only to the claims of which she then has notice.

EVERY & EVERY, solicitors, V.P.C. Building, Bull Street, Bendigo 54

Creditors, Next-of-Kin and Others having claims in respect of the Estate of Ivy Daphne Burrell late of Bendigo Psychiatric Centre, Holdsworth Road, Eaglehawk Spinster deceased who died on the 19th day of October, 1978 are to send particulars of their claims to the Executrix Beryl Irene Smith of Howard Street, Epsom by the 3rd day of March, 1979 after which date she will distribute the assets having regard only to the claims of which she then has notice.

EVERY & EVERY, solicitors, V.P.C. Building, Bull Street, Bendigo 55

Creditors, next-of-kin and others having claims in respect of the Estate of Edith Verona Angwin Casley late of Lilley Lodge Private Nursing Home, 18 Bray Street, Long Gully Spinster deceased who died on the 17th day of November, 1978 are to send particulars of their claims to the Executor John Henry Casley of 3 Grattan Street, Bendigo by the 3rd day of March, 1979 after which date he will distribute the assets having regard only to the claims of which he then has notice.

EVERY & EVERY, solicitors, V.P.C. Building, Bull Street, Bendigo 56

Creditors, next-of-kin and others having claims in respect of the Estate of Thomas Alfred Harris also known as Alfred Thomas Harris late of 18 Graham Street, Bendigo Retired Railway Employee deceased who died on the 27th day of August, 1978 are to send particulars of their claims to the Executrix Dorothy Jean Harris of 18 Graham Street, Bendigo by the 3rd day of March, 1979 after which date she will distribute the assets having regard only to the claims of which she then has notice.

EVERY & EVERY, solicitors, V.P.C. Building, Bull Street, Bendigo 57

PERCY BADEN ANSELL, late of 368 (formerly 142) Beveridge Street, Swan Hill, in the State of Victoria, retired saddler, DECEASED (who died on 12th September, 1978)

Creditors next-of-kin and all other persons having claims against the Estate of the deceased are required by the Executrix of the Will, Lucy Agnes Augustine Ansell, to send particulars to her care of the undersigned on or before the 5th day of March 1979 after which date she will distribute the assets having regard only to the claims of which she then has notice.

GARDEN & GREEN, solicitors, 4 McCallum Street, Swan Hill 58

JOHN HALLEY GRINHAM, late of Smith Street, Woorinen South, in the State of Victoria, retired motor mechanic, DECEASED (who died on 13th September, 1978)

Creditors next-of-kin and all other persons having claims against the Estate of the deceased are required by the Executrix of the Will, Lauvinia Rose Grinham, to send particulars to her care of the undersigned on or before the 22nd day of February 1979 after which date she will distribute the assets having regard only to the claims of which she then has notice.

GARDEN & GREEN, solicitors, 4 McCallum Street, Swan Hill 59

ROY COPELAND STANYER, late of 13 Bath Street, Swan Hill, in the State of Victoria, retired farmer, DECEASED (who died on 1st September 1978)

Creditors next-of-kin and all other persons having claims against the Estate of the deceased are required by the Executors of the Will, Ian Dickson Stanyer, Howard Keith Stanyer, Ralph Bruce Stanyer, and Maxwell Roy Stanyer, to send particulars to them care of the undersigned on or before the 22nd day of February 1979 after which date they will distribute the assets having regard only to the claims of which they then have notice.

GARDEN & GREEN, solicitors, 4 McCallum Street, Swan Hill 60

ALFRED JOSEPH WHALEY, late of 74 Splatt Street, Swan Hill, in the State of Victoria, retired motor mechanic, DECEASED (who died on 17th October, 1978)

Creditors next-of-kin and all other persons having claims against the Estate of the deceased are required by the Executors of the Will, Russell Stuart McFarland and Thelma Florence McFarland, to send particulars to them care of the undersigned on or before the 22nd day of February 1979 after which date they will distribute the assets having regard only to the claims of which they then have notice.

GARDEN & GREEN, solicitors, 4 McCallum Street, Swan Hill 61

Creditors next-of-kin and others having claims in respect of the Estate of Norman Lutwyche Landon formerly of 77 Grey Street Traralgon late of 14 Lyons Street Rosedale Retired deceased who died on 19th September 1978 and Probate of whose Will and two Codicils thereto was granted by the Supreme Court of Victoria on the 12th December 1978 to John Barassi formerly of Hyde Park Road Traralgon Paper Mill Manager now of 23 Cleveland Avenue Lower Plenty Operations Manager are to send particulars of their claims to the said Executor care of the below mentioned Solicitors by the 25th February 1979 after which date he will distribute the assets of the deceased having regard only to the claims of which he then has notice.

LITTLETON, HACKFORD & MALKIN, solicitors, Traralgon 62

HAROLD FRANCIS McLENNAN, late of 93 Bluff Road, Black Rock, grazier, DECEASED

Creditors next of kin and others having claims in respect of the estate of the deceased who died on the 20th day of September, 1978 are required by The Perpetual Executors and Trustees Association of Australia Limited of 50 Queen Street, Melbourne and Norman James McLennan Retired Manager of 15 Thames Street, West Heidelberg the

Applicants for a Grant of Administration to send particulars of their claims to the said Applicants in the care of the said Company by the 7th day of March, 1979 after which date they will convey or distribute the assets having regard only to the claims of which they then have notice.

HENDERSON & BALL, solicitors, of 430 Little Collins Street, Melbourne 63

IRENE GLADYS FLEMING, late of Carnsworth, Garoopna, 18 Barry Street, Kew, in the State of Victoria, spinster, DECEASED

Creditors next of kin and others having claims in respect of the estate of the deceased who died on the 30th day of August, 1978 are required by her Executor The Equity Trustees Executors and Agency Company Limited of 472 Bourke Street, Melbourne in the said State to send particulars to it by the 6th day of March 1979 after which date the Executor may convey or distribute the assets having regard only to the claims of which it then has notice.

CLEARY, ROSS & DOHERTY, solicitors, 406 Collins Street, Melbourne 64

BRIDGET WALSH, late of 2 Spencer Street, Hawthorn, in the State of Victoria, gentlewoman, DECEASED

Creditors next of kin and others having claims in respect of the estate of the abovenamed deceased (who died on the 28th day of July, 1978) are required to send particulars of their claims to the Executor National Trustees Executors and Agency Company Limited of 95 Queen Street Melbourne before the 12th day of March 1979 after which date it will distribute the assets of the said deceased having regard only to the claims of which it then has notice.

PETER HASSETT & CO., solicitors, 1160 Toorak Road, Hartwell 65

Creditors next of kin and others having claims in respect of the Estate of Clarence Aldous Hurst late of Judge Book Memorial Village, Diamond Street Eltham in the State of Victoria Gentleman deceased who died on the 28th day of September 1978 are to send the particulars of their claims to John James Campbell Insurance Broker of care of Henderson & Ball, Solicitors of 430 Little Collins Street Melbourne by the 13th day of March 1979 after which date he will distribute the assets having regard only to the claims of which he then has notice.

HENDERSON & BALL, solicitors, of 430 Little Collins Street, Melbourne 66

EDITH IRENE BALMER, of Unit 26 Inala Village, Middleborough Road, Blackburn, spinster, DECEASED

Creditors next of kin and others having claims in respect of the estate of the deceased who died on the 7th day of July 1978 are required by the Executor of the Estate, John Wallace Ball of 430 Little Collins Street, Melbourne Solicitor to send particulars of their claim to him care of the undermentioned Solicitors by the 13th day of March 1979 after which date he will convey or distribute the assets having regard only to the claims of which he then has notice.

HENDERSON & BALL, solicitors, of 430 Little Collins Street, Melbourne 67

BARBARA PITHARAS (also known as Barbara Pithara), late of 480 Lygon Street, Carlton, married woman, DECEASED

Creditors next of kin and others having claims in respect of the estate of the abovenamed deceased who died on 5th May 1978 are required by the trustee Nicolas Pitharas of Flat 3, 673 Gilbert Road, Reservoir, Automotive Electrician, to send particulars to his solicitors, Nunan & Bloom, at their address below by 15th March 1979 after which date the trustee may convey or distribute the assets having regard only to the claims of which he then has notice.

NUNAN & BLOOM, solicitors, 343 Little Collins Street, Melbourne 109

Creditors next of kin and others having claims in respect of the estate of Ada Harriet Wellings late of 30 Gwynne Street Richmond in the State of Victoria Widow deceased who died on the 20th day of September 1978 are hereby required to send particulars of their claims to Laurence L'Estrange the Executor of her estate care of the undermentioned Solicitors by the 1st day of March 1979 after which date he will distribute the assets having regard only to the claims of which he then has had notice.

L'ESTRANGE & KENNEDY, solicitors, of 291 Bridge Road, Richmond 110

CLIFFORD THOMAS GLADSTONE GARRARD, late of 16 Bunker Avenue, Kingsbury, in the State of Victoria, invalid pensioner, DECEASED

Creditors, next of kin and others having claims in respect of the estate of the deceased (who died on the 26th day of June, 1978) are required to send particulars of their claims to Wayne Philip Garrard and Alison Edith Dow Care of Walsh, Johnston & Co. Solicitors of 452 High Street, Northcote before the 14th day of March, 1979 after which date they will distribute the assets having regard only to the claims of which they then have notice.

WALSH, JOHNSTON & CO., solicitors, 452 High Street, Northcote 111

TED STEWART ALLISON, late of 44 Kiniry Street, Boort, in the State of Victoria, farmer, DECEASED

Creditors next of kin and others having claims against the estate of the abovenamed deceased who died on the 17th day of October 1977 are required to send particulars thereof to National Trustees Executors and Agency Company of Australasia Limited of 46 Queen Street Bendigo and Mavis Jean Allison, Edward Alexander Allison and Geoffrey Albert Allison all of Boort Care of the said Company at 46 Queen Street Bendigo by the 15th day of February 1979 after which date the said Company will distribute the assets of the said deceased having regard only to the claims of which it and they then have notice.

WATSON, JAMES & ROGERS, solicitors, 61 Bull Street, Bendigo 112

MARY AGNES ARMSTRONG, late of 27 Farm Street, Newport, invalid pensioner, DECEASED

Creditors, next of kin and others having claims in respect of the estate of the deceased (who died on the 18th day of September, 1978) are required by the Executrix Irene Ernice Courtts of 34 Lynch Street, Sunshine, Married Woman to send particulars to her, care of the under-mentioned Solicitors, by the 16th day of March, 1979 after which date the Executrix will distribute the assets having regard only to the claims of which she then has notice.

SIEVERS & SIEVERS, solicitors, 17 Sun Crescent, Sunshine 113

Creditors next of kin and others having claims against the estate of Leon Mendel Sheeziel late of 23 Irving Road Toorak, Retired Gentleman, deceased who died on the 6th December 1970 are required by the Executors Brian Charles Samuel Sheeziel of 23 Irving Road Toorak, Company Director, and Philip Leon Sheeziel of 4 Walstab Street Brighton East, Solicitor, to send particulars of such claims to them at the office of the undersigned Solicitors on or before the 5th March 1979 after which date they will distribute the assets having regard only to the claims of which they shall then have had notice.

ARCHER SHULMAN AND CO., solicitors, 140 Queen Street, Melbourne 114

HENRY ERNEST MENADUE, late of 65 Rupert Street, West Footscray, retired, DECEASED

Creditors next-of-kin and others having claims in respect of the estate of the abovenamed Deceased are required by the Executors Roy Menadue of 63 Rupert Street, West Footscray Traveller and William Menadue of 65 Rupert Street, West Footscray Retired to send their claims to them care of the undernamed Solicitor by the 12th day of March, 1979 after which date they will distribute the assets of the estate having regard only to the claims of which they then have notice.

JOHN GINNANE, solicitor, 20 Droop Street, Footscray 115

ROY WALTER MORTON (also known as Raymond Walter Morton), late of Flat 2, 144 Nepean Highway, Seaford, railway employee, DECEASED

Creditors, next of kin and others having claims against the estate of the abovenamed deceased who died on the 16th day of November, 1977 are required by the Executor thereof Sandhurst and Northern District Trustees Executors and Agency Company Limited of 18 View Street, Bendigo to forward particulars thereof care of the said Company on or before the 21st day of March, 1979 after which date it will distribute the assets of the above said estate having regard only to the claims of which it then has notice.

Dated this 5th day of January, 1979

ERIC C. COHEN, of Victoria Chambers, Pall Mall, Bendigo, solicitor for the executor 116

All persons having claims against the estate of Marguerite Callingham late of 27 Viljoen Street, Rouxville, Johannesburg South Africa, deceased who died on 22nd August, 1977 and Probate of whose Will was on the 22nd August, 1977 granted by the Master of the Supreme Court of South Africa to Hermanus Albertus Pienaar in his capacity as Nominee of the Standard Bank of South Africa Limited and application to the Supreme Court of Victoria (Probate Jurisdiction) by The Perpetual Executors and Trustees Association of Australia Limited for a grant of Letters of Administration with a copy Will annexed having been granted on the 19th December, 1978 are hereby required to send particulars of such claims to The Perpetual Executors and Trustees Association of Australia Limited at its registered office at 50 Queen Street, Melbourne on or before 5th March, 1979 after which date the said Company will proceed to Transfer convey or distribute the said estate to or among the persons entitled thereto having regard only to the claims of which it shall then have had notice and will not be liable for the assets so transferred, or conveyed or distributed to any persons of whose claim it shall not then have had notice. 117

RIPLEY KINGSLEY DAWBORN, late of 8 Clendon Court, Toorak, in the State of Victoria, retired dental surgeon, DECEASED

Creditors, next of kin, and others having claims in respect of the estate of the deceased, who died on the 7th day of September, 1978, are required by the Executors The Union-Fidelity Trustee Company of Australia Limited of 100 Exhibition Street, Melbourne, John Kingsley Dawborn of 20 Highfield Road, Canterbury Medical Practitioner and Anne Josephine Kingsley Dawborn of 8 Clendon Court, Toorak, teacher, to send particulars of their claims to them at 100 Exhibition Street, Melbourne by the 9th day of March, 1979 after which date they will distribute and/or convey the assets amongst the persons entitled thereto having regard only to the claims of which they then have notice.

RICHARD K. PITMAN, LL.B., solicitor, of corner of Kingsway and Railway Parade, Glen Waverley 3150 118

Creditors next of kin and others having claims against the estate of Charles William Johnson late of 17 Grandview Avenue Dandenong in the State of Victoria Foreman deceased who died on the 20th day of May 1978 are required by the Administrator Harold Francis Johnson of 17 Grandview Avenue Dandenong to send particulars of their claims to the said Administrator care of Messrs. F. R. Monotti & Co. of 13 Scott Street, Dandenong, Solicitors, by the 22nd day of February 1979 after which date they will distribute the assets of the said estate having regard only to the claims of which they then have notice.

F. R. MONOTTI & CO., solicitors, 13 Scott Street, Dandenong 119

Creditors, next-of-kin and other persons having claims against the estate of Hector Henry McLennan late of Caroline Private Nursing Home, 42 Marine Parade, St. Kilda in the State of Victoria, Gentleman deceased, who died on the 17th day of November, 1978 are required to send particulars of their claims to the Executor, The Trustees Executors and Agency Company Limited of 401 Collins Street, Melbourne in the said State by the 15th day of March, 1979 after which date the Executor will distribute the assets having regard only for the claims of which it then has had notice.

COLE & O'HEARE, solicitors, of 380 Lonsdale Street, Melbourne 120

In the Will of Stanley Harry Chirside, formerly of 67 Brunswick Street, Fitzroy, but late of "Sumner House", 130 Fitzroy Street, Fitzroy, in Victoria, gentleman, DECEASED

Creditors, next-of-kin and others having claims in respect of the estate of the abovenamed deceased (who died on the 17th July, 1978) are required by the Executors Bruce Henry Baird Chirside of 8 Broder Street, Brackenridge in Queensland, Manager and Helen Chirside of 61 Macarthur Road, Ivanhoe in Victoria, Accountant to send particulars of their claims to them care of the under-mentioned solicitors by the 6th March 1979 after which date they will distribute the assets having regard only to the claims of which they then have notice.

AITKEN, WALKER & STRACHAN, solicitors, 114 William Street, Melbourne, 3000 168

RUBY FLORENCE HUSTON, late of 17 Alfred Street, Kew, in the State of Victoria, widow, DECEASED

Creditors next of kin and others having claims in respect of the estate of the deceased who died on the 30th day of September 1978 are required by The Perpetual Executors and Trustees Association of Australia Limited of 50 Queen Street Melbourne and Betty Olive Huston, of 17 Alfred Street Kew in the said State Bank Officer the applicants for a grant of administration to send particulars of their claims to the said applicants in the care of the said Company by the 8th day of March 1979 after which date they will convey or distribute the assets having regard only to the claims of which they then have notice.

NEDOVIC & CO., solicitors, 470 Bourke Street, Melbourne, 3000. Telephone 679367 179

ELIZABETH ANN WILKINSON, formerly of 395 Toorak Road, South Yarra, but late of Flat 12, 33 Albany Road, Toorak, both in the State of Victoria, secretary, DECEASED

Creditors, next of kin and others having claims in respect of the estate of the deceased (who died on the 20th day of April 1978) are required by The Perpetual Executors and Trustees Association of Australia Limited of 50 Queen Street, Melbourne, to send particulars of their claims to the said Company by the 21st day of March 1979 after which date it will convey or distribute the assets, having regard only to the claims of which the Company then has notice. 180

COLIN ALEXANDER GRANT, late of The Hall Nursing Home, Mill Street, Mildenhall, Suffolk, England, retired medical practitioner, DECEASED

Creditors next of kin and others having claims against the Estate of the said deceased who died on 12th August 1977 are to send particulars of their claims to The Trustees Executors and Agency Company Limited of 401 Collins Street Melbourne by the 6th day of April 1979 after which date it will distribute the assets having regard only to the claims of which it then has notice.

BLAKE & RIGGALL, solicitors, 140 William Street, Melbourne 181

Creditors next of kin and others having claims in respect of the Estate of Stanislaus Vincent Diskin late of 40 Clausen Street, North Fitzroy in the State of Victoria Retired Chef deceased who died on the 31st day of July, 1978 having a Will dated the 6th day of February, 1978 are required by the Executor appointed by the said Will, Francis James Ryan Solicitor of 2A Brunswick Road, East Brunswick in the said State, the Principal for the time being of the firm Rossi & Ryan Solicitors of 2A Brunswick Road, East Brunswick in the said State, to send particulars of their claims care of the under mentioned Solicitors by the 8th day of March, 1979 after which date the Executor will distribute the assets having regard only to the claims of which he shall then have had notice.

ROSSI & RYAN, solicitors, of 2A Brunswick Road, East Brunswick. 169

WILLIAM MURRAY, formerly of 775 Park Street, West Brunswick, in the State of Victoria, but late of Mount Gravatt Nursing Centre, Mount Gravatt, in the State of Queensland, retired, DECEASED

Creditors, next of kin, and others having claims in respect of the estate of the deceased, who died on the 12th day of November 1977, are required by the trustee, David Stuart Murray of 55 Harcourt Street, Hawthorn in the State of Victoria to send particulars to him by the 8th day of March 1979 after which date the trustee may convey or distribute the assets, having regard only to the claims of which he then has notice.

Dated this 3rd day of January, 1979 170

WALTER PAUL RUDOLF HEINE, late of 503 Orrong Road, Armadale, company director, DECEASED

Creditors, next of kin and others having claims in respect of the estate of the deceased who died on the 4th May 1978 are required by the personal representatives Leslie Max Heine of 219 Dandenong Road, Prahran, Michael Max Heine of "Halten" Walchwil Zug Switzerland and Gert Silver of 15 Howard Street Kew to send particulars to them by the 7th March 1979 after which date the personal representatives may convey or distribute the assets, having regard only to the claims of which they then have notice.

WEIGALL & CROWTHER, 459 Little Collins Street, Melbourne, solicitors for the estate 178

Creditors next of kin and others having claims against the estate of Lillian Constance Wintle late of Flat 3, 380 Orrong Road, North Caulfield Home Duties Deceased who died on the 11th day of April, 1978 are required by the Executor of her estate, The Trustees Executors and Agency Company Limited to send particulars of their claims to the said Company at 401 Collins Street, Melbourne before the 7th day of March, 1979 after which date it will distribute the assets having regard only to the claims of which it then has notice.

PEARCE & WEBSTER, solicitors, 430 Little Collins Street, Melbourne 217

Creditors next of kin and other persons having claims against the Estate of Ethel Larmenie Linane formerly of 190 Douglas Parade Newport but late of Flat 8, 43 Alma Road, St. Kilda Pensioner deceased who died on the twenty-second day of September 1978 are required to send particulars of their claims to the Executors in care of National Trustees Executors and Agency Company of Australasia Limited at 95 Queen Street Melbourne by the seventh day of March 1979 after which date the Executors will distribute the assets having regard only for the claims of which they then have had notice.

JAMES P. OGGE & CO., solicitors, 165 Greville Street, Prahran 224

In the Supreme Court of the State of Victoria
SALE BY THE SHERIFF

On Thursday the 8th of February 1979 at 10.30 a.m. at the Police Station, Box Hill (unless process be stayed or satisfied).

All the Estate and Interest (if any) of Leslie John Stack, builder, of 18 Packham Street, Box Hill as proprietor of an estate in fee simple in the land described in Certificate of Title Volume 7976 Folio 033 upon which is erected a weatherboard dwelling with fibro cement shed known as No. 18 Packham Street, Box Hill.

Registered Mortgage No. C.805928 and Caveat G.877125 affect the said estate and interest.

Terms—Cash only
209 H. BUETTNER, Sheriff's Officer

In the Supreme Court of the State of Victoria
SALE BY THE SHERIFF

On Thursday the 8th of February 1979 at 10.30 a.m. at the Police Station, Box Hill (unless process be stayed or satisfied).

All the Estate and Interest (if any) of Penry Charles Winston, manager, of 1 McColl Road, Box Hill as joint proprietor with Dorothy Joy Winston, married woman of an estate in fee simple in the land described in Certificate of Title Volume 8071 Folio 975 upon which is erected a dwelling house known as No. 1 McColl Road, Box Hill.

Registered Mortgage Nos. F.555595, G.306413 and G.741602 affect the said estate and interest.

Terms—Cash only
210 H. BUETTNER, Sheriff's Officer

In the Supreme Court of the State of Victoria
SALE BY THE SHERIFF

On Friday the 16th of February 1979 at 10.30 a.m. at the Police Station Mordialloc (unless process be stayed or satisfied).

All the Estate and Interest (if any) of Douglas Bruce Gittens and Janis Lillian Gittens, of 56 Iluka Avenue, Aspendale as joint proprietors of an estate in fee simple in the land described in Certificate of Title Volume 8938 Folio 355 upon which is erected a dwelling known as No. 56 Iluka Avenue, Aspendale.

Registered Mortgage Nos. F.660704, G.579889 and G.802456 affect the said estate and interest.

Terms—Cash only
211 DOUGLAS S. HALL, Sheriff's Officer

In the Supreme Court of the State of Victoria
SALE BY THE SHERIFF

On Friday the 9th of February 1979 at 11.30 a.m. at the Police Station, Malvern (unless process be stayed or satisfied).

All the Estate and Interest (if any) of Andreas Bougioukos, builder, and Vassiliki Bougioukos, married woman, both of 159 Tooronga Road, Glen Iris as joint

proprietors of an estate in fee simple in the land described in Certificate of Title Volume 7255 Folio 980 upon which are erected two luxury town houses known as No. 159 Tooronga Road, Glen Iris.

Registered Mortgage No. H.261230 affects the said estate and interest.

Terms—Cash only
212 H. BUETTNER, Sheriff's Officer

In the Supreme Court of the State of Victoria
SALE BY THE SHERIFF

On Friday the 9th of February 1979 at 10.30 a.m. at the Police Station, Glen Waverley (unless process be stayed or satisfied).

All the Estate and Interest (if any) of Frederick Thomas Hawkins, builder, and Allison May Hawkins, married woman, both of 42 Paxton Drive, Glen Waverley, as joint proprietors of an estate in fee simple in the land described in Certificate of Title Volume 8949 Folio 945 upon which is erected a brick dwelling known as No. 42 Paxton Drive, Glen Waverley.

Registered Mortgage Nos. G.903552 and G.951323 and Caveat H.175847 affect the said estate and interest.

Terms—Cash only
213 H. BUETTNER, Sheriff's Officer

In the Supreme Court of the State of Victoria
SALE BY THE SHERIFF

On Wednesday the 7th of March 1979 at 11.45 a.m. at the Police Station, Hamilton (unless process be stayed or satisfied).

All the Estate and Interest (if any) of Maxwell John Hutchins, cartage contractor of 126 Mt. Napier Road, Hamilton and Elizabeth May Hutchins, married woman of 4 Kitchener Street, Hamilton as proprietors of an estate in fee simple of the land described in Conveyance Book 736 No. 78 said land being known as 124 Mt. Napier Road, Hamilton upon which is erected a brick veneer dwelling.

Registered Mortgages in Mortgage Books 743 No. 438 and 756 No. 422 affects the said estate and interest.

Terms—Cash only
214 J. OLIVER, Sheriff's Officer

In the Supreme Court of the State of Victoria
SALE BY THE SHERIFF

On Friday the 16th February 1979 at 11.30 a.m. at the Police Station, Red Cliffs (unless process be stayed or satisfied).

All the Estate and Interest (if any) of Sidney John Robertson, Horticulturist, of Block 265 Sunny Cliffs as proprietor of an estate in fee simple in the land described in Certificate of Title Volume 7443 Folio 565 upon which is erected a weatherboard dwelling and sheds known as Block 265 Sunny Cliffs and is located approximately half-mile along the turn off road to Kings Billabong from The Calder Highway near Red Cliffs.

Registered Mortgage Nos. G.745280 and H.26751 affects the said estate and interest.

Terms—Cash only
215 G. L. WHITE, Sheriff's Officer

In the Supreme Court of the State of Victoria
SALE BY THE SHERIFF

On Friday the 16th of February 1979 at 10.30 a.m. at the Police Station, Ringwood (unless process be stayed or satisfied).

All the Estate and Interest (if any) of Derek Thomson, furniture manufacturer, of 22 Heathmont Road, Heathmont as proprietor of an estate in fee simple in the land described in Certificate of Title Volume 7597 Folio 160 upon which is erected a weatherboard dwelling known as No. 22 Heathmont Road, Heathmont.

Registered Mortgage No. G.993160 affects the said estate and interest.

Terms—Cash only
216 H. BUETTNER, Sheriff's Officer

STATE ACTS, 1977

Copies of the following Acts of the Parliament of Victoria may be obtained at the Government Printing Office, Sale of Publications Branch, 7A Parliament Place, Melbourne, phone 651 2754 or 651 2759, or from any accredited agent, at the price set opposite to each (these prices do not include postage).

Postage costs must be added to your remittance when ordering by mail as follows:—

Act Price.	Postage Cost.
10c-40c	25c
45c-70c	35c
75c-\$1.70	45c
\$1.75c-\$4.00	70c
Above \$4.00	\$1.15

Also available are:—

Bound Volumes	\$18.00
Index to the Bound Volumes	\$8.00
No.	Price
8969. Small Claims Tribunals (Amendment)	\$0.10
8970. Local Government (Rate Relief)	\$0.10
8971. State Electricity Commission (Financial Accommodation)	\$0.10
8972. Geelong (Kardinia Park) Land	\$0.10
8973. Revocation and Excision of Crown Reservations	\$0.30
8974. Agricultural Authorities (Members Insurance)	\$0.10
8975. Racing (Tabella Totalizators)	\$0.30
8976. Fuel Emergency	\$0.20
8977. Australia and New Zealand Banking Group	\$0.20
8978. Co-operative Housing Societies (Leasehold Securities)	\$0.10
8979. Geelong Waterworks and Sewerage (Amendment)	\$0.20
8980. Yooralla Society of Victoria	\$0.10
8981. Melbourne Underground Rail Loop (Amendment)	\$0.20
8982. Tattersall Consultations (Gold Lottery Consultations)	\$0.10
8983. Public Service (Government Offices)	\$0.10
8984. Anglican Church of Australia Constitution (Amendment)	\$0.20
8985. Portland Harbor Trust (Financial)	\$0.10
8986. Epworth Hospital (Guarantee)	\$0.10
8987. Mildura College Lands (Mildura Schools Fund)	\$0.10
8988. Lotteries Gaming and Betting (Raffles and Bingo)	\$0.40
8989. Racing (Amendment)	\$0.10
8990. Land Surveyors (Surveyors Board)	\$0.10
8991. Railways (Participation in Pipelines)	\$0.10
8992. Melbourne and Metropolitan Tramways (Borrowing Powers)	\$0.10
8993. Melbourne Wholesale Fruit and Vegetable Market Trust	\$0.80
8994. Geelong Grammar Schools Amalgamations	\$0.50
8995. Melton Land	\$0.10
8996. Land (Surrender of Lands)	\$0.10
8997. Shepparton Abattoirs (Amendment)	\$0.10
8998. Magistrates' Courts (Commitment)	\$0.10
8999. Melbourne and Geelong Corporations (Regent Theatre Buildings)	\$0.10
9000. Dental Technicians (Amendment)	\$0.10
9001. Motor Car (Breath Testing Stations) (Amendment)	\$0.10
9002. Marriage (Amendment)	\$0.10
9003. Public Contracts (Amendment)	\$0.10
9004. Victorian Dairy Industry Authority	\$0.60
9005. Public Service (Director-General of Agriculture)	\$0.20
9006. Local Authorities Superannuation (Contributions)	\$0.20
9007. County Court (Amendment)	\$0.10
9008. Bail	\$0.60
9009. Supply (1977-78, No. 1)	\$0.20
9010. Grain Elevators (Amendment)	\$0.30
9011. State Electricity Commission (Newport Power Station)	\$0.10
9012. Police Offences (Child Pornography)	\$0.10
9013. Milk Board (Milk Vendors)	\$0.20
9014. Dandenong Valley Authority (Cardinia Creek)	\$0.20
9015. Motor Car (Amendment)	\$0.50
9016. State Library and National Museum Buildings Committee	\$0.20
9017. Superannuation Benefits	\$0.20
9018. Social Welfare (Administration)	\$0.20
9019. Statute Law Revision	\$0.70

STATE ACTS, 1977—continued.

No.	PRICE
9020. Emerald Tourist Railway	\$0.50
9021. The Uniting Church in Australia .. .	\$0.60
9022. Local Government (Amendment) .. .	\$0.60
9023. Health Commission	\$1.10
9024. Geelong Regional Commission	\$0.60
9025. Equal Opportunity	\$0.60
9026. Land (Land Surrender)	\$0.10
9027. Zoological Parks and Gardens (Borrowing Powers)	\$0.10
9028. Essential Services (Right to Work) .. .	\$0.10
9029. La Trobe University (Amendment) .. .	\$0.10
9030. Melbourne and Metropolitan Board of Works (Borrowing Powers)	\$0.10
9031. Victorian Institute of Marine Sciences (Council)	\$0.20
9032. Committees (Attendance Fees)	\$0.10
9033. Public Accounts (Amendment)	\$0.10
9034. Epworth Hospital (Guarantee) (Amendment) .. .	\$0.10
9035. Oakleigh Lands (Bowling Club Lands) .. .	\$0.10
9036. Consumer Affairs (Amendment)	\$0.10
9037. Melbourne and Metropolitan Board of Works (Powers)	\$0.10
9038. Racing (Fees)	\$0.10
9039. Crown Reservations (Revocation and Exclusion)	\$0.20
9040. State Forests Works and Services	\$0.10
9041. Administration and Probate (Amendment) .. .	\$0.10
9042. Commissioners and Justices	\$0.10
9043. Property Law (Deeds)	\$0.10
9044. Wills (Interested Witnesses)	\$0.20
9045. Taxation Appeals (Fees)	\$0.10
9046. Labour and Industry	\$0.20
9047. Social Welfare (Homeless Persons)	\$0.10
9048. Crimes (Armed Robbery)	\$0.10
9049. Cattle Compensation (Amendment)	\$0.10
9050. Racing (Mixed Sports Gatherings)	\$0.10
9051. Labour and Industry (Industrial Appeals Court)	\$0.10
9052. Cemeteries (Amendment)	\$0.10
9053. Water Supply Works and Services	\$0.40
9054. Appropriation (1977-78, No. 1)	\$3.10
9055. Pay-roll Tax	\$0.10
9056. Gift Duty (Amendment)	\$0.10
9057. Youth, Sport and Recreation (State Recreation Council)	\$0.30
9058. Macleod Land	\$0.10
9059. Statute Law Revision	\$0.20
9060. Superannuation (Amendment)	\$0.10
9061. Building Industry Long Service Leave (Amendment)	\$0.20
9062. Educational Grants (Continuation)	\$0.10
9063. Judges Salaries	\$0.10
9064. Transport Works and Services	\$0.10
9065. Stamps (Amendment)	\$0.10
9066. Police Regulation (Amendment)	\$0.10
9067. Marine (Pilots Superannuation)	\$0.10
9068. Public Works and Services	\$0.20
9069. Hospitals Superannuation (Amendment) .. .	\$0.20
9070. Probate Duty	\$0.30
9071. Land Tax	\$0.20
9072. Rural Finance and Settlement Commission (Amendment)	\$0.30
9073. Crimes (Married Persons' Liability)	\$0.10
9074. Wycheproof Land	\$0.10
9075. Age of Majority	\$0.20
9076. Health (Amendment)	\$0.30
9077. Constitution	\$0.10
9078. Change of Ownership Notices	\$0.20
9079. Local Government (Promotion of Decentralization)	\$0.10
9080. Litter	\$0.10
9081. Transport Regulation (Amendment)	\$0.10
9082. Egg Industry Stabilization (Amendment) .. .	\$0.20
9083. Victorian Government Travel Authority .. .	\$0.40

Postage costs must be added to your remittance when ordering by mail as follows:—

Act Price.	Postage Cost.
10c-40c	25c
45c-70c	35c
75c-\$1.70	45c
\$1.75c-\$4.00	70c
Above \$4.00	\$1.15

Bound Volumes of 1977 State Acts (\$18.00) and the Index to the Bound Volumes (\$8.00) are also available.

No.	PRICE.
9084. Aerial Spraying Control (Amendment) .. .	\$0.10
9085. Dairy Products (Repeal)	\$0.10
9086. Gas and Fuel Corporation (Borrowing Powers Amendment)	\$0.10
9087. Constitution	\$0.10
9088. Marine (Amendment)	\$0.10
9089. Architects (Professional Conduct)	\$0.10
9090. Victorian Film Corporation (Amendment) .. .	\$0.10
9091. Melbourne and Metropolitan Board of Works (Borrowing Powers Amendment)	\$0.10
9092. Co-operative Farmers and Graziers District Meat Supply Limited	\$0.10
9093. Reference Areas	\$0.10
9094. Molesworth (Land Exchange)	\$0.10
9095. Melbourne Wholesale Fruit and Vegetable Market Trust (Licences)	\$0.10
9096. Public Service (Amendment)	\$0.10
9097. St. Andrew's Hospital	\$0.30
9098. Environment Protection (Amendment) .. .	\$0.30
9099. State Savings Bank (Amendment)	\$0.20
9100. St. Andrew's Hospital (Guarantee)	\$0.10
9101. Education (Amendment)	\$0.10
9102. Land (Amendment)	\$0.10
9103. Probate Duty (Application)	\$0.10
9104. Supply (1978-79, No. 1)	\$0.20
9105. Teaching Service (Appointments)	\$0.10
9106. Fisheries (Amendment)	\$0.20
9107. Road Traffic (Amendment)	\$0.10
9108. Co-operative Housing Societies (Amendment) .. .	\$0.10
9109. Granya (Land Exchange)	\$0.10
9110. Sandringham Land	\$0.10
9111. Vegetation and Vine Diseases (Parasites) .. .	\$0.10
9112. Melbourne Underground Rail Loop (Borrowing Powers)	\$0.10
9113. Railways (Legal Actions)	\$0.10
9114. National Parks (Amendment)	\$0.40
9115. Co-operation (Amendment)	\$0.10
9116. Local Government (Promotion of Decentralization)	\$0.10
9117. Parliamentary Salaries and Superannuation .. .	\$0.10
9118. Country Fire Authority (Borrowing Powers) .. .	\$0.10
9119. Teaching Service (Migrant Instructors) .. .	\$0.10
9120. Stamps (Amendment)	\$0.20
9121. State Electricity Commission (Amendment)	\$0.10
9122. Building Industry Long Service Leave (Amendment)	\$0.10
9123. Melbourne University (Amendment)	\$0.10
9124. Motor Car (Fees and Penalties)	\$0.20
9125. Superannuation (Amendment)	\$0.20
9126. State Development Decentralization and Tourism	\$0.20
9127. Melbourne Harbor Trust (Borrowing Powers) .. .	\$0.10
9128. Cluster Titles (Amendment)	\$0.20
9129. Victoria Conservation Trust	\$0.20
9130. Melbourne and Metropolitan Board of Works (Rate Exemption)	\$0.10
9131. Geelong Waterworks and Sewerage (Administration and Rates)	\$0.10
9132. Mildura Irrigation and Water Trust (Merbein) .. .	\$0.10
9133. Egg Industry Stabilization (Amendment) .. .	\$0.10
9134. Workers Compensation (Special Provisions) .. .	\$0.10
9135. Environment Effects	\$0.10
9136. Workers Compensation (Amendment)	\$0.20
9137. Motor Car (Amendment)	\$0.10
9138. Town and Country Planning (Amendment) .. .	\$0.20
9139. Sewerage Districts (Amendment)	\$0.10
9140. Petroleum Products Subsidy (Amendment) .. .	\$0.10
9141. Water (Amendment)	\$0.10
9142. Railways (Amendment)	\$0.40
9143. Local Government (Regional Refuse Disposal)	\$0.40
9144. Dandenong Valley Authority (Amendment) .. .	\$0.20
9145. Post-Secondary Education	\$0.30
9146. Racing (Amendment)	\$0.10
9147. Physiotherapists	\$0.30
9148. Local Government (Municipal Districts) .. .	\$0.10
9149. Ministry of Transport (Passenger Services) .. .	\$0.20
9150. Geelong Regional Interim Development Order (Validation)	\$0.10
9151. Credit Reporting	\$0.20

STATE ACTS, 1978

Copies of the following Acts of the Parliament of Victoria may be obtained at the Government Printing Office, Sale of Publications Branch, 7A Parliament Place, Melbourne, phone 651 2754 or 651 2759, or from any accredited agent, at the price set opposite to each (these prices do not include postage).

STATE ACTS, 1978—continued

No.	PRICE
9152. Magistrates' Courts (Amendment) ..	\$0.10
9153. Wrongs (Actions for Damages) ..	\$0.10
9154. Magistrates (Interstate Enforcement) ..	\$0.20
9155. Crimes (Hijacking and Other Offences) ..	\$0.10
9156. Evidence (Amendment) ..	\$0.10
9157. Motor Car Traders (Amendment) ..	\$0.20
9158. Bail (Amendment) ..	\$0.10
9159. Water Drainage ..	\$0.30
9160. Legal Profession Practice (Solicitors' Disciplinary Tribunal) ..	\$0.80
9161. Chiropractors and Osteopaths ..	\$0.50
9162. Local Government (Miscellaneous Provisions) ..	\$0.60
9163. Hospitals Remuneration Tribunal ..	\$0.30
9164. Legal Profession Practice (Amendment) ..	\$0.10
9165. Melbourne and Metropolitan Board of Works (Reconstitution) ..	\$0.30
9166. Victoria Conservation Trust (Amendment) ..	\$0.10
9167. Shrine of Remembrance ..	\$0.20
9168. Pounds (Amendment) ..	\$0.10
9169. Queensland Land ..	\$0.10
9170. Securities Industry (Amendment) ..	\$0.10
9171. Labour and Industry ..	\$0.20
9172. Dandenong Valley Authority (Recreational Areas and Environmental Areas) ..	\$0.10
9173. Petroleum (Amendment) ..	\$0.50
9174. Victoria Law Foundation ..	\$0.20
9175. Mildura Irrigation and Water Trusts (Amendment) ..	\$0.10
9176. Judges Salaries ..	\$0.10

AGENTS FOR THE "VICTORIA GOVERNMENT GAZETTE"

The following have been appointed agents to receive Advertisements and Subscriptions for the Victoria Government Gazette:—

- ARMSTRONG'S AGENCY, 217 Queen Street, Melbourne, Victoria 3000.
- ARNALL & JACKSON, 390 Barkly Street, Brunswick, Victoria 3056
- BAIRNSDALE AUTHORIZED NEWSAGENCY, 132 Main Street, Bairnsdale, Victoria 3875.
- BENALLA AUTHORIZED NEWSAGENCY, 45 Bridge Street, Benalla, Victoria 3672.
- BLANE'S AUTHORIZED NEWSAGENTS, 162 Murray Street, Colac, Victoria 3250.
- CARTER, R. G., ADVERTISING SERVICE PTY. LTD., Suite 11, 285 Carlisle Street, Balaclava, Victoria 3183.
- DAVIS, WM. (MILDURA) PTY. LTD., 126 Eighth Street, Mildura, Victoria 3500.
- FAROE, S. W. & E. P., 79 Henty Street, Casterton, Victoria 3311.
- FRANKS, H., & CO., 184 Ryrie Street, Geelong, Victoria 3220.
- GORDON & GOTCH AUSTRALASIA LTD., 25-37 Huntingdale Road, Burwood, Victoria 3125.
- GULLAN'S NEWSAGENCY, 88 Bridge Street, Ballarat, Victoria 3350.
- HARSTON, PARTRIDGE & CO. PTY. LTD., 455 Little Collins Street, Melbourne, Victoria 3000.
- KYNETON GUARDIAN PTY. LTD., P.O. Box 18, Kyneton, Victoria 3444.
- LONSDALE NEWSAGENCY, 250 Lonsdale Street, Dandenong, Victoria 3175.
- LOVELL'S SHEPPARTON NEWSAGENCY, 246 Wyndham Street, Shepparton, Victoria 3630.
- THE MERCANTILE EXCHANGE, 15 Queen Street, Melbourne, Victoria 3000.
- MCGILL'S AUTHORIZED NEWSAGENCY, 183-5 Elizabeth Street, Melbourne, Victoria 3000.
- MCAUGHTON, P. R. & L. A., 112-114 Gray Street, Hamilton, Victoria 3300.
- POWNEY'S AUTHORIZED NEWSAGENCY, 293 Hargreaves Street, Bendigo, Victoria 3550.
- PURDIE, J., & CO., 138 Moorabool Street, Geelong, Victoria 3220.

SALE AUTHORIZED NEWSAGENCY 292-294 Raymond Street, Sale, Victoria 3850.

VERNONS OF RICHMOND, 162 Bridge Road, Richmond, Victoria 3121.

VIEW POINT AUTHORIZED NEWSAGENCY, 4 View-Point, Bendigo, Victoria 3550.

A copy of the Gazette is filed at each place for public reference.

THE "VICTORIA GOVERNMENT GAZETTE"

SUBSCRIPTIONS.—The subscription, including postage, is \$56 per annum, or \$28 per half year, payable in advance.

Subscriptions are required for whole months, and must cover at least a half year.

Subscribers do not receive the Acts of Parliament with the GAZETTE.

GAZETTES are held in stock for five years only. Single copies posted may be obtained for 95 cents.

PRIVATE ADVERTISEMENTS.—The charge for insertion is 65 cents per line single column, and \$1.30 cents per line double column. The title forms one or more lines as a heading. On an average ten words make a line of single column. Every signature must likewise be counted as a line. The final words of a paragraph, though only portion of a line, must be counted as one line. Signatures (in particular) and proper names must be written very plainly in the text; ONE SIDE ONLY of each sheet of paper should be WRITTEN UPON. The charge for a full page is \$98.

All documents illegibly written will be returned unpublished, and where brands occur unprovided for by the ordinary letters of the alphabet, a worded explanatory description must be furnished.

PUBLICATION.—A VICTORIA GOVERNMENT GAZETTE is published every WEDNESDAY EVENING, unless advertised otherwise. ADVERTISEMENTS for insertion will be received by the Government Printer not later than the day preceding publication—at ordinary rates at or before ONE p.m. and at double rates between ONE p.m. and half-past THREE p.m.

PAYMENTS.—Unless the advertiser has a credit account, all payments are required in advance. Remittances should be made by cheque, postal order, or money order payable to "GOVERNMENT PRINTER".

ADDRESS.—All communications should be addressed to "The Government Printer, Box 203, P.O., North Melbourne, 3051".

CONTENTS	PAGE
Acts of Parliament on Sale at the Government Printing Office ..	74
Appointments ..	35
Companies Act 1961—Notice ..	33
Contracts ..	31
Estates of Deceased Persons ..	29
Government Notices ..	14
Honours and Awards ..	13
Lands ..	48
Notice to Mariners ..	15
Orders in Council—	
Acts—Local Government; Country Roads Board; Housing; Hospitals and Charities; Land; Superannuation; Road Traffic; Historic Buildings; National Parks; Fisheries; State Electricity Commission; Wildlife.	37 et seq
Police Sale ..	26
Private Advertisements ..	52
Regulations—	
Acts—Police ..	22
Teaching Service ..	50
Resignations ..	37
State Rivers and Water Supply Commission ..	28
Transport Regulation Board—Public Hearings ..	16