



# Victoria Government Gazette

No. 90—Wednesday, 31 October 1979

## PROCLAMATIONS

### ACTS OF PARLIAMENT

#### PROCLAMATION

By His Excellency the Governor of the State of Victoria and its Dependencies in the Commonwealth of Australia, &c., &c., &c.

I, the Governor of the State of Victoria, in the Commonwealth of Australia, do hereby declare that I have this day assented, in Her Majesty's name, to the Bills passed by the Parliament of the said State, the titles whereof are hereunder set forth, together with the short titles that is to say:—

No. 9292. "An Act to amend the *Wrongs Act 1958* in relation to Defamatory Words and Libel." (*Wrongs (Defamation) Act 1979*.)

No. 9293. "An Act to amend the *Constitution Act 1975* and the *County Court Act 1958* with respect to the Salaries of Judges." (*Judges Salaries Act 1979*.)

No. 9294. "An Act to amend the *Poisons Act 1962*." (*Poisons (Amendment) Act 1979*.)

Given under my Hand and the Seal of the State of Victoria aforesaid, at Melbourne, this twenty-third day of October, in the year of our Lord One thousand nine hundred and seventy-nine, and in the twenty-eighth year of the reign of Her Majesty Queen Elizabeth II.

(L.S.) HENRY WINNEKE

By His Excellency's Command

R. J. HAMER  
Premier

GOD SAVE THE QUEEN!

NOTE—Act No. 9292 shall come into operation on the day of Royal Assent.

Act No. 9293, several provisions of this Act shall come into operation on a day or the respective days to be fixed by Proclamation or successive Proclamations.

Act No. 9294 shall come into operation on the day of Royal Assent.

### LEGAL PROFESSION PRACTICE (AMENDMENT) ACT 1979 (No. 9288)

DATE OF COMING INTO OPERATION

#### PROCLAMATION

By His Excellency the Governor of the State of Victoria and its Dependencies in the Commonwealth of Australia, &c., &c., &c.

Whereas by an Act of Parliament of the State of Victoria passed in the twenty-eighth year of the reign of Her Majesty Elizabeth the Second, Queen of Australia, intituled

the *Legal Profession Practice (Amendment) Act 1979* (No. 9288) it is amongst other things enacted that the said Act shall come into operation on the day or the respective days to be fixed by Proclamation or successive Proclamations of the Governor in Council published in the *Government Gazette*.

Now therefore I, the Governor of the State of Victoria, acting by and with the advice of the Executive Council thereof, do by this my Proclamation fix Tuesday, the first day of January, One thousand nine hundred and eighty, as the day upon which the provisions of the *Legal Profession Practice (Amendment) Act 1979* shall come into operation.

Given under my Hand and the Seal of the State of Victoria aforesaid, at Melbourne, this thirtieth day of October, in the year of our Lord One thousand nine hundred and seventy-nine, and in the twenty-eighth year of the reign of Her Majesty Elizabeth the Second, Queen of Australia.

(L.S.) HENRY WINNEKE

By His Excellency's Command

HADDON STOREY  
Attorney-General

GOD SAVE THE QUEEN!

### JUDGES SALARIES ACT 1979, No. 9293

DATE OF COMING INTO OPERATION

#### PROCLAMATION

By His Excellency the Governor of the State of Victoria and its Dependencies in the Commonwealth of Australia, &c., &c., &c.

Whereas by an Act of Parliament of the State of Victoria passed in the twenty-eighth year of the reign of Her Majesty Elizabeth II., Queen of Australia, entitled the *Judges Salaries Act 1979*, No. 9293, it is amongst other things enacted that the several provisions of the said Act shall come into operation on a day or the respective days to be fixed by Proclamation or successive Proclamations of the Governor in Council published in the *Government Gazette*.

Now therefore, I, the Governor of the State of Victoria in the Commonwealth of Australia, by and with the advice of the Executive Council of the said State, do by this my Proclamation fix Wednesday, the thirty-first day of October, One thousand nine hundred and seventy-nine, as the day on which the whole of the provisions of the said *Judges Salaries Act 1979*, No. 9293, shall come into operation.

Given under my Hand and the Seal of the State of Victoria aforesaid, at Melbourne, this thirtieth day of October, in the year of Our Lord One thousand, nine hundred and seventy-nine, and in the twenty-eighth year of the reign of Her Majesty Elizabeth II., Queen of Australia.

(L.S.) HENRY WINNEKE

By His Excellency's Command

R. J. HAMER  
Premier

GOD SAVE THE QUEEN!

**FIREARMS ACT 1958**

**PROCLAMATION**

By His Excellency the Governor of the State of Victoria and its Dependencies in the Commonwealth of Australia, &c., &c., &c.

Whereas by section 4B (1) of the *Firearms Act 1958* it is provided that "Antique firearm" means, amongst other things, any firearm of a make model or type declared by the Governor in Council by Proclamation published in the *Government Gazette* to be an antique firearm for the purposes of the said section.

Now therefore I, the Governor of the State of Victoria, in the Commonwealth of Australia, by and with the advice of the Executive Council of the said State, in pursuance of the powers conferred by the said Act and all other powers me thereunto enabling, do by this my Proclamation declare those firearms listed in the Schedule hereunder to be antique firearms for the purposes of section 4B of the *Firearms Act 1958*.

**SCHEDULE**

- 6 mm Remington Lee Rifle
- 8 mm French Lebel Rifle
- 8 mm Siamese (type 45 and 66) Rifle
- 8 mm Portuguese Kropatscheck Rifle
- 8.1 mm Lee Nagant (model 92) Rifle
- 10.4 mm Swiss Vetterli Rifle
- 10.4 mm Italian Vetterli Rifle
- 10.5 mm Swiss Vetterli Rifle
- 10.15 mm Serbian Mauser Rifle
- 10.15 mm Turkish Mauser Rifle
- 10.74 mm Serbian Mauser Rifle
- 10.75 x 58 mm Russian Berdan Rifle
- .430 Rook Rifle
- 11 mm Belgian Comblain Rifle
- 11 x 50 mm Beaumont Rifle
- 11 x 52 mm Dutch Rifle
- 11.4 x 50 mm Werndl Rifle
- 11.5 mm Hotchkiss (model 74) Rifle
- 11.5 mm Werder Lightning Carbine
- 11.7 mm Danish Rifle
- 11.15 x 58 mm Werndl Rifle
- 11.15 mm Mauser (model 71 and 84) Rifle

Given under my Hand and the Seal of the State of Victoria aforesaid, at Melbourne, this ninth day of October, in the year of our Lord One thousand nine hundred and seventy-nine, and in the twenty-eighth year of the reign of Her Majesty Elizabeth the Second, Queen of Australia.

(L.S.) HENRY WINNEKE

By His Excellency's Command  
L. H. S. THOMPSON  
Minister for Police and Emergency Services

GOD SAVE THE QUEEN!

**BANK HOLIDAYS**

**PROCLAMATION**

By His Excellency the Governor of the State of Victoria and its Dependencies in the Commonwealth of Australia, &c., &c., &c.

In pursuance of the provisions of the *Bank Holidays Act 1958*, I, the Governor of the State of Victoria, in the Commonwealth of Australia, do by this my Proclamation appoint the days and dates named hereunder special days to be observed as Bank Holidays or Bank Half-Holidays (as the case may be) at the places respectively mentioned, that is to say:—

**Bank Holidays:—**

- TUESDAY, 6 NOVEMBER 1979, at Healesville and Yarra Glen.
- TUESDAY, 6 NOVEMBER 1979, at Yarrowonga.
- TUESDAY, 6 NOVEMBER 1979, at Heathcote.
- WEDNESDAY, 7 NOVEMBER 1979, at Kyneton.

*Bank Half-Holidays from the Hour of Eleven a.m.:—*  
FRIDAY, 30 NOVEMBER 1979, at Ararat.

Given under my Hand and the Seal of the State of Victoria aforesaid, at Melbourne, this thirtieth day of October, in the year of our Lord One thousand nine hundred and seventy-nine, and in the twenty-eighth year of the reign of Her Majesty Elizabeth the Second, Queen of Australia.

(L.S.) HENRY WINNEKE

By His Excellency's Command  
J. H. RAMSAY  
Minister of Labour and Industry

GOD SAVE THE QUEEN!

**Land Act 1958  
ROAD PROCLAIMED**

**PROCLAMATION**

By His Excellency the Governor of the State of Victoria and its Dependencies in the Commonwealth of Australia, &c., &c., &c.

I, the Governor of the State of Victoria, in the Commonwealth of Australia, by and with the advice of the Executive Council of the said State, pursuant to the provisions of section 25 (3) (c) of the *Land Act 1958*, do hereby proclaim as road the Crown Land hereinafter described, viz.:—

Parish of Berrigama being the land indicated by hatching on plan hereunder—(B.677<sup>(a)</sup> and c) (H.O.27842).

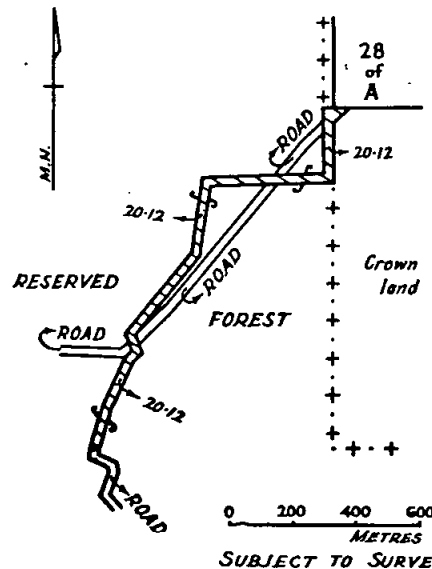

Given under my Hand and the Seal of the State of Victoria aforesaid, at Melbourne, this twenty-third day of October, in the year of our Lord One thousand nine hundred and seventy-nine, and in the twenty-eighth year of the reign of Her Majesty Elizabeth the Second, Queen of Australia.

(L.S.) HENRY WINNEKE

By His Excellency's Command  
W. V. HOUGHTON  
Minister of Lands

GOD SAVE THE QUEEN!

Land Act 1958  
ROAD PROCLAIMED

## PROCLAMATION

By His Excellency the Governor of the State of Victoria and its Dependencies in the Commonwealth of Australia, &c., &c., &c.

I, the Governor of the State of Victoria, in the Commonwealth of Australia, by and with the advice of the Executive Council of the said State, pursuant to the provisions of section 25 (3) (c) of the Land Act 1958, do hereby proclaim as road the Crown land hereinafter described, viz.:

At Bendigo Parish of Sandhurst, being the land indicated by hatching on plan hereunder—(S.372<sup>(122)</sup>) (L.6-1586).

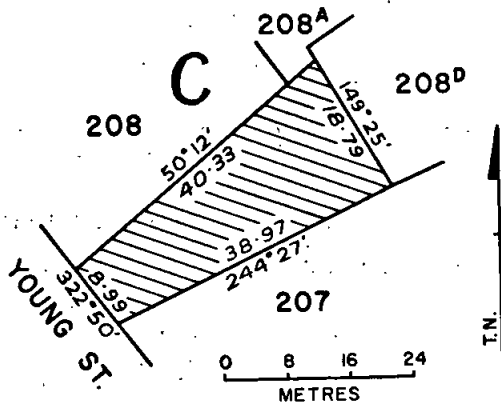

Given under my Hand and the Seal of the State of Victoria aforesaid, at Melbourne, this twenty-third day of October, in the year of our Lord One thousand nine hundred and seventy-nine, and in the twenty-eighth year of the reign of Her Majesty Elizabeth the Second, Queen of Australia.

(L.S.) HENRY WINNEKE

By His Excellency's Command

W. V. HOUGHTON  
Minister of Lands

GOD SAVE THE QUEEN!

CRIMES (OFFENCE AT SEA) ACT 1978 (No. 9229)  
DATE OF COMING INTO OPERATION

## PROCLAMATION

By His Excellency the Governor of the State of Victoria and its Dependencies in the Commonwealth of Australia, &c., &c., &c.

Whereas by an Act of Parliament of the State of Victoria passed in the twenty-seventh year of the reign of Her Majesty Elizabeth the Second Queen of Australia, intitled the Crimes (Offences at Sea) Act 1978 (No. 9229) it is amongst other things enacted that the said Act shall come into operation on a day to be fixed by Proclamation of the Governor in Council published in the Government Gazette.

Now therefore I, the Governor of the State of Victoria, acting by and with the advice of the Executive Council thereof, do by this my Proclamation fix Thursday, the first

day of November, One thousand nine hundred and seventy-nine, as the day upon which the provisions of the Crimes (Offences at Sea) Act 1978 shall come into operation.

Given under my Hand and the Seal of the State of Victoria aforesaid, at Melbourne, this thirtieth day of October, in the year of our Lord One thousand nine hundred and seventy-nine, and in the twenty-eighth year of the reign of Her Majesty Elizabeth the Second, Queen of Australia.

(L.S.) HENRY WINNEKE

By His Excellency's Command

HADDON STOREY  
Attorney-General

GOD SAVE THE QUEEN!

## GOVERNMENT NOTICES

Town and Country Planning Act 1961.

SHIRE OF MORNINGTON PLANNING SCHEME 1959

REVOCATION No. 6

Notice of Revocation

In pursuance of the provisions of section 32 of the Town and Country Planning Act 1961, the Governor in Council on 23 October 1979, made an Order:

- (a) revoking the Shire of Mornington Planning Scheme in so far as it applies to all that land being Lot 2 on Plan of Subdivision<sup>2</sup> 42769,<sup>3</sup> and situated on the north-western corner of Bungower Road and Baldock Road, Mornington; and
- (b) providing that the land so revoked may be used or developed only as if:
  - (i) it were land to which the Shire of Mornington Planning Scheme applies;
  - (ii) it were land partly included in the Inter Urban Landscape Protection Zone and partly included in a reserve for a proposed road widening as shown on the planning scheme map; and
  - (iii) notwithstanding any provision in the Shire of Mornington Planning Scheme, it were permissible, subject to the permission of the Responsible Authority, to subdivide the land into not more than two allotments each of which shall have an area of not less than 0.5 ha and to use or develop each allotment for the purpose of a house.

A copy of the Order may be inspected during office hours at the office of the Town and Country Planning Board, 235 Queen Street, Melbourne, and at the office of the Council of the Shire of Mornington at Mornington.

W. H. CRAIG, Secretary  
Town and Country Planning Board

Labour and Industry Act 1958, Section 45c (1)  
DETERMINATION OF THE SUGAR REFINERS' BOARD  
(No. 3 OF 1979)

Notice is hereby given that in accordance with the provisions of section 45c (1) of the Labour and Industry Act 1958, the Minister of Labour and Industry, on behalf of the State of Victoria, has requested the Industrial Appeals Court to review sub-clause (a) of Clause 7 "Wages per Week" of the Determination made by the Sugar Refiners Board on 2 October 1979 (No. 3 of 1979).

Section 45c (3) of Act 6283 (as amended) provides that when a request is made under this section the determination to be reviewed shall be deemed not to have come into operation.

A. S. DOWLING, Registrar  
Industrial Appeals Court

Transport Regulation Act  
**TRANSPORT REGULATION BOARD**  
 HEARING OF APPLICATIONS

Notice is hereby given that the following applications will be considered by the Transport Regulation Board on 20 November 1979.

HOY'S TOURIST SERVICE PTY. LTD., Mordialloc. Application for variation of conditions of licence No. T.O.83 to include the ability to operate a stage service between Melbourne and Harrietteville-Mt. Hotham during the snow season.

TIME-TABLE

Depart Melbourne, Friday,	6.00 p.m.
Arrive Harrietteville, Friday,	10.30 p.m.
Depart Harrietteville, Friday,	11.00 p.m.
Arrive Mt. Hotham, Saturday,	12.45 a.m.
Depart Harrietteville, Saturday,	9.00 a.m.
Arrive Mt. Hotham, Saturday,	10.45 a.m.
Depart Mt. Hotham, Saturday,	4.00 p.m.
Arrive Harrietteville, Saturday,	5.45 p.m.
Depart Harrietteville, Sunday,	9.00 a.m.
Arrive Mt. Hotham, Sunday,	10.45 a.m.
Depart Mt. Hotham, Sunday,	4.30 p.m.
Arrive Harrietteville, Sunday,	6.15 p.m.
Depart Harrietteville, Sunday,	6.30 p.m.
Arrive Melbourne, Sunday,	10.30 p.m.

NOTE—Pick up rights of Melbourne and Harrietteville only are sought in this application.

JOHNSTON, J. H., & PHILLIPS, J. H., Casterton. Application to license one commercial passenger vehicle with seating capacity for 41 persons to operate as follows: (a) In substitution for, but not in addition to, existing T.S. licences in the name of the applicants. (b) Under charter conditions from Portland. (c) Under charter conditions from Casterton.

NOTE—This application replaces a previous application which appeared in *Victoria Government Gazette*, No. 84, of 10 October 1979.

TRARALGON BUS LINES LTD. & MORWELL BUS LINES LTD. (trading as Latrobe Valley Bus Lines), Morwell. Application to license three commercial passenger vehicles, two with seating capacity for 48 persons and one with seating capacity for 39 persons to operate under the same terms and conditions as existing C.O. licensed vehicles in the name of the applicant.

SHARP, J. A., Branxholme. Application for variation of conditions of licence S.V.168 which authorises the carriage of passengers of the applicant's holiday farm at Branxholme to include the ability to operate under charter conditions from Hamilton.

Applications for renewal of licences as shown by the persons listed hereunder to operate under the same terms and conditions.

CLARK, G. W. & B. A., Cressy; T.S.1437; T.S.1536.  
 EASTERN SUBURBS OMNIBUS SERVICE PTY. LTD., Caulfield; M.O.157; M.O.205; M.O.206; M.O.207; M.O.208; M.O.209; M.O.210; M.O.212; M.O.312; M.O.421; M.O.609; M.O.701.

LEES, R. G. & DAUNT, D. J., Sunny Cliffs; T.O.51; T.O.52.  
 NIDIS, C. & M., Altona North; M.O.124; M.O.299; M.O.300; M.O.301; M.O.304; M.O.317; M.O.318; M.O.360; M.O.303; M.O.696.

NOTE—Licences M.O.124, M.O.299, M.O.301 and M.O.696 are in the course of transfer to Reggio Transport Pty. Ltd.

POPE, W. J. T. & J., Timboon; T.S.25; T.S.63; T.S.166; T.S.570; T.S.608; T.S.691; T.S.625; T.S.955; T.S.973; T.S.1148; T.S.1336; T.S.1346; T.S.1391; T.S.1414; T.S.1434.

SAIT, M. J., Charlton; T.S.320.

SINCLAIR COACHES PTY. LTD., Murrumbidgee; M.C.653.

BEDY, S., North Altona; M.T.4878.

BENNETT, J. F. & L. I., Newton; U.T.847.

BITAXIS, P., Brunswick; M.T.5091.

BRYSON, W. J. & E. M., Pascoe Vale; M.T.5433.

CAVKA, J. & R., Spotswood; S.T.6284.

GONDOPOULOS, T., Moorabbin; M.T.5483.

HANDLEY, R. F., Maffra; M.T.5214.

HANNA, Y. A. & N., Pascoe Vale; M.T.4930.

LUCIEER, W. S., Traralgon; C.T.334.

MAKRAKIS, G., Richmond; M.T.5472.

MEERKIN, L., Elwood; M.T.1304.

SODING, D. H., Balwyn; M.T.5186.

STOLL, G. R., Robinvale; C.T.382.

Notice of any objections should be forwarded to reach the Secretary of the Board not later than 14 November 1979.

Applicants are advised that it will not be necessary to appear on the hearing date specified, unless advised in writing by the Board.

C. J. V. SMITH, Secretary

Corner Lygon and Princes Streets, Carlton, 3053,  
 Wednesday, 31 October 1979

Commercial Goods Vehicles Act  
**TRANSPORT REGULATION BOARD**

HEARING OF APPLICATIONS

Notice is hereby given that the following applications will be considered by the Transport Regulation Board on 20 November 1979.

ARGENT, R. R., 10 Badel Court, Ringwood, 3134. One commercial goods vehicle (L/C. 1.25 tonne) to operate throughout the State of Victoria in course of business as "Electrical and Hydraulics Engineers"—tools of trade, spare parts and equipment required for the on-site servicing and maintenance of electrical and hydraulic equipment.

BERTALLI, T. W., 20 Old Monbulk Road, Belgrave, 3160. One commercial goods vehicle (L/C. 3.40 and 3.00 tonne trailer) to operate throughout the State of Victoria in the course of business as "Caterers"—own catering equipment and victuals.

BODINNAR, S. R., 30 Horace Street, Sea Lake, 3533. One commercial goods vehicle (L/C. 1.20 tonne) to operate: (a) Within that part of the State of Victoria north of a line drawn due east and west through the City of Horsham and west of a line drawn due north and south through the City of Bendigo in course of business as "Motor Vehicle and Farm Machinery Distributors"—tools of trade, spare parts and material required for on site servicing of motor vehicles and farm machinery, motor vehicles and farm machinery for delivery and automotive parts, electrical equipment, hardware lines and agricultural machinery. (b) (i) From places within the area specified in paragraph (a) above to own premises at Sea Lake, an approved decentralized secondary industry (Engineering)—raw materials required for use in the manufacturing processes of such industry. (ii) From the approved decentralized secondary industry premises at Sea Lake to places within the area specified in paragraph (a) above—manufactured products from such industry.

CENTRAL GIPPSLAND HERD IMPROVEMENT CO-OP SOCIETY LTD., Foster Street, Maffra, 3860. One commercial goods vehicle (L/C. 1.81 tonne) to operate within an 80-km radius of own premises at Maffra in the course of business as Herd Recording and Artificial Breeding Service—testing equipment and materials incidental to the completion of contracts.

CLELANDS COLD STORES PTY. LTD., 560 Clayton Road, Clayton, 3168. One commercial goods vehicle (L/C. 9.86 tonne) to operate throughout the State of Victoria in the course of business as "Frozen Food Carrier" as a specially constructed refrigerated vehicle for the purpose of servicing retail stores—frozen poultry, frozen fish, frozen and fresh meat, ice-cream, frozen and chilled fruit juice in plastic and waxed containers, frozen processed vegetables, cream, special soft cheese, yoghurt, dripping and lard, frozen pies, frozen prepared meals, butter and margarine.

NOTE—Butter and margarine is only to be carried from Melbourne as a mixed load when being carried with other frozen foods under refrigeration for distribution to retail stores and provided that the combined weight of butter and margarine carried does not exceed 3000 kgs on any one load.

- COLLINS & STOTT PTY. LTD.**, Nowa Nowa, 3887. One commercial goods vehicle (L/C. 18.00 tonne) to operate: (a) To own mill at Nowa Nowa from forest landings within an 80-km radius of the said mill at Nowa Nowa—logs. (b) From own sawmill at Nowa Nowa to consignees within an 80-km radius thereof—sawn timber. (c) Within an 80-km radius of mill at Nowa Nowa—own plant and equipment.
- CORBETT, G. G.**, 18 Rodney Road, North Geelong, 3215. One commercial goods vehicle (L/C. 1.15 tonne) to operate: (a) Within an 80-km radius of own premises at North Geelong in the course of business as "Furniture Manufacturer"—own goods. (b) Throughout the State of Victoria in the course of business as a "Furniture Manufacturer"—new furniture.
- CRADDOCK, H. J.**, 20 Thompson Street, Colac, 3250. One commercial goods vehicle (L/C. 0.75 and 1.95 tonne trailer) to operate throughout the State of Victoria in the course of business as "Automotive Wreckers"—wrecked motor vehicles on a specially constructed car carrying trailer and also used second-hand spare parts being dismantled from wrecked vehicles in country areas, but excluding the ability to remove any wrecked or disabled car from the scene or area where damaged or disabled in any accident or collision.
- DOUGLAS, H. J.**, 57 Dundas Road, Maryborough, 3465. Application to vary the conditions of licence Nos. D.A.5622 and D.A.69246 by adding additional paragraph—(i) From the premises of Beecham Wright at Altona to Maryborough—new empty boxes. (ii) From Maryborough to the premises of A.P.M. Ltd. at Broadford—waste paper.
- FRITZPATRICK, P.**, 16 Victoria Street, Numurkah, 3636. One commercial goods vehicle (L/C. 10.00 tonne) to operate: (a) Within an 80-km radius from the post office at Numurkah—plant the property of a contractor and required by him for use in connection with the construction or maintenance of some specific, existing or proposed road, street, footpath, bridge, pier, wharf, weir or channel and also the following materials, viz.:—metal, stones, screenings, ashes, gravel, sand and earth. (b) Within a 32-km radius from the site of any construction or maintenance work performed pursuant to paragraph (a) above, or from the railway station nearest thereto—any other materials required for such work. (c) Within a 40-km radius of the post office at Numurkah—general goods.
- FREETH, W.**, 32 Ernest Street, Broadmeadows, 3047. One commercial goods vehicle (L/C. 11.65 tonne) to operate within a 112-km radius of the premises of Clifton Brick Holdings Pty. Ltd. at Brunswick on behalf of the said company—bricks.
- KAY, J. D.**, Myers Creek Road, Healesville, 3777. One commercial goods vehicle (L/C. 13.50 tonne) to operate: (a) Within an 80-km radius of own premises at Healesville in course of business as "Marine Collector and Scrap Metal Dealer"—marine stores and old metals as defined in the *Marine Stores and Old Metals Act 1958*, No. 6303 Part 1 Section 3. (b) Within an 80-km radius of own business at Healesville in course of business as Primary Producer—own goods. (c) Within that part of the State of Victoria east of a north/south line drawn through Werribee—live-stock.
- LEURY, A. C.**, 13 Daley Street, Pascoe Vale, 3044. One commercial goods vehicle (L/C. 7.90 tonne) to operate within a 112 km radius of the premises of Clifton Brick Holdings Pty. Ltd. at Brunswick on behalf of the said company—bricks.
- MINA FLEUR NOMINEES PTY. LTD.**, 49 Binney Street, Euroa, 3666. One commercial goods vehicle (L/C. 2.05 tonne) to operate throughout the State of Victoria in course of business as "Shearing Contractor"—own tools of trade and equipment incidental to completion of own shearing contracts.
- MCGLASHANS TRANSPORT PTY. LTD.**, P.O. Box 1612, Mildura, 3500. One commercial goods vehicle (L/C. 14.40 tonne) to operate throughout the State of Victoria in course of business as "Frozen Food Distributors" as a specially constructed refrigerated vehicle—frozen fish, frozen and fresh meat, ice-cream, frozen fruit juice, frozen processed vegetables, fresh cream and frozen poultry and up to 0.10 tonnes of special cheese under refrigeration and up to 0.25 tonne of yoghurt.
- MCGLASHAN, D. K.**, 13 Wallaby Avenue, Kangaroo Flat, 3555. Application to vary the conditions of licence No. D.A.69287 by adding an additional paragraph (b) "From places within the City of Bendigo to the Bendigo Railway Station—empty return beer barrels".
- MCKENZIE, R.**, 29 McLaughlin Street, Sale 3850. One commercial goods vehicle (L/C. 3.95 tonne) to operate: (a) From places within the Melbourne metropolitan area to places in that part of the State of Victoria east of a north-south line drawn through Melbourne and south of an east-west line drawn through Omeo—new furniture. (b) Throughout the State of Victoria—second-hand furniture.
- PONTIN, P. A.**, 77 Bellevue Avenue, Doncaster East, 3109. One commercial goods vehicle (L/C. 11.70 tonne) to operate: (a) Within a 40-km radius of own premises at East Doncaster in the course of business as "Soil Sand, Screening and Garden Supply"—own goods. (b) From Beveridge to own premises at East Doncaster—own scoria. (c) From Bacchus Marsh to own premises at East Doncaster—own river pebbles and rock. (d) From The Gurdies to own premises at East Doncaster—own sand. (e) From Yea to own premises at East Doncaster—own river pebbles. (f) From Warburton to own premises at East Doncaster—own mountain soil.
- RUSSELL, B. F.**, 919 Raglan Parade, Warrnambool, 3280. One commercial goods vehicle (L/C. 5.70 tonne) to operate: (a) Throughout the State of Victoria in the course of business as "Marine Dealer"—special wares, marine stores and old metals as designated in the *Marine Stores and Old Metals Act 1958*, No. 6303, section 1 (3) but excluding the carriage of any such goods to wharves, docks or ships for shipment or export purposes. (b) Within a 32-km radius of the post office at Warrnambool—general goods.
- NOTE—The combined load capacity of the vehicle as prime mover and of any trailer hauled in conjunction with the vehicle shall not exceed 6000 kgs.
- SCHRADER, R. H.**, 16 Wood Street, Bairnsdale, 3875. One commercial goods vehicle (L/C. 21.95 tonne) to operate: (a) Within that part of the State of Victoria bounded on the west by the Mitchell and Dargo Rivers, on the east by the Snowy River and on the north by a line drawn due east and west through the settlement of Glen Wills but excluding any operations within a 32-km radius of the post office at Omeo—logs and own logging equipment. (b) From sawmills situated within the area defined in part (a) of this document—sawn timber for delivery to the nearest railway station within the said radius and to customers and/or direct to building sites within a 32-km radius of the Post Office at Bruthen.
- VELLELEY, P. R.**, 178 Boundary Street, Kerang, 3579. One commercial goods vehicle (L/C. 1.40 and 0.60 tonne trailer) to operate throughout the State of Victoria in the course of business as "Sandblasting Contractor"—tools of trade, own equipment and sufficient sand for the completion of contracts.
- YENCKEN GALE PTY. LTD.**, 9 Benalla Road, Shepparton, 3030. One commercial goods vehicle (L/C. 1.30 tonne) to operate: (a) Within an 80-km radius of the post office at Shepparton in course of business as "Hardware and Glass Merchants"—own goods. (b) Within an 80-km radius of the post office at Shepparton and to Wangaratta, Wodonga, Mansfield, Yea, Kerang, Cohuna and Swan Hill in course of business as "Glass Merchants"—tools of trade, glass and glass fixing materials.

## TOW TRUCK.

- FECHNER, A.**, South Gippsland Highway, Tooradin, 3980. Application to vary the conditions of licence No. D.A.65040/2 by deleting "40-km" and adding in lieu "80-km".

RENEWALS

Applications for renewal of licences as shown by persons listed hereunder to operate under the same terms and conditions from the expiry shown in each case.

- ATKINS, A. C., Main Street, Dingee, 3571; D.A.64951; 17 January 1980; 0.50 tonne.
- B.C.X. PURE FRUIT DRINKS PTY. LTD., Allingham Street, Golden Square, 3555; D.A.3576/18; 29 January 1980; 3.50 tonne.
- BARRY, N. U., & ORENSHAW, K. A., King Street, Yarra Glen, 3775; D.A.60223/3; 6 November 1979; 11.60 tonne.
- BEAUREPAIRE TYRE SERVICE PTY. LTD., 689 Burke Road, Camberwell, 3124; D.A.629/76; 6 November 1979; 0.50 tonne.
- BATH, J. F., corner Napier and Dundas Streets, Inverleigh, 3321; D.A.45199/2; 11 January 1980; 6.75 tonne.
- WILLIAM BOYLE & SONS, 24 Dalamahoy Street, Bairnsdale, 3875; D.A.36979/4; 11 December 1979; 2.70 tonne.
- BOYER, R., 24 Epping Street, Kyneton, 3444; D.A.68182; 11 January 1980; 4.95 tonne.
- BRADLEY-SMITH, J. T., R.S.D. Denison Road, Denison, 3858; D.T.1658; 11 February 1979; 13.00 tonne.
- CAMPERDOWN-GLENORMISTON DAIRYING Co. LTD., 225 Manifold Street, Camperdown, 3260; D.A.54036/9; 23 October 1979; 0.85 tonne.
- DALE, C. W., 16 Elizabeth Street, Castlemaine, 3450; T.D.A.61056; 12 December 1979; 0.60 and 1.00 tonne trailer.
- ERBS, B. F., Wirra Mirra Drive, Wurruk; 3851; D.A.69877; 2 December 1979; 19.20 tonne.
- HUNTER, R. J., 244 Commercial Road, Yarram, 3971; D.A.37819/4; 27 November 1979; 6.60 and 6.35 tonne trailer.
- KANE, B. J., 23 Turner Street, North Wonthaggi; D.A.66942; 20 December 1979; 10.35 tonne.
- KEENE, G. N., 5 Anderson Street, Heyfield, 3858; D.T.1398/1; 11 December 1979; 13.85 tonne.
- KURBAN, P. H., 5 Hyacinth Street, Violet Town, 3669; D.A.33936/1; 21 December 1979; 6.85 tonne.
- MAJOR, A. B., Box 41, Goroke, 3412; D.A.66099/1; 18 January 1980; 7.80 tonne.
- MAJOR, J., Torquay Road, Grovedale, 3216; D.A.45767/3; 4 November 1979; 3.40 tonne.
- MCMECKEN, K. C. & J. F., 3 George Street, Yinnar, 3869; D.A.66829/1; 2 December 1979; 9.10 tonne.
- O'LOUGHLIN, B. A., 17 Gillies Crescent, Morwell, 3840; D.A.67791/1; 25 September 1979; 3.80 tonne; D.A.67791/2; 25 September 1979; 2.55 tonne.
- PETERSVILLE LTD., 254-294 Wellington Road, Mulgrave, 3170; D.A.1813/175; 30 January 1980; 2.95 tonne.
- PETRUNIC, I., 20 Gosford Crescent, Broadmeadows, 3047; D.A.68230; 18 January 1980; 7.15 tonne.
- PLAZZER, E., & SONS, 67 Williams Road, Horsham, 3400; D.A.64905; 6 December 1979; 8.35 tonne.
- RIORDAN, R., 22-28 Princes Highway, Colac East, 3250; D.A.63270/11; 2 December 1979; 7.10 tonne.
- SCAPIN, A., 10 Dickson Street, Wonthaggi, 3995; D.A.64940; 20 December 1979; 3.05 tonne.
- W. E. SEARLE PTY. LTD., 26 Coster Street, Alexandra, 3714; D.A.16878/1; 5 December 1979; 3.10 tonne.
- SURKITT, R. G., Brown Street, Caramut, 3274; D.A.61150; 11 December 1979; 6.95 tonne.
- TRANSDYER MANAGEMENT PTY. LTD., 34-46 York Street, Sale, 3850; D.A.43146/21; 2 December 1979; 21.60 tonne; D.A.43146/18; 2 December 1979; 15.15 tonne; D.A.43146/22; 2 December 1979; 21.60 tonne.
- TURNER, F. W., R.S.D. Box 62, Wodonga, 3690; D.A.68153; 11 December 1979; 3.75 tonne.
- WILSON, R. F., 21 Robertson Street, Casterton, 3311; D.A.68214; 18 January 1980; 0.75 tonne.

TOW TRUCKS

- BENDERS BUSWAYS PTY. LTD., Edol Street, North Geelong, 3215; D.A.62229; 17 January 1980; 4.60 tonne.
- FOSTER, J., 81-83 Lloyd Street, Moe, 3825; D.A.47381; 25 March 1979; 2.50 tonne.
- KELLY BROS. MOTORS MORWELL PTY. LTD., Princes Highway, Morwell, 3840; D.A.1416; 28 June 1979; 2.15 tonne.
- TOOLES MOTORS PTY. LTD., 28 High Street, Wodonga, 3690; D.A.2173/6; 20 October 1979; 5.55 tonne.

Notice of any objection should be forwarded to reach the Secretary of the Board not later than 14 November 1979.

Applicants are advised that it will not be necessary to appear on the hearing date specified above, unless advised in writing by the Board.

C. J. V. SMITH, Secretary

Corner Lygon and Princes streets, Carlton, 3053, Wednesday, 31 October 1979.

STATE RIVERS AND WATER SUPPLY COMMISSION

LICENCES TO DIVERT WATER PURSUANT TO THE PROVISIONS OF SECTION 204 OF THE WATER ACT 1958. (AS AMENDED).

The Governor in Council has approved of the granting by the State Rivers and Water Supply Commission of licences as detailed hereunder for the term of years from the date specified in each case to the persons named in the following Schedule:—

SCHEDULE

Licence No.	Term of Licence and Commencing Date	Name and Address of Person to whom Licence is to be Granted	Source of Supply	Volume of Water Authorized to be Irrigated Per Annum		Annual Fee
				hectares	megalitres	
942	Fifteen years from 1.7.79	B. F. and J. M. Dowie of Carisbrook	Tullaroop Creek	20.7	124.0	233.12
12909	Fifteen years from 1.7.77	F. R. Ham of Bendigo	Campaspe River	21.4	129.0	190.92
3563	Fifteen years from 1.7.77	Donald and Alma Lampard of Nangiloc	River Murray	27.2	245.0	333.20
3809	Fifteen years from 1.7.77	A. F. Kenny of Bendigo	Campaspe River	9.7	59.0	87.32
3831	Twelve years from 1.7.78	B. R. and I. A. Sweet and L. D. Wright of Bacchus Marsh	River Murray	5.0	30.0	50.40
3835	Twelve years from 1.7.79	J. and V. Dippel of Sydney	River Murray	2.0	18.0	34.20
3836	Ten years from 1.7.78	B. and S. Archer of Koowecerup	Bunyip Main Drain	2.5	15.0	25.20

Office of the State Rivers and Water Supply Commission  
Melbourne, 23 October 1979

R. BIRD, Secretary  
State Rivers and Water Supply Commission

## Water Act 1958

STATE RIVERS AND WATER SUPPLY COMMISSION  
BELLARINE URBAN DISTRICT

Notice to owners of tenements in the under-mentioned streets in the Bellarine Urban District and the private streets, lanes, courts and alleys opening thereto:

*Anglesea*

Greeves Street, from end of existing main (opposite lot 3) to a point opposite lot 3 about 32 metres south-easterly.  
O'Donohue Road (east side only), from Fourth Avenue to a point opposite lot 6 about 75 metres northerly.  
Weir Street, from end of existing main (opposite lot 144) to a point opposite lot 147 about 51 metres north-easterly.

*Birregurra*

Barwon Street, from Jenner Street to Main Street.  
Jenner Street, from end of existing main (opposite lot 9, C.A. C., Township of Birregurra) to Barwon Street about 41 metres easterly.  
Main Street, from end of existing main (opposite lot 10, C.A. C., Township of Birregurra) to Barwon Street about 27 metres easterly.

*Clifton Springs*

Carawatha Avenue, from Panpandi Drive to a point opposite lot 3053 about 411 metres easterly.  
Coorumbly Avenue, from Gumbowie Avenue to a point opposite lot 2611 about 100 metres easterly.  
Dunburra Avenue.  
Dundundra Drive, from Gumbowie Avenue to Tarcoola Way about 70 metres northerly.  
Kalimna Court.  
Kanyana Avenue, from Kadumba Avenue to Shore Line Drive.  
Lacorra Court.  
Lowanna Court.  
Tarcoola Way, from Dundundra Drive to a point opposite lot 2776 about 5 metres easterly.  
Wardoo Court.  
Warrawee Court.

*Drysdale*

Barrands Lane, from East Street to a point opposite lot 153 about 550 metres northerly.  
Carolanne Drive.  
Condy Street, from Kimberly Street to a point opposite lot 132 about 115 metres northerly.  
Cullen Court.  
David Street.  
Deacon Court.  
Diana Court.  
Duke Street—(1) from Newcombe Street to a point opposite lot 11 about 150 metres north-easterly; (2) from end of existing main (opposite lot 5) to East Street about 85 metres north-easterly.  
East Street, from Duke Street to a point opposite lot 1 about 15 metres easterly.  
Huntingdon Street, from Princess Street to a point opposite lot 21 about 375 metres easterly.  
Kimberly Street.  
Patricia Court.  
Terry Court.  
Tony Street.  
Wyndham Street, from Barrands Lane to Springs Road.

*Leopold*

Bellarine Highway, from end of existing main (opposite lot 52) to Melaluka Road about 1006 metres westerly.  
Burlington Crescent, from Rebecca Drive to a point opposite lot 6 about 54 metres northerly.  
Clifton Avenue, from Geelong-Portarlinton Road to a point opposite lot 1 about 1576 metres northerly.  
Kensington Road, from end of existing main (opposite lot 40) to Bellarine Highway about 65 metres southerly.  
Melaluka Road, from end of existing main (opposite lot 1) to Portarlinton Road about 489 metres northerly.  
Nathan Court.

Portarlinton Road, from Melaluka Road to a point opposite lot 4 about 703 metres easterly.  
Rebecca Drive, from Kensington Road to a point opposite lot 51 about 191 metres westerly.

*Marcus Hill*

Ocean Grand Drive, from Banks Road to a point opposite lot 1 about 552 metres westerly.

*Ocean Grove*

Canis Crescent, from Halibut Avenue to a point opposite lot 396 about 250 metres easterly.  
Grubb Road, from Adco Grove to a point opposite lot 1 about 132 metres northerly.  
Halibut Avenue, from a point opposite lot 190 to Marlin Drive.  
Marlin Drive—(a) from a point opposite lot 161 to Alderbaran Road about 89 metres easterly; (b) from Tuckfield Street to a point opposite lot 51 about 700 metres south-easterly.  
Nautilus Court.

*Portarlinton*

Agonis Court.  
Hakea Court.  
Pieris Court.  
Punica Court.  
Reaby Street, from end of existing main (opposite lot 34) to Smythe Street.  
Tristania Court.

*Torquay*

Antares Court.  
Aquilla Avenue, from Fischer Street to a point opposite lot 94 about 305 metres easterly.  
Caitness Court.  
Coffey Court.  
Duffields Road, from Sunningdale Avenue to a point opposite lot 52 about 156 metres southerly.  
Dunkeith Avenue, from end of existing main (opposite lot 59) to a point opposite lot 31 about 213 metres north-easterly.  
Endeavour Drive, from Aquilla Avenue to a point opposite lot 79 about 245 metres northerly.  
Fischer Street, from Parkside Crescent to a point opposite lot 18 about 680 metres northerly.  
Highlander Street, from Fischer Street to a point opposite lot 2 about 60 metres westerly.  
Meaby Street.  
Nestor Court.  
Ocean Boulevard, from end of existing main (opposite Lot 19) to a point opposite lot 135 about 183 metres south-westerly.  
Osprey Court.  
Scammell Crescent, from Endeavour Drive to a point opposite lot 84 about 55 metres easterly.  
Seabird Court.  
Tathra Court.  
Weron Court.

*Wallington*

Bellarine Highway, from Grubb Road to a point opposite lot 1, part C.A. 11, about 1460 metres westerly.  
Grubb Road, from Swan Bay Road to a point opposite lot 6, L.P.62165 about 1925 metres southerly.  
Rhinds Road—(a) from Grubb Road to a point opposite lot 2 part C.A. 11, section 4, about 1175 metres westerly; (b) from end of existing main (opposite lot 2, part C.A. 11, section 4, Parish of Bellarine) to a point opposite lot 6, part C.A. 15, section 4, about 137 metres westerly.  
Swan Bay Road, from Grubb Road to a point opposite lot 2, part C.A. 13, about 1042 metres easterly.

The main pipe in the said streets being laid down, the owners of all tenements situated as above are hereby required, on or before 1. December next, to cause proper pipes and stop cocks to be laid, so as to supply water within such tenements from the main pipe.

Armadaale, 5 October 1979

R. BIRD, Secretary  
State Rivers and Water Supply Commission

## STATE RIVERS AND WATER SUPPLY COMMISSION

BY-LAW No. 5864

## Flood Protection Charge—Loch Garry Flood Protection District

The State Rivers and Water Supply Commission, in pursuance and exercise of the powers conferred by the Water Act, doth hereby make the By-law following:—

1. The following Flood Protection Charge is hereby made under the provisions of the Water Act and shall be levied upon the occupiers or owners of all lands within the Loch Garry Flood Protection District:—

For the service rendered to such district by the flood protection works constructed for such service:—

A Flood Protection Charge of 19.6 cents for each and every hectare of all lands in the Loch Garry Flood Protection District.

Provided that the sum of Twelve dollars shall be the minimum charge in respect of any such land or tenement in the said District.

2. Such Flood Protection Charge is made and shall be levied for the year beginning with 1 July 1979 and ending with 30 June 1980 and shall be payable on 1 December 1979, at the office of the State Rivers and Water Supply Commission at Shepparton.

3. In accordance with Section 348 of the Water Act, interest will be chargeable on all Flood Protection Charges remaining unpaid after 15 April 1980.

4. Such person or persons as the State Rivers and Water Supply Commission may from time to time appoint for that purpose shall be and is or are hereby authorised to demand, receive, collect and recover the said Flood Protection Charges.

The foregoing By-law was made by the State Rivers and Water Supply Commission on 22 October 1979 and the common seal of the said Commission was hereunto affixed, 22 October 1979, in the presence of—

(SEAL) J. S. ROGERSON, Commissioner  
D. J. CONSTABLE, Commissioner

Approved by the Governor in Council, 30 October 1979—  
K. GILKINSON, Acting Clerk of the Executive Council

## STATE RIVERS AND WATER SUPPLY COMMISSION

BY-LAW No. 5863

## Flood Protection Rate—Koo-wee-rup Flood Protection District

The State Rivers and Water Supply Commission, in pursuance and exercise of the powers conferred by the Water Act, doth hereby make the By-law following:—

1. The following Flood Protection Rates are hereby made under the provisions of the Water Act and shall be levied upon the occupiers or owners of all lands within the respective divisions of the Koo-wee-rup Flood Protection District for the service rendered to such District by the flood protection works constructed for such services:—

(1) First Division—A Flood Protection Rate of 16.9 cents in the dollar of the rateable value of all lands in the First Division, being the lands included within the red border on the plans of such district signed and sealed by the State Rivers and Water Supply Commission and lodged at the office of the Commission at Melbourne, excepting and excluding all lands in the Second, Third, Fourth and Fifth Divisions as described hereunder.

(2) Second Division—A Flood Protection Rate of 5.18 cents in the dollar of the rateable value of all lands in the Second Division marked on the aforesaid plans in the manner shown opposite the words "Second Division" in the legend thereto.

(3) Third Division—A Flood Protection Rate of 3.45 cents in the dollar of the rateable value of all lands in the Third Division marked on the aforesaid plans in the manner shown opposite the words "Third Division" in the legend thereto.

(4) Fourth Division—A Flood Protection Rate of 1.73 cents in the dollar of the rateable value of all lands in the Fourth Division marked on the aforesaid plans in the manner shown opposite the words "Fourth Division" in the legend thereto.

(5) Fifth Division—No rate is made or shall be levied in respect of lands marked on the aforesaid plans in the manner shown opposite the words "Fifth Division" in the legend thereto.

Provided that the sum of Twelve Dollars shall be the minimum amount of rate in respect of any land or tenement liable to be rated in the said district.

2. Such Flood Protection Rates are made and shall be levied for the year beginning with 1 July 1979 and ending with 30 June 1980 and shall be payable on 1 December 1979, at the office of the State Rivers and Water Supply Commission at Koo-wee-rup.

3. In accordance with Section 348 of the Water Act, interest will be chargeable on all Flood Protection Rates remaining unpaid after 15 April 1980.

4. For making and levying such rates the net annual value as set out in the municipal valuation as at 30 June 1979, shall be deemed and taken to be the rateable value of such lands and tenements.

5. Such person or persons as the State Rivers and Water Supply Commission may from time to time appoint for that purpose shall be and is, or are, hereby authorised to demand, receive, collect and recover the said Rate.

The foregoing By-law was made by the State Rivers and Water Supply Commission on 22 October 1979 and the common seal of the said Commission was hereunto affixed, 22 October 1979, in the presence of—

(SEAL) J. S. ROGERSON, Commissioner  
D. J. CONSTABLE, Commissioner

Approved by the Governor in Council, 30 October 1979—  
K. GILKINSON, Acting Clerk of the Executive Council

## STATE RIVERS AND WATER SUPPLY COMMISSION

BY-LAW No. 5865

## General Rate—Millewa Rural District

The State Rivers and Water Supply Commission, in pursuance and exercise of the powers conferred by the Water Act, doth hereby make the By-law following:—

1. The following General Rate is hereby made under the provisions of the Water Act and shall be levied upon all occupiers or owners of all lands within the Millewa Rural District which has been described in notices published in accordance with Section 207A of the Act, except within any Urban District thereof for the supply of water for the domestic and ordinary use of persons dwelling upon such lands and for watering cattle or other stock.

2. Such Rate shall be an amount of forty cents in the dollar of the Net Annual Value (N.A.V.) as set out in the Municipal Valuation of such lands as at 30 June 1979.

3. Such Rate is made and shall be levied for the year beginning with 1 July 1979 and ending with 30 June 1980 and shall be payable on 1 December 1979, at the office of the State Rivers and Water Supply Commission at Red Cliffs.

4. Interest will be chargeable on all Rates remaining unpaid after 15 April 1980.

5. Such person or persons as the State Rivers and Water Supply Commission may from time to time appoint for that purpose shall be, and is or are hereby authorised to demand, receive, collect and recover the said Rate.

The foregoing By-law was made by the State Rivers and Water Supply Commission on 22 October 1979 and the common seal of the said Commission was hereunto affixed, 22 October 1979, in the presence of—

(SEAL) J. S. ROGERSON, Commissioner  
D. J. CONSTABLE, Commissioner

Approved 29 October 1979—F. J. GRANTER, Minister of Water Supply



**AIREYS INLET WATERWORKS TRUST**  
INCREASING THE LIMIT OF BANK OVERDRAFT

His Excellency the Governor of the State of Victoria by and with the advice of the Executive Council thereof has by Order made on 23 October 1979 increased the total amount of the sums which the Aireys Inlet Waterworks Trust may owe at any one time in respect of moneys borrowed by overdraft of current account pursuant to the provisions of section 288 of the Water Act fixed by the Governor in Council on 23 May 1978 at Sixty thousand dollars (\$60 000) to Eighty thousand dollars (\$80 000).

K. GILKINSON  
Acting Clerk of the Executive Council

At the Executive Council Chamber  
Melbourne, 23 October 1979

**TRARALGON WATERWORKS TRUST**  
INCREASING THE LIMIT OF BANK OVERDRAFT

His Excellency the Governor of the State of Victoria by and with the advice of the Executive Council thereof has by Order made on 23 October 1979 increased the total amount of the sums which the Traralgon Waterworks Trust may owe at any one time in respect of moneys borrowed by overdraft of current account pursuant to the provisions of section 288 of the Water Act fixed by the Governor in Council on 25 July 1978, at Two hundred thousand dollars (\$200 000), to Five hundred thousand dollars (\$500 000).

K. GILKINSON  
Acting Clerk of the Executive Council

At the Executive Council Chamber  
Melbourne, 23 October 1979

**ANGLESEA SEWERAGE AUTHORITY**  
INCREASING THE LIMIT OF BANK OVERDRAFT

His Excellency the Governor of the State of Victoria by and with the advice of the Executive Council thereof has by Order made on 23 October 1979 increased the total amount of the sums which the Anglesea Sewerage Authority may owe at any one time in respect of moneys borrowed by overdraft of current account pursuant to the provisions of section 79 of the Sewerage Districts Act 1958, fixed by the Governor in Council on 9 April 1974 at Thirty thousand dollars (\$30 000), to Seventy thousand dollars (\$70 000).

K. GILKINSON  
Acting Clerk of the Executive Council

At the Executive Council Chamber  
Melbourne, 23 October 1979

**ANGLESEA SEWERAGE AUTHORITY**  
FIXING THE LIMIT OF BANK OVERDRAFT

His Excellency the Governor of the State of Victoria by and with the advice of the Executive Council thereof has by Order made on 23 October 1979 fixed the total amount of the sums which the Anglesea Sewerage Authority may owe at any one time in respect of moneys borrowed by overdraft of current account pursuant to the provisions of section 78 of the Sewerage Districts Act 1958, at Ten thousand dollars (\$10 000).

K. GILKINSON  
Acting Clerk of the Executive Council

At the Executive Council Chamber  
Melbourne, 23 October 1979

**HASTINGS SEWERAGE AUTHORITY**  
FIXING THE LIMIT OF BANK OVERDRAFT

His Excellency the Governor of the State of Victoria by and with the advice of the Executive Council thereof has by Order made on 23 October 1979 fixed the total amount of the sums which the Hastings Sewerage Authority may owe at any one time in respect of moneys borrowed by overdraft of current account pursuant to the provisions of section 78 of the Sewerage Districts Act 1958, at One hundred thousand dollars (\$100 000).

K. GILKINSON  
Acting Clerk of the Executive Council

At the Executive Council Chamber  
Melbourne, 23 October 1979

LOCAL GOVERNMENT DEPARTMENT  
**ORDER CONFIRMED—SHIRE OF ROCHESTER**

The Minister of the Crown administering the Local Government Act 1958, on 23 October 1979, confirmed the Order hereinafter referred to in pursuance of section 514 of the said Act namely:

An Order of the Council of the Shire of Rochester made on 4 October 1979 directing the compulsory taking of part of the land described as Lot 3 on Plan of Subdivision No. 9922 lodged in the Office of Titles and being the land shown by hatching on the plan hereunder for road purposes.

19/2655

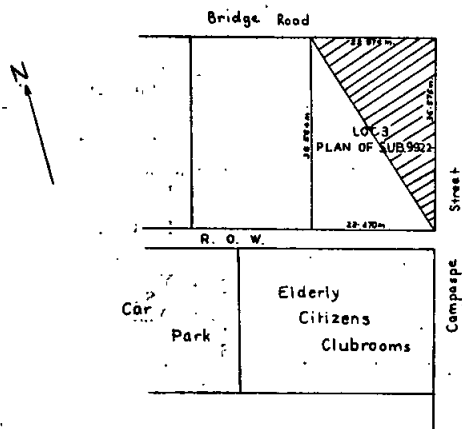

D. G. CROZIER  
Minister for Local Government  
Local Government Department  
Melbourne (79/2655)

LOCAL GOVERNMENT DEPARTMENT  
**ORDER CONFIRMED—SHIRE OF ROCHESTER**

The Minister of the Crown administering the Local Government Act 1958, on 23 October 1979, confirmed the Order hereinafter referred to in pursuance of section 514 of the said Act namely:

An Order of the Council of the Shire of Rochester made on 4 October 1979 directing the compulsory taking of part of the land described as Lot 3 on Plan of Subdivision No. 9922 lodged in the Office of Titles and being the land shown by hatching on the plan hereunder for the purpose of providing a place for public resort and recreation.

79/2650

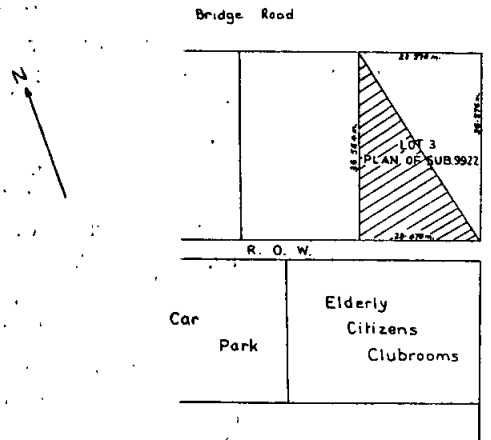

D. G. CROZIER  
Minister for Local Government  
Local Government Department  
Melbourne (79/2650)

*Private Agents Act 1966*

## NOTICE OF RECEIPT OF APPLICATIONS FOR LICENCES UNDER THE PROVISIONS OF THE PRIVATE AGENTS ACT 1966

The Clerk(s) of the Magistrates' Court(s) as listed hereunder hereby give notice that applications, as under, have been lodged for hearing by the said Court(s) on the date(s) specified.

Any person desiring to object to any of such applications must—

- (a) lodge with the respective Clerk of the Magistrates' Court a notice in the prescribed form of his objection and of the grounds thereof ;
- (b) cause a copy of such notice to be served personally or by post upon the applicant at least three days before the hearing of the application ; and
- (c) send or deliver—
- (i) where the objection is not made by the officer in charge of the police district in which the Court is situated—a copy of the notice to such officer ; and
- (ii) where the objection is not made by the Registrar or Deputy Registrar—a copy to the Registrar.

Full Name of Applicant*	Place of Abode of Applicant or Nominee	Name of Firm or Corporation	Address for Registration	Type of Licence	Date of Hearing
<b>MAGISTRATES' COURT, SOUTH MELBOURNE</b>					
Brand, Ronald Michael	17 Luxton Tce, Seaford	T.N.T. Group 4 Total Security Pty. Ltd.	425 St. Kilda Rd, Melbourne	Watchman	7.11.79
O'Connor, Daniel Joseph	31 Crellin Cres, Watsonia	" "	" "	" "	14.11.79
Schramm, Graeme Paul	4/745 Punt Rd, South Yarra	" "	" "	" "	" "
Serafy, Peter	2 Pardy St, Pascoe Vale	" "	" "	" "	" "
McBain, Suzanné	13 Sylvester Cres, St. Albans	" "	" "	" "	" "
Turner, Richard Edward	16 Coolamon St, Albion	" "	" "	" "	" "
Dated at South Melbourne 12 October 1979 JOHN ARDLIE, Clerk of the Magistrates' Court					
<b>MAGISTRATES' COURT, SPRINGVALE</b>					
Herry, Richard Emmanuel	17 Bundamba Dve, Noble Park		17 Bundamba Dve, Noble Park	Process Server	14.11.79
Dated at Springvale 19 October 1979 P. COUTTS, Clerk of the Magistrates' Court					
<b>MAGISTRATES' COURT, LILYDALE</b>					
Howarth, Michael	Lot 4 Leggett Dr, Mt. Evelyn		Lot 4 Leggett Dr, Mt. Evelyn	Guard Agent	13.11.79
Birrell, Arthur John	4 Galilee Cres, Mill Park	Downtown Security Company Pty. Ltd.	" "	" "	" "
Evans, Neal Edwin	1/15 Burnt St, Nunawading		" "	" "	" "
Dated at Lilydale 22 October 1979 V. V. KELLY, Clerk of the Magistrates' Court					
<b>MAGISTRATES' COURT, MELBOURNE</b>					
Borgmeyer, Donald Harley	55 Boyana Crt, Croydon	John McLean Bennett and Co. Pty. Ltd.	8th Floor 118 Queen St, Melbourne	Watchman	9.1.80
Johnston, Leslie	6 Jonathen Ave, East Burwood	Armaguard	94 York St, South Melbourne	Watchman	27.11.79
Dated at Melbourne 19 October 1979 L. W. HUSSEY, Clerk of the Magistrates' Court					
<b>MAGISTRATES' COURT, PORT MELBOURNE</b>					
Kreltzeim, Rober Tyrone	Lot 2, Stevensons Rd, Bannockburn	Mayne Nickless	94 York St, South Melbourne	Watchman	29.11.79
Dated at Port Melbourne 19 October 1979 I. H. BRUCE, Clerk of the Magistrates' Court					
<b>MAGISTRATES' COURT, GEELONG</b>					
Jennings, Ian James	46 Carr St, Barwon Heads	Transurety Australia Limited	19-21 Baldwin Ave, Norlane	Watchman	12.11.79
Dated at Geelong 22 November 1979 J. E. REILLY, Clerk of the Magistrates' Court					

\* Or in the case of a firm or corporation, of the Nominee

## PRIVATE AGENTS—continued

Full Name of Applicant*	Place of Abode of Applicant or Nominee	Name of Firm or Corporation	Address for Registration	Type of Licence	Date of Hearing
MAGISTRATES' COURT, SOUTH MELBOURNE					
Herring, John	30 Molesworth St, Seaford	T.N.T. Group 4, Total Security Pty. Ltd.	425 St Kilda Rd, Melbourne	Watchman	21.11.79
Bennett, David Rodney	40 Maher Rd, Laverton	" "	" " " "	" "	" "
Sage, James Phillip	42 Ripplebrook Dve, Broadmeadows	" "	" " " "	" "	" "
Dated at South Melbourne 25 October 1979 JOHN ARDLIE, Clerk of the Magistrates' Court					
MAGISTRATES' COURT, SUNBURY					
Kirley, Mark Anthony	Flat 7, 137 Evans St, Sunbury		Flat 7, 137 Evans St, Sunbury	Watchman	20.11.79
Dated at Sunbury 23 October 1979 R. R. BOURKE, Clerk of the Magistrates' Court					
MAGISTRATES' COURT, FITZROY					
Dingovski, Dragan	Flat 10, 117 Kerr St, Fitzroy		Flat 10, 117 Kerr St, Fitzroy	Inquiry Agent	21.11.79
Dated at Fitzroy 24 October 1979 L. P. BYRNE, Clerk of the Magistrates' Court					
MAGISTRATES' COURT, MELBOURNE					
De Mooy, Jacobus Marinus Maria	8 Anita Crt, East Doncaster	Armaguard	94 York St, South Melbourne	Watchman	3.12.79
Goff, Gary Raymond	23 Stuart St, Bayswater	Transurety Limited	Cnr. Arden and Lothian Sts, North Melbourne	"	9.1.80
Dated at Melbourne 23 October 1979 L. W. HUSSEY, Clerk of the Magistrates, Court					

\* Or in the case of a firm or corporation, of the Nominee

## DEPARTMENT OF MINERALS AND ENERGY

Subject to any necessary excisions, etc., it is proposed to grant the following Mining Leases:—

No. 588; John Stephen Curthoys; 10.1 ha, Parish of Koroganeit.

No. 600; Robert William Coburn; 69 ha, Parish of Piangil West.

## MINING LEASES EXPIRED

2831 Ararat; David Feiglin; 195.2 ha, Parish of BurrumbEEP.

9227 Ballarat; Sarah Sapwell; 22.2 ha, Parish of Korweinguboora.

## APPLICATIONS FOR EXPLORATION LICENCES REFUSED

No. 741; William John Watson McAuley; 792 km<sup>2</sup>, County of Delatite.

No. 742; William John Watson McAuley; 132 km<sup>2</sup>, County of Delatite.

No. 751; William John Watson McAuley; 264 km<sup>2</sup>, County of Delatite.

## TAILINGS LICENCES GRANTED

No. 4389; Kelvin Alcock; to remove tailings from the "Moon and Catherine Sand Dumps" situated at Eaglehawk.

No. 4395; Cyril Mannix; to remove tailings from the "Moon and Catherine Sand Dumps" situated at Eaglehawk.

No. 4396; Allan Chan; to remove tailings from the "New Moon Mine Sand Dump" situated in the Parish of Nerring.

No. 4397; Allan Chan; to remove tailings from the "Catherine Sand Dump" situated at Eaglehawk.

No. 4398; Frederick Allen; to remove tailings from the "Moon and Catherine Sand Dumps" situated at Eaglehawk.

No. 4399; John W. Henderson Builders Pty. Limited; to remove tailings from the "Moon and Catherine Sand Dumps" situated at Eaglehawk.

## TAILINGS LICENCES EXPIRED

No. 4200; Albert Charles Bonser; to remove tailing situated north of Crown Allotment 11A and south-east of Crown Allotment 11B, Section 2 situated in the Parish of Drummond.

No. 4212; The Borough of Eaglehawk; to remove tailings from the "Golden Pike Mine Dump" situated at Eaglehawk.

No. 4266; Brian Burton; to remove tailings from the "Leggo's Mine Dump" situated at Bendigo.

## EXTRACTIVE INDUSTRY LEASE TRANSFERRED

No. 229; From Barro Group Pty. Limited to Boral Resources (Vic.) Pty. Ltd.

## EXTRACTIVE INDUSTRY LICENCE TRANSFERRED

No. 830; From Rupert John Aldous to Ronald John Wickham.

J. C. M. BALFOUR  
Minister for Minerals and Energy

**CONTRACTS ACCEPTED—(Series 1979-80).  
AMENDMENTS**

Schedule Number	Item Number	New Rate	Effective Date
\$			
<i>Fire Protection Equipment, etc.</i>			
1/06	14	49.52	10.10.79
"	15	58.43	"
"	16	41.85	"
"	17	111.14	"
<i>Glass</i>			
1/07	1	3.82*	1.10.79
	2	5.16*	
	3	7.58*	
	4	15.17*	
	5-7	10.30*	
	8-10	14.92*	
	20	6.08*	
	21	8.11*	
	22	11.72*	
	23	11.86*	

\* Less 1%, 30 days.

*Painters' Brushware, etc.*

1/12	22-24, 26, 29	*	1.10.79
------	------------------	---	---------

\* Change of agents:—W. C. Seamons, 1 Lemon Grove, Nunawading, 3131. Telephone 874 6551.

*Crockery, Cutlery and Kitchenware*

1/29	59	0.965	10.10.79
	60	0.984	
	64	0.92	
	65	1.5336	
	66	0.806	

*Motor Spirit, etc.*

1/53	Outlets	*	18.10.79
------	---------	---	----------

\* Werrimull—Delete. No substitute.

Yarram—Delete. Substitute—B.P. Yarram Service Station, Commercial Street.

*Hand Tools (General)*

1/56	1	2.23 (6-11 mm)	15.10.79
		2.29 (13 mm)	
		2.61 (14-16 mm)	
		2.92 (18-19 mm)	
		3.47 (21-22 mm)	
		3.71 (25 mm)	
		3.94 (28 mm)	
		4.43 (32 mm)	
	12	2.68 (6-11 mm)	
		3.00 (13 mm)	
		3.09 (14-16 mm)	
		3.43 (19 mm)	
		3.78 (22 mm)	
		4.14 (25 mm)	
	18	5.60	
	20	3.85	
	21	17.44 (12 in.)	
		20.61 (14 in.)	
	24	11.68	
	36	5.88 (38 mm)	
		7.78 (50 mm)	
	37	5.88 (38 mm)	
		7.59 (44 mm)	
		7.78 (50 mm)	
	38	5.88 (38 mm)	
		7.78 (50 mm)	
	50	7.72 (No. 918)	9.10.79
		13.75 (No. 936)	
	69	*	4.10.79
	109, 111	2.77	15.10.79
	113	2.96	
	116, 117	1.58	
	148	16.77	
	149	20.17	

**AMENDMENTS—continued**

Schedule Number	Item Number	New Rate	Effective Date
\$			
<i>Hand Tools (General)—continued</i>			
1/56	150	20.17	15.10.79
	151	26.91	
	152	31.65	
	153	25.32	
	154	18.90	
	201	4.53	
	212	List HT1079R†	
	232, 233	6.64	
	244	4.74	
	245	5.38	
	246	1.26	
	276	1.49	9.10.79
	299	10.10‡	18.10.79
	388-390	16.02	3.10.79
	391	17.94	
	437	*	11.10.79
	462-466	\$	25.9.79
	470	*	11.10.79

\* Apply Tender Board.

† Less 41%.

‡ Substitute "Trojan 116-033". Supplier—A. J. Calder.

\$ Minimum Order 5 kg per size.

*Provisions*

2/01	164	11.60	3.10.79
2/21 (4)	9	25.23 (Corn Flakes)	1.10.79
	36	7.86	
	110	7.24	
	111	7.24	
	123	4.86	
	137	24.78	
	138	3.28	
	142	22.68	
2/23 (2)	6	3.28	1.10.79
	9	25.23*	

\* per case (32 packets)

J. M. PAWSON, Secretary to the Tender Board

**CONTRACTS ACCEPTED—(Series 1979-80)**

**VICTORIAN RAILWAYS**

16. The manufacture, supply, delivery and erection of two (2) number electric overhead travelling cranes at number 6 road, Newport Workshops for the amount of \$89 800.00 (Contract 64667)—Arundale Holdings Pty. Ltd. 17. The erection and completion of the North Melbourne Relay Room at the North Melbourne Railway Station for the amount of \$37 647.00 (Contract 64677)—Fiedler Builders Pty. Ltd. 18. The supply of plant mixed concrete to Melbourne Underground Rail Loop construction sites at East Melbourne and North Melbourne as required during the period from 1 September 1979 to 1 September 1980 at rates (Contract 64708)—Pioneer Concrete (Vic.) Pty. Ltd. 19. The manufacture, supply and delivery of precast, prestressed concrete deck units for the road bridge at Elgin Street, Hawthorn at rates, Contract 64710)—McDougall-Ireland Pty. Ltd. 20. The manufacture, supply and delivery of precast, reinforced concrete units for box culvert railway bridges at rates (Contract 64720)—Antonello Pre-Stressed Concrete Pty. Ltd. 21. The construction of reinforced concrete pier for the extension of the existing railway bridge over the Nepean Highway at Gardenvale for the amount of \$41 420.00 (Contract 64734)—Nicholls Engineers and Constructors Pty. Ltd.

By order of the Victorian Railways Board  
I. J. REIHER, Secretary. 29.10.79

**ORDERS IN COUNCIL—(Series 1979-80)**  
**PUBLIC WORKS**

His Excellency the Governor of the State of Victoria by and with the advice of the Executive Council thereof has by Order made on 23 October 1979 approved of the acceptance by the Minister of Public Works of the under-mentioned offers without public tenders being invited, viz.:-

Offer of the State Electricity Commission of Victoria for supply of electricity to Marine Science Laboratories and Wharf, Queenscliff, for the sum of thirteen thousand seven hundred dollars (\$13 700.00)—(W.224563K).

Offer of Ralph Mackie & Staff Pty. Ltd. for work carried out to restore fire damaged Dandenong South Primary School for the sum of fifteen thousand six hundred and six dollars (\$15 606.00)—(E.19952).

Offers at the amounts shown for necessary works as a result of fire damage to Doncaster Primary School No. 197—(N.205512C).

	\$
Tulmel Plumbing & Drainage Pty. Ltd. (Connect Portables to Hydraulic Services)	16 508.52
Ernies Concrete Work (Site works)	16 959.00

Offer of the Gas & Fuel Corporation of Victoria for the conversion of gas heating, Narmara Primary School No. 4953, for the sum of ten thousand six hundred and ninety-one dollars (\$10 691.00)—(N.205650).

Offer of McInerney & Donaldson Pty. Ltd. for supply and installation of P.M.G. cables, &c., for fire alarm system, Bendigo Psychiatric Centre for the sum of eleven thousand seven hundred and ninety-two dollars eighty cents (\$11 792.80)—(N.50310).

Offer of Philips Electronic Systems for supply and installation of closed circuit television and lighting, Frankston Police Station, for the sum of ten thousand two hundred and ninety-five dollars (\$10 295.00)—(E.17367).

Offer of Harrison's & Crosfield (Aust.) Ltd. for supply of fire hose, Storeyard, Port Melbourne, for the sum of ten thousand three hundred and twenty dollars (\$10 320.00)—(S.123235).

Offer of Camatic Pty. Ltd. for supply and installation of Theatre Seats, Banyule High School, for the sum of eighteen thousand three hundred and fifty-four dollars (\$18 354.00)—(C.24765w).

K. GILKINSON  
Acting Clerk of the Executive Council

At the Executive Council Chamber  
Melbourne, 23 October 1979

**Police Offences Act 1958, No. 6337**  
**DIVISION 1A—STATE CLASSIFICATION OF PUBLICATIONS BOARD**

Take note that the State Classification of Publications Board has classified the following publications in accordance with the provisions of section 180H (1) of the Police Offences Act 1958.

Each publication shall be subject to the following restrictions:

- (a) It shall not be offered for sale, sold, delivered, exhibited or displayed to any person under the age of 18 years;
- (b) It shall not be made available for inspection or perusal to any person under the age of 18 years;

- (c) it shall not be exhibited or displayed in any place to which persons under the age of 18 years have access or so that it is visible from any such place;
- (d) it shall not be advertised in any manner whatsoever.

**SCHEDULE OF PUBLICATIONS**

Title	Distributor
Act Of Love—Playing Cards	Venus Enterprises Pty. Ltd.
After Hours No. 1	Lovecraft
Britain's Kittens Vol. 1 No. 1	Lovecraft
Color Sperma No. 8	Lovecraft
Country Girl No. 1	Lovecraft
Dirty Old Man, The	Lovecraft
Easyriders—December 1979	Gordon & Gotch (A'sia) Ltd.
Ecstasy—No. 3	Wathen Wholesale Pty. Ltd.
Ecstasy No. 4	Wathen Wholesale Pty. Ltd.
Erotica Nos. 1 & 2	Lovecraft
Exciting Cinema No. 16	Wathen Wholesale Pty. Ltd.
Flesh Nr. 7	Lovecraft
4orty Plus Vol. 5 No. 3	Lovecraft
Giant Sex Laff Cartoons No. 1	Lovecraft
Him Monthly No. 21	Wathen Wholesale Pty. Ltd.
Hot, Wet And Willing	Wathen Wholesale Pty. Ltd.
If—Vol. 1 Nos. 7 & 9	Wathen Wholesale Pty. Ltd.
Kingsize International Vol. 2 Nos. 4 & 9	Wathen Wholesale Pty. Ltd.
Kinque No. 3	W. J. Horne
Late Night Extra Vol. 5 No. 10	Gordon & Gotch (A'sia) Ltd.
London Life Magazine Vol. 1 Nos. 1, 4 & 5	Wathen Wholesale Pty. Ltd.
Lovebirds No. 24	Wathen Wholesale Pty. Ltd.
Love-In No. 1	Wathen Wholesale Pty. Ltd.
Peaches No. 50	Gordon & Gotch (A'sia) Ltd.
Peaches Special No. 13	Wathen Wholesale Pty. Ltd.
Peaches—Special Nos. 14 & 19	Lovecraft
Playbirds, The—Erotic Film Guide No. 2	Wathen Wholesale Pty. Ltd.
Road Runner No. 1	Lovecraft
Schoolgirl Sex Teasers	Lovecraft
Sex-Ace Cartoons	Gordon & Gotch (A'sia) Ltd.
Sexaction	Lovecraft
Sex-Elent Cartoons No. 2	Lovecraft
Sexfun Cartoons No. 1	Lovecraft
Sex Humor Cartoons No. 1	Lovecraft
Sexorama No. 6	Lovecraft
Sexpert Cartoons And Jokes	Lovecraft
Sexploit	Lovecraft
Sexplosion Cartoons No. 1	Lovecraft
Sexpose' Cartoons No. 1	Lovecraft
Sexsation Cartoons Nos. 1 & 2	Lovecraft
Sexstatic No. 1	Lovecraft
Sextasy	Lovecraft
Sextasy No. 2	Lovecraft
Sex Time Cartoons	Lovecraft
Sex To Sixty No. 46	Gordon & Gotch (A'sia) Ltd.
Sextoons No. 1	Lovecraft
Sextra Cartoons No. 1	Lovecraft
Super—Sex Cartoons Nos. 1 & 2	Lovecraft
Third, Sex, The	Lovecraft
Virgins Are Best	Lovecraft

J. SMITH, Secretary  
State Classification of Publications Board

COUNTRY ROADS BOARD

RESOLUTIONS OF THE COUNTRY ROADS BOARD

The Country Roads Board, in pursuance of the provisions of the *Country Roads Act 1958*, has passed Resolutions the dates whereof and the terms of which are scheduled hereunder:

SCHEDULE

State Highway

Resolution dated the First day of October, One thousand nine hundred and seventy-nine, made pursuant to sections 21, 58 and 74 of the *Country Roads Act 1958* declaring the deviation from the Sunraysia Highway in the Shires of Avoca and Lexton as indicated by diagonal hatching on plans numbered G.P.14745, G.P.14746, G.P.14747A and G.P.14747B hereunder to be part of a State highway within the meaning and for the purposes of the said Act; and also declaring that such deviation shall be in lieu of the existing road or part, thereof indicated by cross hatching on plan numbered G.P.14747B and horizontal hatching on plans numbered G.P.14745 and G.P.14746 which part indicated by cross hatching on plan numbered G.P.14747B shall be discontinued.

STATE HIGHWAY  
SUNRAYSIA HIGHWAY  
SHIRES OF AVOCA & LEXTON.  
Lengths in metres

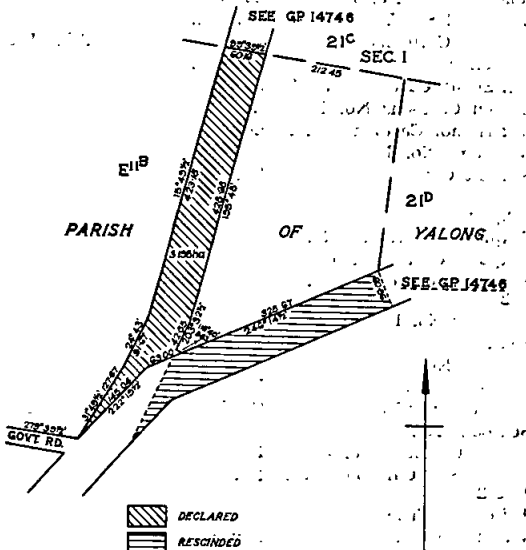

GP 14745  
Compiled from SP14745

STATE HIGHWAY  
SUNRAYSIA HIGHWAY  
SHIRES OF AVOCA  
& LEXTON  
Lengths in metres

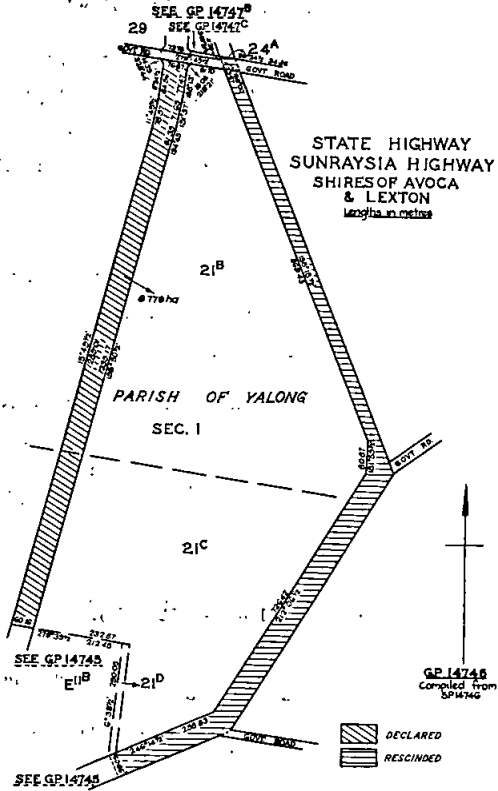

GP 14746  
Compiled from SP14746

STATE HIGHWAY  
SUNRAYSIA HIGHWAY  
SHIRE OF AVOCA  
Lengths in metres

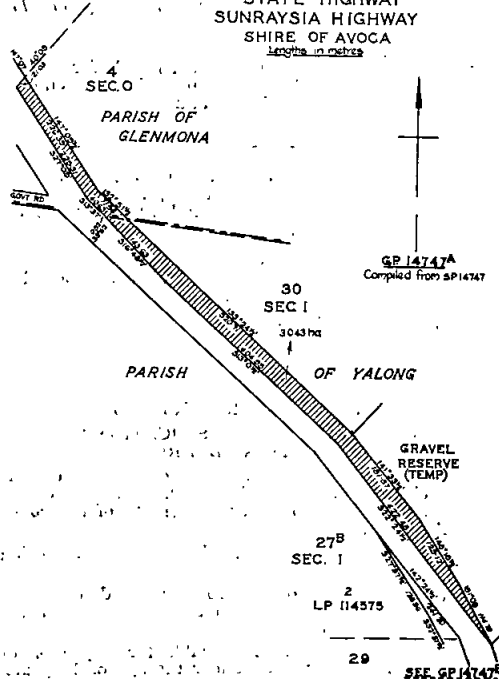

GP 14747A  
Compiled from SP14747

GP 14747B  
Compiled from SP14747B

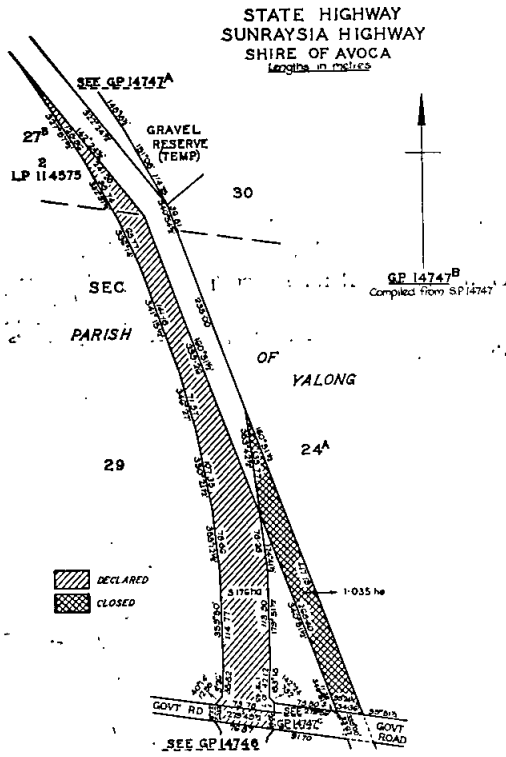

MAIN ROAD  
SUNBURY ROAD  
SHIRE OF BULLA  
Lengths in metres

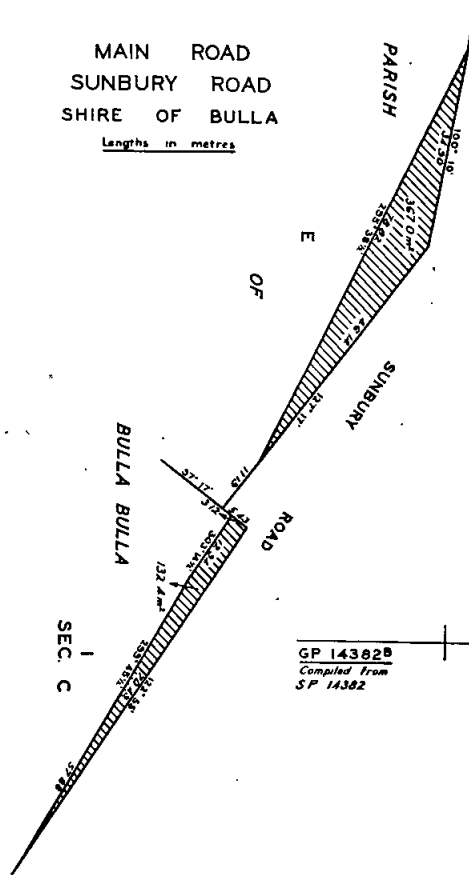

Main Roads

Resolution dated the First day of October, One thousand nine hundred and seventy-nine, made pursuant to section 21 of the Country Roads Act 1958, declaring the widening of Sunbury Road in the Shire of Bulla as shown hatched on plans numbered G.P.14382A and G.P.14382B hereunder to be part of a main road within the meaning and for the purposes of the said Act.

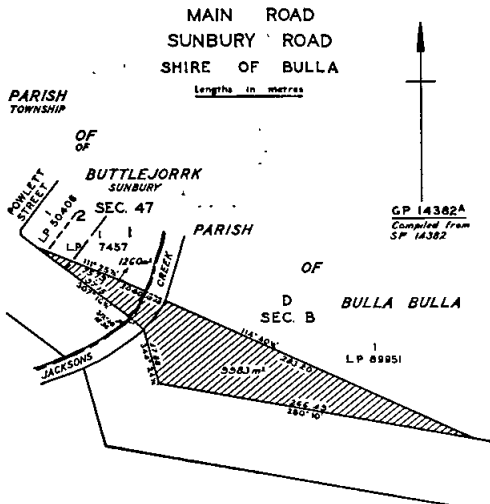

Resolution dated the Eighth day of October, One thousand nine hundred and seventy-nine, made pursuant to section 21 of the *Country Roads Act 1958*, declaring the widening of the Baxter-Tooradin Road in the Shire of Cranbourne as shown hatched on plan numbered G.P.14821 hereunder to be part of a main road within the meaning and for the purposes of the said Act.

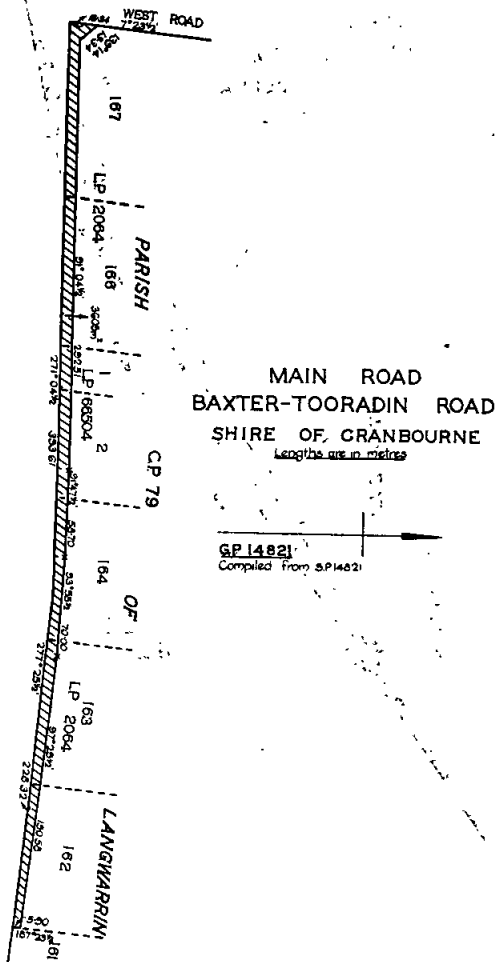

Resolution dated the Eighth day of October One thousand nine hundred and seventy-nine, made pursuant to section 21 of the *Country Roads Act 1958*, declaring the widening of the Mirboo North-Thorpdale Road in the Shire of Mirboo as shown hatched on plans numbered G.P.14845b, G.P.14845e and G.P.14845f hereunder to be part of a main road within the meaning and for the purposes of the said Act.

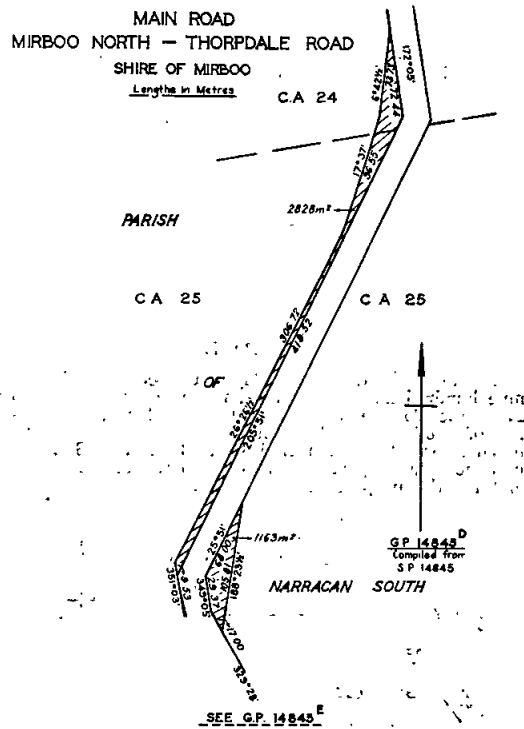



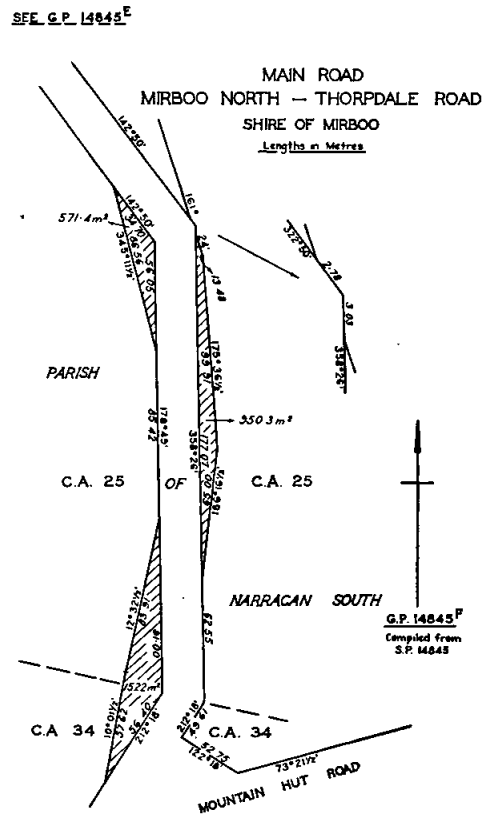
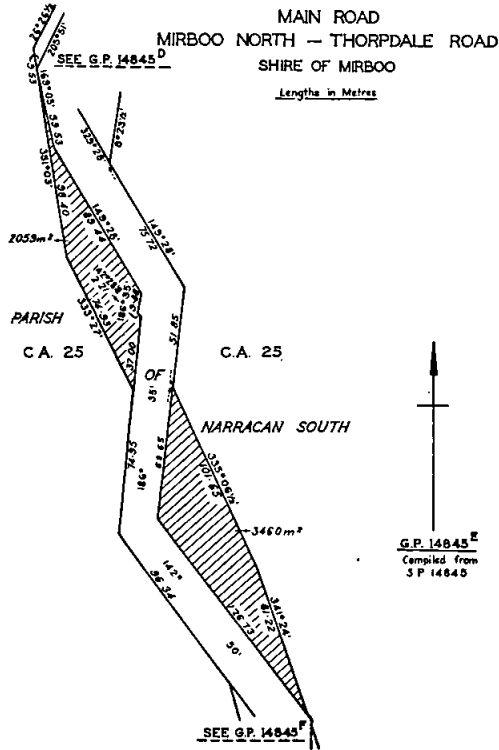

Resolution dated the First day of October, One thousand nine hundred and seventy-nine, made pursuant to sections 21 and 58 of the *Country Roads Act 1958*, declaring the deviation from the Leongatha—Mirboo Road in the Shire of Mirboo as indicated by diagonal hatching on plans numbered G.P.14779A, G.P.14779B, G.P.14780A, G.P.14780B and G.P.14780C hereunder to be part of a main road within the meaning and for the purposes of the said Act, and also declaring that such deviation shall be in lieu of the existing road or part thereof indicated by cross hatching on plans numbered G.P.14779B, G.P.14780B and G.P.14780C and that such part of the said existing road shall be discontinued.

MAIN ROAD  
LEONGATHA—MIRBOO ROAD  
SHIRE OF MIRBOO  
*Lengths are in metres*

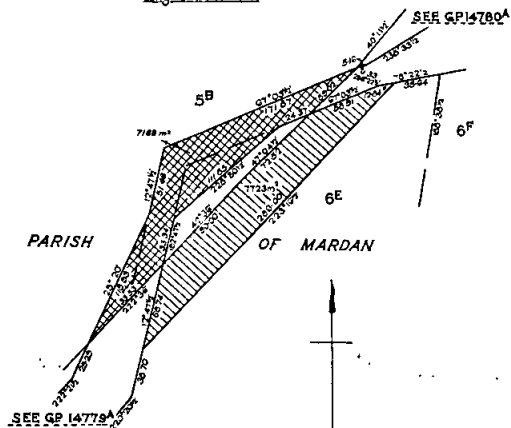

MAIN ROAD  
LEONGATHA—MIRBOO ROAD  
SHIRE OF MIRBOO  
*Lengths are in metres*

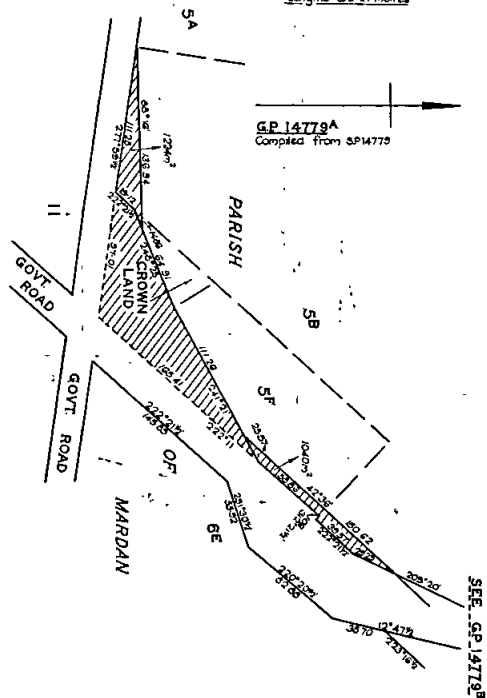

MAIN ROAD  
LEONGATHA—MIRBOO ROAD  
SHIRE OF MIRBOO  
*Lengths are in metres*

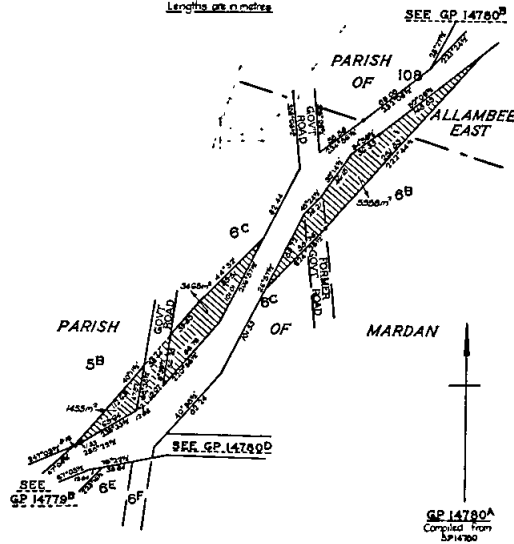

E. S. V. ...

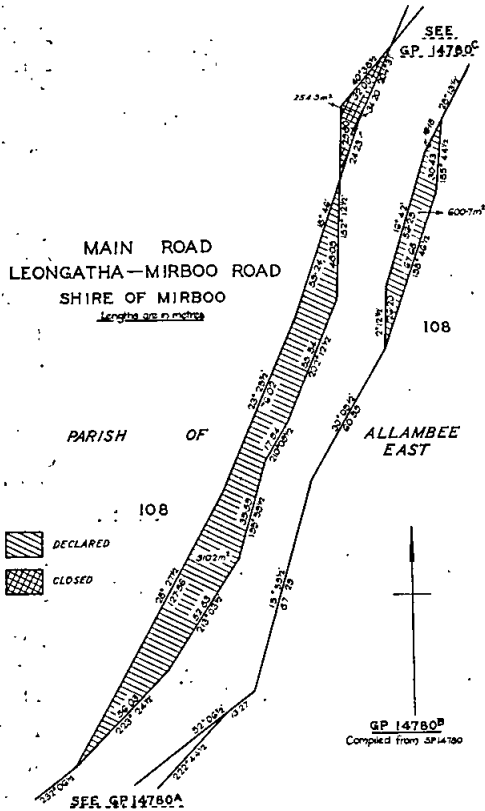

**Unclassified Roads**  
 Resolution dated the First day of October, One thousand nine hundred and seventy-nine, made pursuant to sections 21 and 110 of the Country Roads Act 1958, declaring the widening of a road in the Shire of Avoca as shown hatched on plan numbered G.P.14747c hereunder to be part of a road within the meaning and for the purposes of the said Act.

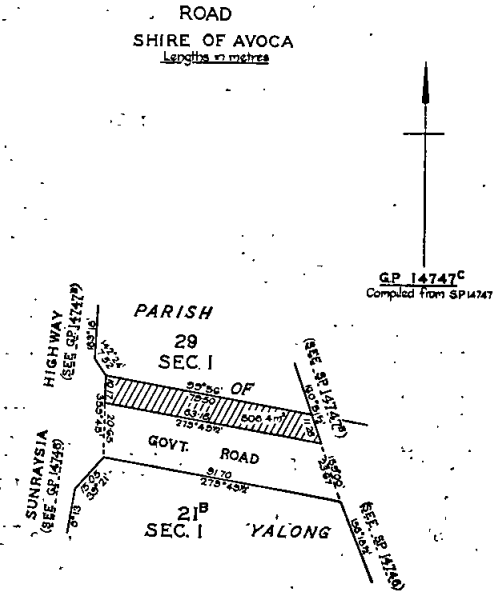

MAIN ROAD  
 LEONGATHA—MIRBOO ROAD  
 SHIRE OF MIRBOO  
 Lengths are in metres

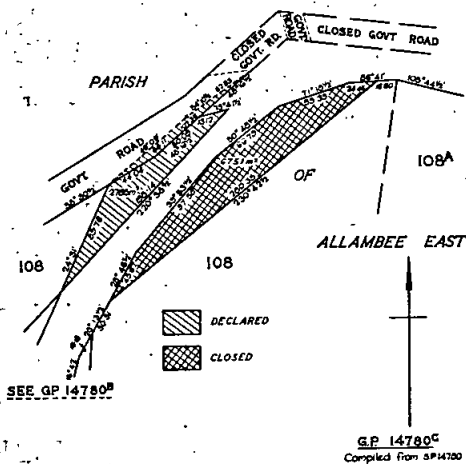

Resolution dated the First day of October, One thousand nine hundred and seventy-nine, made pursuant to sections 21 and 110 of the Country Roads Act 1958 declaring the road in the Shire of Mirboo, as shown hatched on plan numbered G.P.14780b hereunder to be a road within the meaning and for the purposes of the said Act.

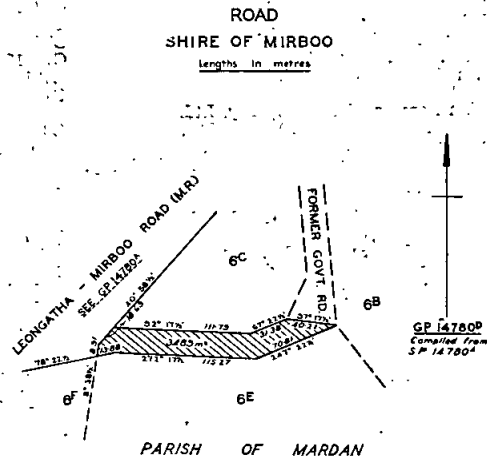

22 October 1979

G. K. COX, Secretary

## COMPANIES ACT 1961

Notice is hereby given in pursuance of section 308 (2) and 308 (3) of the Companies Act 1961 that at the expiration of three months from the date hereof the names of the following Companies will, unless cause is shown to the contrary, be struck off the Register and the said Companies will be dissolved.

Dated 17 October 1979

E. B. MITCHAM  
Acting Commissioner for Corporate Affairs

Corporate Affairs Office  
Melbourne

## COMPANIES ABOVE REFERRED TO

Name of Company	Number of Registration
Victorian Casing Company Pty. Ltd.	C12455N
Quickfills Pty. Ltd.	C22764T
Custom Builders Pty. Ltd.	C29718N
Lowan Meat Supply Pty. Ltd.	C34242G
Lawrence Roberts & Co. Pty. Ltd.	C35548U
Chesham Securities Pty. Ltd.	C41211J
Laine Export Company Pty. Ltd.	C44004Z
W. A. Edgar Pty. Ltd.	C47274F
Winronia Pty. Ltd.	C47928L
Glenmore Investments Ltd.	C48867Z
Intranex Pty. Ltd.	C53452M
Dandy Brakes Pty. Ltd.	C55264Z
Lancaster Ammunition and Explosive Company Pty. Ltd.	C55515B
Birmingham's Food Centres Pty. Ltd.	C56286T
L. F. Raines and Metal Products Pty. Ltd.	C57130R
David Jennings Sand & Screenings Supply Pty. Ltd.	C58111U
Spruzen Pty. Ltd.	C59596K
Grayjan Investments Pty. Ltd.	C61162W
Tucker Shipping Pty. Ltd.	C61343C
Vickery Holdings Pty.	C62668U
Axum Investments Pty. Ltd.	C62957E
Bunyip Investments Pty. Ltd.	C62998V
Klari Meat Export (Aust.) Pty. Ltd.	C63105Y
Eliforp Pty. Ltd.	C63411J
Blunt Machinery Pty. Ltd.	C64214M
K. J. Waters Pty. Ltd.	C64790G
Pomeranz Sales (Vic.) Pty. Ltd.	C66488V
Westwood, Williams & Associates Pty. Ltd.	C66811D
South Coast Yacht Brokers Pty. Ltd.	C67130C
Lansell Laboratories (Vic.) Pty. Ltd.	C67297T
The Waldegrave Family Pty. Ltd.	C67882L
Victoria & Albert (Berties) Pty. Ltd.	C67883N
Prince Albert George Sebastian II. Pty. Ltd.	C67884R
A.E.S.S. (Manufacturing) Pty. Ltd.	C69500E
M. Feldhagen & Associates Pty. Ltd.	C69965G
Kingsley Investments Pty. Ltd.	C73665G
P.J.C. Tip Truck Pool Pty. Ltd.	C75273Z
Holiday Travel Insurance Pty. Ltd.	C75980J
Y. & S. Yarns Pty. Ltd.	C76117R
Kevin Gannan Pty. Ltd.	C78108E
Legsol Nominees Pty. Ltd.	C79851B
Adrian Lamers (Holdings) Pty. Ltd.	C80885N
Southern Billiards (Vic.) Pty. Ltd.	C81086E
Southern Billiards (S.A.) Pty. Ltd.	C81087G
Ararat Vibrated Products (Manufacturing) Pty. Ltd.	C81511Y
Arll Pty. Ltd.	C81589N
Bay Star M.B. Automobiles Pty. Ltd.	C82360J
Nodek Holdings Pty. Ltd.	C82710P
Prospect Meat Supply Pty. Ltd.	C83365C
A. Fabiani & Co. Pty. Ltd.	C84582W
Talus Pty. Ltd.	C85011B
Stylemaker Curtains Pty. Ltd.	C85443M
Hellenic Plastics Pty. Ltd.	C85770G
Espinouse Pty. Ltd.	C86019B
Global Petroleums Pty. Ltd.	C87012U
Milltrav Pty. Ltd.	C87288R
Clarold Investments Pty. Ltd.	C88217Y
Seventh Steph Pty. Ltd.	C88573A
Park Street (Investments) Pty. Ltd.	C89146H
J. Ormond & Associates Pty. Ltd.	C89405J
Mid-Western Auctions Pty. Ltd.	C90280G
L. & A. Delle-Vergin Pty. Ltd.	C90605N
Barnby Pty. Ltd.	C97017B
Tenos Pty. Ltd.	C90930D
Southern Billiards (N.S.W.) Pty. Ltd.	C91429A
Len-Del Manufacturing Pty. Ltd.	C91590J
Exclusive Ornamental Arches Pty. Ltd.	C92138T
Ian Clements Pty. Ltd.	C92803K
Southern Industrial Enterprises Pty. Ltd.	C92931W
Ian Clements Nominees Pty. Ltd.	C93139C
W.K. Plumbing Services Pty. Ltd.	C93877Z
Southern Billiards (W.A.) Pty. Ltd.	C94517W
Oakhaven Homes Pty. Ltd.	C95344W
S.B. Southern Star Traders Pty. Ltd.	C95836Z
Eldon Holdings Pty. Ltd.	C95892K
Dennis Edmonds Pty. Ltd.	C96492W
Flikkas Pty. Ltd.	C96694L
Denkriswil Pty. Ltd.	C96939U
Ruset Pty. Ltd.	C97734E
Etzel Nominees Pty. Ltd.	C98031T
Kitchen City Pty. Ltd.	C98403J
Glen Eadie Pty. Ltd.	C99007D
Coomoora Management Pty. Ltd.	C99278P
Chalambar Investments Pty. Ltd.	C99283G
J. A. Mitchell Ltd.	C99810K
Pejay S. Nominees Pty. Ltd.	C99889C
Louco Nominees Pty. Ltd.	C100593P
Bolwarrah Pastoral Co. Pty. Ltd.	C101472H
Abina Nominees Pty. Ltd.	C101792F
Cargo Loss Prevention Pty. Ltd.	C102046T
Radio Controlled Parcel Messengers Pty. Ltd.	C102245B
International Fasteners Pty. Ltd.	C102560N
A. Asi Pty. Ltd.	C103013J
Delne Investments Pty. Ltd.	C103387G
Independent Business Management Pty. Ltd.	C103685U
Conical Traders Pty. Ltd.	C105261X
Morobe Pty. Ltd.	C105415A
Pamric Pty. Ltd.	C105450C
Insul-Rite Pty. Ltd.	C105777R
J.K. Vending (Australia) Pty. Ltd.	C106041M
Magnum Investments Pty. Ltd.	C106896H
Berverna Pastoral Co. Pty. Ltd.	C108210B
Mervro Nominees Pty. Ltd.	C108273C
Petrolan Nominees Pty. Ltd.	C109050L
Donanglin Pty. Ltd.	C109406E
Yap Nominees Pty. Ltd.	C109537X
Gemprint Pty. Ltd.	C109796A
Dial Consolidated Holdings Pty. Ltd.	C109977G
Tandor Pty. Ltd.	C110385S
Datascan Corporation—Lifeguard Systems— Pty. Ltd.	C114179S
Beachway Home Improvements Proprietary Limited	C114263F
Jay Chemical Company (Aust.) Pty. Ltd.	C137692G
Reflex Transport Marketing Services Pty. Ltd.	C141981J

## Co-operative Housing Societies Act 1958

## NOTICE OF AMALGAMATION OF SOCIETIES

Notice is hereby given that, pursuant to the provisions of The Co-operative Housing Societies Act 1958, Moorabbin Co-operative Housing Society Limited, Moorabbin No. 2 Co-operative Housing Society Limited, Moorabbin No. 3 Co-operative Housing Society Limited, Moorabbin No. 4 Co-operative Housing Society Limited and Moorabbin No. 5 Co-operative Housing Society Limited were amalgamated into one society under the name of Moorabbin No. 6 Co-operative Housing Society Limited on 24 October 1979.

Dated at Melbourne 24 October 1979

E. P. LIDDELL  
Deputy Registrar

## Co-operative Housing Societies Act 1958

## NOTICE OF AMALGAMATION OF SOCIETIES

Notice is hereby given that, pursuant to the provisions of The Co-operative Housing Societies Act 1958, Southland Co-operative Housing Society Limited, Southland No. 2 Co-operative Housing Society Limited, Southland No. 3 Co-operative Housing Society Limited, Southland No. 4 Co-operative Housing Society Limited and Southland No. 5 Co-operative Housing Society Limited were amalgamated into one society under the name of Southland No. 8 Co-operative Housing Society Limited on 24 October 1979.

Dated at Melbourne 24 October 1979

E. P. LIDDELL  
Deputy Registrar

## PUBLIC TRUSTEE ACT 1958, SECTION 17

I hereby give notice that on 17 October 1979, the Public Trustee filed Elections to Administer the following deceased persons' estates in accordance with section 17 of the Public Trustee Act 1958.

CHIPMAN, RAYMOND BROOK, formerly of Flat 3, 14 Marine Parade, St. Kilda, but late of 8 Haverlock Street, St. Kilda, retired clerk, died 25 July 1979.

HELMING, EDWARD DENNIS, late of Lot 21 Mickleham Road, Greenvale, pensioner, died 29 July 1977.

HORBACIO, MICHAEL, in the Will called Horbacio Mychajlo, formerly of 47 Chapman Avenue, Glenroy, but late of Greenvale Geriatric Centre, Providence Road, Greenvale, pensioner, died 4 June 1978.

LANG, EMIL SACHEL, late of 240 Reynard Street, West Coburg, oil blender, died 14 October 1955.

WALLIS, AGNES CAROLINE, formerly of 6 Percy Street, Mitcham, Kingston Centre, Warrigal Road, Cheltenham, widow, died 4 August 1979.

WHITE, ROBERT ARNOLD, late of 46 Davis Street, Carlton, production manager, died 20 May 1979.

P. T. SPENCER  
Public Trustee

168 Exhibition Street, Melbourne, 3000  
24 October 1979

Creditors, next of kin, and others having claims against the estate of any of the under-mentioned deceased persons are required to send particulars of their claims to the Public Trustee, 168 Exhibition Street, Melbourne, Vic. 3000, the personal representative, on or before 10 January 1980, after which date the Public Trustee may convey or distribute the assets having regard only to the claims of which the Public Trustee then has notice:—

BANNAN, ANNIE, late of Castlemaine, widow, died 29 November 1978.

BOOTH, ETHEL, formerly of 37 Kensington Road, Savile Park, Halifax, late of 7 Eastwood Court, Albert Promenade, Halifax, West Yorkshire, England, married woman, died 7 July 1978.

CATER, LESLIE JACK, late of 12 Biarritz Avenue, Beaumaris, marketing manager, died 20 July 1979.

CHIPMAN, RAYMOND BROOK, formerly of Flat 3, 14 Marine Parade, St. Kilda, but late of 8 Haverlock Street, St. Kilda, retired clerk, died 25 July 1979.

FLANAGAN, WILLIAM, late of Spencer Hotel, 44-54 Spencer Street, Melbourne, retired teacher, died 26 March 1979.

FLEMING, DORA MARGARET, late of 12 Madden Street, Albert Park, widow, died 25 November 1953.

GONSALVES, ANNIE, late of 95 Church Street, Hawthorn, spinster, died 3 August 1977.

HELMING, EDWARD DENNIS, late of Lot 21 Mickleham Road, Greenvale, pensioner, died 29 July 1977.

HORBACIO, MICHAEL, in the Will called Horbacio Mychajlo, formerly of 47 Chapman Avenue, Glenroy, but late of Greenvale Geriatric Centre, Providence Road, Greenvale, pensioner, died 4 June 1978.

JAMES, ROGER ANTHONY, also known as Roger James, late of Mont Park, retired factory employee, died 27 June 1979.

LANG, EMIL SACHEL, late of 240 Reynard Street, West Coburg, oil blender, died 14 October 1955.

MCCULLAGH, MYRTLE, late of Flat 2, 133 Epsom Road, Ascot Vale, retired hotel employee, died 24 July 1979.

MCDONALD, WILLIAM HENRY, late of Kew Cottages, Princess Street, Kew, gentleman, died 5 August 1978.

ROWE, IDA DEBORAH, also known as Ida Debra Rowe, late of 43 Toolangi Road, Alphington, widow, died 27 July 1979.

STENHOUSE, KENNETH RUSSELL, late of 47 Wingrove Street, Cheltenham, retired policeman, died 16 July 1979.

SULLIVAN, RUBY ELLEN, formerly of 46 Begonia Road, Gardenvale, late of Unit 1, 646-648 Centre Road, East Bentleigh, widow, died 28 August 1979.

TIERNEY, JAMES JOSEPH PAUL, formerly of 333 Dandenong Road, Armadale, but late of St. Ronan's Private Nursing Home, 51 Adelaide Street, Armadale, retired Parliament officer, died 10 July 1979.

WALKER, IRENE ELLEN, late of 92 Cross Street, West Footscray, widow, died 15 August 1979.

WALLIS, AGNES CAROLINE, formerly of 6 Percy Street, Mitcham, but late of Kingston Centre, Warrigal Road, Cheltenham, widow, died 4 August 1979.

WHITE, ROBERT ARNOLD, late of 46 Davis Street, Carlton, production manager, died 20 May 1979.

WINTER, CONSTANCE MARY, late of 15 Balmoral Avenue, Pascoe Vale South, widow, died 29 July 1979.

Melbourne, 24 October 1979

P. T. SPENCER  
Public Trustee

## AUCTION SALES ACT 1958

BENALLA—Notice is hereby given that the Annual Meeting of Justices for the Licensing of Auctioneers will be held at the Magistrates' Court at Benalla on Tuesday, 27 November 1979, at 10 o'clock in the forenoon. Dated at Benalla, 19 October 1979—G. K. EBERT, Clerk of the Magistrates' Court, Benalla.

## APPOINTMENTS AND RESIGNATIONS

### APPOINTMENTS

His Excellency the Governor of the State of Victoria, by and with the advice of the Executive Council thereof, has, by Orders made on 23 October 1979, been pleased to make the under-mentioned appointments, viz.:—

#### DEPARTMENT OF HEALTH

##### Psychiatrist Superintendents

ROSEMARY RUTH WEST, M.B., B.S., D.P.M., M.R.A.N.Z.C.P., to be Superintendent, Traralgon Mental Hospital and Psychiatric Hospital, pursuant to the provisions of section 26 (1) of the *Mental Health Act 1959* for the period 28 October 1979 to 9 November 1979, vice Dr A. Bell, on leave.

DAVID JOHN HARDING BARLOW, M.B., B.Ch., D.P.M., F.R.A.N.Z.C.P., to be Superintendent, Traralgon Mental Hospital and Psychiatric Hospital, pursuant to the provisions of section 26 (1) of the *Mental Health Act 1959* for the period 10 November 1979 to 25 November 1979, vice Dr A. Bell, on leave.

#### LAW DEPARTMENT

##### Justices of the Peace

GERALD BARRY ASHMAN, 114 Forest Road, Ferntree Gully, WILLIAM JOHN BEYER, "Tarwinlea", Mirboo North, RAMON JAMES DRUMMOND, 33-35 Sydney Street, Kilmore, WALTER NORMAN GERSCH, Clegg Road, Mount Evelyn, PAUL BENJAMIN HOLMES, 83-85 Anderson Street, Yarraville, WINIFRED MARY VEARS, 33 Molesworth Street, Prahran, and DAVID DOUGLAS WRIGHT, Condon Street, Kennington, to be Justices of the Peace for the State of Victoria.

##### Commissioners for Taking Declarations, &c.

NICOLA LINO ASCENZO, 12 Geoffrey Street, Thomastown, LAURENCE GEORGE ASHCROFT, Lilydale, RICHARD DAMIEN FINBAR BREEN, 1 Taylor Street, Moorabbin, HAROLD EDWARD BUCK, 43 Florey Crescent, Mulgrave, KEVIN FRANCIS CHAMBERLIN, 555 Queensberry Street, North Melbourne,

LAURENCE FRANCIS HARKIN, 3 Edinburgh Street, Hampton,  
 THOMAS REGINALD MAXWELL KERR, 260 Lonsdale Street,  
 Dandenong,  
 DEBORAH CAROL LEWIS, 5 Hall Street, Moonee Ponds,  
 THOMAS GERRARD LONERGAN, corner Springvale Road and  
 Princes Highway, Springvale,  
 DENNIS HALL MITCHELL, Hinkler Road, Glen Waverley,  
 YVONNE MARGARET ORR, 48A Watton Street, Werribee,  
 and  
 PIETER GERTRUDIS TABAK, 11 Harlington Street, Clayton,  
 to be Commissioners for taking Declarations and Affidavits  
 under the Evidence Act 1958.

K. GILKINSON  
 Acting Clerk of the Executive Council  
 At the Executive Council Chamber  
 Melbourne, 23 October 1979

**APPOINTMENT**

EDUCATION DEPARTMENT

*Member of the Technical Teachers Registration Board*

His Excellency the Governor of the State of Victoria  
 by and with the advice of the Executive Council thereof  
 has by Order made on 16 October 1979 been pleased to  
 make the under-mentioned appointment, viz.:—

WILLIAM JAMES MAXWELL  
 to be a member of the Technical Teachers Registration  
 Board during the period of absence of Douglas Van Reein  
 Alkemade, pursuant to the powers conferred by the Educa-  
 tion Act 1958:

K. GILKINSON  
 Acting Clerk of the Executive Council  
 At the Executive Council Chamber  
 Melbourne, 16 October 1979

Transport Regulation Act  
**TRANSPORT REGULATION BOARD**  
 NOTICE No. 125

*Appointment of Inspectors*

Take notice that, pursuant to the powers conferred on  
 the Board by the provisions of section 16 of the *Transport  
 Regulation Act 1958*; the Board hereby notifies in accord-  
 ance with Regulation 5 of Part I. of the *Transport Con-  
 solidated Regulations 1977*, the appointment as Inspectors  
 of—

JOHN BLAIR HILLGROVE and  
 DAVID MICHAEL DICKINSON  
 whilst such persons are on duty, in uniform within the  
 corporate limits of the City of Sandringham, during the  
 period of their appointment as traffic officers with the  
 said municipality.

By order of the Transport Regulation Board  
 C. J. V. SMITH, Secretary

*Liquor Control Act 1968*

**APPOINTMENT OF LICENSING INSPECTORS**

In accordance with the authority conferred upon me by Section 6  
 of the *Police Regulation Act 1958*, I, Aubrey William Conn,  
 Deputy Commissioner of Police, do hereby appoint under  
 sub-section (1) of Section 22 of the *Liquor Control Act 1968*, the  
 following Officers of Police as Licensing Inspectors for the Divisions  
 of the Police Districts as shown:

Division Number	Police District	Rank and Name
2	Melbourne	Inspector Ernest William Cartwright (from 23.9.79 to 10.11.79)
3	Prahran	Inspector Donald Henry Guilfoyle (from 28.10.79 to 24.11.79)
		A. W. CONN Deputy Commissioner
25.10.1979		

**REVOCAION OF APPOINTMENTS**

His Excellency the Governor of the State of Victoria  
 by and with the advice of the Executive Council thereof  
 has by Order made on 23 October 1979 revoked the appoint-  
 ments of the persons named hereunder to the offices men-  
 tioned, viz.:

LAW DEPARTMENT

*Justices of the Peace*

ALBERT ASHCROFT, and  
 FRANK COMER,  
 as Justices of the Peace for the State of Victoria,  
*Commissioner for Taking Declarations, &c.*

MICHAEL WILKINSON  
 as a Commissioner for taking Declarations and  
 Affidavits under the Evidence Act 1958.

K. GILKINSON  
 Acting Clerk of the Executive Council  
 At the Executive Council Chamber  
 Melbourne, 23 October 1979

**RESIGNATIONS**

His Excellency the Governor of the State of Victoria  
 by and with the advice of the Executive Council thereof  
 has by Order made on 23 October 1979, accepted the  
 resignations of the persons named hereunder of the offices  
 mentioned, viz.:

LAW DEPARTMENT

*Justice of the Peace*

ROBERT JOHN MURDEN  
 as a Justice of the Peace for the State of Victoria,  
*Commissioners for Taking Declarations, &c.*

RAYMOND BARRY HYND and  
 JOHN THOMAS RONAN,  
 as Commissioners for, taking Declarations and  
 Affidavits under the Evidence Act 1958.

K. GILKINSON  
 Acting Clerk of the Executive Council  
 At the Executive Council Chamber  
 Melbourne, 23 October 1979

**ORDERS IN COUNCIL**

**LOCAL GOVERNMENT ACT 1958**

At the Executive Council Chamber, Melbourne, the  
 twenty-third day of October, 1979

PRESENT:

His Excellency the Governor of Victoria  
 Mr Haddon Storey | Mr Granter  
 Mr Jona.

**ROAD DISCONTINUED—SHIRE OF WOORAYL**

Whereas it is provided in section 528 (2) of the *Local  
 Government Act 1958*, that where a road (whether or not  
 a public highway but not being a road set out on land of  
 the Crown) or any part thereof is not required for public  
 use the Governor in Council on the request of the Council  
 of the municipality in which such road is situated, made not  
 less than one month after publishing in a newspaper gener-  
 ally circulating in the district and posting to the registered  
 proprietor (if any) of the land and the owners and occu-  
 piers (if any) of lands abutting or immediately adjacent to  
 the road notice of intention to make such a request may  
 by Order published in the *Government Gazette* direct that  
 such road or part shall be discontinued and thereupon such  
 road or part shall be discontinued accordingly.

And whereas it is further provided that where a planning scheme under the Town and Country Planning Act 1961 provides for the closing of a road or part of a road and notice of approval of the planning scheme has been published in the Government Gazette, it shall not be necessary for the Council to publish or to post to any person notice of its intention to request the Governor in Council to discontinue such road or part thereof.

And whereas the Shire of Woorayl Planning Scheme 1961 provides that a road off Clerk Crescent, Inverloch is not required for public use and notice of approval of the planning scheme was published in the Government Gazette of 27 February 1974.

And whereas the Council of the Shire of Woorayl has requested that the Governor in Council direct that the said road be discontinued.

Now therefore, His Excellency the Governor of the State of Victoria, by and with the advice of the Executive Council thereof, hereby directs:

- (a) that the said road which is shown by hatching and cross-hatching on the plan hereunder, shall be discontinued;
- (b) that notwithstanding such discontinuance the Inverloch Sewerage Authority shall continue to have and possess the same right title power authority or interest in or in relation to the whole of the land shown by cross-hatching on the said plan as it had or possessed prior to such discontinuance with respect to or in connection with any drains or pipes laid or erected in on over such land for the purposes of drainage and sewerage; and
- (c) that subject to any such right title power authority or interest, the land in the said road may be sold by the Council of the Shire of Woorayl by agreement.

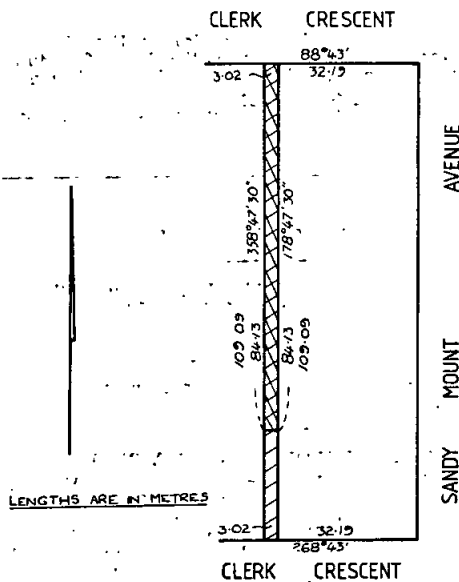

And the Honorable Digby Glen Crozier, Her Majesty's Minister for Local Government for the State of Victoria, shall give the necessary directions herein accordingly.

K. GILKINSON  
Acting Clerk of the Executive Council

LOCAL GOVERNMENT ACT 1958

At the Executive Council Chamber, Melbourne, the twenty-third day of October, 1979

PRESENT:

His Excellency the Governor of Victoria  
Mr Haddon Storey | Mr Granter  
Mr Jona

ROAD DISCONTINUED—CITY OF PRESTON

Whereas it is provided in section 528 (2) of the Local Government Act 1958, that where a road (whether or not a public highway but not being a road set out on land of the Crown) or any part thereof is not required for public use the Governor in Council on the request of the Council of the municipality in which such road is situated made not less than one month after publishing in a newspaper generally circulating in the district and posting to the registered proprietor (if any) of the land and the owners and occupiers (if any) of the lands abutting or immediately adjacent to the road notice of intention to make such a request may by Order published in the Government Gazette direct that such road or part shall be discontinued and thereupon such road or part shall be discontinued accordingly.

And whereas the Council of the City of Preston has requested that the Governor in Council direct that part of Bradshaw Street, Kingsbury be discontinued and not less than one month previously has published in a newspaper generally circulating in the district and posted to the registered proprietor of the land in the road and to the owners and occupiers of lands abutting or immediately adjacent to the road notice of intention to make such request.

Now therefore, His Excellency the Governor of the State of Victoria, by and with the advice of the Executive Council thereof, hereby directs:

- (a) that the said part of a road which is shown by hatching and cross-hatching on the plan hereunder, shall be discontinued;
- (b) that notwithstanding such discontinuance the Melbourne and Metropolitan Board of Works shall continue to have and possess the same right title power authority or interest in or in relation to the whole of the land shown by cross hatching on the said plan as it had or possessed prior to such discontinuance with respect to or in connection with any drains or pipes laid or erected in on over such land for the purposes of drainage or sewerage;
- (c) that subject to any such right title power authority or interest the land in the said part of a road may be sold by the Council of the City of Preston by agreement.

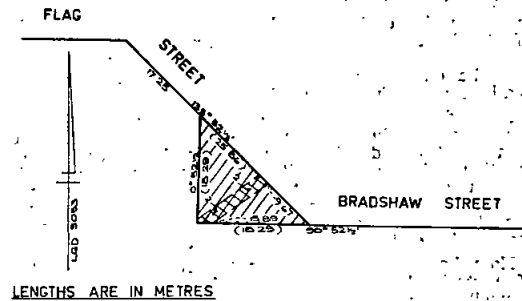

And the Honorable Digby Glen Crozier, Her Majesty's Minister for Local Government for the State of Victoria, shall give the necessary directions herein accordingly.

K. GILKINSON  
Acting Clerk of the Executive Council

LOCAL GOVERNMENT ACT 1958

At the Executive Council Chamber, Melbourne, the twenty-third day of October, 1979

PRESENT:

His Excellency the Governor of Victoria  
 Mr Haddon Storey | Mr Granter  
 Mr Jona

ALTERATION OF TIME FOR CLOSING POLL AT MUNICIPAL ELECTIONS—CITY OF WARRNAMBOOL

His Excellency the Governor of the State of Victoria, by and with the advice of the Executive Council thereof, in pursuance of the powers conferred by section 134 of the Local Government Act 1958, and in compliance with the prayer of a petition presented by the Council of the City of Warrnambool declares that the hour for closing the poll at municipal elections for the said City shall be six o'clock in the afternoon.

And the Honorable Digby Glen Crozier, Her Majesty's Minister for Local Government for the State of Victoria, shall give the necessary directions herein accordingly.

K. GILKINSON  
 Acting Clerk of the Executive Council

LOCAL GOVERNMENT ACT 1958

At the Executive Council Chamber, Melbourne, the twenty-third day of October, 1979

PRESENT:

His Excellency the Governor of Victoria  
 Mr Haddon Storey | Mr Granter  
 Mr Jona

ROAD DISCONTINUED—CITY OF CROYDON

Whereas it is provided in section 528 (2) of the Local Government Act 1958, that where a road (whether or not a public highway but not being a road set out on land of the Crown) or any part thereof is not required for public use the Governor in Council on the request of the Council of the municipality in which such road is situated made not less than one month after publishing in a newspaper generally circulating in the district and posting to the registered proprietor (if any) of the land and the owners and occupiers (if any) of lands abutting or immediately adjacent to the road notice of intention to make such a request may by Order published in the Government Gazette direct that such road or part shall be discontinued and thereupon such road or part shall be discontinued accordingly.

And whereas the Council of the City of Croydon has requested that the Governor in Council direct that part of Ann Street, Croydon be discontinued and not less than one month previously has published in a newspaper generally circulating in the district and posted to the registered proprietor of the land in the road and to the owners and occupiers of lands abutting or immediately adjacent to the road notice of intention to make such a request.

Now therefore, His Excellency the Governor of the State of Victoria, by and with the advice of the Executive Council thereof, hereby directs:

- (a) that the said part of a road which is shown by hatching and cross-hatching on the plan hereunder, shall be discontinued;
- (b) that notwithstanding such discontinuance the State Electricity Commission shall continue to have and possess the same right title power authority or interest in or in relation to the whole of the land shown by cross-hatching on the said

- plan as it had or possessed prior to such discontinuance with respect to or in connection with any wires or cables laid or erected in on or over such land for the purpose of electricity supply;
- (c) that subject to any such right title power authority or interest the land in the said part of a road shall be retained by the Council of the City of Croydon for municipal purposes.

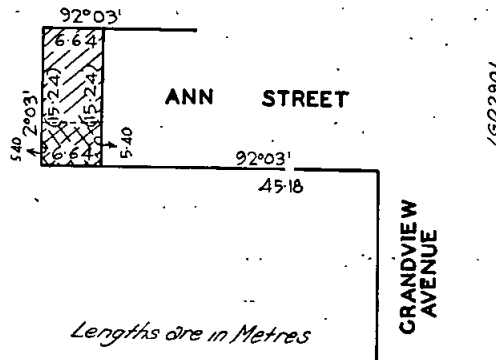

And the Honorable Digby Glen Crozier, Her Majesty's Minister for Local Government for the State of Victoria, shall give the necessary directions herein accordingly.

K. GILKINSON  
 Acting Clerk of the Executive Council

STAMPS ACT 1958, No. 6375

At the Executive Council Chamber, Melbourne, the twenty-third day of October, 1979

PRESENT:

His Excellency the Governor of Victoria  
 Mr Haddon Storey | Mr Granter  
 Mr Jona

DECLARATION OF APPROVED VENDOR

His Excellency the Governor of the State of Victoria, by and with the advice of the Executive Council thereof, doth by this Order made pursuant to section 131c (1) of the Stamps Act 1958 declare the undermentioned person carrying on business as a vendor of goods under instalment purchase agreements to be an "approved vendor" for the purposes of subdivision (14) of Division 3 of Part II. of the Stamps Act 1958.

319. DAVID JONES HOUSEHOLD FINANCE LIMITED

And the Honorable Lindsay Hamilton Simpson Thompson, Her Majesty's Treasurer for the State of Victoria, shall give the necessary directions herein accordingly.

K. GILKINSON  
 Acting Clerk of the Executive Council



COUNTRY ROADS BOARD  
Act No. 6229

At the Executive Council Chamber, Melbourne, the  
twenty-third day of October, 1979

PRESENT:

His Excellency the Governor of Victoria  
Mr Haddon Storey | Mr Granter  
Mr Jona

ORDER APPROVING OF LAND BEING ACQUIRED AND  
ROADS, DEVIATIONS OR WIDENINGS BEING MADE  
TOGETHER WITH ALL ANCILLARY WORKS REQUIRED  
TO BE EXECUTED IN CONJUNCTION THEREWITH

His Excellency the Governor of the State of Victoria,  
by and with the advice of the Executive Council thereof,  
being satisfied that there are funds legally available for  
acquiring the land, doth hereby approve the acquiring of  
the land described in the schedule hereunder and the making  
of new roads and deviations from and widenings  
of existing roads, together with all ancillary works required  
to be executed in conjunction therewith, referred to in  
the said schedule.

SCHEDULE

State Highway

The land shown hatched on plans numbered G.P.15079  
and G.P.15080 hereunder required for the widening of the  
Princes Highway in the Shire of Pakenham and making  
of the widening thereon.

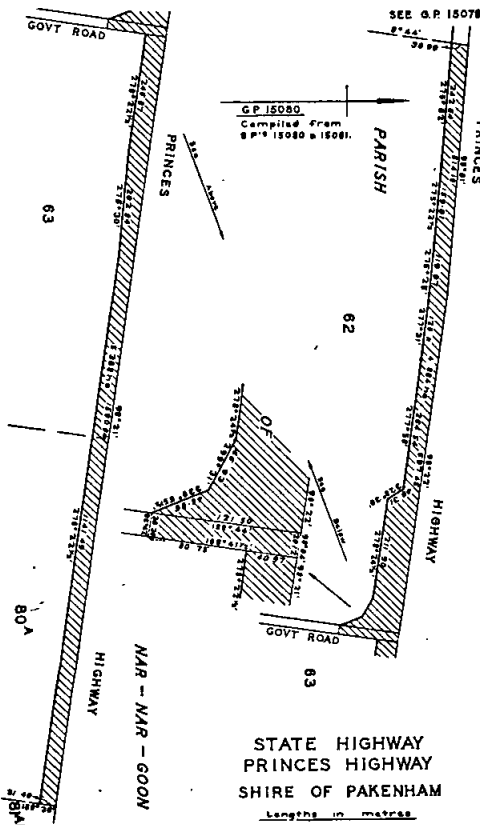
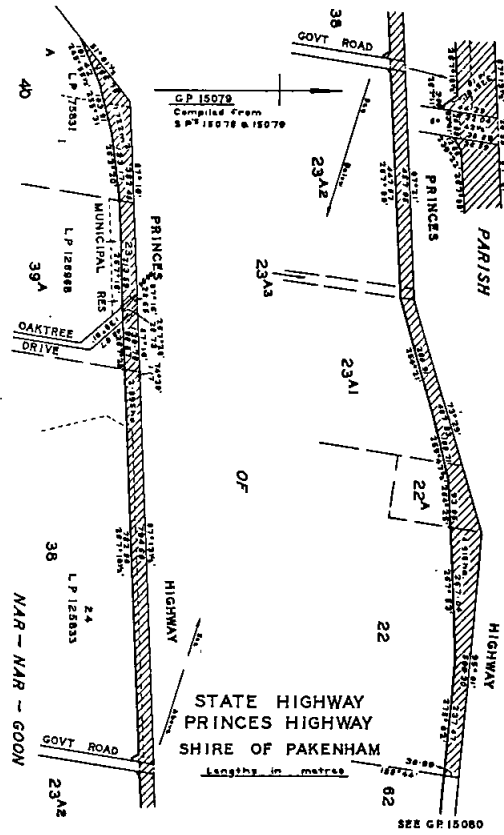

**Main Roads**  
The land shown hatched on plan numbered G.P.14856  
hereunder required for the widening of the Grand Ridge  
Road in the Shire of Morwell and making of the widening  
thereon.

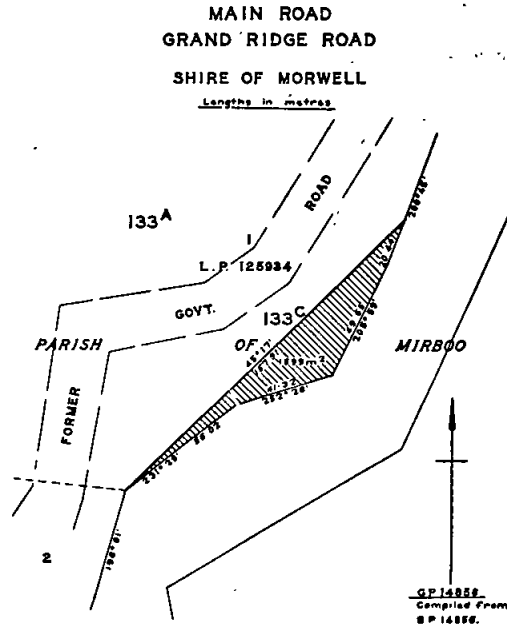

The land shown hatched on plan numbered G.P.15058 hereunder required for the widening of Combienbar Road in the Shire of Orbost and making of the widening thereon.

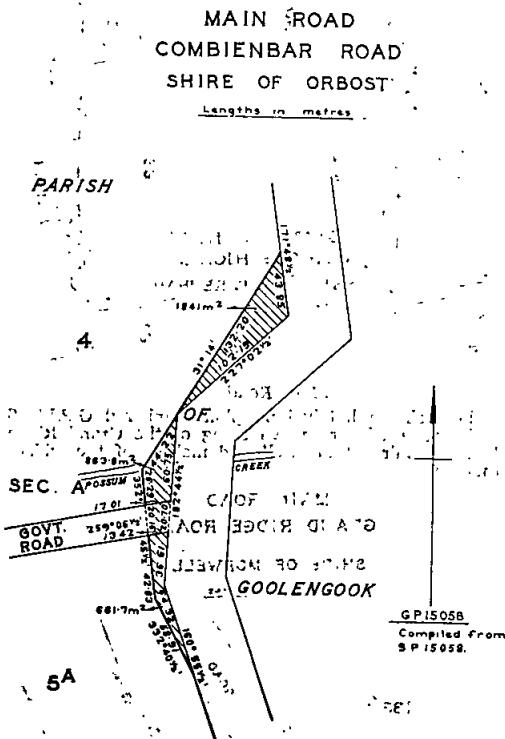

The land shown hatched on plan numbered G.P.15100 hereunder required for the making of a new freeway (West Gate Freeway) in the City of South Melbourne.

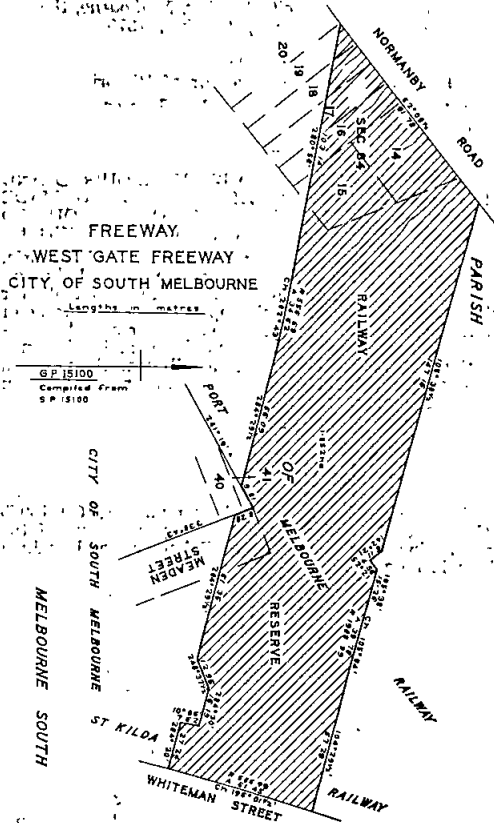

And the Honorable Robert Roy Cameron Maclellan, Her Majesty's Minister of Transport for the State of Victoria, shall give the necessary directions herein accordingly.

K. GILKINSON  
Acting Clerk of the Executive Council

SUPERANNUATION ACT, 1958

At the Executive Council Chamber, Melbourne, the twenty-third day of October, 1979

PRESENT:

His Excellency the Governor of Victoria  
Mr Haddon Storey | Mr Granter  
Mr Jona

Pursuant to the powers conferred by the provisions of paragraph (ja) of sub-section (1) of section 3 of the Superannuation Act 1958, His Excellency the Governor of the State of Victoria, by and with the advice of the Executive Council thereof doth by this Order declare that the provisions of the Superannuation Act shall apply to JOHN MINOTTI, an officer of the Victorian Institute of Secondary Education.

And the Honorable Lindsay Hamilton Simpson Thompson, Her Majesty's Treasurer for the State of Victoria, shall give the necessary directions herein accordingly.

K. GILKINSON  
Acting Clerk of the Executive Council

CROWN LAND (RESERVES) ACT 1978

At the Executive Council Chamber, Melbourne, the twenty-third day of October, 1979

PRESENT:

His Excellency the Governor of Victoria  
 Mr Haddon Storey | Mr Granter  
 Mr Jona

REVOCATION OF TEMPORARY RESERVATIONS OF LANDS BY ORDERS IN COUNCIL

His Excellency the Governor of the State of Victoria, in the Commonwealth of Australia, by and with the advice of the Executive Council of the said State, pursuant to the provisions of section 10 of the Crown Land (Reserves) Act 1978, doth hereby revoke the temporary reservations of lands by Orders in Council hereinafter described, viz.:

**LANGI-GHIRAN**—The temporary reservation by Order in Council of 27 October 1910 of 9687 square metres of land near Crown allotment 3 section 31, Parish of Langi-Ghiran as a site for a State School—(L.6(B<sup>1</sup>)) (Rs.5798).

**BALLARAT EAST**—The temporary reservation by Order in Council of 5 April 1892 of 12.14 hectares of land in the Township of Ballarat East as a site for Public Purposes, revoked as to part by Order of 7 August 1956, so far only as regards the portion thereof containing 24.7 square metres, as defined by description and hatching on plan published in the *Government Gazette* of 3 October 1979, is concerned—(B.128<sup>(41)</sup>) (Rs.5114).

**WARRABKOOK**—The temporary reservation by Order in Council of 17 October 1870 of 18.21 hectares, more or less, of land in the Parish of Warrabkook as a site for Road purposes, so far only as regards the portion thereof containing 5.840 hectares, as defined by description and hatching on plan published in the *Government Gazette* of 3 October 1979, is concerned—(W.249<sup>(2)</sup>) (Rs.10965).

**WOMBAT**—The temporary reservation by Order in Council of 31 December 1866 (see *Government Gazette* of 11 January 1867) of 70.82 hectares, more or less, of land in the Parish of Wombat as a site for Victorian Water Supply purposes, revoked as to part by various Orders, so far only as regards the portion thereof containing 185 square metres, as defined by description and hatching on plan published in the *Government Gazette* of 3 October 1979, is concerned—(W.179<sup>(37)</sup>) (C.86093).

And the Honorable William Vasey Houghton, Her Majesty's Minister of Lands for the State of Victoria, shall give the necessary directions herein accordingly.

K. GILKINSON  
 Acting Clerk of the Executive Council

URBAN RENEWAL ACT 1970

At the Executive Council Chamber, Melbourne, the twenty-third day of October, 1979

PRESENT:

His Excellency the Governor of Victoria  
 Mr Haddon Storey | Mr Granter  
 Mr Jona

COUNCIL OF THE CITY OF HEIDELBERG AUTHORISED TO PREPARE AN URBAN RENEWAL PROPOSAL

Whereas it is provided in Part I. of the *Urban Renewal Act 1970* that the Governor in Council may, by Order published in the *Government Gazette*, authorise a renewal authority to prepare an urban renewal proposal.

And whereas the Council of the City of Heidelberg is a renewal authority for the purposes of the *Urban Renewal Act 1970*.

Now therefore, the Governor of the State of Victoria, by and with the advice of the Executive Council thereof, hereby authorises the Council of the City of Heidelberg to prepare an urban renewal proposal in respect of the Ivanhoe Shopping Centre being the area defined on the plan hereunder.

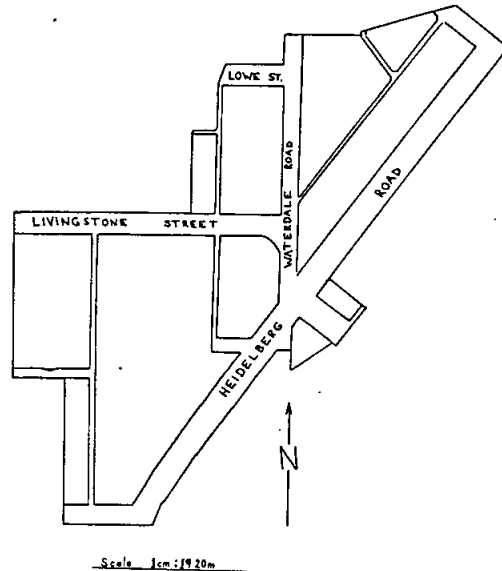

And the Honorable Digby Glen Crozier, Her Majesty's Minister for Local Government for the State of Victoria, shall give the necessary directions herein accordingly.

K. GILKINSON  
 Acting Clerk of the Executive Council

BRIGHT WATERWORKS TRUST

At the Executive Council Chamber, Melbourne, the twenty-third day of October, 1979

PRESENT:

His Excellency the Governor of Victoria  
 Mr Haddon Storey | Mr Granter  
 Mr Jona

CONSENT TO BORROWING \$90 000

Under the powers conferred by the *Water Act* and all other powers enabling him in that behalf, His Excellency the Governor of the State of Victoria, by and with the advice of the Executive Council of the said State, hereby consents to the Bright Waterworks Trust borrowing the sum of Ninety thousand dollars (\$90 000) to meet the cost of water supply works.

And the Honorable Frederick James Granter, Her Majesty's Minister of Water Supply for the State of Victoria, shall give the necessary directions herein accordingly.

K. GILKINSON  
 Acting Clerk of the Executive Council

**MELTON WATERWORKS TRUST**

*At the Executive Council Chamber, Melbourne, the  
twenty-third day of October, 1979*

**PRESENT:**

His Excellency the Governor of Victoria  
Mr Haddon Storey | Mr Granter  
Mr Jona

**CONSENT TO BORROWING \$200 000**

Under the powers conferred by the Water Act and all other powers enabling him in that behalf, His Excellency the Governor of the State of Victoria, by and with the advice of the Executive Council of the said State, hereby consents to the Melton Waterworks Trust borrowing the sum of Two hundred thousand dollars (\$200 000) to meet the cost of water supply works.

And the Honorable Frederick James Granter, Her Majesty's Minister of Water Supply for the State of Victoria, shall give the necessary directions herein accordingly.

**K. GILKINSON**  
Acting Clerk of the Executive Council

**ROMSEY WATERWORKS TRUST**

*At the Executive Council Chamber, Melbourne, the  
twenty-third day of October, 1979*

**PRESENT:**

His Excellency the Governor of Victoria  
Mr Haddon Storey | Mr Granter  
Mr Jona

**EXTENT OF WATERWORKS AND URBAN DISTRICTS INCREASED—APPROVAL OF SITE OF PIPELINE**

Under the powers conferred by the Water Act and all other powers enabling him in that behalf, His Excellency the Governor of the State of Victoria, by and with the advice of the Executive Council of the said State, doth hereby—

- (a) declare, order and direct that the extent of the Waterworks and Urban Districts of the Romsey Waterworks Trust be increased by adding thereto the areas shown by red and yellow colours respectively on the plan approved by the Governor in Council, by and with this Order and deposited in the office of the State Rivers and Water Supply Commission, Melbourne (Corr. No. 77/1367/W9/125) and as on and from the date hereof the extent of such Districts shall be and be deemed to be increased accordingly; and
- (b) approve of the site required for a pipeline as shown by green colour on the said plan.

And the Honorable Frederick James Granter, Her Majesty's Minister of Water Supply for the State of Victoria, shall give the necessary directions herein accordingly.

**K. GILKINSON**  
Acting Clerk of the Executive Council

**SHEPPARTON URBAN WATERWORKS TRUST**

*At the Executive Council Chamber, Melbourne, the  
twenty-third day of October, 1979*

**PRESENT:**

His Excellency the Governor of Victoria  
Mr Haddon Storey | Mr Granter  
Mr Jona

**EXTENT OF SHEPPARTON URBAN DISTRICT DIMINISHED**

Under the powers conferred by the Water Act and all other powers enabling him in that behalf, His Excellency the Governor of the State of Victoria, by and with the

advice of the Executive Council of the said State, doth hereby declare, order and direct that the extent of the Shepparton Urban District of the Shepparton Urban Waterworks Trust be diminished by excising from the same the land shown by green colour on the plans marked "A" and "B" approved by the Governor in Council by and with this Order and deposited in the office of the State Rivers and Water Supply Commission, Melbourne (Corr. No. 78/2582/20) and as on and from the date hereof the extent of such District shall be and be deemed to be diminished accordingly.

And the Honorable Frederick James Granter, Her Majesty's Minister of Water Supply for the State of Victoria, shall give the necessary directions herein accordingly.

**K. GILKINSON**  
Acting Clerk of the Executive Council

**CRESWICK SEWERAGE AUTHORITY**

*At the Executive Council Chamber, Melbourne, the  
twenty-third day of October, 1979*

**PRESENT:**

His Excellency the Governor of Victoria  
Mr Haddon Storey | Mr Granter  
Mr Jona

**CONSENT TO BORROWING \$100 000**

Under the powers conferred by the Sewerage Districts Act and all other powers enabling him in that behalf, His Excellency the Governor of the State of Victoria, by and with the advice of the Executive Council of the said State, hereby consents to the Creswick Sewerage Authority borrowing the sum of One hundred thousand dollars (\$100 000) to meet the cost of sewerage works as set forth in the detailed statement bearing date 18 October 1979.

And the Honorable Frederick James Granter, Her Majesty's Minister of Water Supply for the State of Victoria, shall give the necessary directions herein accordingly.

**K. GILKINSON**  
Acting Clerk of the Executive Council

**PORT FAIRY SEWERAGE AUTHORITY**

*At the Executive Council Chamber, Melbourne, the  
twenty-third day of October, 1979*

**PRESENT:**

His Excellency the Governor of Victoria  
Mr Haddon Storey | Mr Granter  
Mr Jona

**CONSENT TO BORROWING \$15 000**

Under the powers conferred by the Sewerage Districts Act and all other powers enabling him in that behalf, His Excellency the Governor of the State of Victoria, by and with the advice of the Executive Council of the said State, hereby consents to the Port Fairy Sewerage Authority borrowing the sum of Fifteen thousand dollars (\$15 000) to meet the cost of house connections.

And the Honorable Frederick James Granter, Her Majesty's Minister of Water Supply for the State of Victoria, shall give the necessary directions herein accordingly.

**K. GILKINSON**  
Acting Clerk of the Executive Council

## STOCK DISEASES ACT 1968

At the Executive Council Chamber, Melbourne, the  
twenty-fifth day of October, 1979

## PRESENT:

His Excellency the Governor of Victoria  
Mr Houghton | Mr Granter

Whereas by section 4 of the Stock Diseases Act 1968, the Governor in Council amongst other things is empowered to prohibit or restrict the introduction into Victoria of any stock or carcase or animal product either generally or from such places and during such periods as may appear to him necessary or expedient for the purpose of preventing the introduction into Victoria of any diseases; And whereas infection of swine with Vesicular Exanthema is suspected to have occurred in the State of Tasmania; And whereas Vesicular Exanthema was declared a "disease" for the purpose of the Act by Order approved by the Governor in Council on 4 August 1970: Now therefore the Governor of the State of Victoria, by and with the advice of the Executive Council thereof, doth by this Order prohibit the introduction into Victoria at any time of any pigs or pig products from any part of the State of Tasmania.

And the Honorable Ian Winton Smith, Her Majesty's Minister of Agriculture for the State of Victoria, shall give the necessary directions herein accordingly.

K. GILKINSON  
Acting Clerk of the Executive Council

## HURSTBRIDGE WATERWORKS TRUST

At the Executive Council Chamber, Melbourne, the  
thirtieth day of October, 1979

## PRESENT:

His Excellency the Governor of Victoria  
Mr Crozier | Mr Balfour  
Mr Maclellan | Mr Lieberman

## CONSENT TO BORROWING \$50 000

Under the powers conferred by the Water Act and all other powers enabling him in that behalf, His Excellency the Governor of the State of Victoria, by and with the advice of the Executive Council of the said State, hereby consents to the Hurstbridge Waterworks Trust borrowing the sum of Fifty thousand dollars (\$50 000) to meet the cost of water supply works.

And the Honorable Frederick James Granter, Her Majesty's Minister of Water Supply for the State of Victoria, shall give the necessary directions herein accordingly.

K. GILKINSON  
Acting Clerk of the Executive Council

## TYERS AND GLENGARRY WATERWORKS TRUST

At the Executive Council Chamber, Melbourne, the  
thirtieth day of October, 1979

## PRESENT:

His Excellency the Governor of Victoria  
Mr Crozier | Mr Balfour  
Mr Maclellan | Mr Lieberman

## CONSENT TO BORROWING \$30 000

Under the powers conferred by the Water Act and all other powers enabling him in that behalf, His Excellency the Governor of the State of Victoria, by and with the advice of the Executive Council of the said

State, hereby consents to the Tyers and Glengarry Waterworks Trust borrowing the sum of Thirty thousand dollars (\$30 000) to meet the cost of water supply works.

And the Honorable Frederick James Granter, Her Majesty's Minister of Water Supply for the State of Victoria, shall give the necessary directions herein accordingly.

K. GILKINSON  
Acting Clerk of the Executive Council

## GEELONG WATERWORKS AND SEWERAGE TRUST

At the Executive Council Chamber, Melbourne, the  
thirtieth day of October, 1979

## PRESENT:

His Excellency the Governor of Victoria  
Mr Crozier | Mr Balfour  
Mr Maclellan | Mr Lieberman

## CONSENT TO BORROWING \$350 000

Under the powers conferred by the Geelong Waterworks and Sewerage Act and all other powers enabling him in that behalf, His Excellency the Governor of the State of Victoria, by and with the advice of the Executive Council of the said State, hereby consents to the Geelong Waterworks and Sewerage Trust borrowing the sum of Three hundred and fifty thousand dollars (\$350 000) in two separate loans of Three hundred thousand dollars (\$300 000) and Fifty thousand dollars (\$50 000) to meet the cost of sewerage works.

And the Honorable Frederick James Granter, Her Majesty's Minister of Water Supply for the State of Victoria, shall give the necessary directions herein accordingly.

K. GILKINSON  
Acting Clerk of the Executive Council

## GEELONG WATERWORKS AND SEWERAGE TRUST

At the Executive Council Chamber, Melbourne, the  
thirtieth day of October, 1979

## PRESENT:

His Excellency the Governor of Victoria  
Mr Crozier | Mr Balfour  
Mr Maclellan | Mr Lieberman

## CONSENT TO BORROWING \$650 000

Under the powers conferred by the Geelong Waterworks and Sewerage Act and all other powers enabling him in that behalf, His Excellency the Governor of the State of Victoria, by and with the advice of the Executive Council of the said State, hereby consents to the Geelong Waterworks and Sewerage Trust borrowing the sum of Six hundred and fifty thousand dollars (\$650 000) in two separate loans of Five hundred thousand dollars (\$500 000) and One hundred and fifty thousand dollars (\$150 000) to meet the cost of water supply works.

And the Honorable Frederick James Granter, Her Majesty's Minister of Water Supply for the State of Victoria, shall give the necessary directions herein accordingly.

K. GILKINSON  
Acting Clerk of the Executive Council

ANGLESEA SEWERAGE AUTHORITY

At the Executive Council Chamber, Melbourne, the thirtieth day of October, 1979

PRESENT: His Excellency the Governor of Victoria

- Mr Crozier, Mr Balfour, Mr Maclellan, Mr Lieberman

CONSENT TO BORROWING \$40 000

Under the powers conferred by the Sewerage Districts Act and all other powers enabling him in that behalf, His Excellency the Governor of the State of Victoria by and with the advice of the Executive Council of the said State, hereby consents to the Anglesea Sewerage Authority borrowing the sum of Forty thousand dollars (\$40 000) to meet the cost of sewerage works as set forth in the detailed statement bearing date 24 October 1979.

And the Honorable Frederick James Granter, Her Majesty's Minister of Water Supply for the State of Victoria, shall give the necessary directions herein accordingly.

K. GILKINSON Acting Clerk of the Executive Council

DANDENONG SEWERAGE AUTHORITY

At the Executive Council Chamber, Melbourne, the thirtieth day of October, 1979

PRESENT: His Excellency the Governor of Victoria

- Mr Crozier, Mr Balfour, Mr Maclellan, Mr Lieberman

CONSENT TO BORROWING \$350 000

Under the powers conferred by the Sewerage Districts Act and all other powers enabling him in that behalf, His Excellency the Governor of the State of Victoria, by and with the advice of the Executive Council of the said State, hereby consents to the Dandenong Sewerage Authority borrowing the sum of Three hundred and fifty thousand dollars (\$350 000) in two separate loans of Two hundred and fifty thousand dollars (\$250 000) and One hundred thousand dollars (\$100 000) to meet the cost of unsubsidised sewerage works.

And the Honorable Frederick James Granter, Her Majesty's Minister of Water Supply for the State of Victoria, shall give the necessary directions herein accordingly.

K. GILKINSON Acting Clerk of the Executive Council

MELTON SEWERAGE AUTHORITY

At the Executive Council Chamber, Melbourne, the thirtieth day of October, 1979

PRESENT: His Excellency the Governor of Victoria

- Mr Crozier, Mr Balfour, Mr Maclellan, Mr Lieberman

CONSENT TO BORROWING \$600 000

Under the powers conferred by the Sewerage Districts Act and all other powers enabling him in that behalf, His Excellency the Governor of the State of Victoria, by and with the advice of the Executive Council of the said State, hereby consents to the Melton Sewerage Authority borrowing the sum of Six hundred thousand dollars (\$600 000) to meet the cost of sewerage works as set forth in the detailed statement bearing date 24 October 1979.

And the Honorable Frederick James Granter, Her Majesty's Minister of Water Supply for the State of Victoria, shall give the necessary directions herein accordingly.

K. GILKINSON Acting Clerk of the Executive Council

LANDS DEPARTMENT NOTICES

APPROACHING LAND SALES

Sale of Crown Land, in fee-simple, will be held at the under-mentioned places and dates, viz.:

Table with 2 columns: Location and Date, and No. of Gazette. Rows include Beech Forest, Koroit, and Underbool.

SALE OF FREEHOLD LAND BY AUCTION

Table with 2 columns: Location and Date, and No. Rows include Agnes and Kerang.

SALE OF FREEHOLD LAND BY AUCTION

KERANG—A sale of Freehold Land, by auction, for and on behalf of the Minister of Education, will be held at the LAND INSPECTOR'S OFFICE, STATE PUBLIC OFFICES, WELLINGTON STREET, KERANG, on WEDNESDAY, 5 DECEMBER 1979, at TWO O'CLOCK P.M. To be conducted by P. Richardson, Land Officer, Mildura.

The land will be offered for sale, subject to the following conditions: A deposit of at least 10 per cent. of the purchase price must be paid at the sale and balance within 60 days. Purchaser to arrange for and bear cost of registration of transfer of title.

Office of Crown Lands and Survey Melbourne, 31 October 1979

Lot 1

PARISH OF MURRABIT WEST

Being the former Gonn Crossing State School site 2.2 kilometres north of the Murray Valley Highway

Area—2 acres (8093 square metres). Allotment 14B of section A and being the whole of the land more particularly described in Certificate of Title Volume 7370 Folio 849 and Certificate of Title Volume 6333 Folio 569. Improvements consist of house, school, outbuildings, tank, windmill, &c.—(L.5-1348).

SALE OF FREEHOLD LAND BY AUCTION

AGNES—A sale of Freehold Land, by auction, for and on behalf of the Minister of Education, will be held ON THE SITE, GASSONS ROAD, AGNES, on WEDNESDAY, 12 DECEMBER 1979, at ONE THIRTY P.M. To be conducted by H. J. Macdonald, Land Officer, Traralgon.

The land will be offered for sale, subject to the following conditions: A deposit of at least 10 per cent. of the purchase price must be paid at the sale and balance within 60 days. Purchaser to arrange for and bear cost of registration of transfer of title.

Office of Crown Lands and Survey Melbourne, 31 October 1979

Lot 1

PARISH OF TOORA

Being the former Agnes State School site fronting the west side of Gassons Road, Agnes, about 40 metres south of the South Gippsland Highway about 5 kilometres west of Welshpool

Area—2 acres (8094 square metres). Allotment 9A of section C and being the whole of the land more particularly described in Certificate of Title Volume 3781 Folio 078—(L.10-2105).

REGULATIONS FOR THE CARE, PROTECTION AND  
MANAGEMENT OF THE "SWAN HILL SWIMMING  
POOL RESERVE"

I, William Vasey Houghton, Her Majesty's Minister of Lands in and for the State of Victoria, in pursuance of the powers conferred on me by section 13 of the *Crown Land (Reserves) Act 1978*, do hereby make the following Regulations for or with respect to the Crown land in the Township of Swan Hill, Parish of Castle Donnington (hereinafter referred to as the "Reserve") temporarily reserved as a site for Swimming Pool Purposes by Order in Council dated 27 March 1979 (*vide Government Gazette of 4 April 1979*)—

## REGULATIONS

## Definitions

1. "Committee" means the Corporation of the City of Swan Hill;

"Town Clerk" means the person for the time being holding the office or performing the duties of the Town Clerk of the said Corporation;

"Reserve Attendant" means any employee of the said Corporation performing any duties on or in connection with the Reserve;

"bottle" means any article made wholly or partly of glass, china, porcelain, bakelite, plastic or other like composition.

## Admission and Use of Reserve

2. The Reserve shall be open to the public on such days and between such hours as may be determined from time to time by resolution of the Committee.

3. (a) No person shall enter the Reserve or use any facility therein without first obtaining from a Reserve attendant a ticket permitting his or her entry for the use of that facility and paying the proper fee according to the scale of charges fixed by the Committee.

(b) No child under the age of six years shall be permitted to enter the Reserve unless, in the opinion of a Reserve Attendant, such child is in the care of a responsible person.

(c) No boy or girl under the age of ten years who is unable to swim shall use the main pool without the permission of a Reserve Attendant unless accompanied by an adult or other person approved by a Reserve Attendant, and no adult who is unable to swim shall enter the main pool beyond his or her depth.

(d) No person eight years or over shall use the wading pool unless, in the opinion of a Reserve Attendant, that person is in charge of a child under the age of eight years.

4. No person shall pay and no Reserve Attendant or other officer or servant of the Committee shall receive any fee for admission to or for the use of any facility in the Reserve except in exchange for a printed ticket bearing the name of the Committee or in exchange for a printed ticket issued from the cash register of the Committee.

## Dressing and Changing

5. (a) No person shall dress or undress or remove any part of his or her bathing costume in any part of the Reserve open to the view of the public or in or upon any part of the Reserve except places specifically set apart or appropriated for such purpose.

(b) A male person shall not enter or use any part of the Reserve for the time being set apart or appropriated for the use of females, nor shall a female person enter or use any part of the Reserve for the time being set apart or appropriated for the use of males, provided that this Regulation shall not apply to a child under the age of four years when accompanied by a responsible adult of the opposite sex.

(c) No person shall use any swimming pool in the Reserve unless properly attired in a bathing costume so as to preserve public decency.

## Pollution

6. No person shall—

(a) enter any swimming pool until he has thoroughly cleansed himself, to the satisfaction of a Reserve Attendant, under a shower bath on the Reserve in which the use of soap is permitted;

(b) enter or remain in any swimming pool whilst in an unclean condition;

(c) use soap in any part of the Reserve except in the shower or slipper baths in which the use of soap is permitted;

(d) use any substance or preparation whilst in any swimming pool whereby the water in that swimming pool may be discoloured or rendered turbid or unfit in any way for the use of bathers;

(e) wilfully foul or pollute the water in any shower bath, separate bath or swimming pool;

(f) occupy the shower baths for an unreasonable time or enter any shower or water closet occupied by another person.

## Behaviour

7. No person shall—

(a) expectorate on the concourse of the pool or on any lawns or in any dressing rooms, compartments, passages or entrances thereto, or in the vicinity of the kiosk, or on the walls or any sealed surface of the Reserve;

(b) expectorate, spout water, blow his or her nose or urinate in any part of the swimming pools;

(c) wilfully or negligently break, injure, damage, destroy or tamper with any part of the Reserve or any key or other property of the Committee;

(d) wilfully or negligently mark or deface any part of the Reserve or any article or furniture therein or attached thereto;

(e) bring into or place in the Reserve or any part thereof any chemical substance, liquid or powder;

(f) wilfully or negligently damage, deface or remove any placard or notice board within the Reserve;

(g) use or interfere with any rope, raft, lifebuoy or lifesaving appliance or apparatus in the Reserve except in the case of an accident and danger occurring to a bather;

(h) place, roll or throw stones or other articles into any of the swimming pools;

(i) use indecent or offensive language or behave in an indecent or offensive manner in the Reserve;

(j) loiter or commit any nuisance in the Reserve, or bring rubbish, filth or other offensive matter therein or deposit or leave therein any tins, bottles, broken glass, orange peel, papers or any other litter except in receptacles provided for such purpose;

(k) interfere with the use and enjoyment of any of the facilities on the Reserve by any other person. Any person so acting or otherwise behaving in an unseemly or improper manner shall leave any swimming pool when requested to do so by any Reserve Attendant;

(l) engage in boisterous or rough play or conduct in the Reserve;

(m) climb or attempt to climb over, into or remain in or upon any fixture, fence, roof, building or structure in the Reserve, unless authorised by a Reserve Attendant;

(n) enter the plant room, its enclosure or any store room within the Reserve unless authorised by a Reserve Attendant;

(o) distribute in the Reserve any handbill or advertising matter;

(p) hawk or sell or offer for sale in the Reserve any goods, articles or services without first having obtained permission, in writing, from the Committee.

*Prohibitions*

8. No person shall—
- bring into the Reserve any intoxicating liquor;
  - consume intoxicating liquor in the Reserve;
  - enter into or upon the Reserve if intoxicated.
9. No person suffering from any cutaneous, infectious or contagious disease shall use or enter the Reserve.
10. No person shall cause or permit any dog or other animal belonging to him or her or under his or her control to enter or remain in or upon the Reserve.
11. No person shall bring any bicycle or tricycle into the Reserve.

12. No person shall bring into or have in his possession in the Reserve any bottle.

13. No person shall bring into or have in the main swimming pools any balls, motor tubes or other inflatable rubber articles except with the permission of any Reserve Attendant.

14. No ball games shall be permitted in the Reserve except the playing of water polo which may be practised and played at such times and by such teams from time to time approved by the Committee.

15. No ticket, token, licence or receipt issued as provided for by these Regulations shall be transferable and no person other than the person to whom the same was originally issued shall enjoy any benefit therefrom or any privileges thereunder.

*Professional Coaches*

16. (a) No person shall, for fee or reward, instruct or coach any person in the Reserve unless registered as hereinafter provided as a professional coach in respect of such Reserve.

(b) Every person applying to be so registered shall make application, in writing, to the Town Clerk supplying such information as the Committee requires and stating his full name and his private and business addresses.

(c) The Committee may grant such application on such terms and conditions as it deems reasonable or may refuse the same as it sees fit.

*Suspension of Charges*

17. During any period for which the Reserve or any part thereof has been let for galas or other entertainments—

- the charges for admission fixed by the Committee shall be suspended;
- no season or other tickets, licences or tokens issued by or on behalf of the Committee shall have any force or effect or be available for entrance to or use at any such galas or other entertainments;
- neither the Committee or any of its officers or employees shall be in any way responsible for the running of such galas or other entertainments;
- neither the Committee or any of its officers or employees shall be in any way responsible for any articles deposited with any person in charge of or in any way connected with any such galas or other entertainments;
- neither the Committee or any of its officers or employees shall be in any way responsible for any injury to or any loss or damage sustained by any person during the time any such gala or entertainment is being held and any person or body hiring the Reserve for any such gala or other entertainment shall indemnify the Committee against any claims for such injury, loss or damage.

*Temporary Closure of the Reserve*

18. Admittance to the Reserve may be temporarily suspended or the Reserve may be cleared of all persons if, in the opinion of the Reserve Attendant in charge, such action is necessary for the effective care, protection and management of the Reserve or any part thereof.

*Lost Property*

19. (a) A Reserve Attendant shall keep at the Reserve, a book (hereinafter referred to as the "lost property register").

(b) Any person finding any article left in the Reserve shall forthwith deliver the same to the Reserve Attendant.

(c) The Reserve Attendant receiving any such article shall forthwith take charge of the same and enter or cause to be entered in the lost property register a description of the article, the time and date of its receipt and the name of the finder.

(d) The Reserve Attendant having the custody of the lost property register may deliver to any person apparently the owner thereof, any article, particulars of which have been entered in the lost property register, upon receiving satisfactory proof of ownership and on payment of any fee fixed by the Committee, and upon such delivery such person shall acknowledge receipt of the said article by entering his or her name and address in the lost property register.

*Hiring*

20. Every person who hires any article being the property of the Committee or under its control, shall pay a deposit in respect of such article according to the scale of hire charges which may be determined from time to time by resolution of the Committee, and shall return any article so hired to a Reserve Attendant before leaving the Reserve. If any article so hired is returned in good order and condition the deposit so paid in respect thereof shall be refunded to the person returning the article; if, however, any article is not returned or is returned in a damaged condition then, without prejudice to any other remedies of the Committee, a Reserve Attendant may, at his discretion, forfeit the whole of or any part of the deposit to the Committee.

*Obstruction, &c.*

21. (a) Any person offending against these Regulations shall, if requested by the Reserve Attendant, immediately leave the Reserve.

(b) Any person refusing to carry out any such direction to leave the Reserve shall, in addition to any offence already committed, be guilty of a further offence against these Regulations.

(c) A Reserve Attendant may remove from the Reserve or any part thereof any person who refuses to obey such a direction.

(d) A Reserve Attendant may refuse admission to the Reserve to any person who has previously offended against these Regulations and who, in his opinion, is likely to offend against the Regulations again.

(e) Should any person, who is the holder of a permit to use the Reserve, be convicted of any offence relating to morals or of a breach of any Regulations relating to or applying to the Reserve, the Committee may cancel such permit and such conviction shall debar such person from obtaining any further permit.

22. No person shall obstruct, hinder or interfere with any Reserve Attendant or any person employed at the Reserve or any officer of the Committee on duty or any lifesaver or approved swimming instructor in the performance of his or her duties on the Reserve.

23. The Committee or any officer or employee of the Committee shall not be responsible for any article lost by or stolen from any person whilst in the Reserve or for any article damaged or destroyed whilst in or on the Reserve—(Rs.10708).

Given under my hand at Melbourne 25 October 1979

W. V. HOUGHTON, Minister of Lands

Every person who contravenes or fails to comply with these Regulations shall be liable to the penalties prescribed in section 13 of the *Crown Land (Reserves) Act 1978*.



REGULATIONS FOR THE CARE, PROTECTION AND  
MANAGEMENT OF THE "WIRIDJIL RECREATION  
RESERVE", PARISH OF WAARRE

I, William Vasey Houghton, Her Majesty's Minister of Lands in and for the State of Victoria, in pursuance of the powers conferred on me by section 13 (1) (xii) of the *Crown Land (Reserves) Act 1978*, do hereby apply the Regulations made on 14 July 1969 (*vide Government Gazette* of 16 July 1969) for or with respect to the above-named Reserve to the land in the Parish of Waarre temporarily reserved as a site for Public Recreation by Order in Council dated 25 September 1979 (*vide Government Gazette* of 3 October 1979)—(Rs.9060).

Given under my hand at Melbourne 25 October 1979

W. V. HOUGHTON, Minister of Lands

REGULATIONS FOR THE CARE, PROTECTION AND  
MANAGEMENT OF THE RESERVE FOR PUBLIC  
RECREATION PURPOSES, AT WERRIBEE, KNOWN AS  
"CHIRNSIDE PARK"

I, William Vasey Houghton, Her Majesty's Minister of Lands in and for the State of Victoria, in pursuance of the powers conferred on me by section 13 (1) (xii) of the *Crown Land (Reserves) Act 1978*, do hereby apply the Regulations made on 10 April 1952 (*vide Government Gazette* of 18 April 1952) for or with respect to the above-named Reserve, to the lands in the Township of Werribee, Parish of Deutgam, permanently reserved as sites for Public Purposes as are shown bordered red and light blue on plan marked "W/6.10.76" attached to Lands Department correspondence No. Rs.2263, excluding, however, that portion of the above lands as is shown coloured yellow on the said plan—(Rs.2263).

Given under my hand at Melbourne 25 October 1979

W. V. HOUGHTON, Minister of Lands

COMMITTEE OF MANAGEMENT OF THE "APOLLO  
BAY AERODROME RESERVE"

In pursuance of section 14 of the *Crown Land (Reserves) Act 1978*, I hereby appoint the Corporation of the Shire of Otway as the Committee of Management of the land in the Parish of Krambruk temporarily reserved as a site for an Aerodrome by Order in Council dated 25 October 1966 (*vide Government Gazette* dated 2 November 1966)—(Corres. No. Rs.2945).

W. V. HOUGHTON, Minister of Lands

Department of Crown Lands and Survey  
Melbourne, 25 October 1979

COMMITTEE OF MANAGEMENT OF CERTAIN LAND  
IN THE TOWNSHIP OF EPPING RESERVED FOR A  
PUBLIC PARK

In pursuance of section 14 of the *Crown Land (Reserves) Act 1978*, I hereby appoint the Corporation of the Shire of Whittlesea as the Committee of Management of the land in the Township of Epping, Parish of Wollert, temporarily reserved as a site for Public Park by Order in Council dated 11 September 1979 (*vide Government Gazette* dated 19 September 1979)—(Corres. No. Rs.10943).

W. V. HOUGHTON, Minister of Lands

Department of Crown Lands and Survey  
Melbourne, 25 October 1979

COMMITTEE OF MANAGEMENT OF CERTAIN LAND  
IN THE PARISH OF EILDON TEMPORARILY RESERVED  
FOR PUBLIC RECREATION

In pursuance of section 14 of the *Crown Land (Reserves) Act 1978*, I hereby appoint the Corporation of the Shire of Alexandra as a Committee of Management of the land in the Parish of Eildon temporarily reserved by Order in Council of 11 September 1979 as a site for Public Recreation—(Rs.10767).

W. V. HOUGHTON, Minister of Lands

Department of Crown Lands and Survey  
Melbourne, 25 October 1979

No. 90—13400/79—3

TENDERS

PUBLIC WORKS DEPARTMENT

Tenders are invited for the purposes indicated hereunder and will be received at 2 Treasury Place, Melbourne, 3002, until TWO p.m. on dates shown.

Tenders must be addressed to the Minister of Public Works with the envelope endorsed "Tender for

". Hand-delivered tenders must be placed in the Department's tender box in the foyer, Ground Floor, 2 Treasury Place, Melbourne.

Tenders documents are available from the Contracts Office, Room 28, 2 Treasury Place, Melbourne, and where indicated, at offices of Inspectors of Works.

Tuesday, 13 November 1979

Building, Electrical and Mechanical Works

BROADFORD—Extensions to office, Police Station. (W.O., Alexandra.)

FOOTSCRAY—Internal and external repairs and painting, Police Station.

GEELONG—(Re-advertisement)—Improvements to cell accommodation, Police Station. (W.O., Geelong.)

MELBOURNE—Supply and install interconnecting movable screens, Public Service Board.

SPRINGVALE—New tile and steel deck roof, Primary School.

Tuesday, 20 November 1979

Building, Electrical and Mechanical Works

ANTONIO PARK—Exterior and interior renovations, Primary School No. 4844.

BENTLEIGH WEST—Erection of steel fire escape stairs and allied works, Primary School.

BOX HILL—Lifts services—erection of stage 1, phase 3, Technical College.

BRUNSWICK—Renewal of fire service and domestic supply, Police Traffic Centre.

CAULFIELD SOUTH—Supply and installation of new boiler, Primary School No. 4315.

COBURG—Retiling of roof to officers club rooms, H.M. Prison, Pentridge.

COOLAROO—Security fencing, Primary School.

GLENTHOMPSON—Internal and external painting and repairs, Primary School. (W.O., Hamilton.)

HORSHAM—Minor building maintenance, High School. (W.O., Horsham.)

LONGERENONG—Erection of Library Resource Centre, Agricultural College. (W.O., Horsham.)

MOUNT CLEAR—P.A.B.X. telephone system—erection of new school, Technical/High School.

ORMOND—Mechanical services—staff admin. improvements, art craft and library conversion, cyclic maintenance, 1 No. 5 modular classroom, Primary School.

UPPER FERNTREE GULLY—Exterior and interior renovations, Primary School No. 3926.

WESTERNPORT—STONY POINT—The design, manufacture and installation of one five tonne hydraulic winch, Ports and Harbors Buoy Depot.

THOMASTOWN—Alterations to "J" block and library work room, High School.

WARRAWONG—Replacement of roof, Primary School No. 4835.

Site Works

ORBOST—Siteworks, Primary School. (W.O., Bairnsdale.)

Miscellaneous

COBRAM—Maintenance cleaning, period 1 December 1979 to 30 November 1982, Police Station. (W.O., Shepparton.)

EAST MELBOURNE—Maintenance cleaning, period 1 December 1979 to 30 November 1982, Public Offices.

NORTH MELBOURNE—Maintenance cleaning, period 1 December 1979 to 30 November 1982, Fruit Inspection Depot.

PORT MELBOURNE—Purchase of six (6) only 5 cylinders. (3.82 m<sup>3</sup>) tipping trucks, Depot.

PORT MELBOURNE—Purchase of two (2) only 7 cylinders (5.53 m<sup>3</sup>) tipping trucks, Depot.

PORT MELBOURNE—Supply, delivery and assembly of six (6) No. relocatable modular buildings services, Relocatable Buildings. (W.O., Geelong, Ballarat, Bendigo, Wangaratta, Benalla, Traralgon.)

ST. KILDA—Maintenance cleaning, period 1 December 1979 to 30 November 1982, Youth Advisory Service.

Tuesday, 12 February 1980

Building, Electrical and Mechanical Works

MELBOURNE—New communications centre, stage I, Control-Room—D.24, Police Station.

TOM AUSTIN  
Minister of Public Works

Public Works Department  
Melbourne, 30 October 1979

PRIVATE  
ADVERTISEMENTS

CITY OF BERWICK

LOAN NO. 48

Notice of Intention to Borrow the Sum of \$179 500 for Permanent Works and Undertakings

Notice is hereby given that the Council of the City of Berwick proposes to borrow the principal sum of \$179 500 secured by a charge over the general rates of the municipality, such sum to be raised by the grant of a mortgage in accordance with the provisions of the Local Government Act 1958.

1. The maximum rate of interest that may be paid is 10.8 per cent per annum.

2. The purpose for which the loan is to be applied is:—

Drainage, kerb and channel—Sections, Oleander, Eugenia, Wattle, Matipo, Box, Chestnut Streets and Power Road.	80 000
Fire Brigade Track—Joint Construction Netball Complex—Olive Road, Hallam (part)	30 000
Watering System—Power Road, Doveton (Auto)	12 000
Watering System—Frawley Road, Hallam (Auto)	12 000
Final Seal—Funston, Cardinia, Scanlan Streets	10 000
Council contribution towards extensions—Pavilion, Narre Warren Recreation Reserve	5 000
Betula Reserve—Watering System	6 000
Charles Green Reserve—Car Park	6 500
Realignment—Box Street, Doveton	18 000
	<hr/> 179 500

3. The period of the loan shall be ten years.

4. The moneys borrowed shall be repayable by providing out of the municipal fund twenty half-yearly instalments of approximately \$14 896.07 each including principal and interest on 1 December and 1 June during the currency of the loan. The first instalment shall be payable on 1 June 1980.

5. Such moneys shall be repayable to the Commissioners of the State Savings Bank of Victoria at the office of the said Commissioners, 233 Collins Street, Melbourne.

The plans and specifications and the estimate of the cost of the proposed works and a statement showing the proposed expenditure on the moneys to be borrowed are open for inspection at the office of the Council of the City of Berwick, Civic Centre, Princes Highway, Fountain Gate, Narre Warren, Victoria 3805.

Dated 31 October 1979

3068

P. J. NORTHEAST, Town Clerk

CITY OF CROYDON

LOAN NO. 164

Notice of Intention to Borrow the Sum of \$200 000 for Permanent Works and Undertakings

Notice is hereby given that the Council of the City of Croydon proposes to borrow the sum of \$200 000, secured by a charge over the general rates of the Municipality, such sum to be raised by grant of mortgage, in accordance with the provisions of the Local Government Act 1958.

1. The maximum rate of interest that may be paid is 10.8 per cent per annum.

2. The purpose for which the loan is to be applied is:

	\$
Council contribution to Private Street Schemes	19 600
Golf Course—Construction of Main Dam (Part)	10 000
Dorset Recreational Area—Construct Access from Dorset Road	15 000
Beryl Street and Alwyn Street (Part), Reconstruction	60 000
Council contribution to CRB unclassified roads	39 100
Public lighting	2 000
Half Cost Works (Council contribution)	33 800
Eastfield Park—sealing of Access Road	8 000
Keystone Club—new fire services	2 500
Continuation of Cycle Path—Croydon Main Drain	10 000
	<hr/> 200 000

3. The period of the loan will be 10 years.

4. The loan is to be liquidated by investment and accumulation of a Sinking Fund by investing approximately \$15 900.91 annually with interest being paid six monthly in arrears from the Municipal Fund on 31 January and 31 July during the currency of the loan. The first payment of interest being payable on 31 July 1980.

5. Such moneys shall be repayable at the State Insurance Office, 480 Collins Street, Melbourne.

The plans and specifications and the estimate of the cost of the proposed works, and a statement showing the proposed expenditure of the moneys to be borrowed, are open for inspection at the Office of the Council of the City of Croydon, Foch Avenue, Croydon.

3069

R. BURTON, Town Clerk

CORRIGENDUM

Town and Country Planning Act 1961 (Twelfth Schedule)  
CITY OF CROYDON—CITY OF CROYDON PLANNING  
SCHEME 1961

AMENDMENT No. 86

With regard to the private advertisement No. 2951 published in the Government Gazette No. 89 dated 24 October 1979 pages 3437-3438, the date 12 December 1979 should read 24 January 1980.

29 October 1979

3150

R. BURTON, Town Clerk

## CITY OF ESSENDON

## LOAN No. 129

*Notice of Intention to Borrow the Sum of Thirty-five Thousand Dollars (\$35 000) for Permanent Works and Undertakings*

Notice is hereby given that the Council of the City of Essendon proposes to borrow the principal sum of Thirty-five thousand dollars (\$35 000) secured by a charge over the general rates of the municipality, such sum to be raised by the grant of a mortgage in accordance with the provisions of the *Local Government Act 1958* (as amended).

In connection therewith the following information is stated:—

1. The amount of the principal moneys which it is proposed to borrow is Thirty-five thousand dollars (\$35 000).
2. The maximum rate of interest that may be paid is 10·8 per centum per annum.
3. The period of the loan shall be ten (10) years.
4. The moneys borrowed shall be repayable by providing out of the municipal fund twenty half-yearly instalments of \$2904·38, including principal and interest, on 1 January and 1 July during the currency of the loan. The first instalment shall be payable on 1 July 1980.
5. Such moneys shall be repayable at the Office of the Commissioners of the State Savings Bank of Victoria, 233 Collins Street, Melbourne.
6. The purpose for which the loan is to be applied is as follows:—

Essendon, Community Centre—Reinstatement (Part)—\$35 000

The plans and specifications and the estimate of the cost of the proposed works and a statement showing the proposed expenditure of the moneys to be borrowed are open for inspection at the office of the Council of the City of Essendon at the Civic Centre, Moonee Ponds.

3050 B. C. BEATTIE, City Manager/Town Clerk

## Town and Country Planning Act 1961, (Twelfth Schedule)

## CITY OF FRANKSTON PLANNING SCHEME

NOTICE THAT A PLANNING SCHEME HAS BEEN PREPARED AND IS AVAILABLE FOR INSPECTION

Amendment No. 22, 1979

Notice is hereby given that the Council of the City of Frankston in pursuance of its powers under the *Town and Country Planning Act 1961*, as amended, has prepared an Amending Planning Scheme for the purpose of consolidating the provisions of the City of Frankston Planning Scheme and the Melbourne Metropolitan Planning Scheme regarding Home Occupation and the control of Outdoor Advertising.

A copy of the Amending Planning Scheme has been deposited at the Council Offices, Civic Centre, Davey Street, Frankston and at the Office of the Town and Country Planning Board, 235 Queen Street, Melbourne, and will be open for inspection during office hours by any person free of charge.

Any persons affected by the Amending Planning Scheme are required to set forth in writing all objections they may have, addressed to the Town Clerk, City of Frankston, Civic Centre, Davey Street, Frankston 3199, on or before 30 November 1979, and to state whether they wish to be heard in respect of their objections.

A. H. BUTLER, Town Clerk

Civic Centre, Frankston 3096

## CITY OF HEIDELBERG

## LOAN No. 209

*Notice of Intention to Borrow the Sum of \$135 000 for Permanent Works and Undertakings*

Notice is hereby given that the Council of the City of Heidelberg intends to borrow the sum of One hundred and thirty five thousand dollars (\$135 000) secured by a charge over the general rates of the Municipality, such sum to be raised by the grant of a mortgage in accordance with the provisions of the *Local Government Act 1958*.

1. The maximum rate of interest that may be paid is 10·7 per centum per annum.

2. The purpose for which the loan is to be applied is:—

Capital Works in the Electricity Supply Undertaking.

3. The period of the loan shall be Five (5) years.

4. The moneys borrowed shall be liquidated by the establishment and accumulation of a sinking fund, pursuant to the provisions of Section 428 (a) of the *Local Government Act 1958*, by provision out of the municipal fund of an amount of \$12 049·93 each half year during the period of the loan.

5. Interest shall be payable to the Melbourne and Metropolitan Board of Works, 625 Little Collins Street, Melbourne, on 1 December and in each year during the currency of the loan. The first interest payment shall be made on 1 June 1980.

6. Such moneys borrowed shall be repayable to the Melbourne and Metropolitan Board of Works, 625 Little Collins Street, Melbourne.

The plans and specifications and the estimate of the cost of the proposed works and a statement showing the proposed expenditure of the money to be borrowed are open for inspection at the Office of the Council, Town Hall, Ivanhoe.

3089

ALAN JONES, Town Clerk

## CITY OF KEW

## LOAN No. 81

*Notice of Intention to Borrow the Sum of \$450 000 for Permanent Works and Undertakings*

Notice is hereby given that the Council of the City of Kew proposes to borrow the sum of \$450 000 (Four hundred and Fifty Thousand Dollars) secured by a charge over the general rates of the Municipality, such sum to be raised by the grant of a Mortgage in accordance with the provisions of the *Local Government Act 1958*.

1. The maximum rate of interest that may be paid is 10·8 per centum per annum.

2. The period of the loan shall be 15 years.

3. The loan is to be liquidated by providing out of the Municipal Fund thirty (30) equal half-yearly instalments of \$30 621·28 principal and interest, payable on 14 June and 14 December each year during the currency of the loan. The first instalment shall be payable on 14 June 1980.

4. Such moneys shall be repayable at the office of the National Bank Savings Bank Limited.

5. The purpose for which the loan is to be applied is:—

\$

## Road &amp; street construction—

Alfred Street (John to Thomas); Belford Road (Kilby to Beresford); Cecil Street (Parkhill to Downton); Fitzwilliam Street (Edgevale to Coleridge); Hartwood Street (Kilby to Cadow); Normanby Road (Cotham to Downton); Parkhill Road (Wimba to Marshall); Peel Street (Eglinton to Malmsbury); Stevenson Street (Hodgson to Carson); Studley Avenue (Holroyd to Molesworth); Tanner Avenue; Woodford Avenue; Willsmere Road/Pakington Street intersection	214 000
C.R.B. Works—Council Contribution	120 000
Parks Development—Victoria Park, Hay's Paddock and Stradbroke Park	86 000
Ramp Access—Municipal Offices	30 000

The plans and specifications and the estimate of the cost of the proposed works and a statement showing the proposed expenditure of the moneys to be borrowed are open for inspection at the Municipal Offices, Charles Street, Kew.

Dated 31 October 1979

3108 L. FELL, City Manager (Town Clerk)

## CITY OF PORT MELBOURNE

LOAN No. 55

*Notice of Intention to Borrow the Sum of \$200 000 for Permanent Works and Undertakings*

Notice is hereby given that the Council of the City of Port Melbourne proposes to borrow the sum of Two Hundred Thousand Dollars on the credit of the municipal revenue of the Mayor, Councillors and Citizens of the said City, such sum to be raised by Mortgage deed in accordance with the provisions of the Local Government Act 1958.

1. The maximum rate of interest that may be paid is 10.8 per cent per annum.

2. The purpose for which the loan is to be applied is as follows:—

Capital Extensions and Plant Purchases for the Electric Supply Undertaking	\$200 000
--	-----------

3. The period of the loan shall be 10 years.

4. The moneys borrowed shall be repayable by providing out of the municipal fund, 19 half-yearly instalments of approximately \$13 609.45, including principal and interest on 17 December and June in each year during the currency of the loan and a final payment of \$116 686.41. The first instalment shall be payable on 17 June 1980.

5. Such moneys shall be repayable at the Australia and New Zealand Banking Group or at the Council's Bankers for the time being in Melbourne.

The plans and specifications and the estimate of the cost of the proposed works and a statement showing the proposed expenditure of the moneys to be borrowed are open for inspection at the Town Hall, Port Melbourne, during office hours.

3097 F. C. JACKSON, Town Clerk

## CITY OF RICHMOND

LOAN No. 65

*Notice of Intention to Borrow the Sum of \$300 000 for Permanent Works and Undertakings*

Notice is hereby given that the Council of the City of Richmond proposes to borrow the sum of \$300 000 (Three hundred thousand dollars) secured by a charge over the General Rates of the Municipality, such sum to be raised by the grant of a mortgage in accordance with the provisions of the Local Government Act 1958.

1. The amount of the Principal moneys which it is proposed to borrow is \$300 000.

2. The rate of interest to be paid is 10.8 per centum per annum.

3. The period of the loan shall be fifteen years.

4. The times which the moneys borrowed are repayable are on 12 December and 12 June during the years 1980 to 1994, and the place such moneys shall be repayable is at the Commonwealth Savings Bank of Australia or at the Council's Bankers for the time being in Melbourne.

5. The purpose for which the loan is to be applied is for:—

	\$
(a) Improvements to Recreation area, Coppin Street	10 000
(b) Improvements to Council property, Lord Street	10 000
(c) Council contribution, including Consultant fees for Bridge Road and Church Street design and construction	100 000
(d) Fees for the design and the construction of various kerb and channel adjustments to roads	180 000

6. The manner in which the loan is to be liquidated is by provision within the municipal funds each half-year during the currency of the loan by the payment of interest and the repayment of principal to be made by 30 (thirty) equal half-yearly instalments of \$20 414.19. The first instalment shall be payable on 12 June 1980.

Dated 29 October 1979

3151 CHAS. C. EYRES, Town Clerk

## CITY OF SPRINGVALE

LOAN No. 186

*Notice of Intention to Borrow the Sum of \$150 000 for Permanent Works and Undertakings*

Notice is hereby given that the Council of the City of Springvale proposes to borrow the principal sum of \$150 000 secured by a charge over the general rates of the municipality, such sum to be raised by the grant of a mortgage in accordance with the provisions of the Local Government Act 1958.

1. The maximum rate of interest that may be paid is 10.8 per cent per annum.

2. The purposes for which the loan is to be applied are:—

	\$
(a) M.M.B.W. Land Purchase	64 000
(b) Land Purchase Extension—Keysborough Reserve, West Side	26 000
(c) Racecourse Road Reserve—Toilet Block (Part Cost)	5 000
(d) Automatic Water Systems—	
Alex Nelson Reserve	10 000
Beazley Reserve	10 000
Edinburgh Reserve	12 000
(e) Dingley Hall and Community Centre—Construction of Car Park	23 000

3. The period of the loan shall be ten years.

4. The moneys borrowed shall be repayable by providing out of the municipal fund half-yearly instalments of approximately \$12 447.98 each including principal and interest on 17 June and 17 December during the currency of the loan and the first instalment shall be payable on 17 June 1980. Such moneys shall be repayable at the Australia and New Zealand Savings Banks Limited, 55 Collins Street, Melbourne.

The plans and specifications and the estimate of the cost of such works and a statement showing the proposed expenditure of the moneys to be borrowed are open for inspection by ratepayers, during office hours, at the City Offices, Civic Centre, Springvale Road, Springvale, for one month after the publication of this notice.

3090 K. D. MOODY, Town Clerk

*Town and Country Planning Act 1961 (Twelfth Schedule)*

## TOWN OF BAIRNSDALE—BAIRNSDALE PLANNING SCHEME

NOTICE THAT A PLANNING SCHEME HAS BEEN PREPARED AND IS AVAILABLE FOR INSPECTION

## Amendment No. 24

Notice is hereby given that the Council of the Town of Bairnsdale in pursuance of its powers under the *Town and Country Planning Act 1961*, has prepared a planning scheme for the purpose of:—

Amending the planning scheme map with particular reference to rural areas within the Township and with substantial amendment to the planning ordinance affecting many zones and conditions.

A copy of the scheme has been deposited at the Town Offices, Nicholson Street, Bairnsdale, and at the office of the Town and Country Planning Board, 235 Queen Street, Melbourne, and will be open for inspection during office hours by any persons free of charge.

Any persons affected by the Planning Scheme are required to set forth in writing all objections they may have addressed to the Town Clerk, Town of Bairnsdale, P.O. Box 485, Bairnsdale, 3875, on or before 30 November 1979 and to state whether they wish to be heard in respect of their objections.

Dated 25 October 1979

3099 G. G. McWHINNEY, Town Clerk

**Town and Country Planning Act 1961 (Twelfth Schedule)**  
**TOWN OF BAIRNSDALE—BAIRNSDALE PLANNING**  
**SCHEME**

NOTICE THAT A PLANNING SCHEME HAS BEEN PREPARED AND IS AVAILABLE FOR INSPECTION

**Amendment No. 25**

Notice is hereby given that the Council of the Town of Bairnsdale in pursuance of its powers under the Town and Country Planning Act 1961, has prepared a planning scheme for the purpose of:—

Amending the Planning Scheme map to rezone a number of areas within the Township to varying types of reservations.

A copy of the scheme has been deposited at the Town Offices, Nicholson Street, Bairnsdale and at the office of the Town and Country Planning Board, 235 Queen Street, Melbourne and will be open for inspection during office hours by any persons free of charge.

Any persons affected by the Planning Scheme are required to set forth in writing all objections they may have addressed to the Town Clerk, Town of Bairnsdale, P.O. Box 485, Bairnsdale, 3875, on or before 31 January 1980, and to state whether they wish to be heard in respect of their objections.

Dated 25 October 1979

3100

G. G. McWHINNEY, Town Clerk

**Town and Country Planning Act 1961 (Twelfth Schedule)**  
**TOWN OF BAIRNSDALE—BAIRNSDALE PLANNING**  
**SCHEME**

NOTICE THAT A PLANNING SCHEME HAS BEEN PREPARED AND IS AVAILABLE FOR INSPECTION

**Amendment No. 26**

Notice is hereby given that the Council of the Town of Bairnsdale in pursuance of its powers under the Town and Country Planning Act 1961, has prepared a planning scheme for the purpose of:—

Re-zoning 2-4 Robb Street (Lot 2 L.P. 2488) Bairnsdale from Public Open Space to Residential A.

A copy of the scheme has been deposited at the Town Offices, Nicholson Street, Bairnsdale and at the office of the Town and Country Planning Board, 235 Queen Street, Melbourne and will be open for inspection during office hours by any persons free of charge.

Any persons affected by the Planning Scheme are required to set forth in writing all objections they may have addressed to the Town Clerk, Town of Bairnsdale, P.O. Box 485, Bairnsdale, 3875, on or before 31 January 1980, and to state whether they wish to be heard in respect of their objections.

Dated 25 October 1979

3101

G. G. McWHINNEY, Town Clerk

**BOROUGH OF EAGLEHAWK**  
**CHANGE OF STREET NAME**

Notice is hereby given that the Council of the Borough of Eaglehawk ordered on 18 October 1979, pursuant to the Local Government Acts, that Arblaster Street north-east of Bright Street be re-named Oswald Street.

3088

A. J. SMARK, Town Clerk

Subdivision Number 75541 Parish of Bellarine being part of the land described in Certificate of Title Volume 8655 Folio 693 registered in the names of Russell Wayne Grant and Sandra Lillian Thelma Grant.

2. A copy of a plan of such land and a Schedule of the parties having interests therein are deposited at the Municipal Offices at Drysdale and are there available for inspection by all interested parties during office hours free of charge for the period of 40 clear days from the date of publication of this Notice in the *Government Gazette*.

3. The Council hereby requires all persons affected by the said proposal to set forth in writing addressed to the Shire Secretary, Shire of Bellarine, Shire Office, Drysdale, 3222 within 40 clear days from the date of publication aforesaid all objections which they may have to the taking of the said easement.

4. At the ordinary meeting of the Council next after the expiration of the said 40 clear days the Council will consider any such objection and any person so objecting as aforesaid may appear before the Council in support of such objection.

Dated 16 October 1979

By order of the Council

G. L. PEARCE, Shire Secretary

Harwood & Pincott, Geelong, solicitors for the Council

3051

**SHIRE OF BELLARINE**

NOTICE OF INTENTION TO ACQUIRE EASEMENT COMPULSORILY

To All Whom it may Concern—

Whereas the Council of the Shire of Bellarine deems it expedient to exercise its powers of taking land (including easements) compulsorily for the work or undertaking mentioned hereunder.

Notice is hereby given as follows—

1. The Council intends to acquire an easement for drainage purposes over all that strip of land two metres wide along and within the eastern boundary of Lot 70 on Plan of Subdivision Number 75541 Parish of Bellarine being part of the land described in Certificate of Title Volume 8655 Folio 694 registered in the name of Gary Charles Hooper.

2. A copy of a plan of such land and a Schedule of the parties having interests therein are deposited at the Municipal Offices at Drysdale and are there available for inspection by all interested parties during office hours free of charge for the period of 40 clear days from the date of publication of this Notice in the *Government Gazette*.

3. The Council hereby requires all persons affected by the said proposal to set forth in writing addressed to the Shire Secretary, Shire of Bellarine, Shire Office, Drysdale, 3222 within 40 clear days from the date of publication aforesaid all objections which they may have to the taking of the said easement.

4. At the ordinary meeting of the Council next after the expiration of the said 40 clear days the Council will consider any such objection and any person so objecting as aforesaid may appear before the Council in support of such objection.

Dated 16 October 1979

By order of the Council

G. L. PEARCE, Shire Secretary

Harwood & Pincott, Geelong, solicitors for the Council

3052

**SHIRE OF BELLARINE**

NOTICE OF INTENTION TO ACQUIRE EASEMENT COMPULSORILY To All Whom it may Concern—

Whereas the Council of the Shire of Bellarine deems it expedient to exercise its powers of taking land (including easements) compulsorily for the work or undertaking mentioned hereunder.

Notice is hereby given as follows—

1. The Council intends to acquire an easement for drainage purposes over all that strip of land two metres wide along and within the eastern boundary of Lot 69 on Plan of

**SHIRE OF BELLARINE**

LOAN No. 95

*Notice of Intention to Borrow the Sum of \$400 000 for Permanent Works and Undertakings*

Notice is hereby given that the Council of the Shire of Bellarine proposes to borrow the principal sum of Four Hundred Thousand Dollars secured by a charge over the general rates of the municipality, such sum to be raised by the grant of a mortgage in accordance with the provisions of the *Local Government Act 1958*.

1. The maximum rate of interest that may be paid is 10.8 per centum per annum.

2. The purposes for which the loan is to be applied are:

	\$
Purchase of Clifton Springs Community Centre—Payment 5 (Part Cost)	42 750
Purchase of Quarry and Land—Found's Road, Drysdale—Payment 1 (Part Cost)	90 000
Purchase of Moolap Depot Site—Payment 2 (Part Cost)	6 250
Purchase of Pre-school Centre Site—Apollo Drive, Whittington—Payment 3 (Part Cost)	6 000
Construction of Community Hall, Whittington (Part Cost)	20 000
Construction of Pre-school Centre—Apollo Drive—Payment 3	12 000
Construction of Pre-school Centre—Clifton Springs	100 000
Clifton Springs Community Centre—Minor Capital Works	25 000
Depot Improvements—Drysdale, Moolap, Clifton Springs, Portarlinton and Ocean Grove	15 000
Purchase of Relocatable Building Field Street, Ocean Grove—Kerb and Channelling	5 000
Smythe Street West, Portarlinton Outlet Drainage (Part Cost)	15 000
Major Drainage Works—Vicinity of Portarlinton Road, Newcomb (Part Cost)	36 000
	27 000
	400 000

3. The period of the loan shall be 10 years.

4. The moneys borrowed shall be repayable by providing out of the municipal fund half-yearly instalments of approximately \$24 601.48 each including principal and interest on 1 June and 1 December during the currency of the loan, (with a final instalment of \$304 604.70 payable on 1 December 1989. The first instalment shall be payable on 1 June 1980.

5. Such moneys shall be repayable to the National Bank of Australasia Limited, Newcombe Street, Portarlinton.

The plans and specifications and the estimate of the cost of the proposed works and a statement showing the proposed expenditure of the moneys to be borrowed are open for inspection at the office of the Council of the Shire of Bellarine, at Drysdale.

31 October 1979

3098

G. L. PEARCE, Shire Secretary

SHIRE OF CRANBOURNE SEWERAGE AUTHORITY  
GENERAL NOTICE

The Shire of Cranbourne Sewerage Authority, having made provision for carrying of sewage from each and every property which or any part of which is within the sewerage area hereinafter described hereby declares that on and after 1 October 1979, each and every property which or any part of which is within the said sewerage area shall be deemed to be a sewerage property within the meaning of the *Sewerage Districts Act 1958*. The boundaries of the sewerage area hereinbefore referred to are:—

Description—Declared Area No. 38

Comprising Lots 1 and 2 of the Fetch subdivision, Frankston—Dandenong Road, Carrum Downs North, formerly being Lot 2 of L.P. 64575.

By order of the Shire of Cranbourne Sewerage Authority  
G. WOOD, Chairman  
T. VICKERMAN, Secretary

3107

SHIRE OF ELTHAM

LOAN No. 146

Notice of Intention to Borrow the Sum of \$150 000 for  
Permanent Works and Undertakings

Notice is hereby given that the Council of the Shire of Eltham proposes to borrow the principal sum of \$150 000 secured by a charge over the general rates of the Municipality, such sum to be raised by the grant of a Mortgage in accordance with the provisions of the *Local Government Act 1958*.

1. The maximum rate of interest that may be paid is 10.8 per centum per annum.

2. The purposes for which the loan is to be applied are:

	\$
Eltham Swimming Pool and Games Hall Project (Part)	120 000
Roadworks—Bolton Street	20 000
Park Development—West Riding	10 000
	150 000

3. The period of the loan shall be 15 years.

4. The moneys borrowed shall be repayable by providing out of the Municipal Fund 30 half-yearly instalments of \$10 207.09 each, including principal and interest on 10 June and 10 December during the currency of the loan. The first instalment to be repayable on 10 June 1980.

5. Such moneys borrowed shall be repayable to the Commercial Bank of Australia Ltd., 953 Main Road, Eltham.

The plans and specifications and the estimate of the cost of the abovementioned works and a statement showing the proposed expenditure of the moneys to be borrowed are open for inspection at the Office of the Shire of Eltham, Main Road, Eltham.

Dated 30 October 1979

3163

R. M. WALKER, Chief Executive Officer

Town and Country Planning Act 1961 (Twelfth Schedule)  
SHIRE OF FLINDERS PLANNING SCHEME 1962

NOTICE THAT A PLANNING SCHEME HAS BEEN PREPARED AND IS AVAILABLE FOR INSPECTION

Amendment No. 124, 1979

Notice is hereby given that the Shire of Flinders, in pursuance of its powers under the *Town and Country Planning Act 1961*, has prepared a Planning Scheme for rezoning of land between Weeroona Street, Rye, and Canterbury Jetty Road, Blairgowrie, for the purpose of a Freeway from Residential "A" zone, Residential "B" zone and Reserves for Public Purposes (Recreation) to New Freeway.

A copy of the Scheme has been deposited at the Office of the Responsible Authority, Municipal Offices, Boneo Road, Rosebud, and at the Office of the Town and Country Planning Board, 235 Queen Street, Melbourne, and will be open for inspection during office hours by any person free of charge.

Any persons affected by the Planning Scheme are required to set forth in writing all objections they may have addressed to the Shire Secretary, Shire of Flinders, Municipal Offices, Boneo Road, Rosebud 3939, on or before 31 January 1980, and state whether they wish to be heard in respect of these objections.

24 October 1979

3070

G. W. WHITE, Shire Secretary

Town and Country Planning Act 1961 (Twelfth Schedule)  
SHIRE OF FLINDERS PLANNING SCHEME 1962

NOTICE THAT A PLANNING SCHEME HAS BEEN PREPARED AND IS AVAILABLE FOR INSPECTION

Amendment No. 125, 1979

Notice is hereby given that the Shire of Flinders, in pursuance of its powers under the *Town and Country Planning Act 1961*, has prepared a Planning Scheme for rezoning of Lots 73 and 74, L/P22177 Noel Street, Dromana, from Residential "A" zone to Special Uses "S" zone.

A copy of the Scheme has been deposited at the Office of the Responsible Authority, Municipal Offices, Boneo Road, Rosebud, and at the Office of the Town and Country Planning Board, 235 Queen Street, Melbourne, and will be open for inspection during office hours by any person free of charge.

Any persons affected by the Planning Scheme are required to set forth in writing all objections they may have addressed to the Shire Secretary, Shire of Flinders, Municipal Offices, Boneo Road, Rosebud 3939, on or before 30 November 1979 and state whether they wish to be heard in respect of these objections.

24 October 1979

3071 G. W. WHITE, Shire Secretary

Town and Country Planning Act 1961 (Twelfth Schedule)

SHIRE OF FLINDERS PLANNING SCHEME 1962

NOTICE THAT A PLANNING SCHEME HAS BEEN PREPARED AND IS AVAILABLE FOR INSPECTION

Amendment No. 126, 1979

Notice is hereby given that the Shire of Flinders, in pursuance of its powers under the Town and Country Planning Act 1961, has prepared a Planning Scheme for rezoning of land owned by the Council with frontage to Truemans Road, West Rosebud, from Public Purposes Reserve (proposed)—Municipal Purposes—Caravan Park to Public Open Space Reserve (existing) Recreation.

A copy of the Scheme has been deposited at the Office of the Responsible Authority, Municipal Offices, Boneo Road, Rosebud, and at the Office of the Town and Country Planning Board, 235 Queen Street, Melbourne, and will be open for inspection during office hours by any person free of charge.

Any persons affected by the Planning Scheme are required to set forth in writing all objections they may have addressed to the Shire Secretary, Shire of Flinders, Municipal Offices, Boneo Road, Rosebud 3939, on or before 31 January 1980 and state whether they wish to be heard in respect of these objections.

24 October 1979

3072 G. W. WHITE, Shire Secretary

SHIRE OF KERANG

Notice is hereby given that the Shire of Kerang has applied for a lease pursuant to section 134 of the Land Act 1958 for a term of 21 years in respect of an area of 12 acres 1 rood 39 perches being the Allotment 31c, section C, in the Parish of Benjeroop as a site for providing accommodation and facilities for tourists. (Reference L.5-389.)

2683

P. L. WIGNALL, Shire Secretary

SHIRE OF KORUMBURRA

LOAN No. 87

Notice of Intention to Borrow the Sum of \$150 000 for Permanent Works and Undertakings

Notice is hereby given that the Council of the Shire of Korumburra proposes to borrow the principal sum of One hundred and fifty thousand dollars secured by a charge over the General rates of the Municipality, such sum to be raised by a grant of a mortgage in accordance with the provisions of the Local Government Act 1958.

1. The maximum rate of interest to be paid is 10.8 per cent.

2. The purpose of the loan is—

	\$
Korumburra, Saleyards' Extensions	130 000
Industrial Estate Development	20 000

3. The period of the loan is 10 years.

4. The money borrowed shall be repayable by providing out of the Municipal fund half-yearly instalments, including principal and interest on 20 June and 20 December during the currency of the loan. The first instalment shall be payable on 20 June 1980.

5. Such moneys shall be repayable to the Commonwealth Savings Bank of Australia, Korumburra.

The plans and specifications together with the estimate of costs of the proposed works and a statement showing the proposed expenditure of the moneys to be borrowed are open for inspection at the Shire Office, Korumburra.

3067

W. O. CLARK, Shire Secretary

SHIRE OF MANSFIELD SEWERAGE AUTHORITY

CONSTRUCTION OF SEWERAGE WORKS

Notice is hereby given that the Shire of Mansfield Sewerage Authority intends to construct sewers in the area bounded by Highton Lane, Ogilvies Lane, Crosby's Lane and Mt. Buller Road, Mansfield.

Plans and specifications may be inspected at the Authority's office, 46-48 High Street, Mansfield between the hours of 9 a.m.-5 p.m.

3074

G. D. PAYNE, Secretary

SHIRE OF METCALFE

NOTICE OF INTENTION TO BORROW \$40 000 FOR PERMANENT WORKS AND UNDERTAKINGS

Notice is hereby given that the Council of the Shire of Metcalfe proposes to borrow the sum of \$40 000 secured by a charge over the general rates of the municipality, such sum to be raised by the grant of a Mortgage in accordance with the provisions of the Local Government Act 1958, and states—

1. The amount of the principal moneys which it is proposed to borrow is Forty thousand dollars.

2. The maximum rate of interest that may be paid is 10.7 per centum per annum.

3. The purposes for which the loan is to be applied is the purchase of road making plant and equipment—Front End Loader, and completion of renovations to Chewton Post Office and Residence.

4. The period of the loan shall be seven years.

5. The moneys borrowed shall be repayable out of the municipal fund by fourteen half-yearly instalments of \$4131.89 each including principal and interest.

6. Such moneys shall be repayable to the National Bank Savings Bank, Kyneton.

The plans and specifications and the estimate of the cost of the proposed works and a statement showing the proposed expenditure of the moneys to be borrowed are open for inspection at the Shire Office, Metcalfe.

Dated 23 October 1979

3073

J. R. DENNIS, Shire Secretary

Town and Country Planning Act 1961 (Twelfth Schedule)

SHIRE OF MORNINGTON PLANNING SCHEME 1959  
(AS AMENDED)

NOTICE THAT A PLANNING SCHEME HAS BEEN PREPARED AND IS AVAILABLE FOR INSPECTION

Amendment No. 125, 1979

Notice is hereby given that the Council of the Shire of Mornington in pursuance of its powers under the Town and Country Planning Act 1961 has prepared a Planning Scheme for—

Land bounded by Bungower Road, Balcombe Creek, Tyabb Road and Roberts Road, Mornington, to rationalise the Special Uses 1 and Rural Residential 1 Zones so as to consolidate the Special Uses 1 Zone at the northern end of Roberts Road, with discretionary provisions in regard to the width of accessways to two contiguous battleaxe allotments within the Rural Residential and Special Uses Zones.

A copy of the Scheme has been deposited at the office of the Council, Queen Street, Mornington, and at the office of the Town and Country Planning Board, 235 Queen Street, Melbourne, and will be open for inspection during office hours by any person free of charge.

Any persons affected by the Planning Scheme are required to set forth in writing all objections they may have, addressed to the Shire Secretary, Mornington Shire Council, P.O. Box 78, Mornington, 3931, on or before 30 November 1979, and to state whether they wish to be heard in respect of their objections.

31 October 1979

3103

D. G. COLLINGS, Shire Secretary

*Town and Country Planning Act 1961 (Twelfth Schedule)*  
SHIRE OF MORNINGTON PLANNING SCHEME 1959 (AS AMENDED)

NOTICE THAT A PLANNING SCHEME HAS BEEN PREPARED AND IS AVAILABLE FOR INSPECTION  
Amendment No. 114, 1979

Notice is hereby given that the Council of the Shire of Mornington in pursuance of its powers under the *Town and Country Planning Act 1961* has prepared a Planning Scheme for land on the corner of Tanti Avenue and Barkly Street, Mornington, rezoning from Special Use 1 Zone to Residential Medium Density 1 Zone.

A copy of the Scheme has been deposited at the office of the Council, Queen Street, Mornington, and at the office of the Town and Country Planning Board, 235 Queen Street, Melbourne, and will be open for inspection during office hours by any person, free of charge.

Any persons affected by the Planning Scheme are required to set forth in writing all objections they may have, addressed to the Shire Secretary, Mornington Shire Council, P.O. Box 78, Mornington 3931, on or before 30 November 1979, and to state whether they wish to be heard in respect of their objections.

31 October 1979

3102

D. G. COLLINGS, Shire Secretary

*Town and Country Planning Act 1961 (Twelfth Schedule)*  
SHIRE OF MORNINGTON PLANNING SCHEME 1959 (AS AMENDED)

NOTICE THAT A PLANNING SCHEME HAS BEEN PREPARED AND IS AVAILABLE FOR INSPECTION  
Amendment No. 126, 1979

Notice is hereby given that the Council of the Shire of Mornington in pursuance of its powers under the *Town and Country Planning Act 1961* has prepared a Planning Scheme for—

Land in Tanti Avenue, Mornington known as "Sutton Grange" rezoning from "Public Purposes Reservation—Victoria Police Department" to Residential Medium Density 1 Zone.

A copy of the Scheme has been deposited at the office of the Council, Queen Street, Mornington, and at the office of the Town and Country Planning Board, 235 Queen Street, Melbourne, and will be open for inspection during office hours by any persons free of charge.

Any persons affected by the Planning Scheme are required to set forth in writing all objections they may have, addressed to the Shire Secretary, Mornington Shire Council, P.O. Box 78, Mornington, 3931, on or before 31 January 1980, and to state whether they wish to be heard in respect of their objections.

31 October 1979

3104

D. G. COLLINGS, Shire Secretary

*Town and Country Planning Act 1961 (Twelfth Schedule)*  
SHIRE OF MORNINGTON PLANNING SCHEME 1959 (AS AMENDED)

NOTICE THAT A PLANNING SCHEME HAS BEEN PREPARED AND IS AVAILABLE FOR INSPECTION  
Amendment No. 127, 1979

Notice is hereby given that the Council of the Shire of Mornington in pursuance of its powers under the *Town and Country Planning Act 1961* has prepared a Planning Scheme for—

Land at 105 Main Street and 77-81 Tanti Avenue, Mornington rezoning from Sub-Regional Business and Residential Medium Density 1 Zones (respectively) to "Proposed Road" for the purpose of pedestrian ways; and land at 34 Spray Street rezoning from Residential Medium Density 1 Zone to Public Purpose Reserve—Municipal Car Park.

A copy of the Scheme has been deposited at the office of the Council, Queen Street, Mornington, and at the office of the Town and Country Planning Board, 235 Queen Street, Melbourne, and will be open for inspection during office hours by any person; free of charge.

Any persons affected by the Planning Scheme are required to set forth in writing all objections they may have, addressed to the Shire Secretary, Mornington Shire Council, P.O. Box 78, Mornington 3931, on or before 31 January 1980, and to state whether they wish to be heard in respect of their objections.

31 October 1979

3105

D. G. COLLINGS, Shire Secretary

SHIRE OF ORBOST

ROAD NAME

The Council of the Shire of Orbost has assigned a name to the road previously un-named and described below:—

That road bounded by allotments 1 to 15 of Section 18 in the Township of Mallacoota.

New Name—Commercial Road.

A plan showing the above road is available for inspection at the Shire Offices, Orbost.

3049

R. E. VERNON, Shire Secretary

SHIRE OF WOORAYL

NAMING OF STREET

The Council of the Shire of Woorayl has resolved that the unnamed Government Road between Crown Allotments 7 and 8 Section 7 in the Township and Parish of Leongatha, together with the road set out on Plan of Subdivision 123355, shall be named Haw Street.

3066

R. G. STANLEY, Shire Secretary

SHIRE OF WYCHEPROOF

LOAN No. 70

Notice of Intention to Borrow the Sum of \$117 500 for Permanent Works and Undertakings

Notice is hereby given that the Council of the Shire of Wycheproof proposes to borrow the principal sum of \$117 500, secured by a charge over the general rates of the municipality, such sum to be raised by the grant of a mortgage in accordance with the provisions of the *Local Government Act 1958*.

1. The loan is interest-free.

2. The purposes for which the loan is to be applied is part cost of construction of the Sea Lake and District Community Centre.

3. The period of the loan shall be 5 years.

4. The moneys borrowed shall be repayable by providing out of the municipal fund, annual instalments of \$23 500, the first instalment shall be payable on 4 February 1981.

5. Such moneys shall be repayable to the Department of Youth, Sport and Recreation, 570 Bourke Street, Melbourne.

The plans and specifications and the estimate of the cost of the Sea Lake and District Community Centre and a statement showing the proposed expenditure of the moneys to be borrowed are open for inspection at the office of the Council of the Shire of Wycheproof at 367 Broadway, Wycheproof.

Dated at Shire Office, Wycheproof 26 October 1979

3161

G. R. DRYDEN, Shire Secretary

I, Yvonne Maree Lendon of 9 Kars Street Beechworth in the State of Victoria Home Duties do hereby give notice that I have assumed the name and henceforth upon all occasions and at all times to use and be called and known by the surname of Lendon in lieu of the surname of McKenzie-McHarg and to use the name Yvonne Maree Lendon as my full name and that such intended change is endorsed by a Deed Poll dated 17 September 1979 and deposited in the Office of the Registrar General of the State of Victoria and numbered 86757.

Dated 23 October 1979

YVONNE MAREE LENDON

(formerly Yvonne Maree McKenzie-McHarg)

McSwineys, solicitors, 57 Reid Street, Wangaratta 3677

3039



**NOTICE OF INTENTION TO APPLY FOR A LICENCE TO DIVERT WATER AND CUT RACE (\*RE-ISSUE) FROM THE KING RIVER AT CHESHUNT**

We hereby give notice that we intend to apply for a Licence empowering us to divert water for a term of 15 years to the extent of 90 ML acre feet per annum at a maximum rate of 2 ML/D per day of 24 hours for the Irrigation of Tobacco, being part of Allotment 28 Part 15 and 12 Section 1 Parish of Whitfield, and to occupy certain Crown Lands for works of diversion, and to cut a race thereon.

Any objection to such application must be forwarded in writing to reach the State Rivers and Water Supply Commission, Melbourne before 29 November 1979 being thirty days from the first publication of this Notice.

VINCENT RITA  
L. BRIZZI

Box 35, Cheshunt

3149

**SEWERAGE DISTRICTS ACT  
PROPOSED SEWERAGE DISTRICT**

Notice is hereby given that the Shire of Mansfield has made application to the Minister of Water Supply for the proclamation of a Sewerage District at Bonnie Doon and for the construction, maintenance and continuance of sewerage works within that District under the provisions of the Sewerage Districts Act.

A general plan and description of the proposed works have been submitted with the application and copies of same may be seen at Shire Office, Mansfield.

Dated at Mansfield 17 October 1979

E. CAIRNS, Secretary

NOTE—The Act requires that this notice be published weekly for three weeks in a newspaper circulating locally and in the *Government Gazette*, and provides that within one month of the third notice in the *Government Gazette* any persons having an interest therein who is likely to be injuriously affected by the proposed sewerage works may forward to the Minister of Water Supply a petition seeking refusal or amendment to the application. In this case the period for objections will expire on 8 December 1979.

2956

**CRESWICK SEWERAGE AUTHORITY  
BY-LAW No. 1**

Notice is hereby given that the Creswick Sewerage Authority has made under the provisions of the *Sewerage Districts Act 1958* a by-law numbered 1 for the purpose of regulating consents, licences, fees, trade wastes and other matters relating to house connection works and that such by-law was approved by the Governor in Council at the Executive Council Meeting held on 11 September 1979.

A copy of the by-law is open for inspection free of charge during office hours at the office of the Sewerage Authority, Municipal Office, 68 Albert Street, Creswick, 3363.

3053

B. C. REES, Shire Secretary

**FRANKSTON SEWERAGE AUTHORITY  
COMMENCEMENT OF WORKS**

Notice is hereby given that the Authority intends constructing sewers between McKenzie Street and Margaret Avenue, Seaford.

Details of the proposed works are available for inspection at the office of the Authority, Civic Centre Annexe, 34 Davey Street, Frankston during office hours.

A. H. BUTLER, Secretary

Civic Centre Annexe, Frankston 3199

3106

Notice is hereby given that the Lakes Entrance Golf Club has applied for a Lease for a term of 21 years under Section 134 of the *Land Act 1958* of allotment 62, Township of Cunninghame containing approximately 64 hectares as a site for amusement and recreation (Golf Club).

3075

R. GRAY, Hon. Secretary

Notice is hereby given that the Merino Golf Club has applied for a lease under section 134 of the *Land Act 1958* for a term of 21 years for allotment 1, section 46, Parish of Merino containing 21 acres, 2 roods, 28 perches as a site for Amusement and Recreation.

2659

Notice is hereby given that the Boy Scouts Association, Victorian Branch, and Girl Guides Association of Victoria have applied for a lease pursuant to Section 134 of the *Land Act 1958* for a term of 21 years in respect of Crown Land in Section 30 at Eaglehawk Parish of Sandhurst containing approximately 6904 square metres as a site for amusement and recreation—Bendigo L.6—1608.

2660

Notice is hereby given that G. F. Cook Holdings Pty. Ltd. has applied for a lease pursuant to Section 134 of the *Land Act 1958* for a term of 10 years in respect of Allotment 2B Section 63B Parish of Melbourne South City of Port Melbourne containing 2046 square metres as a site for General Industrial purposes.

3024

The partnership of F. H. J. and C. A. Walker and D. S. and F. L. Haupt, trading as Baywood Panel Service was dissolved on 17 August 1979. Hence no further debts and liabilities will be accepted under this partnership.

F. H. J. and C. A. Walker will continue the business trading as Baywood Panel Service.

3058

**LEGAL NOTICE**

Take notice that on 16 October 1979 a partnership carried on between Rodney James Stephenson of 84 Marshall Road, Airport West of the one part and Anthony Cunningham of 351 Watlington Road, East Malvern, Victoria and Colin Fairbrother of 538 Military Road, Mosman, N.S.W. (both of the other two parts) trading under the registered business name of Copier Technicians Sales & Service Co. and carrying on business at premises situate and known as 480 St. Kilda Road, Melbourne in the State of Victoria and engaged in the business of service and sales of photocopiers and associated activities, did forthwith determine and cease to carry on business.

B. J. FORSYTH, barrister and solicitor, 147 Lincoln Road, Essendon, Vic. 3040 for and on behalf of the said Rodney James Stephenson

3043

Take notice that the partnership between ourselves registered and known as David Johnson Mens & Boys Wear by a written Agreement dated 30 December 1977 is hereby dissolved pursuant to Section 36 (c) of the *Partnership Act 1958* as and from 27 June 1979.

Dated 25 October 1979

3145

DAVID LINDSAY JOHNSON

Notice is hereby given that the partnership heretofore subsisting between John Anthony Murgia of 20 Mt. Pleasant Road, West Preston in the State of Victoria, and Jenny Donoudis formerly of 3/50 Packington Street, Kew but now of 22/154 Rathmines Road, Hawthorn in the said State, who carried on business as Retailers of ladies' garments under the firm name of Gianca at Shop 5, Myer House Arcade, 250 Elizabeth Street, Melbourne in the said State, was dissolved as from 26 February 1979 insofar as concerned the said John Anthony Murgia who retired from the said firm on that date.

Dated 23 October 1979

J. A. MURGIA

Perillo, Adami & Frank, solicitors, of 209 Nicholson Street, Footscray

3153

**B. J. & G. CARTER, TRADING AS ORCHARD CLOSE ARABIAN STUD**

Take notice that Mr Michael Ashley Coppins of Wilson Bishop Bowes & Craig, 271 William Street, Melbourne was appointed Receiver and Manager of the abovementioned partnership on 5 October pursuant to an Order of the Supreme Court of Victoria, for the purpose of winding up the affairs of the said partnership.

Notice is also given that after 21 days from this date I shall proceed to distribute the assets of the partnership. All creditors having any claims against the partnership should furnish particulars of such claims to the undersigned by that date, otherwise I shall proceed to distribute the assets without regard to their claim.

Dated 31 October 1979

MICHAEL A. COPPINS, Receiver and Manager  
Care of Wilson, Bishop, Bowes & Craig, 271 William Street, Melbourne 3000 3118

*Companies Act 1961*

SELECT PRINTING PTY. LIMITED (IN VOLUNTARY LIQUIDATION)

Notice is hereby given in pursuance of Section 272 of the Companies Act 1961, that a Final Meeting of the Members of Select Printing Pty. Limited will be held at 284 Sydney Road, Coburg on 3 December 1979 at Six O'Clock in the afternoon for the purpose of having the Liquidator's Account laid before them showing the manner in which the winding up has been conducted and the property of the Company disposed of and of hearing any explanation that may be given by the Liquidator.

Dated 22 October 1979

3044 K. D. FERGUSON, Liquidator

In the matter of the Companies Act 1961; and in the matter of DAMOND PTY. LIMITED (in Voluntary Liquidation)—Notice Pursuant to Section 272 of the Companies Act 1961

Notice is hereby given that in accordance with Section 272 of the Companies Act 1961 (as amended) a final General Meeting of the Company will be held at the offices of the Liquidator, C/- Rezak, Bendel & Rochman, 3rd Floor, 390 St. Kilda Road, Melbourne on Wednesday, 5 December 1979 at 10 a.m. for the purpose of having laid before it by the Liquidator an account showing how the winding up has been conducted and the property of the Company disposed of.

Dated 23 October 1979

3045 E. ROCHMAN, Liquidator

*Companies Act 1961*—In the matter of TENNESSEE ENGINEERING PTY. LTD. (in Liquidation)

Notice is hereby given that at an extraordinary Meeting of the Members of the abovenamed Company held on 22 October 1979; it was resolved that the Company be wound up voluntarily and at a Meeting of Creditors held on the same day pursuant to Section 260, it was resolved that for such purpose Everett Thomson Bent of Suite 18, 545 St. Kilda Road, Melbourne, Public Accountant, be appointed Liquidator.

Notice is also given that after 21 days from this date I shall proceed to distribute the assets. All creditors having any claims against the Company should furnish particulars of same by that date, otherwise I shall proceed to distribute the assets without regard to their claim.

Dated 23 October 1979

E. T. BENT, Liquidator  
Bent & Cogle, public accountants, Suite 18, 545 St. Kilda Road, Melbourne 3004 3047

*Companies Act 1961*—In the matter of POLMAC INDUSTRIES PTY. LTD., of Unit 7, 8 Hamlet Street, Cheltenham—Notice Re Meeting of Creditors, Pursuant to Section 260

Notice is hereby given that a Meeting of Creditors of the abovenamed Company will be held at Suite 18, 545 St. Kilda Road, Melbourne on Wednesday, 14 November 1979 at 11.00 a.m., the Company having convened a Meeting of its Members for the same day for the purpose of considering a Resolution that the Company be wound up voluntarily.

Dated 23 October 1979

D. WOLLERT, Director  
M. SUNDSTROM, Director  
Bent & Cogle, public accountants, Suite 18, 545 St. Kilda Road, Melbourne 3004 3046

*Companies Act 1961, Section 254 (2)*

FRANLIGHT PTY. LTD. (IN LIQUIDATION)

Notice is hereby given that at an Extraordinary Meeting of Members of the abovenamed Company held on Monday, 22 October 1979, the following Special Resolutions were duly passed:

"That as Franlight Pty. Ltd., could not pay its debts as and when they fell due, that the Company should be wound up voluntarily."

"That David Henry Scott, a Registered Company Liquidator, be appointed to act as Liquidator of Franlight Pty. Ltd., and to attend to all matters necessary for the winding up of the Company."

At a meeting of creditors held the same day, my appointment as Liquidator was confirmed.

Notice is also given that all creditors having claims against the Company should furnish particulars of such claims to the undersigned within 21 days, otherwise I shall proceed to distribute the assets without regard to their claim.

D. H. SCOTT, Liquidator

Scott and Lamb, 325 Warrigal Road, Burwood, Vic., 3125. Telephone 288 5911 3048

*Companies Act 1961*—In the matter of LOTUS BODY WORKS PTY. LTD.—Notice Re Meeting of Creditors, Pursuant to Section 260

Notice is hereby given that a meeting of creditors of the abovenamed company will be held at the Meeting Room, B. K. Taylor & Co., 3rd Floor, Dairy Industry House, 576 St. Kilda Road, Melbourne, on Thursday 15 November 1979, at 11.00 a.m. the company having convened a meeting of its members for the same day for the purpose of considering a Resolution that the company be wound up voluntarily.

Dated 24 October 1979

G. KARADIMOS, Director

B. K. Taylor & Co., accountants, 576 St. Kilda Road, Melbourne, Vic. 3004 3059

*The Companies Act 1961*—In the matter of ORIENA INTERNATIONAL PTY. LTD.—Notice of Meeting of Creditors, Pursuant to Section 260

Notice is hereby given that a meeting of creditors of the abovenamed company will be held at the Committee Room, Victoria Club, 141 Queen Street, Melbourne, at 10.15 a.m. on 8 November 1979 the company having convened a Meeting of its Members for the same day for the purpose of considering a Resolution that the company be wound up voluntarily.

Dated 23 October 1979

W. HAUW, Director

R. D. Widdows, 703 South Road, Moorabbin, 3189 3060

WHELAN THE WRECKER FINANCE PROPRIETARY LIMITED

At an extraordinary general meeting of shareholders of Whelan the Wrecker Finance Pty. Ltd. duly convened and held at 605 Sydney Road, Brunswick on 17 October 1979, the following special resolution was duly passed—

"That the company be wound up voluntarily and that John Muller be appointed as liquidator."

COLEMAN, McCLURE AND WILBY, 367 Victoria Street, Abbotsford, 3067 3061

*The Companies Act 1961*

BALCLUTHA INVESTMENTS PTY. LTD.

At a general meeting of the members of the above named Company, duly convened and held at 434 Nepean Highway, Frankston the following special resolution was duly passed.

"That the Company be wound up voluntarily and that Douglas Ivan Perry of 434 Nepean Highway, Frankston be appointed Liquidator for the purpose of the Winding Up."

Dated 18 October 1979

3062 N. CREASER, Director

In the matter of the Companies Act 1961; and in the matter of BONDS WEAVING MILLS PTY. LIMITED (in Voluntary Liquidation)—Members' Voluntary Winding Up

Notice is hereby given that a final meeting of members of the abovenamed company will be held at the offices of Messrs Carpenter Owens, 50 Bridge Street Sydney on Tuesday 30 November 1979 at 9.30 a.m. for the purpose of receiving the Liquidator's account and his report upon the winding-up.

Dated 31 October 1979

C. J. CARPENTER, liquidator, 50 Bridge Street, Sydney, 2000 3063

In the matter of the Companies Act 1961; and in the matter of SHOE WORLD PROPRIETARY LIMITED (in Voluntary Liquidation)—Notice Pursuant to Section 272 of the Companies Act 1961

Notice is hereby given that in accordance with Section 272 of the Companies Act 1961 (as amended) a final General Meeting of the Company will be held at the offices of the Liquidator, C/- Rezak, Bendel & Rochman, 3rd Floor, 390 St. Kilda Road, Melbourne on Wednesday 5 December 1979 at 10.30 a.m. for the purpose of having laid before it by the Liquidator an account showing how the winding up has been conducted and the property of the Company disposed of.

Dated 24 October 1979  
3064

E. ROCHMAN, Liquidator

In the Supreme Court of Victoria—Co. No. 10981 of 1979—In the matter of the Companies Act 1961; and in the matter of AVA CONSTRUCTIONS PTY. LTD.

Notice is hereby given that a Petition for the winding up of the abovenamed Company by the Supreme Court was, on 14 September 1979, presented by Consolidated Partition Industries Holdings Pty. Ltd. And that the said Petition is directed to be heard before the Court sitting at Melbourne at the hour of 10.30 o'clock in the forenoon on 29 November 1979, and any creditor or contributory of the said Company desiring to support or oppose the making of an Order on the said Petition may appear at the time of hearing by himself or his Counsel for that purpose; and a copy of the Petition will be furnished to any creditor or contributory of the said Company requiring the same by the undersigned on payment of the regulated charge for the same.

The Petitioner's address is 14-16 Williamsons Road, Maribyrnong, Victoria.

The Petitioner's solicitors are Messrs G. W. P. Aarons & Co., of 3rd Floor, 380 Lonsdale Street, Melbourne.

G. W. P. AARONS & CO.

NOTE—Any person who intends to appear on the hearing of the said Petition must serve on, or send by post to, the abovenamed Solicitors, notice in writing of his intention so to do. The notice must state the name and address of the person, or, if a firm, the name and address of the firm and must be signed by the person or firm or his or their Solicitor (if any) and must be served or, if posted, must be sent by post in sufficient time to reach the abovenamed not later than 4.00 o'clock in the afternoon of 28 November 1979. 3065

#### SINCLAIR INVESTMENTS PROPRIETARY LIMITED

##### NOTICE OF VOLUNTARY LIQUIDATION

At an Extraordinary General Meeting of Sinclair Investments Proprietary Limited held at 104 Liebig Street, Warrnambool on 24 October 1979 the following resolutions were passed as Special Resolutions:—

1. That the company be wound up voluntarily and that William Robert Phillpot of Mortlake Road, Warrnambool, Accountant, be and he is hereby appointed Liquidator for the purpose of such winding up.

2. That the Liquidator be and he is hereby authorized when and so soon as the debts and liabilities of the company have been paid and satisfied or duly provided for to distribute in specie or kind amongst the members of the

company in accordance with their respective rights, and interest therein the whole or any part of the assets of the company as he shall think fit.

WILLIAM R. PHILLPOT, A.A.S.A., Liquidator

Sinclair & Wilson, public accountants, 104 Liebig Street, Warrnambool, Vic. 3280 3079

##### Companies Act, Section 254 (2) (b)

TAKE-A-GUIDE TRAVEL SERVICE (AUSTRALIA) PTY. LTD.

Notice is hereby given that at an Extraordinary General Meeting of the members of the abovenamed company held on 22 October 1979, it was resolved that the company be wound up voluntarily and that Michael Irvine Wansley of Messrs Yarwood Vane & Co., 461 Bourke Street, Melbourne, be appointed liquidator.

Notice is also given that after 21 days from this date I shall proceed to distribute the assets. All creditors having any claims against the company should furnish particulars of same by that date, otherwise I shall proceed to distribute the assets without regard to their claim.

Dated 23 October 1979

M. I. WANSLEY, Liquidator

Yarwood Vane & Co., 461 Bourke Street, Melbourne 3000 3078

#### LADY BAY AMUSEMENTS PROPRIETARY LIMITED

Notice is hereby given that, pursuant to section 272 of the Companies Act 1961, a meeting of members of the above-named company will be held at 104 Liebig Street, Warrnambool on Friday, 30 November 1979 at 10.30 o'clock in the forenoon for the purpose of having an account laid before them showing how the winding up of the company has been conducted and the property of the company disposed of.

Dated 24 October 1979

WILLIAM R. PHILLPOT, A.A.S.A., Liquidator

Sinclair & Wilson, public accountants, 104 Liebig Street, Warrnambool, Vic. 3280 3080

Companies Act 1961—In the matter of J. & J. FROZEN FOODS PTY. LTD.—Notice Re Meeting of Creditors, Pursuant to Section 260

Notice is hereby given that a meeting of creditors of the abovenamed company will be held at the Meeting Room, B. K. Taylor & Co., 3rd Floor Dairy Industry House, 576 St. Kilda Road, Melbourne, on Friday, 16 November 1979, at 11.00 a.m. the company having convened a meeting of its members for the same day for the purpose of considering a Resolution that the company be wound up voluntarily.

Dated 25 October 1979

J. McGRANE, Director

B. K. Taylor & Co., accountants, 576 St. Kilda Road, Melbourne, Vic. 3004 3081

##### Companies Act 1961-1975, Section 260 (2)

#### ENNIS CLAY PROPRIETARY LIMITED

##### NOTICE OF MEETING OF CREDITORS

Notice is hereby given that, pursuant to Section 260 (2) of the Companies Act 1961-1975, a meeting of Creditors of Ennisclay Proprietary Limited will be held at the Offices of Messrs Coffey and Co., Public Accountants, 67-69 Kepler Street, Warrnambool, on 15 November 1979, at 10 a.m. to consider the following proposed resolution to be placed before and considered by an extraordinary general meeting of the said Company to be held at 9.30 a.m. on the same day.

"That the Company be wound up voluntarily and that Mr Joseph James Purcell be and is now appointed Liquidator of the Company and that the provisions of Section 277A (1A) of the Companies Act shall not operate to invalidate the appointment of the above named Liquidator."

A person is not entitled to vote as a creditor at the meeting unless he has lodged with the Chairman of the meeting a proof of debt which he claims is due to him from the Company. 3082

GLOBE VENDING SERVICE PTY. LIMITED (IN LIQUIDATION)

GLOBE VENDING MUSIC PTY. LIMITED (IN LIQUIDATION)

NOTICE OF GENERAL MEETING

Notice is hereby given that a General Meeting of the members of the company in pursuance of Section 272 of the Companies Act will be held at 31st Level Australia Square, Sydney at 11.30 and 11.45 a.m. on 29 November 1979 for the purpose of:—

1. Having an account showing how the winding up has been conducted and the property of the company disposed of laid before them.

2. Hearing any explanation given by the Liquidator.

3. Determining by resolution the manner in which the books and papers of the company shall be disposed of.

Dated at Sydney 22 October 1979

3083

A. R. M. MACINTOSH, Liquidator

PORT FAIRY ROADWAYS PROPRIETARY LIMITED

Notice is hereby given that, pursuant to section 272 of the Companies Act 1961, a meeting of members of the above-named company will be held at 104 Liebig Street, Warrnambool on Friday, 30 November 1979 at 2 o'clock in the afternoon for the purpose of having an account laid before them showing how the winding up of the company has been conducted and the property of the company disposed.

Dated 23 October 1979

WILLIAM G. SINCLAIR, F.A.S.A., Liquidator

Sinclair and Wilson, public accountants, 104 Liebig Street, Warrnambool, Vic. 3280

3084

MID CITY (MOTEL CATERERS) PROPRIETARY LIMITED

Notice is hereby given that, pursuant to section 272 of the Companies Act 1961, a meeting of members of the above-named company will be held at 104 Liebig Street, Warrnambool on Friday, 30 November 1979 at 10 o'clock in the forenoon for the purpose of having an account laid before them showing how the winding up of the company has been conducted and the property of the company disposed.

Dated 23 October 1979

WILLIAM G. SINCLAIR, F.A.S.A., Liquidator

Sinclair and Wilson, public accountants, 104 Liebig Street, Warrnambool, Vic. 3280

3085

GLENKYLE HOLDINGS PROPRIETARY LIMITED

Notice is hereby given that, pursuant to section 272 of the Companies Act 1961, a meeting of members of the above-named company will be held at 104 Liebig Street, Warrnambool on Friday, 30 November 1979 at 11 o'clock in the forenoon for the purpose of having an account laid before them showing how the winding up of the company has been conducted and the property of the company disposed.

Dated 23 October 1979

WILLIAM G. SINCLAIR, F.A.S.A., Liquidator

Sinclair and Wilson, public accountants, 104 Liebig Street, Warrnambool, Vic. 3280

3086

Companies Act 1961

SNEE & FROST PTY. LTD. (IN VOLUNTARY LIQUIDATION)

Notice is hereby given that a general meeting of members and creditors of the abovenamed company will be held at 2 Walker Street, Braeside at 11.30 a.m. on 3 December 1979 for the purpose of laying before the meeting an account of the liquidator's acts and dealings and of the conduct of the winding up.

Dated 26 October 1979

P. T. RUTH, liquidator, 75 Weatherall Road, Cheltenham

3087

In the matter of IMPALA INDUSTRIES (WHOLESALE) PTY. LTD. (in Voluntary Liquidation)—Members' Voluntary Winding Up; and in the matter of the Companies Act 1961

Take notice that the affairs of the abovenamed Company are now fully wound up and in pursuance of section 272 of the above Act an Extraordinary General Meeting of the above Company will be held at 141 High Street, Prahran 3181, on Friday, 7 December 1979 at 2 o'clock in the afternoon for the purpose of laying before the meeting an account showing how the winding up has been conducted and the property of the Company disposed of and giving an explanation thereon.

Dated 25 October 1979

3095

D. J. LITHGOW, Liquidator

Companies Act 1961, as Amended, Section 254 (2) (b)—  
In the matter of A. JOYCE INVESTMENTS PTY. LIMITED (in Liquidation)

Notice is hereby given that at an Extraordinary General Meeting of the members of the abovenamed Company held on 23 October 1979 it was resolved that the Company be wound up voluntarily and that Mr Alan Tasman Tudor of Wilson Bishop Bowes and Craig, 271 William Street, Melbourne, be appointed Liquidator for the purposes of the winding up.

Notice is also given that after 21 days from this date I shall proceed to distribute the assets. All creditors having any claims against the company should furnish particulars of same by that date, otherwise I shall proceed to distribute the assets without regard to their claim.

Dated 23 October 1979

A. T. TUDOR, Liquidator

Wilson, Bishop, Bowes and Craig, chartered accountants,  
271 William Street, Melbourne 3000

3114

Companies Act 1961, section 272 (2)

LECHLADE HOLDINGS' PTY. LIMITED (IN VOLUNTARY LIQUIDATION)

NOTICE OF FINAL MEETING

Notice is hereby given that pursuant to section 272 of the Companies Act 1961 a general meeting of the Members and Creditors of Lechlade Holdings Pty. Ltd. will be held in the 10th Floor Boardroom of Wilson Bishop Bowes and Craig, 271 William Street, Melbourne, on 3 December 1979 at 11.00 o'clock in the forenoon.

The purpose of the meeting is to lay account before it showing the manner in which the winding up has been conducted and the property of the company disposed of and of hearing any explanation that may be given by the Liquidator.

Dated 31 October 1979

M. A. COPPINS AND J. B. HUTCHINS, Joint and Several Liquidators

Wilson, Bishop, Bowes and Craig, chartered accountants,  
271 William Street, Melbourne

3115

Companies Act 1961

N. J. STIBBARD & SONS PTY. LTD. (IN LIQUIDATION)

NOTICE TO CREDITORS OF INTENTION TO DECLARE DIVIDEND

A first dividend is intended to be declared in the above matter. Creditors who have not proved their debt by 15 November 1979, will be excluded from this dividend. The date of liquidation was 4 April 1979.

Dated 25 October 1979

3116

ROBERT A. WATERS, Liquidator

Companies Act 1961

QUARRY CARTAGE CONTRACTORS PTY. LTD. (IN LIQUIDATION)

A first dividend is intended to be declared in the above matter. Creditors who have not proved their debt by 15 November 1979, will be excluded from this dividend. The date of liquidation was 4 April 1979.

Dated 25 October 1979

ROBERT A. WATERS, Liquidator

Orr, Martin & Waters, chartered accountants, 460  
Bourke Street, Melbourne, 3000. Telephone 602 1644

3117

**Companies Act 1961**

In the matter of CASHA INVESTMENTS PTY. LTD., trading as "WEMBLEY DISCOUNTS"—Notice Regarding Meeting of Creditors, Pursuant to Section 260

Notice is hereby given that a meeting of creditors of the abovenamed company will be held at the Chamber of Manufacturers, 370 St. Kilda Road, Melbourne, 3004, Room 3, at 2.30 p.m. on 14 November 1979 the company having convened a meeting of its members for the same day for the purpose of considering a Resolution that the company be wound up voluntarily.

Dated 26 October 1979

V. J. CASHA, Director  
G. R. CASHA, Director

Neville Bird, chartered accountant, 3 Bowen Crescent, Melbourne, 3004. Telephone 267 5111 3129

**Companies Act 1961**

BRUCE CAWLEY CRANE SERVICES PROPRIETARY LIMITED (IN VOLUNTARY LIQUIDATION)

At an Extraordinary General Meeting of the abovenamed Company duly convened and held at Princes Highway, Morwell on Monday 29 October 1979 the following was passed as a Special Resolution:

"That the Company be wound up voluntarily."

At the abovenamed meeting Alfred Cawley and Bruce John Cawley were appointed Joint Liquidators for the purpose of the Winding Up.

Notice is also given that after 30 days from this date we shall proceed to distribute the assets. All creditors having any claim against the Company should furnish particulars of same by that date otherwise we shall proceed to distribute the assets without regard to their claims.

Dated 29 October 1979

ALFRED CAWLEY AND BRUCE JOHN CAWLEY,  
Joint Liquidators, Princes Highway, Morwell 3130

**Companies Act 1961, Section 260 (3)**

P. & L. GEORGE HOLDINGS PTY. LTD.

**NOTICE OF MEETING OF CREDITORS**

Notice is hereby given that a meeting of creditors of P. & L. George Holdings Pty. Ltd. will be held at the Board Room, The Institute of Chartered Accountants in Australia, 140 Queen Street, Melbourne on Friday 9 November 1979 at 10.30 a.m., the company having convened a meeting of its members for the same day for the purpose of considering a resolution that the company be wound up voluntarily.

Dated 24 October 1979

P. F. GEORGE, Director

V. R. Dye & Co., chartered accountants, 536 Whitehorse Road, Mitcham 3132 3131

**Companies Act 1961—In the matter of CONCISE BUILDING CONTRACTORS PTY. LTD., 82 Hull Road, Croydon. 3136—**  
Notice Re Meeting of Creditors, Pursuant to Section 260

Notice is hereby given that a Meeting of Creditors of the abovenamed Company will be held at the Office of D. Ferguson & Co., Public Accountants, 428c Toorak Road, Toorak on Friday 9 November 1979 at 10.30 a.m., the Company having convened a Meeting of its Members for the same day for the purpose of considering a Resolution that the Company be wound up voluntarily.

Dated 23 October 1979

S. MUNRO, Director  
C. MCKENZIE, Director

D. Ferguson & Co., public accountants, 428c Toorak Road, Toorak, 3142 3133

It was resolved at an Extraordinary General Meeting of Members of Bonire Flat Rentals Pty. Ltd. held on 26 October 1979 that the Company be placed in Voluntary Liquidation and that John H. Donegan of 390 Lonsdale Street, Melbourne be appointed Liquidator.

3134

JOHN H. DONEGAN

**Companies Act 1961**

**NOTICE OF MEETINGS OF CREDITORS, PURSUANT TO SECTION 260**

Notice is hereby given that meetings of creditors of the companies listed below will be held at 4th Floor, 335 Flinders Lane, Melbourne on 20 November 1979 at the times indicated, the companies have convened meetings of their members to be held on the same day for the purpose of considering special resolutions that the company be wound up voluntarily.

Company	Time of meeting
Abecid Pty. Ltd.	9.30 a.m.
Droppa Investments Pty. Ltd.	9.40 a.m.
Labbra Pty. Ltd.	10.10 a.m.
Ruschia Pty. Ltd.	10.20 a.m.
Sheryl Creaks Pty. Ltd.	10.30 a.m.
First Sulotkap Pty. Ltd.	11.10 a.m.
Second Sulotkap Pty. Ltd.	11.20 a.m.
Third Sulotkap Pty. Ltd.	11.30 a.m.
Fourth Sulotkap Pty. Ltd.	11.40 a.m.
Fifth Sulotkap Pty. Ltd.	11.50 a.m.

Dated 30 October 1979

Paul M. O'Reilly, for and on behalf of the Directors of the above Companies

PAUL M. O'REILLY, chartered accountant, G.P.O. Box 1359M, Melbourne, 3001 3132

**BRUNSWICK ICE & COLD STORAGE CO. PROPRIETARY LIMITED**

The above Company was placed in Voluntary Liquidation by a Resolution of Members at an Extraordinary General Meeting held on 20 October 1979.

W. P. WATSON, liquidator, 406 Lonsdale Street, Melbourne 3000 3135

**The Companies Act 1961**

**MOTHER HUBBARD FREEZER & FOOD SERVICES PTY. LTD. (IN LIQUIDATION)**

**NOTICE CONVENING FINAL MEETING OF MEMBERS AND CREDITORS, PURSUANT TO SECTION 272**

Notice is hereby given pursuant to Section 272 of the Companies Act 1961, that a meeting of the abovementioned company and its creditors will be held in the offices of Wallace, McMullin & Smail, 499 St. Kilda Road, Melbourne 3004, on Monday, 3 December 1979, at 10.00 a.m. for the purpose of having an account laid before them showing the manner in which the winding up has been conducted and the property of the company disposed of and of hearing any explanations that may be given by the Liquidators.

Dated 31 October 1979

A. M. HORSBURGH, Liquidator  
R. P. NEWMAN, Liquidator

Wallace, McMullin & Smail, 499 St. Kilda Road, Melbourne, 3004 3136

**The Companies Act 1961—In the matter of DALORAMA INVESTMENTS PTY. LTD. (in Liquidation)—Notice of Meeting of Members, Pursuant to Section 272**

Notice is hereby given that a final meeting of members of the abovenamed company will be held at 130 Commercial Road, Morwell on 5 November 1979, at 2.30 o'clock in the afternoon for the purpose of laying before the meeting the liquidator's final account and report and giving any explanation thereof.

Dated 16 October 1979

3137

R. D. M. SMITH, Liquidator

**Companies Act 1961, Section 272**

**BUSINESS & GENERAL FINANCE CORPORATION LIMITED (IN VOLUNTARY LIQUIDATION)**

Notice is hereby given pursuant to Section 272 of the Companies Act 1961 that a General Meeting of the members of the company will be held at Room 3, 12 Wellington Parade, East Melbourne on 4 December 1979 at 9.00 a.m. for the purpose of having an account laid before it showing the manner in which the winding up has been conducted

and the property of the company disposed of, and of hearing any explanation that may be given by the liquidator.

Dated 23 October 1979

J. L. C. McINNES, Liquidator

J. L. C. McInnes, chartered accountant, 12 Wellington Parade, East Melbourne, 3002 3138

**Companies Act 1961**—In the matter of **CYGNATREX PROPRIETARY LIMITED** (in Liquidation)—Notice of Meeting

Notice is hereby given that pursuant to Section 272 of the Companies Act, the final meeting of the members of the abovenamed company will be held at 11th Floor, 447 Collins Street, Melbourne on 30 November 1979 at 10.00 a.m. for the purpose of having an account laid before it showing the manner in which the winding up has been conducted and the property of the company disposed of and hearing any explanation that may be given by the liquidator.

Dated 23 October 1979

P. W. HARVEY, Liquidator

Price Waterhouse & Co., 447 Collins Street, Melbourne, 3000 3139

**Companies Act 1961**

**HAMILTON IMPEX PTY. LTD. (IN VOLUNTARY LIQUIDATION)**

Notice is hereby given, in pursuance of Section 272 of the Companies Act 1961, that a General Meeting of the members of the abovenamed company will be held at the offices of Arthur Young & Company, 500 Bourke Street, Melbourne on 12 December 1979 at 10.00 a.m. for the purpose of having the liquidator's accounts laid before them showing the manner in which the winding up has been conducted and the property of the company disposed of and of hearing any explanation that may be given by the liquidator; and also of determining the manner in which the books, accounts and documents of the company and of the liquidator thereof shall be disposed of.

Dated 19 October 1979

C. S. WIGHT, Liquidator

Arthur Young & Company, chartered accountants, 500 Bourke Street, Melbourne, Vic., 3000 3140

**Companies Act 1961**—In the matter of **P. & I. AND ASSOCIATED SERVICES PROPRIETARY LIMITED** (in Voluntary Liquidation)

Notice is hereby given that a general meeting of the members of P. & I. and Associated Services Proprietary Limited (in Voluntary Liquidation) will be held at the offices of Messrs Logan Jacobs & Company 1st Floor, 56 Claremont Street, South Yarra on 5 December 1979 at 10.00 a.m. for the purpose of receiving the liquidator's account showing the manner in which the winding up has been conducted and the property of the company disposed of.

3141 GRAEME JOHN JACOBS, Liquidator

#### NOTICE OF MEETING

Notice is hereby given that the liquidator's final meeting of Taylor Door Co. (Vic.) Pty. Ltd. (in Voluntary Liquidation) for the purpose of considering the Liquidator's Statement as to how the liquidation has been conducted, and the Company's assets disposed of, and such other matters as permitted by law, will be held at the office of John H. Donegan & Co., 390 Lonsdale Street, Melbourne on 28 November 1979 at 9.00 a.m.

3142 JOHN H. DONEGAN, Liquidator

**The Companies Act 1961**—In the matter of **DALEY HOT WATER SERVICES PTY. LTD.**

Notice is hereby given that at an Extraordinary General Meeting of the abovenamed Company held on 24 October 1979 it was resolved that the Company be wound up voluntarily, and at a meeting of Creditors held on the same day, pursuant to Section 260, it was resolved that for such purpose, Thomas Dunn Maclean, of 260 Auburn Road, Hawthorn, be appointed Liquidator.

Notice is also given that after 21 days from this date I shall proceed to distribute the assets. All Creditors having any claims against the Company should furnish particulars of same by that date, otherwise I shall proceed to distribute the assets without regard to their claims.

Dated 25 October 1979

THOMAS D. MACLEAN, Liquidator

Maclean & Patterson, chartered accountants, 260 Auburn Road, Hawthorn, 3122 3146

In the Supreme Court of Victoria—1979 No. Co. 11041—In the matter of the **Companies Act 1961**; and in the matter of **UNITED DIVERS PTY. LTD.**

Notice is hereby given that a Petition for winding up of the abovenamed Company by the Supreme Court was on 19 October 1979 presented by Consolidated Automotive Services Pty. Ltd. and that the same Petition is directed to be heard before the Court sitting at the Law Courts Melbourne at the hour of 10.30 in the forenoon on 29 November 1979 and any creditor or contributory of the Company desiring to support or oppose the making of an order on the said Petition may appear at the time of the hearing by himself or his Counsel for that purpose and a copy of the Petition will be furnished to any creditor or contributory of that said Company requiring the same by the undersigned on payment of the regulated charge of the same.

The Petitioner's address and registered office is 710 Burke Road, Camberwell.

The Petitioner's Solicitor is Paul J. Ambrosy of 517 Chapel Street, South Yarra.

**NOTE**—Any person who intends to appear on the hearing of the said Petition must serve on or send by post to the abovenamed Solicitor notice in writing of his intention so to do. The notice must state the name and address of the person or if a firm, the name and address of the firm and must be signed by the person or firm or his or their solicitor (if any) and must be served or if posted, must be sent by post in sufficient time to reach the abovenamed not later than four o'clock in the afternoon on 28 November 1979. 3147

In the Supreme Court of Victoria—1979 No. Co. 11040—In the matter of the **Companies Act 1961**; and in the matter of **UNLIMITED PARCEL SYSTEMS (VIC.) PTY. LTD.**

Notice is hereby given that a Petition for winding up of the abovenamed Company by the Supreme Court was on 19 October 1979 presented by Geoffrey McLean and that the same Petition is directed to be heard before the Court sitting at the Law Courts Melbourne at the hour of 10.30 o'clock in the forenoon on 29 November 1979 and any creditor or contributory of the Company desiring to support or oppose the making of an order on the said Petition may appear at the time of the hearing by himself or his Counsel for that purpose and a copy of the Petition will be furnished to any creditor or contributory of that said Company requiring the same by the undersigned on payment of the regulated charge of the same.

The Petitioner's address is 345 Nepean Highway, Chelsea.

The Petitioner's Solicitor is Paul J. Ambrosy of 517 Chapel Street, South Yarra.

**NOTE**—Any person who intends to appear on the hearing of the said Petition must serve on or send by post to the abovenamed Solicitor notice in writing of his intention so to do. The notice must state the name and address of the person or if a firm, the name and address of the firm and must be signed by the person or firm or his or their solicitor (if any) and must be served or if posted, must be sent by post in sufficient time to reach the abovenamed not later than four o'clock in the afternoon on 28 November 1979. 3148

Form 92

The Companies Act 1961, Section 272 (1)  
Companies Regulation

RICHLIEU INTERNATIONAL PTY. LTD. (IN LIQUIDATION)

NOTICE OF MEETING OF CREDITORS AND CONTRIBUTORIES

Notice is hereby given that a final meeting of the creditors and contributories of Richlieu International Pty. Ltd. (in Liquidation) will be held at the office of Orr, Martin & Waters, Top Floor, 460 Bourke Street, Melbourne, on Thursday, 6 December 1979, at 11.45 a.m., to receive the liquidator's account of his acts and dealings and of the conduct of the winding up and of hearing any explanations thereof.

Dated 31 October 1979

ROBERT A. WATERS, Liquidator

Orr, Martin & Waters, chartered accountants, 460 Bourke Street, Melbourne, 3000. Telephone 602 1644 3154

Form 92

The Companies Act 1961, Section 272 (1)  
Companies Regulation

LECH CONSTRUCTIONS PTY. LTD. (IN LIQUIDATION)

NOTICE OF MEETING OF CREDITORS AND CONTRIBUTORIES

Notice is hereby given that a final meeting of the creditors and contributories of Lech Constructions Pty. Ltd. (in Liquidation) will be held at the office of Orr, Martin & Waters, Top Floor, 460 Bourke Street, Melbourne, on Thursday, 6 December 1979, at 11.30 a.m. to receive the liquidator's account of his acts and dealings and of the conduct of the winding up and of hearing any explanations thereof.

Dated 31 October 1979

ROBERT A. WATERS, Liquidator

Orr, Martin & Waters, chartered accountants, 460 Bourke Street, Melbourne, 3000. Telephone 602 1644 3155

Companies Act 1961

PEGASUS FASHIONS PTY. LTD. (IN LIQUIDATION)

NOTICE TO CREDITORS OF INTENTION TO DECLARE A DIVIDEND

A first and final dividend is intended to be declared to those creditors whose debts were incurred after 30 November 1975. Creditors who have not proved their debt by 14 November 1979 will be excluded from this dividend. The date of liquidation was 20 November 1978.

Dated 31 October 1979

ROBERT A. WATERS, Liquidator

Orr, Martin & Waters, chartered accountants, 460 Bourke Street, Melbourne, 3000. Telephone 602 1644 3156

The Companies Act 1961—In the matter of SOFTFORM FURNITURE PTY. LTD.—Notice of Meeting of Creditors, Pursuant to Section 260

Notice is hereby given that a meeting of the creditors of Softform Furniture Pty. Ltd. will be held in the conference room of Messrs Wertkin Cran Douglas & Co., Chartered Accountants, Floor 9, 128 Exhibition Street, Melbourne on Tuesday 13 November 1979 at 11.00 o'clock in the forenoon, the Company having convened a meeting of its members for the same day for the purpose of considering a resolution that the Company be wound up voluntarily.

Dated 30 October 1979

3157

B. LANG, Director/Secretary

MAWER HOLDINGS PTY. LIMITED

FINAL MEETING OF MEMBERS

Notice is hereby given in pursuance to Section 272 of the Companies Act 1961, that a general meeting of the members of the abovenamed company will be held at Arthur Young & Company, 50 Bridge Street, Sydney on Friday, 14 December, 1979 at 10 o'clock in the forenoon for the purpose of having the Liquidator's account laid before them showing the manner in which the winding up

has been conducted and the property of the company disposed of and of hearing any explanation that may be given by the Liquidator; and also of determining by resolution the manner in which the books, accounts and documents of the company and of the liquidator thereof shall be disposed of.

Dated 26 October 1979

R. G. DUNN, Liquidator

C/- Arthur Young & Company, 50 Bridge Street, Sydney 2000 3160

MORNINGTON ELECTRICAL SERVICES PTY. LIMITED  
(IN LIQUIDATION)

NOTICE OF FINAL MEETING OF CREDITORS

Take notice that the affairs of the abovenamed company are now fully wound up and that pursuant to Section 272 (1) of the Victorian Companies Act a general meeting of the company and its creditors will be held at the offices of Messrs B. O. Smith & Son, Chartered Accountants, 23rd Floor, 500 Collins Street, Melbourne on Thursday 29 November, 1979 at 10.30 a.m. for the purpose of laying before it an account showing how the winding up has been conducted and any explanation thereof.

Dated 31 October 1979

J. S. ROMANIS, Liquidator

B. O. Smith & Son, 23rd Floor, 500 Collins Street, Melbourne 3162

The Companies Act 1961

LA ROCHE CERAMICS PTY. LTD. (IN LIQUIDATION)

NOTICE CONVENING FINAL MEETING OF THE COMPANY  
PURSUANT TO SECTION 272 (1)

Notice is hereby given that the Final Meeting of Members and Creditors of the abovenamed Company will be held at the offices of Touche Ross & Co., 12th Floor, 440 Collins Street, Melbourne on 6 December, 1979 at 10.30 a.m. for the purpose of laying before the Meeting an account showing how the winding up has been conducted and the property of the Company has been disposed of and giving any explanation thereof.

Dated 31 October 1979

G. O. HARRISON AND R. M. H. COLE, Joint and Several Liquidators

Touche Ross & Co., chartered accountants, 440 Collins Street, Melbourne, 3000 3166

SHEEN HOLDINGS PROPRIETARY LIMITED

Take notice that the affairs of the abovenamed Company are now fully wound-up and that in pursuance of Section 272 (1) of the Companies Act 1961 a general meeting of the Company will be held at the office of Gair & Brahe, 23rd Floor, 367 Collins Street, Melbourne, on 29 November 1979 at 3.00 o'clock in the afternoon for the purpose of laying before it an account showing how the winding-up has been conducted and the property of the Company disposed of and giving any explanation thereof.

Dated 29 October 1979

3167

A. N. WEBB, Liquidator

Companies Act 1961

WESTERN SUBURBS REAL ESTATE AGENCY PTY. LTD.

NOTICE OF MEETING OF CREDITORS

Notice is hereby given that pursuant to Section 260 of the Companies Act 1961 a meeting of the creditors of Western Suburbs Real Estate Agency Pty. Ltd. will be held at the offices of Duesbury Johnston & Marks, 19th Floor, 114 William Street, Melbourne 3000, on 9 November 1979, at 11.30 a.m., the Company having convened a meeting of its members for the same day for the purpose of considering and, if thought fit, passing a special resolution that the company be wound up voluntarily.

Dated 31 October 1979

P. SULFARO, Secretary

Duesbury Johnston & Marks, chartered accountants, 114 William Street, Melbourne, Vic. 3000 3168

*Companies Act 1961*

## NEWMAN'S CHOCOLATES (ELIZ. ST.) PTY. LTD. (IN VOLUNTARY LIQUIDATION)

Notice is hereby given that at an Extraordinary General Meeting of the members of the abovenamed Company held at 84 Church Street, Richmond on 26 October, 1979 the following Special Resolution was passed—

"That the Company be wound up voluntarily and that Mr Peter Norman Brush, Chartered Accountant, of 119 High Street, Northcote be appointed Liquidator."

Dated 26 October 1979

3169 PETER NORMAN BRUSH, Liquidator

*Companies Act 1961*

## NEWMAN'S CHOCOLATES (COLLINS ST.) PTY. LTD. (IN VOLUNTARY LIQUIDATION)

Notice is hereby given that at an Extraordinary General Meeting of the members of the abovenamed Company held at 84 Church Street, Richmond on 26 October, 1979 the following Special Resolution was passed—

"That the Company be wound up voluntarily and that Mr Peter Norman Brush, Chartered Accountant, of 119 High Street, Northcote be appointed Liquidator."

Dated 26 October 1979

3170 PETER NORMAN BRUSH, Liquidator

*Companies Act 1961*

## BLICK'S INN PTY. LTD. (IN VOLUNTARY LIQUIDATION)

Notice is hereby given that at an Extraordinary General Meeting of the members of the abovenamed Company held at 84 Church Street, Richmond on 26 October, 1979 the following Special Resolution was passed—

"That the Company be wound up voluntarily and that Mr Peter Norman Brush, Chartered Accountant, of 119 High Street, Northcote be appointed Liquidator."

Dated 26 October 1979

3171 PETER NORMAN BRUSH, Liquidator

In the matter of the *Companies Act 1961*; and in the matter of LA POUPELLE PTY. LTD. (in Liquidation)

Notice is hereby given that at an Extraordinary General Meeting of the members of La Poupelle Pty. Ltd. held on 25 October 1979, it was resolved that the company be wound up voluntarily, and at a meeting of creditors held on the same day pursuant to Section 260 of the *Companies Act*, it was resolved that for such purpose Kevin James Browne and Robert John Hoar, both of 1 Palmerston Crescent, South Melbourne, be appointed joint and several liquidators.

Dated 26 October 1979

K. J. BROWNE, Liquidator  
R. J. HOAR, Liquidator

Bentley, Wheeler, Cartledge & Co., chartered accountants, 1 Palmerston Crescent, South Melbourne, Vic. 3205. Telephone: 690 3666 3172

*Companies Act 1961*

## NORSELDA PTY. LTD. (IN LIQUIDATION)

## NOTICE OF RESOLUTION

Notice is hereby given that at an extraordinary general meeting of members of the abovenamed company held on 19 October 1979 it was resolved that the company be wound up voluntarily and that Messrs John Desmond Rodger and Russell Edwin Chancellor be appointed to act jointly and severally as liquidators for the purpose of such winding up.

Dated 24 October 1979

J. D. RODGER, Liquidator  
R. E. CHANCELLOR, Liquidator

Price Waterhouse & Co., 447 Collins Street, Melbourne, 3000 3173

In the Supreme Court of Victoria—1979 No. Co. 11049—  
In the matter of the *Companies Act 1961*; and in the matter of EXXFORD SALES PTY. LTD.—Advertisement of Petition

Notice is hereby given that a Petition for the winding up of the abovenamed Company by the Supreme Court was on 26 October 1979 presented by Exxford Sales Pty. Ltd. and that the said Petition is directed to be heard before the Court sitting at the Law Courts, William Street Melbourne in the State of Victoria on 22 November 1979 at 10.30 o'clock in the forenoon; and any creditor or contributory of the said Company desiring to support or oppose the making of an Order on the said Petition may appear at the time of the Hearing by himself or his Counsel for that purpose; and a copy of the Petition will be furnished to any creditor or contributory of the said Company requiring the same by the undersigned on payment of the regulated charge for the same.

The Petitioner's address is 125-127 Flinders Lane, Melbourne in the State of Victoria.

The Petitioner's Solicitors are Messrs Weigall & Crowther, 12th Floor 459 Little Collins Street Melbourne in the said State.

WEIGALL & CROWTHER, solicitors for the petitioner

NOTE—Any person who intends to appear at the Hearing of the said Petition must serve on or send by post to the above-named Solicitors, a notice in writing of this intention to do so. The Notice must state the name and address of the person, or, if a firm, the name and address of the firm and must be signed by the person or firm, or his or their Solicitor (if any) and must be served, or if posted, must be sent by post in sufficient time to reach the abovenamed not later than 4.00 o'clock in the afternoon of 21 November 1979. 3174

In the Supreme Court of Victoria—1979 Co. 11050—In the matter of the *Companies Act 1961*; and in the matter of ADDLE PTY. LTD.

Notice is hereby given that a petition for the winding up of the abovenamed Company by the Supreme Court was on 26 October 1979 presented by Kevin Patrick Brady, Deputy Commissioner of Taxation of the Commonwealth of Australia and that the said petition is directed to be heard before the Court sitting at the Fifteenth Court, Law Courts, Lonsdale Street, Melbourne at the hour of 10.30 o'clock in the forenoon on 15 November 1979 and any creditor or contributory of the said company desiring to support or oppose the making of an order on the said petition may appear at the time of hearing by himself or his Counsel for the purpose; and a copy of the said petition will be furnished to any creditor or contributory of the said company requiring the same by the undersigned on payment of the regulated charge for the same.

The Petitioner's official address is 350 Collins Street, Melbourne.

The Petitioner's Solicitor is B. J. O'Donovan, Acting Crown Solicitor for the Commonwealth of 99 Queen Street, Melbourne.

B. J. O'DONOVAN

NOTE—Any person who intends to appear on the hearing of the said petition must serve on or send by post to the abovenamed B. J. O'Donovan, notice in writing of his intention so to do. The notice must state the name and address of the person, or, if a firm, the name and address of the firm, and must be signed by the person or firm, or his, or their solicitor (if any), and must be served or, if posted, must be sent by post in sufficient time to reach the abovenamed not later than 4 o'clock in the afternoon of 14 November 1979. 3175

In the Supreme Court of Victoria—1979 Co. 11051—In the matter of the *Companies Act 1961*; and in the matter of VENICE FOOTWEAR PTY. LIMITED

Notice is hereby given that a petition for the winding up of the abovenamed Company by the Supreme Court was on 26 October 1979 presented by Kevin Patrick Brady, Deputy Commissioner of Taxation of the Commonwealth of Australia and that the said petition is directed to be heard before the Court sitting at the Fifteenth Court, Law



Courts, Lonsdale Street, Melbourne at the hour of 10.30 o'clock in the forenoon on 15 November 1979 and any creditor or contributory of the said company desiring to support or oppose the making of an order on the said petition may appear at the time of hearing by himself or his Counsel for the purpose; and a copy of the said petition will be furnished to any creditor or contributory of the said company requiring the same by the undersigned on payment of the regulated charge for the same.

The Petitioner's official address is 350 Collins Street, Melbourne.

The Petitioner's Solicitor is B. J. O'Donovan, Acting Crown Solicitor for the Commonwealth of 99 Queen Street, Melbourne.

B. J. O'DONOVAN

NOTE—Any person who intends to appear on the hearing of the said petition must serve on or send by post to the abovenamed B. J. O'Donovan, notice in writing of his intention so to do. The notice must state the name and address of the person, or, if a firm, the name and address of the firm, and must be signed by the person or firm, or his, or their solicitor (if any), and must be served or, if posted, must be sent by post in sufficient time to reach the abovenamed not later than 4 o'clock in the afternoon of 14 November 1979. 3176

In the Supreme Court of Victoria—1979 Co. 11052—In the matter of the *Companies Act 1961*; and in the matter of *VENICE FOOTWEAR DISTRIBUTORS PTY. LIMITED*

Notice is hereby given that a petition for the winding up of the abovenamed Company by the Supreme Court was on 26 October 1979 presented by Kevin Patrick Brady, Deputy Commissioner of Taxation of the Commonwealth of Australia and that the said petition is directed to be heard before the Court sitting at the Fifteenth Court, Law Courts, Lonsdale Street, Melbourne at the hour of 10.30 o'clock in the forenoon on 15 November 1979 and any creditor or contributory of the said company desiring to support or oppose the making of an order on the said petition may appear at the time of hearing by himself or his Counsel for the purpose; and a copy of the said petition will be furnished to any creditor or contributory of the said company requiring the same by the undersigned on payment of the regulated charge for the same.

The Petitioner's official address is 350 Collins Street, Melbourne.

The Petitioner's Solicitor is B. J. O'Donovan, Acting Crown Solicitor for the Commonwealth of 99 Queen Street, Melbourne.

B. J. O'DONOVAN

NOTE—Any person who intends to appear on the hearing of the said petition must serve on or send by post to the abovenamed B. J. O'Donovan, notice in writing of his intention so to do. The notice must state the name and address of the person, or, if a firm, the name and address of the firm, and must be signed by the person or firm, or his, or their solicitor (if any), and must be served or, if posted, must be sent by post in sufficient time to reach the abovenamed not later than 4 o'clock in the afternoon of 14 November 1979. 3177

In the Supreme Court of Victoria—1979 Co. 11053—In the matter of the *Companies Act 1961*; and in the matter of *OBSIDIAN PTY. LTD.*

Notice is hereby given that a petition for the winding up of the abovenamed Company by the Supreme Court was on 26 October 1979 presented by Kevin Patrick Brady, Deputy Commissioner of Taxation of the Commonwealth of Australia and that the said petition is directed to be heard before the Court sitting at the Fifteenth Court, Law Courts, Lonsdale Street, Melbourne at the hour of 10.30 o'clock in the forenoon on 15 November 1979 and any creditor or contributory of the said company desiring to support or oppose the making of an order on the said petition may appear at the time of hearing by himself or his Counsel for the purpose; and a copy of the said

No. 90—13400/79—4

petition will be furnished to any creditor or contributory of the said company requiring the same by the undersigned on payment of the regulated charge for the same.

The Petitioner's official address is 350 Collins Street, Melbourne.

The Petitioner's Solicitor is B. J. O'Donovan, Acting Crown Solicitor for the Commonwealth of 99 Queen Street, Melbourne.

B. J. O'DONOVAN

NOTE—Any person who intends to appear on the hearing of the said petition must serve on or send by post to the abovenamed B. J. O'Donovan, notice in writing of his intention so to do. The notice must state the name and address of the person, or, if a firm, the name and address of the firm, and must be signed by the person or firm, or his, or their solicitor (if any), and must be served or, if posted, must be sent by post in sufficient time to reach the abovenamed not later than 4 o'clock in the afternoon of 14 November 1979. 3178

In the Supreme Court of Victoria—Co. 10979—In the matter of the *Companies Act 1961*; and in the matter of *MAREEBA MINING N.L.* which has now changed its name to *MAREEBA MINING LIMITED*

Notice is hereby given that on 11 October 1979, the Supreme Court of Victoria confirmed the reduction of the share capital of Mareeba Mining N.L. which has now changed its name to Mareeba Mining Limited effected by the following special resolution passed on 16 August 1979:

"That, subject to confirmation by the Court, the share capital of the Company be, and it is hereby, reduced from \$6 000 000 divided into 12 000 000 shares of 50 cents each of which—

- (a) 2 000 000 shares are issued and fully paid;
- (b) 9 000 000 shares are issued and paid to 38 cents; and
- (c) 1 000 000 shares are unissued to \$4 920 000 divided into;
- (d) 3 000 000 shares of 50 cents each of which 2 000 000 are issued and fully paid and 1 000 000 are unissued; and
- (e) 9 000 000 shares of 38 cents each all of which are issued and fully paid,

by extinguishing the liability on each of the 9 000 000 shares referred to in paragraph (b) in respect of the 12 cents share capital not paid up thereon and by reducing the nominal value of each of those shares from 50 cents to 38 cents."

The amount of the share capital of the Company, as altered by the order is \$4 920 000 divided into—

- (a) 3 000 000 shares of 50 cents each of which 2 000 000 are issued and fully paid and 1 000 000 are unissued; and
- (b) 9 000 000 shares of 38 cents each all of which are issued and fully paid.

An office copy of the Order was lodged with the Commissioner for Corporate Affairs on 25 October 1979. Dated 26 October 1979

3781

D. R. WORRALL, Secretary

In the Supreme Court of Victoria—1979 Co. 11054—In the matter of the *Companies Act 1961*; and in the matter of *TEL-PRO PRODUCTS PTY. LTD.*

Notice is hereby given that a petition for the winding up of the abovenamed Company by the Supreme Court was on 26 October 1979 presented by Kevin Patrick Brady, Deputy Commissioner of Taxation of the Commonwealth of Australia and that the said petition is directed to be heard before the Court sitting at the Fifteenth Court, Law Courts, Lonsdale Street, Melbourne at the hour of 10.30 o'clock in the forenoon on 15 November 1979 and any creditor or contributory of the said company desiring to support or oppose the making of an order on the said petition may appear at the time of hearing by himself or his Counsel for the purpose; and a copy of the said petition will be furnished to any creditor or contributory of the said company requiring the same by the undersigned on payment of the regulated charge for the same.

The Petitioner's official address is 350 Collins Street, Melbourne.

The Petitioner's Solicitor is B. J. O'Donovan, Acting Crown Solicitor for the Commonwealth of 99 Queen Street, Melbourne.

B. J. O'DONOVAN

NOTE—Any person who intends to appear on the hearing of the said petition must serve on or send by post to the abovenamed B. J. O'Donovan, notice in writing of his intention so to do. The notice must state the name and address of the person, or, if a firm, the name and address of the firm, and must be signed by the person or firm, or his, or their solicitor (if any), and must be served or, if posted, must be sent by post in sufficient time to reach the abovenamed not later than 4 o'clock in the afternoon of 14 November 1979. 3179

In the Supreme Court of Victoria—1979 Co. 11002—In the matter of the *Companies Act 1961*; and in the matter of A. & R. BENTLEY PTY. LTD.—Notice of Winding Up Order

Winding Up Order: Made 25 October 1979

Name and Address of Liquidator: Geoffrey Ormond Harris C/- Touche Ross & Co., 440 Collins Street, Melbourne, Vic. 3000.

B. J. O'DONOVAN, Acting Crown Solicitor for the Commonwealth and solicitor for the petitioner 3180

Creditors next of kin and others having claims in respect of the estate of Rotha Mary McPherson formerly of 20 Eleanor Street, Ashburton but late of 1 Spinosa Court, Endeavour Hills, Widow, deceased, who died on 17 June 1979, are required by the Executors of her Will Edith Nancy Todd and Arthur Bennett McPherson to forward particulars of their claims to the said Executors in the care of the undermentioned Solicitors by 2 January 1980 after which date the Executors will distribute the assets having regard only to the claims of which they then have notice.

VERA FOWLER & CO., solicitors, 1 Evandale Road, Malvern, 3144 3038

MARGARET HASELL, late of Unit 10, 233 Brighton Road, Elwood, in the State of Victoria, widow, DECEASED

Creditors next of kin and others having claims in respect of the estate of the deceased, who died on 18 August 1979, are required by the Executors The Union Fidelity Trustee Company of Australia Limited of 100 Exhibition Street, Melbourne and Leo Joseph Canavan Webster of 3 Creswick Street, Brighton, retired, to send particulars of their claims to them at 100 Exhibition Street, Melbourne by 7 January 1980 after which date they will distribute and/or convey the assets amongst the persons entitled thereto having regard only to the claims of which they then have notice.

RICHARD K. PITMAN, LL.B., solicitor, of corner of Kingsway and Railway Parade, Glen Waverley, 3150 3040

WILLIAM LINDSAY SAMPEY, late of Wannon Avenue, Edenhope, retired farmer, DECEASED

Creditors next of kin and others having claims in respect of the estate of the deceased who died on 16 January 1979 are required by the personal representative Graeme John Lester Sampey C/- 12 Pynsent Street, Horsham to send particulars to him by 7 January 1980 after which date he may convey or distribute the assets having regard only to the claims of which he then has notice.

POWER & BENNETT, solicitors, 12 Pynsent Street, Horsham, 3400 3041

Estate of JOSEPH FRANCIS O'KEEFE, late of St. Bernard's Presbytery, 151 High Street, Belmont, Catholic Priest, DECEASED

Creditors next of kin and others having claims in respect of the estate of the deceased who died on 4 July 1977 are required by Thomas Francis Little of "Raheen", 86 Studley Park Road, Kew, Archbishop, the Executor to whom Probate was granted to send particulars to him in care of Roger O'Halloran & Co., Solicitors of 63 Gheringhap

Street, Geelong by 1 January 1980 after which date the Executor may convey or distribute the assets, having regard only to the claims of which he then has notice.

Dated 23 October 1979.

ROGER O'HALLORAN & CO., solicitors, of 63 Gheringhap Street, Geelong, Victoria 3042

Pursuant to the *Trustee Act 1958* Notice is hereby given that all persons having claims against the estate of John Harry Jeffries, deceased, late of "Nyanda", Meeniyani in the State of Victoria, grazier, deceased who died on 2 March 1978 and Probate of whose Will was granted by the Supreme Court of the said State in its Probate Jurisdiction on 5 December 1978 to Jacqueline Anne Lisle (in the Will referred to as Ann Jacqueline Lisle), married woman and Phillip John Lisle, farmer, both of "Nyanda", Meeniyani aforesaid are hereby required to send particulars in writing of such claims to the undersigned at their Office hereunder mentioned on or before 31 December 1979 after which date the said Jacqueline Anne Lisle and Phillip John Lisle will proceed to distribute the assets of the said John Harry Jeffries, deceased, which shall have come to their hands amongst the persons entitled thereto having regard only to the claims of which they shall then have had notice.

Notice is hereby given that the said Jacqueline Anne Lisle and Phillip John Lisle will not be liable for the assets so distributed or any part thereof to any person of whose claim they shall not have had notice as aforesaid.

GRAHAM V. McLEAN & CO., solicitors, of 57 Mount Dandenong Road, Croydon, proctors for the said Jacqueline Anne Lisle and Phillip John Lisle 3054

Creditors next of kin and others having claims against the estate of Philomena O'Brien formerly of the Atlantic Hotel, 625 Skipton Street, Ballarat but late of 618 Skipton Street, Ballarat in the State of Victoria, widow, deceased (who died on 23 May 1979) are required to send particulars of their claims to Byrne, Jones & Torney of 38 Lydiard Street, South Ballarat in the said State the Solicitors of the estate of the said deceased by 31 December 1979 after which date the Solicitors will distribute the assets having regard only to the claims of which they then have notice.

BYRNE, JONES & TORNEY, solicitors, Ballarat 3055

LLEWELLYN DAVIES, formerly of 4 Wattle Grove, East Malvern, but late of Noorat, retired, DECEASED

Creditors next of kin and others having claims in respect of the estate of the abovenamed deceased who died on 30 August 1979 are required by the Executor Ian James Hamilton of Noorat Factory Engineer to send particulars to him care of the undermentioned Solicitors by 1 February 1980 after which date he may convey or distribute the assets of the deceased having regard only to the claims of which he then shall have had notice.

DAVID TRICKETT & FRANK GARSIDE, solicitors, 140 High Street, Terang 3056

REGINALD CLARKE CORR, late of 31 McKinnon Street, Terang, pensioner, DECEASED

Creditors next of kin and others having claims in respect of the estate of the abovenamed deceased who died on 14 September 1979 are required by the Executor Ross Paton of 9 Emeny Street, Terang, builder, to send particulars to him care of the undermentioned Solicitors by 1 February 1980 after which date he may convey or distribute the assets of the deceased having regard only to the claims of which he then shall have had notice.

DAVID TRICKETT & FRANK GARSIDE, solicitors, 140 High Street, Terang 3057

WILLIAM GEORGE JOSEPH OSBORNE (also known as William George Osborne and William Joseph Osborne), late of 9 Ethel Street, Oak Park, retired baker, DECEASED

Creditors next of kin and others having claims in respect of the estate of the deceased (who died on 5 September 1979) are required to send particulars of their claims to Irene Dewan, care of Walsh Johnston & Co., Solicitors of 452 High Street, Northcote before 26 December 1979 after which date she will distribute the assets having regard only to the claims of which she then has notice.

WALSH JOHNSTON & CO., solicitors, 452 High Street, Northcote 3076

CLARENCE HENRY WHELAN (also known as Clarence Henry Cole), late of 68 Russell Street, Tootgarook, Victoria, business proprietor, DECEASED

Creditors next of kin and others having claims in respect of the estate of the deceased, who died on 7 February 1978 are required by the Administrator of the Deceased's estate, Thomas Henry Whelan of 52 Hughes Crescent, North Dandenong, Victoria to send particulars to him by 15 January 1980 after which date the Administrator may convey or distribute the assets, having regard only to the claims of which he has notice.

Dated 25 October 1979.

LLOYD P. GOODE & CO., solicitors, 406 Lonsdale Street, Melbourne 3077

Creditors next of kin and others having claims against the estate of Leslie Leonard Alabaster late of 12 Merrida Avenue Glenhuntly Victoria formerly Manager but late Retired Manager deceased who died on 23 June 1979 are required to send particulars of their claims to the executrix of his Will, Mary Teresa Alabaster care of the under-mentioned Solicitors before 28 January 1980 after which date the said executrix will distribute the estate of the said deceased having regard only to the claims of which she had then notice.

VITIELLO AND TUSZYNSKI, solicitors, 99 Springvale Road, Springvale, Victoria 3171 3091

Creditors next of kin and others having claims in respect of the estate of Gheorghe Miutescu late of Lot 88 Glenholme Avenue, Mt. Evelyn Fitter and Turner deceased intestate who died on 7 June 1978 are required by Mary Corrone of 69 Esther Crescent Mooroolbark Married Woman the Administratrix to whom Letters of Administration of the Estate of the said deceased were granted to send particulars of their claims to her care of the under-mentioned Solicitors by 3 January 1980 after which date she will distribute the assets having regard only to the claims of which she then has notice.

J. W. GLOVER & CO., solicitors, 422 Collins Street, Melbourne 3092

Creditors next of kin and others having claims against the estate of George William Holland late of Boundary Road, Heatherton in the State of Victoria Vegetable Grower deceased who died on 1 August 1979 are required by the Executors Daisy Mary Holland, Widow, and Edwin George Holland, Unemployed, both of Boundary Road, Heatherton to send particulars of their claims to the said Executors care of Messrs F. R. Monotti & Co. of 13 Scott Street, Dandenong, Solicitors, by 30 December 1979 after which date they will distribute the assets of the said estate having regard only to the claims of which they then have notice.

F. R. MONOTTI & CO., solicitors, 13 Scott Street, Dandenong 3093

FREDERICK CHARLES LEWIS, late of Flat 3, 187 Beaconsfield Parade, Middle Park, in the State of Victoria, gentleman, DECEASED

Creditors next of kin and others having claims in respect of the Estate of the Deceased who died on 29 June 1979 are required by the Executor National Trustees Executors & Agency Company of Australasia Limited of 95 Queen Street, Melbourne to send particulars of their claims to National Trustees Executors & Agency Company of Australasia Limited to 95 Queen Street, Melbourne by 4 January 1980 after which date the Executor may convey or distribute the assets having regard only to claims of which it then has notice.

COLE & O'HEARE, solicitors, of 380 Lonsdale Street, Melbourne 3094

Creditors, next of kin and others having claims in respect of the Estate of Veronica Mary Apted late of 12 Francis Crescent, Ferntree Gully Widow who died on 20 May 1979 are to send particulars of their claims to the Executors care of the undersigned by 11 January 1980 after which date they will commence to distribute the assets having regard only to the claims of which they then have notice.

T. D. ARMSTRONG & GILLMAN, solicitors, 646 Main Street, Belgrave 3109

Creditors next of kin and others having claims in respect of the Estate of Lucy Bath late of Aaron Private Nursing Home, 577 Neerim Road, Hughesdale, Widow, deceased, who died on 3 May 1979 and Probate of whose Will has been granted to The Equity Trustees Executors and Agency Company Limited of 472 Bourke Street, Melbourne, are required to send particulars of their claims to the said Executor by 1 January 1980 after which date it will distribute the assets having regard only to the claims of which it then has notice.

MESSRS H. L. YUNCKEN & YUNCKEN, solicitors, 443 Little Collins Street, Melbourne. 3000 3110

FREDERICK JOSEPH LEWIS late of 23 Victoria Avenue, Canterbury, in the State of Victoria, gentleman, DECEASED

Creditors, next of kin and others having claims in respect of the Estate of the Deceased (who died on 4 July 1979) are required by The Perpetual Executors and Trustees Association of Australia Limited of 50 Queen Street, Melbourne, to send particulars of their claims to the said Company by 14 January 1980 after which date it will convey or distribute the assets, having regard only to the claims of which the Company then has notice.

HENDERSON & BALL, solicitors, of 430 Little Collins Street, Melbourne 3111

HELEN STEWART ENGLISH, late of 77 Boundary Street, Kerang, in the State of Victoria, married woman, DECEASED

Creditors next of kin and all other persons having claims against the Estate of the said Deceased are required by Richard Bruce English and James William English both of Meran Downs, R.S.D., Kerang aforesaid Farmers the Executors to send particulars of such claims to the under-mentioned Solicitors on or before 22 December 1979 after which date they will distribute the assets having regard only to the claims of which they then have notice.

BASILE & CO., barristers and solicitors, 46 Wellington Street, Kerang 3112

ROBERT GRAHAM, late of 230 Westblade Avenue, Kerang, in the State of Victoria, retired patrolman, DECEASED

Creditors next of kin and other persons having claims against the Estate of the said deceased who died on 2 July 1979 are required to send particulars of same to the Executor Sandhurst and Northern District Trustees Executors and Agency Company Limited in care of the undersigned on or before 2 January 1980 after which date they will distribute the assets having regard only to the claims of which they then have notice.

DWYER & BENNETT, barristers and solicitors, 201 Campbell Street, Swan Hill 3113

Creditors next of kin and all other persons having claims in respect of the estate of Stephen William John Ahlberg late of 58 St. George's Road, Toorak, in the State of Victoria Investor deceased who died on 24 August 1979 are required by The Perpetual Executors and Trustees Association of Australia Limited of 50 Queen Street, Melbourne and Elsa Reatha Ahlberg of 58 St. George's Road, Toorak Widow the applicants for a grant of administration are required to send particulars of their claims to the said applicants in the care of the said company by 31 December 1979 after which date they will convey or distribute the assets having regard only to the claims of which they may then have notice.

MICHAEL J. MEEHAN & CO., solicitors, 513 Toorak Road, Toorak 3119

Creditors next of kin and others having claims in respect of the Estate of Elizabeth Mary Ann Mackay late of 42 Main Road, Clayton Widow Deceased who died on 16 August 1979 are to send particulars of their claims to the Union-Fidelity Trustee Company of Australia Limited of 100 Exhibition Street, Melbourne by 3 January 1980 after which date the said Company will distribute the assets having regard to the claims of which it then has notice.

R. WADHAM & DOIG, solicitors, of 383 Flinders Lane, Melbourne 3120

ALEXANDRINA HELLEN McLENNAN, late of Unit 2, 3 Meredith Street, Malvern, spinster, DECEASED

Creditors next of kin and others having claims in respect of the estate of the deceased (who died on 1 August 1979) are required by The Perpetual Executors and Trustees Association of Australia Limited of 50 Queen Street, Melbourne to send particulars of their claims to the said Company by 3 January 1980 after which date it will convey or distribute the assets having regard only to the claims of which the Company then has notice.

LYNCH & MACDONALD, FLOOD & PERMEZEL, solicitors, 360 Collins Street, Melbourne 3121

LAWRENCE LEONARD ROBISON, late of Majestic Hotel, 151 Fitzroy Street, St. Kilda, retired life assurance officer, DECEASED

Creditors, next of kin and others having claims in respect of the estate of the deceased (who died on 18 August 1979) are required by The Perpetual Executors and Trustees Association of Australia Limited of 50 Queen Street Melbourne to send particulars of their claims to the said Company by 11 January 1980 after which date it will convey or distribute the assets, having regard only to the claims of which the Company then has notice.

Dated 31 October 1979

MADDEN, BUTLER, ELDER & GRAHAM, solicitors, 500 Collins Street, Melbourne 3122

Creditors, next of kin and other having claims against the estate of Ruby Matilda Stevens late of 230 Victoria Road, Northcote in the State of Victoria, Widow deceased instestate who died on 30 July 1979 are required by the Administrator Arthur Frederick Thomas Stevens of 236 Spring Road, Dingley in the State of Victoria, to forward particulars of their claim to the said Administrator care of the undermentioned Solicitors by 9 January 1980 after which date the Administrator will distribute the assets having regard only to the claims of which he will then have had notice.

F. J. ORAMES & DOWNING, of 121 William Street, Melbourne, solicitors for the administrator 3123

Creditors next of kin and others having claims in respect of the estate of Frank Broadhurst late of 130 Princess Street, Kew gentleman who died on 20 September 1979 are to send particulars of their claims to The Equity Trustees Executors and Agency Company Limited of 472 Bourke Street, Melbourne by 1 January 1980 after which date it will distribute the assets having regard only to the claims of which it then has notice.

RYLAH & RYLAH, solicitors, 191 Queen Street, Melbourne 3124

CLARA ALVENA MULLER, late of Nhill, in the State of Victoria, spinster, DECEASED

Creditors next of kin and others having claims in respect of the estate of the deceased who died on 1 December 1978 are required by the Trustee Lyle Robert Schulz of Winiam East in the said State Farmer to send particulars to him care of the undersigned by 15 January 1980 after which date the Trustee may convey or distribute the assets having regard only to the claims of which he then has notice.

Dated 22 October 1979

TURNER & HOBDAY, 30 Victoria Street, Nhill, solicitors for the said trustee 3125

ERNST JOHANN REICHEL, late of 10 Albert Street, Nhill, in the State of Victoria, retired farmer, DECEASED

Creditors next of kin and others having claims in respect of the estate of the deceased who died on 29 April 1979 are required by the Trustees John Matheson Hobday Solicitor and Barry Ross Cramer Law Clerk both of 30 Victoria Street Nhill aforesaid to send particulars to them care of the undersigned by 15 January 1980 after which date the Trustees may convey or distribute the assets having regard only to the claims of which they then have notice.

Dated 22 October 1979

TURNER & HOBDAY, 30 Victoria Street, Nhill, solicitors for the said trustee 3126

VICTOR ARNOLD WILKSCH, late of Netherby, in the State of Victoria, farmer, DECEASED

Creditors next of kin and others having claims in respect of the estate of the said deceased who died on 14 April 1979 are required by the Trustee John Matheson Hobday of 30 Victoria Street Nhill in the said State Solicitor to send particulars to him care of the undersigned by 15 January 1980 after which date the Trustee may convey or distribute the assets having regard only to the claims of which he then has notice.

Dated 22 October 1979

TURNER & HOBDAY, 30 Victoria Street, Nhill, solicitors for the said trustee 3127

JAMES MALCOM MACKENZIE, late of Tarranyurk, in the State of Victoria, farmer, DECEASED

Creditors next of kin and others having claims in respect of the estate of the deceased who died on 24 October 1978 are required by the Trustees John Matheson Hobday of 30 Victoria Street Nhill in the said State Solicitor and John Brian Shanahan of 29 Church Street Dimboola in the said State Teacher to send particulars to them care of the undersigned by 15 January 1980 after which date the Trustees may convey or distribute the assets having regard only to the claims of which they then have notice.

Dated 22 October 1979

TURNER & HOBDAY, 30 Victoria Street, Nhill, solicitors for the said trustee 3128

MARIANNA CORVAN, late of 12 Bayview Avenue, Upwey, in the State of Victoria, widow, DECEASED

Creditors Next of kin and all other persons having claims against the Estate of the said deceased are required by the Executor of her Will The Equity Trustees Executors and Agency Company Limited of 472 Bourke Street, Melbourne in the said State, to send particulars of such claims to the said Executor at its **aforementioned address, on or before 2 January 1980**, after which date the Executor will distribute the assets having regard only to the claims of which it then has notice.

ROSS MORGAN & TRAGEAR, solicitors, 20-22 Station Street, Sandringham 3143

GEOFFREY MORRIS JONES, late of 84 Bible Street, Eltham, in the State of Victoria, internal auditor, DECEASED

Creditors next of kin and others having claims in respect of the Estate of the deceased who died on 6 February 1979 are required by the administrator, Frederick Geoffrey Jones of 84 Bible Street Eltham in the State of Victoria Retired to send particulars to the undermentioned firm by 31 January 1980 after which date the said administrator may convey or distribute the assets having regard only to the claims of which notice has by then been given.

SETON, WILLIAMS & SMITH, solicitors, 408 Collins Street, Melbourne 3144

JESSIE LETITIA BLAIR VIVIAN, late of 9 Walker Street, Moonee Ponds, widow, DECEASED

Creditors next of kin and others having claims in respect of the estate of the deceased who died on 19 July 1979 are required to send particulars of their claims to The Equity Trustees Executors and Agency Company Limited of 472 Bourke Street Melbourne by 9 January 1980 after which date it will distribute the assets having regard only to the claims of which it then has notice.

LEACH & THOMSON, solicitors, 472 Bourke Street, Melbourne 3152

Creditors next of kin and others having claims in respect of the estate of Gwendoline Jeffrey Reid late of 9 Edward Street Maffra widow deceased who died on 8 September 1979 are required by her executors Marget Grace Paterson Langley of "Avon Park" Bordertown South Australia married woman and Norman George Williams of 119 Johnson Street Maffra public accountant to send particulars to them care of the undermentioned solicitors by 15 January 1980 after which date they will convey and distribute the assets having regard only to the claims of which they then have notice.

SEMMENS & HATCH, solicitors, 69 Johnson Street, Maffra, 3860 3158

Creditors next of kin and others having claims in respect of the estate of Grace Georgina Quirk late of 31 Foster Street Maffra widow deceased who died on 5 September 1979 are required by her executor Elizabeth Jean Scantlebury of 47 Powerscourt Street Maffra widow to send particulars to her care of the undermentioned solicitors by 15 January 1980 after which date she will convey and distribute the assets having regard only to the claims of which she then has notice.

SEMMENS & HATCH, solicitors, 69 Johnson Street,  
Maffra, 3860 3159

Creditors next of kin and others having claims in respect of the Estate of Donald Leslie Harold Slavin late of 32 Power Street, Hawthorn in the State of Victoria, Solicitor, deceased who died on 8 June 1979, are to send particulars of their claims to J. & S. Shatin & Bernstein, Solicitors of 224 Queen Street, Melbourne in the said State, the Solicitors for the Executor appointed by the Will of the deceased, by 10 January 1980.

J. & S. SHATIN & BERNSTEIN, solicitors, of 224 Queen  
Street, Melbourne 3164

CHARLOTTE MYRTLE ROWORTH, late of "Ombersley",  
Inverleigh, in the State of Victoria, widow, DECEASED

Creditors next of kin and others having claims in respect of the abovenamed deceased (who died on 7 July 1979) are required by the Executor Alfred Collins Burrell (in the Will called Burrell) of 32 Beltana Street, Grovedale, Retired to send particulars to the undermentioned firm by 7 January 1980 after which date the said executor may convey or distribute the assets having regard only to the claims of which it then has notice.

HARWOOD & PINCOTT, solicitors, 77 Moorabool  
Street, Geelong 3165

In the Supreme Court of the State of Victoria  
SALE BY THE SHERIFF

On Wednesday 5 December 1979 at 12 noon at Police  
Station, Sandringham (unless process be stayed or satis-  
fied).

All the Estate and Interest (if any) of Keith Josua  
Murphy, Salesman, of 14A Dreadnought Street, Sand-  
ringham, as proprietor of an estate in fee simple in the  
land described in Certificate of Title Volume 8051 Folio 023  
upon which is erected a dwelling house known as No. 14A  
Dreadnought Street, Sandringham.

Registered Mortgage No. G.546960 affects the said estate  
and interest.

Terms—Cash only  
3182 T. M. NICHOLLS, Sheriff's Officer

In the Supreme Court of the State of Victoria  
SALE BY THE SHERIFF

On Friday 14 December 1979 at 10.30 a.m. at the Police  
Station, Thomastown (unless process be stayed or satis-  
fied).

All the Estate and Interest (if any) of Peter Koemtsidis,  
Supermarket Manager, of 3 Tambor Court, Lalor as joint  
proprietor with Helen Koemtsidis, Clerk, of an estate in  
fee simple in the land described in Certificate of Title  
Volume 8904 Folio 023 upon which is erected a dwelling  
known as No. 3 Tambor Court, Lalor.

Registered Mortgage No. H.282356 affects the said estate  
and interest.

Terms—Cash only  
3183 KEITH R. MARTIN, Sheriff's Officer

In the Supreme Court of the State of Victoria  
SALE BY THE SHERIFF

On Thursday 13 December 1979 at 11.30 a.m. at the  
Police Station, Balwyn (unless process be stayed or satis-  
fied).

All the Estate and Interest (if any) of Grant Marshall  
Hecke, Insurance Consultant, of 36 Talbot Avenue, Balwyn  
as joint proprietor with Shelagh Christine Hecke, Married  
Woman, of an estate in fee simple in the land described

in Certificate of Title Volume 3949 Folio 648 upon which  
is erected a three bedroom weatherboard home known as  
No. 36 Talbot Avenue, Balwyn.

Registered Mortgage No. G.938678 and Caveat H.37733  
affect the said estate and interest.

Terms—Cash only  
3184 H. BUETTNER, Sheriff's Officer

In the Supreme Court of the State of Victoria  
SALE BY THE SHERIFF

On Friday 14 December 1979 at 10.30 a.m. at the Police  
Station, Doncaster (unless process be stayed or satisfied).

All the Estate and Interest (if any) of Anthony Earl  
Waldren, Sales Manager, and Patricia Anne Waldren,  
Married Woman, both of 13 Hillcroft Drive, Templestowe  
as joint proprietors of an estate in fee simple in the land  
described in Certificate of Title Volume 9166 Folio 072  
upon which is erected a dwelling house known as No. 13  
Hillcroft Drive, Templestowe.

Registered Mortgages Nos. H.38853 and H.120809 and  
Caveats H.53672, H.226031 and H.300666 affect the said  
estate and interest.

Terms—Cash only  
3185 H. BEUTTNER, Sheriff's Officer

In the Supreme Court of the State of Victoria  
SALE BY THE SHERIFF

On Friday 14 December 1979 at 11.30 a.m. at the Police  
Station, Box Hill (unless process be stayed or satisfied).

All the Estate and Interest (if any) of Stergios Liouas,  
Accountant, of 565 Middleborough Road, Box Hill North  
as joint proprietor with Stella Liouas, Married Woman,  
of an estate in fee simple in the land described in Certificate  
of Title Volume 8465 Folio 249 upon which is erected a  
brick house known as No. 565 Middleborough Road, Box  
Hill North.

Registered Mortgage No. E.896608 and Caveat H.482833  
affect the said estate and interest.

Terms—Cash only  
3186 H. BEUTTNER, Sheriff's Officer

In the Supreme Court of the State of Victoria  
SALE BY THE SHERIFF

On Thursday 13 December 1979 at 10.30 a.m. at the  
Police Station, Bayswater (unless process be stayed or  
satisfied).

All the Estate and Interest (if any) of Frederic Donald  
Munro (shown on Certificate of Title as Frederick Donald  
Munro), Section Leader, of 21 Fitzgerald Street, Bays-  
water North as proprietor of an estate in fee simple in  
the land described in Certificate of Title Volume 8290  
Folio 590 upon which is erected a brick veneer residence  
with a shed at the rear known as No. 21 Fitzgerald  
Street, Bayswater North.

Registered Mortgages Nos. B.732651 and F.843779 affect  
the said estate and interest.

Terms—Cash only  
3187 H. BEUTTNER, Sheriff's Officer

In the Supreme Court of the State of Victoria  
SALE BY THE SHERIFF

On Friday 7 December 1979 at 12.00 noon at the Police  
Station, Greensborough (unless process be stayed or satis-  
fied).

All the Estate and Interest (if any) of Julie Roccas  
(shown on Certificate of Title as Georgia Roccas), Hair-  
dresser, of 1190 Plenty Road, Bundoora as joint proprietor  
with Dimitrios Roccas, Labourer, of an estate in fee  
simple in the land described in Certificate of Title Volume  
8481 Folio 837 upon which is erected a triple fronted brick  
veneer dwelling with tiled roof and a tool shed known as  
No. 1190 Plenty Road, Bundoora.

Registered Mortgages Nos. G.90760 and G.90761 and  
Caveat G.725917 affect the said estate and interest.

Terms—Cash only  
3188 KEITH R. MARTIN, Sheriff's Officer

In the Supreme Court of the State of Victoria  
**SALE BY THE SHERIFF**

On Wednesday 5 December 1979 at 2.00 p.m. at the Police Station, Castlemaine (unless process be stayed or satisfied).

All the Estate and Interest (if any) of R. Burnside (shown on Certificate of Title as Robert Charles Burnside), Builder, of 4 Kangaroo Ground Road, Wattle Glen as joint proprietor with Susan Dawn Burnside, Married Woman, of an estate in fee simple in the land described in Certificate of Title Volume 8850 Folio 474 upon which is erected a dwelling house known as No. 18 Roberts Avenue, Castlemaine.

Registered Mortgage No. H.552575 affects the said estate and interest.

Terms—Cash only  
 3189 H. BEUTTNER, Sheriff's Officer

**NOTICE OF MAKING OF  
 STATUTORY RULES**

In pursuance of the provisions of the *Subordinate Legislation Act 1962* and the Regulations made thereunder, notice is given of the making of the following statutory rules:—

No.	Statutory Rule	Price
	<i>Chiropodists Act 1968</i>	
399/1979	Chiropodists (Registration) Regulations 1979	10c
	<i>Land Tax Act 1958</i>	
400/1979	Land Tax Regulations 1979	10c
	<i>Police Regulation Act 1958</i>	
401/1979	Police (Constitution Strength Organization and Seniority) (Amendment No. 3) Regulations 1979	10c
	<i>Marine Act 1958</i>	
402/1979	Marine (Compass Adjustment Fees) Regulations 1979	10c
	<i>Public Service Act 1974</i>	
PSD74/1979	Public Service Amendment Determinations (No. 74) 1979	10c
PSD75/1979	Public Service Amendment Determinations (No. 75) 1979	10c
PSD77/1979	Public Service Amendment Determinations (No. 77) 1979	10c
PSD78/1979	Public Service Amendment Determinations (No. 78) 1979	10c

Copies of these statutory rules when printed may be purchased at the Sale of Publications Section of the Government Printing Office, located at 7A Parliament Place, Melbourne, 3002. If ordered by mail, remittance should be addressed to "The Government Printer, Box 203, P.O., North Melbourne, 3051", and should include 25c extra for postage.

The annual subscription rates for Statutory Rules for the year commencing 1st January, 1979; payable in advance, are as follows:—

*Statutory Rules (other than Public Service Determinations), Pamphlet copies only	\$33.00
Public Service Determinations	\$23.00

\*The Bound Volume of Statutory Rules is not included in the subscription rate.

F. D. ATKINSON  
 Government Printer

**STATE ACTS, 1978**

Copies of the following Acts of the Parliament of Victoria may be obtained at the Government Printing Office, Sale of Publications Branch, 7A Parliament Place, Melbourne, phone 651 2754 or 651 2759, or from any accredited agent, at the price set opposite to each (these prices do not include postage).

Postage costs must be added to your remittance when ordering by mail as follows:—

Act Price.	Postage Cost.
10c-40c	25c
45c-70c	35c
75c-\$1.70	45c
\$1.75c-\$4.00	70c
Above \$4.00	\$1.15

Bound Volumes of 1977 State Acts (\$18.00) and the Index to the Bound Volumes (\$8.00) are also available.

No.	Act	Price.
9084.	Aerial Spraying Control (Amendment)	\$0.10
9085.	Dairy Products (Repeal)	\$0.10
9086.	Gas and Fuel Corporation (Borrowing Powers Amendment)	\$0.10
9087.	Constitution	\$0.10
9088.	Marine (Amendment)	\$0.10
9089.	Architects (Professional Conduct)	\$0.10
9090.	Victorian Film Corporation (Amendment)	\$0.10
9091.	Melbourne and Metropolitan Board of Works (Borrowing Powers Amendment)	\$0.10
9092.	Co-operative Farmers and Graziers District Meat Supply Limited	\$0.10
9093.	Reference Areas	\$0.10
9094.	Molesworth (Land Exchange)	\$0.10
9095.	Melbourne Wholesale Fruit and Vegetable Market Trust (Licences)	\$0.10
9096.	Public Service (Amendment)	\$0.10
9097.	St. Andrew's Hospital	\$0.30
9098.	Environment Protection (Amendment)	\$0.30
9099.	State Savings Bank (Amendment)	\$0.20
9100.	St. Andrew's Hospital (Guarantee)	\$0.10
9101.	Education (Amendment)	\$0.10
9102.	Land (Amendment)	\$0.10
9103.	Probate Duty (Application)	\$0.10
9104.	Supply (1978-79, No. 1)	\$0.20
9105.	Teaching Service (Appointments)	\$0.10
9106.	Fisheries (Amendment)	\$0.20
9107.	Road Traffic (Amendment)	\$0.10
9108.	Co-operative Housing Societies (Amendment)	\$0.10
9109.	Granya (Land Exchange)	\$0.10
9110.	Sandringham Land	\$0.10
9111.	Vegetation and Vine Diseases (Parasites)	\$0.10
9112.	Melbourne Underground Rail Loop (Borrowing Powers)	\$0.10
9113.	Railways (Legal Actions)	\$0.10
9114.	National Parks (Amendment)	\$0.40
9115.	Co-operation (Amendment)	\$0.10
9116.	Local Government (Promotion of Decentralization)	\$0.10
9117.	Parliamentary Salaries and Superannuation	\$0.10
9118.	Country Fire Authority (Borrowing Powers)	\$0.10
9119.	Teaching Service (Migrant Instructors)	\$0.10
9120.	Stamps (Amendment)	\$0.20
9121.	State Electricity Commission (Amendment)	\$0.10
9122.	Building Industry Long Service Leave (Amendment)	\$0.10
9123.	Melbourne University (Amendment)	\$0.10
9124.	Motor Car (Fees and Penalties)	\$0.20
9125.	Superannuation (Amendment)	\$0.20
9126.	State Development Decentralization and Tourism	\$0.20
9127.	Melbourne Harbor Trust (Borrowing Powers)	\$0.10
9128.	Cluster Titles (Amendment)	\$0.20
9129.	Victoria Conservation Trust	\$0.20
9130.	Melbourne and Metropolitan Board of Works (Rate Exemption)	\$0.10
9131.	Geelong Waterworks and Sewerage (Administration and Rates)	\$0.10
9132.	Mildura Irrigation and Water Trust (Merbein)	\$0.10
9133.	Egg Industry Stabilization (Amendment)	\$0.10

STATE ACTS, 1978—continued

No.	PRICE
9134. Workers Compensation (Special Provisions)	\$0.10
9135. Environment Effects	\$0.10
9136. Workers Compensation (Amendment)	\$0.20
9137. Motor Car (Amendment)	\$0.10
9138. Town and Country Planning (Amendment)	\$0.20
9139. Sewerage Districts (Amendment)	\$0.10
9140. Petroleum Products Subsidy (Amendment)	\$0.10
9141. Water (Amendment)	\$0.10
9142. Railways (Amendment)	\$0.40
9143. Local Government (Regional Refuse Disposal)	\$0.40
9144. Dandenong Valley Authority (Amendment)	\$0.20
9145. Post-Secondary Education	\$0.30
9146. Racing (Amendment)	\$0.10
9147. Physiotherapists	\$0.30
9148. Local Government (Municipal Districts)	\$0.10
9149. Ministry of Transport (Passenger Services)	\$0.20
9150. Geelong Regional Interim Development Order (Validation)	\$0.10
9151. Credit Reporting	\$0.20
9152. Magistrates' Courts (Amendment)	\$0.10
9153. Wrongs (Actions for Damages)	\$0.10
9154. Magistrates (Interstate Enforcement)	\$0.20
9155. Crimes (Hijacking and Other Offences)	\$0.10
9156. Evidence (Amendment)	\$0.10
9157. Motor Car Traders (Amendment)	\$0.20
9158. Bail (Amendment)	\$0.10
9159. Water Drainage	\$0.30
9160. Legal Profession Practice (Solicitors' Disciplinary Tribunal)	\$0.80
9161. Chiropractors and Osteopaths	\$0.50
9162. Local Government (Miscellaneous Provisions)	\$0.60
9163. Hospitals Remuneration Tribunal	\$0.30
9164. Legal Profession Practice (Amendment)	\$0.10
9165. Melbourne and Metropolitan Board of Works (Reconstitution)	\$0.30
9166. Victoria Conservation Trust (Amendment)	\$0.10
9167. Shrine of Remembrance	\$0.20
9168. Pounds (Amendment)	\$0.10
9169. Queenscliff Land	\$0.10
9170. Securities Industry (Amendment)	\$0.10
9171. Labour and Industry	\$0.20
9172. Dandenong Valley Authority (Recreational Areas and Environmental Areas)	\$0.10
9173. Petroleum (Amendment)	\$0.50
9174. Victoria Law Foundation	\$0.20
9175. Mildura Irrigation and Water Trusts (Amendment)	\$0.10
9176. Judges Salaries	\$0.10
9177. Country Roads (Amendment)	\$0.30
9178. Port of Melbourne Authority	\$0.50
9179. Melbourne (Snowden Gardens) Land	\$0.10
9181. State Forests Works and Services	\$0.10
9182. Gas and Fuel Corporation (Municipal Rates)	\$0.10
9183. Land (Amendment)	\$0.20
9184. Road Traffic	\$0.10
9185. Tocumwal Railway Extension (Supplementary Agreement Ratification)	\$0.10
9186. Appropriation (1978-79, No. 1)	\$3.80
9187. Lifts and Cranes (Amusement Structures)	\$0.20
9188. Health Commission (Amendment)	\$0.20
9189. Railways	\$0.10
9190. Land Tax	\$0.20
9191. Country Roads (Borrowing Powers)	\$0.30
9192. Pay-roll Tax	\$0.10
9193. Melbourne and Metropolitan Tramways (Bundoora Tramway)	\$0.10
9194. Melbourne Wholesale Fruit and Vegetable Market Trust (Amendment)	\$0.10
9195. Education (Work Experience for Handicapped Children)	\$0.10
9196. Market Court	\$0.40
9197. Consumer Affairs (Amendment)	\$0.30
9198. Co-ordination Council (Amendment)	\$0.10
9199. Broiler Chicken Industry	\$0.10
9200. Liquor Control	\$0.40
9201. Racing (Amendment)	\$0.40
9202. Legal Profession Practice (Discipline)	\$0.40
9203. Ballarat (Childrens Home)	\$0.20
9204. Trustee (Authorized Investments)	\$0.20
9205. Public Works and Services	\$0.20
9206. Co-operative Housing Societies (Indemnities)	\$0.10
9207. Environment Protection (Noise Control)	\$0.30

STATE ACTS, 1978—continued

No.	Price
9208. Stamps	\$0.20
9209. Water Supply Works and Services	\$0.40
9210. Transport Works and Services	\$0.10
9211. The Constitution Act Amendment (Conduct of Elections)	\$0.60
9212. Crown Land (Reserves)	\$0.80
9213. Wine Grape Processing Industry	\$0.30
9214. Summary Offences (Amendment)	\$0.10
9215. Workers Compensation (Share Farmers)	\$0.10
9216. The Constitution Act Amendment (Conjoint Elections)	\$0.10
9217. Education (Further Amendment)	\$0.10
9218. Country Fire Authority (Borrowing Powers)	\$0.10
9219. Public Records (Transfer of Administration)	\$0.10
9220. Educational Grants (Continuation)	\$0.10
9221. Port of Melbourne (World Trade Centre)	\$0.10
9222. Town and Country Planning (Miscellaneous Provisions)	\$0.30
9223. Members of Parliament (Register of Interests)	\$0.20
9224. Local Government (Rates and Fees)	\$0.30
9225. Valuation of Land	\$0.20
9226. Magistrates' Courts (Stipendiary Magistrates)	\$0.10
9227. Charities	\$0.20
9228. Crimes (Criminal Damage)	\$0.30
9229. Crimes (Offences at Sea)	\$0.30
9230. Crimes (Competence and Compellability of Spouse Witnesses)	\$0.10
9231. Domicile	\$0.10
9232. Dog (Amendment)	\$0.20
9233. Dental Technicians (Amendment)	\$0.10
9234. Administrative Law	\$0.10
9235. Melbourne and Metropolitan Board of Works (Miscellaneous Amendments)	\$0.20
9236. Mines (Miscellaneous Provisions)	\$0.40
9237. Wheat Industry Stabilization (Amendment)	\$0.20
9238. Victorian Dairy Industry Authority (Amendment)	\$0.20
9239. Melbourne and Metropolitan Board of Works (Trade Waste)	\$0.10
9240. Trustee Companies (Amendment)	\$0.10
9241. Sewerage Districts (Transfer of Works)	\$0.10
9242. Crimes (Amendment)	\$0.10
9243. Motor Car	\$0.20
9244. Health (Amendment)	\$0.30
9245. Legal Aid Commission	\$0.80
9246. Housing (Amendment)	\$0.80
9247. National Parks	\$0.50
9248. Community Welfare Services	\$0.80
9249. Victorian Brown Coal Council	\$0.20
9250. Police Offences (Offensive Publications)	\$0.20
9180. Surveyors	\$0.60

STATE ACTS, 1979

Copies of the following Acts of the Parliament of Victoria may be obtained at the Government Printing Office, Sale of Publications Branch, 7A Parliament Place, Melbourne, phone 651 2754 or 651 2759, or from any accredited agent, at the price set opposite to each (these prices do not include postage).

Postage costs must be added to your remittance when ordering by mail as follows:—

Act Price.	Postage Cost.
10c-40c	25c
45c-70c	35c
75c-\$1.70	45c
\$1.75-\$4.00	70c
Above \$4.00	\$1.15

Bound Volumes of 1977 State Acts (\$18.00) and the Index to the Bound Volumes (\$8.00) are also available.

No.	PRICE
9251. Constitution (Governor's Pension)	\$0.10
9252. Joint Select Committee (Road Safety)	\$0.20
9253. Cattle Compensation	\$0.10
9254. Constitution (Local Government)	\$0.30

STATE ACTS, 1979—continued

No.	PRICE.
9255. Gas and Fuel Corporation (Borrowing Powers)	\$0.10
9256. Ombudsman (Co-operation)	\$0.10
9257. Geelong (Haines Homes) Land	\$0.20
9258. Motor Car (Breath Testing Stations) (Amendment)	\$0.10
9259. Geelong Waterworks and Sewerage (Trust)	\$0.30
9260. Bright (Land Exchange)	\$0.20
9261. Supply (1979-80, No. 1)	\$0.30
9262. Money Lenders (Fees)	\$0.10
9263. Exhibition (Amendment)	\$0.30
9264. Health (Cattle)	\$0.10
9265. Victorian Public Offices Corporation (Amendment)	\$0.10
9266. Community Welfare Services (Amendment)	\$0.10
9267. Margarine (Amendment)	\$0.10
9268. Youth, Sport and Recreation (State Youth Council)	\$0.10
9269. Racing (Restricted Trotting Meetings)	\$0.10
9270. State Electricity Commission (Morwell Land Compensation)	\$0.10
9271. Construction Safety	\$1.00
9272. Business Franchise (Petroleum Products)	\$0.40
9273. Albury-Wodonga Agreement (Amendment)	\$0.40
9274. City of Melbourne (Re-subdivision)	\$0.10
9275. Co-operation	\$0.40
9276. Cemeteries (Melbourne General Cemetery)	\$0.10
9277. Melbourne and Metropolitan Board of Works (Amendment)	\$0.30
9278. River Improvement (Trusts and Valuations)	\$0.10
9279. Instruments (Writs)	\$0.10
9280. Forests (Reserved Land)	\$0.10
9281. Trinity College	\$0.50
9282. Revocation and Excision of Crown Reservations	\$0.30
9283. Local Government (Amendment)	\$0.50
9284. Tattersall Consultations (Amendment)	\$0.10
9285. Prahran Market	\$0.10
9286. Geelong Regional Commission (Amendment)	\$0.10
9287. Pharmacists (Amendment)	\$0.10
9288. Legal Profession Practice (Amendment)	\$0.10

THE "VICTORIA GOVERNMENT GAZETTE"

PUBLICATION—A VICTORIA GOVERNMENT GAZETTE is published every WEDNESDAY EVENING unless advertised otherwise.

SUBSCRIPTIONS—The Subscription, including postage, is \$56 per annum, or \$28 per half year, payable in advance. Subscriptions are required for whole months, but must cover at least a half-year.

PRIVATE ADVERTISEMENTS—Advertisements will be received by the Government Printer not later than the day preceding publication—at ordinary rates at or before ONE p.m. and at double rates between ONE p.m. and HALF PAST THREE p.m. The charge for ADVERTISEMENTS is 65 cents per line single column and \$1.30 per line double column. The charge for a full page is \$98. The title forms one or more lines as a heading. On an average ten words make a line of single column. Every signature must likewise be counted as a line. The final words of a paragraph though only portion of a line, must be counted as one line. Signatures (in particular) and proper names must be written very clearly in the text: ONE SIDE ONLY of each sheet of paper should be written upon.

All documents NOT CLEARLY PREPARED will be returned unpublished. Where brands occur, not provided for by the ordinary letters of the alphabet, a written explanatory description also must be furnished.

PAYMENTS—Unless the advertiser has a Credit Account, all payments are required in advance. Remittances should be made by cheque, postal order or money order, payable to "GOVERNMENT PRINTER".

CORRESPONDENCE—All correspondence should be addressed to "The Victorian Government Printer, P.O. Box 203, North Melbourne, 3051".

PUBLICATION OF OFFICIAL MATTER

Attention is invited to the following procedure in relation to the publication of official matter in the *Government Gazette*:—

Publication will be facilitated by the submission of carbon copies for the use of the *Gazette Officer*.

1. Matter submitted to the Executive Council

Matter submitted to the Executive Council which requires gazettal will normally be published in the issue of the following week.

Where urgent gazettal is required, special arrangements should be made with the *Gazette Officer*, Room 15, first floor, Old Treasury Building.

2. Other matter

(a) All other matter duly certified by a responsible officer for publication should be lodged with the *Gazette Officer* not later than half-past Nine a.m. on Tuesday.

(b) Lengthy or involved notices should be forwarded several days before publication.

(c) Proofs, which will be supplied only when specifically requested or at the direction of the *Gazette Officer*, should be returned promptly to avoid delay in publication.

(d) No additions or amendments to matters for publication will be accepted by telephone.

CONTENTS

	Page
Acts of Parliament	3461
Acts of Parliament on Sale at the Government Printing Office	3514
Appointments	3481
Auction Sales Act	3481
Bank Holidays	3462
Companies Act 1961—Notice	3480
Contracts	3472
Country Roads Board	3474
Estates of Deceased Persons	3481
Government Notices	3463
Lands	3490
Minerals and Energy	3471
Notice of Making of Statutory Rules	3514
Orders in Council—	
Acts—Local Government; Stamps; Country Roads Board; Superannuation; Crown Land (Reserves); Urban Renewal; Water; Sewerage Districts; Stock Diseases; Water; Geelong Waterworks and Sewerage; Sewerage Districts	3482 et seq
Private Advertisements	3494
Proclamations	3461
Resignations	3482
State Rivers and Water Supply Commission	3466
Tenders	3493
Transport Regulation Board—Public Hearings	3464
Waterworks Trusts	3469