



# Victoria Government Gazette

No. 102—Wednesday, 19 November 1980

## PROCLAMATIONS

### ACT OF PARLIAMENT

#### PROCLAMATION

By His Excellency the Governor of the State of Victoria and its Dependencies in the Commonwealth of Australia, &c., &c., &c.

I, the Governor of the State of Victoria, in the Commonwealth of Australia, do hereby declare that I have this day assented, in Her Majesty's name, to the Bill passed by the Parliament of the said State, the title whereof is hereunder set forth, together with the short title, that is to say:—

No. 9431. "An Act to amend the *Cemeteries Act 1958* to permit Burials in Private Mausoleums at Public Cemeteries and for other Purposes." (*Cemeteries (Amendment) Act 1980.*)

Given under my Hand and the Seal of the State of Victoria aforesaid, at Melbourne, this seventh day of October, in the year of our Lord One thousand nine hundred and eighty, and in the twenty-ninth year of the reign of Her Majesty Queen Elizabeth II.

(L.S.) HENRY WINNEKE

By His Excellency's Command

R. J. HAMER  
Premier

GOD SAVE THE QUEEN!

NOTE—Act No. 9431 shall come into operation on a day to be fixed by Proclamation.

### ACTS OF PARLIAMENT

#### PROCLAMATION

By His Excellency the Governor of the State of Victoria and its Dependencies in the Commonwealth of Australia, &c., &c., &c.

I, the Governor of the State of Victoria, in the Commonwealth of Australia, do hereby declare that I have this day assented, in Her Majesty's name, to the Bills passed by the Parliament of the said State, the titles whereof are hereunder set forth, together with the short titles, that is to say:—

No. 9435. "An Act to amend the *Educational Institutions (Guarantees) Act 1976.*" (*Educational Institutions (Guarantees) (Amendment) Act 1980.*)

No. 9436. "An Act to amend the *Business Franchise (Tobacco) Act 1974* and for other purposes." (*Business Franchise (Tobacco) (Amendment) Act 1980.*)

No. 9437. "An Act to amend section 113 of the *Country Roads Act 1958.*" (*Country Roads (Road Marking) Act 1980.*)

No. 102—29130/80—Price 60 cents, delivered \$1.10. Subscription rate: \$72 per annum.

Given under my Hand and the Seal of the State of Victoria aforesaid, at Melbourne, this eighteenth day of November, in the year of our Lord One thousand nine hundred and eighty, and in the twenty-ninth year of the reign of Her Majesty Queen Elizabeth II.

(L.S.) HENRY WINNEKE

By His Excellency's Command

R. J. HAMER  
Premier

GOD SAVE THE QUEEN!

NOTE—Act Nos. 9435, 9436, 9437 shall come into operation on the Day of Royal Assent.

*Post-Secondary Education (Amendment) Act 1980, No. 9424*  
PROCLAMATION PURSUANT TO SECTION 3 (1) TO REPEAL SEVERAL PROVISIONS OF THE VICTORIA INSTITUTE OF COLLEGES ACT 1965 AND OF THE STATE COLLEGE OF VICTORIA ACT 1972

#### PROCLAMATION

By His Excellency the Governor of the State of Victoria and its Dependencies in the Commonwealth of Australia, &c., &c., &c.

Whereas by an Act of the Parliament of the State of Victoria passed in the twenty-ninth year of the reign of Her Majesty Queen Elizabeth II, intitled the *Post-Secondary Education (Amendment) Act 1980, No. 9424* it is enacted in Section 3 (1) thereof that the several provisions of the *Victoria Institute of Colleges Act 1965* and the *State College of Victoria Act 1972* shall be repealed on a day or on the respective days to be fixed by proclamation or successive proclamations of the Governor in Council published in the *Government Gazette*.

Now therefore I, the Governor of the State of Victoria, in the Commonwealth of Australia, by and with the advice of the Executive Council of the said State, do by this my Proclamation fix Wednesday the nineteenth day of November, One thousand nine hundred and eighty, as the day on which the several provisions enumerated herein of the *Victoria Institute of Colleges Act 1965* and the *State College of Victoria Act 1972* shall be repealed:

*Victoria Institute of Colleges Act 1965 Act No. 7291* Section 29 (3) (aa);

*State College of Victoria Act 1972, No. 8376* Section 28 (3) (b).

Given under my Hand and the Seal of the State of Victoria aforesaid, at Melbourne, this eighteenth day of November, in the year of our Lord One thousand nine hundred and eighty, and in the twenty-ninth year of the reign of Her Majesty Queen Elizabeth II.

(L.S.) HENRY WINNEKE

By His Excellency's Command

ALAN JOHN HUNT  
Minister of Education

GOD SAVE THE QUEEN!



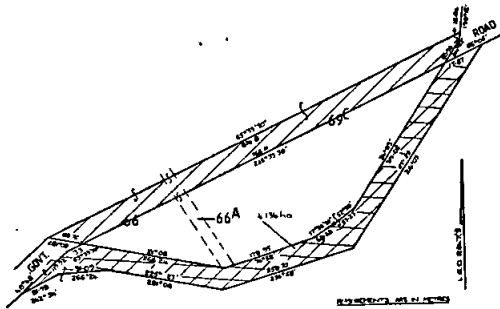

The common seal of the President, Councillors and Ratepayers of the Shire of Morwell was hereunto affixed, 6 October 1980—

(SEAL) J. C. VINALL, Shire President  
G. W. DYER, Councillor  
R. H. WATERS, Shire Secretary

Confirmed by the Governor in Council, 11 November 1980—TOM FORRISTAL, Clerk of the Executive Council

SHIRE OF MORWELL  
ROAD DEVIATION ORDER

Pursuant to the provisions of sections 522 and 526 of the Local Government Act 1958 the Council of the Shire of Morwell hereby directs that the land in the Parish of Narracan South indicated by hatching on the diagram hereunder shall be a public highway on and from the date of publication of this Order in the Government Gazette and declares that such land shall be a public highway in lieu of the land indicated by cross hatching on the said diagram.

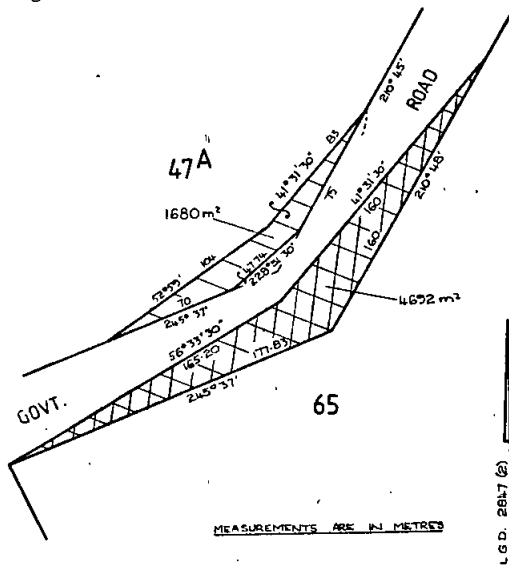

The common seal of the President, Councillors and Ratepayers of the Shire of Morwell was hereunto affixed, 6 October 1980—

(SEAL) J. C. VINALL, Shire President  
G. W. DYER, Councillor  
R. H. WATERS, Shire Secretary

Confirmed by the Governor in Council, 11 November 1980—TOM FORRISTAL, Clerk of the Executive Council

VICTORIA

ACT 391—SECOND SCHEDULE

A Statement of Trusts having been submitted by the head or authorized representative of the denomination known as The Uniting Church in Australia, pursuant to the provisions of the Act to provide for the abolition of State Aid to Religion, for allowance of His Excellency the Governor (the same was allowed by him on 11 November 1980) and the following is the form in which such statement of trusts has been allowed.

STATEMENT OF TRUSTS

**Description of Land**—Site for Wesleyan Church purposes temporarily reserved by Order in Council of 9 May 1864, 4860 square metres (by re-survey) Township of Craigie, Parish of Craigie, being Crown allotment 9, section 6. Commencing at the south-eastern angle of Crown allotment 16f, section A, Parish of Craigie; bounded thence by that allotment bearing 15 deg. 11 min. 119.39 metres, further by that allotment and allotment 16e bearing 105 deg. 11 min. 40.23 metres, thence by allotment 16d bearing 195 deg. 11 min. 122.21 metres and thence by Maryborough Street bearing 289 deg. 08 min. 40.33 metres to the point of commencement—(C.88121).

**Names of Trustees**—The Uniting Church in Australia Property Trust (Victoria).

**Powers of Disposition**—Such powers of disposition, including powers of sale, lease or mortgage as are given to the Trust by the *Uniting Church in Australia Act 1977*, No. 9021.

**Purposes to which Proceeds of Disposition are to be Applied**—To such Uniting Church in Australia purposes as shall be approved by the Committee of the Victorian Synod of The Uniting Church in Australia.

As witness, the Hand of the Governor of the State of Victoria.

11 November 1980

HENRY WINNEKE  
Governor of the State of Victoria'

Melbourne and Metropolitan  
BOARD OF WORKS

NOTICE TO THE OWNERS OF TENEMENTS IN THE UNDERMENTIONED STREETS AND THE PRIVATE STREETS, LANES, COURTS AND ALLEYS OPENING THERETO

The main pipe in the said streets being laid down, the owners of all tenements situated as under are hereby required on or before 22 December 1980 to cause a proper pipe and stop cocks to be laid so as to supply water within such tenements from the main pipe.

Broadmeadows

Kenny Street, from 62 metres west of Eyre Street further westwards, 450 metres.

Bulla

Medway Road, from Southern Crescent westwards, 452 metres.

Southern Crescent, from Medway Road southwards and eastwards, 214 metres.

Lee Street, from Medway Road southwards, 225 metres.

Beacon Hill Crescent, from Medway Road to Lee Street.

Woodlands Court, total street from Beacon Hill Crescent eastwards.

Bank Street, from Medway Road southwards, 224 metres.

Kingston Heath Court, total street from Medway Road northwards.

Waverley Court, total street from Medway Road northwards.

Huntingdale Court, total street from Medway Road northwards.

Keysborough Street, from Medway Road northwards, 228 metres.

Metropolitan Avenue, from Keysborough Street westwards, 310 metres.

Pines Way, from Keysborough Street to Riversdale Street.

Rosanna Court, total street from Pines Way northwards.

Riversdale Street from 100 metres north of Pines Way further northwards, 50 metres.

Hanson Road, from 136 metres north-west of Medway Road further north-westwards, 83 metres.

Commonwealth Court, from 130 metres west of Spurr Street, further westwards around the bowl of the court including allotments 222 to 225, 35 metres.

Kenny Street, from the Bulla-Broadmeadows municipal boundary westwards, 438 metres.

**Croydon**

Lacey Street, from Sturt Street westwards, 30 metres.

**Nunawading**

Crimson Avenue, from 70 metres north of Sandgate Road further northwards, 36 metres.

**Ringwood**

Tortice Drive, from Wonga Road north-westwards, 554 metres.

Bramley Drive, from Tortice Drive south-westwards and southwards, 109 metres.

Furnell Way, from Tortice Drive north-eastwards and northwards, 156 metres.

Avery Court, total street from Furnell Way eastwards. Stamford Court, total street from Tortice Drive north-eastwards.

**Sherbrooke**

Fairy Dell Road, from Clifford Grove to Hazel Vale Road. Laurie Avenue, from Fairy Dell Road to Burnham Road.

Burnham Road, from 8 metres north of Laurie Avenue further northwards, 70 metres.

Hazel Vale Road, from Fairy Dell Road, north-eastwards and north-westwards, 210 metres.

Centre Road, from Glenfern Road eastwards to R.O.W. and southwards, 130 metres.

Kensley Street, from Jones Avenue northwards, 20 metres. Jones Avenue, from Kensley Street to Olivette Avenue.

Glassford Avenue, total street from Janiesleigh Road northwards.

Olivette Avenue, from Jones Avenue to Hughes Street.

Irene Avenue, total street from Olivette Avenue south-westwards.

**Whittlesea**

Hakea Court, total street from Gardenia Road westwards. 11 November 1980

O. T. W. COSGRIFF, Secretary

**Town and Country Planning Act 1961  
GEELONG REGIONAL PLANNING SCHEME**

NOTICE THAT AN AMENDMENT TO THE GEELONG REGIONAL PLANNING SCHEME HAS BEEN PREPARED AND IS AVAILABLE FOR INSPECTION

**Amendment No. 17**

Notice is hereby given that the Geelong Regional Commission, in pursuance of its powers under the *Town and Country Planning Act 1961* has prepared a planning scheme for part of the Geelong Region for the purpose of regulating, restricting or prohibiting the use and development of land within the following areas:

**Item Number 1**—Land bounded by Reservoir Road to the north, Anglesea Road to the east, Mt. Duneed Road to the south and Bogans Lane to the west, Freshwater Creek.

A copy of the scheme has been deposited at this office, Geelong Regional Commission, State Government Offices, Cnr. Lt. Malop & Fenwick Streets, Geelong, and at Barrabool Shire Council, 441 Moorabool Street, Geelong, and at the offices of The Town and Country Planning Board, 235 Queen Street, Melbourne, and will be open for inspection during office hours by any person, free of charge.

Any persons affected by the scheme are required to set forth in writing any submissions they may wish to make with respect to the scheme, addressed to the Secretary, Geelong Regional Commission, P.O. Box 770, Geelong, on or before 19 December 1980, and to state whether they wish to be heard in respect of their submissions.

G. R. COWLING, Secretary  
Geelong Regional Commission

**Town and Country Planning Act 1961  
GEELONG REGIONAL PLANNING SCHEME**

NOTICE THAT AN AMENDMENT TO THE GEELONG REGIONAL PLANNING SCHEME HAS BEEN PREPARED AND IS AVAILABLE FOR INSPECTION

**Amendment No. 18**

Notice is hereby given that the Geelong Regional Commission, in pursuance of its powers under the *Town and Country Planning Act 1961* has prepared a planning scheme for part of the Geelong Region for the purpose of regulating, restricting or prohibiting the use and development of land within the following areas:

**Item Number 1**—Land east of the Princes Highway, Corio, north of St. Georges Road.

**Item Number 2**—Land on the north-west corner of the Barwon Heads Road and Crows Road, Belmont.

A copy of the scheme has been deposited at this office, Geelong Regional Commission, State Government Offices, Cnr. Lt. Malop & Fenwick Streets, Geelong, and at Corio Shire Council, "Osborne House", Swinburne Street, North Geelong, and South Barwon City Council, 2 Colac Road, Belmont, and at the offices of The Town and Country Planning Board, 235 Queen Street, Melbourne, and will be open for inspection during office hours by any person, free of charge.

Any persons affected by the scheme are required to set forth in writing any submissions they may wish to make with respect to the scheme, addressed to the Secretary, Geelong Regional Commission, P.O. Box 770, Geelong, on or before 19 February 1981, and to state whether they wish to be heard in respect of their submissions.

G. R. COWLING, Secretary  
Geelong Regional Commission

**Town and Country Planning Act 1961  
GEELONG REGIONAL PLANNING SCHEME**

NOTICE THAT AN AMENDMENT TO THE GEELONG REGIONAL PLANNING SCHEME HAS BEEN PREPARED AND IS AVAILABLE FOR INSPECTION

**Amendment No. 19**

Notice is hereby given that the Geelong Regional Commission, in pursuance of its powers under the *Town and Country Planning Act 1961* has prepared a planning scheme for part of the Geelong Region for the purpose of regulating, restricting or prohibiting the use and development of land within the following areas:

**Item Number 3**—Land west of Forest Road, Lara, north of Heales Road.

**Item Number 4**—Land east of Ballarat Road, Bell Park, south of Anakie Road.

**Item Number 7**—Ordinance change relating to entry to and exit from a service station.

The conditions of use or development of a service station currently require that the site (for a service station), *inter alia*, shall be more than 90 metres from the junction or intersection of an arterial road with another arterial road.

The item proposes that, *inter alia*, the entry to or exit from the site (for a service station) whichever is nearest, is distant more than 45 metres from the junction or intersection of an arterial road with another arterial road.

The item will affect land in the following zones under the Geelong Regional Planning Scheme Residential B, Central Business, District Business, Local Business, Commercial Office, Service Business, Industrial A, Industrial B, Special Industrial, Reserved Industrial and Township Zones.

A copy of the scheme has been deposited at this office, Geelong Regional Commission, State Government Offices, Cnr. Lt. Malop & Fenwick Streets, Geelong, and at Bannockburn Shire Council, High Street, Bannockburn, Barrabool Shire Council, 441 Moorabool Street, Geelong, Bellarine Shire Council, Collins Street, Drysdale, Corio Shire Council, "Osborne House", Swinburne Street, North Geelong, Geelong City Council, Gheringhap Street, Geelong, Geelong West City Council, 153 Pakington Street, Geelong West, Newtown City Council, 263 Pakington Street, Geelong West, Queenscliffe Borough Council, 50 Learmonth Street, Queenscliff, South Barwon City Council, 2 Colac Road, Belmont, and at the offices of The Town and Country Planning

Board, 235 Queen Street, Melbourne, and will be open for inspection during office hours by any person, free of charge.

Any persons affected by the scheme are required to set forth in writing any submissions they may wish to make with respect to the scheme, addressed to the Secretary, Geelong Regional Commission, P.O. Box 770, Geelong, by 19 December 1980, and to state whether they wish to be heard in respect of their submissions.

G. R. COWLING, Secretary  
Geelong Regional Commission

*Town and Country Planning Act 1961*

**GEELONG REGIONAL INTERIM DEVELOPMENT ORDER**

NOTICE THAT AN AMENDMENT TO THE GEELONG REGIONAL INTERIM DEVELOPMENT ORDER HAS BEEN PREPARED AND IS AVAILABLE FOR INSPECTION

*Amendment No. 37*

Notice is hereby given that the Geelong Regional Commission, in pursuance of its powers under the *Town and Country Planning Act 1961* has prepared an Amendment to the Geelong Regional Interim Development Order for part of the Geelong Region for the purpose of regulating, restricting or prohibiting the use and development of land within the following areas:

*Item Number 1*—Land bounded by Reservoir Road to the north, Anglesea Road to the east, Mt. Duneed Road to the south and Bogans Lane to the west, Freshwater Creek.

A copy of the Amendment has been deposited at this office, Geelong Regional Commission, State Government Offices, Cnr. Lt. Malop and Fenwick Streets, Geelong, and at Barrabool Shire Council, 441 Moorabool Street, Geelong, and at the offices of The Town and Country Planning Board, 235 Queen Street, Melbourne, and will be open for inspection during office hours by any person, free of charge.

Any persons affected by the Amendment are required to set forth in writing any submissions they may wish to make with respect to the Amendment addressed to the Secretary, Mr G. R. Cowling, Geelong Regional Commission, P.O. Box 770, Geelong, on or before 19 December 1980, and to state whether they wish to be heard in respect of their submissions.

G. R. COWLING, Secretary  
Geelong Regional Commission

*Town and Country Planning Act 1961*

**GEELONG REGIONAL INTERIM DEVELOPMENT ORDER**

NOTICE THAT AN AMENDMENT TO THE GEELONG REGIONAL INTERIM DEVELOPMENT ORDER HAS BEEN PREPARED AND IS AVAILABLE FOR INSPECTION

*Amendment No. 38*

Notice is hereby given that the Geelong Regional Commission, in pursuance of its powers under the *Town and Country Planning Act 1961* has prepared an Amendment to the Geelong Regional Interim Development Order for part of the Geelong Region for the purpose of regulating, restricting or prohibiting the use and development of land within the following areas:

*Item Number 1*—Land east of the Princes Highway, Corio, north of St. Georges Road.

*Item Number 2*—Land on the north-west corner of the Barwon Heads Road and Crows Road, Belmont.

*Item Number 3*—Land west of Forest Road, Lara, north of Heales Road.

*Item Number 4*—Land east of Ballarat Road, Bell Park, south of Anakie Road.

*Item Number 5*—Land bounded by Stewart's Road, Horse-shoe Bend Road, Lower Duneed Road and Torquay Road, Connemarre.

*Item Number 6*—Land north of Mt. Duneed Road, Freshwater Creek, east of Bogans Lane. Land west of Bogans Lane, north of Mt. Duneed Road and land south of Reservoir Road, west of Bogans Lane, Pettavel.

*Item Number 7*—Ordinance change relating to entry to and exit from a service station.

The conditions of use or development of a service station currently require that the site (for a service station), *inter alia*, shall be more than 90 metres from the junction or intersection of an arterial road with another arterial road.

The item proposes that, *inter alia*, the entry to or exit from the site (of a service station) whichever is nearest, is distant more than 45 metres from the junction or intersection of an arterial road with another arterial road.

The item will affect land in the following zones under the Geelong Regional Planning Scheme Residential B, Central Business, District Business, Local Business, Commercial Office, Services Business, Industrial A, Industrial B, Special Industrial, Reserved Industrial and Township Zones.

A copy of the amendment has been deposited at this office, Geelong Regional Commission, State Government Offices, Cnr. Lt. Malop & Fenwick Streets, Geelong, and at Bannockburn Shire Council, High Street, Bannockburn, Barrabool Shire Council, 441 Moorabool Street, Geelong, Bellarine Shire Council, Collins Street, Drysdale, Corio Shire Council, "Osborne House", Swinburne Street, North Geelong, Geelong City Council, Gheringhap Street, Geelong, Geelong West City Council, 153 Pakington Street, Geelong West, Newtown City Council, 263 Pakington Street, Geelong West, Queenscliffe Borough Council, 50 Learmonth Street, Queenscliff, South Barwon City Council, 2 Colac Road, Belmont, and at the offices of The Town and Country Planning Board, 235 Queen Street, Melbourne, and will be open for inspection during office hours by any person, free of charge.

Any persons affected by the Amendment are required to set forth in writing any submissions they may wish to make with respect to the Amendment addressed to the Secretary, Mr G. R. Cowling, Geelong Regional Commission, P.O. Box 770, Geelong, on or before 19 December 1980, and to state whether they wish to be heard in respect of their submissions.

G. R. COWLING, Secretary  
Geelong Regional Commission

*Town and Country Planning Act 1961*

**MELBOURNE METROPOLITAN PLANNING SCHEME**

AMENDMENT No. 34, PART 6

*Notice of Approval*

In pursuance of the powers conferred by the *Town and Country Planning Act 1961*, the Governor in Council on 11 November 1980 approved a planning scheme entitled the Melbourne Metropolitan Planning Scheme, Amendment No. 34, Part 6, in respect of part of the municipal district of the City of Kew and such planning scheme comes into operation on the date this Notice of Approval is published in the *Government Gazette*.

A copy of the planning scheme as approved may be inspected, free of charge, during office hours at the office of the Town and Country Planning Board, 235 Queen Street, Melbourne, at the office of the Melbourne and Metropolitan Board of Works at 625 Little Collins Street, Melbourne, and when available, at the Office of Titles, Melbourne, and at the Central Plan Office of the Department of Crown Lands and Survey, Melbourne.

H. R. TROTTER, Acting Secretary  
Town and Country Planning Board

*Town and Country Planning Act 1961*

**MELBOURNE METROPOLITAN PLANNING SCHEME**

AMENDMENT No. 115, PART 1B

*Notice of Approval*

In pursuance of the powers conferred by the *Town and Country Planning Act 1961*, the Governor in Council on 11 November 1980, approved a planning scheme entitled the Melbourne Metropolitan Planning Scheme, Amendment No. 115, Part 1B, in respect of part of the municipal district of the City of Sunshine and such planning scheme comes into operation on the date this Notice of Approval is published in the *Government Gazette*.

A copy of the planning scheme as approved may be inspected, free of charge, during office hours at the office of the Town and Country Planning Board, 235

Queen Street, Melbourne, at the office of the Melbourne and Metropolitan Board of Works at 625 Little Collins Street, Melbourne, and when available, at the Office of Titles, Melbourne, and at the Central Plan Office of the Department of Crown Lands and Survey, Melbourne.

H. R. TROTTER, Acting Secretary  
Town and Country Planning Board

*Town and Country Planning Act 1961*

MELBOURNE METROPOLITAN PLANNING SCHEME

AMENDMENT No. 128

*Notice of Amendment*

In pursuance of the powers conferred by sub-section 6 of section 32 of the *Town and Country Planning Act 1961*, the Governor in Council, on 11 November 1980 amended the Melbourne Metropolitan Planning Scheme to include in the ordinance a definition of the expression "separate tenement".

A copy of the amendment may be inspected during office hours at the office of the Town and Country Planning Board, 235 Queen Street, Melbourne, at the office of the Melbourne and Metropolitan Board of Works, and when available at the Office of Titles, Melbourne, and at the Central Plan Office of the Department of Crown Lands and Survey, Melbourne.

W. H. CRAIG, Secretary  
Town and Country Planning Board

*Town and Country Planning Act 1961*

TOWN OF BAIRNSDALE PLANNING SCHEME

AMENDMENT No. 24, PART 1

*Notice of Approval*

In pursuance of the powers conferred by the *Town and Country Planning Act 1961*, the Governor in Council on 11 November 1980, approved a planning scheme entitled the Town of Bairnsdale Planning Scheme, Amendment No. 24, Part 1, in respect of part of the municipal district of the Town of Bairnsdale and such planning scheme comes into operation on the date this Notice of Approval is published in the *Government Gazette*.

A copy of the planning scheme as approved may be inspected, free of charge, during office hours at the office of the Town and Country Planning Board, 235 Queen Street, Melbourne, at the office of the Council of the Town of Bairnsdale at Bairnsdale, and when available, at the Office of Titles, Melbourne, and at the Central Plan Office of the Department of Crown Lands and Survey, Melbourne.

H. R. TROTTER, Acting Secretary  
Town and Country Planning Board

*Town and Country Planning Act 1961*

SHIRE OF BACCHUS MARSH PLANNING SCHEME

REVOCATION No. 16

*Notice of Revocation*

In pursuance of the provisions of Section 32 of the *Town and Country Planning Act 1961* the Governor in Council on 11 November 1980, made an Order:—

- (i) Revoking the Shire of Bacchus Marsh Planning Scheme in so far as applies to about 207 hectares of land being part of Crown Allotments 4 and 5, Section 2, and part of Crown Allotment 1, Section 3, Parish of Korkuperrimul; and
- (ii) providing that the land so revoked may be used or developed only as if—
  - (a) it were land to which the Shire of Bacchus Marsh Planning Scheme applies; and
  - (b) it were land within Rural 'A' Zone; and
  - (c) the provisions of sub-clause 21 (2) of the Shire of Bacchus Marsh Planning Scheme Ordinance do not apply; and
  - (d) it were permissible subject to the grant of a permit by the Responsible Authority to subdivide the land into not more than three allotments.

A copy of the Order may be inspected during office hours at the office of the Town and Country Planning Board, 235 Queen Street, Melbourne, and at the office of the Council of the Shire of Bacchus Marsh at Bacchus Marsh.

H. R. TROTTER, Acting Secretary  
Town and Country Planning Board

*Town and Country Planning Act 1961*

SHIRE OF GORDON PLANNING SCHEME

INTERIM DEVELOPMENT ORDER

AMENDMENT No. 2

*Notice of Amendment*

In pursuance of the powers conferred by section 26 of the *Town and Country Planning Act 1961*, the Governor in Council on 11 November 1980 amended the Shire of Gordon Interim Development Order to delete the words "or bank" from the definition of "works" contained in Schedule 1 to ensure that levee banks require permits.

A copy of the amendment may be inspected during office hours at the office of the Town and Country Planning Board, 235 Queen Street, Melbourne, and at the office of the Council of the Shire of Gordon at Bort.

H. R. TROTTER, Acting Secretary  
Town and Country Planning Board

*Town and Country Planning Act 1961*

SHIRE OF LILLYDALE PLANNING SCHEME

AMENDMENT No. 124

*Notice of Approval*

In pursuance of the powers conferred by the *Town and Country Planning Act 1961*, the Governor in Council on 11 November 1980 approved a planning scheme entitled the Shire of Lillydale Planning Scheme, Amendment No. 124, in respect of part of the municipal district of the Shire of Lillydale and such planning scheme comes into operation on the date this Notice of Approval is published in the *Government Gazette*.

A copy of the planning scheme as approved may be inspected, free of charge, during office hours at the office of the Town and Country Planning Board, 235 Queen Street, Melbourne, at the office of the Council of the Shire of Lillydale, at Lillydale, and when available, at the Office of Titles, Melbourne, and at the Central Plan Office of the Department of Crown Lands and Survey, Melbourne.

H. R. TROTTER, Acting Secretary  
Town and Country Planning Board

*Town and Country Planning Act 1961*

OCEAN ROAD PLANNING SCHEME

(SHIRE OF OTWAY)

AMENDMENT No. 19

*Notice of Amendment*

In pursuance of the powers conferred by sub-section 6 of section 32 of the *Town and Country Planning Act 1961*, the Governor in Council, on 11 November 1980 amended the Ocean Road Planning Scheme (Shire of Otway) to make the erection of outbuildings (i.e., carports) within the prescribed setback from any road alignment subject to the consent of the Responsible Authority.

A copy of the amendment may be inspected during office hours at the office of the Town and Country Planning Board, 235 Queen Street, Melbourne, at the office of the Council of the Shire of Otway at Beech Forest, and when available at the Office of Titles, Melbourne, and at the Central Plan Office of the Department of Crown Lands and Survey, Melbourne.

H. R. TROTTER, Acting Secretary  
Town and Country Planning Board

## STOCK DISEASES ACT 1968

In pursuance of section 32 (1) of the *Stock Diseases Act 1968*, the name and address of owners of properties, together with the name and location of properties within the footrot control area which are at present under quarantine restrictions because of footrot, are listed below.

Name	Address	Farm Location
Afton Hills Props	Kadnook, via Harrow	Powers Creek
Allan, W.S. and Golding, T.G.	Box 446, Horsham	Goroke
Arran Past. Co.	Box 339, Hamilton	Byaduk
Balmoral Honey Traders	"Banyula", Box 36, Balmoral	Balmoral
Beaton, N.D.	Gritjurk, via Coleraine	Gritjurk
Broad, M.H. and S.V.	R.S.D. 237, Peshurst	Banemore
Bryant, G.	Box 292, Portland	Heywood
Dalton, E.J.	Condah	"Cornforth", Condah
Dayman, G.C. and A.	Box 144, Narracoorte, S.A.	Apsley
Edwards, A.S.	R.S.D. 213, Hamilton	Morgiana
Four Brothers Farm (D. Hoffin)	"Lower Crawford", Lyons	Lyons
Ferrell, C.R. and R.M.	"Woodbrook", Nareen	Nareen
Frahn, J.	"Clover Downes", Strathdownie	Strathdownie
Fullston, B.	R.M.B. 724, Edenhope	Edenhope
Gavin, B.A. and J.M.	R.S.D. 218, Hamilton	Yulecart
George, J.H. and J.E.	Teloepa Downs	Teloepa Downs
Gough, W.J. and A.P.	"Gomatra", Branxholme	Branxholme
Grummet, J.S. and P. J.	Langkoop	Apsley
Guthrie, R.C. and M.H.	R.S.D. 70, Coleraine	"Ruthven", Brit Brit
Harob Nominees (Hedditch, R.H.R.)	Box 17, Heywood	Hotspur
Hawkins Bros.	Minimay	Minimay
Heenan, J.G.	"Bellmont", Tyrendarra	Tyrendarra
Herring, R.M.	R.S.D. 114, Coleraine	Coleraine
Hines, B.W.	Box 10, Dartmoor	Dartmoor
Hobbes, J.H., F.M. and N.F.	Box 116, Merino	Merino
Hodgson, A.H. and U.	R.S.D. 74, Coleraine	"Nundora", Brit Brit
Jolliffe, S.J. and T.W. (Estate of)	Box 93, Merino	Merino
Kerr, M.S.	Edenhope	Edenhope
Kinvonvie Partnership	"Kinvonvie", Hamilton	Yulecart
Lane, D.J.	Box 61, Merino	Digby
Lewis, P.W. and P.L.	P.B. Cavendish	Moorella
Lewis, R.R. and M.J.	"Wirreanda", R.S.D. 1068, Heywood	Drumborg
McLean, R.K., R.J. and H.S.	"Carinya", Drik Drik	Wanwin
Marney, R.J.	Box 93, Heywood	Greenvale
Menzel, A.P. and M.R.	Telangatuk	Telangatuk
Milne, R.S.	Gritjurk, R.S.D. 12, Coleraine	Gritjurk
Mulcahy, M.J.	Harrow	Harrow
Newtown, W.R.	Box 468, Portland	Portland
Noske, J.O.	Moutajup	Moutajup
Ogilvie, B.I. and J.W.	Apsley	Apsley
Peters, E.A. and C.T.	Tyrendarra	Tyrendarra
Pleasant Hills Past. Co.	Digby	Digby
Price, G.F.	Box 66, Heywood	Heywood
Quayle, S. and Son	Heywood	"Oakbank", Heywood
Randell, J.M. and Co.	Harrow	"Tuloona", Harrow
Riddock, A.G. and P.J.	R.S.D. 370, Coleraine	Nareen
Rogers, W.I. and G.J.	Balmoral	Balmoral
Ross, E.B.	Telangatuk	Telangatuk and Harrow
Rothwell and Sons	R.M.B. 5432, Horsham	Nurrabiel
Roulston, L.G. and D.E.	R.S.D. Coleraine	Gritjurk
Russell, I.M. and J.M.	"Carmona", Balmoral	Balmoral
Russell, J.B. and G.E.	R.M.B. 5434, Horsham	Nurrabiel
Russell, J.B. and G.E.	"Rosewood", Balmoral	Balmoral
Schultz, R.	Box 193, Heywood	Heywood
Shoebridge, E.B.	Box 17, Merino	Tahara
Sims, T.	"Ruthven", Lake Mundi	Lake Mundi
Steele, J.A. and R.D.	R.S.D. 208, Hamilton	Yulecart
Stringer, N.	Beneyeo	Beneyeo
Watson, M.J.	"Dunlea", McArthur	McArthur
Weecura Pastoral Co.	Range Rd, Merino	Merino
Wan Wan Prop.	Apsley	Langkoop
White, D.B. and Huntley, M.G.	P.M.B. 18, Mt Gambier	Lyons

The following is a list of those properties within the footrot control area which have been released or recommended to be released from quarantine or restriction since 1 June 1980.

Name	Address	Farm Location
Cossens, M.R. and Son	Tarrara Park, Balmoral	Balmoral
Chute Partnership	Chute, Hamilton	Hamilton
Holmes, T.J.	Tyrendarra	Tyrendarra
McClure, L.W.T.	Denhills Rd, Coleraine	Coleraine
Mitchell, L.C. and H.M.	18 Menadue St, Horsham	Green Lake
Muller, P. and K.	R.S.D. 256 Peshurst	Mt Napier
Papsley, J.	Tyrendarra	Tyrendarra
Stas Park Pty. Ltd. (Stasinowski, K.)	Rainbow	Pella

Dated 1 November 1980

IAN SMITH, Minister of Agriculture

Transport Regulation Act  
TRANSPORT REGULATION BOARD

## HEARING OF APPLICATIONS

Notice is hereby given that the following applications will be considered by the Transport Regulation Board on 9 December 1980.

DOWNES, I. S. & J. E., Beechworth. Application to license two commercial passenger vehicles, each with a seating capacity for 45 persons to operate as follows: (a) Under the same terms and conditions as existing licences, C.O.1118 and C.O.1166 which authorise various stage, school, charter and tour services. (b) Under contract to the Delaney Environmental Education Centre, Beechworth, for the carriage of groups from anywhere within the State of Victoria to the Centre.

NOTE—1. The two vehicles intended for licensing are of 3 star standard under the Board's Omnibus Star Rating Charter Classifications.

2. This application is subject to the cancellation of licences C.O.1118 and C.O.1166.

REID'S BUS SERVICE PTY. LTD., Thornbury. Application to license one commercial passenger vehicle with seating capacity for 18 persons to operate as a Metropolitan Special Service Omnibus.

SHARP, J. A. & D. C., Branxholme. Application to license one commercial passenger vehicle with seating capacity for 16 persons to operate as follows: (a) Between Hamilton Railway Station and the applicant's holiday farm at Branxholme for the carriage of guests and luggage as and when required. (b) For the carriage of guests to places of interest within an 80-km radius of Branxholme. (c) For the carriage of guests from Melbourne and Geelong to the holiday farm at Branxholme returning to Melbourne and Geelong as and when required.

NOTE—This application is subject to the cancellation of licence S.V.168 at present in the name of J. A. Sharp which authorises parts (a) and (b) above.

HRKALOVIC, M., Epping. Application for one Metropolitan taxi licence to be issued subject to the cancellation of Suburban Taxi Licence No. S.T.6418.

Application for renewal of licences as shown by the persons listed hereunder to operate under the same terms and conditions.

ALTMAN, A. J., Rainbow; T.S.598.  
BALABANIS, M., North Fitzroy; M.T.4901.  
BEITZEL, F. J., Balook; T.S.1482.  
CAREY, A. & J., Frankston; C.T.277.  
CHEBIB, N., West Footscray; M.T.5549.  
GRAHAM, J. J., Bundoora; M.T.1702.  
KANE, J., Queenscliff; C.O.222.  
PRITSIS, S., Pascoe Vale; M.T.4718.  
PSALIDAS, A., Prahran; M.T.4182.  
STAMERS, K. N., Traralgon; C.T.650.  
SURKITT, M. V. & B. A., Caramut; T.S.443.  
ESTATE OF THE LATE E. V. WHISTON, North Fitzroy; M.H.2475; M.H.2476.

Notice of any objections should be forwarded to reach the Secretary of the Board not later than 3 December 1980.

Applicants are advised that it will not be necessary to appear on the hearing date specified, unless advised in writing by the Board.

C. J. V. SMITH, Secretary

Corner Lygon and Princes Streets, Carlton, 3053,  
Wednesday, 19 November 1980.

Commercial Goods Vehicles Act  
TRANSPORT REGULATION BOARD  
HEARING OF APPLICATIONS

Notice is hereby given that the following applications will be considered by the Transport Regulation Board on 2 December 1980.

AUSTRAL PUMPS PTY. LTD., 5 Fink Street, Kensington, 3031.  
One commercial goods vehicle (L/C. 2.05 tonne) to operate throughout the State of Victoria in the course

of business as "Pump Distributor and Service"—tools of trade, spare parts and materials incidental to the on-site servicing and installation of pumps and pumps for specialised installation or for repair or having been repaired.

BERGMEIER, R. J., Kongwak Road, Inverloch, 3996. One commercial goods vehicle (L/C. 25.00 tonne) to operate: (a) Within an 80-km radius of the post office at Inverloch in the course of business as "Earthmoving Contractor"—own plant and equipment and plant and equipment being the property of a contractor including sufficient fuels and lubricants for operation of same. (b) Within a 32-km radius of any contract site engaged upon within the area defined in paragraph (a) above or from the railway station nearest thereto—materials and equipment necessary for completion of such contract. (c) Within a 40-km radius of the post office at Inverloch—general goods.

BLAKELEY, N. W., Midland Highway, Barkers Creek, 3450. One commercial goods vehicle (L/C. 3.50 and 1.25 tonne trailer) to operate within a 160-km radius of own premises at Barkers Creek in the course of business as "Motor Wreckers" with a specially constructed car carrying trailer—vehicles for wrecking and secondhand parts from wrecked vehicles with the proviso that no operations are undertaken from the scene of an accident or breakdown and excluding the carriage of secondhand parts from places within a 40-km radius of the G.P.O. Melbourne.

BRICKLAND, B. T., 1 O'Donnell Street, Viewbank, 3084. Application to vary the conditions of licence No. D.A.63252 by adding an additional paragraph—(b) Within an 80-km radius of own premises at Viewbank in the course of business as "Industrial Machinery Agent"—industrial machine for removal from site to site.

BROOKS, S. G., P.O. Box 755, Horsham, 3400. One commercial goods vehicle (L/C. 8.00 tonne) to operate throughout the State of Victoria in the course of business as "Marine Collector"—special wares, marine stores and old metals as defined in the *Marine Stores and Old Metals Act 1958*, provided that the load capacity of the vehicle shall not be increased without the prior written consent of the Board and that no trailer shall be hauled in conjunction with the vehicle.

CARAFI, J., 2 Robinson Grove, Bulleen, 3105. One commercial goods vehicle (L/C. 9.95 tonne) to operate for the premises of Melbourne Sand Supplies (Vic.) Pty. Ltd. at Springvale to places within a 56-km radius of the G.P.O. Melbourne and to Geelong as an "Exclusive Carrier" solely on behalf of Melbourne Sand Supplies (Vic.) Pty. Ltd.—sand.

CLOSTER, P. A., McLeod Road, Tongala, 3621. One commercial goods vehicle (water tanker) to operate throughout the State of Victoria in the course of business as "Roadmaking Contractor" as a specially constructed water spraying vehicle for the purpose of spraying own contracts.

GRAZCOS CO-OPERATIVE LTD., 500 Collins Street, Melbourne, 3000. One commercial goods vehicle (L/C. 1.15 tonne) to operate within an 80-km radius of own branch premises at Hamilton in course of business as "Shearing Contractors and General Merchants"—own goods.

HANNING, A. V., Middle Creek Road, Yinnar South, 3869. One commercial goods vehicle (L/C. 1.05 tonne) to operate: (a) Within an 80-km radius of the post office at Yinnar in the course of business as a "Glass Sand Blaster and Engraver"—own goods. (b) Between own premises at Yinnar South and places situated within a 40-km radius of the G.P.O. Melbourne in the course of business as a "Glass Sand Blaster and Engraver"—uncrated glass and glass products including items for such treatment or having been treated.

HAWKER SIDDELEY ENGINEERING PTY. LTD., 262-284 Heidelberg Road, Fairfield, 3078. One commercial goods vehicle (L/C. 1.10 tonne) to operate throughout the State of Victoria in the course of business as Contract Engineers—tools of trade, spare parts and materials incidental to the on-site servicing, maintenance and installation of diesel, electrical and sewage treatment equipment.



**KALARI PTY. LTD.**, 127 Harbour Road, Portland, 3305. One commercial goods vehicle (L/C. 24.80 tonne) to operate: (a) Within an 80-km radius of the post office at Hamilton—plant the property of a contractor and required by him for use in connection with the construction or maintenance of some specific, existing or proposed road, street, footpath, bridge, pier, wharf, weir or channel and also the following materials, viz.: metal, stones, screenings, ashes, gravel, sand and earth. (b) Within a 32-km radius from the site of any construction or maintenance work performed pursuant to paragraph (a) above, or from the railway station nearest thereto—any other materials required for such work. (c) Within a 40-km radius of the post office at Hamilton—general goods.

**KALARI PTY. LTD.**, 127 Harbour Road, Portland, 3305. One commercial goods vehicle (L/C. 13.50 and 5.50 tonne trailer) to operate: (a) Within an 80-km radius of the post office at Hamilton—plant the property of a contractor and required by him for use in connection with the construction or maintenance of some specific, existing or proposed road, street, footpath, bridge, wharf, pier, weir or channel and also the following materials, viz.: metal, stones, screenings, ashes, gravel, sand and earth. (b) Within a 32-km radius from the site of any construction or maintenance work performed pursuant to paragraph (a) above, or from the railway station nearest thereto—any other materials required for such work. (c) Within a 40-km radius of the post office at Hamilton—general goods.

**LESTER, G. G.**, 102 McDowalls Road, Bendigo, 3550. One commercial goods vehicle (L/C. 7.80 tonne) to operate: (a) Within a 120-km radius from the post office at Elmore and/or within a 150-km radius of the post office at Nyah—(Bendigo Division of the C.R.B.)—plant the property of a contractor and required for use in connection with the construction or maintenance of some specific, existing or proposed road, street, footpath, bridge, wharf, pier, weir or channel. (b) Within a 32-km radius from the site of any construction or maintenance work performed pursuant to paragraph (a) above, or from the railway station nearest thereto—metal, stones, screenings, ashes, gravel, sand, earth and any other materials required for such work. (c) Within a 40-km radius of the post office at Bendigo—general goods.

**LOVELL, A. J.**, 112 Livingstone Street, Orbost, 3888. One commercial goods vehicle (L/C. 26.62 tonne) to operate: (a) Throughout that part of the State of Victoria east of the Snowy River—logs. (b) From and to points within the area specified in paragraph (a) to and from sawmills at Newmerella and Waygara—logs. (c) From sawmills within the area specified in part (a) and at Newmerella to the Orbost railway station—sawn timber. (d) From sawmills within the area specified in part (a) and at Newmerella to consignees and/or building contract sites within a 32-km radius of the post office at Orbost—sawn timber.

**MAJOR, A. B.**, Box 41, Goroke, 3412. Application to vary the conditions of licence No. D.A.66099/5 by adding an additional paragraph—(d) Within that part of the State of Victoria west of a north/south line drawn through Dandenong—livestock.

**MAYNE NICKLESS LTD.**, 94 York Street, South Melbourne, 3205. One commercial goods vehicle (L/C. 0.95 tonne) to operate throughout the State of Victoria as an Armoured Vehicle in the course of business as "Armoured Escorts" for the purpose of making special deliveries.

**MITCHELL, G. L.**, 13 Benjamin Street, Kangaroo Flat, 3555. One commercial goods vehicle (L/C. 2.00 tonne) to operate: (a) From Bendigo to Mildura and return via Irymple, Red Cliffs, Ouyen, Sea Lake, Berriwillock, Culgoa, Nullawil, Wycheproof, Charlton, Wedderburn, Inglewood, Bridgewater on behalf of Australia Post—mails. (b) From Bendigo to Robinvale and return via Manangatang, Piangil, Wood Wood, Nyah, Nyah West, Vinifera, Beverford and Durham Ox on behalf of Australia Post—mail.

**PARK AVENUE LAUNDRY & DRY CLEANERS PTY. LTD.**, 8 Peace Avenue, Warragul, 3820. One commercial goods vehicle (L/C. 1.15 tonne) to operate within an 80-km

radius of the Post office at Warragul and to Sale in the course of business as "Laundrerers and Dry Cleaners"—own goods and articles for cleaning or having been cleaned.

**PATERSON S. J.**, Lot 38, Tillios Road, Scarsdale, 3351. One commercial goods vehicle (L/C. 10.50 tonne) to operate from the premises of Monier Roof Tiles at Ballarat to places throughout the State of Victoria solely on behalf of the said firm—roofing tiles and related roof battens.

**TURNER, R. V.**, Lot 2, Prince Street, Gisborne, 3437. One commercial goods vehicle (L/C. 7.00 tonne) to operate: (a) From places within an 80-km radius of own premises at Gisborne to such premises in course of business as "Produce Merchant"—own goods. (b) From own premises at Gisborne to places within an 80-km radius thereof in course of business as "Produce Merchant"—own goods.

**WALKER, D. W.**, 102 Great Ryrie Street, Heathmont, 3135. One commercial goods vehicle (L/C. 0.85 tonne) to operate throughout the State of Victoria in the course of business as "Tree Surgeon"—tools of trade and equipment incidental to completion of own contracts.

**VAN DER WEERDEN, L.**, 3 Tudgey Street, Wangaratta, 3677. One commercial goods vehicle (L/C. 22.60 tonne) to operate throughout the State of Victoria in the course of business as "Frozen Food Carrier" as a specially constructed refrigerated vehicle for the purpose of servicing retail stores—frozen poultry, frozen fish, frozen and fresh meat, ice cream, frozen and chilled fruit juice in plastic and waxed containers, frozen processed vegetables, cream, special soft cheese, yoghurt, dripping and lard, frozen pies, frozen prepared meals, butter and margarine.

NOTE—Butter and margarine is only to be carried from Melbourne as a mixed load when being carried with other frozen foods under refrigeration for distribution to retail stores and provided that the combined weight of butter and margarine carried does not exceed 3000 kgs on any one load.

**WEBSTER, B. M.**, 18 Oriffield Road, Morwell, 3840. Four commercial goods vehicles (L/C. 1.00, 0.40, 0.50, and 0.80 tonne) to operate within an 80-km radius of the post office at Morwell in the course of business as "Electrical Appliance Service and Repairs"—own equipment and electrical appliances for service and repair or having been serviced and repaired.

**WHITELAW, G. A.**, Nadenbouschs Road, Yinnar, 3869. One commercial goods vehicle (L/C. 4.50 and 3.50 tonne trailer) to operate as a specially constructed car carrying unit—(a) From the premises of Datsun Distribution Pty. Ltd. at Cheltenham and Clayton to the premises of Latrobe Valley Motors Pty. Ltd. at Morwell, V. & G. Motors Pty. Ltd. at Moe, Tokyo Motors Pty. Ltd. at Sale, Vin Rowe Pty. Ltd. at Warragul and Wights Datsun at Traralgon with a specially constructed car carrying trailer combination—New Datsun motor vehicles. (b) From the premises of Renault (Australia) Pty. Ltd. at Heidelberg, Moorabbin and Richmond to the premises of Albroy Service Station Pty. Ltd. at Traralgon with a specially constructed car carrying trailer combination—new Renault and Peugeot motor vehicles. (c) From the premises of Volkswagen (Australia) Pty. Ltd. at Clayton to the premises of Albroy Service Station Pty. Ltd. at Morwell and Traralgon with a specially constructed car carrying trailer—new Volkswagen motor vehicles. (d) From J. Geurts (Warragul Mobil Depot) petroleum products agency at Warragul to own premises at Morwell—petroleum products in drums. (e) From the premises of Australia Motor Industries Ltd. at Port Melbourne and Campbellfield to the premises of Colin Lucas Toyota at Sale with a specially constructed car carrying trailer—new Toyota motor vehicles. (f) From the various dealerships mentioned in paragraphs (a), (b), (c) and (e) above to various motor car auctions and wholesalers within a 40-km radius of the G.P.O. Melbourne—used motor vehicles. (g) From Ramsay Fibreglass at Bayswater to Stephens Boat Manufacturing (an approved decentralised secondary industry) at Moe—fibreglass boat hulls.

## TOW TRUCK

COMELLI, A., Grants Road, Somerville, 3912. One commercial goods vehicle (L/C. to operate within a 6-km radius of own premises at Somerville as a "Tow Truck" solely—(a) For the purpose of lifting and carrying or towing of wrecked or disabled motor vehicles and the carriage of tools and equipment necessary for such purposes. (b) The carriage of spare parts necessary for the repair of a disabled motor vehicle to and from the place at which such disablement has occurred.

## RENEWALS

Applications for renewal of licences as shown by persons listed hereunder to operate under the same terms and conditions from the expiry shown in each case.

AMORE, A., Corner Jennifer Street and South Gippsland Highway, Five Ways, 3977; D.A.49133/2; 27 February 1981; 6.80 tonne.

ANSETT TRANSPORT IND. (OPS.) PTY. LTD., Midland Highway, Epsom, 3551; D.A.64785/2; 3 February 1981; 0.55 tonne.

BARRY, N. U., King Street, Yarra Glen, 3775; D.A.60233/1; 1 February 1981; 9.30 and 12.10 tonne trailer.

BOURBOULIS, M., 32 Tarana Crescent, St. Albans, 3021; D.A.68498; 1 February 1981; 10.00 tonne.

BRAMBLES HOLDINGS LTD., 1846 Princes Highway, Clayton, 3168; D.A.63215; 26 September 1980; 11.35 tonne; D.A.63215/13; 26 September 1980; 10.25 tonne.

BRAMBLES HOLDINGS LTD., 1846 Princes Highway, Clayton, 3148; D.A.68940; 24 February 1981; 0.75 tonne.

CONNELL, J. G., Elaine, 3334; D.A.70938; 18 February 1981; 3.60 tonne.

P. J. DUCAT & SONS PTY. LTD., 116-124 Corio Street, Shepparton, 3630; D.A.66631/18; 19 November 1980; 5.35 tonne.

GARRETT, K. C., 76 McLeod Road, Carrum, 3197; D.A.69028; 21 February 1981; 0.75 tonne.

GREENWAYS REFRIGERATED TRANSPORT PTY. LTD., Grant Road, Somerville, 3912; D.A.63918/20; 1 February 1981; 11.64 tonne.

HOLLAND, C. I., Lockwood South, 3551; D.A.68897; 3 February 1981; 3.85 tonne.

JAMES, G. E., 7 Vermont Street, Horsham, 3400; D.A.65793; 13 January 1981; 5.95 tonne.

JUDD, B. E., 67 Jones Road, Tyabb, 3913; D.A.65774; 15 January 1981; 8.95 tonne.

K.M.M. PTY. LTD., 461 Bourke Street, Melbourne, 3000; D.A.63895/21; 13 January 1981; 10.90 tonne.

KRSTIC, D., 105 Church Street, Traralgon, 3844; D.A.65869; 12 February 1981; 18.00 tonne.

MELWIRE PTY. LTD., 522-534 Clayton Road, Clayton South, 3169; D.A.62107; 17 February 1981; 0.50 tonne.

MERCURI, F., 53 Michael Street, Lalor, 3075; D.A.67602/1; 7 November 1980; 9.25 and 9.75 tonne trailer.

MCKEAN, G. M., 24 Church Road, Yarram, 3971; D.T.1694; 1 February 1981; 27.85 tonne.

OWENS OF WARRNAMBOOL LTD., 159-165 Lava Street, Warrnambool, 3286; D.A.68367/1; 24 February 1981; 1.00 tonne.

F. T. RAFFERTY PTY. LTD., 2 Nicholas Street, Lilydale, 3140; D.T.323/1; 17 February 1981; 15.60 tonne.

SORDELLO, P., 49 Stawell Road, Horsham, 3400; D.A.70792; 30 January 1981; 7.40 tonne.

THE VICTORIAN PORTLAND CEMENT CO. PTY. LTD., St. Kilda Road, Melbourne, 3004; D.A.65031/4; 21 February 1981; 18.30 tonne; D.A.65031/3; 21 February 1981; 18.80 tonne.

Notice of any objection should be forwarded to reach the Secretary of the Board not later than 26 November 1980.

Applicants are advised that it will not be necessary to appear on the hearing date specified above, unless advised in writing by the Board.

C. J. V. SMITH, Secretary

Corner Lygon and Princes Streets, Carlton, 3053, Wednesday, 19 November 1980.

Police Offences Act 1958, No. 6337  
DIVISION 1A—STATE CLASSIFICATION OF  
PUBLICATIONS BOARD

Take note that the State Classification of Publications Board has classified the following publications in accordance with the provisions of section 180H (1) of the Police Offences Act 1958.

Each publication shall be subject to the following restrictions:

- it shall not be offered for sale, sold, delivered, exhibited or displayed to any person under the age of 18 years;
- it shall not be made available for inspection or perusal to any person under the age of 18 years;
- it shall not be exhibited or displayed in any place to which persons under the age of 18 years have access or so that it is visible from any such place;
- it shall not be advertised in any manner whatsoever.

## SCHEDULE OF PUBLICATIONS

Title	Distributor
Accidental Affair	Borderline Distributors
As You Like It . . . Hot & Strong!	Borderline Distributors
Bitch Goddesses, The Vol. 1 No. 2	Elcarim Publishing Co. Pty. Ltd.
Bizarre Fantasies Vol. 1 No. 1	Elcarim Publishing Co. Pty. Ltd.
Bizarre Stars Vol. 1 No. 1	Elcarim Publishing Co. Pty. Ltd.
Bondage Life Vol. 1 No. 6	Elcarim Publishing Co. Pty. Ltd.
Bondage Movie Review Vol. 1 No. 2	Elcarim Publishing Co. Pty. Ltd.
Bondage Nudes No. 2	Elcarim Publishing Co. Pty. Ltd.

Title	Distributor
Bondage Parade No. 2	Elcarim Publishing Co. Pty. Ltd.
Bound Beauties Of Harmony No. 4	Elcarim Publishing Co. Pty. Ltd.
Bound Flesh Vol. 1 No. 1	Elcarim Publishing Co. Pty. Ltd.
Bound To Please Vol. 2 No. 12	Elcarim Publishing Co. Pty. Ltd.
Domina Vol. 1 No. 2	Elcarim Publishing Co. Pty. Ltd.
Exotique Vol. 1 Nos. 2 and 3	Elcarim Publishing Co. Pty. Ltd.
Gags	Claredale Holdings Pty. Ltd.
Leather Bondage	Claredale Holdings Pty. Ltd.
Lesbian Co-Ed	Venus Enterprises Pty. Ltd.
Libby Curtis Bondage Photo Book, the No. 1	Elcarim Publishing Co. Pty. Ltd.
Lyndia — The Bondage Years No. 2	Elcarim Publishing Co. Pty. Ltd.
Nude Bondage Studies No. 1	Elcarim Publishing Co. Pty. Ltd.
Penthouse—December, 1980	Gordon & Gotch (Asia) Ltd.
Playbirds No. 45	Claredale Holdings Pty. Ltd.
Revolt Of The Bondage Models—Book 1	Elcarim Publishing Co. Pty. Ltd.
Rubber Bondage	Claredale Holdings Pty. Ltd.
Spread—Eagle	Claredale Holdings Pty. Ltd.
Super Stud	Borderline Distributors
Sweet Eighteen No. 2	Borderline Distributors
Taskmaster Vol. 1 No. 4	Elcarim Publishing Co. Pty. Ltd.
Taskmaster Vol. 3 No. 1	Elcarim Publishing Co. Pty. Ltd.
29 Photo Packs	Claredale Holdings Pty. Ltd.
Whitehouse No. 56	Claredale Holdings Pty. Ltd.

J. SMITH, Secretary  
State Classification of Publications Board

## Police Regulation Act 1958, Section 122

## SALE OF UNCLAIMED AND CONFISCATED PROPERTY

An auction of unclaimed and confiscated property held by Police will be conducted at the auction rooms of J. W. Styles and Son Pty. Ltd, of 280 Spencer Street, Melbourne at 11.00 a.m. on Tuesday 25 November 1980.

S. I. MILLER  
Chief Commissioner

## Police Regulation Act 1958, Section 122

## SALE OF UNCLAIMED MOTOR VEHICLE

An owner is required for a white Holden station sedan Reg. No. LWB 712, engine No. 186A111690.

The vehicle came into the possession of Police on 23 May 1980, and if not claimed will be sold by public auction at the Caulfield Police Station yard, 289 Hawthorn Road, Caulfield on Thursday 11 December 1980 at 10.30 a.m.

S. I. MILLER  
Chief Commissioner

## NOTICE TO MARINERS

[No. 47 (T) OF 1980]

## AUSTRALIA—VICTORIA

## PORT PHILLIP

*Display of Festoon Lighting*

Mariners are advised that coloured lights will be visible during the hours of darkness for approximately two months from 12 December 1980 from a tall tree between Queenscliff and Point Lonsdale and located 012 degrees distant 1.14 miles from Point Lonsdale Lighthouse (Lat. 38 deg. 17 min. S., Long. 144 deg. 37 min. E. approx.). A cluster of white lights may also be visible.

The lights will be discontinued at the end of January 1981.

A. J. WAGGLEN  
Port Officer

Public Works Department  
Ports and Harbors Division  
168 Exhibition Street  
Melbourne 3000, 12 November 1980

## NOTICE TO MARINERS

[No. 48 (T) OF 1980]

## AUSTRALIA—VICTORIA

## BARWON HEADS

*Light Buoy Missing*

Barwon Heads Entrance Light-buoy, Lat. 38 deg. 17.3 min. S., Long. 144 deg. 30.2 min. E. (Approx.) is missing from station.

Further Notice will issue.

*Charts Temporarily Affected*—AUS 143, AUS 350, AUS 788.

A. J. WAGGLEN  
Port Officer

Public Works Department  
Ports and Harbors Division  
168 Exhibition Street  
Melbourne 3000, 12 November 1980

## Country Fire Authority Act 1958

## DECLARATION OF FIRE DANGER PERIOD

In pursuance of the powers conferred by section 4 of the *Country Fire Authority Act 1958*, I, Lindsay Hamilton Simpson Thompson, Minister for Police and Emergency Services, after consultation with the Minister of Forests, hereby declare the following period to be the fire danger period in municipalities or parts of municipalities specified:

23 NOVEMBER 1980 TO 30 APRIL 1981

City of Swan Hill.  
Shires of Birchip, Karkaroc and Swan Hill.

Part Shire of Dimboola (Northern portion—those portions within the counties of Karkaroc and Weeah).

Part Shire of Wycheproof (Northern portion—those portions north of the Woomelang-Banyan-Berriwillock Road, the western, southern and eastern boundaries of the township of Berriwillock and the Berriwillock-Springfield-Ultima Road).

L. H. S. THOMPSON  
Minister for Police and Emergency Services

Ministry for Police and Emergency Services  
Melbourne

## Labour and Industry Act 1958

## DETERMINATION OF THE BRICKLAYERS BOARD

(No. 5 OF 1980)

Notice is hereby given that an appeal to the Industrial Appeals Court has been lodged against the amendments made by the Bricklayers Board on 27 October 1980 to clause 12.1 (p) of its Determination (No. 5 of 1980).

Section 45 (1) (b) of Act 6283 provides that when an appeal is made in accordance with that Act, the part of the Determination appealed against shall be deemed not to have come into operation until the appeal has been dealt with by the Court.

A. S. DOWLING, Registrar  
Industrial Appeals Court

## Labour and Industry Act 1958

## ORDER OF EXCEPTION ISSUED UNDER THE PROVISIONS OF SECTION 80F

Pursuant to the provisions of section 80F of the *Labour and Industry Act 1958*, I, James Halford Ramsay, Minister of Labour and Industry, having considered an application from the Council of the Shire of Deakin, hereby make this Order exempting shopkeepers of shops in the Tongala Tent Town from being required to close and keep closed their shops in accordance with Part VI of the said Act during the two day festival to be held on the Saturday and Sunday immediately preceding the public holiday on the second Monday in March each year.

This Order does not operate to permit the sale or disposal of liquor within the meaning of the *Liquor Control Act 1968* by any shopkeeper at any time when he would, but for this Order, be required to close and keep closed his shop in accordance with Part VI.

This Order shall apply each year until revoked by the Minister of Labour and Industry.

Dated at Melbourne, 12 November 1980

J. H. RAMSAY  
Minister of Labour and Industry

## Labour and Industry Act 1958

## ORDER OF EXEMPTION UNDER SECTION 80D

Whereas pursuant to Section 80D of the *Labour and Industry Act 1958* the City of St. Kilda has applied to the Minister for an Order exempting shopkeepers of shops in its municipal district from being required to close and keep closed their shops in accordance with Part VI of the said Act:

Now therefore I, James Halford Ramsay, Her Majesty's Minister of Labour and Industry in the State of Victoria do pursuant to the aforesaid Section 80D of the *Labour and Industry Act 1958* make this Order granting exemption to:

Yakov Krapinsky, trading as Yakov—The Hairdresser, 111 Barkly Street, St. Kilda.

Jacob Daniel, Raymond Elias and Benny Cohen, trading as St. Kilda Liquidation Centre, 179 Acland Street, St. Kilda.

Salvatore Amato, Shop 3, 112 Acland Street, St. Kilda— from being required to close and keep closed their shops in accordance with Part VI of the said Act, provided that such exemption shall not apply to Good Friday and Anzac Day.

Dated at Melbourne 13 November 1980

J. H. RAMSAY  
Minister of Labour and Industry

## Private Agents Act 1966

## NOTICE OF RECEIPT OF APPLICATIONS FOR LICENCES UNDER THE PROVISIONS OF THE PRIVATE AGENTS ACT 1966

The Clerk(s) of the Magistrates' Court(s) as listed hereunder hereby give notice that applications, as under, have been lodged for hearing by the said Court(s) on the date(s) specified.

Any person desiring to object to any of such applications must—

- (a) lodge with the respective Clerk of the Magistrates' Court a notice in the prescribed form of his objection and of the grounds thereof;
- (b) cause a copy of such notice to be served personally or by post upon the applicant at least three days before the hearing of the application; and
- (c) send or deliver—
  - (i) where the objection is not made by the officer in charge of the police district in which the Court is situated—a copy of the notice to such officer; and
  - (ii) where the objection is not made by the Registrar or Deputy Registrar—a copy to the Registrar.

Full Name of Applicant*	Place of Abode of Applicant or Nominee	Name of Firm or Corporation	Address for Registration	Type of Licence	Date of Hearing
<b>MAGISTRATES' COURT, COBURG</b>					
Welsh, John Hartley	2 Davon Pl, West Melton	Mayne Nickless	390 St. Kilda Rd, Melbourne	Watchman	26.11.80
Dated at Coburg 3 November 1980 J. F. ISAACS, Clerk of the Magistrates' Court					
<b>MAGISTRATES' COURT, FRANKSTON</b>					
McIntyre, George Arthur	3 Leighton Ct, Frankston	G. A. McIntyre and Associates Pty. Ltd.	35 Ross Smith Ave, Frankston	Guard Agent—Corporation	1.12.80
Dated at Frankston 7 November 1980 J. T. FERGUSON, Clerk of the Magistrates' Court					
<b>MAGISTRATES' COURT, MELBOURNE</b>					
Jeffries, Anthony Edward	19 Sunhill Rd, Lower Templestowe	Wormalds	340 Abbotsford St, North Melbourne	Watchman	13.1.81
Dated at Melbourne 6 November 1980 M. J. QUIRK, Clerk of the Magistrates' Court					
<b>MAGISTRATES' COURT, PRESTON</b>					
Buckingham, Trevor Lawrence	17 Cuthbert Rd, Reservoir		78 Roseberry Ave, Preston	Watchman	10.12.80
Dated at Preston 5 November 1980 P. D. STREET, Clerk of the Magistrates' Court					
<b>MAGISTRATES' COURT, SUNSHINE</b>					
Rashleigh, Robert William	258 Hilton St, Glenroy		146 Ashley St, Maidstone	Watchman	12.12.80
Dated at Sunshine 11 November 1980 B. J. STOCKS, Clerk of the Magistrates' Court					
<b>MAGISTRATES' COURT, MELBOURNE</b>					
Bristow, Ian Charles	19 Vaina St, Werribee	Transurety Limited	Cnr. Arden and Lothian Sts, North Melbourne	Watchman	13.1.81
Roberts, Keith William	16 Huntingfield Dr, Hoppers Crossing	" "	" "	" "	" "
Dated at Melbourne 13 November 1980 M. J. QUIRK, Clerk of the Magistrates' Court					

\* Or in the case of a firm or corporation, of the Nominee

## PUBLIC TRUSTEE ACT 1958, SECTION 17

Creditors, next of kin and others having claims against the estate of any of the under-mentioned deceased persons are required to send particulars of their claims to the Public Trustee, 168 Exhibition Street, Melbourne, Vic. 3000, the personal representative, on or before 26 January 1981, after which date the Public Trustee may convey or distribute the assets having regard only to the claims of which the Public Trustee then has notice:

GLEESON, IRENE, late of 71 Bayview Street, Prahran; widow, died 30 August 1980.

GREEN, HAROLD THOMAS, formerly of 9 Fanny Street, Moonee Ponds, but late of 26 Highview Road, East Bentleigh, retired school teacher, died 12 September 1980.

JORDAN, MABEL EMMA, formerly of 55 Wallace Street, West Brunswick, but late of Galilee Nursing Home, 87 Chapel Street, St. Kilda, pensioner, died 15 June 1980.

MCGOWAN, GORDON THOMAS, formerly of 7 Woodward Street, Springvale, but late of 10 Nabilla Avenue, Seaford, engineer, died 20 August 1980.

TRASS, LEONARD ERNEST, late of Flat 14, 312 Beaconsfield Parade, Middle Park, pensioner, died 30 July 1980.

TRIBOLET, ETHEL MAUDE, also known as Maude Ethel Bergan, late of "Ballochmyle", Brushy Park Road, Croydon North, married woman, died 30 August 1980.

WATSON, ROY BOOTY, also known as Roy Botty Watson, late of 2 Kemp Street, Upwey, retired accountant, died 13 August 1980.

Melbourne, 12 November 1980

P. T. SPENCER  
Public Trustee

NOTICE OF VARIATION OF CONDITIONS OF A  
PIPELINE LICENCE

Whereas sub-section (3) of section 30 of the *Pipelines Act 1967* provides that the Minister may by notice published in the *Government Gazette* amend vary add to or revoke any conditions stated or included in a licence, I, James Charles Murray Balfour, Minister for Minerals and Energy, do now hereby vary the conditions of Pipeline Licence No. 27 in the manner indicated in the Schedule hereto:

## SCHEDULE

1. Add to the first paragraph of Condition I. (A) the following—

"The pipeline shall be operated in accordance with the requirements of the Australian Standard 2018-1977 : SAA Liquid Petroleum Pipeline Code."

2. Delete first two lines in Condition I. (B) and substitute—

"Except as hereinafter provided in Condition II. (D) the materials used in the pipeline shall conform to the following specifications—"

3. Insert under Condition I. (C) Connections to Pipeline System the following—

"Except as hereinafter provided in Condition II. (D) the following connections shall be provided—"

4. Replace Condition II. (B) with the following—

"(B) Maintenance and Routine Test Procedures

The pipeline shall be maintained in accordance with section 7 of the Australian Standard 2018-1977 : SAA Liquid Petroleum Pipeline Code to the extent that this standard is not inconsistent with the following:

(i) Corrosion Control

Subject to compliance with the State Electricity Commission Cathodic Protection Regulations 1970, the licensee shall—

(a) carry out a monthly check of the transformer and rectifier units of any impressed current systems that may be installed to ensure they are operating satisfactorily. A log of such checks, giving details of amperage output and meter readings shall be maintained by the licensee;

(b) at intervals not exceeding six months conduct corrosion surveys of the pipeline including tests for stray current electrolysis. Measuring instruments approved for the purpose by the Chief Electrical Inspector, State Electricity Commission of Victoria shall be used for these surveys which shall be carried out only after the licensee has used his best endeavours to ensure that no abnormal condition exists which is likely to affect the validity of the results;

(c) submit a summary of the results of these surveys annually to the said Chief Electrical Inspector for advice on action to be taken to maintain the cathodic nature of the pipeline so that corrosion is limited, and shall take all reasonable steps to give effect to the advice received;

(d) submit to the Director, Oil and Gas Division of the Department of Minerals and Energy an annual report outlining the results of the corrosion surveys, the recommendations made by the said Chief Electrical Inspector and the details of the resulting action taken by the licensee.

(ii) Pipeline Markers and Signs

The licensee shall check the signs required by the Pipelines (Construction and Operation) Regulations 1971 at intervals

not exceeding three months and shall where necessary forthwith replace, repair and repaint the same.

(iii) Patrol of Pipeline

Unless otherwise approved by the Director, Oil and Gas Division of the Department of Minerals and Energy, the licensee shall cause the pipeline to be patrolled in accordance with the procedure laid down in Rule 7.2.5 of the Australian Standard 2018-1977 : SAA Liquid Petroleum Pipeline Code with patrols being carried out on—

(a) a regular working day basis in areas designated as Class 3 and Class 4 locations; and

(b) a weekly basis in areas designated as Class 1 and Class 2 locations; the said class locations being as specified in Rule 3.1.2 of the Australian Standard 1697-1979 : SAA Gas Pipeline Code;

and shall on demand produce to the said Director a written report on the results of such patrolling."

5. Replace Condition II. (D) with the following—

"(D) Alterations to Pipeline

Except in the case of emergencies, the licensee shall not effect any repairs or make any additions or alterations to the pipeline without the prior approval in writing of the Director, Oil and Gas Division of the Department of Minerals and Energy."

6. Add Condition II. (E)—

"(E) Pressure Control

Unless otherwise approved by the Minister the pressure of the liquid hydrocarbons being conveyed in the pipeline shall at no time exceed 1200 p.s.i.g. (8274 kPa)."

Dated 29 October 1980

J. C. M. BALFOUR  
Minister for Minerals and Energy

DEPARTMENT OF MINERALS AND ENERGY  
APPLICATION FOR MINING LEASE DECLARED  
ABANDONED

No. 562; Robert Maxwell Waterson; 50 ha, Parish of Minapre.

## TERMS OF EXPLORATION LICENCES EXTENDED

No. 558; Planet Mining Company Pty. Ltd.; 66 km<sup>2</sup>, County of Rodney.

No. 665; International Mining Corporation NL; 132 km<sup>2</sup>, Counties of Gladstone and Bendigo.

No. 685; Western Mining Corporation Limited; 741 km<sup>2</sup>, Counties of Follett, Dundas and Lowan.

No. 686; Western Mining Corporation Limited; 660 km<sup>2</sup>, Counties of Follett, Dundas and Normanby.

No. 687; Western Mining Corporation Limited; 792 km<sup>2</sup>, Counties of Dundas and Normanby.

## SEARCH LICENCES GRANTED

No. 1481; Reginald Wood; 40 ha, Parish of Dorchap.

No. 1500; Reginald Wood; 40 ha, Parish of Dorchap.

No. 1501; Reginald Wood; 40 ha, Parish of Dorchap.

No. 1502; Reginald Wood; 40 ha, Parish of Dorchap.

No. 1503; Reginald Wood; 40 ha, Parish of Dorchap.

## TAILINGS LICENCES EXPIRED

No. 4188; Bendigo Sewerage Authority; to remove tailings from the "Catherine Reef Extended Sand Dump" situated in the Borough of Eaglehawk.

No. 4291; Brian Joseph Hollingworth, Kenneth Edwin Mills; to remove tailings from the "New Moon Mine Sand Dump" situated in the Parish of Nerring.

- No. 4350; Heathcote Waterworks Trust; to remove tailings from Spring Plains, Forest Area, Dairy Flat Road, situated at Heathcote.
- No. 4368; Malcolm McClure Pty. Ltd.; to remove tailings from "Dunnes Reef Mine" situated near Muckleford.
- No. 4369; Malcolm McClure Pty. Ltd.; to remove tailings from the "New Era Dump" situated at Fryers-town.
- No. 4381; Shire of Strathfieldsaye; to remove tailings from the "Moon and Catherine Sand Dumps" situated at Eaglehawk.
- No. 4382; Bendigo Sewerage Authority; to remove tailings from the "Moon and Catherine Sand Dumps" situated at Eaglehawk.
- No. 4384; State Rivers and Water Supply Commission; to remove tailings from the "Moon and Catherine Sand Dumps" situated at Eaglehawk.
- No. 4385; Edward Arthur Pilcher, Olive Isobel Pilcher; to remove tailings from the "Moon and Catherine Sand Dumps" situated at Eaglehawk.
- No. 4386; G. Lester; to remove tailings from the "Moon and Catherine Sand Dumps" situated at Eaglehawk.
- No. 4387; J. B. Fitzgerald, J. Fitzgerald; to remove tailings from the "Moon and Catherine Sand Dumps" situated at Eaglehawk.
- No. 4388; Roy Griffin; to remove tailings from the "Moon and Catherine Sand Dumps" situated at Eaglehawk.
- No. 4389; Kelvin Alcock; to remove tailings from the "Moon and Catherine Sand Dumps" situated at Eaglehawk.
- No. 4390; Kelvin Donaldson; to remove tailings from the "Moon and Catherine Sand Dumps" situated at Eaglehawk.
- No. 4391; Ralph Conboy, Elizabeth Conboy; to remove tailings from the "Moon and Catherine Sand Dumps" situated at Eaglehawk.
- No. 4392; Frederick Hartland; to remove tailings from the "Moon and Catherine Sand Dumps" situated at Eaglehawk.
- No. 4395; Cyril Mannix; to remove tailings from the "Moon and Catherine Sand Dumps" situated at Eaglehawk.
- No. 4396; Allan Chan; to remove tailings from the "New Moon Mine Sand Dump" situated in the Parish of Nerring.
- No. 4397; Allan Chan; to remove tailings from the "Catherine Sand Dump" situated at Eaglehawk.
- No. 4398; Frederick Allen; to remove tailings from the "Moon and Catherine Sand Dumps" situated at Eaglehawk.
- No. 4399; John W. Henderson Builders Pty. Limited; to remove tailings from the "Moon and Catherine Sand Dumps" situated at Eaglehawk.
- No. 4427; Shire of Bet Bet; to remove tailings from an area of 1.5 km north of the Township of Tarnagulla.
- No. 4453; Shire of Creswick; to remove tailings from "O'Keefes Dump" situated in the Parish of Creswick.
- No. 4454; Shire of Creswick; to remove tailings situated in Nuggetty Gully in the Township of Creswick.
- No. 4456; Brian Patrick Keogh; to remove tailings from the "Moon and Catherine Sand Dumps" situated at Eaglehawk.
- No. 4465; William John Kiel; to remove tailings from the "Moon and Catherine Sand Dumps" situated at Eaglehawk.

## EXTRACTIVE INDUSTRY LICENCES GRANTED

- No. 829-1; Tusko Nominees Pty. Ltd.; 63.1 ha, Parish of Gorong.

No. 1032; Gordon William Rudolph; 8.8 ha, Parish of Tallangatta.

No. 1037; Raymond James Coe; 0.9 ha, Parish of Kialla.

J. C. M. BALFOUR  
Minister for Minerals and Energy

## SEARCH LICENCE DECLARED VOID

No. 1571; Neville Ross Edwards, Annette Helen Edwards; 500 metres of river bed—Goulburn River, Parish of Jamieson.

B. W. COURT  
Secretary for Minerals and Energy

## Co-operative Housing Societies Act 1958

- A.N.A. CO-OPERATIVE HOUSING SOCIETY (No. 3) LIMITED
- A.N.A. CO-OPERATIVE HOUSING SOCIETY (No. 4) LIMITED
- BELGRAVE CO-OPERATIVE HOUSING SOCIETY LIMITED
- BELGRAVE (No. 2) CO-OPERATIVE HOUSING SOCIETY LIMITED
- CARRUM AND SEAFORD No. 1 CO-OPERATIVE HOUSING SOCIETY LIMITED
- CHELTENHAM AND HIGGETT No. 4 CO-OPERATIVE HOUSING SOCIETY LIMITED
- CORIO AND MOORPANYAL (No. 2) CO-OPERATIVE HOUSING SOCIETY LIMITED
- DEER PARK (No. 2) CO-OPERATIVE HOUSING SOCIETY LIMITED
- FOOTSCRAY AND DISTRICT No. 2 CO-OPERATIVE HOUSING SOCIETY LIMITED
- GLOBUS CO-OPERATIVE HOUSING SOCIETY LIMITED
- HALLAM CO-OPERATIVE HOUSING SOCIETY LIMITED
- HOTHAM CO-OPERATIVE HOUSING SOCIETY LIMITED
- KYABRAM AND DISTRICT (No. 2) CO-OPERATIVE HOUSING SOCIETY LIMITED
- LONSDALE CO-OPERATIVE HOUSING SOCIETY LIMITED
- MITCHAM (No. 2) CO-OPERATIVE HOUSING SOCIETY LIMITED
- MORELAND AND DISTRICT No. 2 CO-OPERATIVE HOUSING SOCIETY LIMITED
- PRESTON AND DISTRICT No. 2 CO-OPERATIVE HOUSING SOCIETY LIMITED
- PRESTON AND DISTRICT No. 3 CO-OPERATIVE HOUSING SOCIETY LIMITED
- RINGWOOD (No. 5) CO-OPERATIVE HOUSING SOCIETY LIMITED
- SHEPPARTON AND DISTRICT (No. 2) CO-OPERATIVE HOUSING SOCIETY LIMITED
- THE STRATUM TITLES CO-OPERATIVE HOUSING SOCIETY (No. 3) LIMITED
- WESTERNPORT CO-OPERATIVE HOUSING SOCIETY LIMITED
- YARRA GRANGE No. 2 CO-OPERATIVE HOUSING SOCIETY LIMITED

## NOTICE OF DISSOLUTION OF SOCIETIES

Notice is hereby given that I have this day registered the dissolution of the above-named societies and cancelled their registration under the above-named Act.

Dated at Melbourne 28 October 1980

J. W. BLACKMAN  
Acting Deputy Registrar

## Health Act 1958

## NOTICE OF CANCELLATION OF THE REGISTRATION OF A PROPRIETARY MEDICINE

Whereas sub-section 1 (d) of section 263b of the Health Act 1958 provides that the Minister may, after consultation with the Health Commission of Victoria, by order published in the Government Gazette, declare that the registration of any proprietary medicine shall be cancelled.

And whereas, after consultation with the Health Commission of Victoria, it is considered that the registration of the proprietary medicine known as A-200 should be cancelled.

Now therefore, I William Archibald Borthwick, Her Majesty's Minister of Health for the State of Victoria, in pursuance of the powers vested in me by the said section 263B, do by this Order, declare that the registration of the proprietary medicine known as A-200 shall be cancelled from the day of publication of this Order in the *Government Gazette*.

W. A. BORTHWICK  
Minister of Health

Health Department  
Melbourne, 7 November 1980

Housing Act 1958

NOTICE OF RESOLUTION UNDER SECTION 99 (4) OF  
ACT 6275

Notice is hereby given that Housing Commission on 12 November 1980 resolved as follows:

"Whereas Housing Commission in respect of the lands described in the Schedule hereto has given notice to the parties interested under section 9 of the *Lands Compensation Act 1958* as incorporated with the *Housing Act 1958*, Housing Commission hereby resolves that the lands described in the Schedule hereto are finally appropriated for the purposes of the *Housing Act 1958*."

SCHEDULE

Part Crown Allotments 22 and 23, section 2, Township and Parish of Yackandandah, being the land described in Memorial of Conveyance No. 664 of Book 745 and Memorial of Conveyance No. 797 of Book 735 in the Office of the Registrar General.

N. GREEN  
Manager, Administration

Public Hearings

PUBLIC BODIES REVIEW COMMITTEE

The Public Bodies Review Committee will hear evidence from the following organizations in regard to the Committee's current Inquiry into the State Rivers and Water Supply Commission and each constituted water, sewerage, drainage and river improvement trust or authority, except the Melbourne and Metropolitan Board of Works.

- 19.11.1980 State Electricity Commission.  
26.11.1980 Association of Consulting Engineers Australia, Victorian Chapter.  
3.12.1980 State Treasury.  
10.12.1980 Plenty-Yarrambat Waterworks Trust, Upper Yarra Valley and Dandenong Ranges Authority.

The venue for these hearings will be Parliament House, Melbourne, commencing at 9.30 a.m., except for the hearing on 26.11.80 which will commence at 9.15 a.m.

KEVIN J. FOLEY  
Chairman

CONTRACTS ACCEPTED—(Series 1980-81)

PUBLIC WORKS

Cann River Primary School, siteworks and hydraulics services, original, \$9839.00; extras, \$1973.00—\$11 812.00—K. P. Harrison.

Milparinka S.D.S., Middle Park, new double brick home, original, \$9578.50; extras \$5230.00—\$14 808.50—Ellas Electrics.

Newlands High School, cyclic maintenance, mechanical services, original, \$9788.70; extras, \$652.00—\$10 440.70—A. & V. Hart Pty. Ltd.

Various Locations, testing of structural steelwork, original, \$9800.00; extras, \$7744.40—\$17 544.40—V.W.S. Pty. Ltd.

Caulfield South Primary School, replacement of domestic water supply, original, \$9950.00, extras, \$1410.00—\$11 360.00—Lamb & Bell Pty. Ltd.

Preston North East Primary School, repairs and painting to junior toilet block, original, \$9617.00; extras, \$2625.40—\$12 242.40—L. E. Fitzgerald.

Benalla Directorate, maintenance of oil burners, original, \$8897.00; extras, \$1315.75—\$10 212.75—S. & R. Air Conditioning & Electrical Services.

Sunbury Police Station extensions, original, \$9950.00; extras, \$4100.00—\$14 050.00—Lewton Building Services.

Whittlesea Technical/High School, electrical connections, original, \$9000.00; extras, \$6324.00—\$15 324.00—P. J. Lynch.

Preston Technical College, signage works, original, \$9956.83; extras, \$601.30—\$10 558.13—Modulex Systems Aust. Pty. Ltd.

Coburg Primary School, supply and replacement of bituminous concrete, original, \$9895.60; extras, \$1550.02—\$11 445.61—Pioneer Asphalts Pty. Ltd.

Princess Hill Primary School No. 2955, electrical services, original, \$5530.00; extras, \$5755.00—\$11 285.00—D. L. & J. L. Suttle.

D. J. LITTLE, Director-General. 19.11.80

CONTRACTS ACCEPTED—(Series 1980-81)

VICTORIAN RAILWAYS

40. Supply and delivery of low and high tension brush holder bodies for English electric motor generators, at rates (Contract 64813)—J. Swift Die Casters Pty. Ltd.  
41. Supply and delivery of air motors for point operation, at rates (Contract 64900)—Compair (Australasia) Ltd.  
42. Fabrication, supply and delivery of structural steelwork for the extension of verandahs at Richmond station for the amount of \$44 565.00 (Contract 64940)—Northern Welding Service Pty. Ltd.  
43. Manufacture, supply and delivery of steel reinforcement for down track sub-structure at Ashley Street, grade separation project, Tottenham, at rates (Contract 64946)—Humes Limited.

By order of the Victorian Railways Board  
I. J. REIHER, Secretary. 19.11.80

CONTRACTS ACCEPTED—(Series 1980-81)

PUBLIC WORKS

His Excellency the Governor of the State of Victoria by and with the advice of the Executive Council thereof has by Order made on 11 November 1980 approved of the acceptance by the Minister of Public Works of the under-mentioned offers without public tenders being invited, viz.:

Offer of R. L. Halpin Pty. Ltd. for electrical services at Sunraysia College of T.A.F.E. for the sum of Eleven thousand five hundred and twelve dollars (\$11 512.00)—(W.227478A).

Offer of Cockram Constructions Pty. Ltd. for sound proofing second floor of T.V. Studio at Collingwood Mid Level College for the sum of Thirty-nine thousand nine hundred dollars (\$39 900.00)—(C.30650F).

Offer of Thompsons-Byron Jackson for supply of spare parts to gravel pump on the Ports and Harbors Dredge Paynesville for the sum of Ten thousand four hundred and sixty-one dollars (\$10 461.00)—(P. & H. 94284n).

Offer of Tungamah Primary School Council for provision of community swimming pool at Tungamah Primary School No. 2225 for the sum of Thirty-five thousand dollars (\$35 000.00)—(N.205561).

Offer of Jenkins Prebuilt Homes Pty. Ltd. for supply and erection of modular residence for Police and Emergency Services at Henry Street, Coleraine, for the sum of Eleven thousand nine hundred and forty-four dollars (\$11 944.00)—(W.227122).

TOM FORRISTAL

Clerk of the Executive Council

At the Executive Council Chambers  
Melbourne, 11 November 1980

## COMPANIES ACT 1961

Notice is hereby given in pursuance of sections 308 (2) and 308 (3) of the Companies Act 1961 that at the expiration of three months from the date hereof the names of the following Companies will, unless cause is shown to the contrary, be struck off the Register and the said Companies will be dissolved.

Dated 7 November 1980

E. B. MITCHAM  
Deputy Commissioner for Corporate Affairs  
Corporate Affairs Office  
Melbourne

## COMPANIES ABOVE REFERRED TO

Name of Company	Number of Registration
Vernon Ansell & Co. Pty. Ltd.	C17105U
V.W.C. Nominees Pty. Ltd.	C24522E
Markfam Investments Pty. Ltd.	C26067S
Amalgamated Industries (A/asia) Pty. Ltd.	C26512S
Hillcrest Dry Cleaning Service Pty. Ltd.	C27090U
Yunki Pty.	C27933E
Marjorie C. Moore & Associates Pty. Ltd.	C32466T
Peta Fashions Pty.	C37787F
Edwards Investments Pty. Ltd.	C37905L
Inter-lock Brick & Machinery Co. Pty. Ltd.	C38376L
C. M. Francis Pty. Ltd.	C39660U
A. K. Pyers Pty. Ltd.	C40540A
Tambo Investments Pty. Ltd.	C40954J
M. C. Herd (Bye Products) Pty.	C42798K
M. C. Herd (Mutton Killing) Pty.	C42799M
W. T. Henley's Telegraph Works Australia Pty. Ltd.	C45530K
Mercer Nominees Pty. Ltd.	C47025F
Dado Investments Pty. Ltd.	C47287R
Arraglen Pty. Ltd.	C50133U
Mincustodians Limited	C50378D
Ladyland Pty. Ltd.	C51853W
D. Wilkson & Co. Pty. Ltd.	C53151U
A. & F. Trading Pty. Ltd.	C55992T
The French Art Embroidery & Pleating Co. Pty. Ltd.	C56999R
R. K. Williams Pty. Ltd.	C57023N
J. A. & S. Kirkman Pty. Ltd.	C57442P
C. & I. Constructions Pty. Ltd.	C57908S
Comnia Engineering Pty. Ltd.	C61742X
Twite's Bakeries (Manufacturing) Pty. Ltd.	C63604Y
Furniture and Design Centre Pty. Ltd.	C64380G
Burns-Anderson Pty. Ltd.	C67314R
Little River Pastoral Co. Pty. Ltd.	C67872H
Cumquat Sportswear Pty. Ltd.	C68201H
W.P.E. Engineering Pty. Ltd.	C70689Z
Sherlock Homes Pty. Ltd.	C71050V
Morvest Pty. Ltd.	C71275Y
Lara Pastoral Co. Pty. Ltd.	C72613D
S. & E. Maber Pty. Ltd.	C72920S
Manmart Glass Processing Pty. Ltd.	C75069Y
York Interstate Transport Co. Pty. Ltd.	C75326V
South Yarra Rug Store Pty. Ltd.	C76177K
Kingsway Sheetmetal Pty. Ltd.	C76887B
The Staff Centre (Investments) Pty. Ltd.	C77357X
Echuca Accommodation Pty. Ltd.	C77362P
Tragerbie Pastoral Co. Pty. Ltd.	C78488X
Joan Chesney Frost Publicity Services Pty. Ltd.	C78831M
Modewarre Pastoral Co. Pty. Ltd.	C80066R
South Sand Keys Pty. Ltd.	C80709R
Mid Jewel Pty. Ltd.	C81276M
Schroeder & Holland (Distributors) Pty. Ltd.	C82215Y
Korora Pty. Ltd.	C82373U
John Arthur Sutherland Pty. Ltd.	C82812Z
Richards Restaurant Pty. Ltd.	C85406F
Independent Hotel Holdings Pty. Ltd.	C87308V
All Plant Installation Services Pty. Ltd.	C87593Z
521 Toorak Pty. Ltd.	C88406D
Cash Loans and Investments Finance Corporation Pty. Ltd.	C90668P
E. W. Crooks Machinery Pty. Ltd.	C91617D
E. W. Crooks Plastics Pty. Ltd.	C91618F
Dalveen Investments Pty. Ltd.	C92794L
Canean Developments Pty. Ltd.	C95177B
Westernport Cloverdale Pty. Ltd.	C95411K

Name of Company	Number of Registration
Keuffel & Esser (Aust.) Pty. Ltd.	C95804K
Maritrel Pty. Ltd.	C98148S
Victorian Public Interest Research Group Ltd.	C98683W
Otirag Pty. Ltd.	C99223M
Rob Con Nominees Pty. Ltd.	C99864K
Dale Anthony Marine Services Pty. Ltd.	C99993Y
Grandstand Pty. Ltd.	C100471Y
Relu Nominees Pty. Ltd.	C101002N
P. & M. O'Connor Pty. Ltd.	C101227S
Parts of Europe Pty. Ltd.	C104481G
Duggan & Bernard Pty. Ltd.	C104791B
Locksley Nominees Pty. Ltd.	C107792B
Nasis and Mills' Constructions Pty. Ltd.	C107898V
Wannague Pty. Ltd.	C110533G
Millefois Pty. Ltd.	C110674C
Narrawatuk Pty. Ltd.	C110919K
Sholl Rutzou Sharman Pty. Ltd.	C111159M
Tandarook Nominees Pty. Ltd.	C112083L
Elizabeth Scott Nominees Pty. Ltd.	C112250F
Wool Certification Ltd.	C112345U
Colproof Pty. Ltd.	C113341T
G.A.S. Investments Pty. Ltd.	C114843G
J.G.D. Investments Pty. Ltd.	C114846N
Leto Bronya Nominees Pty. Ltd.	C116899B
Betlin Nominees Pty. Ltd.	C121601T
Softpak Pty. Ltd.	C122658G
Roseprim Pty. Ltd.	C124482H
Melform Construction Pty. Ltd.	C125051G
Jill Andrea Pty. Ltd.	C125276K
Tanith Pty. Ltd.	C125536N
Connell & Abbott Car Sales Pty. Ltd.	C128213G
Enlim Staff Pty. Ltd.	C127878M
Monard Pty. Ltd.	C129700G
Armoj Pty. Ltd.	C129701J
Ardbraccan Pty. Ltd.	C129702L
Ardbane Pty. Ltd.	C129738J
Kidole Pty. Ltd.	C131167K
Wynnetern Nominees Pty. Ltd.	C133727V
C. P. Cameron Constructions Pty. Ltd.	C134878B
Sumo Pumps Pty. Ltd.	C135230W
Hayward Tyler Pumps Pty. Ltd.	C135231Y
Prospero May Nominees Pty. Ltd.	C145191Z
World Bowls (1980) Ltd.	C147600K
Systematic Marketing (Vic.) Pty. Ltd.	C147626E
Chichester Pty. Ltd.	C151507L
Urlingford Pty. Ltd.	C155282R
Pritchard Steam Ltd.	C162043H

## APPOINTMENTS AND RESIGNATIONS

### APPOINTMENTS

His Excellency the Governor of the State of Victoria, by and with the advice of the Executive Council thereof, has, by Orders made on 11 November 1980 been pleased to make the under-mentioned appointments, viz.:

#### DEPARTMENT OF CROWN LANDS AND SURVEY

##### Baillifs of Crown Lands

IAN ROCHE,  
LESLIE PERRY,  
GRAEME DAVIES,  
DAVID HURLEY,  
KEVIN SLEEP,  
ANTHONY MORRIS,  
ROBERT FISHER,  
JOHN WILLIAMS,  
DENNIS WARD,  
GERARD DRIESSEN, and  
CHARLES DICKIE,  
to be Baillifs of Crown lands pursuant to the provisions of section 30 of the Land Act 1958 in respect of all Crown lands in the State of Victoria, and with authority to discharge and exercise all the duties and powers of Baillifs of Crown lands.



## LAW DEPARTMENT

*Commissioners for Taking Declarations, &c.*

JAMES CAMPBELL, 658 Church Street, Richmond,  
COLIN CROMPTON, 1-7 Wendouree Parade, Ballarat,  
CAROL ANNE HUGHES, 450 St. Kilda Road, Melbourne,  
JACK JOHN JACOBY, 619 St. Kilda Road, Melbourne,  
FREDERICK THOMAS LEE, 1970-84 Princes Highway, Clayton,  
ALAN WALLIS RAY, 570 Bourke Street, Melbourne,  
EDWARD SELLERS REES, 19 Banksia Crescent, Churchill,  
ALEXANDER SHAW, 530 Lt. Collins Street, Melbourne,  
TERRY FRANCIS TAYLOR, Banksia Street, Heidelberg West,  
and  
WILLIAM HOWARD TERRILL, 45-51 Maroondah Highway, Ringwood,  
to be Commissioners for taking Declarations and Affidavits under the Evidence Act 1958.

*Bailiff of the County Court*

BRIAN JAMES CARLSON, Officer in Charge, Police Station, Numurkah,  
to be a Bailiff of the County Court at Numurkah pursuant to the provisions of the County Court Act 1958.

TOM FORRISTAL  
Clerk of the Executive Council

At the Executive Council Chamber  
Melbourne, 11 November 1980

## LAW DEPARTMENT

## TERMINATION OF APPOINTMENT OF BAILIFF OF COUNTY COURT

His Excellency the Governor of the State of Victoria by and with the advice of Executive Council thereof has by Order made on 11 November 1980, terminated the appointment of Senior Constable COLIN SUTCLIFFE of the Police Station at Numurkah as a Bailiff of the County Court at Numurkah.

TOM FORRISTAL  
Clerk of the Executive Council

At the Executive Council Chamber  
Melbourne, 11 November 1980

## Forests Act 1958 (No. 6254)

## APPOINTMENT OF COMMITTEE OF MANAGEMENT OF STEAVENSON FALLS SCENIC RESERVE

Whereas by section 50 of the Forest Act 1958 (No. 6254), it is provided that the Minister of Forests may, on the recommendation of the Forests Commission, appoint any number of persons, not less than three, to be a Committee of Management of any land forming part of any reserved forest, such land being set aside as a Scenic Reserve, and may remove any of those persons: Now therefore, I, Frederick James Granter, Her Majesty's Minister of Forests for the State of Victoria, on the recommendation of the Forests Commission, do hereby appoint—

GEOFFREY GORDON CUZENS,  
JACK HAYCRAFT,  
SABATINO GIANFORTE,  
IAN LOUIS GHERASHE,  
NORMAN JAMES FISKE, and  
NEIL THOMAS GUSCOTT,

as members of the Committee of Management for a period of three years until 15 October 1983 of the land forming part of the reserved forest in the Parish of Steavenson, County of Anglesey, described in the accompanying Schedule, and known as "Steavenson Falls Scenic Reserve".

## SCHEDULE ABOVE REFERRED TO

Parish of Steavenson, County of Anglesey, 189.8 hectares, more or less, being the area shown by pink colour on plan marked A-58/613 over 15.10.59, on file of correspondence No. 75/2230 of the Forests Department.  
Dated at Melbourne, 13 November 1980

F. J. GRANTER  
Minister of Forests

Forests Act 1958 (No. 6254)  
APPOINTMENT OF COMMITTEE OF MANAGEMENT OF LERDERBERG GORGE FOREST PARK

Whereas by section 50 of the Forests Act 1958 (No. 6254), it is provided that the Minister of Forests may, on the recommendation of the Forests Commission, appoint any number of persons not less than three to be a Committee of Management of any land forming part of any reserved forest, such land being set aside as a forest park, and may remove any of those persons: Now therefore, I, Frederick James Granter, Her Majesty's Minister of Forests for the State of Victoria, on the recommendation of the Forests Commission, do hereby appoint—

WILLIAM GEORGE MANLY  
as a member of the Committee of Management until 5 June 1981 of the land forming part of the reserved forest in the Parishes of Blackwood, Coimadai, Coornmill and Myrning, County of Bourke, described in the accompanying Schedule, and known as the "Lerderberg Gorge Forest Park".

## SCHEDULE ABOVE REFERRED TO

Parishes of Blackwood, Coimadai, Coornmill and Myrning, County of Bourke, containing 4019 hectares, more or less, being the area shown by yellow and red borders on the plan marked A67/1020 over 25.1.63, on file of correspondence No. 75/1078 of the Forests Department.

Dated at Melbourne, 13 November 1980

F. J. GRANTER  
Minister of Forests

## Liquor Control Act 1968

## APPOINTMENT OF LICENSING INSPECTORS

In accordance with the authority conferred upon me by Section 6 of the Police Regulation Act 1958, I, Aubrey William Conn, Deputy Commissioner of Police, do hereby appoint under sub-section (1) of Section 22 of the Liquor Control Act 1968, the following Officers of Police as Licensing Inspectors for the Divisions of the Police Districts as shown:

Division Number	Police District	Rank and Name
1	Cheltenham	Inspector Lionel Bruce Schade (from 2.11.80 to 13.12.80)
3	Maroondah	Inspector Russell Louis Bertram (from 6.11.80 to 13.12.80)
2	Moonee Ponds	Inspector James Patrick Keegan (from 9.11.80 to 6.12.80)
13.11.1980		A. W. CONN Deputy Commissioner (Operations)

## RESIGNATIONS

His Excellency the Governor of the State of Victoria, by and with the advice of the Executive Council thereof, has, by Orders made on 11 November 1980, accepted the resignations of the persons named hereunder of the office mentioned, viz.:

## LAW DEPARTMENT

*Commissioners for Taking Declarations, &c.*

ROGER PAUL CARREL,  
DONALD MAX FRENCH,  
PETER WILLIAM HALES,  
JEANNE HENDY,BARRY BERNARD LEITH,CLEMENT JOSEPH QUINLAN, and

EDWARD ALBERT TREWARTHA TUCKER,  
as Commissioners for taking Declarations and Affidavits under the Evidence Act 1958.

TOM FORRISTAL  
Clerk of the Executive Council

At the Executive Council Chamber  
Melbourne, 11 November 1980



LOCAL GOVERNMENT ACT 1958

At the Executive Council Chamber, Melbourne, the eleventh day of November, 1980

PRESENT:

His Excellency the Governor of Victoria  
 Mr Borthwick | Mr Ramsay  
 Mr Austin | Mr Lieberman

ROAD DISCONTINUED—CITY OF SUNSHINE

Whereas it is provided in section 528 (2) of the *Local Government Act 1958* that where a road (whether or not a public highway but not being a road set out on land of the Crown) or any part thereof is not required for public use, the Governor in Council on the request of the Council of the municipality in which such road is situated made not less than one month after publishing in a newspaper generally circulating in the district and posting to the registered proprietor (if any) of the land and the owners and occupiers (if any) of lands abutting or immediately adjacent to the road notice of intention to make such a request may by Order published in the *Government Gazette* direct that such road or part shall be discontinued and thereupon such road or part shall be discontinued accordingly.

And whereas the Council of the City of Sunshine has requested that the Governor in Council direct that part of Maxwell Street, Ardeer, be discontinued and not less than one month previously has published in a newspaper generally circulating in the district and posted to the registered proprietor of the land in the road and to the owners and occupiers of lands abutting or immediately adjacent to the road notice of intention to make such a request.

Now therefore, His Excellency the Governor of the State of Victoria, by and with the advice of the Executive Council thereof, hereby directs that the said part of a road which is shown by hatching on the plan hereunder, shall be discontinued and the land in the said part of a road may be sold by the Council of the City of Sunshine by public auction.

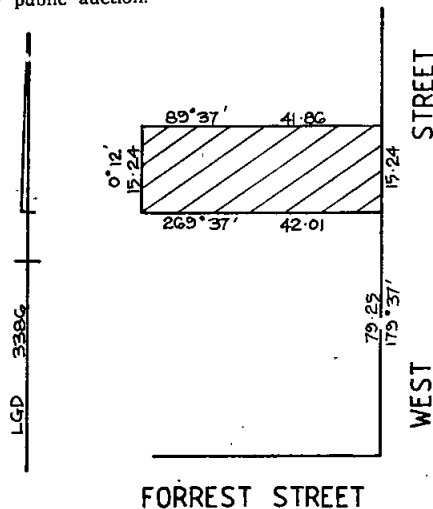

LENGTHS ARE IN METRES

And the Honourable Digby Glen Crozier, Her Majesty's Minister for Local Government for the State of Victoria, shall give the necessary directions herein accordingly.

TOM FORRISTAL  
 Clerk of the Executive Council

LOCAL GOVERNMENT ACT 1958

At the Executive Council Chamber, Melbourne, the eleventh day of November, 1980

PRESENT:

His Excellency the Governor of Victoria  
 Mr Borthwick | Mr Ramsay  
 Mr Austin | Mr Lieberman

VESTING OF A RESERVE IN THE KEW CITY COUNCIL

Whereas it is provided by section 569BA of the *Local Government Act 1958*, that where any map or plan has been lodged or deposited with the Registrar of Titles pursuant to section 97 of the *Transfer of Land Act 1958*, or any corresponding previous enactment (whether before or after the commencement of the *Local Government Act 1963*) and any allotment on that map or plan has been transferred the Governor in Council on the request of the council of the municipality may by Order published in the *Government Gazette* direct that the whole or any part of the land comprised in any reserve shown on that map or plan shall vest freed and discharged from any mortgage charge lease or sub-lease.

And whereas the Council of the City of Kew has requested that a reserve shown on a plan of subdivision be vested in the Council and an allotment on that plan has been transferred.

Now therefore, His Excellency the Governor of the State of Victoria, by and with the advice of the Executive Council thereof and in pursuance of the provisions of sub-section 1 of section 569BA of the *Local Government Act 1958* by this Order vests in the Council of the City of Kew a Reserve for Drainage on Plan of Subdivision No. 2807 lodged in the Office of Titles and shown by hatching on the plan hereunder.

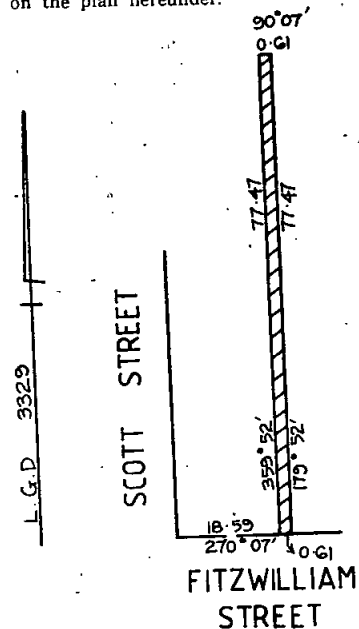

LENGTHS ARE IN METRES

And the Honourable Digby Glen Crozier, Her Majesty's Minister for Local Government for the State of Victoria, shall give the necessary directions herein accordingly.

TOM FORRISTAL  
 Clerk of the Executive Council



LOCAL GOVERNMENT ACT 1958

At the Executive Council Chamber, Melbourne, the  
eleventh day of November, 1980

PRESENT:

His Excellency the Governor of Victoria  
Mr Borthwick | Mr Ramsay  
Mr Austin | Mr Lieberman

APPROVAL OF RATING AGREEMENT BETWEEN THE  
CITY OF HAMILTON AND HAMILTON COUNTRY  
MEATS PTY. LTD.

Whereas—

- (a) Hamilton Country Meats Pty. Ltd., are liable to be rated in respect of the land situated at Portland Road, Hamilton and known as the Hamilton Abattoirs which land is not within the Metropolitan area within the meaning of the *Town and Country Planning Act 1961*;
- (b) the Council of the City of Hamilton is of the opinion that the establishment and maintenance of the industry within the municipality is making and will continue to make a substantial contribution to the industrial development of the municipality and encourage the decentralization of industry in Victoria; and
- (c) the President, Councillors and Ratepayers of the Council of the City of Hamilton and Hamilton Country Meats Pty. Ltd., on 7 July 1980 entered into an agreement in respect of the above described land as to the amount of rates that will be payable thereon by the said firm under the *Local Government Act 1958*, and copies of such agreement have been submitted to the Minister for Local Government.

Now, therefore, His Excellency the Governor of the State of Victoria, by and with the advice of the Executive Council thereof, and in pursuance of the provisions of the said section 811BA of the *Local Government Act 1958*, hereby approve the said agreement.

And the Honourable Digby Glen Crozier, Her Majesty's Minister for Local Government for the State of Victoria, shall give the necessary directions herein accordingly.

TOM FORRISTAL  
Clerk of the Executive Council

LOCAL GOVERNMENT ACT 1958

At the Executive Council Chamber, Melbourne, the  
eleventh day of November, 1980

PRESENT:

His Excellency the Governor of Victoria  
Mr Borthwick | Mr Ramsay  
Mr Austin | Mr Lieberman

ROAD DISCONTINUED—CITY OF CROYDON

Whereas it is provided in section 528. (2) of the *Local Government Act 1958*, that where a road (whether or not a public highway but not being a road set out on land of the Crown) or any part thereof is not required for public use the Governor in Council on the request of the council of the municipality in which such road is situated made not less than one month after publishing in a newspaper generally circulating in the district and posting to the registered proprietor (if any) of the land and the owners and occupiers (if any) of lands abutting or immediately adjacent to the road notice of intention to make such a request may by Order published in the *Government Gazette* direct that such a road or part shall be discontinued and thereupon such road or part shall be discontinued accordingly.

And whereas the Council of the City of Croydon has requested that the Governor in Council direct that part of Trawalla Street, Croydon, be discontinued and not less than one month previously has published in a newspaper generally circulating in the district and posted to the registered proprietor of the land in the road and to the owners and occupiers of lands abutting or immediately adjacent to the road notice of intention to make such a request.

Now therefore, His Excellency the Governor of the State of Victoria, by and with the advice of the Executive Council thereof, hereby directs that the said part of a road which is shown by hatching on the plan hereunder, shall be discontinued and that the land may be sold by the Council of the City of Croydon, by agreement.

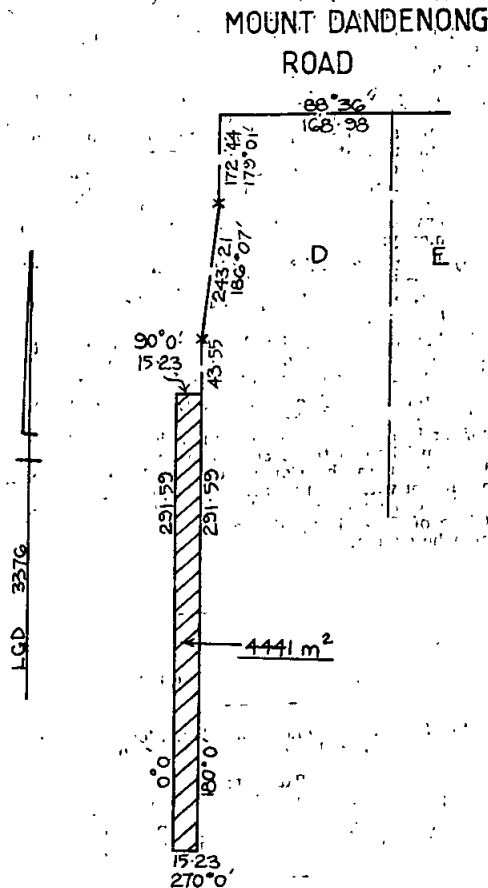

LENGTHS ARE IN METRES  
AREA IS IN SQUARE METRES (m²)

And the Honourable Digby Glen Crozier, Her Majesty's Minister for Local Government for the State of Victoria, shall give the necessary directions herein accordingly.

TOM FORRISTAL  
Clerk of the Executive Council

LOCAL GOVERNMENT ACT 1958

At the Executive Council Chamber, Melbourne, the eleventh day of November, 1980

PRESENT:

His Excellency the Governor of Victoria  
 Mr Borthwick                      Mr Ramsay  
 Mr Austin                              Mr Lieberman

CONSENT TO SALE OF A RESERVE BY THE FLINDERS SHIRE COUNCIL

Whereas certain land being the Drainage Reserve coloured green on Plan of Subdivision No. 8767 lodged in the Office of Titles was vested in the Council of the Shire of Flinders by Order published in the *Government Gazette* No. 47 of 13 June 1979 and the said Council is now of the opinion that part of the land is no longer required for the purpose for which it was reserved and has requested that consent be given to the sale of the said land.

And whereas the said Council:

- (a) has published in a newspaper generally circulating in the municipal district a notice describing the land and the proposal for the sale of the land and stating that at the next ordinary meeting of the Council after the expiration of 40 days after publication of the notice the Council would consider any objections to the proposal and consider any representations as to the disposal of purchase money;
- (b) being the registered proprietor of the land in question and there being no mortgagee chargee or lessee thereof has posted a similar notice upon the land.

And whereas no objection has been made against the proposal and no representations were made as to the disposal of any purchase money for the sale of the land.

Now therefore, His Excellency the Governor of the State of Victoria, by and with the advice of the Executive Council thereof, and in pursuance of the provisions of sub-section 2 of section 569BA of the *Local Government Act 1958* doth hereby consent to the Council of the Shire of Flinders selling by private treaty part of the Drainage Reserve coloured green on Plan of Subdivision No. 8767 lodged in the Office of Titles being the land shown by hatching on the plan hereunder.

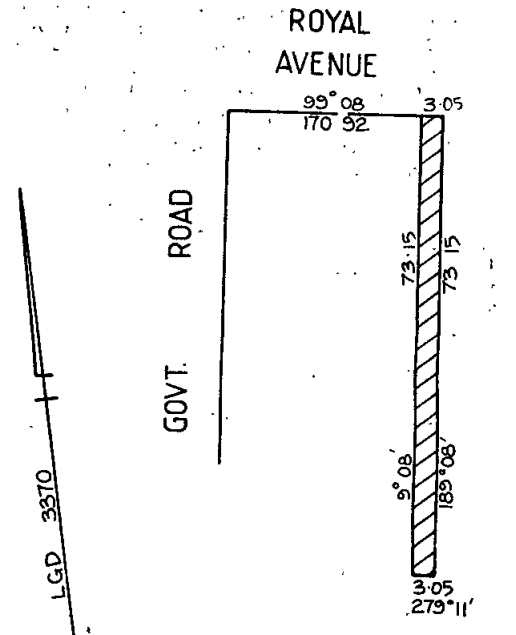

LENGTHS ARE IN METRES

And the Honourable Digby Glen Crozier, Her Majesty's Minister for Local Government for the State of Victoria, shall give the necessary directions herein accordingly.

TOM FORRISTAL  
 Clerk of the Executive Council

LOCAL GOVERNMENT ACT 1958

At the Executive Council Chamber, Melbourne, the eleventh day of November, 1980

PRESENT:

His Excellency the Governor of Victoria  
 Mr Borthwick                      Mr Ramsay  
 Mr Austin                              Mr Lieberman

ROAD DISCONTINUED—CITY OF PRESTON

Whereas it is provided in section 528 (2) of the *Local Government Act 1958*, that where a road (whether or not a public highway but not being a road set out on land of the Crown) or any part thereof is not required for public use, the Governor in Council on the request of the council of the municipality in which such road is situated made not less than one month after publishing in a newspaper generally circulating in the district and posting to the registered proprietor (if any) of the land and the owners and occupiers (if any) of the lands abutting or immediately adjacent to the road notice of intention to make such a request may by Order published in the *Government Gazette* direct that such a road or part shall be discontinued and thereupon such road or part shall be discontinued accordingly.

And whereas the Council of the City of Preston has requested that the Governor in Council direct that a road off Godley Street, Reservoir, be discontinued and not less than one month previously has published in a newspaper generally circulating in the district and posted to the registered proprietors of the land in the road and to the owners and occupiers of lands abutting or immediately adjacent to the road notice of intention to make such request.

Now therefore, His Excellency the Governor of the State of Victoria, by and with the advice of the Executive Council thereof, hereby directs:

- (a) that the said road which is shown by hatching and cross hatching on the plan hereunder shall be discontinued;
- (b) that notwithstanding such discontinuance the Melbourne and Metropolitan Board of Works shall continue to have and possess the same right title power authority or interest in or in relation to the whole of the land shown by cross hatching on the said plan as it had or possessed prior to such discontinuance with respect to or in connection with any drains or pipes laid or erected in on or over such land for the purposes of drainage or sewerage;
- (c) that notwithstanding such discontinuance the Council of the City of Preston shall continue to have and possess the same right title power

authority or interest in or in relation to the whole of the land shown on the said plan as it had or possessed prior to such discontinuance; and  
 (d) that, subject to any such right title power authority or interest the land in the said road and part of a road may be sold by the Council of the City of Preston by agreement.

Now therefore, His Excellency the Governor of the State of Victoria, by and with the advice of the Executive Council thereof, hereby directs that the said part of a road which is shown by hatching on the plan hereunder, shall be discontinued and that the land shall be sold by the Council of the City of Sunshine by public auction.

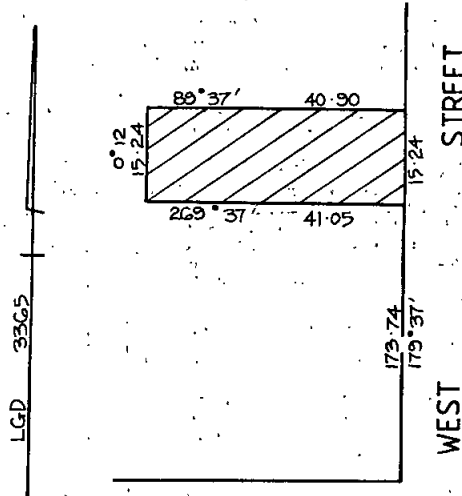
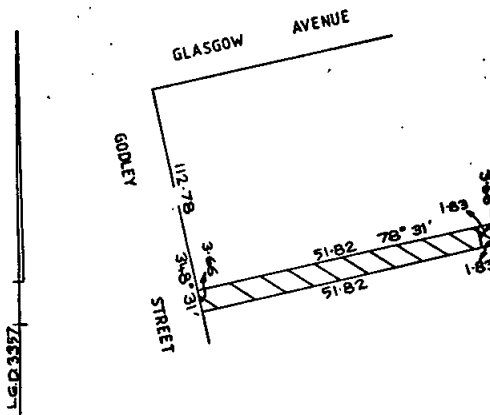

And the Honourable Digby Glen Crozier, Her Majesty's Minister for Local Government for the State of Victoria, shall give the necessary directions herein accordingly.

TOM FORRISTAL  
 Clerk of the Executive Council

FORREST STREET

LENGTHS ARE IN METRES

LOCAL GOVERNMENT ACT 1958

At the Executive Council Chamber, Melbourne, the eleventh day of November, 1980

PRESENT:

His Excellency the Governor of Victoria  
 Mr Borthwick | Mr Ramsay  
 Mr Austin | Mr Lieberman

ROAD DISCONTINUED—CITY OF SUNSHINE

Whereas it is provided in section 528 (2) of the Local Government Act 1958, that where a road (whether or not a public highway but not being a road set out on land of the Crown) or any part thereof is not required for public use the Governor in Council on the request of the council of the municipality in which such road is situated made not less than one month after publishing in a newspaper generally circulating in the district and posting to the registered proprietor (if any) of the land and the owners and occupiers (if any) of lands abutting or immediately adjacent to the road notice of intention to make such a request may by Order published in the Government Gazette direct that such a road or part shall be discontinued and thereupon such road or part shall be discontinued accordingly.

And whereas the Council of the City of Sunshine has requested that the Governor in Council direct that part of Suspension Street, Ardeer, be discontinued and not less than one month previously has published in a newspaper generally circulating in the district and posted to the registered proprietor of the land in the road and to the owners and occupiers of lands abutting or immediately adjacent to the road notice of intention to make such a request.

And the Honourable Digby Glen Crozier, Her Majesty's Minister for Local Government for the State of Victoria, shall give the necessary directions herein accordingly.

TOM FORRISTAL  
 Clerk of the Executive Council

LOCAL GOVERNMENT ACT 1958

At the Executive Council Chamber, Melbourne, the eleventh day of November, 1980

PRESENT:

His Excellency the Governor of Victoria  
 Mr Borthwick | Mr Ramsay  
 Mr Austin | Mr Lieberman

ROAD DISCONTINUED—SHIRE OF CORIO

Whereas it is provided in section 528 (2) of the Local Government Act 1958, that where a road (whether or not a public highway but not being a road set out on land of the Crown) or any part thereof is not required for public use the Governor in Council on the request of the council of the municipality in which such road is situated made not less than one month after publishing in a newspaper generally circulating in the district and posting to the registered proprietor (if any) of the land and the owners and occupiers (if any) of lands abutting or immediately adjacent to the road notice of intention to make such a request may by Order published in the Government Gazette direct that such roads or part shall be discontinued and thereupon such road or part shall be discontinued accordingly.

And whereas the Council of the Shire of Corio has requested that the Governor in Council direct that a road between Darcy Street and Forest Road, Lara be discontinued and not less than one month previously has published in a newspaper generally circulating in the district and posted to the registered proprietor of the land in the road and to the owners and occupiers of lands abutting or immediately adjacent to the road notice of intention to make such request.

Now therefore, His Excellency the Governor of the State of Victoria, by and with the advice of the Executive Council thereof, hereby directs that the said road which is shown by hatching on the plan hereunder shall be discontinued and that the land in the said road may be sold by the Council of the Shire of Corio by agreement.

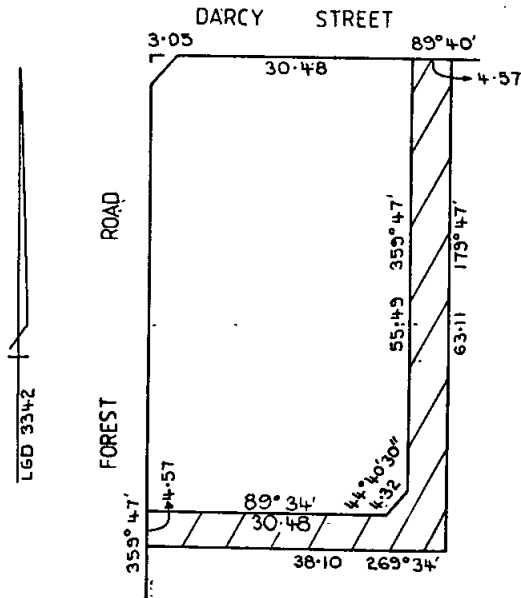

MEASUREMENTS ARE IN METRES

And the Honourable Digby Glen Crozier, Her Majesty's Minister for Local Government for the State of Victoria, shall give the necessary directions herein accordingly.

TOM FORRISTAL  
Clerk of the Executive Council

LOCAL GOVERNMENT ACT 1958\*

At the Executive Council Chamber, Melbourne, the eleventh day of November, 1980

PRESENT:  
His Excellency the Governor of Victoria  
Mr Borthwick | Mr Ramsay  
Mr Austin | Mr Lieberman

FIXATION AND DECLARATION OF BREADTHS OF CARRIAGEWAY AND FOOTWAYS—CITY OF HEIDELBERG

In pursuance of the provisions of section 520 of the Local Government Act 1958, His Excellency the Governor of the State of Victoria, by and with the advice of the Executive Council thereof, and in compliance with a

request of the Council of the City of Heidelberg hereby fixes and declares the breadths of carriageway and footways of parts of Yarra Street, Heidelberg, in the manner indicated on the plan hereunder.

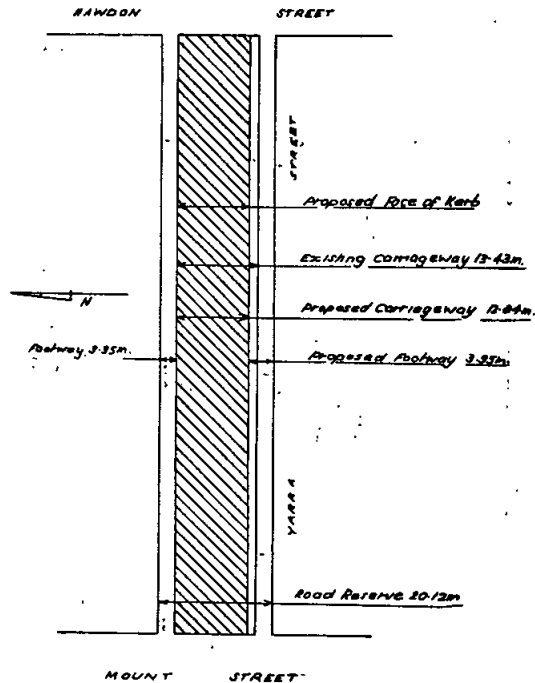

And the Honourable Digby Glen Crozier, Her Majesty's Minister for Local Government for the State of Victoria, shall give the necessary directions herein accordingly.

TOM FORRISTAL  
Clerk of the Executive Council

GAS AND FUEL CORPORATION ACT 1958

At the Executive Council Chamber, Melbourne, the eleventh day of November, 1980

PRESENT:  
His Excellency the Governor of Victoria  
Mr Borthwick | Mr Ramsay  
Mr Austin | Mr Lieberman

APPOINTMENT OF STATE DIRECTOR OF THE GAS AND FUEL CORPORATION OF VICTORIA

In pursuance of the powers conferred by the Gas and Fuel Corporation Act 1958, No. 6260, His Excellency the Governor of the State of Victoria, by and with the advice of the Executive Council thereof, doth by this Order appoint—

PETER BRUCE RONALD  
to be a State Director of the Gas and Fuel Corporation of Victoria, for a period of three years from and including 26 November 1980.

And the Honourable James Charles Murray Balfour, Her Majesty's Minister for Minerals and Energy for the State of Victoria, shall give the necessary directions herein accordingly.

TOM FORRISTAL  
Clerk of the Executive Council



COUNTRY ROADS BOARD  
Act No. 6229

At the Executive Council Chamber, Melbourne, the  
eleventh day of November, 1980

PRESENT:

His Excellency the Governor of Victoria  
Mr Borthwick                      Mr Ramsay  
Mr Austin                              Mr Lieberman

ORDER APPROVING OF LAND BEING ACQUIRED AND  
ROADS, DEVIATIONS OR WIDENINGS BEING MADE  
TOGETHER WITH ALL ANCILLARY WORKS REQUIRED  
TO BE EXECUTED IN CONJUNCTION THEREWITH

His Excellency the Governor of the State of Victoria, by  
and with the advice of the Executive Council thereof, being  
satisfied that there are funds legally available for acquiring  
the land, doth hereby approve the acquiring of the land  
described in the schedule hereunder and the making of new  
roads and deviations from and widenings of existing roads,  
together with all ancillary works required to be executed  
in conjunction therewith, referred to in the said schedule.

SCHEDULE

Main Roads

The land shown hatched on plans numbered G.P.15114A  
and G.P.15114B hereunder required for the widening of the  
Mirboo North-Thorpdale Road and The Grand Ridge Road in  
the Shire of Mirboo and making of the widenings  
thereon.

MAIN ROAD  
MIRBOO NORTH - THORPDALE ROAD  
SHIRE OF MIRBOO

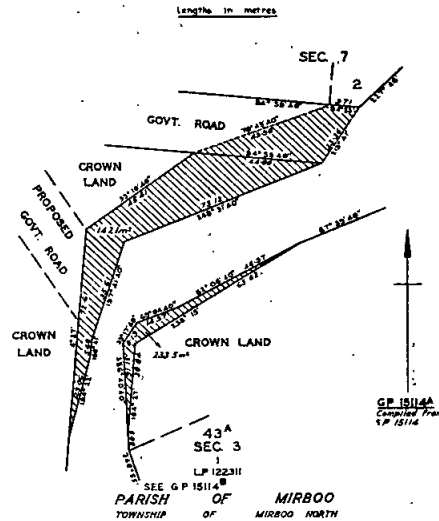

Tourists' Road

The land shown hatched on plans numbered G.P.15363A,  
G.P.15363B, G.P.15363C, G.P.15364 and G.P.15365 hereunder  
required for the deviation from Mallacoota Road in the  
Shire of Orbost and making of the deviation thereon.

MAIN ROAD  
THE GRAND RIDGE ROAD  
SHIRE OF MIRBOO

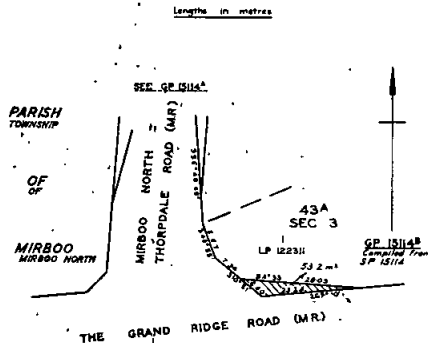

TOURISTS' ROAD  
MALLACOOTA ROAD  
SHIRE OF ORBOST

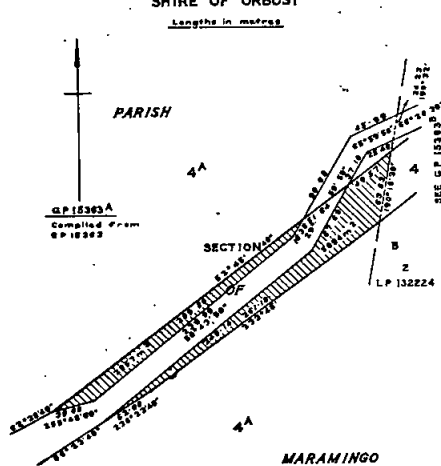

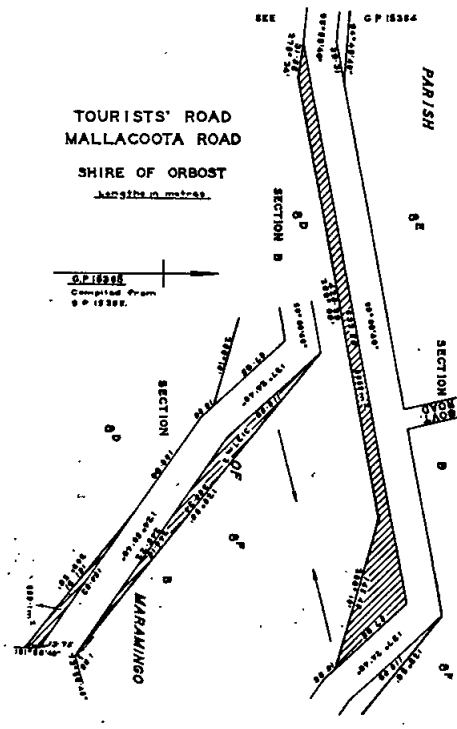
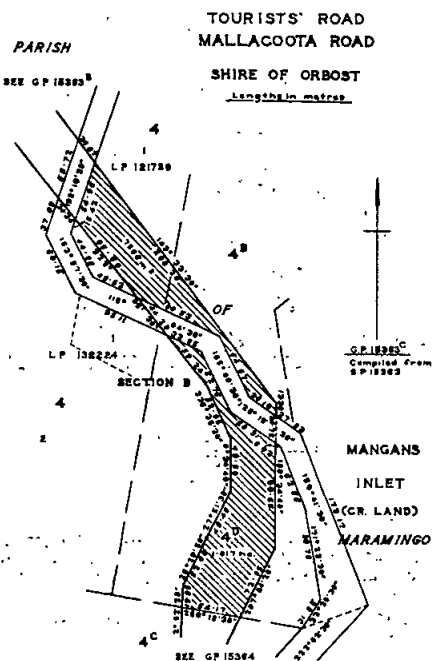
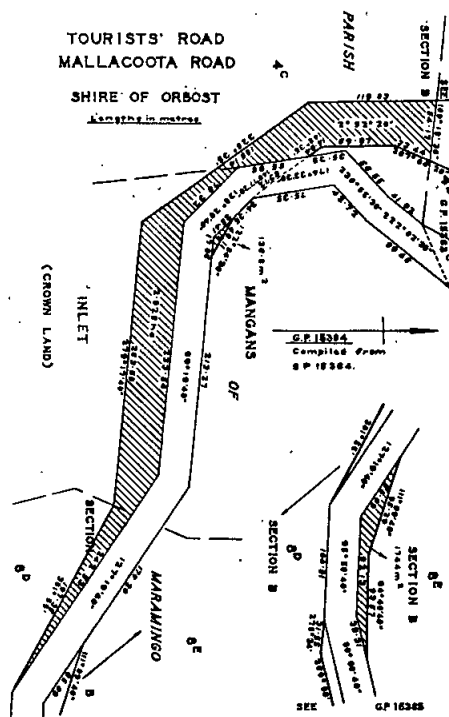
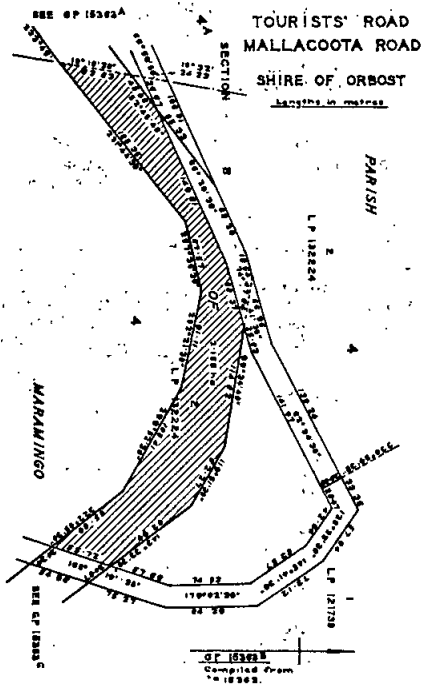

And the Honourable Robert Roy Cameron Maclellan, Her Majesty's Minister of Transport for the State of Victoria, shall give the necessary directions herein accordingly.  
TOM FORRISTAL  
Clerk of the Executive Council

CROWN LAND (RESERVES) ACT 1978

At the Executive Council Chamber, Melbourne, the eleventh day of November, 1980.

PRESENT:

His Excellency the Governor of Victoria  
 Mr Borthwick                      Mr Ramsay  
 Mr Austin                              Mr Lieberman

REVOCATION OF TEMPORARY RESERVATIONS OF LANDS BY ORDERS IN COUNCIL

His Excellency the Governor of the State of Victoria, in the Commonwealth of Australia, by and with the advice of the Executive Council of the said State, pursuant to the provisions of section 10 of the *Crown Land (Reserves) Act 1978*, doth hereby revoke the temporary reservations of lands by Orders in Council hereinafter described, viz.:

**BEREMBOKE**—The temporary reservation by Order in Council of 23 June 1890 of 4.256 hectares of land in the Parish of Beremboke (adjoining allotment 44) as a site for Watering purposes, so far only as the portion thereof containing 296 square metres, as defined by description and hatching on plan published in the *Government Gazette* of 22 October 1980, is concerned—(Parish 2123) (Rs.5308).

**ECHUCA**—The temporary reservation by Order in Council of 21 December 1921 of 2.977 hectares of land in the Township of Echuca as a site for Public purposes, revoked as to part by various Orders, so far only as the portion thereof in section 38A containing 4528 square metres, as defined by description and hatching on plan published in the *Government Gazette* of 22 October 1980, is concerned—(E.3<sup>(8)</sup>) (Rs.6175).

**JIKA JIKA (AT PRESTON)**—The temporary reservation by Order in Council of 21 August 1945 of 2.459 hectares of land in the Parish of Jika Jika as a site for Hospital purposes, so far only as the portion thereof containing 288 square metres, as defined by description and hatching on plan published in the *Government Gazette* of 22 October 1980, is concerned—(J.16<sup>(4)</sup>) (Rs.5691).

**KEELBUNDORA**—The temporary reservation by Order in Council of 25 March 1975 of 250 hectares, more or less, of land in the Parish of Keelbundora as a site for Public purposes (Mental Health purposes), revoked as to part by Order of 16 January 1979, so far only as the portion thereof containing 46.4 hectares, more or less, as defined by description and hatching on plan published in the *Government Gazette* of 22 October 1980, is concerned—(K.25<sup>(7)</sup>) (Rs.1436).

**PORTARLINGTON**—The temporary reservation by Order in Council of 28 November 1938 of 4.358 hectares of land in the Township of Portarlington as a site for Public purposes, revoked as to part by Order of 19 December 1967, so far only as the portion thereof containing 1.856 hectares, as defined by description and hatching on plan published in the *Government Gazette* of 22 October 1980, is concerned—(P.37<sup>(2)</sup>) (Rs.4899).

**PORTARLINGTON**—The temporary reservation by Order in Council of 27 February 1968 of 9106 square metres, more or less, of land in the Township of Portarlington as a site for Public purposes (Municipal Depot), so far only as the portion thereof containing 595 square metres, as defined by description and hatching on plan published in the *Government Gazette* of 22 October 1980, is concerned—(P.37<sup>(2)</sup>) (Rs.8958).

**SCORESBY**—The temporary reservation by Order in Council of 15 October 1946 of 44.90 hectares of land in the Parish of Scoresby as a site for Horticultural Research Station, revoked as to part by Order of 11 January 1966, so far only as the portion thereof containing 7.1 hectares, more or less, as indicated by hatching on plan published in the *Government Gazette* of 22 October 1980, is concerned—(S.250(A6)) (Rs.5885).

And the Honourable William Vasey Houghton, Her Majesty's Minister of Lands for the State of Victoria, shall give the necessary directions herein accordingly.

TOM FORRISTAL  
 Clerk of the Executive Council

CROWN LAND (RESERVES) ACT 1978

At the Executive Council Chamber, Melbourne, the eleventh day of November, 1980

PRESENT:

His Excellency the Governor of Victoria  
 Mr Borthwick                      Mr Ramsay  
 Mr Austin                              Mr Lieberman

CROWN LANDS TEMPORARILY RESERVED

His Excellency the Governor of the State of Victoria, in the Commonwealth of Australia, by and with the advice of the Executive Council of the said State, pursuant to the provisions of sections 4 and 7 of the *Crown Land (Reserves) Act 1978*, and being of the opinion that the Crown lands concerned are required for the public purposes respectively mentioned, doth hereby temporarily reserve and also except from occupation for mining purposes under any miner's right, the Crown lands hereinafter described, viz.:

**ARARAT**—For Departmental Residence, 1141 square metres, being Crown allotment 7, section 113, Township of Ararat, as shown on Certified Plan No. 104630 lodged in the Central Plan Office—(A.148<sup>(9)</sup>).

**HOLDEN**—For Departmental Residence, 1125 square metres, being Crown allotment 7, section 25, Parish of Holden, as shown on Certified Plan No. 104689 lodged in the Central Plan Office—(H.99<sup>(2)</sup>) (Rs.11511).

**TOWANWAY**—For the protection of the bed and banks of a lake, 38 hectares, more or less, being Crown allotment 46c, Parish of Towanway, as indicated by hatching on plan hereunder—(T.148<sup>(2)</sup>) (Rs.11252).

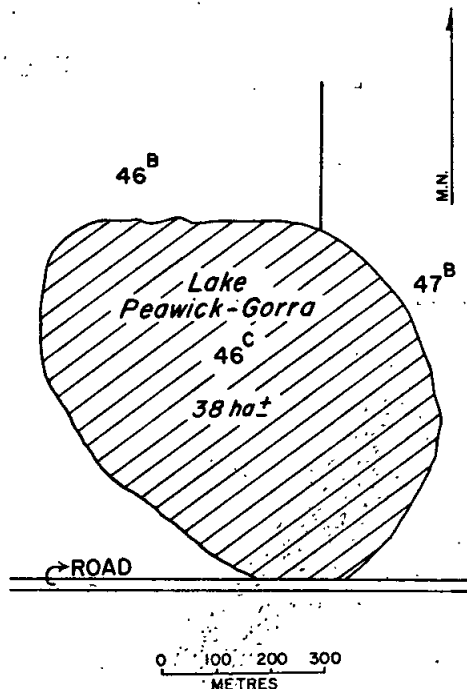

And the Honourable William Vasey Houghton, Her Majesty's Minister of Lands for the State of Victoria, shall give the necessary directions herein accordingly.

TOM FORRISTAL  
 Clerk of the Executive Council

CROWN LAND (RESERVES) ACT, 1978.

At the Executive Council Chamber, Melbourne; the  
eleventh day of November, 1980

PRESENT:

His Excellency the Governor of Victoria.  
Mr Borthwick: | Mr Ramsay:  
Mr Austin: | Mr Lieberman

CROWN LANDS TEMPORARILY RESERVED

His Excellency the Governor of the State of Victoria, in the Commonwealth of Australia; by and with the advice of the Executive Council of the said State, pursuant to sections 4 and 7 of the Crown Land (Reserves) Act 1978, and being of the opinion that the Crown lands concerned are required for the purposes respectively mentioned, doth hereby temporarily reserve and also except from occupation for mining purposes under any miner's right, the Crown lands hereinafter described, viz.:

ARARAT—For Public Recreation, 6486 square metres, being Crown allotment 5, section 113, Township of Ararat, as shown on Certified Plan No. 104630 lodged in the Central Plan Office—(A.148<sup>(9)</sup>) (Rs.2346).

BAMBRA—For Public Hall and Recreation, 5463 square metres, being Crown allotments 70D and 70E, Parish of Bamba, as shown on Certified Plan No. 104734 lodged in the Central Plan Office—(B.90<sup>(D<sup>2</sup>)</sup>) (Rs.2584).

CESSY—For Public Recreation, 2024 square metres, being Crown allotment 1B, section A, Township of Cressy, as shown on Certified Plan No. 104679 lodged in the Central Plan Office—(C.335<sup>(2)</sup>) (Rs.1539).

CESSY—For Public Recreation, 5358 square metres, being Crown allotment 1A, section A, Township of Cressy, as shown on Certified Plan No. 104679 lodged in the Central Plan Office—(C.335<sup>(2)</sup>) (Rs.7995).

GHERANG GHERANG—For Supply of Stone, 2.609 hectares, being Crown allotment 71C, Parish of Gherang Gherang, as indicated by hatching on plan hereunder—(G.34<sup>(8)</sup>) (Rs.11238).

PATCHEWOLLOCK—For Water Supply, 7.052 hectares, being Crown allotment 30E, Parish of Patchewollock, as indicated by hatching on plan hereunder—(P.146<sup>(7)</sup>) (Rs.11366).

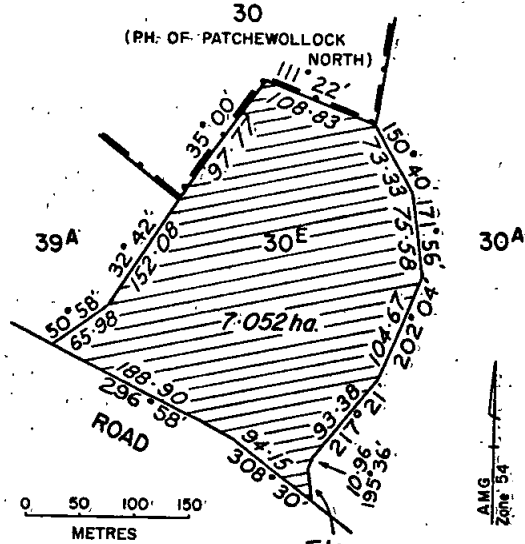

STANLEY—For Conservation of Area of Natural Interest—7840 square metres, being Crown allotment 12E, section 12A, Parish of Stanley, as indicated by hatching on plan hereunder—(S.339<sup>(10)</sup>) (Rs.11170).

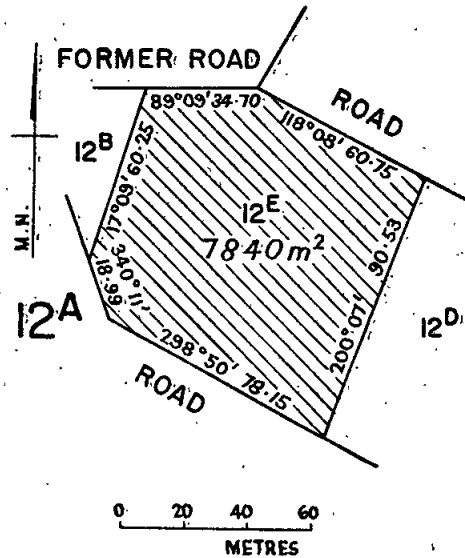
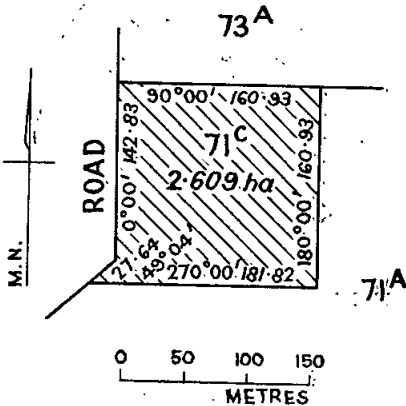

**TAHARA**—For Public Recreation—1.967 hectares, being Crown allotments 1 and 2, section 7, Parish of Tahara, as shown on Certified Plan No. 104680 lodged in the Central Plan Office—(T.43<sup>(s)</sup>) (Rs.11525).

**WATCHUPGA**—For Conservation of Area of Natural Interest, 11.32 hectares, being Crown allotment 4a, Parish of Watchupga, as indicated by hatching on plan hereunder—(W.392<sup>(s)</sup>) (Rs.11274).

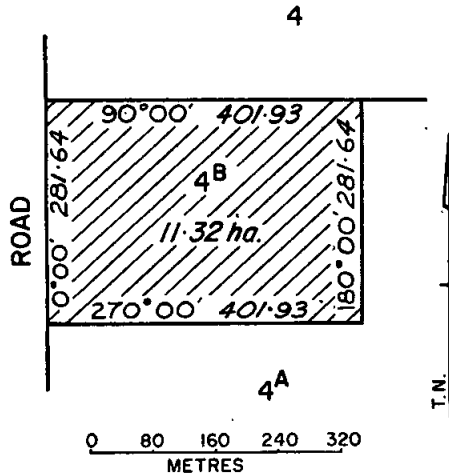

And the Honourable William Vasey Houghton, Her Majesty's Minister of Lands for the State of Victoria, shall give the necessary directions herein accordingly.

TOM FORRISTAL  
Clerk of the Executive Council

**CROWN LAND (RESERVES) ACT 1978**

At the Executive Council Chamber, Melbourne, the eleventh day of November, 1980

PRESENT:

His Excellency the Governor of Victoria  
Mr Borthwick | Mr Ramsay  
Mr Austin | Mr Lieberman

**REVOCATION OF TEMPORARY RESERVATIONS OF LANDS BY ORDERS IN COUNCIL**

His Excellency the Governor of the State of Victoria, in the Commonwealth of Australia, by and with the advice of the Executive Council of the said State, pursuant to the provisions of section 10 of the Crown Land (Reserves) Act 1978, doth hereby revoke the temporary reservations of lands by Orders in Council hereinafter described, viz.:

**CANN RIVER**—The temporary reservation by Order in Council of 1 August 1978 of 859 square metres of land being Crown allotment 21A, section 14, Township of Cann River for Public purposes (Teacher Housing Authority purposes)—(N.156<sup>(s)</sup>) (Rs.10593).

**EURACK**—The temporary reservation by Orders in Council of 22 and 25 September 1902 of 4047 square metres of land in the Township of Eurack (being Crown allotment 6) as a site for a State School—(C.18996).

**GANOO GANOO**—The temporary reservation by Order in Council of 31 May 1904 of 1.679 hectares of land in the Parish of Ganoo Ganoo (in section A1) as a site for Supply of Material for Road Making—(G.190<sup>(1)</sup>) (C.24211).

**KORRAK KORRAK**—The temporary reservation by Order in Council of 18 January 1887 of 20.23 hectares of land in the Parish of Korrak Korrak (being Crown allotment 5, section 3) as a site for Water Supply purposes—(L.5-2190).

**TOWANINNY**—The temporary reservation as a site for Water Supply purposes and the withholding from sale, leasing and licensing by Order in Council of 26 October 1882 of 57.07 hectares of land in the Parish of Towaninny (in section one)—(L.5-2187).

**WHROO**—The temporary reservation by Order in Council of 6 February 1865 of 1012 square metres of land in the Township of Whroo (being Crown allotment 23, section 7) as a site for Mechanics' Institute—(Rs.11458).

**WINYAR**—The temporary reservation by Order in Council of 8 September 1964 of 3895 square metres of land in the Parish of Winyar as a site for the purposes of the Forests Act—(Rs.8364).

And the Honourable William Vasey Houghton, Her Majesty's Minister of Lands for the State of Victoria, shall give the necessary directions herein accordingly.

TOM FORRISTAL  
Clerk of the Executive Council

**CROWN LAND (RESERVES) ACT 1978**

At the Executive Council Chamber, Melbourne, the eleventh day of November, 1980

PRESENT:

His Excellency the Governor of Victoria  
Mr Borthwick | Mr Ramsay  
Mr Austin | Mr Lieberman

**CROWN LAND PERMANENTLY RESERVED**

His Excellency the Governor of the State of Victoria, in the Commonwealth of Australia, by and with the advice of the Executive Council of the said State, pursuant to the provisions of sections 4 and 7 of the Crown Land (Reserves) Act 1978, and being of the opinion that the Crown land concerned is required for the purpose mentioned, doth hereby permanently reserve and also except from occupation for mining purposes under any miner's right, the Crown land hereinafter described, viz.:

**MURMUNGEE**—For Conservation of Area of Natural Interest, 10 hectares, more or less, being Crown allotment 5A, section 14, Parish of Murrungee, as indicated by hatching on plan hereunder—(Parish 3227-2) (Rs.11099).

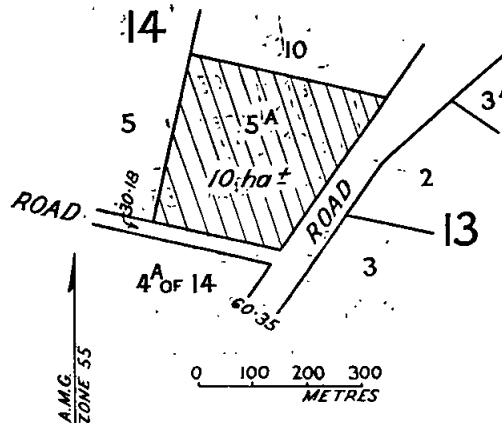

And the Honourable William Vasey Houghton, Her Majesty's Minister of Lands for the State of Victoria, shall give the necessary directions herein accordingly.

TOM FORRISTAL  
Clerk of the Executive Council



ROAD TRAFFIC ACT 1958

At the Executive Council Chamber, Melbourne, the eleventh day of November, 1980

PRESENT:

His Excellency the Governor of Victoria  
 Mr Borthwick | Mr Ramsay  
 Mr Austin | Mr Lieberman

In pursuance of the powers conferred by the Road Traffic Act 1958, His Excellency the Governor of the State of Victoria, in the Commonwealth of Australia, by and with the advice of the Executive Council of the said State, and at the request in writing of the Council of the City of Malvern, doth by this Order extend the provisions of the said Act to the land under the control of the City of Malvern as shown by hachure on the plan hereunder.

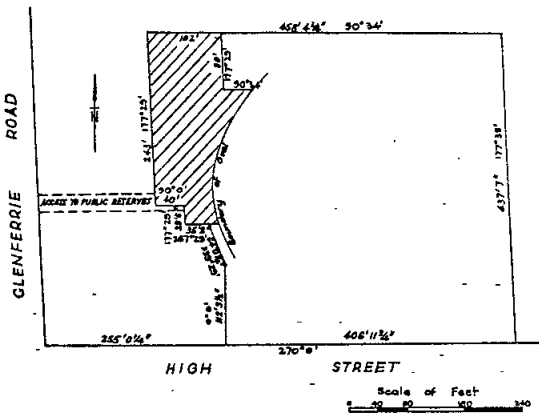

And the Honourable Lindsay Hamilton Simpson Thompson, Her Majesty's Minister for Police and Emergency Services for the State of Victoria, shall give the necessary directions herein accordingly.

TOM FORRISTAL  
 Clerk of the Executive Council

ROAD TRAFFIC ACT 1958

At the Executive Council Chamber, Melbourne, the eleventh day of November, 1980

PRESENT:

His Excellency the Governor of Victoria  
 Mr Borthwick | Mr Ramsay  
 Mr Austin | Mr Lieberman

In pursuance of the powers conferred by the Road Traffic Act 1958, His Excellency the Governor of the State of Victoria, in the Commonwealth of Australia, by and with the advice of the Executive Council of the said State, and at the request in writing of the Council of the Shire of Flinders, doth by this Order extend the provisions of the said Act to the lands under the control of the Shire of Flinders shown by shading on the plans hereunder.

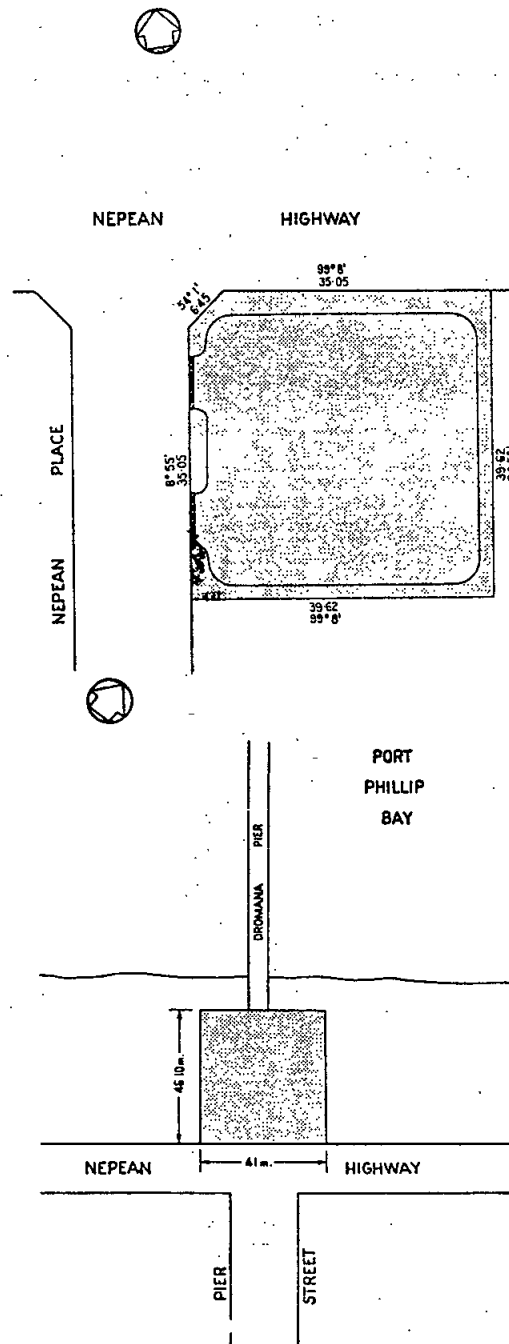

NOTE: AREA TO BE COVERED BY THE PROVISIONS OF THE ROAD TRAFFIC ACT 1958 SHOWN SHADED.

And the Honourable Lindsay Hamilton Simpson Thompson, Her Majesty's Minister for Police and Emergency Services for the State of Victoria, shall give the necessary directions herein accordingly.

TOM FORRISTAL  
 Clerk of the Executive Council

**RAILWAY CONSTRUCTION AND PROPERTY BOARD  
ACT 1979**

At the Executive Council Chamber, Melbourne, the  
eleventh day of November, 1980

PRESENT:

His Excellency the Governor of Victoria	
Mr Borthwick	Mr Ramsay
Mr Austin	Mr Lieberman

**DEVELOPMENT OF RAILWAY LAND**

Whereas it is provided by section 20 (7) of the *Railway Construction and Property Board Act 1979* that where the Governor in Council has approved (whether with or without variations) recommendations of the Board for the use or development of any land and where the approval relates to the use or development, otherwise than for the carrying out of the functions of the Victorian Railways Board under the *Railways Act 1958*, of land vested in the Victorian Railways Board, the Governor in Council may make an order vesting that land in the Railway Construction and Property Board.

And whereas a recommendation of the Railway Construction and Property Board with respect to the use or development of certain lands, known as Railway lots 11 and 39 at Colac, vested in the Victorian Railways Board was approved on 19 August 1980 and published in the *Government Gazette* on 27 August 1980.

Now therefore, His Excellency the Governor of the State of Victoria, by and with the advice of the Executive Council thereof, doth hereby vest in the Railway Construction and Property Board the lands comprising 2.442 hectares being the land in the Township and Parish of Colac as indicated by hatching on the plan hereunder.

**VESTING PLAN  
RAILWAY LOTS 11 & 39 COLAC**

PART OF CROWN ALLOTMENT 157 E  
TOWNSHIP & PARISH OF COLAC  
COUNTY OF POLWARTH.

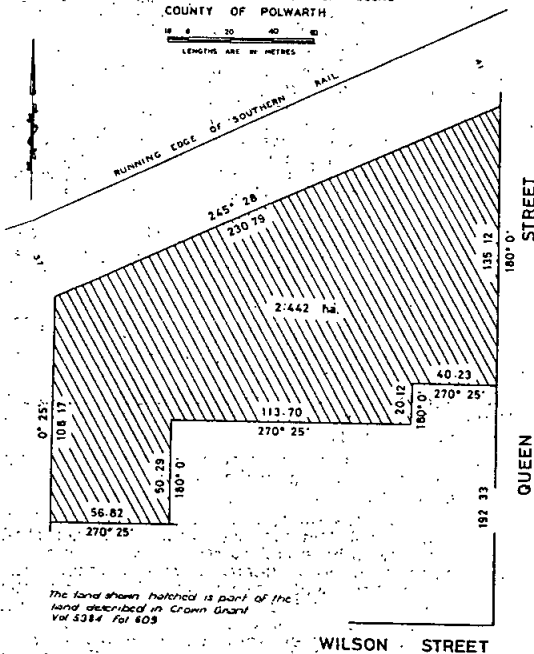

The land shown hatched is part of the land described in Crown Grant Vol 5314 Fol 803

WILSON STREET

And the Honourable Robert Roy Cameron Maclellan, Her Majesty's Minister of Transport for the State of Victoria, shall give the necessary directions herein accordingly.

TOM FORRISTAL  
Clerk of the Executive Council

*Water Act 1958*  
**STATE RIVERS AND WATER SUPPLY COMMISSION**

At the Executive Council Chamber, Melbourne, the  
eleventh day of November, 1980

PRESENT:

His Excellency the Governor of Victoria	
Mr Borthwick	Mr Ramsay
Mr Austin	Mr Lieberman

**STANHOPE URBAN DISTRICT—AREA OF DISTRICT  
INCREASED**

Under the powers conferred by the *Water Act 1958* and all other powers enabling him in that behalf, His Excellency the Governor of the State of Victoria, with the advice of the Executive Council of the said State, on the recommendation of the State Rivers and Water Supply Commission, doth hereby declare, order and direct that the area of the Stanhope Urban District be increased by adding to the same the lands shown by blue colour on a plan approved by the Governor in Council and deposited in the office of the State Rivers and Water Supply Commission at 590 Orrong Road, Armadale (Corr. Nos. 64/2897, 78/2726) and as on and from 1 December 1980, the area of such District shall be deemed to be so increased.

And the Honourable Frederick James Granter, Her Majesty's Minister of Water Supply for the State of Victoria, shall give the necessary directions herein accordingly.

TOM FORRISTAL  
Clerk of the Executive Council

**ROCHESTER WATERWORKS TRUST**

At the Executive Council Chamber, Melbourne, the  
eleventh day of November, 1980

PRESENT:

His Excellency the Governor of Victoria	
Mr Borthwick	Mr Ramsay
Mr Austin	Mr Lieberman

**CONSENT TO BORROWING \$20 000**

Under the powers conferred by the *Water Act* and all other powers enabling him in that behalf, His Excellency the Governor of the State of Victoria, by and with the advice of the Executive Council of the said State, hereby consents to the Rochester Waterworks Trust borrowing the sum of Twenty Thousand Dollars (\$20 000) to meet the cost of water supply works.

And the Honourable Frederick James Granter, Her Majesty's Minister of Water Supply for the State of Victoria, shall give the necessary directions herein accordingly.

TOM FORRISTAL  
Clerk of the Executive Council

**HORSHAM SEWERAGE AUTHORITY**

At the Executive Council Chamber, Melbourne, the  
eleventh day of November, 1980

PRESENT:

His Excellency the Governor of Victoria	
Mr Borthwick	Mr Ramsay
Mr Austin	Mr Lieberman

**CONSENT TO BORROWING \$100 000**

Under the powers conferred by the *Sewerage Districts Act* and all other powers enabling him in that behalf, His Excellency the Governor of the State of Victoria, by and with the advice of the Executive Council of the said



State, hereby consents to the Horsham Sewerage Authority borrowing the sum of One Hundred Thousand Dollars (\$100 000), to meet the cost of sewerage works as set forth in the detailed statement bearing 5 November 1980.

And the Honourable Frederick James Granter, Her Majesty's Minister of Water Supply for the State of Victoria, shall give the necessary directions herein accordingly.

TOM FORRISTAL  
Clerk of the Executive Council

COAL MINES ACT 1958

At the Executive Council Chamber, Melbourne, the  
eleventh day of November, 1980

PRESENT:

His Excellency the Governor of Victoria	
Mr Borthwick	Mr Ramsay
Mr Austin	Mr Lieberman

In pursuance of the powers conferred by the Coal Mines Act 1958, His Excellency the Governor of the State of Victoria, by and with the advice of the Executive Council thereof, doth hereby appoint Kevin Campbell Findlay, nominated by the Victorian Railways Board, and Edwin Harmer, nominated by the body known as the Wonthaggi Retired Mine Workers Pensions Association, to be members of the Coal Mine Workers Pensions Tribunal for a period of one year.

And the Honourable James Charles Murray Balfour, Her Majesty's Minister for Minerals and Energy for the State of Victoria, shall give the necessary directions herein accordingly.

TOM FORRISTAL  
Clerk of the Executive Council

COAL MINES ACT 1958

At the Executive Council Chamber, Melbourne, the  
eleventh day of November, 1980

PRESENT:

His Excellency the Governor of Victoria	
Mr Borthwick	Mr Ramsay
Mr Austin	Mr Lieberman

In pursuance of the powers conferred by the Coal Mines Act 1958, His Excellency the Governor of the State of Victoria, by and with the advice of the Executive Council thereof, doth hereby re-appoint Albert Frederick Cullen a member and Chairman of the Coal Mine Workers Pensions Tribunal for a period of one year.

And the Honourable James Charles Murray Balfour, Her Majesty's Minister for Minerals and Energy for the State of Victoria, shall give the necessary directions herein accordingly.

TOM FORRISTAL  
Clerk of the Executive Council

COAL MINES ACT 1958

At the Executive Council Chamber, Melbourne, the  
eleventh day of November, 1980

PRESENT:

His Excellency the Governor of Victoria	
Mr Borthwick	Mr Ramsay
Mr Austin	Mr Lieberman

CHANGES IN RATES OF PENSIONS PAYABLE UNDER  
PART III. OF COAL MINES ACT 1958

Whereas it is provided in section 110 of the Coal Mines Act 1958 that whenever rates of Commonwealth pensions are increased, rates of pensions payable under Part III. of

the Coal Mines Act 1958 shall be increased and that whenever rates of pensions are increased by the operation of that provision the Governor in Council may, by Order published in the Government Gazette, declare those rates to be the rates payable under the said Part.

And whereas rates of Commonwealth pensions have been increased from 6 November 1980.

Now therefore, I, the Governor of the State of Victoria, by and with the advice of the Executive Council thereof, do by this Order declare the rates of pension shown hereunder to be the rates of pensions payable under the several provisions of the said Part.

\$69.35, section 104.  
\$69.35, section 105.  
\$45.45, paragraphs (a) and (c) of section 106.  
\$10.00, paragraph (b) of section 106.  
\$68.35, sub-sections (1) and (1A) of section 107.

And the Honourable James Charles Murray Balfour, Her Majesty's Minister for Minerals and Energy for the State of Victoria, shall give the necessary directions herein accordingly.

TOM FORRISTAL  
Clerk of the Executive Council

LOCAL GOVERNMENT ACT 1958

At the Executive Council Chamber, Melbourne, the  
eighteenth day of November, 1980

PRESENT:

His Excellency the Governor of Victoria	
Mr Hunt	Mr Smith
Mr Dixon	Mr Wood

ROADS DISCONTINUED—CITY OF FOOTSCRAY

Whereas it is provided in section 528 (2) of the Local Government Act 1958, that where a road (whether or not a public highway but not being a road set out on land of the Crown) or any part thereof is not required for public use, the Governor in Council on the request of the council of the municipality in which such road is situated made not less than one month after publishing in a newspaper generally circulating in the district and posting to the registered proprietor (if any) of the land and the owners and occupiers (if any) of lands abutting or immediately adjacent to the road notice of intention to make such a request may by Order published in the Government Gazette direct that such road or part shall be discontinued accordingly and thereupon such road or part shall be discontinued.

And whereas the Council of the City of Footscray has requested that the Governor in Council direct that Stephenson Street, Footscray and a road off Stephenson Street be discontinued and not less than one month previously has published in a newspaper generally circulating in the district and posted to the registered proprietor of the land in the roads and the owners and occupiers of land abutting or immediately adjacent to the roads notice of intention to make such request.

Now therefore, His Excellency the Governor of the State of Victoria, by and with the advice of the Executive Council thereof, hereby directs:—

- (a) that the said roads which are shown by hatching and cross-hatching on the plan hereunder shall be discontinued;
- (b) that notwithstanding such discontinuance the Melbourne and Metropolitan Board of Works shall continue to have and possess the same right title power authority or interest in or in relation to the whole of the land shown by cross-hatching on the said plan as it had or possessed prior to such discontinuance with respect to or in connection with any drains or pipes laid or erected in or on over such lands for the purposes of drainage or sewerage;
- (c) that, subject to any such right title power authority or interest the land in the said roads may be sold by the Council of the City of Footscray by agreement.

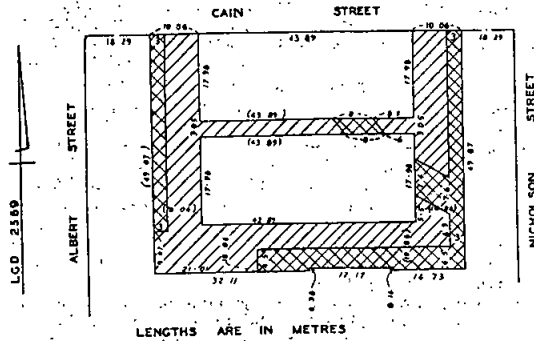

- with any drains or pipes laid or erected in on or over such lands for the purposes of drainage or sewerage;
- (c) that, subject to any such right title power authority or interest the land in the said roads may be sold by the Council of the City of Footscray by agreement.

And the Honourable Digby Glen Crozier, Her Majesty's Minister for Local Government for the State of Victoria, shall give the necessary directions herein accordingly.

TOM FORRISTAL  
Clerk of the Executive Council

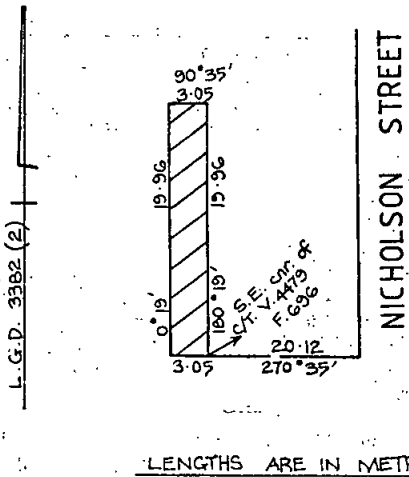

LOCAL GOVERNMENT DEPARTMENT

At the Executive Council Chamber, Melbourne, the eighteenth day of November, 1980

PRESENT:

- His Excellency the Governor of Victoria
- Mr Hunt | Mr Smith  
Mr Dixon | Mr Wood

ROAD DISCONTINUED—CITY OF FOOTSCRAY

Whereas it is provided in section 528 (2) of the Local Government Act 1958, that where a road (whether or not a public highway but not being a road set out on land of the Crown) or any part thereof is not required for public use, the Governor in Council on the request of the council of the municipality in which such road is situated made not less than one month after publishing in a newspaper generally circulating in the district and posting to the registered proprietor (if any) of the land and the owners and occupiers (if any) of lands abutting or immediately adjacent to the road notice of intention to make such a request may by Order published in the Government Gazette direct that such road or part shall be discontinued and thereupon such road or part shall be discontinued accordingly.

And whereas the Council of the City of Footscray has requested that the Governor in Council direct that School and Cain Streets, Footscray and roads off these two streets be discontinued and not less than one month previously has published in a newspaper generally circulating in the district and posted to the registered proprietor of the land in the roads and to the owners and occupiers of the lands abutting or immediately adjacent to the roads notice of intention to make such a request.

Now therefore, His Excellency the Governor of the State of Victoria, by and with the advice of the Executive Council thereof, hereby directs:—

- (a) that the said roads which are shown by hatching and cross-hatching on the plans hereunder, shall be discontinued;
- (b) that notwithstanding such discontinuance the Melbourne and Metropolitan Board of Works shall continue to have and possess the same right title power authority or interest in or in relation to the whole of the land shown by cross-hatching on the said plan as it had or possessed prior to such discontinuance with respect to or in connection

BUCKLEY STREET

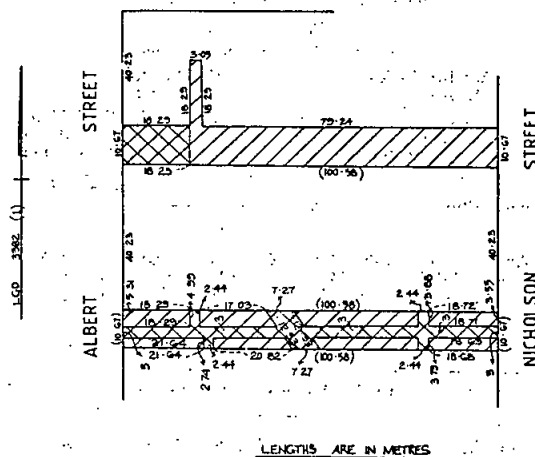

And the Honourable Digby Glen Crozier, Her Majesty's Minister for Local Government for the State of Victoria, shall give the necessary directions herein accordingly.

TOM FORRISTAL  
Clerk of the Executive Council



MERRI—Electrical services—Upgrade of existing building, Primary School.

MERRI—Mechanical services—Upgrade of existing building, Primary School.

MONT PARK—Remodelling of Ward F6, Mental Hospital.

#### Miscellaneous

BOX HILL—Supply of laboratory equipment—optical (microscopes and telescope), Technical College T.A.F.E.

EAST MELBOURNE—Supply and installation of curtains, Head Office.

GEELONG—Window cleaning of premises, period 1 December 1980 to 30 November 1982, Court House. (W.O., Geelong.)

VARIOUS (KENSINGTON, KINGSVILLE AND FOOTSCRAY)—Maintenance cleaning, period 1 January 1981 to 31 October 1984, Dental Therapy Units.

YALLOURN—Supply and delivery of welding equipment, Technical College T.A.F.E.

YALLOURN—Supply and delivery of metalwork machinery Part 2, Technical College T.A.F.E.

#### Tuesday, 9 December 1980

##### Building, Electrical, Mechanical Works

BALNARRING—Fire service, water supply and drainage, "Coolart" residence. (W.O., Mornington.)

BENDIGO—Fitting out works, Mental Retardation Division. (W.O., Bendigo.)

COLAC—Upgrading of food distribution system, Training Centre. (W.O., Geelong.)

ECHUCA—Extensions and internal alterations, Police Station. (W.O., Shepparton and Bendigo.)

GEELONG—Fitting out works, State Electoral Office. (W.O., Geelong.)

HEIDELBERG—Hydraulic services to 10 module relocatable building, Police Station.

KNOXFIELD—Conversion of 5 large cool rooms from ammonia to freon refrigeration, Horticultural Research Institute.

MELBOURNE—Alterations and fitting out works to Health Commission tenancy, Enterprise House.

MELBOURNE—(Readvertisement and amended specification)—Supply and installation of heating for dining room, Cadet Academy.

MORWELL RIVER—Electrical installation, Reforestation Prison. (W.O., Traralgon.)

NOBLE PARK—Supply and delivery of relocatable buildings, F.O.G. Port Melbourne store, Technical College T.A.F.E. (W.O., Geelong, Ballarat, Bendigo, Benalla and Traralgon.)

PARKVILLE—Building alterations "Warrawong", Baltara Reception Centre.

SUNBURY—Construction of E.C.A. Centre, High School.

TALLANGATTA—Alterations and additions, exterior and interior repairs and painting, Police Residence. (W.O. Wangaratta.)

VARIOUS—Supply, install and commission two-way radios, stage IV, various prisons.

WHITTINGTON, GEELONG—Automatic watering system, Primary School No. 5188. (W.O., Geelong.)

##### Site Works

ELTHAM—Siteworks—construction of playing area, Montmorency High School.

##### Miscellaneous

ASCOT VALE—Maintenance cleaning—period 1 December 1980 to 30 November 1983, Crime Car Squad.

BROADMEADOWS—Maintenance Cleaning—period 1 January 1981 to 31 December 1983, Court House.

KYNETON—Maintenance cleaning—period 1 January 1981 to 31 December 1983, Police Station. (W.O. Kyneton.)

NORTHCOTE—Maintenance cleaning—period 22 December 1980 to 31 December 1983, Court House.

STONY POINT—Supply of mobile crane, Stony Point Port Depot.

VARIOUS—Manufacture and deliver manual jetty cranes, Ports and Harbors.

YALLOURN—Supply, delivery and place in position kitchen equipment for the cafeteria, Technical College.

TOM AUSTIN  
Minister of Public Works

Public Works Department  
Melbourne, 18 November 1980

#### Teaching Service Act 1958

#### TEACHING SERVICE (TEACHERS TRIBUNAL) REGULATIONS

#### AMENDMENT No. 527 (T.T. 91)

The Teachers Tribunal, in pursuance of the powers conferred by the Teaching Service Act 1958, hereby amends Regulation 3 of the Teaching Service (Teachers Tribunal) Regulations as follows:—

#### Regulation 3

After sub-clause 13(b) insert the following sub-clause:—

"(ba) The Tribunal, after consideration of any relevant report from the Director-General, may transfer a professional officer to a classified position in the Primary Schools Division or the Secondary Schools Division or the Technical Schools Division on the completion of his term of appointment as a Curriculum Officer, Grade-V (Special Projects) on such terms and conditions as may be determined".

J. J. KENNEDY, Chairman  
L. D. KEEN, Acting Secretary

Office of the Teachers Tribunal  
Melbourne, 6 November 1980

Teaching Service Act 1958

TEACHING SERVICE—PROFESSIONAL (CLASSIFICATION, SALARIES, AND ALLOWANCES) REGULATION

AMENDMENT No. 526 (PROF. C.S. & A.2)

The Teachers Tribunal, in pursuance of the powers conferred by the Teaching Service Act 1958, hereby amends the Teaching Service—Professional (Classification, Salaries, and Allowances) Regulation as follows:—

1. In clause 4 delete the following expressions:—

“Curriculum and Research Officer; Supervisor of Physical Education;”, “Assistant Supervisor of Physical Education; Curriculum Officer, Grade I;”, “Supervisor of Art (Primary Schools); Supervisor of Music; Supervisor of School Camps; Supervisor of School Forestry;”, “Curriculum Officer, Grade II; Design-Research Officer; Music Officer;”, “Curriculum Officer . . . \$21 967”, and “Curriculum Officer . . . \$20 764”.

2. After sub-clause 5 (b) insert the following sub-clause:—

“(ba) Curriculum Services Unit

Curriculum Officer, Grade I  
Subdivisions

1	2	3
\$	\$	\$
27 286	28 346	29 330

Curriculum Officer, Grade II  
Subdivisions

1	2
\$	\$
25 420	26 225

Curriculum Officer, Grade III  
Subdivisions

1	2	3
\$	\$	\$
23 420	24 147	24 878

Curriculum Officer, Grade IV  
Subdivisions

1	2
\$	\$
22 113	22 759

Curriculum Officer, Grade V  
Subdivisions

\$	\$	\$	\$	\$
1	2	3	4	5
14 716	15 202	15 874	16 508	17 145
6	7	8	9	10
\$	\$	\$	\$	\$
17 968	18 788	19 572	20 507	21 309

(To take effect from and including 6 November 1980)

J. J. KENNEDY, Chairman  
L. D. KEEN, Acting Secretary

Office of the Teachers Tribunal  
Melbourne, 6 November 1980

**PRIVATE  
ADVERTISEMENTS**

**CITY OF BERWICK  
LOAN No. 58**

*Notice of Intention to Borrow the Sum of \$125 000 for  
Permanent Works and Undertakings*

Notice is hereby given that the Council of the City of Berwick proposes to borrow the principal sum of \$125 000 secured by a charge over the general rates of the municipality, such sum to be raised by the grant of a mortgage in accordance with the provisions of the *Local Government Act 1958*.

1. No interest shall be payable on the loan.
2. The purpose for which the loan is to be applied:  
Construction of Berwick Leisure Centre (Part)—  
\$125 000.
3. The period of the loan shall be five years.
4. The moneys borrowed shall be repayable by providing out of the Municipal Fund five annual instalments of \$25 000. The first instalment shall be payable on 1 February 1982.
5. Such moneys shall be repayable to the office of the Department of Youth, Sport and Recreation, 570 Bourke Street, Melbourne, or such other place or places as the Department from time to time may require.

The plans and specifications and the estimate of the cost of the proposed works and a statement showing the proposed expenditure of the moneys to be borrowed are open for inspection at the office of the Council of the City of Berwick, Civic Centre, Princes Highway, Fountain Gate, Narre Warren.

Dated 12 November 1980

11113 P. J. NORTHEAST, City Manager/Town Clerk

**CITY OF BRUNSWICK  
LOAN No. 115**

*Notice of Intention to Borrow the Sum of \$200 000 for  
Permanent Works and Undertakings*

Notice is hereby given that the Council of the City of Brunswick proposes to borrow the principal sum of \$200 000 secured by a charge over the general rates of the municipality, such sum to be raised by the grant of a mortgage in accordance with the provisions of the *Local Government Act 1958*.

1. The maximum rate of interest that may be paid is 12.6 per cent. per annum.
2. The purpose for which the loan is to be applied is:

	\$
(a) Melville Road Reconstruction— Victoria Street to Moreland Road (part cost)	70 000
(b) Grantham Street Reconstruction— Brunswick Road to Dawson Street (part cost)	60 000
(c) Recreation Land Improvements—	
Fraser Reserve	12 000
Brunswick Park Water Service	7 000
Heller Street Water Service	3 000
A. Fisher Reserve Water Service	3 000
Hudson Reserve Water Service	3 000
Fleming Park	2 000
Temple Park	7 000
Balfe Park	4 000
Allard Park	5 000
Holbrook Reserve	4 000
(d) Swimming Pool—Heaf Exchanger	20 000

3. The period of the loan shall be 10 years.
4. The loan shall be repaid by the creation of a sinking fund and an amount of \$15 173.59 being set aside annually out of the municipal fund for such purpose as determined by the State Auditor General.

5. Such moneys shall be repayable to State Insurance, 480 Collins Street, Melbourne.

The plans and specifications and the estimate of the cost of the proposed works and a statement showing the proposed expenditure of the moneys to be borrowed are open for inspection at the office of the Council of the City of Brunswick, at 233 Sydney Road, Brunswick.

11105

K. D. WILSON, Town Clerk

**CITY OF CAULFIELD  
LOAN No. 90**

*Notice of Intention to Borrow the Sum of \$100 000 for  
Permanent Works and Undertakings*

Notice is hereby given that the Council of the City of Caulfield proposes to borrow the sum of \$100 000 secured by a charge over the general rates of the municipality, such sum to be raised by the grant of a mortgage in accordance with the provisions of the *Local Government Act 1958*.

In connection therewith, the following information is stated:

- (a) The amount of principal monies it is proposed to borrow is \$100 000.
- (b) The maximum rate of interest that may be paid is 13.0 per cent. per annum.
- (c) The days on which the monies borrowed are to be repayable are 22 June and December during the years 1981 to 1985 inclusive, the first payment being on 22 June 1981, and the place at which the monies are to be repayable is the Royal Southern Memorial Hospital, 270 Kooyong Road, Caulfield 3162.
- (d) The purposes for which the loan is to be applied are:

	\$
(1) Refurbishing the Councillors Suite at City Hall	12 000
(2) Video Taping Facilities	10 000
(3) Suite of Flags	2 000
(4) One Motor Vehicle—Administration Section	6 000
(5) Office Dictation System	8 000
(6) Public Address System for City Hall	10 000
(7) Chess Set—Harleston Park	3 320
(8) Caulfield Park Centre Playground	1 600
(9) Lord Park Cricket Practice Wickets	2 300
(10) Packer Park Cricket Practice Wickets	1 500
(11) Resurface Packer Park Pavilion Roof	330
(12) Hit-up Wall in Packer Park	1 000
(13) Beautification—Rosanna Street Reserve	2 800
(14) Development—Elsternwick Station Reserve	20 000
(15) Provision of Drinking Fountains	2 000
(16) Traffic Counting Equipment	3 000
(17) Hot Water Service at Caulfield Swimming Pool	3 500
(18) Mobile Radio Units	2 000
(19) Koornang Park Cricket Practice Wickets (part)	450
(20) Provision of Barbeques in Parks	5 000
(21) Provision of Shelter and Seating in Parks (part)	3 200
	100 000

- (e) The manner in which the loan is to be liquidated is by providing out of Municipal Fund, 10 half-yearly instalments of \$13 910.47.

The plans and specifications and estimate of the costs of the works, and an estimate showing the proposed expenditure of the monies to be borrowed are available for inspection at the office of the Council, City Hall, corner Glen Eira and Hawthorn Roads, Caulfield.

11170

G. K. CALDER, City Manager

## CITY OF FOOTSCRAY

LOAN No. 159

*Notice of Intention to Borrow the Sum of \$500 000 for Permanent Works and Undertakings*

Notice is hereby given that the Council of the City of Footscray proposes to borrow the sum of Five hundred thousand dollars (\$500 000) secured by a charge over the general rates of the Municipality, such sum to be raised by the grant of a mortgage in accordance with the provisions of the *Local Government Act 1958*.

1. The maximum rate of interest that may be paid is 12.6 per centum per annum.
2. The period of the loan shall be 10 years.
3. The monies borrowed shall be liquidated by the creation of a sinking fund pursuant to the provisions of section 428A of the *Local Government Act 1958*.
4. Such monies shall be repayable to the State Superannuation Board of Victoria, Melbourne, 3000.
5. The purposes for which the loan is to be applied are:

Construction of Pavilion—Hansen Reserve	\$ 30 000
Purchase of Ring Road properties—Footscray Business District Distributor Road	95 000
Electricity Supply Department—various equipment	125 000
Roads, Streets and Footpaths—construction and reconstruction	250 000
	500 000

The plans and specifications and the estimate of the cost of the proposed works, and a statement showing the proposed expenditure of the monies to be borrowed, are open for inspection at the Town Hall, Footscray.

Dated 12 November 1980

11108

B. J. WARD, Town Clerk

## CITY OF FOOTSCRAY

LOAN No. 160

*Notice of Intention to Borrow the Sum of \$400 000 for Permanent Works and Undertakings*

Notice is hereby given that the Council of the City of Footscray proposes to borrow the sum of Four hundred thousand dollars (\$400 000) secured by a charge over the general rates of the Municipality, such sum to be raised by the grant of a mortgage in accordance with the provisions of the *Local Government Act 1958*.

1. The maximum rate of interest that may be paid is 12.6 per centum per annum.
2. The period of the loan shall be ten years.
3. The loan is to be liquidated by providing out of the municipal fund nineteen equal consecutive half-yearly instalments of \$29 998.45 including principal and interest, payable on 1 July and 1 January in each year during the currency of the loan, with a final instalment of \$247 685.07 at the end of 10 years. The first instalment shall be payable on 1 July 1981.
4. Such monies shall be repayable at the office of the Commonwealth Savings Bank of Australia, Melbourne.
5. The purposes for which the loan is to be applied are:

Footscray Park—Reticulation	\$ 25 000
Contribution to Country Roads Board Works	100 000
Electricity Supply Department—various equipment	100 000
Roads, Streets and Footpaths—construction and reconstruction	175 000
	400 000

The plans and specifications, the estimate of the cost of the proposed works and a statement showing the proposed expenditure of the monies to be borrowed are open for inspection at the Town Hall, Footscray.

Dated at Footscray, 12 November 1980

11109

B. J. WARD, Town Clerk

## CITY OF MOE

LOAN No. 87

*Notice of Intention to Borrow \$25 000 for Permanent Works and Undertakings*

Notice is hereby given that the City of Moe intends to borrow \$25 000 and that this amount will be raised upon the execution of an Agreement with the Housing Commission, Victoria.

The loan period will be three years and the maximum rate of interest payable is 5 per cent per annum.

The loan proceeds will be expended on the purchase of land to enable the construction of elderly person units.

The amount borrowed will be repaid to the Housing Commission, Victoria by three annual instalments of principal with interest calculated on the unpaid balance. The first instalment of \$9583.33 will be due on about 2 February 1982 and the remaining instalments of \$9 166.66 and \$8750.01 will be due on about 2 February 1983 and 1984 respectively.

Any further information, including details of the cost and proposed expenditure can be obtained from the City Offices, Albert Street, Moe.

11107

R. J. PUGSLEY, Town Clerk

## CITY OF MORDIALLOC

LOAN No. 104

*Notice of Intention to Borrow the Sum of \$175 000 for Permanent Works and Undertakings*

Notice is hereby given that the Council of the City of Mordialloc proposes to borrow the principal sum of One Hundred and Seventy-Five Thousand Dollars (\$175 000) secured by a charge over the general rates in the Municipality, such sum to be raised by the grant of a mortgage in accordance with the provisions of the *Local Government Act 1958* (as amended).

1. The maximum rate of interest that may be paid is 12.6 per centum per annum.
2. The purpose for which the loan is to be supplied is:

	\$
Purchase of properties	40 000
Reconstruction of Roads and Channels	74 000
Footbridge over Mordialloc creek	26 000
Drain extensions—Foreshire Parkdale	15 000
CRB Works 1980-81	20 000
	175 000

3. The period of the loan shall be ten years.

4. The moneys borrowed shall be repayable by providing out of the municipal fund twenty half-yearly instalments of approximately \$15 630.96 each including principal and interest on 16 December and 16 June during the currency of the loan. The first instalment shall be repayable on 16 June 1981.

5. Such moneys shall be repayable to the Australia and New Zealand Savings Bank Ltd., 55 Collins Street, Melbourne.

Plans and specifications and the estimate of the cost of the proposed works and a statement showing the proposed expenditure of the moneys to be borrowed are open for inspection at the Office of the Council of the City of Mordialloc, at the corner of Mentone Parade and Brindisi Street, Mentone, Victoria.

11106

D. H. CORBEN, Town Clerk and City Manager

## CITY OF SOUTH BARWON

LOAN No. 123

Notice is hereby given that the Council of the City of South Barwon intends to borrow the principal sum of eight hundred and fifty thousand dollars (\$850 000) secured by a charge over the general rates of the municipality, such sum to be raised by the grant of a mortgage in accordance with the provisions of the *Local Government Act 1958*.

1. The maximum rate of interest that may be paid is 12.6 per centum per annum.

2. The purpose of the loan is for:

	\$	\$
<b>Drainage—</b>		
Kardinia Creek Main Drain	28 000	
Bailey Street Main Drain	80 000	
East Belmont Main Drain	15 000	
Thomson Street/Somers Street	80 000	
Grandview Parade	22 000	
Geelong Road, Torquay	11 000	
Minor Drainage	10 000	
	246 000	
<b>Buildings—</b>		
Highton Recreation Centre	9 000	
Spring Creek Reserve	77 000	
	86 000	
<b>Land Purchase—</b>		
Public Open Space	250 000	
Public Open Space—Improvements	53 000	
<b>Recreation Reserves—Improvements—</b>		
Spring Creek Reserve	18 000	
Other Reserves	25 000	
Playground Equipment	21 000	
	64 000	
<b>Miscellaneous—</b>		
Belmont Shopping Centre Toilet Block	10 000	
<b>Roads and Streets—</b>		
Prospect Avenue—Right of Way	3 000	
Watson Avenue	58 000	
Mornane Road	36 000	
Wimmera Street	10 000	
The Esplanade, Torquay	19 000	
Roberts Road	5 000	
Private Street Construction	10 000	
	141 000	
	850 000	

3. The period of the loan shall be 10 years.
  4. The moneys borrowed shall be repayable by providing out of the Municipal Fund 20 equal half yearly instalments of \$75 921.82 including principal and interest on 29 June and 29 December during the currency of the loan. The first instalment shall be payable on 29 December 1980.
  5. Such money borrowed shall be repayable at the Bank of New South Wales Savings Bank, Belmont.
  6. Plans, specifications and an estimate of the cost of the works and a statement showing the proposed expenditure of moneys to be borrowed are open for inspection at the City Offices, 2 Colac Road, Belmont, during office hours.
- 11110 K. B. McDONALD, Town Clerk

CITY OF WARRNAMBOOL

LOAN No. 147

Notice of Intention to Borrow the Sum of \$300 000  
 Notice is given that the Council of the City of Warrnambool proposes to borrow the principal sum of Three Hundred Thousand Dollars (\$300 000) secured by a charge over the general rates of the Municipality, such sum to be raised by the Grant of a Mortgage in accordance with the provisions of the Local Government Act 1958.

1. That maximum rate of interest which may be paid is 13.2 per cent.
2. The purpose for which the Loan is to be applied is:

	\$
Completion of Friendly Societies Reserve Pavilion (part costs)	80 000
Construction of Facilities for Performing Arts (part cost)	120 000
Construction of Buildings and Installation of Services at Flagstaff Hill Tourist Project Site	100 000
	300 000

3. The period of the Loan shall be Fifteen (15) years.
4. The moneys borrowed shall be repayable by providing out of the Municipal Fund 30 equal amounts of principal and interest payable half yearly of \$23 211.88 with

the first instalment payable on 23 June 1981 and subsequent instalments payable on 23 December and 23 June during the currency of the Loan.

5. Such moneys shall be repayable to the Commercial Banking Company of Sydney Ltd., Liebig Street, Warrnambool.

11166 V. G. ROBSON, Town Clerk

TOWN OF KYABRAM

LOAN No. 45

Notice of Intention to Borrow the Sum of \$30 000.00 for Permanent Works and Undertakings

Notice is hereby given that the Council of the Town of Kyabram proposes to borrow the principal sum of Thirty thousand dollars secured by a charge over the general rates of the municipality, such sum to be raised by the grant of a mortgage in accordance with the provisions of the Local Government Act 1958.

1. The maximum rate of interest that may be paid is 13.2 per cent per annum.
2. The purpose for which the loan is to be applied is as follows:

Purchase and installation of 500 litre per second drainage pump and fittings and associated ancillary equipment—\$30 000.00.

3. The period of the loan shall be 10 years.
4. The moneys borrowed will be repayable by providing out of the municipal fund twenty half-yearly instalments of \$2744.36 each including principal and interest on 10 January and 10 July during the currency of the loan. The first instalment shall be repayable on 10 July 1981.

5. Such moneys, shall be repayable at the Commonwealth Savings Bank, Melbourne.

The plans and specifications and estimate of the proposed works and a statement showing the proposed expenditure of moneys to be borrowed are open for inspection at the Municipal Offices, Kyabram.

Dated 18 November 1980

11171

E. T. CORNISH, Town Clerk

TOWN OF STAWELL

LOAN No. 70

Notice of Intention to borrow the Sum of \$50 000 for Permanent Works and Undertakings

Notice is hereby given that the Council of the Town of Stawell, in pursuance of the powers conferred by the Local Government Act, intends to borrow the sum of \$50 000 secured by a charge over the general rates of the Municipality, such sum to be raised by the grant of a mortgage in accordance with the said Acts and states:

- (a) That the maximum rate of interest that may be paid is 16.6 per cent per annum.
- (b) The period of the loan shall be 10 years, notional term 15 years.
- (c) The purposes for which the loan is to be applied are:

Council's share of Footpath, Kerb and Channel Works—\$50 000.

- (d) The moneys borrowed shall be repayable by providing out of the Municipal Fund nineteen half-yearly instalments of \$3749.80, each including principal and interest, on 1 January and 1 July during the period of the loan and a final instalment of \$30 960. The first instalment shall be payable on 1 July 1981.

(e) The place of repayment will be at the office of the Australia and New Zealand Savings Bank Limited, 148 Main Street, Stawell or at such other place as the Board may require.

Plans and specifications and estimates of such works and undertakings and a statement showing the proposed expenditure of the money to be borrowed are available for inspection at the Town Hall, Main Street, Stawell during office hours.

11205

D. H. HUTTON, Town Clerk



**BOROUGH OF SEBASTOPOL**

**LOAN No. 20**

*Notice of Intention to Borrow the Sum of \$50 000 for Permanent Works and Undertakings*

Notice is hereby given that the Council of the Borough of Sebastopol proposes to borrow the principal sum of fifty thousand dollars (\$50 000), secured by a charge over the general rates of the municipality, such sum to be raised by the grant of a mortgage in accordance with the provisions of the *Local Government Act 1958*.

1. The maximum amount of interest which may be paid is 12.6 per cent per annum.

2. The purpose for which the loan is to be applied is:—

Construction of footpaths in portions of the following streets:—Albert, Bala, Birdwood, Cromwell, Grant, Hertford, Kyle, Morgan, Nelson, Prince, Sayle, Vale, Vickers, Walker and Yarrowee.

Construction of kerb and channel in portions of the following streets:—Albert, Birdwood, Cromwell, Grant, Hertford, Victoria, Walker and Yarrowee.

Construction of underground drainage in the following streets:—Alfred, Grant, Hertford and Yarrowee.

3. The period of the loan shall be ten years.

4. The money borrowed shall be repayable by providing out of the Municipal Fund twenty half-yearly instalments of \$4465.99 including principal and interest on 1 January and 1 July during the currency of the loan. The first instalment shall be repayable on 1 July 1981.

5. Such moneys shall be repayable at the office of the National Bank Savings Bank Ltd., Melbourne.

The plans and specifications and estimate of the cost of the proposed works and a statement showing the proposed expenditure of the moneys to be borrowed are open for inspection at the office of the Council, Town Hall, Sebastopol.

11114

P. B. COOK, Town Clerk

**SHIRE OF BELLARINE**

**LOAN No. 108**

*Notice of Intention to Borrow the Sum of \$100 000 for Permanent Works and Undertakings*

Notice is hereby given that the Council of the Shire of Bellarine proposes to borrow the principal sum of One Hundred Thousand Dollars secured by a charge over the general rates of the municipality, such sum to be raised by the grant of a mortgage in accordance with the provisions of the *Local Government Act 1958*.

1. The maximum rate of interest that may be paid is 13.2 per cent per annum.

2. The purposes for which the loan is to be applied are:

	\$
Reseals of various roads and streets	53 000
Footpath construction—The Terrace, Ocean Grove	6 000
Kerb and channel construction—Fairfax Street (Newcombe to Fenwick Streets), Portarlington	6 000
Kerb and channel construction—The Esplanade (Second to First Avenue), St. Leonards	3 000
Kerb and channel construction—Kensington Road (Darrambal Crescent to School), Leopold	5 000
Capital Improvements Ervin Recreation Reserve, Newcomb	6 000
Capital Improvements Collendina Recreation Reserve	3 000
Development of Wilsons Road Playground Reserve, Newcomb	4 000
Bluewater Lake Improvements, Ocean Grove	1 000
Purchase of Office Equipment—Data Processing	9 000
Office Modifications to General Office, Municipal Office, Drysdale	4 000
	100 000

3. The period of the loan shall be twenty years.

4. The moneys borrowed shall be repayable by providing out of the municipal fund half-yearly instalments of approximately \$7155.04 each including principal and interest on 1 January and 1 July during the currency of the loan. The first instalment shall be payable on 1 July 1981.

5. Such moneys shall be repayable to the National Bank of Australasia Limited, Newcombe Street, Portarlington.

The plans and specifications and the estimate of the cost of the proposed works and a statement showing the proposed expenditure of the moneys to be borrowed are open for inspection at the office of the Council of the Shire of Bellarine, at Drysdale.

14 November 1980

11172

G. L. PEARCE, Shire Secretary

**SHIRE OF BRIGHT**

**LOAN No. 77**

*Notice of Intention to Borrow the Sum of \$103 000 for Permanent Works and Undertakings*

Notice is hereby given that the Council of the Shire of Bright proposes to borrow the principal sum of One Hundred and Three Thousand Dollars secured by a charge over the General Rates of the Municipality, such sum to be raised by the grant of a Mortgage in accordance with the provisions of the *Local Government Act 1958*.

1. The maximum rate of interest that may be paid is 13.2% per annum.

2. The purposes for which the loan is to be applied are:—

	\$
(i) Extension to the Shire Office	20 000
(ii) Extension to the Bright Kindergarten	5 000
(iii) Plant Storage Shed, Bright Depot	7 000
(iv) Fire Plug Installation, Porepunkah	8 000
(v) Purchase of Survey Equipment	2 000
(vi) Preparation of the Ovens Valley Town Planning Scheme	12 000
(vii) Off Street Parking—Nicholson Street, Porepunkah	20 000
(viii) Intersection Service Street/Back Porepunkah Road	1 000
(ix) Kerb and Channel—Delany Avenue	3 000
(x) Off Street Parking—E.C.C. area, Bright	5 000
(xi) Footpath—Mt. Beauty Community Centre	5 000
(xii) Extension to Star Bridge, Bright	5 000
(xiii) Purchase of Office Equipment	10 000

3. The period of the Loan shall be 20 years.

4. The moneys borrowed shall be repayable by providing out of the Municipal Fund 40 half-yearly instalments of \$7369.69 each including principal and interest, on 1 August and 1 February during the currency of the loan. The first instalment shall be payable on 1 August 1981.

5. Such moneys shall be repayable to The Commissioners of the State Savings Bank of Victoria, at the Office of the said Commissioners, 233 Collins Street, Melbourne.

6. The plans and specifications and estimates of the cost of the proposed works and a statement showing the proposed expenditure of the moneys to be borrowed, are open for inspection at the Offices of the Council, Ireling Street, Bright; and at the Offices of the Mt. Beauty Waterworks Trust and Sewerage Authority, Kiewa Crescent, Mt. Beauty.

Dated 13 November 1980

11115

H. J. WILLIAMS, Shire Secretary

**SHIRE OF COLAC**

**LOAN No. 47**

(Re-advertised)

*Notice of Intention to Borrow the Sum of \$45 000 for Permanent Works and Undertakings*

Notice is hereby given that the Council of the Shire of Colac proposes to borrow the principal sum of \$45 000 secured by a charge over the general rates of the municipality, such sum to be raised by the grant of a mortgage in accordance with the provisions of the *Local Government Act 1958*.

1. The maximum rate of interest that may be paid is 12.4 per centum per annum.

2. The purposes for which the loan is to be applied are:

Construct Toilet Blocks—Beeac and Elliminyt	\$ 13 000
Construct Garage—Shire Depot	3 000
Sewerage Connection—Elliminyt Recreation Reserve	5 000
Road Construction—Kennys Lane	12 000
Purchase and Install Radio Equipment for Plant	6 000
Purchase Office Equipment	6 000
	45 000

3. The period of the loan shall be Five Years.

4. The moneys borrowed shall be repayable by providing out of the municipal fund nine half yearly instalments of approximately \$3066.48 each including principal and interest on 30 March and 30 September each year during the currency of the loan and a final instalment of \$44 387.84 which includes principal and interest. The first instalment will be payable on 30 March 1981.

5. Such moneys shall be payable to the C.B.C. Savings Bank Limited, Melbourne.

The plans, specifications and estimates of the cost of the proposed works and a statement showing the proposed expenditure of the moneys to be borrowed, are open for inspection at the Office of the Council of the Shire of Colac, Shire Hall, Murray Street, Colac.

11153 W. J. MAUNSELL, Shire Secretary

SHIRE OF HUNTLY

LOAN No. 46

(Re-advertised)

*Notice of Intention to Borrow the Sum of \$51 000 Secured by a Charge Over the General Rate of the Municipality, Such Sum to be Raised by a Grant of a Mortgage in Accordance with the Local Government Act 1958*

1. The maximum rate of interest that may be paid is 13.0 per centum per annum.

2. The purpose for which the loan is to be applied is Council contribution to C.R.B. Capital Works and Kerb and Channelling Works.

3. The period of the loan shall be nine years.

4. The money shall be repayable by providing out of the Municipal Fund eighteen half yearly instalments of approximately \$4888.59 including principal and interest on 23 December and 23 June during the currency of the loan. The first instalment shall be payable on 23 June 1981.

5. Such money shall be repayable to the C.B.C. Savings Bank Limited Melbourne.

The plans and specifications and an estimate of the cost of the proposed works and a statement showing the proposed expenditure of money are open for inspection at the office of the Council of the Shire of Huntly, Huntly.

11157 J. W. TIPPETT, Shire Secretary

SHIRE OF HUNTLY

LOAN No. 47

(Re-advertised)

*Notice of Intention to Borrow the Sum of \$4500 Secured by a Charge Over the General Rate of the Municipality, Such Sum to be Raised by a Grant of a Mortgage in Accordance with the Local Government Act 1958*

1. The maximum rate of interest that may be paid is 13.0 per centum per annum.

2. The purpose for which the loan is to be applied is implementation of the Strategy Plan and implementation of new I.D.O.

3. The period of the loan shall be nine years.

4. The money shall be repayable by providing out of the Municipal Fund eighteen half yearly instalments of approximately \$431.35 including principal and interest on 23 December and 23 June during the currency of the loan. The first instalment shall be payable on 23 June 1981.

5. Such money shall be repayable to the C.B.C. Savings Bank Limited, Melbourne.

The plans and specifications and an estimate of the cost of the proposed works and a statement showing the proposed expenditure of money are open for inspection at the Office of the Council of the Shire of Huntly, Huntly.

11158 J. W. TIPPETT, Shire Secretary

SHIRE OF HUNTLY

LOAN No. 48

(Re-advertised)

*Notice of Intention to Borrow the Sum of \$7000 Secured by a Charge Over the General Rate of the Municipality, Such Sum to be Raised by a Grant of a Mortgage in Accordance with the Local Government Act 1958*

1. The maximum rate of interest that may be paid is 13.0 per centum per annum.

2. The purpose for which the loan is to be applied is Plant Purchases—one tonne Utility.

3. The period of the loan shall be five years.

4. The money shall be repayable by providing out of the Municipal Fund ten half yearly instalments of approximately \$973.73 including principal and interest on 23 December and 23 June during the currency of the loan. The first instalment shall be payable on 23 June 1981.

5. Such money shall be repayable to the C.B.C. Savings Bank Limited, Melbourne.

The plans and specifications and an estimate of the cost of the proposed works and a statement showing the proposed expenditure of money are open for inspection at the office of the Council of the Shire of Huntly, Huntly.

11159 J. W. TIPPETT, Shire Secretary

SHIRE OF MAFFRA

DECLARATION OF PUBLIC HIGHWAY

Pursuant to the powers conferred by section 522 of the Local Government Act 1958 the Council of the Shire of Maffra hereby directs that the land in the Parish of Coongulla shown hatched on the plan hereunder which has been purchased or acquired by it shall be a public highway from and after the date of publication of this Order in the Government Gazette.

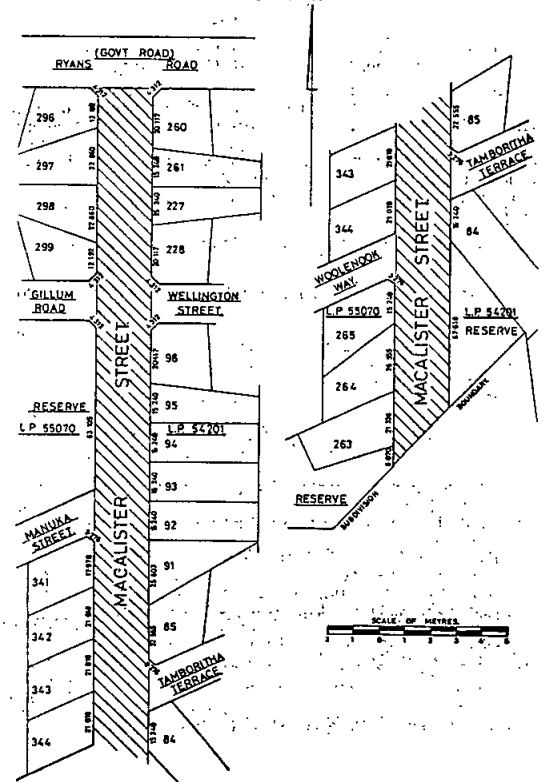

The common seal of the President, Councillors and Ratepayers of the Shire of Maffra was hereunto affixed this 11 November 1980, in the presence of—

(SEAL) A. R. REYNOLDS, President  
H. M. ROWLEY, Councillor  
J. RENNICK, Secretary

11102

SHIRE OF MELTON

The streets described hereunder have been renamed by the Council as shown:

Old Name; New Name; Location

Watson Street; Broga Court; between Oldershaw Road and Swan Street, Melton.

Watson Street; Watson Court; between Swan Street and Robin Street, Melton.

Falcon Drive; Carlew Close; between Robin Street and Scott Street, Melton.

M. B. WATSON  
Shire Secretary/Chief Executive Officer

11174

SHIRE OF MORWELL

DECLARATION OF PUBLIC HIGHWAY

Pursuant to the provisions of Section 522 of the Local Government Act the Council of the Shire of Morwell hereby directs that the land in the Parish of Narracan South indicated by hatching on the diagram hereunder, which has been purchased, taken or acquired by it, shall be a public highway on and from the date of publication of this Order in the Government Gazette.

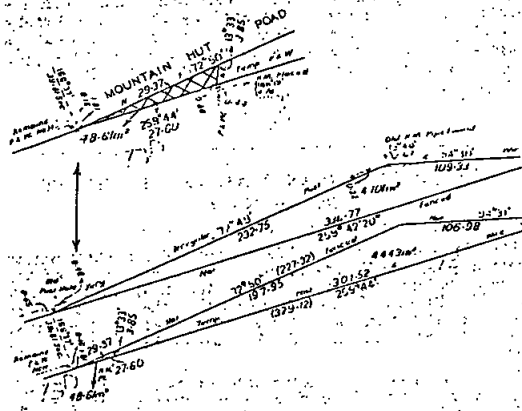

The common seal of the President, Councillors and Ratepayers of the Shire of Morwell was hereunto affixed 6 October 1980—

(SEAL) J. C. VINALL, Shire President  
G. W. DYER, Councillor  
R. H. WATERS, Shire Secretary

11111

SHIRE OF MORWELL

LOAN No. 79

Notice of Intention to Borrow

Notice is hereby given that the Council of the Shire of Morwell intends to borrow the sum of \$355,000 secured by a charge over the general rates of the municipality by the grant of a mortgage in accordance with the provisions of the Local Government Act 1958 as amended.

The conditions of the loan are as follows:

1. The maximum rate of interest that may be paid is 13.2 per cent per annum.

2. The purpose for which the loan is to be applied is:

Contribution	Latrobe Valley Fund	Works	\$
Elderly Citizens Centre			100 000
Churchill Leisure Centre			45 000
Off Street Parking			110 000
Kerb & Channel Works			50 000
			50 000
			355 000

3. The period of the loan shall be for twenty (20) years.
4. The monies borrowed shall be repayable by providing out of the municipal fund forty (40) half-yearly instalments of \$25,400.90 each including principal and interest due on 15 February and 15 August during the currency of the loan. The first instalment shall be payable on 15 August 1981.
5. Such monies shall be repayable to the National Bank of Australasia Limited, Melbourne, 3000.
6. An estimate of the cost of the proposed works is available for inspection at the Council Chambers, Morwell, during office hours.

Dated 19 November 1980

11173

R. H. WATERS, Shire Secretary

SHIRE OF NATHALIA

LOAN No. 60

Notice of Intention to Borrow the Sum of \$50,000 for Permanent Works and Undertakings

Notice is hereby given that the Council of the Shire of Nathalia proposes to borrow the principal sum of Fifty Thousand Dollars secured by the charge over the general rates of the municipality such sum to be raised by the grant of a mortgage in accordance with the provisions of the Local Government Act 1958.

1. The maximum rate of interest that may be paid is 13.2 per cent per annum.
2. The purpose for which the loan is to be applied is:

Council's proportion of various C.R.B. allocations—

	\$	\$
(a) Construction and ancillary works on Elrington's Bridge		6 000
(b) Construction reconstruction and sealing on Shepparton Barmah, Echuca Nathalia and Nathalia Katamatite roads		9 900
(c) Construction reconstruction sealing of unclassified roads—		
Nathalia-Barmah Road	6 000	
Katunga-Picola	2 800	
Nathalia-Waaia	3 000	
Leafs	4 300	
Walsh's Bridge South	2 500	
		18 600
(d) Resealing etc. various unclassified roads		15 500
		50 000

3. The period of the loan shall be 10 years.
4. The moneys borrowed shall be repayable by providing out of the municipal fund half-yearly instalments of approximately \$4,573.93 each including principal and interest on 3 September and 3 March during the currency of the loan. The first instalment shall be payable on 3 September 1981.

5. Such moneys shall be repayable to the Australia and New Zealand Savings Bank Limited at the office of the said Bank, Blake Street, Nathalia.

The plans and specifications and the estimate of the cost of the proposed works and a statement showing the proposed expenditure of the moneys to be borrowed are open for inspection at the office of the Council of the Shire of Nathalia, at Blake Street, Nathalia.

Dated 17 November 1980

11169

J. K. DANCOCKS, Shire Secretary

Town and Country Planning Act 1961  
**SHIRE OF RODNEY—SHIRE OF RODNEY INTERIM  
 DEVELOPMENT ORDER**  
 NOTICE OF A PROPOSED AMENDMENT TO THE SHIRE OF RODNEY  
 INTERIM DEVELOPMENT ORDER

Notice is hereby given that the Minister has required that the Shire of Rodney give notice of and deposit for inspection by the public for a period of one month, a proposed amendment to the Shire of Rodney Interim Development Order to introduce a new "Rural B1" zoning over part of Crown Allotment 47, Parish of Toolamba West to enable the establishment of racing stables on the subject land.

The proposed amendment is available for inspection at the office of the Shire of Rodney, Casey Street, Tatura and at the office of the Town and Country Planning Board, 235 Queen Street, Melbourne, and will be open for inspection during office hours, free of charge.

Any persons affected by the proposed amendment may advise the Minister, in writing, of their objections thereto and such advice must reach the Minister on or before 19 December 1980.

Dated 19 November 1980

11206

JOHN L. PURDEY, Shire Secretary

**SHIRE OF WINCHELSEA**

ORDERS PURSUANT TO THE DOG ACT 1970

*Specification of Shopping Area and Beaches within the  
 Shire of Winchelsea and Township of Lorne*

In pursuance of the powers conferred by Section 16 of the Dog Act 1970 and all other powers thereunto enabling the Council of the Shire of Winchelsea hereby orders—

- (i) that the area specified in Schedule 1 hereto shall be a shopping area for the purpose of the said Section;
- (ii) that the area specified in Schedule 2 hereto shall be a beach specified for the purposes of the said Section upon which dogs are not permitted between the hours of 8.00 a.m. and 8.00 p.m. each day during the period from 1 December and 1 May next ensuing;
- (iii) that the area specified in Schedule 3 hereto shall be a beach specified for the purposes of the said Section upon which dogs are not permitted during the period from 1 December and 1 May next ensuing (both days inclusive).

**SCHEDULE 1**

*Shopping Area*

All that area lying between the building lines (real or imaginary) of Mountjoy Parade between a point commencing at the prolongation of the north-western building line of Bay Street across Mountjoy Parade and the south-western building line of Otway Street prolonged across Mountjoy Parade.

**SCHEDULE 2**

*Beach*

All that area of beach bounded on the north by Stony Creek and on the south by the prolongation of the southern building line of Grove Road to the low water mark of the beach.

**SCHEDULE 3**

*Beach*

All that area of beach bounded on the north by the prolongation of the southern building line of Grove Road to the low water mark of the beach and on the south by the prolongation of the eastern building line of Beal Street to the low water mark of the beach.

(c) Publish the aforesaid Orders in the *Government Gazette* and in the Public Notices Section of the Geelong Advertiser and the Lorne News newspaper.

(d) Post any Notices necessary to notify the public of the restrictions imposed by this Order.

In witness whereof the common seal of the Municipality of the Shire of Winchelsea was affixed hereto 12 November 1980—

(SEAL) L. A. HINTON, President  
 E. D. BEAUREPAIRE, Councillor  
 W. K. MATHISON, Shire Secretary

11167

**HAMILTON WATERWORKS TRUST**

By Law No. 99

Be advised that the Hamilton Waterworks Trust has confirmed and sealed By Law No. 99 being a By Law entitled as "Restricting the use of Water in the Hamilton Waterworks District". The By Law proposes six progressively restrictive stages in the supply of water to consumers which may be invoked by the Hamilton Waterworks Trust. A copy of the said By Law is open for inspection free of charge during office hours at the office of the Trust.

Civic Centre, Brown Street, Hamilton, 3300

11112

R. J. WORLAND, Secretary

Water Act 1958

**ROCHESTER WATERWORKS TRUST**

Notice to the Owners of Tenements in the under-mentioned Streets in the Rochester Waterworks Trust Urban District and the Private Streets, Lanes, Courts, and Alleys opening thereto—

Kerford Street, from Stephen Street to Lowry Street  
 Baynes Street, from Gray Street to Lowry Street  
 Railway Road from Mary Street to Dingee Road  
 High Street from Gray Street to Pascoe Street

The Main Pipe in the said Streets being laid down the Owners of all Tenements situated as above are hereby required on or before 1 January 1981 next to cause a proper Pipe and Stop-Cocks to be laid so as to supply water within such Tenements from the Main Pipe.

3 November 1978

11103

C. H. PARSONS, Secretary

**SHEPPARTON URBAN WATERWORKS TRUST**

By-Law No. 4

*Water Restrictions—Urban Districts*

The Shepparton Urban Waterworks Trust (hereinafter referred to as the Trust) in pursuance and exercise of the powers conferred by the Water Act 1958 doth hereby make the By-Law following, restricting the use for other than domestic purposes of water supplied by the Trust within the Shepparton and Shepparton East Urban Districts.

1. This By-Law shall come into operation and in such districts or parts of districts (hereinafter referred to as "The Specified Area") as the Trust from time to time directs by notice published in a newspaper circulating generally within the districts and cease to have operation at such time as the Trust from time to time directs by a notice so published.

2. Subject to the provisions of Clause 3 of this By-Law no person shall, with water supplied by the Trust:

- (a) Water any garden, lawn or other land (other than commercial market gardens, commercial nurseries or land used for the growing of green feed for commercial poultry farms) within the specified area between the hours of 5 p.m. and 10 p.m. each day except by means of a hose held in the hand or by means of a can or other vessel held in the hand.
- (b) Fill, add to or cleanse any private swimming pool within the specified area.

3. No person shall, with water supplied by the Trust water any land comprising sports grounds, golf courses, racecourses, public and club bowling and croquet greens and public and club tennis courts within the specified area by means of fixed sprinklers between the hours of 5 p.m. and 10 p.m. each day.

7.4. Every person who uses or permits or suffers water supplied by the Trust to be used contrary to the provisions of this By-Law shall be guilty of an offence and shall be liable to a penalty not exceeding one hundred dollars.

5. If any person with water supplied by the Trust wrongfully does, or causes or permits to be done anything in contravention of the By-Law, the Trust may (without prejudice to any remedy in respect thereof) close or cut off any of the pipes by or through which water is supplied to him or for his use and may cease to supply him with water as provided by the Water Act 1958.

The foregoing By-Law was made by the Shepparton Urban Waterworks Trust on 14 October 1980, and the common seal of the said Trust was hereunto affixed, in the presence of—

(SEAL) A. W. TAIG, Commissioner  
L. O. COLLODETTI, Commissioner  
ALAN SKILBECK, Acting Secretary

Approved by the Governor in Council, on 28 October 1980—TOM FORRISTAL, Clerk of the Executive Council

11168

## WESTERNPORT WATERWORKS TRUST

Notice to owners of tenements in the under-mentioned streets and private streets, lanes, courts, and alleys opening thereto. The main pipe in the said street being down, the owners of all tenements situated as under are hereby required on or before 1 December 1980 to cause a proper pipe and stop cocks to be laid so as to supply water with such tenements from the main pipe:

Newhaven Urban District

To lot 4 Phillip Island Highway, Surf Beach.

Cowes Urban District

To lot 77 McKenzie Road, Cowes.

Ventnor Urban District

To lot 109 Ophir Avenue.

To lot 21 Lymington Avenue.

11104 C. F. BEASLEY, Secretary

## GEELONG WATERWORKS AND SEWERAGE TRUST

The abovementioned Trust having made provision for carrying off the sewage from each and every property which or any part of which is within the sewerage area hereinafter described doth hereby declare that on or after 1 December 1980 each and every property which or any part of which is within the said sewerage area shall be deemed and taken to be seweraged property within the meaning of the said Geelong Waterworks and Sewerage Act 1958.

SHIRE OF BELLARINE, PARISH OF MOOLAP, COUNTY OF GRANT

Sewerage Area No. 753

Commencing at a point being the south-west corner of the intersection of Portarlington Road and Helms Street, Newcomb—the said point being also on the boundary of Sewerage Area No. 450, thence south-easterly across Helms Street and continuing south-easterly along the south side of Portarlington Road to the north-east corner of allotment No. 6, Portarlington Road, thence southerly along the eastern boundary of the said allotment No. 6 to the south-east corner of the said allotment No. 6, thence north-westerly along the southern boundaries of allotments Nos. 6 to 4 inclusive Portarlington Road and allotment No. 1 Helms Street and crossing Helms Street to the boundary of Sewerage Area No. 450, thence northerly following the boundary of Sewerage Area No. 450 and crossing Sally Court to the point of commencement.

SHIRE OF CORIO, PARISH OF MOORFANYAL, COUNTY OF GRANT

Sewerage Area No. 754

Commencing at a point being the south-east corner of the intersection of Goldsworthy Road and Cobham Court, Corio—the said point being also on the boundary of Sewerage Area No. 647, thence easterly along the south side of Goldsworthy Road and crossing Appleton Road to

the south east corner of the intersection of Goldsworthy and Appleton Roads, which is also on the boundary of Sewerage Area No. 641, thence southerly, westerly and northerly following the boundaries of Sewerage Areas Nos. 641, 591 and 647 and crossing Appleton Road to the point of commencement.

SHIRE OF BELLARINE, PARISH OF MOOLAP, COUNTY OF GRANT

Sewerage Area No. 755

Commencing at a point being the north-west corner of the intersection of Coppards and Aldershot Roads, Whittington—thence westerly across Municipal Purposes Reserve and continuing westerly along the north side of Aldershot Road and crossing West End Crescent to the south-west corner of allotment No. 1 Aldershot Road, thence northerly along the western boundary of the said allotment No. 1 and continuing northerly along the western boundaries of allotments Nos. 4 to 10 inclusive East End Crescent and crossing Wandle Grove to the north-west corner of the said allotment No. 10, thence easterly along the northern boundary of the said allotment No. 10 and northern boundaries of allotments Nos. 11 to 23 inclusive East End Crescent and crossing Trenton Parade and Municipal Purposes Reserve to the west side of Coppards Road, then southerly along the west side of Coppards Road to the point of commencement.

Signed under seal of the Geelong Waterworks and Sewerage Trust 12 November 1980—

(SEAL) R. W. WHITESIDE, Chairman  
L. C. SPITTY, Secretary

11131

SHIRE OF MANSFIELD SEWERAGE AUTHORITY—  
BONNIE DOON SEWERAGE DISTRICT

COMPULSORY ACQUISITION OF LAND

The Authority proposes to compulsorily acquire the freehold of land:—

- (a) being the site of maturation and emergency storage ponds for the holding of effluent, and effluent pumping station and associated pipelines and irrigation disposal works;
- (b) shown on plans available for inspection at the Authority's Office, 46 High Street, Mansfield, during normal office hours; and
- (c) comprising approximately 18.82 hectares in area being part of Crown Allotments 21 and 22 Parish of Brankeet, Counties of Anglesey and Delatite.

11152

G. D. PAYNE, Secretary

NOTICE OF APPLICATION FOR A LICENCE TO DIVERT  
WATER FROM THE KING RIVER AT CHESHUNT TO  
ALLOTMENT 3A AND PART 5A, SECTION 1, PARISH  
OF WABONGA

I hereby give notice of an application for a licence empowering me to divert water for a term of 15 years to the extent of 30 megalitres per annum at a maximum rate of 1.5 megalitres per day of 24 hours for the irrigation of 6.6 ha and to occupy certain Crown Lands for diversion works:

Any objection to the granting of this application must be forwarded in writing to reach the State Rivers and Water Supply Commission, 590 Orrong Road, Armadale, 3143, before 19 November 1980, being thirty days from the publication of this notice.

CARL FRANCIS PETERSEN

Box 33, Cheshunt, 3678

11129

## THE PARTNERSHIP ACT 1958

Notice is hereby given that the partnership heretofore subsisting between Jessie Mason King of 4 Cardiff Close, Rosanna in the State of Victoria and Irene Catherine Lewis of 14 Cooina Crescent, Watsonia in the said State pursuant to the Partnership Agreement dated 24 May 1978 and carrying on business of retail sale of wool, haberdashery, babywear, handicrafts, scarves and handkerchiefs in partnership under the firm name of "Burgundy Wool and Babywear" at Shop 3 Burgundy Plaza 101 Burgundy Street, Heidelberg in the said State has been dissolved as and from 23 October 1980. Jessie Mason King will carry on the above business on her own account from that date.

11118

## NOTICE OF DISSOLUTION OF PARTNERSHIP

Take note that the Partnership between Elizabeth Joy Mitchell and Anthony Barclay Thomas Mitchell—Trading as "Cookies Tuck Shop" at 23 Fulton Street, Huntingdale was on 12 November 1980 dissolved

11117

In the Supreme Court of Victoria—1980 No. Co. 11642—  
In the matter of the Companies Act 1961; and in the matter of COMBINED FOOD SERVICES PTY. LTD.

Notice is hereby given that a petition for the winding up of the abovenamed company by the Supreme Court was on 6 November 1980, presented by Garry James Sebo, Commissioner of Pay-Roll Tax, and that the said petition is directed to be heard before the Court sitting at the Fifteenth Court, Law Courts, Lonsdale Street, Melbourne at the hour of 10.30 o'clock in the forenoon on 11 December 1980, and any creditor or contributory of the said company desiring to support or oppose the making of an order on the said petition may appear at the time of hearing by himself or his counsel for the purpose; and a copy of the said petition will be furnished to any creditor or contributory of the company requiring the same by the undersigned on payment of the regulated charge for the same.

The petitioner's official address is 436 Lonsdale Street, Melbourne.

The petitioner's solicitor is D. Yeaman, Crown Solicitor of 221 Queen Street, Melbourne.

D. YEAMAN

NOTE—Any person who intends to appear on the hearing of the said petition must serve on or send by post to the abovenamed D. Yeaman, notice in writing of his intention so to do. The notice must state the name and address of the person, of, if a firm, the name and address of the firm, and must be signed by the person or firm, or his, or their solicitor (if any), and must be served or, if posted, must be sent by post in sufficient time to reach the abovenamed not later than 4 o'clock in the afternoon of 10 December 1980.

11116

## Companies Act 1961

Companies Regulations, Regulation 54

ALAN BISHOP IMPORTS PTY. LTD. (IN LIQUIDATION)

Take notice that the Liquidator of the abovenamed company has fixed Thursday 4 December 1980 as the day on or before which creditors of the company are to prove their debts or claims and to establish any title they may have to priority under section 292 of the Act or be excluded from the benefit of an interim distribution made before such debts are proved or otherwise from objecting to such distribution.

Dated 7 November 1980

M. A. COPPINS AND J. B. HUTCHINS, Joint and Several Liquidators.

Pannell Kerr Forster, 271 William Street, Melbourne, 3000

11119

## REGENT MOTORS (ALBURY) PTY. LIMITED

At an extraordinary general meeting of the members of the abovenamed company held at 140 Arthur Street, North Sydney on Thursday, 6 November 1980, the resolution set out below was duly passed as a special resolution—

"That—

- (a) the company be wound up voluntarily,
- (b) Mr Paul Thomas Cambage Wenham, Chartered Accountant, be hereby appointed Liquidator for the purpose of winding up the company, and
- (c) following dissolution the books and papers of the company and of the Liquidator be destroyed at the discretion of the Liquidator."

11120

W. F. SIMPSON, Chairman

MUZZIN & BEMDORICCHIO PROPRIETARY LIMITED  
(IN VOLUNTARY LIQUIDATION)

Notice is hereby given that a final meeting in the voluntary liquidation of the abovenamed company will be held at 15 Stroud Street, Balwyn on 4 December 1980 at 8 p.m. to consider the liquidator's final accounts of the voluntary winding up.

11121

G. R. HOWARD, Liquidator

## The Companies Act 1961

FIRST CREMA ESTATES LTD. (IN VOLUNTARY LIQUIDATION)

SECOND CREMA ESTATES LTD. (IN VOLUNTARY LIQUIDATION)

THIRD CREMA ESTATES LTD. (IN VOLUNTARY LIQUIDATION)

FOURTH CREMA ESTATES LTD. (IN VOLUNTARY LIQUIDATION)

FIFTH CREMA ESTATES LTD. (IN VOLUNTARY LIQUIDATION)

## NOTICE OF FINAL MEETING OF MEMBERS

Notice is hereby given that pursuant to section 272 of the Companies Act 1961 a general meeting of the members of the above companies will be held at 2 Martin Street, St. Kilda on 15 December 1980 at 9.00 a.m. for the purpose of laying before the meetings an account showing how the winding up has been conducted and the property of the companies have been disposed of, and giving an explanation of the account.

11122

SAMUEL RICHWOL, Liquidator.

Companies Act 1961—In the matter of WOOLTEX PTY. LTD., 137 Flinders Lane, Melbourne—Notice Re Meeting of Creditors, Pursuant to Section 260

Notice is hereby given that a Meeting of Creditors of the abovenamed Company will be held at 144 Jolimont Road, East Melbourne, on Friday, 5 December 1980 at 11.00 a.m., the Company having convened a Meeting of its Members for the same day for the purpose of considering a Special Resolution that the Company be wound up voluntarily.

Dated 11 November 1980

R. ZABLUD, Director

Bent &amp; Cogle, public accountants, 144 Jolimont Road, East Melbourne, Vic. 3002

11123

## Companies Act 1961

LUGDON HOTEL PROPRIETARY LIMITED (IN VOLUNTARY LIQUIDATION)

Notice is hereby given that the Final Meeting of the Members of Lugdon Hotel Proprietary Limited (in Voluntary Liquidation) will be held at Lot 1, Maroondah Highway, Lilydale on 22 December 1980 at 2.00 p.m. for the purpose of having an account laid before it showing how the winding up of the Company has been conducted and the property of the Company has been disposed of and to pass a resolution to destroy the Company's books and papers pursuant to section 284 (3) (b) of the Companies Act.

Dated 11 November 1980

11124

J. A. DOBRIGH, Liquidator

## Companies Act 1961

B. B. &amp; J. W. INVESTMENT PTY. LTD.

NOTICE OF FINAL MEETING OF MEMBERS

Notice is hereby given that pursuant to section 272 of the Companies Act 1961 the final meeting of members of the Company will be held at the offices of Messrs Darvas Hodson Stainmagen, 8 Aberdeen Road, Prahran on Monday, 15 December 1980 at 9.00 a.m. for the purpose of laying before the meeting an account showing how the winding up has been conducted and the property has been disposed of and giving any explanation thereof.

Dated 13 November 1980

11135

J. STAINMAGEN, Liquidator

FEUERSTEIN PTY. LIMITED  
BAKER SECURITY SERVICES PTY. LIMITED  
METROPOLITAN NIGHT PATROL SERVICE  
(HOLDINGS) PTY. LIMITED  
WORMALD McCARRON BIRD PTY. LIMITED  
FINAL MEETING OF MEMBERS

Notice is hereby given, in pursuance to section 272 of the Companies Act 1961, that General Meetings of the members of the abovenamed Companies will be held at 35th Floor, 50 Bridge Street, Sydney, N.S.W., on Friday, 12 December 1980, at 10 o'clock in the forenoon, for the purpose of having the liquidator's accounts laid before them showing the manner in which the windings up have been conducted.

Dated 30 October 1980

11136

N. F. STEVENS, Liquidator

LIBRUC (VIC.) PTY. LIMITED  
RILBUK (VIC.) PTY. LIMITED  
KOHET PTY. LIMITED  
FINAL MEETING OF MEMBERS

Notice is hereby given, in pursuance to section 272 of the Companies Act 1961, that General Meetings of the members of the abovenamed Companies will be held at 35th Floor, 50 Bridge Street, Sydney, N.S.W., on Friday, 12 December 1980, at 10 o'clock in the forenoon, for the purpose of having the Liquidator's accounts laid before them showing the manner in which the windings up have been conducted.

Dated 30 October 1980

11137

N. F. STEVENS, Liquidator

Companies Act 1961, Section 272

ALBOURNE PTY. LTD. (IN VOLUNTARY LIQUIDATION)  
NOTICE OF FINAL MEETING

Notice is hereby given that pursuant to section 272 of the Companies Act 1961, the final meeting of the members of the company will be held at the offices of Danby Bland Provan & Co., 339 Punt Road, Richmond, on 22 December 1980 at 10.00 a.m. for the purpose of laying before the meeting an account of the manner in which the winding up has been conducted and the property of the company disposed of, and hearing any explanation thereof.

Dated 12 November 1980

R. W. FRANKLAND, Liquidator

Danby Bland Provan & Co., 339 Punt Road, Richmond  
3121 11138

In the matter of the Companies Act 1961; and in the matter of AQUILLA PLYWOOD & TIMBER SUPPLIES PTY. LTD.—Notice of Appointment of Provisional Liquidator  
Order for the Appointment of an Official Liquidator as Provisional Liquidator made 17 October 1980.

Provisional Liquidator: Warick A. Leeming, of Duesbury, Johnston & Marks, Chartered Accountants, 114 William Street, Melbourne 3000.

Petitioner: Hancock Bros. Pty. Ltd., Dunstons Court, Keon Park, Reservoir.

Petitioner's Solicitor: Paul A. Crisp & Associates, 109 Drummond Street, Carlton 3053. 11139

Companies Act 1961—In the matter of A. E. HUDSON (HOLDINGS) PTY. LTD. (in Voluntary Liquidation)

Notice is hereby given that at an Extraordinary General Meeting of the Members of the above Company held on Monday, 10 November 1980, it was resolved that the Company be wound up voluntarily and that Barry Garnham, Chartered Accountant of 4th Floor, 691 Burke Road, Camberwell, be appointed Liquidator of the Company.

Dated 10 November 1980

11140 BARRY GARNHAM, Liquidator

Companies Act 1961—In the matter of A. E. HUDSON INVESTMENTS PTY. LTD. (in Voluntary Liquidation)

Notice is hereby given that at an Extraordinary General Meeting of the Members of the above Company held on Monday, 10 November 1980, it was resolved that the

Company be wound up voluntarily and that Barry Garnham, Chartered Accountant of 4th Floor, 691 Burke Road, Camberwell, be appointed Liquidator of the Company.

Dated 10 November 1980

11141

BARRY GARNHAM, Liquidator

Form 92

Companies Act 1961, Section 271

Companies Regulations—Regulations 26 (2) (b)

NOTICE OF JOINT MEETING OF CREDITORS AND MEMBERS OF J. F. CLARKE CONSTRUCTIONS PTY. LIMITED (IN LIQUIDATION)

Notice is hereby given that a Joint Meeting of the Creditors and Members of J. F. Clarke Constructions Pty. Limited (in Liquidation) will be held in the Boardroom, 9th Floor, Institute of Chartered Accountants, 140 Queen Street, Melbourne, on Friday, 5 December 1980 at 2.00 p.m.

Agenda

1. To receive a Report on the conduct of the Liquidation to date.
2. To receive and discuss Counsel's opinion on claim against Dillingham Constructions Pty. Limited.
3. Determine whether court action should proceed.
4. To obtain indemnity from the creditors for the cost of any court action.

Dated 13 November 1980

M. J. O'KEEFFE, Liquidator

Messrs O'Keeffe & Deckker, accountants, 66 High Street, Glen Iris, Victoria, 3146 11142

In the Supreme Court of Victoria—In the matter of the Companies Act 1961; and in the matter of W. J. VINE PTY. LTD. (in Liquidation)—Form 92—Companies Act 1961, Sections 232 and 241—Companies Regulations—Regulations 26 (2) (b)—Notice of Meeting of Creditors of W. J. Vine Pty. Ltd. (in Liquidation).

Notice is hereby given that a Meeting of the Creditors of W. J. Vine Pty. Ltd. (in Liquidation), will be held in the Boardroom, 9th Floor, Institute of Chartered Accountants, 140 Queen Street, Melbourne, on Friday, 12 December 1980, at 2.00 p.m.

Agenda

1. To consider whether to appoint a Committee of Inspection, and if thought fit, to consider the persons and number thereof to be appointed.
2. If a Committee of Inspection is not appointed to determine the remuneration of the Liquidator.
3. To receive a Report on the conduct of the Liquidation to date.

Dated 13 November 1980

M. J. O'KEEFFE, Official Liquidator

Messrs O'Keeffe & Deckker, accountants, 66 High Street, Glen Iris, Victoria, 3146 11143

Companies Act 1961

C. H. TUTTON PTY. LTD.

NOTICE CONVENING FINAL MEETING, PURSUANT TO SECTION 272

Notice is hereby given in pursuance of Section 272 of the Companies Act 1961 that a General Meeting of the Company and the Creditors will be held at the office of B. M. Cook, Jones & Co., 1 Yarra Street, South Yarra on Tuesday, 16 December 1980 at 10 o'clock in the forenoon for the purpose of having an account laid before them showing the manner in which the winding up has been conducted and the property of the company has been disposed of and hearing any explanation that may be given by the liquidator.

DAVID W. JONES, Liquidator

B. M. COOK, JONES & CO., chartered accountants, 1 Yarra Street, South Yarra 11154

**TEMPO RECORD SALES PTY. LTD. (IN VOLUNTARY LIQUIDATION)**

Notice is hereby given in pursuance of Section 272 of the Companies Act 1961 that the final meeting of members of the above Company will be held at Kellett, Till & Associates, 382 Middleborough Road, Blackburn on Monday 15 December 1980 at 10 a.m. for the purpose of having an account laid before it, showing the manner in which the winding up has been conducted and to hear any explanation that may be given by the Liquidator.

Dated 14 November 1980

M. J. KELLETT, Liquidator

Kellett, Till & Associates, public accountants, 382 Middleborough Road, Blackburn, 3130 11155

In the Supreme Court of Victoria—1980 No. Co. 11595—  
In the matter of the Companies Act 1961; and in the matter of SIRKAL CONSTRUCTIONS PTY. LTD.—Notice of Winding Up Order

Winding up Order made on 13 November 1980.

Name and address of Liquidator appointed Mr. Warick Allen Leeming of Duesbury Johnston & Marks, 114 William Street, Melbourne.

F. R. E. DAWSON & SON, 114 William Street, Melbourne, solicitors for the petitioner 11156

Companies Act 1961; Section 254 (2) (b)  
**VEALLS INDUSTRIAL LEASING PTY. LTD.  
VEALLS RICHMOND PTY. LTD.**

Notice is hereby given that at Extraordinary General Meetings of the members of the abovenamed companies held on 14 November 1980 it was resolved that each company be wound up voluntarily and that Mr Warick A. Leeming of Duesbury Johnston & Marks, Chartered Accountants, 114 William Street, Melbourne be appointed Liquidator for the purpose of such winding up.

Notice is also given that after 21 days from this date, I shall proceed to distribute the assets. All creditors having any claims against the companies should furnish particulars of same by that date, otherwise I shall proceed to distribute the assets without regard to their claims.

Dated, 14 November 1980

WARICK A. LEEMING, Liquidator

Messrs Duesbury Johnston & Marks, 114 William Street, Melbourne, 3000 11160

Companies Act 1961—In the matter of CHABAIL PTY. LTD.

At an Extraordinary General Meeting of the abovenamed Company, duly convened and held at 351 Collins Street, Melbourne on 13 November 1980, the following resolution was duly passed as a Special Resolution:

"That the Company be wound up voluntarily."

And at such meeting, Ronald George Baillieu, Company Director of Flat 5, 40 Upton Road, Windsor, was appointed Liquidator for the purposes of the winding up.

Dated 13 November 1980

11161

R. G. BAILLIEU, Liquidator

Companies Act 1961—In the matter of COLLINS WOOL PTY. LTD.

At an Extraordinary General Meeting of the abovenamed Company, duly convened and held at 32 Waimarie Drive, Mount Waverley, on 15 November 1980, the following Resolution was duly passed as a Special Resolution:

"That the Company be wound up voluntarily."

And at such meeting, Phyllis May Lamb, of 32 Waimarie Drive, Mount Waverley, was appointed Liquidator for the purposes of the winding up.

Dated 15 November 1980

11162

P. M. LAMB, Liquidator

In the Supreme Court of Victoria—1980 No. Co. 11623—

In the matter of the Companies Act 1961; and in the matter of CALCA PTY. LTD.—Advertisement of Petition

Notice is hereby given that a Petition for the winding up of the abovenamed Company by the Supreme Court was, on 27 October 1980; presented by Standard Patten

Samuelson (Vic.) Pty. Ltd. And that the said Petition is directed to be heard before the Court sitting at the Practice Court, Law Courts, Melbourne at the hour of 10.30 o'clock in the forenoon on 11 December 1980; and any creditor or contributory of the said Company desiring to support or oppose the making of an Order on the said Petition may appear at the time of hearing by himself or his Counsel for that purpose; and a copy of the Petition will be furnished to any creditor or contributory of the said Company requiring the same by the undersigned on payment of the regulated charge for the same.

The Petitioner's address is 79 Palmerston Crescent, South Melbourne.

The Petitioner's Solicitors are Cleary, Ross & Doherty of 406 Collins Street, Melbourne.

CLEARY, ROSS & DOHERTY

NOTE—Any person who intends to appear on the hearing of the said Petition must serve on or send by post to the abovenamed Solicitors notice in writing of his intention so to do. The notice must state the name and address of the person, or, if a firm, the name and address of the firm, and must be signed by the person or firm, or his or their Solicitor (if any) and must be served, or, if posted, must be sent by post in sufficient time to reach the abovenamed not later than 4.00 o'clock in the afternoon of 10 December 1980. 11163

Companies Act 1961

**O.B.C. INTERNATIONAL MARKETING PTY. LTD.**

Notice is hereby given that pursuant to section 260 a meeting of the creditors of O.B.C. International Marketing Pty. Ltd. will be held at the offices of Nelson, Wheeler, Chartered Accountants, 430 William Street, Melbourne on 2 December 1980 at 10.30 a.m., the company having convened a meeting of its members for the same day for the purpose of considering a Special Resolution that the company be wound up voluntarily.

Dated 14 November 1980

11175

B. K. SIMMONS, Receiver and Manager

The Companies Act 1961

**MAPHEN PTY. LTD. (IN MEMBERS' VOLUNTARY LIQUIDATION)**

NOTICE CONVENING FINAL MEETING OF MEMBERS, PURSUANT TO SECTION 272

Notice is hereby given in pursuance of section 272 of the Companies Act 1961 that a Meeting of the Members of the abovenamed Company will be held on 22 December 1980 at the offices of Haines Toner & Co., 343 Little Collins Street, Melbourne, at 9.00 a.m. for the purpose of having an account laid before them showing the manner in which the winding up has been conducted and the property of the Company disposed of and of hearing any explanations that may be given by the Liquidator.

Dated 17 November 1980

E. E. HAINES, Liquidator

Haines Toner & Co., chartered accountants, 343 Little Collins Street, Melbourne, Vic. 3000 11176

Companies Act 1961—In the matter of M.B.V. CONSTRUCTIONS PTY. LTD., Suite 2, 10 Ringwood Street, Ringwood  
—Notice Re Meeting of Creditors, Pursuant to Section 260

Notice is hereby given that a Meeting of Creditors of the abovenamed Company will be held at The Board Room, Harle & Associates, James Parker Centre, 112 Parker Street, Templestowe, on Tuesday, 9 December 1980, at 3.30 p.m., the Company having convened a Meeting of its Members for the same day for the purpose of considering a Special Resolution that the Company be wound up voluntarily.

Dated 13 November 1980

M. YOXON, Director

Bent & Cogle, public accountants, 144 Jolimont Road, East Melbourne, Vic. 3302 11178



The Companies Act 1961  
**CONGETT TRADING COMPANY PROPRIETARY LIMITED**  
 NOTICE OF MEETING OF CREDITORS

In accordance with section 260 (1) of the Companies Act 1961, notice is hereby given that a meeting of the creditors of Congett Trading Company Proprietary Limited, will be held in the Meeting Rooms of the Victorian Chamber of Manufactures, 370 St. Kilda Road, Melbourne on 4 December 1980 at 10.00 o'clock for the purpose of considering that the Company be wound up voluntarily. The Company having convened a meeting of members for the same day for the purpose and if thought fit passing the following special resolution:—

"That the Company be wound up voluntarily."

Dated 17 November 1980

CONSTANTINO OKKAS, Director

Stephen G. Marks & Co., chartered accountants, 60 Albert Road, South Melbourne 3205. Telephone: 699 3766

11177

In the Supreme Court of Victoria—1980 Company No. 11634—In the matter of the Companies Act 1961; and in the matter of GLOBLE WORLD WIDE EXPORT ESTABLISHMENT LIMITED—Notice of Appointment of Provisional Liquidator

Order for appointment of an Official Liquidator as Provisional Liquidator made on Thursday 13 November 1980.

Name and address of Provisional Liquidator—Warick Allen Leeming of 114 William Street, Melbourne in the State of Victoria.

Dated 14 November 1980

PHILLIPS, FOX & MASEL, solicitors for the petitioner

11188

The Companies Act 1961

**BEAUFORT HOUSE PTY. LTD. (IN VOLUNTARY LIQUIDATION)**

NOTICE CONVENING FINAL MEETING OF MEMBERS, PURSUANT TO SECTION 272

Notice is hereby given in pursuance of section 272 of the Companies Act 1961 that a General Meeting of the Members of the abovementioned Company will be held on 22 December 1980 at 2.30 p.m. at the office of Hughes, Fincher & Rodda, 44 Market Street, Melbourne, for the purpose of having an account laid before them showing the manner in which the winding up has been conducted and the property of the Company disposed of and hearing any explanation that may be given by the Liquidator.

Dated 12 November 1980

11189

N. HARRIS, Liquidator

The Companies Act 1961

**MELWIRE AUSTRALIA PROPRIETARY LIMITED (IN VOLUNTARY LIQUIDATION)**

NOTICE CONVENING FINAL MEETING, PURSUANT TO SECTION 272

Pursuant to section 272 of the Companies Act 1961 a general meeting of members of the above mentioned Company will be held at 522 Clayton Road, Clayton, Victoria on Monday, 22 December 1980 at 8.45 a.m. for the purpose of having an account laid before them showing the manner in which the winding up has been conducted and the property disposed of and of hearing any explanation that may be given by the liquidator.

Dated 12 November 1980

11190

W. P. HARRINGTON, Liquidator

The Companies Act 1961, Section 272 (2)

**JOHNSWAY GALVANISING CO. PTY. LTD. (IN VOLUNTARY LIQUIDATION)**

NOTICE OF FINAL MEETING

Notice is hereby given that pursuant to section 272 of the Companies Act 1961, a general meeting of members of Johnsway Galvanising Co. Pty. Ltd. will be held at Messrs Peat, Marwick, Mitchell & Co., 500 Bourke Street, Melbourne, 3000, on 22 December 1980, at 9.30 a.m.

No. 102—29130/80—4

The purpose of the meeting is to lay accounts before it, showing the manner in which the winding up has been conducted and the property of the company disposed of, and of hearing any explanation that may be given by the liquidator.

Dated 19 November 1980

D. A. CRAWFORD, Liquidator

Peat, Marwick, Mitchell & Co., 500 Bourke Street, Melbourne, Vic. 3000

11191

The Companies Act, 1961, Section 272 (2)

**HACIENDA CARAVANS PTY. LTD. (IN LIQUIDATION)**

NOTICE OF FINAL MEETING

Notice is hereby given that pursuant to section 272 of the Companies Act 1961; a general meeting of members and creditors of Hacienda Caravans Pty. Ltd. will be held at Messrs Duesbury Johnston & Marks, 19th Floor, 114 William Street, Melbourne 3000, on 19 December 1980 at 10.00 a.m.

The purpose of the meeting is to lay accounts before it, showing the manner in which the winding up has been conducted and the property of the company disposed of, and of hearing any explanation that may be given by the liquidator.

Dated 19 November 1980

WARICK A. LEEMING, Liquidator

Duesbury Johnston & Marks, 114 William Street, Melbourne, Vic. 3000

11192

The Companies Act 1961

**HAWICK INVESTMENTS PTY. LTD. (IN VOLUNTARY LIQUIDATION)**

NOTICE OF CONVENING FINAL MEETING OF MEMBERS, PURSUANT TO SECTION 272

Notice is hereby given, in pursuance of section 272 of the Companies Act 1961, that a General Meeting of the members of the abovementioned Company will be held on 12 December 1980 at 10.00 a.m. at the office of M. R. M. Smith, Peacock & Henshaw, 5th Floor, 124 Exhibition Street, Melbourne, for the purpose of having an account laid before them showing the manner in which the winding up has been conducted and the property of the Company disposed of, and hearing any explanation that may be given by the Liquidator.

Dated 12 November 1980

D. A. N. McLARDY, Liquidator

M. R. M. Smith, Peacock & Henshaw, chartered accountants, 5th Floor, 124 Exhibition Street, Melbourne

11193

The Companies Act 1961

**PHELAN INDUSTRIES PTY. LIMITED**

(RECEIVER AND MANAGER APPOINTED)

PURSUANT TO SECTION 260 OF THE COMPANIES ACT 1961

Notice is hereby given that a Meeting of Creditors of Phelan Industries Pty. Limited (Receiver and Manager Appointed) will be held at the City Mutual Meeting Room, 18th Floor, 459 Collins Street, Melbourne on Thursday, 4 December 1980 at 10.30 a.m. for the purpose of considering the Company's affairs, the Company having convened an Extraordinary General Meeting of its Members to be held on Thursday, 4 December 1980 at 10.00 a.m. for the purpose of considering and if thought-fit passing a Special Resolution that the Company be wound up voluntarily.

Dated 12 November 1980

M. H. DINGLE, Director

Ferrier Hodgson Green & Co., chartered accountants, 459 Collins Street, Melbourne, 3000

11194

The Companies Act 1961

**TOBIAS SALON PTY. LIMITED (IN LIQUIDATION)**

NOTICE CONVENING FINAL MEETING OF MEMBERS AND CREDITORS, PURSUANT TO SECTION 272

Notice is hereby given pursuant to section 272 of the Companies Act 1961 that a General Meeting of the Members and Creditors of the abovenamed Company will be held at the offices of Ferrier Hodgson Green & Co., 459

Collins Street, Melbourne on Friday, 19 December 1980 at 10.00 a.m. for the purpose of having an account laid before them showing the manner in which the winding up has been conducted and the property of the Company disposed of and of hearing any explanations that may be given by the Liquidator.

Dated 17 November 1980

A. G. HODGSON, Liquidator  
Ferrier Hodgson Green & Co., chartered accountants,  
459 Collins Street, Melbourne, 3000. 11195

Company No. 89197

In the Supreme Court of Victoria—1980 No. Co. 11652—  
In the matter of the Companies Act 1961; and in the  
matter of K. D. K. CONSTRUCTIONS PTY. LTD.—Advertisement  
of Petition

Notice is hereby given that a Petition for the winding up of the abovenamed Company by the Supreme Court was on 14 November 1980, presented by Peter Demediuk and Thaisa Demediuk and that the said Petition is directed to be heard before the Court sitting in the Practice Court, Law Courts, William Street, Melbourne on the 4 December 1980, at the hour of 10.30 o'clock in the forenoon and any creditor or contributory of the said Company desiring to support or oppose the making of an Order on the said Petition may appear at the time of hearing by himself or his Counsel for that purpose and a copy of the Petition will be furnished to any creditor or contributory of the said Company requiring the same by the undersigned on payment of the regulated charge for the same.

The Petitioner's address is 22 Dawson Avenue, Elwood.  
The Petitioner's solicitors are Lethlean, Howie & Maher,  
555 Lonsdale Street, Melbourne.

LETHLEAN HOWIE & MAHER, solicitors for the  
petitioners

NOTE.—Any person who intends to appear on the hearing of the said petition must serve on or send by post to the abovenamed solicitors, notice in writing of his intention so to do. The notice must state the name and address of the person, or, if a firm, the name and address of the firm and must be signed by the person or firm, or his or their Solicitor (if any) and must be served, or if posted, must be sent by post in sufficient time to reach the abovenamed not later than 4 o'clock in the afternoon on 3 December 1980.  
11204

Companies Act 1961—In the matter of FRENCH INVESTMENTS PROPRIETARY LIMITED (in Voluntary Liquidation)

Notice is hereby given that pursuant to section 272 of the Companies Act 1961, a General Meeting of members of the abovenamed Company will be held at 95 Bridge Road, Richmond, on Wednesday 24 December 1980, at 10.30 o'clock in the forenoon.

The purpose of the Meeting is to lay accounts before it showing the manner in which the winding up has been conducted and the property of the Company disposed of and of hearing any explanation that may be given by the Liquidator.

Dated 17 November 1980

NEIL G. RAVEN, Liquidator  
Davis & Raven, 95 Bridge Road, Richmond, 3121. 11207

Companies Act 1961, Section 272

SARTON SECURITIES PTY. LTD., (IN VOLUNTARY  
LIQUIDATION)

NOTICE OF FINAL MEETING

Notice is hereby given that pursuant to Section 272 of the Companies Act 1961, the final meeting of the members of the Company will be held at 29 Aikman Crescent, Chadstone on the 22 December 1980 at 8.30 a.m. for the purpose of laying before the meeting an account of the manner in which the winding up has been conducted and the property of the Company disposed of and hearing any explanation thereof.

Dated 17 November 1980  
11209

B. E. WILLIAMS, Liquidator

The Companies Act 1961

NIXON INVESTMENTS PTY. LTD.

NOTICE OF MEETING OF CREDITORS

Notice is hereby given that pursuant to section 260-(2) of the Companies Act 1961 a meeting of creditors of Nixon Investments Pty. Ltd. will be held at the office of Maclean & Patterson, 260 Auburn Road, Hawthorn on Friday 12 December 1980 at 10.15 a.m. for the purpose of considering the company's affairs, the company having convened a meeting of members for the same day for the purpose of considering and if thought fit passing a special resolution that the company be wound up voluntarily.

Dated 17 November 1980

EDWIN J. STEWARD, Director

Maclean & Patterson, chartered accountants, 260 Auburn  
Road, Hawthorn 3122. 11208

BROADMEADOWS BANDAG PTY. LIMITED (IN  
VOLUNTARY LIQUIDATION)

NOTICE OF GENERAL MEETING

Notice is hereby given that a General Meeting of the members of the company in pursuance of section 272 of the Companies Act will be held at 31st Level, Australia Square, Sydney at 9.15 a.m. on 30 December 1980 for the purpose of:

1. Having an account showing how the winding up has been conducted and the property of the company disposed of laid before them.

2. Hearing any explanation given by the Liquidator.

3. Determining by resolution the manner in which the books and papers of the company shall be disposed of.

Dated at Sydney 11 November 1980

11210

A. G. SHERLOCK, Liquidator

In the matter of the Companies Act 1961; and in the  
matter of EILDON INN PTY. LTD. (in Liquidation)

Notice is hereby given that pursuant to Section 272 of the Companies Act 1961 the final meeting of the members of the Company will be held at 361 Nepean Highway, Mordialloc on 22 December 1980 at 9.30 a.m. for the purpose of laying before the meeting the account of the winding up and any explanation thereof.

Dated 17 November 1980

11211

F. J. QUINTON, Liquidator

The Companies Act 1961

H. B. McCOMB & SON PTY. LTD. (IN LIQUIDATION)

NOTICE CONVENING FINAL MEETING OF MEMBERS AND  
CREDITORS PURSUANT TO SECTION 272

Notice is hereby given pursuant to section 272 of the Companies Act 1961 that a meeting of the abovenamed company and its creditors will be held in the offices of Wallace, McMullin & Smail, 499 St. Kilda Road, Melbourne, 3004, on Monday 22 December 1980 at 10.00 a.m. for the purpose of having an account laid before them showing the manner in which the winding up has been conducted and the property of the company disposed of and of hearing any explanations that may be given by the Liquidator.

Dated 19 November 1980

J. M. WALSH, Joint Liquidator  
Wallace, McMullin & Smail, chartered accountants 11223

The Companies Act 1961, Section 206 (4)

BENDIGO INVESTMENTS LTD. (OFFICIAL MANAGER  
APPOINTED)

NOTICE OF MEETING OF CREDITORS

Notice is hereby given that a meeting of Creditors of Bendigo Investments Ltd. will be held at the offices of Wallace, McMullin and Smail in the Meeting Room, 3rd Floor, 499 St. Kilda Road, Melbourne on Wednesday 3 December 1980 at 10.15 a.m.

AGENDA

1. To receive the report of the Official Management on the conduct of the Official Manager for the period 3 April 1980 to 3 October 1980 pursuant to Section 203A (1) of the Companies Act 1961.

2. The Members, having convened an Extraordinary General Meeting on the same date, to consider a Scheme of Arrangement between the Company, its Members and its Creditors or alternatively to consider a resolution to wind up the affairs of the company. Further—

- (a) Appoint a Chairman of the Meeting
- (b) To receive a Statement of Assets and Liabilities of the company as at 3 October 1980.

3. If necessary;

- (a) To consider, and if thought fit, resolve that Section 277A (1A) (i) of the Companies Act shall not apply with regard to the appointment of the Joint Liquidators.
- (b) To appoint Joint Liquidators.
- (c) To consider the appointment of a Committee of Inspection.
- (d) To authorize the opening of a Bank Account.
- (e) To fix the remuneration of the Joint Liquidators.
- (f) Any other matters arising.

Copies of the statement of Assets and Liabilities referred to in point 2 (b) above will be available prior to the meeting and from 3 December 1980, at the registered office of the company, Abel Street, Bendigo and at the offices of Wallace, McMullin and Smail, 499 St. Kilda Road, Melbourne.

Dated 17 November 1980

11224 R. E. RAMSAY, Official Manager

The Companies Act 1961

BENDIGO INVESTMENTS LTD. (OFFICIAL MANAGER APPOINTED)

NOTICE OF EXTRAORDINARY GENERAL MEETING OF MEMBERS

Notice is hereby given that an Extraordinary General Meeting of Members of the abovenamed Company will be held at the offices of Wallace, McMullin and Smail in the Meeting Room, 3rd Floor, 499 St. Kilda Road, Melbourne on Wednesday 3 December 1980 at 9.45 a.m. for the purpose of considering a Scheme of Arrangement between the Company, its Members and its Creditors, or alternatively, passing a Resolution to wind up the affairs of the Company.

Dated 17 November 1980

R. E. RAMSAY, Official Manager

Wallace, McMullin & Smail, chartered accountants 11225

The Companies Act 1961, Section 291 and Regulation 54  
In the matter of MIRA BARBARA NOMINEES PTY. LTD. (IN LIQUIDATION)

Take notice that as Liquidator of the abovenamed Company I have fixed Thursday 4 December 1980 as the day on or before which creditors of the company are to prove their debts or claims and to establish any title they may have to priority under Section 292 or be excluded from the benefit of a first distribution made before such debts are proved or as the case may be from objecting to such distribution.

Dated 19 November 1980

A. M. HORSBURGH, Liquidator

Wallace, McMullin & Smail, chartered accountants, 499 St. Kilda Road, Melbourne 3004 11226

Companies Act 1961, Section 272

J. J. MULLINS PTY. LTD. (IN LIQUIDATION)

NOTICE OF FINAL MEETING OF MEMBERS

Notice is hereby given that a meeting of members of J. J. Mullins Pty. Ltd. (in Liquidation) will be held at 351 Collins Street, Melbourne (16th Floor) on 17 December 1980 at 10.00 a.m.

Agenda

To lay before the meeting the Liquidator's account showing how the winding up has been conducted and the property of the company has been disposed of, and to give any explanation of the account which may be required.

Dated 17 November 1980

11229

MAX G. CHAPMAN, Liquidator

Companies Act 1961, Section 260

B. & R. ELECTRIC COMPANY PTY. LTD.

NOTICE OF MEETING OF CREDITORS

Notice is hereby given that a meeting of Creditors of B. & R. Electric Company Pty. Ltd. will be held at the Meeting Room of Hosking Dyer and Co., 1st Floor, 153 Park Street, South Melbourne on Thursday 20 November 1980 at 10.00 a.m., the Company having convened a meeting of its members for the same day for the purpose of considering a resolution that the Company be wound up voluntarily.

Dated 11 November 1980

M. RICH, Director

Hosking, Dyer and Co., public accountants, 1st Floor, 153 Park Street, South Melbourne, 3205. Telephone: 690 6466 11227

Companies Act 1961, Section 272 (1)

BOUSTEAD UNOCHROME AUSTRALIA LTD. (IN VOLUNTARY LIQUIDATION)

NOTICE OF FINAL MEETING

Take notice that the affairs of the abovenamed company are now fully wound up and that in pursuance of Section 272 (1) of the Companies Act 1961, a general meeting of the company will be held at 9th Floor, 461 Bourke Street, Melbourne, on 22 December 1980 at 10.00 o'clock in the forenoon for the purpose of laying before it an account showing how the winding-up has been conducted and the property of the company disposed of and giving any explanation thereof.

Dated 17 November 1980

P. C. SIMMONS, Liquidator

Sherlock & Co., 459 Collins Street, Melbourne, Vic. 3000 11228

Companies Act 1961

ADSUM PTY. LTD. (formerly B. W. D. ELECTRONICS PTY. LTD.)

(Receivers and Managers Appointed)

NOTICE OF MEETING OF CREDITORS

Notice is hereby given that pursuant to section 260 of the Companies Act 1961 a meeting of the creditors of Adsum Pty. Ltd. (Receivers and Managers Appointed) will be held at the A.M.P. Theatre, 535 Bourke Street, Melbourne on 27 November 1980, at 11.00 a.m., the Company having convened a meeting of its members for the same day for the purpose of considering and, if thought fit, passing the special resolution that the company be wound up voluntarily.

Dated 17 November 1980

J. L. BURNS, Secretary

Duesbury Johnston & Marks, chartered accountants, 114 William Street, Melbourne, Vic. 3000 11230

The Companies Act 1961, Section 254 (2) (b)

ALLISON INVESTMENTS PTY. LIMITED

Notice is hereby given that an Extraordinary General Meeting of Members of the abovenamed Company held on 12 November 1980, it was resolved that the Company be wound up voluntarily, as a Members' Voluntary Winding-up pursuant to the provisions of Sub-division 2 of Division 3 of Part X of the Companies Act 1961, and it was further resolved that for such purpose, Mr Keith Fizelle, solicitor, of 224 Queen Street, Melbourne, be appointed Liquidator.

Notice is also given that after twenty-one days from this date I shall proceed to distribute the assets. Any creditors having any claims against the Company should furnish particulars of same by that date, otherwise I shall proceed to distribute the assets without regard to their claim.

Dated 19 November 1980

KEITH FIZELLE, Liquidator

Wallace, McMullin & Smail, chartered accountants, 499 St. Kilda Road, Melbourne, Vic. 3004 11231

In the matter of the Companies Act 1961; and in the matter of DIMATTINA ESTATES PTY. LIMITED

Notice is hereby given that an Extraordinary General Meeting of the abovenamed company duly convened and held at 500 Collins Street, Melbourne on 11 November 1980, the following special resolution was duly passed—

"That the company be wound-up voluntarily and that John Stuart Walker, Chartered Accountant of 500 Collins Street, Melbourne be appointed Liquidator for the purpose of such winding-up."

Dated 11 November 1980

11232

D. B. DIMATTINA, Chairman

In the Supreme Court of Victoria—Co. 11602—In the matter of the Companies Act 1961; and in the matter of GAROZZO BUILDERS PROPRIETARY LIMITED—Notice of Winding Up Order

Winding-Up Order made 13 November 1980.

Name and address of liquidator: Dennis John Cogle, C/- Bent & Cogle, 144 Jolimont Road, East Melbourne.

B. J. O'DONOVAN, Crown Solicitor for the Commonwealth and Solicitor for the Petitioner 11233

In the Supreme Court of Victoria—Co. 11601—In the matter of the Companies Act 1961; and in the matter of BOSLEY'S SALONS PTY. LTD.—Notice of Winding Up Order

Winding-Up Order made 13 November 1980.

Name and address of liquidator: Alex Neville Bird, 3 Bowen Crescent, Melbourne, Vic. 3000.

B. J. O'DONOVAN, Crown Solicitor for the Commonwealth and Solicitor for the Petitioner 11234

In the Supreme Court of Victoria—In the matter of the Companies Act 1961; and in the matter of BRIGHTON AUTO SPARES PTY. LTD.

Notice is hereby given that a petition for the winding up of the above-named company by the Supreme Court was, on 14 November 1980, presented by Edward Lipohar one of the members thereof and that the said petition is directed to be heard before the Court sitting at Melbourne at the hour of 10.30 in the forenoon on Thursday 5 February 1981; and any creditor or contributory of the said company desiring to support or oppose the making of an order on the said petition may appear at the time of hearing by himself or his counsel for that purpose; and a copy of the petition will be furnished to any creditor or contributory of the said company requiring the same by the undersigned on payment of the regulated charge for the same.

The Petitioner's address is 2 Ellison Street, Ardeer.

The Petitioner's solicitors are Messrs Darvall & Hambleton of 147 Collins Street, Melbourne.

MESSRS DARVALL & HAMBLETON

NOTE—Any person who intends to appear on the hearing of the said petition must serve on or send by post to the above named solicitors notice in writing of his intention to do so. The notice must state the name and address of the person, or, if a firm, the name and address of the firm, and must be signed by the person or firm, or his or their solicitor (if any), and must be served, or, if posted, must be sent by post in sufficient time to reach the above-named not later than four o'clock in the afternoon of 4 February 1981. 11235

In the Supreme Court of Victoria—In the matter of the Companies Act 1961; and in the matter of CIRCUITRONICS PTY. LTD.

Notice is hereby given that a petition for the winding-up of the abovenamed Company by the Supreme Court was on 17 November 1980 presented by Eric John Unger, Deputy Commissioner of Taxation of the Commonwealth of Australia and that the said petition is directed to be heard before the Court sitting at the Fifteenth Court, Law Courts, Lonsdale Street, Melbourne at the hour of 10.30 o'clock in the forenoon on 11 December 1980 and any creditor or contributory of the said company desiring to

support or oppose the making of an order on the said petition may appear at the time of hearing by himself or his Counsel for the purpose; and a copy of the said petition will be furnished to any creditor or contributory of the said company requiring the same by the undersigned on payment of the regulated charge for the same.

The Petitioner's official address is 350 Collins Street, Melbourne.

The Petitioner's Solicitor is B. J. O'Donovan, Crown Solicitor for the Commonwealth of 99 Queen Street, Melbourne.

B. J. O'DONOVAN

NOTE—Any person who intends to appear on the hearing of the said petition must serve on or send by post to the abovenamed B. J. O'Donovan, notice in writing of his intention so to do. The notice must state the name and address of the person, or, if a firm, the name and address of the firm, and must be signed by the person or firm, or his, or their solicitor (if any), and must be served, or, if posted, must be sent by post in sufficient time to reach the above-named not later than 4.00 o'clock in the afternoon of 10 December 1980. 11236

In the Supreme Court of Victoria—In the matter of the Companies Act 1961; and in the matter of TONGALA PET FOOD PTY. LTD.

Notice is hereby given that a petition for the winding-up of the abovenamed Company by the Supreme Court was on 17 November 1980 presented by Eric John Unger, Deputy Commissioner of Taxation of the Commonwealth of Australia and that the said petition is directed to be heard before the Court sitting at the Fifteenth Court, Law Courts, Lonsdale Street, Melbourne at the hour of 10.30 o'clock in the forenoon on 11 December 1980 and any creditor or contributory of the said company desiring to support or oppose the making of an order on the said petition may appear at the time of hearing by himself or his Counsel for the purpose; and a copy of the said petition will be furnished to any creditor or contributory of the said company requiring the same by the undersigned on payment of the regulated charge for the same.

The Petitioner's official address is 350 Collins Street, Melbourne.

The Petitioner's Solicitor is B. J. O'Donovan, Crown Solicitor for the Commonwealth of 99 Queen Street, Melbourne.

B. J. O'DONOVAN

NOTE—Any person who intends to appear on the hearing of the said petition must serve on or send by post to the abovenamed B. J. O'Donovan, notice in writing of his intention so to do. The notice must state the name and address of the person, or, if a firm, the name and address of the firm, and must be signed by the person or firm, or his, or their solicitor (if any), and must be served, or, if posted, must be sent by post in sufficient time to reach the above-named not later than 4.00 o'clock in the afternoon of 10 December 1980. 11237

In the Supreme Court of Victoria—In the matter of the Companies Act 1961; and in the matter of TONGALA ANIMAL BY PRODUCTS PTY. LTD.

Notice is hereby given that a petition for the winding-up of the abovenamed Company by the Supreme Court was on 17 November 1980 presented by Eric John Unger, Deputy Commissioner of Taxation of the Commonwealth of Australia and that the said petition is directed to be heard before the Court sitting at the Fifteenth Court, Law Courts, Lonsdale Street, Melbourne at the hour of 10.30 o'clock in the forenoon on 11 December 1980 and any creditor or contributory of the said company desiring to support or oppose the making of an order on the said petition may appear at the time of hearing by himself or his Counsel for the purpose; and a copy of the said petition will be furnished to any creditor or contributory of the said company requiring the same by the undersigned on payment of the regulated charge for the same.

The Petitioner's official address is 350 Collins Street, Melbourne.

The Petitioner's Solicitor is B. J. O'Donovan, Crown Solicitor for the Commonwealth of 99 Queen Street, Melbourne.

B. J. O'DONOVAN

NOTE—Any person who intends to appear on the hearing of the said petition must serve on or send by post to the abovenamed B. J. O'Donovan, notice in writing of his intention so to do. The notice must state the name and address of the person, or, if a firm, the name and address of the firm, and must be signed by the person or firm, or his, or their solicitor (if any), and must be served, or, if posted, must be sent by post in sufficient time to reach the abovenamed not later than 4.00 o'clock in the afternoon of 10 December 1980. 11238

In the Supreme Court of Victoria—In the matter of the Companies Act 1961; and in the matter of B. S. & G. WILLIAMSON NOMINEES PTY. LTD.

Notice is hereby given that a petition for the winding-up of the abovenamed Company by the Supreme Court was on 17 November 1980 presented by Eric John Unger, Deputy Commissioner of Taxation of the Commonwealth of Australia and that the said petition is directed to be heard before the Court sitting at the Fifteenth Court, Law Courts, Lonsdale Street, Melbourne at the hour of 10.30 o'clock in the forenoon on 11 December 1980 and any creditor or contributory of the said company desiring to support or oppose the making of an order on the said petition may appear at the time of hearing by himself or his Counsel for the purpose; and a copy of the said petition will be furnished to any creditor or contributory of the said company requiring the same by the undersigned on payment of the regulated charge for the same.

The Petitioner's official address is 350 Collins Street, Melbourne.

The Petitioner's Solicitor is B. J. O'Donovan, Crown Solicitor for the Commonwealth of 99 Queen Street, Melbourne.

B. J. O'DONOVAN

NOTE—Any person who intends to appear on the hearing of the said petition must serve on or send by post to the abovenamed B. J. O'Donovan, notice in writing of his intention so to do. The notice must state the name and address of the person, or, if a firm, the name and address of the firm, and must be signed by the person or firm, or his, or their solicitor (if any), and must be served, or, if posted, must be sent by post in sufficient time to reach the abovenamed not later than 4.00 o'clock in the afternoon of 10 December 1980. 11239

Companies Act 1961, Section 260 (2)

WRIDE & ABLEY CONSTRUCTIONS (VIC.) PTY. LTD.

NOTICE OF MEETING OF CREDITORS

Notice is hereby given that pursuant to section 260 (2) of the Companies Act 1961, a meeting of creditors of Wride & Abley Constructions (Vic.) Pty. Ltd. will be held at the offices of Messrs Arthur Young & Company Chartered Accountants, 20th Floor, 500 Bourke Street, Melbourne on Thursday, 27 November 1980 at 12.00 noon, for the purposes mentioned in section 260 to 262 of the Companies Act 1961, namely nominating a Liquidator and of appointing a committee of inspection.

A person is not entitled to vote as a creditor at the meeting unless he has lodged with the Chairman of the meeting a proof of the debt which he claims is due to him from the Company.

Dated 4 November 1980  
11259

R. E. A. EMMS, Director

CZESLAW LINKOWSKI, late of 14 Sullivan Street, Springvale, Victoria, retired gentleman, DECEASED

Take notice that Felix Vitiello, of 77 Darren Road Keysborough, Victoria, Solicitor, the executor of the Will of Czeslaw Linkowski the above-named deceased who died on 14 October 1980 requires all creditors next of kin and others having claims against the property or estate

of the said deceased to send to him care of the under-mentioned Solicitors on or before 19 February 1981 particulars in writing of such claims after which date the said executor intends to convey or distribute such property or estate to or among the persons entitled thereto having regard only to the claims of which he shall have had notice.

Dated 13 November 1980

VITIELLO AND TUSZYNSKI, solicitors, 99 Springvale Road, Springvale, Victoria 3171 11125

LESLEY MARGARET NORQUAY, late of 2 Tudor Road, North Sunshine, in the State of Victoria, widow, DECEASED

Creditors, next of kin and others having claims in respect of the Estate of the Deceased who died on 21 June 1980 are required by Evan Maxwell Norquay, of 2 Tudor Road North Sunshine in the State of Victoria Assistant Manager the Administrator to whom Letters of Administration of the said deceased were granted by the Supreme Court of Victoria to send particulars to him by 26 January 1981 after which date the said Administrator may convey or distribute the assets having regard only to the claims of which he then has notice.

PATRICK J. CANNON, TESTRO & COBURN, solicitors, 117 Durham Road, Sunshine 11126

HERBERT NORMAN BLACK, late of 3 Lisban Court, West Sunshine, in the State of Victoria, retired council employee, DECEASED

Creditors, next of kin and others having claims in respect of the Estate of the Deceased who died on 24 August 1980 are required by Eileen Elizabeth Guthrie of 17 Carlton Street, Braybrook in the State of Victoria Widow the Executrix to whom Probate of the Will of the said deceased was granted by the Supreme Court of Victoria to send particulars to her by 26 January 1981 after which date the said Executrix may convey or distribute the assets having regard only to the claims of which she then has notice.

PATRICK J. CANNON, TESTRO & COBURN, solicitors, 117 Durham Road, Sunshine 11127

FREDERICK CHARLES TRIGG, late of Tresco, in the State of Victoria, pensioner, DECEASED

Creditors, next of kin and others having claims in respect of the estate of the deceased (who died on 26 December 1979) are required by the executors Mervyn Trigg of Ouyen in the said State and Christopher Paul Pola of Swan Hill in the said State, to send particulars to them care of the undersigned by 14 January 1981, after which date the executors may convey or distribute the assets, having regard only to the claims of which they then have notice.

HAYES (ALEC M.) & MCINERNEY, solicitors, 148 Campbell Street, Swan Hill 11144

GILBERT GORDON MITCHELL, late of 6 Burton Street, Warragul, electricity commission employee, DECEASED

Creditors, next of kin and others having claims in respect to the estate of the deceased who died on 12 February 1980 are required by the administrator Lorraine Fay Northcott to send particulars of their claims to her care of the undersigned Solicitors by 2 February 1981 after which date the administrator may convey or distribute the assets having regard only to the claims of which she then has notice.

GRAY, FRIEND & LONG, solicitors, Warragul 11145

ALICE CLAIRE MCKENZIE, late of Rokeby Road, Jindivick, widow, DECEASED

Creditors, next of kin and others having claims in respect to the estate of the deceased who died on 16 July 1980 are required by the Trustees Lorraine Dawn Hammond, Cheryl Martin and Clive Frederick Stammers to send particulars of their claims to them care of the undersigned Solicitors by 23 January 1981 after which date the Trustees may convey or distribute the assets having regard only to the claims of which they then have notice.

GRAY, FRIEND & LONG, solicitors, Warragul 11146

Creditors, next of kin and others having claims against the Estate of Annie Sophie Granfors formerly of Flat 5/35 Nepean Highway Elsternwick but late of Kingston Centre Cheltenham in the State of Victoria, Spinster who died on 10 July 1980 Probate of whose estate was granted to Robert Kendall Parnell of 35 Ulupna Road Ormond Accountant are to send particulars of such claims to the undersigned at his address hereunder mentioned by 20 January 1981 after which date the said Robert Kendall Parnell will distribute the assets having regard only to the claims of which he shall then have had notice.

JOHN KEATING & ASSOCIATES, solicitors, 191 Greville Street, Prahran, 3181  
11147

Creditors, next of kin and others having claims against the estate of Catherine Josephine Elliott (also known as Kathleen Josephine Elliott), late of Unit 4/684 Hawthorn Road East Brighton Widow deceased who died on 31 August 1980 are required to send particulars thereof to The Equity Trustees Executors and Agency Company Limited the Executors of the will of the deceased addressed to the care of the said company at its registered office at 472 Bourke Street Melbourne by 28 January 1981 after which date the executor will distribute the assets having regard only to the claims of which it then has notice.

KIERNAN AND FORREST, solicitors, 186 Elgin Street, Carlton  
11148

MARIE IRENE MURPHY, late of 89 Banyule Road, Rosanna, Victoria, spinster, DECEASED

Creditors, next of kin and others having claims in respect of the Estate of the abovenamed deceased who died on 20 September 1980 are required by the proving Executrix of the Will Mary McGinty of 58 Hodgson Street Rosanna aforesaid Married Woman to send particulars of their claims to her care of the undermentioned Solicitors by 21 January 1981 after which date the Executrix may distribute the assets of the deceased having regard only to the claims of which she then has notice.

F. J. O'CONNOR & DUNNE, of 1 Timmins Street, Northcote  
11149

Creditors, next of kin and others having claims in respect of the Will of Frederick Donald Gonsal late of 22 West Gateway East Keilor Rubber Worker who died on 22 August 1980 are requested to send particulars of their claims to the Executrix Eleanor Jean Gonsal care of the undermentioned Solicitor by 28 January 1981 after which date she will distribute the assets having regard only as to the claims of which she then has notice.

JOHN STEWART, of 290 Racecourse Road, Newmarket  
11150

REGINALD FRANK MAY, late of 15 Avenel Road, Kooyong, in the State of Victoria, medical practitioner, DECEASED

Creditors, next of kin and others having claims in respect of the estate of the deceased who died on 13 August 1980 are required by The Perpetual Executors and Trustees Association of Australia Limited of 50 Queen Street, Melbourne and John Gilbert May of 2 Evans Court, Toorak Stock Broker the applicants for a grant of administration to send particulars of their claims to the said applicants in the care of the said Company by 2 February 1981 after which date they will convey or distribute the assets having regard only to the claims of which they have notice.

MESSRS. HENDERSON & BALL, solicitors, of 430 Little Collins Street, Melbourne  
11151

Creditors, next of kin and others having claims in respect of the Estate of Constance Rupuerta Reseigh late of 15 Zetland Road, Mont Albert Widow deceased who died on 28 August 1979 are requested to send particulars of their claims to the Executors Richard Lawrence Park and Geoffrey Arthur Park care of the undermentioned Solicitors on or before 21 January 1981 after which date they will distribute the assets having regard only to the claims of which they then have notice.

McKEAN & PARK, solicitors, 450 Little Collins Street, Melbourne  
11164

Creditors, next of kin and others having claims in the Estate of Isabella Marinelli late of 325 Brunswick Road West Brunswick in the State of Victoria formerly married Woman now deceased who died on 12 December 1979 are to send the notices of their claims to Francesco Domenico Marinelli of 325 Brunswick Road West Brunswick in the said State Retired Cleaner Administrator of the Estate of the said deceased care of Leo Browne Solicitor of 180 Elgin Street Carlton in the said State by 30 January 1981 after which date the said Francesco Domenico Marinelli will distribute the Estate having regard only for the claims of which he then has notice.

LEO BROWNE, solicitor, of 180 Elgin Street Carlton  
11165

Creditors, next of kin and others having claims in respect of the estate of William Raymond Hargreaves late of 18 Mahon Avenue, Bendigo, Farmer deceased who died on 18 May 1980 are to send particulars of their claims to the executors National Trustees Executors and Agency Company of Australasia Limited of 46 Queen Street, Bendigo and 95 Queen Street, Melbourne and Florence Ann McDonald Hargreaves of 18 Mahon Avenue, Bendigo care of the under-mentioned Solicitors by 26 January 1981 after which date it and she will distribute the assets having regard only to the claims of which it and she then have notice.

EVERY & EVERY, solicitors, 71 Bull Street, Bendigo  
11179

EILEEN MATILDA SMITH, late of 115 Maple Street, Golden Square, married woman, DECEASED

Creditors, next of kin and others having claims in respect of the Estate of the abovenamed deceased who died on 22 September 1980 are required by the Executor National Trustees Executors and Agency Company of Australasia Limited of 46 Queen Street, Bendigo to send particulars to the said Company care of the undermentioned solicitors by 31 January 1981 after which date the said Company may distribute the assets having regard only to the claims of which it then has notice.

COHEN KIRBY ISER O'HAIRE, solicitors, 47 Myers Street, Bendigo  
11180

NORA FRANCES RULE, late of Unit 3, No. 10, Rosedale Avenue, Glenhuntly, widow, DECEASED

Creditors, next of kin and others having claims in respect of the Estate of the abovenamed deceased who died on 27 August 1980 are requested by the Trustee Honora Mary Southorn to send particulars of their claims to her care of the undersigned solicitors by 27 January 1980 after which date the Trustees may convey or distribute the assets having regard only to the claims of which she then has notice.

JOHN I. SULLIVAN, CHISHOLM & ASSOCIATES, solicitors, corner of Kooyong and Glenhuntly Roads, Caulfield, Victoria 3162  
11181

EUGENE THOMAS SMITH, late of 22 Talmage Street, Sunshine, in the State of Victoria, retired company director, DECEASED

Creditors, next of kin and others having claims in respect of the Estate of the deceased who died on 8 July 1980 are required by Frank Alan Smith of 22 Talmage Street Sunshine in the State of Victoria Accountant and Patrick John Cannon of 117 Durham Road, Sunshine in the State of Victoria, Solicitor the Executors to whom Probate of the Will of the said deceased was granted by the Supreme Court of Victoria to send particulars to them by 31 January 1981 after which date the said Executors may convey or distribute the assets having regard only to the claims of which they then have notice.

PATRICK J. CANNON, TESTRO & COBURN, solicitors, of 117 Durham Road, Sunshine, 3020  
11182

NEIL FREDERICK GOULD, late of 10 Briggs Street, Caulfield, gentleman, DECEASED

Creditors, next of kin and others having claims in respect of the estate of the deceased who died on 10 September 1980 are required by his personal representatives Philip Douglas Smith and Lois Irene Smith to send

particulars to them care of the undersigned Solicitors by 4 February 1981 after which date the personal representatives may convey or distribute the assets having regard only to the claims of which they then have notice.

VERA FOWLER & CO., solicitors, 1 Evandale Road, Malvern, 3144 11183

ROBERT SINCLAIR SCOUGALL, late of Tyrell Downs, via Sea Lake, in the State of Victoria, grazier, DECEASED

Creditors, next of kin and other persons having claims against the Estate of the said deceased who died on 24 September 1980 are required to send particulars of same to the Executors Robert James Scougall and John Sinclair Scougall in care of the undersigned on or before 21 January 1981 after which date they will distribute the assets having regard only to the claims of which they then have notice.

DWYER & BENNETT, barristers and solicitors, 201 Campbell Street, Swan Hill 11184

DOROTHY ISABEL HENDERSON, late of Camperdown, widow, DECEASED

Creditors, next of kin and others having claims in respect of the estate of the deceased, who died on 4 July 1980 are required by the Administrator Kerran Robert Henderson of Camperdown Maintenance Carpenter to send particulars to him care of the undermentioned Solicitors by 16 February 1981 after which date the Administrator may convey or distribute the assets, having regard only to the claims of which he then has notice.

ARTHUR E. GEORGE & SONS, solicitors, 202 Manifold Street, Camperdown 11185

Creditors, next of kin and others having claims in respect of the estate of Linda Dorothy Drummond late of 330 Rathmines Street, Thornbury in the State of Victoria, Widow, deceased who died on 12 September 1980 are, to send particulars of their claims to Roy Curtis Lidgerwood of 12 Summerhill Road, Glen Iris in the said State, Retired Law Clerk by 19 January 1981 after which date he will distribute the assets having regard only to the claims of which he then has notice.

FRENKEL, BERKOVITCH, KEFFORD & NEW, solicitors, of 114 William Street, Melbourne 11186

Creditors, next of kin and others having claims in respect of the Estate of Robert Marsh late of 97 Glyndon Road, Camberwell in the State of Victoria, Architect deceased who died on 6 May 1980 are to send particulars of their claims to Daryl Robert Francis Marsh of 3 Nioka Court, Park Orchards in the said State, Architect the sole Executor appointed by the said Will by 19 January 1981 after which date the Executor will distribute the assets having regard only to the claims of which he then has notice.

SEDDON & WITT, solicitors, 406 Collins Street, Melbourne 11187

Creditors, next of kin and others having claims against the Estate of Brenda Joan Gurner late of Unit 4, 40 Bruce Street, Toorak in the State of Victoria Spinster deceased who died on 7 October 1980 are requested by the Executor of the Will of the said deceased, The Equity Trustees Executors and Agency Company Limited of 472 Bourke Street Melbourne in the said State to send particulars of their claims to the said Executor on or before 26 January 1981 after which date the Executor will distribute the assets having regard only to the claims of which it shall then have had notice.

ELLISON HEWISON & WHITEHEAD, solicitors, 379 Collins Street, Melbourne, 3000. Telephone 62 7821 11196

Creditors, next of kin and others having claims in respect of the estate of Hazel Sarah Agnes George late of 12 Wolverhampton Street, Footscray Widow deceased who died on 29 July 1980 are to send particulars of their claims to The Equity Trustees Executors and Agency Company

Limited of 472 Bourke Street, Melbourne by 20 January 1981 after which date it will distribute the assets having regard only to the claims of which it then has notice.

MARTIN & MARTIN, solicitors, 37 Queen Street, Melbourne 11197

GLORIA EMMA SHANNOS, late of Flat 8, 558 Toorak Road, Toorak, married woman, DECEASED

Creditors, next of kin and others having claims in respect of the estate of the deceased who died on 11 August 1980 are required by The Perpetual Executors and Trustees Association of Australia Limited of 50 Queen Street, Melbourne, to send particulars of their claims to the said company by 21 January 1981 after which date it will convey or distribute the assets, having regard only to the claims of which the Company then has notice.

HEDDERWICK, FOOKES & ALSTON, 121 William Street, Melbourne, 3000, 11198

JEAN AUDREY PECK, late of 8 Point Road, Crib Point, in the State of Victoria, widow, DECEASED

Creditors, next of kin and others having claims in respect of the Estate of the said deceased, who died on 6 August 1980, are required by the Executor of her Will and the Codicil thereto, to wit, The Perpetual Executors and Trustees Association of Australia Limited, of 50 Queen Street, Melbourne, 3000, to send particulars in writing of such claims to the said Executor at its said address by 31 January 1981 after which date the said Executor may convey or distribute the assets of the said deceased having regard only to the claims of which it then has notice.

ROBERT C. TAYLOR & SON, solicitors, 13 Davey Street, Frankston 11199

Creditors next of kin and others having claims against the Estate of Doris Isabel Serman late of 6/20 Lisson Grove Hawthorn, Widow, deceased who died on 28 June 1980 are required by Hugh Norman Serman and Joan Isabel Hall the Executors to send particulars of their claims to the Executors care of the undermentioned Solicitors by 21 January 1981 after which date the Executors will convey or distribute the Estate of the said deceased having regard only to the claims of which they then have notice.

WEIGALL & CROWTHER, solicitors, of 459 Little Collins Street, Melbourne 11200

Creditors, next of kin and others having claims in respect of the Estate of Isabella Beech late of Karrakatta Western Australia Widow deceased intestate who died on 23 June 1971 are to send particulars of their claims to the Administratrix Thelma Olive Clark care of the undermentioned Solicitors by 20 January 1981 after which date the said Administratrix will distribute the assets having regards to the claims of which she then has notice.

R. WADHAM & DOIG, solicitors, of 383 Flinders Lane, Melbourne 11201

Creditors, next of kin and others having claims in respect of the estate of William Forrest Passmore late of 30 Myrmong Crescent Ascot Vale retired butcher who died on 7 August 1980 are to send the particulars of their claims to The Equity Trustees Executors and Agency Company Limited of 472 Bourke Street, Melbourne by 20 January 1981 after which date it will distribute the assets having regard only to the claims of which it then has notice.

RYLAH & RYLAH, solicitors, 191 Queen Street, Melbourne 11202

Creditors, next of kin and others having claims in respect of the estate of Herbert William Richardson late of 70 Robert Street, Bentleigh retired Accountant who died on 9 September 1980 are to send the particulars of their claims to The Equity Trustees Executors and Agency Company Limited, of 472 Bourke Street, Melbourne by 20 January 1981 after which date it will distribute the assets having regard only to the claims of which it then has notice.

RYLAH & RYLAH, solicitors, 191 Queen Street, Melbourne 11203

WINIFRED ELEANOR GIBSON, late of 29 Primrose Street, Essendon, widow, DECEASED

Creditors, next of kin and others having claims in respect of the estate of the abovenamed deceased who died on 29 August 1980 are to send particulars of their claims to the Executrix Mrs Irene Rose Raffaele care of the undermentioned Solicitors by 27 January 1981 after which date the said Executrix will distribute the assets having regard only to the claims of which she then has notice.

O'BRIEN & GALANTE, solicitors, 44 Pascoe Vale Road, Moonee Ponds 11212

RHODA FRANCES CHESTERS, late of 100 Gordon Street, Footscray, in the State of Victoria, widow, DECEASED

Creditors, next of kin and others having claims in respect of the Estate of the Deceased who died on 15 July 1980 are required by Stanley Albert Chesters of 13 Thyra Street Sunshine in the said State Truck Driver the substituted Executor to whom Probate of the Will of the said deceased was granted by the Supreme Court of Victoria to send particulars to him by 31 January 1981 after which date the said substituted Executor may convey or distribute the assets having regard only to the claims of which he then has notice.

PATRICK J. CANNON, TESTRO & COBURN, solicitors, 117 Durham Road, Sunshine 11213

Creditors, next of kin and others having claims in respect of the estate of Eric Reginald Hudson late of 17 Bettina Street, Clayton North Supervisor deceased (who died on 25 June 1980) are to send particulars of their claims to the Executor of the Will of the deceased care of Agg and Engel, Solicitors, 109 Main Street, Bairnsdale by 22 January 1981, after which date the Executor will distribute the assets, having regard only to the claim of which he then has notice.

AGG & ENGEL, solicitors, 109 Main Street, Bairnsdale 11214

Creditors, next of kin and others having claims in respect of the Will of Catherine Mary O'Byrne late of 26 Lothian Street, North Melbourne Spinster who died on 19 January 1980 are requested to send particulars of their claims to the Executrix Margaret Cecilia O'Byrne care of the undermentioned Solicitor by 28 January 1981 after which date she will distribute the assets having regard only as to the claims of which she then has notice.

EDWARD CURMI, solicitor, of 440 Victoria Street, North Melbourne 11215

NICKOLAOS KALADIS, late of 12 Bayne Street (in the Will of Bayne Street), Bendigo, retired café proprietor (in the Will café proprietor), DECEASED

Creditors, next of kin and others having claims in respect of the estate of the deceased who died on 21 June 1980, are required by the Executrix Cleopatra Kaladis of 12 Bayne Street, Bendigo, to send particulars to her care of the undermentioned Solicitors by 23 January 1981, after which date she may convey or distribute the assets having regard only to the claims of which they then have notice.

R. H. SCHLEIGER & ASSOCIATES, solicitors, 33-35 Williamson Street, Bendigo 11216

Creditors, next of kin and others having claims in respect of the estate of Isabel Harrop late of Woorinen South in the State of Victoria, Widow, deceased (who died on 5 June 1980) are required by the Executor Frank Lawson Harrop to send particulars to him care of the undersigned by 28 January 1981, after which date the Executor may convey or distribute the assets having regard only to the claims of which he then has notice.

HAYES (ALEC M.) & McINERNEY, solicitors, 148 Campbell Street, Swan Hill 11217

Creditors, next of kin and others having claims in respect of the estate of Evelyn Hedley formerly of 8 Spring Road South Caulfield Victoria but late of Springslade Nursing Home Legana Launceston Tasmania widow deceased who died on 19 August 1980 are required to send particulars of their claims to The Equity Trustees Executors and

Agency Company Limited of 472 Bourke Street Melbourne by 27 January 1981 after which date it will distribute the assets having regard only to the claims of which it then has notice.

LEACH & THOMSON, solicitors, 472 Bourke Street, Melbourne 11221

Creditors, next of kin and others having claims in respect of the estate of Frederick Claude Ryland late of The White House No. 61 Mont-es-Croix St. Brelade Island of Jersey Channel Islands retired director deceased who died on 21 May 1980 are required to send particulars of their claims to The Equity Trustees Executors and Agency Company Limited of 472 Bourke Street Melbourne by 27 January 1981 after which date it will distribute the assets having regard only to the claims of which it then has notice.

LEACH & THOMSON, solicitors, 472 Bourke Street, Melbourne 11222

CAMERON McDOUGALL FORSTER, late of Flat 15, 628 St. Kilda Road, Melbourne, medical practitioner, DECEASED

Creditors, next of kin and others having claims in respect of the estate of the deceased who died on 2 March 1980 are required by the personal representatives, The Trustees Executors and Agency Company Limited of 401 Collins Street Melbourne, Cameron Elton Hugh Forster of 43 Connell Street Hawthorn and Jean Adelaide Seaward of Flat 15, 628 St. Kilda Road, Melbourne to send particulars to them by 24 January 1981 after which date the personal representatives may convey or distribute the assets, having regard only to the claims of which they then have notice.

WEIGALL & CROWTHER, of 459 Little Collins Street, Melbourne, solicitors for the estate 11240

ROY CECIL McLENNAN, late of 83 Armstrong Street, Middle Park, chef, presumed dead

Creditors, next of kin and others having claims in respect of the estate of deceased (who is presumed to have died) are required by The Perpetual Executors and Trustees Association of Australia Limited of 50 Queen Street, Melbourne, to send particulars of their claims to the said Company by 30 January 1981 after which date it will convey or distribute the assets, having regard only to the claims of which the Company then has notice.

BEST, HOOPER, RINTOUL & SHALLARD, solicitors, 400 Little Collins Street, Melbourne 11241

MARJORIE VIOLET MITCHEL TERRY, late of 19 Ferncroft Avenue, East Malvern, gentlewoman, DECEASED

Creditors, next of kin and others having claims in respect of the estate of the abovenamed deceased are required by the Executor The Trustees Executors and Agency Company Limited of 401 Collins Street Melbourne to send particulars to the Executor by 21 January 1981 after which date the Executor may convey or distribute the estate having regard only to the claims of which it then has notice.

DAVIES CAMPBELL & PIESSE, solicitors, of 401 Collins Street, Melbourne, 3000 11242

#### Trustee Act 1958

#### NOTICE TO CLAIMANTS

Pursuant to the Trustee Act 1958, creditors next of kin and all other persons having claims in respect of the estate of any deceased person named below are required to send particulars to the legal personal representative or representatives at the addresses stated, after which date the representatives will distribute the assets, having regard only to the claims of which notice has been received:—

Edith Emma Malinda MacGillivray late of 70 Hall Street Newport Widow deceased, died on 21 October 1980. Claims to the Executor Harvey William MacGillivray of 70 Hall Street Newport Retired by 21 January 1981—JOHN F. CARROLL, LL.B., solicitor, 4 Paisley Street, Footscray. 11218

Pretoria May Hynson late of 303 Somerville Road West Footscray Widow deceased, died on 14 August 1980. Claims to the Executors Ivan George Hynson of 9 Booral



Drive West Sunshine Auto Electrician and Nancy May Ryan of 13 Dean Court North Altona Married Woman by 21 January 1981—JOHN F. CARROLL, LL.B., solicitor, 4 Paisley Street, Footscray. 11219

Archibald Daniel Campbell Gordon late of 33 Cowper Street Footscray Pensioner deceased, died on 18 October 1980. Claims to the Executor Lindsay Gordon of 38 Saitley Street South Kingsville by 21 January 1981—JOHN F. CARROLL, LL.B., solicitor, 4 Paisley Street, Footscray. 11220

In the Supreme Court of the State of Victoria  
SALE BY THE SHERIFF

On Wednesday 3 December 1980 at 11.00 a.m. at 846 High Street, Glen Waverley (unless process be stayed or satisfied).

All the Estate and Interest (if any) of Alan Philip Sasseen and Robyn Lynette Sasseen of 846 High Street, Glen Waverley in and to: Washing machine, clothes dryer, refrigerator, colour T.V. set, lounge suite, sideboard, 2 tables, cadazena, stereo, dining room suite, all other furniture and chattels.

Terms—Cash only  
11243 T. M. NICHOLLS, Sheriff's Officer

In the Supreme Court of the State of Victoria  
SALE BY THE SHERIFF

On Thursday 22 January 1981 at 2.30 p.m. at the Bailiff's Office, 2nd Floor, 300 Burwood Road, Hawthorn (unless process be stayed or satisfied).

All the Estate and Interest (if any) of Jozsef Kuti, concreter and Victoria Kuti (shown on Certificate of Title as Viktoria Kuti) married woman both of 45 Burden Street, Springvale, as joint proprietors of an estate in fee simple in the land described in Certificate of Title Volume 8347 Folio 427 upon which is erected a brick veneer dwelling known as No. 45 Burden Street Springvale.

Registered Mortgage No. H.363812 affects the said estate and interest.

Terms—Cash only  
11244 T. M. NICHOLLS, Sheriff's Officer

In the Supreme Court of the State of Victoria  
SALE BY THE SHERIFF

On Thursday 22 January 1981 at 2.30 p.m. at the Bailiff's Office, 2nd Floor 300 Burwood Road, Hawthorn (unless process be stayed or satisfied).

All the Estate and Interest (if any) of Ronald J. Simpson, builder (shown on Certificate of Title as Ronald John Simpson) of 15 Solway Drive, Glen Waverley, as proprietor of an estate in fee simple in the land described in Certificate of Title Volume 8603 Folio 049 upon which is erected a brick veneer dwelling known as No. 15 Solway Drive, Glen Waverley.

Registered Mortgage Nos. H.280628 and H.280629 affects the said estate and interest.

Terms—Cash only  
11245 T. M. NICHOLLS, Sheriff's Officer

In the Supreme Court of the State of Victoria  
SALE BY THE SHERIFF

On Thursday 22 January 1981 at 2.30 p.m. at the Bailiff's Office, 2nd Floor, 300 Burwood Road, Hawthorn (unless process be stayed or satisfied).

All the Estate and Interest (if any) of Barbara Jean Eade (now Mafodda) (shown on Certificate of Title as Barbara Jean Mafodda), married woman of 700 Toorak Road, Malvern as proprietor of an estate in fee simple in the land described in Certificate of Title Volume 8989 Folio 319 upon which is erected a brick dwelling known as No. 700 Toorak Road, Malvern.

Registered Mortgage Nos. H.81906 and H.433589 affects the said estate and interest.

Terms—Cash only  
11246 T. M. NICHOLLS, Sheriff's Officer

In the Supreme Court of the State of Victoria  
SALE BY THE SHERIFF

On Monday 22 December 1980 at 2.30 p.m. at the Bailiff's Office, 2nd Floor, 300 Burwood Road, Hawthorn (unless process be stayed or satisfied).

All the Estate and Interest (if any) of Alex Stegman, sales manager (shown on Certificate of Title as Alexander Stegman) of 51 Willmott Drive, Hoppers Crossing as joint proprietor with Dianne Mary Stegman of an estate in fee simple in the land described in Certificate of Title Volume 9001 Folio 039 upon which is erected a brick veneer dwelling known as No. 51 Willmott Drive, Hoppers Crossing.

Registered Mortgage Nos. H.684399 and H.693556 and Caveat J.134926 affects the said estate and interest.

Terms—Cash only  
11247 K. MARTIN, Sheriff's Officer

In the Supreme Court of the State of Victoria  
SALE BY THE SHERIFF

On Monday 22 December 1980 at 2.30 p.m. at the Bailiff's Office, 2nd Floor, 300 Burwood Road, Hawthorn (unless process be stayed or satisfied).

All the Estate and Interest (if any) of Domonic Bruzesse, employee (shown on Certificate of Title as Domenico Bruzesse) and Elia Bruzesse, married woman (shown on Certificate of Title as Elia Bruzesse) both of 125 Eastwood Street, Kensington as joint proprietors of an estate in fee simple in the land described in Certificate of Title Volume 3493 Folio 581 upon which is erected a house known as No. 125 Eastwood Street Kensington.

Registered Mortgage No. H.836739 and Caveat No. G.493043 affect the said estate and interest.

Terms—Cash only  
11248 K. R. MARTIN, Sheriff's Officer

In the Supreme Court of the State of Victoria  
SALE BY THE SHERIFF

On Monday 22 December 1980 at 2.30 p.m. at the Bailiff's Office, 2nd Floor, 300 Burwood Road, Hawthorn (unless process be stayed or satisfied).

All the Estate and Interest (if any) of Milan Adamjak, electrician, 6 Charles Road, Altona as proprietor of an estate in fee simple in the land described in Certificate of Title Volume 8724 Folio 367 upon which is erected a dwelling house known as No. 6 Charles Road, Altona.

Registered Mortgage No. F.417018 affects the said estate and interest.

Terms—Cash only  
11249 K. R. MARTIN, Sheriff's Officer

In the Supreme Court of the State of Victoria  
SALE BY THE SHERIFF

On Thursday 22 January 1981 at 2.30 p.m. at the Bailiff's Office, 2nd Floor, 300 Burwood Road, Hawthorn (unless process be stayed or satisfied).

All the Estate and Interest (if any) of John Arthur Harrison, cartage contractor of 2 Excelsior Drive, Frankston as joint proprietor with Yvonne Lorraine Harrison married woman of an estate in fee simple in the land described in Certificate of Title Volume 8670 Folio 635 upon which is erected a dwelling house known as No. 2 Excelsior Drive, Frankston.

Registered Mortgage Nos. H.353805 and H.371542 affects the said estate and interest.

Terms—Cash only  
11250 T. M. NICHOLLS, Sheriff's Officer

In the Supreme Court of the State of Victoria  
SALE BY THE SHERIFF

On Thursday, 29 January 1981 at 2.30 p.m. at Bailiff's Office, 2nd Floor, 300 Burwood Road, Hawthorn (unless process be stayed or satisfied).

All the Estate and Interest (if any) of Raymond Frederick Stewart, truck driver, of 48 Marianne Way, Mount Waverley, as joint-proprietor with Glenys Stewart, married

woman, of an estate in fee simple in the land described in Certificate of Title Volume 8457 Folio 124 upon which is erected a weatherboard dwelling known as No. 48 Marianne Way, Mount Waverley.

Registered Mortgage Nos. C.602776 and E.683537.

Terms—Cash only

11251 T. M. NICHOLLS, Sheriff's Officer

In the Supreme Court of the State of Victoria

SALE BY THE SHERIFF

On Thursday, 22 January 1981 at 2.30 p.m. at Bailiff's Office, 2nd Floor, 300 Burwood Road, Hawthorn (unless process be stayed or satisfied).

All the Estate and Interest (if any) of Anthony Rae, builder, and Joanne Gaye Rae, married woman, both of 22 Emerald Road, Guy's Hill, as proprietor of an estate in fee simple in the land described in Certificate of Title Volume 9178 Folio 151 upon which is erected a brick veneer dwelling known as No. 52 Surrey Close, Hallam.

Registered Mortgage No. H.302298 and Caveat No. H.753159 affect the said estate and interest.

Terms—Cash only

11252 A. G. McCORMACK, Sheriff's Officer

In the Supreme Court of the State of Victoria

SALE BY THE SHERIFF

On Thursday, 22 January 1981 at 2.30 p.m. at Bailiff's Office, 2nd Floor, 300 Burwood Road, Hawthorn (unless process be stayed or satisfied).

All the Estate and Interest (if any) of Peter John Hudson, driver, and Lynda Janice Hudson, dental nurse, both of No. 4 Lot 16 Tara Court, Wantirna, as proprietors of an estate in fee simple in the land described in Certificate of Title Volume 8947 Folio 222 upon which is erected a dwelling known as No. 4 Lot 16 Tara Court, Wantirna.

Registered Mortgage No. H.683957 affects the said estate and interest.

Terms—Cash only

11253 H. BUETTNER, Sheriff's Officer

In the Supreme Court of the State of Victoria

SALE BY THE SHERIFF

On Thursday, 22 January 1981 at 2.30 p.m. at Bailiff's Office, 2nd Floor, 300 Burwood Road, Hawthorn (unless process be stayed or satisfied).

All the Estate and Interest (if any) of David John Stephens, operator, and Margaret Stephens, home duties, both of 9 Pembroke Drive, Somerville, as joint proprietors of an estate in fee simple in the land described in Certificate of Title Volume 8997 Folio 704 upon which is erected a brick veneer dwelling known as No. 9 Pembroke Drive, Somerville.

Registered Mortgage Nos. F.517532, F.528549 and Caveat Nos. G.316176 and G.673138 affect the said estate and interest.

Terms—Cash only

11254 T. M. NICHOLLS, Sheriff's Officer

In the Supreme Court of the State of Victoria

SALE BY THE SHERIFF

On Thursday, 29 January 1981 at 2.30 p.m. at Bailiff's Office, 2nd Floor, 300 Burwood Road, Hawthorn (unless process be stayed or satisfied).

All the Estate and Interest (if any) of Richard John Savill, chartered accountants, of 22 Napoleon Street, Collingwood, as joint proprietor with Margaret Jennifer Savill, chartered accountant, of 22 Napoleon Street, Certificate of Title Volume 6891 Folio 090 upon which is erected a brick veneer dwelling known as No. 1 Hopetoun Street, Mitcham.

Registered Caveat No. H.19889 affects the said estate and interest.

Terms—Cash only

11255 H. BUETTNER, Sheriff's Officer

In the Supreme Court of the State of Victoria

SALE BY THE SHERIFF

On Thursday, 22 January 1981 at 2.30 p.m. at Bailiff's Office, 2nd Floor, 300 Burwood Road, Hawthorn (unless process be stayed or satisfied).

All the Estate and Interest (if any) of Elizabeth Helen Corcoran, married woman, of 1 Sarah Street, Black Rock, as to one equal undivided third part or share as tenant in common with Christina Marion Corcoran, widow, as to two equal undivided third parts or shares, as joint proprietors of an estate in fee simple in the land described in Certificate of Title Volume 4948 Folio 511 upon which is erected a dwelling house known as No. 1 Sarah Street, Black Rock.

Registered Mortgage No. H.191901 affects the said estate and interest.

Terms—Cash only

11256 T. M. NICHOLLS, Sheriff's Officer

In the Supreme Court of the State of Victoria

SALE BY THE SHERIFF

On Thursday, 29 January 1981 at 2.30 p.m. at Bailiff's Office, 2nd Floor, 300 Burwood Road, Hawthorn (unless process be stayed or satisfied).

All the Estate and Interest (if any) of Michalle Portelli (shown on Certificate of Title as Michele Portelli), spray painter, and Concetta Portelli, married woman, both of 67 Woodhouse Grove, Box Hill, as joint proprietors of an estate in fee simple in the land described in Certificate of Title Volume 8115 Folio 932 upon which is erected a white weatherboard dwelling known as No. 67 Woodhouse Grove, Box Hill.

Registered Mortgages Nos. G.976937 and H.112750 affect the said estate and interest.

Terms—Cash only

11257 H. BUETTNER, Sheriff's Officer

In the Supreme Court of the State of Victoria

SALE BY THE SHERIFF

On Wednesday, 28 January 1981 at 11.30 a.m. at the Police Station, Drysdale (unless process be stayed or satisfied).

All the Estate and Interest (if any) of Alan George Walkerden, plumber, of 1 Rhonda Avenue, St Leonards, as proprietor of an estate in fee simple in the land described in Certificate of Title Volume 8297 Folio 839 upon which is erected a dwelling known as No. 1 Rhonda Avenue, St Leonards.

Registered Mortgage No. H.861636 affects the said estate and interest.

Terms—Cash only

11258 Sgt. H. A. F. WIELENS, Sheriff's Officer

## INSOLVENCY NOTICE

Bankruptcy Act 1966

GARY FRANCIS CONNELLY

No. 275 of 1980

Creditors are advised that the abovementioned Debtor has executed a Deed of Arrangement under the provisions of Part X of the Bankruptcy Act 1966 on 6 November 1980. The Trustee is Mr Edward Peter Taylor of 583 Hampton Street, Hampton and Creditors are advised that they should now lodge their Proof of Debt with the Trustee within 21 days.

11130

E. P. TAYLOR, Trustee

### NOTICE OF MAKING OF STATUTORY RULES

In pursuance of the provisions of the *Subordinate Legislation Act 1962* and the Regulations made thereunder, notice is given of the making of the following Statutory Rules:—

No.	Marine Act 1958	Price
431/1980.	Marine (Inspection Fees for "Hire and Drive Yourself" Motor Boat and Rowing Boat) Regulations 1980, No. 2	10c
	<i>Marine Act 1958</i>	
432/1980.	Marine (Fishing Vessels) (Penalties) Regulations 1980	10c
	<i>Water Act 1958</i>	
433/1980.	Water (Engineer of Water Supply Certificates) Regulations 1980	30c
	<i>Second-hand Dealers Act 1958</i>	
434/1980.	Second-hand Dealers (Exemption No. 17) Regulations 1980	10c
	<i>Fisheries Act 1968</i>	
435/1980.	Fishing (General) (Amendment No. 4) Regulations 1980	10c
	<i>State Electricity Commission Act 1958</i>	
436/1980.	State Electricity Commission Falls Creek Tourist Area (Amendment) Regulations 1980	10c
	<i>Racing Act 1958</i>	
437/1980.	Racing (Doubles Totalizator Amendment) Regulations 1980	10c
	<i>Supreme Court Act 1958</i>	
438/1980.	Supreme Court (Masters' Powers) Rules 1980	10c
	<i>Public Service Act 1974</i>	
PSD124/1980.	Public Service Amendment Determinations (No. 124) 1980	10c
PSD128/1980.	Public Service Amendment Determinations (No. 128) 1980	10c
PSD129/1980.	Public Service Amendment Determinations (No. 129) 1980	10c
PSD130/1980.	Public Service Amendment Determinations (No. 130) 1980	20c
PSD131/1980.	Public Service Amendment Determinations (No. 131) 1981	10c

Copies of these Statutory Rules when printed may be purchased at the Sale of Publications Branch of the Government Printing Office, located at 7A Parliament Place, Melbourne, 3002. If ordered by mail, remittance should be addressed to "The Government Printer, Box 203, P.O., North Melbourne, 3051", and should include 50c delivery and handling fee.

The annual subscription rates for Statutory Rules for the year commencing 1 January 1981, payable in advance, are as follows:—

*Statutory Rules (other than Public Service Determinations), Pamphlet copies only	\$42.00
Public Service Determinations	\$30.00
* The Bound Volume of Statutory Rules is not included in the subscription rate.	

F. D. ATKINSON  
Government Printer

### STATE ACTS, 1979

Copies of the following Acts of the Parliament of Victoria may be obtained at the Government Printing Office, Sale of Publications Branch, 7A Parliament Place, Melbourne, phone 651 2754 or 651 2759, or from any accredited agent, at the price set opposite to each.

A delivery and handling fee must be added to your remittance when ordering by mail as follows:—

Total Value of Acts Ordered	Delivery and Handling Fee
10c-\$2.00	0.50c
\$2.05-\$5.00	\$1.00
\$5.05-\$20.00	\$1.50
Above \$20.00	\$2.00

Also available are—

Bound Volumes	\$22
Index to the Bound Volumes	\$10

No.	Price
9251. Constitution (Governor's Pension)	\$0.10
9252. Joint Select Committee (Road Safety)	\$0.20
9253. Cattle Compensation	\$0.10
9254. Constitution (Local Government)	\$0.30
9255. Gas and Fuel Corporation (Borrowing Powers)	\$0.10
9256. Ombudsman (Co-operation)	\$0.10
9257. Geelong (Haimes Homes) Land	\$0.20
9258. Motor Car (Breath Testing Stations) (Amendment)	\$0.10
9259. Geelong Waterworks and Sewerage (Trust)	\$0.30
9260. Bright (Land Exchange)	\$0.20
9261. Supply (1979-80, No. 1)	\$0.30
9262. Money Lenders (Fees)	\$0.10
9263. Exhibition (Amendment)	\$0.30
9264. Health (Cattle)	\$0.10
9265. Victorian Public Offices Corporation (Amendment)	\$0.10
9266. Community Welfare Services (Amendment)	\$0.10
9267. Margarine (Amendment)	\$0.10
9268. Youth, Sport and Recreation (State Youth Council)	\$0.10
9269. Racing (Restricted Trotting Meetings)	\$0.10
9270. State Electricity Commission (Morwell Land Compensation)	\$0.10
9271. Construction Safety	\$1.00
9272. Business Franchise (Petroleum Products)	\$0.40
9273. Albury-Wodonga Agreement (Amendment)	\$0.40
9274. City of Melbourne (Re-subdivision)	\$0.10
9275. Co-operation	\$0.40
9276. Cemeteries (Melbourne General Cemetery)	\$0.10
9277. Melbourne and Metropolitan Board of Works (Amendment)	\$0.30
9278. River Improvement (Trusts and Valuations)	\$0.10
9279. Instruments (Writs)	\$0.10
9280. Forests (Reserved Land)	\$0.10
9281. Trinity College	\$0.50
9282. Revocation and Excision of Crown Reservations	\$0.30
9283. Local Government (Amendment)	\$0.50
9284. Tattersall Consultations (Amendment)	\$0.10
9285. Prahran Market	\$0.10
9286. Geelong Regional Commission (Amendment)	\$0.10
9287. Pharmacists (Amendment)	\$0.10
9288. Legal Profession Practice (Amendment)	\$0.10
9289. Barley Marketing (Amendment)	\$0.10
9290. Water Authorities (Constitution and Powers)	\$0.20
9291. Sewerage Authorities (Constitution and Powers)	\$0.30
9292. Wrongs (Defamation)	\$0.10
9293. Judges Salaries	\$0.10
9294. Poisons (Amendment)	\$0.10
9295. Business Franchise (Petroleum Products) (Licence Fees)	\$0.20
9296. State Electricity Commission (Amendment)	\$0.30

## STATE ACTS, 1979—continued.

No.	Price
9297. Workers Compensation (Miscellaneous Provisions)	\$1.00
9298. Motor Car (Surcharge)	\$0.10
9299. Unclaimed Moneys	\$0.10
9300. Land Tax	\$0.10
9301. Business Franchise (Tobacco)	\$0.10
9302. Public Authorities (Contributions)	\$0.10
9303. Appropriation (1979-80, No. 1)	\$3.50
9304. Gift Duty (Amendment)	\$0.10
9305. Pay-roll Tax	\$0.30
9306. Transport Works and Services	\$0.20
9307. Melbourne and Metropolitan Tramways (Borrowing Powers)	\$0.10
9308. County Court (Jurisdiction)	\$0.10
9309. State Forests Works and Services	\$0.10
9310. Young Men's Christian Association of Ballarat (Guarantee)	\$0.20
9311. Water Supply Works and Services	\$0.40
9312. Trustee Companies (Trustees Executors)	\$0.10
9313. Commercial Goods Vehicles (Aviation Fuel)	\$0.10
9314. Victorian Development Corporation (Powers)	\$0.20
9315. Town and Country Planning (Planning Schemes)	\$1.00
9316. Victorian Government Travel Authority (Reconstitution)	\$0.10
9317. Stamps (Amendment)	\$0.30
9318. Motor Car (Fees)	\$0.30
9319. Racing (Financial Provisions)	\$0.30
9320. Urban Land Authority	\$0.50
9321. Public Works and Services	\$0.30
9322. Second-hand Dealers (Closing Hours)	\$0.10
9323. Crimes (Amendment)	\$0.10
9324. Transfer of Land (Amendment)	\$0.40
9325. Melbourne College of Divinity	\$0.30
9326. Transport Regulation (Car Pools)	\$0.10
9327. Fisheries (Amendment)	\$0.10
9328. Egg Industry Stabilization (Amendment)	\$0.10
9329. Local Authorities Superannuation	\$0.30
9330. Latrobe Valley (Amendment)	\$0.10
9331. Liquor Control (Amendment)	\$0.10
9332. Motor Accidents (Amendment)	\$0.40
9333. Young Farmers' Finance Council	\$0.30
9334. Probate Duty	\$0.20
9335. Railways (Board)	\$0.10
9336. Ministry of Transport (Amendment)	\$0.10
9337. Abattoir and Meat Inspection (Amendment)	\$0.20
9338. Public Service (Amendment)	\$0.20
9339. Trustee Companies (Amendment)	\$0.20
9340. Vermin and Noxious Weeds (Amendment)	\$0.30
9341. Canned Fruits Marketing	\$0.40
9342. Marine (Amendment)	\$0.40
9343. Shire of Ormeo (Tourist Gold Mine)	\$0.30
9344. Presbyterian Trusts	\$0.90
9345. Railway Construction and Property Board	\$0.90
9346. Motor Car (Insurance by Pensioners)	\$0.10
9347. Town and Country Planning (Amendment of Schemes)	\$0.10
9348. Labour and Industry (Amendment)	\$0.20
9349. Magistrates' Courts (Civil Jurisdiction)	\$0.40
9350. Master Builders' Association of Victoria (Guarantee)	\$0.20
9351. Education (Amendment)	\$0.20
9352. Educational Grants (Continuation)	\$0.10
9353. Wrongs (Assessment of Damages)	\$0.10
9354. Victorian Arts Centre	\$0.40
9355. Building Industry Long Service Leave (Amendment)	\$0.50
9356. Local Government (Land Liable to Flooding)	\$0.30
9357. Parliamentary Committees (Public Accounts and Expenditure Review Committee)	\$0.20
9358. Superannuation (Amendment)	\$0.30
9359. Health (Proprietary Medicines)	\$0.20
9360. Victorian Fishing Industry Council	\$0.30
9361. Grain Handling Improvement Authorities	\$0.30
9362. Wheat Marketing	\$0.80
9363. State Employees Retirement Benefits	\$1.00
9364. Town and Country Planning (General Amendment)	\$1.00
9365. Industrial Relations	\$1.40

## STATE ACTS, 1980

Copies of the following Acts of the Parliament of Victoria may be obtained at the Government Printing Office, Sale of Publications Branch, 7A Parliament Place, Melbourne, phone 651 2754 or 651 2759, or from any accredited agent, at the price set opposite to each.

A delivery and handling fee must be added to your remittance when ordering by mail as follows:

Total Value of Acts Ordered	Delivery and Handling Fee
10c-\$2.00	0.50c
\$2.05-\$5.00	\$1.00
\$5.05-\$20.00	\$1.50
Above \$20.00	\$2.00

Bound Volumes of 1979 State Acts (\$22.00) and the Index to the Bound Volumes (\$10.00) are also available.

The annual subscription rate for State Acts for the year commencing 1 January 1981 is \$37.

No.	Price
9366. Constitutional Powers (Coastal Waters)	20c
9367. Parliamentary Committees (Public Bodies Review)	40c
9368. Agricultural Chemicals	\$0.50
9369. Central Gippsland (Brown Coal Land Compensation)	\$0.20
9370. Motor Car (Payments by Pensioners)	\$0.20
9371. Navigable Waters (Oil Pollution) (Amendment)	\$0.20
9372. Workers Compensation (General Amendment)	\$0.20
9373. Extractive Industries (Amendment)	\$0.30
9374. Health (Special Accommodation Houses)	\$0.20
9375. Cancer (Amendment)	\$0.20
9376. Victorian Film Corporation (Amendment)	\$0.30
9377. Railways (Bridges)	\$0.10
9378. Wangarrip (Land Exchange)	\$0.20
9379. Supply (1980-81, No. 1)	\$0.30
9380. Crown Land (Mineral Springs)	\$0.20
9381. Groundwater (Mineral Water)	\$0.20
9382. Melbourne Underground Rail Loop (Land Development)	\$0.30
9383. Chiropodists (Amendment)	\$0.10
9384. Youth, Sport and Recreation (Guarantees)	\$0.20
9385. Pensioners' Rates Remission	\$0.30
9386. Motor Car Traders (Amendment)	\$0.40
9387. Victorian Solar Energy Council	\$0.30
9388. Racing (Amendment)	\$0.20
9389. Country Fire Authority (Amendment)	\$0.20
9390. Local Government (Validation)	\$0.10
9391. Professional Boxing Control (Amendment)	\$0.10
9392. Police Regulation (Retired Police Reserve)	\$0.10
9393. Local Authorities Superannuation (Amendment)	\$0.30
9394. Water (Valuation Equalization)	\$0.20
9395. Upper Yarra Valley and Dandenong Ranges Authority (Amendment)	\$0.20
9396. Dog (Amendment)	\$0.20
9397. Hospitals Superannuation (Amendment)	\$0.20
9398. Hospitals and Charities (Appointment of Administrators)	\$0.10
9399. Home Finance (Borrowing Powers)	\$0.20
9400. State Employees Retirement Benefits (Amendment)	\$0.30
9401. Wodonga Area Land Acquisition (Validation)	\$0.30
9402. Local Government (General Amendment)	\$0.40
9403. Motor Registration	\$0.50
9404. Epworth Hospital	\$0.50
9405. Archaeological and Aboriginal Relics Preservation (Amendment)	\$0.20
9406. Geelong Performing Arts Centre Trust	\$0.40
9407. Imperial Law Re-enactment	\$0.30
9408. Constitutional Powers (Request)	\$0.20
9409. Friendly Societies (Benefits)	\$0.10
9410. Magistrates' Courts (Jurisdiction)	\$0.10
9411. Baker Medical Research Institute	\$0.50
9412. Protection of Animals (Amendment)	\$0.30
9413. Stamps (Amendment)	\$0.40
9414. Liquefied Petroleum Gas Subsidy	\$0.30

STATE ACTS, 1980—continued		Price
No.		
9415.	Revocation and Excision of Crown Reservations	\$0.30
9416.	Forests (Amendment)	\$0.20
9417.	Forests (Further Amendment)	\$0.20
9418.	Transport (Road Funds)	\$0.20
9419.	Building Societies (Amendment)	\$0.60
9420.	Legal Profession Practice (Leo Cussen Institute)	\$0.10
9421.	Instruments (Powers of Attorney)	\$0.30
9422.	Melbourne (Yarra Park) Land	\$0.20
9423.	Sale of Land (Deposits)	\$0.20
9424.	Post-Secondary Education (Amendment)	\$0.60
9425.	Town and Country Planning (Amalgamation)	\$0.90
9426.	Imperial Acts Application	\$1.00
9427.	Statute Law Revision	\$0.80
9428.	Estate Agents	\$1.60

ACTS REPRINTED IN ACCORDANCE WITH THE AMENDMENTS INCORPORATION ACT 1958 (No. 6422), AND FOR SALE AS STOCKS ARE AVAILABLE AT THE SALE OF PUBLICATIONS BRANCH OF THE GOVERNMENT PRINTING OFFICE, 7A PARLIAMENT PLACE, MELBOURNE, 3002.

A delivery and handling fee must be added to your remittance when ordering by mail as follows:—

Total Value of Acts Ordered	Delivery and Handling Fee
10c—\$2.00	0.50c
\$2.05—\$5.00	\$1.00
\$5.05—\$20.00	\$1.50
Above \$20.00	\$2.00

No.		Price
8404.	Abattoir and Meat Inspector (First Reprint—Incorporating amendments up to No. 9005)	\$0.85
6189.	Acts Interpretation (Fifth Reprint—Incorporating amendments up to Act No. 9229)	\$0.70
6191.	Administration and Probate Act 1958 (Fifth Reprint—Incorporating amendments up to No. 9075)	\$1.05
7147.	Adoption of Children (First Reprint—Incorporating amendments up to Act No. 8602)	\$0.75
6194.	Agricultural Colleges (First Reprint—Incorporating amendments up to No. 7302)	\$0.15
7772.	Alcoholic and Drug-Dependent Persons Act 1968 (First Reprint—Incorporating amendments up to Act No. 9023)	\$0.60
6198.	Anzac Day (First Reprint—Incorporating amendments up to No. 8344)	\$0.15
7117.	Appeal Costs Fund Act 1964 (Second Reprint—Incorporating amendments up to No. 8145)	\$0.35
8273.	Archaeological and Aboriginal Preservation Act 1972 (First Reprint—Incorporating amendments up to Act No. 9019)	\$0.30
6201.	Architects (First Reprint—Incorporating amendments up to No. 8077)	\$0.30
6202.	Auction Sales (First Reprint—Incorporating amendments up to No. 8490)	\$0.35
6203.	Audit (First Reprint—Incorporating amendments up to No. 7377)	\$0.35
9008.	Bail Act 1977 (First Reprint—Incorporating amendments up to Act No. 9158)	\$0.70
6206.	Barley Marketing (First Reprint—Incorporating amendments up to No. 9005)	\$0.30
6208.	Benefit Associations (First Reprint—Incorporating amendments up to No. 6961)	\$0.65
8004.	Boilers and Pressure Vessels Act 1970—(Second Reprint—Incorporating amendments up to Act No. 9019)	\$0.65
6529.	Bread Industry Act 1959 (Second Reprint—Incorporating amendments up to Act No. 8542)	\$0.20
6973.	Building Contracts (Deposits) Act 1962 (Second Reprint—Incorporating amendments from No. 8938)	\$0.20
8693.	Building Industry Long Service Leave (First Reprint—Incorporating Amendments up to No. 9122)	\$0.85

ACTS REPRINTED IN ACCORDANCE WITH THE AMENDMENTS INCORPORATION ACT 1958 (No. 6422)—continued

No.		Price
8597.	Business Franchise (Tobacco) Act 1974 (First Reprint—Incorporating amendments up to No. 9301)	\$0.70
6853.	Business Names Act 1962 (First Reprint—Incorporating amendments up to Act No. 9427)	\$0.90
6213.	Cancer Act 1958 (Second Reprint—Incorporating amendments up to No. 9023)	\$1.10
6214.	Carriers and Innkeepers (Second Reprint—Incorporating amendments up to No. 8534)	\$0.20
6215.	Cattle Breeding (First Reprint—Incorporating amendments up to No. 6886)	\$0.10
6217.	Cemeteries Act 1958 (Second Reprint—Incorporating amendments up to Act No. 9052)	\$0.90
8477.	Children's Court Act 1973 (Second Reprint—Incorporating amendments up to Act No. 9008)	\$1.30
6220.	Clean Air (Third Reprint—Incorporating amendments up to No. 8324)	\$0.15
4597.	Closer Settlement Act 1980 (First Reprint—Incorporating amendments up to Act No. 9212)	\$1.20
8661.	Cluster Titles Act 1974 (First Reprint—Incorporating amendments up to Act No. 9128)	\$0.85
6221.	Coal Mines (Second Reprint—Incorporating amendments up to No. 8953)	\$2.15
6222.	Commercial Goods Vehicles (Third Reprint—Incorporating amendments up to No. 8525)	\$0.55
6223.	Commonwealth Arrangements (First Reprint—Incorporating amendments from No. 7809)	\$0.10
6839.	Companies (Sixth Reprint—Incorporating amendments up to No. 8788)	\$9.60
8750.	Constitution Act 1975 (Third Reprint—Incorporating amendments up to Act No. 9251)	\$1.30
6224.	Constitution Act Amendment Act 1959 (Second Reprint—Incorporating amendment up to No. 9216)	\$3.00
8276.	Consumer Affairs Act 1972 (Fourth Reprint—Incorporating amendments up to Act No. 9197)	\$1.50
6225.	Co-operation Act 1958 (Fourth Reprint—Incorporating amendments up to Act No. 9136)	\$1.60
6226.	Co-operative Housing Societies Act 1958 (Third Reprint—Incorporating amendments up to No. 9206)	\$1.50
6227.	Coroners (Second Reprint—Incorporating amendments up to No. 8184)	\$0.35
6228.	Country Fire Authority (Third Reprint—Incorporating amendments up to No. 8813)	\$1.25
6229.	Country Roads Act 1958 (Fifth Reprint—Incorporating amendments up to No. 9212)	\$2.00
6230.	County Court (Fourth Reprint—Incorporating amendments up to No. 9075)	\$0.95
6231.	Crimes Act 1958 (Sixth Reprint—Incorporating amendments up to Act No. 9073)	\$3.15
6232.	Crown Proceedings (Second Reprint—Incorporating amendments up to No. 8731)	\$0.40
7060.	Dandenong Valley Authority Act 1963 (Second Reprint—Incorporating amendments up to Act No. 9172)	\$1.20
8383.	Decentralized Industry Incentive Payments (First Reprint—Incorporating Amendments up to No. 8751)	\$0.20
6235.	Dietitians Registration (First Reprint—Incorporating amendments up to No. 6886)	\$0.20
4989.	Discharged Servicemen's Preference Act 1943 (Second Reprint—Incorporating amendments up to No. 7991)	\$0.20
6815.	Disposal of Uncollected Goods Act 1961 (Second Reprint—Incorporating amendments up to No. 8246)	\$0.30
8079.	Dog Act 1970 (First Reprint—Incorporating amendments up to No. 8664)	\$0.30
6237.	Drainage Areas Act 1958 (Second Reprint—Incorporating amendments up to Act No. 8811)	\$0.75
6239.	Dried Fruits Act 1968 (First Reprint—Incorporating amendments up to No. 7337)	\$0.25

## ACTS REPRINTED IN ACCORDANCE WITH THE AMENDMENTS INCORPORATION ACT 1958 (No. 6422)—continued

No.	Price
6240. Education Act 1958 ( <i>Third Reprint</i> —Incorporating amendments up to Act No. 9248)	\$1.50
6241. Electric Light and Power Act 1958 ( <i>Second Reprint</i> —Incorporating amendments up to Act No. 9296)	\$1.10
8056. Environment Protection Act 1970 ( <i>Third Reprint</i> —Incorporating amendments up to Act No. 9098)	\$0.95
6244. Essential Services ( <i>First Reprint</i> —Incorporating amendments up to No. 8353)	\$0.20
6245. Estate Agents—( <i>Fifth Reprint</i> —Incorporating amendments up to No. 8490)	\$0.85
6246. Evidence Act 1958 ( <i>Sixth Reprint</i> —Incorporating amendments up to Act No. 9230)	\$1.60
6715. Explosives Act 1960 ( <i>First Reprint</i> —Incorporating amendments up to Act No. 8920)	\$0.85
7499. Extractive Industries Act 1966 ( <i>Third Reprint</i> —Incorporating amendments up to No. 8647)	\$0.48
7733. Fences Act 1968 ( <i>Second Reprint</i> —Incorporating amendments up to Act No. 9019)	\$0.70
6468. Filled Milk ( <i>First Reprint</i> —Incorporating amendments up to No. 6886)	\$0.15
6251. Firearms ( <i>Fifth Reprint</i> —Incorporating amendments up to No. 8427)	\$1.05
7780. Fisheries Act 1968 ( <i>First Reprint</i> —Incorporating amendments up to No. 8694)	\$1.05
6916. Foreign Judgments Act 1962 ( <i>First Reprint</i> including amendments made by No. 7332)	\$0.15
6585. Forests (Pulpwood Agreement) (Incorporating amendments up to No. 6886)	\$0.15
6254. Forests ( <i>Second Reprint</i> —Incorporating amendments up to No. 8702)	\$1.35
6225. Friendly Societies Act 1958 ( <i>Second Reprint</i> —Incorporating amendments up to Act No. 9019)	\$1.60
6255. Friendly Societies ( <i>First Reprint</i> —Incorporating amendments up to No. 7554)	\$0.60
6256. Fruit and Vegetables ( <i>First Reprint</i> —Incorporating amendments up to No. 6944)	\$0.30
6260. Gas and Fuel Corporation Act 1958 ( <i>Second Reprint</i> —Incorporating amendments up to Act No. 9255)	\$2.40
6262. Geelong Harbor Trust Act 1958 ( <i>Second Reprint</i> —Incorporating amendments up to Act No. 9019)	\$1.40
6263. Geelong Waterworks and Sewerage ( <i>First Reprint</i> —Incorporating amendments up to No. 7547)	\$0.75
8176. Gift Duty Act 1971 ( <i>First Reprint</i> —Incorporating amendments from No. 8202)	\$0.55
6265. Goods ( <i>Sixth Reprint</i> —Incorporating amendments up to No. 8425)	\$0.75
6266. Grain Elevators ( <i>First Reprint</i> —Incorporating amendments up to No. 7486)	\$0.35
7849. Groundwater ( <i>Second Reprint</i> —Incorporating amendments up to No. 9019)	\$0.75
6267. Hairdressers Registration ( <i>First Reprint</i> —Incorporating amendments up to No. 7659)	\$0.30
6269. Hawkers and Pedlars ( <i>Second Reprint</i> —Incorporating amendments up to No. 8247)	\$0.40
6270. Health ( <i>Third Reprint</i> —Incorporating amendments up to No. 8506)	\$3.25
6531. Hire Purchase Act 1959 ( <i>Second Reprint</i> —Incorporating amendments from No. 8232)	\$0.85
6933. Home Finance Act 1962 ( <i>First Reprint</i> —Incorporating amendments up to No. 7363)	\$0.25
6274. Hospitals and Charities Act 1958 ( <i>Third Reprint</i> —Incorporating amendments up to No. 9212)	\$1.70
6275. Housing Act 1958 ( <i>Fourth Reprint</i> —Incorporating amendments up to Act No. 9246)	\$3.30
3270. Imperial Acts Application ( <i>First Reprint</i> —Incorporating Amendments up to No. 8037)	\$1.30
6276. Imprisonment of Fraudulent Debtors ( <i>Second Reprint</i> —Incorporating amendments up to No. 8731)	\$0.55

## ACTS REPRINTED IN ACCORDANCE WITH THE AMENDMENTS INCORPORATION ACT 1958 (No. 6422)—continued

No.	Price
6277. Industrial and Provident Societies Act 1958 ( <i>First Reprint</i> )—Incorporating amendments up to Act No. 7547	\$1.10
6279. Instruments Act 1958 ( <i>Sixth Reprint</i> —Incorporating amendments up to No. 9421)	\$1.40
6280. Judicial Proceedings Reports ( <i>First Reprint</i> —Incorporating amendments up to No. 7596)	\$0.20
7651. Juries ( <i>First Reprint</i> —Incorporating amendments up to No. 8170)	\$0.55
6283. Labour and Industry Act 1958 ( <i>Seventh Reprint</i> —Incorporating amendments up to Act No. 9163)	\$1.90
6284. Land Act ( <i>Fourth Reprint</i> —Incorporating amendments up to No. 9212)	\$4.40
6534. Land Settlement Act 1959 ( <i>First Reprint</i> —Incorporating amendments up to No. 7328)	\$0.30
6288. Land Surveyors ( <i>First Reprint</i> —Incorporating amendments up to No. 7065)	\$0.30
6289. Land Tax Act 1958 ( <i>Third Reprint</i> —Incorporating amendments to Act No. 9190)	\$1.40
6285. Landlord and Tenant ( <i>Fourth Reprint</i> —Incorporating amendments up to No. 8208)	\$1.90
6286. Lands Compensation Act ( <i>Third Reprint</i> —Incorporating amendments up to No. 8899)	\$0.45
6290. Latrobe Valley ( <i>First Reprint</i> —Incorporating amendments up to No. 7332)	\$0.35
7919. Legal Aid—( <i>First Reprint</i> —Incorporating amendments up to No. 8427)	\$0.30
6291. Legal Profession Practice Act ( <i>Fourth Reprint</i> —Incorporating amendments up to No. 8778)	\$1.45
6292. Libraries ( <i>First Reprint</i> —Incorporating amendments up to No. 7364)	\$0.15
7629. Lifts and Cranes Act 1967 ( <i>Second Reprint</i> —Incorporating amendments up to Act No. 9236)	\$0.90
6295. Limitation of Actions ( <i>Third Reprint</i> —Incorporating amendments up to No. 8300)	\$0.55
7695. Liquor Control Act 1968 ( <i>Fourth Reprint</i> —Incorporating amendments up to Act No. 9225)	\$2.40
7145. Litter Act 1964 ( <i>Second Reprint</i> —Incorporating amendments up to No. 8702)	\$0.20
6298. Local Authorities Superannuation Act 1958 ( <i>Third Reprint</i> —Incorporating amendments up to Act No. 9393)	\$1.50
5479. Local Government Department Act 1958 ( <i>First Reprint</i> —Incorporating amendments up to Act No. 8656)	\$0.10
6299. Local Government ( <i>Third Reprint</i> —Incorporating amendments up to No. 8781)	\$10.90
7429. Lotteries Gaming and Betting Act 1966 ( <i>Second Reprint</i> —Incorporating amendments up to No. 9075)	\$1.20
8184. Magistrates' Courts ( <i>First Reprint</i> —Incorporating amendments up to No. 8718)	\$0.75
7289. Maintenance ( <i>Second Reprint</i> —Incorporating amendments up to No. 9019)	\$1.35
6302. Marine Act ( <i>Second Reprint</i> —Incorporating amendments up to No. 9178)	\$2.40
6303. Marine Stores and Old Metals Act 1958 ( <i>Second Reprint</i> —Incorporating amendments up to Act No. 8622)	\$0.65
6304. Marketing of Primary Products Act 1958 ( <i>Second Reprint</i> —Incorporating amendments up to Act No. 8965)	\$1.50
6305. Markets Act ( <i>Second Reprint</i> —Incorporating amendments up to No. 8247)	\$0.30
6306. Marriage ( <i>Second Reprint</i> —Incorporating amendments up to No. 8602)	\$0.45
6309. Medical Act 1958 ( <i>Third Reprint</i> —Incorporating amendments up to No. 8593)	\$0.45
8061. Medical Practitioner ( <i>First Reprint</i> —Incorporating amendments up to No. 8754)	\$0.75
6310. Melbourne and Metropolitan Board of Works Act 1958 ( <i>Fifth Reprint</i> —Incorporating amendments up to Act No. 9427)	\$3.30
6311. Melbourne and Metropolitan Tramways Act 1958 ( <i>Second Reprint</i> —Incorporating amendments up to Act No. 8992)	\$1.45
6312. Melbourne Harbor Trust ( <i>Second Reprint</i> —Incorporating amendments up to No. 8796)	\$1.35

ACTS REPRINTED IN ACCORDANCE WITH THE AMENDMENTS  
INCORPORATION ACT 1958 (No. 6422)—continued

No.	Price
6405. Melbourne University Act 1958 (Second Reprint—Incorporating amendments up to Act No. 9123)	\$0.85
6605. Mental Health Act 1959 (Third Reprint—Incorporating amendments up to Act No. 9023)	\$1.40
6315. Metropolitan Fire Brigades (Third Reprint—Incorporating amendments up to No. 9019)	\$0.95
6316. Mildura Irrigation and Water Trusts Act 1958 (Second Reprint—Incorporating amendments up to No. 9204)	\$2.60
6317. Milk and Dairy Supervision (Second Reprint—Incorporating amendments up to No. 8655)	\$0.85
6318. Milk Board Act 1958 (Second Reprint—Incorporating amendments up to Act No. 9238)	\$1.00
6319. Milk Pasteurization (First Reprint—Incorporating amendments up to No. 7480)	\$0.20
6320. Mines Act 1958 (Third Reprint—Incorporating amendments up to Act No. 8953)	\$2.60
6322. Ministry of Transport Act 1958 (First Reprint—Incorporating amendments up to Act No. 9345)	\$0.60
6184. Monash University (First Reprint—Incorporating amendments up to No. 7533)	\$0.30
6324. Money Lenders (Fourth Reprint—Incorporating amendments up to No. 8490)	\$0.55
8429. Motor Accidents Act 1973 (Second Reprint—Incorporating amendments up to Act No. 9427)	\$1.40
6832. Motor Boating Act 1961 (Third Reprint—Incorporating amendment up to No. 8662)	\$0.55
6325. Motor Car Act 1958 (Fifth Reprint—Incorporating amendments up to No. 8657)	\$2.25
8526. Municipalities Assistance Act 1973 (First Reprint—Incorporating amendments up to Act No. 9385)	\$0.20
6705. Navigable Waters (Oil Pollution) Act 1960 (Second Reprint—Incorporating amendments up to No. 8816)	\$0.65
6328. Nurses Act 1958 (Fourth Reprint—Incorporating amendments up to Act No. 9059)	\$1.00
8414. Ombudsman Act 1973 (Second Reprint—Incorporating amendments up to Act No. 9256)	\$0.60
6329. Optometrists Registration Act 1958 (Second Reprint—Incorporating amendments up to Act No. 8800)	\$0.70
7727. Parliamentary Committees Act 1968 (First Reprint—Incorporating amendments up to Act No. 9367)	\$1.10
7723. Parliamentary Salaries and Superannuation (First Reprint—Incorporating amendments up to No. 8687)	\$0.35
6330. Partnership (Second Reprint—Incorporating amendments up to No. 7315)	\$0.45
6331. Patriotic Funds (First Reprint—Incorporating amendments up to No. 7338)	\$0.25
6332. Pawnbrokers Act 1958 (Second Reprint—Incorporating amendments up to No. 8181)	\$0.35
8154. Pay-Roll Tax Act 1971 (First Reprint—Incorporating amendments up to No. 9059)	\$1.15
7417. Pensions Supplementation (First Reprint—Incorporating amendments up to No. 8475)	\$0.20
6257. Pesticides Act 1958 (Second Reprint—Incorporating amendments up to No. 8589)	\$0.35
6334. Petroleum Act 1958 (Second Reprint—Incorporating amendments up to Act No. 9212)	\$1.30
6335. Petrol Pumps (Second Reprint—Incorporating amendments up to No. 7315)	\$0.15
6889. Poisons Act 1962 (Fifth Reprint—Incorporating amendments up to Act No. 9427)	\$1.70
6337. Police Offences Act 1958 (Third Reprint—Incorporating amendments up to No. 8433)	\$0.45
6338. Police Regulation (Third Reprint—Incorporating amendments up to No. 8722)	\$0.95
6340. Portland Harbor Trust Act 1958 (Second Reprint—Incorporating amendments up to Act No. 9204)	\$1.10

ACTS REPRINTED IN ACCORDANCE WITH THE AMENDMENTS  
INCORPORATION ACT 1958 (No. 6422)—continued

No.	Price
7498. Port Phillip Authority Act 1966 (Second Reprint—Incorporating amendments from No. 8081)	\$0.20
6341. Pounds Act 1958 (Second Reprint—Incorporating amendments up to Act No. 9168)	\$0.60
6342. Printers and Newspapers (Second Reprint—Incorporating amendments up to No. 8556)	\$0.30
7494. Private Agents Act 1966 (Third Reprint—Incorporating amendments up to Act No. 9075)	\$1.00
6890. Probate Duty Act 1962. (Fourth Reprint—Incorporating amendments up to Act No. 9019)	\$1.15
6344. Property Law Act 1958 (Fourth Reprint—Incorporating amendments up to Act No. 9075)	\$3.00
7432. Protection of Animals (First Reprint—Incorporating Amendments Up to No. 9019)	\$0.40
6345. Public Account (Second Reprint—Incorporating amendments up to No. 9033)	\$0.40
6346. Public Authorities Marks (First Reprint—Incorporating amendments from No. 7315)	\$0.10
8656. Public Service Act 1974 (Second Reprint—Incorporating amendments up to Act No. 9248)	\$1.40
6350. Public Trustee Act 1958 (Second Reprint—Incorporating amendments up to No. 8125)	\$1.05
6353. Racing (Fourth Reprint—Incorporating amendments up to No. 8690)	\$1.55
6355. Railways Act 1958 (Second Reprint—Incorporating amendments up to Act No. 9142)	\$1.55
8407. Recreation Vehicles Act 1973 (First Reprint—Incorporating amendments made by Act No. 8561)	\$0.30
6564. Registration of Births Deaths and Marriages Act 1959 (Second Reprint—Incorporating amendments up to Act No. 8602)	\$0.70
6357. Religious Successory and Charitable Trusts Act 1958 (First Reprint—Incorporating amendments made by Act No. 7315)	\$0.75
6358. River Improvements Act (Second Reprint—Incorporating amendments up to No. 8967)	\$0.85
2596. River Murray Waters Act 1915 (First Reprint—Incorporating amendments up to No. 7228)	\$0.35
6359. Road Traffic (Fourth Reprint—Incorporating amendments up to No. 8353)	\$0.35
6360. Rural Finance (First Reprint—Incorporating amendments up to No. 7328)	\$0.15
6846. Rural Finance and Settlement Commission Act 1961 (First Reprint—Incorporating amendments up to No. 7332)	\$0.30
6917. Sale of Human Blood Act 1962 (First Reprint—Incorporating amendments from No. 7332)	\$0.10
6975. Sale of Land Act 1962 (Third Reprint—Incorporating amendments up to No. 8861)	\$0.55
8146. Scaffolding Act 1971 (Second Reprint—Incorporating amendments up to No. 8666)	\$0.35
6363. Second-hand Dealers (First Reprint—Incorporating amendments up to No. 7529)	\$0.25
6367. Settled Land Act 1958 (Third Reprint—Incorporating amendments up to Act No. 9075)	\$1.50
6368. Sewerage Districts Act 1958 (Third Reprint—Incorporating amendments up to Act No. 9139)	\$1.90
6809. Sheep Owners Protection Act 1961 (Third Reprint—Incorporating amendments up to No. 8247)	\$0.20
8089. Social Welfare Act 1970 (First Reprint—Incorporating amendments up to No. 8821)	\$1.90
6372. Soil Conservation and Land Utilization Act (Third Reprint—Incorporating amendments up to No. 8432)	\$0.45
6373. Soldier Settlement (First Reprint—Incorporating amendments up to No. 7328)	\$0.42
6375. Stamps Act 1958 (Sixth Reprint—Incorporating amendments up to No. 8624)	\$2.15

ACTS REPRINTED IN ACCORDANCE WITH THE AMENDMENTS INCORPORATING ACT 1958 (NO. 6422)—continued

No.	Price
6376. State Development Committee Act 1958 (First Reprint—Incorporating amendments up to No. 8827)	\$0.30
6377. State Electricity Commission Act 1958 (Third Reprint—Incorporating amendments up to Act No. 9121)	\$1.35
6378. State Relief Committee (First Reprint—Incorporating amendments from No. 6886)	\$0.10
6379. State Savings Bank Act 1958 (Third Reprint—Incorporating amendments up to No. 8519)	\$0.95
6380. Statistics (First Reprint—Incorporating amendments up to No. 6961)	\$0.20
6877. Stock (Artificial Breeding) Act 1962 (First Reprint—Incorporating amendments up to No. 8709)	\$0.30
7724. Stock Diseases Act 1968 (First Reprint—Incorporating amendments up to Act No. 8775)	\$0.90
6383. Stock Foods (First Reprint—Incorporating amendments up to No. 7607)	\$0.28
6384. Stock Medicines Act 1958 (Second Reprint—Incorporating amendments up to No. 9005)	\$0.50
7551. Strata Titles Act 1967 (Third Reprint—Incorporating amendments up to No. 8661)	\$1.00
6886. Subordinate Legislation Act 1962 (Second Reprint—Incorporating amendments up to No. 8127)	\$0.15
7405. Summary Offences Act 1966 (Second Reprint—Incorporating amendments up to No. 8276)	\$0.55
7634. Sunday Entertainment (First Reprint—Incorporating amendments up to No. 8173)	\$0.15
6386. Superannuation Act 1958 (Fourth Reprint—Incorporating amendments up to No. 9125)	\$1.70
6387. Supreme Court (Second Reprint—Incorporating amendments up to No. 8951)	\$1.35
6388. Survey Co-ordination Act 1958 (Second Reprint—Incorporating amendments up to No. 9180)	\$0.70
6390. Tattersall Consultations (Second Reprint—Incorporating amendments up to No. 8982)	\$0.30
8274. Taxation Appeals Act 1972 (First Reprint—Incorporating amendments up to Act No. 9045)	\$0.55
6391. Teaching Service (Second Reprint—Incorporating amendments up to No. 8691)	\$0.55
6393. Theatres (First Reprint—Incorporating amendments up to No. 8161)	\$0.15
6849. Town and Country Planning Act 1961 (Fifth Reprint—Incorporating amendments up to No. 8716)	\$1.25
6397. Trade Unions (Second Reprint—Incorporating amendments up to No. 8181)	\$0.20
6399. Transfer of Land Act 1958 (Sixth Reprint—Incorporating amendments up to Act No. 9324)	1.90
6400. Transport Regulation Act (Third Reprint—Incorporating amendments up to No. 8700)	\$0.75
6401. Trustee Act 1958 (Fifth Reprint—Incorporating amendments up to Act No. 9204)	\$1.50
6402. Trustee Companies Act 1958 (Second Reprint—Incorporating amendments up to Act No. 9075)	\$0.55
6879. Unclaimed Moneys Act 1962 (Second Reprint—Incorporating amendments up to No. 8448)	\$0.20
7095. Underseas Mineral Resources Act 1963 (First Reprint—Incorporating amendments from No. 7591)	\$0.10
6653. Valuation of Land Act 1960 (Fifth Reprint—Incorporating amendments up to Act No. 9225)	\$1.10
6407. Vegetation and Vine Diseases (First Reprint—Incorporating amendments up to No. 7423)	\$0.30
6408. Venereal Diseases (First Reprint—Incorporating amendments made by Act No. 6886)	\$0.55
6409. Vermin & Noxious Weeds (First Reprint—Incorporating amendments up to No. 7463)	\$0.35

ACTS REPRINTED IN ACCORDANCE WITH THE AMENDMENTS INCORPORATION ACT 1958 (NO. 6422)—continued

No.	Price
6410. Veterinary Surgeons' (First Reprint—Incorporating amendments up to No. 7343)	\$0.15
7291. Victoria Institute of Colleges Act 1965 (Second Reprint—Incorporating amendments up to Act No. 8710)	\$0.90
8428. Victorian Development Corporation Act 1973 (First Reprint—Incorporating amendments up to Act No. 9314)	\$1.00
6412. Warehousemen's Liens (First Reprint—Incorporating amendments up to No. 7876)	\$0.15
6413. Water (Third Reprint—Incorporating amendments up to No. 8729)	\$3.45
6414. Weights and Measures Act 1958 (Fourth Reprint—Incorporating amendments up to Act No. 9019)	\$1.90
6415. Wild Flowers and Native Plants Protection (First Reprint—Incorporating amendments up to No. 6976)	\$0.15
6416. Wills Act 1958 (Second Reprint—Incorporating amendments up to Act No. 9075)	\$0.60
6417. Wire Netting (Second Reprint—Incorporating amendments up to No. 7876)	\$0.65
6419. Workers Compensation Act 1958 (Eighth Reprint—Incorporating amendments up to Act No. 9372)	\$2.40
6420. Wrongs Act 1958. (Third Reprint—Incorporating amendments up to Act No. 9153)	\$0.60
8344. Youth, Sport and Recreation Act 1972 (First Reprint—Incorporating amendments up to No. 8550)	\$0.35

F. D. ATKINSON  
Government Printer

CONTENTS

	Page
Acts of Parliament	3983
Acts of Parliament on Sale at the Government Printing Office	4041
Appointments	3998
Companies Act 1961—Notice	3998
Contracts	3997
Estates of Deceased Persons	3994
Government Notices	3984
Insolvency Notice	4040
Lands	4017
Melbourne and Metropolitan Board of Works—Notice	3985
Minerals and Energy	3995
Notice to Mariners	3993
Notice of Making of Statutory Rules	4041
Orders in Council—	
Acts—Local Government; Gas and Fuel Corporation; Country Roads Board; Crown Land (Reserves); Land; Road Traffic; Railway Construction and Property; Water; Sewerage Districts; Coal Mines; Local Government.	4000 et seq
Police Sale	3993
Private Advertisements	4020
Proclamations	3983
Regulations—	
Act—Teaching Service	4018
Resignations	3999
Tenders	4017
Transport Regulation Board—Public Hearings	3990