

PROCLAMATIONS

Land Act 1958
ROAD PROCLAIMED

PROCLAMATION

By His Excellency the Governor of the State of Victoria and its Dependencies in the Commonwealth of Australia, &c., &c., &c.

I, the Governor of the State of Victoria, in the Commonwealth of Australia, by and with the advice of the Executive Council of the said State, pursuant to the provisions of Section 25 (3) (c) of the Land Act 1958, do hereby proclaim as road the Crown land hereinafter described, viz.:

Parish of Murrabit West, being the land indicated by hatching on plan hereunder—(M.474?) (L5-1138).

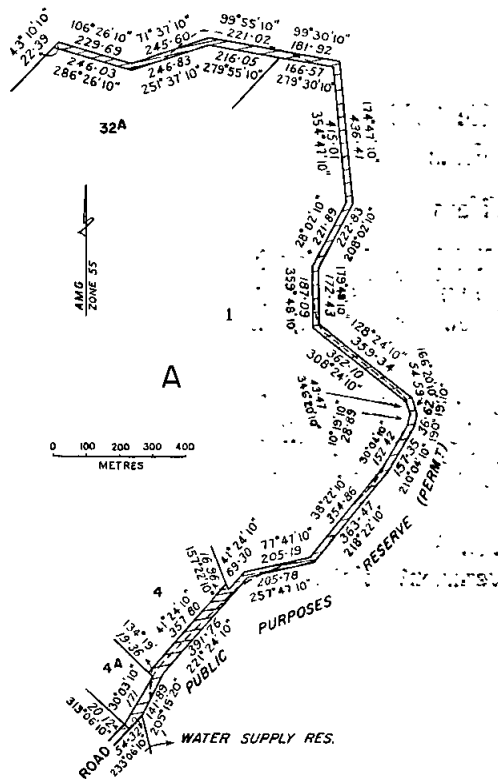

Given under my Hand and the Seal of the State of Victoria aforesaid, at Melbourne, this fourth day of March, in the year of our Lord One thousand nine hundred and eighty, and in the twenty-ninth year of the reign of Her Majesty Elizabeth the Second, Queen of Australia.

(L.S.) **HENRY WINNEKE**
By His Excellency's Command
W. V. HOUGHTON
Minister of Lands

GOD SAVE THE QUEEN !

Land Act 1958
UNALIENATED CROWN LAND MADE AVAILABLE FOR SETTLEMENT UNDER IMPROVEMENT PURCHASE LEASES

PROCLAMATION

By His Excellency the Governor of the State of Victoria and its Dependencies in the Commonwealth of Australia, &c., &c., &c.

I, the Governor of the State of Victoria, in the Commonwealth of Australia, by and with the advice of the Executive Council of the said State, pursuant to the provisions of Section 153 of the Land Act 1958, do hereby proclaim the Crown lands hereinafter described to be available for settlement under improvement purchase leases at the purchase price respectively mentioned, viz.:

| Allotment No. | Parish | Purchase Price | |
|---------------|-----------|----------------|-------------------|
| | | Area ha | \$ |
| 18A | Burnell | 650 | 8051.00 (L5-439) |
| 18 | Burnell | 700 | 7136.00 (L5-2040) |
| 28, 29 | Pallarang | 769 | 9501.00 (L5-2078) |

Given under my Hand and the Seal of the State of Victoria aforesaid, at Melbourne, this fourth day of March, in the year of our Lord One thousand nine hundred and eighty, and in the twenty-ninth year of the reign of Her Majesty Elizabeth the Second, Queen of Australia.

(L.S.) **HENRY WINNEKE**
By His Excellency's Command
W. V. HOUGHTON
Minister of Lands

GOD SAVE THE QUEEN !

Land Act 1958
UNALIENATED CROWN LAND MADE AVAILABLE FOR SETTLEMENT UNDER IMPROVEMENT PURCHASE LEASES

PROCLAMATION

By His Excellency the Governor of the State of Victoria and its Dependencies in the Commonwealth of Australia, &c., &c., &c.

I, the Governor of the State of Victoria, in the Commonwealth of Australia, by and with the advice of the Executive Council of the said State, pursuant to the provisions of Section 153 of the Land Act 1958, do hereby proclaim the Crown lands hereinafter described to be available for settlement under improvement purchase leases at the purchase price respectively mentioned, viz.:

| Allotment No. | Parish | Purchase Price | |
|---------------|------------|----------------|--------------------|
| | | Area ha | \$ |
| 7 | Boo lungal | 925 | 9460.00 (L5-436) |
| 8 | Boo lungal | 1500 | 16120.00 (L5-2038) |
| 13, 3A, 4 | Koonda | 463 | 6876.00 (L5-2079) |
| 1 | Nyoongin | 1915 | 9460.00 (L5-435) |

Given under my Hand and the Seal of the State of Victoria aforesaid, at Melbourne, this fourth day of March, in the year of our Lord One thousand nine hundred and eighty, and in the twenty-ninth year of the reign of Her Majesty Elizabeth the Second, Queen of Australia.

(L.S.) **HENRY WINNEKE**
By His Excellency's Command
W. V. HOUGHTON
Minister of Lands

GOD SAVE THE QUEEN !

**Land Act 1958
ROAD PROCLAIMED**

PROCLAMATION

By His Excellency the Governor of the State of Victoria and its Dependencies in the Commonwealth of Australia, &c., &c., &c.

I, the Governor of the State of Victoria, in the Commonwealth of Australia, by and with the advice of the Executive Council of the said State, pursuant to the provisions of Section 25 (3) (c) of the *Land Act 1958*, do hereby proclaim as road the Crown land hereinafter described, viz.:

Parish of Narrawong, being the land indicated by hatching on plan hereunder—(N.33⁽⁸⁾) (C.100313).

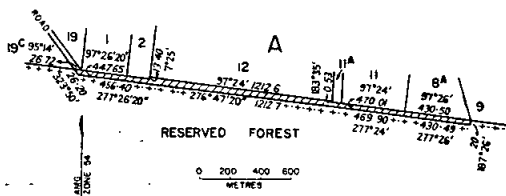

Given under my Hand and the Seal of the State of Victoria aforesaid, at Melbourne, this fourth day of March, in the year of our Lord One thousand nine hundred and eighty, and in the twenty-ninth year of the reign of Her Majesty Elizabeth the Second, Queen of Australia.

(L.S.) **HENRY WINNEKE**
By His Excellency's Command
W. V. HOUGHTON
Minister of Lands

GOD SAVE THE QUEEN!

**URBAN LAND AUTHORITY ACT 1979, No. 9320
DATE OF COMING INTO OPERATION**

PROCLAMATION

By His Excellency the Governor of the State of Victoria and its Dependencies in the Commonwealth of Australia, &c., &c., &c.

Whereas by sub-section (2) of section 1 of the *Urban Land Authority Act 1979 No. 9320* it is provided that the said Act shall come into operation on a day to be fixed by proclamation of the Governor in Council published in the *Government Gazette*.

Now therefore, I, the Governor of the State of Victoria in the Commonwealth of Australia, by and with the advice of the Executive Council of the said State, do by this proclamation fix Wednesday the twelfth day of March, One thousand nine hundred and eighty as the day on which the said Act shall come into operation.

Given under my Hand and the Seal of the State of Victoria aforesaid, at Melbourne, this fourth day of March, in the year of our Lord One thousand nine hundred and eighty, and in the twenty-ninth year of the reign of Her Majesty Queen Elizabeth II.

(L.S.) **HENRY WINNEKE**
By His Excellency's Command
B. J. DIXON
Minister of Housing

GOD SAVE THE QUEEN!

PUBLIC HOLIDAYS

PROCLAMATION

By His Excellency the Governor of the State of Victoria and its Dependencies in the Commonwealth of Australia, &c., &c., &c.

In pursuance of the provisions contained in Section 71 (2) of the *Public Service Act 1974, I*, the Governor of the State of Victoria, in the Commonwealth of Australia, by and with the advice of the Executive Council of the said State, do by this my Proclamation appoint the days and dates hereunder mentioned to be observed as Public Holidays or Public Half-Holidays (as the case may be) at the places respectively specified, viz.:

Public Holidays:—

THURSDAY, 20 MARCH 1980, throughout the Shire of Newham and Woodend.

Public Half-Holidays from the Hour of Twelve o'clock noon:—

WEDNESDAY, 16 APRIL 1980, throughout the City of Hamilton.

THURSDAY, 1 MAY 1980, throughout the City of Warrnambool.

Given under my Hand and the Seal of the State of Victoria aforesaid, at Melbourne, this fourth day of March, in the year of our Lord One thousand nine hundred and eighty, and in the twenty-ninth year of the reign of Her Majesty Elizabeth the Second, Queen of Australia.

(L.S.) **HENRY WINNEKE**
By His Excellency's Command
R. J. HAMER
Premier

GOD SAVE THE QUEEN!

BANK HOLIDAYS

PROCLAMATION

By His Excellency the Governor of the State of Victoria and its Dependencies in the Commonwealth of Australia, &c., &c., &c.

In pursuance of the provisions of the *Bank Holidays Act 1958, I*, the Governor of the State of Victoria, in the Commonwealth of Australia, do by this my Proclamation appoint the days and dates named hereunder special days to be observed as Bank Holidays or Bank Half-Holidays (as the case may be) at the places respectively mentioned, that is to say:—

Bank Holidays:—

THURSDAY, 20 MARCH 1980, throughout the Shire of Newham and Woodend.

Bank Half-Holidays from the Hour of Eleven a.m.:—

WEDNESDAY, 16 APRIL 1980, throughout the City of Hamilton.

THURSDAY, 1 MAY 1980, throughout the City of Warrnambool.

Given under my Hand and the Seal of the State of Victoria aforesaid, at Melbourne, this fourth day of March, in the year of our Lord One thousand nine hundred and eighty, and in the twenty-ninth year of the reign of Her Majesty Elizabeth the Second, Queen of Australia.

(L.S.) **HENRY WINNEKE**
By His Excellency's Command
R. J. HAMER
Premier

GOD SAVE THE QUEEN!

GOVERNMENT NOTICES

LOCAL GOVERNMENT DEPARTMENT

ORDER CONFIRMED—SHIRE OF MYRTLEFORD

The Minister of the Crown administering the *Local Government Act 1958*, on 5 March 1980, confirmed the Order hereinafter referred to in pursuance of section 514 of the said Act namely:

An Order of the Council of the Shire of Myrtleford made on 5 February 1980 directing the compulsory taking of the land described as Lots 4, 5, 6, 7, 9, 10, 11, 12 and 13 on Plan of Subdivision No. 11256 lodged in the Office of Titles for the purpose of constructing a road and associated redevelopment of the surrounding area, pursuant to a scheme prepared under the provisions of section 605 of the *Local Government Act 1958* and approved by the Governor in Council on 27 April 1976.

D. G. CROZIER
Minister for Local Government

Local Government Department
Melbourne (80/0872)

HEADS OF CONSULAR POSTS WITH JURISDICTION
IN MELBOURNE

His Excellency the Governor advises that the under-mentioned Heads of Consular Posts have been granted full recognition and have jurisdiction throughout the State of Victoria.

Canada:

Mr. B. A. Gagosz,
Consul-General of Canada

Britain:

Mr. E. J. Anglin,
Consul-General of Britain

The Netherlands:

Mr. J. G. de Jong,
Consul-General of The Netherlands

Switzerland:

Mr. W. A. Zelweger,
Consul-General of Switzerland

4 March 1980

R. J. HAMER
Premier

Pounds Act 1958

SHIRE OF TULLAROOP

Table of Rates to be charged for the Trespass of Cattle, and their sustenance while impounded fixed by the Council of the Shire of Tullaroop.

A. For Trespass

| Description of Cattle Trespassing | Upon | Upon land |
|--|--|---|
| | tillage land enclosed by a substantial fence | other than tillage land enclosed by a substantial fence |
| | \$ | \$ |
| For every sheep | 0.10 | 0.10 |
| For every goat | 3.00 | 3.00 |
| For every pig | 3.00 | 3.00 |
| For every head of other cattle | 3.00 | 3.00 |
| In addition for the trespass of any entire horse | | 20.00 |
| In addition for the trespass of any bull | | 20.00 |
| In addition for the trespass of any ram | | 20.00 |

B. For Sustenance

| Description of Cattle | Amounts to be charged daily for sustenance while impounded |
|--------------------------------|--|
| | \$ |
| For every sheep | 0.10 |
| For every goat | 0.50 |
| For every pig | 0.50 |
| For every head of other cattle | 1.00 |

NOTE—Section 10A of the *Pounds Act 1958* provides where a person intending to impound cattle conveys them to the pound or makes arrangements for their conveyance to the pound there shall be payable as a transport rate the expenses reasonably incurred by him in so conveying them to the pound or making arrangements for their conveyance to the pound.

By order of the Council
B. F. O'CONNOR, Shire Secretary

Confirmed by the Governor in Council, 4 March 1980
—TOM FORRISTAL, Clerk of the Executive Council

NOTICE TO MARINERS

[No. 9 of 1980]

AUSTRALIA—VICTORIA

PORT PHILLIP

Brighton Harbour Light

Date—On or about 11 March 1980.

Previous Notice—No. 21 (T) of 1979 is cancelled.

Details—The light off the end of Middle Brighton Breakwater (Lat. 37 deg. 55 min. S., Long. 144 deg. 59 min. E. approximately) has been established on a new pile structure situated in the same position as the previous structure.

Light characteristics remain unchanged.

Charts Affected—AUS 143, AUS 155.

A. J. WAGGLEN, Port Officer

Public Works Department
Ports and Harbors Division
168 Exhibition Street
Melbourne, 3000, 28 February 1980

NOTICE TO MARINERS

[No. 10 (T) of 1980]

AUSTRALIA—VICTORIA

PORT OF GIPPSLAND LAKES

Nicholson River Entrance—Dredging Operations

Dredging operations will commence on or about 3 March 1980 and continue each week-day between 8.00 a.m. and 4.00 p.m. in the Nicholson River entrance channel, for a period of approximately 3 months.

Floating pipelines and other associated dredging equipment may be encountered within the area.

Caution—During such times the river entrance channel will be closed to all craft.

Boat operators seeking alternate means of entry/exit are warned of the shallow depths of water that exist alongside the channel.

A. J. WAGGLEN, Port Officer

Public Works Department
Ports and Harbors Division
168 Exhibition Street
Melbourne, 3000, 29 February 1980

Transport Regulation Act
TRANSPORT REGULATION BOARD

HEARING OF APPLICATIONS

Notice is hereby given that the following applications will be considered by the Transport Regulation Board on 1 April 1980.

ERNST, B., Camberwell. Application to license one Range Rover vehicle, with seating capacity for four passengers to operate in conjunction with another licensed vehicle operated by Mr D. Ervine of Mooroolbark on one-day tours between Melbourne and metropolitan hotels and motels and forest land in the Powelltown area. All tours will commence in the Melbourne and metropolitan area and travel express to Powelltown, and then operate on any one or any combination of the following tours, before returning express to the point of pick up. Tour 1—Black Sand Road, Big Creek Road, Horner Jeep Track and Monett Road. Tour 2—Mackley Road, Dowey Spur Road and Dowey Jeep Track. Tour 3—Gilderoy Road (or alternatively via Watson Road and Gilderoy Road), Bunyip Road, Beenak Lookout, Bunyip Road, Koblolke Road, Koblolke Jeep Track and Pioneer Creek Road. Tour 4—Powelltown Fire Line Track, Burges Track, Koblolke Road Bunyip Road, Mt. Beenak Lookout, Mount Beenak Road. Tour 5—Pioneer Creek Road, Koblolke Road, Bunyip Road, Beenak Lookout and Mount Beenak Road. Tour 6—Black Sand Road, Big Creek Road, Horner Jeep Track, Monett Road, Powelltown—Noojee Road, Turner Road, Learmonth Creek Road, Bunyip Road, Beenak Lookout and Mount Beenak Road.

Fares—To be determined, but an approximate fare of \$70.00 per head is envisaged, including a picnic lunch.

NOTE—This application is subject to the Board withholding issue of one of the two "TO" licences recently granted to Mr D. Ervine of Mooroolbark.

ANSETT TRANSPORT INDUSTRIES (OPERATIONS) PTY. LTD., Hamilton. Application for variation of "CO" licence conditions as follows: (a) On the Portland—Hamilton stage service on journey's from Portland any passengers taken up to and including the Township of Branxholme may transfer at Hamilton to the applicant's Mt. Gambier—Melbourne stage service and proceed to Melbourne subject to the condition that no passengers taken up east of the Township of Branxholme shall make a journey extending east of Hamilton Railway Station. (b) On the Melbourne—Mt. Gambier stage service on journey's from Melbourne passengers may transfer at Hamilton to the applicant's Hamilton—Portland stage service subject to the condition that passengers transferring from the Melbourne—Mt. Gambier stage service at Hamilton may be taken up at any point *en route* but shall not be set down nearer to Melbourne than the Township of Branxholme.

NOTE—Transfer of passengers to operate Monday—Friday only.

CAVANAGH, B. J. & C. E., Tallangatta. Application for variation of licences T.S.896 and T.S.1642 which authorise various school contracts to also operate as follows: (a) On a stage service between Tallangatta—Wodonga—Albury via Kiewa and Baranduda.

TIME-TABLE
(Fridays Only)

| | | | |
|----------------------------|------------|--------|--------|
| Depart Tallangatta | 10.00 a.m. | | |
| Depart Kiewa | 10.20 a.m. | | |
| Depart Baranduda | 10.30 a.m. | | |
| Arrive Wodonga | 10.45 a.m. | | |
| Arrive Albury | 11.00 a.m. | | |
| Depart Albury | 1.00 p.m. | | |
| Arrive Wodonga | 1.15 p.m. | | |
| Depart Baranduda | 1.30 p.m. | | |
| Depart Kiewa | 1.40 p.m. | | |
| Arrive Tallangatta | 2.00 p.m. | | |
| Fares | | Single | Return |
| Tallangatta—Albury—Wodonga | | \$1.50 | \$3.00 |
| Tallangatta—Kiewa | | 75c | \$1.50 |
| Kiewa—Baranduda | | 50c | \$1.00 |
| Kiewa—Albury—Wodonga | | 75c | \$1.50 |

(b) For the carriage of parcels and general goods *en route*. (c) Under charter conditions of Tallangatta.

DORRON, T. C. & G. E., Mallacoota. Application to license a Ford Station Wagon to operate in Mallacoota as a Country Hire Car from Maurice Avenue, Mallacoota.

NOTE—Applicant currently holds two (2) C.O. licences.

GENTILE NOMINEES PTY. LTD., Reservoir. Application to license one commercial passenger vehicle with seating capacity for eleven persons to operate free of charge, for the carriage of *bona fide* company employees between the Reservoir and Lalor areas and work sites within the metropolitan area.

HURSTBRIDGE BUS & TAXI SERVICE PTY. LTD., Hurstbridge. Application to license one commercial passenger vehicle with seating capacity for 23 persons to operate in substitution for, but not in addition to, existing T.S. licences in the name of the applicant.

NOTE—No charter rights are sought in this application.

MCGREGOR, G. A. & R. M., Reservoir. Application to license one commercial passenger vehicle with seating capacity for eleven persons to operate as follows: (a) For the carriage of patrons of his Study Centre Camp at Dunkeld on study tours and excursions within an 80-km radius of the camp. (b) Between Dunkeld Railway Station and the camp for the carriage of patrons and their luggage.

MEE'S BUS LINES PTY. LTD., West Heidelberg. Application to license one commercial passenger vehicle with seating capacity for seventeen persons, to be purchased, to operate as a metropolitan special service omnibus.

MELBOURNE BRIGHTON BUS LINES PTY. LTD., Elwood. Application to license one commercial passenger vehicle with seating capacity for 49 persons to operate as a metropolitan special service omnibus.

E. J. & L. PINCINI (MELB.) PTY. LTD., Airport West. Application to license one commercial passenger vehicle with seating capacity for 41 persons to operate in substitution for, but not in addition to existing T.S. licences in the name of the applicant.

NOTE—No charter rights are sought in this application.

E. J. & L. PINCINI (MELB.) PTY. LTD., Airport West. Application to license one commercial passenger vehicle with seating capacity for 45 persons to operate as a metropolitan special service omnibus.

SAMSON, H., SAMSON, M., SHAW, S. (trading as Taxis of Portland), Portland. Application to license a Ford sedan to operate as a Country Taxi at Portland.

TOMKINS, G. R., Herne Hill. Application for variation of licence T.S.1473 which authorises an Education Department school contract service between Anglesea and Geelong to operate under school charter conditions from the Grovedale Technical High School and Oberon High School, which are schools to which students are carried under the Education Department contract.

NOTE—This application replaces an application which appeared in the *Victoria Government Gazette* No. 17 dated 5 March 1980.

Application for renewal of licences as shown by the persons listed hereunder to operate under the same terms and conditions.

BORDONARO, P., Flemington; M.T.1981.

CASALE, V., Doncaster; M.T.1770.

HEANEY, M. D., Box Hill; M.T.4089.

LUCAS, J. E., East Melbourne; M.T.2341.

F. J. MARLAND PTY. LTD., North Melbourne; M.T.2346.

MIRABELLI, G., Carlton; M.T.4213.

NISTOR, D., Abbotsford; M.T.1844.

PAYTON, A. F. & J. A., Moonee Ponds; M.T.5632.

ROUBOS, G., Moorabbin; M.T.5626.

STATHOPOULOS, G., Abbotsford; M.T.4914.

PARKINSON, M. & D. (for the Estate of the late T. Parkinson), Beechworth. Application for renewal of licences C.O.198 and C.O.236 authorising operations under the same terms and conditions.

Notice of any objections should be forwarded to reach the Secretary of the Board not later than 26 March 1980.

Applicants are advised that it will not be necessary to appear on the hearing date specified, unless advised in writing by the Board.

C. J. V. SMITH, Secretary

Corner Lygon and Princes Streets, Carlton, 3053, Wednesday, 12 March 1980

Commercial Goods Vehicles Act
TRANSPORT REGULATION BOARD
HEARING OF APPLICATIONS

Notice is hereby given that the following applications will be considered by the Transport Regulation Board on 1 April 1980.

BRAGGS, S. A., 11 Carawa Street, Mooroolbark, 3138. One commercial goods vehicle (L/C. 1.15 tonne) to operate throughout the State of Victoria in course of business as "Manufacture and Installation of Flywire Screens"—tools of trade, flywire screens for installation and associated fitting materials.

BRENNANS (HOLDINGS) PTY. LTD., Hamilton Road, Horsham, 3400. One commercial goods vehicle (to be purchased) to operate: (a) From and to Melbourne to and from Horsham—general goods excluding any goods which may be prescribed as restricted goods. (b) From the Melbourne warehouse of Woolworths (Vic.) Ltd. to that company's supermarket at Horsham—groceries.

BRYER, K. J., 40 Tyson Road, Heyfield, 3858. One commercial goods vehicle (L/C. 13.80 tonne) to operate from forest landings within that part of an 80-km radius of the post office at Licola which is situated north of Licola to Sawmills at Heyfield—mill logs and pulp logs.

A. J. BUSH & SONS (MANUFACTURERS) PTY. LTD., McDonald Road, Brooklyn, 3025. One commercial goods vehicle (L/C. 5.80 tonne) to operate within an 80-km radius from own premises at Brooklyn in the course of business as "Meat-Meal, Tallow and Casing Manufacturers"—own goods, excluding the carriage of restricted goods which may be specified by notice in the *Government Gazette* from time to time.

J. I. CASE (AUSTRALIA) PTY. LTD., Princes Highway, Warragul, 3820. One commercial goods vehicle (L/C. 4.40 tonne) to operate within an 80-km radius of own branch premises at Warragul in the course of business as "Tractor and Agricultural Implement Distributor"—tractors and agricultural implements for sale, demonstration, repair or having been repaired, spare parts, tools of trade and equipment provided that all new goods carried on the vehicle have been initially consigned by rail to Warragul.

CELLCO (VIC.) PTY. LTD., 13 Union Road, Dandenong, 3175. One commercial goods vehicle (L/C. 2.35 tonne) to operate throughout the State of Victoria in the course of business as "Insulation Contractor"—own tools of trade and equipment together with insulation materials for installation.

RON DEW HAULAGE PTY. LTD., 202 Station Street, Norlane, 3214. One commercial goods vehicle (L/C. 15.80 tonne) to operate: (a) Within a 40-km radius of the chief post office in the City of Geelong—general goods. (b) Within a 112-km radius from each of the operating companies of Clifton Brick Holdings Ltd. at Craigieburn, Oakleigh, Brunswick and Preston respectively and also Clifton Brick Colac Pty. Ltd. at Colac—bricks and on return journeys empty pallets and excess bricks to such of the above plants as may be appropriate.

DIVERSE PRODUCTS LIMITED, Albert Street, Warrnambool, 3280. One commercial goods vehicle (L/C. 6.95 tonne) to operate within a 112-km radius of own premises at Warrnambool in the course of business as "Aerated Water Distributor"—aerated waters and empty return containers.

EGAN, W. D., "Beltana", Vite Vite, 3325. One commercial goods vehicle (L/C. 7.50 tonne) to operate: (a) Within a 40-km radius of the post office at Vite Vite

—general goods. (b) Within an 80-km radius of own premises situated at Vite Vite in course of business as "Primary Producer"—own goods. (c) Within an 80-km radius of own premises at Vite Vite—live-stock.

ELDER SMITH GOLDSBROUGH MORT LTD., 499-501 Bourke Street, Melbourne, 3000. One commercial goods vehicle (L/C. 7.80 tonne) to operate within a 40-km radius of the G.P.O. Melbourne and to Cranbourne and places on the Mornington Peninsula in course of business as "Wool Brokers and General Merchants"—own goods.

FATCHEN, P. R., 13 Albert Street, Kilmore, 3601. One commercial goods vehicle (L/C. 3.55 tonne) to operate: (a) From and to places situated within the corporate limits of the City of Melbourne and within a distance of 19 km of the limits thereof and from and to Scoresby direct only via the route set out below to and from places situated within a 12-km radius from the post office at Kilmore and to and from properties 3 km either side of the Northern Highway as far as High Camp and for delivery to places situated along the Hume Highway between Craigieburn and Kilmore and to Broadford—general goods.

ROUTE REFERRED TO

The Hume Highway from the City of Melbourne to Kilmore. (b) Within a 40-km radius of own premises at Kilmore and to Heathcote in the course of business as "Aerated Water Manufacturers"—own aerated waters and empty return containers manufactured at own factory at Kilmore. (c) From Sawmill of R. H. Ennis at Tallarook to the premises of C. F. Clancy at Kilmore—sawn timber. (d) From own premises at Kilmore to A.P.M. Ltd. at Broadford—scrap paper.

HARDINGHAM, G. L., 39 Pye Street, Swan Hill, 3585. One commercial goods vehicle (L/C. 11.80 tonne) to operate: (a) Within a 152-km radius of the post office at Cohuna and/or within a 160-km radius of the post office at Merbein (Bendigo Division of C.R.B.) and within a 40-km radius of G.P.O. Melbourne (Metropolitan Division of C.R.B.)—plant the property of a contractor and required by him for use in connection with the construction or maintenance of some specific, existing or proposed road, street, footpath, bridge, wharf, pier, weir or channel. (b) Within a 32-km radius from site of construction or maintenance work performed pursuant to paragraph (a) above, or from the railway station nearest thereto—metal, stones, screenings, ashes, gravel, sand, earth and any other materials required for such work. (c) Within a 32-km radius of the Post Office at Swan Hill—general goods.

HUTTON, R. D., 78 Roadnight Street, Lakes Entrance, 3909. Six commercial goods vehicles (to be purchased approximately 23.00 tonne each) to operate from Melbourne to Bairnsdale and Lakes Entrance—general goods.

G. G. KAY & Co. PTY. LTD., 109 Carinish Road, Clayton, 3168. One commercial goods vehicle (L/C. 3.40 tonne) to operate throughout the State of Victoria in the course of business as "Electrical Engineers and Distributors" for the purpose of installing, servicing and maintaining generators—tools of trade, spare parts required for on-site servicing and maintenance of generators and generators for specialised installation.

LOBB, C. L., Liebig Street, Avoca, 3467. Two commercial goods vehicle (L/C. 4.70 and 5.45 tonne) to operate: (a) Within a 40-km radius from the Post Office at Avoca—general goods. (b) From and to the City of Ballarat to and from the following places—(i) the Town of Avoca; (ii) places en route between Ballarat and Avoca via Lexton including places not more than 8-km distant from any point along the said route—general goods provided that no such goods as aforesaid shall be carried for consignment to the railhead at Ballarat and no such goods as aforesaid consigned to the railhead at Ballarat Railway Station to any place situate within a 10-km radius of the post office at Avoca.

NOTE—This application replaces licences No. D.A.65818 and D.A.65818/1 previously held by the applicant.

LYNCH, G. A., P.O. Box 54, Beaconsfield, 3807. One commercial goods vehicle (L/C. 6.47 tonne) to operate within a 112-km radius of own premises at Beaconsfield in the course of business as "Plasterers"—tools of trade, own equipment and materials incidental to the completion of own contracts.

MCINNIS, D. L., Riverslea via Maffra, 3860. Two commercial goods vehicles (L/C. 19.00 and 12.20 tonne) to operate within an 80-km radius of Riverslea in the course of business as "Earthmoving Contractor"—own goods.

A. & V. MCKENDRICK TRANSPORT PTY. LTD., 391 Townsend Street, Albury, 2640. One commercial goods vehicle (L/C. 12.40 tonne) to operate from the premises of Rocla Concrete Pipes Ltd. an approved decentralised secondary industry at Bandiana to consignees within a 112-km radius thereof solely on behalf of the said company—Rocla Concrete Pipes and Concrete Products.

MCPHERSON'S LTD., 22 Hargreaves Street, Huntingdale, 3166. One commercial goods vehicle (L/C. 0.75 tonne) to operate throughout the State of Victoria in the course of business as "Electrical and Mechanical Engineers" for the purpose of installing, servicing and maintenance of own manufactured electric motors and pumps—tools of trade, spare parts and materials incidental thereto.

MCPHERSON, R. L., 14 Carnarvon Street, Lang Lang, 3984. One commercial goods vehicle (L/C. 7.65 tonne) to operate within a 150-km radius of Lang Lang in course of business as "Water Boring Contractor"—own tools of trade, equipment and bore casing provided that all bore casing carried is for drilling purposes only.

PROGRESS PRESS DISTRIBUTORS PTY. LTD., 2 Keys Road, Moorabbin, 3189. One commercial goods vehicle (L/C. 2.20 tonne) to operate: (a) Within a 40-km radius of G.P.O., Melbourne and to Geelong and places on the Mornington Peninsula in course of business as "Printers and Distributors"—magazines for distribution. (b) Within a 80-km radius of own premises at Moorabbin in course of business as "Printers"—own goods excluding the carriage of restricted goods which may be specified by notice in the *Government Gazette* from time to time.

PARISH, E. J., 6 Fechler Avenue, Horsham, 3400. One commercial goods vehicle to be purchased (L/C. approximately 16.00 tonne) to operate from and to Horsham to and from Melbourne and Geelong—general goods.

RAE, K. G., 197 Princes Highway, Morwell, 3840. One commercial goods vehicle (L/C. 1.00 tonne) to operate throughout that part of the State of Victoria situated east of a north/south line drawn through the City of Melbourne and south of an east/west line drawn through the Township of Omeo in the course of business as "Musical Instrument Retailer"—new and second-hand organs.

SYKES, H., Granite Rock via Bairnsdale, 3875. One commercial goods vehicle (L/C. 6.00 tonne) to operate from places throughout that part of the State of Victoria east of a north/south line drawn through the G.P.O., Melbourne to own premises at Granite Rock—tools of trade, own damaged or disabled tractors and machinery for return to own premises at Granite Rock for wrecking excluding the carriage of any new tractors or new machinery whatsoever.

TRANS BRICK PTY. LTD., 78 Middleborough Road, Burwood, 3125. One commercial goods vehicle (L/C. 9.85 and 13.70 tonne trailer) to operate: (a) Within a 40-km radius from the post office at Springvale—general goods provided that no goods shall be carried whether by one stage or by more than one stage between places within the above radius which are more than 50 road kms apart by the nearest practicable route. (b) Within an 80-km radius from each of the plants of Brick and Pipe Industries Ltd. at Burwood, Northcote, Scoresby and Craigieburn respectively—bricks and on return journeys empty pallets and excess bricks to such of the above plants as may be appropriate. (c) From Columbia Concrete Masonry Pty. Ltd. at Springvale to consignees within an 80-km radius therefrom—concrete masonry and on return journeys empty pallets and excess concrete masonry to the said plant, provided that the concrete masonry blocks do not exceed 18 kilograms in weight each.

WHITEWAY SALES & MANUFACTURING PTY. LTD., 399 Fern-tree Gully Road, Mt. Waverley, 3149. One commercial goods vehicle (L/C. 2.50 tonne) to operate throughout the State of Victoria in the course of business as "Sign Manufacturers" for the purpose of installing and servicing of Neon Signs and Fluorescent and commercial lighting—lights for installation tools of trade, spare parts and materials incidental to such installation and servicing.

YOUNG, R. A., 13 McGrettons Road, Healesville, 3339. One commercial goods vehicle (L/C. 11.00 tonne) to operate from the sawmill of Toolangi Timber Co. at Toolangi to consignees within a 40-km radius of Toolangi and to consignees within a 40-km radius of the G.P.O. Melbourne but no further west than a north/south line drawn through Werribee—sawn timber.

VOSTI, P. A., 19 Sherwood Crescent, Mt. Martha, 3938. One commercial goods vehicle (L/C. 0.50 tonne) to operate throughout the State of Victoria in the course of business as "Trailer Hire"—trailers for hire or for return after having been hired provided that not more than one trailer shall be hauled at any one time.

TOW TRUCK

PETER MACS TOWING SERVICE (VIC.) PTY. LTD., 67 Osborne Avenue, Springvale, 3171. Application to vary the conditions of licence No. D.A.69552/4 by adding to paragraph (i) of the Special Conditions—Provided however that in the event of the damaged or disabled motor vehicle being a passenger or goods carrying vehicle with a tare weight exceeding 3 tonnes the requisition by the owner or driver thereof for the service of the tow truck may be given at the scene of such accident. Such proviso shall apply so long as the tow truck holding this licence is a salvage vehicle of class 3 or class 4 specifications.

RENEWALS

Applications for renewal of licences as shown by persons listed hereunder to operate under the same terms and conditions from the expiry shown in each case.

BARTLETT, K. A., 4 Ryan Grove, South Blackburn, 3130; D.A.61948; 30 January 1980; 6.80 tonne.

BRAMBLES HOLDINGS LTD., 1846 Princes Highway, Clayton, 3168; D.A.39531; 31 May 1980; 3.60 tonne.

BRAMLEY, J. H., 105 Princes Highway, Port Fairy, 3284; D.A.68280; 5 February 1980; 11.55 and 11.65 tonne trailer.

BRUNI & BISOGNI PTY. LTD., Broadway Street, Cobram, 3644; D.A.63299/54; 8 April 1980; 0.95 tonne; D.A.63299/56; 27 May 1980; 0.75 tonne.

CITY BRICK WORKS PTY. LTD., 124 Camberwell Road, East Hawthorn, 3123; D.A.64393/1; 22 May 1980; 5.80 tonne.

COBELAS, R., Lot 3, Freemans Road, Traralgon, 3844; D.T.1258/1; 8 May 1980; 11.50 and 11.00 tonne trailer.

A. G. COOMBS GROUP PTY. LTD., 26 Cochrans Road, Moorabbin, 3189; D.A.891/17; 20 May 1980; 0.75 tonne; D.A.891/28; 15 May 1980; 0.75 tonne; D.A.891/29; 15 May 1980; 0.50 tonne.

CRYSTAL TRANSPORT PTY. LTD., Lyric Building, Charing Cross, Bendigo, 3550; D.A.54662/7; 27 May 1980; 9.90 tonne; D.A.54662/8; 27 May 1980; 12.05 tonne.

DEVLIN, T., 4 Ronalds Court, Drouin, 3818; D.T.1679; 13 May 1980; 18.62 tonne.

GOLEC, S., 18 Albert Street, Kilmore, 3601; D.A.51430; 18 May 1980; 0.30 tonne.

GREENE, M. L., 12 Manuka Drive, Warrnambool, 3280; D.A.65269; 1 May 1980; 3.90 tonne.

IRWIN MOTORS PTY. LTD., 31 Wilson Street, Horsham, 3400; D.A.40111/7; 29 May 1980; 0.75 tonne.

JONES, A. D., 146 Bevern Street, Sebastopol, 3356; D.A.68447; 13 May 1980; 8.00 and 3.85 tonne trailer.

KETLEY, R. O., Kellys Road, Warburton, 3199; D.A.63610/4; 18 September 1979; 11.60 tonne.

LEAR, R. K., 6 Cohuna Court, East Burwood, 3151; D.A.68460; 13 May 1980; 2.55 tonne.

MAY'S V.C. TRANSPORT PTY. LTD., 277/281 Wickham Road, Moorabbin, 3189; D.A.34611/2; 24 May 1980; 13.95 tonne.

MENZ, R. G. & M. P., Murchison Street, Marysville, 3779; D.T.1563; 20 May 1980; 16.05 tonne.
 MCDUGALL-IRELAND PTY. LTD., 9 Merton Avenue, Carnegie, 3163; D.A.1672/5; 8 May 1980; 0.40 tonne.
 NICOL, I. R., 87 Norma Crescent, Knoxfield, 3180; D.A.65292; 15 May 1980; 6.65 tonne.
 READ, P. W., Private Bag 44, Branxholme, 3302; D.A.68381; 22 April 1980; 7.00 tonne.
 REPCO LTD., 618 Elizabeth Street, Melbourne, 3000; D.A.68791/44; 24 May 1980; 0.75 tonne.
 P. E. SHELLY PTY. LTD., 10 Labilliere Street, Bacchus Marsh, 3340; D.A.2022/15; 20 May 1980; 16.60 tonne.
 TEMPERATURE EXPRESS PTY. LTD., 16 Advantage Road, Highett, 3190; D.A.65652/7; 5 February 1980; 9.51 tonne.
 TENNIS HOLDINGS PTY. LTD., 499 St. Kilda Road, Melbourne, 3004; D.A.65934; 16 May 1980; 5.75 tonne.
 THOMPSON, J. R., Millawa Road, Werrimull, 3496; D.A.68463; 27 May 1980; 11.50 tonne.
 WALKER, E., Western Highway, Stawell, 3380; D.A.61679; 22 April 1980; 0.40 tonne.

TOW TRUCKS

FITZPATRICK, M. J., Murphy Street, Bendigo, 3550; D.A.65950; 7 May 1980; 4.80 tonne.
 KERRIGAN, T. E., 317 Whitehorse Road, Balwyn, 3103; D.A.41847/3; 16 December 1979; 2.15 tonne.

Notice of any objection should be forwarded to reach the Secretary of the Board not later than 26 March 1980.

Applicants are advised that it will not be necessary to appear on the hearing date specified above, unless advised in writing by the Board.

C. J. V. SMITH, Secretary
 Corner Lygon and Princes Streets, Carlton, 3053,
 Wednesday, 12 March 1980

Melbourne and Metropolitan
BOARD OF WORKS

GENERAL NOTICE

The Melbourne and Metropolitan Board of Works having made provision for carrying off the sewage of each and every property which or any part of which is situate in the Sewerage Areas hereinafter described doth hereby declare that on and after 17 March 1980 each and every property so situate shall be deemed to be a sewered property within the meaning of the *Melbourne and Metropolitan Board of Works Act 1958*.

The Sewerage Areas hereinbefore referred to are:—

SEWERAGE AREA No. 3928

City of Keilor—This area comprises lots 88 to 90 Blair Court, lots 72, 73, 91 to 93 and 10 to 15 Feathertop Drive.

SEWERAGE AREA No. 3934

City of Doncaster and Templestowe—This area comprises all lots in Lyndal Close, Lisa Close and Kris Court, lots 47, 31 to 28, 19 to 14, 112 to 110, 101, 100 and a Municipal Reserve in Deep Creek Road, a Municipal Reserve abutting Vivienne Court and Lyndal Close.

SEWERAGE AREA No. 3936

City of Knox—This area comprises lots 288 to 292, 329, 286 to 276, 253, 252 and 241 to 238 Fraser Crescent, lots 242 to 244 and 247 to 251 Hogan Court, lots 254 to 259, 266 to 269, part of a Municipal Reserve and lots 270 to 275 Argyle Way, lots 339 to 330 Holland Crescent, a Tree Reserve abutting High Street Road.

SEWERAGE AREA No. 3939

City of Keilor—This area comprises all lots bounded by Marshall Avenue, Ashley Avenue, Ralph Avenue, Milton Avenue and Harcourt Avenue, lots 166 to 163 Marshall Avenue, lots 206 to 209 Ralph Avenue.

SEWERAGE AREA No. 3941

City of Doncaster and Templestowe—This area comprises all lots in Dellwood Court and Hampden Court, lots 264, 263, 285 to 282 and 336 to 334 Chippendale Court, lots 293 to 291, 306 to 308, 315 to 325, 326 to 333, 338, 337 and 290 to 287 The Grange, lots 296 to 305 Church Road, a Reserve abutting Chippendale Court and Mossdale Court.

SEWERAGE AREA No. 3944

City of Sandringham—This area comprises lots 14 to 17 Brixton Road.

SEWERAGE AREA No. 3946

City of Broadmeadows—This area comprises lots 11 to 3, that piece of land described on Plan of Consolidation No. 100632, those pieces of land described on Plans of Consolidation No. 102916 and No. 101937, lot 36 and that piece of land described on Plan of Consolidation No. 108129 Freight Road.

SEWERAGE AREA No. 3947

Shire of Werribee—This area comprises all lots in Penn Close, lots 35, 34, 3 to 1 and a further lot 1 Wattle Avenue, lots 4 to 11 and 19 to 33 Nantilla Crescent, part of a Channel Reserve abutting Wattle Avenue.

SEWERAGE AREA No. 3949

City of Keilor—This area comprises lots 37 to 49 Carmyle Court.

SEWERAGE AREA No. 3950

Shire of Whittlesea—This area comprises lots 38 to 41 Lynne Street, lots 99 and 113 McKimmies Road, lot 61 Darebin Drive, lots 60 to 57 and 46 to 37 Casey Drive, lot 95 Canberra Grove, lots 94 to 88 Griffin Court, lot 47 Whitehall Place.

SEWERAGE AREA No. 3951

City of Waverley—This area comprises lots 7 to 1, 15 to 19 and 14 to 8 Browning Drive, lots 247 to 238 Plymouth Street, a Reserve abutting Browning Drive and Troy Street.

SEWERAGE AREA No. 3952

City of Altona—This area comprises all lots in Leathers Court and O'Shannessy Court, lots 307 to 319 Fiddan Court, lots 321 to 329, 342 to 344, 381 and 380 to 370 Roach Drive, lots 369 and 368 Elizabeth Street, a Municipal Reserve abutting O'Shannessy Court and Philip Street.

SEWERAGE AREA No. 3953

City of Sunshine—This area comprises lots 48 to 41 and 20 to 16 Furlong Road, lots 15 to 1 St. Albans Road, lots 30 to 21 and 40 to 37 Gillon Court.

SEWERAGE AREA No. 3954

Shire of Whittlesea—This area comprises all lots in Watford Court and Ealing Close, lots 418, 417, 405, 404, 181 to 179, 834, 835 and 434 to 437 Northumberland Drive, lots 395 to 392 and 182 Carlisle Drive, lots 183 to 189, 247 and 248 Scarborough Road, lots 249 to 251 and 391 to 388 Tatlow Drive, lots 387 to 384 McDonalds Road, lots 173 to 178 Finchley Court.

SEWERAGE AREA No. 3955

Shire of Bulla—This area comprises all lots in Carlton Court, lots 71, 70, 69 to 61 and 30 Newbold Street, lots 29 and 60 to 56 Carlisle Street, a Municipal Reserve abutting Carlton Court, Newbold Street, Carlisle Street and Selby Place, lots 78 to 91 and 31 to 37 Bainbridge Close.

SEWERAGE AREA No. 3956

City of Knox—This area comprises all lots in Brown Street and Marland Road, lots 1, 2, 38, 1 to 5, 32, 33, 34, 35, 1, 2, 1 to 4, 1 to 5, 2 to 9 and 1 Olive Grove, lot 2, that piece of land described on Certificate of Title Volume 7208 Folio 543, lots 10 to 12 and 29 to 34 Albert Avenue, lots 35 to 43, 13, 15, 16 and 8 to 4 Elsie Street, lots 1, 2, 26, 24, 22, 20, 19, 21, 23, 25, 27 and 28 Girdwood Road.

SEWERAGE AREA No. 3957

Shire of Werribee—This area comprises lots 527 to 538 Jika Court, lots 543 to 549 Walls Road.

SEWERAGE AREA No. 3960

City of Springvale—This area comprises all lots in Crawford Street, lots 1 to 4, 32 to 34 and those pieces of land described on Certificates of Title Volume 8131 Folio 792 and Volume 8472 Folio 162 Governor Road, lots 6 to 10, 21 to 25 and 20 to 11 Industrial Drive.
 4 March 1980

By order of the Board

O. T. W. COSGRIFF, Secretary

625 Little Collins Street, Melbourne, Vic. 3000

Melbourne and Metropolitan
BOARD OF WORKS

NOTICE TO THE OWNERS OF TENEMENTS IN THE
UNDERMENTIONED STREETS AND THE PRIVATE STREETS,
LANES, COURTS AND ALLEYS OPENING THERETO

The main pipe in the said streets being laid down, the owners of all tenements situated as under are hereby required on or before 14 April 1980 to cause a proper pipe and stop cocks to be laid so as to supply water within such tenements from the main pipe.

Berwick

John Edgcumbe Way, from 50 metres north-east of Tunley Close further north-eastwards and north-westwards 277 metres.
Oxley Way, from John Edgcumbe Way westwards and north-westwards 352 metres.
Lindsay Close, total street from Oxley Way northwards.
Goldsmith Close, total street from Oxley Way northwards.

Coburg

Newlands Road, from 32 metres south-west of Norfolk Court further south-westwards 148 metres.

Croydon

Holloway Road, from Yarra Road north-eastwards 165 metres.

Dandenong

Exner Drive, from Brady Road northwards and north-eastwards 336 metres.
Taylor Court, total street from Exner Drive south-westwards.
Manks Court, total street from Exner Drive north-westwards.
Simpson Drive, from 20 metres north of Jarvis Crescent, further northwards 250 metres.
Jarvis Crescent, from Simpson Drive to Deidre Street.
Crouch Court, total street from Simpson Drive eastwards.
Hicks Court, total street from Simpson Drive north-westwards.
Sheehan Court, total street from Simpson Drive south-westwards.

Doncaster and Templestowe

Bali Hi Boulevard, from Serpells Road northwards 280 metres.
Lalani Terrace, total street from Bali Hi Boulevard eastwards.
Paoa Place, total street from Bali Hi Boulevard south-westwards.
Malei Court, total street from Bali Hi Boulevard eastwards.
Valepark Drive, from 25 metres north of Wallace Avenue further northwards 70 metres.
Akoonah Close, from the north title boundary of lot 7 southwards including allotments 7, 6, 5, 4, 3, 2 and 1, 99 metres.

Eltham

Valonia Drive, from 60 metres east of Quentin Way further eastwards 160 metres.
Baringa Place, total street from Valonia Drive southwards.
Anka Close, total street from Baringa Place eastwards.
Jinkana Grove, total street from Valonia Drive north-westwards.
Eurah Place, total street from Jinkana Grove north-eastwards.

Essendon

Mary Street, from Hedderwick Street westwards 58 metres.

Keilor

Prescott Place, total street from Templewood Crescent southwards and south-westwards.
Templewood Crescent, from Military Road north-eastwards 172 metres.
Odessa Avenue, from Elba Close northwards 460 metres.
Tarella Drive, from Odessa Avenue eastwards 38 metres.
Aldershot Drive, from Odessa Avenue westwards 456 metres.
Sorrell Court, total street from Aldershot Drive north-westwards.

Cadiz Place, total street from Aldershot Drive northwards.
Morley Court, total street from Aldershot Drive southwards.
Verden Place, total street from Aldershot Drive southwards.
Medina Road, from Aldershot Drive southwards 142 metres.
Rayson Court, total street from Aldershot Drive eastwards.
Wexford Court, total street from Aldershot Drive southwards.

Knox

Amay Crescent, from 36 metres south-east of William Street further south-eastwards and south-westwards to Fitzgerald Street, 215 metres.
Fitzgerald Street, from Burwood Highway to Amay Crescent.
Amay Crescent, from Fitzgerald Street eastwards 31 metres.
Davis Street, from Amay Crescent north-eastwards 35 metres.
Garnet Street, from Newton Street south-eastwards 31 metres.

Lillydale

Beaulieu Avenue, from 225 metres west of Edinburgh Road further westwards and northwards to Birmingham Road, 575 metres.
Sonia Close, total street from Beaulieu Avenue eastwards.
Edinburgh Road, from 43 metres south of Beaulieu Avenue further southwards and south-eastwards 787 metres.
Landscape Drive, from 38 metres south of Churchill Drive further southwards 76 metres.
Ashbrook Place, total street from Landscape Drive westwards.
Cardigan Road, from 295 metres east of Pine Road further eastwards 404 metres.

Ringwood

Tortice Drive, from 35 metres north-east of Lucy Place further north-eastwards 235 metres.
Heape Way, from Tortice Drive south-eastwards and southwards 160 metres.
Appleberry Place, total street from Heape Way north-eastwards.
Stringybark Court, total street from Heape Way eastwards.
Debbie Place, total street from Kubis Drive south-eastwards.
Pamela Place, total street from Kubis Drive south-westwards.

Springvale

Acacia Crescent, from 55 metres north-east of Gladesville Boulevard further northwards 98 metres.
Swallow Court, total street from Acacia Crescent south-westwards.
Timberglade Drive, from 110 metres south of Justin Drive further southwards and westwards 272 metres.
Tate Court, total street from Timberglade Drive south-eastwards.
Taro Place, total street from Timberglade Drive westwards.
Divai Close, total street from Timberglade Drive westwards.

Werribee

Fitzroy Street, from Alma Avenue to Central Avenue.
Grace Street, from Princes Highway to Central Avenue.
High Street, from Princes Highway to Central Avenue.
Jamison Street, from Alma Avenue to Central Avenue.
Triholm Avenue, from Oakdene Grove to Strezlecki Grove.
Strezlecki Grove, from the Princes Highway to Triholm Avenue.
Cooraminta Avenue, from Triholm Avenue southwards 103 metres.
Purchas Street, from Tarneit Road westwards 614 metres.
Derwent Road, from Purchas Street southwards and south-westwards 314 metres.
Torrens Street, from Purchas Street south-eastwards 13 metres.
Wimmera Court, total street from Purchas Street south-eastwards.

4 March 1980

O. T. W. COSGRIFF, Secretary

COMPANIES ACT 1961

Notice is hereby given in pursuance of section 308 (4) of the *Companies Act 1961* that the name of the Company referred to below has been struck off the Register.

Dated 6 March 1980

E. B. MITCHAM

Deputy Commissioner for Corporate Affairs

Corporate Affairs Office
Melbourne

COMPANIES ABOVE REFERRED TO

| Name of Company | Number of Registration |
|------------------------------------|------------------------|
| Territorial Developments Pty. Ltd. | F11926F |

COMPANIES ACT 1961

Notice is hereby given that in pursuance of section 308 (4) of the *Companies Act 1961* the names of the Companies referred to below have been struck off the Register and on publication of this notice in the *Government Gazette* the said companies will be dissolved.

Dated 6 March 1980

E. B. MITCHAM

Deputy Commissioner for Corporate Affairs

Corporate Affairs Office
Melbourne

COMPANIES ABOVE REFERRED TO

| Name of Company | Number of Registration |
|---|------------------------|
| Anderson's Electric Motor Services Pty. Ltd. | C23776H |
| Gemel Trading Co. Pty. Ltd. | C25249T |
| Victorian Plywood Distributors Pty. Ltd. | C31051Z |
| James Alton Pty. Ltd. | C32149B |
| Harold Wix Pty. Ltd. | C36252A |
| Mileage Tyre Service Pty. Ltd. | C38495W |
| Gulucav Investments Pty. Ltd. | C38578B |
| Andersons' Electric Motor Services Springvale Pty. Ltd. | C40973N |
| Rubber Extruders Pty. Ltd. | C43393K |
| Springdale Pty. Ltd. | C44843D |
| Serpells Investments Pty. Ltd. | C46614A |
| White Wings (Fats) Pty. Ltd. | C47397Z |
| Mileage Batteries Pty. Ltd. | C48671D |
| Darcy Osteopathic and Chiropractic Centre Pty. Ltd. | C50048C |
| D.I.J.O. Nominees Pty. Ltd. | C53807D |
| De-Pat Pty. Ltd. | C55405T |
| Duramould Pty. Ltd. | C56735B |
| Chapman Brothers Machinery Merchants Pty. Ltd. | C59622J |
| Linemarking Equipment Pty. Ltd. | C59989K |
| Laboratory Accessories Pty. Ltd. | C61528T |
| Masaga Holdings Pty. Ltd. | C62301T |
| O. Gruber Machines (Aust.) Pty. Ltd. | C64008G |
| Marlaine Investments Pty. Ltd. | C64536P |
| Macpherson Bros. (Donga) Pty. Ltd. | C67074U |
| Metal Components Pty. Ltd. | C68199Z |
| Matchless Enamelling Works Pty. Ltd. | C68726C |
| Little Reata Pty. Ltd. | C69246P |
| Little Reata Catering Pty. Ltd. | C69247S |
| Striker Pty. Ltd. | C70409M |
| Thomas George Pty. Ltd. | C72619S |
| Smith & Lazar Building Constructions Pty. Ltd. | C72706M |
| L. & E. Tait Building Co. Pty. Ltd. | C72873U |
| L. & E. Tait Development Co. Pty. Ltd. | C72874L |
| Champion Pest Control Pty. Ltd. | C73664E |
| Wreckitt Demolition Pty. Ltd. | C73806A |
| Kel-Rub Constructions Pty. Ltd. | C75306N |
| Harrison Eastmel Pty. Ltd. | C76022C |
| D.C.M. Abrasives Pty. Ltd. | C76532H |
| Lionel Cohen Holdings Pty. Ltd. | C77506P |
| Abbott & Dean Pty. Ltd. | C79206N |
| Tie Weave Pty. Ltd. | C81411T |
| Manczal Painting Services Pty. Ltd. | C81990U |
| Prinreturn Pty. Ltd. | C83269F |
| Pridecraft Engineering Pty. Ltd. | C84900M |
| Star Flooring Preparations Pty. Ltd. | C87796S |
| Michael Kane Pty. Ltd. | C89454Y |
| Richard D. Campbell & Associates Pty. Ltd. | C90561U |
| V. & C. Engineering Pty. Ltd. | C90764L |

| Name of Company | Number of Registration |
|---|------------------------|
| Makana Development Pty. Ltd. | C91316K |
| Felbon-Green Pty. Ltd. | C94748U |
| Harrison Belmont Pty. Ltd. | C94949G |
| C.L.E. Sales Pty. Ltd. | C95026C |
| Narharp Investments Pty. Ltd. | C95536H |
| Gondor Pty. Ltd. | C95775E |
| Leigh Instruments Pty. Ltd. | C96120C |
| Greenpastures Properties Pty. Ltd. | C96704M |
| Accountancy Placement Services Pty. Ltd. | C97312X |
| Remus Investments Pty. Ltd. | C97397J |
| Greenpastures Investments Pty. Ltd. | C97590E |
| Greenpastures Developments Pty. Ltd. | C97591G |
| Siren Pty. Ltd. | C98522U |
| Mulligan Earthmovers Pty. Ltd. | C100951U |
| Boronia Victoria Pty. Ltd. | C102096J |
| Oak Star Motors Pty. Ltd. | C102343C |
| Gedj Pty. Ltd. | C102769U |
| Jeney Nominees Pty. Ltd. | C102947U |
| Automated Library Systems Pty. Ltd. | C103221U |
| Moped (Australia) Pty. Ltd. | C103797G |
| Brosam Pty. Ltd. | C104872C |
| Locums Real Estate Pty. Ltd. | C105735Y |
| Noel M. Heather & Co. Pty. Ltd. | C105740R |
| Dial Residential Constructions Pty. Ltd. | C107595X |
| Clouds (Australia) Pty. Ltd. | C107697G |
| Smallbridge Investments Pty. Ltd. | C113886U |
| Jeffrey Auctions Pty. Ltd. | C114145Y |
| Daytyre Pty. Ltd. | C114159K |
| P. & C. Feltham Pty. Ltd. | C115567N |
| Reservoir Tyre Retreaders Pty. Ltd. | C115958J |
| Craft Pipeline and Distribution Pty. Ltd. | C116178E |
| Metrovincial Sales (Vic.) Pty. Ltd. | C118459G |
| John Cassidy Pty. Ltd. | C118523P |
| Sitanus Pty. Ltd. | C119253R |
| Saffron Systems Pty. Ltd. | C120126A |
| Keyman Pty. Ltd. | C121025A |
| Whitehall Air Charter Pty. Ltd. | C121133E |
| Trellico Pty. Ltd. | C121430P |
| Lyons Court Pty. Ltd. | C123411A |
| L. G. & K. J. Nominees Pty. Ltd. | C124459N |
| Applon Pty. Ltd. | C125324V |
| G. & T. Crea Nominees Pty. Ltd. | C126326G |
| Select Automobiles Pty. Ltd. | C127459L |
| Lenstel Enterprises Pty. Ltd. | C127542Y |
| City West Tile Company Pty. Ltd. | C128478Y |
| Nelgray Pty. Ltd. | C128797U |
| Toffa Nominees Pty. Ltd. | C128798W |
| Petmic Holdings Pty. Ltd. | C132261K |
| Trounson Properties Pty. Ltd. | C134815A |
| Ross Mitchell (Vic.) Pty. Ltd. | C135003G |
| International Fun Castles Pty. Ltd. | C135281P |
| Lavar Pty. Ltd. | C140952U |
| South Western Investments Company Pty. Ltd. | C157167E |

COMPANIES ACT 1961, SECTION 80

Whereas Alycidon Syndications Limited (hereinafter called "the company") is the management company within the meaning of section 76 of the *Companies Act 1961* in relation to a deed dated 30 August 1979 relating to Pioneer Syndicate (hereinafter called "the trust deed"):

And whereas Eagle Star Nominees Limited is the trustee for the purposes of the trust deed:

And whereas application has been made by the company for exemption from compliance with certain provisions of Division 5 of Part IV. of the said Act in respect of the trust deed:

Now therefore I, the undersigned, the Minister administering the said Act hereby exempt the company from compliance with the provisions of section 80 (1) (b) (iii) of the said Act.

Signed at Melbourne, 5 March 1980

HADDON STOREY
Attorney-General

COMPANIES ACT 1961, SECTION 80

Whereas Alycidon Syndications Limited (hereinafter called "the company") is the management company within the meaning of section 76 of the *Companies Act 1961* in relation to a deed dated 22 February 1980 relating to Princess Syndicate (hereinafter called "the trust deed"):

And whereas Eagle Star Nominees Limited is the trustee for the purposes of the trust deed:

And whereas application has been made by the company for exemption from compliance with certain provisions of Division 5 of Part IV. of the said Act in respect of the trust deed:

Now therefore I, the undersigned, the Minister administering the said Act hereby exempt the company from compliance with the provisions of section 80 (1) (b) (iii) of the said Act.

Signed at Melbourne, 5 March 1980

HADDON STOREY
Attorney-General

COMPANIES ACT 1961, SECTION 80

Whereas Alycidon Syndications Limited (hereinafter called "the company") is the management company within the meaning of section 76 of the *Companies Act 1961* in relation to a deed dated 22 February 1980 relating to Jewel Syndicate (hereinafter called "the trust deed"):

And whereas Eagle Star Nominees Limited is the trustee for the purposes of the trust deed:

And whereas application has been made by the company for exemption from compliance with certain provisions of Division 5 of Part IV. of the said Act in respect of the trust deed:

Now therefore I, the undersigned, the Minister administering the said Act hereby exempt the company from compliance with the provisions of section 80 (1) (b) (iii) of the said Act.

Signed at Melbourne, 5 March 1980

HADDON STOREY
Attorney-General

COMPANIES ACT 1961, SECTION 80

Whereas Hascarda Limited (hereinafter called "the company") is the management company within the meaning of section 76 of the *Companies Act 1961* in relation to a deed dated 20 March 1979 relating to H.S.D. Property Trust (hereinafter called "the trust deed"):

and whereas The Equity Trustees Executors and Agency Company Limited is the trustee for the purposes of the trust deed:

and whereas application has been made by the company for exemption from compliance with certain provisions of Division 5 of Part IV. of the said Act in respect of the trust deed:

Now therefore I, the undersigned, the Minister administering the said Act hereby exempt the company from compliance with the provisions of section 80 (1) (b) (iii) of the said Act during such period as the units to which the trust deed relates are listed for quotation on the official list of any Member Exchange of The Australian Associated Stock Exchanges.

Signed at Melbourne, 3 April 1979

HADDON STOREY
Attorney-General

Labour and Industry Act 1958

ORDER OF EXEMPTION UNDER SECTION 80b

Whereas pursuant to section 80b of the *Labour and Industry Act 1958* the City of St. Kilda has applied to the Minister for an Order exempting a shopkeeper of a shop in its municipal district from being required to close and keep closed her shop in accordance with Part VI. of the said Act:

Now therefore I, James Halford Ramsay, Her Majesty's Minister of Labour and Industry in the State of Victoria do pursuant to the aforesaid section 80b of the *Labour and Industry Act 1958* make this Order granting exemption to:—

Mrs I. I. Madden, trading as Izzy's Gearbox, 231 Barkly Street, St. Kilda
from being required to close and keep closed her shop in accordance with Part VI. of the said Act, provided that such exemption shall not apply to Good Friday and Anzac Day.

Dated at Melbourne, 29 February 1980

J. H. RAMSAY
Minister of Labour and Industry

Labour and Industry Act 1958

ORDER OF EXEMPTION UNDER SECTION 80A

Whereas pursuant to section 80A of the *Labour and Industry Act 1958* the Council of the Shire of Bellarine has applied to the Minister for an order exempting shopkeepers of shops in its municipal district from being required to close and keep closed their shops in accordance with the provisions of Part VI. of the said Act:

Now therefore I, James Halford Ramsay, Her Majesty's Minister of Labour and Industry in the State of Victoria, do pursuant to the aforesaid section 80A of the *Labour and Industry Act 1958* make this Order granting exemption to any shopkeeper within the area mentioned in the First Schedule hereto from being required to close and keep closed his shop, at any time when he would but for this Order be required to close and keep closed that shop in accordance with Part VI. of the said Act on any day between the hours of 8 a.m. and 11 p.m. during the periods of the year mentioned in the Second Schedule hereto:

FIRST SCHEDULE—THE AREA

The Townships of Clifton Springs, Drysdale, Portarlington, Ocean Grove, St. Leonards and Indented Heads and that part of the Shire of Bellarine which is within a radius of one mile from the intersection of Portarlington-Queenscliffe Road and Swan Bay Road.

SECOND SCHEDULE—THE PERIODS

1. A period of fourteen consecutive weeks commencing on 1 November each year.
2. The second Monday in March each year and the two days immediately preceding that day.
3. A period of one week commencing on the day immediately preceding Good Friday each year, but excluding Good Friday and excluding Anzac Day if the latter should fall within that period.
4. A period of three consecutive weeks commencing on 11 May each year.
5. The day observed as Queen's Birthday each year and the two days immediately preceding that day.
6. A period of three consecutive weeks commencing on 24 August each year.

Dated at Melbourne 29 February 1980

J. H. RAMSAY
Minister of Labour and Industry

LABOUR AND INDUSTRY ACT 1958

ORDER OF EXEMPTION UNDER SECTION 80A REVOKED

Whereas pursuant to section 80A of the *Labour and Industry Act 1958* the Minister may at any time by order revoke an order made exempting shopkeepers of shops in a Municipal district from being required to close and keep closed their shops in accordance with the provisions of Part VI. of the said Act:

Now therefore I, James Halford Ramsay, Her Majesty's Minister of Labour and Industry in the State of Victoria, do pursuant to the aforesaid section 80A of the *Labour and Industry Act 1958* hereby revoke the order made on the date mentioned in the Schedule hereto and published in the *Government Gazette* on the date as indicated in the said Schedule granting exemption to any shopkeepers within the Municipal district mentioned in the said Schedule from being required to close and keep closed his shop at any time when he would but for the Order be required to close and keep closed that shop in accordance with Part VI. of the said Act.

SCHEDULE

| Date of Order | Date of Publication in Government Gazette | Municipal District |
|------------------|---|--------------------|
| 22 November 1967 | 29 November 1967 | Shire of Bellarine |

Dated at Melbourne 29 February 1980

J. H. RAMSAY
Minister of Labour and Industry

Private Agents Act 1966

NOTICE OF RECEIPT OF APPLICATIONS FOR LICENCES UNDER THE PROVISIONS OF THE PRIVATE AGENTS ACT 1966

The Clerk(s) of the Magistrates' Court(s) as listed hereunder hereby give notice that applications, as under, have been lodged for hearing by the said Court(s) on the date(s) specified.

Any person desiring to object to any of such applications must—

- (a) lodge with the respective Clerk of the Magistrates' Court a notice in the prescribed form of his objection and of the grounds thereof ;
- (b) cause a copy of such notice to be served personally or by post upon the applicant at least three days before the hearing of the application ; and
- (c) send or deliver—
- (i) where the objection is not made by the officer in charge of the police district in which the Court is situated—a copy of the notice to such officer ; and
- (ii) where the objection is not made by the Registrar or Deputy Registrar—a copy to the Registrar.

| Full Name of Applicant* | Place of Abode of Applicant or Nominee | Name of Firm or Corporation | Address for Registration | Type of Licence | Date of Hearing |
|------------------------------------|--|-----------------------------|--------------------------------|-----------------|-----------------|
| MAGISTRATES' COURT, PRAHRAN | | | | | |
| Bromilow, Peter | 40 Nicholas St, Ashburton | Mayne Nickless | 390 St. Kilda Rd, Melbourne | Watchman | 21.3.80 |
| Dole, Edrich | 6 Brackley Crt, St Albans | " " | " " | " " | " " |
| Lawford, Stephen John | 33 Drinkwater Cres, Sunshine | " " | " " | " " | " " |
| Williamson, Anthony James | 44 Leigh St, Huntingdale | " " | " " | " " | 28.3.80 |
| Booth, Paul | 120 Tope St, South Melbourne | " " | " " | " " | " " |
| Kearns, Patrick | 36 Eagle Dr, Noble Park | " " | " " | " " | " " |
| Gold, Ian | 1/44 Edward St, Brunswick | " " | " " | " " | " " |

Dated at Prahran 3 March 1980
H. ADAMS, Clerk of the Magistrates' Court

| | | | | | |
|---------------------------------------|----------------------------------|--------|--------------------------------|----------------|---------|
| MAGISTRATES' COURT, SPRINGVALE | | | | | |
| Huszak, Frank | 197 Brandon Park Dr, Mulgrave | M.S.S. | 94 York St, South Melbourne | Watchman | 28.3.80 |
| Pensa, Vivienne Isobel | 10 Saniky St, North Clayton | " " | " " | Guard Agent | 2.4.80 |
| Rollings, Bronwyn Joy | 3/1 View Rd, Springvale | " " | " " | Inquiry Agent | 26.3.80 |
| Rollings, Bronwyn Joy | " " | " " | " " | Process Server | " " |

Dated at Springvale 3 March 1980
P. COUTTS, Clerk of the Magistrates' Court

| | | | | | |
|-------------------------------------|----------------------------|---|-----------------------------|----------|---------|
| MAGISTRATES' COURT, LILYDALE | | | | | |
| Cruickshank, William | 18 Hillman St, Laverton | Excel Security and Invest. Pty. Ltd. | 5 Taylor Rd, Mooroolbark | Watchman | 27.3.80 |

Dated at Lilydale 3 March 1980
T. BEDOHAZY, Clerk of the Magistrates' Court

| | | | | | |
|---------------------------------------|-----------------------------------|------------------------------------|-----------------------------------|------------------------------|---------|
| MAGISTRATES' COURT, SPRINGVALE | | | | | |
| Starvaggi, Antonio | 21 Clarke Rd, Springvale South | Domingo Lisa Nominees Pty. Ltd. | 21 Clarke Rd, Springvale South | Guard Agent (Corporation) | 28.3.80 |
| " " | " " | " " | " " | Guard Agent (Individual) | " " |
| " " | " " | Starvaggi Enterprises Pty. Ltd. | " " | Guard Agent (Corporation) | " " |

Dated at Springvale 5 March 1980
P. COUTTS, Clerk of the Magistrates' Court

| | | | | | |
|-------------------------------------|-------------------------|---|----------------------------------|-------------------------|--------|
| MAGISTRATES' COURT, LILYDALE | | | | | |
| Beekman, Bernardus | 3 Benson St, Emerald | Smiths Mercantile Agency Security and Armed Escort Services | 1 Carol-Anne Crt, Mooroolbark | Watchman | 3.4.80 |
| " " | " " | " " | " " | Commercial Sub-Agent | " " |

Dated at Lilydale 6 March 1980
T. BEDOHAZY, Clerk of the Magistrates' Court

* Or in the case of a firm or corporation, of the Nominee

PRIVATE AGENTS—continued

| Full Name of Applicant* | Place of Abode of Applicant or Nominee | Name of Firm or Corporation | Address for Registration | Type of Licence | Date of Hearing |
|--|--|--------------------------------|--|--------------------------------|-----------------|
| MAGISTRATES' COURT, BALLARAT | | | | | |
| Scarff, Richard | 14 Simpson St, Ballarat North | Pritchard Security Services | 206 South St, Ballarat | Watchman | 25.3.80 |
| Ellen, Robert Charles | 605 Havelock St, Ballarat | " " | " " | " | " |
| Dated at Ballarat 4 March 1980 D. J. CROFT, Clerk of the Magistrates' Court | | | | | |
| MAGISTRATES' COURT, FERNTREE GULLY | | | | | |
| Murdoch, Yvonne Gail | 1 Wingate Cl, Knoxfield | | 1 Wingate Cl, Knoxfield | Process Server (Individual) | 28.3.80 |
| Dated at Ferntree Gully 5 March 1980 B. DOBSON, Clerk of the Magistrates' Court | | | | | |
| MAGISTRATES' COURT, MARYBOROUGH | | | | | |
| Singleton, Neville Robert | 28 Palmerston St, Maryborough | St Arnaud Security Service | 4 George St, St Arnaud | Guard Agent | 3.4.80 |
| Dated at Maryborough 3 March 1980 R. A. ISON, Clerk of the Magistrates' Court | | | | | |
| MAGISTRATES' COURT, SPRINGVALE | | | | | |
| Preston, Robert Charles | Lot 6 Olinda-Monbulk Rd, Monbulk | | 23 Buckley St, Noble Park | Commercial Agent | 28.3.80 |
| Dated at Springvale 6 March 1980 P. M. COUTTS, Clerk of the Magistrates' Court | | | | | |
| MAGISTRATES' COURT, MELBOURNE | | | | | |
| Andres, Lloyd | 186-188 Osborne Dve, Mt. Martha | Transurety Limited | Cnr Arden and Lothian Sts, North Melbourne | Watchman | 15.4.80 |
| Davies, Warren James | 21 Marlborough St, Fawkner | " " | " " | " | " |
| Hastilow, David Edward | 6/26 Dunlop Ave, Ascot Vale | " " | " " | " | " |
| Leslie, Donald Keith | 92 Eliza St, Keilor Park | " " | " " | " | " |
| Rich, Denis George | 12 Howey St, Gisborne | " " | " " | " | " |
| Dated at Melbourne 5 March 1980 M. J. QUIRK, Clerk of the Magistrates' Court | | | | | |

* Or in the case of a firm or corporation, of the Nominee

Education Act 1958

NOTICE OF THE MAKING OF ORDERS UNDER SECTION 13 OF THE EDUCATION ACT

Pursuant to section 13 of the Education Act 1958 I hereby give notice that Orders of the Governor in Council were made on 4 March 1980 under sub-section (4) of the said Act amending certain provisions relating to the membership of the State Schools Councils listed hereunder.

Primary Schools

Corio
Maryborough
Newstead
Leopold
Tallangatta
Mooroopna
Rupanyup
Oakleigh
Casterton
Mulgrave
Pahran
Myall
Kennington
Mitta North
Malvern East Central
Greythorn
Laburnum
Pinewood

Primary Schools—continued

Warrnambool West
Guthrie Street Shepparton
Diamond Creek East
Glengala
Whealers Hill
Lincolnvile

Secondary Schools

Corryong
Orbost
Kiewa Valley Consolidated

A. J. HUNT
Minister of Education

Co-operation Act 1958

CHANGE OF NAME OF A SOCIETY

Notice is hereby given that Manifold Co-operative Credit Society Limited which is incorporated as a Credit Society under the above-named Act on 12 December 1962, has registered a change of its name and is now incorporated under the name of Manifold Credit Co-operative Society Limited under the said Act.

Dated at Melbourne 26 February 1980

J. W. BLACKMAN
Acting Deputy Registrar

COUNTRY ROADS BOARD

RESOLUTIONS OF THE COUNTRY ROADS BOARD

The Country Roads Board, in pursuance of the provisions of the *Country Roads Act 1958*, has passed Resolutions the dates whereof and the terms of which are scheduled hereunder:

SCHEDULE

State Highway

Resolution dated the Twenty-fifth day of February, One thousand nine hundred and eighty, made pursuant to sections 21, 58 and 74 of the *Country Roads Act 1958* declaring the deviation from the Hume Highway in the Shire of Wangaratta as indicated by diagonal hatching on plan numbered G.P.12760 hereunder to be part of a State highway within the meaning and for the purposes of the said Act, and also declaring that such deviation shall be in lieu of the existing road or part thereof indicated by cross hatching on the said plan and that such part of the said existing road shall be discontinued.

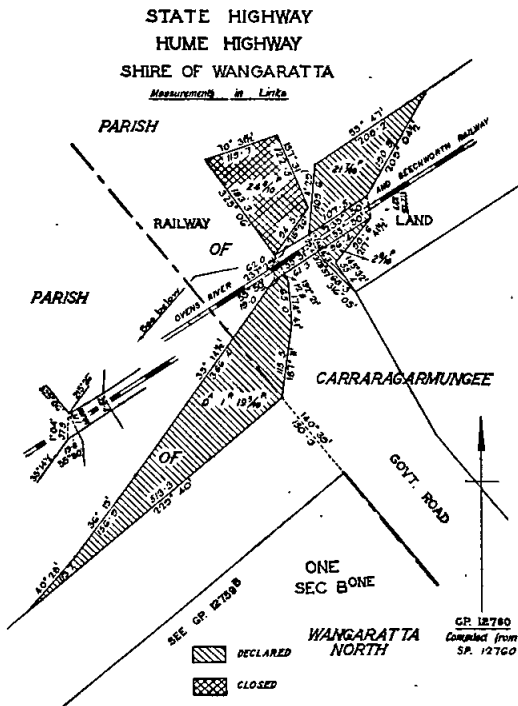

Main Roads

Resolution dated the Twenty-fifth day of February, One thousand nine hundred and eighty, made pursuant to section 21 of the *Country Roads Act 1958* declaring the widening of the Dandenong-Frankston Road in the Shire of Cranbourne and City of Dandenong as shown hatched on plan numbered G.P.14811A hereunder to be part of a main road within the meaning and for the purposes of the said Act.

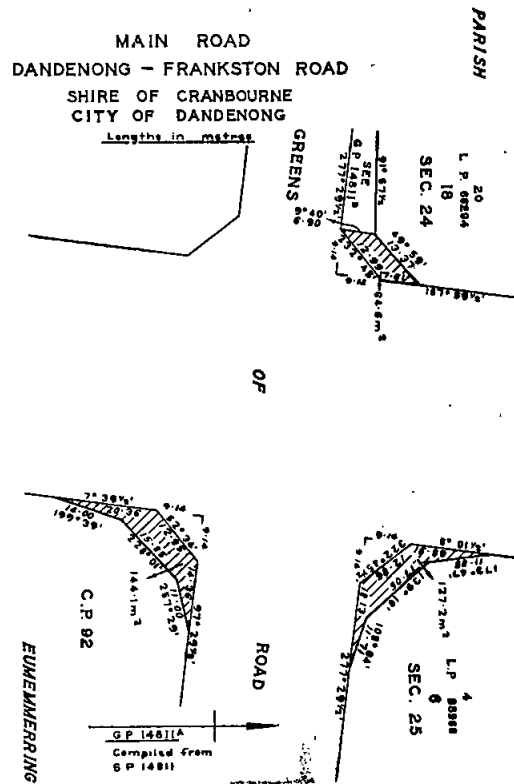

Resolution dated the Twenty-fifth day of February, One thousand nine hundred and eighty, made pursuant to section 21 of the *Country Roads Act 1958* declaring the widening of the Cobden-Port Campbell Road in the Shire of Heytesbury as shown hatched on plans numbered G.P.15101 and G.P.15102 hereunder to be part of a main road within the meaning and for the purposes of the said Act.

Resolution dated the Twenty-fifth day of February, One thousand nine hundred and eighty, made pursuant to sections 21 and 110 of the Country Roads Act 1958 declaring the widening of Bay Street in the City of Port Melbourne as shown hatched on plan numbered G.P.14800 hereunder to be part of a road within the meaning and for the purposes of the said Act.

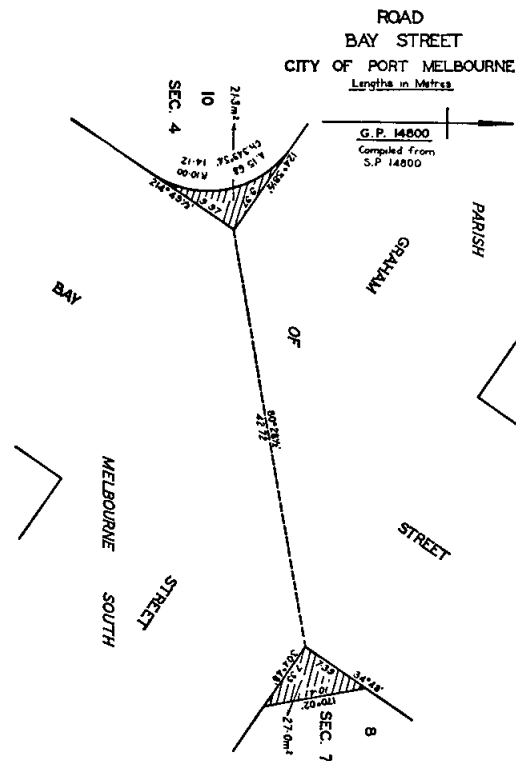

4 March 1980

G. K. COX, Secretary

Town and Country Planning Act 1961
CITY OF MILDURA PLANNING SCHEME

AMENDMENT No. 30, 1979

Notice of Approval

In pursuance of the powers conferred by the Town and Country Planning Act 1961, the Governor in Council on 4 March 1980, approved a planning scheme entitled the City of Mildura Planning Scheme, Amendment No. 30, 1979, in respect of the municipal district of the City of Mildura and such planning scheme comes into operation on the date this Notice of Approval is published in the Government Gazette.

A copy of the planning scheme as approved may be inspected, free of charge, during office hours at the office of the Town and Country Planning Board, 235 Queen Street, Melbourne; at the office of the Council of the City of Mildura at Mildura, and when available, at the Office of Titles, Melbourne, and at the Central Plan Office of the Department of Crown Lands and Survey, Melbourne.

W. H. CRAIG, Secretary
Town and Country Planning Board

Town and Country Planning Act 1961
SHIRE OF LILLYDALE PLANNING SCHEME

AMENDMENT No. 111

INTERIM DEVELOPMENT ORDER

AMENDMENT No. 2

Notice of Amendment

In pursuance of the powers conferred by section 26 of the Town and Country Planning Act 1961, the Governor in Council on 4 March 1980, amended the Shire of Lillydale Planning Scheme, Amendment No. 111, Interim Development Order to remove the provision which requires the issue of a permit for the erection of a house, except for the Yarra Brae, Stane Brae and Mt. Lofty areas.

A copy of the amendment may be inspected during office hours at the office of the Town and Country Planning Board, 235 Queen Street, Melbourne and at the office of the Council of the Shire of Lillydale at Lilydale.

W. H. CRAIG, Secretary
Town and Country Planning Board

Country Fire Authority Act 1958

VARIATION OF FIRE DANGER PERIOD IN RESPECT OF SPECIFIED PARTS OF THE COUNTRY AREAS IN VICTORIA

Whereas by section 4 of the Country Fire Authority Act 1958 it is enacted that the Minister for Police and Emergency Services of Victoria, after consultation with the Minister of Forests, may from time to time by declaration published in the Government Gazette declare any period to be the fire danger period in respect of the country area of Victoria, or any specified part or parts thereof and, without affecting the generality of the foregoing, may declare different periods to be the fire danger period in respect of different parts of the said country area.

And whereas by the said section it is further enacted that any declaration so published may be revoked, amended or varied by a subsequent declaration so published.

And whereas by declaration issued on the date stated in Schedule "A" hereunder, different fire danger periods expiring on 30 April 1980 were declared in respect of different parts of the country area of Victoria, situated within the municipal districts or parts of municipal districts specified in Schedule "B" hereunder.

And whereas the Minister for Police and Emergency Services and the Minister of Forests have consulted accordingly.

Now therefore I, the Minister for Police and Emergency Services of Victoria, do by this my declaration vary the aforesaid declaration by declaring that the fire danger period in respect of the parts of the country area of Victoria situated within the municipal districts or parts of municipal districts specified in Schedule "B" hereunder shall end at midnight on 16 March 1980.

SCHEDULE "A"

Date of Issue of Declaration; Date of Commencement of Fire Danger Period; Date of Publication in Government Gazette

| | | |
|----------|----------|----------|
| 27.11.79 | 2.12.79 | 28.11.79 |
| 4.12.79 | 9.12.79 | 5.12.79 |
| 11.12.79 | 16.12.79 | 12.12.79 |

SCHEDULE "B"

- Borough of Kerang.
- Shires of Cohuna, Kaniva, Kerang, Warracknabeal.
- Part Shire of Dimboola (southern portion—those portions within the Counties of Borung and Lowan).
- Part Shire of Wycheproof (southern portion—those portions south of the Woomelang-Banyon-Berriwillock Road, the western, southern and eastern boundaries of the Township of Berriwillock and the Berriwillock-Springfield-Ultima Road).

L. H. S. THOMPSON
Minister for Police and Emergency Services
Ministry for Police and Emergency Services
Melbourne, 11 March 1980

PLACE NAMES COMMITTEE
Survey Co-ordination Act 1958
PROPOSAL TO ASSIGN NAME

The Place Names Committee hereby gives notice that it proposes to assign the name shown hereunder. Any objections to this proposal must be lodged with the Committee within two months of the publication of this notice. Where an objection is lodged it must be in writing and state the grounds of objection.

| Ref. | Name | Municipality | Location |
|--------|-------------|-----------------|--|
| M036/1 | Hughes Park | City of Croydon | On the Kilsyth map sheet (No. 7922-2-NW) at map reference 500 183, the area of park land enclosing the North Croydon Tennis Club |

ASSIGNMENT OF NAMES

The Place Names Committee hereby gives notice that it has assigned the undermentioned names, in respect of which no objections to previously published proposals were received.

| Ref. | Name | Municipality | Map Name, No. and Grid Ref. |
|--------|---------------------------------|-------------------------|---------------------------------|
| M040/1 | Gregson Park | Shire of Dimboola | Horsham; SJ54-3; 500 500 |
| M039/1 | Central Park | Shire of Diamond Valley | Epping; 7922-4-SW; 327 239 |
| M076/1 | Mount Carberry | Shire of Melton | Melbourne; SJ55-5; 262 348 |
| M087/1 | Blue Rock Dam Blue Rock Lake | Shire of Narracan | Moe; 8121; 280 865 |
| M192/1 | Tyrol Park | City of Nunawading | Nunawading; 7922-3-NE; 406 079 |
| M199/1 | Lions Park | City of Sale | Sale; 8321; 060 820 |
| M107/1 | Gilmour Park | Shire of Sherbrooke | Lysterfield; 7922-2-SW; 510 033 |
| M080/1 | Baromi | Shire of Mirboo | Moe; 8121; 260 490 |

ALTERATION OF NAME

The Place Names Committee hereby gives notice that it has altered the undermentioned name in the manner shown, in respect of which no objection was received to a previously published proposal.

| Ref. | Former Name | New Name | Municipality |
|--------|--------------------------------------|------------------------|------------------|
| M110/1 | Halls Gap Camping and Picnic Reserve | Halls Gap Caravan Park | Shire of Stawell |

P. G. SEWELL, Secretary

Place Names Committee
Department of Crown Lands and Survey
2 Treasury Place
Melbourne, 3002, 5 March 1980

Police Offences Act 1958, No. 6337

DIVISION 1A—STATE CLASSIFICATION OF PUBLICATIONS BOARD

Take note that the State Classification of Publications Board has classified the following publications in accordance with the provisions of section 180H (1) of the Police Offences Act 1958.

Each publication shall be subject to the following restrictions:

- It shall not be offered for sale, sold, delivered, exhibited or displayed to any person under the age of 18 years;
- It shall not be made available for inspection or perusal to any person under the age of 18 years;
- It shall not be exhibited or displayed in any place to which persons under the age of 18 years have access or so that it is visible from any such place;
- It shall not be advertised in any manner whatsoever.

SCHEDULE OF PUBLICATIONS

| Title | Distributor | Title | Distributor |
|-----------------------------|------------------------------|-----------------------------------|------------------------------|
| Adult Sex Cartoons and Gags | Gordon & Gotch (A'sia) Ltd. | Ero No. 12 | Venus Enterprises Pty. Ltd. |
| Bold! & Gay Vol. 1 No. 1 | Wathen Wholesale Pty. Ltd. | Femina Vol. 7 No. 4 | Claredale Holdings Pty. Ltd. |
| Bucks! Vol. 1 No. 1 | Wathen Wholesale Pty. Ltd. | Flat Tops Vol. 1 No. 4 | Claredale Holdings Pty. Ltd. |
| Busty Babe Vol. 1 No. 1 | Claredale Holdings Pty. Ltd. | Fun Sex Gags and Cartoons | Gordon & Gotch (A'sia) Ltd. |
| Conquest Issue 1 | Wathen Wholesale Pty. Ltd. | Heels & Hose Vol. 11 No. 1 | Claredale Holdings Pty. Ltd. |
| Elite No. 1 | Wathen Wholesale Pty. Ltd. | Human Digest—February 1980 | Gordon & Gotch (A'sia) Ltd. |
| | | International Cover Models No. 16 | Claredale Holdings Pty. Ltd. |
| | | Kingsize Vol. 10 No. 4 | Claredale Holdings Pty. Ltd. |
| | | Kinky Life Vol. 2 No. 1 | Claredale Holdings Pty. Ltd. |
| | | Letters—March 1980 | Gordon & Gotch (A'sia) Ltd. |
| | | Lovebirds No. 27 | Claredale Holdings Pty. Ltd. |
| | | Numbers | Wathen Wholesale Pty. Ltd. |
| | | Park Lane No. 42 | Claredale Holdings Pty. Ltd. |
| | | Peaches Special No. 22 | Wathen Wholesale Pty. Ltd. |
| | | Penthouse—April 1980 | Gordon & Gotch (A'sia) Ltd. |
| | | Playbirds No. 37 | Claredale Holdings Pty. Ltd. |
| | | Popular Cartoons—April 1980 | Gordon & Gotch (A'sia) Ltd. |
| | | Proud! Vol. 2 No. 1 | Wathen Wholesale Pty. Ltd. |
| | | Sex Guide—April 1980 | Gordon & Gotch (A'sia) Ltd. |
| | | Sex—Stunning Gags and Cartoons | Gordon & Gotch (A'sia) Ltd. |
| | | Tender Teasers Vol. 1 No. 4 | Claredale Holdings Pty. Ltd. |
| | | Whitehouse No. 50 | Claredale Holdings Pty. Ltd. |

J. SMITH, Secretary
State Classification of Publications Board

CONTRACTS ACCEPTED—(Series 1979-80)
AMENDMENTS

| Schedule Number | Item Number | New Rate | Effective Date |
|---|-----------------|---|----------------|
| \$ | | | |
| <i>Electrical Goods</i> | | | |
| 1/05 | 41-43 56, 58 | Change Contractor's name to Rank-General Electric Major Appliances Pty. Ltd. other details unchanged. | 13.12.79 |
| <i>Toilet Requirements</i> | | | |
| 1/16 | 9 | 20.47* | 3.3.80 |
| | 16 | 15.59* | |
| | 17a | 17.70* | |
| | 17b | 20.91* | |
| | (1-9 cases) | (1-9 cases) | |
| *Less 3, 3/4%, 10 days | | | |
| <i>Motor Spirit (Bulk)—State Petrol Centre</i> | | | |
| 1/53A | 1 | .2692 | 1.3.80 |
| <i>Motor Spirit, Kerosene, Fuel Oils and Lubricants</i> | | | |
| 1/53B | 3 | .2722 | 1.3.80 |
| | 4 | .2756 | |
| | 5 | .2842+x | |
| | 6 | .2842x | |
| | 7 | .2823 | |
| | 8 | .2857 | |
| | 9 | .2943+x | |
| | 10 | .2943x | |
| | 11 | .2792 | |
| | 12 | .2962† | |
| | 13 | .2792 | |
| | 14 | .2962† | |
| | 15 | .2893 | |
| | 16 | .3063† | |
| | 17 | .2893 | |
| | 18 | .3063† | |
| | 20 | .3338+x | |
| | 27 | .2147* | |
| | 29 | .2443x* | |

x Plus \$15 drum deposit
+ Minimum order 3 drums in metropolitan area
† The Shell Co. of Australia Ltd.
* Plus \$0.0740 unless diesel fuel exemption certificate number quoted.

AMENDMENTS—continued

| Schedule Number | Item Number | New Rate | Effective Date |
|---|-------------|---------------|----------------|
| \$ | | | |
| <i>Motor Vehicles</i> | | | |
| 1/58 | 3 | 4359.00* | 4.2.8 |
| * Plus \$14.45 delivery in Metropolitan area | | | |
| <i>Stationery General</i> | | | |
| 1/64 | 41 | .066 | 4.3.80 |
| | 151 | 5.40* | 25.1.80 |
| | 152 | 4.80* | |
| * Change contractor to Humbley and Waghorn Sales | | | |
| <i>Carbon Papers and Typewriter Ribbons</i> | | | |
| 1/72 | 17.18 18 | 3.35* .67* | 7.3.80 |
| * Change contractor to Beclay Imports, 4-8 Yambra Street, Clifton Hill, Vic. 3068. Telephone 489 5322 | | | |
| <i>Groceries—Melbourne and Metropolitan District</i> | | | |
| 2/02 | 3 | 7.38* | 1.3.80 |
| | 5 | 1.67* | |
| | 19 | 9.28 | |
| | 20 | 9.28 | |
| | 21 | 8.51 | |
| | 24 | 7.29+ | |
| | 89 | 19.00 | |
| | 136 | 2.68 | |
| | 146 | 13.31 | |
| | 178 | 9.35x | |
| | 200 | 4.86 | |
| | 208 | 0.36 | |
| * Per 6 + Other flavours x Dante Spanish Olive Oil | | | |

J. M. PAWSON, Secretary to the Tender Board

CONTRACTS ACCEPTED—(Series 1979-80)
PUBLIC WORKS

His Excellency the Governor of the State of Victoria, by and with the advice of the Executive Council thereof has by Orders made on 4 March 1980, approved of the acceptance by the Minister of Public Works of the under-mentioned offers, without public tenders being invited, viz.:-

Offer of Gas & Fuel Corporation of Victoria for supply and installation of new gas boiler at State Library Museum Annexe, Abbotsford, for the sum of twenty-one thousand six hundred and thirty-seven dollars (\$21 637.00)—(C.191281).

Offer of Brownbuilt Ltd. for supply of specimen cabinets at National Museum of Victoria, Swanston Street, Melbourne, for the sum of fifteen thousand two hundred and seventy-seven dollars fifty cents (\$15 277.50)—(S.300027/0011).

Offer of Duncan & Russell (Vic.) Pty. Ltd. for dredging of entrance channel at Kororoit Creek, for the sum of fifteen thousand four hundred and forty dollars (\$15 440.00)—(P. & H.113838a).

Offer of Anderson Connell Consultants Pty. Ltd. for professional services at Mont Park Mental Hospital Out-patients Clinic, for the sum of twenty-five thousand dollars (\$25 000.00)—(C.188562p).

Offers and at the amounts shown for professional services at Public Offices, 3A, 3B Treasury Place and 11 Parliament Place, Melbourne—(P.C.186732p).

| | |
|------------------------------|-------------|
| Eggleston MacDonald & Secomb | \$85 000.00 |
| R. J. Nagel & Associates | \$52 000.00 |
| Rider Hunt & Partners | \$15 000.00 |

Offers and at the amounts shown for professional services at Special Development School, Frankston (Woorinyan)—(E.19234p).

| | |
|----------------------------------|-------------|
| T. Waisberg & Associates | \$12 500.00 |
| John W. Joyce & Associates | \$13 500.00 |
| Richardson & Christoff Pty. Ltd. | \$18 000.00 |

TOM FORRISTAL
Clerk of the Executive Council

At the Executive Council Chamber
Melbourne, 4 March 1980

PUBLIC TRUSTEE ACT 1958, SECTION 17

I hereby give notice that on 3 March 1980, the Public Trustee filed elections to administer the following deceased persons' estates in accordance with section 17 of the *Public Trustee Act 1958*.

BOYCE, THOMAS WILLIAM, late of 3A Mason Street, Westgarth, retired bootmaker, died 5 December 1979.

YOUNG, CHARLES ANDREW, formerly of Stewart Street, Horsham, but late of Ballarat, labourer, died 16 November 1979.

P. T. SPENCER
Public Trustee

168 Exhibition Street, Melbourne, 3000
5 March 1980

Creditors, next of kin, and others having claims against the estate of any of the under-mentioned deceased persons are required to send particulars of their claims to the Public Trustee, 168 Exhibition Street, Melbourne, Vic. 3000, the personal representative, on or before 19 May 1980, after which date the Public Trustee may convey or distribute the assets having regard only to the claims of which the Public Trustee then has notice:—

BOYCE, THOMAS WILLIAM, late of 3A Mason Street, Westgarth, retired bootmaker, died 5 December 1979.

BURGESS, STANLEY VINCENT, late of 62 Berry Street, Coburg, retired pattern maker, died 4 January 1980.

CRONEAN, FRANCIS GREGORY, also known as Richard Cleary, late of Ballarat, pensioner, died 26 September 1979.

DOWLING, JAMES THOMAS, late of 95 Malpas Street, East Preston, retired butcher, died 22 August 1979.

DRAPER, EDWIN RICH MOLLET, also known as Edward Arthur Stewart and Edward Rich Little, late of 62 Regent Street, Elsternwick, retired labourer, died 6 December 1979.

GEISE, ELSIE MAY, late of Flat 74, 260 Pascoe Vale Road, Essendon, widow, died 4 November 1979.

GUNN, RUBY VICTORIA MAY, formerly of 16 Liberator Street, Ashburton, but late of Abbey Lodge Private Hospital, 645 High Street, East Prahran, widow, died 5 November 1979.

HAGGART, THOMAS, formerly of 8 Preston Street, Preston, but late of Flat 5, 78 Droop Street, Footscray, retired carter, died 18 June 1979.

HALL, DEBORAH KATHLEEN, late of Flat 5/150 Barkers Road, Hawthorn, telephonist, died 29 October 1979.

HILL, MAISIE MARGARET ELLEN, late of 31 Charles Street, Cheltenham, widow, died 29 December 1979.

HISLOP, WINIFRED ELSIE, late of 34 Trevascus Street, Caulfield, widow, died 14 December 1979.

HOGAN, GLORIA ELLEN, late of 15 Kuranda Street, Langwarrin, widow, died 11 October 1979.

HOWARD, LESLIE JOHN, late of 259 Beaconsfield Parade, Middle Park, retired, died 24 December 1979.

MCPhAIL, HARRY THOMAS, late of 28 James Street, Glenhuntly, retired salesman, died 23 August 1979.

MODRZEJEWSKI, MICHAEL, late of Commercial Hotel, Wellington Street, Kerang, retired labourer, died 11 August 1978.

ROBERTSON, LYNETTE JOY, late of Dreeite, married woman, died 11 December 1979.

SATCHWELL, JOHN WILLIAM, late of 78 Erskine Street, North Melbourne, retired clerk, died 12 December 1979.

YOUNG, CHARLES ANDREW, formerly of Stewart Street, Horsham, but late of Ballarat, labourer, died 16 November 1979.

Melbourne, 5 March 1980

P. T. SPENCER
Public Trustee

APPOINTMENTS AND RESIGNATIONS

APPOINTMENTS

His Excellency the Governor of the State of Victoria, by and with the advice of the Executive Council thereof, has, by Orders made on 4 March 1980, been pleased to make the under-mentioned appointments, viz.:—

DEPARTMENT OF COMMUNITY WELFARE SERVICES

Honorary Probation Officers

RAYMOND BRIAN EGAN, Yarraview, St. John of God, P.O. Box 130, Lilydale,
PAUL ANTHONY GUNNING, Flat 12, 133 Grange Road, Glenhuntly,

ALAN GEOFFREY KEMP, 2/4 Mason Court, Highett,
AVIS LORRAINE LEIGH, 10 Elizabeth Court, Ringwood East,

LAURENCE IAN PERRY, 114 The Esplanade, Brighton,
GRAEME GEORGE SHELDEN, 12 McArthur Street, Moorabbin,

MALCOLM JOHN WALMSLEY, 45 Castlewood Street, East Bentleigh,
MARSHALL WHITE, 26 Sunlight Crescent, East Brighton, and

EUNICE EVELYN WOOLLARD, Lot 3, Warburton Highway, Woori Yallock,

to be Honorary Probation Officers, for all Adult and Children's Courts in Victoria, pursuant to the provisions of section 507 (2) of the *Crimes Act 1958*, and section 9 of the *Children's Court Act 1973*.

DEPARTMENT OF CROWN LANDS AND SURVEY

Bailiff of Crown Lands

ALLAN THOMAS RAMPAL, an officer of the National Parks Service, Ministry for Conservation, to be a bailiff of Crown lands, without additional salary, pursuant to the provisions of section 30 of the *Land Act 1958* in respect of all Crown lands in the State of Victoria.

Appointment of a Trustee—Hall for the Use of the Royal Society of Victoria, City of Melbourne

The Honorable Mr JUSTICE ALBERT EDWARD WOODWARD, L.L.M., Q.C., O.B.E., as a Trustee of the land in the City of Melbourne, Parish of Melbourne North, permanently reserved by Order in Council of 2 April 1883 (*Government Gazette* of 6 April 1883) as a site for a Hall for the use of the Royal Society of Victoria, in the place of the Honorable Mr Justice Clifford Inch Menhennitt, deceased—(Rs.1271).

HEALTH COMMISSION

Inspector of Treatment Centres

WARREN MURRAY WHITE, M.B., B.S., D.P.M., F.R.A.N.Z.C.P., to be an Inspector of Treatment Centres pursuant to the provisions of section 19 of the *Alcoholics and Drug-Dependent Persons Act 1968* for the period 26 February 1980 to 5 March 1980, vice Dr T. Stephens, interstate.

Superintendents

CHRISTOPHER PERCIVAL, M.B., B.S., D.P.M., M.R.A.N.Z.C.P., to be Superintendent, Shepparton Psychiatric Hospital, pursuant to the provisions of section 26 (1) of the *Mental Health Act 1959* for the period 27 March 1980 to 30 March 1980.

DIWAKARLA LALITH BHASKA SHARMA, M.B., B.S., M.D., F.R.A.C.G.P., to be Superintendent, Children's Cottages, Kew, pursuant to the provisions of section 26 (1) of the *Mental Health Act 1959* for the period 18 February 1980 to 22 February 1980, vice Dr G. McBrearty, on study leave.

DAVID PHILLIP OLLERENSHAW, M.B., B.S., D.P.M., M.R.C. Psych., to be Superintendent, Ararat Mental Hospital and Training Centre, pursuant to the provisions of section 26 (1) of the *Mental Health Act 1959* for the period 24 March 1980 to 29 March 1980, vice Dr B. Currie, on study leave.

LAW DEPARTMENT
Justices of the Peace

TERRENCE JOHN CHANDLER, 590 Orrong Road, Armadale,
DOUGLAS HENRY GONSALVES, 3 Smith Street, Maidstone, and
JACOBUS WIEBENGA, Lot 28, Goldsmith Street, Somers, to be Justices of the Peace for the State of Victoria.
Commissioners for Taking Declarations, &c.
IAN LANGHAM ARMSTRONG, 114 William Street, Melbourne,
BEVERLEY-ANNE ARTHUR-PFEIL, 167 Flinders Lane, Melbourne,
GEOFFREY ADAM BANN, 227 Collins Street, Melbourne,
JOSEPH FOSTER CAMPBELL, R.M.B. 5073, Tallangatta,
JAMES THOMAS CASEY, 14 Churchill Street, East Doncaster,
ROBERT JOHN COOKE, Banksia Street, Heidelberg West,
JAMES ALISTER COOMBS, 47 Alfreda Street, St. Albans,
HAROLD TREVOR DAVIS,
LEO REUBEN DOBBIN,
COLIN WILLIAM RIES,
ROBERT EDWARD SPIVEY, and
COLIN LESLIE WILSON,
370 St. Kilda Road, Melbourne,
HANNELORE GERDA FORSTER, 140 Queen Street, Melbourne,
JOHN ROBERTSON MCKINDLEY, 140 William Street, Melbourne,
THOMAS WILLIAM JACKSON, 5 Yarck Court, Westmeadows,
DONALD EDWARD JOHNSON, 4 Carrington Road, Reservoir,
CLYDE ROYAL KEAM, and
NOEL RONALD KEAM,
2 Russell Street, Essendon,
MARY JEAN LOMAS, 249 High Street, Bendigo,
WILLIAM RAYMOND MCKENZIE, Main Road, Archies Creek,
RONALD STANLEY McLENNAN, 550 Princes Highway, Noble Park,
HARVEY CHARLES PEARCE, corner Evans and Brooks Streets, Sunbury,
IAN STUART GORDON PERRINS, 335-339 Collins Street, Melbourne,
GLENN WILTON REDENBACH, 2 Treasury Place, Melbourne, and
ROBERT ROSENZWEIG, 68 Milton Street, Elwood, to be Commissioners for taking Declarations and Affidavits under the Evidence Act 1958.

Judge of the Supreme Court

ROBERT CLIVE TADGELL, Q.C., who has been a practising Barrister of the Supreme Court of Victoria of not less than eight years standing,
to be a Judge of the Supreme Court of the State of Victoria pursuant to the provisions of section 7 of the Supreme Court Act 1958.

Judge of the County Court

ALAN ELMSLIE DIXON, Barrister, who has practised as a Barrister in Victoria for a period of seven years,
to be a Judge of the County Court of the State of Victoria.

Assistant Registrar of the County Court

JOSEPH GERARD SHIELS, Clerk of Courts,
to be Assistant Registrar at Camperdown for the County Court at Warrnambool, vice R. C. Waters, transferred.

Deputy Public Trustee

PETER GERARD DEWAN, 168 Exhibition Street, Melbourne,
to be a Deputy Public Trustee pursuant to the provisions of section 6 of the Public Trustee Act 1958.

DEPARTMENT OF MINERALS AND ENERGY

Member of Board of Examiners for Quarry Managers

JOSEPH EDWARD SALTER
to be a member of the Board of Examiners for Quarry Managers for a period of three years from 8 February 1980.

TOM FORRISTAL

Clerk of the Executive Council
At the Executive Council Chamber
Melbourne, 4 March 1980

APPOINTMENT

EDUCATION DEPARTMENT

Member of Secondary Teachers Registration Board

His Excellency the Governor of the State of Victoria, by and with the advice of the Executive Council thereof, has by Order made on 26 February 1980, been pleased to appoint KENNETH WILLIAM EVELY, duly elected deputy, to be a member of the Secondary Teachers Registration Board during the absence of Graeme Shaw Stuart, pursuant to the powers conferred by the Education Act 1958.

TOM FORRISTAL

Clerk of the Executive Council
At the Executive Council Chamber
Melbourne, 26 February 1980

ADOPTION OF CHILDREN ACT 1964

Pursuant to the provisions of section 21 the Adoption of Children Act 1964, I hereby appoint Miss. KATHARINE BARTLAM LANCASTER as Principal Officer of the Child Care Service of the Uniting Church Private Adoption Agency, vice Mrs Alexandra Mercer.

Given under my hand at Melbourne, 4 March 1980

WALTER JONA

Minister for Community Welfare Services

Vermin and Noxious Weeds Act 1958

APPOINTMENT OF INSPECTORS

It is hereby notified that the Public Service Board in exercise of its powers has appointed the under-mentioned persons as Inspectors under the provisions of section 4 of the Vermin and Noxious Weeds Act 1958, without additional salary:

JOHN CHARLES JAMES
GLENN WILTON REDENBACH
Melbourne, 11 March 1980

C. E. MIDDLETON,
Secretary for Lands

Liquor Control Act 1968

APPOINTMENT OF LICENSING INSPECTORS

In accordance with the authority conferred upon me by section 6 of the Police Regulation Act 1958, I, Aubrey William Conn, Deputy Commissioner of Police, do hereby appoint under subsection (1) of Section 22 of the Liquor Control Act 1968, the following Officers of Police as Licensing Inspectors for the Divisions of the Police Districts as shown:

| Division Number | Police District | Rank and Name |
|-----------------|-----------------|---|
| 2 | East Gippsland | Inspector William John Gibbons (vice Inspector F. O. Stephenson) |
| 5 | Maroondah | Inspector Kevin Neville Hastings (from 29.2.80 to 27.3.80) |
| 1 | Melbourne | Inspector Albert Maxwell Newell (from 2.3.80 to 22.3.80) |
| 6.3.1980 | | A. W. CONN Deputy Commissioner (Operations) |

RESIGNATIONS

His Excellency the Governor of the State of Victoria, by and with the advice of the Executive Council thereof, has, by Orders made on 4 March 1980, accepted the resignations of the persons named hereunder of the offices mentioned, viz.:-

LAW DEPARTMENT

Justices of the Peace

ALAN LORIMER CAPELL,
COLIN JOSHUA WARD, and
GEORGE HENRY HAGG,
as Justices of the Peace for the State of Victoria.

Commissioners for Taking Declarations, &c.

IAN JAMES BERRY,
 CEDRIC WILFRED FAIRHALL,
 JAMES FRENCH,
 DOUGLAS HENRY GONSALVES,
 PAUL FRANCIS O'FARRELL,
 GEORGE WOODINGS PORTER,
 ALAN GARNET STEWART,
 MOLLIE SULLIVAN,
 JACOBUS WIEBENGA, and
 ALAN ALBERT WOODHOUSE,
 as Commissioners for taking Declarations and Affidavits under the Evidence Act 1958.

DEPARTMENT OF COMMUNITY WELFARE SERVICES

Honorary Probation Officers

RONALD ALBERT BURTON,
 HILDA ISOBEL CLAYTON,
 RALPH JOSEPH COYNE,
 KEITH WILFRED HARBOUR,
 WALLACE DAVID KEIR,
 PATRICIA LAIRD,
 DOUGLAS ALAN LEEDEN,
 FLORA LOUKIDES,
 MARY MAHER,
 DENNIS BERTHOLD MANGER,
 DENIS NORMAN MARETT,
 REITA JOSEPHINE MAYS,
 WILLIAM BONNER MESSER,
 JOHN JAMES MILROY,
 CHARLES COLIN MORGAN,
 GODFREY WALTER ALFRED NOTT,
 PETER BRAITHWAITE ROBSON,
 LIONEL SIMON SHARPE, and
 TED SZELEST,

as Honorary Probation Officers pursuant to the provisions of section 507 (2) of the Crimes Act 1958, and section 9 of the Children's Court Act 1973, for all Adult and Children's Courts in Victoria.

TOM FORRISTAL
 Clerk of the Executive Council

At the Executive Council Chamber
 Melbourne, 4 March 1980

ORDERS IN COUNCIL

LOCAL GOVERNMENT ACT 1958

At the Executive Council Chamber, Melbourne, the fourth day of March, 1980

PRESENT:

His Excellency the Governor of Victoria
 Mr Crozier | Mr Balfour

ROADS DISCONTINUED—CITY OF FOOTSCRAY

Whereas it is provided in section 528 (2) of the Local Government Act 1958, that where a road (whether or not a public highway but not being a road set out on land of the Crown) or any part thereof is not required for public use, the Governor in Council on the request of the council of the municipality in which such road is situated made not less than one month after publishing in a newspaper generally circulating in the district and posting to the registered proprietor (if any) of the land and the owners and occupiers (if any) of lands abutting or immediately adjacent to the road notice of intention to make such a request may by Order published in the Government Gazette direct that such road or part shall be discontinued and thereupon such road or part shall be discontinued accordingly.

And whereas the Council of the City of Footscray has requested that the Governor in Council direct that roads bounded by North, South Charles and Austin Streets,

Footscray be discontinued and not less than one month previously has published in a newspaper generally circulating in the district and posted to the registered proprietor of the land in the road and to the owners and occupiers of lands abutting or immediately adjacent to the road notice of intention to make such request.

Now therefore, His Excellency the Governor of the State of Victoria, by and with the advice of the Executive Council thereof, hereby directs:

- (a) that the said roads which are shown by hatching and cross hatching on the plan hereunder shall be discontinued;
- (b) that notwithstanding such discontinuance the Melbourne and Metropolitan Board of Works shall continue to have and possess the same right title power authority or interest in or in relation to the whole of the land shown by cross hatching on the said plan as it had or possessed prior to such discontinuance with respect to or in connection with any drains or pipes laid or erected in on or over such land for the purposes of drainage or sewerage;
- (c) that, subject to any such right title power authority or interest the land in the said roads may be sold by the Council of the City of Footscray by agreement.

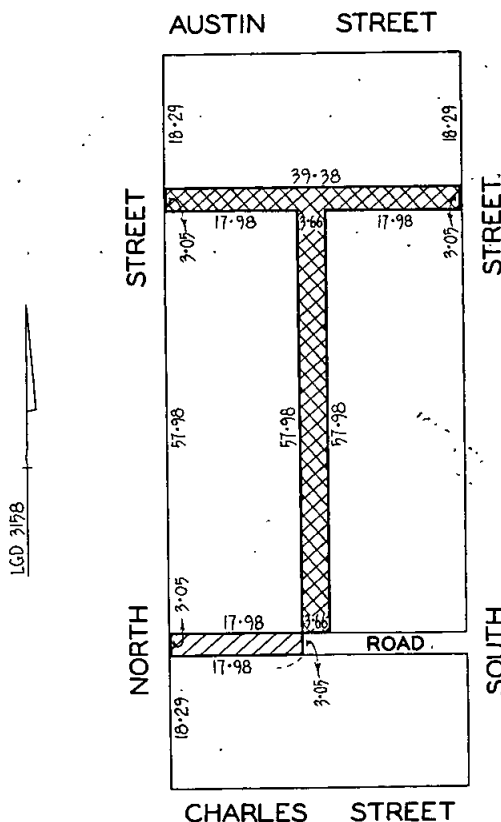

LENGTHS ARE IN METRES

And the Honorable Digby Glen Crozier, Her Majesty's Minister for Local Government for the State of Victoria, shall give the necessary directions herein accordingly.

TOM FORRISTAL
 Clerk of the Executive Council

LOCAL GOVERNMENT ACT 1958

At the Executive Council Chamber, Melbourne, the fourth day of March, 1980

PRESENT:

His Excellency the Governor of Victoria
Mr Crozier | Mr Balfour

ROAD DISCONTINUED—CITY OF FITZROY

Whereas it is provided in section 528 (2) of the *Local Government Act 1958*, that where a road (whether or not a public highway but not being a road set out on land of the Crown) or any part thereof is not required for public use, the Governor in Council on the request of the council of the municipality in which such road is situated made not less than one month after publishing in a newspaper generally circulating in the district and posting to the registered proprietor (if any) of the land and the owners and occupiers (if any) of lands abutting or immediately adjacent to the road notice of intention to make such a request may by Order published in the *Government Gazette* direct that such road or part shall be discontinued and thereupon such road or part shall be discontinued accordingly.

And whereas the Council of the City of Fitzroy has requested that the Governor in Council direct that part of a road off Grant Street, North Fitzroy be discontinued and not less than one month previously has published in a newspaper generally circulating in the district and posted to the registered proprietors of the land in the road and to the owners and occupiers of lands abutting or immediately adjacent to the road notice of intention to make such a request.

Now therefore, His Excellency the Governor of the State of Victoria, by and with the advice of the Executive Council thereof, hereby directs that the said part of a road which is shown by hatching on the plan hereunder, shall be discontinued and that the land may be sold by the Council of the City of Fitzroy by agreement.

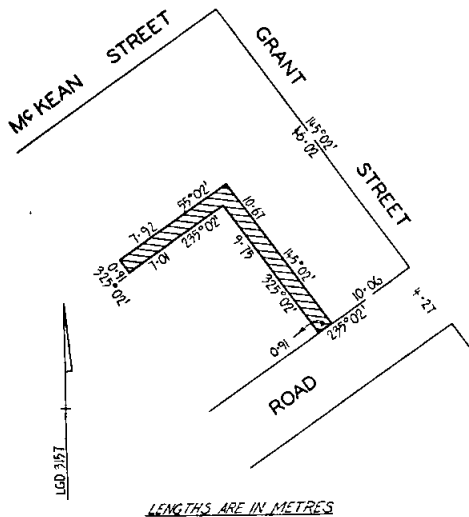

And the Honorable Digby Glen Crozier, Her Majesty's Minister for Local Government for the State of Victoria, shall give the necessary directions herein accordingly.

TOM FORRISTAL
Clerk of the Executive Council

LOCAL GOVERNMENT ACT 1958

At the Executive Council Chamber, Melbourne, the fourth day of March, 1980

PRESENT:

His Excellency the Governor of Victoria
Mr Crozier | Mr Balfour

ROAD DISCONTINUED—CITY OF OAKLEIGH

Whereas it is provided in section 528 (2) of the *Local Government Act 1958*, that where a road (whether or not a public highway but not being a road set out on land of the Crown) or any part thereof is not required for public use, the Governor in Council on the request of the council of the municipality in which such road is situated made not less than one month after publishing in a newspaper generally circulating in the district and posting to the registered proprietor (if any) of the land and the owners and occupiers (if any) of lands abutting or immediately adjacent to the road notice of intention to make such a request may by Order published in the *Government Gazette* direct that such road or part shall be discontinued and thereupon such road or part shall be discontinued accordingly.

And whereas the Council of the City of Oakleigh has requested that the Governor in Council direct that a road at the rear of No. 50 Atherton Road, Oakleigh be discontinued and not less than one month previously has published in a newspaper generally circulating in the district and posted to the registered proprietor of the land in the road and to the owners and occupiers of lands abutting or immediately adjacent to the road notice of intention to make such a request.

Now therefore, His Excellency the Governor of the State of Victoria, by and with the advice of the Executive Council thereof, hereby directs that the said road which is shown by hatching on the plan hereunder, shall be discontinued and the land in the said road may be sold by the Council of the City of Oakleigh by agreement.

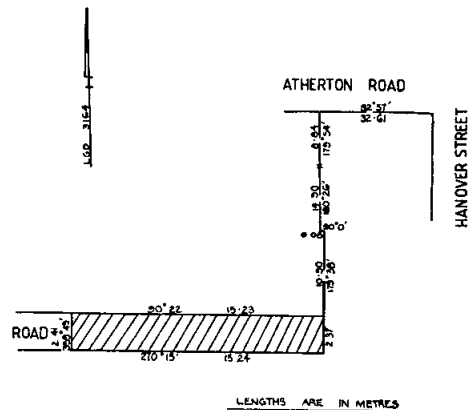

And the Honorable Digby Glen Crozier, Her Majesty's Minister for Local Government for the State of Victoria, shall give the necessary directions herein accordingly.

TOM FORRISTAL
Clerk of the Executive Council

LOCAL GOVERNMENT ACT 1958

At the Executive Council Chamber, Melbourne, the fourth day of March, 1980

PRESENT:

His Excellency the Governor of Victoria
Mr Crozier | Mr Balfour

APPLICATION TO ELECTIONS OF COUNCILLORS FOR THE SHIRE OF NEWSTEAD OF REGULATIONS RELATING TO COMPULSORY VOTING

Whereas it is provided in section 149 of the *Local Government Act 1958*, that the Governor in Council on the petition of the council of any municipality, may by Order published in the *Government Gazette* apply to elections of councillors for such municipality with any modifications provided for in such Order, all or any of the Regulations relating to compulsory voting made under the said section 149.

Now therefore, His Excellency the Governor of the State of Victoria, by and with the advice of the Executive Council thereof, and in pursuance of a petition of the Council of the Shire of Newstead doth hereby Order that the Regulations relating to the compulsory voting at municipal elections made pursuant to the provisions of the said section 149 shall apply to elections of councillors for the said municipality.

And the Honorable Digby Glen Crozier, Her Majesty's Minister for Local Government for the State of Victoria, shall give the necessary directions herein accordingly.

TOM FORRISTAL
Clerk of the Executive Council

LOCAL GOVERNMENT ACT 1958

At the Executive Council Chamber, Melbourne, the fourth day of March, 1980

PRESENT:

His Excellency the Governor of Victoria
Mr Crozier | Mr Balfour

ALTERATION OF TIME FOR CLOSING POLL AT MUNICIPAL ELECTIONS—SHIRE OF NEWSTEAD

His Excellency the Governor of the State of Victoria, by and with the advice of the Executive Council thereof, in pursuance of the powers conferred by section 134 of the *Local Government Act 1958*, and in compliance with the prayer of a petition presented by the Council of the Shire of Newstead declares that the hour for closing the poll at municipal elections for the said Shire shall be six o'clock in the afternoon.

And the Honorable Digby Glen Crozier, Her Majesty's Minister for Local Government for the State of Victoria, shall give the necessary directions herein accordingly.

TOM FORRISTAL
Clerk of the Executive Council

SUPERANNUATION ACT 1958

At the Executive Council Chamber, Melbourne, the fourth day of March, 1980

PRESENT:

His Excellency the Governor of Victoria
Mr Crozier | Mr Balfour

Pursuant to the powers conferred by the provisions of paragraph (ja) of sub-section (1) of section 3 of the *Superannuation Act 1958*, His Excellency the Governor of the State of Victoria, by and with the advice of the Executive Council thereof doth by this Order declare that the provisions of the *Superannuation Act* shall apply to the officers named in the schedule set out hereunder.

SCHEDULE

GRUBB, LESLIE ADELE,
RAYMOND, STUART ADRIAN, and
SMITH, DAVID JOHN HUME, Ballarat College of Advanced Education.
DIXON, MARGARET RUTH,
HANLY, JOHN REGINALD,
HARROP, ROSS CHARLES,
JOHNSTON, ALAN DAVID,
MORROCCO, LEON FRANCESCO,
RODAN, PAUL KENNETH,
DE ROZAIRO, TANIA,
SROKA, RICHARD,
SWEATMAN, WILLIAM RHYS,
WATSON, MARK WILLIAM, and
ZAKS, LEAH, Caulfield Institute of Technology.
CAIRNS, SUSAN DENISE, Gippsland Institute of Advanced Education.
BLUNDEN, JULIA FRANCES, Prahran College of Advanced Education.
ASKEY, VIVIAN ROSE, Victorian Institute of Secondary Education.

And the Honorable Lindsay Hamilton Simpson Thompson, Her Majesty's Treasurer for the State of Victoria, shall give the necessary directions herein accordingly.

TOM FORRISTAL
Clerk of the Executive Council

KILMORE AND DISTRICT WATERWORKS TRUST

At the Executive Council Chamber, Melbourne, the fourth day of March, 1980

PRESENT:

His Excellency the Governor of Victoria
Mr Crozier | Mr Balfour

ANNUAL ELECTION OF COMMISSIONERS

Under the powers conferred by the Water Act and all other powers enabling him in that behalf, His Excellency the Governor of the State of Victoria, by and with the advice of the Executive Council of the said State, hereby directs that—

- (a) two of the Commissioners elected by the rate-payers of the Kilmore and District Waterworks Trust shall retire each year with the exception of every third year when only one shall retire and the Commissioners who shall so retire shall be those who have held office for the longest term without re-election and if by reason of two or more Commissioners having become Commissioners at the same time it is not apparent which of such last mentioned Commissioners ought at any time to go out of office, then such Commissioners as to whom it is not apparent shall go out of office in the order of the number of votes obtained by each at his election commencing with the smallest number and proceeding upwards, and in all such cases if the votes given for any Commissioners of whom a number less than the whole are to go out of office at any one time have been equal or if such Commissioners have been elected without a poll the Trust fourteen days at least previously to the day appointed for the going out of office, and in the Trust's default the Governor in Council, shall for such occasion determine in what order and which of such Commissioners shall go out of office; and
- (b) the first retirement of Commissioner's under this Order shall be on the fourth Thursday in October 1980.

And the Honorable Frederick James Granter, Her Majesty's Minister of Water Supply for the State of Victoria, shall give the necessary directions herein accordingly.

TOM FORRISTAL
Clerk of the Executive Council

COUNTRY ROADS BOARD
Act No. 6229

At the Executive Council Chamber, Melbourne, the
fourth day of March, 1980

PRESENT:

His Excellency the Governor of Victoria
Mr Crozier | Mr Balfour

ORDER APPROVING OF LAND BEING ACQUIRED
AND ROADS, DEVIATIONS OR WIDENINGS BEING
MADE TOGETHER WITH ALL ANCILLARY WORKS
REQUIRED TO BE EXECUTED IN CONJUNCTION
THEREWITH

His Excellency the Governor of the State of Victoria,
by and with the advice of the Executive Council thereof,
being satisfied that there are funds legally available for
acquiring the land, doth hereby approve the acquiring of
the land described in the schedule hereunder and the making
of new roads and deviations from and widenings of
existing roads, together with all ancillary works required
to be executed in conjunction therewith, referred to in
the said schedule.

SCHEDULE

Main Roads

The land shown hatched on plans numbered G.P.15036A,
G.P.15036B, G.P.15037A and G.P.15037B hereunder required
for the deviation from the Yarram-Traralgon Road in the
Shire of Alberton and making of the deviation thereon.

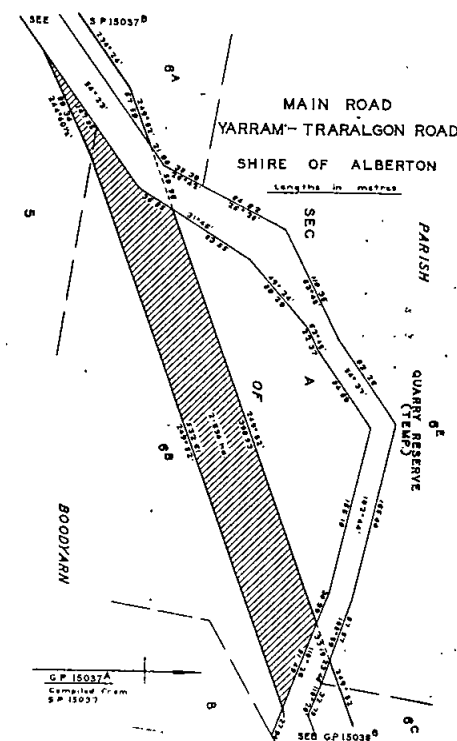
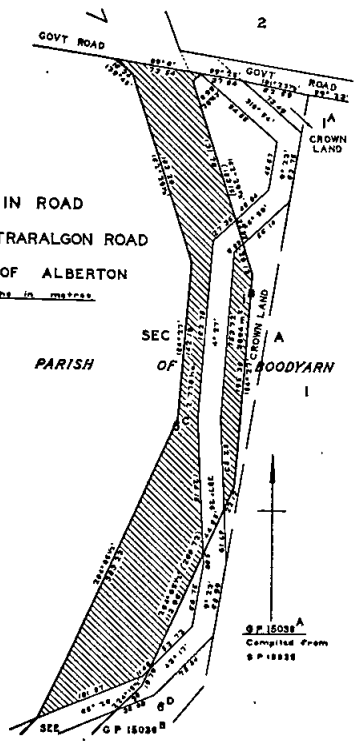
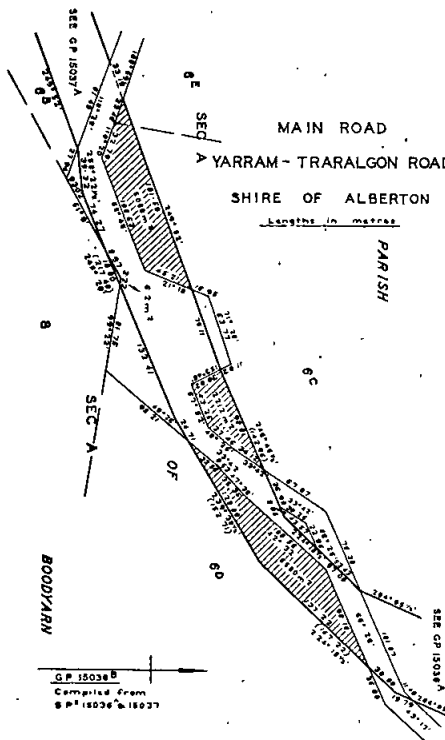

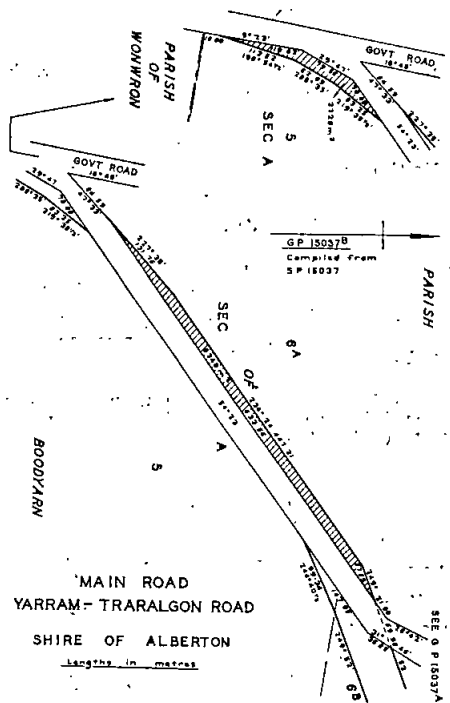

The land shown hatched on plan numbered G.P.15131 hereunder required for the widening of Yarck Road in the Shire of Alexandra and making of the widening thereon.

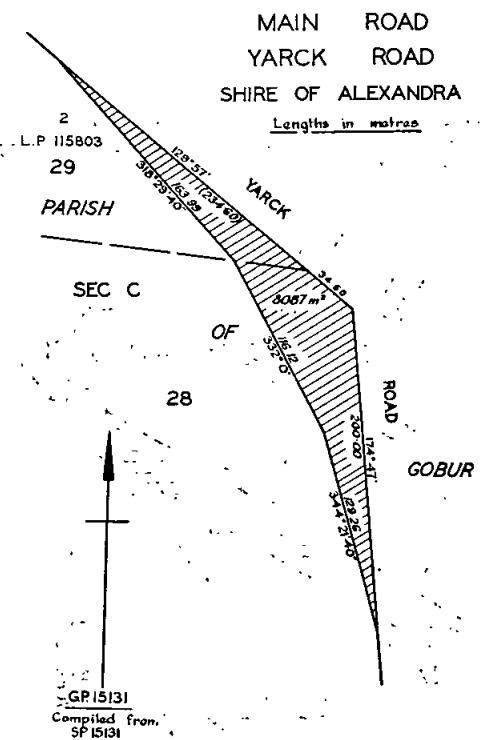

The land shown hatched on plan numbered G.P.15111 hereunder required for the widening of the Bacchus Marsh-Gisborne Road in the Shire of Bacchus Marsh and making of the widening thereon.

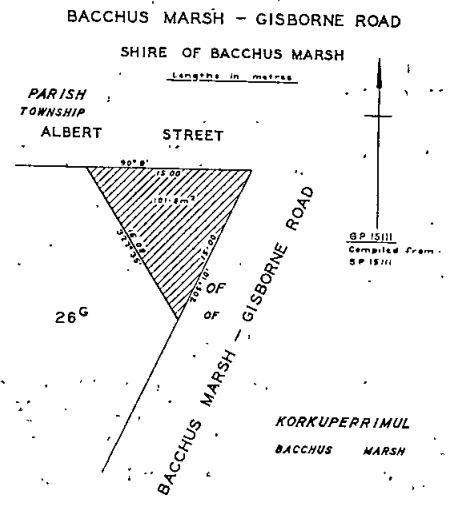

Unclassified Road
The land shown hatched on plan numbered G.P.14346F hereunder required for the making of a new road in the Shire of Seymour.

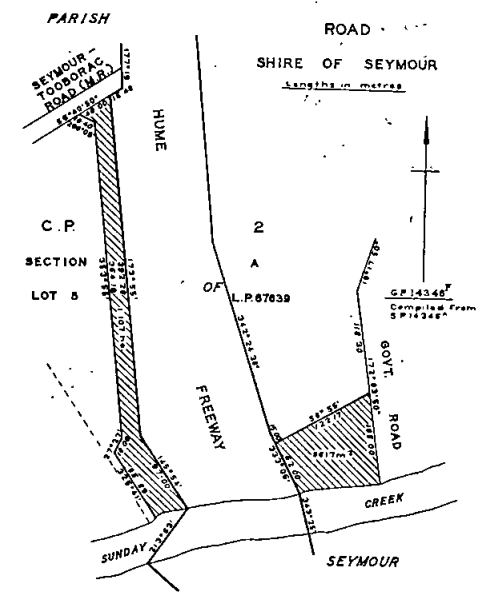

And the Honorable Robert Roy Cameron Maclellan, Her Majesty's Minister of Transport for the State of Victoria, shall give the necessary directions herein accordingly.
TOM FORRISTAL
Clerk of the Executive Council

COUNTRY ROADS ACT 1958
Act No. 6229

At the Executive Council Chamber, Melbourne, the fourth day of March, 1980

PRESENT:
His Excellency the Governor of Victoria
Mr Crozier | Mr Balfour

ORDER CONFIRMING RESOLUTIONS OF THE COUNTRY ROADS BOARD

His Excellency the Governor of the State of Victoria, by and with the advice of the Executive Council thereof, doth hereby, in pursuance of the provisions of the Country Roads Act 1958, confirm the resolutions of the Country Roads Board, the dates whereof and the terms of which are scheduled hereunder:

SCHEDULE
Main Road

Resolution dated the Eighteenth day of February, One thousand nine hundred and eighty, made pursuant to section 18 of the Country Roads Act 1958 declaring the highway in the Shire of Woorayl as shown hatched on plan numbered G.P.964T hereunder to be a main road (Wild Dog Valley Road) within the meaning and for the purposes of the said Act.

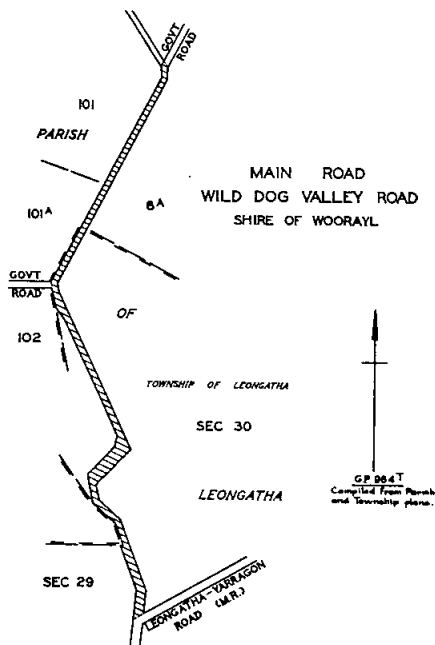

And the Honorable Robert Roy Cameron Maclellan, Her Majesty's Minister of Transport for the State of Victoria shall give the necessary directions herein accordingly.

TOM FORRISTAL
Clerk of the Executive Council

LAND ACT 1958

At the Executive Council Chamber, Melbourne, the fourth day of March, 1980

PRESENT:
His Excellency the Governor of Victoria
Mr Crozier | Mr Balfour

UNUSED ROADS CLOSED

His Excellency the Governor of the State of Victoria, in the Commonwealth of Australia, by and with the advice of the Executive Council of the said State, pursuant to the provisions of Section 349 of the Land Act 1958 and with the concurrence in writing of the council of the municipality concerned and that of any adjoining land owners, doth hereby close the unused roads hereinafter described, viz.:

Municipal District of the Shire of Grenville—Township of Haddon, being the road indicated by hatching on plan hereunder—(H.2⁽⁵⁾) (L.3-378).

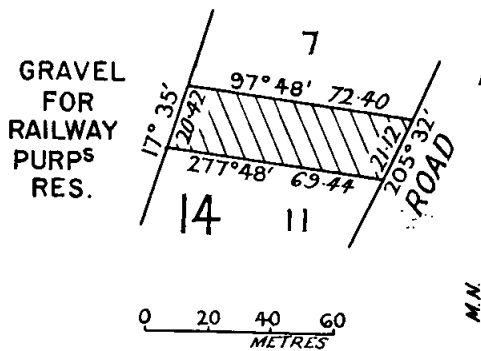

Municipal District of the Shire of Upper Murray—Township of Towong, being the roads indicated by hatching on plan hereunder—(T.134⁽⁹⁾) (H.O.17892).

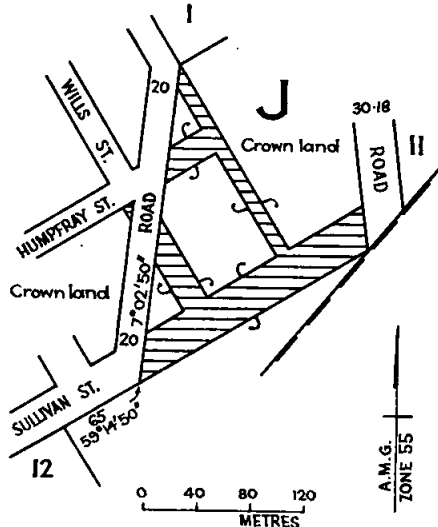

Municipal District of the City of Echuca—Township of Echuca, being the road indicated by hatching on plan hereunder—(E.3⁽⁷⁾) (L.6-1331).

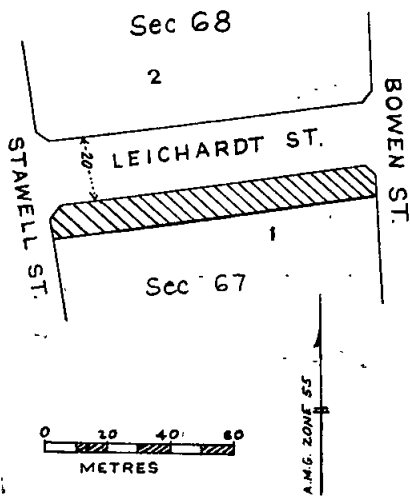

Municipal District of the City of Melbourne—Parish of Douutta Galla, being the road indicated by hatching on plan hereunder—(D.85⁽⁸⁾) (02825/138).

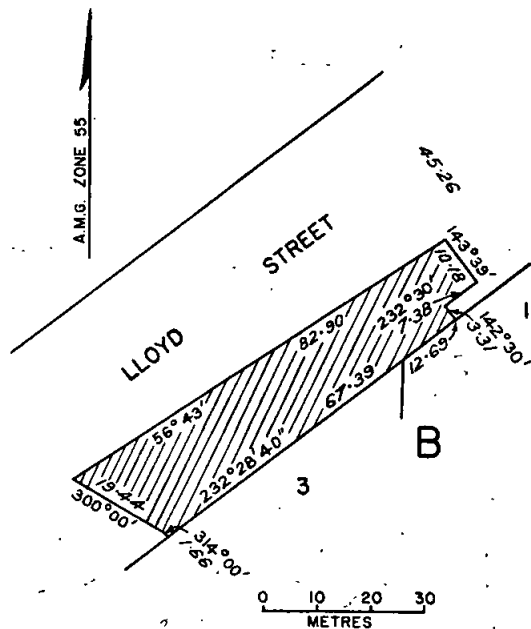

And the Honorable William Vasey Houghton, Her Majesty's Minister of Lands for the State of Victoria, shall give the necessary directions herein accordingly.

TOM FORRISTAL
Clerk of the Executive Council

CROWN LAND (RESERVES) ACT 1978

At the Executive Council Chamber, Melbourne, the fourth day of March, 1980

PRESENT:

His Excellency the Governor of Victoria
Mr Crozier | Mr Balfour.

CROWN LAND SPECIFIED AS BEING PERMANENTLY RESERVED FOR THE MANAGEMENT OF WILDLIFE

His Excellency the Governor of the State of Victoria, in the Commonwealth of Australia, by and with the advice of the Executive Council of the said State, pursuant to the provisions of section 4 (5) of the Crown Land (Reserves) Act 1978, doth hereby specify that the land hereinafter described, being permanently reserved for unspecified purposes, is so permanently reserved for the Management of Wildlife, viz.:

The portion of the permanent reservation for Public Purposes along the Murray River in the Parish of Tintaldra abutting the Crown land in the said Parish (being Crown allotment 1B, section 11) permanently reserved for the Management of Wildlife by Order in Council of 27 November 1979 (see Government Gazette dated 5 December 1979)—(Rs.10922).

And the Honorable William Vasey Houghton, Her Majesty's Minister of Lands for the State of Victoria, shall give the necessary directions herein accordingly.

TOM FORRISTAL
Clerk of the Executive Council

CROWN LAND (RESERVES) ACT 1978

At the Executive Council Chamber, Melbourne, the fourth day of March, 1980

PRESENT:

His Excellency the Governor of Victoria
Mr Crozier | Mr Balfour

REVOCATION OF TEMPORARY RESERVATIONS OF LANDS BY ORDERS IN COUNCIL

His Excellency the Governor of the State of Victoria, in the Commonwealth of Australia, by and with the advice of the Executive Council of the said State, pursuant to the provisions of section 10 of the Crown Land (Reserves) Act 1978, doth hereby revoke the temporary reservations of lands by Orders in Council hereinafter described, viz.:

ALEXANDRA—The temporary reservation by Order in Council of 14 October 1969 of 6.323 hectares of land in the Parish of Alexandra (adjoining Crown allotments 29 and 29B) as a site for Public Purposes (Forests Act purposes)—(Rs.9222).

BOOTAHPOOL—The temporary reservation by Order in Council of 30 September 1912 of 4.062 hectares of land in the Parish of Bootahpool (in section H) as a site for Public purposes—(B.580(A¹)) (Rs.1409).

CARGERIE—The temporary reservation by Order in Council of 3 March 1890 of 15.24 hectares of land in the Parish of Cargerie (being Crown allotment 25A) as a site for Quarry and Watering purposes—(C.365⁽²⁾) (Rs.10874).

NEUARPUR—The temporary reservation as a site for Public purposes and the withholding from sale, leasing and licensing by Order in Council of 17 November 1884 of 8094 square metres of land in the Parish of Neuarpur (in section 3)—(Rs.10940).

PAARATTE—The temporary reservation by Order in Council of 30 June 1959 of 2023 square metres of land in the Parish of Paaratte (near Crown allotment 13, section 5) as a site for a Public Hall—(Rs.7762).

SANDHURST (EAGLEHAWK)—The temporary reservation by Order in Council of 23 August 1949 of 1517 square metres of land at Eaglehawk, Parish of Sandhurst (in section 41) as a site for a Rubbish Depot—(Rs.6356).

BIRREGURRA—The temporary reservation by Order in Council of 21 December 1868 of 1.487 hectares of land in the Parish of Birregurra (adjoining Crown allotment

LOYOLA—For Conservation of an Area of Natural Interest, 22 hectares, more or less, being Crown allotment 82B, Parish of Loyola, as indicated by hatching on plan hereunder—(L.90⁽³⁾) (L.90) (Rs.10915).

ST. ARNAUD—For Departmental Residence, 1012 square metres, being Crown allotment 8A, section 4, Township of St. Arnaud, as indicated by hatching on plan hereunder—(S.206⁽¹⁾) (Rs.10966).

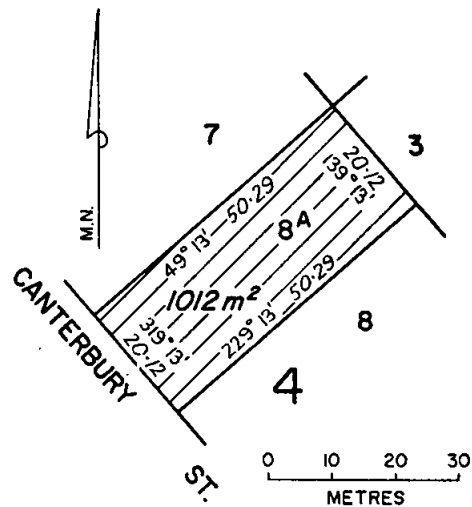
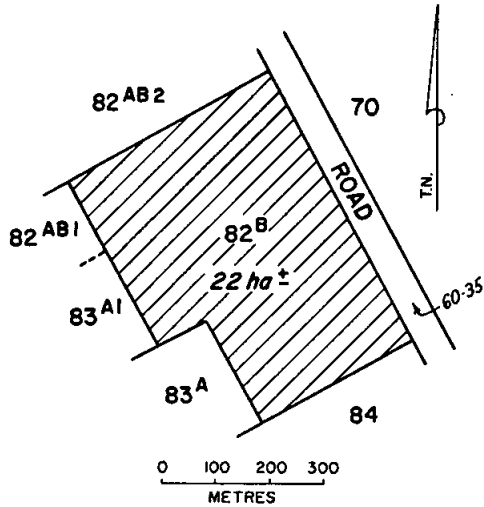

YARCK—For Conservation of an Area of Natural Interest, 2.7 hectares, more or less, being Crown allotments 30B and 30C, section B, Township of Yarck, as indicated by hatching on plan hereunder—(Y.84⁽⁷⁾) (Rs.10955).

MOREEP—For Public Recreation, 7392 square metres, being Crown allotment 17, section A, Parish of Moreep, as indicated by hatching on plan hereunder—(M.468⁽³⁾) (Rs.4415).

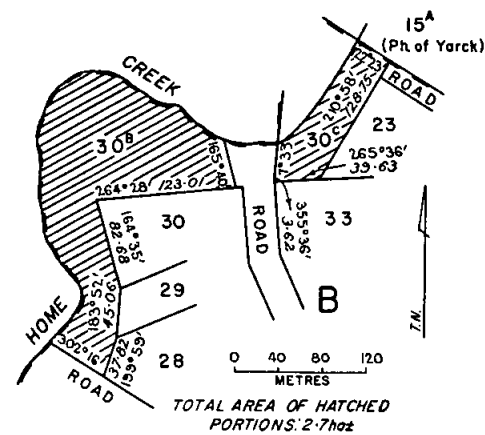
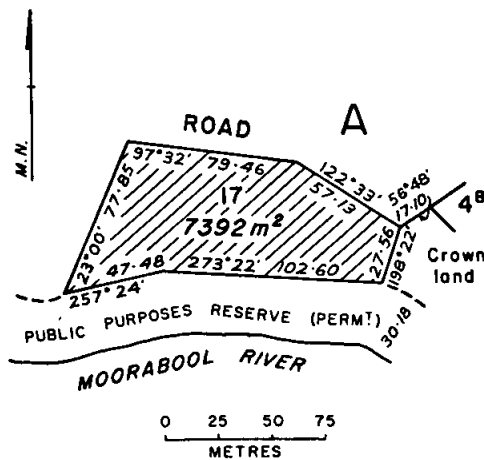

And the Honorable William Vasey Houghton, Her Majesty's Minister of Lands for the State of Victoria, shall give the necessary directions herein accordingly.

TOM FORRISTAL
Clerk of the Executive Council

HISTORIC BUILDINGS ACT 1974 (No. 8569)

At the Executive Council Chamber, Melbourne, the
fourth day of March, 1980

PRESENT:

His Excellency the Governor of Victoria
Mr Crozier | Mr Balfour

AMENDMENT OF REGISTER OF HISTORIC BUILDINGS

Whereas it is provided by section 3 of the *Historic Buildings Act 1974* that the Governor in Council, on the recommendation of the Minister, may by notice of Historic Buildings established under the said Act—

- (a) by adding any specified building;
- (b) by removing any specified building; or
- (c) by altering any item.

And whereas the Minister has recommended that the Register be amended.

Now therefore, His Excellency the Governor of the State of Victoria, by and with the advice of the Executive Council thereof, doth hereby amend the Registrar of Historic Buildings in the manner and to the extent shown as follows, by amending—

Historic Building No. 103

"Virginia", 116 Wellington Parade, East Melbourne to Historic Building No. 103 "Virginia" 116 Wellington Parade, East Melbourne (to the extent of the total exterior fabric of the building including its rear service wing as defined by the blue perimeter on plans No. 103.1 and No. 103.2 respectively held at the offices of the Historic Buildings Preservation Council and that area of land comprising the front garden as defined by the red perimeter on Plan No. 103.3 held at the offices of the Historic Buildings Preservation Council.

And the Honorable Louis Stuart Lieberman, Her Majesty's Minister for Planning for the State of Victoria, shall give the necessary directions herein accordingly.

TOM FORRISTAL
Clerk of the Executive Council

HISTORIC BUILDINGS ACT 1974 (No. 8569)

At the Executive Council Chamber, Melbourne, the
fourth day of March, 1980

PRESENT:

His Excellency the Governor of Victoria
Mr Crozier | Mr Balfour

AMENDMENT OF REGISTER OF HISTORIC BUILDINGS

Whereas it is provided by section 3 of the *Historic Buildings Act 1974* that the Governor in Council, on the recommendation of the Minister, may by notice of Historic Buildings established under the said Act—

- (a) by adding any specified building;
- (b) by removing any specified building; or
- (c) by altering any item.

And whereas the Minister has recommended that the Register be amended.

Now therefore, His Excellency the Governor of the State of Victoria, by and with the advice of the Executive Council thereof, doth hereby amend the Registrar of Historic Buildings in the manner and to the extent shown as follows, by adding—

Historic Building No. 463

St. Judes Church of England, 351-357 Lygon Street,
Carlton.

And the Honorable Louis Stuart Lieberman, Her Majesty's Minister for Planning for the State of Victoria, shall give the necessary directions herein accordingly.

TOM FORRISTAL
Clerk of the Executive Council

HISTORIC BUILDINGS ACT 1974 (No. 8569)

At the Executive Council Chamber, Melbourne, the
fourth day of March, 1980

PRESENT:

His Excellency the Governor of Victoria
Mr Crozier | Mr Balfour

AMENDMENT OF REGISTER OF HISTORIC BUILDINGS

Whereas it is provided by section 3 of the *Historic Buildings Act 1974* that the Governor in Council, on the recommendation of the Minister, may by notice of Historic Buildings established under the said Act—

- (a) by adding any specified building;
- (b) by removing any specified building; or
- (c) by altering any item.

And whereas the Minister has recommended that the Register be amended.

Now therefore, His Excellency the Governor of the State of Victoria, by and with the advice of the Executive Council thereof, doth hereby amend the Registrar of Historic Buildings in the manner and to the extent shown as follows, by adding—

Historic Building No. 462

Blacksmith Cottage and Shop, 100-102 Main Street,
Bacchus Marsh.

And the Honorable Louis Stuart Lieberman, Her Majesty's Minister for Planning for the State of Victoria, shall give the necessary directions herein accordingly.

TOM FORRISTAL
Clerk of the Executive Council

PORT OF MELBOURNE AUTHORITY ACT 1958

At the Executive Council Chamber, Melbourne, the
fourth day of March, 1980

PRESENT:

His Excellency the Governor of Victoria
Mr Crozier | Mr Balfour

RE-APPOINTMENT OF A MEMBER OF THE PORT OF MELBOURNE AUTHORITY

In accordance with the provisions of the *Port of Melbourne Authority Act 1958*, His Excellency the Governor of the State of Victoria, by and with the advice of the Executive Council thereof, doth by this Order re-appoint ROY ANGUS CAMERON as a Member of the Port of Melbourne Authority for a period of three years commencing on 29 March 1980.

And the Honorable Tom Austin, Her Majesty's Minister of Public Works for the State of Victoria, shall give the necessary directions herein accordingly.

TOM FORRISTAL
Clerk of the Executive Council

**LANDS DEPARTMENT
NOTICES**

APPROACHING LAND SALES

Sale of Crown Land, in fee-simple, will be held at the under-mentioned places and dates, viz.:-

| | No. of Gazette |
|-------------------------------------|-------------------|
| Bendigo—Wednesday, 16 April 1980 | 15 |
| Bendigo—Wednesday, 16 April 1980 | 16 |
| Heathcote—Wednesday, 16 April 1980 | 16 |
| Murrayville—Friday, 18 April 1980 | 15 |
| Narbethong—Wednesday, 16 April 1980 | 15 |
| Ormond—Wednesday, 26 March 1980 | 15 |
| Rainbow—Monday, 31 March 1980 | 15 |
| Stawell—Wednesday, 16 April 1980 | 16 |

**PROPOSED REVOCATION OF TEMPORARY
RESERVATIONS OF LANDS BY ORDERS IN COUNCIL**

In pursuance of the provisions of section 10 of the *Crown Land (Reserves) Act 1978*, notice is hereby given that it is the intention of the Governor in Council to revoke the temporary reservations of lands by Orders in Council hereunder referred to, viz.:-

HADDON—The temporary reservation by Order in Council of 8 July 1902 of 3.524 hectares of land in the Township of Haddon (in section 14) as a site for Supply of Gravel for Railway purposes—(H.2⁽⁵⁾) (Rs.514).

TARRAWINGEE—The temporary reservation by Order in Council of 27 September 1886 of 10.52 hectares of land, being Crown allotment 20b, Parish of Tarrawingee as a site for Water Supply purposes—(Rs.10992).

YARROCK—The temporary reservation by Order in Council of 18 July 1887 of 37.73 hectares of land in the Parish of Yarrock as a site for Water Supply purposes, revoked as to part by various Orders, so far as the portions containing 2.054 hectares, as shown on Certified Plan No. 104429 lodged in the Central Plan Office, is concerned—(Rs.2829).

W. V. HOUGHTON
Minister of Lands

LOCAL LAND BOARDS

In pursuance of the provisions of section 34 of the *Land Act 1958*, notice is hereby given that public hearings at the following place and times will be conducted by a Local Land Board being duly appointed in that behalf.

OUYEN—Shire of Walpeup Council Chambers commencing at 9.15 a.m. on Tuesday, 25 March 1980, and continuing on following days as necessary. The Local Land Board will deal with applications which have been received for Improvement Purchase Leases for the allotments as advertised as being available in the "Sunraysia Daily" of 23 February 1980, the "North West Express" of 5 March 1980, "The Guardian" of 27 February 1980 and the "Pinnaroo Border Times" of 28 February 1980.

W. V. HOUGHTON
Minister of Lands

Department of Crown Lands and Survey
Melbourne, 4 March 1980

**AMENDMENT TO REGULATIONS FOR "ALBERT PARK" IN THE MUNICIPAL DISTRICTS OF SOUTH MELBOURNE
AND ST. KILDA**

I, William Vasey Houghton, Her Majesty's Minister of Lands in and for the State of Victoria, in pursuance of the powers conferred on me by section 13 of the *Crown Land (Reserves) Act 1978* do hereby amend the additional Regulation made on 23 May 1978 (*vide Government Gazette* of 31 May 1978) for or with respect to the above-named Park as follows:-

Regulation No. 3 (e) shall be amended to read:-

3. (e) Notwithstanding the provisions of Regulation No. 2 of these Regulations, on any day as may be determined by the Committee, but on not more than 72 days in any calendar year, the Committee may refuse admittance, or may, on such terms and conditions as it thinks proper, in writing, authorise any person to refuse admittance to any other person to that portion of the Reserve shown hatched on the plan hereunder except upon payment of an admission charge or fee, the amount of which shall not exceed three dollars (\$3.00), provided always that an additional charge not exceeding three dollars (\$3.00) may be made in respect of any seat which is set apart as a reserved seat—(Rs.3321).

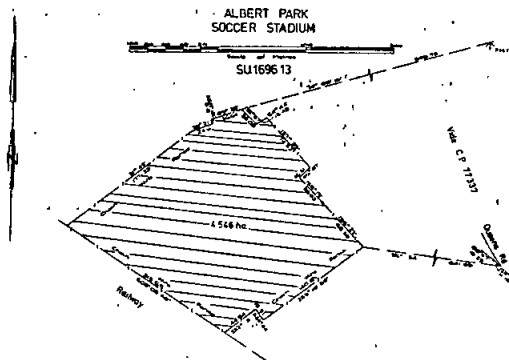

Given under my Hand at Melbourne on 28 February 1980.

W. V. HOUGHTON
Minister of Lands

TENDERS

PUBLIC WORKS DEPARTMENT

Tenders are invited for the purposes indicated hereunder and will be received at 2 Treasury Place, Melbourne, 3002, until **TWO** p.m. on dates shown.

Tenders must be addressed to the Minister of Public Works with the envelope endorsed "Tender for

.....". Hand-delivered tenders must be placed in the Department's tender box in the foyer, Ground Floor, 2 Treasury Place, Melbourne.

Tenders documents are available from the Contracts Office, Room 29, 2 Treasury Place, Melbourne, and where indicated, at offices of Inspectors of Works.

Tuesday, 25 March 1980

Building, Electrical and Mechanical Works.

ALTONA WEST—Internal and external painting and repairs, Primary School No. 4862.

ARDEER—External painting and repairs, Primary School.

BURWOOD—Installation of fire service, High School.

BURWOOD HEIGHTS—Replacement of fire service, Primary School.

DANDENONG—Alterations and minor additions to single storey brick building and timber framed building, delivery and erection of 1 No. relocatable building, erection of covered ways, associated site development works, Primary School.

EAST GEELONG—New staff toilets of 70 m² area in single storey concrete veneer construction, Technical School. (W.O., Geelong.)

HORSHAM—Minor building maintenance works, High School. (W.O., Horsham.)

MELBOURNE—Supply and installation of stand-by pumps for air conditioning system, chilled water plant, Russell Street Police Station.

NOWA NOWA—(Re-advertisement.) Internal and external renovations, Primary School. (W.O., Bairnsdale.)

OMEO—Mechanical services to residence and new station, Police Station. (W.O., Bairnsdale, Traralgon.)

PAKENHAM—Toilet renovations and painting, Consolidated School.

SEASPRAY—Internal and external repairs and painting, Primary School No. 4324. (W.O., Traralgon.)

SUNBURY WEST—(Re-advertisement, amended specification.) Connection to sewer, Primary School No. 5006.

SUNSHINE WEST—Extensions to fire service and water supply, High School.

ST. KILDA EAST—Construction of outdoor learning area, Building 5—Ardoch Education Village.

Miscellaneous

BENALLA REGION—Oil burner maintenance, Wangaratta Inspectorate, Various Schools. (W.O., Wangaratta.)

BENALLA REGION—Oil burner maintenance, Shepparton Inspectorate, Various Schools. (W.O., Shepparton.)

BENDIGO REGION—Oil burner maintenance, Various Schools. (W.O., Bendigo.)

CARLTON—Replacement of ultraphot microscope, St. Nicholas Hospital.

No. 18—18120/80—3

VARIOUS—Supply of paperback stands, Various.

EASTERN METROPOLITAN REGION—Oil burner maintenance, Area 2, Various Schools.

EASTERN METROPOLITAN REGION—Oil burner maintenance, Area 1, Various Schools.

WESTERN METROPOLITAN REGION—Oil burner maintenance 1979—80, Various.

TALLANGATTA—Maintenance cleaning—1 April 1980 to 31 March 1983, P.O.'s, Court and Police Stations. (W.O., Wangaratta.)

Tuesday, 1 April 1980

Building, Electrical and Mechanical Works

CHELTENHAM—Replacement of gas heaters, Primary School.

DEER PARK NORTH—External painting and repairs, Primary School.

EAST GEELONG—Cyclic maintenance of existing buildings including resheeting asphalt areas, Geelong East Technical School. (W.O., Geelong.)

GEELONG EAST—Gas conversion and reticulation, Technical School.

GOROKE—Cyclic maintenance of L.T.C. Building (incl.) mechanical and electrical services, Consolidated School. (W.O., Horsham.)

HEALESVILLE—Asphalt repairs site works, High School.

MALDON—External and internal repairs and painting, Primary School No. 1254. (W.O., Bendigo.)

MARIBYRNONG—Replace boundary fencing, High School.

SUNBURY—Exterior repairs and painting to Ward F1 and F1A, Training Centre.

SUNBURY—Heating and hot water service, male hostel, Mental Hospital, Male Hostel.

TATURA—Mechanical services, proposed art and craft and pottery room, Primary School No. 1441. (W.O., Shepparton.)

TATURA—Proposed art and craft and pottery room, Primary School No. 1441. (W.O., Shepparton.)

UPPER BEACONSFIELD—Alterations and additions to existing single storey brick veneer building, erection of covered ways, associated site development work, Primary School.

Site Works

COBRAM—Site works (Re-advertisement), High School. (W.O., Wangaratta, Shepparton.)

Miscellaneous

ELSTERNWICK—Gordon Street, maintenance cleaning 1 April 1980 to 31 March 1983, Court Houses.

FOOTSCRAY ROAD, WEST MELBOURNE—Maintenance cleaning 1 April 1980 to 31 March 1983, Horticultural and Potato Inspectorates.

69 SALMON STREET, PORT MELBOURNE—Supply of (1) one only 8-tonne, cap. 4-wheel trailer, Depot.

LARKINS PARADE, QUEENSCLIFF—Security service 24 March 1980 to 31 March 1981, Marine Service Laboratory's. (W.O., Geelong P.W.D.)

TOM AUSTIN
Minister of Public Works

Public Works Department
Melbourne, 11 March 1980

Teaching Service Act 1958
TEACHING SERVICE (TEACHERS TRIBUNAL)
REGULATIONS

AMENDMENT No. 510 (T.T. 81)

The Teachers Tribunal, in pursuance of the powers conferred by the *Teaching Service Act 1958*, hereby amends Regulation 23 of the Teaching Service (Teachers Tribunal) Regulations as follows:—

REGULATION 23

Rescind sub-clauses (a) and (b) of clause 20 and substitute therefor the following sub-clauses:—

"20. (a) Where a member is a voluntary member of the Citizen Forces and is required to attend an annual training camp the Director-General may grant him such leave with pay as will enable him to attend such camp—

- (i) for its duration—where such does not exceed fourteen calendar days; or
- (ii) for its duration or for the period of eighteen calendar days (whichever is the less)—where the Commanding Officer of the relevant service unit certifies that such duration exceeds fourteen days.

(b) In addition to any leave granted under sub-clause (a), the Director-General may grant a member such leave of absence as will enable him to attend not more than two schools, classes, or courses of instruction conducted by or on behalf of the Citizen Forces in any year and, in connection with any such leave of absence, he may be paid only the amount (if any) by which the pay (exclusive of any overtime, higher duties or other allowance, or payment of a temporary character) he would have received had he remained on duty exceeds the pay (including marriage and separation allowances) he receives by reason of his attendance at any such school, class, or course."

J. J. KENNEDY, Alternate Chairman
A. F. LE CLERCQ, Secretary

Office of the Teachers Tribunal
Melbourne, 4 March 1980

**PRIVATE
ADVERTISEMENTS**

CITY OF BALLAARAT
STREET NAME

At a meeting held on 3 March 1980, the Council attached the name "Little Bagge Street" to an unnamed road situated west of Grant Street, and which extends from Wainwright to English Street.

5618 I. C. SMITH, Town Clerk

CITY OF CROYDON
LOAN No. 165

*Notice of Intention to Borrow the Sum of \$100 000 for
Permanent Works and Undertakings*

In accordance with the provisions of section 400 of the *Local Government Act 1958*, notice is hereby given that the Council of the City of Croydon proposes to borrow the principal sum of \$100 000 secured by a charge over the general rates of the municipality, such sum to be raised by the grant of a mortgage in accordance with the provisions of the *Local Government Act 1958*.

1. The maximum rate of interest that may be paid is 11.2 per centum per annum.

2. The purpose for which the loan shall be applied is:—

| | \$ |
|---|---------|
| 1. Initial funding extensions, Club House, Croydon Bowling Club | 50 000 |
| 2. Completion of Modal Interchange and Roadworks, northern end of Main Street | 11 450 |
| 3. Part cost—Street Lighting and Contribution to C.R.B. Works | 4 450 |
| 4. Croydon Community Library (part cost) | 34 100 |
| | 100 000 |

In relation to Item 4 above, the estimated total cost of the Croydon Community Library including Building, Architects fees, furniture and fittings, access roads and car parking is \$979 690, of which \$455 000 has been previously borrowed, and the balance of loan funds required to finance the project (estimated \$490 590) is proposed to be borrowed in 1980-81 under section 392 Sub-section (2) of the Act.

3. The period of the loan shall be 20 years.

4. The moneys borrowed shall be repayable by providing out of the municipal fund 20 half yearly instalments of \$6314.10 each including principal and interest on 1 May and 1 November during the currency of the loan. The first instalment shall be payable on 1 November 1980.

5. Such moneys shall be repayable at the Office of the Local Authorities Superannuation Board, Rigby House, 15 Queens Road, Melbourne.

The plans and specifications and estimates of the cost of the works and a statement showing the proposed expenditure of the moneys to be borrowed are open for inspection at the office of the Council of the City of Croydon, Foch Avenue, Croydon.

5565

R. BURTON, Town Clerk

CITY OF ESSENDON

NOTICE FOR THE FIXING OF NEW ALIGNMENT
GLADSTONE STREET, MOONEE PONDS

Notice is hereby given pursuant to Section 623 (1) of the *Local Government Act 1958* that the Council of the City of Essendon, at a meeting held on 19 November 1979, resolved to widen Gladstone Street, Moonee Ponds, by 3.35 metres on the north side from Shuter Street to Pratt Street and on 4 February 1980 resolved to widen Gladstone Street by 3.35 metres on the north side from Pratt Street to Moore Street.

A plan showing the new alignment has been prepared and certified by a licensed surveyor as required by Section 622 (1) of the *Local Government Act 1958* and is available for inspection at the Essendon Civic Centre, cnr. Kellaway Avenue and Pascoe Vale Road, Moonee Ponds, during normal office hours.

B. C. BEATTIE, City Manager/Town Clerk
Civic Centre, Moonee Ponds, 3039 5697

CITY OF FRANKSTON

LOAN No. 201

*Notice of Intention to Borrow the Sum of \$50 000 for
Permanent Works and Undertakings*

Notice is hereby given that the Council of the City of Frankston proposes to borrow the principal sum of \$50 000 secured by a charge over the general rates of the municipality, such sum to be raised by the grant of a mortgage in accordance with the provisions of the *Local Government Act 1958*.

In connection therewith, the following information is stated:—

- The amount of principal moneys which it is proposed to borrow is \$50 000.
- The maximum rate of interest that may be paid is 11.2 per centum per annum.
- The times which moneys borrowed are to be repayable are 15 April and 15 October during the currency of the loan, the first instalment being payable on 15 October 1980.
- The place such moneys shall be repayable is at the office of the Commonwealth Savings Bank of Australia, Wells Street, Frankston.
- The purpose for which the loan is to be applied is:—
Seaford Community Centre (part cost).
- The manner in which the loan is to be liquidated is by provision out of the Municipal Fund of nineteen (19) equal half-yearly instalments of \$3157.05 and a twentieth and final instalment of \$40 573.76 including principal and interest.

The plans and specifications and estimates of the cost of the works and a statement showing the proposed expenditure of the moneys to be borrowed are open for inspection at the Civic Centre, Frankston.

5566

A. H. BUTLER, Town Clerk

CITY OF HEIDELBERG

LOAN No. 212

*Notice of Intention to Borrow the Sum of \$100 000 for
Permanent Works and Undertakings*

Notice is hereby given that the Council of the City of Heidelberg intends to borrow the sum of One hundred thousand dollars (\$100 000) secured by a charge over the general rates of the Municipality, such sum to be raised by the grant of a mortgage in accordance with the provisions of the *Local Government Act 1958*.

- The maximum rate of interest that may be paid is 12.0 per centum per annum.

2. The purposes for which the loan is to be applied are:—Liberty Parade Pavilion, View Bank Pavilion Extension, Toilet Block Winsor Reserve (part), Drainage Works on Salt Creek (part)—\$100 000.

3. The period of the loan shall be Ten (10) years.

4. The moneys borrowed shall be repayable by providing out of the municipal fund Twenty (20) half-yearly instalments of approximately \$8718.46 each, including principal and interest, on 15 May and 15 November in each year during the currency of the loan. The first instalment shall be payable on 15 November 1980.

5. Such moneys shall be repayable to the Australian Mutual Provident Society, Melbourne.

The plans and specifications and the estimate of the cost of the proposed works and a statement showing the proposed expenditure of the money to be borrowed are open for inspection at the office of the Council, Civic Centre, Ivanhoe.

5700

ALAN JONES, Town Clerk

Town and Country Planning Act 1961

CITY OF MOE—CITY OF MOE PLANNING SCHEME
1966

NOTICE THAT A PLANNING SCHEME HAS BEEN PREPARED AND IS AVAILABLE FOR INSPECTION

Amendment No. 56

Notice is hereby given that the City of Moe, in pursuance of its powers under the *Town and Country Planning Act 1961* has prepared a Planning Scheme for the area generally bounded by Narracan Drive, the Narracan Creek, Old Sale Road and an irregular line drawn from the intersection of Southwell Avenue and Old Sale Road to Ollerton Avenue.

The purpose of the rezoning is to restore as of right zoning to an area earlier revoked from the City of Moe Planning Scheme and within which area all development was made subject to the grant of a permit by the Council.

A copy of the scheme may be inspected at the City Offices, Albert Street, Moe and at the offices of the Town and Country Planning Board, located at 235 Queen Street, Melbourne and 71 Hotham Street, Traralgon free of charge during working hours.

Any persons affected by the Planning Scheme are required to set forth in writing all objections they may have, addressed to the Town Clerk, City of Moe, Albert Street, Moe on or before 12 June 1980 and to state whether they wish to be heard in respect of their objections.

5575

R. J. PUGSLEY, Town Clerk

CITY OF SOUTH BARWON

LOAN No. 125

Notice is hereby given that the Council of the City of South Barwon intends to borrow the principal sum of One hundred thousand dollars (\$100 000) secured by a charge over the General Rates of the Municipality, such sum to be raised by the grant of a Mortgage in accordance with the provisions of the *Local Government Act 1958*.

- The maximum rate of interest that may be paid is 11.2 per centum per annum.
- The purpose of the loan is for:

| Drainage | \$ |
|--|----------|
| Kardinia Creek West Main Drain—part cost | 21 000 |
| Marshalltown Drain—Stage 1 | 79 000 |
| | <hr/> |
| | 100 000. |

3. The period of the loan shall be 10 years.

4. The moneys borrowed shall be repayable by providing out of the Municipal Fund 20 equal half yearly instalments of \$8437.49 including principal and interest on 18 April and 18 October during the currency of the loan. The first instalment shall be payable on 18 October 1980.

5. Such money borrowed shall be repayable at the Bank of New South Wales Savings Bank, Belmont.

6. Plans, specifications and an estimate of the cost of the works and a statement showing the proposed expenditure of moneys to be borrowed are open for inspection at the City Offices, 2 Colac Road, Belmont, during office hours.

5616

K. B. McDONALD, Town Clerk

CITY OF SOUTH BARWON

LOAN No. 126

Notice is hereby given that the Council of the City of South Barwon intends to borrow the principal sum of Twenty thousand dollars (\$20 000) secured by a charge over the General Rates of the Municipality, such sum to be raised by the grant of a Mortgage in accordance with the provisions of the *Local Government Act 1958*.

1. The maximum rate of interest that may be paid is 9.3 per centum per annum.

2. The purpose of the loan is for:

Provision of electrical power supply to additional sites in the Barwon Heads Caravan Park \$20 000

3. The period of the loan shall be 10 years.

4. The moneys borrowed shall be repayable by providing out of the Municipal Fund 20 equal half yearly instalments of \$1557.58 including principal and interest on 1 May and 1 November during the currency of the loan. The first instalment shall be payable on 1 November 1980.

5. Such money borrowed shall be repayable to the Ministry for State Development Decentralization and Tourism at 228 Victoria Parade, East Melbourne, or such other place or places as the Ministry from time to time may require.

6. Plans, specifications and an estimate of the cost of the works and a statement showing the proposed expenditure of moneys to be borrowed are open for inspection at the City Offices, 2 Colac Road, Belmont, during office hours.

5617

K. B. McDONALD, Town Clerk

CITY OF WILLIAMSTOWN

LOAN No. 78

Notice of Intention to Borrow the Sum of \$62 000.00 for Permanent Works and Undertakings

Notice is hereby given that the Council of the City of Williamstown proposes to borrow the principal sum of Sixty-two Thousand Dollars (\$62 000.00), secured by a charge over the general rates of the Municipality, such sum to be raised by the grant of a Mortgage, in accordance with the provisions of the *Local Government Act 1958* (as amended).

1. The maximum rate of interest that may be paid is 11.1 per cent. per annum.

2. The purpose for which the loan is to be applied:—

(a) Purchase of Street Sweeper \$62 000.00

3. The period of the loan shall be five years.

4. The moneys borrowed shall be repayable by providing out of the Municipal Fund, ten half-yearly instalments of \$8245.14 each, including principal and interest on 18 April and on 18 October during the currency of the loan. The first instalment shall be payable on 18 October 1980.

5. Such moneys shall be repayable at the Commonwealth Savings Bank of Australia, Melbourne.

The plans and specifications and the estimate of the cost of the proposed works and a statement showing the proposed expenditure of the moneys to be borrowed, are open for inspection at the office of the Council of the City of Williamstown, Municipal Offices, 104 Ferguson Street, Williamstown.

5620

J. T. SLOAN, Town Clerk

CITY OF WILLIAMSTOWN

LOAN No. 79

Notice of Intention to Borrow the Sum of \$338 000.00 for Permanent Works and Undertakings

Notice is hereby given that the Council of the City of Williamstown proposes to borrow the principal sum of Three Hundred and Thirty-eight Thousand Dollars (\$338 000.00), secured by a charge over the general rates of the Municipality, such sum to be raised by the grant of a Mortgage, in accordance with the provisions of the *Local Government Act 1958* (as amended).

1. The maximum rate of interest that may be paid is 11.2 per cent. per annum.

2. The purpose for which the loan is to be applied:—

| | \$ |
|--|------------|
| (a) Railway Place land acquisition | 40 000.00 |
| (b) Swanston Street land acquisition | 40 000.00 |
| (c) Parks and Gardens Depot | 50 000.00 |
| (d) Power Street Drain (Part Cost) | 39 000.00 |
| (e) Victoria Street Drain | 110 000.00 |
| (f) Council Depot Reconstruction (Part Cost) | 39 000.00 |
| (g) Electricity Supply Capital Works | 20 000.00 |
| | 338 000.00 |

3. The period of the loan shall be fifteen years.

4. The moneys borrowed shall be repayable by providing out of the Municipal Fund, thirty half-yearly instalments of \$23 513.67 each, including principal and interest on 18 April and on 18 October during the currency of the loan. The first instalment shall be payable on 18 October 1980.

5. Such moneys shall be repayable at the Commonwealth Savings Bank of Australia, Melbourne.

The plans and specifications and the estimate of the cost of the proposed works and a statement showing the proposed expenditure of the moneys to be borrowed, are open for inspection at the Office of the Council of the City of Williamstown, Municipal Offices, 104 Ferguson Street, Williamstown.

5621

J. T. SLOAN, Town Clerk

TOWN OF KYABRAM

BY-LAW No. 26

A By-Law of the Town of Kyabram made under section 197 of the *Local Government Act 1958* and numbered 26 for the purpose of:

(a) Adopting the Fifteenth Schedule of the *Local Government Act* for the regulation of proceeding of Council and

(b) Repealing By-Law No. 10.

In pursuance of the powers conferred by the *Local Government Act 1958* and of every other power there unto enabling The Mayor Councillors and Burgesses of the Town of Kyabram order as follows:

1. That By-Law No. 10 of the Town of Kyabram shall be and is hereby repealed.

2. That all of the provisions of the Fifteenth Schedule of the *Local Government Act 1958*—Regulation of Proceedings of Council—shall be and are hereby adopted.

3. This By-Law shall apply to and have operation throughout the whole of the municipal district of the Town of Kyabram.

Resolution for passing this By-Law was agreed to by the Council of the Town of Kyabram on 22 January 1980, and confirmed on 26 February 1980.

The common seal of the Mayor, Councillors and Burgesses of the Town of Kyabram was hereunto affixed, in the presence of—

(SEAL) ANNE ADAMS, Mayor
F. C. FINDLAY, Councillor
E. T. CORNISH, Town Clerk

5599

Town and Country Planning Act 1961

BOROUGH OF EAGLEHAWK PLANNING SCHEME

NOTICE THAT A PLANNING SCHEME HAS BEEN PREPARED AND IS AVAILABLE FOR INSPECTION

Amendment No. 1

Notice is hereby given that the Council of the Borough of Eaglehawk in pursuance of its powers under the *Town and Country Planning Act 1961* has prepared a Planning Scheme for the municipal area of the Borough of Eaglehawk for the purposes of:

(a) Providing for the introduction of an amended definition for "Mineral Prospecting", so as to enable buildings (whether temporary or not) to be erected and other site works to be carried out in conjunction with such use.

(b) Providing for the introduction of an amended definition for "Mining" so as to exclude from this activity (and help to create the distinction between) processes normally associated with "Mineral Prospecting".

(c) Including the purpose of "Mineral Prospecting" in Column 4 in the Table to Clause 7 for both the "Residential A" and "Residential B" zones (under the present Scheme this purpose is included in Column 5 for each of these zones).

(d) Including a special range of conditions (i.e. in Part VII of the Ordinance) which should apply to all future "Mineral Prospecting" activities which are to be undertaken within the Borough.

A copy of the Scheme has been deposited at the Municipal Offices, Eaglehawk and at the Office of the Town and Country Planning Board, 235 Queen Street, Melbourne, and will be open for inspection during office hours by any person free of charge.

Any persons affected by the Planning Scheme are required to set forth in writing all objections they may have addressed to The Town Clerk, Borough of Eaglehawk, P.O. Box 55, Eaglehawk 3556 on or before 14 April 1980 and to state whether they wish to be heard in respect of their objections.

12 March 1980
5570

A. J. SMARK, Town Clerk

SHIRE OF BULLA

At Council Meeting on 3 December 1979, Council resolved to change the following street name.

Old Name; New Name...

Reservoir Road to Stockfield Street being that section of Reservoir Road joining Stewards Road and Reservoir Lane on L.P.115249 and shown on Plan.

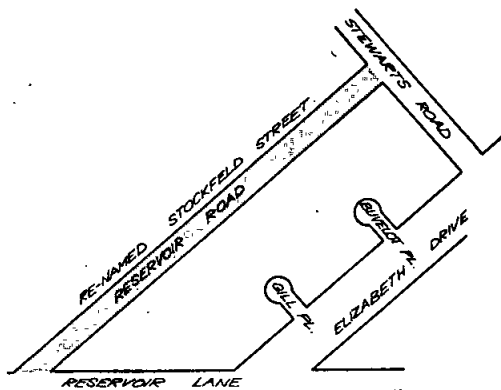

5595

JOHN M. KELLY, Shire Secretary

SHIRE OF BULLA

LOAN No. 97

Notice of Intention to Borrow the Sum of \$100 000

Notice is hereby given that the Council of the Shire of Bulla propose to borrow the sum of \$100 000 secured by a charge over the general rates of the municipality, such sum to be raised by the grant of a Mortgage in accordance with the provisions of the *Local Government Act 1958*.

1. The maximum rate of interest that may be paid is 11.2% per annum.
2. The purposes for which the loan is to be applied are:

| | |
|--|---------|
| | \$ |
| Footpath, Kerb & Channel—Sunbury Township | 10 000 |
| Street Closures—Sunbury Township and Intersection Improvements | 20 000 |
| Land Fill Depot—Sunbury (Vehicle Washing Bays and Drainage, Fencing and Tree Planting) | 10 000 |
| Branch Works Depot—Craigieburn | 20 000 |
| Government Road Construction | 40 000 |
| | 100 000 |

3. The period of the loan shall be 10 years.

4. The moneys borrowed shall be repayable by 20 half-yearly instalments of principal and interest of \$8437.50; first instalment being payable on 1 November 1980.

Plans, specifications and estimate of the cost of the work, and a statement showing the proposed expenditure of the moneys to be borrowed, are open for inspection at the Municipal Offices, Sunbury.

5596 JOHN M. KELLY, Shire Secretary

SHIRE OF COHUNA

LOAN No. 35

Notice of Intention to Borrow the Sum of \$90 000 for Permanent Works and Undertakings

Notice is hereby given that the Council of the Shire of Cohuna proposes to borrow the principal sum of \$90 000 secured by a charge over the general rates of the municipality, such sum to be raised by the grant of a mortgage in accordance with the provisions of the *Local Government Act 1958*.

1. The maximum rate of interest that may be paid is 10.8 per cent per annum.
2. The purpose for which the loan is to be applied is—

| | |
|------------------------------|--------|
| | \$ |
| Purchase of Grader | 70 000 |
| Purchase of Tractor | 18 000 |
| Purchase of Pump | 1 000 |
| Purchase of ancillary equip. | 1 000 |

3. The period of the loan shall be 10 years.

4. The moneys borrowed shall be repayable by providing out of the municipal fund half-yearly instalments of approximately \$7469 each including principal and interest on 1 October and 1 April during the currency of the loan. The first instalment shall be payable on 1 October 1980.

5. Such moneys shall be repayable to the Commissioners of the State Savings Bank of Victoria at the Office of the said Commissioners, 233 Collins Street, Melbourne.

The plans and specifications and the estimate of the cost of the proposed works and a statement showing the proposed expenditure of the moneys to be borrowed are open for inspection at the office of the Council of the Shire of Cohuna at the Civic Centre, King Edward Street Cohuna.

5563 GEOFF KOHLMAN, Shire Secretary

SHIRE OF COHUNA

LOAN No. 36

Notice of Intention to Borrow the Sum of \$100 000 for Permanent Works and Undertakings

Notice is hereby given that the Council of the Shire of Cohuna proposes to borrow the principal sum of \$100 000 secured by a charge over the general rates of the municipality, such sum to be raised by the grant of a mortgage in accordance with the provisions of the *Local Government Act 1958*.

1. The maximum rate of interest that may be paid is 10.8 per cent per annum.
2. The purpose for which the loan is to be applied is—

| | |
|--|--------|
| | \$ |
| Street Construction | 46 500 |
| Kerb and Channel Construction | 32 500 |
| Purchase of land for elderly persons units | 12 500 |
| Purchase of land for off-street parking access | 8 500 |

3. The period of the loan shall be 20 years.

4. The moneys borrowed shall be repayable by providing out of the municipal fund half-yearly instalments of approximately \$6150 each including principal and interest on 1 April and 1 October during the currency of the loan. The first instalment shall be payable on 1 October 1980.

5. Such moneys shall be repayable to the Commissioners of the State Savings Bank of Victoria at the Office of the said Commissioners, 233 Collins Street, Melbourne.

The plans and specifications and the estimate of the cost of the proposed works and a statement showing the proposed expenditure of the moneys to be borrowed are open for inspection at the office of the Council of the Shire of Cohuna at the Civic Centre, King Edward Street Cohuna.

5564 GEOFF KOHLMAN, Shire Secretary

SHIRE OF EUROA

LOAN No. 43

Notice of Intention to Borrow the Sum of \$100 000 for Permanent Works and Undertakings

Notice is hereby given that the Council of the Shire of Euroa intends to borrow the principal sum of One Hundred Thousand Dollars (\$100 000) by the grant of a mortgage secured by a charge over the general rates of the municipality in accordance with the provisions of the Local Government Acts.

In connection therewith the following information is stated:—

- (a) The amount of the principal moneys which it is proposed to borrow is One Hundred Thousand Dollars (\$100 000).
- (b) The maximum rate of interest that may be paid is 11.1 per centum per annum.
- (c) The times which the moneys borrowed are to be repayable are 1 November and May during the years 1980–1985 inclusive and the place such moneys shall be repayable is at the National Bank Savings Bank of Australasia Limited, Melbourne.
- (d) The purpose for which the loan is to be applied is for the purchase of plant.
- (e) The manner in which the loan is to be liquidated is by provision out of the Municipal Fund in each half year during the currency of the loan the sum of \$13 298.61 which includes Principal and Interest.

The plans and specifications and estimate of the cost of the works and a statement showing the proposed expenditure of the moneys to be borrowed are open for inspection at the Shire Office, Euroa.

Dated 7 March 1980

5615 B. MORAN, Shire Secretary

Town and Country Planning Act 1961 (Twelfth Schedule)

SHIRE OF FLINDERS PLANNING SCHEME 1962

NOTICE THAT A PLANNING SCHEME HAS BEEN PREPARED AND IS AVAILABLE FOR INSPECTION

Amendment No. 128, 1980

Notice is hereby given that the Shire of Flinders in pursuance of its powers under the *Town and Country Planning Act 1961* has prepared a Planning Scheme for the rezoning of a portion of the Recreation Reserve, Barkers Street, Flinders, from Public Open Space Reserve (Existing)—Recreation to Public Purposes Reserve (Existing)—Fire Brigade.

A copy of the Scheme has been deposited at the Office of the Responsible Authority, Municipal Offices, Boneo Road, Rosebud, and at the Office of the Town and Country Planning Board, 235 Queen Street, Melbourne, and will be open for inspection during office hours by any person free of charge.

Any persons affected by the Planning Scheme are required to set forth in writing all objections they may have addressed to the Shire Secretary, Shire of Flinders, Municipal Offices, Boneo Road, Rosebud, 3939, on or before 12 June 1980 and state whether they wish to be heard in respect of these objections.

6 March 1980

5598 G. W. WHITE, Shire Secretary

Town and Country Planning Act 1961 (Twelfth Schedule)

SHIRE OF FLINDERS PLANNING SCHEME 1962

NOTICE THAT A PLANNING SCHEME HAS BEEN PREPARED AND IS AVAILABLE FOR INSPECTION

Amendment No. 129, 1980

Notice is hereby given that the Shire of Flinders, in pursuance of its powers under the *Town and Country Planning Act 1961*, has prepared a Planning Scheme for the purpose of incorporating the Sorrento Township within a Special Control Area.

A copy of the Scheme has been deposited at the Office of the Responsible Authority, Municipal Offices, Boneo Road, Rosebud, and at the Office of the Town and Country Planning Board, 235 Queen Street, Melbourne, and will be open for inspection during office hours by any person free of charge.

Any persons affected by the Planning Scheme are required to set forth in writing all objections they may have addressed to the Shire Secretary, Shire of Flinders, Municipal Offices, Boneo Road, Rosebud, 3939, on or before 12 April 1980 and state whether they wish to be heard in respect of these objections.

6 March 1980

5597 G. W. WHITE, Shire Secretary

SHIRE OF GISBORNE

LOAN No. 33

Notice of Intention to Borrow

Notice is hereby given that the Council of the Shire of Gisborne intends to borrow the sum of Eighty Thousand Dollars (\$80 000.00) by the grant of a Mortgage secured by a charge over the General Rates of the Municipality in accordance with the provisions of the *Local Government Act 1958*.

In connection therewith, the following information is stated:—

- (a) The amount of the principal moneys which it is proposed to borrow is Eighty Thousand Dollars (\$80 000.00):
- (b) The maximum rate of interest that may be paid is 11.2 per centum per annum.
- (c) The purposes for which the loan is to be applied are:

(i) Roadworks—

Footpath Construction \$2400; Drainage Works in Taylors Road and Carrington Street \$5800; Construction of a Service Road on the West Side of Aitken Street and partial construction of Haig Street and Crombie Road \$22 800.

(ii) Office equipment amounting to \$4500.

(iii) Plant Purchase—

Traxcavator \$40 000; Linemarker \$3000 and plant replacement \$1500.

- (d) The period of the loan shall be based on a Ten (10) year repayment Schedule.
- (e) The money borrowed shall be repayable by providing out of the Municipal fund half-yearly instalments of Six Thousand, Seven Hundred and Fifty Dollars (\$6750) including principal and interest on 28 April and 28 October during the currency of the loan. The first instalment shall be repayable on 28 October 1980.
- (f) Such moneys shall be repayable at the Office of the State Savings Bank, 125 Swanston Street, Melbourne, 3000 or at such other place or places as the Bank from time to time requires.

The Plans and Specifications and estimate of the cost of the works and a statement showing the proposed expenditure of the moneys to be borrowed are open for inspection at the Shire Offices, Robertson Street, Gisborne up to 4.00 p.m. on Monday, 14 April 1980, during office hours.

Dated 3 March 1980

5567 T. H. LARKINS, Shire Secretary

SHIRE OF GLENELG

LOAN No. 51

Notice of Intention to Borrow the Sum of \$30 000 for Permanent Works and Undertakings

Notice is given that the Council of the Shire of Glenelg intends to borrow the principal sum of Thirty thousand dollars (\$30 000) secured by a charge over the general rates of the Municipality, such sum to be secured by the grant of a mortgage in accordance with the provisions of the *Local Government Act 1958*.

1. The maximum rate of interest is 11.9 per cent per annum.

Paragraph 2—Refers to authorised directions given to campers to cease occupancy of roadway.

Paragraph 3—Advises that the By-Law shall have operation throughout the whole of the Municipal District of the Shire of Oxley.

Paragraph 4—States penalties pertaining to breaches of the By-Law.

This By-Law shall come into operation on the day following its publication, in the *Victoria Government Gazette*.

Resolution adopting this By-Law was agreed to by Council on 6 February 1980 and confirmed on 5 March 1980.

A copy of the By-Law is open for inspection free of charge during office hours at the Shire Offices, 22 Rowan Street, Wangaratta.

12 March 1980

5601 E. F. VAN LEEUWEN, Shire Secretary

SHIRE OF PORTLAND

LOAN No. 44

Notice of Intention to Borrow the Sum of \$14 000 for Permanent Works and Undertakings

Notice is hereby given that the Council of the Shire of Portland intends to borrow the principal sum of Fourteen Thousand Dollars (\$14 000) secured by a charge over the general rates of the municipality by the grant of a mortgage in accordance with the provisions of the *Local Government Act 1958*, as amended.

1. The maximum rate of interest that may be paid is 11.9 per centum per annum.
2. The period of the loan shall be eight years.
3. The monies borrowed shall be repayable by providing out of the Municipal Fund sixteen half-yearly instalments of \$1380.58 each including principal and interest on 10 November and 10 May during the currency of the loan. The first instalment shall be payable on 10 November 1980.
4. Such monies shall be repayable at the Commercial Bank of Australia Limited, Heywood.
5. The purpose for which the Loan is to be applied is: Extensions to the Heywood and District Elderly Citizens Clubrooms.

A statement showing the proposed expenditure of the money to be borrowed is open for inspection at the Shire Offices, 77 Edgar Street, Heywood, during normal office hours.

5701 I. E. BENBOW, Shire Secretary

SHIRE OF TRARALGON

LOAN No. 62

Notice of Intention to Borrow the Sum of \$200 000 for Permanent Works and Undertakings

Notice is hereby given that the Council of the Shire of Traralgon proposes to borrow the principal sum of Two hundred thousand dollars (\$200 000) secured by a charge over the general rates of the municipality such sum to be raised by the grant of a mortgage in accordance with the provisions of the *Local Government Act 1958*.

1. The maximum rate of interest that may be paid is 11.9 per cent.
2. The purpose for which the Loan is to be applied is road and bridge construction associated with the Loy Yang project development.
3. The period of the Loan shall be four (4) years.
4. The manner in which the Loan is to be liquidated is by the provision out of the Municipal Fund in each half year during the currency of the Loan of a sum which includes principal and interest.
5. Such moneys shall be repayable to the State Electricity Commission of Victoria, or such other place as the Commission from time to time may require.

The plans specifications and estimates of the cost of the works and a statement showing the proposed expenditure of the moneys to be borrowed are open for inspection at the Municipal Offices, Kay Street, Traralgon.

Dated 6 March 1980

5619 W. TEASDALE, Shire Secretary

Town and Country Planning Act 1961 (Twelfth Schedule)

SHIRE OF WARRAGUL—SHIRE OF WARRAGUL PLANNING SCHEME 1954

NOTICE THAT A PLANNING SCHEME HAS BEEN PREPARED AND IS AVAILABLE FOR INSPECTION

Amendment No. 37, 1980

Notice is hereby given that the Shire of Warragul in pursuance of its powers under the *Town and Country Planning Act 1961* has prepared a Planning Scheme for the following area, that land bounded by Albert Street, Smith Street, Palmerston Street and Victoria Street, Warragul.

A copy of the scheme has been deposited at the Shire Office, Civic Place, Warragul; at the office of the Town and Country Planning Board, 235 Queen Street, Melbourne and at the office of the Town and Country Planning Board, Regional Office, 71 Hotham Street, Traralgon and will be open for inspection during office hours by any person free of charge.

Any persons affected by the Planning Scheme are required to set forth in writing all objections they may have, addressed to the Shire Secretary, Civic Place, Warragul on or before 12 June 1980 and to state whether they wish to be heard in respect of their objections.

NOTE—The purpose of this scheme is to rearrange some of the land reserved for Proposed Public Purposes (car parking) and to rezone some land to Commercial "A".

Dated 3 March 1980

5579 V. B. DAVIDSON, Shire Secretary

SHIRE OF WERRIBEE

NOTICE OF INTENTION TO ACQUIRE LAND COMPULSORILY

Part of Lot 43, Block M, Bruce Street, Laverton

Whereas the Council of the Shire of Werribee deems it expedient to exercise its power of taking compulsorily the land being part of Lot 43, Block M, L.P. 1234, Bruce Street, Laverton, Parish of Truganina, County of Bourke, for the work or undertaking of providing same as a place for public purposes and whereas the Council has caused to be prepared a map and other papers setting out the general description of the work or undertaking for which the land proposed to be taken is to be used the description of the land proposed to be taken and the names of the owners or reputed owners Lessees or reputed Lessees Mortgagees and occupiers of that land so far as those names are known to or can be ascertained by the Council and whereas the said map and other papers are deposited at the Office of the said Council at Werribee and shall be open for inspection by all persons interested at all reasonable hours for the space of forty clear days after publication of this notice in the *Government Gazette* now notice is hereby given to all persons affected by the proposed taking of the said land to set forth in writing addressed to the Council or Shire Secretary within forty clear days of the publication of this notice in the *Government Gazette* all objections which they may have to the taking of the said land.

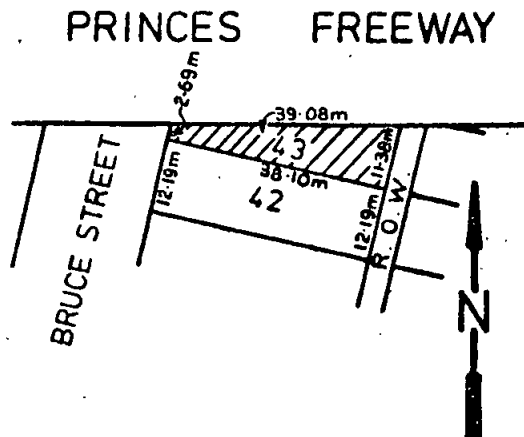

Dated 25 February 1980

5577 M. J. BLOXHAM, Shire President

SHIRE OF WERRIBEE

BY-LAW No. 72

Petrol Pumps By-Law

A By-Law of the Shire of Werribee made under Section 7 of the *Petrol Pumps Act 1958* and numbered 72 for or with respect to:

- (a) the placing fixing and maintaining of petrol pumps in or on footways and of any apparatus pipes and appliances in on or under footways for the supply of Motor or other spirit to such petrol pumps and the removal of such petrol pumps apparatus pipes and appliances;
- (b) the granting renewal and transfer of licences and applications therefore;
- (c) licences and conditions to be contained in licences;
- (d) prescribing fees—
 - (1) for the granting or renewal of a licence;
 - (2) for the transfer of a licence;
- (e) providing for a proportionate reduction of fees payable in respect of licences granted for any number of months less than twelve months; and
- (f) insurance by licensees against liabilities which may be incurred by them in respect of petrol pumps.

In pursuance of the powers conferred by the *Petrol Pumps Act 1958* the President Councillors and Ratepayers of the Shire of Werribee order as follows:—

1. In this By-Law—

“Council” shall mean the Council of the Shire of Werribee.

“Licence” shall mean a licence granted in accordance with the *Petrol Pumps Act 1958*.

“Licensee” shall mean the holder for the time being of a licence granted in accordance with the *Petrol Pumps Act 1958*.

“Municipality” shall mean the municipality of the Shire of Werribee.

“Petrol Pump” shall mean any pump for supplying motor or other spirit and shall include a portable Petrol Pump.

“Portable Petrol Pump” shall mean a petrol pump which is constructed on wheels and is not fixed in to or on the footway and is not allowed to remain on the footway.

“Regulations” shall mean the Regulations from time to time made and in force under the *Petrol Pumps Act 1958*.

2. Any person may apply for a licence in respect of any petrol pump placed or to be placed in to on or under any footway in any highway within the municipal district of Werribee used or to be used by such person for the purpose of the business carried on or to be carried on by such person of selling and supplying motor or other spirit. Every such application shall be in the form of the first schedule to this By-Law. Every licence granted shall be in the form of the second schedule to this By-Law.

3. It shall be the duty of every person to whom a licence has been granted under the provisions of the *Petrol Pumps Act 1958* to maintain in a safe and efficient condition and free from leakage and in accordance with this By-Law all petrol pumps, apparatus, pipes and appliances in or under footways for the supply of motor spirit to such petrol pumps.

4. Every licence shall expire on 30 September next following the date of issue and shall after such 30 September be of no force and effect.

- (a) There shall be paid to the Council in respect of every licence for a petrol pump in or on any footway a licence fee of \$21.00 per annum.
- (b) Provided that where a licence is granted for any number of months less than twelve months a proportionate reduction of the fee based on the number of months unexpired shall be made by the Council.

5. No licence or renewal of a licence or transfer of a licence shall be granted unless the fee prescribed in such cases has first been paid.

6. Where a licence granted under the provisions of this By-Law is about to expire the Council may upon application being made to it in the form of the third Schedule to this By-Law renew such licence for a further term of one year.

7. Every application for the renewal of a licence shall be lodged with the Council at least fourteen days before the expiration of the licence and shall be accompanied by the annual licence fee hereinbefore prescribed.

8. The Council may refuse to grant or renew or transfer any licence where the pump in respect of which an application for a licence or transfer or renewal of a licence is made is not placed or proposed to be placed in front of premises occupied or to be occupied by the applicant for the purpose of carrying on the business of selling or supplying motor or other spirit.

9. No licence shall be transferred save in accordance with the following provisions. The person desiring to transfer the licence shall first make application in writing to the Council for the approval of the Council to such transfer and shall enclose with such application a transfer of the licence in writing signed by the licensee and an acceptance of such transfer (conditional upon the approval of the Council being granted thereto) by the transferee and shall pay to the Council a transfer fee of \$1.00.

10. Immediately on the approval of the Council of any transfer of licence being given the policy of insurance hereinafter referred to taken out by the transferor shall be transferred to the transferee or the transferee shall effect a new policy in a company of repute to the same effect.

11. Every licensee under the provisions of this By-Law shall before the petrol pump is erected in respect of which such licence is granted or if erected prior to the application before the petrol pump is used for the sale or supply of motor or other spirit; insure himself and thereafter at all times keep himself insured during the currency of such licence and any renewal thereof in some insurance company of good repute against all damages and liabilities for which he may become liable to any person arising from the use control or possession by him of such petrol pump in the sum of at least \$100 000.00. Every licensee shall on demand produce to the Council or any duly appointed officer of the Council the said policy of insurance and the receipt for the premium for the then unexpired period of the licence, at his own expense.

12. A licensee shall to the satisfaction of the Engineer of the Council make good any damage to conduits, drains or pipes under any footway caused by or arising from the installation or removal of a petrol pump or any part thereof or any apparatus, pipes or appliances for the supply of motor spirit or other spirit to such pump and shall make good any portion of the footway broken up or damaged for the purpose of such installation or removal.

13. Every licensee whose licence shall have expired and has not been renewed or whose licence shall have been cancelled under the provisions of the *Petrol Pumps Act 1958* shall within seven days after such expiring or cancellation and at his own expense remove the petrol pump referred to in such licence and all apparatus pipes and appliances connected therewith in on or under the footway and shall at his own expense and to the satisfaction of the Engineer of the Council make good any damage to the footway caused by such removal.

14. No licensee shall cause or permit the petrol pump in respect of which his licence is granted or the apparatus pipes or appliances connected therewith to be altered in design or position without first obtaining the consent of the Council thereto in writing.

15. This By-Law shall apply to and have operation throughout the whole municipal district of the Shire of Werribee.

Resolution for passing this By-Law agreed to by the Council 28 November 1977 and confirmed 27 February 1978.

The common seal of the President, Councillors, and Ratepayers of the Shire of Werribee was hereunto affixed, in the presence of—

(SEAL) S. D. SOUTHWICK, President
M. J. BLOXHAM, Councillor
J. T. KERR, Shire Secretary

2. The moneys borrowed are to be repaid to the Commercial Banking Company of Sydney Ltd., Henty Street, Casterton.

3. The purpose for which the loan is to be applied is as follows:—

| | |
|--|--------|
| | \$ |
| (a) Half costs of Kerb and Channel works— Casterton | 15 000 |
| (b) Half costs of Drainage construction— Casterton | 15 000 |
| | 30 000 |

4. The period of the loan shall be five (5) years.

5. The moneys borrowed shall be repayable by providing out of the Municipal Fund half yearly instalments of approximately \$2604.93 including principal and interest on 1 May and 1 November during the currency of the loan together with a final payment to be made of approximately \$21 822.95. The first instalment shall be payable on 1 November 1980.

The plans and specifications and the estimate of the proposed works and a statement showing the proposed expenditure of the money to be borrowed, are open for inspection at the Shire Office, Casterton.

Dated 5 March 1980

5699 D. A. TICKELL, Shire Secretary

SHIRE OF GLENELG

LOAN No. 52

Notice of Intention to Borrow the Sum of \$100 000 for Proposed Works and Undertakings

Notice is given that the Council of the Shire of Glenelg intends to borrow the principal sum of One hundred thousand dollars (\$100 000) secured by a charge over the general rates of the Municipality such sum to be secured by the grant of a mortgage in accordance with the provisions of the Local Government Act 1958.

1. The maximum rate of interest is 11.2 per cent per annum.

2. The moneys borrowed are to be repaid to the National Bank, Casterton.

3. The purpose for which the loan is to be applied is:

| | |
|--|---------|
| | \$ |
| (a) Purchase of Plant | 50 980 |
| (b) Half cost Footpath construction— Casterton | 8 715 |
| (c) Construction of Storm water drainage— Casterton | 16 280 |
| (d) Half cost Kerb and Channel works— Casterton | 16 350 |
| (e) Half cost Drainage construction— Casterton | 7 675 |
| | 100 000 |

4. The period of the loan shall be 10 (ten) years.

5. The moneys borrowed shall be repayable by provision out of the Municipal Fund, half yearly instalments of principal and interest of approximately \$8437.50 on 1 May and 1 November during the currency of the loan. The first instalment shall be payable on 1 November 1980.

The plans and specifications and the estimate of the proposed works and a statement showing the proposed expenditure of the money are open for inspection at the Shire Office, Casterton.

Dated 5 March 1980

5698 D. A. TICKELL, Shire Secretary

SHIRE OF HASTINGS

APPOINTMENT OF PROSECUTING OFFICER

Notice is hereby given that the Council of the Shire of Hastings has appointed Senior Sergeant John Alan Quirk, No. 13634, as Prosecuting Officer in lieu of Senior Sergeant William Dennis Richard Aylward, No. 13753, transferred.

W. R. FEATHERSON, Shire Secretary

Municipal Offices, Hastings, 3915 .5571

SHIRE OF KORONG

LOAN No. 44

Notice of Intention to Borrow the Sum of \$25 000 for Permanent Works and Undertakings

Notice is hereby given that the Council of the Shire of Korong proposes to borrow the principal sum of twenty-five thousand dollars secured by the grant of a mortgage in accordance with the provisions of the Division 1 of Part XV. of the Local Government Act 1958.

1. The maximum rate of interest that may be paid is 9.3 per centum per annum.

2. The money shall be repayable by providing out of the Municipal Fund thirty equal half-yearly instalments of \$1561.99 each including principal and interest.

Such instalments being repayable on 1 May and 1 November in each year during the currency of the Loan at the Offices of the Department of State Development, Decentralisation and Tourism.

The first repayment shall be due on 1 November 1980.

3. The purpose for which the Loan is to be applied is:

Part cost of construction of Amenities Building for the Pioneer Caravan Park, Wedderburn.

The Plans and Specifications and Estimate of Cost of the proposed works and a Statement showing the proposed expenditure of the moneys to be borrowed are open for inspection at the Office of the Council of the Shire of Korong, Shire Office, Wedderburn.

Dated 29 February 1980

5568 J. R. WALTON, Shire Secretary

SHIRE OF LILLYDALE

CHANGE OF STREET NAME

Notice is hereby given pursuant to the provisions of section 535 of the Local Government Act 1958 that the Council of the Shire of Lillydale did resolve at a meeting held on Monday, 25 February 1980, to name the following un-named Government Road in Montrose as follows:—

Old Name—Unnamed Government Road.

New Name—Taruna Rise.

Location—Running easterly off Sheffield Road South, Montrose adjacent to the northern boundary of the Billanook Primary School.

5600 K. D. WILSON, Shire Secretary

SHIRE OF MILDURA

LOAN No. 75

Notice is hereby given that the Council of the Shire of Mildura proposes to borrow the principal sum of Two Hundred Thousand Dollars (\$200 000), secured by a charge over the General Rates of the Municipality, such sum to be raised by the granting of a Mortgage in accordance with the provisions of the Local Government Act 1958.

1. The maximum rate of interest that may be paid is 11.1% per annum.

2. The purpose to which the loan is to be applied is:

Purchase of Plant \$200 000

3. The period of the loan shall be seven (7) years.

4. The monies borrowed shall be repayable by providing out of the Municipal Fund half yearly instalments of \$20 921.49, each including principal and interest, on 31 May and 31 November during the currency of the loan. The first instalment shall be payable on 31 November 1980.

5. Such monies shall be repayable at the Offices of the Commercial Banking Company of Sydney Savings Bank Limited, Melbourne.

A statement showing the proposed expenditure of the money to be borrowed is open for inspection at the Office of the Council of the Shire of Mildura, Fifteenth Street, Irymple.

DANIEL F. DREW, Shire Secretary

Shire Offices, Irymple, 28 February 1980 5569

SHIRE OF MORWELL
NAMING OF ROAD

Notice is hereby given pursuant to the provisions of Section 535 (4) of the *Local Government Act 1958* (as amended) that the Council of the Shire of Morwell has, by resolution, changed the name of the following street or road—

Old Name—Driffield Road.

New Name—Scrubby Forest Road.

5572 R. H. WATERS, Shire Secretary

SHIRE OF MORWELL

NOTICE OF THE MAKING OF A BY LAW
BY LAW NO. 56

Prohibiting or Regulating the Placing of Caravans on Private Property and for Other Purposes

The Council of the Shire of Morwell by resolution made on 1 November 1979 and confirmed on 6 December 1979, has made By Law No. 56 for the purpose of:

Prohibiting or regulating the placing of caravans on private property throughout the whole of the municipal district and regulating the occupancy of any caravan on any private property.

The By Law shall come into operation on the day after this notice is published in the *Victoria Government Gazette*, viz.: 12 March 1980.

A copy of the By Law is available for inspection, free of charge, during office hours at the Shire Offices, Commercial Road, Morwell.

5573 R. H. WATERS, Shire Secretary

SHIRE OF MORWELL

NOTICE OF THE MAKING OF A BY LAW
BY LAW NO. 57

Regulating the Keeping of Dogs

The Council of the Shire of Morwell by resolution made on 15 November 1979 and confirmed on 24 January 1980, has made By Law No. 57 for the purpose of:

Regulating the keeping of dogs and limiting the number of dogs left on any property defined in the by law and declared for the purpose of this By Law as a residential area.

The By Law shall come into operation on the day after this notice is published in the *Government Gazette*, viz.: 12 March 1980.

A copy of the By Law is available for inspection, free of charge, during office hours at the Shire Offices, Commercial Road, Morwell.

5574 R. H. WATERS, Shire Secretary

Town and Country Planning Act 1961 (Twelfth Schedule)
SHIRE OF MYRTLEFORD

NOTICE THAT AN INTERIM DEVELOPMENT ORDER HAS BEEN PREPARED AND IS AVAILABLE FOR INSPECTION

Shire of Myrtleford Rural Area Interim Development Order 1980

Notice is hereby given that the Council of the Shire of Myrtleford in pursuance of its powers under the *Town and Country Planning Act 1961* has prepared an Interim Development Order for the whole of the Municipal District of the Shire of Myrtleford, excepting that part of the Shire contained within the Shire of Myrtleford (Myrtleford Township) Planning Scheme approved by the Governor in Council on 20 January 1976.

A copy of the Interim Development Order has been deposited at the office of the Council of the Shire of Myrtleford, Civic Centre, Myrtleford, at the office of the Town and Country Planning Board, 235 Queen Street Melbourne, and at the Regional Office of the Town and Country Planning Board, Astra House, Cnr. Jack Hore Place and Howell Street, Wodonga, and will be open for inspection during office hours by any person free of charge.

Any persons affected by the Planning Scheme are required to set forth in writing all objections they may have, addressed to the Municipal Clerk, Shire of Myrtle-

ford, Civic Centre, Myrtleford, 3737, on or before 12 April 1980, and to state whether they wish to be heard in respect of their objections.

10 March 1980

5576

P. BALDWIN, Municipal Clerk

Town and Country Planning Act 1961

SHIRE OF NARRACAN—SHIRE OF NARRACAN
PLANNING SCHEME INTERIM DEVELOPMENT
ORDER (UNCONTROLLED AREAS)

NOTICE THAT AN AMENDMENT HAS BEEN PREPARED AND IS AVAILABLE FOR INSPECTION

Amendment No. 14

Notice is hereby given that the Shire of Narracan in pursuance of its powers under the Shire of Narracan Interim Development Order (Uncontrolled Areas) has prepared an amendment for the Shire of Narracan I.D.O. (Uncontrolled Areas) to amend the maps to the scheme being map notated D to rezone Part C.A. 7g and Part C.A. 13A, Section C, Parish of Tanjil East from Rural to Rural Residential.

A copy of the scheme has been deposited at the Office of the Shire of Narracan Princes Highway, Trafalgar, and at the office of the Town and Country Planning Board, 235 Queen Street, Melbourne, and will be open for inspection during office hours by any person free of charge.

Any persons affected by the planning scheme are required to set forth in writing all objections they may have addressed to the Shire Secretary, Shire of Narracan, Trafalgar, on or before 12 April 1980, and to state whether they wish to be heard in respect of their objections.

Dated 12 March 1980

5580

W. F. NELSON, Shire Secretary

Town and Country Planning Act 1961

SHIRE OF NARRACAN—SHIRE OF NARRACAN
PLANNING SCHEME INTERIM DEVELOPMENT ORDER
(UNCONTROLLED AREAS)

NOTICE THAT AN AMENDMENT HAS BEEN PREPARED AND IS AVAILABLE FOR INSPECTION

Amendment No. 12

Notice is hereby given that the Shire of Narracan in pursuance of its powers under the Shire of Narracan Planning Scheme Interim Development Order (Uncontrolled Areas) has prepared an Amendment for the Shire of Narracan to amend the maps to the Scheme being map noted D for the land and to the zonings indicated in the following schedule:

| Schedule No. | Description | Present Zoning | Proposed Zoning |
|--------------|-------------------------------|----------------|-------------------|
| 1 | Pt. C.A. 50, Parish of Tanjil | Rural | Township |
| 2 | Pt. C.A. 39, Parish of Moe | Rural | Rural Residential |

A copy of the scheme has been deposited at the Office of the Shire of Narracan Princes Highway, Trafalgar, and at the office of the Town and Country Planning Board, 235 Queen Street, Melbourne, and will be open for inspection during office hours by any person free of charge.

Any persons affected by the planning scheme are required to set forth in writing all objections they may have addressed to the Shire Secretary, Shire of Narracan, Trafalgar, on or before 12 April 1980, and to state whether they wish to be heard in respect of their objections.

Dated 12 March 1980

5581

W. F. NELSON, Shire Secretary

SHIRE OF OXLEY

BY-LAW NO. 24

Prohibiting and Regulating Camping on Roads

Notice is hereby given pursuant to section 207 of the *Local Government Act 1958* that By-Law No. 24 for the purpose of prohibiting and regulating camping on roads has been made and sealed by the Council of the Shire of Oxley.

The following is a summary of the By-Law's contents:—

Paragraph 1—Defines caravan and any other object or structure which may be used for unauthorised camping on roads.

SECOND SCHEDULE
SHIRE OF WERRIBEE
Petrol Pumps Act 1958
PETROL PUMP LICENCE

Pursuant to the provisions of Section 4 of the "Petrol Pumps Act 1958", the Council of the Shire of Werribee doth hereby grant licence to

of
for the period of _____ months from the
to 30 September 19 _____ in respect of a Petrol Pump to be
placed on the footway of _____
Street _____ Road
Situate _____ in the Municipal District of the
Shire of Werribee, subject to the conditions following,
that is to say:—

That this Licence is issued subject to the provisions of the "Petrol Pumps Act 1958" and of any Regulations made by the Governor in Council under the powers conferred by Section 8 of the said Act and of any By-Laws made by the Council under Section 7 of the Act aforesaid.

That every authorised Officer of the Council shall be at all times allowed free access to the premises of the Licensee, for the purpose of ascertaining whether the conditions of the Licence have been properly observed and that the Licensee shall by himself or his representatives, give every assistance for that purpose which such Officer may require.

This Licence is in respect of an application made to the Council on the _____ and numbered _____

Dated this _____ day of _____ 19 _____

By Order of the Council
Shire Secretary

Licence Fee Paid \$ _____

152
37

THIRD SCHEDULE
APPLICATION FOR RENEWAL OF LICENCE

Whereas a Licence numbered _____ was, on
the _____ day of _____ 19 _____, issued
under the provisions of By-Law No. _____ to
_____ in respect of a Petrol Pump to be
placed or retained or used on the footway in front of
premises _____
(such Petrol Pump being fully described in application No. _____
for licence) and whereas such licence will
expire on 30 September 19 _____, I/We, the undersigned,
hereby apply for renewal of such licence for the year
ending 30 September 19 _____

Dated this _____ day of _____ 19 _____

Signature(s) _____

FIRST SCHEDULE
Application No. _____
(To be filled in by the Municipal
Clerk)

SHIRE OF WERRIBEE
"Petrol Pumps Act 1958"

Application to the Council of the Shire of Werribee for a Licence in respect of a Petrol Pump to be placed or retained or used on the footway of a highway within the Municipality of the Shire of Werribee.

This application must be fully filled up in accordance with the following instructions before it can be considered by the Council.

If a licence is required for more than one Petrol Pump it will be necessary for the applicant to make separate applications in respect of every such licence so required.

State Christian name and
Surname of the Applicant.

If a firm, the name of each
member in full. If a com-
pany, the registered name
and registered office of the
company and its secretary.

State occupation of the
Applicant.

State postal address of the
Applicant.

State if licence or licences
have already been granted
by the Council in respect of
any petrol pump or pumps.

If so, state fully the number
and where such petrol pump
or pumps are situate.

State name and part of the
street on which the petrol
pump is or on which it is
proposed to erect the petrol
pump and attach plan
showing clearly the position
on the footway where it is
proposed to erect the petrol
pump.

State class or type of petrol
pump for which a licence is
applied for. If a portable
petrol pump (which is
allowed to remain on the
footway only during the
period of selling or supply-
ing motor spirit) state
class or type of such pump.

Signature of Applicant _____

Date _____ 19 _____

To: The Shire Secretary,
Civic Centre,
Princes Highway,
Werribee, 3030

5578

THE ROYAL HUMANE SOCIETY OF AUSTRALASIA
ANNOUNCES THE FOLLOWING AWARDS TO RESIDENTS OF
VICTORIA

Silver Medal

Mijo Crnkovic of Carlton.

Bronze Medals

Police Sergeant Leigh G. Delmenico of Noble Park;
Alexander George Fergusson of Ivanhoe; Lucy Joy Froomes
of Brighton; Alan James Lewer of Williamstown; Margaret
Ada Menegol of North Blackburn; John William Schmidt
of Bacchus Marsh.

Certificates of Merit

Raymond John Beyer of Niddrie; Marlene Joy Elsegood
of Emerald; Rodney Philip Jones of Doveton; Brian
Kershaw of Williamstown; Peter Robert Loosley of Croy-
don; Alan William McLean of Ormond; Edward Joseph
Menegol of North Blackburn; Police Sergeant Patrick
Francis Noonan of Doncaster East; Susanne Jean Ramsdale
of Clematis; Stien Frederick Seterdal of Croydon.

5631

L. J. STEPHENS, Secretary

DIMBOOLA SEWERAGE AUTHORITY

The Dimboola Sewerage Authority, pursuant to and in
exercise of the powers conferred on it by the Sewerage
Districts Act 1958 does hereby make the following By-
Law, entitled By-Law No. 16 for its Sewerage District.

By-Law No. 16, for the control and/or removal of trees
affecting or likely to affect sewers and manholes, was
passed at a meeting of the Dimboola Sewerage Authority
on 5 November, 1979, confirmed at a meeting on 3 Decem-
ber 1979 and approved by the Governor-in-Council on 18
December 1979.

A copy of this By-Law is deposited at the Offices of the
Authority, 102 Lloyd Street, Dimboola and is open to
inspection by any person free of charge.

5702

DIANA MAHER, Secretary

MOUNT BEAUTY SEWERAGE AUTHORITY

Notice is hereby given that in pursuance of the powers
conferred by the Sewerage Districts Act 1958, the Mount
Beauty Sewerage Authority has made a By-Law No. 5
entitled "Relating to Consents and Licences for House
Connection Work".

A copy of this By-Law is open for inspection during office hours at the office of the Authority, Kiewa Crescent, Mount Beauty.

Resolution for the passing of this By-Law was agreed to by the Authority on 18 December 1979, and confirmed on 15 January 1980.

The By-Law was approved by the Governor in Council on 12 February 1980.

5602

J. B. O'BRIEN, Manager

NOTICE OF DISSOLUTION

Notice is hereby given that the partnership heretofore subsisting between Roelof Gort, Selma Gort and Herman Schuring carrying on business as Gas Service Laying Contractors at 154 James Cook Drive, Endeavour Hills under the firm name or style of "Roebren Contractors" has been dissolved by mutual consent as from 31 October 1979 so far as concerns the said Roelof Gort and Selma Gort who retire from the business. All debts due to and owing by the said firm will be received and paid by Herman Schuring who will continue the business under the said firm name or style.

Dated 31 October 1979

5632

ROELOF GORT
SELMA GORT
HERMAN SCHURING

Notice is hereby given that the partnership heretofore subsisting between Alexander George Jenner and Dorothy Frances Jenner carrying on a caravan rental business in Melbourne, The Grampians, Porepunkah, in the State of Victoria, and in Mount Gambier in the State of South Australia, has been dissolved as from the date hereof so far as concerns the said Dorothy Frances Jenner who retires from the said firm.

EGGLESTON CLIFTON-JONES & CO., solicitors, 20 Queen Street, Melbourne, 3000. 5694

Notice is hereby given that the partnership heretofore subsisting between Henry Chan, Irene Chan, Martin Poon and Kitty Poon carrying on business as Restaurateurs at 36 Main Street, Upwey, under the style or firm name of "Pearl Garden Restaurant" has been dissolved as from 3 March 1980 so far as concerns the said Henry Chan and the said Irene Chan who retire from the said firm. All debts due to and owing by the said firm will be received and paid respectively by the said Martin Poon and the said Kitty Poon who will continue to carry on the said business in partnership under the firm name or style of "Pearl Garden Restaurant".

Dated 3 March 1980

HENRY CHAN
IRENE CHAN
MARTIN POON
KITTY POON

John D. Mustow & Co., solicitors, of 401 Collins Street, Melbourne 5695

Notice is hereby given that the partnership between Alec Hall McKay, Melford Henry Russell Roberts, John Charles Evans, David James Hughes, Graham Davies and Michael Arthur Blewett carrying on the practice of Barristers and Solicitors at 44 Market Street, Melbourne, 254 Spring Street, Reservoir and 479 South Road, Moorabbin under the firm name of H. S. W. Lawson Hughes & Co. and E. S. Vance & Co. has been dissolved as from 29 February 1980 so far as concerns the said Graham Davies who has retired from the partnership as from the date aforesaid.

The continuing partners shall carry on the practice in the firm names at 44 Market Street, Melbourne and 254 Spring Street, Reservoir, and the retiring partner will practise at 479 South Road, Moorabbin in partnership with Mr Harry Stathis under the firm name of Davies Stathis & Co.

H. S. W. LAWSON HUGHES & CO., solicitors, 44 Market Street, Melbourne 5696

GREATER GEELONG No. 1 CO-OPERATIVE HOUSING SOCIETY LIMITED (IN LIQUIDATION)

NOTICE OF FINAL MEETING IN VOLUNTARY WINDING UP

Take notice that the affairs of the above named Society are now fully wound up and that in pursuance of Section 272 (1) of the Companies Act 1961 and of the Co-operative Housing Societies Act 1958, a General Meeting of the Society will be held at Kirrewur Court, 77 Prospect Road, Newtown on Thursday, 1 May 1980 at 7.00 p.m. for the purpose of:—

- (i) Laying before it an account showing how the winding-up has been conducted and the property of the Society disposed of and giving any explanations thereof; and
- (ii) Passing a Resolution that the Books and Papers of the said Society and of the Liquidator relevant to the affairs of the Society be destroyed after a period of twelve months from the date of the meeting.

Dated 3 March 1980

5582

C. L. CARR, Liquidator

Companies Act 1961—In the matter of FUNNELL & ASSOCIATES PTY. LTD. (in Liquidation), 14 Munster Terrace, North Melbourne

Notice is hereby given that at an extraordinary Meeting of the Members of the abovenamed Company held on 4 March 1980 it was resolved that the Company be wound up voluntarily and at a Meeting of Creditors held on the same day pursuant to Section 260, it was resolved that for such purpose Mr E. T. Bent of 144 Jolimont Road, East Melbourne be appointed Liquidator.

Notice is also given that after 21 days from this date I shall proceed to distribute the assets. All creditors having any claims against the Company should furnish particulars of same by that date, otherwise I shall proceed to distribute the assets without regard to their claim.

Dated 4 March 1980

E. T. BENT, Liquidator

Bent & Cogle, public accountants, 144 Jolimont Road, East Melbourne 5583

ALANDEE PTY. LIMITED

MEMBERS' VOLUNTARY WINDING UP

Notice is hereby given that at an Extraordinary General Meeting of the members of the above Company held on 4 March 1980 it was resolved that the company be wound up voluntarily and that Mr N. W. Curwood be appointed liquidator of the Company.

Notice is also given that after 21 days from this date I shall proceed to distribute the assets. All creditors having any claims against the company should furnish particulars of such claim by that date, otherwise I shall proceed to distribute the assets without regard to their claim.

Dated 5 March 1980

N. W. CURWOOD, Liquidator

Sicree, Nixon, Watt & Co., 257 Collins Street, Melbourne 5589

ASHBURTON CO-OPERATIVE HOUSING SOCIETY LIMITED (IN LIQUIDATION)

SPECIAL RESOLUTION

Passed 8 November 1979

At a special general meeting of the abovenamed society duly convened and held at 261 Thomas Street, Dandenong on 8 November, 1979 at 12 noon, the subjoined special resolution was duly passed:—

That the Society having successfully completed its objectives eighty-eight months ahead of its expected term be wound up voluntarily, and that K. W. W. Ewert of 261 Thomas Street, Dandenong be appointed Liquidator for the purpose of the winding up.

5591

E. C. THOMPSON, Chairman of Meeting
K. W. W. EWERT, Secretary

Unclaimed Moneys Act 1962

Register of Unclaimed Moneys held by the—

| Name of Owner on Books and Last Known Address | Total Amount Due to Owner | Description of Unclaimed Money | Date when Amount first became Payable |
|--|---------------------------|--------------------------------|---------------------------------------|
| 5 | | | |
| MICHAELIS BAYLEY LIMITED | | | |
| Paine, Alexander G. L., 28 Jansz Cres, Griffiths, A.C.T. | 26.25 | Dividend | — 4.78 |
| Clark, W. H. (estate of), 1604 Sturt St, Ballarat | 15.00 | " | — 11.78 |
| Cort, Volney S. W., 28 Medusa St, Mosman, N.S.W. | 97.04 | " | " |
| Handbury, Allan J. (estate of), 64 Coppin St, East Malvern | 18.64 | " | " |
| Waters, John F., P.O. Box 3, Neutral Bay Junction, N.S.W. | 20.00 | " | " |
| 5604 | | | |
| AUSTRALIAN PORTLAND CEMENT LIMITED | | | |
| Barrett, P., c/o Caravan Park, Waurn Ponds | 149.18 | Wages | 10.5.77 |
| Humm, R., 15 Breadalbane St, Newcomb | 179.42 | " | 27.10.77 |
| Kee, B., 8 Holyrood Ave, Newtown | 47.67 | " | 28.6.77 |
| Love, C., (address unknown) | 29.92 | " | 8.9.77 |
| Ryan, D., 1 Brice St, Newtown | 421.33 | " | 9.2.78 |
| McCarthy, P., 88 Bacchus Marsh Rd, Corio | 12.25 | " | 7.2.78 |
| 5605 | | | |

The Companies Act 1961

R. L. WHITE & SONS PTY. LTD. (IN VOLUNTARY LIQUIDATION)

NOTICE OF FINAL MEETING

Notice is hereby given pursuant to Section 272 Companies Act 1961 that a meeting of the members of the abovementioned Company will be held at the offices of Messrs Warren, Graham and Murphy of 119 Main Street, Bairnsdale on Friday 18 April 1980 at 10.00 a.m. for the purpose of having an account laid before the meeting showing the manner in which the winding up has been conducted and the property of the Company disposed of and giving any explanation thereof.

Dated 3 March 1980

A. M. GRAHAM, Liquidator

Warren, Graham & Murphy, 119 Main Street, Bairnsdale
5592

Companies Act 1961

SPORTSCENE LTD.

Notice is hereby given that all creditors of Sportscene Ltd. must lodge their Proof of Debt forms with the Liquidator, Mr G. Knott, Davis, Knott & Co., 121 Rosamond Road, Maidstone, by 21 March 1980. Otherwise, they will be excluded from the list of creditors.

Dated 4 March 1980

5590

In the matter of I: VEE INDUSTRIES PTY. LTD.—Notice of Winding Up Order

Winding-up Order made on 28 February 1980.

Name and address of liquidator, Michael Joseph O'Keefe of 66 High Street, Glen Iris.

BRISTOLS, 269 Carlisle Street, Balaclava, solicitors, acting on behalf of the petitioner
5594

In the Supreme Court of Victoria—1980 No. Co. 11219—
In the matter of the Companies Act 1961; and in the matter of BEAU GENTRY PTY. LTD.

Notice is hereby given that a Petition for winding up of the abovenamed Company by the Supreme Court was on 26 February 1980 presented by Michael Anthony Sharp and Evelyn Maureen Sharp and that the same Petition is directed to be heard before the Court sitting at the Law Courts Melbourne at the hour of 10.30 o'clock in the forenoon on 17 April 1980 and any creditor or contributory of the Company desiring to support or oppose the making of an order on the said petition may appear at the time of the hearing by himself or his Counsel for that purpose and a copy of the petition will be furnished to any creditor or contributory of that said company requiring the same by the undersigned on payment of the regulated charge of the same.

The Petitioners' address is 7 Kirra Court, Croydon.

The Petitioners' solicitor is Paul J. Ambrosy of 517 Chapel Street, South Yarra.

NOTE—Any person who intends to appear on the hearing of the said petition must serve on or send by post to the abovenamed Solicitor notice in writing of his intention so to do. The Notice must state the name and address of the person or if a firm, the name and address of the firm and must be signed by the person or firm or his or their solicitor (if any) and must be served or if posted, must be sent by post in sufficient time to reach the abovenamed not later than four o'clock in the afternoon on 16 April 1980.

5593

In the Supreme Court of Victoria—Co. 11229—In the matter of the Companies Act 1961; and in the matter of A. R. MARINE PTY. LTD.; and in the matter of ADGAMS NOMINEES PTY. LTD., formerly known as Hallett Boats Pty. Ltd.

Notice is hereby given that the Petition for the winding up of the abovenamed Company by the Supreme Court was on 3 March 1980 presented by A. R. Marine Pty. Ltd. and that the said Petition is directed to be heard before the Court sitting at the Law Courts, Lonsdale Street, Melbourne at the hour of 10.00 a.m. on 27 March 1980 and any creditor or contributory of the said Petition may appear at the time of hearing by himself or his Counsel for the purpose and a copy of the said Petition will be furnished to any creditor or contributory of the said company requiring the same by the undersigned on payment of the regulated charge for the same.

The Petitioner's official address is 6 Petrona Street, Dandenong.

The Petitioner's solicitor is Messrs W. E. Trumble & Associates of 407 Malvern Road, South Yarra:

NOTE—Any person who intends to appear on the hearing of the said Petition must serve on or send by post to the abovenamed W. E. Trumble & Associates notice in writing of his intention so to do. The notice must state the name and address of the person or, if a firm, the name and address of the firm and must be signed by the person or firm or his or their solicitor (if any) and must be sent by post in sufficient time to reach the abovenamed not later than 4 o'clock in the afternoon of 26 March 1980.

5603

KAYBILL INVESTMENTS PTY. LTD (IN VOLUNTARY LIQUIDATION)

SPECIAL RESOLUTION TO WIND UP

At an Extraordinary General Meeting of the abovenamed company duly convened and held at 288 Brunswick Street, Fitzroy, on 7 March 1980 the following Resolution was passed as a Special Resolution:

"That the company be wound up voluntarily."

At the abovementioned meeting Allan Ernest Williams was appointed Liquidator for the purpose of the winding up.

Notice is also given that after 30 days from this date, I shall proceed to distribute the assets. All creditors having any claim against the company should furnish particulars of same by that date, otherwise I shall proceed to distribute the assets without regard to their claim.

Dated 7 March 1980

5622

A. E. WILLIAMS, Liquidator

Companies Act 1961, as Amended—In the matter of KAYBILL INVESTMENTS PTY. LTD. (in Voluntary Liquidation)

Notice is hereby given that pursuant to Section 272 of the Companies Act 1961 as amended, the final meeting of the members of the company will be held at 288 Brunswick Street, Fitzroy, on 25 April 1980 at 12 noon for the purpose of laying before the meeting the account of the winding up and any explanation thereof.

Dated 11 March 1980

5623

A. E. WILLIAMS, Liquidator

Companies Act 1961

F., A., & J. SMEATON BROTHERS PTY. LTD. (IN VOLUNTARY LIQUIDATION)

Notice is hereby given that pursuant to Section 272 of the Companies Act 1961 the final meeting of members of the Company will be held at the office of D. K. Everett, 1135 Dandenong Road, East Malvern, on 24 April 1980 at 9 a.m. for the purpose of laying before the meeting an account showing how the winding-up has been conducted and to give any explanation thereof.

5624

D. K. EVERETT, Liquidator

Western Australian Companies Act 1961—1975, Section 206 (3)—Notice to Creditors of JOHN COCHRAN PTY. LTD. (Receiver and Manager Appointed)

Notice is hereby given that, pursuant to section 206 (3) of the Western Australian Companies Act 1961—1975, a meeting of creditors of John Cochran Pty. Ltd. (Receiver and Manager appointed) will be held at the office of J. Wade & Co., Public Accountants, 135 St. George's Terrace, Perth W.A. on Wednesday 2 April 1980 at 2.30 p.m. to consider the following proposed resolution to be placed before and considered by an extraordinary general meeting of the said company to be held at 2.00 p.m. on the same day:

"That the company be wound up voluntarily and that Colin George Herrington of J. Wade & Co., Public Accountants be appointed liquidator of the company."

A person is not entitled to vote as a creditor at the meeting unless he has lodged with the chairman of the meeting a proof of the debt which he claims is due to him from the company.

Dated at Perth 4 March 1980

5625

R. J. SMITH, Receiver/Manager

Companies Act 1961—In the matter of GLENHUNTLY DISTRIBUTIONS PTY. LTD. (in Liquidation)

Notice is hereby given that at an extraordinary meeting of the Members of the abovenamed Company held on 5 March 1980, it was resolved that the Company be wound up voluntarily and at a Meeting of Creditors held on the same day pursuant to Section 260 it was resolved that for such purpose Mr D. J. Cogle of 144 Jolimont Road, East Melbourne, Public Accountant, be appointed Liquidator.

Notice is also given that after twenty-one days from this date I shall proceed to distribute the assets. All creditors having any claim against the Company should

furnish particulars of same by that date, otherwise I shall proceed to distribute the assets without regard to their claim.

Dated 6 March 1980

D. J. COUGLE, Liquidator

Bent & Cogle, public accountants, 144 Jolimont Road, East Melbourne 5626

Companies Act 1961

VICTORIAN AUTOMOTIVE RUST PREVENTION PTY. LTD.

NOTICE OF RESOLUTION

At a General Meeting of Members of Victorian Automotive Rust Prevention Pty. Ltd. held at 9-12 Hood Street Collingwood on 4 March 1980 the Special Resolution set out below was duly passed.

"That the Company Victorian Automotive Rust Prevention Pty. Ltd. be placed into liquidation under section 260 of the Victorian Companies Act 1961 and that Cecil Paul Stephens Suite 1, 130 Albert Road, South Melbourne be appointed liquidator for the purpose of the winding up."

5627

GRAHAM DUNCAN, Director

In the Supreme Court of Victoria—1979 No. 11136—In the matter of the Companies Act 1961; and in the matter of HARRY NICHOLAS LEASING PTY. LTD.—Notice of Winding Up Order

Winding Up Order made 21 February 1980.

Name and Address of Liquidator: Geoffrey Ormond Harrison of Touche Ross & Co. 440 Collins Street Melbourne.

SCHETZER BROTT & CO., solicitors for the petitioner

5628

The Companies Act 1961

RIDOUT ROAD PTY. LTD. (IN VOLUNTARY LIQUIDATION)

NOTICE CONVENING FINAL MEETING OF MEMBERS, PURSUANT TO SECTION 272

Notice is hereby given in pursuance of Section 272 of the Companies Act 1961, that a Meeting of Members of the abovenamed Company will be held at the office of Deloitte Haskins & Sells, 12th Floor, 461 Bourke Street, Melbourne on Monday 14 April 1980 at 9.00 a.m. for the purpose of having an account laid before them showing the manner in which the winding up has been conducted and the property of the company disposed of and of hearing any explanations that may be given by the liquidator.

Dated 11 March 1980

5633

M. I. WANSELEY, Liquidator

In the Supreme Court of Victoria—1980 No. 11239—In the matter of the Companies Act 1961; and in the matter of MCKUKE PTY. LTD.

Notice is hereby given that a Petition for the winding up of the abovenamed Company by the Supreme Court of Victoria was on 7 March 1980 presented by Vitafort Pty. Ltd. And that the said Petition is directed to be heard before the Court sittings at the 15th Court, Law Courts, William Street, Melbourne on Thursday, 17 April 1980 at the hour of 10.30 o'clock in the forenoon; and any Creditor or contributory of the said Company desiring to support or oppose the making of an Order on the said Petition may appear at the time of hearing by himself or his Counsel for that purpose; and a copy of the Petition will be furnished to any Creditor or contributory of the said Company requiring the same by the undersigned on payment of the regulated charge for the same.

The Petitioner's address is 99 Bakers Road, North Coburg.

The Petitioner's Solicitors are Messrs Madden Butler Elder & Graham, of 500 Collins Street, Melbourne.

MADDEN BUTLER ELDER & GRAHAM, solicitors for the petitioner

NOTE—Any person who intends to appear on the hearing of the said Petition must serve on or send by post to the abovenamed Solicitors notice in writing of his intention to do so. The Notice must state the name and

address of the person, or if a firm, the name and address of the firm and must be signed by the person or firm or his or their Solicitor (if any) and must be served or if posted, must be sent by post in sufficient time to reach the abovenamed not later than 4 o'clock in the afternoon on 16 April 1980. 5634

In the Supreme Court of Victoria—1980 No. 11229—In the matter of the *Companies Act 1961*; and in the matter of RAZIBA PTY. LTD.

Notice is hereby given that a Petition for the winding up of the abovenamed Company by the Supreme Court of Victoria was on 29 February 1980 presented by Hersfield Developments Corporation Pty. Ltd. And that the said Petition is directed to be heard before the Court sittings at the 15th Court, Law Courts, William Street, Melbourne on Thursday, 10 April 1980 at the hour of 10.30 o'clock in the forenoon; and any Creditor or contributory of the said Company desiring to support or oppose the making of an Order on the said Petition may appear at the time of hearing by himself or his Counsel for that purpose; and a copy of the Petition will be furnished to any Creditor or contributory of the said Company requiring the same by the undersigned on payment of the regulated charge for the same.

The Petitioner's address is 520 Collins Street, Melbourne.

The Petitioner's Solicitors are Messrs Madden Butler Elder & Graham, of 500 Collins Street, Melbourne.

MADDEN BUTLER ELDER & GRAHAM, solicitors for the petitioner

NOTE—Any person who intends to appear on the hearing of the said Petition must serve on or send by post to the abovenamed Solicitors notice in writing of his intention to do so. The Notice must state the name and address of the person, or if a firm, the name and address of the firm and must be signed by the person or firm or his or their Solicitor (if any) and must be served or if posted, must be sent by post in sufficient time to reach the abovenamed not later than 4 o'clock in the afternoon on 9 April 1980. 5635

In the Supreme Court of Victoria—1980 No. 11227—In the matter of the *Companies Act 1961*; and in the matter of FOOTSCRAY MARKET PTY. LTD.

Notice is hereby given that a Petition for the Winding up of the abovenamed Company by the Supreme Court of Victoria was on 29 February 1980 presented by Hersfield Development Corporation Pty. Ltd. and that the said Petition is directed to be heard before the Court sittings at the 15th Court, Law Courts, William Street, Melbourne on Thursday, 10 April 1980 at the hour of 10.30 o'clock in the forenoon; and any Creditor or contributory of the said Company desiring to support or oppose the making of an Order on the said Petition may appear at the time of hearing by himself or his Counsel for that purpose; and a copy of the Petition will be furnished to any Creditor or contributory of the said Company requiring the same by the undersigned on payment of the regulated charge for the same.

The Petitioner's address is 520 Collins Street, Melbourne.

The Petitioner's Solicitors are Messrs. Madden Butler Elder & Graham of 500 Collins Street, Melbourne.

MADDEN BUTLER ELDER & GRAHAM, solicitors for the petitioner

NOTE—Any person who intends to appear on the hearing of the said Petition must serve on or send by post to the abovenamed Solicitors notice in writing of his intention to do so. The Notice must state the name and address of the person, or if a firm, the name and address of the firm and must be signed by the person or firm or his or their Solicitor (if any) and must be served or if posted, must be sent by post in sufficient time to reach the abovenamed not later than 4 o'clock in the afternoon on 9 April 1980. 5636

In the Supreme Court of Victoria—1980 No. 11228—In the matter of the *Companies Act 1961*; and in the matter of 94 GRIMSHAW STREET PTY. LTD.

Notice is hereby given that a Petition for the Winding up of the abovenamed Company by the Supreme Court of Victoria was on 29 February 1980 presented by Hersfield Development Corporation Pty. Ltd. and that the said Petition is directed to be heard before the Court sittings at the 15th Court, Law Courts, William Street, Melbourne on Thursday, 10 April 1980 at the hour of 10.30 o'clock in the forenoon; and any Creditor or contributory of the said Company desiring to support or oppose the making of an Order on the said Petition may appear at the time of hearing by himself or his Counsel for that purpose; and a copy of the Petition will be furnished to any Creditor or contributory of the said Company requiring the same by the undersigned on payment of the regulated charge for the same.

The Petitioner's address is 520 Collins Street, Melbourne.

The Petitioner's Solicitors are Messrs. Madden Butler Elder & Graham of 500 Collins Street, Melbourne.

MADDEN BUTLER ELDER & GRAHAM, solicitors for the petitioner

NOTE—Any person who intends to appear on the hearing of the said Petition must serve on or send by post to the abovenamed Solicitors notice in writing of his intention to do so. The Notice must state the name and address of the person, or if a firm, the name and address of the firm and must be signed by the person or firm or his or their Solicitor (if any) and must be served or if posted, must be sent by post in sufficient time to reach the abovenamed not later than 4 o'clock in the afternoon on 9 April 1980. 5637

In the Supreme Court of Victoria—No. Co. 11240—In the matter of the *Companies Act 1961*; and in the matter of DARO AUSTRALASIA PTY. LTD.

Notice is hereby given that a Petition for the winding-up of the abovenamed Company by the Supreme Court was on 11 March 1980 presented by Robotron Export-Import and that the said Petition is directed to be heard before the Court sitting at the Law Courts, William Street, Melbourne at the hour of 10.30 in the forenoon on Thursday, 27 March 1980; and any creditor or contributory of the said Company desiring to support or oppose the making of an order on the said Petition may appear at the time hearing by himself or his Counsel for that purpose; and a copy of the Petition will be furnished to any creditor or contributory of the said Company requiring the same by the undersigned on payment of the regulated charge for the same.

The Petitioner's address is 61 Friedrich Street, East Berlin, 108, German Democratic Republic and care of the Office of Technical Advisers of the German Democratic Republic, 96-100 Albert Road, South Melbourne in the State of Victoria.

The Petitioner's solicitors are Holding Redlich & Co. of 174 Victoria Parade, East Melbourne in the said State.

HOLDING REDLICH & CO.

NOTE—Any person who intends to appear on the hearing of the said Petition must serve on or send by post to the abovenamed solicitors notice in writing of his intention so to do. The notice must state the name and address of the person, or, if a firm, the name and address of the firm, and must be signed by the person or firm, or his or their solicitor (if any), and must be served, or if posted, must be sent by post in sufficient time to reach the above-¹ name not later than 4.00 o'clock in the afternoon of Wednesday, 26 March 1980. 5638

In the Supreme Court of Victoria—C.O.11231—In the matter of the *Companies Act 1961*; and in the matter of OGLE S. & M. PTY. LTD.

Notice is hereby given that a petition for the winding up of the abovenamed Company by the Supreme Court was on 4 March 1980 presented by Kevin Patrick Brady, Deputy Commissioner of Taxation of the Commonwealth of Australia and that the said petition is directed to be heard before the Court sitting at the Fifteenth Court, Law Courts,

Lonsdale Street, Melbourne at the hour of 10.30 o'clock in the forenoon on 27 March 1980 and any creditor or contributory of the said company desiring to support or oppose the making of an order on the said petition may appear at the time of hearing by himself or his Counsel for the purpose; and a copy of the said petition will be furnished to any creditor or contributory of the said company requiring the same by the undersigned on payment of the regulated charge for the same.

The Petitioner's official address is 350 Collins Street, Melbourne.

The Petitioner's Solicitor is B. J. O'Donovan, Crown Solicitor for the Commonwealth of 99 Queen Street, Melbourne.

B. J. O'DONOVAN

NOTE—Any person who intends to appear on the hearing of the said petition must serve on or send by post to the abovenamed B. J. O'Donovan, notice in writing of his intention so to do. The notice must state the name and address of the person, or, if a firm, the name and address of the firm, and must be signed by the person or firm, or his, or their solicitor (if any), and must be served, or, if posted, must be sent by post in sufficient time to reach the abovenamed not later than 4 o'clock in the afternoon of 26 March 1980. 5639

In the Supreme Court of Victoria—C.O.11232—In the matter of the *Companies Act 1961*; and in the matter of **YOBO SAYO INVESTMENTS PROPRIETARY LIMITED**

Notice is hereby given that a petition for the winding up of the abovenamed Company by the Supreme Court was on 4 March 1980 presented by Kevin Patrick Brady, Deputy Commissioner of Taxation of the Commonwealth of Australia and that the said petition is directed to be heard before the Court sitting at the Fifteenth Court, Law Courts, Lonsdale Street, Melbourne at the hour of 10.30 o'clock in the forenoon on 27 March 1980 and any creditor or contributory of the said company desiring to support or oppose the making of an order on the said petition may appear at the time of hearing by himself or his Counsel for the purpose; and a copy of the said petition will be furnished to any creditor or contributory of the said company requiring the same by the undersigned on payment of the regulated charge for the same.

The Petitioner's official address is 350 Collins Street, Melbourne.

The Petitioner's Solicitor is B. J. O'Donovan, Crown Solicitor for the Commonwealth of 99 Queen Street, Melbourne.

B. J. O'DONOVAN

NOTE—Any person who intends to appear on the hearing of the said petition must serve on or send by post to the abovenamed B. J. O'Donovan, notice in writing of his intention so to do. The notice must state the name and address of the person, or, if a firm, the name and address of the firm, and must be signed by the person or firm, or his, or their solicitor (if any), and must be served, or, if posted, must be sent by post in sufficient time to reach the abovenamed not later than 4 o'clock in the afternoon of 26 March 1980. 5640

In the Supreme Court of Victoria—C.O.11233—In the matter of the *Companies Act 1961*; and in the matter of **POWLEY & BOOTH EXCAVATIONS PROPRIETARY LIMITED**

Notice is hereby given that a petition for the winding up of the abovenamed Company by the Supreme Court was on 4 March 1980 presented by Kevin Patrick Brady, Deputy Commissioner of Taxation of the Commonwealth of Australia and that the said petition is directed to be heard before the Court sitting at the Fifteenth Court, Law Courts, Lonsdale Street, Melbourne at the hour of 10.30 o'clock in the forenoon on 27 March 1980 and any creditor or contributory of the said company desiring to support or oppose the making of an order on the said petition may appear at the time of hearing by himself or his Counsel for the purpose; and a copy of the said petition will be furnished to any creditor or contributory of the said company requiring the same by the undersigned on payment of the regulated charge for the same.

The Petitioner's official address is 350 Collins Street, Melbourne.

The Petitioner's Solicitor is B. J. O'Donovan, Crown Solicitor for the Commonwealth of 99 Queen Street, Melbourne.

B. J. O'DONOVAN

NOTE—Any person who intends to appear on the hearing of the said petition must serve on or send by post to the abovenamed B. J. O'Donovan, notice in writing of his intention so to do. The notice must state the name and address of the person, or, if a firm, the name and address of the firm, and must be signed by the person or firm, or his, or their solicitor (if any), and must be served, or, if posted, must be sent by post in sufficient time to reach the abovenamed not later than 4 o'clock in the afternoon of 26 March 1980. 5641

In the Supreme Court of Victoria—C.O.11234—In the matter of the *Companies Act 1961*; and in the matter of **CREIGHTON WINDOW FURNISHINGS PTY. LTD.**

Notice is hereby given that a petition for the winding up of the abovenamed Company by the Supreme Court was on 4 March 1980 presented by Kevin Patrick Brady, Deputy Commissioner of Taxation of the Commonwealth of Australia and that the said petition is directed to be heard before the Court sitting at the Fifteenth Court, Law Courts, Lonsdale Street, Melbourne at the hour of 10.30 o'clock in the forenoon on 27 March 1980 and any creditor or contributory of the said company desiring to support or oppose the making of an order on the said petition may appear at the time of hearing by himself or his Counsel for the purpose; and a copy of the said petition will be furnished to any creditor or contributory of the said company requiring the same by the undersigned on payment of the regulated charge for the same.

The Petitioner's official address is 350 Collins Street, Melbourne.

The Petitioner's Solicitor is B. J. O'Donovan, Crown Solicitor for the Commonwealth of 99 Queen Street, Melbourne.

B. J. O'DONOVAN

NOTE—Any person who intends to appear on the hearing of the said petition must serve on or send by post to the abovenamed B. J. O'Donovan, notice in writing of his intention so to do. The notice must state the name and address of the person, or, if a firm, the name and address of the firm, and must be signed by the person or firm, or his, or their solicitor (if any), and must be served, or, if posted, must be sent by post in sufficient time to reach the abovenamed not later than 4 o'clock in the afternoon of 26 March 1980. 5642

In the Supreme Court of Victoria—Co. 11190—In the matter of the *Companies Act 1961*; and in the matter of **TAILORING SPECIALISTS PTY. LIMITED—Notice of Winding Up Order**

Winding-Up Order: Made 6 March 1980.

Name and Address of Liquidator: Kenneth James Russell, Coopers & Lybrand, 461 Bourke Street, Melbourne.

B. J. O'DONOVAN, Crown Solicitor for the Commonwealth and solicitor for the petitioner. 5644

In the Supreme Court of Victoria—Co. 11189—In the matter of the *Companies Act 1961*; and in the matter of **THORNBURY CONSTRUCTIONS PTY LIMITED—Notice of Winding Up Order**

Winding-Up Order: Made 6 March 1980.

Name and Address of Liquidator: Maxwell George Gee, Maxwell Gee & Co., corner Grant and Pilmer Streets, Bacchus Marsh.

B. J. O'DONOVAN, Crown Solicitor for the Commonwealth and solicitor for the petitioner. 5645

In the Supreme Court of Victoria—Co. 11188—In the matter of the *Companies Act 1961*; and in the matter of ARCHILL CONSTRUCTIONS PTY. LTD.—Notice of Winding Up Order

Winding Up Order: made 6 March 1980.

Name and Address of Liquidator: Alex Neville Bird, A. N. Bird, 3 Bowen Crescent, Melbourne.

B. J. O'DONOVAN, Crown Solicitor for the Commonwealth and solicitor for the petitioner 5646

In the matter of PALMDALE INSURANCE LIMITED—Notice of Winding Up Order

Winding Up Order, made 28 February 1980.

Name and Address of Liquidator: Ernest Harding Niemann c/- Hungerfords, Chartered Accountants, 8th Floor, 44 Market Street, Melbourne.

ELLISON HEWISON & WHITEHEAD, 379 Collins Street, Melbourne, solicitors for the petitioner 5647

In the Supreme Court of Victoria—C.O.11235—In the matter of the *Companies Act 1961*; and in the matter of INDRISIE INVESTMENTS PTY. LTD.

Notice is hereby given that a petition for the winding up of the abovenamed Company by the Supreme Court was on 4 March 1980 presented by Kevin Patrick Brady, Deputy Commissioner of Taxation of the Commonwealth of Australia and that the said petition is directed to be heard before the Court sitting at the Fifteenth Court, Law Courts, Lonsdale Street, Melbourne at the hour of 10.30 o'clock in the forenoon on 27 March 1980 and any creditor or contributory of the said company desiring to support or oppose the making of an order on the said petition may appear at the time of hearing by himself or his Counsel for the purpose; and a copy of the said petition will be furnished to any creditor or contributory of the said company requiring the same by the undersigned on payment of the regulated charge for the same.

The Petitioner's official address is 350 Collins Street, Melbourne.

The Petitioner's Solicitor is B. J. O'Donovan, Crown Solicitor for the Commonwealth of 99 Queen Street, Melbourne.

B. J. O'DONOVAN

NOTE—Any person who intends to appear on the hearing of the said petition must serve on or send by post to the abovenamed B. J. O'Donovan, notice in writing of his intention so to do. The notice must state the name and address of the person, or, if a firm, the name and address of the firm, and must be signed by the person or firm, or his, or their solicitor (if any), and must be served, or, if posted, must be sent by post in sufficient time to reach the abovenamed not later than 4 o'clock in the afternoon of 26 March 1980. 5643

Companies Act 1961, Section 272 (2)—In the matter of WILLIAMSTOWN PRODUCTS PTY. LTD.—Notice of Final Meeting

Notice is hereby given that pursuant to section 272 of the *Companies Act*, the final meeting of the members of the above company will be held on 11th floor, 447 Collins Street Melbourne on 15 April 1980 at 10 a.m. for the purpose of having an account laid before it showing the manner in which the winding up has been conducted and the property of the company disposed of and hearing any explanation that may be given by the liquidator.

Dated 5 March 1980

R. E. CHANCELLOR, Liquidator

Price Waterhouse & Co., 447 Collins Street, Melbourne 3000 5648

Companies Act 1961, Section 272 (2)—In the matter of FLEETWAYS AGENCY PTY. LTD.—Notice of Final Meeting

Notice is hereby given that pursuant to section 272 of the *Companies Act*, the final meeting of the members of the above company will be held on 11th floor, 447 Collins Street Melbourne on 15 April 1980 at 10 a.m. for the purpose of having an account laid before it showing the

No. 18—18120/80—4

manner in which the winding up has been conducted and the property of the company disposed of and hearing any explanation that may be given by the liquidator.

Dated 5 March 1980

R. E. CHANCELLOR, Liquidator

Price Waterhouse & Co., 447 Collins Street, Melbourne 3000 5649

Companies Act 1961, Section 272 (2)—In the matter of FLEETWAYS HAULWAY PTY. LTD.—Notice of Final Meeting

Notice is hereby given that pursuant to section 272 of the *Companies Act*, the final meeting of the members of the above company will be held on 11th floor, 447 Collins Street Melbourne on 15 April 1980 at 10 a.m. for the purpose of having an account laid before it showing the manner in which the winding up has been conducted and the property of the company disposed of and hearing any explanation that may be given by the liquidator.

Dated 5 March 1980

R. E. CHANCELLOR, Liquidator

Price Waterhouse & Co., 447 Collins Street, Melbourne 3000 5650

Companies Act 1961, Section 272 (2)—In the matter of FLEETWAYS FERRY SERVICE PTY. LTD.—Notice of Final Meeting

Notice is hereby given that pursuant to section 272 of the *Companies Act*, the final meeting of the members of the above company will be held on 11th floor, 447 Collins Street Melbourne on 15 April 1980 at 10 a.m. for the purpose of having an account laid before it showing the manner in which the winding up has been conducted and the property of the company disposed of and hearing any explanation that may be given by the liquidator.

Dated 5 March 1980

R. E. CHANCELLOR, Liquidator

Price Waterhouse & Co., 447 Collins Street, Melbourne 3000 5651

Companies Act 1961, Section 272 (2)

AUSTRALIAN CEMENT RESEARCH SERVICES PTY. LTD. (IN VOLUNTARY LIQUIDATION)

NOTICE OF FINAL MEETING

Notice is hereby given that pursuant to section 272 of the *Companies Act 1961* a general meeting of the members of Australian Cement Research Services Pty. Ltd. will be held at the offices of Messrs. Peat, Marwick, Mitchell & Co., 500 Bourke Street, Melbourne on 14 April 1980 at 10.00 a.m.

The purpose of the meeting is to lay accounts before it showing the manner in which the winding up has been conducted and the property of the company disposed of and of hearing any explanation that may be given by the liquidator.

Dated 12 March 1980

D. A. CRAWFORD, Liquidator

Peat, Marwick, Mitchell & Co., 500 Bourke Street, Melbourne, 3000 5652

Companies Act 1961, Section 272

Companies Regulations

N. F. DAVIES PROPRIETARY LIMITED.

NOTICE OF FINAL MEETING IN VOLUNTARY WINDING UP :

Regulation 28 (2) (b)

Take notice that the affairs of the abovenamed company are now fully wound up and that in pursuance of section 272 (1) of the *Companies Act 1961* a general meeting of the company will be held at the Offices of J. S. Walker, Chartered Accountant, 4th Floor, 500 Collins Street, Melbourne, on 16 April 1980, at 9.30 o'clock in the forenoon for the purpose of laying before it an account showing how the winding up has been conducted and the property of the company disposed of and giving any explanation thereof.

Dated 27 February 1980

5654

J. S. WALKER, Liquidator

Form 92

Companies Regulations

The Companies Act 1961

PRECISION TIMBER COMPONENTS (SALES) PTY. LTD.
(IN LIQUIDATION)NOTICE CONVENING FINAL MEETING OF MEMBERS AND
CREDITORS PURSUANT TO SECTION 272 (1)

Notice is hereby given that the Final Meeting of Members and Creditors of the abovenamed company will be held at the offices of Messrs Peat, Marwick, Mitchell & Co., 16th Floor, 500 Bourke Street, Melbourne on Monday, 14 April 1980 at 11.00 a.m., for the purpose of (1) laying before the meeting an account showing how the winding up has been conducted and the property of the company disposed of and giving any explanation thereof, and (2) considering, and if thought fit passing a resolution to destroy the books and records of the company pursuant to section 284 (3) (c) of the Companies Act 1961, as amended.

7 March 1980

5653

D. A. CRAWFORD, Liquidator

Companies Act 1961—In the matter of MARK WINSTON PTY.
LTD., Formerly Ramsay Fibreglass Pty. Ltd.—Notice Re
Meeting of Creditors Pursuant to Section 260

Notice is hereby given that a Meeting of Creditors of the abovenamed Company will be held at the Meeting Room, B. K. Taylor & Co., 3rd Floor Dairy Industry House, 576 St. Kilda Road, Melbourne, on Thursday, 27 March 1980, at 11.00 a.m. the company having convened a meeting of its members for the same day for the purpose of considering a Resolution that the Company be wound up voluntarily.

Dated 7 March 1980

B. A. CURMI, Director

B. K. Taylor & Co., accountants, 576 St. Kilda Road,
Melbourne, Vic. 3004 5655Companies Act 1961—In the matter of ACE TRADING &
INSULATION Co. PTY. LTD.—Notice Re Meeting of
Creditors Pursuant to Section 260

Notice is hereby given that a Meeting of creditors of the abovenamed Company will be held at the Fitzgerald Room, Accountants House, 49 Exhibition Street, Melbourne on Friday 28 March 1980 at 11.00 a.m. the company having convened a meeting of its members for the same day for the purpose of considering a Resolution that the Company be wound up voluntarily.

Dated 6 March 1980

G. GOLDING, Director

B. K. Taylor & Co., accountants, 576 St. Kilda Road,
Melbourne, Vic. 3004 5656

Companies Act 1961

SUSSEX HOMES PTY. LTD.

NOTICE OF MEETING OF CREDITORS

Notice is hereby given that pursuant to Section 260 of the Companies Act 1961 a meeting of the creditors of Sussex Homes Proprietary Limited will be held at the C.B.A. Auditorium, 5th Floor, 114 William Street, Melbourne, Vic. 3000, on 25 March 1980, at 2.30 p.m., the Company having convened a meeting of its members for the same day for the purpose of considering and, if thought fit, passing a special resolution that the company be wound up voluntarily.

Dated 5 March 1980

B. M. JOSKE, Director

Duesbury Johnston & Marks, chartered accountants, 114
William Street, Melbourne, Vic. 3000 5657South Australian Companies Act 1962—In the matter of
O. P. DISTRIBUTING Co. PTY. LTD.—Notice Re Meeting of
Creditors, Pursuant to Section 260

Notice is hereby given that a Meeting of Creditors of the abovenamed Company will be held at the offices of the Victorian Chamber of Manufactures, 370 St. Kilda Road, Melbourne on Friday, 21 March 1980 at 10.30 a.m.

The meeting is convened for the purpose of considering the position of the company's affairs, the company having convened an Extraordinary General Meeting of its members to be held on 21 March 1980, for the purpose of considering and if deemed expedient, passing a special resolution to wind up the company voluntarily, and to nominate Kevin James Browne and Stirling Lindley Horne, Chartered Accountants, 1 Palmerston Crescent, South Melbourne, as Liquidators to act jointly and severally.

Dated 7 March 1980

C. HANSEN, Director

Bentley, Wheeler, Cartledge & Co., chartered accountants,
1 Palmerston Crescent, South Melbourne, 3205. Telephone
690 3666 5658The Companies Act 1961—In the matter of POT BELLY
HOME STYLED FOODS PTY. LTD. (in Liquidation)

Notice is hereby given that at an Extraordinary General Meeting of the Members of the abovenamed Company held on 27 February 1980 it was resolved that the Company be wound up voluntarily and at a Meeting of Creditors held later on the same day, it was resolved that for such purposes Robert Molesworth Hobill Cole, of 440 Collins Street, Melbourne, Chartered Accountant, be appointed Liquidator.

Notice is also given that after twenty-one (21) days from this date, I shall proceed to distribute the assets. All creditors having any claim against the Company should furnish particulars of same by that date, otherwise I shall proceed to distribute the assets without regard to their claim.

Dated 6 March 1980

R. M. H. COLE, Liquidator

Touche Ross & Co., chartered accountants, 440 Collins
Street, Melbourne, 3000 5659

A. E. HUMPHRIES PROPRIETARY LIMITED

At an Extraordinary General Meeting of the abovenamed Company, duly convened and held at 257 Collins Street, Melbourne on 4 March 1980 the following resolutions were duly passed:—

That the Company be wound up voluntarily.

That Alan John Fookes of 257 Collins Street, Melbourne, Victoria be appointed Liquidator.

Dated 4 March 1980

5660

ALAN J. FOOKES, Liquidator

Companies Act 1961, Section 254 (2)

BULLDOG LIME COMPANY PROPRIETARY LIMITED

NOTICE OF RESOLUTION

At an extraordinary general meeting of Bulldog Lime Company Proprietary Limited duly convened and held at 344 Swan Street, Richmond, on 10 March 1980, the special resolution set out below was passed:

"Resolved that the company be wound up voluntarily as a members' voluntary winding up in accordance with the provisions of the Companies Act 1961."

Notice is also given that after twenty-one days from this date I shall proceed to distribute the assets. All creditors having any claims against the company should furnish particulars of same by that date, otherwise I shall proceed to distribute the assets without regard to their claim.

Dated 11 March 1980

RONALD GEOFFREY DICK, liquidator, 19 Britten
Street, Glen Iris 3146 5661COMMERCIAL GOAT MILK PRODUCERS
CO-OPERATIVE LIMITED

NOTICE OF DIVIDEND

Notice is hereby given that a First Dividend is intended to be declared in this matter. Creditors who have not proved their debts or had their claims admitted by the Liquidator by 28 March 1980, will be excluded from this dividend.

Dated 3 March 1980

C. S. WIGHT, Liquidator

Arthur Young & Company, 500 Bourke Street, Mel-
bourne 5664

Companies Act 1961

DREFEW PTY. LTD.

Notice is hereby given that by a Special Resolution passed at a Meeting of Shareholders of Drefew Pty. Ltd., held on 3 March 1980, it was resolved that the Company be wound up voluntarily.

Notice is also given that creditors having any claims against the Company should furnish particulars of that claim within 21 days of this date, otherwise distributions of the assets will take place without regard to such claims.

Dated 7 March 1980

N. HARRIS, Liquidator

Hughes, Fincher & Rodda, chartered accountants, Fifth Floor, 44 Market Street, Melbourne, Vic. 3000 5662

NA VALLEY PARK PTY. LTD.

The above Company was placed in Voluntary Liquidation by a Resolution of Members at an Extraordinary General Meeting held on 7 March 1980.

I. E. DAVEY, liquidator, cnr. Scott & Thomas Streets, Dandenong 5663

The Companies Act 1961, Section 291 and Regulation 54—In the matter of CRAMDEN CELLARS PTY. LTD. (in Liquidation)

Take notice that as Liquidator of the abovenamed company I have fixed Wednesday, 26 April 1980, as the day on or before which creditors of the company are to prove their debts or claims and to establish any title they may have to priority under section 292 or be excluded from the benefit of a second and final distribution made before such debts are proved or as the case may be from objecting to such distribution.

Dated 12 March 1980

A. M. HORSBURGH, Liquidator

Wallace, McMullin & Smail, 499 St. Kilda Road, Melbourne 3004 5665

The Companies Act 1961

PURSUANT TO SECTION 260 OF THE COMPANIES ACT 1961

Notice is hereby given that a Meeting of Creditors of Disco-O'-Asis Pty. Ltd., will be held at the offices of Messrs Ferrier Hodgson Green & Co., Chartered Accountants, 24th Floor, 259 Collins Street, Melbourne on Wednesday 26 March 1980 at 10.00 a.m. for the purpose of considering the Company's affairs, the Company having convened an Extraordinary General Meeting of its Members to be held on Wednesday 26 March 1980 and for the purpose of considering and if thought fit, passing a Special Resolution that the Company be wound up voluntarily. Dated 7 March 1980

K. BULLOCK, Director

Messrs. Ferrier Hodgson Green & Co., chartered accountants, 24th Floor, 459 Collins Street, Melbourne 3000 5666

In the Supreme Court of Victoria—Co. 11178—In the matter of the Companies Act 1961; and in the matter of WELLSKNIT PTY. LTD.—Notice of Winding Up Order

In the matter of Wellsknit Pty. Ltd. (Co. No. 136615) Winding Up Order made 28 February 1980.

Name and Address of Liquidator, Robert Arthur Waters of 460 Bourke Street, Melbourne.

HALL & WILCOX, solicitors for the petitioner 5691

Companies Act 1961

BEAUMONT HOME DEVELOPMENTS PTY. LTD. (IN VOLUNTARY LIQUIDATION)

Notice is hereby given that at an extraordinary general meeting of members of the above named company held on 4 March 1980, it was resolved that the company be wound up voluntarily and at a meeting of creditors held on the same day it was resolved that for such purpose Robert A. Waters and John M. Spark, Chartered Accountants of 460 Bourke Street, Melbourne, be appointed joint and several liquidators.

Notice is also given that after twenty-one days from this date we shall proceed to distribute the assets. All creditors who have any claim against the company should furnish particulars of same by that date, otherwise we shall proceed to distribute the assets without regard to their claim.

Dated 6 March 1980

ROBERT A. WATERS AND JOHN M. SPARK, Joint and Several Liquidators

Orr, Martin & Waters, chartered accountants, 460 Bourke Street, Melbourne 3000. Telephone 602 1644

5667

In the Supreme Court of Victoria—1980 Co. No. 11199—In the matter of the Companies Act 1961; and in the matter of AMAD N.L.

Notice is hereby given that the Supreme Court of Victoria did on Thursday, 6 March 1980 confirm the reduction of the capital of Amad N.L. in accordance with the following Special Resolution passed by a Meeting of the members of Amad N.L. on 17 January 1980:—

"That the issued capital and the share premium account of the Company be reduced from a total of \$6 124 000 (comprising issued capital of \$1 440 000 and share premium account of \$4 684 000) to \$576 000 by distributing to the members of the Company two hundred and forty-six (246) shares in Petroleum Securities Australia Limited for every one hundred (100) shares in the Company held by such members and that such reduction be debited as to \$4 356 000 against the amount standing to the credit of the share premium account and as to \$864 000 by reducing the amount of the issued capital from \$1 440 000 to \$576 000 divided into 2 880 000 shares of 20 cents each fully paid and by writing off \$328 000 from the share premium account. So often as the said distribution in specie would, apart from this qualification, entitle any member of the Company to a fraction of or a fractional interest in one share in Petroleum Securities Australia Limited then, the number of shares in Petroleum Securities Australia Limited which represent the total of all such fractions shall be transferred to a person to be nominated by the Directors upon trust to sell the same and to pay the net proceeds of such sale to the members of the company in proportion to the fractions of one share in Petroleum Securities Australia Limited that each would otherwise have been entitled to receive.

The amount of the share capital of Amad N.L. as altered by the Order is \$2 136 000 divided into 2 880 000 ordinary shares of 20 cents each and 3 120 000 unclassified ordinary shares of 50 cents each of which all of the 2 880 000 ordinary shares of 20 cents each have been issued and are fully paid up and the said unclassified ordinary shares are all unissued.

Take notice that an Office Copy of the Order was lodged at the office of the Commissioner for Corporate Affairs on 7 March 1980

5692

By Order, The Secretary

In the matter of the Companies Act 1961; and RONALD FREDERICK PROPRIETARY LIMITED (in Voluntary Liquidation)—Notice of Final Meeting of Members pursuant to Section 272

Notice is hereby given that a general meeting of the members of the above Company will be held in the offices of A. A. Gibbs and Company, 56 Claremont Street, South Yarra on 16 April 1980 at 10 a.m., for the purpose of having an account laid before it showing the manner in which the winding-up has been conducted and the property of the Company disposed of and hearing any explanation of the account that may be required.

Dated 10 March 1980

5693

R. F. REID, Liquidator

GEORGE FAWCETT, late of Service Street, Clunes, gentleman, DECEASED, (who died on 15 July 1979)

Creditors next of kin and all other persons having claims against the estate of the said deceased are required by the Executor The Union-Fidelity Trustee Company of Australia Limited of 100 Exhibition Street Melbourne to send detailed particulars of their claims in respect of the said property to the said Executor care of the said Company at 101

Lydiard Street North Ballarat on or before 12 June 1980 after which date it will proceed to distribute the estate having regard only to the claims of which it then has notice.

Dated 12 March 1980

RAMSAY, GAUNT & FRASER, solicitors, of 41 Lydiard Street South, Ballarat 5584

Creditors next of kin and others having claims in respect of the Estate of Ada Eliza Doubleday Bennett late of 863 Toorak Road, South Hawthorn Gentlewoman in the State of Victoria Deceased who died on 8 October 1978 are required by the Executors Ian Anthony Loft of 12 Singleton Road, North Balwyn in the said State Solicitor Robert Frederick Geyer of 7 Hillview Road, North Balwyn in the said State Valuer and Eldred Jaffray Hamilton-Moore of 78 Main Street, Blackburn in the said State Industrial Consultant to send particulars of their claims to them in care of the undermentioned Solicitors by 21 May 1980 after which date they will distribute the assets having regard only to the claims of which they then have notice. And notice is hereby further given that the said executors will not be liable for the assets so distributed or any part thereof to any person of whose claim they shall not have had notice as aforesaid.

Dated 4 March 1980

LOFT & ASSOCIATES, solicitors, 16 Droop Street, Footscray 5585

Creditors next of kin and others having claims in respect of the estate of Gladys Elizabeth MacDermid late of Mooroopna in the State of Victoria, Widow deceased who died on 15 October 1979 are hereby required by William Heylock Thorne of 11 Camp Street, Mooroopna in the said State to send particulars of their claims in writing to the said William Heylock Thorne at 11 Camp Street, Mooroopna or or before 7 May 1980 and after which date he may proceed to distribute the assets of the said Gladys Elizabeth MacDermid having regard only to the claims of which he then has notice.

CAMERON & CAMERON, barristers and solicitors, 9-11 Fraser Street, Shepparton 5586

Creditors next of kin and others having claims in respect of the Estate of James Jafer formerly of 29 Lister Court, Shepparton but late of 3 Montpellier Crescent, Lower Templestowe in the State of Victoria, Orchardist, deceased who died on 31 October 1978 are hereby required by Robyn Jafer of 3 Montpellier Crescent, Lower Templestowe aforesaid to send particulars of their claims in writing to the said Robyn Jafer at 3 Montpellier Crescent, Lower Templestowe on or before 7 May 1980 and after which date she may proceed to distribute the assets of the said James Jafer having regard only to the claims of which she then has notice.

CAMERON & CAMERON, barristers and solicitors, 9-11 Fraser Street, Shepparton 5587

PERCY WOODHOUSE, late of 9 Gairloch Drive, Frankston, in the State of Victoria, pensioner, DECEASED

Creditors, next of kin and others having claims in respect of the estate of the deceased, who died on 29 November 1978 are required by the Administrator John James Gordon Woodhouse of care of 13 Davey Street, Frankston in the said State to send particulars to him by 16 May 1980 after which date the Administrator may convey or distribute the assets having regard only to the claims of which he then has notice.

ROBERT C. TAYLOR & SON, solicitors for the administrator, 13 Davey Street, Frankston, 3199 5588

BLANCHE GERTRUDE BRAGG, late of Benlyne Private Nursing Home, 8 Nolan Street, Frankston, widow, DECEASED

Creditors, next of kin and others having claims in respect of the estate of the deceased who died on 4 September 1979 are required by the personal representatives Edwin Colquit Kennon and George Herbert O'Dell Crowther both of 459 Little Collins Street, Melbourne to send particulars to them by 14 May 1980 after which date they may convey or distribute the assets, having regard only to the claims of which they then have notice.

WEIGALL & CROWTHER of 459 Little Collins Street, Melbourne, solicitors for the estate 5673

CLARA KAHLE, formerly of The After Care Hospital, 45 Victoria Parade, Collingwood, but late of 410 Waverley Road, East Malvern, in the State of Victoria, widow, DECEASED

Creditors, next of kin and others having claims in respect of the estate of the deceased, who died on 6 December 1979, are required by the Executor The Equity Trustees Executors and Agency Company Limited of 472 Bourke Street Melbourne to send particulars to the said Executor by 13 May 1980 after which date the said Executor will distribute the assets having regard only to the claims of which the said Executor then has notice.

JOHN F. SIERAKOWSKI, solicitor, of 82 Poath Road, Hughesdale, 3166 5629

Creditors, next of kin and others having claims in respect of the Estate of Kenneth Charles Kenyon late of 225 Amess Street, North Carlton in the State of Victoria, Pet Ambulance Driver deceased who died on 25 November 1979, are to send particulars of their claims to J. & S. Shatin & Bernstein, Solicitors of 224 Queen Street, Melbourne in the said State, the Solicitors for the Executrix appointed by the Will of the deceased, by 10 May 1980.

5630

ROY TARR Junior, late of 14 Alexandra Avenue, Kerang, in the State of Victoria, State Rivers and Water Supply Commission employee, DECEASED

Creditors, next of kin and all other persons having claims against the Estate of the said Deceased are required by Ruby Georgina Tarr of 14 Alexandra Avenue, Kerang aforesaid Widow the Executrix of the Estate of the said Deceased to send particulars of such claims to her in the care of the undermentioned Solicitors on or before 8 May 1980 after which date she will distribute the assets having regard only to the claims of which she then has notice.

WILLAN & MCKENZIE, solicitors, Cohuna 5670

GRACE DARLING ADDISON, late of Flat 4, 144 Marshall Street, Ivanhoe, widow

Creditors, next of kin and others having claims in respect of the estate of the deceased who died on 8 July 1979 Probate of whose Will was granted by the Supreme Court of Victoria on 30 November 1979 to William George Addison and Ronald Richard Addison the executors named in the said Will, are to send particulars of their claims to the said Executors at their address at the undermentioned Solicitors by 19 May 1980 after which they will convey or distribute the assets having regard only to the claims of which they then have notice.

ALECK SACKS & SON, solicitors, of 341-3 Drummond Street, Carlton 5671

Creditors, next of kin and others having claims in respect of the Estate of Emily Violet Tongway late of 165 High Street, Kangaroo Flat Married Woman deceased who died on 24 November 1979 are to send particulars of their claims to the executors Samuel John Tongway of 165 High Street, Kangaroo Flat and David John Tongway of Lawson Syphon Road, Deniliquin in the State of New South Wales care of the undermentioned Solicitors by 19 April 1980 after which date they will distribute the assets having regard only to the claims of which they then have notice.

EVERY & EVERY, solicitors, 71 Bull Street, Bendigo

5672

HENRIETTA HINEMOA ROTH, formerly of 35 Driscoll Street, Rosetta, in the State of Tasmania, but late of 25 Nile Avenue, Sandy Bay, in the said State, widow, DECEASED

Creditors, next of kin and others having claims in respect of the estate of the abovenamed deceased are required by the executor The Trustees Executors and Agency Company Limited of 401 Collins Street, Melbourne in the State of Victoria to send particulars to the executor by 13 May 1980 after which date the executor may convey or distribute the assets having regard only to the claims of which it then has notice.

DAVIES CAMPBELL & PIESSE, solicitors, of 401 Collins Street, Melbourne 5674

Creditors, next of kin and others having claims in respect of the estate of Louise Ettie Scanlon late of 209 Mont Albert Road, Surrey Hills, Retired Machinist deceased who died on 7 May 1979, are to send particulars of their claims to the executor Maurice Albert Scanlon care of The Equity Trustees Executors and Agency Company Limited of 472 Bourke Street, Melbourne by 16 May 1980 after which date he will distribute the assets having regard only to the claims of which he then has notice.

MARTIN & MARTIN, solicitors, 37 Queen Street, Melbourne 5675

Creditors, next of kin and others having claims in respect of the unadministered estate of Karl Abraham Glance late of 20 Third Street, Black Rock, Retired Gardener deceased who died on 19 July 1972 are required to send particulars of their claims to National Trustees Executors and Agency Company of Australasia Limited of 95 Queen Street, Melbourne the duly appointed Syndic of Royal Victorian Institute for the Blind of 557 St. Kilda Road, Melbourne, one of the residuary beneficiaries named in the said Will by 21 May 1980 after which date it will distribute the assets having regard only to the claims of which it then has notice.

G. R. HERBERT & CO., solicitors, 612-614 Balcombe Road, Black Rock 5676

LESLIE FLORENCE WALKER, late of Flat 19, 11 Findon Street, Hawthorn, spinster, DECEASED

Creditors, next of kin and others having claims in respect of the Estate of the deceased (who died on 2 January 1980) are required by the Perpetual Executors and Trustees Association of Australia Limited of 50 Queen Street, Melbourne to send particulars of their claims to the said Company by 20 May 1980 after which date it will convey or distribute the assets, having regard only to the claims of which the Company then has notice.

THE PERPETUAL EXECUTORS AND TRUSTEES ASSOCIATION OF AUSTRALIA LIMITED, 50 Queen Street, Melbourne, 3000 5677

Creditors, next of kin and others having claims against the estate of Rita Phyllis McKenzie late of Surrey Hills Private Nursing Home, 16 Florence Road, Surrey Hills in the State of Victoria Widow deceased who died on 8 November 1979 are requested by the Executor of the Will of the said deceased The Equity Trustees Executors and Agency Company Limited of 472 Bourke Street, Melbourne in the said State to send particulars of their claims to the said Executor on or before 19 May 1980 after which date the Executor will distribute the assets having regard only to the claims of which it shall then have had notice.

ELLISON HEWISON & WHITEHEAD, solicitors, 379 Collins Street, Melbourne, Vic. 3000. Telephone 62 2911 5678

In the Supreme Court of the State of Victoria
SALE BY THE SHERIFF

On Friday 18 April 1980 at 12.00 Noon at the Police Station, Geelong (unless process be stayed or satisfied).

All the Estate and Interest (if any) of Graham John Ward, motor mechanic, and Carlene Ann Ward, married woman, both of Latrobe Street, Kyneton, as joint proprietors of an estate in fee simple in the land described in Certificate of Title Volume 8796 Folio 132 upon which is erected a brick veneer dwelling known as No. 5 Donax Road, Corio.

Registered Mortgage Nos. E.885385 and G.541834 and G.821928 and Caveat No. H.732236 affect the said estate and interest.

Terms—Cash only
5679

J. GREEN, Deputy Sheriff

In the Supreme Court of the State of Victoria
SALE BY THE SHERIFF

On Friday 18 April 1980 at 11.30 a.m. at the Police Station Oakleigh (unless process be stayed or satisfied).

All the Estate and Interest (if any) of Mr D. Daviotis (shown on Certificate of Title as Dimitrios Daviotis) of 25A Latrobe Street, Oakleigh, as joint proprietor with

Olimbia Daviotis, married woman, of an estate in fee simple in the land described in Certificate of Title Volume 5028 Folio 458 upon which is erected a weatherboard dwelling house known as No. 25A Latrobe Street, Oakleigh.

Registered Mortgage No. H.319144 affects the said estate and interest.

Terms—Cash only
5680

T. M. NICHOLLS, Sheriff's Officer

In the Supreme Court of the State of Victoria
SALE BY THE SHERIFF

On Tuesday 15 April 1980 at 10.30 a.m. at the Police Station, Doncaster (unless process be stayed or satisfied).

All the Estate and Interest (if any) of Douglas Gordon Johnston, company director, of 7 Silverdale Court, Doncaster, as joint proprietor with Glenice Marie Johnston, married woman, of an estate in fee simple in the land described in Certificate of Title Volume 8693 Folio 840 upon which is erected a brick veneer house and garage known as No. 7 Silverdale Court, Doncaster.

Registered Mortgages Nos. E.614048 and H.175217 and Caveat H.297199 affect the said estate and interest.

Terms—Cash only
5681

H. BUETTNER, Sheriff's Officer

In the Supreme Court of the State of Victoria
SALE BY THE SHERIFF

On Friday 18 April 1980 at 11.30 a.m. at the Police Station St. Albans (unless process be stayed or satisfied).

All the Estate and Interest (if any) of Vasilios Apostolou, plumber, of 49 Novara Parade, East St. Albans as joint proprietor with Eleftheria Apostolou of an estate in fee simple in the land described in Certificate of Title Volume 8832 Folio 685 upon which is erected a brick veneer house known as No. 49 Novara Parade, East St. Albans.

Registered Mortgage Nos. G.462174, G.619732 and Caveat G.872943 affect the said estate and interest.

Terms—Cash only
5682

K. R. MARTIN, Sheriff's Officer

In the Supreme Court of the State of Victoria
SALE BY THE SHERIFF

On Thursday 24 April 1980 at 10.30 a.m. at the Police Station Avondale Heights (unless process be stayed or satisfied).

All the Estate and Interest (if any) of William Michael Stapleton, butcher, of 24 Swan Avenue, West Meadows, as joint proprietor with Robyn Bernadette Stapleton, married woman, of an estate in fee simple in the land described in Certificate of Title Volume 8775 Folio 234 upon which is erected a dwelling house known as No. 24 Swan Avenue, West Meadows.

Registered Mortgage No. G.433585 affects the said estate and interest.

Terms—Cash only
5683

K. R. MARTIN, Sheriff's Officer

In the Supreme Court of the State of Victoria
SALE BY THE SHERIFF

On Friday 18 April 1980 at 2.30 p.m. at the Police Station, Melton (unless process be stayed or satisfied).

All the Estate and Interest (if any) of David Paul Eyers, salesman, of 36 Essex Drive, Melton, as joint proprietor with Judith Anne Eyers, married woman, of an estate in fee simple in the land described in Certificate of Title Volume 8368 Folio 242 upon which is erected a brick veneer dwelling known as No. 36 Essex Drive, Melton.

Registered Mortgage No. F.641198 affects the said estate and interest.

Terms—Cash only
5684

K. R. MARTIN, Sheriff's Officer

In the Supreme Court of the State of Victoria
SALE BY THE SHERIFF

On Wednesday 30 April 1980 at 10.30 a.m. at the Police Station, Thomastown (unless process be stayed or satisfied) at the best price offered.

All the Estate and Interest (if any) of Mr and Mrs G. Vakalopoulos (shown on Certificate of Title as George Vakalopoulos, labourer, and Helen Vakalopoulos, married woman) both of 3 Halston Road, Lalor as joint proprietors of an estate in fee simple in the land described in Certificate of Title Volume 8819 Folio 955 upon which is erected a dwelling house known as No. 3 Halston Road, Lalor.

Registered Mortgage No. G.119343 affects the said estate and interest.

Terms—Cash only—property to be sold to the highest bidder, no reserve set.

5685 K. R. MARTIN, Sheriff's Officer

In the Supreme Court of the State of Victoria
SALE BY THE SHERIFF

On Wednesday 23 April 1980 at 10.30 a.m. at the Police Station, Glenroy (unless process be stayed or satisfied).

All the Estate and Interest (if any) of Leslie George Hooper, mechanic, of 47 Tassell Street, Glenroy as joint proprietor with Irene Agnes Hooper, married woman, of an estate in fee simple in the land described in Certificate of Title Volume 8129 Folio 027 upon which is erected a brick veneer dwelling known as No. 47 Tassell Street, Glenroy.

Registered Mortgage No. G.737881 affects the said estate and interest.

Terms—Cash only
5686 K. R. MARTIN, Sheriff's Officer

In the Supreme Court of the State of Victoria
SALE BY THE SHERIFF

On Thursday 17 April 1980 at 10.30 a.m. at the Police Station, Northcote (unless process be stayed or satisfied).

All the Estate and Interest (if any) of Maroun El Asmar, driver, and Renee El Asmar, married woman, of 22A Wilmoth Street, Northcote as joint proprietors of an estate in fee simple in the land described in Certificate of Title Volume 8078 Folio 267 upon which is erected a dwelling house known as No. 22A Wilmoth Street, Northcote.

Registered Mortgage Nos. G.919360 and H.439540 affect the said estate and interest.

Terms—Cash only
5687 K. R. MARTIN, Sheriff's Officer

In the Supreme Court of the State of Victoria
SALE BY THE SHERIFF

On Friday 18 April 1980 at 12.00 noon at the Police Station, Sunshine (unless process be stayed or satisfied).

All the Estate and Interest (if any) of Clementina Sammartino, telephonist, of 10 Braim Street, Sunshine North as proprietor of an estate in fee simple in the land described in Certificate of Title Volume 8329 Folio 686 upon which is erected a weatherboard dwelling known as No. 10 Braim Street, Sunshine North.

Registered Mortgage No. H.84977 affects the said estate and interest.

Terms—Cash only
5688 K. R. MARTIN, Sheriff's Officer

In the Supreme Court of the State of Victoria
SALE BY THE SHERIFF

On Friday 18 April 1980 at 10.30 a.m. at the Police Station, Preston (unless process be stayed or satisfied).

All the Estate and Interest (if any) of V. J. Murphy and A. P. Murphy (shown on Certificate of Title as Vincent James Murphy, sales manager, and Anne Patricia Murphy, home duties) as joint proprietors of an estate in fee simple

in the land described in Certificate of Title Volume 5618 Folio 413 upon which is erected a dwelling house known as No. 35 May Street, Preston.

Registered Mortgage Nos. G.88563, H.804830 and Caveat H.610895.

Terms—Cash only
5689 K. R. MARTIN, Sheriff's Officer

In the Supreme Court of the State of Victoria
SALE BY THE SHERIFF

On Thursday 1 May 1980 at 10.30 a.m. at the Richmond Police Station (unless process be stayed or satisfied).

All the Estate and Interest (if any) of William Johnston, retired, of 3 Veronica Street, Ferntree Gully, as proprietor of an estate in fee simple in the land described in Certificate of Title Volume 4248 Folio 468 which is vacant land occupied as a Car Yard known as No. 100-102 Hightt Street, Richmond.

Terms—Cash only
5690 T. M. NICHOLLS, Sheriff's Officer

INSOLVENCY NOTICES

MEETING OF CREDITORS UNDER PART X.

Take notice that Norman Geoffrey Heritage has on 28 February 1980 signed an authority under sub-section (1) of section 188 of the Bankruptcy Act 1966-73 authorising Peter Raymond Kennedy, Solicitor of 440 Collins Street, Melbourne to call a Meeting of Creditors and that in pursuance of section 194 of the Bankruptcy Act 1966-73 a Meeting of Creditors of the abovementioned Debtor will be held at the City Mutual Meeting Room, 18th Floor, 459 Collins Street, Melbourne on Monday 17 March 1980 at 10.00 a.m.

P. R. KENNEDY, Solicitor
Madgwicks, solicitors, 440 Collins Street, Melbourne,
3000 5668

MEETING OF CREDITORS UNDER PART X.

Take notice that Mildred Elizabeth Heritage has on 28 February signed an authority under subsection (1) of Section 188 of the Bankruptcy Act 1966-73 authorising Peter Raymond Kennedy, Solicitor of 440 Collins Street, Melbourne to call a Meeting of Creditors and that in pursuance of Section 194 of the Bankruptcy Act 1966-73 a Meeting of Creditors of the abovementioned Debtor will be held at the City Mutual Meeting Room, 18th Floor, 459 Collins Street, Melbourne on Monday 17 March 1980 at 10.30 a.m.

P. R. KENNEDY, Solicitor
Madgwicks, solicitors, 440 Collins Street, Melbourne,
3000 5669

NOTICE OF MAKING OF STATUTORY RULES

In pursuance of the provisions of the *Subordinate Legislation Act 1962* and the Regulations made thereunder, notice is given of the making of the following Statutory Rules:—

| | | |
|---------|---|-------|
| No. | Road Traffic Act 1958 | Price |
| 51/1980 | Road Traffic (Footways and Reservations) Regulations 1980 | 10c |
| | Motor Boating Act 1961 | |
| 52/1980 | Motor Boating (Port of Westernport Speed Restrictions) (Amendment) Regulations 1980 | 20c |

| No. | Price |
|--|-------|
| <i>Second-hand Dealers Act 1958</i> | |
| 53/1980 Second-hand Dealers (Exemption No. 4) Regulations 1980 | 10c |
| <i>Supreme Court Act 1958</i> | |
| 54/1980 Supreme Court (Adjournment) Rules 1980 | 10c |
| <i>Supreme Court Act 1958</i> | |
| 55/1980 Supreme Court (Costs) Rules 1980 | 10c |
| <i>Public Service Act 1974</i> | |
| PSD23/1980 Public Service Amendment Determinations (No. 23) 1980 | 20c |

Copies of these Statutory Rules when printed may be purchased at the Sale of Publications Branch of the Government Printing Office, located at 7A Parliament Place, Melbourne, 3002. If ordered by mail, remittance should be addressed to "The Government Printer, Box 203, P.O., North Melbourne, 3051", and should include 50c delivery and handling fee.

The annual subscription rates for Statutory Rules for the year commencing 1 January 1980, payable in advance, are as follows:—

| | |
|---|---------|
| *Statutory Rules (other than Public Service Determinations), Pamphlet copies only | \$36.00 |
| Public Service Determinations | \$25.00 |

* The Bound Volume of Statutory Rules is not included in the subscription rate.

F. D. ATKINSON
Government Printer

STATE ACTS, 1979

Copies of the following Acts of the Parliament of Victoria may be obtained at the Government Printing Office, Sale of Publications Branch, 7A Parliament Place, Melbourne, phone 651 2754 or 651 2759, or from any accredited agent, at the price set opposite to each.

A delivery and handling fee must be added to your remittance when ordering by mail as follows:—

| Total Value of Acts Ordered | Delivery and Handling Fee |
|-----------------------------|---------------------------|
| 10c-\$2.00 | 0.50c |
| \$2.05-\$5.00 | \$1.00 |
| \$5.05-\$20.00 | \$1.50 |
| Above \$20.00 | \$2.00 |

Bound Volumes of 1978 State Acts (\$21.00) and the Index to the Bound Volumes (\$9.00) are also available.

| No. | Price |
|---|--------|
| 9251. Constitution (Governor's Pension) | \$0.10 |
| 9252. Joint Select Committee (Road Safety) | \$0.20 |
| 9253. Cattle Compensation | \$0.10 |
| 9254. Constitution (Local Government) | \$0.30 |
| 9255. Gas and Fuel Corporation (Borrowing Powers) | \$0.10 |
| 9256. Ombudsman (Co-operation) | \$0.10 |
| 9257. Geelong (Haines Homes) Land | \$0.20 |
| 9258. Motor Car (Breath Testing Stations) (Amendment) | \$0.10 |
| 9259. Geelong Waterworks and Sewerage (Trust) | \$0.30 |
| 9260. Bright (Land Exchange) | \$0.20 |
| 9261. Supply (1979-80, No. 1) | \$0.30 |
| 9262. Money Lenders (Fees) | \$0.10 |
| 9263. Exhibition (Amendment) | \$0.30 |
| 9264. Health (Cattle) | \$0.10 |
| 9265. Victorian Public Offices Corporation (Amendment) | \$0.10 |
| 9266. Community Welfare Services (Amendment) | \$0.10 |
| 9267. Margarine (Amendment) | \$0.10 |
| 9268. Youth, Sport and Recreation (State Youth Council) | \$0.10 |
| 9269. Racing (Restricted Trotting Meetings) | \$0.10 |

| No. | Price |
|---|--------|
| <i>STATE ACTS, 1979—continued</i> | |
| 9270. State Electricity Commission (Morwell Land Compensation) | \$0.10 |
| 9271. Construction Safety | \$1.00 |
| 9272. Business Franchise (Petroleum Products) | \$0.40 |
| 9273. Albury-Wodonga Agreement (Amendment) | \$0.40 |
| 9274. City of Melbourne (Re-subdivision) | \$0.10 |
| 9275. Co-operation | \$0.40 |
| 9276. Cemeteries (Melbourne General Cemetery) | \$0.10 |
| 9277. Melbourne and Metropolitan Board of Works (Amendment) | \$0.30 |
| 9278. River Improvement (Trusts and Valuations) | \$0.10 |
| 9279. Instruments (Writs) | \$0.10 |
| 9280. Forests (Reserved Land) | \$0.10 |
| 9281. Trinity College | \$0.50 |
| 9282. Revocation and Excision of Crown Reservations | \$0.30 |
| 9283. Local Government (Amendment) | \$0.50 |
| 9284. Tattersall Consultations (Amendment) | \$0.10 |
| 9285. Prahran Market | \$0.10 |
| 9286. Geelong Regional Commission (Amendment) | \$0.10 |
| 9287. Pharmacists (Amendment) | \$0.10 |
| 9288. Legal Profession Practice (Amendment) | \$0.10 |
| 9289. Barley Marketing (Amendment) | \$0.10 |
| 9290. Water Authorities (Constitution and Powers) | \$0.20 |
| 9291. Sewerage Authorities (Constitution and Powers) | \$0.30 |
| 9292. Wrongs (Defamation) | \$0.10 |
| 9293. Judges Salaries | \$0.10 |
| 9294. Poisons (Amendment) | \$0.10 |
| 9295. Business Franchise (Petroleum Products) (Licence Fees) | \$0.20 |
| 9296. State Electricity Commission (Amendment) | \$0.30 |
| 9297. Workers Compensation (Miscellaneous Provisions) | \$1.00 |
| 9298. Motor Car (Surcharge) | \$0.10 |
| 9299. Unclaimed Moneys | \$0.10 |
| 9300. Land Tax | \$0.10 |
| 9301. Business Franchise (Tobacco) | \$0.10 |
| 9302. Public Authorities (Contributions) | \$0.10 |
| 9303. Appropriation (1979-80, No. 1) | \$3.50 |
| 9304. Gift Duty (Amendment) | \$0.10 |
| 9305. Pay-roll Tax | \$0.30 |
| 9306. Transport Works and Services | \$0.20 |
| 9307. Melbourne and Metropolitan Tramways (Borrowing Powers) | \$0.10 |
| 9308. County Court (Jurisdiction) | \$0.10 |
| 9309. State Forests Works and Services | \$0.10 |
| 9310. Young Men's Christian Association of Ballarat (Guarantee) | \$0.20 |
| 9311. Water Supply Works and Services | \$0.40 |
| 9312. Trustee Companies (Trustees Executors) | \$0.10 |
| 9313. Commercial Goods Vehicles (Aviation Fuel) | \$0.10 |
| 9314. Victorian Development Corporation (Powers) | \$0.20 |
| 9315. Town and Country Planning (Planning Schemes) | \$1.00 |
| 9316. Victorian Government Travel Authority (Reconstitution) | \$0.10 |
| 9317. Stamps (Amendment) | \$0.30 |
| 9318. Motor Car (Fees) | \$0.30 |
| 9319. Racing (Financial Provisions) | \$0.30 |
| 9320. Urban Land Authority | \$0.50 |
| 9321. Public Works and Services | \$0.30 |
| 9322. Second-hand Dealers (Closing Hours) | \$0.10 |
| 9323. Crimes (Amendment) | \$0.10 |
| 9324. Transfer of Land (Amendment) | \$0.40 |
| 9325. Melbourne College of Divinity | \$0.30 |
| 9326. Transport Regulation (Car Pools) | \$0.10 |
| 9327. Fisheries (Amendment) | \$0.10 |
| 9328. Egg Industry Stabilization (Amendment) | \$0.10 |
| 9329. Local Authorities Superannuation | \$0.30 |
| 9330. Latrobe Valley (Amendment) | \$0.10 |
| 9331. Liquor Control (Amendment) | \$0.10 |
| 9332. Motor Accidents (Amendment) | \$0.40 |
| 9333. Young Farmers' Finance Council | \$0.30 |
| 9334. Probate Duty | \$0.20 |
| 9335. Railways (Board) | \$0.10 |
| 9336. Ministry of Transport (Amendment) | \$0.10 |
| 9337. Abattoir and Meat Inspection (Amendment) | \$0.20 |
| 9338. Public Service (Amendment) | \$0.20 |
| 9339. Trustee Companies (Amendment) | \$0.20 |
| 9340. Vermin and Noxious Weeds (Amendment) | \$0.30 |
| 9341. Canned Fruits Marketing | \$0.40 |
| 9342. Marine (Amendment) | \$0.40 |
| 9343. Shire of Omeo (Tourist Gold Mine) | \$0.30 |



Victoria Government Gazette

No. 19—Wednesday, 12 March 1980

FUEL EMERGENCY ACT 1977

Direction No. 1

PROCLAMATION OF STATE OF EMERGENCY

By His Excellency the Governor of the State of Victoria and its Dependencies in the Commonwealth of Australia, &c., &c., &c.

Whereas it is provided by Section 3 (1) of the *Fuel Emergency Act 1977* that where at any time it appears to the Governor in Council that any action has been taken or is immediately threatened by any person or body of persons whereby any kind of fuel is or is likely to become unavailable to meet the reasonable requirements of the community and that a state of emergency exists or is likely to exist in relation to fuel the Governor in Council may by Proclamation published in the *Government Gazette* declare that a state of emergency exists in relation to that fuel:

And whereas it appears to the Governor in Council that the supplies of certain fuels that is to say petroleum and petroleum products is likely to become unavailable to meet the reasonable requirements of the community and that a state of emergency is likely to exist in relation to that fuel:

Now therefore I the Governor of the said State of Victoria by and with the advice of the Executive Council thereof do by this Proclamation declare that a state of emergency exists in relation to petroleum and petroleum products and I further declare that unless sooner revoked this Proclamation shall remain in force for the period of seven days from the date hereof.

For the purposes of this Proclamation—

“petroleum” means—

- (a) any naturally occurring hydrocarbon, whether in a gaseous, liquid or solid state;
- (b) any naturally occurring mixture of hydrocarbons, whether in a gaseous, liquid or solid state; or
- (c) any naturally occurring mixture of one or more hydrocarbons, whether in a gaseous, liquid or solid state, and one or more of the following, that is to say, hydrogen sulphide, nitrogen, helium and carbon dioxide;

and includes any petroleum as defined by paragraph (a), (b) or (c) of this definition that has been returned to a natural reservoir; and

“petroleum product” means any derivative of petroleum obtained by distillation, catalytic, cracking or other refining process and includes motor spirit (petrol), aviation fuel, heating oil, kerosene, lubricating oil, diesel fuel and liquefied petroleum gases.

Given under my Hand and the Seal of State of Victoria aforesaid, at Melbourne, this twelfth day of March in the year of our Lord One thousand nine hundred and eighty and in the twenty-ninth year of the reign of Her Majesty Elizabeth the Second, Queen of Australia.

(L.S.)

HENRY WINNEKE

By His Excellency's Command

R. J. HAMER
Premier

GOD SAVE THE QUEEN!

Fuel Emergency Act 1977

DIRECTION UNDER SECTION 4

To the owner or operator of a service station in the areas specified in the Second Schedule.

I, James Charles Murray Balfour, Minister for Minerals and Energy, pursuant to Section 4 of the *Fuel Emergency Act 1977*, hereby direct the owner or operator of each service station in the areas specified in the Second Schedule hereto, to comply with the terms and conditions specified in the First Schedule hereto relating to the provision and distribution of motor spirit and diesel fuel at or from the service station.

This direction operates as and from 12 March 1980 and ends on 16 March 1980.

Dated 12 March 1980

J. C. M. BALFOUR
Minister for Minerals and Energy

SCHEDULE 1

Schedule of Terms and Conditions relating to the provision and distribution of motor spirit and diesel fuel.

Motor spirit and diesel fuel shall not be provided or distributed by you, your employees or agents at the service station owned or operated by you except under the following conditions:

- (a) The sale or supply of motor spirit or diesel fuel to any person at any time shall not exceed in value \$7 or to be less than the value of \$2, and the price which the motor spirit is sold or supplied shall not exceed 34.5c per litre for standard grade fuel, 35.5c per litre for super grade fuel and 35.5c per litre for diesel fuel.
- (b) Motor spirit or diesel fuel shall only be supplied on Tuesday, Thursday and Saturday in each week to drivers of motor vehicles on which the last numeral of the number plate is an even number; and
- (c) Motor Spirit or diesel fuel shall only be supplied on Monday, Wednesday and Friday in each week to drivers of motor vehicles on which the last numeral of the number plate is an odd number.
- (d) Motor spirit or diesel fuel shall only be supplied into the tank fitted to vehicles.
- (e) Supply referred to above shall on 12 March 1980 not be permitted outside the hour of 2.00 p.m.
- (f) Supply referred to above is not permitted outside the hours of 7.00 a.m. to 6.00 p.m. on Thursday, 13 March; Friday, 14 March 1980.
- (g) Supply referred to above is not permitted outside the hours of 6.00 a.m. to 12 noon on Saturday, 15 March 1980.
- (h) Supply referred to above is not permitted on Sunday, 16 March 1980.

SCHEDULE 2

The Municipal districts of the following Municipalities:

(a) *Melbourne Area*

The Cities of:

| | |
|-------------------------|-----------------|
| Altona | Kew |
| Berwick | Knox |
| Box Hill | Malvern |
| Brighton | Melbourne |
| Broadmeadows | Moorabbin |
| Brunswick | Mordialloc |
| Camberwell | Northcote |
| Caulfield | Nunawading |
| Chelsea | Oakleigh |
| Coburg | Port Melbourne |
| Collingwood | Prahran |
| Croydon | Preston |
| Dandenong | Richmond |
| Doncaster & Templestowe | Ringwood |
| Essendon | St. Kilda |
| Fitzroy | Sandringham |
| Footscray | South Melbourne |
| Frankston | Springvale |
| Hawthorn | Sunshine |
| Heidelberg | Waverley |
| Kellor | Williamstown |

And the Shires of:

| | |
|----------------|------------|
| Bulla | Lillydale |
| Cranbourne | Melton |
| Diamond Valley | Mornington |
| Eltham | Sherbrooke |
| Flinders | Werribee |
| Hastings | Whittlesea |

(b) *Geelong Area*

The Cities of:

Geelong
Geelong West
Newtown
South Barwon

The Borough of Queenscliffe

And the Shires of:

Bellarine
Corio.