



# Victoria Government Gazette

No. 42—Wednesday, 4 June 1980

## PROCLAMATIONS

### PUBLIC HOLIDAYS

#### PROCLAMATION

By His Excellency the Governor of the State of Victoria and its Dependencies in the Commonwealth of Australia, &c., &c., &c.

In pursuance of the provisions contained in section 71 (2) of the *Public Act 1974, I*, the Governor of the State of Victoria, in the Commonwealth of Australia, by and with the advice of the Executive Council of the said State, do by this my Proclamation appoint the days and dates hereunder mentioned to be observed as Public Holidays or Public Half-Holidays (as the case may be) at the places respectively specified, viz.:—

#### Public Holidays:

FRIDAY, 10 OCTOBER 1980, throughout the Shire of Shepparton.

FRIDAY, 10 OCTOBER 1980, throughout the City of Shepparton.

TUESDAY, 4 NOVEMBER 1980, throughout the Shire of McIvor.

*Public Half-Holidays from the Hour of Twelve o'clock noon:*

WEDNESDAY, 15 OCTOBER 1980, throughout the North and Tyrrell Ridings, Shire of Wycheproof.

WEDNESDAY, 22 OCTOBER 1980, throughout the South and Central Ridings, Shire of Wycheproof.

Given under my Hand and the Seal of the State of Victoria aforesaid, at Melbourne, this twenty-seventh day of May, in the year of our Lord One thousand nine hundred and eighty, and in the twenty-ninth year of the reign of Her Majesty Elizabeth the Second, Queen of Australia.

(L.S.)

HENRY WINNEKE

By His Excellency's Command

R. J. HAMER  
Premier

GOD SAVE THE QUEEN!

*Soil Conservation and Land Utilization Act 1958*

*Land Conservation Act 1970*

### TULLAROOP RESERVOIR WATER SUPPLY CATCHMENT

#### PROCLAMATION

By His Excellency the Governor of the State of Victoria and its Dependencies in the Commonwealth of Australia, &c., &c., &c.

I, the Governor of the State of Victoria in the Commonwealth of Australia, by and with the advice of the Executive Council of the said State and having considered a recommendation of the Land Conservation Council in pursuance of the provisions contained in section 22 (1) of the *Soil Conservation and Land Utilization Act 1958* (No. 6372) and sections 5 (1) (b) of the *Land Conservation Act 1970* (No. 8008) do by this Proclamation define the water supply catchment area to be known as the Tullaroop Reservoir Water Supply Catchment.

The area proclaimed is the catchment to a dam constructed by the State Rivers and Water Supply Commission on Tullaroop Creek within Crown Allotments 14 and 17c, Parish of Moolort.

The use of land within this catchment is subject to specification by notice or by determination made by the Soil Conservation Authority, acting under the provisions of sections 22 (2) and 23 (1) (a), (b) and (c) of the *Soil Conservation and Land Utilization Act 1958*, as amended.

The area described is indicated on Plan No. S-768 hereunder, the original of which is lodged at Head Office of the Soil Conservation Authority, 378 Cotham Road, Kew, 3101.

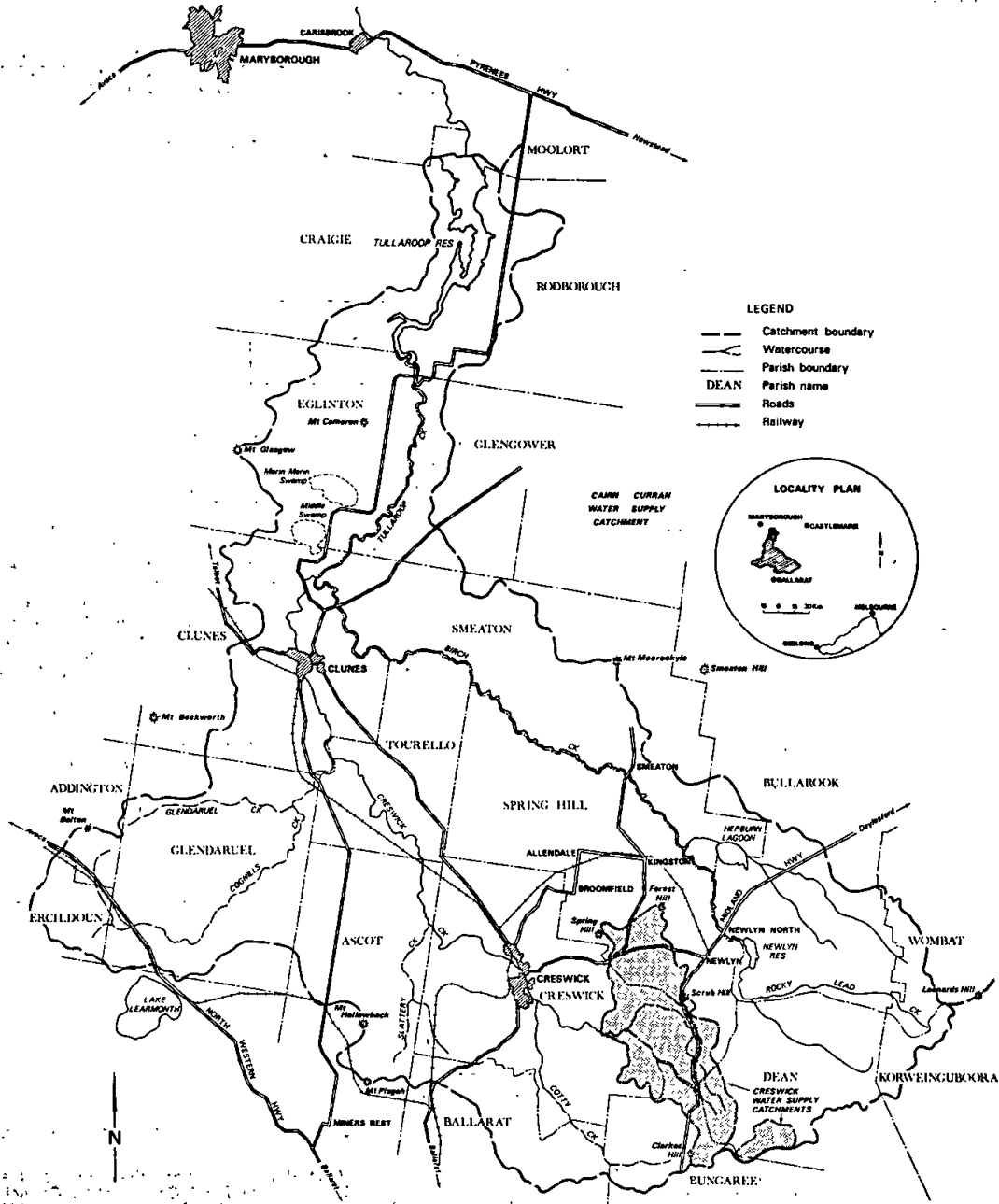

TULLAROOP WATER SUPPLY CATCHMENT PLAN NO S-768

Given under my Hand and the Seal of the State of Victoria aforesaid, at Melbourne, this twenty-seventh day of May, in the year of our Lord One thousand nine hundred and eighty, and in the twenty-ninth year of the reign of Her Majesty Queen Elizabeth II.

(L.S.)

HENRY WINNEKE

By His Excellency's Command

W. V. HOUGHTON  
Minister for Conservation

GOD SAVE THE QUEEN!

Soil Conservation and Land Utilization Act 1958  
 Land Conservation Act 1970  
**BRITANNIA CREEK WATER SUPPLY CATCHMENT**

**PROCLAMATION**

By His Excellency the Governor of the State of Victoria and its Dependencies in the Commonwealth of Australia, &c., &c., &c.

I, the Governor of the State of Victoria in the Commonwealth of Australia, by and with the advice of the Executive Council of the said State and having considered a recommendation of the Land Conservation Council in pursuance of the provisions contained in section 22 (1) of the *Soil Conservation and Land Utilization Act 1958* (No. 6372) and section 5 (1) (b) of the *Land Conservation Act 1970* (No. 8008) do by this Proclamation define the water supply catchment area to be known as the Britannia Creek Water Supply Catchment.

The area proclaimed is the catchment to an offtake weir constructed by the Yarra Junction Waterworks Trust on Britannia Creek within the Parish of Warburton.

The use of land within this catchment is subject to specification by notice or by determination made by the Soil Conservation Authority, acting under the provisions of sections 22 (2) and 23 (1) (a), (b) and (c) of the *Soil Conservation and Land Utilization Act 1958*, as amended.

The area described is indicated on Plan No. S-843 hereunder, the original of which is lodged at Head Office of the Soil Conservation Authority, 378 Cotham Road, Kew, 3101.

**BRITANNIA CREEK CATCHMENT**

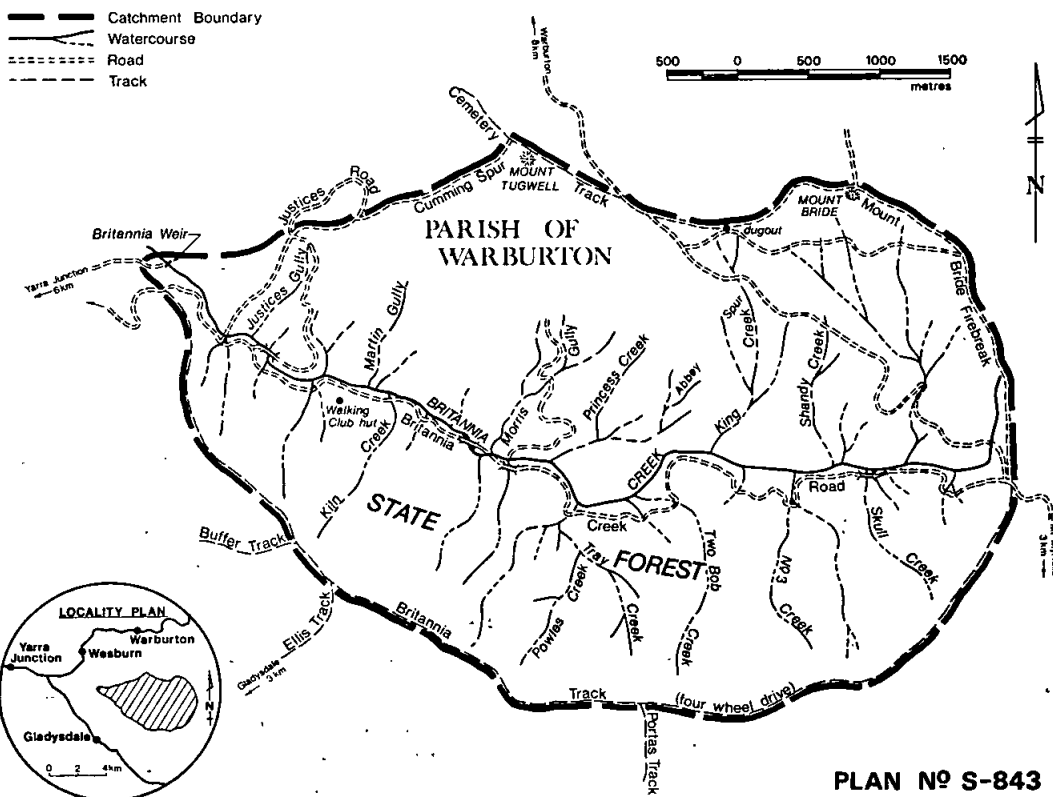

Given under my Hand and the Seal of the State of Victoria aforesaid, at Melbourne, this twenty-seventh day of May, in the year of our Lord One thousand nine hundred and eighty, and in the twenty-ninth year of the reign of Her Majesty Queen Elizabeth II.

(L.S.)

By His Excellency's Command

HENRY WINNEKE

W. V. HOUGHTON  
 Minister for Conservation

GOD SAVE THE QUEEN!

*Game Act 1958*  
**THE MELBOURNE AND METROPOLITAN BOARD OF WORKS FARM, WERRIBEE**  
**SANCTUARY FOR NATIVE GAME**

**PROCLAMATION**

By His Excellency the Governor of the State of Victoria and its Dependencies in the Commonwealth of Australia, &c., &c., &c.

I, the Governor of the State of Victoria, in the Commonwealth of Australia, by and with the advice of the Executive Council of the said State and in pursuance of the powers conferred by the *Game Act 1958*, and all other powers thereunto enabling, do by this my Proclamation direct that the part of Victoria within the area hereinafter described shall be a locality in which from the first day of January to the thirty-first day of December (both days inclusive) in each year, it shall be unlawful for any person to kill or destroy any native game included in the Third Schedule to the *Game Act 1958*.

PART OF VICTORIA REFERRED TO:

Land in the Parishes of Murtcain and Cocoroc, County of Grant, as indicated by hatching on the plan hereunder—

M.M.B.W. SANCTUARY

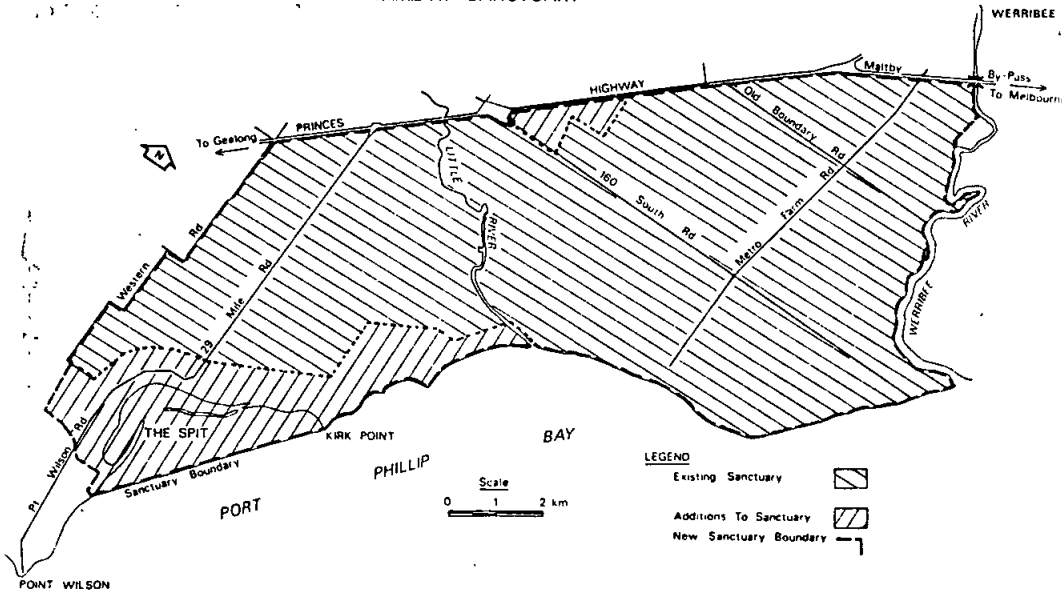

Given under my Hand and the Seal of the State of Victoria aforesaid, at Melbourne, this twenty-seventh day of May, in the year of our Lord One thousand nine hundred and eighty, and in the twenty-ninth year of the reign of Her Majesty Queen Elizabeth II.

(L.S.)

By His Excellency's Command

HENRY WINNEKE

W. V. HOUGHTON  
 Minister for Conservation

GOD SAVE THE QUEEN !

**TRANSFER OF LAND (AMENDMENT) ACT 1979**  
 (No. 9324)

DATE OF COMING INTO OPERATION

**PROCLAMATION**

By His Excellency the Governor of the State of Victoria and its Dependencies in the Commonwealth of Australia, &c., &c., &c.

Whereas by an Act of Parliament of the State of Victoria passed in the twenty-eighth year of the reign of Her Majesty Elizabeth the Second, Queen of Australia, intitled the *Transfer of Land (Amendment) Act 1979* (No. 9324), it is amongst other things enacted that the said Act shall come into operation on a day or the respective days to be fixed by Proclamation or successive Proclamations of the Governor in Council published in the *Government Gazette*.

Now therefore I, the Governor of the State of Victoria, acting by and with the advice of the Executive Council thereof, do by this my Proclamation fix Wednesday, the fourth day of June, One thousand nine hundred and eighty, as the day upon which the provisions of section 4 of the *Transfer of Land (Amendment) Act 1979* shall come into operation.

Given under my Hand and the Seal of the State of Victoria aforesaid, at Melbourne, this third day of June, in the year of our Lord One thousand nine hundred and eighty, and in the twenty-ninth year of the reign of Her Majesty Elizabeth the Second, Queen of Australia.

(L.S.)

By His Excellency's Command

HENRY WINNEKE

HADDON STOREY  
 Attorney-General

GOD SAVE THE QUEEN !

## GOVERNMENT NOTICES

### PUBLIC HOLIDAY—QUEEN'S BIRTHDAY

It is hereby notified that on—

MONDAY, 16 JUNE 1980

the Public Offices will be closed, such day having been appointed under the provisions of the *Public Service Act 1974*, to be observed as a holiday in the Public Offices throughout the State of Victoria.

This notice relates only to the closing of the State Public Offices. All inquiries regarding the holiday in other offices and in shops and industry should be directed to the Department of Labour and Industry, Industrial Information Service, 500 Bourke Street, Melbourne, 3000. (Telephone 651 3911.)

R. J. HAMER  
Premier

Department of the Premier  
Melbourne, 26 May 1980

### *Films Act 1971*

#### EXEMPTION PURSUANT TO SECTION 11 (2)

Whereas:

1. Section 11 (2) of the *Films Act 1971* provides that the Governor in Council may in any particular case by direction in writing under his hand exempt any film from the operation of Part II. of the Act to the extent specified in the direction.

2. It is expedient that the films set out in the Schedule hereto be exempted from the provisions of Part II. of the said Act as would require:

- the films to be examined and classified;
- advertising relating to the films on display classification or classification symbols;
- applications for the registration of films to be accompanied by the prescribed fee.

Subject to the following conditions:

- (i) the films will be exhibited only at the "Week of Chinese Films" Season between the period commencing on 5 May 1980 and expiring on 31 May 1980 (both dates inclusive);
- (ii) the films will be exhibited not more than twice;
- (iii) persons under the age of 18 years shall not be admitted to screenings of the films; and
- (iv) the films be exported at the conclusion of the Season.

Now therefore, I, the Governor of the State of Victoria, by and with the advice of the Executive Council thereof, in pursuance of the powers conferred by the *Films Act 1971*, do direct that the films set out in the Schedule hereto be exempted from the provisions of Part II. of the *Films Act 1971*, subject to the conditions set out in Item 2 above.

#### SCHEDULE

Girl Divers	Li Siguan
The Lin Family Shop	Tear Stains
Early Spring	Darting Swallows
Two Actresses	Seven Star Mountain
Mount Tai	Serfs
New Year's Sacrifice	

Given under my Hand and the Seal of the State of Victoria aforesaid, at Melbourne, this twenty-seventh day of May, in the year of our Lord One thousand nine hundred and eighty, and in the twenty-ninth year of the reign of Her Majesty Elizabeth the Second, Queen of Australia.

(L.S.)

HENRY WINNEKE

By His Excellency's Command

GOD SAVE THE QUEEN !

### *Liquor Control (Orderly Marketing) Act 1976* NOTICE OF INTENTION TO MAKE A FURTHER DETERMINATION OF PRICE OF PACKAGED BEER

Take notice that the Liquor Control Commission pursuant to the authority conferred upon it by the *Liquor Control Act 1968* (as amended by the *Liquor Control (Orderly Marketing) Act 1976*) intends to make a further determination of the price at which licensed persons may sell and dispose of packaged beer to unlicensed persons in the State of Victoria.

For the purpose of making such further determination the Commission proposes to investigate written requests from the Australian Hotels Association and the Retail Liquor Merchants Association of Victoria to the Commission to determine a new minimum price for packaged beer based on the most recent increases in wholesale prices of packaged beer, produced by Carlton and United Breweries Limited and Tooth Brewery (Victoria) Pty. Ltd.

Any person may make a submission in writing to the Commission in relation to such particular proposals or as to the intention generally. Such submissions are required to be forwarded to the Secretary of the Commission at its offices 232 Victoria Parade, East Melbourne, 3002, not later than noon on Friday, 27 June 1980.

Before making any determination the Commission shall consider any submission or submissions received by it and shall give such weight thereto as it considers appropriate.

Any person or body of persons desiring to produce evidence before the Commission and be heard on the matters under investigation or as to the intention generally should notify the Commission in writing of such desire. Such notification is required to be forwarded to the Secretary of the Commission at its offices 232 Victoria Parade, East Melbourne, 3002, not later than noon on Friday 27 June 1980.

The Commission shall in making its determination endeavour to determine prices which shall so far as possible ensure the interests of the public generally.

J. C. KOHN  
Deputy Secretary

### *Hospitals and Charities Act 1958*

#### PETITION TO INCORPORATE LAKES ENTRANCE COMMUNITY HEALTH CENTRE

It is notified in accordance with the provisions of sections 46 and 64 of the *Hospitals and Charities Act 1958*, that the Health Commission of Victoria has received a petition signed by twenty-five contributors to an organisation known as the Lakes Entrance Community Health Centre praying that the organisation be incorporated as a Benevolent Society under the provisions of the said Act.

The organisation will have for its objects:

- (a) To manage and maintain a Community Health Centre in Lakes Entrance which will provide facilities for family physicians, specialists, district nurses, physiotherapists, occupational therapists, social workers, psychiatric nurses and other medical and/or para-medical personnel as are required.
- (b) To provide facilities for diagnosis and treatment of illness and for provision of preventive health services for all persons including those in necessitous circumstances.
- (c) To purchase or acquire any real and/or personal property and other buildings to be used for the above purpose.
- (d) To do all such other things as are incidental or conducive to the attainment of the above objects.

If a counter petition signed by an equal or greater number of contributors is not lodged with the aforesaid Commission at 555 Collins Street, Melbourne, within one calendar month of publication of this notice, the Governor in Council, may, by Order pursuant to the *Hospitals and Charities Act 1958*, declare the contributors for the time being to the Lakes Entrance Community Health Centre to be a body corporate by the name set forth in such Order.

W. BORTHWICK  
Minister of Health

Health Commission of Victoria  
Melbourne, 26 May 1980

Transport Regulation Act  
TRANSPORT REGULATION BOARD

## HEARING OF APPLICATIONS

Notice is hereby given that the following applications will be considered by the Transport Regulation Board on 24 June 1980.

**DOWNES, I. S. & J. E.,** Beechworth. Application for variation of C.O. licence conditions to operate for the carriage of elderly citizens within the Township of Beechworth, between their homes or place of abode to the elderly citizens clubrooms, sporting facilities, public halls or meeting places.

## TIME-TABLE

As and when required under prior arrangement with the elderly citizens club secretary.

Fares—40c single, 80c return.

**JOHNSTON, J. H. & PHILLIPS, J. H.,** Casterton. Application to license one commercial passenger vehicle with seating capacity for seventeen persons to operate a service for the carriage of school children between Nareen Primary School and Wando Vale under contract to the Education Department.

NOTE—No charter rights are sought in this application.

**SEYMOUR PASSENGER SERVICE PTY. LTD.,** Seymour. Application to license one commercial passenger vehicle with seating capacity for eighteen persons to operate a service for the carriage of school children between Sugarloaf Creek and Broadford Primary School under contract to the Education Department.

NOTE—No charter rights are sought in this application.

**WHISTON (estate of the late), E. V.,** North Fitzroy. Application for four (4) Metropolitan Hire Car licences in respect of luxury sedans to operate from 22 Scotchmer Street, Fitzroy.

Application by the persons listed hereunder for one metropolitan taxi licence to be issued subject to the cancellation of each suburban taxi licence shown.

**CHRISTIANA, F.,** Box Hill South; S.T.7891.  
**CIVITELLA, B.,** Burwood; S.T.7676.  
**CRAINE, E.,** Croydon; S.T.7872.  
**DEARAVGO, M. & T.,** Bonbeach; S.T.6094.  
**DEARNESS, S.,** Mordialloc; S.T.5696, S.T.5984, S.T.6236.  
**DEBATTISTA, C.,** South Melbourne; S.T.8007.  
**GALVIN, G.,** Croydon; S.T.6405.  
**GARDINER, R.,** Mount Martha; S.T.6391.  
**GIDLEY, R.,** North Balwyn; S.T.5366.  
**HATZISTAVROU, C.,** St. Albans; S.T.5664.  
**LATIMER, P.,** Bentleigh; S.T.5446, S.T.5666, S.T.6046, S.T.6212.  
**LIVNE, M. A. A. NOMINEES PTY. LTD.,** McKinnon; S.T.6146.  
**MURONE, G. & M.,** Glenroy; S.T.5047.  
**MCCOY, J.,** S.T.5334.  
**PETTINELLA, S.,** West Preston; S.T.7526.  
**ROPIS, R.,** Corio; S.T.5791.  
**ROUSSIS, D. & D.,** Northcote; S.T.5926.  
**THOMAS, D.,** Mordialloc; S.T.5476, S.T.5939, S.T.6321.  
**TRICKEY, P.,** S.T.5306, S.T.5596.  
**YOUNG, G.,** S.T.7696, S.T.5876.

Application for renewal of licences as shown by the persons listed hereunder to operate under the same terms and conditions.

**GRIEVE, J. NOMINEES PTY. LTD.,** Mooroopna; T.S.1044, T.S.1239.  
**DOYLE, P.,** Shepparton; C.O.51, C.O.53, C.O.223, C.O.618, C.O.763, C.O.876, C.O.1000, C.O.1157, C.O.1171, C.O.1177.  
**PRATER, S.,** Wycheproof; C.H.164.  
**DUNN, N. H.,** Greenvale; M.T.1808.  
**ZOTOS, E.,** Reservoir; M.T.4423.  
**KARDAS, E. J.,** Belmont; U.T.855.  
**FREEMAN, M.,** East Malvern; M.T.4611.  
**RYAN, W. J.,** East St. Kilda; M.T.5404.  
**MCDONALD, J. & F. TAXIS PTY. LTD.,** Kew; M.T.2365.  
**LIAPIS, S. & P.,** Burwood East; M.T.5419.  
**WALLACE, A. W. & R.,** Mulgrave; M.T.5395.

Notice of any objections should be forwarded to reach the Secretary of the Board not later than 18 June 1980.

Applicants are advised that it will not be necessary to appear on the hearing date specified, unless advised in writing by the Board.

C. J. V. SMITH, Secretary

Corner Lygon and Princes Streets, Carlton, 3053,  
Wednesday, 4 June 1980

Commercial Goods Vehicles Act  
TRANSPORT REGULATION BOARD

## HEARING OF APPLICATIONS

Notice is hereby given that the following applications will be considered by the Transport Regulation Board on 24 June 1980.

**A.P.D. SNACK FOODS PTY. LTD.,** 8-20 King Street, Oakleigh, 3166. One commercial goods vehicle (L/C. 3.00 tonne) to operate within an 80-km radius of own premises at Geelong and to Apollo Bay in the course of business as "Foodstuff Manufacturers and Distributors"—own goods with the proviso that all goods are to be initially consigned by rail to Geelong.

**WILLIAM BOBY & Co. (AUST.) PTY. LTD.,** 44 Koornane Road, Scoresby, 3179. One commercial goods vehicle (L/C. 0.75 tonne) to operate throughout the State of Victoria in the course of business as "Water and Sewage Treatment Engineers" for purpose of supervising own installations and servicing contracts—tools of trade, spare parts and materials incidental to on-site servicing.

**BORAL RESOURCES (VIC.) PTY. LTD.,** 350 Latrobe Street, Melbourne, 3000. One commercial goods vehicle (L/C. 10.50 tonne) to operate: (a) Within an 80-km radius of the chief post office in the City of Geelong in the course of business as "Quarry Masters and Road Making Contractors"—road contracting plant and materials, hot asphalt and premix but excluding the carriage of cement from the Geelong Urban District (as defined in the *Transport Regulation Act 1958*). (b) Within a 240-km radius from the chief post office in the City of Geelong—(i) bulk bitumen and bulk tar; (ii) sand, screenings, hot bitumen and tar incidental to own contracts. (c) On any operation within the radius referred to in paragraphs (a) and (b) above for the use of liquefied roadmaking materials, drums of special emulsion may also be carried subject to the condition that such emulsion shall only be carried to the contract site and that not more than six drums shall be carried on the vehicle at any one time.

**BURR, B. A.,** 11 Harrison Drive, Cranbourne, 3977. One commercial goods vehicle (L/C. 23.25 tonne) to operate from the premises of Golden Poultry Farm Pty. Ltd. at Clyde to places within an 80-km radius thereof solely on behalf of the said company—bulk stock-feed.

**CAMOBRECO, M. D.,** Woodend Road, Tylden, 3444. One commercial goods vehicle (L/C. 11.75 tonne) to operate: (a) From points throughout the State of Victoria to the premises of Water Wheel Flour Mills Pty. Ltd. solely on behalf of said company, an approved decentralized secondary industry (flour milling and stockfood manufacturing) at Bridgewater—raw materials and goods used solely in the manufacturing processes of such industry. (b) From the premises of Water Wheel Flour Mills Pty. Ltd. at Bridgewater being an approved decentralized secondary industry (flour milling and stockfood manufacturing) solely on behalf of the said company to points throughout the State of Victoria—manufactured articles or products from such industry.

**DEVELYN, F. I.,** 64 Church Street, Drouin, 3818. One commercial goods vehicle (L/C. 22.00 tonne) to operate from the premises of Sure Quarries Pty. Ltd. at Jindivick to consignees situated within an 80-km radius of the said premises at Jindivick—screenings, sand, soil and quarry products solely on behalf of the said company.

**ELMS, R. N.,** P.O. Box 12, Korumburra, 3950. Application to vary the conditions of licence numbers D.A.68218, D.A.68218/1, D.A.68218/2, D.A.68218/3 by deleting

- existing conditions and adding in lieu—(a) From Lang Lang to Cowes and Inverloch via Wonthaggi—Sun morning newspaper. (b) From Melbourne to Yarram servicing places en route from Five Ways—Sun morning newspapers.
- ELMS, R. N., P.O. Box 12, Korumburra, 3950. Two commercial goods vehicles (L/C. 3.59 and 3.70 tonne) to operate: (a) From Lang Lang to Cowes and Inverloch via Wonthaggi—Sun morning newspapers. (b) From Melbourne to Yarram serving places en route from Five Ways—Sun newspapers.
- FRY, F. R., 46 Church Street, Woomelang, 3485. Application to vary the conditions of licence No. D.A.62302/1 by adding an additional paragraph—"From own yabby farms and various lakes to restaurants, fish wholesalers and zoos, situated throughout the State of Victoria—live and cooked yabbies".
- GLAUM, R. G., 32 Kent Road, Lator, 3075. Application to vary the conditions of licence No. D.A.70056 by adding to existing conditions—" (b) Within an 80-km radius of the premises of V.I.A. Ltd. at Traralgon solely on behalf of the said company as an 'Exclusive Installation Contractor'—prefabricated timber roof trusses, wall frames, tools of trade and erection equipment for specialized installation".
- GRIFFITH, D. J., 17 Errol Street, Braybrook, 3019. One commercial goods vehicle (L/C. 11.95 tonne) to operate throughout the State of Victoria in the course of business as "House Remover"—houses, sheds and outbuilding for removal from site to site and for subsequent re-erection, tools of trade, equipment and materials incidental to own contracts.
- HAWKER SIDDELEY ENGINEERING PTY. LTD., 262-284 Heidelberg Road, Fairfield, 3078. One commercial goods vehicle (L/C. 1.05 tonne) to operate throughout the State of Victoria in the course of business as "Contract Engineers"—tools of trade, spare parts and materials incidental to the on-site servicing, maintenance and installation of diesel, electrical and sewage treatment equipment.
- KENNEY, L. P., 14 Hill Court, Macleod, 3085. One commercial goods vehicle (L/C. 1.25 tonne) to operate throughout the State of Victoria for the purpose of attending second-hand auctions and second-hand goods sales—second-hand goods for return to own premises at Macleod for resale.
- KERR'S QUARRIES PTY. LTD., Butlers Road, Ferntree Gully, 3156. One commercial goods vehicle (L/C. 0.75 tonne) to operate throughout the State of Victoria in the course of business as "Earthmoving Contractors"—tools of trade, own equipment and spare parts incidental to the servicing and maintenance of own vehicles.
- LATROBE VALLEY AMUSEMENTS PTY. LTD., Livingston Street, Traralgon, 3844. One commercial goods vehicle (L/C. 0.75 tonne) to operate within that part of Victoria situated east of a north/south line drawn through the G.P.O. Melbourne in the course of business as "Amusement Machine Operators"—own amusement machines for hire or returning for hire.
- MELBOURNE ESTATES & FINANCE CO. PTY. LTD., 380 Lonsdale Street, Melbourne, 3000. Two commercial goods vehicles (L/C. 11.90 and 6.70 tonne) to operate within an 80-km radius of the G.P.O. Melbourne in course of business as "Land Developers"—own goods excluding the carriage of restricted goods.
- O'BRIEN GLASS INDUSTRIES LTD., corner Watson and Benalla Roads, Shepparton, 3630. One commercial goods vehicle (L/C. 1.15 tonne) to operate within an 80-km radius of own branch premises at Shepparton in the course of business as "Windscreen Suppliers"—own goods.
- PROGRESS PRESS DISTRIBUTORS PTY. LTD., P.O. Box 310, Moorabbin, 3189. Application to vary the conditions of licence numbers D.A.70883/1, D.A.70883/2, D.A.70883/3 and D.A.70883/4 by adding to existing conditions after magazines "and Advertising Literature".
- REYNE, R. E., 10 Bowen Street, St. Arnaud, 3478. One Commercial goods vehicle (L/C. 21.00 tonne) to operate: (a) From points throughout the State of Victoria to the premises of K.M.M. Pty. Ltd. solely on behalf of the said company, an approved decentralized secondary industry (stock feed manufacturing) at St. Arnaud—raw materials and goods used solely in the manufacturing processes of such industry. (b) From the premises of K.M.M. Pty. Ltd. at St. Arnaud being an approved decentralized secondary industry (stock feed manufacturing) solely on behalf of the said company to points throughout the State of Victoria—manufactured articles and products from the said industry.
- SCOTT, K. L., R.S.D. Dargo Road, Walpa, 3875. One commercial goods vehicle (L/C. 20.00 tonne) to operate: (a) To the sawmill of R.W.A. Dargo Pty. Ltd. at Dargo, from any forest landing within an 80-km radius of the Dargo Post Office—logs. (b) To railway stations at either Fernbank or Stratford and Sale, from the sawmill of R.W.A. Dargo Pty. Ltd. at Dargo—sawn timber.
- SIEMENS INDUSTRIES LTD., Dartmouth Power Station, Dartmouth, 3701. One commercial goods vehicle (L/C. 1.15 tonne) to operate within an 80-km radius of the site of Dartmouth Power Station at Dartmouth in course of business as "Electrical Engineers"—tools of trade, equipment and materials for use in the installation of electrical equipment.
- TAYLOR, J. C., & SONS (AUST.) PTY. LTD., 108 Gheringhap Street, Geelong, 3220. One commercial goods vehicle (L/C. 0.75 tonne) to operate: (a) Within a 40-km radius of the chief post office at Geelong in the course of business as "Builders"—own goods. (b) From and to places within a 40-km radius of the G.P.O. Melbourne to and from own premises at Geelong and Altona—own goods (other than restricted goods which may be specified by notice in the *Government Gazette* from time to time).
- NOTE—Nothing contained in paragraph (b) shall be deemed to authorise any goods taken up within a 40-km radius of the G.P.O. Melbourne to be carried to or set down at any point beyond the company's own premises at Geelong.
- WESTWICK, E. M., 2 Osburne Court, Warrnambool, 3280. Application to vary the existing conditions of licence No. D.A.70794 by deleting existing conditions and adding in lieu—(a) Within an 80-km radius of the post office at Warrnambool in course of trade as a tree removalist—own goods. (b) Within the area bounded by a north/south line drawn through Panmure in the east and south of an east/west line drawn through Hamilton, in the north to the South Australian Border in the west—own equipment and tools of trade in course of trade as a tree removalist on contract to the State Electricity Commission.
- WILKIE, B. M., Merrick Street, Stratford, 3862. One commercial goods vehicle (L/C. 10.50 tonne) to operate within an 80-km radius of Stratford in a specially constructed water tanker vehicle for the purpose of spraying road contracts and replenishing domestic water supplies.

## TOW TRUCK

- PHILLIPS, I., Elizabeth Street, Edenhope, 3318. Application to vary the conditions of licence No. D.A.62713 by deleting "Throughout the State" and adding in lieu "Within an 80-km radius of Edenhope".

## RENEWALS

- Applications for renewal of licences as shown by persons listed hereunder to operate under the same terms and conditions from the expiry shown in each case.
- WILLIAM ADAMS TRACTORS PTY. LTD., Nantilla Road, Clayton, 3168; D.A.512/13; 6 August 1980; 1.85 tonne.
- WILLIAM ADAMS & COMPANY LTD., 691 Geelong Road, Brooklyn, 3025; D.A.46219/2; 12 August 1980; 0.75 tonne.
- ANSETT TRANSPORT INDUSTRIES OPERATIONS PTY. LTD., 89-100 High Street, Bendigo, 3550; D.A.67589/5; 5 July 1980; 0.75 tonne.
- ARNOTT BROCKHOFF GUEST PTY. LTD., 53 Huntingdale Road, Burwood, 3125; D.A.60213/29; 26 August 1980; 3.75 tonne.

- BOFF, J. E., 2A Bruce Street, West Coburg, 3058; D.A.70720; 31 August 1980; 3.55 tonne.
- BOFF, M. E., 2A Bruce Street, Coburg West, 3058; D.A.53274/1; 31 August 1980; 3.35 tonne.
- BORAL RESOURCES (VIC.) PTY. LTD., 350 Latrobe Street, Melbourne, 3000; D.A.520/206; 19 August 1980; 10.50 tonne.
- BRAMBLES HOLDINGS LTD., 1846 Princes Highway, Clayton, 3168; D.A.63215/11; 19 August 1980; 10.30 tonne; D.A.63215/9; 19 August 1980; 10.30 tonne; D.A.63215/10; 19 August 1980; 10.40 tonne.
- CARMICHAEL, J., Stony Creek, 3957; D.A.46195/1; 8 July 1980; 8.00 tonne.
- CASH ENGINEERING CO. PTY. LTD., 249 Bridge Road, Richmond, 3121; D.A.65365; 1 August 1980; 0.75 tonne.
- COCKSON, C. R., Old Mt. Gambier Road, Casterton, 3311; D.A.68879; 19 August 1980; 1.15 tonne.
- DALGETY AUST. LTD., 1 Malop Street, Geelong, 3220; D.A.46170/91; 10 August 1980; 0.30 tonne and 0.20 tonne trailer.
- DELLA BOSCA, B., 8 Von Nida Court, Dingley, 3172; D.A.53842/1; 14 May 1979; 10.80 tonne.
- FAGG BROS. PTY. LTD., 531 Moorabool Street, South Geelong, 3220; D.A.50085/2; 26 July 1980; 6.95 and 3.95 tonne trailer; D.A.50085/1; 26 July 1980; 7.60 and 3.95 tonne trailer.
- FLEETWAYS TRANSPORT SERVICES PTY. LTD., 61 Bertie Street, Port Melbourne, 3207; D.A.48588/47; 7 June 1980; 5.05 tonne and 1.45 tonne trailer.
- JAMES HARDIE & CO. PTY. LTD., Hardie Road, Brooklyn, 3025; D.A.63064/4; 7 June 1980; 0.70 tonne.
- HEAVY TRUCK SERVICES PTY. LTD., 55 Amberley Crescent, Dandenong, 3175; D.A.62063; 19 October 1980; 0.50 tonne.
- KANE, T. M., 17 Carolyn Court, Warrnambool, 3280; D.A.43855/4; 5 June 1980; 0.70 tonne.
- KILPATRICK GREEN PTY. LTD., 33 Slevin Street, North Geelong, 3215; D.A.67326/9; 11 July 1980; 0.75 tonne.
- LAMBERT, A. J., 25 McFarlane Road, Mooropna, 3629; D.A.66400/1; 27 June 1980; 3.65 tonne.
- MISHANOVICH, M., 10 Medowra Avenue, Wangaratta, 3677; D.A.60868/1; 14 August 1980; 7.55 tonne.
- NOTT & DREW PTY. LTD., 31-33 Ryrie Street, Geelong, 3220; D.A.49888/1; 31 August 1980; 2.80 tonne.
- PEAGRAM, W. N., McKeiller Avenue, Mordialloc, 3195; D.A.1790/1; 31 August 1980; 6.05 tonne.
- PETERSVILLE LTD., 254-294 Wellington Road, Mulgrave, 3170; D.A.1813/185; 14 August 1980; 4.25 tonne.
- POPEK, M., Newstead Road, Maldon, 3463; D.A.61477/1; 26 July 1980; 7.95 tonne.
- POWER, J. J., 28 Community Street, Shepparton, 3630; D.A.62069; 19 August 1980; 6.70 tonne.
- RAND, D. B., Lot 17, Kelvin Grove, Centreville, 3910; D.A.52344/3; 12 August 1980; 10.88 tonne.
- RAUSCH, B., 8 Crookston Road, Reservoir, 3073; D.A.62013; 5 August 1980; 1.15 tonne.
- REEDMAN, L., 132 Kidds Road, Doveton, 3177; D.A.65515; 28 August 1980; 6.55 tonne.
- REPCO LTD., 618-640 Elizabeth Street, Melbourne, 3000; D.A.68791/47; 12 August 1980; 0.65 tonne; D.A.1907/67; 12 August 1980; 1.55 tonne; D.A.1907/68; 12 August 1980; 0.70 tonne.
- ROBB, G. A., 16 Wynne Street, Colac, 3250; D.A.68580; 18 July 1980; 0.90 tonne.
- SARTORI, A. G., 79 Wentworth Road, Wonthaggi, 3995; D.A.68570; 11 July 1980; 7.65 tonne.
- NOEL SEARLE PTY. LTD., 115 Sackville Street, Collingwood, 3066; D.A.39317/1; 27 June 1980; 20.00 tonne.
- SKADINS, J., 7 Nebel Street, Lalor, 3075; D.A.63900; 13 July 1980; 7.05 tonne.
- SMYTH & MURPHY PTY. LTD., 33 Gillies Street, Benalla, 3672; D.A.60859/5; 17 June 1980; 3.50 tonne.
- TILBROOK, N. K., 504 High Street Road, Mt. Waverley, 3149; D.A.68600; 2 August 1980; 1.15 tonne and 0.85 tonne trailer.
- TOBIN BROS. PTY. LTD., 425 Flemington Road, North Melbourne, 3051; D.A.3656/2; 7 August 1980; 0.95 tonne.
- WHITE ENGINEERING PTY. LTD., 31 Edelmaier Street, Bayswater, 3153; D.A.66377/4; 18 August 1980; 1.15 tonne.
- WILLIAMSON, R. T., 124 Grant Street, Alexandra, 3714; D.A.524/2; 23 April 1980; 15.00 tonne.

TOW TRUCKS

- AARJENT TOWING & SALVAGE SERVICE PTY. LTD., 136 Weston Street, East Brunswick, 3056; D.A.35190/9; 16 June 1980; 1.45 tonne.
- MANENTI, S., 167 Plenty Road, Preston, 3072; D.A.64227/7; 11 September 1979; 1.95 tonne.
- ROGER MANSON MOTORS PTY. LTD., Main Street, Drouin, 3818; D.A.69300; 14 August 1980; 3.05 tonne.
- SUMMERHILL CRASH REPAIRS (THOMASTOWN) PTY. LTD., 222 Station Street, Thomastown, 3074; D.A.67769/1; 11 July 1980; 1.90 tonne.
- Notice of any objection should be forwarded to reach the Secretary of the Board not later than 18 June 1980.
- Applicants are advised that it will not be necessary to appear on the Hearing Date specified above, unless advised in writing by the Board.
- C. J. V. SMITH, Secretary  
 Corner Lygon and Princes Streets, Carlton, Vic. 3053,  
 Wednesday, 4 June 1980

Survey Co-ordination Act 1958

ASSIGNMENT OF NAMES

PLACE NAMES COMMITTEE

The Place Names Committee hereby gives notice that it has assigned the undermentioned names, in respect of which no objections were received in response to previously published proposals :-

Ref.	Name	Municipality	Location
PN 750	Chirnside Reserve	Shire of Corio	The reserve of 4.86 ha fronting Benjamin Drive and Patullos Road, Lara
PN 750	Haines Reserve	Shire of Corio	The reserve of 4.42 ha abutting Chaucer, Glengate, and Wilkes Streets, Hamlyn Heights
PN 750	Sutcliffe Reserve	Shire of Corio	The reserve of 18.21 ha fronting Plantation Road, Corio

Place Names Committee  
 Department of Crown Lands and Survey  
 2 Treasury Place  
 Melbourne, 3002

P. G. SEWELL, Secretary



*Private Agents Act 1966*

## NOTICE OF RECEIPT OF APPLICATIONS FOR LICENCES UNDER THE PROVISIONS OF THE PRIVATE AGENTS ACT 1966

The Clerk(s) of the Magistrates' Court(s) as listed hereunder hereby give notice that applications, as under, have been lodged for hearing by the said Court(s) on the date(s) specified.

Any person desiring to object to any of such applications must—

- (a) lodge with the respective Clerk of the Magistrates' Court a notice in the prescribed form of his objection and of the grounds thereof ;
- (b) cause a copy of such notice to be served personally or by post upon the applicant at least three days before the hearing of the application ; and
- (c) send or deliver—
  - (i) where the objection is not made by the officer in charge of the police district in which the Court is situated—a copy of the notice to such officer ; and
  - (ii) where the objection is not made by the Registrar or Deputy Registrar—a copy to the Registrar.

Full Name of Applicant*	Place of Abode of Applicant or Nominee	Name of Firm or Corporation	Address for Registration	Type of Licence	Date of Hearing
MAGISTRATES' COURT, MELBOURNE					
Welsh, J. G.	153 Victory Rd, Airport West	Wormald International Security	340 Abbotsford St, North Melbourne	Watchman	24.6.80
Maher, C. J.	15 French St, Mt Waverley	" "	" "	" "	" "
Muratovic, S.	3 Adamson Dr, Endeavour Hills	" "	" "	" "	" "
Northey, I. R.	Unit 2, 66 Westbrook St, East Kew	" "	" "	" "	" "
Olsson, W. J.	15 Timor Pde, Heidelberg West	" "	" "	" "	" "
Roberts, R. L.	12 Ferguson St, Ascot Vale	" "	" "	" "	" "
Robertson, D. T.	42 Brooks St, South Oakleigh	" "	" "	" "	" "
Rose, N. S.	7/5 Station St, Mentone	" "	" "	" "	" "
Silvestri, N.	7 Gloaming Crt, Hill Park	" "	" "	" "	" "
Jones, P. M.	127 Cornwall Rd, Sunshine	" "	" "	" "	" "
Unsworth, G. R.	14 Clauscen St, Lower Templestowe	" "	" "	" "	" "
Accetto, P.	9 Allandale Rd, Boronia	" "	" "	" "	" "
Bleek, H. W.	13 Vine St, Moonee Ponds	" "	" "	" "	" "
Carson, M. J.	Finsbury Rd, Devon Meadows	" "	" "	" "	" "
Cooke, A. A.	11 Powell Cres, Maidstone	" "	" "	" "	" "
Earle, L. W.	3/36 Gellibrand Cres, Reservoir	" "	" "	" "	" "
Edwards, R. C. L.	19 Myrtle St, Werribee	" "	" "	" "	" "
Heinrich, A. C.	20 Guildford Ave, Coolaroo	" "	" "	" "	" "
Kennett, B. R.	1/24 Clarinda Rd, Essendon	" "	" "	" "	" "
Langford, R. J.	45 Watson St, Watsonia	" "	" "	" "	" "

Dated at Melbourne 23 May 1980  
M. J. QUIRK, Clerk of the Magistrates' Court

MAGISTRATES' COURT, PRAHRAN					
Loane, Brian	73 Wheatley Rd, Bentleigh	Mayne Nickless	28 Stephenson St, Richmond	Watchman	20.6.80
Ledger, Bernard	12 Munro St, Brighton	" "	" "	" "	" "
Linton, Francis	32 Royal Cres, Kingslake	" "	" "	" "	" "
Alderson, Paul	21 Cropley Cres, Laverton	" "	" "	" "	" "
Burton, Ronald	109 Wilson St, Brunswick	" "	" "	" "	" "
Allen, Leslie	35 Chapel St, St Kilda	" "	" "	" "	" "
Drysdale, John	18 Orrong Cres, Camberwell	" "	" "	" "	" "

Dated at Prahran 23 May 1980  
J. A. GIDLEY, Clerk of the Magistrates' Court

\* Or in the case of a firm or corporation, of the Nominee

## PRIVATE AGENTS—continued

Full Name of Applicant*	Place of Abode of Applicant or Nominee	Name of Firm or Corporation	Address for Registration	Type of Licence	Date of Hearing
<b>MAGISTRATES' COURT, PRESTON</b>					
Uket, Osman	23 Pinetree Cres, Lalor		23 Pinetree Cres, Lalor	Process Server	26.6.80
Dated at Preston 23 May 1980 J. C. TOBIN, Clerk of the Magistrates' Court					
<b>MAGISTRATES' COURT, SOUTH MELBOURNE</b>					
Krivosija, Michael	9/757 Burwood Rd, East Hawthorn	TNT Group 4 Total Security P/L	425 St Kilda Rd, Melbourne	Watchman	25.6.80
Rapa, Joseph Andrew	10/11 Auburn Gve, East Hawthorn	" "	" "	"	10.6.80
Jones, Wayne John	6 Seborah St, Werribee	" "	" "	"	"
Robertson, Patricia Margaret	2/25 Carisbrook Cres, Lower Plenty	" "	" "	"	"
Dated at South Melbourne 18 May 1980 A. R. BELLIS, Clerk of the Magistrates' Court					
<b>MAGISTRATES' COURT, SPRINGVALE</b>					
Childs, Raymond Ellis	993 Heatherton Rd, Narre Warren North		41 Fairview St, Springvale	Watchman	19.6.80
Dated at Springvale 22 May 1980 P. M. COUTTS, Clerk of the Magistrates' Court					
<b>MAGISTRATES' COURT, YARRAM</b>					
Scolyer, Christopher Ian	Balooing Rd, Woodside	Wormald International Security	340 Abbotsford St, North Melbourne	Watchman	20.6.80
Dated at Yarram 21 May 1980 J. W. KEE, Clerk of the Magistrates' Court					
<b>MAGISTRATES' COURT, COBURG</b>					
Buffham, John Frederick	9 Severn St, Epping	Armaguard (Victoria)	390 St Kilda Rd, Melbourne	Watchman	2.7.80
Dated at Coburg 26 May 1980 J. ISAACS, Clerk of the Magistrates' Court					
<b>MAGISTRATES' COURT, SPRINGVALE</b>					
Zaffiro, Dominic Anthony	36 Stuart St, Noble Park		23 Buckley St, Noble Park	Process Server	18.6.80
Dated at Springvale 26 May 1980 P. COUTTS, Clerk of the Magistrates' Court					
<b>MAGISTRATES' COURT, SPRINGVALE</b>					
Brooks, Norman John	Buchan St, Dandenong		41 Fairview St, Springvale	Watchman	18.6.80
Dated at Springvale 27 May 1980 P. COUTTS, Clerk of the Magistrates' Court					
<b>MAGISTRATES' COURT, OAKLEIGH</b>					
Owen, Alan David	355 Tooronga Rd, Hawthorn East		23 Avondale Gve, Mount Waverley	Watchman	17.6.80
Dated at Oakleigh 26 May 1980 G. J. CONDON, Clerk of the Magistrates' Court					
<b>MAGISTRATES' COURT, YARRAM</b>					
Ferguson, John McKenzie	9 Walpole Crt, Yarram	Wormald International Security	340 Abbotsford St, North Melbourne	Watchman	20.6.80
Dated at Yarram 26 May 1980 J. W. KEE, Clerk of the Magistrates' Court					

\*Or in the case of a firm or corporation, of the Nominee

## PRIVATE AGENTS—continued

Full Name of Applicant*	Place of Abode of Applicant or Nominee	Name of Firm or Corporation	Address for Registration	Type of Licence	Date of Hearing
<b>MAGISTRATES' COURT, PORT MELBOURNE</b>					
Neilson, Ross Alexander	6 Leburnya Cl, Mooroolbark	Armaguard	117 Dow St, Port Melbourne	Watchman	3.7.80
Dated at Port Melbourne 27 May 1980 S. R. MERBACK, Clerk of the Magistrates' Court					
<b>MAGISTRATES' COURT, MELBOURNE</b>					
Watson, Ian Alfred	140 Curtain St, Carlton North	Armaguard	390 St Kilda Rd, Melbourne	Watchman	24.6.80
Dated at Melbourne 27 May 1980 M. J. QUIRK, Clerk of the Magistrates' Court					
<b>MAGISTRATES' COURT, WARRNAMBOOL</b>					
McKenzie, Kenneth John	20 Koroit St, Warrnambool	Armaguard	390 St Kilda Rd, Melbourne	Watchman	17.6.80
Dated at Warrnambool 27 May 1980 P. J. LIVINGSTONE, Clerk of the Magistrates' Court					

\* Or in the case of a firm or corporation, of the Nominee

In the Supreme Court of Victoria—1980 Co. No. 11347—  
In the matter of the Companies Act 1961; and in the matter of a Petition for the Winding Up of M.G.B. STEEL CONSTRUCTIONS PTY. LTD.

Notice is hereby given that a petition for the winding up of M.G.B. Steel Constructions Pty. Ltd. was on 23 May 1980 presented by the Commissioner of Pay-Roll Tax and that the said petition is directed to be heard before the Court sitting at the Practice Court, Law Courts, William Street, Melbourne at the hour of 10.30 o'clock in the forenoon on 17 July 1980 and any Creditor or Contributory of the said company desiring to support or oppose the making of an order on the said petition may appear at the time of hearing by himself or his Counsel for that purpose and a copy of the petition will be furnished to any Creditor or Contributory of the said company requiring the same by the undersigned upon payment of the regulated charge for the same.

The Petitioner's address is 436 Lonsdale Street, Melbourne, in the State of Victoria.

The Petitioner's solicitor is D. Yeaman, Crown Solicitor, of 221 Queen Street, Melbourne.

D. YEAMAN

NOTE—Any person who intends to appear on the hearing of the said petition must serve on or send by post to the abovenamed D. Yeaman notice in writing of his intention so to do. The notice must state the name and address of the person, or, if a firm, the name and address of the firm, and must be signed by the person, or firm, or his, or their solicitor, and must be served, or, if posted, must be sent by post in sufficient time to reach the abovenamed no later than 4.00 o'clock in the afternoon of 16 July 1980.

## Co-operation Act 1958

## PIXIELAND CHILDRENS COMMUNITY CO-OPERATIVE LIMITED

Notice is hereby given in pursuance of section 78 (7) of the Co-operation Act 1958 and section 308 (2) of the Companies Act 1961 that, at the expiration of three months from the date hereof, the name of the aforementioned society will, unless cause is shown to the contrary, be struck off the register and the society will be dissolved.  
Dated 21 May 1980

J. W. BLACKMAN  
Acting Deputy Registrar

## Police Offences Act 1958, No. 6337

## DIVISION 1A—STATE CLASSIFICATION OF PUBLICATIONS BOARD

Take note that the State Classification of Publications Board has classified the following publications in accordance with the provisions of Section 180H (1) of the Police Offences Act 1958.

Each publication shall be subject to the following restrictions:

- It shall not be offered for sale, sold, delivered, exhibited or displayed to any person under the age of 18 years.
- It shall not be made available for inspection or perusal to any person under the age of 18 years.
- It shall not be exhibited or displayed in any place to which persons under the age of 18 years have access or so that it is visible from any such place.
- It shall not be advertised in any manner whatsoever.

## SCHEDULE OF PUBLICATIONS

Title	Distributor
Breast Feeders Vol. 1 No. 3	Venus Enterprises Pty. Ltd.
Color Sperma	Claredale Holdings Pty. Ltd.
Flame No. 1	Claredale Holdings Pty. Ltd.
Fornication No. 2	Venus Enterprises Pty. Ltd.
Happy Hooker, The	Venus Enterprises Pty. Ltd.
Human Insight—May 1980	Gordon & Gotch (A'sia) Ltd.
Internation Cover Models No. 18	Claredale Holdings Pty. Ltd.
Molly	Claredale Holdings Pty. Ltd.
Oui—July 1980	Gordon & Gotch (A'sia) Ltd.
Penthouse—July 1980	Gordon & Gotch (A'sia) Ltd.
Penthouse Variations—April/May 1980	Gordon & Gotch (A'sia) Ltd.
Pillow Talk—April 1980	Gordon & Gotch (A'sia) Ltd.
Playbirds No. 38	Claredale Holdings Pty. Ltd.
Popular Cartoons—July 1980	Gordon & Gotch (A'sia) Ltd.
Rabbit Hutch, The	Claredale Holdings Pty. Ltd.
Romp No. 7	Claredale Holdings Pty. Ltd.
Sex Guide—July 1980	Gordon & Gotch (A'sia) Ltd.
Sex In	Claredale Holdings Pty. Ltd.
Thrust!—Special Edition	Venus Enterprises Pty. Ltd.

J. SMITH, Secretary  
State Classification of Publications Board

## Police Regulation Act 1958

## POLICE FORCE OF VICTORIA

## DETERMINATION NO. 321 OF THE POLICE SERVICE BOARD

The Police Service Board, in pursuance of the powers in that behalf conferred by the *Police Regulation Act 1958*, hereby makes the following Determination (that is to say):—

1. The Determination No. 179 of the Police Service Board of 14 December 1971 and published in the *Government Gazette* of 25 January 1972, as amended, is hereby further amended as follows:—

(a) In the Third Schedule, by deleting the Appendix, and substituting therefor the following:—

## DAILY RATES OF ALLOWANCES FOR PERSONAL EXPENSES OF MEMBERS TRAVELLING ABROAD

Type "A"—Rate is all inclusive.

Type "B"—Rate is the amount specified below, for meals and incidentals plus the actual reasonable cost of accommodation.

Type "C"—Rate is the amount, specified below, for incidentals plus the actual reasonable cost of accommodation and meals.

Country	Currency	Type	Rate
Algeria	A. Dinars	B	169.50
Arab Republic of Egypt	L.E.	B	17.500
Argentina	\$U.S.	B	38
Austria	A.Schilling	B	700
Bahrain	B.Dinars	B	19.50
Bangladesh	Takas	B	289
Belgium	B.Francis	A	3820
Belgium	B.Francis	B	
Brazil—			
Brasilia	\$U.S.	B	25.50
Sao Paulo	\$U.S.	B	34.50
Rio de Janeiro	\$U.S.	B	34
Britain	£Sterling	B	21.80
British Solomon Islands—			
Protectorate—Honiara	\$S.I.	A	41
Protectorate—Honiara	\$S.I.	B	
Protectorate—Elsewhere	\$S.I.	C	6.50
Burma	Kyats	A	196
Burma	Kyats	B	
Canada	\$Can.	B	40
Chile	\$U.S.	B	36.50
China, Peoples Republic of	P.B.Y.	B	22.90
Cyprus	£C	B	13.10
Denmark	D.Krone	A	629
Denmark	D.Krone	B	
Fiji	\$F	A	66.10
Fiji	\$F	B	
Finland	F.Marks	A	353
Finland	F.Marks	B	
France	F.Francis	B	180
French Polynesia	C.F.P.	B	4775
Germany, Democratic Republic of	M.D.N.	B	71
Germany, Federal Republic of	F.R.G.Deutschmarks	B	115
Ghana	New Cedis	A	205
Ghana	New Cedis	B	
Greece	Drachmae	B	1185
Hong Kong	\$H.K.	B	157
India	Rupees	B	195
Indonesia—			
Jakarta	Rupiahs	A	35100
Jakarta	Rupiahs	B	
Elsewhere	Rupiahs	B	16800
Iran	Rials	A	
Iran	Rials	B	2880
Iraq	I.Dinars	A	15.50
Iraq	I.Dinars	B	
Ireland	£Irish	A	43.40
Ireland	£Irish	B	
Israel	\$U.S.	B	50
Italy	Lire	Bt	26000

Country	Currency	Type	Rate
Jamaica	\$U.S.	B	42
Japan	Yen	B	14900
Jordan	J.Dinars	B	14
Kenya	K.Shillings	B	210
Korea, Republic of	Won	A	43000
Korea, Republic of	Won	B	
Kuwait	K.Dinars	B	15.80
Laos	\$U.S.	A	31.70
Laos	\$U.S.	B	
Lebanon	L.L.	B	120
Libya	L.D.	B	7.90
Luxembourg	B.F.	A	2825
Luxembourg	B.F.	B	
Malaysia—			
Kuala Lumpur	\$M	A	151
Kuala Lumpur	\$M	B	
Penang	\$M	A	113
Penang	\$M	B	
Elsewhere	\$M	B	77.50
Malta	£M	B	8.40
Mauritius	Rupees	B	80‡
Mexico	Pesos	B	535
Nauru, Republic of	\$A	A	42.40
Nauru, Republic of	\$A	B	
Nepal	NR's	A	650
Nepal	NR's	B	
Netherlands	N.Florins	A	201
Netherlands	N.Florins	B	
New Caledonia	CFP Francs	B	3840
New Hebrides	N.H. Fr.	A	5030
New Hebrides	N.H. Fr.	B	
New Zealand	\$N.Z.	A	66.00
Nigeria	N.	B	38
Norway	N.Krone	A	497
Norway	N.Krone	B	
Oman	\$A	C	11
Pakistan—Karachi	PRs.	B	250
Papua New Guinea—			
Port Moresby	Kina	A	51.50
Port Moresby	Kina	B	
Elsewhere	Kina	B	22.50
Paraguay	\$U.S.	B	30
Peru	\$U.S.	B	22
Philippines	Pesos	A	530
Philippines	Pesos	B	
Poland	Zloties	B	
Poland	Zloties	B*	710
Portugal	Escudos	B	1660
Qatar	\$A	C	11
Saudi Arabia	S.Riyals	B	163
Singapore	\$S	A	175.50
Singapore	\$S	B	
South Africa	Rand	B	27.50
Spain	Pesetas	B	2920
Sri Lanka—			
Colombo	\$A	A	69.50
Colombo	\$A	B	
Elsewhere	Rupees†	B	170.60
Sudan	Lsd	C	5.600
Sweden	S.Krona	A	506
Sweden	S.Krona	B	
Switzerland	S.Francs	B	86
Syria	S.Pound (LS)	B	179
Tanzania	T.Shillings	B	185
Thailand	Baht	A	1319
Thailand	Baht	B	
Tonga—			
Nuku' alofa	\$T	A	30
Nuku' alofa	\$T	B	
Elsewhere	\$T	C	3.50
Turkey	T.Liras	B	1242
Union of Soviet Socialist Republics	Roubles	B	20.50
United Arab Emirates	\$A	C	11
United Arab Emirates	BD	B	
United States of America—			
New York	\$U.S.	B	46.50
Washington and Los Angeles	\$U.S.	B	43.50
Elsewhere	\$U.S.	B	39.00
Uruguay	\$U.S.	B	19.20
Venezuela	\$U.S.	B	51
Vietnam, Socialist Republic of	Dongs	B	36
Western Samoa—			
Apia	\$WS	A	47-35
Apia	\$WS	B	
Elsewhere	\$WS	C	6-50

Country	Currency	Type	Rate
Yugoslavia	New Dinar	A	925
Yugoslavia	New Dinar	B	
Other Countries	\$A	C	10.00

\* Rate is cost of accommodation and breakfast plus the amount specified for lunch, dinner and incidentals.

† Officers are to receive the \$A equivalent converted at the tourist exchange rate.

‡ Rate is cost of accommodation (including breakfast and dinner) plus the amount specified for lunch and incidentals.

2. This Determination shall come into operation on and from 21 April 1980.

Dated 20 May 1980

B. J. HARDING  
Member of the Police Service Board

N. A. VICKERY  
A Judge of the County Court of Victoria  
Chairman and Member of the Police Service Board

G. DAVIDSON  
Member of the Police Service Board

*Police Regulation Act 1958*

POLICE FORCE OF VICTORIA

DETERMINATION NO. 322 OF THE POLICE SERVICE BOARD

The Police Service Board, in pursuance of the powers in that behalf conferred by the *Police Regulation Act 1958*, hereby makes the following Determination (that is to say):—

1. The Determination No. 179 of the Police Service Board of 14 December 1971, and published in the *Government Gazette* of 25 January 1972, as amended, is hereby further amended as follows:—

(a) In Sub-division VIII of Division III, under the heading "Travelling and Incidental Expenses"—

(i) In paragraph 42, sub-paragraph (6), clause (a), by deleting the amount "\$12 000.00" and substituting therefor the amount "\$13 000.00".

2. This Determination shall come into operation on and from 20 May 1980.

Dated 20 May 1980

N. A. VICKERY  
A Judge of the County Court of Victoria,  
Chairman and Member of the Police  
Service Board

G. DAVIDSON  
Member of the Police Service Board

B. J. HARDING  
Member of the Police Service Board

## Police Regulation Act 1958

## POLICE FORCE OF VICTORIA

## DETERMINATION NO. 323 OF THE POLICE SERVICE BOARD

The Police Service Board, in pursuance of the powers in that behalf conferred by the *Police Regulation Act 1958*, hereby makes the following Determination (that is to say):—

1. The Determination No. 179 of the Police Service Board of 14 December 1971, and published in the *Government Gazette* of 25 January 1972, as amended, is hereby further amended as follows:—

- (a) In paragraph 42, under the heading "Travelling and Incidental Expenses"—
- (i) In sub-paragraph (1), clause (a) (i), by deleting the amount "\$48.00" and substituting therefor the amount "\$54.00".
  - (ii) In sub-paragraph (1), clause (a) (ii), by deleting the amount "\$34.00" and substituting therefor the amount "\$42.00".
  - (iii) In sub-paragraph (1), clause (b), by deleting the amount "\$34.00" and substituting therefor the amount "\$42.00".
  - (iv) In sub-paragraph (2), clause (a) by deleting the amount "\$48.00" and substituting therefor the amount "\$54.00".
  - (v) In sub-paragraph (3), clause (a) (i), (ii), (iii) and clause (b) (i), (ii), (iii), by deleting the amounts "\$2.60" and "\$4.20" where appearing and substituting therefor the amounts "\$3.00" and "\$4.80" respectively.
  - (vi) In sub-paragraph (3), clause (c), by deleting the amount "\$9.40" and substituting therefor the amount "\$10.80".
  - (vii) In sub-paragraph (3), clause (d), by deleting the amount "\$17.00" and substituting therefor the amount "\$20.00".
  - (viii) In sub-paragraph (3), clause (e), by deleting the amounts "\$34.00" and "\$1.42" and substituting therefor the amounts "\$42.00" and "\$1.75" respectively.
  - (ix) In sub-paragraph (3), clause (f), by deleting the amount "\$1.42" and substituting therefor the amount "\$1.75".
  - (x) In sub-paragraph (4), clause (a), by deleting the amount "\$9.40" and substituting therefor the amount "\$10.80".
  - (xi) In sub-paragraph (5), clause (a), by deleting the amount "\$8.60" and substituting therefor the amount "\$9.88".
  - (xii) In sub-paragraph (5), clause (b), by deleting the amount "\$11.35" and substituting therefor the amount "\$13.04".
- (b) In paragraph 43, under the heading "Travelling Expenses—Journey by Rail", by deleting the amount "\$17.00" and substituting therefor the amount "\$20.00".
- (c) In paragraph 44, under the heading "Food and Sleeping Accommodation", by deleting the amount "\$3.90" and substituting therefor the amount "\$4.50".
- (d) In paragraph 45, under the heading "Court", by deleting the amount "\$2.60" and substituting therefor the amount "\$3.00".

- (e) In paragraph 46, sub-paragraph (1), clauses (a), (b) and (c), by deleting the amounts "\$2.60" and "\$4.20" where appearing and substituting therefor the amounts "\$3.00" and "\$4.80" respectively.
- (f) In paragraph 47, under the heading "Living Away from Home Allowance"—
- (i) In sub-paragraph (3), clause (b), by deleting the amounts "\$2.60", "\$4.20" and "\$6.80" and substituting therefor the amounts "\$3.00", "\$4.80" and "\$7.80" respectively.
- (ii) In sub-paragraph (4), clause (a), by deleting the amount "\$9.40" and substituting therefor the amount "\$10.80".
- (iii) In sub-paragraph (4), clause (b) (i), (ii), (iii), by deleting the amounts "\$2.60" and "\$4.20" where appearing and substituting therefor the amounts "\$3.00" and "\$4.80" respectively.
- (g) In paragraph 49, by deleting the expression "15 miles" and substituting therefor the expression "24 kilometres".

2. This Determination shall come into operation on and from 21 April 1980.

Dated 20 May 1980

N. A. VICKERY  
A Judge of the County Court of Victoria,  
Chairman and Member of the Police  
Service Board

G. DAVIDSON  
Member of the Police Service Board

B. J. HARDING  
Member of the Police Service Board

---

*Police Regulation Act 1958*

POLICE FORCE OF VICTORIA

DETERMINATION NO. 324 OF THE POLICE SERVICE BOARD

The Police Service Board, in pursuance of the powers in that behalf conferred by the *Police Regulation Act 1958*, hereby makes the following Determination (that is to say):—

1. The Determination No. 179 of the Police Service Board of 14 December 1971, and published in the *Government Gazette* of 25 January 1972, as amended, is hereby further amended as follows:—

- (a) In paragraph 42, sub-paragraph (6), clause (c) by deleting the amount "\$240.00" where twice appearing and substituting therefor the amount "\$260.00".

2. This Determination shall come into operation on and from 21 April 1980.

Dated 20 May 1980

N. A. VICKERY  
A Judge of the County Court of Victoria,  
Chairman and Member of the Police  
Service Board

G. DAVIDSON  
Member of the Police Service Board

B. J. HARDING  
Member of the Police Service Board



Local Government Act 1958

NOTICE OF CONFIRMATION OF AN ORDER OF THE COUNCIL OF THE CITY OF MELBOURNE ADOPTING A PROPOSAL FOR THE CLOSURE OF PART OF THE WIDTH OF GREY STREET, EAST MELBOURNE TO THROUGH TRAFFIC

Pursuant to the provisions of section 539c of the Local Government Act 1958, the Governor in Council, on 27 May 1980 confirmed an Order of the Council of the City of Melbourne made on 19 November 1979 adopting a proposal with modification for the closure of the south carriageway of Grey Street, East Melbourne to through traffic by the erection of a barrier at the location shown on the plan hereunder.

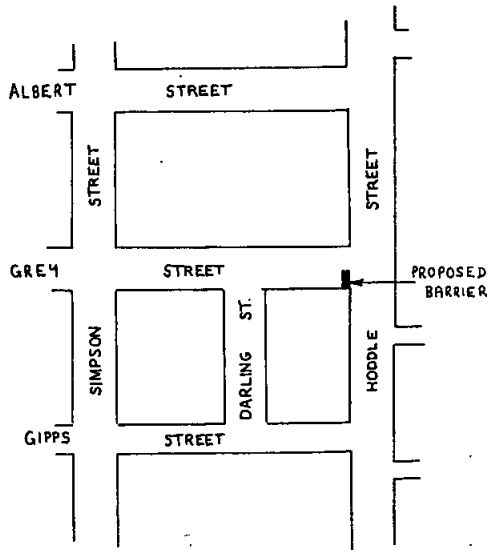

TOM FORRISTAL  
Clerk of the Executive Council

SHIRE OF TALLANGATTA  
Road Deviation Order

Pursuant to the provisions of sections 522 and 526 of the Local Government Act 1958 the Council of the Shire of Tallangatta hereby directs that the land in the Parish of Tatonga indicated by hatching on the diagrams hereunder which have been purchased taken or acquired by it, shall be a public highway on and from the date of publication of this Order in the Government Gazette and declares that such land shall be a public highway in lieu of the land indicated by cross-hatching on the said diagrams.

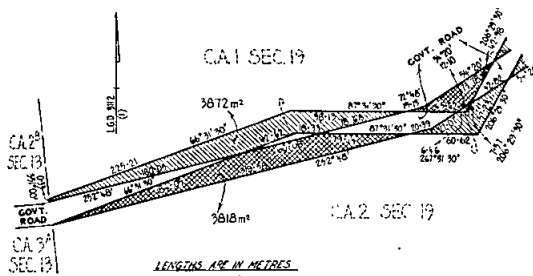

No. 42—21850/80—2

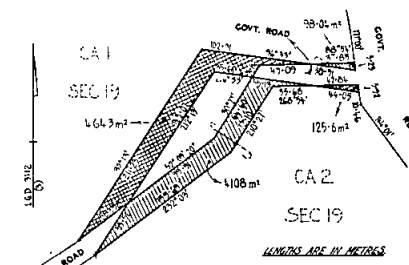
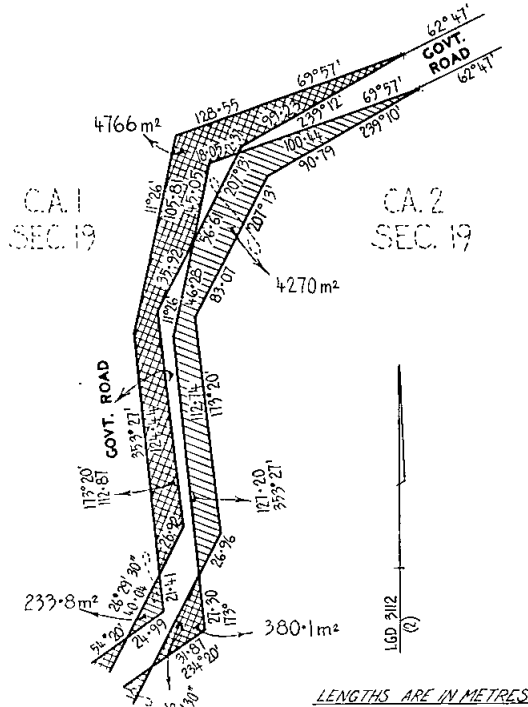

The common seal of the President, Councillors and Ratepayers of the Shire of Tallangatta was hereunto affixed, 21 April 1980—

(SEAL) JAS. H. HARVEY, President  
M. C. FRASER, Councillor  
I. BOWMAN, Secretary

Approved by the Governor in Council, 27 May 1980—  
TOM FORRISTAL, Clerk of the Executive Council

LOCAL GOVERNMENT DEPARTMENT  
ORDER CONFIRMED—CITY OF COBURG

The Minister of the Crown administering the Local Government Act 1958, on 29 May 1980 confirmed the Order hereinafter referred to in pursuance of section 514 of the Local Government Act 1958.

An Order of the Council of the City of Coburg made on 17 September 1979 directing the compulsory taking of the land described hereunder for road widening purposes.

All that piece of land being a 4.572 metre wide strip along the eastern boundary of lot 56 on Plan of Sub-division No. 1755.

All those pieces of land being a 4.572 metre wide strip along the western boundaries of lots 62, 65, 71, 72 and 73 on Plan of Subdivision No. 1755.

D. G. CROZIER  
Minister for Local Government

Local Government Department  
Melbourne, 29 May 1980

LOCAL GOVERNMENT DEPARTMENT  
ORDER CONFIRMED—SHIRE OF BELLARINE

The Minister of the Crown Administering the *Local Government Act 1958*, on 29 May 1980 confirmed the Order hereinafter referred to in pursuance of section 514 of the said Act namely:

An Order of the Council of the Shire of Bellarine made on 7 May 1980 directing the compulsory taking of certain land being the land described by Conveyance No. 709 Book 613 in the Office of the Registrar General for the purpose of providing a place of public resort and recreation.

D. G. CROZIER  
Minister for Local Government

Local Government Department  
Melbourne, 29 May 1980

Melbourne and Metropolitan  
BOARD OF WORKS

NOTICE TO THE OWNERS OF TENEMENTS IN THE UNDER-  
MENTIONED STREETS AND THE PRIVATE STREETS, LANES,  
COURTS AND ALLEYS OPENING THERETO

The main pipe in the said streets being laid down, the owners of all tenements situated as under are hereby required on or before 7 July 1980 to cause a proper pipe and stop cocks to be laid so as to supply water within such tenements from the main pipe.

*Broadmeadows*

Forman Street, from 15 metres west of Bramcote Drive further westwards 16 metres.

Fawcner Street, from Forman Street north-eastwards 108 metres.

Gentles Avenue, from Hume Highway westwards 42 metres.  
Hume Highway, west side from Gentles Avenue to Augusta Avenue.

Gentles Avenue, from 300 metres west of Hume Highway further westwards 74 metres.

*Bulla*

Craigieburn Road West south side, from Bridgewater Road westwards 120 metres.

Bridgewater Road, from Craigieburn Road West southwards 158 metres.

Clovelly Drive, from Bridgewater Road westwards then south-westwards 88 metres.

Dorking Court, total street from Clovelly Drive, northwards.  
Newbold Street, from Bainbridge Close to Carlisle Street, including lot 30, 180 metres.

Carlisle Street, from Newbold Street to Hardy Avenue, including lot 29, 96 metres.

*Diamond Valley*

Bayonne Close, total street from Plenty River Drive southwards then south-westwards.

*Heidelberg*

Walker Court, total street from Banyule Road northwards.

*Kettlor*

Gillespie Road, from 24 metres west of Braeswood Road further westwards 216 metres.

Cheleon Way, from Gillespie Road southwards 18 metres.

*Springvale*

Bridgewater Drive, from Howard Road westwards then northwards 237 metres.

Casco Place, total street from Bridgewater Drive southwards.

*Werribee*

Tarneit Road, from Tamarind Crescent southwards 120 metres.

Magnolia Court, total street from Tarneit Road eastwards.  
Tamarind Crescent, from Tarneit Road eastwards 130 metres.

Argyle Crescent, from Tamarind Crescent northwards 100 metres.

Berrigan Court, total street from Argyle Crescent eastwards.

Nicklaus Drive, from 50 metres southeast of Crampton Court further eastwards 214 metres.

Watson Close, total street from Nicklaus Drive northwards then eastwards.

Von Nida Drive, from Nicklaus Drive southwards 35 metres.

*Whittlesea*

Carlisle Drive, from Northumberland Drive westwards 36 metres.

Northumberland Drive, from 34 metres north of Watford Court further northwards 112 metres.

Pembroke Street, from Northumberland Drive to Ladbroke Street.

Argyll Court, total street from Pembroke Street southwards.

Ladbroke Street, from Buckland Crescent north-westwards 38 metres.

Roxburgh Court, total street from Buckland Crescent westwards.

Durham Court, total street from Buckland Crescent south-eastwards.

Buckland Crescent, from Roxburgh Court to Northumberland Drive.

Northumberland Drive, from Somerset Street to Buckland Crescent 120 metres.

Holburn Way, from Northumberland Drive eastwards 34 metres.

27 May 1980

O. T. W. COSGRIFF  
Secretary

Melbourne and Metropolitan  
BOARD OF WORKS

*Town and Country Planning Act 1961*

MELBOURNE METROPOLITAN PLANNING SCHEME

NOTICE THAT A PLANNING SCHEME HAS BEEN PREPARED  
AND IS AVAILABLE FOR INSPECTION

*Amendment No. 138*

Notice is hereby given that the Melbourne and Metropolitan Board of Works in pursuance of its powers under the *Town and Country Planning Act 1961*, has prepared a Planning Scheme which proposes to amend and vary the Ordinance and to reserve land and to amend and vary land use zonings and reservations of land within the Planning Area of the Melbourne Metropolitan Planning Scheme which was approved by the Governor in Council on 30 April 1968 and notice thereof published in the *Government Gazette* on 22 May 1968.

A copy of the Amending Scheme has been deposited at the office of the Melbourne and Metropolitan Board of Works, 625 Little Collins Street, Melbourne, at the office of the Town and Country Planning Board, 235 Queen Street, Melbourne, and as to so much of the Planning Schemes as relates to land within the municipal district of any municipality at the office of such municipality, and will be open for inspection during office hours, free of charge.

Any persons affected by the Planning Scheme are required to set forth in writing all objections they may have, addressed to the Secretary, Melbourne and Metropolitan Board of Works, Box 4342, Melbourne, 3001, on or before 4 September 1980, and to state whether they wish to be heard in respect of their objections.

Dated 28 May 1980

O. T. W. COSGRIFF  
Secretary

## CONTRACTS ACCEPTED—(Series 1980-82)

SCHEDULE No. 1/76

## PHOTOCOPYING MACHINES AND CONSUMABLES

1 August 1980 to 31 July 1982

1980/204—Nashua Australia Pty. Limited, 523-533 Victoria St, Abbotsford 3067

1980/205—OCE Reprographics Limited, 31 Queensbridge St, South Melbourne 3205

Installation of photocopying machines under this contract must be approved by the Tender Board.

Description of Items	Rate	Name of Contractor
Photocopying machine "Minoltafax 1114TC" including consumables and maintenance	†	Oce Reprographics Limited
† Paper available in widths of:		
210 mm @ \$10.96 per roll	} Minimum order—10 rolls	
216 mm @ \$10.96 per roll		
279 mm @ \$14.65 per roll		
Photocopying machines (as detailed)—		
Existing "Nashua 1210/1215". Minimum monthly billing (3000 copies included)	\$ 57.00	Nashua Australia Pty. Limited
Existing "Nashua 1220DF/1240". Minimum monthly billing (6000 copies included)	94.00	
New "Nashua 1215". Minimum monthly billing (3000 copies included)	67.00	
"Nashua 1220S". Minimum monthly billing (5000 copies included)	92.00	
"Nashua 1230DF". Minimum monthly billing (6000 copies included)	123.00	
"Nashua 1260". Minimum monthly billing (8000 copies included)	222.00	
"Nashua 1250". Minimum monthly billing (6000 copies included)	109.00	
Charge for copies in excess of the volume provided for in above minimum monthly billings	0.09 cents*	
Toner (supplied in kits sufficient for 20 000 copies)	\$ 20.00	

\* The copy charge for Nashua 1220S, 1230DF, 1260 and 1250 machines decreases to 0.08 cents for copies in excess of 10 000.

Approved—L. H. S. THOMPSON, Treasurer—16.5.80

## CONTRACTS ACCEPTED—(Series 1979-80)

## PUBLIC WORKS

His Excellency the Governor of the State of Victoria has by Order made on 27 May 1980 approved of the acceptance by the Minister of Public Works of the under-mentioned offers without public tenders being invited, viz.:

Offer of Geelong Fencing Suppliers for Pinus Treated Fence at Erskine House, Lorne, for the sum of eleven thousand one hundred and eighty-six dollars (\$11 186.00)—(P.W.79004).

Offer of Ken Foster for supply and spreading of crushed rock at Glen Waverley State School Nursery for the sum of thirteen thousand two hundred and twenty dollars (\$13 220.00)—(N.206562).

Offer of the State Schools' Horticultural Society for erection of bluestone retaining wall at Glen Waverley State School Nursery for the sum of eleven thousand six hundred and fifty dollars (\$11 650.00)—(N.204518).

Offer of Ralph Mackie & Staff Pty. Ltd. for brick veneering to relocatable module library at Westall High School for the sum of thirteen thousand four hundred and forty-four dollars (\$13 444.00)—(P.E.20486).

Offer of W. E. Bassett & Partners Pty. Ltd. for Professional Services (Mechanical and Electrical Engineers) at Dromana Technical School, Stage 3, for the sum of twenty-three thousand dollars (\$23 000.00)—(E.18154P).

Offers at the amounts shown for professional services at Hamilton High School—(P.W.79301P).

Vanne Trompf (Hamilton) (Architectural)	\$ 35 000.00
William Andell, Flowers & Associates (Mechanical and Electrical Engineers)	16 000.00

Offer of Ralph Mackie & Staff Pty. Ltd. for renovations to toilet block at Noble Park Primary School No. 3675 for the sum of nineteen thousand four hundred and forty-four dollars (\$19 444.00)—(P.E.20216).

Offer of Bowater Tutt Industries Pty. Ltd. for supply and delivery of 3 No. Post Primary Classrooms to P.W.D. Storeyard, Port Melbourne, for the sum of eighty-eight thousand seven hundred and twenty-five dollars (\$88 725.00)—(B.G.161916).

TOM FORRISTAL

Clerk of the Executive Council

At the Executive Council Chamber  
Melbourne, 27 May 1980

## CONTRACTS ACCEPTED—(Series 1979-80)

## PUBLIC WORKS

Contractor; Description of Works; Amount

Evans Deakin Industries Ltd.; supply of electric Ride-On Towing Tractor, Jika Jika High Security Unit, H.M. Prison, Pentridge, Coburg; \$6540.00—(C.186469K).

TOM AUSTIN

Minister of Public Works

Public Works Department  
Melbourne, 27 May 1980

## CONTRACTS ACCEPTED—(Series 1979-80)

## VICTORIAN RAILWAYS

67. Manufacture, supply, delivery, installation and commissioning of a centralized announcement system for the Metropolitan Train Control Centre Building, Batman Avenue, Melbourne for the amount of \$25 785.00 (Contract 64772)—Syntec Electronic Distributors Pty. Ltd. 68. Manufacture, supply and delivery of precast prestressed concrete deck units for road bridge at Power Street, Hawthorn at rates (Contract 64839)—McDougall-Ireland Pty. Ltd. 69. Collection and disposal of rubbish during the period 1 December 1979 to 30 June 1982 at rates (Contract 64789)—Superior Waste Services Pty. Ltd. 70. Construction of

concrete foundations for Cremorne substation extensions at Richmond for the amount of \$41 750.00 (Contract 64859)—Nicholls Engineers and Constructors Pty. Ltd. 71. Design, supply, delivery and installation of automatic fire protection systems in the Metropolitan Train Control Centre Building, Batman Avenue, Melbourne for the amount of \$236 730.00 (Contract 64717)—Wormald International (Aust.) Pty. Ltd. 72. Design, supply, delivery and installation of an automatic sprinkler system in the administrative offices and amenities areas at Flinders Street Station for the amount of \$148 118.00 (Contract 64528)—Wormald International (Aust.) Pty. Ltd. 73. Design, supply, delivery and installation of an automatic sprinkler system in the Chalet at Mount Buffalo for the amount of \$230 146.00 (Contract 64635)—Wormald International (Aust.) Pty. Ltd. 74. Supply and installation of waterproof surfacing and loose-laid paving slabs in the Metropolitan Train Control Centre Building, Batman Avenue, Melbourne for the amount of \$15 571.00 (Contract 64822)—Building Plastics (Melb.) Pty. Ltd.

By order of the Victorian Railways Board  
I. J. REIHER, Secretary. 2.6.80

*Town and Country Planning Act 1961*  
**GEE LONG REGIONAL PLANNING SCHEME**

NOTICE THAT AN AMENDMENT TO THE GEE LONG REGIONAL PLANNING SCHEME HAS BEEN PREPARED AND IS AVAILABLE FOR INSPECTION

*Amendment No. 12*

Notice is hereby given that the Geelong Regional Commission in pursuance of its powers under the *Town and Country Planning Act 1961*, has prepared an Amendment to the Geelong Regional Planning Scheme for parts of the Geelong Region, for the purpose of regulating, restricting or prohibiting the use and development of land and the reservation of land for public purposes within the said area.

A copy of the Amendment has been deposited at the office of the Geelong Regional Commission, 5th Floor, State Government Offices, corner Little Malop and Fenwick Streets, Geelong, and Bannockburn Shire Council, High Street, Bannockburn; Barrabool Shire Council, 441 Moorabool Street, Geelong; and Bellarine Shire Council, Collins Street, Drysdale (insofar as the Amendment affects this Municipality), and at the office of the Town and Country Planning Board, 235 Queen Street, Melbourne, and will be open for inspection during office hours by any person, free of charge.

Any persons affected by the Amendment are required to set forth in writing all objections they may have, addressed to the Secretary, Geelong Regional Commission, P.O. Box 770, Geelong, 3220, on or before 4 September 1980, and to state whether they wish to be heard in respect of their objections.

G. R. COWLING, Secretary

*Town and Country Planning Act 1961*  
**GEE LONG REGIONAL PLANNING SCHEME**

NOTICE THAT AN AMENDMENT TO THE GEE LONG REGIONAL PLANNING SCHEME HAS BEEN PREPARED AND IS AVAILABLE FOR INSPECTION

*Amendment No. 13*

Notice is hereby given that the Geelong Regional Commission in pursuance of its powers under the *Town and Country Planning Act 1961* has prepared an Amendment to the Geelong Regional Interim Development Order for parts of the Geelong Region for the purpose of regulating, restricting or prohibiting the use and development of land, and the reservation of land for public purposes within the said area.

A copy of the Amendment has been deposited at this office, Geelong Regional Commission, 5th Floor, State Government Offices, corner Little Malop and Fenwick Streets, Geelong, and at Newtown City Council, 269 Pakington Street, Newtown; Geelong West City Council, 153 Pakington Street, Geelong West; South Barwon City Council, 2 Colac Road, Belmont; Corio Shire Council, "Osborne House", Swinburne Street, North Geelong; Barrabool Shire Council, Moorabool Street, South Geelong; Bannockburn Shire Council, High Street, Bannockburn; Bellarine Shire Council, Collins Street, Drysdale; Geelong City Council, Gheringhap Street, Geelong; and Borough

of Queenscliffe, Learmonth Street, Queenscliff (insofar as the Amendment affects those municipalities) and at the offices of the Town and Country Planning Board, 235 Queen Street, Melbourne, and will be open for inspection during office hours by any person free of charge.

Any persons affected by the Amendment are required to set forth in writing all objections they may have, addressed to the Secretary, Mr G. R. Cowling, Geelong Regional Commission, State Government Buildings, corner Little Malop and Fenwick Streets, Geelong, 3220, on or before 4 July 1980 and to state whether they wish to be heard in respect of their objections.

G. R. COWLING, Secretary

*Town and Country Planning Act 1961*  
**GEE LONG REGIONAL INTERIM DEVELOPMENT ORDER**

NOTICE THAT AN AMENDMENT TO THE GEE LONG REGIONAL INTERIM DEVELOPMENT ORDER HAS BEEN PREPARED AND IS AVAILABLE FOR INSPECTION

*Amendment No. 29*

Notice is hereby given that the Geelong Regional Commission in pursuance of its powers under the *Town and Country Planning Act 1961* has prepared an Amendment to the Geelong Regional Interim Development Order for parts of the Geelong Region for the purpose of regulating, restricting or prohibiting the use and development of land, and the reservation of land for public purposes within the said area.

A copy of the Amendment has been deposited at this office, Geelong Regional Commission, corner Little Malop and Fenwick Streets, Geelong, and at Newtown City Council, 269 Pakington Street, Newtown; Geelong West City Council, 153 Pakington Street, Geelong West; Corio Shire Council, "Osborne House", Swinburne Street, North Geelong; Barrabool Shire Council, Moorabool Street, South Geelong; Bannockburn Shire Council, High Street, Bannockburn; Bellarine Shire Council, Collins Street, Drysdale; Geelong City Council, Gheringhap Street, Geelong; Borough of Queenscliffe, Learmonth Street, Queenscliff; and South Barwon City Council, 2 Colac Road, Belmont (insofar as the Amendment affects those municipalities) and at the offices of the Town and Country Planning Board, 235 Queen Street, Melbourne, and will be open for inspection during office hours by any person free of charge.

Any persons affected by the Amendment are required to set forth in writing all objections they may have, addressed to the Secretary, Mr G. R. Cowling, Geelong Regional Commission, P.O. Box 770, Geelong, on or before 4 July 1980 and to state whether they wish to be heard in respect of their objections.

G. R. COWLING, Secretary

*Town and Country Planning Act 1961*  
**SHIRE OF WOORAYL PLANNING SCHEME**

*Revocation No. 3*

*Notice of Revocation*

In pursuance of the provisions of section 32 of the *Town and Country Planning Act 1961* the Governor in Council on 3 June 1980, made an Order:—

- (i) Revoking the Shire of Woorayl Planning Scheme in so far as it applies to Crown Allotments 3 and 4, section 30, Township and Parish of Leongatha being land fronting Yarragon Road, Leongatha and;
- (ii) providing that the land so revoked may be used or developed only as if;
  - (a) it were land to which the Shire of Woorayl Planning Scheme applies;
  - (b) it were land within the Industrial B Zone of that Scheme; and
  - (c) the provisions of Clause 33 (2) (setbacks in the Industrial B zone) do not apply.

A copy of the Order may be inspected during office hours at the office of the Town and Country Planning Board, 235 Queen Street, Melbourne, and at the office of the Council of the Shire of Woorayl at Leongatha.

W. H. CRAIG, Secretary  
Town and Country Planning Board

## DEPARTMENT OF MINERALS AND ENERGY

## MINING LEASES GRANTED

- No. 614; Ian Thomas Derham, Barbara Lois Derham, James William Frederick Thor, Eileen Mabel Thor; 1.3 ha, Parish of Tinamba.
- No. 629; Allan Clement Preston, George Broadbear, Eric James Pitt; 32.3 ha, Parish of Tullyvea.

## EXPLORATION LICENCE CANCELLED

- No. 628; Western Mining Corporation Limited; 726 km<sup>2</sup>, comprising Graticular Blocks Nos. 153, 154, 155, 224, 225, 226, 227, 296, 297, 299 and 368 Melbourne Map Sheet, Counties of Gunbower, Bendigo and Rodney.

## EXPLORATION LICENCES GRANTED

- No. 750; Aberfoyle Exploration Pty. Ltd.; 396 km<sup>2</sup>, comprising Graticular Blocks Nos. 471, 472, 543, 544, 545 and 617 Melbourne Map Sheet, Counties of Bogong and Benambra.
- No. 837; Western Mining Corporation Limited; 462 km<sup>2</sup>, comprising Graticular Blocks Nos. 849, 850, 851, 923, 993, 994 and 995 Hamilton Map Sheet, Counties of Bogong and Kara Kara.

## TAILINGS LICENCES GRANTED

- No. 4327; Shire of Rutherglen; to remove tailings from the "Great Southern Tailings Dump" situated in the Parish of Chiltern West.
- No. 4372; Shire of Bet Bet; to remove tailings from the "Low Slum Dumps" north and south of the Burnt Creek in the Parish of Dunolly.
- No. 4433; Frank Crimeen, Laurence David Crimeen; to remove tailings from two small mullock heaps situated north of the Township of Berriga and  $\frac{1}{4}$  mile from the Birthday Tunnel Mine.
- No. 4459; Paddy O'Brien Pty. Ltd.; to remove tailings from a mullock heap located at the corner of Wall and Albert Streets at Sebastopol.
- No. 4462; A. G. Leech Pty. Ltd.; to remove tailings from the "Gladstone Mine Dump" situated in the Parish of Maryborough.
- No. 4466; Michael Gerard Moloney; to remove tailings from the "Racecourse Mine" situated in the Parish of Haddon.
- No. 4467; Maryborough Public Cemetery Trust; to remove tailings from "Bluchers Mine Sand Dump" situated at Maryborough.
- No. 4472; Forests Commission, Victoria; to remove tailings from the "Tonsil Mine" situated in the Parish of Derril.
- No. 4481; Shire of Talbot and Clunes; to remove tailings located 1 km north-west of the Township of Amherst.
- No. 4503; W. C. Stevens; to remove tailings from the "Moon and Catherine Sand Dumps" situated at Eaglehawk.

## APPLICATION FOR TAILINGS TREATMENT LICENCE REFUSED

- No. 4474; Eric Alan Mead, Stephen Francis Mead; to treat tailings from the "West Ajax Mine Dump" situated in the Parish of Wombat.

J. C. M. BALFOUR  
Minister for Minerals and Energy

## SEARCH LICENCE DECLARED VOID

- No. 1362; Charles Radcliffe Jardine; 20 ha, Parish of Dunolly.

B. W. COURT  
Secretary for Minerals and Energy

## Labour and Industry Act 1958

## ORDER OF EXEMPTION UNDER SECTION 80c

Whereas pursuant to section 80c of the *Labour and Industry Act 1958* as amended by the *Labour and Industry (Further Amendment) Act 1969* the Shire of Bellarine has applied to the Minister for an order exempting certain shopkeepers of shops in its municipal district from being required to close and keep closed their shops in accordance with Part VI. of the said Act.

Now therefore I, James Halford Ramsay, Her Majesty's Minister of Labour and Industry in the State of Victoria, do pursuant to the aforesaid section 80c of the *Labour and Industry Act 1958* make this order granting exemption to

Mr A. R. LANGDON, The Esplanade, Portarlington, in the Shire of Bellarine from being required to close and keep closed his shop on

Saturdays between the hours of 1 p.m. and 5 p.m. and Sundays and public holidays between the hours of 11 a.m. and 4 p.m.

provided that such exemption shall not apply to Good Friday or Anzac Day.

Dated at Melbourne, 30 May 1980

J. H. RAMSAY  
Minister of Labour and Industry

## Labour and Industry Act 1958

## ORDER OF EXEMPTION UNDER SECTION 80c

Whereas pursuant to section 80c of the *Labour and Industry Act 1958* as amended by the *Labour and Industry (Further Amendment) Act 1969* the Shire of Bellarine has applied to the Minister for an order exempting certain shopkeepers of shops in its municipal district from being required to close and keep closed their shops in accordance with Part VI. of the said Act.

Now therefore I, James Halford Ramsay, Her Majesty's Minister of Labour and Industry in the State of Victoria, do pursuant to the aforesaid section 80c of the *Labour and Industry Act 1958* make this order granting exemption to

Mrs G. D. KENNEDY, 38 Newcombe Street, Portarlington, in the Shire of Bellarine, from being required to close and keep closed her shop on

Saturdays between the hours of 1 p.m. and 6 p.m. and Sundays and public holidays between the hours of 10 a.m. and 6 p.m.

provided that such exemption shall not apply to Good Friday or Anzac Day.

Dated at Melbourne, 30 May 1980

J. H. RAMSAY  
Minister of Labour and Industry

## Labour and Industry Act 1958

## ORDER OF EXEMPTION UNDER SECTION 80c

Whereas pursuant to section 80c of the *Labour and Industry Act 1958* as amended by the *Labour and Industry (Further Amendment) Act 1969* the Shire of Bellarine has applied to the Minister for an order exempting certain shopkeepers of shops in its municipal district from being required to close and keep closed their shops in accordance with Part VI. of the said Act.

Now therefore I, James Halford Ramsay, Her Majesty's Minister of Labour and Industry in the State of Victoria, do pursuant to the aforesaid section 80c of the *Labour and Industry Act 1958* make this order granting exemption to

Mr A. R. LANGDON, The Esplanade, Indented Head, in the Shire of Bellarine, from being required to close and keep closed his shop on

Saturdays between the hours of 1 p.m. and 5 p.m. and Sundays and public holidays between the hours of 11 a.m. and 4 p.m.

provided that such exemption shall not apply to Good Friday or Anzac Day.

Dated at Melbourne, 30 May 1980

J. H. RAMSAY  
Minister of Labour and Industry

*Labour and Industry Act 1958*

## ORDER OF EXEMPTION UNDER SECTION 80c

Whereas pursuant to section 80c of the *Labour and Industry Act 1958* as amended by the *Labour and Industry (Further Amendment) Act 1969* the Shire of Bellarine has applied to the Minister for an order exempting certain shopkeepers of shops in its municipal district from being required to close and keep closed their shops in accordance with Part VI. of the said Act.

Now therefore I, James Halford Ramsay, Her Majesty's Minister of Labour and Industry in the State of Victoria, do pursuant to the aforesaid section 80c of the *Labour and Industry Act 1958* make this order granting exemption to

Mr A. R. LANGDON, The Esplanade, St. Leonards, in the Shire of Bellarine from being required to close and keep closed his shop on

Saturdays between the hours of 1 p.m. and 5 p.m. and Sundays and public holidays between the hours of 11 a.m. and 4 p.m.

provided that such exemption shall not apply to Good Friday or Anzac Day.

Dated at Melbourne, 30 May 1980

J. H. RAMSAY  
Minister of Labour and Industry

## STATE RIVERS AND WATER SUPPLY COMMISSION

NOTICE OF INTENTION TO DECLARE FLOOD PRONE AREA  
*Echuca West*

Pursuant to section 35 of the *Drainage of Land Act 1975*, the State Rivers and Water Supply Commission, as the Drainage Authority, proposes on or after 6 August 1980 to request the Governor in Council to proclaim as liable to flooding that land at Echuca West below the 1 per cent. probability flood level within the area generally bounded by the Campaspe River, Luth Street, the Murray Valley Highway and Terricks Road, and more particularly detailed on Plan No. 132615 a copy of which is available for inspection at—

The offices of the State Rivers and Water Supply Commission, 590 Orrong Road, Armadale.

The Municipal Offices of the City of Echuca.

Any objections to the making of this proclamation lodged at the above offices within six weeks of this notice will be considered by the State Rivers and Water Supply Commission before any recommendation is made to the Governor in Council—(Corres. No. 80/1755).

Dated 2 June 1980

R. BIRD, Secretary

## STATE RIVERS AND WATER SUPPLY COMMISSION

## By-Law No. 5877

*Fixing Fees for Connections to the Commission's Water Supply System*

The State Rivers and Water Supply Commission, in pursuance and exercise of powers conferred by the Water Act, doth hereby make the By-law following:—

1. By-law No. 5827 is hereby revoked from 1 June 1980.

2. This By-law shall apply to and have force in the Mount Duneed and Otway Rural Districts, the Antwerp, Bellarine, Berrivillock, Beulah, Birchip, Brim, Carwarp, Chillingollah, Chinkapook, Corop, Cuihoa, Dimboola, Dingee, Dooen, Eildon, Gunbower, Hopetoun, Jeparit, Jung Jung, Koondrook, Lalbert, Lascelles, Leitchville, Lockington, Macorna, Manangatang, Marnoo, Merbein, Meringur, Minyip, Mitiamo, Mornington Peninsula, Murrabit, Nandaly, Natimuk, Newstead, Nullawil, Nyah, Nyah West, Otway, Ouyen, Patchewollock, Piangil, Pimpinio, Pyramid Hill, Quambatook, Rainbow, Red Cliffs, Robinvale, Rupanyp, Sea Lake, Speed, Stanhope, Tallygaroopna, Tempy, Ultima, Upper Beaconsfield, Waitchie, Walpeup, Watchem, Werrimull, Wonthaggi, Woomelang, Woorinen, Wycheproof and Yaapeet Urban Districts, the Urban District supplied with water from the Coliban System of Waterworks, and the Bellarine Peninsula, Mornington Peninsula and Otway Waterworks Districts.

3. As on and from 1 June 1980 fees for connections to the Commission's water supply system in the beforementioned districts shall be calculated as follows using the component charges set out in Clause 4:—

- (a) for new connections—the fee shall be the sum of the Tapping Charge and Meter Charge for that size connection;
- (b) for a connection replacing an existing connection of like or larger size—the fee shall be the Tapping Charge for the new connection size; and
- (c) for a connection replacing an existing connection of smaller size the fee shall be the sum of the Tapping Charge for the new connection and the difference in Meter Charges for the new and existing meter sizes.

4. The component charges to be used to calculate the connection fee are as follows:—

- (a) for connections to rated or rateable properties within Urban and Rural districts and for supplies by agreement from pipelines 300 mm or less where the tapping requires only standard tapping fittings:
  - (i) where the work is performed by the Commission—

Size of Tapping	Tapping Charge	Meter Charge
	\$	\$
20 mm	50	45
25 mm	60	90
32 mm	95	180
40 mm	110	225
Over 40 mm	Actual Cost	Actual Cost

- (ii) where it is not possible for the work to be performed by the Commission and permission is granted to a plumber to perform the work—

the Tapping Charge shall be \$5.00 plus the cost of any materials supplied other than the meter and the Meter Charge shall be as in (i) above.

- (b) for connection to properties supplied by agreement, from pipeline and aqueducts the Tapping Charge shall be the actual cost regardless of tapping size and the Meter Charge shall be as in (a) (i) above, except where the pipeline is of 300 mm diameter or less, and the connection requires only a standard tapping saddle and ferrule cock.

5. Such person or persons as the State Rivers and Water Supply Commission may from time to time appoint for that purpose shall be and is or are hereby authorised to demand, receive, collect and recover the said fees.

The foregoing By-law was made by the Commission on 12 May 1980 and the common seal of the Commission was hereunto affixed, on 12 May 1980, in the presence of—

(SEAL) W. E. BROMFIELD, Commissioner  
J. S. ROGERSON, Commissioner

Approved by the Governor in Council, 20 May 1980—  
Tom FORRISTAL, Clerk of the Executive Council

SHIRE OF RUTHERGLEN WATERWORKS TRUST  
By-Law No. 1*Water Quantities and Scale of Charges*

The Shire of Rutherglen Waterworks Trust in pursuance of and in exercise of the powers conferred by the Water Act 1958 and of any and every other power it thereunto enabling doth hereby make a By-law as follows:—

1. The meter or meters measuring the supply of water to any land or tenement shall be read as near as practicable to twelve months from the date that it was read previously and the quantity of water so measured as having been supplied during the period between any two

successive such readings (hereinafter called "The Meter Year") shall be the basis of the calculations of charges payable under this By-law provided always that where a meter has been installed on any land or tenement during the course of the meter year, the quantity of water measured as having been supplied during the period between the date of such installation and the date of the reading shall be the basis of calculating such charges.

2. Subject as hereinafter provided in respect of any land or tenement rated by the Trust—

(a) The maximum quantity of water to be supplied in any meter year without charge is hereby fixed as a quantity which if charged at 9.9 cents per kilolitre for any meter year would give an amount equal to the amount of the rate payable in respect to the land or tenement for the financial year in which the said meter year ended.

(b) For all water supplied in any meter year in excess of the maximum quantity referred to in paragraph (a) of this Clause, the charge is hereby fixed at 9.9 cents per kilolitre.

3. Subject as in hereafter provided, the charge for water supplied by measure to any property not rated by the Trust is hereby fixed at 9.9 cents per kilolitre.

4. The minimum charge for water supplied by measure to any property not rated by the Trust is hereby fixed at the minimum Annual Charge imposed by the Trust for any land or tenement.

5. The aforesaid charges shall be payable within seven days of demand upon the Owners or Occupiers at the Office of the Trust during normal business hours.

6. The provisions of Clauses 4, 5 and 6 of this By-law shall not apply to any land, tenement or property supplied with water by the Trust under a Special Agreement pursuant to section 215 of the Water Act 1958.

Resolution for passing this By-law agreed to by the Trust on 22 April 1980 and the Common Seal of the Shire of Rutherglen Waterworks Trust was hereto affixed, in the presence of:—

(SEAL) BRIAN S. JASPER, Chairman  
S. T. DOWNS, Commissioner  
W. J. MCQUILLEN, Secretary

Approved, 19 May 1980—F. J. GRANTER, Minister of Water Supply

#### LEONGATHA WATERWORKS TRUST

##### INCREASING THE LIMIT OF BANK OVERDRAFT

His Excellency the Governor of the State of Victoria by and with the advice of the Executive Council thereof doth by Order made on 3 June 1980 increase the total amount of the sums which the Leongatha Waterworks Trust may owe at any one time in respect of moneys borrowed by overdraft of current account pursuant to the provisions of section 288 of the Water Act 1958, fixed by the Governor in Council on 16 September 1975, at One hundred thousand dollars (\$100 000), to Two hundred thousand dollars (\$200 000).

TOM FORRISTAL  
Clerk of the Executive Council

At the Executive Council Chamber  
Melbourne, 3 June 1980

#### BALMORAL WATERWORKS TRUST

##### ANNUAL BALANCE

His Excellency the Governor of the State of Victoria, by and with the advice of the Executive Council thereof, doth by Order made on 27 May 1980 in pursuance of the provisions of the Water Act, fix 30 September in each year as the day to which the accounts of the Balmoral Waterworks Trust shall be balanced.

TOM FORRISTAL  
Clerk of the Executive Council

At the Executive Council Chamber  
Melbourne, 27 May 1980

#### KING PARROT CREEK RIVER IMPROVEMENT TRUST By-Law No. 13

##### King Parrot Creek River Improvement Trust

In pursuance and exercise of the powers conferred by the River Improvement Act 1958 doth hereby make the following By-Law.

1. The following rate, to be called the King Parrot Creek River Improvement rate, is hereby made and shall be levied upon the occupiers or owners of all properties within the King Parrot Creek River Improvement District which are rateable to any municipality.

A rate of point two of one cent in the dollar on the site value of such properties.

Provided that the sum of Four dollars shall be the minimum amount payable in respect of any property liable to be rated in the said division.

2. Such rates are made and shall be levied for the period beginning 1 January 1980 and ending with 31 December 1980 and shall be payable on 15 July 1980 to the Secretary, P.O. Box 70, Kilmore, 3601.

3. Such person or persons as the King Parrot Creek River Improvement Trust may from time to time appoint for that purpose shall be and is or are hereby authorized to demand, receive, collect and recover the said rate.

The foregoing By-Law was made by the King Parrot Creek River Improvement Trust on 9 May 1980 and the common seal of the said Trust was hereto affixed, 9 May 1980, in the presence of—

(SEAL) GERALD J. TEHAN, Chairman  
K. LAND, Commissioner  
R. G. MACARTNEY, Secretary

Approved, 26 May 1980—F. J. GRANTER, Minister of Water Supply

#### Education Act 1958

##### NOTICE OF THE MAKING OF ORDERS UNDER SECTION 13 (4) OF THE ACT

Pursuant to section 13 of the Education Act 1958 I hereby give notice that Orders of the Governor in Council were made on 27 May 1980 under sub-section (4) of the said Act amending certain provisions relating to the membership of the State Primary School Councils listed hereunder.

528 Riddells Creek Primary School	3495 Appin South Primary School
1211 Strathfieldsaye Primary School	3515 Mallacoota Primary/Central School
1578 Keilor Primary School	3551 Belgrave South Primary School
1848 Drummond Primary School	3773 The Victorian School for Deaf Children
1924 Drouin Primary School	3780 South Merbein Primary School
1975 Morang South Primary School	3806 Pender's Grove Primary School
2093 Little Bendigo Primary School	3824 Ascot Vale Special School
2185 Trafalgar Primary School	3916 Echuca West Primary School
2188 Kinglake Primary School	3924 Devon Meadows Primary School
2219 Glen Waverley Primary School	3982 Gladysdale Primary School
2647 Ecklin South Primary School	4324 Seaspray Primary School
2744 Orbost Primary School	4332 Anglesea Primary School
2820 Seville Primary School	4428 Nilma North Primary School
2837 Moreland Primary School	4496 Nirranda Primary School
3100 Ocean Grove Primary School	4662 Moe Primary School
3165 Meenyan Primary School	4748 Shannon Park Special School
3397 Wando Vale Primary School	4753 Rosanna Golf Links Primary School
3401 Nyora Primary School	4914 Glen Devon Primary School
3433 Marlo Primary School	

4916 Ruskin Park Primary School	5180 Kismet Park Primary School
4921 Doveton North Primary School	5185 Mandama Primary School
5009 Manchester Primary School	6255 Tongala Consolidated School
5029 Broadmeadows West Primary School	4761 Yarrunga Primary School
5054 Marlborough Primary School	4818 Sunvale Primary School
5082 Kent Park Primary School	4826 Merrilands Primary School
5088 Mooroopna Park Primary School	4832 Sussex Heights Primary School
5168 Serpell Primary School	4986 Highvale Primary School
5179 Albanvale Primary School	4784 Doveton Primary School

ROBERT MACLELLAN  
Acting Minister of Education

#### PUBLIC TRUSTEE ACT 1958, SECTION 17

I hereby give notice that on 13 May 1980, the Public Trustee filed elections to administer the following deceased persons' estates in accordance with section 17 of the *Public Trustee Act 1958*.

JENSEN, RITA, late of Flat 6/3 Scarborough Drive, Moorabbin, spinster, died 25 February 1980.

MARTIN, JAMES LAURENCE WILFRED, late of 15 Kookaburra Avenue, Bendigo, retired Country Roads Board employee, died 29 September 1979.

I hereby give notice that on 22 May 1980, the Public Trustee filed elections to administer the following deceased persons' estates in accordance with section 17 of the *Public Trustee Act 1958*.

DARE, JOHN, late of Broadwood, New Zealand, tea room proprietor, died 19 July 1979.

FOGELMAN, ELIZABETH HULDA, formerly of Cresthaven Private Nursing Hospital, 26 Lightwood Road, Springvale, late of Kew, widow, died 10 February 1980.

HUNTER, VERONICA MARGARET, also known as Margaret Timothee, late of 400 Station Street, North Carlton, widow, died 6 March 1980.

MEREDITH, IVY WINIFRED, late of Mont Park, retired wardsmaid, died 28 August 1979.

WELHAM, ALAN HENRY, late of 265 Gooch Street, Thornbury, fitter, died 21 January 1980.

P. T. SPENCER  
Public Trustee

168 Exhibition Street, Melbourne, 3000  
28 May 1980

DARE, JOHN, late of Broadwood, New Zealand, tea room proprietor, died 19 July 1979.

DOUGLAS, ELAINE ANNET, late of 77 Mullum Road, Ringwood, married woman, died 1 February 1980.

FOGELMAN, ELIZABETH HULDA, formerly of Cresthaven Private Nursing Hospital, 26 Lightwood Road, Springvale, late of Kew, widow, died 10 February 1980.

GIBTON, MABEL ANNIE JANE, late of 9 Locksley Road, Ivanhoe, widow, died 1 April 1980.

GRAY, ELSIE MAY, late of 31 Tongue Street, Yarraville, widow, died 28 February 1980.

HILDEBRAND, EDWARD JOHN, late of 117 Suffolk Road, Sunshine, retired railway employee, died 26 March 1980.

HOGG, ADELIN WILHELMINA, also known as Adeline Hogg, late of 39 Halpin Street, West Brunswick, widow, died 25 March 1980.

HUNTER, VERONICA MARGARET, also known as Margaret Timothee, late of 400 Station Street, North Carlton, widow, died 6 March 1980.

JENSEN, RITA, late of Flat 6/3 Scarborough Drive, Moorabbin, spinster, died 25 February 1980.

KIELY, PATRICK JOHN, late of 18 Charon Street, Brooklands, Christchurch, New Zealand, retired carrier, died 30 August 1958.

LANNING, MAISIE GWENDOLINE, late of Unit 2, 97 Pump-ton Avenue, Glenroy, widow, died 21 November 1979.

LEO, JAMES ANGELO, formerly of 74 Richardson Street, Albert Park, late of Llandyssl Private Nursing Home, 4 Scott Street, Essendon, retired railway employee, died 15 December 1979.

MARTIN, JAMES LAURENCE WILFRED, late of 15 Kookaburra Avenue, Bendigo, retired Country Roads Board employee, died 29 September 1979.

MAXFIELD, IVOR LAWSON, late of 129 Page Street, Albert Park, retired compositor, died 9 August 1979.

MEREDITH, IVY WINIFRED, late of Mont Park, retired wardsmaid, died 28 August 1979.

MUNDY, FREDERICK GEORGE BERNARD, late of 49 St. Leonards Road, Ascot Vale, retired, died 9 January 1980.

O'CONNELL, MARIE TERESA, late of 70 Richelieu Street, Maidstone, widow, died 9 March 1980.

PIRANI, ESTELLA DAISY, late of 18 Hope Street, Glen Iris, widow, died 26 February 1980.

SMITH, DONALD FREDERICK, late of 2 Harris Street, Blackburn, retired life assurance officer, died 21 March 1980.

WELHAM, ALAN HENRY, late of 265 Gooch Street, Thornbury, fitter, died 21 January 1980.

WESCOTT, ROBERT FREDERICK, late of 263 Station Street, North Carlton, retired carpenter, died 6 February 1980.

Melbourne, 28 May 1980

P. T. SPENCER  
Public Trustee

Creditors, next of kin, and others having claims against the estate of any of the under-mentioned deceased persons are required to send particulars of their claims to the Public Trustee, 168 Exhibition Street, Melbourne, Vic. 3000, the personal representative, on or before 11 August 1980, after which date the Public Trustee may convey or distribute the assets having regard only to the claims of which the Public Trustee then has notice:—

BLACK, RONALD WILLIAM, formerly of 18 Phoenix Street, Sunshine, but late of 176 Mont Albert Road, Canterbury, painter, died 26 January 1980.

BLACKLEY, PATRICIA EILEEN, formerly of 7 Tweedside Street, Essendon, but late of Unit 2, 394 Station Street, Bonbeach, widow, died 18 February 1980.

BLACKNEY, SIDNEY GEORGE, also known as Sydney George Blackney, late of care of Hume Court, Bank Street, Lara, retired fisherman, died 11 February 1980.

CAIRNES, ALAN EDWARD, late of 4 Pardy Street, Pascoe Vale, salesman, died 18 December 1979.

CORN, GEORGE PERCY, late of 36 Kooyong Road, North Caulfield, retired, died 2 April 1980.

## APPOINTMENTS AND RESIGNATIONS

### APPOINTMENTS

His Excellency the Governor of the State of Victoria, by and with the advice of the Executive Council thereof, has, by Orders made on 27 May 1980, been pleased to make the under-mentioned appointments, viz.:—

DEPARTMENT OF CROWN LANDS AND SURVEY

#### Bailiffs of Crown Lands

RAYMOND WILLIAM ELLIS and  
TERENCE COLE  
to be Bailiffs of Crown lands pursuant to the provisions of section 30 of the *Land Act 1958* in respect of the Crown lands situated within the municipality of the City



of Chelsea which have been placed under the control of the said municipality as a Committee of Management, and with authority to enforce all the regulations made with respect to the care, protection and management of the said reserves.

## HEALTH COMMISSION

*Member of Medical Board of Victoria*

MARGARET McLAREN SUSSEX, M.B., B.S., to be a Member of the Medical Board of Victoria pursuant to the provisions of section 4 of the *Medical Practitioners Act 1970* for the remainder of the period ending 15 July 1981, vice Dr L. E. Rothstadt.

*Deputy Superintendents*

ALAGAPPA ARUMUGAM, M.B., B.S., D.P.M., M.R.A.N.Z.C.P., to be Deputy Superintendent of the Larundel Psychiatric Hospital and Mental Hospital pursuant to the provisions of section 26 (1) of the *Mental Health Act 1959* as from 12 May 1980, vice Dr D. P. Leonard, promoted.

DILEEP SINGH RASTOGI, M.B., B.S., M.R.A.N.Z.C.P., to be Deputy Superintendent of the Royal Park Psychiatric Hospital pursuant to the provisions of section 26 (1) of the *Mental Health Act 1959* for the period 12 May 1980 to 18 May 1980, vice Dr H. D. Chopra, on leave.

## LAW DEPARTMENT

*Justices of the Peace*

ROBERT WINSTANLEY BARNES, 18 Gaynor Crescent, Glen Waverley,  
ANN DUNKLEY, 11 Sheppard Street, Moorabbin,  
PETER ALBERT FERNE, 9 Anthony Street, Melbourne,  
COLIN RUSSELL FINDLAY, Plenty Road, Bundoora,  
PATRICK JOSEPH FITZPATRICK, 16 Victoria Street, Numurkah,  
CHRISTOPHER FOX, 62 The Terrace, Ocean Grove,  
ALAN BEAUMONT HALL, 81A-85 King George Street, Cohuna,  
FREDERICK ALFRED JOHN HUNT, 20 Tarnard Drive, Braeside,  
JOHN WILSON IRVING, 9 Valley Road, Skye,  
TERENCE JOHN MEAD, 3A Moore Street, Moe,  
LAWRENCE GEORGE MORISON, 3 Martin Street, Seaford, and  
MARIE THERESE WALLACE, 4 Bolac Street, Bayswater, to be Justices of the Peace for the State of Victoria.

*Commissioners for Taking Declarations, &c.*

WILLIAM JOHN BAKER, 50 Moore Street, Moe,  
PAUL RICHARD BECK, 50 Moore Street, Moe,  
PETER GEORGE CHRISTIE, Chadstone,  
KEITH LENARD CORMICAN, 330 Wyndham Street, Shepparton,  
BRIAN COX, 171 City Road, South Melbourne,  
EMILIO DELEIDI, 21 Lowson Street, Fawkner,  
MICHAEL DEMKIW, 2 Trentwood Avenue, North Balwyn,  
RINO JULIUS DIDONATO, 718 Burwood Highway, Ferntree Gully,  
FREDERICK GARY ECKEL, 40 Hotham Street, Traralgon,  
BRIAN FARTHING, 60 Albert Road, South Melbourne,  
IAN PATTERSON HENDRY, 40 Hotham Street, Traralgon,  
BARRY KINGSLEY JOHNSON, 267 Collins Street, Melbourne,  
ROD KENNEDY, 8-84 Canning Street, Carlton,  
ALEXANDER GEORGE LEVELL, Greig Street, Korong Vale,  
GARY GEORGE NIXON, 114 William Street, Melbourne,  
WILLIAM CHARLES PIMM, 13 George Street, Morwell,  
BRIAN JOHN SAW, Seymour, Victoria, and  
LENARD VICTOR VANSTONE, 192 Raymond Street, Sale, to be Commissioners for taking Declarations and Affidavits under the *Evidence Act 1958*.

TOM FORRISTAL  
Clerk of the Executive Council

At the Executive Council Chamber  
Melbourne, 27 May 1980

*Vermin and Noxious Weeds Act 1958*

## APPOINTMENT OF AN INSPECTOR

It is hereby notified that the Public Service Board in exercise of its powers has appointed the under-mentioned person as an Inspector under the provisions of section 4 of the *Vermin and Noxious Weeds Act 1958*, without additional salary:

PETER RONALD CODD.

C. E. MIDDLETON  
Secretary for Lands

Melbourne, 2 June 1980

*Liquor Control Act 1968*

## APPOINTMENT OF LICENSING INSPECTORS

Whereas on the 6 February 1980, Sinclair Imrie Miller, the Chief Commissioner of Police for the State of Victoria acting pursuant to the power vested in him by Section 6A of the *Police Regulation Act 1958* delegated to me the undersigned David John Swanson being an Assistant Commissioner of Police for the said State and the person referred to in the said delegation all powers and functions vested in him by the *Liquor Control Act 1968*, from 6 February 1980, now therefore I do hereby appoint the following Officer of Police as a Licensing Inspector for the Division of the Police District as shown:

Division Number	Police District	Rank and Name
4	Altona	Inspector Brian Brown (from 1.6.80 to 30.6.80)
		D. J. SWANSON Assistant Commissioner (Services)

29.5.1980

## REVOCATION OF APPOINTMENT

His Excellency the Governor of the State of Victoria, by and with the advice of the Executive Council thereof, has, by Order made on 27 May 1980, revoked the appointment of the person named hereunder to the office mentioned, viz.:—

DEPARTMENT OF CROWN LANDS AND SURVEY  
*Bailiff of Crown Lands*

THOMAS VALENTINE FIELD  
as a Bailiff of Crown lands pursuant to the provisions of section 30 of the *Land Act 1958* in respect of the Crown lands situated within the municipality of the City of Chelsea which have been placed under the control of the said municipality as a Committee of Management.

TOM FORRISTAL  
Clerk of the Executive Council

At the Executive Council Chamber  
Melbourne, 27 May 1980

## RESIGNATIONS

His Excellency the Governor of the State of Victoria, by and with the advice of the Executive Council thereof, has, by Orders made on 27 May 1980 accepted the resignations of the persons named hereunder of the office mentioned, viz.:—

## LAW DEPARTMENT

*Commissioners for Taking Declarations, &c.*

JOHN ALFRED BANNISTER,  
CARYL LOXTON,  
TERENCE JOHN CHANDLER,  
PHILIP EDWARD COOK,  
HECTOR AUBREY CRAIG, and  
LAWRENCE GEORGE MORISON,  
as Commissioners for taking Declarations and Affidavits under the *Evidence Act 1958*.

TOM FORRISTAL  
Clerk of the Executive Council

At the Executive Council Chamber  
Melbourne, 27 May 1980

**ORDERS IN COUNCIL**

**LOCAL GOVERNMENT ACT 1958**

At the Executive Council Chamber, Melbourne, the  
twenty-seventh day of May, 1980

PRESENT:

His Excellency the Governor of Victoria  
Mr Haddon Storey | Mr Crozier  
Mr Ramsay

**CONFIRMATION OF SEPARATE RATE—CITY OF HEIDELBERG**

In pursuance of the provisions of section 287 of the *Local Government Act 1958*, His Excellency the Governor of the State of Victoria, by and with the advice of the Executive Council thereof, hereby confirms a separate rate of nought point nought two eight five (0.0285) cents in the dollar on the site value of the properties described hereunder, which rate was made by the Council of the City of Heidelberg on 18 February 1980 for the purpose of providing car parking facilities, landscaping and other ancillary works for the Moresby Court, West Heidelberg, Shopping Centre.

Properties to be rated at 0.0285 cents in the dollar on site value

Nos. 1, 3, 5-7, 9, 11, 13, 15, 17, 19, 21-23, 25, 27 Moresby Court, West Heidelberg.

And the Honorable Digby Glen Crozier, Her Majesty's Minister for Local Government for the State of Victoria, shall give the necessary directions herein accordingly.

TOM FORRISTAL  
Clerk of the Executive Council

**LOCAL GOVERNMENT ACT 1958**

At the Executive Council Chamber, Melbourne, the  
twenty-seventh day of May, 1980

PRESENT:

His Excellency the Governor of Victoria  
Mr Haddon Storey | Mr Crozier  
Mr Ramsay

**ROADS DISCONTINUED—SHIRE OF TAMBO**

Whereas it is provided in section 528 (2) of the *Local Government Act 1958*, that where a road (whether or not a public highway but not being a road set out on land of the Crown) or any part thereof is not required for public use the Governor in Council on the request of the council of the municipality in which such road is situated made not less than one month after publishing in a newspaper generally circulating in the district and posting to the registered proprietor (if any) of the land and the owners and occupiers (if any) of lands abutting or immediately adjacent to the road notice of intention to make such a request may by Order published in the *Government Gazette* direct that such road or part shall be discontinued and thereupon such road or part shall be discontinued accordingly:

And whereas it is further provided that where a planning scheme under the *Town and Country Planning Act 1961* provides for the closing of a road or part of a road and notice of approval of the planning scheme has been published in the *Government Gazette*, it shall not be necessary for the council to publish or to post to any person notice of its intention to request the Governor in Council to discontinue such road or part thereof:

And whereas the Shire of Tambo (Lakes Entrance) Planning Scheme provides that parts of roads off Myer Street, Lakes Entrance are not required for public use and notice of approval of the planning scheme was published in the *Government Gazette* of 10 November 1976:

And whereas the Council of the Shire of Tambo has requested that the Governor in Council direct that the said parts of roads be discontinued:

Now therefore, His Excellency the Governor of the State of Victoria, by and with the advice of the Executive Council thereof, hereby directs:—

- (a) that the said parts of roads which are shown by hatching and cross-hatching on the plans hereunder shall be discontinued;
- (b) that notwithstanding such discontinuance the Lakes Entrance Sewerage Authority shall continue to have and possess the same right title power authority or interest in or in relation to the whole of the land shown by cross-hatching on the said plan marked L.G.D.3274 (2) as it had or possessed prior to such discontinuance with respect to or in connection with any drains or pipes laid or erected in on or over such land for the purposes of sewerage; and
- (c) that subject to any such right title power authority or interest, the land shown hatched on the said plan marked L.G.D.3274 (1) may be sold by the Council of the Shire of Tambo by agreement and the land shown hatched and cross-hatched on the said plan marked L.G.D.3274 (2) shall be sold by the Council of the Shire of Tambo by public auction.

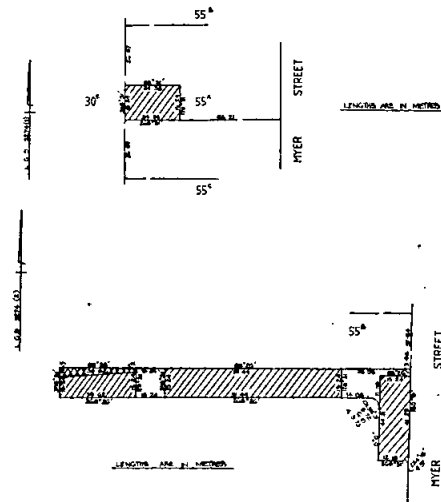

And the Honorable Digby Glen Crozier, Her Majesty's Minister for Local Government for the State of Victoria, shall give the necessary directions herein accordingly.

TOM FORRISTAL  
Clerk of the Executive Council

**STATE ELECTRICITY COMMISSION ACT 1958, No. 6377**

At the Executive Council Chamber, Melbourne, the  
twenty-seventh day of May, 1980

PRESENT:

His Excellency the Governor of Victoria  
Mr Haddon Storey | Mr Crozier  
Mr Ramsay

Whereas His Excellency the Governor of the State of Victoria, by and with the advice of the Executive Council thereof, has this day consented pursuant to the provisions of the *State Electricity Commission Act 1958* to the State Electricity Commission of Victoria raising by way of a

loan the sum of Five hundred thousand dollars (\$500 000): And whereas the Governor in Council is satisfied that a sufficient proportion of the loan to be raised will fall due and be repaid in each year during the currency of the proposed loan: Now therefore, it is directed pursuant to the provisions of section 91 (3) of the said Act, that it shall not be necessary to provide a sinking fund in connection with such loan.

And the Honorable Lindsay Hamilton Simpson Thompson, Her Majesty's Treasurer for the State of Victoria, shall give the necessary directions herein accordingly.

TOM FORRISTAL  
Clerk of the Executive Council

#### COUNTRY FIRE AUTHORITY ACT 1958

At the Executive Council Chamber, Melbourne, the  
twenty-seventh day of May, 1980

PRESENT:

His Excellency the Governor of Victoria	
Mr Haddon Storey	Mr Crozier
Mr Ramsay	

#### CONSENT TO BORROWING FIFTY THOUSAND DOLLARS BY THE COUNTRY FIRE AUTHORITY

Whereas:

1. By section 82 of the *Country Fire Authority Act 1958*, it is enacted that the Country Fire Authority, with the consent of the Governor in Council may, from time to time, borrow such moneys as it deems necessary in order to enable it to carry out and perform the powers, authorities and duties vested in or conferred or imposed upon it by the said Act:
2. The Country Fire Authority deems it necessary to borrow the sum of Fifty thousand dollars for the purposes aforesaid:

Now therefore, His Excellency the Governor of the State of Victoria, in the Commonwealth of Australia, by and with the advice of the Executive Council of the said State and in pursuance of the powers conferred by the said section 82 of the *Country Fire Authority Act 1958* and all other powers him thereunto enabling, doth by this Order consent to the borrowing by the Country Fire Authority of the sum of Fifty thousand dollars (\$50 000) for a period of fifteen (15) years, to be repaid on 1 June 1995 with interest meantime at the rate of 12.0 per centum per annum payable half-yearly.

And the Honorable Lindsay Hamilton Simpson Thompson, Her Majesty's Minister for Police and Emergency Services, for the State of Victoria, shall give the necessary directions herein accordingly.

TOM FORRISTAL  
Clerk of the Executive Council

#### COUNTRY FIRE AUTHORITY ACT 1958

At the Executive Council Chamber, Melbourne, the  
twenty-seventh day of May, 1980

PRESENT:

His Excellency the Governor of Victoria	
Mr Haddon Storey	Mr Crozier
Mr Ramsay	

#### CONSENT TO BORROWING THREE HUNDRED AND THIRTY-FIVE THOUSAND DOLLARS BY THE COUNTRY FIRE AUTHORITY

Whereas:

1. By section 82 of the *Country Fire Authority Act 1958*, it is enacted that the Country Fire Authority, with the consent of the Governor in Council may,

from time to time, borrow such moneys as it deems necessary in order to enable it to carry out and perform the powers, authorities and duties vested in or conferred or imposed upon it by the said Act:

2. The Country Fire Authority deems it necessary to borrow the sum of Three hundred and thirty-five thousand dollars for the purposes aforesaid:

Now therefore, His Excellency the Governor of the State of Victoria, in the Commonwealth of Australia, by and with the advice of the Executive Council of the said State and in pursuance of the powers conferred by the said section 82 of the *Country Fire Authority Act 1958* and all other powers him thereunto enabling, doth by this Order consent to the borrowing by the Country Fire Authority of the sum of Three hundred and thirty-five thousand dollars (\$335 000) for a period of fifteen (15) years to be repaid on 1 June 1995 with interest meantime at the rate of 11.2 per centum per annum payable half-yearly.

And the Honorable Lindsay Hamilton Simpson Thompson, Her Majesty's Minister for Police and Emergency Services, for the State of Victoria, shall give the necessary directions herein accordingly.

TOM FORRISTAL  
Clerk of the Executive Council

#### COUNTRY FIRE AUTHORITY ACT 1958

At the Executive Council Chamber, Melbourne, the  
twenty-seventh day of May, 1980

PRESENT:

His Excellency the Governor of Victoria	
Mr Haddon Storey	Mr Crozier
Mr Ramsay	

#### CONSENT TO BORROWING TWO HUNDRED AND FIFTY THOUSAND DOLLARS BY THE COUNTRY FIRE AUTHORITY

Whereas:

1. By section 82 of the *Country Fire Authority Act 1958*, it is enacted that the Country Fire Authority, with the consent of the Governor in Council may, from time to time, borrow such moneys as it deems necessary in order to enable it to carry out and perform the powers, authorities and duties vested in or conferred or imposed upon it by the said Act:
2. The Country Fire Authority deems it necessary to borrow the sum of Two hundred and fifty thousand dollars for the purposes aforesaid:

Now therefore, His Excellency the Governor of the State of Victoria, in the Commonwealth of Australia, by and with the advice of the Executive Council of the said State and in pursuance of the powers conferred by the said section 82 of the *Country Fire Authority Act 1958* and all other powers him thereunto enabling, doth by this Order consent to the borrowing by the Country Fire Authority of the sum of Two hundred and fifty thousand dollars (\$250 000) for a period of ten (10) years, to be repaid on 1 June 1990 with interest meantime at the rate of 12.0 per centum per annum payable half-yearly.

And the Honorable Lindsay Hamilton Simpson Thompson, Her Majesty's Minister for Police and Emergency Services, for the State of Victoria, shall give the necessary directions herein accordingly.

TOM FORRISTAL  
Clerk of the Executive Council

COUNTRY ROADS BOARD  
Act No. 6229

At the Executive Council Chamber, Melbourne, the  
twenty-seventh day of May, 1980

PRESENT:

His Excellency the Governor of Victoria  
Mr Haddon Storey | Mr Crozier  
Mr Ramsay

ORDER APPROVING OF LAND BEING ACQUIRED AND  
ROADS, DEVIATIONS OR WIDENINGS BEING MADE  
TOGETHER WITH ALL ANCILLARY WORKS REQUIRED  
TO BE EXECUTED IN CONJUNCTION THEREWITH

His Excellency the Governor of the State of Victoria,  
by and with the advice of the Executive Council thereof,  
being satisfied that there are funds legally available for  
acquiring the land, doth hereby approve the acquiring of  
the land described in the schedule hereunder and the  
making of new roads and deviations from and widenings of  
existing roads, together with all ancillary works required  
to be executed in conjunction therewith, referred to in  
the said schedule.

SCHEDULE  
Freeway

The land shown hatched on plans numbered G.P.15052A,  
G.P.15053A and G.P.15053B hereunder required for  
the making of a new freeway (Hume Freeway) in the Rural  
City of Wodonga.

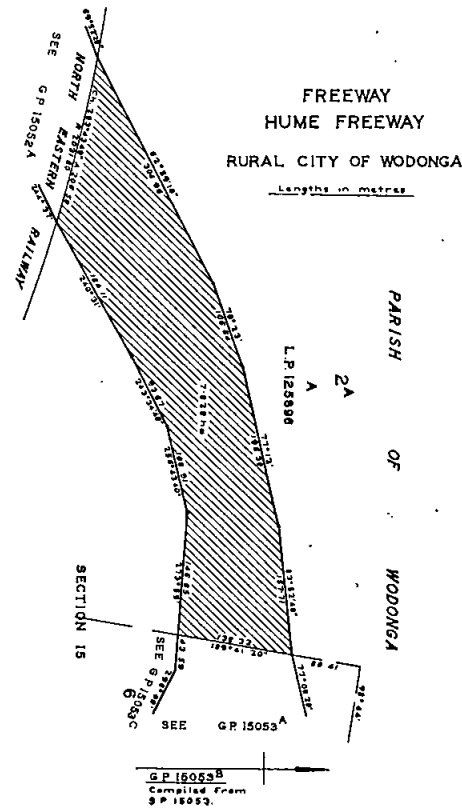
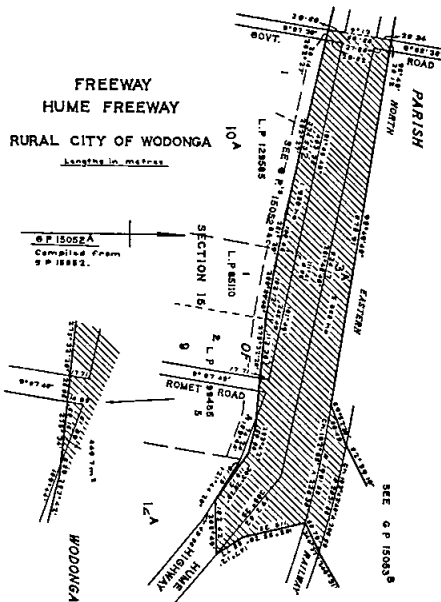
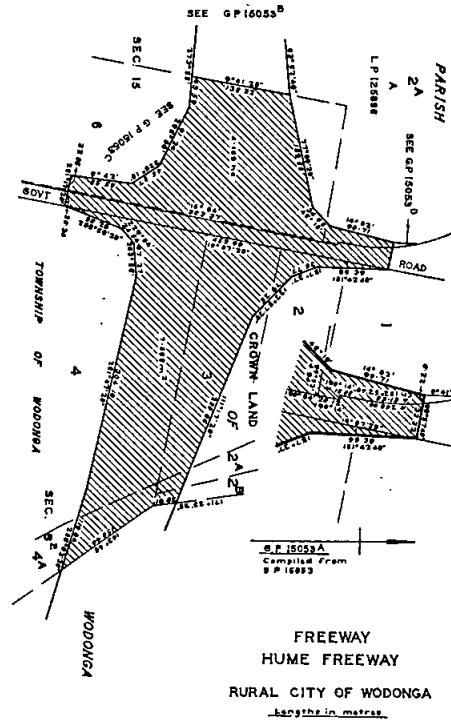

**Unclassified Roads**

The land shown hatched on plans numbered G.P.15052b and G.P.15053c hereunder required for the making of new roads in the Rural City of Wodonga.

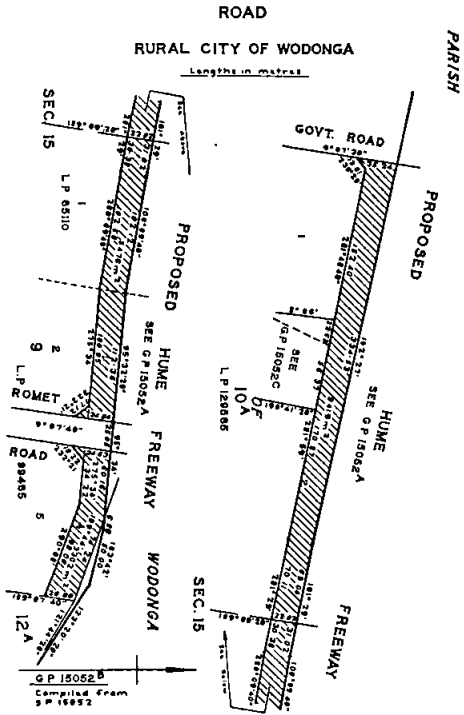

The land shown hatched on plan numbered G.P.15053b hereunder required for the widening of a road in the Rural City of Wodonga and making of the widening thereon.

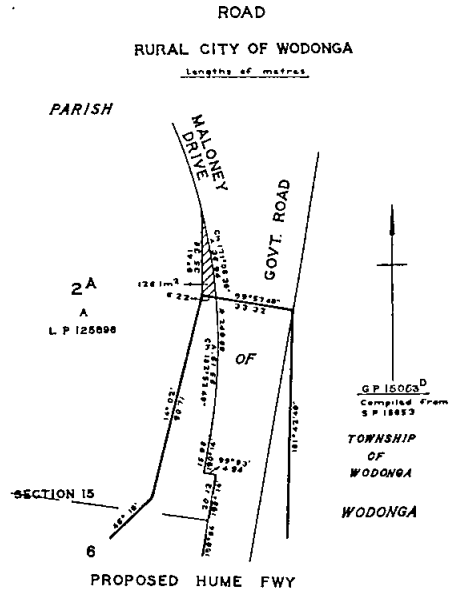

**Ancillary Works**

The land shown hatched on plan numbered G.P.15052c hereunder required for ancillary works required to be executed in conjunction with the Hume Freeway in the Rural City of Wodonga.

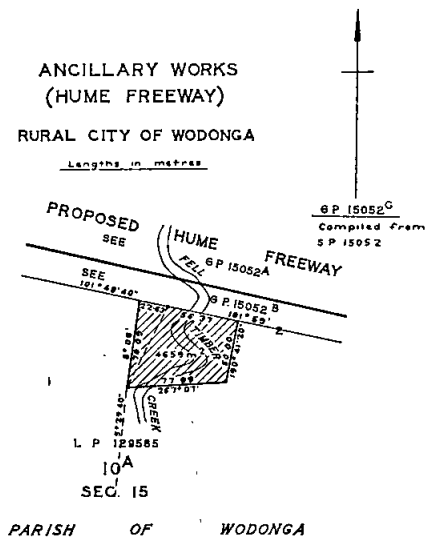
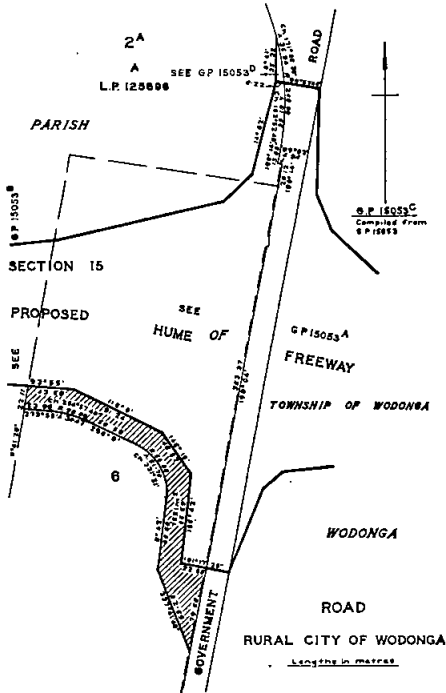

And the Honorable Robert Roy Cameron Maclellan, Her Majesty's Minister for Transport for the State of Victoria, shall give the necessary directions herein accordingly.

TOM FORRISTAL  
Clerk of the Executive Council

COUNTRY ROADS ACT 1958  
Act No. 6229

At the Executive Council Chamber, Melbourne, the  
twenty-seventh day of May, 1980

PRESENT:

His Excellency the Governor of Victoria  
Mr Haddon Storey | Mr Crozier  
Mr Ramsay

ORDER CONFIRMING RESOLUTIONS OF THE COUNTRY  
ROADS BOARD

His Excellency the Governor of the State of Victoria,  
by and with the advice of the Executive Council thereof,  
doth hereby, in pursuance of the provisions of the Country  
Roads Act 1958, confirm the resolutions of the Country  
Roads Board, the dates whereof and the terms of which  
are scheduled hereunder:

SCHEDULE

Main Road

Resolution dated the Thirteenth day of May, One  
thousand nine hundred and eighty, made pursuant to  
section 18 of the Country Roads Act 1958, rescinding the  
resolution passed by the Country Roads Board on the Thir-  
teenth day of December, One thousand nine hundred and  
forty-eight and confirmed by an Order in Council pub-  
lished in the Government Gazette of the Second day of  
February, One thousand nine hundred and forty-nine on  
pages 855 and 856 declaring the highway to be a main  
road (Woods Point Road) in the Shire of Upper Yarra  
so far as it relates to the part of the said main road  
indicated by cross-hatching on plans numbered G.P.5016,  
G.P.5017A and G.P.5017B hereunder.

MAIN ROAD  
WOODS POINT ROAD  
SHIRE OF UPPER YARRA  
Lengths in links

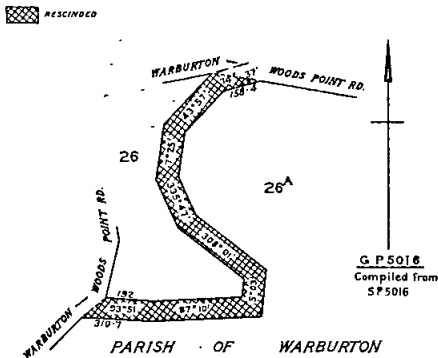

MAIN ROAD  
WOODS POINT ROAD  
SHIRE OF UPPER YARRA  
Lengths in links

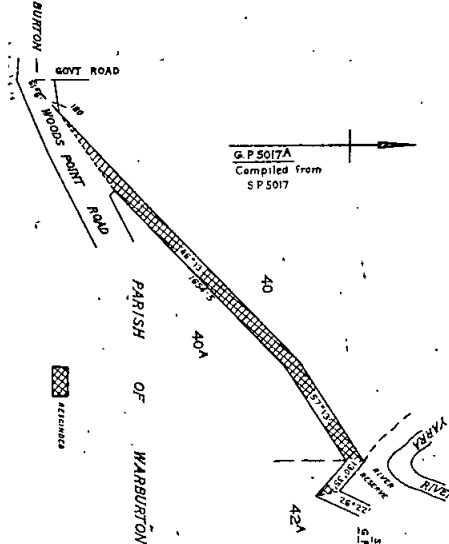

MAIN ROAD  
WOODS POINT ROAD  
SHIRE OF UPPER YARRA  
Lengths in links

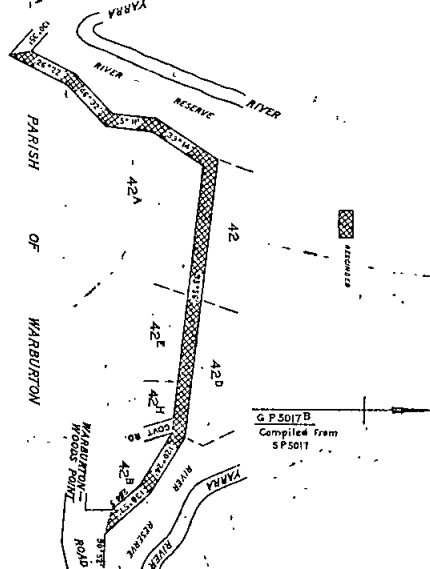

And the Honorable Robert Roy Cameron Maclellan, Her  
Majesty's Minister of Transport for the State of Victoria,  
shall give the necessary directions herein accordingly.

TOM FORRISTAL  
Clerk of the Executive Council

CROWN LAND (RESERVES) ACT 1978

At the Executive Council Chamber, Melbourne, the  
twenty-seventh day of May, 1980

PRESENT:

His Excellency the Governor of Victoria  
Mr Haddon Storey | Mr Crozier  
Mr Ramsay

CROWN LANDS TEMPORARILY RESERVED

His Excellency the Governor of the State of Victoria, in the Commonwealth of Australia, by and with the advice of the Executive Council of the said State, pursuant to the provisions of sections 4 and 7 of the *Crown Land (Reserves) Act 1978*, and being of the opinion that the Crown lands concerned are required for the public purposes respectively mentioned, doth hereby temporarily reserve and also except from occupation for mining purposes under any miner's right, the Crown lands hereinafter described, viz.:

**ECHUCA NORTH**—For Mental Health Authority Purposes, 1614 square metres, being Crown allotment 61, section A, Parish of Echuca North, as shown on Certified Plan No. 104372 lodged in the Central Plan Office—(E.96<sup>(6)</sup>) (Rs.10598).

**OUYEN**—For Retirement Units, 809 square metres, being Crown allotment 18, section 1, Parish of Ouyen, as shown on Certified Plan No. 103446 lodged in the Central Plan Office—(Rs.11301).

**OUYEN**—For Retirement Units, 809 square metres, being Crown allotment 22, section 1, Parish of Ouyen, as shown on Certified Plan No. 103446 lodged in the Central Plan Office—(Rs.11301).

**WILL-WILL-ROOK (BROADMEADOWS)**—For Police purposes, 6303 square metres, being Crown allotment 10c, Parish of Will-will-rook, as indicated by hatching on plan hereunder—(W.151<sup>(2)</sup>) (Rs.10902).

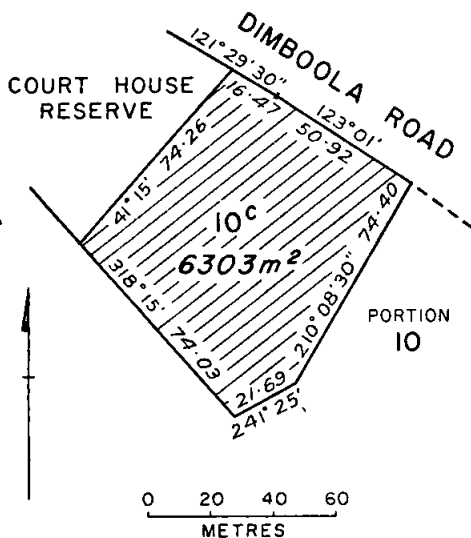

**WODONGA**—For Departmental depot and workshop, 1432 square metres, being Crown allotment 1A, section X, Township of Wodonga, as shown on Certified Plan No. 104444 lodged in the Central Plan Office—(Rs.3948).

And the Honorable William Vasey Houghton, Her Majesty's Minister of Lands for the State of Victoria, shall give the necessary directions herein accordingly.

TOM FORRISTAL  
Clerk of the Executive Council

CROWN LAND (RESERVES) ACT 1978

At the Executive Council Chamber, Melbourne, the  
twenty-seventh day of May, 1980

PRESENT:

His Excellency the Governor of Victoria  
Mr Haddon Storey | Mr Crozier  
Mr Ramsay

CROWN LANDS PERMANENTLY RESERVED

His Excellency the Governor of the State of Victoria, in the Commonwealth of Australia, by and with the advice of the Executive Council of the said State, pursuant to the provisions of sections 4 and 7 of the *Crown Land (Reserves) Act 1978*, and being of the opinion that the Crown lands concerned are required for the purposes respectively mentioned, doth hereby permanently reserve and also except from occupation for mining purposes under any miner's right, the Crown lands hereinafter described, viz.:

**BETKA**—For Water Supply purposes, 2.023 hectares, more or less, being the land in the Parish of Betka temporarily reserved as a site for Water Supply purposes by Order in Council of 23 May 1972 (see *Government Gazette* dated 31 May 1972)—(Rs.9613).

**MALLACOOTA**—For Water Supply purposes, 8.093 hectares, more or less, being the land in the Parish of Mallacoota temporarily reserved as a site for Water Supply purposes by Order in Council of 23 May 1972 (see *Government Gazette* dated 31 May 1972)—(Rs.9613).

**LANGWARRIN**—For Conservation of an Area of Natural Interest, 2.023 hectares, being Crown allotment 32A, Parish of Langwarrin, as indicated by hatching on plan hereunder—(L.16<sup>(4)</sup>) (Rs.10871).

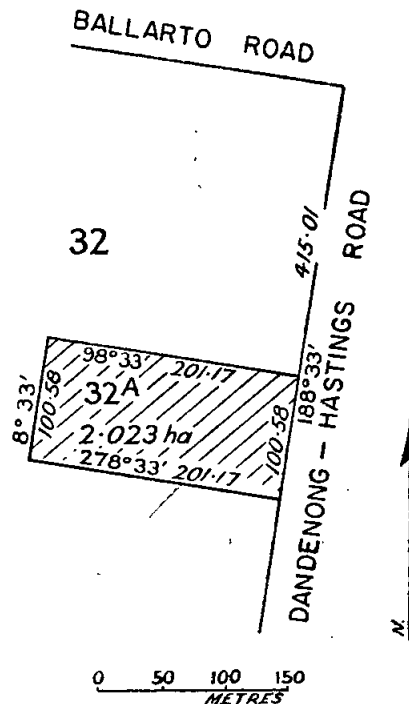

YANNATHAN—For Conservation of an Area of Natural Interest, 10.12 hectares, being Crown allotment 60D, Parish of Yannathan, as indicated by hatching on plan hereunder—(Y.114<sup>(4)</sup>) (Rs.10860).

under any miner's right, the Crown lands hereinafter described, viz.:

GOBUR—For Conservation of an Area of Natural Interest, 1.2 hectares, more or less, being Crown allotment 10C, section B<sup>1</sup>, Parish of Gobur, as indicated by hatching on plan hereunder—(G.188<sup>(6)</sup>) (Rs.10934).

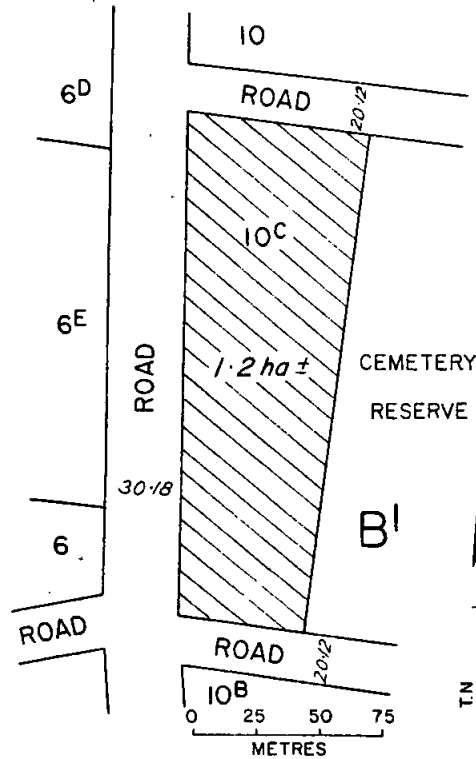
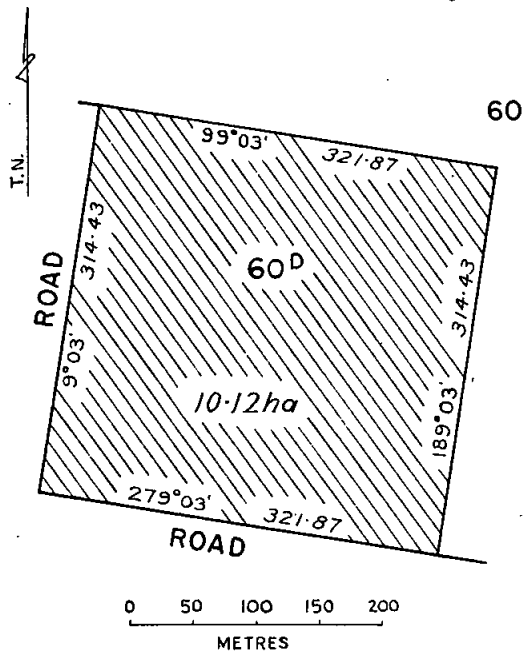

And the Honorable William Vasey Houghton, Her Majesty's Minister of Lands for the State of Victoria, shall give the necessary directions herein accordingly.

TOM FORRISTAL  
Clerk of the Executive Council

LOWRY—For Conservation of an Area of Natural Interest, 8 hectares, more or less, being Crown allotment 27A, Parish of Lowry, as indicated by hatching on plan hereunder—(Parish 3018) (Rs.10885).

CROWN LAND (RESERVES) ACT 1978

At the Executive Council Chamber, Melbourne, the twenty-seventh day of May, 1980

PRESENT:

His Excellency the Governor of Victoria  
Mr Haddon Storey | Mr Crozier  
Mr Ramsay

CROWN LANDS PERMANENTLY RESERVED

His Excellency the Governor of the State of Victoria, in the Commonwealth of Australia, by and with the advice of the Executive Council of the said State, pursuant to the provisions of section 4 and 7 of the Crown Land (Reserves) Act 1978, and being of the opinion that the Crown lands concerned are required for the purposes respectively mentioned, doth hereby permanently reserve and also except from occupation for mining purposes

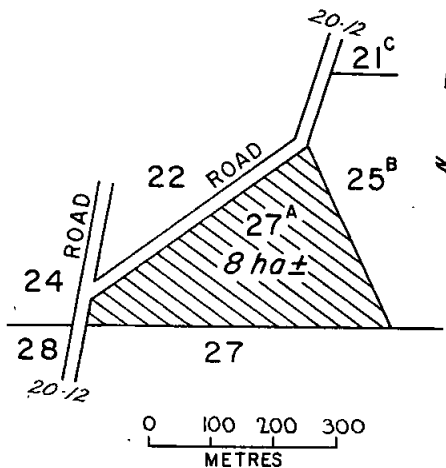



MAINTONGOON—For Conservation of an Area of Natural Interest, 21.62 hectares, being Crown allotment 11, section A, Parish of Maintongoon, as indicated by hatching on plan hereunder—(M.540<sup>(a)</sup>) (Rs.10928).

MURRINDINDI—For Conservation of an Area of Natural Interest, 35 hectares, more or less, being Crown allotment 47A, Parish of Murrindindi, as indicated by hatching on plan hereunder—(M.287<sup>(a)</sup>) (Rs.11002).

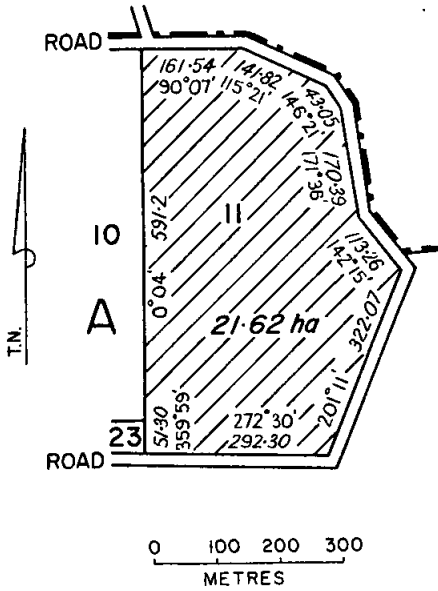

MORANDING—For Conservation of an Area of Natural Interest, 2.9 hectares, more or less, being Crown allotments 126A and 126B, Parish of Moranding, as indicated by hatching on plan hereunder—(M.139<sup>(2)</sup>) (Rs.10886).

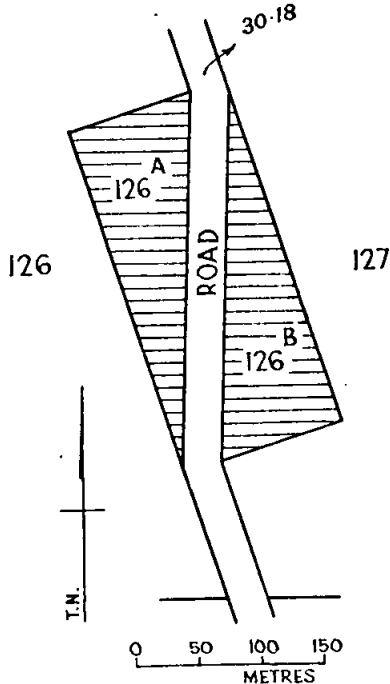

Total area of hatched portions 2.9 ha ±  
No. 42—21850/80—3

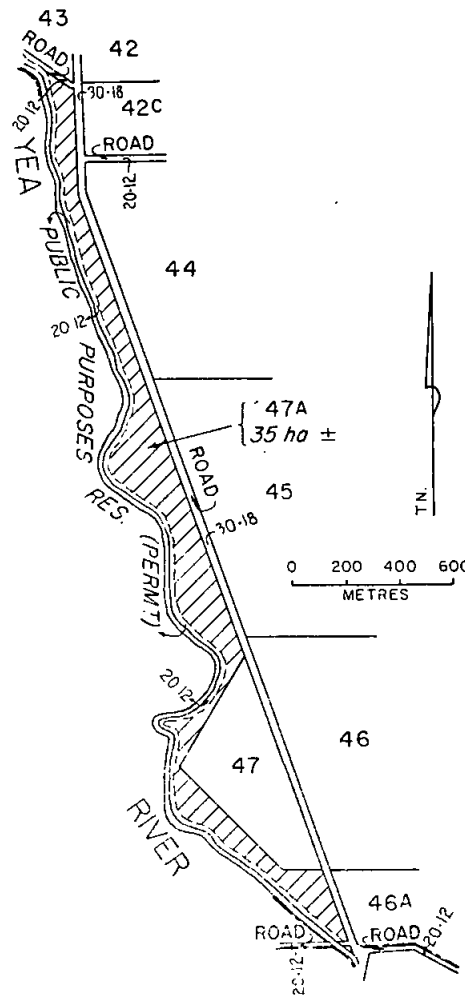

And the Honorable William Vasey Houghton, Her Majesty's Minister of Lands for the State of Victoria, shall give the necessary directions herein accordingly.

TOM FORRISTAL  
Clerk of the Executive Council

CROWN LAND (RESERVES) ACT 1978

At the Executive Council Chamber, Melbourne, the  
twenty-seventh day of May, 1980

PRESENT:

His Excellency the Governor of Victoria  
Mr Haddon Storey | Mr Crozier  
Mr Ramsay

CROWN LANDS TEMPORARILY RESERVED

His Excellency the Governor of the State of Victoria, in the Commonwealth of Australia, by and with the advice of the Executive Council of the said State, pursuant to the provisions of sections 4 and 7 of the Crown Land (Reserves) Act 1978, and being of the opinion that the Crown lands concerned are required for the purposes respectively mentioned, doth hereby temporarily reserve and also except from occupation for mining purposes under any miner's right, the Crown lands hereinafter described, viz.:

**BALLAN**—For Public Park and Recreation, 2024 square metres, being Crown allotment 1, section B, Township of Ballan, as shown on Certified Plan No. 104434 lodged in the Central Plan Office—(B.23) (Rs.6597).

**BURRA**—For Conservation of an Area of Natural Interest, 10.90 hectares, being Crown allotment 8A, Parish of Burra, as indicated by hatching on plan hereunder—(B.781<sup>(1)</sup>) (Rs.11013).

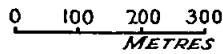
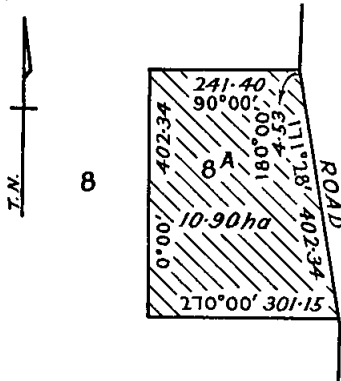

**BIMBOURIE**—For Water Supply, 4.209 hectares, being Crown allotment 49B, Parish of Bimbourie, as indicated by hatching on plan hereunder—(B.758<sup>(2)</sup>) (Rs.11030).

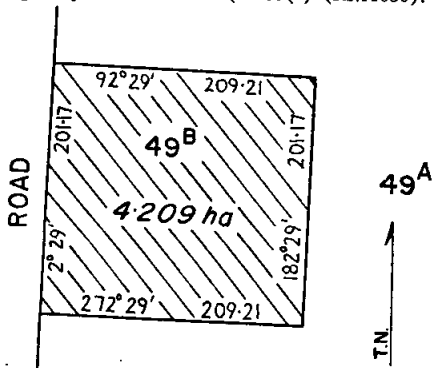

**COONIMUR**—For Conservation of an Area of Natural Interest, 31.16 hectares, being Crown allotments 4A and 5A, Parish of Coonimur, as indicated by hatching on plan hereunder—(C.450<sup>(1)</sup>) (Rs.11020).

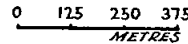
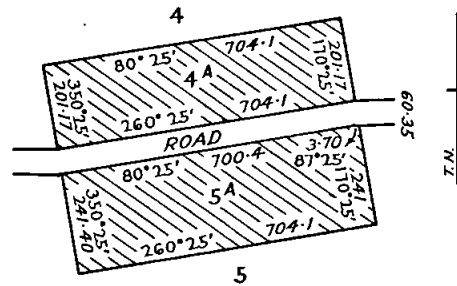

Total area of hatched portions 31.16ha

**KARAWINNA**—For Conservation of an Area of Natural Interest, 15.48 hectares, being Crown allotment 49A, Parish of Karawinna, as indicated by hatching on plan hereunder—(K.213<sup>(3)</sup>) (Rs.11019).

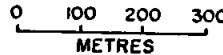
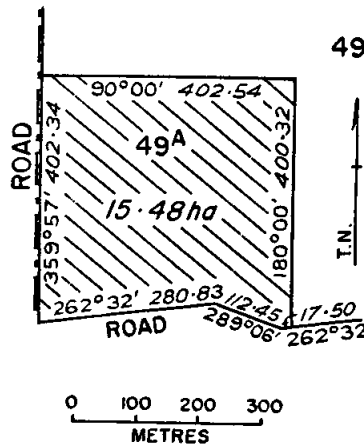

**KILLARA**—For Conservation of an Area of Natural Interest, 40 hectares, more or less, being Crown allotment 14, section D, Parish of Killara, as indicated by hatching on plan hereunder—(K.151<sup>(3)</sup>) (Rs.11017).

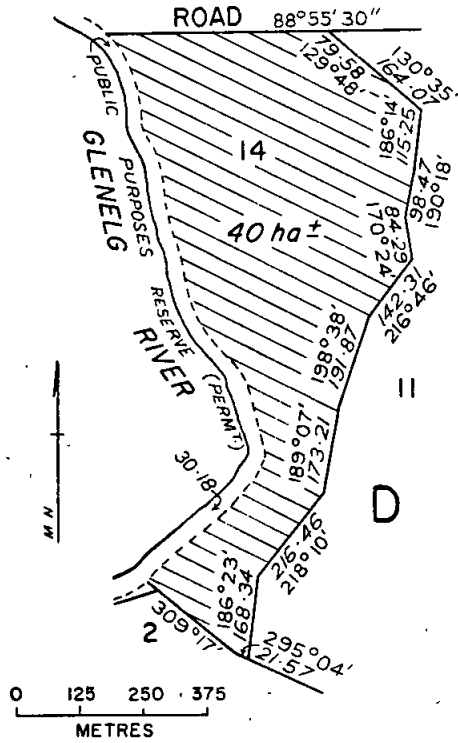

**MILDURA**—For Water Supply, 3·681 hectares, being Crown allotment 1, section 3, block G, Parish of Mildura, as indicated by hatching on plan hereunder—(M.556<sup>(14)</sup>) (Rs.10977).

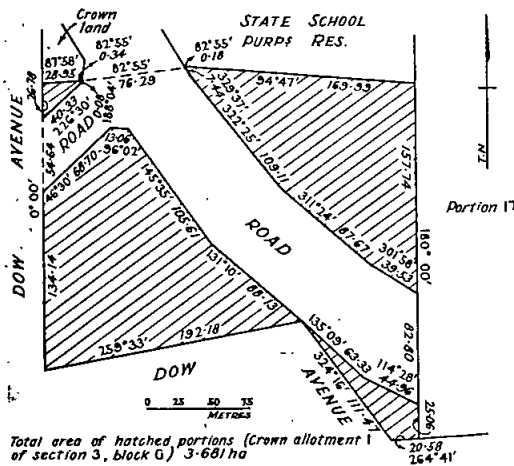

**PROOINGA**—For Conservation of an Area of Natural Interest, 35·23 hectares, being Crown allotments 26b and 26c, Parish of Prooinga, as indicated by hatching on plan hereunder—(P.179<sup>(3)</sup>) (Rs.11023).

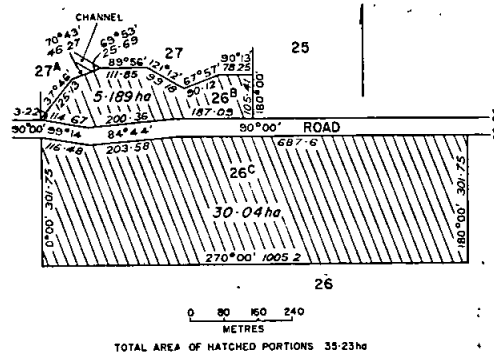

**SANDHURST (AT BENDIGO)**—For Preservation of Species of Native Plants, 55·80 hectares, being Crown allotment 8, section F<sup>10</sup>, Crown allotment 2, section F<sup>11</sup> and Crown allotment 3, section F<sup>12</sup>, at Bendigo, Parish of Sandhurst, as shown on Certified Plan No. 104317 lodged in the Central Plan Office—(S.372<sup>(101)</sup> and <sup>(102)</sup>) (Rs.11086).

**WALPEUP**—For Conservation of an Area of Natural Interest, 41·95 hectares, being Crown allotments 59 and 59c, Parish of Walpeup, as indicated by hatching on plan hereunder—(W.406<sup>(4)</sup>) (Rs.11015).

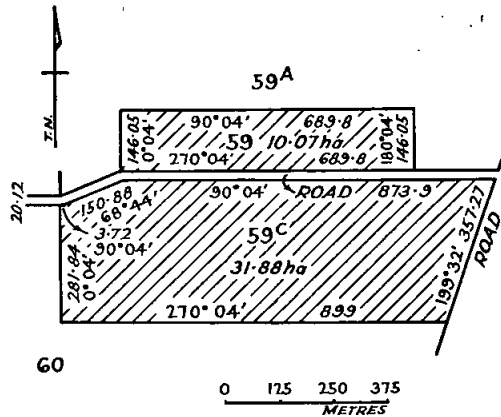

**WALPEUP**—For Conservation of an Area of Natural Interest, 51·52 hectares, being Crown allotment 70, Parish of Walpeup, as indicated by hatching on plan hereunder—(W.406<sup>(4)</sup>) (Rs.11113).

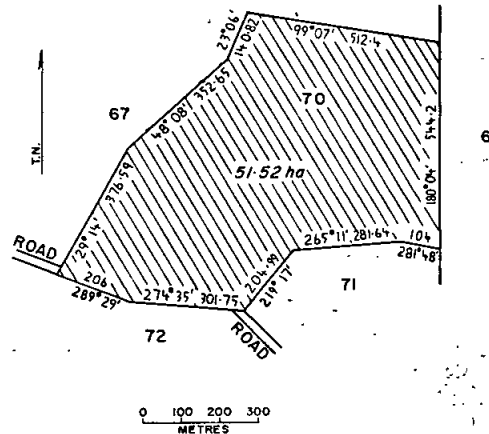

**YARIMA**—For Public Park, 1.214 hectares, being Crown allotment 1A, section C, Parish of Yarima, as indicated by hatching on plan hereunder—(Y.48<sup>(3)</sup>) (Rs.11045).

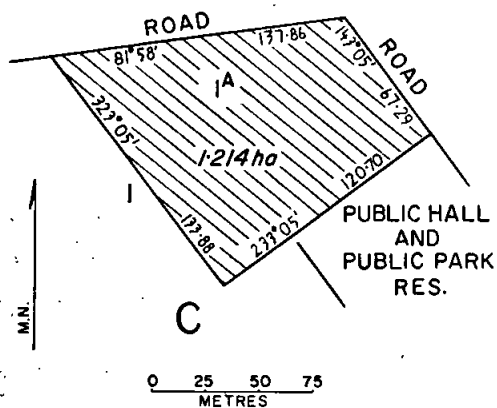

municipality concerned and that of any adjoining land owners, doth hereby close the unused road hereinafter described, viz.:

Municipal District of the Shire of Mansfield—Township of Mansfield, being the road indicated by hatching on plan hereunder—(M.35<sup>(6)</sup>) (Rs.1817).

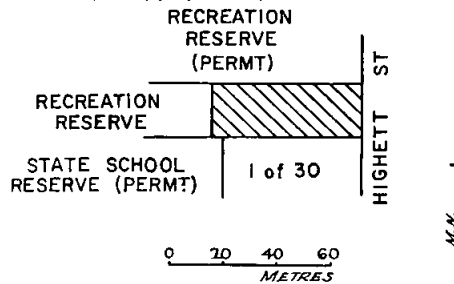

And the Honorable William Vasey Houghton, Her Majesty's Minister of Lands for the State of Victoria, shall give the necessary directions herein accordingly.

**TOM FORRISTAL**  
Clerk of the Executive Council

**YATPOOL**—For Conservation of an Area of Natural Interest, 151.3 hectares, being Crown allotment 7A, Parish of Yatpool, as indicated by hatching on plan hereunder—(Y.126<sup>(4)</sup>) (Rs.11010).

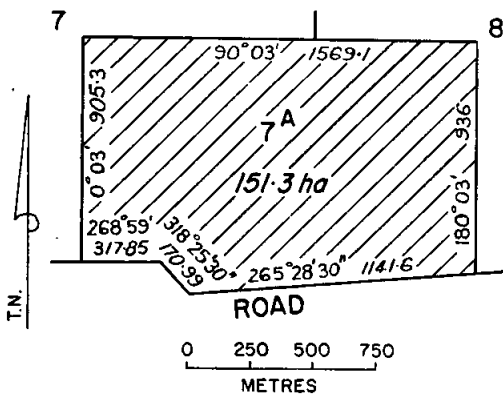

**HOSPITALS AND CHARITIES ACT 1958, SECTION 65**

At the Executive Council Chamber, Melbourne, the twenty-seventh day of May, 1980

PRESENT:

His Excellency the Governor of Victoria  
Mr Haddon Storey | Mr Crozier  
Mr Ramsay

**AUTHORITY FOR THE SALE OF LAND BY THE SOUTH GIPPSLAND DISTRICT AMBULANCE SERVICE**

Whereas the South Gippsland District Ambulance Service, an incorporated benevolent society within the meaning of the *Hospitals and Charities Act 1958*, is the owner of certain land known as 27 Korumburra Road, Wonthaggi and more particularly described in the Schedule hereto:

And whereas no part of such land is granted reserved or set apart by the Crown for the purposes of the South Gippsland District Ambulance Service:

And whereas the Committee of Management of the South Gippsland District Ambulance Service desire that the said land be sold:

And whereas the Health Commission of Victoria after inquiry has reported that it would be an advantageous to the South Gippsland Ambulance Service if the said land was sold:

Now therefore, His Excellency the Governor of the State of Victoria, by and with the advice of the Executive Council of the said State, being satisfied that in the herebefore recited special circumstances the sale of the said land would be advantageous to the South Gippsland District Ambulance Service, doth hereby authorise the sale of such land freed and discharged from any trusts affecting the same to Oswald William Webb, 4 Rushworth Street, Watsonia for the sum of nineteen thousand dollars (\$19 000) subject to the terms and conditions in the Draft Contract of Sale.

**SCHEDULE**

"All that piece of land being lot 3 on Plan of Subdivision No. 40388 Parish of Wonthaggi and being the whole of the land described in Certificate of Title Volume 8493 Folio 139."

And the Honorable William Archibald Borthwick, Her Majesty's Minister of Health for the State of Victoria, shall give the necessary directions herein accordingly.

**TOM FORRISTAL**  
Clerk of the Executive Council

And the Honorable William Vasey Houghton, Her Majesty's Minister of Lands for the State of Victoria, shall give the necessary directions herein accordingly.

**TOM FORRISTAL**  
Clerk of the Executive Council

**LAND ACT 1958**

At the Executive Council Chamber, Melbourne, the twenty-seventh day of May, 1980

PRESENT:

His Excellency the Governor of Victoria  
Mr Haddon Storey | Mr Crozier  
Mr Ramsay

**UNUSED ROAD CLOSED**

His Excellency the Governor of the State of Victoria, in the Commonwealth of Australia, by and with the advice of the Executive Council of the said State, pursuant to the provisions of section 349 of the *Land Act 1958* and with the concurrence in writing of the council of the

## RAILWAY CONSTRUCTION AND PROPERTY BOARD ACT 1979

At the Executive Council Chamber, Melbourne, the twenty-seventh day of May, 1980

## PRESENT:

His Excellency the Governor of the State of Victoria

Mr Haddon Storey  
Mr Ramsay

Mr Crozier

## VESTING OF HOUSES IN THE RAILWAY CONSTRUCTION AND PROPERTY BOARD

Whereas it is provided by section 24 (1) of the *Railway Construction and Property Board Act 1979*, that where the Victorian Railways Board by resolution determines that a dwelling house and appurtenant land vested in the Victorian Railways Board that is or has been used for the purposes of a residence for persons employed in the Railway Service should be transferred to the Railway Construction and Property Board for the purposes of Part V. of that Act the Governor in Council may, by order published in the *Government Gazette*, vest the land described in the resolution in the Board for the purposes of Part V., subject to all existing leases, tenancies and other rights or interests of or in that land.

And whereas the Victorian Railways Board by resolution dated 12 May 1980 determined that the dwelling houses and appurtenant lands described in the Schedule hereunder should be transferred to the Railway Construction and Property Board for the purposes of Part V. of the *Railway Construction and Property Board Act 1979*.

Now therefore, His Excellency the Governor of the State of Victoria, by and with the advice of the Executive Council thereof, and in pursuance of the provisions of section 24 (1) of the *Railway Construction and Property Board Act 1979* by this Order vests in the Railway Construction and Property Board the dwelling houses and appurtenant lands described in the Schedule hereunder subject to all existing leases, tenancies and other rights or interests of or in that land.

## SCHEDULE

## TITLE PARTICULARS

Address	Lot No.	L.P. No.	Volume	Folio
13 Cameron St, Sunshine	59	34261	8136	767 (part)
61 Couch St, Sunshine	20	26883	8030	024 (part)
91 Couch St, Sunshine	24	26883	8030	024 (part)
16 Dorothy Ave, Sunshine	41	9673	5586	119 (whole)
11 Hampshire Rd, Sunshine	19	26883	8030	024 (part)
93 Cornwall Rd, Sunshine	50	34261	8136	767 (part)
126 Cornwall Rd, Sunshine	1	9673	5349	624 (whole)
97 Devonshire Rd, Sunshine	63	34261	8136	767 (part)
8 Wilkinson Rd, Sunshine	28	34261	8136	767 (part)
17 Wilkinson Rd, Sunshine	39	34261	8136	767 (part)
19 Wilkinson Rd, Sunshine	76	34261	8136	767 (part)
2 Dulcie St, Sunshine	214	34261	8136	767 (part)
8 Islington St, Sunshine	71	34261	8136	767 (part)
108 Wright St, Sunshine	12	26883	8030	024 (part)
118 Wright St, Sunshine	7	26883	8030	024 (part)

And the Honourable Robert Roy Cameron Maclellan, Her Majesty's Minister of Transport for the State of Victoria, shall give the necessary directions therein accordingly.

TOM FORRISTAL  
Clerk of the Executive Council

VICTORIAN INSTITUTE OF MARINE SCIENCES ACT  
1974 (No. 8607)

At the Executive Council Chamber, Melbourne, the  
twenty-seventh day of May, 1980

## PRESENT:

His Excellency the Governor of Victoria  
Mr Haddon Storey | Mr Crozier  
Mr Ramsay

APPOINTMENT OF MEMBERS OF THE COUNCIL OF  
THE VICTORIAN INSTITUTE OF MARINE SCIENCES

In pursuance of the powers conferred by the provisions of section 7 (1) (h) of the *Victorian Institute of Marine Sciences Act 1974* and all other powers him thereunto enabling, His Excellency the Governor of the State of Victoria, by and with the advice of the Executive Council thereof, doth by this Order appoint the following persons,

being recommended by the Minister from a panel of names submitted by the Council of the Victorian Institute of Marine Sciences, other than members appointed under section 7 (1) (h) or co-opted members of the Council to be members of the Council of the Victorian Institute of Marine Sciences during the period from 21 May 1980 to 20 May 1983, both dates inclusive:

NORMAN KEITH BAKER,  
ALFRED DUNBAVIN BUTCHER,  
ALASTAIR GEORGE FERGUSON EDDIE,  
ROBERT JACOMB FOSTER,  
FREDERICK CHARLES JAMES, and  
DAVID STUART MURRAY.

And the Honourable William Vasey Houghton, Her Majesty's Minister for Conservation for the State of Victoria, shall give the necessary directions herein accordingly.

TOM FORRISTAL  
Clerk of the Executive Council

## SUPERANNUATION ACT 1958

At the Executive Council Chamber, Melbourne, the  
twenty-seventh day of May, 1980

PRESENT:

His Excellency the Governor of Victoria  
Mr Haddon Storey | Mr Crozier  
Mr Ramsay

Pursuant to the powers conferred by the provisions of paragraph (a) of sub-section (1) of section 3 of the Superannuation Act 1958, His Excellency the Governor of the State of Victoria, by and with the advice of the Executive Council thereof, doth by this Order declare that the provisions of the Superannuation Act shall apply to the officer named in the schedule set out hereunder.

## SCHEDULE

SMITH, BARBARA BEATRICE JOYCE, State College of Victoria at Burwood.

And the Honorable Lindsay Hamilton Simpson Thompson, Her Majesty's Treasurer for the State of Victoria, shall give the necessary directions herein accordingly.

TOM FORRISTAL  
Clerk of the Executive Council

## PORTARLINGTON SEWERAGE AUTHORITY

At the Executive Council Chamber, Melbourne, the  
twenty-seventh day of May, 1980

PRESENT:

His Excellency the Governor of Victoria  
Mr Haddon Storey | Mr Crozier  
Mr Ramsay

## CONSENT TO BORROWING \$150 000

Under the powers conferred by the Sewerage Districts Act and all other powers enabling him in that behalf, His Excellency the Governor of the State of Victoria, by and with the advice of the Executive Council of the said State, hereby consents to the Portarlington Sewerage Authority borrowing the sum of One hundred and fifty thousand dollars (\$150 000) to meet the cost of the sewerage works as set forth in the detailed statement bearing date 16 April 1980.

And the Honorable Frederick James Granter, Her Majesty's Minister of Water Supply for the State of Victoria, shall give the necessary directions herein accordingly.

TOM FORRISTAL  
Clerk of the Executive Council

## LATROBE VALLEY WATER AND SEWERAGE BOARD

At the Executive Council Chamber, Melbourne, the  
third day of June, 1980

PRESENT:

His Excellency the Governor of Victoria  
Mr Crozier | Mr Balfour  
Mr Borthwick | Mr Maclellan

## CONSENT TO BORROWING \$100 000

Under the powers conferred by the Latrobe Valley Act and all other powers enabling him in that behalf, His Excellency the Governor of the State of Victoria, by and with the advice of the Executive Council of the said State, hereby consents to the Latrobe Valley Water and

Sewerage Board borrowing the sum of One hundred thousand dollars (\$100 000) to meet the cost of water supply and sewerage works.

And the Honorable Frederick James Granter, Her Majesty's Minister of Water Supply for the State of Victoria, shall give the necessary directions herein accordingly.

TOM FORRISTAL  
Clerk of the Executive Council

## MORNINGTON SEWERAGE AUTHORITY

At the Executive Council Chamber, Melbourne, the  
third day of June, 1980

PRESENT:

His Excellency the Governor of Victoria  
Mr Crozier | Mr Balfour  
Mr Borthwick | Mr Maclellan

## CONSENT TO BORROWING \$100 000

Under the powers conferred by the Sewerage Districts Act and all other powers enabling him in that behalf, His Excellency the Governor of the State of Victoria, by and with the advice of the Executive Council of the said State, hereby consents to the Mornington Sewerage Authority borrowing the sum of One hundred thousand dollars (\$100 000) to meet the cost of sewerage works as set forth in the detailed statement bearing date 28 May 1980.

And the Honorable Frederick James Granter, Her Majesty's Minister of Water Supply for the State of Victoria, shall give the necessary directions herein accordingly.

TOM FORRISTAL  
Clerk of the Executive Council

LANDS DEPARTMENT  
NOTICES

## SALE OF FREEHOLD LAND BY AUCTION

	No. of Gazette
Mundoona, Friday, 1 August 1980	38
Swan Hill, Monday, 23 June 1980	29

## "OLYMPIC PARK" CITY OF MELBOURNE

## COMMITTEE OF MANAGEMENT

In pursuance of section 14 of the Crown Land (Reserves) Act 1978, I hereby appoint the following persons as a Committee of Management for the period ending 31 May 1983 of the land in the City of Melbourne, Parish of Melbourne North, permanently reserved for Recreation, Convenience and Amusement of the People and for a Children's Playground by Order in Council of 17 March 1970 (*vide Government Gazette* dated 25 March 1970):

SIR MAURICE ARNOLD NATHAN, K.B.E., as Chairman,  
STANDISH MICHAEL KEON,  
LEWIS LUXTON, C.B.E.,  
EDWARD WALLACE BEST,  
PERCY PEMBROKE PAGE, O.B.E.,  
BERT ANDREW JELICOE KEDDIE,  
LAWRENCE KITCHEN KERR,  
MERYVN GEORGE LINCOLN, M.B.E., together with Councillor JAMES GORDON MOFFAT, for so long only as he shall continue to be a Councillor and the elect of the Council of the City of Melbourne but nevertheless for no longer than 31 May 1983.

Department of Crown Lands and Survey,  
Melbourne, 29 May 1980

W. V. HOUGHTON  
Minister of Lands

NARREE WORRAN NORTH HALL AND RECREATION RESERVES

I, William Vasey Houghton, Her Majesty's Minister of Lands in and for the State of Victoria, in pursuance of the powers conferred on me by section 13 of the *Crown Land (Reserves) Act 1978*, do hereby make the following Regulations for or with respect to the Crown lands described in the Schedule hereunder (hereinafter referred to as the "Reserves") in lieu of all previous Regulations relating to the said lands which are hereby rescinded:—

SCHEDULE

(a) The land in the Parish of Narree Worrان permanently reserved as a site for a Mechanics' Institute and Free Library by Order in Council dated 2 October 1894 (*vide Government Gazette* of 5 October 1894)—(Rs.1735).

(b) The remaining portion of the land in the Parish of Narree Worrان temporarily reserved as a site for a Mechanics' Institute and for Public Recreation by Order in Council dated 25 May 1886 (*vide Government Gazette* of 28 May 1886). This land now reserved for Public Recreation only by Order in Council dated 18 June 1894 (*vide Government Gazette* of 22 June 1894)—(Rs.5163).

REGULATIONS

1. The Committee shall have power to hold entertainments, shows or performances in or upon the Reserves or hall building thereon and to make a charge for admission thereto.

2. The Committee shall have power to let any portion of the Reserves or hall building thereon to any club, association, person or society for the purposes of holding cricket, tennis, football or other matches, bicycle or other races, ceremonies, entertainments, performances, shows or sports, subject on the payment of such fees and on such terms as may be deemed to be reasonable and consistent with these Regulations and to authorise any club, association, society or person to make a charge for admission thereto.

3. No person shall enter or remain in the Reserves or hall building thereon who may offend against decency as regards dress, language or conduct.

4. No male person shall enter or use any place, room, building or lavatory set apart for the use of females, and no female person shall enter or use any place, room, building or lavatory set apart for the use of males. The provisions of this Regulation shall not apply to male or female persons under the age of seven years under the supervision of their respective parents or other responsible person.

5. No person other than the players, performers, competitors or exhibitors, shall enter into or upon or remain in or upon any room, building, structure, enclosure set apart for players, performers, competitors or exhibitors at any games, sports, entertainments, competitions, shows, fetes or exhibits.

6. No person shall damage or interfere in any way with the trees, shrubs or flowers in the Reserves, nor light any fires therein without the consent, in writing, of the Committee.

7. No person shall jump or climb over or under the fences or gates in or around the Reserves, stick bills thereon, or cut names on any fences, trees or seats or damage them in any way, no roll or throw stones, sticks or other missiles in the Reserves.

8. No person shall climb on any buildings, rooms, gates or structures in the Reserves, nor force any doors or windows of such buildings, rooms or structures, or in any way deface, damage or injure any such buildings, rooms or structures in the Reserves or hall building thereon.

9. No person shall camp in the Reserves or in any room, building or structure thereon, nor shall any person erect any building, hut or attachment without the consent, in writing, of the Committee.

10. No person shall remain in the Reserves or hall building thereon at any time when lawfully directed by any officer or employee or member of the Committee to leave the same.

11. No person shall buy, sell or offer for sale in the Reserves or hall building thereon any goods, wares, articles or other merchandise without the consent, in writing, of the Committee.

12. No person shall bet or wager in the Reserves or hall building thereon without the permission of the Committee.

13. No person shall expectorate or otherwise commit any nuisance in any part of the Reserves or in any room, building, structure or enclosure therein.

14. No person shall disturb, obstruct, interrupt or annoy any officer, employee or authorised agent of the Committee in the execution of his duty or work in the Reserves, nor disturb, obstruct, interrupt or annoy any hirers of the Reserves or hall building thereon.

15. No person shall bring into the Reserves or hall building thereon any horse or any motor vehicle, cycle, carriage, cart or other vehicle except into such places as may be set apart for the purpose.

16. Any person committing on any part of Reserves or in any of the rooms, buildings, structures, erections or enclosures for the time being thereon, any of the following offences shall be guilty of a breach of these Regulations:

(a) Assaulting or threatening any other person or persons.

(b) Being under the influence of intoxicating liquor.

(c) Entering, crossing, being on or trespassing on any playing ground, area, enclosure, course or any building, room or any part thereof whilst any games, sports, races, competitions, entertainments or amusements are being played, conducted or carried on, or at any time between the commencement and conclusion of such events without the consent of the Committee.

(d) Using threatening, abusive, offensive or insulting words.

(e) Using profane, indecent, obscene or unseemly language.

(f) Behaving improperly, offensively or riotously.

(g) Interfering with or interrupting any games, sports, competitions, entertainments or amusements.

(h) Obtaining or attempting to obtain admission to any part of the Reserves or hall building thereon when not entitled to admission under these Regulations.

(i) Consuming alcoholic liquor contrary to the provisions of the *Liquor Control Act 1968* and/or without the permission of the Committee.

17. For the purpose of maintaining good order, any person authorised by the Committee may refuse admission to any person to the Reserves or hall building thereon.

18. No person shall play, practise or engage in any organised game or sport or take part in any public entertainment, meeting or organised gathering in the Reserves or hall building thereon without the permission of the Committee first obtained—(Rs.1735, Rs.5163).

Given under my Hand at Melbourne on 29 May 1980.

W. V. HOUGHTON  
Minister of Lands

Every person who contravenes or fails to comply with these Regulations shall be liable to the penalties prescribed in section 13 of the *Crown Land (Reserves) Act 1978*.

"BUNDOORA PARK", PARISH OF KEELBUNDORA  
REGULATIONS

I, William Vasey Houghton, Her Majesty's Minister of Lands in and for the State of Victoria, in pursuance of the powers conferred on me by section 13 (1) (xii) of the *Crown Land (Reserves) Act 1978*, do hereby apply the Regulations made on 24 April, 1972 (*vide Government Gazette* of 3 May, 1972) for or with respect to the above-named Park, to the Crown land in the Parish of Keelbundora temporarily reserved for Public Recreation by Order in Council dated 1 April 1980 (*vide Government Gazette* of 11 April 1980)—(Rs.9113).

Given under my hand at Melbourne on 29 May 1980

W. V. HOUGHTON  
Minister of Lands

Teaching Service Act 1958  
TEACHING SERVICE (TEACHERS TRIBUNAL)  
REGULATIONS

AMENDMENT No. 514 (T.T. 84)

The Teachers Tribunal, in pursuance of the powers conferred by the *Teaching Service Act 1958*, hereby amends Regulation 14 of the Teaching Service (Teachers Tribunal) Regulations as follows:—

REGULATION 14

In the *Staffing Schedule—Special Schools* in sub-clause 2 (a) under *Children's Homes/Reception Centres and Emotionally Disturbed* make the following alterations for 3538 Allambie Special:—

Under the heading *Heads of Schools*, in the column *Principal Grade A School, Principal Class*, delete the figure "1" and in the column *Principal Grade B School, Principal Class*, insert the figure "1".

Under the heading *Deputy Principals*, in the column *Deputy Principal Grade A School, Senior Teacher Class*, delete the figure "1" and in the column *Deputy Principal Grade B School, Senior Teacher Class*, insert the figure "1".

Under the heading *Other Positions*, in the column *Assistant Teacher (Responsibility), Teacher Class*, delete the figure "4" and substitute therefor the figure "3".

Under the heading *Total Establishment*, delete the figure "17" and substitute therefor the figure "16".

J. J. KENNEDY, Alternate Chairman  
A. F. LE CLERCQ, Secretary

Office of the Teachers Tribunal  
Melbourne, 17 April 1980

## TENDERS

### PUBLIC WORKS DEPARTMENT

Tenders are invited for the purposes indicated hereunder and will be received at 2 Treasury Place, Melbourne, 3002, until TWO p.m. on dates shown.

Tenders must be addressed to the Minister of Public Works with the envelope endorsed "Tender for

". Hand-delivered tenders must be placed in the Department's tender box in the foyer, Ground Floor, 2 Treasury Place, Melbourne.

Tenders documents are available from the Contracts Office, Room 2B, 2 Treasury Place, Melbourne, and where indicated, at offices of Inspectors of Works.

★Tenders for works identified with star (★) will only be considered from Contractors qualified for repairs and painting works. Any Tenderers wishing to qualify may obtain the application form from the Contracts Office.

**Wednesday, 18 June 1980**

#### Building, Electrical and Mechanical Works

★BAYVIEW—Internal and external repairs and painting, Primary School No. 4752.

★BENALLA—External and internal renovations, including mechanical and electrical services, Primary School No. 31. (W.O., Benalla and Wangaratta.)

CHADSTONE PARK—Alterations, additions and cyclic maintenance (library and staff admin. conversion), Primary School.

CHADSTONE PARK—Mechanical service, alterations, additions and cyclic maintenance (library and staff admin. conversion), Primary School.

CHATHAM—Alterations to school (staff improvements, art craft conversion), Primary School.

CHATHAM—Mechanical services, alterations, staff improvements, art craft conversion, Primary School.

★CHILTERN—General repairs and painting, Primary School No. 327. (W.O., Benalla and Wangaratta.)

HAMILTON—New covered way, Serology Laboratory. (W.O., Hamilton and Warrnambool.)

★INVERLEIGH—Internal renovations, Police Station and Residence. (W.O., Geelong.)

KANGAROO FLAT—Mechanical services, fire reinstatement and staff upgrade, Technical School. (W.O., Bendigo.)

KANGAROO FLAT—Electrical services, fire reinstatement and staff upgrade, Technical School. (W.O., Bendigo.)

★KERANG—Cyclic maintenance, external repairs and painting, Technical/High School. (W.O., Bendigo and Swan Hill.)

MANANGATANG—Services to relocatable buildings (electrical services), Consolidated School. (W.O., Bendigo and Swan Hill.)

MELBOURNE—Supply and installation of card and key access system, Police Building.

MYRTLEFORD—Staff and administration improvements, art craft conversion, Consolidated School. (W.O., Wangaratta.)



MYRTLEFORD—Electrical services, staff and administration improvements, art craft conversion, Consolidated School. (W.O., Wangaratta.)

PRESTON—Partition alterations, first floor, Labour and Industry.

★WOODEND—(Amended specification.) External and part internal repairs and painting, Primary School.

#### Siteworks

PRESTON—Sitework and external hydraulic services, Special Development School.

#### Miscellaneous

PORT MELBOURNE—Purchase of three (3) only 50 mm (2") diaphragm pumps, Depot.

PORT MELBOURNE—Purchase of six (6) x 50 mm (2") trash pumps and two (2) only 75 mm (3") trash pumps, Depot.

ROYAL PARK—Supply of a tractor C/W mid-mounted mower and front end loader, Collingwood Tech. Horticultural Trades Annex.

VARIOUS—Supply of sheet steel furniture for the period 1 July 1980 to 30 June 1981, Various.

VARIOUS—Supply of hand planers and jointers (buzzers), period 1 July 1980 to 30 June 1981, Schools and other Government Buildings.

VARIOUS—Supply of shaping machines, period 1 July 1980 to 30 June 1981, Schools and other Government Buildings.

VARIOUS—Supply of woodworking thicknessing machines, period 1 July 1980 to 30 June 1981, Schools and other Government Buildings.

VARIOUS—Supply of grinding machines, period 1 July 1980 to 30 June 1981, Schools and other Government Buildings.

VARIOUS—Supply of woodworking lathes, period 1 July 1980 to 30 June 1981, Schools and other Government Buildings.

VARIOUS—Supply of hacksaw machines and marking off table, period 1 July 1980 to 30 June 1981, Schools and other Government Buildings.

VARIOUS—Supply of universal turret head milling machines, period 1 July 1980 to 30 June 1981, Schools and other Government Buildings.

VARIOUS—Supply of 13 mm drilling machines, period 1 July 1980 to 30 June 1981, Schools and other Government Buildings.

VARIOUS—Supply of woodworking saw-benches, period 1 July 1980 to 30 June 1981, Schools and other Government Buildings.

VARIOUS—Supply of bandsaw machines and spindle borer, period 1 July 1980 to 30 June 1981, Schools and other Government Buildings.

VARIOUS—Supply of plain horizontal milling machines, period 1 July 1980 to 30 June 1981, Schools and other Government Buildings.

VARIOUS—Supply of 260 mm swing engineers' lathes, period 1 July 1980 to 30 June 1981, Schools and other Government Buildings.

VARIOUS—Supply of universal horizontal milling machines, period 1 July 1980 to 30 June 1981, Schools and other Government Buildings.

VARIOUS—Supply of 255/280 mm swing screw-cutting lathes, period 1 July 1980 to 30 June 1981, Schools and other Government Buildings.

VARIOUS—Supply of 305/330 mm swing screw-cutting lathes, period 1 July 1980 to 30 June 1981, Schools and other Government Buildings.

## Tuesday, 24 June 1980

### Building, Electrical and Mechanical Works

BUNDOORA—Completion of second kitchen, "J" block, Greenwood High School.

CARLTON—(Re-advertisement, Amended Specification)—Repair external concrete panels, Motor Registration Branch.

COBURG—Supply and locating of unattended steam boiler, Pentridge Prison.

FAIRLEA—Replacement of toilet block, Women's Prison.

KEW—New compressor room to existing laundry, Mental Hospital.

★MIRBOO NORTH—Cyclic maintenance, High School. (W.O., Traralgon.)

TOORAK—Extensions and renovations, Teachers Centre.

#### Siteworks

COBURG—Supply and placement of bituminous concrete at rates, Newlands High School.

ST. ALBANS MEADOWS—Playing field, Primary School No. 5118.

#### Miscellaneous

GEELONG—Maintenance cleaning—Period 10 July 1980 to 31 July 1983, Public Offices. (W.O., Geelong.)

MALMSBURY—Maintenance cleaning—1 July 1980 to 30 June 1983, Youth Training Centre. (W.O., Kyneton.)

PORT MELBOURNE—Supply of furniture (benches, desks, tables, etc.) for period 1 July 1980 to 30 June 1981, Various.

RED CLIFFS—Maintenance cleaning—Period 1 July 1980 to 30 June 1983, Police Station. (W.O., Mildura.)

ROBINVALE—Maintenance cleaning—Period 1 July 1980 to 30 June 1983, Court House. (Court House, Robinvale.)

TOM AUSTIN  
Minister of Public Works

Public Works Department  
Melbourne, 3 June 1980

### STATE TENDER BOARD TENDERS FOR THE SERVICE *Provisions—Meat and Smallgoods*

Tenders will be received until 8.30 a.m. on Friday, 13 June 1980 from persons willing to furnish meat and smallgoods in such quantities as may be ordered by the Victorian Government—delivery to be made at the undermentioned places—during the three months commencing 1 August 1980.

Preference may be given to a tender received from an Industry approved by the Minister for State Development, Decentralization and Tourism.

The places for which tenders will be received are as follows:—

Melbourne and Metropolitan District.

Country Districts:—Anglesea, Ararat, Bacchus Marsh, Ballarat, Beechworth, Bendigo, Castlemaine, Colac, Creswick, French Island, Geelong, Glenormiston, Howman's Gap, Langi Kal Kal, Malmsbury, Millgrove, Morwell River, Mt. Evelyn, Sale, Shepparton, Stawell, Tatura, Traralgon, Warrnambool, Werribee and Won Wron.

Printed forms of tender and the conditions of contract may in all cases, be obtained from the Secretary to the Tender Board, 3rd Floor, 49 Spring Street, Melbourne, 3000, by whom also any information or explanation will be afforded to persons tendering.

Tenders must be deposited in the Tender Box at the Tender Board Office, 3rd Floor, 49 Spring Street, Melbourne, 3000, or, if sent by post, postage must be prepaid, and the

tenders addressed to the Chairman of the Tender Board, Tender Board Office, 3rd Floor, 49 Spring Street, Melbourne, 3000, which office they must reach not later than by first post on the date of the closing of tenders.

J. M. PAWSON  
Secretary to the Tender Board

## STATE TENDER BOARD

## TENDERS FOR THE SERVICE 1980-81

Tenders will be received until eight-thirty a.m. on Friday, 20 June 1980 from persons willing to supply the under-mentioned articles in such quantities as may be ordered by the Victorian Government during the twelve month period commencing 1 September 1980.

Schedule 1/62—Exercise Books and Requisites—Education Department.

Schedule 1/73—Dictation Equipment.

Full particulars may be obtained from the Secretary to the Tender Board, by whom also any information will be afforded to persons tendering.

Preference may be given to a tender received from an industry approved by the Minister for State Development, Decentralization and Tourism.

Tenders enclosed in the envelope provided, must be deposited in the tender-box at the Tender Board Offices, 3rd Floor, 49 Spring Street, Melbourne, 3000, or, if sent by post, postage must be prepaid and the tenders addressed to the Chairman of the Tender Board, Tender Board Offices, 49 Spring Street, Melbourne, 3000, which office they must reach not later than by first post of the date of closing of tenders.

J. M. PAWSON  
Secretary to the Tender Board

**PRIVATE  
ADVERTISEMENTS**

## CITY OF BENDIGO

## LOAN No. 119

*Notice of Intention to Borrow the Sum of \$250 000 for Permanent Works and Undertakings*

Notice is hereby given that the Council of the City of Bendigo proposes to borrow the principal sum of \$250 000 secured by a charge over the general rates of the Municipality, such sum to be raised by the grant of a Mortgage Loan in accordance with the provisions of the *Local Government Act 1958*.

1. The maximum rate of interest that may be paid is 12.6% per annum.

2. The purpose for which the Loan is to be applied is:—

Council Proportion C.R.B. Works—	\$
Knight Street (Part Cost)	11 500
Aspinall Street	6 500
High Street (bituminous cone)	5 000
<b>Road Construction—</b>	
Aspinall Street	5 500
McDougall Road—ITPS only	11 500
Graham Street—Peel to Howard—(Estimated Cost \$78 000)	58 171
Anderson Street (Balance)	23 850
<b>Minor Works—</b>	
Lobb Street—kerb and channel and footpath construction	36 500
<b>Ward Works—</b>	
Knappe Street—kerb and channel and drainage (Balance)	1 500
Skene Street—footpath (Balance)	1 421
Hodgkinson Street—footpath (Balance)	688
Panton Street—footpath (Balance)	801
Prouses Road—footpath and kerb and channel (Balance)	2 988
Burrows Street—footpath	2 700

Miscellaneous—	\$
Adams Road Depot—(Total Estimated Cost \$85 000)	44 000
Conservatory constructions (Balance)	18 473
Rosalind Park Footbridge (Balance)	5 234
<b>Drainage—</b>	
Maple Street Drainage (Balance)	11 460
Grace Street Drainage (Balance)	2 214
	250 000

3. The period of the Loan shall be twenty (20) years.

4. The moneys borrowed shall be repayable by providing out of the Municipal Fund forty (40) half-yearly instalments of principal and interest of \$17 247.60 on 1 February and 1 August during the currency of the Loan. The first repayment shall be payable on 1 February 1981.

5. Such moneys shall be repayable to the Local Authorities Superannuation Board at the Office of the Board, Rigby House, 15 Queens Road, Melbourne.

The plans and specifications and an estimate of the cost of the proposed works and a statement showing the proposed expenditure of the money to be borrowed are open for inspection at the Municipal Offices, Lyttleton Terrace, Bendigo, during office hours.

7563

C. K. BEAMISH, Town Clerk

## CITY OF BERWICK

## NOTICE OF ALLOCATION OF ROAD NAME

Notice is hereby given that in pursuance of the powers conferred by the *Local Government Act 1958* as amended, the Council of the City of Berwick at a meeting held on Tuesday, 20 May 1980 resolved to confirm the following road name:—

*Name*—Blackburne Square.

*Location*—The road shown on Lodged Plan 90331, Parish of Berwick, commencing at the Northern Boundaries of Lots 7-15 and extending to Wilson Street and the 7.62 metre wide section of road extending in a southerly direction from Wilson Street to the south-eastern point of Lot 7.

7398

P. J. NORTHEAST, City Manager/Town Clerk

## CITY OF BRUNSWICK

## BY-LAW No. 207

By-Law of the City of Brunswick numbered 207 made under section 197 (1) of the *Local Government Act 1958* for the proper management and control of libraries belonging to or under the control and management of the Brunswick City Council.

In pursuance of the powers conferred by the *Local Government Act 1958*, the Mayor, Councillors and Citizens of the City of Brunswick make the following By-Law which shall apply to and have operation throughout the whole of the municipal district.

## Definitions

1. In these Regulations unless the context of subject matter otherwise indicated or requires—

- (a) "Book" includes any and every book, periodical, newspaper, pamphlet, music score, gramophone, gramophone record, cassette, picture, print, photograph, map, chart, plan, film, slide, manuscript, tape, tape recording or any other article of a like nature forming part of the contents of the Library, whether or not the property of the City of Brunswick.
- (b) "Council" means the Council of the City of Brunswick.
- (c) "Librarian" means the person for the time being in charge of the Library service generally, or any portion or section thereof, and, in respect of ensuring compliance by members or any other person with this By-Law, members of the Library staff or any security officer employed by the Council.
- (d) "Library" means a library belonging to or under the control or management of the City of Brunswick and includes the buildings, rooms, offices,

passages, staircases, entrances adjacent thereto and sanitary facilities and includes any branch libraries, depots or bookmobiles.

- (e) "Registered member" and "member" means a person to whom a membership card is issued in accordance with this By-Law.
- (f) "Membership Card" means a current and valid Membership Card so entitled and issued by the Librarian in accordance with this By-Law.
- (g) "Municipality" means the municipal district of the City of Brunswick.
- (h) "Voters' Roll" means the voters' roll of the City of Brunswick.

#### Administration

2. The Librarian has general charge of every library and is responsible for the safe custody of books and all other property belonging thereto. The Librarian has power to refuse to issue books to deny the use of a library to any person who neglects or refuses to comply with paragraph 13 hereof or any part thereof and may require such person to forthwith quit the library premises. Failure by a person to forthwith leave the Library premises upon being required to do so by the Librarian is an offence against this By-Law.

#### Hours of Opening

3. The Library is open at such times as the Brunswick City Council determines from time to time.

#### Access and Use of Library

4. Any person may have access to the Library for the purpose of reading or having reference to books and facilities on the premises.

5. Members have access to the Library for the purpose of borrowing books and their representatives will be admitted for that purpose at the discretion of the Librarian. Children under the age of six (6) years may only be admitted to the Library if in the care of an adult who will be responsible for their good behaviour who shall ensure that they do not interfere with the books, catalogues or other facilities of the library.

6. Persons, except members of the Library Staff or other Officers duly authorised by the Brunswick City Council or persons authorised by the Librarian, the Town Clerk or by the Brunswick City Council shall not enter or remain in the Library except during the hours of opening.

#### Membership

7. Subject to the approval of the Librarian, the following persons are eligible to become members and are entitled to borrow books:

- (a) Any person whose name appears on the current Voters' Roll of the Municipality or who can show eligibility for inclusion on the current Voters' Roll.
- (b) Any person resident in the municipality who is recommended in writing by a person on such Voters' Roll.
- (c) Any non-resident attending an educational establishment in the municipality who is approved by the Librarian.
- (d) Any person who is in employment in the municipality and is approved by the Librarian.
- (e) Any member of a public municipal library located in the State of Victoria who presents a letter of accreditation from the Librarian of that municipality.

#### Borrowing

8. A person shall not take away from the Library premises any book unless he has:

EITHER

- (a) Completed and signed the appropriate form provided for application for a Membership Card and been registered as a member.
- (b) Satisfied the Brunswick City Council by such evidence as the Council may require that he is a fit and proper person to be so registered.

(c) Signed an undertaking in a form prescribed by the Brunswick City Council or, if he is under 14 years of age, presented such an undertaking signed on his behalf by a parent or guardian giving the undertaking on his behalf and will—

- (i) Make good the loss or damage to any book whilst in his use or possession and pay any charges incurred under the Local Government Act 1958 and Library Rules.
- (ii) Notify the Library of any change in his address.
- (iii) Not transfer to any other person any book of the Library.
- (iv) Not aid or abet any person in the use of the Library in his name except as his agent.
- (v) Obey all regulations and rules which may apply to the Library and any reasonable directions of the Librarian.

OR

(d) Presented a current and valid Membership Card of a Library operated by any other municipality in Victoria and presented a Reciprocal Membership Card stamped and endorsed by the Library of which he is a Member and satisfied the Librarian that he is the person to whom the Reciprocal Membership Card was issued.

9. (a) A member who damages or permits damage to a book or other borrowed item while in his possession shall on demand by the Librarian pay the amount of the damage such to be assessed by the Librarian.

(b) A member may reserve a book at the Librarian's discretion by filling in a reservation card and paying a fee to be prescribed by the Council from time to time and advertised by notice in the library.

(c) A member who loses a book which he has borrowed or loses a membership card, a transaction card, a plastic lending bag, a cassette or any other article borrowed from the library or of which he has possession pursuant to a borrowing from the library or removes a book or other object or article from the library without permission shall on demand by the Librarian pay the replacement value of the book or other article or object as aforesaid and associated processing costs. The Council may at any time after the borrowing time has elapsed commence legal proceedings for recovery of the book or other article or object or its value.

(d) The Council may make rules from time to time as to the number of books which may be borrowed at any one time. The Council may also fix fees payable in respect of overdue books where the Librarian has not granted an extension of time but such extension shall not be granted where the book has been reserved by another member. Such rules and fees shall be advertised in the library and shall be observed and paid by members.

(e) Each book borrowed must be returned by the borrowing member within the time specified by the Librarian and may not be lent to any other member or person. A member shall not exchange books with another member.

#### Membership Cards

10. A Membership Card shall not be issued until the necessary steps have been taken to ensure that the applicant is eligible for Membership and is not currently a Registered Member.

11. All membership cards, unless previously surrendered or cancelled, shall remain in force not more than four years from the date of issue.

12. Every member on being issued with a Membership Card—

- (a) Is responsible for safe custody of the same.
- (b) Must produce the same to the Librarian when asked whenever a book is borrowed.
- (c) Is responsible for the safe custody, return and care of every book borrowed on the production of such card.
- (d) Must report the loss of the same to the Librarian immediately such loss is discovered and after a lapse of one week a duplicate Membership Card may then be issued upon such payment as may

be levied. It is an offence against this By-Law to use this duplicate Membership Card if the original Membership Card is recovered. Notwithstanding such replacement, the member is responsible for any book borrowed on the original Membership Card.

- (e) Must surrender the same to the Librarian for cancellation on ceasing to be eligible to be a member.
- (f) Must notify any change of address to the Librarian.
- (g) Must not permit his Membership Card to be used by any other person.

13. The Librarian may refuse to issue books to a person who cannot produce his Membership Card or who produces a Membership Card other than his own.

#### Conduct in the Library

14. A person shall not—

- (a) Behave in the Library in such a manner as to cause in the opinion of the Librarian any inconvenience to any other person or interfere with their comfort.
- (b) Enter or remain in the Library while offensively unclean in person or clothing.
- (c) Except with the permission of the Librarian not to bring any animal other than a guide dog for the blind into the Library.
- (d) Eat, drink or commit any nuisance in the Library.
- (e) Make any noise which in the opinion of the Librarian is excessive.
- (f) Wilfully, carelessly or negligently break, injure or improperly interfere with any portion of the Library building furniture, fittings or books therein or otherwise behave in an improper offensive or riotous manner.
- (g) Enter or remain in the Library whilst suffering from any contagious or infectious disease.
- (h) Deface, mutilate or mark by cutting or tearing or by writing or by improper folding or otherwise any part of any book belonging to the Library. Use in the Library any writing, drawing or painting materials or trace on or from any book without the permission of the Librarian.
- (i) Misplace or secrete a book or any record of a book in the Library with intent to hold its use from others.
- (j) Bring into the Library or any part thereof any closed bag (other than a ladies' hand bag, brief case or like receptacle) or any other wheeled vehicle or conveyance (other than an invalid's chair) save that bags, baby carriages or shoppers may be left in the entrance hallway whilst their owners are using the Library but the Council is not responsible for any loss or damages to any bag case or other article or equipment so left.
- (k) Distribute handbills or advertising matter or deliver a public address within the Library without the consent of the Librarian and/or the Council.
- (l) Enter into any part of the Library not set apart for public use, except by permission of the Librarian.
- (m) Remain in the Library beyond the hours fixed for the closing of the Library.
- (n) Smoke, strike a light, or spit in any part of the Library.
- (o) Enter into or remain in the Library whilst intoxicated by alcohol, drugs or any other means.

#### Name and Address

15. Any person who is in the Library shall give his name and address to the Librarian on being requested to do so.

A person shall permit the Librarian to inspect a handbag, case, bag or other container to enable the Librarian to satisfy himself that a book is not being removed from the library without authority.

#### Offences

16. Any person who commits any offence against this By-Law shall, on being requested by the Librarian to do so, forthwith leave the Library and shall not thereafter without the permission of the Librarian enter or use the Library.

17. Any person who commits an offence against this By-Law shall be liable to a penalty not exceeding One Hundred dollars.

#### Application of By-Law

18. This By-Law applies to and has operation throughout the Libraries belonging to and under the control and management of the Council within the municipal district of the City of Brunswick.

19. By-Law Number 202 of the City of Brunswick is hereby revoked.

Resolution for passing this By-Law was agreed to on 28 April 1980 and confirmed on 26 May 1980.

In witness whereof the common seal of the Mayor, Councillors and Citizens of the City of Brunswick was hereunto affixed, 27 May 1980 in the presence of—

7455 (SEAL) H. S. V. JURY, Councillor  
G. INCANTALÙPO, Councillor  
K. D. WILSON, Town Clerk

#### CITY OF CASTLEMAINE

##### LOAN No. 78

#### Notice of Intention to Borrow the Sum of \$15 000 for Permanent Works and Undertakings

Notice is hereby given that the Council of the City of Castlemaine proposes to borrow the principal sum of \$15 000 by grant of a mortgage secured by a charge over the general rates of the municipality in accordance with the provisions of the *Local Government Act 1958*.

1. The maximum rate of interest that may be paid is 11.9% per annum.

2. The purpose for which the loan is to be applied falls under the heading of permanent works and undertakings, being:—

Installation of a Pedestrian Crossing in Barker Street —\$15 000.

3. The period of the loan shall be 5 years.

4. The money borrowed shall be repayable by providing out of the municipal fund ten half-yearly instalments of approximately \$2033.19 including principal and interest on 30 October and 30 April each year during the currency of the loan. The first such instalment shall be payable on 30 October 1980.

5. Such moneys shall be repayable to the Commercial Banking Co. of Sydney Ltd., at the office of the said Bank, 257 Collins Street, Melbourne.

23 May 1980

7399

ROBERT C. WHITE, Town Clerk

#### CITY OF CASTLEMAINE

##### LOAN No. 79

#### Notice of Intention to Borrow the Sum of \$20 000 for Permanent Works and Undertakings

Notice is hereby given that the Council of the City of Castlemaine proposes to borrow the sum of \$20 000 by grant of a mortgage secured by a charge over the general rates of the municipality in accordance with the provisions of the *Local Government Act 1958*.

1. The maximum rate of interest that may be paid is 12.6% per annum.

2. The purpose for which the loan is to be applied falls under the heading of permanent works and undertakings, being:—

To assist Council finance Country Roads Board Grant Works, Town Planning Consultants and purchase of plant.

3. The period of the loan shall be 15 years.

4. The money borrowed shall be repayable by providing out of the municipal fund 30 half-yearly instalments of approximately \$1499.92 including principal and interest on 30 October and 30 April each year during the currency of the loan. The first such instalment shall be payable on 30 October 1980.

5. Such moneys shall be repayable to the Bank of New South Wales, at the office of the said Bank, 425 Collins Street, Melbourne.

23 May 1980

7400

ROBERT C. WHITE, Town Clerk

CITY OF COBURG

NOTICE OF INTENTION TO TAKE LAND COMPULSORILY

Whereas the Council of the City of Coburg deems it expedient to exercise its power of taking compulsorily the land delineated and hatched on the map at the foot hereof for the work or undertaking of provision of road widening and whereas the Council has caused to be prepared a map and other papers setting out the general description of the work or undertaking for which the land proposed to be taken is to be used the description of the land proposed to be taken and the names of the owners or reputed owners lessees or reputed lessees mortgagees and occupiers of that land so far as those names are known to or can be ascertained by the Council and whereas the said map and other papers are deposited at the office of the said Council at Coburg and are and shall be open for inspection by all persons interested at all reasonable hours for the space of forty clear days after the publication of this notice in the *Government Gazette* now notice is hereby given to all persons affected by the proposed taking of the said land to set forth in writing addressed to the Council or the Town Clerk within forty clear days of the publication of this notice in the *Government Gazette* all objections which they may have to the taking of the said land.

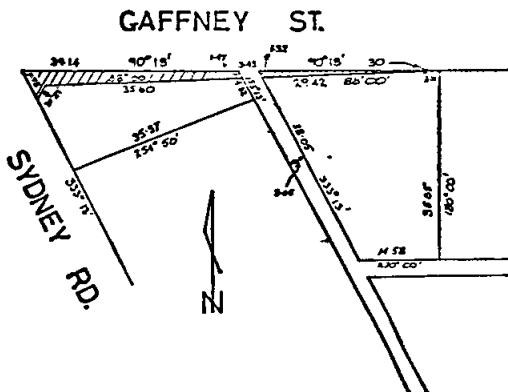

Dated 26 May 1980

By order of the Council

7526

K. G. DOUGLAS, Acting Town Clerk

CITY OF DONCASTER AND TEMPLESTOWE

Notice is hereby given that pursuant to the provisions of the *Local Government Act 1958* the Council of the City of Doncaster and Templestowe has ordered that the name of the following street within the municipality be changed as set out hereunder.

Old Name—Ennismore Crescent.

New Name—Daniel Court.

Location—That part of Ennismore Crescent as shown on L.P. No. 94570 and 11939 between Granard Avenue and Brucevale Crescent, Park Orchards.

G. J. MORTON, Manager Administration/Town Clerk

7401

CITY OF ESSENDON

LOAN NO. 135

Notice of Intention to Borrow the Sum of \$140 000 for Permanent Works and Undertakings

Notice is hereby given that the Council of the City of Essendon proposes to borrow the principal sum of \$140 000 (One Hundred and Forty Thousand Dollars) secured by a charge over the general rates of the municipality, such sum to be raised by the grant of a mortgage in accordance with the provisions of the *Local Government Act 1958* (as amended).

1. The maximum rate of interest that may be paid is 12.6 per centum per annum.

2. The purpose for which the loan is to be applied is as follows:—

For and towards the cost of reconstruction of certain roads within the municipality.

3. The period of the loan shall be fifteen (15) years.

4. The moneys borrowed shall be repayable by providing out of the municipal fund half yearly instalments of approximately \$10 499.46 each, including principal and interest, on 1 January and July of each year during the currency of the loan. The first instalment shall be payable on 1 January 1981.

Such moneys shall be repayable at the office of the Commonwealth Savings Bank of Australia, Head Office, Melbourne, or at such other places as the lender may direct.

The plans and specifications of the proposed works and a statement showing the proposed expenditure of the moneys to be borrowed are open for inspection at the office of the Council of the City of Essendon, State of Victoria, at the Civic Centre, Moonie Ponds.

7456

B. C. BEATTIE, City Manager/Town Clerk

CITY OF HAWTHORN

BY-LAW No. 229

A By-law of the City of Hawthorn made under the provisions of the *Local Government Acts* and numbered 229 for the purpose of preventing and extinguishing fires including the use of incinerators and barbecues.

In pursuance of the powers conferred by the *Local Government Acts* and of every other power it thereunto enabling the Mayor, Councillors and Citizens of the City of Hawthorn order as follows:—

1. By-law No. 217 is hereby repealed.

2. No person shall on any land or premises burn anything which by its burning shall emit toxic or offensive fumes or excessive smoke.

3. Any other burning shall be—

(a) in a properly constructed fireplace internal to a residence and complying with all Regulations made pursuant to the *Local Government Acts*, or

(b) in an incinerator constructed of incombustible materials, having a lid and a spark arrestor so as to prevent the emission of sparks or the spread of fire therefrom, or

(c) in a barbecue constructed of incombustible materials and being used for the cooking of food.

4. No person shall without written permission of the Council use or construct or erect on any land or premises any incinerator or barbecue which is—

(i) within one metre of any boundary fence or wall,

(ii) within three metres of any dwelling on the same land as itself,

(iii) within four metres of any other dwelling.

5. Any person guilty of any act or default contrary to this By-law shall be liable on conviction to a penalty of not more than one hundred dollars (\$100.00) and to a further penalty of not more than ten dollars (\$10.00) for each day such wilful act or default is continued after conviction or order by any Court.

6. This By-law shall apply to and have operation throughout the whole of the City of Hawthorn.

Resolution for passing this By-law agreed to by the Council of the City of Hawthorn on 15 April 1980 and confirmed on 13 May 1980.

The common seal of the Mayor, Councillors and Citizens of the City of Hawthorn was affixed hereto, 22 May 1980, in the presence of—

(SEAL) S. COFFA, Mayor  
A. R. PATTERSON, Councillor  
B. C. SMITH, Town Clerk

7402

## CITY OF MOE

LOAN No. 85

*Notice of Intention to Borrow \$20 000 for Permanent Works and Undertakings*

Notice is hereby given that the City of Moe intends to borrow \$20 000 and that this amount will be raised upon the execution of an agreement with the Housing Commission, Victoria.

The loan period is three years and the maximum rate of interest payable is 5% per annum.

The loan proceeds will be expended on extensions to the Council's Queen Street Kindergarten.

The amount borrowed will be repaid to the Housing Commission, Victoria, by three approximately equal annual instalments of principal, plus interest calculated on the unpaid balance. The first repayment will be due in approximately August 1981.

Any further information, including details of the cost and proposed expenditure, can be obtained from the City Offices, Albert Street, Moe.

7403

R. J. PUGSLEY, Town Clerk

*Town and Country Planning Act 1961 (Twelfth Schedule)*

## CITY OF SALE PLANNING SCHEME

## NOTICE THAT A PLANNING SCHEME HAS BEEN PREPARED AND IS AVAILABLE FOR INSPECTION

*Amendment No. 2 (as amended 1979)*

Notice is hereby given that the City of Sale in pursuance of its powers under the *Town and Country Planning Act 1961*, has prepared a Planning Scheme for the area bounded by Cobains Road, Gibsons Road, Dawson Street, Sale-Maffra Road, Sale-Stratford Railway line, and City Boundary back to Cobains Road for the purpose of zoning the major portion of this land as Light Industrial and the remainder as Residential low Density B and Highway Commercial. And at the request of the Minister of Planning has been placed back on exhibition in accordance with Section 30 (3) of the *Town and Country Planning Act 1961*.

A copy of the scheme has been deposited at the City Council Chambers, Macalister Street, Sale, and the office of the Town and Country Planning Board, 235 Queen Street, Melbourne, and will be open for inspection during office hours by any person, free of charge.

Any persons affected by the Planning Scheme are required to set forth in writing all objections they may have, addressed to the Minister of Planning 500 Collins Street, Melbourne, 3000, on or before 18 June 1980.

7457

J. L. LOW, Town Clerk

*Town and Country Planning Act 1961 (Twelfth Schedule)*

## CITY OF SALE PLANNING SCHEME

## NOTICE THAT A PLANNING SCHEME HAS BEEN PREPARED AND IS AVAILABLE FOR INSPECTION

*Amendment No. 8*

Notice is hereby given that the City of Sale in pursuance of its powers under the *Town and Country Planning Act 1961*, has prepared a Planning Scheme for an amendment to the Sale Planning Scheme Ordinance with respect to the landscaping provisions for Residential A and Residential Low Density B Zones.

A copy of the scheme has been deposited at the City Council Chambers, Macalister Street, Sale, and the office of the Town and Country Planning Board, 235 Queen Street, Melbourne, and will be open for inspection during office hours by any person, free of charge.

Any persons affected by the Planning Scheme are required to set forth in writing all objections they may have, addressed to the Town Clerk, City of Sale, City Council Chambers Sale, 3850, on or before 2 July 1980, and to state whether they wish to be heard in respect of their objections.

7458

J. L. LOW, Town Clerk

*Town and Country Planning Act 1961 (Twelfth Schedule)*

## CITY OF SALE PLANNING SCHEME

## NOTICE THAT A PLANNING SCHEME HAS BEEN PREPARED AND IS AVAILABLE FOR INSPECTION

*Amendment No. 9*

Notice is hereby given that the City of Sale in pursuance of its powers under the *Town and Country Planning Act 1961*, has prepared a Planning Scheme for the area bounded by York Street on the west side between Macarthur and Cunningham Streets for the purpose of rezoning this land from Highway Commercial to Retail Commercial.

A copy of the scheme has been deposited at the City Council Chambers, Macalister Street, Sale, and the office of the Town and Country Planning Board, 235 Queen Street, Melbourne, and will be open for inspection during office hours by any person, free of charge.

Any persons affected by the Planning Scheme are required to set forth in writing all objections they may have, addressed to the Town Clerk, City of Sale, City Council Chambers Sale, 3850, on or before 2 July 1980, and to state whether they wish to be heard in respect of their objections.

7459

J. L. LOW, Town Clerk

## CITY OF SHEPPARTON

LOAN No. 107

*Notice of Intention to Borrow the Sum of \$119 000 for Permanent Works and Undertakings*

Notice is hereby given that the Council of the City of Shepparton proposes to borrow the sum of \$119 000 secured by a charge over the general rates of the municipality, such sum to be raised by the grant of a mortgage in accordance with the provisions of the *Local Government Act 1958*.

1. The principal amount to be borrowed is \$119 000.

2. The times at which moneys borrowed are to be repayable are on 15 July during the currency of the loan, and the first instalment shall be payable on 15 July 1981, and the place such moneys shall be repayable is at the Department of Youth, Sport and Recreation, 570 Bourke Street, Melbourne, 3000.

3. The purpose for which the loan is to be applied is to partially finance the cost of upgrading the Raymond West Swimming Pool. The facilities to be provided in the projected upgrading programme include:

- (a) Construction of new 8 lane 50m chlorinated and filtered Olympic Pool;
- (b) installation of filtration system for leisure pool;
- (c) fencing of entire area known as the "Raymond West Swimming Pool";
- (d) construction of new amenities block, administration and first aid rooms and kiosk;
- (e) relocation of swimming clubrooms;
- (f) provision of life saving clubrooms—Council contribution—(a contribution will be made by the Shepparton Life Saving Club);
- (g) resurfacing of floor of leisure pool;
- (h) lighting;
- (i) ancillary works.

The estimated cost of the project is \$760 000.

4. The period of the loan shall be five years.

5. The manner in which the loan is to be liquidated is by provision out of the Municipal Fund of five annual instalments of \$23 800 being principal only. The first instalment shall be payable on 15 July 1981 and the final instalment on 15 July 1985.

6. The plans, specifications and estimate of the cost of the proposed work and a statement showing the proposed expenditure of the money to be borrowed are open for inspection at the office of the Council, Civic Centre, Welsford Street, Shepparton, during office hours.  
7564 I. L. GILBERT, Acting Town Clerk

CITY OF SWAN HILL  
PUBLIC HIGHWAY

Pursuant to the provision of section 522 of the Local Government Act 1958 the Council of the City of Swan Hill hereby directs that the land in the Parish of Castle Donnington, County of Tatchera indicated by hatching on the diagram hereunder which has been purchased, taken or acquired by it shall be a public highway on and from the date of publication of this Order in the Government Gazette.

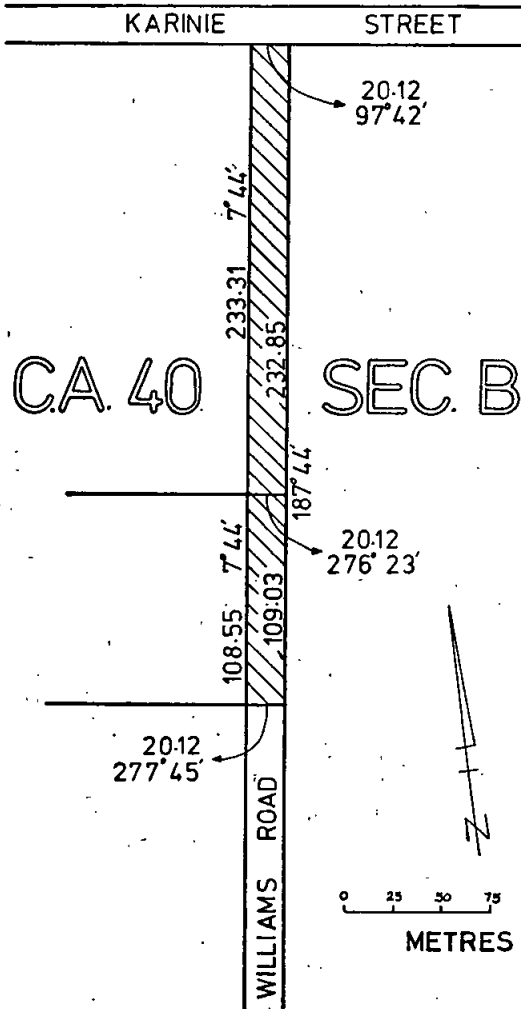

The common seal of the Mayor, Councillors and Citizens of the City of Swan Hill was hereto affixed, 22 May 1980, in the presence of—  
(SEAL) W. R. DUNSTONE, Mayor  
B. E. H. STEGGALL, Councillor  
G. J. MENNIE, Town Clerk

7404

CITY OF WARRNAMBOOL

LOAN No. 144

Notice of Intention to Borrow the Sum of \$150 000 for Permanent Works and Undertakings

Notice is given that the Council of the City of Warrnambool proposes to borrow the principal sum of One Hundred and Fifty Thousand Dollars (\$150 000) secured by a charge over the general rates of the Municipality, such sum to be raised by the Grant of a Mortgage in accordance with the provisions of the Local Government Act 1958.

1. That Maximum rate of interest which may be paid is 12.5 per cent.
2. The purpose for which the Loan is to be applied is:

	\$
Construction of facilities for Performing Arts (including Professional Fees) Part Cost	90 000
Extensions and Improvements at Warrnambool Saleyards, Caramut Road	60 000
	150 000

3. The period of the Loan shall be Five (5) years.
4. The moneys borrowed shall be repayable by providing out of the Municipal Fund 9 equal amounts of principal and interest payable half yearly of \$11 190.43 and one amount of \$136 978.92, with the first instalment payable on 1 July and 1 January during the currency of the Loan.
5. Such moneys shall be repayable at the Commercial Banking Company of Sydney Limited, Liebig Street, Warrnambool.

The plans and specifications and the estimate of the cost of the proposed works and a Statement showing the proposed expenditure of the moneys to be borrowed are open for inspection at the Municipal Offices, Liebig Street, Warrnambool.

7460

V. G. ROBSON, Town Clerk

Town and Country Planning Act 1961 (Twelfth Schedule)  
SHIRE OF ALBERTON (INLAND AREAS)  
PLANNING SCHEME

NOTICE THAT A PROPOSED AMENDMENT TO THE INTERIM DEVELOPMENT ORDER HAS BEEN PREPARED AND IS AVAILABLE FOR INSPECTION

Interim Development Order 1978

Notice is hereby given that the Shire of Alberton in pursuance of its powers under the Town and Country Planning Act 1961 has prepared a proposed amendment to the Interim Development Order 1978 for the following lands:

- (a) All the lands comprising Crown Allotments 44A, 44B, 44D, 45A and 45C Parish of Devon.
- (b) All the lands comprising Lodged Plan No. 127887 and Crown Allotments 41B and 42C and Part of Crown Allotment 40A all Parish of Willung.

A copy of the proposed amendment has been deposited at the Shire Offices, Shire of Alberton, Commercial Road, Yarram and at the office of the Town and Country Planning Board, 235 Queen Street, Melbourne, and will be open for inspection during office hours by any person free of charge.

Any persons affected by the proposed amendment are required to set forth in writing all objections they may have, addressed to the Shire Secretary, Shire of Alberton, P.O. Box 1, Yarram, 3971 on or before 4 July 1980, and to state whether they wish to be heard in respect of their objections.

7473

D. A. CARTLEDGE, Shire Secretary

SHIRE OF BANNOCKBURN  
ROAD NAMING

Pursuant to the provisions of section 535 (4) of the Local Government Act 1958, Notice is given that the Shire of Bannockburn on 10 April 1980 assigned the following road names:—

Old Name—Government Road.  
New Name—Campion Road.  
Location—Meredith Township.

Old Name—Government Road.  
 New Name—Creamery Road.  
 Location—Meredith Township.  
 Old Name—Winters Lane.  
 New Name—Windmeer Road.  
 Location—Inverleigh.  
 New Name—Dunhill Court.  
 Location—Inverleigh.

7565 KELVIN L. SPILLER, Shire Secretary

SHIRE OF BET BET  
 LOAN No. 33

*Notice of Intention to Borrow the Sum of \$15 000 for Permanent Works and Undertakings*

Notice is hereby given that the Council of the Shire of Bet Bet proposes to borrow the sum of Fifteen Thousand Dollars, (\$15 000), secured by a charge over the general rates of the municipality, such sum to be raised by the grant of a mortgage in accordance with the provisions of the *Local Government Act, 1958*.

1. The maximum rate of interest that may be paid is 12.6 per centum per annum.

2. The purpose for which the loan is to be applied is:—

“Dunolly Footpath Construction”	\$15 000
---------------------------------	----------

3. The period of the loan shall be Ten (10) years.

4. The moneys borrowed shall be repayable by providing out of the municipal fund, Twenty half-yearly instalments of approximately \$1339.80, each including principal and interest on 14 March and 14 September during the currency of the loan. The first instalment shall be payable on 23 January 1981.

5. Such moneys shall be repayable at the C.B.C. Savings Bank Limited, Melbourne.

The plans and specifications and the estimate of the cost of the proposed works and a statement showing the proposed expenditure of the moneys to be borrowed are open for inspection at the Shire Office, Dunolly, during normal office hours.

7461 A. J. KENNEDY, Shire Secretary

SHIRE OF CHILTERN  
 LOAN No. 21

*Notice of Intention to Borrow the Sum of \$25 000 for Permanent Works and Undertakings*

Notice is hereby given that the Council of the Shire of Chiltern proposes to borrow the principal sum of twenty-five thousand dollars (\$25 000) secured by a charge over the general rates of the municipality, such sum to be raised by the grant of a mortgage in accordance with the provisions of the *Local Government Act 1958*.

1. The maximum rate of interest that may be paid is 12.6 per centum per annum.

2. The purpose for which the loan is to be applied is:

2.5-tonne Dump Truck	\$ 10 000
Township Streets—Chiltern	15 000
	25 000

3. The period of the loan shall be fifteen (15) years.

4. The moneys borrowed shall be repayable by providing out of the municipal fund thirty (30) half-yearly instalments of approximately \$1 874.90 each including principal and interest on 8 July and 8 January during the currency of the loan. The first instalment shall be payable on 8 January 1981.

5. Such moneys shall be payable at the Bank of New South Wales Savings Bank Limited, Chiltern.

The plans and specifications and the estimates of the cost of the proposed works and a statement showing the proposed expenditure of the moneys to be borrowed are open for inspection at the office of the Council of the Shire of Chiltern at the Shire Office, Chiltern.

7474 M. G. BUTLER, Shire Secretary

Town and Country Planning Act 1961 (Twelfth Schedule)  
 SHIRE OF CRESWICK PLANNING SCHEME

INTERIM DEVELOPMENT ORDER 1978

Notice that amendments to the Interim Development Order of the Planning Scheme have been prepared and are available for inspection.

Notice is hereby given that the Shire of Creswick in pursuance of its powers under the *Town and Country Planning Act 1961* has prepared amendments to the Interim Development Order of the Shire of Creswick Planning Scheme for the whole of the Shire of Creswick.

A copy of the amended Interim Development Order of the scheme has been deposited at the Municipal Office, 68 Albert Street, Creswick and at the office of the Town and Country Planning Board, 235 Queen Street, Melbourne and will be open for inspection during office hours by any person free of charge.

Any persons affected by the amendments are required to set forth in writing all objections they may have, addressed to the Shire Secretary, Shire of Creswick, Municipal Office, 68 Albert Street, Creswick on or before 4 July 1980 and to state whether they wish to be heard in respect of their objections.

7405 B. C. REES, Shire Secretary

SHIRE OF DONALD  
 LOAN No. 72

*Notice of Intention to Borrow the Sum of \$35 000 for Permanent Works and Undertakings*

Notice is hereby given that the Council of the Shire of Donald proposes to borrow the sum of Thirty-five thousand dollars (\$35 000.00) secured by a charge over the general rates of the Municipality, such sum to be raised by the grant of mortgage in accordance with the provisions of the *Local Government Act 1958*.

1. The Maximum rate of interest that may be paid is 11.9 per cent.

2. The purpose for which the loan is to be applied is:

Kerb & Channel Construction	\$ 12 500
Footpath Construction	7 500
Drainage	9 000
Truckwash	6 000
	35 000

3. The period of the loan shall be 5 years.

4. The monies borrowed shall be repayable by providing out of the municipal fund 9 equal amounts of Principal and Interest payable half-yearly of \$2 529.12 and a final instalment of \$31 656.12 with the 1st instalment payable on 3 February 1981 and subsequent instalments payable on 3 February and 3 August during the currency of the Loan.

5. Such monies shall be repayable at the Commercial Banking Company of Sydney Limited, Donald.

The plans and specifications and the estimate of the cost of the proposed works and a statement showing the proposed expenditure of the moneys to be borrowed are open for inspection at the Shire Offices, Donald.

7465 T. H. BOWLES, Shire Secretary

SHIRE OF DONALD  
 LOAN No. 73

*Notice of Intention to Borrow the Sum of \$30 000 for Permanent Works and Undertakings*

Notice is hereby given that the Council of the Shire of Donald proposes to borrow the sum of Thirty thousand dollars (\$30 000) secured by a charge over the general rates of the Municipality, such sum to be raised by the grant of mortgage in accordance with the provisions of the *Local Government Act 1958*.

1. The maximum rate of interest that may be paid is 11.9 per centum per annum.



2. The purpose for which the loan is to be applied is:—

Aerodrome Construction	\$ 22 000
Mall Construction	8 000
	30 000

3. The period of the loan shall be 5 years.

4. The monies borrowed shall be repayable by providing out of the municipal fund 9 equal amounts of Principal and Interest payable half-yearly of \$2 167.82 and a final instalment of \$27 133.78 with the first instalment payable on 3 February 1981, and subsequent instalments payable on 3 February and 3 August during the currency of the Loan.

5. Such monies shall be repayable at the C.B.C. Savings Bank Limited, Donald.

The plans and specifications and the estimate of the cost of the proposed works and a statement showing the proposed expenditure of the moneys to be borrowed are open for inspection at the Shire Offices, Donald.

7464 T. H. BOWLES, Shire Secretary

SHIRE OF ELTHAM  
PROSECUTING OFFICER

Notice is hereby given that Senior Sergeant Graham Vincent Joyce, No. 13452 has been appointed Prosecuting Officer for the Shire of Eltham in lieu of Senior Sergeant Robert Llewellyn Fry, No. 13446.

7475 R. M. WALKER  
Chief Executive Officer

SHIRE OF MILDURA  
LOAN No. 79

Notice is hereby given that the Council of the Shire of Mildura proposes to borrow the principal sum of \$75 000.00 by the grant of a mortgage in accordance with the provisions of the *Local Government Act 1958*.

1. The maximum rate of interest that may be paid is 12.6 per centum per annum.

2. The purpose for which the loan is to be applied is the purchase of office equipment.

3. The period of the loan shall be ten (10) years.

4. The moneys borrowed shall be repayable by providing out of the municipal fund, half-yearly instalments of approximately \$6698.99 each including principal and interest on 1 August and 1 February during the currency of the loan. The first instalment shall be payable on 1 February 1981.

5. Such moneys shall be repayable to the Commissioners of the State Savings Bank of Victoria at the office of the said Commissioners, 233 Collins Street, Melbourne.

The plans and specifications and the estimate of the cost of the proposed works and a statement showing the proposed expenditure of the moneys to be borrowed are open for inspection at the office of the Council of the Shire of Mildura, Fifteenth Street, Irymple.

23 May 1980

DANIEL F. DREW, Shire Secretary  
Shire Offices, Irymple, 3498 7406

SHIRE OF RODNEY  
CARAVAN BY-LAW  
By-Law No. 76

Notice is hereby given that the Shire of Rodney in pursuance of the powers conferred by the *Local Government Act 1958* has made By-Law No. 76 for the purpose of—

Prohibiting or regulating the placing of caravans on private property.

This By-Law shall apply to and have operation throughout the whole of the municipal district of the Shire of Rodney and shall come into operation the day after notice of its making is published in the *Victoria Government Gazette*.

No. 42—21850/80—4

Resolution for passing this By-Law was agreed to by the Council of the Shire of Rodney on 17 December 1979 and confirmed on 29 January 1980.

This By-Law was approved by the Governor in Council on 13 May 1980.

A copy of the By-Law is open for inspection free of charge during office hours at the Municipal Offices, Casey Street, Tatura.

7566 JOHN L. PURDEY, Acting Shire Secretary

SHIRE OF SOUTH GIPPSLAND  
LOAN No. 47

*Notice of Intention to Borrow the Sum of \$25 000 for Permanent Works and Undertakings*

Notice is hereby given that the Council of the Shire of South Gippsland proposes to borrow the principal sum of \$25 000 secured by a charge over the general rates of the municipality, such sum to be raised by the grant of a mortgage in accordance with the provisions of the *Local Government Act 1958*.

1. The maximum rate of interest that may be paid is 12 per cent. per annum.

2. The purpose for which the loan is to be applied is Purchase of property, Pioneer Street, Foster, \$25 000.

3. The period of the loan shall be 20 years.

4. The moneys borrowed shall be repayable by providing out of the municipal fund half-yearly instalments of approximately \$1661.54 each including principal and interest on 1 February and 1 August during the currency of the loan. The first instalment shall be payable on 1 February 1981.

5. Such moneys shall be repayable to The Commissioners of The State Savings Bank of Victoria at the office of the said Commissioners, 233 Collins Street, Melbourne.

The plans and specifications and the estimate of the cost of the proposed works and a statement showing the proposed expenditure of the moneys to be borrowed are open for inspection at the office of the Council of the Shire of South Gippsland at Foster.

16 May 1980

7407 H. R. LOMAX, Shire Secretary

SHIRE OF WINCHELSEA  
LOAN No. 36

*Notice of Intention to Borrow the Sum of \$80 000 for Permanent Works and Undertakings*

Notice is hereby given that the Council of the Shire of Winchelsea proposes to borrow the principal sum of Eighty Thousand Dollars secured by a charge over the general rates of the municipality, such sum to be raised by the grant of a mortgage in accordance with the provisions of the *Local Government Act 1958*.

1. The maximum rate of interest that may be paid is 9.3 per cent per annum.

2. The purpose for which the loan is to be applied is for the construction of amenities block at Kia-Ora Caravan Park, Lorne.

3. The period of the loan shall be 10 years.

4. The moneys borrowed shall be repayable by providing out of the municipal fund half-yearly instalments of approximately \$6230.29 each including principal and interest on 1 February and 1 August during the currency of the loan. The first instalment shall be payable on 1 February 1981.

5. Such moneys shall be repayable to the Department of State Development, Decentralization and Tourism, Melbourne.

7467 W. K. MATHISON, Shire Secretary

BRIAGOLONG WATERWORKS TRUST  
BY-LAW No. 3

The Briagolong Waterworks Trust in pursuance and exercise of the powers conferred by the Water Act doth hereby make a By-Law Numbered 3 for the purpose of amending By-Law No. 2, relating to fees and charges to be made for the licensing of Plumbers and connection to Mains.

The Chairman and Commissioners of the Briagolong Waterworks Trust hereby Order as follows:

*Licensing of Plumbers*

1. Clause 3 of By-Law No. 2, fixing fees and charges for the Licensing of Plumbers is hereby amended as follows:

- For \$2 there shall be substituted \$5.  
For 50c there shall be substituted \$2.

*Connection to Mains*

2. Clause 17A of By-Law No. 2 relating to the connection of any service pipe, there shall be substituted:

- For \$2 there shall be substituted \$65.

In witness hereof the common seal of the Briagolong Waterworks Trust was hereto affixed 27 March 1980, in the presence of—

(SEAL) G. C. HODGE, Chairman  
J. L. MOORE, Commissioner  
J. RENNICK, Secretary

7569

*Water Act 1958*

**COHUNA WATERWORKS TRUST**

**EXTENSION OF WATERWORKS DISTRICT, RECONSTITUTION OF WATERWORKS TRUST—APPROVAL OF SITE OF WORKS**

*Extension of the Waterworks District Boundary and Proclamation of the Leitchville Urban District*

Notice is hereby given that the Cohuna Waterworks Trust proposes to make application to the Honorable the Minister of Water Supply to take over the administration of the water supply to Leitchville township from the State Rivers and Water Supply Commission and desires that its Waterworks District be extended to include the township of Leitchville, the Trust be reconstituted to allow representation from the East Riding of the Shire, approval be given to the site works to relocate the supply to Leitchville, and Leitchville Urban District be proclaimed as an Urban District of the Cohuna Waterworks Trust.

A general plan and description of the proposed works may be seen at the Trust's office, Shire Offices, Cohuna, and any objections must be lodged with the Secretary of the Cohuna Waterworks Trust on or before 7 July 1980.

Dated at Cohuna, 16 May 1980

7111

G. B. KOHLMAN, Secretary

**NHILL WATERWORKS TRUST**

**NOTICE TO THE OWNERS OF TENEMENTS IN THE AREAS DESCRIBED IN THE SCHEDULE TO THIS NOTICE**

Main pipes having been laid down for the supply of water to the areas shown in the Schedule to this notice in such places as are marked on a plan available for inspection at the Office of the Nhill Waterworks Trust at Nhill, the owners of all tenements in the said areas are hereby required on or before 30 June 1980 to cause a proper pipe and stop-cocks to be laid so as to supply water within such tenements from the nearest main pipe.

Dated at Nhill, 28 May 1980

I. D. EFFRETT, Secretary

**SCHEDULE**

Dimboola Road East from the Elevated Storage to a point opposite Lot 1 on Plan of Subdivision No. 67881 being approximately 260 m east.

Goroke Road from the Western Highway to a point 211 m east.

Victoria Street from a point 42 m north of Goroke Road to the Goroke Road corner. 7466

**THE BALLARAT SEWERAGE AUTHORITY**

**GENERAL NOTICE**

The abovementioned Sewerage Authority having made provision for carrying off the sewage from each and every property which or any part of which is within the Sewerage Areas hereinafter described doth hereby declare that on and after 1 July 1980 each and every property which or any part of which is within the said Sewerage Area shall be deemed to be a sewered property within the meaning of the *Sewerage District Act 1958*.

The boundaries of the Sewerage Area hereinbefore referred to are:

**SEWERAGE AREA No. 445**

*City of Ballarat*—Commencing at a point on the south-east corner of Wilson and Kline Streets being also a point on the boundary of Sewerage Area 280 thence easterly along the south building line of Wilson Street to the north-east corner of Lot 6, L.P.23743, Township of Ballarat East Parish of Ballarat County of Grant being also a point on the boundary of Sewerage Area 252 thence southerly to the south-east corner of the said Lot 6 thence westerly along the southern boundaries of Lots 6–9 inc. L.P.23743 thence northerly to the south-east corner of Lot 1 L.P.97818 thence westerly along the southern boundaries of Lots 1–3 inc. L.P.97818 to the south-east corner of the said Lot 3 thence southerly along the eastern boundaries of Lots 6 and 7 L.P.97818 continuing south-westerly across Lot 9, L.P.97818 to the north-east corner of Lot 8 L.P.97818 thence southerly along the eastern boundary of the said Lot 8 continuing southerly and westerly along the boundary of Lot 1 L.P.87902 to a point on the east building line of Kline Street thence northerly along the said east building line to the point of commencement.

**SEWERAGE AREA No. 446**

*Shire of Bungaree*—Commencing at a point on the east boundary of C.A. 3 section 21 Township of Ballarat North Parish of Ballarat County of Grenville approximately 33 metres north of Howitt Street being also a point on the boundary of Sewerage Area 210 thence southerly along the east boundary of the said C.A. 3 to the north building line of Howitt Street thence westerly along the said north building line to the boundary of Sewerage Area 162 thence northerly along the boundary of the said Sewerage Area 162 to a point on the boundary of Sewerage Area 210 continuing northerly and easterly along the boundary of the said Sewerage Area 210 to a point on the boundary of Sewerage Area 203 thence easterly along the boundary of the said Sewerage Area 203 to a point on the boundary of Sewerage Area 210 thence southerly, easterly and southerly along the boundary of the said Sewerage Area 210 to the point of commencement.

**SEWERAGE AREA No. 447**

*Shire of Buninyong*—Commencing at a point being the south-east corner of C.A. 10 section 119 Township of Ballarat East Parish of Ballarat County of Grant being also a point on the north building line of Elsworth Street and also a point on the boundary of Sewerage Area 444 thence south-westerly across Elsworth Street to the north-east corner of C.A. 21 section 15 Parish of Ballarat thence southerly and westerly along the boundary of the said C.A. 21 to a point on the eastern boundary of C.A. 20 section 21 thence southerly, westerly, northerly and westerly along the boundary of the said C.A. 20 to the south-east corner of C.A. 19 section 21 continuing south-westerly along the boundary of the said C.A. 19 to the east building line of Flockhart Street thence north-westerly across Flockhart Street to the north-west corner of Flockhart Street and Sykes Avenue being also a point on the boundary of Sewerage Area 412 thence northerly and north-westerly along the boundary of the said Sewerage Area 412 to the north-east corner of Heales and Elsworth Streets being also a point on the boundary of Sewerage Area 272 thence generally easterly along the northern boundary of Elsworth Street to a point on the boundary of Sewerage Area 444 continuing easterly along the boundary of the said Sewerage Area 444 to the point of commencement.

**SEWERAGE AREA No. 448**

*City of Ballarat*—Commencing at a point on the north-west corner of Eureka and Stawell Streets being also a point on the boundary of Sewerage Area 95 thence south-westerly to the south-west corner of Eureka and Kline Streets being also a point on the boundary of Sewerage Area 191 thence south-westerly along the boundary of the said Sewerage Area 191 to the north-east corner of C.A. 2 section 49 Township of Ballarat East Parish of Ballarat County of Grant thence generally southerly, westerly and north-westerly along the boundary of the said C.A. 2 to the east building line of Regan Street being also a point on the boundary of S.A. 191 thence northerly along the boundary of the said Sewerage Area 191 to the south-

east corner of Regan Street and Eureka Street thence north-westerly across Eureka Street to the south-west corner of the Eureka Reserve being also a point on the boundary of Sewerage Area 95 thence generally easterly along the boundary of the said Sewerage Area 95 to the point of commencement.

Further particulars regarding the streets or parts of streets in which sewers have been laid may be ascertained on inquiry at the Authority's office.

By order of the said Sewerage Authority

7567 J. H. HEINZ, Chairman  
B. E. LEACH, Secretary

#### THE BALLARAT SEWERAGE AUTHORITY

Pursuant to section 119 (2) of the *Sewerage Districts Act 1958* (No. 6368), notice is hereby given of the intention to construct a sewer to provide for a property situated in the vicinity of the following streets.

*City of Ballarat*—Old Melbourne Road, Ballarat East; Little Bridge Street, Ballarat; Wilson and Joseph Streets, Ballarat East.

*Shire of Ballarat*—Elaine Avenue and Caroline Street, Alfredton.

More particularly as shown on maps which are open for inspection at this office between the hours of 8.45 a.m. and 4.30 p.m., Monday to Friday inclusive.

Dated 30 May 1980

7568 B. E. LEACH, Secretary

#### THE BALLARAT SEWERAGE AUTHORITY

Pursuant to section 119 (2) of the *Sewerage Districts Act 1958* (No. 6368), notice is hereby given of the intention to construct a sewer to provide for a property situated in the vicinity of the following streets:—

*Shire of Ballarat*—Ring Road and Trewin Street, Wendouree,  
more particularly as shown on maps which are open for inspection at this office between the hours of 8.45 a.m. and 4.30 p.m. Monday to Friday inclusive.

26 May 1980

7408 B. E. LEACH, Secretary

#### Victoria

##### ACT 391—FIRST SCHEDULE

I, Donald Murray Macrae, authorized representative of the denomination known as the Presbyterian Church of Victoria with the consent of The Presbyterian Church of Victoria Trusts Corporation trustees of the land described in the subjoined statement of trusts, and of Arthur John Minchin being the person entitled to minister in or occupy a building or buildings upon the said land, hereby apply to the Governor of the State of Victoria for leave to dispose of the said land by the means and for the purposes mentioned in the said statement of trusts, and I hereby certify that the said land was temporarily reserved by Order in Council on 23 October 1865, for the purpose of Presbyterian Church purposes at Rosedale.

That the only trustees of the said land resident in the State of Victoria are The Presbyterian Church of Victoria Trusts Corporation.

That the only buildings upon the said land are Church and Manse.

And that the only person entitled to minister in or occupy the same is the above-named Arthur John Minchin.

Signature of authorized representative—D. M. Macrae.

We consent to this application.

The common seal of the Presbyterian Church of Victoria Trusts Corporation was hereto affixed, in the presence of—

N. J. McCOLL, Trustee  
(SEAL) I. V. PARTON, Trustee  
A. R. GILLESPIE, Treasurer/Financial Secretary

Attested by Ian D. Mackinnon, Law Agent.

Signature of person entitled to minister in or occupy building or buildings—A. J. Minchin.

#### STATEMENT OF TRUSTS

*Description of Land*—8094 square metres, Township of Rosedale, Parish of Rosedale, County of Buln Buln, being Crown allotment 7, section 21. Commencing at the south-western angle of Crown allotment 2, section 21; bounded thence by Queen Street bearing 270 deg. 00 min 100.58 metres; by Wood Street bearing 0 deg. 00 min. 80.47 metres; by Crown allotment 1 bearing 90 deg. 00 min. 100.58 metres; and thence by Crown allotment 2 bearing 180 deg. 00 min. 80.47 metres to the point of commencement.

*Names of Trustees*—The Presbyterian Church of Victoria Trusts Corporation.

*Powers of Disposition*—With the consent of the General Assembly of "The Presbyterian Church of Victoria", to mortgage, sell, lease, exchange and transfer, and grant easements over the said land, or any part or parts thereof, and, subject to such powers and the exercise thereof, to hold the said land, or so much thereof as may from time to time remain vested in the said trustees, upon such trusts for the said Presbyterian Church of Victoria, and for such purposes, and with and subject to such powers, and provisions as are contained in the document enrolled by the Registrar-General of the State of Victoria, pursuant to the provisions of the *Presbyterian Trusts Act 1890*, and styled "The Presbyterian Church of Victoria Model Trust Deed for Church and Manse Site".

*Purposes to which Proceeds of Disposition are to be Applied*—To pay the money coming to the hands of such trustees by virtue of any such power of disposition to the Treasurer for the time being of the Presbyterian Church of Victoria, to be by him applied first in payment of all incidental costs, next in payment to the said Presbyterian Church of Victoria, of all deductions heretofore or hereafter to be authorized, by the General Assembly of the said Church and as to the residue, for such purposes as the said Assembly has heretofore authorized or may hereafter authorize.

7452

#### Victoria

##### ACT 391—FIRST SCHEDULE

I, Donald Murray Macrae, authorized representative of the denomination known as the Presbyterian Church of Victoria with the consent of The Presbyterian Church of Victoria Trusts Corporation trustees of the land described in the subjoined statement of trusts, and of George Struan Robertson being the person entitled to minister in or occupy a building or buildings upon the said land, hereby apply to the Governor of the State of Victoria for leave to dispose of the said land by the means and for the purposes mentioned in the said statement of trusts, and I hereby certify that the said land was temporarily reserved by Order in Council on 18 October 1869 for the purpose of Presbyterian Place of Public Worship and Minister's Dwelling at Cowwarr.

That the only trustees of the said land resident in the State of Victoria are The Presbyterian Church of Victoria Trusts Corporation.

That the only buildings upon the said land are Nil.

And that the only person entitled to minister in or occupy the same is the above-named George Struan Robertson.

Signature of authorized representative—D. M. Macrae.  
We consent to this application.

The common seal of the Presbyterian Church of Victoria Trusts Corporation was hereto affixed, in the presence of—

T. STALEY, Trustee  
(SEAL) W. M. HODGES, Trustee  
A. R. GILLESPIE, Treasurer/Financial Secretary

Attested by Ian D. Mackinnon, Law Agent.

Signature of person entitled to minister in or occupy building or buildings—G. S. Robertson.

#### STATEMENT OF TRUSTS

*Description of Land*—6070 square metres, Township of Cowwarr, Parish of Toongabbie North, County of Tanjil, being Crown allotment 6A, section 1. Commencing at the south-eastern angle of Crown allotment 5, section 1; bounded thence by roads bearing 178 deg. 12 min. 60.35

metres, 268 deg. 12 min. 100.58 metres and 358 deg. 12 min. 60.35 metres; and thence by Crown allotment 5 bearing 88 deg. 12 min. 100.58 metres to the point of commencement.

**Names of Trustees**—The Presbyterian Church of Victoria Trusts Corporation.

**Powers of Disposition**—With the consent of the General Assembly of "The Presbyterian Church of Victoria", to mortgage, sell, lease, exchange and transfer, and grant easements over the said land, or any part or parts thereof, and, subject to such powers and the exercise thereof, to hold the said land, or so much thereof as may from time to time remain vested in the said trustees, upon such trusts for the said Presbyterian Church of Victoria, and for such purposes, and with and subject to such powers, and provisions as are contained in the document enrolled by the Registrar-General of the State of Victoria, pursuant to the provisions of the *Presbyterian Trusts Act 1890*, and styled "The Presbyterian Church of Victoria Model Trust Deed for Church and Manse Site".

**Purposes to which Proceeds of Disposition are to be Applied**—To pay the money coming to the hands of such trustees by virtue of any such power of disposition to the Treasurer for the time being of the Presbyterian Church of Victoria, to be by him applied first in payment of all incidental costs, next in payment to the said Presbyterian Church of Victoria, of all deductions heretofore or hereafter to be authorized, by the General Assembly of the said Church and as to the residue, for such purposes as the said Assembly has heretofore authorized or may hereafter authorize. 7453

#### Victoria

##### ACT 391—FIRST SCHEDULE

I, Donald Murray Macrae, authorized representative of the denomination known as the Presbyterian Church of Victoria with the consent of The Presbyterian Church of Victoria Trusts Corporation trustees of the land described in the subjoined statement of trusts, and of Rosalind Richards Terry being the person entitled to minister in or occupy a building or buildings upon the said land, hereby apply to the Governor of the State of Victoria for leave to dispose of the said land by the means and for the purposes mentioned in the said statement of trusts, and I hereby certify that the said land was permanently reserved by Order in Council on 21 February 1870 for the purpose of Presbyterian Church purposes.

That the only trustees of the said land resident in the State of Victoria are The Presbyterian Church of Victoria Trusts Corporation.

That the only buildings upon the said land are the Church, Manse and School Hall.

And that the only person entitled to minister in or occupy the same is the above-named Rosalind Richards Terry.

Signature of authorized representative—D. M. Macrae.

We consent to this application.

N. J. McCOLL, Trustee

I. V. PARTON, Trustee

A. R. GILLESPIE, Treasurer/Financial Secretary

Attested by Ian D. Mackinnon, Law Agent.

Signature of person entitled to minister in or occupy building or buildings—R. R. Terry.

##### STATEMENT OF TRUSTS

**Description of Land**—8094 square metres, Township of Kyneton, Parish of Lauriston, County of Dalhousie, being Crown allotment 6, section 8. Commencing at the north-western angle of Crown allotment 5; bounded thence by that allotment bearing 180 deg. 00 min. 100.58 metres; by Hutton Street bearing 270 deg. 00 min. 80.47 metres; by Edden Street bearing 0 deg. 00 min. 100.58 metres; and thence by Yaldwyn Street bearing 90 deg. 00 min. 80.47 metres to the point of commencement.

**Names of Trustees**—The Presbyterian Church of Victoria Trusts Corporation.

**Powers of Disposition**—With the consent of the General Assembly of "The Presbyterian Church of Victoria", to mortgage, sell, lease, exchange and transfer, and grant easements over the said land, or any part or parts thereof, and, subject to such powers and the exercise thereof, to hold the said land, or so much thereof as may from time to time remain vested in the said trustees, upon such trusts for the said Presbyterian Church of Victoria, and for such purposes, and with and subject to such powers, and provisions as are contained in the document enrolled by the Registrar-General of the State of Victoria, pursuant to the provisions of the *Presbyterian Trusts Act 1890*, and styled "The Presbyterian Church of Victoria Model Trust Deed for Church and Manse Site".

**Purposes to which Proceeds of Disposition are to be Applied**—To pay the money coming to the hands of such trustees by virtue of any such power of disposition to the Treasurer for the time being of the Presbyterian Church of Victoria, to be by him applied first in payment of all incidental costs, next in payment to the said Presbyterian Church of Victoria, of all deductions heretofore or hereafter to be authorized, by the General Assembly of the said Church and as to the residue, for such purposes as the said Assembly has heretofore authorized or may hereafter authorize. 7454

#### VICTORIA

##### ACT 391—FIRST SCHEDULE

I, Ronald William Allardice, head or authorised representative of the denomination known as The Uniting Church in Australia with the consent of The Uniting Church in Australia Property Trust (Victoria) trustees of the land described in the subjoined statement of trusts, and of Clement Andrew Dickinson, 30 Urquhart Street, Horsham and/or Peter Den Houting, 8 Neill Street, Maryborough being the person entitled to minister in or occupy a building or buildings upon the said land, hereby apply to the Governor of the State of Victoria for leave to dispose of the said land by the means and for the purposes mentioned in the said statement of trusts, and I hereby certify that the said land was temporarily reserved by Order in Council on 9 May 1864 for Wesleyan Church purposes.

That the only trustees of the said land resident in the State of Victoria are The Uniting Church in Australia Property Trust (Victoria).

That the only buildings upon the said land are Bluestone Church with galvanised iron roof and wooden floor.

And that the only persons entitled to minister in or occupy the same are the abovenamed Clement Andrew Dickinson and/or Peter Den Houting.

Signature of head or authorised representative—Ronald William Allardice.

We consent to this application.

The common seal of The Uniting Church in Australia Property Trust (Victoria) was hereto affixed in pursuance of a resolution passed at a meeting of the members of the Trust in the presence of—

(SEAL)

R. W. ALLARDICE, Trustee

N. E. EATON, Trustee

Signature of person entitled to minister in or occupy building or buildings—C. A. Dickinson, Resident Minister.

##### STATEMENT OF TRUSTS

**Description of Land**—Craigie Wesleyan Church. Site for Wesleyan Church purposes temporarily reserved by Order in Council of 9 May 1864. 4860 square metres (by re-survey), Township of Craigie, Parish of Craigie, County of Talbot being Crown Allotment 9 Section 6. Commencing at the south-eastern angle of Crown Allotment 16f Section A Parish of Craigie; bounded thence by that allotment bearing 15 deg. 11 min. 119.39 metres further by that allotment and allotment 16e bearing 105 deg. 11 min. 40.23 metres thence by allotment 16d bearing 195 deg. 11 min. 122.21 metres and thence by Maryborough Street bearing 289 deg. 8 min. 40.33 metres to the point of commencement.

**Name of Trustees**—The Uniting Church in Australia Property Trust (Victoria).

**Powers of Disposition**—Such powers of disposition, including powers of sale, lease or mortgage as are given to the Trust by The Uniting Church in Australia Property Trust (Victoria) Act No. 9021 of 1977.

**Purposes to which Proceeds of Disposition are to be applied**—To such Uniting Church in Australia purposes as shall be approved by the Committee of the Victorian Synod of The Uniting Church in Australia. 7511

Notice is hereby given that Derite Proprietary Limited has applied for a lease pursuant to section 134 of the Land Act 1958 for a term of 30 years in respect of Allotments 1b and 1c Section 63b Parish of Melbourne South City of Port Melbourne containing 4948 square metres as a site for General Industrial Purposes. 7451

Notice is hereby given that the partnership which has heretofore been subsisting between John Phillip Murphy of 8 Orford Avenue, Kew in the State of Victoria and James Francis Murphy of 148 High Street, Ashburton in the said State and carrying on the business of Wine Exporters in the style and firm name of Southern Colonial Wine Shippers has been dissolved as from 1 July 1979 so far as concerns the said Dolitol Nominees Pty. Limited which retires from the said partnership.

Dated 26 May 1980

PICONE & BORGHESI, of 2 Stanley Street, Collingwood, solicitors and agents for John Phillip Murphy and James Francis Murphy 7409

Notice is hereby given that the partnership heretofore subsisting between Athol Thomas Smith and Rosa Smith carrying on business as Concreting Contractors at Mildura under the style or firm of "A. T. & R. Smith Concreting Contractors" has been dissolved as from 4 February 1980.

Dated 4 February 1980

7449

R. SMITH  
A. T. SMITH

#### DISSOLUTION OF PARTNERSHIP

PATRICIA M. ANDREWS, CUMING & CO.

Ms Angela V. Cuming has retired from partnership in the firm of Patricia M. Andrews, Cuming & Co., Barristers & Solicitors, as from 27 May 1980, but will continue as an employee of the firm. Miss Patricia M. Andrews will continue the practice under the same business name at 524 Elizabeth Street, Melbourne; Main Street, Warburton; Main Street, Yarra Junction, and Main Street, Seville.

7450

#### NOTICE OF DISSOLUTION OF PARTNERSHIP

Notice is hereby given that the Partnership heretofore subsisting between the undersigned Sydney Robert Mounsey, Lynette Margaret Mounsey, John Anthony Paszkiewicz and Gaynor Ann Paszkiewicz carrying on business as Builders at Moe under the name of "S. & J. Mounsey Builders" has been dissolved by mutual consent as from 31 March 1980. All debts due to and owing by the said late firm will be received at 22 Ross Avenue Moe and paid by S. R. Mounsey, L. M. Mounsey, J. A. Paszkiewicz and G. A. Paszkiewicz in equal shares.

Dated at Newborough, 12 May 1980

7468

S. R. MOUNSEY  
L. M. MOUNSEY  
J. A. PASZKIEWICZ  
G. A. PASZKIEWICZ

#### DISSOLUTION OF PARTNERSHIP

As of 30 May 1980 the partnership between Mr K. L. Horne and Mr C. J. Guest, trading under the name of "The Weekly Trading Guide" has been completely dissolved.

7562

**Companies Act 1961**—In the matter of RACECOURSE MOWER AND GARDEN SUPPLIES PTY. LIMITED (in Liquidation)

Notice is hereby given that a Meeting of Members of Racecourse Mower & Garden Supplies Pty. Limited held on 8 May 1980 it was resolved by a Special Resolution "that the Company be wound up voluntarily and Mr Michael Joseph O'Keeffe, Chartered Accountant, be appointed Liquidator".

On the following day pursuant to section 260 a Meeting of Creditors confirmed the appointment.

O'KEEFFE & DECKKER, accountants, 66 High Street, Glen Iris, 3146 7410

#### The Companies Act 1961

114 WILLIAM STREET HOLDINGS PTY. LIMITED (IN LIQUIDATION)

At an extraordinary general meeting of shareholders of 114 William Street Holdings Pty. Limited convened and held at 55 Clarence Street, Sydney on 15 May 1980 the following special resolution was duly passed.

"That the company be wound up voluntarily and that Alan Malcolm Scott of care of Deloitte, Haskins & Sells, G.P.O. Box 243, Sydney, New South Wales, be appointed Liquidator for the purposes of such winding up and that the remuneration of the said Alan Malcolm Scott be such sums as may be agreed upon from time to time between him and the contributories and that the Liquidator may divide among the contributories *in specie* or kind any part of the assets of the company."

7411

ALAN MALCOLM SCOTT, Liquidator

#### The Companies Act 1961

AUSTRALIAN ESTATES (PORTLAND) PTY. LIMITED (IN LIQUIDATION)

At an extraordinary general meeting of shareholders of Australian Estates (Portland) Pty. Limited convened and held at 55 Clarence Street, Sydney on 15 May 1980 the following special resolution was duly passed.

"That the company be wound up voluntarily and that Alan Malcolm Scott of care of Deloitte, Haskins & Sells, G.P.O. Box 243, Sydney, New South Wales, be appointed Liquidator for the purposes of such winding up and that the remuneration of the said Alan Malcolm Scott be such sums as may be agreed upon from time to time between him and the contributories and that the Liquidator may divide among the contributories *in specie* or kind any part of the assets of the company."

7412

ALAN MALCOLM SCOTT, Liquidator

**Companies Act 1961**—In the matter of BRINAN PTY. LTD. (in Liquidation), formerly trading as "Brinan's Footwear" and "Murfi Boutique"

Notice is hereby given that at an extraordinary meeting of the Members of the abovenamed Company held on 26 May 1980, it was resolved that the Company be wound up voluntarily and at a Meeting of Creditors held on the same day pursuant to Section 260 it was resolved that for such purpose Mr D. J. Cogle of 144 Jolimont Road, East Melbourne, Public Accountant, be appointed Liquidator.

Notice is also given that after 21 days from this date I shall proceed to distribute the assets. All creditors having any claim against the Company should furnish particulars of same by that date, otherwise I shall proceed to distribute the assets without regard to their claim.

Dated 27 May 1980

7413

D. J. COUGLE, Liquidator

McKELSON INVESTMENTS PTY. LIMITED (IN VOLUNTARY LIQUIDATION)

#### SPECIAL RESOLUTION TO WIND UP

At an Extraordinary General Meeting of the abovenamed company duly convened and held at 21 Vale Street, Moe on 27 May 1980 the following Resolution was passed as a Special Resolution:

"That the company be wound up voluntarily."

At the abovementioned meeting Desmond John Grigg was appointed Liquidator for the purpose of the winding up.

Notice is also given that after 30 days from this date, I shall proceed to distribute the assets. All creditors having any claim against the company should furnish particulars of same by that date, otherwise I shall proceed to distribute the assets without regard to their Claim.

Dated 27 May 1980

7415

D. J. GRIGG, Liquidator

In the matter of the Companies Act 1961; and in the matter of CRAIGIEBURN HEIGHTS PTY. LIMITED—Notice Pursuant to Section 254 (2) of the Companies Act 1961

Notice is hereby given that an Extraordinary General Meeting of Members of the above Company duly convened and held at 39 Dendy Street, Middle Brighton on 22 May 1980 in the forenoon the following resolution was passed, viz:

"1. That Craigieburn Heights Pty. Ltd. being solvent be wound up voluntarily; and

2. That Mr Emile Rochman, Accountant of the firm of Rezak & Associates, Accountants, 3rd Floor, 390 St. Kilda Road, Melbourne, be appointed liquidator for the purpose of such winding up and that the liquidator's remuneration be calculated on a time basis."

Dated 22 May 1980

7414

I. SILVER, Chairman

WENDOUREE NO. 1 CO-OPERATIVE HOUSING SOCIETY LIMITED (IN LIQUIDATION)

SPECIAL RESOLUTION

(Passed 26 May 1980)

At a special general meeting of the abovenamed society duly convened and held at 44 Armstrong Street South, Ballarat on 26 May 1980 at 5.30 p.m. the subjoined special resolution was duly passed:—

That the Society having successfully completed its objectives be wound up voluntarily, and that Mr Geoffrey W. Cunningham of 102 Walker Street, Ballarat be appointed liquidator for the purposes of the winding up.

7416

G. B. RICHMOND, Chairman of Meeting  
G. W. CUNNINGHAM, Secretary

In the matter of the Co-operative Housing Societies Act 1958; and the Companies Act 1961; and in the matter of WENDOUREE NO. 1 CO-OPERATIVE HOUSING SOCIETY LIMITED (in Liquidation)—Notice to Creditors

Notice is hereby given that all persons having any claim against the above society are required on or before 25 June 1980 to send their names and addresses and particulars of their debts or claims to Mr G. W. Cunningham of 44 Armstrong Street South, Ballarat the liquidator of the said society, at his office and if so required by notice in writing from the said liquidator are personally, or by their solicitors, to come in and prove their said debts or claims at such time and place as shall be specified in such notice; or, in default thereof, they shall be excluded from the benefit of any distribution made before such debts or claims are so lodged or proved.

Dated at Ballarat, 27 May 1980

7417

G. W. CUNNINGHAM, Liquidator

The Companies Act 1961

COUNTRY INVESTMENTS PROPRIETARY LIMITED  
(IN VOLUNTARY LIQUIDATION)

NOTICE OF FINAL MEETING

Notice is hereby given that, pursuant to section 272 of the Companies Act 1961, a final meeting of the members of the abovenamed Company will be held at the office of the Liquidator, 2 Drummond Street South, Ballarat on 4 July 1980 at 10 a.m., for the purpose of presenting the Liquidator's account of the winding up.

Dated 26 May 1980

7418

M. P. SEGRAVE, Liquidator

In the Supreme Court of Victoria—No. 'Co.' 11323 of 1978—In the matter of the Companies Act 1961; and in the matter of F. & R. DE MARIA & SON PTY. LTD.

Notice is hereby given that a Petition for the winding up of the abovenamed Company by the Supreme Court was on 13 May 1980 presented by Calsil Limited; and that the said Petition is directed to be heard before the Court sitting at the Fourteenth Court, Law Courts, William Street, Melbourne on 19 June 1980 at the hour of 10.30 o'clock in the forenoon; and any creditor or contributory of the said company desiring to support or oppose the making of an Order on the said Petition may appear at the time of hearing by himself or his Counsel for that purpose; and a copy of the Petition will be furnished to any creditor or contributory of the said company requiring the same by the undersigned on payment of the regulated charge for the same.

The Petitioner's Address is 197 St. George's Terrace, Perth, Western Australia.

The Petitioner's Solicitors are Messrs Corr & Corr, 290 Latrobe Street, Melbourne.

CORR & CORR, Solicitors for the Petitioner

NOTE—Any person who intends to appear on the hearing of the said Petition must serve on or send by post to the abovenamed Solicitors, notice in writing of his intention so to do. The notice must state the name and address of the person, or, if a firm, the name and address of the firm and must be signed by the person or firm, or his or their Solicitor (if any) and must be served, or if posted, must be sent by post in sufficient time to reach the abovenamed not later than 4.00 o'clock in the afternoon on 18 June 1980.

7419

IN THE SUPREME COURT OF VICTORIA

Companies Act 1961, as Amended

LA TROBE PACKAGING PTY. LIMITED

Notice is hereby given that a Petition for the winding up of the abovenamed company by the Supreme Court was on 14 May 1980 presented by Cope Allman (Marrickville) Pty. Limited (trading as Aerosol Research and Development) and that the said Petition is directed to be heard before the Court sitting at the Practice Court Law Courts, Melbourne on 19 June 1980 at the hour of 10.30 a.m. in the forenoon, and any creditor or contributory of the said Company desiring to support or oppose the making of an Order on the said Petition may appear at the time of hearing by himself or his Counsel for that purpose, and a copy of the Petition will be furnished to any creditor or contributory of the said Company requiring the same by the undersigned on payment of the regulated charge for the same.

The Petitioner's Address is 35 Fitzroy Street, Marrickville, in the State of New South Wales.

The Petitioner's Solicitors are J. F. Lamich and Co., of 31A Florence Street, Hornsby, N.S.W., whose Melbourne Agent is Adrian R. Bieske, Barrister and Solicitor of 397 Little Collins Street, Melbourne.

J. F. LAMICH & CO., Solicitors for the Petitioner

NOTE—Any person who intends to appear on the hearing of the said Petition must serve on or send by post to the abovenamed Solicitors, notice in writing of his intention so to do. The notice must state the name and address of the person, or, if a firm, the name and address of the firm and must be signed by the person or firm, or his or their Solicitor (if any) and must be served, or if posted, must be sent by post in sufficient time to reach the abovenamed not later than 4 o'clock in the afternoon of 18 June 1980.

7420

F. BENDLE INVESTMENTS PTY. LTD. (IN VOLUNTARY LIQUIDATION)

SPECIAL RESOLUTION TO WIND UP

At an extraordinary General Meeting of the abovenamed company duly convened and held at 1784 Ferntree Gully Road, Ferntree Gully on 27 May 1980, the following Resolution was passed as a Special Resolution.

"That the company be wound up voluntarily."

At the abovementioned meeting Anthony L. Taggart was appointed Liquidator for the purposes of the winding up.

"Notice is also given that after 30 days from this date, I shall proceed to distribute the assets. All creditors having any claim against the company should furnish particulars of same by that date, otherwise I shall proceed to distribute the assets without regard to their claim."

Dated 28 May 1980

7437 ANTHONY L. TAGGART, Liquidator

The Companies Act 1961

PAUL ALEXANDER PTY. LTD. (trading as Giselle Boutique)

PURSUANT TO SECTION 260 OF THE COMPANIES ACT 1961  
Notice is hereby given that a Meeting of Creditors of Paul Alexander Pty. Ltd. trading as Giselle Boutique, Shop 4, 111 Pakington Street, Geelong West, Vic. 3218 and Shop 3, 161 Moorabool Street, Geelong, Vic. 3220 will be held at the Institute of Chartered Accountants Board Room, 140 Queen Street, Melbourne on Friday, 6 June 1980 at 11 a.m. for the purpose of considering the Company's affairs, the Company having convened an Extraordinary General Meeting of its members to be held on the same day at 10.30 a.m. for the purpose of considering and if thought fit passing a Special Resolution that the Company be wound up voluntarily.

Dated 28 May 1980

PAUL KELLY, Director

Day, Neilson, Jenkins & Johns, chartered accountants, 199-203 Moorabool Street (P.O. Box 1) Geelong, 3220

7438

The Companies Act 1961

U-BUILD HOMES PTY. LTD.

PURSUANT TO SECTION 260 OF THE COMPANIES ACT 1961

Notice is hereby given that a meeting of creditors of U-Build Homes Pty. Ltd., of 45 Gheringhap Street, Geelong, Vic. 3220 will be held at the Geelong Branch of the Victorian Chamber of Manufactures, 50 Western Beach, Geelong, 3220 on Thursday, 12 June 1980 at 11 a.m. for the purposes of considering the Company's affairs, the Company having convened an extraordinary general meeting of its members to be held on the same day at 10.30 a.m. for the purpose of considering and if thought fit passing a Special Resolution that the Company be wound up voluntarily.

Dated 30 May 1980

ALEX JIGALIN, Director

Day, Neilson, Jenkins & Johns, chartered accountants, 199-203 Moorabool Street (P.O. Box 1), Geelong, 3220

7439

Companies Act 1961—Company No. 55930—In the matter of MONETA INVESTMENTS PTY. LTD. (in Voluntary Liquidation)

Notice is hereby given that at an Extraordinary General Meeting of the Members of the abovenamed Company held on 30 May 1980, it was resolved that the Company be wound up voluntarily and that Thomas Patrick Bennett of 53 Through Road, Burwood be appointed Liquidator.

Notice is also given that after 21 days from this date I shall proceed to distribute the assets. All creditors having any claims against the Company should furnish particulars of same by that date otherwise I shall proceed to distribute the assets without regard to their claim.

Dated 30 May 1980

7440 T. P. BENNETT, Liquidator

Companies Act 1961—CHEPSTOW NOMINEES PTY. LTD., the Registered Office of which is 38 Roderick Street, East Doncaster

Notice is hereby given that a Petition for the winding up of the abovenamed Company by the Supreme Court was on 12 May 1980 presented by Laminex Industries a Division of A. V. Wehl Industries Limited and that the said Petition is directed to be heard before the Court

sitting at Melbourne at the hour of 10.30 o'clock in the forenoon on Thursday 19 June 1980 and any creditor or contributory of the Company desiring to support or oppose the making of an Order on the said Petition may appear at the time of hearing by himself or his Counsel for that purpose; and a copy of the Petition will be furnished to any creditor or contributory of the said Company requiring the same by the undersigned on payment of the regulated charge for the same.

The Petitioner's address is 22-26 Webb Road, Niddrie.

The Petitioner's solicitors are Messrs Remington & Co., of 6th Floor, 60 Albert Road, South Melbourne.

MESSRS REMINGTON & CO., solicitors for the petitioner

NOTE—Any person who intends to appear on the hearing of the said Petition must serve on or send by post to the abovenamed Solicitors notice in writing of his intention so to do. The notice must state the name and address of the firm and must be signed by the person or firm or his or their Solicitor (if any) and must be served or if posted must be sent by post in sufficient time to reach the abovenamed not later than 4 o'clock in the afternoon on 18 June 1980.

7441

The Companies Act 1961, Section 254 (2) (b)

J. RUYS & ASSOCIATES PTY. LTD. (IN LIQUIDATION)

Notice is hereby given that at an Extraordinary General Meeting of members of the abovenamed company held pursuant to the provisions of section 254 (1) on 16 May 1980 it was resolved by special resolution that the company be wound up voluntarily and that Mr Bruce Edward Fordham be appointed liquidator.

Notice is hereby given that after 21 days from this date I shall proceed to distribute the assets of the company. All creditors having any claims against the company should furnish particulars of such claims to the liquidator by that date, otherwise I shall proceed to distribute the assets without regard to their claim.

B. E. FORDHAM, Liquidator

Fordham, Williams & Co., chartered accountants, 521 Toorak Road, Toorak, Vic. 3142

7442

Notice is hereby given that at an extraordinary general meeting of Members of Doric Plate Proprietary Limited held at 148 Mountain View Parade, Macleod, on 25 May 1980 the following resolutions were passed:—

*Special Resolution*—That the Company be wound up voluntarily in accordance with the provisions of the Companies Act 1961.

*Ordinary Resolution*—That Mr Peter Raymond Troedel care of Messrs Edward R. J. Hall & Co., Chartered Accountants, be appointed Liquidator for the purposes of such winding up.

Dated 27 May 1980

7443 JOHN G. COUSLAND, Secretary

The Companies Act 1961

ROYMAR INVESTMENTS PTY. LTD. (IN VOLUNTARY LIQUIDATION)

Notice is hereby given that an Extraordinary Meeting of the members of the abovenamed Company held on 16 May 1980 it was resolved that the Company be wound up voluntarily and that Samuel Richwol, Public Accountant, 4th Floor, 450 Little Collins Street, Melbourne be appointed Liquidator.

Dated 29 May 1980

7444

Companies Act 1961—In the matter of INTERIOR DISCOUNT SUPPLIES PTY. LTD.—Notice Convening Final Meeting of Members, Pursuant to Section 272

Notice is hereby given pursuant to section 272 of the Companies Act 1961, that a General Meeting of Members of the abovenamed Company will be held at the office of B. K. Taylor & Co., Dairy Industry House, 576 St. Kilda Road, Melbourne on Monday, 14 July 1980 at 10.30 a.m. for the purpose of having an account laid before it

showing the manner in which the winding up has been conducted and the property of the Company disposed of and of hearing any explanations that may be given by the Liquidator.

Dated 14 July 1980

B. K. TAYLOR, Liquidator

B. K. Taylor & Co., accountants, 576 St. Kilda Road, Melbourne, Vic. 3004 7445

The Companies Act 1961

TRADE STREET PROPERTIES PTY. LIMITED (IN VOLUNTARY LIQUIDATION)

NOTICE CONVENING FINAL MEETING OF MEMBERS, PURSUANT TO SECTION 272

Notice is hereby given in pursuance of section 272 of the Companies Act 1961, that a Meeting of Members of the abovenamed Company will be held at the office of Deloitte Haskins & Sells, 12th Floor, 461 Bourke Street, Melbourne on Monday, 7 July 1980 at 9.00 a.m. for the purpose of having an account laid before them showing the manner in which the winding up has been conducted and the property of the company disposed of and of hearing any explanations that may be given by the liquidator.

Dated 28 May 1980

M. I. WANSLEY, Liquidator

Deloitte Haskins & Sells, chartered accountants, 461 Bourke Street, Melbourne, Vic. 3000 7446

Companies Act 1961, Section 254 (2) (b)

CONNELL & ROCHFORD PTY. LTD.

Notice is hereby given that at an Extraordinary General Meeting of the members of the abovenamed Company held on 30 May 1980 it was resolved that the Company be wound up voluntarily and that Joseph Anthony Santa Maria of 5th Floor, 71 Queens Road, Melbourne, 3004, be appointed liquidator.

Notice is also given that after 21 days from this date, I shall proceed to distribute the assets. All creditors having any claims against the Company should furnish particulars of same by that date otherwise I shall proceed to distribute the assets without regard to their claim.

Dated 30 May 1980

7447

J. SANTA MARIA, Liquidator

Companies Act 1961

PAUL GILLHOFF PTY. LIMITED (IN LIQUIDATION)

NOTICE CONVENING FINAL MEETING OF MEMBERS, PURSUANT TO SECTION 272 (1)

Notice is hereby given that the final meeting of members of the abovenamed Company will be held at the office of H. Lytton Reed & Co., 416 St. Kilda Road, Melbourne on 9 July 1980 at 4.00 p.m. for the purpose of laying before the meeting an account showing how the winding up has been conducted and the property of the Company disposed of and giving any explanation thereof.

Dated 30 May 1980

7469

H. LYTTON REED, Liquidator

Companies Act 1961—In the matter of VITESSE PRINTING PROMOTIONS PTY. LTD. of 1124 Lincoln Street, Brunswick East—Notice Re Meeting of Creditors, Pursuant to Section 260

Notice is hereby given that a meeting of creditors of the abovenamed Company will be held at the Fitzgerald Room, Accountants House, 49 Exhibition Street, Melbourne on Wednesday, 18 June 1980 at 11.00 a.m., the Company having convened a meeting of its members for the same day for the purpose of considering a resolution that the Company be wound up voluntarily.

Dated 29 May 1980

M. ROSSER, Director

B. K. Taylor & Co., accountants, 576 St. Kilda Road, Melbourne, 3004 7470

The Companies Act 1961, Section 254

JAY'S INTERIORS PTY. LIMITED

SPECIAL RESOLUTION TO WIND UP

At an Extraordinary General Meeting of the abovenamed Company duly convened and held at 2/27 Venus Street, South Caulfield on 29 May 1980 the following resolution was passed as a Special Resolution:

"That the Company be wound up voluntarily."

At the abovementioned meeting Roger D. Evans of 228 Albert Road, South Melbourne was appointed Liquidator for the purpose of the winding up.

"Notice is also given that after twenty-one days from this date, I shall proceed to distribute the assets. All creditors having any claim against the Company should furnish particulars of same by that date, otherwise I shall proceed to distribute the assets without regard to their claim."

Dated 29 May 1980

7471

ROGER D. EVANS, Liquidator

Companies Act 1961

GEO. FERRIES PTY. LTD. (IN LIQUIDATION)

NOTICE OF FINAL MEETING

Pursuant to section 272 of the Companies Act 1961 a meeting of the company will be held at the offices of Ham and Johanson, Chartered Accountants, Lyric Building, Charing Cross, Bendigo at 10.00 a.m., Monday, 14 July 1980 for the purpose of laying before it an account showing how the winding up has been conducted and giving any explanation thereof.

Dated 27 May 1980

W. N. JOHANSON, Liquidator, Lyric Building, Charing Cross, Bendigo 7476

The Companies Act 1961—In the matter of SOFTFORM FURNITURE PTY. LTD. (in Liquidation)—Notice to Creditors of SOFTFORM FURNITURE PTY. LTD. (in Liquidation)

Take notice that I, Adrian Douglas Cran, Liquidator of the abovenamed company, have fixed Thursday, 26 June 1980 as the day on or before which the creditors of the abovenamed company are to prove their debts or claims or after which they will be excluded from the benefit of any distribution made before those debts are proved.

Dated 2 June 1980

A. D. CRAN, Liquidator

Wertkin Cran Douglas & Co., 9th Floor, 128 Exhibition Street, Melbourne 7477

FOTOSCREEN PTY. LTD. (IN LIQUIDATION)

SPECIAL RESOLUTION TO WIND UP

At an Extraordinary General Meeting of the abovenamed company duly convened and held at 368 Hawthorn Road, South Caulfield on 30 May 1980, the following resolution was passed as a Special Resolution:

"That the company be wound up voluntarily."

At the abovementioned meeting, P. J. McMahon of 10 Benjamin Street, Thornbury was appointed liquidator for the purpose of the winding up.

Notice is also given that after 30 days from this date, I shall proceed to distribute the assets. All creditors having any claim against the company should furnish particulars of same by that date, otherwise I shall proceed to distribute the assets without regard to their claim.

Dated 31 May 1980

7478

P. J. McMAHON, Liquidator

In the matter of FOTOSCREEN PTY. LTD. (in Liquidation); and in the matter of the Companies Act 1961—Notice Inviting Proof of Debt or Claim

The creditors of the abovenamed company are required on or before 30 June 1980, to prove their debt or claims and to establish any title they may have to priority by delivering or sending through the post to the liquidator at the undermentioned address an affidavit verifying their



respective debts or claims. In default they will be excluded from the benefit of any distribution made before such debts or claims are proved or such priority is established and from objecting to any such distribution. Form of Proof may be obtained from the liquidator at the address shown below.

Dated 30 May 1980

P. J. McMAHON, Liquidator, 10 Benjamin Street, Thornbury 7479

**BERNLEIGH (WOOLSTHORPE) PROPRIETARY LIMITED  
DABELAN PROPRIETARY LIMITED**

Notice is hereby given that, pursuant to section 272 of the Companies Act 1961, a meeting of members of the above-named companies will be held at 104 Liebig Street, Warrnambool on Wednesday, 2 July 1980 in each case for the purpose of having an account laid before them showing how the winding up of the company has been conducted and the property of the company disposed.

Dated 30 May 1980

WILLIAM G. SINCLAIR, F.A.S.A., Liquidator  
Sinclair & Wilson, public accountants, 104 Liebig Street,  
Warrnambool, Vic. 3280 7480

**SPENCE INVESTMENTS PROPRIETARY LIMITED  
NOTICE OF VOLUNTARY LIQUIDATION**

At an Extraordinary General Meeting of Spence Investments Proprietary Limited held at 104 Liebig Street, Warrnambool on 29 May 1980 the following resolutions were passed as Special Resolutions:

1. That the company be wound up voluntarily and that William George Sinclair of "Rosebank", Woodford, Accountant, be and he is hereby appointed Liquidator for the purpose of such winding up.

2. That the Liquidator be and he is hereby authorized when and so soon as the debts and liabilities of the company have been paid and satisfied or duly provided for to distribute in specie or kind amongst the members of the company in accordance with their respective rights, and interest therein the whole or any part of the assets of the company as he shall think fit.

WILLIAM G. SINCLAIR, F.A.S.A., Liquidator  
Sinclair & Wilson, public accountants, 104 Liebig Street,  
Warrnambool, Vic. 3280 7481

**Companies Act 1961, Section 272**

A. R. TAYLOR & CO. PTY. LTD. (IN LIQUIDATION)  
CALDY PTY. LTD. (IN LIQUIDATION)  
LIGHTEN PTY. LTD. (IN LIQUIDATION)  
NANUS KIERON PTY. LTD. (IN LIQUIDATION)  
NOVELPALLA PTY. LTD. (IN LIQUIDATION)  
PRE HERIT PTY. LTD. (IN LIQUIDATION)  
R. & A. JENKINS ENTERPRISES PTY. LTD. (IN LIQUIDATION)  
RUTINA PTY. LTD. (IN LIQUIDATION)  
SALDO PTY. LTD. (IN LIQUIDATION)  
SARDOZ PTY. LTD. (IN LIQUIDATION)  
TORTS TARTZ & TORQUE PTY. LTD. (IN LIQUIDATION)  
YAPLEY PTY. LTD. (IN LIQUIDATION)  
ADLON PTY. LTD. (IN LIQUIDATION)  
CIRCLE RIDGE PTY. LTD. (IN LIQUIDATION)  
LEXFOL DISTRIBUTORS PTY. LTD. (IN LIQUIDATION)  
MELBOURNE MOTOR ENGINEERING WORKS PTY. LTD. (IN LIQUIDATION)  
R. G. HOLDINGS PTY. LTD. (IN LIQUIDATION)  
WIENERS PLUMBING SERVICE PTY. LTD. (IN LIQUIDATION)

**NOTICE OF FINAL MEETINGS**

Notice is hereby given that the final meetings of the members of the abovenamed companies will be held at my offices on 30 June 1980 commencing at 11.00 a.m., for the purpose of laying before the meetings an account showing how the windings up have been conducted and the property of the companies disposed of and giving any explanation thereof.

Dated 26 May 1980

M. L. DYE, Liquidator

V. R. Dye & Co., chartered accountants, 536 Whitehorse Road, Mitcham, 3132 7482

**Companies Act 1961, Section 272**

B. J. F. TYRES (NUNAWADING) PTY. LTD. (IN LIQUIDATION)  
PRESTON TELEVISION SERVICE PTY. LTD. (IN LIQUIDATION)

**NOTICE OF FINAL MEETINGS**

Notice is hereby given that the final meetings of the members and creditors of the abovenamed companies will be held at my offices on 3 July 1980 commencing at 11.00 a.m., for the purpose of laying before the meetings an account showing how the windings up have been conducted and the property of the companies disposed of and giving any explanation thereof.

Dated 29 May 1980

V. R. DYE, Liquidator

V. R. Dye & Co., chartered accountants, 536 Whitehorse Road, Mitcham 3132 7483

The Companies Act 1961—In the matters of CHESTER-LANE PROJECTS PTY. LTD.; LANES MOTORS PARTS PTY. LTD.—Members windings up

Notice is hereby given that at the Extraordinary General Meetings of the above companies duly convened and held at 222 Exhibition Street, Melbourne in the State of Victoria on 30 May 1980 it was resolved that the companies be wound up voluntarily.

Dated 30 May 1980

J. C. BARNES, Liquidator

Mr J. C. Barnes, accountant, 470 Bourke Street, Melbourne, Vic. 3000 7486

The Companies Act 1961—In the matter of ALCOA HOLDINGS LIMITED—Members' Winding Up

Notice is hereby given that at the Extraordinary General Meeting of the above company duly convened and held at 535 Bourke Street, Melbourne in the State of Victoria on 30 May 1980 it was resolved that the company be wound up voluntarily.

Dated 30 May 1980

R. F. HUGHES, Liquidator

Mr R. F. Hughes, chartered accountant, 18th Floor, 461 Bourke Street, Melbourne, Vic. 3000 7487

In the matter of the Companies Act 1961; and in the matter of MOCOPAN (SALES) PTY. LTD.

Notice is hereby given that at an Extraordinary General Meeting of the abovenamed company duly convened and held at 257 Plenty Road, Preston at 10 a.m. on 16 May 1980 the following special resolution was duly passed—

That the company be wound up voluntarily and that John Sheehan, Chartered Accountant of 500 Collins Street, Melbourne be appointed Liquidator for the purpose of such winding-up.

Dated 16 May 1980

7488

J. F. DIMATTINA, Chairman

**Companies Act 1961, Section 272**

PYRENEES PTY. LTD. (IN LIQUIDATION)

**NOTICE OF FINAL MEETING OF MEMBERS**

Notice is hereby given that pursuant to section 272 of the Companies Act 1961, the final meeting of the members of the Company will be held at the offices of Marquand & Co., Mezzanine Floor, 51 Queen Street, Melbourne, on 4 July 1980 at 9.30 a.m. for the purpose of laying before the meeting an account showing how the winding up has been conducted and the property has been disposed of and giving any explanation thereof.

Dated 30 May 1980

D. E. TONKIN, Liquidator

Marquand & Co., chartered accountants, 51 Queen Street, Melbourne 7489

*Companies Act 1961, Section 254 (2)*

## CAROLINE MEDICAL SERVICES PTY. LTD.

Notice is hereby given that at an extraordinary general meeting of Caroline Medical Services Pty. Ltd. duly convened and held at 30 Albert Road, South Melbourne on 26 May 1980 the following resolution was passed as a Special Resolution:

That the Company be wound up voluntarily and that Barry Lorne Jenner Chartered Accountant, 51 Queen Street, Melbourne, 3000 be and is hereby appointed liquidator to act for the purpose of such winding up, with the right to distribute assets *in specie*.

Notice is also given that I shall proceed to distribute the assets after 4 July 1980. All creditors should prove their debts by that date otherwise I shall proceed to distribute the assets without regard to their claim.

Dated 28 May 1980

B. L. JENNER, Liquidator

Marquand &amp; Co., chartered accountants, 51 Queen Street, Melbourne, Vic. 3000 7490

*Companies Act 1961, Section 254 (2) (b)*

## THE SIDNEY MYER MUSIC BOWL TRUST (A Company Limited by Guarantee)

Notice is hereby given that at an Extraordinary General Meeting of the Members of the abovenamed Company held on 27 May 1980, it was resolved that the Company be wound up voluntarily and Mr Harold George Alexander of Messrs Hungerford Hancock & Offner, 29th Floor, 367 Collins Street, Melbourne, Victoria be and is appointed Liquidator for the purpose of such winding up.

Notice is also given that after 21 days from this date I shall proceed to distribute the assets. All Creditors having any claims against the Company should furnish particulars of same by that date, otherwise I shall proceed to distribute the assets without regard to their claim.

Dated 29 May 1980

7491 HAROLD GEORGE ALEXANDER, Liquidator

## ASPHALT PLANT PROPRIETARY LIMITED

Notice is hereby given in pursuance of section 254 (2) (b) of the *Companies Act 1961*, that an Extraordinary General Meeting of Members of Asphalt Plant Proprietary Limited held at 93 Yarrhat Avenue, Balwyn on 24 May 1980, the following Special Resolution was passed—

"That the Company be voluntarily wound up"

7492 G. REID, Director

## LORRE PROPRIETARY LIMITED

Notice is hereby given in pursuance of section 254 (2) (b) of the *Companies Act 1961*, that an Extraordinary General Meeting of Members of Lorre Proprietary Limited held at 47 Denbigh Road, Armadale on 24 May 1980, the following Special Resolution was passed—

"That the Company be voluntarily wound up"

7493 T. M. ULMAN, Director

*Companies Act 1961*DOSIS PTY. LTD. (IN LIQUIDATION)  
DRECKIG PTY. LTD. (IN LIQUIDATION)

Notice is hereby given that at extraordinary general meetings of the members of the abovenamed companies held on 20 May 1980 it was resolved that the companies be wound up voluntarily and that for such purpose George Walter Long, Chartered Accountant, of 536 Whitehorse Road, Mitcham be appointed liquidator.

Notice is also given that after 21 days from this date I shall proceed to distribute the assets of the companies. All creditors who have any claim against the companies should furnish particulars of the same by that date, otherwise I shall proceed to distribute the assets without regard to their respective claim.

Dated 23 May 1980

G. W. LONG, Liquidator

V. R. Dye and Co., chartered accountants, 536 Whitehorse Road, Mitcham, 3132 7495

## J. GEGGIE PROPRIETARY LIMITED

The above Company was placed in Voluntary Liquidation by a Resolution of Members at an Extraordinary General Meeting held 26 May 1980.

W. P. WATSON, Liquidator, 406 Lonsdale Street, Melbourne, 3000 7494

*The Companies Act 1961, Section 254 (2) and Regulation 54 I.O.N. PTY. LTD. (IN LIQUIDATION) (Formerly Venus Sunglasses Pty. Ltd.)*

Notice is hereby given that at an Extraordinary General Meeting of the Members of the abovenamed Company held on 26 May 1980, it was resolved that the Company be wound up voluntarily, and at a meeting of creditors held on the same day pursuant to section 260, it was resolved that for such purpose Alan Murray Horsburgh and Roland Petrie Newman, both of 499 St. Kilda Road, Melbourne, Chartered Accountants, be appointed Liquidators, to act jointly and severally.

Notice is also given that after 21 days from this date we shall proceed to distribute the assets. Take notice that the Liquidators have fixed Wednesday 25 June 1980, as a day on or before which Creditors are to prove their debts or claims and to establish any entitlement they may have to priority under section 292, or be excluded from the benefit of any distribution made before such debts are proved or, as the case may be, from objecting to such distribution.

Dated 4 June 1980

A. M. HORSBURGH, Liquidator  
R. P. NEWMAN, Liquidator

Wallace, McMullin &amp; Smail, chartered accountants, 499 St. Kilda Road, Melbourne, Vic. 3004 7496

*The Companies Act 1961—In the matter of SMEATH BROS. PTY. LTD.*

Notice is hereby given that at an Extraordinary General Meeting of the Members of the abovenamed Company held on 22 May 1980 it was resolved that the Company be wound up voluntarily, as a Members' Voluntary Winding Up pursuant to the provisions of subdivision 2 of Division 3 of Part X. of the *Companies Act 1961*, and it was further resolved that for such purpose Norman Eric Stretton and John Martin Walsh of 499 St. Kilda Road, Melbourne, Chartered Accountants, be appointed Liquidators.

Notice is also given that after 21 days from this date, we shall proceed to distribute the assets. Any creditors having any claims against the Company should furnish particulars of same by that date, otherwise we shall proceed to distribute the assets without regard to their claim.

Dated 23 May 1980

N. E. STRETTON, Liquidator  
J. M. WALSH, Liquidator

Messrs Wallace, McMullin &amp; Smail, chartered accountants, 499 St. Kilda Road, Melbourne, 3004 7497

*Companies Act 1961, Pursuant to Section 272 (2) WIZARD MINED PTY. LTD. (IN VOLUNTARY LIQUIDATION)*

Notice is hereby given that the Final Meeting of Creditors and Shareholders of Wizard Mined Pty. Ltd. (In Liquidation) will be held at the offices of C. W. Stirling & Co., 5th Floor, 499 St. Kilda Road, Melbourne on Tuesday, 15 July 1980 at 10.30 a.m. for the purpose of having an account laid before it showing how the winding up of the company has been conducted and the property of the company has been disposed of and to pass a resolution to destroy the company's books and records pursuant to section 284 (3) of the *Companies Act*.

30 May 1980

7498

R. A. BERRY, Liquidator

PIMM'S (AUSTRALASIA) PTY. LTD. (IN VOLUNTARY LIQUIDATION)

PURSUANT TO SECTION 254 (2) OF THE COMPANIES ACT 1961

At an Extraordinary General Meeting of Members of the said company duly convened and held at 120-130 Queens Parade, North Fitzroy on Friday, 30 May 1980 the following resolution was passed:—

"That the company be wound up voluntarily and that John Charles Barbour of 450 Little Collins Street, Melbourne be appointed liquidator for the purpose of the winding up."

Dated 30 May 1980

7499

L. G. RITTER, Secretary

SILMAN PROPERTIES PROPRIETARY LIMITED (IN VOLUNTARY LIQUIDATION)

Notice is hereby given that pursuant to section 272 (i) of the Companies Act 1961, a general meeting of members of Silman Properties Proprietary Limited (In Voluntary Liquidation) will be held at 10.00 a.m. on 8 July 1980 at the offices of Hungerford Hancock & Offner, 29th Floor, 367 Collins Street, Melbourne for the purpose of having an account laid before it showing how the winding up of the company has been conducted and the property of the company has been disposed of.

Dated 26 May 1980

7500

D. HALLIDAY, Liquidator

The Companies Act 1961

THISTLETHWAITE INVESTMENT CO. PTY. LTD. (IN MEMBERS' VOLUNTARY LIQUIDATION)

Notice is hereby given that at an Extraordinary General Meeting of Members of the abovenamed Company held on 22 May 1980 it was resolved that the Company be wound up voluntarily and that Herbert A. B. McWilliam of Touche Ross & Co., 11th Floor, 440 Collins Street, Melbourne be appointed Liquidator.

Notice is also given that after 21 days from this date, I shall proceed to distribute the assets. All Creditors having any claims against the Company should furnish particulars of their claims by that date, otherwise I shall proceed to distribute the assets without regard to their claim.

Dated 27 May 1980

H. A. B. McWILLIAM, chartered accountant, Touche Ross & Co., 11th Floor, 440 Collins Street, Melbourne, Vic. 3000

7501

In the Supreme Court of Victoria—1980 No. Co. 11344—In the matter of the Companies Act 1961; and in the matter of MATHER COURT PTY. LTD.; and in the matter of a Petition dated 22 May 1980

Notice is hereby given that a Petition for the winding up of the abovenamed Company by the Supreme Court was on 22 May 1980 presented by C.S. Graphic Reproduction Pty. Ltd. and that the said Petition is directed to be heard before the Court sitting at the Law Courts, Lonsdale Street, Melbourne at the hour of 10.30 o'clock in the forenoon on 24 July 1980 and any Creditor or contributory of the said company desiring to support or oppose the making of an order on the said Petition may appear at the time of the hearing by himself or his Counsel for that purpose; and a copy of the Petition will be furnished to any Creditor or any contributory of the said Company requiring the same by the undersigned on payment of the regulated charge for the same.

The Petitioner's address is 1 Buckland Street, Clayton, Victoria.

The Petitioner's Solicitors are Messrs Ellison, Hewison and Whitehead of 379 Collins Street, Melbourne.

NOTE—Any person who intends to appear on the hearing of the said Petition must serve or send by post to the abovenamed Solicitors, notice in writing of his intention so to do. The notice must state the name and address of the person, or, if a firm, the name and address of the firm and must be signed by the person or firm or his or their Solicitor (if any) and must be served, or if posted must be sent by post, in sufficient time to reach the above-

named not later than four o'clock in the afternoon of Wednesday, 23 July 1980, the day before the day appointed for hearing of the Petition.

ELLISON HEWISON & WHITEHEAD, solicitors for the petitioner

7502

In the Supreme Court of Victoria—1980 No. Co. 11329—In the matter of the Companies Act 1961; and in the matter of BAMBRA EXPORT PTY. LTD.

Notice is hereby given that a petition for the winding up of the abovenamed company by the Supreme Court of Victoria was on 16 May 1980 presented by Gardner Smith Pty. Ltd. and that the said petition is directed to be heard before the Court sitting at Melbourne at the hour of 10.30 a.m. on Thursday, 26 June 1980 and any creditor or contributory of the said company desiring to support or oppose the making of an order on the said petition may appear at the time of hearing by himself or his Counsel for that purpose and a copy of the petition will be furnished to any creditor or contributory of the company requiring the same by the undersigned on payment of the regulated charge for the same.

The Petitioner's address is No. 1 Berth Maribyrnong, Mackenzie Road, Footscray in the State of Victoria.

The Petitioner's solicitors are Mallesons, 121 William Street, Melbourne.

NOTE—Any person who intends to appear on the hearing of the said petition must serve or send by post to the abovenamed solicitors, Mallesons, notice in writing of his intention so to do. The notice must state the name and address of the person or if a firm the name and address of the firm and must be signed by the person or firm or his or their solicitors (if any) and must be served or if posted must be sent by post in sufficient time to reach the abovenamed not later than four o'clock in the afternoon of 25 June 1980.

7505

In the Supreme Court of Victoria—1980 No. Co. 11349—In the matter of the Companies Act 1961; and in the matter of MINERAL SEARCH & DEVELOPMENT LTD.

Notice is hereby given that a Petition for the winding up of the abovenamed Company by the Supreme Court of Victoria was on 26 May 1980 presented by Dan Maddrell Osborne and that the said Petition is directed to be heard before the Court sitting at Melbourne at the hour of 10.30 a.m. on 26 June 1980 and any creditor or contributory of the said company desiring to support or oppose the making of an Order on the said Petition may appear at the time of hearing by himself or his Counsel for that purpose and a copy of the Petition will be furnished to any creditor or contributory of the company requiring the same by the undersigned on payment of the regulated charge for the same.

The Petitioner's address is care of Messrs Barton Hall and Partners, 65 York Street, Sydney in the State of New South Wales.

The Petitioner's solicitors are Mallesons, 121 William Street, Melbourne.

MALLESONS, solicitors for the petitioner

NOTE—Any person who intends to appear on the hearing of the said Petition must serve or send by post to the abovenamed Solicitors, Mallesons, notice in writing of his intention so to do. The notice must state the name and address of the person or if a firm the name and address of the firm and must be signed by the person or firm or his or their Solicitors (if any) and must be served or if posted must be sent by post in sufficient time to reach the abovenamed not later than four o'clock in the afternoon of 25 June 1980.

7506

In the Supreme Court of Victoria—1980 Co. 11304—In the matter of the Companies Act 1961; and in the matter of CASALE CONSTRUCTIONS PTY. LTD.—Notice of Winding Up Order

Winding Up Order made 22 May 1980.

Name and address of Liquidator: Ronald Dennis Widdows, care of R. D. Widdows, 703 South Road, Moorabbin.

B. J. O'DONOVAN, Crown Solicitor for the Commonwealth and Solicitor for the Petitioner

7504

In the Supreme Court of Victoria—1980 Co. 11300—In the matter of the Companies Act 1961; and in the matter of BROWNVILLE PROPRIETARY LIMITED—Notice of Winding Up Order

Winding Up Order made 22 May 1980.

Name and address of Liquidator: Maxwell George Gee, care of Max Gee and Co., corner Grant and Pilmer Streets, Bacchus Marsh.

B. J. O'DONOVAN, Crown Solicitor for the Commonwealth and Solicitor for the Petitioner 7503

The Companies Act 1961, Section 254  
MELIS PTY. LIMITED (IN LIQUIDATION)  
SPECIAL RESOLUTION TO WIND UP

At an Extraordinary General Meeting of the abovementioned Company duly convened and held at South Melbourne on 30 May 1980 the following resolution was passed as a Special Resolution:

"That the company be wound up voluntarily."

At the abovementioned meeting Douglas Orson Oldfield, 351 Collins Street, Melbourne, was appointed Liquidator for the purpose of the winding up.

Dated 2 June 1980

7527

D. O. OLDFIELD, Liquidator

The Companies Act 1961, Section 254  
VAN MAAREN PTY. LIMITED (IN LIQUIDATION)  
SPECIAL RESOLUTION TO WIND UP

At an Extraordinary General Meeting of the abovementioned Company duly convened and held at South Melbourne on 30 May 1980 the following resolution was passed as a Special Resolution:

"That the company be wound up voluntarily."

At the abovementioned meeting Douglas Orson Oldfield, 351 Collins Street, Melbourne, was appointed Liquidator for the purpose of the winding up.

Dated 2 June 1980

7528

D. O. OLDFIELD, Liquidator

Companies Act 1961—In the matter of KEVIN MCARDLE CONTRACTORS PTY. LTD. (in Liquidation)

Notice is hereby given that at an extraordinary meeting of the Members of the abovementioned Company held on 29 May 1980, it was resolved that the Company be wound up voluntarily and Graeme Maurice O'Toole, of Room 310, 343 Little Collins Street, Melbourne, be appointed Liquidator.

Notice is also given that after 21 days from this date I shall proceed to distribute the assets. All creditors having any claim against the Company should furnish particulars of same by that date, otherwise I shall proceed to distribute the assets without regard to their claim.

Dated 29 May 1980

7529

G. M. O'TOOLE, Liquidator

Form 92

The Companies Act 1961, Section 272 (1)  
Companies Regulation

PURITAN PAINTS PROPRIETARY LIMITED (IN LIQUIDATION)

NOTICE OF MEETING OF CREDITORS AND CONTRIBUTORIES

Notice is hereby given that a final meeting of the creditors and contributories of Puritan Paints Proprietary Limited (In Liquidation) will be held at the office of Orr, Martin & Waters, Top Floor, 460 Bourke Street, Melbourne, on Monday, 7 July 1980, at 10.30 a.m. to receive the liquidator's account of his acts and dealings and of the conduct of the winding up and of hearing any explanations thereof.

Dated 2 June 1980

ROBERT A. WATERS, Liquidator

Orr, Martin & Waters, chartered accountants, 460 Bourke Street, Melbourne, 3000. Telephone 602 1644 7508

Companies Act 1961, Section 254 (2) (b)

MUSTANG MANUFACTURING (VIC.) PTY. LTD.

Notice is hereby given that at an Extraordinary General Meeting of the Members of the abovementioned company held on 28 May 1980 it was resolved that the Company be wound up voluntarily and that Messrs Michael Ashley Coppins and John Barry Hutchins of Pannell Kerr Forster, Chartered Accountants, 271 William Street, Melbourne be appointed joint and several Liquidators for the purposes of the winding up. At a meeting of Creditors held later on the same day, the appointment of Messrs Michael Ashley Coppins and John Barry Hutchins as Liquidators was confirmed.

Notice is also given that after 21 days from this date, we shall proceed to distribute the assets. All creditors having any claims against the company should furnish particulars of same by that date, otherwise we shall proceed to distribute the assets without regard to their claims.

Dated 28 May 1980

M. A. COPPINS AND J. B. HUTCHINS, Joint and Several Liquidators

Messrs Pannell Kerr Forster, 271 William Street, Melbourne, 3000 7507

Form 92

The Companies Act 1961, Section 272 (1)

Companies Regulation

U.S. CHEMICAL CO. OF AUSTRALIA PROPRIETARY LIMITED (IN LIQUIDATION)

NOTICE OF MEETING OF CREDITORS AND CONTRIBUTORIES

Notice is hereby given that a final meeting of the creditors and contributories of U.S. Chemical Co. of Australia Proprietary Limited (In Liquidation) will be held at the office of Orr, Martin & Waters, Top Floor, 460 Bourke Street, Melbourne, on Monday, 7 July 1980, at 10.00 a.m. to receive the liquidator's account of his acts and dealings and of the conduct of the winding up and of hearing any explanations thereof.

Dated 2 June 1980

ROBERT A. WATERS, Liquidator

Orr, Martin & Waters, chartered accountants, 460 Bourke Street, Melbourne, 3000. Telephone 602 1644 7509

NORTHCOTE AND DISTRICT No. 2 CO-OPERATIVE HOUSING SOCIETY LIMITED (IN LIQUIDATION)

Take notice that the affairs of the above-named Society are now fully wound up and that in pursuance of section 272 (1) of the Companies Act 1961 and of the Co-operative Housing Societies Act 1958, a General Meeting of the Society will be held at the Society's Office, 505 Little Collins Street, Melbourne on 8 July 1980 at 5.30 p.m. for the purpose of—

- (i) laying before it an account showing how the winding up has been conducted and the property of the Society disposed of and giving any explanations thereof; and
- (ii) passing a resolution that the books and papers of the said Society and of the Liquidator relevant to the affairs of the Society be destroyed after a period of twelve months from the date of the meeting.

Dated 3 June 1980

H. C. HOLMES AND R. J. ANDERSON, Joint Liquidators 7524

Companies Act 1961, Section 254 (2) (b)

BOOROONDARA HOME SITES CO-OPERATIVE No. 1 LIMITED (IN VOLUNTARY LIQUIDATION)

Notice is hereby given that at an Extraordinary General Meeting of the members of the abovementioned Co-operative held on 27 May 1980 it was resolved that the Co-operative be wound up voluntarily and that Messrs Michael Ashley Coppins and John Barry Hutchins of Pannell Kerr Forster, Chartered Accountants, 271 William Street, Melbourne be appointed joint and several Liquidators and at a meeting of creditors held on 28 May 1980 the appointment of Messrs Michael Ashley Coppins and John Barry Hutchins as Liquidators was confirmed.

All Creditors having any claims against the Co-operative should furnish particulars of same within 21 days of this date, after which it is proposed, in due course, to distribute the assets to Members.

Dated 28 May 1980

M. A. COPPINS AND J. B. HUTCHINS, Joint and Several Liquidators

Care of Pannell Kerr Forster, chartered accountants,  
271 William Street, Melbourne, 3000 7510

Notice is also given that after 21 days from this date we shall proceed to distribute the assets. All creditors having any claims against the company should furnish particulars of same by that date, otherwise we shall proceed to distribute the assets without regard to their claim.

Dated 28 May 1980

K. J. RUSSELL, Liquidator

Coopers & Lybrand, 461 Bourke Street, Melbourne,  
3000 7532

DIMATH COIFFURE PTY. LTD. (IN VOLUNTARY LIQUIDATION)

SPECIAL RESOLUTION TO WIND UP

At an Extraordinary General Meeting of the abovenamed company duly convened and held at 174 Bouverie Street, Carlton on 30 May 1980 the following Resolution was passed as a Special Resolution:

"That the company be wound up voluntarily."

At the abovementioned meeting Mr Jim Nicolaou was appointed Liquidator for the purpose of the winding up.

Notice is also given that after 30 days from this date, I shall proceed to distribute the assets. All creditors having any claim against the company should furnish particulars of same by that date, otherwise I shall proceed to distribute the assets without regard to their claim.

Dated 30 May 1980

JIM NICOLAOU, Liquidator

Care of Greening, Schulz & Associates, 174 Bouverie Street, Carlton 7525

Companies Act 1961, Section 254 (2) (b)

NKS LABORATORIES PTY. LTD.

Notice is hereby given that at an Extraordinary General Meeting of the members of the abovenamed company held on 27 May 1980, it was resolved that the company be wound up voluntarily and that Mr K. J. Russell of Messrs Coopers & Lybrand, 461 Bourke Street, Melbourne be appointed Liquidator.

Notice is also given that after 21 days from this date we shall proceed to distribute the assets. All creditors having any claims against the company should furnish particulars of same by that date, otherwise we shall proceed to distribute the assets without regard to their claim.

Dated 28 May 1980

K. J. RUSSELL, Liquidator

Coopers & Lybrand, 461 Bourke Street, Melbourne,  
3000 7533

Companies Act 1961, Section 146 (1)

GUST INVESTMENTS PTY. LIMITED

To: The Commissioner for Corporate Affairs

At an Extraordinary General Meeting of the Contributors of Gust Investments Pty. Limited duly convened and held at Suite 46, 4th Floor, 8-12 Bridge Street, Sydney, on 28 May 1980, at 10.15 a.m., the following Special Resolution was duly passed:

Special Resolution

That the Company be wound up voluntarily and that Ernest Harding Niemann of 44 Market Street, Melbourne, Vic., be and is hereby appointed Liquidator for the purpose of winding up, effective as and from 1.00 p.m. on this day.

Dated 28 May 1980

PETER BERGE-PHILLIPS, Chairman

Cambridge Credit Corporation Limited (Receiver Appointed), 4th Floor, 53 Queen Street, Melbourne, Vic. 3000. Telephone: 62 2504 7534

Companies Act 1961, Section 146 (1)

MOONEE PONDS HOTEL PTY. LIMITED

To: The Commissioner for Corporate Affairs

At an Extraordinary General Meeting of the Contributors of Moonee Ponds Hotel Pty. Limited duly convened and held at Suite 46, 4th Floor, 8-12 Bridge Street, Sydney on 28 May 1980, at 10.00 a.m., the following Special Resolution was duly passed:

Special Resolution

That the Company be wound up voluntarily and that Ernest Harding Niemann of 44 Market Street, Melbourne, Vic., be and is hereby appointed Liquidator for the purpose of winding up, effective as and from 1.00 p.m. on this day.

Dated 28 May 1980

PETER BERGE-PHILLIPS, Chairman

Cambridge Credit Corporation Limited (Receiver Appointed), 4th Floor, 53 Queen Street, Melbourne, Vic. 3000. Telephone: 62 2504 7535

Companies Act 1961

BEAUFORT HOUSE PTY. LTD.

Notice is hereby given that by a Special Resolution passed at a Meeting of Shareholders of Beaufort House Pty. Ltd., held on 2 June 1980 it was resolved that the Company be wound up voluntarily.

Notice is also given that creditors having any claim against the Company should furnish particulars of that claim within 21 days of this date, otherwise distribution of the assets will take place without regard to such claims.

Dated 2 June 1980

N. HARRIS, Liquidator

Hughes, Fincher and Rodda, chartered accountants,  
44 Market Street, Melbourne, Vic. 3000 7530

Companies Act 1961, Section 254 (2)

FLODA LENS PROPRIETARY LIMITED (IN LIQUIDATION)

NOTICE OF VOLUNTARY LIQUIDATION

At an Extraordinary General Meeting of Floda Lens Proprietary Limited (in Liquidation) duly convened and held at 618 Sturt Street, Ballarat on 2 June 1980, the following Resolution was passed as a Special Resolution.

"That the company be wound up voluntarily as a members' voluntary winding up in accordance with the provisions of the Companies Act 1961, and that the Liquidators may distribute the assets amongst the members in specie if they so desire."

Dated 2 June 1980

A. R. REED AND S. L. HORNE, Joint and Several Liquidators 7531

Companies Act 1961, Section 254 (2) (b)

AUSTRALIAN DIE CASTINGS PTY. LTD.

Notice is hereby given that at an Extraordinary General Meeting of the members of the abovenamed company held on 27 May 1980, it was resolved that the company be wound up voluntarily and that Mr K. J. Russell of Messrs Coopers & Lybrand, 461 Bourke Street, Melbourne be appointed liquidator.

In the matter of the Companies Act 1961; and in the matter of ROBLOW PTY. LTD.—Notice of Meeting of Creditors to Consider Winding Up Resolution

Notice is hereby given that pursuant to section 260 of the Companies Act 1961, a meeting of creditors of Roblow Pty. Ltd. will be held at the offices of Messrs Marquand & Co., 51 Queen Street, Melbourne on Thursday, 19 June 1980 at 11.30 a.m.

The meeting is convened for the purpose of considering the position of the Company's affairs, the Company having convened an extraordinary general meeting of its members to be held on Thursday, 19 June 1980 for the purpose of considering and if deemed expedient, passing a Special Resolution to wind up the Company voluntarily and to nominate Douglas Ewart Tonkin of Marquand & Co., 51 Queen Street, Melbourne, 3000 as Liquidator.

R. W. LOWE, Director  
Messrs Marquand & Co., 51 Queen Street, Melbourne  
7536

*Companies Act 1961*

P.P.W. INVESTMENTS PTY. LTD.

NOTICE OF MEETING OF CREDITORS

Notice is hereby given that pursuant to section 260 of the Companies Act 1961 a meeting of the creditors of P.P.W. Investments Pty. Ltd. will be held at the Community Resource Centre, 510 Mair Street, Ballarat on 18 June 1980 at 11.00 a.m., the Company having convened a meeting of its members for the same day for the purpose of considering and, if thought fit, passing the special resolution that the Company be wound up voluntarily.

Dated 2 June 1980

D. N. PUNSHON, Secretary  
Duesbury Johnston & Marks, chartered accountants,  
114 William Street, Melbourne, Vic. 3000  
7537

*Companies Act 1961*

JOHN FARNBACH PTY. LIMITED (IN LIQUIDATION)

NOTICE OF MEETING OF THE COMPANY AND CREDITORS

Notice is hereby given that a meeting of the members and creditors of John Farnbach Pty. Limited (in liquidation) will be held on Monday, 30 June 1980 at 10.00 a.m. at the office of Mr. G. A. McRae, 11th Floor, 440 Collins Street, Melbourne, for the following purposes:

1. Receiving an account of the conduct of the winding up of the Company and any explanations relating thereto.
2. Determination of the remuneration of the liquidator.
3. Consideration of a motion that, at the expiration of a period of three months from the date of the meeting, the books and records of the Company be disposed of.

Dated 30 May 1980

7538 G. A. McRAE, Liquidator

In the matter of the Companies Act 1961; and in the matter of ARTHUR N. LANE HOLDINGS PTY. LTD. (in Liquidation)

Notice is hereby given that pursuant to section 272 of the Companies Act 1961, the final meeting of the members of the Company will be held at 4th Floor, 335 Flinders Lane, Melbourne, on 7 July 1980 at 12 noon, for the purpose of laying before the meeting the account of the winding up and any explanation thereof.

Dated 30 May 1980

7539 DAVID H. ENGLAND, Liquidator

The Companies Act 1961, Section 291 and Regulation 54—  
In the matter of PRESTON CONSOLIDATED INVESTMENTS PTY. LTD. (in Liquidation)

Take notice that as Liquidator of the abovenamed Company I have fixed Wednesday, 18 June 1980 as the day on or before which creditors of the Company are to prove their debts or claims and to establish any title they may have to priority under section 292 or be excluded from the benefit of a first distribution made before such debts are proved or as the case may be from objecting to such distribution.

Dated 4 June 1980

R. E. RAMSAY, Liquidator  
Wallace, McMullin & Smail, chartered accountants, 499  
St. Kilda Road, Melbourne, 3004  
7540

In the Supreme Court of Victoria—In the matter of the Companies Act 1961; and in the matter of ANTRIM INTERIORS PTY. LIMITED

Notice is hereby given that a petition for the winding up of the abovenamed Company by the Supreme Court was on 2 June 1980 presented by Kevin Patrick Brady, Deputy Commissioner of Taxation of the Commonwealth of Australia and that the said petition is directed to be heard before the Court sitting at the Fifteenth Court, Law Courts, Lonsdale Street, Melbourne at the hour of 10.30 o'clock in the forenoon on 19 June 1980 and any creditor or contributory of the said company desiring to support or oppose the making of an order on the said petition may appear at the time of hearing by himself or his Counsel for the purpose; and a copy of the said petition will be furnished to any creditor or contributory of the said company requiring the same by the undersigned on payment of the regulated charge for the same.

The Petitioner's official address is 350 Collins Street, Melbourne.

The Petitioner's Solicitor is B. J. O'Donovan, Crown Solicitor for the Commonwealth of 99 Queen Street, Melbourne.

B. J. O'DONOVAN

NOTE—Any person who intends to appear on the hearing of the said petition must serve on or send by post to the abovenamed B. J. O'Donovan, notice in writing of his intention so to do. The notice must state the name and address of the person, or, if a firm, the name and address of the firm, and must be signed by the person or firm, or his, or their solicitor (if any), and must be served, or, if posted, must be sent by post in sufficient time to reach the abovenamed not later than 4 o'clock in the afternoon of 18 June 1980. 7541

In the Supreme Court of Victoria—In the matter of the Companies Act 1961; and in the matter of AUSTRALIAN WORD PROCESSING PTY. LTD.

Notice is hereby given that a petition for the winding up of the abovenamed Company by the Supreme Court was on 2 June 1980 presented by Kevin Patrick Brady, Deputy Commissioner of Taxation of the Commonwealth of Australia and that the said petition is directed to be heard before the Court sitting at the Fifteenth Court, Law Courts, Lonsdale Street, Melbourne at the hour of 10.30 o'clock in the forenoon on 19 June 1980 and any creditor or contributory of the said company desiring to support or oppose the making of an order on the said petition may appear at the time of hearing by himself or his Counsel for the purpose; and a copy of the said petition will be furnished to any creditor or contributory of the said company requiring the same by the undersigned on payment of the regulated charge for the same.

The Petitioner's official address is 350 Collins Street, Melbourne.

The Petitioner's Solicitor is B. J. O'Donovan, Crown Solicitor for the Commonwealth of 99 Queen Street, Melbourne.

B. J. O'DONOVAN.

NOTE—Any person who intends to appear on the hearing of the said petition must serve on or send by post to the abovenamed B. J. O'Donovan, notice in writing of his intention so to do. The notice must state the name and address of the person, or, if a firm, the name and address of the firm, and must be signed by the person or firm, or his, or their solicitor (if any), and must be served, or, if posted, must be sent by post in sufficient time to reach the abovenamed not later than 4 o'clock in the afternoon of 18 June 1980. 7542

In the Supreme Court of Victoria—In the matter of the Companies Act 1961; and in the matter of R. B. and J. M. SMITH PROPRIETARY LIMITED

Notice is hereby given that a petition for the winding up of the abovenamed Company by the Supreme Court was on 2 June 1980 presented by Kevin Patrick Brady, Deputy Commissioner of Taxation of the Commonwealth of Australia and that the said petition is directed to be heard before the Court sitting at the Fifteenth Court, Law

Courts, Lonsdale Street, Melbourne at the hour of 10.30 o'clock in the forenoon on 19 June 1980 and any creditor or contributory of the said company desiring to support or oppose the making of an order on the said petition may appear at the time of hearing by himself or his Counsel for the purpose; and a copy of the said petition will be furnished to any creditor or contributory of the said company requiring the same by the undersigned on payment of the regulated charge for the same.

The Petitioner's official address is 350 Collins Street, Melbourne.

The Petitioner's Solicitor is B. J. O'Donovan, Crown Solicitor for the Commonwealth of 99 Queen Street, Melbourne.

B. J. O'DONOVAN

NOTE—Any person who intends to appear on the hearing of the said petition must serve on or send by post to the abovenamed B. J. O'Donovan, notice in writing of his intention so to do. The notice must state the name and address of the person, or, if a firm, the name and address of the firm, and must be signed by the person or firm, or his, or their solicitor (if any), and must be served, or, if posted, must be sent by post in sufficient time to reach the abovenamed not later than 4 o'clock in the afternoon of 18 June 1980. 7543

In the Supreme Court of Victoria—In the matter of the Companies Act 1961; and in the matter of NORLENA FASHIONS PROPRIETARY LIMITED

Notice is hereby given that a petition for the winding up of the abovenamed Company by the Supreme Court was on 2 June 1980 presented by Kevin Patrick Brady, Deputy Commissioner of Taxation of the Commonwealth of Australia and that the said petition is directed to be heard before the Court sitting at the Fifteenth Court, Law Courts, Lonsdale Street, Melbourne at the hour of 10.30 o'clock in the forenoon on 19 June 1980 and any creditor or contributory of the said company desiring to support or oppose the making of an order on the said petition may appear at the time of hearing by himself or his Counsel for the purpose; and a copy of the said petition will be furnished to any creditor or contributory of the said company requiring the same by the undersigned on payment of the regulated charge for the same.

The Petitioner's official address is 350 Collins Street, Melbourne.

The Petitioner's Solicitor is B. J. O'Donovan, Crown Solicitor for the Commonwealth of 99 Queen Street, Melbourne.

B. J. O'DONOVAN

NOTE—Any person who intends to appear on the hearing of the said petition must serve on or send by post to the abovenamed B. J. O'Donovan, notice in writing of his intention so to do. The notice must state the name and address of the person, or, if a firm, the name and address of the firm, and must be signed by the person or firm, or his, or their solicitor (if any), and must be served, or, if posted, must be sent by post in sufficient time to reach the abovenamed not later than 4 o'clock in the afternoon of 18 June 1980. 7544

In the Supreme Court of Victoria—In the matter of the Companies Act 1961; and in the matter of PETISE PROPRIETARY LIMITED

Notice is hereby given that a petition for the winding up of the abovenamed Company by the Supreme Court was on 2 June 1980 presented by Kevin Patrick Brady, Deputy Commissioner of Taxation of the Commonwealth of Australia and that the said petition is directed to be heard before the Court sitting at the Fifteenth Court, Law Courts, Lonsdale Street, Melbourne at the hour of 10.30 o'clock in the forenoon on 19 June 1980 and any creditor or contributory of the said company desiring to support or oppose the making of an order on the said petition may appear at the time of hearing by himself or his Counsel for the purpose; and a copy of the said petition will be

furnished to any creditor or contributory of the said company requiring the same by the undersigned on payment of the regulated charge for the same.

The Petitioner's official address is 350 Collins Street, Melbourne.

The Petitioner's Solicitor is B. J. O'Donovan, Crown Solicitor for the Commonwealth of 99 Queen Street, Melbourne.

B. J. O'DONOVAN

NOTE—Any person who intends to appear on the hearing of the said petition must serve on or send by post to the abovenamed B. J. O'Donovan, notice in writing of his intention so to do. The notice must state the name and address of the person, or, if a firm, the name and address of the firm, and must be signed by the person or firm, or his, or their solicitor (if any), and must be served, or, if posted, must be sent by post in sufficient time to reach the abovenamed not later than 4 o'clock in the afternoon of 18 June 1980. 7545

Companies Act 1961—In the matter of OVERHEAD PROJECTION SUPPLIES SERVICES PTY. LTD. (in Liquidation)  
—Notice Convening Final Meeting of Members and Creditors, Pursuant to Section 272

Notice is hereby given pursuant to Section 272 of the Companies Act 1961, that a General Meeting of Members and Creditors of the abovenamed Company will be held at the Meeting Room, B. K. Taylor & Co., 3rd Floor, Dairy Industry House, 576 St. Kilda Road, Melbourne, on Tuesday 15 July 1980, at 11.00 a.m. for the purpose of having an account laid before them showing the manner in which the winding up has been conducted and the property of the Company disposed of and of hearing any explanations that may be given by the Liquidator.

Dated 2 June 1980

B. K. TAYLOR, Liquidator

B. K. Taylor & Co., accountants, 576 St. Kilda Road, Melbourne, Vic. 3004 7546

Companies Act 1961—In the matter of WATSONIA PLUMBING SUPPLIES PTY. LTD. (in Liquidation)

A first dividend is intended to be declared in the abovenamed matter. Creditors who have not proved their debts by 7 July 1980, will be excluded from the dividend.

The date of Liquidation was 10 May 1979.

Dated 2 June 1980

B. K. TAYLOR, Liquidator

B. K. Taylor & Co., 576 St. Kilda Road, Melbourne, Vic. 3004 7547

Creditors, next of kin and others having claims against Margaret Jane Hickingbotham late of 67 Sussex Street, Coburg in the State of Victoria Widow deceased who died on 13 January 1980 are required by the Executor Keith Formby Hickingbotham of 20 Pye Street Eugowra in the State of New South Wales to send particulars of their claims to the said Executor care of Messrs Maurice J. Brophy, O'Dea & Co. of 281 Sydney Road, Coburg Solicitors by 11 August 1980 after which he will distribute the assets of the said estate having regard only to the claims of which he then has notice.

MAURICE J. BROPHY, O'DEA & CO., solicitors, of 281 Sydney Road, Coburg 7421

ETHEL MAUD WIRTH, late of 55 Somerville Street (in the Will called 16 Somerville Street), Bendigo, widow, DECEASED

Creditors, next of kin and others having claims in respect of the unadministered Estate of the deceased who died on 21 January 1969 are required by the Administrator William Clive Wirth of Boldcreek Parade Reservoir to send particulars to him care of the undermentioned Solicitors by 6 August 1980 after which date he may convey or distribute the assets having regard only to the claims of which he then has notice.

R. H. SCHLEIGER & ASSOCIATES, solicitors, of 33-35 Williamson Street, Bendigo 7422

Creditors, next of kin and others having claims in respect of the Estate of Robert Francis Thresher late of 62 Gowrie Street South Oakleigh, in the State of Victoria, Gentleman deceased, who died on 7 February 1980 are to send particulars of their claims to the executor National Trustees, Executors and Agency Company of Australasia Limited of 95 Queen Street Melbourne by 4 August 1980, after which date it will distribute the assets having regard only to the claims of which it then has notice.

LE GRAND, RANGLES, GAFFNEY & CO., 644 Sydney Road, Brunswick, the solicitors for the applicant 7423

DAVID WHITE McINNES, late of 4 Park Crescent, Boronia, retired public servant, DECEASED

Creditors, next of kin and others having claims in respect of the Estate of the deceased who died on 28 October 1979 are required by the Executrix Marjorie Edith McInnes of 4 Park Crescent Boronia to send particulars to the undermentioned firm by 31 July 1980 after which date the said Executrix may convey or distribute the assets having regard only to the claims to which notice has by then been given.

SETON WILLIAMS & SMYTH, solicitors, 408 Collins Street, Melbourne 7424

KATHLEEN MARY MEEHAN, formerly of 162 Kangaroo Road, Oakleigh, in the State of Victoria, but late of Flat 1, 3 Canterbury Street, Oakleigh, widow, DECEASED

Creditors, next of kin and others having claims in respect of the estate of the deceased who died on 9 April 1980 are required by Wilma Cochrane of 198 Clayton Road, Clayton aforesaid, Married Woman the Executrix of the Will of the said deceased to send particulars to her in the care of the undermentioned Solicitors by 22 August 1980 after which date the said Executrix may convey or distribute the assets having regard only to the claims of which she then has notice.

BORCHARD & MOORE, solicitors, of 44 Douglas Street, Noble Park 7425

ADELINE HOLMES, late of 36 Cumberland Street, Newtown, widow, DECEASED

Creditors, next of kin and others having claims in respect of the estate of the deceased who died on 29 June 1977 are requested by the Administratrix Mardie Grace Brame of 312 Eureka Street Ballarat Married Woman to send particulars to her care of the undersigned by 7 August 1980 after which date the Administratrix may convey or distribute the assets having regard only to the claims of which she then has notice.

J. CURWEN-WALKER & CO., solicitors, Ballarat 7426

Creditors, next of kin and others having claims in respect of the estate of Mary Josephine Tims formerly of 3 Hunter Road, Camberwell in Victoria but late of 245 Warrigal Road, Burwood in Victoria Widow deceased (who died on 15 January 1980) are required to send particulars of their claims to the Executors Norman Charles Tims of 123A Abbott Street, Sandringham in Victoria Managing Director and John Moore Dobbie of 245 Warrigal Road, Burwood Victoria Manager care of the undermentioned Solicitors by 5 August 1980 after which date they may convey or distribute the assets having regard only to the claims of which they then have notice.

AITKEN WALKER & STRACHAN, solicitors, 114 William Street, Melbourne, 3000 7427

Creditors, next of kin and others having claims in respect of the Estate of Andrew Hayden Hensher late of 5/858 Hampton Street, Brighton in the State of Victoria, Commercial Artist deceased who died on 17 May 1980 are required to send particulars of their claims to the Executor Colin Henry East care of Messrs. Havyatt & Steward, Solicitors, 432 William Street, Melbourne by 6 August 1980 after which date the Executor will distribute the assets of the deceased having regard only to the claims of which he then has notice.

HAVYATT & STEWARD, solicitors, 432 William Street, Melbourne 7428

HAZEL EILEEN HEATH, late of Geelong Travelodge, Gheringhap Street, Geelong, married woman, DECEASED

Creditors, next of kin and others having claims in respect of the estate of the said deceased who died 1 March 1980 are required by the Applicants for Grant of Probate of the Will Daryl Parlett Heath of 37 Skene Street Newtown Company Director and Hilary Mary Blakiston of 279 Pakington Street Newtown Married Woman to send particulars to them care of the undersigned Solicitors by 6 August 1980, after which date the said Applicants may convey or distribute the assets having regard only to the claims of which they then have notice.

WIGHTON & McDONALD, solicitors, 89 Myers Street, Geelong 7429

Creditors, next of kin and all other persons having claims against the Estate of Thomas Michael Gilgallon late of 50 Clifton Street, Richmond in the State of Victoria, Invalid Pensioner deceased intestate are required by the Administratrix of his Estate, Joan Gilgallon, to send their claims to her, care of the undersigned, by 2 August 1980 after which date she will distribute the assets of his Estate, having regard only to the claims of which she then has notice.

HOLDING, REDLICH & CO., solicitors, 174 Victoria Parade, East Melbourne 7430

Creditors, next of kin and all other persons having claims against the Estate of Ian James Dale late of 30 Allister Close, Knoxfield in the State of Victoria, Water-side Worker deceased are required by the Executrix of his Will Jessie Selina Lockyer to send their claims to her, care of the undersigned, by 2 August 1980 after which date she will distribute the assets of his Estate, having regard only to the claims of which she then has notice.

HOLDING, REDLICH & CO., solicitors, 174 Victoria Parade, East Melbourne 7431

Creditors, next of kin and others having claims against the Estate of James King (also known as James Francis King) formerly of Southern Cross, farmer, but late of "Lyndoch" Warrnambool, retired farmer, deceased who died on 30 June 1979 are requested to send particulars of their claims to the executor James Vincent Russell of 255 Timor Street, Warrnambool, retired factory employee, care of Conlan & Leishman, Solicitors, 38 Bank Street, Port Fairy by 30 July 1980 after which date he will distribute the assets, having regard only to the claims of which he then has notice.

CONLAN & LEISHMAN, solicitors, 38 Bank Street, Port Fairy 7432

Creditors, next of kin and others having claims in respect of the Estate of Victor Norman Sieber late of 11 Devon Terrace Pinnaroo Retired Farmer deceased who died on 8 February 1978 are required to send particulars of their claims to the Executor The Union-Fidelity Trustee Company of Australia Limited at its address 101 Lydiard Street North Ballarat by 10 August 1980 after which date the said Company will distribute the assets having regard only to the claims of which it then has notice.

7433

Creditors, next of kin and others having claims in respect of the estate of Maude Emma Roach formerly of 42 Langdon Road Caulfield and 29 Cedar Street Caulfield South but late of Kalimna Hospital 107 Darling Road East Malvern in the State of Victoria Widow deceased who died on 12 November 1979 are to send particulars of their claims to Marie Denese Paddon formerly of 14 Valdemar Court South Brighton but now of Flat 7, 76 Whyte Street Brighton in the said State Married Woman care of the undermentioned Solicitors by 4 August 1980 after which date she will distribute the assets having regard only to the claims to which she then has notice.

REGINALD C. BUTLER & CO., solicitors, 312 Centre Road, Bentleigh 7434



HILDA VERA WINFORD, late of 75 Alfred Street, Kew,  
widow, DECEASED

Creditors, next of kin and others having claims in respect of the estate of the deceased who died on 9 December 1979 are required by the personal representative Reginald Warren Winford to send particulars to him care of the undersigned solicitors by 4 August 1980 after which date the personal representative may convey or distribute the assets, having regard only to the claims of which he then has notice.

VERA FOWLER & CO., solicitors, 1 Evandale Road,  
Malvern, 3144 7435

ERNEST JOHN STUCHBERY, late of North Portland,  
in the State of Victoria, farmer, DECEASED

Creditors, next of kin and others having claims in respect of the estate of the deceased who died on 5 August 1979 are required by John Allenby Stuchbery of Marnie Road Bendigo in the said State Retired and Stanley Lloyd Stuchbery of North Portland in the said State Pensioner to send particulars to them as Executors to whom Probate of the Will of the said deceased has been granted by the Supreme Court of Victoria care of the undermentioned Solicitors by 7 August 1980 after which date the Executors may convey or distribute the assets having regard only to the claims of which they then have notice.

HULL, NEWNS & BALLANTYNE, solicitors, 44B Percy  
Street, Portland 7436

Creditors, next of kin and others having claims in respect of the estate of Lawrence David Boyle, late of 24 Wood Street, Nunawading, Engineer, deceased, who died on 23 October 1979 are required by the Administrator Norman James Boyle of 243 Springvale Road, Nunawading, to send particulars of their claims to him by 6 August 1980 after which date he will distribute the assets having regard only to the claims of which it then has notice. 7512

ALAN WAYNE REYNOLDS, late of Lavarack Barracks,  
Townsville, in the State of Queensland, soldier, DECEASED

Creditors, next of kin and others having claims in respect of the estate of the deceased (who died on 17 June 1979) are required by the Executor of the Estate Harold Thomas Reynolds of 95 Victoria Street, Altona Meadows in the State of Victoria to send particulars of their claims to the said Harold Thomas Reynolds care of the undermentioned Solicitors by 18 August 1980 after which date he will convey or distribute the assets, having regard only to the claims of which the said Harold Thomas Reynolds then has notice.

HENDERSON & BALL, solicitors, of 430 Little Collins  
Street, Melbourne 7513

NIKOLAOS NIKOLOUDIS, late of 268 Burnley Street,  
Richmond, and 6 Clifton Road, Hawthorn, shop proprietor,  
DECEASED, intestate

Creditors, next of kin and others having claims in respect of the Estate of the deceased who died on 23 August 1978 are requested to send particulars of their claims to the personal representative Kanella Nikoloudis care of the undermentioned solicitors, by 5 August 1980 after which date she will distribute the assets having regard only to the claims of which she then has notice.

T. W. BRENNAN & CO., solicitors, 118 Queen Street,  
Melbourne 7514

Creditors, next of kin and others having claims in respect of the Estate of Sarah McCracken Richards late of Gippsland Home and Hospital Bairnsdale Pensioner deceased who died on 23 February 1980 are to send particulars of their claims to The Union-Fidelity Trustee Company of Australia Limited of 100 Exhibition Street Melbourne the Executor appointed by the Will of the said deceased by 11 August 1980 after which date the said Company will distribute the assets having regard only to the claims of which it shall then have had notice.

WARREN, GRAHAM & MURPHY, solicitors, Bairnsdale,  
Vic. 3875 7515

FRANCIS LEMUEL JOHNSTON, late of 31 Eden Street,  
Cheltenham, retired builder, DECEASED

Creditors, next of kin and others having claims against the Estate of the deceased who died on 9 March 1980 are required by the Executor The Trustees Executors and Agency Company Limited of 401 Collins Street, Melbourne to send particulars of their claims to the said Company on or before 6 August 1980 after which date it will convey or distribute the assets having regard only to the claims of which it then has notice.

HOME, WILKINSON & LOWRY, solicitors, of 401 Collins  
Street, Melbourne 7516

Creditors, next of kin and others having claims in respect of the estate of Charles Augustus Carter late of 8 Bethela Street Burwood Gentleman deceased who died on 10 October 1979 are to send the particulars of their claims to The Equity Trustees Executors and Agency Company Limited of 472 Bourke Street Melbourne by 5 August 1980 after which date it will distribute the assets having regard only to the claims of which it then has notice.

MCCRACKEN & MCCRACKEN, solicitors, 414 Collins  
Street, Melbourne 7517

Creditors, next of kin and others having claims in respect of the estate of Louie Antonia Carter late of 8 Bethela Street Burwood Spinster deceased who died on 2 October 1979 are to send the particulars of their claims to The Equity Trustees Executors and Agency Company Limited of 472 Bourke Street Melbourne by 5 August 1980 after which date it will distribute the assets having regard only to the claims of which it then has notice.

MCCRACKEN & MCCRACKEN, solicitors, 414 Collins  
Street, Melbourne 7518

Creditors, next of kin and others having claims in respect of the estate of Nellie Christmas Carter late of 8 Bethela Street Burwood Spinster deceased who died on 16 August 1979 are to send particulars of their claim to The Equity Trustees Executors and Agency Company Limited of 472 Bourke Street Melbourne by 5 August 1980 after which date it will distribute the assets having regard only for claims of which it then has notice.

MCCRACKEN & MCCRACKEN, solicitors, 414 Collins  
Street, Melbourne 7519

EDWARD ARNOLD VAN SENDEN, late of 115a Woodland  
Street, North Essendon, in the State of Victoria, retired  
public servant, DECEASED

Creditors, next of kin and others having claims in respect of the estate of the abovenamed deceased are required by the executor The Trustees Executors and Agency Company Limited of 401 Collins Street Melbourne in the said state to send particulars to the executor by 30 July 1980 after which date the executor may convey or distribute the assets having regard only to the claims of which it then has notice.

DAVIES CAMPBELL & PIESSE, solicitors, of 401 Collins  
Street, Melbourne 7520

Creditors, next of kin and others having claims in respect of the estate of Florence Alice Trollope late of 75 Roseberry Street, Ascot Vale in the State of Victoria Widow deceased who died on 19 April 1980 are required to send particulars of their claims to the Executrix Lois Ada Johns care of the undermentioned Solicitors by 6 August 1980 after which date the Executrix will distribute the assets of the deceased having regard only for the claims of which she then has had notice.

JOHN McDONALD SMITH, BOX & ROYSTON, solicitors,  
of 59-63 Irving Street, Footscray 7521

MAY PRETORIA BRASHER, late of "Mon Repos" Private  
Nursing Home, 14 Combermere Street, Essendon, widow,  
DECEASED

Creditors, next of kin and others having claims in respect of the estate of the deceased (who died on 12 February 1980) are required by The Perpetual Executors and Trustees Association of Australia Limited of 50 Queen Street, Melbourne to send particulars of their claims to the

said Company by 8 August after which date it will convey or distribute the assets having regard only to the claims of which the Company then has notice.

CORR & CORR, solicitors, 290 La Trobe Street, Melbourne 7522

Creditors, next of kin and others having claims against the estate of Ellen Jane Hipwell formerly of Cumberland Hotel Smeaton Hotelkeeper but late of 143 Church Street Creswick in the State of Victoria Widow deceased (who died on 4 July 1977) are required to send particulars of their claims to Byrne, Jones & Torney of 38 Lydiard Street South Ballarat in the said State the Solicitors of the estate of the said deceased by 4 August 1980 after which date the Solicitors will distribute the assets having regard only to the claims of which they then have notice.

Dated 4 June 1980

BYRNE, JONES & TORNEY, solicitors, Ballarat 7523

ALFRED HENRY COUTTS, late of 36 Chapel Street, Colac, farmer, DECEASED

Creditors, next of kin and others having claims in respect of the estate of the deceased who died on or about 9 November 1979 are required by his personal representatives Alan Hamilton Coutts of Apollo Bay and Edward Thomas Martin of Irrewarra both Farmers to send particulars to them or to the undermentioned solicitors on their behalf by 25 August 1980 after which date the personal representatives may convey or distribute the assets having regard only to the claims of which they then have notice.

SEWELLS, solicitors, 38 Murray Street, Colac 7550

JESSIE HALL, late of 13 Exeter Street, Ballarat, spinster, DECEASED (who died on 9 April 1980)

Creditors next of kin and all persons having claims against the estate of the deceased are required to send particulars to the Executors John Joseph Rawlings of 1033 Howitt Street, Ballarat Retired Funeral Director and Walter Henry Heinz of 209 Dana Street, Ballarat Solicitor on or before 5 August 1980 after which date they will distribute the assets having regard only to the claims of which they shall then have notice.

HEINZ & GORDON, solicitors, 209 Dana Street, Ballarat 7551

ASDRUEBAL JAMES KEAST, late of 8 Avoca Street, Canterbury, mining engineer, DECEASED

Creditors next of kin and others having claims in respect of the estate of the deceased (who died on 17 March 1980) are required by The Perpetual Executors and Trustees Association of Australia Limited of 50 Queen Street Melbourne to send particulars of their claims to the said Company by 14 August 1980 after which date it will convey or distribute the assets, having regard only to the claims of which the Company then has notice.

PAUL JONES, late of 3 Kemsley Court, Hawthorn, medical practitioner, DECEASED

Creditors next of kin and others having claims against the Estate of the said deceased who died on 6 September 1979 are to send particulars of their claims to Alexander Allen Stewart c/- Messrs Blake & Riggall Solicitors 140 William Street Melbourne by 3 September 1980 after which date he will distribute the assets having regard only to the claims of which he then has notice.

BLAKE & RIGGALL, solicitors, 140 William Street, Melbourne 7553

All persons having claims against the estate of Alfred Leonard Gate late of "Mangoola" Main Street Upwey in the State of Victoria Gentleman deceased (who died on 8 March 1980 and Probate of whose Will was on 24 April 1980 granted by the Supreme Court of Victoria in its Probate Jurisdiction to Reginald Mervyn Friend and Colin John Daniels both of 10 Queen Street Melbourne in the said State) are hereby required to send particulars of such claims to Reginald Mervyn Friend and Colin John Daniels at their address at 10 Queen Street Melbourne aforesaid on or before 6 August 1980 after which date

they will proceed to transfer, convey or distribute the said Estate to or among the persons entitled thereto having regard only to the claims of which they shall then have had notice and will not be liable for the assets so transferred, conveyed or distributed to any persons of whose claim they shall not then have had notice.

AKEHURST FRIEND & HAACK, solicitors, 10 Queen Street, Melbourne 7554

ALICE MAUD MURRAY-SMITH, late of 4 Canberra Road, Toorak, in the State of Victoria, widow, DECEASED

Creditors, next of kin and others having claims against the Estate of the abovenamed deceased who died on 20 February 1980 are required by the Executrix Mary Josephine Winter of 6 Viewbank Road Glen Iris Solicitor to send particulars of their claims to her by 5 August 1980 after which date she will convey or distribute the assets having regard only to claims of which she then has notice.

MARY J. WINTER, solicitor, 6 Viewbank Road, Glen Iris 7555

Creditors, next of kin and others having claims in respect of the Estate of Brian McCall, late of 2 Nicholson Street, South Yarra Retired Sales Manager deceased who died on 20 December 1979 are to send the particulars of their claims to National Trustees Executors and Agency Company of Australasia Limited of 95 Queen Street, Melbourne by 6 August 1980 after which date it will distribute the assets having regard only to the claims of which it then has notice.

LYNCH & MACDONALD, FLOOD & PERMEZEL, solicitors, of 360 Collins Street, Melbourne 7556

ZELMA ELIZABETH KING, late of 15 Moralla Road, Kooyong, married woman, DECEASED

Creditors, next of kin and others having claims in respect of the estate of the deceased, who died on 1 January 1980 are required by her Executors, Reginald John Essington King of 15 Moralla Road, Kooyong and David James Essington King of 16 Docker Street, Richmond to send particulars to them by 8 August 1980 after which date they may convey or distribute the assets, having regard only to the claims of which they then have notice.

HEDDERWICK, FOOKES & ALSTON, 121 William Street, Melbourne 7557

ALFRED LAWRENCE KEEP, late of 26 St. Georges Road Toorak, gentleman, DECEASED

Creditors, next of kin and others having claims in respect of the estate of the deceased (who died on 14 February 1980) are required by The Union-Fidelity Trustee Company of Australia Limited of 100 Exhibition Street, Melbourne, to send particulars of their claims to the said Company by 6 August 1980 after which date it will convey or distribute the assets having regard only to the claims of which the Company then has notice.

TURNER, NESS & DAVIS, solicitors, 8-12 Batman Street, Melbourne 7558

In the Supreme Court of the State of Victoria  
SALE BY THE SHERIFF

On Wednesday, 16 July 1980, at 12 noon at the Police Station, Cobden (unless process be stayed or satisfied).

All the Estate and Interest (if any) of C. J. Opt'Hoog (shown on Purchase Lease as Cornelius Jozefes Opt'Hoog), farmer of Nareen Road, Coorimungle, as Purchase Lessee of the land described in Purchase Lease Volume 1208 Folio 344 upon which is erected a weatherboard dwelling plus outbuildings.

The property can be located as follows: from Simpson proceed along the road to Princetown then take the right hand turn along the Gallum Road and then proceed along that road until the Nareen Road on the left. Proceed along the Nareen Road until passing the Turrong Road which is on the left and it is the second farm on the right past the Turrong Road. It is Block 154.

Terms—Cash only

7559

P. DUNCAN, Deputy Sheriff

In the Supreme Court of the State of Victoria  
SALE BY THE SHERIFF

On Thursday, 10 July 1980, at 10.30 a.m. at the Police Station, Sandringham (unless process be stayed or satisfied).

All the Estate and Interest (if any) of Mrs I. Fersterer (shown on Certificate of Title as Inge Fersterer, married woman), of 1 Minnie Street, Sandringham, as joint proprietor with Franz Alois Fersterer, builder, of an estate in fee simple in the land described in Certificate of Title Volume 4441 Folio 005 upon which is erected a brick house with double garage known as No. 1 Minnie Street, Sandringham.

Registered Mortgage Nos. E.837330 and F.766774 affect the said estate and interest.

Terms—Cash only  
7560

T. NICHOLLS, Sheriff's Officer

In the Supreme Court of the State of Victoria  
SALE BY THE SHERIFF

On Thursday, 17 July 1980, at 12 noon at the Police Station, Mildura (unless process be stayed or satisfied).

All the Estate and Interest (if any) of Kenneth George Walters, manager of Robinvale as proprietor of the land described in Crown Grant Volume 7549 Folio 130 upon which is erected a residential home and a steel shed known as The Flats, Allotment 63, Ninth Road, Robinvale. The land is on the north side of Ninth Road and commences 750 chains in a westerly direction from the nearest road which runs north-south and is unnamed. The land is rectangular and measures 400 chains by 750 chains.

Registered Mortgage No. H.372109 and Caveat No. H.608661 affect the said estate and interest.

Terms—Cash only  
7561

J. GREEN, Deputy Sheriff

**NOTICE OF MAKING OF  
STATUTORY RULES**

In pursuance of the provisions of the *Subordinate Legislation Act 1962* and the Regulations made thereunder, notice is given of the making of the following Statutory Rules:—

No.		Price
175/1980.	<i>Liquefied Petroleum Gas Act 1958</i> Liquefied Petroleum Gas (Amendment) Regulations 1980	60c
176/1980.	<i>Liquefied Gases Act 1968</i> Liquefied Gases (Transportation and Gas Transfer) Regulations 1980	\$1.80
177/1980.	<i>Police Regulation Act 1958</i> Police (Police Bands) Regulations 1980	10c
178/1980.	<i>Water Act 1958</i> Water (Lake Eildon Recreational Area) Amendment Regulations 1980	20c
179/1980.	<i>Country Fire Authority Act 1958</i> Country Fire Authority (Loan No. 135) Regulations 1980	10c
180/1980.	<i>Country Fire Authority Act 1958</i> Country Fire Authority (Loan No. 136) Regulations 1980	10c
181/1980.	<i>Country Fire Authority Act 1958</i> Country Fire Authority (Loan No. 137) Regulations 1980	10c
182/1980.	<i>Hairdressers Registration Act 1958</i> Hairdressers Registration (Amendment) Regulations 1980	10c

No.		Price
183/1980.	<i>Education Act 1958</i> Council of Adult Education (Amendment) Regulations 1980 (Amendment No. 1)	10c
184/1980.	<i>Legal Profession Practice Act 1958</i> Rules of the Council of Legal Education (Amendment No. 2) 1980	10c
PSD56/1980.	<i>Public Service Act 1974</i> Public Service Amendment Determina- tions (No. 56) 1980	10c
PSD57/1980.	Public Service Amendment Determina- tions (No. 57) 1980	10c
PSD58/1980.	Public Service Amendment Determina- tions (No. 58) 1980	10c

Copies of these Statutory Rules when printed may be purchased at the Sale of Publications Branch of the Government Printing Office, located at 7A Parliament Place, Melbourne, 3002. If ordered by mail, remittance should be addressed to "The Government Printer, Box 203, P.O., North Melbourne, 3051", and should include 50c delivery and handling fee.

The annual subscription rates for Statutory Rules for the year commencing 1 January 1980, payable in advance, are as follows:—

*Statutory Rules (other than Public Service Determinations), Pamphlet copies only	\$36.00
Public Service Determinations	\$25.00
*The Bound Volume of Statutory Rules is not included in the subscription rate.	

F. D. ATKINSON  
Government Printer

**INSOLVENCY NOTICES**

In the matter of the *Bankruptcy Act 1966*; and in the matter of P. F. RISSSTROM No. 68 OF 1978 PART X. and G. M. RISSSTROM No. 69 OF 1978 PART X.

Those creditors who have made claim against the abovenamed, but have not proved their debts, are hereby given notice in pursuance of section 145 of the *Bankruptcy Act 1966*, that if they do not prove their debt on or before 27 June 1980 I shall proceed to declare a final dividend in the above Estates, without regard to their claims.

Dated 4 June 1980

B. H. SMITH, trustee, 23rd Floor, 500 Collins Street, Melbourne

NOTE—Under sub-section (2) of section 145 of the *Bankruptcy Act 1966*, creditors may make application to the Court for further time to prove their debts. However, if they do not prove before the expiration of the time set out in this notice or any further time allowed by the Court, the moneys not yet distributed by me are required to be distributed without regard to their debts.  
7448

The *Bankruptcy Act 1966-73*, Part X.—In the matter of  
ARNOLD & MARGARET HOWARD

Notice is hereby given that a first dividend is intended to be declared in the above matter. Creditors who have not proved their debts by 7 July 1980 may be excluded from this dividend.

Dated 2 June 1980

B. K. TAYLOR & CO., Trustee  
B. K. Taylor & Co., accountants, 576 St. Kilda Road,  
Melbourne, Vic. 3004  
7548

The Bankruptcy Act 1966-73, Part X.—In the matter of  
MAXWELL COLIN & DOROTHY MAY HENDERSON

Notice is hereby given that a first dividend is intended to be declared in the above matter. Creditors who have not proved their debts by 7 July 1980 may be excluded from this dividend.

Dated 2 June 1980

B. K. TAYLOR & CO., Trustee

B. K. Taylor & Co., accountants, 576 St. Kilda Road,  
Melbourne, Vic. 3004 7549

**STATE ACTS, 1979**

Copies of the following Acts of the Parliament of Victoria may be obtained at the Government Printing Office, Sale of Publications Branch, 7A Parliament Place, Melbourne, phone 651 2754 or 651 2759, or from any accredited agent, at the price set opposite to each.

A delivery and handling fee must be added to your remittance when ordering by mail as follows:—

Total Value of Acts Ordered	Delivery and Handling Fee
10c-\$2.00	0.50c
\$2.05-\$5.00	\$1.00
\$5.05-\$20.00	\$1.50
Above \$20.00	\$2.00

Bound Volumes of 1978 State Acts (\$21.00) and the Index to the Bound Volumes (\$9.00) are also available.

No.	Price
9251.	Constitution (Governor's Pension) .. \$0.10
9252.	Joint Select Committee (Road Safety) .. \$0.20
9253.	Cattle Compensation .. \$0.10
9254.	Constitution (Local Government) .. \$0.30
9255.	Gas and Fuel Corporation (Borrowing Powers) .. \$0.10
9256.	Ombudsman (Co-operation) .. \$0.10
9257.	Geelong (Haimes Homes) Land .. \$0.20
9258.	Motor Car (Breath Testing Stations) (Amendment) .. \$0.10
9259.	Geelong Waterworks and Sewerage (Trust) .. \$0.30
9260.	Bright (Land Exchange) .. \$0.20
9261.	Supply (1979-80, No. 1) .. \$0.30
9262.	Money Lenders (Fees) .. \$0.10
9263.	Exhibition (Amendment) .. \$0.30
9264.	Health (Cattle) .. \$0.10
9265.	Victorian Public Offices Corporation (Amendment) .. \$0.10
9266.	Community Welfare Services (Amendment) .. \$0.10
9267.	Margarine (Amendment) .. \$0.10
9268.	Youth, Sport and Recreation (State Youth Council) .. \$0.10
9269.	Racing (Restricted Trotting Meetings) .. \$0.10
9270.	State Electricity Commission (Morwell Land Compensation) .. \$0.10
9271.	Construction Safety .. \$1.00
9272.	Business Franchise (Petroleum Products) .. \$0.40
9273.	Albury-Wodonga Agreement (Amendment) .. \$0.40
9274.	City of Melbourne (Re-subdivision) .. \$0.10
9275.	Co-operation .. \$0.40
9276.	Cemeteries (Melbourne General Cemetery) .. \$0.10
9277.	Melbourne and Metropolitan Board of Works (Amendment) .. \$0.30
9278.	River Improvement (Trusts and Valuations) .. \$0.10
9279.	Instruments (Writs) .. \$0.10
9280.	Forests (Reserved Land) .. \$0.10
9281.	Trinity College .. \$0.50
9282.	Revocation and Excision of Crown Reservations .. \$0.30
9283.	Local Government (Amendment) .. \$0.50
9284.	Tattersall Consultations (Amendment) .. \$0.10
9285.	Prahran Market .. \$0.10
9286.	Geelong Regional Commission (Amendment) .. \$0.10
9287.	Pharmacists (Amendment) .. \$0.10
9288.	Legal Profession Practice (Amendment) .. \$0.10

STATE ACTS, 1979—continued

No.	Price
9289.	Barley Marketing (Amendment) .. \$0.10
9290.	Water Authorities (Constitution and Powers) .. \$0.20
9291.	Sewerage Authorities (Constitution and Powers) .. \$0.30
9292.	Wrongs (Defamation) .. \$0.10
9293.	Judges Salaries .. \$0.10
9294.	Poisons (Amendment) .. \$0.10
9295.	Business Franchise (Petroleum Products) (Licence Fees) .. \$0.20
9296.	State Electricity Commission (Amendment) .. \$0.30
9297.	Workers Compensation (Miscellaneous Provisions) .. \$1.00
9298.	Motor Car (Surcharge) .. \$0.10
9299.	Unclaimed Moneys .. \$0.10
9300.	Land Tax .. \$0.10
9301.	Business Franchise (Tobacco) .. \$0.10
9302.	Public Authorities (Contributions) .. \$0.10
9303.	Appropriation (1979-80, No. 1) .. \$3.50
9304.	Gift Duty (Amendment) .. \$0.10
9305.	Pay-roll Tax .. \$0.30
9306.	Transport Works and Services .. \$0.20
9307.	Melbourne and Metropolitan Tramways (Borrowing Powers) .. \$0.10
9308.	County Court (Jurisdiction) .. \$0.10
9309.	State Forests Works and Services .. \$0.10
9310.	Young Men's Christian Association of Ballarat (Guarantee) .. \$0.20
9311.	Water Supply Works and Services .. \$0.40
9312.	Trustee Companies (Trustees Executors) .. \$0.10
9313.	Commercial Goods Vehicles (Aviation Fuel) .. \$0.10
9314.	Victorian Development Corporation (Powers) .. \$0.20
9315.	Town and Country Planning (Planning Schemes) .. \$1.00
9316.	Victorian Government Travel Authority (Reconstitution) .. \$0.10
9317.	Stamps (Amendment) .. \$0.30
9318.	Motor Car (Fees) .. \$0.30
9319.	Racing (Financial Provisions) .. \$0.30
9320.	Urban Land Authority .. \$0.50
9321.	Public Works and Services .. \$0.30
9322.	Second-hand Dealers (Closing Hours) .. \$0.10
9323.	Crimes (Amendment) .. \$0.10
9324.	Transfer of Land (Amendment) .. \$0.40
9325.	Melbourne College of Divinity .. \$0.30
9326.	Transport Regulation (Car Pools) .. \$0.10
9327.	Fisheries (Amendment) .. \$0.10
9328.	Egg Industry Stabilization (Amendment) .. \$0.10
9329.	Local Authorities Superannuation .. \$0.30
9330.	Latrobe Valley (Amendment) .. \$0.10
9331.	Liquor Control (Amendment) .. \$0.10
9332.	Motor Accidents (Amendment) .. \$0.40
9333.	Young Farmers' Finance Council .. \$0.30
9334.	Probate Duty .. \$0.20
9335.	Railways (Board) .. \$0.10
9336.	Ministry of Transport (Amendment) .. \$0.10
9337.	Abattoir and Meat Inspection (Amendment) .. \$0.20
9338.	Public Service (Amendment) .. \$0.20
9339.	Trustee Companies (Amendment) .. \$0.20
9340.	Vermin and Noxious Weeds (Amendment) .. \$0.30
9341.	Canned Fruits Marketing .. \$0.40
9342.	Marine (Amendment) .. \$0.40
9343.	Shire of Omeo (Tourist Gold Mine) .. \$0.30
9344.	Presbyterian Trusts .. \$0.90
9345.	Railway Construction and Property Board .. \$0.90
9346.	Motor Car (Insurance by Pensioners) .. \$0.10
9347.	Town and Country Planning (Amendment of Schemes) .. \$0.10
9348.	Labour and Industry (Amendment) .. \$0.20
9349.	Magistrates' Courts (Civil Jurisdiction) .. \$0.40
9350.	Master Builders' Association of Victoria (Guarantee) .. \$0.20
9351.	Education (Amendment) .. \$0.20
9352.	Educational Grants (Continuation) .. \$0.10
9353.	Wrongs (Assessment of Damages) .. \$0.10
9354.	Victorian Arts Centre .. \$0.40
9355.	Building Industry Long Service Leave (Amendment) .. \$0.50
9356.	Local Government (Land Liable to Flooding) .. \$0.30
9357.	Parliamentary Committees (Public Accounts and Expenditure Review Committee) .. \$0.20
9358.	Superannuation (Amendment) .. \$0.30
9359.	Health (Proprietary Medicines) .. \$0.20
9360.	Victorian Fishing Industry Council .. \$0.30
9361.	Grain Handling Improvement Authorities .. \$0.30

STATE ACTS, 1979—continued

No.	Price
9362. Wheat Marketing .. .. .	\$0.80
9363. State Employees Retirement Benefits .. .. .	\$1.00
9364. Town and Country Planning (General Amendment) .. .. .	\$1.00
9365. Industrial Relations .. .. .	\$1.40

**STATE ACTS, 1980**

Copies of the following Acts of the Parliament of Victoria may be obtained at the Government Printing Office, Sale of Publications Branch, 7A Parliament Place, Melbourne, phone 651 2754 or 651 2759, or from any accredited agent, at the price set opposite to each.

A delivery and handling fee must be added to your remittance when ordering by mail as follows:

Total Value of Acts Ordered	Delivery and Handling Fee
10c-\$2.00	0.50c
\$2.05-\$5.00	\$1.00
\$5.05-\$20.00	\$1.50
Above \$20.00	\$2.00

Bound Volumes of 1978 State Acts (\$21.00) and the Index to the Bound Volumes (\$9.00) are also available.

No.	Price
9366. Constitutional Powers (Coastal Waters)	20c
9367. Parliamentary Committees (Public Bodies Review)	40c

ACTS REPRINTED IN ACCORDANCE WITH THE AMENDMENTS INCORPORATION ACT 1958 (No. 6422), AND FOR SALE AS STOCKS ARE AVAILABLE AT THE SALE OF PUBLICATIONS BRANCH OF THE GOVERNMENT PRINTING OFFICE, 7A PARLIAMENT PLACE, MELBOURNE, 3002.

A delivery and handling fee must be added to your remittance when ordering by mail as follows:—

Total Value of Acts Ordered	Delivery and Handling Fee
10c-\$2.00	0.50c
\$2.05-\$5.00	\$1.00
\$5.05-\$20.00	\$1.50
Above \$20.00	\$2.00

No.	Price
8404. Abattoir and Meat Inspector (First Reprint—Incorporating amendments up to No. 9005)	\$0.85
6189. Acts Interpretation (Fifth Reprint—Incorporating amendments up to Act No. 9229)	\$0.70
6191. Administration and Probate Act 1958 (Fifth Reprint—Incorporating amendments up to No. 9075)	\$1.05
7147. Adoption of Children (First Reprint—Incorporating amendments up to Act No. 8602)	\$0.75
6194. Agricultural Colleges (First Reprint—Incorporating amendments up to No. 7302)	\$0.15
7772. Alcoholic and Drug-Dependent Persons Act 1968 (First Reprint—Incorporating amendments up to Act No. 9023)	\$0.60
6198. Anzac Day (First Reprint—Incorporating amendments up to No. 8344)	\$0.15
7117. Appeal Costs Fund Act 1964 (Second Reprint—Incorporating amendments up to No. 8145)	\$0.35
8273. Archaeological and Aboriginal Preservation Act 1972 (First Reprint—Incorporating amendments up to Act No. 9019)	\$0.30
6201. Architects (First Reprint—Incorporating amendments up to No. 8077)	\$0.30
6202. Auction Sales (First Reprint—Incorporating amendments up to No. 8490)	\$0.35
6203. Audit (First Reprint—Incorporating amendments up to No. 7377)	\$0.35

ACTS REPRINTED IN ACCORDANCE WITH THE AMENDMENTS INCORPORATION ACT 1958 (No. 6422)—continued

No.	Price
9008. Bail Act 1977 (First Reprint—Incorporating amendments up to Act No. 9158)	\$0.70
6206. Barley Marketing (First Reprint—Incorporating amendments up to No. 9005)	\$0.30
6208. Benefit Associations (First Reprint—Incorporating amendments up to No. 6961)	\$0.65
8004. Boilers and Pressure Vessels Act 1970—(Second Reprint—Incorporating amendments up to Act No. 9019)	\$0.65
6529. Bread Industry Act 1959 (Second Reprint—Incorporating amendments up to Act No. 8542)	\$0.20
6973. Building Contracts (Deposits) Act 1962 (Second Reprint—Incorporating amendments from No. 8938)	\$0.20
8693. Building Industry Long Service Leave (First Reprint—Incorporating Amendments up to No. 9122)	\$0.85
6213. Cancer Act 1958 (Second Reprint—Incorporating amendments up to No. 9023)	\$1.10
6214. Carriers and Innkeepers (Second Reprint—Incorporating amendments up to No. 8534)	\$0.20
6215. Cattle Breeding (First Reprint—Incorporating amendments up to No. 6886)	\$0.10
6217. Cemeteries Act 1958 (Second Reprint—Incorporating amendments up to Act No. 9052)	\$0.90
8477. Children's Court Act 1973 (First Reprint—Incorporating amendments up to No. 8731)	\$0.95
6220. Clean Air (Third Reprint—Incorporating amendments up to No. 8324)	\$0.15
4597. Closer Settlement Act 1980 (First Reprint—Incorporating amendments up to Act No. 9212)	\$1.20
8661. Cluster Titles Act 1974 (First Reprint—Incorporating amendments up to Act No. 9128)	\$0.85
6221. Coal Mines (Second Reprint—Incorporating amendments up to No. 8953)	\$2.15
6222. Commercial Goods Vehicles (Third Reprint—Incorporating amendments up to No. 8525)	\$0.55
6223. Commonwealth Arrangements (First Reprint—Incorporating amendments from No. 7809)	\$0.10
6839. Companies (Sixth Reprint—Incorporating amendments up to No. 8788)	\$9.60
8750. Constitution Act 1975 (Third Reprint—Incorporating amendments up to Act No. 9251)	\$1.30
6224. Constitution Act Amendment Act 1959 (Second Reprint—Incorporating amendment up to No. 9216)	\$3.00
8276. Consumer Affairs Act 1972 (Third Reprint—Incorporating amendments up to No. 8824)	\$1.15
6225. Co-operation Act 1958 (Fourth Reprint—Incorporating amendments up to Act No. 9136)	\$1.60
6226. Co-operative Housing Societies Act 1958 (Third Reprint—Incorporating amendments up to No. 9206)	\$1.50
6227. Coroners (Second Reprint—Incorporating amendments up to No. 8184)	\$0.35
6228. Country Fire Authority (Third Reprint—Incorporating amendments up to No. 8813)	\$1.25
6229. Country Roads Act 1958 (Fifth Reprint—Incorporating amendments up to No. 9212)	\$2.00
6230. County Court (Fourth Reprint—Incorporating amendments up to No. 9075)	\$0.95
6231. Crimes Act 1958 (Sixth Reprint—Incorporating amendments up to Act No. 9073)	\$3.15
6232. Crown Proceedings (Second Reprint—Incorporating amendments up to No. 8731)	\$0.40
7060. Dandenong Valley Authority Act 1963 (Second Reprint—Incorporating amendments up to Act No. 9172)	\$1.20
8383. Decentralized Industry Incentive Payments (First Reprint—Incorporating Amendments up to No. 8751)	\$0.20
6235. Dietitians Registration (First Reprint—Incorporating amendments up to No. 6886)	\$0.20
4989. Discharged Servicemen's Preference Act 1943 (Second Reprint—Incorporating amendments up to No. 7991)	\$0.20

ACTS REPRINTED IN ACCORDANCE WITH THE AMENDMENTS  
INCORPORATION ACT 1958 (No. 6422)—*continued*

No.	Price
6815. Disposal of Uncollected Goods Act 1961 (Second Reprint—Incorporating amendments up to No. 8246)	\$0.30
8079. Dog Act 1970 (First Reprint—Incorporating amendments up to No. 8664)	\$0.30
6237. Drainage Areas Act 1958 (Second Reprint—Incorporating amendments up to Act No. 8811)	\$0.75
6239. Dried Fruits Act 1968 (First Reprint—Incorporating amendments up to No. 7337)	\$0.25
6240. Education Act 1958 (Third Reprint—Incorporating amendments up to Act No. 9248)	\$1.50
6241. Electric Light and Power. (First Reprint—Incorporating amendments up to No. 7315)	\$0.30
8056. Environment Protection Act 1970 (Third Reprint—Incorporating amendments up to Act No. 9098)	\$0.95
6244. Essential Services (First Reprint—Incorporating amendments up to No. 8353)	\$0.20
6245. Estate Agents—(Fifth Reprint—Incorporating amendments up to No. 8490)	\$0.85
6246. Evidence Act 1958 (Sixth Reprint—Incorporating amendments up to Act No. 9230)	\$1.60
6715. Explosives Act 1960 (First Reprint—Incorporating amendments up to Act No. 8920)	\$0.85
7499. Extractive Industries Act 1966 (Third Reprint—Incorporating amendments up to No. 8647)	\$0.45
7733. Fences Act 1968 (Second Reprint—Incorporating amendments up to Act No. 9019)	\$0.70
6468. Filled Milk (First Reprint—Incorporating amendments up to No. 6886)	\$0.15
6251. Firearms (Fifth Reprint—Incorporating amendments up to No. 8427)	\$1.05
7780. Fisheries Act 1968 (First Reprint—Incorporating amendments up to No. 8694)	\$1.05
6916. Foreign Judgments Act 1962 (First Reprint including amendments made by No. 7332)	\$0.15
6585. Forests (Pulpwood Agreement) (Incorporating amendments up to No. 6886)	\$0.15
6254. Forests (Second Reprint—Incorporating amendments up to No. 8702)	\$1.35
6225. Friendly Societies Act 1958 (Second Reprint—Incorporating amendments up to Act No. 9019)	\$1.60
6255. Friendly Societies (First Reprint—Incorporating amendments up to No. 7554)	\$0.60
6256. Fruit and Vegetables (First Reprint—Incorporating amendments up to No. 6944)	\$0.30
6260. Gas and Fuel Corporation Act 1958 (Second Reprint—Incorporating amendments up to Act No. 9255)	\$2.40
6262. Geelong Harbor Trust Act 1958 (Second Reprint—Incorporating amendments up to Act No. 9019)	\$1.40
6263. Geelong Waterworks and Sewerage (First Reprint—Incorporating amendments up to No. 7547)	\$0.75
8176. Gift Duty Act 1971 (First Reprint—Incorporating amendments from No. 8202)	\$0.55
6265. Goods (Sixth Reprint—Incorporating amendments up to No. 8425)	\$0.75
6266. Grain Elevators (First Reprint—Incorporating amendments up to No. 7486)	\$0.35
7849. Groundwater (Second Reprint—Incorporating amendments up to No. 9019)	\$0.75
6267. Hairdressers Registration (First Reprint—Incorporating amendments up to No. 7659)	\$0.30
6269. Hawkers and Pedlers (Second Reprint—Incorporating amendments up to No. 8247)	\$0.40
6270. Health (Third Reprint—Incorporating amendments up to No. 8506)	\$3.25
6531. Hire Purchase Act 1959 (Second Reprint—Incorporating amendments from No. 8232)	\$0.85
6933. Home Finance Act 1962 (First Reprint—Incorporating amendments up to No. 7363)	\$0.25
6274. Hospitals and Charities (Second Reprint—Incorporating amendments up to No. 7455)	\$0.50
6275. Housing (Third Reprint—Incorporating amendments up to No. 8713)	\$2.40

ACTS REPRINTED IN ACCORDANCE WITH THE AMENDMENTS  
INCORPORATION ACT 1958 (No. 6422)—*continued*

No.	Price
3270. Imperial Acts Application (First Reprint—Incorporating Amendments up to No. 8037)	\$1.30
6276. Imprisonment of Fraudulent Debtors (Second Reprint—Incorporating amendments up to No. 8731)	\$0.55
6277. Industrial and Provident Societies Act 1958 (First Reprint)—Incorporating amendments up to Act No. 7547	\$1.10
6279. Instruments (Fifth Reprint—Incorporating amendments up to No. 8565)	\$0.75
6280. Judicial Proceedings Reports (First Reprint—Incorporating amendments up to No. 7596)	\$0.20
7651. Juries (First Reprint—Incorporating amendments up to No. 8170)	\$0.55
6283. Labour and Industry Act 1958 (Seventh Reprint—Incorporating amendments up to Act No. 9163)	\$1.90
6284. Land Act (Fourth Reprint—Incorporating amendments up to No. 9212)	\$4.40
6534. Land Settlement Act 1959 (First Reprint—Incorporating amendments up to No. 7328)	\$0.30
6288. Land Surveyors (First Reprint—Incorporating amendments up to No. 7065)	\$0.30
6289. Land Tax Act 1958 (Third Reprint—Incorporating amendments up to Act No. 9190)	\$1.40
6285. Landlord and Tenant (Fourth Reprint—Incorporating amendments up to No. 8208)	\$1.90
6286. Lands Compensation Act (Third Reprint—Incorporating amendments up to No. 8899)	\$0.45
6290. Latrobe Valley (First Reprint—Incorporating amendments up to No. 7332)	\$0.35
7919. Legal Aid—(First Reprint—Incorporating amendments up to No. 8427)	\$0.30
6291. Legal Profession Practice Act (Fourth Reprint—Incorporating amendments up to No. 8778)	\$1.45
6292. Libraries (First Reprint—Incorporating amendments up to No. 7364)	\$0.15
7629. Lifts and Cranes Act 1967 (Second Reprint—Incorporating amendments up to Act No. 9236)	\$0.90
6295. Limitation of Actions (Third Reprint—Incorporating amendments up to No. 8300)	\$0.55
7695. Liquor Control Act 1968 (Third Reprint—Incorporating amendments up to No. 8598)	\$1.70
7145. Litter Act 1964 (Second Reprint—Incorporating amendments up to No. 8702)	\$0.20
6298. Local Authorities Superannuation (Second Reprint—Incorporating amendments up to No. 7161)	\$0.40
6479. Local Government Department Act 1958 (First Reprint—Incorporating amendments up to Act No. 8656)	\$0.10
6299. Local Government (Third Reprint—Incorporating amendments up to No. 8781)	\$10.90
7429. Lotteries Gaming and Betting Act 1966 (Second Reprint—Incorporating amendments up to No. 9075)	\$1.20
8184. Magistrates' Courts (First Reprint—Incorporating amendments up to No. 8718)	\$0.75
7289. Maintenance (Second Reprint—Incorporating amendments up to No. 9019)	\$1.35
6302. Marine Act (Second Reprint—Incorporating amendments up to No. 9178)	\$2.40
6303. Marine Stores and Old Metals Act 1958 (Second Reprint—Incorporating amendments up to Act No. 8622)	\$0.65
6304. Marketing of Primary Products (First Reprint—Incorporating amendments up to No. 7491)	\$0.45
6305. Markets Act (Second Reprint—Incorporating amendments up to No. 8247)	\$0.30
6306. Marriage (Second Reprint—Incorporating amendments up to No. 8602)	\$0.45
6309. Medical Act 1958 (Third Reprint—Incorporating amendments up to No. 8593)	\$0.45
8061. Medical Practitioner (First Reprint—Incorporating amendments up to No. 8754)	\$0.75
6310. Melbourne and Metropolitan Board of Works (Fourth Reprint—Incorporating amendments up to No. 8650)	\$1.95

ACTS REPRINTED IN ACCORDANCE WITH THE AMENDMENTS  
INCORPORATION ACT 1958 (No. 6422)—*continued*

No.	Price
6311. Melbourne and Metropolitan Tramways Act 1958 ( <i>Second Reprint</i> —Incorporating amendments up to Act No. 8992) ..	\$1.45
6312. Melbourne Harbor Trust ( <i>Second Reprint</i> —Incorporating amendments up to No. 8796)	\$1.35
6405. Melbourne University Act 1958 ( <i>Second Reprint</i> —Incorporating amendments up to Act No. 9123) ..	\$0.85
6605. Mental Health ( <i>Second Reprint</i> —Incorporating amendments up to No. 8679) ..	\$0.75
6315. Metropolitan Fire Brigades ( <i>Third Reprint</i> —Incorporating amendments up to No. 9019)	\$0.95
6316. Mildura Irrigation and Water Trusts Act 1958 ( <i>Second Reprint</i> —Incorporating amendments up to No. 9204) ..	\$2.60
6317. Milk and Dairy Supervision ( <i>Second Reprint</i> —Incorporating amendments up to No. 8655) ..	\$0.85
6318. Milk Board Act 1958 ( <i>Second Reprint</i> —Incorporating amendments up to Act No. 9238)	\$1.00
6319. Milk Pasteurization ( <i>First Reprint</i> —Incorporating amendments up to No. 7480)	\$0.20
6320. Mines Act 1958 ( <i>Third Reprint</i> —Incorporating amendments up to Act No. 8953) ..	\$2.60
6184. Monash University ( <i>First Reprint</i> —Incorporating amendments up to No. 7533) ..	\$0.30
6324. Money Lenders ( <i>Fourth Reprint</i> —Incorporating amendments up to No. 8490) ..	\$0.55
8429. Motor Accidents Act 1973 ( <i>First Reprint</i> —Incorporating amendment up to No. 8669)	\$1.15
6832. Motor Boating Act 1961 ( <i>Third Reprint</i> —Incorporating amendment up to No. 8662)	\$0.55
6325. Motor Car Act 1958 ( <i>Fifth Reprint</i> —Incorporating amendments up to No. 8657) ..	\$2.25
6705. Navigable Waters (Oil Pollution) Act 1960 ( <i>Second Reprint</i> —Incorporating amendments up to No. 8816) ..	\$0.65
6328. Nurses Act 1958 ( <i>Fourth Reprint</i> —Incorporating amendments up to Act No. 9059) ..	\$1.00
8414. Ombudsman Act 1973 ( <i>Second Reprint</i> —Incorporating amendments up to Act No. 9256) ..	\$0.60
6329. Optometrists Registration Act 1958 ( <i>Second Reprint</i> —Incorporating amendments up to Act No. 8800) ..	\$0.70
7723. Parliamentary Salaries and Superannuation ( <i>First Reprint</i> —Incorporating amendments up to No. 8687) ..	\$0.35
6330. Partnership ( <i>Second Reprint</i> —Incorporating amendments up to No. 7315) ..	\$0.45
6331. Patriotic Funds ( <i>First Reprint</i> —Incorporating amendments up to No. 7338) ..	\$0.25
6332. Pawnbrokers Act 1958 ( <i>Second Reprint</i> —Incorporating amendments up to No. 8181)	\$0.35
8154. Pay-Roll Tax Act 1971 ( <i>First Reprint</i> —Incorporating amendments up to No. 9059)	\$1.15
7417. Pensions Supplementation ( <i>First Reprint</i> —Incorporating amendments up to No. 8475) ..	\$0.20
6257. Pesticides Act 1958 ( <i>Second Reprint</i> —Incorporating amendments up to No. 8589)	\$0.35
6334. Petroleum Act 1958 ( <i>Second Reprint</i> —Incorporating amendments up to Act No. 9212) ..	\$1.30
6335. Petrol Pumps ( <i>Second Reprint</i> —Incorporating amendments up to No. 7315) ..	\$0.15
6889. Poisons Act 1962 ( <i>Fourth Reprint</i> —Incorporating amendments up to No. 8456) ..	\$0.95
6337. Police Offences Act 1958 ( <i>Third Reprint</i> —Incorporating amendments up to No. 8433) ..	\$0.45
6338. Police Regulation ( <i>Third Reprint</i> —Incorporating amendments up to No. 8722) ..	\$0.95
6340. Portland Harbor Trust Act 1958 ( <i>Second Reprint</i> —Incorporating amendments up to Act No. 9204) ..	\$1.10
7498. Port Phillip Authority Act 1966 ( <i>Second Reprint</i> —Incorporating amendments from No. 8081) ..	\$0.20
6341. Pounds Act 1958 ( <i>Second Reprint</i> —Incorporating amendments up to Act No. 9168)	\$0.60

ACTS REPRINTED IN ACCORDANCE WITH THE AMENDMENTS  
INCORPORATION ACT 1958 (No. 6422)—*continued*

No.	Price
6342. Printers and Newspapers ( <i>Second Reprint</i> —Incorporating amendments up to No. 8556)	\$0.30
7494. Private Agents Act 1966 ( <i>Third Reprint</i> —Incorporating amendments up to Act No. 9075) ..	\$1.00
6890. Probate Duty Act 1962. ( <i>Fourth Reprint</i> )—Incorporating amendments up to Act No. 9019 ..	\$1.15
6344. Property Law Act 1958 ( <i>Fourth Reprint</i> —Incorporating amendments up to Act No. 9075) ..	\$3.00
7432. Protection of Animals ( <i>First Reprint</i> —Incorporating Amendments Up to No. 9019) ..	\$0.40
6345. Public Account ( <i>Second Reprint</i> —Incorporating amendments up to No. 9033)	\$0.40
6346. Public Authorities Marks ( <i>First Reprint</i> —Incorporating amendments from No. 7315)	\$0.10
8656. Public Service Act 1974 ( <i>Second Reprint</i> —Incorporating amendments up to Act No. 9248) ..	\$1.40
6350. Public Trustee Act 1958 ( <i>Second Reprint</i> —Incorporating amendments up to No. 8125) ..	\$1.05
6353. Racing ( <i>Fourth Reprint</i> —Incorporating amendments up to No. 8690) ..	\$1.55
6355. Railways Act 1958 ( <i>Second Reprint</i> —Incorporating amendments up to Act No. 9142)	\$1.55
6564. Registration of Births Deaths and Marriages Act 1959 ( <i>Second Reprint</i> —Incorporating amendments up to Act No. 8602) ..	\$0.70
6357. Religious Successory and Charitable Trusts Act 1958 ( <i>First Reprint</i> —Incorporating amendments made by Act No. 7315) ..	\$0.75
6358. River Improvements Act ( <i>Second Reprint</i> —Incorporating amendments up to No. 8967) ..	\$0.85
2596. River Murray Waters Act 1915 ( <i>First Reprint</i> —Incorporating amendments up to No. 7228) ..	\$0.35
6359. Road Traffic ( <i>Fourth Reprint</i> —Incorporating amendments up to No. 8353) ..	\$0.35
6360. Rural Finance ( <i>First Reprint</i> —Incorporating amendments up to No. 7328) ..	\$0.15
6846. Rural Finance and Settlement Commission Act 1961 ( <i>First Reprint</i> —Incorporating amendments up to No. 7332) ..	\$0.30
6917. Sale of Human Blood Act 1962 ( <i>First Reprint</i> —Incorporating amendments from No. 7332) ..	\$0.10
6975. Sale of Land Act 1962 ( <i>Third Reprint</i> —Incorporating amendments up to No. 8861) ..	\$0.55
8146. Scaffolding Act 1971 ( <i>Second Reprint</i> —Incorporating amendments up to No. 8666)	\$0.35
6363. Second-hand Dealers ( <i>First Reprint</i> —Incorporating amendments up to No. 7529) ..	\$0.25
6367. Settled Land Act 1958 ( <i>Third Reprint</i> —Incorporating amendments up to Act No. 9075) ..	\$1.50
6368. Sewerage Districts Act 1958 ( <i>Third Reprint</i> —Incorporating amendments up to Act No. 9139) ..	\$1.90
6809. Sheep Owners Protection Act 1961 ( <i>Third Reprint</i> —Incorporating amendments up to No. 8247) ..	\$0.20
8089. Social Welfare Act 1970 ( <i>First Reprint</i> —Incorporating amendments up to No. 8821)	\$1.90
6372. Soil Conservation and Land Utilization Act ( <i>Third Reprint</i> —Incorporating amendments up to No. 8432) ..	\$0.45
6373. Soldier Settlement ( <i>First Reprint</i> —Incorporating amendments up to No. 7328) ..	\$0.42
6375. Stamps Act 1958 ( <i>Sixth Reprint</i> —Incorporating amendments up to No. 8624) ..	\$2.15
6376. State Development Committee Act 1958 ( <i>First Reprint</i> —Incorporating amendments up to No. 8827) ..	\$0.30
6377. State Electricity Commission Act 1958 ( <i>Third Reprint</i> —Incorporating amendments up to Act No. 9121) ..	\$1.35
6378. State Relief Committee ( <i>First Reprint</i> —Incorporating amendments from No. 6886)	\$0.10

ACTS REPRINTED IN ACCORDANCE WITH THE AMENDMENTS INCORPORATING ACT 1958 (No. 6422)—*continued*

No.	Price
6379. State Savings Bank Act 1958 ( <i>Third Reprint</i> —Incorporating amendments up to No. 8519) ..	\$0.95
6380. Statistics ( <i>First Reprint</i> —Incorporating amendments up to No. 6961) ..	\$0.20
6877. Stock (Artificial Breeding) Act 1962 ( <i>First Reprint</i> —Incorporating amendments up to No. 8709) ..	\$0.30
6383. Stock Foods ( <i>First Reprint</i> —Incorporating amendments up to No. 7607) ..	\$0.28
6384. Stock Medicines Act 1958 ( <i>Second Reprint</i> —Incorporating amendments up to No. 9005) ..	\$0.50
7551. Strata Titles Act 1967 ( <i>Third Reprint</i> —Incorporating amendments up to No. 8661) ..	\$1.00
6886. Subordinate Legislation Act 1962 ( <i>Second Reprint</i> —Incorporating amendments up to No. 8127) ..	\$0.15
7405. Summary Offences Act 1966 ( <i>Second Reprint</i> —Incorporating amendments up to No. 8276) ..	\$0.55
7634. Sunday Entertainment ( <i>First Reprint</i> —Incorporating amendments up to No. 8173) ..	\$0.15
6386. Superannuation Act 1958 ( <i>Fourth Reprint</i> —Incorporating amendments up to No. 9125) ..	\$1.70
6387. Supreme Court ( <i>Second Reprint</i> —Incorporating amendments up to No. 8951) ..	\$1.35
6388. Survey Co-ordination ( <i>First Reprint</i> —Incorporating amendments up to No. 8107) ..	\$0.35
6390. Tattersall Consultations ( <i>Second Reprint</i> —Incorporating amendments up to No. 8982) ..	\$0.30
8274. Taxation Appeals Act 1972 ( <i>First Reprint</i> —Incorporating amendments up to Act No. 9045) ..	\$0.55
6391. Teaching Service ( <i>Second Reprint</i> —Incorporating amendments up to No. 8691) ..	\$0.55
6393. Theatres ( <i>First Reprint</i> —Incorporating amendments up to No. 8161) ..	\$0.15
6849. Town and Country Planning Act 1961 ( <i>Fifth Reprint</i> —Incorporating amendments up to No. 8716) ..	\$1.25
6397. Trade Unions ( <i>Second Reprint</i> —Incorporating amendments up to No. 8181) ..	\$0.20
6399. Transfer of Land ( <i>Fifth Reprint</i> —Incorporating amendments up to No. 8531) ..	\$1.15
6400. Transport Regulation Act ( <i>Third Reprint</i> —Incorporating amendments up to No. 8700) ..	\$0.75
6401. Trustee Act 1958 ( <i>Fourth Reprint</i> —Incorporating amendments up to Act No. 9075) ..	\$1.15
6402. Trustee Companies Act 1958 ( <i>Second Reprint</i> —Incorporating amendments up to Act No. 9075) ..	\$0.55
6879. Unclaimed Moneys Act 1962 ( <i>Second Reprint</i> —Incorporating amendments up to No. 8448) ..	\$0.20
7095. Underseas Mineral Resources Act 1963 ( <i>First Reprint</i> —Incorporating amendments from No. 7591) ..	\$0.10
6653. Valuation of Land Act 1960 ( <i>Fifth Reprint</i> —Incorporating amendments up to Act No. 9225) ..	\$1.10
6407. Vegetation and Vine Diseases ( <i>First Reprint</i> —Incorporating amendments up to No. 7423) ..	\$0.30
6408. Venereal Diseases ( <i>First Reprint</i> —Incorporating amendments made by Act No. 6886) ..	\$0.55
6409. Vermin & Noxious Weeds ( <i>First Reprint</i> —Incorporating amendments up to No. 7463) ..	\$0.35
6410. Veterinary Surgeons ( <i>First Reprint</i> —Incorporating amendments up to No. 7343) ..	\$0.15
7291. Victoria Institute of Colleges Act 1965 ( <i>Second Reprint</i> —Incorporating amendments up to No. 8710) ..	\$0.65
8428. Victorian Development Corporation Act 1973 ( <i>First Reprint</i> —Incorporating amendments up to Act No. 9314) ..	\$1.00
6412. Warehousemen's Liens ( <i>First Reprint</i> —Incorporating amendments up to No. 7876) ..	\$0.15

ACTS REPRINTED IN ACCORDANCE WITH THE AMENDMENTS INCORPORATION ACT 1958 (No. 6422)—*continued*

No.	Price
6413. Water ( <i>Third Reprint</i> —Incorporating amendments up to No. 8729) ..	\$3.45
6414. Weights and Measures Act 1958 ( <i>Fourth Reprint</i> —Incorporating amendments up to Act No. 9019) ..	\$1.90
6415. Wild Flowers and Native Plants Protection ( <i>First Reprint</i> —Incorporating amendments up to No. 6976) ..	\$0.15
6416. Wills Act 1958 ( <i>Second Reprint</i> —Incorporating amendments up to Act No. 9075) ..	\$0.60
6417. Wire Netting ( <i>Second Reprint</i> —Incorporating amendments up to No. 7876) ..	\$0.65
6419. Workers Compensation Act ( <i>Seventh Reprint</i> —Incorporating amendments up to No. 8804) ..	\$1.45
6420. Wrongs Act 1958. ( <i>Third Reprint</i> —Incorporating amendments up to Act No. 9153) ..	\$0.60
8344. Youth, Sport and Recreation Act 1972 ( <i>First Reprint</i> —Incorporating amendments up to No. 8550) ..	\$0.35

F. D. ATKINSON  
Government Printer

**CONTENTS**

	Page
Acts of Parliament on Sale at the Government Printing Office	1828
Appointments	1784
Contracts	1779
Estates of Deceased Persons	1784
Government Notices	1765
Insolvency Notices	1827
Lands	1798
Melbourne and Metropolitan Board of Works—Notice	1778
Minerals and Energy	1781
Notice of Making of Statutory Rules	1827
Orders in Council—	
Acts—Local Government; State Electricity Commission; Country Fire Authority; et seq Country Roads; Crown Land (Reserves); Land; Hospitals and Charities; Railway Construction and Property Board; Victorian Institute of Marine Sciences; Superannuation; Sewerage Districts; Latrobe Valley; Sewerage Districts.	1786
Private Advertisements	1802
Proclamations	1761
Public Holiday—Queen's Birthday	1765
Regulations—	
Acts—Police Regulation	1772
Teaching Service	1800
Resignations	1785
State Rivers and Water Supply Commission	1782
Tenders	1800
Transport Regulation Board—Public Hearings	1766
Waterworks Trusts	1782