



Victoria Government Gazette

No. 68—Wednesday, 13 August 1980

PROCLAMATIONS

Land Act 1958
ROAD PROCLAIMED

PROCLAMATION

By His Excellency the Governor of the State of Victoria and its Dependencies in the Commonwealth of Australia, &c., &c., &c.

I, the Governor of the State of Victoria, in the Commonwealth of Australia, by and with the advice of the Executive Council of the said State, pursuant to the provisions of section 25 (3) (c) of the *Land Act 1958*, do hereby proclaim as road the Crown land hereinafter described, viz.: Township of Marlo, being the land indicated by hatching on plan hereunder—(M.538⁽⁶⁾) (L.9-1088).

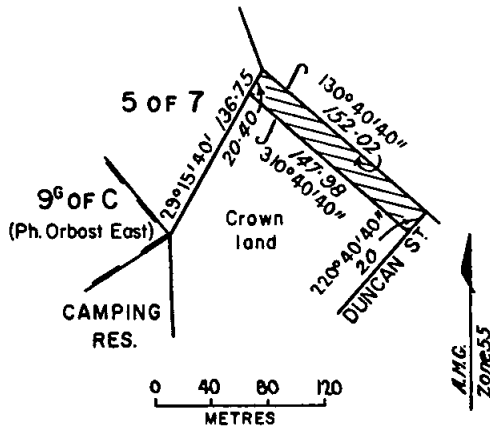

Given under my Hand and the Seal of the State of Victoria aforesaid, at Melbourne, this fifth day of August, in the year of Our Lord One thousand nine hundred and eighty and in the twenty-ninth year of the reign of Her Majesty Elizabeth the Second, Queen of Australia.

(L.S.) HENRY WINNEKE

By His Excellency's Command
W. V. HOUGHTON
Minister of Lands

GOD SAVE THE QUEEN !

Land Act 1958
UNALIENATED CROWN LAND MADE AVAILABLE FOR SETTLEMENT UNDER IMPROVEMENT PURCHASE LEASES

PROCLAMATION

By His Excellency the Governor of the State of Victoria and its Dependencies in the Commonwealth of Australia, &c., &c., &c.

I, the Governor of the State of Victoria, in the Commonwealth of Australia, by and with the advice of the Executive Council of the said State, pursuant to the provisions of Section 153 of the *Land Act 1958*, do hereby proclaim the Crown lands hereinafter described to be available for settlement under improvement purchase leases at the purchase prices respectively mentioned, viz.:

Allotment No.	Parish	Area	Purchase Price	
			ha	\$
20b	Baring	37.02	1 373.00	(L5-2100)
22	Baring	425.7	6 312.00	(L5-2101)
2b	Carwarp	14.1	175.00	(L5-2021)
49	Nulkwyne	2 180	13 537.50	(L5-2044)
5A	Walpamunda			
15A	Tyenna	20.34	625.00	(L5-2117)
2, 3, 50	Wagant	1 006	18 108.00	(L5-437)
39A	Wargan	18	308.00	(L5-2013)

Given under my Hand and the Seal of the State of Victoria aforesaid, at Melbourne, this fifth day of August, in the year of our Lord One thousand nine hundred and eighty, and in the twenty-ninth year of the reign of Her Majesty Elizabeth the Second, Queen of Australia.

(L.S.) HENRY WINNEKE

By His Excellency's Command
W. V. HOUGHTON
Minister of Lands

GOD SAVE THE QUEEN !

Land Act 1958
LAND DECLARED UNDER SECTION 22c OF THE LAND ACT 1958

PROCLAMATION

By His Excellency the Governor of the State of Victoria and its Dependencies in the Commonwealth of Australia, &c., &c., &c.

I, the Governor of the State of Victoria, in the Commonwealth of Australia, by and with the advice of the Executive Council of the said State, pursuant to the provisions of section 22c (2) of the *Land Act 1958*, and upon receipt of certification by the clerk of the municipality concerned (Shire of Rosedale) that the subject land constitutes land which is or has been used for sporting and recreation purposes, do by this Proclamation declare to be land to which section 22c of the said Act applies all that piece of land

being allotment 39c, section B, Parish of Wurruk Wurruk, and being the land described in Crown Grant Volume 6658 Folio 591—(L.10-1218).

Given under my Hand and the Seal of the State of Victoria aforesaid, at Melbourne, this fifth day of August, in the year of Our Lord One thousand nine hundred and eighty and in the twenty-ninth year of the reign of Her Majesty Elizabeth the Second, Queen of Australia.

(L.S.) HENRY WINNEKE

By His Excellency's Command

W. V. HOUGHTON
Minister of Lands

GOD SAVE THE QUEEN!

MARINE (AMENDMENT) ACT 1979 (No. 9342)

DATE OF COMING INTO OPERATION

PROCLAMATION

By His Excellency the Governor of the State of Victoria and its Dependencies in the Commonwealth of Australia, &c., &c., &c.

Whereas by an Act of Parliament of the State of Victoria passed in the twenty-eighth year of the reign of Her Majesty Queen Elizabeth the Second, Queen of Australia, entitled the *Marine (Amendment) Act 1979*, No. 9342, it is amongst other things enacted that the several provisions of the said Act shall come into operation on a day or the respective days to be fixed by proclamation or successive proclamations by the Governor in Council published in the *Government Gazette*.

Now therefore I, the Governor of the State of Victoria in the Commonwealth of Australia, by and with the advice of the Executive Council of the said State, do by this my proclamation fix Tuesday 12 August 1980 as the day on which: Sections 3, 7 to 14 inclusive, 20, 21, 25, 27, 29, 30 and 35 of the said *Marine (Amendment) Act 1979*, No. 9342 shall come into operation.

Given under my Hand and the Seal of the State of Victoria aforesaid, at Melbourne, this twelfth day of August in the year of our Lord One thousand nine hundred and eighty and in the twenty-ninth year of the reign of Her Majesty Queen Elizabeth II.

(L.S.) HENRY WINNEKE

By His Excellency's Command

TOM AUSTIN
Minister of Public Works

GOD SAVE THE QUEEN!

Litter Act 1964

APPLICATION OF THE PROVISIONS OF SECTION 3B TO THE MUNICIPAL DISTRICT OF THE BOROUGH OF WONTHAGGI

PROCLAMATION

By His Excellency the Governor of the State of Victoria and its Dependencies in the Commonwealth of Australia, &c., &c., &c.

Whereas by the *Litter Act 1964*, section 3B it is provided that the Governor in Council on the application of the council of a municipality may by proclamation published in the *Government Gazette* declare that the municipal district of the municipality or any part thereof shall be a district to which the said section applies.

And whereas the Council of the Borough of Wonthaggi has made application to have its municipal district declared to be a district to which the said section 3B applies.

Now therefore, I, the Governor of the State of Victoria, in the Commonwealth of Australia, by and with the advice of the Executive Council of the said State do by this Proclamation declare that the municipal district of the Borough of Wonthaggi shall be a district to which the provisions of section 3B of the *Litter Act 1964* apply.

Given under my Hand and the Seal of the State of Victoria aforesaid, at Melbourne, this fifth day of August, in the year of Our Lord One thousand nine hundred and eighty and in the twenty-ninth year of the reign of Her Majesty Queen Elizabeth II.

(L.S.) HENRY WINNEKE

By His Excellency's Command

A. J. HUNT
Acting Minister for Local Government

GOD SAVE THE QUEEN!

PUBLIC HOLIDAYS

PROCLAMATION

By His Excellency the Governor of the State of Victoria and its Dependencies in the Commonwealth of Australia, &c., &c., &c.

In pursuance of the provisions contained in Section 71 (2) of the *Public Service Act 1974*, I, the Governor of the State of Victoria, in the Commonwealth of Australia, by and with the advice of the Executive Council of the said State, do by this my Proclamation appoint the days and dates hereunder mentioned to be observed as Public Holidays or Public Half-Holidays (as the case may be) at the places respectively specified, viz:—

Public Holidays:—

TUESDAY, 21 OCTOBER 1980, throughout the Shire of Karkaroc.

SATURDAY, 4 OCTOBER 1980, throughout the Shire of Nathalia.

Public Half-Holidays from the Hour of Twelve o'clock noon:—

THURSDAY, 2 OCTOBER 1980, throughout the City of Horsham.

MONDAY, 13 OCTOBER 1980, throughout the Shire of Birchip.

FRIDAY, 24 OCTOBER 1980, throughout the Borough of Eaglehawk.

TUESDAY, 7 OCTOBER 1980, throughout the Borough of Kerang.

TUESDAY, 4 NOVEMBER 1980, throughout the Township of Wedderburn within the Shire of Korong.

Given under my Hand and the Seal of the State of Victoria aforesaid, at Melbourne, this fifth day of August, in the year of our Lord One thousand nine hundred and eighty, and in the twenty-ninth year of the reign of Her Majesty Queen Elizabeth the Second, Queen of Australia.

(L.S.) HENRY WINNEKE

By His Excellency's Command

R. J. HAMER
Premier

GOD SAVE THE QUEEN!

BANK HOLIDAYS

PROCLAMATION

By His Excellency the Governor of the State of Victoria and its Dependencies in the Commonwealth of Australia, &c., &c., &c.

In pursuance of the provisions of the *Bank Holidays Act 1958*, I, the Governor of the State of Victoria, in the Commonwealth of Australia, do by this my Proclamation

appoint the days and dates named hereunder special days to be observed as Bank Holidays at the places respectively mentioned, that is to say:—

Bank Holidays:—

TUESDAY, 21 OCTOBER 1980, at Hopetoun and Woomelang, within the Shire of Karkaroc.

WEDNESDAY, 24 SEPTEMBER 1980, at Healesville and Yarra Glen, within the Shire of Healesville.

TUESDAY, 4 NOVEMBER 1980, at Cowes, within the Shire of Phillip Island.

Given under my Hand and the Seal of the State of Victoria aforesaid, at Melbourne, this fifth day of August, in the year of our Lord One thousand nine hundred and eighty, and in the twenty-ninth year of the reign of Her Majesty Elizabeth the Second, Queen of Australia.

(L.S.) HENRY WINNEKE

By His Excellency's Command

R. J. HAMER
Premier

GOD SAVE THE QUEEN!

GOVERNMENT NOTICES

SHIRE OF NARRACAN
ROAD DEVIATION

Pursuant to the provisions of sections 522 and 526 of the *Local Government Act 1958* the Council of the Shire of Narracan hereby directs that the land in the Parish of Tanjil East indicated by hatching on the diagram hereunder which has been purchased taken or acquired by it, shall be a Public Highway on and from the date of publication of this Order in the *Government Gazette* and declares that such land shall be a Public Highway in lieu of the land indicated by cross-hatching on the said diagram.

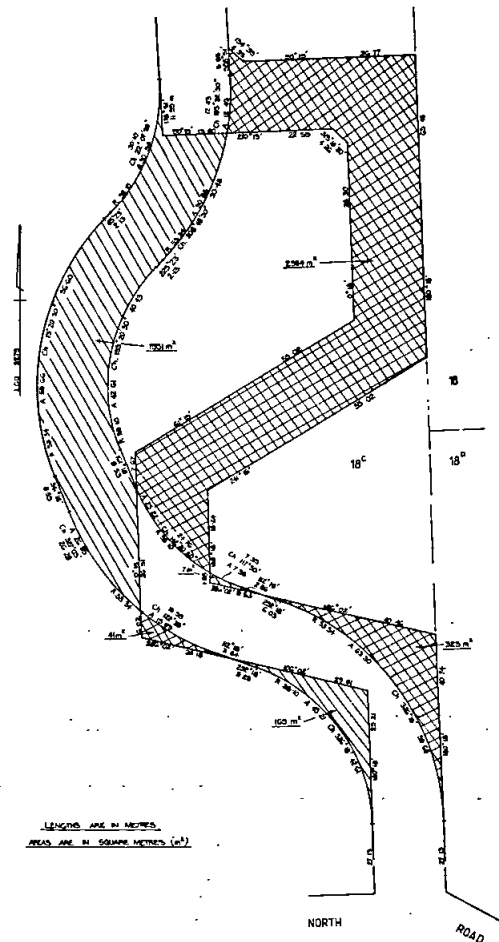

PUBLIC HIGHWAY—SHIRE OF RODNEY

PROCLAMATION

By His Excellency the Governor of the State of Victoria and its Dependencies in the Commonwealth of Australia, &c., &c., &c.

Whereas by the *Local Government Act 1958*, section 519 it is amongst other things enacted that it shall be lawful for the Governor in Council at any time and from time to time upon the request of the council of any municipality by notice in the *Government Gazette* to proclaim any land reserved used or by purchase or exchange acquired for a street, road, highway, thoroughfare, bridge, square, court, alley, or right-of-way or any street, road, lane or passage made or laid out or proposed to be made or laid out on any land of which a plan of subdivision delineating that street, road, lane or passage has been sealed with the seal of the municipality under subdivision (3) of Division 9 of Part XIX of the *Local Government Act 1958* or a corresponding previous enactment to be a public highway and that land shall thereupon and thenceforth from the date of such proclamation become and be absolutely dedicated to the public as a public highway within the meaning of any law then or thereafter in force.

And whereas the Council of the Shire of Rodney has requested that the land hereinafter mentioned being a street, road, lane or passage made or laid out on land of which a plan of subdivision delineating the street, road, lane or passage has been sealed with the seal of the municipality under subdivision (3) of Division 9 of Part XIX of the *Local Government Act 1958*, or a corresponding previous enactment be so declared to be a public highway.

Now therefore, I, the Governor of the State of Victoria, in the Commonwealth of Australia by and with the advice of the Executive Council of the said State, do by this proclamation declare that Larsen Street coloured brown on Plan of Subdivision No. 69713 lodged in the Office of Titles shall be a public highway within the meaning of the said Act.

Given under my Hand and the Seal of the State of Victoria aforesaid, at Melbourne, this fifth day of August, in the year of Our Lord One thousand nine hundred and eighty and in the twenty-ninth year of the reign of Her Majesty Queen Elizabeth II.

(L.S.) HENRY WINNEKE

By His Excellency's Command

D. G. CROZIER
Minister for Local Government

GOD SAVE THE QUEEN!

Dated 14 July 1980

The common seal of the President, Councillors and Ratepayers of the Shire of Narracan was hereunto affixed, in the presence of—

(SEAL) E. J. KEATING, President
R. S. BAYLEY, Councillor
D. J. STEVENS, Acting Secretary

Confirmed by the Governor in Council, 5 August 1980—
TOM FORRISTAL, Clerk of the Executive Council

Liquor Control Act 1968
Liquor Control (Orderly Marketing) Act 1976
DETERMINATION OF LIQUOR CONTROL COMMISSION
 No. 2 of 1980

The Liquor Control Commission, pursuant to powers conferred upon it by Section 11A *Liquor Control Act 1968* as amended, hereby determines the prices below which licensed persons may not sell and dispose of packaged beer to unlicensed persons in the State of Victoria.

By this determination, the Liquor Control Commission determines different prices for different types and sizes of packaged beer and different prices at which packaged beer may be sold in different parts of Victoria as set out in the table hereunder. The different parts of Victoria in respect of which different prices are hereby determined are referred to as "METROPOLITAN AREA", "COUNTRY AREAS" Groups 1, 2, 3, 4 and 5 and "SPECIAL AREA GROUP 1", respectively, in the said table. Except where otherwise defined the areas referred to in the said table are defined by reference to municipal districts or subdivisions within the meaning of the *Local Government Act 1958* as amended.

"METROPOLITAN AREA" means the municipal districts of Altona, Box Hill, Brighton, Broadmeadows, Brunswick, Bulla, Camberwell, Caulfield, Chelsea, Coburg, Collingwood, Croydon, Dandenong, Diamond Valley, Doncaster and Templestowe, Eltham, Essendon, Fitzroy, Footscray, Hawthorn, Heidelberg, Keilor, Kew, Knox, Malvern, Melbourne, Melton, Moorabbin, Mordialloc, Northcote, Nunawading, Oakleigh, Port Melbourne, Prahran, Preston, Richmond, Ringwood, Ringwood, Sandringham, South Melbourne, Springvale, St. Kilda, Sunshine, Waverley, Whittlesea, Williamstown, the subdivision of the municipal district of Werribee known as the East Riding and that portion of the municipal district of Lilydale within the area bounded as follows:

Commencing at the intersection of Colchester Road and the Dandenong Creek; thence south-easterly, southerly and easterly by the Dandenong Creek to Liverpool Road; thence northerly by Liverpool Road to Mount Dandenong Road; thence south-easterly by Mount Dandenong Road to Durham Road; thence north-easterly and easterly by Durham Road to Cambridge Road; thence north-westerly by Cambridge Road to Holmes Road; thence northerly by Holmes Road and Dryden Concourse to Cardigan Road; thence westerly and north-westerly by Cardigan Road to Hull Road; thence north-easterly by Hull Road to Ellen Road; thence north-westerly by Ellen Road to the railway line; thence south-westerly by the railway line to Manchester Road; thence northerly by Manchester Road to Diane Crescent; thence westerly by Diane Crescent to the Brushy Creek; thence southerly by the Brushy Creek to Sherlock Road; thence westerly by Sherlock Road to Newman Road; thence southerly by Newman Road to Lincoln Road; thence easterly by Lincoln Road and Cambridge Road to Hawthory Road; thence southerly by Hawthory Road to Mount Dandenong Road; thence westerly by Mount Dandenong Road to Colchester Road and thence southerly by Colchester Road to the point of commencement.

Insofar as the abovementioned description relates to the municipal district of Lilydale and where the boundaries described run along a road, street, concourse, crescent, creek or railway line, the centre of such road, street, concourse, crescent, creek or railway line shall be taken to be the boundary line.

"COUNTRY AREA GROUP ONE" means the municipal districts of Bacchus Marsh, Bannockburn, Berwick, Broadford, Corio, Cranbourne, Frankston, Geelong, Geelong West, Gisborne, Kilmore, Lilydale, save and except that portion thereof which is earlier described as situate in the Metropolitan Area, Mornington, Newham and Woodend, Newtown, Pakenham, Romsey, Sherbrooke, Upper Yarra and Werribee, save and except the subdivision of the municipal district of Werribee known as the East Riding.

"COUNTRY AREA GROUP TWO" means the municipal districts of Ballan, Ballarat City, Bendigo, Barrabool, Bass, Bellarine, Buln Buln, Castlemaine, Colac, Colac City, Daylesford and Glenlyon, Eaglehawk Borough, Euroa, Flinders, Goulburn, Hastings, Healesville, Korumburra, Kyneton, McIvor, Maldon, Maryborough City, Metcalfe, Moe, Morwell, Narracan, Newstead, Phillip Island, Pyalong, Queenscliffe Borough, Ripon, Seymour, South Barwon, Strathfieldsaye, Talbot and Clunes, Traralgon, Traralgon City, Tullaroop, Violet Town, Warragul, Wonthaggi Borough, Winchelsea, Yallourn and Yea.

"COUNTRY AREA GROUP THREE" means the municipal districts of Alberton, Alexandra, Ararat, Ararat City, Avon, Bairnsdale, Bairnsdale Town, Ballarat, Beechworth, Belfast, Benalla, Benalla City, Bet Bet, Bright, Bungaree, Buninyong, Camperdown Town, Charlton, Chiltern, Cobram, Cohuna, Creswick, Deakin, Donald, Dunmunkle, East Loddon, Echuca City, Gordon, Grenville, Hamilton City, Hampden, Heytesbury, Horsham City, Huntly, Kara Kara, Kerang, Kerang Borough, Koroi Borough, Korong, Kyabram Town, Leigh, Lexton, Maffra, Marong, Minhamite, Mirboo, Mortlake, Mt. Rouse, Myrtleford, Nathalia, Numurkah, Otway, Oxley, Port Fairy Borough, Rochester, Rodney, Rosedale, Rutherglen, St. Arnaud Town, Sale City, Sebastopol Borough, Shepparton, Shepparton City, South Gippsland, Stawell, Stawell Town, Tungamah, Wangaratta, Wangaratta City, Waranga, Warrnambool, Warrnambool City, Wimmera, Wodonga, Woorayl, Yarrowonga, and that part of the municipal district of Arapiles which is within the Parish of Bungally.

"COUNTRY AREA GROUP FOUR" means the municipal district of Arapiles except that part of the said municipal district which is within the Parish of Bungally, the municipal districts of Avoca, Birchip, Dimboola, Dundas, Glenelg, Kaniva, Karkaroc, Lowan, Mansfield, Portland, Town of Portland, Swan Hill, Swan Hill City, Tambo, Wannon, Warracknabeal, Wycheproof and Yackandandah.

"COUNTRY AREA GROUP FIVE" means the municipal districts of Kowree, Omeo, Orbost, Tallangatta, Upper Murray and Walpeup.

"SPECIAL AREA GROUP ONE" means the municipal districts of Mildura and Mildura City.

THE TABLE REFERRED TO
 Minimum retail prices for single units of packaged beer determined by the Liquor Control Commission.

	Metropolitan Area	Country Areas Group					Special Area Group 1
		1	2	3	4	5	
	\$ c	\$ c	\$ c	\$ c	\$ c	\$ c	\$ c
Bottles—1000 ml	1.13	1.15	1.16	1.17	1.18	1.19	1.18
Bottles—740 ml	.89	.91	.92	.93	.94	.95	.82
Bottles—500 ml	.67	.69	.70	.71	.72	.73	.72
Bottles—370 ml	.51	.53	.54	.55	.56	.57	.50
Cans—740 ml	.93	.95	.96	.97	.98	.99	.98
Cans—500 ml	.67	.69	.70	.71	.72	.73	.72
Cans—370 ml	.51	.53	.54	.55	.56	.57	.56

The Commission hereby authorises a licensee to offer or give to any unlicensed person any or all of the following considerations, benefits and advantages in connection with or in consideration of the purchase of packaged beer by any unlicensed person, namely, free chilling of packaged beer, free delivery of packaged beer, free wrapping of packaged beer, loan of glasses free of charge, credit, and return of unopened bottles.

This determination replaces No. 1 of 1980.

Dated 7 August 1980.

J. R. CAMPTON, Chairman
 W. F. HAYES, Commissioner
 L. S. BROKENSHIRE, Commissioner

Transport Regulation Act
TRANSPORT REGULATION BOARD

HEARING OF APPLICATIONS

Notice is hereby given that the following applications will be considered by the Transport Regulation Board on 2 September 1980.

DONADIO, L. E., South Vermont. Application for two special purpose vehicle licences in respect of two 1974 Cadillac Sedans each with seating capacity for five persons to operate for the carriage of wedding parties only.

NOTE—This application replaces a previous application which appeared in *Victoria Government Gazette* No. 29, 23 April 1980.

GARDNER, J. W., Snake Valley. Application to license one commercial passenger vehicle with seating capacity for 18 persons to operate a service for the carriage of school children between Linton—Mannibadar—Linton under contract to the Education Department.

NOTE—No charter rights are sought in this application.

POINT COOK—WERRIBEE PASSENGER SERVICE PTY. LTD., Werribee. Application to license four commercial passenger vehicles each with large seating capacity to operate as follows: (a) On any Education Department contract or conveyance allowance service operated by the company. (b) On charter hirings from any school served in accordance with (a) above by any of the company's licensed vehicles.

STANYER, J. A., Kyneton. Application to license two vehicles each with small seating capacity to operate as country taxis at Kyneton.

Application by the persons listed hereunder for one Metropolitan Taxi licence to be issued subject to the cancellation of each Suburban Taxi licence shown.

AGGELAKOS, G., Coburg; S.T.5637.
ALTAVILLA, O. R., Reservoir; S.T.5899.
CHRISTOFI, A., East Keilor; S.T.7884.
COBERN, D. J., Glen Waverley; S.T.5954.
COCKS, B. R., Reservoir East; S.T.5843.
DEDOMENICO, A. & BARBAYANNIS, M., Doncaster; S.T.6184.
DONOVAN, G., Ringwood East; S.T.4369.
MORAITIS, N., Mulgrave; S.T.6076.
MORRIS, P. D., South Caulfield; S.T.5286.
PRESTON, J. T., Yarraville; S.T.7851.
ROUBOS, V., Northcote; S.T.6287.
ROZENBERG, C., Rye; S.T.5512.
SPADA, F., Nunawading; S.T.7870.
VIOLA, A., Glenroy; S.T.5653.
WRIGHT, D. F., Kilsyth; S.T.5531; S.T.6315; S.T.6149; S.T.6138; S.T.6071.
ZUBIANI, P. B., West Preston; S.T.6399; S.T.6407.

Application for renewal of licences as shown by the persons listed hereunder to operate under the same terms and conditions.

BLUE & SILVER BUS LINES PTY. LTD.; M.O.1002; M.O.1003; M.O.1004; M.O.1005.
EL FAKAHANI, M., Melton; M.T.5374.
FALLA, D. E., Marmoo; T.S.209.
HOCKING, J. R., Wangaratta; C.O.288.
SCOFFIN, D. E., Grovedale; T.S.1273.
SCOFFIN, J., Grovedale; T.S.1479.
SKRYPKO, R., Sebastopol; U.T.186.
LVNE, M., McKinnon; S.T.6146.
JOHNSON, V. A., Gisborne; S.T.8024.
ANDERSON, J. R., Ballarat; U.T.146.

Notice of any objections should be forwarded to reach the Secretary of the Board not later than 27 August 1980.

Applicants are advised that it will not be necessary to appear on the hearing date specified, unless advised in writing by the Board.

C. J. V. SMITH, Secretary

Corner Lygon and Princes Streets, Carlton, 3053,
Wednesday, 13 August 1980

Commercial Goods Vehicles Act
TRANSPORT REGULATION BOARD

HEARING OF APPLICATIONS

Notice is hereby given that the following applications will be considered by the Transport Regulation Board on 1 September 1980.

A.R.C. ENGINEERING PTY. LTD., 528 Ballarat Road, Sunshine, 3020. One commercial goods vehicle (L/C. 21.01 tonne) to operate from own premises at Sunshine to places within an 80-km radius thereof in the course of business as "Engineers and Manufacturers of Reinforcing and Fencing Materials"—own reinforcing mesh, reinforcing rod and fencing material.

ALLIED BUILDING TRANSPORT SYSTEMS PTY. LTD., 91 Meadowgate Drive, Chirnside Park, 3140. One commercial goods vehicle (L/C. 17.92 tonne) to operate throughout the State of Victoria in the course of business as a "House Remover" with specially constructed house removal float—tools of trade, house removal equipment, houses, sheds, outbuildings, classrooms and houseboats for removal from site to site.

ANDISON, K. R., 270 Barnard Street, Bendigo, 3550. Two commercial goods vehicles (L/C. 0.45 and 0.75 tonne) to operate within an 80-km radius of the chief post office in the City of Bendigo in the course of business as "Electrician"—tools of trade, spare parts and materials incidental to the servicing, repair and maintenance of electrical appliances, also electrical appliances for repair or having been repaired.

ANNETT, A. E., 16 Burns Street, Wangaratta, 3677. Application to vary the conditions of licence No. D.A.67128 by adding to paragraph (b) of the existing conditions after Bright "and Mt. Beauty".

AUSTIN, T. W., 51 Mackenzie Street West, Golden Square, 3555. One commercial goods vehicle (L/C. 0.50 and 1.00 tonne trailer) to operate within that part of the State of Victoria bounded in the west by the Victorian—South Australian border, in the south by an east-west line drawn through Ballarat; thence by a straight line drawn through and joining the townships of Mansfield and Wodonga and then by the Murray River to the Victorian—South Australian border in course of business as "Aluminium Siding Installation Contractor"—tools of trade, battens, trestles, planks and small quantities of aluminium weatherboards when required to complete contract.

BAULCH, B. S., "Murraba", Hawkesdale, 3287. Application to vary the conditions of licence No. D.A.65603 by adding an additional paragraph "From places within a 40-km radius of G.P.O. Melbourne to own premises at Hawkesdale, an approved decentralized secondary industry (Electric Fencing)—raw materials required for use in the manufacturing processes of such industry.

BOMFORD, J. R., 11 Kelvin Drive, Ferntree Gully, 3156. One commercial goods vehicle (L/C. 9.45 tonne) to operate throughout the State of Victoria in the course of business as "Frozen Food Carrier" as a specially constructed refrigerated vehicle for the purpose of servicing retail stores—frozen poultry, frozen fish, frozen and fresh meat, ice cream, frozen and chilled fruit juice in plastic and waxed containers, frozen processed vegetables, cream, special soft cheese, yoghurt, dripping and lard, frozen pies, frozen prepared meals, butter and margarine, frozen snack foods, frozen and fresh fruit and vegetables, fresh fish, frozen coagulated protein, frozen crumpets and up to 500 kgs of refrigerated compressed yeast on any one trip.

NOTE—Butter and margarine is only to be carried from Melbourne as a mixed load when being carried with other frozen foods under refrigeration for distribution to retail stores and provided that the combined weight of butter and margarine carried does not exceed 3000 kgs on any one load.

BOTTOMLEY, D. J., Lot 75, Gap Road, Sunbury, 3429. One commercial goods vehicle (L/C. 6.20 tonne) to operate within an 80-km radius of own premises at Sunbury in course of business as "Excavation Contractors"—own earthmoving plant and equipment.

CASE, J. I. (AUST.) PTY. LTD., P.O. Box 332, Warragul, 3820. Application to vary the conditions of licence No. D.A.70313/7 by deleting from the existing conditions "Provided that all new goods carried on the vehicle have been initially consigned on rail to Warragul.

CLIFFORD, T. J., Weerite via Camperdown, 3260. One commercial goods vehicle (L/C. 3.45 tonne) to operate: (a) Within an 80-km radius of the post office at Weerite—own goods in course of trade as a Primary Producer. (b) Within an 80-km radius of the post office at Weerite—livestock. (c) Within a 40-km radius of the post office at Weerite—general goods.

DUNLOP AUSTRALIA LTD., 27 George Street, Sandringham, 3191. One commercial goods vehicle (L/C. 0.75 tonne) to operate throughout the State of Victoria in the course of business as "Battery Manufacturers"—for the purpose of servicing and maintaining electric materials handling equipment—tools of trade, spare parts and materials incidental to on-site servicing.

FIELD AIR (COLAC) PTY. LTD., Private Bag 25, Ballarat, 3351. One commercial goods vehicle (L/C. 0.55 tonne) to operate throughout the State of Victoria in the course of business as "Aerial Sprayers" for the purpose of undertaking aerial spraying contracts—tools of trade, spraying equipment and small quantities of materials (not exceeding 200 kgs) incidental to own contracts.

NOTE—No goods to be carried from places within a 40-km radius of the G.P.O. Melbourne.

FLEET X PRESS PTY. LTD., 61 Bertie Street, Port Melbourne, 3207. One commercial goods vehicle (L/C. 5.85 and 3.35 tonne trailer) to operate: (a) From the premises of motor vehicle distributors and dealers direct to consignees throughout the State of Victoria—complete motor vehicles. (b) From the premises of motor vehicle manufacturers situated at Melbourne, Geelong and Dandenong direct to those wharves only where there are no rail facilities—motor car bodies.

FOGOLYAN, J., 18 Willis Street, Greensborough, 3088. One commercial goods vehicle (L/C. 1.20 tonne) to operate: (a) Within an 80-km radius of own premises at Greensborough in course of business as "Machinery Manufacturers"—own goods. (b) Throughout the State of Victoria for the purpose of attending country shows and field days demonstrating own manufactured machinery but excluding the carriage of such machinery for delivery other than as defined in paragraph (a).

GAFFNEY TIMBER CO. LTD., Hertford Street, Sebastopol, 3356. One commercial goods vehicle (L/C. 2.75 tonne) to operate from own branch premises at Sebastopol to places within an 80-km radius thereof and to Ararat in course of business as "Timber and Builders Supplies"—own goods.

GREENWAY'S REFRIGERATED TRANSPORT (VIC.) PTY. LTD., Grant Road, Somerville, 3912. One commercial goods vehicle (L/C. 16.00 tonne) to operate throughout the State of Victoria in the course of business as "Frozen Food Carrier" as a specially constructed refrigerated vehicle for the purpose of servicing retail stores—frozen poultry, frozen fish, frozen and fresh meat, ice cream, frozen and chilled fruit juice in plastic and waxed containers, frozen processed vegetables, cream, special soft cheese, yoghurt, dripping and lard, frozen pies, frozen prepared meals, butter and margarine.

NOTE—Butter and margarine is only to be carried from Melbourne as a mixed load when being carried with other frozen foods under refrigeration for distribution to retail stores and provided that the combined weight of butter and margarine carried does not exceed 3000 kgs on any one load.

R. W. JOHNSON HOMES PTY. LTD., 247 Beach Street, Frankston, 3939. One commercial goods vehicle (L/C. 0.50 and 1.00 tonne trailer) to operate throughout the State of Victoria in course of business as "Builder"—own tools of trade, equipment and a small quantity of materials required for the completion of own contracts.

KALARI PTY. LTD., Jessop Street, Hamilton, 3300. Two commercial goods vehicles (L/C. 9.40 and 20.00 tonne) to operate: (a) Within an 80-km radius of the post

office at Hamilton—plant the property of a contractor and required by him for use in connection with the construction or maintenance of some specific, existing or proposed road, street, footpath, bridge, pier, wharf, weir or channel and also the following materials, viz. metal, stones, screenings, ashes, gravel, sand and earth. (b) Within a 32-km radius from the site of any construction or maintenance work performed pursuant to paragraph (a) above, or from the railway station nearest thereto—any other materials required for such work. (c) Within a 40-km radius of the post office at Hamilton—general goods.

KOOLMURT PASTORAL PTY. LTD., "Koolomurt", Coleraine, 3315. Application to vary the conditions of licence No. D.A.66972/2 by deleting the existing conditions and adding in lieu—(a) Within a 40-km radius of own premises at Coleraine—general goods. (b) Within that part of the State of Victoria west of a north-south line drawn through Dandenong—livestock.

MELROSE, J. C., 82 Maroondah Highway, Healesville, 3777. One commercial goods vehicle (L/C. 7.55 tonne) to operate: (a) Within a 40-km radius of own premises at Healesville in the course of business as "Garden Supplies"—own goods. (b) From Dandenong, Clayton and Cranbourne to own premises at Healesville—own sand. (c) From Dandenong to own premises at Healesville—own paving stones and own bricks. (d) From Yea to own premises at Healesville—own sand and own river pebbles.

ORRELL, G. P., Grubb Road, Ocean Grove, 3226. One commercial goods vehicle (L/C. 1.00 tonne) to operate: (a) Throughout the State of Victoria as a "Shearer"—own tools of trade and equipment. (b) Throughout the State of Victoria as a "Horsebreaker"—horses.

ROBERT, C., 34 Bruce Street, Dandenong, 3175. One commercial goods vehicle (L/C. 7.00 tonne) to operate: (a) Within a 40-km radius of own premises at Narre Warren in course of business as "Garden Supply"—own goods. (b) From Bacchus Marsh to own premises at Narre Warren—own river pebbles and own sand and own rock. (c) From Harcourt to own premises at Narre Warren—own slate. (d) From Diggers Rest and Beveridge and to own premises at Narre Warren—own scoria. (e) From Ballarat to own premises at Narre Warren—own quartz. (f) From Seymour and Yea to own premises at Narre Warren—own river pebbles. (g) From Dromana, Deer Park to own premises at Narre Warren—own screenings. (h) From Toolangi and the Gurdies to own premises at Narre Warren—sand and soil.

S.P.C. LIMITED, Andrew Fairley Avenue, Shepparton, 3630. One commercial goods vehicle (L/C. 11.30 and 7.35 tonne) to operate: (a) Within a 40-km radius of own branch premises at Monbulk in the course of business as "Food Processors"—own goods. (b) From and to own premises at Monbulk to and from places within the Metropolitan area of Melbourne and places on the Mornington Peninsula—own goods. (c) Within an 80-km radius of own premises at Shepparton in the course of business as "Food Processors"—own goods.

TORRINGTON, C., 38 Cuthberts Road, Alfredton, 3350. One commercial goods vehicle (L/C. 3.80 tonne) to operate: (a) Within a 40-km radius of the chief post office at Ballarat—general goods. (b) Throughout the State of Victoria—household furniture, being furniture or personal effects of a householder or a member of his family when being moved from residence to residence, from residence for storage or sale; from storage to residence; from a vendor to the residence of the purchaser. (c) From places within a 40-km radius of the G.P.O. Melbourne to the Ballarat Urban District (as defined in the Transport Regulation Act, 1958)—(i) new furniture; (ii) goods as described in paragraph (c) (i) above being returned to Melbourne from Ballarat under direction of retailing organizations to whom goods were first delivered (damaged, superseded and stock transfer).

WALTON, R. J., 13 Oxford Street, Oakleigh, 3166. One commercial goods vehicle (L/C. 9.35 tonne) to operate throughout the State of Victoria in the course of business as "Frozen Food Carrier", as a specially constructed refrigerated vehicle for the purpose of servicing retail stores—frozen poultry, frozen fish, frozen

and fresh meat, ice cream, frozen and chilled fruit juice in plastic and waxed containers, frozen processed vegetables, meals, butter and margarine, frozen snack foods, frozen and fresh fruit and vegetables, fresh fish, frozen coagulated protein, frozen crumpets and up to 500 kgs of refrigerated compressed yeast on any one trip.

NOTE—Butter and margarine is only to be carried from Melbourne as a mixed load when being carried with other frozen foods under refrigeration for distribution to retail stores and provided that the combined weight of butter and margarine carried does not exceed 3000 kgs on any one load.

WOODBRIDGE, B. R., Northern Highway, Heathcote, 3606. One commercial goods vehicle (L/C. 11.50 tonne) to operate: (a) Within an 80-km radius of Heathcote in the course of business as "Septic Tank Installations"—own earthmoving equipment, septic tanks, sand and screenings required for the installation of the septic tanks and overburden from the installation sites. (b) Within a 40-km radius of the Heathcote Post Office—general goods.

TOW TRUCKS

CASTELLO, S., 67 Osborne Avenue, Springvale, 3171. One commercial goods vehicle (L/C. 3.30 tonne) to operate throughout the State of Victoria as a specially constructed tray body tow truck fitted with vehicle ramps and a winch for the purpose of collecting damaged or disabled motor vehicles the locations of which have been previously bespoke but not to include the ability to attend the scenes of accidents for the purposes of lifting and towing motor vehicles involved in any such accident unless involving an R.A.C.V. members vehicle and specifically requesting the services of the tow truck.

STONE, M. P., 768 Mountain Highway, Bayswater, 3153. One commercial goods vehicle (L/C. 1.80 tonne) to operate throughout the State of Victoria as a specially constructed tray tow truck for the purpose of collecting damaged or disabled motor vehicles the locations of which have been previously bespoke but not to include the ability to attend the scenes of accidents for the purposes of lifting and towing motor vehicles involved in any such accident. The vehicle shall at all times exhibit a black plate 13 cm x 6.5 cm on which appears in white letters 4 cm high the word "Restricted" to be affixed immediately above the front and rear registration plates.

N. & B. WILKIE NOMINEES PTY. LTD., 286 Barkers Road, Hawthorn, 3122. One commercial goods vehicle (L/C. 3.15 tonne) to operate within an 80-km radius of own premises at Hawthorn as a "Tray Tow Truck" with winch and ramps for the purpose of lifting and carrying wrecked and disabled motor cars.

RENEWALS

Applications for renewal of licences as shown by persons listed hereunder to operate under the same terms and conditions from the expiry shown in each case.

ALTO CONSTRUCTIONS PTY. LTD., 19 Anderson Road, Thornbury, 3071; D.A.65658/4; 30 October 1980; 3.25 tonne.

BAULCH, B. R., Murraba, Hawkesdale, 3287; D.A.65603; 9 October 1980; 1.75 and 2.15 tonne trailer.

BELL, N. W., 23 Buchan Avenue, Wangaratta, 3677; D.A.68770; 7 October 1980; 3.60 tonne.

BRUNYEE, T. P., P.O. Box 74, Stratford, 3862; T.D.A.66283/1; 1 September 1980; 0.80 tonne.

CARACELLA, L. R., 72 Jellicoe Street West, Ivanhoe, 3079; D.A.68772; 7 October 1980; 6.50 tonne.

T. J. COUTTS PTY. LTD., 54 Lydiard Street North, Ballarat, 3350; D.A.7611/12; 19 August 1980; 1.10 tonne.

DARKON HOLDINGS PTY. LTD., 30 Wileen Road, Westall, 3169; D.A.58509/5; 14 October 1980; 3.85 tonne.

DUNKLEY, D., 7 Gardiner Street, Berwick, 3806; D.A.53411; 5 October 1980; 7.95 tonne.

ESSO AUST. LTD., 70 Foster Street, Sale, 3850; D.A.60640/15; 16 October 1980; 1.10 tonne; D.A.60640/16; 16 October 1980; 1.10 tonne; D.A.60640/17; 16 October 1980; 1.00 tonne; D.A.60640/20; 16 October 1980; 0.80 tonne.

GARDINER, W. B., P.O. Box 57, Warracknabeal, 3393; D.A.3522/2; 19 October 1980; 0.50 tonne.

GARDNER & NAYLOR PTY. LTD., 192 Burwood Road, Hawthorn, 3122; D.A.1128/2; 1 October 1980; 0.75 tonne.

GERRISH, K. E., Old Tolmie Road, Barwite via Mansfield, 3722; D.T.481/4; 21 October 1980; Forklift.

GILBARCO AUST. LTD., 42 Moore Road, Airport West, 3042; D.A.1144/27; 1 October 1980; 0.45 tonne.

HARTWICH, A. R. & R. N. COOPER, P.O. Box 94, Ararat, 3377; D.A.53156; 26 October 1980; 8.40 tonne.

J. C. HUTTON PTY. LTD., 60 Oakover Road, Preston, 3072; D.A.48355/1; 4 October 1980; 1.35 tonne; D.A.48355/3; 4 October 1980; 2.90 tonne; D.A.48355/6; 4 October 1980; 1.35 tonne; D.A.48355/10; 4 October 1980; 2.60 tonne; D.A.48355/29; 4 October 1980; 4.25 tonne.

JOYCE, K. W., 22 Rodney Avenue, Merlynston, 3058; T.D.A.67832/1; 28 October 1980; 8.40 tonne.

KELLY, J. E., 1 Bruce Street, Strathmore, 3041; D.A.53034; 5 October 1980; 10.40 tonne.

KNIGHT, A. J., Lot 27, Bakewell Street, Tooradin, 3980; D.A.68776; 14 October 1980; 7.15 tonne.

INNS, B. C., 30 Marfell Road, Warrnambool, 3280; D.A.68767; 7 October 1980; 0.30 tonne.

MANDEL, N., 54 Spray Street, Elwood, 3184; D.A.53586; 19 October 1980; 8.60 tonne.

MARSHALL, R. M., 4 Janet Avenue, Hamilton, 3300; D.A.68779; 14 October 1980; 1.45 tonne.

MULLINS, J. B., 7 Robert Drive, Ballarat, 3350; D.A.51378/1; 29 October 1980; 7.00 tonne.

MENDELSON, N. R., Lot 26, Scotts Angle Road, Wattle Glen, 3096; D.A.62223; 14 October 1980; 8.25 and 4.70 tonne trailer.

MURPHY, J. F., 1 Wondall Avenue, Tallangatta, 3700; D.A.40348/1; 24 October 1980; 6.55 tonne.

RYANS REMOVALS PTY. LTD., 50 Eddington Street, Warrnambool, 3280; D.A.52681/1; 29 October 1980; 3.60 tonne.

PETERSVILLE LTD., 254-294 Wellington Road, Mulgrave, 3170; D.A.1813/186; 29 October 1980; 1.85 tonne.

SMALIOURIUS, B., 21 Haldane Road, Niddrie, 3042; D.A.53350; 5 October 1980; 11.60 tonne.

STONE, R. D., Nicholson Street, Pyalong, 3603; D.A.56299; 21 October 1980; 13.05 tonne.

SURE TRANSPORT PTY. LTD., P.O. Box 350, Warragul, 3820; D.A.66271/1; 2 August 1980; 24.00 tonne.

THE TERANG & DISTRICT CO-OP. SOCIETY LTD., 30-38 High Street, Terang, 3264; D.A.28610; 8 October 1980; 3.00 tonne.

TOWARD, R. H., 251 Koroit Street, Warrnambool, 3280; D.A.67071; 3 October 1980; 0.40 tonne.

TRANS WEST HAULAGE PTY. LTD., 202 Station Street, Norlane, 3214; D.A.65323/124; 14 October 1980; 16.60 tonne.

TURNBULL, D. R., 111 Dunlop Street, Mortlake, 3272; D.A.41048/3; 6 October 1980; 0.50 tonne.

WESTON, P., 5 Pender Street, Thornbury, 3071; D.A.40658; 10 October 1980; 6.80 tonne.

TOW TRUCK RENEWALS

CARROLL, J. P., Mountjoy Parade, Lorne, 3232; D.A.53370; 5 October 1980; 3.00 tonne.

HEATHS MOTORS AUST. PTY. LTD., 160 Little Malop Street, Geelong, 3220; D.A.68164/4; 28 October 1980; 3.55 tonne.

Notice of any objection should be forwarded to reach the Secretary of the Board not later than 27 August 1980.

Applicants are advised that it will not be necessary to appear on the hearing date specified above, unless advised in writing by the Board.

C. J. V. SMITH, Secretary

Corner Lygon and Princes Streets, Carlton, Vic. 3053, Wednesday, 13 August 1980

Private Agents Act 1966

NOTICE OF RECEIPT OF APPLICATIONS FOR LICENCES UNDER THE PROVISIONS OF THE PRIVATE AGENTS ACT 1966

The Clerk(s) of the Magistrates' Court(s) as listed hereunder hereby give notice that applications, as under, have been lodged for hearing by the said Court(s) on the date(s) specified.

Any person desiring to object to any of such applications must—

- (a) lodge with the respective Clerk of the Magistrates' Court a notice in the prescribed form of his objection and of the grounds thereof ;
- (b) cause a copy of such notice to be served personally or by post upon the applicant at least three days before the hearing of the application ; and
- (c) send or deliver—
- (i) where the objection is not made by the officer in charge of the police district in which the Court is situated—a copy of the notice to such officer ; and
- (ii) where the objection is not made by the Registrar or Deputy Registrar—a copy to the Registrar.

Full Name of Applicant*	Place of Abode of Applicant or Nominee	Name of Firm or Corporation	Address for Registration	Type of Licence	Date of Hearing
MAGISTRATES' COURT, MELBOURNE					
Moloney, Peter Geoffrey	21 Coorie Cres, Rosanna	Transurety Limited	Cnr Arden and Lothian Sts, North Melbourne	Watchman	2.9.80
Dated at Melbourne 1 August 1980 M. J. QUIRK, Clerk of the Magistrates' Court					
MAGISTRATES' COURT, PRESTON					
McLean, William McGory	322 Melbourne Rd, Newport	Downtown Security Company Pty. Ltd.	4 Galilee Cres, Mill Park	Watchman	29.8.80
Dated at Preston 1 August 1980 J. C. TOBIN, Clerk of the Magistrates' Court					
MAGISTRATES' COURT, LILYDALE					
Pillinger, Trevor James	9 Dwyer St, Blackburn	Security and Investigations Pty. Ltd.	5 Taylor Rd, Mooroolbark	Watchman	28.8.80
Dated at Lilydale 31 July 1980 D. D. REES, Clerk of the Magistrates' Court					
MAGISTRATES' COURT, OAKLEIGH					
Legg, Norman Drayton	217 Lum Rd, Whealers Hill		23 Avondale Gve, Mt Waverley	Watchman	20.8.80
Dated at Oakleigh 29 July 1980 G. J. CONDON, Clerk of the Magistrates' Court					
MAGISTRATES' COURT, CHELTENHAM					
Marshall, Peter Colin	9 Ross St, Bentleigh		9 Ross St, Bentleigh	Process Server	26.8.80
" " "	"		"	Inquiry Agent	"
" " "	"		"	Watchman	"
Dated at Cheltenham 4 August 1980 R. J. McHUGH, Clerk of the Magistrates' Court					
MAGISTRATES' COURT, FRANKSTON					
Gibbins, Ross Hanlon	17 Paterson Ave, Langwarrin		17 Paterson Ave, Langwarrin	Process Server Individual	25.8.80
" " "	" "		" "	Inquiry Agent Individual	"
Dated at Frankston 4 August 1980 J. T. FERGUSON, Clerk of the Magistrates' Court					
MAGISTRATES' COURT, FERNTREE GULLY					
Coyle, Herbert Andrew	1/17 Hampton Dr, Hampton Park		1/17 Hampton Dr, Hampton Park	Watchman	1.9.80
Dated at Ferntree Gully 4 August 1980 B. DOBSON, Clerk of the Magistrates' Court					

* Or in the case of a firm or corporation, of the Nominee

PRIVATE AGENTS—continued

Full Name of Applicant*	Place of Abode of Applicant or Nominee	Name of Firm or Corporation	Address for Registration	Type of Licence	Date of Hearing
MAGISTRATES' COURT, BROADMEADOWS					
Smith, Douglas Graham	23 Carol Gve, Tullamarine		23 Carol Gve, Tullamarine	Guard Agent	8.9.80
Marshall, Rodney Frank	21 Rainsford Tce, Campbellfield	Security Protection Pty. Ltd.	1-115 Lynch Rd, Fawkner	Watchman	8.9.80
Dated at Broadmeadows 5 August 1980 P. D. STREET, Clerk of the Magistrates' Court					
MAGISTRATES' COURT, BRUNSWICK					
Belia, Odino	313 Rossmoyne St, Thornbury		248-250 Victoria St, Brunswick	Watchman	10.9.80
" "	" "		" "	Guard Agent	"
Dated at Brunswick 1 August 1980 D. M. SCULLY, Clerk of the Magistrates' Court					
MAGISTRATES' COURT, SOUTH MELBOURNE					
Sutherland, Susan May	3-73 Dickens St, Elwood	T.N.T. Group 4 Total Security	425 St Kilda Rd, Melbourne	Watchman	27.8.80
Papadopoulos, Chris	6 Watson St, Dromana	" "	" "	"	"
Anderson, John Henry Bore	12/44 Princes Hwy, Dandenong	" "	" "	"	"
O'Donoghue, Frances May	15 Sycamore St, Caulfield	" "	" "	"	"
Dated at South Melbourne 1 August 1980 A. R. BELLIS, Clerk of the Magistrates' Court					
MAGISTRATES' COURT, BROADMEADOWS					
Cavanagh, Glendon Ian	Lot 27 Frasers Rd, Lancefield	Security Protection Pty. Ltd.	1-115 Lynch Rd, Fawkner	Watchman	8.9.80
Raffaele, Leo Paul	27 Beuron Rd, North Altona	" "	" "	"	"
Dated at Broadmeadows 6 August 1980 P. D. STREET, Clerk of the Magistrates' Court					
MAGISTRATES' COURT, FRANKSTON					
Roberts, Robert James	2 Beaconsfield Ave, Frankston		2 Beaconsfield Ave, Frankston	Inquiry Agent	27.8.80
Dated at Frankston 5 August 1980 J. T. FERGUSON, Clerk of the Magistrates' Court					
MAGISTRATES' COURT, BROADMEADOWS					
Huddle, Edward Basil	28 Crown St, Laverton	Security Protection Pty. Ltd.	1-115 Lynch Rd, Fawkner	Watchman	15.9.80
Dated at Broadmeadows 7 August 1980 P. D. STREET, Clerk of the Magistrates' Court					
MAGISTRATES' COURT, PRAHRAN					
Moahengi, Joseph	131 Johnston St, Fitzroy	Mayne Nickless	28 Stephenson St, Richmond	Watchman	5.9.80
Latta, Wayne	5/28 Elgin Ave, Armadale	J.I.G.G.S.	51 Fawkner St, South Yarra	Watchman	12.9.80
Palmer, Barbara	27 Rathmines Rd, Hawthorn	Bargene Enterprises	27 Rathmines Rd, Hawthorn	Guard Agent	29.8.80
Dobson, Barry	2/46 Herbert St, Dandenong	Armaguard (Hawthorn)	Cnr Glenferrie and Kinkora Rds, Hawthorn	Watchman	5.9.80
Lochert, Peter	108 Rathdowne St, Carlton	Mayne Nickless	28 Stephenson St, Richmond	"	"
Batchelor, Lynne	4 Chatswood Cl, Glen Waverley	Expert Investigation Service	256 Victoria St, Richmond	Inquiry Agent Individual	"
Dated at Prahran 6 August 1980 J. A. GIDLEY, Clerk of the Magistrates' Court					

* Or in the case of a firm or corporation, of the Nominee

PRIVATE AGENTS—continued

Full Name of Applicant*	Place of Abode of Applicant or Nominee	Name of Firm or Corporation	Address for Registration	Type of Licence	Date of Hearing
MAGISTRATES' COURT, WARRNAMBOOL					
McCarthy, James Hugh	117 Rooneys Rd, Warrnambool		117 Rooneys Rd, Warrnambool	Process Server	1.9.79
Dated at Warrnambool 5 August 1980 P. J. LIVINGSTON, Clerk of the Magistrates' Court					
MAGISTRATES' COURT, FERNTREE GULLY					
Joyce, George Alan Rockley	30 Merricks Cl, Ferntree Gully		30 Merricks Cl, Ferntree Gully	Guard Agent	3.9.80
Dated at Ferntree Gully 6 August 1980 B. DOBSON, Clerk of the Magistrates' Court					
MAGISTRATES' COURT, BALLARAT					
McLelland, Robert James	313 Ripon St South, Ballarat		313 Ripon St South, Ballarat	Guard Agent	26.8.80
Dated at Ballarat 25 August 1980 D. L. CROFT, Clerk of the Magistrates' Court					
MAGISTRATES' COURT, SPRINGVALE					
Roney, Kenneth Wayne	Flat 1, 38 Princes Hwy, Dandenong	Armaguard—Vic. (A Unit of Mayne Nickless Ltd.)	94 York St, South Melbourne	Watchman	27.8.80
Dated at Springvale 6 August 1980 ALAN ROBERT TYERS, Clerk of the Magistrates' Court					
MAGISTRATES' COURT, MELBOURNE					
Power, Dennis Allan	6 Farringdon St, Pascoe Vale	Armaguard	390 St. Kilda Rd, Melbourne	Watchman	9.9.80
Dated at Melbourne 6 August 1980 M. J. QUIRK, Clerk of the Magistrates' Court					

* Or in the case of a firm or corporation, of the Nominee

NOTICE TO MARINERS

[No. 33 OF 1980]

AUSTRALIA—VICTORIA

WESTERNPORT

Re-Alignment of Channel

Date—On or about 12 August 1980.

Reference Position—Long Island Triangulation Station Lat. 38 deg. 18.6 min. S., Long. 145 deg. 13.4 min. E. (Approximately).

Details—The approach channel from Long Island Swinging Basin to the Steel Industry Wharves will be re-aligned to the eastward to provide greater clearance to Long Island Liquids Pier in accordance with the following information:

- (a) Number 32 Light Buoy—The buoy will be moved 120 metres 075 deg. (T) to position 045.6 deg. (T) distance 895 metres from the reference position. The description and characteristic of this light buoy will not be altered.
- (b) Number 33 Light Buoy—The buoy will be moved 5 metres 214 deg. (T) to position 025 deg. (T) distance 1410 metres from reference position. The description and characteristic of this light buoy will not be altered.
- (c) Direction Light—Position 013.0 deg. (T) distance 1840 from reference position. The green, white and red sectors will be shown from the top of the Eastern side of the loading gantry at the Number 1 Steel Industry wharf.

Characteristics

Fixed green from 339.2 deg.—342.2 deg.

Fixed white from 342.2 deg.—346.2 deg.

Fixed red from 364.2 deg.—349.2 deg.

Elevation 13.7 metres. Visibility 3 miles.

Remarks—The directional light, established as a lead light will show a fixed white light 41 metres on either side of the axis of the channel abreast of Number 32 light buoy, a fixed green light to starboard for a distance of 62 metres to the eastern line of the channel and a fixed red light to port for a distance of 62 metres to the western line of the channel.

Caution—Mariners proceeding to the Steel Industry Wharf should be abeam of the Number 31 light buoy before steering in the white sector of the directional light.

The eastern edge of the 206 metre wide channel passes through light buoys Number 31 and 33. Vessels using the 8.5 metre anchorage should anchor to the east of this line.

Least depth of water in the new approach channel is 8.9 metres. It is proposed to carry out dredging to restore the depth to 9.1 metres when a further notice will issue.

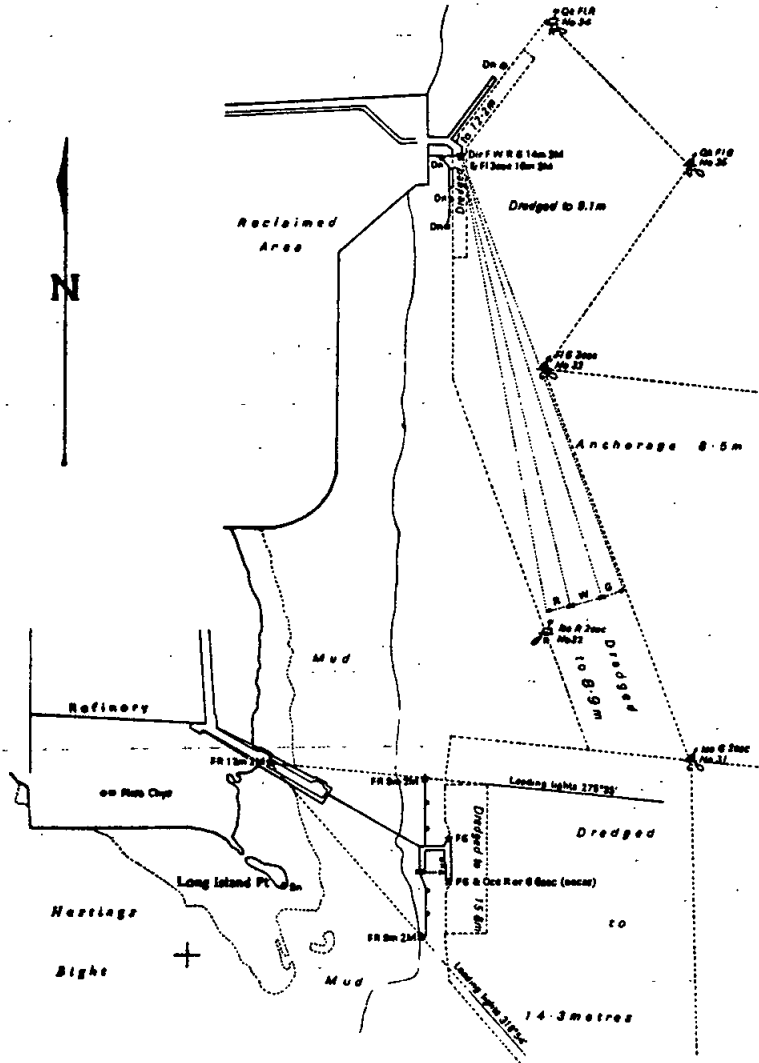

WESTERNPORT

LONG ISLAND POINT TO STEEL INDUSTRY WHARF

AUS. 156

SCALE 1:12 000
June 1980

Charts Affected—AUS. 156, AUS. 149Y.

Publication Affected—Sailing Directions, Victoria. Pages 348, 360 and 655.

Public Works Department
Ports and Harbors Division
168 Exhibition Street
Melbourne, 6 August 1980

A. J. WAGGLEN
Port Officer

NOTICE TO MARINERS
[No. 32 OF 1980]

AUSTRALIA—VICTORIA

The following information which has been received from the Harbor Master, Geelong, is published for general information.

A. J. WAGGLEN
Port Officer

Public Works Department
Ports and Harbors Division
168 Exhibition Street
Melbourne 3000, 4 August 1980

THE GEELONG HARBOR TRUST COMMISSIONERS
PORT OF GEELONG

Introduction of I.A.L.A. "A" Maritime Buoyage System
Former Notice—26 of 1979 refers.

Remarks—Alteration of beacon colours and lights in conformity with the above notice has been completed in respect of all light beacons as listed in the table.

Chart Affected—AUS. 157.

AXEDALE WATERWORKS TRUST

INCREASING THE LIMIT OF BANK OVERDRAFT

His Excellency the Governor of the State of Victoria by and with the advice of the Executive Council thereof has by Order made on 5 August 1980, increased the total amount of the sums which the Axedale Waterworks Trust may owe at any one time in respect of moneys borrowed by overdraft of current account pursuant to the provisions of section 288 of the *Water Act 1958*, fixed by the Governor in Council on 24 April 1963, at Four thousand dollars (\$4000), to Ten thousand dollars (\$10000).

TOM FORRISTAL
Clerk of the Executive Council

At the Executive Council Chamber
Melbourne, 5 August 1980

BALMORAL WATERWORKS TRUST

FIXING THE LIMIT OF BANK OVERDRAFT

His Excellency the Governor of the State of Victoria, by and with the advice of the Executive Council thereof, has by Order made on 5 August 1980, fixed the total amount of the sums which the Balmoral Waterworks Trust may owe at any one time in respect of moneys borrowed by overdraft of current account pursuant to the provisions of section 286 of the *Water Act 1958*, at Ten thousand dollars (\$10000).

TOM FORRISTAL
Clerk of the Executive Council

At the Executive Council Chamber
Melbourne, 5 August 1980

MORNINGTON SEWERAGE AUTHORITY

FIXING THE LIMIT OF BANK OVERDRAFT

His Excellency the Governor of the State of Victoria, by and with the advice of the Executive Council thereof, has by Order made on 5 August 1980, fixed the total amount of the sums which the Mornington Sewerage Authority may owe at any one time in respect of moneys

borrowed by overdraft of current account pursuant to the provisions of section 79A of the *Sewerage Districts Act 1958*, at One million dollars (\$1 000 000).

TOM FORRISTAL
Clerk of the Executive Council

At the Executive Council Chamber
Melbourne, 5 August 1980

MOUNT ELIZA SEWERAGE AUTHORITY

INCREASING THE LIMIT OF BANK OVERDRAFT

His Excellency the Governor of the State of Victoria by and with the advice of the Executive Council thereof has by Order made on 5 August 1980, increased the total amount of the sums which the Mount Eliza Sewerage Authority may owe at any one time in respect of moneys borrowed by overdraft of current account pursuant to the provisions of section 79A of the *Sewerage Districts Act 1958*, fixed by the Governor in Council on 22 October 1974, at Sixty thousand dollars (\$60 000), to One million and sixty thousand dollars (\$1 060 000).

TOM FORRISTAL
Clerk of the Executive Council

At the Executive Council Chamber
Melbourne, 5 August 1980

Drainage Areas Act 1958

SPECIAL MAINTENANCE CHARGE MADE BY THE COUNCIL OF THE SHIRE OF WARRNAMBOOL IN RESPECT OF THE NULLAWARRE DRAINAGE AREA

Notice is hereby given that on 5 August 1980 in accordance with the provisions of section 36 of the *Drainage Areas Act 1958*, the Governor in Council approved the estimate of the cost of proposed maintenance works in the Nullawarre Drainage Area submitted by the Council of the Shire of Warrnambool and the making by the Council of a Special Maintenance Charge on properties within the said Drainage Area, for the year ending 30 September 1980.

TOM FORRISTAL
Clerk of the Executive Council

Labour and Industry Act 1958

DETERMINATION OF THE FIRE FIGHTERS BOARD
(No. 4 OF 1980)

Notice is hereby given that an appeal to the Industrial Appeals Court has been lodged against the determination of the Fire Fighters Board made on 25 July 1980, whereby the following clause was inserted into its Determination:

"If for any reason there is insufficient man power to maintain the rostered manning of 3 on any fire-fighting vehicle then it shall respond to any fire call with the minimum of 2 men."

Section 45 (1) of Act 6283 provides that when an appeal is made in accordance with that Act, the parts of the Determination appealed against shall not come into operation until the appeal has been dealt with by the Court.

A. S. DOWLING, Registrar
Industrial Appeals Court

SITTINGS OF THE SUPREME COURT FOR THE HEARING OF CRIMINAL TRIALS IN MELBOURNE FOR THE YEAR 1981

The Judges of the Supreme Court have appointed that the Sittings of the said Supreme Court for the hearing of Criminal Trials in Melbourne shall, during the year 1981, be held on the days and dates indicated on the Schedule following, that is to say:

February	March	April	May	June	July	August	September	October	November	December
Mon. 2	Mon. 2	Wed. 1	Fri. 1	Mon. 1	Wed. 15	Mon. 3	Tue. 1	Thur. 1	Mon. 2	Tue. 1

Dated 5 August 1980

P. S. MALBON
Prothonotary of the Supreme Court

CONTRACTS ACCEPTED—(Series 1980-81)				AMENDMENTS—continued			
AMENDMENTS				Schedule Number	Item Number	New Rate	Effective Date
Schedule Number	Item Number	New Rate	Effective Date				
\$				\$			
<i>Cleaning and Polishing Requirements</i>				<i>Hand Tools (General)</i>			
1/04	37	4.45	10.7.80	1/56	456	11.67	30.6.80
	38	7.00					
	42	11.84					
	43	18.00					
<i>Fasteners</i>				<i>Stationery (General)</i>			
1/26	23	*	11.8.80	1/64	161	.27*†	5.8.80
					162	.41*†	
					163	.54*†	
*Delete Machined Brass Substitute Cold Formed				*Less 2½%, 30 Days.			
				†Change Contractor to Beiersdorf (Australia) Ltd., P.O. Box 440, Ringwood, Vic. 3134. Telephone 873 1133.			
<i>Steel (Mild)</i>				<i>Provisions—School of Forestry, Creswick</i>			
1/35	1	*	11.8.80	2/12(4)	2	.28	20.7.80
*Delete Reinforcing (Plain Round and Deformed Bar)					7	1.15	
					8	11.06	
					12	2.25	
					13	37.08	
					14	.67	
<i>Motor Spirit (Bulk)—State Petrol Centre</i>					15	6.36	
1/53A	1	.2871	4.8.80		16	5.40	
	2	.2879	15.7.80		17	.99	
					19	1.95	
					20	21.00	
					22	2.16	
					25	4.34	
					26	9.72	
					27	9.72	
					28	10.32	
					32	2.76	
					33	8.64	
					34	.86	
					36	2.80	
					36(a)	3.66	
					39	.61	
					40	3.27	
					41	5.64	
					42	1.25	
					43	.72	
					44	.45	
					45	.35	
					49	14.28	
					56	.61	
					60	1.00	
					61	.37	
					62	14.25	
					63	.39	
					64	.42	
					65	1.05	
					67	18.00	
					69	.59	
					70	.59	
					71	.48	
					74	.82	
					75	.89	
					76	15.84	
					80	1.65	
					81	.90	
					82	1.02	
					85	1.79	
					87	2.34	
					89	1.78	
					90	3.38	
					91	3.20	
					92	3.20	
					99	.49	
					100	.70	
					101	2.49	
					106	2.13	
†Supply Conditions Unchanged.							
‡B.P. Australia Ltd.							
*The Shell Company of Australia Ltd.							
Outlet: Change Numurkah, Shell Numurkah Roadhouse, D. W. and J. A. Moon, Goulburn Valley Hwy. From a Service Station to a Depot. Trading Hours M—Sat. 8—6. 4.8.80							

J. M. PAWSON, Secretary to the Tender Board

CONTRACTS ACCEPTED—(Series 1980-81)

Annex to Contract Nos: 1980/207, 209, 210, 211, 212, 213, 215, 218, 219

SCHEDULE No: 1/25

BEDDING AND TEXTILES

Contract from 1 July 1980 to 30 June 1982

1980/207—Actil Marketing Ltd., 390 St Kilda Rd. Melbourne 3004. Telephone 267 4422
 1980/209—Cable Makers Australia Pty. Ltd., 272 Wickham Rd, Moorabbin, Vic. 3189. Telephone 95 4688
 1980/210—Dermide Distributors Pty. Ltd., P.O. Box 181 Smithfield, N.S.W. 2164. Telephone 604 7430
 1980/211—Dunlopillo—Sleepmaker (Foam Division), P.O. Box 1 Mordialloc, Vic. 3195. Telephone 551 2355
 1980/212—Formac Products, 132A Cotham Rd, Kew, Vic. 3101. Telephone 80 4461
 1980/213—North Western Woollen Mills Pty. Ltd., Playford St, Stawell, Vic. 3380. Telephone 581 966
 1980/215—Sanross Trading Co., 378 Flinders St, Melbourne 3000. Telephone 625 430
 1980/218—Supertex Industries Ltd., 220 Henderson Rd, Alexandria, N.S.W. 2015. Telephone 514 355
 1980/219—Warrnambool Woollen Mill, A Division of Dunlop Australia Ltd., Harris St, Warrnambool, Vic. 3280. Telephone 62 4166

Item No.	Description of Articles	Rate	Name of Contractor
Sub-Schedule A		\$	
BEDDING			
1	Bedspreads, Chenille, assorted selected colours	each	11.50*
	Blankets, Wool, 228 cm x 160 cm (to specifications)—		
2	White, "Warrnambool"	each	19.44*
3	Blue or Gold, "Warrnambool"	each	21.82*
4	Assorted, selected colours, "Warrnambool"	each	21.82*
5	Multi check, "Warrnambool"	each	22.48*
6	Cot wool, 1600 mm x 1143 mm check patterns, "Warrnambool"	each	11.50*
7	Grey, ordinary, 228 cm x 160 cm, plain or striped, "Norwellan"	each	11.00*
8	Covers, Mattress, Polyurethane, 190 cm x 92 cm x 10 cm to specification, "Dermide"	each	14.60
Mattresses (to specification)—			
9	Innerspring, 1880 mm x 915 mm x 102 mm O/A	each	..
10	Polyurethane Foam, 1905 mm x 915 mm x 102 mm, "Dunlopillo 8404"	each	10.77*
11	Polyurethane Foam, 1905 mm x 760 mm x 102 mm, "Dunlopillo 8404"	each	8.64*
12	Pillows, 68 cm x 46 cm to specification	each	3.56
Pillowcases, Cotton, Standard envelope type, 483 mm x 737 mm hemmed 32 mm top, 178 mm, Flap—			
13	White, "PHPAAW"	per doz.	23.40*†
14	Coloured, "PHPDAD, 1141, 2217, 2218, 4417, 5514"	per doz.	25.20*‡
15	Pillow Covers—Waterproof, envelope type	each	3.67
16	Rugs, Bed, 1829 mm x 1524 mm to specification	each	..
Sheets, Cotton (cut length) 2617 mm hemmed length 2540/2566 mm—			
17	White—160 cm width, "SHPAA160W"	each	7.60*‡
18	Coloured	each	..
* Less 2½%, 30 days.			
† Minimum order 50 dozen pairs.			
‡ Minimum order 50 dozen pairs per shade.			
‡ Minimum order 200.			
Sub-Schedule B			
TEXTILES			
All supplies under this Sub-schedule are for the Mental Health Division or Department of Community Welfare Services only			
Calico—			
19	Unbleached, 160 cm, 220 gms per M ² to include 3 only 7 mm red or blue stripes woven as follows—		
	1 stripe to be woven down centre and 1 stripe woven 305 mm from each edge, "SGPAA160L"	per metre	2.05*‡
20	Unbleached, 92 cm, 208 gms per M ² to include 2 only 7 mm red or blue stripes woven as follows—		
	1 stripe woven 305 mm from each edge, "PGPAA92L"	per metre	1.23*§
21	Unbleached, 92 cm, 208 gms per M ² no stripe	per metre	..
22	White, 92 cm, 99 gms to 113 gms per M ²	per metre	0.58*
23	Denim, 92 cm, blue, yarn dyed, 269 gms to 283 gms per M ²	per metre	1.90*
Drill—Sanforised 74 cm—			
24	Grey	per metre	..
25	Khaki	per metre	..
26	Navy Blue	per metre	..
27	White	per metre	..
Drill—Sanforised 92 cm—			
28	White	per metre	..
Flannelette 92 cm—			
29	White	per metre	0.80*
30	Coloured as selected 505 HF	per metre	..

SCHEDULE NO. 1/25—continued

Item No.	Description of Articles	Rate	Name of Contractor
Sub-Schedule B—continued			
Printed, assorted selected patterns—			
31	(a) suitable for manufacture of men's and boys' pyjamas	per metre 0.84*	Sanross Trading Co. } Purchase (Regulation 109)
32	(b) suitable for manufacture of women's nightdresses	per metre ..	
33	(c) suitable for manufacture of children's pyjamas	per metre ..	
34	Check patterns, for manufacture of work shirts	per metre 0.90*	Sanross Trading Co.
Poplin 92 cm—			
35	Printed, floral patterns, assorted colours (suitable for manufacture of women's nightgowns)	per metre ..	Purchase (Regulation 109)
SHEETING			
36	Pastel Green, 160 cm, 156 gms per M ² , "SGPDA180D, 1141, 2217, 2218, 4417, 5514"	per metre 2.65*†	Actil Marketing Ltd. }
37	Pastel Green, 92 cm, 114 gms per M ² , "SGPDA180D, 1141, 2217, 2218, 4417, 5514"	per metre 1.50*‡	
38	Tweed, 135 cm, cotton sanforised, 312 gms per M ²	per metre ..	Purchase (Regulation 109) North Western Woolen Mills Pty. Ltd.
39	Woolen, Blue/Grey—152 cm uniform cloth, "Norwellan"	per metre 8.35*	

* Less 2½%, 30 days.

† Minimum Order 10 000 metres.

‡ Minimum order 22 250 metres

‡ Minimum order 660 metres.

¶ Minimum order 1 329 metres per shade.

Approved—L. H. S. THOMPSON, Treasurer—31.7.80

CONTRACTS ACCEPTED—(Series 1980-81)

PUBLIC WORKS

His Excellency the Governor of the State of Victoria by and with the advice of the Executive Council thereof has by Orders made on 5 August 1980, approved of the acceptance by the Minister of Public Works of the under-mentioned offers, without public tenders being invited, viz.:

Offer of Menzies Cleaning Services Aust. Pty. Ltd. for maintenance cleaning for period 6 August 1980 to 5 August 1983 at Public Works Department Offices, 7 and 7A Parliament Place, Melbourne, for the sum of Forty-eight thousand five hundred and fifty-five dollars (\$48 550.00) per annum—(P.990).

Offer of R. & B. Schultz Builders Pty. Ltd. for fire reinstatement at Fawkner Technical School for the sum of Forty-nine thousand four hundred and sixty-six dollars sixty-five cents (\$49 466.65)—(C.192554).

Offer of Southwell Constructions for cyclic maintenance at Yarrowonga High School for the sum of Eighty-six thousand eight hundred dollars (\$86 800.00)—(N.47253).

Offer of S. J. Moran Constructions Pty. Ltd. for siteworks at Wantirna High School for the sum of Twenty thousand two hundred and thirty-two dollars ninety-nine cents (\$20 232.99)—(N.204920c).

Offer of Shepparton Asphalt Pty. Ltd. for supply and laying of asphalt at Cobram High School for the sum of Twenty-seven thousand eight hundred and fifty dollars (\$27 850.00)—(P.N.57706c).

TOM FORRISTAL
Clerk of the Executive Council

At the Executive Council Chamber
Melbourne, 5 August 1980

Police Offences Act 1958, No. 6337

DIVISION 1A—STATE CLASSIFICATION OF PUBLICATIONS BOARD

Take note that the State Classification of Publications Board has classified the following publications in accordance with the provisions of section 180H (1) of the Police Offences Act 1958.

Each publication shall be subject to the following restrictions:

- It shall not be offered for sale, sold, delivered, exhibited or displayed to any person under the age of 18 years;
- It shall not be made available for inspection or perusal to any person under the age of 18 years;
- It shall not be exhibited or displayed in any place to which persons under the age of 18 years have access or so that it is visible from any such place;
- It shall not be advertised in any manner whatsoever.

SCHEDULE OF PUBLICATIONS

Title	Distributor
Cheri—July, 1980	Gordon & Gotch (A'sia) Ltd.
Couples—September, 1980	Gordon & Gotch (A'sia) Ltd.
Gettin' It On	Venus Enterprises Pty. Ltd.
Human Insight—September, 1980	Gordon & Gotch (A'sia) Ltd.
Libertine, The, Issue No. 5	Gordon & Gotch (A'sia) Ltd.
Penthouse—September, 1980	Gordon & Gotch (A'sia) Ltd.
Penthouse Variations—June/July, 1980	Gordon & Gotch (A'sia) Ltd.
Response—July, 1980	Gordon & Gotch (A'sia) Ltd.
Rooting & Whoring	Venus Enterprises Pty. Ltd.
Sex Guide—October, 1980	Gordon & Gotch (A'sia) Ltd.
Sexology Today—July, 1980	Gordon & Gotch (A'sia) Ltd.
Sex to Sixty No. 50	Gordon & Gotch (A'sia) Ltd.
Young Fuckers	Venus Enterprises Pty. Ltd.

J. SMITH, Secretary
State Classification of Publications Board

PUBLIC TRUSTEE ACT 1958, SECTION 17

I hereby give notice that on 27 July 1980, the Public Trustee filed elections to administer the following deceased persons' estates in accordance with section 17 of the Public Trustee Act 1958.

GALLOWAY, GEORGE WILFRED, also known as George Galloway, late of 47 Arnold Street, South Yarra, retired bricklayer, died 13 June 1980.

HALES, ESTHER, late of Flat 19, 2 Bell Street, Ballarat, widow, died 23 April 1980.

HARRIS, MONTAGUE ROBERT, late of "Pine Hill" Caravan Park, Warburton Road, Lilydale, retired foreman, died 27 May 1980.

HUDSON, JOHN MACKIE, formerly of 37A Power Street, Hawthorn, but late of 31 Metung Street, Balwyn, retired, died 11 March 1980.

WILSON, RODNEY JAMES, formerly of 12 Dundonald Avenue, East Malvern, but late of Shady Glen Caravan Park, Darwin, fitter and turner, died 30 July 1979.

P. T. SPENCER
Public Trustee

168 Exhibition Street, Melbourne, 3000
6 August 1980

Creditors, next of kin, and others having claims against the estate of any of the under-mentioned deceased persons are required to send particulars of their claims to the Public Trustee, 168 Exhibition Street, Melbourne, Vic. 3000, the personal representative, on or before 20 October 1980, after which date the Public Trustee may convey or distribute the assets having regard only to the claims of which the Public Trustee then has notice:—

AUSTIN, CLARE, late of Ararat, pensioner, died 25 April 1980.

AVERY, THOMAS HENRY, late of 24 Hubert Avenue, Glenroy, aircraft inspector, died 14 May 1980.

BERRIGAN, LESLIE JAMES, late of 750 Whitehorse Road, Mitcham, retired law clerk, died 20 April 1980.

BUTLER, GEORGE FREDERICK, late of 59 Clarence Street, East Brunswick, retired grocer's assistant, died 24 July 1980.

DAVEY, AUGUSTA ELSIE MAY, usually known as Elsie May Davey, late of 13 Eltham Street, Flemington, widow, died 24 June 1980.

EASTWOOD, GEORGE KEVIN, late of 7 Tooronga Road, Malvern East, retired, died 14 April 1980.

FOSTER, WILLIAM ALFRED, formerly of 10 Edwards Street, Nedlands, Western Australia, but late of 65 Riversdale Road, Hawthorn, Vic., engineer, died 27 February 1980.

FOX, CHARLES EDGAR, formerly of 70 Medway Street, Box Hill, but late of 18 Stewart Street, Pascoe Vale, retired carpenter, died 20 April 1980.

FRANKS, RUBY IRENE, late of St. Omars Private Hospital, 44 Prospect Hill Road, Camberwell, widow, died 29 April 1980.

GALLOWAY, GEORGE WILFRED, also known as George Galloway, late of 47 Arnold Street, South Yarra, retired bricklayer, died 13 June 1980.

GRAHAM, ROBERT JAMES, formerly of 133 Mitcham Road, Mitcham, but late of Mont Park, retired welder, died 11 January 1980.

HALES, ESTHER, late of Flat 19, 2 Bell Street, Ballarat, widow, died 23 April 1980.

HALEY, FREDERICK, formerly of 55 Kerferd Road, Albert Park, but late of 260 Nepean Highway, Seaford, driver, died 2 May 1980.

HARRIS, MONTAGUE ROBERT, late of "Pine Hill" Caravan Park, Warburton Road, Lilydale, retired foreman, died 27 May 1980.

HAYES, MILLICENT LORMER, formerly of care of 126 Power Street, Hawthorn, but late of Canterbury Private Hospital, 14 Balwyn Road, Canterbury, widow, died 28 June 1980.

HUDSON, JOHN MACKIE, formerly of 37A Power Street, Hawthorn, but late of 31 Metung Street, Balwyn, retired, died 11 March 1980.

LANG, JAMES EDWARD, late of Narre Warren North, pensioner, died 13 February 1950.

No. 68—24640/80—2

LENGGENHAGER, HERMANN, also known as Harry Lenggenhager, late of Lot 24 Churchill Park Drive, Endeavour Hills, retired diesel mechanic, died 30 May 1980.

MILLER, AMELIA MAY, late of "Murihiku", 18 Tagell Road, Ringwood, spinster, died 8 June 1980.

MORRIS, JESSIE ETHEL, late of 20 Valerie Court, Heathmont, widow, died 1 May 1980.

NICHOL, EVA ALICE, late of 464 Station Street, North Carlton, widow, died 20 June 1980.

NICHOLSON, WILLIAM IRVING, late of 31 Beaulah Road, Thornton Heath, Croydon, Surrey, England, retired cabinet maker, died 5 September 1974.

O'BRIEN, JOHN ROBERT, late of 15/462 Victoria Parade, East Melbourne, retired fitter, found on 14 May 1980.

PARKER, VALENCIA JOAN, late of 183 Verner Street, East Geelong, widow, died 2 March 1980.

PREDEVILLE, HONORIA, also known as Nora, formerly of 12 Albany Road, Toorak, but late of Unit 10, 122 Nepean Highway, Aspendale, pensioner, died 31 March 1980.

RILEY, MARGARET ALEXANDER, late of 43 Catherine Road, East Bentleigh, spinster, died 18 March 1980.

SAINTY, STANLEY JOSEPH, late of 16 Rowan Street, Croydon, gardener, died 7 May 1979.

SHALLARD, ARTHUR JAMES, formerly of 763 High Street, Epping, retired clerk, died 21 April 1980.

WILSON, RODNEY JAMES, formerly of 12 Dundonald Avenue, East Malvern, but late of Shady Glen Caravan Park, Darwin, fitter and turner, died 30 July 1979.
Melbourne, 6 August 1980

P. T. SPENCER
Public Trustee

Town and Country Planning Act 1961

CITY OF KNOX PLANNING SCHEME 1965

REVOCATION No. 29

In pursuance of the provisions of section 32 of the Town and Country Planning Act 1961 the Governor in Council on 5 August 1980, made an Order:—

- (i) Revoking the City of Knox Planning Scheme in so far as it applies to approximately 0.04 hectares of land located at the south-east corner of Sydney Road and Joel Court, Bayswater; and
- (ii) providing that the land so revoked may be used or developed only as if:
 - (a) it were land to which the City of Knox Planning Scheme applies;
 - (b) it were land within the Residential A Zone;
 - (c) Condition No. 2 pertaining to the use General Store in the Residential A Zone in Clause 7 to the Planning Scheme Ordinance did not apply.

A copy of the Order may be inspected during office hours at the office of the Town and Country Planning Board, 235 Queen Street, Melbourne, and at the office of the Council of the City of Knox at Knoxfield.

W. H. CRAIG, Secretary
Town and Country Planning Board

Town and Country Planning Act 1961

CITY OF KNOX PLANNING SCHEME 1965

REVOCATION No. 28

Notice of Revocation

In pursuance of the provisions of section 32 of the Town and Country Planning Act 1961 the Governor in Council on 5 August 1980, made an Order:—

- (i) Revoking the City of Knox Planning Scheme in so far as it applies to lot 1, lodged plan 127430, in Scoresby Road, Boronia; and
- (ii) providing that the land so revoked may be used or developed only as if:
 - (a) it were land to which the City of Knox Planning Scheme applies;
 - (b) it were land within the Rural A Zone;

(c) the uses Office and Meeting Rooms were uses permitted subject to the grant of a permit by the Responsible Authority and to any conditions imposed by such permit.

A copy of the Order may be inspected during office hours at the office of the Town and Country Planning Board, 235 Queen Street, Melbourne, and at the office of the Council of the City of Knox at Knoxfield.

W. H. CRAIG, Secretary
Town and Country Planning Board

Town and Country Planning Act 1961
CITY OF MILDURA PLANNING SCHEME

AMENDMENT No. 33, 1979

Notice of Amendment

In pursuance of the powers conferred by sub-section 6 of section 32 of the *Town and Country Planning Act 1961*, the Governor in Council, on 5 August 1980 amended the City of Mildura Planning Scheme to rezone approximately 3200 square metres of land in Lime Street to Commercial B, and to rezone approximately 4125 square metres of land in Pine Street to Public Purposes—Proposed to enable G. J. Coles Pty. Ltd. to establish a K-Mart store.

A copy of the amendment may be inspected during office hours at the office of the Town and Country Planning Board, 235 Queen Street, Melbourne, at the office of the Council of the City of Mildura at Mildura, and when available at the Office of Titles, Melbourne and at the Central Plan Office of the Department of Crown Lands and Survey, Melbourne.

H. R. TROTTER, Acting Secretary
Town and Country Planning Board

Town and Country Planning Act 1961
PHILLIP ISLAND PLANNING SCHEME

AMENDMENT No. 6

Notice of Approval

In pursuance of the powers conferred by the *Town and Country Planning Act 1961*, the Governor in Council on 5 August 1980, approved a planning scheme entitled the Phillip Island Planning Scheme, Amendment No. 6, in respect of part of the municipal district of the Shire of Phillip Island and such planning scheme comes into operation on the date this Notice of Approval is published in the *Government Gazette*.

A copy of the planning scheme as approved may be inspected, free of charge, during office hours at the office of the Town and Country Planning Board, 235 Queen Street, Melbourne; at the office of the Council of the Shire of Phillip Island at Cowes; and when available, at the Office of Titles, Melbourne, and at the Central Plan Office of the Department of Crown Lands and Survey, Melbourne.

W. H. CRAIG, Secretary
Town and Country Planning Board

Town and Country Planning Act 1961
GISBORNE SHIRE PLANNING SCHEME

NOTICE OF APPROVAL

In pursuance of the powers conferred by the *Town and Country Planning Act 1961*, the Governor in Council on 5 August 1980, approved a planning scheme entitled the Gisborne Shire Planning Scheme in respect of the municipal district of the Shire of Gisborne and such planning scheme comes into operation on the date this Notice of Approval is published in the *Government Gazette*.

A copy of the Planning Scheme as approved may be inspected, free of charge, during office hours at the office of the Town and Country Planning Board, 235 Queen Street, Melbourne, at the office of the Council of the Shire of Gisborne at Gisborne, and when available, at the Office of Titles, Melbourne, and at the Central Plan Office of the Department of Crown Lands and Survey, Melbourne.

H. R. TROTTER, Acting Secretary
Town and Country Planning Board

Town and Country Planning Act 1961

SHIRE OF ROSEDALE PLANNING SCHEME, PART 2

AMENDMENT No. 4

Notice of Amendment

In pursuance of the power conferred by sub-section 6 of section 32 of the *Town and Country Planning Act 1961*, the Governor in Council on 12 August 1980 amended the Shire of Rosedale Planning Scheme, Part 2, to provide for a proposed public open space reserve and limited housing development on part of the Boole Poole Peninsula.

A copy of the amendment may be inspected during office hours at the office of the Town and Country Planning Board, 235 Queen Street, Melbourne, at the office of the Council of the Shire of Rosedale, at Rosedale, and when available, at the Office of Titles, Melbourne, and at the Central Plan Office of the Department of Crown Lands and Survey, Melbourne.

W. H. CRAIG, Secretary
Town and Country Planning Board

Marketing of Primary Products Act 1958 (No. 6304)

THE VICTORIAN EGG MARKETING BOARD

By Proclamation published in the *Government Gazette* No. 66 dated 1 August 1979, the Governor in Council of the State of Victoria, provided and declared on 31 July 1979 that all eggs (with certain exceptions) coming into existence within a period of two years from 16 August 1979, shall become vested in and be delivered by producers to The Victorian Egg Marketing Board or its Authorized Agents.

The Victorian Egg Marketing Board by this public notice, directs that all eggs (excepting eggs which are exempt from delivery according to section 21 of the *Marketing of Primary Products Act 1958 (No. 6304)* and eggs which in any particular case the Board directs in writing to be delivered at a place or places specified in such direction) shall be delivered to the Board or its Authorized Agents at any one or more of the following grading and selling floors and/or receiving depots.

1. GRADING AND SELLING FLOORS

Metropolitan

Keysborough—The Victorian Egg Marketing Board, corner Chandler and Kirkham Roads.

Thomastown—T. J. Neylon & Son Pty. Ltd., 10 Charnfield Court.

Country

Bendigo—Crystal Egg Company, 21 Garsed Street.

Euroa—Euroa Co-operative Society Ltd., Railway Street.

Mildura—Mildura Co-operative Producers' Egg Floor Pty. Ltd., 155 Seventh Street.

2. RECEIVING AND SELLING DEPOTS.

Ballarat—The Victorian Egg Marketing Board, 612 Talbot Street.

Charlton—Crystal Transport Co., 62 High Street.

Dimboola—Nettlebeck & Stalker, 22 Wimmera Street.

Geelong South—The Geelong & Cressy Trading Co. (1979) Pty. Ltd., 118 Fyans Street.

Hamilton—Grange Dairies Pty. Ltd., 1 Moore Street.

Horsham—Lehmann Distributors, 72 Darlot Street.

Koroit—Murray Goulburn Co-Op. Ltd., Midgley Street.

Shepparton—J. & L. Clark Pty. Ltd., Callister Street.

Stawell—W. J. Barker, 1 Napier Street.

Wangaratta—North-East Dairy Co., 35 Warby Street.

Warragul—Permewans Pty. Ltd., Princes Highway.

The Victorian Egg Marketing Board by this public notice further directs that eggs delivered to the Board of a person authorized in that behalf by the Board for

grading and testing and for marketing and stamping so as to indicate the grade and quality shall be delivered in the following manner:—

1. All of the provisions of The Victorian Egg Marketing Board Regulations 1979 as amended relating to the manner in which eggs are to be delivered as aforesaid shall be observed.

2. All eggs so delivered shall be delivered packed in clean, serviceable and uncontaminated egg fillers in containers approved by the Board and legibly marked with the name and registered number allocated by the Board of the producer consigning the eggs. Approved containers will normally include 15 or 30 dozen heavy duty re-usable cardboard cartons and 360 dozen egg trolleys and when presented to the Board be in clean uncontaminated and serviceable condition.

3. Eggs which are fertile shall be clearly identified by labelling each container as "Fertile".

C. L. JEFFERSON
Secretary

Marketing of Primary Products Act 1958 (No. 6304)

THE VICTORIAN EGG MARKETING BOARD

Section 41c of the Marketing of Primary Products Act 1958, provides that any person who owns or is entitled to sell or dispose of any eggs may present the same to The Victorian Egg Marketing Board or a person authorized in that behalf by the Board at a place and in such manner as the Board by notice published in the *Government Gazette*, directs for grading and testing and for marking and stamping so as to indicate the grade and quality.

The Victorian Egg Marketing Board, by this public notice, directs that unless the Board otherwise directs eggs may be presented to the Board or persons duly authorized by the Board in that behalf for grading and testing and for marking and stamping so as to indicate the grade and quality at any one or more of the following places:—

1. METROPOLITAN GRADING AND SELLING FLOORS.

Keysborough—The Victorian Egg Marketing Board, corner Chandler and Kirkham Roads.

Thomastown—T. J. Neylon & Son Pty. Ltd., 10 Charnfield Court.

2. COUNTRY GRADING AND SELLING FLOORS.

Bendigo—Crystal Egg Company, 21 Garsed Street.

Euroa—Euroa Co-operative Society Ltd., Railway Street.

Mildura—Mildura Co-operative Producers' Egg Floor Pty. Ltd., 155 Seventh Street.

The Victorian Egg Marketing Board by this public notice further directs that eggs presented to the Board or a person authorized in that behalf by the Board for grading and testing and for marking and stamping so as to indicate the grade and quality shall be presented in the following manner:—

1. All of the provisions of The Victorian Egg Marketing Board Regulations 1979 as amended relating to the manner in which eggs are to be presented as aforesaid shall be observed.

2. All eggs so presented shall be presented properly packed in 2½ dozen trays in a clean and sanitary condition in suitable containers as approved by the Board. "Suitable containers" will normally include only 15 or 30 dozen heavy duty re-usable cardboard cartons.

3. The person who presents the eggs shall supply to the Board or the person authorized as aforesaid such number of additional empty egg cases or containers and clean and sanitary 2½ dozen trays as the Board or such person may reasonably require for the purpose of re-packing the eggs after grading according to their separate grades.

4. All approved egg containers and egg fillers in which eggs are packed when presented and all additional empty egg containers and egg fillers presented aforesaid shall be clean, uncontaminated and in serviceable condition.

5. There shall be durably and legibly written or marked on each egg case or container in which eggs are so presented or which is supplied as aforesaid, or on a label firmly affixed thereto—

(a) The name and address of the person by whom the eggs are presented.

(b) Any other requirements as notified by the Board from time to time.

(c) A clear notification that eggs are presented pursuant to the said section 41c and not pursuant to section 21 of the *Marketing of Primary Products Act 1958*.

6. (a) The fee chargeable to persons submitting eggs for grading under section 41c of the Act will be 7.0 cents per dozen or at such other rate as fixed by the Board from time to time in accordance with the Act.

(b) Persons who deliver eggs for grading shall be responsible for costs of delivery to the Grading Floor or such other place as required by the Board.

7. All inquiries regarding the requirements of the Act should be directed to the Board at its Head Office address, corner Chandler and Kirkham Roads, Keysborough, 3173, telephone 798 7077.

C. L. JEFFERSON
Secretary

Cemeteries Act 1958

SCALE OF FEES OF THE LONGWOOD PUBLIC CEMETERY

In pursuance of the powers conferred upon them by the Cemeteries Act, the trustees of the Longwood Public Cemetery hereby make the following scale of fees, which shall come into operation upon publication in the *Government Gazette*, and from and after such publication every scale of fees heretofore made by the said trustees shall be and is hereby rescinded to the extent to which it conflicts with this scale.

Private Graves

	\$
Land, 2.44 m x 1.22 m	20.00
Land, 2.44 m x 2.44 m	40.00
Reopening grave (with cover)	20.00
Reopening grave (without cover)	10.00
Permission to erect a headstone or monument	10.00

M. G. COX, Trustee
T. J. BRODIE, Trustee
F. H. TUBB, Trustee

Approved by the Governor in Council, 5 August 1980—
TOM FORRISTAL, Clerk of the Executive Council.

Cemeteries Act 1958

SCALE OF FEES OF THE QUAMBATOOK PUBLIC CEMETERY

In pursuance of the powers conferred upon them by the Cemeteries Act, the trustees of the Quambatook Public Cemetery hereby make the following scale of fees, which shall come into operation upon publication in the *Government Gazette*, and from and after such publication every scale of fees heretofore made by the said trustees shall be and is hereby rescinded to the extent to which it conflicts with this scale.

Public Graves

	\$
Interment in grave without exclusive right— stillborn child	11.00
Interment in grave without exclusive right— others	23.00
Number peg or label	5.00

Private Graves

Land, 2.44 m x 1.22 m	33.00
Own selection of land	8.00

<i>Miscellaneous Charges</i>		\$	\$
Interment fee	15.00	28. Permission to construct a brick grave or to erect any stone, kerb, brick, tile work or concrete	15.00
Certificate of right of burial	3.00	29. Grave renovations or additional inscription	10.00
Number plate or brick	5.00	30. Exhuming the remains of a body (when authorised)	290.00
Permission to erect a headstone or monument—5 per cent of cost with a minimum of \$8.00.		31. Interment of ashes in a private grave	15.00
Permission to construct a brick grave or to erect any stone kerb, brick tile-work or concrete	7.00	32. Removal of slab at owner's risk	10.00
Exhuming the remains of a body (when authorised)	100.00	33. Vaults, including land, sinking charges and construction, as arranged with the engineering department of the Wangaratta City Council	900.00
Interment of ashes in a private grave	15.00	34. Searching records and providing written information	5.00
	L. P. CURRAN, Trustee E. F. DOYLE, Trustee G. F. NOBLET, Trustee		

Approved by the Governor in Council, 5 August 1980—
TOM FORRISTAL, Clerk of the Executive Council

L. W. GREENWOOD, Trustee
JOHN K. HOWARD, Trustee
R. C. BEDFORD, Trustee

Cemeteries Act 1958

SCALE OF FEES OF THE WANGARATTA PUBLIC CEMETERY

In pursuance of the powers conferred upon them by the Cemeteries Act, the trustees of the Wangaratta Public Cemetery hereby make the following scale of fees, which shall come into operation upon publication in the *Government Gazette*, and from and after such publication every scale of fees heretofore made by the said trustees shall be and is hereby rescinded to the extent to which it conflicts with this scale.

Scale of Fees and Charges

	\$
1. 2440 mm x 1220 mm, general area	70.00
2. 3050 mm x 1220 mm, lawn area	145.00
3. 2440 mm x 1220 mm, (external measurement) vault area	70.00
4. 1830 mm x 910 mm, Children's lawn area (including sinking)	45.00
5. 1520 mm x 910 mm, Children's lawn area (including sinking)	28.00
6. 760 mm x 610 mm, Children's lawn area (including sinking)	22.00
7. Own selection of land, general area (extra)	28.00
<i>Land for Public Graves</i>	
8. Interment in grave without exclusive right—stillborn child	10.00
9. Interment in grave without exclusive right, (others)	70.00
10. Number peg or label	2.00
<i>Sinking Charges for Private Graves</i>	
11. Sinking grave 1600 mm deep	90.00
12. Sinking grave 2130 mm deep	100.00
13. Each additional 300 mm	15.00
14. Sinking oversize grave (extra)	15.00
15. Sinking oversize grave for American Type casket (extra)	15.00
16. Cancellation of order to sink (if commenced)	15.00
17. Vault preparation and sealing	28.00
<i>Re-opening Charges</i>	
18. Reopening grave (no cover)	90.00
19. Reopening grave (with cover)	100.00
20. Reopening grave (American type casket)	110.00
<i>Extra Charges</i>	
21. Interment in private grave without due notice	15.00
22. Late fee (per half or part thereof in excess of the first fifteen minutes)	5.00
23. Interments on Saturdays, Sundays or Public Holidays (extra)	40.00
<i>Miscellaneous Charges</i>	
24. Certificate of right of burial	2.00
25. Inspection of plan or register	2.00
26. Annual maintenance (single grave), optional	15.00
27. Permission to erect a headstone or monument—General Area— Plus an additional \$10.00 if flower containers (2) are to be supplied by trustees.	25.00
Lawn area, children's 760 mm x 610 mm (excludes flower containers)	10.00
Remainder of lawn area (including supply of two flower containers by trustees)	35.00

Approved by the Governor in Council, 5 August 1980—
TOM FORRISTAL, Clerk of the Executive Council

APPOINTMENTS AND RESIGNATIONS

APPOINTMENTS

His Excellency the Governor of the State of Victoria, by and with the advice of the Executive Council thereof, has, by Orders made on 5 August 1980, been pleased to make the under-mentioned appointments, viz.:

HEALTH COMMISSION

Deputy Superintendent

KEITH MCLEOD BENN, M.B., B.S., D.P.M., M.R.A.N.Z.C.P., to be Deputy Superintendent of the Warrnambool Mental Hospital, Psychiatric Hospital and Lewana Clinic, pursuant to the provisions of section 26 (1) of the *Mental Health Act 1959* as from 8 August 1980, vice S. N. Ahmed.

Trustees of Public Cemeteries

RONALD WALTER SCHUBERT to be an additional Trustee of the Horsham Public Cemetery,
WALTER JOHN PRICE to be a Trustee of the Yalca North Public Cemetery, vice N. R. Sutton, deceased,
DUNCAN HENRY MCNAUGHT to be a Trustee of the Patho and Torumbarry Public Cemetery, vice J. H. McNaught, deceased,
STANLEY JEANS, ALFRED JEANS, WILLIAM HIGGS, WILLIAM PETSCHACK, and LOUCLAN MITCHELL, to be additional Trustees of the Drouin West Public Cemetery,
GEORGE MACKAY to be a Trustee of the Warncoort Public Cemetery, vice S. C. England, resigned,
FRANK DIGNAN to be a Trustee of the Warncoort Public Cemetery, vice A. Dignan, deceased,
IAN DENNIS to be a Trustee of the Warncoort Public Cemetery, vice R. C. Dennis, deceased,
LESLEY PEARCE to be a Trustee of the Warncoort Public Cemetery, vice W. G. Collyer, resigned,
FREDERICK HENRY TUBB to be a Trustee of the Longwood Public Cemetery, vice R. Thomson, resigned, and
MAXWELL GEORGE COX to be an additional Trustee of the Longwood Public Cemetery, pursuant to section 3 (1) of the *Cemeteries Act 1958*.

LAW DEPARTMENT

Justices of the Peace

MALCOLM WESTWOOD FEARNLEY, 23 Roseberry Street, Lang Lang,
 GEORGE ARTHUR GILLINGHAM, Lake Charm, and
 VELIA TREUEL, Wonthaggi,
 to be Justices of the Peace for the State of Victoria.

Commissioners for Taking Declarations, &c.

ALAN JAMES BOULTON, 254 La Trobe Street, Melbourne,
 WILFRED CARMELO BUHAGIAR, 369 Sydney Road, Brunswick,
 MARGARET JUNE CLARK, 38 View Street, Bendigo,
 JACQUES DESIRE ROGER DUHAU, 226 Lorimer Street, Port Melbourne,
 RAYMOND LESLIE EDWARDS, Corio, Geelong,
 OXLEY ARTHUR GORDON-BROWN, 320 St. Kilda Road, Melbourne,
 WESLEY STEPHEN GUSE, 151 Campbell Street, Swan Hill,
 PETER WILLIAM HARRIS, 34 Wellington Road, Clayton North,
 EVAN HERBERT HICKS, 101 Lydiard Street North, Ballarat,
 DONALD GARRICK WUSTEMANN HOWGATE, 95 Main Street, Croydon,
 PAMELA CLAIRE HUBBARD, and
 DAVID WINSTON JONES, Westernport,
 IVAN KOVANOVIC, 42 Hall Street, Newport,
 PATRICK JOSEPH LIMA, 54 Fairbairn Road, Cranbourne,
 NOEL ALEXANDER MELVILLE, 37 Sunhill Road, Mount Waverley,
 RONALD JAMES MILLARD, 51 Nelson Street, Ringwood,
 DAVID PETER SHARPE, 82 Powlett Street, Altona Meadows,
 RUSSELL MILTON SMITH, 4 Teleta Crescent, Corio,
 COLIN JAMES SPIDEN, 44-60 Stokes Street, Port Melbourne,
 FRANK TRIPOLINO, 10 Station Street, Norlane,
 JOAN TYSON, 336 Glenferrie Road, Malvern,
 PATRICK RANDOLPH VETHECAN, 30 Winmalee Drive, Glen Waverley,
 RICHARD EDWIN WALLER, Wellington Road, Clayton, and
 JOHN SYDNEY WAREHAM, 2 Cope Street, Preston,
 to be Commissioners for taking Declarations and Affidavits under the Evidence Act 1958.

TOM FORRISTAL
 Clerk of the Executive Council

At the Executive Council Chamber
 Melbourne, 5 August 1980

Liquor Control Act 1968

APPOINTMENT OF LICENSING INSPECTORS

Whereas on 6 February 1980, Sinclair Imrie Miller, the Chief Commissioner of Police for the State of Victoria acting pursuant to the power vested in him by Section 6A of the Police Regulation Act 1958 delegated to me the undersigned David John Swanson being an Assistant Commissioner of Police for the said State and the person referred to in the said delegation all powers and functions vested in him by the Liquor Control Act 1968, from 6 February 1980, now therefore I do hereby appoint the following Officers of Police as Licensing Inspectors for the Divisions of the Police Districts as shown:

Division Number	Police District	Rank and Name
2	Altona	Chief Inspector Mervyn Henry Goltz (vice Superintendent W. J. Gore)
1	Avondale Heights	Inspector Joseph William Crawford (from 10.8.80 to 6.9.80)
3	Malvern	Inspector Raymond Ernest Ridley (from 10.8.80 to 30.8.80)
5	Maroondah	Inspector Russell Louis Bertram (from 17.8.80 to 20.9.80)
2	Prahran	Inspector Graeme Francis Crawford (from 17.8.80 to 6.9.80)

D. J. SWANSON
 Assistant Commissioner (Services)

7.8.1980

APPOINTMENT OF THE QUEEN ELIZABETH GERIATRIC CENTRE AS A TRUSTEE

His Excellency the Governor of the State of Victoria, in the Commonwealth of Australia, by and with the advice of the Executive Council of the said State, has approved the appointment of THE QUEEN ELIZABETH GERIATRIC CENTRE, a body corporate under the provisions of the Hospitals and Charities Act 1958, as sole Trustee of the land in the Township of Ballarat, permanently reserved as a site for Benevolent Asylum by Order in Council of 9 September 1878 (see Government Gazette, dated 13 September 1878) and being the land described in Crown Grants Volume 1091 Folio 218018 and Volume 1176 Folio 235061, in the place of Robert Lewis, Andrew Anderson, William Dimsey, James Oddie and Daniel Brophy, all deceased—(L3-840).

TOM FORRISTAL
 Clerk of the Executive Council

At the Executive Council Chamber
 Melbourne, 5 August 1980

Forests Act 1958

APPOINTMENT OF COMMITTEE OF MANAGEMENT OF MOUNT MACEDON MEMORIAL CROSS RESERVE

Whereas by section 50 of the Forests Act 1958 (No. 6254), it is provided that the Minister of Forests may, on the recommendation of the Forests Commission, appoint any number of persons, not less than three, to be a Committee of Management of any land forming part of any reserved forest, such land being set aside and declared to be a reserve for special purposes, and may remove any of those persons: Now therefore, I, Frederick James Granter, Her Majesty's Minister of Forests for the State of Victoria, on the recommendation of the Forests Commission, do hereby appoint—

RONALD ALEXANDER MCKENZIE
 as a member of the Committee of Management, until 4 July 1981 of the land forming part of the reserved forest in the Parish of Macedon, County of Bourke, described in the accompanying Schedule, and known as "Mount Macedon Memorial Cross Reserve".

SCHEDULE ABOVE REFERRED TO

Parish of Macedon, County of Bourke, comprising 4-414 hectares more or less, being the area shown by pink colour on plan marked 44/933 over S.684, in file of correspondence No. 73/1200 of the Forests Department.

Dated at Melbourne, 6 August 1980

F. J. GRANTER
 Minister of Forests

PARISH OF MOOROOPNA

APPOINTMENT OF COMMITTEE OF MANAGEMENT

Urban Waterworks Trust Area

Whereas by section 50 of the Forests Act 1958 (No. 6254), it is provided that the Minister of Forests may, on the recommendation of the Forests Commission, appoint any board, committee, commission, trust or other body corporate or unincorporate established by or under any Act for a public purpose, to be a Committee of Management of any land forming part of any reserved forest, such land being set aside and declared to be a reserve for special purposes, and may remove any of those bodies. Now therefore, I, Frederick James Granter, Her Majesty's Minister of Forests for the State of Victoria, on the recommendation of the Forests Commission, do hereby appoint—

SHEPPARTON URBAN WATERWORKS TRUST
 as the Committee of Management, until 30 September 1982 of the land forming part of the reserved forest in the Parish of Mooroopna County of Rodney shown by pink colour on plan marked B.39/26/71/1.10.40 in file of correspondence 67/64 of the Forests Department.

Dated at Melbourne, 6 August 1980

F. J. GRANTER
 Minister of Forests

REVOCATION OF APPOINTMENTS

His Excellency the Governor of the State of Victoria, by and with the advice of the Executive Council thereof, has, by Orders made on 5 August 1980, revoked the appointments of the persons named hereunder to the offices mentioned, viz.:—

LAW DEPARTMENT

Commissioners for Taking Declarations, &c.

GEORGE FREDERICK HOOD,
HARRY KEVIN SHARP, and
TASMAN SMITH,

as Commissioners for taking Declarations and Affidavits under the Evidence Act 1958.

TOM FORRISTAL
Clerk of the Executive Council

At the Executive Council Chamber
Melbourne, 5 August 1980

RESIGNATIONS

His Excellency the Governor of the State of Victoria, by and with the advice of the Executive Council thereof, has, by Orders made on 5 August 1980, accepted the resignations of the persons named hereunder of the offices mentioned, viz.:—

LAW DEPARTMENT

Justices of the Peace

THOMAS BISHOP NEIGHBOUR, and
JOHN TALBOT,
as Justices of the Peace for the State of Victoria.

Commissioners for Taking Declarations, &c.

HENRY GEORGE ARTHUR,
PETER BOWEN JACKSON,
STUART WILLIAM MCGREGOR,
KARL LEOPOLD MASES,
RICHARD LEWELLYN SHEPPARD,
GORDON READ SLEEMAN,
ALEXANDER WILLIAM WHITMORE, and
ERIC LLOYD WOOD,

as Commissioners for taking Declarations and Affidavits under the Evidence Act 1958.

TOM FORRISTAL
Clerk of the Executive Council

At the Executive Council Chamber
Melbourne, 5 August 1980

ORDERS IN COUNCIL

LOCAL GOVERNMENT ACT 1958

At the Executive Council Chamber, Melbourne, the
fifth day of August, 1980

PRESENT:

His Excellency the Governor of Victoria
Mr Dixon | Mr Jona
Mr Lieberman | Mr Lacy

ROAD DISCONTINUED—SHIRE OF BULN BULN

Whereas it is provided in section 528 (2) of the Local Government Act 1958, that where a road (whether or not a public highway but not being a road set out on land of the Crown) or any part thereof is not required for public use, the Governor in Council on the request of the Council of the municipality in which such road is situated made not less than one month after publishing in a newspaper generally circulating in the district and posting to the registered proprietor (if any) of the land and the owners and occupiers (if any) of lands abutting or immediately adjacent to the road notice of intention to make such a request may by Order published in the Government

Gazette direct that such road or part shall be discontinued and thereupon such road or part shall be discontinued accordingly.

And whereas the Council of the Shire of Buln Buln has requested that the Governor in Council direct that part of Roberts Road, Drouin be discontinued and not less than one month previously has published in a newspaper generally circulating in the district and posted to the registered proprietor of the land in the road and to the owners and occupiers of lands abutting or immediately adjacent to the road notice of intention to make such a request.

Now therefore, His Excellency the Governor of the State of Victoria by and with the advice of the Executive Council thereof, hereby directs that the said part of a road which is shown by hatching on the plan hereunder, shall be discontinued and the land in the said part of a road be sold by the Council of the Shire of Buln Buln by agreement.

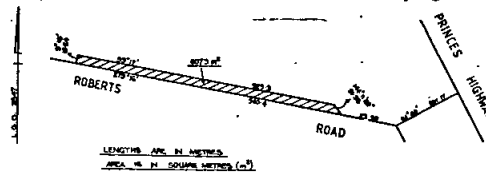

And the Honorable Digby Glen Crozier, Her Majesty's Minister for Local Government for the State of Victoria, shall give the necessary directions herein accordingly.

TOM FORRISTAL
Clerk of the Executive Council

LOCAL GOVERNMENT ACT 1958

At the Executive Council Chamber, Melbourne, the
fifth day of August, 1980

PRESENT:

His Excellency the Governor of Victoria
Mr Dixon | Mr Jona
Mr Lieberman | Mr Lacy

ROAD DISCONTINUED—CITY OF FRANKSTON

Whereas it is provided in section 528 (2) of the Local Government Act 1958, that where a road (whether or not a public highway but not being a road set out on land of the Crown) or any part thereof is not required for public use, the Governor in Council on the request of the council of the municipality in which such road is situated made not less than one month after publishing in a newspaper generally circulating in the district and posting to the registered proprietor (if any) of the land and the owners and occupiers (if any) of lands abutting or immediately adjacent to the road notice of intention to make such a request may by Order published in the Government Gazette direct that such road or part shall be discontinued and thereupon such road or part shall be discontinued accordingly.

And whereas the Council of the City of Frankston has requested that the Governor in Council direct that part of Fenton Crescent, Frankston, be discontinued and not less than one month previously has published in a newspaper generally circulating in the district and posted to the registered proprietor of the land in the road and to the owners and occupiers of lands abutting or immediately adjacent to the road notice of intention to make such a request:

Now therefore, His Excellency the Governor of the State of Victoria, by and with the advice of the Executive Council thereof, hereby directs:

- (a) that the said part of road which is shown by hatching and cross hatching on the plan hereunder, shall be discontinued;
- (b) that notwithstanding such discontinuance the Frankston Sewerage Authority shall continue to have and possess the same right title power authority or interest in or in relation to the whole of the land shown by cross hatching on the said

plan as it had or possessed prior to such discontinuance with respect to or in connection with any drains or pipes laid or erected in on or over such land for the purposes of sewerage; and

- (c) that subject to any such right title power authority, or interest, the land shown by hatching and cross hatching on the said plan shall be retained by the Council of the City of Frankston for municipal purposes.

LOCAL GOVERNMENT ACT 1958

At the Executive Council Chamber, Melbourne, the fifth day of August, 1980

PRESENT:

His Excellency the Governor of Victoria
Mr Dixon | Mr Jona
Mr Lieberman | Mr Lacy

FIXATION AND DECLARATION OF BREADTHS OF CARRIAGEWAY AND FOOTWAYS—CITY OF BRIGHTON

In pursuance of the provisions of section 520 of the Local Government Act 1958, His Excellency the Governor of the State of Victoria, by and with the advice of the Executive Council thereof, and in compliance with a request of the Council of the City of Brighton hereby fixes and declares the breadths of carriageway and footways of Munro Street, Brighton, in the manner indicated on the plan hereunder.

CITY OF BRIGHTON

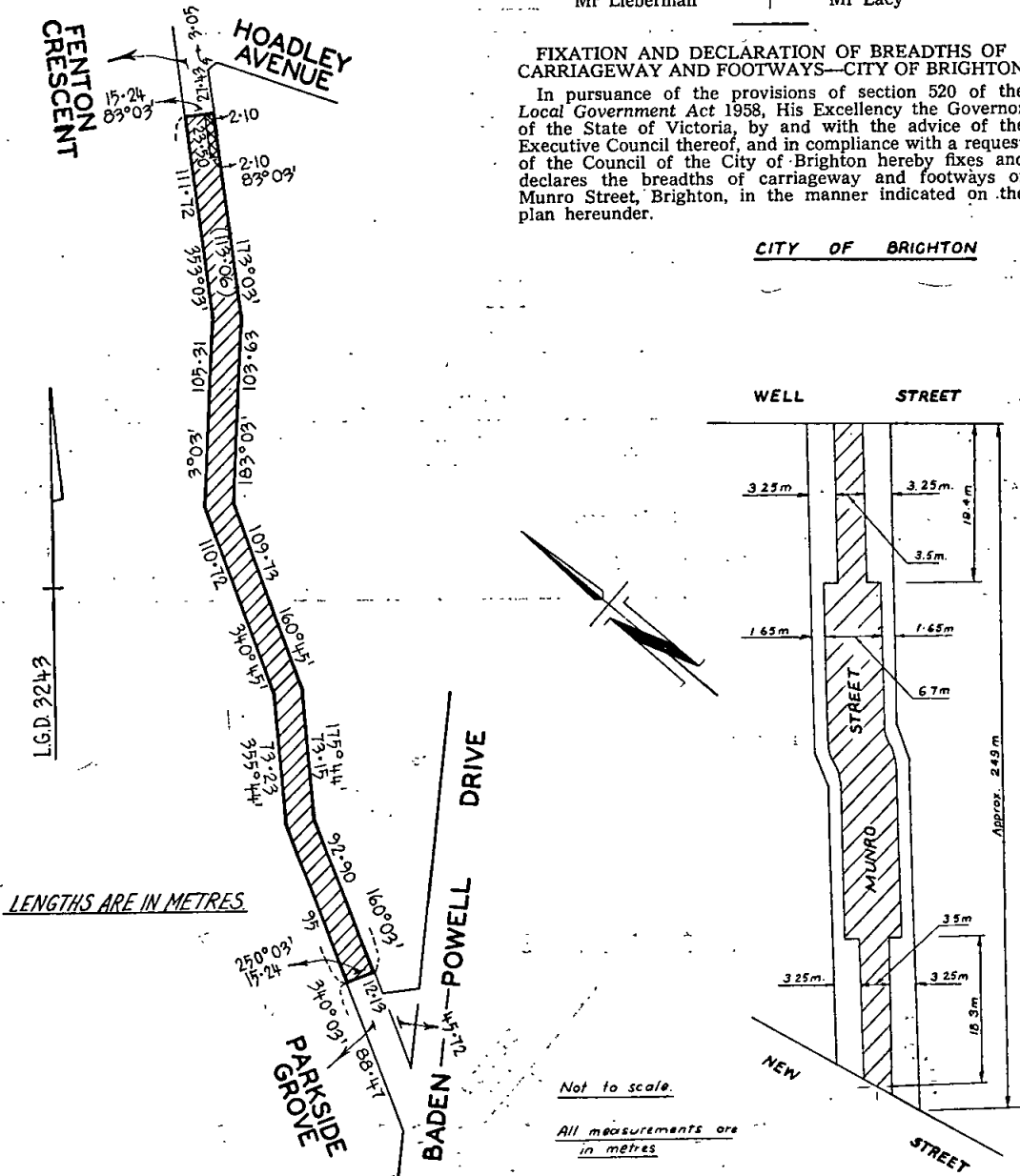

LENGTHS ARE IN METRES.

Not to scale.
All measurements are in metres

And the Honorable Digby Glen Crozier, Her Majesty's Minister for Local Government for the State of Victoria, shall give the necessary directions herein accordingly.

TOM FORRISTAL
Clerk of the Executive Council

And the Honorable Digby Glen Crozier, Her Majesty's Minister for Local Government for the State of Victoria, shall give the necessary directions herein accordingly.

TOM FORRISTAL
Clerk of the Executive Council

RAILWAY CONSTRUCTION AND PROPERTY BOARD ACT 1979

At the Executive Council Chamber, Melbourne, the fifth day of August, 1980

PRESENT:

His Excellency the Governor of Victoria
 Mr Dixon | Mr Jona
 Mr Lieberman | Mr Lacy

VESTING OF HOUSES IN THE RAILWAY CONSTRUCTION AND PROPERTY BOARD

Whereas it is provided by section 24 (1) of the *Railway Construction and Property Board Act 1979*, that where the Victorian Railways Board by resolution determines that a dwelling house and appurtenant land vested in the Victorian Railways Board that is or has been used for the purposes of a residence for persons employed in the Railway Service should be transferred to the Railway Construction and Property Board for the purposes of Part V. of that Act the Governor in Council may, by order published in the *Government Gazette*, vest the land described in the resolution in the Board for the purposes of Part V., subject to all existing leases, tenancies and other rights or interests of or in that land.

And whereas the Victorian Railways Board by resolution dated 14 July 1980 determined that the dwelling houses and appurtenant lands described in the Schedule hereunder should be transferred to the Railway Construction and Property Board for the purposes of Part V. of the *Railway Construction and Property Board Act 1979*.

Now therefore, His Excellency the Governor of the State of Victoria, by and with the advice of the Executive Council thereof, and in pursuance of the provisions of section 24 (1) of the *Railway Construction and Property Board Act 1979* by this Order vests in the Railway Construction and Property Board the dwelling houses and appurtenant lands described in the Schedule hereunder subject to all existing leases, tenancies and other rights or interests of or in that land.

SCHEDULE

Address	Lot No.	L.P. No.	Title Particulars	
			Volume	Folio
41 Station Pl, Sunshine } 43 Station Pl, Sunshine }	See Plan "A" hereunder		Both Part of Conveyance Book 311 Memorial 909 and Part of former Subdivisional Road (Durham Road)	
41 Hanover Pl, Oakleigh			3435	968 (whole)
24 Lorensen Ave, Merlynston—See Plan "B" hereunder			2049	788 (part)
91 Rupert St, Tottenham } 93 Rupert St, Tottenham }	See Plan "C" hereunder		3575	980 (part)
105 Rupert St, Tottenham }			3575	980 (part)
			3560	979 (part)

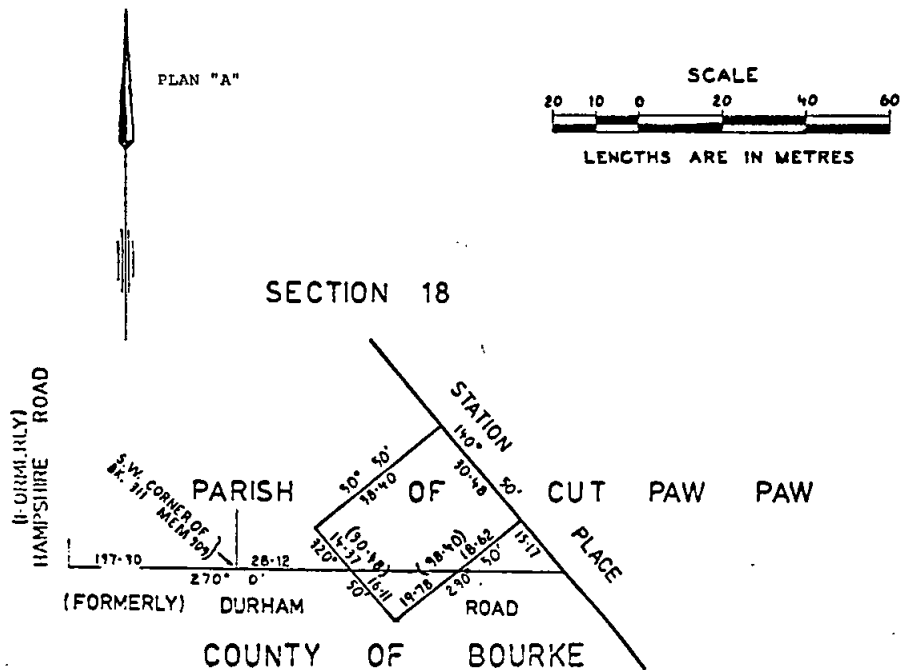

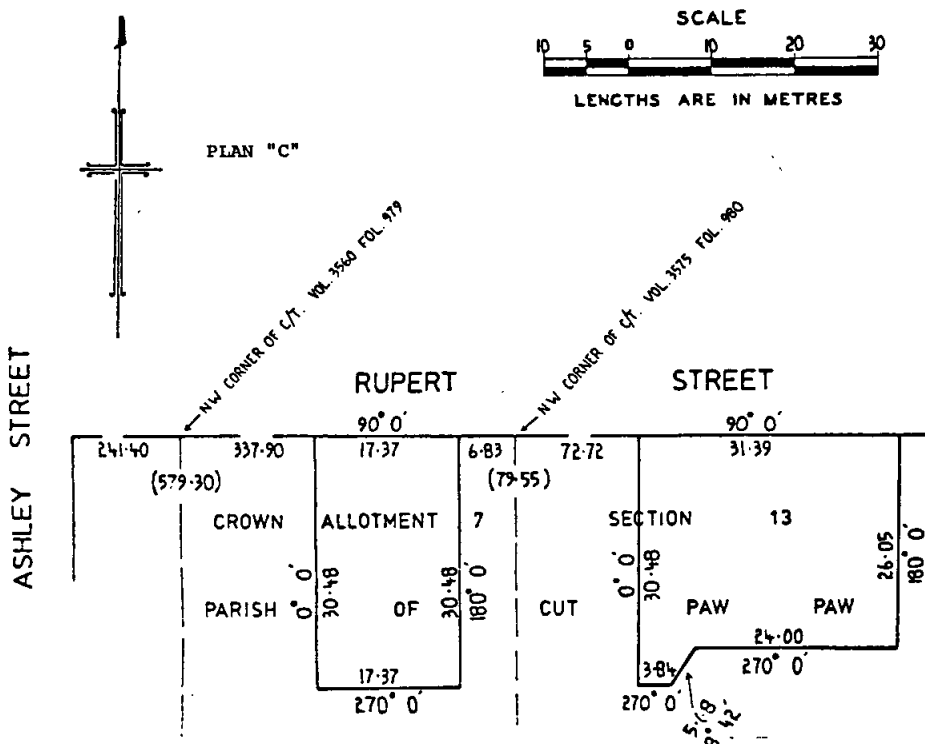
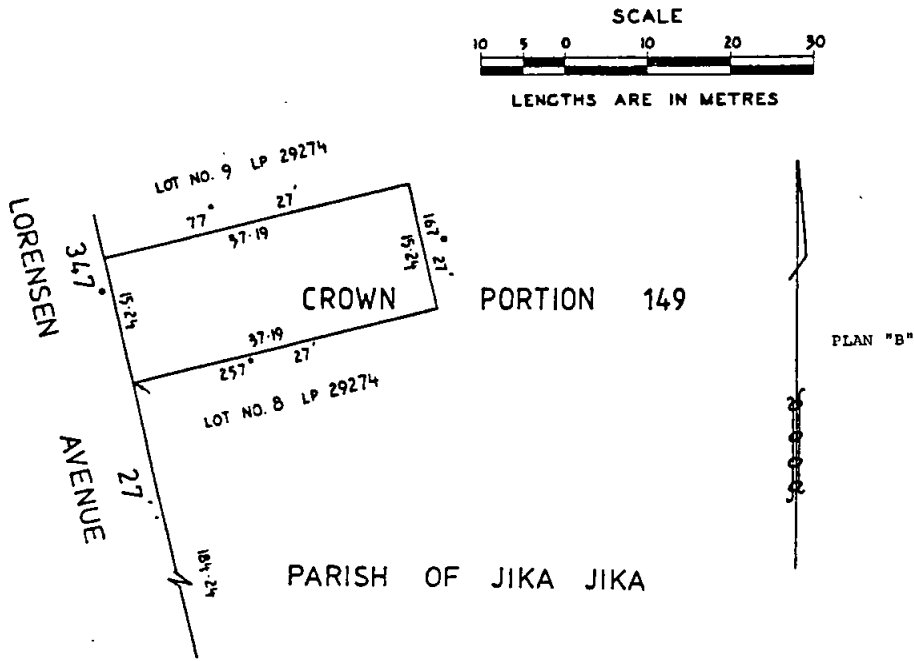

And the Honorable Robert Roy Cameron Maclellan, Her Majesty's Minister of Transport for the State of Victoria, shall give the necessary directions herein accordingly.

TOM FORRISTAL
Clerk of the Executive Council

COUNTRY ROADS ACT 1958
Act No. 6229

At the Executive Council Chamber, Melbourne, the
fifth day of August, 1980

PRESENT:

His Excellency the Governor of Victoria
Mr Dixon | Mr Jona
Mr Lieberman | Mr Lacy

ORDER CONFIRMING RESOLUTIONS OF THE
COUNTRY ROADS BOARD

His Excellency the Governor of the State of Victoria,
by and with the advice of the Executive Council thereof,
doth hereby, in pursuance of the provisions of the *Country
Roads Act 1958*, confirm the resolutions of the Country
Roads Board, the dates whereof and the terms of which
are scheduled hereunder:

SCHEDULE
Main road

Resolution dated the Twenty-first day of July One
thousand nine hundred and eighty made pursuant to
section 18 of the *Country Roads Act 1958* rescinding the
resolution passed by the Country Roads Board on the
Twentieth day of January One thousand nine hundred and
forty-one and confirmed by an Order in Council published
in the *Government Gazette* of the Twenty-ninth day of
January One thousand nine hundred and forty-one on
page 298 declaring the highway to be a main road
(Dalyston-Glen Forbes Road) in the Shire of Bass so far
as it relates to the part of the said main road indicated by
cross-hatching on plan numbered G.P.1826P hereunder.

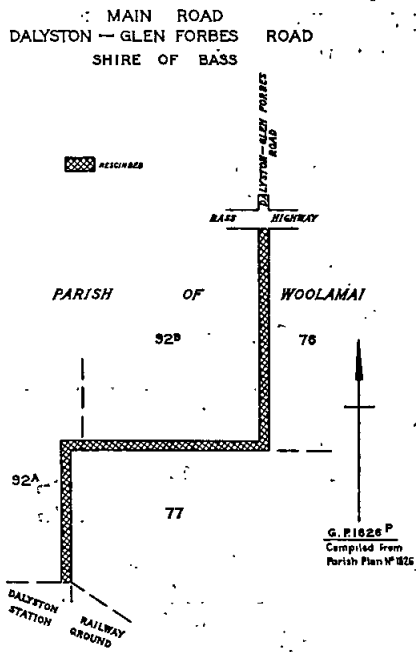

COUNTRY ROADS BOARD
Act No. 6229

At the Executive Council Chamber, Melbourne, the
fifth day of August, 1980

PRESENT:

His Excellency the Governor of Victoria
Mr Dixon | Mr Jona
Mr Lieberman | Mr Lacy

ORDER APPROVING OF LAND BEING ACQUIRED AND
ROADS, DEVIATIONS OR WIDENINGS BEING MADE
TOGETHER WITH ALL ANCILLARY WORKS REQUIRED
TO BE EXECUTED IN CONJUNCTION THEREWITH

His Excellency the Governor of the State of Victoria,
by and with the advice of the Executive Council thereof,
being satisfied that there are funds legally available for
acquiring the land, doth hereby approve the acquiring of
the land described in the schedule hereunder and the
making of new roads and deviations from and widenings
of existing roads, together with all the ancillary works
required to be executed in conjunction therewith, referred
to in the said schedule.

SCHEDULE
State highway

The land shown hatched on plan numbered G.P.15077
hereunder required for the widening of and deviation from
the Omeo Highway in the Shire of Tambo and making
of the widening and deviation thereon.

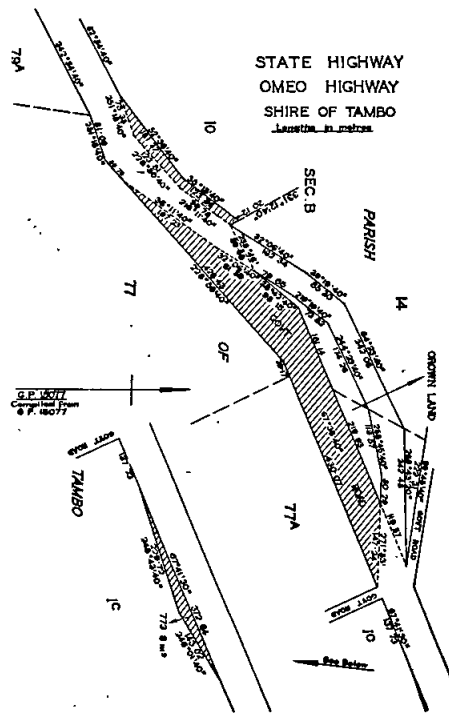

And the Honorable Robert Roy Cameron Maclellan, Her
Majesty's Minister of Transport for the State of Victoria,
shall give the necessary directions herein accordingly.

TOM FORRISTAL
Clerk of the Executive Council

And the Honorable Robert Roy Cameron Maclellan, Her
Majesty's Minister of Transport for the State of Victoria,
shall give the necessary directions herein accordingly.

TOM FORRISTAL
Clerk of the Executive Council

CROWN LAND (RESERVES) ACT 1978

At the Executive Council Chamber, Melbourne, the fifth day of August, 1980

PRESENT:

His Excellency the Governor of Victoria
 Mr Dixon | Mr Jona
 Mr Lieberman | Mr Lacy

CROWN LANDS TEMPORARILY RESERVED

His Excellency the Governor of the State of Victoria, in the Commonwealth of Australia, by and with the advice of the Executive Council of the said State, pursuant to the provisions of sections 4 and 7 of the Crown Land (Reserves) Act 1978, and being of the opinion that the Crown lands concerned are required for the purposes respectively mentioned, doth hereby temporarily reserve and also except from occupation for mining purposes under any miner's right the Crown lands hereinafter described, viz.:

BARNAWARTHA SOUTH—For Conservation of Area of Natural Interest—3.6 hectares, more or less, being Crown allotment 1A, section 40, Parish of Barnawartha South, as indicated by hatching on plan hereunder—(Parish 2077) (Rs.11169).

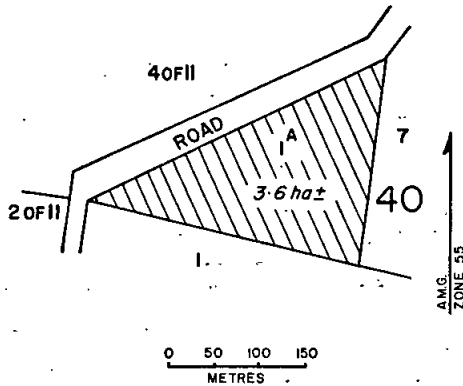

BOORONGIE—For Conservation of Area of Natural Interest—13.67 hectares, being Crown allotment 31A, Parish of Boorongie, as indicated by hatching on plan hereunder—(B.772^(a)) (Rs.11144).

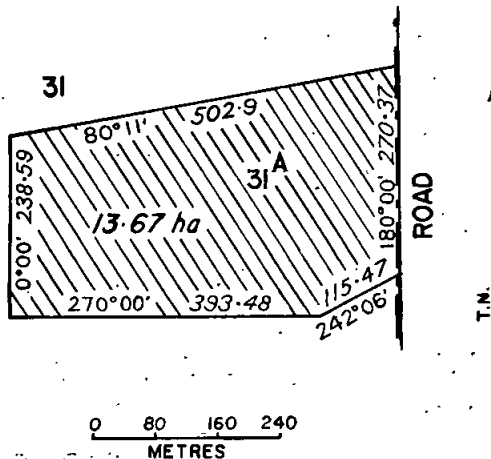

GERAHMIN—For Conservation of Area of Natural Interest—20.87 hectares, being Crown allotments 29A, 37A and 38A, Parish of Gerahmin, as indicated by hatching on plan hereunder—(G.219^(a)) (Rs.11320).

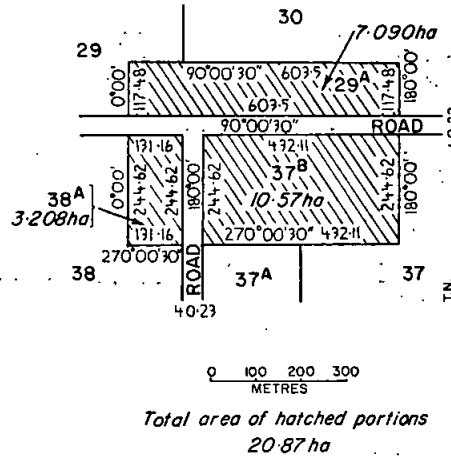

PATCHEWOLLOCK—For Racecourse, Showgrounds and Public Recreation—28.67 hectares, being Crown allotment 31C, Parish of Patchewollock, as shown on Certified Plan No. 104546 lodged in the Central Plan Office—(P.146^(?)) (Rs.3563).

PATCHEWOLLOCK—For Landing Ground for Aircraft—56.02 hectares, being Crown allotments 28 and 28A, Parish of Patchewollock, as shown on Certified Plan No. 104546 lodged in the Central Plan Office—(P.146^(?)) (Rs.10811).

SANDHURST (AT EAGLEHAWK)—For Public Park and Preservation of Species of Native Plants—10.97 hectares, being Crown allotments 207E, 208B, 246A and 304, section N, at Eaglehawk, Parish of Sandhurst, as indicated by hatching on plan hereunder—(Parish 3473) (1 and 6) (Rs.11088).

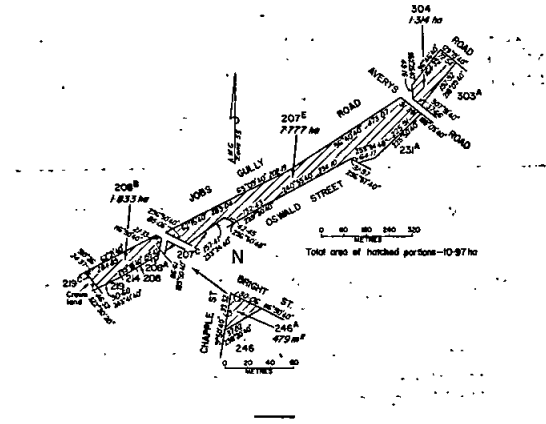

And the Honorable William Vasey Houghton, Her Majesty's Minister of Lands for the State of Victoria, shall give the necessary directions herein accordingly.

TOM FORRISTAL
 Clerk of the Executive Council

CROWN LAND (RESERVES) ACT 1978

At the Executive Council Chamber, Melbourne, the fifth day of August, 1980

PRESENT:

His Excellency the Governor of Victoria
 Mr Dixon | Mr Jona
 Mr Lieberman | Mr Lacy

CROWN LANDS TEMPORARILY RESERVED

His Excellency the Governor of the State of Victoria, in the Commonwealth of Australia, by and with the advice of the Executive Council of the said State, pursuant to the provisions of sections 4 and 7 of the *Crown Land (Reserves) Act 1978*, and being of the opinion that the Crown lands concerned are required for the public purposes mentioned, doth hereby temporarily reserve and also except from occupation for mining purposes under any miner's right, the Crown lands hereinafter described, viz.:

PANTON HILL—For Educational purposes, 2.242 hectares, being Crown allotment 3A, Township of Panton Hill, as shown on Certified Plan No. 104612 lodged in the Central Plan Office—(Rs.10585).

WARRION—For the Protection of the bed and banks of a Lake, 27 hectares, more or less, being Crown allotment 19P, Parish of Warrion, as indicated by hatching on plan hereunder—(W.59(4)) (Rs.11213).

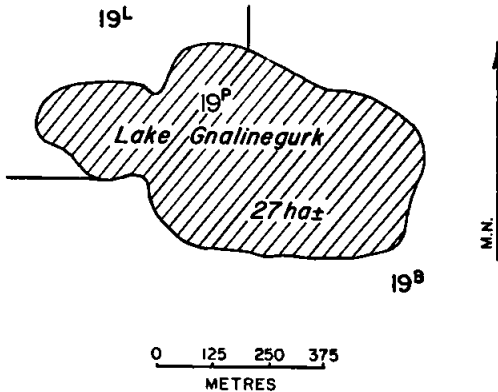

And the Honorable William Vasey Houghton, Her Majesty's Minister of Lands for the State of Victoria, shall give the necessary directions herein accordingly.

TOM FORRISTAL
 Clerk of the Executive Council

REVOCATION AND EXCISION OF CROWN RESERVATIONS ACT 1976

At the Executive Council Chamber, Melbourne, the fifth day of August, 1980

PRESENT:

His Excellency the Governor of Victoria
 Mr Dixon | Mr Jona
 Mr Lieberman | Mr Lacy

LAND VESTED IN THE MELBOURNE AND METROPOLITAN BOARD OF WORKS

His Excellency the Governor of the State of Victoria, in the Commonwealth of Australia, by and with the advice of the Executive Council of the said State, pursuant to the provisions of section 5 of the *Revocation and Excision of*

Crown Reservations Act 1976, No. 8847, doth hereby vest in the Melbourne and Metropolitan Board of Works Allotment 28E in the Parish of Keelbundora as indicated by hatching on plan hereunder—(K.25(5)) (C.100911).

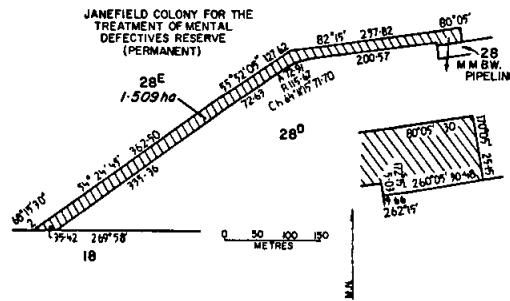

And the Honorable William Vasey Houghton, Her Majesty's Minister of Lands for the State of Victoria, shall give the necessary directions herein accordingly.

TOM FORRISTAL
 Clerk of the Executive Council

INDUSTRIAL TRAINING ACT 1975

At the Executive Council Chamber, Melbourne, the fifth day of August, 1980

PRESENT:

His Excellency the Governor of Victoria
 Mr Dixon | Mr Jona
 Mr Lieberman | Mr Lacy

APPOINTMENT OF MEMBERS OF THE INDUSTRIAL TRAINING COMMISSION OF VICTORIA

In pursuance of the powers conferred by Section 7 of the *Industrial Training Act 1975*, and all other powers him thereunto enabling, His Excellency the Governor of the State of Victoria, by and with the advice of the Executive Council thereof, doth by this Order make the under-mentioned appointments to the Industrial Training Commission of Victoria for a term of three years commencing on 1 September 1980—

WILLIAM NORMAN ROEBUCK
 being an officer of the Education Department nominated by the Minister of Education, as Deputy President;

THEODORE JOHN COUTTS and
REGINALD EDWARD BASSETT RAYNER
 as members representing employers and who were nominated by the Victorian Chamber of Manufacturers;

DONALD COCKRAM
 as a member representing employers and who was nominated by the Victorian Employers' Federation;

DAVID LINNEY WILLS
 as a member representing employers and who was nominated by the Victorian Branch of the Metal Trades Industry Association of Australia; and

FRANCIS HENRY BOSWELL
STANLEY BITMEAD
KEVIN FRANCIS CASEY and
FREDERICK CHARLES NELSON
 as members representing employees and who were nominated by the Victorian Trades Hall Council.

And the Honorable James Halford Ramsay, Her Majesty's Minister of Labour and Industry for the State of Victoria, shall give the necessary directions herein accordingly.

TOM FORRISTAL
 Clerk of the Executive Council

SUPERANNUATION ACT 1958

At the Executive Council Chamber, Melbourne, the
fifth day of August, 1980

PRESENT:

His Excellency the Governor of Victoria

Mr Dixon	Mr Jona
Mr Lieberman	Mr Lacy

Pursuant to the powers conferred by the provisions of paragraph (ja) of sub-section (1) of section (3) of the Superannuation Act 1958, His Excellency the Governor of the State of Victoria, by and with the advice of the Executive Council thereof doth by this Order declare that the provisions of the Superannuation Act shall apply to the officers named in the Schedule set out hereunder.

SCHEDULE

McCARTHY, PETER LYLE, Ballarat College of Advanced Education.
LEES, CAROLE MAY, and
SVALBE, IMANTS,
Caulfield Institute of Technology.
BALDWIN, BARBARA JANE,
CARUANA, ANTHONY GERALD,
DORIAN, ANITA MARY,
FRENCH, EDITH GEORGINA,
GAMBLE, JENNIFER MARGOR,
GLEISNER, KERRY ANNE,
LANCIANA, JOE,
MORRISON, ROBYN MAREE,
WALKER, SUSAN, and
WALSH, PATRICIA ROSALIE,
Motor Accidents Board.
BACON, HELEN MAREE, Warrnambool Institute of Advanced Education.

And the Honorable Lindsay Hamilton Simpson Thompson, Her Majesty's Treasurer for the State of Victoria, shall give the necessary directions herein accordingly.

TOM FORRISTAL
Clerk of the Executive Council

SHIRE OF MANSFIELD SEWERAGE AUTHORITY

At the Executive Council Chamber, Melbourne, the
fifth day of August, 1980

PRESENT:

His Excellency the Governor of Victoria

Mr Dixon	Mr Jona
Mr Lieberman	Mr Lacy

EXTENT OF SHIRE OF MANSFIELD SEWERAGE DISTRICT INCREASED

Under the powers conferred by the Sewerage Districts Act and all other powers enabling him in that behalf, His Excellency the Governor of the State of Victoria, by and with the advice of the Executive Council of the said State, doth hereby declare, order and direct that the extent of the Shire of Mansfield Sewerage District of the Shire of Mansfield Sewerage Authority be increased by adding thereto the land shown by red border on the plan approved by the Governor in Council, by and with this Order and deposited in the office of the State Rivers and Water Supply Commission, Melbourne (Corr. No. 79/3611/7) and as on and from the date hereof the extent of such district shall be and be deemed to be increased accordingly.

And the Honorable Frederick James Granter, Her Majesty's Minister of Water Supply for the State of Victoria, shall give the necessary directions herein accordingly.

TOM FORRISTAL
Clerk of the Executive Council

MOOROOPNA SEWERAGE AUTHORITY

At the Executive Council Chamber, Melbourne, the
fifth day of August, 1980

PRESENT:

His Excellency the Governor of Victoria

Mr Dixon	Mr Jona
Mr Lieberman	Mr Lacy

APPROVAL TO SITE OF OUTFALL PIPELINE

Under the powers conferred by the Sewerage Districts Act and all other powers enabling him in that behalf, His Excellency the Governor of the State of Victoria, by and with the advice of the Executive Council of the said State, doth hereby approve of the site required for an outfall pipeline by the Mooroopna Sewerage Authority as shown by orange colour on a plan approved by the Governor in Council and deposited in the office of the State Rivers and Water Supply Commission, Melbourne (Corr. No. 77/3834/47).

And the Honorable Frederick James Granter, Her Majesty's Minister of Water Supply for the State of Victoria, shall give the necessary directions herein accordingly.

TOM FORRISTAL
Clerk of the Executive Council

STATE ELECTRICITY COMMISSION ACT 1958, No. 6377

At the Executive Council Chamber, Melbourne, the
fifth day of August, 1980

PRESENT:

His Excellency the Governor of Victoria

Mr Dixon	Mr Jona
Mr Lieberman	Mr Lacy

Whereas His Excellency the Governor of the State of Victoria by and with the advice of the Executive Council thereof has this day consented pursuant to the provisions of the State Electricity Commission Act 1958 to the State Electricity Commission of Victoria raising by way of a loan the sum of Nineteen thousand dollars (\$19 000); and whereas the Governor in Council is satisfied that a sufficient proportion of the loan to be raised will fall due and be repaid in each year during the currency of the proposed loan; now therefore it is directed pursuant to the provisions of section 91 (3) of the said Act, that it shall not be necessary to provide a sinking fund in connection with such loan.

And the Honorable Lindsay Hamilton Simpson Thompson, Her Majesty's Treasurer for the State of Victoria, shall give the necessary directions herein accordingly.

TOM FORRISTAL
Clerk of the Executive Council

STATE ELECTRICITY COMMISSION ACT 1958, No. 6377

At the Executive Council Chamber, Melbourne, the
fifth day of August, 1980

PRESENT:

His Excellency the Governor of Victoria

Mr Dixon	Mr Jona
Mr Lieberman	Mr Lacy

Whereas His Excellency the Governor of the State of Victoria by and with the advice of the Executive Council thereof has this day consented pursuant to the provisions

of the *State Electricity Commission Act 1958* to the State Electricity Commission of Victoria raising by way of loan the sum of One hundred and fifty-four thousand dollars (\$154 000); and whereas the Governor in Council is satisfied that a sufficient proportion of the loan to be raised will fall due and be repaid in each year during the currency of the proposed loan; now therefore it is directed pursuant to the provisions of section 91 (3) of the said Act, that it shall not be necessary to provide a sinking fund in connection with such loan.

And the Honorable Lindsay Hamilton Simpson Thompson, Her Majesty's Treasurer for the State of Victoria, shall give the necessary directions herein accordingly.

TOM FORRISTAL
Clerk of the Executive Council

LIQUOR CONTROL ACT 1968

At the Executive Council Chamber, Melbourne, the fifth day of August, 1980

PRESENT:

His Excellency the Governor of Victoria	
Mr Dixon	Mr Jona
Mr Lieberman	Mr Lacy

APPOINTMENT OF DEPUTY JUDICIAL MEMBER AND DEPUTY CHAIRMAN OF THE LIQUOR CONTROL COMMISSION

Whereas sub-section (6) of section 7 of the *Liquor Control Act 1968* provides, *inter alia*, that if a member of the Liquor Control Commission is unable to act as a member, the Governor in Council may appoint an eligible person to act as deputy for such member while he is unable to act:

And whereas John Richard Campton a judicial member and Chairman of the Commission will be unable to act as a member in connection with the hearing of the under-mentioned applications—

Reasons for determination in the matter of an application by Australian Safeway Stores Proprietary Limited for a retail bottled liquor licence for premises known as Safeway Store located at 361 High Street, Lalor.

Judgment in the matter of an application by Decameron Proprietary Limited for the grant of a retail bottled liquor licence for premises to be constructed, altered and repaired at Shop 1, Shopping Centre, Corner of McKimmies Road and Darebin Drive, Lalor:

Now therefore, in pursuance of the powers conferred by the said sub-section, His Excellency the Governor of the State of Victoria, by and with the advice of the Executive Council thereof, doth by this Order appoint—

WARREN FAGAN, a person qualified to be appointed a Judge of the County Court—

to be a deputy judicial member and Deputy Chairman of the Commission in respect of those applications during the period 5 August 1980 to 15 August 1980, both dates inclusive.

And the Honorable James Halford Ramsay, Her Majesty's Minister of Labour and Industry for the State of Victoria, shall give the necessary directions herein accordingly.

TOM FORRISTAL
Clerk of the Executive Council

COBRAM WATERWORKS TRUST

At the Executive Council Chamber, Melbourne, the twelfth day of August, 1980

PRESENT:

His Excellency the Governor of Victoria	
Mr Smith	Mr Houghton
Mr Ramsay	

CONSENT TO BORROWING \$100 000

Under the powers conferred by the Water Act and all other powers enabling him in that behalf, His Excellency the Governor of the State of Victoria, by and with the advice of the Executive Council of the said State, hereby consents to the Cobram Waterworks Trust borrowing the sum of One hundred thousand dollars (\$100 000) to meet the cost of water supply works.

And the Honorable Frederick James Granter, Her Majesty's Minister of Water Supply for the State of Victoria, shall give the necessary directions herein accordingly.

TOM FORRISTAL
Clerk of the Executive Council

CORRYONG WATERWORKS TRUST

At the Executive Council Chamber, Melbourne, the twelfth day of August, 1980

PRESENT:

His Excellency the Governor of Victoria	
Mr Smith	Mr Houghton
Mr Ramsay	

CONSENT TO BORROWING \$10 000

Under the powers conferred by the Water Act and all other powers enabling him in that behalf, His Excellency the Governor of the State of Victoria, by and with the advice of the Executive Council of the said State, hereby consents to the Corryong Waterworks Trust borrowing the sum of Ten thousand dollars (\$10 000) to meet the cost of water supply works.

And the Honorable Frederick James Granter, Her Majesty's Minister of Water Supply for the State of Victoria, shall give the necessary directions herein accordingly.

TOM FORRISTAL
Clerk of the Executive Council

MARYBOROUGH WATERWORKS TRUST

At the Executive Council Chamber, Melbourne, the twelfth day of August, 1980

PRESENT:

His Excellency the Governor of Victoria	
Mr Smith	Mr Houghton
Mr Ramsay	

CONSENT TO BORROWING \$100 000

Under the powers conferred by the Water Act and all other powers enabling him in that behalf, His Excellency the Governor of the State of Victoria, by and with the advice of the Executive Council of the said State,

hereby consents to the Maryborough Waterworks Trust borrowing the sum of One hundred thousand dollars (\$100 000) to meet the cost of water supply works.

And the Honorable Frederick James Granter, Her Majesty's Minister of Water Supply for the State of Victoria, shall give the necessary directions herein accordingly.

TOM FORRISTAL
Clerk of the Executive Council

CITY OF WARRNAMBOOL—WATER SUPPLY DISTRICT

At the Executive Council Chamber, Melbourne, the
twelfth day of August, 1980

PRESENT:

His Excellency the Governor of Victoria	
Mr Smith	Mr Houghton
Mr Ramsay	

CONSENT TO BORROWING \$200 000

Under the powers conferred by the Water Act and all other powers enabling him in that behalf, His Excellency the Governor of the State of Victoria, by and with the advice of the Executive Council of the said State, hereby consents to the City of Warrnambool borrowing the sum of Two hundred thousand dollars (\$200 000) to meet the cost of water supply works.

And the Honorable Frederick James Granter, Her Majesty's Minister of Water Supply for the State of Victoria, shall give the necessary directions herein accordingly.

TOM FORRISTAL
Clerk of the Executive Council

WESTERNPORT WATERWORKS TRUST

At the Executive Council Chamber, Melbourne, the
twelfth day of August, 1980

PRESENT:

His Excellency the Governor of Victoria	
Mr Smith	Mr Houghton
Mr Ramsay	

CONSENT TO BORROWING \$250 000

Under the powers conferred by the Water Act and all other powers enabling him in that behalf, His Excellency the Governor of the State of Victoria, by and with the advice of the Executive Council of the said State, hereby consents to the Westernport Waterworks Trust borrowing the sum of Two hundred and fifty thousand dollars (\$250 000) to meet the cost of unsubsidised water supply works.

And the Honorable Frederick James Granter, Her Majesty's Minister of Water Supply for the State of Victoria, shall give the necessary directions herein accordingly.

TOM FORRISTAL
Clerk of the Executive Council

GEELONG WATERWORKS AND SEWERAGE TRUST

At the Executive Council Chamber, Melbourne, the
twelfth day of August, 1980

PRESENT:

His Excellency the Governor of Victoria	
Mr Smith	Mr Houghton
Mr Ramsay	

CONSENT TO BORROWING \$300 000

Under the powers conferred by the Geelong Waterworks and Sewerage Act and all other powers enabling him in that behalf, His Excellency the Governor of the State of Victoria, by and with the advice of the Executive Council of the said State, hereby consents to the Geelong Waterworks and Sewerage Trust borrowing the sum of Three hundred thousand dollars (\$300 000) to meet the cost of water supply works.

And the Honorable Frederick James Granter, Her Majesty's Minister of Water Supply for the State of Victoria, shall give the necessary directions herein accordingly.

TOM FORRISTAL
Clerk of the Executive Council

GEELONG WATERWORKS AND SEWERAGE TRUST

At the Executive Council Chamber, Melbourne, the
twelfth day of August, 1980

PRESENT:

His Excellency the Governor of Victoria	
Mr Smith	Mr Houghton
Mr Ramsay	

CONSENT TO BORROWING \$269 000

Under the powers conferred by the Geelong Waterworks and Sewerage Act and all other powers enabling him in that behalf, His Excellency the Governor of the State of Victoria, by and with the advice of the Executive Council of the said State, hereby consents to the Geelong Waterworks and Sewerage Trust borrowing the sum of Two hundred and sixty-nine thousand dollars (\$269 000), in two separate loans of Fifty thousand dollars (\$50 000) and Two hundred and nineteen thousand dollars (\$219 000) to meet the cost of conversion of Loan Nos. H9, 19 and S.11.

And the Honorable Frederick James Granter, Her Majesty's Minister of Water Supply for the State of Victoria, shall give the necessary directions herein accordingly.

TOM FORRISTAL
Clerk of the Executive Council

LATROBE VALLEY ACT 1958

At the Executive Council Chamber, Melbourne, the
twelfth day of August, 1980

PRESENT:

His Excellency the Governor of Victoria	
Mr Smith	Mr Houghton
Mr Ramsay	

APPOINTMENT OF A DEPUTY MANAGER TO THE LATROBE VALLEY WATER AND SEWERAGE BOARD

Under the powers conferred upon him by section 29 of the Latrobe Valley Act 1958, His Excellency the Governor of the State of Victoria, by and with the advice

of the Executive Council thereof, hereby appoints GORDON THOMAS COULSON to be Deputy Manager of the Latrobe Valley Water and Sewerage Board for the period from 1 September 1980 up to and including 24 October 1980.

And the Honorable Frederick James Granter, Her Majesty's Minister of Water Supply for the State of Victoria, shall give the necessary directions herein accordingly.

TOM FORRISTAL
Clerk of the Executive Council

DROMANA-ROSEBUD SEWERAGE AUTHORITY

At the Executive Council Chamber, Melbourne, the twelfth day of August, 1980

PRESENT:

His Excellency the Governor of Victoria	
Mr Smith	Mr Houghton
Mr Ramsay	

CONSENT TO BORROWING \$300 000

Under the powers conferred by the Sewerage Districts Act and all other powers enabling him in that behalf, His Excellency the Governor of the State of Victoria, by and with the advice of the Executive Council of the said State, hereby consents to the Dromana-Rosebud Sewerage Authority borrowing the sum of Three hundred thousand dollars (\$300 000) in two separate loans of Fifty thousand dollars (\$50 000) and Two hundred and fifty thousand dollars (\$250 000) to meet the cost of sewerage works as set forth in the detailed statement bearing date 5 August 1980.

And the Honorable Frederick James Granter, Her Majesty's Minister of Water Supply for the State of Victoria, shall give the necessary directions herein accordingly.

TOM FORRISTAL
Clerk of the Executive Council

DROMANA-ROSEBUD SEWERAGE AUTHORITY

At the Executive Council Chamber, Melbourne, the twelfth day of August, 1980

PRESENT:

His Excellency the Governor of Victoria	
Mr Smith	Mr Houghton
Mr Ramsay	

CONSENT TO BORROWING \$200 000

Under the powers conferred by the Sewerage Districts Act and all other powers enabling him in that behalf, His Excellency the Governor of the State of Victoria, by and with the advice of the Executive Council of the said State, hereby consents to the Dromana-Rosebud Sewerage Authority borrowing the sum of Two hundred thousand dollars (\$200 000) in two separate loans of One hundred thousand (\$100 000) and One hundred thousand dollars (\$100 000) to meet the cost of sewerage works as set forth in the detailed statement bearing date 6 August 1980.

And the Honorable Frederick James Granter, Her Majesty's Minister of Water Supply for the State of Victoria, shall give the necessary directions herein accordingly.

TOM FORRISTAL
Clerk of the Executive Council

MOORoopNA SEWERAGE AUTHORITY

At the Executive Council Chamber, Melbourne, the twelfth day of August, 1980

PRESENT:

His Excellency the Governor of Victoria	
Mr Smith	Mr Houghton
Mr Ramsay	

CONSENT TO BORROWING \$65 000

Under the powers conferred by the Sewerage Districts Act and all other powers enabling him in that behalf, His Excellency the Governor of the State of Victoria, by and with the advice of the Executive Council of the said State, hereby consents to the Mooroopna Sewerage Authority borrowing the sum of Sixty-five thousand dollars (\$65 000) to meet the cost of sewerage works as set forth in the detailed statement bearing date 5 August 1980.

And the Honorable Frederick James Granter, Her Majesty's Minister of Water Supply for the State of Victoria, shall give the necessary directions herein accordingly.

TOM FORRISTAL
Clerk of the Executive Council

SHEPPARTON SEWERAGE AUTHORITY

At the Executive Council Chamber, Melbourne, the twelfth day of August, 1980

PRESENT:

His Excellency the Governor of Victoria	
Mr Smith	Mr Houghton
Mr Ramsay	

CONSENT TO BORROWING \$35 000

Under the powers conferred by the Sewerage Districts Act and all other powers enabling him in that behalf, His Excellency the Governor of the State of Victoria, by and with the advice of the Executive Council of the said State, hereby consents to the Shepparton Sewerage Authority borrowing the sum of Thirty-five thousand dollars (\$35 000) for the conversion of Loan No. 7.

And the Honorable Frederick James Granter, Her Majesty's Minister of Water Supply for the State of Victoria, shall give the necessary directions herein accordingly.

TOM FORRISTAL
Clerk of the Executive Council

WODONGA SEWERAGE AUTHORITY

At the Executive Council Chamber, Melbourne, the twelfth day of August, 1980

PRESENT:

His Excellency the Governor of Victoria	
Mr Smith	Mr Houghton
Mr Ramsay	

CONSENT TO BORROWING \$100 000

Under the powers conferred by the Sewerage Districts Act and all other powers enabling him in that behalf, His Excellency the Governor of the State of Victoria, by and with the advice of the Executive Council of the said State, hereby consents to the Wodonga Sewerage Authority borrowing the sum of One hundred thousand

dollars (\$100 000) to meet the cost of the sewerage works as set forth in the detailed statement bearing date 5 August 1980.

And the Honorable Frederick James Granter, Her Majesty's Minister of Water Supply for the State of Victoria, shall give the necessary directions herein accordingly.

TOM FORRISTAL
Clerk of the Executive Council

RACING ACT 1958

At the Executive Council Chamber, Melbourne, the twelfth day of August, 1980

PRESENT:

His Excellency the Governor of Victoria
Mr Smith | Mr Houghton
Mr Ramsay

APPOINTMENT OF MEMBERS OF THE GREYHOUND RACING CONTROL BOARD

In pursuance of the powers conferred by the *Racing Act 1958* and all other powers him thereunto enabling, His Excellency the Governor of the State of Victoria, in the Commonwealth of Australia, by and with the advice of the Executive Council of the said State, doth by this Order appoint the following six persons to be members of the Greyhound Racing Control Board for a term of three years from 24 August 1980:

RONALD MICHAEL NESTOR, as the member referred to in paragraph (b) of sub-section (2) of section 69 of the said Act;

ROSS EDWARD MITCHELL, as the member referred to in paragraph (c) of sub-section (2) of the said section 69;

NOEL JAMES BANKS, as the member referred to in paragraph (d) of sub-section (2) of the said section 69;

GEORGE HECTOR SCHOFIELD, as the member referred to in paragraph (e) of sub-section (2) of the said section 69;

LESLIE GEORGE FORAN, as the member referred to in paragraph (f) of sub-section (2) of the said section 69;

RONALD JOSEPH MAURICE SNELL, as the member referred to in paragraph (g) of sub-section (2) of the said section 69.

And the Honorable Brian James Dixon, Her Majesty's Minister for Youth, Sport and Recreation for the State of Victoria, shall give the necessary directions herein accordingly.

TOM FORRISTAL
Clerk of the Executive Council

OMBUDSMAN ACT 1973

At the Executive Council Chamber, Melbourne, the twelfth day of August, 1980

PRESENT:

His Excellency the Governor of Victoria
Mr Smith | Mr Houghton
Mr Ramsay

APPOINTMENT OF A COMMISSIONER FOR ADMINISTRATIVE INVESTIGATIONS, TO BE CALLED THE OMBUDSMAN

In pursuance of the provisions of section 3 of the *Ombudsman Act 1973*, the Governor of the State of Victoria, by and with the advice of the Executive Council thereof, hereby appoints Charles Norman Geschke to be the Ombudsman from and including 1 September 1980.

And the Honorable Rupert James Hamer, Her Majesty's Premier for the State of Victoria, shall give the necessary directions herein accordingly.

TOM FORRISTAL
Clerk of the Executive Council

LANDS DEPARTMENT NOTICES

APPROACHING LAND SALES

Sale of Crown Land, will be held at the under-mentioned places and dates, viz.:—

	No. of Gazette
Dartmoor—Friday, 19 September 1980	66
Kew—Wednesday, 3 September 1980	61
Kaniva—Monday, 13 October 1980	68
Mortlake—Wednesday, 20 August 1980	53
Warracknabeal—Monday, 25 August 1980	61

SALE OF FREEHOLD LAND BY AUCTION

Gannawarra North—Saturday, 13 September 1980 64

SALE BY AUCTION OF THE RIGHT TO LEASE CROWN LAND

Wonthaggi—Thursday, 4 September 1980 66

SALE OF CROWN LAND BY AUCTION

The land will be offered for sale subject to the provisions of the *Land Act* and Regulations thereunder.

The upset price is the sum at which bidding will start, and no bid below that sum can be accepted. The highest bidder at or above that sum shall be the purchaser, subject to signature of contract and any necessary payment.

TERMS:—

A deposit of at least 12½% of the purchase price must be paid at the sale, either in cash or by cheque.

The residue is payable in half-yearly instalments, in accordance with the following scale, or may be paid off at any earlier time.

Over \$40, and not exceeding \$100,	8 instalments.
Over \$100, and not exceeding \$200,	10 instalments.
Over \$200, and not exceeding \$400,	12 instalments.
Over \$400, and not exceeding \$600,	14 instalments.
Over \$600, and not exceeding \$800,	16 instalments.
Over \$800, and not exceeding \$1000,	18 instalments.
Over \$1000,	20 instalments.

Interest at the rate of 9% per annum is payable with all payments of residue, and is computed for each instalment from the date of sale to the date of such payment. Additional interest is charged if any instalment is not paid on or before the due date.

If paid off within 30 days of sale, no interest is payable.

FEES, ETC.:

Survey fee payable at the sale.

Payable with balance of purchase money—

Crown Grant fee—\$25.00.

Assurance Fund contribution.—One cent in every Five dollars or part thereof of purchase price. (This is a fund established to guarantee the validity of freehold titles.)

Transfer of interest prior to completion of payment may be allowed on payment of \$20 fee and subject to stamp duty.

If unable to attend personally, a prospective purchaser may arrange for another person to bid as his agent.

Attention is drawn to section 95, *Land Act 1958*, which provides that the purchaser shall be deemed to be the owner for the purposes of other Acts; also to an amendment to the *Local Government Act* providing for Government roads, in certain circumstances, to be declared "private streets", thus making the purchaser liable to contribute to the cost of street construction.

W. V. HOUGHTON
Minister of Lands

Department of Crown Lands and Survey
Melbourne, 13 August 1980

KANIVA—Sale (No. 12314) of Crown land, by auction, will be held at the LAND INSPECTOR'S OFFICE, KANIVA, on MONDAY, 13 OCTOBER 1980, at TWO O'CLOCK P.M. To be conducted by P. T. LEDGAR, Land Officer, Horsham.

Lot 1

PARISH OF YANIPY

Facing the south side of the Miram-Kaniva Road immediately south-east of the north-western railway line crossing.

Upset price \$250.00 the lot. Survey fee \$300.00. Area 8772 square metres. Allotment 78c—(M.56678).

Lot 2

TOWNSHIP OF MIRAM, PARISH OF MIRAMPIRAM

At the corner of the Miram-Kaniva Road and a Government Road about 75 metres west of the Miram Railway Station.

Upset price \$50.00 the lot. Survey fee \$250.00. Area 1872 square metres. Allotment 1 of section 7—(L.4-1239).

PROPOSED REVOCATIONS OF TEMPORARY RESERVATIONS OF LANDS BY ORDERS IN COUNCIL

In pursuance of the provisions of section 10 of the Crown Land (Reserves) Act 1978, notice is hereby given that it is the intention of the Governor in Council to revoke the temporary reservations of lands by Orders in Council hereunder referred to, viz.:

CHILTERN—The temporary reservation by Order in Council of 9 July 1912 of 11.64 hectares of land in the Parish of Chiltern as a site for Supply of Gravel, so far only as the portion thereof containing 1.831 hectares, as indicated by hatching on plan hereunder, is concerned—(Parish 2381) (Rs.3819).

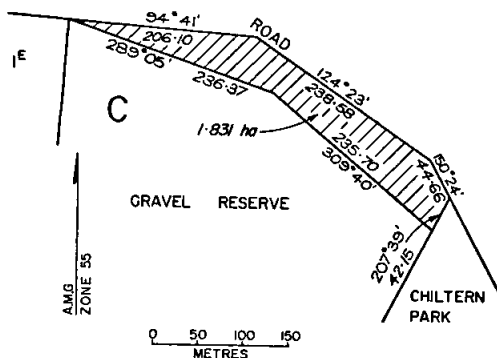

STREATHAM—The temporary reservation by Order in Council of 28 August 1906 of 1.416 hectares of land in the Township of Streatham (in section 5) as a site for a State School, so far only as the portion thereof containing 360 square metres, as shown on Certified Plan No. 104384 lodged in the Central Plan Office—(Rs.6838).

W. V. HOUGHTON
Minister of Lands

TENDERS

PUBLIC WORKS DEPARTMENT

Tenders are invited for the purposes indicated hereunder and will be received at 2 Treasury Place, Melbourne, 3002, until TWO p.m. on dates shown.

Tenders must be addressed to the Minister of Public Works with the envelope endorsed "Tender for

". Hand-delivered tenders must be placed in the Department's tender box in the foyer, Ground Floor, 2 Treasury Place, Melbourne.

Tenders documents are available from the Contracts Office, Room 29, 2 Treasury Place, Melbourne and where indicated, at offices of Inspectors of Works.

★Tenders for works identified with star (★) will only be considered from Contractors qualified for repairs and painting works. Any Tenderers wishing to qualify may obtain the application form from the Contracts Office.

Tuesday, 26 August 1980

Building, Electrical and Mechanical Works

LANGI KAL KAL—Improvements to water supply, Training Centre. (W.O., Ballarat.)

Miscellaneous

ALEXANDRA—Maintenance cleaning, period 15 September 1980 to 30 September 1983, Police Station. (W.O., Alexandra.)

ALEXANDRA—Maintenance cleaning, period 15 September 1980 to 30 September 1983, Soil Conservation Authority. (W.O., Alexandra.)

BERWICK—Maintenance cleaning, period 1 September 1980 to 31 August 1983, Court House.

COLLINGWOOD—Maintenance cleaning, period 1 September 1980 to 31 August 1983, Stores Branch, Education.

FLEMINGTON AREA—Maintenance cleaning, period 1 September 1980 to 31 August 1983, Dental Units.

THORNBURY—Maintenance cleaning, period 1 September 1980 to 31 August 1983, Attendance Centre, Community Welfare Services.

Tuesday, 2 September 1980

Building, Electrical and Mechanical Works

AUBURN SOUTH—Fire protection system, electrical, Primary School.

Miscellaneous

BALLARAT—Maintenance cleaning, period 15 September 1980 to 30 September 1981, Public Offices. (W.O., Ballarat.)

BOX HILL—Maintenance cleaning, period 29 September 1980 to 30 September 1983, Labour and Industry.

DANDENONG—Maintenance cleaning, period 29 September 1980 to 30 September 1983, Labour and Industry.

LEONGATHA—(Re-advertisement)—Maintenance cleaning, period 15 September 1980 to 31 August 1983, Court-house. (W.O., Korumburra.)

SERENDIP—Maintenance cleaning, period 1 September 1980 to 31 August 1983, Fowl Research Station. (W.O., Geelong.)

TOM AUSTIN
Minister of Public Works

Public Works Department
Melbourne, 12 August 1980

Teaching Service Act 1958
TEACHING SERVICE (TEACHERS TRIBUNAL)
REGULATIONS

AMENDMENT No. 519 (T.T. 86)

The Teachers Tribunal, in pursuance of the powers conferred by the *Teaching Service Act 1958*, hereby amends Regulation 14 of the Teaching Service (Teachers Tribunal) Regulations as follows:—

REGULATION 14

Rescind sub-clauses 6 (a) and 6 (b) and substitute therefor the following sub-clauses:—

“6. (a) In addition to the number of classified teachers provided for, relieving teachers shall be appointed as follows:—

<i>Principal, Grade "A" School</i>	<i>Principal, Grade "B" School</i>	<i>Assistant Teachers in Receipt of Responsibility Allowance</i>	<i>Other Assistant Teachers</i>
3	4	52	116

(b) Relieving teachers in receipt of the responsibility allowance shall be appointed on the basis of one for the Knox Region, one for the Frankston Region, nine for the Sunshine Region, nine for the Preston Region, five for the Central Region, fourteen for country districts, and thirteen for State-wide relievers.”

(To take effect from and including 1 January 1981.)

J. J. KENNEDY, Chairman
L. D. KEEN, Acting Secretary

Office of the Teachers Tribunal
Melbourne, 4 August 1980

**PRIVATE
ADVERTISEMENTS**

CITY OF BENDIGO

LOAN No. 106

*Notice of Intention to Borrow the Sum of \$150 000 for
Permanent Works and Undertakings*

Notice is hereby given that the Council of the City of Bendigo proposes to borrow the principal sum of \$150 000 secured by a charge over the general rates of the Municipality, such sum to be raised by the grant of a Mortgage Loan in accordance with the provisions of the *Local Government Act 1958*.

1. The maximum rate of interest that may be paid is 12.6 per cent per annum.

2. The purpose for which the Loan is to be applied is:

	\$
Construction of Multi-Storey Car Park, Hargreaves Street, Bendigo	100 000
Carwardine Street Construction	33 300
Council proportion Knight Street Bridge Construction (Total Cost \$38 955)	16 700

3. The period of the Loan shall be ten (10) years.

4. The moneys borrowed shall be repaid by the creation of a sinking fund and an appropriate amount will be set aside annually out of the Municipal Fund for such purposes as determined by the State Auditor-General.

5. Such moneys shall be repayable at the State Superannuation Board of Victoria, 35 Spring Street, Melbourne.

The plans and specifications and an estimate of the cost of the proposed works and a statement showing the proposed expenditure of the money to be borrowed are open for inspection at the Municipal Offices, Lyttleton Terrace, Bendigo during office hours.

9061

C. K. BEAMISH, Town Clerk

CITY OF BERWICK

*Notice of Intention to Borrow the Sum of \$250 000 for
Permanent Works and Undertakings*

Notice is hereby given that the Council of the City of Berwick proposes to borrow the principal sum of \$250 000 secured by a charge over the general rates of the municipality, such sum to be raised by the grant of a mortgage loan in accordance with the provisions of the *Local Government Act 1958*.

1. Maximum rate of interest that may be paid is 12.6 per centum per annum.

2. The purpose for which the loan is to be applied:—

Construction of Berwick Leisure Centre (Part)	\$250 000
--	-----------

3. The period of the loan shall be twenty years.

4. The moneys borrowed shall be repayable by providing out of the Municipal fund forty half yearly instalments of \$17 247.61 each including principal and interest, on the 1 April and 1 September during the currency of the loan. The first instalment shall be payable on 1 April 1981.

5. Such moneys shall be repayable to the office of the Local Authorities Superannuation Board, Rigby House, 15 Queens Road, Melbourne, or such other place or places as the Board from time to time may require.

The plans and specifications and the estimate of the cost of the proposed works and a statement showing the proposed expenditure of the moneys to be borrowed are open for inspection at the office of the Council of the City of Berwick, Civic Centre, Princes Highway, Fountain Gate, Narre Warren.

Dated 13 August 1980

9004 P. J. NORTHEAST, City Manager/Town Clerk

CITY OF CAMBERWELL

LOAN No. 123

Notice of Intention to Borrow the Sum of \$1 000 000 for Permanent Works and Undertakings

Notice is hereby given that the Council of the City of Camberwell proposes to borrow the sum of \$1 000 000 secured by a charge over the General Rates of the Municipality, such sum to be raised by the grant of a mortgage in accordance with the provisions of the *Local Government Act 1958*.

(1) The maximum rate of interest that may be paid is 12.6 per cent.

(2) The purpose for which the Loan is to be applied is:

Re-development—Council Depot (Part Cost) \$1 000 000

(3) The period of the Loan shall be fifteen (15) years.

(4) The monies borrowed shall be repayable by providing out of the Municipal Fund thirty (30) half-yearly instalments of approximately \$74 996.12 each including principal and interest on 10 May and 10 November during the currency of the Loan. The first instalment shall be repayable on 10 May 1981.

(5) Such monies shall be repayable to the Commercial Savings Bank of Australia Limited, at the Head Office of the bank in Melbourne, or at such other place as the said bank may require.

The plans and specifications and estimate of the cost of the proposed expenditure of the money to be borrowed are open for inspection at the Municipal Offices, 350 Camberwell Road, Camberwell during business hours.

8971 L. F. CHEFFERS, Chief Administrator

CITY OF CAMBERWELL

LOAN No. 124

Notice of Intention to Borrow the Sum of \$200 000 for Permanent Works and Undertakings

Notice is hereby given that the Council of the City of Camberwell proposes to borrow the sum of \$200 000 secured by a charge over the General Rates of the Municipality, such sum to be raised by the grant of a mortgage in accordance with the provisions of the *Local Government Act 1958*.

(1) The maximum rate of interest that may be paid is 12.6 per cent.

(2) The purpose for which the Loan is to be applied is:

	\$
Residential Street Construction	(Part Cost)
Yeovil Road	30 200
Montague Street	55 500
Hazeldine Street	114 300
	200 000

(3) The period of the Loan shall be fifteen (15) years.

(4) The monies borrowed shall be repayable by providing out of the Municipal Fund thirty (30) half-yearly instalments of approximately \$14 999.22 each including principal and interest on 10 June and 10 December during the currency of the Loan. The first instalment shall be repayable on 10 June 1981.

(5) Such monies shall be repayable to the Commercial Savings Bank of Australia Limited, at the Head Office of the bank in Melbourne, or at such other place as the said bank may require.

The plans and specifications and the estimate of the cost of the proposed expenditure of the money to be borrowed are open for inspection at the Municipal Offices, 350 Camberwell Road, Camberwell during business hours.

8972 L. F. CHEFFERS, Chief Administrator

CITY OF ECHUCA

NAMING OF STREETS

Notice is hereby given that the Council of the City of Echuca has caused the following roadway to be named:—

Woolar Road: The whole of that un-named roadway adjacent to the eastern boundary of Lot 30, L.P.121687, Parish of Echuca North, County of Rodney.

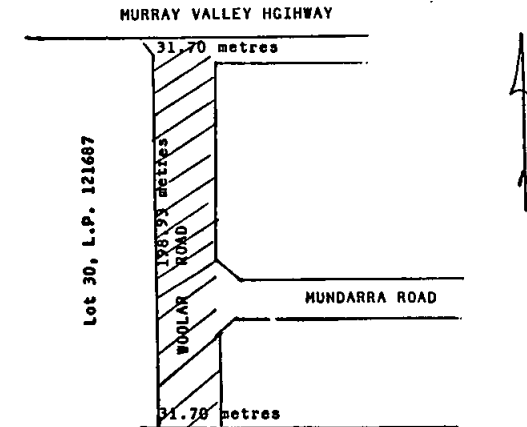

8985

K. F. McCARTNEY, Town Clerk

Town and Country Planning Act 1961 (Twelfth Schedule)
CITY OF MILDURA PLANNING SCHEME

NOTICE THAT A PLANNING SCHEME HAS BEEN PREPARED AND IS AVAILABLE FOR INSPECTION

Amendment No. 35, 1980

Notice is hereby given that the Mildura City Council in pursuance of its powers under the *Town and Country Planning Act 1961* has prepared a planning scheme to rezone the following land:

known as 130-164 and 129-163 Langtree Avenue having a south-eastern and north-western frontage of 181.10 m with a depth of 47.25 m and commencing 20.12 m south-west of Tenth Street; and also areas of land being 130-164 and 129-163 Lime Avenue having a south-eastern and north-western frontage of 181.10 m with a depth of 47.25 m and commencing 20.12 m south-west of Tenth Street; and also areas of land being 130-164 and 131-163 Pine Avenue having a south-eastern frontage of 181.10 m and a north-western frontage of 171.04 m with a depth of 47.25 m and commencing 20.12 m south-west of Tenth Street on the south-eastern side and 30.18 m south-west of Tenth Street on the north-western side of Pine Avenue, to Commercial "E".

A copy of the scheme has been deposited at the offices of the Mildura City Council, Deakin Avenue, Mildura, and at the office of the Town and Country Planning Board, 235 Queen Street, Melbourne, and will be open for inspection during office hours by any person free of charge.

Any persons affected by the planning scheme are required to set forth in writing all objections they may have addressed to the Town Clerk, City of Mildura, Civic Buildings, Deakin Avenue, Mildura, on or before 13 September 1980, and to state whether they wish to be heard in respect of their objections.

30 July 1980

8941

DAMIAN B. GOSS
Town Clerk and Chief Executive

BOROUGH OF KOROIIT

By-Law No. 22

Notice is hereby given that the Council of the Borough of Koroit has made a By-Law, numbered 22, under the provisions of the *Local Government Act 1958* and the *Uniform Building Regulations, Victoria*, for the following purpose:—

Minimum Area, Depth and Width of Frontage

The minimum areas, depths and widths of frontage specified in Column 4 of Table 804 of the *Uniform Building Regulations, Victoria, 1974* (as amended) are hereby adopted as the minimum areas, depths and widths of frontage of land on which a building of Class I. or Class II. occupancy shall be constructed throughout the whole of the municipal district.

The resolution for passing the By-Law was agreed to at a meeting held on 7 November 1979 and confirmed on 5 December 1979. Governor in Council approval was given on 22 July 1980.

A copy of the By-Law is available for inspection at the Municipal Offices, High Street, Koroit, during office hours.
8942 A. J. MACDONALD, Town Clerk

SHIRE OF BULLA

LOAN NO. 95

Notice of Intention to Borrow the Sum of \$30 000

Notice is hereby given that the Council of the Shire of Bulla propose to borrow the sum of \$30 000 secured by a charge over the general rates of the municipality, such sum to be raised by the grant of a Mortgage in accordance with the provisions of the *Local Government Act 1958*.

1. The maximum rate of interest that may be paid is 11.2 per cent per annum.
2. The purpose for which the loan is to be applied is towards the cost of extension at the D. S. Aitken Reserve, Craigieburn.
3. The period of the loan shall be 10 years.
4. The moneys borrowed shall be repayable by 20 half-yearly instalments of principal and interest of \$2531.25, first instalment being payable on 1 October 1980.
5. Such moneys shall be repayable at the office of Australia and New Zealand Savings Bank Limited, 69-71 Evans Street, Sunbury.

Plans, specifications and estimate of the cost of the work, and a statement showing the proposed expenditure of the moneys to be borrowed, are open for inspection at the Municipal Offices, Sunbury.

8986 JOHN M. KELLY, Shire Secretary

SHIRE OF FLINDERS

RENAMING OF STREETS

Notice is hereby given that pursuant to the provisions of section 535 of the *Local Government Act 1958*, the council of the Shire of Flinders has resolved that the following street names be changed.

Old Name—Toolern Avenue.

New Name—Manna Street.

Description—From a point commencing at the junction of Manna Street, Anne Drive and the north western boundary of lot 41 on plan of subdivision 13270 south to Jamieson Street.

Old Name—Pier Street.

New Name—Frieda Street.

Description—From a point commencing at the southern peninsula freeway south east to the junctions of Mary Street and Panoramic Avenue.

Old Name—Pier Street.

New Name—Mary Street.

Description—From a point commencing at the southern most point of Lot 138 on Plan of Subdivision 12635 and the easternmost point of Lot 101 on Plan of Subdivision 12635 south east then south to boundary Road.

Old Name—Burrell Road.

New Name—La Trobe Parade.

Description—From a point commencing at Nepean Highway south east to Palmerston Avenue.

Old Name—Howitt Street.

New Name—Clifftop Court.

Description—From a point commencing at the south easternmost point of Lot 90 and north easternmost point of Lot 91 both on Plan of Subdivision 15265 then in a south west direction to the eastern boundary of Lot 86 on Plan of Subdivision 15265.

Old Name—Howitt Street.

New Name—Foord Lane.

Description—That section of road running along the south west boundary of Lot 10 on Plan of Subdivision 10775 and the north east boundary of Lot 91 on Plan of Subdivision 15265.

Old Name—Howitt Street.

New Name—Drury Lane.

Description—Commencing at the north west corner of Lot 28 on Plan of Subdivision 10775 and the north east corner of Lot 99 on Plan of Subdivision 15265 then in a south easterly direction to the south east corner of Lot 48 on Plan of Subdivision 10775 and the easternmost point of Lot 2 on Plan of Subdivision 116317.

Old Name—Wattle Road.

New Name—Agonis Court.

Description—Commencing at South Road and then in a north east direction to the Mornington Peninsula Freeway access road.

Old Name—Wattle Road.

New Name—Myrtle Street.

Description—Commencing at South Road and then in a southerly direction to the boundary of the Mornington Peninsula Freeway.

Old Name—Violet Street.

New Name—Eliza Street.

Description—Commencing at Broadway and then in a south east direction to Swans Way.

Old Name—Wynne Street.

New Name—Vale Street.

Description—Commencing at Broadway and then in a south west direction to Swans Way.

Old Name—Elanora Avenue.

New Name—Elanora Court.

Description—Located on Plan of Subdivision 11991 and running in an easterly direction off Elizabeth Avenue.

Old Name—Yaringa Crescent.

New Name—Yaringa Court.

Description—Commencing at Marshall Street and running in a westerly direction to Highbury Road.

Old Name—Yaringa Crescent.

New Name—Farm Street.

Description—Commencing at Highbury Road and running in a westerly direction to Bella Vista Drive.

Old Name—Bella Vista Drive.

New Name—Eureka Street.

Description—Commencing at Marshall Street and running in a westerly direction to Highbury Road.

Old Name—Bella Vista Drive.

New Name—Teresa Court.

Description—Commencing from the south west corner of Lot 159 on Plan of Subdivision 551136 and the north west corner of Lot 178 on Plan of Subdivision 44884 then in an easterly direction to Highbury Road.

Old Name—Bella Vista Drive.

New Name—Grandview Avenue.

Description—Commencing at Grandview Avenue then in a north westerly direction to Meadow Avenue.

Old Name—Meadow Avenue.

New Name—Carlton Court.

Description—Commencing at the south west corner of Lot 109 and the north west corner of Lot 134 both on Plan of Subdivision 51136 then in an easterly direction to Highbury Road.

Old Name—Meadow Avenue.

New Name—Grandview Avenue.

Description—Commencing at the south west corner of Lot 109 and the north west corner of Lot 134 both of Plan of Subdivision 51136 then in a westerly direction to Government Road.

Old Name—Saville Street.

New Name—Saville Court.

Description—Located on Plan of Subdivision 26728 and running south of Sullivan Street.

Old Name—Michael Road.

New Name—Michael Street.

Description—Commencing at the Nepean Highway and running south to Sarazen Street.

Old Name—Olive Street.

New Name—Blairgowrie Avenue.

Description—Commencing at the Nepean Highway and running in a south westerly direction to the western corner of Lot 21 on Plan of Subdivision 23871 and the south east corner of Lot 2 on Plan of Subdivision 70799.

Old Name—Blairgowrie Avenue.

New Name—Olive Street.

Description—Commencing at Scott Wynd and running in a north westerly direction to the western corner of Lot 21 on Plan of Subdivision 23871 and the northern corner of Lot 17 on Plan of Subdivision 23871.

Old Name—Unnamed.

New Name—Hay Street.

Description—Commencing at Heyfield Road and running in a south easterly direction and being the south west boundary of Lot 15 on Plan of Subdivision 41106 and being the north eastern boundaries of Plans of Subdivision 112776 and 112777.

Old Name—Eastbourne Road.

New Name—Hove Road.

Description—Commencing at Purvis Road and running in an easterly direction then a southerly direction and then an easterly direction to Bayview Road. 8987

SHIRE OF FLINDERS

APPOINTMENT OF PROSECUTING OFFICER

Notice is hereby given that the Council of the Shire of Flinders has appointed Sergeant Raymond Noel Smith, No. 19733 as prosecuting officer in lieu of Sergeant Hayden Charles Whitmore No. 11772, retired.
4 August 1980

G. W. WHITE, Shire Secretary

Municipal Office
Boneo Road
Rosebud, 3939

8988

Town and Country Planning Act 1961 (Twelfth Schedule)

SHIRE OF FLINDERS PLANNING SCHEME 1962

NOTICE THAT A PLANNING SCHEME HAS BEEN PREPARED AND IS AVAILABLE FOR INSPECTION

Amendment No. 133, 1980

Notice is hereby given that the Shire of Flinders, in pursuance of its powers under the *Town and Country Planning Act 1961*, has prepared a Planning Scheme for

the purpose of amending the requirements for on-site car parking as related to industrial development within Industrial "A" and Urban Related Industry zones of the Shire of Flinders Planning Scheme.

A copy of the Scheme has been deposited at the Office of the Responsible Authority, Municipal Offices, Boneo Road, Rosebud, and at the Office of the Town and Country Planning Board, 235 Queen Street, Melbourne, and will be open for inspection during office hours by any person free of charge.

Any persons affected by the Planning Scheme are required to set forth in writing all objections they may have addressed to the Shire Secretary, Shire of Flinders, Municipal Offices, Boneo Road, Rosebud, 3939, on or before 13 September 1980 and state whether they wish to be heard in respect of these objections.

5 August 1980

8943

G. W. WHITE, Shire Secretary

Town and Country Planning Act 1961 (Twelfth Schedule)

SHIRE OF FLINDERS PLANNING SCHEME 1962

NOTICE THAT A PLANNING SCHEME HAS BEEN PREPARED AND IS AVAILABLE FOR INSPECTION

Amendment No. 132, 1980

Notice is hereby given that the Shire of Flinders, in pursuance of its powers under the *Town and Country Planning Act 1961*, has prepared a Planning Scheme for rezoning of land at Cape Schanck from Residential "B" zone, Agricultural zone and Cape Schanck Hinterland zone to Reservation—Recreation and Conservation, Proposed Reservation—Recreation and Conservation and The Cups zone.

A copy of the Scheme has been deposited at the Office of the Responsible Authority, Municipal Offices, Boneo Road, Rosebud, and at the Office of the Town and Country Planning Board, 235 Queen Street, Melbourne, and will be open for inspection during office hours by any person free of charge.

Any persons affected by the Planning Scheme are required to set forth in writing all objections they may have addressed to the Shire Secretary, Shire of Flinders, Municipal Offices, Boneo Road, Rosebud, 3939, on or before 13 November 1980 and state whether they wish to be heard in respect of these objections.

5 August 1980

8944

G. W. WHITE, Shire Secretary

Town and Country Planning Act 1961 (Twelfth Schedule)

SHIRE OF FLINDERS PLANNING SCHEME 1962

NOTICE THAT A PLANNING SCHEME HAS BEEN PREPARED AND IS AVAILABLE FOR INSPECTION

Amendment No. 131, 1980

Notice is hereby given that the Shire of Flinders, in pursuance of its powers under the *Town and Country Planning Act 1961*, has prepared a Planning Scheme for the purposes of amending the provisions of the Shire of Flinders Planning Scheme 1962, to allow for control over development of private tennis courts within the Special Residential zone.

A copy of the Scheme has been deposited at the Office of the Responsible Authority, Municipal Offices, Boneo Road, Rosebud, and at the Office of the Town and Country Planning Board, 235 Queen Street, Melbourne, and will be open for inspection during office hours by any person free of charge.

Any persons affected by the Planning Scheme are required to set forth in writing all objections they may have addressed to the Shire Secretary, Shire of Flinders, Municipal Offices, Boneo Road, Rosebud, 3939, on or before 13 September 1980 and state whether they wish to be heard in respect of these objections.

5 August 1980

8945

G. W. WHITE, Shire Secretary

Town and Country Planning Act 1961
SHIRE OF KILMORE PLANNING SCHEME 1973
NOTICE THAT A PLANNING SCHEME HAS BEEN PREPARED
AND IS AVAILABLE FOR INSPECTION
Amendment No. 47, 1980

Notice is hereby given that the Shire of Kilmore, in pursuance of its powers under the *Town and Country Planning Act 1961*, has prepared a Planning Scheme for land bounded by Watson Street, Windham Street, Duke Street and the Northern Highway in the township of Wallan. The purpose of this scheme is to reserve the said land for a proposed Public Purpose (Education Department Purposes).

A copy of the said scheme has been deposited at the office of the Shire of Kilmore, Civic Centre, Sydney Street, Kilmore and at the office of the Town and Country Planning Board, 5th Floor, 235 Queen Street, Melbourne, and will be open for inspection during office hours by any person free of charge.

Any persons affected by the Planning Scheme are required to set forth in writing all objections they may have addressed to the Shire Secretary, Shire of Kilmore, Civic Centre, Sydney Street, Kilmore on or before the 13 November 1980 and to state whether they wish to be heard in respect to their objections.

8 August 1980

9000

JIM ELVEY, Shire Secretary

Town and Country Planning Act 1961
SHIRE OF KILMORE PLANNING SCHEME 1973
NOTICE THAT A PLANNING SCHEME HAS BEEN PREPARED
AND IS AVAILABLE FOR INSPECTION
Amendment No. 46, 1980

Notice is hereby given that the Shire of Kilmore, in pursuance of its powers under the *Town and Country Planning Act 1961*, has prepared a Planning Scheme to rezone Lots 1 and 2 LP 114048, plus land contained in certificate of title volume 8196 folio 219 plus Memorial 722 book 770 being part of Rutledge's Special Survey, Parish of Willowmavin, located in George Street, Kilmore to "Special Use Zone No. 7—Equestrian Uses".

A copy of the said scheme has been deposited at the office of the Shire of Kilmore, Civic Centre, Sydney Street, Kilmore and at the office of the Town and Country Planning Board, 5th Floor, 235 Queen Street, Melbourne, and will be open for inspection during office hours by any person free of charge.

Any persons affected by the Planning Scheme are required to set forth in writing all objections they may have addressed to the Shire Secretary, Shire of Kilmore, Civic Centre, Sydney Street, Kilmore on or before the 13 September 1980 and to state whether they wish to be heard in respect to their objections.

8 August 1980

9001

JIM ELVEY, Shire Secretary

4. Any person of whose act or by or in consequence of whose order any water supplied by the Trust is used or consumed or allowed to run, and any person who permits or suffers any such water to be used or consumed or allowed to run, and the occupier of any premises on or in which any such water is used or consumed or allowed to run in contravention of the provisions of this By-Law, shall severally be guilty of a breach of this By-Law.

5. Every person guilty of a breach of this By-Law shall for every such breach be liable to a penalty not exceeding One Hundred Dollars (\$100).

6. If any person supplied with water by the Trust wrongly does, or causes or permits to be done, anything in contravention of this By-Law, the Trust may (without prejudice to any remedy in respect thereof) close or cut off any pipes by or through which water is supplied by the Trust to him or for his use, and may cease to supply him with water, as provided by the Water Acts.

Resolution for making this By-Law agreed to by the Trust on 5 March 1980.

The common seal of the Kyneton Shire Waterworks Trust was hereto affixed, on 5 March 1980 by order of the Trust in the presence of:

T. G. DRIDAN, Chairman
L. A. GLOSTER, Commissioner
S. G. PORTER, Secretary

9062

Town and Country Planning Act 1961
SHIRE OF LILLYDALE PLANNING SCHEME
NOTICE OF A PROPOSED PARTIAL REVOCATION OF THE
SHIRE OF LILLYDALE PLANNING SCHEME

Notice is hereby given that the Minister has required that the Shire of Lillydale give notice of and deposit for inspection by the public for a period of one month, a proposed partial revocation of the Shire of Lillydale Planning Scheme insofar as it applies to all that land being Crown Allotment 11, Section A, Parish of Gruyere to enable the erection of a house on the land subject to the grant of a permit by the Responsible Authority and in accordance with any conditions attached by the Responsible Authority.

The proposed partial revocation is available for inspection at the office of the Shire of Lillydale, Anderson Street, Lillydale, and at the office of the Town and Country Planning Board, 235 Queen Street, Melbourne and will be open for inspection during office hours, free of charge.

Any persons affected by the proposed partial revocation may advise the Minister, in writing, of their objections thereto and such advice must reach the Minister on or before 13 September 1980.

Dated 8 August 1980

K. D. WILSON, Shire Secretary
Shire of Lillydale, Anderson Street, Lillydale, 3140 9059

KYNETON SHIRE WATERWORKS TRUST
By-Law No. 28c

The Kyneton Shire Waterworks Trust in pursuance of and in exercise of the powers conferred by the *Water Act 1958* and of any and every other power it thereunto enabling doth hereby make a By-Law as follows:

1. This By-law shall have effect throughout the whole of the Kyneton Urban District, The Tylden Urban District and the Kyneton West Rural District, of the said Trust.

2. This By-Law shall come into operation at such time as the Trust from time to time directs by notice published in a newspaper circulating generally within the said district, and shall cease to have operation at such time as the Trust from time to time directs by a notice so published.

3. No person shall, with water supplied by the Trust, water any garden, lawn, plantation, orchard, uncovered place, tree plant or vegetation by means of fixed sprinklers except between the hours of 6 a.m. and 10 a.m. on a Monday, Tuesday, Thursday and Sunday of each week.

SHIRE OF McIVOR
By-Law No. 60

Prevention and Extinguishing of Fires

Notice is hereby given that the Council of the Shire of McIvor in pursuance of the powers conferred by the *Local Government Act 1958*, as amended, has made By-Law No. 60 for the purpose of:—

1. Prohibiting the lighting of stumps between 1 September and commencement of the next ensuing proclaimed fire danger period of each year.

2. Providing a penalty of up to \$100.00 for breach of this By-Law.

The resolution passing this By-Law was approved by the Council on 12 June 1980 and confirmed on 14 August 1980.

A copy of the By-Law is open for inspection free of charge during office hours at the Shire Office, 125 High Street, Heathcote.

9003

R. C. McDIARMID, Shire Secretary

SHIRE OF MORNINGTON

By-Law No. 133

Meetings Procedure (Further Amendment) By-Law

Notice is hereby given that the Council of the Shire of Mornington has by Special Order made a By-Law, numbered 133 under the provisions of the *Local Government Act 1958* (as amended) and all other powers it thereunto enabling, for the purpose of:—

- (a) Carrying out certain of the purposes provided for in the Fifteenth Schedule to the said Act.
- (b) Regulating the proceedings of the Council of the Shire of Mornington.
- (c) Generally for maintaining the good rule and government of the Municipality of Mornington.
- (d) Further amending By-Law No. 123 of the said Shire.

A summary of the contents of By-Law No. 133 of the Shire of Mornington is set out hereunder:—

Clause 1: Name of By-Law. Meetings Procedure (Amendment) By-Law.

Clause 2: Date of Operation. The By-Law operates from the day after Notice of its making is published in the *Government Gazette*.

Clause 3: Extent of Operation. The By-Law has operation throughout the Municipal District of the Shire of Mornington.

Clauses 4 and 5: Meeting Dates and Times. Appointment of the dates and times of Ordinary Council Meetings by Council resolution.

Clause 6: The Order of Business at a Meeting. Lists the order of business at Annual, Ordinary and Special Council Meetings and at a Committee Meeting.

Clause 7: Correspondence to be placed before a Council Meeting.

Clauses 8, 9 and 10: The Procedure for Adoption of Reports.

Clause 11: Agenda Format for Annual Council Meeting (Schedule 1).

Clause 12: Agenda Format for Ordinary Council Meeting (Schedule 2).

Clause 13: Postponement Request Format (Schedule 7).

Notice is also given that a copy of By-Law No. 133 is open for inspection free of charge during office hours at the Office of the Council, Civic Centre, Queen Street, Mornington.

9060

D. G. COLLINGS, Shire Secretary

Town and Country Planning Act 1961

SHIRE OF PAKENHAM INTERIM DEVELOPMENT ORDER 1974

Amendment No. 31, 1980

Notice is hereby given that the Council of the Shire of Pakenham in pursuance of its powers under the *Town and Country Planning Act 1961*, has made and adopted an Interim Development Order known as the Shire of Pakenham Interim Development Order—Amendment No. 31 which amends the Shire of Pakenham Interim Development Order 1974 as follows:

Land being part of Crown Allotment 79A, Parish of Nar Nar Goon, having frontage to Home Road, Mulcare Street, George Street and Bayles—Nar Nar Goon Road shall be rezoned from Agricultural A to Country Residential Zone.

A copy of the Shire of Pakenham Interim Development Order—Amendment No. 31 has been deposited at the Office of the Town and Country Planning Board, 5th Floor, 235 Queen Street, Melbourne and at the Office of the Shire of Pakenham, Main Street, Pakenham, and may be inspected during office hours by any persons free of charge.

Any persons affected by the Shire of Pakenham Interim Development Order 1974—Amendment No. 31 are required to set forth in writing to the Shire Secretary, Shire of Pakenham, Main Street, Pakenham all objections they may have on or before 13 September 1980 and to state whether they wish to be heard in respect of their objections.

8973

B. J. WALLIS, Shire Secretary

Local Government Act 1958, Section 288, as amended

SHIRE OF ROCHESTER

VARIATION FROM PRAYER OF PETITION REGARDING SEPARATE RATE SCHEME

Take notice that the Council of the Shire of Rochester, in making and levying a Separate Rate, by resolution passed at a meeting held on 3 July 1980, did vary from the prayer of the original petition submitted by 14 persons being the owners of property fronting Ramsay Street, Rochester, by including an additional property, known as 73 Victoria Street, Rochester, with those properties in respect of which the Separate Rate was made and levied.

And take further notice that:—

- (a) within one month of 13 August 1980, any person who signed the original petition or is the owner or occupier of property of which the previous owner or occupier signed the original petition, may withdraw his signature or the signature of the previous owner or occupier (as the case may be) and any person qualified to sign the petition may in like manner accede to the petition; and
- (b) at the expiration of such month the rate as varied shall be confirmed by the Governor in Council if the signatures to the petition remaining undrawn together with the signatures of any persons who may have acceded to the petition are such as are required to a petition, and not otherwise.

8999

K. W. JACKEL, Shire Secretary

SHIRE OF STRATHFIELDSAYE

By-Law No. 80

Repealing By-Law

Notice is hereby given in accordance with section 228 of the *Local Government Act 1958*, that the Council of the Shire of Strathfieldsaye has made By-Law No. 80 for the purpose of repealing the following By-Law.

By-Law No. 62—Prescribing fees for Health Act Registration.

The resolution for passing this by-law was agreed to by the Council of the Shire of Strathfieldsaye on 3 July 1980 and confirmed by resolution on 7 August 1980.

A copy of the by-law may be inspected free of charge during office hours at the Office of the Council, Condon Street, Kennington.

9002

D. D. WRIGHT, Shire Secretary

GOORAMBAT WATER TRUST

NOTICE TO OWNERS OF TENEMENTS IN DOOKIE COLLEGE ROAD

The main pipe in the said street being laid down, the owners of all tenements situated as above are hereby required on or before 22 August next to cause a proper pipe and stop-cocks to be laid so as to supply water within such tenements from the main pipe.

8998

MARIE R. SAUNDERS, Secretary

MEENIYAN WATERWORKS TRUST

WATER SERVICES BY-LAW

Notice is hereby given that the Meeniyon Waterworks Trust in pursuance and exercise of the powers conferred by the Water Act, section 330, did, on 4 June 1980, make a By-Law for the Licencing of Plumbers; the Execution of Works of Water Supply; Private Extensions; Connections to Main Pipes and Aqueducts; Repairs; Materials; Meters; Fire Services; General; Misuse and Waste of Water; and Penalties.

The said Water Services By-Law was approved by the Governor in Council on 22 July 1980.

A copy of the By-Law is available for inspection by any person, without charge, during office hours, at the office of the Trust.

8974

M. D. SAMSON, Secretary

INVERLOCH SEWERAGE AUTHORITY

BY-LAW No. 1

The Inverloch Sewerage Authority has made By-law No. 1 for the purpose of regulating access to Authority land at Inverloch.

A copy of the By-law is available for inspection free of charge during office hours at the office of the Authority.
8946

I. M. SYMINGTON, Secretary

Sewerage Area No. 13

Centenary Avenue, Gisborne-Melton Road, Government Road, and Little Blind Creek.

The areas are shown on plans which may be inspected at the Authority's office, High Street, Melton.

By Order of the Melton Sewerage Authority

D. W. SODERBLOM, Chairman
M. B. WATSON, Secretary

8947

MELTON SEWERAGE AUTHORITY

GENERAL NOTICE

The Melton Sewerage Authority, having made provision for carrying off the sewage from each and every property which or any part of which is within Sewerage Areas hereinafter described, hereby declares that on and after 1 July 1980, each and every such property shall be deemed to be a seweraged property within the meaning of the *Sewerage Districts Act 1958*.

The general boundaries of the Sewerage Areas referred to above are:

Sewerage Area No. 1

Centenary Avenue, Coburns Road, High Street and Palmerston Street.

Sewerage Area No. 2

Church Street, Raleighs Road, Palmerston Street, McKenzie Street and Yuille Street.

Sewerage Area No. 3

High Street, Palmerston Street, McKenzie Street and Yuille Street.

Sewerage Area No. 4

High Street, Alexandra Street, Henry Street and Palmerston Street.

Sewerage Area No. 5

Henry Street, Atkin Street, Barries Road, Ryan Court and Judy Court together with Lots 92 to 95 Judy Court and Lots 111 to 114 Palmerston Street.

Sewerage Area No. 6

Barries Road (Lots 103 to 115), Weatherly Street, Gretel Grove (Lots 77 to 84) and the Municipal Purposes Reserve.

Sewerage Area No. 7

High Street, Joyce Street, Christopher Crescent (both sides to Amanda Court), Sandra Street, Fay Street, and the western boundaries of Crown Allotments 43 and 45, together with Lots 26 to 30 Christopher Crescent, Lots 31 to 46 Barries Road, and Lot 45 Sandra Crescent.

Sewerage Area No. 8

Station Road, Brooklyn Road, Toolern Creek and the northern boundaries of Lots 141 and 47 Andrew Street, Lots 38 to 46 Charles Court and Lot 1 L.P. 58855, Station Road.

Sewerage Area No. 9

Morshead Street, Monash Street, Risson Street and Blamey Drive.

Sewerage Area No. 10

Staughton Street, Wickham Street, Wilson Road, Exford Road.

Sewerage Area No. 11

Bulmans Road, Westmelton Drive, and Coburns Road, and the southern boundaries of Crown Allotments C and D, Section 11, Parish of Djirriwarrh.

Sewerage Area No. 12

Westmelton Drive, James Cook Drive, Western Highway, and Coburns Road.

NOTICE OF INTENTION TO ACQUIRE AN EASEMENT COMPULSORILY

To whom it may concern:

Whereas the Sale Sewerage Authority deems it expedient to exercise its powers of taking lands (including easements) compulsorily for the work or undertaking mentioned hereunder notice is hereby given as follows:—

- (i) The Sewerage Authority intends to acquire an easement for the purpose of access to and sewerage works over all that strip of land of approximately 41.43 square metres along part of the south-eastern boundary of Crown Allotment 22 Section E Parish of Wurruk Wurruk and being part of the land more particularly described in Certificate of Title Volume 9173 Folio 095 registered in the name of The Salvation Army (Victoria) Property Trust.
- (ii) A copy of the Plan of the land is deposited at the Office of the Sale Sewerage Authority Municipal Chambers Macalister Street Sale and is there available for inspection between the hours of 9.00 a.m. and 5.00 p.m. Mondays to Fridays inclusive for the period of 30 days from the date of the first publication of this notice.

Dated 13 August 1980

9090

JOHN L. LOW, Secretary

COMPULSORY ACQUISITION OF LAND

SETTLEMENT ROAD, WURRUK

Notice is hereby given that the Sale Sewerage Authority having obtained the consent of the Governor in Council proposes the compulsory acquisition of certain lands described hereunder:—

- (a) the land is proposed to be taken for the purpose of erecting thereon a pump station on the sewerage main at Wurruk;
- (b) the plan together with description of the proposed works are open for inspection at the Offices of the Authority Municipal Offices Macalister Street Sale between the hours of 9.00 a.m. and 5.00 p.m. Mondays to Fridays inclusive;
- (c) The land proposed to be acquired comprises part of Crown Allotment 22c Section E Parish of Wurruk Wurruk in the County of Tanjil and has a frontage to Settlement Road Wurruk of 31.62 metres by a depth of 31.63 metres and is part of the land more particularly described in Certificate of Title Volume 9173 Folio 095.

9091

JOHN L. LOW, Secretary

Notice is hereby given that I.C.I. Operations Pty. Ltd. of I.C.I. House, 1 Nicholson Street, Melbourne 3000 has applied for a lease pursuant to section 134 of the *Land Act 1958* for a term of 50 years in respect of Lake Wahpool in the Parishes of Moortworra and Lianiduck containing 2700 hectares as a site for production and removal of salt.

8561

Notice is hereby given that the Port Fairy Golf Club has applied for a Lease of Allotment 12c, Parish of Koroit containing 49.87 ha pursuant to section 134, *Land Act 1958* for the purpose of amusement and recreation and social activities associated therewith for a term of twenty-one (21) years.

8687

Notice is hereby given that the partnership heretofore subsisting between Gregory Painter, Margery May Painter, John Allan Scoffin and Yvonne Glenys Scoffin carrying on business as retail Jewellers at 6 Bridge Street, Ballarat under the style or firm of Scoffin and Painter has been dissolved by mutual consent as from 1 July 1980 so far as concerns the said Gregory Painter and Margery May Painter who retire from the said firm. The said John Allan Scoffin and the said Yvonne Glenys Scoffin shall continue to carry on the business at the same address under the style of "Scoffin's Jewellers".

JOHN ALLAN SCOFFIN
YVONNE GLENYS SCOFFIN
8975

Take notice that on 16 May 1980 James Hansen retired from the partnership of Matilda's Singing Telegrams and Australian Singing Telegrams and is not liable for any debts incurred by the partnership after that date. 8949

Take notice that on 16 May 1980 Catherine Samsom retired from the partnership of Matilda's Singing Telegrams and Australian Singing Telegrams and is not liable for any debts incurred by the partnership after that date. 8948

I, Alfred Robert Wragg of 58 Wunalla Road, North Seaford hereby give notice that as from 30 June 1980 I ceased to be a partner in the business W.K. Knitting and Repair Service which carried on business at 146 Austin Road, Seaford. 8989

Notice is hereby given that the partnership heretofore subsisting between Alan Stuart Smith and Neil Stuart Smith carrying on business as Farmers and Graziers at Bega Park Romsey under the style or firm of Bega Park has been dissolved as from 30 June 1980.

Dated 30 June 1980

A. S. SMITH
N. S. SMITH
9005

Take notice that the partnership of Leo Anthony Nally and Shane Michael Nolan carrying on business of Panel Beaters at Thistle Street Golden Square has been dissolved as from 4 August 1980. Any person having any claims for any debts against the partnership are requested to forward their accounts to Leo Anthony Nally at the above address, who will be continuing to conduct the business of Panel Beaters. 9006

PARTNERSHIP ACT 1958

I, Annelore Erna Schneider, hereby notify that as from 1 July 1980, the partnership formerly subsisting between myself and Rohan Louis Schneider which carried on a Pottery business at Swan Reach in the State of Victoria, has been terminated. As from 1 July 1980 I will carry on the above business for my own account.

Dated 8 August 1980

AGG & ENGEL, solicitors for Annelore Erna Schneider
9007

PARTNERSHIP ACT 1958

To: Colin Douglas Kennedy, 411 High Street, Golden Square

Take notice that Pamela May Kennedy desires that the partnership carried on by herself with you be dissolved pursuant to section 30 (1) of the *Partnership Act 1958* within 7 days from the date of this notice.

The said Pamela May Kennedy requires that you within 14 days of this notice do render to her final accounts of the partnership by delivering the same to her solicitors, R. H. Schleiger and Associates of 33-35 Williamson Street, Bendigo 3550, Victoria.

Dated 7 August 1980

9008 PAMELA MAY KENNEDY

- Notice is hereby given that the partnership between Daniel Charles Derody and Beatrice Claude Marie Derody formerly carried on in the restaurant business at Shop 4, Village Arcade, 462 Toorak Road, Toorak in the State of Victoria under the name style or firm of "Coccinelle Bistro" has been dissolved as from 5 August 1980.

Dated 7 August 1980

9046 B. C. M. DERODY

Notice is hereby given that the partnership heretofore subsisting between us carrying on business as Dairy Farmers at Falls Road, Fish Creek under the firm name or style of A. G., N. H. & G. C. Thompson has been dissolved by mutual consent as from 30 June 1980.

Dated 8 August 1980

A. G. THOMPSON
N. H. THOMPSON
G. C. THOMPSON
9063

THE PARTNERSHIP ACT 1958

Notice is hereby given that the partnership heretofore subsisting between William Gerard Lyon deceased late of 27 Greensborough Road, Rosanna in the State of Victoria and Stanley Gillis of 349 Gaffney Street, Pascoe Vale in the said State pursuant to the Partnership Agreement dated 13 August 1952 and carrying on business in partnership under the style or name of Bearing and Cylinder Specialists at 252 Abbotsford Street, North Melbourne in the said State has been dissolved as and from 23 November 1979. 9064

Companies Act 1961—In the matter of TOTAL SECURITY (AUST.) PTY. LIMITED—Notice Re Meeting of Creditors Pursuant to Section 260

Notice is hereby given that a Meeting of Creditors of the abovenamed Company will be held at 144 Jolimont Road, East Melbourne on Wednesday, 20 August 1980 at 10.30 a.m. the Company having convened a Meeting of its Members for the same day for the purpose of considering a Special Resolution that the Company be wound up voluntarily.

Dated 5 August 1980

R. G. BRIEN, Director
Bent & Cogle, public accountants, 144 Jolimont Road,
East Melbourne 8950

Companies Act 1961—In the matter of AABBAR INVESTMENTS PTY. LTD. (in Liquidation), formerly trading as "The Bird 'n' Bottle Restaurant", 333 Maroondah Highway, Croydon

Notice is hereby given that at an extraordinary Meeting of the Members of the abovenamed Company held on 4 August 1980 it was resolved that the Company be wound up voluntarily and at a Meeting of Creditors held on the same day pursuant to Section 260, it was resolved that for such purpose Mr E. T. Bent of 144 Jolimont Road, East Melbourne be appointed Liquidator.

Notice is also given that after twenty-one days from this date I shall proceed to distribute the assets. All creditors having any claims against the Company should furnish particulars of same by that date, otherwise I shall proceed to distribute the assets without regard to their claim.

Dated 5 August 1980

E. T. BENT, Liquidator
Bent & Cogle, public accountants, 144 Jolimont Road,
East Melbourne 8951

Companies Act 1961—In the matter of MODLINE CONSTRUCTIONS PTY. LTD.—Notice of Winding Up Order

Winding up Order made on 20 March 1980.

Name and address of Liquidator appointed Everett Thomson Bent 545 St. Kilda Road, Melbourne.

8952 REMINGTON & CO., Solicitors for the Petitioner

In the matter of CAISSON CONTRACTORS PTY. LIMITED—Notice of Winding Up Order

Winding-up Order made 31 July 1980.

Name and Address of Liquidator—Alan Murray Horsburgh, C/- Messrs Wallace McMullin & Smail, 499 St. Kilda Road, Melbourne, Vic. 3004.

CORNWALL STODART & CO., solicitors for the petitioner 8953

Unclaimed Moneys Act 1962

Register of Unclaimed Moneys held by the—

<i>Name of Owner on Books and Last Known Address</i>	<i>Total Amount Due to Owner</i>	<i>Description of Unclaimed Money</i>	<i>Date when Amount first became Payable</i>
§			
MARYBOROUGH HOLDINGS LIMITED			
Burkinshaw, Percival R. A. J., El Dorado, Brookvale Mall, Lockhart, N.S.W.	15.40	Dividend	9.2.79
Cairns, Andrew A., Tweedale St, Dunolly	137.50	"	"
Chisholme, A. H., (estate of) (address unknown)	231.77	"	"
Cheshire, R. B., 159 Bayview Rd, McCrae	27.50	"	"
Dyke, Loraine B. (Mrs), 3 Doynton Pde, Syndal	11.00	"	"
Hamilton, Margaret J., Bairnsdale	39.60	"	"
Hood, P. M. (Mrs), 11 Roger St, Kyabram	10.45	"	"
Looney, Oliver J. P., 1 Dana St, West Doncaster	13.75	"	"
Parker, Lindsay W., 10 High St, Maryborough	12.32	"	"
Parker, W. (estate of), (address unknown)	21.12	"	"
Pike, Frederick, Goldsborough	41.47	"	"
Porter, Olive S. (Miss), 54 Booth St, Golden Square	16.06	"	"
Roberts, John R., Dayboro Rd, Petrie, Qld.	13.75	"	"
Shay, James L., C/o Mrs. A. Pike, R. S. S. Goldsborough	41.25	"	"
Smart, A. B. (Mrs) Flat 3, "Roma" 88 Koroit St, Warrnambool	13.75	"	"
Talbot, K. E. (Miss), 25 Bowen St, Warragul	76.56	"	"
Watts, N. (Mrs), 49 Mariners Reef Rd, Maryborough	72.71	"	"
Wood, D. E. (estate of), (address unknown)	18.92	"	"
8797			
WOODSIDE PETROLEUM LTD.			
Axtell, Sam Weir (estate of), C/o Mrs. Agnes M. Axtell, K-18 Lake Bloomington, Hudson, Illinois, U.S.A.	72.68	Sale of Rights	16.2.79
Barati, George, P.O. Box 158 Saratoga, California, U.S.A.	15.18	"	"
Bjork, Robert, C/o Union Capital Management, 800 Third Avenue, New York, U.S.A.	38.18	"	"
Burka, Robert Alan, Apartment 7D 283 Ave C, New York, U.S.A.	23.00	"	"
Doyle, Ray Martin, 10434 Brimwood Crt, Houston, Texas, U.S.A.	15.18	"	"
Dunkle, Dennis Gerald, 3530 Gray Street, Laureldale, Pa, U.S.A.	15.18	"	"
Durham, Harold H., 909 South Seaman St, Eastland, Texas, U.S.A.	15.18	"	"
E. F. Hutton and Co. Incorp., 1 Battery Park Plaza, New York, U.S.A.	690.00	"	"
Gerrard, Malcolm John & Geske, C/o Global Marine Incorp., Box 54031 Los Angeles, California, U.S.A.	23.00	"	"
Greenwood, Bobby Marcum, 1302W Brooklake Dr, Houston, Texas, U.S.A.	30.59	"	"
Hale, David, 99 Joralemon St, Brooklyn Heights, New York, U.S.A.	76.59	"	"
Hill, Beryl Catherine, Box 444, Inglewood, Florida, U.S.A.	12.65	"	"
Irvin, Robert, P.O. Box 809, Tyler, Texas, U.S.A.	214.59	"	"
Hudig, Harriet, 1350 No. West Ave, Lake Forest, Illinois, U.S.A.	18.40	"	"
Kovalick, Stephen and Mary, 1804 Root Street, Joliet, Illinois, U.S.A.	23.00	"	"
Lees, William Donald, Pompano Beach, Florida, U.S.A.	76.59	"	"
Lindsey, Ed, P.O. Box 809, Tyler, Texas, U.S.A.	107.18	"	"
Nelson, Cholmondeley M., 1240 S Grand Rd., Pasadena, California, U.S.A.	15.18	"	"
Paul Taylor Co. Inc., 232 North Lake Ave, Pasadena, California, U.S.A.	76.59	"	"
Peterson, Rolf Arlyn and Sandra Brown, 9158 50 Bell Ave, Chicago, Illinois, U.S.A.	26.68	"	"
Roberts, Harold Evan, 101 Maple Dr, Fairbanks, Alaska, U.S.A.	11.50	"	"
Smith, Haywood Headquarters, 8 Marine Corp District, New Orleans, Louisiana, U.S.A.	21.85	"	"
Smoot, Joe Henry, 204 Jefferson, Big Spring, Texas, U.S.A.	10.12	"	"
Walsh, May Edith, 10529 Longworth Ave, Santa Fe Springs, California, U.S.A.	36.80	"	"
Wolf, James Miller, 110 Juniper Dr, Ithaca, New York, U.S.A.	76.59	"	"
Hanson, Stanley and Mary, 170 Ridge Rd, St. Anselmo, California, U.S.A.	15.18	"	"
Kelly, Patrick and Winnie, 1401 Ocean Ave, Brooklyn, New York, U.S.A.	23.00	"	"
Someck, Joseph, 11 York Rd, Larchmont, New York, U.S.A.	28.75	"	"
8798			
THE MILDURA CO-OPERATIVE FRUIT CO. LTD.			
Claringbull, D. E. (estate of), (address unknown)	21.06	Dividend	1.3.78
Conran, H. M. (estate of), (address unknown)	145.26	"	"
Humphreys, T. J. H., (address unknown)	18.00	"	"
Schnapper, K. G. (Mrs), c/o C. Batchelor, Mildura	11.70	"	"
Giles, A. L. (estate of), 147 Lime Ave, Mildura	25.20	"	"
Hall, K. E. (estate of), c/o M. Buxton, Beaumaris	24.30	"	"
Holland, O. B., Box 84, Mildura	18.00	"	"
Hudson, L. E., c/o 50 Carrol St, Oakleigh	11.97	"	"
Marshall, R. J. and V. J., P.O. Box 85, Merbein	44.19	"	"
Parker, Charles, c/o 3 Godfrey St, Sunshine	19.05	"	"
Stregas, G., (address unknown)	31.73	"	"
Tyson, R. and R. M., c/o P.O. Berriwilllock	14.85	"	"
Yalchin, M. I., (address unknown)	10.00	"	"
8984			

Unclaimed Moneys Act 1962

Register of Unclaimed Moneys held by the—

Name of Owner on Books and Last Known Address	Total Amount Due to Owner	Description of Unclaimed Money	Date when Amount first became Payable
\$			
H. C. SLEIGH LIMITED			
Abbot, W., 14 Seaforth St. Bexley, N.S.W.	27.50	Dividend	31.5.78
Ambler, B., 874 Nepean Hwy, Moorabbin	22.00	"	"
Arkle, L. A. (Mrs), 5/11 Clanalpine St, Mosman, N.S.W.	55.00	"	"
Baird, W. A., c/o Mrs. A. G. Rutman, 74 Dresden St, Heidelberg	36.30	"	"
Baker, J. C., 74 Byron Rd, Mt Yokine, W.A.	16.50	"	30.11.78
Balharrie, E. R. (Mrs), 17 The Esplanade, Seaholme	86.71	"	31.5.78
Barrett, J. O. G. and A. W. L. (Mrs), 68 Links Ave, North Strathfield, N.S.W.	15.57	"	30.11.78
Barwood, C. F., 36 Aroona Rd, Caulfield	55.00	"	"
Black, D. C. M., c/o Whatmore Gee and Co., 20 Bridge St, Sydney, N.S.W.	36.96	"	31.5.78
Blyte, M. N., 7 Belmont Ave, Wollstonecraft, N.S.W.	13.75	"	30.11.78
Brace, A. M. (Mrs), 24 Cavanaugh St, Wynnum West, Qld.	33.66	"	31.5.78
Brace, W., 24 Cavanaugh St, Wynnum West, Qld.	25.44	"	"
Barr-Brown, A. J., Route 6, Box 510, Lakeland, Florida, U.S.A.	54.14	"	"
Buckney, L., 8/45 Adelaide Tce, Perth, W.A.	55.00	"	"
Burns, J., 112 Mt Pleasant Rd, Belmont	27.50	"	"
Burns, P. J. C., c/o Wilson Henry Sinclair, P.O. Box 130, Auckland 1, N.Z.	23.37	"	"
Burton, E. R. (Mrs), 6/3 Werambie St, Woolwich, N.S.W.	27.50	"	"
Cameron, D. A. (Mrs), "Lochiel", Private Bag, Tuakau, N.Z.	50.62	"	"
Chalmers, M. D., 1 Eva Lane, Northwood, N.S.W.	27.50	"	30.11.78
Cheyne, H. L. T. (Mrs), c/o National Westminster Bank Limited, 77 Sandgate Rd, Folkestone, Kent, U.K.	23.37	"	31.5.78
Choy, N., 95 Symonds St, Royal Oak, Auckland 5, N.Z.	25.71	"	"
Christie, J. E. (Mrs), 56 Drabsch St, Loxton, S.A.	11.00	"	23.11.78
Churchill, C. A. (Miss), 10 Monash Ave, Como, W.A.	11.41	"	31.5.78
Clarke, E. J. (Mrs), 40 Madeline St, Glen Waverley	13.75	"	"
Clarke, H. N., c/o Johnston Prichard Fee, P.O. Box 1115, Auckland 1, N.Z.	38.95	"	31.5.78
Clissold, N. G., Cobbitty, N.S.W.	27.50	"	30.11.78
Clouten, A., 8/21 Yerrick Rd, Lakemba, N.S.W.	22.00	"	31.5.78
Couper, W., P.O. Box 214, Dunedin, N.Z.	24.55	"	30.11.78
Currey, N. R., c/o Miss E. H. Wallace, 117 Hoddle St, Richmond West	33.00	"	"
Dallywater, S. W., 3 Penfield Ave, Salisbury, S.A.	55.72	"	31.5.78
Donaldson, T., Schoolhouse, Inch, Downpatrick, Down, Eire	23.10	"	"
Duffy, J. F., 356 Macquarie St, Windsor, N.S.W.	11.00	"	"
Endres, D. R. (Mrs), 77 Orford St, Wellers Hill, Qld.	155.98	"	30.11.78
Endres, D. R. (Mrs) and H. W. (Dr), 77 Orford St, Wellers Hill, Qld.	40.51	"	"
Ford, K. J., 340 Old North Rd, Castle Hill, N.S.W.	27.50	"	31.5.78
Frilay, V., 16 Bloomfield Rd, Ascot Vale	68.75	"	30.11.78
Fuller, T. (Miss), 9 Edgeworth Ave, Dapto, N.S.W.	13.75	"	31.5.78
Gibson, J. E. (Miss), 5 Warde St, Bairnsdale	26.35	"	"
Glaser, I. V. (Dr), 44 Findlay Ave, Roseville	22.00	"	"
Goercke, L. W., 2 Charles St, Norwood, S.A.	10.70	"	30.11.78
Goldsworthy, E. D. A. (Mrs), 16 Kent St, West Toowong, Qld.	15.57	"	31.5.78
Grange, D. B., 30 Devonshire St, North Walkerville, S.A.	11.00	"	30.11.78
Green, G. T., 29 Graydon Rd, Kalamunda, W.A.	27.50	"	31.5.78
Hammond, S. M. (estate of), c/o Langley Twigg Doole Cowley, P.O. Box 606, Napier, N.Z.	11.69	"	30.11.78
Hewson, P. M. (Mrs), 14 Bundoran Pde, Box Hill North	36.44	"	31.5.78
Hunt, E. M. (Mrs), 345 Stafford Rd, Stafford, Qld.	13.75	"	"
Jarratt, F. E. E. (Mrs), 31 North St, Marrickville, N.S.W.	44.47	"	30.11.78
Keavy, F. F., 122 Thompson St, Williamstown	13.75	"	31.5.78
Kenny, G. M. (estate of), c/o Mrs. D. Scott, 106 Katrina St, Blackburn North	13.75	"	30.11.78
King, J. A., 74 Queens Pole East, Newport, N.S.W.	27.50	"	"
Latham, A. W., P.O. Box 150, Frankston	15.95	"	"
Layman, K. R., 43 McIntosh St, Mascot, N.S.W.	22.60	"	31.5.78
MacVean, A. V. (Mrs), 16 Cambridge Cres, White Hills	52.11	"	30.11.78
Manser, M., 3/15 Glamis St, Newtown	11.00	"	31.5.78
McAulay, R. A. (Mrs), 32 Prahran Ave, Frenchs Forest, N.S.W.	11.00	"	"
McDonald, M. T. (Mrs), c/o Rank McDonald Systems, 168 Walker St, North Sydney, N.S.W.	82.50	"	30.11.78
Mogg, M. A. (Miss), 45 Bucknell St, Newtown, N.S.W.	11.00	"	31.5.78
Murray, F. c/o Travers, Bizannes and Solomon, P.O. Box 358, Strathfield, N.S.W.	55.00	"	"
Murray, J., c/o P.O. Andamooka, via Woomera West, S.A.	27.50	"	"
Newell, G. (Mrs), 4 Rotherwood Rd, Ivanhoe	27.50	"	30.11.78
Ottrey, C. (Mrs), Private Bag 8, "Walmer" via Maldon	27.50	"	"
Parker, J. K., Moore St, Colac	13.75	"	"
Parsons, C. M. (Mrs), Orwell, Coonamble, N.S.W.	13.75	"	31.5.78
Pogson, N. (Mrs), 12 Moore St, Clontarf, N.S.W.	13.75	"	30.11.78
Pollock, P. V. (Mrs), 7 Grandview Gve, Morwell	27.50	"	31.5.78
Prideaux, M. J. (Mrs), 7 Yackatoon Ave, Aspendale	18.15	"	30.11.78
Provera, A., P.O. Box 160, Hanwood, N.S.W.	27.50	"	31.5.78
Pryce, V. A., c/o H. C. Sleigh Limited, 160 Queen St, Melbourne	23.32	"	"
Rasmussen, S. N., 12 Burns St, Toowoomba, Qld.	11.00	"	30.11.78
Roach, N. I. (Mrs), 27 Vance St, Shannon, N.Z.	11.69	"	"
Rundle, E. B. (Mrs), Wesley Gardens, 2B Morgan Rd, Belrose, N.S.W.	34.38	"	31.5.78

Unclaimed Moneys Act 1962

Register of Unclaimed Moneys held by the—

Name of Owner on Books and Last Known Address	Total Amount Due to Owner	Description of Unclaimed Money	Date when Amount first became Payable
\$			
H. C. SLEIGH LIMITED—continued.			
Scott, C. W., P.O. Box 182, Gosford, N.S.W.	13.75	Dividend	30.11.78
Scripsec Nominees Ltd., P.O. Box 1917, Auckland 1, N.Z.	23.37	"	31.5.78
Sharah, J., Unit 4, 128 Glenayr Ave. Bondi, N.S.W.	11.00	"	"
Simms, E. W., 28 Finch St, East Malvern	10.31	"	30.11.78
Skeat, H. L. (Miss), 25 Rosenthal St, Campbell, N.S.W.	13.75	"	31.5.78
Smith, G. J., 14c Queens Dr, Dunedin, N.Z.	14.02	"	30.11.78
Smith, R. L., 480 Bourke St, Melbourne	27.50	"	31.5.78
Snow, G. L. (Miss), 15 Park Rd, Five Dock, N.S.W.	22.00	"	"
Stuart, E. G., 464 Hamer St, Earlwood, N.S.W.	27.50	"	"
Tempest, R. T., 71 Sixth Ave, Kedron, Qld.	22.00	"	"
Thersites Pty. Limited, c/o Peat, Marwick, Mitchell and Co., 29th Level, Town Building, Australia Square, N.S.W.	82.50	"	"
Thompson, V. C., P.O. Box 13, Lae, P.N.G.	23.38	"	"
Van De Wall, M. K. (Mrs), P. O. Box 182, Cooma, N.S.W.	16.56	"	"
Van Tongeren, H. F. M., c/o A.N.Z. Bank Ltd., Cnr. Queen and Wharf Sts, Brisbane, Qld.	53.16	"	"
Vincent and Lam. Noms. Pty. Ltd., 35/36 Phillip St, Singapore, 1	116.87	"	30.11.78
Waite, M. F. (estate of), c/o Loughrey and Loughrey, 118 Queen St, Melbourne	22.83	"	31.5.78
Weston, N. P., c/o Department of Public Works, P. O. Box 1108, Boroko, P.N.G.	11.69	"	"
Worthington, C. W. (Miss), 1A/23 Baden St, Neutral Bay, N.S.W.	38.50	"	"
Yuill, C. K., 3 Karranga Ave, Killara	115.50	"	"
Clinton, R. A. (Mrs), c/o H. C. Sleigh Limited, 160 Queen St, Melbourne	31.24	Interest	30.6.78
Gill, R. A., c/o Tolhurst Druce and Emmerson, 357 Lt. Collins St, Melbourne	35.12	"	"
Handbury, A. J., 64 Coppin St, East Malvern	14.12	"	31.12.78
Snow, G. L. (Miss), 15 Park Rd, Five Dock, N.S.W.	12.00	"	"

8983

CLEARY PRODUCE CO. PTY. LIMITED (IN LIQUIDATION)

A meeting of the above company will be held at 10.00 a.m. on 15 September 1980 at 2nd Floor, Market Plaza Building, Flemington Markets N.S.W. for the purpose of receiving the Liquidator's Final Account together with his explanations thereon.

By Order of the Board

8955

R. W. JOSEPH, Director

The Companies Act 1961—In the matter of ANSIS MOTOR CORPORATION PTY. LTD.—Notice Re Meeting of Creditors Pursuant to Section 260

Notice is hereby given that a Meeting of the Creditors of the abovenamed company will be held at the Settling Room, Amateur Sports Club, 141 Queen Street, Melbourne at 10.30 a.m. on 19 August 1980, the company having convened a Meeting of its members for the same day for the purpose of considering a Resolution that the Company be wound up voluntarily.

Dated 5 August 1980

8956

A. DIZGALVIS, Director

In the Supreme Court of Victoria—1980 No. Co. 11471—In the matter of the Companies Act 1961; in the matter of KEVIN J. POYNTON & ASSOCIATES PTY. LTD.; and in the matter of a Petition by Harry Crompton and Diane Crompton dated 4 August 1980

Notice is hereby given that a Petition for the winding up of the abovenamed Company by the Supreme Court was, on 4 August 1980, presented by the said Harry Crompton and Diane Crompton and that the said Petition is directed to be heard before the Court sitting at The Law Courts, Lonsdale Street, Melbourne at the hour of 10.30 o'clock in the forenoon on 18 September 1980 and any Creditor or Contributory of the said Company desiring to support or oppose the making of an Order on the said Petition may appear at the time of hearing by himself or his Counsel for that purpose; and a copy of the Petition will be furnished to any Creditor or Contributory of the said Company requiring the same by the undersigned on payment of the regulated charges for the same.

The Petitioner's address is care of Messrs Rowson, Eddy & Co., of 309 Thomas Street, Dandenong, Victoria.

The Petitioner's solicitors are Messrs Rowson, Eddy & Co., of 309 Thomas Street, Dandenong, Victoria.

MESSRS ROWSON, EDDY & CO., solicitors for the petitioner

NOTE—Any person who intends to appear on the hearing of the said Petition must serve on or send by post to the abovenamed Solicitors Notice in writing of his intention to do so. The Notice must state the name and address of the person, or, if a firm, the name and address of the firm, and must be signed by the person or firm, or his or their Solicitor (if any), and must be served, or, if posted, must be sent by post in sufficient time to reach the abovenamed not later than 4.00 o'clock in the afternoon of the 17 September 1980, the day before the day appointed for the hearing of the Petition

8957

Companies Act 1961

MITCHELLS ALMA VALE PROPRIETARY LIMITED
SPECIAL RESOLUTION TO WIND UP, PURSUANT TO SECTION 254

At an extraordinary General Meeting of the above-named company, duly convened and held at Hume Highway, Beveridge on 4 August 1980, the following resolution was duly passed as a Special Resolution:

"That the company be wound up voluntarily."

And at such last-mentioned meeting Albert John Mitchell was appointed liquidator for the purpose of the winding up.

Notice is hereby given that after 21 days from this date I shall proceed to distribute the assets. All creditors having any claims against the company should furnish particulars of same by that date, otherwise I shall proceed to distribute the assets without regard to their claim.

Dated 4 August 1980

8978

A. J. MITCHELL, Liquidator

ALL STATES PRODUCE (VIC.) PTY. LIMITED (IN LIQUIDATION)

A meeting of the above company will be held at 10.00 a.m. on 15 September 1980 at 2nd Floor, Market Plaza Building, Flemington Markets N.S.W. for the purpose of receiving the Liquidator's Final Account together with his explanations thereon.

By Order of the Board

8954

R. W. JOSEPH, Director

an account laid before them showing the manner in which the winding up had been conducted and hearing any explanations that may be given by the liquidator.

Dated 30 July 1980

N. W. CURWOOD, Liquidator

Sicree, Nixon, Watt & Co., 257 Collins Street, Melbourne

8979

The Companies Act 1961, Section 254

EPMH PTY. LIMITED

SPECIAL RESOLUTION TO WIND UP

At an Extraordinary General Meeting of the abovenamed Company duly convened and held at 185 William Street, Melbourne on 8 July 1980 the following Resolution was passed as a Special Resolution:

"That the company be wound up voluntarily."

At the abovementioned meeting Roger D. Evans of 228 Albert Road, South Melbourne was appointed Liquidator for the purpose of the winding up.

Notice is also given that after 21 days from this date I shall proceed to distribute the assets. All creditors having any claim against the Company should furnish particulars of same by that date, otherwise I shall proceed to distribute the assets without regard to their claim.

Dated 15 July 1980

8980

ROGER D. EVANS, Liquidator

Companies Act 1961

THE SARLI CORPORATION PTY. LTD., the registered office of which is 7A Wells Street, Frankston

Notice is hereby given that a petition for the winding up of the above-named company by the Supreme Court was, on 30 July 1980, presented by Glenford Clothing Co. Pty. Ltd., and that the said petition is directed to be heard before the Court sitting at Melbourne at the hour of 10.30 o'clock in the forenoon on 18 September 1980 and any creditor or contributory of the said company desiring to support or oppose the making of an order on the said petition may appear at the time of hearing by himself or his Counsel for that purpose; and a copy of the petition will be furnished to any creditor or contributory of the said company requiring the same by the undersigned on payment of the regulated charge for the same.

The petitioner's address is 180 Goulburn Street, Sydney, New South Wales.

The petitioner's solicitors are Strongman and Crouch, of 118 Queen Street, Melbourne

STRONGMAN & CROUCH, solicitors for the petitioner

NOTE—Any person who intends to appear on the hearing of the said petition must serve on or send by post to the above-named Solicitors notice in writing of his intention so to do. The notice must state the name and address of the person, or, if a firm, the name and address of the firm, and must be signed by the person or firm or his or their solicitor (if any), and must be served, or, if posted, must be sent by post in sufficient time to reach the above-named not later than 4 o'clock in the afternoon of 17 September 1980.

8982

Companies Act 1961, as amended

COMPOSITE PRESS PTY. LTD.

NOTICE OF MEETING OF CREDITORS, PURSUANT TO SECTION 260

Notice is hereby given that a Meeting of Creditors of the abovenamed Company will be held at 332 Albert Street, East Melbourne on Wednesday, 10 September 1980, at 11.30 a.m. (Auditorium 1, Ground Floor).

It is intended that at the earlier meeting of members of the Company a Special Resolution, *inter alia*, will be considered for the purpose of placing the Company in liquidation pursuant to the provisions of the Companies Act relevant to a Creditors' Voluntary Winding Up.

Dated 13 August 1980

K. G. ROHDE, Director

Brendan O'Connor & Co., 562 St. Kilda Road, Melbourne
3004. Telephone 529 4722

8991

ALL STATES PRODUCE (VIC.) PTY. LIMITED (IN LIQUIDATION)

A meeting of the above company will be held at 10.00 a.m. on 15 September 1980 at 2nd Floor, Market Plaza Building, Flemington Markets N.S.W. for the purpose of receiving the Liquidator's Final Account together with his explanations thereon.

By Order of the Board

8954

R. W. JOSEPH, Director

In the matter of the following 19 Companies:

- ADARA LEE PTY. LTD. (IN VOLUNTARY LIQUIDATION)
- BARUNGA PTY. LTD. (IN VOLUNTARY LIQUIDATION)
- BUYRITE ELECTRIX (VIC.) PTY. LTD. (IN VOLUNTARY LIQUIDATION)
- D.K. INVESTMENTS PTY. LTD. (IN VOLUNTARY LIQUIDATION)
- DAVID KEYS (HOLDINGS) PTY. LTD. (IN VOLUNTARY LIQUIDATION)
- DAVID KEYS MILLS PTY. LTD. (IN VOLUNTARY LIQUIDATION)
- FARIO PTY. LTD. (IN VOLUNTARY LIQUIDATION)
- GREENSBOROUGH SALES PTY. LTD. (IN VOLUNTARY LIQUIDATION)
- HERMAN CURT PTY. LTD. (IN VOLUNTARY LIQUIDATION)
- JOHN RICHMOND PTY. LTD. (IN VOLUNTARY LIQUIDATION)
- KRUTSCH HOLDINGS PTY. LTD. (IN VOLUNTARY LIQUIDATION)
- KRUTSCH PLASTICS PTY. LTD. (IN VOLUNTARY LIQUIDATION)
- LINDA MILLS PTY. LTD. (IN VOLUNTARY LIQUIDATION)
- METCAST DISTRIBUTORS PTY. LTD. (IN VOLUNTARY LIQUIDATION)
- N.C.A. HOLDINGS PTY. LTD. (IN VOLUNTARY LIQUIDATION)
- PEAK PLATEMAKERS PTY. LTD. (IN VOLUNTARY LIQUIDATION)
- BARUNGA FILLED PTY. LTD. (IN VOLUNTARY LIQUIDATION)
- STULVA AGENCIES PTY. LTD. (IN VOLUNTARY LIQUIDATION)

NOTICE OF FINAL MEETINGS OF MEMBERS

Notice is hereby given in pursuance of section 272 of the Companies Act 1961 that a General Meeting of each of the Companies will be held at the office of R. A. Duncan and Co., Suite 6, 189 Darling Street, Balmain, N.S.W. on 8 September 1980 at 10 a.m. for the purpose of having laid before such meetings the Liquidator's account showing how the windings up have been conducted and the property of the Companies been disposed of and of hearing any explanations that may be given by the liquidator.

Dated 5 August 1980

R. A. DUNCAN, Liquidator

R. A. Duncan, Suite 6, 189 Darling Street, Balmain,
N.S.W. 2041

8976

Companies Act 1961, Section 254 (2) (b)

SMITH MITCHELL MALTING PROPRIETARY LIMITED

Notice is hereby given that at an Extraordinary General Meeting of the members of the abovenamed company held on 23 July 1980, it was resolved that the company be wound up voluntarily and that Eric Edwin Haines of 343 Little Collins Street, Melbourne, be appointed Liquidator.

Notice is also given that after 21 days from this date I shall proceed to distribute the assets. All creditors having any claims against the company should furnish particulars of same by that date, otherwise I shall proceed to distribute the assets without regard to their claim.

Dated 31 July 1980

8977

E. E. HAINES, Liquidator

PARAMOUNT-TEMPLEVALE HOMES PTY. LTD. (IN VOLUNTARY LIQUIDATION)

NOTICE OF FINAL MEETING

Notice is hereby given that pursuant to section 272 of the Companies Act 1961 the final meeting of the members of the Company will be held at the office of Sicree, Nixon, Watt and Co., 257 Collins Street, Melbourne on Monday, 15 September 1980 at 9.45 a.m. for the purpose of having

The Companies Act 1961

BELL & MITCHELL PTY. LTD., trading as Collections, Records and Books

CIRCULAR TO CREDITORS, PURSUANT TO SECTION 260

Notice is hereby given that a Meeting of Creditors of Bell and Mitchell Pty. Ltd., trading as Collections, Records and Books, of 106 Little Malop Street, Geelong, Vic., will be held at the Geelong Branch of the Victorian Chamber of Manufactures (Lower Meeting Room), 50 Western Beach, Geelong, 3220 on Thursday, 21 August 1980 at 11 a.m. for the purpose of considering the Company's affairs, the Company having convened an Extraordinary General Meeting of its members to be held on the same day at 10 a.m. for the purpose of considering and if thought fit passing a Special Resolution that the Company be wound up voluntarily.

Dated 7 August 1980

H. BELL, Director

Day, Neilson, Jenkins & Johns, chartered accountants,
199-203 Moorabool Street, Geelong, Vic. 3220 8990

Companies Act 1961, Section 272

M.A. BULK BUYERS PTY. LTD.
AT YOUR SERVICE CAR DEALERS PTY. LTD.
I.H. CAR DISTRIBUTORS PTY. LTD.
RELIABLE CAR DISTRIBUTORS PTY. LTD.
I.H. CAR HOLDINGS PTY. LTD.
A.C. MANUFACTURING CO. PTY. LTD.
KARINI PTY. LTD.
I. & M. AUTOS (ASHBURTON) PTY. LTD.
I. & M. AUTOS (BALWYN) PTY. LTD.
I. & M. AUTOS (CAMBERWELL) PTY. LTD.
I. & M. AUTOS (DONCASTER) PTY. LTD.
I. & M. AUTOS (ELTHAM) PTY. LTD.
I. & M. AUTOS (FOOTSCRAY) PTY. LTD.
I. & M. AUTOS (GARDENVALE) PTY. LTD.
I. & M. AUTOS (HAWTHORN) PTY. LTD.
I. & M. AUTOS (IVANHOE) PTY. LTD.
I. & M. AUTOS (JORDANVILLE) PTY. LTD.
I. & M. AUTOS (KEW) PTY. LTD.
I. & M. AUTOS (LALOR) PTY. LTD.
MEDI PRODUCTS PTY. LTD.
SNOW GLOW PRODUCTS PTY. LTD.
NIMANEB PTY. LTD.
HOTHAM HOLDINGS PTY. LTD.
DORANITA PROPERTIES PTY. LTD.
ROB-ROH HOLDINGS PTY. LTD.
BARDENS PTY. LTD.
BETA KNITS (TEXTILE DISTRIBUTORS) PTY. LTD.
F. & L. KIPEN KNITTING MILLS PTY. LTD.
F. & L. KIPEN KNITTING MILLS (SALES) PTY. LTD.
CONDIV MANAGEMENT SERVICES PTY. LTD.
BETA KNITS PTY. LTD.
BETA KNITS (FABRICS) PTY. LTD.
BETA KNITS (FINISHERS) PTY. LTD.
BETA KNITS (WOOLLENS) PTY. LTD.
BETA KNITS (YARNS) PTY. LTD.
STANRO BROKERS PTY. LTD.
STANRO HOLDINGS PTY. LTD.
CONDIV HEAT TREATMENT PTY. LTD.
CONDIV MACHINERY PTY. LTD.
CONDIV METAL FINISHINGS PTY. LTD.
CONDIV TOOL & DIE PTY. LTD.
E. J. DIVER PTY. LTD.
RAINBOW FISHERIES PTY. LTD.
LANSDOWNE INVESTMENTS PTY. LTD.
G.W.E.Z. INVESTMENTS PTY. LTD.
P.M.V.Z. INVESTMENTS PTY. LTD.
CARLISLE INVESTMENTS PTY. LTD.
COMO INVESTMENTS PTY. LTD.
T.H.H.Z. INVESTMENTS PTY. LTD.
S.B.S.Z. INVESTMENTS PTY. LTD.
R.E.C.Z. INVESTMENTS PTY. LTD.
W.B.B.Z. INVESTMENTS PTY. LTD.

(EACH OF THE ABOVE COMPANIES IN LIQUIDATION)

Notice is hereby given that the Final General Meeting of each of the above companies will be held at 17 Landcox Street, East Brighton, Victoria, at 11 a.m. on Monday, 29 September 1980 for the purposes set out in the above section.

Dated 6 August 1980

MURRAY DEWAR, liquidator, 17 Landcox Street, East Brighton, Victoria 3187 8981

Companies Act 1961, Section 254

CORNBAY PROPRIETARY LIMITED

Notice is hereby given that at an extraordinary general meeting of members of the abovenamed Company held on 10 July 1980 the following resolution was passed as a Special Resolution:—

"That the Company be wound up voluntarily and that R. Pigg of 2 Bay Street, Port Melbourne be appointed Liquidator."

Dated 4 August 1980

8992

R. PIGG, Liquidator

LANE'S TAXI SERVICES PROPRIETARY LIMITED

Notice is hereby given that, pursuant to section 272 of the Companies Act 1961, a meeting of members of the abovenamed Company will be held at 104 Liebig Street, Warrnambool on Wednesday, 17 September 1980 at 10 o'clock in the forenoon for the purpose of having an account laid before them showing how the winding up of the Company has been conducted and the property of the Company disposed.

Dated 6 August 1980

WILLIAM R. PHILLPOT, A.A.S.A. Liquidator

Sinclair & Wilson, public accountants, 104 Liebig Street, Warrnambool, Vic. 3280 8993

J. D. ANDERSON & SONS (1966) PTY. LTD.

BELAR PTY. LTD.

LEBASI PTY. LTD.

Notice is hereby given that, pursuant to section 272 of the Companies Act 1961, meetings of members of the abovementioned Companies will be held at 104 Liebig Street, Warrnambool on Wednesday, 17 September 1980 at 10.30 o'clock in the forenoon for the purpose of having accounts laid before them showing how the winding up of the Companies has been conducted and the property of the Companies disposed.

Dated 6 August 1980

W. G. SINCLAIR, F.A.S.A., Liquidator

Sinclair & Wilson, public accountants, 104 Liebig Street, (P.O. Box 217) Warrnambool, Vic, 3280 8994

Companies Act 1961-1976, Section 254 (2)

GOONSEC PTY. LTD.

NOTICE OF RESOLUTION

Notice is hereby given that at an extraordinary general meeting of the members of Goonsec Pty. Ltd. duly convened and held on 7 August 1980 the special resolution set out below was duly passed—

That the company be wound up voluntarily and that Mr V. C. Court be appointed liquidator.

Dated 8 August 1980

V. COURT, Liquidator

Hendry Rae & Court, 1st Floor, Homeric House, 442 Murray Street, Perth 9009

CLEARLOPES PTY. LIMITED (IN LIQUIDATION)

NOTICE OF FINAL MEETING

Notice is hereby given pursuant to section 272 of the Companies Act 1961 that the final meeting of members of the company will be held at 41 John Street, Lower Templestowe on 15 September 1980 at 10 a.m. for the purpose of laying before the meeting an account showing how the winding up has been conducted and the property of the company disposed of and hearing any explanation that may be given by the liquidator and to pass a resolution to destroy the company's books and papers and those of the liquidator pursuant to section 284 of the Companies Act 1961.

Dated 8 August 1980

9010.

B. C. THOMSON, Liquidator

ROLLS INVESTMENTS PTY. LTD.

At an Extraordinary General Meeting of the abovenamed Company duly convened and held at 491 Yackatoo Court, Ocean Shores, Brunswick Heads, N.S.W. on 5 August 1980, the following Resolution was duly passed as a Special Resolution:

- (1) That the Company be wound up voluntarily.
- (2) That Mr. John Learmont of 368 Hawthorn Road, Caulfield South be and is hereby appointed Liquidator.

Dated 8 August 1980

9011

J. LEARMONT, Liquidator

In the matter of the *Companies Act 1961*; and in the matter of **E. & E.S. PRY. LTD. (in Liquidation)**—Notice of Final Meeting of Members, pursuant to Section 272

Notice is hereby given in pursuance of section 272 of the *Companies Act 1961* that a General Meeting of the members of the Company will be held at the office of Hinsley & Watmuff, 4th Floor, 691 Burke Road, Camberwell on 15 September 1980 at 9.45 o'clock in the forenoon for the purpose of having an account laid before it showing the manner in which the winding up has been conducted and the property of the Company disposed of, and hearing any explanation that may be given by the liquidator.

Dated 11 August 1980

9012

In the matter of the *Companies Act 1961*; and in the matter of **NEW YORK FASHIONS (CAMBERWELL) PTY. LTD. (in Liquidation)**—Notice of Final Meeting of Members, pursuant to Section 272

Notice is hereby given in pursuance of section 272 of the *Companies Act 1961* that a General Meeting of the members of the Company will be held at the office of Hinsley & Watmuff, 4th Floor, 691 Burke Road, Camberwell on 15 September 1980 at 9.30 o'clock in the forenoon for the purpose of having an account laid before it showing the manner in which the winding up has been conducted and the property of the Company disposed of, and hearing any explanation that may be given by the liquidator.

Dated 18 August 1980

9013

Companies Act 1961**W. R. W. PTY. LTD. (IN VOLUNTARY LIQUIDATION)****NOTICE OF FINAL MEETING OF MEMBERS**

Notice is hereby given that the final meeting of members of the abovenamed Company shall be held on Friday 19 September 1980 at the offices of J. N. Cooke, Foley & Co., 3rd Floor, A.M.P. Building, 17 Lydiard Street North, Ballarat at 10.00 a.m.

Agenda

1. Presentation by the Liquidator of an account showing how the winding up has been conducted and the property of the company has been disposed of, and to give any explanation of the account.

2. The meeting to consider the following resolution:

"That immediately after the dissolution of the company the liquidator may destroy the books and papers of the company pursuant to section 284 of the Act."

Dated 8 August 1980

KEVIN FOLEY, Liquidator

J. N. Cooke, Foley & Co., public accountants, 3rd Floor, A.M.P. Building, 17 Lydiard Street North, Ballarat, 3350

9014

CLAN INVESTMENTS PROPRIETARY LIMITED

At an extraordinary general meeting of shareholders held on 29 July 1980, the following Special Resolution was passed:—

"That the Company be wound up voluntarily and that Kurt Edward Lippmann of 29 Alma Road, St. Kilda, be appointed Liquidator."

Dated 8 August 1980

9015

K. E. LIPPMANN, Liquidator

The Companies Act 1961**CHAD VALLEY CO. PTY. LTD. (IN MEMBERS VOLUNTARY LIQUIDATION)****NOTICE CONVENING FINAL MEETING OF MEMBERS, PURSUANT TO SECTION 272**

Notice is hereby given in pursuance of section 272 of the *Companies Act 1961* that a meeting of the members of the abovenamed Company will be held on 22 September 1980 at the offices of Haines Toner & Co., 343 Little Collins Street, Melbourne, at 9.00 a.m. for the purpose of having an account laid before them showing the manner in which the winding up has been conducted and the property of the Company disposed of and of hearing any explanations that may be given by the Liquidator.

Dated 6 August 1980

D. F. GORDON, Liquidator

Haines Toner & Co., chartered accountants, 343 Little Collins Street, Melbourne, Vic. 3000

9016

Companies Act 1961**S. G. GRAHAM-SMITH PTY. LTD. (IN LIQUIDATION)****NOTICE TO CREDITORS OF INTENTION TO DECLARE A DIVIDEND**

A first dividend is intended to be declared in the abovenamed Company. Creditors who have not proved their debt by 25 August 1980 will be excluded from this dividend. The date of liquidation was 24 April 1978.

Dated 8 August 1980

ROBERT A. WATERS, Liquidator

Orr, Martin & Waters, chartered accountants, 460 Bourke Street, Melbourne, 3000. Telephone 602 1644

9033

Companies Act 1961**CONCISE BUILDING CONTRACTORS PTY. LTD.****(IN LIQUIDATION)****NOTICE CONVENING FINAL MEETING OF CREDITORS OF THE COMPANY PURSUANT TO SECTION 272 (1)**

Notice is hereby given that the final meeting of members and creditors of the abovenamed Company will be held at the Office of D. Ferguson & Co., Public Accountants, Suite 9, 696 High Street, East Kew, on Friday, 5 September 1980 at 9.30 a.m. for the purpose of laying before the meeting an account showing how the winding up has been conducted and the property of the Company disposed of and of giving any explanation thereof.

Dated 4 August 1980

9034

D. J. FERGUSON, Liquidator

Companies Act 1961**HEANOR ENGINEERING CO. PTY. LTD.****(IN LIQUIDATION)****NOTICE CONVENING FINAL MEETING OF CREDITORS OF THE COMPANY PURSUANT TO SECTION 272 (1)**

Notice is hereby given that the final meeting of members and creditors of the abovenamed Company will be held at the Office of D. Ferguson & Co., Public Accountants, Suite 9, 696 High Street, East Kew on Friday, 5 September 1980 at 11 a.m. for the purpose of laying before the meeting an account showing how the winding up has been conducted and the property of the Company disposed of and of giving any explanation thereof.

Dated 4 August 1980

9035

D. J. FERGUSON, Liquidator

Companies Act 1961, Pursuant to Section 272 (2)**DEFCHIE PTY. LTD. (IN VOLUNTARY LIQUIDATION)**

Notice is hereby given that the final meeting of the shareholders of Defchie Pty. Ltd. (in voluntary liquidation) will be held at 5 Welham Street, Beecroft, New South Wales on 21 September 1980 at 7.00 p.m. for the purpose of having an account laid before it showing how the winding up of the Company has been conducted and the property of the Company has been disposed of and to pass a resolution to destroy the Company's books and papers pursuant to section 284 (3) (b) of the *Companies Act*.

6 August 1980

9037

R. A. BERRY, Liquidator

Companies Act 1961, Section 272
NORFOLK STATIONERY ENTERPRISES PTY. LTD.
(IN LIQUIDATION)

NOTICE OF FINAL MEETING

Notice is hereby given that pursuant to section 272 of the Companies Act 1961, a general meeting of members of the Company will be held at 14 Norfolk Road, Surrey Hills, at 10 a.m. on Wednesday, 24 September 1980.

The purpose of the meeting is to lay accounts before it, showing the manner in which the winding up has been conducted and the property of the Company disposed of and of hearing any explanation that may be given by the Liquidator.

Dated 13 August 1980

9036 LEONARD A. WOOLCOCK, Liquidator

The Companies Act 1961

F. X. WALSH LAND DEVELOPMENT CO. PTY. LTD.
(IN VOLUNTARY LIQUIDATION)

NOTICE OF FINAL MEETING

Notice is hereby given that pursuant to section 272 (2) of the Companies Act 1961, a general meeting of members of F. X. Walsh Land Development Co. Pty. Ltd. (in voluntary liquidation) will be held on 12 September 1980 at 11.00 a.m. at the offices of Touche Ross & Co., 440 Collins Street, Melbourne, for the purpose of receiving the Liquidator's account showing how the winding up has been conducted, and the property of the Company has been disposed of, and of hearing any explanations that may be given by the Liquidator.

Dated 8 August 1980

H. A. B. McWILLIAM, Liquidator

Touche Ross & Co., chartered accountants, 440 Collins Street, Melbourne, 3000 9038

Companies Act 1961—In the matter of R. POTTS PROPRIETARY LIMITED (Receiver and Manager Appointed)—Notice Regarding Meeting of Creditors Pursuant to Section 260

Notice is hereby given that a meeting of creditors of the abovenamed company will be held at The Victorian Chamber of Manufactures, Rooms 3 and 4, 370 St. Kilda Road, Melbourne at 10.30 o'clock on 26 August 1980 the company having convened a meeting of its members for the same day for the purpose of considering a Resolution that the company be wound up voluntarily.

Dated 7 August 1980

KEITH POTTS, Director

Neville Bird, chartered accountant, 3 Bowen Crescent, Melbourne, 3004, telephone 267 5111 9039

Form 92

Companies Act 1961, Section 272
MOCOPAN (SALES) PTY. LTD.

COMPANIES REGULATIONS

REGULATIONS 28 (2) (b)

Notice of Final Meeting in Voluntary Winding-Up

Take notice that the affairs of the abovenamed company are now fully wound-up and that in pursuance of Section 272 (1) of the Companies Act 1961 a general meeting of the company will be held at the Offices of J. Sheehan, Chartered Accountant, 4th Floor, 500 Collins Street, Melbourne on 1 September 1980 at 9.30 o'clock in the forenoon for the purpose of laying before it an account showing how the winding-up has been conducted and the property of the company disposed of and giving any explanation thereof.

Dated 1 August 1980

9040

J. SHEEHAN, Liquidator

The Companies Act 1961—In the matter of R. P. CARROLL PTY. LTD. (in Voluntary Liquidation)

Notice is hereby given that at an Extraordinary Meeting of Members of the abovenamed Company held on Wednesday 6 August 1980 it was resolved that the Company be wound up voluntarily and at a Meeting of Creditors held on Wednesday 6 August 1980 it was resolved that for such

purpose Anthony George Hodgson of Ferrier Hodgson Green & Co., Chartered Accountants be appointed Liquidator.

Notice is also given that after 21 days from this date I shall proceed to distribute the assets. All creditors having any claim against the Company should furnish particulars of same by that date, otherwise I shall proceed to distribute the assets without regard to their claim.

Dated 6 August 1980

A. G. HODGSON, Liquidator

Ferrier Hodgson Green & Co., chartered accountants, 459 Collins Street, Melbourne, 3000 9042

In the Supreme Court of Victoria—Co. 11421—In the matter of the Companies Act 1961; and in the matter of LIDRANA PTY. LTD.—Notice of Winding Up Order

Winding up Order made 31 July 1980.

Name and address of Liquidator: David Alexander Crawford C/- Messrs Peat Marwick & Mitchell Chartered Accountants, 500 Bourke Street, Melbourne.

9041 WEIGALL & CROWTHER, Petitioner's Solicitor

COMPANIES ACT 1961

Notice is hereby given that by a Special Resolution passed at a Meeting of Shareholders of Redmond Investments Pty. Ltd. held on 3 August 1980 it was resolved that the Company be wound up voluntarily.

Notice is also given that creditors having any claim against the Company should furnish particulars of that claim within 21 days of this date, otherwise distribution of the assets will take place without regard to such claims.

Dated 6 August 1980

R. C. PENNELL, Joint and Several Liquidators

Hughes, Fincher & Rodda, chartered accountants, 5th Floor, 44 Market Street, Melbourne, Vic., 3000 9043

Companies Act 1961

LINEAR ELECTRONICS AUSTRALIA PTY. LTD (IN LIQUIDATION)

CREDITORS' VOLUNTARY WINDING UP

(Receiver & Manager Appointed)

Notice is hereby given that at an Extraordinary General Meeting of the members of the above-mentioned company, held on 7 August 1980, it was resolved that the company be wound up voluntarily and at a Meeting of Creditors held on the same day it was resolved that for such purposes Warwick Allen Leeming of Duesbury Johnston & Marks, 114 William Street, Melbourne 3000, be appointed Liquidator.

Notice is also given that after twenty-one (21) days from this date, I shall proceed to distribute the assets. All creditors having any claim against the company should furnish particulars of same by that date, otherwise I shall proceed to distribute the assets without regard to their claim.

Dated 8 August 1980

W. A. LEEMING, Liquidator

Duesbury Johnston & Marks, chartered accountants, 114 William Street, Melbourne, Vic. 3000. Telephone: 67 8331 9044

Companies Act 1961

W. MUELLER & ASSOCIATES PTY. LTD.

NOTICE OF MEETING OF CREDITORS

Notice is hereby given that pursuant to Section 260 of the Companies Act 1961 a meeting of the creditors of W. Mueller & Associates Pty. Ltd. will be held at the Institute of Chartered Accountants, 140 Queen Street, Melbourne on 22 August 1980, at 11 a.m., the Company having convened a meeting of its members for the same day for the purpose of considering and, if thought fit, passing the special resolution that the company be wound up voluntarily.

Dated 11 August 1980

W. MUELLER, Director

Duesbury Johnston & Marks, chartered accountants, 114 William Street, Melbourne, Vic. 3000 9045

COBURG No. 6 CO-OPERATIVE HOUSING SOCIETY
LIMITED (IN LIQUIDATION)
SPECIAL RESOLUTION

Passed 31 July 1980.

At a special general meeting of the above-named society duly convened and held at 131 Bell Street, Coburg on 31 July 1980 at 6.20 p.m. the subjoined special resolution was duly passed—

That the Society having successfully completed its objectives seventeen months ahead of its expected term be wound up voluntarily and that Harry Chalmers of 131 Bell Street, Coburg, be appointed liquidator for the purposes of the winding up.

N. F. NIMMO, Chairman of Meeting
9065 H. CHALMERS, Secretary

In the Supreme Court of Victoria—Co. 11481—In the matter of the *Companies Act 1961*; and in the matter of BARRY NICHOLSON & SON PTY. LTD.

Notice is hereby given that a Petition for the winding up of the abovenamed company by the Supreme Court was on 7 August 1980 presented by Cadenza Pty. Ltd. and that the said Petition is directed to be heard before the Court sitting at the Practice Court, Law Courts, Lonsdale Street, Melbourne at the hour of 10.30 o'clock in the forenoon on 11 September 1980 and any creditor or contributory of the said company desiring to support or oppose the making of an order on the said Petition may appear at the time of hearing by himself or his Counsel for the purpose; and a copy of the said Petition will be furnished to any creditor or contributory of the said company requiring the same by the undersigned on payment of the regulated charge for the same.

The Petitioner's official address is 486 Sydney Road, Coburg.

The Petitioner's solicitors are Messrs. Cornwall Stodart & Co. of 380 Lonsdale Street, Melbourne.

CORNWALL STODART & CO.

NOTE—Any person who intends to appear on the hearing of the said Petition must serve on or send by post to the abovenamed Cornwall Stodart & Co., notice in writing of his intention so to do. The notice must state the name and address of the person or, if a firm, the name and address of the firm, and must be signed by the person or from or his or their solicitor (if any), and must be served or, if posted, must be sent by post in sufficient time to reach the abovenamed not later than 4.00 o'clock in the afternoon on 10 September 1980

9066

Companies Act 1961-1975, Section 260 (2)
SUETONE INVESTMENTS PROPRIETARY LIMITED
NOTICE OF MEETING OF CREDITORS

Notice is hereby given that, pursuant to section 260 (2) of the *Companies Act 1961-1975*, a Meeting of Creditors of Suetone Investments Proprietary Limited will be held at the offices of Messrs. Coffey & Co., Public Accountants, 67-69 Kepler Street, Warrnambool on 28 August 1980, at 11 a.m., to consider the following proposed resolution to be placed before and considered by an Extraordinary General Meeting of the said Company to be held at 10.30 a.m. on the same day.

That the Company be wound up voluntarily and that Mr Joseph James Purcell be and is now appointed Liquidator of the Company and that the provisions of Section 277A (1a) of the *Companies Act* shall not operate to invalidate the appointment of the abovenamed Liquidator.

A person is not entitled to vote as a creditor at the Meeting unless he has lodged with the Chairman of the Meeting a Proof of Debt which he claims is due to him, from the Company.

Dated at Warrnambool, 5 August 1980

9067

A. T. LORKIN, Director

Companies Act 1961-1975, Section 260 (2)
LORKIN ENTERPRISES PROPRIETARY LIMITED
NOTICE OF MEETING OF CREDITORS

Notice is hereby given that, pursuant to section 260 (2) of the *Companies Act 1961-1975*, a Meeting of Creditors of Lorkin Enterprises Proprietary Limited will be held at the offices of Messrs Coffey & Co., Public Accountants, 67-69 Kepler Street, Warrnambool on 28 August 1980, at 10 a.m., to consider the following proposed resolution to be placed before and considered by an Extraordinary General Meeting of the said Company to be held at 9.30 a.m. on the same day.

That the Company be wound up voluntarily and that Mr Joseph James Purcell be and is now appointed Liquidator of the Company and that the provisions of Section 277A (1a) of the *Companies Act* shall not operate to invalidate the appointment of the abovenamed Liquidator.

A person is not entitled to vote as a creditor at the Meeting unless he has lodged with the Chairman of the Meeting a Proof of Debt which he claims is due to him, from the Company.

Dated at Warrnambool, 5 August 1980

9068

A. T. LORKIN, Director

Companies Act 1961—In the matter of HOBART DUFF PROPRIETARY LIMITED (in Voluntary Liquidation)—Notice of Resolution, Pursuant to section 254

Notice is hereby given pursuant to section 254 of the *Companies Act 1961* that at a General Meeting of Members of Hobart Duff Proprietary Limited duly convened and held at 24 Mason Street, Dandenong on 6 August 1980 the Special Resolution set out below was duly passed.

That the Company be wound up voluntarily.

Dated at Dandenong, 8 August 1980

9069

R. J. SPAIN, Liquidator
D. W. CARMODY, Liquidator

In the Supreme Court of Victoria—In the matter of the *Companies Act 1961*; and in the matter of LONGLIFE SPORTING PRODUCTS PTY. LTD.

Notice is hereby given that a petition for the winding-up of the abovenamed Company by the Supreme Court was on 5 August 1980 presented by Eric John Unger, Deputy Commissioner of Taxation of the Commonwealth of Australia and that the said petition is directed to be heard before the Court sitting at the Fifteenth Court, Law Courts, Lonsdale Street, Melbourne, at the hour of 10.30 o'clock in the forenoon on 28 August 1980 and any creditor or contributory of the said company desiring to support or oppose the making of an order on the said petition may appear at the time of hearing by himself or his Counsel for the purpose; and a copy of the said petition will be furnished to any creditor or contributory of the said company requiring the same by the undersigned on payment of the regulated charge for the same.

The Petitioner's official address is 350 Collins Street, Melbourne.

The Petitioner's Solicitor is B. J. O'Donovan, Crown Solicitor for the Commonwealth of 99 Queen Street, Melbourne.

B. J. O'DONOVAN

NOTE—Any person who intends to appear on the hearing of the said petition must serve on or send by post to the abovenamed B. J. O'Donovan, notice in writing of his intention so to do. The notice must state the name and address of the person, or, if a firm, the name and address of the firm, and must be signed by the person or firm, or his, or their solicitor (if any), and must be served, or, if posted, must be sent by post in sufficient time to reach the abovenamed not later than 4.00 o'clock in the afternoon of 27 August 1980.

9078

In the Supreme Court of Victoria—In the matter of the *Companies Act 1961*; and in the matter of **STASTRA PAGE AND ASSOCIATES PTY. LTD.**

Notice is hereby given that a petition for the winding-up of the abovenamed Company by the Supreme Court was on 5 August 1980 presented by Eric John Unger, Deputy Commissioner of Taxation of the Commonwealth of Australia and that the said petition is directed to be heard before the Court sitting at the Fifteenth Court, Law Courts, Lonsdale Street, Melbourne, at the hour of 10.30 o'clock in the forenoon on 28 August 1980 and any creditor or contributory of the said company desiring to support or oppose the making of an order on the said petition may appear at the time of hearing by himself or his Counsel for the purpose; and a copy of the said petition will be furnished to any creditor or contributory of the said company requiring the same by the undersigned on payment of the regulated charge for the same.

The Petitioner's official address is 350 Collins Street, Melbourne.

The Petitioner's Solicitor is B. J. O'Donovan, Crown Solicitor for the Commonwealth of 99 Queen Street, Melbourne.

B. J. O'DONOVAN

NOTE—Any person who intends to appear on the hearing of the said petition must serve on or send by post to the abovenamed B. J. O'Donovan, notice in writing of his intention so to do. The notice must state the name and address of the person, or, if a firm, the name and address of the firm, and must be signed by the person or firm, or his, or their solicitor (if any), and must be served, or, if posted, must be sent by post in sufficient time to reach the abovenamed not later than 4.00 o'clock in the afternoon of 27 August 1980. 9079

In the Supreme Court of Victoria—In the matter of the *Companies Act 1961*; and in the matter of **VESTR-LAND NOMINEES PTY. LTD.**

Notice is hereby given that a petition for the winding-up of the abovenamed Company by the Supreme Court was on 5 August 1980 presented by Eric John Unger, Deputy Commissioner of Taxation of the Commonwealth of Australia and that the said petition is directed to be heard before the Court sitting at the Fifteenth Court, Law Courts, Lonsdale Street, Melbourne, at the hour of 10.30 o'clock in the forenoon on 28 August 1980 and any creditor or contributory of the said company desiring to support or oppose the making of an order on the said petition may appear at the time of hearing by himself or his Counsel for the purpose; and a copy of the said petition will be furnished to any creditor or contributory of the said company requiring the same by the undersigned on payment of the regulated charge for the same.

The Petitioner's official address is 350 Collins Street, Melbourne.

The Petitioner's Solicitor is B. J. O'Donovan, Crown Solicitor for the Commonwealth of 99 Queen Street, Melbourne.

B. J. O'DONOVAN

NOTE—Any person who intends to appear on the hearing of the said petition must serve on or send by post to the abovenamed B. J. O'Donovan, notice in writing of his intention so to do. The notice must state the name and address of the person, or, if a firm, the name and address of the firm, and must be signed by the person or firm, or his, or their solicitor (if any), and must be served, or, if posted, must be sent by post in sufficient time to reach the abovenamed not later than 4.00 o'clock in the afternoon of 27 August 1980. 9080

In the Supreme Court of Victoria—In the matter of the *Companies Act 1961*; and in the matter of **Vic CASH REGISTERS PROPRIETARY LIMITED**

Notice is hereby given that a petition for the winding-up of the abovenamed Company by the Supreme Court was on 5 August 1980 presented by Eric John Unger, Deputy Commissioner of Taxation of the Commonwealth of Australia and that the said petition is directed to be

heard before the Court sitting at the Fifteenth Court, Law Courts, Lonsdale Street, Melbourne, at the hour of 10.30 o'clock in the forenoon on 28 August 1980 and any creditor or contributory of the said company desiring to support or oppose the making of an order on the said petition may appear at the time of hearing by himself or his Counsel for the purpose; and a copy of the said petition will be furnished to any creditor or contributory of the said company requiring the same by the undersigned on payment of the regulated charge for the same.

The Petitioner's official address is 350 Collins Street, Melbourne.

The Petitioner's Solicitor is B. J. O'Donovan, Crown Solicitor for the Commonwealth of 99 Queen Street, Melbourne.

B. J. O'DONOVAN

NOTE—Any person who intends to appear on the hearing of the said petition must serve on or send by post to the abovenamed B. J. O'Donovan, notice in writing of his intention so to do. The notice must state the name and address of the person, or, if a firm, the name and address of the firm, and must be signed by the person or firm, or his, or their solicitor (if any), and must be served, or, if posted, must be sent by post in sufficient time to reach the abovenamed not later than 4.00 o'clock in the afternoon of 27 August 1980. 9081

In the Supreme Court of Victoria—In the matter of the *Companies Act 1961*; and in the matter of **CHESTER ACCOUNTING SERVICES PTY. LTD.**

Notice is hereby given that a petition for the winding-up of the abovenamed Company by the Supreme Court was on 5 August 1980 presented by Kevin Patrick Brady, Deputy Commissioner of Taxation of the Commonwealth of Australia and that the said petition is directed to be heard before the Court sitting at the Fifteenth Court, Law Courts, Lonsdale Street, Melbourne, at the hour of 10.30 o'clock in the forenoon on 28 August 1980 and any creditor or contributory of the said company desiring to support or oppose the making of an order on the said petition may appear at the time of hearing by himself or his Counsel for the purpose; and a copy of the said petition will be furnished to any creditor or contributory of the said company requiring the same by the undersigned on payment of the regulated charge for the same.

The Petitioner's official address is 350 Collins Street, Melbourne.

The Petitioner's Solicitor is B. J. O'Donovan, Crown Solicitor for the Commonwealth of 99 Queen Street, Melbourne.

B. J. O'DONOVAN

NOTE—Any person who intends to appear on the hearing of the said petition must serve on or send by post to the abovenamed B. J. O'Donovan, notice in writing of his intention so to do. The notice must state the name and address of the person, or, if a firm, the name and address of the firm, and must be signed by the person or firm, or his, or their solicitor (if any), and must be served, or, if posted, must be sent by post in sufficient time to reach the abovenamed not later than 4.00 o'clock in the afternoon of 27 August 1980. 9082

The Companies Act 1961–1975, Section 254 (1), Section 261 (1)

OSCAN PTY. LTD.

NOTICE OF PASSING OF SPECIAL RESOLUTION FOR VOLUNTARY WINDING UP

Notice is hereby given that at a meeting of members of the abovenamed company duly convened and held at the offices of Hungerford Hancock and Offner, Chartered Accountants, 16th Floor, 37 St. George's Terrace, Perth on 24 July 1980 the following Special Resolution was duly passed, namely—

“That the company be wound up voluntarily and that Ronald Wyndham Brown and Ross Stewart Norgard, Chartered Accountants be appointed Joint and Several Liquidators thereof.”

The appointment of the Joint and Several Liquidators was ratified by Resolution of the Creditors at a meeting of creditors held later that day aforesaid.

Dated at Perth, 24 July 1980

B. W. WOODS, Director

Hungerford Hancock & Offner, chartered accountants,
16th Floor, T. & G. Building, 37 St. George's Terrace,
Perth, W.A. 6000 9083

Companies Act 1961

VXL NOMINEES PTY. LTD.

NOTICE OF MEETING OF CREDITORS

Notice is hereby given that pursuant to section 260 of the Companies Act 1961 a meeting of the creditors of VXL Nominees Pty. Ltd. will be held at the Meeting Room, 10th Floor, 44 Market Street, Melbourne on 25 August 1980, at 10.30 a.m., the Company having convened a meeting of its members for the same day for the purpose of considering and, if thought fit, passing the special resolution that the company be wound up voluntarily.

Dated 11 August 1980

JACK SCURRAH, Secretary

Duesbury Johnston & Marks, chartered accountants, 114
William Street, Melbourne, Vic. 3000 9084

Companies Act 1961

VX LAUNDRY PTY LTD

NOTICE OF MEETING OF CREDITORS

Notice is hereby given that pursuant to Section 260 of the Companies Act 1961 a meeting of the creditors of VX Laundry Pty Ltd will be held at the Meeting Room, 10th Floor, 44 Market Street, Melbourne on 25 August 1980, at 12.00 noon, the Company having convened a meeting of its members for the same day for the purpose of considering and, if thought fit, passing the special resolution that the company be wound up voluntarily.

Dated 11 August 1980

JACK SCURRAH, Secretary

Duesbury Johnston & Marks, chartered accountants, 114
William Street, Melbourne, Vic. 3000 9085

The Companies Act 1961—In the matter of J. MOLONEY
(SALES) PTY. LTD. (in Liquidation)

Notice is hereby given that at an Extraordinary Meeting of Members of the abovenamed Company held on Thursday 10 July 1980 it was resolved that the Company be wound up voluntarily and at a Meeting of Creditors held on Thursday 10 July 1980 it was resolved that for such purpose Anthony George Hodgson of Ferrier Hodgson Green & Co., Chartered Accountants be appointed Liquidator.

Notice is also given that after 21 days from this date I shall proceed to distribute the assets. All creditors having any claim against the Company should furnish particulars of same by that date, otherwise I shall proceed to distribute the assets without regard to their claim.

Dated 11 August 1980

A. G. HODGSON, Liquidator

Ferrier Hodgson Green & Co., chartered accountants, 459
Collins Street, Melbourne, 3000 9086

Form 37

In the matter of PAN PACIFIC PLASTICS PTY. LTD.; and
Compromise of Creditors

The creditors of the abovenamed company are required on or before 5 September 1980 to advise details of debts or claims at 31 May 1980 and to establish any title they may have to priority by delivering or sending through the post to Mr E. Adamson at the undermentioned address an account specifying their respective debts or claims. In default they will be excluded from the benefit of any distribution made before such debts or claims are advised or such priority is established from objecting to any such distribution.

Further details may be obtained from the undersigned.
Dated 11 August 1980

E. ADAMSON, 57 Haig Street, South Melbourne, Vic.
3205 9087

Creditors, next of kin and others having a claim against the Estate of Vernon Henry McLeod formerly of 27 Hassett Street Leongatha but late of Woorayl Lodge Leongatha Retired Gentleman deceased who died on 7 April 1980, are required to send particulars to Colin Andrew McKenzie-McHarg of 23 Bair Street Leongatha the Executor to whom Probate of the Will has been granted and Solicitor of the Estate of the said deceased by 20 October 1980, after which date the Executor will distribute the assets having regard only to the claims of which he then has notice.

OAKLEY THOMPSON & CO., solicitors, 23 Bair Street,
Leongatha, 3953, and at 205 King Street, Melbourne, 3000

8958

Creditors, next of kin and others having claims in respect of the estate of Stanley James Clough formerly of 152 Nepean Highway Seaford but late of 14 Campbell Street Bentleigh in the State of Victoria formerly Despatch Clerk but then Gentleman deceased who died on 14 May 1980 are to send particulars of their claims to Dorothy Beatrice June Clough of 14 Campbell Street Bentleigh in the said State Spinster care of the undermentioned Solicitors by 13 October 1980 after which date she will distribute the assets having regard only to the claims of which she then has notice.

REGINALD C. BUTLER & CO., solicitors, 312 Centre
Road, Bentleigh 8959

Creditors, next of kin and others having claims in respect of the Estate of Olive Dolores Tucker late of Unit 3, 81-83 Dobson Street, Ferntree Gully, Widow, deceased, who died on 14 April 1980 are requested to send particulars of their claims to John Roger Wallis the Executor of the Will of the said deceased in care of the undermentioned firm of Solicitors by 20 October 1980, after which date the Executor will distribute the assets having regard only to the claims of which he has notice.

CLEMENTS, MOTT & BENT, solicitors, 221-229 Glen-
huntly Road, Elsternwick 8960

Creditors, next of kin and others having claims against the Estate of Frederick Patrick Braithwaite late of 13 Mountfield Avenue, Chadstone Motor Painter deceased who died on 23 February 1980 are required by Arthur Thomas Braithwaite of Daramalan College, Dickson, A.C.T. and Kevin William Liston of 2 Bonview Road, Malvern to send particulars of their claim to the undermentioned Solicitor by 17 October 1980 after which date they will convey or distribute the assets having regard only to the claims of which they then have notice.

THOMAS BURKE, solicitor, 152 Wattletree Road,
Malvern 8961

YOLANDE SIBELLA CARRE RIDDELL, formerly of Came-
ston, Werril Street, Swan Hill in the State of Victoria,
but late of Sackville Private Hospital, 48 Sackville Street,
Kew in the said State, spinster, DECEASED (who died on
22 February 1980)

Creditors, next of kin and all other persons having claims against the Estate of the deceased are required by the Executors of the Will, John Albert Hepworth, John Walter Carre Riddell and William Robert Potter, to send particulars to them care of the undersigned on or before 5 November 1980 after which date they will distribute the assets having regard only to the claims of which they then have notice.

GARDEN & GREEN, solicitors, 4 McCallum Street,
Swan Hill 8962

NORMAN GRABHAM SMITH, late of "Clearview", corner
Heather Avenue and Geelong Road, Ballarat, retired
farmer, DECEASED (who died on 4 April 1980)

Creditors, next of kin and all persons having claims against the estate of the deceased are required to send particulars to the Executor The Union-Fidelity Trustee Company of Australia Limited of 101 Lydiard Street North, Ballarat on or before 14 October 1980, after which date it will distribute the assets having regard only to the claims of which it shall then have notice.

HEINZ & GORDON, solicitors, 209 Dana Street, Ballarat

8963

Creditors, next of kin and others having claims in respect of the estate of Gertrude Mary Brooks late of Maldon in the State of Victoria Spinster deceased who died on 6 May 1980 are required to send particulars of their claims to the Executor The Equity Trustees Executors and Agency Company Limited of 472 Bourke Street, Melbourne in the State of Victoria by 12 October 1980 after which date the Executor will distribute the assets having regard only to the claims of which it then has notice.

SEDDON & WITT, solicitors, of 406 Collins Street, Melbourne 8964

WILLIAM MARK MOTTERSHEAD, late of 2 Ballantyne Street, Thornbury, retired, DECEASED

Creditors, next of kin and others having claims against the estate of the said deceased who died on 30 May 1980 are to send particulars of their claims to Kevin William Mottershead C/- 452 High Street, Northcote by 15 October 1980, after which date he will distribute the assets having regard only to the claims of which he then has notice.

WALSH JOHNSTON & CO., solicitors, 452 High Street, Northcote 8965

EILEEN HAZEL LYMER, late of 146 Beavers Road, Northcote, music teacher, DECEASED

Creditors, next of kin and others having claims against the estate of the said deceased who died on 21 April 1980 are to send particulars of their claims to Margaret Power C/- 452 High Street, Northcote by 15 October 1980, after which date she will distribute the assets having regard only to the claims of which she then has notice.

WALSH JOHNSTON & CO., solicitors, 452 High Street, Northcote 8966

IRENE MAY MURPHY, formerly of Arthurs Creek but late of 34 High Street, Sorrento, widow, DECEASED

Creditors, next of kin and others having claims against the estate of the said deceased who died on 7 March 1980 are to send particulars of their claims to Leonard George David Murphy and Roy Raymond Murphy C/- 452 High Street, Northcote by 15 October, 1980, after which date they will distribute the assets having regard only to the claims of which they then have notice.

WALSH JOHNSTON & CO., solicitors, 452 High Street, Northcote 8967

Creditors, next of kin and others having claims against the Estate of David Whiteside late of 12 Craileen Street Donvale in the State of Victoria Retired Railway Ganger deceased who died on 1 May 1980 are required to send particulars of the claims to the Executor Herbert Austin Whiteside care of the undermentioned Solicitors by 21 October 1980 after which date he will distribute the Estate of the said Deceased having regard only to the claims of which he then has notice.

HOWELL & GARDINER, solicitors, 346 High Street, Preston 8968

Creditors, next of kin and others having claims in respect of the Estate of Herbert John Morton Ellis late of Devon House, 18 Olympic Avenue, South Springvale in the State of Victoria, Pensioner deceased who died on 30 March 1980, are to send particulars of their claims to J. & S. Shatin & Bernstein, Solicitors of 224 Queen Street, Melbourne in the said State, the Solicitors for the Executrix appointed by the Will of the deceased, by 25 October 1980.

J. & S. SHATIN & BERNSTEIN, solicitors, of 224 Queen Street, Melbourne 8969

Creditors, next of kin and others having claims in respect of the Will and Estate of Edith Elizabeth Mills late of Arawa, North Solomons, Papua New Guinea, Widow, deceased who died on 4 August 1979 are to send particulars of their claim to the Administrator of the Estate Colin Bruce Anthony Lobb care of the undersigned by 20 October 1980, after which date he will distribute the assets having regard only to the claims of which he then has notice.

C. B. A. LOBB & ASSOCIATES, solicitors, 4 Hamilton Place, Mount Waverley 8995

VIDA MAY ANDERSON, late of 184 Roslyn Road, Belmont, in the State of Victoria, widow, DECEASED

Creditors, next of kin and others having claims in respect of the abovenamed deceased (who died on 24 September 1979) are required by the Executors (Richard Frank Lloyd Annois of 77 Moorabool Street, Geelong and Jamie Dennett Eldon Fisher of 77 Moorabool Street, Geelong, both Solicitors) to send particulars of such claims to the undermentioned firm by 13 October 1980 after which date the said Executors may convey or distribute the assets having regard only to the claims of which they then have notice.

HARWOOD & PINCOTT, solicitors of 77 Moorabool Street, Geelong 8970

STEPHEN WALTER MCINTYRE, late of Yarragon, retired managing director, DECEASED

Creditors, next of kin and others having claims in respect to the estate of the deceased who died on 8 June 1980 are required by the Trustee, Kenneth George Graydon to send particulars of their claims to him care of the undersigned Solicitors by 20 October 1980 after which date the Trustee may convey or distribute the assets having regard only to the claims of which he then has notice.

GRAY, FRIEND & LONG, solicitors, Warragul 8996

JOHN FRANCIS TOMS, late of Nyah West in the State of Victoria, labourer, DECEASED (who died on 6 March 1980)

Creditors, next of kin and all other persons having claims against the Estate of the deceased are required by the Executrix of the Will, Lillian Evelyn Elizabeth Toms, to send particulars to her care of the undersigned on or before 8 October 1980 after which date she will distribute the assets having regard only to the claims of which she then has notice.

GARDEN & GREEN, solicitors, 4 McCallum Street, Swan Hill 8997

Creditors, next of kin and others having claims in respect of the estate of Basilia Mary McDonald late of 11 Fourth Street, Mentone in the State of Victoria, Widow deceased who died on 9 May 1980 are to send particulars of their claims to John Archibald McDonald of 11 Fourth Street, Mentone the sole Executor appointed by the said Will by 13 October 1980 after which date the Executor will distribute the assets having regard only to the claims of which he then has notice.

SEDDON & WITT, solicitors, 406 Collins Street, Melbourne 9017

Creditors, next of kin and others having claims in respect of the Estate of Eileen Annie McConneil late of Unit 9, Judgebook Memorial Village, Diamond Street, Eltham in the State of Victoria, Widow deceased who died on 29 April 1980 are to send particulars of their claims to Cecil Raymond King of 4 Rogerson Court, Balwyn the sole Executor appointed by the said Will by 13 October 1980 after which date the Executor will distribute the assets having regard only to the claims of which he then has notice.

SEDDON & WITT, solicitors, 406 Collins Street, Melbourne 9018

LESLIE THOMAS REILLY, formerly of Camperdown, but late of Lakeside Hospital, Ballarat, retired civil servant, DECEASED

Creditors, next of kin and others having claims in respect of the Estate of the deceased who died on 29 January 1979, are required by the Executors, Henry James Reilly of 10 Harrison Street, Camperdown, Victoria Pensioner and Ethel Emma Perry of Flat 3, 452 Kothhoff Street, Lavington, New South Wales Married Woman to send particulars to them care of the undermentioned solicitors by 25 October 1980 after which date they may convey or distribute the assets having regard only to the claims of which they then have notice.

BUCKLAND & NEVETT, solicitors, Camperdown 9019

Creditors, next of kin and others having claims against the Estate of Gladys Morrice Love late of 3 Salisbury Street, Yarraville in the State of Victoria Married Woman deceased who died on 24 June, 1980 are required by the Executor The Union-Fidelity Trustee Company of Australia Limited of 100 Exhibition Street, Melbourne to send particulars of their claims addressed to the said Executor The Union-Fidelity Trustee Company of Australia of 100 Exhibition Street, Melbourne aforesaid before 1 November, 1980 after which date the said Company will distribute the Estate having regard only to the claims of which it then has notice.

ROMUALD J. MARTIN, solicitor, of 100 Exhibition Street, Melbourne 9020

DEREK THOMAS VICTOR FARROW, late of 4 Maple Close, Puriton, Bridgewater, Somerset, formerly of Bridgewater, in the State of Victoria, Australia, retired, DECEASED

Creditors, next of kin and others having claims in respect of the Victorian Estate of the deceased who died on 10 July, 1977, are required by the Executrix Diana May Farrow whose address in Victoria is 33-35 Williamson Street, Bendigo, to send particulars to her care of the undermentioned solicitors by 15 October, 1980, after which date she may convey or distribute the assets having regard only to the claim or claims of which she then has notice.

R. H. SCHLEIGER & ASSOCIATES, solicitors, 33-35 Williamson Street, Bendigo 9021

Creditors next of kin and others having claims against the Estate of Harold Jerome Driscoll late of 13 Missouri Avenue, Gardenvale in the State of Victoria, Customs and Shipping Agent, deceased who died on 26 February 1979 are required by the Executor Richard James Davis of 8-12 Batman Street, Melbourne in the said State, Solicitor, to send particulars to him care of the undermentioned solicitors by 15 October 1980 after which date the Executor may distribute the assets having regard only to the claims of which he then has notice.

TURNER, NESS & DAVIS, solicitors, 8-12 Batman Street, Melbourne 9022

ROSEMARY FISH, late of Hadleigh Court, Unit 1, 22 Langford Street, Surrey Hills, widow, DECEASED

Creditors, next of kin, and others having claims in respect of the estate of the deceased, who died on 7 March 1980 are required by her Executrix, Rhonda Joan Gaze of 9 Viewhill Road, North Balwyn to send particulars to her by 15 October 1980 after which date she may convey or distribute the assets, having regard only to the claims of which she then has notice.

HEDDERWICK, FOOKES & ALSTON, 121 William Street, Melbourne 9023

APPOLONIA HOLMES, late of 19 MacGregor Street, East Malvern, in the State of Victoria, widow, DECEASED

Creditors, next of kin and others having claims in respect of the estate of the deceased (who died on 13 May 1980) are required by National Trustees Executors and Agency Company of Australasia Limited of 95 Queen Street, Melbourne in the said State to send particulars of their claims to the said Company by 24 October 1980, after which date the said Company will convey or distribute the assets having regard only to the claims of which it then has notice.

BOOTHBY & BOOTHBY, solicitors, 883 Dandenong Road, Caulfield East 9024

Creditors next of kin and others having claims in respect of the estate of Ernest Dugdale late of 5 Norman Street Coburg in the State of Victoria Gentleman deceased who died on 21 March 1980 are required to send particulars of their claims to the Executor National Trustees Executors & Agency Company of Australasia Limited of 95 Queen Street Melbourne by 13 October 1980 after which date the executor will distribute the assets having regard only to the claims of which it then has notice.

GODFREY STEWART, FRANK CURTAIN & CO., solicitors, 493 Bourke Street, Melbourne 9025

WILLIAM MCKENZIE MACKIE GOW, late of 177 The Avenue, East Coburg, retired, DECEASED

Creditors, next-of-kin and others having claims in respect of the Estate of the deceased who died on 29 June 1980 are requested to send particulars of their claims to the Executrices Dorothy Ellen Gow and Helen Margaret Gow C/- the undersigned Solicitor by 15 October 1980 after which date the said Executrices will proceed to distribute the Estate having regard only to the claims of which they then have notice.

MARJORY C. COATES, solicitor, of 422 Collins Street, Melbourne, 3000 9026

RUPERT WILLIAM FISHER, late of 3 Macartney Street, Reservoir, retired, DECEASED

Creditors, next-of-kin and others having claims in respect of the Estate of the deceased who died on 9 April 1971 are requested to send particulars of their claims to the Executor Harold Daniel Fisher care of the undersigned Solicitor by 15 October 1980 after which date the said Executor will proceed to distribute the Estate having regard only to the claims of which he then has notice.

MARJORY C. COATES, Solicitor, of 422 Collins Street, Melbourne, 3000 9027

LUCY JOY PETER, late of 16 McDonald Street, West Preston, gentlewoman, DECEASED

Creditors, next-of-kin and others having claims in respect of the Estate of the deceased who died on 16 May 1980 are requested to send particulars of their claims to the Executors Allan Edgar Peter and Marjorie Joyce Drake care of the undersigned Solicitor by 14 October 1980 after which date the said Executors will proceed to distribute the Estate having regard only to the claims of which they then have notice.

MARJORY C. COATES, solicitor, of 422 Collins Street, Melbourne 9028

RALPH MALVERN RICHARDS, late of 8 Sebastopol Street, Caulfield, gentleman, DECEASED

Creditors next of kin and others having claims against the Estate of the deceased who died on 23 May 1980 are required by the Executor Kenneth Reginald Snelling of 401 Collins Street Melbourne to send particulars of their claims to the Executor care of the undersigned Solicitors on or before 15 October 1980 after which date he will convey or distribute the assets having regard only to the claims of which he then has notice.

HOME, WILKINSON & LOWRY, solicitors, of 401 Collins Street, Melbourne 9029

THOMAS REUBEN JOSEPH PEACE, late of Horfield, in the State of Victoria, farmer, DECEASED

Creditors next of kin and all other persons having claims against the estate of the said deceased are required by Doris Elizabeth Peace Widow and Graeme Thomas Peace Farmer both of Leitchville in the said State the Executors of the Estate of the said Deceased to send particulars of such claims to them care of the undermentioned Solicitors on or before 10 October 1980 after which date they will distribute the assets having regard only to the claims of which they then have Notice.

BASILE & CO., barristers and solicitors, 77 King George Street, Cohuna 9030

MARIE FRANCES WYPER, late of 7 Copelen Street, South Yarra, married woman, DECEASED

Creditors next of kin and others having claims in respect of the estate of the deceased (who died on 9 February 1980) are required by Alec Hall McKay, Melford Henry Russell Roberts and David James Hughes all of 44 Market Street Melbourne Solicitors (the executors to whom Probate was granted on 20 June 1980) to send particulars to them in care of the undersigned Solicitors by 15 October 1980 after which date the executors may convey or distribute the assets having regard only to the claims of which they then have notice.

H. S. W. LAWSON HUGHES & CO., solicitors, 44 Market Street, Melbourne 9031

ARTHUR HARRY JOHNSTON, late of "Milford Hall", 8 Mercer Road, Armadale, retired solicitor, DECEASED

Creditors next of kin and others having claims in respect of the estate of the said deceased who died on 26 June 1980 are to send particulars of their claims to the Executors of his Will and Codicil namely The Perpetual Executors and Trustees Association of Australia Limited and Lady Nina Gwendoline Sunderland care of the said Company at 50 Queen Street Melbourne by 16 October 1980 after which date the Executors will distribute the assets in the estate having regard only to the claims of which they then have notice.

W. B. & O. McCUTCHEON, solicitors, 250 Elizabeth Street, Melbourne 9032

ETHEL MARY TIEGS, late of 139 Atherton Road, Oakleigh, Victoria, widow, DECEASED

Creditors, next of kin and others having claims in respect of the estate of the deceased who died on 30 June 1980 are required to send particulars thereof to the Executors of her Will, David Anthony Lee and Robert Addison care of the undermentioned Solicitors, on or before 10 October 1980, after which date they will distribute the assets in the estate having regard only to the claims of which they then have notice.

J. M. SMITH & EMMERTON, solicitors, 224 Queen Street, Melbourne 9070

HILDA MAY DUNN, late of 39 Margaret Street, North Geelong, widow, DECEASED

Creditors, next of kin and others having claims against the estate of the deceased who died on 24 May 1980 are required by the Executors of the will Ian Howard Roediger and Nancy Ethel Taylor to send particulars to them care of Birdsey, Dedman & Bartlett, of 166A Ryrie Street, Geelong, Solicitors, by 20 October 1980 after which date they may convey or distribute the assets having regard only to the claims of which they then have notice.

Dated 11 August 1980

BIRDSEY, DEDMAN & BARTLETT, solicitors, 166A Ryrie Street, Geelong 9071

Creditors, next of kin and others having claims in respect of the Estate of George Edward Tasman Johnson, late of 3 Hawthorn Road, Northcote in the State of Victoria, Bookmaker, deceased who died on 4 May 1980 are to send particulars of their claim to The Equity Trustees Executors and Agency Company Limited of 472 Bourke Street, Melbourne, the Executor appointed by the deceased's Will by 20 October 1980, after which date the said company will distribute the assets having regard only to the claims of which it shall then have had notice.

WILLIAM M. SERONG, solicitor, 274 Queens Parade, Clifton Hill, Vic. 3068 9072

ALFREDA HYLDA SENIOR, late of 100 Mount Dandenong Road, Ringwood East in the State of Victoria, widow, DECEASED

Creditors, next of kin and others having claims in respect of the estate of the abovenamed deceased (who died on 23 May 1980) are required to send particulars of their claims to the Executor National Trustees Executors and Agency Company of Australasia Limited of 95 Queen Street, Melbourne on or before 21 October 1980 after which date the Executor will distribute the assets of the said deceased having regard only to the claims of which it shall then have had notice.

PETER HASSETT & CO., solicitors, of 1156 Toorak Road, Hartwell 9073

DOROTHY BRUMBY, formerly of 25 Princes Highway, Newborough, but late of 114 Coaldrake Court, Carrum Downs, home duties, DECEASED

Creditors, next of kin and others having claims in respect of the estate of the deceased who died on 28 December 1979 are required by the Executor Francis Xavier O'Halloran of Trafalgar Solicitor to send particulars to his Solicitors Messrs F. X. O'Halloran, Davis

& Co., Kirk Street, Moe by 14 October 1980 after which date the Executor may convey or distribute the assets of the deceased having regard only to the claims of which he then has notice.

Dated 14 August 1980

F. X. O'HALLORAN, DAVIS & CO., solicitors, Moe 9074

ALICE MAUD PARKINSON, late of 99 Maud Street, North Balwyn, in the State of Victoria, home duties, DECEASED

Creditors, next of kin and other persons having claims against the estate of the said deceased who died on 26 March 1980 are required to send particulars of same to the Executor Bryan William Delany in care of the undersigned on or before 30 October 1980 after which date he will distribute the assets having regard only to the claims which he then has notice.

GERALD E. DELANY & CO., solicitors, of 185 William Street, Melbourne, 3000 9075

JESSIE DOWNIE, late of Ripplebrook, gentelwoman, DECEASED

Creditors, next of kin and others having claims in respect of the estate of the said deceased who died on 12 February 1980 are required by the Trustees Clive Downie and Ian James Downie to send particulars of their claims to them care of the undersigned Solicitors by 27 October 1980 after which date the Trustees may convey or distribute the assets having regard only to the claims of which they then have notice.

GRAY, FRIEND & LONG, solicitors, Warragul 9076

ARTHUR JOHN HILL, late of 34 Hopetoun Street, Bendigo, gentleman, DECEASED

Creditors, next of kin and others having claims in respect of the estate of the deceased who died on 21 March 1980 are required by the executrix Elva Dulcie Hill of 34 Hopetoun Street, Bendigo, to send particulars to her care of the undermentioned solicitors by 11 October 1980 after which date she may convey or distribute the assets having regard only to the claims of which she then has notice.

R. H. SCHLEIGER & ASSOCIATES, solicitors, 33-35 Williamson Street, Bendigo 9077

Creditors, next of kin and others having claims in respect of the Estate of Phyllis Craven Hemmons late of Lyndoch Home for the Aged, Warrnambool Spinster deceased who died on 14 March 1980 are to send particulars of their claims to The Equity Trustees Executors and Agency Company Limited at its registered office situated at 472 Bourke Street Melbourne by 15 October 1980 after which date it will distribute the assets having regard only to the claims of which it then has notice.

COOK & McCALLUM, solicitors, 422 Collins Street, Melbourne 9088

After the expiration of fourteen clear days application will be made to the Supreme Court of Victoria that Probate of the Will dated 1 March 1973 of Johanna Paula Eleonore Forell late of "Coronella" Seventh-day Adventist Homes, 163-165 Central Road, Nunawading in the State of Victoria, Widow deceased be granted to Claude Rainer Forell formerly of 31 North Road, Brighton but now of 27 Brickwood Street, Gardenvale in the said State, Journalist and Leonard William Jones Manager of Calder Highway, Macedon in the said State (the Manager of the said "Coronella" Seventh-day Adventist Homes) the Executors appointed by the said Will.

KHAN AND CLAHR, solicitors, of 213 Lonsdale Street, Melbourne 9089

In the Supreme Court of the State of Victoria
SALE BY THE SHERIFF

On Monday, 24 September 1980 at 2.30 p.m. at the Bailiff's Office, 2nd Floor, 300 Burwood Road, Hawthorn (unless process be stayed or satisfied) at the best price offered.

All the Estate and Interest (if any) of Mr and Mrs G. Vakalopoulos (shown on Certificate of Title as George Vakalopoulos, and Helen Vakalopoulos, married woman) both of 3 Halston Road, Lalor as joint proprietor of an estate in fee simple in the land described in Certificate of Title Volume 8819 Folio 955 upon which is erected a dwelling house known as No. 3 Halston Road, Lalor.

Registered Mortgage No. G.119343 affects the said estate and interest.

Terms—Cash only—Property to be sold to the highest bidder—No reserve set

9047

K. R. MARTIN, Sheriff's Officer

In the Supreme Court of the State of Victoria
SALE BY THE SHERIFF

On Wednesday, 17 September 1980 at 11.00 a.m. at the Police Station, Wallan (unless process be stayed or satisfied).

All the Estate and Interest (if any) of Kevin Innis shown on Certificate of Title as Kevin Albert Innis, horse trainer, as joint proprietor with Wilma Joan Innis, married woman, of an estate in fee simple in the land described in Certificate of Title Volume 8838 Folio 557 upon which is erected a dwelling house and trotting stables on the south side of William Street, Wallan.

Registered Mortgages Nos. E.185698 and F.804118 affect the said estate and interest.

Terms—Cash only

9048

J. GREEN, Deputy Sheriff

In the Supreme Court of the State of Victoria
SALE BY THE SHERIFF

On Thursday, 18 September 1980 at 2.30 p.m. at the Bailiff's Office, 2nd Floor, 300 Burwood Road, Hawthorn (unless process be stayed or satisfied).

All the Estate and Interest (if any) of Noel John Graham, builder, and Annette Ruth Graham, married woman, both of Lot 4 Thompsons Road, Lyndhurst, as joint proprietors of an estate in fee simple in the land described in Certificate of Title Volume 8702 Folio 511 upon which is erected a large ranch style brick veneer house some distance back from Thompsons Road on the south side of the street. The property is approached by means of a sweeping drive known as Lot 4 Thompsons Road, Lyndhurst.

Registered Mortgages Nos. D.990979, F.432075, G.189440 and Caveat No. H.745603 affect the said estate and interest.

Terms—Cash only

9049

T. M. NICHOLLS, Sheriff's Officer

In the Supreme Court of the State of Victoria
SALE BY THE SHERIFF

On Thursday, 18 September 1980 at 2.30 p.m. at the Bailiff's Office, 2nd Floor, 300 Burwood Road, Hawthorn (unless process be stayed or satisfied).

All the Estate and Interest (if any) of Geoffrey Alfred Mantell, air conditioning contractor, of 19 Winifred Street, East Oakleigh as joint proprietor with Anne Margaret Mantell, married woman, of an estate in fee simple in the land described in Certificate of Title Volume 7968 Folio 016 upon which is erected a dwelling house known as No. 19 Winifred Street East Oakleigh.

Registered Mortgage No. F.754028 and H.594384 affect the said estate and interest.

Terms—Cash only

9050

T. M. NICHOLLS, Sheriff's Officer

In the Supreme Court of the State of Victoria
SALE BY THE SHERIFF

On Wednesday, 24 September 1980, at 2.30 p.m. at the Bailiff's office, 2nd Floor, 300 Burwood Road, Hawthorn (unless process be stayed or satisfied).

All the Estate and Interest (if any) of Leo Vidra (shown on Certificate of Title as Lajos Vidra) storeman of 11 Vaucluse Avenue, Tullamarine, as joint proprietor with Milka Vidra, married woman, of an estate in fee simple in the land described in Certificate of Title Volume 8987 Folio 550 upon which is erected a brick veneer dwelling known as No. 11 Vaucluse Avenue, Tullamarine.

Registered Mortgage No. F.204437 the discharge of which has been lodged in the Titles Office but is not yet registered, Mortgage No. H.950072 which has been lodged in the Titles Office, but is not yet registered and Caveat H.727763, affect the said estate and interest.

Terms—Cash only

9051

K. R. MARTIN, Sheriff's Officer

In the Supreme Court of the State of Victoria
SALE BY THE SHERIFF

On Wednesday, 24 September 1980, at 2.30 p.m. at the Bailiff's office, 2nd Floor, 300 Burwood Road, Hawthorn (unless process be stayed or satisfied).

All the Estate and Interest (if any) of Rosario Condello, concreter and Caterina Condello, married woman, both of 78 Ripplebrook Drive, Broadmeadows, as joint proprietors of an estate in fee simple in the land described in Certificate of Title Volume 8979 Folio 436 upon which is erected a brick veneer house known as No. 78 Ripplebrook Drive, Broadmeadows.

Registered Mortgage No. G.727610 and Caveat No. H.502586 affect the said estate and interest subject to the covenant contained in Transfer G.727609.

Terms—Cash only

9052

K. R. MARTIN, Sheriffs' Officer

In the Supreme Court of the State of Victoria
SALE BY THE SHERIFF

On Wednesday, 24 September 1980, at 2.30 p.m. at the Bailiff's office, 2nd Floor, 300 Burwood Road, Hawthorn (unless process be stayed or satisfied).

All the Estate and Interest (if any) of Shaqir Sejdijaj, tradesman, and Elmedina Sejdijaj, married woman, of 20 Belfort Street, St. Albans, as joint proprietors of an estate in fee simple in the land described in Certificate of Title Volume 9009 Folio 324 upon which is erected a dwelling house known as No. 20 Belfort Street, St. Albans.

Registered Mortgage No. H.300764 and the Covenant contained in Transfer No. D.422047 affect the said estate and interest.

Terms—Cash only.

9053

K. R. MARTIN, Sheriffs' Officer

In the Supreme Court of the State of Victoria
SALE BY THE SHERIFF

On Wednesday, 24 September 1980, at 2.30 p.m. at the Bailiff's office, 2nd Floor, 300 Burwood Road, Hawthorn (unless process be stayed or satisfied).

All the Estate and Interest (if any) of W. Butler, business proprietor (shown on Certificate of Title as William Butler) of 44 Apex Street, Dandenong, as proprietor of an estate in fee simple in the land described in Certificate of Title Volume 8848 Folio 798 upon which is erected a brick veneer dwelling house known as No. 44 Apex Street, Dandenong.

Registered Mortgage No. G.858667 affects the said estate and interest.

Terms—Cash only

9054

T. M. NICHOLLS, Sheriff's Officer

In the Supreme Court of the State of Victoria

SALE BY THE SHERIFF

On Thursday 24 September 1980 at 2.30 at Bailiff's Office, 2nd Floor, 300 Burwood Road, Hawthorn (unless process be stayed or satisfied).

All the Estate and Interest (if any) of I. A. Murdoch, public servant (shown on Certificate of Title as Ian Alexander Murdoch) of 34 Woodside Crescent, Toorak as proprietor of an estate in fee simple in the land described in Certificate of Title Volume 9295 Folio 344 and 360 upon which is erected a brick unit and car park accessory unit known as Unit Nos. 22 and 38, 488-492 Glenhuntly Road, Elsternwick.

Registered Mortgage Nos. H.486313, H.486314 and the rights created by Section 12 of the *Strata Titles Act 1967* affect the said estate and interest.

Terms—Cash only

9055

T. M. NICHOLLS, Sheriff's Officer

In the Supreme Court of the State of Victoria

SALE BY THE SHERIFF

On Wednesday 24 September 1980 at 2.30 p.m. at Bailiff's Office, 2nd Floor, 300 Burwood Road, Hawthorn (unless process be stayed or satisfied).

All the Estate and Interest (if any) of Amorino Culinas, builder, of 27 Jeffrey Avenue, North Altona as joint proprietor with Emilia Culinas, married woman of an estate in fee simple in the land described in Certificate of Title Volume 8109 Folio 301 upon which is erected a triple fronted brick veneer dwelling known as No. 27 Jeffrey Avenue North Altona.

Registered Mortgage Nos. D.302441 and B.941205 affect the said estate and interest.

Terms—Cash only

9056

K. MARTIN, Sheriff's Officer

In the Supreme Court of the State of Victoria

SALE BY THE SHERIFF

On Thursday 18 September 1980 at 2.30 p.m. at Bailiff's Office, 2nd Floor, 300 Burwood Road, Hawthorn (unless process be stayed or satisfied).

All the Estate and Interest (if any) of Mr David Coggin (shown on Certificate of Title as David William Coggin) chef, of 379 High Street Road, Mount Waverley as joint proprietor with Brenda May Coggin of an estate in fee simple in the land described in Certificate of Title Volume 8071 Folio 706 upon which is erected a brick veneer dwelling house known as No. 379 High Street Road, Mount Waverley.

Registered Mortgage Nos. E.270191 and F.461199 and Caveat F.870942 affect the said estate and interest.

Terms—Cash only

9057

T. M. NICHOLLS, Sheriff's Officer

In the Supreme Court of the State of Victoria

SALE BY THE SHERIFF

On Thursday 18 September 1980 at 2.30 p.m. at Bailiff's Office, 2nd Floor, 300 Burwood Road, Hawthorn (unless process be stayed or satisfied).

All the Estate and Interest (if any) of Herbert Liston, retired, of Flat 1, No. 39 Holyrood Street, Hampton as proprietor of an estate in fee simple in the land described in Certificate of Title Volume 8488 Folio 098 upon which is erected a unit and garage known as Flat 1, No. 39 Holyrood Street Hampton.

Charge No. B.568832 affects the said estate and interest.

Terms—Cash only

9058.

T. M. NICHOLLS, Sheriff's Officer

**NOTICE OF MAKING OF
STATUTORY RULES**

In pursuance of the provisions of the *Subordinate Legislation Act 1962* and the Regulations made thereunder, notice is given of the making of the following Statutory Rules:—

No.	Vermin and Noxious Weeds Act 1958	Price
268/1980.	Vermin and Noxious Weeds (Amendment) Regulations 1980	20c
	<i>Motor Boating Act 1961</i>	
269/1980.	Motor Boating (Port of Gippsland Lakes Speed Restrictions) (Amendment) Regulations 1980	10c
	<i>Industrial Training Act 1975</i>	
270/1980.	Industrial Training (Sewing Machine Mechanics Trade Apprenticeship) Regulations 1980	30c
	<i>Industrial Training Act 1975</i>	
271/1980.	Industrial Training (Apprenticeship) (Amendment No. 2) Regulations 1980	10c
	<i>Police Regulation Act 1958</i>	
272/1980.	Police (Constitution Strength Organization and Seniority) (Amendment No. 3) Regulations 1980	10c
	<i>Post-Secondary Education (Amendment) Act 1980</i>	
273/1980.	Post-Secondary Education Commission (Terms and Conditions) (Amendment) Regulations 1980	10c
	<i>Racing Act 1958</i>	
274/1980.	Racing (Mixed Sports Gatherings) Regulations 1980	10c
	<i>Professional Boxing Control Act 1975</i>	
275/1980.	Professional Boxing Control Regulations 1980	10c
	<i>Environment Protection Act 1970</i>	
276/1980.	Environment Protection (Appeal Board—Remuneration and Allowances) (Amendment No. 3) Regulations 1980	10c
	<i>Public Service Act 1974</i>	
PSD89/1980.	Public Service Amendment Determinations (No. 89) 1980	10c
PSD90/1980.	Public Service Amendment Determinations (No. 90) 1980	10c
PSD91/1980.	Public Service Amendment Determinations (No. 91) 1980	10c
PSD92/1980.	Public Service Amendment Determinations (No. 92) 1980	10c
PSD93/1980.	Public Service Amendment Determinations (No. 93) 1980	10c
PSD94/1980.	Public Service Amendment Determinations (No. 94) 1980	10c

Copies of these Statutory Rules when printed may be purchased at the Sale of Publications Branch of the Government Printing Office, located at 7A Parliament Place, Melbourne, 3002. If ordered by mail, remittance should be addressed to "The Government Printer, Box 203, P.O., North Melbourne, 3051", and should include 50c delivery and handling fee.

The annual subscription rates for Statutory Rules for the year commencing 1 January 1980, payable in advance, are as follows:—

*Statutory Rules (other than Public Service Determinations), Pamphlet copies only	\$36.00
Public Service Determinations	\$25.00

* The Bound Volume of Statutory Rules is not included in the subscription rate.

F. D. ATKINSON
Government Printer

STATE ACTS, 1978

Copies of the following Acts of the Parliament of Victoria may be obtained at the Government Printing Office, Sale of Publications Branch, 7A Parliament Place, Melbourne, phone 651 2754 or 651 2759, or from any accredited agent, at the price set opposite to each.

A delivery and handling fee must be added to your remittance when ordering by mail as follows:—

Total Value of Acts Ordered	Delivery and Handling Fee
10c-\$2.00	0.50c
\$2.05-\$5.00	\$1.00
\$5.05-\$20.00	\$1.50
Above \$20.00	\$2.00

Also available are:—

Bound Volumes	\$21.00
Index to the Bound Volumes	\$9.00

No.	Price
9084. Aerial Spraying Control (Amendment)	\$0.10
9085. Dairy Products (Repeal)	\$0.10
9086. Gas and Fuel Corporation (Borrowing Powers Amendment)	\$0.10
9087. Constitution	\$0.10
9088. Marine (Amendment)	\$0.10
9089. Architects (Professional Conduct)	\$0.10
9090. Victorian Film Corporation (Amendment)	\$0.10
9091. Melbourne and Metropolitan Board of Works (Borrowing Powers Amendment)	\$0.10
9092. Co-operative Farmers and Graziers District Meat Supply Limited	\$0.10
9093. Reference Areas	\$0.10
9094. Molesworth (Land Exchange)	\$0.10
9095. Melbourne Wholesale Fruit and Vegetable Market Trust (Licences)	\$0.10
9096. Public Service (Amendment)	\$0.10
9097. St. Andrew's Hospital	\$0.30
9098. Environment Protection (Amendment)	\$0.30
9099. State Savings Bank (Amendment)	\$0.20
9100. St. Andrew's Hospital (Guarantee)	\$0.10
9101. Education (Amendment)	\$0.10
9102. Land (Amendment)	\$0.10
9103. Probate Duty (Application)	\$0.10
9104. Supply (1978-79, No. 1)	\$0.20
9105. Teaching Service (Appointments)	\$0.10
9106. Fisheries (Amendment)	\$0.20
9107. Road Traffic (Amendment)	\$0.10
9108. Co-operative Housing Societies (Amendment)	\$0.10
9109. Granya (Land Exchange)	\$0.10
9110. Sandringham Land	\$0.10
9111. Vegetation and Vine Diseases (Parasites)	\$0.10
9112. Melbourne Underground Rail Loop (Borrowing Powers)	\$0.10
9113. Railways (Legal Actions)	\$0.10
9114. National Parks (Amendment)	\$0.40
9115. Co-operation (Amendment)	\$0.10
9116. Local Government (Promotion of Decentralization)	\$0.10
9117. Parliamentary Salaries and Superannuation	\$0.10
9118. Country Fire Authority (Borrowing Powers)	\$0.10
9119. Teaching Service (Migrant Instructors)	\$0.10
9120. Stamps (Amendment)	\$0.20
9121. State Electricity Commission (Amendment)	\$0.10
9122. Building Industry Long Service Leave (Amendment)	\$0.10
9123. Melbourne University (Amendment)	\$0.10
9124. Motor Car (Fees and Penalties)	\$0.20
9125. Superannuation (Amendment)	\$0.20
9126. State Development Decentralization and Tourism	\$0.20
9127. Melbourne Harbor Trust (Borrowing Powers)	\$0.10
9128. Cluster Titles (Amendment)	\$0.20
9129. Victoria Conservation Trust	\$0.20
9130. Melbourne and Metropolitan Board of Works (Rate Exemption)	\$0.10
9131. Geelong Waterworks and Sewerage (Administration and Rates)	\$0.10
9132. Mildura Irrigation and Water Trust (Merbein)	\$0.10

STATE ACTS, 1978—continued

No.	Price
9133. Egg Industry Stabilization (Amendment)	\$0.10
9134. Workers Compensation (Special Provisions)	\$0.10
9135. Environment Effects	\$0.10
9136. Workers Compensation (Amendment)	\$0.20
9137. Motor Car (Amendment)	\$0.10
9138. Town and Country Planning (Amendment)	\$0.20
9139. Sewerage Districts (Amendment)	\$0.10
9140. Petroleum Products Subsidy (Amendment)	\$0.10
9141. Water (Amendment)	\$0.10
9142. Railways (Amendment)	\$0.40
9143. Local Government (Regional Refuse Disposal)	\$0.40
9144. Dandenong Valley Authority (Amendment)	\$0.20
9145. Post-Secondary Education	\$0.30
9146. Racing (Amendment)	\$0.10
9147. Physiotherapists	\$0.30
9148. Local Government (Municipal Districts)	\$0.10
9149. Ministry of Transport (Passenger Services)	\$0.20
9150. Geelong Regional Interim Development Order (Validation)	\$0.10
9151. Credit Reporting	\$0.20
9152. Magistrates' Courts (Amendment)	\$0.10
9153. Wrongs (Actions for Damages)	\$0.10
9154. Magistrates (Interstate Enforcement)	\$0.20
9155. Crimes (Hijacking and Other Offences)	\$0.10
9156. Evidence (Amendment)	\$0.10
9157. Motor Car Traders (Amendment)	\$0.20
9158. Bail (Amendment)	\$0.10
9159. Water Drainage	\$0.30
9160. Legal Profession Practice (Solicitors' Disciplinary Tribunal)	\$0.80
9161. Chiropractors and Osteopaths	\$0.50
9162. Local Government (Miscellaneous Provisions)	\$0.60
9163. Hospitals Remuneration Tribunal	\$0.30
9164. Legal Profession Practice (Amendment)	\$0.10
9165. Melbourne and Metropolitan Board of Works (Reconstitution)	\$0.30
9166. Victoria Conservation Trust (Amendment)	\$0.10
9167. Shrine of Remembrance	\$0.20
9168. Pounds (Amendment)	\$0.10
9169. Queenscliff Land	\$0.10
9170. Securities Industry (Amendment)	\$0.10
9171. Labour and Industry	\$0.20
9172. Dandenong Valley Authority (Recreational Areas and Environmental Areas)	\$0.10
9173. Petroleum (Amendment)	\$0.50
9174. Victoria Law Foundation	\$0.20
9175. Mildura Irrigation and Water Trusts (Amendment)	\$0.10
9176. Judges Salaries	\$0.10
9177. Country Roads (Amendment)	\$0.30
9178. Port of Melbourne Authority	\$0.50
9179. Melbourne (Snowden Gardens) Land	\$0.10
9180. Surveyors	\$0.60
9181. State Forests Works and Services	\$0.10
9182. Gas and Fuel Corporation (Municipal Rates)	\$0.10
9183. Land (Amendment)	\$0.20
9184. Road Traffic	\$0.10
9185. Tocumwal Railway Extension (Supplementary Agreement Ratification)	\$0.10
9186. Appropriation (1978-79, No. 1)	\$3.80
9187. Lifts and Cranes (Amusement Structures)	\$0.20
9188. Health Commission (Amendment)	\$0.20
9189. Railways	\$0.10
9190. Land Tax	\$0.20
9191. Country Roads (Borrowing Powers)	\$0.30
9192. Pay-roll Tax	\$0.10
9193. Melbourne and Metropolitan Tramways (Bundoora Tramway)	\$0.10
9194. Melbourne Wholesale Fruit and Vegetable Market Trust (Amendment)	\$0.10
9195. Education (Work Experience for Handicapped Children)	\$0.10
9196. Market Court	\$0.40
9197. Consumer Affairs (Amendment)	\$0.30
9198. Co-ordination Council (Amendment)	\$0.10
9199. Broiler Chicken Industry	\$0.30
9200. Liquor Control	\$0.10
9201. Racing (Amendment)	\$0.40
9202. Legal Profession Practice (Discipline)	\$0.40
9203. Ballarat (Childrens Home)	\$0.20
9204. Trustee (Authorized Investments)	\$0.20
9205. Public Works and Services	\$0.20
9206. Co-operative Housing Societies (Indemnities)	\$0.10

STATE ACTS, 1978—continued

No.	Price
9207. Environment Protection (Noise Control) ..	\$0.30
9208. Stamps ..	\$0.20
9209. Water Supply Works and Services ..	\$0.40
9210. Transport Works and Services ..	\$0.10
9211. The Constitution Act Amendment (Conduct of Elections) ..	\$0.60
9212. Crown Land (Reserves) ..	\$0.80
9213. Wine Grape Processing Industry ..	\$0.30
9214. Summary Offences (Amendment) ..	\$0.10
9215. Workers Compensation (Share Farmers) ..	\$0.10
9216. The Constitution Act Amendment (Conjoint Elections) ..	\$0.10
9217. Education (Further Amendment) ..	\$0.10
9218. Country Fire Authority (Borrowing Powers) ..	\$0.10
9219. Public Records (Transfer of Administration) ..	\$0.10
9220. Educational Grants (Continuation) ..	\$0.10
9221. Port of Melbourne (World Trade Centre) ..	\$0.10
9222. Town and Country Planning (Miscellaneous Provisions) ..	\$0.30
9223. Members of Parliament (Register of Interests) ..	\$0.20
9224. Local Government (Rates and Fees) ..	\$0.30
9225. Valuation of Land ..	\$0.20
9226. Magistrates' Courts (Stipendiary Magistrates) ..	\$0.10
9227. Charities ..	\$0.20
9228. Crimes (Criminal Damage) ..	\$0.30
9229. Crimes (Offences at Sea) ..	\$0.30
9230. Crimes (Competence and Compellability of Spouse Witnesses) ..	\$0.10
9231. Domicile ..	\$0.10
9232. Dog (Amendment) ..	\$0.20
9233. Dental Technicians (Amendment) ..	\$0.10
9234. Administrative Law ..	\$0.10
9235. Melbourne and Metropolitan Board of Works (Miscellaneous Amendments) ..	\$0.20
9236. Mines (Miscellaneous Provisions) ..	\$0.40
9237. Wheat Industry Stabilization (Amendment) ..	\$0.20
9238. Victorian Dairy Industry Authority (Amendment) ..	\$0.20
9239. Melbourne and Metropolitan Board of Works (Trade Waste) ..	\$0.10
9240. Trustee Companies (Amendment) ..	\$0.10
9241. Sewerage Districts (Transfer of Works) ..	\$0.10
9242. Crimes (Amendment) ..	\$0.10
9243. Motor Car ..	\$0.20
9244. Health (Amendment) ..	\$0.30
9245. Legal Aid Commission ..	\$0.80
9246. Housing (Amendment) ..	\$0.80
9247. National Parks ..	\$0.50
9248. Community Welfare Services ..	\$0.80
9249. Victorian Brown Coal Council ..	\$0.20
9250. Police Offences (Offensive Publications) ..	\$0.20

STATE ACTS, 1979—continued

No.	Price
9256. Ombudsman (Co-operation) ..	\$0.10
9257. Geelong (Haines Homes) Land ..	\$0.20
9258. Motor Car (Breath Testing Stations) (Amendment) ..	\$0.10
9259. Geelong Waterworks and Sewerage (Trust) ..	\$0.30
9260. Bright (Land Exchange) ..	\$0.20
9261. Supply (1979-80, No. 1) ..	\$0.30
9262. Money Lenders (Fees) ..	\$0.10
9263. Exhibition (Amendment) ..	\$0.30
9264. Health (Cattle) ..	\$0.10
9265. Victorian Public Offices Corporation (Amendment) ..	\$0.10
9266. Community Welfare Services (Amendment) ..	\$0.10
9267. Margarine (Amendment) ..	\$0.10
9268. Youth, Sport and Recreation (State Youth Council) ..	\$0.10
9269. Racing (Restricted Trotting Meetings) ..	\$0.10
9270. State Electricity Commission (Morwell Land Compensation) ..	\$0.10
9271. Construction Safety ..	\$1.00
9272. Business Franchise (Petroleum Products) ..	\$0.40
9273. Albury-Wodonga Agreement (Amendment) ..	\$0.40
9274. City of Melbourne (Re-subdivision) ..	\$0.10
9275. Co-operation ..	\$0.40
9276. Cemeteries (Melbourne General Cemetery) ..	\$0.10
9277. Melbourne and Metropolitan Board of Works (Amendment) ..	\$0.30
9278. River Improvement (Trusts and Valuations) ..	\$0.10
9279. Instruments (Writs) ..	\$0.10
9280. Forests (Reserved Land) ..	\$0.10
9281. Trinity College ..	\$0.50
9282. Revocation and Excision of Crown Reservations ..	\$0.30
9283. Local Government (Amendment) ..	\$0.50
9284. Tattersall Consultations (Amendment) ..	\$0.10
9285. Prahran Market ..	\$0.10
9286. Geelong Regional Commission (Amendment) ..	\$0.10
9287. Pharmacists (Amendment) ..	\$0.10
9288. Legal Profession Practice (Amendment) ..	\$0.10
9289. Barley Marketing (Amendment) ..	\$0.10
9290. Water Authorities (Constitution and Powers) ..	\$0.20
9291. Sewerage Authorities (Constitution and Powers) ..	\$0.30
9292. Wrongs (Defamation) ..	\$0.10
9293. Judges Salaries ..	\$0.10
9294. Poisons (Amendment) ..	\$0.10
9295. Business Franchise (Petroleum Products) (Licence Fees) ..	\$0.20
9296. State Electricity Commission (Amendment) ..	\$0.30
9297. Workers Compensation (Miscellaneous Provisions) ..	\$1.00
9298. Motor Car (Surcharge) ..	\$0.10
9299. Unclaimed Moneys ..	\$0.10
9300. Land Tax ..	\$0.10
9301. Business Franchise (Tobacco) ..	\$0.10
9302. Public Authorities (Contributions) ..	\$0.10
9303. Appropriation (1979-80, No. 1) ..	\$3.50
9304. Gift Duty (Amendment) ..	\$0.10
9305. Pay-roll Tax ..	\$0.30
9306. Transport Works and Services ..	\$0.20
9307. Melbourne and Metropolitan Tramways (Borrowing Powers) ..	\$0.10
9308. County Court (Jurisdiction) ..	\$0.10
9309. State Forests Works and Services ..	\$0.10
9310. Young Men's Christian Association of Ballarat (Guarantee) ..	\$0.20
9311. Water Supply Works and Services ..	\$0.40
9312. Trustee Companies (Trustees Executors) ..	\$0.10
9313. Commercial Goods Vehicles (Aviation Fuel) ..	\$0.10
9314. Victorian Development Corporation (Powers) ..	\$0.20
9315. Town and Country Planning (Planning Schemes) ..	\$1.00
9316. Victorian Government Travel Authority (Reconstitution) ..	\$0.10
9317. Stamps (Amendment) ..	\$0.30
9318. Motor Car (Fees) ..	\$0.30
9319. Racing (Financial Provisions) ..	\$0.30
9320. Urban Land Authority ..	\$0.50
9321. Public Works and Services ..	\$0.30
9322. Second-hand Dealers (Closing Hours) ..	\$0.10
9323. Crimes (Amendment) ..	\$0.10
9324. Transfer of Land (Amendment) ..	\$0.40
9325. Melbourne College of Divinity ..	\$0.30
9326. Transport Regulation (Car Pools) ..	\$0.10
9327. Fisheries (Amendment) ..	\$0.10

STATE ACTS, 1979

Copies of the following Acts of the Parliament of Victoria may be obtained at the Government Printing Office, Sale of Publications Branch, 7A Parliament Place, Melbourne, phone 651 2754 or 651 2759, or from any accredited agent, at the price set opposite to each.

A delivery and handling fee must be added to your remittance when ordering by mail as follows:—

Total Value of Acts Ordered	Delivery and Handling Fee
10c-\$2.00	0.50c
\$2.05-\$5.00	\$1.00
\$5.05-\$20.00	\$1.50
Above \$20.00	\$2.00

Bound Volumes of 1978 State Acts (\$21.00) and the Index to the Bound Volumes (\$9.00) are also available.

No.	Price
9251. Constitution (Governor's Pension) ..	\$0.10
9252. Joint Select Committee (Road Safety) ..	\$0.20
9253. Cattle Compensation ..	\$0.10
9254. Constitution (Local Government) ..	\$0.30
9255. Gas and Fuel Corporation (Borrowing Powers) ..	\$0.10

STATE ACTS, 1979—continued	
No.	Price
9328. Egg Industry Stabilization (Amendment) ..	\$0.10
9329. Local Authorities Superannuation ..	\$0.30
9330. Latrobe Valley (Amendment) ..	\$0.10
9331. Liquor Control (Amendment) ..	\$0.10
9332. Motor Accidents (Amendment) ..	\$0.40
9333. Young Farmers' Finance Council ..	\$0.30
9334. Probate Duty ..	\$0.20
9335. Railways (Board) ..	\$0.10
9336. Ministry of Transport (Amendment) ..	\$0.10
9337. Abattoir and Meat Inspection (Amendment) ..	\$0.20
9338. Public Service (Amendment) ..	\$0.20
9339. Trustee Companies (Amendment) ..	\$0.20
9340. Vermin and Noxious Weeds (Amendment) ..	\$0.30
9341. Canned Fruits Marketing ..	\$0.40
9342. Marine (Amendment) ..	\$0.40
9343. Shire of Ormeo (Tourist Gold Mine) ..	\$0.30
9344. Presbyterian Trusts ..	\$0.90
9345. Railway Construction and Property Board ..	\$0.90
9346. Motor Car (Insurance by Pensioners) ..	\$0.10
9347. Town and Country Planning (Amendment of Schemes) ..	\$0.10
9348. Labour and Industry (Amendment) ..	\$0.20
9349. Magistrates' Courts (Civil Jurisdiction) ..	\$0.40
9350. Master Builders' Association of Victoria (Guarantee) ..	\$0.20
9351. Education (Amendment) ..	\$0.20
9352. Educational Grants (Continuation) ..	\$0.10
9353. Wrongs (Assessment of Damages) ..	\$0.10
9354. Victorian Arts Centre ..	\$0.40
9355. Building Industry Long Service Leave (Amendment) ..	\$0.50
9356. Local Government (Land Liable to Flooding) ..	\$0.30
9357. Parliamentary Committees (Public Accounts and Expenditure Review Committee) ..	\$0.20
9358. Superannuation (Amendment) ..	\$0.30
9359. Health (Proprietary Medicines) ..	\$0.20
9360. Victorian Fishing Industry Council ..	\$0.30
9361. Grain Handling Improvement Authorities ..	\$0.30
9362. Wheat Marketing ..	\$0.80
9363. State Employees Retirement Benefits ..	\$1.00
9364. Town and Country Planning (General Amendment) ..	\$1.00
9365. Industrial Relations ..	\$1.40

STATE ACTS, 1980

Copies of the following Acts of the Parliament of Victoria may be obtained at the Government Printing Office, Sale of Publications Branch, 7A Parliament Place, Melbourne, phone 651 2754 or 651 2759, or from any accredited agent, at the price set opposite to each.

A delivery and handling fee must be added to your remittance when ordering by mail as follows:

Total Value of Acts Ordered	Delivery and Handling Fee
10c-\$2.00	0.50c
\$2.05-\$5.00	\$1.00
\$5.05-\$20.00	\$1.50
Above \$20.00	\$2.00

Bound Volumes of 1978 State Acts (\$21.00) and the Index to the Bound Volumes (\$9.00) are also available.

No.	Price
9366. Constitutional Powers (Coastal Waters) ..	20c
9367. Parliamentary Committees (Public Bodies Review) ..	40c
9368. Agricultural Chemicals ..	\$0.50
9369. Central Gippsland (Brown Coal Land Compensation) ..	\$0.20
9370. Motor Car (Payments by Pensioners) ..	\$0.20
9371. Navigable Waters (Oil Pollution) (Amendment) ..	\$0.20
9372. Workers Compensation (General Amendment) ..	\$0.20
9373. Extractive Industries (Amendment) ..	\$0.30
9374. Health (Special Accommodation Houses) ..	\$0.20
9375. Cancer (Amendment) ..	\$0.20
9376. Victorian Film Corporation (Amendment) ..	\$0.30

STATE ACTS, 1980—continued	
No.	Price
9377. Railways (Bridges) ..	\$0.10
9378. Wangarrip (Land Exchange) ..	\$0.20
9379. Supply (1980-81, No. 1) ..	\$0.30
9380. Crown Land (Mineral Springs) ..	\$0.20
9381. Groundwater (Mineral Water) ..	\$0.20
9382. Melbourne Underground Rail Loop (Land Development) ..	\$0.30
9383. Chiropodists (Amendment) ..	\$0.10
9384. Youth, Sport and Recreation (Guarantees) ..	\$0.20
9385. Pensioners' Rates Remission ..	\$0.30
9386. Motor Car Traders (Amendment) ..	\$0.40
9387. Victorian Solar Energy Council ..	\$0.30
9388. Racing (Amendment) ..	\$0.20
9389. Country Fire Authority (Amendment) ..	\$0.20
9390. Local Government (Validation) ..	\$0.10
9391. Professional Boxing Control (Amendment) ..	\$0.10
9392. Police Regulation (Retired Police Reserve) ..	\$0.10
9393. Local Authorities Superannuation (Amendment) ..	\$0.30
9394. Water (Valuation Equalization) ..	\$0.20
9395. Upper Yarra Valley and Dandenong Ranges Authority (Amendment) ..	\$0.20
9396. Dog (Amendment) ..	\$0.20
9397. Hospitals Superannuation (Amendment) ..	\$0.20
9398. Hospitals and Charities (Appointment of Administrators) ..	\$0.10
9399. Home Finance (Borrowing Powers) ..	\$0.20
9400. State Employees Retirement Benefits (Amendment) ..	\$0.30
9401. Wodonga Area Land Acquisition (Validation) ..	\$0.30
9402. Local Government (General Amendment) ..	\$0.40
9403. Motor Registration ..	\$0.50
9404. Epworth Hospital ..	\$0.50
9405. Archaeological and Aboriginal Relics Preservation (Amendment) ..	\$0.20
9406. Geelong Performing Arts Centre Trust ..	\$0.40
9407. Imperial Law Re-enactment ..	\$0.30
9408. Constitutional Powers (Request) ..	\$0.20
9409. Friendly Societies (Benefits) ..	\$0.10
9410. Magistrates' Courts (Jurisdiction) ..	\$0.10
9411. Baker Medical Research Institute ..	\$0.50
9412. Protection of Animals (Amendment) ..	\$0.30
9413. Stamps (Amendment) ..	\$0.40
9414. Liquefied Petroleum Gas Subsidy ..	\$0.30
9415. Revocation and Excision of Crown Reservations ..	\$0.30
9416. Forests (Amendment) ..	\$0.20
9417. Forests (Further Amendment) ..	\$0.20
9418. Transport (Road Funds) ..	\$0.20
9419. Building Societies (Amendment) ..	\$0.60
9420. Legal Profession Practice (Leo Cussen Institute) ..	\$0.10
9421. Instruments (Powers of Attorney) ..	\$0.30
9422. Melbourne (Yarra Park) Land ..	\$0.20
9423. Sale of Land (Deposits) ..	\$0.20
9424. Post-Secondary Education (Amendment) ..	\$0.60
9425. Town and Country Planning (Amalgamation) ..	\$0.90
9426. Imperial Acts Application ..	\$1.00
9427. Statute Law Revision ..	\$0.80
9428. Estate Agents ..	\$1.60

ACTS REPRINTED IN ACCORDANCE WITH THE AMENDMENTS INCORPORATION ACT 1958 (No. 6422), AND FOR SALE AS STOCKS ARE AVAILABLE AT THE SALE OF PUBLICATIONS BRANCH OF THE GOVERNMENT PRINTING OFFICE, 7A PARLIAMENT PLACE, MELBOURNE, 3002.

A delivery and handling fee must be added to your remittance when ordering by mail as follows:—

Total Value of Acts Ordered	Delivery and Handling Fee
10c-\$2.00	0.50c
\$2.05-\$5.00	\$1.00
\$5.05-\$20.00	\$1.50
Above \$20.00	\$2.00

No.	Price
8404. Abattoir and Meat Inspector (First Reprint—Incorporating amendments up to No. 9005) ..	\$0.85
6189. Acts Interpretation (Fifth Reprint—Incorporating amendments up to Act No. 9229) ..	\$0.70

ACTS REPRINTED IN ACCORDANCE WITH THE AMENDMENTS
INCORPORATION ACT 1958 (No. 6422)—*continued*

No.	Price
6191. Administration and Probate Act 1958 (<i>Fifth Reprint</i> —Incorporating amendments up to No. 9075)	\$1.05
7147. Adoption of Children (<i>First Reprint</i> —Incorporating amendments up to Act No. 8602)	\$0.75
6194. Agricultural Colleges (<i>First Reprint</i> —Incorporating amendments up to No. 7302)	\$0.15
7772. Alcoholic and Drug-Dependent Persons Act 1968 (<i>First Reprint</i> —Incorporating amendments up to Act No. 9023)	\$0.60
6198. Anzac Day (<i>First Reprint</i> —Incorporating amendments up to No. 8344)	\$0.15
7117. Appeal Costs Fund Act 1964 (<i>Second Reprint</i> —Incorporating amendments up to No. 8145)	\$0.35
8273. Archaeological and Aboriginal Preservation Act 1972 (<i>First Reprint</i> —Incorporating amendments up to Act No. 9019)	\$0.30
6201. Architects (<i>First Reprint</i> —Incorporating amendments up to No. 8077)	\$0.30
6202. Auction Sales (<i>First Reprint</i> —Incorporating amendments up to No. 8490)	\$0.35
6203. Audit (<i>First Reprint</i> —Incorporating amendments up to No. 7377)	\$0.35
9008. Bail Act 1977 (<i>First Reprint</i> —Incorporating amendments up to Act No. 9158)	\$0.70
6206. Barley Marketing (<i>First Reprint</i> —Incorporating amendments up to No. 9005)	\$0.30
6208. Benefit Associations (<i>First Reprint</i> —Incorporating amendments up to No. 6961)	\$0.65
8004. Boilers and Pressure Vessels Act 1970—(<i>Second Reprint</i> —Incorporating amendments up to Act No. 9019)	\$0.65
6529. Bread Industry Act 1959 (<i>Second Reprint</i> —Incorporating amendments up to Act No. 8542)	\$0.20
6973. Building Contracts (Deposits) Act 1962 (<i>Second Reprint</i> —Incorporating amendments from No. 8938)	\$0.20
8693. Building Industry Long Service Leave (<i>First Reprint</i> —Incorporating Amendments up to No. 9122)	\$0.85
8597. Business Franchise (Tobacco) Act 1974 (<i>First Reprint</i> —Incorporating amendments up to No. 9301)	\$0.70
6853. Business Names Act 1962 (<i>First Reprint</i> —Incorporating amendments up to Act No. 9427)	\$0.90
6213. Cancer Act 1958 (<i>Second Reprint</i> —Incorporating amendments up to No. 9023)	\$1.10
6214. Carriers and Innkeepers (<i>Second Reprint</i> —Incorporating amendments up to No. 8534)	\$0.20
6215. Cattle Breeding (<i>First Reprint</i> —Incorporating amendments up to No. 6886)	\$0.10
6217. Cemeteries Act 1958 (<i>Second Reprint</i> —Incorporating amendments up to Act No. 9052)	\$0.90
8477. Children's Court Act 1973 (<i>Second Reprint</i> —Incorporating amendments up to Act No. 9008)	\$1.30
6220. Clean Air (<i>Third Reprint</i> —Incorporating amendments up to No. 8324)	\$0.15
4597. Closer Settlement Act 1980 (<i>First Reprint</i> —Incorporating amendments up to Act No. 9212)	\$1.20
8661. Cluster Titles Act 1974 (<i>First Reprint</i> —Incorporating amendments up to Act No. 9128)	\$0.85
6221. Coal Mines (<i>Second Reprint</i> —Incorporating amendments up to No. 8953)	\$2.15
6222. Commercial Goods Vehicles (<i>Third Reprint</i> —Incorporating amendments up to No. 8525)	\$0.55
6223. Commonwealth Arrangements (<i>First Reprint</i> —Incorporating amendments from No. 7809)	\$0.10
6839. Companies (<i>Sixth Reprint</i> —Incorporating amendments up to No. 8788)	\$9.60
8750. Constitution Act 1975 (<i>Third Reprint</i> —Incorporating amendments up to Act No. 9251)	\$1.30
6224. Constitution Act Amendment Act 1959 (<i>Second Reprint</i> —Incorporating amendment up to No. 9216)	\$3.00

ACTS REPRINTED IN ACCORDANCE WITH THE AMENDMENTS
INCORPORATION ACT 1958 (No. 6422)—*continued*

No.	Price
8276. Consumer Affairs Act 1972 (<i>Fourth Reprint</i> —Incorporating amendments up to Act No. 9197)	\$1.50
6225. Co-operation Act 1958 (<i>Fourth Reprint</i> —Incorporating amendments up to Act No. 9136)	\$1.60
6226. Co-operative Housing Societies Act 1958 (<i>Third Reprint</i> —Incorporating amendments up to No. 9206)	\$1.50
6227. Coroners (<i>Second Reprint</i> —Incorporating amendments up to No. 8184)	\$0.35
6228. Country Fire Authority (<i>Third Reprint</i> —Incorporating amendments up to No. 8813)	\$1.25
6229. Country Roads Act 1958 (<i>Fifth Reprint</i> —Incorporating amendments up to No. 9212)	\$2.00
6230. County Court (<i>Fourth Reprint</i> —Incorporating amendments up to No. 9075)	\$0.95
6231. Crimes Act 1958 (<i>Sixth Reprint</i> —Incorporating amendments up to Act No. 9073)	\$3.1t
6232. Crown Proceedings (<i>Second Reprint</i> —Incorporating amendments up to No. 8731)	\$0.4c
7060. Dandenong Valley Authority Act 1963 (<i>Second Reprint</i> —Incorporating amendments up to Act No. 9172)	\$1.20
8383. Decentralized Industry Incentive Payments (<i>First Reprint</i> —Incorporating Amendments up to No. 8751)	\$0.20
6235. Dietitians Registration (<i>First Reprint</i> —Incorporating amendments up to No. 6886)	\$0.20
4989. Discharged Servicemen's Preference Act 1943 (<i>Second Reprint</i> —Incorporating amendments up to No. 7991)	\$0.20
6815. Disposal of Uncollected Goods Act 1961 (<i>Second Reprint</i> —Incorporating amendments up to No. 8246)	\$0.30
8079. Dog Act 1970 (<i>First Reprint</i> —Incorporating amendments up to No. 8664)	\$0.30
6237. Drainage Areas Act 1958 (<i>Second Reprint</i> —Incorporating amendments up to Act No. 8811)	\$0.75
6239. Dried Fruits Act 1968 (<i>First Reprint</i> —Incorporating amendments up to No. 7337)	\$0.25
6240. Education Act 1958 (<i>Third Reprint</i> —Incorporating amendments up to Act No. 9248)	\$1.50
6241. Electric Light and Power Act 1958 (<i>Second Reprint</i> —Incorporating amendments up to Act No. 9296)	\$1.10
8056. Environment Protection Act 1970 (<i>Third Reprint</i> —Incorporating amendments up to Act No. 9098)	\$0.95
6244. Essential Services (<i>First Reprint</i> —Incorporating amendments up to No. 8353)	\$0.20
6245. Estate Agents—(<i>Fifth Reprint</i> —Incorporating amendments up to No. 8490)	\$0.85
6246. Evidence Act 1958 (<i>Sixth Reprint</i> —Incorporating amendments up to Act No. 9230)	\$1.60
6715. Explosives Act 1960 (<i>First Reprint</i> —Incorporating amendments up to Act No. 8920)	\$0.85
7499. Extractive Industries Act 1966 (<i>Third Reprint</i> —Incorporating amendments up to No. 8647)	\$0.45
7733. Fences Act 1968 (<i>Second Reprint</i> —Incorporating amendments up to Act No. 9019)	\$0.70
6468. Filled Milk (<i>First Reprint</i> —Incorporating amendments up to No. 6886)	\$0.15
6251. Firearms (<i>Fifth Reprint</i> —Incorporating amendments up to No. 8427)	\$1.05
7780. Fisheries Act 1968 (<i>First Reprint</i> —Incorporating amendments up to No. 8694)	\$1.05
6916. Foreign Judgments Act 1962 (<i>First Reprint</i> including amendments made by No. 7332)	\$0.15
6585. Forests (Pulpwood Agreement) (Incorporating amendments up to No. 6886)	\$0.15
6254. Forests (<i>Second Reprint</i> —Incorporating amendments up to No. 8702)	\$1.35
6225. Friendly Societies Act 1958 (<i>Second Reprint</i> —Incorporating amendments up to Act No. 9019)	\$1.60
6255. Friendly Societies (<i>First Reprint</i> —Incorporating amendments up to No. 7554)	\$0.60
6256. Fruit and Vegetables (<i>First Reprint</i> —Incorporating amendments up to No. 6944)	\$0.30

ACTS REPRINTED IN ACCORDANCE WITH THE AMENDMENTS
INCORPORATION ACT 1958 (No. 6422)—*continued*

No.	Price
6260. Gas and Fuel Corporation Act 1958 (<i>Second Reprint</i> —Incorporating amendments up to Act No. 9255)	\$2.40
6262. Geelong Harbor Trust Act 1958 (<i>Second Reprint</i> —Incorporating amendments up to Act No. 9019)	\$1.40
6263. Geelong Waterworks and Sewerage (<i>First Reprint</i> —Incorporating amendments up to No. 7547)	\$0.75
8176. Gift Duty Act 1971 (<i>First Reprint</i> —Incorporating amendments from No. 8202)	\$0.55
6265. Goods (<i>Sixth Reprint</i> —Incorporating amendments up to No. 8425)	\$0.75
6266. Grain Elevators (<i>First Reprint</i> —Incorporating amendments up to No. 7486)	\$0.35
7849. Groundwater (<i>Second Reprint</i> —Incorporating amendments up to No. 9019)	\$0.75
6267. Hairdressers Registration (<i>First Reprint</i> —Incorporating amendments up to No. 7659)	\$0.30
6269. Hawkers and Pedlars (<i>Second Reprint</i> —Incorporating amendments up to No. 8247)	\$0.40
6270. Health (<i>Third Reprint</i> —Incorporating amendments up to No. 8506)	\$3.25
6531. Hire Purchase Act 1959 (<i>Second Reprint</i> —Incorporating amendments from No. 8232)	\$0.85
6933. Home Finance Act 1962 (<i>First Reprint</i> —Incorporating amendments up to No. 7363)	\$0.25
6274. Hospitals and Charities Act 1958 (<i>Third Reprint</i> —Incorporating amendments up to No. 9212)	\$1.70
6275. Housing Act 1958 (<i>Fourth Reprint</i> —Incorporating amendments up to Act No. 9246)	\$3.30
3270. Imperial Acts Application (<i>First Reprint</i> —Incorporating Amendments up to No. 8037)	\$1.30
6276. Imprisonment of Fraudulent Debtors (<i>Second Reprint</i> —Incorporating amendments up to No. 8731)	\$0.55
6277. Industrial and Provident Societies Act 1958 (<i>First Reprint</i> —Incorporating amendments up to Act No. 7547)	\$1.10
6279. Instruments (<i>Fifth Reprint</i> —Incorporating amendments up to No. 8565)	\$0.75
6280. Judicial Proceedings Reports (<i>First Reprint</i> —Incorporating amendments up to No. 7596)	\$0.20
7651. Juries (<i>First Reprint</i> —Incorporating amendments up to No. 8170)	\$0.55
6283. Labour and Industry Act 1958 (<i>Seventh Reprint</i> —Incorporating amendments up to Act No. 9163)	\$1.90
6284. Land Act (<i>Fourth Reprint</i> —Incorporating amendments up to No. 9212)	\$4.40
6534. Land Settlement Act 1959 (<i>First Reprint</i> —Incorporating amendments up to No. 7328)	\$0.30
6288. Land Surveyors (<i>First Reprint</i> —Incorporating amendments up to No. 7065)	\$0.30
6289. Land Tax Act 1958 (<i>Third Reprint</i> —Incorporating amendments to Act No. 9190)	\$1.40
6285. Landlord and Tenant (<i>Fourth Reprint</i> —Incorporating amendments up to No. 8208)	\$1.90
6286. Lands Compensation Act (<i>Third Reprint</i> —Incorporating amendments up to No. 8899)	\$0.45
6290. Latrobe Valley (<i>First Reprint</i> —Incorporating amendments up to No. 7332)	\$0.35
7919. Legal Aid—(<i>First Reprint</i> —Incorporating amendments up to No. 8427)	\$0.30
6291. Legal Profession Practice Act (<i>Fourth Reprint</i> —Incorporating amendments up to No. 8778)	\$1.45
6292. Libraries (<i>First Reprint</i> —Incorporating amendments up to No. 7364)	\$0.15
7629. Lifts and Cranes Act 1967 (<i>Second Reprint</i> —Incorporating amendments up to Act No. 9236)	\$0.90
6295. Limitation of Actions (<i>Third Reprint</i> —Incorporating amendments up to No. 8300)	\$0.55
7695. Liquor Control Act 1968 (<i>Fourth Reprint</i> —Incorporating amendments up to Act No. 9225)	\$2.40
7145. Litter Act 1964 (<i>Second Reprint</i> —Incorporating amendments up to No. 8702)	\$0.20

ACTS REPRINTED IN ACCORDANCE WITH THE AMENDMENTS
INCORPORATION ACT 1958 (No. 6422)—*continued*

No.	Price
6298. Local Authorities Superannuation Act 1958 (<i>Third Reprint</i> —Incorporating amendments up to Act No. 9393)	\$1.50
6479. Local Government Department Act 1958 (<i>First Reprint</i> —Incorporating amendments up to Act No. 8656)	\$0.10
6299. Local Government (<i>Third Reprint</i> —Incorporating amendments up to No. 8781)	\$10.90
7429. Lotteries Gaming and Betting Act 1966 (<i>Second Reprint</i> —Incorporating amendments up to No. 9075)	\$1.20
8184. Magistrates' Courts (<i>First Reprint</i> —Incorporating amendments up to No. 8718)	\$0.75
7289. Maintenance (<i>Second Reprint</i> —Incorporating amendments up to No. 9019)	\$1.35
6302. Marine Act (<i>Second Reprint</i> —Incorporating amendments up to No. 9178)	\$2.40
6303. Marine Stores and Old Metals Act 1958 (<i>Second Reprint</i> —Incorporating amendments up to Act No. 8622)	\$0.65
6304. Marketing of Primary Products Act 1958 (<i>Second Reprint</i> —Incorporating amendments up to Act No. 8965)	\$1.50
6305. Markets Act (<i>Second Reprint</i> —Incorporating amendments up to No. 8247)	\$0.30
6306. Marriage (<i>Second Reprint</i> —Incorporating amendments up to No. 8602)	\$0.45
6309. Medical Act 1958 (<i>Third Reprint</i> —Incorporating amendments up to No. 8593)	\$0.45
8061. Medical Practitioner (<i>First Reprint</i> —Incorporating amendments up to No. 8754)	\$0.75
6310. Melbourne and Metropolitan Board of Works (<i>Fourth Reprint</i> —Incorporating amendments up to No. 8650)	\$1.95
6311. Melbourne and Metropolitan Tramways Act 1958 (<i>Second Reprint</i> —Incorporating amendments up to Act No. 8992)	\$1.45
6312. Melbourne Harbor Trust (<i>Second Reprint</i> —Incorporating amendments up to No. 8796)	\$1.35
6405. Melbourne University Act 1958 (<i>Second Reprint</i> —Incorporating amendments up to Act No. 9123)	\$0.85
6605. Mental Health Act 1959 (<i>Third Reprint</i> —Incorporating amendments up to Act No. 9023)	\$1.40
6315. Metropolitan Fire Brigades (<i>Third Reprint</i> —Incorporating amendments up to No. 9019)	\$0.95
6316. Mildura Irrigation and Water Trusts Act 1958 (<i>Second Reprint</i> —Incorporating amendments up to No. 9204)	\$2.60
6317. Milk and Dairy Supervision (<i>Second Reprint</i> —Incorporating amendments up to No. 8655)	\$0.85
6318. Milk Board Act 1958 (<i>Second Reprint</i> —Incorporating amendments up to Act No. 9238)	\$1.00
6319. Milk Pasteurization (<i>First Reprint</i> —Incorporating amendments up to No. 7480)	\$0.20
6320. Mines Act 1958 (<i>Third Reprint</i> —Incorporating amendments up to Act No. 8953)	\$2.60
6184. Monash University (<i>First Reprint</i> —Incorporating amendments up to No. 7533)	\$0.30
6324. Money Lenders (<i>Fourth Reprint</i> —Incorporating amendments up to No. 8490)	\$0.55
8429. Motor Accidents Act 1973 (<i>Second Reprint</i> —Incorporating amendments up to Act No. 9427)	\$1.40
6832. Motor Boating Act 1961 (<i>Third Reprint</i> —Incorporating amendment up to No. 8662)	\$0.55
6325. Motor Car Act 1958 (<i>Fifth Reprint</i> —Incorporating amendments up to No. 8657)	\$2.25
6705. Navigable Waters (Oil Pollution) Act 1960 (<i>Second Reprint</i> —Incorporating amendments up to No. 8816)	\$0.65
6328. Nurses Act 1958 (<i>Fourth Reprint</i> —Incorporating amendments up to Act No. 9059)	\$1.00
8414. Ombudsman Act 1973 (<i>Second Reprint</i> —Incorporating amendments up to Act No. 9256)	\$0.60
6329. Optometrists Registration Act 1958 (<i>Second Reprint</i> —Incorporating amendments up to Act No. 8800)	\$0.70

ACTS REPRINTED IN ACCORDANCE WITH THE AMENDMENTS
INCORPORATING ACT 1958 (No. 6422)—*continued*

No.	Price
7723. Parliamentary Salaries and Superannuation (First Reprint—Incorporating amendments up to No. 8687) ..	\$0.35
6330. Partnership (Second Reprint—Incorporating amendments up to No. 7315) ..	\$0.45
6331. Patriotic Funds (First Reprint—Incorporating amendments up to No. 7338) ..	\$0.25
6332. Pawnbrokers Act 1958 (Second Reprint—Incorporating amendments up to No. 8181) ..	\$0.35
8154. Pay-Roll Tax Act 1971 (First Reprint—Incorporating amendments up to No. 9059) ..	\$1.15
7417. Pensions Supplementation (First Reprint—Incorporating amendments up to No. 8475) ..	\$0.20
6257. Pesticides Act 1958 (Second Reprint—Incorporating amendments up to No. 8589) ..	\$0.35
6334. Petroleum Act 1958 (Second Reprint—Incorporating amendments up to Act No. 9212) ..	\$1.30
6335. Petrol Pumps (Second Reprint—Incorporating amendments up to No. 7315) ..	\$0.15
6889. Poisons Act 1962 (Fifth Reprint—Incorporating amendments up to Act No. 9427) ..	\$1.70
6337. Police Offences Act 1958 (Third Reprint—Incorporating amendments up to No. 8433) ..	\$0.45
6338. Police Regulation (Third Reprint—Incorporating amendments up to No. 8722) ..	\$0.95
6340. Portland Harbor Trust Act 1958 (Second Reprint—Incorporating amendments up to Act No. 9204) ..	\$1.10
7498. Port Phillip Authority Act 1966 (Second Reprint—Incorporating amendments from No. 8081) ..	\$0.20
6341. Pounds Act 1958 (Second Reprint—Incorporating amendments up to Act No. 9168) ..	\$0.60
6342. Printers and Newspapers (Second Reprint—Incorporating amendments up to No. 8556) ..	\$0.30
7494. Private Agents Act 1966 (Third Reprint—Incorporating amendments up to Act No. 9075) ..	\$1.00
6890. Probate Duty Act 1962. (Fourth Reprint)—Incorporating amendments up to Act No. 9019 ..	\$1.15
6344. Property Law Act 1958 (Fourth Reprint—Incorporating amendments up to Act No. 9075) ..	\$3.00
7432. Protection of Animals (First Reprint—Incorporating Amendments Up to No. 9019) ..	\$0.40
6345. Public Account (Second Reprint—Incorporating amendments up to No. 9033) ..	\$0.40
6346. Public Authorities Marks (First Reprint—Incorporating amendments from No. 7315) ..	\$0.10
8656. Public Service Act 1974 (Second Reprint—Incorporating amendments up to Act No. 9248) ..	\$1.40
6350. Public Trustee Act 1958 (Second Reprint—Incorporating amendments up to No. 8125) ..	\$1.05
6353. Racing (Fourth Reprint—Incorporating amendments up to No. 8690) ..	\$1.55
6355. Railways Act 1958 (Second Reprint—Incorporating amendments up to Act No. 9142) ..	\$1.55
6564. Registration of Births Deaths and Marriages Act 1959 (Second Reprint—Incorporating amendments up to Act No. 8602) ..	\$0.70
6357. Religious Successory and Charitable Trusts Act 1958 (First Reprint—Incorporating amendments made by Act No. 7315) ..	\$0.75
6358. River Improvements Act (Second Reprint—Incorporating amendments up to No. 8967) ..	\$0.85
2596. River Murray Waters Act 1915 (First Reprint—Incorporating amendments up to No. 7228) ..	\$0.35
6359. Road Traffic (Fourth Reprint—Incorporating amendments up to No. 8353) ..	\$0.35
6360. Rural Finance (First Reprint—Incorporating amendments up to No. 7328) ..	\$0.15
6846. Rural Finance and Settlement Commission Act 1961 (First Reprint—Incorporating amendments up to No. 7332) ..	\$0.30

ACTS REPRINTED IN ACCORDANCE WITH THE AMENDMENTS
INCORPORATING ACT 1958 (No. 6422)—*continued*

No.	Price
6917. Sale of Human Blood Act 1962 (First Reprint—Incorporating amendments from No. 7332) ..	\$0.10
6975. Sale of Land Act 1962 (Third Reprint—Incorporating amendments up to No. 8861) ..	\$0.55
8146. Scaffolding Act 1971 (Second Reprint—Incorporating amendments up to No. 8666) ..	\$0.35
6363. Second-hand Dealers (First Reprint—Incorporating amendments up to No. 7529) ..	\$0.25
6367. Settled Land Act 1958 (Third Reprint—Incorporating amendments up to Act No. 9075) ..	\$1.50
6368. Sewerage Districts Act 1958 (Third Reprint—Incorporating amendments up to Act No. 9139) ..	\$1.90
6809. Sheep Owners Protection Act 1961 (Third Reprint—Incorporating amendments up to No. 8247) ..	\$0.20
8089. Social Welfare Act 1970 (First Reprint—Incorporating amendments up to No. 8821) ..	\$1.90
6372. Soil Conservation and Land Utilization Act (Third Reprint—incorporating amendments up to No. 8432) ..	\$0.45
6373. Soldier Settlement (First Reprint—Incorporating amendments up to No. 7328) ..	\$0.42
6375. Stamps Act 1958 (Sixth Reprint—Incorporating amendments up to No. 8624) ..	\$2.15
6376. State Development Committee Act 1958 (First Reprint—Incorporating amendments up to No. 8827) ..	\$0.30
6377. State Electricity Commission Act 1958 (Third Reprint—incorporating amendments up to Act No. 9121) ..	\$1.35
6378. State Relief Committee (First Reprint—Incorporating amendments from No. 6886) ..	\$0.10
6379. State Savings Bank Act 1958 (Third Reprint—Incorporating amendments up to No. 8519) ..	\$0.95
6380. Statistics (First Reprint—Incorporating amendments up to No. 6961) ..	\$0.20
6877. Stock (Artificial Breeding) Act 1962 (First Reprint—Incorporating amendments up to No. 8709) ..	\$0.30
6383. Stock Foods (First Reprint—Incorporating amendments up to No. 7607) ..	\$0.28
6384. Stock Medicines Act 1958 (Second Reprint—Incorporating amendments up to No. 9005) ..	\$0.50
7551. Strata Titles Act 1967 (Third Reprint—Incorporating amendments up to No. 8661) ..	\$1.00
6886. Subordinate Legislation Act 1962 (Second Reprint—Incorporating amendments up to No. 8127) ..	\$0.15
7405. Summary Offences Act 1966 (Second Reprint—Incorporating amendments up to No. 8276) ..	\$0.55
7634. Sunday Entertainment (First Reprint—Incorporating amendments up to No. 8173) ..	\$0.15
6386. Superannuation Act 1958 (Fourth Reprint—Incorporating amendments up to No. 9125) ..	\$1.70
6387. Supreme Court (Second Reprint—Incorporating amendments up to No. 8951) ..	\$1.35
6388. Survey Co-ordination Act 1958 (Second Reprint—Incorporating amendments up to No. 9180) ..	\$0.70
6390. Tattersall Consultations (Second Reprint—Incorporating amendments up to No. 8982) ..	\$0.30
8274. Taxation Appeals Act 1972 (First Reprint—Incorporating amendments up to Act No. 9045) ..	\$0.55
6391. Teaching Service (Second Reprint—Incorporating amendments up to No. 8691) ..	\$0.55
6393. Theatres (First Reprint—Incorporating amendments up to No. 8161) ..	\$0.15
6849. Town and Country Planning Act 1961 (Fifth Reprint—Incorporating amendments up to No. 8716) ..	\$1.25
6397. Trade Unions (Second Reprint—Incorporating amendments up to No. 8181) ..	\$0.20
6399. Transfer of Land Act 1958 (Sixth Reprint—Incorporating amendments up to Act No. 9324) ..	1.90

ACTS REPRINTED IN ACCORDANCE WITH THE AMENDMENTS INCORPORATION ACT 1958 (No. 6422)—continued

No.	Price
6400. Transport Regulation Act (Third Reprint—Incorporating amendments up to No. 8700)	\$0.75
6401. Trustee Act 1958 (Fifth Reprint—Incorporating amendments up to Act No. 9204)	\$1.50
6402. Trustee Companies Act 1958 (Second Reprint—Incorporating amendments up to Act No. 9075)	\$0.55
6879. Unclaimed Moneys Act 1962 (Second Reprint—Incorporating amendments up to No. 8448)	\$0.20
7095. Underseas Mineral Resources Act 1963 (First Reprint—Incorporating amendments from No. 7591)	\$0.10
6653. Valuation of Land Act 1960 (Fifth Reprint—Incorporating amendments up to Act No. 9225)	\$1.10
6407. Vegetation and Vine Diseases (First Reprint—Incorporating amendments up to No. 7423)	\$0.30
6408. Venereal Diseases (First Reprint—Incorporating amendments made by Act No. 6886)	\$0.55
6409. Vermin & Noxious Weeds (First Reprint—Incorporating amendments up to No. 7463)	\$0.35
6410. Veterinary Surgeons (First Reprint—Incorporating amendments up to No. 7343)	\$0.15
7291. Victoria Institute of Colleges Act 1965 (Second Reprint—Incorporating amendments up to Act No. 8710)	\$0.90
8428. Victorian Development Corporation Act 1973 (First Reprint—Incorporating amendments up to Act No. 9314)	\$1.00
6412. Warehousemen's Liens (First Reprint—Incorporating amendments up to No. 7876)	\$0.15
6413. Water (Third Reprint—Incorporating amendments up to No. 8729)	\$3.45
6414. Weights and Measures Act 1958 (Fourth Reprint—Incorporating amendments up to Act No. 9019)	\$1.90
6415. Wild Flowers and Native Plants Protection (First Reprint—Incorporating amendments up to No. 8976)	\$0.15
6416. Wills Act 1958 (Second Reprint—Incorporating amendments up to Act No. 9075)	\$0.60
6417. Wire Netting (Second Reprint—Incorporating amendments up to No. 7876)	\$0.65
6419. Workers Compensation Act (Seventh Reprint—Incorporating amendments up to No. 8804)	\$1.45
6420. Wrongs Act 1958. (Third Reprint—Incorporating amendments up to Act No. 9153)	\$0.60
8344. Youth, Sport and Recreation Act 1972 (First Reprint—Incorporating amendments up to No. 8550)	\$0.35

F. D. ATKINSON
Government Printer

THE "VICTORIA GOVERNMENT GAZETTE"

PUBLICATION—A VICTORIA GOVERNMENT GAZETTE is published every WEDNESDAY EVENING unless advertised otherwise.

SUBSCRIPTIONS—The Subscription, including postage, is \$62 per annum, or \$31 per half year, payable in advance. Subscriptions are required for whole months, but must cover at least a half-year.

PRIVATE ADVERTISEMENTS—Advertisements will be received by the Government Printer not later than the day preceding publication—at ordinary rates at or before ONE p.m. and at double rates between ONE p.m. and HALF PAST THREE p.m. The charge for ADVERTISEMENTS is 78 cents per line single column and \$1.56 per line double column. The charge for a full page is \$118. The title forms one or more

lines as a heading. On an average ten words make a line of single column. Every signature must likewise be counted as a line. The final words of a paragraph though only portion of a line, must be counted as one line. Signatures (in particular) and proper names must be written very clearly in the text: ONE SIDE ONLY of each sheet of paper should be written upon.

All documents NOT CLEARLY PREPARED will be returned unpublished. Where brands occur, not provided for by the ordinary letters of the alphabet, a written explanatory description also must be furnished.

PAYMENTS—Unless the advertiser has a Credit Account, all payments are required in advance. Remittances should be made by cheque, postal order or money order, payable to "GOVERNMENT PRINTER".

CORRESPONDENCE—All correspondence should be addressed to "The Victorian Government Printer, P.O. Box 203, North Melbourne, 3051".

CONTENTS

	Page
Acts of Parliament on Sale at the Government Printing Office	2826
Appointments	2788
Bank Holidays	2770
Cemeteries—Scale of Fees	2787
Contracts	2781
Country Roads Board	2784
Courts	2780
Estates of Deceased Persons	2784
Government Notices	2771
Lands	2801
Notice to Mariners	2778
Notice of Making of Statutory Rules	2852
Orders in Council—	
Acts—Local Government; Railway Construction and Property Board; Country Roads Board; Crown Land (Reserves); Revocation and Excision of Crown Reservations; Industrial Training; Superannuation; Sewerage Districts; State Electricity Commission; Liquor Control; Water; Geelong Waterworks and Sewerage; Latrobe Valley; Sewerage Districts; Racing; Ombudsman.	2790 et seq
Police Sale	2784
Private Advertisements	2803
Proclamations	2769
Public Holidays	2770
Regulations—	
Act—	
Teaching Service	2803
Resignations	2790
Tenders	2802
Transport Regulation Board—Public Hearings	2773
Waterworks Trusts	2780