



# Victoria Government Gazette

No. 93—Wednesday, 29 October, 1980

## PROCLAMATIONS

### ACT OF PARLIAMENT

#### PROCLAMATION

By His Excellency the Governor of the State of Victoria and its Dependencies in the Commonwealth of Australia, &c., &c., &c.

I, the Governor of the State of Victoria, in the Commonwealth of Australia, do hereby declare that I have this day assented, in Her Majesty's name, to the Bill passed by the Parliament of the said State, the title whereof is hereunder set forth, together with the short title, that is to say:

No. 9432. "An Act to amend the *Parliamentary Salaries and Superannuation Act 1968*." (*Parliamentary Salaries and Superannuation Act 1980*.)

Given under my Hand and the Seal of the State of Victoria aforesaid, at Melbourne, this twenty-eighth day of October, in the year of our Lord One thousand nine hundred and eighty and in the twenty-ninth year of the reign of Her Majesty Queen Elizabeth II.

(L.S.) HENRY WINNEKE

By His Excellency's Command

R. J. HAMER  
Premier

GOD SAVE THE QUEEN!

NOTE—No. 9432. Section 2 of this Act shall be deemed to have come into operation on 30 March 1975 and section 3 on 12 August 1980, and sections 1 and 4 on the day which this Act receives the Royal Assent. (i.e. 28 October 1980.)

### PUBLIC HIGHWAY—SHIRE OF DIAMOND VALLEY

#### PROCLAMATION

By His Excellency the Governor of the State of Victoria and its Dependencies in the Commonwealth of Australia, &c., &c., &c.

Whereas by the *Local Government Act 1958*, section 519 it is amongst other things enacted that it shall be lawful for the Governor in Council at any time and from time to time upon the request of the council of any municipality by notice in the *Government Gazette* to proclaim any land reserved, used or by purchase or exchange acquired for a street, road, highway, thoroughfare, bridge, square, court, alley or right-of-way or any street, road, lane or passage made or laid out or proposed to be made or laid out on any land of which a plan of subdivision delineating that street, road, lane or passage has been sealed with the seal of the municipality under subdivision (3) of Division 9 of Part XIX of the *Local Government Act 1958* or a corresponding previous enactment to be a public highway and that land shall thereupon and thenceforth from the

date of such proclamation become and be absolutely dedicated to the public as a public highway within the meaning of any law then or thereafter in force;

And whereas the Council of the Shire of Diamond Valley requested that the land hereinafter mentioned being a road laid out on land of which a plan of subdivision delineating the street, road, lane or passage has been sealed with the seal of the municipality under subdivision (3) of Division 9 of Part XIX of the *Local Government Act 1958*, or a corresponding previous enactment be so declared to be a public highway.

Now therefore, I, the Governor of the State of Victoria, in the Commonwealth of Australia by and with the advice of the Executive Council of the said State, do by this Proclamation declare that a road off Main Street, Greensborough as shown by hatching on the attached plan shall be a public highway within the meaning of the said Act.

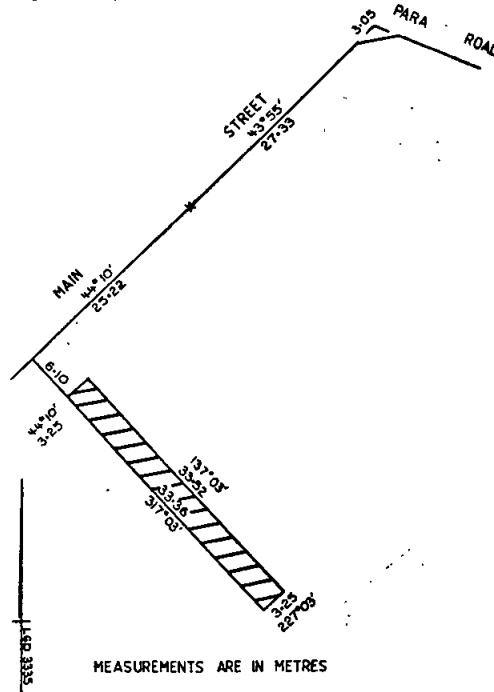

Given under my Hand and the Seal of the State of Victoria aforesaid, at Melbourne this twenty-first day of October in the year of our Lord One thousand nine hundred and eighty and in the twenty-ninth year of the reign of Her Majesty Queen Elizabeth II.

(L.S.) HENRY WINNEKE

By His Excellency's Command

D. G. CROZIER  
Minister for Local Government

GOD SAVE THE QUEEN!

PUBLIC HIGHWAY—CITY OF CROYDON

PROCLAMATION

By His Excellency the Governor of the State of Victoria and its Dependencies in the Commonwealth of Australia, &c., &c., &c.

Whereas by the *Local Government Act 1958*, section 519 it is amongst other things enacted that it shall be lawful for the Governor in Council at any time and from time to time upon the request of the council of any municipality by notice in the *Government Gazette* to proclaim any land reserved used or by purchase or exchange acquired for a street, road, highway, thoroughfare, bridge, square, court, alley, or right-of-way or any street, road, lane or passage made or laid out or proposed to be made or laid out on any land of which a plan of subdivision delineating that street, road, lane or passage has been sealed with the seal of the municipality under subdivision (3) of Division 9 of Part XIX of the *Local Government Act 1958* or a corresponding previous enactment to be a public highway and that land shall thereupon and thenceforth from the date of such proclamation become and be absolutely dedicated to the public as a public highway within the meaning of any law then or thereafter in force;

And whereas the Council of the City of Croydon has requested that the land hereinafter mentioned being a road laid out on land of which a plan of subdivision delineating the street, road, lane or passage has been sealed with the seal of the municipality under subdivision (3) of Division 9 of Part XIX of the *Local Government Act 1958*, or corresponding previous enactment be so declared to be a public highway;

Now therefore, I, the Governor of the State of Victoria, in the Commonwealth of Australia by and with the advice of the Executive Council of the said State, do by this proclamation declare that part of the land described in Certificates of Title Volume 8224 Folios 539 and 541 being more particularly the land shown by hatching on the attached plan shall be a public highway within the meaning of the said Act.

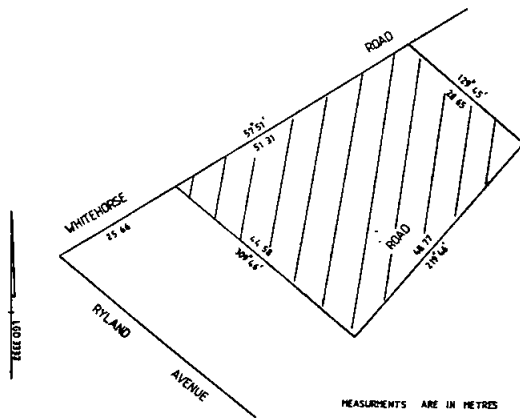

Given under my Hand and the Seal of the State of Victoria aforesaid, at Melbourne, this twenty-first day of October in the year of our Lord One thousand nine hundred and eighty and in the twenty-ninth year of the reign of Her Majesty Queen Elizabeth II.

(L.S.) HENRY WINNEKE

By His Excellency's Command  
D. G. CROZIER  
Minister for Local Government

GOD SAVE THE QUEEN!

LOCAL AUTHORITIES SUPERANNUATION ACT 1958

PROCLAMATION

By His Excellency the Governor of the State of Victoria and its Dependencies in the Commonwealth of Australia, &c., &c., &c.

Whereas by the *Local Authorities Superannuation Act 1958*, Section 3, it is amongst other things enacted that it shall be lawful for the Governor in Council to declare any body constituted under any Act for any public or local governing purpose or any body constituted for a joint purpose by two or more authorities within the meaning of that Act to be an authority for the purposes of the Act.

And whereas the Municipal Saleyards Association (Vic.) has requested that it be declared to be such an authority.

Now therefore, I, the Governor of the State of Victoria in the Commonwealth of Australia, by and with the advice of the Executive Council of the said State, do by this Proclamation declare that the Municipal Saleyards Association (Vic.) being a body constituted by several municipalities for a joint purpose shall be an authority for the purposes of the *Local Authorities Superannuation Act 1958*.

Given under my Hand and the Seal of the State of Victoria aforesaid, at Melbourne, this twenty-first day of October, in the year of our Lord One thousand nine hundred and eighty, and in the twenty-ninth year of the reign of Her Majesty Queen Elizabeth II.

(L.S.) HENRY WINNEKE

By His Excellency's Command  
D. G. CROZIER  
Minister for Local Government

GOD SAVE THE QUEEN!

Post-Secondary Education (Amendment) Act 1980, No. 9424  
DATE OF COMING INTO OPERATION

PROCLAMATION

By His Excellency the Governor of the State of Victoria and its Dependencies in the Commonwealth of Australia, &c., &c., &c.

Whereas by an Act of the Parliament of the State of Victoria passed in the twenty-ninth year of the reign of Her Majesty Queen Elizabeth II, intituled the *Post-Secondary Education (Amendment) Act 1980*, No. 9424 it is amongst other things enacted that the several provisions of the said Act shall come into operation on a day or on the respective days to be fixed by proclamation or successive proclamations of the Governor in Council published in the *Government Gazette*.

Now therefore I, the Governor of the State of Victoria in the Commonwealth of Australia, by and with the advice of the Executive Council of the said State, do by this my Proclamation fix Wednesday day the twenty-ninth day of October, One thousand nine hundred and eighty as the day on which so much of section 2 as has not already been brought into operation shall come into operation.

Given under my Hand and the Seal of the State of Victoria aforesaid, at Melbourne, this twenty-eighth day of October, in the year our Lord One thousand nine hundred and eighty and in the twenty-ninth year of the reign of Her Majesty Queen Elizabeth II.

(L.S.) HENRY WINNEKE

By His Excellency's Command  
A. J. HUNT  
Minister of Education

GOD SAVE THE QUEEN!

MARINE ACT 1958, No. 6302

PROCLAMATION

By His Excellency the Governor of the State of Victoria and its Dependencies in the Commonwealth of Australia, &c., &c., &c.

In pursuance of the provisions of the *Marine Act 1958*, I, the Governor of the State of Victoria, in the Commonwealth of Australia, do by this my Proclamation fix Saturday the first day of November, One thousand nine hundred and eighty, as the day on which:

Certificates of Service as prescribed by section 53 (a) of the said *Marine Act 1958*, No. 6302 shall cease to be issued.

Given under my Hand and the Seal of the State of Victoria aforesaid, at Melbourne, this thirtieth day of September in the year of our Lord One thousand nine hundred and eighty and in the twenty-ninth year of the reign of Her Majesty Queen Elizabeth II.

(L.S.) HENRY WINNEKE

By His Excellency's Command  
TOM AUSTIN  
Minister of Public Works

GOD SAVE THE QUEEN!

BANK HOLIDAY

PROCLAMATION

By His Excellency the Governor of the State of Victoria and its Dependencies in the Commonwealth of Australia, &c., &c., &c.

In pursuance of the provisions of the *Bank Holidays Act 1958*, I, the Governor of the State of Victoria, in the Commonwealth of Australia, do by this my Proclamation appoint the day and date named hereunder as a special day to be observed as a Bank Holiday at the place respectively mentioned, that is to say:

Bank Holiday

TUESDAY, 4 NOVEMBER 1980, at Mildura, Merbein and Redcliffs.

Given under my Hand and the Seal of the State of Victoria aforesaid, at Melbourne, this twenty-eighth day of October in the year of our Lord One thousand nine hundred and eighty, and in the twenty-ninth year of the reign of Her Majesty Elizabeth the Second, Queen of Australia.

(L.S.) HENRY WINNEKE

By His Excellency's Command  
R. J. HAMER  
Premier

GOD SAVE THE QUEEN!

Land Act 1958

LAND DECLARED UNDER SECTION 22c OF THE LAND ACT 1958

PROCLAMATION

By His Excellency the Governor of the State of Victoria and its Dependencies in the Commonwealth of Australia, &c., &c., &c.

I, the Governor of the State of Victoria, in the Commonwealth of Australia, by and with the advice of the Executive Council of the said State, pursuant to section 22c (2) of the *Land Act 1958*, and upon receipt of certification of the clerk of the municipality concerned (Shire of Benalla) to the effect that the subject land constitutes land which is or has been used for cultural sporting or

recreational purposes, do hereby declare to be land to which the said section 22c of the *Land Act 1958* applies, part Crown allotment 17, section B, Parish of Moorngag, being the land described in Certificate of Title Volume 8061 Folio 811—(L7-701).

Given under my Hand and the Seal of the State of Victoria aforesaid, at Melbourne, this twenty-first day of October, in the year of our Lord One thousand nine hundred and eighty, and in the twenty-ninth year of the reign of Her Majesty Elizabeth the Second, Queen of Australia.

(L.S.) HENRY WINNEKE

By His Excellency's Command  
W. V. HOUGHTON  
Minister of Lands

GOD SAVE THE QUEEN!

GOVERNMENT NOTICES

SHIRE OF SOUTH GIPPSLAND  
ROAD DEVIATION ORDER  
Corcorans Road

Pursuant to the provisions of sections 522 and 526 of the *Local Government Act 1958*, the Council of the Shire of South Gippsland hereby directs that the land in the Parish of Wonga Wonga indicated by hatching on the diagram set out below, which has been purchased taken or acquired by it, shall be a public highway on and from the date of the publication of this Order in the *Government Gazette*, and declares that such land shall be a public highway in lieu of the land indicated by cross-hatching on the said diagram.

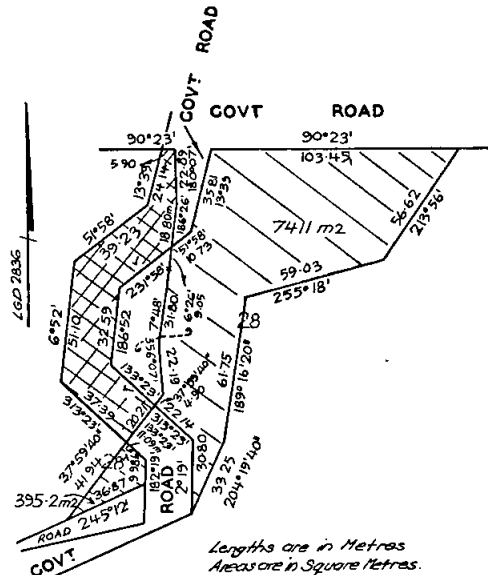

The common seal of the President, Councillors and Ratepayers of the Shire of South Gippsland was hereunto affixed, 10 April 1979, in the presence of—

(SEAL) W. COOK, Shire President  
L. MOON, Councillor  
H. LOMAX, Shire Secretary

Confirmed by the Governor in Council, 21 October 1980  
—L. G. HOUSTON, Acting Clerk of the Executive Council

Transport Regulation Act  
**TRANSPORT REGULATION BOARD**  
 HEARING OF APPLICATIONS

Notice is hereby given that the following applications will be considered by the Transport Regulation Board on 18 November 1980.

Applications by the persons listed hereunder for one Metropolitan Taxi licence to be issued subject to the cancellation of each Suburban Taxi licence shown.

SINCLAIR, K. W., East Bentleigh; S.T.6015.  
 HARRISS, H. C., Ringwood East; S.T.5750.

Application for renewal of licences as shown by the persons listed hereunder to operate under the same terms and conditions.

AFKODIAS, A., North Balwyn; M.T.1832.  
 ARMSTRONG, I. R., Mt. Eliza; C.T.275.  
 ARMSTRONG, I. & J., Mt. Eliza; C.T.725.  
 ARMSTRONG, J. I., Mt. Eliza; C.T.487.  
 ARZEVSKY, P., St. Kilda; M.T.5862.  
 BOUSSOUNI, S. A., Bulleen; M.T.4749.  
 BOUTERAKOS, D., Clifton Hill; M.T.4132.  
 BRINDLEY, N. R. & J. M., Frankston; C.T.282.  
 BROWN, J. H. & V. M., Shepparton; C.T.503.  
 BURD, R., Carnegie; M.T.5469.  
 CHALIKIAS, G., Brunswick West; M.T.4866.  
 DORRAN, T. C. & G. E., Mallaacoota; C.O.366, C.O.367.  
 GIANNARELLI, A., Thornbury; M.T.5560.  
 GRANT, H., Doncaster; M.T.4231.  
 HARKNESS, R. R. & D. L., Frankston; C.T.768.  
 HERSANT, H. E. & J. J., Frankston; C.T.59.  
 HOCHEGGER, O., Frankston; C.T.276.  
 HOGAN, R. A., Coolaroo; M.T.5452.  
 KRUZIC, C., Moonee Ponds; M.T.5524.  
 MARTIN, C. A., Frankston; C.T.668.  
 MAURO TAXI SERVICES PTY. LTD., North Caulfield; M.T.4987.  
 MAURO TAXI SERVICES PTY. LTD., North Caulfield; M.T.5210.  
 MAURO, D., North Caulfield; M.T.5698.  
 MELBOURNE AND METROPOLITAN BOARD OF WORKS, Melbourne; S.V.238.  
 MORRISON, M. J. & J. L., Frankston; C.T.424.  
 MOUTIDIS, A., Vermont South; M.T.4880.  
 O'DEA, J., Mt. Eliza; C.T.255, C.T.13.  
 PANAGIOTOPOULOS, A., Canterbury; M.T.4028.  
 PAYTON, A. F. & J. A., Moonee Ponds; M.T.5399.  
 PILLA, I., & BONO, J., Cheltenham; M.C.683.  
 PIVETTA, R. A. M., Frankston; C.T.440.  
 POLITIS, F., Brunswick; M.T.5456.  
 REVILL, K. R., Welshpool; T.S.1486.  
 ROMANOS, S., Coburg; M.T.5333.  
 SALMAS, K., Pascoe Vale; M.T.4832.  
 SMALE, G. V., Frankston; C.T.644.  
 TOMKINS, G. R., Herne Hill; T.S.1473.  
 TOWN OF ST. ARNAUD, St. Arnaud; S.V.106.  
 TRAVERS, W. R., West Brunswick; M.T.2542.  
 VAGENAS, A., East Doncaster; M.T.4830.  
 WILLIAMS, A. J., North Balwyn; M.T.2539.

Notice of any objections should be forwarded to reach the Secretary of the Board not later than 12 November 1980.

Applicants are advised that it will not be necessary to appear on the hearing date specified, unless advised in writing by the Board.

C. J. V. SMITH, Secretary

Corner Lygon and Princes Streets, Carlton, 3053,  
 Wednesday, 29 October 1980

Commercial Goods Vehicles Act  
**TRANSPORT REGULATION BOARD**  
 HEARING OF APPLICATIONS

Notice is hereby given that the following applications will be considered by the Transport Regulation Board on 18 November 1980.

ANDERSON TIMBER & HARDWARE PTY. LTD., Main Road, Monbulk, 3793. One commercial goods vehicle (L/C. 6.85 tonne) to operate: (a) Within a 32-km radius of the post office at Monbulk and from and to Monbulk to and from the City of Melbourne in the course of business as "General Merchants and Sawmillers"—own goods. (b) From own sawmill at Monbulk to places within a 40-km radius of the post office at the corner of Bourke and Elizabeth Streets in the City of Melbourne and also to places on the Mornington Peninsula—own sawn timber.

ASCOM EQUIPMENT PTY. LTD., 499 St. Kilda Road, Melbourne, 3004. One commercial goods vehicle (L/C. 8.00 tonne) to operate: (a) Within an 80-km radius of own premises at Clayton in the course of business as "Engineers and Constructors"—own goods excluding the carriage of restricted goods which may be specified by notice in the *Government Gazette*. (b) Throughout the State of Victoria—tools of trade and equipment incidental only to own contracts. (c) Within a 40-km radius of the site of any contract currently engaged upon or from the railway station nearest thereto—own materials for use on such contract.

B. L. & M. GROLLO HOMES PTY. LTD., 261 Bulleen Road, Bulleen, 3105. Two commercial goods vehicles (L/C. 3.40 and 2.40 tonne) to operate: (a) Throughout the State of Victoria in the course of business as "Building Contractors"—tools of trade, own equipment and up to 1000 kgs of materials at any one time. (b) Within an 80-km radius of own premises at Bulleen—own goods.

BAKER, K. J., 63 Lake Street, Murtoa, 3390. One commercial goods vehicle (L/C. 8.90 and 9.80 tonne trailer) to operate: (a) Within an 80-km radius from the post office at Murtoa and to and from Mooree—plant the property of a contractor and required by him for use in connection with the construction or maintenance of some specific, existing or proposed road, street, footpath, bridge, pier, wharf, weir or channel and also the following materials viz: metal, stones, screenings, ashes, gravel, sand, earth and gypsum. (b) Within a 32-km radius from the site of construction or maintenance work performed pursuant to paragraph (a) above, or from the railway station nearest thereto—metal, stones, screenings, ashes, gravel, sand, earth and any other materials required for such work. (c) Within a 40-km radius of the post office at Murtoa—general goods.

BINNEY, A. R., Pink Cliffs Road, Heathcote, 3606. One commercial goods vehicle (L/C. 20.00 tonne) to operate: (a) Within an 80-km radius of the post office at Heathcote—plant the property of a contractor and required by him for use in connection with the construction or maintenance of some specific, existing or proposed road, street, footpath, bridge, pier, wharf, weir or channel and also the following materials viz: metal, stones, screenings, ashes, gravel, sand and earth. (b) Within a 32-km radius from the site of any construction or maintenance work performed pursuant to paragraph (a) above, or from the railway station nearest thereto—any other materials required for such work. (c) Within a 40-km radius of the post office at Heathcote—general goods.

BLACK, R. J., 221 High Street, Nagambie, 3608. One commercial goods vehicle (L/C. 0.55 tonne) to operate: (a) Within an 80-km radius of own premises at Nagambie in the course of business as "Machinery Sales"—own goods. (b) To and from places within a 40-km radius of the G.P.O. Melbourne from and to own premises at Nagambie in the course of business as "Machinery Sales Agent"—machinery and implements for demonstration and display purposes only, excluding the ability to carry machinery or implements for sale under paragraph (b). (c) Within a 40-km radius of the post office at Nagambie—general goods.

BROWN, P., Mary Street, Morwell, 3840. One commercial goods vehicle (L/C. 8.00 tonne) to operate throughout the State of Victoria in the course of business as "Marine Collector"—special wares, marine stores and old metals as designated in the *Marine Stores and Old Metals Act 1958*, Part I, Section (3) and own plant and equipment incidental thereto, provided that the load capacity of the vehicle is not increased without the prior written permission of the Board and that no trailer shall be hauled in conjunction with the vehicle.

COBB, N. J., 48 Westmoreland Street, Whittington, 3219. One commercial goods vehicle (L/C. 8.30 tonne) to operate: (a) Within a 40-km radius of the chief post office in the City of Geelong—own goods. (b) Within an 80-km radius of the chief post office in the City of Geelong in the course of business as a "Trenching and Foundation Contractor"—own gear, tools and equipment.

JOHN DANKS & SON PTY. LTD., 621 Whitehorse Road, Mitcham, 3132. One commercial goods vehicle (L/C. 7.90 tonne) to operate within a 40-km radius of own premises at Mitcham and to Geelong, Bunyip, Lang

- Lang and points on the Mornington Peninsula in the course of business as "Steel Merchants"—own goods other than restricted goods which may be specified by notice in the *Government Gazette* from time to time.
- DRIVER, R. D., 6 Balmoral Place, West Melton, 3337. One commercial goods vehicle (L/C. 0.70 tonne) to operate throughout the State of Victoria in the course of business as "Security Alarm Systems Service"—tools of trade, spare parts and materials required for on site servicing and maintenance of alarm systems.
- EMOLEUM (AUST.) LTD., 221 Arden Street, North Melbourne, 3051. One commercial goods vehicle (L/C. 4.00 tonne) to operate: (a) Throughout the State of Victoria in course of business as "Road Spraying Contractors" for the purpose of supervising own contracts—tools of trade and own equipment. (b) Within a 40-km radius of any contract site or from the nearest railway station thereto—materials required for such contracts.
- GAS & FUEL CORPORATION OF VICTORIA, 171 Flinders Street, Melbourne, 3000. One commercial goods vehicle (L/C. 0.75 tonne) to operate throughout the State of Victoria in the course of business as "Liquid Gas Suppliers"—tools of trade and materials incidental to servicing and maintaining liquid gas cylinders.
- GRAY, T., 16 Genoa Road, Mallacoota, 3889. One commercial goods vehicle (L/C. 10.50 tonne) to operate: (a) Within a 152-km radius of the post office at Orbost (Bairnsdale Division of the Country Roads Board)—plant the property of a contractor and required for use in connection with the construction or maintenance of some specific, existing or proposed road, street, footpath, bridge, wharf, pier, weir or channel. (b) Within a 32-km radius of the site of construction or maintenance work performed pursuant to paragraph (a) above, or from the railway station nearest thereto—metal, stones, screenings, ashes, gravel, sand, earth and any other materials required for such work. (c) Within a 40-km radius of the post office at Mallacoota—general goods.
- HARDINGHAM, M. E., 39 Pye Street, Swan Hill, 3585. One commercial goods vehicle (L/C. 11.40 tonne) to operate: (a) Within a 152-km radius of the post office at Cohuna and/or within a 160-km radius of the post office at Merbein (Bendigo Division of the C.R.B.) and within a 40-km radius of G.P.O. Melbourne (Metropolitan Division of the C.R.B.)—plant the property of a contractor and required by him for use in connection with the construction or maintenance of some specific existing or proposed road, street, footpath, bridge, wharf, pier, weir or channel. (b) Within a 32-km radius from site of construction or maintenance work performed pursuant to paragraph (a) above, or from the railway station nearest thereto—metal, stones, screenings, ashes, gravel, sand, earth and any other materials required for such work. (c) Within a 40-km radius of the post office at Swan Hill—general goods.
- HAYDEN, I. J., 37 Moonah Street, Warrnambool, 3280. One commercial goods vehicle (L/C. 8.00 and 1.00 tonne trailer) to operate: (a) Within an 80-km radius of the post office at Warrnambool—plant the property of a contractor and required by him for use in connection with the construction or maintenance of some specific, existing or proposed road, street, footpath, bridge, wharf, pier or channel and also the following materials viz.: metal, stones, screenings, ashes, gravel, sand and earth. (b) Within a 40-km radius from the site of any construction or maintenance performed pursuant to paragraph (a) above or from the railway station nearest thereto—any other materials required for such work. (c) Within a 40-km radius of the post office at Warrnambool—general goods.
- JANSEN, A., 60 Victoria Street, Pyramid Hill, 3575. One commercial goods vehicle (L/C. 6.05 tonne) to operate: (a) Within a 40-km radius from the post office at Pyramid Hill—general goods. (b) Within an 80-km radius of the post office at Pyramid Hill in the course of business as "Septic Tank Cleaner"—own tools of trade, own equipment and septic tank effluent for disposal.
- JONES, E. C., 13 Mitchell Street, Benalla, 3672. One commercial goods vehicle (L/C. 14.40 tonne) to operate: (a) Within a 40-km radius of the post office at Benalla—general goods. (b) From forest landings situated within an 80-km radius of the post office at Mansfield to sawmills within such radius—sawmill logs.
- MAYNE NICKLESS LTD., 94 York Street, South Melbourne, 3205. Six commercial goods vehicles (L/C. 2.80, 2.30, 2.75, 2.75, 2.75, and 5.95 tonne) to operate throughout the State of Victoria in the course of business as "Armed Escorts" as a specially constructed armoured vehicle for the purpose of making special deliveries.
- MEBAM EQUIPMENT PTY. LTD., 881 Princes Highway, Springvale, 3171. Two commercial goods vehicles (L/C. 0.75 tonne) each to operate: (a) Within an 80-km radius of the G.P.O. Melbourne in the course of business as "Materials Handling Equipment Distributors"—own goods. (b) Throughout the State of Victoria in the course of business as "Materials Handling Equipment Distributors" for the purpose of servicing such equipment—tools of trade, spare parts and materials incidental to the on-site servicing of such equipment.
- MONIER SERVICES PTY. LTD., Frankston Road, Dandenong, 3175. Application to vary the conditions of licences numbered D.A.65751, D.A.65751/3 and D.A.6571/7 by adding additional paragraphs—"From quarries at Ballarat and Smythesdale to own plants in the metropolitan area of Melbourne—own screenings—From Yea to own plants in the metropolitan area of Melbourne—own river pebbles; From Bacchus Marsh to own plants in the metropolitan area of Melbourne—own sand and own river pebbles".
- MONIER LTD., Frankston Road, Dandenong, 3175. Application to vary the conditions of licences numbered D.A.62922/15, D.A.62922/17, D.A.62922/18 and D.A.62922/19 by adding additional paragraphs—"From quarries at Ballarat and Smythesdale to own plants in the metropolitan area of Melbourne—own screenings". "From Yea to own plants in the metropolitan area of Melbourne—own river pebbles". "From Bacchus Marsh to own plants in the metropolitan area of Melbourne—own sand and own river pebbles".
- MONIER LIMITED, Frankston Road, Dandenong, 3175. One commercial goods vehicle (L/C. 7.50 tonne) to operate within a 112-km radius of own premises at Broadmeadows and Springvale in the course of business as "Roofing Tile Manufacturers"—roofing tiles, tile fixing materials, roofing battens, handling equipment and empty return pallets.
- PENGELLY, RONALD G., 1 Rawson Avenue, Sunshine, 3020. One commercial goods vehicle (L/C. 1.15 tonne) to operate throughout the State of Victoria in the course of business as "Building Contractors"—tools of trade, own equipment and materials incidental thereto.
- READ'S EARTHMOVERS PTY. LTD., 14 Bailey Street, California Gully, 3556. One commercial goods vehicle (L/C. 7.85 tonne) to operate: (a) Within an 80-km radius of the post office at Bendigo—plant the property of a contractor and required by him for use in connection with the construction or maintenance of some specific, existing or proposed road, street, footpath, bridge, pier, wharf, weir or channel and also the following materials viz.: metal, stones, screenings, ashes, gravel, sand and earth. (b) Within a 32-km radius from the site of any construction or maintenance work performed pursuant to paragraph (a) above or from the railway station nearest thereto—any other materials required for such work. (c) Within a 40-km radius of the post office at Bendigo—general goods.
- READ, D., 14 Bailey Street, California Gully, 3556. One commercial goods vehicle (L/C. 0.60 tonne) to operate within a 160-km radius of the chief post office at Bendigo and to the City of Swan Hill in the course of business as "Earthmoving Contractor" for the purpose of servicing own equipment—tools of trade, spare parts and a maximum of 3 x 200 litre drums of fuel for operating machinery on site.
- RORIE, D., 17 Thorpedale Road, Mirboo North, 3871. One commercial goods vehicle (L/C. 10.50 tonne) to operate: (a) From the premises of Motor Vehicle Distributors and Dealers direct to consignees throughout the State of Victoria on behalf of Arnolds Transport Pty. Ltd.—complete motor vehicles excluding tractors. (b) From the premises of Motor Vehicle Manufacturers situated at Melbourne, Geelong and Dandenong direct to those wharves only where there are no rail facilities—motor car bodies.
- T.F.N. NOMINEES PTY. LTD., 3 Victoria Street, Port Fairy, 3284. One commercial goods vehicle (L/C. 3.50 tonne) to operate throughout the State of Victoria in the

course of business as "House Removalist" as a pilot vehicle—own tools of trade and house removing equipment.

- W. H. YOUNG & SONS (PLANT HIRE) PTY. LTD., 182 High Street, Shepparton, 3630. One commercial goods vehicle (L/C. 12.54 tonne) to operate: (a) Within an 80-km radius of the post office at Shepparton—plant the property of a contractor and required by him for use in connection with the construction or maintenance of some specific, existing or proposed road, street, footpath, bridge, pier, wharf, weir or channel and also the following materials, viz: metal, stones, screenings, ashes, gravel, sand and earth. (b) Within a 32-km radius from the site of any construction or maintenance work performed pursuant to paragraph (a) above, or from the railway station nearest thereto—any other materials required for such work. (c) Within a 40-km radius of the post office at Shepparton—general goods, provided that no goods shall be carried whether by one stage or by more than one stage between places within the above radius which are more than 48-km apart by the nearest practicable route. (d) Within an 80-km radius of Shepparton—hot asphalt and premixed bituminous products.

#### RENEWALS

Applications for renewal of licences as shown by persons listed hereunder to operate under the same terms and conditions from the expiry shown in each case.

- ARNOTT BROCKOFF GUEST PTY. LTD., 53 Huntingdale Road, Burwood, 3125; D.A.60213/59; 22 January 1981; 3.15 tonne; D.A.60213/60; 30 January 1981; 2.65 tonne.
- ARNOTT BROCKOFF GUEST PTY. LTD., 53 Huntingdale Road, Burwood, 3125; D.A.60213/61; 30 January 1981; 1.75 tonne.
- AUSTRALASIAN CONFERENCE ASSOCIATION LTD., 118 Union Street, Windsor, 3181; D.A.1984/2; 12 January 1981; 5.55 tonne.
- AVIATION INDUSTRIES PTY. LTD., P.O. Box 7, Cheltenham, 3192; D.A.32508/26; 26 January 1981; Mobile Crane.
- BANK OF NEW SOUTH WALES, 275 City Road, South Melbourne, 3205; D.A.28156; 14 January 1981; 3.10 tonne.
- BEAUREPAIRE TYRE SERVICE PTY. LTD., 83 Franklin Street, Melbourne, 3000; D.A.629/5; 21 January 1981; 1.10 tonne; D.A.629/55; 16 January 1981; 0.80 tonne.
- BELLINGHAM, D. R., Box 36/5, Shingler Street, Leongatha, 3953; D.A.54062; 8 December 1980; 6.95 tonne.
- BRITTON, A. R., Box 7, Seymour, 3660; D.A.41486; 16 January 1981; 6.55 tonne.
- CHESTER, W. J., 20 Rolland Street, Sale, 3850; D.A.62950/4; 14 November 1980; 2.65 and 0.85 tonne.
- CLARK, K. L., Sumner Street, Stawell, 3380; D.A.68879; 5 December 1980; 1.35 and 1.55 tonne trailer.
- CLINTON, G. M., 542 Dorset Road, South Croydon, 3136; D.A.68471; 13 January 1981; 2.30 tonne.
- THE COMMONWEALTH INDUSTRIAL GASES LTD., 90 Bell Street, Preston, 3072; D.A.838/45; 11 January 1981; 18.90 tonne.
- A. G. COOMBS GROUP PTY. LTD., 26 Cochranes Road, Moorabbin, 3189; D.A.891/37; 15 January 1981; 0.75 tonne; D.A.891/38; 15 January 1981; 0.75 tonne.
- CUTHBERTSON & RICHARDS SAWMILLS PTY. LTD., P.O. Box 124, Drouin, 3818; T.D.A.43930/3; 30 July 1980; 12.10 tonne.
- DIVERSE PRODUCTS LTD., Golf Links Road, Horsham, 3400; D.A.65160/6; 9 December 1980; 7.45 tonne.
- DORAN, R. P., 155 Kingsway Drive, Lalor, 3075; D.A.62435; 16 December 1980; 10.60 tonne.
- DELORENZO, V. F., Roadside Delivery, Warrion, 3249; D.A.65832; 30 January 1981; 8.34 tonne.
- EMOLEUM AUST. LTD., Arden Street, North Melbourne, 3051; D.A.1042/23; 13 January 1981; 7.05 tonne.
- FARM PRODUCE PTY. LTD., Bayles Road, Tynong, 3813; D.A.68329; 18 March 1980; 11.80 tonne.
- FOARDS FREEHOLDS PTY. LTD., 25 Wangaratta Street, Richmond, 3121; D.A.41240/2; 28 January 1981; 0.75 tonne.
- G.M.D. REFRIGERATION PTY. LTD., Miller Street, Epping, 3076; D.A.55573/8; 15 January 1981; 0.40 tonne.
- GAS & FUEL CORPORATION OF VICTORIA, 171 Flinders Street, Melbourne, 3000; D.A.49393/55; 11 January 1981; 0.80 tonne.
- GILBERT, J. W., 15 Borg Street, Scoresby, 3179; D.A.68868; 5 December 1980; 7.05 tonne.
- R. J. GILBERTSON PTY. LTD., Kyle Road, Altona North, 3025; D.A.58594/7; 18 January 1981; 16.50 tonne; D.A.58594/4; 18 January 1981; 19.50 tonne; D.A.58594/5; 18 January 1981; 18.50 tonne; D.A.58594/6; 18 January 1981; 19.60 tonne; D.A.58594/3; 18 January 1981; 22.75 tonne.
- ALF HANNAFORD & CO. PTY. LTD., 64 East Avenue, Beverley, 5009; D.A.1232/40; 15 January 1981; 1.10 tonne.
- HANNEYSEE, M. J., 41-42 Sandra Avenue, Corio, 3214; D.A.65599; 9 October 1980; 7.02 and 2.00 tonne trailer.
- LEO HEMINGWAY & PICKETT PTY. LTD., 330 Sydney Road, Brunswick, 3056; D.A.39955/18; 21 January 1981; 2.05 tonne; D.A.39955/52; 18 January 1981; 1.95 tonne; D.A.39955/57; 18 January 1981; 1.95 tonne.
- HODGSON, C. J., Yarra Glen Road, Healesville, 3777; D.A.68979/3; 1 December 1980; 8.00 tonne.
- NORMAN J. HURLL & CO. (AUST.) PTY. LTD., 14 Aristoc Road, Glen Waverley, 3150; D.A.57246/1; 18 October 1980; 0.50 tonne.
- INTERNATIONAL HARVESTER AUST. PTY. LTD., The Esplanade, North Shore, 3214; D.A.1351/96; 13 January 1981; 1.00 tonne; D.A.1351/98; 13 January 1981; 1.00 tonne.
- J. JEFFREY & SONS PTY. LTD., 537 Princes Highway, Morwell, 3840; D.A.32735/50; 22 January 1981; 1.15 tonne.
- KARSLAKE, E. H., P.O. Box 49, Wedderburn, 3518; D.A.68463; 13 January 1981; 1.85 tonne.
- MARTIN, D. L., 80 McIvor Road, Bendigo, 3550; D.A.65437/1; 22 January 1981; 3.60 tonne.
- MORAN, W., Livingstone Street, Avenel, 3664; D.A.64180; 12 October 1980; 6.85 tonne.
- MCPHERSON, R. L., 14 Carnavon Street, Lang Lang, 3984; D.A.68348; 14 November 1980; 3.35 tonne.
- MCLELLAN, S. M., 11 Main Street, St. Andrews, 3761; D.A.65803; 15 January 1981; 0.70 tonne.
- THE NATIONAL BANK OF AUSTRALASIA LTD., 31 Queen Street, Melbourne, 3000; D.A.1706; 14 January 1981; 3.70 tonne.
- PETERSVILLE LTD., 254-294 Wellington Road, Mulgrave, 3170; D.A.1813/111; 11 January 1981; 3.80 tonne; D.A.1813/25; 23 January 1981; 5.90 tonne; D.A.1813/192; 30 January 1981; 4.00 tonne; D.A.1813/84; 27 January 1981; 3.75 tonne.
- PETERSVILLE LTD., 254-294 Wellington Road, Mulgrave, 3170; D.A.1813/22; 8 January 1981; 3.65 tonne; D.A.1813/110; 11 January 1981; 3.50 tonne; D.A.1813/112; 26 January 1981; 1.00 tonne; D.A.1813/243; 30 January 1981; 3.40 tonne.
- W. PRIDHAM AUST. PTY. LTD., 11 Evans Street Braybrook, 3019; D.A.1864/36; 13 January 1981; 3.25 tonne; D.A.1864/1; 21 January 1981; 7.15 tonne.
- A. R. RATHGEBER & SONS, Hodges Street, Stawell, 3380; D.A.28173; 21 January 1981; 3.95 tonne.
- RENOUF, A. H., 429 Springfield Road, Micham, 3132; D.A.24042; 31 January 1981; 8.50 tonne.
- REPCO LTD., 618-640 Elizabeth Street, Melbourne, 3000; D.A.68791/41; 11 January 1981; 0.60 tonne.
- RITCHIE, R., Main Road, Gembrook, 3783; D.A.28100; 21 January 1981; 2.55 tonne.
- SCHEUFFELE, F. J., P.O. Box 670, Epsom, 3551; D.A.12534/2; 26 January 1981; 7.30 tonne.
- SPERRY RAND AUST. LTD., 334-342 City Road South Melbourne, 3205; D.A.828/9; 16 January 1981; 0.80 tonne.
- SPERRY RAND AUST. LTD., 334-342 City Road South Melbourne, 3205; D.A.828/6; 16 January 1981; 0.50 tonne.
- TOLEDO BERKEL PTY. LTD., 525 Graham Street, Port Melbourne, 3207; D.A.2168/8; 15 January 1981; 1.15 tonne; D.A.2168/9; 15 January 1981; 0.50 tonne.
- TRANS WEST HAULAGE PTY. LTD., 202 Station Street, Norlane, 3214; D.A.65323/60; 22 January 1981; 1.45 tonne.
- TRANSURETY AUST. LTD., 19-21 Baldwin Avenue, Norlane, 3214; D.A.69435/3; 11 January 1981; 2.50 tonne.
- TREVOR BOILER & ENG. CO. PTY. LTD., corner Steel and Langford Streets, North Melbourne, 3951; D.A.28850/4; 21 December 1980; 3.55 tonne.
- VINKID PTY. LTD., 363 Francis Street, Yarraville, 3013; D.A.68470; 13 January 1981; 1.95 tonne.
- WESTERN MINING CORP. LTD., 304 Seymour Street, Ballarat, 3350; D.A.67902/1; 21 December 1980; 1.35 tonne.

#### TOW TRUCK RENEWAL

STEPHENS, G. F., Conness Street, Chiltern, 3683; D.A.71076; 28 January 1981; 3.90 tonne.

Notice of any objection should be forwarded to reach the Secretary of the Board not later than 12 November 1980.

Applicants are advised that it will not be necessary to appear on the hearing date specified above, unless advised in writing by the Board.

C. J. V. SMITH, Secretary

Corner Lygon and Princes Streets, Carlton, Vic. 3053, Wednesday, 29 October 1980

*Water Act 1958*STATE RIVERS AND WATER SUPPLY COMMISSION  
MORNINGTON PENINSULA URBAN DISTRICT

Notice to owners of tenements in the undermentioned streets in the Mornington Peninsula Urban District and the private streets, lanes, courts and alleys opening thereto:

*Blairgowrie*

Cowper Street, (1) from Hilltop Avenue to a point opposite Lot 1925 about 51 metres north-westerly; (2) from Arnold Street to Dana Avenue.

Dana Avenue, from St. Johns Wood Road to a point opposite Lot 2052 about 201 metres south-easterly.

Hilltop Avenue, (1) from Old Melbourne Road to Champion Street; (2) from Cowper Street to a point opposite Lot 2282 about 84 metres south-westerly; (3) from Ridley Street to Ritchie Avenue.

Melbourne Road, (1) (south-west side only) from Summoner Street to Dana Avenue; (2) (south-west side only) from William Road to a point opposite Lot 2 about 330 metres south-easterly; (3) (south-west side only) from end of existing main (opposite Lot 44) to a point opposite Lot 75 about 100 metres south-easterly.

Munro Street, from Old Melbourne Road to a point opposite Lot 53 about 200 metres south-westerly.

Ridley Street, from Old Melbourne Road to a point opposite Lot 2255 about 89 metres south-westerly.

Royadie Road, from Old Melbourne Road to a point opposite Lot 76 about 273 metres south-westerly.

St. Johns Wood Road, (1) from Dana Avenue to a point opposite Lot 45 about 94 metres north-easterly; (2) from end of existing main (opposite Lot 1843) to a point opposite Lot 1841 about 50 metres north-easterly.

Sinclair Street, from Dana Avenue to Summoner Street.  
Summoner Street, from Dana Avenue to a point opposite Lot 2056 about 77 metres north-easterly.

*Clyde*

Beechers Road, from end of existing main (opposite Lot 1) to Derricks Road about 245 metres northerly.

Derricks Road, from Beechers Road to Yallambe Road.

Yallambe Road (south side only), from Derricks Road to a point opposite Lot 37 about 424 metres north-easterly.

*Cranbourne South*

Carr-Boyd Road, from Dandenong-Hastings Road to Roslyn Road.

Roslyn Road

*Devon Meadows*

Browns Road (south side only), from Kelly Road to a point opposite Lot 9 about 130 metres easterly.

Kelly Road, from Browns Road to a point opposite Lot 6 about 110 metres southerly.

*Langwarrin*

Homestead Road, from Cranbourne-Frankston Road to a point opposite Lot 1 about 60 metres southerly.

*McCrae*

Burunda Road, from Wilgah Road to a point opposite Lot 11 about 190 metres easterly.

Eastbourne Road (north side only), from Rosebud Avenue to a point opposite Lot 2 about 170 metres easterly.

Fairway Grove, from Wilgah Road to a point opposite Lot 2 about 186 metres westerly.

Rosebud Avenue, from end of existing main (opposite Lot 16) to Eastbourne Road about 27 metres northerly.

Sunningdale Road, (1) from Wilgah Road to a point opposite Lot 6 about 315 metres easterly; (2) from Wilgah Road to a point opposite Lot 5 about 167 metres westerly.

Wilgah Road

*Mornington*

Maxwell Street, from Ruth Road to a point opposite Lot 45 about 150 metres southerly.

*Mount Martha*

Latrobe Drive, from Barossa Court to a point opposite Lot 21 about 150 metres north-westerly.

*Narre Warren*

Bunbury Avenue, from Guildford Crescent to a point opposite Lot 134 about 130 metres northerly.

Dianella Court  
Greenmount Close

Guildford Crescent, from end of existing main (opposite Lot 124) to Pemberton Drive about 700 metres westerly.

Highgate Place

*Somerville*

Soderlund Place

*Sorrento*

Cecil Street, from end of existing main (opposite Lot 2) to Richard Street about 100 metres northerly.

*Tootgarook*

Monica Street, from end of existing main (opposite Lot 15) to a point opposite Lot 14 about 18 metres northerly.

*Warneet*

Fishermans Drive, from end of existing main (opposite Lot 93) to a point opposite Lot 184 about 57 metres south-westerly.

Tern Close

Warneet Road (south side only), from end of existing main (opposite Lot 70) to a point opposite Lot 193 about 97 metres westerly.

The main pipe in the said streets being laid down, the owners of all tenements situated as above are hereby required, on or before 1 December next, to cause proper pipes and stop cocks to be laid, so as to supply water within such tenements from the main pipe.

R. BIRD, Secretary

State Rivers and Water Supply Commission

Armada, 6 October 1980

*Water Act 1958*STATE RIVERS AND WATER SUPPLY COMMISSION  
BELLARINE PENINSULA URBAN DISTRICT

Notice to owners of tenements in the undermentioned streets in the Bellarine Peninsula Urban District and the private streets, lanes, courts and alleys opening thereto:

*Angelsea*

Elizabeth Street, from Paton Street to Ellimatta Road.

Ellimatta Road (south side only), from Elizabeth Street to a point about 110 metres easterly of Great Ocean Road.

*Clifton Springs*

Ada Street—

(1) From Adina Way to a point opposite lot 2252 about 90 metres easterly.

(2) From Adina Way to a point opposite lot 2246 about 110 metres westerly.

Alchera Court.

Allara Avenue—

(1) From Achilpa Avenue to a point opposite lot 2260 about 65 metres easterly.

(2) From Adina Way to a point opposite lot 2234 about 115 metres westerly.

Barrands Lane, from Parrakoola Drive to a point opposite lot 1846 about 74 metres northerly.

Berrigan Street.

Bundarra Street.

Clifton Avenue, from Bogan Street to Spring Street.

Coronae Drive, from Country Club Drive to Beacon Point Road.

Gaddang Court.

Gumarooka Avenue, from Thambalina Road to Gaddang Court.

Gwinganna Drive, from end of existing main (opposite lot 2816) to Thamballina Road about 250 metres northerly.

Kalang Court.

Kanyanya Avenue, from Kadumba Avenue to Kewarra Drive.

Kewarra Drive, from Kirra Way to Jetty Road.

Mirrabooka Drive—

(1) From Gooniwindi Avenue to Yarramundi Drive.

(2) From Maraboora Avenue to Kawana Court.

Mokera Avenue.

Narawi Avenue, from Dandarriga Drive to a point opposite lot 2591 about 94 metres southerly.

Shoreline Drive, from Kewarra Drive to Hill Street.

Tarcoola Way.

Thamballina Way, from Coolabah Way to a point opposite lot 2801 about 510 metres easterly.

*Jan Juc*

Barnett Place.

Curtis Court.

Duffields Road, from Nicholson Crescent to Carnarvon Avenue.

Glyn Street.

Nicholson Crescent, from end of existing main (opposite lot 81) to Duffields Road about 170 metres southerly and easterly.

*Leopold*

Claremont Drive, from end of existing main (opposite lot 13) to Myuna Street about 114 metres southerly.

Clifton Avenue, from Geelong-Portarlinton Road to a point opposite lot 1 about 1576 metres northerly.

Dorothy Street, from end of existing main (opposite lot 82) to a point opposite lot 93 about 110 metres easterly.

Karumba Court.

Myuna Street.

Pindari Court.

Tania Court.

*Ocean Grove*

Dolphin Court.

Grubb Road, from Adco Grove to a point opposite lot 1 about 132 metres northerly.

Halibut Avenue, from Canis Crescent to a point opposite lot 212 about 140 metres westerly.

Marlin Drive, from end of existing main (opposite lot 51) to Halibut Avenue about 260 metres easterly.

*St. Leonards*

Old Drysdale-St. Leonards Road (south side only), from end of existing main opposite lot 3 to a point opposite lot 1 about 50 metres easterly.

*Torquay*

Dunkeith Avenue, from end of existing main (opposite lot 519) to a point opposite lot 31 about 312 metres north-easterly.

*Wallington*

Rhinds Road, from end of existing main (opposite lot 2: part of Crown Allotment 11, Section 4, Parish of Bellarine) to a point opposite lot 6, part of Crown Allotment 15, Section 4, Parish of Bellarine about 137 metres westerly.

The main pipe in the said streets being laid down, the owners of all tenements situated as above are hereby required, on or before 1 December next, to cause proper pipes and stop cocks to be laid, so as to supply water within such tenements from the main pipe.

Armadale, 6 October 1980

R. BIRD, Secretary  
State Rivers and Water Supply Commission

*Water Act 1958*

STATE RIVERS AND WATER SUPPLY COMMISSION  
COLIBAN URBAN DISTRICT

Notice to owners of tenements in the under-mentioned streets in the Coliban Urban District and the private streets, lanes, courts and alleys opening thereto:

*Ascot*

Taylor Street—

(1) from end of existing main (opposite Crown allotment 82, Township of Ascot) to a point opposite the south-western boundary of Crown allotment 82, Township of Ascot.

(2) (north-west side only) from end of existing main (opposite the south-western boundary of Crown allotment 82, Township of Ascot) to a point opposite lot 2 about 2 metres south-westerly.

(3) from Golf Course Road to a point opposite Crown allotment 82, Township of Ascot about 183 metres south-westerly.

*Bendigo*

Barton Court, from Deakin Drive to a point opposite lot 18, L.P.122159 about 112 metres southerly.

Craig Court, from Kinross Street to a point opposite lot L, section A, Parish of Sandhurst about 148 metres southerly.

Deakin Drive, from Osborne Street to a point opposite lot 12, L.P.122159 about 254 metres easterly.

Hillview Street, from Sharon Street to Race Street.

Kinross Street, from end of existing main (opposite Crown allotment 17b, section A, Parish of Sandhurst) to a point opposite Crown allotment 17b, section A, Parish of Sandhurst.

McDonald Crescent

Osborne Street—

(1) from end of existing main (opposite Crown allotment 231H, Parish of Sandhurst) to a point opposite lot 1, L.P.122159 about 125 metres easterly.

(2) (east side only) from end of existing main (opposite lot 1, L.P.122159) to a point opposite the southern boundary of lot 30 about 245 metres southerly.

Preshaw Street, from Landseer Street to a point opposite lot 8, L.P.110717 about 216 metres southerly.

Taylor Street—

(1) from end of existing main (opposite Crown allotment 1, section 4, Township of Ascot) to a point opposite Crown allotment 5, section 5A, Township of Ascot about 196 metres southerly.

(2) from Forest Drive to a point opposite Crown allotment 3, section 13, Parish of Sandhurst about 605 metres southerly.

Tchumlock Court

*Huntly*

Tecoma Court—

(1) from Hakea Road to a point opposite lot 298 about 40 metres north-easterly.

(2) (west side only) from end of existing main (opposite lot 298) to a point opposite lot 301 about 80 metres north-easterly.

(3) from end of existing main (lot 301) to a point opposite lot 302 about 70 metres north-easterly.

*Junortoun*

Binks Road—

(1) from Trotting Terrace to the northern boundary of lot 2 about 192 metres southerly.

(2) (west side only) from end of existing main (opposite northern boundary of lot 2) to the northern boundary of lot 64 about 588 metres southerly.



- (3) from end of existing main (opposite northern boundary of lot 64) to the un-named Government Road about 410 metres southerly.

Trotting Terrace, from end of existing main (opposite lot 8) L.P.122723 to Binks Road about 114 metres easterly.

Un-named Road—

- (1) from Binks Road to a point opposite the western boundary of lot 1 about 85 metres westerly.
- (2) (north and west sides only) from end of existing main (opposite western boundary of lot 1) to Strathfieldsaye—Junortoun Road about 1130 metres westerly and southerly.

*Kangaroo Flat*

Alma Court

Browning Street, from end of existing main (opposite Crown allotment K, section 8, Township of Kangaroo Flat, Parish of Sandhurst) to a point opposite the Public Recreation Reserve.

Capewell Street, from Crusoe Road to a point opposite lot 2 about 68 metres westerly.

Retreat Road—

- (1) from a point opposite lot 4, L.P.89173 to a point opposite Crown allotment 549A, section H, Parish of Sandhurst about 610 metres northerly.
- (2) from a point opposite lot 33, L.P. 79177 to a point opposite Crown allotment 543A, section H, Parish of Sandhurst about 315 metres northerly.

Rule Street—

- (1) from Eaglehawk Road to a point opposite lot 2 about 45 metres easterly.
- (2) from Christian Street to a point opposite Crown allotment 360s about 40 metres westerly.

Summitt Drive, from Houlahan Street to Strathfieldsaye Road.

Whip Court, from Craig Street to a point opposite lot J, section A, Parish of Sandhurst about 82 metres easterly.

*Castlemaine*

Diamond Gully Road, from Pyrenees Highway to a point opposite part of Crown allotment 1A, section F, Parish of Castlemaine about 430 metres southerly and easterly.

Odgers Road, (west side only) from end of existing main (opposite Crown allotment 46, section 5, Parish of Castlemaine) to a point opposite lot 2, L.P.92770 about 85 metres northerly.

*Eaglehawk*

Darcy Street

Un-named Road, from Williams Road to a point opposite lot 4, L.P.127996 about 288 metres southerly.

Un-named Road (west and north sides only) from Williams Road to a point opposite lot 5, L.P.127996 about 427 metres southerly and westerly.

Williams Road—

- (1) from end of existing main (opposite lot 87) to the western boundary of Crown allotment 382, Parish of Nerring about 130 metres westerly.
- (2) (south side only) from end of existing main (opposite Crown allotment 382, Parish of Nerring) to un-named Government Road about 390 metres westerly.

*Epsom*

Corella Court

Forest Drive, from Taylor Street to Strickland Street, Strickland Street—

- (1) (east side only) from Forest Drive to a point opposite lot 15, L.P.134368 about 63 metres southerly.

- (2) from Howard Street to a point opposite Crown allotment 4, section 1, Parish of Sandhurst about 200 metres northerly.

Church Street, from end of existing main (opposite Crown allotment 13, section 2, Township of Kangaroo Flat) to Camp Street about 154 metres southerly.

Coonoer Street, from Ham Street to a point opposite Crown allotment 9A, section H3, Parish of Sandhurst about 143 metres northerly.

Ham Street, from end of existing main (opposite Crown allotment 1, section H3, Parish of Sandhurst) to Coonoer Street about 55 metres easterly.

No. 7 Reservoir Road, from Melbourne Road to a point opposite the northern boundary of Crown allotment 129, section D, Parish of Mandurang about 290 metres southerly.

Olympic Parade—

- (1) (south-west side only) from Aspinall Street to a point opposite the north-western boundary of lot 3, L.P.82472 about 250 metres north-westerly.
- (2) (north-east side only) from end of existing main (opposite the north-western boundary of lot 3, L.P.82472) to Norelle Crescent about 161 metres north-westerly.

Un-named Road (north side only) from No. 7 Reservoir Road to a point opposite lot 8, L.P.129045 about 194 metres westerly.

Un-named Road—

- (1) from Phillis Street to the north-eastern boundary of lot 73 about 140 metres easterly and north-easterly.
- (2) southern boundary of Crown allotment 95c, section D, Parish of Mandurang.

*Maldon*

Oswald Street, from Morris Street to a point opposite Crown allotment 4, section 26, Township of Maldon about 117 metres southerly.

*Sebastian*

Main Street, from Crown allotment 1, section 1, Township of Sebastian to a point opposite section 8, Township of Sebastian about 700 metres westerly.

*Spring Gully*

Shakespeare Street, from end of existing main (opposite lot 1, L.P. 97642) to a point opposite Crown allotment 468, section H, Parish of Sandhurst about 127 metres southerly.

Shelley Street, from end of existing main (opposite lot 3, L.P.95039) to a point opposite lot 4, L.P.95039 about 15 metres southerly.

Spring Street, from Carpenter Street to Spring Gully Road.

*Strathfieldsaye*

Bamboo Court

Elizabeth Court

Un-named Road, from Sullivans Road to a point opposite lot 5 about 100 metres southerly.

*White Hills*

Church Street, from end of existing main (opposite Crown allotment 9, section F7, Parish of Sandhurst) to a point opposite Crown allotment 10, section F7, Parish of Sandhurst about 78 metres northerly.

The main pipe in the said streets being laid down, the owners of all tenements situated as above are hereby required, on or before 1 December next, to cause proper pipes and stop cocks to be laid, so as to supply water within such tenements from the main pipe.

R. BIRD, Secretary

State Rivers and Water Supply Commission

Armadale, 7 October 1980

*Water Act 1958*STATE RIVERS AND WATER SUPPLY COMMISSION  
JEPARIT URBAN DISTRICT

Notice to owners of tenements in the undermentioned street in the Jeparit Urban District and the private streets, lanes, courts and alleys opening thereto:

*Jeparit*

David Street, from Daphne Street to a point opposite lot 4 about 80 metres south-westerly.

The main pipe in the said street being laid down, the owners of all tenements situated as above are hereby required, on or before 1 December next, to cause proper pipes and stop cocks to be laid, so as to supply water within such tenements from the main pipe.

R. BIRD, Secretary  
State Rivers and Water Supply Commission  
Armadale, 8 October 1980

Un-named Street, from Wimmera Street to a point opposite lot 8 about 195 metres north-westerly.

St. Leonards Street, from Lloyd Street to a point opposite lot 2 about 52 metres north-easterly.

The main pipe in the said streets being laid down, the owners of all tenements situated as above are hereby required, on or before 1 December next, to cause proper pipes and stop cocks to be laid, so as to supply water within such tenements from the main pipe.

R. BIRD, Secretary  
State Rivers and Water Supply Commission  
Armadale, 8 October 1980

*Water Act 1958*STATE RIVERS AND WATER SUPPLY COMMISSION  
DIMBOOLA URBAN DISTRICT

Notice to owners of tenements in the under-mentioned streets in the Dimboola Urban District and the private street, lanes, courts and alleys opening thereto:

*Dimboola*

Elizabeth Street, from end of existing main (opposite lot 32) to a point opposite lot 36 about 60 metres westerly and northly.

Anna Street, from Elizabeth Street to a point opposite lot 8 about 90 metres north-westerly.

*Water Act 1958*STATE RIVERS AND WATER SUPPLY COMMISSION  
RAINBOW URBAN DISTRICT

Notice to owners of tenements in the under-mentioned street in the Rainbow Urban District and the private streets, lanes, courts and alleys opening thereto:

*Rainbow*

Railway Street, from Sanders Street to Lake Street.

The main pipe in the said street being laid down, the owners of all tenements situated as above are hereby required, on or before 1 December next, to cause proper pipes and stop cocks to be laid, so as to supply water within such tenements from the main pipe.

R. BIRD, Secretary  
State Rivers and Water Supply Commission  
Armadale, 8 October 1980

## STATE RIVERS AND WATER SUPPLY COMMISSION

LICENCES TO DIVERT WATER PURSUANT TO THE PROVISIONS OF SECTION 204 OF THE WATER ACT 1958. (AS AMENDED).

The Governor in Council has approved of the granting by the State Rivers and Water Supply Commission of licences as detailed hereunder for the term of years from the date specified in each case to the persons named in the following Schedule.

## SCHEDULE

Licence No.	Terms of Licence and Commencing Date	Name and Address of Person to whom Licence is to be Granted	Source of Supply	Volume of Water		Annual Fee
				Area Authorized to be Irrigated Per Annum	Authorized to be Diverted Per Annum	
2087	Eight years from 1.7.80	E. and E. Pippin of Mildura	River Murray	2.4	21.6	\$ 34.20
3537	Fifteen years from 1.7.77	K. J. and E. P. Colvin of Torrumbarry	River Murray	45.3	272.0	402.56
3695	Fifteen years from 1.7.79	A. J. Henderson of Eltham	Lake Mulwala	2.5	15.0	28.20
3720	Fifteen years from 1.7.79	P. F. and H. M. Hosking of Shepparton	Broken River	12.0	72.0	135.36
3869	Six years from 1.7.79	J. G., P. R., R. M., and R. F. Brown of Milawa	River Murray	33.3	200.0	376.00
3870	Six years from 1.7.79	W. F. Penny and S. Miller of Noble Park	Goulburn River	4.0	24.0	45.12
3871	Six years from 1.7.79	B. K. and K. M. Campbell of Scoresby	Goulburn River	4.0	24.0	45.12
3872	Six years from 1.7.79	S. B. and L. D. Wild of Kanyapella	Goulburn River	4.5	27.0	50.76
3873	Fifteen years from 1.7.79	Barnadown Co-op Irrigators Syndicate of Goornong	Campaspe River	142.0	852.0	1601.76

Office of the State Rivers and Water Supply Commission  
Melbourne, 21 October 1980

R. BIRD, Secretary  
State Rivers and Water Supply Commission

*Liquor Control (Orderly Marketing) Act 1976*  
**NOTICE OF INTENTION TO MAKE A FURTHER  
 DETERMINATION OF PRICE OF PACKAGED BEER**

Take notice that the Liquor Control Commission pursuant to the authority conferred upon it by the *Liquor Control Act 1968* (as amended by the *Liquor Control (Orderly Marketing) Act 1976*) intends to make a further determination of the price below which licensed persons may not sell and dispose of packaged beer to unlicensed persons in the State of Victoria.

For the purpose of making such further determination the Commission proposes to investigate the following written requests to the Commission:—

- (i) from the Australian Hotels Association and the Retail Liquor Merchants' Association of Victoria to determine a new minimum price for packaged beer based on the most recent increases in the wholesale prices for packaged beer produced by Carlton and United Breweries Limited and Tooth Brewery (Victoria) Pty. Ltd.;
- (ii) from the Retail Liquor Merchants' Association of Victoria to determine a minimum price for 375 ml and 750 ml bottles and cans;
- (iii) from Taspac Commercial Operations Pty. Ltd., 309 Pitt Street, Sydney, N.S.W. to determine a minimum price for 340 ml cans;
- (iv) from J. W. & B. J. Hiscock, 101F Cardigan Road, Mooroolbark, that their premises be determined to be part of the Metropolitan Area; and
- (v) from various licensees in Mildura that the municipal districts of Mildura and Mildura City be determined to be part of Country Area Group 4.

Any persons may make a submission in writing to the Commission in relation to such particular proposals or as to the intention generally. Such submissions are required to be forwarded to the Secretary of the Commission at its offices, 232 Victoria Parade, East Melbourne, 3002, not later than noon on Friday, 21 November 1980.

Before making any determination the Commission shall consider any submission or submissions received by it and shall give such weight thereto as it considers appropriate.

Any person or body of persons desiring to produce evidence before the Commission and be heard on the matters under investigation generally should notify the Commission in writing of such desire. Such notification is required to be forwarded to the Secretary of the Commission at its offices, 232 Victoria Parade, East Melbourne, 3002, not later than noon on Friday, 21 November 1980.

The Commission shall in making its determination endeavour to determine prices which shall so far as possible ensure the interests of the public generally.

J. C. KOHN  
 Deputy Secretary

**PUBLIC TRUSTEES ACT 1958, SECTION 17**

I hereby give notice that on 15 October 1980, the Public Trustee filed Elections to Administer the following deceased persons' estates in accordance with Section 17 of the *Public Trustee Act 1958*.

GIFFORD, LESLIE JOHN, late of Grieves Caravan Park, Shepparton, pensioner, died on 2 July 1980.

HOFMAN, LEOPOLD, late of Bethlehem Hospital, 476 Koo-yong Road, Caulfield, storeman, died on 11 May 1980.

JOHNSON, BRIDGET, late of Vince Paul Hostel for the aged, Strabane Avenue Box Hill North, widow, died on 6 July 1980.

JONES, FLORENCE MAY, late of 16 Spencer Street, Melbourne, home duties, died on 17 August 1980.

PARKER, ELVIE MAY, late of 85 Highett Street, Richmond, pensioner, died on 6 August 1980.

PITMAN, MELVA RUBY, late of 19 Butters Street, Reservoir, married woman, died on 1 August 1980.

REED, HAROLD BADEN, late of 154 Spensley Street, Clifton Hill, pensioner, died on 28 July 1980.

RYAN, DAPHNE, formerly of 34 Winter Street, Malvern, but late of Flat 6/5 Wattletree Road, Armadale, widow, died on 15 May 1980.

P. T. SPENCER  
 Public Trustee

168 Exhibition Street, Melbourne 3000  
 22 October 1980

Creditors, next of kin, and others having claims against the estate of any of the under-mentioned deceased persons are required to send particulars of their claims to the Public Trustee, 168 Exhibition Street, Melbourne, Vic. 3000, the personal representative, on or before 5 January 1980, after which date the Public Trustee may convey or distribute the assets having regard only to the claims of which the Public Trustee then has notice:

ALDRIDGE, ROSE MARY, late of Frew Avenue, Frankston, widow, died on 18 August 1980.

BLAIR, ANN JANE, late of Kingston Road, Heatherton, domestic worker, died on 12 July 1980.

BUCHANAN, ROBERT ANDREW, late of 310 Maroondah Highway, Ringwood, paint salesman, died on 14 July 1980.  
 BUTTIGIEG, VICTOR, late of 23 Montasell Avenue, Deer Park, driver, died on 12 December 1978.

CONTE, ASSUNTA, formerly of 206 Drummond Street, Carlton, but late of Eganstown, married woman, died on 5 July 1980.

CORRIE, FRANCIS WILLIAM, formerly of 24 Denman Avenue, Glen Iris, but late of 41 Ferndale Road, Glen Iris, retired civil servant, died on 28 July 1980.

CRABTREE, WILLIAM GORDON, late of Glenmore Park, Goroke, farmer, died on 27 June 1980.

CRAIG, HERBERT, late of Repatriation General Hospital, Banksia Street, Heidelberg, pensioner, died on 20 June 1980.

GIFFORD, LESLIE JOHN, late of Grieves Caravan Park, Shepparton, pensioner, died on 2 July 1980.

HOFMAN, LEOPOLD, late of Bethlehem Hospital, 476 Koo-yong Road, Caulfield, storeman, died on 11 May 1980.

JOHNSON, BRIDGET, late of Vince Paul Hostel for the aged, Strabane Avenue Box Hill North, widow, died on 6 July 1980.

JONES, FLORENCE MAY, late of 16 Spencer Street, Melbourne, home duties, died on 17 August 1980.

LEARY, ADA, late of 25 Boothby Street, Northcote, married woman, died on 28 August 1980.

MASTERS, DAISY KATHLEEN, formerly of Eastbourne, but late of Wellington, New Zealand, spinster, died on 5 October 1979.

MEDFORTH, MARY ALICE, formerly of 16 Green Street, Northcote, but late of Mont Park, pensioner, died on 20 June 1980.

MELODYSTA, FRIEDA, late of 10 Woodstock Street, Balclava, widow, died on 12 December 1979.

PARKER, ELVIE MAY, late of 85 Highett Street, Richmond, pensioner, died on 6 August 1980.

PITMAN, MELVA RUBY, late of 19 Butters Street, Reservoir, married woman, died on 1 August 1980.

RASMUSSEN, LEONARD CHARLES, late of 10 Falmouth Street, Hawthorn, retired P.M.G. employee, died on 29 July 1980.

REED, HAROLD BADEN, late of 154 Spensley Street, Clifton Hill, pensioner, died on 28 July 1980.

RIALL, CLIVE CECIL, late of 343 Danks Street, Middle Park, retired printer, died on 27 August 1980.

RYAN, DAPHNE, formerly of 34 Winter Street, Malvern, but late of Flat 6/5 Wattletree Road, Armadale, widow, died on 15 May 1980.

TWEEDIE, EDITH, late of 20 Langs Road, Ascot Vale, widow, died on 28 July 1980.

WALTON, EDNA VICTORIA, formerly of 194 Settlement Road, Cowes, Phillip Island, late of Delrey Private Hospital, Traralgon, widow, died on 13 July 1980.

WRIGHT, RAYMOND, late of 18 Gavin Street, Broadmeadows, gentleman, died on 17 August 1980.

Melbourne, 22 October 1980

P. T. SPENCER  
 Public Trustee

*Private Agents Act 1966*

## NOTICE OF RECEIPT OF APPLICATIONS FOR LICENCES UNDER THE PROVISIONS OF THE PRIVATE AGENTS ACT 1966

The Clerk(s) of the Magistrates' Court(s) as listed hereunder hereby give notice that applications, as under, have been lodged for hearing by the said Court(s) on the date(s) specified.

Any person desiring to object to any of such applications must—

- (a) lodge with the respective Clerk of the Magistrates' Court a notice in the prescribed form of his objection and of the grounds thereof;
- (b) cause a copy of such notice to be served personally or by post upon the applicant at least three days before the hearing of the application; and
- (c) send or deliver—
  - (i) where the objection is not made by the officer in charge of the police district in which the Court is situated—a copy of the notice to such officer; and
  - (ii) where the objection is not made by the Registrar or Deputy Registrar—a copy to the Registrar.

Full Name of Applicant*	Place of Abode of Applicant or Nominee	Name of Firm or Corporation	Address for Registration	Type of Licence	Date of Hearing
<b>MAGISTRATES' COURT, BOX HILL</b>					
Hiam, William Andrew	18 Albert Cres, Surrey Hills		c/o Donald A. Westwood, 2 George St, Mont Albert	Watchman	7.11.80
Dated at Box Hill 17 October 1980 N. T. DAVIDSON, Clerk of the Magistrates' Court					
<b>MAGISTRATES' COURT, BROADMEADOWS</b>					
Bigelow, Brian Murray	19 Darebin Blvd, Reservoir	Security Protection Pty. Ltd.	1/115 Lynch St, Fawkner	Watchman	24.11.80
Dated at Broadmeadows 20 October 1980 P. D. STREET, Clerk of the Magistrates' Court					
<b>MAGISTRATES' COURT, FOOTSCRAY</b>					
Browne, Peter Julian	2 McCarten St, Regent	Armaguard	390 St Kilda Rd, Melbourne	Watchman	11.11.80
Dated at Footscray 20 October 1980 G. WILLIAMSON, Clerk of the Magistrates' Court					
<b>MAGISTRATES' COURT, CARLTON</b>					
Michail, Raouf	28/6-8 Glen Eira Rd, Ripponlea	Michail Guard and Inquiry Agents	144 Elgin St, Carlton	Inquiry Agent	2.12.80
	" "	" "	" "	Guard Agent	"
Dated at Carlton 20 October 1980 B. J. BOLTON, Clerk of the Magistrates' Court					
<b>MAGISTRATES' COURT, CASTLEMAINE</b>					
Green, Lyle James	Coolstore Rd, Harcourt		Coolstore Rd, Harcourt	Process Server	20.11.80
Dated at Castlemaine 20 October 1980 R. W. COOK, Clerk of the Magistrates' Court					
<b>MAGISTRATES' COURT, PORT MELBOURNE</b>					
Norris, Arnel Owen	16 Horner Cl, Knoxfield	Mayne Nickless	94 York St, South Melbourne	Watchman	20.11.80
Dated at Port Melbourne 14 October 1980 S. MERBACH, Clerk of the Magistrates' Court					
<b>MAGISTRATES' COURT, PRAHRAN</b>					
Evans, Ronald Anthony	Lot 1 Henley Rd, Kangaroo Ground	Armaguard Victoria	390 St Kilda Rd, Melbourne	Watchman	7.11.80
Sargent, Kevin John	13 Fisher St, Coburg	Mayne Nickless Limited	" "	"	31.10.80
Findlay, Ian David	1/19 Prince St, Fernree Gully	" "	" "	"	7.11.80
Williams, Ian-Ernest	6 Foster St, St Kilda	" "	6 Foster St, St Kilda	Process Server	14.11.80
" " "	" "	" "	" "	Guard Agent	"
" " "	" "	" "	" "	Inquiry Agent	"
Dated at Prahran 21 October 1980 J. A. GIDLEY, Clerk of the Magistrates' Court					

\* Or in the case of a firm or corporation, of the Nominee

## PRIVATE AGENTS—continued

Full Name of Applicant*	Place of Abode of Applicant or Nominee	Name of Firm or Corporation	Address for Registration	Type of Licence	Date of Hearing
<b>MAGISTRATES' COURT, SPRINGVALE</b>					
Singleton, Rodney Frederick	19 Lorna St, Frankston	R. F. Singleton and Associates	46 Alfred St, Noble Park	Commerical Agent (Individual)	14.11.80
Dated at Springvale 21 October 1980 P. COUTTS, Clerk of the Magistrates' Court					
<b>MAGISTRATES' COURT, BALLARAT</b>					
Robertson, Gary David	36 Albion St, Sebastopol		423 Cobden St, Ballarat	Watchman	12.11.80
Dated at Ballarat 22 October, 1980 D. L. CROFT, Clerk of the Magistrates' Court					
<b>MAGISTRATES' COURT, MELBOURNE</b>					
Drew, Alan	Crystal Brook Caravan Park, Donvale	Armaguard	699 Queensberry St, North Melbourne	Watchman	25.11.80
Dunbabin, Bruce	19 Hosken St, Reservoir	"	" " "	"	"
Wilson, Wayne Rees	47 Grace St, St. Albans	TNT Group 4, Total Securities Pty. Ltd.	213 Arden St, North Melbourne	"	"
Dated at Melbourne 21 October 1980 M. J. QUIRK, Clerk of the Magistrates' Court					
<b>MAGISTRATES' COURT, FOOTSCRAY</b>					
Fisher, Dennis John (Nominee)	141 Sparks Rd, Norlane	Melbourne Markets Co-Operative Accounting Scheme Limited	Shop 11-14, 542 Footscray Rd, Footscray	Process Server	12.11.80
Dated at Footscray 21 October 1980 G. G. WILLIAMSON, Clerk of the Magistrates' Court					
<b>MAGISTRATES' COURT, SPRINGVALE</b>					
Grice, Frank John	3/70 James St, Dandenong		173 Springvale Rd, Springvale	Watchman	14.11.80
Dated at Springvale 23 October 1980 PETER COUTTS, Clerk of the Magistrates' Court					
<b>MAGISTRATES' COURT, WARRNAMBOOL</b>					
Fuhrer, Paul Anthony	Johnstone Rd, Grassmere	Wormald International Security	Belleraine St, Geelong	Watchman	17.11.80
Dated at Warrnambool 23 October 1980 P. J. LIVINGSTONE, Clerk of the Magistrates' Court					

\* Or in the case of a firm or corporation, of the Nominee

## DEPARTMENT OF MINERALS AND ENERGY

## MINING LEASE GRANTED

No. 305; Alluvial Prospectors Limited; 250.7 ha, Parishes of Clarkesdale, Dereel and Lynchfield.

## APPLICATION FOR EXPLORATION LICENCE REFUSED

No. 932; Mineral Management Pty. Ltd.; 330 km<sup>2</sup>, County of Rodney.

## EXPLORATION LICENCE CANCELLED

No. 689; Cleveland Tin Limited; 396 km<sup>2</sup>, County of Bogong.

## APPLICATION FOR SEARCH LICENCE DECLARED ABANDONED

No. 1403; Michael John Kent; 40 ha, Parish of Goongerah.

## SEARCH LICENCE GRANTED

No. 1587; Winifred Ruth Kemsley; 16 ha, Parish of Maldon.

## APPLICATION FOR TAILINGS LICENCE REFUSED

No. 4546; James Thomas Quince, Gweneth Ann Quince; to remove tailings from Browns Road situated at Smythesdale.

## TAILINGS LICENCES GRANTED

No. 4515; Brian Joseph Hollingworth, Barbara Glenis Hollingworth; to treat tailings, Parish of Huntly

No. 4582; Ronald William Dixon; to remove tailings from the "Moon and Catherine Sand Dump" situated at Eaglehawk.

## EXTRACTIVE INDUSTRY LICENCE GRANTED

No. 675-1; Thomas Wren; 3 ha, Parish of Yourang.

J. C. M. BALFOUR

Minister for Minerals and Energy

## Cemeteries Act 1958

## SCALE OF FEES OF THE FAWKNER CREMATORIUM AND MEMORIAL PUBLIC CEMETERY

In pursuance of the powers conferred upon them by the Cemeteries Act, the trustees of the Fawkner Crematorium and Memorial Public Cemetery hereby make the following scale of fees, which shall come into operation upon publication in the *Government Gazette*, and from and after such publication every scale of fees heretofore made by the said trustees shall be and is hereby rescinded to the extent to which it conflicts with this scale.

## 1. Cremation Memorial Gardens:

- A. Memorial right is for a tenure period of twenty-five years from date of purchase and fees include maintenance cost of memorials over tenure period.
- B. All memorial areas are exclusively reserved for memorialisation with special bronze plaques solely supplied and affixed in position by the Trust. Size of special bronze plaques conform to specification pre-determined by the Trust for each memorial area.
- C. Memorial fees include cost of first special bronze plaque and where memorials provide for future additional special bronze plaques and or attachments, cost of supply and installation shall be the fee prevailing at that time.

	No. of Positions	Cost
		\$
2. Memorial standard rose in concrete surround	Four	895.00
3. Memorial standard rose in garden bed—Individual position	Two	465.00
4. Memorial standard rose—garden bed position	One	245.00
5. Memorial shrub in concrete surround	Four	725.00
6. Memorial shrub/rose bush in garden bed—Individual position	Two	370.00
7. Memorial shrub/rose bush—garden bed position	One	190.00
8. Memorial ground niche in garden feature setting for two	One	340.00
9. Memorial ground niche in garden feature setting for one	One	205.00
10. Memorial wall niche for one	One	125.00
11. Memorial wall niche for four	One	350.00
12. Special Areas:		
Memorial Trees, Boulders and Garden Seats—Prices range from \$1000 to \$4500. Actual charge within price range will be made by Trustees at time of selection of memorial.		
13. Memorial Wall Niches—For One—Pine Ridge Memorial Park—Coburg	One	75.00
14. Flower containers		
A. For wall niche—when ordered with plaque		10.00
B. For wall niche—fitted after		20.00
C. Rose garden containers		25.00

## 1. Cemetery:

Lawn areas are exclusively reserved for memorialisation with special bronze plaques solely supplied and affixed in position by the Trust.

Size of special bronze plaques conform to specifications pre-determined by the Trust for each memorial area.

## 2. Lawn Areas:

	\$
A. 560 mm x 305 mm bronze plaque for one (no provision for attachment)	160.00
560 mm x 305 mm bronze plaque with 2 line detachable plate	182.00
560 mm x 305 mm bronze plaque with 3 line detachable plate	185.00
560 mm x 305 mm bronze plaque with 5 line detachable plate	192.00

## Additional charges:—

Drilling and Tapping plaque to affix additional detachable plate	9.00
2 line detachable plate	15.00
5 line detachable plate	24.00

B. 560 mm x 305 mm bronze book of life plaque—base and first page	212.00
second page	86.00

## Additional charges to A. and B.:—

Supply of cylindrical bronze flower container—Alpha	14.00
Supply of cylindrical bronze flower container—Glen	12.00
Supply of rectangular bronze flower container—Worra	24.00
Supply of cylindrical plastic flower container—Alpha	6.00
Supply of rectangular plastic flower container—Worra	7.00
Supply of cylindrical bronze flower container—Large	25.00

C. 380 mm x 280 mm bronze plaque with 8 lines	80.00
---	-------

380 mm x 280 mm bronze plaque with 8 lines with cross and crest	90.00
---	-------

380 mm x 280 mm bronze plaque with 8 lines and coloured shield	114.00
--	--------

D. 380 mm x 280 mm Non-War plaque with 6 lines and inclusion of Service Badge	88.00
---	-------

N.B.—Permission must be obtained from the Australian War Graves Commission to use services Badge before plaque can be manufactured.

## Additional charges to A, B, C, and D:—

Each additional line on bronze plaque	6.00
---------------------------------------	------

## 3. Wall Niches Plates:

## A. Engraved

141 mm x 111 mm with 3 lines	19.00
141 mm x 111 mm—Latvian—with 3 lines	42.00
143 mm x 111 mm with 3 lines	19.00
184 mm x 184 mm with 4 lines	39.00
200 mm x 200 mm with 4 lines	41.00
229 mm x 229 mm with 4 lines	59.00
260 mm x 260 mm with 4 lines	57.00
Hexagonal plate—130 mm a side—with 3 lines	52.00
Each additional line on bronze plate	4.50
Removing and refitting plaque	15.00

## Additional Engraved Inscription:—

Additional inscription on existing plaques—up to 4 lines:—	
184 mm x 184 mm	21.00
200 mm x 200 mm	22.00
229 mm x 229 mm	
260 mm x 260 mm	
Hexagonal—130 mm per side	
Additional Lines	4.50
Removing and refitting plate	15.00

## B. Cast

141 mm x 111 mm with 3 lines	18.00
143 mm x 111 mm with 3 lines	19.00
184 mm x 184 mm with 5 lines	31.00
200 mm x 200 mm with 4 lines	41.00
229 mm x 229 mm with 4 lines	61.00
260 mm x 260 mm with 4 lines	56.00
141 mm x 111 mm Soldier Niche Plate (Cast or Engraved) with 4 lines	25.00
Each additional line on bronze plate	4.50

## Additional Charges:—

B only—2 line detachable plate	15.00
A & B—Niche vase	10.00

## 4. Ground Wall Niche Plates:

A. 229 mm x 229 mm with 6 lines	57.00
B. 178 mm x 178 mm with 4 lines—Polished or plain edge	38.00
C. 229 mm x 184 mm Tree plate with 6 lines	37.00

	\$	Private Graves	\$
D. 178 mm x 178 mm Rose Tree plate with 4 lines	25.00	Land, 2.44 m x 1.22 m	20.00
Each additional line on niche plate	4.50	Land, 2.44 m x 2.44 m	40.00
2 line detachable plate	15.00	Interment fee	10.00
5. Ceramic Reproduction on 560 mm x 530 mm Bronze Plaques:		Permission to erect memorial—	
A. Supply of ceramic and frame, ordered with plaque—		Single grave	5.00
90 mm x 70 mm Rectangular Coloured Ceramic	74.00	Double grave	10.00
90 mm x 70 mm Rectangular Black and White Ceramic	54.00		
B. Supply of ceramic and frame, ordered with plaque—			
70 mm x 50 mm Oval Coloured Ceramic	67.00		
70 mm x 50 mm Oval Black and White Ceramic	48.00		
C. Ceramic reproduction only—			
90 mm x 70 mm Rectangular Coloured Ceramic	49.00		
90 mm x 70 mm Rectangular Black and White Ceramic	29.00		
D. Ceramic reproduction only—			
70 mm x 50 mm Oval Coloured Ceramic	41.00		
70 mm x 50 mm Oval Black and White Ceramic	22.00		
E. Frame for ceramic reproduction	25.00		
F. Milling plaque and attaching Oval ceramic supplied—			
90 mm x 70 mm	27.00		
70 mm x 50 mm	19.00		
Additional charges:—			
For removal and or fitting ceramic	15.00		
6. Service Plaques			
Supply and fit 2 line strip on concrete headstone at base of 380 mm x 280 mm Australian War Grave Plate	22.00		
7. Badges			
Masonic, Service or Cross—One Badge without charge when ordered with plaque.			
Others—each	6.00		
8. Motifs			
Price on Application			
9. Wooden Crosses			
Small with Plate	20.00		
Large without Plate	8.00		
10. Concrete Rests			
Large	30.00		
Small	10.00		
11. Reconditioning—Including removal and refitting plaques—			
Small	24.00		
Medium	33.00		
Large	40.00		

KEITH W. JOYCE, Trustee  
 CLIVE W. CRICK, Trustee  
 RONALD J. COOPER, Trustee  
 KEITH R. DICK, General Manager

Approval by the Governor in Council, 21 October 1980—L. G. HOUSTON, Acting Clerk of the Executive Council

Cemeteries Act 1958  
 SCALE OF FEES OF THE EAGLEHAWK PUBLIC CEMETERY

In pursuance of the powers conferred upon them by the Cemeteries Act, the trustees of the Eaglehawk Public Cemetery hereby make the following scale of fees, which shall come into operation upon publication in the *Government Gazette*, and from and after such publication every scale of fees heretofore made by the said trustees shall be and is hereby rescinded to the extent to which it conflicts with this scale.

Cemeteries Act 1958  
 SCALE OF FEES OF THE EAGLEHAWK PUBLIC CEMETERY

Monumental Section

	\$
Grave sites—	
Private ground	235.00
Private ground in special position	260.00
Sinking and re-opening—	
Adult graves	120.00
Child grave (under five years or stillborn)	20.00
Monumental fees—	
Erection of new monument	20.00
Alterations to existing monument	10.00

Lawn Section

First interment (including plaque, flower container and right to second interment)	425.00
Second interment (including plaque)	190.00

Lawn Monumental Section

First interment (including right to second interment)	475.00
Second interment	120.00

Extra Charges—Lawn and Monumental

Interment on Saturdays and Public Holidays	55.00
Interment where order is given after 3.45 p.m. on day previous to funeral	25.00
Shaping grave to fit rectangular coffin	25.00
Extra sinking charge per 0.3048 m	25.00

Memorial Wall

Niche (including plaque)	80.00
Reserved niche (including plaque)	90.00

Memorial Rose (Tenure 25 Years)

Rose in special bed with positions for two bronze plaques (plaque at ruling rate)	120.00
---	--------

Other Charges

Interment of cremated remains in grave	25.00
Exhumation (when authorised)	250.00
Search of records	6.00

The Council of the Borough of Eaglehawk—Trustees.

Cemeteries Act 1958  
 SCALE OF FEES OF THE LETHBRIDGE PUBLIC CEMETERY

In pursuance of the powers conferred upon them by the Cemeteries Act, the trustees of the Lethbridge Public Cemetery hereby make the following scale of fees, which shall come into operation upon publication in the *Government Gazette*, and from and after such publication every scale of fees heretofore made by the said trustees shall be and is hereby rescinded to the extent to which it conflicts with this scale.

Approved by the Governor in Council, 21 October 1980—L. G. HOUSTON, Acting Clerk of the Executive Council

AMENDMENT TO LIST OF CONSULAR  
REPRESENTATIVES RESIDENT IN MELBOURNE

His Excellency the Governor advises the following amendment to the list of consular representatives resident in Melbourne with effect from the date shown.

## EGYPT

A Consulate-General of the Arab Republic of Egypt has been established in Melbourne.

Mr Farouk El-Hofy, Consul, has been appointed Consul-General a.i. and Head of Post with effect from 6 September 1980.

Monday, 20 October 1980

R. J. HAMER  
Premier

## NOTICE

TO: ALL PERSONS IN THE STATE OF VICTORIA

Re: DELIVERY OF WHEAT

Take notice that, pursuant to section 9 (2) of the *Wheat Marketing Act 1979* of the State of Victoria you are required to deliver to the Australian Wheat Board (hereinafter referred to as "the Board") wheat that is in your possession on the date of gazettal of this notice.

Delivery to the Board may be made by delivering the wheat to the Board's authorised receiver.

The requirements of this notice do not apply to:

- (a) wheat retained by the grower for use on the farm where it is grown;
- (b) wheat which with the permission of the Board is delivered to a miller for gristing with the object of having the produce of the gristing returned for use on that farm;
- (c) wheat which with the permission of the Board is moved from the farm of production to an associated farm;
- (d) wheat that has been sold by the Board.

It should be noted that, pursuant to section 9 (5) of the *Wheat Marketing Act 1979* of the State of Victoria:

A person shall not—

- (i) without reasonable excuse, refuse or fail to deliver wheat to the Board as required by this notice; or
- (ii) deliver to the Board wheat that has previously been sold by the Board.

*Penalty*—\$1000 in the case of a person not being a body corporate, or \$2000 in the case of a body corporate.

*Enquiries*—For further information as to the name and address of the authorised receiver or any other information required please contact—

The State Manager, Australian Wheat Board,  
14th Floor, "Marland House",  
570 Bourke Street, Melbourne, Vic. 3000.  
Telephone: (03) 676261.

Dated at Melbourne 21 October 1980

The common seal of the Australian Wheat Board hereunto affixed, pursuant to a resolution of the Board, in the presence of—

(SEAL)

M. BOURKE, Member  
T. C. DELAHUNT, Secretary

Co-operation Act 1958  
CHANGE OF NAME OF A SOCIETY

Notice is hereby given that Bayside Turkish Community Child Care Co-operative Limited which was incorporated as a Community Advancement Society under the above-named Act on 12 March 1979, has registered a change of its name and is now incorporated under the name of Australian Turkish Association Child Care Co-operative Limited under the said Act.

Dated at Melbourne 16 October 1980

J. W. BLACKMAN  
Acting Deputy Registrar

## Co-operation Act 1958

## CHANGE OF NAME OF A SOCIETY

Notice is hereby given that 10th Dandenong North Boy Scout Co-operative Limited which was incorporated as a Community Advancement Society under the above-named Act on 16 December 1968, has registered a change of its name and is now incorporated under the name of 1st Wooranna Park Scout Co-operative Limited under the said Act.

Dated at Melbourne 9 October 1980

J. W. BLACKMAN  
Acting Deputy Registrar

## Town and Country Planning Act 1961

## EILDON RESERVOIR PLANNING SCHEME

(SHIRE OF MANSFIELD)

AMENDMENT No. 26

Notice of Amendment

In pursuance of the powers conferred by sub-section 6 of section 32 of the *Town and Country Planning Act 1961*, the Governor in Council, on 28 October 1980 amended the Eildon Reservoir Planning Scheme (Shire of Mansfield) to reserve land adjacent to Lake Eildon for the establishment of a sewage treatment plant to service Bonnie Doon.

A copy of the amendment may be inspected during office hours at the office of the Town and Country Planning Board, 235 Queen Street, Melbourne, at the office of the Council of the Shire of Mansfield at Mansfield, and when available at the Office of Titles, Melbourne and at the Central Plan Office of the Department of Crown Lands and Survey, Melbourne.

H. R. TROTTER, Acting Secretary  
Town and Country Planning Board

## Town and Country Planning Act 1961

## SHIRE OF SHERBROOKE PLANNING SCHEME 1965

AMENDMENT No. 133

Notice of Amendment

In pursuance of the powers conferred by sub-section 6 of section 32 of the *Town and Country Planning Act 1961*, the Governor in Council, on 28 October 1980 amended the Shire of Sherbrooke Planning Scheme to extend the date contained in Clause 38 of the Planning Scheme Ordinance from 31 October 1980 to 30 April 1981.

A copy of the amendment may be inspected during office hours at the office of the Town and Country Planning Board, 235 Queen Street, Melbourne, at the office of the Council of the Shire of Sherbrooke at Upwey, and when available at the Office of Titles, Melbourne and at the Central Plan Office of the Department of Crown Lands and Survey, Melbourne.

H. R. TROTTER, Acting Secretary  
Town and Country Planning Board

## CORRIGENDUM

On page 3465 of *Government Gazette*, No. 87, of 15 October 1980 under the heading—

## Town and Country Planning Act 1961

## MELBOURNE METROPOLITAN PLANNING SCHEME

REVOCATION No. 16

Notice of Revocation

In paragraph (i) after the word "being", the words "Nos. 43-45 Church Road, Keysborough" shall be deleted and substituted by the following words "4.426 hectares of land located on the north side of Church Road Keysborough commencing 129 metres east of Perry Road and having a frontage of 280 metres to Church Road."

## Police Regulation Act 1958, Section 122

## CANCELLATION OF SALE OF MOTOR CYCLE

The 1967 model Harley Davidson motor cycle Registered No. MK-175, Engine No. 4A 66546 H3 has been claimed and the public auction due to be held at the Wangaratta Police Station at 2.00 p.m. on Wednesday, 29 October 1980, has therefore been cancelled.

S. I. MILLER  
Chief Commissioner



## Police Regulation Act 1958, Section 122

## SALE OF ABANDONED MOTOR VEHICLE

A 1963 model Holden sedan motor car Registered No. HUH-731 (expired), at present in the possession of Police, has been abandoned by the owner and will be sold by public auction at 10.00 a.m. on 28 November 1980, at the Police Complex, Wellington Street, Collingwood.

S. I. MILLER  
Chief Commissioner

## Police Offences Act 1958, No. 6337

## DIVISION 1A—STATE CLASSIFICATION OF PUBLICATIONS BOARD

Take note that the State Classification of Publications Board has classified the following publications in accordance with the provisions of section 180H (1) of the Police Offences Act 1958.

Each publication shall be subject to the following restrictions:

- it shall not be offered for sale, sold, delivered, exhibited or displayed to any person under the age of 18 years;
- it shall not be made available for inspection or perusal to any person under the age of 18 years;
- it shall not be exhibited or displayed in any place to which persons under the age of 18 years have access or so that it is visible from any such place;
- it shall not be advertised in any manner whatsoever.

## SCHEDULE OF PUBLICATIONS

Title	Distributor
Aggressive Women Vol. 4 No. 6	Venus Enterprises Pty. Ltd.
Arcadia No. 15	Claredale Holdings Pty. Ltd.
Bondage Review Vol. 1 No. 2	Venus Enterprises Pty. Ltd.
Cock Sure No. 6	Claredale Holdings Pty. Ltd.
Couples—October, 1980	Gordon & Gotch (A'sia) Ltd.
Creme Vol. 1 No. 1	Claredale Holdings Pty. Ltd.
Embrace	Claredale Holdings Pty. Ltd.
Fellowes 9—The Plumbers Tool	Venus Enterprises Pty. Ltd.
Fellowes 10—The Caning Of Deidre	Venus Enterprises Pty. Ltd.
Fellowes 11 — Petunia's Punishment	Venus Enterprises Pty. Ltd.
Fellowes 12 — Trial By Enema	Venus Enterprises Pty. Ltd.
Grossband Girls International No. 1	Claredale Holdings Pty. Ltd.
Jaybird Experiences No. 8	Claredale Holdings Pty. Ltd.
Knave Vol. 12 Nos. 6 & 9	Gordon & Gotch (A'sia) Ltd.
Lesbo Lust Vol. 3 No. 4	Claredale Holdings Pty. Ltd.
Love Sisters Vol. 3 No. 2	Claredale Holdings Pty. Ltd.
Mayfair Vol. 15 No. 11	Gordon & Gotch (A'sia) Ltd.
Pleasure Seekers Vol. 3 No. 4	Claredale Holdings Pty. Ltd.
Pretty Girl Nos. 1, 2 & 3	Claredale Holdings Pty. Ltd.
Punished! Vol. 1 No. 6	Venus Enterprises Pty. Ltd.
Sexology Vol. 3 No. 4	Claredale Holdings Pty. Ltd.
Sun Era No. 32	Claredale Holdings Pty. Ltd.
Suspended! Vol. 1 No. 2	Venus Enterprises Pty. Ltd.
Teenage Jaybird No. 4	Claredale Holdings Pty. Ltd.
Teenage Nudish No. 22	Claredale Holdings Pty. Ltd.
Teenage Nymphomaniacs	Venus Enterprises Pty. Ltd.
Thrill Seekers Vol. 3 No. 4	Claredale Holdings Pty. Ltd.
Tight Ropes! Vol. 1 No. 1	Venus Enterprises Pty. Ltd.
Young Fucks	Venus Enterprises Pty. Ltd.

J. SMITH, Secretary  
State Classification of Publications Board

## Education Act 1958

## NOTICE OF THE MAKING OF ORDERS UNDER SECTION 13 (4) OF THE ACT

Pursuant to Section 13 of the Education Act 1958 I hereby give notice that Orders of the Governor in Council were made on 21 October 1980 under Sub-section (4) of the Act, amending certain provisions relating to the membership of the State Schools Councils listed below:

Ellinbank Primary School  
Frankston Technical College  
Glenroy Primary School  
Hurstbridge High School  
Mooroopna Primary School  
St Albans Special School  
Sunraysia College of T.A.F.E.  
Swift's Creek High School  
Warrambool Technical School  
Werribee Technical School

A. J. HUNT  
Minister of Education

## Education Act 1958

## NOTICE OF THE MAKING OF ORDERS UNDER SECTION 13 (4) OF THE ACT

Pursuant to Section 13 (4) of the Education Act 1958 I hereby give notice that Orders of the Governor in Council were made on 21 October 1980 rescinding previous Orders made with regard to the Constitutions of the School Councils of Nepean and Broadmeadows Special Schools.

A. J. HUNT  
Minister of Education

## Education Act 1958

## NOTICE OF THE MAKING OF AN ORDER UNDER SECTION 13 (1) OF THE ACT

Pursuant to Section 13 of the Education Act 1958 I hereby give notice that an Order of the Governor in Council was made on 21 October 1980 under sub-section (4) of the said Act constituting a Council for the Shepparton Special School.

A. J. HUNT  
Minister of Education

## Education Act 1958

## NOTICE OF THE MAKING OF ORDERS UNDER SECTION 13 (4) OF THE ACT

Pursuant to section 13 of the Education Act 1958 I hereby give notice that Orders of the Governor in Council were made on 21 October 1980 under sub-section (4) of the said Act amending certain provisions relating to the membership structures of Serpell and Whittlesea Primary School Councils.

A. J. HUNT  
Minister of Education

## Country Fire Authority Act 1958

## DECLARATION OF FIRE DANGER PERIOD

In pursuance of the powers conferred by section 4 of the Country Fire Authority Act 1958, I, Lindsay Hamilton Simpson Thompson, Minister for Police and Emergency Services, after consultation with the Minister of Forests hereby declare the following period to be the fire danger period in the municipalities or parts of municipalities specified:

31 October 1980 to 30 April 1981, inclusive throughout that part of the Shire of Rosedale between the western boundary of the Lakes National Park and the eastern boundary of the Gippsland Lakes Coastal Park.

L. H. S. THOMPSON  
Minister for Police and Emergency Services

Ministry for Police and Emergency Services  
Melbourne, 28 October 1980

**CONTRACTS ACCEPTED—(Series 1980-81)****PUBLIC WORKS**

- External repairs and painting, Laverton Primary School No. 4765, \$12 820.00—A. C. Krstev, Preston.
- Connection of hydraulic services, Brunswick Technical School No. 7065, \$12 982.00—A. & D. Kitchin, Reservoir.
- Heating to occupied premises, Building No. 1, Miller Ropeworks, Brunswick, \$109 850.00—A. E. Atherton & Sons Pty. Ltd., Thornbury.
- Air conditioning to Editing Room, Audio Visual Centre, Carlton, \$12 740.00—A. G. Coombs Contracting, Moorabbin.
- New compressor Room to existing laundry, Kew Mental Hospital, \$28 000—Ajanda Constructions Pty. Ltd., Footscray.
- Air conditioning to computer area, Russell Street Police Station, Melbourne, \$56 316.00—Alistaff Air Conditioning Pty. Ltd., Dingley.
- Supply and installation of compressed air equipment for laundry, Willsmere Hospital, Kew, \$45 980.00—Avalon Engineering Industries Pty. Ltd., Hampton Park.
- Hydraulic services, relocatables (contract 2), Ashwood Primary School No. 4698, \$11,625.00—Bayswater Septic Tanks, Bayswater.
- Supply of drawing tables, Box Hill Technical School No. 7050, \$15 880.20—Bera Furniture Pty. Ltd., Airport West.
- Supply and erection of Rangers' Residence, Yaapect, \$34 264.00—Blunts Homes, Shepparton.
- Supply and erection of Rangers' Residence, Underbool, \$34 745.00—Blunts Homes, Shepparton.
- Supply and delivery of 5 No. Primary and 25 No. Post Primary Relocatable Module Buildings, \$1 138 000.00—Bowater Tutt Industries Pty. Ltd., Ballarat.
- Supply and delivery 6 No. Relocatable Modular Buildings, F.O.G. P.W.D. Storeyard, Port Melbourne, \$238 275.00—Bowater Tutt Industries Pty. Ltd., Ballarat.
- Erection of workshop complex, Stage 1, Glenroy Technical School No. 7175, \$253 000.00—Bowden Fraser Industries Pty. Ltd., Vermont.
- Supply of kitchen equipment, 1 July 1980 to 30 June 1981, at rates—Brice Equipment Pty. Ltd., Burwood.
- Compactus units to Public Records Office, Ballarat State Government Offices, \$106 525.00—Brownbuilt Ltd., Thornbury.
- Repairs and painting, Richmond Primary School, \$42 000.00—Buckle Painting Co., South Kensington.
- Supply of kitchen equipment, 1 July 1980 to 30 June 1981, at Rates—Canteen Systems and Supplies, South Yarra.
- Additions and alterations to bathroom and laundry area, Speed, Police Station/Residence, \$20 050.00—C. & D. Troeth, Horsham.
- Supply and delivery 1 No. 2 Module Relocatable Modular Building, F.O.G. P.W.D. Storeyard, Salmon Street, Port Melbourne, Sebastopol, \$24 598.00—Cemac Associated Ltd., Reservoir.
- Supply and delivery of 1 No. Type A187 and 1 No. Type A77 Relocatable Modular Building F.O.G., Port Melbourne, Bendigo Technical College No. 7035, \$66 966.00—Cemac Associated Limited, Reservoir.
- Staff improvements and art/craft conversion, mechanical services, Chatham Primary School No. 4314, \$13 210.00—Chadstone Air Conditioning Services Pty. Ltd., Glen Waverley.
- Interior and exterior renovations, Kingsbury Technical School No. 7215, \$75 900.00—Colore Decorating Co., Reservoir.
- Supply of kitchen equipment, 1 July 1980 to 30 June 1981, at Rates—Commercial Catering Equipment Pty. Ltd., Fitzroy.
- Exterior and minor interior renovations, Lilydale High School No. 7995, \$38 850.00—Cook & Morton, Mooroolbark.
- Dredging approach to boat haven and facilities, Werribee River, \$53 292.00—Duncan & Russell (Vic.) Pty. Ltd., Footscray.
- Supply of kitchen equipment, 1 July 1980 to 30 June 1981, at Rates—Elanco Pty. Ltd., Richmond.
- Additions to PABX, Head Office, 256 Flinders Street, Melbourne, \$13 205.00—Ericsson Communications, Broadmeadows.
- Stage 2, office and laboratory complex, Knoxfield Horticultural Research Institute, \$100 972.00—E. & R. Roberts Pty. Ltd., North Dandenong.
- Supply and delivery of 5 No. Primary, 5 No. Post Primary Relocatable Modular Buildings F.O.G. Salmon Street, Port Melbourne, various sites, \$365 360.00—Everstbrook Pty. Ltd., Pascoe Vale.
- Foundation work, Warrnambool Community School, \$14 800.00—Fotheringham Constructions, Warrnambool.
- Supply of kitchen equipment, 1 July 1980 to 30 June 1981, at rates—F.S.M. Food Service Machinery, South Melbourne.
- Modifications to air conditioning, Collingwood Mid Level College, \$13 853.00—F. W. Nielson Pty. Ltd., Cheltenham.
- Secure Gardens to Ward N8, Larundel Mental Hospital, \$56 480.00—Garner The Gardener Pty. Ltd., Ringwood.
- Installation of T.V. studio and production facility, Mount Clear Technical/High School No. 7267, \$65 499.00—G.E.C. Australia Limited, Hawthorn.
- Supply of applied mechanics equipment, Collingwood Technical College, T.A.F.E., \$12 697.00—GEDGE Systems Pty. Ltd., South Melbourne.
- Supply of kitchen equipment, 1 July 1980 to 30 June 1981, at Rates—Glenross Stainless Steel Pty. Ltd., Brunswick East.
- External repairs and painting, Rosebud Primary School No. 2627, \$24 160.00—I. Bulat, North Balwyn.
- Renovations to boys' and girls' toilets (main wing), Beaumaris High School No. 7570, \$21 016.00—Ivan Kosciuk Painting and Renovating Service Pty. Ltd., Murrumbena.
- Minor alteration to residence and erection of steel framed garage, Jeparit Police Station and Residence, \$10 435.00—J. & G. Panozzo, Horsham.
- Staff accommodation improvements sick bay, stores and toilet, Tottenham Primary School No. 4707, \$37 300.00—John Toth & Co., West Sunshine.
- Replacement of fire services, St. Albans Technical School No. 7340, \$36 450.00—J. R. & B. L. Kendall, Greensborough.
- Internal renovations, Ouyen Primary School No. 3615, \$13 606.00—K. L. & E. M. Cooke, Mildura.
- Covered way, Sunbury Special School, \$11 200.00—Lewton Building Services, Carlton.
- Playing Field, St. Albans Meadows Primary School No. 5118, \$22 493.67—L. & S. Morrison, East Brighton.
- Exterior and part interior repairs and painting, Croydon South Primary School No. 4890, \$18 228.00—Mattoli Bros. (Aust.) Pty. Ltd., Burwood.
- New toilet block renovations, Prahran Primary School No. 2855, \$76 380.00—M. & J. Rawlings, Mt. Waverley.
- Supply of kitchen equipment, 1 July 1980 to 30 June 1981, at Rates—Pioneer Refrigeration Pty. Ltd., South Melbourne.
- Supply of applied mechanics equipment, Collingwood Technical College, T.A.F.E., \$36 381.00—SELBYS Scientific Ltd., Nottingham.
- Supply and installation of television studio, Huntingdale Technical School, No. 7196, \$93 100.00—Pacific Communications Pty. Ltd., South Melbourne.
- Internal and external repairs and painting, Fairfield North Primary School No. 4329, \$67 970.00—Pascoe Vale Painters Construction Co., Pascoe Vale.
- External and part internal repairs and painting, Donvale High School, No. 7777, \$29 063.00—P. E. & L. E. McNally, Beaconsfield.
- Supply and placement of bituminous concrete, Newlands High School No. 8155, at rates—Pioneer Asphalts Pty. Ltd., Clayton.
- Concrete works for "stand-by" generator room east wing roof, Police Headquarters, Russell Street, Melbourne, \$18 685.00—Polman Constructions, Coburg.

Repairs, alterations and painting, Tanjil South Primary School No. 2840, \$11 975.00—Progressive Painting Services, Ascot Vale.

Alterations, repair and painting, Hill End Primary School No. 3054, \$13 780.00—Progressive Painting Services, Ascot Vale.

Fire damage, Doveton West Primary School No. 4820, \$11 882.00—Ralph Mackie & Staff Pty. Ltd., Frankston.

Restoration of Fire Damage, Doveton Technical School No. 7120, \$39 990.00—Ralph Mackie & Staff Pty. Ltd., Frankston.

Internal and external renovations, Warrandyte Primary School No. 12, \$29 860.00—R. & M. B. Fredriksson Pty. Ltd., East Doncaster.

Supply of universal turret head milling machines, Schools and other Government Buildings, 1 July 1980 to 30 June 1981, at Rates—Scruttons Ltd., North Melbourne.

Supply of universal horizontal milling machines, Schools and other Government Buildings, 1 July 1980 to 30 June 1981, at Rates—Scruttons Ltd., North Melbourne.

Supply of swing screw cutting lathes, Schools and other Government Buildings, 1 July 1980 to 30 June 1981, at Rates—Scruttons Ltd., North Melbourne.

Supply and lay asphalt, Cobram High School No. 7725, \$27 850.00—Shepparton Asphalt Pty. Ltd., Shepparton.

Construction of crushed rock car park, Cobram High School No. 7725, \$11 875.00—Shire of Cobram, Cobram.

Internal repairs and painting to old wing, Camberwell High School No. 7680, \$36 730.00—S. M. P. & J. Ronkovich, Noble Park.

Renovations to toilet blocks, South Yarra High School, \$57 000.00—S. S. Srockovic, East Oakleigh.

Supply and installation of eleven (11) air conditioning units, Benalla High School No. 7590, \$10 263.00—State Electricity Commission, Benalla.

Recommissioning of P.A.B.X., Batman Automotive College No. 7027, North Coburg, \$15 600.00—Telecom Australia, Melbourne.

Supply of kitchen equipment, 1 July 1980 to 30 June 1981, at Rates—The Hobart Manufacturing Co. Pty. Ltd., Doncaster.

Re-leveling of the Marnoo Community Hall Slab Marnoo, Public Hall, \$11 158.00—T.J.S. Constructions Pty. Ltd., Richmond.

Supply and delivery of 1 No. Module Type 192 Relocatable Modular Building F.O.G., Salmon Street, Port Melbourne, Mt. Waverley A.V.E.C. Relocatable Building, Education Department, \$54 500.00—Tranbuild Geelong Pty. Ltd., Geelong.

Supply of drilling machines, Schools and other Government Buildings, 1 July 1980 to 30 June 1981, at Rates—Waldown Machine Tools Pty. Ltd., Abbotsford.

Electrical services, Relocatable Buildings, Preston Special Development School, \$18 834.00—Wiseman Electric Pty. Ltd., Collingwood.

D. J. LITTLE, Director-General. 27.10.80

#### CONTRACTS ACCEPTED—(Series 1980-81)

##### PUBLIC WORKS

His Excellency the Governor of the State of Victoria by and with the advice of the Executive Council thereof has by Order made on 21 October 1980 approved of the acceptance by the Minister of Public Works of the under-mentioned offers, without public tenders being invited, viz:—

Offer of Otis Elevator Company Pty Ltd for reconditioning of two passenger lifts at the Police Cadet Academy, Melbourne, for the sum of Three hundred and fifteen thousand nine hundred and fifteen dollars (\$315 915.00)—(C.191289).

Offer of Security Engineering for supply of security equipment at various schools for the sum of Nineteen thousand and fifty eight dollars seventy five cents (\$19 058.75)—(C.193217).

Offer of Shire of Cranbourne Sewerage Authority for Water Supply and Sewerage at Cranbourne Meadows Technical School for the sum of Thirty four thousand six hundred and seventy five dollars (\$34 675.00)—(PE. 19735w).

Offer of James L. Williams Pty Ltd for additional mechanical works at Pentridge Prison (Jika Jika Unit) for the sum of Fifteen thousand six hundred and forty five dollars (\$15 645.00)—(C.193407).

Offer of Ansair for Tenancy Accommodation for Citizen Council for the Victoria 150th Anniversary Celebrations for the sum of Ninety one thousand five hundred and seventy eight dollars (\$91 578.00)—(PC105730).

Offer of Consolidated Partition Industries Holdings Pty Ltd for fitting out works for Municipal Offices, Ovens Street, Wangaratta, for the sum of Twenty eight thousand five hundred and thirty four dollars (\$28 534.00)—(PN206840).

Offer of Tektronix Australia Pty Ltd for supply of electronics equipment to Collingwood Technical College for the sum of Seventeen thousand four hundred and thirty one dollars eighty cents (\$17 431.80)—(139584n).

The following offers at the amounts shown for professional services at Melbourne La Trobe Street Complex (TAFE)—(PC.190335p).

Conarg Architects and Town Planners Pty Ltd	\$16 500.00
(Architects)	
Newton Davies Partners Pty Ltd	\$18 500.00
(Quantity Surveyors)	

Offer of Ansair for Tenancy accommodation for Ministry of Transport at 35 Spring Street, Melbourne for the sum of Forty nine thousand nine hundred and eight dollars (\$49 908.00)—(PC. 192909).

L. G. HOUSTON  
Acting Clerk of the Executive Council

At the Executive Council Chamber  
Melbourne, 21 October 1980

#### CONTRACTS ACCEPTED—(Series 1980-81)

##### VICTORIAN RAILWAYS

38. Earthworks, including sub ballast course for Railway Tracks to be laid at North Geelong in the Corio Quay area and between Separation Street and Thompsons Road, Ballarat line at rates. (Contract 64913)—L. J. Wellam and Sons Pty. Ltd. 39. Manufacture, supply, delivery and commissioning of sleeper unloading equipment at rates. (Contract 64769)—Portec (Aust.) Pty. Ltd.

By order of the Victorian Railways Board  
I. J. REIHER, Secretary. 27.10.80.

#### AUCTION SALES ACT 1958

**BENALLA**—Notice is hereby given that the Annual Meeting of Justices for the Licensing of Auctioneers will be held at the Court House, Benalla, on Tuesday, 25 November 1980, at 10 o'clock in the forenoon. Dated at Benalla, 9 October 1980—T. J. NIHILL, Clerk of the Magistrates' Court, Benalla.

**EUROA**—Notice is hereby given that the Annual Meeting of Justices for the Licensing of Auctioneers will be held at the Court House, Euroa, on Tuesday, 25 November 1980, at 10 o'clock in the forenoon. Dated at Euroa 9 October 1980—T. J. NIHILL, Clerk of the Magistrates' Court, Benalla.

**MAFFRA**—Notice is hereby given that the Annual Meeting of Justices for the Licensing of Auctioneers will be held at the Magistrates' Court, Maffra, on Tuesday, 25 November 1980, at ten o'clock in the forenoon. Dated at Sale 21 October 1980—W. F. FROUDE, Clerk of the Magistrates' Court, Maffra.

**SHEPPARTON**—Notice is hereby given that the Annual Meeting of Justices for the Licensing of Auctioneers will be held at the Magistrates' Court, Shepparton, on Tuesday, 25 November 1980 at 10.00 o'clock in the forenoon. Dated at Shepparton 16 October 1980—K. T. RYAN, Clerk of the Magistrates' Court, Shepparton.

## NOTICE TO MARINERS

[No. 44 of 1980]

AUSTRALIA—VICTORIA  
AMENDMENTS TO PORT RULES

Mariners are advised that new Port Rules relative to navigation in the Port of Port Phillip are now in effect and are as follows—

- (1) Port Rule (Navigation of Hampered Vessels in Port of Port Phillip) 1980 and numbered as Port Rule 12c.
- (2) Port Rule (Navigation of South Channel, Port of Port Phillip) 1980 and numbered as Port Rule 12d. (This rule is substituted for former Port Rules 117c and 117d.)

Copies of the above Rules are available from:—

Ports and Harbors Division, 168 Exhibition Street, Melbourne 3000; or

The Government Printing Office, 7A Parliament Place, Melbourne 3002.

A. J. WAGGLEN  
Port Officer

Public Works Department  
Ports and Harbors Division  
168 Exhibition Street  
Melbourne 3000, 21 October 1980

## APPOINTMENTS AND RESIGNATIONS

### APPOINTMENTS

His Excellency the Governor of the State of Victoria, by and with the advice of the Executive Council thereof, has, by Orders made on 21 October 1980, been pleased to make the under mentioned appointments, viz:—

#### DEPARTMENT OF COMMUNITY WELFARE SERVICES Honorary Probation Officers

BARBARA AJZENBERG, 36 Goldsmith Street, Elwood,  
STEWART JAMES MCCULLOCH ANDERSON, 88 Union Street,  
Kyabram,  
REX OSCAR BAKES, Smythesdale,  
FRANCES PATRICIA BLOOD, 4/242 Forest Street, Wendouree,  
LYNETTE ANNE BOYD, 20 Loch Avenue, Ballarat,  
MARION BRADY, Invermay RSD H905, Via Ballarat,  
LYNETTE JOY CHALK, Highton Lane, (P.O. Box 83),  
Mansfield,  
MICHAEL VINCENT CLANCY, 2109 Geelong Road, Mt Helen,  
MARGARET GWEN COLLINS, 3/217 Charman Road, Cheltenham,  
GEOFFREY HERBERT CURNOW, 20 Verdon Street, Sebastopol,  
WENDY ELIZABETH DANIEL, 7 Brawn Avenue, Ballarat,  
THEODORA HELANA DEN OUDEN, 18 Verdon Street,  
Sebastopol,  
KENNETH ROBERT DONALDSON, RSD Daylesford Road,  
Pootilla,  
MARY JOY DWYER, 7 Devon Street, Ballarat,

GRAHAM JEFFREY EAGLES, 61 Fox Street, St Albans,  
SANDRA KAY FISHWICK, 619 Sherrard Street, Ballarat,  
ALBERT FRANKLAND GODDEN, Katandra West P.O.,  
SYLVIA KRISTINA GRAY, 123 Lexton Street, Ballarat,  
THOMAS JAMES HIGHAM, 15 Junction Street, Ballarat,  
JOAN MARGARET HOPE, 511A Lydiard Street North,  
Ballarat,  
JERZY TADENSZ KACZKOWSKI, 86 Cuthberts Road,  
Alfredton,  
DAVID MARTIN KENNY, 19 Mansfield Avenue, Mt Clear,  
MAXWELL KEITH KERR, Lisa Lodge, 214 Armstrong Street  
South, Ballarat,  
LARAINNE ESTER LANCASTER, 205 Sutton Street, Ballarat,  
CHRISTINA MARIA MADER, 80 Monash Street, Sunshine,  
JOHN RUSSELL MALPASS, 1 Malbec Drive, Mt Clear,  
WENDY LILLIAN NORTHEY, 14 Pleasant Street, South Ballarat,  
BEVERLEY CAROLINE PAYNE, Ardmona,  
BERNADETTE MARY QUIN, 7 Victoria Street, Numurkah,  
SUSAN WENDY ROBINSON, Home Farm, RMB 1292, Warrenbayne,  
KEVIN FREDERICK QUIN, 7 Victoria Street, Numurkah,  
ROBERT ANTHONY SHEEHAN, P.O. Box 88, Lake Bolac,  
HELEN FRANCES TAMPION, 19 Ripon Street North, Ballarat,  
GAIL TIMMERS, Tatong,  
ALBERT SEBASTION VAN DER LINDEN, 23 Clyde Lane, Ballarat,  
ELIZABETH WILLIAMSON WAUD, 22 Ponting Street, Tatura,  
PHILLIP JAMES WHEELER, 6 Regan Street, Ballarat,  
LEIGH MCPHERSON WILLIAMS, 15 Oxford Street, Wendouree, and  
MARGARET ANNE WILSON, 413 Nicholson Street, Black Hill,

to be Honorary Probation Officers, for all Adult and Children's Courts in Victoria, pursuant to the provisions of section 507 (2) of the Crimes Act 1958, and section 9 of the Children's Court Act 1973.

#### DEPARTMENT OF CROWN LANDS AND SURVEY Bailiff of Crown Lands

JAMES BROWN HUNTER,  
to be a bailiff of Crown lands, pursuant to the provisions of section 30 of the Land Act 1958, in respect of the reserved Crown lands in the Township of Mornington and Parish of Moorooduc known as the "Mornington Foreshore Reserves" and the "Mount Martha Camping Reserve", and with authority to enforce all the regulations made with respect to the care, protection and management of the said Reserves.

#### HEALTH COMMISSION

##### Trustees of Public Cemeteries

SILAS ALFRED ELLERY  
to be a Trustee of the Chewton General Cemetery, vice A. W. Baglin, resigned,  
JOHN DWYER,  
to be a Trustee of the Shepparton Public Cemetery, vice G. R. Alexander, resigned,  
MAXWELL AINLEY, and  
DONALD ARTHUR HENDER,  
to be additional Trustees of the Creswick Public Cemetery,  
BERNARD MILESI  
to be a Trustee of the Daylesford Public Cemetery, vice C. H. Menz, deceased, and  
ADRIAN JOSEPH WATT  
to be a Trustee of the Balmoral Public Cemetery, vice W. T. Byrne, deceased, pursuant to section 3 (1) of the Cemeteries Act 1958.  
THE COUNCIL OF THE MUNICIPALITY OF THE SHIRE OF COBRAM  
to be Trustees of the Cobram Public Cemetery, vice W. R. Denson, P. H. Corbett, R. Cooper, R. W. Black, J. M. Hyde, A. W. Denson, H. Dick and H. Barthelson, resigned, and  
THE COUNCIL OF THE MUNICIPALITY OF THE SHIRE OF FLINDERS  
to be Trustees of the Flinders Public Cemetery, vice J. M. Buchanan, A. Cairns, M. T. Twitty, H. Harper, E. A. Lucas, C. McKenzie and B. A. Trahair, resigned, appointed pursuant to section 3 (2) of the Cemeteries Act 1958.

*Superintendent, Children's Cottages, Kew*

ANTHONY PHILLIP JAMES JOSEPH CHANDRASEKARA, M.B., B.S., D.P.M.  
to be Superintendent, Children's Cottages, Kew, pursuant to the provisions of section 26 (1) of the *Mental Health Act 1959*, for the period 18 October 1980, to 23 November 1980, vice Dr. G. J. McBrearty, assigned higher duties.

LAW DEPARTMENT  
*Justices of the Peace*

BERNARD HENRY CLARKE, 13 Thompson Street, Terang,  
GARNET GEORGE EDWARDS, 294 Kooyong Road, Caulfield,  
JOHN BARRIE EMERTON, 22-26 Wells Street, Frankston,  
LEONARD FAIRWEATHER, Templeton Street, Guildford,  
IVY LILY HAMMOND, 13 Irvine Street, Mt. Evelyn,  
BARRY ROBERT MICHAEL HUNTER, 39 Ebb Street, Aspendale,  
BETTY NOLAN, 2/13 First Street, Black Rock,  
RONALD JOSEPH NOLAN, Harker Street, Healesville,  
ROY ALBERT POWELL, 14 Powell Street, Yarraville,  
DESMOND HAROLD STITFOLD, 260 Kooyong Road, Caulfield,  
and  
WILLIAM JAMES TURNER, 11 View Street, Glenroy,  
to be Justices of the Peace for the State of Victoria.

*Commissioners for Taking Declarations, &c.*

PETER DEAN, 19 Banool Court, Frankston,  
ROSS HANLON GIBBINS, 17 Paterson Avenue, Langwarrin,  
JAMES ALFRED GILLESPIE, 13-31 Barrett Street, Kensington,  
GARRY DAVID OATES, 121 Keys Road, Moorabbin,  
HELEN POKUSAY, 928 Mt. Alexander Road, Essendon,  
FREDERICK WILLIAM SMITH, 6 Kerrie Road, Riddells Creek,  
and  
JOSEPH BERTRAM WALLS, 4 Kerferd Road, Glen Waverley,  
to be Commissioners for taking Declarations and Affidavits under the *Evidence Act 1958*.

MINISTRY OF WATER RESOURCES AND WATER SUPPLY  
*Member of Metcalfe Recreation Area Management Committee*

CLARENCE WILLIAM NASH of Metcalfe  
to be a member of the Metcalfe Recreation Area Committee for a period of three years from the date hereof, pursuant to the Water (Metcalfe Recreation Area) Regulations 1969 (as amended by Statutory Rule No. 141 of 1977).

L. G. HOUSTON  
Acting Clerk of the Executive Council

At the Executive Council Chamber  
Melbourne, 21 October 1980

*Forests Act 1958*APPOINTMENT OF COMMITTEE OF MANAGEMENT  
OF MYERS CREEK SCENIC RESERVE

Whereas by section 50 of the *Forests Act 1958* (No. 6254), it is provided that the Minister of Forests may, on the recommendation of the Forests Commission, appoint any number of persons, not less than three, to be a Committee of Management of any land forming part of any reserved forest, such land being set aside as a Scenic Reserve, and may remove any of those persons: Now therefore I, Frederick James Granter, Her Majesty's Minister of Forests for the State of Victoria, on the recommendation of the Forests Commission, do hereby appoint—

JAMES HENRY BROUSSAND

as a member of the Committee of Management for the period until 30 June 1983, of the land forming part of the reserved forest in the Parish of Tarrawarra North, County of Evelyn, described in the accompanying Schedule, and known as "Myers Creek Scenic Reserve".

## SCHEDULE ABOVE REFERRED TO

Parish of Tarrawarra North, County of Evelyn, 83.37 hectares, more or less, being the area shown by pink colour on plan marked D over 15.5.68, on file of correspondence No. 74/2173 of the Forests Department.

Dated at Melbourne, 16 October 1980

F. J. GRANTER  
Minister of Forests

*Forests Act 1958*APPOINTMENT OF COMMITTEE OF MANAGEMENT  
OF THE MCKENZIE RIVER RESERVE

Whereas by section 50 of the *Forests Act 1958* (No. 6254), it is provided that the Minister of Forests may, on the recommendation of the Forests Commission, appoint any number of persons, not less than three, to be a Committee of Management of any land forming part of any reserved forest, such land being set aside as a Special Purpose Reserve, and may remove any of those persons: Now therefore, I, Frederick James Granter, Her Majesty's Minister of Forests for the State of Victoria, on the recommendation of the Forests Commission do hereby appoint—

CHARLES MAXWELL GRIMBLE  
VALERIE CHARLOTTE CARTER  
PETER JOHN GRAY  
GEOFFREY LANCELOT MCTAVISH  
OWEN JAMES THOMAS  
JOHN WILLIAM HEID  
PETER THOMAS LEDGAR  
JOHN DAVID GILLESPIE  
DAVID LLEWELLYN HOOKE and  
JOHN MICHAEL McDONELL

as members of the Committee of Management until 12 December 1981, of the land forming part of the reserved forest in the Parishes of Burrong North and Burrong South, County of Borung, described in the accompanying Schedule and known as "McKenzie River Reserve".

## SCHEDULE ABOVE REFERRED TO

Parishes of Burrong North and Burrong South, County of Borung, comprising 359.8 hectares, more or less, being the area shown by pink colour, on plan marked A.52/1382 over 13.12.54, on file of correspondence No. 74/1850 of the Forests Department.

Dated at Melbourne, 16 October 1980

F. J. GRANTER  
Minister of Forests

## MENTAL HEALTH ACT 1959, SECTION 26

Notice is hereby given that the following appointment has been made pursuant to the *Mental Health Act 1959*.

WILLIAM JOSEPH SERTORI—Manager, Bendigo Psychiatric Hospital and Mental Hospital as from 26 October 1980, vice P. A. Arch, promoted.

21 October 1980

G. TREVAKS, Chairman  
Health Commission of Victoria

*Liquor Control Act 1968*

## APPOINTMENT OF LICENSING INSPECTORS

Whereas on 6 February 1980, Sinclair Imrie Miller, the Chief Commissioner of Police for the State of Victoria acting pursuant to the power vested in him by Section 6A of the *Police Regulation Act 1958* delegated to me the undersigned David John Swanson being an Assistant Commissioner of Police for the said State and the person referred to in the said delegation all powers and functions vested in him by the *Liquor Control Act 1968*, from 6 February 1980, now therefore I do hereby appoint the following Officers of Police as Licensing Inspectors for the Divisions of the Police Districts as shown:—

Division Number	Police District	Rank and Name
4	Altona	Inspector Paul Harold Guest Hickman (vice Chief Inspector F. C. Dempsey)
1	Cheltenham	Inspector Barrie Hamilton Stanton (from 12.10.80 to 1.11.80)
1	Dandenong	Inspector Rex Albert Painter (from 9.11.80 to 29.11.80)
3	Heidelberg	Inspector John Beveridge Barclay (from 9.11.80 to 6.12.80)
4	Heidelberg	Inspector Cedric Herbert Victor Elmore (from 2.11.80 to 29.11.80)
1	Prahran	Inspector John Robert Calvern McIver (from 9.11.80 to 29.11.80)
4	Prahran	Inspector Graeme Francis Crawford (from 16.11.80 to 13.12.80)

23.10.1980

D. J. SWANSON  
Assistant Commissioner (Services)



## LOCAL GOVERNMENT ACT 1958

At the Executive Council Chamber, Melbourne, the  
twenty-first day of October, 1980

## PRESENT:

His Excellency the Governor of Victoria	
Mr Hunt	Mr Smith
Mr Ramsay	Mr Wood

## MAKING OF TREE RESERVE—CITY OF MELBOURNE

His Excellency the Governor of the State of Victoria, by and with the advice of the Executive Council thereof, in pursuance of the provisions of section 557 of the *Local Government Act 1958* and in compliance with a request by the Council of the City of Melbourne, hereby directs that the land shown hatched on the plan hereunder being part of Chapman Street, between Abbotsford Street and Harker Street, North Melbourne, shall be a Tree Reserve.

CITY OF MELBOURNE  
PARISH OF JIKA JIKA IN NORTH MELBOURNE  
COUNTY OF BOURKE

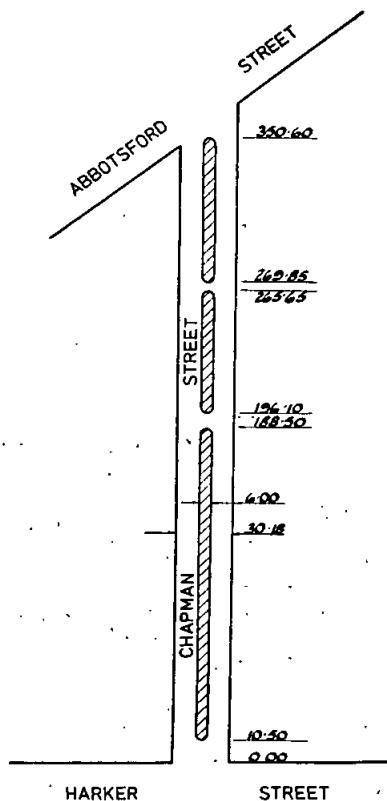

And the Honourable Digby Glen Crozier, Her Majesty's Minister for Local Government for the State of Victoria, shall give the necessary directions herein accordingly.

L. G. HOUSTON  
Acting Clerk of the Executive Council

N.B.—This Order is in lieu of that published in *Government Gazette* No. 21 of 21 March 1979.

## LOCAL GOVERNMENT ACT 1958

At the Executive Council Chamber, Melbourne, the  
twenty-first day of October, 1980

## PRESENT:

His Excellency the Governor of Victoria	
Mr Hunt	Mr Smith
Mr Ramsay	Mr Wood

## VESTING OF A RESERVE IN THE MORDIALLOC CITY COUNCIL

Whereas it is provided by section 569BA of the *Local Government Act 1958*, that where any map or plan has been lodged or deposited with the Registrar of Titles, pursuant to section 97 of the *Transfer of Land Act 1958*, or any corresponding previous enactment (whether before or after the commencement of the *Local Government Act 1963*) and any allotment on that map or plan has been transferred the Governor in Council on the request of the council of the municipality may by Order published in the *Government Gazette* direct that the whole or any part of the land comprised in any reserve shown on that map or plan shall vest in the council whereupon such land shall so vest freed and discharged from any mortgage charge lease or sub-lease.

And whereas the Council of the City of Mordialloc has requested that a reserve shown on a plan of subdivision be vested in the Council and allotments on that plan have been transferred.

Now therefore, His Excellency the Governor of the State of Victoria, by and with the advice of the Executive Council thereof, by this Order vests in the Council of the City of Mordialloc the Drainage Reserve coloured green on Plan of Subdivision No. 9647 lodged in the Office of Titles.

And the Honourable Digby Glen Crozier, Her Majesty's Minister for Local Government for the State of Victoria, shall give the necessary directions herein accordingly.

L. G. HOUSTON  
Acting Clerk of the Executive Council

## LOCAL GOVERNMENT ACT 1958

At the Executive Council Chamber, Melbourne, the  
twenty-first day of October, 1980

## PRESENT:

His Excellency the Governor of Victoria	
Mr Hunt	Mr Smith
Mr Ramsay	Mr Wood

## ROADS DISCONTINUED—CITY OF BROADMEADOWS

Whereas it is provided in section 528 (2) of the *Local Government Act 1958*, that where a road (whether or not a public highway but not being a road set out on land of the Crown) or any part thereof is not required for public use, the Governor in Council on the request of the council of the municipality in which such road is situated made not less than one month after publishing in a newspaper generally circulating in the district and posting to the registered proprietor (if any) of the land and the owners and occupiers (if any) of the lands abutting or immediately adjacent to the road notice of intention to make such a request may by Order published in the *Government Gazette* direct that such a road or part shall be discontinued and thereupon such road or part shall be discontinued accordingly.

And whereas the Council of the City of Broadmeadows has requested that the Governor in Council direct that a road between Lee Street and Lorne Street, Fawkner and part of a road off Lee Street, Fawkner be discontinued and not less than one month previously has published in a newspaper generally circulating in the district and posted to the registered proprietors of the land in the roads and to the owners and occupiers of lands abutting or immediately adjacent to the roads notice of intention to make such request.

Now therefore, His Excellency the Governor of the State of Victoria, by and with the advice of the Executive Council thereof, hereby directs:

- (a) that the said road and part of a road which are shown by hatching and cross-hatching on the plan hereunder shall be discontinued;
- (b) that notwithstanding such discontinuance the Melbourne and Metropolitan Board of Works shall continue to have and possess the same right title power authority or interest in or in relation to the whole of the land shown by hatching on the said plan as it had or possessed prior to such discontinuance with respect to or in connection with any drains or pipes laid or erected in on or over such land for the purposes of drainage or sewerage;
- (c) that notwithstanding such discontinuance the Gas and Fuel Corporation of Victoria shall continue to have and possess the same right title power authority or interest in or in relation to the whole of the land shown by cross-hatching on the said plan as it had or possessed prior to such discontinuance with respect to or in connection with any mains or pipes laid or erected in on or over such land for gas supply purposes; and
- (d) that, subject to any such right title power authority or interest the land in the said road and part of a road may be sold by the Council of the City of Broadmeadows by agreement.

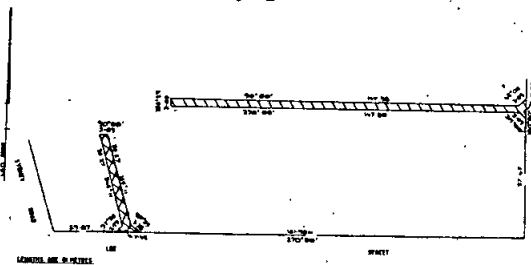

And the Honourable Digby Glen Crozier, Her Majesty's Minister for Local Government for the State of Victoria, shall give the necessary directions herein accordingly.

L. G. HOUSTON  
Acting Clerk of the Executive Council

LOCAL GOVERNMENT ACT 1958

At the Executive Council Chamber, Melbourne, the twenty-first day of October, 1980

PRESENT:

His Excellency the Governor of Victoria	
Mr Hunt	Mr Smith
Mr Ramsay	Mr Wood

ROAD DISCONTINUED—CITY OF COLAC

Whereas it is provided in section 528 (2) of the Local Government Act 1958, that where a road (whether or not a public highway but not being a road set out on land of the Crown) or any part thereof is not required for public use, the Governor in Council on the request of the council of the municipality in which such a road is situated made not less than one month after publishing in a newspaper generally circulating in the district and posting to the registered proprietor (if any) of the land and the owners and occupiers (if any) of lands abutting or immediately adjacent to the road notice of intention to make such a request may by Order published in the Government Gazette direct that such road or part shall be discontinued and thereupon such road or part shall be discontinued accordingly:

And whereas the Council of the City of Colac requested that the Governor in Council direct that a road off Murray Street, Colac be discontinued and not less than one month

previously has published in a newspaper generally circulating in the district and posted to the registered proprietor of the land in the road and to the owners and occupiers of lands abutting or immediately adjacent to the road notice of intention to make such a request:

Now therefore, His Excellency the Governor of the State of Victoria, by and with the advice of the Executive Council thereof, hereby directs that the said road which is shown by hatching on the plan hereunder, shall be discontinued and that the land may be sold by the Council of the City of Colac by agreement.

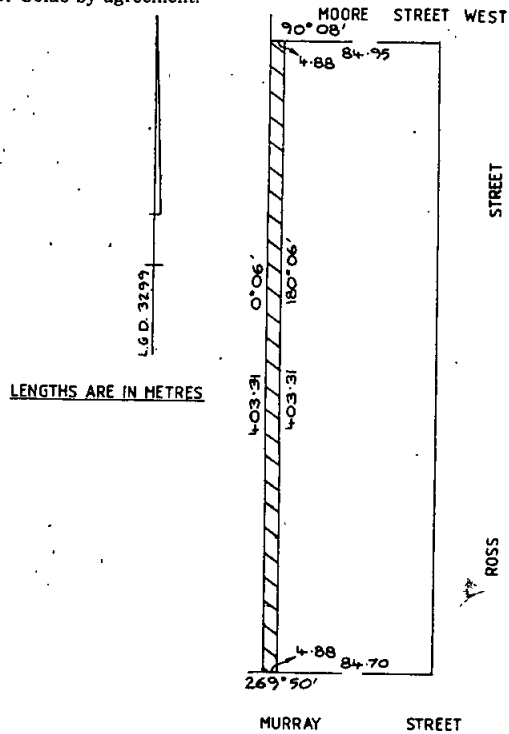

And the Honourable Digby Glen Crozier, Her Majesty's Minister for Local Government for the State of Victoria, shall give the necessary directions herein accordingly.

L. G. HOUSTON  
Acting Clerk of the Executive Council

LOCAL GOVERNMENT ACT 1958

At the Executive Council Chamber, Melbourne, the twenty-first day of October, 1980

PRESENT:

His Excellency the Governor of Victoria	
Mr Hunt	Mr Smith
Mr Ramsay	Mr Wood

ROAD DISCONTINUED—CITY OF FOOTSCRAY

Whereas it is provided in section 528 (2) of the Local Government Act 1958, that where a road (whether or not a public highway but not being a road set out on land of the Crown) or any part thereof is not required for public use the Governor in Council on the request of the council of the municipality in which such road is situated made not less than one month after publishing in a newspaper generally circulating in the district and posting to the registered proprietor (if any) of the land and the owners and occupiers (if any) of the lands abutting or immediately adjacent to the road notice of intention to make such request may by Order published in the Government Gazette



direct that such road or part thereof shall be discontinued and thereupon such road or part thereof shall be discontinued accordingly.

And whereas the Council of the City of Footscray has requested the Governor in Council direct that a road off Geelong Street, Footscray, be discontinued and not less than one month previously has published in a newspaper generally circulating in the district and posted to the registered proprietor of the land in the road and to the owners and occupiers of land abutting or immediately adjacent to the said road notice of intention to make such request.

Now therefore, His Excellency the Governor of the State of Victoria, by and with the advice of the Executive Council thereof, hereby directs:

- (a) that the said road which is shown by hatching on the plan hereunder shall be discontinued;
- (b) that notwithstanding such discontinuance the Melbourne and Metropolitan Board of Works shall continue to have and possess the same right title power authority or interest in or in relation to the whole of the land shown by hatching on the said plan as it had or possessed prior to such discontinuance with respect to or in connection with any drains or pipes laid or erected in on or over such land for the purposes of drainage or sewerage; and
- (c) that, subject to any such right title power authority or interest, the land in the said road may be sold by the Council of the City of Footscray by agreement.

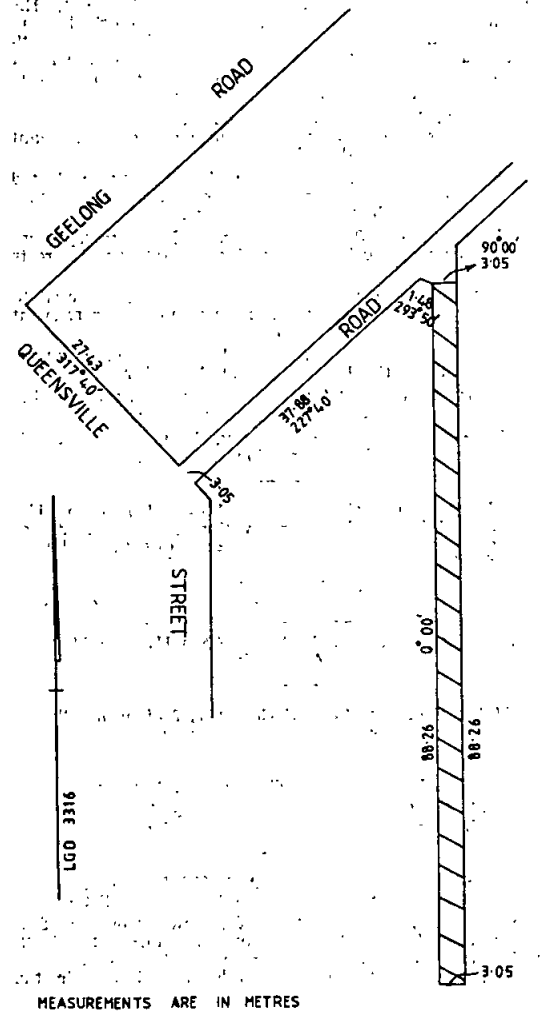

MEASUREMENTS ARE IN METRES

And the Honourable Digby Glen Crozier, Her Majesty's Minister for Local Government for the State of Victoria, shall give the necessary directions herein accordingly.

L. G. HOUSTON  
Acting Clerk of the Executive Council

COUNTRY ROADS BOARD

ACT No. 6229

At the Executive Council Chamber, Melbourne, the twenty-first day of October, 1980

PRESENT:

His Excellency the Governor of Victoria  
Mr Hunt | Mr Smith  
Mr Ramsay | Mr Wood

ORDER APPROVING OF LAND BEING ACQUIRED AND ROADS, DEVIATIONS OR WIDENINGS BEING MADE TOGETHER WITH ALL ANCILLARY WORKS REQUIRED TO BE EXECUTED IN CONJUNCTION THEREWITH

His Excellency the Governor of the State of Victoria, by and with the advice of the Executive Council thereof, being satisfied that there are funds legally available for acquiring the land, doth hereby approve the acquiring of the land described in the Schedule hereunder and the making of new roads and deviations from and widenings of existing roads, together with all ancillary works required to be executed in conjunction therewith, referred to in the said Schedule.

SCHEDULE

Unclassified Road

The land shown hatched on plans numbered G.P.15173A and G.P.15173B hereunder required for the widening of Williamstown Road in the City of Footscray and making of the widening hereon.

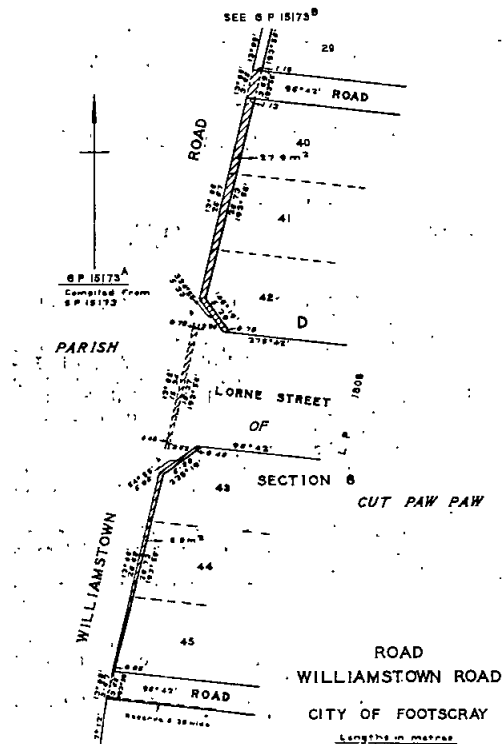

ROAD  
WILLIAMSTOWN ROAD  
CITY OF FOOTSCRAY  
Lengths in metres.

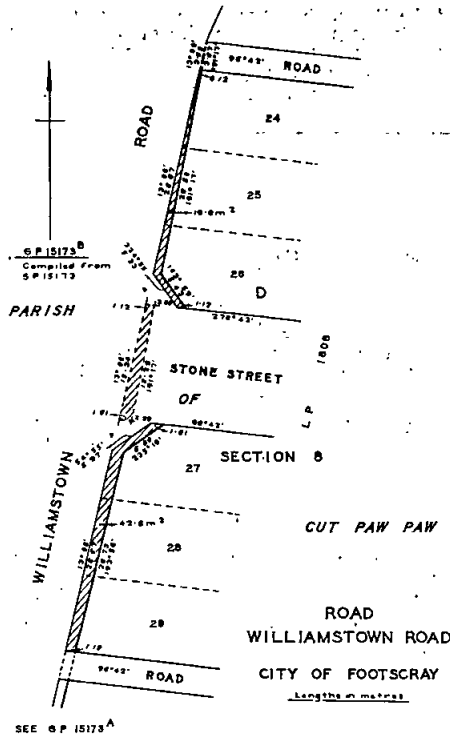

And the Honourable Robert Roy Cameron Maclellan, Her Majesty's Minister for Transport for the State of Victoria, shall give the necessary directions herein accordingly.

L. G. HOUSTON  
Acting Clerk of the Executive Council

**SOIL CONSERVATION AND LAND UTILIZATION ACT 1958**

At the Executive Council Chamber, Melbourne, the twenty-first day of October, 1980

PRESENT:

His Excellency the Governor of Victoria	
Mr Hunt	Mr Smith
Mr Ramsay	Mr Wood

**DISTRICT ADVISORY COMMITTEE—AVOCA RIVER SOIL CONSERVATION DISTRICT**

In pursuance of the powers conferred by section 15 of the Soil Conservation and Land Utilization Act, His Excellency the Governor of the State of Victoria by and with the advice of the Executive Council thereof doth hereby appoint the following persons to be members of the District Advisory Committee of the Avoca River Soil Conservation District for a term of three years.

- FRANK OSWALD SANDERSON, being a person elected to represent grazing, agricultural and other relevant interests in the District.
- ALLAN SMALL, being a person elected to represent grazing, agricultural and other relevant interests in the District.
- OLIVER RICHARD POOLE, being a person elected to represent grazing, agricultural and other relevant interests in the District.
- ALAN MORESI SCOTT, being a person elected to represent grazing, agricultural and other relevant interests in the District.
- BRYAN CLIVE CURNOW, being the person representing the Department of Agriculture.

JOHN KEMSHALL DONOVAN, being the person representing the Forests Commission Victoria.  
DENIS FRANK MARTIN, being the person representing the Soil Conservation Authority.

And the Honourable William Vasey Houghton, Her Majesty's Minister for Conservation for the State of Victoria, shall give the necessary directions herein accordingly.

L. G. HOUSTON  
Acting Clerk of the Executive Council

**SOIL CONSERVATION AND LAND UTILIZATION ACT 1958**

At the Executive Council Chamber, Melbourne, the twenty-first day of October, 1980

PRESENT:

His Excellency the Governor of Victoria	
Mr Hunt	Mr Smith
Mr Ramsay	Mr Wood

**DISTRICT ADVISORY COMMITTEE—EASTERN MALLEE SOIL CONSERVATION DISTRICT**

In pursuance of the powers conferred by section 15 of the Soil Conservation and Land Utilization Act, His Excellency the Governor of the State of Victoria by and with the advice of the Executive Council thereof doth hereby appoint the following persons to be members of the District Advisory Committee of the Eastern Mallee Soil Conservation District for a term of three years.

- GEORGE ANDREW CULLINAN, being a person elected to represent grazing, agricultural and other relevant interests in the District.
- RAYMOND FREDERICK GORMANN, being a person elected to represent grazing, agricultural and other relevant interests in the District.
- EDWARD LESLIE PAY, being a person elected to represent grazing, agricultural and other relevant interests in the District.
- GERARD MICHAEL MACKAY, being a person elected to represent grazing, agricultural and other relevant interests in the District.
- NORMAN KENNETH McSWAIN, being the person representing the Department of Agriculture.
- KEITH MCKENZIE MILLS, being the person representing the State Rivers and Water Supply Commission.
- THOMAS WILLIAM SPEEDIE, being the person representing the Soil Conservation Authority.

And the Honourable William Vasey Houghton, Her Majesty's Minister for Conservation for the State of Victoria, shall give the necessary directions herein accordingly.

L. G. HOUSTON  
Acting Clerk of the Executive Council

**SOIL CONSERVATION AND LAND UTILIZATION ACT 1958**

At the Executive Council Chamber, Melbourne, the twenty-first day of October, 1980

PRESENT:

His Excellency the Governor of Victoria	
Mr Hunt	Mr Smith
Mr Ramsay	Mr Wood

**DISTRICT ADVISORY COMMITTEE—LOWER GOULBURN SOIL CONSERVATION DISTRICT**

Whereas a vacancy exists on the Lower Goulburn Soil Conservation District Advisory Committee due to the death of Thomas Gall, being the person elected to represent grazing, agricultural and other relevant interests in the

District, now, therefore, I, the Governor of the State of Victoria, by and with the advice of the Executive Council thereof, and in pursuance of the provisions of section 15 of the Soil Conservation and Land Utilization Act do hereby appoint the following person to such vacancy for a period up to and including 11 September 1982.

JEFFREY PETER TALLIS, being a person appointed to represent grazing, agricultural and other relevant interests in the District.

And the Honourable William Vasey Houghton, Her Majesty's Minister for Conservation for the State of Victoria, shall give the necessary directions herein accordingly.

L. G. HOUSTON  
Acting Clerk of the Executive Council

SOIL CONSERVATION AND LAND UTILIZATION  
ACT 1958

At the Executive Council Chamber, Melbourne, the  
twenty-first day of October, 1980

PRESENT:

His Excellency the Governor of Victoria	
Mr Hunt	Mr Smith
Mr Ramsay	Mr Wood

DISTRICT ADVISORY COMMITTEE—MOORARBOOL  
SOIL CONSERVATION DISTRICT

In pursuance of the powers conferred by section 15 of the Soil Conservation and Land Utilization Act, His Excellency the Governor of the State of Victoria by and with the advice of the Executive Council thereof doth hereby appoint the following persons to be members of the District Advisory Committee of the Moorarbool Soil Conservation District for a term of three years.

EDWARD WILLIAM GILLESPIE, being a person elected to represent grazing, agricultural and other relevant interests in the District.

HERBERT ARTHUR BOARDMAN, being a person elected to represent grazing, agricultural and other relevant interests in the District.

JAMES GEOFFREY HENDERSON, being a person elected to represent grazing, agricultural and other relevant interests in the District.

WENDY MORRIS, being the person representing the Town and Country Planning Board.

ROBERT McDONALD MOODIE, being the person representing the Soil Conservation Authority.

And the Honourable William Vasey Houghton, Her Majesty's Minister for Conservation for the State of Victoria, shall give the necessary directions herein accordingly.

L. G. HOUSTON  
Acting Clerk of the Executive Council

SOIL CONSERVATION AND LAND UTILIZATION ACT  
1958

At the Executive Council Chamber, Melbourne, the  
twenty-first day of October, 1980

PRESENT:

His Excellency the Governor of Victoria	
Mr Hunt	Mr Smith
Mr Ramsay	Mr Wood

DISTRICT ADVISORY COMMITTEE—NORTHERN  
WIMMERA SOIL CONSERVATION DISTRICT

In pursuance of the powers conferred by section 15 of the Soil Conservation and Land Utilization Act, His Excellency the Governor of the State of Victoria, by and with the advice of the Executive Council thereof doth hereby appoint

the following persons to be members of the District Advisory Committee of the Northern Wimmera Soil Conservation District for a term of three years.

VICTOR GEORGE CHAMPNESS, being a person elected to represent grazing, agricultural and other relevant interests in the District.

ALEXANDER HENRY LAVERTY, being a person elected to represent grazing, agricultural and other relevant interests in the District.

LLOYD GEORGE ATKIN, being a person elected to represent grazing, agricultural and other relevant interests in the District.

FRANK NORMAN PITT, being a person elected to represent grazing, agricultural and other relevant interests in the District.

OSWALD CARL PIETSCH, being a person elected to represent grazing, agricultural and other relevant interests in the District.

DEREK DYKSTRA, being the person representing the Department of Agriculture.

IAN RICHARD MCALPIN, being the person representing the Soil Conservation Authority.

And the Honourable William Vasey Houghton, Her Majesty's Minister for Conservation for the State of Victoria, shall give the necessary directions herein accordingly.

L. G. HOUSTON  
Acting Clerk of the Executive Council

SOIL CONSERVATION AND LAND UTILIZATION  
ACT 1958

At the Executive Council Chamber, Melbourne, the  
twenty-first day of October, 1980

PRESENT:

His Excellency the Governor of Victoria	
Mr Hunt	Mr Smith
Mr Ramsay	Mr Wood

DISTRICT ADVISORY COMMITTEE—CAMPASPE SOIL  
CONSERVATION DISTRICT

In pursuance of the powers conferred by section 15 of the Soil Conservation and Land Utilization Act, His Excellency the Governor of the State of Victoria by and with the advice of the Executive Council thereof doth hereby appoint the following persons to be members of the District Advisory Committee of the Campaspe Soil Conservation District for a term of three years.

RALPH FREDERICK LUDEMAN, being a person elected to represent grazing, agricultural and other relevant interests in the District.

WILLIAM ISAAC BELL, being a person elected to represent grazing, agricultural and other relevant interests in the District.

DESMOND JOHN KNIGHT, being a person elected to represent grazing, agricultural and other relevant interests in the District.

DONALD NEIL LOWNDES, being a person elected to represent grazing, agricultural and other relevant interests in the District.

IAN JOSEPH JOHNSON, being a person elected to represent grazing, agricultural and other relevant interests in the District.

IAN SMITH, being the person representing the Department of Agriculture.

ALISTAIR ARGYLE STIRLING, being the person representing the Soil Conservation Authority.

And the Honourable William Vasey Houghton, Her Majesty's Minister for Conservation for the State of Victoria, shall give the necessary directions herein accordingly.

L. G. HOUSTON  
Acting Clerk of the Executive Council

**SOIL CONSERVATION AND LAND UTILIZATION ACT 1958**

At the Executive Council Chamber, Melbourne, the twenty-first day of October, 1980

PRESENT:

His Excellency the Governor of Victoria  
 Mr Hunt | Mr Smith  
 Mr Ramsay | Mr Wood

**DISTRICT ADVISORY COMMITTEE—UPPER GOULBURN SOIL CONSERVATION DISTRICT**

In pursuance of the powers conferred by section 15 of the Soil Conservation and Land Utilization Act, His Excellency the Governor of the State of Victoria by and with the advice of the Executive Council thereof doth hereby appoint the following persons to be members of the District Advisory Committee of the Upper Goulburn Soil Conservation District for a term of three years.

PETER OWEN MILLER, being a person elected to represent grazing, agricultural and other relevant interests in the District.

KENNETH WEBB WARE, being a person elected to represent grazing, agricultural and other relevant interests in the District.

GEOFFREY AUSTIN SCOTT, being a person elected to represent grazing, agricultural and other relevant interests in the District.

JAMES JOSEPH TEHAN, being a person elected to represent grazing, agricultural and other relevant interests in the District.

JOHN MONTGOMERY, being the person representing the Department of Agriculture.

HARRY BARNETT PREWETT, being the person representing the Forests Commission.

ROBERT FRANCIS CHAFFE, being the person representing the Soil Conservation Authority.

And the Honourable William Vasey Houghton, Her Majesty's Minister for Conservation for the State of Victoria, shall give the necessary directions herein accordingly.

L. G. HOUSTON  
 Acting Clerk of the Executive Council

**SOIL CONSERVATION AND LAND UTILIZATION ACT 1958**

At the Executive Council Chamber, Melbourne, the twenty-first day of October, 1980

PRESENT:

His Excellency the Governor of Victoria  
 Mr Hunt | Mr Smith  
 Mr Ramsay | Mr Wood

**DISTRICT ADVISORY COMMITTEE—UPPER LODDON SOIL CONSERVATION DISTRICT**

In pursuance of the powers conferred by section 15 of the Soil Conservation and Land Utilization Act, His Excellency the Governor of the State of Victoria, by and with the advice of the Executive Council thereof doth hereby appoint the following persons to be members of the District Advisory Committee of the Upper Loddon Soil Conservation District for a term of three years.

ROBERT MAXWELL NICHOLSON, being a person elected to represent grazing, agricultural and other relevant interests in the District.

GRAEME STANLEY HURST MILLER, being a person elected to represent grazing, agricultural and other relevant interests in the District.

FRANKLIN THOMAS LONGMIRE, being a person elected to represent grazing, agricultural and other relevant interests in the District.

KENNETH O'CONNELL, being a person elected to represent grazing, agricultural and other relevant interests in the District.

REGINALD KINNERSLY, being a person elected to represent grazing, agricultural and other relevant interests in the District.

BEN JOSEPH MCCONCHIE, being the person representing the Department of Agriculture.

BRUCE JAMIESON OSBORN, being the person representing the Soil Conservation Authority.

And the Honourable William Vasey Houghton, Her Majesty's Minister for Conservation for the State of Victoria, shall give the necessary directions herein accordingly.

L. G. HOUSTON  
 Acting Clerk of the Executive Council

**CROWN LAND (RESERVES) ACT 1978**

At the Executive Council Chamber, Melbourne, the twenty-first day of October, 1980

PRESENT:

His Excellency the Governor of Victoria  
 Mr Hunt | Mr Smith  
 Mr Ramsay | Mr Wood

**CROWN LANDS TEMPORARILY RESERVED**

His Excellency the Governor of the State of Victoria, in the Commonwealth of Australia, by and with the advice of the Executive Council of the said State, pursuant to the provisions of sections 4 and 7 of the Crown Land (Reserves) Act 1978, and being of the opinion that the Crown lands concerned are required for the public purposes mentioned, doth hereby temporarily reserve and also except from occupation for mining purposes under any miner's right, the Crown lands hereinafter described, viz.:

CASTLEMAINE—For Departmental Residence, 1233 square metres, being Crown allotment 21, section 140, Township of Castlemaine, as indicated by hatching on plan hereunder—(C.99(\*) (Rs.10948).

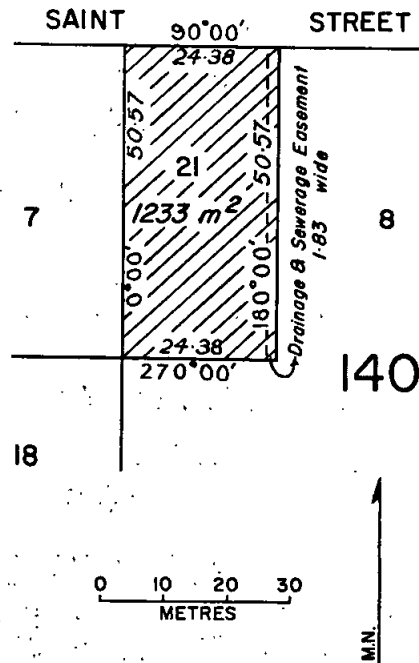

MARYBOROUGH—For Police purposes, 637 square metres, being Crown allotment 27A, section 21A, Parish of Maryborough, as indicated by hatching on plan hereunder—(M.66<sup>(18)</sup>) (Rs.10953).

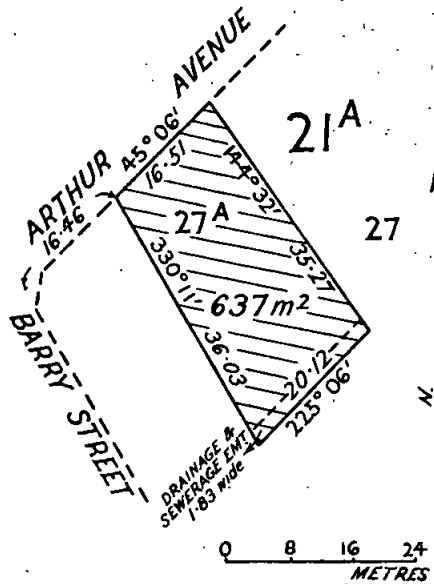

MOONDARRA—For Police purposes, 2550 square metres, being Crown allotment 4p, section B, Parish of Moondarra, as shown on Certified Plan No. 104670 lodged in the Central Plan Office—(M.508<sup>(5)</sup>) (Rs.10488).

NHILL—For Educational Department purposes, 5.139 hectares, being Crown allotment 26A, section 25, Township of Nhill, as shown on Certified Plan No. 104703 lodged in the Central Plan Office—(N.102<sup>(4)</sup>) (Rs.4446).

YUROKE—For Department of Community Welfare Services purposes, 46.5 hectares, more or less, being Crown allotment 1, section 1, Parish of Yuroke, as indicated by hatching on plan hereunder—(Y.74<sup>(4)</sup>) (Rs.11494).

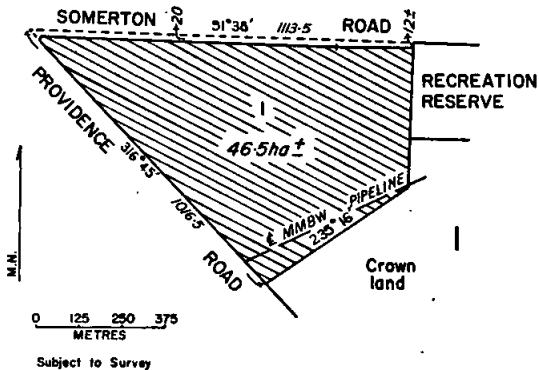

And the Honourable William Vasey Houghton, Her Majesty's Minister of Lands for the State of Victoria, shall give the necessary directions herein accordingly.

L. G. HOUSTON  
Acting Clerk of the Executive Council

CROWN LAND (RESERVES) ACT 1978

At the Executive Council Chamber, Melbourne, the twenty-first day of October, 1980

PRESENT:

His Excellency the Governor of Victoria	
Mr Hunt	Mr Smith
Mr Ramsay	Mr Wood

CROWN LANDS TEMPORARILY RESERVED

His Excellency the Governor of the State of Victoria, in the Commonwealth of Australia, by and with the advice of the Executive Council of the said State, pursuant to the provisions of sections 4 and 7 of the Crown Land (Reserves) Act 1978, and being of the opinion that the Crown lands concerned are required for the purposes respectively mentioned, doth hereby temporarily reserve and also except from occupation for mining purposes under any miner's right, the Crown lands hereinafter described, viz.:

COHUNA—For Public Hall, 4051 square metres, being Crown allotment 1A, section B, Parish of Cohuna, as shown on Certified Plan No. 103690 lodged in the Central Plan Office—(Rs.11505).

MARAMINGO—For Public Recreation, 5.275 hectares, being Crown allotment 13E, section A, Parish of Maramingo, as shown on Certified Plan No. 104700 lodged in the Central Plan Office—(M.547<sup>(4)</sup>) (Rs.10649).

MURCHISON NORTH—For Water Supply purposes, 2.336 hectares, being Crown allotment 69A, Parish of Murchison North, as indicated by hatching on plan hereunder—(M.273<sup>(10)</sup>) (Rs.11206).

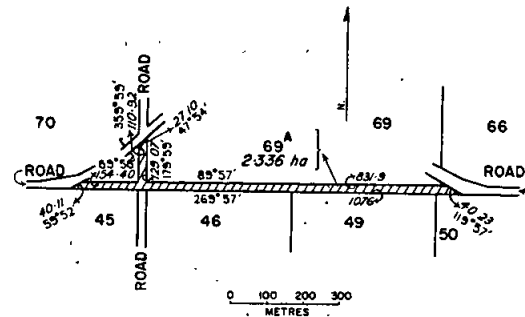

And the Honourable William Vasey Houghton, Her Majesty's Minister of Lands for the State of Victoria, shall give the necessary directions herein accordingly.

L. G. HOUSTON  
Acting Clerk of the Executive Council

CROWN LAND (RESERVES) ACT 1978

At the Executive Council Chamber, Melbourne, the twenty-first day of October, 1980

PRESENT:

His Excellency the Governor of Victoria	
Mr Hunt	Mr Smith
Mr Ramsay	Mr Wood

REVOCATION OF TEMPORARY RESERVATIONS OF LANDS BY ORDERS IN COUNCIL

His Excellency the Governor of the State of Victoria, in the Commonwealth of Australia, by and with the advice of the Executive Council of the said State, pursuant to the

provisions of section 10 of the Crown Land (Reserves) Act 1978, doth hereby revoke the temporary reservations of lands by Orders in Council hereinafter described, viz.:

**BRUTHEN**—The temporary reservation by Order in Council of 24 September 1912 of 4047 square metres of land in the Township of Bruthen as a site for Public purposes—(B.790<sup>(\*)</sup>) (Rs.1670).

**CARRARAGARMUNGEE**—The temporary reservation by Order in Council of 14 June 1898 of 9358 square metres of land in the Parish of Carraragarmungee (in section 8A) as a site for Water Supply purposes—(L.8-1406).

**NEWMERELLA**—The temporary reservation by Order in Council of 7 March 1961 of 59.89 hectares, more or less, of land in the Parish of Newmerella (in section C) as a site for Public Recreation—(Rs.8016).

**CASTLEMAINE**—The temporary reservation by Order in Council of 23 August 1966 of 2.832 hectares, more or less, of land in the Township of Castlemaine, as a site for Public Recreation, so far only as the portion thereof containing 1140 square metres, more or less, as defined by description and hatching on plan published in the Government Gazette dated 1 October 1980, is concerned—(C.99<sup>(\*)</sup>) (Rs.8634).

**HAMILTON NORTH**—The temporary reservation by Order in Council of 27 October 1970 of 1.128 hectares of land in the Parish of Hamilton North as a site for Public Purposes (Trigonometrical Survey Station), so far only as the portion thereof containing 7323 square metres, as defined

by description and hatching on plan published in the Government Gazette dated 1 October 1980, is concerned—(H.46<sup>(\*)</sup>) (Rs.9293).

**PURRUMBETE NORTH**—The temporary reservation as a site for affording access to Water and the withholding from sale, leasing and licensing by Order in Council of 28 November 1881 of 26.22 hectares of land in the Parish of Purrumbete North, revoked as to part by Order of 12 February 1980, so far as the balance thereof containing 23.17 hectares, is concerned—(P.100<sup>(\*)</sup>) (Rs.9787).

**SANDHURST (AT EAGLEHAWK)**—The temporary reservation as a site for Storm Water Channel and the withholding from sale, leasing and licensing by Order in Council of 11 February 1878 of 1.796 hectares of land at Eaglehawk, Parish of Sandhurst (called municipal district of Eaglehawk in Order), revoked as to part by various Orders, so far only as the portion thereof containing 9400 square metres, more or less, as defined by description and hatching on plan published in the Government Gazette dated 1 October 1980, is concerned—(Parish 3473-3) (Rs.6900).

And the Honourable William Vasey Houghton, Her Majesty's Minister of Lands for the State of Victoria, shall give the necessary directions herein accordingly.

L. G. HOUSTON  
Acting Clerk of the Executive Council

LAND ACT 1958

At the Executive Council Chamber, Melbourne, the twenty-first day of October, 1980

PRESENT:

His Excellency the Governor of Victoria  
Mr Hunt | Mr Smith  
Mr Ramsay | Mr Wood

UNUSED ROADS CLOSED

His Excellency the Governor of the State of Victoria, in the Commonwealth of Australia, by and with the advice of the Executive Council of the said State, pursuant to the provisions of section 349 of the Land Act 1958, and with the concurrence in writing of the council of the municipality concerned and that of any adjoining land owners, doth hereby close the unused roads hereinafter described, viz.:

Municipal District of the City of Hamilton, Township of Hamilton, being the roads indicated by hatching on plan hereunder—(H.45<sup>(\*)</sup>) (L.2-357).

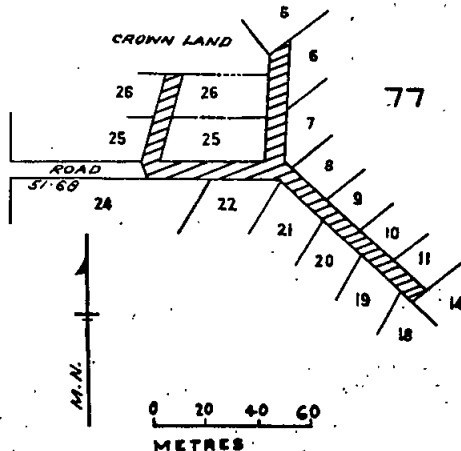

Municipal District of the Shire of Alberton, Parish of Willung, being the road indicated by hatching on plan hereunder—(W.342<sup>(\*)</sup>) (H.O.35957).

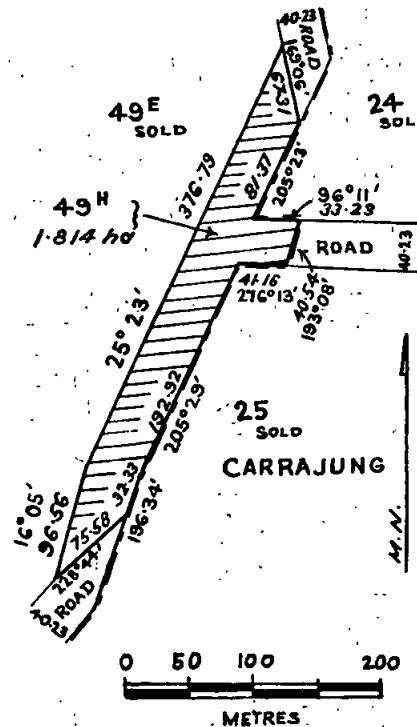

Municipal District of the Shire of Portland, Parishes of Glenaulin and Hotspur, being the roads indicated by hatching on plan hereunder—(G.89<sup>(a)</sup>) (H.104<sup>(a)</sup>) (C.101033).

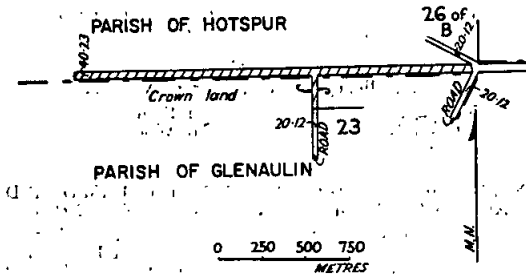

And the Honourable William Vasey Houghton, Her Majesty's Minister of Lands for the State of Victoria, shall give the necessary directions herein accordingly.

L. G. HOUSTON  
Acting Clerk of the Executive Council

#### HOSPITALS AND CHARITIES ACT 1958

At the Executive Council Chamber, Melbourne, the twenty-first day of October, 1980.

PRESENT:

His Excellency the Governor of Victoria

Mr Hunt	Mr Smith
Mr Ramsay	Mr Wood

Whereas by sub-section (1) of section 63A of the *Hospitals and Charities Act 1958*, the Governor in Council may by order published in the *Government Gazette* add the name of a subsidized incorporated institution to, or delete the name of an institution from, Table A in the Fifth Schedule.

Now therefore His Excellency the Governor of the State of Victoria in the Commonwealth of Australia, by and with the advice of the Executive Council of the said State, doth by this order delete the names of the following institutions from Table A in the Fifth Schedule of the *Hospitals and Charities Act 1958*:—

Boort District Hospital  
Grace McKellar House—Geelong  
Hamilton Base Hospital  
Kingston Centre  
Maffra District Hospital  
Mount Royal Hospital  
Queen Elizabeth Geriatric Centre, The  
Royal Talbot General Rehabilitation Hospital  
Yea and District Memorial Hospital  
Woorayl District Memorial Hospital  
Yarram and District Hospital

And, the Honourable William Archibald Borthwick, Her Majesty's Minister of Health for the State of Victoria, shall give the necessary directions herein accordingly.

L. G. HOUSTON  
Acting Clerk of the Executive Council

#### STATE EMPLOYEES RETIREMENT BENEFITS ACT 1979

At the Executive Council Chamber, Melbourne, the twenty-first day of October, 1980.

PRESENT:

His Excellency the Governor of Victoria	
Mr Hunt	Mr Smith
Mr Ramsay	Mr Wood

Whereas the *State Employees Retirement Benefits Act 1979* provides that an employee means *inter alia* any person who is not an officer within the meaning of the *Superannuation Act 1958* who holds any office as a member or of a class of persons who are members or in the service or employment of any body created by or under any Act of

Parliament to which person or office or class of persons the Governor in Council, on the recommendation of the Treasurer, by Order published in the *Government Gazette* declares that the provisions of the *State Employees Retirement Benefits Act 1979* shall apply; And whereas the Treasurer has recommended that the provisions of the said Act shall apply to all those staff of the Discharged Servicemen's Employment Board and officers and employees of the Victorian Government Travel Authority who are not eligible for membership of the State Superannuation Fund; Now therefore the Governor of the State of Victoria, acting by and with the advice of the Executive Council thereof doth hereby declare that the provisions of the *State Employees Retirement Benefits Act 1979* shall apply to the aforesaid classes of persons, as and from 1 November 1980.

And the Honourable Lindsay Hamilton Simpson Thompson, Her Majesty's Treasurer for the State of Victoria, shall give the necessary directions herein accordingly.

L. G. HOUSTON  
Acting Clerk of the Executive Council

#### ZOOLOGICAL PARKS AND GARDENS ACT 1967

At the Executive Council Chamber, Melbourne, the twenty-first day of October, 1980.

PRESENT:

His Excellency the Governor of Victoria	
Mr Hunt	Mr Smith
Mr Ramsay	Mr Wood

In pursuance of the powers conferred by the *Zoological Parks and Gardens Act 1967*, and all other powers him thereunto enabling, His Excellency the Governor of the State of Victoria, by and with the advice of the Executive Council thereof doth hereby appoint Allan James Watson to be a member of the Zoological Board of Victoria for the period ending 16 May 1981 (vice Maurice Ress) or such prior date as he ceases to be a councillor of the City of Melbourne.

And the Honourable William Vasey Houghton, Her Majesty's Minister for Conservation for the State of Victoria, shall give the necessary directions herein accordingly.

L. G. HOUSTON  
Acting Clerk of the Executive Council

#### WORKERS COMPENSATION ACT 1958

At the Executive Council Chamber, Melbourne, the twenty-first day of October, 1980.

PRESENT:

His Excellency the Governor of Victoria	
Mr Hunt	Mr Smith
Mr Ramsay	Mr Wood

#### WORKERS COMPENSATION BOARD—APPOINTMENT OF LAY MEMBER

In pursuance of the powers conferred by section 80 of the *Workers Compensation Act 1958*, and all other powers him thereunto enabling, His Excellency the Governor of the State of Victoria, by and with the advice of the Executive Council thereof, doth by this Order appoint—

GEORGE HARVEY NICHOLSON  
to be a lay member of the Workers Compensation Board for the period from 28 October 1980 to 2 June 1982, both dates inclusive.

And the Honourable James Halford Ramsay, Her Majesty's Minister of Labour and Industry for the State of Victoria, shall give the necessary directions herein accordingly.

L. G. HOUSTON  
Acting Clerk of the Executive Council

## HISTORIC BUILDINGS ACT 1974 (No. 8569)

At the Executive Council Chamber, Melbourne, the  
twenty-first day of October, 1980

## PRESENT:

His Excellency the Governor of Victoria	
Mr Hunt	Mr Smith
Mr Ramsay	Mr Wood

## AMENDMENT OF REGISTER OF HISTORIC BUILDINGS

Whereas it is provided by section 3 of the *Historic Buildings Act 1974* that the Governor in Council, on the recommendation of the Minister, may by notice published in the *Government Gazette*, amend the Register of Historic Buildings established under the said Act—

- (a) by adding any specified building;
- (b) by removing any specified building; or
- (c) by altering any item.

And whereas the Minister has recommended that the Register be amended.

Now therefore His Excellency the Governor of the State of Victoria, by and with the advice of the Executive Council thereof, doth hereby amend the Register of Historic Buildings in the manner and to the extent shown as follows: by adding—

"Historic Building No. 479: 'Pholiota', 23 Glennard Drive, Eaglemont."

And the Honourable Louis Stuart Lieberman, Her Majesty's Minister for Planning for the State of Victoria, shall give the necessary directions herein accordingly.

L. G. HOUSTON  
Acting Clerk of the Executive Council

## HASTINGS SEWERAGE AUTHORITY

At the Executive Council Chamber, Melbourne, the  
twenty-first day of October, 1980

## PRESENT:

His Excellency the Governor of Victoria	
Mr Hunt	Mr Smith
Mr Ramsay	Mr Wood

## EXTENT OF SEWERAGE DISTRICT INCREASED AND APPROVAL OF SITE FOR TREATMENT WORKS

Under the powers conferred by the *Sewerage Districts Act* and all other powers enabling him in that behalf, His Excellency the Governor of the State of Victoria, by and with the advice of the Executive Council of the said State, doth hereby:

- (a) declare, order and direct that the extent of the Sewerage District of the Hastings Sewerage Authority be increased by adding thereto the land as shown by red colour on the plan approved by the Governor in Council by and with this Order and deposited in the office of the State Rivers and Water Supply Commission, Melbourne. (Corr. No. 80/1096/13) and as on and from the date hereof the extent of such District shall be deemed to be increased accordingly; and
- (b) approve of the site required for a temporary treatment works as shown by brown colour on the aforementioned plan.

And the Honourable Frederick James Granter, Her Majesty's Minister of Water Supply for the State of Victoria, shall give the necessary directions herein accordingly.

L. G. HOUSTON  
Acting Clerk of the Executive Council

## PORTLAND HARBOR TRUST ACT 1958 No. 6340

At the Executive Council Chamber, Melbourne, the  
twenty-first day of October, 1980

## PRESENT:

His Excellency the Governor of Victoria	
Mr Hunt	Mr Smith
Mr Ramsay	Mr Wood

Whereas His Excellency the Governor of the State of Victoria by and with the advice of the Executive Council thereof has this day consented pursuant to the provisions of the *Portland Harbor Trust Act 1958* to the Portland Harbor Trust Commissioners raising by way of a loan the sum of One hundred and ninety-two thousand dollars (\$192 000).

And whereas the Governor in Council is satisfied that a sufficient proportion of the loan to be raised will fall due and be repaid in each year during the currency of the proposed loan.

Now therefore it is directed pursuant to the provisions of section 33 (3) of the said Act, that it shall not be necessary to provide a sinking fund in connection with such loan.

And the Honourable Lindsay Hamilton Simpson Thompson, Her Majesty's Treasurer for the State of Victoria, shall give the necessary directions herein accordingly.

L. G. HOUSTON  
Acting Clerk of the Executive Council

## HASTINGS SEWERAGE AUTHORITY

At the Executive Council Chamber, Melbourne, the  
twenty-first day of October, 1980

## PRESENT:

His Excellency the Governor of Victoria	
Mr Hunt	Mr Smith
Mr Ramsay	Mr Wood

## EXTENT OF SEWERAGE DISTRICT INCREASED

Under the powers conferred by the *Sewerage Districts Act* and all other powers enabling him in that behalf, His Excellency the Governor of the State of Victoria, by and with the advice of the Executive Council of the said State, doth hereby declare, order and direct that the extent of the Sewerage District of the Hastings Sewerage Authority be increased by adding thereto the land as shown by red colour on the plan approved by the Governor in Council by and with this Order and deposited in the office of the State Rivers and Water Supply Commission, Melbourne (Corr. No. 80/1096/12) and as on and from the date hereof the extent of such District shall be and be deemed to be increased accordingly.

And the Honourable Frederick James Granter, Her Majesty's Minister of Water Supply for the State of Victoria, shall give the necessary directions herein accordingly.

L. G. HOUSTON  
Acting Clerk of the Executive Council



## BAIRNSDALE WATERWORKS TRUST

At the Executive Council Chamber, Melbourne, the  
twenty-eighth day of October, 1980

## PRESENT:

His Excellency the Governor of Victoria	
Mr Haddon Storey	Mr Granter
Mr Jona	Mr Lacy

## CONSENT TO BORROWING \$150 000

Under the powers conferred by the Water Act and all other powers enabling him in that behalf, His Excellency the Governor of the State of Victoria, by and with the advice of the Executive Council of the said State, hereby consents to the Bairnsdale Waterworks Trust borrowing the sum of One hundred and fifty thousand dollars (\$150 000) to meet the cost of water supply works.

And the Honourable Frederick James Granter, Her Majesty's Minister of Water Supply for the State of Victoria, shall give the necessary directions herein accordingly.

L. G. HOUSTON  
Acting Clerk-of-the Executive Council

## HORSHAM WATERWORKS TRUST

At the Executive Council Chamber, Melbourne, the  
twenty-eighth day of October, 1980

## PRESENT:

His Excellency the Governor of Victoria	
Mr Haddon Storey	Mr Granter
Mr Jona	Mr Lacy

## CONSENT TO BORROWING \$100 000

Under the powers conferred by the Water Act and all other powers enabling him in that behalf, His Excellency the Governor of the State of Victoria, by and with the advice of the Executive Council of the said State, hereby consents to the Horsham Waterworks Trust borrowing the sum of One hundred thousand dollars (\$100 000) to meet the cost of water supply works.

And the Honourable Frederick James Granter, Her Majesty's Minister of Water Supply for the State of Victoria, shall give the necessary directions herein accordingly.

L. G. HOUSTON  
Acting Clerk of the Executive Council

## GEELONG WATERWORKS AND SEWERAGE TRUST

At the Executive Council Chamber, Melbourne, the  
twenty-eighth day of October, 1980

## PRESENT:

His Excellency the Governor of Victoria.	
Mr Haddon Storey	Mr Granter
Mr Jona	Mr Lacy

## CONSENT TO BORROWING \$50 000

Under the powers conferred by the Geelong Waterworks and Sewerage Act and all other powers enabling him in that behalf, His Excellency the Governor of the State of Victoria, by and with the advice of the Executive Council

No. 93—28260/80—3

of the said State, hereby consents to the Geelong Waterworks and Sewerage Trust borrowing the sum of Fifty thousand dollars (\$50 000) to meet the cost of water supply works.

And the Honourable Frederick James Granter, Her Majesty's Minister of Water Supply for the State of Victoria, shall give the necessary directions herein accordingly.

L. G. HOUSTON  
Acting Clerk of the Executive Council

## GEELONG WATERWORKS AND SEWERAGE TRUST

At the Executive Council Chamber, Melbourne, the  
twenty-eighth day of October, 1980

## PRESENT:

His Excellency the Governor of Victoria	
Mr Haddon Storey	Mr Granter
Mr Jona	Mr Lacy

## CONSENT TO BORROWING \$500 000

Under the powers conferred by the Geelong Waterworks and Sewerage Act and all other powers enabling him in that behalf, His Excellency the Governor of the State of Victoria, by and with the advice of the Executive Council of the said State, hereby consents to the Geelong Waterworks and Sewerage Trust borrowing the sum of Five hundred thousand dollars (\$500 000), in two separate loans of Two hundred thousand dollars (\$200 000) and Three hundred thousand dollars (\$300 000), to meet the cost of sewerage works.

And the Honourable Frederick James Granter, Her Majesty's Minister of Water Supply for the State of Victoria, shall give the necessary directions herein accordingly.

L. G. HOUSTON  
Acting Clerk of the Executive Council

## DROMANA-ROSEBUD SEWERAGE AUTHORITY

At the Executive Council Chamber, Melbourne, the  
twenty-eighth day of October, 1980

## PRESENT:

His Excellency the Governor of Victoria	
Mr Haddon Storey	Mr Granter
Mr Jona	Mr Lacy

## CONSENT TO BORROWING \$50 000

Under the powers conferred by the Sewerage Districts Act and all other powers enabling him in that behalf, His Excellency the Governor of the State of Victoria, by and with the advice of the Executive Council of the said State, hereby consents to the Dromana-Rosebud Sewerage Authority borrowing the sum of Fifty thousand dollars (\$50 000) to meet the cost of sewerage works as set forth in the detailed statement bearing date 17 October 1980.

And the Honourable Frederick James Granter, Her Majesty's Minister of Water Supply for the State of Victoria, shall give the necessary directions herein accordingly.

L. G. HOUSTON  
Acting Clerk of the Executive Council

**FRANKSTON SEWERAGE AUTHORITY**

At the Executive Council Chamber, Melbourne, the  
twenty-eighth day of October, 1980

**PRESENT:**

His Excellency the Governor of Victoria	
Mr Haddon Storey	Mr Granter
Mr Jona	Mr Lacy

**CONSENT TO BORROWING \$700 000**

Under the powers conferred by the Sewerage Districts Act and all other powers enabling him in that behalf, His Excellency the Governor of the State of Victoria, by and with the advice of the Executive Council of the said State, hereby consents to the Frankston Sewerage Authority borrowing the sum of Seven hundred thousand dollars (\$700 000), in three separate loans of Two hundred thousand dollars (\$200 000), Fifty thousand dollars (\$50 000) and Four hundred and fifty thousand dollars (\$450 000) to meet the cost of sewerage works as set forth in the detailed statement bearing date 17 October 1980.

And the Honourable Frederick James Granter, Her Majesty's Minister of Water Supply for the State of Victoria, shall give the necessary directions herein accordingly.

L. G. HOUSTON  
Acting Clerk of the Executive Council

**HAMILTON SEWERAGE AUTHORITY**

At the Executive Council Chamber, Melbourne, the  
twenty-eighth day of October, 1980

**PRESENT:**

His Excellency the Governor of Victoria	
Mr Haddon Storey	Mr Granter
Mr Jona	Mr Lacy

**CONSENT TO BORROWING \$40 000**

Under the powers conferred by the Sewerage Districts Act and all other powers enabling him in that behalf, His Excellency the Governor of the State of Victoria, by and with the advice of the Executive Council of the said State, hereby consents to the Hamilton Sewerage Authority borrowing the sum of Forty thousand dollars (\$40 000) for the conversion of Loan No. 23. A detailed statement bearing date 17 October 1980, as required under section 80 of the above Act is attached.

And the Honourable Frederick James Granter, Her Majesty's Minister of Water Supply for the State of Victoria, shall give the necessary directions herein accordingly.

L. G. HOUSTON  
Acting Clerk of the Executive Council

**HEYTESBURY SEWERAGE AUTHORITY**

At the Executive Council Chamber, Melbourne, the  
twenty-eighth day of October, 1980

**PRESENT:**

His Excellency the Governor of Victoria	
Mr Haddon Storey	Mr Granter
Mr Jona	Mr Lacy

**CONSENT TO BORROWING \$250 000**

Under the powers conferred by the Sewerage Districts Act and all other powers enabling him in that behalf, His Excellency the Governor of the State of Victoria, by and with the advice of the Executive Council of the said State, hereby consents to the Heytesbury Sewerage Authority

borrowing the sum of Two hundred and fifty thousand dollars (\$250 000) in two separate loans of One hundred and fifty thousand dollars (\$150 000) and One hundred thousand dollars (\$100 000) to meet the cost of sewerage works as set forth in the detailed statement bearing date 20 October 1980.

And the Honourable Frederick James Granter, Her Majesty's Minister of Water Supply for the State of Victoria, shall give the necessary directions herein accordingly.

L. G. HOUSTON  
Acting Clerk of the Executive Council

**LILYDALE SEWERAGE AUTHORITY**

At the Executive Council Chamber, Melbourne, the  
twenty-eighth day of October, 1980

**PRESENT:**

His Excellency the Governor of Victoria	
Mr Haddon Storey	Mr Granter
Mr Jona	Mr Lacy

**CONSENT TO BORROWING \$150 000**

Under the powers conferred by the Sewerage Districts Act and all other powers enabling him in that behalf, His Excellency the Governor of the State of Victoria, by and with the advice of the Executive Council of the said State, hereby consents to the Lilydale Sewerage Authority borrowing the sum of One hundred and fifty thousand dollars (\$150 000) to meet the cost of sewerage works as set forth in the detailed statement bearing date 20 October 1980.

And the Honourable Frederick James Granter, Her Majesty's Minister of Water Supply for the State of Victoria, shall give the necessary directions herein accordingly.

L. G. HOUSTON  
Acting Clerk of the Executive Council

**MELBOURNE AND METROPOLITAN BOARD OF WORKS ACT 1958**

At the Executive Council Chamber, Melbourne, the  
twenty-eighth day of October, 1980

**PRESENT:**

His Excellency the Governor of Victoria	
Mr Haddon Storey	Mr Granter
Mr Jona	Mr Lacy

**ORDER VESTING CERTAIN LAND IN THE MELBOURNE AND METROPOLITAN BOARD OF WORKS**

In pursuance of the powers conferred by section 288 of the Melbourne and Metropolitan Board of Works Act 1958, His Excellency the Governor of the State of Victoria by and with the advice of the Executive Council thereof does by this Order determine that the area of land situated in the municipal district of the City of Melbourne containing 240 square metres, being Crown allotment 22, section 6 as shown on Certified Plan No. 104542 lodged in the Central Plan Office of the Department of Crown Lands and Survey be vested in the Melbourne and Metropolitan Board of Works constituted under the said Act.

And the Honourable James Granter, Her Majesty's Minister of Water Supply for the State of Victoria, shall give the necessary directions herein accordingly.

L. G. HOUSTON  
Acting Clerk of the Executive Council

## LANDS DEPARTMENT NOTICES

### APPROACHING LAND SALES

Sale of Crown Land, will be held at the under-mentioned places and dates, viz.:-

	No. of Gazette
Avoca—Thursday, 11 December 1980	93
Bright—Wednesday, 10 December 1980	93
Ballarat—Tuesday, 2 December 1980	93
Daylesford—Tuesday, 9 December 1980	93
Fitzroy—Saturday, 1 November 1980	84

### LOCAL LAND BOARDS

In pursuance of the provisions of section 34 of the Land Act 1958, notice is hereby given that a public hearing at the following place and time will be conducted by the persons mentioned, being duly appointed in that behalf.

HAMILTON REGIONAL LAND OFFICE, 11.00 a.m., Thursday, 13 November 1980—K. C. Gittins and A. L. Kellond.

W. V. HOUGHTON  
Minister of Lands

Department of Crown Lands and Survey  
Melbourne, 27 October 1980

### SALE OF CROWN LAND BY AUCTION

The land will be offered for sale subject to the provisions of the Land Act and Regulations thereunder.

The **upset price** is the sum at which bidding will start, and no bid below that sum can be accepted. The highest bidder at or above that sum shall be the purchaser, subject to signature of contract and any necessary payment.

#### TERMS:-

A deposit of at least 12½% of the purchase price must be paid at the sale, either in cash or by cheque.

The residue is payable in equal half-yearly instalments, in accordance with the following scale, or may be paid off at any earlier time.

Under \$2000—8 instalments.

\$2000 and under \$5000—10 instalments.

Interest at the rate of 9% per annum is payable with all payments of residue, and is computed for each instalment from the date of sale to the date of such payment. Additional interest is charged if any instalment is not paid on or before the due date.

If paid off within 30 days of sale, no interest is payable.

#### FEES, ETC.:

Survey fee payable at the sale.

**Payable with balance of purchase money—**

Crown Grant fee—\$30.00.

Assurance Fund contribution.—One cent in every Five dollars or part thereof of purchase price. (This is a fund established to guarantee the validity of freehold titles.)

Transfer of interest prior to completion of payment may be allowed on payment of \$22 fee and subject to stamp duty.

If unable to attend personally, a prospective purchaser may arrange for another person to bid as his agent.

Attention is drawn to section 95, Land Act 1958, which provides that the purchaser shall be deemed to be the owner for the purposes of other Acts; also to an amendment to the Local Government Act providing for Government roads, in certain circumstances, to be declared "private streets", thus making the purchaser liable to contribute to the cost of street construction.

W. V. HOUGHTON  
Minister of Lands

Department of Crown Lands and Survey  
Melbourne, 29 October 1980

AVOCA—Sale (No. 12320) of Crown Land, by auction will be held at the LAND INSPECTOR'S OFFICE, AVOCA, ON THURSDAY, 11 DECEMBER 1980 AT ELEVEN O'CLOCK A.M. To be conducted by N. J. Fitzgerald, Land Officer, Ballarat.

#### Lot 1

TOWNSHIP OF AVOCA, PARISH OF AVOCA

*Fronting west side of Mountain View Street about 150 metres south of Railway Station*

Upset price \$1500.00. Survey fee \$300.00

Area 1077 square metres allotment H4 of section A<sup>2</sup>.  
Special condition—Drainage easement—(L3-281).

#### Lot 2

TOWNSHIP OF AVOCA, PARISH OF AVOCA

*Fronting south side of Bridport Street about 11 metres east of Charles Street*

Upset price \$1750.00. Survey fee \$300.00

Area 1226 square metres, allotment 2 of section 23A—  
(L3-751).

#### Lot 3

TOWNSHIP OF AVOCA, PARISH OF AVOCA

*Facing the south side of Bridport Street about 337 metres east of Charles Street*

Upset price \$1500.00. Survey fee \$300.00

Area 1281 square metres, allotment 14 of section 23A.  
Special condition—One month allowed for removal of improvements (fencing)—(L3-752).

#### Lot 4

TOWNSHIP OF AVOCA, PARISH OF AVOCA

*Facing the south side of Bridport Street and the north side of Davy Street about 235 metres east of Pascoe Street*

Upset price \$2000.00. Survey fee \$300.00

Area 2197 square metres, allotment 13 of section 23A—  
(L3-634).

### SALE OF CROWN LAND BY AUCTION

The land will be offered for sale subject to the provisions of the Land Act and Regulations thereunder.

The **upset price** is the sum at which bidding will start, and no bid below that sum can be accepted. The highest bidder at or above that sum shall be the purchaser, subject to signature of contract and any necessary payment.

#### TERMS:-

A deposit of at least 12½% of the purchase price must be paid at the sale, either in cash or by cheque.

The residue is payable in equal half yearly instalments, in accordance with the following scale, or may be paid off at any earlier time.

Under \$2000—8 instalments.

\$2000 and under \$5000—10 instalments.

\$5000 and over—20 instalments.

Interest at the rate of 9% per annum is payable with all payments of residue, and is computed for each instalment from the date of sale to the date of such payment. Additional interest is charged if any instalment is not paid on or before the due date.

If paid off within 30 days of sale, no interest is payable.

#### FEES, ETC.:

Survey fee payable at the sale.

**Payable with balance of purchase money—**

Crown Grant fee—\$30.00.

Assurance Fund contribution.—One cent in every Five dollars or part thereof of purchase price. (This is a fund established to guarantee the validity of freehold titles.)

Transfer of interest prior to completion of payment may be allowed on payment of \$22 fee and subject to stamp duty.

If unable to attend personally, a prospective purchaser may arrange for another person to bid as his agent.

Attention is drawn to section 95, Land Act 1958, which provides that the purchaser shall be deemed to be the owner for the purposes of other Acts; also to an amendment to the Local Government Act providing for Government roads, in certain circumstances, to be declared "private streets", thus making the purchaser liable to contribute to the cost of street construction.

W. V. HOUGHTON  
Minister of Lands

Department of Crown Lands and Survey  
Melbourne, 29 October 1980

BALLARAT—Sale (No. 12318) of Crown land by auction, will be held at the LAND OFFICE, STATE PUBLIC OFFICES, CORNER MAIR AND DOVETON STREETS, BALLARAT, on TUESDAY, 2 DECEMBER 1980, at TWO O'CLOCK P.M. To be conducted by N. J. Fitzgerald, Land Officer, Ballarat.

Lot 1

PARISH OF BEAUFORT

Fronting the east side of the Beaufort-Amphitheatre Road about 4.8 kilometres north of Beaufort

Upset price \$1750.00 the lot. Survey fee \$350.00  
Area 6291 square metres. Allotment 6A of section A—(L.3-1271).

Lot 2

PARISH OF SCARSDALE

Abutting Brewer, O'Connor and Macauley Streets

Upset price \$1000.00 the lot. Survey fee \$350.00  
Area 5053 square metres. Allotment 1 of section 2A—(J.25499).

Lot 3

PARISH OF SCARSDALE

Fronting the north-west side of a Government Road near the intersection of Hamilton and Cope Streets.

Upset price \$1500.00 the lot. Survey fee \$300.00  
Area, 3495 square metres. Allotment 4C of section 5—(G.76412).

Lot 4

PARISH OF DEREEL

Fronting the west side of the Rokewood-Cape Clear Road at Illabarook

Upset price \$500.00 the lot. Survey fee \$300.00  
Area 3006 square metres. Allotment D1—(L.3-1286).

Lot 5

PARISH OF KERRIT BAREET

Fronting the south side of a Government Road opposite the south end of Nightingale Street, Gordon

Upset price \$2000.00 the lot. Survey fee \$300.00  
Area, 2977 square metres. Allotment 8C of section 15—(L.3-805).

Lot 6

TOWNSHIP OF CRESWICK, PARISH OF CRESWICK

Facing the south-west side of Bell Street 20.12 metres north-west of Orr Street

Upset price \$6000.00 the lot. Survey fee \$300.00  
Area 1125 square metres. Allotment 22 of section, 50A.  
Special condition—Subsidence indemnity—(J.23365).

Lot 7

TOWNSHIP OF CRESWICK, PARISH OF CRESWICK

Fronting the south side of Castlemaine Road about 23 metres east of Moore Street

Upset price \$2750.00 the lot. Survey fee \$300.00  
Area 1276 square metres. Allotment 6 of section 84A.  
Special conditions—Drainage easement 2 metres wide.  
Drainage easement 1.5 metres wide—(L.3-524).

Lot 8

TOWNSHIP OF SEBASTOPOL, PARISH OF BALLARAT

Fronting the east side of Beverin Street about 65 metres south of Vickers Street

Upset price \$3000.00 the lot. Survey fee \$300.00  
Area 474 square metres. Allotment 29A of section 5.  
Special condition—Subsidence indemnity—(J.33188).

Lot 9

TOWNSHIP OF BALLARAT, PARISH OF BALLARAT

Fronting the north side of Lonsdale Street about 92 metres west of Pleasant Street

Upset price \$4500.00 the lot. Survey fee \$300.00  
Area 588 square metres. Allotment 15 of section 109.  
Special conditions—Subsidence indemnity. Sewerage easement 3 metres wide—(L.3-762).

Lot 10

TOWNSHIP OF BALLARAT, PARISH OF BALLARAT

Fronting the north side of Lonsdale Street about 127 metres west of Pleasant Street

Upset price \$5000.00 the lot. Survey fee \$300.00  
Area 626 square metres. Allotment 16 of section 109.  
Special conditions—Subsidence indemnity. Sewerage easement 3 metres wide—(L.3-762).

Lot 11

TOWNSHIP OF BALLARAT, PARISH OF BALLARAT

Fronting the north-west side of Hickman Street 25.14 metres north of Sebastopol Street

Upset price \$6000.00 the lot. Survey fee \$300.00  
Area 1007 square metres. Allotment 17 of section 79.  
Special condition—Subsidence indemnity—(L.3-795).

Lot 12

TOWNSHIP OF CLUNES, PARISH OF CLUNES

At the south-east corner of Paddock and Canterbury Streets

Upset price \$3000.00 the lot. Survey fee \$300.00  
Area 1176 square metres. Allotment 1 of section 58—(J.25642).

Lot 13

TOWNSHIP OF CLUNES, PARISH OF CLUNES

Fronting the east side of Canterbury Street about 36.6 metres south of Paddock Street

Upset price \$3300.00 the lot. Survey fee \$300.00  
Area 1316 square metres. Allotment 1A of section 58—(J.25642).

Lot 14

TOWNSHIP OF CLUNES, PARISH OF CLUNES

Fronting the east side of Canterbury Street about 58.6 metres south of Paddock Street

Upset price \$3500.00 the lot. Survey fee \$300.00  
Area 1503 square metres. Allotment 2 of section 58—(J.25642).

Lot 15

TOWNSHIP OF CLUNES, PARISH OF CLUNES

Frontage the east side of Canterbury Street about 81.6 metres south of Paddock Street

Upset price \$3000.00 the lot. Survey fee \$300.00

Area 1178 square metres. Allotment 2A of section 58—(J.25642).

Lot 16

TOWNSHIP OF CLUNES, PARISH OF CLUNES

Fronting the north side of Cameron Street about 34.6 metres west of Leslie Street

Upset price \$4000.00 the lot. Survey fee \$300.00

Area 1828 square metres. Allotment 2 of section 24. Special conditions—Subsidence indemnity. Drainage easement 2 metres wide—(L.3-764).

Lot 17

TOWNSHIP OF CLUNES, PARISH OF CLUNES

Fronting the east side of Angus Street about 18 metres north of Cameron Street

Upset price \$4500.00 the lot. Survey fee \$300.00

Area 1968 square metres. Allotment 10 of section 24. Special condition—Subsidence indemnity—(L.3-763).

Lot 18

TOWNSHIP OF CLUNES, PARISH OF CLUNES

Fronting the west side of Templeton Street about 30 metres north of Purcell Street

Upset price \$2000.00 the lot. Survey fee \$300.00

Area 308 square metres. Allotment 46 of section D—(J.25171).

Lot 19

TOWNSHIP OF BALLARAT EAST, PARISH OF BALLARAT

Fronting the east side of Joseph Street about 167 metres north of Elsworth Street

Upset price \$10 000.00 the lot. Survey fee \$300.00

Area 2327 square metres. Allotment 2A of section 38B. Special condition—Subsidence indemnity—(L.3-855).

## SALE OF CROWN LAND BY AUCTION

The land will be offered for sale subject to the provisions of the Land Act and Regulations thereunder.

The upset price is the sum at which bidding will start, and no bid below that sum can be accepted. The highest bidder at or above that sum shall be the purchaser, subject to signature of contract and any necessary payment.

## TERMS:

A deposit of at least 12½% of the purchase price must be paid at the sale, either in cash or by cheque.

The residue is payable in equal half-yearly instalments, in accordance with the following scale, or may be paid off at any earlier time.

\$2000 and under \$5000—10 instalments;

\$5000 and over—20 instalments.

Interest at the rate of 9% per annum is payable with all payments of residue, and is computed for each instalment from the date of sale to the date of such payment. Additional interest is charged if any instalment is not paid on or before the due date.

If paid off within 30 days of sale, no interest is payable.

## FEES, ETC.:

Survey fee payable at the sale.

Payable with balance of purchase money—

Crown Grant fee—\$30.00.

Assurance Fund contribution—One cent in every Five dollars or part thereof of purchase price. (This is a fund established to guarantee the validity of freehold titles.)

Transfer of interest prior to completion of payment may be allowed on payment of \$22 fee and subject to stamp duty.

If unable to attend personally, a prospective purchaser may arrange for another person to bid as his agent.

Attention is drawn to section 95, Land Act 1958, which provides that the purchaser shall be deemed to be the owner for the purposes of other Acts; also to an amendment to the Local Government Act providing for Government roads, in certain circumstances, to be declared "private streets", thus making the purchaser liable to contribute to the cost of street construction.

W. V. HOUGHTON  
Minister of LandsDepartment of Crown Lands and Survey  
Melbourne, 29 October 1980

BRIGHT—Sale (No. 12323) of Crown land, by auction, will be held at the COURT HOUSE, BRIGHT on WEDNESDAY, 10 DECEMBER 1980 at TEN O'CLOCK A.M. To be conducted by F. F. HOLT, Land Officer, Wangaratta.

Lot 1

TOWNSHIP OF WANDILIGONG, PARISH OF BRIGHT

Fronting the western side of a government road approximately 350 metres north of State School

Upset price \$3500.00. Survey fee \$300.00

Area 3856 square metres. Allotment 27A.

Special condition—Subsidence indemnity.

Lot 2

TOWNSHIP OF WANDILIGONG, PARISH OF BRIGHT

Fronting the western side of a government road approximately 325 metres north of State School

Upset price \$3200.00. Survey fee \$300.00

Area 3842 square metres. Allotment 29B.

Special condition—Subsidence indemnity.

Lot 3

TOWNSHIP OF WANDILIGONG, PARISH OF BRIGHT

Fronting the western side of a government road approximately 286 metres north of State School

Upset price \$3000.00. Survey fee \$300.00

Area 3874 square metres. Allotment 30A.

Special condition—Subsidence indemnity.

(HO23305)

## SALE OF CROWN LAND BY AUCTION

The land will be offered for sale subject to the provisions of the Land Act and Regulations thereunder.

The upset price is the sum at which bidding will start, and no bid below that sum can be accepted. The highest bidder at or above that sum shall be the purchaser, subject to signature of contract and any necessary payment.

## TERMS:

A deposit of at least 12½% of the purchase price must be paid at the sale, either in cash or by cheque.

The residue is payable in equal half-yearly instalments, in accordance with the following scale, or may be paid off at any earlier time.

Under \$2000—8 instalments.

\$2000 and under \$5000—10 instalments.

\$5000 and over—20 instalments.

Interest at the rate of 9% per annum is payable with all payments of residue, and is computed for each instalment from the date of sale to the date of such payment. Additional interest is charged if any instalment is not paid on or before the due date.

If paid off within 30 days of sale, no interest is payable.

**FEES, ETC.:**

Survey fee payable at the sale.

Payable with balance of purchase money—  
Crown Grant fee—\$30.00.

Assurance Fund contribution.—One cent in every Five dollars or part thereof of purchase price. (This is a fund established to guarantee the validity of freehold titles.)

Transfer of interest prior to completion of payment may be allowed on payment of \$22 fee and subject to stamp duty.

If unable to attend personally, a prospective purchaser may arrange for another person to bid as his agent.

Attention is drawn to section 95, *Land Act 1958*, which provides that the purchaser shall be deemed to be the owner for the purposes of other Acts; also to an amendment to the Local Government Act providing for Government roads, in certain circumstances, to be declared "private streets", thus making the purchaser liable to contribute to the cost of street construction.

W. V. HOUGHTON  
Minister of Lands

Department of Crown Lands and Survey  
Melbourne, 29 October 1980

DAYLESFORD—Sale (No. 12319) of Crown Land, by auction will be held at the LAND INSPECTOR'S OFFICE, VINCENT STREET, DAYLESFORD ON TUESDAY, 9 DECEMBER 1980, AT TWO O'CLOCK P.M. To be conducted by N. J. Fitzgerald, Land Officer, Ballarat.

**Lot 1**

TOWNSHIP OF HEPBURN, PARISH OF WOMBAT  
*Fronting the south side of a Government Road about 51.6 metres east of Golden Spring Road*  
Upset price \$3000.00. Survey fee \$300.00  
Area 1902 square metres, allotment 40 of section 24—(G.76497).

**Lot 2**

PARISH OF WOMBAT  
*Fronting the south side of Midland Highway at Eganstown about 300 metres west of Deep Creek*  
Upset price \$5000.00. Survey fee \$300.00  
Area 3278 square metres, allotment 4A of section 1—(L3-1152).

**Lot 3**

PARISH OF WOMBAT  
*At north-east corner of a Government Road and the old Ballarat Road approximately 3 kilometres south-west of Daylesford*  
Upset price \$3000.00. Survey fee \$300.00  
Area 824 square metres, allotment M<sup>o</sup> of section A.  
Special Condition: One month allowed for removal of improvements. (Bus shelter.)—(L3-1256).

**Lot 4**

PARISH OF WOMBAT  
*Fronting an unmade Government Road in the south-west corner of the parish, 3 kilometres east of Rocklyn*  
Upset price \$5700.00. Survey fee \$500.00  
Area 4.6 hectares, allotment 3 of section 7A—(W.89237).

**Lot 5**

PARISH OF WOMBAT  
*Fronting the north-east side of Burrall Street, opposite the public park and about 85 metres south-east of Leggatt Street*  
Upset price \$3000.00. Survey fee \$300.00  
Area 1821 square metres, allotment 8 of section 9A.  
Special Condition: Drainage easement 2 metres wide—(L3-379).

**Lot 6**

PARISH OF WOMBAT  
*Fronting the north-east side of Burrall Street and the south-east side of a Government Road, about 240 metres south-east of Leggatt Street.*  
Upset price \$1500.00. Survey fee \$300.00  
Area 2504 square metres, allotment 12 of section 9A.  
Special Condition: Drainage easement 2 metres wide—(L3-379).

**Lot 7**

PARISH OF DRUMMOND  
*Fronting the west side of a formed Government Road west of the Calder Highway approximately 3.21 kilometres south of Taradale.*  
Upset price \$5000.00. Survey fee \$350.00  
Area 8088 square metres, allotment 8A of section 1A—(L3-757).

**Lot 8**

PARISH OF DRUMMOND  
*Fronting the west side of a formed Government Road west of the Calder Highway approximately 3.2 kilometres south of Taradale*  
Upset price \$3500.00. Survey fee \$300.00  
Area 4463 square metres, allotment 10A of section 1A—(L3-757).

**PROPOSED REVOCATION OF TEMPORARY RESERVATION OF LAND BY ORDER IN COUNCIL**

In pursuance of the provisions of section 10 of the *Crown Land (Reserves) Act 1978*, notice is hereby given that it is the intention of the Governor in Council to revoke the temporary reservation of land by Order in Council hereunder referred to, viz.:

CARRARAGARMUNGEE—The temporary reservation by Order in Council of 9 November 1920 of 7.132 hectares of land in the Parish of Carraragarmungee (being Crown allotment 197B) as a site for Supply of Gravel—(C.188(?) (Rs.1944).

HAMILTON SOUTH—The temporary reservation by Order in Council of 22 June 1926 of 3.237 hectares of land in the Parish of Hamilton South (in section C) as a site for Public Park and Recreation—(H.46(?) (Rs.3329).

KATANDRA—The temporary reservation as a site for Public purposes and the withholding from sale leasing and licensing by Order in Council of 30 July 1877 of 8094 square metres of land in the Township of Katandra (in section 1)—(Rs.11493).

MARMA—The temporary reservation as a site for Public Purposes (State School) and the withholding from sale, leasing and licensing by Order in Council of 24 June 1879 of 2.023 hectares of land in the Parish of Marma—(L.4-1244).

MONBULK—The temporary reservation by Order in Council of 1 February 1898 of 2023 square metres of land in the Parish of Monbulk (in section H) as a site for a Mechanics' Institute—(Rs.8501).

MONBULK—The temporary reservation by Order in Council of 26 November 1968 of 1.014 hectares of land in the Parish of Monbulk (in section H) as a site for Public Purposes (Recreation and Picnic Ground)—(Rs.9090).

WARRANOOK—The temporary reservation by Order in Council of 29 November 1894 of 6045 square metres of land in the Parish of Warranook (near allotment 227H) as a site for a State School—(L.4-1238).

**CUNNINGHAME**—The temporary reservation by Order in Council of 23 September 1901, of 2.263 hectares of land in the Township of Cunninghame as a site for Supply of Gravel, so far only as the portion thereof containing 6750 square metres, as indicated by hatching on plan hereunder—(C.486<sup>(s)</sup>) (Rs.7065).

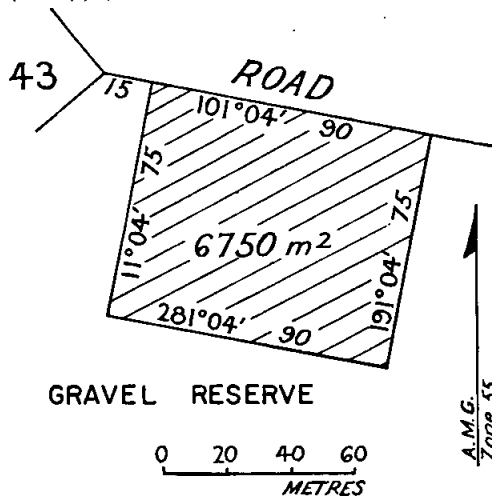

**TANJIL**—The temporary reservation by Order in Council of 9 July 1957 of 7.284 hectares, more or less, of land in the Parish of Tanjil, being Crown allotments 38A and 38B, as a site for a Rubbish Depot and for Supply of Gravel, revoked as to part by various Orders, so far as the balance thereof containing 7.198 hectares, more or less, is concerned—(Rs.3452).

W. V. HOUGHTON  
Minister of Lands

**QUEENSLIFF PUBLIC PARK AND RECREATION RESERVE, PARISH OF PAYWIT REGULATIONS**

I, William Vasey Houghton, Her Majesty's Minister of Lands in and for the State of Victoria, in pursuance of the powers conferred on me by section 13 (1) (xii) of the *Crown Land (Reserves) Act 1978*, do hereby apply the regulations made on 4 September 1931 (*vide Government Gazette* dated 9 September 1931) for or with respect to the land in the Parish of Paywit known as "Lonsdale Bay Foreshore", to the land in the said Parish temporarily reserved for Public Park and Recreation by Orders in Council of 11 March 1959 and 4 September 1979—(Rs.7372).

Given under my Hand on 21 October 1980

W. V. HOUGHTON  
Minister of Lands

**TENDERS**

**PUBLIC WORKS DEPARTMENT**

Tenders are invited for the purposes indicated hereunder and will be received at 2 Treasury Place, Melbourne, 3002, until **TWO** p.m. on dates shown.

Tenders must be addressed to the Minister of Public Works with the envelope endorsed "Tender for

". Hand-delivered tenders must be placed in the Department's tender box in the foyer, Ground Floor, 2 Treasury Place, Melbourne.

Tenders documents are available from the Contracts Office, Room 29, 2 Treasury Place, Melbourne and where indicated, at offices of Inspectors of Works.

★Tenders for works identified with star (★) will only be considered from Contractors qualified for repairs and painting works. Any Tenderers wishing to qualify may obtain the application form from the Contracts Office.

**Tuesday, 11 November 1980**

**Building, Electrical, Mechanical Works**

**BOISDALE**—Attention to roof over main building, Consolidated School. (W.O., Bairnsdale and Traralgon.)

★**BULN BULN**—Repairs and painting, Primary School No. 2017. (W.O., Warragul.)

**COLAC WEST**—Toilet block upgrade, Primary School No. 4064. (W.O., Camperdown.)

**COLLINGWOOD**—Supply and installation of television system, Technical College.

**CRANBOURNE**—(Re-advertisement, amended specification)—Supply and install PABX system, Police Station.

★**PAYNESVILLE**—Internal and external renovations, Primary School No. 2343. (W.O., Bairnsdale.)

★**TARWIN LOWER**—Internal and external renovations, Primary School No. 4275. (W.O., Korumburra.)

★**YARRA GLEN**—Renovations and recladding, Station and Residence.

**Site Works**

**WARRAGUL**—(Re-advertisement, amended specification)—Road reconstruction, Technical School. (W.O., Warragul.)

**Miscellaneous**

**BOX HILL**—Stage 1/Phase 2—Laboratory equipment, optical, Technical College T.A.F.E.

**BOX HILL**—Supply of laboratory equipment, Technical College.

**BRIGHTON**—Manufacture and delivery of prestressed concrete deck units and kerb units to Middle Brighton Jetty, The Esplanade, Brighton, Ports and Harbors.

**COLLINGWOOD**—Supply and delivery of applied mechanics equipment, Technical College T.A.F.E.

**FITZROY**—Purchase one only battery operated reach truck, 2000 kg capacity, 237 Napier Street, Construction Group Depot.

**PORT MELBOURNE**—Purchase of (1) one only communications caravan, 13 ft. x 7 ft., Depot.

**VARIOUS**—Supply of stoneware pipes and fittings for the period 1 December 1980 to 30 November 1981, Various.

**Tuesday, 18 November 1980**

**Building, Electrical and Mechanical Works**

**BALLARAT**—Installation of P.A.B.X. telephone system, District Headquarters.

**DELACOMBE**—Electrical services—new "half core" school building and associated site development, Primary School (W.O., Ballarat.)

**MELBOURNE**—Roof covering and painting to lift lobby, kitchen and office, seventh and eighth floors, Taxation Office.

**ROYAL PARK**—(Re-advertisement, amended specification)—Fire escape stairs and fire-proof doors, Mental Hospital.

**Miscellaneous**

**VARIOUS**—Supply of three leaf acoustic screens for the period 1 December 1980 to 30 June 1981, Various.

**VARIOUS**—Supply of office acoustic screens for the period 1 December 1980 to 30 June 1981, Various.

TOM AUSTIN  
Minister of Public Works

Public Works Department  
Melbourne, 28 October 1980

*Teaching Service Act 1958*TEACHING SERVICE—PROFESSIONAL (CLASSIFICATION,  
SALARIES, AND ALLOWANCES) REGULATION

## AMENDMENT No. 523 (PROF. C.S. &amp; A. 1)

The Teachers Tribunal, in pursuance of the powers conferred by the *Teaching Service Act 1958*, hereby amends the *Teaching Service—Professional (Classification, Salaries, and Allowances) Regulation* as follows:

Rescind sub-clause 5 (e) and substitute therefor the following sub-clause:

“(e) *Planning Services Division*

Principal Planning Officer; Supervisor (T.A.F.E. Planning)

*Subdivisions*

1	2	3	4	5
\$	\$	\$	\$	\$
25 240	26 225	27 286	28 346	29 330

Planning Officer, Grade I.

*Subdivisions*

1	2	3
\$	\$	\$
24 147	24 878	25 849

Assistant Supervisor (T.A.F.E. Planning)

*Subdivisions*

1	2	3	4
\$	\$	\$	\$
20 507	22 113	23 420	24 878

Consultant Community Education Planning Officer, Grade II. \$23 420

*Subdivisions*

1	2
\$	\$
22 759	23 420

Planning Officer, Grade III.

*Subdivisions*

1	2	3
\$	\$	\$
20 507	21 309	22 113

Planning Officer, Grade IV.

*Subdivisions*

1	2	3	4	5
\$	\$	\$	\$	\$
14 716	15 202	15 874	16 508	17 145
	6	7	8	
	\$	\$	\$	
	17 968	18 788	19 572	

(To take effect from and including 17 October 1980)

J. J. KENNEDY, Chairman  
L. D. KEEN, Acting Secretary

Office of the Teachers Tribunal  
Melbourne, 17 October 1980



**PRIVATE  
ADVERTISEMENTS**

*Town and Country Planning Act 1961 (Twelfth Schedule)*  
**CITY OF BENALLA PLANNING SCHEME**

NOTICE THAT A PLANNING SCHEME HAS BEEN PREPARED AND IS AVAILABLE FOR INSPECTION

*Amendment No. 31*

Notice is hereby given that the City of Benalla in pursuance of its powers under the *Town and Country Planning Act 1961* has prepared a Planning Scheme for:

Rezoning approximately 20.12 metres by 42.06 metres of land comprising Part Crown Allotment 3, Section 6A, Town of Benalla, Church Street, Benalla, from Commercial B to Existing Public Open Space.

A copy of the Scheme has been deposited at the Civic Offices, Benalla, and at the Office of the Town and Country Planning Board, 235 Queen Street, Melbourne, and will be open for inspection during office hours by any person free of charge.

Any persons affected by the Planning Scheme are required to set forth in writing all objections they may have, addressed to the Town Clerk, City of Benalla, Fawckner Drive, Benalla, on or before 22 January 1981, and to state whether they wish to be heard in respect of their objections.

22 October 1980

10662

L. A. HEMLEY, Town Clerk

**CITY OF BRUNSWICK**

*LOAN No. 116*

*Notice of Intention to Borrow the Sum of \$45 000 for Permanent Works and Undertakings*

Notice is hereby given that the Council of the City of Brunswick proposes to borrow the principal sum of \$45 000 secured by a charge over the general rate of the municipality, such sum to be raised by the grant of a mortgage in accordance with the provisions of the *Local Government Act 1958*.

1. The maximum rate of interest that may be paid is 12.3 per cent per annum.

2. The purpose for which the loan is to be applied is—

General Department	\$
Computer Processing Equipment (part cost)	20 000
Electricity Supply Department	
Computer Processing Equipment (part cost)	25 000

3. The period of the loan shall be 5 years.

4. The moneys borrowed shall be repayable by providing out of the municipal fund half yearly instalments of approximately \$6157.58 each including principal and interest on 10 June and 10 December during the currency of the loan. The first instalment shall be payable on 10 June 1981.

5. Such moneys shall be repayable to the Commercial Banking Company of Sydney Limited, Brunswick.

The plans and specifications and the estimate of the cost of the proposed works and a statement showing the proposed expenditure of the moneys to be borrowed are open for inspection at the office of the Council of the City of Brunswick at 233 Sydney Road, Brunswick.

10723

K. D. WILSON, Town Clerk

**CITY OF FITZROY**

*LOAN No. 68*

*Notice of Intention to Borrow the Sum of \$110 000 for Permanent Works and Undertakings*

Notice is hereby given that the Council of the City of Fitzroy proposes to borrow the principal sum of \$110 000 secured by a charge over the general rates of the Municipality, such sum to be raised by the grant of a mortgage in accordance with the provisions of the *Local Government Act 1958* and its amendments.

1. No interest is payable for the loan.

2. The period of the loan shall be 5 years and the times at which the moneys borrowed are to be repayable will be on 1 October in each year during the currency of the loan commencing on 1 October 1982. The place of repayment shall be the Department of Youth, Sport and Recreation, 570 Bourke Street, Melbourne.

3. The purpose for which the loan is to be applied is:

(1) The redevelopment of the Fitzroy Cricket Ground.

4. The manner in which the loan is to be liquidated is by provision out of the municipal fund in each year during the currency of the loan of the sum of \$22 000.

5. Plans and specifications of the estimated cost of the proposed works and a statement showing the proposed expenditure of the money to be borrowed are open for inspection at the office of Council, Town Hall Fitzroy during office hours.

10651

J. JAMES, Town Clerk

**CITY OF KEILOR**

*LOAN No. 162*

*Notice of Intention to Borrow the Sum of \$250 000 for Permanent Works and Undertakings*

Notice is hereby given that the Council of the City of Keilor intends to borrow the principal sum of Two hundred and fifty thousand dollars (\$250 000) secured by a charge over the general rates of the municipality, such sum to be raised by the grant of a mortgage in accordance with the provisions of the *Local Government Act 1958*.

1. The rate of interest that is to be paid is 12.6 per cent per annum.

2. Such moneys shall be repayable at Commonwealth Savings Bank Niddrie.

3. The loan is to be liquidated by providing out of the municipal fund 30 half yearly instalments of approximately \$18 749.03 each including principal and interest on 1 December and 1 June during the currency of the loan. The first instalment shall be payable on 1 June 1981.

4. The purpose for which the loan is to be applied is—

Council's proportion of Country Roads Board Road Construction Works for 1980-81: <i>Essendon-St. Albans Connector Route</i> Buckley Street-Lily Street to Medway 83/CFL/199	20 000
Main Roads Reimbursement (Based Expenditure 1979-80)	30 000
Land Acquisition—Buckley Street	7 000
<i>Keilor-Deer Park Connector Road</i>	
Keilor-St. Albans-Green Gully (Driscoll's Road-Campaspe Crescent) 83/CFA/200	60 000
Taylor's Road-Kings Road-Sydenham	103 000
Sydenham Road	20 000
Sunshine Avenue (Part Cost)	10 000
	250 000

5. The period of the loan shall be 15 years. The plans, specifications, estimate of the cost of the proposed works and a statement showing the proposed expenditure of the moneys to be borrowed are open for inspection at the Municipal Offices, Keilor.

Dated 24 October 1980

10609

G. E. RICE, Acting Town Clerk

**CITY OF KEILOR**

*LOAN No. 164*

*Notice of Intention to Borrow the Sum of \$50 000 for Permanent Works and Undertakings*

Notice is hereby given that the Council of the City of Keilor intends to borrow the principal sum of Fifty thousand dollars (\$50 000) secured by a charge over the general rates of the municipality, such sum to be raised by the grant of a mortgage in accordance with the provisions of the *Local Government Act 1958*.

1. The rate of interest that is to be paid is 12.6 per cent per annum.

2. Such moneys shall be repayable at Commercial Bank of Australia, St. Albans Branch.

3. The loan is to be liquidated by providing out of the municipal fund 30 half yearly instalments of approximately \$3749.81 each including principal and interest on 1 December and 1 June during the currency of the loan. The first instalment shall be payable on 1 June 1981.

4. The purposes for which the loan is to be applied is—  
Council's Proportion of Country Roads Board  
Road Construction Works for 1980-81:

*Essendon-St. Albans Connector Route*  
Buckley Street-Lily Street to Medway  
83/CFL/199 \$50 000

5. The period of the loan shall be 15 years. The plans, specifications, estimate of the cost of the proposed works and a statement showing the proposed expenditure of the moneys to be borrowed are open for inspection at the Municipal Offices, Keilor.

Dated 24 October 1980

10610

G. E. RICE, Acting Town Clerk

CITY OF KEW

LOAN No. 82

*Notice of Intention to Borrow the Sum of \$550 000 for Permanent Works and Undertakings*

Notice is hereby given that the Council of the City of Kew proposes to borrow the sum of \$550 000 (Five hundred and fifty thousand dollars) secured by a charge over the general rates of the municipality, such sum to be raised by the grant of a mortgage in accordance with the provisions of the *Local Government Act 1958*.

1. The maximum rate of interest that may be paid is 12.6 per cent (twelve point six per centum) per annum.

2. The period of the loan shall be 15 years.

3. The loan is to be liquidated by providing out of the Municipal Fund thirty (30) equal half-yearly instalments of \$41 247.87 principal and interest, payable on 17 June and 17 December each year during the currency of the loan. The first instalment shall be payable on 17 June 1981.

4. Such moneys shall be repayable at the office of the National Bank Savings Bank Limited.

5. The purpose for which the loan is to be applied is:

*Parks Improvements—*  
Reservoir Reserve and Victoria Park \$ 38 500

*Road and Street Reconstruction—*  
Belford Road-Wattle Avenue to north end  
Campbell Street-Normanby Road to east end

Childers Street-High Street to Eglinton Street

John Street—full length

Kevin Grove—full length

Namur Street—full length

Spruzen Avenue-Willsmere Road to Tanner Avenue

Stoke Avenue—full length

Stratford Avenue—full length

Walpole Street-Eglinton Street to Willsmere Road

Yarravale Road—full length

Alfred Street (John-Thomas); Belford Road (Kilby-Beresford); Cecil Street (Parkhill-Downton); Fitzwilliam Street (Edgevale-Coleridge); Hartwood Street (Kilby-Cadow); Normanby Road (Cotham-Downton); Parkhill Road (Wimba-Marshall); Peel Street (Eglinton-Malmsbury); Stevenson Street (Hodgson-Carson); Studley Avenue (Holroyd-Molesworth); Tanner Avenue 275 000

*C.R.B. Works—Council Contribution* 236 500

The plans and specifications and the estimate of the cost of the proposed works and a statement showing the proposed expenditure of the moneys to be borrowed are open for inspection at the Municipal Offices, Charles Street, Kew.

Dated 29 October 1980

10613

L. FELL, City Manager, Town Clerk

CITY OF OAKLEIGH

LOAN No. 157

*Notice of Intention to Borrow*

Notice is hereby given that the Council of the City of Oakleigh proposes to borrow the principal sum of Two Hundred Thousand Dollars (\$200 000) secured by a charge over the General Rates of the Municipality, such sum to be raised by the grant of a mortgage in accordance with the provisions of the *Local Government Act 1958* (as amended).

1. The rate of interest to be paid is the maximum rate of interest approved by the Loan Council (at present 12.6 per cent).

2. The purposes for which the Loan is to be applied is:

	\$
Land Purchase—Estelle Street	82 500
Clayton Youth Club—toilet facilities	23 500
Shortfall—Tennis Courts—The Grange	34 500
Toilet Block—corner Huntingdale and North Roads	16 500
Drainage—Clapham Road Pre-School and Paget Street	9 000
Clayton Bowling Club—Fire Service	3 000
Removal of S.E.C. poles in Centre Road vicinity of Knight Street and Melaleuca Drive	4 200
New furniture—Council Chambers	4 800
Road to service tennis courts and frail aged homes—The Grange	8 000
Beautification of Princes Highway Reserve	6 500
Clayton Football Ground pavilion—hot water service and heating	2 500
Hughesdale Primary School Oval Development	5 000
	200 000

3. The period of the Loan will be 10 years.

4. The Loan is to be liquidated by the creation of a sinking fund, pursuant to the provisions of the *Local Government Act 1958*.

5. The moneys borrowed shall be repayable at the expiration of the Loan at the office of the Insurance Commissioner, State Insurance Office, 480 Collins Street, Melbourne 3000, or such other place as the Commissioner may require.

The plans, specifications and estimates of the cost of the proposed works and a statement showing the proposed expenditure of the moneys to be borrowed, are open for inspection at the office of the Council of the City of Oakleigh, at Atherton Road, Oakleigh.

10611

B. R. PREBBLE, Town Clerk

CITY OF PRAHRAN

LOAN No. 103

*Notice of Intention to Borrow the Sum of \$25 000 for Permanent Works and Undertakings*

Notice is hereby given that the Council of the City of Prahran proposes to borrow the sum of \$25 000 secured by a charge over the general rates of the Municipality, such sum to be raised by a grant of a mortgage in accordance with the provisions of the *Local Government Act 1958*.

1. The maximum rate of interest that may be paid is 12.3 per cent per annum.

2. The purpose for which the loan is to be applied is the refurbishing of the municipal administrative facilities.

The estimated total cost (at September 1980 prices) is \$1 685 000, covering:

	\$
Office re-accommodation (including \$600 000 to update the fire protection services)	1 450 000
Re-location of the library	140 000
Conversion of existing Children's Library to meeting rooms and public hall	95 000

3. The loan shall have a currency of 4 years and interest thereon shall be payable half-yearly on 15 January and 15 July in each year, the first payment to be made on 15 July 1981; the principal sum to be repayable in full at the expiration of the 4-year term. All payments are to be made to the Melbourne and Metropolitan Board of Works, 625 Little Collins Street, Melbourne, 3000.

4. The loan is to be liquidated by a Sinking Fund which shall be created in accordance with the provisions of the Local Government Act by the half-yearly investment of \$2 811.41 at not less than 6 per cent per annum.

The plans and specifications and the estimate of the cost of the proposed works and a statement showing the proposed expenditure of the monies to be borrowed are open for inspection at the Office of the Council of the City of Prahran, Chapel Street, Prahran, 3181.

10742 D. G. JESSON, Town Clerk

CITY OF SALE

LOAN NO. 108

Notice of Intention to Borrow

Notice is hereby given that the Council of the City of Sale intends to borrow Three hundred thousand dollars (\$300 000) secured by a charge over the General Rates of the Municipality by the grant of a mortgage in accordance with the provisions of the Local Government Acts.

In connection therewith the following information is stated:

- (a) The amount of the principal moneys which it is proposed to borrow is \$300 000.
- (b) The maximum rate of interest that may be paid is 12.6 per centum per annum.
- (c) The times which the moneys borrowed are to be repayable are 1 December and 1 June during the years 1981-1990 inclusive and that the place such moneys shall be repayable is at the Bank of New South Wales, Sale Branch.
- (d) The purpose for which the loan is to be applied is:
 

	\$
1. East Sale Drain, Stages 3-5	29 306
2. St. John Ambulance Building. Council Proportion of Public Toilet Area.	10 000
3. Road Program including Drainage (Reeve, Union, Macarthur, York Street South, Raglan and Montgomery).	199 194
4. Landscape and Car Park. Band Hall/Museum	11 500
5. Sale Football Clubrooms	50 000
- (e) The manner in which the loan is to be liquidated is by provision out of the Municipal Fund in each half-year during the currency of the Loan of the sum of \$26 795.93 which includes Principal and Interest.

The plans and specifications and estimate of the cost of the works and a statement showing the proposed expenditure of the moneys to be borrowed are open for inspection at the Council Chambers, Sale.

Dated 22 October 1980

10617 J. L. LOW, Town Clerk

CITY OF SANDRINGHAM

LOAN No. 137

Notice of Intention to Borrow the Sum of \$400 000 for Permanent Works and Undertakings

Notice is hereby given that the Council of the City of Sandringham intends to borrow Four Hundred Thousand Dollars (\$400 000) secured by a charge over the general rates of the Municipality by the grant of a mortgage in accordance with the provisions of the Local Government Acts.

In connection therewith the following information is stated:—

- 1. The amount of the principal moneys which it is proposed to borrow is \$400 000.
- 2. The maximum rate of interest that may be paid is 12.6 per centum per annum.
- 3. The period of the loan shall be 10 years.

4. The times at which the moneys borrowed are to be repayable are 15 June and 15 December in each year during the currency of the loan. The first instalment shall be payable on 15 June 1981 and the final instalment on 15 December 1990.

5. The place at which the moneys borrowed are to be repayable is the National Bank Savings Bank, 24 Bay Road, Sandringham, or such other place as the Bank from time to time may require.

6. The purposes for which the loan is to be applied are—

	\$	\$
Municipal Offices Extensions (Part cost)		200 000
Municipal Offices — Landscaping and Car Park (Part cost)		5 000
Construction of Pavilions—		
Sandringham Technical School (Part cost)	15 000	
Sillitoe Reserve	65 000	80 000
Beach Park Improvements—		
Public Conveniences and Change Sheds	35 000	
Resurfacing Ramps	10 000	
Fire Restoration (Part cost)	20 000	65 000
Reserve Improvements—		
Sillitoe Reserve	10 000	
Municipal Golf Course (Part cost)	17 000	27 000
Willis Street House Improvements		5 000
Traffic Management Works (Bay Road/Station Street and Hood/Littlewood Streets and Orlando Street)		13 000
Bayside Bicycle Path (Part cost)		5 000
		400 000

7. The manner in which the loan is to be liquidated is by the provision out of the Municipal Fund in each half year during the currency of the loan of the sum of \$35 727.92 which includes principal and interest.

The plans, specifications and estimate of the cost of works and a statement showing the proposed expenditure of the moneys to be borrowed are open for inspection at the Municipal Offices, Royal Avenue, Sandringham.

Dated 27 October 1980

10612 P. S. SHERMAN, Town Clerk

TOWN OF KYABRAM

APPOINTMENT OF A PROSECUTING OFFICER

Notice is hereby given that the Council of the Town of Kyabram has appointed Senior Sergeant Cecil Rodgers, No. 12394, as Prosecuting Officer for the Town of Kyabram in lieu of Senior Sergeant Neil Thomas Patterson, No. 13578, transferred.

10614 E. T. CORNISH, Town Clerk

Town and Country Planning Act 1961 (Twelfth Schedule)

SHIRE OF ALEXANDRA PLANNING SCHEME

NOTICE THAT A PLANNING SCHEME HAS BEEN PREPARED AND IS AVAILABLE FOR INSPECTION

Amendment No. 15

Notice is hereby given that the Shire of Alexandra in pursuance of its powers under the Town and Country Planning Act 1961, has prepared a Planning Scheme for Part of Lot 33 L.P. 40728, Parish of Eildon being land facing Shaw Avenue and South Crescent for the purpose of rezoning the land from "Industrial" to "Residential 'A'".

A copy of the scheme has been deposited at the office of the Shire of Alexandra, Perkins Street, Alexandra and at the office of the Town and Country Planning Board, 235 Queen Street, Melbourne and will be open for inspection during office hours by any person free of charge.

Any persons affected by the Planning Scheme are required to set forth in writing all objections they may have, addressed to the Shire Secretary, Shire Offices, Perkins Street, Alexandra on or before 29 November 1980 and to state whether they wish to be heard in respect of their objections.

10653

G. I. WALSHE, Shire Secretary

## SHIRE OF AVOCA

## NOTICE OF MAKING OF BY-LAW No. 40

Notice is hereby given that the Council of the Shire of Avoca has made By-Law No. 40 for the following purposes—

- (a) The regulating of the keeping of animals and the regulating or prohibiting of the keeping of any place or the storage of any things which in the opinion of the Council may be offensive injurious to health or dangerous.
- (b) Fixing the distance from any dwelling within which it shall be unlawful to keep any animal or store any such thing.
- (c) The provision use and control of receptacles for the deposit and collection of refuse and rubbish and prescribing the size and shape of the materials to be used in the construction of such receptacles.
- (d) Providing for the health of residents in the municipal district and against the spreading of contagious or infectious diseases.
- (e) Suppressing nuisances.
- (f) The regulating of the keeping of animals with power to limit the number of animals kept on any property within any area within the municipal district set forth in the By-Law and declared herein to be a populous or residential area and the prohibiting of the keeping of any specified kind of animal in such area.

The said By-Law was passed by the Council of the Shire of Avoca on 19 December 1979, confirmed on 13 February 1980, and approved by the Governor in Council on 7 October 1980.

A copy of By-Law No. 40 is open for inspection free of charge during office hours at the office of the Council, Rutherford Street, Avoca.

10616

F. C. S. EDWARDS, Shire Secretary

## SHIRE OF BENALLA

## LOAN No. 38

*Notice of Intention to Borrow the Sum of \$30 000 for Permanent Works and Undertakings*

Notice is hereby given that the Council of the Shire of Benalla proposes to borrow the principal sum of Thirty thousand dollars secured by a charge over the general rates of the municipality, such sum to be raised by the grant of a mortgage in accordance with the provisions of the *Local Government Act 1958*.

1. The maximum rate of interest that may be paid is 12.3 per centum per annum.
2. The purpose for which the loan is to be applied is—  
Construction of a pre-school centre at Glenrowan (Part cost)
3. The period of the loan shall be 5 years.
4. The moneys borrowed shall be repayable by providing out of the municipal fund 10 half-yearly instalments of \$4105.05 each including principal and interest on 15 June and 15 December during the currency of the loan. The first instalment will be payable on 15 June 1981.
5. Such moneys shall be repayable to National Bank of Australasia Ltd., Nunn Street, Benalla.

The plans and specifications and estimate of the cost of the proposed works and a statement showing the proposed expenditure of moneys to be borrowed are open for inspection at the Shire Offices, Benalla.

10665

S. LONDON, Shire Secretary

## SHIRE OF BULLA

## By-Law No. 64

*Incinerator and Nuisance By-Law*

Notice is hereby given that in pursuance of the powers conferred by the *Local Government Act 1958*, the Council of the Shire of Bulla has made a By-Law numbered 64 for the purpose of preventing and extinguishing fires and suppressing nuisances.

A copy of the By-law is open for inspection, free of charge, during office hours at the Municipal Offices, Macedon Street, Sunbury.

A resolution approving the By-law was carried at a meeting of Council held 1 September 1980 and confirmed at a meeting of the Council held on 6 October 1980.

10666

JOHN M. KELLY, Shire Secretary

## SHIRE OF BULN, BULN

## LOAN No. 107

*Notice of Intention to Borrow the Sum of \$70 000 for Permanent Works and Undertakings*

Notice is hereby given that the Council of the Shire of Buln Buln proposes to borrow the principal sum of \$70 000 secured by a charge over the general rates of the municipality, such sum to be raised by the grant of a mortgage in accordance with the provisions of the *Local Government Act 1958*.

1. The maximum rate of interest that may be paid is 12.6 per cent per annum.
2. The purpose for which the loan is applied is:  
Purchase of Factory Building and Land—Neerim South.
3. The period of the loan shall be 20 years.
4. The moneys borrowed shall be repayable by providing out of the municipal fund half-yearly instalments of approximately \$4829.33 each including principal and interest on 10 June and 10 December during the currency of the loan. The first instalment shall be payable on 10 June 1981.

5. Such moneys shall be repayable to The Commercial Savings Bank of Australia Limited, Neerim South, 3831.

The plans and specifications and the estimate of the cost of the proposed works and a statement showing the proposed expenditure of the moneys to be borrowed are open for inspection at the office of the Council of the Shire of Buln Buln, at Drouin.

Dated 23 October 1980

10663

K. A. PRETTY, Shire Secretary

## SHIRE OF CRANBOURNE

## LOAN No. 98

*Notice of Intention to Borrow*

Notice is hereby given that the Council of the Shire of Cranbourne intends to borrow the principal sum of \$25 000 secured by a charge over the General Rates of this Municipality, such sum to be raised by the grant of a mortgage in accordance with the provisions of the *Local Government Act 1958* (as amended).

1. The maximum rate of interest that may be paid is 12.3 per cent per annum.
2. The purposes for which the loan is to be applied are:

End Loader (replacement)	\$ 22 000
Brunt Street, Cranbourne (part cost)	3 000
	25 000

3. The period of the loan shall be four years.
4. The loan is to be liquidated by the creation of a Sinking Fund pursuant to the provisions of Section 428A of the *Local Government Act 1958*.
5. The principal shall be repayable to the Melbourne and Metropolitan Board of Works, 625 Little Collins Street, Melbourne.

The plans and specifications and estimate of the cost of the proposed works and statement showing the proposed expenditure of the moneys to be borrowed are open for inspection at the Office of the Council of the Shire of Cranbourne, Sladen Street, Cranbourne.

27 October 1980

10664

T. VICKERMAN, Shire Secretary

SHIRE OF DIAMOND VALLEY  
PUBLIC HIGHWAY

That Council having acquired all the roads and streets on Plan of Subdivision No. 12403 doth by Order hereby direct that the roads and streets created on Plan of Subdivision No. 12403 and shown hatched on Council Plan No. 3365 shall be a public highway in accordance with Section 522 of the Local Government Act and from the date of publication in the Government Gazette such land shall become and be a public highway and be deemed to be dedicated to the public accordingly.

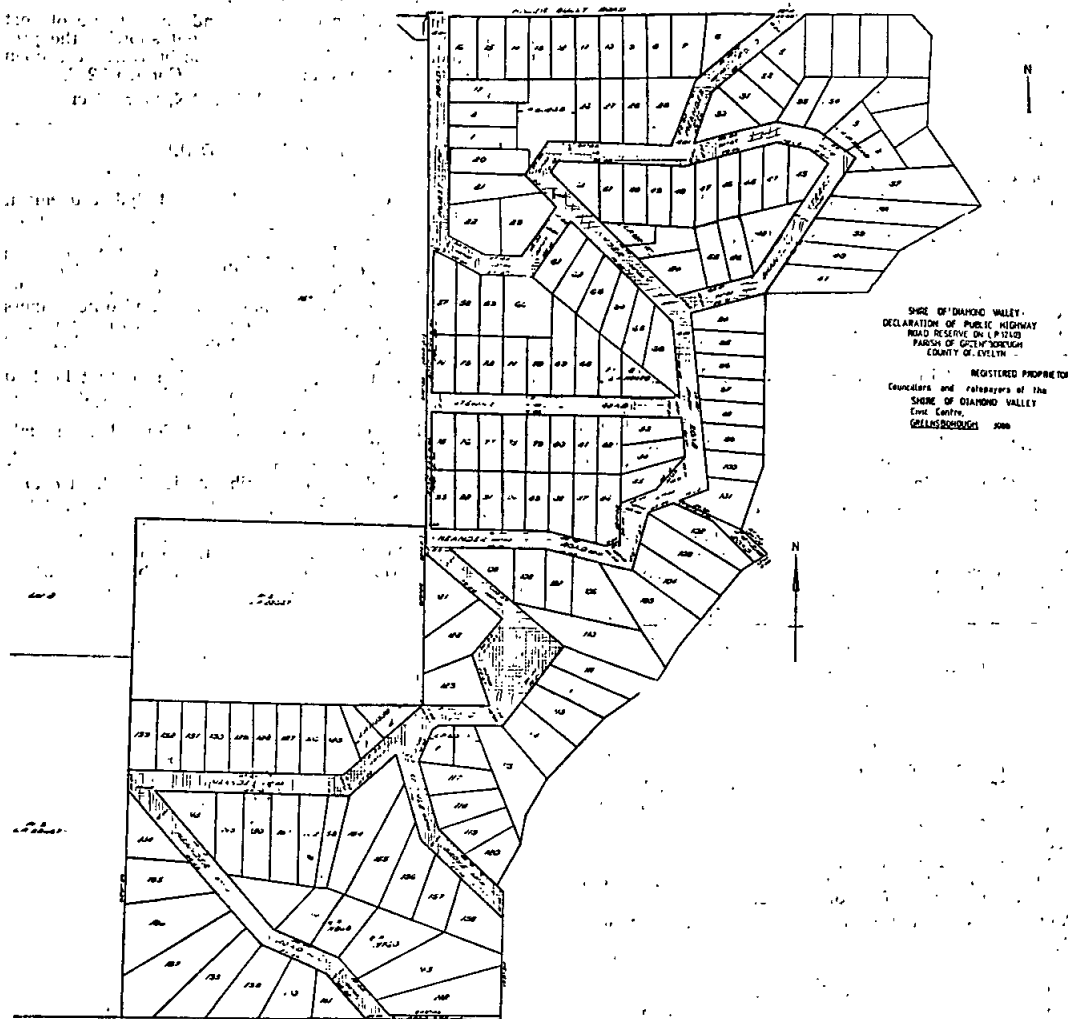

SHIRE OF DIAMOND VALLEY  
DECLARATION OF PUBLIC HIGHWAY  
ROAD RESERVE ON L.P. 12403  
PARISH OF GREENBOROUGH  
COUNTY OF EVELYN  
REGISTERED PROPRIETOR  
Councilors and ratepayers of the  
SHIRE OF DIAMOND VALLEY  
Eme. Centre  
GREENSBOROUGH 3000

10740

B. J. MORGAN, Shire Secretary

SHIRE OF DIAMOND VALLEY  
By-Law No. 258  
Control of Caravans

Notice is hereby given that the Council has made By-law No. 258 for prohibiting, or regulating the, placing of caravans on private property.

A summary of the By-law is as follows:

- Clause 1. Short title.
- Clause 2. By-law 247 repealed.
- Clause 3. Definition.
- Clause 4. Relates to caravan on caravan park or site, camping park or site.
- Clause 5. Restriction on placing caravan upon private property without authority.

- Clause 6. Regulation re period caravan can be placed on property.
- Clause 7. Limit of Council permit.
- Clause 8. Responsibility of permit holder.
- Clause 9. Conditions relating to Council revocation.
- Clause 10. Penalties.
- Clause 11. Area of operation of By-law.

The By-law was adopted by the Council on 23 June 1980 and confirmed on 21 July 1980.

It was subsequently approved by the Governor in Council on 7 October 1980.

The By-law may be inspected at the Civic Centre, Greensborough, free of charge, during office hours.

10661

B. J. MORGAN, Shire Secretary

**Town and Country Planning Act 1961 (Twelfth Schedule)**  
**SHIRE OF FLINDERS PLANNING SCHEME 1962**  
 NOTICE THAT A PLANNING SCHEME HAS BEEN PREPARED AND IS AVAILABLE FOR INSPECTION  
*Amendment No. 134, 1980*

Notice is hereby given that the Shire of Flinders, in pursuance of its powers under the *Town and Country Planning Act 1961*, has prepared a Planning Scheme for rezoning of land being part of Lot 5, L/P 115095, Melbourne Road and Campbells Road, Portsea, from Special Uses zone to Special Residential zone.

A copy of the Scheme has been deposited at the Office of the Responsible Authority, Municipal Offices, Boneo Road, Rosebud, and at the Office of the Town and Country Planning Board, 235 Queen Street, Melbourne, and will be open for inspection during office hours by any person free of charge.

Any persons affected by the Planning Scheme are required to set forth in writing all objections they may have addressed to The Shire Secretary, Shire of Flinders, Municipal Offices, Boneo Road, Rosebud, 3939 on or before 29 November 1980 and state whether they wish to be heard in respect of these objections.

22 October 1980

10618

G. W. WHITE, Shire Secretary

**SHIRE OF GISBORNE SEWERAGE AUTHORITY**  
 NOTICE OF PLANS FOR SEWERAGE WORKS  
 Notice is hereby given, pursuant to section 119 of the *Sewerage District Act 1958* of the following works:—

- (i) Temporary Rising Main and Treatment Site Construction.
- (ii) Sewer Main—Gisborne High School.
- (iii) Stage 1 (A)—Gisborne Township.

A copy of a plan indicating the above works is available for inspection at the Civic Centre, Robertson Street, Gisborne during office hours.

10744

T. H. LARKINS, Secretary

**Town and Country Planning Act 1961**  
**SHIRE OF GORDON INTERIM DEVELOPMENT ORDER**  
 NOTICE THAT AN AMENDMENT TO INTERIM DEVELOPMENT ORDER HAS BEEN PREPARED AND IS AVAILABLE FOR INSPECTION

Notice is hereby given that the Shire of Gordon in pursuance of its powers under the *Town and Country Planning Act 1961* has prepared an amendment to Interim Development Order to permit Gypsum Mining (Mineral Working) in an area known as the Salt Swamp, west of Boort.

A copy of the scheme has been deposited at the Shire Offices, Godfrey Street, Boort, and at the office of the Town and Country Planning Board, 235 Queen Street, Melbourne, and will be open for inspection during office hours by any person free of charge.

Any persons affected by the planning scheme are required to set forth in writing all objections they have, addressed to Shire Secretary, Shire of Gordon, Boort on or before 29 November 1980, and to state whether they wish to be heard in respect to their objections.

10652

T. H. FORBES, Municipal Clerk

**SHIRE OF HEYTESBURY**  
 LOAN No. 48

*Notice of Intention to Borrow the Sum of \$150 000 for Permanent Works and Undertakings*

Notice is hereby given that the Council of the Shire of Heytesbury proposes to borrow the principal sum of One hundred and fifty thousand dollars (\$150 000) secured by a charge over the general rates of the municipality, such sum to be raised by the grant of a mortgage in accordance with the provisions of the *Local Government Act 1958*.

1. The maximum rate of interest that may be paid is 12.6 per cent per annum.
2. The loan is to be used to:
  - (i) purchase land and erect a Community Centre at Timboon—\$120 000.
  - (ii) Construct and equip a Soil Testing Laboratory at Cobden—\$30 000.

3. The period of the loan shall be twenty years.
4. The monies borrowed shall be repayable by providing out of Municipal Fund half-yearly instalments of \$10 348.57 each including principal and interest on 1 November and 1 May during the currency of the loan. The first instalment shall be payable on 1 May 1981.

5. Such monies shall be repayable to the National Bank Savings Bank Limited, Melbourne.

6. The plans and specifications and an estimate of cost of the proposed works and a statement showing the proposed expenditure of the monies to be borrowed are open for inspection at the Municipal Office, Cobden 3266.

10650

M. L. WHELAN, Shire Secretary

**SHIRE OF LILLYDALE**  
 NOTICE OF COMPULSORY ACQUISITION

Whereas the Council of the Shire of Lillydale deems it expedient to exercise its powers of taking compulsorily the land for the Erection of Playground Equipment Purposes being part of Lot No. 14 on Plan of Subdivision No. 14464, Parish of Wandin Yallock and located on Lot 14, Glen Valley Crescent, Seville East and whereas the Council has caused to be prepared maps and other papers setting out a general description of the work or undertaking for which the land is proposed to be taken and the names of the owners or reputed owners, lessees or reputed lessees, mortgagees and occupiers of that land so far as those names are known or can be ascertained by the Council and whereas the said maps and other papers are deposited at the office of the said Council at Lillydale and are and shall be open for inspection by all persons interested at all reasonable hours for the space of 40 clear days after the publication of this notice in the *Government Gazette*. Now notice is hereby given to all persons affected by the proposed taking of the said land to set forth in writing addressed to the Council or the Shire Secretary within 40 clear days of the publication of this notice in the *Government Gazette* all objections which they may have to the taking of the said land.

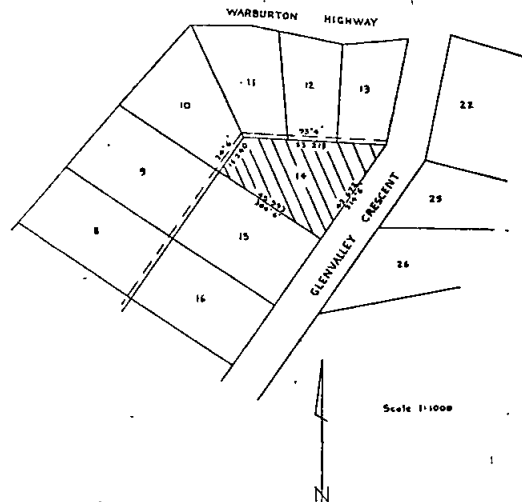

Dated 29 October 1980

10615

K. D. WILSON, Shire Secretary  
 W. N. GERSCH, Shire President

**Town and Country Planning Act 1961**  
**SHIRE OF LILLYDALE PLANNING SCHEME**  
 NOTICE OF A PROPOSED AMENDMENT TO THE SHIRE OF LILLYDALE PLANNING SCHEME  
*Amendment No. 127*

Notice is hereby given that pursuant to sub-section 7 of Section 32 of the *Town and Country Planning Act 1961*, the Minister has required that the Shire of Lillydale give notice of and deposit for inspection by the public for a

period of two weeks, a proposed amendment to the Planning Scheme Map No. 10 of the Shire of Lillydale Planning Scheme.

The amendment, known as Amendment No. 127, is to rezone approximately 5 hectares of land in Quarry Road, Lillydale (volume 7132, folio 1426363) from Rural Zone to Garden Industrial Zone to enable some form of light industrial use on the site.

The proposed amendment is available for inspection at the office of the Shire of Lillydale, Anderson Street, Lillydale, and at the office of the Town and Country Planning Board, 235 Queen Street, Melbourne, and will be open for inspection during office hours, free of charge.

Any persons affected by the proposed Amendment may advise the Minister, in writing, of their objections thereto and such advice must reach the Minister on or before 12 November 1980.

Dated 24 October 1980

K. D. WILSON, Shire Secretary

Shire of Lillydale  
Anderson Street, Lillydale, 3140

10660

SHIRE OF MORNINGTON

ORDER UNDER DOG ACT 1970

*Restrictions on Dogs in Shopping Areas within the Municipality*

The Mornington Shire Council has made the following Order under the provisions of the Dog Act 1970 with respect to shopping areas:—

On and after 1 November 1980, the OWNER of any dog found in any shopping area within the Shire of Mornington, if the dog is not under the effective control of some person by means of a chain, cord or leash, shall be liable to a PENALTY of \$50.00 (first offence) \$100.00 (second or subsequent offence).

10741

D. G. COLLINGS, Shire Secretary

Town and Country Planning Act 1961 (Twelfth Schedule)

SHIRE OF MORNINGTON PLANNING SCHEME 1959  
(AS AMENDED)

NOTICE THAT A PLANNING SCHEME HAS BEEN PREPARED AND IS AVAILABLE FOR INSPECTION

Amendment No. 131, 1980

Notice is hereby given that the Council of the Shire of Mornington in pursuance of its powers under the Town and Country Planning Act 1961 has prepared a Planning Scheme to—

Rezone land in Shotton Road, Mount Eliza from Inter Urban Landscape Protection Zone to Public Purpose Reservation—State Rivers and Water Supply Commission, for the purpose of locating two high level water supply tanks.

A copy of the Scheme has been deposited at the office of the Council, Queen Street, Mornington, and at the office of the Town and Country Planning Board, 235 Queen Street, Melbourne, and will be open for inspection during office hours by any person, free of charge.

Any persons affected by the Planning Scheme are required to set forth in writing all objections they may have, addressed to the Shire Secretary, Mornington Shire Council, P.O. Box 78, Mornington, 3931, on or before 29 January 1981, and to state whether they wish to be heard in respect of their objections.

10781

D. G. COLLINGS, Shire Secretary

SHIRE OF NEWHAM AND WOODEND

APPOINTMENT AND REVOCATION OF POUND

Notice is hereby given that the Council of the Shire of Newham and Woodend, pursuant to Section 4 of the Pounds Act, has:

1. Appointed Crown Allotment M, Section 71, Parish of Woodend, situated corner Kronks Lane and Lancefield Road, as a pound;

2. Appointed Crown Allotment Part 2, Section 4, Township of Woodend, situated 92 High Street, Woodend, as a pound for impounding of dogs; and

3. Revoked the appointment of Crown Allotment 7, Section 12, Township of Woodend, situated Nicholson Street, as a pound.

By Order of the Council, 21 October 1980

10743

R. J. PEKIN, Shire Secretary

THE BALLARAT SEWERAGE AUTHORITY

Pursuant to section 119 (2) of the *Sewerage Districts Act 1958* (No. 6368), notice is hereby given of the intention to construct a sewer to provide for a property situated in the vicinity of the following streets:

SHIRE OF BUNINYONG—Semillon Grove, Mt Clear more particularly as shown on maps which are open for inspection at this office between the hours of 8.45 a.m. and 4.30 p.m.. Monday to Friday, inclusive.

B. E. LEACH, Secretary

20 October 1980

Water and Sewerage Offices, Grenville Street South,  
Ballarat 3350

10620

MELTON SEWERAGE AUTHORITY

The Sewerage Areas described as Nos. 1 and 2 in the General Notice published by this Authority in the *Government Gazette* on 13 August 1980, have been re-numbered 14 and 15 respectively.

The general boundaries of these Sewerage Areas are:

*Sewerage Area No. 14*—Centenary Avenue, Coburns Road, High Street, Palmerston Street.

*Sewerage Area No. 15*—Church Street, Raleighs Road, Palmerston Street, McKenzie Street and Yuille Street.

10621

M. B. WATSON, Secretary

MORNINGTON SEWERAGE AUTHORITY

NOTICE OF MAKING BY-LAW No. 11

*House Connection Works*

Notice is hereby given that the Mornington Sewerage Authority has made a By-Law Numbered 11 and titled—“House Connection Works” which repeals Section 14 (2) Division 4 of By-Law No. 8 and prescribes in relation to house connection works, including licences.

The By-Law was approved by the Governor in Council on 23 September 1980.

A copy of the By-Law is open for inspection free of charge during office hours at the office of the Authority, Civic Centre, Queen Street, Mornington.

10668

D. G. COLLINGS, Secretary

MOUNT ELIZA SEWERAGE AUTHORITY

NOTICE OF MAKING BY-LAW No. 8

*House Connection Works*

Notice is hereby given that the Mount Eliza Sewerage Authority has made a By-Law Numbered 8 and titled—“House Connection Works” which repeals Section 14 (2) Division 4 of By-Law No. 5 and prescribes in relation to house connection works, including licences.

The By-Law was approved by the Governor in Council on 23 September 1980.

A copy of the By-Law is open for inspection free of charge during office hours at the office of the Authority, Civic Centre, Queen Street, Mornington.

10667

D. G. COLLINGS, Secretary

SIXTH SCHEDULE

SEYMOUR SEWERAGE AUTHORITY

GENERAL NOTICE

The above mentioned Sewerage Authority having made provision for carrying off the sewage from each and every property which or any part of which is within the sewerage area hereinafter described doth hereby declare that on and after 1 November 1980 each and every property which or any part of which is within the said sewerage area shall be deemed to be a sewered property within the meaning of the *Sewerage Districts Act 1958*.

The boundaries of the sewerage area hereinbefore referred to are: Tarcombe Road east of the corner of Abdullah Road and eastern side of Avenel Road to the Gun Club as designated on Plan No. 1452/44.

The eastern side of Redbank Road north of the present, Sewerage Pumping Station to 114 Redbank Road as designated on Plan No. 1452/43.

The Plans may be inspected during office hours at the office of the Seymour Sewerage Authority located at Elizabeth Street, Seymour.

By order of the said Sewerage Authority

10619 T. G. WILKINSON, Chairman  
J. T. WILKINSON, Secretary

Notice is hereby given that John Francis Bullen Fuel Agent, John Matheson Hobday Solicitor and Digby Ian Harris Medical Practitioner all of Nhill, as Trustees for the Nhill Tennis Club have applied for a lease under Section 134 of the Land Act 1958, for a term of 21 years of Allotment 18 Section 25 Township of Nhill, containing 2 acres 3 roods 27 perches as a site for tennis courts. 10408

Take notice that Eva Patricia MacPherson of Boonah R.S.D. Birregurra, Birregurra in the State of Victoria by deed poll dated 9 October 1980 changed her name to Eva Patricia Johnston. 10682

Take notice that it is intended to apply to the Corporate Affairs Commission to change the name of Brooke Bond (Australia) Pty. Limited to Bushells Pty. Limited consequent upon the change of name of Bushells Pty. Limited to Bushells Foods Pty. Limited.

The reason for the proposed change of name is that Brooke Bond (Australia) Pty. Limited has, since its reorganisation of its corporate structure in July 1979, been trading under the name of Bushells Pty. Limited and it is proposed to make this trading arrangement permanent by changing the name of Brooke Bond (Australia) Pty. Limited to Bushells Pty. Limited consequent upon the change of Bushells Pty. Limited to Bushells Foods Pty. Limited.

These proposals are internal matters of a technical nature and do not affect the current or future trading situation so far as the public at large and the creditors are concerned.

Dated 10 October 1980

10724

A. E. DONLAN, Secretary

**NOTICE OF INTENTION TO APPLY FOR A LICENCE TO DIVERT WATER AND CUT RACE FROM THE RIVER MURRAY AT MURRABIT**

We hereby give notice that we have applied to the State Rivers and Water Supply Commission for the excision of Register Entry No. 387 in the Koondrook Irrigation Area of the Goulburn Murray Irrigation District and intend to lodge application for a diversion licence of equivalent volume (85 megalitres) including extra water right, for the purpose of irrigating Allotment 67, Parish of Murrabit West, and to occupy certain Crown Lands for works of diversion and to cut a race thereon.

Any objection to such application must be forwarded in writing to reach the State Rivers and Water Supply Commission, Melbourne before 28 November 1980 being thirty days from the first publication of this Notice.

DAVID OFFICER HALE  
NOELENE GENEVIEVE HALE

Box 43, Murrabit 3579

10657

Notice is hereby given that the partnership heretofore subsisting between Rodney James Brown and Barry Iddles carrying on business as Delicatessen Proprietors and Caterers under the registered name "La Chambree" was dissolved on 28 May 1980 pursuant to the Partnership Act 1958. The business was carried on by the said Rodney James Brown on behalf of the Partners until 1 October 1980. The said Barry Iddles had no authority to bind the said Firm from 28 May 1980 in any manner whatsoever.

KERRY E. McDONALD, solicitor, 60 Lyttleton Street, Castlemaine 10623

Notice is hereby given that the Partnership heretofore subsisting between Kevin Francis Cain and Peter John Sargent carrying on business as Landscape and Earthmoving Contractors under the name style or form "Western Port Landscapes" has been dissolved as from 20 October 1980.

10622

PETER JOHN SARGENT

Notice is hereby given that the Partnership heretofore subsisting between Romeo Rigo and Mario Ciciello carrying on the business of "Franco's Seafoods" Restaurant at 400 Nicholson Street, North Fitzroy, has been dissolved by mutual consent as from 11 October 1980. All debts due to and owing by the said Partnership will be received and paid by Mario Ciciello and Domenico Pedulla who will continue to carry on the said business at the same place.

Dated 21 October 1980

MORRIS MARGOLIS, solicitor, 133 Hawthorn Road, Caulfield 10624

**MARCO POLO RESTAURANT**

**NOTICE OF CHANGE IN PARTNERSHIP**

Frank and Dianne Joy Wong hereby give notice that they have dissolved their partnership with David and Lisa Ho which carried on business in the above name at Shops 12 and 13, Diamond Creek Plaza, corner Wensley and Main Streets, Diamond Creek. Frank and Dianne Joy Wong are continuing the said business in their own right at that address 10669

Take notice that the partnership between Peter Alan Goode, Rodney Clifford Quince and Robert Branton Portbury carried on under the name "Harbord Lodge" at Flat 8, Bluff Lodge, Summit Road, Mt. Buller has been dissolved as from 24 October 1980 and that business under the name will continue to be carried on by Rodney Clifford Quince and Robert Branton Portbury.

Dated 24 October 1980.

10685

Take notice that the partnership of Messrs Middletons, Oswald Burt & Co., Solicitors, carrying on business at 140 William Street, Melbourne and constituted by Francis Edward Lascelles Steuart, Robert Daniel Desmond, Ronald Lewis Eilenberg, Russell McDonald Brown, Neville Arthur Lane, Peter Morphett Taylor, Ian Geoffrey Middleton, Austin John Parnell, Denis Worrall, Lawrence William Quinn, Robert John Albert Cornall, John Robert Birrell, Timothy Russell Green, Ashley Michael Pelman, Ian Maxwell Dixon and David Roynance has been dissolved as to John Robert Birrell as at 29 September 1980 the said John Robert Birrell ceasing to be a partner of the firm as at that date the remaining partners to continue to carry on the legal practice under the name Messrs Middletons, Oswald Burt & Co. at the aforesaid address. 10721

**Companies Act 1961-1979, Section 254 (2) (b)**

**ROSSDALE PARK ESTATE PTY. LTD.**

**MEMBERS' VOLUNTARY WINDING UP**

Notice is hereby given that an Extraordinary General Meeting of the abovenamed Company duly convened and held at Brisbane on 15 October 1980, the following Special Resolution was passed:

"That the Company be voluntarily wound up and that Edward John Ahern of 31 Upper Cairns Terrace, Red Hill, be and is appointed Liquidator for the purpose of such winding up."

Dated 15 October 1980

19625

J. W. AHERN, Secretary

In the matter of the Companies Act 1961; and in the matter of DEHAN PTY. LIMITED (in Liquidation)—Notice Pursuant to Section 272 of the Companies Act 1961

Notice is hereby given that in accordance with section 272 of the Companies Act 1961 (as amended) a Final General Meeting of the Company will be held at the offices of the Liquidator, c/- Rezak, Bendel and Rochman, 3rd Floor, 390 St. Kilda Road, Melbourne, on Monday, 1 December 1980, at 11 a.m. for the purpose of having



laid before it by the Liquidator an account showing how the winding up has been conducted and the property of the Company disposed of and to hear any explanations that may be given by the Liquidator.

Dated 22 October 1980

J. REZAK, Liquidator

Rezak, Bendel & Rochman, public accountants, 390 St. Kilda Road, Melbourne 10626

In the matter of the Companies Act 1961; and in the matter of REGENT SHOE COMPANY PROPRIETARY LIMITED (in Liquidation)—Notice Pursuant to Section 272 of the Companies Act 1961

Notice is hereby given that in accordance with section 272 of the Companies Act 1961 (as amended) a Final General Meeting of the Company will be held at the offices of the Liquidator, c/- Rezak, Bendel & Rochman, 3rd Floor, 390 St. Kilda Road, Melbourne, on Monday, 1 December 1980, at 10 a.m. for the purpose of having laid before it by the Liquidator an account showing how the winding up has been conducted and the property of the Company disposed of and to hear any explanations that may be given by the Liquidator.

Dated 22 October 1980

E. ROCHMAN, Liquidator

Rezak, Bendel & Rochman, public accountants, 390 St. Kilda Road, Melbourne 10627

Companies Act 1961, Section 272

BERRY BANK PTY. LTD.  
A.Z.S.Z. INVESTMENTS PTY. LTD.  
COLERIDGE INVESTMENTS PTY. LTD.  
A.U.H.Z. INVESTMENTS PTY. LTD.  
H.H.O.Z. INVESTMENTS PTY. LTD.  
W.O.O.Z. INVESTMENTS PTY. LTD.  
A.F.A.Z. INVESTMENTS PTY. LTD.  
H.I.G.Z. INVESTMENTS PTY. LTD.  
W.P.C.Z. INVESTMENTS PTY. LTD.  
K. C. HOOPER PTY. LTD.  
SCOTTISH METALS PTY. LTD.  
BOOSTER INVESTMENTS PTY. LTD.  
DUNDEE PTY. LTD.  
CYPRESS GARDENS PTY. LTD.  
RAY CHAMBERS & ASSOCIATES PTY. LTD.  
FINANCE AMALGAMATED PTY. LTD.  
BEITRITT PTY. LTD.  
F.Y.I.Z. INVESTMENTS PTY. LTD.  
K.M.T.Z. INVESTMENTS PTY. LTD.  
PARAMOUNT MENS WEAR PTY. LTD.  
P.T.B.Z. INVESTMENTS PTY. LTD.  
R.A.O.Z. INVESTMENTS PTY. LTD.  
STANMARK PTY. LTD.  
BALLATEX TRADING CO. PTY. LTD.  
RAMAREL INVESTMENTS PTY. LTD.  
ANDERSON & TREMELLEN PTY. LTD.  
M.X.B.Z. INVESTMENTS PTY. LTD.  
HUTLEY ENTERPRISES PTY. LTD.  
N.O.R.Z. INVESTMENTS PTY. LTD.

(EACH OF THE ABOVE COMPANIES IN LIQUIDATION)

Notice is hereby given that the Final General Meeting of each of the above companies will be held at 17 Landcox Street, East Brighton, Victoria at 11 a.m. on 27 December 1980 for the purposes set out in the above Section.

Dated 23 October 1980

MURRAY DEWAR, liquidator, 17 Landcox Street, East Brighton, Victoria, 3187 10628

SOLVEIG HOLDINGS PTY. LIMITED (IN VOLUNTARY LIQUIDATION)

Notice is hereby given pursuant to Section 272 (2) of the Companies Act 1961 that a General Meeting of the members of the abovenamed Company will be held at 29 Alma Road, St. Kilda, at 10 a.m. in the forenoon on 1 December 1980, for the purpose of having an account laid before them showing the manner in which the winding up has been conducted and the assets of the Company disposed of and of hearing any explanations that may be given by the Liquidator.

J. FRANCK, Liquidator

R. Lowe, Lippmann, Figdor & Franck 10629  
No. 93—28260/80—4

Take notice that the affairs of the undermentioned companies are now wound up and that pursuant to section 272 (1) of the Companies Act a general meeting of the company will be held at the offices of Messrs P. N. Burke & Co., 7th Floor, 15 Young Street, Sydney on 27 November 1980 at the times shown below for the purpose of laying before them an account showing how the winding ups have been conducted and an explanation thereof.

10.20 a.m. M. & I.N. Pty. Limited  
10.25 a.m. Vernol Pty. Limited  
10.30 a.m. Genoa Pty. Limited  
10.35 a.m. Combines Knitting (Vic.) Pty. Limited  
10.40 a.m. Allure Manufacturing Pty. Limited  
10.45 a.m. Tex Fair Pty. Limited  
10.50 a.m. Midway Arcade Pty. Limited  
10.55 a.m. Enfour Pty. Limited  
11.00 a.m. Ash Services Pty. Limited  
11.05 a.m. Combines Knitting Mills Pty. Limited  
11.10 a.m. Ash Manufacturing Pty. Limited  
11.15 a.m. Silman Stores Pty. Limited  
11.20 a.m. Double S Investments Pty. Limited  
11.25 a.m. Rock Investments Pty. Limited  
11.30 a.m. Third Hamilton Industries Pty. Limited  
11.35 a.m. Sussan (Chadstone) Pty. Limited  
11.40 a.m. Valview Pty. Limited  
11.45 a.m. Ormany Pty. Limited  
11.50 a.m. Scott Street Pty. Limited  
11.55 a.m. Alandale Pty. Limited  
12.00 a.m. Sussan (Camberwell) Pty. Limited  
12.05 p.m. Ash Distributors Pty. Limited  
12.10 p.m. Toolern Pty. Limited  
12.15 p.m. Port Phillip Food Centre Pty. Limited  
12.20 p.m. Sterog Pty. Limited  
12.25 p.m. Sussan (Retailers) Pty. Limited  
12.30 p.m. Jonmar Investments Pty. Limited  
12.35 p.m. Palladium Theatres Pty. Limited  
12.40 p.m. Silza Developments Pty. Limited  
12.45 p.m. Silman Electrical Pty. Limited  
12.50 p.m. M. C. Herd (Exports) Pty. Limited  
12.55 p.m. R.F.T. Holdings Pty. Limited  
1.00 p.m. Krextiles Industries Pty. Limited  
1.05 p.m. Robendan Investments Pty. Limited  
1.10 p.m. Issol Builders Pty. Limited  
1.15 p.m. Silman Holdings Pty. Limited  
1.20 p.m. Waylyn Pty. Limited  
1.25 p.m. Nitor Pty. Limited  
1.30 p.m. Fourteenth Hamilton Industries Pty. Limited  
1.35 p.m. Eleventh Hamilton Industries Pty. Limited  
1.40 p.m. Eighth Hamilton Industries Pty. Limited  
1.45 p.m. Hamilton Shopfitters Pty. Limited  
1.50 p.m. Emmanuel Elastics Pty. Limited  
1.55 p.m. Third Manew Pty. Limited  
2.00 p.m. Fifth Manew Pty. Limited  
2.05 p.m. Sixth Manew Pty. Limited  
2.10 p.m. Seventh Manew Pty. Limited  
2.15 p.m. Gilad Pty. Limited  
2.20 p.m. Second Silzhm Properties Pty. Limited  
2.25 p.m. Tenth Manew Pty. Limited  
2.30 p.m. Sunline Investments Pty. Limited  
2.35 p.m. Black Range Timber Co. Pty. Limited  
2.40 p.m. Johnsville Pty. Limited  
2.45 p.m. Silman Investments Pty. Limited  
2.50 p.m. Fifth Hamilton Industries Pty. Limited  
2.55 p.m. Tenth Hamilton Industries Pty. Limited  
3.00 p.m. Sixth Hamilton Industries Pty. Limited  
3.05 p.m. Ninth Hamilton Industries Pty. Limited  
3.10 p.m. Seventh Hamilton Industries Pty. Limited  
3.15 p.m. Thirteenth Hamilton Industries Pty. Limited  
3.20 p.m. Fifteenth Hamilton Industries Pty. Limited  
3.25 p.m. Szydio Outwear Pty. Limited  
3.30 p.m. Szydio Sportswear Pty. Limited  
3.35 p.m. Marina Knitwear Pty. Limited  
3.40 p.m. Szydio Frocks Pty. Limited  
3.45 p.m. Fourth Yankton Investments Pty. Limited  
3.50 p.m. Hamilton Glass (Investments) Pty. Limited  
3.55 p.m. Third Pierre Investments Pty. Limited  
4.00 p.m. Szydio Coats Pty. Limited  
4.05 p.m. Eighth Holdrege Investments Pty. Limited  
4.10 p.m. Eighteenth Hamilton Industries Pty. Limited  
4.15 p.m. Regen (Colac) Theatres Pty. Limited  
4.20 p.m. Rene Holdings Pty. Limited  
4.25 p.m. Shirley Holdings Pty. Limited  
4.30 p.m. Roatin Pty. Limited

Dated 15 October 1980

B. H. SMITH, Liquidator

K. R. SHIRLAW, Liquidator

10630

## Unclaimed Moneys Act 1962

## Register of Unclaimed Moneys held by the—

Name of Owner on Books and Last Known Address	Total Amount Due to Owner	Description of Unclaimed Money	Date when Amount first became Payable
VAMGAS LTD.			
Abbott, William, 7/22 Warilda St, Bexley, N.S.W.	30.00	Dividend	31.5.79
Akerman, Allan, 201 Beaumont St, Hamilton, N.S.W.	15.00	"	"
Allen and Horsburgh Pty. Limited, Unit 31, Canal Rd, Saint Peters, S.A.	12.00	"	"
All State Securities Pty. Ltd., 3rd Floor, 30 Kings Park Rd, West Perth, W.A.	36.00	"	"
Alroma Pty. Limited, 20 Ash St, Sydney, N.S.W.	12.00	"	"
Anderson, Ivan Valdimar, 30 Thomas Ave, Saint Morris, S.A.	15.00	"	"
Arbuckle, Graeme Beresford, c/o P.O. Box 2, Kununurra, W.A.	120.00	"	"
Autoterms Pty. Limited, c/o J. F. Crouch, 70 Bourke St, Potts Point, N.S.W.	60.00	"	"
Bailey, Russell Stuart, c/o Russell Stuart Pty. Ltd., 392 Oxford St, Paddington, N.S.W.	600.00	"	"
Barker, John William, 4/1 Bates St, East Malvern	12.00	"	"
Barnes, Clyde John, 22 The Parade, Five Dock, N.S.W.	12.00	"	"
Barter, Betty, 7 Fourth Ave, Lane Cove, N.S.W.	12.00	"	"
Battaglini, Leo, c/o Post Office, Rasmussen via Townsville, Qld.	30.00	"	"
Bayley, Clive Spencer, c/o M. J. Hobbs and Co., G.P.O. Box 4914, Sydney, N.S.W.	30.00	"	"
Beasley, John R. and Gertrude A., 15 Hill Ave, Cumberland Park, S.A.	12.00	"	"
Bennett, Ivan Leonard, 78 St. Leonards Ave, Leederville, W.A.	102.00	"	"
Bennett, John Edwin, 168 Nyleta St, Cooper Plains, Qld.	15.00	"	"
Berry, Kenneth John, 29 Coventry Rd, Strathfield West, N.S.W.	15.00	"	"
Best, Audrey, 31 Bibby St, Carlton, N.S.W.	12.00	"	"
Bialylew, Halina, 14 Kambea Gve, Caulfield	24.00	"	"
Black, Lynette Ruth, 11/230 Glebe Point Rd, Glebe, N.S.W.	12.00	"	"
Blake, Gerald Thomas, 40 Duxford St, Paddington, N.S.W.	24.00	"	"
Bolster, John Douglas, 7/11 Nicholson St, Footscray	12.00	"	"
Bolza, Joe, 3 Bedford Ave, Surrey Hills	27.00	"	"
Bond, Richard Peter, c/o Duffield Hastwell and Co., 44 Grenfell St, Adelaide, S.A.	15.00	"	"
Bott, Donald Roland, 4 Ryan Ave, Dianella, W.A.	12.00	"	"
Bourne, Edna May, Box 316, Port Macquarie, N.S.W.	30.00	"	"
Bradman, George William, 429 Maroubra Bay Rd, Maroubra, N.S.W.	12.00	"	"
Bratner, Maurice, c/o Plastics Assessories Pty. Ltd., 24/26 Bowden St, Alexandria, N.S.W.	30.00	"	"
Brewster, John Arthur S., 4 Stirling St, Tusmore, S.A.	12.00	"	"
Bridges, Winifred Frances, 8 Monterey St, St. Ives, N.S.W.	12.00	"	"
Broadbent, Frederick Verdun, 21 Lackey St, Haymarket, N.S.W.	24.00	"	"
Burrows, Zita Josephine, 65 Sampson St, Orange, N.S.W.	12.00	"	"
Byrne, Anthony Clive, P.O. Box 52, Cammeray, N.S.W.	15.00	"	"
Cahill, Maria, 30 Waratah Pde, Narrawenna, N.S.W.	15.00	"	"
Caoustos, Basil, 308 Barkly St, Brunswick	15.00	"	"
Carey, John, c/o P.O. Box 182, Milsons Point, N.S.W.	12.00	"	"
Carmody, Gaye and Lorelei P.O. Box 210, Mount Waverley	15.00	"	"
Carroll, Hugh James and Jean, 5 Beresford Cres, Rose Bay, N.S.W.	15.00	"	"
Carter, Doris Edith, 5 Felstead Cres, Hammersley, W.A.	15.00	"	"
Carter, Edward Samuel, Victoria House, 175 Goderich St, East Perth, W.A.	30.00	"	"
Caspari, Peter George, 4/10 Carlisle St, Bondi, N.S.W.	15.00	"	"
Chalker, William, 9 Macey St, Avondale Heights	15.00	"	"
Chandler, George Thomas, 56 Yale Rd, Thornlie, W.A.	12.00	"	"
Cornfield Investment Services Pty. Ltd., 341 Military Rd, Mosman, N.S.W.	30.00	"	"
Cross, Keith, c/o Bank of New South Wales, Box 2722 G.P.O., Sydney, N.S.W.	12.00	"	"
Delohery, Robert Arthur, 28 Sargood St, Toorak	42.00	"	"
Delohery, Susan, 17A Edward St, Gordon, N.S.W.	18.00	"	"
Dent, Peter, 180 Phillip St, Sydney, N.S.W.	15.00	"	"
De Santis, Domenico, 180 Lygon St, East Brunswick	30.00	"	"
Dines, Jean Alice (Sqn. Officer), Officers Mess, R.A.A.F., Penrith, N.S.W.	15.00	"	"
Dinghy Pty. Limited, c/o Carr Horden and Co., 19-31 Pitt St, Sydney, N.S.W.	42.00	"	"
Dinte, Nathan, 35 Towns Rd, Vaucluse, N.S.W.	45.00	"	"
Dinte, Rachael, 35 Towns Rd, Vaucluse, N.S.W.	12.00	"	"
Ditchmen, Arthur Clarence, Kilkivan, Qld.	12.00	"	"
Doherty, Brian Joseph (estate of), c/o C.B.H. Rowlandson and Co., 268 Old Northern Rd, Castle Hill, N.S.W.	21.00	"	"
Doubleday, Arthur Ernest, 23 Railway St, Mount Kuringai, N.S.W.	15.00	"	"
Drayton, Alan, 1 Bolinda Rd, North Balwyn	18.00	"	"
Dzubiel, Jurgen Peter, 7/18 Prince St, Randwick, N.S.W.	12.00	"	"
Economos, Margaret Joy, 6 Wattle St, Fullarton, S.A.	24.00	"	"
Edwards, Janice, 74 Waverley St, Scone, N.S.W.	30.00	"	"
Elwes, Gillian, c/o A.N.Z. Bank, Mortlake	24.00	"	"
Evans, Idris, 33 Miller St, Hughes, A.C.T.	24.00	"	"
Fallon, Terry Patrick, 8 Frances Ave, Para Hill, S.A.	12.00	"	"
Fenton, Patrick, P.O. Box 125, North Sydney, N.S.W.	15.00	"	"
Figerova, Anna, 11 Wakefield St, Hawthorn	15.00	"	"
Fisken, Breton Byng, 38 Guildford Rd, Surrey Hills	12.00	"	"
Foggo, James Gordon and Gale Leslie, 24 Picton St, Broken Hill, N.S.W.	15.00	"	"
Freeman, Elizabeth Miriam, 11 Florence St, Strathfield, N.S.W.	15.00	"	"
Friems, Willi and Christine, 4/6 Albenca St, Mentone	15.00	"	"
Gardiner, Bernard Owen, 194 St. Georges Terrace, Perth, W.A.	14.25	"	"
Geegan, Ellen Agnes, 68 Ryeland St, Miller, A.C.T.	30.00	"	"

## Unclaimed Moneys Act 1962

## Register of Unclaimed Moneys held by the—

Name of Owner in Records and Last Known Address	Total Amount Due to Owner	Description of Unclaimed Money	Date when Amount first became Due
\$			
VAMGAS LTD.—continued			
George, Rex Peter Ernest, 9 Market Crt, Reservoir	30.00	Dividend	31.5.79
Giaquinta, Phillip Michael, 70 Point Walter Rd, Picton, W.A.	12.00	"	"
Goldman, Vera, 2 Ramsgate Ave, North Bondi, N.S.W.	36.00	"	"
Gordon, Elizabeth Anne, 25 Whelan St, Surfers Paradise, Qld.	18.00	"	"
Gosson, Leslie George, 23 Eurobin Ave, Manly, N.S.W.	18.00	"	"
Grant, Helene, 147 Bronte Rd, Waverley, N.S.W.	36.00	"	"
Green, Allan John, G.P.O. Box 254c, Adelaide, S.A.	102.00	"	"
Griffiths, Aileen Scott, 72 Malsbury Rd, Normanhurst, N.S.W.	30.00	"	"
Griffiths, David, 45 Irving St, Mount Waverley	18.00	"	"
Griffiths, Sandra Jay S., 63 Parriwi Rd, Mosman, N.S.W.	18.00	"	"
Grubisic, Marinko, 14 Claude Ave, Cremorne, N.S.W.	12.00	"	"
Guest, William John C., 446 Collins St, Melbourne	30.00	"	"
Haber, Harry Fred, 14 Liverpool Rd, Croydon, N.S.W.	12.00	"	"
Haines, Norman Lindsay, 44 Kyre Ave, Kingswood, S.A.	30.00	"	"
Hall, Anthony Lloyd, 42 Trevi St, Jindalee, Qld.	12.00	"	"
Hall, Clive Gordon, 41A Arkana Rd, Balga, W.A.	18.00	"	"
Hans, Beverley, 11 Holford Cres, Gordon, N.S.W.	15.00	"	"
Harrison, Jeffrey Edmond, c/o Valder and Co., 275 George St, Sydney, N.S.W.	15.00	"	"
Hart, Dorothy Beryl, 1/41 Central Ave, Mosman, N.S.W.	60.00	"	"
Hauser, John, 46 Hawkins St, Cooma, N.S.W.	30.00	"	"
Heaney, Lawrence Henry, 1/14A Henson St, Summer Hill, N.S.W.	15.00	"	"
Hebbard, Patricia E. and Ronald Rieman, 67 Georges River Cres, Oyster Bay, N.S.W.	12.00	"	"
Hennelly, Victoria Grace, Crafers High Rd, West Pennant Hills, N.S.W.	24.00	"	"
Henshaw, Joan G. and Barbara J. Bond, 84 Shortland Ave, Homebush, N.S.W.	18.00	"	"
Herrman, Richard Peter, 100 Grandview Rd, Newport, N.S.W.	12.00	"	"
Holliday, Michael John A., 63 Greer St, Bardon, Qld.	30.00	"	"
Hookway, Grahame Arthur, 19 Wilson St, Peppermint Grove, W.A.	15.00	"	"
Horden, Helen, c/o 28 Quarry Rd, Dundas, N.S.W.	30.00	"	"
Horsfall, Gwendoline, 6 Horsfall St, Ermington, N.S.W.	43.20	"	"
Howes, Dorothy Lynette, 48 South St, Preston	12.00	"	"
Hribar, Jan Patricia, c/o John Holland Construction, 65 Queens Rd, Melbourne	15.00	"	"
Hughes, William, 6 Whiteleaf Cres, Glengowrie, S.A.	21.00	"	"
Hulme, William Edmond, 50 The Avenue, Nedlands, W.A.	24.00	"	"
Hunt, Carolyn Ann, 14 Shepherd Rd, Artarmon, N.S.W.	12.00	"	"
Hunt, Peter Anthony, 39 The Boulevard, Lilyfield, N.S.W.	12.00	"	"
Hurley, Lindsay B. and Patricia M. c/o Botanical Hotel, Domain Rd, South Yarra	60.00	"	"
Hutchinson, Joy Irene, 65 Eastern Arterial Rd, St. Ives, N.S.W.	36.00	"	"
Ingham, Gordon Henry, 4 Short Cres, Beaumont, S.A.	24.00	"	"
Jackel Nominees, c/o Morlen and Co., 201 Balaclava Rd, Caulfield	12.00	"	"
Jackson, Franklin Henry, 12 Cadell St, Toowong, Qld.	18.00	"	"
Jenkins, Frederick George, 12 Moorhead St, Camberwell	12.00	"	"
Joan Davis Holdings Pty. Ltd., c/o Francis Grill and Company, 115 Clarence St, Sydney, N.S.W.	48.00	"	"
Johnson, Elsie Florence, 45 Arnold St, Killara, N.S.W.	18.00	"	"
Jones, Antony David Stanford, 4 Mangola St, Darwin, N.T.	12.00	"	"
Keam, Geoffrey R. (estate of), c/o Norton Gibbs and Logan, 397 Little Collins St, Melbourne	12.00	"	"
Keddie, Peter McKay, P.O. Box 59, Port Kembla, N.S.W.	15.00	"	"
Kelen, George, Royal Prince Alfred Hospital, Camperdown, N.S.W.	18.00	"	"
Kasinowski, Lubow, 2 Glenview St, Paddington, N.S.W.	12.00	"	"
Kimpton, Janice Elizabeth, 56 Peacock Pde, Belrose, N.S.W.	12.00	"	"
Knoblauch, Margaret G.P., Lucinda Park, Logan Rd, Mount Gravitt, Qld.	15.00	"	"
Lamb, Mary, 3/2 Dudley St, Randwick, N.S.W.	12.00	"	"
Lamble, Geoffrey Brian, 396 Kent St, Sydney, N.S.W.	12.00	"	"
Lancashire, Elsie Elizabeth, 108 Toorak Rd, Camberwell	15.00	"	"
Landry, Robert Brousard, 112 Cascade St, Paddington, N.S.W.	30.00	"	"
Lanyon, Brian Frederick S., 54 Plummer Rd, Mentone	12.00	"	"
Larcombe, Alan Leonard, 8 Anembo Cres, Killara, N.S.W.	12.00	"	"
Laws, Robert Anthony, c/o Aust. Aquitaine Petroleum Ltd., G.P.O. Box 142, Brisbane, Qld.	15.00	"	"
Lazarus, Mina, 4/645 Toorak Rd, Toorak	12.00	"	"
Lean, Jack Harvey, 2/1 The Esplanade, Balmoral Beach, N.S.W.	30.00	"	"
Leatch, Evelyn May, 14 Morden St, Cammeray, N.S.W.	12.00	"	"
Lesnicki, Jan Steffn, 270 Hanson Rd, Mansfield Park, S.A.	15.00	"	"
Lewis, Henry James Brock, 2 Mawhera Ave, Sandy Bay, Tasmania	12.00	"	"
Lewis, Peter, 135 Orchardleigh St, Guilford, N.S.W.	12.00	"	"
Lightfoot, Dorothy, c/o A. J. Hardy and Sons, P.O. Box 234, Burleigh Heads, Qld.	45.00	"	"
Loader, William John, G.P.O. Box 103c, Perth, W.A.	12.00	"	"
Magnetti, Walter Domenico and Carmen Magnetti, P.O. Box 106, Proserpine, Qld.	12.00	"	"
Malechi, Henry V., 14 Kambea Gve, Caulfield	18.00	"	"
Manuel, William Oliver, 4 Chiltern Crt, Fern St, Surfers Paradise, Qld.	18.00	"	"
Martin, Kathleen Rosa, 3 Bakewell Cres, Marino, S.A.	15.00	"	"
Maslin, Irene Mary, Tally Ho, Curlewis, N.S.W.	120.00	"	"
Mason, Lionel John, P.O. Box 958, Mount Isa, Qld.	12.00	"	"

## Unclaimed Moneys Act 1962

Register of Unclaimed Moneys held by the—

Name of Owner on Books and Last Known Address	Total Amount Due to Owner	Description of Unclaimed Money	Date when Amount first became Payable
5			
VAMGAS LTD.—continued			
Megahey, Ruth, 74 Kingston St, Haberfield, N.S.W.	12.00	Dividend	31.5.79
Mellin, Bruce William, 10/263 Dandenong Rd, Prahran	15.00	"	"
Mercer, Robert B. and Wendy L. Jarrett, c/o F. C. Bryant and Co., P.O. Box 116 Rockdale, N.S.W.	12.00	"	"
Minahan, Carmel Maria, 5 Sluman St, Denistone, N.S.W.	12.00	"	"
Mooney, Josephine, 18/91 West Esplanade, Manly, N.S.W.	30.00	"	"
Morassut, Agostino, P.O. Box 71, Darlinghurst, N.S.W.	15.00	"	"
Morgan, Sydney R. and Terance P. Canny, 7 Red Gum Dve, Belair, S.A.	15.00	"	"
Morrow, Robert Blake, 23 Simmons St, Box Hill North	12.00	"	"
Muggeridge, Robert Owen, P.O. Box 11, Stirling, S.A.	21.00	"	"
McCubbery, William Maurice, P.O. Box 2625x, G.P.O. Melbourne	15.00	"	"
McDonnell, William, G.P.O. Box 483, Sydney, N.S.W.	30.00	"	"
McElhinney, Adrian John, 8/85 Ryan St, Hill End, Qld.	12.00	"	"
McInnes, Myee, 51 Armitree St, Kingsgrove, N.S.W.	15.00	"	"
McInnes, Noel M. and Johanna C. McInnes, 23 Bass Gardens, Manuka, S.A.	12.00	"	"
McInnes, Raymond Gordon, 25 Amberdale Ave, Picnic Point, N.S.W.	90.00	"	"
McIntosh, Peter John, Inverness, Muttaborra, Qld.	12.00	"	"
McNamara, Michael Denis, 96A Broomfield St, Cabramatta, N.S.W.	30.00	"	"
McRostie, Colin George, c/o F. H. Faulding and Company, 13 James St, Adelaide, S.A.	18.00	"	"
McSwain, Heather, 25 River Pde, Salter Point, W.A.	15.00	"	"
Nahum, Jeffrey and Sylvia Nahum, P.O. Box 26, Crows Nest, N.S.W.	45.00	"	"
Neville, Kathleen, 19 Glen Rd, Arncliffe, N.S.W.	12.00	"	"
Ngongataha Limited, G.P.O. Box 4910, Sydney, N.S.W.	60.00	"	"
Nicholls, William Bona, 20 Harkness St, Bendigo	24.00	"	"
O'Brien, Florris Ada, 52 Adelaide St, Armadale	24.00	"	"
Olbourne, Norman Adrian, Royal Prince Alfred Hospital, Camperdown, N.S.W.	18.00	"	"
Oliver, Brian Hall, 670A Toorak Rd, Toorak	15.00	"	"
O'Neill, Joseph, 8 Fitzroy Pl, Hobart, Tasmania	18.00	"	"
Pace, Sam, P.O. Box 346, Mackay, Qld.	24.00	"	"
Packer, Charles Lionel, 5 Collins Ave, Rose Bay, N.S.W.	12.00	"	"
Paton, Alexander, 25 Pine St, Brookvale, N.S.W.	12.00	"	"
Perkins, Keith Frederick, 34 Woomboo Rd, Longreach, Qld.	24.00	"	"
Perkins, Robert Austin, 419 Glynburn Rd, Leabrook, S.A.	216.00	"	"
Perks, Arthur James, 420 Fitzroy St, Dubbo, N.S.W.	15.00	"	"
Perry, David George, Waikerie, S.A.	12.00	"	"
Peters, James, 36 Neil St, Kangaroo Flat	12.00	"	"
Phillips, Ralph, 14 Robe St, Newmarket, Qld.	30.00	"	"
Pindari Pty. Ltd., Hill St, Merimbula, N.S.W.	135.00	"	"
P. L. Clingan Pty. Ltd., 58 Pemberton St, Botany, N.S.W.	12.00	"	"
Pocock, Charles Henry, 143 Ludstone St, Hampton	12.00	"	"
Potter, Valerie Mary, 4/37 Moruben Rd, Mosman, N.S.W.	18.00	"	"
Preston, Miles Geoffrey, c/o Shell Co. of Aust., 2-12 Carrington St, Sydney, N.S.W.	24.00	"	"
Prince, Marjorie, 5 Marana Rd, Earlwood, N.S.W.	12.00	"	"
Pyne, Marie, 107 Cassowry St, Longreach, Qld.	12.00	"	"
Quigley, Barry John, 30 Taro St, Blakehurst, N.S.W.	12.00	"	"
Raff, Pamela Margaret, Sunnydale, Harlin, Qld.	30.00	"	"
Rech, Valerio, 1/29 Toolamboool Rd, Carnegie	12.00	"	"
Reniro Pty. Ltd., c/o M. Wainberg, P.O. Box 129 Lindfield, N.S.W.	48.00	"	"
Richards, Joy, 7/27 Ormond Rd, Elwood	18.00	"	"
Richards, Joycelyn Lorna, 7/27 Ormond Rd, Elwood	12.00	"	"
Riley, Joyce Ada Ena, 19 Ocean Rd, Manly, N.S.W.	24.00	"	"
Ripka, Dawn Margaret, 111 High St, Willoughby, N.S.W.	27.00	"	"
Ritchard, Ian Geoffrey, 20 Heights Cres, Middle Cove, N.S.W.	12.00	"	"
Robertson, Stewart, 3/22 Airport Rd, Brooklyn Park, W.A.	12.00	"	"
Robinson, Phillip, 3/7 Railway Ave, Armadale	15.00	"	"
Rohan, Bridie, 5A Hayes St, Neutral Bay, N.S.W.	21.00	"	"
Rojan Pty. Limited, 23 Kiamala Cres, Lindfield, N.S.W.	12.00	"	"
Rowell, Judith Addison, 3 Canberra Gve, Brighton	15.00	"	"
Schultz, Lois Ebris, 173 Moggill Rd, Taringa, Qld.	12.00	"	"
Schwarz, Anton, c/o 26 Service St, Hampton	60.00	"	"
Seaton, John C., 161 Parramatta Rd, Homebush, N.S.W.	33.00	"	"
Seedsman, Mardi Caroline A., 10 Garnett St, Killara, N.S.W.	12.00	"	"
Seymour, Gregory John, 100 Bunaebard Rd, Gynea, N.S.W.	12.00	"	"
Sharpe, Lilian Jean, Hill St, Merimbula, N.S.W.	15.00	"	"
Sharpe, William Alexander W., Hill St, Merimbula, N.S.W.	96.00	"	"
Sharpe, William George, P.O. Box 13, Warrandyte	15.00	"	"
Simmons, David Winston, 2 Cygnet St, Novar Gardens, S.A.	18.00	"	"
Simpkin, George Francis, c/o A.N.Z. Bank Ltd., Wycheproof	15.00	"	"
Simpson, Joan, 6/369 Abbotsford St, North Melbourne	24.00	"	"
Smith, Alan Frederick, 24 Highlands Ave, Wahroonga, N.S.W.	15.00	"	"
Smith, Henry Landon, 62 Margaret St, Sydney, N.S.W.	330.00	"	"
Smythe, Terrance E., and Jill Smythe, 79 Gywdir St, Moree, N.S.W.	12.00	"	"
Solomon, Sarah, 885 New South Head Rd, Rose Bay, N.S.W.	30.00	"	"
Spilva, Andrew, 1 Anselm Gve, Glenroy	12.00	"	"
Spinks, Ed Frank, 7 McIntosh Ave, Pasadena, S.A.	120.00	"	"
Spooner, Berry Dubois, 55 Greengate Rd, Killara, N.S.W.	15.00	"	"

## Unclaimed Moneys Act 1962

## Register of Unclaimed Moneys held by —

Name of Owner on Books and Last Known Address	Total Amount Due to Owner	Description of Unclaimed Moneys	Date when Amount first became Payable
5			
VAMGAS LTD.—continued			
Spreadborough, James, 75 Miles St, Mount Isa, Qld.	10.50	Dividend	31.5.79
Stephen, Barbara, 18 Hewlett St, Granville, N.S.W.	30.00	"	"
Stevenson, Albert W. and Betty F. Stevenson, 1 Gill St, Belmont	12.00	"	"
Stocker, John William, 15 Corcen Ave, Beaumaris	30.00	"	"
Sumich, Kellie, 143 Simpson St, East Melbourne	15.00	"	"
Sutton, John M. and Joan C. Sutton, 63 Central Ave, Como, N.S.W.	30.00	"	"
Tarbett, Barbara, 95 Charnley St, Deniliquin, N.S.W.	12.00	"	"
Tavolaro, Rosa and Antonio Tavalaro, 130 Lygon St, East Brunswick	60.00	"	"
Taylor, Sylvia Jean, 13 Thorne Cres, Mitchell Park, S.A.	15.00	"	"
Thoroughgood, Terresse, 177 Doncaster Ave, Kensington, N.S.W.	30.00	"	"
Tierney, Peter Thomas, 2 Lawrence Tce, Oaklands Park, S.A.	18.00	"	"
Tooley, David Maxwell, 126 King St, Sydney, N.S.W.	12.00	"	"
Towler, John, c/o G.P.O. Box 254C, Adelaide, S.A.	10.65	"	"
Rudball, Frances Dorothy, 2 Nanoon Cl, Elsternwick	12.00	"	"
265 Elizabeth Street Pty. Ltd., c/o Dr. Reginald V. McFadzean, G.P.O. Box 4910, Sydney, N.S.W.	60.00	"	"
Vallence, George, 3 Brisbane St, Harris Park, N.S.W.	108.00	"	"
Wagner, Mervyn Arthur, 44 Rosetta St, Collinswood, S.A.	15.00	"	"
Wakim, Paul Vincent, 88 Amaherst St, Cammeray, N.S.W.	30.00	"	"
Ward, Denis Kevin, 19 Rabbett St, Frenchs Forest, N.S.W.	12.00	"	"
Watson, Kenneth Graham, 6 Murray Street, Tanunda, S.A.	12.00	"	"
Welch, John B., 6 Savery St, Garran, A.C.T.	12.00	"	"
Wertkin, Vivian, 377 Bourke St, Melbourne	60.00	"	"
Wheeler, June Ada, 173 Moggill Rd, Taringa, Qld.	12.00	"	"
Whyte, John Anthony, 1 Lower North East Rd, Campbelltown, S.A.	12.00	"	"
Wiggins, Francis Markham, 44 Briggs St, Oakleigh	60.00	"	"
Wignall, Mary, 30 High St, Glenelg, S.A.	12.00	"	"
Willett, Lilian Cecilia, 7/5 Sir Fred Schonell Dve, St. Lucia, Qld.	42.00	"	"
Williams, Alan Coombes, 48 Cranbrook Rd, Rose Bay, N.S.W.	570.00	"	"
Williams, Anthony R., 271 Bourke St, Wagga Wagga, N.S.W.	36.00	"	"
Williams, Laurence Edgington, 753 Mowbray Rd, Lane Cove, N.S.W.	15.00	"	"
Wills, Christopher R., 2/3 Campbell St, Parramatta, N.S.W.	21.00	"	"
Wilson, Julia M. and Nicholas C. Wilson, 17 Hoseason St, Mawson, A.C.T.	30.00	"	"
Wilson, Margaret Elizabeth, 332 West Coast Hwy, Scarborough, W.A.	30.00	"	"
Wood, Patricia Louise, 65 Railway Pde, Lakemba, N.S.W.	30.00	"	"
Wreford, John Lawrence, 61 Russell St, Adelaide, S.A.	120.00	"	"
Wyner, Michael, c/o Socomin (N.S.W.) Pty. Ltd., P.O. Box 384, Chatswood, N.S.W.	12.00	"	"
Yeowart, John, c/o J. Yeowart and Son, 293 Queen St, Brisbane, Qld.	12.00	"	"
Yong, Shui Foh, 4/1431 High St, Glen Iris	30.00	"	"
Yuill, Colin Kenneth, 3 Karranga Ave, Killara, N.S.W.	72.00	"	"
Zurcher, Hans Ulrich, 4/22 Royston St, Kings Cross, N.S.W.	15.00	"	"
Choy, Sidney, and Rita Choy, 80 Great South Rd, Papakura, N.Z.	10.20	"	"
Colwell, Peter, c/o Shaw Savill Line, P.O. Box 592, Wellington, N.Z.	25.50	"	"
Mulligan, Pauline Judith C., 10 Keith Ave, Remuera, Auckland, N.Z.	10.20	"	"
Skipper, John, P.O. Box 242, Dannevirke, N.Z.	25.50	"	"
Deathridge, Ernest Frederick, Coach and Horses, 178 High St, Stoke, Newington, London, U.K.	25.50	"	"
Mesh, Frederick Lance, Cnr. Bungalow Kingswood Rd, Shortlands Bromley, Kent, U.K.	25.50	"	"
Morley, Victor Frederick, 1 Beckman Cl, Fort Rd, Halstead, Kent, U.K.	10.20	"	"
Spencer, George Robert, Langton Hall, Market Harborough, Leicestershire, U.K.	51.00	"	"
Repacholi, Michael Harry, 103 Monterey Dve, Ottawa, Ontario, Canada	38.25	"	"
Broadley, David Colin, 101 West Birchcroft St, Arcadia, California, U.S.A.	12.75	"	"
Beaty, Irma Vera, Kerema Traders Ltd., Kerema, T.P.N.G.	12.75	"	"
Hanslow, Leslie George, c/o G. J. Reid, Gumine, via Goroka, T.P.N.G.	25.50	"	"
Jean, Brian Phillip, c/o Beathel W. K. E., P.O. Box 12, Kieta, Bougainville, T.P.N.G.	10.20	"	"
Usher, Leonard G. and Jane H. Usher, c/o Fiji Times, P.O. Box 1167 Suva, Fiji	12.60	"	"
Volk, Rainer Herbert, 8000 Munchen 2, Turkenstr, 28 West Germany	25.50	"	"
Cheung, Peter, 12 Carmel Rd, Stanley, Hong Kong	21.00	"	"
Neppelenbroek, Hermanus E., Vinkenlaan 5, Malden, Holland	10.20	"	"
10482			
VAN LEER AUSTRALIA PTY. LIMITED			
Dimcogle, B., 12 Prinsell St, North Altona	15.15	Wages	30.6.74
Dozet, M., 13 Marigold Ave, North Altona	19.55	"	"
Carroll, C., 4 Maddox Rd, Newport	53.47	"	"
Franze, S., 297 Blackshaws Rd, North Altona	54.82	"	"
Camilleri, J., (address unknown)	15.66	"	"
Caffey, S., (address unknown)	25.55	"	"
Hook, G., 2/9 McDonald St, Mordialloc	15.64	"	"
Abbate, W., 35 Stenhouse Ave, Brooklyn	56.40	"	"
Mearns, B., 4 Ferguson St, South Kingsville	28.61	"	"
Kerdanowski, Z., (address unknown)	16.21	"	"
Bakker, R., 21 Staples Cres, North Altona	26.11	"	"
10481			

## Unclaimed Moneys Act 1962

Register of Unclaimed Moneys held by the—

Name of Owner on Books and Last Known Address	Total Amount Due to Owner	Description of Unclaimed Money	Date when Amount first became Payable
\$			
NICHOLAS INTERNATIONAL LIMITED			
Baume, Anette M. (Mrs), 178 Eastern Rd, Wahroonga, N.S.W.	20.00	Dividend	3.11.78
Blake, John A., 11/45A Ormond Esp, Elwood	20.00	"	"
Kingston, Mary C. (Miss), 205 William St, Melbourne	60.00	"	"
Kreutl, Frank, 5 Meredith St, Elwood	20.00	"	"
Lamb, Kathleen M. (Miss), 3 Grant St, East Malvern	80.00	"	"
Lee, Anthony, G.P.O. Box 37, Kensington, N.S.W.	12.00	"	"
Lojon Pty. Ltd., P.O. Box 160, Eastwood, N.S.W.	40.00	"	"
Mack, Kathleen (Mrs), 369 Church Rd, Templestowe	12.00	"	"
Mansfield, George B., 58 Belair Ave, Glenroy	12.00	"	"
Masters, Frederick, 17 Buchanan Ave, North Balwyn	20.00	"	"
Newman, Stanley F., Flat 9, 41 Rockley Rd, South Yarra	20.00	"	"
Travis, Leon P. (Dr), 44 Felix Cres, Ringwood	80.00	"	"
Varipatis, Jack, Box 185 P.O., Coffs Harbour Jetty, N.S.W.	16.00	"	"
Wright, Lynette J. (Mrs), Flat 12, 12 Grange Rd, Glenhuntly	16.00	"	"
Cessford, Jenny W. (Mrs), Chalet Shalimar, Rua Da Beira Litoral, Estoril, Portugal	21.28	"	"
Henderson, Kenneth M. (Dr), Apt, 42, 15 Av De Miremont, 1206 Geneva, Switzerland	15.43	"	"
Bank of America N.T. and S.A., a/c 3854 Swift, Santa Monica Branch 218, 1301 Fourth St, Santa Monica, California	12.92	"	"
Barr, Adam W., 17 O'Connors Rd, Beacon Hill, N.S.W.	12.80	"	"
Erth Pty. Ltd., c/o Mr J. M. Fox, 12 Govett Ave, Hawthorne, Queensland	40.00	"	"
Jem Pty. Ltd., c/o J. W. Tate, 186 Belgrave Esp, Sylvania Waters, N.S.W.	400.00	"	"
Doyle, Thomas J., Littleton, Stillorgan Rd, Co. Dublin, Eire	16.41	"	"
Asherson, Raphael, Netherlands Bank Buildings, 85 St Georges St, Cape Town, South Africa	21.28	"	"
Coffey, Mervyn N., c/o Ulster Bank Limited, Athboy Co., Meath, Eire	19.94	"	"
O'Mahoney, Kate (Mrs) and James D., 52 Grand Pde, c/o T. A. Buckley and Son, Cork, Eire	54.52	"	"
Rennie, Margaret, (Mrs.), Box 3113, Wellington, N.Z.	10.44	"	"
Campbell, Mary T. (Mrs.), 6 Wellington Park, Belfast, BT9 6DJ, Northern Ireland	11.43	"	"
Curtis, M. P. National Westminster Bank, 12 High St, Colchester, Essex	24.47	"	"
Deakin, Kenneth V., 15 High St, Atherton, Manchester	30.60	"	"
Filshie, James, North Dalmottar Farm, Old Kilpatrick, Glasgow	18.36	"	"
Holroyd, Marie E., 23 York Rd, Windsor, Berks.	30.60	"	"
Laurence, Irene M. (Mrs.), Welbeck, Canvey Island, Essex	15.30	"	"
Levingstone, Louis, 11 Chapman St, Glasgow.	15.30	"	"
Sewell, Douglas and Marjorie E., 1 Sidney Cres., Newbiggin by the Sea, Northumberland	15.30	"	"
Hamilton, Andrew, 91 Ormonde Dr. Glasgow, S4	12.25	"	"
Douglas-Joyce, Charlotte M. (Miss) c/o Keehans Hotel, Regency Square, Brighton, Sussex	45.90	"	"
Kernick, Alice M. (Miss), 14 Black Heath Rise, London SE13	30.60	"	"
Leivers, George, 180 Standhill Rd, Carlton, Nottingham	22.94	"	"
Lewis, Theresa (Mrs.), 12 Old Hall Road, Salford, 7 Lancs.	15.30	"	"
Morris, Harold F., Carramorr, 14 Heol Isaf, Radyr, Cardiff, CF 4 8AL	16.81	"	"
Pearce, John, 12 Sheffield Rd, Slough, Berks	10.09	"	"
Sidney, Hugh R., 2 Barnard Ct, Chislehurst, Kent	30.60	"	"
Wicks, Alfred E., 39 Merrieield Ave, Broadstone, Poole, Dorset BH 18 8DA	35.17	"	"
Wright, Mary C., Dalveen, Edinburgh Rd, Linlithgow, West Lothian	36.72	"	"
Baume, Anette, M. (Mrs.) 178 Eastern Rd, Wahroonga, N.S.W.	17.50	"	"
Lamb, Kathleen M., (estate of), c/o Fell and Starkey, 505 St Kilda Rd, Melbourne	70.00	"	"
Lee, Anthony, G.P.O. Box 37, Kensington, N.S.W.	10.50	"	"
Mansfield, George B., 58 Belair Rd, Glenroy	10.50	"	"
Morton, Roderick E., 85 Roslyn St, Brighton	17.50	"	"
Schulz, Maree A. (Mrs.), 7 Violet Ct, Doncaster	35.00	"	"
Standish, Graeme B., 4/42 Beaumaris Pde, Highbett	17.50	"	"
Varipatis, Jack, Box 185 G.P.O., Coffs Harbour Jetty, N.S.W.	14.00	"	"
Wright, Lynette J. (Mrs.), Flat 12, 12 Grange Rd, Glenhuntly	14.00	"	"
Cessford, Jenny W. (Mrs.), Chalet Shalimar, Rua Da Beira Litoral, Estoril, Portugal	18.62	"	"
Henderson, Kenneth (Dr.), Apt. 42, 15A Av De Miremont, 1206 Geneva, Switzerland	13.50	"	"
Swift, Bessie (Mrs.), 5060 La Jolla Boulevard 3F, San Diego, California, 92109	11.30	"	"
Barr, Adam W., 17 O'Connors Rd, Beacon Hill, N.S.W.	11.20	"	"
Gillian, Annie (Mrs.), 17 Gregory Tce, Lapstone, N.S.W.	38.50	"	"
Kitson, Ian M. 1 Braeside Ave, Smithfield, N.S.W.	14.00	"	"
Doyle, Thomas J., Littleton, Stillorgan Rd, Co. Dublin, Eire	14.36	"	"
Coffey, Mervyn N., c/o Ulster Bank Limited, Athboy Co., Meath, Eire	17.44	"	"
Crimmins, Leila (Miss), 445 Howth Rd, Dublin, Eire	27.93	"	"
Fitzgerald, Thomas, 11 Merrion Sq, Dublin, 2, Eire	13.96	"	"
O'Mahoney, Kate (Mrs.) and James D., c/o T.A. Buckley and Son, 52 Grand Pde, Cork, Eire	47.70	"	"
Doggett, Albert H. Clifton, 13 South View Letchworth, Herts	50.92	"	"
Filshie, James, North Dalmottar Farm, Old Kilpatrick, Glasgow	15.28	"	"

## Unclaimed Moneys Act 1962

Register of Unclaimed Moneys held by the—

Name of Owner on Books and Last Known Address	Total Amount Due to Owner	Description of Unclaimed Money	Date when Amount first became Payable
<b>S</b>			
<b>NICHOLAS INTERNATIONAL LIMITED—continued</b>			
Levingstone, Louis, 11 Chapman St, Glasgow, Scotland	12.73	Dividend	3.11.78
Rushbrook, Harold E., 137 Prices Gardens, West Acton, London W3	10.19	"	"
Smith, Sidney, 2 Bradbrook House, Studio Pl, Kinnerton St, London W1	12.73	"	"
Alderwood, James H., 6 Vicarage La, Humberstone, Leics.	12.73	"	"
Brown Jessie G., (Mrs.) and Hall, Jessie M. Harrison, Ivey House, Church St, Barford, Warwick	19.07	"	"
Buxton, Julia (Mrs.), Barclays Bank Limited, 31 High Row, Darlington	34.54	"	"
Cuthbertson, Kathleen G. (Mrs.), 22 The Hythe, Maldon, Essex	23.61	"	"
Hamilton, Andrew, 91 Ormonds Dr, Glasgow S4, Scotland	10.19	"	"
Hirst, Harry, c/o National Westminster Bank Ltd., 40 Commercial Rd, Swindon, Wilts, England	25.45	"	"
Douglas-Joyce, Charlotte M. (Miss), c/o Keehans Hotel, Regency Square, Brighton, Sussex	38.18	"	"
Kenn, Laura M. (Mrs.), Elses Farm, Weald, Sevenoaks, Kent	25.45	"	"
Leivers, George, 180 Standhill Rd, Carlton, Nottingham	19.07	"	"
Lewis, Theresa (Mrs.), 12 Old Hall Rd, Salford, 7 Lancs.	12.73	"	"
Livingstone, Gwendoline I. (Mrs.), c/o Lloyds Bank Ltd, 177 High St, Orpington, Kent	22.25	"	"
Morris, Harold F., Carramorr, 14 Heol Isaf, Radyr, Cardiff CF4 8AL	13.98	"	"
Sidey, Hugh R., 2 Barnard Cl., Chislehurst, Kent	25.45	"	"
Waid, Margaret (Miss), c/o George Waid, Flat 1, Lot 2, Clonaver Drive, Belfast, BT 4	10.19	"	"
Wicks, Alfred B., 39 Merriemfield Ave, Broadstone, Poole, Dorset	29.26	"	"
Wight, Mary C., Dalveen, Edinburgh Rd, Linlithgow, West Lothian	30.54	"	"
Murray, Tim J., Court Farm, Mulhuddart, Dublin 2, Ireland	19.25	"	"
10480			
<b>AFL HOLDINGS LIMITED</b>			
Adams, Gwladys (address unknown)	47.52	Dividend	21.7.78
Bath, Mark, (address unknown)	43.20	"	9.2.78
Brown, Rea S., Yahna, Dundee, N.S.W.	51.04	"	21.7.78
Chapman, W. V. Pty. Ltd., (address unknown)	27.62	"	17.2.77
Cockrane, Harry C., Calimpa Siding, T.P.O. North West, N.S.W.	12.72	"	8.2.79
Hamilton, Raymond G., 26 Middle Head Rd, Mosman, N.S.W.	12.72	"	"
Hawke, Clarence G., 16a Mitchell Rd, Rose Bay, N.S.W.	10.16	"	"
Hibberson, James B., (estate of) 8 Vancouver St, Red Hill, A.C.T.	61.44	"	21.7.78
Hosking, Norman J., Allora, Good Hope Rd, Yass, N.S.W.	19.20	"	8.2.79
Jamiesons (Australia) Pty. Ltd., P.O. Box 66, Newport Beach, N.S.W.	12.72	"	"
Kintore Pastoral Co. Pty. Ltd., (address unknown)	41.92	"	17.2.77
Lawton, Leslie C., Leona, Berremanga, N.S.W.	19.20	"	8.2.79
Levy Investments Pty. Ltd., A. L., (address unknown)	82.16	"	9.2.78
McDougall, Graeme V., Tarawonga, Walcha, N.S.W.	17.04	"	8.2.79
Naroogal Park Pty. Ltd., (address unknown)	22.86	"	9.2.78
Northanga Pastoral Co. Pty. Ltd., c/o L. R. Nomchong, 91 Wallace St, Braidwood, N.S.W.	33.67	"	"
Price, Glenda C., Ashton, Warialda, N.S.W.	17.04	"	8.2.79
Robinson, David R., (address unknown)	14.24	"	"
Sanderson, Geoffrey T., (address unknown)	80.80	"	21.7.78
Smith, William B., P.O. Box 30, Barmedman, N.S.W.	15.36	"	8.2.79
Thompson, Ian R., (address unknown)	25.27	"	19.2.76
Tobitt, Wendy B., (address unknown)	67.28	"	21.7.78
Ward, Douglas K., Balmerino, R.M.B. 403 Cowra Rd, Young, N.S.W.	13.52	"	8.2.79
Kelly, Phyllis E., 10 Bank Rd, Edithvale	355.96	"	9.2.78
Winter, Hans, c/o 161 Little Malop St, Geelong	67.20	"	"
<b>SYDNEY REGISTER</b>			
Huggett, Elizabeth, (address unknown)	15.00	"	17.2.77
Mason, Albert E., 92 Amherst, St, Cammeray, N.S.W.	143.68	"	21.7.78
Dickson, Peta L., c/o T.G.J. Maule, P.O. Box 30, Mater Hill, Qld.	51.04	"	9.2.78
10658			

## COMPANIES ACT 1961

Notice is hereby given that meetings of creditors will be held at 332 Albert Street, East Melbourne on 27 November 1980 pursuant to section 261 (5) at the respective times indicated:—

- 10.00 a.m. Alan Howard & Co. Pty. Ltd. (in Liquidation)  
 11.00 a.m. Regency Homes Group Pty. Ltd. (in Liquidation)  
 12.00 p.m. Starina Nominees Pty. Ltd. (in Liquidation)  
 12.30 p.m. Stockley & Co. Pty. Ltd. (in Liquidation)

## Agenda

(1) To accept the resignation of Mr B. J. O'Connor as Liquidator of the Company.

(2) To appoint another Liquidator in his place as appropriate according to the wishes of creditors.

Dated 29 October 1980

B. J. O'CONNOR, Liquidator.

Brendan O'Connor & Co., Suite 19 562 St. Kilda Road, Melbourne, 3004 10654

**Companies Act 1961****BASFORD PTY. LTD.****MEMBERS' VOLUNTARY LIQUIDATION***Notice of Final Meeting*

Notice is hereby given that pursuant to section 272 of the Companies Act 1961, a Final Meeting of the members of the above-named Company will be held at the office of N. L. Hocking, 8 Market Street, Box Hill on 3 December 1980 at 10.00 a.m. for the purpose of presenting the Liquidator's account of the winding up.

Dated 21 October 1980

10631

N. L. HOCKING, Liquidator

**COMPANIES ACT (SECTION 254 (2) (b))**

On 16 October 1980 the following special resolutions were passed by R. & S. Kirwan Enterprises Pty. Ltd.:

(a) That the Company be wound up voluntarily.

(b) That Barry James Rumpf of 390 St. Kilda Road, Melbourne be appointed Liquidator.

10632

B. J. RUMPF, Liquidator

**ALPAREX PROPRIETARY LIMITED**

At an Extraordinary General Meeting of Shareholders held on 6 October 1980, the following Special Resolution was passed:—

"That the company be wound up voluntarily and that Kurt Edward Lippmann of 29 Alma Road, St. Kilda, be appointed liquidator."

Dated 20 October 1980

10633

K. E. LIPPMANN, Liquidator

**Companies Act 1961, Section 254 (2) (b)****VIVIAN HOLDINGS PROPRIETARY LIMITED**

Notice is hereby given that at an Extraordinary General Meeting of the members of the above-named Company held on 20 October 1980 it was resolved that the Company be wound up voluntarily and that Michael Warson of 5th Floor, 71 Queens Road, Melbourne, 3004 be appointed liquidator.

Notice is also given that after 21 days from this date, I shall proceed to distribute the assets. All creditors having any claims against the Company should furnish particulars of same by that date otherwise I shall proceed to distribute the assets without regard to their claim.

Dated 20 October 1980

10634

M. WARSON, Liquidator

In the Supreme Court of Victoria—1980 Co. No. 11600—

In the matter of the Companies Act 1961; and in the matter of NATURAL AIR PTY. LTD.

Notice is hereby given that a Petition for the winding-up of the above-named Company by the Supreme Court was on 14 October 1980 presented by Rank General Electric Major Appliances Pty. Ltd. whose registered office is situate at 12 Barcoo Street, East Roseville in the State of New South Wales and that the said Petition is directed to be heard before the Court sitting at Melbourne at the hour of 10.30 a.m. on Thursday 20 November 1980 at the Practice Court and any Creditor or contributory of the said Company desiring to support or oppose the making of an Order on the said Petition may appear at the time of hearing by himself or his Counsel for that purpose; and a copy of the Petition will be furnished to any Creditor or contributory of the said Company requiring the same by the undersigned on payment of the regulated charge for same.

The Petitioner's address is 12 Barcoo Street, East Roseville in the State of New South Wales.

The Petitioner's Solicitors are A. E. Wundele & Co., 253 Lonsdale Street, Melbourne.

A. E. WUNDELE &amp; CO., solicitors for the petitioner

NOTE—Any person who intends to appear on the hearing of the said Petition must serve on or send by post to the above-named A. E. Wundele & Co., notice in writing of his intention to do so. The notice must state the name and

address of the person, or if a firm, the name and address of the firm and must be signed by the person or firm or his or their Solicitor (if any) and must be served or, if posted, must be sent by post in sufficient time to reach the above-named not later than four o'clock in the afternoon on 19 November 1980. 10635

In the Supreme Court of Victoria—1980 No. C.11599—In the matter of the Companies Act 1961; and in the matter of MARTIN JOYCE COLOUR STUDIOS PROPRIETARY LIMITED

Notice is hereby given that a petition for the winding up of the above-named company by the Supreme Court was, on 14 October 1980, presented by Bond Colour Laboratories Pty. Ltd.

And that the said petition is directed to be heard before the Court sitting at Melbourne at the hour of 10.30 in the forenoon, on 27 November 1980; and any creditor or contributory of the said company desiring to support or oppose the making of an order on the said petition may appear at the time of hearing by himself or his counsel for that purpose; and a copy of the petition will be furnished to any creditor or contributory of the said company requiring the same by the undersigned on payment of the regulated charge for the same.

The Petitioner's address is 4 Gwynne Street, Richmond in the State of Victoria.

The Petitioner's solicitor is Mr Michael J. Pharr of Suite 13, 285 Carlisle Street, Balacava in the State of Victoria.

MICHAEL J. PHARR, solicitor and authorized agent for the petitioner

NOTE—Any person who intends to appear on the hearing of the said petition must serve on or send by post to the above-named Michael J. Pharr notice in writing of his intention so to do. The notice must state the name and address of the person, or if a firm, the name and address of the firm, and must be signed by the person or firm, or his or their solicitor (if any), and must be served, or, if posted, must be sent by post in sufficient time to reach the above-named not later than four o'clock in the afternoon of 26 November 1980 10656

Companies Act 1961, Section 272 (2)—In the matter of MONETA INVESTMENTS PTY. LTD. (in Liquidation)—Notice of Final Meeting

Notice is hereby given that pursuant to Section 272 of the Companies Act, the final meeting of the members of the abovenamed Company will be held at 23 Alta Street, Canterbury, Victoria, on 29 November 1980 at 12.15 p.m. for the purpose of having an account laid before it showing the manner in which the winding up has been conducted and the property of the Company disposed of and hearing any explanation that may be given by the liquidator. Dated 24 October 1980

T. P. BENNETT, liquidator, 53 Through Road, Burwood 10659

**H. & M. K. PTY. LTD. (IN VOLUNTARY LIQUIDATION)**

Notice is hereby given in pursuance of Section 272 of the Companies Act 1961, that a General Meeting of the Members of the above-mentioned Company will be held at the offices of Morris Cohen, Glen & Co., 26 Commercial Road, Prahran on Tuesday, 2 December 1980 at 2.30 p.m. for the purpose of receiving the Liquidator's account showing how the winding up has been conducted and the Company's property disposed of.

Dated 22 October 1980

10670

MICHAEL KLARBERG, Liquidator

**GEORGE GRANT PTY. LTD. (IN VOLUNTARY LIQUIDATION)**

Notice is hereby given that by a Resolution of the Company, Arthur Edward Duldig of 19A Springfield Avenue, Toorak was appointed Liquidator of George Grant Pty. Ltd. on 24 October 1980 and that the situation of the Liquidator's office is 19A Springfield Avenue, Toorak.

10671

ARTHUR E. DULDIG, Liquidator



**Companies Act 1961, Section 254 (2) (b)****PRAGLOWSKI PTY. LTD. (IN LIQUIDATION)**

Notice is hereby given that at an extraordinary General Meeting of the Members of the abovementioned Company held on 21 October 1980 it was resolved that the Company be wound up voluntarily and that Mr Edward Peter Taylor of 583 Hampton Street, Hampton be, and is appointed Liquidator for the purposes of such winding up.

Notice is also given that after 21 days from this date I shall proceed to distribute the assets.

All Creditors having any claims against the Company should furnish particulars of same by that date otherwise I shall proceed to distribute the assets without regard to their claims.

Dated 22 October 1980  
10672

E. P. TAYLOR, Liquidator

**Companies Act 1961****SURLINGHAM GRAZING COMPANY PTY. LTD.**

At a General Meeting of the members of Surlingham Grazing Company Pty. Ltd. duly convened and held at Mena Park, Beaufort on 11 October 1980 it was resolved that the company be wound up voluntarily, and that Mr Kevin Foley, Public Accountant, of 17 Lydiard Street North, Ballarat be appointed Liquidator.

Dated 20 October 1980

KEVIN FOLEY, Liquidator

J. N. Cooke, Foley & Co., public accountants, 3rd Floor, A.M.P. Building, 17 Lydiard Street North, Ballarat, 3350  
10673

**Companies Act 1961****STUDHEATH DEVELOPMENTS PTY. LTD. (IN VOLUNTARY LIQUIDATION)**

At an Extraordinary General Meeting of the abovenamed company duly convened and held at 9 Langhorne Street, Dandenong, on 16 October 1980, the following resolution was duly passed as a Special Resolution.

That the company be wound up voluntarily and that Mr L. A. Jaensch of P. R. Charlwood & Co., 2nd Floor, 237 Lonsdale Street, Dandenong, be appointed liquidator for the purpose of such winding up.

Dated 16 October 1980

10674

L. A. JAENSCH, Liquidator

**Companies Act 1961****GORDON NORRIS PTY. LTD. (IN VOLUNTARY LIQUIDATION)**

At an Extraordinary General Meeting of the abovenamed company duly convened and held at 9 Langhorne Street, Dandenong, on 17 October 1980, the following resolution was duly passed as a special resolution.

That the company be wound up voluntarily and that Mr L. A. Jaensch of P. R. Charlwood & Co., 2nd Floor, 237 Lonsdale Street, Dandenong, be appointed liquidator for the purpose of such winding up.

Dated 17 October 1980

10675

L. A. JAENSCH, Liquidator

**CANNON HILL INVESTMENTS PROPRIETARY LIMITED (IN VOLUNTARY LIQUIDATION)****SPECIAL RESOLUTION TO WIND UP**

At an Extraordinary General Meeting of the Company duly convened and held at 67-69 Kepler Street, Warrnambool on 21 October 1980, the following resolution was passed as a Special Resolution:

"That the Company be wound up voluntarily."

At the meeting Mr Joseph James Purcell was appointed liquidator for the purpose of winding up.

Dated 21 October 1980

10676

J. J. PURCELL, Liquidator

**Companies Act 1961—In the matter of MANDRAKE PROPRIETARY LIMITED (in Liquidation)**

A first dividend is intended to be declared in the abovementioned matter. Creditors who have not proved their debts by 24 November 1980, will be excluded from the dividend.

The date of Liquidation was 2 November 1979

Dated 24 October 1980

B. K. TAYLOR, Liquidator

B. K. Taylor & Co., 576 St. Kilda Road, Melbourne, Vic.,  
3004 10677

**Companies Act 1961—In the matter of DULAK STORES PROPRIETARY LIMITED (in Liquidation)**

A first dividend is intended to be declared in the abovementioned matter. Creditors who have not proved their debts by 24 November 1980, will be excluded from the dividend.

The date of Liquidation was 13 June 1980

Dated 24 October 1980

B. K. TAYLOR, Liquidator

B. K. Taylor & Co., 576 St. Kilda Road, Melbourne, Vic.,  
3004 10678

**Companies Act 1961, Section 254 (2) (b)****KELTHORN PTY. LIMITED****MEMBERS' VOLUNTARY WINDING UP**

Notice is hereby given that at an Extraordinary General Meeting of the Members of Kelthorn Pty. Limited held on 22 October 1980, it was resolved that the company be wound up voluntarily and that Colin Stanley Wight and John Alexander Hutson Chartered Accountants of 500 Bourke Street, Melbourne be appointed joint and several liquidators.

Notice is also given that 21 days from this date we shall proceed to distribute the assets. All creditors having any claims against the company should furnish particulars of same by that date, otherwise we shall proceed to distribute the assets without regard to their claim.

Dated 23 October 1980

C. S. WIGHT AND J. A. HUTSON, liquidators, 500 Bourke Street, Melbourne, Vic., 3000  
10684

**The Companies Act 1961****DANDENONG INDUSTRIAL HARDWARE CO. PTY. LTD. (IN LIQUIDATION)****NOTICE CONVENING FINAL MEETING OF THE COMPANY, PURSUANT TO SECTION 272 (1)**

Notice is hereby given that the final meeting of members and creditors of the abovenamed Company will be held at the offices of Touche Ross & Co., 12th Floor, 440 Collins Street, Melbourne on 27 November 1980 at 10.00 a.m. for the purpose of laying before the Meeting an account showing how the winding up has been conducted and the property of the Company has been disposed of and giving any explanation thereof.

Dated 28 October 1980

G. O. HARRISON, Liquidator

Touche Ross & Co., chartered accountants, 440 Collins Street, Melbourne, 3000  
10686

**Companies Act 1961, Section 272 (1)****NEACOR PTY. LTD.****NOTICE OF FINAL MEETING**

Take notice that the affairs of the abovenamed Company are now fully wound up and that in pursuance of section 272 (1) of the Companies Act 1961, a general meeting of the Company will be held at 8 Station Street, Ringwood on 28 November 1980 at 10.00 o'clock in the forenoon for the purpose of laying before it an account showing how the winding up has been conducted and the property of the company disposed of and giving any explanation thereof.

Dated 23 October 1980

10687

B. H. WHITAKER, Liquidator

## The Companies Act 1961

OLIAN HOLDINGS PTY. LTD. (IN LIQUIDATION)  
NOTICE CONVENING FINAL MEETING OF THE COMPANY,  
PURSUANT TO SECTION 272 (1)

Notice is hereby given that the final meeting of members and creditors of the abovenamed Company will be held at the offices of Touche Ross & Co., 12th Floor, 440 Collins Street, Melbourne on 28 November 1980 at 10.00 a.m. for the purpose of laying before the meeting an account showing how the winding up has been conducted and the property of the Company has been disposed of and giving any explanation thereof.

Dated 28 October 1980

G. O. HARRISON, Liquidator

Touche Ross &amp; Co., chartered accountants, 440 Collins Street, Melbourne, 3000 10688

## Companies Act 1961, Section 272

FOLLALEX PTY. LTD. (IN LIQUIDATION)  
MORGAN DRAINAGE PTY. LTD. (IN LIQUIDATION)  
MAGDALENE PTY. LTD. (IN LIQUIDATION)  
MUCHA RUBBER TYRE WHOLESALE (VIC.) PTY.  
LTD. (IN LIQUIDATION)  
POLVAL PTY. LTD. (IN LIQUIDATION)  
R. G. HOLDINGS PTY. LTD. (IN LIQUIDATION)  
SHOLDON PTY. LTD. (IN LIQUIDATION)  
THELEMANNIANA PTY. LTD. (IN LIQUIDATION)

Notice is hereby given that the final meetings of the members of the abovenamed companies will be held at my offices on Friday 28 November 1980 commencing at 11.00 a.m., for the purpose of laying before the meetings an account showing how the windings up have been conducted and the property of the companies disposed of and giving any explanation thereof.

Dated 21 October 1980

V. R. DYE, Liquidator

V. R. Dye &amp; Co., chartered accountants, 536 Whitehorse Road, Mitcham 3132 10689

## Companies Act 1961—In the matter of MILEAWAY CARRYING PTY. LTD. (in Liquidation)

Notice is hereby given that at an extraordinary General Meeting of the members of the abovenamed Company held on 20 October 1980, it was resolved that the Company be wound up voluntarily and that Michael William Ernest Hosking be nominated as Liquidator for the purposes of such winding up, and that at a meeting of Creditors held later on the same day my appointment as Liquidator was confirmed.

Notice is also given that persons having claims against the Company should lodge a proof of debt within 21 days at my office at 153 Park Street, South Melbourne, 3205.

Dated 20 October 1980

MICHAEL W. E. HOSKING, Liquidator

Hosking, Dyer &amp; Co., public accountants, 153 Park Street, South Melbourne, 3205. Telephone: 690 6466 10690

## The Companies Act 1961—In the matter of LANHAR PTY. LIMITED

Pursuant to section 254 (2) (b) of the Companies Act 1961 notice is hereby given that at an Extraordinary General Meeting of the company duly convened and held on 21 October 1980 the following Resolution was passed as a Special Resolution:—

"That the company be wound up voluntarily" and at such meeting James Stanley Phillips of 25 Faulkner Street, Blackburn, Chartered Accountant was appointed liquidator for the purposes of the winding up.

Dated 21 October 1980

10692

E. K. TATNALL, Director

## Companies Act 1961

D. N. & P. M. REAL ESTATE PTY. LTD. (IN LIQUIDATION)  
(Formerly Punshon & Plummer Pty. Ltd.)

## CREDITORS' VOLUNTARY WINDING UP

Notice is hereby given that at an Extraordinary General Meeting of the members of the above-mentioned company, held on 17 October 1980, it was resolved that the company

be wound up voluntarily and at a Meeting of Creditors held on the same day it was resolved that for such purposes Warick Allen Leeming & Kevin Francis Courtney of Duesbury Johnston & Marks, 114 William Street, Melbourne 3000, be appointed Liquidators.

Notice is also given that after twenty-one (21) days from this date, I shall proceed to distribute the assets. All creditors having claim against the company should furnish particulars of same by that date, otherwise I shall proceed to distribute the assets without regard to their claim.

Dated 20 October 1980

W. A. LEEMING, Liquidator

Duesbury Johnston &amp; Marks, chartered accountants, 114 William Street, Melbourne, Vic. 3000. Telephone: 67 8331 10691

## The Companies Act 1961—In the matter of PMATS PTY. LIMITED (in Voluntary Liquidation)—Creditors' Winding Up

Notice is hereby given that at the Extraordinary General Meeting of PMATS Pty. Limited duly convened and held at 461 Bourke Street, Melbourne in the State of Victoria on 9 October 1980 the following Resolution was proposed and passed as a Special Resolution.

"That the company be wound up voluntarily."

Dated 9 October 1980

10693

K. J. RUSSELL, Liquidator

## The Companies Act 1961—In the matter of STAMPKO HOLDINGS PTY. LIMITED (in Voluntary Liquidation)—Creditors' Winding Up

Notice is hereby given that at the Extraordinary General Meeting of Stampko Holdings Pty. Limited duly convened and held at 461 Bourke Street, Melbourne in the State of Victoria on 9 October 1980, the following Resolution was proposed and passed as a Special Resolution.

"That the company be wound up voluntarily."

Dated 9 October 1980

10694

K. J. RUSSELL, Liquidator

## The Companies Act 1961—In the matter of STAMPKO ENGINEERING PTY. LIMITED (in Voluntary Liquidation)—Creditors' Winding Up

Notice is hereby given that at the Extraordinary General Meeting of Stampko Engineering Pty. Limited duly convened and held at 461 Bourke Street, Melbourne in the State of Victoria on 9 October 1980, the following Resolution was proposed and passed as a Special Resolution.

"That the company be wound up voluntarily."

Dated 9 October 1980

10695

K. J. RUSSELL, Liquidator

## In the matter of FIRESTONES STORES (KYNETON) PTY. LIMITED (in Liquidation); and in the matter of the Companies Act 1961

Take notice that the abovenamed company on 17 October 1980 duly resolved by special resolution that it be wound up voluntarily, and resolved by ordinary resolution that Anthony Gardiner Sherlock be appointed liquidator for the purposes of the winding up.

21 October 1980

F. H. BAINS, Secretary

Coopers &amp; Lybrand, chartered accountants, G.P.O. Box 2650, Sydney, N.S.W. 2000 10696

## In the Supreme Court of Victoria—1980 No. Co. 11608—In the matter of the Companies Act 1961; and in the matter of ROBIN WHITE SERVICES PTY. LTD.

Notice is hereby given that a Petition for the winding up of the abovenamed Company by the Supreme Court was on 16 October 1980 presented by Robin White Services Pty. Ltd., and that the said Petition is directed to be heard before the Court sitting at the 15th Court, Law Courts, William Street, Melbourne on 27 November 1980 at the hour of 10.30 o'clock in the forenoon; and any creditor or contributory of the said Company desiring to support

or oppose the making of an Order on the said Petition may appear at the time of hearing by himself or his Counsel for that purpose; and a copy of the Petition will be furnished to any Creditor or contributory of the said Company requiring the same by the undersigned on payment of the regulated charge for the same.

The Petitioner's registered office in the State of Victoria is 332 Chapel Street, Prahran.

The Petitioner's solicitors are Messrs Madden Butler Elder & Graham, of 500 Collins Street, Melbourne.

MADDEN BUTLER ELDER AND GRAHAM, solicitors for the petitioner.

NOTE—Any person who intends to appear on the hearing of the said Petition must serve on or send by post to the abovenamed solicitors, notice in writing of his intention to do so. The notice must state the name and address of the person or if a firm, the name and address of the firm and must be signed by the person, or firm, or his or their Solicitors (if any) and must be served, or if posted, must be sent by post in sufficient time to reach the abovenamed not later than 4 o'clock in the afternoon of 26 November 1980.

#### The Companies Act 1961

##### P. & L. GEORGE HOLDINGS PTY. LTD. (IN LIQUIDATION)

Notice is hereby given that as liquidator of the abovenamed Company I have fixed Friday 14 November 1980 as the day on or before which creditors of the Company are to prove their debts or claims and to establish any title they may have to priority under Section 292 or be excluded from the benefit of a first and final distribution made before such debts are proved or as the case may be from objecting to such distribution.

Dated 20 October 1980

V. R. DYE, Liquidator

V. R. Dye & Co., chartered accountants, 536 Whitehorse Road, Mitcham 3132 10697

In the Supreme Court of Victoria—1980 Co. No. 11518—  
In the matter of the Companies Act 1961; and in the matter of SELWOOD INTERSTATE TRANSPORT PTY. LTD.

Winding-up Order made 16 October 1980.

Name and Address of Liquidator: Dennis John Cogle, 144 Jolimont Road, East Melbourne.

G. D. BURNETT & CO., solicitors for the petitioner 10717

In the Supreme Court of Victoria—No. Co. 11612 of 1980—  
In the matter of the Companies Act 1961; and in the matter of INDORE PTY. LTD. (formerly named and called Australian Buying Advisory Service Proprietary Limited); and in the matter of a Petition dated 21 October 1980

Notice is hereby given that a Petition for the winding up of the abovenamed Company by the Supreme Court of Victoria was on 22 October 1980, presented by Victorian Automobile Chamber of Commerce; and that the said Petition is directed to be heard before the Court sitting at the Practice Court, Supreme Court, Lonsdale Street, Melbourne, at the hour of 10.30 o'clock on 4 December 1980; and any creditor or contributory of the said Company desiring to support or oppose the making of an Order on the said Petition may appear at the time of hearing by himself or his Counsel for that purpose; and a copy of the Petition will be furnished to any creditor or contributory of the said Company requiring the same by the undersigned on payment of the regulated charge for the same.

The Petitioner's address is VACC Building, 464 St. Kilda Road, Melbourne.

The Petitioner's Solicitors are Messrs Keith Hercules & Sons of 464 St. Kilda Road, Melbourne.

MESSRS KEITH HERCULES & SONS, solicitors for the petitioner

NOTE—Any person who intends to appear on the hearing of the said Petition must serve on or send by post to the abovenamed Solicitors, Notice in writing of his intention so to do. The Notice must state the name and address of the person, or, if a firm, the name and address of the

firm; and must be signed by the person or firm, or his or their Solicitor (if any), and must be served, or, if posted, must be sent by post in sufficient time to reach the abovenamed not later than four o'clock in the afternoon of 3 December 1980. 10718

#### Companies Act 1961, Section 272 (2)

##### APOLLO PRODUCTS PTY. LIMITED (IN VOLUNTARY LIQUIDATION)

#### NOTICE OF FINAL MEETING

Notice is hereby given that pursuant to Section 272 (1) of the Companies Act 1961 a general meeting of the members and creditors of Apollo Products Pty. Ltd. will be held in 10th Floor Boardroom, of Pannell Kerr Forster 271 William Street Melbourne on 1 December 1980 at 11.00 o'clock in the forenoon.

The purpose of the meeting is to lay accounts before it showing the manner in which the winding up has been conducted and the property of the Company disposed of and of hearing any explanation that may be given by the Liquidator.

Dated 22 October 1980

M. A. COPPINS AND J. B. HUTCHINS, joint and several liquidators Apollo Products Pty. Ltd. care of Pannell Kerr Forster, 271 William Street, Melbourne, 3000 10719

#### Companies Act 1961

##### COMPANIES REGULATIONS, REGULATION 54

##### J. E. NEWBEGIN & CO. PTY. LTD. (RECEIVER AND MANAGER APPOINTED) (IN LIQUIDATION)

Take notice that the Liquidator of the abovenamed company has fixed Friday 14 November 1980 as the day on or before which creditors of the company are to prove their debts or claims and to establish any title they may have to priority under Section 292 of the Act or be excluded from the benefit of an interim distribution made before such debts are proved or otherwise from objecting to such distribution.

Dated 23 October 1980

M. A. COPPINS AND J. B. HUTCHINS, Joint and Several Liquidators

Pannell Kerr Forster, 271 William Street, Melbourne

10720

#### Companies Act 1962, Section 254 (2) (b)

##### SDR SHEETMETAL PROPRIETARY LIMITED

Notice is hereby given that at an Extraordinary General Meeting of the members of the abovenamed company held on 23 October 1980, it was resolved that the company be wound up voluntarily and that Bruce Herbert Whitaker of 8 Station Street, Ringwood, be appointed Liquidator.

Notice is also given that after 21 days from this date I shall proceed to distribute the assets. All creditors having any claims against the company should furnish particulars of same by that date, otherwise I shall proceed to distribute the assets without regard to their claim.

Dated 27 October 1980

10722

B. H. WHITAKER, Liquidator

Notice is hereby given that the Final General Meetings of Members of R. & S. Kirwan Enterprises Pty. Ltd. (in Voluntary Liquidation) and John Taylor Marketing Services Pty. Ltd. (in Voluntary Liquidation) pursuant to Section 272 (1) of the Companies Act, will be held at 9.00 a.m. on 21 November 1980 at 15th Floor, 390 St. Kilda Road, Melbourne.

Dated 24 October 1980

10739

B. J. RUMPF, Liquidator

#### Companies Act 1961—In the matter of MICHAEL BRIDGE PROPRIETARY LIMITED—Notice of Winding Up Order

Winding Up Order made on 16 October 1980.

Name and address of Liquidator appointed: Bruce Edward Fordham 521 Toorak Road, Toorak Vic.

REMINGTON & CO., Solicitors for the Petitioner 10745

**Companies Act 1961—In the matter of PENINSULA HAULAGE PTY. LTD. (in Voluntary Liquidation)—Notice of Final Meeting**

Notice is hereby given that pursuant to section 272 of the Companies Act 1961 the final meeting of the members of the abovenamed Company will be held at 10 Jerula Avenue, Mt. Eliza on 29 November 1980 at 4 p.m. for the purpose of having an Account laid before it showing the manner in which the winding up has been conducted and the property of the Company disposed of and hearing any explanation that may be given by the Liquidator.

Dated 25 October 1980

10746 S. L. WILLIAMS Liquidator

**OAKLEIGH (No. 7) CO-OPERATIVE HOUSING SOCIETY LIMITED (IN LIQUIDATION)**

PASSED 23 OCTOBER 1980

At a Special General Meeting of the abovenamed Society duly convened and held at the Registered Office, 63 Atherton Road, Oakleigh, at 7.30 p.m. on Thursday 23 October 1980 the subjoined special resolution was duly passed:

That the Society, having successfully completed its objectives 6 months ahead of the notional period, be wound up voluntarily and that Ernest Alfred Best Graham of 63 Atherton Road, Oakleigh, be appointed Liquidator for the purposes of the winding-up.

10747 E. A. B. GRAHAM, Liquidator

**MIREEN INVESTMENTS PTY. LTD. (IN VOLUNTARY LIQUIDATION)**

**NOTICE OF MEETING AT END OF LIQUIDATION**

Notice is given that a meeting of shareholders of the abovenamed company shall be held at 12 noon on 14 November 1980 at First Floor, 407 Malvern Road, South Yarra for the purpose of laying before the shareholders a report showing how the winding up has been conducted, how the property of the company has been disposed of and providing any necessary explanations.

10748 PETER SZANTO, Liquidator

**NETHERLANDS AUSTRALIAN No. 1 CO-OPERATIVE HOUSING SOCIETY LIMITED (IN LIQUIDATION)**

Take notice that the affairs of the above-named Society are now fully wound up and that in pursuance of section 272 (1) of the Companies Act 1961 and of the Co-operative Housing Societies Act 1958, a General Meeting of the Society will be held at the Society's Office 505 Little Collins Street, Melbourne on 27 November 1980 at 5.30 p.m. for the purpose of—

- (i) laying before it an account showing how the winding up has been conducted and the property of the Society disposed of and giving any explanations thereof; and
- (ii) passing a resolution that the books and papers of the said Society and of the Liquidator relevant to the affairs of the Society be destroyed after a period of twelve months from the date of the meeting.

Dated 27 October 1980

H. C. HOLMES AND R. J. ANDERSON, Joint or either Liquidators 10749

**The Companies Act 1961—In the matter of JAMES ARMSTRONG PTY. LTD.—Members Winding Up**

Notice is hereby given that at the Extraordinary General Meeting of the above company duly convened and held at 1 Maxine Court, Mentone, in the State of Victoria on 18 October 1980 the following resolution was proposed and passed as a special resolution:—

"That the company be wound up voluntarily"

Dated 27 October 1980

D. C. CHRISTENSEN, Liquidator  
Coopers & Lybrand, chartered accountants, 18th Floor, 461 Bourke Street, Melbourne, Vic. 3000 10754

**Companies Act 1961, Section 254 (2)  
THOMAS EVANS PROPRIETARY LIMITED (IN LIQUIDATION)**

**NOTICE OF VOLUNTARY LIQUIDATION**

At an Extraordinary General Meeting of Thomas Evans Proprietary Limited (in Liquidation) duly convened and held at 370 St. Kilda Road, Melbourne on 22 October 1980 the following Resolution was passed as a Special Resolution.

"That the company be wound up voluntarily as a members voluntary winding up in accordance with the provisions of the Companies Act 1961, and that the Liquidators may distribute the assets amongst the members in specie if they so desire."

Dated 28 October 1980

S. L. HORNE AND B. K. MARTIN, Joint and Several Liquidators.

Bentley, Wheeler, Cartledge & Co., chartered accountants, 1 Palmerston Crescent, South Melbourne, Vic. 3205 10755

**The Companies Act 1961, Rule 99—In the matter of SIMMONDS JOINERY & CABINET WORKS (SALES) PTY. LTD. (in Liquidation)**

Take notice that the Liquidator of the abovenamed Company has fixed 15 November 1980 as the day on or before which creditors of the Company are to prove their debts or claims and to establish any title they may have to priority under section 292 or be excluded from the benefit of a first dividend made before such debts are proved or as the case may be from objecting to such a dividend.

Dated 24 October 1980

A. M. HORSBURGH, Liquidator  
Wallace, McMullin & Smail, chartered accountants, 499 St. Kilda Road, Melbourne, Vic. 3004 10756

**The Companies Act 1961, Rule 99—In the matter of SIMMONDS JOINERY & CABINET WORKS PTY. LTD. (in Liquidation)**

Take notice that the Liquidator of the abovenamed Company has fixed 12 November 1980 as the day on or before which creditors of the Company are to prove their debts or claims and to establish any title they may have to priority under section 292 or be excluded from the benefit of a first dividend made before such debts are proved or as the case may be from objecting to such a dividend.

Dated 24 October 1980

A. M. HORSBURGH, Liquidator  
Wallace, McMullin & Smail, chartered accountants, 499 St. Kilda Road, Melbourne, Vic. 3004 10757

**Companies Act 1961, Section 272**

**PULVER NOMINEES PTY. LTD. (IN LIQUIDATION)**

**NOTICE OF FINAL MEETING OF MEMBERS AND CREDITORS**

Notice is hereby given that pursuant to section 272 of the Companies Act 1961, the final meeting of the members and creditors of the Company will be held at the offices of Marquand & Co., Mezzanine Floor, 51 Queen Street, Melbourne on Monday, 1 December 1980 at 11.00 a.m. for the purpose of laying before the meeting an account showing how the winding up has been conducted and the property of the Company has been disposed of and of giving any explanation of the account.

Dated 24 October 1980

D. E. TONKIN, Liquidator  
Marquand & Co., chartered accountants, 51 Queen Street, Melbourne 10758

**In the Supreme Court of Victoria—In the matter of the Companies Act 1961; and in the matter of SONYDEC PTY. LTD.**

Notice is hereby given that a petition for the winding-up of the abovenamed Company by the Supreme Court was on 22 October 1980 presented by Eric John Unger, Deputy Commissioner of Taxation of the Commonwealth of Australia and that the said petition is directed to be heard

before the Court sitting at the Fifteenth Court, Law Courts, Lonsdale Street, Melbourne at the hour of 10.30 o'clock in the forenoon on 20 November 1980 and any creditor or contributory of the said company desiring to support or oppose the making of an order on the said petition may appear at the time of hearing by himself or his Counsel for the purpose; and a copy of the said petition will be furnished to any creditor or contributory of the said company requiring the same by the undersigned on payment of the regulated charge for the same.

The Petitioner's official address is 350 Collins Street, Melbourne.

The Petitioner's Solicitor is C. R. Morrison, Crown Solicitor for the Commonwealth of 99 Queen Street, Melbourne.

C. R. MORRISON

NOTE—Any person who intends to appear on the hearing of the said petition must serve on or send by post to the abovenamed C. R. Morrison, notice in writing of his intention so to do. The notice must state the name and address of the person, or, if a firm, the name and address of the firm, and must be signed by the person or firm, or his, or their solicitor (if any), and must be served, or, if posted, must be sent by post in sufficient time to reach the abovenamed not later than 4.00 o'clock in the afternoon of 19 November 1980.

10764

In the Supreme Court of Victoria—In the matter of the Companies Act 1961; and in the matter of RICHARDS L.S.D. ENGINEERING PROPRIETARY LIMITED

Notice is hereby given that a petition for the winding-up of the abovenamed Company by the Supreme Court was on 22 October 1980 presented by Eric John Unger, Deputy Commissioner of Taxation of the Commonwealth of Australia and that the said petition is directed to be heard before the Court sitting at the Fifteenth Court, Law Courts, Lonsdale Street, Melbourne at the hour of 10.30 o'clock in the forenoon on 20 November 1980 and any creditor or contributory of the said company desiring to support or oppose the making of an order on the said petition may appear at the time of hearing by himself or his Counsel for the purpose; and a copy of the said petition will be furnished to any creditor or contributory of the said company requiring the same by the undersigned on payment of the regulated charge for the same.

The Petitioner's official address is 350 Collins Street, Melbourne.

The Petitioner's Solicitor is C. R. Morrison, Crown Solicitor for the Commonwealth of 99 Queen Street, Melbourne.

C. R. MORRISON

NOTE—Any person who intends to appear on the hearing of the said petition must serve on or send by post to the abovenamed C. R. Morrison, notice in writing of his intention so to do. The notice must state the name and address of the person, or, if a firm, the name and address of the firm, and must be signed by the person or firm, or his, or their solicitor (if any), and must be served, or, if posted, must be sent by post in sufficient time to reach the abovenamed not later than 4.00 o'clock in the afternoon of 19 November 1980.

10765

In the Supreme Court of Victoria—In the matter of the Companies Act 1961; and in the matter of KLUTE DEVELOPMENT & INVESTMENT CO. PTY. LTD.

Notice is hereby given that a petition for the winding-up of the abovenamed Company by the Supreme Court was on 22 October 1980 presented by Eric John Unger, Deputy Commissioner of Taxation of the Commonwealth of Australia and that the said petition is directed to be heard before the Court sitting at the Fifteenth Court, Law Courts, Lonsdale Street, Melbourne at the hour of 10.30 o'clock in the forenoon on 20 November 1980 and any creditor or contributory of the said company desiring to support or oppose the making of an order on the said petition may appear at the time of hearing by himself or his Counsel for the purpose; and a copy of the said petition

will be furnished to any creditor or contributory of the said company requiring the same by the undersigned on payment of the regulated charge for the same.

The Petitioner's official address is 350 Collins Street, Melbourne.

The Petitioner's Solicitor is C. R. Morrison, Crown Solicitor for the Commonwealth of 99 Queen Street, Melbourne.

C. R. MORRISON

NOTE—Any person who intends to appear on the hearing of the said petition must serve on or send by post to the abovenamed C. R. Morrison, notice in writing of his intention so to do. The notice must state the name and address of the person, or, if a firm, the name and address of the firm, and must be signed by the person or firm, or his, or their solicitor (if any), and must be served, or, if posted, must be sent by post in sufficient time to reach the abovenamed not later than 4.00 o'clock in the afternoon of 19 November 1980.

10766

In the Supreme Court of Victoria—In the matter of the Companies Act 1961; and in the matter of J. H. GARNET & CO. PTY. LTD.

Notice is hereby given that a petition for the winding-up of the abovenamed Company by the Supreme Court was on 22 October 1980 presented by Eric John Unger, Deputy Commissioner of Taxation of the Commonwealth of Australia and that the said petition is directed to be heard before the Court sitting at the Fifteenth Court, Law Courts, Lonsdale Street, Melbourne at the hour of 10.30 o'clock in the forenoon on 20 November 1980 and any creditor or contributory of the said company desiring to support or oppose the making of an order on the said petition may appear at the time of hearing by himself or his Counsel for the purpose; and a copy of the said petition will be furnished to any creditor or contributory of the said company requiring the same by the undersigned on payment of the regulated charge for the same.

The Petitioner's official address is 350 Collins Street, Melbourne.

The Petitioner's Solicitor is C. R. Morrison, Crown Solicitor for the Commonwealth of 99 Queen Street, Melbourne.

C. R. MORRISON

NOTE—Any person who intends to appear on the hearing of the said petition must serve on or send by post to the abovenamed C. R. Morrison, notice in writing of his intention so to do. The notice must state the name and address of the person, or, if a firm, the name and address of the firm, and must be signed by the person or firm, or his, or their solicitor (if any), and must be served, or, if posted, must be sent by post in sufficient time to reach the abovenamed not later than 4.00 o'clock in the afternoon of 19 November 1980.

10767

In the Supreme Court of Victoria—In the matter of the Companies Act 1961; and in the matter of PROM MUSIC PTY. LTD.

Notice is hereby given that a petition for the winding-up of the abovenamed Company by the Supreme Court was on 22 October 1980 presented by Eric John Unger, Deputy Commissioner of Taxation of the Commonwealth of Australia and that the said petition is directed to be heard before the Court sitting at the Fifteenth Court, Law Courts, Lonsdale Street, Melbourne at the hour of 10.30 o'clock in the forenoon on 20 November 1980 and any creditor or contributory of the said company desiring to support or oppose the making of an order on the said petition may appear at the time of hearing by himself or his Counsel for the purpose; and a copy of the said petition will be furnished to any creditor or contributory of the said company requiring the same by the undersigned on payment of the regulated charge for the same.

The Petitioner's official address is 350 Collins Street, Melbourne.

The Petitioner's Solicitor is C. R. Morrison, Crown Solicitor for the Commonwealth of 99 Queen Street, Melbourne.

C. R. MORRISON

**NOTE**—Any person who intends to appear on the hearing of the said petition must serve on or send by post to the abovenamed C. R. Morrison, notice in writing of his intention so to do. The notice must state the name and address of the person, or, if a firm, the name and address of the firm, and must be signed by the person or firm, or his, or their solicitor (if any), and must be served, or, if posted, must be sent by post in sufficient time to reach the abovenamed not later than 4.00 o'clock in the afternoon of 19 November 1980. 10768

*Companies Act 1961, Section 272*

**A. & R. STEEL FURNITURE INDUSTRIES PTY. LTD.**  
(IN LIQUIDATION)

**NOTICE OF FINAL MEETING OF CREDITORS AND MEMBERS**

Notice is hereby given that at a meeting of the creditors and members of A. & R. Steel Furniture Industries Pty. Limited (in Liquidation) will be held at 351 Collins Street, Melbourne (20th Floor) on 1 December 1980 at 9.00 a.m.

*Agenda*

To lay before the meeting the liquidator's account showing how the winding up has been conducted and the property of the Company has been disposed of and to give any explanation of the account which may be required.  
Dated 27 October 1980

10759

D. O. OLDFIELD, Liquidator

In the Supreme Court of Victoria—Co. 11560—In the matter of the *Companies Act 1961*; and in the matter of **DANDY TILES PTY. LTD.**—Notice of Winding Up Order  
Winding-up Order made 23 October 1980.

Name and Address of Liquidator: Kenneth James Russell, C/- Coopers & Lybrand, 461 Bourke Street, Melbourne.

C. R. MORRISON, Acting Crown Solicitor for the Commonwealth and Solicitor for the Petitioner 10760

In the Supreme Court of Victoria—Co. 11561—In the matter of the *Companies Act 1961*; and in the matter of **NOVA CANVAS PTY. LTD.**—Notice of Winding Up Order  
Winding-up Order made 23 October 1980.

Name and Address of Liquidator: Ian Kenneth McKinnon, C/- John McKinnon & Co., 4th Floor, Dairy Industry House, 576 St. Kilda Road, Melbourne.

C. R. MORRISON, Acting Crown Solicitor for the Commonwealth and Solicitor for the Petitioner 10761

In the Supreme Court of Victoria—Co. 11563—In the matter of the *Companies Act 1961*; and in the matter of **RAKAL PTY. LTD.**—Notice of Winding Up Order  
Winding-up Order made 23 October 1980.

Name and Address of Liquidator: Dennis John Cogle, C/- Bent & Cogle, 144 Jolimont Road, East Melbourne.

C. R. MORRISON, Acting Crown Solicitor for the Commonwealth and Solicitor for the Petitioner 10762

In the Supreme Court of Victoria—Co. 11564—In the matter of the *Companies Act 1961*; and in the matter of **SHELBY INVESTMENTS PTY. LTD.**—Notice of Winding Up Order

Winding-up Order made 23 October 1980.

Name and Address of Liquidator: James Manson Poulton, C/- Peat, Marwick, Mitchell & Co., 500 Bourke Street, Melbourne.

C. R. MORRISON, Acting Crown Solicitor for the Commonwealth and Solicitor for the Petitioner 10763

*The Companies Act 1961*

**HARMAAG GALLERIES PTY. LTD. (IN LIQUIDATION)**

**NOTICE CONVENING FINAL MEETING OF MEMBERS AND CREDITORS, PURSUANT TO SECTION 272**

Notice is hereby given in pursuance of section 272 of the *Companies Act 1961*, that a Meeting of Members and Creditors of the abovenamed Company will be held at the office of Deloitte Haskings & Sells, 6th Floor, 461 Bourke Street, Melbourne on Thursday, 4 December 1980 at 9.00

a.m. for the purpose of having an account laid before them showing the manner in which the winding up has been conducted and the property of the company disposed of and of hearing any explanations that may be given by the liquidator.

Dated 28 October 1980

10782

M. I. WANSLEY, Liquidator

**JOHN SGROI**, late of 24 Freame Street, Yarraville, in the State of Victoria, gentleman, DECEASED

Creditors, next of kin and others having claims in respect of the estate of the deceased who died on 22 February 1980 are required by Maria Sgroi and Salvatore Sgroi both of 98 Williamstown Road, West Footscray in the said State, the Administrators of the said Estate, to send particulars by 6 January 1981 to their Solicitors Gullaci & Gullaci, of 158 Bell Street, Coburg after which date the Administrators may convey or distribute the assets having regard only to claims of which they then have notice.

**GULLACI & GULLACI**, solicitors, of 158 Bell Street, Coburg 10636

Creditors, next of kin and others having claims in respect of the Estate of Ivy Florence Muriel Nixon late of Benalla Widow (who died on 27 July 1980) are requested to send particulars of their claims in writing to the undermentioned Solicitors being the Solicitors for the Executors Trevor William Macartney, Ronald Douglas Badenhop and Jean Frances Badenhop by 5 January 1981 after which date the executors will distribute the assets having regard only to the claims of which they then have notice.

**HAMILTON CLARKE & BALKIN**, solicitors, 55 Nunn Street, Benalla 10637

**ELSIE BOWEN McNEE**, late of 31 Chrystobel Crescent, Hawthorn, in the State of Victoria, widow, DECEASED

Creditors, next of kin and other persons having claims against the Estate of the said deceased who died on 31 July 1980 are required to send particulars of the same to the Executrix Nancy May Watson in care of the undersigned on or before 31 January 1980 after which date she will distribute the assets having regard only to the claims of which she then has notice.

**BELL, McCULLAGH & ROWE**, solicitors, 600 Burke Road, Camberwell 10638

Creditors, next of kin and others having claims against the estate of Mary Josephine Duffy late of Lisfarron Avenue, Cobram, Spinster, deceased are required to send notice of their claims in care of National Trustees, Executors and Agency Company of Australasia Limited of 95 Queen Street, Melbourne prior to 30 December 1980 after which date the company will proceed with the distribution of the estate of the deceased having regard only to the claims of which it has notice.

**MESSRS CASSIDY & O'RORKE**, solicitors, 22 Main Street, P.O. Box 19, Cobram, Vic. 3644 10639

**GRETA MILLICENT WAUGH**, late of 7 Lee Court, Heathmont, widow, DECEASED

Creditors, next of kin and others having claims in respect of the estate of the deceased who died on 25 June 1980 are required by the Trustees Robert John Waugh and Betty Peters to send particulars of their claims to them care of the undersigned Solicitors by 31 December 1980 after which date the Trustees may convey or distribute the assets having regard only to the claims of which they then have notice.

**GRAY, FRIEND & LONG**, solicitors, Warragul 10640

Creditors, next of kin and others having claims in respect of the Estate of Hazel May Cabena late of 46 Westbrook Street, East Kew in the State of Victoria, Widow deceased who died on 24 August 1980 are required to send particulars of their claims to the Executrix June Margaret Cabena care of Messrs Havyatt & Steward, Solicitors, 432 William Street, Melbourne by 29 December 1980 after which date the Executrix will distribute the assets of the deceased having regard only to the claims of which she then has notice.

**HAVYATT & STEWARD**, solicitors, 432 William Street, Melbourne 10641

STEPHEN LEONARD KNOX, late of 1 Station Street, Kangaroo Flat, in the State of Victoria, accountant, DECEASED

Creditors, next of kin and others having claims against the estate of the abovenamed deceased who died on 9 June 1980 are required to send particulars thereof to National Trustees Executors and Agency Company of Australasia Limited of 46 Queen Street Bendigo by 24 December 1980 after which date the said Company will distribute the assets of the said deceased having regard only to the claims of which it then has notice.

WATSON JAMES & ROGERS, solicitors, 61 Bull Street, Bendigo 10642

Creditors, next of kin and others having claims in respect of the estate of Evelyn Hope Smyth late of Flat 4, 40 Benelong Road Cremorne New South Wales Assistant Control Manager deceased who died on 30 January 1980 and Probate of whose Will has been granted to Susan Amanda O'Brien of 36 Nepean Highway Elsternwick Librarian by the Supreme Court of New South Wales and an exemplification thereof sealed by the Supreme Court of Victoria are required to send particulars of their claims to the said executrix care of the undermentioned Solicitors by 29 December 1980 after which date she will distribute the assets having regard only to the claims of which she then has notice.

PEARCE & WEBSTER solicitors, 430 Little Collins Street, Melbourne 10643

Creditors, next of kin and others having claims in respect of the estate of Nellie Grace Heriot late of 43 Shawlands Avenue South Blackburn Widow deceased who died on 21 February 1980 and Probate of whose Will has been granted to David Richmond Rex of 170-172 Phillip Street Sydney New South Wales Solicitor are required to send particulars of their claims to the said executor care of the undermentioned Solicitors by 29 December 1980 after which date he will distribute the assets having regard only to the claims of which he then has notice.

PEARCE & WEBSTER, solicitors, 430 Little Collins Street, Melbourne 10644

MICHAEL DAMIEN HOARE, late of 66 High Street, Swan Hill, in the State of Victoria, farmer, DECEASED

Creditors, next of kin and other persons having claims against the Estate of the said deceased who died on 27 December 1979 are required to send particulars of same to the Administrator Ronald James Hoare in care of the undersigned on or before 31 December 1980 after which date he will distribute the assets having regard only to the claims of which he then has notice.

DWYER & BENNETT, barristers and solicitors, 201 Campbell Street, Swan Hill 10645

ALAN VINCENT HARTSHORN, late of 807 Doveton Street North, Ballarat, pensioner, DECEASED (who died on 3 May 1980)

Creditors, next of kin and all persons having claims against the estate of the deceased are required to send particulars to the Executor The Union-Fidelity Trustee Company of Australia Limited of 101 Lydiard Street North, Ballarat, on or before 30 December 1980 after which date it will distribute the assets having regard only to the claims of which it shall then have notice.

HEINZ & GORDON, solicitors, 209 Dana Street, Ballarat 10646

DOUGLAS WILLIAM MORRISON, late of Boort, in the State of Victoria, farmer, DECEASED

Creditors, next of kin and other persons having claims against the Estate of the said deceased who died on 20 May 1979 are required to send particulars of same to the Executrix and Executors Ethel Margaret Morrison, Alan Steven Morrison and Gary Scott Wood in care of the undersigned on or before 6 January 1981 after which date they will distribute the assets having regard only to claims of which they then have notice.

HERCULES & WORLAND, barristers and solicitors, 130 Godfrey Street, Boort 10647

Creditors, next of kin and others having claims in respect of the Estate of Jean Bredle formerly of 87 Pitt Street Eltham but late of Marby Street Narbethong, in the State of Victoria, Widow deceased, who died on 24 July 1980 are to send particulars of their claims to the executor National Trustees, Executors and Agency Company of Australasia Limited of 95 Queen Street Melbourne by 29 December 1980, after which date it will distribute the assets having regard only to the claims of which it then has notice.

LE GRAND, RANDLES, GAFFNEY & CO., 644 Sydney Road, Brunswick, the solicitors for the applicant. 10648

Pursuant to the Trustee Act 1958 notice is hereby given that all persons having claims against the estate of Elizabeth Hacker late of 129 King Street, East Doncaster in the State of Victoria, widow, deceased who died on 25 March 1980 and Probate of whose Will was granted by the Supreme Court of the said State in its Probate Jurisdiction on 3 June 1980 to Warren Arthur George Hacker of 55 Whittens Lane, Doncaster and Noela Grace Johnston of 5 Elizabeth Street, East Doncaster in the said State, are hereby required to send particulars in writing of such claims to the undersigned at their office hereunder mentioned on or before 12 November 1980 after which date the said Warren Arthur George Hacker and Noela Grace Johnston will proceed to distribute the assets of the said Elizabeth Hacker deceased which shall have come to their hands amongst the persons entitled thereto, having regard only to the claims of which they shall then have had notice. And notice is hereby further given that the said Warren Arthur George Hacker and Noela Grace Johnston will not be liable for the assets so distributed or any part thereof to any person of whose claim they shall not have had notice as aforesaid.

Dated 22 October 1980

LLOYD P. GOODE & CO., of 406 Lonsdale Street, Melbourne, solicitors for the said Warren Arthur George Hacker and Noela Grace Johnston 10649

Creditors, next of kin and others having claims in respect of the Estate of Norman Charles Firth formerly of 30 Halley Avenue Camberwell but late of St. Vincent's Private Hospital, Melbourne, Company Director deceased who died on 1 April 1980 are to send particulars of their claims to The Union-Fidelity Trustee Company of Australia Limited of 100 Exhibition Street Melbourne by 12 January 1981 after which date it will distribute the assets having regard only to the claims of which it then has notice.

MORIARTY & PELLICANO, solicitors, 57 Portman Street, Oakleigh 10679

All persons having claims against the estate of Lucie Mirlwyn Segrave late of 107 Webster Street Ballarat Widow deceased Probate of whose Will has been applied for by The Union-Fidelity Trustee Company of Australia Limited and Frank Frederick Gummow the Executors appointed by the said Will are hereby required to send particulars thereof in writing to the said Executors care of The Union-Fidelity Trustee Company of Australia Limited at its office at 101 Lydiard Street North Ballarat before 31 December 1980 after which date the said Executors will proceed to distribute the assets of the said deceased having regard only to the claims of which they shall then have had notice and the said Executors will not be liable for the assets so distributed or any part thereof to any person of whose claim they shall not then have had notice.

R. G. DOBSON & CO., of 52 Lydiard Street South, Ballarat, solicitors for the said applicants 10680

ELEANOR WILSON, late of 2 Kasouka Road, Camberwell, retired, DECEASED

Creditors, next of kin and others having claims in respect of the estate of the deceased who died on 2 October 1978 are required by the personal representative National Trustees Executors and Agency Company of Australasia Limited to send particulars to it at 95 Queen Street, Melbourne by 15 January 1981 after which date the personal representative may convey or distribute the assets having regard only to the claims of which it then has notice.

ROBERT T. PITTS, solicitor, 151 Eley Road, Blackburn, 3130 10681

**REGINALD FRANK LINCOLN**, late of 139 Swan Street, Wangaratta, in Victoria, retired, DECEASED, intestate

Creditors, next of kin and others having claims in respect of the estate of the abovenamed deceased (who died on 12 February 1980) are requested to send particulars of their claims to the administratrix, Gladys Lincoln care of the under-mentioned, by 1 January 1981, after which date she may distribute the assets having regard only to the claims of which she has had notice.

McSWINEYS, solicitors, of Wangaratta 10683

**ANN ELIZABETH AITCHISON**, late of 3 Grandview Road, West Preston, widow, DECEASED

Creditors, next of kin and others having claims in respect of the Estate of the deceased who died on 8 August 1980 are requested to send particulars of their claims to the Administratrix Joyce Margaret Aitchison C/- the undersigned Solicitor by 30 December 1980 after which date the said Administratrix will proceed to distribute the Estate having regard only to the claims of which she then has notice.

MARJORY C. COATES, solicitor, of 422 Collins Street, Melbourne, 3000 10699

**JEAN MARGARET BURGOYNE**, late of 2/25 Millswyn Street, South Yarra, in the State of Victoria, DECEASED

Creditors, next of kin and others having claims in respect of the estate of the deceased (who died on 6 July 1980) are required by The Perpetual Executors and Trustees Association of Australia Limited of 50 Queen Street, Melbourne to send particulars to their claims to the said Company by 31 January 1981 after which date it will convey or distribute the assets, having regard only to the claims of which the Company then has noticed.

RIGBY & FIELDING, solicitors, 4 Bank Place, Melbourne, 3000 10700

Creditors, next of kin and others having claims in respect of the estate of Edward James Delany late of 307 Hawthorn Road Caulfield in the State of Victoria Retired School Teacher who died on 10 July 1980 are to send particulars of their claims to John Desmond Curtin the Executor care of the undersigned by 31 December 1980 after which date he will commence to distribute the assets having regard only to the claims of which he then has notice.

RENNICK & GAYNOR, solicitors, 427 Riversdale Road, Hawthorn East 10701

**ROSENA MAY LONGSTAFF**, late of Unit 5, 33 Leila Road, Carnegie, in the State of Victoria, widow, DECEASED

Creditors next of kin and others having claims in respect of the Estate of the abovenamed deceased who died on 24 May 1980 are required by the Executor Gordon Palmer Lamb of 1 Everett Street, West Brunswick to send particulars to him by 30 December 1980 after which date the Executor intends to convey or distribute the assets of the Estate having regard only to the claims of which he may then have notice.

TURNER, NESS & DAVIS, solicitors, 8-12 Batman Street, Melbourne, 3003 10702

**JOHN ELDRED WATTS**, late of 11 Talbot Crescent, Kooyong, gentleman, DECEASED

Creditors, next of kin and others having claims in respect of the estate of the deceased, who died on 12 August 1980 are required by his Executors, George Rae Watts of 13 Talbot Crescent, Kooyong, John Bryce Watts of 28 Hortense Street, Burwood and Malcolm Graeme Roberts of 2 Marock Place, Balwyn to send particulars to them by 31 December 1980 after which date they may convey or distribute the assets, having regard only to the claims of which they then have notice.

HEDDERWICK, FOOKES & ALSTON, 121 William Street, Melbourne, 3000 10703

**ANNIE LAWRY**, late of Graceton Private Nursing Home, 26 Livingston Street, Ivanhoe, spinster, DECEASED

Creditors, next of kin and others having claims in respect of the estate of the deceased who died on 4 September 1980 are required by the executor Mary Agnes Hayle of 2

Nungerner Street Deepdene Widow to send particulars to her care of the undermentioned solicitors by 31 December 1980 after which date the executor may convey or distribute the assets having regard only to the claims of which she then has notice.

HADEN SMITH & FITCHETT, solicitors, 423 Bourke Street, Melbourne 10704

**ALEXANDER FOXCROFT BOTTOMLEY**, late of 75 Outer Crescent, Middle Brighton, retired managing director, DECEASED

Creditors, next of kin and others having claims in respect of the estate of the deceased who died on 14 October 1975 are required by Keith Lewis Paroissien of 19 Sherwood Street, Glen Iris, Accountant and Frederick Maurice Van Cuylenburg of 109 Boundary Road, Merlynston, Solicitor to send particulars of their claims to the said executors care of the undermentioned solicitors by 3 January 1981 after which date they will distribute the assets having regard only to the claims of which they have notice.

LYNCH & MACDONALD, FLOOD & PERMEZEL, solicitors, of 191 Queen Street, Melbourne 10705

**JAMES ALLAN RYAN**, late of 53 Suffolk Road, Surrey Hills, in the State of Victoria, insurance officer, DECEASED

Creditors, next of kin and others having claims in respect of the estate of the deceased, who died on 14 July 1980 are required by the trustees Anne Ryan of Dominican Convent, Grant Street, Maitland in the State of New South Wales in the State of Victoria Teacher and Michael Martin Ryan 53 Suffolk Road, Surrey Hills in the State of Victoria Student to send particulars to them care of the undersigned solicitor by 2 January 1981 after which date the trustees may convey or distribute the assets having regard only to the claims of which they then have notice.

WHITING AND BYRNE, solicitors, 440 Collins Street, Melbourne 10706

**GEORGE ALAN DAVIS**, late of "Saint Pierre", 1 Torresdale Road, Toorak, in the State of Victoria, gentleman, DECEASED

Creditors, next of kin and others having claims in respect of the estate of the deceased, who died on 2 August 1980 are required by the trustees Marie Germaine Davis of "Saint Pierre" 1 Torresdale Road, Toorak in the State of Victoria Widow and Marguerite Anne Ryan of 18 Glyndebourne Avenue, Toorak in the State of Victoria Married Woman to send particulars to them care of the undersigned solicitors by 6 January 1981 after which date the trustees may convey or distribute the assets having regard only to the claims of which they then have notice.

WHITING AND BYRNE, solicitors, 440 Collins Street, Melbourne 10707

**MARGUERITE MARY HORAN**, late of "Mount Royal", Poplar Road, Parkville, in the State of Victoria, retired chiropodist, DECEASED

Creditors, next of kin and other persons having claims in respect of the Estate of the abovenamed deceased are required by the Executors Finlay McNab and Colin Edward McNab both of 20 Queen Street, Melbourne, Solicitors to send particulars in writing of their claims to them on or before 5 January 1981, after which date they will distribute the assets, having regard only to the claims of which they then have notice.

MENAB & McNAB, solicitors, 20 Queen Street, Melbourne, 3000 10708

**MARGARET WAKEFIELD DANN**, late of 9 Wilson Street, Berwick, in the State of Victoria, widow, DECEASED

Creditors, next of kin and others having claims in respect of the estate of the deceased (who died on 9 July 1980) are required by The Perpetual Executors and Trustees Association of Australia Limited of 50 Queen Street, Melbourne to send particulars of their claims to the said Company by 30 December 1980 after which date it will convey or distribute the assets, having regard only to the claims of which the Company then has notice.

10709



EVELYN WRIGHT (also known as Evelyn Hedges, Kay McCart and Faith Lovell), late of 6/45 Jackson Street, St. Kilda, in the State of Victoria, widow, DECEASED

Creditors, next of kin and others having claims in respect of the estate of the deceased (who died on 1 February 1980) are required by the Executor George Donald Preece of 32 Kardinia Street, Watsonia in the said State to send particulars to him care of the undermentioned solicitors by 31 December 1980 after which date the Executor may convey or distribute the assets having regard only to the claims of which he then has notice.

SLATER & GORDON, solicitors, 60 Market Street, Melbourne 10710

Creditors, next of kin and others having claims in respect of the Estate of Mary MacKenzie, formerly of 57 Repton Road, East Malvern, but late of Dimboola District Hospital, Dimboola, Gentlewoman, deceased who died on 3 July 1980 are required by the Executor The Trustees Executors and Agency Company Limited of 401 Collins Street, Melbourne to send particulars of their claims to the said Trustee Company by 30 December 1980 after which date it will distribute the assets having regard only to the claims of which it then has notice.

MESSRS. H. L. YUNCKEN & YUNCKEN, solicitors, 443 Little Collins Street, Melbourne, 3000 10711

Creditors, next of kin and others having claims against the Estate of Mary Wellings, late of Cleeland Street, Newhaven, Phillip Island, Widow, deceased are required to send notice of their claims care of The Equity Trustees Executors and Agency Company Limited of 472 Bourke Street, Melbourne prior to 22 December 1980, after which date the Company will proceed with the distribution of the Estate of the deceased, having regard only to the claims of which it has notice.

LANDER & ROGERS, solicitors, 140 Queen Street, Melbourne 10712

DORA MARY SCOTT, late of 64 Sycamore Street, East Malvern, widow, DECEASED, who died on 5 August 1980

Creditors, next of kin and all other persons having claims against the estate of the deceased are required by the Executor of her Will The Equity Trustees Executors and Agency Company Limited of 472 Bourke Street, Melbourne to send particulars thereof to the abovementioned executor before 2 January 1981 after which date the executor will distribute the assets having regard only to the claims of which it then has notice.

COLTMANS, solicitors, 367 Collins Street, Melbourne, 3000 10713

HARRY ALEXANDER MUNRO, late of 1, Walter Street, Port Melbourne, pensioner, DECEASED

Creditors, next of kin and others having claims in respect of the estate of the abovenamed who died on 10 October 1979 are required to send particulars thereof to the Executors of his Will Kenneth Ray Wilson and Wesley Herbert Wilson care of the undermentioned Solicitors, on or before 31 December 1980, after which date they will distribute the assets in the estate having regard only to the claims of which they then have notice.

J. M. SMITH & EMMERTON, solicitors, 224 Queen Street, Melbourne 10714

Creditors, next of kin and all others having claims against the Estate of Thomas Henry Curwood late of 1 North Street, Footscray in the State of Victoria, Fitter's Assistant deceased are required by the Executors of his Estate William John Albert Curwood and Joy-Maree Demmi to send their claims to them care of the undermentioned by 29 December 1980 after which date they will distribute the assets of his Estate, having regard only to the claims of which they then have notice.

HOLDING REDLICH & CO., solicitors, 174 Victoria Parade, East Melbourne 10726

WILLIAM LINDSAY CAMPBELL, late of 5 Grantham Court, Brighton, in the State of Victoria, retired company director, DECEASED

Creditors, next of kin and others having claims in respect of the estate of the deceased who died on 7 June 1980 are required by his Executors National Trustees Executors

and Agency Company of Australasia Limited of 95 Queen Street, Melbourne in the said State and Elizabeth Ann Tully of 7 Turner Street, East Malvern in the said State Married Woman to send particulars to them by 30 December 1980, after which date the executors may convey or distribute the assets having regard only to the claims of which they then have notice.

CLEARY ROSS & DOHERTY, solicitors, 406 Collins Street, Melbourne 10715

Creditors, next of kin and all others having claims against the Estate of Sheila Arradele Catherine Wallace late of K3 High Street, Windsor in the State of Victoria, retired deceased are required by the Executors of her Estate Terence Francis O'Brien, Paul Edmond O'Brien and Bernard Michael O'Brien to send their claims to them care of the undersigned by 29 December 1980 after which date they will distribute the assets of her Estate, having regard only to the claims of which they then have notice.

HOLDING REDLICH & CO., solicitors, 174 Victoria Parade, East Melbourne 10725

RAYMOND PAUL ELLIOTT, late of 13 Cook Street, West Brunswick, in the State of Victoria, brass finisher, DECEASED

Creditors, next of kin and others having claims in respect of the estate of the deceased who died on 10 June 1980 are required by his Executor the National Trustees Executors and Agency Company of Australasia Limited of 95 Queen Street, Melbourne in the said State to send particulars to it by 30 December 1980, after which date the Executor may convey or distribute the assets having regard only to the claims of which it then has notice.

CLEARY ROSS & DOHERTY, solicitors, 406 Collins Street, Melbourne 10716

Creditors, next of kin and all others having claims against the Estate of Ronald Offord late of 9 Orange Street, Braybrook in the State of Victoria, deceased Intestate are required by the Administrators of his Estate Garry Offord and Norman Offord to send their claims to them care of the undersigned by 29 December 1980 after which date they will distribute the assets of his Estate, having regard only to the claims of which they then have notice.

HOLDING REDLICH & CO., solicitors, 174 Victoria Parade, East Melbourne 10727

Creditors, next of kin and all others having claims against the Estate of Sze Khan Poon, late of 5 Bernborough Avenue, Balwyn in the State of Victoria, Fitter and Turner deceased are required by the Executrix of his Estate Margaret Elizabeth Poon to send their claims to her care of the undersigned by 29 December 1980 after which date she will distribute the assets of his Estate, having regard only to the claims of which she then has notice.

HOLDING REDLICH & CO., solicitors, 174 Victoria Parade, East Melbourne 10728

Creditors, next of kin and all others having claims against the Estate of Henry Edward Francis late of 132 Graham Street, Port Melbourne in the State of Victoria, Motor Industry Storeman deceased Intestate are required by the Administratrix of his Estate Lola Francis to send their claims to her care of the undersigned by 29 December 1980 after which date she will distribute the assets of his Estate, having regard only to the claims of which she then has notice.

HOLDING REDLICH & CO., solicitors, 174 Victoria Parade, East Melbourne 10729

Creditors, next of kin and all others having claims against the Estate of Peter Adomaitis late of 222 St. Georges Road, Northcote in the State of Victoria, Water-side Worker deceased are required by the Executrix of his Estate Marta Tuul to send their claims to her care of the undersigned by 29 December 1980 after which date she will distribute the assets of his Estate, having regard only to the claims of which she then has notice.

HOLDING REDLICH & CO., solicitors, 174 Victoria Parade, East Melbourne 10730

Creditors, next of kin and all others having claims against the Estate of Poul Erik Heien Jensen late of 917 Toorak Road, South Camberwell in the State of Victoria, Fitter deceased are required by the Executrix of his Estate Una Lucy Jensen to send their claims to her care of the undersigned by 29 December 1980 after which date she will distribute the assets of his Estate, having regard only to the claims of which she then has notice.

HOLDING REDLICH & CO., solicitors, 174 Victoria Parade, East Melbourne 10731

Creditors, next of kin and all others having claims against the Estate of Alfred Marcel Bloch late of Unit 1, 601 Burke Road, Camberwell in the State of Victoria, Retired Gentleman deceased are required by the Executrix of his Estate, Grete Bloch to send their claims to her care of the undersigned by 29 December 1980 after which date she will distribute the assets of his Estate, having regard only to the claims of which she then has notice.

HOLDING REDLICH & CO., solicitors, 174 Victoria Parade, East Melbourne 10732

Creditors, next of kin and all others having claims against the Estate of Mavis Vida Wilkins late of 20 Stella Avenue, Noble Park in the State of Victoria, Pensioner deceased are required by the Executor of her Estate David Wilkins to send their claims to him care of the undersigned by 29 December 1980 after which date he will distribute the assets of her Estate, having regard only to the claims of which he then has notice.

HOLDING REDLICH & CO., solicitors, 174 Victoria Parade, East Melbourne 10733

Creditors, next of kin and all others having claims against the Estate of James Matthews late of 20 Blair Street, Broadmeadows in the State of Victoria, Gentleman deceased are required by the Executors of his Estate Graham Matthews and James Matthews to send their claims to them care of the undersigned by 29 December 1980 after which date they will distribute the assets of his Estate, having regard only to the claims of which they then have notice.

HOLDING REDLICH & CO., solicitors, 174 Victoria Parade, East Melbourne 10734

Creditors, next of kin and all others having claims against the Estate of Otto Meyer late of 16 Harris Avenue, Werribee in the State of Victoria, Fitter deceased intestate are required by the Administratrix of his Estate Ingrid Meyer to send their claims to her care of the undersigned by 29 December 1980 after which date she will distribute the assets of his Estate, having regard only to the claims of which she then has notice.

HOLDING REDLICH & CO., solicitors, 174 Victoria Parade, East Melbourne 10735

Creditors, next of kin and all others having claims against the Estate of Michael Patrick Tuohy late of 34 Abbotsford Street, Abbotsford in the State of Victoria, Retired deceased are required by the Executrix of his Estate Geraldine Machelie Leigh Bonello to send their claims to her care of the undersigned by 29 December 1980 after which date she will distribute the assets of his Estate, having regard only to the claims of which she then has notice.

HOLDING REDLICH & CO., solicitors, 174 Victoria Parade, East Melbourne 10736

Creditors, next of kin and all others having claims against the Estate of Elvie May Mogford late of Unit 11, 9 The Strand, Essendon in the State of Victoria, Gentlewoman deceased are required by the Executors of her Estate Norma Lillian Huggard and Noel Peter John Mogford to send their claims to them care of the undersigned by 29 December 1980 after which date they will distribute the assets of her Estate, having regard only to the claims of which they then have notice.

HOLDING REDLICH & CO., solicitors, 174 Victoria Parade, East Melbourne 10737

Creditors, next of kin and all others having claims against the Estate of Ernest Victor Bell late of 248 Esplanade East, Port Melbourne in the State of Victoria, Waterside Worker deceased Intestate are required by the

Administratrix of his Estate Mary Margaret Bell to send their claims to her care of the undersigned by 29 December 1980 after which date she will distribute the assets of his Estate, having regard only to the claims of which she then has notice.

HOLDING REDLICH & CO., solicitors, 174 Victoria Parade, East Melbourne 10738

HERBERT EDWARD GREEN, late of Midland Highway, Epsom, grazier, DECEASED

Creditors, next of kin and others having claims in respect of the estate of the deceased who died on 21 April 1980 are required by the Trustee National Trustees Executors and Agency Company Limited of 46 Queen Street, Bendigo to send particulars to it by 31 December 1980 after which date the Trustee may convey or distribute the assets having regard only to the claims of which it then has notice.

Messrs BECK SHEAHAN & CO., barristers & solicitors, 238A Hargreaves Street, Bendigo 3550 10750

Creditors, next of kin and others having claims in respect of the estate of Lilian Merritt late of 85 Sandells Road, Tecoma in the State of Victoria Widow who died on 17 August 1980 are to send particulars of their claims to the Administrators care of the undersigned by 23 January 1981 after which date they will commence to distribute the assets having regard only to the claims of which they then have notice.

T. D. ARMSTRONG & GILLMAN, solicitors, 646 Main Street, Belgrave 10751

Creditors, next of kin and others having claims in respect to the Estate of Salek Freitag late of Flat 3, 24 Acland Street, St. Kilda in the State of Victoria, Clothing Retailer deceased who died on 28 March 1980 are required to send particulars of their claims to the Administrator Samuel Saffir care of Messrs Havyatt & Steward, Solicitors, 432 William Street, Melbourne in the said State by 29 December 1980 after which date the Administrator will distribute the assets of the deceased having regard only to the claims of which he then has notice.

HAVYATT & STEWARD, solicitors, of 432 William Street, Melbourne 10752

Creditors, next of kin and others having claims in respect of the Estate of Norma May Mahony late of Unit 2, 39 Queen Street, Frankston in the State of Victoria Widow deceased who died on 3 August 1980 are to send particulars of their claims to The Trustees Executors and Agency Company Limited of 401 Collins Street, Melbourne in the said State by 29 December 1980 after which date it will distribute the assets having regard only to the claims of which it then has notice.

FRENKEL, BERKOVITCH, KEFFORD & NEW, solicitors, of 114 William Street, Melbourne 10753

EDWIN LESLIE WEBBER, late of 1 Tobias Avenue, Glen Waverley, gentleman, DECEASED

Creditors, next of kin and others having claims in respect of the estate of the deceased (who died on 31 July 1980) are required by The Perpetual Executors and Trustees Association of Australia Limited of 50 Queen Street, Melbourne to send particulars of their claims to the said Company by 9 January 1981, after which date it will convey or distribute the assets, having regard only to the claims of which the Company then has notice.

MADDEN BUTLER ELDER & GRAHAM, solicitors, 500 Collins Street, Melbourne 10769

MARY HOPE, late of Jen Mar Nursing Home, of 2 Chilcote Avenue, Malvern in the State of Victoria, widow, DECEASED

Creditors, next of kin and others having claims in respect of the estate of the deceased, who died on 1 June 1980 are required by the trustee Jennifer Mary Wood of 36 Oakern Street, Mount Waverley in the State of Victoria Married Woman to send particulars to her care of the undersigned Solicitor by 6 January 1981 after which date the trustee may convey or distribute the assets having regard only to the claims of which she then has notice.

WHITING AND BYRNE, solicitors, 440 Collins Street, Melbourne 10770

In the Supreme Court of the State of Victoria  
SALE BY THE SHERIFF

On Thursday, 4 December 1980 at 2.30 p.m. at the Bailiff's Office, 2nd Floor, 300 Burwood Road, Hawthorn (unless process be stayed or satisfied).

All the Estate and Interest (if any) of Thomas Hugh McKay, photographer of 24 Maranoa Crescent, Moreland as proprietor of an estate in fee simple in the land described in Certificate of Title Volume 5293 Folio 408 upon which is erected a weatherboard dwelling known as No. 24 Maranoa Crescent Moreland.

Registered Caveat No. H.502601 affects the said estate and interest.

Terms—Cash only  
10771 K. R. MARTIN, Sheriff's Officer

In the Supreme Court of the State of Victoria  
SALE BY THE SHERIFF

On Thursday, 4 December 1980 at 2.30 p.m. at the Bailiff's Office, 2nd Floor, 300 Burwood Road, Hawthorn (unless process be stayed or satisfied).

All the Estate and Interest (if any) of Malcolm Browne-Kerr, butcher, of 75 Argyle Circuit, Melton (shown on Certificate of Title as Malcolm Bruce Browne-Kerr) as joint proprietor with Marjorie Theresa Browne-Kerr, married woman of an estate in fee simple in the land described in Certificate of Title Volume 9145 Folio 617 upon which is erected a brick veneer dwelling known as No. 75 Argyle Circuit Melton.

Registered Mortgage No. H.447828 and Caveat H.480748 affect the said estate and interest.

Terms—Cash only  
10772 K. R. MARTIN, Sheriff's Officer

In the Supreme Court of the State of Victoria  
SALE BY THE SHERIFF

On Thursday, 4 December 1980 at 2.30 p.m. at the Bailiff's Office, 2nd Floor, 300 Burwood Road, Hawthorn (unless process be stayed or satisfied).

All the Estate and Interest (if any) of Pangelis Apostolidis, labourer (shown on Certificate of Title as Pantelis Apostolidis) of 89 Spring Street, West Preston as joint proprietor with Eleftheria Apostolidis, married woman of an estate in fee simple in the land described in Certificate of Title Volume 5852 Folio 203 upon which is erected a dwelling house known as No. 89 Spring Street Reservoir.

Registered Mortgage No. G.391317 affects the said estate and interest.

Terms—Cash only  
10773 K. R. MARTIN, Sheriff's Officer

In the Supreme Court of the State of Victoria  
SALE BY THE SHERIFF

On Thursday, 4 December 1980 at 2.30 p.m. at the Bailiff's Office, 2nd Floor, 300 Burwood Road, Hawthorn (unless process be stayed or satisfied).

All the Estate and Interest (if any) of Saleem Buksh, fitter and welder of Flat 1, No. 12 Charlotte Place, St. Kilda as proprietor of an estate in fee simple in the land described in Certificate of Title Volume 9193 Folio 814 upon which is a vacant block of land known as Lot 1, No. 15 Harold Street Ascot Vale.

Registered Caveat No. H.94070 affects the said estate and interest.

Terms—Cash only  
10774 K. R. MARTIN, Sheriff's Officer

In the Supreme Court of the State of Victoria  
SALE BY THE SHERIFF

On Thursday, 4 December 1980 at 2.30 p.m. at the Bailiff's Office, 2nd Floor, 300 Burwood Road, Hawthorn (unless process be stayed or satisfied).

All the Estate and Interest (if any) of Tamme Klaster, contractor, and Judith Rose Klaster, married woman, both of 9 Gerald Drive, Langwarrin as joint proprietors of an

estate in fee simple in the land described in Certificate of Title Volume 8890 Folio 737 upon which is erected a brick veneer house known as No. 9 Gerald Drive Langwarrin.

Registered Mortgage Nos. G.882965, G.984140 and Caveat No. H.752945 affects the said estate and interest.

Terms—Cash only  
10775 T. M. NICHOLLS, Sheriff's Officer

In the Supreme Court of the State of Victoria  
SALE BY THE SHERIFF

On Thursday 4, December 1980 at 2.30 p.m. at Bailiff's Office, 2nd Floor, 300 Burwood Road, Hawthorn (unless process be stayed or satisfied).

All the Estate and Interest (if any) of Uwe Paul and Gertrude Paul, Company Directors, shown on Certificate of Title as Uwe August Heinrich Paul and Gertrud Martha Anne Paul, both of 27 Carrum Street, Chadstone as joint proprietors of an estate in fee simple in the land described in Certificate of Title Volume 4652 Folio 232 upon which is erected a dwelling house known as No. 27 Carrum Street Chadstone.

Registered Mortgage Nos. G.94348 and G.943290 and Caveat J.136497.

Terms—Cash only  
10776 T. M. NICHOLLS, Sheriff's Officer

In the Supreme Court of the State of Victoria  
SALE BY THE SHERIFF

On Thursday 11 December 1980 at 2.30 p.m. at Bailiff's Office, 2nd Floor, 300 Burwood Road, Hawthorn (unless process be stayed or satisfied).

All the Estate and Interest (if any) of Margaret Louise Dowling, pensioner, of 15 Wattle Grove, McKinnon as joint proprietor with Donald Julian Dowling, commission agent of an estate in fee simple in the land described in Certificate of Title Volume 6148 Folio 480 upon which is erected a brick veneer dwelling known as No. 15 Wattle Grove, McKinnon.

Queens Caveat No. H.534670 affects the said estate and interest.

Terms—Cash only  
10777 T. M. NICHOLLS, Sheriff's Officer

In the Supreme Court of the State of Victoria  
SALE BY THE SHERIFF

On Thursday 4 December 1980 at 2.30 p.m. at Bailiff's Office, 2nd Floor, 300 Burwood Road, Hawthorn (unless process be stayed or satisfied).

All the Estate and Interest (if any) of William John Barr, cleaning contractor, and June Janette Barr, housewife, both of 41 Canadian Bay Road, Mt. Eliza as joint proprietors of an estate in fee simple in the land described in Certificate of Title Volume 8158 Folio 940 upon which is erected a timber dwelling known as No. 41 Canadian Bay Road Mt. Eliza.

Registered Mortgage No. H.778714 affects the said estate and interest.

Terms—Cash only  
10778 T. M. NICHOLLS, Sheriff's Officer

In the Supreme Court of the State of Victoria  
SALE BY THE SHERIFF

On Thursday 4 December 1980 at 2.30 p.m. at Bailiff's Office, 2nd Floor, 300 Burwood Road, Hawthorn (unless process be stayed or satisfied).

All the Estate and Interest (if any) of S. Yildiz, labourer (shown on Certificate of Title as Selahattin Yildiz), of 9 The Avenue, Coburg as joint proprietor with Emine Yildiz, married woman of an estate in fee simple in the land described in Certificate of Title Volume 4573 Folio 568 upon which is erected a weatherboard house known as No. 9 The Avenue, Coburg.

Registered Mortgage No. F.986005 and unregistered Caveat No. J.124027 affect the said estate and interest.

Terms—Cash only  
10779 K. R. MARTIN, Sheriff's Officer

In the Supreme Court of the State of Victoria  
**SALE BY THE SHERIFF**

On Tuesday 2 December 1980 at 2.30 p.m. at Bailiff's Office, 2nd Floor, 300 Burwood Road, Hawthorn (unless process be stayed or satisfied).

All the Estate and Interest (if any) of Andreas Bougioukos, builder, and Vassiliki Bougioukos, married woman, both of 354 Neerim Road, Carnegie.

Firstly: as joint proprietors of an estate in fee simple in the land described in Certificate of Title Volume 9197 Folio 179 and Certificate of Title Volume 8965 Folio 858 which are Vacant Blocks of Land known as No. 27 Young Street, Malvern. Registered Mortgage No. G.535698 and Caveat No. H.142422 affect the said estate and interest.

Secondly: as joint proprietors of an estate in fee simple in the land described in Certificate of Title Volume 9328 Folio 917 Unit 1 Registered Plan No. 13641 and an undivided share in the common property for the time being described on the said plan upon which is erected a Luxury Town House known as No. 159 Tooronga Road, Glen Iris. Registered Mortgage No. H.261230 affects the said estate and interest.

Thirdly: as joint proprietors of an estate in fee simple in the land described in Certificate of Title Volume 9328 Folio 918 Unit 2 Registered Plan No. 13641 and an undivided share in the common property for the time being described on the said plan upon which is erected a Luxury Town House known as No. 159 Tooronga Road, Glen Iris. Registered Mortgage No. H.261230 affects the said estate and interest.

Fourthly: as joint proprietors of an estate in fee simple in the land described in Certificate of Title Volume 9278 Folio 202 upon which is erected a shop and dwelling known as No. 354 Neerim Road, Carnegie. Registered Mortgage No. H.158240 affects the said estate and interest.

Terms—Cash only

10780

J. GREEN, Deputy Sheriff

**NOTICE OF MAKING OF STATUTORY RULES**

In pursuance of the provisions of the *Subordinate Legislation Act 1962* and the Regulations made thereunder, notice is given of the making of the following Statutory Rules:—

No.	Police Regulation Act 1958	Price
410/1980.	Police (Constitution, Strength, Organization and Seniority) (Amendment No. 4) Regulations 1980	10c
411/1980.	Country Fire Authority Act 1958 (Amendment) Regulations 1980	10c
412/1980.	Country Fire Authority (Loan No. 141) Regulations 1980	20c
413/1980.	Cattle Compensation Act 1967 Regulations 1980	10c

Copies of these Statutory Rules when printed may be purchased at the Sale of Publications, Branch of the Government Printing Office, located at 7A Parliament Place, Melbourne, 3002. If ordered by mail, remittance should be addressed to "The Government Printer, Box 203, P.O., North Melbourne, 3051", and should include 50c delivery and handling fee.

The annual subscription rates for Statutory Rules for the year commencing 1 January 1980, payable in advance, are as follows:—

*Statutory Rules (other than Public Service Determinations), Pamphlet copies only	\$36.00
Public Service Determinations	\$25.00

\* The Bound Volume of Statutory Rules is not included in the subscription rate.

F. D. ATKINSON  
 Government Printer

ACTS REPRINTED IN ACCORDANCE WITH THE AMENDMENTS INCORPORATION ACT 1958 (No. 6422), AND FOR SALE AS STOCKS ARE AVAILABLE AT THE SALE OF PUBLICATIONS BRANCH OF THE GOVERNMENT PRINTING OFFICE, 7A PARLIAMENT PLACE, MELBOURNE, 3002.

A delivery and handling fee must be added to your remittance when ordering by mail as follows:—

Total Value of Acts Ordered	Delivery and Handling Fee
10c—\$2.00	0.50c
\$2.05—\$5.00	\$1.00
\$5.05—\$20.00	\$1.50
Above \$20.00	\$2.00

No.	Price
8404. Abattoir and Meat Inspector (First Reprint—Incorporating amendments up to No. 9005)	\$0.85
6189. Acts Interpretation (Fifth Reprint—Incorporating amendments up to Act No. 9229)	\$0.70
6191. Administration and Probate Act 1958 (Fifth Reprint—Incorporating amendments up to No. 9075)	\$1.05
7147. Adoption of Children (First Reprint—Incorporating amendments up to Act No. 8602)	\$0.75
6194. Agricultural Colleges (First Reprint—Incorporating amendments up to No. 7302)	\$0.15
7772. Alcoholic and Drug-Dependent Persons Act 1968 (First Reprint—Incorporating amendments up to Act No. 9023)	\$0.60
6198. Anzac Day (First Reprint—Incorporating amendments up to No. 8344)	\$0.15
7117. Appeal Costs Fund Act 1964 (Second Reprint—Incorporating amendments up to No. 8145)	\$0.35
8273. Archaeological and Aboriginal Preservation Act 1972 (First Reprint—Incorporating amendments up to Act No. 9019)	\$0.30
6201. Architects (First Reprint—Incorporating amendments up to No. 8077)	\$0.30
6202. Auction Sales (First Reprint—Incorporating amendments up to No. 8490)	\$0.35
6203. Audit (First Reprint—Incorporating amendments up to No. 7377)	\$0.35
9008. Bail Act 1977 (First Reprint—Incorporating amendments up to Act No. 9158)	\$0.70
6206. Barley Marketing (First Reprint—Incorporating amendments up to No. 9005)	\$0.30
6208. Benefit Associations (First Reprint—Incorporating amendments up to No. 6961)	\$0.65
8004. Boilers and Pressure Vessels Act 1970—(Second Reprint—Incorporating amendments up to Act No. 9019)	\$0.65
6529. Bread Industry Act 1959 (Second Reprint—Incorporating amendments up to Act No. 8542)	\$0.20
6973. Building Contracts (Deposits) Act 1962 (Second Reprint—Incorporating amendments from No. 8938)	\$0.20
8693. Building Industry Long Service Leave (First Reprint—Incorporating Amendments up to No. 9122)	\$0.85
8597. Business Franchise (Tobacco) Act 1974 (First Reprint—Incorporating amendments up to No. 9301)	\$0.70
6853. Business Names Act 1962 (First Reprint—Incorporating amendments up to Act No. 9427)	\$0.90
6213. Cancer Act 1958 (Second Reprint—Incorporating amendments up to No. 9023)	\$1.10
6214. Carriers and Innkeepers (Second Reprint—Incorporating amendments up to No. 8534)	\$0.20
6215. Cattle Breeding (First Reprint—Incorporating amendments up to No. 6886)	\$0.10
6217. Cemeteries Act 1958 (Second Reprint—Incorporating amendments up to Act No. 9052)	\$0.90
8477. Children's Court Act 1973 (Second Reprint—Incorporating amendments up to Act No. 9008)	\$1.30
6220. Clean Air (Third Reprint—Incorporating amendments up to No. 8324)	\$0.15
4597. Closer Settlement Act 1980 (First Reprint—Incorporating amendments up to Act No. 9212)	\$1.20

ACTS REPRINTED IN ACCORDANCE WITH THE AMENDMENTS  
INCORPORATION ACT 1958 (No. 6422)—continued

No.	Price
8661. Cluster Titles Act 1974 (First Reprint—Incorporating amendments up to Act No. 9128) ..	\$0.85
6221. Coal Mines (Second Reprint—Incorporating amendments up to No. 8953) ..	\$2.15
6222. Commercial Goods Vehicles (Third Reprint—Incorporating amendments up to No. 8525) ..	\$0.55
6223. Commonwealth Arrangements (First Reprint—Incorporating amendments from No. 7809) ..	\$0.10
6839. Companies (Sixth Reprint—Incorporating amendments up to No. 8788) ..	\$9.60
8750. Constitution Act 1975 (Third Reprint—Incorporating amendments up to Act No. 9251) ..	\$1.30
6224. Constitution Act Amendment Act 1959 (Second Reprint—Incorporating amendment up to No. 9216) ..	\$3.00
8276. Consumer Affairs Act 1972 (Fourth Reprint—Incorporating amendments up to Act No. 9197) ..	\$1.50
6225. Co-operation Act 1958 (Fourth Reprint—Incorporating amendments up to Act No. 9136) ..	\$1.60
6226. Co-operative Housing Societies Act 1958 (Third Reprint—Incorporating amendments up to No. 9206) ..	\$1.50
6227. Coroners (Second Reprint—Incorporating amendments up to No. 8184) ..	\$0.35
6228. Country Fire Authority (Third Reprint—Incorporating amendments up to No. 8813) ..	\$1.25
6229. Country Roads Act 1958 (Fifth Reprint—Incorporating amendments up to No. 9212) ..	\$2.00
6230. County Court (Fourth Reprint—Incorporating amendments up to No. 9075) ..	\$0.95
6231. Crimes Act 1958 (Sixth Reprint—Incorporating amendments up to Act No. 9073) ..	\$3.15
6232. Crown Proceedings (Second Reprint—Incorporating amendments up to No. 8731) ..	\$0.46
7060. Dandenong Valley Authority Act 1963 (Second Reprint—Incorporating amendments up to Act No. 9172) ..	\$1.20
8383. Decentralized Industry Incentive Payments (First Reprint—Incorporating Amendments up to No. 8751) ..	\$0.20
6235. Dietitians Registration (First Reprint—Incorporating amendments up to No. 6886) ..	\$0.20
4989. Discharged Servicemen's Preference Act 1943 (Second Reprint—Incorporating amendments up to No. 7991) ..	\$0.20
6815. Disposal of Uncollected Goods Act 1961 (Second Reprint—Incorporating amendments up to No. 8246) ..	\$0.30
8079. Dog Act 1970 (First Reprint—Incorporating amendments up to No. 8664) ..	\$0.30
6237. Drainage Areas Act 1958 (Second Reprint—Incorporating amendments up to Act No. 8811) ..	\$0.75
6239. Dried Fruits Act 1968 (First Reprint—Incorporating amendments up to No. 7337) ..	\$0.25
6240. Education Act 1958 (Third Reprint—Incorporating amendments up to Act No. 9248) ..	\$1.50
6241. Electric Light and Power Act 1958 (Second Reprint—Incorporating amendments up to Act No. 9296) ..	\$1.10
8056. Environment Protection Act 1970 (Third Reprint—Incorporating amendments up to Act No. 9098) ..	\$0.95
6244. Essential Services (First Reprint—Incorporating amendments up to No. 8353) ..	\$0.20
6245. Estate Agents—(Fifth Reprint—Incorporating amendments up to No. 8490) ..	\$0.85
6246. Evidence Act 1958 (Sixth Reprint—Incorporating amendments up to Act No. 9230) ..	\$1.60
6715. Explosives Act 1960 (First Reprint—Incorporating amendments up to Act No. 8920) ..	\$0.85
7499. Extractive Industries Act 1966 (Third Reprint—Incorporating amendments up to No. 8647) ..	\$0.45
7733. Fences Act 1968 (Second Reprint—Incorporating amendments up to Act No. 9019) ..	\$0.70

ACTS REPRINTED IN ACCORDANCE WITH THE AMENDMENTS  
INCORPORATION ACT 1958 (No. 6422)—continued

No.	Price
6468. Filled Milk (First Reprint—Incorporating amendments up to No. 6886) ..	\$0.15
6251. Firearms (Fifth Reprint—Incorporating amendments up to No. 8427) ..	\$1.05
7780. Fisheries Act 1968 (First Reprint—Incorporating amendments up to No. 8694) ..	\$1.05
6916. Foreign Judgments Act 1962 (First Reprint including amendments made by No. 7332) ..	\$0.15
6585. Forests (Pulpwood Agreement) (Incorporating amendments up to No. 6886) ..	\$0.15
6254. Forests (Second Reprint—Incorporating amendments up to No. 8702) ..	\$1.35
6225. Friendly Societies Act 1958 (Second Reprint—Incorporating amendments up to Act No. 9019) ..	\$1.60
6255. Friendly Societies (First Reprint—Incorporating amendments up to No. 7554) ..	\$0.60
6256. Fruit and Vegetables (First Reprint—Incorporating amendments up to No. 6944) ..	\$0.30
6260. Gas and Fuel Corporation Act 1958 (Second Reprint—Incorporating amendments up to Act No. 9255) ..	\$2.40
6262. Geelong Harbor Trust Act 1958 (Second Reprint—Incorporating amendments up to Act No. 9019) ..	\$1.40
6263. Geelong Waterworks and Sewerage (First Reprint—Incorporating amendments up to No. 7547) ..	\$0.75
8176. Gift Duty Act 1971 (First Reprint—Incorporating amendments from No. 8202) ..	\$0.55
6265. Goods (Sixth Reprint—Incorporating amendments up to No. 8425) ..	\$0.75
6266. Grain Elevators (First Reprint—Incorporating amendments up to No. 7486) ..	\$0.35
7849. Groundwater (Second Reprint—Incorporating amendments up to No. 9019) ..	\$0.75
6267. Hairdressers Registration (First Reprint—Incorporating amendments up to No. 7659) ..	\$0.30
6269. Hawkers and Pedlers (Second Reprint—Incorporating amendments up to No. 8247) ..	\$0.40
6270. Health (Third Reprint—Incorporating amendments up to No. 8506) ..	\$3.25
6531. Hire Purchase Act 1959 (Second Reprint—Incorporating amendments from No. 8232) ..	\$0.85
6933. Home Finance Act 1962 (First Reprint—Incorporating amendments up to No. 7363) ..	\$0.25
6274. Hospitals and Charities Act 1958 (Third Reprint—Incorporating amendments up to No. 9212) ..	\$1.70
6275. Housing Act 1958 (Fourth Reprint—Incorporating amendments up to Act No. 9246) ..	\$3.30
3270. Imperial Acts Application (First Reprint—Incorporating Amendments up to No. 8037) ..	\$1.30
6276. Imprisonment of Fraudulent Debtors (Second Reprint—Incorporating amendments up to No. 8731) ..	\$0.55
6277. Industrial and Provident Societies Act 1958 (First Reprint—Incorporating amendments up to Act No. 7547) ..	\$1.10
6279. Instruments Act 1958 (Sixth Reprint—Incorporating amendments up to No. 9421) ..	\$1.40
6280. Judicial Proceedings Reports (First Reprint—Incorporating amendments up to No. 7596) ..	\$0.20
7651. Juries (First Reprint—Incorporating amendments up to No. 8170) ..	\$0.55
6283. Labour and Industry Act 1958 (Seventh Reprint—Incorporating amendments up to Act No. 9163) ..	\$1.90
6284. Land Act (Fourth Reprint—Incorporating amendments up to No. 9212) ..	\$4.40
6534. Land Settlement Act 1959 (First Reprint—Incorporating amendments up to No. 7328) ..	\$0.30
6288. Land Surveyors (First Reprint—Incorporating amendments up to No. 7065) ..	\$0.30
6289. Land Tax Act 1958 (Third Reprint—Incorporating amendments to Act No. 9190) ..	\$1.40
6285. Landlord and Tenant (Fourth Reprint—Incorporating amendments up to No. 8208) ..	\$1.90
6286. Lands Compensation Act (Third Reprint—Incorporating amendments up to No. 8899) ..	\$0.45

ACTS REPRINTED IN ACCORDANCE WITH THE AMENDMENTS  
INCORPORATION ACT 1958 (No. 6422)—*continued*

No.	Price
6290. Latrobe Valley ( <i>First Reprint</i> —Incorporating amendments up to No. 7332) ..	\$0.35
7919. Legal Aid—( <i>First Reprint</i> —Incorporating amendments up to No. 8427) ..	\$0.30
6291. Legal Profession Practice Act ( <i>Fourth Reprint</i> —Incorporating amendments up to No. 8778) ..	\$1.45
6292. Libraries ( <i>First Reprint</i> —Incorporating amendments up to No. 7364) ..	\$0.15
7629. Lifts and Cranes Act 1967 ( <i>Second Reprint</i> —Incorporating amendments up to Act No. 9236) ..	\$0.90
6295. Limitation of Actions ( <i>Third Reprint</i> —Incorporating amendments up to No. 8300) ..	\$0.55
7695. Liquor Control Act 1968 ( <i>Fourth Reprint</i> —Incorporating amendments up to Act No. 9225) ..	\$2.40
7145. Litter Act 1964 ( <i>Second Reprint</i> —Incorporating amendments up to No. 8702) ..	\$0.20
6298. Local Authorities Superannuation Act 1958 ( <i>Third Reprint</i> —Incorporating amendments up to Act No. 9393) ..	\$1.50
6479. Local Government Department Act 1958 ( <i>First Reprint</i> —Incorporating amendments up to Act No. 8656) ..	\$0.10
6299. Local Government ( <i>Third Reprint</i> —Incorporating amendments up to No. 8781) ..	\$10.90
7429. Lotteries Gaming and Betting Act 1966 ( <i>Second Reprint</i> —Incorporating amendments up to No. 9075) ..	\$1.20
8184. Magistrates' Courts ( <i>First Reprint</i> —Incorporating amendments up to No. 8718) ..	\$0.75
7289. Maintenance ( <i>Second Reprint</i> —Incorporating amendments up to No. 9019) ..	\$1.35
6302. Marine Act ( <i>Second Reprint</i> —Incorporating amendments up to No. 9178) ..	\$2.40
6303. Marine Stores and Old Metals Act 1958 ( <i>Second Reprint</i> —Incorporating amendments up to Act No. 8622) ..	\$0.65
6304. Marketing of Primary Products Act 1958 ( <i>Second Reprint</i> —Incorporating amendments up to Act No. 8965) ..	\$1.50
6305. Markets Act ( <i>Second Reprint</i> —Incorporating amendments up to No. 8247) ..	\$0.30
6306. Marriage ( <i>Second Reprint</i> —Incorporating amendments up to No. 8602) ..	\$0.45
6309. Medical Act 1958 ( <i>Third Reprint</i> —Incorporating amendments up to No. 8593) ..	\$0.45
8061. Medical Practitioner ( <i>First Reprint</i> —Incorporating amendments up to No. 8754) ..	\$0.75
6310. Melbourne and Metropolitan Board of Works Act 1958 ( <i>Fifth Reprint</i> —Incorporating amendments up to Act No. 9427) ..	\$3.30
6311. Melbourne and Metropolitan Tramways Act 1958 ( <i>Second Reprint</i> —Incorporating amendments up to Act No. 8992) ..	\$1.45
6312. Melbourne Harbor Trust ( <i>Second Reprint</i> —Incorporating amendments up to No. 8796) ..	\$1.35
6405. Melbourne University Act 1958 ( <i>Second Reprint</i> —Incorporating amendments up to Act No. 9123) ..	\$0.85
6605. Mental Health Act 1959 ( <i>Third Reprint</i> —Incorporating amendments up to Act No. 9023) ..	\$1.40
6315. Metropolitan Fire Brigades ( <i>Third Reprint</i> —Incorporating amendments up to No. 9019) ..	\$0.95
6316. Mildura Irrigation and Water Trusts Act 1958 ( <i>Second Reprint</i> —Incorporating amendments up to No. 9204) ..	\$2.60
6317. Milk and Dairy Supervision ( <i>Second Reprint</i> —Incorporating amendments up to No. 8655) ..	\$0.85
6318. Milk Board Act 1958 ( <i>Second Reprint</i> —Incorporating amendments up to Act No. 9238) ..	\$1.00
6319. Milk Pasteurization ( <i>First Reprint</i> —Incorporating amendments up to No. 7480) ..	\$0.20
6320. Mines Act 1958 ( <i>Third Reprint</i> —Incorporating amendments up to Act No. 8953) ..	\$2.60
6322. Ministry of Transport Act 1958 ( <i>First Reprint</i> —Incorporating amendments up to Act No. 9345) ..	\$0.60

ACTS REPRINTED IN ACCORDANCE WITH THE AMENDMENTS  
INCORPORATION ACT 1958 (No. 6422)—*continued*

No.	Price
6184. Monash University ( <i>First Reprint</i> —Incorporating amendments up to No. 7533) ..	\$0.30
6324. Money Lenders ( <i>Fourth Reprint</i> —Incorporating amendments up to No. 8490) ..	\$0.55
8429. Motor Accidents Act 1973 ( <i>Second Reprint</i> —Incorporating amendments up to Act No. 9427) ..	\$1.40
6832. Motor Boating Act 1961 ( <i>Third Reprint</i> —Incorporating amendment up to No. 8662) ..	\$0.55
6325. Motor Car Act 1958 ( <i>Fifth Reprint</i> —Incorporating amendments up to No. 8657) ..	\$2.25
8526. Municipalities Assistance Act 1973 ( <i>First Reprint</i> —Incorporating amendments up to Act No. 9385) ..	\$0.20
6705. Navigable Waters (Oil Pollution) Act 1960 ( <i>Second Reprint</i> —Incorporating amendments up to No. 8816) ..	\$0.65
6328. Nurses Act 1958 ( <i>Fourth Reprint</i> —Incorporating amendments up to Act No. 9059) ..	\$1.00
8414. Ombudsman Act 1973 ( <i>Second Reprint</i> —Incorporating amendments up to Act No. 9256) ..	\$0.60
6329. Optometrists Registration Act 1958 ( <i>Second Reprint</i> —Incorporating amendments up to Act No. 8800) ..	\$0.70
7727. Parliamentary Committees Act 1968 ( <i>First Reprint</i> —Incorporating amendments up to Act No. 9367) ..	\$1.10
7723. Parliamentary Salaries and Superannuation ( <i>First Reprint</i> —Incorporating amendments up to No. 8687) ..	\$0.35
6330. Partnership ( <i>Second Reprint</i> —Incorporating amendments up to No. 7315) ..	\$0.45
6331. Patriotic Funds ( <i>First Reprint</i> —Incorporating amendments up to No. 7338) ..	\$0.25
6332. Pawnbrokers Act 1958 ( <i>Second Reprint</i> —Incorporating amendments up to No. 8181) ..	\$0.35
8154. Pay-Roll Tax Act 1971 ( <i>First Reprint</i> —Incorporating amendments up to No. 9059) ..	\$1.15
7417. Pensions Supplementation ( <i>First Reprint</i> —Incorporating amendments up to No. 8475) ..	\$0.20
6257. Pesticides Act 1958 ( <i>Second Reprint</i> —Incorporating amendments up to No. 8589) ..	\$0.35
6334. Petroleum Act 1958 ( <i>Second Reprint</i> —Incorporating amendments up to Act No. 9212) ..	\$1.30
6335. Petrol Pumps ( <i>Second Reprint</i> —Incorporating amendments up to No. 7315) ..	\$0.15
6889. Poisons Act 1962 ( <i>Fifth Reprint</i> —Incorporating amendments up to Act No. 9427) ..	\$1.70
6337. Police Offences Act 1958 ( <i>Third Reprint</i> —Incorporating amendments up to No. 8433) ..	\$0.45
6338. Police Regulation ( <i>Third Reprint</i> —Incorporating amendments up to No. 8722) ..	\$0.95
6340. Portland Harbor Trust Act 1958 ( <i>Second Reprint</i> —Incorporating amendments up to Act No. 9204) ..	\$1.10
7498. Port Phillip Authority Act 1966 ( <i>Second Reprint</i> —Incorporating amendments from No. 8081) ..	\$0.20
6341. Pounds Act 1958 ( <i>Second Reprint</i> —Incorporating amendments up to Act No. 9168) ..	\$0.60
6342. Printers and Newspapers ( <i>Second Reprint</i> —Incorporating amendments up to No. 8556) ..	\$0.30
7494. Private Agents Act 1966 ( <i>Third Reprint</i> —Incorporating amendments up to Act No. 9075) ..	\$1.00
6890. Probate Duty Act 1962. ( <i>Fourth Reprint</i> )—Incorporating amendments up to Act No. 9019 ..	\$1.15
6344. Property Law Act 1958 ( <i>Fourth Reprint</i> —Incorporating amendments up to Act No. 9075) ..	\$3.00
7432. Protection of Animals ( <i>First Reprint</i> —Incorporating Amendments Up to No. 9019) ..	\$0.40
6345. Public Account ( <i>Second Reprint</i> —Incorporating amendments up to No. 9033) ..	\$0.40
6346. Public Authorities Marks ( <i>First Reprint</i> —Incorporating amendments from No. 7315) ..	\$0.10

ACTS REPRINTED IN ACCORDANCE WITH THE AMENDMENTS INCORPORATING ACT 1958 (No. 6422)—*continued*

No.	Price
8656. Public Service Act 1974 ( <i>Second Reprint</i> —Incorporating amendments up to Act No. 9248)	\$1.40
6350. Public Trustee Act 1958 ( <i>Second Reprint</i> —Incorporating amendments up to No. 8125)	\$1.05
6353. Racing ( <i>Fourth Reprint</i> —Incorporating amendments up to No. 8690)	\$1.55
6355. Railways Act 1958 ( <i>Second Reprint</i> —Incorporating amendments up to Act No. 9142)	\$1.55
8407. Recreation Vehicles Act 1973 ( <i>First Reprint</i> —Incorporating amendments made by Act No. 8561)	\$0.30
6564. Registration of Births Deaths and Marriages Act 1959 ( <i>Second Reprint</i> —Incorporating amendments up to Act No. 8602)	\$0.70
6357. Religious Successory and Charitable Trusts Act 1958 ( <i>First Reprint</i> —Incorporating amendments made by Act No. 7315)	\$0.75
6358. River Improvements Act ( <i>Second Reprint</i> —Incorporating amendments up to No. 8967)	\$0.85
2596. River Murray Waters Act 1915 ( <i>First Reprint</i> —Incorporating amendments up to No. 7228)	\$0.35
6359. Road Traffic ( <i>Fourth Reprint</i> —Incorporating amendments up to No. 8353)	\$0.35
6360. Rural Finance ( <i>First Reprint</i> —Incorporating amendments up to No. 7328)	\$0.15
6846. Rural Finance and Settlement Commission Act 1961 ( <i>First Reprint</i> —Incorporating amendments up to No. 7332)	\$0.30
6917. Sale of Human Blood Act 1962 ( <i>First Reprint</i> —Incorporating amendments from No. 7332)	\$0.10
6975. Sale of Land Act 1962 ( <i>Third Reprint</i> —Incorporating amendments up to No. 8861)	\$0.55
8146. Scaffolding Act 1971 ( <i>Second Reprint</i> —Incorporating amendments up to No. 8666)	\$0.35
6363. Second-hand Dealers ( <i>First Reprint</i> —Incorporating amendments up to No. 7529)	\$0.25
6367. Settled Land Act 1958 ( <i>Third Reprint</i> —Incorporating amendments up to Act No. 9075)	\$1.50
6368. Sewerage Districts Act 1958 ( <i>Third Reprint</i> —Incorporating amendments up to Act No. 9139)	\$1.90
6809. Sheep Owners Protection Act 1961 ( <i>Third Reprint</i> —Incorporating amendments up to No. 8247)	\$0.20
8089. Social Welfare Act 1970 ( <i>First Reprint</i> —Incorporating amendments up to No. 8821)	\$1.90
6372. Soil Conservation and Land Utilization Act ( <i>Third Reprint</i> —Incorporating amendments up to No. 8432)	\$0.45
6373. Soldier Settlement ( <i>First Reprint</i> —Incorporating amendments up to No. 7328)	\$0.42
6375. Stamps Act 1958 ( <i>Sixth Reprint</i> —Incorporating amendments up to No. 8624)	\$2.15
6376. State Development Committee Act 1958 ( <i>First Reprint</i> —Incorporating amendments up to No. 8827)	\$0.30
6377. State Electricity Commission Act 1958 ( <i>Third Reprint</i> —Incorporating amendments up to Act No. 9121)	\$1.35
6378. State Relief Committee ( <i>First Reprint</i> —Incorporating amendments from No. 6886)	\$0.10
6379. State Savings Bank Act 1958 ( <i>Third Reprint</i> —Incorporating amendments up to No. 8519)	\$0.95
6380. Statistics ( <i>First Reprint</i> —Incorporating amendments up to No. 6961)	\$0.20
6877. Stock (Artificial Breeding) Act 1962 ( <i>First Reprint</i> —Incorporating amendments up to No. 8709)	\$0.30
7724. Stock Diseases Act 1968 ( <i>First Reprint</i> —Incorporating amendments up to Act No. 8775)	\$0.90
6383. Stock Foods ( <i>First Reprint</i> —Incorporating amendments up to No. 7607)	\$0.28

ACTS REPRINTED IN ACCORDANCE WITH THE AMENDMENTS INCORPORATING ACT 1958 (No. 6422)—*continued*

No.	Price
6384. Stock Medicines Act 1958 ( <i>Second Reprint</i> —Incorporating amendments up to No. 9005)	\$0.50
7551. Strata Titles Act 1967 ( <i>Third Reprint</i> —Incorporating amendments up to No. 8661)	\$1.00
6886. Subordinate Legislation Act 1962 ( <i>Second Reprint</i> —Incorporating amendments up to No. 8127)	\$0.15
7405. Summary Offences Act 1966 ( <i>Second Reprint</i> —Incorporating amendments up to No. 8276)	\$0.55
7634. Sunday Entertainment ( <i>First Reprint</i> —Incorporating amendments up to No. 8173)	\$0.15
6386. Superannuation Act 1958 ( <i>Fourth Reprint</i> —Incorporating amendments up to No. 9125)	\$1.70
6387. Supreme Court ( <i>Second Reprint</i> —Incorporating amendments up to No. 8951)	\$1.35
6388. Survey Co-ordination Act 1958 ( <i>Second Reprint</i> —Incorporating amendments up to No. 9180)	\$0.70
6390. Tattersall Consultations ( <i>Second Reprint</i> —Incorporating amendments up to No. 8982)	\$0.30
8274. Taxation Appeals Act 1972 ( <i>First Reprint</i> —Incorporating amendments up to Act No. 9045)	\$0.55
6391. Teaching Service ( <i>Second Reprint</i> —Incorporating amendments up to No. 8691)	\$0.55
6393. Theatres ( <i>First Reprint</i> —Incorporating amendments up to No. 8161)	\$0.15
6849. Town and Country Planning Act 1961 ( <i>Fifth Reprint</i> —Incorporating amendments up to No. 8716)	\$1.25
6397. Trade Unions ( <i>Second Reprint</i> —Incorporating amendments up to No. 8181)	\$0.20
6399. Transfer of Land Act 1958 ( <i>Sixth Reprint</i> —Incorporating amendments up to Act No. 9324)	1.90
6400. Transport Regulation Act ( <i>Third Reprint</i> —Incorporating amendments up to No. 8700)	\$0.75
6401. Trustee Act 1958 ( <i>Fifth Reprint</i> —Incorporating amendments up to Act No. 9204)	\$1.50
6402. Trustee Companies Act 1958 ( <i>Second Reprint</i> —Incorporating amendments up to Act No. 9075)	\$0.55
6879. Unclaimed Moneys Act 1962 ( <i>Second Reprint</i> —Incorporating amendments up to No. 8448)	\$0.20
7095. Underseas Mineral Resources Act 1963 ( <i>First Reprint</i> —Incorporating amendments from No. 7591)	\$0.10
6653. Valuation of Land Act 1960 ( <i>Fifth Reprint</i> —Incorporating amendments up to Act No. 9225)	\$1.10
6407. Vegetation and Vine Diseases ( <i>First Reprint</i> —Incorporating amendments up to No. 7423)	\$0.30
6408. Venereal Diseases ( <i>First Reprint</i> —Incorporating amendments made by Act No. 6886)	\$0.55
6409. Vermin & Noxious Weeds ( <i>First Reprint</i> —Incorporating amendments up to No. 7463)	\$0.35
6410. Veterinary Surgeons ( <i>First Reprint</i> —Incorporating amendments up to No. 7343)	\$0.15
7291. Victoria Institute of Colleges Act 1965 ( <i>Second Reprint</i> —Incorporating amendments up to Act No. 8710)	\$0.90
8428. Victorian Development Corporation Act 1973 ( <i>First Reprint</i> —Incorporating amendments up to Act No. 9314)	\$1.00
6412. Warehousemen's Liens ( <i>First Reprint</i> —Incorporating amendments up to No. 7876)	\$0.15
6413. Water ( <i>Third Reprint</i> —Incorporating amendments up to No. 8729)	\$3.45
6414. Weights and Measures Act 1958 ( <i>Fourth Reprint</i> —Incorporating amendments up to Act No. 9019)	\$1.90
6415. Wild Flowers and Native Plants Protection ( <i>First Reprint</i> —Incorporating amendments up to No. 6976)	\$0.15
6416. Wills Act 1958 ( <i>Second Reprint</i> —Incorporating amendments up to Act No. 9075)	\$0.60

ACTS REPRINTED IN ACCORDANCE WITH THE AMENDMENTS INCORPORATION ACT 1958 (No. 6422)—continued

No.	Price
6417. Wire Netting (Second Reprint—Incorporating amendments up to No. 7876) . . . . .	\$0.65
6419. Workers Compensation Act 1958 (Eighth Reprint—Incorporating amendments up to Act No. 9372) . . . . .	\$2.40
6420. Wrongs Act 1958. (Third Reprint—Incorporating amendments up to Act No. 9153) . . . . .	\$0.60
8344. Youth, Sport and Recreation Act 1972 (First Reprint—Incorporating amendments up to No. 8550) . . . . .	\$0.35

F. D. ATKINSON  
Government Printer

HARSTON, PARTRIDGE & CO. PTY. LTD., 455 Little Collins Street, Melbourne, Victoria 3000.  
 KYNETON GUARDIAN PTY. LTD., P.O. Box 18, Kyneton, Victoria 3444.  
 LONSDALE NEWSAGENCY, 250 Lonsdale Street, Dandenong, Victoria 3175.  
 LOVELL'S SHEPPARTON NEWSAGENCY, 246 Wyndham Street, Shepparton, Victoria 3630.  
 THE MERCANTILE EXCHANGE, 50 Queen Street, Melbourne, Victoria 3000.  
 McDONALD'S NEWSAGENCY, 88 Bridge Street, Ballarat, Victoria 3350.  
 MCGILL'S AUTHORIZED NEWSAGENCY, 183-5 Elizabeth Street, Melbourne, Victoria 3000.  
 McNAUGHTON, P. R. & L. A., 112-114 Gray Street, Hamilton, Victoria 3300.  
 POWNEY'S AUTHORIZED NEWSAGENCY, 293 Hargreaves Street, Bendigo, Victoria 3550.  
 PURDIE, J., & CO., 138 Moorabool Street, Geelong, Victoria 3220.  
 SALE AUTHORIZED NEWSAGENCY 292-294 Raymond Street, Sale, Victoria 3850.  
 VERNONS OF RICHMOND, 261 Bridge Road, Richmond, Victoria 3121.  
 VIEW POINT AUTHORIZED NEWSAGENCY, 4 View Point, Bendigo, Victoria 3550.

THE "VICTORIA GOVERNMENT GAZETTE"

PUBLICATION—A VICTORIA GOVERNMENT GAZETTE is published every WEDNESDAY EVENING unless advertised otherwise.

SUBSCRIPTIONS—The Subscription, including postage, is \$62 per annum, or \$31 per half year, payable in advance. Subscriptions are required for whole months, but must cover at least a half-year.

PRIVATE ADVERTISEMENTS—Advertisements will be received by the Government Printer not later than the day preceding publication—at ordinary rates at or before one p.m. and at double rates between one p.m. and half past three p.m. The charge for ADVERTISEMENTS is 78 cents per line single column and \$1.56 per line double column. The charge for a full page is \$118. The title forms one or more lines as a heading. On an average ten words make a line of single column. Every signature must likewise be counted as a line. The final words of a paragraph though only portion of a line, must be counted as one line. Signatures (in particular) and proper names must be written very clearly in the text: ONE SIDE ONLY of each sheet of paper should be written upon.

All documents NOT CLEARLY PREPARED will be returned unpublished. Where brands occur, not provided for by the ordinary letters of the alphabet, a written explanatory description also must be furnished.

PAYMENTS—Unless the advertiser has a Credit Account, all payments are required in advance. Remittances should be made by cheque, postal order or money order, payable to "GOVERNMENT PRINTER".

CORRESPONDENCE—All correspondence should be addressed to "The Victorian Government Printer, P.O. Box 203, North Melbourne, 3051".

CONTENTS

	Page
Act of Parliament	3633
Acts of Parliament on Sale at the Government Printing Office	3700
Appointments	3652
Auction Sales Act	3651
Bank Holidays	3635
Cemeteries—Scale of Fees	3646
Contracts	3650
Estates of Deceased Persons	3643
Government Notices	3635
Lands	3667
Minerals and Energy	3645
Notice to Mariners	3652
Notice of Making of Statutory Rules	3700
Orders in Council—	
Acts—Local Government; Country Roads Board; Soil Conservation and Land Utilization; Crown Land (Reserves); Land; Hospitals and Charities; State Employees Retirement Benefits; Zoological Parks and Gardens; Workers Compensation; Historic Buildings; Portland Harbor Trust; Sewerage Districts; Water; Geelong Waterworks and Sewerage; Sewerage Districts; Melbourne and Metropolitan Board of Works.	3654 et seq
Police Sale	3648
Private Advertisements	3673
Proclamations	3633
Regulations—	
Act—Teaching Service	3672
Resignations	3654
State Rivers and Water Supply Commission	3639
Tenders	3671
Transport Regulation Board—Public Hearings	3636

AGENTS FOR THE "VICTORIA GOVERNMENT GAZETTE"

The following have been appointed agents to receive Advertisements and Subscriptions for the Victoria Government Gazette:—

- ARMSTRONG'S AGENCY, 217 Queen Street, Melbourne, Victoria 3000.
- ARNALL & JACKSON, 390 Barkly Street, Brunswick, Victoria 3056
- BAIRNSDALE AUTHORIZED NEWSAGENCY, 132 Main Street, Bairnsdale, Victoria 3875.
- BENALLA AUTHORIZED NEWSAGENCY, 45 Bridge Street, Benalla, Victoria 3672.
- BLANE'S AUTHORIZED NEWSAGENTS, 162 Murray Street, Colac, Victoria 3250.
- CARTER, R. G., ADVERTISING SERVICE PTY. LTD., 129 Church Street, Hawthorn, Victoria 3122.
- CORNELL, R. G., 126 Eighth Street, Mildura.
- FAROE, S. W. & E. P., 79 Henty Street, Casterton, Victoria 3311.
- FRANKS, H., & CO., 184 Ryrie Street, Geelong, Victoria 3220.
- GORDON & GOTCH AUSTRALASIA LTD., 25-37 Huntingdale Road, Burwood, Victoria 3125.