



Victoria Government Gazette

No. 7—Wednesday, 20 January 1982

PROCLAMATIONS

ACTS OF PARLIAMENT

PROCLAMATION

By His Excellency the Governor of the State of Victoria and its Dependencies in the Commonwealth of Australia, &c., &c., &c.

I, the Governor of the State of Victoria, in the Commonwealth of Australia, do hereby declare that I have this day assented, in Her Majesty's name, to the Bills passed by the Parliament of the said State, the titles whereof are hereunder set forth, together with the short titles, that is to say:

- No. 9718. "An Act to re-enact with Amendments the Law relating to the Formation, Registration and Management of Co-operative Societies and Purposes connected therewith." (*Co-operation Act 1981.*)
- No. 9719. "An Act to re-enact with Amendments the Law relating to Drugs, Poisons and Controlled Substances, to amend the *Health Act 1958* and the *Crimes Act 1958* and for other purposes." (*Drugs, Poisons and Controlled Substances Act 1981.*)
- No. 9720. "An Act to consolidate and amend and make further Provision for the Law relating to Building, to provide for the better Regulation of Building, to establish a Division of Building Control, a Building Control Technical Advisory Council, a Building Control Accreditation Authority, a Plumbers Gasfitters and Drainers Registration Board, a Building Qualifications Board and Building Referees Boards, to amend the *Health Act 1958*, the *Housing Act 1958*, the *Labour and Industry Act 1958*, the *Local Government Act 1958* and other Acts and for other purposes." (*Building Control Act 1981.*)

Given under my Hand and the Seal of the State of Victoria aforesaid, at Melbourne, this twelfth day of January, in the year of our Lord One thousand nine hundred and eighty-two, and in the thirtieth year of the reign of Her Majesty Queen Elizabeth II.

(L.S.) HENRY WINNEKE

By His Excellency's Command
L. H. S. THOMPSON
Premier

GOD SAVE THE QUEEN!

NOTE—No. 9718. This Act shall come into operation on a day to be fixed by Proclamation of the Governor in Council published in the *Government Gazette*.

No. 9719. The several provisions of this Act shall come into operation on a day or on the respective days to be fixed by Proclamation or successive Proclamations of the Governor in Council published in the *Government Gazette*.

No. 9720. The several provisions of this Act (except the several items in the Schedule) shall come into operation on the day or on the respective days to be fixed by Proclamation or successive Proclamations of the Governor in Council published in the *Government Gazette*.

Survey Co-ordination Act 1958
PROCLAIMED SURVEY AREA No. 70

PROCLAMATION

By His Excellency the Governor of the State of Victoria and its Dependencies in the Commonwealth of Australia, &c., &c., &c.

I, the Governor of the State of Victoria, in the Commonwealth of Australia, by and with the advice of the Executive Council of the said State, pursuant to the provisions of section 12 (2) of the *Survey Co-ordination Act 1958*, and upon receipt of a report by the Surveyor-General that there are now sufficient permanent marks in the area for the establishment of a local traverse, do hereby proclaim 208 hectares, more or less, being the Township of Mortlake, Parish of Mortlake, County of Hampden as indicated by hatching on plan hereunder, to be a "Proclaimed Survey Area" for the purposes of the *Survey Co-ordination Act 1958*—(M.210⁽²⁾) (C.O.S. 3214).

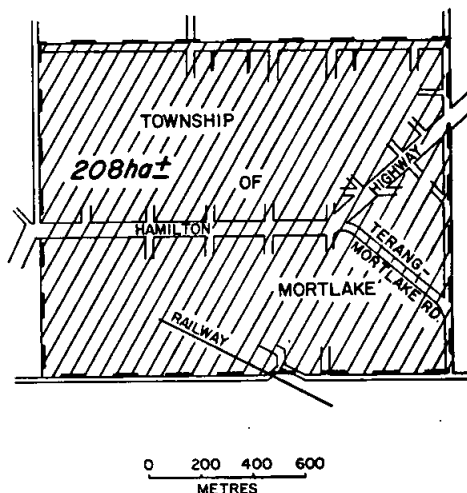

Given under my Hand and the Seal of the State of Victoria aforesaid, at Melbourne, this twelfth day of January, in the year of our Lord One thousand nine hundred and eighty-two, and in the thirtieth year of the reign of Her Majesty Elizabeth the Second, Queen of Australia.

(L.S.) HENRY WINNEKE

By His Excellency's Command
W. V. HOUGHTON
Minister of Lands

GOD SAVE THE QUEEN!

Melbourne and Metropolitan Board of Works (Yarra Development) Act 1981, No. 9700

DATE OF COMING INTO OPERATION

PROCLAMATION

By His Excellency the Lieutenant-Governor as Deputy for the Governor of the State of Victoria and its Dependencies in the Commonwealth of Australia, &c., &c., &c.

Whereas by an Act of Parliament of the State of Victoria passed in the thirtieth year of the reign of Her Majesty Elizabeth the Second, Queen of Australia, entitled the *Melbourne and Metropolitan Board of Works (Yarra Development) Act 1981, No. 9700*, it is amongst other things enacted that the several provisions of the said Act shall come into operation on a day or the respective days to be fixed by Proclamation or successive Proclamations of the Governor in Council published in the *Government Gazette*.

Now therefore I, the Lieutenant-Governor as Deputy for the Governor of the State of Victoria, in the Commonwealth of Australia, by and with the advice of the Executive Council of the said State, do by this Proclamation fix Wednesday, the twentieth day of January, One thousand nine hundred and eighty-two, as the day on which all of the provisions of the said *Melbourne and Metropolitan Board of Works (Yarra Development) Act 1981, No. 9700*, shall come into operation.

Given under my Hand and the Seal of the State of Victoria aforesaid, at Melbourne, this nineteenth day of January, in the year of our Lord One thousand nine hundred and eighty-two, and in the thirtieth year of the reign of Her Majesty Elizabeth the Second, Queen of Australia.

(L.S.) JOHN McI. YOUNG

By His Excellency's Command

GLYN JENKINS
Minister of Water Supply

GOD SAVE THE QUEEN!

PUBLIC HOLIDAYS

PROCLAMATION

By His Excellency the Governor of the State of Victoria and its Dependencies in the Commonwealth of Australia, &c., &c., &c.

In pursuance of the provisions contained in section 71 (2) of the *Public Service Act 1974, I*, the Governor of the State of Victoria, in the Commonwealth of Australia, by and with the advice of the Executive Council of the said State, do by this my Proclamation appoint the days and dates hereunder mentioned to be observed as Public Holidays or Public Half-Holidays (as the case may be) at the places, respectively specified, viz.:

Public Holidays

THURSDAY, 18 MARCH 1982, within the Shire of Newham and Woodend.

Public Half-Holidays from the Hour of Twelve o'clock noon:

WEDNESDAY, 10 FEBRUARY 1982, throughout the Shire of Colac.

MONDAY, 22 MARCH 1982, throughout the Shire of Ballan.

Given under my Hand and the Seal of the State of Victoria aforesaid, at Melbourne, this twelfth day of January, in the year of our Lord One thousand nine hundred and eighty-two, and in the thirtieth year of the reign of Her Majesty Elizabeth the Second, Queen of Australia.

(L.S.) HENRY WINNEKE

By His Excellency's Command

L. H. S. THOMPSON
Premier

GOD SAVE THE QUEEN!

BANK HALF-HOLIDAY

PROCLAMATION

By His Excellency the Governor of the State of Victoria and its Dependencies in the Commonwealth of Australia, &c., &c., &c.

In pursuance of the provisions of the *Bank Holidays Act 1958, I*, the Governor of the State of Victoria, in the Commonwealth of Australia, do by this my Proclamation appoint the days and dates named hereunder special days to be observed as Bank Holidays or Bank Half-Holidays (as the case may be) at the places respectively mentioned, that is to say:

Bank Half-Holiday from the Hour of Eleven a.m.:

THURSDAY, 18 FEBRUARY 1982, throughout the City of Sale.

Given under my Hand and the Seal of the State of Victoria aforesaid, at Melbourne, this twelfth day of January, in the year of our Lord One thousand nine hundred and eighty-two, and in the thirtieth year of the reign of Her Majesty Elizabeth the Second, Queen of Australia.

(L.S.) HENRY WINNEKE

By His Excellency's Command

L. H. S. THOMPSON
Premier

GOD SAVE THE QUEEN!

GOVERNMENT NOTICES

VICTORIA

ACT 391—SECOND SCHEDULE

A statement of trusts having been submitted by the head or authorized representative of the denomination known as the Church of England in Australia in the Diocese of Bendigo in Victoria, pursuant to the provisions of the Act to provide for the abolition of State Aid to Religion, for allowance of His Excellency the Governor (the same was allowed by him on 12 January 1982) and the following is the form in which such statement of trusts has been allowed.

STATEMENT OF TRUSTS

Description of Land—6982 square metres, Township of Corop, Parish of Corop, County of Rodney being Crown allotment 15A, section 1.

Commencing at the north-western angle of Crown allotment 14, section 1; bounded thence by that allotment bearing 180 deg. 00 min. 83.99 metres; by a road bearing 270 deg. 00 min. 80.47 metres; by a line bearing 0 deg. 00 min. 89.52 metres; and thence by a road bearing 93 deg. 56 min. 80.67 metres to the point of commencement.

Name of Trustee—Church of England Trusts Corporation for the Diocese of Bendigo of 32 Forest Street, Bendigo.

Powers of Disposition—To let, lease, sell, mortgage or exchange the said land or any portion thereof.

Purposes to Which Proceeds of Disposition are to be Applied—Monies obtained from sale, lease, mortgages or exchanges to be paid to the said Church of England Trusts Corporation for the Diocese of Bendigo.

As witness, the Hand of the Governor of the State of Victoria, 12 January 1982.

HENRY WINNEKE
Governor of the State of Victoria

SHIRE OF NARRACAN
ROAD DEVIATION

Pursuant to the provisions of sections 522 and 526 of the *Local Government Act 1958* the Council of the Shire of Narracan hereby directs that the land in the Parish of Moondarra indicated by hatching on the plan hereunder which has been purchased, taken or acquired by it, shall be a public highway on and from the date of publication of this Order in the *Government Gazette* and declares that such land shall be a public highway in lieu of the land indicated by cross-hatching on the said plan.

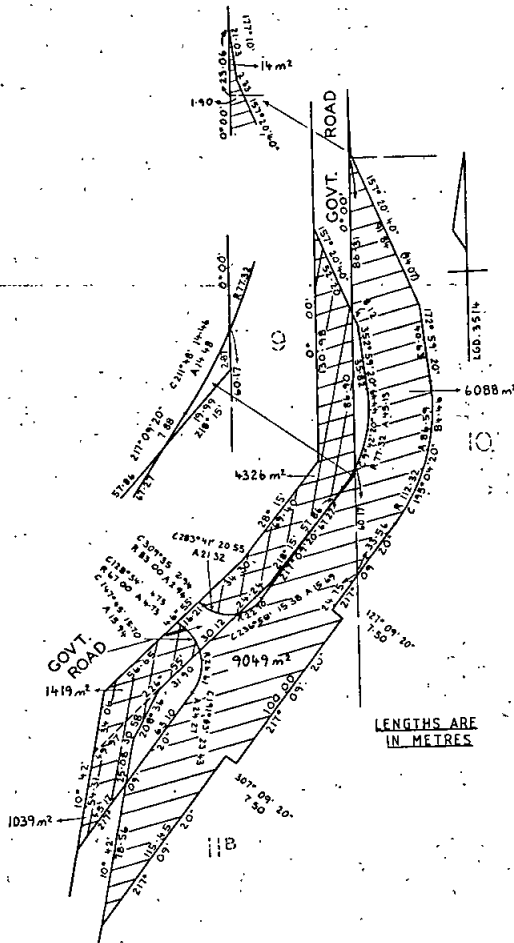

The common seal of the President, Councillors and Ratepayers of the Shire of Narracan was hereunto affixed, 14 September 1981, in the presence of—

(SEAL) J. G. HAMMOND, President
E. J. KEATING, Councillor
W. F. NELSON, Secretary

Confirmed by the Governor in Council, 12 January 1982
—TOM FORRISTAL, Clerk of the Executive Council

Pipelines Act 1967, No. 7541

DEPARTMENT OF MINERALS AND ENERGY

VARIATION TO THE ROUTE OF A PIPELINE

I, Digby Glen Crozier, Minister for Minerals and Energy for the State of Victoria, hereby give notice in accordance with the provisions of Section 12 of the *Pipelines Act 1967*, No. 7541, that the route of the pipeline for which Permit No. 091 to own and use, has been granted by me to the Gas and Fuel Corporation of Victoria, is varied as follows:

Deletion of the expression:

"thence turning to continue in an easterly direction along the northern side of such street for a distance of approximately 700 m (2296 feet) thence turning to enter and continue across Part Allotment 26, Section 9, Township of Warragul and the proposed La Trobe Valley Freeway to Wills Street," and

Substituting in lieu the expression:

"thence turning to continue in an easterly direction along the northern side of such street for a distance of approximately 550 m, thence turning to enter and continue across Part Allotments 27 and 26, Section 9, Township of Warragul, and the La Trobe Valley Freeway en route to Wills Street," and as more particularly shown on the Gas and Fuel Corporation's Plan No. T44-5-1A, a copy of which is held in the office of the Department of Minerals and Energy.

18 January 1982

DIGBY CROZIER
Minister for Minerals and Energy

DEPARTMENT OF MINERALS AND ENERGY

Subject to any necessary excisions, &c., it is proposed to grant the following Mining Lease:
No. 618-1; Australian Gypsum Limited; 48.1 ha, Parish of Woatwoara.

APPLICATIONS FOR MINING LEASES DECLARED ABANDONED

- No. 709; Macnee Investments Pty. Ltd.; 56 ha, Parish of Kangeraar.
- No. 765; Quist's Investments Pty. Ltd.; 0.3 ha, Parish of Bungywarr.
- No. 797; Robert William Bennett and Wendy Jean Bennett; 60 ha, Parish of Boort.
- No. 833; Geoffrey Robert Bates, Lynette Dianne Bates, Edward James Renton and Rika Van der Meer; 60 ha, Parish of Kangeraar.

APPLICATIONS FOR MINING LEASES REFUSED

- No. 622; Alfred George Cox; 3.6 ha, Parish of Castlemaine.
- No. 804; Asian Pacific Development Corporation Pty. Limited; 8 ha, Parish of Huntly.
- No. 821; Barrie Leon Dickie; 50 ha, Parish of Turoar.

MINING LEASES GRANTED

- No. 144-1; Edward Arthur Knox; 21.4 ha, Parish of Enoch's Point.
- No. 723; Australian Gypsum Limited; 34.8 ha, Parish of Bitterang.

APPLICATION FOR MINING LEASE TRANSFERRED

- No. 823; From Maurice Canterbury Investments Pty. Ltd. to Inglewood Gold Mines N.L.

EXPLORATION LICENCES GRANTED

- No. 815; CRA Exploration Pty. Limited; 396 km², comprising Graticular Blocks Nos. 1371, 1372, 1373, 1374, 1375 and 1443-Melbourne Map Sheet.

No. 992; CRA Exploration Pty. Limited; 132 km², comprising Graticular Blocks Nos. 817 and 818 Melbourne Map Sheet.

No. 1000; IBI Pty. Ltd.; 66 km², Graticular Block No. 1078 Hamilton Map Sheet.

No. 1146; Vidor Limited; 660 km², comprising Graticular Blocks Nos. 708, 709, 710, 711, 779, 780, 852, 924, 996 and 1068 Hamilton Map Sheet.

EXPLORATION LICENCE CANCELLED

No. 716; Carpentaria Exploration Company Pty. Ltd.; 132 km², comprising Graticular Block Nos. 356 and 428 Hamilton Map Sheet.

This area will become available again for Exploration Licence on 20 April 1982.

APPLICATIONS FOR SEARCH LICENCES DECLARED ABANDONED

Nos. 2100, 2111, 2112, 2113 and 2114; Peter Ronald Fox; 40 ha's each, Parishes of Wollonaby and Ludrik Munjie.

Nos. 2101, 2102, 2103, 2104 and 2105; Peter Bassett Macquarie Pulley; 40 ha's each, Parishes of Bogong South and Wollonaby.

Nos. 2106, 2107, 2108, 2109 and 2110; Graham David Pitkethley; 40 ha's each, Parish of Bogong South.

Nos. 2129, 2130, 2131 and 2132; BAR Pty. Ltd.; 40 ha's each, Parish of Yehrip.

Nos. 2133, 2134, 2135 and 2136; Ribant Pty. Ltd.; 40 ha's each, Parishes of Yehrip and Warrenmag.

APPLICATIONS FOR SEARCH LICENCES REFUSED

No. 2099; K. Ferrier; 40 ha, Parish of Dunolly.

No. 2218; Victor Roland Davie and William Robert Morris; 20 ha, Parish of Moliagul.

No. 2299; Dolcie May McLean; 40 ha, Parish of Amherst.

No. 2337; Samuel Phillip Farley; 40 ha, Parish of Budgerum East.

No. 2338; Faye Farley; 40 ha, Parish of Budgerum East.

SEARCH LICENCES GRANTED

Nos. 2118 and 2119; Greig Lewis Maver; 40 ha's each, Parish of Moornapa.

No. 2365; Tallangalook Pty. Limited; 40 ha, Parish of Walhalla.

No. 2366; Tallangalook Pty. Limited; 40 ha, Parish of Walhalla.

SEARCH LICENCES EXPIRED

No. 1592; Ronald John Bambery, John Keith Hammond; 40 ha, Parish of Blackwood.

No. 1626; Barry William Hutchinson; 40 ha, Parish of Mockinya.

No. 1627; Graham Robert Hutchinson; 40 ha, Parish of Mockinya.

No. 1749; Clarence William Davis, John Balmain Griffiths; 33 ha, Parish of Numbruk.

No. 1750; Clarence William Davis, John Balmain Griffiths; 26 ha, Parish of Numbruk.

No. 1861; Lord Nelson Gold Reefs Pty. Ltd.; 36 ha, Parish of St. Arnaud.

TAILINGS LICENCES GRANTED

No. 4681; Shire of Newstead; to remove tailings from the Thornhill Mine, situated at Greens Gully.

No. 4701; Town of Stawell; to remove tailings from the "Oriental Sand Dump" situated off Newington Road, 3 km from Stawell.

APPLICATION FOR TAILINGS LICENCE DECLARED ABANDONED

No. 4535; Castlemaine Engineering and Mining Co. Pty. Ltd.; to treat tailings situated east of Spring Gully.

APPLICATION FOR TAILINGS LICENCE REFUSED

No. 81; Neil Imlach, Robert Brown, Merle Sperling and Lawrence Course; to treat tailings from the Burnt Creek Mine situated in the Parish of Dunolly.

EXTRACTIVE INDUSTRY LEASES GRANTED

No. 267; Sure Quarries Pty. Limited; 1.89 ha, Parish of Neerim.

No. 268; Sure Quarries Pty. Limited; 5.4 ha, Parish of Neerim.

No. 284; Pioneer Concrete (Vic.) Pty. Ltd.; 13.4 ha, Parish of Wanwin.

EXTRACTIVE INDUSTRY LICENCE GRANTED

No. 1059; F. R. Bellman and Sons Pty. Ltd.; 31 ha, Parish of Corinella.

D. G. CROZIER
Minister for Minerals and Energy

FARM PRODUCE MERCHANTS AND COMMISSION AGENTS ACT 1965 (No. 7274)

List of names and addresses of licence holders to whom licences have been issued during December 1981. In accordance with the above Act, those issued with a Merchant's or Commission Agent's licence have paid the prescribed contribution to the Farm Produce Merchants and Commission Agents Guarantee Fund. All licences, unless earlier surrendered or cancelled, shall continue in force until 30 June 1982.

D. F. SMITH
Director-General of Agriculture

MERCHANTS

Name; Principal Place of Business

Gearon, A. J. and N. M., Lot 2 Pound Road, North Clyde, 3978.

Giampaolo, Dominico, Woorinen, 3589.

Gippsland Bean Cleaners, 1 Forest Road, Orbost, 3888.

Heba, T. L. and A. C., Curlewis Road, Curlewis, 3222.

Mountain Valley Produce, Monda Avenue, Healesville, 3777.

Pignataro, R., Store 40 Melbourne Wholesale Fruit and Vegetable Market, Footscray Road, Footscray, 3011.

COMMISSION AGENTS

Pignataro, I., Stand 128 Melbourne Wholesale Fruit and Vegetable Market, Footscray Road, Footscray, 3011.

Ripepi, R., Stand 360 Melbourne Wholesale Fruit and Vegetable Market, Footscray Road, Footscray, 3011.

SECONDARY WHOLESALER

Kelly Country Fruit Market, 186 Tone Road, Wangaratta, 3677.

Education Act 1958

COUNCIL OF PUBLIC EDUCATION

In accordance with the provisions of section 43 (4) of the Education Act 1958, the Council of Public Education gives notice that it has cancelled the registration of the following school:

HOLLINGSWORTH COLLEGE, RINGWOOD EAST

M. WILKINSON
Registrar

Private Agents Act 1966

NOTICE OF RECEIPT OF APPLICATIONS FOR LICENCES UNDER THE PROVISIONS OF THE PRIVATE AGENTS ACT 1966

The Clerk(s) of the Magistrates' Court(s) as listed hereunder hereby give notice that applications, as under, have been lodged for hearing by the said Court(s) on the date(s) specified.

Any person desiring to object to any of such applications must—

- (a) lodge with the respective Clerk of the Magistrates' Court a notice in the prescribed form of his objection and of the grounds thereof;
- (b) cause a copy of such notice to be served personally or by post upon the applicant at least three days before the hearing of the application; and
- (c) send or deliver—
 - (i) where the objection is not made by the officer in charge of the police district in which the Court is situated—a copy of the notice to such officer; and
 - (ii) where the objection is not made by the Registrar or Deputy Registrar—a copy to the Registrar.

<i>Full Name of Applicant*</i>	<i>Place of Abode of Applicant or Nominee</i>	<i>Name of Firm or Corporation</i>	<i>Address for Registration</i>	<i>Type of Licence</i>	<i>Date of Hearing</i>
MAGISTRATES' COURT, RINGWOOD					
Turnewidch, Walfried Gerhardt	54 Clarence Rd, Wantirna	Eastern Suburbs Security	54 Clarence Rd, Wantirna	Guard Agent	2.2.82
Beawde, Robert Alexander	17 St David Dr, Wantirna			" "	"
Dated at Ringwood 8 January 1982 J. T. KNIGHT, Clerk of the Magistrates' Court					
MAGISTRATES' COURT, DANDENONG					
Whitfield, Paul Anthony	Lot 216 Neville St, Cockatoo	Shepherd Block Security Doveton	2 Almond Dve, Doveton	Watchman	29.1.82
Dated at Dandenong 8 January 1982 K. T. RYAN, Clerk of the Magistrates' Court					
MAGISTRATES' COURT, HORSHAM					
Lavithis, Paul	71 Stawell Rd, Horsham		28 Searle St, Horsham	Watchman	3.2.82
Dated at Horsham 11 January 1982 A. BELLIS, Clerk of the Magistrates' Court					
MAGISTRATES' COURT, BROADMEADOWS					
Conley, David Brian	83 Sunset Bvde, Jacana	Glenroy & District Night Patrol Service	83 Sunset Bvde, Jacana	Guard Agent	8.2.82
Dated at Broadmeadows 11 January 1982 L. F. HANDLEY, Clerk of the Magistrates' Court					
MAGISTRATES' COURT, GEELONG					
Nielson, Alan Stephen	35 Marshall Town Rd, Marshall, Belmont		146 Ashley St, Maidstone	Watchman	27.1.82
Dated at Geelong 11 January 1982 J. REILLY, Clerk of the Magistrates' Court					
MAGISTRATES' COURT, PORT MELBOURNE					
Johnston, John Noel	24 Station Rd, Montmorency	Fleetexpress Security and Watching Services	61 Bertie St, Port Melbourne	Watchman	4.2.82
Bailey, Ian John	110 Glass St, Essendon	Mayne Nickless	390 St. Kilda Rd, Melbourne	"	"
Brown, Peter Mintern	3 Steedman St, Mordialloc	" "	" "	"	"
Dolenc, James	4 Winstanley Rd, East Geelong	" "	" "	"	"
Giles, Stewart	35 Westmorland St, Whittington	" "	" "	"	"
Huebner, Rudolf	27 Alexander Ave, Clayton	" "	" "	"	"
Koerntjes, Ronald	378 Koornang Rd, Carnegie	" "	" "	"	"
Patterson, Bruce Andrew	44 Blackburn St, Lalor	" "	" "	"	"
Paull, Robert Barry	11 Koonalda Gve, Dandenong North	" "	" "	"	"
Dated at Port Melbourne 11 January 1982 S. BRYANT, Clerk of the Magistrates' Court					

* Or in the case of a firm or corporation, of the Nominee

PRIVATE AGENTS—continued

Full Name of Applicant*	Place of Abode of Applicant or Nominee	Name of Firm or Corporation	Address for Registration	Type of Licence	Date of Hearing
MAGISTRATES' COURT, COBURG					
Davis, Robert Maxwell	9 Nyora Crt, Westmeadows	Mayne Nickless Pty. Ltd.	88 Bakers Rd, Coburg	Watchman	9.2.82
Kline, Wayne Geoffrey	37 Dunn St, Pascoe Vale	" "	" "	" "	8.2.82
Allan, Gary	3/16 Callander Rd, Pascoe Vale	" "	" "	" "	22.2.82
Dated at Coburg 12 January 1982 P. WENDEN, Clerk of the Magistrates' Court					
MAGISTRATES' COURT, WERRIBEE					
Fisher, Michael Francis	4 Bayliss Ave, Hoppers Crossing		4 Bayliss Ave, Hoppers Crossing	Guard Agent	15.2.82
Hamshare, Ian	31 Golden Ave, Werribee		3 Amour Crt, West Sunshine	Watchman	27.1.82
Dated at Werribee 14 January 1982 I. J. SIMMONS, Clerk of the Magistrates' Court					
MAGISTRATES' COURT, ARARAT					
Faneco, Roy Frederick	16 Port Fairy Rd, Ararat		16 Port Fairy Rd, Ararat	Process Server	2.2.82
Dated at Ararat 12 January 1982 W. JEFFREY, Clerk of the Magistrates' Court					
MAGISTRATES' COURT, PRAHRAN					
Joyce, Lawrence Frank	49 Grayling Cres, Croydon		842 High St, Kew	Process Server	29.1.82
Phillips, Alan James	3 Carmen Crt, Ringwood	Mayne Nickless Ltd.	390 St Kilda Rd, Melbourne	Watchman	"
Hendy, Gary Leslie	74A Cameron Pde, Bundoora	" "	" "	" "	"
Van Langenberg, Clive	28/12 Flowervale Rd, Springvale	" "	" "	" "	"
Aloysius Marconie	145 Mt. Pleasant Rd, Highton	" "	" "	" "	"
Buckenara, Robert Frank	8 Seventh Ave, Chelsea Heights	" "	" "	" "	5.2.82
Hare, Brian John	3/131 Plantation Rd, Corio	" "	" "	" "	"
Evans, Graeme Leslie	198 Ballarat Rd, Maidstone	" "	" "	" "	"
MacKay, Colin Lionel		" "	" "	" "	"
Dated at Prahran 12 January 1982 J. A. GIDLEY, Clerk of the Magistrates' Court					
MAGISTRATES' COURT, FRANKSTON					
Goold, Mariene Carol	7 Teri St, Frankston		7 Teri St, Frankston	Inquiry Agent	25.2.82
Dated at Frankston 14 January 1982 GRAEME COLLINS, Clerk of the Magistrates' Court					

* Or in the case of a firm or corporation, of the Nominee

Industrial Relations Act 1979, Section 20 (1)

DETERMINATION OF THE DENTAL TECHNICIANS BOARD (No. 6 of 1981)

Notice is hereby given that in accordance with the provisions of Section 20 (1) of the *Industrial Relations Act 1979* the Minister of Labour and Industry has, on behalf of the State of Victoria, requested the Industrial Relations Commission of Victoria to review the Award made by the Dental Technicians Board on 14 December 1981. (No. 6 of 1981).

Section 20 (3) of Act 9365 provides that when a request is made under this section the Award shall be deemed not to come into operation.

Notice is also given that this matter is listed for mention and programming before the Industrial Relations Commission of Victoria, 5th Floor, Nubrik House, 271 William Street, Melbourne at 9.30 a.m. on Tuesday, 19 January 1982.

G. EVANS, Acting Registrar
Industrial Relations Commission of Victoria

Industrial Relations Act 1979, Section 20 (1)

DETERMINATION OF THE BRICK TRADE BOARD (No. 4 of 1981)

Notice is hereby given that in accordance with the provisions of Section 20 (1) of the *Industrial Relations Act 1979* the Minister of Labour and Industry has, on behalf of the State of Victoria, requested the Industrial Relations Commission of Victoria to review the Award made by the Brick Trade Board on 14 December 1981. (No. 4 of 1981).

Section 20 (3) of Act 9365 provides that when a request is made under this section the Award shall be deemed not to come into operation.

Notice is also given that this matter is listed for mention and programming before the Industrial Relations Commission of Victoria, 5th Floor, Nubrik House, 271 William Street, Melbourne at 9.30 a.m. on Tuesday, 19 January 1982.

G. EVANS, Acting Registrar
Industrial Relations Commission of Victoria

Labour and Industry Act 1958

ORDER OF EXEMPTION ISSUED UNDER THE PROVISIONS OF SECTION 80F

Pursuant to the provisions of Section 80F of the *Labour and Industry Act 1958*, I, Thomas Leslie Austin, Acting Minister of Labour and Industry, having considered an application from the Council of the City of Melbourne, hereby make this Order exempting shopkeepers of shops in the City of Melbourne as follows:

- (a) shops fronting on to Little Bourke Street between Exhibition Street and Swanston Street;
- (b) shops fronting on to any lane or alleyway which connects with Little Bourke Street between Exhibition Street and Swanston Street; and
- (c) shops fronting on to Russell Street between Bourke Street and Lonsdale Street, but excluding Michael's Corner Store which has a side entrance on to Russell Street—

from being required to close and keep closed their shops in accordance with Part VI. of the said Act during the Chinese New Year Festival to be held on Sunday, 31 January 1982.

This Order does not operate to permit the sale or disposal of liquor within the meaning of the *Liquor Control Act 1968* by any shopkeeper at any time when he would, but for this Order, be required to close and keep closed his shop in accordance with Part VI.

Dated at Melbourne, 5 January 1982

TOM AUSTIN
Acting Minister of Labour and Industry

Police Offences Act 1958, No. 6337

DIVISION 1A—STATE CLASSIFICATION OF PUBLICATIONS BOARD

Take note that the State Classification of Publications Board has classified the following publications in accordance with the provisions of section 180H (1) of the *Police Offences Act 1958*.

Each publication shall be subject to the following restrictions:

- (a) It shall not be offered for sale, sold or delivered to any person under the age of eighteen years;
- (b) It shall not be made available for inspection or perusal by any person under the age of eighteen years;
- (c) It shall not be exhibited or displayed in any place to which persons under the age of eighteen years have access or so that it is visible from any such place.

SCHEDULE OF PUBLICATIONS

Title	Distributor
Aggressive Women Vol. 4, No. 8.	Venus Enterprises Pty. Ltd.
Bachelor—March 1982	Gordon & Gotch Ltd.
Bound To Serve—A Servant's Error	View Productions
Buf—March 1982	Gordon & Gotch Ltd.
Cavalier—February 1982	Gordon & Gotch Ltd.
Couples—March 1982	Gordon & Gotch Ltd.
Electric Love	View Productions
Eros—February 1982	Gordon & Gotch Ltd.
Fiesta Vol. 16, No. 1.	Gordon & Gotch Ltd.
Fiesta Late Night Video Vol. 1, No. 3.	Gordon & Gotch Ltd.
Gent—February 1982	Gordon & Gotch Ltd.
Head Stews	Hallmark Book Wholesalers
Letters—January 1982	Gordon & Gotch Ltd.
Letters Magazine Special—Turn-On No. 12.	Gordon & Gotch Ltd.
Letters Magazine Special—Family Affairs No. 13.	Gordon & Gotch Ltd.

Title	Distributor
Penthouse Variations—February 1982	Gordon & Gotch Ltd.
Sex Guide—March 1982	Gordon & Gotch Ltd.
Vibrations—February 1982	Gordon & Gotch Ltd.
White Bodies, Black Lust	Hallmark Book Wholesalers

J. SMITH, Secretary
State Classification of Publications Board

Police Offences Act 1958, No. 6337

DIVISION 1A—STATE CLASSIFICATION OF PUBLICATIONS BOARD

Take note that the State Classification of Publications Board has classified the following publications in accordance with the provisions of section 180H (1) of the *Police Offences Act 1958*.

Each publication shall be subject to the following restrictions:

- (a) It shall not be offered for sale, sold or delivered to any person under the age of eighteen years;
- (b) It shall not be made available for inspection or perusal by any person under the age of eighteen years.

SCHEDULE OF PUBLICATIONS

Title	Distributor
A Rage of Desire	Venus Enterprises Pty. Ltd.
Australian Penthouse—February 1982	Gordon & Gotch Ltd.
Best of Genesis—Spring 1982—Girls/Girls	Gordon & Gotch Ltd.
Club International Vol. 11 No. 1	Gordon & Gotch Ltd.
Erotic Letters & Graffiti	Venus Enterprises Pty. Ltd.
Erotic Weekend	Hallmark Book Wholesalers
Escort Vol. 1, No. 12	Gordon & Gotch Ltd.
Fiesta Vol. 15, No. 12.	Gordon & Gotch Ltd.
Forum—February 1982	Gordon & Gotch Ltd.
Gallery—February 1982	Gordon & Gotch Ltd.
Gallery—March 1982	Gordon & Gotch Ltd.
Genesis—February 1982	Gordon & Gotch Ltd.
Genesis—March 1982	Gordon & Gotch Ltd.
International Cover Models No. 28.	Claredale Holdings Pty. Ltd.
International Cover Models No. 29.	Claredale Holdings Pty. Ltd.
Knave Vol. 13, No. 12.	Gordon & Gotch Ltd.
Knave—Christmas Special 1981	Gordon & Gotch Ltd.
Lust In The Name of the Law	Hallmark Book Wholesalers
Mayfair Vol. 17, No. 1.	Gordon & Gotch Ltd.
Men Only Vol. 47, No. 1.	Gordon & Gotch Ltd.
Model Directory Vol. 2, No. 1.	Gordon & Gotch Ltd.
No Time For Virgins/For Stags Only	Venus Enterprises Pty. Ltd.
Oui—January 1982	Gordon & Gotch Ltd.
Playboy Cartoon Album No. 8.	Gordon & Gotch Ltd.
Sappho of Lesbos	Venus Enterprises Pty. Ltd.
Sexfun Cartoons	Gordon & Gotch Ltd.
Sexology Today—January 1982	Gordon & Gotch Ltd.
Sexology Today—February 1982	Gordon & Gotch Ltd.
Sex To Sixty No. 59	Gordon & Gotch Ltd.

J. SMITH, Secretary
State Classification of Publications Board

Police Offences Act 1958, No. 6337

DIVISION 1A—STATE CLASSIFICATION OF PUBLICATIONS BOARD

Take note that the State Classification of Publications Board has classified the following publications in accordance with the provisions of section 180H (1) of the Police Offences Act 1958.

Each publication shall be subject to the following restrictions:

- (a) It shall not be offered for sale, sold or delivered to any person under the age of eighteen years;
- (b) It shall not be made available for inspection or perusal by any person under the age of eighteen years;
- (c) It shall not be exhibited or displayed in any place to which persons under the age of eighteen years have access or so that it is visible from any such place.

SCHEDULE OF PUBLICATIONS

Title	Distributor
Act of Lust	Hallmark Book Wholesalers
Back Room Action	Wathen Wholesale Pty. Ltd.
Basic Training	Wathen Wholesale Pty. Ltd.
Beach—Ballin' Studs	Wathen Wholesale Pty. Ltd.
Beach Boy	Wathen Wholesale Pty. Ltd.
Beach Bum	Wathen Wholesale Pty. Ltd.
Behind Bars	Wathen Wholesale Pty. Ltd.
Boarding School Studs	Wathen Wholesale Pty. Ltd.
Bonda Europa Vol. No. 1	Claredale Holdings Pty. Ltd.
Bondage Bonanza—Collector's Edition	Claredale Holdings Pty. Ltd.
Bondage Cinema Vol. 1, No. 5	Claredale Holdings Pty. Ltd.
Bondage Revue Vol. 1, No. 3	Claredale Holdings Pty. Ltd.
Bust Orgy Vol. 3, No. 1	Claredale Holdings Pty. Ltd.
Campus Cock	Wathen Wholesale Pty. Ltd.
Cathy	Claredale Holdings Pty. Ltd.
Cavalier—March 1982	Gordon & Gotch Ltd.
Chicken Comin' Up	Wathen Wholesale Pty. Ltd.
Come Hungry	Wathen Wholesale Pty. Ltd.
Come, Killer, Come	Wathen Wholesale Pty. Ltd.
Conquest Vol. 4, No. 1	Claredale Holdings Pty. Ltd.
Cowpoke	Wathen Wholesale Pty. Ltd.
Cruisin' The Quarter	Wathen Wholesale Pty. Ltd.
Darling	Hallmark Book Wholesalers
Dormitory Tricks	Wathen Wholesale Pty. Ltd.
Fast Track	Wathen Wholesale Pty. Ltd.
Fellows 13—Nude Nobility	Claredale Holdings Pty. Ltd.
Fellows 14—Whipped Wife	Claredale Holdings Pty. Ltd.
Fellows 15—Fellows	Claredale Holdings Pty. Ltd.
Rings The Belle	Claredale Holdings Pty. Ltd.
Fellows 16—Pained Pudendum	Claredale Holdings Pty. Ltd.
First—Time Trick	Wathen Wholesale Pty. Ltd.
Freshman Slave	Wathen Wholesale Pty. Ltd.
Frisco Cowboy	Wathen Wholesale Pty. Ltd.
From Steve, With Love	Wathen Wholesale Pty. Ltd.
Gay Awakening	Wathen Wholesale Pty. Ltd.
Gent—March 1982	Gordon & Gotch Ltd.
Growing Up Hard	Wathen Wholesale Pty. Ltd.
Hard Hat	Wathen Wholesale Pty. Ltd.
Hard Leather	Wathen Wholesale Pty. Ltd.
Highway Stud	Wathen Wholesale Pty. Ltd.
Hotpants Housewife	Hallmark Book Wholesalers
Hot Trucker	Wathen Wholesale Pty. Ltd.
Julie	Claredale Holdings Pty. Ltd.
Junior Jocks	Wathen Wholesale Pty. Ltd.

Title	Distributor
Kansas City Roper	Wathen Wholesale Pty. Ltd.
Leather Bike Boy	Wathen Wholesale Pty. Ltd.
Leather Hustler	Wathen Wholesale Pty. Ltd.
Lesbo Lust Vol. 2, No. 2.	Claredale Holdings Pty. Ltd.
Letters—March 1982	Gordon & Gotch Ltd.
Letters—April 1982	Gordon & Gotch Ltd.
Love Trip	Wathen Wholesale Pty. Ltd.
Marine Master	Wathen Wholesale Pty. Ltd.
Meat Rack	Wathen Wholesale Pty. Ltd.
Military Stud	Wathen Wholesale Pty. Ltd.
Number On The John Wall, The	Wathen Wholesale Pty. Ltd.
Orgy Girls Vol. 5, No. 2.	Claredale Holdings Pty. Ltd.
Pillow Talk—Jan./Feb. 1982	Gordon & Gotch Ltd.
Pleasure Boy	Wathen Wholesale Pty. Ltd.
Pleasure Slave No. 3	Wathen Wholesale Pty. Ltd.
Pledge—Slave	Wathen Wholesale Pty. Ltd.
Read Enders Vol. 3, No. 3.	Claredale Holdings Pty. Ltd.
Road Gang	Wathen Wholesale Pty. Ltd.
Robbie	Wathen Wholesale Pty. Ltd.
Sins of Lady Chalfont, The	Hallmark Book Wholesalers
Spanker's Delight Vol. 3, No. 4.	Claredale Holdings Pty. Ltd.
Strapped	Wathen Wholesale Pty. Ltd.
Street Trade	Wathen Wholesale Pty. Ltd.
Susan	Claredale Holdings Pty. Ltd.
Tit World Vol. 2, No. 4.	Claredale Holdings Pty. Ltd.
Trappin' Man No. 3.	Wathen Wholesale Pty. Ltd.
289 Bondage Photos Vol. 1, No. 1.	Claredale Holdings Pty. Ltd.
Wangs Vol. 3, No. 3.	Claredale Holdings Pty. Ltd.
Well-Hung Hustler	Wathen Wholesale Pty. Ltd.

J. SMITH, Secretary
State Classification of Publications Board

Police Offences Act 1958, No. 6337

DIVISION 1A—STATE CLASSIFICATION OF PUBLICATIONS BOARD

Take note that the State Classification of Publications Board has classified the following publications in accordance with the provisions of section 180H (1) of the Police Offences Act 1958.

Each publication shall be subject to the following restrictions:

- (a) It shall not be offered for sale, sold or delivered to any person under the age of eighteen years;
- (b) It shall not be made available for inspection or perusal by any person under the age of eighteen years;
- (c) It shall not be exhibited or displayed in any place to which persons under the age of eighteen years have access or so that it is visible from any such place;
- (d) It shall not be advertised in any manner whatsoever.

SCHEDULE OF PUBLICATIONS

Title	Distributor
Kinque No. 19.	Sloane Street Publishing Co. Pty. Ltd.
Rodox—Special Magazine No. 9.	Venus Enterprises Pty. Ltd.
Teenage Sex No. 17.	Venus Enterprises Pty. Ltd.

J. SMITH, Secretary
State Classification of Publications Board

Police Regulation Act 1958, Section 122

SALE OF UNCLAIMED MOTOR VEHICLE

An owner is required for an HR Holden station wagon, N.S.W. Reg. No. ASN-736 (expired), Engine No. 161R 158725 which came into possession of Police on 24 May 1981.

If not claimed, the vehicle will be sold by public auction at the St. Albans Police Station, 364 Main Road West, St. Albans, at 10 a.m. on Monday, 22 February 1982.

A. W. CONN
Acting Chief Commissioner

Police Regulation Act 1958, Section 122

SALE OF UNCLAIMED MOTOR VEHICLE

An owner is required for an unregistered International Tray truck, Model A.B.130 Engine No. A60 282-7719, which came into possession of Police on 27 April 1981.

If not claimed, the vehicle will be sold by public auction at the St. Albans Police Station, 364 Main Road West, St. Albans, at 10 a.m. on Monday, 22 February 1982.

A. W. CONN
Acting Chief Commissioner

NOTICE TO MARINERS

[No. 1 OF 1982]

AUSTRALIA—VICTORIA

PORT PHILLIP

1. *Hovell Pile Light Established*
2. *Old Hovell Pile Light to be Altered*

Date—On or about 27 January 1982.

Former Notice—No. 26 (T) of 1980 is cancelled.

Reference Position—Hovell Pile Light Lat. 38 deg. 19 min. 43 sec. S., Long., 144 deg. 53 min. 51 sec. E.

Details—1. A new Hovell Pile light has been established at the reference position. The light is a revolving light electrically operated showing an intensive flash every 6 seconds.

Characteristics—Flash every 6 seconds; Flash 0.2 seconds; Eclipse 5.8 seconds.

Elevation—11 metres.

Visibility—11 miles.

Abridged Description—Fl. 6s 11m 11M.

Structure—The light is mounted upon a steel framework tower above a concrete decked pile structure. A white shed 2 metres high is mounted on the decking.

Remarks—If electric current temporarily fails this light will show Fl. (2) 8s 6M.

2. The old Hovell Pile light 269 deg. 48.7 min. distant 96.7 metres from reference position will be altered to show flashing yellow every 10 seconds.

Abridged Description—Fl. Y 10s 7m 3M.

Charts Affected—Aus 143 and Aus 158.

Publications Affected—Sailing Directions, Victoria 1970, pages 200 and 601.

K. H. DANN
Deputy Port Officer

Public Works Department
Ports and Harbors Division
168 Exhibition Street
Melbourne, 3000, 11 January 1982

NOTICE TO MARINERS

[No. 2 OF 1982]

AUSTRALIA—VICTORIA

PORT OF CORNER INLET AND PORT ALBERT

Manns Beach Jetty Light to be Altered

Date—On or about 25 January 1982.

Details—Manns Beach Jetty light (Lat. 38 deg. 38 min. S., Long. 146 deg. 47 min. E., approx.) will be altered as follows:

Characteristics—Fixed Red.

Elevation—6.6 metres.

Visibility—4 miles.

Abridged Description—F.R. 6.6m 4M.

Publications Affected—Sailing Directions, Victoria 1970, pages 498 and 669.

K. H. DANN
Deputy Port Officer

Public Works Department
Ports and Harbors Division
168 Exhibition Street
Melbourne, 3000, 11 January 1982

NOTICE TO MARINERS

[No. 3 (T) OF 1982]

AUSTRALIA—VICTORIA

PORT PHILLIP

Light Buoy missing from Station

The R2 Light Buoy, Lat. 37 deg. 54.6 min. S., Long. 144 deg. 56.2 min. E. (approx.) is missing from station.

Further Notice will issue.

Charts temporarily affected Aus 143, Aus 155.

K. H. DANN
Deputy Port Officer

Public Works Department
Ports and Harbors Division
168 Exhibition Street
Melbourne, 3000, 12 January 1982

PUBLIC TRUSTEE ACT 1958, SECTION 17

I hereby give notice that on 6 January 1982, the Public Trustee filed elections to administer the following deceased persons' estates in accordance with section 17 of the Public Trustee Act 1958.

COCHRANE, MARIE, late of Flat 3, 38 Fitzroy Street, St. Kilda, pensioner, died 1 November 1981.

CUE, GEORGE, late of Aradale Hospital, Ararat, pensioner, died 26 February 1981.

FINDLAY, IVY BRENDA, late of 1/71 Clyde Street, St. Kilda, pensioner, died 6 October 1981.

MCCLEAVE, ENA, late of Mont Park, retired, died 12 October 1981.

MILLER, HOWARD FREDERICK, late of Kew, pensioner, died 8 September 1976.

NEUDORFER, MAXIMILLIAN, late of Flat 53, 24 Dalgety Street, St. Kilda, pensioner, died 11 August 1981.

POMARE, AURELIO, formerly of 12 Levers Terrace, Carlton, but late of Footscray Nursing Home, 10 Geelong Road, Footscray, pensioner, died 1 October 1981.

ROBERTS, VICTOR, late of Kew, pensioner, died 22 September 1981.

SAUNDERS, MELBOURNE FREDERICK, formerly of 32 Livingstone Street, East Coburg, but late of Mont Park, clerk, died 26 October 1981.

STEWART, MARION KEMP, late of 9 Poplar Street, Frankston, pensioner, died 5 May 1981.

WARDROP, HORACE AUGUSTINE, formerly of 59 Shannon Avenue, Geelong West, but late of Ballarat, pensioner, died 4 October 1981.

I hereby give notice that on 11 January 1982, the Public Trustee filed elections to administer the following deceased persons' estates in accordance with section 17 of the Public Trustee Act 1958.

BRIGGS, PETER WILLIAM, late of 1 New Street, Hawthorn, pensioner, was found dead 29 October 1981.

CARR, ROSIE MAY, late of 172/1 Holmes Street, Northcote, pensioner, died 29 October 1981.

COOKSON, MAVIS JOYCE, late of Mont Park, pensioner, died 30 September 1981.

HANSON, CLAYTON ROMSEY, late of Kew, pensioner, died 22 September 1981.

LIEW, FOOT CHING, also known as John Liew C. Foot, late of Flat 4, 3 Austin Street, Hawthorn, machine operator, died 14 November 1981.

POOR, LAVINIA ARABELLA, late of Flat 3/80 Union Road, Ascot Vale (in the Will called Flat 3, 380), widow, died 12 November 1981.

SINGLETON, ELIZABETH ALICE, formerly of 4 Kyup Street, Mt. Eliza, but late of Broughton Private Hospital, Frankston, widow, died 7 October 1981.

P. T. SPENCER
Public Trustee

168 Exhibition Street, Melbourne, 3000
13 January 1982

Creditors, next of kin and others having claims against the estate of any of the under-mentioned deceased persons are required to send particulars of their claims to the Public Trustee, 168 Exhibition Street, Melbourne, Vic. 3000, the personal representative, on or before 3 April 1982 after which date the Public Trustee may convey or distribute the assets having regard only to the claims of which the Public Trustee then has notice:

BANKS, EVELYN MARIE, late of Mont Park, pensioner, died 29 October 1981.

BRIGGS, PETER WILLIAM, late of 1 New Street, Hawthorn, pensioner, was found dead 29 October 1981.

CARR, ROSIE MAY, late of 172/1 Holmes Street, Northcote, pensioner, died 29 October 1981.

COCHRANE, MARIE, late of Flat 3, 38 Fitzroy Street, St. Kilda, pensioner, died 1 November 1981.

COOKSON, HAZEL GLADYS, late of 28 Duffy Street, North Essendon, widow, died 7 November 1981.

COOKSON, MAVIS JOYCE, late of Mont Park, pensioner, died 30 September 1981.

CORNISH, MAXWELL JAMES, late of 10, 2 Victoria Street, Elsternwick, retired insurance executive, died 18 October 1981.

CUE, GEORGE, late of Aradale Hospital, Ararat, pensioner, died 26 February 1981.

DEAN, IVAN CLIFFORD, late of Ozanam House, 179-189 Flemington Road, North Melbourne, pensioner, died 19 January 1981.

DICK, ETHEL LILY ELEANOR, late of Flat 2, 15 Newton Street, Ferntree Gully, pensioner, died 17 October 1981.

DOVER, DONALD JOSEPH WILSON (in the Will called Donald Dover), late of Caddys Road, Lara, pensioner, died 3 October 1981.

FINDLAY, IVY BRENDA, late of 1/71 Clyde Street, St. Kilda, pensioner, died 6 October 1981.

FONAHN, THELMA HOPE, late of "Rosemount", Forest Avenue, Hepburn Springs, pensioner, died 25 May 1981.

GORRINGE, CHARLOTTE ELIZABETH, formerly of 70 Fortescue Avenue, Seaford, but late of Banksia Court Nursing Home, Croydon, widow, died 20 November 1981.

HANSON, CLAYTON ROMSEY, late of Kew, pensioner, died 22 September 1981.

HANUS, VACLAV, late of Murchison Street, Marysville, restaurant proprietor, died 16 August 1981.

HARRISON, ANNA MARGARET, formerly of 11 Bank Road, Glen Iris, but late of 5 Westgate Street, Oakleigh, widow, died 20 October 1981.

LEONARD, WILLIAM JOHN, formerly of 123 George Street, Fitzroy, but late of Flat 7, 52 Clyde Street, St. Kilda, retired film slitter, died 30 October 1981.

LEWIS, THEODORE GORDON, late of 61 Crofton Street, Geelong West, retired salesman, died 19 August 1981.

LIEW, FOOT CHING, also known as John Liew C. Foot, late of Flat 4, 3 Austin Street, Hawthorn, machine operator, died 14 November 1981.

JOHNSON, BARBARA MAY, late of 345 Main Road, Crib Point, married woman, died 29 October 1981.

MCCLEAVE, ENA, late of Mont Park, retired, died 12 October 1981.

MCPLOYE, JAMES THOMAS, also known as James McPoyle, late of 32 Loch Ard Drive, Ocean Grove, pensioner, died 30 October 1981.

MAPHAM, JACK ALFRED JOSEPH, late of 42 Glaneuse Road, Point Lonsdale, pensioner, died 15 September 1981.

MATTHEWS, WILLIAM EDWARD, also known as William Edward Pearce, late of Flat 4, 28 Monash Street, Oakleigh, retired cleaner, died 7 June 1980.

MILLER, HOWARD FREDERICK, late of Kew, pensioner, died 8 September 1976.

NEUDORFER, MAXIMILLIAN, late of Flat 53, 24 Dalgety Street, St. Kilda, pensioner, died 11 August 1981.

POMARE, AURELIO, formerly of 12 Levers Terrace, Carlton, but late of Footscray Nursing Home, 10 Geelong Road, Footscray, pensioner, died 1 October 1981.

POOR, LAVINIA ARABELLA, late of Flat 3/80 Union Road, Ascot Vale (in the Will called Flat 3, 380), widow, died 12 November 1981.

RICH, ERNA, late of 10 Bessie Street, South Oakleigh, widow, died 23 September 1981.

ROBERTS, VICTOR, late of Kew, pensioner, died 22 September 1981.

SAUNDERS, MELBOURNE FREDERICK, formerly of 32 Livingstone Street, East Coburg, but late of Mont Park, clerk, died 26 October 1981.

SAUNDERS, SARAH MIRREN, formerly of Flat 4, 224 Osborne Street, Williamstown, but late of Flat 7, 83 Railway Street, North Altona, home duties, died 22 September 1981.

SINGLETON, ELIZABETH ALICE, formerly of 4 Kyup Street, Mt. Eliza, but late of Broughton Private Hospital, Frankston, widow, died 7 October 1981.

STEWART, MARION KEMP, late of 9 Poplar Street, Frankston, pensioner, died 5 May 1981.

WAINWRIGHT, EDWARD CLIFTON, late of 15 Reid Street, Murrumbeena, retired, died 23 October 1981.

WARDROP, HORACE AUGUSTINE, formerly of 59 Shannon Avenue, Geelong West, but late of Ballarat, pensioner, died 4 October 1981.

WEEKES, VIOLET GRACE FIELD (in the Will called Violet Grace Field Weekes), also known as Violet Weekes, late of 36 Reed Street, Albert Park, widow, died 13 October 1981.

WHITCHURCH, AUBREY GEORGE FRANCIS, late of 18 Miller Grove, East Ringwood, gentleman, died 16 October 1981.

WILLIAMS, HAROLD VICTOR, late of 25 Myrtle Street, Clifton Hill, tally clerk, died 14 October 1981.

WRAY, JOSEPH, formerly of Southbridge, N.Z., but late of Christchurch, N.Z., labourer, died 2 August 1981.

YOUNG, ALEXANDER JOHNSTON, formerly of Rotorua, New Zealand, but late of 7 Jade Court, Wodonga, forestry worker, died 18 November 1980.

CHISHOLM, LAWRENCE WILLIAM, formerly of Unit 8/747 Hawthorn Road, East Brighton, but late of Unit 18/2 Gascoyne Street, Canterbury, retired, died 8 September 1981.

HIBBERT, GERTRUDE EDITH, late of 9 Balmoral Street, South Yarra, retired, died 26 October 1981.

Melbourne, 13 January 1982

P. T. SPENCER
Public Trustee

COUNTRY ROADS BOARD

RESOLUTIONS OF THE COUNTRY ROADS BOARD

The Country Roads Board, in pursuance of the provisions of the *Country Roads Act 1958*, has passed Resolutions the dates whereof and the terms of which are scheduled hereunder:

SCHEDULE

Main Road

Resolution dated the Fourth day of January, One thousand nine hundred and eighty-two, made pursuant to section 21 of the *Country Roads Act 1958*, declaring the widening of Canterbury Road in the City of Croydon and Shire of Lillydale as shown hatched on plan numbered G.P.15347A hereunder to be part of a main road within the meaning and for the purposes of the said Act.

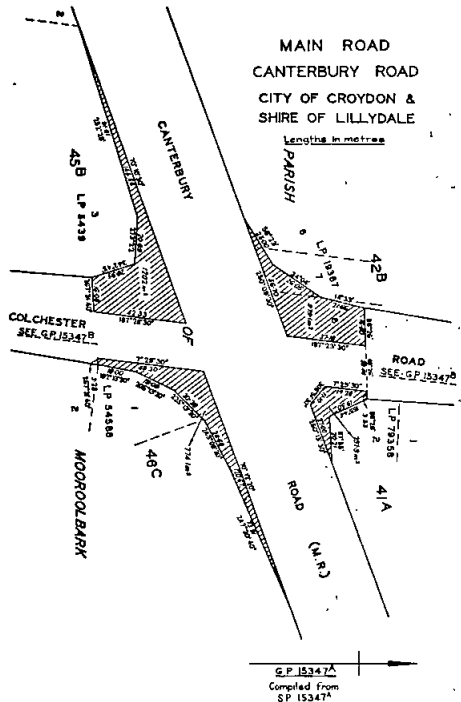

Unclassified Road

Resolution dated the Fourth day of January, One thousand nine hundred and eighty-two, made pursuant to sections 21 and 110 of the *Country Roads Act 1958*, declaring the widening of Colchester Road in the City of Croydon and Shire of Lillydale as shown hatched on plan numbered G.P.15347B hereunder to be part of a road within the meaning and for the purposes of the said Act.

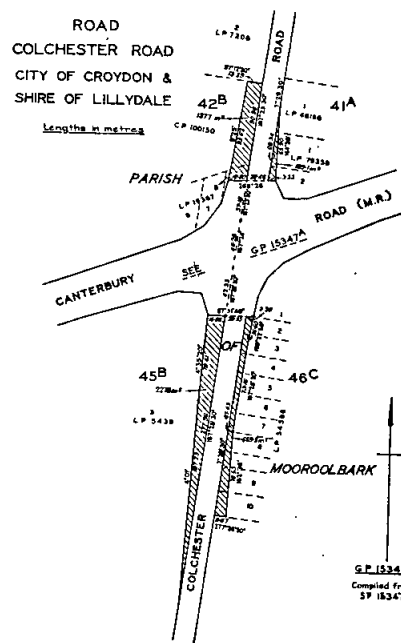

6 January 1982

P. J. McCULLOUGH
Acting Secretary

CONTRACTS ACCEPTED—(Series 1982)

SCHEDULE No. 1/77

TYPEWRITERS, ELECTRIC

Contracts from 1 January 1982 to 31 December 1982

1982/825—Adler Business Machines Pty. Ltd., 35 Albert Road, Melbourne. Ph. 267 5311

Item No.	Description of Articles	Unit of Measurement	Rate	Name of Contractor
			\$	
	Typewriters—Electric, Heavy Duty, Pica or Elite, as selected—			
1	Fitted with fabric/carbon ribbon, minimum 330 mm carriage width	Each	..	Apply Tender Board
2	Fitted with fabric/carbon ribbon, "Adler 131D" with 496 mm carriage	Each	729.00*	Adler Business Machines Pty. Ltd.
3	Typewriters—Electric, Heavy Duty, with Inter-changeable Type Element	Each	..	Apply Tender Board

Approved—L. H. S. THOMPSON, Treasurer—11.1.82

*For Details of Guarantee apply Tender Board

CONTRACTS ACCEPTED—(Series 1981-82)				AMENDMENTS—continued			
AMENDMENTS				Schedule Number	Item Number	New Rate	Effective Date
Schedule Number	Item Number	New Rate	Effective Date				
\$				\$			
<i>Protective Clothing, Uniforms, etc.</i>				<i>Stationery, General</i>			
1/14	34	11.56 *	4.1.82	1/64	161	0.91	11.12.81
	41	13.88 *		<i>Provisions—Melbourne and Metropolitan District</i>			
* Trading terms unchanged.				2/01	2	11.68†	18.1.82
<i>Motor Spirit, Kerosene, Fuel Oils and Lubricants</i>					6	0.4796	2.1.82
1/53B	35(a)	0.5417	7.12.81		8	0.4796	
	(b)	0.5598			9	0.5179	
	(c)	0.6197			10	0.5676	
	36	0.5674			11	1.0156	
	37	0.6042			12	1.0066	
	38	2.3191			13	1.1306	
	39	0.4956			14	0.399	
	40	0.7233			46	3.04	14.1.82
					183	*	5.1.82
Petrol Outlets:-				† Trading terms unchanged			
Avoca—Add:				* Purchase Regulation 84			
B.P., L. M. Lobb,				<i>Groceries—Melbourne and Metropolitan District</i>			
Main St, Avoca				2/02	33	*	29.12.81
8 a.m.—5 p.m., S/Stn.					52	*	
Ballan—Add:					133	*	
B.P., J. and E. Pama,					180	*	
Main St, Ballan					276	*	
6 a.m.—8 p.m., S/Stn.					278	*	
Bannockburn—Add:				* Purchase Regulation 84			
B.P., Tractor and Machinery Supplies				<i>Provisions—Cheese</i>			
of Geelong				2/04	1	2.44	14.1.82
Midland Hwy, Bannockburn					2	2.68	
Beechworth—Add:					3	2.68	
B.P., Golden Era S/Stn.,					4	2.57	
Ford St, Beechworth					5	2.84	
8 a.m.—5 p.m., S/Stn.					6	2.84	
Cohuna—Delete:					7	2.44	
Diesel					8	2.68	
Dederang—Add:					9	2.68	
B.P., Bateman's Garage,					10	2.57	
Gundowring Rd, Dederang					11	2.84	
Kaniva—Add:					12	2.84	
B.P., B.P. Kaniva,					24	2.68	
Western Hwy, Kaniva				<i>Provisions—Ballarat District</i>			
7 a.m.—7 p.m., S/Stn.				2/07(1)	2	0.6710	31.12.81
Mirboo North—Delete:					3	0.6147	
E. and L. Pincini Pty. Ltd.					6	1.20	
Add:					7	26.91	
N. and D. Lawson					8	10.32	
Endee Motors					9	14.59	
Portarlington—Add:				<i>Provisions—School of Forestry, Creswick</i>			
B.P., B.P. Portside Auto S/Stn.,				2/12(1)	2	0.625	31.12.81
Newcombe St, Portarlington					3	0.671	
6 a.m.—9 p.m., S/Stn.					4	1.20	
Quambatook—Add:				<i>Provisions—Langi Kal Kal Training Centre</i>			
Caltex, Quambatook Auto Services,				2/15(1)	1	0.6147	31.12.81
Guthrie St, Quambatook					2	1.20	
Rupanyup—Add:				<i>Provisions—Howman's Gap Alpine Camp</i>			
Caltex, Isabel's Sales and Service,				2/31(1)	1	0.72	5.12.81
Cromie St, Rupanyup					2	0.72	
					3	1.64	
<i>Hand Tools (General)</i>							
1/56	37	25.17 (500 mm)	18.1.82				
		26.19 (750 mm)					
		27.25 (1000 mm)					
		28.63 (1250 mm)					
		29.93 (1500 mm)					
		31.32 (1750 mm)					
	38	31.53 (2000 mm)					
		33.40 (2250 mm)					
		34.47 (2500 mm)					
	39	6.19 (G4)					
		8.38 (G5)					

CONTRACTS ACCEPTED—(Series 1981-82)**PUBLIC WORKS**

His Excellency the Governor of the State of Victoria by and with the advice of the Executive Council thereof has by Order made on 12 January 1982 approved of the acceptance by the Minister of Public Works of the under-mentioned offers without public tenders being invited, viz.:

Offer of Leith Bartlett & Partners Pty. Ltd. for professional services (Architectural) at the Glen Waverley Police Training Academy for the sum of Sixty thousand dollars (\$60 000.00)—(P.N.109743P).

Offer of Underwood & Underwood Pty. Ltd. for professional services (Architectural) at Corryong Consolidated School for the sum of Eighteen thousand dollars (\$18 000.00)—(N.57575P).

Offer of Buchan Laird & Buchan Pty. Ltd. for professional services (Architectural) at Shepparton T.A.F.E. College, Goulburn Valley Region, Stage II, Phase I, for the sum of Eleven thousand two hundred and seventy-five dollars thirty-seven cents (\$11 275.37)—(P.N.205743P).

Offer of Mockridge Stahle & Mitchell for professional services (Architectural) at Dandenong T.A.F.E. College, Stage II, for the sum of Twelve thousand and seventy-six dollars forty cents (\$12 076.40)—(P.E.20199P).

Offer of Ben Alexander & Vincent Chiang Pty. Ltd. for professional services (Architectural) at various major projects for the sum of forty thousand dollars (\$40 000.00)—(E.V.164852).

Offer of Richardson & Christoff Pty. Ltd. for professional services (Architectural) at Frankston Special Development School for the sum of Twenty-five thousand dollars (\$25 000.00)—(E.164851P).

TOM FORRISTAL
Clerk of the Executive Council

At the Executive Council Chamber
Melbourne, 12 January 1982

CONTRACTS ACCEPTED—(Series 1981-82)**PUBLIC WORKS**

Westmeadows Heights High School, siteworks, original, \$6262.75; extras, \$11 435.50—\$17 698.25—Bentleigh Road Constructions.

Syndal High School, renewal of gas service, original, \$6509.00; extras, \$3500.00—\$10 009.00—Williamson Plumbing and Heating Pty. Ltd.

Brighton Beach Primary School, staff improvements, stage I, original, \$9744.00; extras, \$9120.00—\$18 864.00—P. Nicholson.

Brighton Curriculum Serv. Unit, formerly Norris House, internal repairs, original, \$9844.00; extras, \$9300.00—\$19 144.00—Ralph Mackie.

D. J. LITTLE, Director-General. 14.1.82

CONTRACTS ACCEPTED—(Series 1981-82)**VICTORIAN RAILWAYS**

22. Supply and lay bituminous concrete on car park and/or roadways at Ringwood Station, for a total cost of \$14 085.50 (Contract 65079)—Boral Resources (Vic.) Pty. Ltd. 23. Manufacture, supply and delivery of rectifier control cubicles at the rate of \$3499.00 each (Contract 64916)—Roulan-Seymour Switchboards Pty. Ltd.

K. C. BROWN, Acting Secretary 18.1.82

Town and Country Planning Act 1961**MELBOURNE METROPOLITAN PLANNING SCHEME—AMENDING SCHEME No. 172**

NOTICE THAT A PLANNING SCHEME HAS BEEN PREPARED AND IS AVAILABLE FOR INSPECTION

Notice is hereby given that the Melbourne and Metropolitan Board of Works in pursuance of its powers under the *Town and Country Planning Act 1961*, has prepared a Planning Scheme which proposes to amend and vary the Ordinance and to reserve land and to amend and vary land use zonings and reservations of land within the planning area of the Melbourne Metropolitan Planning Scheme which was approved by the Governor in Council on 30 April 1968, and notice thereof published in the *Government Gazette* on 22 May 1968.

A copy of the Amending Scheme has been deposited at the office of the Melbourne and Metropolitan Board of Works, 625 Little Collins Street, Melbourne, at the office of the Department of Planning, 235 Queen Street, Melbourne, and as to so much of the Amending Scheme as relates to land within the municipal district of any municipality at the office of such municipality, and will be open for inspection during office hours by any person free of charge.

Any persons affected by the Amending Scheme are required to set forth in writing, any submissions they may wish to make with respect to the Amending Scheme, addressed to the Secretary, Melbourne and Metropolitan Board of Works, Box 4342, Melbourne, 3001, by 20 April 1982 and to state whether they wish to be heard in respect of their submissions.

Dated 19 January 1982

O. T. W. COSGRIFF, Secretary
Melbourne and Metropolitan Board of Works
625 Little Collins Street, Melbourne, 3000

Town and Country Planning Act 1961**MELBOURNE METROPOLITAN PLANNING SCHEME****AMENDMENT No. 200****Notice of Amendment**

In pursuance of the powers conferred by sub-section 6 of section 32 of the *Town and Country Planning Act 1961*, the Governor in Council on 19 January 1982, amended the Melbourne Metropolitan Planning Scheme.

This amendment will enable a dwelling to be erected on Crown Allotment 90, Reservoir Road, Sunbury.

A copy of the Amendment may be inspected during office hours at the office of the Department of Planning at 235 Queen Street, Melbourne, at the office of the Melbourne Metropolitan Board of Works at 625 Little Collins Street, Melbourne, and when available at the Office of Titles, Melbourne, and at the Central Plan Office of the Department of Crown Lands and Survey, Melbourne.

N. G. HAYNES
Secretary for Planning

Town and Country Planning Act 1961**CITY OF SALE PLANNING SCHEME 1975****INTERIM DEVELOPMENT ORDER****Notice of Extension**

In pursuance of the powers conferred by section 17 (1AD) of the *Town and Country Planning Act 1961*, the Governor in Council on 19 January 1982, extended the operation of the City of Sale Planning Scheme 1975, Interim Development Order for a period of six months.

N. G. HAYNES
Secretary for Planning

Town and Country Planning Act 1961
CITY OF BENALLA PLANNING SCHEME

AMENDMENT No. 33

Notice of Amendment

In pursuance of the powers conferred by sub-section 6 of section 32 of the *Town and Country Planning Act 1961*, the Governor in Council, on 19 January 1982, amended the City of Benalla Planning Scheme.

The amendment introduces a "Holiday Village" Zone into the Scheme and rezones approximately 25 ha from Residential C and Reserved Residential to Holiday Village Zone. The amendment also provides for agreements with owners.

A copy of the Amendment may be inspected during office hours at the office of the Department of Planning at 235 Queen Street, Melbourne, at the office of the Council of the City of Benalla at Benalla and when available at the Office of Titles, Melbourne, and at the Central Plan Office of the Department of Crown Lands and Survey, Melbourne.

N. G. HAYNES
Secretary for Planning

Cemeteries Act 1958

SCALE OF FEES OF THE APSLEY PUBLIC CEMETERY

In pursuance of the powers conferred upon them by the Cemeteries Act, the trustees of the Apsley Public Cemetery hereby make the following scale of fees, which shall come into operation upon publication in the *Government Gazette*, and from and after such publication every scale of fees heretofore made by the said trustees shall be and is hereby rescinded to the extent to which it conflicts with this scale.

Public Graves	
Interment in grave without exclusive right—still-born child	\$ 15.00
Interment in grave without exclusive right—others	30.00
Number peg or label	6.00

Private Graves	
Land, 2.44 m x 1.22 m	44.00
Own selection of land	10.00

Sinking Charges for Private Graves	
Sinking grave 1.83 m deep	80.00
Each additional 0.3 m	13.00
Sinking oversize grave (extra)	25.00
Cancellation of order to sink (if commenced)	13.00

Reopening Charges	
Reopening grave (no cover)	57.00
Reopening grave (with cover)	63.00

Extra Charges	
Interment outside prescribed hours, or on Saturdays, Sundays or Public Holidays	23.00
Interment in a private grave without due notice	23.00

Miscellaneous Charges	
Interment fee	20.00
Certificate of right of burial	4.00
Number plate or brick	6.00
Permission to erect a headstone or monument—5 per cent of cost with a minimum of \$8.00.	
Permission to construct a brick grave or to erect any stone kerb, brick tile-work or concrete	9.00
Exhuming the remains of a body (when authorized)	100.00
Interment of ashes in a private grave	19.00
Memorial wall niche and plaque	63.00

P. M. HANNAFORD, Trustee
J. D. RICHARDSON, Trustee
G. B. CRAIG, Trustee

Approved by the Governor in Council, 12 January 1982
—TOM FORRISTAL, Clerk of the Executive Council

Cemeteries Act 1958

SCALE OF FEES OF THE BORAM BORAM PUBLIC CEMETERY

In pursuance of the powers conferred upon them by the Cemeteries Act, the trustees of the Boram Boram Public Cemetery hereby make the following scale of fees, which shall come into operation upon publication in the *Government Gazette*, and from and after such publication every scale of fees heretofore made by the said trustees shall be and is hereby rescinded to the extent to which it conflicts with this scale.

Public Graves	
Interment in grave without exclusive right—still-born child	\$ 25.00
Interment in grave without exclusive right—others	45.00
Number peg or label	10.00

Private Graves	
Land, 2.44 m x 1.22 m	70.00
Own selection of land	50.00

Sinking Charges for Private Graves	
Sinking grave 1.83 m deep	100.00
Each additional 0.3 m	20.00
Sinking oversize grave	35.00
Cancellation of order to sink (if commenced)	20.00
Reopening grave (no cover)	100.00
Reopening grave (with cover)	110.00

Miscellaneous Charges	
Interment fee	30.00
Interment outside prescribed hours, or on Saturdays, Sundays or Public Holidays or with due notice	40.00
Certificate of right of burial	5.00
Number plate or brick	10.00
Permission to erect a headstone or monument—5 per cent of cost with a minimum of \$10.00	
Permission to construct a brick grave or to erect any stone kerb, brick tile-work or concrete—5 per cent of cost with a minimum of \$10.00	
Exhuming the remains of a body (when authorized)	200.00
Interment of ashes in a private grave	30.00
Memorial wall niches and plaque	100.00

A. WALKER, Trustee
P. FRY, Trustee
M. McLEAN, Trustee

Approved by the Governor in Council, 12 January 1982
—TOM FORRISTAL, Clerk of the Executive Council

Cemeteries Act 1958

SCALE OF FEES OF THE GLENORCHY PUBLIC CEMETERY

In pursuance of the powers conferred upon them by the Cemeteries Act, the trustees of the Glenorchy Public Cemetery hereby make the following scale of fees, which shall come into operation upon publication in the *Government Gazette*, and from and after such publication every scale of fees heretofore made by the said trustees shall be and is hereby rescinded to the extent to which it conflicts with this scale.

Land, 2.44 m x 1.22 m	\$ 30.00
Interment	10.00
Interment in a grave—stillborn child	4.00
Interment in a grave—child under three years	8.00
Erection of headstone or monument—2½ per cent of cost with a minimum of \$8.00	

R. C. PICKERING, Trustee
J. A. CUFFE, Trustee
R. N. COOPER, Trustee

Approved by the Governor in Council, 12 January 1982
—TOM FORRISTAL, Clerk of the Executive Council

Cemeteries Act 1958

SCALE OF FEES OF THE MOE PUBLIC CEMETERY

In pursuance of the powers conferred upon them by the Cemeteries Act, the trustees of the Moe Public Cemetery hereby make the following scale of fees, which shall come into operation upon publication in the *Government Gazette*, and from and after such publication every scale of fees heretofore made by the said trustees shall be and is hereby rescinded to the extent to which it conflicts with this scale.

<i>Sinking Charges for Private Graves</i>	\$
Sinking grave 2·13 m	90.00
Sinking grave 1·83 m	85.00
Sinking each additional 0·3 m	20.00
Sinking oversize 1·83 m grave (extra)	35.00
Sinking oversize grave 2·13 m American casket (extra)	35.00
Cancellation of order to sink (if commenced)	35.00
Sinking grave for stillborn child	20.00
Sinking grave for child under seven years	45.00

Extra Charges

Interment not in the prescribed hours or on Saturdays, Sundays or Public Holidays	40.00
Interment in private graves without due notice	40.00
Late fee (per half hour or part thereof in excess of the first fifteen minutes)	5.00
All necessary Saturday, Sunday and Public Holiday work to be at penalty rates.	

Miscellaneous Charges

Interment fee	20.00
Certificate of right of burial	3.00
Number plate or brick	3.00
Inspection of plan or register	2.00
Annual maintenance (single grave) optional	25.00
Permission to erect a headstone or monument—5 per cent of the cost with a minimum of \$20.00	
Permission to construct a brick grave or to erect any stone kerb, tile or concrete work	20.00
Exhuming the remains of a body (when authorized)	100.00
Interment of ashes in a private grave	20.00
Removal of slab	25.00
Grave renovations or additional inscriptions	10.00
Memorial wall niche and plaque	80.00

Lawn Section (Undenominational)

Land, 2·44 m x 1·22 m	110.00
Sinking grave in lawn section	90.00
Interment fee in lawn section	20.00
Bronze plaque for each interment	80.00

Lawn Section for Children Under Seven Years of Age

Land, 1·22 m x 0·61 m	55.00
Sinking grave in children's lawn section	45.00
Interment fee in children's lawn section	20.00
Bronze plaque for each interment	80.00

Memorials

Trees (from)	130.00
Shrubs	70.00
Ashes buried in lawn	30.00
Memorial plaques for any of the above	80.00

Other Charges

Land, monumental sections, 2·44 m x 1·22 m	80.00
Own selection of land (extra)	15.00

Public Graves

Interment in grave without exclusive right (stillborn child)	15.00
Interment in grave without exclusive right (others)	25.00
Number peg or label	3.00

Reopening Charges

Reopening grave (no cover)	85.00
Reopening grave with cover or kerb	90.00

W. WHITE, Trustee
S. BOONSTRA, Trustee
J. GUEST, Trustee

Approved by the Governor in Council, 12 January 1982
—TOM FORRISTAL, Clerk of the Executive Council

Cemeteries Act 1958

SCALE OF FEES OF THE PORTLAND PUBLIC CEMETERY

In pursuance of the powers conferred upon them by the Cemeteries Act, the trustees of the Portland Public Cemetery hereby make the following scale of fees, which shall come into operation upon publication in the *Government Gazette*, and from and after such publication every scale of fees heretofore made by the said trustees shall be and is hereby rescinded to the extent to which it conflicts with this scale.

Private Graves

	\$
Land, 2·44 m x 1·22 m	120.00
Land, 2·44 m x 2·44 m	240.00
Sinking grave to 1·83 m	100.00
Sinking grave to 2·13 m	110.00
Reopening grave	110.00
Burials on Saturdays or Public Holidays (extra)	30.00
Burials without due notice (extra)	30.00
Interment of child under twelve years	50.00
Burial of stillborn child	10.00

L. P. HUNT, Trustee
E. J. KEMPTON, Trustee
W. W. ELDRIDGE, Trustee

Approved by the Governor in Council, 12 January 1982
—TOM FORRISTAL, Clerk of the Executive Council

Cemeteries Act 1958

SCALE OF FEES OF THE WATCHEM PUBLIC CEMETERY

In pursuance of the powers conferred upon them by the Cemeteries Act, the trustees of the Watchem Public Cemetery hereby make the following scale of fees, which shall come into operation upon publication in the *Government Gazette*, and from and after such publication every scale of fees heretofore made by the said trustees shall be and is hereby rescinded to the extent to which it conflicts with this scale.

Public Graves

	\$
Interment in grave without exclusive right—stillborn child	15.00
Interment in grave without exclusive right—others	30.00
Number, peg or label	6.00

Private Graves

Land, 1·44 m x 1·22 m	44.00
Own selection of land	10.00

Sinking Charges for Private Graves

Sinking grave 1·83 m deep	66.00
Each additional 0·3 m	13.00
Sinking oversize grave (extra)	25.00
Cancellation of order to sink (if commenced)	13.00

Reopening Charges

Reopening grave (no cover)	57.00
Reopening grave (with cover)	63.00

Extra Charges

Interment outside prescribed hours, or on Saturdays, Sundays or Public Holidays	23.00
Interment in a private grave without due notice	23.00

Miscellaneous Charges

	\$
Interment fee	20.00
Certificate of right of burial	4.00
Number plate of brick	6.00
Permission to erect a headstone or monument—5 per cent of cost with a minimum of \$8.00.	
Permission to construct a brick grave or to erect any stone kerb, brick tile-work or concrete	9.00
Exhuming the remains of a body (when authorized)	150.00
Interment of ashes in a private grave	19.00
A. WALDER, Trustee P. O'REILLY, Trustee D. NICHOLS, Trustee K. NUNN, Trustee	

Approved by the Governor in Council, 12 January 1982
—TOM FORRISTAL, Clerk of the Executive Council

Cemeteries Act 1958

SCALE OF FEES OF THE WAUBRA PUBLIC CEMETERY

In pursuance of the powers conferred upon them by the Cemeteries Act, the trustees of the Waubra Public Cemetery hereby make the following scale of fees, which shall come into operation upon publication in the *Government Gazette*, and from and after such publication every scale of fees heretofore made by the said trustees shall be and is hereby rescinded to the extent to which it conflicts with this scale.

	\$
Land, 2.44 m x 1.22 m	50.00
A. R. McDONALD, Trustee W. S. DEAN, Trustee K. J. FRASER, Trustee	

Approved by the Governor in Council, 12 January 1982
—TOM FORRISTAL, Clerk of the Executive Council

DONALD WATERWORKS TRUST

INCREASING THE LIMIT OF BANK OVERDRAFT

His Excellency the Governor of the State of Victoria by and with the advice of the Executive Council thereof has by Order made on 12 January 1982 increased the total amount of the sums which the Donald Waterworks Trust may owe at any one time in respect of moneys borrowed by overdraft of current account pursuant to the provisions of section 288 of the *Water Act 1958*, fixed by the Governor in Council on 17 December 1963, at Thirty thousand dollars (\$30 000), to Sixty thousand dollars (\$60 000).

TOM FORRISTAL
Clerk of the Executive Council

At the Executive Council Chamber
Melbourne, 12 January 1982

HEYFIELD WATERWORKS TRUST

INCREASING THE LIMIT OF BANK OVERDRAFT

His Excellency the Governor of the State of Victoria by and with the advice of the Executive Council thereof has by Order made on 12 January 1982 increased the total amount of the sums which the Heyfield Waterworks Trust may owe at any one time in respect of moneys borrowed by overdraft of current account pursuant to the provisions of section 286 of the *Water Act 1958*, fixed by the Governor in Council on 15 January 1974, at Twenty thousand dollars (\$20 000), to Forty thousand dollars (\$40 000).

TOM FORRISTAL
Clerk of the Executive Council

At the Executive Council Chamber
Melbourne, 12 January 1982

SHIRE OF TULLAROOP WATERWORKS TRUST

ANNUAL BALANCE

His Excellency the Governor of the State of Victoria, by and with the advice of the Executive Council thereof, has, by Order made on 5 January 1982, fixed 30 September in each year as the day to which the accounts of the Shire of Tullaroop Waterworks Trust shall be balanced.

TOM FORRISTAL
Clerk of the Executive Council

At the Executive Council Chamber
Melbourne, 5 January 1982

SHIRE OF MILDURA SEWERAGE AUTHORITY

FIXING THE LIMIT OF BANK OVERDRAFT

His Excellency the Governor of the State of Victoria by and with the advice of the Executive Council thereof has by Order made on 12 January 1982 fixed the total amount of the sums which the Shire of Mildura Sewerage Authority may owe at any one time in respect of moneys borrowed by overdraft of current account pursuant to the provisions of section 78 of the *Sewerage Districts Act 1958*, at Sixty thousand dollars.

TOM FORRISTAL
Clerk of the Executive Council

At the Executive Council Chamber
Melbourne, 12 January 1982

YARRA RIVER IMPROVEMENT TRUST

RATING BY-LAW 1982

The Yarra River Improvement Trust in pursuance and exercise of the powers conferred by the *River Improvement Act 1958*, doth hereby make the By-Law following:

1. The following rate to be called "Yarra River Improvement District River Improvement Rate" is hereby made and shall be levied upon the occupiers or owners of all properties within the Yarra River Improvement District which are rateable to any municipality—

First Division

A rate of 1.4 cents in the dollar on the net annual municipal value of such properties. Provided that the sum of four dollars shall be the minimum amount of rate in respect of any property liable to be rated in the said district.

Second Division

No rate.

2. Such rate is made and shall be levied for the year beginning with 1 January 1982 and ending with 31 December 1982, and shall be payable on 1 June 1982, at the office of the Yarra River Improvement Trust at Healesville.

3. Such person or persons as the Yarra River Improvement Trust may from time to time appoint for that purpose shall be and is or are hereby authorized to demand, receive, collect, and recover the said rate.

The foregoing By-Law was made by the Yarra River Improvement Trust on 3 December 1981 and the common seal of the Trust was hereunto affixed, 3 December 1981, in the presence of—

(SEAL) DAVID HUI-SAI TAN, Chairman
KAYE M. WEBER, Commissioner
R. E. HARDISTY, Secretary

Approved, 8 January 1982—GLYN JENKINS, Minister of Water Supply

STATE RIVERS AND WATER SUPPLY COMMISSION

SEASPRAY FLOOD MITIGATION PROPOSAL

Notice is hereby given pursuant to the provisions of the *Water Act 1958*, that the State Rivers and Water Supply Commission intends, after the expiration of 90 clear days from the date of publication of this Notice in the *Gippsland Times*, to seek the declaration of the Governor in Council that the Seaspray Flood Mitigation proposal be declared an "approved scheme" for the purposes of Division

8 of Part XXI. of the *Local Government Act 1958* (which Division provides that the Shire of Rosedale may construct, operate, control, manage and maintain the works or undertakings forming the proposal).

The proposal comprises remodelling and the construction of a levee along Merriman Creek, land filling, excavation of a channel from Merriman Creek to Lake Reeve and land acquisitions. Capital cost of the scheme is to be shared by the Commonwealth of Australia, State of Victoria and the Shire of Rosedale. Details of the proposal are available for inspection, free of charge, by any interested parties at the offices of the Commission at 590 Orrong Road, Armadale, Pearson Street, Maffra, or at the office of the Shire of Rosedale, Cansick Street, Rosedale, during office hours—(Corr. No. 81/3132).

Dated 7 December 1981

R. BIRD, Secretary

Water Act 1958

STATE RIVERS AND WATER SUPPLY COMMISSION

UPPER BEACONSFIELD URBAN DISTRICT

Notice to owners of tenements in the under-mentioned streets in the Upper Beaconsfield Urban District and the private streets, lanes, courts and alleys opening thereto: Grant Court.

McKenzie Road (west side only), from Salisbury Road to a point opposite Lot 7 about 225 metres northerly.

Salisbury Road, from Corringham Road to McKenzie Road.

The main pipe in the said streets being laid down, the owners of all tenements situated as above are hereby required, on or before 1 March next, to cause proper pipes and stop cocks to be laid, so as to supply water within such tenements from the main pipe.

Armadale, 6 January 1982

R. BIRD, Secretary
State Rivers and Water Supply Commission

Water Act 1958

STATE RIVERS AND WATER SUPPLY COMMISSION

MORNINGTON PENINSULA URBAN DISTRICT

Notice to owners of tenements in the undermentioned streets in the Mornington Peninsula Urban District and the private streets, lanes, courts and alleys opening thereto:

Beaconsfield

Desmond Court.

Berwick

Bemersyde Drive (a) from Cheviot Avenue to a point opposite Lot 94 about 30 metres easterly.

(b) from Cheviot Avenue to a point opposite Lot 3 about 65 metres westerly.

Bemersyde Drive, from end of existing main (opposite Lots 94 and 118 to a point opposite both Municipal Reserves about 247 metres easterly.

Bemersyde Drive, from end of existing main (opposite Municipal Reserves) to a point opposite Lots 260 and 284 about 344 metres easterly.

Bemersyde Drive, from end of existing main (opposite Lot 260) to a point opposite Lot 465 about 115 metres southerly.

Broxburn Court.

Cardinia Street, from Gamble Avenue to link up with existing main opposite Lot 13 about 80 metres northerly.

Carluke Close.

Centre Road, from Bemersyde Drive to a point opposite Lots 410 and 431 about 224 metres easterly.

Cheviot Avenue, from end of existing main (opposite Lot 229) to Bemersyde Drive.

Cheviot Avenue, from Bemersyde Drive to a point opposite eastern boundary of Lot 38.

Earlston Square.

Ettrick Place.

No. 7—45960/82—2

Gamble Avenue, from end of existing main (opposite Lots A and 16) to Cardinia Street.

Gifford Close.

Greenlaw Crescent.

Kelso Place.

Lauder Place.

Manuka Road, from end of existing main (opposite Lots 8 and 24) to a point opposite Lots 6 and 24 about 34 metres northerly.

Melrose Court.

Norham Court.

St. Boswells Avenue, from Bemersyde Drive to a point opposite Lot 174 about 280 metres southerly.

Selkirk Court.

Strathavan Drive, from Centre Road to a point opposite Lots 325 and 374 about 355 metres northerly and then easterly.

Yarrow Court.

Blairgowrie

Egerton Street, from Revell Street to William Road.

Bunyip

Chambers Road, from A'Beckett Road to a point opposite Lots 1 and 3 about 290 metres northerly.

Chambers Road, from a point opposite Lots 1 and 3 to Wattletree Road about 229 metres northerly.

Flett Street, from Chambers Road to a point opposite Lots 10 and 11 about 310 metres, westerly.

Mary Street, from end of existing main (opposite Lots 6 and 2) to a point opposite Lots 1 and 9 about 63 metres easterly.

Wattletree Road, from Chambers Road to a point opposite Lot 3 about 50 metres westerly.

Clyde

Derricks Road, from Moores Road to a point opposite Lots 8 and 1 about 208 metres northerly.

Moores Road, from Campbells Road to a point opposite Lot 11 and C.A.31 about 670 metres easterly.

Cranbourne

Cranbourne—Frankston Road (north side only), from end of existing main (opposite Lot 1) to Monahans Road.

Russell Street, from Bakewell Street to link up with existing main opposite Lots 19 and 7 about 45 metres northerly.

Russell Street, from end of existing main (opposite northern boundaries of Lots 3 and 1) to a point opposite southern boundaries of Lots 18 and 5 about 27 metres northerly.

Flinders

Glen Road, from Vale Street to a point opposite Lots 1 and 52 about 50 metres north-westerly.

Frankston

Partridge Crescent, from Franciscan Avenue to link up with existing main opposite Lots 224 and 188 about 320 metres southerly.

Hastings

Alfred Street, from end of existing main (opposite Lots 136 and 137) to link up to existing mains opposite Lots 133 and 140 about 57 metres northerly.

Elizabeth Street, from Arthur Street to link up to existing main opposite Lot 136 and Recreation Reserve about 203 metres easterly.

Graydens Road (south side only), from Boes Road to a point opposite Lots 1 and 9 about 144 metres westerly.

Railway Crescent (east side only), from Martin Street to James Street.

Simon Street.

McCrae

Somers Close.

Mornington

Ti-Tree Grove (1) from Pender Avenue to a point opposite Lots 115 and 124 about 36 metres westerly.
(2) from Prince Street to a point opposite Lots 103 and 116 about 45 metres easterly.

View Street.

Narre Warren North

Brently Close.

Pakenham

Ryans Road, from end of existing main (opposite Pt. C.A.38 and C.A.23 A2) a point opposite Lot 7 and C.A.23 A2 about 87 metres northerly.

Pearcedale

Padley Street, from a point opposite Lots 352 and 371 to a point opposite Lots 353 and 370 about 24 metres northerly.

Rosebud West

Elizabeth Avenue (west side only), from Gannett Street to Cootamundra Avenue.

Gannett Street.

Shearwater Place, from Kingfisher Avenue to Gannett Street.

Seaford

Armstrongs Road, from end of existing main (opposite Lots 100 and 48) to a point opposite Lots 145 and 50 about 26 metres easterly.

Somers

Reid Court.

Somerville

Cassandra Close, from Eramosa Road West to a point opposite Lots 4 and 1 about 300 metres northerly.

Eramosa Road West (north side only), from end of existing main (opposite Lot 100) to Cassandra Close.

The main pipe in the said streets being laid down, the owners of all tenements situated as above are hereby required, on or before the first day of March next, to cause proper pipes and stop cocks to be laid, so as to supply water within such tenements from the main pipe.
Armadale, 6 January 1982

R. BIRD, Secretary
State Rivers and Water Supply Commission

APPOINTMENTS AND RESIGNATIONS

APPOINTMENTS

His Excellency the Governor of the State of Victoria by and with the advice of the Executive Council thereof has by Orders made on 12 January 1982 been pleased to make the under-mentioned appointments, viz.:

DEPARTMENT OF CROWN LANDS AND SURVEY*Bailiff of Crown Lands*

ROBERT FITZGERALD COOPER,
to be a Bailiff of Crown lands, pursuant to the provisions of section 30 of the *Land Act 1958* in respect of the reserved Crown lands in the Township of Mornington and Parish of Moorooduc known as the "Mornington Fore-shore Reserves" and the "Mount Martha Camping Reserve", and with authority to enforce all the regulations made with respect to the care, protection and management of the said Reserves.

HEALTH COMMISSION*Psychiatrist Superintendent of Psychiatric Hospital*

FRANCIS THOMAS NOOZHUMURRY VARGHESE, B.Sc.Med.,
M.B., B.S., M.R.A.N.Z.C.P.,
to be Psychiatrist Superintendent of the Royal Park Psychiatric Hospital pursuant to the provisions of section

26 (2) of the *Mental Health Act 1959*, for period 4 January 1982 to 16 January 1982, vice W. R. McLeod on leave.

Trustees of Public Cemeteries

LAWRENCE HARVEY MILLER,
to be a Trustee of the Geelong Western Public Cemetery, vice E. J. Lyons, resigned,

KEITH FREDRICK BLUNDEN,
to be a Trustee of the Foster Public Cemetery, vice K. Nichol, resigned, pursuant to section 3 (1) of the *Cemeteries Act 1958*.

Members of Committees of Management of Hospitals

MAXWELL HAMMOND GOODIER,
Dimboola District Hospital, 12 January 1982;

PETER SHELDON MOSS,
Royal Children's Hospital, 12 January 1982;

JOHN TOOSE BENNETT,
Stawell District Hospital, 12 January 1982;

KEITH CHARLES BETHUNE,
Westernport Memorial Hospital, 12 January 1982;

ROBERT EDWARD APPLEBY,
William Angliss Hospital, 12 January 1982;
to be Members of the Committee of Management of the abovementioned Hospitals pursuant to the provisions of section 63F (1) of the *Hospitals and Charities Act 1958* for a period of three years commencing on the dates shown.

LAW DEPARTMENT*Justices of the Peace*

ROBERT JOHN LEYDON, 314 Albert Street, East Melbourne, and
MARTIN ADRIAN VERHOEVEN, 350 Camberwell Road, Camberwell,
to be Justices of the Peace for the State of Victoria.

Commissioners for Taking Declarations, &c.

NEIL ADRIAN FULLARTON, 74 Ardmillan Road, Moonee Ponds,
STEPHEN GREGORY HAYNES, 336-342 Rossiter Road, Koo Wee Rup,
EDMUND CHRISTOPHER JUSTIN MCCARTHY, Kororoit Creek Road, Williamstown,
SEAN MCNELIS, 33 Alfred Street, North Melbourne,
CLIVE JOHN PIGDON, Barry Beach,
LESLIE TAGUE, 409 St. Kilda Road, Melbourne, and
KATHARINE ELAINE THOMAS, 555 Collins Street, Melbourne,
to be Commissioners for Taking Declarations and Affidavits under the *Evidence Act 1958*.

Member of Motor Accidents Tribunal

ANDREW JOHN KIRKHAM, a barrister of not less than seven years standing,
to be a Member of the Motor Accidents Tribunal for the period ending 31 May 1982 pursuant to the provisions of section 37 of the *Motor Accidents Act 1973*.

Bailiff of Supreme and Magistrates' Courts

LUCIANO DE PASQUALE, William Street, Melbourne,
to be a Bailiff pursuant to section 185 (1) of the *Supreme Court Act 1958* and a Bailiff of Magistrates' Courts pursuant to section 31A of the *Magistrates' Court Act 1971*.

MINISTRY FOR POLICE AND EMERGENCY SERVICES*Chief Commissioner of Police*

SINCLAIR IMRIE MILLER, M.V.O., S.B.St.J., Q.P.M.,
to be Chief Commissioner of Police for a period of five years as from 13 June 1982 pursuant to the provisions of the *Police Regulation Act 1958*.

TOM FORRISTAL

Clerk of the Executive Council

At the Executive Council Chamber
Melbourne, 12 January 1982

Liquor Control Act 1968

APPOINTMENT OF LICENSING INSPECTORS

In accordance with the authority conferred upon me by Section 6 of the *Police Regulation Act 1958*, I, Aubrey William Conn, Deputy Commissioner of Police, do hereby appoint under sub-section (1) of Section 22 of the *Liquor Control Act 1968*, the following Officers of Police as Licensing Inspectors for the Divisions of the Police Districts as shown:

Division Number	Police District	Rank and Name
4	Moonee Ponds	Inspector Brian John Gray Annand (from 24.1.82 to 20.2.82)
2	Prahran	Inspector Graeme Francis Crawford (from 4.1.82 to 30.1.82)
		A. W. CONN Deputy Commissioner
14.1.82		

RESIGNATIONS

His Excellency the Governor of the State of Victoria by and with the advice of the Executive Council thereof has by Orders made on 12 January 1982 accepted the resignations of the persons named hereunder of the offices mentioned, viz.:

HEALTH COMMISSION

Members of Committees of Management of Hospitals

VIRGINIA ANNE LINTON-SMITH,
as a Member of the Committee of Management of the Alexandra District Hospital as from 25 November 1981;

LAWRENCE JOHN TULLY,
as a Member of the Committee of Management of the Box Hill Hospital as from 4 December 1981;

HAROLD STEPHEN EWING,
as a Member of the Committee of Management of the Castlemaine District Community Hospital as from 17 December 1981;

ERIC BEATTIE,
as a Member of the Committee of Management of the Royal Children's Hospital as from 31 December 1981, in accordance with the provisions of section 63G (1) of the *Hospitals and Charities Act 1958*.

LAW DEPARTMENT

Justices of the Peace

ROBERT WILLIAM BLACKWOOD,
ERIC BURGESS,
RICHARD ATHOL GRAHAM,
JEAN DAPHNE HORNSBY,
KENNETH DAVID MURDOCH, and
ROBERT SYDNEY TURNER,
as Justices of the Peace for the State of Victoria.

Commissioners for Taking Declarations, &c.

HERMANN BARRY COLLIN,
HAROLD VICTOR FEEHAN,
FRANK HENRY GLOVER,
ROBERT JOHN LEYDON,
KENNETH BRICE MATHER,
JOHN GEORGE PATRICK NEWTON,
ARTHUR ROBERT RITCHIE, and
JACOB VECHT,
as Commissioners for Taking Declarations and Affidavits under the *Evidence Act 1958*.

TOM FORRISTAL
Clerk of the Executive Council

At the Executive Council Chamber
Melbourne, 12 January 1982

ORDERS IN COUNCIL

COUNTRY ROADS BOARD

ACT No. 6229

At the Executive Council Chamber, Melbourne, the fifth day of January, 1982

PRESENT:

His Excellency the Governor of Victoria
Mr Crozier Mr Maclellan
Mr Weideman

ORDER APPROVING OF LAND BEING ACQUIRED AND ROADS, DEVIATIONS OR WIDENINGS BEING MADE TOGETHER WITH ALL ANCILLARY WORKS REQUIRED TO BE EXECUTED IN CONJUNCTION THEREWITH

His Excellency the Governor of the State of Victoria, by and with the advice of the Executive Council thereof, being satisfied that there are funds legally available for acquiring the land, doth hereby approve the acquiring of the land described in the Schedule hereunder and the making of new roads and deviations from and widenings of existing roads, together with all ancillary works required to be executed in conjunction therewith, referred to in the said Schedule.

SCHEDULE

Widening of an Existing Road

The land shown hatched on plan numbered G.P.15604 hereunder required for the Chiltern-Howlong Road in the Shire of Rutherglen.

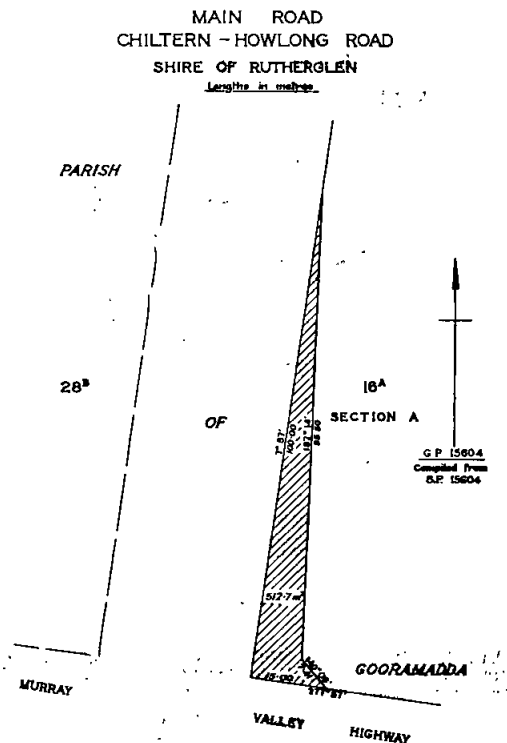

And the Honourable Robert Roy Cameron Maclellan, Her Majesty's Minister of Transport for the State of Victoria, shall give the necessary directions herein accordingly.

TOM FORRISTAL
Clerk of the Executive Council

LAND ACT 1958

At the Executive Council Chamber, Melbourne, the twelfth day of January, 1982

PRESENT:

His Excellency the Governor of Victoria	
Mr Thompson	Mr Hunt
Mr Storey	Mr Crozier
Mr Houghton	Mr Granter
Mr Jona	Mr Austin
Mr Wood	Mr Lacy
Mr Jenkins	Mr Weideman

UNUSED ROADS CLOSED

His Excellency the Governor of the State of Victoria, in the Commonwealth of Australia, by and with the advice of the Executive Council of the said State, pursuant to the provisions of Section 349 of the Land Act 1958 and with the concurrence in writing of the council of the municipality concerned and that of any adjoining land owners, doth hereby close the unused roads hereinafter described, viz.:

Municipal District of the Shire of Shepparton—Parish of Dookie, being the roads indicated by hatching on plan hereunder—(D.96⁽³⁾) (L.7-471).

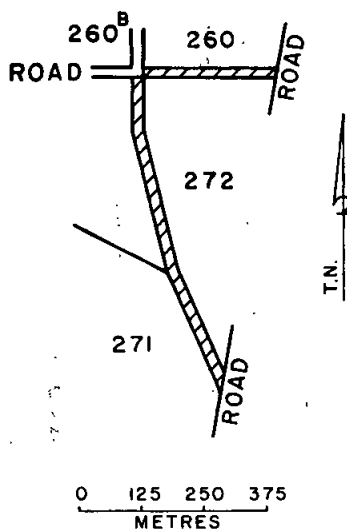

And the Honourable William Vasey Houghton, Her Majesty's Minister of Lands for the State of Victoria, shall give the necessary directions herein accordingly.

TOM FORRISTAL
Clerk of the Executive Council

CROWN LAND (RESERVES) ACT 1978

At the Executive Council Chamber, Melbourne, the twelfth day of January, 1982

PRESENT:

His Excellency the Governor of Victoria	
Mr Thompson	Mr Hunt
Mr Storey	Mr Crozier
Mr Houghton	Mr Granter
Mr Jona	Mr Austin
Mr Wood	Mr Lacy
Mr Jenkins	Mr Weideman

CROWN LAND PERMANENTLY RESERVED

His Excellency the Governor of the State of Victoria, in the Commonwealth of Australia, by and with the advice of the Executive Council of the said State, pursuant to the provisions of sections 4 and 7 of the Crown Land (Reserves) Act 1978, and being of the opinion that the Crown land concerned is required for the purpose mentioned, doth hereby permanently reserve and also except from prospecting or from occupation for mining purposes under any miner's right, the Crown land hereinafter described, viz.:

WALLAN WALLAN—For Conservation of an Area of Natural Interest, 5.174 hectares, being Crown allotment 62D, Parish of Wallan Wallan, as shown on Certified Plan No. 105370 lodged in the Central Plan Office—(W.24⁽³⁾) (Rs.10753).

And the Honourable William Vasey Houghton, Her Majesty's Minister of Lands for the State of Victoria, shall give the necessary directions herein accordingly.

TOM FORRISTAL
Clerk of the Executive Council

CROWN LAND (RESERVES) ACT 1978

At the Executive Council Chamber, Melbourne, the twelfth day of January, 1982

PRESENT:

His Excellency the Governor of Victoria	
Mr Thompson	Mr Hunt
Mr Storey	Mr Crozier
Mr Houghton	Mr Granter
Mr Jona	Mr Austin
Mr Wood	Mr Lacy
Mr Jenkins	Mr Weideman

RESERVED CROWN LAND PLACED UNDER THE CONTROL AND MANAGEMENT OF THE FORESTS COMMISSION

His Excellency the Governor of the State of Victoria, in the Commonwealth of Australia, by and with the advice of the Executive Council of the said State, pursuant to the provisions of section 18 (1) of the Crown Land (Reserves) Act 1978, doth hereby place under the control and management of the Forests Commission, the Crown Land hereinafter described, viz.:

MALLANBOOL—The land being Crown allotment 58A, Parish of Mallanbool permanently reserved for Preservation of Species of Native Plants by Order in Council of 13 October 1981 (see Government Gazette dated 21 October 1981)—(Rs.11676).

WONGARRA—The land being Crown allotment 19c, Parish of Wongarra permanently reserved for Conservation of an Area of Natural Interest by Order in Council of 2 June 1981 (see Government Gazette dated 10 June 1981)—(Rs.11369).

And the Honourable William Vasey Houghton, Her Majesty's Minister of Lands for the State of Victoria, shall give the necessary directions herein accordingly.

TOM FORRISTAL
Clerk of the Executive Council

CROWN LAND (RESERVES) ACT 1978

At the Executive Council Chamber, Melbourne, the twelfth day of January, 1982

PRESENT:

His Excellency the Governor of Victoria

Mr Thompson	Mr Hunt
Mr Storey	Mr Crozier
Mr Houghton	Mr Granter
Mr Jona	Mr Austin
Mr Wood	Mr Lacy
Mr Jenkins	Mr Weideman

CROWN RESERVE VESTED IN SHIRE OF LILLYDALE

His Excellency the Governor of the State of Victoria, in the Commonwealth of Australia, by and with the advice of the Executive Council of the said State, pursuant to section 16 (1) of the Crown Land (Reserves) Act 1978, doth hereby direct that the Crown land described in the Schedule hereunder be vested in the municipality concerned on trust for the purposes for which the land has been reserved, and, pursuant to section 16 (2) of the said Act, doth also empower the said municipality to grant leases or licences for a term not exceeding 21 years in respect of the land for the purposes of the reservation.

SCHEDULE

Township of Olinda, Parish of Mooroolbark and Parish of Monbulk containing 3.43 hectares more or less temporarily reserved for Public Recreation, as indicated by hatching on plan hereunder—(Rs.984).

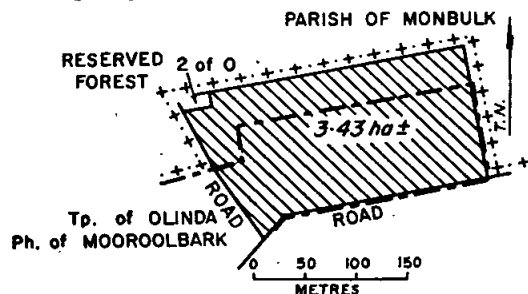

And the Honourable William Vasey Houghton, Her Majesty's Minister of Lands for the State of Victoria, shall give the necessary directions herein accordingly.

TOM FORRISTAL
Clerk of the Executive Council

CROWN LAND (RESERVES) ACT 1978

At the Executive Council Chamber, Melbourne, the twelfth day of January, 1982

PRESENT:

His Excellency the Governor of Victoria

Mr Thompson	Mr Hunt
Mr Storey	Mr Crozier
Mr Houghton	Mr Granter
Mr Jona	Mr Austin
Mr Wood	Mr Lacy
Mr Jenkins	Mr Weideman

CROWN LANDS TEMPORARILY RESERVED

His Excellency the Governor of the State of Victoria, in the Commonwealth of Australia, by and with the advice of the Executive Council of the said State, pursuant to the provisions of sections 4 and 7 of the Crown Land (Reserves) Act 1978, and being of the opinion that the Crown lands concerned are required for the purposes

respectively mentioned, doth hereby temporarily reserve and also except from prospecting or from occupation for mining purposes under any miner's right, the Crown lands hereinafter described, viz.:

BALLARAT EAST—For Public Recreation, 4.137 hectares, being Crown allotment 22, section 84, Township of Ballarat East, as shown on Certified Plan No. 105590 lodged in the Central Plan Office—(B.128⁽¹⁷⁾) (Rs.11994).

BREAMLEA—For Public Recreation, 1920 square metres, being Crown allotment 11A, Section A, Township of Breamlea, as shown on Certified Plan No. 105643 lodged in the Central Plan Office—(B.795⁽⁸⁾) (Rs.10255).

GOYURA—For Water Supply, 2.277 hectares, being Crown allotment 69B, Parish of Goyura, as indicated by hatching on plan hereunder—(G.202⁽⁸⁾) (Rs.11944).

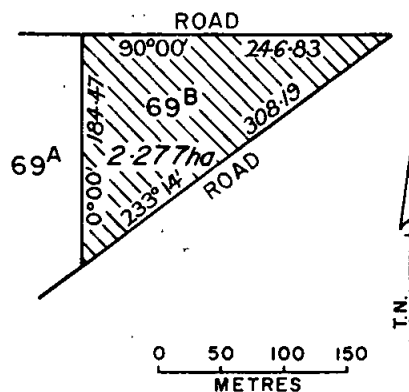

MELBOURNE (WEST MELBOURNE)—For Public Buildings, 410 square metres, being Crown allotment 9A, section 48, At West Melbourne, City of Melbourne, as indicated by hatching on plan hereunder—(M.314⁽¹⁰⁾) (Rs.11441).

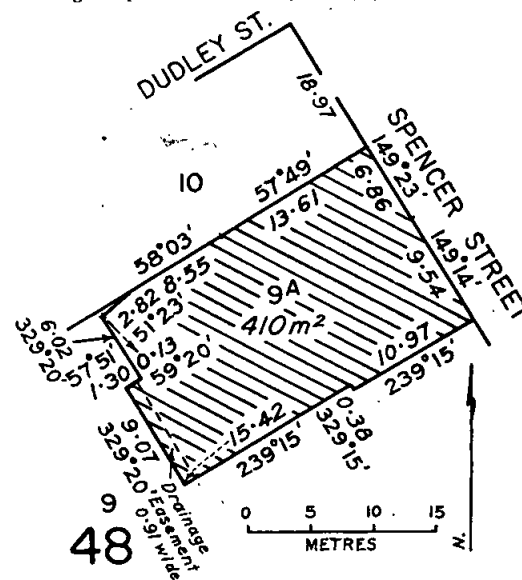

MOORA—For Conservation of an Area of Natural Interest, 6.002 hectares, being Crown allotment 114, Parish of Moora, as shown on Certified Plan No. 104769 lodged in the Central Plan Office—(M.183^(2A)) (Rs.11883).

And the Honourable William Vasey Houghton, Her Majesty's Minister of Lands for the State of Victoria, shall give the necessary directions herein accordingly.

TOM FORRISTAL
Clerk of the Executive Council

CROWN LAND (RESERVES) ACT 1978

At the Executive Council Chamber, Melbourne, the twelfth day of January, 1982

PRESENT:

His Excellency the Governor of Victoria	
Mr. Thompson	Mr Hunt
Mr Storey	Mr Crozier
Mr Houghton	Mr Granter
Mr Jona	Mr Austin
Mr Wood	Mr Lacy
Mr Jenkins	Mr Weideman

CROWN LANDS TEMPORARILY RESERVED

His Excellency the Governor of the State of Victoria, in the Commonwealth of Australia, by and with the advice of the Executive Council of the said State, pursuant to the provisions of sections 4 and 7 of the Crown Land (Reserves) Act 1978, and being of the opinion that the Crown lands concerned are required for the public purposes respectively mentioned, doth hereby temporarily reserve and also except from occupation for mining purposes under any miner's right, the Crown lands hereinafter described, viz.:

COLAC—For Police purposes, 872 square metres, being Crown allotment 43A, Township of Colac, as indicated by hatching on plan hereunder—(C.279⁽⁶⁾) (Rs.11859).

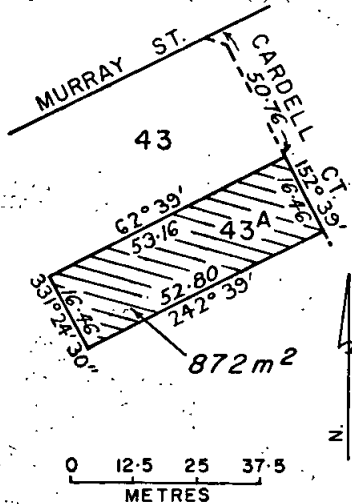

MOE—For Police purposes, 70.1 square metres, being Crown allotment 20, section 9, Township of Moe, as indicated by hatching on plan hereunder—(M.498⁽¹⁰⁾) (Rs.4892).

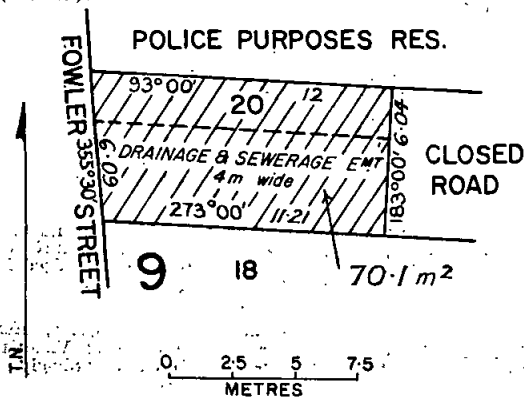

And the Honourable William Vasey Houghton, Her Majesty's Minister of Lands for the State of Victoria, shall give the necessary directions herein accordingly.

TOM FORRISTAL
Clerk of the Executive Council

CROWN LAND (RESERVES) ACT 1978

At the Executive Council Chamber, Melbourne, the twelfth day of January, 1982

PRESENT:

His Excellency the Governor of Victoria	
Mr Thompson	Mr Hunt
Mr Storey	Mr Crozier
Mr Houghton	Mr Granter
Mr Jona	Mr Austin
Mr Wood	Mr Lacy
Mr Jenkins	Mr Weideman

CROWN LAND TEMPORARILY RESERVED

His Excellency the Governor of the State of Victoria, in the Commonwealth of Australia, by and with the advice of the Executive Council of the said State, pursuant to the provisions of sections 4 and 7 of the Crown Land (Reserves) Act 1978, and being of the opinion that the Crown land concerned is required for the purpose mentioned, doth hereby temporarily reserve and also except from prospecting or from occupation for mining purposes under any miner's right, the Crown land hereinafter described, viz.:

KEELBUNDORA—For Public Park—2.514 hectares, being Crown allotment 16C, Parish of Keelbundora, as shown on Certified Plan No. 104658 lodged in the Central Plan Office—(K.25⁽⁷⁾) (Rs.10556).

And the Honourable William Vasey Houghton, Her Majesty's Minister of Lands for the State of Victoria, shall give the necessary directions herein accordingly.

TOM FORRISTAL
Clerk of the Executive Council

CROWN LAND (RESERVES) ACT 1978

At the Executive Council Chamber, Melbourne, the twelfth day of January, 1982

PRESENT:

His Excellency the Governor of Victoria	
Mr Thompson	Mr Hunt
Mr Storey	Mr Crozier
Mr Houghton	Mr Granter
Mr Jona	Mr Austin
Mr Wood	Mr Lacy
Mr Jenkins	Mr Weideman

REVOCATION OF TEMPORARY RESERVATIONS OF LANDS BY ORDERS IN COUNCIL

His Excellency the Governor of the State of Victoria, in the Commonwealth of Australia, by and with the advice of the Executive Council of the said State, pursuant to the provisions of section 10 of the Crown Land (Reserves) Act 1978, doth hereby revoke the temporary reservations of lands by Orders in Council hereinafter described, viz.:

STAWELL—The temporary reservation by Order in Council of 19 January 1971 of 1011 square metres, more or less, of land in the Parish of Stawell (in section 66) as a site for Public Recreation—(S.329⁽¹⁶⁾) (Rs.9396).

QUAMBATOOK—The temporary reservation by Order in Council of 5 August 1919 of 9.336 hectares of land in the Parish of Quambatook (in section 3) as a site for Public Recreation—(Q.37⁽⁹⁾) (Rs.24).

WHARPARILLA—The temporary reservation by Order in Council of 17 May 1898 of 9.029 hectares of land in the Parish of Wharparilla (south of allotment 78) as a site for Water Supply purposes—(Rs.11865).

WYELANGTA—The temporary reservation by Order in Council of 22 July 1912 of 8956 square metres of land in the Township of Wyelangta (in section C) as a site for a State School—(Rs.2225).

WYELANGTA—The temporary reservation by Order in Council of 9 March 1921 of 3642 square metres of land in the Township of Wyelangta (in section C) as a site for State School—(Rs.2225).

And the Honourable William Vasey Houghton, Her Majesty's Minister of Lands for the State of Victoria, shall give the necessary directions herein accordingly.

TOM FORRISTAL
Clerk of the Executive Council

CROWN LAND (RESERVES) ACT 1978

At the Executive Council Chamber, Melbourne, the twelfth day of January, 1982

PRESENT:

His Excellency the Governor of Victoria	
Mr Thompson	Mr Hunt
Mr Storey	Mr Crozier
Mr Houghton	Mr Granter
Mr Jona	Mr Austin
Mr Wood	Mr Lacy
Mr Jenkins	Mr Weideman

CROWN LAND PERMANENTLY RESERVED

His Excellency the Governor of the State of Victoria, in the Commonwealth of Australia, by and with the advice of the Executive Council of the said State, pursuant to the provisions of sections 4 and 7 of the Crown Land (Reserves) Act 1978, and being of the opinion that the Crown land concerned is required for the purpose mentioned, doth hereby permanently reserve and also except from prospecting or from occupation for mining purposes under any miner's right, the Crown land hereinafter described, viz.:

MULLAGONG—For Conservation of an Area of Natural Interest—41.37 hectares, being Crown allotment 59, section 18, Parish of Mullagong, as indicated by hatching on plan hereunder—(M.545⁽⁵⁾) (Rs.11636).

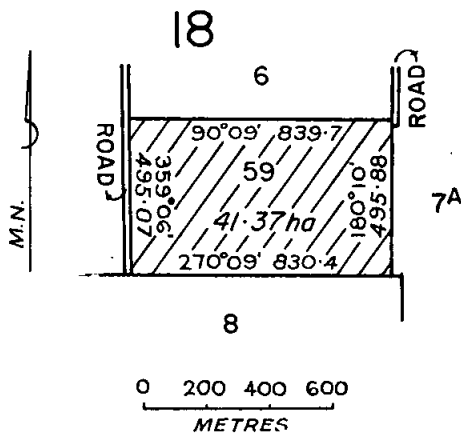

And the Honourable William Vasey Houghton, Her Majesty's Minister of Lands for the State of Victoria, shall give the necessary directions herein accordingly.

TOM FORRISTAL
Clerk of the Executive Council

COAL MINES ACT 1958

At the Executive Council Chamber, Melbourne, the twelfth day of January, 1982

PRESENT:

His Excellency the Governor of Victoria	
Mr Thompson	Mr Hunt
Mr Storey	Mr Crozier
Mr Houghton	Mr Granter
Mr Jona	Mr Austin
Mr Wood	Mr Lacy
Mr Jenkins	Mr Weideman

In pursuance of the powers conferred by the Coal Mines Act 1958, His Excellency the Governor of the State of Victoria, by and with the advice of the Executive Council thereof, doth hereby reappoint ALBERT FREDERICK CULLEN a Member and Chairman of the Coal Mine Workers Pensions Tribunal for a period of one year.

And the Honourable Digby Glen Crozier, Her Majesty's Minister for Minerals and Energy for the State of Victoria, shall give the necessary directions herein accordingly.

TOM FORRISTAL
Clerk of the Executive Council

COAL MINES ACT 1958

At the Executive Council Chamber, Melbourne, the twelfth day of January, 1982

PRESENT:

His Excellency the Governor of Victoria	
Mr Thompson	Mr Hunt
Mr Storey	Mr Crozier
Mr Houghton	Mr Granter
Mr Jona	Mr Austin
Mr Wood	Mr Lacy
Mr Jenkins	Mr Weideman

In pursuance of the powers conferred by the Coal Mines Act 1958, His Excellency the Governor of the State of Victoria, by and with the advice of the Executive Council thereof, doth hereby appoint KEVIN CAMPBELL FINDLAY, nominated by the Victorian Railways Board, and EDWIN HARMER, nominated by the body known as the Wonthaggi Retired Mine Workers Pensions Association, to be members of the Coal Mine Workers Pensions Tribunal for a period of one year.

And the Honourable Digby Glen Crozier, Her Majesty's Minister for Minerals and Energy for the State of Victoria, shall give the necessary directions herein accordingly.

TOM FORRISTAL
Clerk of the Executive Council

SUPERANNUATION ACT 1958

At the Executive Council Chamber, Melbourne, the twelfth day of January, 1982

PRESENT:

His Excellency the Governor of Victoria	
Mr Thompson	Mr Hunt
Mr Storey	Mr Crozier
Mr Houghton	Mr Granter
Mr Jona	Mr Austin
Mr Wood	Mr Lacy
Mr Jenkins	Mr Weideman

Pursuant to the powers conferred by the provisions of paragraph (ja) of sub-section (1) of section 3 of the Superannuation Act 1958, His Excellency the Governor of the State of Victoria, by and with the advice of the

Executive Council thereof doth by this Order declare that the provisions of the Superannuation Act shall apply to the officers named in the schedule set out hereunder.

SCHEDULE

BROWNE, SUSAN KATHLEEN,
GOREVSKA, SALLY,
HARRIS, ROBIN CHARLES,
KELLY, SAMANTHA LEEANNE,
LEAREY, ALISON FAYE,
MCLAUGHLAN, DAVID CHARLES,
PAVLIC, LISA MAREE,
ROBERTS, DOROTHEA ELIZABETH,
STRAFFORD, TIMOTHY GUY,
VRANTSIDIS, FRED A,
WEBSDALE, KAY LOUISE, and
WILKINSON, MARGARET JOY,
Motor Accidents Board.

And the Honourable Lindsay Hamilton Simpson Thompson, Her Majesty's Treasurer for the State of Victoria, shall give the necessary directions herein accordingly.

TOM FORRISTAL
Clerk of the Executive Council

LOCAL GOVERNMENT ACT 1958

At the Executive Council Chamber, Melbourne, the twelfth day of January, 1982

PRESENT:

His Excellency the Governor of Victoria

Mr Thompson	Mr Hunt
Mr Storey	Mr Crozier
Mr Houghton	Mr Granter
Mr Jona	Mr Austin
Mr Wood	Mr Lacy
Mr Jenkins	Mr Weideman

CONSENT TO SALE OF A RESERVE BY THE SOUTH BARWON CITY COUNCIL

Whereas certain land being a Drainage Reserve on Plan of Subdivision No. 31138 lodged in the Office of Titles was transferred to the Council of the City of South Barwon pursuant to the provisions of section 569B (8A) (a) of the Local Government Act 1958 and the said Council is now of the opinion that the land is no longer required for the purpose for which it was reserved and has requested that consent be given to the sale of that land.

And whereas the said Council—

- (a) has published in a newspaper generally circulating in the municipal district a notice describing the land and the proposal for the sale of the land and stating that at the next ordinary meeting of the Council after the expiration of forty days after publication of the notice the Council would consider any objection to the proposal;
- (b) being the registered proprietor of the land in question and there being no mortgagee chargee or lessee thereof has posted a similar notice upon the land.

And whereas no objection has been made against the proposal and no representations were made as to the disposal of any purchase money for the sale of the land.

Now therefore, His Excellency the Governor of the State of Victoria, by and with the advice of the Executive Council thereof and in pursuance of the provisions of sub-section 2 of section 569BA of the Local Government Act 1958 doth hereby consent to the Council of the City of South Barwon selling by private treaty the Drainage Reserve on Plan of Subdivision No. 31138 lodged in the Office of Titles as is shown by hatching and cross-hatching on the plan hereunder.

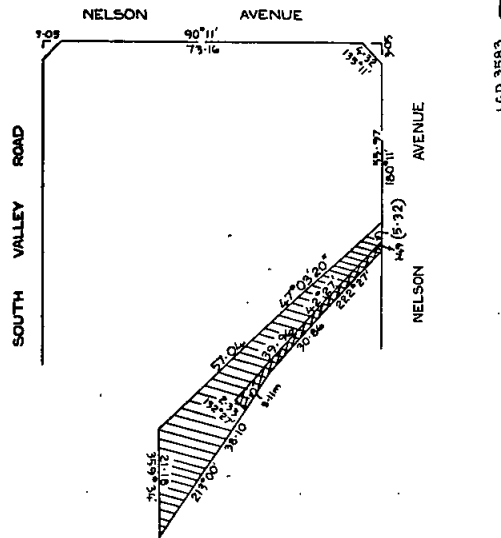

LENGTHS ARE IN METRES

And the Honourable Louis Stuart Lieberman, Her Majesty's Minister for Local Government for the State of Victoria, shall give the necessary directions herein accordingly.

TOM FORRISTAL
Clerk of the Executive Council

COMPANIES ACT 1958

At the Executive Council Chamber, Melbourne, the twelfth day of January, 1982

PRESENT:

His Excellency the Governor of Victoria

Mr Thompson	Mr Hunt
Mr Storey	Mr Crozier
Mr Houghton	Mr Granter
Mr Jona	Mr Austin
Mr Wood	Mr Lacy
Mr Jenkins	Mr Weideman

APPOINTMENT OF COMPANIES AUDITORS BOARD

In pursuance of the powers conferred by Section 8 (2) of the Companies Act 1958 and all other powers him thereunto enabling, His Excellency the Governor of the State of Victoria, by and with the advice of the Executive Council of the said State doth by this Order appoint the undermentioned persons to be members of the Companies Auditors Board for the period ending 9 January 1985:

Mr BRIAN PATRICK MCCARTHY, a duly qualified legal practitioner of not less than five years standing who shall be Chairman of the Board;

Mr LANCE GARNSWORTHY, a person selected from a panel of three names nominated by the State Council of the Institute of Chartered Accountants in Australia; and

Mr JAMES ANGUS MACDONALD, a person selected from a panel of three names nominated by the Council of the State Division of the Australian Society of Accountants.

And the Honourable Haddon Storey, Her Majesty's Attorney-General for the State of Victoria, shall give the necessary directions herein accordingly.

TOM FORRISTAL
Clerk of the Executive Council

FIRST MILDURA IRRIGATION TRUST
MILDURA URBAN WATER TRUST

At the Executive Council Chamber, Melbourne, the twelfth day of January, 1982

PRESENT:

His Excellency the Governor of Victoria	
Mr Thompson	Mr Hunt
Mr Storey	Mr Crozier
Mr Houghton	Mr Granter
Mr Jona	Mr Austin
Mr Wood	Mr Lacy
Mr Jenkins	Mr Weideman

SEWERAGE OF PORTION OF THE FIRST MILDURA IRRIGATION TRUST DISTRICT AND ANNEXATION TO THE MILDURA URBAN WATER TRUST DISTRICT

Under the powers conferred by the Mildura Irrigation and Water Trusts Act and all other powers enabling him in that behalf, His Excellency the Governor of the State of Victoria, by and with the advice of the Executive Council of the said State, doth hereby declare, order and direct that as on and from the date hereof the land shown by red colour on the plan approved by the Governor in Council and deposited in the office of the State Rivers and Water Supply Commission, Melbourne (Corr. No. 80/4325/21) shall be severed from the District of the First Mildura Irrigation Trust and annexed to the District of the Mildura Urban Water Trust.

And the Honourable Glyn Jenkins, Her Majesty's Minister of Water Supply for the State of Victoria, shall give the necessary directions herein accordingly.

TOM FORRISTAL
Clerk of the Executive Council

LILYDALE SEWERAGE AUTHORITY

At the Executive Council Chamber, Melbourne, the twelfth day of January, 1982

PRESENT:

His Excellency the Governor of Victoria	
Mr Thompson	Mr Hunt
Mr Storey	Mr Crozier
Mr Houghton	Mr Granter
Mr Jona	Mr Austin
Mr Wood	Mr Lacy
Mr Jenkins	Mr Weideman

EXTENT OF LILYDALE SEWERAGE DISTRICT DIMINISHED AND EXTENT OF MOUNT EVELYN SEWERAGE DISTRICT INCREASED

Under the powers conferred by the Sewerage Districts Act and all other powers enabling him in that behalf, His Excellency the Governor of the State of Victoria, by and with the advice of the Executive Council of the said State, doth hereby declare, order and direct that the extent of the Lilydale and Mount Evelyn Sewerage Districts of the Lilydale Sewerage Authority be diminished and increased by excising from and adding to the Districts the area shown by green and red colours respectively on a plan approved by the Governor in Council and deposited in the office of the State Rivers and Water Supply Commission, Melbourne (Corr. No. 80/3483/132) and as on and from the date hereof the extent of such Districts shall be and be deemed to be diminished and increased accordingly.

And the Honourable Glyn Jenkins, Her Majesty's Minister of Water Supply for the State of Victoria, shall give the necessary directions herein accordingly.

TOM FORRISTAL
Clerk of the Executive Council

ROAD TRAFFIC ACT 1958

At the Executive Council Chamber, Melbourne, the nineteenth day of January, 1982

PRESENT:

His Excellency the Lieutenant-Governor as Deputy for the Governor of Victoria

Mr Hunt | Mr Storey

In pursuance of the powers conferred by the Road Traffic Act 1958, His Excellency the Lieutenant-Governor as Deputy for the Governor of the State of Victoria, in the Commonwealth of Australia, by and with the advice of the Executive Council of the said State, and at the request of the Council of the City of Camberwell, doth by this Order extend the provisions of the said Act, to the land under the control of the City of Camberwell, indicated by hatching on the plan hereunder.

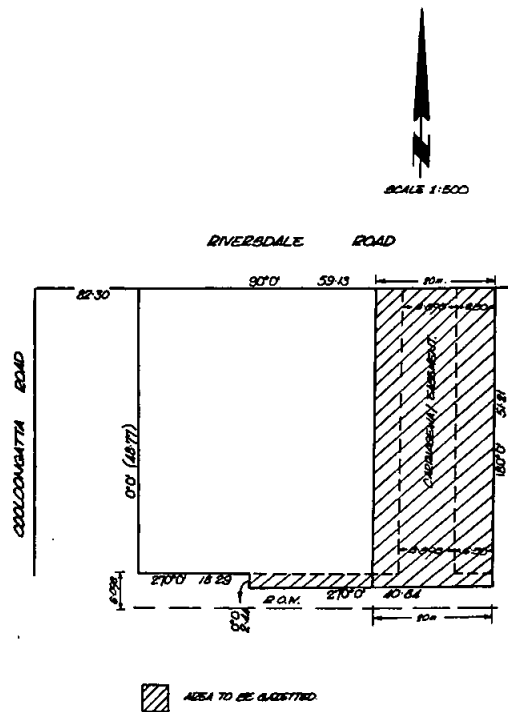

And the Honourable Frederick James Granter, Her Majesty's Minister for Police and Emergency Services for the State of Victoria, shall give the necessary directions herein accordingly.

TOM FORRISTAL
Clerk of the Executive Council

ROAD TRAFFIC ACT 1958

At the Executive Council Chamber, Melbourne, the nineteenth day of January, 1982

PRESENT:

His Excellency the Lieutenant-Governor as Deputy for the Governor of Victoria

Mr Hunt | Mr Storey

In pursuance of the powers conferred by the Road Traffic Act 1958, His Excellency the Lieutenant-Governor as Deputy for the Governor of the State of Victoria,

in the Commonwealth of Australia, by and with the advice of the Executive Council of the said State, and at the request of the Council of the Shire of Eltham, doth by this Order extend the provisions of the said Act to the land under the control of the Shire of Eltham shown by hatching on the plan hereunder.

SHIRE OF ELTHAM

PROPOSED EXTENSION OF THE PROVISIONS OF THE ROAD TRAFFIC ACT 1958, TO THE LAND HATCHED

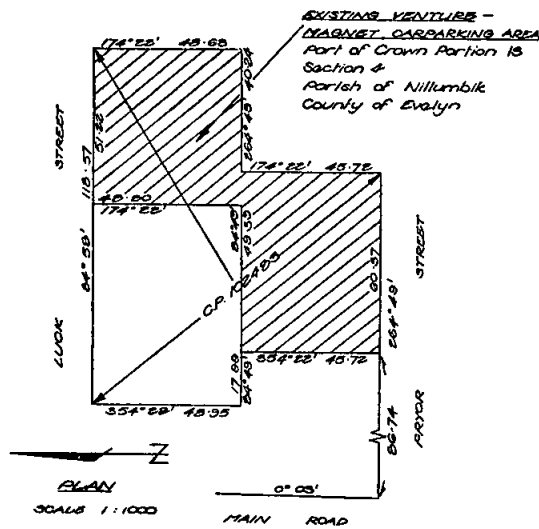

NOTE: MEASUREMENTS ARE IN METRES

And the Honourable Frederick James Granter, Her Majesty's Minister for Police and Emergency Services for the State of Victoria, shall give the necessary directions herein accordingly.

TOM FORRISTAL
Clerk of the Executive Council

LOCAL GOVERNMENT ACT 1958

At the Executive Council Chamber, Melbourne, the nineteenth day of January, 1982

PRESENT:

His Excellency the Lieutenant-Governor as Deputy for the Governor of Victoria

Mr Hunt | Mr Storey

APPROVAL OF RATING AGREEMENT BETWEEN THE TOWN OF PORTLAND AND ALCOA OF AUSTRALIA LIMITED

Whereas—

- (a) Alcoa of Australia Limited is liable to be rated in respect of certain land at Portland which land is not within the Metropolitan area within the meaning of the *Town and Country Planning Act 1961*;
- (b) the Council of the Town of Portland is of the opinion that the establishment and maintenance of the industry within the municipality is making

and will continue to make a substantial contribution to the industrial development of the municipality and encourage the decentralization of industry in Victoria; and

- (c) the Mayor, Councillors and Burgesses of the Council of the Town of Portland and Alcoa of Australia Limited have entered into an agreement dated 24 December 1980 in respect of the land at Portland as to the amount of rates that will be payable thereon by the said firm under the *Local Government Act 1958*, and copies of such agreement have been submitted to the Minister for Local Government.

And whereas by Order published in the *Government Gazette* No. 3 dated 7 January 1981 the Governor in Council in pursuance of section 811BA of the *Local Government Act 1958* approved the said agreement.

And whereas on 16 June 1981 the Mayor, Councillors and Burgesses of the Council of the Town of Portland and Alcoa of Australia Limited entered into a supplementary agreement (the first supplementary agreement) for the amendment of certain matters appearing in the said original agreement of 24 December 1980 and by Order published in the *Government Gazette* No. 68 dated 22 July 1981 the Governor in Council in pursuance of section 811BA of the *Local Government Act 1958* approved the said supplementary agreement.

And whereas on 14 January 1982 the Mayor, Councillors and Burgesses of the Council of the Town of Portland and Alcoa of Australia Limited entered into a supplementary agreement (the second supplementary agreement) for the amendment of certain matters appearing in the said original agreement of 24 December 1980.

Now therefore, His Excellency the Lieutenant-Governor as Deputy for the Governor of the State of Victoria, by and with the advice of the Executive Council thereof and in pursuance of the provisions of the said section 811BA of the *Local Government Act 1958* hereby approve the said second supplementary agreement.

And the Honourable Louis Stuart Lieberman, Her Majesty's Minister for Local Government for the State of Victoria, shall give the necessary directions herein accordingly.

TOM FORRISTAL
Clerk of the Executive Council

LANDS DEPARTMENT NOTICES

APPROACHING LAND SALES

Sale of Crown Land, will be held at the under-mentioned places and dates, viz.:

	No. of Gazette
Castlemaine—Monday, 15 March 1982	7
Donald—Monday, 22 March 1982	7
Fitzroy—Saturday, 6 March 1982	1
Wangaratta—Friday, 12 February 1982	1

SALE OF CROWN LAND BY AUCTION

The land will be offered for sale subject to the provisions of the *Land Act and Regulations* thereunder.

The **upset price** is the sum at which bidding will start, and no bid below that sum can be accepted. The highest bidder at or above that sum shall be the purchaser, subject to signature of contract and any necessary payment.

TERMS:

A deposit of at least 12½% of the purchase price must be paid at the sale, either in cash or by cheque.

The **residue** is payable in equal half yearly instalments, in accordance with the following scale, or may be paid off at any earlier time.

Purchase Price:

Under \$2000—8 instalments.
\$2000 and under \$5000—10 instalments.
\$5000 and over—20 instalments.

Interest at the rate of 12% per annum is payable with all payments of residue, and is computed for each instalment from the date of sale to the date of such payment. Additional interest is charged if any instalment is not paid on or before the due date.

If paid off within 30 days of sale, no interest is payable.

FEES, ETC.:

Also payable at the sale, in addition to the deposit, are the survey fee and, if applicable, the valuation of improvements (if purchaser be not the owner thereof).

Payable with balance of purchase money—
Crown Grant fee—\$35.00.

Assurance Fund contribution—One cent in every Five dollars or part thereof of purchase price. (This is a fund established to guarantee the validity of freehold titles.)

Transfer of interest prior to completion of payment may be allowed on payment of the prescribed fee and subject to stamp duty.

If unable to attend personally a prospective purchaser may arrange for another person to bid as his agent.

Attention is drawn to section 95, *Land Act 1958*, which provides that the purchaser shall be deemed to be the owner for the purposes of other Acts; also to an amendment to the Local Government Act providing for Government roads, in certain circumstances, to be declared "private streets", thus making the purchaser liable to contribute to the cost of street construction.

W. V. HOUGHTON
Minister of Lands

Department of Crown Lands and Survey
Melbourne

CASTLEMAINE—Sale (No. 12356) of Crown land, by auction, will be held at the LAND INSPECTOR'S OFFICE, KENNEDY STREET, CASTLEMAINE on MONDAY, 15 MARCH 1982 at TEN-THIRTY A.M. To be conducted by E. M. FLOYD, Land Officer, Bendigo.

Lot 1

TOWNSHIP OF CASTLEMAINE, PARISH OF CASTLEMAINE

Fronting the north side of Duke Street about 55 metres south-east of Fletcher Street

Upset price \$750 the lot. Survey fee \$350

Area 1595 square metres more or less. Allotment 5 of section 49.

SPECIAL CONDITION—One month allowed for removal of improvements.

Township zoning. Bitumen road frontage. Major services available.

NOTE—Purchaser liable for servicing charges or levies—(W.65322).

Lot 2

PARISH OF CASTLEMAINE

Fronting the north side of McGrath Street about 50 metres south of Duke Street

Upset price \$1200 the lot. Survey fee \$350

Area 733.5 square metres more or less. Allotment 62 of Section C.

SPECIAL CONDITION—Drainage and Sewerage Easement 2 metres wide.

Township zoning. Bitumen road frontage. Major services available.

NOTE—Purchaser liable for servicing charges or levies—(L.6-1479).

Lot 3

PARISH OF CASTLEMAINE

Fronting the south side of Crag Street about 100 metres west of Reckleben Street

Upset price \$1500 the lot. Survey fee \$350

Area 1993 square metres more or less. Allotment 23C of Section D8. Rural zoning. Major services available by extension.

NOTE—Purchaser liable for servicing charges or levies—(L.6-392).

Lot 4

PARISH OF CASTLEMAINE

Fronting the west side of Blanket Gully Road about 1 kilometre south of Campbell's Creek Railway Station

Upset price \$2000 the lot. Survey fee \$450

Area 5791 square metres more or less. Allotment 79 of Section 3A.

SPECIAL CONDITION—One month allowed for removal of improvements (fencing).

Urban zoning. Electricity and telephone available by extension—(W.87652).

Lot 5

TOWNSHIP OF MALMSBURY, PARISH OF EDGEcombe

Fronting the south side of Raleigh Street about 60 metres west of Barker Street

Upset price \$2000 the lot. Survey fee \$350

Area 1057 square metres more or less. Allotment 6A of Section 1.

SPECIAL CONDITIONS—One month allowed for removal of improvements (fencing). Valuation of improvements \$50 (clearing) in favour of Shire of Kyneton.

Electricity and water available.

NOTE—Purchaser liable to servicing charges or levies—(L.6-1442).

Lot 6

TOWNSHIP OF MALMSBURY, PARISH OF EDGEcombe

At the western corner of Walsh and Urquhart Streets

Upset price \$1650 the lot. Survey fee \$350

Area 2429 square metres more or less. Allotment 14 of Section 23.

SPECIAL CONDITION—One month allowed for removal of improvements (fencing).

Electricity and telephone available.

NOTE—Shire of Kyneton advises that a building permit (residence) will not be issued unless the purchaser meets the cost of a reticulated water supply—(L.6-1570).

DONALD—Sale (No. 12355) of Crown land, by auction, will be held at the LAND INSPECTOR'S OFFICE, DONALD on MONDAY 22 MARCH 1982 at TWO P.M. To be conducted by P. T. LEDGAR, Land Officer, Horsham:

Lot 1

TOWNSHIP OF CORACK, PARISH OF CORACK EAST

Being the former Corack East State School site and improvements adjoining western boundary of recreation reserve

Upset price \$400 the lot. Survey fee \$550

Area 1.21 hectares more or less. Allotment 4 of Section F.

SPECIAL CONDITION—Valuation of improvements \$250 in favour of Education Department.

Zoned Rural under Shire of Donald Interim Development Order.

Improvements comprise sheds, toilets and septic tank, fencing—(L.4-1065).

PROPOSED REVOCATION OF TEMPORARY RESERVATIONS OF LANDS BY ORDERS IN COUNCIL

In pursuance of the provisions of section 10 of the *Crown Land (Reserves) Act 1978*, notice is hereby given that it is the intention of the Governor in Council to revoke the temporary reservations of lands by Orders in Council hereunder referred to, viz.:

BENNISON—The temporary reservation by Order in Council of 18 August 1908 of 1.505 hectares of land in the Township of Bennison (called Township of Franklin in Order) as a site for a State School, revoked as to part by Order of 23 December 1936, so far as the balance thereof containing 1.453 hectares—(C.84151).

BAIRNSDALE—The temporary reservation by Order in Council of 16 July 1873 of 2.023 hectares of land in the Parish of Bairnsdale (near allotment 243) as a site for State School purposes—(Rs.6765).

BUNDALONG—The temporary reservation as a site for Public Purposes (State School) and the withholding from sale, leasing and licensing by Order in Council of 10 December 1877 of 8094 square metres of land in the Parish of Bundalong—(Rs.4785).

SERPENTINE—The temporary reservation by Order in Council of 23 July 1957 of 7562 square metres of land in the Township of Serpentine (adjoining Presbyterian Church Reserve) as a site for a Children's Playground—(J.20⁽¹⁾) (Rs.7648).

TANJIL (MT. BAW BAW)—The temporary reservation by Order in Council of 18 March 1977 (see *Government Gazette* dated 27 April 1977) of 35 hectares, more or less, of land in the County of Tanjil for Public Purposes (Alpine Resort)—(County 33) (Rs.8171).

ALEXANDRA—The temporary reservation by Order in Council of 14 June 1943 of 6.779 hectares of land in the Township of Alexandra as a site for Public purposes, so far only as the portion thereof containing 3280 square metres, as indicated by hatching on plan hereunder, is concerned—(A.160⁽²⁾) (Rs.5425).

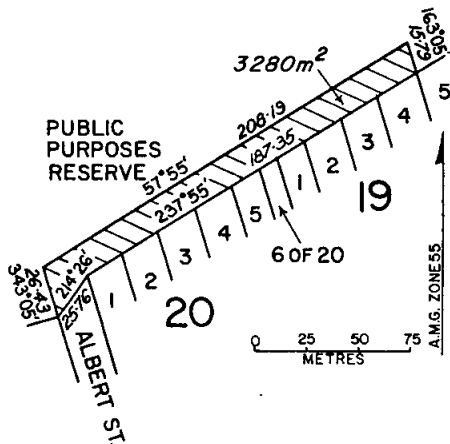

BACCHUS MARSH—The temporary reservation by Order in Council of 9 September 1980 of 6.183 hectares of land being Crown allotment 5, Township of Bacchus Marsh for Public Park, so far only as the portion thereof containing 5600 square metres, as indicated by hatching on plan hereunder, is concerned—(M.47⁽¹⁾) (Rs.4897).

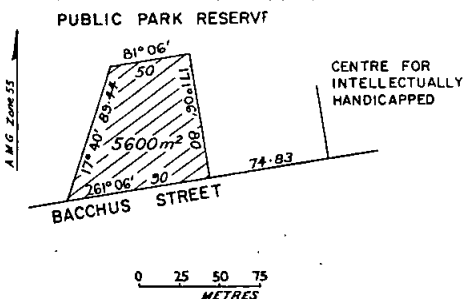

HEPBURN—The temporary reservation by Order in Council of 13 May 1941 of 9.611 hectares of land in the Township of Hepburn as a site for Public Purposes, so far only as the portion thereof containing 1262 square metres, as indicated by hatching on plan hereunder—(H.118⁽⁶⁾) (Rs.5201).

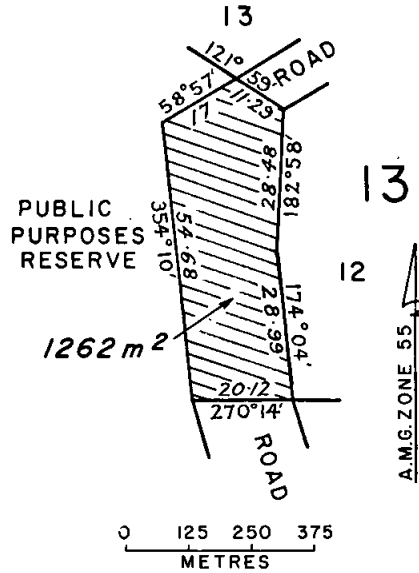

W. V. HOUGHTON
Minister of Lands

Department of Crown Lands and Survey
Melbourne, 12 January 1982

TENDERS

PUBLIC WORKS DEPARTMENT

Tenders are invited for the purposes indicated hereunder and will be received at 2 Treasury Place, Melbourne, 3002, until **TWO** p.m. on dates shown.

Tenders must be addressed to the Minister of Public Works with the envelope endorsed "Tender for

...". Hand-delivered tenders must be placed in the Department's tender box in the foyer, Ground Floor, 2 Treasury Place, Melbourne.

Tenders documents are available from the Contracts Office, Room 29, 2 Treasury Place, Melbourne and where indicated, at offices of Inspectors of Works.

★Tenders for works identified with star (★) will only be considered from Contractors qualified for repairs and painting works. Any Tenderers wishing to qualify may obtain the application form from the Contracts Office.

Tuesday, 26 January 1982

Building, Electrical and Mechanical Works

BARWON HEADS—Replacement of vacant residence, existing police station and new residence—Three-bedroom brick veneer residence including site services, Residence 81—83 Hitchcock Avenue. (W.O., Geelong.)

FRANKSTON—Supply and installation of P.A.B.X. telephone system, Police Station.

GLENMORE—Internal and external repairs and painting, Primary School No. 3688. (W.O., Ballarat.)

HAMILTON—Internal and external repairs and painting, High School. (W.O., Warrnambool and Hamilton.)

HEIDELBERG—Supply and installation of P.A.B.X. telephone system, Police Station.

JANEFIELD—Roof repairs to Ward MF1, Training Centre.

LEONGATHA—Fitting out works, Electoral Office. (W.O., Korumburra.)

MALVERN—Construction of an education and community activity centre, Girls' High School.

MELBOURNE—Supply and installation of acoustic ceiling, Titles Office.

MELBOURNE—Alterations to Floor 10, fitting out works, Urban Land Authority.

MONT PARK—Supply and installation of two (2) tilting kettles in the main kitchen, Plenty Mental Hospital.

MORELAND—(Re-advertisement)—Conversion of existing house to dental therapy unit, Primary School.

★MORNINGTON—(Re-advertisement)—External repairs and painting, Primary School. (W.O., Mornington.)

ORMOND—Conversion of two classrooms to a library, including all electrical, mechanical and hydraulic work as required, Ormond East Primary School.

ROBINVALE—External and internal repairs and painting, cyclic maintenance, Consolidated School. (W.O., Mildura.)

SWAN HILL—External repairs and painting, Technical School. (W.O., Swan Hill.)

ST. KILDA—Interior and exterior painting and repairs, Police Search and Rescue Squad.

WAUBRA—Internal and external repairs and painting, Primary School No. 859. (W.O., Ballarat.)

Miscellaneous

MELBOURNE—Fabrication of 5 mild steel gas buoys, Ports and Harbors.

MELBOURNE—Supply of timber piles for Paynesville Municipal Marina, Ports and Harbors.

MELBOURNE—Supply of squared timber for Paynesville Municipal Marina, Ports and Harbors.

MELBOURNE—Beach restoration by dredging at West Rosebud, Ports and Harbors Division.

MELBOURNE—Two anchor cables, S.S. Rip, Ports and Harbors.

PORT MELBOURNE—Purchase of one (1) only 8 m³ rock body tipper and one (1) only 8 m³ rock body trailer, Depot.

Wednesday, 3 February 1982

Building, Electrical and Mechanical Works

VARIOUS—(Re-advertisement, Amended Specification)—Supply, deliver and assemble 4 No. 10 module relocatable libraries, Various Sites. (W.O., Bendigo, Ballarat and Geelong.)

Miscellaneous

BAIRNSDALE—Supply and delivery of automotive equipment, Technical College.

MELBOURNE—Beach restoration by dredging Brighton Beach, City of Brighton, Ports and Harbors.

Tuesday, 9 February 1982

Building, Electrical and Mechanical Works

ARARAT—Supply and installation of stainless steel dishwasher benchwork in Wards TC3, M/F8, T6 Male and TCI-2, Mental Hospital. (W.O., Ararat.)

APOLLO PARKWAYS—(Readvertisement)—Multi-purpose hall, Primary School.

ASPENDALE—Connection to M.M.B.W. sewer, Technical and Primary Schools.

BALLAM PARK—Installation of intruder detection system, Technical School.

BALLARAT—Supply and delivery of 2 No. relocatable modular buildings, F.O.G. Port Melbourne, Modular Buildings. (W.O., Ballarat, Bendigo and Geelong.)

BEECHWORTH—Supply and installation of timber furniture to Turquoise House. (W.O., Wangaratta.)

CARRUM—Staff and administration upgrade, Primary School.

CAULFIELD NORTH—Library conversion, Primary School.

★CHELSEA HEIGHTS—External repairs and painting, Primary School.

★COBURG WEST—External cyclic maintenance including caretakers residence, Primary School.

★COLLINGWOOD—External repairs and painting, Police Complex.

DROMANA—(Re-advertisement)—Resite existing residence and cell, internal and external renovations and additions, Police Residence. (W.O., Mornington.)

★ELTHAM EAST—Internal and external renovations and painting, Primary School.

GEELONG—Internal and external painting and renovations, Police Residence, Belmont. (W.O., Geelong.)

KEW—Replacement of distribution pillars, Willsmere Hospital.

KEW—Repairs to No. 1 boiler, Willsmere Hospital.

LARUNDEL—Remodelling of Wards B and C, Plastering and Partitions.

LARUNDEL—Remodelling of Wards B and C, Carpentry and Joinery.

★MARYBOROUGH EAST—Repairs and painting, cyclic maintenance, Primary School No. 2828. (W.O., Maryborough.)

MILDURA—Electrical services—Student amenities Building, High School. (W.O., Mildura.)

★MONTMORENCY—Cyclic maintenance, exterior and part interior repairs and painting, Primary School.

MOOROOLBARK—Installation of intruder detection system, High School.

MOOROOLBARK—Installation of intruder detection system, Technical School.

SALE—Construction of mat industry building, H.M. Prison. (W.O., Traralgon and Bairnsdale.)

SALE—Electrical services, industry block, H.M. Prison. (W.O., Traralgon and Bairnsdale.)

SALE—Roofing replacement and roofing repairs, Technical School. (W.O., Traralgon.)

SPRINGVALE—Staff and administration upgrade, High School.

VARIOUS—Supply and delivery of 5 No. special relocatable modular buildings, Port Melbourne, Special Services Modular Buildings. (W.O., Ballarat, Bendigo and Geelong.)

VARIOUS—Oil burner maintenance, period 1982–83, Various.

WARRAGUL—Extension of offices, Police Station. (W.O., Warragul.)

WARRAGUL—Roofing repairs, Technical School. (W.O., Warragul.)

Miscellaneous

PORT MELBOURNE—Purchase of one (1) only pneumatic tyred tractor, Depot.

PORT MELBOURNE—Purchase of two (2) only 8-10 tonne pneumatic tyred tractor mounted cranes, Depot.

RYE—Maintenance cleaning, period 1 March 1982 to 27 February 1985, Police Station. (W.O., Mornington.)

ALAN WOOD
Minister of Public Works

Public Works Department
Melbourne, 19 January 1982

**PRIVATE
ADVERTISEMENTS**

CITY OF BRIGHTON

LOAN No. 125

*Notice of Intention to Borrow the Sum of \$400 000 for
Permanent Works and Undertakings*

Notice is hereby given that the Council of the City of Brighton proposes to borrow the principal sum of \$400 000, secured by a charge over the general rates of the municipality, such sum to be raised by the grant of a mortgage in accordance with the provisions of the *Local Government Act 1958*.

1. The maximum rate of interest that may be paid is 16% per annum.

2. The purpose for which the loan is to be applied is a programme for:

	\$	\$
Brighton Recreational Centre Squash Courts (Plan No. 4674)		140 000
Alterations and Additions to Brighton Beach Reserve Pavilion (Part Cost) (Plan No. 4675)		36 000
Elsternwick Park Tennis Courts Lighting (Plan No. 4676)		19 000
Hurlingham Park Pavilion Extensions (Plan No. 4677)		26 000
Minor Road Reconstruction—		
Huntley Street (Plan No. 4631)	22 000	
Rippon Grove (Plan No. 4628)	18 000	
Hodder Street (Plan No. 4668)	75 000	
Mulgoa Street (Plan No. 4534)	64 000	
	179 000	
		400 000

3. The period of the loan shall be 10 years.

4. The monies borrowed shall be repayable by providing out of the Municipal Fund 19 half yearly instalments of approximately \$35 530.97 with a final instalment of \$273 946.84 at the end of 10 years, each including principal and interest on 1 September and 1 March during the currency of the loan. The first instalment shall be payable on 1 September 1982.

5. Such monies shall be repayable to the Commonwealth Savings Bank of Australia at Melbourne.

The plans and specifications and the estimates of cost of the proposed works and a statement showing the proposed expenditure of the monies to be borrowed are open for inspection at the office of the Council of the City of Brighton.

R. J. COBAIN, Acting Town Clerk

Municipal Offices
Boxshall Street, Brighton, 3186 7950

Town and Country Planning Act 1961 (Twelfth Schedule)

CITY OF ECHUCA PLANNING SCHEME

NOTICE THAT A PLANNING SCHEME HAS BEEN PREPARED AND
IS AVAILABLE FOR INSPECTION

Amendment No. 50

Notice is hereby given that the City of Echuca in pursuance of its powers under the *Town and Country Planning Act 1961* has prepared a Planning Scheme for the following area:

Part Crown Allotments 13A, 14 and 15, Parish of Wharparilla, County of Gunbower.

A copy of the Scheme has been deposited at the City Offices, corner Hare and Heygarth Streets, Echuca and at the office of the Department of Planning, 235 Queen Street, Melbourne, and will be open for inspection during office hours by any person free of charge.

Any persons affected by the Scheme are required to set forth in writing submissions they may wish to make with respect to the Scheme, addressed to the Town Clerk,

City of Echuca, corner Hare and Heygarth Streets, Echuca by 22 February 1982, and to state whether they wish to be heard in respect of their submissions.

Dated 12 January 1982

7896 K. F. McCARTNEY, Town Clerk

CITY OF HEIDELBERG

LOAN No. 225

*Notice of Intention to Borrow the Sum of \$200 000 for
Permanent Works and Undertakings*

Notice is hereby given that the Council of the City of Heidelberg intends to borrow the sum of Two hundred thousand dollars (\$200 000) secured by a charge over the general rates of the Municipality, such sum to be raised by the grant of a mortgage in accordance with the provisions of the *Local Government Act 1958*.

1. The maximum rate of interest that may be paid is 16 per centum per annum.

2. The purposes for which the loan is to be applied are:

	\$
Burgundy Street drain (part)	110 000
Lower Plenty Road roadworks at Radiation Laboratory	10 000
Signalization Greensborough/Yallambie Roads	25 000
Moorwatha Street/Greensborough Road roadworks	5 000
Ford Park South redevelopment Stage 1 (part)	39 000
Banyule Tennis Club pavilion (part)	11 000
	200 000

3. The period of the loan shall be ten (10) years.

4. The moneys borrowed shall be repayable by providing out of the Municipal Fund nineteen (19) equal half-yearly instalments of \$17 765.49 each, including principal and interest, on 1 March and 1 September in each year during the currency of the loan, with a final instalment of \$136 973.19 at the end of 10 years. The first instalment shall be payable on 1 September 1982.

5. Such moneys shall be repayable to the Commonwealth Savings Bank of Australia, Melbourne.

The plans and specifications and the estimate of the cost of the proposed works and a statement showing the proposed expenditure of the money to be borrowed are open for inspection at the office of the Council, Civic Centre, Ivanhoe.

7889 ALAN JONES, Town Clerk/City Manager

No. 2822

CITY OF NUNAWADING

Notice is hereby given in accordance with section 205 (2) of the *Local Government Act* that the Council of the City of Nunawading has made a By-Law entitled as "Management and Control of Libraries By-Law".

The By-Law made under Part VII, section 197 of the *Local Government Act 1958* and numbered 110 is for the purpose of ensuring the proper management and control of libraries belonging to the City of Nunawading or under the management of the Council.

A copy of the By-Law is open for inspection at the Municipal Offices, Whitehorse Road, Nunawading, during office hours.

7871 E. J. JANE, Chief Administrator

CITY OF WANGARATTA

LOAN No. 121

*Notice of Intention to Borrow the Sum of \$100 000 for
Permanent Works and Undertakings*

Notice is hereby given that the Council of the City of Wangaratta intends to borrow the principal sum of One hundred thousand dollars secured by a charge over the general rates of the Municipality, such sum to be raised by the grant of a mortgage in accordance with the provisions of the *Local Government Act 1958*.

1. The maximum current rate of interest that may be paid is 15.8 per cent per annum.

2. Such moneys shall be repayable at the Bank of New South Wales, Murphy Street, Wangaratta or any other branch.

3. The loan is to be liquidated by providing initially out of the Municipal Fund eight half-yearly instalments of approximately \$10 109.54 and thereafter twelve half-yearly instalments based on an instalment amount to extinguish the balance of \$76 582.63 at current interest rates prevailing at the end of the fourth and eighth year of the loan. Such instalments to include principal and interest and payable on 1 September and 1 March of each year during the currency of the loan. The first such instalment shall be payable on 1 September 1982.

4. The purposes for which the loan is to be applied are:

	\$
Contribution to C.R.B. Main Road Grant	7 000
Gravel Pit Road, widening at railway crossing—Joint works with Shire of Wangaratta	1 000
Council contribution to kerb and channel, Evans and Green Streets	2 000
Council contribution to kerb and channel, Phillipson Street and Yarrowonga Road	4 000
Contribution to Unclassified Roads Grant	72 000
Computer installation	14 000
	<u>100 000</u>

5. The loan is a four year notional ten year loan and the period of the loan is therefore ten years.

6. The plans, specifications, estimate of the cost of the proposed works and a statement showing the proposed expenditure of the moneys to be borrowed are open for inspection at the Municipal Offices, Ovens Street, Wangaratta.

Dated 13 January 1982

7895

J. W. ELWARD, Town Clerk

RURAL CITY OF WODONGA

LOAN No. 93

Notice of Intention to Borrow the Sum of \$100 000 for Permanent Works and Undertakings

Notice is hereby given that the Council of the Rural City of Wodonga proposes to borrow the principal sum of \$100 000 secured by a charge over the general rates of the municipality, such sum to be raised by the grant of a mortgage in accordance with the provisions of the *Local Government Act 1958*.

The maximum rate of interest that may be paid is 15.8 per centum per annum.

The purpose for which the loan shall be applied is as follows:

*Part cost of construction of Birallee Park Football Oval and Sporting Complex.

The period of the loan shall be four years, with the balance outstanding being repayable at the end of that term.

The moneys borrowed shall be repayable by providing out of the municipal fund seven half yearly instalments of approximately \$10 109.54 each including principal and interest on 10 March and 10 September, during the currency of the loan, with a final instalment of \$86 692.17. Repayment figures are based on a ten year period. The first instalment shall be payable on 10 September 1982.

Such moneys shall be repayable to the Bank of New South Wales, Wodonga.

The plans and specifications of the cost of the works and a statement showing the proposed expenditure of the moneys to be borrowed are open for inspection at the City Offices, Hovell Street, Wodonga.

7909

R. I. O'TOOLE, Town Clerk

TOWN OF PORTLAND

LOAN No. 90 (CONVERSION)

Notice of Intention to Borrow the Sum of \$43 000 to Liquidate the Principal Moneys Owning by the Municipality on Account of a Previous Loan

Notice is hereby given that the Council of the Town of Portland proposes to borrow the principal sum of \$43 000 secured by a charge over the general rates of the Municipality, such sum to be raised by the grant of a mortgage in accordance with the provisions of the *Local Government Act 1958*.

1. The maximum rate of interest that may be paid is 15.8 per centum per annum.

2. The purpose for which the Loan is to be applied is as follows:

Refinancing of existing Loan No. 90 which was taken up on 31 January 1972 for the construction of the Civic Hall—total \$43 000.

3. The period of the loan shall be 4 years.

4. The moneys borrowed shall be repayable by providing out of the municipal fund half-yearly instalments of approximately \$4347.10 each including principal and interest on 1 September and 1 March during the currency of the loan. The first instalment shall be payable on 1 September 1982 with a final instalment of \$37 277.63 on 1 March 1986.

5. Such moneys shall be repayable to the Bank of New South Wales at the office of the said Bank, Julia Street, Portland, Victoria.

The plans and specifications and estimate of the cost of the proposed works and a statement showing the proposed expenditure of moneys to be borrowed are open for inspection at the office of the Council of the Town of Portland, Gawler Street, Portland.

Dated 15 January 1982

7949

O. K. SHANAHAN, Town Clerk

TOWN OF STAWELL

LOAN No. 75

Notice of Intention to Borrow the Sum of \$60 000 for Permanent Works and Undertakings

Notice is hereby given that the Council of the Town of Stawell, in pursuance of the powers conferred by the *Local Government Acts*, intends to borrow the sum of \$60 000 secured by a charge over the general rates of the Municipality, such sum to be raised by the grant of a mortgage in accordance with the said Acts and states:

(a) That the maximum rate of interest that may be paid is 16% per annum.

(b) The period of the loan shall be 10 years.

(c) The purposes for which the loan are to be applied are:

	\$
1. Water System—Infant Welfare Centre	2 500
2. Water System—Central Park	12 000
3. Toilet Block—North Park (part cost)	15 000
4. Purchase of land—North Park extension	1 400
5. Half cost Footpath, Kerb and Channel	20 000
6. Town Hall—Painting—interior Main Hall	9 100
	<u>60 000</u>

(d) The monies borrowed shall be repayable by providing out of the Municipal Fund twenty half-yearly instalments of approximately \$6111.14 each including principal and interest, on 1 April and 1 October during the period of the loan. The first instalment shall be payable on 1 October 1982.

(e) Such monies shall be repayable to the Commissioners of the State Bank of Victoria at the office of the said Commissioners, 385 Bourke Street, Melbourne.

Plans and specifications and estimates of such works and undertakings and a statement showing the proposed expenditure of the money to be borrowed are available for inspection at the Town Hall, Main Street, Stawell during office hours.

15 January 1982

7891

D. H. HUTTON, Town Clerk

TOWN OF STAWELL

LOAN No. 76

Notice of Intention to Borrow the Sum of \$60 000 for Permanent Works and Undertakings

Notice is hereby given that the Council of the Town of Stawell, in pursuance of the powers conferred by the Local Government Acts, intends to borrow the sum of \$60 000 secured by a charge over the general rates of the Municipality, such sum to be raised by the grant of a mortgage in accordance with the said Acts and states:

- (a) that the maximum rate of interest that may be paid is 16 per cent per annum;
- (b) the period of the loan shall be 10 years;
- (c) the purposes for which the loan are to be applied are:—

	\$
Purchase of properties for expansion of Central Park	45 000
Development of Central Park	10 000
Purchase of office equipment	5 000
	60 000

- (d) the monies borrowed shall be repayable by providing out of the Municipal Fund 20 half-yearly instalments of approximately \$611.14 each including principal and interest, on 1 April and 1 October during the period of the loan. The first instalment shall be payable on 1 October 1982;
- (e) such monies shall be repayable to the Australia and New Zealand Bank Limited at Stawell or at such other place as the Bank from time to time may require.

Plans and specifications and estimates of such works and undertakings and a statement showing the proposed expenditure of the money to be borrowed are available for inspection at the Town Hall, Main Street, Stawell during office hours.

Dated 15 January 1982

7892 D. H. HUTTON, Town Clerk

SHIRE OF BACCHUS MARSH

NOTICE OF INTENTION TO ACQUIRE LAND COMPULSORILY

Part of Crown Portion 8, Township of Bacchus Marsh, Parish of Korkuperrimul, County of Bourke, Main Street, Bacchus Marsh

Whereas the Council of the Shire of Bacchus Marsh deems it expedient to exercise its power of taking compulsorily the land being Part of Crown Portion 8, Township of Bacchus Marsh, Parish of Korkuperrimul, County of Bourke, more particularly described in Certificate of Title Volume 7085, Folio 816, as hatched on the plan below for the future development of the Municipal Complex; and whereas the Council has caused to be prepared a map and other papers setting out the general description of the work, or undertaking for which the land proposed to be taken is to be used, the description of the land proposed to be taken and the aims of the owners or reputed owners, lessees or reputed lessees, mortgagees and occupiers of that land, so far as those names are known to, or can be ascertained by the Council, and whereas the said map, and other papers, are deposited at the office of the said Council, at Bacchus Marsh, and shall be open for inspection by all persons interested, at all reasonable hours for a space of 40 clear days after publication of this notice in the *Government Gazette*. Now notice is hereby given to all persons affected by the proposed taking of the said land, to set forth in writing addressed to the Council or Shire Secretary, within 40 clear days of publication of this notice, in the *Government Gazette*, all objections which they have to the taking of the said land.

Dated 19 November 1981

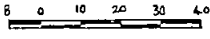
SCALE OF METRES 

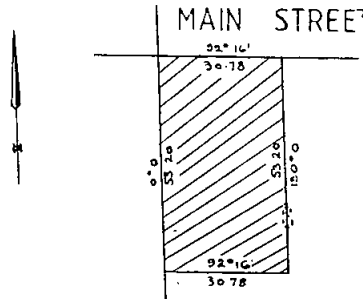

7068 N. S. BOND, Shire President

Town and Country Planning Act 1961

SHIRE OF BAIRNSDALE INTERIM DEVELOPMENT ORDER 1977

NOTICE THAT AN AMENDMENT TO THE INTERIM DEVELOPMENT ORDER 1977 HAS BEEN PREPARED AND IS AVAILABLE FOR INSPECTION

Amendment No. 1

Notice is hereby given that the Shire of Bairnsdale in pursuance of its powers under the *Town and Country Planning Act 1961*, has prepared an amendment to the Shire of Bairnsdale Interim Development Order 1977, for the purpose of re-zoning defined areas of land at Eagle Point for Urban and Rural A use.

A copy of the amendment has been deposited at the Shire Offices, McCulloch Street, Bairnsdale and at the office of the Department of Planning, 235 Queen Street, Melbourne and will be open for inspection during office hours by any person free of charge.

Any persons affected by the amendment are required to set forth in writing any submissions they may wish to make with respect to the amendment addressed to the Shire Secretary, Shire of Bairnsdale, P.O. Box 469, Bairnsdale 3875 by 22 February 1982 and to state whether they wish to be heard in respect of their submissions.

Dated 7 January 1982

7868 P. R. LEWIS, Shire Secretary

SHIRE OF BROADFORD

LOAN No. 77

Notice of Intention to Borrow the Sum of \$116 000 for Permanent Works and Undertakings

Notice is hereby given that the Council of the Shire of Broadford proposes to borrow the principal sum of \$116 000 secured by a charge over the general rates of the municipality, such sum to be raised by the grant of a mortgage in accordance with the provisions of the *Local Government Act 1958*.

1. The maximum rate of interest that may be paid is 16 per cent per annum.
2. The purpose for which the loan is to be applied is:

	\$
Pebble facing, Broadford Swimming Pool	6 000
Sealing and resealing various streets in township of Broadford	39 500
Road reconstruction, various streets in township of Broadford	8 250
Drainage, kerb and channel construction, various locations, township of Broadford	62 250
3. The period of the loan shall be 15 years.
4. The moneys borrowed shall be repayable by providing out of the municipal fund half-yearly instalments of approximately \$10 303.98 each including principal and interest on 1 April and 1 October during the currency of the loan. The first instalment shall be payable on 1 October 1982.
5. Such moneys shall be repayable to the Commissioners of the State Bank of Victoria at the office of the said Commissioners, 385 Bourke Street, Melbourne.

The plans and specifications and the estimate of the cost of the proposed works and a statement showing the proposed expenditure of the moneys to be borrowed are open for inspection at the office of the Council of the Shire of Broadford, 113 High Street, Broadford during office hours.

Dated 7 January 1982

7864

G. J. TINDLE, Shire Secretary

SHIRE OF CHILTERN

LOAN No. 25

Notice of Intention to Borrow the Sum of \$43 500 for Permanent Works and Undertakings

Notice is hereby given that the Council of the Shire of Chiltern proposes to borrow the principal sum of Forty-three Thousand Five Hundred Dollars (\$43 500) secured by a charge over the general rates of the Municipality, such sum to be raised by the grant of a mortgage in accordance with the provisions of the *Local Government Act 1958*.

1. The maximum rate of interest that may be paid is 15.8 per centum per annum.

2. The purpose for which the loan is to be applicable:

Purchase of Front-End Loader	\$43 500
------------------------------	----------

3. The period of the loan shall be four years (4) based on a five year repayment schedule.

4. The moneys borrowed shall be repayable by providing out of the municipal fund: seven equal half-yearly instalments of principal and interest of \$6453.57 on 23 February and 23 August during the currency of the loan. The first instalment shall be due on 23 August 1982, and an eighth and final instalment of \$17 977.78 shall be due on 24 February 1986.

5. Such moneys shall be payable at the Bank of New South Wales Savings Bank Limited, Conness Street, Chiltern.

The plans and specifications and the estimates of the cost of the proposed works and a statement showing the proposed expenditure of the moneys to be borrowed are open for inspection at the office of the Council of the Shire of Chiltern at the Shire Offices, Chiltern.

7906

M. G. BUTLER, Shire Secretary

SHIRE OF CHILTERN

LOAN No. 26

Notice of Intention to Borrow the Sum of \$14 000 for Permanent Works and Undertakings

Notice is hereby given that the Council of the Shire of Chiltern proposes to borrow the principal sum of Fourteen Thousand Dollars (\$14 000) secured by a charge over the general rates of the Municipality, such sum to be raised by the grant of a mortgage in accordance with the provisions of the *Local Government Act 1958*.

1. The loan is interest free.

2. The purpose for which the loan is to be applied is:

Construction of Chiltern Sports Complex (part cost)	\$14 000
-----------------------------------------------------	----------

3. The period of the loan shall be five (5) years.

4. The moneys borrowed shall be repayable by providing out of the municipal fund: five equal yearly instalments of principal of \$2800 on 1 March, during the currency of the loan. The first instalment shall be due on 1 March 1983.

5. Such moneys shall be payable at the Department of Youth Sport and Recreation, 570 Bourke Street, Melbourne.

The plans and specifications and the estimates of the cost of the proposed works and a statement showing the proposed expenditure of the moneys to be borrowed are open for inspection at the office of the Council of the Shire of Chiltern at the Shire Offices, Chiltern.

7907

M. G. BUTLER, Shire Secretary

No. 7—45960/82—3

Town and Country Planning Act 1961

SHIRE OF COBRAM PLANNING SCHEME 1979

NOTICE THAT A PLANNING SCHEME HAS BEEN PREPARED AND IS AVAILABLE FOR INSPECTION

Amendment No. 2, 1981

Notice is hereby given that the Shire of Cobram in pursuance of its powers under the *Town and Country Planning Act 1961* has prepared a planning scheme for the following area:

"Having a frontage to William Street of 23.94 metres and a depth along Punt Road of 33.53 metres and more particularly situated at the south east corner of Punt Road and William Street Cobram, the area to be re-zoned from Residential 'A' to Commercial."

A copy of the Scheme has been deposited at the Shire of Cobram Offices, Station Street, Cobram and at the office of the Department of Planning, 235 Queen Street, Melbourne, and will be open for inspection during office hours by any person free of charge.

Any persons affected by the Scheme are required to set forth in writing any submissions they may wish to make with respect to the Scheme addressed to the Shire Secretary, Shire of Cobram, P.O. Box 182, Cobram on or before 22 February 1982 and to state whether they wish to be heard in respect of the objections.

7908

W. LENYSZYN, Shire Secretary

SHIRE OF DIMBOOLA

LOAN No. 46

Notice of Intention to Borrow

Notice is hereby given that the Council of the Shire of Dimboola intends to borrow Seventy-two thousand dollars (\$72 000) secured by a charge over the general rates of the municipality by the grant of a mortgage in accordance with the provisions of the *Local Government Acts*.

In connection therewith the following information is stated:

(a) The amount of the principal sum which it is proposed to borrow be \$72 000.

(b) The maximum rate of interest that may be paid is 16 per centum per annum.

(c) The period of the loan shall be ten years.

(d) The moneys borrowed and interest thereon be repayable by 20 half-yearly instalments each on 1 March and 1 September in each year by appropriation of such amounts out of the Municipal Fund.

(e) Such amounts shall be payable at the National Bank of Australasia, Jeparit.

(f) The purpose for which the loan is to be applied is:

	\$
Alterations to residence	12 000
Construction of residence	60 000
	72 000

(g) That notice of the intention of the Council to borrow such moneys be advertised in the *Victoria Government Gazette* and twice in the *Dimboola Banner*, *Jeparit Leader* and *Rainbow News* newspapers.

The plans and specifications and estimate of the cost of the works and a statement showing the proposed expenditure of the moneys to be borrowed are open for inspection at the Shire Office, Roy Street, Jeparit.

Dated 16 December 1981

7881

R. G. FERGUSON, Shire Secretary

Town and Country Planning Act 1961 (Twelfth Schedule)

SHIRE OF FLINDERS PLANNING SCHEME 1962

NOTICE THAT A PLANNING SCHEME HAS BEEN PREPARED AND IS AVAILABLE FOR INSPECTION

Amendment No. 141, 1981

Notice is hereby given that the Shire of Flinders, in pursuance of its powers under the *Town and Country Planning Act 1961*, has prepared a Planning Scheme for

the purpose of amending the provisions of the Shire of Flinders Planning Scheme 1962 to prohibit certain recreational uses of an intrusive nature within the Upland Basalt Slopes Zone.

A copy of the Scheme has been deposited at the office of the Responsible Authority, Municipal Offices, Boneo Road, Rosebud and at the office of the Department of Planning, 235 Queen Street, Melbourne, and will be open for inspection during office hours by any person free of charge.

Any persons affected by the Planning Scheme are required to set forth in writing all objections they may have addressed to The Shire Secretary, Shire of Flinders, Municipal Offices, Boneo Road, Rosebud, 3939, on or before 22 February 1982 and state whether they wish to be heard in respect of these objections.

7865

G. WHITE, Shire Secretary

SHIRE OF KILMORE

LOAN No. 84

Notice of Intention to Borrow the Sum of \$70 000 for Permanent Works and Undertakings

Notice is hereby given that the Council of the Shire of Kilmore proposes to borrow the principal sum of \$70 000 secured by a charge over the general rates of the municipality, such sum to be raised by a grant of a mortgage in accordance with the provisions of the *Local Government Act 1958*.

1. Maximum rate of interest that may be paid is 15.8% per annum.

2. Purpose for which the loan is to be applied for is:

	\$
(a) Part cost of construction of footpaths at Powlett Street, Kilmore (between Lumsden and Rutledge Streets); Sydney Street, Kilmore (between Union and Mitchell Streets); Queen Street, Wallan (between Angus Way and Windham Street); Watson Street, Wallan (between High and Raglan Streets)	11 000
Construction of kerbs and channels at Hamilton Street, Kilmore (between Piper and Lumsden Streets) and Patrick Street Kilmore (between Bourke and Mill Streets)	9 000
(b) Road shoulder sealing works at Albert, Foote and Sutherland Streets, Kilmore	10 000
(c) Contribution toward part cost of Tramsheds at Bylands	20 000
(d) Street beautification works in Wallan Township	10 000
(e) Part cost of improvement works at the J. J. Clancy Recreation Reserve, including earthworks, fencing, water supply and construction of access	10 000
	70 000

3. The period of the loan shall be 4 years.

4. The monies borrowed shall be repayable by providing out of the municipal funds half-yearly instalments of \$5807.41 each including principal and interest on 3 September and March each year during the currency of the loan. The first instalment shall be payable on 3 September 1982.

5. Such monies are to be repayable to the Commercial Banking Co. of Sydney Ltd., Sydney Street, Kilmore.

The plans and specifications and the estimates of the costs of the proposed works and a statement showing the proposed expenditure of the monies to be borrowed are open for inspection at the office of the Council of the Shire of Kilmore, corner of Sydney and Bourke Streets, Kilmore.

7869

T. K. HAYES, Acting Shire Secretary

SHIRE OF KILMORE

LOAN No. 85

Notice of Intention to Borrow the Sum of \$24 000 for Permanent Works and Undertakings

Notice is hereby given that the Council of the Shire of Kilmore proposes to borrow the principal sum of \$24 000 secured by a charge over the general rates of the municipality, such sum to be raised by a grant of a mortgage in accordance with the provisions of the *Local Government Act 1958*.

1. Maximum rate of interest that may be paid is 15.8%.

2. Purpose for which the loan is to be applied for is: Acquisition of residential land in Wallan Township.

3. The period of the loan shall be 4 years.

4. The monies borrowed shall be repayable by providing out of the municipal funds half-yearly instalments of \$4160.52 each including principal and interest on 3 April and October each year during the currency of the loan. The first instalment shall be payable on 3 October 1982.

5. Such monies are to be repayable to the Commercial Banking Co. of Sydney Ltd., Sydney Street, Kilmore.

The plans and specifications and the estimates of the costs of the proposed works and a statement showing the proposed expenditure of the monies to be borrowed are open for inspection at the office of the Council of the Shire of Kilmore, corner of Sydney and Bourke Streets, Kilmore.

7870

T. K. HAYES, Acting Shire Secretary

SHIRE OF KILMORE

LOAN No. 87

Notice of Intention to Borrow the Sum of \$189 000 for Permanent Works and Undertakings

Notice is hereby given that the Council of the Shire of Kilmore proposes to borrow the principal sum of \$189 000 secured by a charge over the general rates of the municipality, such sum to be raised by a grant of a mortgage in accordance with the provisions of the *Local Government Act 1958*.

1. Maximum rate of interest that may be paid is 15.8% per annum.

2. Purpose for which the loan is to be applied for is:

The purchase and installation, on behalf of the Moonee Valley Regional Library Committee of a "LIBS 100" Computerized Loan system—\$189 000.

3. The period of the loan shall be 7 years.

4. The monies borrowed shall be repayable by providing out of the municipal funds half-yearly instalments of \$22 792.12 each including principal and interest on 9 September and March each year during the currency of the loan. The first instalment shall be payable on 9 September 1982.

5. Such monies are to be repayable to the Commonwealth Savings Bank of Australia, 83 Puckle Street, Moonee Ponds.

The plans and specifications and the estimates of the costs of the proposed works and a statement showing the proposed expenditure of the monies to be borrowed are open for inspection at the office of the Council of the Shire of Kilmore, corner of Sydney and Bourke Streets, Kilmore.

7870

T. K. HAYES, Acting Shire Secretary

SHIRE OF MANSFIELD

LOAN No. 100

Notice is hereby given that the Council of the Shire of Mansfield intends to borrow the sum of Fifty thousand dollars (\$50 000) secured by a charge over the General Rates of the Municipality by the grant of a mortgage in accordance with the provisions of the *Local Government Acts*.

In connection therewith the following information is stated:

(a) The amount of the principal moneys which it is proposed to borrow is \$50 000.

(b) The maximum rate of interest that may be paid is 15.8 per centum per annum.

- (c) The times which the moneys borrowed are to be repayable are 10 March and 10 September during the currency of the loan, the first instalment being payable 10 September 1982 and the place such moneys shall be repayable is at the Bank of New South Wales, Mansfield.

- (d) The purpose for which the loan is to be applied is:

	\$
Roads and Bridges	11 600
Automatic Watering System	8 400
Office Equipment	30 000
	50 000

- (e) The manner in which the loan is to be liquidated is by provision out of the Municipal Fund of seven (7) half-yearly instalments of \$5054.77 and an eighth and final instalment of \$43 346.08 including principal and interest.

The plans and specifications and estimate of the cost of the works and a statement showing the proposed expenditure of the moneys to be borrowed are open for inspection at the Shire Office.

7882 F. WALSH, Shire Secretary

SHIRE OF MIRBOO
LOAN NO. 36

Notice of Intention to Borrow the Sum of \$18 615.00 for Permanent Works and Undertakings

Notice is hereby given that the Council of the Shire of Mirboo proposes to borrow the principal sum of \$18 615.00 secured by a charge over the general rates of the municipality, such sum to be raised by the grant of a mortgage in accordance with the provisions of the *Local Government Act 1958*.

1. The maximum rate of interest that may be paid is 15.8 per cent per annum.

2. The purpose for which the loan is to be applied is:

	\$
(i) Construction of township drainage in Allen, Balding and Giles Streets	13 915
(ii) Purchase of two utilities	2 400
(iii) Purchase of one rotary mower	2 300
	18 615

3. The period of the loan shall be five years.
4. The moneys borrowed shall be repayable by providing out of the municipal fund half-yearly instalments of approximately \$2761.69 each including principal and interest on 1 March and 1 September during the currency of the loan. The first instalment shall be payable on 1 September 1982.

5. Such moneys shall be repayable to The Commissioners of The State Bank of Victoria at the office of the said Commissioners, 385 Bourke Street, Melbourne.

The plans and specifications and the estimate of the cost of the proposed works and a statement showing the proposed expenditure of the moneys to be borrowed are open for inspection at the office of the Council of the Shire of Mirboo, 30 Ridgway, Mirboo North.

Dated 5 January 1982
7866 R. L. GREGG, Shire Secretary

Town and Country Planning Act 1961 (Twelfth Schedule)
SHIRE OF WARRAGUL—WARRAGUL PLANNING SCHEME 1954

NOTICE THAT A PLANNING SCHEME HAS BEEN PREPARED AND IS AVAILABLE FOR INSPECTION
AMENDMENT NO. 17, 1972—AMENDMENT NO. 5, 1981
Interim Development Order

Notice is hereby given that the Shire of Warragul in pursuance of its powers under the *Town and Country Planning Act 1961* has prepared a planning scheme for all that land being part of Crown Allotment 121, Parish of Warragul as described in Certificate of Title Vol. 9073, Fol. 554.

A copy of the scheme has been deposited at the Municipal Offices, Civic Place, Warragul, at the office of the Department of Planning (Plan Inspection Centre), 5th Floor, 235 Queen Street, Melbourne and at the Regional Office of the Department of Planning at 71 Hotham Street, Traralgon, and will be open for inspection during office hours by any person free of charge.

Any persons affected by the scheme are required to set forth in writing any submissions they may wish to make with respect to the scheme, addressed to the Shire Secretary, Civic Place, Warragul by 20 February 1982, and to state whether they wish to be heard in respect of their submissions.

NOTE—The purpose of this scheme is to change the zoning of the subject land from Conservation Zone to Rural Zone.

Dated 11 January 1982
7863 V. B. DAVIDSON, Shire Secretary

GISBORNE WATERWORKS TRUST

NOTICE TO PROPERTY OWNERS TO CONNECT TO WATER SUPPLY

The supply mains being laid in the streets named in the schedule, the owners of all tenements situated in these streets are hereby required on or before 1 March 1982 to cause a proper pipe and stop cocks to be laid so as to supply water within such tenements from the supply main.

Hastings Road, Hamilton Road, Govans Lane, Pierce Road, Payne Road, Saunders Road, Barry Road, Ladd Road, Kilmore Road, Monaghan Road, Peavey Road, Erinvale Close and Willowbank Road.

7894 K. V. ROBINSON, Secretary

GEELONG WATERWORKS AND SEWERAGE TRUST

Pursuant to section 60 of the *Geelong Waterworks and Sewerage Act 1958* (No. 6263) the Trust has prepared plans to indicate the particulars of sewers and underground works, the construction of which the Trust intends to begin at a date not less than one month after publication of the notices, in or adjacent to the following localities within the Drainage Area.

Barwon Terrace and Dalton Street, South Geelong, City of Geelong.

Trenton Parade, Coppards and Townsend Roads, Whittington, Shire of Bellarine.

Oberon Drive, Olwen Avenue and Edith Court, Belmont, City of South Barwon.

Notice is hereby given that the plans indicated are open for public inspection at the Trust's Offices, 61-67 Ryrie Street, Geelong, between the hours of 8.10 a.m. and 5.00 p.m. from Monday to Friday (public holidays excepted) by the owners or occupiers of land or premises within the Drainage Area.

7893 L. C. SPITTY, Secretary

LILYDALE SEWERAGE AUTHORITY
CONSTRUCTION OF SEWERS—MT. EVELYN

The Lilydale Sewerage Authority gives notice that it intends to construct sewers in the area detailed below.

Plans showing details of the proposed works may be inspected by any persons during office hours 8.30 a.m. to 6.15 p.m. Thursday, and 8.30 a.m. to 5.00 p.m. all other week days at the Authority's office 7-9 John Street, Lilydale.

The proposed areas of construction are generally defined by boundaries of allotments adjacent to and/or the street boundaries of:

Hull Road, Lilydale—Montrose Road, Birmingham Road, Hereford Road, Everton Road, Railway Reserve, Stubbs Avenue thence westwards via Birmingham Primary School to Lilydale—Montrose Road.

Lilydale—Montrose Road, Birmingham Road, West Hill Drive, O'Shannassy Aqueduct, Johns Crescent to a point approximately 800 metres south of Birmingham Road thence generally along lot side boundaries to Lilydale—Montrose Road.

7910 W. L. HALSE, Secretary

BENDIGO SEWERAGE AUTHORITY

Pursuant to section 119 (2) of the *Sewerage Districts Act 1958* (No. 6368), notice is hereby given of the intention to construct sewer in the vicinity of the following streets:

Clee Crescent
Lawson Street
Regent Street
Bright Street

more particularly as shown on plans which are open for inspection at this Office between the hours of 8.45 a.m. and 4.00 p.m. Monday to Friday inclusive.

M. W. BROWN
Secretary

Sewerage Authority Office, 34 Mundy Street, Bendigo,
3550 7905

Notice is hereby given that the Wendouree Youth Centre has applied for a lease under section 134, *Land Act 1958*, for a term of 21 years for allotment 41, section 4, Parish of Dowling Forest, containing 1 acre 0 roods 28 perches as a site for amusement and recreation.

MURRAY BYRNE, LL.B., honorary solicitor, 38 Lydiard Street South, Ballarat 7582

Notice is hereby given that Morley Ford Pty. Ltd. has applied for a Lease pursuant to Section 134 of the *Land Act 1958* for a term of 15 years in respect of Allotment 55bz, Parish of Melbourne South, City of South Melbourne for commercial and industrial purposes. 7297

NOTICE OF DISSOLUTION OF PARTNERSHIP

Notice is hereby given that the Partnership of Electric Floorheating Contractors hitherto carried on at 208 Corio Street, Shepparton under the firm name of G. V. Floorheat by Trevor Maxwell Cottrell and Cheryl Anne Cottrell both of 5 Blaxland Street Shepparton and Kenneth Alan Davidson and Sandra Kaye Davidson both of 14 Smith Street, Shepparton has been dissolved by mutual consent as from 31 December 1981. The said business shall continue to be carried on at the same address under the same firm name by the said Trevor Maxwell Cottrell and Cheryl Anne Cottrell. All monies owing to the said Partnership shall be paid to the said Trevor Maxwell Cottrell and Cheryl Anne Cottrell who shall be responsible for all Partnership debts. Dated 8 January 1982

T. M. COTTRELL
C. A. COTTRELL
K. A. DAVIDSON
S. K. DAVIDSON

Cameron & Cameron, solicitors, 11A Fraser Street, Shepparton, 3630 7872

Notice is hereby given that the partnership heretofore subsisting between John Leslie Chard, James Thomas Hammer and Jeffrey George Faux carrying on business as accounting and taxation consultants at 639A Mt. Alexander Road Moonee Ponds in the State of Victoria under the style or firm of Chard, Hammer & Faux has been dissolved as from 31 December 1981 so far as concerns the said John Leslie Chard who retires from the said firm. Dated 4 January 1982

J. L. CHARD
J. T. HAMMER
J. G. FAUX

7883

Notice is hereby given that the partnership subsisting between Clive Belmont Goodenough of 48 Phillip Street, Lower Plenty and Elizabeth Ann Goodenough formerly of 48 Phillip Street, Lower Plenty carrying on business as marine contractors at 48 Phillip Street, Lower Plenty under the firm name of Peak Marine Services has been dissolved as from 1 July 1981, the said Elizabeth Ann Goodenough having retired from the partnership from that date. 7951

The partnership of "Sunraysia Asphalters" formerly carried on by Robert Charles Skinner and Jack Leo at Mildura is dissolved on 8 January 1982. The partnership business will be carried on by Robert Charles Skinner in his own name. 7911

PARTNERSHIP ACT 1958, SECTIONS 40 AND 41

Mr Michael A. Coppins retired from partnership on 19 October 1981.

Messrs R. Keith Gouldthorpe, Graham J. Carpenter and Richard McK. Hood retired from partnership on 31 December 1981.

PANNELL KERR FORSTER, chartered accountants
7948

Notice is hereby given that Terence Thomas O'Brien has retired from the partnership carried on as a plastic film extrusion and conversion business under the name "Shamrock Poly" in premises situated at 5 Ebdon Street, Moorabbin as from 18 December 1981 and that the said business is carried on from that date and under that name by the remaining partners Joseph Lajos Kocsis and Otto Toth.

7924

J. L. KOCSIS
O. TOTH

Companies Act 1961

PAT CREA AUCTIONS PTY. LTD.

CREDITORS' VOLUNTARY WINDING UP

Notice is hereby given that at an Extraordinary General Meeting of the members of the above-mentioned company, held on 18 January 1982, it was resolved that the company be wound up voluntarily and at a Meeting of Creditors held on the same day it was resolved that for such purposes Michael James Humphris of Duesburys, 114 William Street, Melbourne, Vic. 3000, be appointed Liquidator.

Notice is also given that after 21 days from this date, I shall proceed to distribute the assets. All creditors having any claim against the company should furnish particulars of same by that date, otherwise I shall proceed to distribute the assets without regard to their claim.

Dated 18 January 1982

M. J. HUMPHRIS, Liquidator
Duesburys, chartered accountants, 114 William Street,
Melbourne, Vic. 3000. Telephone 67 8331 7961

Companies Act 1961, Section 254 (2)

MCMILLAN & PYLE PTY. LTD. (IN LIQUIDATION)

NOTICE OF RESOLUTION

At an extraordinary general meeting of the members of McMillan & Pyle Pty. Ltd., duly convened and held at 130 Commercial Road, Morwell, on 15 January 1982 the special resolution set out below was duly passed.

"That the company be wound up voluntarily as a members' voluntary winding up in accordance with the provisions of the *Companies Act 1961*."

"That Roger David Midgley Smith be and is hereby appointed liquidator."

Notice is also given that after 21 days from this date I shall proceed to distribute the assets. All creditors having any claims against the company should furnish particulars of same by that date, otherwise I shall proceed to distribute the assets without regard to their claim. Dated 15 January 1982

ROGER D. M. SMITH, Liquidator
Bentley, Smith & Witts, chartered accountants, 130 Commercial Road, Morwell, 3840 7962

Companies Act—Rule 99 and Regulation 56—In the matter of G. & E. CHARLTON HOLDINGS PTY. LTD. (in Liquidation), Formerly Trading as "Linays Hardware" and "Copper House" at 499 Malvern Road, South Yarra

Notice is hereby given that the Liquidator has fixed 2 February 1982 as the day on or before which creditors of the Company are to prove their debts or claims and to establish any title they may have to priority under section 292 of the *Companies Act* or be excluded from the benefit of the distribution of the Company's assets.

Dated 18 January 1982

E. T. BENT, Official Liquidator
Bent & Cogle, public accountants, 144 Jolimont Road,
East Melbourne, 3002 7953

The Companies Act 1961, Section 232 (3) (b),
Regulation 26 (2) (b)

GARRISSON INDUSTRIES LTD. (IN LIQUIDATION)
NOTICE OF MEETING OF CREDITORS

Notice is hereby given that a Meeting of Creditors will be held in the Meeting Room, 3rd Floor, Wallace, McMullin and Smail, 499 St. Kilda Road, Melbourne on Tuesday, 9 February 1982 at 9.00 a.m.

Agenda

1. To receive the Liquidator's Report on the winding up and Statement of Receipts and Payments.
2. To approve the remuneration of the Liquidator in accordance with section 232 (3) (b) of the Companies Act 1961.
3. Any other business.

Dated 19 January 1982

J. M. WALSH, Official Liquidator
Wallace, McMullin & Smail, chartered accountants 7963

The Companies Act 1961, Section 232 (3) (b),
Regulation 26 (2) (b)

WARATAH LAND DEVELOPMENT PTY. LTD. (IN LIQUIDATION)

NOTICE OF MEETING OF CREDITORS

Notice is hereby given that a Meeting of Creditors will be held in the Meeting Room, 3rd Floor, Wallace, McMullin and Smail, 499 St. Kilda Road, Melbourne, on Tuesday, 9 February 1982 at 9.30 a.m.

Agenda

1. To receive the Liquidator's Report on the winding up and Statement of Receipts and Payments.
2. To approve the remuneration of the Liquidator in accordance with section 232 (3) (b) of the Companies Act 1961.
3. Any other business.

Dated 19 January 1982

7964 J. M. WALSH, Official Liquidator

The Companies Act 1961, Section 254 (2) and
Regulation 54

JOHN MCLEAN BENNETT & CO. PTY. LTD. (IN LIQUIDATION)

Notice is hereby given that at an Extraordinary General Meeting of the Members of the abovenamed Company held on 14 January 1982 it was resolved that the Company be wound up voluntarily, and at a meeting of creditors held on the same day pursuant to section 260, it was resolved that for such purpose Robert Eastaugh Ramsay and John Martin Walsh, both of 499 St. Kilda Road, Melbourne, Chartered Accountants, be appointed Liquidators, to act jointly and severally.

Dated 20 January 1982

R. E. RAMSAY, Liquidator
J. M. WALSH, Liquidator
Wallace, McMullin & Smail, chartered accountants, 499 St. Kilda Road, Melbourne, Vic. 3004 7965

In the matter of the Companies Act 1961; and in the matter of WESTFIELD CORPORATION (MELBOURNE) PTY. LIMITED (in Liquidation)

Notice is hereby given that pursuant to section 272 of the Companies Act, the final meeting of the members of the abovenamed company will be held at Greenwood Challoner & Co., 18th Floor, 50 Bridge Street, Sydney, on Friday, 26 February 1982 at 10.15 a.m. for the purpose of having an account laid before it showing the manner in which the winding up has been conducted and the property of the company disposed of and hearing any explanation that may be given by the Liquidator.

Dated 15 January 1982

7952 A. B. BAGNALL, Liquidator

Companies Act 1961

HARLEY LANE PTY. LTD.

Notice is hereby given that at an extraordinary general meeting of members of the abovenamed company held on Thursday, 14 January 1982, it was resolved that the company be wound up voluntarily and at a meeting of creditors held on the same day it was resolved that for such purpose John M. Spark and Robert A. Waters, Chartered Accountants of 460 Bourke Street, Melbourne, be appointed joint and several liquidators.

Notice is also given that after 21 days from this date we shall proceed to distribute the assets. All creditors who have any claim against the company should furnish particulars of same by that date, otherwise we shall proceed to distribute the assets without regard to their claim.

Dated 19 January 1982

JOHN M. SPARK AND ROBERT A. WATERS, Joint and Several Liquidators

Orr, Martin & Waters, chartered accountants, 460 Bourke Street, Melbourne, 3000. Telephone 602 1644 7960

Companies Act 1961

WALROCK PTY. LTD. (IN VOLUNTARY LIQUIDATION)

NOTICE OF FINAL MEETING, PURSUANT TO SECTION 272

Notice is hereby given, pursuant to Section 272 of the Companies Act, that the final General Meeting of the members of the abovenamed company will be held at 2 Macquarie Road, Toorak, on Thursday, 25 February 1982 at 10.30 a.m. for the purpose of having an account laid before it showing the manner in which the winding up has been conducted and the property of the company disposed of and hearing any explanations that may be given before the Liquidator.

Dated 14 January 1982

7877 FRANK SAUL MAHLAB, Liquidator

DATA KINLOCH PTY. LTD.
DATA PROPERTIES PTY. LTD.
JELBART IMPORTS PTY. LTD.
R. J. JELBART PTY. LTD.
SPADA PTY. LTD.
VENTURA PROPERTIES PTY. LTD.
WYMOR PTY. LTD.

At a general meeting of members of each of the abovenamed Companies duly convened and held at 111 Charles Street, Prahran, Victoria on 17 December 1981, the following resolution was duly passed as a Special Resolution:

"Resolved with the unanimous consent of all shareholders that the Company be wound up voluntarily, that Judith Mary Pateman be appointed liquidator and that the assets of the Company be distributed in specie." 7884

In the matter of the Companies Act 1961; and in the matter of E. GORMAN & SONS PTY. LTD. (in Liquidation)

Notice of Final Meetings of Members pursuant to Section 272 and notice to creditors to Lodge Claims.

Notice is hereby given in pursuance of Section 272 of the Companies Act 1961 that a General Meeting of the members of the above company will be held at the office of Messrs Coopers & Lybrand, 11th Floor, 460 Bourke Street, Melbourne on 24 February 1982 at 10.00 o'clock in the forenoon for the purpose of having accounts laid before them showing the manner in which the winding up has been conducted and the property of the company disposed of, and hearing any explanation that may be given by the liquidator.

Notice is also given that any creditors who have claims which have not yet been satisfied must lodge such claims with me prior to 10 February 1982 or be excluded from settlement.

Dated 20 January 1982

R. F. HUGHES, Liquidator

R. F. HUGHES, chartered accountant, 17th Floor, 461 Bourke Street, Melbourne, Vic., 3000 7928

Companies Act 1961

HARROS HOTEL PTY. LTD. (IN LIQUIDATION)

NOTICE OF FINAL MEETING

Notice is hereby given, in pursuance of Section 272 of the Companies Act 1961, that a Final Meeting of Members of Harros Hotel Pty. Ltd. "In Liquidation" will be held at the offices of J. N. Cooke, Foley & Co., 3rd Floor, A.M.P. Building, 17 Lydiard Street North, Ballarat, on Wednesday 24 February 1982 at 10.00 a.m., for the purpose of having an account laid before it showing the manner in which the winding up has been conducted and the property of the Company disposed of, and hearing any explanations that may be given by the Liquidator.

Dated 12 January 1982

KEVIN FOLEY, Liquidator

J. N. Cooke, Foley & Co., public accountants, 3rd Floor, A.M.P. Building, 17 Lydiard Street North, Ballarat, 3350
7885

In the matter of the Companies Act 1961; and in the matter of HOLIDAYWISE KOALA PTY. LIMITED (in Liquidation)

At an Extraordinary General Meeting of members of Holidaywise Koala Pty. Limited duly convened and held at Tooth & Co. Limited, 26 Broadway, Sydney on Friday, 11 December 1981 at 11 a.m., the following resolutions were passed as special resolutions:

1. That the company be wound up voluntarily and that Alexander Robert Mackay Macintosh of 31st Level, Tower Building, Australia Square, Sydney, be and is hereby appointed Liquidator of the company for the purpose of the winding up effective as and from 5.00 p.m. on Friday, 11 December 1981.

2. The Liquidator may, at his discretion, divide among the members of the company in specie or in kind any part of the assets of the company.

Dated 5 January 1982

7875

A. R. M. MACINTOSH, Liquidator

In the Supreme Court of Victoria—1981 No. Co. 12296—

In the matter of the Companies Act 1961; and in the matter of CASA PORTUGUESA PTY. LTD.—Memorandum of Advertisement

Notice is hereby given that a Petition for the winding up of the abovenamed company by the Supreme Court was on 9 December 1981 presented by Michael George Oades and that the said Petition is directed to be heard before the Court sitting at the Practice Court, Law Courts, Lonsdale Street, Melbourne at the hour of 10.30 o'clock in the forenoon on 25 February 1982 and any creditor or contributory of the said company desiring to support or oppose the making of an order on the said Petition may appear at the time of hearing by himself or his Counsel for the purpose; and a copy of the said Petition will be furnished to any creditor or contributory of the said company requiring the same by the undersigned on payment of the regulated charge for the same.

The Petitioner's official address is No. 4 "Graelyn" 1 Clark Road, North Sydney, in the State of New South Wales.

The Petitioner's Solicitors are Messrs Corr & Corr of 350 William Street, Melbourne.

CORR & CORR

NOTE—Any person who intends to appear on the hearing of the said Petition must serve on or send by post to the abovenamed Messrs Corr & Corr, notice in writing of his intention to do so. The notice must state the name and address of the person or, if a firm, the name and address of the firm, and must be signed by the person or firm, or his, or their solicitors (if any), and must be served, or, if posted, must be sent by post in sufficient time to reach the abovenamed not later than 4.00 o'clock in the afternoon of 24 February 1982.

7897

The Companies Act 1961, Section 272

THAMCHET PTY. LTD. (IN LIQUIDATION)

NOTICE OF FINAL MEETING

Notice is hereby given that pursuant to Section 272 of the Companies Act 1961, the final meeting of the members and creditors of the Company will be held at 434 St. Kilda Road, Melbourne, on 1 March 1982 at 9 a.m., for the purpose of laying before the meeting the account of the winding up and any explanation thereof.

Dated 11 January 1982

7886

ROGER D. EVANS, Liquidator

In the Supreme Court of Victoria—1981 Co. No. 12299—
In the matter of the Companies Act 1961; and in the matter of J. W. & K. M. PROPERTIES PTY. LTD.

Notice is hereby given that a Petition for the winding-up of the abovenamed Company by the Supreme Court was on 11 December 1981 presented by J. Murray More Proprietary Limited whose registered office is situate at 134-166 Wellington Road, Clayton in the State of Victoria and that the said Petition is directed to be heard before the Court sitting at Melbourne at the hour of 10.30 a.m. on Thursday, 25 February 1982 at the Practice Court and any Creditor or contributory of the said Company desiring to support or oppose the making of an Order on the said Petition may appear at the time of hearing by himself or his Counsel for that purpose; and a copy of the Petition will be furnished to any Creditor or contributory of the said Company requiring the same by the undersigned on payment of the regulated charge for same.

The Petitioner's address is 134-166 Wellington Road, Clayton, in the State of Victoria.

The Petitioner's Solicitors are A. E. Wundele & Co., 253 Lonsdale Street, Melbourne.

A. E. WUNDELE & CO., Solicitors for the Petitioner

NOTE—Any person who intends to appear on the hearing of the said Petition must serve on or send by post to the abovenamed A. E. Wundele & Co., notice in writing of his intention to do so. The notice must state the name and address of the person, or if a firm, the name and address of the firm and must be signed by the person or firm or his or their Solicitor (if any) and must be served or, if posted, must be sent by post in sufficient time to reach the abovenamed not later than four o'clock in the afternoon on 24 February 1982.

7874

In the Supreme Court of Victoria—1981 Co. No.—In the matter of the Companies Act 1961; and in the matter of GRECENE T.V. PRODUCTIONS PTY. LTD.

Notice is hereby given that a petition for the winding up of the abovenamed company by the Supreme Court was on 21 December 1981 presented by Southern Television Corporation Limited and that the said petition is directed to be heard before the Court sitting at the Fifteenth Court, Law Courts, William Street, Melbourne, at the hour of 10.30 o'clock in the forenoon on 18 February 1982 and any creditor or contributory of the said company desiring to support or oppose the making of an order on the said petition may appear at the time of the hearing by himself or his counsel for the purpose; and a copy of the said petition will be furnished to any creditor or contributory of the said company requiring the same by the undersigned on payment of the regulated charge for the same.

The petitioner's official address is 202 Tynte Street, North Adelaide, South Australia.

The petitioner's solicitors are Messrs Cornwall Stodart & Co., of 380 Lonsdale Street, Melbourne.

CORNWALL STODART & CO.

NOTE—Any person who intends to appear on the hearing of the said petition must serve on or send by post to the abovenamed Cornwall Stodart & Co., notice in writing of his intention so to do. The notice must state the name and address of the person, or, if a firm, the name and address of the firm, and must be signed by the person or firm, or his or their solicitor (if any), and must be served or, if posted, must be sent by post in sufficient time to reach the abovenamed not later than 4.00 o'clock in the afternoon on 17 February 1982.

7873

Companies Act 1961
**SPRINGHILL PASTORAL COMPANY PTY. LTD. (IN
 VOLUNTARY LIQUIDATION)**
MEMBERS' VOLUNTARY WINDING UP

Notice is hereby given that at a Special General Meeting of Members held on 11 December 1981 it was resolved that the company be wound up voluntarily and that Mr Donald Geoffrey Neilson and Mr Russell Graeme Peake, Chartered Accountants and Registered Liquidators of 177 Moorabool Street, Geelong be appointed Joint and Several Liquidators for the purpose of the winding up. Any person claiming to be a creditor of the company must lodge a Proof of Debt in the required form within 21 days falling which we shall proceed to distribute the assets to shareholders without regard to their claim.

Dated at Geelong, 12 January 1982

**DONALD GEOFFREY NEILSON AND RUSSELL GRAEME
 PEAKE, joint liquidators**

Day, Neilson, Jenkins & Johns, chartered accountants,
 177 Moorabool Street, Geelong, Vic. 3220 7876

In the Supreme Court of Victoria—In the matter of the *Companies Act 1961*; and in the matter of **COMPTON HOLDINGS PTY. LTD.**

Notice is hereby given that a petition for the winding up of the abovenamed Company by the Supreme Court was on 14 January 1982 presented by Eric John Unger, Deputy Commissioner of Taxation of the Commonwealth of Australia and that the said petition is directed to be heard before the Court sitting at the Fifteenth Court, Law Courts, Lonsdale Street, Melbourne at the hour of 10.30 o'clock in the forenoon on 25 February 1982 and any creditor or contributory of the said company desiring to support or oppose the making of an order on the said petition may appear at the time of hearing by himself or his Counsel for the purpose; and a copy of the said petition will be furnished to any creditor or contributory of the said company requiring the same by the undersigned on payment of the regulated charge for the same.

The Petitioner's official address is 350 Collins Street, Melbourne.

The Petitioner's Solicitor is B. J. O'Donovan, Crown Solicitor for the Commonwealth of 99 Queen Street, Melbourne.

B. J. O'DONOVAN

NOTE—Any person who intends to appear on the hearing of the said petition must serve on or send by post to the abovenamed B. J. O'Donovan notice in writing of his intention so to do. The notice must state the name and address of the person, or, if a firm, the name and address of the firm, and must be signed by the person or firm, or his, or their solicitor (if any), and must be served, or, if posted, must be sent by post in sufficient time to reach the abovenamed not later than 4.00 o'clock in the afternoon of 24 February 1982. 7916

In the Supreme Court of Victoria—In the matter of the *Companies Act 1961*; and in the matter of **ANSIR LIGHTING PTY. LIMITED**

Notice is hereby given that a petition for the winding up of the abovenamed Company by the Supreme Court was on 14 January 1982 presented by Eric John Unger, Deputy Commissioner of Taxation of the Commonwealth of Australia and that the said petition is directed to be heard before the Court sitting at the Fifteenth Court, Law Courts, Lonsdale Street, Melbourne at the hour of 10.30 o'clock in the forenoon on 25 February 1982 and any creditor or contributory of the said company desiring to support or oppose the making of an order on the said petition may appear at the time of hearing by himself or his Counsel for the purpose; and a copy of the said petition will be furnished to any creditor or contributory of the said company requiring the same by the undersigned on payment of the regulated charge for the same.

The Petitioner's official address is 350 Collins Street, Melbourne.

The Petitioner's Solicitor is B. J. O'Donovan, Crown Solicitor for the Commonwealth of 99 Queen Street, Melbourne.

B. J. O'DONOVAN

NOTE—Any person who intends to appear on the hearing of the said petition must serve on or send by post to the abovenamed B. J. O'Donovan notice in writing of his intention so to do. The notice must state the name and address of the person, or, if a firm, the name and address of the firm, and must be signed by the person or firm, or his, or their solicitor (if any), and must be served, or, if posted, must be sent by post in sufficient time to reach the abovenamed not later than 4.00 o'clock in the afternoon of 24 February 1982. 7917

In the Supreme Court of Victoria—In the matter of the *Companies Act 1961*; and in the matter of **V.A.K. TRANSPORT PTY. LTD.**

Notice is hereby given that a petition for the winding up of the abovenamed Company by the Supreme Court was on 14 January 1982 presented by Eric John Unger, Deputy Commissioner of Taxation of the Commonwealth of Australia and that the said petition is directed to be heard before the Court sitting at the Fifteenth Court, Law Courts, Lonsdale Street, Melbourne at the hour of 10.30 o'clock in the forenoon on 25 February 1982 and any creditor or contributory of the said company desiring to support or oppose the making of an order on the said petition may appear at the time of hearing by himself or his Counsel for the purpose; and a copy of the said petition will be furnished to any creditor or contributory of the said company requiring the same by the undersigned on payment of the regulated charge for the same.

The Petitioner's official address is 350 Collins Street, Melbourne.

The Petitioner's Solicitor is B. J. O'Donovan, Crown Solicitor for the Commonwealth of 99 Queen Street, Melbourne.

B. J. O'DONOVAN

NOTE—Any person who intends to appear on the hearing of the said petition must serve on or send by post to the abovenamed B. J. O'Donovan notice in writing of his intention so to do. The notice must state the name and address of the person, or, if a firm, the name and address of the firm, and must be signed by the person or firm, or his, or their solicitor (if any), and must be served, or, if posted, must be sent by post in sufficient time to reach the abovenamed not later than 4.00 o'clock in the afternoon of 24 February 1982. 7918

In the Supreme Court of Victoria—In the matter of the *Companies Act 1961*; and in the matter of **GOLDEN CENTURY (AUSTRALIA) PTY. LTD.**

Notice is hereby given that a petition for the winding up of the abovenamed Company by the Supreme Court was on 14 January 1982 presented by Eric John Unger, Deputy Commissioner of Taxation of the Commonwealth of Australia and that the said petition is directed to be heard before the Court sitting at the Fifteenth Court, Law Courts, Lonsdale Street, Melbourne at the hour of 10.30 o'clock in the forenoon on 25 February 1982 and any creditor or contributory of the said company desiring to support or oppose the making of an order on the said petition may appear at the time of hearing by himself or his Counsel for the purpose; and a copy of the said petition will be furnished to any creditor or contributory of the said company requiring the same by the undersigned on payment of the regulated charge for the same.

The Petitioner's official address is 350 Collins Street, Melbourne.

The Petitioner's Solicitor is B. J. O'Donovan, Crown Solicitor for the Commonwealth of 99 Queen Street, Melbourne.

B. J. O'DONOVAN

NOTE—Any person who intends to appear on the hearing of the said petition must serve on or send by post to the abovenamed B. J. O'Donovan notice in writing of his intention so to do. The notice must state the name and address of the person, or, if a firm, the name and address of the firm, and must be signed by the person or firm, or his, or their solicitor (if any), and must be served, or, if posted, must be sent by post in sufficient time to reach the abovenamed not later than 4.00 o'clock in the afternoon of 24 February 1982. 7919

In the Supreme Court of Victoria—In the matter of the Companies Act 1961; and in the matter of B. L. YOUNG ENTERPRISES PROPRIETARY LIMITED

Notice is hereby given that a petition for the winding up of the abovenamed Company by the Supreme Court was on 14 January 1982 presented by Eric John Unger, Deputy Commissioner of Taxation of the Commonwealth of Australia and that the said petition is directed to be heard before the Court sitting at the Fifteenth Court, Law Courts, Lonsdale Street, Melbourne at the hour of 10.30 o'clock in the forenoon on 25 February 1982 and any creditor or contributory of the said company desiring to support or oppose the making of an order on the said petition may appear at the time of hearing by himself or his Counsel for the purpose; and a copy of the said petition will be furnished to any creditor or contributory of the said company requiring the same by the undersigned on payment of the regulated charge for the same.

The Petitioner's official address is 350 Collins Street, Melbourne.

The Petitioner's Solicitor is B. J. O'Donovan, Crown Solicitor for the Commonwealth of 99 Queen Street, Melbourne.

B. J. O'DONOVAN

NOTE—Any person who intends to appear on the hearing of the said petition must serve on or send by post to the abovenamed B. J. O'Donovan notice in writing of his intention so to do. The notice must state the name and address of the person, or, if a firm, the name and address of the firm, and must be signed by the person or firm, or his, or their solicitor (if any), and must be served, or, if posted, must be sent by post in sufficient time to reach the abovenamed not later than 4.00 o'clock in the afternoon of 24 February 1982. 7920

In the Supreme Court of Victoria—1981 Co. No. 12311—In the matter of the Companies Act 1961; and in the matter of ANGLO ARABIAN CORPORATION PTY. LTD.

Notice is hereby given that a Petition for the winding up of the above-named Company by the Supreme Court was on 23 December 1981 presented by Jetset Tours (Australia) Proprietary Limited. The said Petition is directed to be heard before the Court sitting at the Practice Court, Law Courts, Melbourne at the hour of 10.30 o'clock in the forenoon on Thursday, 25 March 1982 and any Creditor or Contributory of the said Company desiring to support or oppose the making of an Order on the said Petition may appear at the time appearing by himself or his Counsel for that purpose. A copy of the Petition will be furnished to any Creditor or Contributory of the said Company requiring the same by the undersigned on payment of the regulated charges for the same.

The Petitioner's registered office is situate at 21st Floor, M.L.C. Building, 303 Collins Street, Melbourne.

The Petitioner's Solicitors are Arnold Bloch, Leibler & Co. of 324 Little Lonsdale Street, Melbourne.

ARNOLD BLOCH, LEIBLER & CO., solicitors for the petitioners

NOTE—Any person who intends to appear on the hearing of the said Petition must serve on or send by post to the abovenamed Solicitors notice in writing of his intention to do so. The Notice must state the name and address of the person, or, if a firm, the name and address of the firm, and must be signed by the person or firm or his or their Solicitors (if any) and must be served, or if posted, must be sent by post in sufficient time to reach the abovenamed Solicitors not later than 4 o'clock in the afternoon of 24 March 1982. 7913

In the Supreme Court of Victoria—1981 No. Co. 12281—In the matter of the Companies Act 1961; and in the matter of THE COOKIE COACH COMPANY (VIC.) PTY. LTD.

Notice is hereby given that a petition for the winding-up of the abovenamed company by the Supreme Court was, on 7 December 1981 presented by Daram Printing Pty. Limited and that the said Petition is directed to be heard before the Court sitting at Law Courts, William Street, Melbourne at the hour of 10.30 a.m., on 18 February 1982; and any creditor or contributory of the said company

desiring to support or oppose the making of an order on the said petition may appear at the time of hearing by himself or his Counsel for that purpose; and a copy of the petition will be furnished to any creditor or contributory of the said company requiring the same by the undersigned on payment of the regulated charge for the same.

The Petitioner's address is 67 Powers Road, Seven Hills, in the State of New South Wales.

The Petitioner's Solicitor is Mr John Cotter of John Cotter, Geoff Roberson & Co. of 42 O'Connell Street, Parramatta, in the State of New South Wales, whose Melbourne Agent is Mr Michael J. Dent of Marshall & Marshall of 380 Lonsdale Street, Melbourne, in the State of Victoria.

MARSHALL & MARSHALL, solicitors for the petitioner

NOTE—Any person who intends to appear on the hearing of the said petition must serve on or send by post to the abovenamed Solicitor notice in writing of his intention to do so. The notice must state the name and address of the person, or, if a firm, the name and address of the firm, and must be signed by the person or firm, or his or their Solicitor (if any), and must be served, or, if posted, must be sent by post in sufficient time to reach the abovenamed not later than four o'clock in the afternoon of 17 February 1982. 7912

STRZELCKI (No. 1) CO-OPERATIVE HOUSING SOCIETY LIMITED (IN LIQUIDATION)

SPECIAL RESOLUTION

Passed 13 January 1982

At a Special General Meeting of the abovenamed Society duly convened and held at 18A Hotham Street, Traralgon, on 13 January 1982 the subjoined Special Resolution was duly passed:

That the Society having successfully completed its objectives be wound up voluntarily, and that Raymond Kevin O'Neill of 7 Hugh Court, Traralgon, be appointed liquidator for the purposes of the winding up.

J. MCENTEE, Chairman of Meeting
7898 R. K. O'NEILL, Secretary

In the matter of the Co-operative Housing Societies Act 1958 and the Companies Act 1961; and in the matter of STRZELECKI (No. 1) CO-OPERATIVE HOUSING SOCIETY LIMITED (in Liquidation)—Notice to Creditors

Notice is hereby given that all persons having any claim against the above Society are required on or before 21 February 1982 to send their names and addresses and particulars of their debts or claims to Raymond K. O'Neill the Liquidator of the Society, at his office and if so required by notice in writing from the said liquidator are personally, or by their Solicitors, to come in and prove their said debts or claims at such time and place as shall be specified in such notice; or, in default thereof, they shall be excluded from the benefit of any distribution made before such debts or claims are so lodged or proved.

Dated at Traralgon, 14 January 1982

7899 R. K. O'NEILL, Liquidator

Companies Act 1961

JASPER COOTE (SALES) PTY. LTD. (IN LIQUIDATION)
TRASIMENE CONSULTANTS PTY. LTD. (IN LIQUIDATION)
PRECISION PAINT INDUSTRIES PTY. LTD. (IN LIQUIDATION)

NOTICE CONVENING FINAL MEETING OF CREDITORS OF THE COMPANY, PURSUANT TO SECTION 272 (1)

Notice is hereby given that the final meeting of members and creditors of the abovementioned companies will be held at the offices of E. P. Taylor, Chartered Accountant, 583 Hampton Street, Hampton on Friday, 26 February 1982 at 9.00 a.m., 9.30 a.m. and 10.30 a.m., respectively, for the purpose of laying before the meeting an account showing how the winding up has been conducted and the property disposed of and of giving any explanations thereof.

Dated 14 January 1982

7900 E. P. TAYLOR, Liquidator

In the Supreme Court of Victoria—1981 No. C.O.12303—
In the matter of the *Companies Act 1961*; and in the
matter of FALCON MEATS PTY. LTD.

Notice is hereby given that a petition for the winding up of the abovenamed Company by the Supreme Court was on 16 December 1981 presented by Grace Express International (Fiji) Limited. And that the said petition is directed to be heard before the Court sitting at Melbourne at the hour of 10.30 in the forenoon on 11 February 1982; and any creditor or contributory of the said Company desiring to support or oppose the making of an order on the said petition may appear at the time of hearing by himself or his Counsel for that purpose; and a copy of the petition will be furnished to any creditor or contributory of the said Company requiring the same to be undersigned on payment of the regulated charge for the same.

The Petitioner's address is Government Building, Suva, Fiji.

The Petitioner's Solicitors are Messrs Purves & Purves of 121 William Street, Melbourne.

PURVES & PURVES

NOTE—Any person who intends to appear on the hearing of the said petition must serve on or send by post to the abovenamed Solicitors notice in writing of his intention so to do. The notice must state the name and address of that person or, if a firm, the name and address of the firm and must be signed by the person or firm or his or their Solicitor (if any) and must be served, or if posted, must be sent by post in sufficient time to reach the abovenamed Solicitors not later than 4.00 o'clock in the afternoon on 10 February 1982. 7921

In the Supreme Court of Victoria—Co. No. C.148055M—
In the matter of the *Companies Act 1961*; and in the
matter of EXPORT INVESTMENTS PTY. LTD.

Notice is hereby given that a Petition for the winding up of the abovenamed Company by the Supreme Court was on 21 December 1981 and presented by Capricorn Meat Packing Pty. Ltd., and that the said Petition is directed to be heard before the Court sitting at the Supreme Court, Law Courts, William Street, Melbourne in the State of Victoria on 25 February 1982 at 10.30 in the forenoon; and any Creditor or Contributory of the said Company desiring to support or oppose the making of an Order on the said Petition may appear at the time of the Hearing by himself or his Counsel for that purpose.

And a copy of the Petition will be furnished to any Creditor or Contributory of the said Company requiring the same by the undersigned on payment of the regulated charge for same.

The Petitioner's address is 5 May Street, Balwyn.

The Petitioner's Solicitor's are Messrs Gillotts of 500 Collins Street, Melbourne, Victoria, 3000.

MESSRS GILLOTT'S, solicitors for the petitioner

NOTE—Any person who intends to appear at the hearing of the said petition must serve on or send by post to the abovenamed Solicitors, a notice in writing of his intention to do so. The notice must state the name and address of the person or, if a firm, the name and address of the firm and must be signed by the person or firm, or their Solicitor (if any) and must be served, or if posted, must be sent by post in sufficient time to reach the abovenamed not later than 4 o'clock in the afternoon of 24 February 1982. 7922

In the Supreme Court of Victoria—1981 No. Co. 12323—
In the matter of the *Companies Act 1961*; and in the
matter of MURFAM PTY. LIMITED; and in the matter of a
Petition dated 31 December 1981

Notice is hereby given that a Petition for the winding up of the abovenamed company by the Supreme Court was on 12 January 1982 presented by C. Phillips Jones & Company Limited and that the said Petition is directed to be heard before the Court sitting at the Law Courts, Lonsdale Street, Melbourne at the hour of 10.30 o'clock in the forenoon on 18 February 1982 and any creditor or contributory of the said company desiring to support or oppose the making of an Order on the said Petition may appear at the time of the hearing by himself or his Counsel for that purpose; and a copy of the Petition will be furnished to

any creditor or contributory of the said company requiring the same by the undersigned on payment of the regulated charge for the same.

The Petitioner's address is 10 Bonhay Road, Exeter, United Kingdom.

The Petitioner's solicitors are Messrs Ellison Hewison & Whitehead of 379 Collins Street, Melbourne.

NOTE—Any person who intends to appear on the hearing of the said Petition must serve or send by post to the abovenamed solicitors, notice in writing of his intention so to do. The Notice must state the name and address of the person, or, if a firm, the name and address of the firm and must be signed by the person or firm or his or their solicitor (if any) and must be served, or if posted must be sent by post, in sufficient time to reach the abovenamed not later than four o'clock in the afternoon of 17 February 1982 the day before the day appointed for hearing of the Petition.

ELLISON HEWISON & WHITEHEAD, solicitors for the petitioner 7923

Companies Act 1961

LANSSELLSTOW PROPRIETARY LIMITED (IN
VOLUNTARY LIQUIDATION)

NOTICE OF RESOLUTION

At an Extraordinary General Meeting of the members of Lansellstow Proprietary Limited duly convened and held at 8th Floor, 500 Collins Street, Melbourne on 15 January 1982 the Special Resolution set out below was duly passed:

That the Company be wound up in accordance with the provisions of the *Companies Act 1961* relating to a members voluntary winding up.

Notice is also given that after 21 days from this date I shall proceed to distribute the assets. All creditors having any claims against the Company should furnish particulars of same by that date, otherwise I shall proceed to distribute the assets without regard to their claims.

Dated 15 January 1982

ANDREW R. G. ORR, Liquidator

A. R. G. Orr & Co., solicitors, 22 Avenue Athol, Canterbury, 3126 7925

The *Companies Act 1961*—In the matter of MELBOURNE
TIMBER & FENCING SUPPLY PROPRIETARY LIMITED

Notice is hereby given that at a meeting of the members of Melbourne Timber & Fencing Supply Proprietary Limited on 14 January 1982 the following Special Resolution was passed:

"That the company be wound up voluntarily and that Joseph Augustine Dobrigh of Lot 1 Maroondah Highway, Lilydale be appointed Liquidator for the purpose of such winding up.

Dated 14 January 1982

7914

J. A. DOBRIGH, Liquidator

Companies Act 1962, Section 272 (2)

COLDSTREAM REFRIGERATORS (MELBOURNE) PTY.
LTD. (IN LIQUIDATION)

Notice is hereby given that a Meeting of the Shareholders of Coldstream Refrigerators (Melbourne) Pty. Ltd. (in Liquidation) will be held at the office of Messrs Peat, Marwick, Mitchell & Co., 124 Waymouth Street, Adelaide in the State of South Australia on 24 February 1982 at 9.00 a.m. for the purpose of the Liquidator laying an account before the Meeting, showing how the winding up has been conducted and the assets of the Company disposed of.

Dated 14 January 1982

7915

D. G. SEATON, Liquidator

The *Companies Act 1961*—In the matter of COUNTRY PRESS
PTY. LTD. (in Liquidation)—Members Winding Up

Notice is hereby given that at the Extraordinary General Meeting of Country Press Pty. Ltd. duly convened and held at 33 Rathdowne Street, Carlton in the State of Victoria on 31 December 1981, the following Resolution was proposed and passed as a Special Resolution.

"That the company be wound up voluntarily."

Dated 8 January 1982

R. F. HUGHES, Liquidator

R. F. HUGHES, chartered accountant, 17th Floor, 461
Bourke Street, Melbourne, Vic. 3000 7926

The Companies Act 1961

JAYSTAR PTY. LTD. (IN LIQUIDATION)

NOTICE CONVENING FINAL MEETING OF MEMBERS AND
CREDITORS, PURSUANT TO SECTION 272

Notice is hereby given in pursuance of Section 272 of the Companies Act 1961, that a Meeting of Members of the abovenamed Company will be held at 6th Floor, 461 Bourke Street, Melbourne on 11 February 1982 at 9.00 a.m. for the purpose of having an account laid before them showing the manner in which the winding up has been conducted and the property of the company disposed of and of hearing any explanations that may be given by the Liquidator.

Dated 11 February 1982

7927

A. FLANDERS, Liquidator

The Companies Act 1961, Section 291 and Regulation 54—
In the matter of J.X.B. NOMINEES PTY. LTD. (in
Liquidation)

Take notice that as Liquidator of the abovenamed Company, I have fixed Thursday 4 February 1982 as the day on or before which creditors of the Company are to prove their debts or claims and to establish any title they may have to priority under Section 292 or be excluded from the benefit of a first and final distribution made before such debts are proved or as the case may be from objecting to such distribution.

Dated 20 January 1982

R. E. RAMSAY, Joint Liquidator

Wallace, McMullin & Smail, chartered accountants, 499
St. Kilda Road, Melbourne, Vic., 3004 7929

MARY ANTHONY, late of 381B Belmore Road, Balwyn,
widow, DECEASED

Creditors, next of kin and others having claims in respect of the estate of the deceased (who died on 19 October 1981) are required to send particulars of their claims to Mary Geraldine Stute and John Desmond Anthony, care of Walsh Johnston & Co. Solicitors of 452 High Street, Northcote before 24 March 1982 after which date they will distribute the assets having regard only to the claims of which they then have notice.

WALSH JOHNSTON & CO., solicitors, 452 High Street,
Northcote 7956

ETHEL MARGARET THOMSON, late of 5 Edgar Street,
North Brighton, widow, DECEASED

Creditors, next of kin and others having claims against the estate of the said deceased who died on 1 January 1981 are to send particulars of their claims to Graham John Thomson and Joan Elizabeth McConachie care of 536 Whitehorse Road, Mitcham by 26 March 1982 after which date they will distribute the assets having regard only to the claims of which they then have notice.

MULCAHY MENDELSON & ROUND, solicitors, 536
Whitehorse Road, Mitcham 7957

KATE JANE BEALE, late of the Swan Hill District
Hospital, Swan Hill, in the State of Victoria, widow,
DECEASED

Creditors, next of kin and other persons having claims against the Estate of the said deceased who died on 31 December 1981 are required to send particulars of same to the Executrix Loris Mary Smith in care of the undersigned on or before 22 March 1982 after which date she will distribute the assets having regard only to the claims of which she then has notice.

DWYER & BENNETT, barristers and solicitors, 194-208
Beveridge Street, Swan Hill 7958

THOMAS WILLIAM FRANKCOM, late of 42 The
Boulevard, North Balwyn, retired printer, DECEASED

Creditors, next of kin and others having claims in respect of the Estate of the deceased (who died on 4 November 1981) are required by The Perpetual Executors and Trustees Association of Australia Limited of 50 Queen Street Melbourne to send particulars of their claims to the said Company by 1 April 1982 after which date it will convey or distribute the assets having regard only to the claims of which the Company then has notice. 7959

Creditors, next of kin and others having claims in respect of the estate of Margaret Elisabeth Rosemary Mitchell late of Flat 29, 26 West Toorak Road, South Yarra in the State of Victoria, Spinster Deceased who died on 2 October 1981 are required to send particulars of their claims to the Administrator, The Union-Fidelity Trustee Company of Australia Limited of 100 Exhibition Street, Melbourne by 20 March 1982 after which date the said company will distribute the assets of the estate having regard only to the claims of which it then has notice.

HALL & WILCOX, solicitors, 140 William Street, Mel-
bourne 7966

FREDERICK WATERTON CROPLEY, late of 7 Dean
Avenue, Hawthorn, in the State of Victoria, retired
electrical engineer, DECEASED

Creditors, next of kin and others having claims in respect of the Estate of the abovenamed Deceased who died on 22 October 1981 are required to send particulars thereof to the Executrix care of the undermentioned Solicitors on or before 5 April 1982 after which date the said Executrix may convey or distribute the assets having regard only to the claims of which she then has notice.

REES, BECKWITH & CO., 118 Queen Street, Mel-
bourne 7967

Creditors, next of kin and others having claims in respect of the estate of Percival James Dunn formerly of Mellool in the State of New South Wales, farmer but late of Broadwater Court, Cowes in the State of Victoria, retired farmer, deceased (who died on 8 December 1980) are required by the Executors Pearl Dorothy Dunn, Rodney James Dunn, and Graeme Neil Dunn to send particulars to them care of the undersigned by 21 March 1982 after which date the Executors may convey or distribute the assets having regard only to the claims of which they then have notice.

C. P. POLA & ASSOC., solicitors, 148 Campbell Street,
Swan Hill 7878

Creditors, next of kin and others having claims against the Estate of Angelina May Belgrove late of Longford in the State of Victoria, Widow, deceased who died on 11 September 1981 are required by the Executor Thomas Boyle Belgrove of Longford in the said State, farmer to send particulars of their claims to the said Executor care of Moir, White & O'Connor, Solicitors, of 113 Cunninghame Street, Sale, by 11 April 1982 after which date he will distribute the assets of the said Estate having regard only to the claims of which he then has notice.

MOIR, WHITE & O'CONNOR, solicitors, of 113 Cun-
ninghame Street, Sale 7879

Creditors, next of kin and others having claims against the estate of Benjamin Thomas Plant late of 102 Ascot Street South, Ballarat T.P.I. Pensioner deceased who died on 11 September 1981 are to send particulars of their claims to the Executor The Union-Fidelity Trustee Company of Australia Limited at its address 101 Lydiard Street North Ballarat by 14 March 1982 after which date the said Company will distribute the assets having regard only to the claims of which it then has notice.

BAIRD & MCGREGOR, solicitors, Ballarat 7880

IRMA AGNES WALTER, late of Centennial House, 105 Punt Road, Windsor, in Victoria, widow, DECEASED

Creditors, next of kin and others having claims in respect of the estate of the abovenamed deceased (who died on 8 October 1981) are required to send particulars of their claims to the Executors Edna Doris Bell of Fernihurst Estate Mysia Retired and James Newth Reid of 31 Mepunga Avenue Wangaratta Retired care of the undermentioned solicitors by 22 March 1982 after which date they may convey or distribute the assets having regard only to the claims of which they then have notice.

AITKEN WALKER & STRACHAN, solicitors, 114 William Street, Melbourne 3000 7887

GORDON HOWARD ELLIS, late of Long Gully Road, Violet Town, grazier, DECEASED

Creditors, next of kin and others having claims in respect of the estate of the deceased who died on 4 July 1981 are required by The Perpetual Executors and Trustees Association of Australia Limited of 50 Queen Street, Melbourne and Geoffrey Gordon Ellis of 53 Salisbury Street, Benalla, Farmer the applicants for a grant of administration to send particulars of their claims to the said applicants in the care of the said Company by 27 March 1982 after which date they will convey or distribute the assets having regard only to the claims of which they then have notice.

WOODHOUSE & WOODHOUSE, solicitors, 264A Doncaster Road, North Balwyn. 7888

Creditors, next of kin and others having claims in respect of the Estate of Olive Winifred Hicks late of 15 Smith Street, Carrum in the State of Victoria, Widow deceased who died on 5 August 1981, are to send particulars of their claims to Olive Lisle Katz of 13 Smith Street, Carrum in the said State the Executrix appointed by the said Will by 27 March 1982 after which date the Executrix will distribute the assets having regard only to the claims of which she then has notice.

RICHES & CO., solicitors, 406 Collins Street, Melbourne 7901

GWENDOLINE MURIEL KAIN, late of Carrum Private Nursing Home, Station Street, Carrum, but formerly of Flat 6, 397 Nepean Highway, Mordialloc, widow, DECEASED

Creditors, next of kin and others having claims in respect of the estate of the deceased who died on 2 December 1981 are required by the Trustee Louis Walton of 1 Creswick Grove, Bentleigh, Engineer to send particulars to him by 30 March 1982 after which date he may convey or distribute the assets having regard only to the claims of which he then has notice.

Dated 20 January 1982 7902

Creditors, next of kin and other persons having claims against the estate of Margaretta Morgan Clarke late of 7 Shirley Grove East St. Kilda in the State of Victoria Gentlewoman deceased who died on 22 October 1981 are required to send particulars of their claims to the Executor National Trustees Executors and Agency Company of Australasia Limited whose registered office is at 95 Queen Street Melbourne by 22 March 1982 after which date the Executor will distribute the assets having regard only to the claims of which it then has had notice.

JAMES P. OGGE & CO. AND E. K. O'DONNELL, Solicitors, 4-6 Howitt Street, South Yarra 7903

ROSINA (known as Rose) MINTO, late of 12 O'Grady Street, North Carlton, widow, DECEASED

Creditors, next of kin and all others having claims in respect of the deceased who died on 1 December 1981 are required by the executor Graeme Minto 9 Home-wood Court, Rosanna to send particulars of such claims to the said executor within two clear months of the date of this advertisement after which date the executor will distribute the assets having regard only to the claims of which he has notice. 7904

JOHN PATERSON ASCHE, late of 15 Howitt Road, Caulfield, retired medical practitioner, DECEASED

Creditors, next of kin and others having claims in respect of the Estate of the deceased who died on 28 August 1981 are required by the personal representative Eric Victor Zichy Asche of 56 Sandells Road, Tecoma gentleman to send particulars to him by 20 March 1982 after which date he may convey or distribute the assets, having regard only to the claims of which he then has notice.

WEIGALL & CROWTHER, of 459 Little Collins Street, Melbourne, solicitors for the estate 7930

HELENA ADELE COCKRAM, late of 5 Conway Avenue, Donvale, widow, DECEASED

Creditors, next of kin and others having claims in respect of the Estate of the deceased who died on 14 August 1981 are required by the Personal Representative Douglas Warren Rowe of 44 Bernard Street, Cheltenham Accountant to send particulars to him by 20 March 1982 after which date he may convey or distribute the assets, having regard only to the claims of which he then has notice.

WEIGALL & CROWTHER, of 459 Little Collins Street, Melbourne, solicitors for the estate 7931

JAN HENDRIK WOLT (also known as John Wolt), late of 25 Yarra Road, Wonga Park, retired builder, DECEASED

Creditors, next of kin and others having claims in respect of the Estate of the deceased who died on 5 July 1981 are required by the Personal Representative John David Claringbould of Sycamore Grove, Mount Evelyn Solicitor to send particulars to him by 20 March 1982 after which date he may convey or distribute the assets, having regard only to the claims of which he then has notice.

WEIGALL & CROWTHER, of 459 Little Collins Street, Melbourne, solicitors for the estate 7932

HAIDEE BERYL MACKEY, late of Willsmere Hospital, Kew, artist, DECEASED

Creditors, next of kin and others having claims in respect of the Estate of the deceased who died on 24 July 1981 are required by the Personal Representative Patricia Doreen Mackey of 38 Belmont Avenue, Kew Home Duties to send particulars to her by 20 March 1982 after which date she may convey or distribute the assets, having regard only to the claims of which she then has notice.

WEIGALL & CROWTHER, of 459 Little Collins Street, Melbourne, solicitors for the estate 7933

MURIEL ARDILL BRIEN, late of 34 Currajong Avenue, Camberwell, spinster, DECEASED

Creditors, next of kin and others having claims in respect of the Estate of the deceased who died on 7 July 1981 are required by the Personal Representative Gladys Elsie Brien of 34 Currajong Avenue, Camberwell Retired Teacher to send particulars to her by 20 March 1982 after which date she may convey or distribute the assets, having regard only to the claims of which she then has notice.

WEIGALL & CROWTHER, of 459 Little Collins Street, Melbourne, solicitors for the estate 7934

RONALD PHILIP GRIFFITHS, late of 14 Kingston Avenue, Ascot Vale, optometrist, DECEASED

Creditors, next of kin and others having claims in respect of the estate of the deceased (who died on 2 October 1981) are required by The Perpetual Executors and Trustees Association of Australia Limited of 50 Queen Street, Melbourne, to send particulars of their claims to the said Company by 24 March 1982 after which date it will convey or distribute the assets, having regard only to the claims of which the Company then has notice. 7935

Creditors, next of kin and others having claims in respect of the estate of Isabel Alfreda Bain late of Centennial House Royal Freemasons Homes 313 Punt Road Prahran Widow deceased who died on 28 April 1981 are to send particulars of their claims to The Equity Trustees Executors and Agency Company Limited of 472 Bourke Street Melbourne by 22 March 1982 after which date it will distribute the assets having regard only to the claims of which it then has notice.

MARTIN & MARTIN, solicitors, 37 Queen Street, Melbourne 7936

JAMES HENRY CRAIG, late of Unit 3, 168 Cotham Road, Kew, retired, DECEASED

Creditors, next of kin and others having claims in respect of the estate of the Deceased, who died on 24 August 1981 are required by the Administratrix Lillias Brown Hamilton Morter of Unit 3, 168 Cotham Road, Kew, Widow, to send particulars to her by 23 March 1982 after which date the Administratrix may convey or distribute the assets, having regard only to the claims of which she then has notice.

Dated 20 January 1982

LOUIS S. LAZARUS, solicitors, 389 Lonsdale Street, Melbourne 7937

GLADYS VICTORIA ROBERTSON, late of 1050 Sydney Road, Coburg, widow, DECEASED

Creditors, next of kin and others having claims in respect of the Estate of the deceased who died on 14 October 1981 are requested to send particulars of their claims to the Executrix Rae Elizabeth Parfett care of the undersigned Solicitor by 21 March 1982 after which date the said Executrix will proceed to distribute the Estate having regard only to the claims of which she then has notice.

MARJORY C. COATES, 422 Collins Street, Melbourne, 3000 7938

ALEXIA IRENE MATCHAN, late of 110 Oakover Road, Preston, widow, DECEASED

Creditors, next of kin and others having claims in respect of the estate of the deceased (who died on 30 October 1981) are required to send particulars of their claims to Mavis Olive Parris care of Walsh Johnston & Co. Solicitors of 452 High Street, Northcote before 24 March 1982 after which date she will distribute the assets having regard only to the claims of which she then has notice.

WALSH JOHNSTON & CO., solicitors, 452 High Street, Northcote 7954

AGNES BARRETT (also known as Agnes Ann Barrett), late of Unit 4, 37 Park Street, Hawthorn, widow, DECEASED

Creditors, next of kin and others having claims in respect of the estate of the deceased (who died on 3 November 1981) are required to send particulars of their claims to Carl John Barrett care of Walsh Johnston & Co. Solicitors of 452 High Street, Northcote before 24 March 1982 after which date he will distribute the assets having regard only to the claims of which he then has notice.

WALSH JOHNSTON & CO., solicitors, 452 High Street, Northcote 7955

In the Supreme Court of the State of Victoria
SALE BY THE SHERIFF

On Thursday, 25 February 1982 at 2.30 p.m. at the Sheriff's Office, Writs and Warrants Division, Top Floor, 241 William Street, Melbourne (unless process be stayed or satisfied).

All the Estate and Interest (if any) of Arthur Ntentis (shown on Certificate of Title as Athas Ntentis), carpenter, of 17 Bendigo Avenue, Elwood, as joint proprietor with Eleftheria Ntentis of an estate in fee simple in the land described in Certificate of Title Volume 5892 Folio 345 upon which is erected a dwelling known as No. 17 Bendigo Avenue, Elwood.

Registered Mortgage No. H.534663 affects the said estate and interest.

Terms—Cash only

7939

T. M. NICHOLLS, Sheriff's Officer

In the Supreme Court of the State of Victoria

SALE BY THE SHERIFF

On Thursday, 25 February 1982 at 2.30 p.m. at the Sheriff's Office, Writs and Warrants Division, Top Floor, 241 William Street, Melbourne (unless process be stayed or satisfied).

All the Estate and Interest (if any) of Mary-Anne McGough (shown on Certificate of Title as Joy Mary-Anne McGough), housewife, and John Francis McGough, marketing manager, both of 22 De Chene Parade, Coburg, as joint proprietors of an estate in fee simple in the land described in Certificate of Title Volume 8384 Folio 883, vacant land known as Lot 13 Juliet Crescent, Healesville. The said land lies on the south side of Juliet Crescent 763 ft. 10 in. east of Graceburn Avenue.

Registered Mortgage No. H.411432 affects the said estate and interest.

Terms—Cash only

7940

T. M. NICHOLLS, Sheriff's Officer

In the Supreme Court of the State of Victoria

SALE BY THE SHERIFF

On Thursday, 4 March 1982 at 2.30 p.m. at the Sheriff's Office, Writs and Warrants Division, Top Floor, 241 William Street, Melbourne (unless process be stayed or satisfied).

All the Estate and Interest (if any) of Graham Howard, retired, and Elva Ann Howard, married woman, both of Unit 6, 35 Nolan Street, Frankston, as proprietors of an estate in fee simple in the land described in Certificate of Title Volume 9202 Folio 249 upon which is erected a unit known as Unit No. 6, 35 Nolan Street, Frankston.

Terms—Cash only

7941

R. J. MARTIN, Sheriff's Officer

In the Supreme Court of the State of Victoria

SALE BY THE SHERIFF

On Thursday, 25 February 1982 at 2.30 p.m. at the Sheriff's Office, Writs and Warrants Division, Top Floor, 214 William Street, Melbourne (unless process be stayed or satisfied).

All the Estate and Interest (if any) of P. Hartigan (shown on Certificate of Title as Peter Denis Hartigan), cartage contractor, and L. Hartigan (shown on Certificate of Title as Lynette Kaye Hartigan), married woman, both of 5 Darinda Avenue, Wandin North, as joint proprietors of an estate in fee simple in the land described in Certificate of Title Volume 6886 Folio 059 upon which is erected a weatherboard house known as No. 5 Darinda Avenue, Wandin North.

Registered Mortgage No. H.433062 and Caveat Nos. H.468386, J.258885 and J.678586 affect the said estate and interest.

Terms—Cash only

7942

T. M. NICHOLLS, Sheriff's Officer

In the Supreme Court of the State of Victoria

SALE BY THE SHERIFF

On Thursday, 25 February 1982 at 2.30 p.m. at the Sheriff's Office, Writs and Warrants Division, Top Floor, 241 William Street, Melbourne (unless process be stayed or satisfied).

All the Estate and Interest (if any) of Giuseppe Jacopino, engineer, and Lois Florence Jacopino, married woman, both of 25 Fountain Drive, Narre Warren, as joint proprietors of an estate in fee simple in the land described in Certificate of Title Volume 8674 Folio 597 upon which is erected a two-storey brick dwelling known as No. 25 Fountain Drive, Narre Warren.

Registered Mortgage Nos. F.503916 and H.721272 and Caveat No. H.711886 affect the said estate and interest.

Terms—Cash only

7943

T. M. NICHOLLS, Sheriff's Officer

In the Supreme Court of the State of Victoria
SALE BY THE SHERIFF

On Thursday, 25 February 1982 at 2.30 p.m. at the Sheriff's Office, Writs and Warrants Division, Top Floor, 241 William Street, Melbourne (unless process be stayed or satisfied).

All the Estate and Interest (if any) of Edward Harris (shown on Certificate of Title as Edward Ivan Harris), sign writer, of 2 Payne Street, Surrey Hills, as joint proprietor with Margaret Ruth Harris, married woman, of an estate in fee simple in the land described in Certificate of Title Volume 4639 Folio 731 upon which is erected a brick dwelling known as No. 2 Payne Street, Surrey Hills.

Registered Mortgage Nos. H.201066 and J.12075 affect the said estate and interest.

Terms—Cash only
7944 T. M. NICHOLLS, Sheriff's Officer

In the Supreme Court of the State of Victoria
SALE BY THE SHERIFF

On Thursday, 25 February 1982 at 2.30 p.m. at the Sheriff's Office, Writs and Warrants Division, Top Floor, 241 William Street, Melbourne (unless process be stayed or satisfied).

All the Estate and Interest (if any) of John Gary Miller, plumber, of 48 Grand Valley Drive, Chirnside Park, as proprietor of an estate in fee simple in the land described in Certificate of Title Volume 8436 Folio 081 upon which is erected a brick veneer home known as No. 48 Grand Valley Drive, Chirnside Park.

Registered Mortgage No. J.663196 and Caveat No. J.708174 affect the said estate and interest.

Terms—Cash only
7945 R. J. MARTIN, Sheriff's Officer

In the Supreme Court of the State of Victoria
SALE BY THE SHERIFF

On Friday, 26 February 1982 at 12.00 noon at the Police Station, Mildura (unless process be stayed or satisfied).

All the Estate and Interest (if any) of Mr Rex Elliot (shown on Certificate of Title as Hugh Rex Elliott), manager, of 19 Parke Street, Robinvale, as joint proprietor with Margaret Lynette Elliott, married woman, of an estate in fee simple in the land described in Certificate of Title Volume 8194 Folio 294 upon which is erected a brick veneer dwelling known as No. 19 Parke Street, Robinvale.

Registered Mortgage Nos. G.5384 and J.22237 and Caveat No. J.609005 affect the said estate and interest.

Terms—Cash only
7946 J. GREEN, Sheriff's Officer

In the Supreme Court of the State of Victoria
SALE BY THE SHERIFF

On Thursday, 25 February 1982 at 2.30 p.m. at the Sheriff's Office, Writs and Warrants Division, Top Floor, 241 William Street, Melbourne (unless process be stayed or satisfied).

All the Estate and Interest (if any) of Mr G. Stewart (shown on Certificate of Title as Gordon Burdett Stewart), horse trainer, of Unit 21, 17 Queens Road, Melbourne, as joint proprietor with Hilda Stewart, married woman, of an estate in fee simple in the land described in Certificate of Title Volume 9397 Folio 199 upon which is erected a unit known as Unit 21, 17 Queens Road, Melbourne.

Registered Mortgage No. J.357730 affects the said estate and interest.

Terms—Cash only
7947 R. J. MARTIN, Sheriff's Officer

INSOLVENCY NOTICE

The Bankruptcy Act 1966 (as Amended), Part X
NOTICE OF ACCEPTANCE OF COMPOSITION

BRUCE ROBERT HARTLAND
No. 293 OF 1981, PART X

Notice is hereby given that the composition of the above-named debtor has been accepted by a special resolution of the creditors passed on 18 January 1982.

The Trustee named in the composition, Clive Henry Morris of 177 Eley Road, Blackburn South, Vic. 3130.
Dated 18 January 1982

CLIVE HENRY MORRIS, Trustee

Clive Morris & Staff, public accountants, 177 Eley Road, Blackburn South, Vic. 3130. Telephone: 232 3027 7968

NOTICE OF MAKING OF STATUTORY RULES WHICH ARE NOT YET AVAILABLE

Notice is given of the making of the following Statutory Rules:

No. Supreme Court Act 1958
535/1981. Solicitors' Remuneration Order 1981

Evidence Act 1958
1/1982. Evidence (Crown Witnesses Allowances)
Regulations 1982

Post-Secondary Education Act 1978
2/1982. Post-Secondary Education Commission
(Terms and Conditions) (Amendment No. 11) Regulations 1982

Evidence Act 1958
3/1982. Evidence (Interpreters Allowances)
(Amendment) Regulations 1982

NOTICE OF MAKING AND AVAILABILITY OF STATUTORY RULES

In pursuance of the provisions of the Subordinate Legislation Act 1962 and the Regulations made thereunder notice is given of the making and availability of the following Statutory Rules:

No.	Public Service Act 1974	Price
500/1981.	Public Service Amendment Regulations (No. 19) 1981	20c
502/1981.	County Court Act 1958 County Court (Costs) Rules 1981	60c
513/1981.	State Bank Act 1958 State Bank (Provident Fund Amendment No. 2) General Orders 1981	20c
522/1981.	Road Traffic Act 1958 Road Traffic (Bicycle Facilities) Regulations 1981	50c

No.	Price	A delivery and handling fee must be added to your remittance when ordering by mail as follows:
<i>Melbourne and Metropolitan Board of Works Act 1958</i>		
527/1981. By-law No. 183—Water Supply (Replacement or Repair of Service Pipe, Fitting or Apparatus)	20c	
<i>Valuation of Land Act 1960</i>		
529/1981. Valuation of Land (Fees for Valuations) Regulations 1981	20c	
<i>Wildlife Act 1975</i>		
532/1981. Wildlife (Duck Seasons). Regulations 1981	20c	
<i>Firearms Act 1958</i>		
534/1981. Firearms (Exemption No. 2) Regulations 1981	20c	
<i>Port of Melbourne Authority Act 1958 (No. 6312)</i>		
536/1981. Port of Melbourne Authority (Tonnage and Wharfage) Regulations 1981, Amendment No. 5/81	40c	

No.	Price
9366. Constitutional Powers (Coastal Waters)	\$0.20
9367. Parliamentary Committees (Public Bodies Review)	\$0.40
9368. Agricultural Chemicals	\$0.50
9369. Central Gippsland (Brown Coal Land Compensation)	\$0.20
9370. Motor Car (Payments by Pensioners)	\$0.20
9371. Navigable Waters (Oil Pollution) (Amendment)	\$0.20
9372. Workers Compensation (General Amendment)	\$0.20
9373. Extractive Industries (Amendment)	\$0.30
9374. Health (Special Accommodation Houses)	\$0.20
9375. Cancer (Amendment)	\$0.20
9376. Victorian Film Corporation (Amendment)	\$0.30
9377. Railways (Bridges)	\$0.10
9378. Wangarrip (Land Exchange)	\$0.20
9379. Supply (1980-81, No. 1)	\$0.30
9380. Crown Land (Mineral Springs)	\$0.20
9381. Groundwater (Mineral Water)	\$0.20
9382. Melbourne Underground Rail Loop (Land Development)	\$0.30
9383. Chiropractors (Amendment)	\$0.10
9384. Youth, Sport and Recreation (Guarantees)	\$0.20
9385. Pensioners' Rates Remission	\$0.30
9386. Motor Car Traders (Amendment)	\$0.40
9387. Victorian Solar Energy Council	\$0.30
9388. Racing (Amendment)	\$0.20
9389. Country Fire Authority (Amendment)	\$0.20
9390. Local Government (Validation)	\$0.10
9391. Professional Boxing Control (Amendment)	\$0.10
9392. Police Regulation (Retired Police Reserve)	\$0.10
9393. Local Authorities Superannuation (Amendment)	\$0.30
9394. Water (Valuation Equalization)	\$0.20
9395. Upper Yarra Valley and Dandenong Ranges Authority (Amendment)	\$0.20
9396. Dog (Amendment)	\$0.20
9397. Hospitals Superannuation (Amendment)	\$0.20
9398. Hospitals and Charities (Appointment of Administrators)	\$0.10
9399. Home Finance (Borrowing Powers)	\$0.20
9400. State Employees Retirement Benefits (Amendment)	\$0.30
9401. Wodonga Area Land Acquisition (Validation)	\$0.30
9402. Local Government (General Amendment)	\$0.40
9403. Motor Registration	\$0.50
9404. Epworth Hospital	\$0.50
9405. Archaeological and Aboriginal Relics Preservation (Amendment)	\$0.20
9406. Geelong Performing Arts Centre Trust	\$0.40
9407. Imperial Law Re-enactment	\$0.30
9408. Constitutional Powers (Request)	\$0.20
9409. Friendly Societies (Benefits)	\$0.10
9410. Magistrates' Courts (Jurisdiction)	\$0.10
9411. Baker Medical Research Institute	\$0.50
9412. Protection of Animals (Amendment)	\$0.30
9413. Stamps (Amendment)	\$0.40
9414. Liquefied Petroleum Gas Subsidy	\$0.30
9415. Revocation and Excision of Crown Reservations	\$0.30
9416. Forests (Amendment)	\$0.20
9417. Forests (Further Amendment)	\$0.20
9418. Transport (Road Funds)	\$0.20
9419. Building Societies (Amendment)	\$0.20
9420. Legal Profession Practice (Leo Cussen Institute)	\$0.10
9421. Instruments (Powers of Attorney)	\$0.30
9422. Melbourne (Yarra Park) Land	\$0.20
9423. Sale of Land (Deposits)	\$0.20
9424. Post-Secondary Education (Amendment)	\$0.60

Copies of these Statutory Rules are available and may be purchased at the Victorian Government Bookshop, located at 7A Parliament Place, Melbourne, 3002. If ordered by mail, remittance should be addressed to "The Government Printer, Box 203, North Melbourne, 3051", and should include 50c delivery and handling fee.

The annual subscription rates for Statutory Rules for the year commencing 1 January 1982 payable in advance, are as follows:

*Statutory Rules (other than Public Service Determinations), Pamphlet copies only \$55.00
Public Service Determinations \$33.00

*The Bound Volume of Statutory Rules is not included in the subscription rate.

F. D. ATKINSON
Government Printer

STATE ACTS, 1980

Copies of the following Acts of the Parliament of Victoria may be obtained at the Victorian Government Bookshop, 7A Parliamentary Place, Melbourne, phone 651 2754 or 651 2759, or from any accredited agent, at the price set opposite to each.

STATE ACTS, 1980—continued

No.		Price No.
9425.	Town and Country Planning (Amalgamation)	\$0.90
9426.	Imperial Acts Application	\$1.00
9427.	Statute Law Revision	\$0.80
9428.	Estate Agents	\$1.60
9429.	Cattle Compensation (Amendment)	\$0.10
9430.	The Bank of Adelaide (Merger)	\$0.30
9431.	Cemeteries (Amendment)	\$0.20
9432.	Parliamentary Salaries and Superannuation	\$0.10
9433.	Police Regulation (Charges and Appeals)	\$0.20
9434.	Alcoa (Portland Aluminium Smelter)	\$0.40
9435.	Educational Institutions (Guarantees) (Amendment)	\$0.20
9436.	Business Franchise (Tobacco) (Amendment)	\$0.40
9437.	Country Roads (Road Marking)	\$0.20
9438.	Victorian Film Corporation (Commencement)	\$0.20
9439.	Gift Duty (Amendment)	\$0.20
9440.	Pay-roll Tax	\$0.40
9441.	Probate Duty	\$0.20
9442.	Market Court (Amendment)	\$0.40
9443.	Appropriation (1980-81, No. 1)	\$5.25
9444.	Port of Melbourne Authority (Amendment)	\$0.20
9445.	Stamps (Amendment No. 2)	\$0.20
9446.	Public Authorities (Contributions) (Amendment)	\$0.20
9447.	Criminal Injuries Compensation (Amendment)	\$0.20
9448.	Transport Works and Services	\$0.20
9449.	Youth, Sport and Recreation (Agreements)	\$0.20
9450.	Victorian Government Travel Authority (Amendment)	\$0.20
9451.	Health Commission (Amendment)	\$0.20
9452.	Old Colonists' Association (Borrowing Powers)	\$0.20
9453.	Nurses (Amendment)	\$0.20
9454.	Supreme Court (Criminal Appeals)	\$0.20
9455.	Land Tax	\$0.40
9456.	Agriculture Acts (Repeal)	\$0.20
9457.	Swine Compensation (Partial Suspension)	\$0.20
9458.	State Bank	\$0.20
9459.	Building Societies (Claims on Liquidation)	\$0.20
9460.	Superannuation	\$0.40
9461.	State Forests Works and Services	\$0.20
9462.	Attorney-General and Solicitor-General	\$0.20
9463.	Railway Construction and Property (Amendment)	\$0.20
9464.	Forests (Penalties)	\$0.20
9465.	Institute of Educational Administration	\$0.50
9466.	Public Service (Amendment)	\$0.20
9467.	Marine (Amendment)	\$0.20
9468.	Judges' Salaries and Pensions	\$0.40
9469.	Police Regulation (Amendment)	\$0.20
9470.	Labour and Industry (Amendment)	\$0.20
9471.	Sale of Land (Deposits Amendment)	\$0.40
9472.	Liquor Control (Fecs)	\$0.40
9473.	Racing (Further Amendment)	\$0.50
9474.	Charlton (Land Exchange)	\$0.40
9475.	Public Lands and Works (Amendment)	\$0.20
9476.	Parliamentary Committees	\$0.40
9477.	Motor Car (Miscellaneous Provisions)	\$0.20
9478.	State Employees Retirement Benefits (Eligibility)	\$0.40
9479.	Health (Reporting to Parliament)	\$0.40
9480.	Mildura Irrigation and Water Trusts	\$0.40
9481.	Protection of Animals	\$0.20
9482.	Forests (Australian Newsprint Mills Limited)	\$0.50
9483.	Egg Industry Stabilization (Amendment)	\$0.20
9484.	Labour and Industry (Lifting of Weights)	\$0.20
9485.	Post-Secondary Education Remuneration Tribunal	\$0.50
9486.	Subordinate Legislation (Amendment)	\$0.20
9487.	Port Phillip Authority (Amendment)	\$0.50
9488.	Country Fire Authority (Penalties)	\$0.20
9489.	Teaching Service (Amendment)	\$0.20
9490.	Water (Amendment)	\$0.40
9491.	Sewerage Districts (Rebates)	\$0.20
9492.	Patriotic Funds (Amendment)	\$0.20
9493.	Coroners (Amendment)	\$0.20
9494.	Cancer (Cancer Reporting)	\$0.20
9495.	Mildura College Lands (Easements)	\$0.20
9496.	Liquor Control (Amendment)	\$1.25

STATE ACTS, 1980—continued

No.		Price
9497.	Educational Grants (Continuation)	\$0.20
9498.	Community Welfare Services (Extradition)	\$0.20
9499.	Court Security	\$0.20
9500.	Estate Agents (Amendment)	\$0.40
9501.	Fisheries (Amendment)	\$0.40
9502.	Stamps (Amendment No. 3)	\$0.40
9503.	Road Traffic (Amendment)	\$0.20
9504.	Public Works and Services	\$0.40
9505.	Wildlife (Amendment)	\$0.50
9506.	Valuation of Land (Interest Rate)	\$0.20
9507.	Water Supply Works and Services	\$0.60
9508.	Hairdressers Registration (Amendment)	\$0.40
9509.	Crimes (Sexual Offences)	\$0.85
9510.	Adoption of Children (Information)	\$0.60
9511.	Transport (Deregulation)	\$0.85
9512.	Planning Appeals Board	\$1.45
9513.	West Gate Bridge Authority	\$0.85
9514.	Residential Tenancies	\$1.95

STATE ACTS, 1981

Copies of the following Acts of the Parliament of Victoria may be obtained at the Victorian Government Bookshop, 7A Parliament Place, Melbourne, telephone 651 2754 or 651 2759, or from any accredited agent, at the price set opposite to each.

A delivery and handling fee must be added to your remittance when ordering by mail as follows:—

Total Value of Acts Ordered	Delivery and Handling Fee
10c-\$2.00	0.60c
\$2.05-\$5.00	\$1.00
\$5.05-\$25.00	\$1.50
\$25.05-\$75.00	\$2.00
Above \$75.00	\$3.00

The annual subscription rate for State Acts for the year commencing 1 January 1982 is \$50.

No.		Price
9515.	Sewerage Districts (Amendment)	\$0.20
9516.	Dandenong Valley Authority (Amendment)	\$0.20
9517.	Latrobe Valley (Amendment)	\$0.40
9518.	Fisheries (Commonwealth-State Arrangements)	\$0.40
9519.	Summary Offences (Corporation Meetings)	\$0.20
9520.	Magistrates (Summary Proceedings)	\$0.20
9521.	Police Offences (Restricted Publications)	\$0.20
9522.	Business Names (Amendment)	\$0.50
9523.	Melbourne Underground Rail Loop (Amendment)	\$0.20
9524.	Industrial Relations	\$0.20
9525.	Local Government (City of Melbourne)	\$0.40
9526.	Flemington Land	\$0.20
9527.	Police Regulation (Appointments)	\$0.20
9528.	Land (Amendment)	\$0.20
9529.	Liquid Petroleum Gas Subsidy (Amendment)	\$0.20
9530.	Revocation and Excision of Crown Reservations	\$0.40
9531.	State Electricity Commission (Amendment)	\$0.20
9532.	Chiropractors and Osteopaths (Registration)	\$0.20
9533.	Port of Melbourne Authority (Lands)	\$0.20
9534.	Rural Finance and Settlement Commission (Amendment)	\$0.20
9535.	Supply (1981-82, No. 1)	\$0.40
9536.	Transport Regulation (Assignment of Licences)	\$0.20
9537.	Local Government (Land Liable to Flooding)	\$0.20
9538.	Geelong Lands	\$0.20
9539.	Local Government (Shires of Melton and Bulla)	\$0.20
9540.	Land Conservation (Amendment)	\$0.20
9541.	Stamps (Miscellaneous Amendment)	\$0.20
9542.	Adoption of Children (Information) (Amendment)	\$0.20
9543.	Railways (Long Service Leave)	\$0.20
9544.	Local Government (House Builders' Liability Amendment)	\$0.20

STATE ACTS, 1981—continued

No.	Price
9545. Building Societies (Amendment)	\$0.20
9546. Rural Finance (Amendment)	\$0.20
9547. Hospitals and Charities (Amendment)	\$0.20
9548. Motor Car (Mass and Dimension Limits)	\$1.05
9549. Statute Law Revision	\$0.85
9550. Government Employee Housing Authority	\$0.60
9551. Crown Land (Reserves) (Amendment)	\$0.40
9552. Urban Renewal (Amendment)	\$0.40
9553. Housing (Amendment)	\$0.40
9554. Penalties and Sentences	\$1.45
9555. Port Bellarine Tourist Resort	\$0.85
9556. Firearms (Shooters' Licences)	\$0.20
9557. Motor Boating (Amendment)	\$0.20
9558. Melbourne and Metropolitan Board of Works (Amendment)	\$0.60
9559. Melbourne Underground Rail Loop (Borrowing Powers)	\$0.20
9560. Motor Car (Pensioner Concessions)	\$0.20
9561. Labour and Industry (Amendment)	\$0.20
9562. Securities Industry (Application of Laws)	\$0.85
9563. Companies and Securities (Interpretation and Miscellaneous Provisions) (Application of Laws)	\$0.50
9564. Companies (Acquisition of Shares) (Application of Laws)	\$0.60
9565. Industrial Training (Amendment)	\$0.20
9566. Victorian College of the Arts	\$0.85
9567. Economic Development	\$0.50
9568. Health (Exemptions)	\$0.20
9569. Wills	\$0.20
9570. National Parks (Amendment)	\$0.60
9571. Environment Protection (Clean Air)	\$0.40
9572. National Companies and Securities Commission (State Provisions)	\$1.05
9573. Water Drainage	\$1.05
9574. Victorian Economic Development Corporation	\$1.05
9575. Local Government (Further Amendment)	\$0.85
9576. Crimes (Classification of Offences)	\$0.85
9577. Royal Visit Race-meeting	20c
9578. Wildlife (Licences)	20c
9579. Port Fairy Land	20c
9580. Government Buildings Advisory Council	50c
9581. The Constitution Act Amendment (Conjoint Elections)	20c
9582. Education (Amendment)	60c
9583. Labour and Industry (Further Amendment)	40c
9584. Industrial Relations (Secret Ballots)	50c
9585. Films (Amendment)	20c
9586. Country Fire Authority (Borrowing Powers)	20c
9587. French Island (Land Exchange)	20c
9588. Business Franchise (Petroleum Products) (Fees)	20c

counted as a line. The final words of a paragraph though only portion of a line, must be counted as one line. Signatures (in particular) and proper names must be written very clearly in the text: ONE SIDE ONLY of each sheet of paper should be written upon.

All documents NOT CLEARLY PREPARED will be returned unpublished. Where brands occur, not provided for by the ordinary letters of the alphabet, a written explanatory description also must be furnished.

PAYMENTS—Unless the advertiser has a Credit Account, all payments are required in advance. Remittances should be made by cheque, postal order or money order, payable to "GOVERNMENT PRINTER".

CORRESPONDENCE—All correspondence should be addressed to "The Victorian Government Printer, P.O. Box 203, North Melbourne, 3051".

CONTENTS

	Page
Acts of Parliament	215
Acts of Parliament on Sale at the Government Printing Office	260
Appointments	232
Bank Half-Holidays	216
Cemeteries—Scale of Fees	228
Contracts	225
Country Roads Board	225
Estates of Deceased Persons	223
Government Notices	216
Insolvency Notice	259
Lands	240
Minerals and Energy	217
Notice to Mariners	223
Notice of Making of Statutory Rules	259
Orders in Council—	
Acts—Country Roads Board; Land; Crown Land (Reserves); Coal Mines; Superannuation; Local Government; Companies; Mildura Irrigation and Water Trusts; Sewerage Districts; Road Traffic; Local Government.	233 et seq
Police Sale	223
Private Advertisements	244
Proclamations	215
Public Holidays	216
Resignations	233
State Rivers and Water Supply Commission	230
Tenders	242
Waterworks Trusts	230

THE "VICTORIA GOVERNMENT GAZETTE"

PUBLICATION—A VICTORIA GOVERNMENT GAZETTE is published every WEDNESDAY EVENING unless advertised otherwise.

SUBSCRIPTIONS—The annual subscription rate, including postage, is \$80, payable in advance.

PRIVATE ADVERTISEMENTS—Advertisements will be received by the Government Printer not later than the day preceding publication—at ordinary rates at or before ONE p.m. and at double rates between ONE p.m. and HALF PAST THREE p.m. The charge for ADVERTISEMENTS is \$1 per line single column and \$2 per line double column. The charge for a full page is \$150. The title forms one or more lines as a heading. On an average ten words make a line of single column. Every signature must likewise be



Victoria Government Gazette

No. 8—Wednesday, 27 January 1982

PROCLAMATIONS

MENTAL HEALTH ACT 1959, No. 6605

PROCLAMATION

By His Excellency the Lieutenant-Governor as Deputy for the Governor of the State of Victoria and its Dependencies in the Commonwealth of Australia, &c., &c., &c. Whereas by sub-section (1) of section 24 of the *Mental Health Act 1959*, it is provided that the Governor in Council may by Proclamation published in the *Government Gazette* proclaim one or more buildings or places provided by the State for the treatment of the mentally ill or the intellectually defective or any part of such building or place to be:

- (a) a psychiatric hospital;
- (b) a mental hospital;
- (c) a training centre; or
- (d) a repatriation mental hospital.

And whereas by sub-section (2) of the said section 24 it is provided that any Proclamation made under section 24 may at any time be varied or revoked by Proclamation of the Governor in Council.

And whereas by Proclamation of the Governor in Council made pursuant to sub-section (1) of section 24 of the *Mental Health Act 1959* dated 23 October 1962 and published in the *Government Gazette* of 31 October 1961, the buildings or place in the Parish of Boroondara, County of Bourke, indicated by hachure on the plan attached to the said Proclamation dated 23 October 1962, were proclaimed as a mental hospital known as the Mental Hospital, Kew.

And whereas the Health Commission of Victoria now desires that certain parts of the building forming part of the Mental Hospital, Kew, and known as Wards G3 and G4 shall become a psychiatric hospital to be known as Willsmere Unit.

Now therefore, I, the Lieutenant-Governor as Deputy for the Governor of the State of Victoria, in the Commonwealth of Australia, by and with the advice of the Executive Council of the said State, do by this my Proclamation—

- (a) revoke as from 1 February 1982, the Proclamation constituting the Mental Hospital, Kew, so far as it relates to the buildings known as Wards G3 and G4; and
- (b) proclaim as from 1 February 1982 the aforementioned buildings known as Wards G3 and G4 to be a psychiatric hospital known as the Willsmere Unit.

Given under my Hand and the Seal of the State of Victoria aforesaid, at Melbourne, this twenty-sixth day of January, in the year of our Lord One thousand nine hundred and eighty-two, and in the thirtieth year of the reign of Her Majesty Elizabeth II, Queen of Australia.

(L.S.) JOHN McI. YOUNG

By His Excellency's Command

W. A. BORTHWICK
Minister of Health

GOD SAVE THE QUEEN!

Vegetation and Vine Diseases Act 1958
DECLARING A PROCLAIMED AREA

PROCLAMATION

By His Excellency the Lieutenant-General as Deputy for the Governor of the State of Victoria and its Dependencies in the Commonwealth of Australia, &c., &c., &c.

Whereas by section 25 of the *Vegetation and Vine Diseases Act 1958* it is provided that where the Governor in Council is of the opinion that it is necessary to protect the fruit industry of Victoria against the introduction or spread of the insects of the family Trypetidae (commonly known as fruit flies), he may by Proclamation declare any portion of Victoria specified therein to be a proclaimed area, and prohibit the removal from any place in the proclaimed area to any place outside that area or from any place in the proclaimed area to any other place in that area of any fruit fly or any fruit or vegetables of a kind or species which in his opinion may provide a host for fruit flies and require occupiers and owners of land in the proclaimed area to take such action for the eradication or prevention of the spread of fruit fly, as is specified in the Proclamation.

Now therefore, I, the Lieutenant-Governor as Deputy for the Governor of the State of Victoria, in the Commonwealth of Australia, being of opinion that it is necessary to protect the fruit industry of Victoria against the introduction or spread of the insects of the family Trypetidae (commonly known as fruit flies) and by and with the advice of the Executive Council of the said State, do by this my Proclamation hereby—

1. Revoke the Proclamation made on 12 January 1982 and published in the *Government Gazette* of 13 January 1982 declaring the whole of the Township of Kyabram within the Country of Rodney to be a proclaimed area.

2. Declare that portion of Victoria described in the First Schedule to this Proclamation to be a proclaimed area.

3. Prohibit the removal from any place within the proclaimed area to any place outside that area or to any other place in that area of any fruit fly or any fruit or vegetables of a kind or species grown within the proclaimed area and named in the Second Schedule to this Proclamation unless such removal is made on the instruction of an Inspector or with his written permission, provided that fruit and vegetables passing through the proclaimed area may leave the proclaimed area without such instruction if the vehicle carrying such fruit or vegetables does not come to a halt within the proclaimed area except as required by traffic regulations.

4. Require occupiers and owners of land in the proclaimed area within 25 metres of any property known to be infested with fruit fly to apply to an Inspector for a permit to remove from any place within the proclaimed area to any place outside that area or to any other place in that area any plant or soil and to refrain from such removal until a permit is granted.

FIRST SCHEDULE

Portion of Victoria Declared by this Proclamation to be a Proclaimed Area

Within the County of Rodney, Parish of Kyabram East, that part of the Town of Kyabram bounded by McEwen Road, North Boundary Road, Bolitho's Road and South Boundary Road.

SECOND SCHEDULE

Fruits and Vegetables which in the Opinion of the Governor in Council may Provide a Host for Fruit Flies

Apples	Loquats
Apricots	Nectarines
Avocadoes	Passionfruit
Banana Passionfruit	Peaches
Cactus	Pears
Capsicums	Peppers
Chillies	Persimmons
Chinese Gooseberries	Plums
Citrus Fruit	Pomegranates
Egg Fruit	Quinces
Feijoas	Tomatoes
Figs	Tree Tomatoes
Guavas	

Given under my Hand and the Seal of the State of Victoria aforesaid, at Melbourne, this twenty-sixth day of January, in the year of our Lord One thousand nine hundred and eighty-two, and in the thirtieth year of the reign of Her Majesty Elizabeth the Second, Queen of Australia.

(L.S.) JOHN McI. YOUNG

By His Excellency's Command

D. G. CROZIER
Acting Minister of Agriculture

GOD SAVE THE QUEEN !

Petroleum Retail Selling Sites Act 1981

DATE OF COMING INTO OPERATION

PROCLAMATION

By His Excellency the Lieutenant-Governor as Deputy for the Governor of the State of Victoria and its Dependencies in the Commonwealth of Australia, &c., &c., &c.

Whereas by an Act of Parliament of the State of Victoria passed, in the thirtieth year of the reign of Elizabeth the Second, by the Grace of God Queen of Australia and Her other Realms and Territories, Head of the Commonwealth, intituled the *Petroleum Retail Selling Sites Act 1981* (No. 9704) it is amongst other things enacted that the Act shall come into operation on a day to be fixed by Proclamation of the Governor in Council published in the *Government Gazette*.

Now therefore, I, the Lieutenant-Governor as Deputy for the Governor of the State of Victoria, in the Commonwealth of Australia, by and with the advice of the Executive Council of the said State, do by this my Proclamation fix 27 January 1982 as the day on which the Act shall come into operation.

Given under my Hand and the Seal of the State of Victoria aforesaid, at Melbourne, this twenty-sixth day of January, in the year of our Lord One thousand nine hundred and eighty-two, and in the thirtieth year of the reign of Her Majesty Queen Elizabeth II.

(L.S.) JOHN McI. YOUNG

By His Excellency's Command

HADDON STOREY
Minister of Consumer Affairs

GOD SAVE THE QUEEN !

Juries (Amendment) Act 1981, No. 9620

DATE OF COMING INTO OPERATION

PROCLAMATION

By His Excellency the Lieutenant-Governor as Deputy for the Governor of the State of Victoria and its Dependencies in the Commonwealth of Australia, &c., &c., &c.

Whereas by an Act of Parliament of the State of Victoria passed in the thirtieth year of the reign of Her Majesty Elizabeth the Second, Queen of Australia, intituled the *Juries (Amendment) Act 1981, No. 9620*, it is amongst other things enacted that the several provisions of that Act shall come into operation on a day or the respective

days to be fixed by Proclamation or successive Proclamations of the Governor in Council published in the *Government Gazette*.

Now therefore I, the Lieutenant-Governor as Deputy for the Governor of the State of Victoria in the Commonwealth of Australia, by and with the advice of the Executive Council of the said State, do by this my Proclamation—

(i) fix Tuesday, 2 February 1982, as the day on which the said Act, save and except section 5 shall come into operation and

(ii) fix Monday, 3 May 1982, as the day on which section 5 of the said Act shall come into operation.

Given under my Hand and the Seal of the State of Victoria aforesaid, at Melbourne, this twenty-sixth day of January, in the year of our Lord One thousand nine hundred and eighty-two, and in the thirtieth year of the reign of Her Majesty Elizabeth the Second, Queen of Australia.

(L.S.) JOHN McI. YOUNG

By His Excellency's Command

HADDON STOREY
Attorney-General

GOD SAVE THE QUEEN !

Racing (Amendment) Act 1981, No. 9671

DATE OF COMING INTO OPERATION

PROCLAMATION

By His Excellency the Lieutenant Governor as Deputy for the Governor of the State of Victoria and its Dependencies in the Commonwealth of Australia, &c., &c., &c.

Whereas by an Act of the Parliament of the State of Victoria passed in the thirtieth year of the reign of Her Majesty Elizabeth the Second, Queen of Australia, intituled the *Racing (Amendment) Act 1981* it is amongst other things enacted that the several provisions of this Act shall come into operation on the day or the respective days to be fixed by Proclamation or successive Proclamations of the Governor in Council published in the *Government Gazette*.

And whereas it is deemed expedient that a day be fixed on which section 24 (c) of the said *Racing (Amendment) Act 1981* shall come into operation.

Now therefore I, the Lieutenant Governor as Deputy for the Governor of the State of Victoria in the Commonwealth of Australia, by and with the advice of the Executive Council of the said State, do by this my Proclamation fix Wednesday, 27 January 1982 as the day on which section 24 (c) of the said *Racing (Amendment) Act 1981* shall come into operation.

Given under my Hand and the Seal of the State of Victoria aforesaid, at Melbourne, this twenty-sixth day of January, in the year of our Lord One thousand nine hundred and eighty-two, and in the thirtieth year of the reign of Her Majesty Elizabeth the Second, Queen of Australia.

(L.S.) JOHN McI. YOUNG

By His Excellency's Command

B. J. DIXON
Minister for Youth, Sport and Recreation

GOD SAVE THE QUEEN !

Education (Amendment) Act 1981, No. 9582

DATE OF COMING INTO OPERATION

PROCLAMATION

By His Excellency the Lieutenant-Governor as Deputy for the Governor of the State of Victoria and its Dependencies in the Commonwealth of Australia, &c., &c., &c.

Whereas by an Act of Parliament of the State of Victoria passed in the thirtieth year of the reign of Her Majesty Queen Elizabeth II, intituled the *Education (Amendment) Act 1981, No. 9582* it is amongst other