

[4141]

PUBLISHED BY AUTHORITY

Victoria Government Gazette

No. 134—Thursday, 22 December 1983

CONTRACTS ACCEPTED

(Series 1984-85)

MOTOR SPIRIT, KEROSENE, FUEL OILS AND LUBRICANTS

Schedule No. 1/53A

MOTOR SPIRIT (BULK)—STATE PETROL CENTRE

Contract from 1 January 1984 to 31 December 1984

1983/638—The Shell Company of Australia Limited, 11 Dorcas St., South Melbourne 3205. Telephone 609 1711

Clause 9 of the Conditions of Contract is not to be enforced without reference to the Tender Board.

For Details of discounts applicable and trading terms, etc. refer Schedule No. 1/53B.

Item No.	Description of Articles	Rate	Name of Contractor
		\$ per litre	
1	Standard Grade	0-3892	The Shell Company of Australia Limited
2	Super Grade	0-4027	

Approved—R. A. JOLLY Treasurer—19.12.1983

Schedule No. 1/53B

MOTOR SPIRIT, KEROSENE, FUEL OILS AND LUBRICANTS

Contract from 1 January 1984 to 31 December 1985

1983/632—Ampol Petroleum (Victoria) Pty. Limited, 499 St. Kilda Rd, Melbourne, 3000. Telephone 268 5333

1983/633—B.P. Australia Ltd., 1 Albert Rd, Melbourne, 3001. Telephone 268 4111

1983/638—The Shell Company of Australia Limited, 11 Dorcas St., South Melbourne, 3205

Clause 9 of the Conditions of Contract is not to be enforced without reference to the Tender Board.

Rates shown cover delivery within the Metropolitan Free Delivery Area. For suppliers outside that area, freight differentials in accordance with the Contractor's differential lists are to be added. Contractors must supply copies of current differential lists to Departments upon request.

DISCOUNTS.

The following settlement discounts will apply for purchases from The Shell Company of Australia Limited.

- 1. Shellcard fuels—30 days—\$0-0015 per litre
- 21 days—\$0-0030 per litre
- 15 days—\$0-0040 per litre

NOTE: The number of days referred to are from the date of the Company computer produced Shellcard invoice.

- Non Shellcard Fuels—30 days—\$0-0025 per litre
- 21 days—\$0-0040 per litre
- 15 days—\$0-0050 per litre

NOTE: The number of days referred to are from the date of delivery of the goods.

PAYMENT OF ACCOUNTS/TRADING TERMS:

Ampol Petroleum (Victoria) Pty. Ltd.—net 30 days.

B.P. Australia Limited—net 30 days, payment for each delivery must be received not later than the last day of the month immediately following the month during which the delivery is made.

The Shell Company of Australia Limited—payment for goods supplied and delivered is to be received no later than the final day of the month following the month in which the goods were delivered.

Item No.	Description of Articles	Rate	Name of Contractor
		\$ per litre	
MOTOR SPIRIT			
3	Standard Grade, bulk into tanks— Metropolitan Area	0-3933	The Shell Company of Australia Limited
4	Country Areas	0-4022	
5	Standard Grade, 200 litre drums— Metropolitan Area	0-4133*	
6	Country Areas	0-4222*	
Super Grade, bulk into tanks—			
7	Metropolitan Area	0-4068	
8	Country Areas	0-4157	
Super Grade, 200 litre drums—			
9	Metropolitan Area	0-4268*	
10	Country Areas	0-4357*	

*Plus \$30 drum deposit refundable upon the return of the drum in good order and condition.

Schedule No. 1/53B—continued

Item No.	Description of Articles	Rate	Name of Contractor	
MOTOR SPIRIT INTO GOVERNMENT OWNED VEHICLES FROM BOWSERS				
NOTE: The contract with The Shell Company of Australia Limited is based on the use of Shellcards. Departments wishing to use nominated Shell outlets will need to apply to Shell for the issue of a customer identity card for each vehicle. A transaction charge of \$0.10 per invoice line item is applicable to all purchases. For further details apply Tender Board.				
		\$		
	Standard Grade—	<i>per litre</i>		
11	From Nominated Metropolitan Depots	0-4173	The Shell Company of Australia Limited	
12	From Nominated Metropolitan Service Stations	0-4173		
13	From Nominated Country Depots	0-4293 0-4215	B.P. Australia Limited	
14	From Nominated Country Service Stations	0-4215 0-4293	The Shell Company of Australia Limited B.P. Australia Limited	
	Super Grade—			
15	From Nominated Metropolitan Depots	0-4308	The Shell Company of Australia Limited	
16	From Nominated Metropolitan Service Stations	0-4308 0-4428		
17	From Nominated Country Depots	0-4350	The Shell Company of Australia Limited	
18	From Nominated Country Service Stations	0-4350 0-4428		
	Distillate—			
19	From Metropolitan Motor Spirit Outlets	0-4434	The Shell Company of Australia Limited B.P. Australia Limited The Shell Company of Australia Limited B.P. Australia Limited	
20	From Country Motor Spirit Outlets	0-4473 0-4415 0-4473		
TWO STROKE FUEL MIXTURE				
21	20 litre drum	0-5638		The Shell Company of Australia Limited
22	200 litre drum	0-4338*		
	KEROSENE			
23	150 Test, 20 litre drum	0-5122	Ampol Petroleum (Victoria) Pty. Ltd.	
24	150 Test, 200 litre drum	0-3842*		
25	Power, 200 litre drum	0-3990*		
	DIESEL OIL			
26	Bulk into tanks		Purchase (Regulation 84)	
27	200 litre drum			
	DISTILLATE			
	Bulk into tanks—			
28	Metropolitan Area	0-4043‡	B.P. Australia Limited	
29	Country Areas	0-4113‡		
	200 litre drums—			
30	Metropolitan Area	0-4287*‡	The Shell Company of Australia Limited	
31	Country Areas	0-4369*‡		
32	Alpine,—8° C Cloud Point, Sealed 200 litre drum		Purchase (Regulation 84)	
	BUNKER FUEL (FOR MARINE USE)			
33	Bulk		Purchase (Regulation 84)	
	HEATING OIL (HOUSEHOLD)			
34	Into tanks	0-3671	The Shell Company of Australia Limited	

* Plus \$30 drum deposit which is refundable on return of the drum in good order and condition.

‡ Rates include \$0-0903 per litre Excise Duty and \$0-0502 per litre State Fuels Tax. If a State Fuels Tax Exemption Certificate is held the number must be quoted at the time of ordering and rates should be reduced accordingly. In addition, departments, etc. which use distillate for the purposes as defined in the Diesel Fuel Rebate Scheme may claim a rebate of \$0-7155 cents per litre Federal Duty from the Department of Industry and Commerce.

Schedule No. 1/53B—continued

Item No.	Description of Articles	Rate	Name of Contractor	
LUBRICATING OILS				
		\$ per litre		
35	Engine oil suitable for services SE/CC— (a) Multigrade SAE 20w/40 "G.T."	0-6070†	Ampol Petroleum (Victoria) Pty. Ltd.	
36	Engine oil suitable for service SE/CD— (a) Single grades SAE 10w to 40 "Deulube S3"	0-6749†		
	Engine oil suitable for service SF/CD— (b) Multigrade SAE 15w/40 "Longhaul"	0-7283†		
	Engine oil suitable for service SF/CC— (d) Multigrade SAE 20 w/50 "Super G.T. Friction modified"	0-6512†		
37	Two Stroke, "Ampol Super Two-Cycle Oil"	0-6914†		
38	Hydraulic Brake Fluid, "Super M.R."	2-422 †		
39	Hydraulic, "Tecoma 46"	0-5665†		
TRANSMISSION OIL				
40	Extreme Pressure, suitable for service GL5 (a) SAE 80w/90 "Gearlube AP" (b) SAE 85w/140	0-7232† 0-7340† per kg.		
GREASES				
41	Chassis—cup,		Purchase under item 43, if suitable.	
42	Wheel Bearing, Lithium Base	"M.P. Red Grease"	Ampol Petroleum (Victoria) Pty. Ltd.	
43	Multit-purpose, Lithium Base			
44	Track Roller, "A.L. Medium"			
45	Water Pump	1-0221	Purchase (Regulation 84)	

† Rate quoted are for 205 litre drums. Plus \$30 drum deposit which is refundable on the return of the drum in good order and condition. For smaller containers, the following package differentials must be added:

per litre
60 litre drums—\$0-1500
20 litre drums—\$0-1280
5 litre drums—\$0-1630
1 litre tins —\$0-3630

Rates quoted are for 170 kg drums. An allowance of \$3.00 per drum will be made on all drums returned in good order and condition. For smaller containers, the following package differentials must be added:

per kg
55 kg drums—\$0-1800
20 kg drums—\$0-1340
4 kg tins \$0-3215
2.5 kg tins—\$0-3770
0.5 kg tins—\$0-6130

Approved R. A. JOLLY—Treasurer. 19.12.1983

DISTRIBUTION FACILITIES—MOTOR SPIRIT FROM BOWSERS

METROPOLITAN AREA

Items 11, 12, 15, 16 and 19

Facilities will be made available from oil company owned outlets only when an application by a Department is considered by the Tender Board to justify the allocation of an outlet. Where a Department has obtained Tender Board approval to use such an outlet, the rates specified for Items 11, 12, 15, 16 and 19 will apply.

Otherwise, Departments are advised that all supplies of petrol required by vehicles within the Metropolitan Area must be obtained from the State Petrol Centre at the following address:

State Petrol Centre, Cnr. Young St. and Victoria Pde., Fitzroy.

COUNTRY AREAS

Items 13, 14, 17, 18 and 20

The following outlets are available at the rates specified for Items 13, 14, 17, 18 and 20. Outlets with the facilities to supply distillate into vehicles are indicated against each location. Freight differentials should be added.

Location	Company	Name	Address	Normal Trading Hours	Depot or Service Station	Diesel (Item 20)
Alexandra	B.P.	G. F. Courtney Motors	102 Grant St	8-8	S/Stn	
Apollo Bay	Shell	Apollo Bay Motors	Collingwood St	M-F 8-6	S/Stn	
Ararat	Shell	Eric Leeke and Sons	420 Barkly St	M-F 8-5	D	Diesel
	Shell	Mt. Ararat Service Station	280 Barkly St	7.30-8	S/Stn	

Schedule No. 1/53B—continued

COUNTRY AREAS—continued

Location	Company	Name	Address	Normal Trading Hours	Depot or Service Station	Diesel (Item 20)
Bacchus Marsh	Shell	Park Service Station	Maddingley Rd	M-F 7-8.30, Sat 8-8.30, Sun 8-6	S/Stn	Diesel
Bairnsdale	Shell	Bairnsdale Petroleum Co.	199 McLeod St	7-9	D	Diesel
Ballan Ballarat	Shell	Shell Bairnsdale A/Port	Cnr Main and Sharpe Sts	6-Midnight	S/Stn	
	B.P.	J. and E. Pama	Main St	6-8	S/Stn	
Beaufort Beechworth	Shell	Shell Ballarat S/Wash	822 Sturt St	24 hours	S/Stn	
	Shell	Pleasant Cnr A/Port	Cnr Sturt and Pleasant Sts	7.30-9.30	S/Stn	Diesel
Belgrave	Shell	Golden Era Service Station	Cnr Neil and Havelock Sts	8-6.30	S/Stn	Diesel
	B.P.	Golden Era Service Station	Ford St	8-5	S/Stn	Diesel
Benalla	Shell	New Belgrave Motors	86 Monbulk Rd	M-F 7.30-6.30, Sat 7.30-1, Sun 9-5.30	S/Stn	
Bendigo	Shell	Shell Benalla S/Serve	Cnr Bridge and Margaret Sts	24 hours	S/Stn	Diesel
Berwick	Shell	View High A/Port	Cnr View and Rowan Sts	7.30-8.30	S/Stn	Diesel
	Shell	Shell Deborah Reef S/Wash	Cnr High and Honeyuckle Sts	7-Midnight	S/Stn	
Boort Bright	Shell	Highway One Service Station	Cnr Princes Hwy and Clyde St	7-7	S/Stn	Diesel
	B.P.	L. Saunders	Durham Ox Rd	8-6	S/Stn	
Camperdown Cann River	Shell	Hothamway Road House	Cnr Gavan and Anderson Sts	6-Midnight	S/Stn	Diesel
	B.P.	B. P. Eastcamp	Manifold St	7-7	S/Stn	
Casterton	Shell	Cann River Garage	Cnr King St and Princes Hwy	6-Midnight	S/Stn	Diesel
	Shell	Downfarm Machinery	Cnr Racecourse Rd and Glenelg Hwy	6-Midnight	S/Stn	Diesel
Castlemaine	Shell	Jefferies Garage	5 Johnson St	M-F 8.30-5.30, Sat 8.30-Noon	S/Stn	Diesel
Charlton	Shell	G. and E. Bishop Pty. Ltd.	Davies St	M-F 8-5	D	Diesel
Cobram Colac	B.P.	A. R. Douglas	Main Rd	8-7	S/Stn	
	Shell	Shell Lakeview Service Station	Cnr Princes Hwy and Parkinson St	24 hours	S/Stn	Diesel
Coleraine	B.P.	L. E. and M. D. Baudinette	65 Whyte St	7-9	S/Stn	
Cowes	B.P.	B.P. Cowes	Cnr Thomson Ave and Settlement Rd	7-8	S/Stn	Diesel
Cranbourne	B.P.	B.P. Cranway	Cnr High and Bakewell Sts	7-7	S/Stn	Diesel
Cullulleraine	B.P.	Lake Cullulleraine Road House	Sturt Highway	8-8	S/Stn	
Dartmoor Daylesford	B.P.	Morton	Main St	8-6	S/Stn	
	Shell	T. A. Whiteley Pty. Ltd.	Vincent St	M-F 8.30-5, Sat 9-Noon, Sun 10-Noon	S/Stn	
Dennington	Shell	Greg Kelly Petroleum Pty. Ltd.	Lindsay St	M-F 8-5	D	Diesel
Dimboola Donald	B.P.	Dimboola Motors	Lloyd St	7-8	S/Stn	
	B.P.	Young Bros	79 Wood St	7-8	S/Stn	
Dromana	B.P.	B.P. Lighthouse	Cnr Nepean Hwy and Wattle Rd, McCrae	7-7	S/Stn	Diesel
Drysdale Echuca	B.P.	Harrolds Engineering	110 High St	8-5	S/Stn	
	Shell	Valley Way A/Port	Cnr Ogilvie and Premier Sts	7.30-10	S/Stn	Diesel
Elmore	Shell	Mid North S/Centre	Cnr Northern Hwy and Margaret St	M-F 8-5.30, Sat/Sun 9-1	S/Stn	Diesel
Emerald	Shell	Emerald Village Auto Supplies	Main St	M-Sat 6-8, Sun 8-6	S/Stn	Diesel
Euroa	Shell	Shell Euroa Road House	Hume Highway	7-Midnight	S/Stn	Diesel
Ferntree Gully	Shell	Shell Ferntree Gully S/Serve	154 Burwood Hwy	6-Midnight	S/Stn	Diesel
Foster Geelong	B.P.	Boyd Rerdon Motors	78 Main St	8-8	S/Stn	
	Shell	Shell Bar One S/Serve	421 Moorabool St	6-10	S/Stn	Diesel
	Shell	Speedwings Service Station	Melbourne Rd	6-7	S/Stn	Diesel
Gisborne Glenrowan	Shell	Shell Geelong North S/Serve	Cnr Ballarat and Stoddart Sts	6-9	S/Stn	
	B.P.	Gisborne Auto Service	36 Aitken St	7-5	S/Stn	
Hamilton	B.P.	Glenrowan General Store	Hume Highway	7-10	S/Stn	
	Shell	Forty Sixth Saldean Pty. Ltd.	7-13 Hughes St	M-F 7.30-5	D	Diesel
Hastings	B.P.	Campbells Petroleum Pty. Ltd.	17 Victoria St	8-5.30	D	Diesel

Schedule No. 1/53B—continued

COUNTRY AREAS—continued

Location	Company	Name	Address	Normal Trading Hours	Depot or Service Station	Diesel (Item 20)
Healesville	Shell	Sanctuary Service Station	125 Maroondah Hwy	M-Sat 7-7, Sun 8-7	S/Stn	Diesel
Heathcote	B.P.	North End Service Station	212-214 High St	8-8	S/Stn	Diesel
Heyfield	B.P.	Thompson Valley Garage	9 Pearson St	7-8	S/Stn	Diesel
Heywood	B.P.	Edwards Service Station	70 Edgar St	7-7	S/Stn	Diesel
Hopetoun	B.P.	R. & M. Poulton	Lascelles St.	7-7	S/Stn	Diesel
Horsham	Shell	Horsham Roadhouse	Cnr Dimboola Rd and David St	24 hours	S/Stn	Diesel
Kaniva	B.P.	B.P. Kaniva	148-150 Commercial St	7-7	S/Stn	Diesel
Kerang	Shell	Model Auto Port	57-59 Wellington St	M-F 8-7, Sat/Sun 8-1	S/Stn	Diesel
Kilmore	Shell	Shell Kilmore Service Station	1-3 Sydney St	M-F 8-7.30, Sat/Sun 8.30-7.30	S/Stn	Diesel
Koroit	B.P.	A. V. Smith Motors	Commercial Rd	7-7	S/Stn	Diesel
Korumburra	B.P.	B.P. Burra	26 Main St	7-10	S/Stn	Diesel
Kyneton	Shell	Southway S/Centre	150 High St	7-7	S/Stn	Diesel
Lake Boga	B.P.	K. G. and J. A. Hamil	Murray Valley Hwy	7-7	S/Stn	Diesel
Lake Bolac	B.P.	Lake Bolac Service	Glenelg Hwy	8-8	S/Stn	Diesel
Lakes Entrance	Shell	Entrance Auto Port	Cnr Esplanade and Carpenter Sts	7.30-6.30	S/Stn	Diesel
Leongatha	Shell	D. & M. Higgins Pty Ltd	Hughes St	M-F 9-5.30	D	Diesel
Lilydale	Shell	Yarra Valley S/Serve	Maroondah Hwy	6-midnight	S/Stn	Diesel
Lismore	B.P.	R. T. Rhook Pty Ltd	Hamilton Rd	8-6	S/Stn	Diesel
Lorne	B.P.	B.P. Surfside	Cnr Mountjoy and Grove Rds	7-10	S/Stn	Diesel
Mt Beauty	B.P.	T. J. Pyle and Sons	Kiewa Valley Rd, Tawonga South	7-10	S/Stn	Diesel
Maldon	B.P.	Laity's Garage	High St	7-7	S/Stn	Diesel
Mansfield	Shell	Alpine Way Service Station	Cnr Malcolm and Chenery Sts	8-7.30	S/Stn	Diesel
Maryborough	Shell	Three Square Service Station	47-49 High St	M-Th 7.30-6, Fri 7.30-8, Sat/Sun 7.30-5.30	S/Stn	Diesel
Melton	Shell	Shell Melton S/Serve	Ballarat Rd	24 hours	S/Stn	Diesel
Mildura	Shell	Riverland Service Station	Cnr Langtree Ave and 10th St	6-Midnight	S/Stn	Diesel
Minyip	B.P.	Fidge and Combs	Main St	7-7	S/Stn	Diesel
Moe	Shell	Narracan Gate Motors	Cnr Kingsford and Lloyd Sts	6-11	S/Stn	Diesel
Mooroopna	B.P.	A. and N. Doona	McLennan St	7-9	S/Stn	Diesel
Mornington	Shell	Bloomfields S/Serve	Tyabb Rd	M-F 8-6, Sat 8.30-Noon	S/Stn	Diesel
Mortlake	Shell	Vale Motors	Townsend St	6-Midnight	S/Stn	Diesel
Morwell	B.P.	B.P. Conara	Princes Hwy	7-7	S/Stn	Diesel
Nathalia	B.P.	Murrell's Motors	60 Elizabeth St	8-5	S/Stn	Diesel
Neerim South	B.P.	T. Parker Motors	Main Rd	8-8	S/Stn	Diesel
Nhill	Shell	East West Roadhouse	Cnr Leahy and Victoria Sts	7.30-8	S/Stn	Diesel
Numurkah	Shell	Shell Numurkah Roadhouse	Goulburn Valley Hwy	6-Midnight	S/Stn	Diesel
Orbost	Shell	Herbert Petroleum Pty Ltd	46-50 Salisbury St	M-Sat 7-6, Sun 8-6	D	Diesel
Ouyen	Shell	Ouyen Roadhouse	Cnr Calder Hwy and Manangatang Rd	6-Midnight	S/Stn	Diesel
Pakenham East	Shell	H. P. and B. J. Monkton Pty Ltd	Bald Hill Rd	M-F 8.30-5.30, Sat 8.30-Noon	D	Diesel
Portarlington	B.P.	B.P. Portside Auto	Newcombe St	6-9	S/Stn	Diesel
Port Campbell	B.P.	Port Campbell Motors	Lord St	7-7	S/Stn	Diesel
Portland	Shell	Double Corner Service Station	Cnr Hurd St and Hanlon Pde	24 hours	S/Stn	Diesel
	Shell	Portland S/Centre	Cnr Henty and Borthwicks Rds	6-Midnight	S/Stn	Diesel
Queenscliff	B.P.	Cliff Service Station	Hesse and Stokes Sts	7-8	S/Stn	Diesel
Rainbow	B.P.	W. F. and B. T. Welsh	Main St, Yaapeet	7-7	S/Stn	Diesel
Rochester	Shell	W. S. and A. M. Newman	Ramsay St	M-F 8-5, Sat 9-11	D	Diesel
Rosebud	B.P.	B.P. Seaspray	Nepean Hwy and Third St	7-7	S/Stn	Diesel
Rushworth	B.P.	Muir's Motor Eng	Cnr Wigg and High Sts	7-6	S/Stn	Diesel
Rutherglen	B.P.	McCartie Motors	Fortune St and Murray St	7-6	S/Stn	Diesel
Rye	B.P.	B.P. Foreshore	Nepean Hwy	7-7	S/Stn	Diesel
St Arnaud	B.P.	Apex Service Station	Silver Mines Road	7.30-8.30	S/Stn	Diesel
Sale	Shell	Prain Petroleum	Foster St	M-F 7-6, Sat 7.30-1	D	Diesel
	Shell	Three Esses S/Centre	Cnr York and Raglan Sts	6-Midnight	S/Stn	Diesel
San Remo	B.P.	San Remo Auto Service	127 Marine Pde	7-7	S/Stn	Diesel

Schedule No. 1/53B—continued

COUNTRY AREAS—continued

Location	Company	Name	Address	Normal Trading Hours	Depot or Service Station	Diesel (Item 20)
Sea Lake Seymour	Shell	R. F. and J. Poole	Lake Road	M-F 8-5	D	Diesel
	Shell	Emily Street Service Station	43 Emily St	M-F 7-7, Sat/Sun 8-9	S/Stn	
	Shell	Northern Way Roadhouse	Hume Highway	6-Midnight	S/Stn	Diesel
Shepparton Skipton	Shell	Appian Service Station	Cnr High and Hoskins Sts	7-7	S/Stn	Diesel
	B.P.	Skipton Roadhouse and Newsagency	Glenelg Highway	6-8	S/Stn	
Stawell	Shell	Lodestone Service Station	Western Hwy	7.30-7.30	S/Stn	Diesel
Sunbury	B.P.	B.P. Satellite	Horne St and Gap Rd	7-7	S/Stn	
Swan Hill	Shell	Holts Auto Service	Cnr Pritchard and Campbell Sts	6-Midnight	S/Stn	Diesel
Swifts Creek Talbot	B.P.	Swifts Creek Agency	Ormeo Hwy	8-5	Agency	
	B.P.	Elliots Farm Supp. Pty Ltd	37 Nolan St	6-7	S/Stn	
Timboon	B.P.	Timboon Motors	Bailey St	7-7	S/Stn	
Tongala	B.P.	Tongala Motors	Hendersons Rd	7-7	S/Stn	
Toora	B.P.	Toora Auto Service	Sth. Gippsland Hwy	8-6	Sth/Stn	Diesel
Trafalgar	B.P.	B.P. Eastway	Princes Hwy	7-8	S/Stn	Diesel
Traralgon	Shell	City Chambers Service Station	Cnr Kay and Church Sts	M-F 7.30-6, Sat/Sun 8-1	S/Stn	
	Shell	Shell Traralgon S/Serve	Princes Hwy	6-Midnight	S/Stn	Diesel
Upwey	Shell	New Belgrave Motors	86 Monbulk Rd	M-F 7.30-6.30 Sat 7.30-1, Sun 9-5.30	S/Stn	
Wangaratta	Shell	Ovens Bridge Roadhouse	Cnr Clement St and Parfitt Rd	6-Midnight	S/Stn	Diesel
Warburton	B.P.	Snowline Service Station	Main Rd	6-7	S/Stn	
Warracknabeal	B.P.	D. L. and E. A. Denham Motors	Scott St	6-7	S/Stn	
Warragul	Shell	South Seas Service Station	Queen St	M-F 7-9, Sat/Sun 7-7	S/Stn	Diesel
Warrnambool	Shell	The Ponderosa Service Station	465-469 Raglan Pde	8-8	S/Stn	Diesel
Werribee	Shell	Sammartino Nominees Pty Ltd	103 Railway Ave	M-F 7.30-6, Sat 7.30-1	D	Diesel
Whitfield	B.P.	Whitfield Store	Main Rd	9-5	S/Stn	
Wodonga	Shell	Joes Service Station	Cnr Melbourne Rd and Smyth St	6-Midnight	S/Stn	Diesel
Woodend	B.P.	Woodend Produce Store	Station St	7-8	S/Stn	Diesel
Wycheproof Yarra Glen	B.P.	V. C. and J. Vearing	Broadway	8-6	S/Stn	Diesel
	B.P.	G.T. Motors and Panel Works	Main St	8-6	S/Stn	
Yarram	Shell	Commercial Motors	Commercial Rd	M-Sat 7.30-7.30, Sun 9-7.30	S/Stn	
Yarrowonga	Shell	Yarrowonga Roadhouse	Murray Valley Hwy	6-Midnight	S/Stn	Diesel
Yea	B.P.	C. V. and J. M. Bowe	31 High St	8-8	S/Stn	



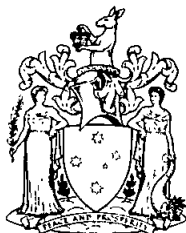

Victoria Government Gazette

No. 135—Thursday, 29 December 1983

PROCLAMATIONS

Land Conservation Act 1970

DECLARATION OF LANDS IN THE RURAL CITY OF WODONGA TO BE PUBLIC LAND

PROCLAMATION

By His Excellency the Governor of the State of Victoria and its Dependencies in the Commonwealth of Australia, &c., &c., &c.

I, the Governor of the State of Victoria in the Commonwealth of Australia, by and with the advice of the Executive Council of the said State and having considered a recommendation of the Land Conservation Council in pursuance of the provisions contained in Section 2(2) (a) of the *Land Conservation Act 1970* (No. 8008) do by this Proclamation declare those lands in the Rural City of Wodonga indicated by hatching on Certified Plan No. S28, the original of which is lodged and available for inspection at the office of the Land Conservation Council, 464 St. Kilda Road, Melbourne, 3004, being either unalienated land of the Crown or lands vested in the Albury-Wodonga (Victoria) Corporation, to be public land for the purposes of the *Land Conservation Act 1970*.

Given under My Hand and the Seal of the State of Victoria aforesaid at Melbourne this twentieth day of December in the year of Our Lord One Thousand Nine hundred and Eighty Three and in the Thirty Second year of the reign of Her Majesty Queen Elizabeth the Second, Queen of Australia.

(L.S.) Brian MURRAY

By His Excellency's Command
EVAN WALKER
Minister for Planning and Environment
GOD SAVE THE QUEEN!

PUBLIC HIGHWAYS—CITY OF HORSHAM

PROCLAMATION

By His Excellency the Governor of the State of Victoria and its Dependencies in the Commonwealth of Australia, &c., &c., &c.

Whereas by the *Local Government Act 1958*, section 519 it is amongst other things enacted that it shall be lawful for the Governor in Council at any time and from time to time upon the request of the council of any municipality by notice in the Government Gazette to proclaim any land reserved used or by purchase or exchange acquired for a street road highway thoroughfare bridge square court alley or right-of way or any street road lane or passage made or laid out or proposed to be made or laid out on any land of which a plan of subdivision delineating that street road lane or passage has been sealed with the seal of the municipality under subdivision (3) of Division 9 of Part XIX of the *Local Government Act 1958* or a corresponding previous enactment to be a public highway and that such land shall thereupon and thenceforth from the date of such proclamation become and be absolutely dedicated to the public as a public highway within the meaning of any law then or thereafter in force;

And whereas the Council of the City of Horsham has requested that the land hereinafter mentioned, reserved for a road, be so declared to be public highways;

Now therefore, I the Governor of the State of Victoria in the Commonwealth of Australia, by and with the advice of the Executive Council of the said State, do by this proclamation declare that the roads shown by hatching on the plan hereunder shall be public highways within the meaning of the said Act.

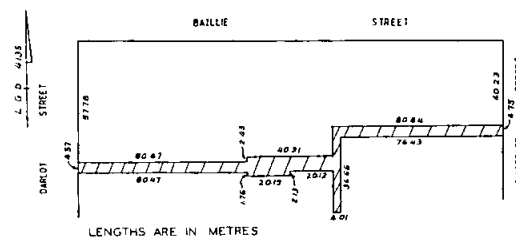

Given under My Hand and the Seal of the State of Victoria aforesaid at Melbourne this twentieth day of December in the year of Our Lord One Thousand Nine hundred and Eighty Three and in the Thirty Second year of the reign of Her Majesty Queen Elizabeth the Second, Queen of Australia.

(L.S.) Brian MURRAY

By His Excellency's Command
F. N. WILKES
Minister for Local Government
GOD SAVE THE QUEEN!

Legal Profession Practice (Further Amendment) Act 1983, No. 10012

DATE OF COMING INTO OPERATION

PROCLAMATION

By His Excellency the Governor of the State of Victoria and its Dependencies in the Commonwealth of Australia, &c., &c., &c.

Whereas by an Act of Parliament of the State of Victoria passed in the thirty-second year of the reign of Her Majesty Elizabeth the Second, Queen of Australia, entitles the *Legal Profession Practice (Further Amendment) Act 1983, No. 10012*, it is amongst other things enacted that the Act shall come into operation on a day to be fixed by proclamation of the Governor in Council published in the *Government Gazette*:

Now therefore, I, the Governor of the State of Victoria, by and with the advice of the Executive Council thereof, do by this my Proclamation fix Sunday, 1 January 1984 as the day upon which the said *Legal Profession Practice (Further Amendment) Act 1983, No. 10012* shall come into operation.

Given under my hand and the Seal of the State of Victoria aforesaid at Melbourne this twentieth day of December in the year of Our Lord One thousand nine hundred and eighty-three and in the thirty-second year of the reign of Her Majesty Elizabeth the Second, Queen of Australia.

(L.S.) Brian MURRAY

By His Excellency's Command
J. H. KENNAN
Attorney-General

GOD SAVE THE QUEEN!

Courts (Powers of Investment) Act 1983, No. 10013

DATE OF COMING INTO OPERATION

PROCLAMATION

By His Excellency the Governor of the State of Victoria and its Dependencies in the Commonwealth of Australia, &c., &c., &c.

Whereas by an Act of Parliament of the State of Victoria passed in the thirty-second year of the reign of Her Majesty Elizabeth the Second, Queen of Australia, entitled the *Courts (Power of Investment) Act 1983, No. 10013*, it is amongst other things enacted that the Act shall come into operation on a day to be fixed by proclamation of the Governor in Council published in the *Government Gazette*:

Now therefore, I, the Governor of the State of Victoria, by and with the advice of the Executive Council thereof, do by this my Proclamation fix Sunday, 1 January 1984 as the day upon which the said *Courts (Powers of Investment) Act 1983, No. 10013*, shall come into operation.

Given under my hand and the Seal of the State of Victoria aforesaid at Melbourne this twentieth day of December in the year of Our Lord One thousand nine hundred and eighty-three and in the thirty-second year of the reign of Her Majesty Elizabeth the Second, Queen of Australia.

(L.S.)

Brian MURRAY

By His Excellency's Command

J. H. KENNAN
Attorney-General

GOD SAVE THE QUEEN!

Trustee Companies (Amendment) Act 1983

DATE OF COMING INTO OPERATION

PROCLAMATION

By His Excellency the Governor of the State of Victoria and its Dependencies in the Commonwealth of Australia, &c., &c., &c.

Whereas by an Act of Parliament of the State of Victoria passed in the thirty-second year of the reign of Her Majesty Elizabeth the Second, Queen of Australia, entitled the *Trustee Companies (Amendment) Act 1983*, it is amongst other things enacted that subject to sub-section (2) of section 2 of the Act, the several provisions of the said Act shall come into operation on a day or the respective days to be fixed by proclamation or successive proclamations of the Governor in Council published in the *Government Gazette*:

Now therefore, I, the Governor of the State of Victoria, by and with the advice of the Executive Council thereof, do by this my Proclamation fix Sunday, 1 January 1984 as the day upon which the whole of the provisions of the said *Trustee Companies (Amendment) Act 1983* with the exception of Section 6 (1) thereof, shall come into operation.

Given under my hand and the Seal of the State of Victoria aforesaid at Melbourne this twentieth day of December in the year of Our Lord One thousand nine hundred and eighty-three and in the thirty-second year of the reign of Her Majesty Elizabeth the Second, Queen of Australia.

(L.S.)

Brian MURRAY

By His Excellency's Command

J. H. KENNAN
Attorney-General

GOD SAVE THE QUEEN!

Reference Areas Act 1978

MINISTRY FOR CONSERVATION

BUNGIL REFERENCE AREA

PROCLAMATION

By His Excellency the Governor of the State of Victoria and its Dependencies in the Commonwealth of Australia, &c., &c., &c.

I, the Governor of the State of Victoria in the Commonwealth of Australia by and with the advice of the Executive Council of the said State and in pursuance of the provisions contained in Section 3 of the *Reference Areas Act 1978* do hereby proclaim the area shown on Plan No. M-250.0044 hereunder, the original of which is lodged at the Ministry for Conservation, 240 Victoria Parade, East Melbourne, 3002, to be the Bungil Reference Area.

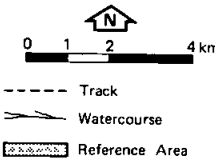
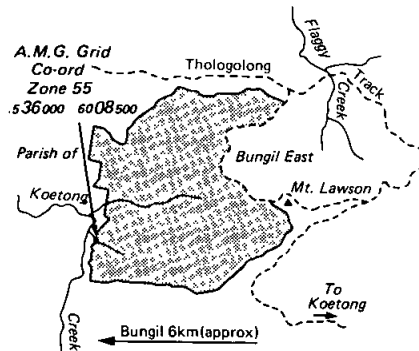
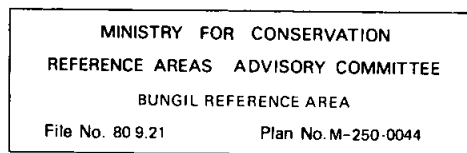

Ref. M-250.0044

Given under my Hand and the Seal of the State of Victoria aforesaid at Melbourne this twentieth day of December in the year of Our Lord One thousand nine hundred and eighty-three in the thirty-second year of the reign of Her Majesty Queen Elizabeth II.

(L.S.)

Brian MURRAY

By His Excellency's Command

R. A. MACKENZIE
Minister for Conservation, Forests and Lands

GOD SAVE THE QUEEN!

Reference Areas Act 1978
 MINISTRY FOR CONSERVATION
 JONES CREEK REFERENCE AREA

PROCLAMATION

By His Excellency the Governor of the State of Victoria and its Dependencies in the Commonwealth of Australia, &c., &c., &c.

I, the Governor of the State of Victoria in the Commonwealth of Australia by and with the advice of the Executive Council of the said State and in pursuance of the provisions contained in Section 3 of the Reference Areas Act 1978 do hereby proclaim the area shown on Plan No. M-250.0043 hereunder, the original of which is lodged at the Ministry for Conservation, 240 Victoria Parade, East Melbourne, 3002, to be the Jones Creek Reference Area.

MINISTRY FOR CONSERVATION
 REFERENCE AREAS ADVISORY COMMITTEE
 JONES CREEK REFERENCE AREA
 File No. 80.9.59 Plan No. M-250-0043

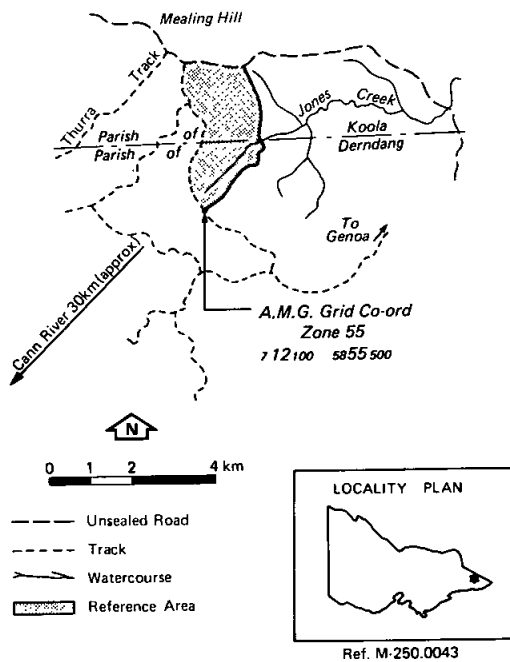

Given under my Hand and the seal of the State of Victoria aforesaid at Melbourne this twentieth day of December in the year of Our Lord One thousand nine hundred and eighty-three in the thirty-second year of the reign of Her Majesty Queen Elizabeth II.

(L.S.) Brian MURRAY
 By His Excellency's Command
 R. A. MACKENZIE
 Minister for Conservation, Forest and Lands

GOD SAVE THE QUEEN!

Reference Areas Act 1978
 MINISTRY FOR CONSERVATION
 EAGLEHAWK CREEK REFERENCE AREA

PROCLAMATION

By His Excellency the Governor of the State of Victoria and its Dependencies in the Commonwealth of Australia, &c., &c., &c.

I, the Governor of the State of Victoria in the Commonwealth of Australia by and with the advice of the Executive Council of the said State and in pursuance of the provisions contained in Section 3 of the Reference Areas Act 1978 do hereby proclaim the area shown on Plan No. M-250.0042 hereunder, the original of which is lodged at the Ministry for Conservation, 240 Victoria Parade, East Melbourne, 3002, to be the Eaglehawk Creek Reference Area.

MINISTRY FOR CONSERVATION
 REFERENCE AREAS ADVISORY COMMITTEE
 EAGLEHAWK CREEK REFERENCE AREA
 File No. 80.9.24 Plan No. M-250-0042

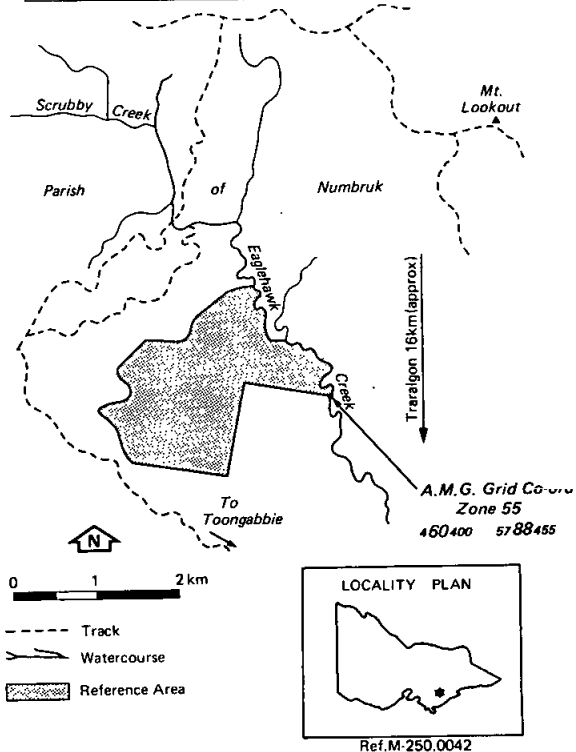

Given under my Hand and the Seal of the State of Victoria aforesaid at Melbourne this twentieth day of December in the year of Our Lord One thousand nine hundred and eighty-three in the thirty-second year of the reign of Her Majesty Queen Elizabeth II.

(L.S.) Brian MURRAY
 By His Excellency's Command
 R. A. MACKENZIE
 Minister for Conservation, Forests and Lands

GOD SAVE THE QUEEN!

GOVERNMENT NOTICES

PUBLIC HOLIDAYS — CHRISTMAS AND NEW YEAR 1983-1984

It is hereby notified that on:

Monday, 26 December 1983, holiday for Boxing Day
Tuesday, 27 December 1983, holiday in lieu of Christmas Day,
25 December 1983

Monday, 2 January 1984, holiday in lieu of New Year's Day, 1
January 1984

The public offices will be closed, such days having been appointed under the provisions of the *Public Service Act 1974*, to be observed as holidays in the public offices throughout the State of Victoria.

This notice relates only to the closing of the State Public Offices. All inquiries regarding the holidays in other offices and in shops and industry should be directed to the Department of Labour and Industry, Industrial Information Service, 500 Bourke Street, Melbourne 3000. (Telephone 602 0251).

Dated 2 December 1983

P.F. PRIOR, Secretary

Department of Labour and Industry

PUBLIC SERVICE ACT 1974

The following is a list of Public Holidays (Whole and Half Days) proclaimed for the year 1983 in municipalities NOT included in the Fifth Schedule to *Public Service Act 1974*.

Municipality	Day and Date	Whole Day or Half Holiday
Arapiles, Shire of (North Riding)	Tues., 30 August	Half holiday
Ararat, City of	Fri., 25 November	Half holiday
Ballaan, Shire of	Mon., 22 March	Half holiday
Ballaarat, City of	Tues., 1 March	Whole day
Ballaarat, City of	Wed., 16 November	Whole day
Ballaarat, Shire of	Wed., 16 November	Whole day
Benalla, City of	Mon., 10 October	Half holiday
Bendigo, City of	Tues., 1 November	Whole day
Bendigo, City of	Wed., 9 November	Half holiday
Birchip, Shire of	Mon., 10 October	Whole day
Bungaree, Shire of	Wed., 16 November	Whole day
Camperdown, Town of	Mon., 21 March	Half holiday
Colac, City of	Wed., 9 February	Half holiday
Colac, Shire of	Wed., 9 February	Half holiday
Cranbourne, Shire of	Wed., 5 October	Half holiday
Dimboola, Shire of— (Central Riding)	Wed., 12 October	Half holiday
(North Riding)	Tues., 11 October	Half holiday
Dundas, Shire of	Wed., 13 April	Half holiday
Dunmunkle, Shire of— (East Riding)	Wed., 5 October	Half holiday
(North Riding)	Tues., 4 October	Half holiday
(West Riding)	Fri., 12 July	Half holiday
(West Riding)	Fri., 30 September	Half holiday
Eaglehawk, Borough of	Tues., 1 November	Whole day
Echuca, City of	Fri., 14 October	Half holiday
Geelong, City of	Wed., 19 October	Whole day
Glenelg, Shire of	Fri., 13 May	Half holiday
Huntly, Shire of— (West and South Ridings)	Tues., 4 October	Whole day
Healesville, Shire of	Wed., 9 November	Half holiday
	Thurs., 22 September	Whole day
Horsham, City of	Thurs., 29 September	Half holiday
Karkaroc, Shire of	Tues., 18 October	Whole day

Kerang, Shire of	Tues., 4 October	Half holiday
Kerang, Borough of	Tues., 4 October	Half holiday
Kilmore, Shire of	Wed., 14 September	Half holiday
Kilmore, Shire of	Mon., 24 October	Half holiday
Kilmore, Shire of (Wallan Riding)	Thurs., 22 September	Whole day
Koroit, Borough of	Thurs., 5 May	Half holiday
Korong, Shire of (Township of Wedderburn)	Tues., 1 November	Half holiday
Kyneton, Shire of	Wed., 2 November	Whole day
Lowan, Shire of	Thurs., 13 October	Half holiday
McIvor, Shire of	Tues., 1 November	Whole day
Marong, Shire of	Wed., 11 May	Half holiday
Mornington, Shire of	Wed., 23 February	Half holiday
Numurkah, Shire of	Wed., 19 October	Half holiday
Phillip Island, Shire of	Mon., 19 September	Whole day
Pyalong, Shire of	Mon., 19 September	Whole day
Queenscliffe, Borough of	Tues., 1 November	Whole day
Sale, City of	Thurs., 17 February	Half holiday
Sebastopol, Borough of	Tues., 1 March	Half holiday
Seymour, Shire of	Wed., 7 September	Half holiday
Shepparton, City of	Fri., 7 October	Whole day
Shepparton, Shire of	Fri., 7 October	Whole day
Strathfieldsaye, Shire of	Wed., 9 November	Half holiday
Walpeup, Shire of (East from Township of Linga)	Tues., 1 November	Whole day
Walpeup, Shire of (West from Township of Linga)	Wed., 12 October	Whole day
Wannon, Shire of (Coleraine Riding)	Fri., 27 May	Half holiday
Waranga, Shire of (West Riding and Township of Corop)	Tues., 4 October	Half holiday
Warracknabeal, Shire of	Thurs., 6 October	Whole day
Warmambool, City of	Thurs., 5 May	Half holiday
Wimmera, Shire of (North Riding)	Thurs., 29 September	Half holiday
	Thurs., 6 October	Half holiday
Wycheproof, Shire of (North and Tyrell Ridings, including Township of Culgoa)	Wed., 12 October	Half holiday
(South and Central Ridings, excluding Township of Culgoa)	Wed., 19 October	Half holiday

In addition, Monday, 19 September has been appointed a Public Holiday in the Shires of Bacchus Marsh, Gisborne, and Romsey in lieu of Melbourne Show Day.

Ministry of Industrial Affairs

G. HOLMES
Director-General

ADDENDUM

In *Government Gazette* No. 128 of 14 December 1983 on page 3980 the appointment of Denis Finn as bailiff of the Supreme Court was shown, however at that time he was also appointed as bailiff of Magistrates' Courts pursuant to Section 31A of the *Magistrates Court Act 1971*; this notification was omitted from the abovementioned Gazette notice.

ERRATUM

In *Government Gazette* No. 112 of 31 October 1983 on page 3539, the maximum retail price of motor spirit 89 RON shown as 47.7 cents per litre should read 47.4 cents per litre.

Private Agents Act 1966

NOTICE OF RECEIPT OF APPLICATIONS FOR LICENCES UNDER THE PROVISIONS OF THE PRIVATE AGENTS ACT 1966

The Clerk(s) of the Magistrates' Court(s) as listed hereunder hereby give notice that applications, as under, have been lodged for hearing by the said Court(s) on the date(s) specified.

Any person desiring to object to any of such applications must—

- (a) lodge with the respective Clerk of the Magistrates' Court a notice in the prescribed form of his objection and of the grounds thereof;
- (b) cause a copy of such notice to be served personally or by post upon the applicant at least three days before the hearing of the application; and
- (c) send or deliver—
 - (i) where the objection is not made by the officer in charge of the police district in which the Court is situated—a copy of the notice to such officer; and
 - (ii) where the objection is not made by the Registrar or Deputy Registrar—a copy to the Registrar.

Full Name of Applicant*	Place of Abode of Applicant or Nominee	Name of Firm or Corporation	Address for Registration	Type of Licence	Date of Hearing
MAGISTRATES' COURT, LILYDALE					
Warren, Rodney Joseph	28 Greenvalley Cres, Hampton Park		26 North Rd, Lilydale	Watchman	10.1.84
Dated at Lilydale 14 December 1983 D. REES, Clerk of the Magistrates' Court					
MAGISTRATES' COURT, FOOTSCRAY					
Fisher, Dennis John	141 Sparks Rd, Norlane		3rd Street East, 542 Footscray Rd, Footscray	Process Server Individual	11.1.84
Fisher, Dennis John	"		"	Inquiry Agent Individual	"
Kukula, Wally	3 Cypress Av, Brooklyn	Mayne Nickless Ltd.	653 Queensberry St, North Melbourne	Watchman	"
Dated at Footscray 12 December 1983 J. T. FERGUSON, Clerk of the Magistrates' Court					
MAGISTRATES' COURT, SPRINGVALE					
Bellis, Colin Neil	1 Glenwood Dve, Springvale South		33 Centreway Mt Waverley	Watchman	13.1.84
Dated at Springvale 14 December 1983 B. DOBSON, Clerk of the Magistrates' Court					
MAGISTRATES' COURT, FRANKSTON					
Porter, Philip James	12 Richmond Ave, Carrum Downs		12 Richmond Ave, Carrum Downs	Process Server Individual	27.1.84
Dated at Frankston 14 December 1983 B. BARROW, Clerk of the Magistrates' Court					
MAGISTRATES' COURT, OAKLEIGH					
Mastandrea, Luigi	66 Cooper Ave, Altona North	Kent Security Services	96 Murrumbeena Rd, Murrumbeena	Watchman	20.1.84
Hefiti, Dominik	47 Westall Rd, South Clayton	Sam Malignaggi	1388 Dandenong Rd, Oakleigh	Watchman	13.1.84
Dated at Oakleigh 9 December 1983 W. E. BYRNE, Clerk of the Magistrates' Court					
MAGISTRATES' COURT, MOE					
Grima, Samuel Anthony	Flat 2/3 Joy St, Newborough		88 Waterloo Rd, Moe	Guard Agent	10.1.84
Dated at Moe 12 December 1983 J. F. SLATTERY, Clerk of the Magistrates' Court					
MAGISTRATES' COURT, MELBOURNE					
Henderson, Gregory Neil	61 Vista Dve, Melton		340 Abottsford St, North Melbourne	Watchman	2.11.83
Dated at Melbourne 14 October 1983 M. J. QUIRK, Clerk of the Magistrates' Court					

*Or in the case of a firm or corporation, of the Nominee

Full Name of Applicant*	Place of Abode of Applicant or Nominee	Name of Firm or Corporation	Address for Registration	Type of Licence	Date of Hearing
MAGISTRATES' COURT, KYABRAM					
Young, Gary Russell	33 Garden Cres, Echuca	Rich River Security	51 Dawes Rd, Kyabram	Watchman	1.2.84
Dated at Echuca 7 December 1983 P. D. SWEENEY, Clerk of the Magistrates' Court					
MAGISTRATES' COURT, FITZROY					
Palise, Colin Jeffrey	25 Bourke St, Reservoir	Roden Security Services	136 Johnston St, Fitzroy	Watchman	9.1.84
Broin, Ray	13 Bainbridge Drive, Eltham	"	"	"	"
Grant, Shayne Stuart	50 Rosedale Dve, Lalor	"	"	"	"
Muntesar, Shevket	5/71 Holland Crt, Flemington	"	"	"	"
Thatcher, Peter Richard	39 Excelsior St, Reservoir	"	"	"	"
Dated at Fitzroy 9 December 1983 G. SHARKEY, Clerk of the Magistrates' Court					
MAGISTRATES' COURT, PORT MELBOURNE					
Smith, Brian Robert	110 Bank St, South Melbourne	Armaguard R/B	Cnr Turner and Graham Sts, Port Melbourne	Watchman	19.1.84
Hillman, Gilbert Ashley	188 Moreland Rd, Brunswick	"	"	"	"
Shortell, Andrew Charles	316 Rae St, North Fitzroy	"	"	"	"
Westley, John	44 Harcourt Ave, Frankston	M.S.S.	634 Graham St, Port Melbourne	"	"
Dated at Port Melbourne 9 December 1983 J. VITALE, Clerk of the Magistrates' Court					
MAGISTRATES' COURT, NORTHCOTE					
Raptis, Anthony Dimitrios	53 Gillies St, Fairfield	A. D. Raptis & Associates	53 Gillies St, Fairfield	Guard Agent Process Server	11.1.84
"	" "	"	" "	"	"
"	" "	"	" "	Guard Agent Inquiry Agent	"
"	" "	"	" "	"	"
Dated at Northcote 8 December 1983 R. MALONEY, Clerk of the Magistrates' Court					
MAGISTRATES' COURT, BOX HILL					
Pugh, Colin Owen	2 Leach Ave, Box Hill North	Pet Care and Secu- rity Services	2 Leach Ave, Box Hill North	Guard Agent	6.1.1984
Dated at Box Hill 9 December 1983 W. BYRNE, Clerk of the Magistrates' Court					
MAGISTRATES' COURT, YARRAM					
Bohn, John Robert	7 Bruce Crt, Foster		340 Abbotsford St, North Melbourne	Watchman	10.1.84
Dated at Yarram 9 December 1983 A. TYERS, Clerk of the Magistrates Court.					
MAGISTRATES' COURT, ECHUCA					
Bruns, Gregory Norman	30 Darling St, Echuca	Rich River Security	51 Dawes Rd, Kyabram	Watchman	25.1.84
Dated at Echuca 19 December 1983 S. CORLETT, Clerk of the Magistrates' Court					

*Or in the case of a firm or corporation, of the Nominee

ROAD CONSTRUCTION AUTHORITY
NOTICE DECLARING THE WIDENINGS OF EXISTING
ROADS TO BE FIT TO BE USED AS PUBLIC HIGHWAYS

The Road Construction Authority is of the opinion that the widenings of the existing roads as set out below are fit to be used as public highways—

Widening of an existing road in the Shire of Bright as shown hatched on plan numbered G.P.15002A below.

ROAD CONSTRUCTION AUTHORITY
MAIN ROAD
BUCKLAND VALLEY ROAD
SHIRE OF BRIGHT
Lengths in metres

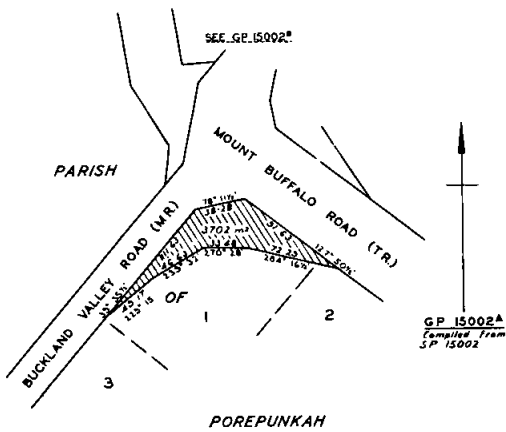

Widening of an existing road in the Shire of Mortlake as shown hatched on plan numbered G.P.15501 below.

ROAD CONSTRUCTION AUTHORITY

MAIN ROAD
WARRNAMBOOL - MORTLAKE ROAD
SHIRE OF MORTLAKE
Lengths in metres

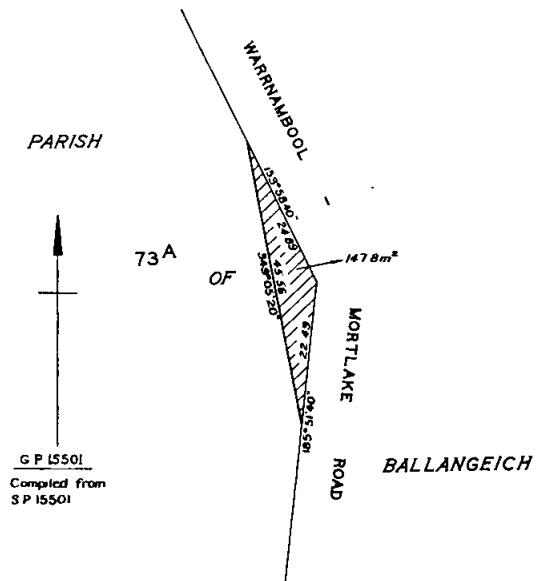

Widening of an existing road in the Shire of Hampden as shown hatched on plan numbered G.P.15608 below.

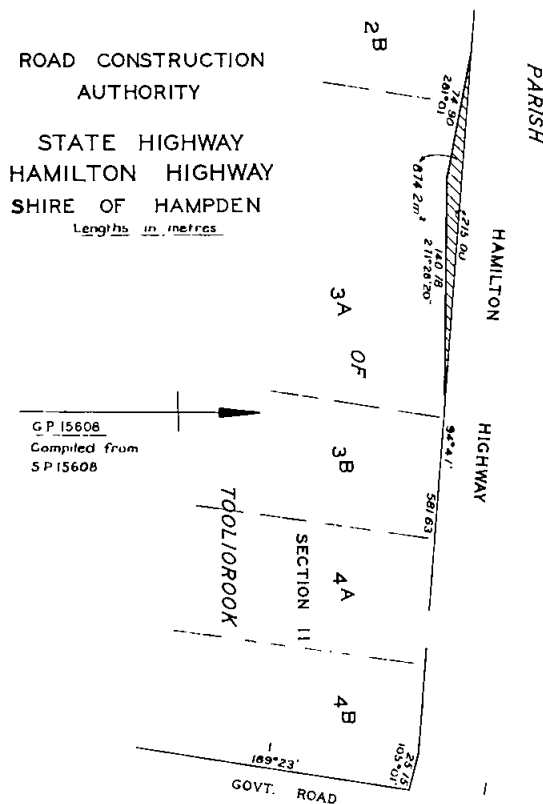

Widenings of an existing road in the Shire of Yea as shown hatched on plan numbered G.P.15726 below.

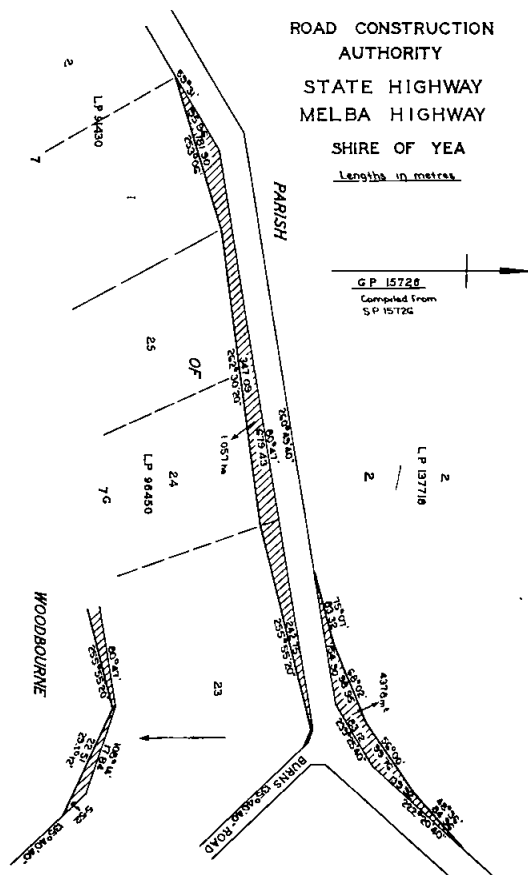

In accordance with the provisions of Clause 2 (2), Schedule 5 of the *Transport Act 1983*, the widenings shall, upon the publication of this notice in the *Government Gazette* become and be absolutely dedicated to the public as public highways within the meaning of any law now or hereafter in force.

12 December 1983

T. H. RUSSELL
Chairman and Managing Director

ROAD CONSTRUCTION AUTHORITY
NOTICE DECLARING THE WIDENINGS OF EXISTING
ROADS TO BE FIT TO BE USED AS PUBLIC HIGHWAYS

The Road Construction Authority is of the opinion that the widenings of the existing roads as set out below are fit to be used as public highways—

The widening of existing roads in the City of Croydon as shown hatched on plans numbered G.P.13444A and G.P.13444B below.

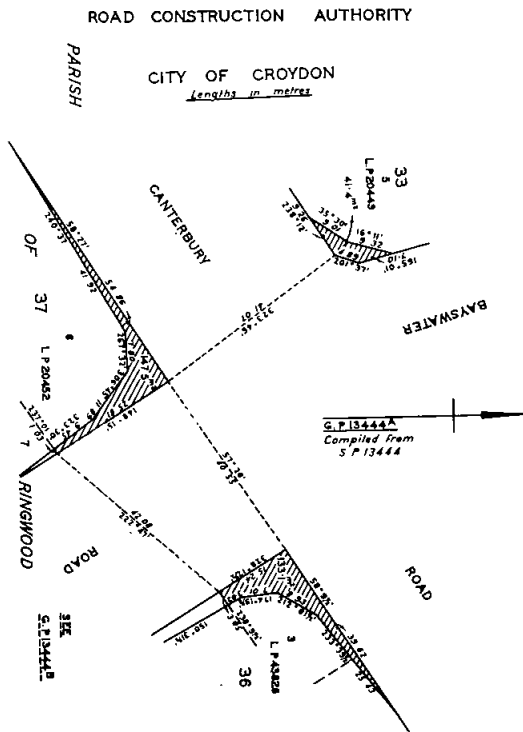

ROAD CONSTRUCTION AUTHORITY
ROAD
BAYSWATER ROAD
CITY OF CROYDON
Lengths in metres

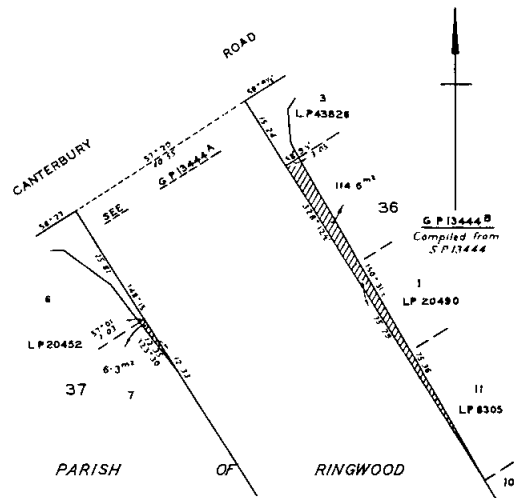

The widening of existing roads in the Shire of Lillydale as shown hatched on plan numbered G.P.15795A below.

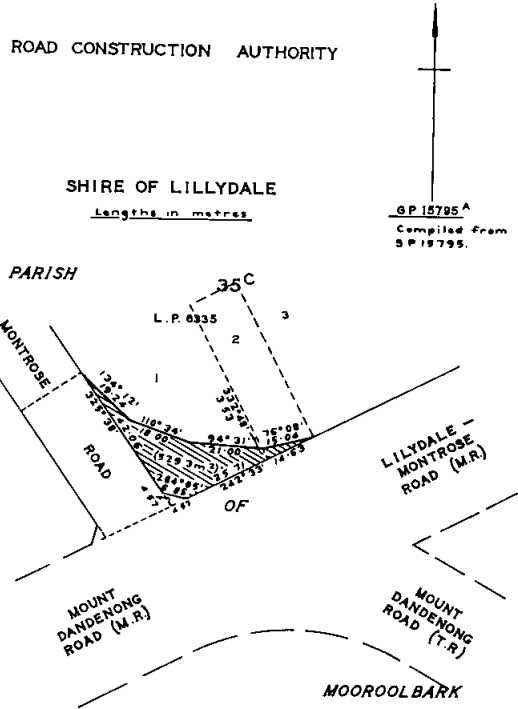

The widening of an existing road in the Shire of Ballan as shown hatched on plan numbered G.P. 15424A below.

ROAD CONSTRUCTION AUTHORITY

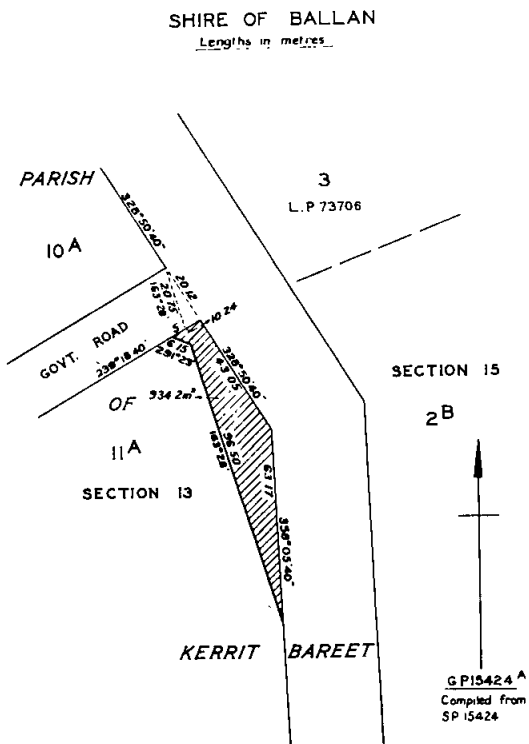

The widening of an existing road in the Shire of Dunmunkle as shown hatched on plan numbered G.P. 15796 below.

ROAD CONSTRUCTION AUTHORITY

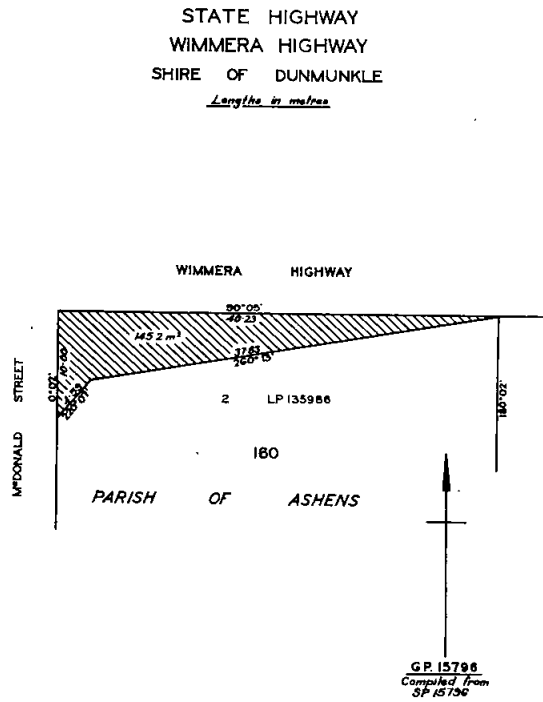

The widening of an existing road in the Shire of Mildura as shown hatched on plan numbered G.P.14111 below.

The widening of an existing road in the Shire of Alexandra as shown hatched on plan numbered G.P.15844 below.

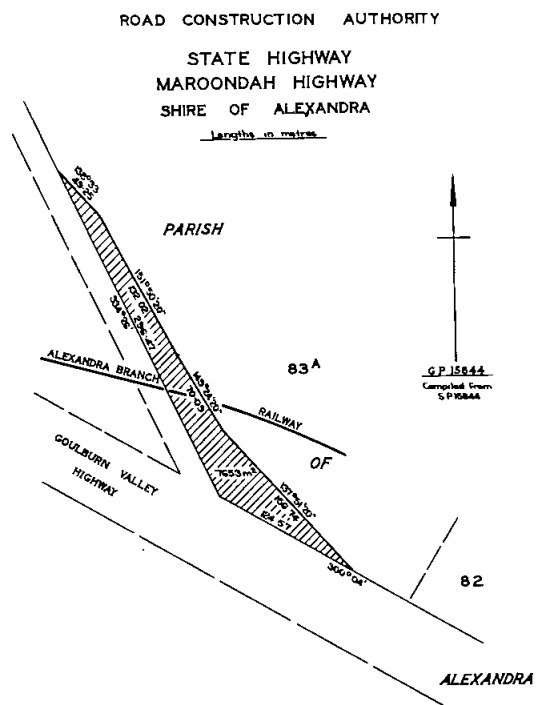
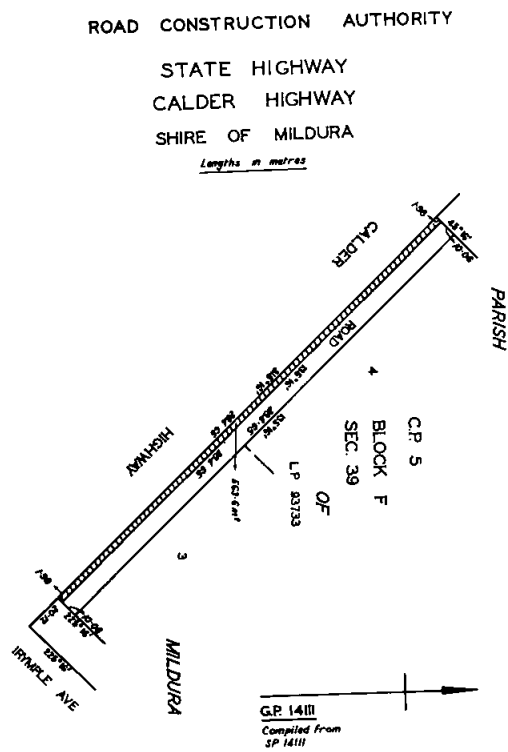

The widening of an existing road in the Shire of Bellarine as shown hatched on plan numbered G.P.10639A below.

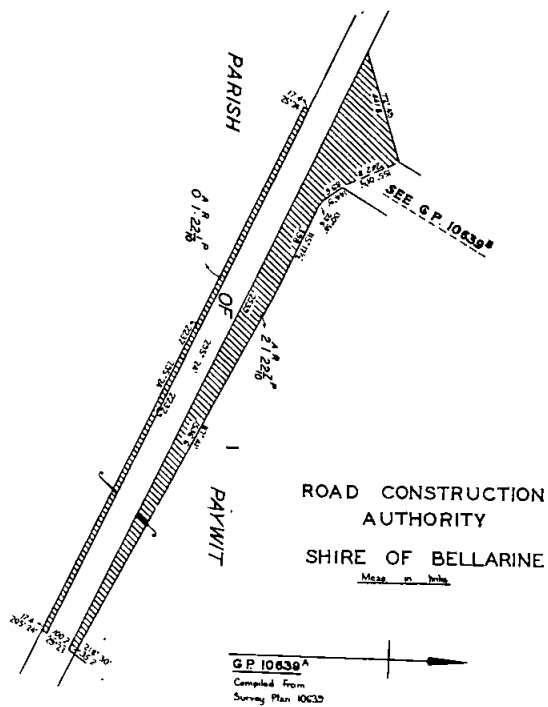

In accordance with the provisions of Clause 2 (2), Schedule 5 of the *Transport Act* 1983, the widenings shall, upon the publication of this notice in the *Government Gazette* become and be absolutely dedicated to the public as public highways within the meaning of any law now or hereafter in force.

12 December 1983

T. H. RUSSELL
Chairman and Managing Director

ROAD CONSTRUCTION AUTHORITY
NOTICE DECLARING THE DEVIATIONS FROM EXISTING
ROADS TO BE FIT TO BE USED AS PUBLIC HIGHWAYS

The Road Construction Authority is of the opinion that the deviations from the existing roads as set out below are fit to be used as public highways—

The deviation from an existing road in the Shire of Mirboo as shown hatched on plans numbered G.P.15425A, G.P. 15426A and G.P.15426B below.

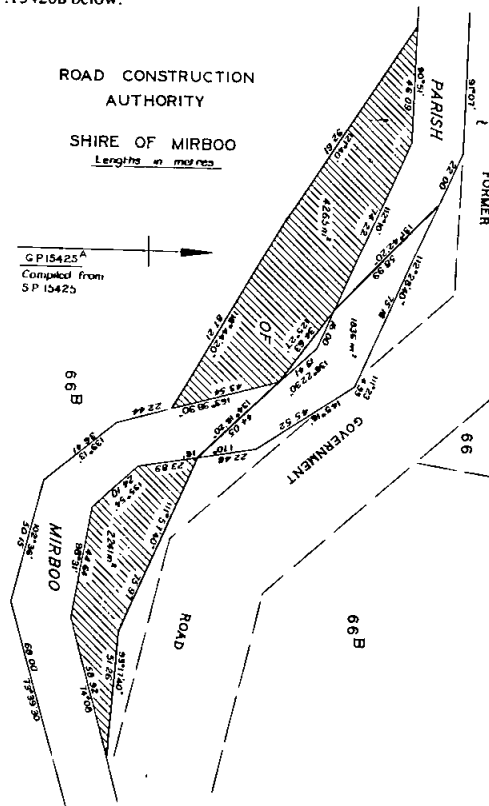

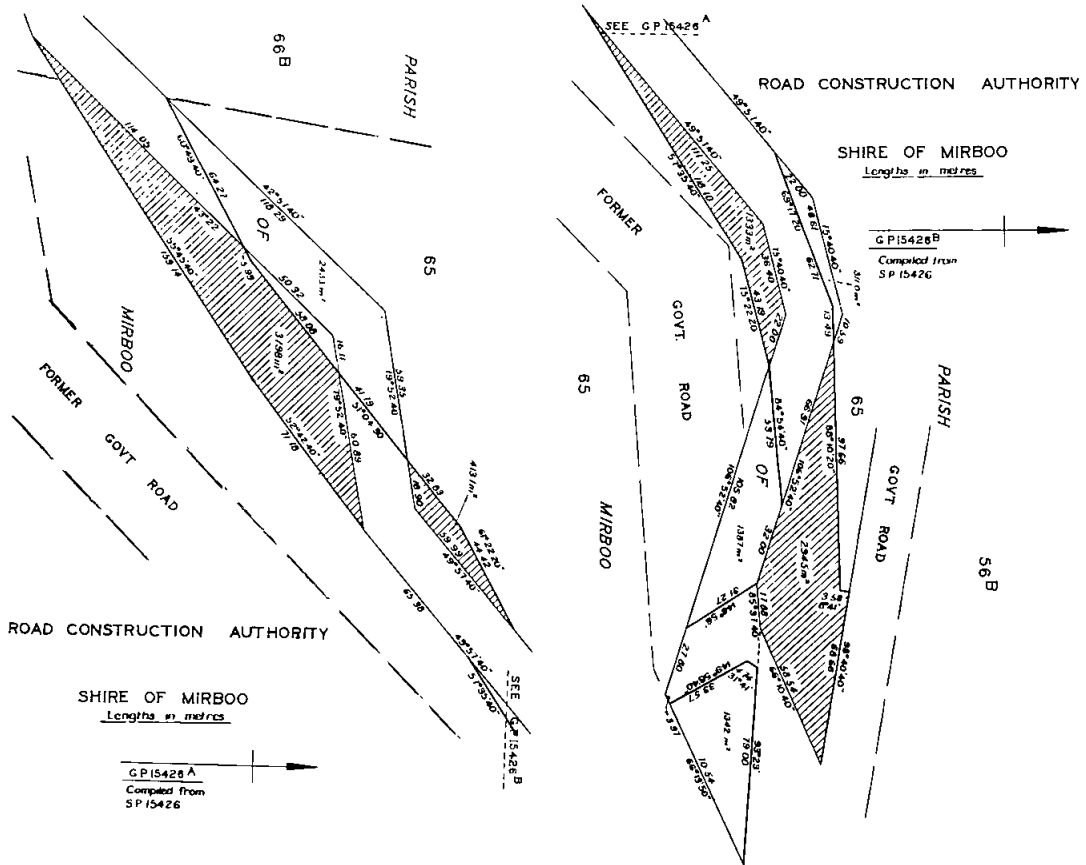

The deviation from an existing road in the Shire of Arapiles shown hatched on plans numbered G.P. 15636A and G.P. 15636B below.

ROAD CONSTRUCTION AUTHORITY

The deviation from an existing road in the Shire of Seymour as shown hatched on plan numbered G.P. 15045A below.

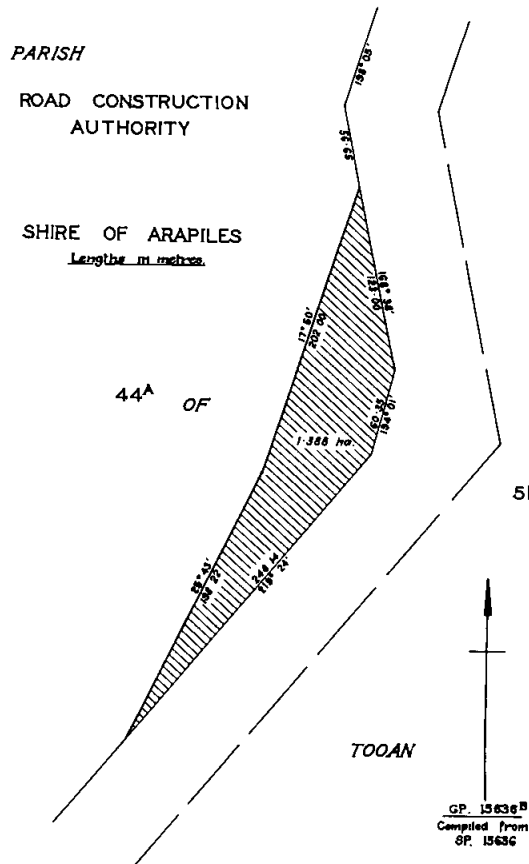
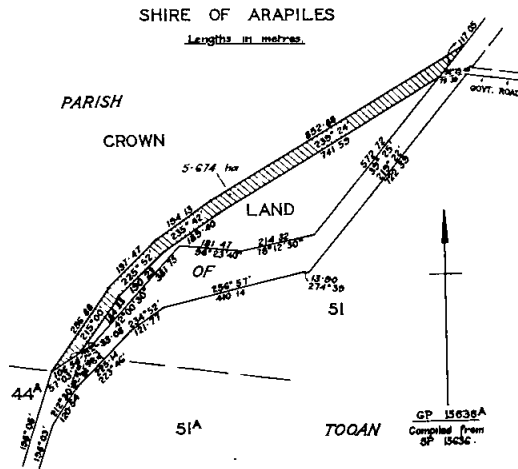
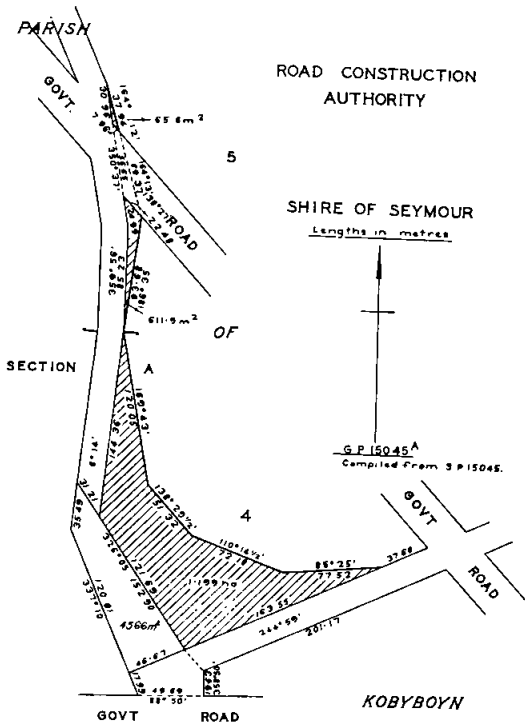

In accordance with the provisions of Clause 2 (2), Schedule 5 of the Transport Act 1983, the deviations shall, upon the publication of this notice in the Government Gazette become and be absolutely dedicated to the public as public highways within the meaning of any law now or hereafter in force.

12 December 1983

T. H. RUSSELL
Chairman and Managing Director

ROAD CONSTRUCTION AUTHORITY
NOTICE DECLARING NEW ROADS TO BE FIT TO BE USED
AS PUBLIC HIGHWAYS

The Road Construction Authority is of the opinion that the new roads as set out below are fit to be used as public highways—

The new road in the Shire of Mansfield as shown hatched on plan numbered G.P.14107A below.

ROAD CONSTRUCTION AUTHORITY

ROAD

SHIRE OF MANSFIELD

Lengths in metres

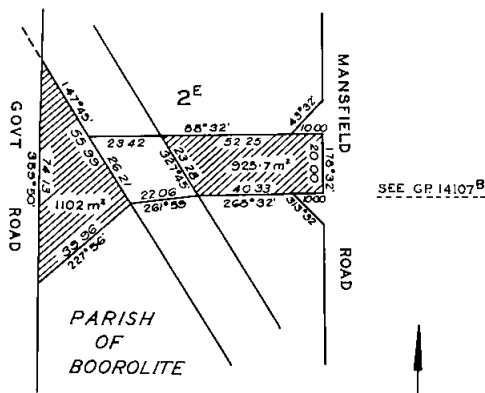

G.P. 14107^A
Compiled from
SP 14107

ROAD CONSTRUCTION AUTHORITY
NOTICE DECLARING THE DEVIATIONS FROM EXISTING
ROADS TO BE FIT TO BE USED AS PUBLIC HIGHWAYS

The Road Construction Authority is of the opinion that the deviations from the existing roads as set out below are fit to be used as public highways—

The deviation from an existing road in the Shire of Bellarine as shown hatched on plan numbered G.P.10639B below.

ROAD CONSTRUCTION AUTHORITY

SHIRE OF BELLARINE

Lengths in metres

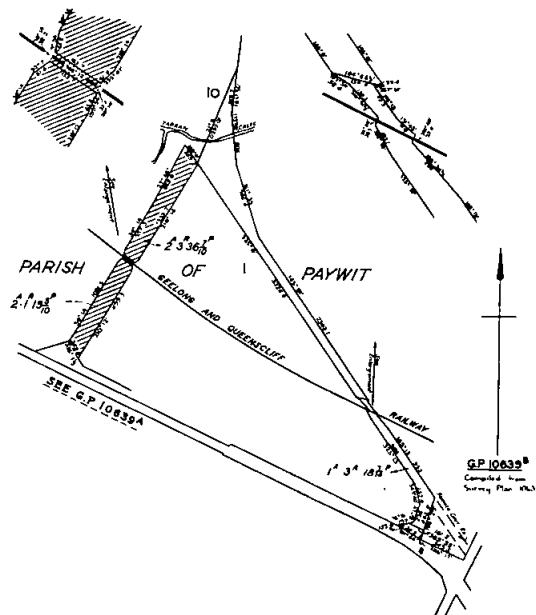

In accordance with the provisions of Clause 2 (2), Schedule 5 of the Transport Act 1983, the new roads shall, upon the publication of this notice in the Government Gazette become and be absolutely dedicated to the public as public highways within the meaning of any law now or hereafter in force.

12 December 1983

T. H. RUSSELL
Chairman and Managing Director

ROAD CONSTRUCTION AUTHORITY

The deviation from an existing road in the Shire of Korumburra as shown hatched on plans numbered G.P.15656D, G.P.15656C, G.P.15655D, G.P.15655C, G.P.15877A, G.P.15654E, G.P.15654F, G.P.15654G and G.P.15654H below.

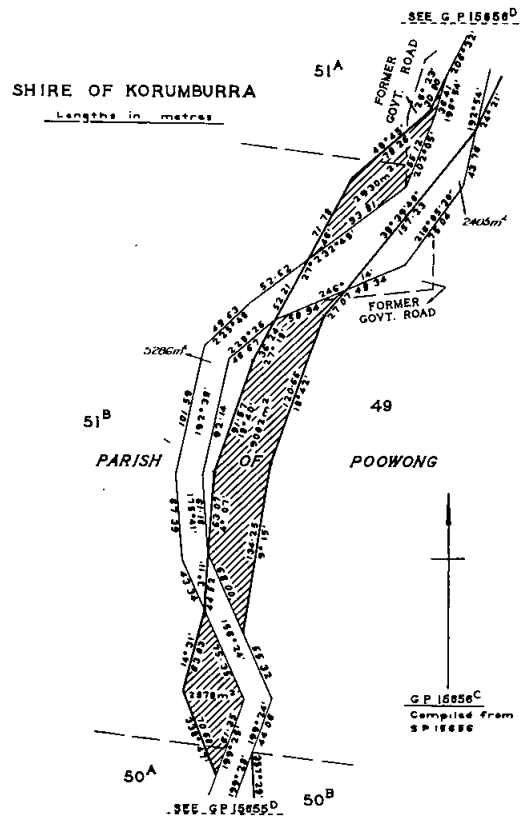
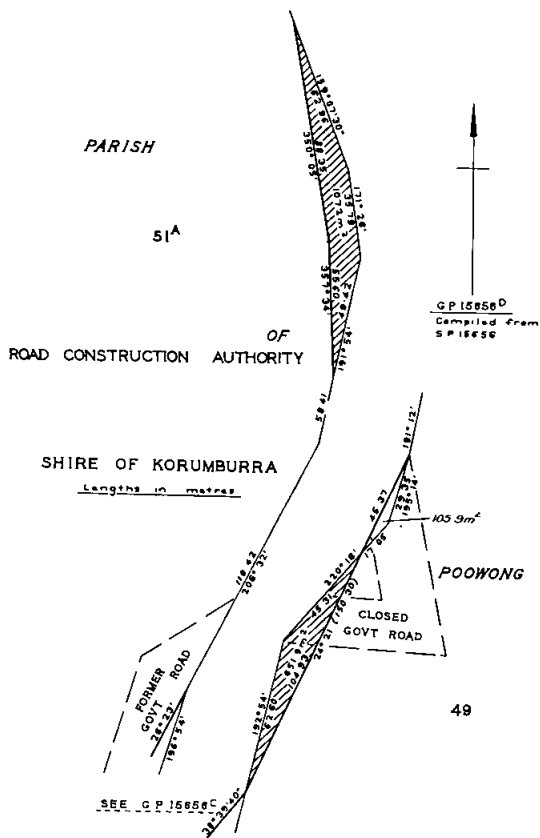

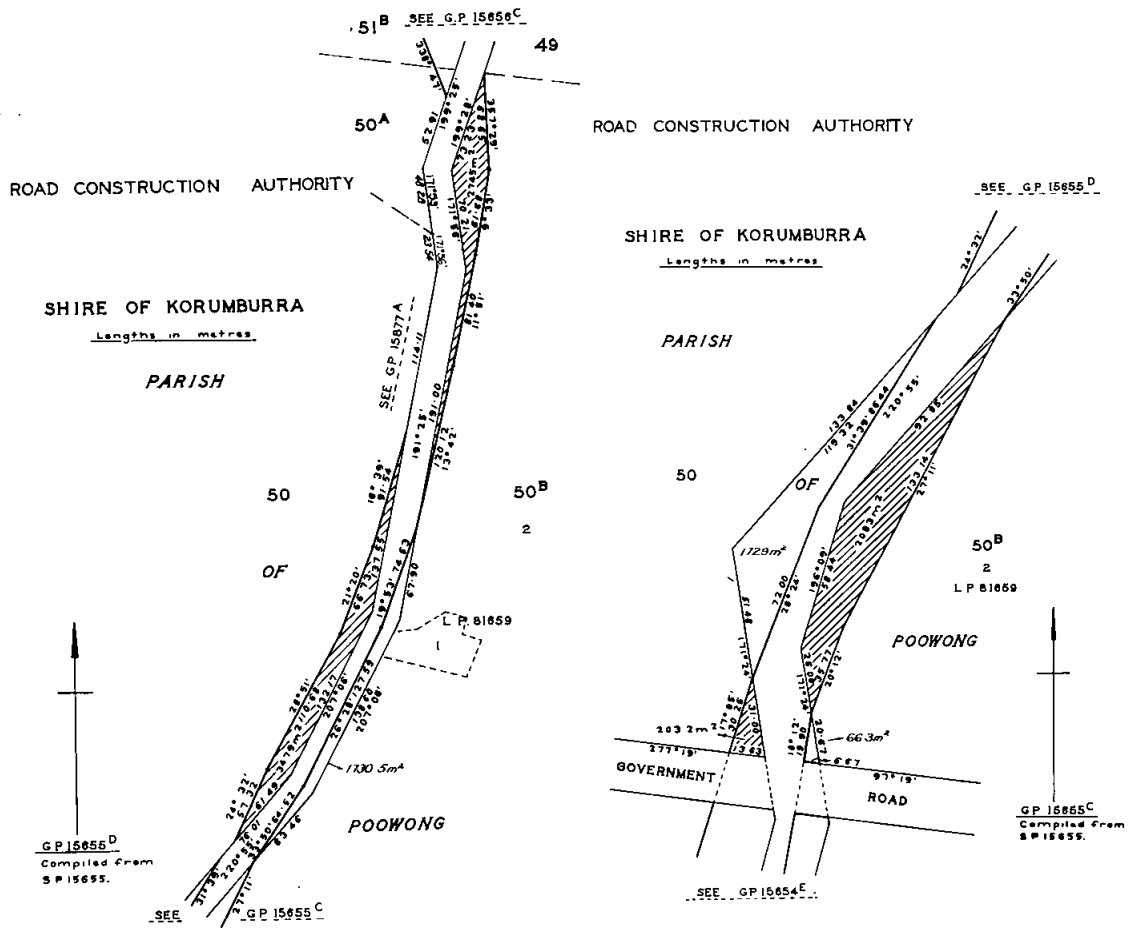

ROAD CONSTRUCTION AUTHORITY

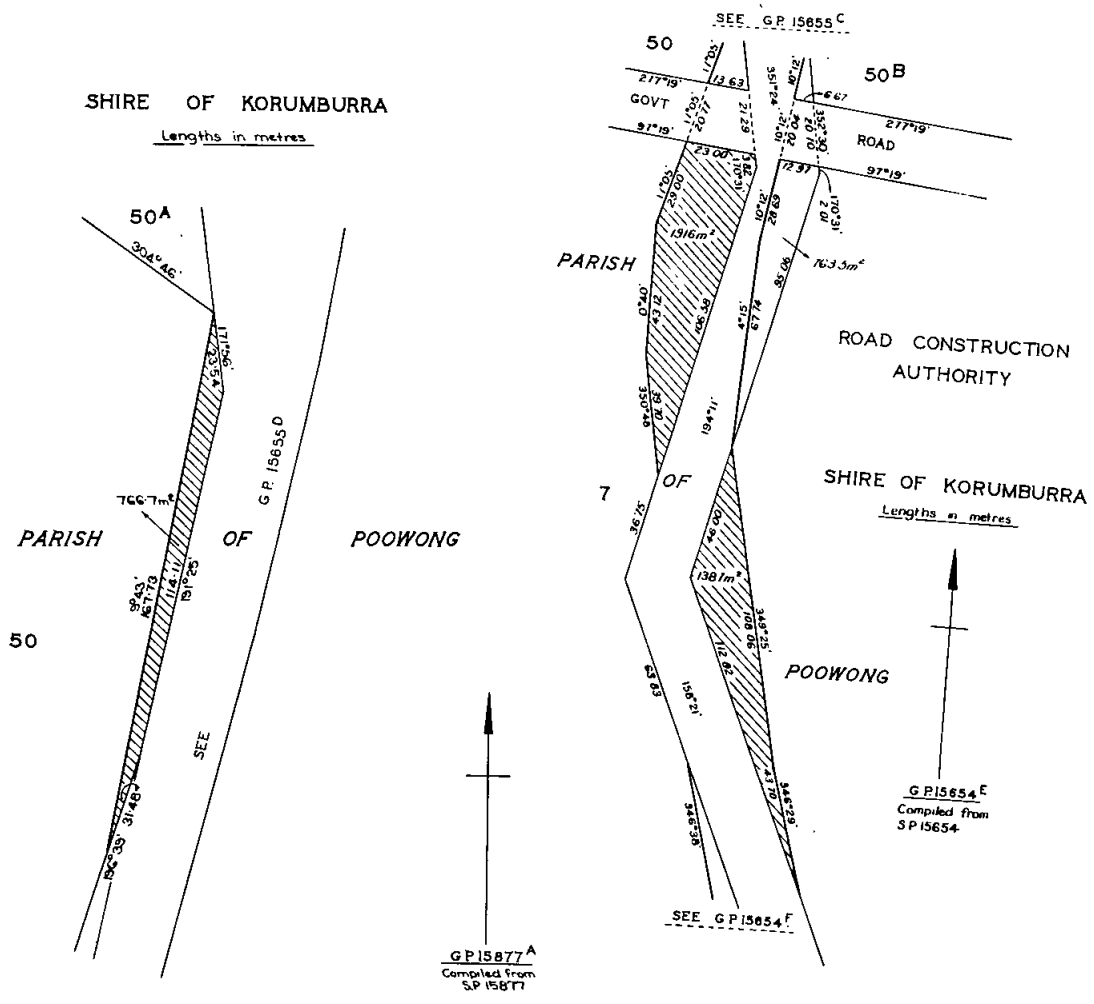

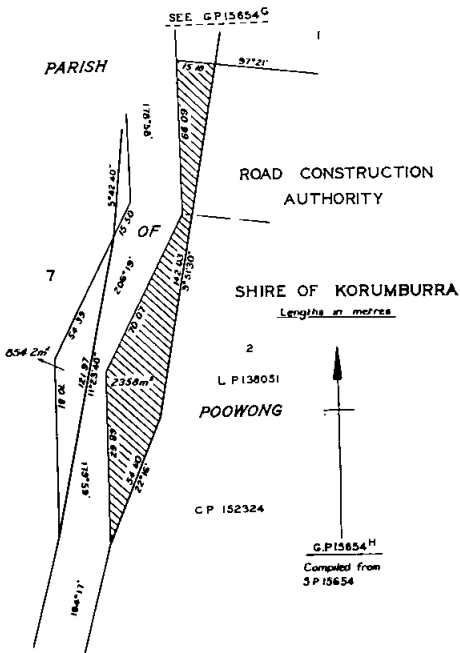
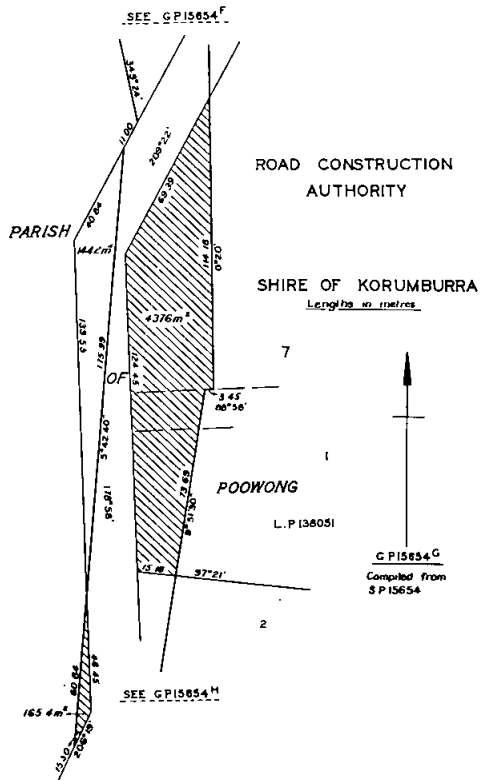
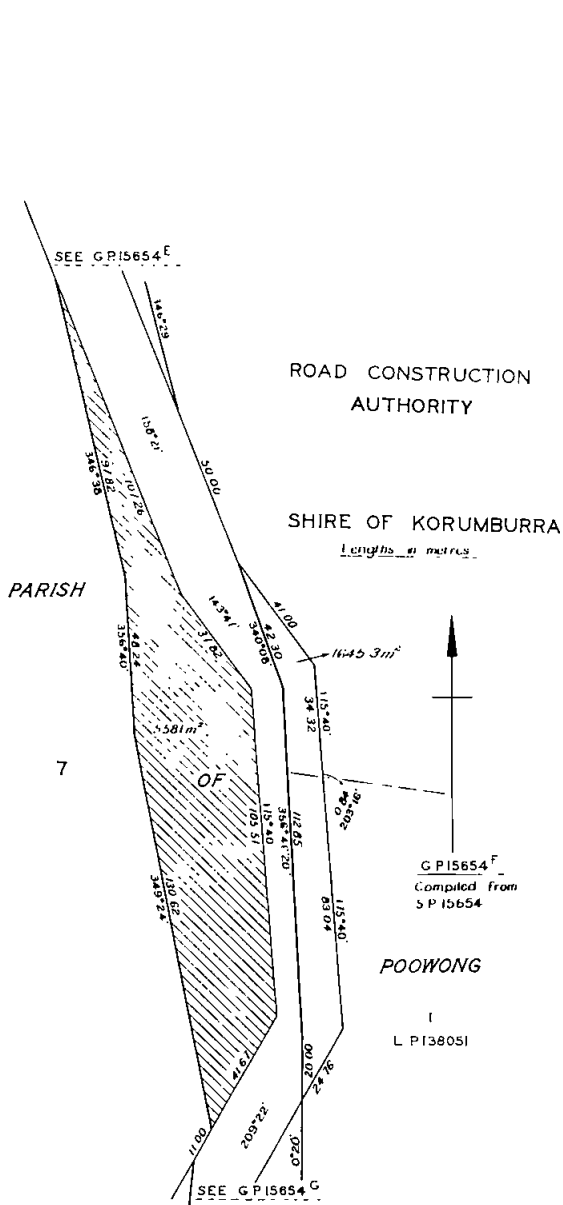

ROAD CONSTRUCTION AUTHORITY

SHIRE OF MANSFIELD
Lengths in metres

The deviation from an existing road in the Shire of Mansfield as shown hatched on plans numbered G.P.14106A, G.P.14107B and G.P. 14108A below.

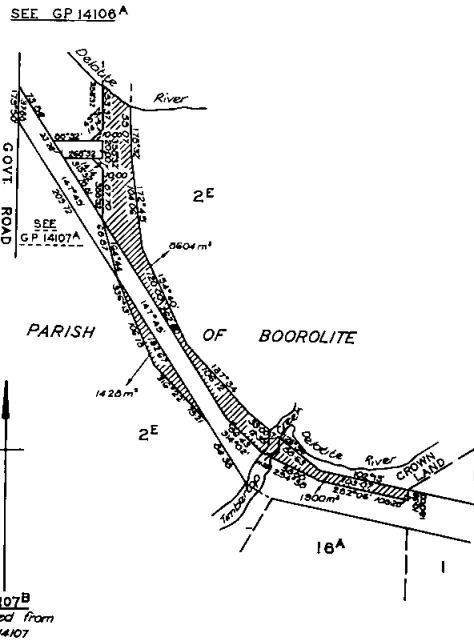
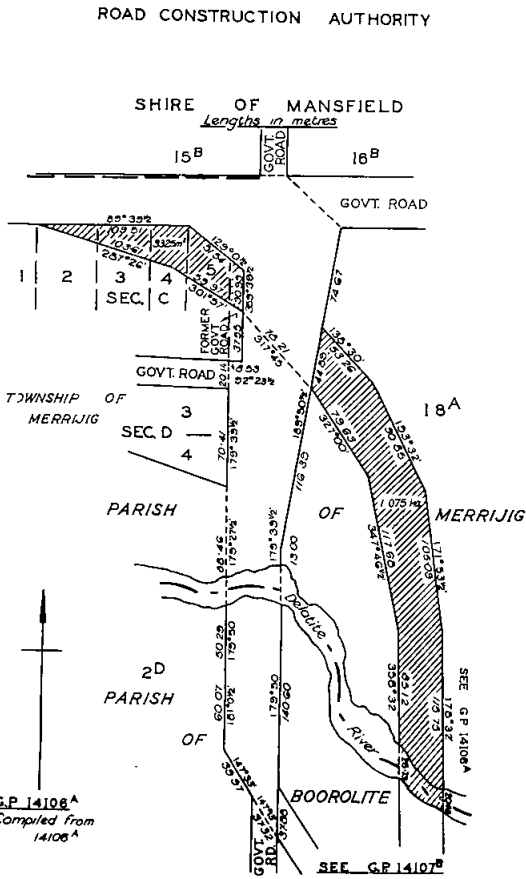

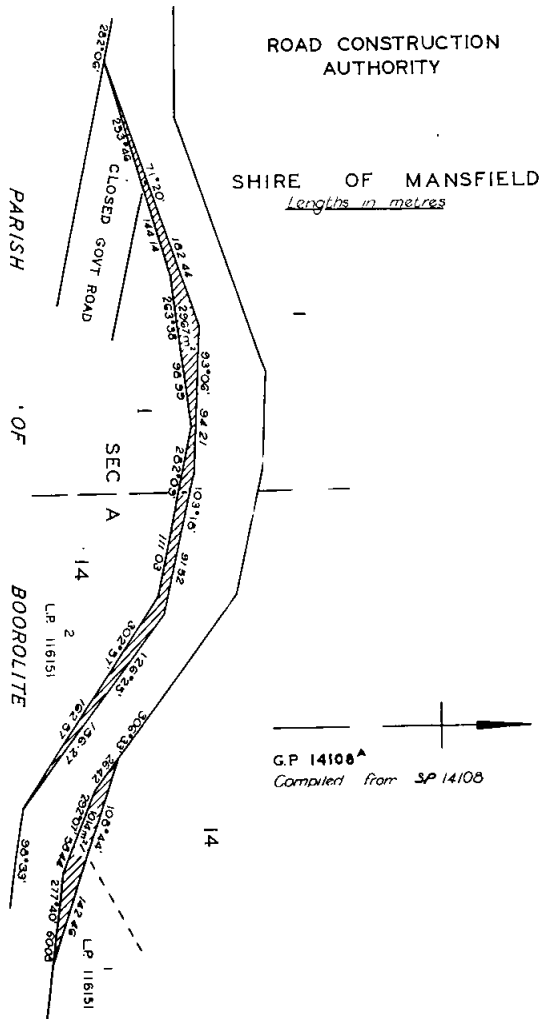

In accordance with the provisions of Clause 2 (2), Schedule 5 of the *Transport Act 1983*, the deviations shall, upon the publication of this notice in the *Government Gazette* become and be absolutely dedicated to the public as public highways within the meaning of any law now or hereafter in force.

12 December 1983

T. H. RUSSELL
Chairman and Managing Director

Town and Country Planning Act 1961
CITY OF MOE PLANNING SCHEME
REVOCATION No. 3
NOTICE OF REVOCATION
Notice of Order under Section 32 (5)

In pursuance of the provisions of Section 32 of the *Town and Country Planning Act 1961*, the Governor in Council on 25 February 1975, revoked in part the City of Moe Planning Scheme, and made an Order with respect to the land affected described as Lot 4, Lodged Plan 55085 at the corner of Old Sale Road and Newark Avenue, Moe.

In pursuance of the provisions of Section 32 of the *Town and Country Planning Act 1961*, the Governor in Council on 20 December 1983, by way of an amendment to the Order, made on 25 February 1975, restricts and regulates the use and development of the land so revoked to allow church activities subject to the consent by the Council of the City of Moe.

A copy of the Order relating to the revocation may be inspected during office hours at the office of the Ministry for Planning and Environment, 235 Queen Street, Melbourne and at the office of the City of Moe, Albert Street, Moe.

DAVID YENCKEN
Secretary for Planning and Environment

Town and Country Planning Act 1961
LORNE PLANNING SCHEME
AMENDMENT No. 8
NOTICE OF APPROVAL

In pursuance of the powers conferred by the *Town and Country Planning Act 1961*, the Governor in Council on 20 December 1983, approved the abovementioned scheme in respect of the municipal district of the Shire of Winchelsea and for which the Shire of Winchelsea is the Responsible Authority.

The scheme comes into operation on the date this notice is published in the *Government Gazette*.

The amendment involves a map change which rezones Crown Allotment 53, Section A, Parish of Lorne from Forest Residential to Forest.

A copy of the documents may be inspected free of charge, during office hours, at the office of the Ministry for Planning and Environment (Plan Inspection Section), 5th Floor, 235 Queen Street, Melbourne and at the office of the Shire of Winchelsea.

DAVID YENCKEN
Secretary for Planning and Environment

Town and Country Planning Act 1961
TOWN OF KYABRAM PLANNING SCHEME 1963
AMENDMENT No. 29
NOTICE OF AMENDMENT

In pursuance of the powers conferred by the *Town and Country Planning Act 1961*, the Governor in Council on 20 December 1983 amended the abovementioned scheme in respect of the municipal district of the Town of Kyabram and for which the Council of the Town of Kyabram is the Responsible Authority.

The amendment comes into operation on the date this Notice is published in the *Government Gazette*.

The amendment includes a correction to the Scheme base map in the vicinity of Sawyers Avenue and Lynton Crescent and consequent minor changes in the zoning of land in that area.

A copy of the documents may be inspected free of charge, during office hours, at the office of the Ministry for Planning and Environment (Plan Inspection Section), 5th Floor, 235 Queen Street, Melbourne and at the office of the responsible authority, Lake Road, Kyabram.

DAVID YENCKEN
Secretary for Planning and Environment

Town and Country Planning Act 1961
MELBOURNE METROPOLITAN PLANNING SCHEME
AMENDMENT No. 192, PART 3
NOTICE OF APPROVAL

In pursuance of the powers conferred by the *Town and Country Planning Act 1961*, the Governor in Council on 20 December 1983 approved the abovementioned scheme in respect of the municipal districts of the Cities of Springvale and Moorabbin and for which the Melbourne and Metropolitan Board of Works is the Responsible Authority.

The scheme comes into operation on the date this notice is published in the *Government Gazette*.

The scheme involves the rezoning of land generally in the Heatherton/Dingley area for extensive recreation or rural uses to give effect to an Interdepartmental Committee report on this former "Special Extractive" land.

A copy of the documents may be inspected free of charge, during office hours, at the office of the Ministry for Planning and Environment (Plan Inspection Section), 5th Floor, 235 Queen Street, Melbourne and at the office of the Melbourne and Metropolitan Board of Works, 625 Little Collins Street, Melbourne.

DAVID YENCKEN
Secretary for Planning and Environment

Special
4846 Ormond
Consolidated
6207 Boisdale
6243 Pakenham
High
7650 Brighton
7837 Flora Hill
7936 Kaniva
8428 Wantirna
8445 Watsonia
Technical
7095 Colac
7135 Essendon
7253 Mitcham
7408 Whittlesea T.H.S.

ROBERT FORDHAM
Minister of Education

Education Act 1958

NOTICE OF THE MAKING OF AN ORDER UNDER SECTION 13(4) OF THE ACT

Pursuant to section 13 of the *Education Act 1958* I hereby give notice that an Order of the Governor in Council was made on 20 December 1983 under sub-section (4) of the said Act amending certain provisions relating to the Primary School Councils listed below:

733 Laanecoorie
737 Milawa
749 Bealiba
793 Eddington
798 Sutton Grange
1008 Axedale
1052 Inglewood
1924 Drouin
2657 Mitiamo
2959 Research
3139 Northcote
3246 Culgoa
3301 Nullawil
3581 The Lake
3983 Mildura West
4084 Middle Tarwin
4148 Woorinen North
4641 Solway
4764 Preston North-East
5008 Waldau
5094 Wheelers Hill

ROBERT FORDHAM
Minister of Education

Education Act 1958

NOTICE OF MAKING OF AN ORDER UNDER SECTION 13(4) OF THE ACT

Pursuant to section 13 of the *Education Act 1958* I hereby give notice that an Order of the Governor in Council was made on 20 December 1983 under sub-section (4) of the said Act amending certain provisions relating to the State Primary, Group, Special, Consolidated, Secondary and Technical School Councils listed below:

Primary
1484 Cape Clear
1488 Tallarook
2090 Whittlesea
2093 Little Bendigo
2136 Morwell
2963 Lindenow South
3261 Perseverance
3433 Marlo
3641 Youanmitte
3691 Combienbar
3719 Narre Warren East
4904 Heatherdale
5169 Robertson
5187 Glen Orden
5228 Bundarra
Group
2953 Ensay

Local Government Act 1958

NOTICE OF CONFIRMATION OF AN ORDER OF THE COUNCIL OF THE SHIRE OF CORIO ADOPTING A PROPOSAL FOR THE CLOSURE OF CREAMERY ROAD, BELL POST HILL TO THROUGH TRAFFIC.

In pursuance to the provisions of section 539C of the *Local Government Act 1958*, the Governor in Council, on 20 December 1983 confirmed an order of the Council of the Shire of Corio made on 25 May 1983 adopting a proposal for the closure of Creamery Road, Bell Post Hill to through traffic by the erection of a barrier at the location shown on the plan hereunder.

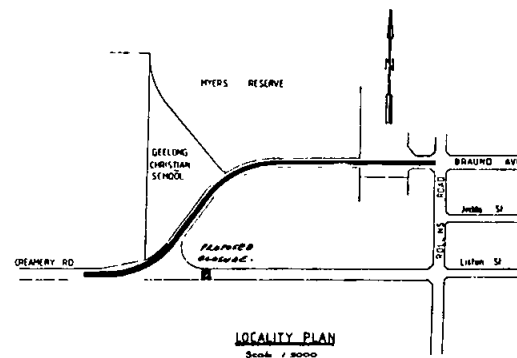

TOM FORRISTAL
Clerk of the Executive Council

Local Government Department,
Melbourne (83/3284)

Local Government Act 1958

NOTICE OF CONFIRMATION OF AN ORDER OF THE COUNCIL OF THE CITY OF BOX HILL ADOPTING A PROPOSAL FOR A SHOPPING MALL

Pursuant to the provisions of section 539B of the *Local Government Act 1958*, the Governor in Council on 20 December 1983 confirmed an Order of the Council of the City of Box Hill made on 3 October, 1983 adopting a proposal for a shopping mall and declaring that Market and Main Streets, Box Hill be a shopping mall.

TOM FORRISTAL
Clerk of the Executive Council

Local Government Department
Melbourne (83/5416)

Local Government Act 1958

NOTICE OF CONFIRMATION OF AN ORDER OF THE COUNCIL OF THE CITY OF MELBOURNE ADOPTING A PROPOSAL FOR THE CLOSURE OF BIGNELL STREET, FLEMINGTON TO THROUGH TRAFFIC.

Pursuant to the provisions of section 539c of the *Local Government Act 1958*, the Governor in Council, on 20 December 1983 confirmed an order of the Council of the City of Melbourne made on 11 July 1983 adopting a proposal for the closure of Bignell Street, Flemington to through traffic by the erection of a barrier as shown on the plan hereunder.

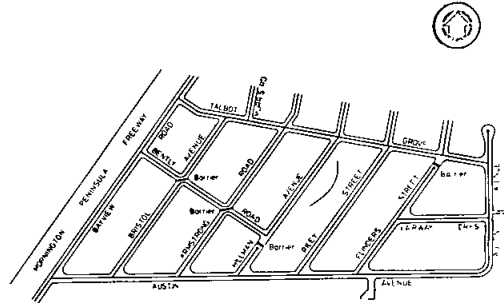

PLAN OF PROPOSED CLOSURE OF BIGNELL STREET, FLEMINGTON

TOM FORRISTAL
Clerk of the Executive Council

Local Government Department,
Melbourne (83/3709)

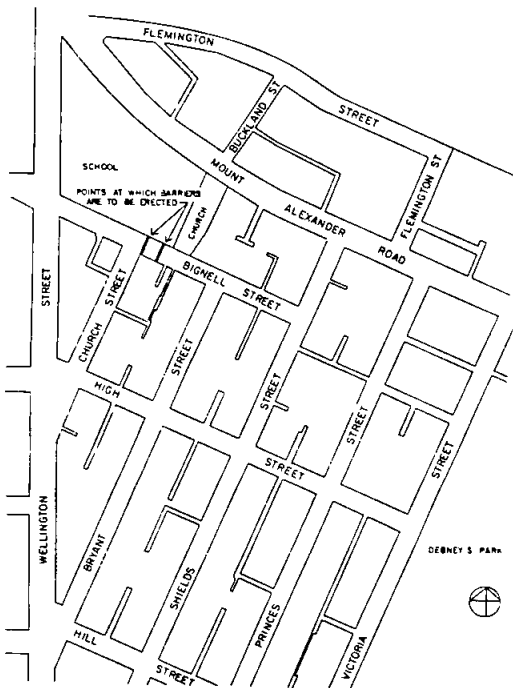

TOM FORRISTAL
Clerk of the Executive Council

Local Government Department,
Melbourne (83/3925)

Local Government Act 1958

NOTICE OF CONFIRMATION OF AN ORDER OF THE COUNCIL OF THE TOWN OF BAIRNSDALE ADOPTING A PROPOSAL FOR THE CLOSURE OF HODGSON STREET, BAIRNSDALE TO THROUGH TRAFFIC

Pursuant to the provisions of section 539c of the *Local Government Act 1958*, the Governor in Council, on 20 December 1983 confirmed an order of the Council of the Town of Bairnsdale made on 11 July 1983 adopting a proposal for the closure of Hodgson Street, Bairnsdale to through traffic by the erection of a barrier at the location shown on the plan hereunder.

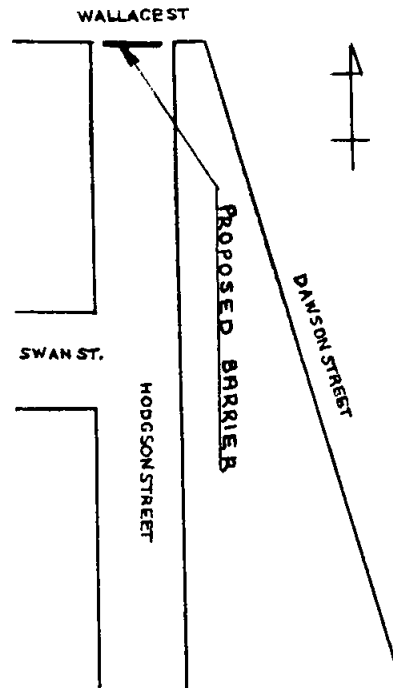

TOM FORRISTAL
Clerk of the Executive Council

Local Government Department,
Melbourne (83/4023)

Local Government Act 1958

NOTICE OF CONFIRMATION OF AN ORDER OF THE COUNCIL OF THE SHIRE OF FLINDERS ADOPTING A PROPOSAL FOR THE CLOSURE OF STREETS TO THROUGH TRAFFIC

Pursuant to the provisions of section 539c of the *Local Government Act 1958*, the Governor in Council, on 20 December 1983 confirmed an order of the Council of the Shire of Flinders made on 15 June 1983 adopting a proposal for the closure of Bristol Avenue, Armstrong Road, Bentley Road, Hillman Avenue and Flinders Street, McCrae to through traffic by the erection of barriers at the locations shown on the plan hereunder.

Town and Country Planning Act 1961
SHIRE OF LILLYDALE PLANNING SCHEME 1958
 AMENDMENT No. 168
 NOTICE OF AMENDMENT

In pursuance of the powers conferred by the *Town and Country Planning Act 1961*, the Governor in Council on 20 December 1983, amended the abovementioned scheme in respect of the municipal district of the Shire of Lillydale and for which the Shire of Lillydale is the Responsible Authority.

The amendment comes into operation on the date this Notice is published in the *Government Gazette*.

The amendment includes the inclusion in an existing public open space reservation of disused aqueduct land in the vicinity of Mount Evelyn.

A copy of the documents may be inspected free of charge, during office hours, at the office of the Ministry for Planning and Environment (Plan Inspection Section), 5th Floor, 235 Queen Street, Melbourne and at the office of the Shire of Lillydale, Shire Office, Anderson Street, Lillydale.

DAVID YENCKEN
 Secretary for Planning and Environment

Town and Country Planning Act 1961
TOWN OF STAWELL PLANNING SCHEME
 AMENDMENT No. 24
 NOTICE OF AMENDMENT

In pursuance of the powers conferred by the *Town and Country Planning Act 1961*, the Governor in Council on 20 December 1983, amended the abovementioned scheme in respect of the municipal district of the Town of Stawell and for which the Town of Stawell is the Responsible Authority.

The amendment comes into operation on the date this Notice is published in the *Government Gazette*.

The amendment rezones Crown Allotment No. 5, Section 150, Parish of Stawell from Public Purposes—Sanitary Depot to Rural.

A copy of the documents may be inspected free of charge, during office hours, at the office of the Ministry for Planning and Environment (Plan Inspection Section), 5th Floor, 235 Queen Street, Melbourne and at the office of the Town of Stawell, Town Hall, Stawell.

DAVID YENCKEN
 Secretary for Planning and Environment

Town and Country Planning Act 1961
RURAL CITY OF WODONGA
 INTERIM DEVELOPMENT ORDER 1979
 AMENDMENT No. 14
Notice of Amendment

In pursuance of the powers conferred by the *Town and Country Planning Act 1961*, the Governor in Council on 20 December 1983, amended the abovementioned Order in respect of the municipal area of the Rural City of Wodonga and for which the Council of the Rural City of Wodonga is the Responsible Authority.

The amendment comes into operation on the date this Notice is published in the *Government Gazette*.

The amendment includes the addition of "Tourist Establishment" and "Road" to Column 2 of the Table to Clause 16 which applies within the Causeway Zone.

A copy of the documents may be inspected free of charge, during office hours, at the office of the Ministry for Planning and Environment (Plan Inspection Section), 5th Floor, 235 Queen Street, Melbourne and Astra House, Jack Hore Place, Wodonga and at the office of the Council of the Rural City of Wodonga, Municipal Offices, Hovell Street, Wodonga.

DAVID YENCKEN
 Secretary for Planning and Environment

PUBLIC TRUSTEE ACT 1958—SECTION 17

I hereby give notice that on 8 December 1983 the public Trustee filed an Election to Administer the following deceased person's estate in accordance with Section 17 of the *Public Trustee Act 1958*:

MILLS, JAMES LEONARD BROUGHTON, formerly of Eastern Hostel, Yallourn but late of Clifton Waters Village, Bairnsdale, Mechanic, died 20 July 1982.

I hereby give notice that on 12 December 1983 the Public Trustee filed Elections to Administer the following deceased persons' estates in accordance with Section 17 of the *Public Trustee Act 1958*:

BONK, ALFRED, late of 1/98 McCrae Street, Dandenong Vehicle Inspector, died 25 November 1982.

CALDWELL, KENNETH RUTHERFORD, late of 41 Marriott Street, St. Kilda, Owner Driver died 9 October 1983.

HARPER, PETER LINDSAY, late of Kew, Pensioner, died 13 October 1983.

MCVITTY, THOMAS CRAIG, late of 81 Beatty Avenue, Glenroy Retired Boiler Attendant, died 22 October 1983.

SUTTON, SHEILA, late of 14 Maroona Road, Glenhuntly, Spinster, died 7 April 1978.

I hereby give notice that on 14 December 1983 the Public Trustee filed Elections to Administer the following deceased persons' estates in accordance with Section 17 of the *Public Trustee Act 1958*:

FIRTH, INEZ CATHERINE, late of Allora Private Hospital, Wood Court, Traralgon, Pensioner died 6 August 1983.

LATZEL, STANISLAWA, late of 9/26 Lewisham Road, Windsor, Retired Machinist, died 25 October 1983.

NOLAN, WILLIAM, late of Ballarat, Retired, died 9 October 1983.

PHILLIPS, JACK, late of Kew, Pensioner, died 12 July 1983.

SUARES, CLAUDE VINCENT, late of 2/837 High Street, Epping, Retired, died 27 April 1983.

21 December, 1983.

168 Exhibition Street, Melbourne

P. T. SPENCER
 Public Trustee

Creditors, next of kin, and others having claims against the estate of any of the under-mentioned deceased persons are required to send particulars of their claims to the Public Trustee, 168 Exhibition Street, Melbourne, Vic. 3000, the personal representative, on or before 7 March 1984 after which date the Public Trustee may convey or distribute the assets having regard only to the claims of which the Public Trustee then has notice:

ANDERSON, JOHN WILLIAM, late of 7 Nursery Close, Queniborough, Leicestershire, England, Plumber Retired, died 4 February 1980.

ANDERSON, LILIAN, late of 7 Nursery Close, Queniborough, Leicestershire, England, Widow, died 19 June 1983.

BAKER, JAMES, formerly of 11 Fordham Court, Richmond but late of Unit 10/50 Baker Street, Richmond, retired Engine Driver, died 25 June 1983.

BONK, ALFRED, late of 1/98 McCrae Street, Dandenong, Vehicle Inspector, died 25 November 1982.

BUTT, WILLIAM RONALD CAMERON, late of 50 City View Road, North Balwyn, Retired Company Director, died 25 July 1983.

CALDWELL, KENNETH RUTHERFOD, late of 41 Marriott Street, St. Kilda, Owner Driver, died 9 October 1983.

FIRTH, INEZ CATHERINE, late of Allora Private Hospital, Wood Court, Traralgon, Pensioner, died 6 August 1983.

GOODE, RONALD, late of 11 Drumcondra, Avenue, Drumcondra, Retired, died between 16 May 1983 and 6 June 1983.

GRAY, GLADYS McDONALD, late of 198 Reserve Road, Beaumaris, Pensioner, died 6 August 1983.

GROTH, EDITH THELMA, also known as Thelma Edith Groth, late of 175 Victoria Road, Northcote, retired Ceramics Supervisor, died 5 October 1983.

HARPER, PETER LINDSAY, late of Kew, Pensioner, died 13 October 1983.

LATZEL, STANISLAWA, late of 9/26 Lewisham Road, Windsor, Retired Machinist, died 25 October 1983.

LEAHY, WILLIAM RUPERT, formerly of 102 Neville Street, Carnegie but late of Unit 1/3 Maroo Street, Oakleigh, Retired Public Servant, died 1 October 1983.

MCVITTY, THOMAS CRAIG, late of 81 Beatty Avenue, Glenroy, Retired Boiler Attendant, died 22 October 1983.

MILLS, JAMES LEONARD BROUGHTON, formerly of Eastern Hostel, Yallourn but late of Clifton Waters Village, Bairnsdale, Mechanic, died 20 July 1982.

NOLAN, WILLIAM, late of Ballarat, Retired, died 9 October 1983.

PHILLIPS, JACK, late of Kew, Pensioner, died 12 July 1983.

ROSS, ALEXANDER, late of House 79/215 Shawbridge Street, Pollokshaws, Glasgow, Scotland, Lorry Driver, died 2 January 1983.

SOWINSKI, STANISLAW, late of Grace McKellar House, Ballarat Road, North Geelong, Retired Labourer, died 21 June 1983.

SUARES, CLAUDE VINCENT, late of 2/837 High, Epping, Retired, died 27 April 1983.

SUTTON, SHEILA, late of 14 Maroona Road, Glenhuntly, Spinster, died 7 April 1978.

Melbourne 21 December 1983

P. T. SPENCER
Public Trustee

INDUSTRIAL RELATIONS COMMISSION OF VICTORIA

Industrial Relations Act 1979

Notice is hereby given that an application has been lodged on behalf of The Amalgamated Metals Foundry and Shipwrights' Union for amalgamation of the jurisdiction of the following Conciliation and Arbitration Boards:

Bedstead and Oven Makers
Boilermakers
Electroplaters
Engineers (Skilled)
Engravers
Farriers
Gas Meter
Ironmoulders
Nailmakers
Nickleware
Tinsmiths
Wire Fence and Tubular Gate
Wireworkers

Notice is also given that this matter is listed for hearing before the Industrial Relations Commission of Victoria in Full Session at 10.30 a.m. Tuesday, 31 January 1984 in Hearing Room No. 1, Level 18 Nauru House, 80 Collins Street, Melbourne.

A. S. DOWLING, Deputy Registrar
Industrial Relations Commission of Victoria

ORDERS IN COUNCIL

AUDIT ACT 1958

*At the Executive Council Chamber, Melbourne, the
thirteenth day of December, 1983*

PRESENT:

His Excellency the Governor of Victoria
Mr Kent | Mr Mathews
Mr Kennan | Mr Spyker

Pursuant to the provisions of Regulation 4 of the Treasury Regulations 1981, His Excellency the Governor of the State of Victoria, by and with the advice of the Executive Council thereof, doth hereby amend the Schedule designating offices the occupants of which shall certify accounts for expenditure and contained in the Order made on 12 October 1982 and amended from time to time by the insertion of the following clauses in addition to those clauses appearing in the aforementioned Order.

SCHEDULE

DIVISION OF THE HONOURABLE THE MINISTER FOR COMMUNITY WELFARE SERVICES

Add—
"Office of Corrections" "The Manager, Finance and
Accounting, the Accountant or
the Deputy to the Accountant,
Office of Corrections"

DIVISION OF THE HONOURABLE THE MINISTER FOR WATER SUPPLY

Add— "Director of Operations, Ministry
of Water Resources and
Water Supply"
after "the Director of Water Resources" where twice appearing.

And the Honourable Robert Allen Jolly, Her Majesty's Treasurer for the State of Victoria, shall give the necessary directions herein accordingly.

TOM FORRISTAL
Clerk of the Executive Council

SUPERANNUATION ACT 1958

*At the Executive Council Chamber, Melbourne, the
thirteenth day of December, 1983*

PRESENT:

His Excellency the Governor of Victoria
Mr Kent | Mr Mathews
Mr Kennan | Mr Spyker

Pursuant to the powers conferred by the provisions of paragraph (ja) of sub-section (1) of section 3 of the *Superannuation Act 1958*, His Excellency the Governor of the State of Victoria, by and with the advice of the Executive Council thereof, doth by this Order declare that the provisions of the Superannuation Act shall apply to the officers named in the Schedule set out hereunder.

SCHEDULE

MOULDER, PETER JAMES, Chisholm Institute of Technology.
MITCHELL, IAN MACPHERSON, Hawthorn Institute of Education.
PRIDMORE, BARTLEY WILLIAM, Hawthorn Institute of Education.
HOGAN, BRIAN JOHN, Road Construction Authority.
MORAN, ROBERT GEORGE, Small Business Development
Corporation.

And the Honourable Robert Allen Jolly, Her Majesty's Treasurer for the State of Victoria, shall give the necessary directions herein accordingly.

TOM FORRISTAL
Clerk of the Executive Council

STATE EMPLOYEES RETIREMENT BENEFITS ACT 1979

At the Executive Council Chamber, Melbourne, the thirteenth day of December, 1983

PRESENT:

His Excellency the Governor of Victoria
 Mr Kent | Mr Mathews
 Mr Kennan | Mr Spyker

Whereas sub-section 26 (2) of the *State Employees Retirement Benefits Act 1979* provides that the Governor in Council shall by Order published in the *Government Gazette* within 30 days after 1 December in each year declare the amount that in his opinion is the amount by which the minimum wage has increased between 30 June 1981 and 1 December then last past.

Now therefore, His Excellency the Governor of the State of Victoria, by and with the advice of the Executive Council thereof, does hereby declare that in his opinion the minimum wage has increased by \$29.10 between 30 June 1981 and 1 December 1983.

And the Honourable Robert Allen Jolly, Her Majesty's Treasurer for the State of Victoria, shall give the necessary directions herein accordingly.

TOM FORRISTAL
 Clerk of the Executive Council

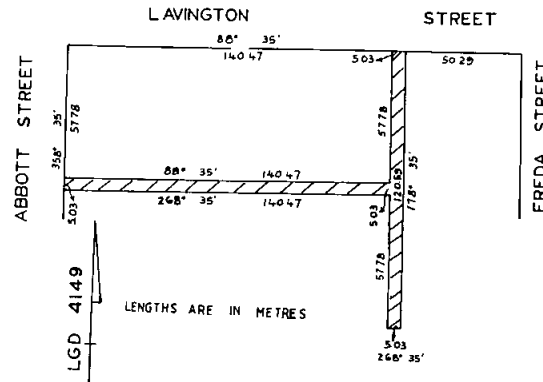

And the Honourable Frank Noel Wilkes, Her Majesty's Minister for Local Government for the State of Victoria, shall give the necessary directions herein accordingly.

TOM FORRISTAL
 Clerk of the Executive Council

LOCAL GOVERNMENT ACT 1958

At the Executive Council Chamber, Melbourne, the twentieth day of December 1983

PRESENT:

His Excellency the Governor of Victoria
 Mr Cathie | Mr Walker
 Mr Trezise

ROAD DISCONTINUED—SHIRE OF WOORAYL

Whereas it is provided in section 528 (2) of the *Local Government Act 1958*, that where a road (whether or not a public highway but not being a road set out on land of the Crown) or any part thereof is not required for public use, the Governor in Council on the request of the council of the municipality in which such road is situated made not less than one month after published in a newspaper generally circulating in the district and posting to the registered proprietor (if any) of the land and the owners and occupiers (if any) of lands abutting or immediately adjacent to the road notice of intention to make such a request may by Order published in the *Government Gazette* direct that such road or part shall be discontinued and thereupon such road or part shall be discontinued accordingly;

And whereas it is further provided that where a planning scheme under the *Town and Country Planning Act 1961* provides for the closing of a road or part of a road and notice of approval of the planning scheme has been published in the *Government Gazette*, it shall not be necessary for the Council to publish or to post to any person notice of its intention to request the Governor in Council to discontinue such road or part thereof.

And whereas the Shire of Woorayl Planning Scheme 1974 provides that a road running east off Abbott Street between Lavington Street and Park Street, and running north off Park Street to Lavington Street, Inverloch is not required for public use and notice of approval of the planning scheme was published in the *Government Gazette* of 27 February, 1974.

And whereas, the Council of the Shire of Woorayl has requested that the Governor in Council direct that the said road be discontinued;

Now therefore, His Excellency the Governor of the State of Victoria, by and with the advice of the Executive Council thereof, hereby directs that the said road which is shown by hatching on the plan hereunder, shall be discontinued and the land in the said road may be sold by the Council of the Shire of Woorayl by agreement.

LOCAL GOVERNMENT ACT 1958

At the Executive Council Chamber, Melbourne, the twentieth day of December 1983

PRESENT:

His Excellency the Governor of Victoria
 Mr Cathie | Mr Walker
 Mr Trezise

ROAD DISCONTINUED—SHIRE OF PAKENHAM

Whereas it is provided in section 528 (2) of the *Local Government Act 1958*, that where a road (whether or not a public highway but not being a road set out on land of the Crown) or any part thereof is not required for public use, the Governor in Council on the request of the council of the municipality in which such road is situated made not less than one month after published in a newspaper generally circulating in the district and posting to the registered proprietor (if any) of the land and the owners and occupiers (if any) of lands abutting or immediately adjacent to the road notice of intention to make such a request may by Order published in the *Government Gazette* direct that such road or part shall be discontinued and thereupon such road or part shall be discontinued accordingly;

And whereas the Council of the Shire of Pakenham has requested that the Governor in Council direct that part of Colin Avenue, Cockatoo be discontinued and not less than one month previously has published in a newspaper generally circulating in the district and posted to the registered proprietor of the land in the road and to the owners and occupiers of lands abutting or immediately adjacent to the road notice of intention to make such a request.

Now therefore, His Excellency the Governor of the State of Victoria, by and with the advice of the Executive Council thereof, hereby directs that the said part of a road which is shown by hatching on the plan hereunder, shall be discontinued and the land in the said part of a road may be sold by the Council of the Shire of Pakenham by agreement.

And the Honourable Frank Noel Wilkes, Her Majesty's Minister for Local Government for the State of Victoria, shall give the necessary directions herein accordingly.

TOM FORRISTAL
 Clerk of the Executive Council

LAND ACT 1958

At the Executive Council Chamber, Melbourne, the twentieth day of December, 1983.

PRESENT:

His Excellency the Governor of Victoria
 Mr. Cathie | Mr. Walker
 Mr. Trezise

UNUSED ROAD CLOSED

His Excellency the Governor of the State of Victoria, in the Commonwealth of Australia, by and with the advice of the Executive Council of the said State, pursuant to the provisions of section 349 of the *Land Act 1958* and with the concurrence in writing of the council of the municipality concerned and that of any adjoining land owners, doth hereby close the unused road hereinafter described, viz:

Municipal District of the Town of Bairnsdale—
 Township of Bairnsdale, being the road indicated by hatching on plan hereunder—(B 66(11)) (L9-669)

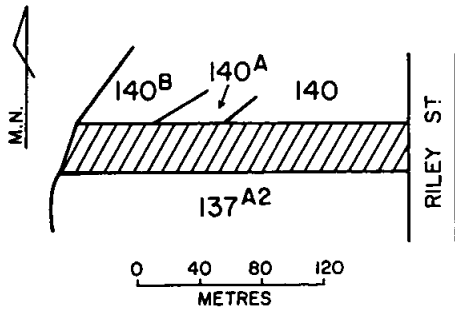

And the Honourable Roderick Alexander Mackenzie, Her Majesty's Minister for Conservation Forests and Lands for the State of Victoria, shall give the necessary directions herein accordingly.

TOM FORRISTAL
 Clerk of the Executive Council

LAND ACT 1958

At the Executive Council Chamber, Melbourne, the twentieth day of December, 1983.

PRESENT:

His Excellency the Governor of Victoria
 Mr. Cathie | Mr. Walker
 Mr. Trezise

UNUSED ROAD CLOSED

His Excellency the Governor of the State of Victoria, in the Commonwealth of Australia, by and with the advice of the Executive Council of the said State, pursuant to the provisions of section 349 of the *Land Act 1958* and with the concurrence in writing of the council of the municipality concerned and that of any adjoining land owners, doth hereby close the unused road hereinafter described, viz:

Municipal District of the City of Keilor—
 Township of Keilor, being the road indicated by hatching on plan hereunder—(K24(2)) (RS.10943)

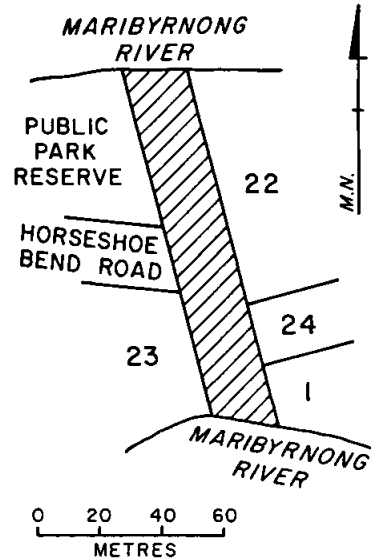

And the Honourable Roderick Alexander Mackenzie, Her Majesty's Minister for Conservation Forests and Lands for the State of Victoria, shall give the necessary directions herein accordingly.

TOM FORRISTAL
 Clerk of the Executive Council

LOCAL GOVERNMENT ACT 1958

At the Executive Council Chamber, Melbourne, the twentieth day of December 1983

PRESENT:

His Excellency the Governor of Victoria
 Mr. Cathie | Mr. Walker
 Mr. Trezise

CONSENT TO SALE OF PART OF A RESERVE BY THE SOUTH BARWON CITY COUNCIL

Whereas certain land being a Recreation Reserve on Plan of Sub-division No. 86882 lodged in the Office of Titles was transferred to the Council of the City of South Barwon pursuant to the provisions of section 569B (8A) (a) of the *Local Government Act 1958* and the said Council is now of the opinion that part of the land is no longer required for the purposes for which it was reserved and has requested that consent be given to the sale of that land.

And whereas the said Council:

- (a) has published in a newspaper generally circulating in the municipal district a notice describing the land and the proposal for the sale of the land and stating that at the next ordinary meeting of the Council after the expiration of forty days after publication of the notice the Council would consider any objections to the proposal and receive any representations as to the disposal of any purchase money;
- (b) being the registered proprietor of the land in question and there being no mortgagee chargee or lessee thereof has posted a similar notice upon the land.
- (c) has taken into consideration all objections made against the proposal.

And whereas the consideration for the sale is an equivalent area of land.

Now therefore, His Excellency the Governor of the State of Victoria, by and with the advice of the Executive Council thereof and in pursuance of the provisions of sub-section (2) of section 569BA of the *Local Government Act 1958* doth hereby consent to the Council

of the City of South Barwon selling by private treaty that part of a Recreation Reserve on Plan of Subdivision No. 86882 lodged in the Office of Titles as shown by hatching on the plan hereunder

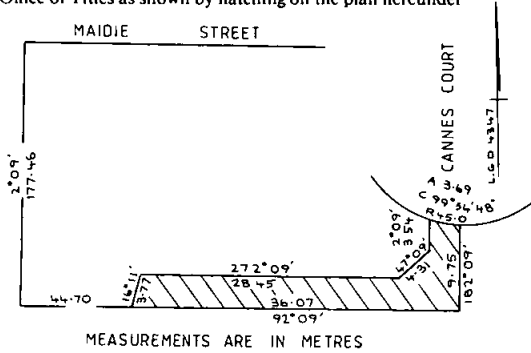

And the Honourable Frank Noel Wilkes, Her Majesty's Minister for Local Government for the State of Victoria, shall give the necessary directions herein accordingly.

TOM FORRISTAL
Clerk of the Executive Council

LOCAL GOVERNMENT ACT 1958

At the Executive Council Chamber, Melbourne, the twentieth day of December 1983.

PRESENT:

His Excellency the Governor of Victoria
Mr Cathie | Mr Walker
Mr Trezise

ROAD DISCONTINUED—SHIRE OF PAKENHAM

Whereas it is provided in section 528 (2) of the *Local Government Act 1958*, that where a road (whether or not a public highway but not being a road set out on land of the Crown) or any part thereof is not required for public use, the Governor in Council on the request of the council of the municipality in which such road is situated made not less than one month after publishing in a newspaper generally circulating in the district and posting to the registered proprietor (if any) of the land and the owners and occupiers (if any) of the lands abutting or immediately adjacent to the road notice of intention to make such a request may by Order published in the *Government Gazette* direct that such road or part shall be discontinued and thereupon such road or part shall be discontinued accordingly.

And whereas the Council of the Shire of Pakenham has requested that the Governor in Council direct that part of Belgrave Avenue, Cockatoo be discontinued and not less than one month previously has published in a newspaper generally circulating in the district and posted to the registered proprietor of the land in the road and to owners and occupiers of lands abutting or immediately adjacent to the road notice of intention to make such a request.

Now therefore, His Excellency the Governor of the State of Victoria, by and with the advice of the Executive Council thereof, hereby directs that the said part of a road which is shown by hatching on the plan hereunder, shall be discontinued and the land in the said part of a road may be sold by the Council of the Shire of Pakenham by agreement.

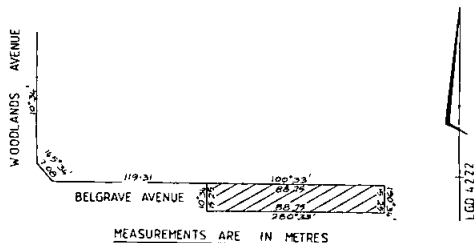

And the Honourable Frank Noel Wilkes, Her Majesty's Minister for Local Government for the State of Victoria, shall give the necessary directions herein accordingly.

TOM FORRISTAL
Clerk of the Executive Council

LAND ACT 1958

At the Executive Council Chamber, Melbourne, the twentieth day of December, 1983.

PRESENT:

His Excellency the Governor of Victoria
Mr. Cathie | Mr. Walker
Mr. Trezise

UNUSED ROAD CLOSED

His Excellency the Governor of the State of Victoria, in the Commonwealth of Australia, by and with the advice of the Executive Council of the said State, pursuant to the provisions of section 349 of the *Land Act 1958* and with the concurrence in writing of the council of the municipality concerned and that of any adjoining land owners, doth hereby close the unused road hereinafter described, viz:

Municipal District of the City of Sale—
Township of Sale, being the road indicated by hatching on lan hereunder—(S 239(3)(L9-1397)

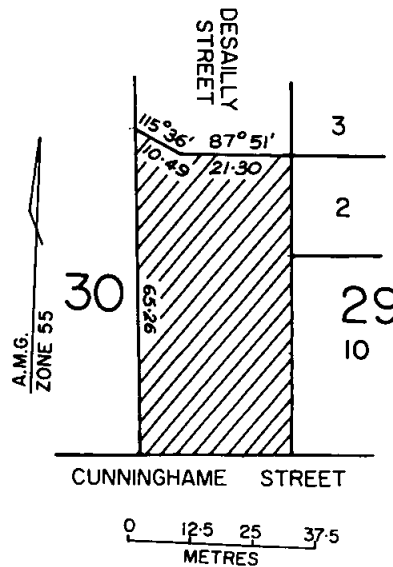

And the Honourable Roderick Alexander Mackenzie, Her Majesty's Minister for Conservation Forests and Lands for the State of Victoria, shall give the necessary directions herein accordingly.

TOM FORRISTAL
Clerk of the Executive Council

LOCAL GOVERNMENT ACT 1958

At the Executive Council Chamber, Melbourne, the twentieth day of December 1983

PRESENT:

His Excellency the Governor of Victoria
 Mr. Cathie | Mr. Walker
 Mr. Trezise

ROAD DISCONTINUED—CITY OF COBURG

Whereas it is provided in section 528 (2) of the *Local Government Act 1958*, that where a road (whether or not a public highway but not being a road set out on land of the Crown) or any part thereof is not required for public use, the Governor in Council on the request of the council of the municipality in which such road is situated made not less than one month after publishing in a newspaper generally circulating in the district and posting to the registered proprietor (if any) of the land and the owners and occupiers (if any) of lands abutting or immediately adjacent to the road notice of intention to make such a request may by Order published in the *Government Gazette* direct that such road or part shall be discontinued and thereupon such road or part shall be discontinued accordingly.

And whereas the Council of the City of Coburg has requested that the Governor in Council direct that part of a road off Orvieto Street, Merlynston be discontinued and not less than one month previously has published in a newspaper generally circulating in the district and posted to the registered proprietor of the land in the road and to the owners and occupiers of lands abutting or immediately adjacent to the road notice of intention to make such a request.

Now therefore, His Excellency the Governor of the State of Victoria, by and with the advice of the Executive Council thereof, hereby directs:

- (a) that the said part of a road which is shown by hatching and cross-hatching on the plan hereunder shall be discontinued;

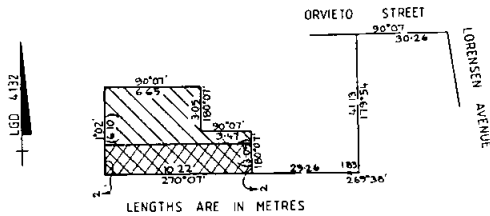

- (b) that notwithstanding such discontinuance the Melbourne and Metropolitan Board of Works shall continue to have and possess the same right title power authority or interest in or in relation to the whole of the land shown by cross-hatching on the said plan as it had or possessed prior to such discontinuance with respect to or in connection with any drains or pipes laid or erected in on or over such land for the purposes of drainage or sewerage;
- (c) that, subject to any such right title power authority or interest the land in the said part of a road may be sold by the Council of the City of Coburg by agreement.

And the Honourable Frank Noel Wilkes, Her Majesty's Minister for Local Government for the State of Victoria, shall give the necessary directions herein accordingly.

TOM FORRISTAL
 Clerk of the Executive Council

LOCAL GOVERNMENT ACT 1958

At the Executive Council Chamber, Melbourne, the twentieth day of December 1983

PRESENT:

His Excellency the Governor of Victoria
 Mr Cathie | Mr Walker
 Mr Trezise

ROAD DISCONTINUATION—CITY OF MELBOURNE

Whereas it is provided in section 528 (2) of the *Local Government Act 1958*, that where a road (whether or not a public highway but not being a road set out on land of the Crown) or any part thereof is not required for public use, the Governor in Council on the request of the council of the municipality in which such road is situated made not less than one month after publishing in a newspaper generally circulating in the district and posting to the registered proprietor (if any) of the land and the owners and occupiers (if any) of the lands abutting or immediately adjacent to the road notice of intention to make such a request may by Order published in the *Government Gazette* direct that such road or part shall be discontinued and thereupon such road or part shall be discontinued accordingly.

And whereas the Council of the City of Melbourne has requested that the Governor in Council direct that part of Corporation Lane No. 1321 be discontinued and not less than one month previously has published in a newspaper generally circulating in the district and posted to the registered proprietor of the land in the road and to owners and occupiers of lands abutting or immediately adjacent to the road notice of intention to make such a request.

Now therefore, His Excellency the Governor of the State of Victoria, by and with the advice of the Executive Council thereof, hereby directs that the said part of a road which is shown by hatching on the plan hereunder, shall be discontinued and the land in the said part of a road may be sold by the City of Melbourne by agreement.

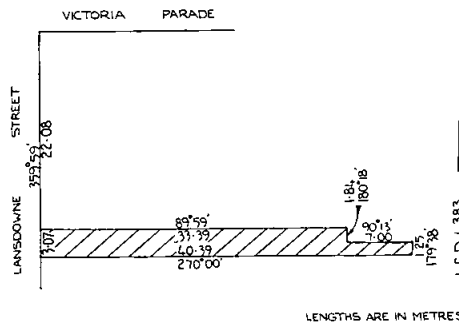

And the Honourable Frank Noel Wilkes, Her Majesty's Minister for Local Government for the State of Victoria, shall give the necessary directions herein accordingly.

TOM FORRISTAL
 Clerk of the Executive Council

LOCAL GOVERNMENT ACT 1958

At the Executive Council Chamber, Melbourne, the twentieth day of December, 1983.

PRESENT:

His Excellency the Governor of Victoria
 Mr. Cathie | Mr. Walker
 Mr. Trezise

CONSENT TO SALE OF PARTS OF RESERVES BY THE BROADMEADOWS CITY COUNCIL

Whereas certain land being the recreation Reserve on Plan of Subdivision No. 76156 and the Reserve for recreation purposes on Plan of Subdivision No. 78811 lodged in the Office of Titles were transferred to the Council of the City of Broadmeadows pursuant to the provisions of section 569B (8A) (a) of the *Local Government Act 1958* and the said Council is now of the opinion that part of that land is no longer required for the purposes for which it was reserved and has requested that consent be given to the sale of that land.

(a) Has published in a newspaper generally circulating in the municipal district a notice describing the land and the proposal for the sale of the land and stating that at the next ordinary meeting of the Council after the expiration of forty days after publication of the notice the Council would consider any objections to the proposal and receive any representations as to the disposal of any purchase money;

(b) Being the registered proprietor of the land in question and there being no mortgage chargee or lessee thereof has posted a similar notice upon the land.

And whereas no objection has been made against the proposal and no representations have been made as to the disposal of any purchase money.

Now therefore, His Excellency the Governor of the state of Victoria, by and with the advice of the executive Council thereof and in pursuance of the provisions of sub-section (2) of section 569BA of the *Local Government Act 1958* doth hereby consent to the Council of the City of Broadmeadows selling by private treaty part of the recreation Reserve on Plan of sub-division No. 716156 and part of the Reserve for Recreation Purpose on Plan of Subdivision No. 78811 lodged in the Office of Titles as shown by hatching and cross hatching on the plans hereunder;

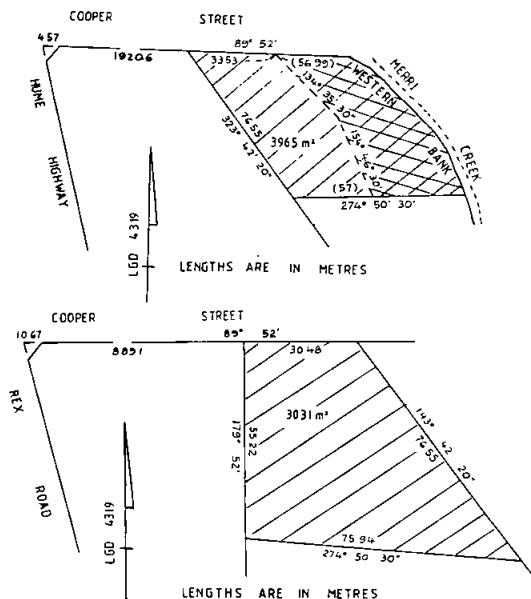

And the Honourable Frank Noel Wilkes, Her Majesty's Minister for Local Government for the State of Victoria, shall give the necessary directions herein accordingly.

TOM FORRISTAL
 Clerk of the Executive Council

CROWN LAND (RESERVES) ACT 1978

At the Executive Council Chamber, Melbourne, the twentieth day of December, 1983.

PRESENT:

His Excellency the Governor of Victoria
 Mr Cathie | Mr Walker
 Mr Trezise

REVOCAION OF TEMPORARY RESERVATION OF LAND BY ORDER IN COUNCIL

His excellency the Governor of the State of Victoria, in the Commonwealth of Australia, by and with the advice of the Executive Council of the said State, pursuant to the provisions of section 10 of the *Crown Land (Reserves) Act 1978*, doth hereby revoke the temporary reservation of land by Order in Council hereinafter described, viz:

KOOREH—The temporary reservation by Order in Council of 27 July 1896 of 1.211 hectares of land in the Parish of Kooreh (in section B) for a State School—(C.815)

And the Honourable Roderick Alexander Mackenzie, Her Majesty's Minister for Conservation Forests and Lands for the State of Victoria, shall give the necessary directions herein accordingly.

TOM FORRISTAL
 Clerk of the Executive Council

PARLIAMENTARY COMMITTEES ACT 1968

At the Executive Council Chamber, Melbourne, the Twentieth day of December 1983

PRESENT:

His Excellency the Governor of Victoria
 Mr Cathie | Mr Walker
 Mr Trezise

REFERRAL OF MATTERS TO THE PUBLIC BODIES REVIEW COMMITTEE

Whereas the Parliamentary Committees Act 1968 as amended by the Parliamentary Committees (Joint Investigatory Committees) Act 1982 provides, among other things, for the establishment of a Joint Investigatory Committee of the Legislative Council of Victoria and the Legislative Council of Victoria and the Legislative Assembly of Victoria to be called the Public Bodies Review Committee.

And whereas section 4M of the Act provides that the Governor in Council may by order published in the Government Gazette at any time nominate a public body for review by the said Committee.

And whereas paragraph (a) of section 4F (1) of the said Act provides, in part, that a Joint Investigatory Committee is required to inquire into, consider and report to the Parliament on any proposal, matter or thing relevant to the functions of the Committee which is referred to the Committee by Order of the Governor in Council published in the Government Gazette.

And whereas section 4F (3) of the said Act provides, in part, that an Order of the Governor in Council referring a proposal, matter or thing to a Joint Investigatory Committee pursuant to paragraph (a) of sub-section (1) may specify a period of time within which the Committee is required to make a final report to the Parliament on the proposal, matter or thing.

Now therefore I, His Excellency the Governor of the State of Victoria in the Commonwealth of Australia by and with the advice of the Executive Council of the said State doth by this Order nomi-

nate Ambulance Service—Melbourne, Ballarat and District Ambulance Service, Central Victoria District Ambulance Service, East Gippsland Ambulance Service, Geelong and District Ambulance Service, Glenelg District Ambulance Service, Goulburn Valley Ambulance Service, Latrobe Valley District Ambulance Service, Mid-Murray District Ambulance Service, North-Eastern Victoria District Ambulance Service, North West Victorian Ambulance Service, Northern District Ambulance Service, Peninsula Ambulance Service, South Gippsland District Ambulance Service, South-Western Victoria Ambulance Service and Wimmera District Ambulance Service for review and require the said Public Bodies Review Committee to inquire into, consider and report to the Parliament on the following proposals, matters or things, that is to say:—

To receive submissions and evidence with regard to matters referred to in the following terms of reference and to report and make recommendation with regard to these matters in order to review the present and future operation of Ambulance Services in Victoria.

Without limiting the scope of the enquiry the Committee is asked to report on:—

- (a) the role of ambulance services in Victoria's health transport system.
- (b) The number and boundaries of Ambulance Services, taking into account regional boundaries being introduced by the Health Commission of Victoria.
- (c) the method of administration of ambulance services, including the rôle, selection and training of committees of management and senior ambulance officers—this should also include the rôle of local ambulance committees.
- (d) financial management and reporting systems.
- (e) the systems of recruitment and initial and in-service training of ambulance officers.
- (f) the relationship between central services such as air ambulance and the various regional and sub-regional services.
- (g) the relationship between hospital and ambulance financial and management systems.
- (h) the rôle of the Health Commission of Victoria in the provision of ambulance services and their administration and planning.

And doth specify that an interim report is to be presented to Parliament by September 1984 if the Parliament is then sitting or if Parliament is not then sitting within seven days after the next meeting of Parliament; and a final report to be presented to Parliament by December 1984 if the Parliament is then sitting or if Parliament is not then sitting within seven days after the next meeting of Parliament.

And the Honourable Thomas William Roper, Her Majesty's Minister of Health for the State of Victoria, shall give the necessary directions herein accordingly.

TOM FORRISTAL
Clerk of the Executive Council

PAYROLL TAX ACT 1971 No. 8154

*At the Executive Council Chamber, Melbourne, the
twentieth day of December, 1983*

PRESENT:

His Excellency the Governor of Victoria
Mr Cathie | Mr. Walker
Mr Trezise

WHEREAS by sub-section (1) of Section 3A of the Pay-roll Tax Act 1971, "prescribed rate" means such rate as is from time to time fixed for the purposes of this Section by the Governor in Council by Order published in the Government Gazette.

NOW THEREFORE His Excellency the Governor of the State of Victoria acting by and with the advice of the Executive Council thereof, doth by this Order fix the prescribed rate to be 11 per centum per annum for the purposes of Section 3A of the Pay-roll Tax Act 1971 and declare that such rate shall come into effect on 1 January, 1984.

And the Honourable Robert Allen Jolly, Her Majesty's Treasurer for the State of Victoria, shall give the necessary directions herein accordingly.

TOM FORRISTAL
Clerk of the Executive Council

VERMIN AND NOXIOUS WEEDS ACT 1958

*At the Executive Council Chamber, Melbourne, the
twentieth day of December, 1983.* PRESENT:

His Excellency the Governor of Victoria

Mr Cathie | Mr Walkier
Mr Trezise

APPOINTMENT OF MEMBERS OF THE VERMIN AND NOXIOUS WEEDS DESTRUCTION BOARD

His Excellency the Governor of the State of Victoria, in the Commonwealth of Australia, by and with the advice of the Executive Council of the said State, pursuant to the provisions of sections 3A and 3B of the Vermin and Noxious Weeds Act 1958, doth hereby appoint WILLIAM THOMAS PARSONS, DAVID CHARLES HOLROYD SEXTON and LEIGHTON MALCOLM HOATSON as members of the Vermin and Noxious Weeds Destruction Board for the period from 1 January 1984 to 30 June 1984, inclusive, or until the Proclamation date of the VERMIN AND NOXIOUS WEEDS (RE-ORGANIZATION) ACT, No. 9950, should this first occur, and the said WILLIAM THOMAS PARSONS as Chairman and the said DAVID CHARLES HOLROYD SEXTON as Deputy Chairman of such Board for the said period.

And the Honourable Roderick Alexander Mackenzie, Her Majesty's Minister for Conservation Forests and Lands for the State of Victoria, shall give the necessary directions herein accordingly.

TOM FORRISTAL
Clerk of the Executive Council

SOIL CONSERVATION AND LAND UTILIZATION ACT 1958

*At the Executive Council Chamber, Melbourne, the
Twentieth day of December 1983*

PRESENT:

His Excellency the Governor of Victoria

Mr Cathie | Mr Walker
Mr Trezise

APPOINTMENT OF A MEMBER OF THE SOIL CONSERVATION AUTHORITY

In pursuance of the powers conferred by the *Soil Conservation and Land Utilization Act, 1958*, and all other powers him thereunto enabling, His Excellency the Governor of the State of Victoria, by and with the advice of the Executive Council thereof doth by this Order reappoint Philip James McCallum to be a member of the Soil Conservation Authority during the period 1st January, 1984, to the 30th June, 1984, inclusive.

And the Honourable Roderick Alexander Mackenzie, Her Majesty's Minister for Conservation, Forests and Lands for the State of Victoria, shall give the necessary directions herein accordingly.

TOM FORRISTAL
Clerk of the Executive Council

SOIL CONSERVATION AND LAND UTILIZATION ACT, 1958

*At the Executive Council Chamber, Melbourne, the
Twentieth day of December 1983*

PRESENT:

His Excellency the Governor of Victoria
 Mr Cathie | Mr Walker
 Mr Trezise

In pursuance of the powers conferred by Section 15 of the *Soil Conservation and Land Utilization Act, 1958*, His Excellency the Governor of the State of Victoria by and with the advice of the Executive Council thereof doth hereby appoint the following persons to be members of the District Advisory Committee of the Western Mallee Soil Conservation District for a term of three years.

- Alan Kenneth Burstall being a person elected to represent the grazing, agricultural and other relevant interests in the District.
- Geoffrey Douglas Anderson being a person elected to represent the grazing, agricultural and other relevant interests in the District.
- Kenneth Cyril Duthie being a person elected to represent the grazing, agricultural and other relevant interests in the District.
- Leo Leslie Fuller being a person elected to represent the grazing, agricultural and other relevant interests in the District.
- John Bernard Griffiths being the person representing the Department of Agriculture.
- Thomas William Speedie being the person representing the Soil Conservation Authority.

And the Honourable Roderick Alexander Mackenzie, Her Majesty's Minister for Conservation, Forests and Lands for the State of Victoria, shall give the necessary directions herein accordingly.

TOM FORRISTAL
Clerk of the Executive Council

SUPERANNUATION ACT 1958

*At the Executive Council Chamber, Melbourne, the
twentieth day of December, 1983.*

PRESENT:

His Excellency the Governor of Victoria
 Mr Cathie | Mr Walker
 Mr Trezise

Pursuant to the powers conferred by the provisions of paragraph (ja) of subsection (1) of Section 3 of the Superannuation Act 1958, His Excellency the Governor of the State of Victoria, by and with the advice of the Executive Council thereof doth by this Order declare that the provisions of the Superannuation Act shall apply to the officers named in the Schedule set out hereunder.

SCHEDULE

- Barker, John Stanley Motor Accidents Board
- Coleman, Frank Police Reserve
- Berketa, Peter Road Construction Authority
- Pool, Rebecca Ruth Road Construction Authority
- Reeve, Patricia Doris State Board of Education

And the Honourable Robert Allen Jolly, Her Majesty's Treasurer for the State of Victoria, shall give the necessary directions herein accordingly.

TOM FORRISTAL
Clerk of the Executive Council

LATROBE VALLEY ACT 1958

Appointment of a Chairman of the Latrobe Valley Water and Sewerage Board

*At the Executive Council Chamber, Melbourne, the
twentieth day of December, 1983:*

PRESENT:

His Excellency the Governor of Victoria
 Mr Cathie | Mr Walker
 Mr Trezise

UNDER the powers conferred upon him by the Latrobe Valley Act 1958, His Excellency the Governor of the State of Victoria by and with the advice of the Executive Council of the said State, hereby appoints Peter Francis Wood to be a Member and Chairman of the Latrobe Valley Water and Sewerage Board, to hold office as such for a period of four years from 1 January, 1984.

And the Honourable David White, Her Majesty's Minister of Water Supply for the State of Victoria shall give the necessary directions herein accordingly.

TOM FORRISTAL
Clerk of the Executive Council

**LANDS DEPARTMENT
NOTICES**

APPROACHING LAND SALES

Sale of Crown Land, will be held at the under-mentioned places and dates, viz.:

	No. of Gazette
Airport West—Saturday, 18 February 1984	120
Clifton Hill—Saturday, 25 February 1984	126
Cobram—Friday, 24 February 1984	126

PROPOSED REVOCATION OF TEMPORARY RESERVATION OF LAND BY ORDER IN COUNCIL

In pursuance of the provisions of section 10 of the *Crown Land (Reserves) Act 1978*, notice is hereby given that it is the intention of the Governor in Council to revoke the temporary reservation of land by Order in Council hereunder referred to, viz.,

MOORMBOOL WEST—The temporary reservation by Order in Council of 10 February 1915 of 2.023 hectares of land in the Parish of Moormbool West (in section C) for a State School—(Rs.539).

R. A. MACKENZIE
Minister for Conservation, Forests and Lands

CONTRACTS ACCEPTED—(Series 1982-83)

PUBLIC WORKS

His Excellency the Governor of the State of Victoria by and with the advice of the Executive Council thereof has by Order made on 20 December 1983 approved of the acceptance by the Minister of Public Works of the undermentioned offers without public tenders being invited, viz.:

Offers at the amounts shown for professional services at the New Remand Centre, Spencer Street, Melbourne—(121471,2).

	\$
Fluor Australia Pty. Ltd. (Working Party Consultants)	390 000.00
Touche Ross Services Pty. Ltd. (Working Party Consultants)	41 000.00

Offer of R. M. Norton & Associates for professional services (Mechanical) at various locations for the sum of Thirty-five thousand dollars (\$35 000.00)—(BG.162256).

Offer of Perrott Lyon Mathieson Pty. Ltd. for professional services (Architectural) at the Footscray College of T.A.F.E. for the sum of Forty-five thousand dollars (\$45 000.00)—(P.W.35920"P").

TOM FORRISTAL
Clerk of the Executive Council

At the Executive Council Chamber
Melbourne, 29 December 1983

ERRATUM

In *Government Gazette* No. 132 of 21 December 1983 on Page 4053 under the heading "Declaration of Fire Danger Period" the Shire of Buninyon should read the Shire of Buninyong.

ERRATUM

PLACE NAMES COMMITTEE
SURVEY CO-ORDINATION ACT 1958

PROPOSALS RELATING TO NAMES

In the notice of the Places names Committee published in the *Government Gazette* No. 128 dated 14 December 1983 (p. 3967) the undermentioned names were spelt incorrectly:

Place Name as Published	Correct Spelling
Ben-Kornai Coastal Park	Ben-Kurnai Coastal Park
Urquhardt Park Primary School	Urquhardt Park Primary School

The time for lodging of objections remains as previously published.
P. G. SEWELL, Secretary

Place Names Committees
Department of Conservation
Forests and Lands
2 Treasury Place
Melbourne 3002

**PRIVATE
ADVERTISEMENTS**

CITY OF ALTONA
LOAN No. 111

Notice of Intention to Borrow the Sum of \$105 500 for Permanent Works and Undertakings

Notice is hereby given that the Council of the City of Altona proposes to borrow the principal sum of One hundred and five thousand, five hundred dollars (\$105 500) secured by a charge over the general rates of the municipality, such sum to be raised by the grant of a mortgage in accordance with the terms of the *Local Government Act 1958*.

1. The maximum rate of interest to be paid is 12.6 per centum per annum.
2. The purposes for which the loan is to be applied are—

	\$
Roundabout construction, Civic Parade/ Pier Street	50 000
Roundabout construction, Pier/Queen Streets	35 000
Paisley Reserve, soccer training lights	5 500
Paisley Reserve, lacrosse training lights	15 000
	<hr/>
	105 500

3. The period of the loan shall be four years.
4. The monies borrowed shall be repayable by providing out of the Municipal Fund seven equal half-yearly instalments of \$10 655.58, including principal and interest on 1 August and 1 February in each year during the currency of the loan, and one final instalment of \$76 046.04, including principal and interest on 1 February 1988.

5. Such monies shall be repayable at the office of the Commonwealth Savings Bank of Australia, Melbourne, or such other place or places which the bank may from time to time require.

The plans and specifications and estimated cost of proposed works and a statement showing the proposed expenditure of the monies to be borrowed are open for inspection at the Civic Offices, 115 Civic Parade, Altona.

370 S. FELL, Chief Executive Officer and Town Clerk

CITY OF HAMILTON

BY-LAW No. 118

Take note that the Council of the City of Hamilton, pursuant to its powers under the *Local Government Act 1958* (as amended) has made a By-Law as follows:

Name—Saleyards By-Law 118

Contents—Regulating the use of the City of Hamilton Saleyards and establishing such fees and charges as are appropriate.

Copies of the By-Law are able to be inspected or purchased during normal office hours.

344 R. J. WORLAND, Town Clerk

CITY OF HAWTHORN

LOAN No. 77

Notice of Intention to Borrow the Sum of \$150 000 for Capital Works

Notice is hereby given that the Council of the City of Hawthorn proposes to borrow the sum of One hundred and fifty thousand dollars secured by a charge over the general rates of the municipality such sum to be raised by the grant of a mortgage, in accordance with the provisions of the *Local Government Act*.

1. The amount of the principal moneys which it is proposed to borrow is \$150 000.
2. The maximum rate of interest that may be paid is 13.5 per centum per annum.
3. The period of the loan shall be seven years.
4. The moneys borrowed shall be repayable by providing out of municipal funds fourteen half-yearly instalments of \$10 125.00 during the currency of the loan and shall be liquidated by the creation of a sinking fund pursuant to the provisions of Section 428 of the *Local Government Act 1958*. The first interest payment shall be made on 15 September 1984.

5. Such moneys shall be repayable at the State Insurance Office, 480 Collins Street, Melbourne.

6. The purpose for which the loan is to be applied is to assist in the purchase of computer facilities (total cost \$290 000)—\$150 000.

The plans and specifications and the estimate of the cost of the proposed computer systems and a statement showing the proposed expenditure of the moneys to be borrowed are open for inspection at the Municipal Offices, Town Hall, during office hours.

Dated 19 December 1983

345 B. C. SMITH, Town Clerk

CITY OF HAWTHORN

LOAN No. 78

Notice of Intention to Borrow the Sum of \$100 000 for Capital Works

Notice is hereby given that the Council of the City of Hawthorn proposes to borrow the sum of One hundred thousand dollars secured by a charge over the general rates of the municipality such sum to be raised by the grant of a mortgage, in accordance with the provisions of the *Local Government Act*.

1. The amount of the principal moneys which it is proposed to borrow is \$100 000.
2. The maximum rate of interest that may be paid is 14.4 per centum per annum.
3. The period of the loan shall be ten years.

4. The moneys borrowed shall be repayable by providing out of municipal funds twenty half-yearly instalments of \$7200.00 during the currency of the loan and shall be liquidated by the creation of a sinking fund pursuant to the provisions of Section 428 of the *Local Government Act 1958*. The first interest payment shall be made on 15 September 1984.

5. Such moneys shall be repayable at the State Insurance Office, 480 Collins Street, Melbourne.

6. The purpose for which the loan is to be applied is for part cost of renovation of Hawthorn City Library building (estimated total cost \$600 000)—\$100 000.

The plans and specifications and the estimate of the cost of the proposed works and a statement showing the proposed expenditure of the moneys to be borrowed are open for inspection at the Municipal Offices, Town Hall, during office hours.

Dated 19 December 1983

346

B. C. SMITH, Town Clerk

SHIRE OF FLINDERS
LOAN No. 153

Notice of Intention to Borrow the Sum of \$308,000 for Permanent Works and Undertakings

Notice is hereby given that the Council of the Shire of Flinders proposes to borrow the sum of \$308,000.00 secured by a charge over the general rates of the municipality, such sum to be raised by the grant of a mortgage in accordance with the provisions of the Local Government Act 1958.

- (a) The maximum rate of interest that may be paid is 13.7% per annum.
- (b) The purposes for which the Loan is to be applied are:

Nepean Highway, Dromana, (Pier to Beach Streets east of Beach Street) Footpath Construction (part provision)	\$25,000
Gibson Street, Dromana (East of Beach Street, and between Pier and Beach) and Solander Street. Reconstruction (part provision)	\$70,000
Cook Street, Flinders (West of the Esplanade) Construction (Part provision)	\$70,000
Morgan Street, Rosebud (From Jetty Road easterly) Footpath and kerb and channel construction (Part provision)	\$16,000
Ninth Avenue—Mount Arthur Road and Associated Carpark Construction (Part provision)	\$55,000
Nepean Highway, Tootgarook (Carmichael Street to Romney Avenue) Footpath Construction (Part provision)	\$18,000
Sorrento Mechanics Institute and adjoining Cottages. Restoration and improvement works. (Part provision)	\$37,000
Southern Peninsula Rescue Squad Helicopter facilities including building new helicopter pad and associated works and realigned road access construction. (Part provision.)	\$17,000
TOTAL	\$308,000

- (c) The period of the Loan shall be for an initial period of 4 years based on a 10 year repayment period.
- (d) The moneys borrowed shall be repayable by providing out of the municipal fund, 7 equal half yearly instalments of \$28,734.95 with a final payment of \$258,803.37, each including principal and interest, on 1 February and 1 August during the currency of the Loan with the first instalment due on 1 August, 1984.
- (e) The repayments will be made to the Westpac Savings Bank Limited at 1025 Nepean Highway, Rosebud, or at such other place as the Lender may require.

Plans and specifications, estimates of the cost and a statement of the proposed expenditure of the moneys to be borrowed are open for inspection at the offices of the Shire of Flinders, Boneo Road, Rosebud, for one month after the publication of this notice.

LARRY M. JONES, Chief Executive

0373

28 December, 1983.

SHIRE OF FLINDERS
STREET NAME CHANGES—RYE

- Old Name—Sherwood Street, Rye.
New Name—Sherwood Forest Drive.
- Old Name—Nelson Street, Rye.
New Name—Tyrone Avenue.

The Council of the Shire of Flinders hereby resolves that pursuant to Section 535 (4) of the Local Government Act to change the names of:

- (1) Sherwood Street Rye to Sherwood Forest Drive, Rye and
- (2) Nelson Street Rye between Nepean Highway and Johnson Avenue to Tyrone Avenue, Rye.

Dated 15 December 1983

347

LARRY M. JONES, Chief Executive

SHIRE OF WOORAYL
ROAD DEVIATION

Pursuant to the provisions of Section 522 of the Local Government Act the Council of the Shire of Woorayl hereby directs that the land in the Parish of Koorooman indicated by hatching on the plan hereunder which has been purchased by it shall be a public highway on and from the date of publication of this order in the *Government Gazette*.

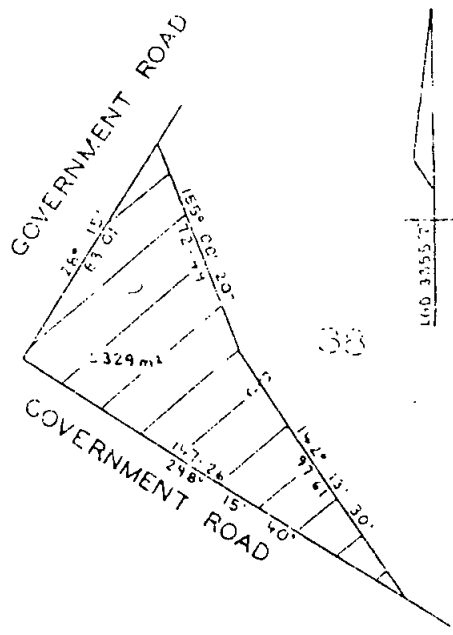

LENGTHS ARE IN METRES

The Common Seal of the President, Councillors and Ratepayers of the Shire of Woorayl was hereunto affixed this ninth day of December 1983.

(SEAL)

T. W. HALL, Councillor
H. G. VAGG, Councillor
R. G. STANLEY, Shire Secretary

350

SHIRE OF WOORAYL
ROAD DEVIATION

Pursuant to the provisions of Sections 522 and 526 of the *Local Government Act 1958* the Council of the Shire of Woorayl hereby directs that the land in the Parish of Tarwin indicated by hatching on the diagram hereunder, which has been purchased taken or acquired by it, shall be a public highway on and from the date of publication of this order in the *Government Gazette*.

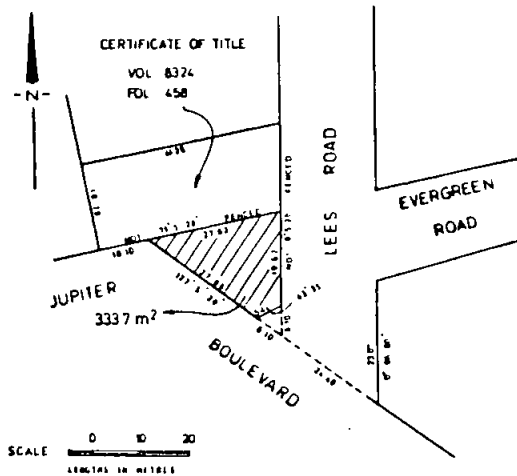

The Common Seal of the President, Councillors and Ratepayers of the Shire of Woorayl was hereto affixed this ninth day of December 1983.

T. W. HALL, Councillor
H. G. VAGG, Councillor
R. G. STANLEY, Shire Secretary

351

SHIRE OF NUMURKAH
LOAN No. 64

Notice of Intention to Borrow

Notice is hereby given that the Council of the Shire of Numurkah proposes to borrow the principal sum of \$105 000, secured by a charge over the general rates of the municipality, such sum to be raised by the grant of a mortgage in accordance with the provisions of the *Local Government Act 1958*.

The maximum rate of interest that may be paid is 12.6 per cent per annum.

The purposes for which the loan is to be applied are:

	\$
Construction and Sealing—Dolphin Street Quinn Street (Part) and Stewart Street	50 000
Construction of Kerb and Gutter—Numurkah	25 000
Council Contribution to R.C.A. Works—Rockliff's Road, Numurkah	30 000

The period of the loan shall be 16 years.

The loan shall be liquidated by providing out of the municipal fund seven half-yearly instalments of \$7 705.85 with a final instalment of \$101 792.52 on 28 February 1988, the rate of interest shall be re-negotiated and further instalments re-calculated accordingly.

Instalments shall be paid on 28 February and 28 August during the currency of the loan, commencing on 28 August 1984.

Such money shall be repayable to the Commonwealth Savings Bank of Australia.

The plans and specifications and estimate of the cost of the proposed works, together with a statement showing the proposed expenditure of the moneys to be borrowed, are open for inspection at the Shire Offices, Melville Street, Numurkah.

L. G. MITCHELL, Shire Secretary

349

Notice is hereby given that the Numurkah Branch of the Country Women's Association of Victoria has applied for a lease under section 134 of the *Land Act 1958*, for a term of twenty one years, in respect of an area of 632.3 square metres, being Allotment 1, section 31, Township of Numurkah as a site for a hall and rest room. 0071

Notice is hereby given that the partnership between Robert Thomas Hope, Margaret Moffatt Hope, Graeme Alexander Veitch and Rosemary Alison Veitch carrying on business as Wholesale and Retail Fruiterers at Bromfield Street Colac under the firm name of "Hope & Veitch" has been dissolved by mutual consent as from 30 November 1983 so far as concerns the said Robert Thomas Hope and Margaret Moffatt Hope who have retired from the said firm. The said Graeme Alexander Veitch and Rosemary Alison Veitch will carry on the said business under the said firm name of "Hope & Veitch" as from 1 December 1983 and Notice is further given that all debts due to and owing by the said late firm will be received and paid respectively by the said Graeme Alexander Veitch and Rosemary Alison Veitch.

Dated 19 December 1983

SEWELLS, solicitors, Colac

365

Take notice that as from 16 December 1983 the partnership formerly carried on by Thomas Walter William Setters of 17 Unavale Crescent, Boronia and Andrew Boggie Downie of 7/132 Alexandra Street, Balaclava which carried on business of wrought iron and structural steel manufacturing from premises situate at 503 Maroon-dah Highway, Ringwood was terminated as from that date.

GALBALLY & O'BRYAN for T. W. W. SETTERS

371

Notice is hereby given that the partnership heretofore subsisting between us the undersigned DONALD JAMES COLLINS Plumber and MAVIS LILLIAN COLLINS Married Woman both of Kaniva in the State of Victoria carrying on business at 80 Commercial Street, Kaniva and known as "Kaniva Hardware" and "Don. J. Collins" has been dissolved by mutual consent as from the 30 November, 1983. All debts due and owing by the firms will be received and paid for by the said Donald James Collins who will continue to carry on the said businesses at 80 Commercial Street, Kaniva under the name of "Don. J. Collins".

D. J. COLLINS
PT0902

M. L. COLLINS
0357

The Companies Code 1981—In the matter of LOGAS KNITTING MILLS PROPRIETARY LIMITED (in Liquidation)

Notice is hereby given that pursuant to Section 411 of the Companies Code 1981, a Final Meeting of the Members of the above Company will be held at the office of H. & H. Guest and Associates Pty. Ltd., 230 Balaclava Road, Caulfield on Monday 23 January 1984 at 10.00 a.m.

Business—To receive the Liquidator's Accounts.

Dated 13 December 1983

355

P. R. BURMAN, Liquidator

NOTICE OF WINDING UP ORDER

In the matter of VINYL WALL SURFACING (GEELONG) PTY. LIMITED —Winding up Order made on 15 December 1983

Name and address of Liquidator is John Martin Walsh of 499 St Kilda Road, Melbourne.

366

O. R. BULKA & CO., solicitors for the applicant

Companies (Victoria) Code (Section 392 (2) (B))
SEALING APPLICATIONS PTY. LTD. (IN VOLUNTARY LIQUIDATION)

SPECIAL RESOLUTION TO WIND UP

Notice is hereby given that at an extraordinary general meeting of the abovenamed Company held on 9 December 1983 the following resolution was passed as a special resolution.

"That the Company be wound up voluntarily."

At the abovementioned meeting Neil Edwin Summerson of Level 28, 68 Queen Street, Brisbane was appointed Liquidator for the purpose of the winding up.

Notice is also given that after 21 days from this date, I shall proceed to distribute the assets. All creditors having any claims against the Company should forward particulars of same by that date otherwise I shall proceed to distribute the assets without any regard to their claim.

Dated 16 December 1983

367

N. E. SUMMERSON, Liquidator

In the Supreme Court of Victoria—Co. 13539—In the Matter of the Companies (Victoria) Code; and in the matter of TUBULAR OUT-DOOR FURNITURE MANUFACTURES PROPRIETARY LIMITED

Winding-up Order made 15 December 1983.

Name and Address of Liquidator: Everett Thomson Bent, Bent and Cogle 144 Jolimont Road East Melbourne Vic., 3002.

T. A. SHERMAN, Acting Crown Solicitor for the Commonwealth and Solicitor for the petitioner 0377

In the Supreme Court of Victoria—Co. 13517—In the Matter of the Companies (Victoria) Code; and in the matter of A. J. WHELAN AND STAFF PTY. LTD.

Notice of Winding Up Order.

Winding-up Order made 15 December 1983.

Name and Address of Liquidator: Geoffrey Ormond Harrison, Touche Ross and Co., 440 Collins street, Melbourne, Vic., 3000.

V. A. SHERMAN, Acting Crown Solicitor for the Commonwealth and Solicitor for the Petitioner 0378

SIR JAMES KENNEDY CO-OPERATIVE HOUSING SOCIETY LIMITED

(IN LIQUIDATION)

At a special general meeting of the abovenamed Society duly convened and held at 464A Lower heidelberg Road, Heidelberg, on the 19th day of December, 1983, at 4.00 p.m. the subjoined resolution was duly passed:—

1. That the Society having successfully completed its objectives forty three months ahead of its expected term be wound up voluntarily and that Peter William Jess of 464A Lower Heidelberg Road, Heidelberg be appointed Liquidator for the purposes of the winding up.

J. D. MACDONALD, Chairman of Meeting
G. PURVIS, Secretary 0379

In the Supreme Court of Victoria—1983 Co. 13498—In the matter of the Companies (Victoria) Code 1982 and in the matter of COLLINS CUSTOM ELECTRICS PTY. LTD.

Notice of Appointment of Liquidator

In the matter of Collins Custom Electrics Pty. Ltd. order for the appointment of Liquidator made the 15 December, 1983.

Name and Address of Liquidator: Anthony George Hodgson, C/o Ferrier Hodgson & Co., Chartered Accountants, 459 Collins Street, Melbourne, 3000.

MESSRS. MADGWICKS of 440 Collins Street, Melbourne Solicitors for the Petitioner. 0380

Companies Act 1961

Section 272 (2)

JAYSEA MARKETING PTY. LTD.

NOTICE OF FINAL MEETING

Notice is hereby given that pursuant to Section 272 of the *Companies Act 1961*, a general meeting of members and creditors of Jaysea Marketing Pty. Ltd. will be held at Messrs. Duesburys, 18th Floor, 114 William Street, Melbourne, Victoria 3000, on the 3rd day of February 1984 at 9.00 a.m.

The purpose of the meeting is to lay accounts before it, showing the manner in which the winding up has been conducted and the property of the company disposed of, and of hearing any explanation that may be given by the liquidator.

Dated this 20th day of December 1983.

0384

WARICK A. LEEMING, Liquidator

In the matter of the *Co-operative Housing Societies Act 1958* and *Companies Act 1961* and in the matter of Sir James Kennedy Co-operative Housing Society Limited (In Liquidation).

NOTICE TO CREDITORS

Notice is hereby given that all persons having any claim against the above Society are required on or before the 20th day of January, 1984 to send their names and addresses and particulars of their debts or claims to Peter W. Jess the liquidator of the said Society, at his office and if so required by notice in writing from the said liquidator are personally, or by their Solicitors, to come in and prove their said debts or claims at such time and place as shall be specified in such notice, or in default thereof, they shall be excluded from the benefit of any distribution made before such debts or claims are so lodged or proved.

Dated at Heidelberg this 19th day of December, 1983.

0387

PETER W. JESS, Liquidator

Form 92

Companies Act 1961

Companies Regulations 26 (2)

Supreme Court (Companies) Rules 1962—Rule 108

PRISM ELECTRONICS PTY LTD (IN LIQUIDATION)

NOTICE OF MEETING OF CREDITORS

Notice is hereby given that a meeting of the creditors of Prism Electronics Pty Ltd (In Liquidation) will be held at the offices of Hungerford Hancock & Offner, 24th Level, 80 Collins Street, Melbourne, on 13 January 1984 at 11.00 in the forenoon.

AGENDA

To consider the resignation of the liquidator from the administration immediately upon lodgement of a Notice of Resignation by him.

Dated this 12th day of December 1983

0388

E. H. NIEMANN, Liquidator

COMPANIES (VICTORIA) CODE — Pursuant to Section 393 (2) (b)

G. T. T. Pty. Ltd.

Members' Voluntary Winding Up

At an extraordinary general meeting of the above company held at Elwood on 5th December, 1983, a special resolution was passed that the company be wound up voluntarily and that Lawrence F. Hodgson of L. F. Hodgson & Co. be appointed as liquidator of the Company.

L. F. HODGSON Liquidator

0397

Companies Act 1961

KWIK-N-EASY FOOD PRODUCTS PTY. LTD. (IN LIQUIDATION)

Notice of Meeting of Members and Creditors

Notice is hereby given that a general meeting of the members and creditors of Kwik-N-Easy Food Products Pty. Ltd., will be held at the offices of V. R. Dye & Co., 159 Springvale Road, Nunawading on Thursday the Twenty Sixth day of January 1984 at 10.30 a.m. to receive an account of my acts and dealings and of the conduct of the winding up during the year ended 25 November 1983.

Dated this Twenty First day of December 1983

V. R. DYE, Liquidator

Nunawading 3131
0381

COMPANIES (VICTORIA) CODE, Section 411 (2)

WANDILIGONG ORCHARDS PTY. LTD. (IN LIQUIDATION)

Notice of Final Meeting

Notice is hereby given that pursuant to Section 411 (2) of the Companies (Victoria) Code, a general meeting of members of Wandiligong Orchards Pty. Ltd. will be held at the offices of Messrs Lockwood Partners Chartered Accountants, 209 Hare Street, Echuca, 3625 on the 31st day of January, 1984 at 2.00 p.m.

The purpose of the meeting is to lay accounts before it, showing the manner in which the winding up has been conducted and the property of the company disposed of, and for hearing any explanation that may be given by the liquidator.

Dated this 16th day of December, 1983.

0382

P. JONES, Liquidator

Form 92

Companies Act 1961

Companies Regulations 26 (2)

Supreme Court (Companies) Rules 1962—Ru'e 108

PRISM ELECTRONICS PTY LTD (IN LIQUIDATION)

Notice of Meeting of Contributors

Notice is hereby given that a meeting of the contributors of Prism Electronics Pty Ltd (In Liquidation) will be held at the offices of Hungerford Hancock & Offner, 24th Level, 80 Collins Street, Melbourne, on 13 January 1984 at 10.45 o'clock in the forenoon.

AGENDA

To consider the resignation of the liquidator from the administration immediately upon lodgement of a Notice of Resignation by him.

Dated this 12th day of December 1983.

0383

E. H. NIEMANN, Liquidator

The Companies Code 1981—In the matter of No. 202-204—
GERTRUDE STREET PROPRIETARY LIMITED (in Liquidation)

Notice is hereby given that pursuant to Section 411 of the Companies Code 1981, a Final Meeting of the Members of the above Company will be held at the office of H. & H. Guest and Associates Pty. Ltd., 230 Balaclava Road, Caulfield on Monday 23 January 1984 at 10.05 a.m.

Business—To receive the Liquidator's Accounts.

Dated 13 December 1983

354

P. R. BURMAN, Liquidator

Creditors, next of kin and others having claims in respect of the corpus of the Peccadillo Trust are required by the Trustee Peccadillo Holding Pty. Ltd. of 229 Thomas Street, Dandenong to send particulars to it by 29 February 1984 after which date the Trustee may convey or distribute the assets, having regard only to the claims of which he then has notice.

Dated 29 December 1983

368

Creditors, next of kin and others having claims in respect of the estate of Cyril Henry Harris Jenkyn late of 14 Connaught Mansions Prince of Wales Drive Battersea Park London England retired sheep farmer deceased who died on the 16 May are to send particulars of their claims to the Equity Trustees Executors and Agency Company Limited of 472 Bourke Street, Melbourne by 6 March 1984 after which date it will distribute the assets having regard only to the claims of which it then has notice.

AITKEN, WALKER & STRACHAN, Solicitors, 114 William Street, Melbourne

369

RAYMOND VICTOR JORDAN, late of "Whitesands" 48 Nepean Highway, Seaford, Gentleman, DECEASED.

Creditors, next of kin and others having claims in respect of the estate of the above deceased who died on 8 June 1983 are required by the Trustee A.N.Z. Executors & Trustee Co. Ltd. of 94 Queen Street, Melbourne to send particulars thereof to the undermentioned Solicitor by 10 March 1984 after which date the Trustee may convey or distribute the assets having regard only to the claims of which it then has notice.

Dated 21 December 1983

GILBERT VICTOIRE of 12 Main Street, Upwey

372

Creditors next of kin and others having claims in respect of the Estate of Beatrice Annie Bayne formerly of 13 Rosslyn Street Hawthorn but late of 11 Hopetoun Avenue, Canterbury in the State of Victoria, Gentlewoman deceased who died on 12 October, 1983 are required by the Executor ANZ Executors & Trustee Company Limited to send particulars to the said Company at 94 Queen Street

Melbourne in the said State by 7th March 1984 after which date it will distribute the assets having regard only to the claims of which it then has notice.

PRICE & CHAMBERLIN, BRENT & STEPHENS, Solicitors, 160 Queen Street, Melbourne.

0398

Creditors next of kin and others having claims in respect of the Estate of Edna May McGrath late of Unit 3, 99 Normanby Road, East Kew Widow deceased who died on the 18th day of October, 1983 are required to send particulars of such claims to National Trustees Executors and Agency Company of Australasia Limited at its registered office at 95 Queen Street, Melbourne by the 2nd of March, 1984 after which date it will distribute the assets having regard only to the claims of which it has then notice.

DOYLE & KERR, 450 Little Collins Street, Melbourne. 0374

Salvatore Casula late of Unit 2, 19 Balmer Street Brunswick in the State of Victoria, Pensioner deceased.

Creditors next-of-kin and others having claims in respect of the estate of the abovenamed deceased who died on the 13th day of June 1983 are required by Pietro Casula of 3 Louis Street Glen Iris the Executor of the deceased's Will to send particulars of their claims to him care of his undermentioned Solicitor by the 10th day of March, 1984 after which date he will convey or distribute the assets having regard only to the claims of which he then has notice.

A. B. NATOLI, LL.B., Solicitor, 24 Cotham Road, Kew. 0376

Creditors next of kin and others having claims in respect of the Estate of Noel Rae Langlands, late of 458 Dorset Road, Boronia, Clerk, who died on 5th November, 1983, are to send the particulars of their claims to ANZ Executors & Trustee Company Limited of 94 Queen Street, Melbourne by the 22nd March, 1984 after which date it will distribute the assets having regard only to the claims of which it then has notice.

0385

Creditors next of kin and others having claims in respect of the Estate of Gladys Richards, late of Bethlehem Home for the Aged, Taylor Street, Specimen Hill, Bendigo, Widow, who died on 30th October, 1983, are to send the particulars of their claims to ANZ Executors & Trustee Company Limited of 94 Queen Street, Melbourne by the 22nd March, 1984 after which date it will distribute the assets having regard only to the claims of which it then has notice.

0386

Creditors, next of kin and others having claims in the Estate of Veronica Elizabeth Hellier (also known as Vera Hellier) formerly of Flat 1, 200 Booran Road, Carnegie but now late of Oakmoor Private Nursing Home of 354 Warrigal Road, Oakleigh South, in the State of Victoria Widow now Deceased who died on 14 September 1983 are to send the notices of their claims to Raymond Aloysius Hellier of 110 Pellat Street, Beaumaris in the said State Director Executor of the Estate of the said deceased care of Leo Browne Solicitor of 180 Elgin Street, Carlton in the said State by 8 March 1984 after which date the said Raymond Aloysius Hellier will distribute the Estate having regard only for the claims of which he then has notice.

LEO BROWNE, Solicitor of 180 Elgin Street Carlton

360

ALFRED EDWARD ROSE, late of 15 Robinson Street, Camperdown in the State of Victoria, pensioner, DECEASED

Creditors, next of kin and others having claims in respect of the Estate of the deceased, who died on 31 October 1983 are required by the personal representative George Howarth to send particulars to him at the solicitors named below by 15 March 1984 after which date he may convey or distribute the assets having regard only to the claims of which he then has notice.

HODGES HALL & CO. of 60 Moorabool Street, Geelong. solicitors

356

EMMA MARIE BEER, late of Salisbury House, Salisbury Road, Upper Beaconsfield in the State of Victoria, spinster, DECEASED

Creditors, next of kin and others having claims in respect of the Estate of the deceased, who died on 21 October 1983, are required by the Executor A.N.Z. Executors & Trustee Company Limited of 94 Queen Street, Melbourne in the said State, to send particulars to

it by 4 March 1984, after which date the Executor may convey or distribute the assets having regard only to the claims of which it then has notice.

ROBERT C. TAYLOR & SON, solicitors for the executor, 13 Davey Street, Frankston 357

COLIN PAUL JONES, late of 9 Hattah Court, Taylors Lakes, in the State of Victoria, bailiff, DECEASED

Creditors, next of kin and others having claims in respect of the Estate of the deceased who died on 3 August 1983 are required by Christina Margaret Jones of 9 Hattah Court, Taylors Lakes, in the State of Victoria, Widow, the Executrix to whom Probate of the Will of the said deceased was granted by the Supreme Court to send particulars to her care of the undersigned by 28 February 1984 after which date the said Executrix may convey or distribute the assets having regard only to claims of which she then has notice.

PATRICK J. CANNON, TESTRO & COBURN, solicitors, 117 Durham Road, Sunshine 358

LUIGI DINATALE, late of 46 Thorndon Drive, St Albans, market gardener, DECEASED

Creditors, next of kin and others having claims in respect of the Estate of the deceased who died on 29 October 1982 are required by Carmel Iannello of 36 High Street, Werribee, Lucia Magazzu of rear 48 Alfreda Street, St Albans and Josephine Weston of 13 Laurel Street, St Albans, Married Women, the Executrices to whom Probate of the Will of the said deceased was granted by the Supreme Court of Victoria to send particulars to them care of the undersigned by 6 March 1984 after which date the said Executrices may convey or distribute the assets having regard only to the claims of which they then have notice.

PATRICK J. CANNON, TESTRO & COBURN, solicitors, 117 Durham Road, Sunshine 359

LATE NOTICES

Cooperative Companies and Securities Scheme PROCLAMATIONS AND OTHER INFORMATION

NOTICE OF MAKING AND AVAILABILITY OF STATUTORY RULE

1. In pursuance of the provisions of the *Subordinate Legislation Act 1962* and the Regulations made thereunder, notice is given of the making of the following Statutory Rules:—

Securities Industry (Application of Laws) Act 1981, No. 9564
423/1983 Securities Industry (Application of Laws) Regulations 1983.

Companies (Acquisition of Shares) (Application of Laws) Act 1981, No. 9564.

421/1983 Companies (Acquisition of Shares) (Application of Laws) Regulations 1983.

Companies (Application of Laws) Act 1981, No. 9712.

422/1983 Companies (Application of Laws) Regulations 1983.

2. Notice is given that the Government Printer is authorized, in accordance with the abovementioned Acts of Victoria and the *Companies and Securities (Interpretation and Miscellaneous Provisions) (Application of Laws) Act 1981*, No. 9563 of Victoria to publish the abovementioned Regulations.

3. Copies of the abovementioned Regulations may be purchased at the Victorian Government Bookshop located at 41 St Andrews Place Melbourne, 3002. If ordered by mail, remittance should be addressed to the Government Printer, Box 203, P.O. North Melbourne 3051 and should include 50c. delivery and handling fees.

DATE OF COMING INTO OPERATION PROCLAMATION

1. Notice is given of the publication of a proclamation in the Commonwealth of Australia Gazette No. 324 dated 16 December 1983 of the commencement on 1 January 1984 of the following Commonwealth Act:

The Companies and Securities Legislation (Miscellaneous Amendments) Act, No. 108 of 1983.

The Act amends the following Commonwealth laws:
the Companies (Acquisition of Shares) Act 1980;
the Companies Act 1981;

the Companies (Transitional Provisions) Act 1981;
the Companies and Securities (Interpretation and Miscellaneous Provisions) Act 1980;
the National Companies and Securities Commission Act 1979;
and the Securities Industry Act 1980.

2. Notice is given of the making of the following Commonwealth Regulations notified in the Commonwealth of Australia Gazette No. 323 dated 16 December 1983:

Companies (Acquisition of Shares) Regulations (Amendment) made under the Commonwealth Companies (Acquisition of Shares) Act 1980;

Companies (Fees) Regulations (Amendment) made under the Commonwealth Companies (Fees) Act 1980;

Securities Industry Regulations (Amendment) made under the Commonwealth Securities Industry Act 1980;

Companies Regulations (Amendment) made under the Commonwealth Companies Act 1981.

3. The Companies (Acquisition of Shares) (Application of Laws) Act 1981, No. 9564, Securities Industry (Application of Laws) Act 1981, No. 9562, Companies (Application of Laws) Act 1981, No. 9712 and the Companies and Securities (Interpretation and Miscellaneous Provisions) (Application of Laws) Act 1981 No. 9563 of Victoria provide that the provisions of—

(a) the respective corresponding Commonwealth Acts amended by the Commonwealth Act mentioned in paragraph 1 above; and

(b) the Commonwealth Regulations mentioned in paragraph 2 above

apply, subject to certain amendments, as laws of Victoria.

4. (1) Schedule 1 to the Companies (Acquisition of Shares) (Application of Laws) Act 1981, No. 9564 is amended as from 1 January 1984 by regulations made under Section 16 of that Act on 20 December 1983, No. 421.

(2) The Companies (Acquisition of Shares) (Victoria) Code is amended as from 1 January 1984—

(a) in accordance with the provisions of Part II. of the Commonwealth Companies and Securities Legislation (Miscellaneous Amendments) Act 1983 by reason of the operation of section 4 of the Companies (Acquisition of Shares) (Application of Laws) Act 1981; and

(b) in accordance with the provisions of Regulations 4 and 5 of the Regulations referred to in sub-clause (1) above.

5. (1) Schedule 1 to the Securities Industry (Application of Laws) Act 1981, No. 9562 is amended as from 1 January 1984 by Regulations made under section 15 of that Act on 20 December 1983, No. 423.

(2) The Securities Industry (Victoria) Code is amended as from 1 January 1984—

(a) in accordance with the provisions of Part VII. of the Commonwealth Companies and Securities Legislation (Miscellaneous Amendments) Act 1983 by reason of the operation of section 6 of the Securities Industry (Application of Laws) Act 1981; and

(b) in accordance with the provisions of Regulation 4 of the Regulations referred to in sub-clause (1) above.

6. (1) Schedule 1 to the Companies (Application of Laws) Act 1981, No. 9712 is amended as from 1 January 1984 by Regulations made under section 15 of that Act on 20 December 1983 No. 422.

(2) The Companies (Victoria) Code is amended from 1 January 1984—

(a) in accordance with the provisions of Part III. of the Commonwealth Companies and Securities Legislation (Miscellaneous Amendments) Act 1983 by reason of the operation of section 6 of the Companies (Application of Laws) Act 1981; and

(b) in accordance with the provisions of Regulations 4 to 13 inclusive of the Regulations referred to in sub-clause (1) above.

7. The Companies and Securities (Interpretation and Miscellaneous Provisions) (Victoria) Code is amended as from 1 January 1984 in accordance with the provisions of Part V. of the Commonwealth Companies and Securities Legislation (Miscellaneous Amendments) Act 1983 by reason of the operation of Section 8 of the Companies and Securities (Interpretation and Miscellaneous Provisions) (Application of Laws) Act 1981.

Drugs Poisons and Controlled Substances Act 1981

PROCLAMATION

By His Excellency the Governor of the State of Victoria and its Dependencies in the Commonwealth of Australia, &c., &c., &c.

Whereas by section 12 of the *Drugs Poisons and Controlled Substances Act 1981* it is amongst other things enacted that the Governor in Council may, by Proclamation published in the Government Gazette, amend any of Schedules One, Two, Three, Four, Five, Six, Seven, Eight or Eleven to such Act by adding to any Schedule or removing therefrom any item.

Now therefore, I, the Governor of the State of Victoria in the Commonwealth of Australia, by and with the advice of the Executive Council of the said State do by this my Proclamation:

1. Amend Schedule Four to the said Act by removing therefrom the following items:

ANTIBIOTICS—Chloramphenicol, Penicillinic Acid, Penicillin, Streptomycin, Tetracycline and any other antibiotic substances however derived and their chemical derivatives, except when—

- (a) included in Schedule Six;
- (b) in animal feedstuffs for growth promotion containing: Bacitracin and its salts, Benzyl Penicillin and its salts (including Procaine Penicillin), Chlorotetracycline, Erythromycin and its salts, Flavomycin, Oleandomycin and its salts, Oxytetracycline, Tylosin and its salts and Virginiamycin and its salts in concentrations of 50 parts per million or less of the total active antibiotic principle;
- (c) in substances containing 50 parts per million or less of Hygromycin B;
- (d) in milk replacers for calves and starter rations for pigs containing Bacitracin and its salts, Benzyl Penicillin and its salts (including Procaine Penicillin), Chlorotetracycline, Erythromycin and its salts, Oxytetracycline and its salts and Tylosin and its salts in concentrations of 100 parts per million or less of the total active antibiotic principle.

SULPHANILAMIDE and SULPHONAMIDES except—

- (a) when included in Schedule Six; or
- (b) in animal feedstuffs containing 200 parts per million or less of Sulphaquinoxaline.

2. Amend Schedule Four to the said Act by adding thereto the following items:

ANTIBIOTIC SUBSTANCES however derived and their chemical derivatives except—

- (a) when included in Schedule Six;
- (b) Hygromycin B in preparations containing 50 milligrams per kilogram or less of the total antibiotic principle;
- (c) the following when in milk replacers for calves and starter rations for pigs, in concentrations of 100 milligrams per kilogram or less of the total active antibiotic principle—Bacitracin and its salts, Erythromycin and its salts, Tylosin and its salts;
- (d) Avoparcin when specifically prepared and packed as an animal feed additive;
- (e) Nisin; and
- (f) Natamycin for use on the surface of cheese or cured manufactured meat.

SULPHONAMIDES, except—

- (a) when included in Schedule Six; and
- (b) Sulphaquinoxaline in animal feedstuffs containing 200 milligrams per kilogram or less of Sulphaquinoxaline.

3. Amend Schedule Six to the said Act by removing therefrom the following items:

ANTIBIOTIC SUBSTANCES, the following:

(1) Bacitracin, Benzyl Penicillin, Chlorotetracycline, Erythromycin, Flavomycin, Oleandomycin, Oxytetracycline, Tylosin or Virginiamycin—

- (a) when incorporated in animal feedstuff premixes that contain 20 000 parts per million or less of any one or more of such antibiotic substances and that are registered as stock medicines and specifically prepared, packed and labelled for the purpose of growth promotion in animals; and
- (b) when labelled with directions stating that the concentration of the antibiotic substance or substances in the feed should not exceed 100 parts per million when given to stock.

(2) Benzyl Penicillin (including Procaine Penicillin), Phenoxymethylpenicillin, Phenethicillin and Streptomycin, or a combination of any of these substances, for bovine intramammary infusion—

- (a) containing not more than 100 000 international units per dose of benzyl penicillin, procaine penicillin, phenoxymethylpenicillin or phenethicillin;
- (b) prepared and packed in accordance with the Regulations; and
- (c) labelled with a statement of the expiry date and the words 'Wear rubber gloves when applying'.

(3) Chloramphenicol when prepared for veterinary purposes for the topical treatment of foot-rot and for ocular use.

SULPHANILAMIDE and SULPHONAMIDES—

- (a) for veterinary use, except animal feedstuffs containing 200 parts per million or less of Sulphaquinoxaline; and
- (b) when specifically prepared and packed for photographic use.

4. Amend Schedule Six to the said Act by adding thereto the following items:

ANTIBIOTIC SUBSTANCES, the following—

(1) Bacitracin, Erythromycin, Flavophospholipol (Bambermycins), Kitasamycin, Oleandomycin, Spiramycin, Tylosin and Virginiamycin when incorporated in animal feedstuff pre-mixes that:

- (a) contain more than 50 milligrams per kilogram but not more than 20 000 milligrams per kilogram of any one or more of such antibiotic substances;
- (b) are registered as stock medicines under the Stock Medicines Act 1958;
- (c) are specifically prepared, packed and labelled for the purpose of growth promotion in animals; and
- (d) where applicable, are labelled with directions stating that the concentration of the antibiotic substance or substances in the feed should not exceed 100 milligrams per kilogram when given to stock.

(2) Benzyl Penicillin (including Procaine Penicillin), Phenoxymethylpenicillin, Phenethicillin and Streptomycin, or a combination of any of these substances, in preparations for bovine intramammary infusion that—

- (a) contain not more than 100 000 international units per dose of Benzyl Penicillin, Procaine Penicillin, Phenoxymethylpenicillin, Phenethicillin or Streptomycin;
- (b) are prepared and packed in accordance with the Regulations; and
- (c) are labelled with a statement of the expiry date and the words 'Wear rubber gloves when applying'.

(3) Chloramphenicol when prepared for veterinary purposes for the topical treatment of foot-rot and for ocular use.

(4) Tetracyclines (See SULPHONAMIDES and TETRACYCLINES).

LASALOCID, except when incorporated into animal feedstuffs containing 100 milligrams or less of the total active principle per kilogram.

SULPHAQUINOXALINE, when prepared, packed and labelled for use as a coccidiostat in poultry except preparations containing 200 milligrams per kilogram or less of sulphaquinoxaline.

SULPHONAMIDES,

- (a) when specifically prepared and packed for external use on animals;
- (b) when in preparations in packs containing a total of 250 grams or less of sulphonamides, labelled for the treatment of disease in animals;
- (c) when specifically prepared and packed for photographic use.

SULPHONAMIDES and TETRACYCLINES when incorporated for the prevention of disease in calves and pigs up to twelve weeks of age in—

- (1) finished calf feeds, milk replacers or pig starter feeds that—
- (a) are registered as stock foods under the Stock Foods Act 1958;
- (b) contain not less than 18 per cent of crude protein;
- (c) are specifically prepared, packed and labelled for the purpose of feeding to calves and young pigs; and
- (d) contain at least 100 milligrams per kilogram but not more than 200 milligrams per kilogram of either a sulphonamide or a tetracycline, but only one such substance; or
- (2) medicated animal feedstuff pre-mix concentrates that—
- (a) are registered as stock medicines under the Stock Medicines Act 1958;
- (b) contain not less than 50 per cent of protein;
- (c) are specifically prepared, packed and labelled for the purpose of preparing pig starter feeds, including directions for mixing with grain to produce only pig starter feeds that contain—
- (i) at least 100 milligrams per kilogram but not more than 200 milligrams per kilogram of either a sulphonamide or a tetracycline, but only one such substance; and
- (ii) not less than 18 per cent of crude protein.

TETRACYCLINES and SULPHONAMIDES (See SULPHONAMIDES and TETRACYCLINES).

Given under my hand and the seal of the State of Victoria aforesaid, at Melbourne this 20 day of December in the year of Our Lord One thousand nine hundred and eighty three, and in the thirty-second year of the reign of Her Majesty Queen Elizabeth the Second, Queen of Australia.

(L.S.)
By His Excellency's Command

Brian MURRAY

T. W. ROPER
Minister of Health

GOD SAVE THE QUEEN!

LOCAL GOVERNMENT ACT 1958

At the Executive Council Chamber, Melbourne, the twentieth day of December 1983.

PRESENT:

His Excellency the Governor of Victoria
Mr Cathie | Mr Walker
Mr Trezise

PART OF A ROAD DISCONTINUED—CITY OF HORSHAM

Whereas it is provided in section 528 (2) of the *Local Government Act 1958*, that where a road (whether or not a public highway but not being a road set out on land of the Crown) or any part thereof is not required for public use, the Governor in Council on the request of the council of the municipality in which such road is situated made not less than one month after publishing in a newspaper generally circulating in the district and posting to the registered proprietor (if any) of the land and the owners and occupiers (if any) of lands abutting or immediately adjacent to the road notice of intention to make such a request may by Order published in the *Government Gazette* direct that such road or part shall be discontinued and thereupon such road or part shall be discontinued accordingly.

And whereas it is further provided that where a planning scheme under the *Town and Country Planning Act 1961* provides for the closing of a road or part of a road and notice of approval of the

planning scheme has been published in the *Government Gazette* it shall not be necessary for the Council to publish or to post to any person notice of its intention to request the Governor in Council to discontinue such road or part thereof.

And whereas the City of Horsham Planning Scheme 1973 provides that part of a road off James Street, Horsham is not required for public use and notice of approval of the planning scheme was published in the *Government Gazette* of 27 June 1973.

And whereas the Council of the City of Horsham has requested that the Governor in Council direct that the said part of a road be discontinued.

Now therefore, His Excellency the Governor of the State of Victoria, by and with the advice of the Executive Council thereof, hereby directs:

- (a) that the said part of a road which is shown by hatching on the plan hereunder shall be discontinued;
- (b) that, subject to any such right title power authority or interest the land in the said part of a road may be sold by the Council of the City of Horsham by agreement.

And the Honourable Frank Noel Wilkes, Her Majesty's Minister for Local Government for the State of Victoria, shall give the necessary directions herein accordingly.

TOM FORRISTAL
Clerk of the Executive Council

LOCAL GOVERNMENT ACT 1958

At the Executive Council Chamber, Melbourne, the twentieth day of December 1983.

PRESENT:

His Excellency the Governor of Victoria
Mr Cathie | Mr Walker
Mr Trezise

ROAD DISCONTINUED—SHIRE OF HASTINGS

Whereas it is provided in section 528 (2) of the *Local Government Act 1958*, that where a road (whether or not a public highway but not being a road set out on land of the Crown) or any part thereof is not required for public use, the Governor in Council on request of the council of the municipality in which such road is situated made not less than one month after publishing in a newspaper generally circulating in the district and posting to the registered proprietor (if any) of the land and the owners and occupiers (if any) of lands abutting or immediately adjacent to the road notice of intention to make such a request may by Order published in the *Government Gazette* direct that such road or part shall be discontinued and thereupon such road or part shall be discontinued accordingly.

And whereas the Council of the Shire of Hastings has requested that the Governor in Council direct that part of a road off Church Street, Hastings be discontinued and not less than one month previously has published in a newspaper generally circulating in the district and posted to the registered proprietor of the land in the road and to the owners and occupiers of lands abutting or immediately adjacent to the road notice of intention to make such a request.

Now therefore, His Excellency the Governor of the State of Victoria, by and with the advice of the Executive Council thereof, hereby directs:

- (a) that the said part of a road which is shown by hatching, cross-hatching and cross-hatching marked "A" on the plan hereunder shall be discontinued;
- (b) that notwithstanding such discontinuance the Hastings Sewerage Authority shall continue to have and possess the same right title power authority or interest in or in relation to the whole of the land shown by cross-hatching marked "A" on the said plan as it had or possessed prior to such discontinuance with respect to or in connection with any drains or pipes laid or erected in on or over such land for the purposes of drainage or sewerage;
- (c) that, subject to any right title power authority or interest the land in the said part of a road shown by hatching on the said plan may be sold by the Council of the Shire of Has-

tings by agreement and the land in the said part of a road shown by cross-hatching and cross-hatching marked "A" on the said plan shall be retained by the said Council for municipal purposes.

And the Honourable Frank Noel Wilkes, Her Majesty's Minister for Local Government for the State of Victoria, shall give the necessary directions herein accordingly.

TOM FORRISTAL
Clerk of the Executive Council

Town and Country Planning Act 1961
SHIRE OF KILMORE PLANNING SCHEME 1973

AMENDMENT No. 50, 1981

NOTICE OF APPROVAL

In pursuance of the powers conferred by the *Town and Country Planning Act 1961*, the Governor in Council on 20 December 1983, approved the abovementioned scheme in respect of the municipal district of the Shire of Kilmore and for which the Council of the Shire of Kilmore is the Responsible Authority.

The scheme comes into operation on the date this Notice is published in the *Government Gazette*.

The scheme rezones land being Crown Allotment 22, Parish of Bylands from Rural "A" Zone to part Rural "B" and part Rural "C" Zones.

A copy of the documents may be inspected free of charge, during office hours, at the office of the Ministry for Planning and Environment (Plan Inspection Section), 5th Floor, 235 Queen Street, Melbourne, and at the office of the Shire of Kilmore, Civic Centre, Kilmore.

DAVID YENCKEN
Secretary for Planning and Environment

Town and Country Planning Act 1961
CITY OF SHEPPARTON PLANNING SCHEME 1953

AMENDMENT No. 70, 1982

NOTICE OF APPROVAL

In accordance of the powers conferred by the *Town and Country Planning Act 1961*, the Governor in Council on 20 December 1983, approved the abovementioned scheme in respect of the municipal district of the City of Shepparton and for which the Council of the City of Shepparton is the Responsible Authority.

The scheme comes into operation on the date this notice is published in the *Government Gazette*.

The scheme amends the Planning Scheme ordinance to the following effect:

- (a) to make "Home Occupation" in a house subject to a permit in all residential and commercial zones and in all industries (other than offensive industrial) Zones; and
- (b) to require car parking spaces for "Home Occupation".

A copy of the documents may be inspected free of charge, during office hours, at the office of the Ministry for Planning and Environment (Plan Inspection Section), 5th Floor, 235 Queen Street, Melbourne and at the office of the Council of the City of Shepparton, Welsford Street, Shepparton.

DAVID YENCKEN
Secretary for Planning and Environment

Town and Country Planning Act 1961
SHIRE OF SHERBROOKE PLANNING SCHEME 1979
(URBAN AREAS)

AMENDMENT No. 20

NOTICE OF AMENDMENT

In pursuance of the powers conferred by the *Town and Country Planning Act 1961*, the Governor in Council on 20 December 1983, approved the abovementioned scheme in respect of the municipal district of the Shire of Sherbrooke and for which the Shire of Sherbrooke is the Responsible Authority.

The amendment comes into operation on the date this Notice is published in the *Government Gazette*.

The amendment includes the alteration of provisions relevant to Lot 1, LP5044 Terry's Avenue, Belgrave to facilitate the construction of a roundabout on the intersection of Monbulk Road and Terry's Avenue, Belgrave.

A copy of the documents may be inspected free of charge, during office hours, at the office of the Ministry for Planning and Environment (Plan Inspection Section), 5th Floor, 235 Queen Street, Melbourne and at the office of the Shire of Sherbrooke.

DAVID YENCKEN
Secretary for Planning and Environment

RESIGNATIONS

His Excellency the Governor of the State of Victoria by and with the advice of the Executive Council thereof has by Orders made on 20 December 1983 accepted the resignations of the persons named hereunder of the offices mentioned, viz:

HEALTH COMMISSION

Members of Committees of Management

Lawrence Guy BARNETT as Member of the Committee of Management of the The Inglewood Hospital as from 2 November, 1983.

James Kee Tak CHUI as Member of the Committee of Management of the Morwell and District Community Hospital as from 17 October, 1983.

Hilda Myrtle JENKINS as Member of the Committee of Management of the Morwell and District Community Hospital as from 21 August, 1983.

Gwladys STAFFORD as Member of the Committee of Management of the Southern Peninsula Hospital as from 22 November, 1983.

Geoffrey Bromell HEARD as Member of the Committee of Management of the Wimmera Base Hospital as from 17 November, 1983.

William Thomas EDWARDS as Member of the Committee of Management of the Burwood and District Community Hospital as from 31 October, 1983.

Robert JAMIESON as Member of the Committee of Management of the Mortlake District Hospital as from 17 October, 1983 in accordance with the provisions of Section 63G(1) of the *Hospitals and Charities Act 1958*.

LAW DEPARTMENT

Justices of the Peace

Herbert Charles SMALE as a Justice of the Peace for the State of Victoria.

Commissioners for Taking Declarations

Nancy Dorothy BROWN, Rupert Alan GASKELL and Linda Jane HOLLIER as Commissioners for taking declarations and affidavits under the *Evidence Act 1958*.

TOM FORRISTAL
Clerk of the Executive Council

At the Executive Council Chamber
Melbourne, 20 December, 1983

MARINE ACT 1958

His Excellency the Governor of the State of Victoria by and with the advice of Executive Council thereof has by Order made on 20 December 1983 appointed Senior Sergeant Colin John Davison, No. 13250, as Wharf Manager at Frankston.

(a) to carry out that portion of Part II of the *Marine Act 1958* which relates to the management of public wharfs,

(b) to be an officer for the purpose of carrying out and enforcing rules and regulations made pursuant to Section 7 of such Act, at a remuneration of \$90 per annum vice Senior Sergeant Terence Charles Hill, No. 13889 transferred.

TOM FORRISTAL
Clerk of the Executive Council

At the Executive Council Chamber
Melbourne, 20 December, 1983

CITY OF CAMBERWELL

LOAN No. 128

Notice of Intention to Borrow the Sum of \$1 000 000 for Permanent Works and Undertakings

Notice is hereby given that the Council of the City of Camberwell proposes to borrow the sum of \$1 000 000 secured by a charge over the General Rates of the municipality, such sum to be raised by the grant of a mortgage in accordance with the provisions of the *Local Government Act 1958*.

(1) The maximum rate of interest that may be paid is 13.2 per centum per annum.

(2) The purposes for which the loan is to be applied is as follows:

Area 7 and 8 Traffic Engineering Permanent Works	\$ 65 000
Purchase of new plant: parks equipment, work-shop equipment, mobile radios, work engineer's vehicle, golf course, containers and playground service van	89 000
Replacement of pitcher channels and minor street reconstruction	200 000
Drainage works Gardenia Road, Burke Road/Head Street	30 000
Car park Canterbury Sports Ground	30 000
Frog Hollow New Pavillion	200 000
Dorothy Laver Reserve New Pavillion	200 000
Camberwell Sports Ground Exhaust Vents	6 000
Macleay Park Window alterations	4 000
Nettleton Park toilets upgrade	60 000
Koonung Creek Reserve	100 000
Frog Hollow Log Rail Fencing	6 000
BMX Track	10 000
	1 000 000

(3) The period of the Loan shall be four years based on a ten-year repayment schedule.

(4) The monies shall be repayable by providing out of the Municipal Fund seven (7) half-yearly instalments of approximately \$91 478.59 each including principal and interest on 14 February and 14 August during the currency of the loan with a residual of \$833 809.50 approximately. The first instalment shall be repayable on 14 August, 1984.

(5) Such monies shall be repayable to the Westpac Banking Corporation Ltd at the Head Office of the Bank in Melbourne, or at such other place as the said Bank may require.

The plans and specifications and the estimate of the cost of the proposed expenditure of the money to be borrowed are open for inspection at the Municipal Offices, 350 Camberwell Road, Camberwell during business hours.

MARTIN VERHOEVEN, Chief Executive Officer and Town Clerk
361

CITY OF SUNSHINE

LOAN No. 166

Notice of Intention to Borrow the Sum of \$900 000 for Permanent Works and Undertakings

Notice is hereby given that the Council of the City of Sunshine proposes to borrow the principal sum of Nine Hundred Thousand Dollars (\$900 000) secured by a charge over the general rates of the municipality such sum to be raised by the grant of a mortgage in accordance with the provisions of the *Local Government Act 1958*.

1. The maximum rate of interest that may be paid is 12.6 per cent per annum.

2. The purposes for which the loan is required are as follows:

Part Construction—South Road	\$ 150 000
Construction—Deakin/Yardley/Montgomery Streets	220 000
Part Construction—Main Road West—Estimated total cost \$580 000—previously borrowed nil—balance to be borrowed in successive years	170 000

Part Reconstruction—Durham Road Estimated total cost \$500 000—previously borrowed \$106 600—balance to be borrowed in current and successive years	201 500
Extensions to Sunshine Bowling Club Rooms	60 000
Renovations to Historic Building/Hunt Club Deer Park. Estimated total cost \$200 000—previously borrowed \$39 200—balance to be borrowed in successive years	40 000
Reconstruction of columns—Municipal Offices	40 000
Acquisition of Kerb and Channel Machine	18 500
	900 000

3. The period of the loan shall be four (4) years.

4. The monies borrowed shall be repayable by providing out of the Municipal Fund seven half-yearly instalments amounting to \$67 496.51 and a final payment of \$859 480.91. Such payments shall be due and payable on 15 August and 15 February during the currency of the loan. The first instalment shall be repayable on 15 August 1984.

5. Such monies shall be repayable at the office of the National Australia Bank, Hampshire Road, Sunshine or such other place of places as the Bank from time to time may require.

The plans and specifications and the estimate of the proposed work and a statement showing the proposed expenditure of the money to be borrowed are open for inspection at the Office of the Council of the City of Sunshine at the Municipal Offices, Alexandra Avenue, Sunshine.

362 T. W. DEUTSCHMANN, Town Clerk

GLENELG RIVER IMPROVEMENT TRUST

RATING BY-LAW FOR 1984

The Glenelg River Improvement Trust, in pursuance and exercise of the powers conferred by the *River Improvement Act 1958*, doth hereby make the By-Law following:

1. The following rate, to be called the "Glenelg River Improvement Rate", is hereby made and shall be levied upon the Glenelg River Improvement District: A rate of 1.8 cents in the dollar on the Net Annual Municipal Valuation of all lands in the First Division, provided that the amount of rate payable in respect of any such land shall not be less than Three Dollars. In respect of lands in the Second Division no rate shall be levied.

2. Such rate is made and shall be levied for the period of twelve months commencing on 1 January 1984, and ending on 31 December 1984, and shall be due and payable at the office of the Trust at Casterton, on 1 January 1984.

3. Such person or persons as the Trust may from time to time appoint for that purpose shall be and is or are hereby authorized to demand, receive, collect and recover the said rate.

The foregoing By-Law was passed by the Glenelg River Improvement Trust on 14 December 1983.

The seal of the Trust was hereunto affixed on 14 December 1983 in the presence of:

	(SEAL)	H. G. ROSS, Chairman
		M. T. DARE, Commissioner
		V. J. SMITH, Secretary

KORUMBURRA WATERWORKS TRUST

EIGHTH SCHEDULE

Notice to owners of tenements in the undermentioned streets and private streets, lanes, courts and alleys opening thereto.

The main pipe in the said street being laid down, the owners of all tenements situated as under are hereby required on or before 1 January 1984 to cause a proper pipe and stop cocks to be laid so as to supply water within such tenements from the main pipe.

GREENHILLS ESTATE
Lot Nos. 1-61 L.P.139826.
Sommers Crescent
Rill Court
Hillcrest Way
Range Court

352 C. J. PATERSON, Secretary/Manager

**MOE SEWERAGE AUTHORITY
GENERAL NOTICE**

The abovementioned Sewerage Authority having made provision for carrying off the sewage from each and every property which or any part of which is within the Sewerage Areas hereinafter described doth hereby declare that on and after 1 January 1984 each and every property which or any part of which is within the said sewerage areas shall be deemed to be seweraged properties within the meaning of the *Sewerage Districts Act 1958*.

The sewerage area hereinbefore referred to shall be known as sewerage area.

No. 116—Lot 1—L.P.126050—C.A. 3B Narracan, corner of Thompsons Road and Hayes Road.

The boundaries of the said Sewerage Area No. 116, are delineated on the plan, which may be inspected at the offices of the Moe Sewerage Authority.

19 December 1983

353 T. VICIC, Chairman
A. DEWAR, Secretary

THE BALLARAT SEWERAGE AUTHORITY

Pursuant to Section 119 (2) of the *Sewerage Districts Act 1958* (No. 6368) notice is hereby given of the intention to construct sewers situated in the vicinity of the following streets:—Vickers Street, Bala Street, Orion Street, Rubicon Street, Sebastopol and also Vale Street, Edwards Street, and King Drive Sebastopol.

More particularly as shown on plans which are open for inspection at this Office between the hours of 8.45 a.m. and 4.30 p.m., Monday to Friday, inclusive.

363 B. E. LEACH, Secretary

**FRANKSTON SEWERAGE AUTHORITY
COMMENCEMENT OF WORKS**

Notice is hereby given that the Authority intends to construct sewers in the vicinity of the corner of Mann Road and Humphries Road, Frankston.

Details of the proposed works are available for inspection at the office of the Authority, Civic Centre Annexe, 34 Davey Street, Frankston between 8.45 a.m. and 4.30 p.m. Tuesday to Friday and 8.45 a.m. to 8.00 p.m. on Monday.

364 A. H. BUTLER, Secretary

**MOUNT BEAUTY SEWERAGE AUTHORITY
EXTENT OF SEWERAGE DISTRICT INCREASED**

*At the Executive Council Chamber, Melbourne, the
twentieth day of December 1983*

PRESENT:

His Excellency the Governor of Victoria
Mr Cathie | Mr Walker
Mr Trezise | Mr Trezise

Under the powers conferred by the Sewerage Districts Act and all other powers enabling him in that behalf, His Excellency the Governor of the State of Victoria, by and with the advice of the Executive Council of the said State, doth hereby declare, order and direct that the extent of the Sewerage District of the Mount Beauty Sewerage Authority be increased by adding thereto the lands shown by red border on the plan approved by the Governor in Council, by and with this Order and deposited in the office of the State Rivers and Water Supply Commission, Melbourne, (Corr. No. 82/1411/52) and as on and from the date hereof the extent of such district shall be and are deemed to be increased accordingly.

And the Honourable David Ronald White, Her Majesty's Minister of Water Supply for the State of Victoria, shall give the necessary directions herein accordingly.

TOM FORRISTAL
Clerk of the Executive Council

PUBLIC SERVICE ACT 1974

*At the Executive Council Chamber, Melbourne, the
twentieth day of December 1983*

PRESENT:

His Excellency the Governor of Victoria
Mr Cathie | Mr Walker
Mr Trezise | Mr Walker

In pursuance of the powers conferred by sub-section 47 (6) of the *Public Service Act 1974*, His Excellency the Governor of the State of Victoria by and with the advice of the Executive Council of the said State, and upon the recommendation of the Public Service Board, doth certify that the following government offices are offices substantially similar to offices in the Public Service:

Director-General of Conservation, Forests and Lands established under Section 4 of the *Director-General of Conservation, Forests and Lands Act 1983*;

Assistant Director-General of Transport (Budget and Accounting Development) established under Section 5 (2) of the *Transport Act 1983*;

Assistant Director-General of Transport (Freight Transport Co-ordination) established under Section 5 (2) of the *Transport Act 1983*;

Assistant Director-General of Transport (Policy and Programming) established under Section 5 (2) of the *Transport Act 1983*.

And the Honourable John Cain, Her Majesty's Premier for the State of Victoria, shall give the necessary directions herein accordingly.

TOM FORRISTAL
Clerk of the Executive Council

**GOVERNMENT EMPLOYEE HOUSING AUTHORITY ACT
1981**

ORDER PURSUANT TO SECTION 12

*At the Executive Council Chamber, Melbourne, the
twentieth day of December 1983*

PRESENT:

His Excellency the Governor of Victoria
Mr Cathie | Mr Walker
Mr Trezise | Mr Trezise

WHEREAS:

1. Section 12(1) of the Government Employee Housing Authority Act 1981 provides that the Governor in Council may, by Order published in the Government Gazette, declare that a department of the public service or a public statutory authority is a participating department for the purposes of Part III of the said Act.

2. Section 12 (2) of the said Act provides that the Governor in Council may, by an Order under Section 12 (1) or by a subsequent order published in the Government Gazette, transfer to the government Employee Housing Authority any land or premises specified in the Order, being land or premises that is or are—

- (a) Vested in or held by any Minister of the Crown or public statutory authority; and
- (b) used or allocated for use as a house for government employees in the participating department:

Now therefore I, the Governor of the State of Victoria, by and with the advice of the Executive Council thereof, and pursuant to the provisions of Section 12 of the said Government Employee Housing Authority Act 1981, do hereby:

1. Declare the Law Department to be a participating department for the purposes of Part III of the said Act with effect from and including 1 January, 1984.

2. Transfer to the Government Employee Housing Authority the land or premises specified in the Schedule hereto with effect from and including 1 January, 1984.

SCHEDULE

- (a) The land described in the following Instruments registered in the Office of Titles numbered A794146, C208861, A251734, B79560, B33039, A554091, 2290237, B468331, B143376, C464611, B725486, B468323, F193722, A362022, A546474, E240156, K96082, B938, C880008, B468326, A949477, B705107, J163265, C258067, J540302, A599077, A537541, E733840, F501291, A599086, D791298, B103670, A346145, G768098, E412688, B125403, C247994, A546475, B621353, A367596.
- (b) the land being:—
- (i) Lot 1 on Plan of Subdivision 69673 being part of Crown Allotment 37 Township and Parish of Colac;
- (ii) Crown Allotment 6 Section 16 Town of Warracknabeal, Parish of Werrigar;
- (iii) Crown Allotment 17 and 18, Section 5, Township and Parish of Wonthaggi.
- (c) The land recorded in the Office of the Registrar-General and being the whole of the land described in:—
- | | |
|-----------------|-------------|
| Conveyance Book | 625 No. 699 |
| | 643 No. 284 |
| | 674 No. 371 |
| | 648 No. 114 |
| | 682 No. 795 |
| | 607 No. 550 |
| | 648 no. 114 |

And the Honourable JAMES HARLEY KENNAN, Her Majesty's Attorney-General for the State of Victoria, shall give the necessary directions herein accordingly.

TOM FORRISTAL
Clerk of the Executive Council

EXRACTIVE INDUSTRIES ACT 1966 No. 7499

*At the Executive Council Chamber, Melbourne, the
thirteenth day of December 1983*

PRESENT:

His Excellency the Governor of Victoria
Mr Spyker | Mr Kennan
Mr Mathews | Mr Kent

APPOINTMENT OF MEMBERS OF THE BOARD OF EXAMINERS FOR QUARRY MANAGERS

In pursuance of the provisions of the Extractive Industries Act 1966 No. 7499 and all other powers enabling him in that behalf, His Excellency the Governor of the State of Victoria, by and with the advice of the Executive Council of the said State doth hereby appoint.

JAMES DAVID ROWLANDS
ANDREW JOSEPH JACKSON

to be members of the Board of Examiners for Quarry Managers for a period of three (3) years as from 14 December 1983.

And the Honourable David Ronald White, Her Majesty's Minister for Minerals and Energy for the State of Victoria, shall give the necessary directions herein accordingly.

TOM FORRISTAL
Clerk of the Executive Council

NOTICE OF WINDING UP ORDER

In The Matter of Stacey Cogle & Co. Pty. Ltd. Winding up Order made the 15th day of December 1983. Name and address of Liquidator: Robert Molesworth Hobill Cole of 440 Collins Street, Melbourne.

R. A. LEWIS & ASSOCIATES, Solicitor for the Petitioner. 0396

IN THE MATTER of SARABAND PTY. LIMITED
(Receivers and Managers Appointed)

AND IN THE MATTER OF SECTION 315 OF THE COMPANIES
(NEW SOUTH WALES) CODE

Notice is hereby given that the creditors of the above named company are required on or before the 11th day of January, 1984 to send in their names and addresses and the particulars of their debts or claims to the undersigned, Geoffrey Noel Crawford-Fish and James Peter Grant, of Deloitte Haskins & Sells, 461 Bourke Street, Melbourne, the proposed administrators of the said company, and if so required in writing from the said administrators are required to come in and prove the said debts or claims at such time and place as shall be specified in such notice, or in default thereof they will be excluded from the benefit of any distribution made before such debts are proved.

Dated this 23rd day of December, 1983.

GEOFFREY NOEL CRAWFORD-FISH and JAMES PETER GRANT
0392

Notice is hereby given that the Supreme Court of New South Wales, Equity Division, has directed that a meeting of the unsecured creditors of Saraband Pty Limited (Receivers and Managers appointed) (hereinafter called "the Company") be summoned pursuant to Section 315 of the Companies (New South Wales) Code, 1982 for the purpose of considering and if thought appropriate approving with or without modification a Scheme of Arrangement between the Company and its creditors.

1. The Meeting will be held at the offices of Messrs. Deloitte Haskins & Sells, Chartered Accountants, 1st Floor, 461 Bourke Street, Melbourne at 10.00 a.m. on Wednesday, 1 February 1984.

2. Creditors of the company may obtain a copy of the Notice calling the meeting, a copy of the Scheme of Arrangement and a copy of the statement explaining the effect of the Scheme of Arrangement as required by Section 316 of the Companies (New South Wales) Code, 1982 from the offices of Messrs. Deloitte Haskins & Sells, Chartered Accountants, at either 13th Floor, 461 Bourke Street, Melbourne or 15 Bent Street, Sydney during normal business hours. Any creditor entitled to attend the meeting may attend by proxy, and a Form of Proxy may also be obtained at the offices of Messrs. Deloitte Haskins & Sells as aforesaid. The proxy to be used at the meeting must be lodged with Messrs. Deloitte Haskins & Sells, 13th Floor, 461 Bourke Street, Melbourne not later than 4.00 p.m. on 31 January 1984. Any proxy lodged after that time will not be treated as valid.

0393

In the Will of David Merrifield Middleton late of 31 upper Skene Street, Newtown, Geelong, Gentleman, deceased.

CREDITORS next-of-kin and others having claims in respect of the Estate of the above named deceased who died on 6 November, 1983 are required by IAN FERGUSON APTED of 63 Yarra Street, Geelong, Solicitor and JOHN JOSEPH TARKA of 45 Hawthory Road, Kilsyth, Bank Officer, the applicants for Grant of Probate of the Will dated 21 April, 1982 of the said deceased to send particulars of their claims to the said Executors care of Messrs. F. R. APTED & Son, Solicitors of 63 Yarra Street, Geelong by 6 March, 1984 after which date the said Executors may convey and distribute the assets having regard only to the claims of which they then had notice.

F. R. APTED & SON, Solicitors, 63 Yarra Street, Geelong
0394

Creditors, next of kin and all other persons having claims against the Estate of KATHLEEN MARY WINTER late of Lakeside Hospital, Ballarat in the State of Victoria, Spinster deceased are required by the Executor of her Estate THE EQUITY TRUSTEES EXECUTORS AND AGENCY COMPANY LIMITED to send their claims to them, care of the undersigned, by 28 February, 1984 after which date they will distribute the assets of her Estate, having regard only to the claims of which they then have notice.

HOLDING REDLICH & Co.
Solicitors, 478 Albert Street, East Melbourne

0401

REGIONAL ADVISORY BOARDS

Pursuant to Section 36 (2) of the *Transport Act 1983*, I Steven Marshall Crabb, Her Majesty's Minister of Transport for the State of Victoria give notice of the establishment of the following regional advisory boards with respect to the Metropolitan Transit Authority.

Moorabbin, Dandenong, Box Hill, Ringwood, Greensborough, Werribee, St. Albans, Broadmeadows, Frankston, Inner West, Inner North, Inner South East.

22 December 1983

Steven Marshall Crabb

Monday-Friday (Daily additional service as required)

Dep	Mornington	7.30 a.m.
Arr	Melbourne	8.30 a.m.
Dep	Melbourne	5.30 p.m.
Arr	Mornington	6.30 p.m.

Note: This application replaces a previous application which appeared in *Victoria Government Gazette* No. 126 dated 7 December 1983.

29 December 1983,

C. J. V. SMITH, Chief General Manager Registration and Regulation.

HALLS GAP SEWERAGE AUTHORITY

HALLS GAP SEWERAGE SCHEME

Notice of Commencement of Construction of Sewerage Works

Pursuant to Clause 119 (2) of the *Sewerage Districts Act 1958*, Notice is hereby given that construction of sewerage works will commence in the area of properties fronting Buckler Road, Warren Road, Grampians Road between Buckler Road and the Halls Gap Caravan Park, Fyans Street and Allison Street at least 30 days after the date of this Notice.

A map showing the locations of the works is open for inspection and may be inspected at the Authority's Offices, Shire Hall, Longfield Street Stawell from Monday to Friday during the hours of 8.15 a.m. to 12.30 p.m. and 1.15 p.m. to 5.00 p.m.

V. C. NIELSEN
Secretary

0391

TRANSPORT ACT 1983

ROAD TRAFFIC AUTHORITY

Passenger Ferry Application

Notice is hereby given that the following application will be considered by the Metropolitan Transit Authority on 17 January 1984.

Notice if any objections should be forwarded to reach the Officer in Charge, Passenger and Goods Division, Road Traffic Authority not later than 12 January 1984.

It will not be necessary for interested parties to appear on the hearing date specified, unless advised in writing by the Road Traffic Authority.

M B M MANAGEMENT PTY LTD MELBOURNE

Application to license a passenger ferry with facilities to accommodate 300 passengers to operate between:—

- (i) Melbourne, Queenscliff and Sorrento.
- (ii) Melbourne, Portarlington and Geelong.
- (iii) Melbourne, Geelong, Portsea and Mornington.
- (iv) Melbourne and Mornington.

Fares: To be determined.

Timetable: Service to operate 7 days per week during summer and school holidays periods, 5–6 days per week during spring and autumn and 4–5 days per week during the winter months.

Thursday—Saturday		Sunday	
Melbourne	Dep 9.30 a.m.	Melbourne	Dep 9.30 a.m.
Queenscliff	Arr 11.00 a.m.	Queenscliff	Arr 11.00 a.m.
Queenscliff	Dep 12.30 p.m.	Queenscliff	Arr 11.15 a.m.
Sorrento	Arr 1.00 p.m.	Sorrento	Arr 11.45 a.m.
Sorrento	Dep 2.30 p.m.	Sorrento	Arr 2.00 p.m.
Melbourne	Arr 4.00 p.m.	Melbourne	Arr 2.30 p.m.
	Arr Queenscliff		Arr 2.45 p.m.
	Dep Queenscliff		Arr Melbourne
	Arr Melbourne		Arr 4.15 p.m.

Monday and Tuesday		Wednesday	
Melbourne	Dep 9.30 a.m.	Melbourne	Dep 7.30 a.m.
Portarlington	Arr 11.00 a.m.	Geelong	Dep 9.30 a.m.
Portarlington	Dep 12.00 noon	Portsea	Arr 11.00 a.m.
Geelong	Arr 12.45 p.m.	Portsea	Dep 12.00 noon
Geelong	Dep 2.30 p.m.	Mornington	Arr 1.00 p.m.
Melbourne	Arr 4.30 p.m.	Mornington	Dep 2.00 p.m.
		Geelong	Arr 4.00 p.m.
		Melbourne	Arr 6.00 p.m.

Transport Act 1983
ROAD TRAFFIC AUTHORITY

Commercial Passenger and Goods Vehicle Applications

Notice is hereby given that the following applications will be considered by the Road Traffic Authority on 17 January 1984.

Notice of any objections should be forwarded to reach the Officer in Charge, Passenger and Goods Division not later than 12 January 1984.

It will not be necessary for interested parties to appear on the hearing date specified, unless advised in writing by the Authority.

Notification of the date for consideration of applications which are objected to and which require determination by the Road Transport Licensing Tribunal will be published by further notice in this Gazette.

ARNOTT R L VICTORIA VALLEY

Application for variation of the conditions of licence TO 182, which authorises a two day tour between Geelong and Port Fairy, to also commence the tour as and when required from Melbourne.

Note: This application replaces a previous application which appeared in *Victoria Government Gazette* No. 126 dated 7 December 1983.

CROYDON BUS SERVICE (BELGRAVE) PTY LTD CROYDON

Application for variation of MO, MC and TS licence conditions to operate day tours during January and February 1984, commencing at Lilydale, Mooroolbark, Croydon or Ringwood Railway Stations to the following places:—

	Fares		
	Adult \$	Pensioner \$	Child \$
Mornington Peninsula	10.00	8.00	4.00
Philip Island (Penguin Parade)	14.00	12.00	6.00
Barringa Wildlife Park, Gisborne	12.00	9.50	6.00
Lake Eildon	11.50	8.00	5.50
Gumbuya Park, Tynong	10.00	8.00	6.00
Winneke Reservoir, Yarra Valley Wineries	8.00	6.50	4.00
Drouin, Noojee, Yarra Junction	10.00	6.50	5.00

Note: This application replaces a previous application which appeared in *Victoria Government Gazette* No. 126 dated 7 December 1983.

FITZGERALD G & J EAST RINGWOOD

Application for one Metropolitan Taxi licence to be issued, to operate under radio control from the depot of Regal Taxis Limited, subject to the cancellation of Ferntree Gully Country Taxi licence No. CT 548.

HEBER-BULL J BRIGHTON

Application for two Special Purpose Vehicle licences in respect of a 1955 Rolls Royce sedan and a 1949-1955 Bentley sedan, to be purchased, to operate from 9 Emily Street, Brighton for the carriage of passengers for wedding parties.

McKENZIE'S TOURIST SERVICES PTY LTD KEW

Application for variation of permit numbered 8062 which authorises school service from Mt Waverley and Doncaster to Camberwell Grammar School as follows:—

1. Delete that part of the route on the Mt Waverley service between the corner of Station Street and Maroondah Highway and

Springfield Road and Middleborough Road via Williamsons Road and Springfield Road and instead operate from the corner of Station Street and Maroondah Highway, via Maroondah Highway, Middleborough Road and Wetherby road to normal route.

2. Delete the existing route on the Doncaster service and instead operate from the corner of Doncaster Road and Burke Road, North Balwyn via Doncaster Road, High Street, Manningham Road, Williamsons Road, Tram Road, Woodhouse Grove, Elgar Road, Belmore Road, Balwyn Road and Mont Albert Road to the school.

3. Delete the existing fares and charge revised fares as follows:-

Route 1

Camberwell Grammar School—Mt Waverley		Term Fare	Single
Section		\$	\$
1	School—Balwyn Road & Grosvenor Parade	38.00	0.35
2	Doncaster & View Hill Roads	63.90	0.58
3	Doncaster Road & High Street	77.90	0.71
4	Manningham & Williamsons Roads	96.20	0.87
5	Blackburn R/S	103.20	0.94
5a	Samuel & Eley Roads to Middleborough & Marsham Roads	103.20	0.94
6	Blackburn Railway Station to Samuel & Eley Roads	105.60	0.96
6a	Middleborough & Marsham Roads to High Street	105.60	0.96

Route 2

Camberwell Grammar School—Doncaster		Term Fare	Single
Section		\$	\$
1	School—Balwyn Road & Grosvenor Parade	38.70	0.35
2	Belmore Road & Greythorn Road	63.90	0.58
2a	Burke Road Doncaster Road to Doncaster Road & Viewhill Road	63.90	0.58
3	Belmore Road & Valda Avenue	77.90	0.71
3a	Doncaster Road & Viewhill Road to Doncaster Road & High Street	77.90	0.71
4	Belmore Road & Valda Avenue to Doncaster Road & High Street	96.20	0.87

VICTORIA DOCK BUS CO PTY LTD NORTH MELBOURNE

Application for permit authority to operate any MC Licensed vehicle on a service between Melbourne and Falls Creek with pick-up and set-down rights at Myrtleford and Bright en route to Falls Creek.

Timetable:

Saturdays during the snow season only—

Depart Ansett Terminal	Melbourne —	10.00 a.m.
Depart Ansett Terminal	Tullamarine —	10.30 a.m.
Arrive	Falls Creek —	4.00 p.m.
Depart	Falls Creek —	4.30 p.m.
Arrive Ansett Terminal	Melbourne —	10.30 p.m.

Note:

This service is to operate under contract to Trekset Tours (Aust) Pty Ltd and the only passengers that may be carried on this service are clients of Trekset Tours (Aust) Pty Ltd.

Application for renewal of licences as shown by the persons listed hereunder to operate under the same terms and conditions.

Aoun, S. M. West Heidelberg	MT 4951
Avgeris, G., Thomastown	MT 4996
Lane, L. A., Wendouree	UT 1010
Lynch, E., Surrey Hills	MT 2954
McCarthy, T., Hampton	MT 1532
Marinis, A., East St Albans	MT 4773
Mills, E. A., Belmont	UT 651
Mt Dandenong Passenger Service Pty Ltd., Olinda	MC 134, MC 135, MC 136, MC 137 and MC 138

Stamopoulos, G., St Albans	MT 4654
T. J. Pyle & Sons Pty Ltd., Tawonga South	CC 93
Transfield Pty Ltd., Traralgon	SV 285
Watson, G. McN. Ivanhoe	MT 4975

29 December 1983.

C. J. V. SMITH, Chief General Manager Registration and Regulation.

APPOINTMENTS

His Excellency the Governor of the State of Victoria by and with the advice of the Executive Council thereof has by Order made on 20 December 1983 been pleased to make the under-mentioned appointments, viz:

DEPARTMENT OF COMMUNITY WELFARE SERVICES

Honorary Probation Officers

- CREBBIN, GLENICE, 405 Raglan Street, South Ballarat, 3350.
- DILLON, MAREE, 26 Oliver Street, Ballarat 3350.
- FORSYTHE, GLENNIS, Sand Road, Durrham Lead, 3352.
- POWER, WARREN, 535 York Street, Ballarat, 3350
- WILLIAMS, RAMSAY THOMAS, 198 Yarrowee Street Sebastopol 3356 to be Honorary Probation Officer for all Adult and Children's Courts in the State of Victoria, pursuant to the provisions of section 507 (2) of the *Crimes Act 1958* and Section 9 of the *Children's Court Act 1973*.

HEALTH COMMISSION

Members of the Committee of Management of Hospitals

- FITZGERALD, FRANCIS ALLAN, Goulburn Valley Base Hospital, 30 September 1984.
- DICKSON, ANN ELIZABETH, Wimmera Base Hospital, 30 September 1984.
- FAVALORO, SHEILA JOSEPHINE, Wimmera Base Hospital, 30 September 1984.
- WERNER, NEIL FRANCIS, PULLAR, FRANCIS RUTHERFORD, LOWE, EDWIN JOHN, Goulburn Valley Base Hospital, 30 September, 1986 to be members of the Committees of Management of the above-mentioned hospitals pursuant to the provisions of Section 63F (1) of the *Hospitals and Charities Act 1958*, the period of office expiring on the dates indicated.

Deputy Psychiatrist Superintendent

- HARMS, LOIS PHILIPPA, M.B.B.S., D.P.M. to be Deputy Psychiatrist Superintendent of the Dandenong Psychiatric Centre pursuant to the provisions of Section 26(1) of the *Mental Health Act 1959*, for period 16 January 1984 to 3 February 1984, vice T. M. Hardiker on leave.

LAW DEPARTMENT

Justices of the Peace

- BELL, JOHN BERNARD, McClelland Street, Ultima.
- COLVILLE, JOHN SPITAL HUSBAND, Department of Defence, Vehicle Wing, RAEME Training Centre, Bandiana, to be Justices of the Peace for the State of Victoria.

Commissioners for taking Declarations etc.

- BAKER, CHERYL ANNE, 186 High Street, Maryborough.
- CATTACH, ERNEST LIONEL, 378 Cotham Road, Kew.
- CROFT, RUSSELL MCKENZIE, Toorak Avenue, Loch Sport.
- DAVIES, DESMOND ROBERT, South Dynon Locomotive Depot, West Melbourne.
- DIEZ-SIMSON, DOLORES, 124 Little Lonsdale Street, Melbourne.
- FARMER, GRAHAM WILLIAM, Davey's Lane, Hoddles Creek.
- HARGRAVE, JAMES ADDISON, 136 Jolimont Road, East Melbourne.
- HOLLOWAY, GRAHAM ERIC, 699 Doncaster Road, Doncaster.
- HORSTEN, MARTINUS, 82 Darriwill Street, Bell Post Hill.
- MCFARLANE, PAUL CHARLES, 107 Fernside Avenue, Briar Hill.
- MASTROSAVAS, PANTELEON, 1 Johnston Street, Collingwood.

QUARTERMAIN, MAXWELL CHARLES, 223 William Street, Melbourne.

RANGER, TERENCE FRANCIS, 5 Lyons Street South, Ballarat.

SHELLEY, ALLAN THOMAS, 618 Elizabeth Street, Melbourne.

SMITH, ROBYN ELIZABETH, 4 Riverview Street, Avondale Heights.

TSCHIRPIG, GRAEME RAYMOND, Ouyen and District Hospital, Ouyen.

YOUNG, PETER JAMES, 527 Little Collins Street, Melbourne.

To be Commissioners for taking declarations and affidavits under the Evidence Act 1958.

Law Reform Commissioner

WALLER, PROFESSOR PETER LOUIS, LL.B. Hons., B.C.L. Oxon., F.A.S.S.A., Currently on leave from the Faculty of Law, Monash University, Clayton, to be the Law Reform Commissioner pursuant to Section 3 of the Law Reform Act 1973 for the period 15 February 1984 to 31 January 1985 inclusive.

TOM FORRISTAL
Clerk of the Executive Council

At the Executive Council Chamber
Melbourne, 20 December 1983.

SHIRE OF BRIGHT

LOAN No. 88

NOTICE OF INTENTION TO BORROW THE SUM OF \$70,000 FOR PERMANENT WORKS AND UNDERTAKINGS

NOTICE is hereby given that the Council of the Shire of Bright proposes to borrow the principal sum of Seventy Thousand Dollars secured by a charge over the General Rates of the Municipality, such sum to be raised by the grant of a Mortgage in accordance with the provisions of the Local Government Act 1958, as amended.

1. The maximum rate of interest that may be paid is 13.5 per centum per annum.
2. The purpose for which the Loan is to be applied is the provision of an amenities building at the Bright Caravan Park.
3. The period of the Loan shall be 15 years.
4. The monies borrowed shall be repayable by providing out of the Municipal Fund, thirty half yearly instalment of \$5500.05 each including principal and interest, on the 15th February and the 15th August during the currency of the Loan. The first instalment shall be payable on the 15th August, 1984.
5. Such monies shall be repayable to the Victorian Tourism Commission, 500 Bourke Street, Melbourne 3000.
6. The plans and specifications and estimates of the cost of the proposed works and a statement showing the proposed expenditure of the monies to be borrowed are open for inspection at the Offices of the Council, Churchill Avenue, Bright; and at the Offices of the Mt. Beauty Waterworks Trust and Sewerage Authority, Kiewa Crescent, Mt. Beauty.

Dated: 20th December, 1983

Shire Offices, Bright 3471

H. J. WILLIAMS, Shire Secretary/Chief Executive Officer
0399

SHIRE OF BRIGHT

LOAN No. 89

NOTICE OF INTENTION TO BORROW THE SUM OF \$30,000 FOR PERMANENT WORKS AND UNDERTAKINGS

NOTICE is hereby given that the Council of the Shire of Bright proposes to borrow the principal sum of Thirty Thousand Dollars secured by a charge over the General Rates of the Municipality, such sum to be raised by the grant of a Mortgage in accordance with the provisions of the Local Government Act 1958, as amended.

1. The loan is to be interest free.
2. The purposes for which the Loan is to be applied is the part cost of undergrounding of the power supply between Quins Bridge and Mountbatten Avenue, Bright.

3. The period of the Loan shall be 10 years.

4. The monies borrowed shall be repayable by providing out of the Municipal Fund, twenty half yearly instalments of \$1,500.00 each being principal on the 15th February and the 15th August during the currency of the Loan. The first instalment shall be payable on the 15th August, 1984.

5. Such monies shall be repable to the Victorian Tourism Commission, 500 Bourke Street, Melbourne 3000.

6. The plans and specifications and estimates of the cost of the proposed works and a statement showing the proposed expenditure of the monies to be borrowed are open for inspection at the Offices of the Council, Churchill Avenue, Bright; and at the Offices of the Mt. Beauty Waterworks Trust and Sewerage Authority, Kiewa Crescent, Mt. Beauty.

Dated: 20th December, 1983

Shire Offices, Bright 3741

H. J. WILLIAMS, Shire Secretary/Chief Executive Officer
0400

CITY OF KEILOR

CHANGE OF STREET NAME

Notice is hereby given that pursuant to the provisions of Section 535 (4) of the Local Government Act 1958 the Council of the City of Keilor did at a meeting held on Tuesday 16 August, 1983, resolve to change the name of the following street:

Old Name:	Ashley Avenue—St. Albans East
New Name:	Ashton Avenue—St. Albans East
Location:	Plan of subdivision of Crown Allotment 6 Parish of Maribyrnong, County of Bourke and shown cross hatched on the plan hereunder.

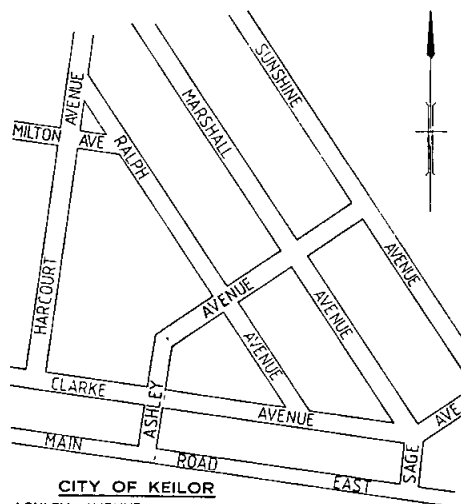

CITY OF KEILOR

ASHLEY AVENUE
TO BE RENAMED
ASHTON AVENUE

G. E. RICE
Acting Town Clerk/Chief Executive Officer

0389

CITY OF KEILOR

LOAN NO: 173

Notice of Intention to Borrow the sum of \$350 000 for Permanent Works and Undertakings.

Notice is hereby given that the Council of the City of Keilor intends to borrow the principal sum of three hundred and fifty thousand dollars (\$350 000.00) secured by a charge over the general rates of the Municipality, such sum to be raised by the grant of a mortgage in accordance with the provisions of the *Local Government Act 1958*.

1. The current maximum rate of interest that may be paid is 14.5 per cent per annum.
2. Such moneys shall be repayable at the offices of Local Authorities Superannuation Board, Queens Road Melbourne, 3004.
3. The loan is to be liquidated by providing out of the Municipal fund thirty (30) half yearly instalments of approximately \$28 774.02 each including principal and interest on the 1st day of March and the 1st day of September during the currency of the loan. The first instalment shall be payable on the 1st day of September 1984.
4. The loan funds to be applied to the following purposes:

	Part Cost
(i) Council Contribution to Rim Cross Drive, Avondale Heights Private Street Scheme (Total Cost \$65 000)	\$20 000
(ii) Route Lighting for the Keilor-Laverton Connector Road, Kealba, Driscoll's Road to Arthur Street Section (Total Cost \$45 000)	\$25 000
(iii) Construction of Athletics Complex at Keilor Park Reserve, Keilor Park (Total Cost \$640 000)	\$45 000
(iv) Construction of Hansen Street/Etzel Street Reserve Change-rooms, Airport West (Total Cost \$210 000)	\$90 000
(v) Relocation of St. Albans Branch Library in St. Albans Shopping Centre (Total Cost \$170 000)	\$120 000
(vi) Construction of Garbage Transfer Station within the City of Keilor (Total Cost \$910 000)	\$50 000
	\$350 000

5. The period of the loan shall be fifteen (15) years. The plans, specifications, estimate of the cost of the proposed works and a statement showing the proposed expenditure of the moneys to be borrowed are open for inspection at the Municipal Offices, Keilor.

Dated 21 December, 1983.

G. E. RICE
Acting Town Clerk/Chief Executive Officer 0390

CITY OF ARARAT

LOAN NO: 118

NOTICE OF INTENTION TO BORROW

Notice is hereby given that the Council of the City of Ararat intends to borrow the sum of One Hundred and Five Thousand, Two Hundred and Eighty-Five Dollars (\$105 285) secured by a charge over the general rates of the municipality by a grant of a Mortgage in accordance with the provisions of the *Local Government Act 1958*.

In connection therewith the following information is stated:

- (a) The amount of the principal moneys which it is proposed to borrow is One Hundred and Five Thousand, Two Hundred and Eighty Five Dollars (\$105,285).
- (b) The maximum rate of interest that may be paid is 14.5 per centum per annum.
- (c) The times which the moneys borrowed are to be repayable are on the first day of February and August in each year during the currency of the Loan, and the first instalment shall be payable on the first day of August 1984; and the place such moneys shall be repayable is at the Local Authorities Superannuation Board, 15 Queens Road, Melbourne.

(d) The purposes for which the Loan is to be applied are:

Purchase items of plant (part cost), being	\$35 000
one backhoe	
one tip truck (6 cubic metres)	
one tractor	
Council contribution to road construction works	42 000
Council contribution to extend Alexandra Hall	28 285
	\$105 285

(e) The period of the Loan shall be for ten years.

(f) The Manner in which the Loan is to be liquidated is by provision out of the Municipal Fund of twenty equal half yearly payments of \$10,132.09 including both principal and interest.

A Statement showing the proposed expenditure of the moneys to be borrowed, together with plans, specifications and estimates of cost, is open for inspection during Office hours, at the Municipal Offices, Ararat.

Dated 22 December, 1983.

I. A. KEITH
Town Clerk 0395

NOTICE OF MAKING AND AVAILABILITY OF STATUTORY RULES

In pursuance of the provisions of the *Subordinate Legislation Act 1962* and the Regulations made thereunder notice is given of the making and availability of the following Statutory Rules:

No. <i>Marketing of Primary Products Act 1958</i>	Price
382/1983. The Citrus Fruit Marketing Board (Amendment No. 2) Regulations 1983	20c
<i>Water Act 1958</i>	
383/1983. Water (Laanecoore Reservoir Recreational Area) (Amendment) Regulations 1983	20c
<i>Local Government Act 1958</i>	
393/1983. Municipal Accounting (Amendment) Regulations 1983	20c
<i>Country Fire Authority Act 1958</i>	
394/1983. Country Fire Authority (Members' Allowances) Regulations 1983	20c
<i>Lotteries Gaming and Betting Act 1966</i>	
398/1983. Lotteries Gaming and Betting (Raffles and Bingo Permits) (Fees) Regulations 1983	20c
<i>Racing Act 1958</i>	
399/1983. Racing (Greyhound Racing Control Board) (Fees) Regulations 1983	20c
<i>Racing Act 1958</i>	
400/1983. Racing (Greyhound Racing Grounds Development Board) (Fees) Regulations 1983	20c
<i>Companies (Administration) Act 1981</i>	
406/1983. Companies (Auditors and Liquidators Disciplinary Board) (Amendment) Regulations 1983	20c
<i>Chiropractors and Osteopaths Act 1978</i>	
407/1983. Chiropractors and Osteopaths (Amendment) Regulations 1983	20c
<i>Discharged Servicemen's Preference Act 1943</i>	
409/1983. Discharged Servicemen's Preference (Amendment) Regulations 1983	20c

- Extractive Industries Act 1966*
410/1983. Extractive Industries (Board of Examiners Fees) Regulations 1983 20c
- Law Reform Act 1973*
412/1983. Law Reform (Advisory Council Fees and Allowances) (Amendment) Regulations 1983 20c
- Mines Act 1958*
415/1983. Mines (Board of Examiners Fees) Regulations 1983 20c
- Motor Car Traders Act 1973*
416/1983. Motor Car Traders (Amendment No. 2) Regulations 1983 20c

Copies of these Statutory Rules are available and may be purchased at the Victorian Government Bookshop, located at 41 St. Andrews Place, East Melbourne (formerly 7A Parliament Place, Melbourne, 3002). If ordered by mail, remittance should be addressed to "The Government Printer, Box 203, North Melbourne, 3051", and should include 50c delivery and handling fee.

The annual subscription rates for Statutory Rules for the year commencing 1 January 1982, payable in advance are as follows:

*Statutory Rules (other than Public Service Determinations), Pamphlet copies only	\$55.00
Public Service Determinations	\$33.00

*The Bound Volume of Statutory Rules is not included in the subscription rate.

F. D. ATKINSON
Government Printer

**NOTICE OF MAKING OF
STATUTORY RULES
WHICH ARE NOT YET
AVAILABLE**

Notice is given of the making of the following Statutory Rules:

- No. *Land Tax Act 1958*
384/1983. Land Tax Regulations 1983
- Marine Act 1958*
385/1983. Port Rule (Management of Slipways) 1974 Amendment No. 1/1983
- Marine Act 1958*
386/1983. Port Rule (Berthing Permits) 1978 Amendment No. 1/1983
- Marine Act 1958*
387/1983. Port Rule (Accommodation of Vessels upon Piers and Jetties) 1973 Amendment No. 1/1983
- Marine Act 1958*
388/1983. Port Rule (Port Welshpool Harbor Services—Rates and Charges) 1981 Amendment No. 1/1983
- Marine Act 1958*
389/1983. Port Rule (Licences) 1981 Amendment No. 2/1983
- Marine Act 1958*
390/1983. Wharfage Charges Regulations 1981 Amendment No. 1/1983
- Marine Act 1958*
391/1983. Marine (Rolls of Electors and Elections) (Amendment) Regulations 1983
- Motor Boating Act 1961*
392/1983. Motor Boating (Port of Melbourne) Regulations 1983
- Post-Secondary Education Act 1978*
395/1983. Post-Secondary Education Commission (Terms and Conditions) (Amendment No. 16) Regulations 1983
- Racing Act 1958*
396/1983. Racing (Bookmakers, Bookmakers' Clerks and Bookmakers' Course Agents Registration) Regulations 1983
- Local Government Act 1958*
397/1983. Local Government (Elections and Polls) (Amendment) Regulations 1983 No. 2
- Racing Act 1958*
401/1983. Racing (Harness Racing Board) (Fees) Regulations 1983
- Racing Act 1958*
402/1983. Racing (Racecourses Licences Board) (Amendment) Regulations 1983
- Racing Act 1958*
403/1983. Racing (Totalizator Agency Board) (Fees) Regulations 1983
- Youth, Sport and Recreation Act 1972*
404/1983. Youth, Sport and Recreation (Council Fees and Allowances) Regulations 1983
- Appeal Costs Fund Act 1964*
405/1983. Appeal Costs Fund (Amendment) Regulations 1983
- Drugs, Poisons and Controlled Substances Act 1981*
408/1983. Drugs, Poisons and Controlled Substances (Fees) Regulations 1983
- Groundwater Act 1969*
411/1983. Groundwater (Board of Committee Members' Attendance Fees) Regulations 1983
- Industrial Relations Act 1979*
413/1983. Industrial Relations (Industrial Relations Commission) (Salaries, Expenses and Allowances) (Amendment) Regulations 1983
- Mines Act 1958*
414/1983. Mines (Mining Titles) (Amendment) Regulations 1983
- Supreme Court Act 1958*
417/1983. Supreme Court (Further Powers of Masters) Rules 1983
- Supreme Court Act 1958*
418/1983. Supreme Court (Medical Examination and Report) Rules 1983
- Public Service Act 1974*
419/1983. Public Service Amendment Regulations (No. 13) 1983
- Public Service Act 1974*
420/1983. Public Service Amendment Regulations (No. 14) 1983
- Companies (Acquisition of Shares) (Application of Laws) Act 1981*
421/1983. Companies (Acquisition of Shares) (Application of Laws) Regulations 1983
- Companies (Application of Laws) Act 1981*
422/1983. Companies (Application of Laws) Regulations 1983
- Securities Industry (Application of Laws) Act 1981*
423/1983. Securities Industry (Application of Laws) Regulations 1983