



# Victoria Government Gazette

No. 45—Wednesday, 18 May 1983

## PROCLAMATION

Land Act 1958  
ROAD PROCLAIMED

### PROCLAMATION

By His Excellency the Governor of the State of Victoria and its Dependencies in the Commonwealth of Australia, &c., &c., &c.

I, the Governor of the State of Victoria, in the Commonwealth of Australia, by and with the advice of the Executive Council of the said State, pursuant to the provisions of section 25 (3) (c) of the *Land Act 1958*, doth hereby proclaim as road the Crown land hereinafter described, viz.:

Municipal District of the Shire of Kerang—

Township of Murrabit, being the land indicated by hatching on plan hereunder — (M474<sup>(1)</sup>) (L5-655)

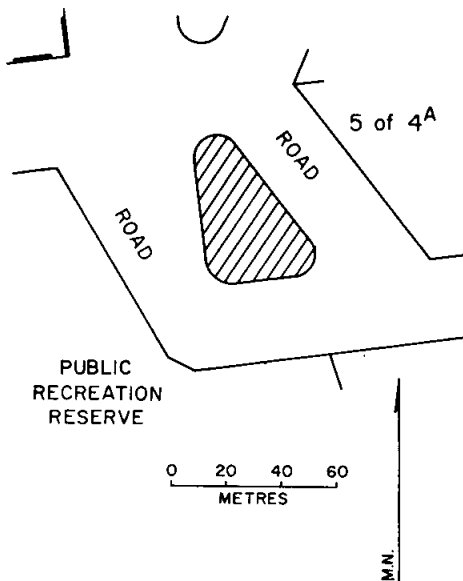

Given under my Hand and the Seal of the State of Victoria aforesaid, at Melbourne, this tenth day of May, in the year of our Lord One thousand nine hundred and eighty-three, and in the thirty-second year of the reign of Her Majesty Elizabeth the Second, Queen of Australia.

By His Excellency's Command

B. S. MURRAY

R. A. MACKENZIE  
Minister of Lands

God Save the Queen!

## ACTS OF PARLIAMENT

### PROCLAMATION

By His Excellency the Governor of the State of Victoria and its Dependencies in the Commonwealth of Australia, &c., &c., &c.

I, the Governor of the State of Victoria, in the Commonwealth of Australia, do hereby declare that I have this day assented, in Her Majesty's name, to the Bills passed by the Parliament of the said State, the titles whereof are hereunder set forth, together with the short titles, that is to say:—

No. 9888—An Act to amend the *Hospital Benefits (Levy) Act 1982*.

(*Hospital Benefits (Levy) (Amendment) Act 1983*)

No. 9889—An Act to regulate the keeping and use of radioactive substances and ionizing and non-ionizing radiation apparatus, to provide for protection against the harmful effects of radiation, to establish a Radiation Advisory Committee, a Radiographers and Radiation Technologists Registration Board, to amend the *Health Act 1958*, the *Nuclear Activities (Prohibitions) Act 1983* and for other purposes.  
(*Health (Radiation Safety) Act 1983*)

No. 9890—An Act to amend the *Historic Buildings Act 1981*, to repeal the *Government Buildings Advisory Council Act 1972*, the *Government Buildings Advisory Council (Amendment) Act 1981*, the *Planning Appeals Board Act 1980*, and for other purposes.  
(*Historic Buildings (Amendment) Act 1983*)

Given under my Hand and the Seal of the State of Victoria aforesaid, at Melbourne, this seventeenth day of May, in the year of our Lord One thousand nine hundred and eighty-three in the thirty-second year of the reign of Her Majesty Queen Elizabeth II.

(L.S.)

B. S. MURRAY  
JOHN CAIN  
Premier

God Save the Queen

No. 9888—This Act shall come into operation on the day on which it receives the Royal Assent.

No. 9889—The several provisions of this Act shall come into operation on a day or the respective days to be fixed by proclamation or successive proclamations of the Governor in Council published in the *Government Gazette*.

No. 9890—The several provisions of this Act shall come into operation on a day or the respective days to be fixed by proclamation or successive proclamations of the Governor in Council published in the *Government Gazette* except for section 3 which shall be deemed to have come into operation on 1 June 1982.

### Public Service Act 1974

#### PUBLIC HOLIDAYS

### PROCLAMATION

By His Excellency the Governor of the State of Victoria and its Dependencies in the Commonwealth of Australia, &c., &c., &c.

In pursuance of the provisions contained in Section 71 (2) of the *Public Service Act 1974*, I, the Governor of the State of Victoria, in the Commonwealth of Australia, by and with the

advice of the Executive Council of the said State, do by this my Proclamation appoint the days and dates mentioned hereunder to be observed as Public Holidays or Public Half-Holidays (as the case may be) at the places respectively specified:

*Public Holidays*

Tuesday, 1 November 1983 throughout the City of Bendigo.

*Public Half-Holidays from the Hour of Twelve noon*

Friday, 27 May 1983 throughout the Coleraine Riding of the Shire of Wannon.

Wednesday, 9 November 1983 within the boundaries of the Borough of Eaglehawk.

Wednesday, 9 November 1983 throughout the City of Bendigo.

Given under my Hand and the Seal of the State of Victoria aforesaid, at Melbourne, this seventeenth day of May, in the year of our Lord One thousand nine hundred and eighty-three in the thirty-second year of the reign of Her Majesty Queen Elizabeth II.

(L.S.)

B. S. MURRAY

W. A. LANDERYOU

Minister of Labour and Industry

God Save the Queen!

*Bank Holidays Act 1958*

**BANK HOLIDAYS**

**PROCLAMATION**

By His Excellency the Governor of the State of Victoria and its Dependencies in the Commonwealth of Australia, &c., &c., &c.

In pursuance of the provisions of the *Bank Holidays Act 1958*, I, the Governor of the State of Victoria, in the Commonwealth of Australia, do by this my Proclamation appoint the days and dates mentioned hereunder as special days to be observed as Bank Holidays or Bank Half-Holidays (as the case may be) at the places respectively specified:

*Bank Half-Holidays from the Hour of Eleven a.m.*

Friday, 27 May 1983 at Coleraine within the Shire of Wannon.

Tuesday, 4 October 1983 at Minyip within the Shire of Dunmunkle.

Given under my Hand and the Seal of the State of Victoria aforesaid, at Melbourne, this seventeenth day of May, in the year of our Lord One thousand nine hundred and eighty-three in the thirty-second year of the reign of Her Majesty Queen Elizabeth II.

(L.S.)

B. S. MURRAY

W. A. LANDERYOU

Minister of Labour and Industry

God Save the Queen!

**GOVERNMENT NOTICES**

**POLICE REGULATION ACT SECTION 122  
SALE OF UNCLAIMED MOTOR VEHICLE**

An owner is required for a White 1978 model Ford Panel Van former Reg. No. AFF 201, Engine No. JG 42UJ39853C.

The vehicle came into possession of Police on 5 January 1983, and if not claimed, will be sold by public auction at the Police Workshops, Wellington Street, Collingwood, at 10.00 a.m. on Monday 20 June 1983.

S. I. MILLER

Chief Commissioner of Police

**POLICE REGULATION ACT SECTION 122  
SALE OF UNCLAIMED MOTOR VEHICLE**

An owner is required for an Orange 1976 model Ford Escort Panel Van Reg. No. BEL 890, Engine No. CK 5150 35064A.

The vehicle came into possession of Police on 5 January 1983, and if not claimed, will be sold by public auction at the Mornington C.I.B., The Esplanade, Mornington at 10.00 a.m. on Monday 20 June 1983.

S. I. MILLER

Chief Commissioner of Police

*Police Offences Act 1958, No. 6337*

**DIVISION 1A — STATE CLASSIFICATION OF  
PUBLICATIONS BOARD**

Take note that the State Classification of Publications Board has classified the following publications in accordance with the provisions of Section 180H (1) of the *Police Offences Act 1958*.

Each publication shall be subject to the following restrictions:

- (a) It shall not be offered for sale, sold or delivered to any person under the age of 18 years;
- (b) It shall not be made available for inspection or perusal by any person under the age of 18 years.

*Schedule of Publications*

<i>Title</i>	<i>Distributor</i>
Busen, No. 19	Hallmark Book Wholesalers
Fiesta, Vol. 17 No. 5	Gordon & Gotch Ltd.
Hustler Sex Play, May 1983	Gordon & Gotch Ltd.
Superstar, No. 2	Hallmark Book Wholesalers

GLEN HIBBERT, Acting Secretary

State Classification of Publications Board

*Police Offences Act 1958, No. 6337*

**DIVISION 1A — STATE CLASSIFICATION OF  
PUBLICATIONS BOARD**

Take note that the State Classification of Publications Board has classified the following publications in accordance with the provisions of Section 180H (1) of the *Police Offences Act 1958*.

Each publication shall be subject to the following restrictions:

- (a) It shall not be offered for sale, sold or delivered to any person under the age of 18 years;
- (b) It shall not be made available for inspection or perusal by any person under the age of 18 years;
- (c) It shall not be exhibited or displayed in any place to which persons under the age of 18 years have access or so that it is visible from any such place.

*Schedule of Publications*

<i>Title</i>	<i>Distributor</i>
Penthouse Variations, June 1983	Gordon & Gotch Ltd.

GLEN HIBBERT, Acting Secretary

State Classification of Publications Board

**ERRATUM**

In *Government Gazette* No. 43 of 4 May 1983 on page 1033 under the heading "Appointments" with reference to Members of the Victorian Psychological Council the names Francis Thomas and Noozhumurry Varghese should read Francis Thomas Noozhumurry Varghese.

## Private Agents Act 1966

## NOTICE OF RECEIPT OF APPLICATIONS FOR LICENCES UNDER THE PROVISIONS OF THE PRIVATE AGENTS ACT 1966

The Clerk(s) of the Magistrates' Court(s) as listed hereunder hereby give notice that applications, as under, have been lodged for hearing by the said Court(s) on the date(s) specified.

Any person desiring to object to any of such applications must—

- (a) lodge with the respective Clerk of the Magistrates' Court a notice in the prescribed form of his objection and of the grounds thereof;
- (b) cause a copy of such notice to be served personally or by post upon the applicant at least three days before the hearing of the application; and
- (c) send or deliver—
  - (i) where the objection is not made by the officer in charge of the police district in which the Court is situated—a copy of the notice to such officer; and
  - (ii) where the objection is not made by the Registrar or Deputy Registrar—a copy to the Registrar.

Full Name of Applicant*	Place of Abode of Applicant or Nominee	Name of Firm or Corporation	Address for Registration	Type of Licence	Date of Hearing
<b>MAGISTRATES' COURT, PRAHRAN</b>					
Affleck, Alan Lindsay	18 Crown Point Ridge, Chirnside Park	Mayne Nickless Ltd,	390 St Kilda Rd, Melbourne	Watchman	10. 6. 83
Boyle, Patrick	34 Roehampton Ave, Wantirna		" "	"	"
Clarke, Terence Patrick	5 Hales Crt, Keysborough		" "	"	"
Laurie, Ian Geoffrey	5 Tanderra Cres, Wantirna		" "	"	"
McKay, John Taylor	1 Wahroonga Ave, Keysborough		" "	"	"
Dated at Prahran 11 May 1983 V. J. ARDLIE, Clerk of the Magistrates' Court					
<b>MAGISTRATES' COURT, DANDENONG</b>					
Stephenson, Robert	40 Loch Rd, Dandenong North		3rd Floor, National Bank Building, 237 Lonsdale St, Dandenong	Inquiry Agent	24. 5. 83
" "	" "	" "	" "	Guard Agent	"
Dated at Dandenong 2 May 1983 L. T. GOULD, Clerk of the Magistrates' Court					
<b>MAGISTRATES' COURT, MORWELL</b>					
Sturmer, Eric George	2 McKay Crt, Churchill	Armaguard	1st Floor, 390 St. Kilda Rd, Melbourne	Watchman	25. 5. 83
Dated at Morwell 4 May 1983 R. R. BOURKE, Clerk of the Magistrates' Court					
<b>MAGISTRATES' COURT, RINGWOOD</b>					
Hussein, Ibrahim	94 Messmate St, Lalor	Vic-State Security Services	20 Bayswater Village, High St, Bayswater	Watchman	19. 5. 83
Dated at Ringwood 28 April 1983 J. T. KNIGHT, Clerk of the Magistrates' Court					
<b>MAGISTRATES' COURT, BOX HILL</b>					
Theofanides, Basil Pericles	19 Jeffery St, Blackburn		19 Jeffery St, Blackburn	Guard Agent (Individual)	27. 5. 83
" " "	" "	K9 Plant Protection and Security Service	" "	Guard Agent	"
Dated at Box Hill 29 April 1983 W. E. BYRNE, Clerk of the Magistrates' Court					
<b>MAGISTRATES' COURT, HORSHAM</b>					
Anderson, Raymond Mervyn	3 Calder Crt, Horsham		3 Calder Crt, Horsham	Process Server	18. 5. 83
Dated at Horsham 27 April 1983 A. BELLIS, Clerk of the Magistrates' Court					

\*Or in the case of a firm or corporation, of the Nominee

## PRIVATE AGENTS—continued

Full Name of Applicant*	Place of Abode of Applicant or Nominee	Name of Firm or Corporation	Address for Registration	Type of Licence	Date of Hearing
<b>MAGISTRATES' COURT, FITZROY</b>					
Ward, Colin Edward	2/26 Bohdi Rd, Bonbeach	Roden Security	136 Johnston St, Fitzroy	Watchman	23.5.83
Dated at Fitzroy 28 April 1983 G. SHARKEY, Clerk of the Magistrates' Court					
<b>MAGISTRATES' COURT, MILDURA</b>					
Bateman, Andrew Paul	1541 Koorlong Ave, Irymple	John Fossey Timmis	135A 8th St, Mildura	Commercial Sub- Agent Process Server	24.5.83 "
Dated at Mildura 26 April 1983 G. SCHMIDT, Clerk of the Magistrates' Court					
<b>MAGISTRATES' COURT, SPRINGVALE</b>					
Reid, Robert Henry	3 Claremont Crt, Keysborough		11 Wardale Rd, Springvale South	Process Server	27.5.83
Dated at Springvale 27 April 1983 G. EBERT, Clerk of the Magistrates' Court					
<b>MAGISTRATES' COURT, PRAHRAN</b>					
Kastis, Marc	135 Blackburn Rd, East Doncaster	Mayne Nickless Ltd.	390 St. Kilda Rd, Melbourne	Watchman	27.5.83
Dated at Prahran 27 April 1983 V. J. ARDLIE, Clerk of the Magistrates' Court					
<b>MAGISTRATES' COURT, FITZROY</b>					
Simpson, Mark James	8/458 Waterdale Rd, West Heidelberg	Roden Security Services	136 Johnson St, Fitzroy	Watchman	23.5.83
Bastow, Grantly Edward W.	6 Ceres Crt, Coolaroo	" "	" "	"	"
Howard, Stephen James	81/8 The Esplanade, St. Kilda	" "	" "	"	"
Dated at Fitzroy 27 April 1983 G. A. SHARKEY, Clerk of the Magistrates' Court					
<b>MAGISTRATES' COURT, SPRINGVALE</b>					
Thurlow, Peter Albert	3 Lacebark St, Doveton		11 Wardale Rd, South Springvale	Guard Agent	27.5.83
Lidgerwood, Brendon John	34 "Vincent" St, Mulgrave		" " " " " " 173 Springvale Rd, Springvale	Watchman	"
Starvaggi, Antonio	21-23 Clarke Rd, Springvale	Domingo Lisa Nominees Pty. Ltd.	21-23 Clarke Rd, Springvale	"	"
Dated at Springvale 26 April 1983 G. EBERT, Clerk of the Magistrates' Court					
<b>MAGISTRATES' COURT, CRANBOURNE</b>					
Franks, Richard	29 Circle Dve, North Cranbourne	National Security and Property Con- sultants Pty. Ltd.	29 Circle Dve, North Cranbourne	Guard Agent (Corporation)	11.5.83
Brown-Sarre, Ronald John	69 Orwil St, Frankston		57A High St, Cranbourne	Process Server	18.5.83
" " "	" " "		" " "	Inquiry Agent	"
Driver, Robert Trevor	43 Wallace Rd, Cranbourne		29 Circle Dve, North Cranbourne	Guard Agent Watchman	" 11.5.83
Dated at Cranbourne 20 April 1983 B. M. FOGARTY, Clerk of the Magistrates' Court					

\*Or in the case of a firm or corporation, of the Nominee

## PRIVATE AGENTS—continued

Full Name of Applicant*	Place of Abode of Applicant or Nominee	Name of Firm or Corporation	Address for Registration	Type of Licence	Date of Hearing
<b>MAGISTRATES' COURT, PRAHRAN</b>					
Tonkin, Allan Charles	197 Gillespie Rd, St Albans	Mayne Nickless Ltd.	390 St Kilda Rd, Melbourne	Watchman	3.6.83
Simpson, John Geoffrey Kennedy, Ian	2 Pollard Crt, Altona 179 Ascot Vale Rd, Ascot Vale	" "	" "	" "	" "
Dated at Prahran 6 May 1983 V. J. ARDLIE, Clerk of the Magistrates' Court					
<b>MAGISTRATES' COURT, DANDENONG</b>					
Dakin, Paul Robert	6 Crouch Crt, North Dandenong		6 Crouch Crt, North Dandenong	Guard Agent	27.5.83
Dated at Dandenong 6 May 1983 L. T. GOULD, Clerk of the Magistrates' Court					
<b>MAGISTRATES' COURT, OAKLEIGH</b>					
Carver, Regis	27 Kent St, Mount Waverley		1388 Dandenong Rd, Oakleigh	Watchman	30.5.83
Dated at Oakleigh 5 May 1983 G. CONDON, Clerk of the Magistrates' Court					
<b>MAGISTRATES' COURT, BALLARAT</b>					
Biggs, Peter Charles	22 James St, Ballarat	N.I.R. Security Services	602 Bond St, Ballarat	Watchman	30.5.83
Dated at Ballarat 6 May 1983 D. CROFT, Clerk of the Magistrates' Court					
<b>MAGISTRATES' COURT, PORT MELBOURNE</b>					
Mulrooney, Francis Gerrard	3/54 Yarra St, Williamstown	Armaguard	653 Queensberry St, North Melbourne	Watchman	2.6.83
Seedsman, James Bernard	28 East Rd, Seaford	" "	" "	" "	" "
Dated at Port Melbourne 5 May 1983 I. F. TAYLOR, Clerk of the Magistrates' Court					
<b>MAGISTRATES' COURT, PRAHRAN</b>					
Parkes, David Francis	1/49 Balcombe Rd, Mentone	Mayne Nickless Ltd.	390 St Kilda Rd, Melbourne	Watchman	3.6.83
Dated at Prahran 5 May 1983 V. J. ARDLIE, Clerk of the Magistrates' Court					
<b>MAGISTRATES' COURT, DANDENONG</b>					
Christensen, Susan	110 Paperbark St, Doveton		110 Paperbark St, Doveton	Process Server	27.5.83
Dated at Dandenong 5 May 1983 L. T. GOULD, Clerk of the Magistrates' Court					
<b>MAGISTRATES' COURT, COBURG</b>					
Rawson, Kevin Deane	96 Oakover Rd, Preston	M.S.S.	28 Stephenson St, Richmond	Watchman	7.6.83
Dated at Coburg 3 May 1983 P. WENDEN, Clerk of the Magistrates' Court					
<b>MAGISTRATES' COURT, PRESTON</b>					
Hodkinson, David George	56 Clingin St, Reservoir		56 Clingin St, Reservoir	Guard Agent	19.5.83
Dated at Preston 3 May 1983 R. WILSON, Clerk of the Magistrates' Court					

\*Or in the case of a firm or corporation, of the Nominee

PRIVATE AGENTS—*continued*

<i>Full Name of Applicant*</i>	<i>Place of Abode of Applicant or Nominee</i>	<i>Name of Firm or Corporation</i>	<i>Address for Registration</i>	<i>Type of Licence</i>	<i>Date of Hearing</i>
<b>MAGISTRATES' COURT, PRAHRAN</b>					
Leahy, Gavan Patrick	7/36 Murray St, West Brunswick	Mayne Nickless Ltd.	390 St Kilda Rd, Melbourne	Watchman	3. 6. 83
Rausch, Helmut Joseph	7 Greenhill Cres, Werribee	" "	" "	"	"
Dated at Prahran 4 May 1983 V. J. ARDLIE, Clerk of the Magistrates' Court					
<b>MAGISTRATES' COURT, MANSFIELD</b>					
Morrell, Wallace James	Mt. Buller		Mt. Buller	Guard Agent	26. 5. 83
Dated at Mansfield 28 April 1983 R. F. TOMKINS, Clerk of the Magistrates' Court					
<b>MAGISTRATES' COURT, MARYBOROUGH</b>					
Downie	Sullivan St, Epsom		174 Railway St, Maryborough	Watchman	9. 6. 83
Dated at Maryborough 5 May 1983 R. A. ISON, Clerk of the Magistrates' Court					
<b>MAGISTRATES' COURT, RINGWOOD</b>					
Foster, Dennis James	27 Kenilworth Cres, Glen Waverley		291a Maroondah Highway, Ringwood	Process Server	26. 5. 83
" "	" "		" "	Inquiry Agent	"
" "	" "		" "	Guard Agent	"
Dated at Ringwood 5 May 1983 J. T. KNIGHT, Clerk of the Magistrates' Court					
<b>MAGISTRATES' COURT, SALE</b>					
Dunne, George Richard	7 Chelmer Crt, Sale		Nicolls St, Longford	Watchman	27. 4. 83
Dated at Sale 6 May 1983 G. O'CONNOR, Clerk of the Magistrates' Court					
<b>MAGISTRATES' COURT, PRAHRAN</b>					
Martin, Andrew Hawthorn	25/91-3 Manningham St, Parkville	Mayne Nickless Ltd.	390 St Kilda Rd, Melbourne	Watchman	3. 6. 83
Dated at Prahran 5 May 1983 V. J. ARDLIE, Clerk of the Magistrates' Court					
<b>MAGISTRATES' COURT, PRAHRAN</b>					
Barnes, Edward George	13 Moomba Ave, Seaford	Mayne Nickless Ltd.	390 St Kilda Rd, Melbourne	Watchman	3. 6. 83
Dated at Prahran 3 May 1983 V. J. ARDLIE, Clerk of the Magistrates' Court					
<b>MAGISTRATES' COURT, CHELSEA</b>					
Brand, Ronald Michael	17 Luxton Tce, Seaford		17 Luxton Tce, Seaford	Inquiry Agent	30. 5. 83
Dated at Chelsea 2 May 1983 R. W. COOK, Clerk of the Magistrates' Court					
<b>MAGISTRATES' COURT, TRARALGON</b>					
Moore, Peter Andrew	5 Eden St, Moe		14 Doyne Cres, Traralgon	Process Server	26. 5. 83
Dated at Traralgon 3 May 1983 K. McMAHON, Clerk of the Magistrates' Court					

\*Or in the case of a firm or corporation, of the Nominee

*Industrial Relations Act 1979*

## NOTICE OF APPLICATION FOR RECOGNITION AS AN ASSOCIATION

Notice is hereby given that the Royal Australian Nursing Federation has filed an application to be recognized as an association under the *Industrial Relations Act 1979* with respect to the trade of State Enrolled Nurse for which the Hospital and Benevolent Homes Conciliation and Arbitration Board has been appointed.

Pursuant to regulation 33 (5) of the Industrial Relations Regulations any recognized association or person interested may on or before 17 June 1983 file in the Registry (9th Floor, 271 William Street, Melbourne) an objection to the application.

The objection shall be in, or to the effect of Form 9 prescribed by the Regulations.

A. S. DOWLING, Deputy Registrar  
Industrial Relations Commission of Victoria

*Marine Act 1958*

## ROLL OF PILOTS

The following Roll of Names, etc., of all persons who are licensed to act as Pilots for the port of Port Phillip and entitled as such to vote for election of one Member of the Marine Board of Victoria under the provisions of the *Marine Act 1958*, is published in accordance with the 30th Section of the said Act.

Public Works Department  
Melbourne, April 1983

J. SIMPSON  
Minister of Public Works

*Number  
on Roll*

*Name*

*Address*

<i>Number on Roll</i>	<i>Name</i>	<i>Address</i>
1.	Abbott, John George Victor	Care of Post Office, Williamstown
2.	Ballantyne, Peter Llewellyn	Care of Post Office, Williamstown
3.	Beevers, Geoffrey Peter	Care of Post Office, Williamstown
4.	Bolton, John Nicholas	Care of Post Office, Williamstown
5.	Chapman, John Chadwick	Care of Post Office, Williamstown
6.	Cobal, Mauro	Care of Post Office, Williamstown
7.	Collicot, Ian Kenneth	Care of Post Office, Williamstown
8.	Craig, John	Care of Post Office, Williamstown
9.	Daniel, Neville George Richard	Care of Post Office, Williamstown
10.	Edwards, John David	Care of Post Office, Williamstown
11.	Femon, Robert Stanley	Care of Post Office, Williamstown
12.	Finnimore, Keith Stanley	Care of Post Office, Williamstown
13.	Fisher, Robin Weatheritt	Care of Post Office, Williamstown
14.	Gaunt, Michael Vernon	Care of Post Office, Williamstown
15.	Griffiths, Charles King	Care of Post Office, Williamstown
16.	Hearn, Patrick Joseph Godwin	Care of Post Office, Williamstown
17.	Ingram, Francis Dawson	Care of Post Office, Williamstown
18.	Johnson, Norman	Care of Post Office, Williamstown
19.	Jolly, Frank Norman	Care of Post Office, Williamstown
20.	Jordan, Keith Robert	Care of Post Office, Williamstown
21.	Keys, Graham Thomas	Care of Post Office, Williamstown
22.	Lewis, Brian William Thomas	Care of Post Office, Williamstown
23.	Liley, Richard William	Care of Post Office, Williamstown
24.	MacSween, Lachlan Alistair	Care of Post Office, Williamstown
25.	McCaskill, Ian Ross	Care of Post Office, Williamstown
26.	McKeown, Peter	Care of Post Office, Williamstown
27.	Nance, John Roddy	Care of Post Office, Williamstown
28.	Phoenix, Peter Kendrick	Care of Post Office, Williamstown
29.	Randall, Colin Stuart	Care of Post Office, Williamstown
30.	Ringe, Paul Rexford	Care of Post Office, Williamstown
31.	Rose, Michael Stuart	Care of Post Office, Williamstown
32.	Schutt, Raymond Charles Duncan	Care of Post Office, Williamstown
33.	Seal, Peter Watson	Care of Post Office, Williamstown
34.	Sladen, Ian James	Care of Post Office, Williamstown
35.	Springall, Clive Colin	Care of Post Office, Williamstown
36.	Taylor, John Jeffries	Care of Post Office, Williamstown
37.	Taylor, John Glyn	Care of Post Office, Williamstown
38.	Toone, Richard	Care of Post Office, Williamstown
39.	Tyler, Howard Langley	Care of Post Office, Williamstown
40.	Westwater, Brian John	Care of Post Office, Williamstown
41.	Wilkie, Robert William	Care of Post Office, Williamstown
42.	Willard, Christopher Julian	Care of Post Office, Williamstown
43.	Woodhead, Richard John	Care of Post Office, Williamstown

Marine Board of Victoria  
Melbourne, 31 March 1983

K. T. MANALLACK, Secretary

*Marine Act 1958*  
ROLL OF MASTERS

The following Roll of Names, etc., of all persons entitled as Members to vote for the election of one Member of the Marine Board of Victoria under the provisions of the *Marine Act 1958* is published in accordance with the 31st Section of the said Act.

Public Works Department  
Melbourne, April 1983

J. SIMPSON  
Minister of Public Works

<i>Number on Roll</i>	<i>Name</i>	<i>Address</i>
1.	Brown, Lawrence John	242 Canterbury Road, Heathmont
2.	Burgess, Roy McKeown	19 Victoria Street, Williamstown
3.	Carruthers, James William	6 Baggott Drive, Hoppers Crossing
4.	Edwards, John Walter Martin	10 Tennyson Street, Brighton
5.	Forsyth, Harry Boyd	10 Salem Court, Vermont
6.	Gairdner, Alistair Roy	Unit 3, 49 Rayner Street, Altona
7.	Grant, Peter Francis	43 Glenburnie Road, Mitcham
8.	Haisman, Robert	23 Macedon Street, Hoppers Crossing
9.	Hindmarch, Thomas	6 Watson Court, Altona
10.	Huisman, Rokus	4 Chifley Avenue, Altona
11.	Logan, John Aynsley	6 Durkin Street, Newport
12.	Love, Haddon	32 Ramblers Road, Portarlington
13.	Lueders, Fred	29 Powlett Street, Altona Meadows
14.	Money, Lawrence Francis	2 Lindwood Avenue, Altona
15.	Robertson, James Murray	47 Amelia Avenue, Wheelers Hill
16.	Scott, Ivan James	1 Moonie Court, Werribee
17.	Shepard, Peter John	c/- Australian National Line, Box 2238T, G.P.O. Melbourne
18.	Stevens, John Gavin	12 Douch Street, Williamstown North
19.	Stockman, Christopher	53 Aitken Avenue, Hoppers Crossing
20.	Wetteland, Ole	1 Mountain View Avenue, Avondale Heights
21.	Wilson, Douglas Gordon	Flat 27, 8 Avondale Road, Armadale

Marine Board of Victoria  
Melbourne, 31 March 1983

K. T. MANALLACK, Secretary

*Marine Act 1958*  
ROLL OF ENGINEERS

The following Roll of Names, etc., of all persons entitled as Engineers to vote for the election of one Member of the Marine Board of Victoria under the provisions of the *Marine Act 1958* is published in accordance with the 30th Section of the said Act.

Public Works Department,  
Melbourne, April 1983

J. SIMPSON  
Minister of Public Works

<i>Number on Roll</i>	<i>Name</i>	<i>Address</i>
1.	Bennetts, John Leslie	4 Hurd Street, Portland
2.	Campbell, William Joseph	17 Noordenne Avenue, Altona
3.	Cumming, Ronald John	"Suide Chuimein", 58 Nicholson Street, Warrnambool
4.	Dart, Bruce Edmund	22A Fenton Crescent, Frankston
5.	Drewnicki, Zbigniew	16 Bernard Street, Balwyn North
6.	Fair, David	134 High Street, Drysdale
7.	Gordon, John Alexander	26 Dagonet Street, Strathmore
8.	Hill, James Arthur Murray	69 Victoria Street, Williamstown
9.	Lear, John Connor	5 Shoubra Court, Highton
10.	MacGregor, Keith Rob-Roy	10 Worthing Avenue, Doncaster East
11.	McCracken, Barry George	44 Myers Drive, Shoreham
12.	McLean, Graeme Russell	24 Wilkinson Street, Ocean Grove
13.	Moody, Keith Thomas	25 Cumola Court, Doncaster
14.	Osborne, Colin Alexander	42 Park Lane, Mount Waverley
15.	Rowell, James	15 Peacedale Grove, Nunawading
16.	Roy, Milton Allan	63 Northumberland Road, Pascoe Vale
17.	Scott, John Fitzlanders	107 Cranbourne Road, Frankston
18.	Snoey, Pieter	70 Florence Street, Williamstown North
19.	Stone, James Chester	18 Mill Street, Aspendale
20.	Urquhart, Kenneth	33 Craig Road, Donvale
21.	Walsh, Terence John	153 Oak Street, Beaumaris

Marine Board of Victoria  
Melbourne, 31 March 1983

K. T. MANALLACK, Secretary



*Marine Act 1958*  
ROLL OF SEAMEN

The following Roll of Names, etc., of all persons entitled as Seamen to vote for the election of one Member of the Marine Board of Victoria under the provisions of the *Marine Act 1958* is published in accordance with the 31st Section of the said Act.

Public Works Department,  
Melbourne, April 1983

J. SIMPSON  
Minister of Public Works

Number on Roll	Name	Address
1.	Andrews, William Frederick	7 Station Way, Tyabb
2.	Appleton, David Patrick	73 Walkers Road, Mount Eliza
3.	Betts, Peter Anthony	4 Dorsett Road, Mount Martha
4.	Bruce, Anthony Francis	97 Thompson Street, Williamstown
5.	Brown, James William	11 Haslam Street, Williamstown
6.	Byrne, Donald Fitzpatrick	99 Lewisham Road, Prahran
7.	Chumbley, Terence William	111 Dunstan Parade, Port Melbourne
8.	Clark, Gordon Leslie	c/- Oriental Hotel, Williamstown
9.	Close, Peter David	8 Braw Street, Williamstown
10.	Cox, Norman Francis Victor	43 Brayshay Road, Newcomb
11.	Dean, Francis Phillip	203 Richardson Street, Middle Park
12.	Docherty, James Neville	Flat 1, 29 Brighton Road, St. Kilda
13.	Doherty, Paul	122 Aitkens Street, Williamstown
14.	Gilmour, David Farmer	12 Macquarie Street, Williamstown
15.	Griffiths, Edgar Francis	7A Takapuna Street, Caulfield South
16.	Harris, Barry Robert	4 Darrivill Street, Geelong North
17.	Hatfield, John Charles	2 Jopling Street, Ballan
18.	Heath, William Herbert	92 Simmonds Drive, Altona
19.	Ireland, Albert Ngamoki	85 Mason Street, Newport
20.	Lacey, Allan	34 Oakbank Street, Newport
21.	Lanyon, Bernie Raymond	22 Russell Place, Williamstown
22.	Mannion, Barry Thomas	23 Nodding Avenue, Frankston
23.	McColl, Robert	18 Nursery Avenue, Frankston
24.	McNerney, Patrick Joseph	40 O'Farrell Street, Yarraville
25.	Metzthen, James Walter	36 Railway Crescent, Williamstown
26.	McLean, Thomas Moffat	55 Libau Avenue, Bell Park
27.	Phillips, Arthur Sidney Bion	2/85 Merton Street, Albert Park
28.	Roworth, Alfred Ernest	25 Langibanool Avenue, Geelong North
29.	Schofield, William	136 Douglas Parade, Williamstown
30.	Seraceno, Lewis Cologero	5 Ferris Avenue, Mitcham
31.	Simpson, Alfred George	140 Disney Street, Crib Point
32.	Smith, Alan	24 Marma Road, Murrumbena
33.	Smith, Barry John	90 McClelland Avenue, Lara
34.	Soultanakis, George	1/14 Gnarwyn Road, Carnegie
35.	Soultanakis, John	32 Nirvana Avenue, Malvern East
36.	Suters, William Henry	28 Hereford Drive, Belmont
37.	Wallace, William	1 Carbon Court, Werribee

Marine Board of Victoria  
Melbourne, 31 March 1983

K. T. MANALLACK, Secretary

**POST-SECONDARY EDUCATION REMUNERATION  
TRIBUNAL ACT 1980**

Pursuant to Regulation 12 of the Post-Secondary Education Remuneration Tribunal Regulations 1981 notice is hereby given that an association or body entitled the Council of the Footscray Institute of Technology has made application to be an approved association or body for the purposes of the *Post-Secondary Education Remuneration Tribunal Act 1980*.

Any person or approved association or body which desires to object to the application may do so by lodging at the office of the Tribunal within 14 days after the publication of this advertisement a notice of objection in accordance with Form 6 appearing in the Post-Secondary Education Remuneration Tribunal Regulations 1981.

The application for approval may be inspected at the office of the Tribunal between the hours of 9.30 a.m. to 1.00 p.m. and 2.00 p.m. to 4.30 p.m. on Monday to Friday.

Dated 12 May 1983

J. E. TAYLOR, President

*Cemeteries Act 1958*

**SCALE OF FEES OF THE BOX HILL PUBLIC CEMETERY**

In pursuance of the powers conferred upon them by the Cemeteries Act, the trustees of the Box Hill Public Cemetery hereby make the following scale of fees, which shall come into operation upon publication in the *Government Gazette*, and from and after such publication every scale of fees heretofore made by the said trustees shall be and is hereby rescinded to the extent to which it conflicts with this scale.

*Concrete Vault*

Concrete lined vault, 2·44mm x 1·22mm, 2·76mm deep,  
with lid and including first interment \$2200

R. V. COUCHE  
A. E. HARVEY  
J. HUGHES, Trustees

Approved by the Governor in Council, 10 May 1983—TOM  
FORRISTAL, Clerk of the Executive Council

*Cemeteries Act 1958*

## SCALE OF FEES OF THE COLBINABBIN PUBLIC CEMETERY

In pursuance of the powers conferred upon them by the Cemeteries Act, the trustees of the Colbinabbin Public Cemetery hereby make the following scale of fees, which shall come into operation upon publication in the *Government Gazette*, and from and after such publication every scale of fees heretofore made by the said trustees shall be and is hereby rescinded to the extent to which it conflicts with this scale.

<i>Private Graves</i>	
Land, 2·44m x 1·22m	\$ 44.00
Own selection of land (extra)	10.00
<i>Sinking Charges for Private Graves</i>	
Sinking grave 1·83m deep	66.00
Each additional 0·3m	13.00
Sinking oversize grave (extra)	25.00
<i>Miscellaneous Charges</i>	
Interment fee	20.00
Permission to erect a headstone or monument, 5% of cost with a minimum of	8.00
Exhuming the remains of a body (when authorised)	200.00

R. R. WEST  
T. M. MORGAN  
D. J. BROWN  
S. W. WEPPNER, Trustees

Approved by the Governor in Council, 10 May 1983—TOM FORRISTAL, Clerk of the Executive Council

*Cemeteries Act 1958*

## SCALE OF FEES OF THE TOWER HILL PUBLIC CEMETERY

In pursuance of the powers conferred upon them by the Cemeteries Act, the trustees of the Tower Hill Public Cemetery hereby make the following scale of fees, which shall come into operation upon publication in the *Government Gazette*, and from and after such publication every scale of fees heretofore made by the said trustees shall be and is hereby rescinded to the extent to which it conflicts with this scale.

Purchase of Land	\$ 100.00
Sinking grave to 1·83m	100.00
Sinking grave each additional 0·3m	20.00
Sinking grave for child under 10 years	40.00
Sinking grave on weekends or holidays	40.00
Sinking grave for American Casket (extra)	35.00
Reopening of a grave	90.00
Interment fee	75.00
Interment of ashes	30.00
Permission to erect kerb	10.00
Permission to erect slab	10.00
Permission to erect monument	25.00
Permission to inspect copy of register	5.00

J. L. CORBETT  
L. W. GUNN  
A. H. FARAGHER, Trustees

Approved by the Governor in Council, 10 May 1983—TOM FORRISTAL, Clerk of the Executive Council

*Cemeteries Act 1958*

## SCALE OF FEES OF THE THORPDALE PUBLIC CEMETERY

In pursuance of the powers conferred upon them by the Cemeteries Act, the trustees of the Thorpdale Public Cemetery hereby make the following scale of fees, which shall come into operation upon publication in the *Government Gazette*, and from and after such publication every scale of fees heretofore made by the said trustees shall be and is hereby rescinded to the extent to which it conflicts with this scale.

	\$
Land 2·44m x 1·22m	20.00
A. F. GUNN F. R. BLACKSHAW J. F. TILGNER, Trustees	

Approved by the Governor in Council, 10 May 1983—TOM FORRISTAL, Clerk of the Executive Council

*Cemeteries Act 1958*

## SCALE OF FEES OF THE SAN REMO PUBLIC CEMETERY

In pursuance of the powers conferred upon them by the Cemeteries Act, the trustees of the San Remo Public Cemetery hereby make the following scale of fees, which shall come into operation upon publication in the *Government Gazette*, and from and after such publication every scale of fees heretofore made by the said trustees shall be and is hereby rescinded to the extent to which it conflicts with this scale.

	\$
Sinking grave 1·83m deep	80.00
Sinking grave 2·13m deep	95.00
Re-opening grave (without cover)	65.00
Re-opening grave (with cover)	72.00
Interment on Saturdays or Public Holidays (extra)	28.00

J. ALLEN  
M. D. LEGG  
G. M. LEGG, Trustees

Approved by the Governor in Council, 10 May 1983—TOM FORRISTAL, Clerk of the Executive Council

*Labour and Industry Act 1958*

## ORDER OF EXEMPTION ISSUED UNDER THE PROVISIONS OF SECTION 80F

Pursuant to the provisions of section 80F of the *Labour and Industry Act 1958*, I, William Albert Landeryou, Minister of Labour and Industry, having considered an application from the Council of the City of Malvern, hereby make this Order exempting shopkeepers of shops in High Street, Malvern between Glenferrie Road and Kooyong Road from being required to close and keep closed their shops in relation to the "Armada Expo Festival" during the undermentioned times:

From 1.00 p.m. Saturday 14 May until midnight Sunday 15 May 1983.

From 1.00 p.m. Saturday 21 May until midnight Sunday 22 May 1983.

This Order does not operate to permit the sale or disposal of liquor within the meaning of the *Liquor Control Act 1968* by any shopkeeper at any time when he would, but for this Order, be required to close and keep closed his shop in accordance with Part VI.

Dated 6 May 1983

W. A. LANDERYOU  
Minister of Labour and Industry



Resolution dated 2 May 1983 made pursuant to Section 21 of the *Country Roads Act* 1958, declaring the widening of Doncaster Road in the City of Doncaster and Templestowe as shown hatched on plan numbered G.P. 15635 below to be part of a main road within the meaning and for the purposes of the said Act.

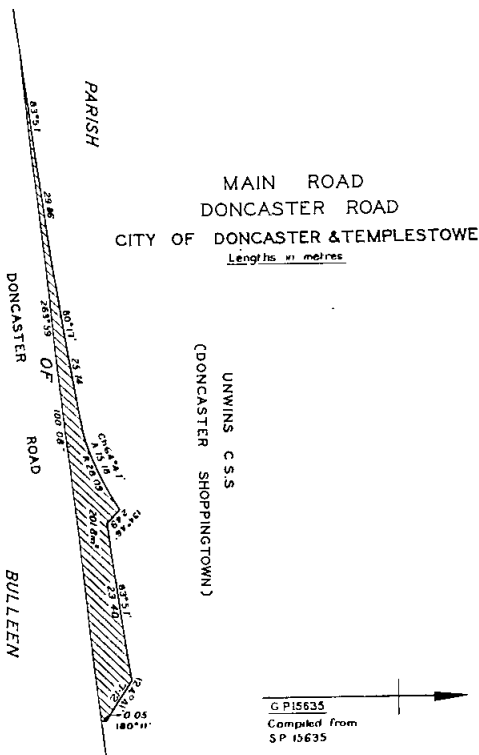

Resolution dated 2 May 1983, made pursuant to Sections 21 and 58 of the *Country Roads Act* 1958, declaring the deviation from Mardan Road in the Shire of Mirboo as indicated by diagonal hatching on plans numbered G.P. 15648B, G.P. 15649A, G.P. 15649B, G.P. 15649C and G.P. 15650 below to be part of a main road within the meaning and for the purposes of the said Act, and also declaring that such deviation shall be in lieu of the existing road or part thereof indicated by cross hatching on plans numbered G.P. 15649A and G.P. 15649C and that such part of the said existing road shall be discontinued.

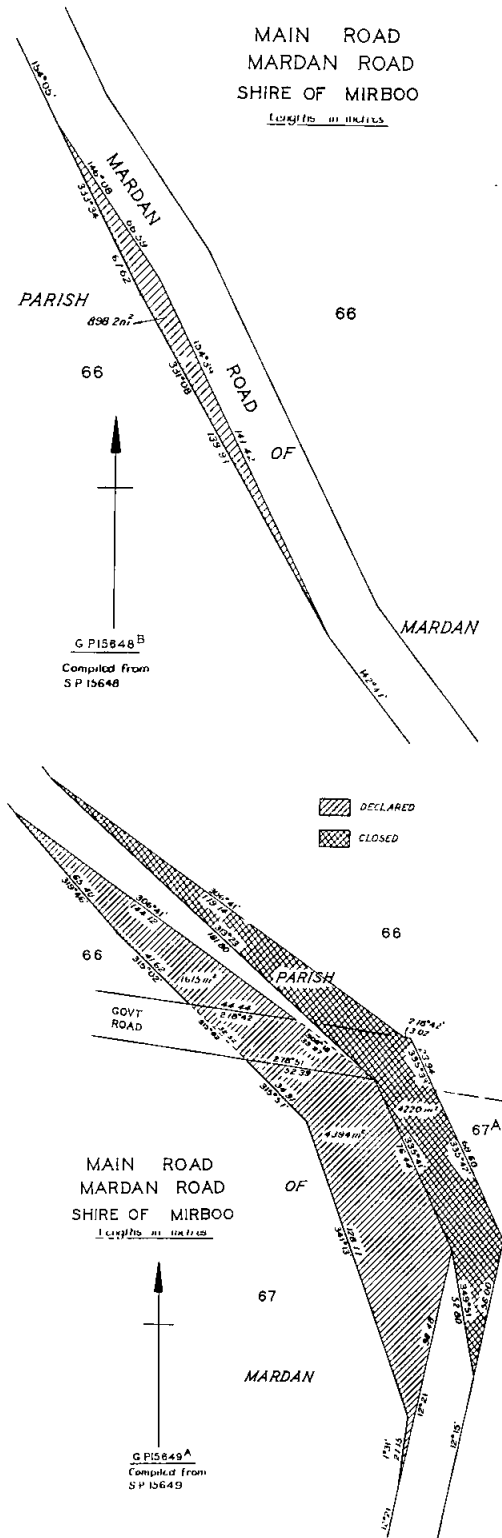



Resolution dated 2 May 1983, made pursuant to Sections 21 and 58 of the *Country Roads Act 1958* declaring the deviation from the Myrtleford-Yackandandah Road in the Shire of Yackandandah as indicated by diagonal hatching on plans numbered G.P. 15434B, G.P. 15434C, G.P. 15434D and G.P. 15435 below to be part of a main road within the meaning and for the purposes of the said Act, and also declaring that such deviation shall be in lieu of the existing road or part thereof indicated by cross hatching and horizontal hatching on plan numbered G.P. 15434B which part indicated by cross hatching on plan numbered G.P. 15434B shall be discontinued.

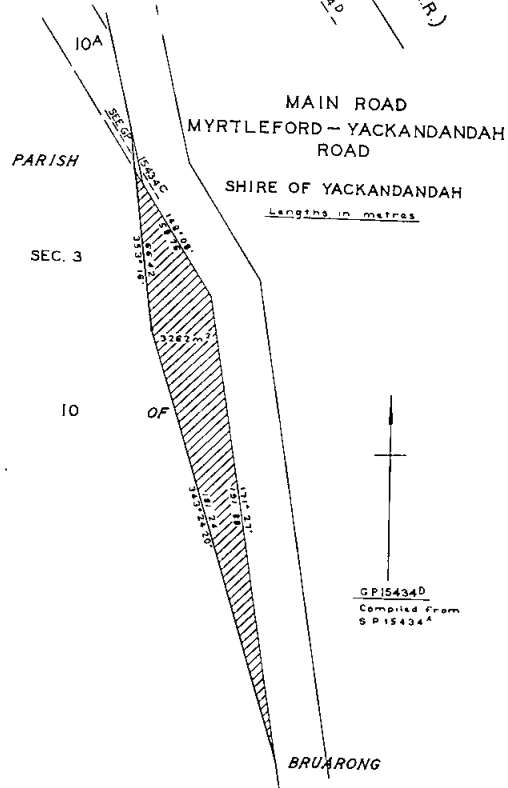
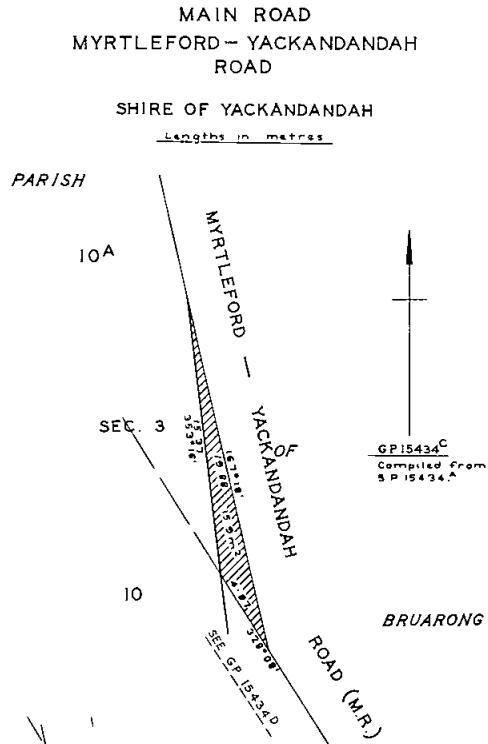
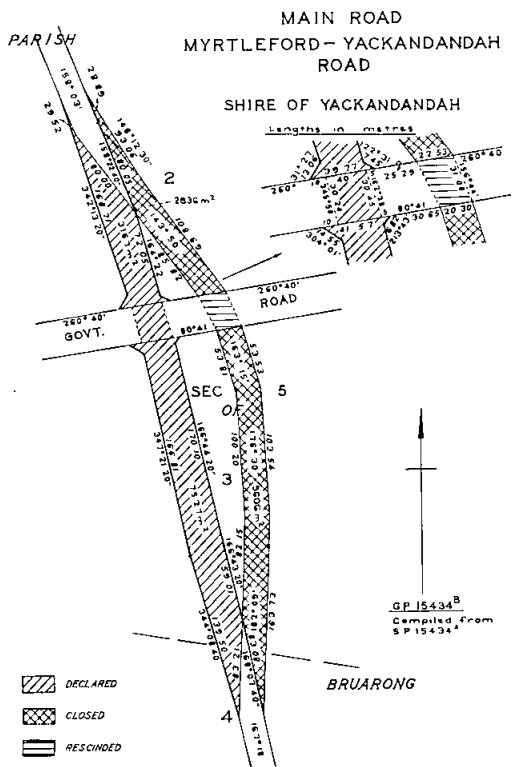

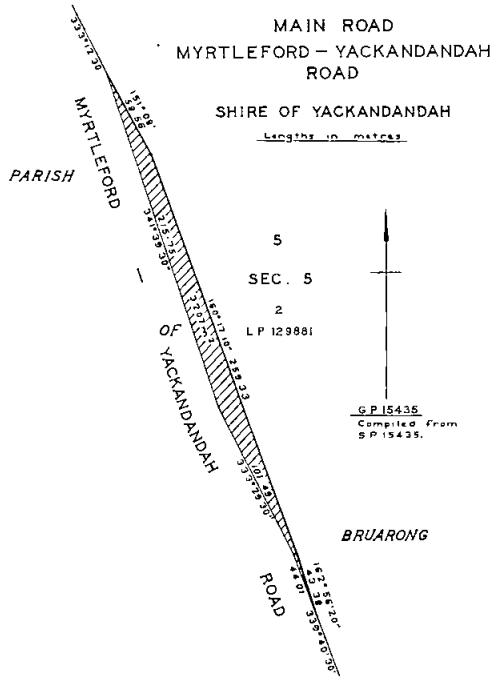

**Roadside Reserves**  
 Resolution dated 2 May 1983 declaring areas of land in the Shire of Bannockburn as shown hatched on plans numbered G.P. 15738A and G.P. 15739 below to be roadside reserves.

**ROADSIDE RESERVE  
 (HAMILTON HIGHWAY)**

SHIRE OF BANNOCKBURN

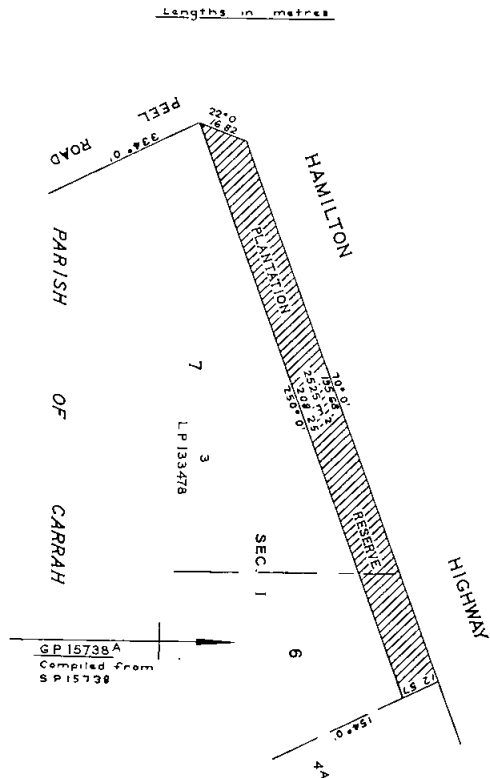

**Unclassified Road**  
 Resolution dated 2 May 1983 made pursuant to Sections 21 and 110 of the *Country Roads Act 1958*, declaring the widening of the Old Mardan Road in the Shire of Mirboo as shown hatched on plan numbered G.P. 15648A below to be part of a road within the meaning and for the purposes of the said Act.

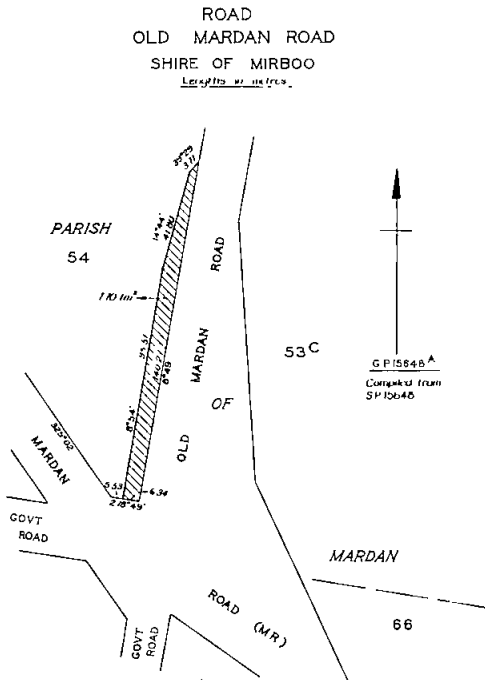

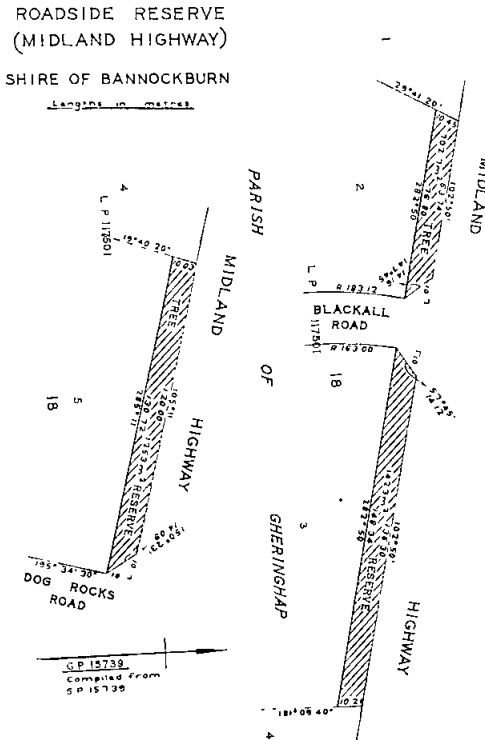

10 May 1983

P. J. McCULLOUGH, Acting Secretary

**SHIRE OF MARONG  
ROAD DEVIATION ORDER**

In pursuance of the powers conferred by Section 522 and Section 526 of the *Local Government Act 1958*, the Council of the Shire of Marong doth hereby direct that the land in the Parish of Marong shown hatched on the plan hereunder, which has been purchased taken or acquired by it, shall be a public highway on and from the date of publication of this order in the *Government Gazette* and declares that such land shall be a public highway in lieu of the land indicated by cross hatching on the said plan.

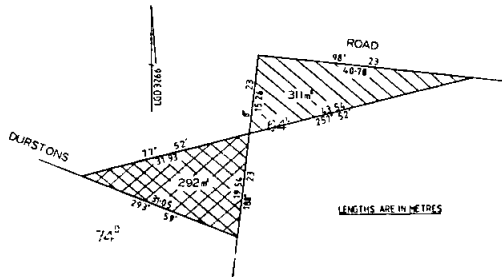

The common seal of the President, Councillors and Ratepayers of the Shire of Marong was hereunto affixed on 15 December 1982 in the presence of—

L. W. THURROWGOOD, President  
J. F. POWER, Councillor  
G. L. ELVEY, Secretary

Confirmed by the Governor in Council, 10 May 1983—TOM FORRISTAL, Clerk of the Executive Council.

*Local Government Act 1958*

**NOTICE OF CONFIRMATION OF AN ORDER OF THE COUNCIL OF THE SHIRE OF FLINDERS ADOPTING A PROPOSAL FOR THE CLOSURE OF REVELL STREET, BLAIRGOWRIE TO THROUGH TRAFFIC**

Pursuant to the provisions of section 539C of the *Local Government Act 1958*, the Governor in Council, on 10 May 1983 confirmed an order of the Council of the Shire of Flinders made on 21 July 1982 adopting a proposal for the closure of Revell Street, Blairgowrie to through traffic by the erection of a barrier at the location shown on the plan hereunder.

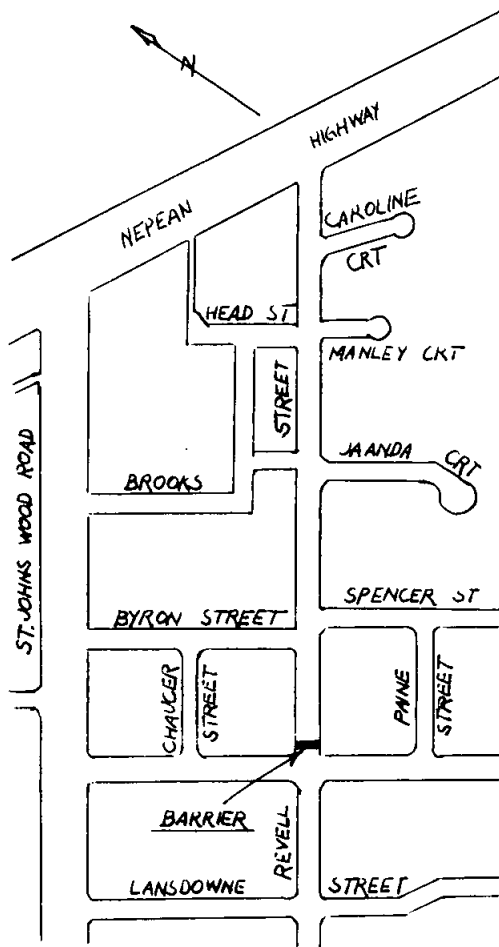

TOM FORRISTAL  
Clerk of the Executive Council

Local Government Department,  
Melbourne (82/4869)



*Local Government Act 1958*NOTICE OF CONFIRMATION OF AN ORDER OF THE  
COUNCIL OF THE CITY OF CAMBERWELL ADOPTING A  
PROPOSAL FOR A SHOPPING MALL

Pursuant to the provisions of section 539B of the *Local Government Act 1958*, the Governor in Council on 10 May 1983 confirmed an order of the Council of the City of Camberwell made on 13 December 1982 adopting a proposal for a shopping mall and declaring Theatre Place, Canterbury to be a shopping mall.

TOM FORRISTAL  
Clerk of the Executive Council

Local Government Department,  
Melbourne (83/0420)

TRANSPORT REGULATION ACT  
TRANSPORT REGULATION BOARD

## Hearing of Applications

Notice is hereby given that the following applications will be considered by the Transport Regulation Board on 7 June 1983.

Amarant, D. & A., Kilsyth—Application for one Metropolitan Taxi licence to be issued subject to the cancellation of Suburban Taxi licence No. ST 6470.

M. E. Cockburn, Port Melbourne—Application to license one commercial passenger vehicle with seating capacity for 7 persons, to be purchased, to operate for the carriage of clients of the applicants' 'Victorian Hang Gliding School', between Melbourne and areas suitable for hang gliding throughout the state of Victoria. Cost of transport is included in tuition fees.

C. G. Foran (Padua College), Mornington—Application to license one commercial passenger vehicle with seating capacity for 22 persons, to operate for the carriage of students attending Padua College, Mornington, between the College and their homes, as follows:—

Route: Depart Padua College via Oakbank Road, Nepean Highway, Canadian Bay Road, Walkers Road, Humphries Road, Bellbird Road, Canadian Bay Road, Winona Road and Allison Road to the intersection of Allison Road and Heath Road. Returning via Allison Road, Winona Road, Canadian Bay Road, Nepean Highway and Oakbank Road to the College.

Fares: Single 75c; Return \$1.50.

Timetable: Monday to Friday, depart Padua College 7.57 a.m., 3.45 p.m.; Arrive Padua College 8.25 a.m., 4.13 p.m.

G. G. Harrison, Echuca—Application to license one commercial passenger vehicle with seating capacity for 18 persons, to operate for the carriage of school children between Pianta's Road and Echuca under temporary contract to the Education Department. No charter rights are sought in this application.

B. J. and V. D. Hulm, Portland—Application to license one commercial passenger vehicle with seating capacity for 25 persons to operate as a country Stage Omnibus for the carriage of passengers, newspapers and parcels along the following routes:—

- (i) Between Portland and Mt Gambier via Nelson.
- (ii) Between Portland and Warrnambool via Port Fairy.

Timetable: (All times shown are Victorian)

(i) Dep Portland	7.30 a.m.	Dep Mt Gambier	3.30 p.m.
Arr Nelson	8.26 a.m.	Arr Nelson	4.05 p.m.
Arr Mt Gambier	9.01 a.m.	Arr Portland	5.01 p.m.
(ii) Dep Portland	5.05 p.m.	Dep Warrnambool	
			7.30 p.m.
Arr Warrnambool		Arr Portland	9.00 p.m.
	6.29 p.m.		

## Fares:

	Adult	Pensioner/Child Under 15 years
Portland to		
1. Nelson	\$4.10	\$2.05
2. Mt Gambier	\$6.60	\$3.30
3. Warrnambool	\$6.20	\$3.10
Mt Gambier to		
1. Nelson	\$2.50	\$1.25
2. Warrnambool	\$12.80	\$6.40

G. J. and P. R. Hutchinson, Birregurra—Application to license one commercial passenger vehicle with seating capacity for 18 persons, to operate for the carriage of school children between Murroon and Birregurra Primary School under temporary contract to the Education Department. No charter rights are sought in this application.

Littles Gippsland Coaches (Maffra) Pty. Ltd., Maffra—Application to license one commercial passenger vehicle with seating capacity for 41 persons, to operate for the carriage of school children between Maffra and Sale under temporary contract to the Education Department. No charter rights are sought in this application.

Nken Pty. Ltd., Box Hill North—Application for two Special Purpose Vehicle licences in respect of a 1975 Daimler sedan and a 1976 Jaguar sedan each with seating capacity for 4 persons, to operate from 98 Strabane Avenue, Box Hill North for the carriage of passengers for wedding parties.

Point Cook-Werribee Passenger Service Pty. Ltd., Werribee—Application to license two commercial passenger vehicles each with large seating capacity, to operate under the same terms and conditions as existing MO licences at present in the name of the applicant.

D. K. Rose (Nagle College), Bairnsdale—Application to license one commercial passenger vehicle with seating capacity for 28 persons, to operate for the carriage of students attending Nagle College, Bairnsdale, between the College and Orbost.

Fares: \$8.00 per week.

Timetable: Monday to Friday

Dep Orbost 7.15 a.m., Arr Nagle College 8.45 p.m.

Dep Nagle College 3.30 p.m., Arr Orbost 5.00 p.m.

Application for renewal of licences as shown by the persons listed hereunder to operate under the same terms and conditions.

A. F. and R. G. Bennett, Coleraine—TS 156.

Kangaroo Flat Bus Lines Pty. Ltd., Kangaroo Flat—CO 49.

E. V. and G. J. Shortis, Kyabram—CC 5.

Sitch Bus Service Pty. Ltd., Sunshine—MC 619

L. T. and J. L. Wood, Donald—CH 10.

Notice of any objections should be forwarded to reach the Secretary of the Board not later than 1 June 1983.

Interested parties are advised that it will not be necessary to appear on the hearing date specified, unless advised in writing by the Board.

18 May 1983

C. J. V. SMITH, Secretary

## MELBOURNE AND METROPOLITAN BOARD OF WORKS

Notice to the Owners of Tenements in the Undermentioned Streets and the Private Streets, Lanes, Courts and Alleys opening thereto. The main pipe in the said streets being laid down, the owners of all tenements situated as under are hereby required on or before 20 June 1983 to cause a proper pipe and stop cocks to be laid so as to supply water within such tenements from the main pipe.

## Croydon

Angelica Crescent, from Narr-Maen Drive westwards and north-westwards, 271 metres.

Rosemary Avenue, from Narr-Maen Drive eastwards, 81 metres.

Narr-Maen Drive, from 25 metres north of Lemongrove Crescent further northwestwards, 210 metres.

## Dandenong

Keating Crescent, from 35 metres southwestwards of Tarene Drive further westwards, 201 metres.

Lind Court, total street from Keating Crescent northwards.

Hyde Court, total street from Keating Crescent northwards.

## Diamond Valley

Phipps Crescent, from Reynolds Road westwards then south-westwards excluding lot 54 and part of lot 59 on Lodged Plan 4085, 465 metres.

Reynolds Road, from Phipps Crescent northeastwards, 750 metres.

## Keilor

Tekapo Crescent, from Wanaka Drive to Mantaura Avenue.

Sunshine Avenue, from Wanaka Drive southwards, 120 metres.

Wanaka Drive, from Sunshine Avenue eastwards, 60 metres.

Pia Court, total street from Tekapo Crescent westwards.

Mantaura Avenue, from Rutherglen Way to Hawea Court.

Hawea Court, total street from Mantaura Avenue northwestwards.

Rutherglen Way, from 40 metres northeast of Wanaka Drive further northeastwards, 159 metres.

Wanganui Court, total street from Rutherglen Way northwestwards.

## Knox

Cerutty Way, from Fewster Drive southeastwards, 211 metres.

Cawley Court, total street from Cerutty Way westwards.

Clarke Crescent, from Fewster Drive to Cerutty Way.

Player Close, total street from Clarke Crescent southwards.

## Lillydale

Stephen Avenue, from Mount Dandenong Tourist Road south-eastwards, 422 metres.

Arunga Drive, from Old Yarra Road to Plumtree Court.

## Moorabbin

Baringhup Street, from 80 metres east of Wilson Street further southeastwards, 97 metres.

## Northcote

St. Georges Road, from 80 metres north of Westbourne Grove further northwards, 12 metres.

## Sunshine

Lacy Street, from Cranwell Street northwards, 100 metres.

## Sherbrooke

Gilmore Court, from Belgrave-Hallam Road northwestwards, 140 metres.

Prince Street, from Runnymede Road northwestwards and north-eastwards, 170 metres.

## Waverley

Clarke Avenue, from 60 metres southeast of Landy Court further southeastwards, southwestwards and westwards, 196 metres.

10 May 1983

H. G. FORD

Acting Director of Administration

## DEPARTMENT OF MINERALS AND ENERGY

## APPLICATION FOR MINING LEASE REFUSED

No. 963; Duval Mining (Australia) Ltd. and Picon Explorations Pty Limited; 100 ha. Parishes of Burrumbeep and Ararat.

## MINING LEASES GRANTED

No. 860; John Murray Steer and Lorraine Margaret Steer; 10 ha. Parish of Kunat Kunat.

No. 880; Neville Eric McCann and Kathleen Eliza McCann; 4.8 ha. Parish of Korrak Korrak.

No. 887; John Knuckey; 7.2 ha. Parish of Budgerum East.

## APPLICATIONS FOR SEARCH LICENCES DECLARED ABANDONED

No. 2705; Lindsay Rowe; 40 ha. Parish of Kingower.

Nos. 2906 and 2907; Allan James McMillan; 40 ha's each. Parishes of Knockwood and Kevington.

## APPLICATIONS FOR SEARCH LICENCES REFUSED

No. 2719; Apollo International Minerals NL; 20 ha. Parish of Jirnkee.

No. 2720; Apollo International Minerals NL; 21 ha. Parish of Jirnkee.

No. 2721; Apollo International Minerals NL; 40 ha. Parish of Jirnkee.

No. 2849; Apollo International Minerals NL; 4 ha. Parish of Jirnkee.

## SEARCH LICENCES GRANTED

No. 2734; Amber Gem Pty. Ltd.; 4 ha. Parish of Moliagul.

No. 2860; Allison Banner Pty. Ltd.; 25 ha. Parish of Youarrabuk.

## TAILINGS LICENCE GRANTED

No. 4875; Gerald Peter Clarke and Patrick James Clarke; to remove tailings from the "Catherine Reef United Dump" situated in the Parish of Sandhurst.

## TAILINGS LICENCE EXPIRED

No. 4449; Forests Commission Victoria; to remove tailings from two dumps situated on Crown Land, east of Crown Allotment 5A in the Parish of Wooragee.

## APPLICATION FOR EXTRACTIVE INDUSTRY LICENCE REFUSED

No. 1135; Gippsland Pty. Ltd.; Parish of Koorooman.

D. R. WHITE

Minister for Minerals and Energy

## SEARCH LICENCE DECLARED VOID

No. 2388; Malcolm John Weston; 40 ha. Parish of Kevington.

Dr E. W. RUSSELL

Secretary for Minerals and Energy

## CONTRACTS ACCEPTED—(Series 1982/83)

## VICTORIAN RAILWAYS BOARD

45. Erection and completion of Signal and Communication buildings in the following combinations and locations: Diesel generator room plus relay at Dimboola, Diapur and Leeor Loop and diesel generator room at Gerang Gerang, Salisbury Loop, Nhill, Diapur-Miram, Kaniva, Lillimur and Serviceton for an amount of \$133 967.40—Contract No. 65164—Onley's Holdings Pty. Ltd.

46. Supply and consolidation of embankment material, including Sub-ballast course, for railway tracks to be laid at Inverleigh between 98.859 km and 99.653 km for an estimated contract amount of \$185 171.00—Contract No. 65147—L. J. Wellam & Sons Pty. Ltd.

47. Erection of scaffolding to Tower at Ballarat Railway Station for a contract amount of \$44 000.00—Contract No. 65214—S. J. Weir Pty. Ltd.

48. Replacement of water supply mains at the Bendigo Workshops for a contract amount of \$37 992.00—Contract No. 65217—A. H. McMeeken.

49. The design, supply, delivery, installation, testing and commissioning of replacement of air conditioning system at the Photography Division, Railway Administrative Offices for an amount of \$22 120.00—Contract No. 65286—Almak Air Conditioning Pty. Ltd.

Melbourne 10 May 1983

C. P. J. BERRY  
Acting Secretary for Railways

*Town and Country Planning Act 1961*

SHIRE OF RODNEY (SHOPPING CENTRES) INTERIM  
DEVELOPMENT ORDER 1983

Notice of Approval

In pursuance of the powers conferred by the *Town and Country Planning Act 1961*, the Governor in Council on 17 May 1983 approved the abovementioned Order in respect of land within the Shire of Rodney known as Nos. 107-123 Echuca Road, Mooroopna and more particularly described as Lots 5-13 (inclusive) L.P. 78968 and Part of Lot 1 L.P. 78968, having a frontage of about 158.60 metres to the Echuca Road and a depth of about 100.58 metres, and for which the Minister for Planning is the Responsible Authority.

The Order comes into operation on the date this Notice is published in the *Government Gazette*.

The Order provides that except in accordance with a permit granted by the Responsible Authority land within the area to which this Order applies shall not be used or developed for the purpose of a shop.

A copy of the documents may be inspected free of charge, during office hours at the office of the Department of Planning (Plan Inspection Section), 5th Floor, 235 Queen Street, Melbourne, and at the office of the Council of the Shire of Rodney, Council Offices, Casey Street, Tatura.

DAVID YENCKEN  
Secretary for Planning

PUBLIC TRUSTEE ACT 1958, SECTION 17

I hereby give notice that on 21 April 1983 the Public Trustee filed an Election to Administer the following deceased person's estate in accordance with Section 17 of the *Public Trustee Act 1958*:

Cunningham, Walter John, late of 178 The Parade, Ascot Vale, retired, died 11 February 1983.

I hereby give notice that on 22 April 1983 the Public Trustee filed an Election to Administer the following deceased person's estate in accordance with Section 17 of the *Public Trustee Act 1958*.

Bergin, James Leo, late of 40 King Street, Queenscliff (in the Will called 25 King Street, Queenscliff), retired teacher, died 6 October 1982.

I hereby give notice that on 27 April 1983 the Public Trustee filed an Election to Administer the following deceased person's estate in accordance with Section 17 of the *Public Trustee Act 1958*.

Rankin, Bruce Hamilton, late of 1 Queen Street, Blackburn, retired, died 8 January 1983.

I hereby give notice that on 3 May 1983 the Public Trustee filed Elections to Administer the following deceased persons' estates in accordance with Section 17 of the *Public Trustee Act 1958*.

Cummings, Doris Hilda, late of Queen Elizabeth Geriatric Centre, 102 Ascot Street, Ballarat, pensioner, died 8 May 1983.

Gilbert, Keith Douglas, also known as Keith Douglass Gilbert, late of 16 Meakin Street, Watsonia, wood machinist, died 1 February 1983.

McLaughlan, Lyla Olive Mary, late of 91 Mitchell Street, Brunswick, married woman, died 19 February 1983.

Peacock, Agnes, late of Mont Park, pensioner, died 19 January 1983.

Reid, Albert John Alexander, also known as Albert John Reid, formerly of 269 Moray Street, South Melbourne, but late of 29 Campbell Street, Wonthaggi, pensioner, died 9 March 1983.

Yattah, Maurice, late of 11 Manchester Grove, Glenhuntly, pensioner, died 26 December 1982.

I hereby give notice that on 5 May 1983 the Public Trustee filed Elections to Administer the following deceased persons' estates in accordance with Section 17 of the *Public Trustee Act 1958*:

Campbell, John Joseph, formerly of Flat 11, 125 Victoria Street, East Brunswick, but late of Victoria Caravan Park, Echuca, retired timber worker, died 8 March 1983.

Inston, Ewel Robert, late of Heatherton Hospital, Kingston Road, Heatherton, pensioner, died 30 January 1983.

O'Brien, Nancy Mary, formerly of 23 Kemp Street, Thornbury, but late of Olympia Private Hospital, 12 Francis Grove, Thornbury, widow, died 8 March 1983.

11 May 1983

168 Exhibition Street,  
Melbourne 3000.

P. T. SPENCER  
Public Trustee

Creditors, next of kin and others having claims against the estate of any of the under-mentioned deceased persons are required to send particulars of the claims to the Public Trustee, 168 Exhibition Street, Melbourne, Victoria 3000, the personal representative, on or before 25 July 1983 after which date the Public Trustee may convey or distribute the assets having regard only to the claims of which the Public Trustee then has notice:—

Bergin, James Leo, late of 40 King Street, Queenscliff (in the Will called 25 King Street, Queenscliff), retired teacher, died 6 October 1982.

Campbell, John Joseph, formerly of Flat 11, 125 Victoria Street, East Brunswick, but late of Victoria Caravan Park, Echuca, retired timber worker, died 8 March 1983.

Coutts, William Phillip, late of 65 Bendigo Avenue, Bentleigh, retired railway employee, died 18 February 1983.

Cummings, Doris Hilda, late of Queen Elizabeth Geriatric Centre, 102 Ascot Street, Ballarat, pensioner, died 8 May 1982.

Cunningham, Walter John, late of 178 The Parade, Ascot Vale, retired, died 11 February 1983.

Gilbert, Keith Douglas, also known as Keith Douglass Gilbert, late of 16 Meakin Street, Watsonia, wood machinist, died 1 February 1983.

Goode, Donald Clyde, late of 54 Yerrin Street, Balwyn, gentleman, died 16 January 1958.

Hart, Stephen, late of Flat 5, 1B Wild Cherry Road, Carnegie, retired, died 5 February 1983.

Inston, Ewel Robert, late of Heatherton Hospital, Kingston Road, Heatherton, pensioner, died 30 January 1983.

Lynch, Margaret Mary, late of 4 Graham Avenue, Wangaratta, retired, died 29 December 1982.

McLaughlin, Lyla Olive Mary, late of 91 Mitchell Street, Brunswick, married woman, died 19 February 1983.

Murby, Edwin, formerly of 7 Walwa Street, Mitcham, but late of Leighton Nursing Home, Bulleen, gentleman, died 12 January 1983.

O'Brien, Nancy Mary, formerly of 23 Kemp Street, Thornbury but late of Olympia Private Hospital, 12 Francis Grove, Thornbury, widow, died 8 March 1983.

Peacock, Agnes, late of Mont Park, pensioner, died 19 January 1983.

Phillips, Ivy Elizabeth, late of 169 Nicholson Street, Carlton, widow, died 4 December 1982.

Rankin, Bruce Hamilton, late of 1 Queen Street, Blackburn, retired, died 8 January 1983.

Reid, Albert John Alexander, also known as Albert John Reid, formerly of 269 Moray Street, South Melbourne, but late of 29 Campbell Street, Wonthaggi, pensioner, died 9 March 1983.

Rogers, Frederick, formerly of Wahgunyah, Victoria, but late of "Glenora", Corowa, New South Wales, retired, died 23 October 1982.

Wadsworth, Lionel Charles, formerly of 11 Neville Avenue, Frankston, but late of Mt. Eliza Geriatric Centre, Jackson Road, Mount Eliza, retired insurance agent, died 15 October 1982.

Yattah, Maurice, late of 11 Manchester Grove, Glenhuntly, pensioner, died 26 December 1982.  
Melbourne 11 May 1983

P. T. SPENCER  
Public Trustee

**PUBLIC MEETING OF THE PUBLIC SERVICE BOARD TO FACILITATE A WIDER DISCUSSION OF POLICY MATTERS BEING CONSIDERED BY THE BOARD**

The decision making processes of the Public Service Board evolved at a time when the Board decided a wide range of individual transactions, many of which directly affected specific individuals. In such circumstances, it was appropriate that Board submissions and discussions were restricted to the affected position.

In recent times the Board has moved to provide for delegations to its Office and to Departments for many such transactions and has placed an increased emphasis on the development of policies and guidelines for managing the Public Service personnel system. This has provided an opportunity to strengthen and improve the Public Service personnel system by changing policies rather than by addressing individual transactions.

In order for the full potential of this development to be realised, it is important that there be debate and discussion of major policy issues coming before the Board for decision. The Board considers that this would be facilitated by arranging regular public meetings of the Board to discuss major policy issues. Policy proposals would be distributed for comment prior to each meeting. Those attending such meetings would have the opportunity to comment and raise issues on the policy options under consideration.

The following guidelines will apply to public Board meetings:

1. The Board will approve the policy issues to be considered at each meeting at least two weeks prior to the meeting.
2. To ensure that seating is available and that papers can be distributed, those wishing to attend the meeting are asked to reserve a place via the Secretary, Public Service Board (phone notifications and enquiries 651 1373).
3. The Board will distribute a discussion paper on each policy item prior to the meeting.
4. At the meeting:
  - a Board Officer will address the policy issues involved;
  - other parties with a major interest will be invited to comment; and
  - the Board will invite those attending to comment on the policy proposals and to raise relevant issues for discussion.
5. Subsequent to the meeting the Board will finalise its consideration of the policy issues involved and will publish a statement summarising its decisions or conclusions.

Public Servants wishing to attend such meetings should obtain approval for appropriate time off from their Permanent Head. Permanent Heads are asked to assist interested staff to participate in the Board's public meeting process.

The next Public Meeting on policy issues will be held at 2.00 p.m. Thursday 2 June 1983 in the Board Room, 4th Floor, 1 Treasury Place, Melbourne. The Agenda items for that meeting are:

- the introduction of a new occupational category for Clerical Officers;
- Public Service Board activities 1981/82.

Other public meetings on policy matters will be held on the first Thursday of each month and agenda items will be published in the Victorian Public Service Notices and the *Government Gazette* in all instances and, depending on the subject matter, may also be by press notification.

A. P. PHILLIPS, Secretary

**APPOINTMENTS AND RESIGNATIONS**

**APPOINTMENTS**

His Excellency the Governor of the State of Victoria by and with the advice of the Executive Council thereof has by Orders made on 10 May 1983 been pleased to make the undermentioned appointments, viz.:

Department of Community Welfare Services

*Member of Youth Parole Board*

Beverley Margaret Bates

as a member of the Youth Parole Board for a period of 3 years commencing from 1 April 1983.

Department of Crown Lands and Survey

*Bailiffs of Crown Lands*

Russell Wayne Wells

Adrian Edward Morton and

Geoffrey John King

to be bailiffs of Crown lands, pursuant to the provisions of section 30 of the *Land Act 1958*, in respect of the reserved Crown lands in the City of Melbourne known as the Royal Botanic Gardens, and with authority to enforce all the Regulations made with respect to the care, protection and management of the said Reserve.

Health Commission

*Trustees of Public Cemeteries*

Roy Douglas Telford

as Trustee of the Colac Public Cemetery, vice Donald Walter Kilpatrick, deceased.

John Neale and

Francis Barnard

as Trustees of the Ondit and Cundare Public Cemetery, vice B. Watson deceased and B. M. Lang resigned, respectively, pursuant to Section 3 (1) of the *Cemeteries Act 1958*.

*Superintendent of Mental Hospitals*

Thomas Mathew Peyton, M.B., Ch.B., M.R.A.N.Z.C.P.

as a Superintendent of the Warrnambool Mental Hospital, Training Centre and Lewana Clinic pursuant to the provisions of Section 26 (1) of the *Mental Health Act 1959*, for period 24 April 1983 to 1 May 1983, vice I. M. Fitzgerald.

Horace Wellesley Hannah, M.B.B.S., D.P.M., M.R.A.N.Z.C.P.

as a Superintendent of the Warrnambool Mental Hospital, Training Centre and Lewana Clinic pursuant to the provisions of Section 26 (1) of the *Mental Health Act 1959*, for period 2 May 1983 to 30 June 1983, vice T. M. Peyton.

## Law Department

*Justices of the Peace*

Terence Walter Appleby, HMAS Lonsdale, Port Melbourne  
 Bevan John French, Robertson Street, Derrinallum  
 Douglas Hamilton, 31 Strachan Street, Hamilton  
 Herbert Thomas Holden Lister, Dinglee  
 Joan Elma Lodolo, Diamond Creek  
 Graeme Michel Long, 42 Main Street, Greensborough  
 Kenneth Hugh Whan, Invergordon  
 Elaine Hazel Mary Wightman, 21-23 Egan Street, Diamond Creek  
 Graham Wood, 19 Fletcher Road, Five Ways  
 to be Justices of the Peace for the State of Victoria.

*Commissioners for Taking Declarations etc.*

David William Arts, Knox City Shopping Centre, Wantirna  
 Helma Wilhelmina Johanna Maria Dam, 35 Robinson Street, Dandenong  
 Sam Antony de Gabrielle, 366 St. Kilda Road, Melbourne  
 Ian Aubrey Dodds, Commercial Road, Prahran  
 John Goodwin, 500 Collins Street, Melbourne  
 Martin Greville Grogan, Victoria Barracks, Melbourne  
 Carmel (Leonard) Testa, 35 St. Johns Avenue, Springvale  
 James Wesley Tippett, Midland Highway, Huntly  
 to be Commissioners for taking declarations and affidavits under the *Evidence Act 1958*.

TOM FORRISTAL

Clerk of the Executive Council

At the Executive Council Chamber,  
 Melbourne, 10 May 1983

*Liquor Control Act 1968*

## APPOINTMENT OF LICENSING INSPECTORS

In accordance with the authority conferred upon me by Section 6 of the *Police Regulation Act 1958*, I, Eric Thomas Millar, Deputy Commissioner of Police, do hereby appoint under subsection (1) of Section 22 of the *Liquor Control Act 1968*, the following Officers of Police as Licensing Inspectors for the Divisions of the Police Districts as shown:—

<i>Division Number</i>	<i>Police District</i>	<i>Rank and Name</i>
1	Cheltenham	Chief Superintendent Keith Wallace Hawkins, No. 10131 (vice Chief Superintendent Holmberg, No. 10227)
2	Dandenong	Inspector Maurice Leonard Lindsay, No. 13280 (from 13.4.1983 to 30.4.1983)
4	Dandenong	Inspector Maurice Leonard Lindsay, No. 13280 (from 1.5.1983 to 14.5.1983)
2	Upper Murray	Senior Sergeant Ralph Dewhurst, No. 13801 (from 1.4.1983 to 30.6.1983)

E. T. MILLAR  
 Deputy Commissioner

## RESIGNATIONS

His Excellency the Governor of the State of Victoria by and with the advice of the Executive Council thereof has by Orders made on 10 May 1983 accepted the resignations of the persons named hereunder of the offices mentioned, viz.:

## Health Commission

*Members of Committees of Management of Hospitals*

Barry Julius Solomon  
 as Member of the Committee of Management of the Geelong Hospital as from 11 March 1983.

Westmore Roy Stephens  
 as Member of the Committee of Management of the Mortlake District Hospital as from 18 April 1983 in accordance with the provisions of Section 63G (1) of the *Hospitals and Charities Act 1958*.

## Law Department

*Commissioners for taking Declarations etc.*

Pamela Mary Fox  
 William Arthur Kellow and  
 Paul Gordon Ross  
 as Commissioners for taking declarations and affidavits under the *Evidence Act 1958*.

TOM FORRISTAL

Clerk of the Executive Council

At the Executive Council Chamber,  
 Melbourne, 10 May 1983

## ORDERS IN COUNCIL

## LOCAL GOVERNMENT ACT 1958

At the Executive Council Chamber, Melbourne, the  
 Tenth day of May, 1983

Present:

His Excellency the Governor of Victoria

Mr Landeryou	Mr Trezise
Mr White	Mr Kent

## ROAD DISCONTINUED — CITY OF ESSENDON

Whereas it is provided in section 528 (2) of the *Local Government Act 1958*, that where a road (whether or not a public highway but not being a road set out on land of the Crown) or any part thereof is not required for public use, the Governor in Council on the request of the council of the municipality in which such road is situated made not less than one month after publishing in a newspaper generally circulating in the district and posting to the registered proprietor (if any) of the land and the owners and occupiers (if any) of lands abutting or immediately adjacent to the road notice of intention to make such a request may by Order published in the *Government Gazette* direct that such road or part shall be discontinued and thereupon such road or part shall be discontinued accordingly.

And whereas the Council of the City of Essendon has requested that the Governor in Council direct that part of a road off Aberdeen Street, Essendon be discontinued and not less than one month previously has published in a newspaper generally circulating in the district and posted to the registered proprietor of the land in the road and to the owners and occupiers of lands abutting or immediately adjacent to the road notice of intention to make such a request.

And whereas an objection from an owner or occupier of land abutting or immediately adjacent to the road has been received and has been considered.

And whereas an objection from an owner or occupier of land abutting or immediately adjacent to the road has been received and has been considered.

Now therefore, His Excellency the Governor of the State of Victoria, by and with the advice of the Executive Council thereof, hereby directs:—

(a) that the said part of a road which is shown by hatching on the plan hereunder shall be discontinued;

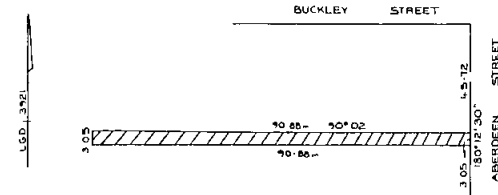

LENGTHS ARE IN METRES

- (b) that notwithstanding such discontinuance the Melbourne and Metropolitan Board of Works shall continue to have and possess the same right title power authority or interest in or in relation to the whole of the land shown by hatching on the said plan as it had or possessed prior to such discontinuance with respect to or in connection with any drains or pipes laid or erected in on or over such land for the purposes of drainage or sewerage;
- (i) that, subject to any such right title power authority or interest the land in the said part of a road may be sold by the Council of the City of Essendon by agreement.

And the Honourable Frank Noel Wilkes, Her Majesty's Minister for Local Government for the State of Victoria, shall give the necessary directions herein accordingly.

TOM FORRISTAL  
Clerk of the Executive Council

LOCAL GOVERNMENT ACT 1958

At the Executive Council Chamber, Melbourne, the  
Tenth day of May, 1983

Present:

His Excellency the Governor of Victoria  
Mr Landryou                      Mr Trezise  
Mr White                              Mr Kent

ROAD DISCONTINUED — CITY OF COBURG

Whereas it is provided in section 528 (2) of the *Local Government Act 1958*, that where a road (whether or not a public highway but not being a road set out on land of the Crown) or any part thereof is not required for public use, the Governor in Council on the request of the council of the municipality in which such road is situated made not less than one month after publishing in a newspaper generally circulating in the district and posting to the registered proprietor (if any) of the land and the owners and occupiers (if any) of lands abutting or immediately adjacent to the road notice of intention to make such a request may by Order published in the *Government Gazette* direct that such road or part shall be discontinued and thereupon such road or part shall be discontinued accordingly.

And whereas the Council of the City of Coburg has requested that the Governor in Council direct that a road off Sylvan Grove, between Essex Road and Olive Grove, Pascoe Vale be discontinued and not less than one month previously has published in a newspaper generally circulating in the district and posted to the registered proprietor of the land in the road and to the owners and occupiers of lands abutting or immediately adjacent to the road notice of intention to make such a request.

And whereas an objection from an owner or occupier of land abutting or immediately adjacent to the road has been received and has been considered.

Now therefore, His Excellency the Governor of the State of Victoria, by and with the advice of the Executive Council thereof, hereby directs:—

- (a) that the said road which is shown by hatching on the plan hereunder shall be discontinued;

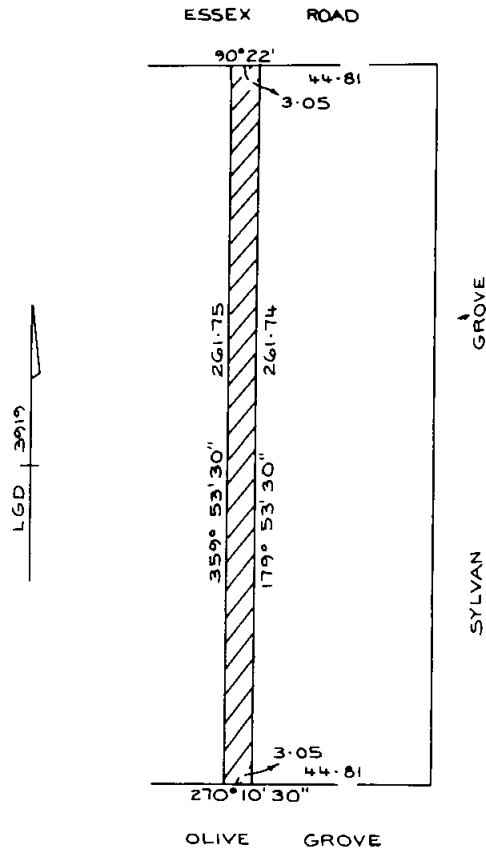

LENGTHS ARE IN METRES

- (b) that notwithstanding such discontinuance the Melbourne and Metropolitan Board of Works shall continue to have and possess the same right title power authority or interest in or in relation to the whole of the land shown by hatching on the said plan as it had or possessed prior to such discontinuance with respect to or in connection with any drains or pipes laid or erected in on or over such land for the purposes of drainage or sewerage;
- (c) that, subject to any such right title power authority or interest the land in the said road may be sold by the Council of the City of Coburg by agreement.

And the Honourable Frank Noel Wilkes, Her Majesty's Minister for Local Government for the State of Victoria, shall give the necessary directions herein accordingly.

TOM FORRISTAL  
Clerk of the Executive Council

LOCAL GOVERNMENT ACT 1958

At the Executive Council Chamber, Melbourne, the Tenth day of May, 1983

Present:

His Excellency the Governor of Victoria  
 Mr Landeryou | Mr Trezise  
 Mr White | Mr Kent

MAKING OF TREE RESERVE — CITY OF MELBOURNE

His Excellency the Governor of the State of Victoria, by and with the advice of the Executive Council thereof, in pursuance of the provisions of section 557 of the *Local Government Act 1958* and in compliance with a request by the Council of the City of Melbourne, hereby directs that the land shown hatched on the plan hereunder being part of Royal Parade, Parkville shall be a Tree Reserve.

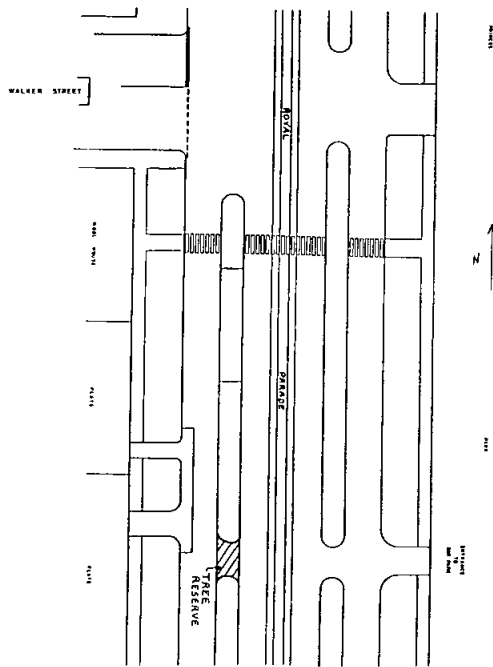

And the Honourable Frank Noel Wilkes, Her Majesty's Minister for Local Government for the State of Victoria, shall give the necessary directions herein accordingly.

TOM FORRISTAL  
 Clerk of the Executive Council

LOCAL GOVERNMENT ACT 1958

At the Executive Council Chamber, Melbourne, the Tenth day of May, 1983

Present:

His Excellency the Governor of Victoria  
 Mr Landeryou | Mr Trezise  
 Mr White | Mr Kent

ROAD DISCONTINUED — CITY OF ESSENDON

Whereas it is provided in section 528 (2) of the *Local Government Act 1958*, that where a road (whether or not a public highway but not being a road set out on land of the Crown) or any part thereof is not required for public use, the Governor in Council on the

request of the council of the municipality in which such road is situated made not less than one month after publishing in a newspaper generally circulating in the district and posting to the registered proprietor (if any) of the land and the owners and occupiers (if any) of lands abutting or immediately adjacent to the road notice of intention to make such a request may by Order published in the *Government Gazette* direct that such road or part shall be discontinued and thereupon such road or part shall be discontinued accordingly.

And whereas the Council of the City of Essendon has requested that the Governor in Council direct that part of a road between Beaver Street and St. Kinnord Street, Essendon be discontinued and not less than one month previously has published in a newspaper generally circulating in the district and posted to the registered proprietor of the land in the road and to the owners and occupiers of lands abutting or immediately adjacent to the road notice of intention to make such a request.

Now therefore, His Excellency the Governor of the State of Victoria, by and with the advice of the Executive Council thereof, hereby directs:—

- (a) that the said part of a road which is shown by hatching on the plan hereunder shall be discontinued;

BUCKLEY STREET

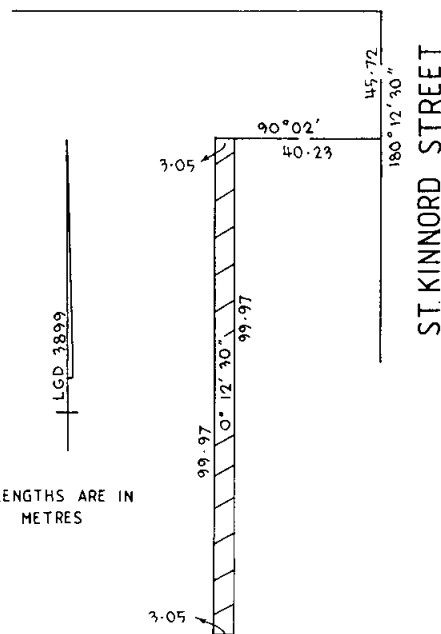

LENGTHS ARE IN METRES

- (b) that notwithstanding such discontinuance the Melbourne and Metropolitan Board of Works shall continue to have and possess the same right title power authority or interest in or in relation to the whole of the land shown by hatching on the said plan as it had or possessed prior to such discontinuance with respect to or in connection with any drains or pipes laid or erected in on or over such land for the purposes of drainage or sewerage;

- (i) that, subject to any such right title power authority or interest the land in the said part of a road may be sold by the Council of the City of Essendon by agreement.

And the Honourable Frank Noel Wilkes, Her Majesty's Minister for Local Government for the State of Victoria, shall give the necessary directions herein accordingly.

TOM FORRISTAL  
Clerk of the Executive Council

LOCAL GOVERNMENT ACT 1958

At the Executive Council Chamber, Melbourne, the  
Tenth day of May, 1983

Present:

His Excellency the Governor of Victoria  
Mr Landeryou | Mr Trezise  
Mr White | Mr Kent

ROAD DISCONTINUED — SHIRE OF WARRAGUL

Whereas it is provided in section 528 (2) of the *Local Government Act 1958*, that where a road (whether or not a public highway but not being a road set out on land of the Crown) or any part thereof is not required for public use, the Governor in Council on the request of the council of the municipality in which such road is situated made not less than one month after publishing in a newspaper generally circulating in the district and posting to the registered proprietor (if any) of the land and the owners and occupiers (if any) of lands abutting or immediately adjacent to the road notice of intention to make such a request may by Order published in the *Government Gazette* direct that such road or part shall be discontinued and thereupon such road or part shall be discontinued accordingly.

And whereas the Council of the Shire of Warragul has requested that the Governor in Council direct that a road off Queen Street, Warragul be discontinued and not less than one month previously has published in a newspaper generally circulating in the district and posted to the registered proprietor of the land in the road and to the owners and occupiers of lands abutting or immediately adjacent to the road notice of intention to make such a request.

Now therefore, His Excellency the Governor of the State of Victoria, by and with the advice of the Executive Council thereof, hereby directs:—

- (a) that the said road which is shown by hatching and cross-hatching on the plan hereunder shall be discontinued;

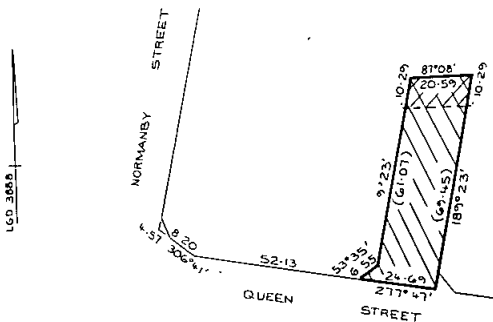

LENGTHS ARE IN METRES

- (b) that notwithstanding such discontinuance the Warragul Sewerage Authority shall continue to have and possess the same right title power authority or interest in or in relation to the whole of the land shown by cross-hatching on the said plan as it had or possessed prior to such discontinuance with respect to or in connection with any drains or pipes laid or erected in on or over such land for the purposes of drainage and sewerage;

- (i) that, subject to any such right title power authority or interest the land in the said road may be sold by the Council of the Shire of Warragul by agreement.

And the Honourable Frank Noel Wilkes, Her Majesty's Minister for Local Government for the State of Victoria, shall give the necessary directions herein accordingly.

TOM FORRISTAL  
Clerk of the Executive Council

LOCAL GOVERNMENT ACT 1958

At the Executive Council Chamber, Melbourne, the  
Tenth day of May, 1983

Present:

His Excellency the Governor of Victoria  
Mr Landeryou | Mr Trezise  
Mr White | Mr Kent

ROAD DISCONTINUED — CITY OF MOE

Whereas it is provided in section 528 (2) of the *Local Government Act 1958*, that where a road (whether or not a public highway but not being a road set out on land of the Crown) or any part thereof is not required for public use, the Governor in Council on the request of the Council of the municipality in which such road is situated made not less than one month after publishing in a newspaper generally circulating in the district and posting to the registered proprietor (if any) of the land and the owners and occupiers (if any) of lands abutting or immediately adjacent to the road notice of intention to make such a request may by Order published in the *Government Gazette* direct that such road or part shall be discontinued and thereupon such road or part shall be discontinued accordingly.

And whereas the Council of the City of Moe has requested that the Governor in Council direct that a road off Princes Highway, Moe be discontinued and not less than one month previously has published in a newspaper generally circulating in the district and posted to the registered proprietor of the land in the road and to the owners and occupiers of lands abutting or immediately adjacent to the road notice of intention to make such a request.

Now therefore, His Excellency the Governor of the State of Victoria, by and with the advice of the Executive Council thereof, hereby directs:—

- (a) that the said road which is shown by hatching and cross-hatching on the plan hereunder shall be discontinued;

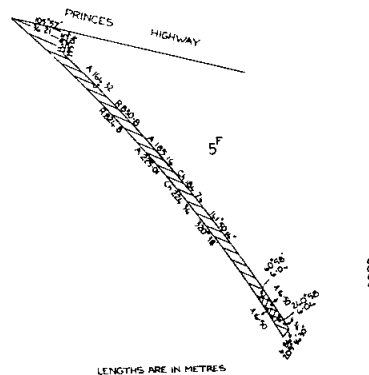

LENGTHS ARE IN METRES

- (a) that notwithstanding such discontinuance the State Electricity Commission of Victoria shall continue to have and possess the same right title power authority or interest in or in relation to the whole of the land shown by cross hatching on the said plan as it had or possessed prior to





**LOCAL GOVERNMENT ACT 1958**

*At the Executive Council Chamber, Melbourne, the  
Tenth day of May, 1983*

Present:

His Excellency the Governor of Victoria  
 Mr Landeryou                      Mr Trezise  
 Mr White                              Mr Kent

**ROAD DISCONTINUED — CITY OF FITZROY**

Whereas it is provided in section 528 (2) of the *Local Government Act 1958*, that where a road (whether or not a public highway but not being a road set out on land of the Crown) or any part thereof is not required for public use, the Governor in Council on the request of the council of the municipality in which such road is situated made not less than one month after publishing in a newspaper generally circulating in the district and posting to the registered proprietor (if any) of the land and the owners and occupiers (if any) of lands abutting or immediately adjacent to the road notice of intention to make such a request may by Order published in the *Government Gazette* direct that such road or part shall be discontinued and thereupon such road or part shall be discontinued accordingly.

And whereas the Council of the City of Fitzroy has requested that the Governor in Council direct that a road at the rear of Princes Street and Fitzroy Street, Fitzroy be discontinued and not less than one month previously has published in a newspaper generally circulating in the district and posted to the registered proprietor of the land in the road and to the owners and occupiers of lands abutting or immediately adjacent to the road notice of intention to make such a request.

Now therefore, His Excellency the Governor of the State of Victoria, by and with the advice of the Executive Council thereof, hereby directs:—

- (a) that the said road which is shown by hatching on the plan hereunder shall be discontinued;

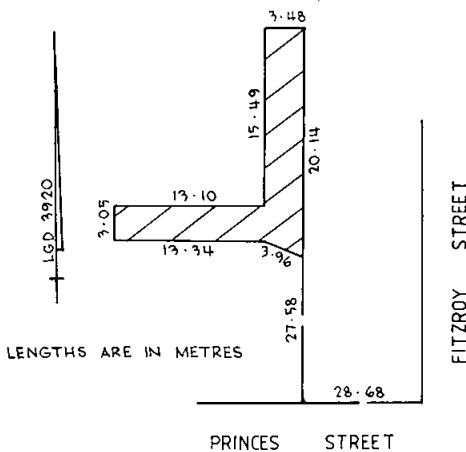

- (b) that notwithstanding such discontinuance the Melbourne and Metropolitan Board of Works shall continue to have and possess the same right title power authority or interest in or in relation to the whole of the land shown by hatching on the said plan as it had or possessed prior to such discontinuance with respect to or in connection with any drains or pipes laid or erected in on or over such land for the purposes of drainage or sewerage;
- (c) that, subject to any such right title power authority or interest the land in the said road may be sold by the Council of the City of Fitzroy by agreement.

And the Honourable Frank Noel Wilkes, Her Majesty's Minister for Local Government for the State of Victoria, shall give the necessary directions herein accordingly.

TOM FORRISTAL  
Clerk of the Executive Council

**LOCAL GOVERNMENT ACT 1958**

*At the Executive Council Chamber, Melbourne, the  
Tenth day of May, 1983*

Present:

His Excellency the Governor of Victoria  
 Mr Landeryou                      Mr Trezise  
 Mr White                              Mr Kent

**ROAD DISCONTINUED — CITY OF MOORABBIN**

Whereas it is provided in section 528 (2) of the *Local Government Act 1958*, that where a road (whether or not a public highway but not being a road set out on land of the Crown) or any part thereof is not required for public use, the Governor in Council on the request of the council of the municipality in which such road is situated made not less than one month after publishing in a newspaper generally circulating in the district and posting to the registered proprietor (if any) of the land and the owners and occupiers (if any) of lands abutting or immediately adjacent to the road notice of intention to make such a request may by Order published in the *Government Gazette* direct that such road or part shall be discontinued and thereupon such road or part shall be discontinued accordingly.

And whereas the Council of the City of Moorabbin has requested that the Governor in Council direct that a part of a road off Bent Street, Bentleigh be discontinued and not less than one month previously has published in a newspaper generally circulating in the district and posted to the registered proprietor of the land in the road and to the owners and occupiers of lands abutting or immediately adjacent to the road notice of intention to make such a request.

Now therefore, His Excellency the Governor of the State of Victoria by and with the advice of the Executive Council thereof, hereby directs that the said part of the road which is shown by hatching on the plan hereunder, shall be discontinued and the land in the said road shall be retained by the Council of the City of Moorabbin for municipal purposes.

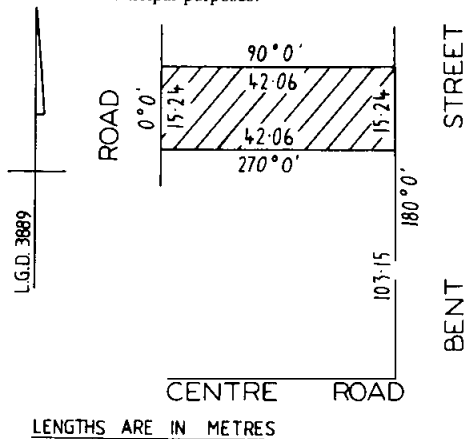

And the Honourable Frank Noel Wilkes, Her Majesty's Minister for Local Government for the State of Victoria, shall give the necessary directions herein accordingly.

TOM FORRISTAL  
Clerk of the Executive Council

LOCAL GOVERNMENT ACT 1958

At the Executive Council Chamber, Melbourne, the  
Tenth day of May, 1983

Present:

His Excellency the Governor of Victoria  
Mr Landeryou | Mr Trezise  
Mr White | Mr Kent

CONFIRMATION OF SEPARATE RATE — CITY OF  
CROYDON

In pursuance of the provisions of section 287 of the *Local Government Act 1958*, His Excellency the Governor of the State of Victoria, by and with the advice of the Executive Council thereof, hereby confirms a separate rate of 0.126 cents in the dollar on the site value of the properties described in Schedule A hereunder and 0.378 cents in the dollar on the site value of the properties described in Schedule B hereunder which rate was made by the Council of the City of Croydon on 6 April 1983 for the purpose of beautification of the Croydon Shopping Centre by the planting of trees and provision of paving and other improvements.

Schedule A

Properties to be Rated at 0.126 cents in the dollar on Site Value  
Devon Street—No. 2.

Lacey Street—No. 1.

Main Street—Nos. 99 VR site 23, 161 Shop 2, 161 Shop 3, 12, 14, 16, 18, 20, 22, 24, 26-28, 30, 32, 34, 36-38, 40, 42, 30-42 Office 1, 30-42 Office 2, 30-42 Office 3, 30-42 Offices 4 and 5, 30-42 Office 6, 44-46, 48, 44-48 Office 1, 44-48 Office 2, 44-48 Office 3, 44-48 Store, 62-64 Shop 2, 62-64 Shop 3, 100, 1/114, 2/114, 168 Shop 2, 168 Shop 3, 168 Shop 4, 180 (Rear).

Reserve Walk—Nos. 2, 4, 6.

The Centreway—Shops 3, 4, 5 and 6, 7, 8, 9.

Schedule B

Properties to be Rated at 0.378 cents in the dollar on Site Value  
Hewish Road—Nos. 2, 4, 6, 8, 10, 10A, 12, 14.

Main Street—Nos. 53, 55, 57, 59, 61, 63, 65, 67-69, 71, 73, 75, 77-79, 81, 83, 85, 87, 89, 91, 87-91 Office 1, 87-91 Office 2, 87-91 Office 3, 87-91 Office 4, 87-91 Office 5, 87-91 Office 6, 93, 95, 97, 99 Office 1, 99 Office 2, 99 Office 3, 99 Office 4, 101, 103, 105, 107, 109, 111-115, 117, 119, 121, 123, 125-129, 131-135, 137-139, 141-145, 147, 149, 151-155, 157 Part Lot 21 LP 6556, 157 Offices 1-3, 157 Offices 5-6, 159, 161 Shop 1, 163, 165-169, 50-54, 50-54 Office 1st Floor, 56-60, 62-64 Shop 1, 66-92, 94-96, 98, 100 Shop, 102, 104-112, 114, 116, 118, 120, 122, 126, 128, 130-132, 134-136, 150, 152, 154-156, 158, 160-162, 164, 166, 168 Shop 1, 170-172, 174, 176-178, 180, 182, 184, 186, 188, 190, 192.

Mt. Dandenong Road—Nos. 193, 195, 197, 199, 207, 209.

And the Honourable Frank Noel Wilkes, Her Majesty's Minister for Local Government for the State of Victoria, shall give the necessary directions herein accordingly.

TOM FORRISTAL  
Clerk of the Executive Council

CROWN LAND (RESERVES) ACT 1978

At the Executive Council Chamber, Melbourne, the  
Tenth day of May, 1983

Present:

His Excellency the Governor of Victoria  
Mr Landeryou | Mr Trezise  
Mr White | Mr Kent

CROWN LAND TEMPORARILY RESERVED

His Excellency the Governor of the State of Victoria, in the Commonwealth of Australia, by and with the advice of the Executive

Council of the said State, pursuant to the provisions of sections 4 and 7 of the *Crown Land (Reserves) Act 1978*, and being of the opinion that the Crown land concerned is required for the public purpose mentioned, doth hereby temporarily reserve and also except from prospecting or from occupation for mining purposes under any miner's right, the Crown land hereinafter described, viz.:

Municipal District of the Shire of Mansfield—

MANSFIELD—For Department of Crown Lands and Survey purposes — 8094 square metres, being Crown allotment 23<sup>J</sup>, Parish of Mansfield, as indicated by hatching on plan hereunder — (M35<sup>(3)</sup>) (Rs.10573)

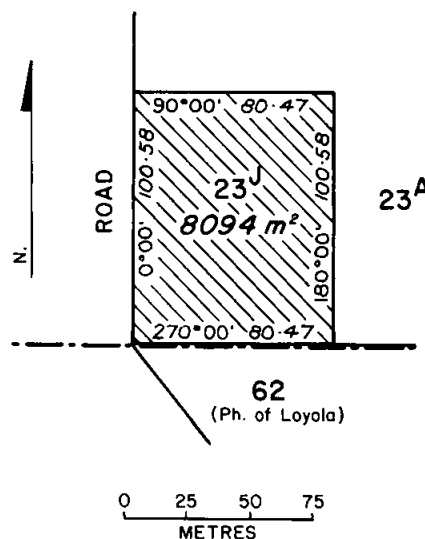

And the Honourable Roderick Alexander Mackenzie, Her Majesty's Minister of Lands for the State of Victoria, shall give the necessary directions herein accordingly.

TOM FORRISTAL  
Clerk of the Executive Council

CROWN LAND (RESERVES) ACT 1978

At the Executive Council Chamber, Melbourne, the  
Tenth day of May, 1983

Present:

His Excellency the Governor of Victoria  
Mr Landeryou | Mr Trezise  
Mr White | Mr Kent

CROWN LAND TEMPORARILY RESERVED

His Excellency the Governor of the State of Victoria, in the Commonwealth of Australia, by and with the advice of the Executive Council of the said State, pursuant to the provisions of sections 4 and 7 of the *Crown Land (Reserves) Act 1978*, and being of the opinion that the Crown land concerned is required for the purpose mentioned, doth hereby temporarily reserve and also except from prospecting or from occupation for mining purposes under any miner's right, the Crown land hereinafter described, viz.:

Municipal District of the Shire of Buninyong—

BALLARAT—For Public Recreation and State School purposes — 3525 square metres, being Crown allotment 18<sup>b</sup>, section 4, Parish of Ballarat, as indicated by hatching on plan hereunder — (B126<sup>(18)</sup>) (Rs.12260)

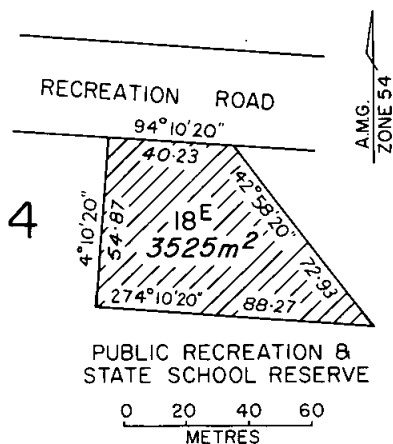

And the Honourable Roderick Alexander Mackenzie, Her Majesty's Minister of Lands for the State of Victoria, shall give the necessary directions herein accordingly.

TOM FORRISTAL  
Clerk of the Executive Council

**CROWN LAND (RESERVES) ACT 1978**

*At the Executive Council Chamber, Melbourne, the Tenth day of May, 1983*

Present:

His Excellency the Governor of Victoria  
Mr Landeryou | Mr Trezise  
Mr White | Mr Kent

**REVOCATION OF TEMPORARY RESERVATIONS OF LANDS BY ORDERS IN COUNCIL**

His Excellency the Governor of the State of Victoria, in the Commonwealth of Australia, by and with the advice of the Executive Council of the said State, pursuant to the provisions of section 10 of the *Crown Land (Reserves) Act 1978*, doth hereby revoke the temporary reservations of lands by Orders in Council hereinafter described, viz.:

**WALHALLA**—The temporary reservation by Order in Council of 23 April 1894 of 3.043 hectares of land in the Township of Walhalla (called Parish of Walhalla in Order) as a site for a Cemetery — (Rs.8925)

**WALHALLA**—The temporary reservation by Order in Council of 24 September 1900 of 575 hectares, more or less, of land in the Township of Walhalla and Parish of Walhalla as a site for Water Supply purposes — (Rs.10242)

**CARALULUP**—The temporary reservation by Order in Council of 16 January 1968 of 81.34 hectares, more or less, of land in the Parish of Caralulup as a site for Water Supply purposes, so far only as the portion thereof containing 4233 square metres, as defined by description and hatching on plan published in the *Government Gazette* dated 20 April 1983, is concerned — (C356(5) (Rs.8911)

**HEXHAM**—The temporary reservation by Order in Council of 12 October 1909 of 2023 square metres of land in the Township of Hexham as a site for Water Supply purposes, so far only as the portion thereof containing 121 square metres, as defined by description and hatching on plan published in the *Government Gazette* dated 20 April 1983, is concerned — (H83(5) (Rs.986)

And the Honourable Roderick Alexander Mackenzie, Her Majesty's Minister of Lands for the State of Victoria, shall give the necessary directions herein accordingly.

TOM FORRISTAL  
Clerk of the Executive Council

**CROWN LAND (RESERVES) ACT 1978**

*At the Executive Council Chamber, Melbourne, the Tenth day of May, 1983*

Present:

His Excellency the Governor of Victoria  
Mr Landeryou | Mr Trezise  
Mr White | Mr Kent

**CROWN LAND TEMPORARILY RESERVED**

His Excellency the Governor of the State of Victoria, in the Commonwealth of Australia, by and with the advice of the Executive Council of the said State, pursuant to the provisions of sections 4 and 7 of the *Crown Land (Reserves) Act 1978*, and being of the opinion that the Crown land concerned is required for public purposes, doth hereby temporarily reserve and also except from prospecting or from occupation for mining purposes under any miner's right, the Crown land hereinafter described, viz.:

Municipal District of the Shire of Newstead—

**NEWSTEAD**—For Public purposes — 2013 square metres, being Crown allotment 2, section 31, Township of Newstead, as indicated by hatching on plan hereunder — (N39<sup>30</sup>) (Rs.12087)

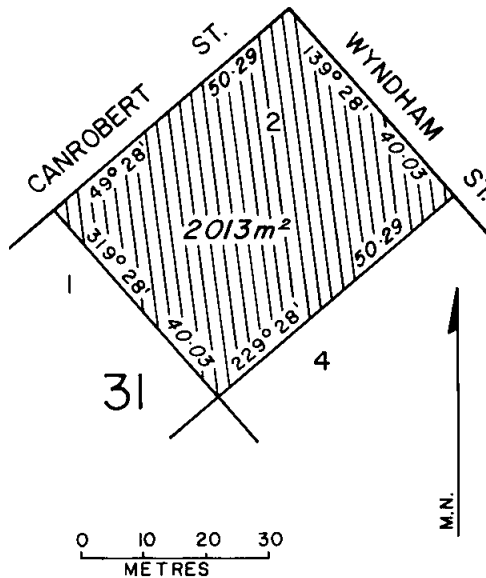

And the Honourable Roderick Alexander Mackenzie, Her Majesty's Minister of Lands for the State of Victoria, shall give the necessary directions herein accordingly.

TOM FORRISTAL  
Clerk of the Executive Council

**ROAD TRAFFIC ACT 1958**

*At the Executive Council Chamber, Melbourne, the Tenth day of May, 1983*

Present:

His Excellency the Governor of Victoria  
 Mr Landeryou                      |                      Mr Trezise  
 Mr White                              |                      Mr Kent

In pursuance of the powers conferred by the *Road Traffic Act 1958*, His Excellency the Governor of the State of Victoria, in the Commonwealth of Australia, by and with the advice of the Executive Council of the said State, and at the request in writing of the Council of the City of Prahran, doth by this Order extend the provisions of the said Act to the land under the control of the City of Prahran shown by hatching on the plan hereunder.

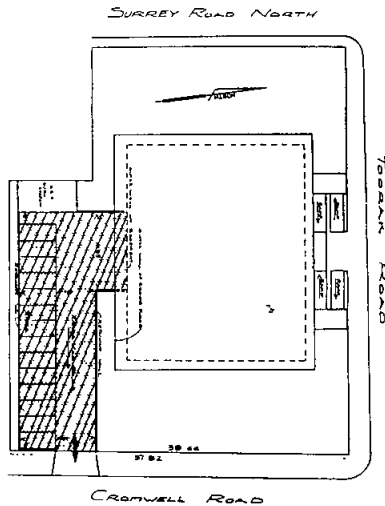

**ROAD TRAFFIC ACT 1958**

*At the Executive Council Chamber, Melbourne, the Tenth day of May, 1983*

Present:

His Excellency the Governor of Victoria  
 Mr Landeryou                      |                      Mr Trezise  
 Mr White                              |                      Mr Kent

In pursuance of the powers conferred by the *Road Traffic Act 1958*, His Excellency the Governor of the State of Victoria, in the Commonwealth of Australia, by and with the advice of the Executive Council of the said State, and at the request in writing of the Council of the City of Heidelberg, doth by this Order extend the provisions of the said Act to the land under the control of the City of Heidelberg as shown by hatching on the plan hereunder.

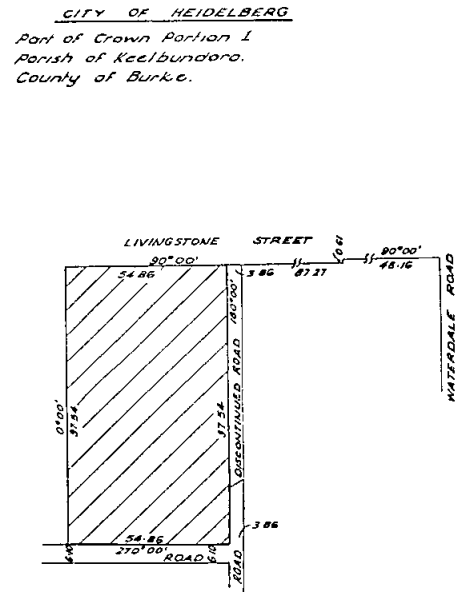

And the Honourable Charles Race Thorson Mathews, Her Majesty's Minister for Police and Emergency Services for the State of Victoria, shall give the necessary directions herein accordingly.

**TOM FORRISTAL**  
 Clerk of the Executive Council

And the Honourable Charles Race Thorson Mathews, Her Majesty's Minister for Police and Emergency Services for the State of Victoria, shall give the necessary directions herein accordingly.

**TOM FORRISTAL**  
 Clerk of the Executive Council

**ROAD TRAFFIC ACT 1958**

*At the Executive Council Chamber, Melbourne, the Tenth day of May, 1983*

Present:

His Excellency the Governor of Victoria  
 Mr Landeryou                      |                      Mr Trezise  
 Mr White                              |                      Mr Kent

In pursuance of the powers conferred by the *Road Traffic Act 1958*, His Excellency the Governor of the State of Victoria, in the Commonwealth of Australia, by and with the advice of the Executive Council of the said State, and at the request in writing of the Council of the Shire of Diamond Valley, doth by this Order extend the provisions of the said Act to the land under the control of the Shire of Diamond Valley as shown by hatching on the plan hereunder.

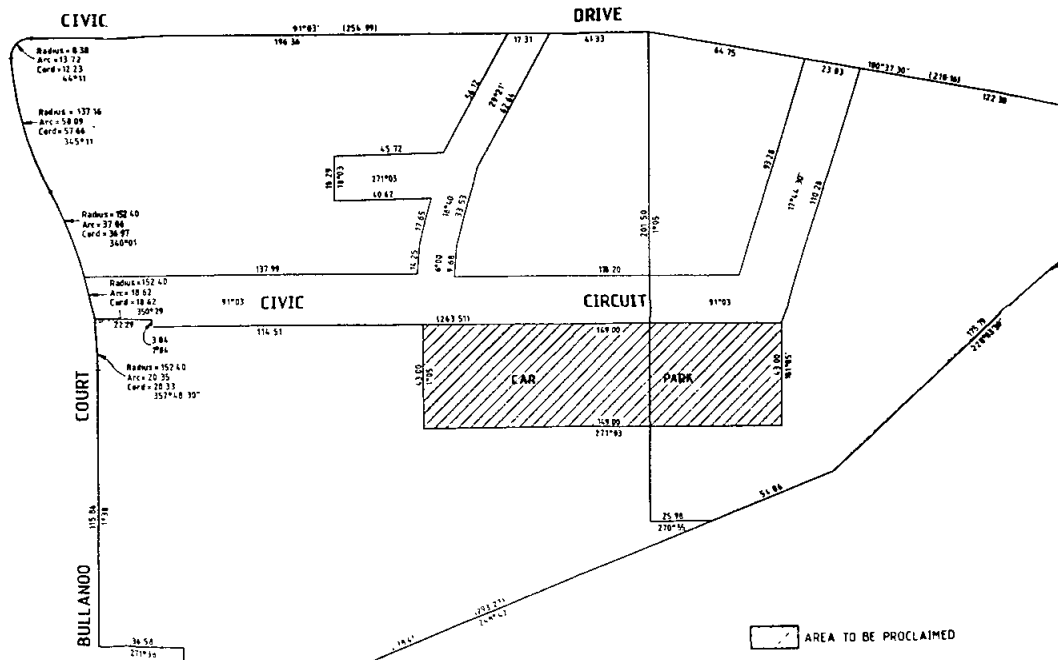

And the Honourable Charles Race Thorson Mathews, Her Majesty's Minister for Police and Emergency Services for the State of Victoria, shall give the necessary directions herein accordingly.

TOM FORRISTAL  
Clerk of the Executive Council

**HOUSING ACT 1958**

At the Executive Council Chamber, Melbourne, the  
Tenth day of May, 1983

Present:

His Excellency the Governor of Victoria

Mr Landeryou	Mr Trezise
Mr White	Mr Kent

**DECLARATION OF PRIVATE STREETS AS PUBLIC HIGHWAYS WITHIN THE BOROUGH OF EAGLEHAWK**

Whereas pursuant to Section 107 of the *Housing Act 1958* it is among other things enacted that where works have been carried out in accordance with an agreement for the full construction of any roads, pavements, culverts or drains made pursuant to the provisions of the said Section 107 such roads, pavements, culverts or drains shall be under the care and management of the Municipality which shall be liable for the cost of any maintenance, repair, alteration or reconstruction thereof and the Governor in Council may by order published in the *Government Gazette* declare any road so constructed to be a public highway.

And whereas by Order dated 6 May 1980 the Governor in Council consented to an agreement between the Housing Commission and the Borough of Eaglehawk regarding street and drainage construction in Whitfield Court, Fitzpatrick Court and Llewellyn Court in the Arblaster Estate situate in the municipality of the Borough of Eaglehawk and the carrying out of the works enumerated in the said Agreement.

And whereas the works of road pavements, culvert and drainage construction have now been carried out in accordance with the said Agreement between the Housing Commission and the Borough of Eaglehawk.

Now therefore His Excellency the Governor of the State of Victoria by and with the advice of the Executive Council of the said State and in pursuance of the powers conferred by Section 107 of the *Housing Act* and upon recommendation of the Housing Commission doth by this order declare the streets more particularly delineated and shown hatched on the plan hereunder to be absolutely dedicated to the public as Public Highways within the meaning of any law now or hereafter in force and that the Council of the Municipality in which the streets are situate shall hereafter be liable for all cost of any maintenance, repair, alteration or reconstruction thereof.

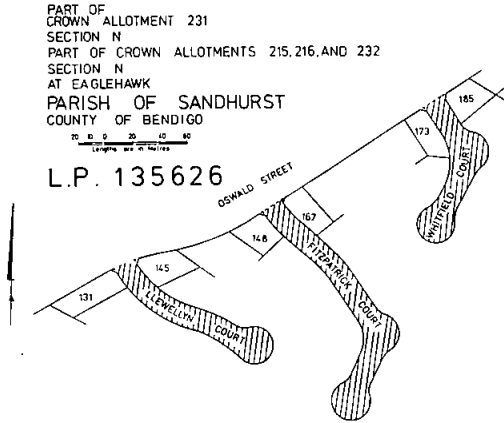

And the Honourable Ian Robert Cathie, Her Majesty's Minister of Housing for the State of Victoria, shall give the necessary directions herein accordingly.

TOM FORRISTAL  
Clerk of the Executive Council

HOUSING ACT 1958

At the Executive Council Chamber, Melbourne, the Tenth day of May, 1983

Present:

His Excellency the Governor of Victoria	
Mr Landeryou	Mr Trezise
Mr White	Mr Kent

DECLARATION OF PRIVATE STREETS AS PUBLIC HIGHWAYS WITHIN THE CITY OF SWAN HILL

Whereas pursuant to Section 107 of the *Housing Act 1958* it is among other things enacted that where works have been carried out in accordance with an agreement for the full construction of any roads, pavements, culverts or drains made pursuant to the provisions of the said Section 107 such roads, pavements, culverts or drains shall be under the care and management of the Municipality which shall be liable for the cost of any maintenance, repair, alteration or reconstruction thereof and the Governor in Council may by order published in the *Government Gazette* declare any road so constructed to be a public highway.

And whereas by Order dated 25 September 1979 the Governor in Council consented to an agreement between the Housing Commission and the City of Swan Hill regarding street and drainage construction in Frazer Street, McBain Street, Cato Court and Miles Court in the Koorong Estate situate in the municipality of the City of Swan Hill and the carrying out of the works enumerated in the said Agreement.

And whereas the works of road pavements, culvert and drainage construction have now been carried out in accordance with the said Agreement between the Housing Commission and the City of Swan Hill.

Now therefore His Excellency the Governor of the State of Victoria by and with the advice of the Executive Council of the said State and in pursuance of the powers conferred by Section 107 of the *Housing Act* and upon recommendation of the Housing Commission doth by this order declare the streets more particularly delineated and shown hatched on the plan hereunder to be absolutely dedicated to the public as Public Highways within the meaning of any law now or hereafter in force and that the Council of the Municipality in which the streets are situate shall hereafter be liable for all cost of any maintenance, repair, alteration or reconstruction thereof.

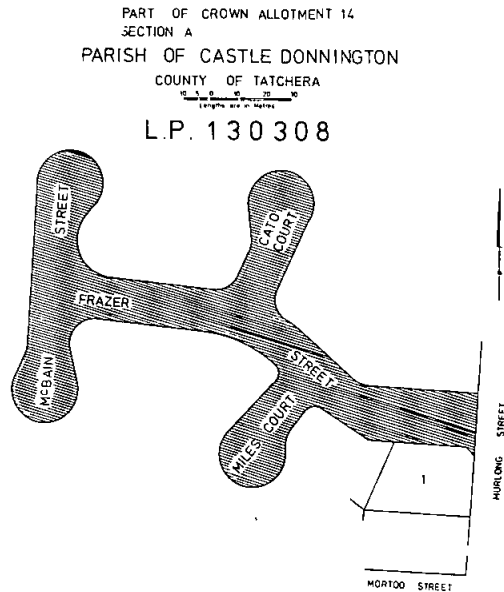

And the Honourable Ian Robert Cathie, Her Majesty's Minister of Housing for the State of Victoria, shall give the necessary directions herein accordingly.

TOM FORRISTAL  
Clerk of the Executive Council

SOIL CONSERVATION AND LAND UTILIZATION ACT 1958

At the Executive Council Chamber, Melbourne, the Tenth day of May, 1983

Present:

His Excellency the Governor of Victoria	
Mr Landeryou	Mr Trezise
Mr White	Mr Kent

DISTRICT ADVISORY COMMITTEE — YARRA SOIL CONSERVATION ACT

In pursuance of the powers conferred by Section 15 of the *Soil Conservation and Land Utilization Act 1958*, His Excellency the Governor of the State of Victoria by and with the advice of the Executive Council thereof, doth hereby appoint the following persons to be members of the District Advisory Committee of the Yarra Soil Conservation District for a term of three years.

Ian Harold Macmillan — being a person elected to represent grazing, agricultural and other relevant interests in the District.

Daryl Arthur Lawrence Abrahams — being a person elected to represent grazing, agricultural and other relevant interests in the District.

Brian Francis Mullens — being a person elected to represent grazing, agricultural and other relevant interests in the District.

Peter Laurence Pedersen — being a person elected to represent grazing, agricultural and other relevant interests in the District.

Garry William LeGet — being the person representing the Soil Conservation Authority.

And the Honourable Evan Walker, Her Majesty's Minister for Conservation for the State of Victoria, shall give the necessary directions herein accordingly.

TOM FORRISTAL  
Clerk of the Executive Council

**LAND ACT 1958**

*At the Executive Council Chamber, Melbourne, the Tenth day of May, 1983*

Present:

His Excellency the Governor of Victoria  
 Mr Landeryou                      |                      Mr Trezise  
 Mr White                                |                      Mr Kent

**UNUSED ROAD CLOSED**

His Excellency the Governor of the State of Victoria, in the Commonwealth of Australia, by and with the advice of the Executive Council of the said State, pursuant to the provisions of section 349 of the *Land Act* 1958 and with the concurrence in writing of the council of the municipality concerned and that of any adjoining land owners, doth hereby close the unused road hereinafter described, viz.:

Municipal District of the City of Doncaster and Templestowe—  
 TOWNSHIP OF WARRANDYTE—Being the road indicated by hatching on plan hereunder — (W25<sup>10</sup> (Rs.11653))

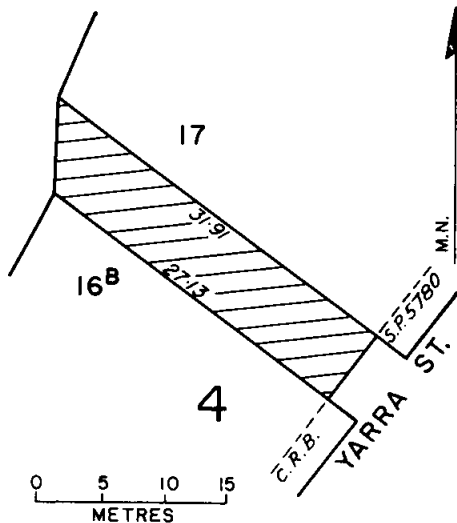

And the Honourable Roderick Alexander Mackenzie, Her Majesty's Minister of Lands for the State of Victoria, shall give the necessary directions herein accordingly.

TOM FORRISTAL  
 Clerk of the Executive Council

**COAL MINES ACT 1958**

*At the Executive Council Chamber, Melbourne, the Third day of May, 1983*

Present:

The Lieutenant-Governor as Deputy for  
 His Excellency the Governor of the State of Victoria  
 Mr Jolly                                      |                                      Mr Spyker  
 Mr White                                      |                                      Mr Kent

In pursuance of the powers conferred by the *Coal Mines Act* 1958 and all other powers him thereunto enabling, the Lieutenant-Governor, as Deputy for His Excellency the Governor of the State of Victoria, by and with the advice of the Executive Council of the said State doth hereby appoint Joseph Salter to be a member of the Board of Examiners for Quarry Managers for a period of twelve months.

And the Honourable David Ronald White, Her Majesty's Minister for Minerals and Energy for the State of Victoria, shall give the necessary directions herein accordingly.

TOM FORRISTAL  
 Clerk of the Executive Council

**COAL MINES ACT 1958**

*At the Executive Council Chamber, Melbourne, the Third day of May, 1983*

Present:

The Lieutenant-Governor as Deputy for  
 His Excellency the Governor of the State of Victoria  
 Mr Jolly                                      |                                      Mr Spyker  
 Mr White                                      |                                      Mr Kent

In pursuance of the powers conferred by the *Coal Mines Act* 1958 and all other powers him thereunto enabling, the Lieutenant-Governor, as Deputy for His Excellency the Governor of the State of Victoria, by and with the advice of the Executive Council of the said State doth hereby appoint James Byrne, Joseph Soppitt and William Hall to be members of the Victorian Coal Miners' Accidents Relief Board for a period of twelve months.

And the Honourable David Ronald White, Her Majesty's Minister for Minerals and Energy for the State of Victoria, shall give the necessary directions herein accordingly.

TOM FORRISTAL  
 Clerk of the Executive Council

**WEST MOORABOOL WATER BOARD ACT 1968**

*At the Executive Council Chamber, Melbourne, the Tenth day of May, 1983*

Present:

His Excellency the Governor of Victoria  
 Mr Landeryou                      |                      Mr Trezise  
 Mr White                                |                      Mr Kent

**APPOINTMENT OF A MEMBER OF THE WEST MOORABOOL WATER BOARD**

Under the powers conferred by the *West Moorabool Water Board Act* 1968, and all other powers enabling him in that behalf, His Excellency the Governor of the State of Victoria, by and with the advice of the Executive Council of the said State doth hereby appoint Raymond William George Evans as a Member of the West Moorabool Water Board for a period of three years from 20 June 1983.

And the Honourable David Ronald White, Her Majesty's Minister of Water Supply for the State of Victoria, shall give the necessary directions herein accordingly.

TOM FORRISTAL  
 Clerk of the Executive Council

**KILMORE AND DISTRICT WATERWORKS TRUST**

*At the Executive Council Chamber, Melbourne, the Tenth day of May, 1983*

Present:

His Excellency the Governor of Victoria  
 Mr Landeryou                      |                      Mr Trezise  
 Mr White                                |                      Mr Kent

Under the powers conferred by the *Water Act* and all other powers enabling him in that behalf, His Excellency the Governor of the State of Victoria, by and with the advice of the Executive Council of the said State hereby repeals the Order made on 16 March 1983, and published in the *Victoria Government Gazette*



of 16 March 1983, imposing restrictions on the use of water supplied by the Kilmore and District Waterworks Trust.

And the Honourable David Ronald White, Her Majesty's Minister of Water Supply for the State of Victoria, shall give the necessary directions herein accordingly.

TOM FORRISTAL  
Clerk of the Executive Council

WATER ACT 1958  
STATE RIVERS AND WATER SUPPLY COMMISSION

*At the Executive Council Chamber, Melbourne, the  
Tenth day of May, 1983*

Present:

His Excellency the Governor of Victoria

Mr Landeryou	Mr Trezise
Mr White	Mr Kent

NORMANVILLE WATERWORKS DISTRICT — DISTRICT  
EXTENDED

Under the powers conferred by the *Water Act 1958* and all other powers enabling him in that behalf, His Excellency the Governor of the State of Victoria, with the advice of the Executive Council of the said State, on the recommendation of the State Rivers and Water Supply Commission doth hereby declare, order and direct that the Normanville Waterworks District be extended by adding to the same the land shown by blue colour on a plan approved by the Governor in Council and deposited in the office of the State Rivers and Water Supply Commission, at 590 Orrong Road, Armadale (Corr. No. 78/1147) and as on and from 1 June 1983, such District shall be deemed to be so extended.

And the Honourable David Ronald White, Her Majesty's Minister of Water Supply for the State of Victoria, shall give the necessary directions herein accordingly.

TOM FORRISTAL  
Clerk of the Executive Council

DRAINAGE OF LAND ACT 1975  
STATE RIVERS AND WATER SUPPLY COMMISSION

*At the Executive Council Chamber, Melbourne, the  
Tenth day of May, 1983*

Present:

His Excellency the Governor of Victoria

Mr Landeryou	Mr Trezise
Mr White	Mr Kent

DECLARATION OF A DRAINAGE COURSE — MOSQUITO  
DEPRESSION SHIRES OF DEAKIN AND RODNEY

Whereas under Section 38 of the *Drainage of Land Act 1975* the Governor in Council may upon application by the Drainage Authority by proclamation published in the *Government Gazette* declare any area of land which water flows to be a drainage course.

And whereas a request has been received from the State Rivers and Water Supply Commission to proclaim a drainage course and to appoint the State Rivers and Water Supply Commission as the Responsible Authority for that part of the Mosquito Depression in the Shires of Deakin and Rodney and more particularly detailed on Plan 136091 (Sheets 1-20) lodged in the Plan Room of the State Rivers and Water Supply Commission at 590 Orrong Road, Armadale.

And whereas under Section 38 of the Act the State Rivers and Water Supply Commission may be cited as the Drainage Authority in relation to the land.

Now therefore I the Governor of the State of Victoria with the advice of the Executive Council of the State and in pursuance of the above recited powers do by this my proclamation declare that

land along the Mosquito Depression particularly described on Plan No. 136091 (Sheets 1-20) to be a Drainage Course and that the State Rivers and Water Supply Commission be appointed as the Responsible Authority for the area so proclaimed.

And the Honourable David Ronald White, Her Majesty's Minister of Water Supply for the State of Victoria, shall give the necessary directions herein accordingly.

TOM FORRISTAL  
Clerk of the Executive Council

NATIONAL GALLERY OF VICTORIA ACT 1966

*At the Executive Council Chamber, Melbourne, the  
Tenth day of May, 1983*

Present:

His Excellency the Governor of Victoria

Mr Landeryou	Mr Trezise
Mr White	Mr Kent

APPOINTMENT OF MEMBERS OF THE COUNCIL OF  
TRUSTEES OF THE NATIONAL GALLERY OF VICTORIA

Pursuant to the provisions of Section 6 of the *National Gallery of Victoria Act 1966*, His Excellency the Governor of the State of Victoria by and with the advice of the Executive Council thereof, doth by this Order appoint the following persons to be members of the Council of Trustees of the National Gallery of Victoria for the periods specified hereunder:—

Mr N. L. Batt, 18 May 1983 to 17 May 1986

Mr D. Jackson, 18 May 1983 to 17 May 1986

Mrs E. L. Williams, 18 May 1983 to 17 May 1986.

And the Honourable Charles Race Thorson Mathews, Her Majesty's Minister for the Arts for the State of Victoria, shall give the necessary directions herein accordingly.

TOM FORRISTAL  
Clerk of the Executive Council

HOSPITALS AND CHARITIES ACT 1958, SECTION 65

*At the Executive Council Chamber, Melbourne, the  
Tenth day of May, 1983*

Present:

His Excellency the Governor of Victoria

Mr Landeryou	Mr Trezise
Mr White	Mr Kent

AUTHORITY FOR SALE OF LAND BY THE ROYAL  
CHILDREN'S HOSPITAL

Whereas the Royal Children's Hospital, an incorporated institution within the meaning of the *Hospitals and Charities Act 1958* is the owner of certain land known as Nos. 94-112 Courtney Street, North Melbourne and more particularly described in the Schedule hereto.

And whereas no part of such land is granted, reserved or set aside for the purpose of the Royal Children's Hospital.

And whereas the Committee of Management of the Royal Children's Hospital desire that the said land be sold.

And whereas the Health Commission of Victoria, after inquiry has reported that it would be advantageous to the Royal Children's Hospital, if the said land was sold.

Now therefore His Excellency the Governor of the State of Victoria by and with the advice of the Executive Council of the said State, being satisfied that in the hereinbefore recited special circumstances the sale of the said land would be advantageous to the Royal Children's Hospital, doth hereby authorise the sale of such land, freed and discharged from any trusts affecting the same, to Housing Commission of 250 Elizabeth Street, Melbourne for the sum of Five Hundred and Six Thousand Dollars (\$506 000.00) subject to the terms and conditions of the Draft Contract of Sale.

Schedule

All that piece of land being Crown Allotment 18 and part of Crown Allotments 17 and 19 Section 13 at North Melbourne Parish of Jika Jika being the whole of the land more particularly described in Certificate of Title Volume 8847 Folio 799.

And the Honourable Thomas William Roper, Her Majesty's Minister of Health for the State of Victoria, shall give the necessary directions herein accordingly.

TOM FORRISTAL  
Clerk of the Executive Council

DECENTRALIZED INDUSTRY (HOUSING) ACT 1973.  
SECTION 4

At the Executive Council Chamber, Melbourne  
on the seventeenth day of May 1983

Present:

His Excellency the Governor of Victoria

Mr Cathie		Mr Mathews
		Mr Walker

Pursuant to the provisions of Section 4 of the *Decentralized Industry (Housing) Act 1973*, His Excellency the Governor of the State of Victoria by and with the advice of the Executive Council thereof hereby appoints Daryl Gary Hill, a person nominated by the Minister for Economic Development, and Robert John Magowan, a person nominated by the Treasurer, as members of the Decentralized Industry Housing Authority up to and including 31 October 1983.

And the Honourable Ian Robert Cathie, Her Majesty's Minister of Housing for the State of Victoria, shall give the necessary directions herein accordingly.

TOM FORRISTAL  
Clerk of the Executive Council

STATE EMPLOYEES RETIREMENT BENEFITS ACT 1979

At the Executive Council Chamber, Melbourne, the  
Tenth day of May, 1983

Present:

His Excellency the Governor of Victoria

Mr Landeryou		Mr Trezise
Mr White		Mr Kent

Whereas the State Employees Retirement Benefits Act 1979 provides that an employee means inter alia any person not being an officer within the meaning of the *Superannuation Act 1958* who holds any office as a member or of a class of persons who are members or in the service or employment of any body created by or under any Act of Parliament to which person or office or class of persons the Governor in Council on the recommendation of the Treasurer, declares that the provisions of the *State Employees Retirement Benefits Act 1979* shall apply.

And whereas the Treasurer has recommended that the provisions of the State Employees Retirement Benefits Act shall continue to apply on and from 10 May 1983 to that class of persons who on 21 December 1982 were employees for the purposes of the State Employees Retirement Benefits Act, were employed within the Department of the Premier and Cabinet and on and from 22 December 1982 were employed by the Werribee Park Corporation.

And whereas the Treasurer has recommended that the provisions of the said Act shall apply on and from 10 May 1983 to that class of persons appointed to and employed by the Werribee Park Corporation on and from or subsequent to 22 December 1982 who are not eligible for membership of the State Superannuation Fund and who are employees for the purposes of the State Employees Retirement Benefits Act.

Now therefore His Excellency the Governor of the State of Victoria, acting by and with the advice of the Executive Council thereof doth hereby declare that the provisions of the *State Employees Retirement Benefits Act 1979* shall apply to the persons mentioned herein.

And the Honourable Robert Allen Jolly, Her Majesty's Treasurer for the State of Victoria, shall give the necessary directions herein accordingly.

TOM FORRISTAL  
Clerk of the Executive Council

LANDS DEPARTMENT  
NOTICES

APPROACHING LAND SALES

Sale of Crown Land, will be held at the under-mentioned places and dates, viz.:

	No. of Gazette
Murrayville—Friday, 10 June 1983	28
Wahgunyah—Tuesday, 17 May 1983	37

SALE OF CROWN LAND BY AUCTION

The land will be offered for sale subject to the provisions of the Land Act and Regulations thereunder.

The upset price is the sum at which bidding will start, and no bid below that sum can be accepted. The highest bidder at or above that sum shall be the purchaser, subject to signature of contract and any necessary payment.

Terms:

A deposit of at least 12½% of the purchase price must be paid at the sale, either in cash or by cheque.

The residue is payable on 28 September 1983 or may be paid off at any earlier time.

Fees, etc.:

Survey fee is payable at the sale.

Payable with balance of purchase money—Crown Grant fee—\$41.00.

Transfer of interest prior to completion of payment may be allowed on payment of the prescribed fee and subject to stamp duty.

If unable to attend personally a prospective purchaser may arrange for another person to bid as his agent.

Attention is drawn to section 95, *Land Act 1958*, which provides that the purchaser shall be deemed to be the owner for the purposes of other Acts; also to an amendment to the Local Government Act providing for Government roads, in certain circumstances, to be declared "private streets", thus making the purchaser liable to contribute to the cost of street construction.

R. A. MACKENZIE  
Minister of Lands

Department of Crown Lands and Survey  
Melbourne

SALE—Sale (No. 12391) of Crown land, by auction, will be held on site, 99 Market Street. Sale on Thursday 30 June 1983 at eleven o'clock a.m. To be conducted by J. R. Buck, Regional Land Officer, Bairnsdale.

Lot 1—Township of Sale Parish of Sale—Former departmental residence being the property known as 99 Market Street, Sale.

Upset price \$30 000.00 the lot. Survey fee \$140.00.

Area 1012 square metres more or less. Allotment 8<sup>A</sup> of Section 39. Improvements comprise a weatherboard dwelling with 4 bedrooms, lounge, kitchen, bathroom and separate toilet; garage; workshop.

Special Conditions—Until the purchase money has been paid in full the following Special Conditions shall apply—

- (i) The purchaser shall at his own expense maintain the property in good order and repair and keep all improvements thereon insured against fire, storm and tempest in the name of the Secretary for Lands.
- (ii) A cover note for such insurance shall be lodged in the Department of Crown Lands and Survey, by the purchaser, within one week of the date of sale, and the policy shall be lodged immediately on issue.
- (iii) The purchaser shall not remove or make any alterations to the improvements on the site without prior consent of the Secretary for Lands.

Enquiries:—Regional Land Officer, Bairnsdale. Phone (051) 52 4223.

## REGULATIONS

### KORONG VALE RECREATION RESERVE

I, Roderick Alexander Mackenzie, Her Majesty's Minister of Lands for the State of Victoria, in pursuance of the powers conferred on me by section 13 of the *Crown Land (Reserves) Act 1978*, do hereby make the following Regulations for or with respect to the remaining Crown Lands in the Township of Korong Vale Parish of Kinypanial temporarily reserved for Public Recreation by Orders in Council of 11 August 1888, 19 October 1915, 11 March 1924, 28 March 1928, 6 December 1937, 28 January 1941, 15 February 1955, 7 October 1959 and 24 April 1979 (see *Government Gazettes* dated 17 August 1888, 27 October 1915, 19 March 1924, 4 April 1928, 8 December 1937, 29 January 1941, 23 February 1955, 14 October 1959 and 2 May 1979 respectively), such lands hereinafter referred to as the "Reserve".

The Reserve has been placed under the control of a Committee of Management (hereinafter referred to as the "Committee") with full power and authority to enforce these Regulations.

#### Regulations

1. The Reserve shall be open to the public from sunrise to sunset free of charge, except on such days (not exceeding twenty in any one year) as the Reserve or any part thereof may be set apart for golf, horse racing, cricket, or football matches, fetes, sports or other amusements, on any of which occasions the fees set out hereunder may be charged and taken for the admission of each adult to the Reserve:—

- (a) on such days as the Reserve or any part thereof may be set apart for horse racing, a sum not exceeding \$10.00;
- (b) on such days as the Reserve or any part thereof may be set apart for golf, cricket or football matches, fetes, sports or other amusements, a sum not exceeding \$5.00.

2. No person shall enter or remain in the Reserve who may offend against decency as regards dress, language or conduct.

3. No person shall damage in any way the trees, shrubs or flowers in the Reserve, nor light fires therein, without the permission of the Committee.

4. No person shall climb or jump over the gates or fences in or around the Reserve, stick bills thereon, or cut names on or in any way damage or injure any of the buildings, gates, fences,

seats or trees in the Reserve, nor leave or deposit any glass, paper or rubbish, nor roll or throw stones or any missiles of any kind.

5. The Committee may set apart any portion of the Reserve for the purpose of any lawful games, amusements or sports and from time to time grant to any club or association of clubs the use of the grounds so set apart upon such terms and conditions as it may deem to be reasonable and consistent with these Regulations.

6. Persons renting or hiring the Reserve or any portion thereof for any purpose whatsoever and who make any charge to the public for admission to the Reserve shall pay to the Committee a fee for the use thereof, such fee to be fixed by the said Committee but shall not exceed the sum of \$60.00 per day.

7. No person shall put in the Reserve any cattle, horses, sheep, goats, pigs or other animals without the permission, in writing, of the Committee first obtained. Provided always that the moneys received for agistment shall be expended in the maintenance and improvement of the Reserve and that an account thereof shall be furnished annually to the Minister of Lands.

8. The Committee shall have full power and authority to impound any cattle found trespassing on the Reserve and shall be taken to be the occupier of the Reserve (with all the power incidental to that status) within the meaning of any law for the time being in force relating to the impounding of cattle. And for the purposes of this clause "cattle" shall mean cattle as interpreted by Section 3 of the *Pounds Act 1958*.

9. No person shall bring into the Reserve any dog unless controlled by a chain or cord without the permission, in writing, of the Committee first obtained.

10. No person shall camp in the Reserve nor erect therein any dwelling nor any booth or other structure for the purpose of offering for sale any article without the permission, in writing, of the Committee.

11. No person shall take part in any public entertainment of any sort in the Reserve without the permission, in writing, of the Committee first obtained at least seven days prior to such entertainment or event.

12. No person shall spit or expectorate on the paths, nor in or on any structure or erection in the Reserve.

13. No person shall carry on the trade, business or calling of a bookmaker, except in or on such portions of the Reserve as may be set apart for that purpose, and then only when he shall have complied with the conditions imposed by the Committee.

14. Persons renting or hiring any stand, building, erection or enclosure on the occasion of any fetes, sports, or other amusements may be required to deposit any sum which the Committee may at the time determine not exceeding One hundred dollars (\$100) by way of guarantee, that due care shall be taken of such stand, building, erection, or enclosure and such Committee in its absolute discretion may make good any damage or injury sustained by such stand, building, erection, or enclosure or anything contained therein, during such occupancy or hiring and deduct the cost of making good such loss or damage from the sum of money deposited by way of guarantee, and all persons so renting or hiring shall abide by these Regulations and by any order given by such Committee.

15. Persons obtaining from the Committee the key to any gate, door, stand, building or enclosure to, in or upon the Reserve on any occasion whatsoever may be required to deposit with such committee the sum of Five Dollars for each key so obtained. Such deposit will be refunded on the return of the key, undamaged to the said Committee.

16. No person, except labourers and workmen employed in the Reserve, shall enter any plots therein which may be enclosed for plantation of young trees or shrubs.

17. No persons or person shall park a motor car or motor cycle within the Reserve except at such parking areas as are set apart by the Committee for that purpose, and every person using such parking area shall on demand, pay a fee not exceeding Twenty

cents per motor car or motor cycle per day for entrance to and use thereof on such days as a charge is being made for admission as provided in clause 1.

18. No person, except labourers or workmen employed in the Reserve, shall ride or drive any horse or vehicle of any kind in or through the Reserve except as herein provided without the permission of the Committee, and no person shall ride any bicycle or motor bicycle therein except on the tracks set apart for the purpose.

19. No person shall behave in a disorderly manner, or create or take part in any disturbance, or use indecent or abusive language, or commit any nuisance, or in any way offend against decency in the Reserve or the buildings therein, and any person found in a state of intoxication or otherwise offending against this Regulation, shall be liable to be forthwith removed from the Reserve, notwithstanding that such person shall have purchased a ticket for admission thereto, and shall also be liable to the penalty hereinafter provided.

20. No male person other than a boy under the age of seven years shall enter or use any playground, oval, place, room or building set apart for the use of females, and no female person shall enter or use any playground, place, room or building set apart for the use of males.

21. No person other than the players and officials connected with any game (football, cricket, tennis, golf, bowls or hockey), and other than any competitor at any sports gathering, shall intrude upon the playground or oval during the course of such games and sport.

22. No person shall remove or displace any board, plate or tablet, or any support, fastening, or fitting used or constructed or adapted to be used for the exhibition of any regulation or notice and fixed or set up by the Committee on the Reserve.

23. No person shall affix, print, post, paint or cut or mark any advertisement, sign, picture, bill, placard, notice, words, letters or figures to or upon any wall or fence in or enclosing the Reserve, or to or upon any tree, building, barrier, railing, seat, structure, erection, flagging or path in the Reserve without the consent of the Committee.

24. No person shall play, practise, or engage in any sport, including tennis, football, golf, cricket, hockey or any game or foot-racing except in the portions of the Reserve set apart for that purpose, and then only subject to such terms and conditions as the Committee may determine.

These Regulations are made in lieu of all previous Regulations made for or with respect to the Reserve, which are hereby rescinded.—(Rs. 166)

Given under my hand at Melbourne, 9 May 1983.

R. A. MACKENZIE  
Minister of Lands

Every person who contravenes or fails to comply with these Regulations shall be liable to the penalties prescribed in section 13 of the *Crown Land (Reserves) Act 1978*.

## TENDERS

### PUBLIC WORKS DEPARTMENT

Tenders are invited for the purposes indicated hereunder and will be received at 2 Treasury Place, Melbourne, 3002, until TWO p.m. on dates shown.

Tenders must be addressed to the Minister of Public Works with the envelope endorsed "Tender for

". Hand-delivered tenders must be placed in the Department's tender box in foyer, Ground Floor, 2 Treasury Place, Melbourne.

Tenders documents are available from the Contracts Office, Room 29, 2 Treasury Place, Melbourne and where indicated, at offices of Inspectors of Works.

\* Tenders for works identified with star (★) will only be considered from Contractors qualified for repairs and painting works. Any Tenderers wishing to qualify may obtain the application form from the Contracts Office.

### Wednesday, 25 May 1983

#### Miscellaneous

COLAC—Supply of 7 only dishwashing machines, Training Centre.

LARUNDEL—Supply of kitchen equipment, main kitchen, Psychiatric Hospital.

#### Building, Electrical and Mechanical Services

WATSONIA—Improvements to lighting and exhaust in metal shop, Technical School.

### Wednesday, 1 June 1983

#### Building, Electrical and Mechanical Services

ARDOCH—New tiled roof to block 3, Education Village.

BAIRNSDALE—Electrical services, College of T.A.F.E. (W.O., Bairnsdale.)

\* BONBEACH—Repairs and maintenance, High School.

\* DANDENONG—External repairs and painting to all buildings, High School. (W.O., Dandenong.)

ECHUCA—Home economics centre, High School. (W.O., Shepparton and Bendigo.)

GLADSTONE PARK—Boys and girls toilet upgrade, High School.

\* KOO-WEE-RUP—External repairs and painting to two storey building, High School. (W.O., Dandenong.)

LARUNDEL—Supply and installation of ironer, sheet spreader and folder, Psychiatric Hospital.

MALVERN—Fitting out works of main shop area, State Electorate Office, 1207 High Street.

MELBOURNE—Alterations to executive suite, 2 Treasury Place, Education Department.

WARRNAMBOOL—Installation of an intruder detection system, High School and North Technical School.

#### Miscellaneous

FOSTER—Maintenance cleaning, period 1/7/83 to 30/6/85, (Lands and Agriculture,) public offices, Pioneer Street. (W.O., Korumburra.)

KEW—Maintenance cleaning, period 1/7/83 to 30/6/86, 378 Cotham Road, Soil Conservation Authority.

LARUNDEL—Supply of armchairs, Psychiatric Hospital.

LILYDALE—Maintenance cleaning, corner Nelson and Quarry Roads, Crown Lands and Survey.

MELBOURNE—Maintenance cleaning, period 1/7/83 to 30/6/86, 2 Treasury Place, Public Works Department.

MYRTLEFORD—Maintenance cleaning, period 1/7/83 to 30/6/85, 84 Myrtle Street, Crown Lands and Survey. (Police Station, Myrtleford.)

RIDDELL'S CREEK—Maintenance cleaning, period 1/7/83 to 30/6/85, Police Station. (Police Station, Riddell's Creek.)

ROBINVALE—Maintenance cleaning, period 1/7/83 to 30/6/85, Court House, George Street. (Police Station, Robinvale.)

VARIOUS—Supply of domestic equipment for schools and other Government departments, 1/7/83 to 30/6/84, Public Works Department.

WANGARATTA—Supply of print/graphics equipment, College of T.A.F.E.

WINDSOR—Maintenance cleaning, period 1/7/83 to 30/6/86, 1 Lewisham Road, Community Welfare Services.

YEA—Maintenance cleaning, period 1/7/83 to 30/6/85, Police Station. (Police Station, Yea.)

**Site Works**

PARKVILLE—Replace water main, Royal Park Psychiatric Hospital, Mental Health Authority.

STAWELL—Modifications to balconies—fire services, Pleasant Creek Training Centre. (W.O., Horsham.)

**Wednesday, 8 June 1983**

**Building, Electrical and Mechanical Services**

\* CAULFIELD—External repairs and painting, Primary School.

EDENHOPE—Upgrade weather protection/duplicating room, High School. (W.O., Horsham and Warracknabeal.)

HEIDELBERG—Covered vehicle wash down area and hoist, Technical School.

MELBOURNE—P.A. system for courts 2, 3, 11 and 12, Supreme Court, 210 William Street, Attorney-General.

\* MOORABBIN—External cyclic maintenance, High School.

\* MOORLEIGH—External maintenance, High School.

\* MORWELL—Cyclic maintenance, Primary School. (W.O., Traralgon.)

NHILL—Stage 1b—Staff/Administration upgrade, School. (W.O., Horsham and Warracknabeal.)

ORHOST NORTH—Replacement of roofing to classrooms, Primary School. (W.O., Bairnsdale.)

\* SWIFTS CREEK—Cyclic maintenance, Primary School. (W.O., Bairnsdale.)

\* TOORAK—External painting and repairs to 1880's building, Central School.

VARIOUS—Contract 13, 82-83—Supply and delivery of 27 No. modular buildings, F.O.G. P.W.D. storeyard, Salmon Street, Port Melbourne.

WANGARATTA—(Re-advertised and amended)—Library security system, stage 1, phase II., Technical College.

WINDSOR—Renovations to science rooms, Technical School.

**Siteworks**

AUBURN—Fire service, Primary School.

HUNTINGDALE—Connection to sewer, High School.

**Miscellaneous**

BERWICK—Maintenance cleaning, period 1/9/83 to 31/8/86, Court House. (W.O., Dandenong.)

KYABRAM—Maintenance cleaning, period 1/8/83 to 31/7/85, 178 Allan Street, Agriculture Department. (Police Station, Kyabram.)

MARYBOROUGH—Maintenance cleaning, period 1/8/83 to 31/7/86, Court House. (W.O., Maryborough.)

VARIOUS—Supply of hacksaw machines and marking off tables, period 1/7/83 to 30/6/84, Various Schools and Government Buildings.

VARIOUS—Supply of swing screw cutting lathes, period 1/7/83 to 30/6/84, Various Schools and Government Buildings.

VARIOUS—Supply of woodworking thicknessing machines, period 1/7/83 to 30/6/84, Various Schools and Government Buildings.

VARIOUS—Supply of woodworking saw benches, period 1/7/83 to 30/6/84, Various Schools and Government Buildings.

VARIOUS—Supply of woodworking lathes, period 1/7/83 to 30/6/84, Various Schools and Government Buildings.

VARIOUS—Supply of hand planers and jointers, period 1/7/83 to 30/6/84, Various Schools and Government Buildings.

VARIOUS—Supply of 203mm grinding machines, period 1/7/83 to 30/6/84, Various Schools and Government Buildings.

VARIOUS—Supply of bandsaw machines and spindle borer, period 1/7/83 to 30/6/84, Various Schools and Government Buildings.

JACK SIMPSON  
Minister of Public Works

Public Works Department  
Melbourne, 17 May 1983

**PRIVATE  
ADVERTISEMENTS**

CITY OF CAULFIELD

Loan No. 104

*Notice of Intention to Borrow the Sum of \$320 000 for  
Permanent Works and Undertakings*

Notice is hereby given that the Council of the City of Caulfield proposes to borrow the sum of \$320 000 secured by a charge over the general rates of the municipality, such sum to be raised by the grant of a mortgage in accordance with the provisions of the *Local Government Act 1958*.

In connection therewith, the following information is stated:

- (a) The amount of principal monies it is proposed to borrow is \$320 000.
- (b) The maximum rate of interest that may be paid is 15·0 per cent per annum.
- (c) The days on which the monies borrowed are to be repayable are 27 January and 27 July during the years 1984 to 1994 inclusive, the first payment being on 27 January 1984 and the place at which the monies are to be repayable is National Australia Bank, Glenhuntly Road, Caulfield South.
- (d) The purposes for which the loan is to be applied are:

	\$
1. Meals on Wheels Kitchen and Equipment (part)	34 892
2. Purchase of 296 Glenhuntly Road (part)	200 000
3. Youth Equipment	5 000
4. Archive shelving and microfilm equipment	8 000
5. Display screens and lights	3 500
6. Footpath Reconstruction (part)	
Hawthorn Road	11 640
Neerim Road	41 668
7. Kerb and Channel Modernisation (part)	15 300
Total	320 000

- (e) The manner in which the loan is to be liquidated is by providing out of Municipal Fund the sum of \$31 389.50 on each repayment date until the loan is fully repaid.

The plans and specifications and an estimate of the costs of the works, and an estimate showing the proposed expenditure of the monies to be borrowed are available for inspection at the office of the Council, City Hall, Corner Glen Eira and Hawthorn Roads, Caulfield.

6897

G. K. CALDER, City Manager

CITY OF CAULFIELD

Loan No. 105 (Re-advertised)

*Notice of Intention to Borrow the Sum of \$200 000 for  
Permanent Works and Undertakings*

Notice is hereby given that the Council of the City of Caulfield proposes to borrow the sum of \$200 000 secured by a charge over the general rates of the municipality, such sum to be raised by the grant of a mortgage in accordance with the provisions of the *Local Government Act 1958*.

In connection therewith, the following information is stated:

- (a) The amount of principal monies it is proposed to borrow is \$200 000.
- (b) The maximum rate of interest that may be paid is 15·0 per cent per annum.
- (c) The days on which the monies borrowed are to be repayable are 15 January and 15 July during the years 1984 to 1993 inclusive, the first payment being on 15 January 1984

and the place at which the monies are to be repayable is The Office of the Insurance Commissioner, State Insurance Office, Melbourne.

(d) The purposes for which the loan is to be applied are:

	\$
1. Implementation of Structure Plan Recommendations	60 000
2. Upgrade Pavilion — Packer Park (part)	40 000
3. Depot — Garage Extensions	30 000
4. Public Toilet — Elsternwick Shopping Centre	25 000
5. Upgrade Right-of-Ways (part)	10 000
6. Upgrade Concrete Roads (part)	10 000
7. Footpath Reconstruction — Hawthorn Road (part)	10 360
8. Kerb and Channel Modernisation — Briggs Street (part)	14 640
Total	<u>200 000</u>

(e) The sum of \$7443.14 shall be provided at half yearly intervals out of the Municipal Fund for the establishment and accumulation of a sinking fund for the redemption of the loan.

The plans and specifications and an estimate of the costs of the works, and an estimate showing the proposed expenditure of the monies to be borrowed are available for inspection at the office of the Council, City Hall, Corner Glen Eira and Hawthorn Roads, Caulfield.

6898

G. K. CALDER, City Manager

## CITY OF CHELSEA

Loan No. 86

*Notice of intention to borrow the sum of Forty five thousand dollars (\$45,000.00) for Permanent Works and Undertakings*

Notice is hereby given that the Council of the City of Chelsea proposes to borrow the sum of \$45,000.00 secured by a charge over the General Rate of the Municipality and such sum to be raised by the grant of a mortgage in accordance with the *Local Government Act 1958*, as amended.

1. The maximum rate of interest that may be made is 15.6 per centum per annum.

2. The purpose for which the loan is sought is:—

Extensions to Northcliffe Lodge Part cost \$45,000.00

3. The period of the loan is four (4) years.

4. The moneys borrowed shall be repayable by providing out of the Municipal Fund seven equal half-yearly instalments of \$4,515.34 including principal and interest (based on a ten year period) on the 1st day of January and the 1st day of July during the currency of the loan plus the balance then outstanding of \$38,898.84. The first instalment shall be payable on the 1st day of January 1984.

5. Such moneys shall be repayable, to Westpac Savings Bank 454 Nepean Highway, Chelsea 3196.

The plans and specifications together with the estimate of the cost of the proposed works and a statement showing the proposed expenditure of the moneys to be borrowed are open for inspection at the Offices of the Council, Station Street, Chelsea 3196.

6819

J. J. DRINAN, Town Clerk

## CITY OF CROYDON

Loan No. 181

*Notice of Intention to Borrow the Sum of \$75 000 for Permanent Works and Undertakings*

Notice is hereby given that the Council of the City of Croydon proposes to borrow the principal sum of Seventy-five thousand dollars (\$75 000) secured by a charge over the general rates of the

municipality, such sum to be raised by the grant of a mortgage in accordance with the provisions of the *Local Government Act 1958*.

1. The maximum rate of interest that may be paid is 14.3 per centum per annum.

2. The purpose for which the loan is to be applied is — Barneong Reserve Pavilion (part cost) \$75 000.

3. The period of the loan shall be four years.

4. The moneys borrowed shall be repayable by eight half-yearly instalments of approximately \$6135.31 including principal and interest on 1 July and 1 January, during the currency of the loan, with the balance of principal being repaid on 1 July 1987. The first instalment shall be repayable on 1 January 1984.

5. Such moneys shall be repayable at the National Commercial Banking Corporation of Australia Ltd., 165 Main Street, Croydon.

The plans and specifications and the estimate of the cost of the proposed works and a statement showing the proposed expenditure of the moneys to be borrowed are open for inspection at the office of the Council of the City of Croydon at City Offices, Foch Avenue, Croydon.

6760

J. N. STEVENS, Acting Town Clerk

## CITY OF DANDENONG

Loan No. 107

*Notice of Intention to Borrow the Sum of \$350 000 for Permanent Works and Undertakings*

Notice is hereby given that the Council of the City of Dandenong proposes to borrow the principal sum of Three hundred and fifty thousand dollars (\$350 000), secured by a charge over the general rates of the municipality, such sum to be raised by the grant of a mortgage in accordance with the provisions of the *Local Government Act 1958*.

1. The maximum rate of interest that may be paid is 15.0 per centum per annum.

2. The purpose for which the loan is to be applied is:—

Construction of Car Parking Station — Thomas Street (part cost) \$350 000

3. The period of the loan shall be ten years.

4. The moneys borrowed shall be repayable by providing out of the Municipal Fund twenty half-yearly instalments of \$34 332.27 each, including principal and interest, on 1 January and 1 July, during the currency of the loan. The first instalment shall be repayable on 1 January 1984.

5. Such moneys shall be repayable to the Commissioners of The State Bank of Victoria, at the Office of the said Commissioners, 385 Bourke Street, Melbourne.

The plans and specifications and the estimate of the cost of the proposed works, and a statement showing the proposed expenditure of the moneys to be borrowed, are open for inspection at the Office of the Council of the City of Dandenong, at the Municipal Offices, 39 Clow Street, Dandenong.

6761

C. G. DICKIE, Town Clerk

## CITY OF DONCASTER AND TEMPLESTOWE

Notice is hereby given that the Council of the City of Doncaster and Templestowe has pursuant to Section 621 of the *Local Government Act 1958* fixed a new alignment of the east side of Springvale Road (for approximately 157m north of a point approximately 500m north from the intersection with Old Warrandyte Road) such new alignment being as shown on the plan at the foot of this notice. Copies of such plan are open for inspection at the Municipal Offices, 699 Doncaster Road, Doncaster, by any person without fee at any time at which such offices are open for business. Dated 17 May 1983

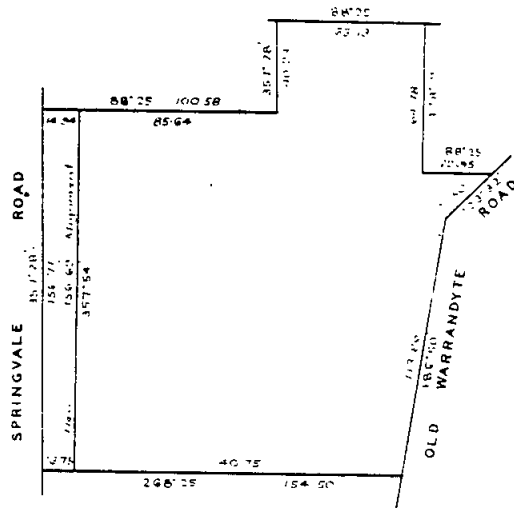

By Order of the Council  
G. J. MORTON, Town Clerk

6762

CITY OF KNOX  
By-Law No. 37

A By-Law of the City of Knox made under the provisions of Section 36 of the *Hawkers and Pedlers Act 1958* and numbered 37 for the purposes of amending By-law No. 34 (Metropolitan Hawkers By-Law).

In pursuance of the powers conferred by the *Hawkers and Pedlers Act 1958* and of any and every other power it thereunto enabling the Mayor, Councillors and Citizens of the City of Knox order as follows:

1. The Third Schedule of By-Law No. 34 shall be amended by the deletion of Trading Area "B".

Resolution for passing this By-Law agreed to by the Council of the City of Knox on 19 October 1982 and confirmed on 30 November 1982.

The Common Seal of the Mayor, Councillors and Citizens of the City of Knox was hereto affixed this 30 November 1982 in the presence of:

PETER K. MALEY, Mayor  
M. K. JONES, Councillor  
TIM NEVILLE, Town Clerk

Approved by the Governor in Council, 7 April 1983—TOM FORRISTAL, Clerk of the Executive Council. 6798

Form 2.1

*Town and Country Planning Act 1961*  
CITY OF KNOX PLANNING SCHEME 1965  
Amendment No. 259, 1983

*Notice that a Planning Scheme has been Prepared and is Available for Inspection*

Notice is hereby given that the Council of the City of Knox in pursuance of its powers under the *Town and Country Planning Act 1961*, has prepared a Planning Scheme for the purpose of:

Rezoning land at the south-west corner of Burwood Highway and Acacia Road, Ferntree Gully, from Commercial (Local) and Stream Zone and Special Uses Zone to Service Zone and Stream Zone.

Reserving land currently zoned Special Uses Zone to Proposed Public Purposes Reserve No. 6 (S.E.C.).

A copy of the Scheme has been deposited at the Office of the City of Knox, Civic Centre, 511 Burwood Highway, Knoxfield, and at the Office of the Department of Planning, 5th Floor, 235 Queen Street, Melbourne, and will be available for inspection during office hours by any person free of charge.

Any persons affected by the Planning Scheme are required to set forth in writing any submissions they may wish to make with respect to the Scheme, addressed to the Town Clerk, City of Knox, Civic Centre, 511 Burwood Highway, Knoxfield, by 18 August 1983, and to state whether they wish to be heard in respect of their submissions.

Dated 12 May 1983

6799

T. J. NEVILLE, Town Clerk

CITY OF KNOX  
DECLARATION PURSUANT TO SECTION 587 (3) OF THE LOCAL GOVERNMENT ACT 1958

The private street in excess of 4.6 metres in width shown cross hatched on the plan endorsed hereon having been constructed to the satisfaction of the Council of the City of Knox otherwise than pursuant to Division 10 of Part XIX or to Part XLII of the Local Government Act, the Mayor, Councillors and Citizens of the City of Knox on the application of the owner of so many premises fronting on such street as in rateable value are the greater part of all the premises so fronting, hereby declares the same to be dedicated to the public as a public highway.

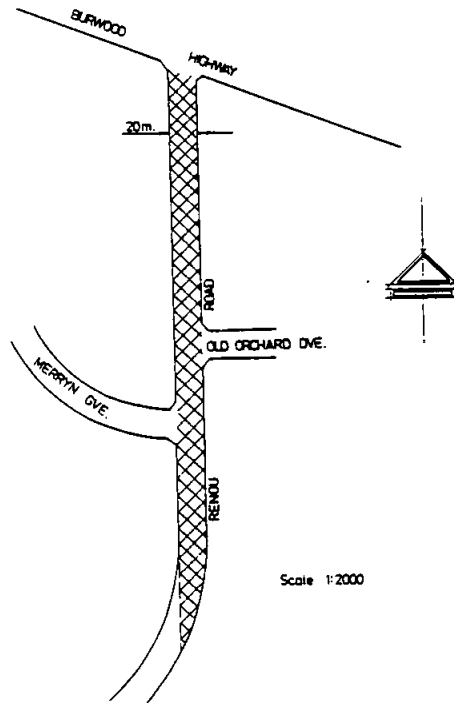

Dated 3 May 1983

The Common Seal of the Mayor, Councillors and Citizens of the City of Knox was hereto affixed in the presence of:

PETER K. MALEY, Mayor  
W. H. TEW, Councillor  
TIM NEVILLE, Town Clerk

6797

CITY OF PRESTON

Loan No. 125

Notice of Intention to Borrow

Notice is hereby given that the Council of the City of Preston intends to borrow the sum of Five Hundred Thousand Dollars (\$500 000) by the grant of a mortgage secured by a charge over the General Rates of the municipality in accordance with the provisions of the Local Government Acts.

In connection therewith, the following information is stated—

- (a) The amount of the principal moneys which it is proposed to borrow is \$500 000.
- (b) The maximum rate of interest that may be paid is 16.1 per centum per annum.
- (c) The times which the moneys borrowed are to be repayable are 30 December and 30 June during the years 1983 to 1998 and that the place such moneys shall be repayable is at the Office of the Local Authorities Superannuation Board, Rigby House, 15 Queens Road, Melbourne or such other place or places as the Board from time to time may require.

(d) The purposes for which the Loan is to be applied are—

	\$
Electricity Supply Department Capital Works	400 000
Council Contribution to Country Roads Board Works	100 000
	500 000

(e) The manner in which the Loan is to be liquidated is by provision out of the Municipal Fund in each half year during the currency of the loan of the sum of \$44 623.40, which includes principal and interest.

The plans and specifications and estimate of the cost of the works and a statement showing the proposed expenditure of the moneys to be borrowed are open for inspection at the Town Hall, Preston during office hours.

Dated 9 May 1983

6763

D. O. McLEAN, Town Clerk

Water Act 1958

CITY OF WARRNAMBOOL (GOVERNING BODY)

Water Restrictions

Notice is hereby given that By-Law No. 4 for the purpose of restricting the use of water within the City of Warrnambool Waterworks Trust District has been made by the City of Warrnambool and approved by the Governor in Council on 19 April 1983.

This By-Law—

- (a) empowers the Trust to implement at any time any of the 8 stages of water restriction in any special part or parts of districts as the Trust deems necessary by notice published in a local newspaper.
- (b) repeals By-Laws 69, 70, 71.

A copy of By-Law No. 4 may be inspected at the Office of the City of Warrnambool, Liebig Street, Warrnambool.

Cr. R. W. ANDERSON

Cr. F. R. BARHAM

V. G. ROBSON, Town Clerk

6800

CITY OF WAVERLEY

DECLARATION OF PUBLIC HIGHWAY

Pursuant to the provisions of Section 522 of the *Local Government Act 1958*, the Council of the City of Waverley hereby directs that the land as shown by hatching on the plan hereunder and as laid out on Title Volume 9497 Folio 467, which has been taken,

purchased or acquired by the Council shall be a public highway on and from the date of publication of this Order in the *Government Gazette*.

**PART CROWN PORTION 76  
PARISH OF MULGRAVE  
COUNTY OF BOURKE**

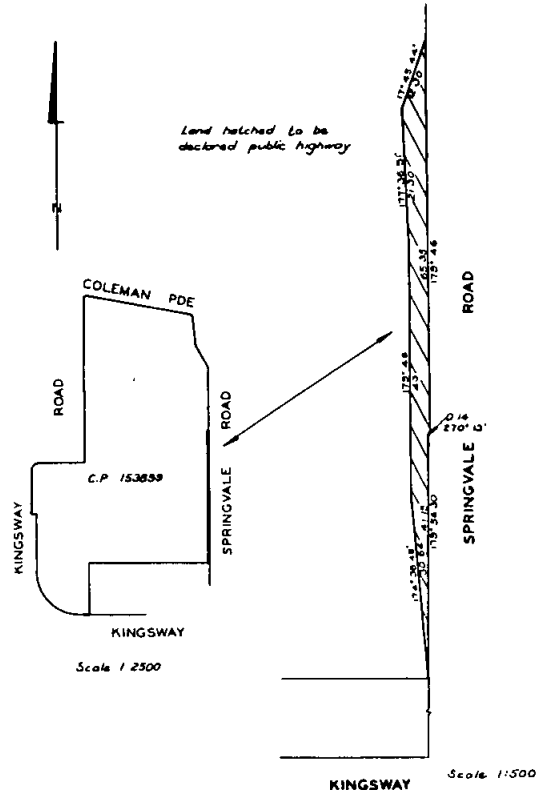

The Common Seal of the Mayor, Councillors and Citizens of the City of Waverley was hereunto affixed in the presence of:

IRIS M. PEDERICK, Mayor  
GRAEME B. FRECKER, Councillor  
COLIN J. BOCK, Town Clerk

6801

TOWN OF BAIRNSDALE

Loan No. 56

Notice of Intention to Borrow the Sum of \$72 000

Notice is hereby given that the Council of the Town of Bairnsdale proposes to borrow the sum of \$72 000, secured by a charge over the general rates of the Municipality, such sum to be raised by the grant of a mortgage in accordance with the provisions of the *Local Government Act 1958*.

- 1. The maximum rate of interest that may be paid is 15.1 per cent per annum.
- 2. The purpose for which the loan is to be applied is the liquidation of the principal moneys owing by the Municipality on Loan No. 1.
- 3. The period of the loan shall be 10 years.
- 4. The moneys borrowed shall be repayable by providing out of the Municipal Fund half yearly instalments of approximately \$7089.52 each including principal and interest on 28 June and 28



December during the duration of the loan. The first instalment shall be repayable on 28 December 1983 continuing until the final payment on 28 June 1993.

5. The moneys shall be repayable to the Australia and New Zealand Savings Bank, Bairnsdale.

6802 A. R. MOORE, Acting Town Clerk

## TOWN OF STAWELL

*Notice of Intention to Acquire Land Compulsorily*

Notice is hereby given that the Council of the Town of Stawell has deemed it expedient to exercise its powers of taking compulsorily the land hereunder for the following works or undertakings:—

## Provision of Car Parking.

Council has caused to be prepared and approved a map and other papers showing the general description of the undertaking for which the land proposed to be taken is to be used, the description of the lands proposed to be so taken and the names of the owners or reputed owners, lessees or reputed lessees, mortgagees and occupiers of those lands so far as those names are known to or can be ascertained by the Council and such map and other papers have been deposited at the office of the Council, Town Hall, Main Street, Stawell and are open for inspection by all persons interested at all reasonable hours for forty (40) clear days after publication in the *Victorian Government Gazette*.

The purport of the said map and other papers is the acquisition of land hereinafter described for the following works and undertakings:—

## Provision of Car Parking.

The land to be acquired is:—

Part of Crown Allotment 7, Section 33, Parish of Stawell, County of Borung.

Notice is also given to all persons affected by the proposed taking of the land to set forth, in writing, addressed to the Council or the Town Clerk within 40 clear days of the publication of this notice in the *Victorian Government Gazette*, all objections which they may have to the taking of the said land.

6765 D. H. HUTTON, Town Clerk

## TOWN OF STAWELL

Loan No. 78

*Notice of Intention to Borrow the Sum of \$110 000 for Permanent Works and Undertakings*

Notice is hereby given that the Council of the Town of Stawell, in pursuance of the powers conferred by the Local Government Act, intends to borrow the sum of \$110 000 secured by a charge over the general rates of the Municipality, such sum to be raised by the grant of a mortgage in accordance with the said Acts and states:—

- (a) That the maximum rate of interest that may be paid is 15.5% per annum;
- (b) The period of the loan shall be 10 years;
- (c) The purpose for which the loan is to be applied is the construction of a factory for decentralized industry (fish-processing industry, F. W. and L. Diment), pursuant to Part XLA of the *Local Government Act 1958*;
- (d) The monies borrowed shall be repayable by providing out of the Municipal Fund twenty half-yearly instalments of \$10 996.12 each including principal and interest, on 1 January and 1 July during the period of the loan. The first instalment shall be payable on 1 January 1984;
- (e) Such monies shall be repayable to the Commonwealth Savings Bank of Australia at Stawell or at such other place as the Bank from time to time may require.

Plans and specifications and estimates of such works and undertakings and a statement showing the proposed expenditure of the money to be borrowed are available for inspection at the Town Hall, Main Street, Stawell during office hours.

6764

D. H. HUTTON, Town Clerk

## BOROUGH OF EAGLEHAWK

Loan No. 66

*Notice of Intention to Borrow the Sum of \$20 000 for Permanent Works and Undertakings*

Notice is hereby given that the Council of the Borough of Eaglehawk proposes to borrow the principal sum of Twenty Thousand Dollars (\$20 000) secured by a charge over the general rates of the Municipality, such sum to be raised by the grant of a mortgage in accordance with the provisions of the *Local Government Act 1958*.

1. The maximum rate of interest to be paid is 15.00 per centum per annum.
2. The purpose for which the loan is to be applied is the acquisition of the property known as 43 Napier Street, Eaglehawk for car parking purposes and development of the site as a car park.
3. The period of the loan shall be ten (10) years.
4. The moneys borrowed shall be repayable by providing out of the Municipal Fund 20 half-yearly instalments of \$1961.84 each including principal and interest on 1 July and 1 January during the currency of the loan. The first instalment shall be payable on 1 January 1984.
5. The moneys shall be payable at the National Australia Savings Bank Limited, Melbourne.

6. The plans and specifications and the estimate of the cost of the proposed works and a statement showing the proposed expenditure of the money to be borrowed are open for inspection at the office of the Council of the Borough of Eaglehawk, at the Town Hall, Eaglehawk.

Dated 13 May 1983.

6773

A. J. SMARK, Town Clerk

## BOROUGH OF WONTHAGGI

Loan No. 68—\$50,000

Notice is hereby given that the following resolution was passed by the Council of the Borough of Wonthaggi on 18th April, 1983 and confirmed 16th May, 1983:

That the Borough of Wonthaggi borrow the sum of \$50,000 from the National Australia Bank by the grant of a mortgage secured by a charge over the general rates of the municipality and under the following terms:—

1. The Amount of loan to be \$50,000.
2. Rate of interest to be paid is 14.1 per centum per annum.
3. The loan is to be repaid at the National Australia Bank, 64 McBride Avenue, Wonthaggi.
4. The proceeds of the loan are to be applied for the funding of construction of private streets pursuant to Division 10 of Part XIX of the *Local Government Act*.
5. The loan is to be liquidated by 7 half yearly instalments each of \$4,738.00 on 23 May and 23 November including principal and interest, the first to be payable on 23 November 1983. The final payment of \$42,270.43, due on 23 May 1987 will be subject to re-negotiation in light of the then prevailing interest rate.
6. The period of the loan shall be four years.

6843

A. A. N. DEED, Secretary

## SHIRE OF BALLAN

By-law No. 32

*Keeping of Animals or Birds, etc.*

Notice is hereby given that the Council of the Shire of Ballan has, by resolution carried on 6 December 1982 and confirmed on 7 February 1983, passed By-law No. 32 under the provisions of the *Local Government Act* 1958 and the *Health Act* 1958, as amended.

The contents of this By-law are:—

1. The Regulating of the keeping of any animals or birds, the regulating or prohibiting of any place or the storage of any things which in the opinion of the Council may be offensive, injurious to health or dangerous;
2. Suppressing nuisance;
3. Fixing the distance within which it shall be unlawful to keep any such place or animal or bird or to store any such thing;
4. Regulating the keeping of animals and limiting the number of any such animals kept on any property; and
5. Generally for maintaining the good rule and government of the municipality.

A copy of the By-law is available for public inspection free of charge during office hours as the Shire Offices, Steiglitz Street, Ballan.

18 May 1983

6820 JEREMY JOHNSON, Shire Secretary

## SHIRE OF BULLA

By-Law No. 73

## NUMBER OF DOGS

Notice is hereby given that in pursuance of the powers conferred by the *Local Government Act* 1958, the Council of the Shire of Bulla has made a By-Law number 73 for the purpose of regulating the number of dogs that may be kept on certain properties within areas of the Municipality described in the schedule of the By-Law.

A copy of the By-Law is open for inspection free of charge, during office hours, at the Municipal Offices, Macedon Street, Sunbury.

A resolution approving the By-Law was carried at a meeting of Council held 21 March 1983 and confirmed at a meeting of the Council held 2 May 1983.

6766 JOHN M. KELLY, Shire Secretary

## SHIRE OF CHARLTON

Loan No. 44

*Notice of Intention to Borrow the Sum of \$80 000 for Permanent Works and Undertakings*

Notice is hereby given that the Council of the Shire of Charlton proposes to borrow the principal sum of \$80 000, secured by a charge over the general rates of the municipality, such sum to be raised by the grant of a mortgage in accordance with the provisions of the *Local Government Act* 1958.

In connection therewith, the following information is stated:—

- (a) The amount of principal monies which it is proposed to borrow is \$80 000;
- (b) The maximum rate of interest that may be paid is 14.3% per annum;
- (c) The times which monies borrowed are to be repayable are 1 June and 1 December, during the currency of the loan; first instalment being payable on 1 December 1983;
- (d) The place such monies shall be repayable is at the Office of the National Australian Savings Bank Limited, 505 Bourke Street, Melbourne;

(e) The purpose for which the loan is to be applied is — Purchase of Motor Grader;

(f) The manner in which the loan is to be liquidated is by provision out of the municipal fund of ten (10) half-yearly instalments of \$11 469.30.

The plans and specifications and estimates of the cost of the works and a statement showing the proposed expenditure of the monies to be borrowed are open for inspection at the Municipal Offices, Charlton.

6663 J. K. GIOVANETTI, Shire Secretary

*Town and Country Planning Act 1961*

## SHIRE OF COBRAM PLANNING SCHEME 1979

*Notice that a Planning Scheme has been Prepared and is Available for Inspection*

Amendment No. 7, 1983

Notice is hereby given that the Shire of Cobram in pursuance of its powers under the *Town and Country Planning Act* 1961 has prepared a planning scheme for the following area:—

“For the purpose of amending the Principal Scheme Ordinance to provide a reduced minimum setback for the construction of buildings in Campbell Road, Cobram between the Murray Valley Highway and Mookarri Street.”

The reduced setback to apply is proposed as follows:—

	House, Flat	
	or	All other
	Outbuilding	buildings
Minimum setback from road alignment	6.0 metres	3.0 metres

A copy of the Scheme has been deposited at the Shire of Cobram Offices, Station Street, Cobram and at the office of the Department of Planning, 235 Queen Street, Melbourne and will be open for inspection during office hours by any person free of charge.

Any person affected by the Scheme is required to set forth in writing any submissions they may wish to make with respect to the Scheme addressed to the Shire Secretary, Shire of Cobram, P.O. Box 182, Cobram on or before 21 June 1983 and to state whether they wish to be heard in respect of their objections.

6767 W. LENYSZYN, Shire Secretary

*Town and Country Planning Act 1961*

## SHIRE OF COBRAM PLANNING SCHEME 1979

Amendment No. 8 1983

*Notice that a Planning Scheme has been Prepared and is Available for Inspection*

Notice is hereby given that the Shire of Cobram in pursuance of its powers under the *Town and Country Planning Act* 1961 has prepared a planning scheme for the following area:—

“For the purpose of amending the Shire of Cobram Planning Scheme 1979, for part of Crown Allotment 33, Parish of Cobram, being a portion of Crown Land currently occupied by the Cobram Police Station in William Street, Cobram — such part of the allotment to be re-zoned from “Public Purposes — Police Department” to “Existing Public Open Spaces.”

A copy of the Scheme has been deposited at the Shire of Cobram Offices, Station Street, Cobram and at the office of the Department of Planning, 235 Queen Street, Melbourne and will be open for inspection during office hours by any person free of charge.

Any person affected by the Scheme is required to set forth in writing any submissions they may wish to make with respect to the Scheme addressed to the Shire Secretary, Shire of Cobram, P.O. Box 182, Cobram on or before 19 August 1983 and to state whether they wish to be heard in respect of the objections.

6804 W. LENYSZYN, Shire Secretary

*Town and Country Planning Act 1961*  
SHIRE OF COBRAM PLANNING SCHEME 1979  
Amendment No. 9, 1983

*Notice that a Planning Scheme has been Prepared and is Available for Inspection*

Notice is hereby given that the Shire of Cobram in pursuance of its powers under the *Town and Country Planning Act 1961* has prepared a planning scheme for the following area:—

“For the purpose of amending the Shire of Cobram Planning Scheme 1979 for the part of Crown Allotment 104, Parish of Cobram, situated on the south-east corner of Healy and Chapel Roads, Cobram East — such allotment to be re-zoned from Rural A to “Public Purposes — Reserved for S.E.C. Purposes.”

A copy of the Scheme has been deposited at the Shire of Cobram Offices, Station Street, Cobram and at the office of the Department of Planning, 235 Queen Street, Melbourne and will be open for inspection during office hours by any person free of charge.

Any person affected by the Scheme is required to set forth in writing any submissions they may wish to make with respect to the Scheme addressed to the Shire Secretary, Shire of Cobram, P.O. Box 182, Cobram on or before 19 August 1983 and to state whether they wish to be heard in respect of the objections.

6803 W. LENYSZYN, Shire Secretary

SHIRE OF ELTHAM  
By-Law No. 70  
ANIMALS AND BIRDS

Notice is hereby given in accordance with Section 207 of the *Local Government Act 1958* that the Council of the Shire of Eltham has made By-Law No. 70 for the purposes of—

- (a) Regulating the keeping of animals (including birds) and the regulating or prohibiting of the keeping of any place or the storage of any things which in the opinion of the Council may be offensive, injurious to health or dangerous.
- (b) Regulating the keeping of animals, birds, reptiles and bees, limiting the number of animals, birds and reptiles kept on any property within any area of the municipal district set forth in this by-law and declared to be a populous or residential area and prohibiting the keeping of any specified kind of animal, bird or reptile in such area.
- (c) Fixing subject to Part IV of the *Health Act 1958* the distance from any dwelling within which it shall be unlawful to keep any such place or animal or to store any such thing.
- (d) Suppressing nuisances.
- (e) Controlling and regulating the use of premises with a view to preventing objectionable noises at unreasonable times.
- (f) Generally maintaining the good rule and government of the municipality.

The resolution for passing this by-law was agreed to by the Council on 7 March 1983, and confirmed on 11 April 1983.

A copy of the by-law may be inspected free of charge during office hours at the Shire Offices, Main Road, Eltham.

6768 R. M. WALKER, Chief Executive Officer.

SHIRE OF ELTHAM  
By-Law No. 73  
INCINERATORS AND BARBECUES

Notice is hereby given in accordance with Section 207 of the *Local Government Act 1958* that the Council of the Shire of Eltham has made By-Law No. 73 for the purpose of preventing and extinguishing fires, suppressing nuisances and regulating the times during which incinerators may be used.

The resolution for the passing of this by-law was agreed to by the Council on 7 March 1983 and confirmed on 11 April 1983.

A copy of the by-law may be inspected free of charge during office hours at the Shire Offices, Main Road, Eltham.

6769 R. M. WALKER, Chief Executive Officer

SHIRE OF GOULBURN  
By-Law No. 40

Notice is hereby given that in pursuance of the powers conferred by Section 197 (1) (xxix) (a) of the *Local Government Act 1958*, the Council of the Shire of Goulburn has made a By-Law numbered 40 for the purpose of:

- (a) regulating the management and control of library services provided by the Council jointly with the Goulburn Valley Regional Library Committee;
- (b) imposing penalties not exceeding \$100 for breaches of this By-Law.

A copy of the By-Law is open for inspection, free of charge, during office hours at the Municipal Offices, High Street, Nagambie.

A resolution approving the By-Law was carried at a meeting of the Council held on 28 March 1983 and confirmed at a meeting of the Council held on 2 May 1983.

6770 R. E. VERNON, Shire Secretary

*Town and Country Planning Act 1961*  
SHIRE OF HEALESVILLE  
Form 2.1

*Notice that an amendment has been prepared and is available for inspection*

SHIRE OF HEALESVILLE INTERIM DEVELOPMENT  
ORDER 1976  
Amendment No. 4

Notice is hereby given that the Shire of Healesville in pursuance of its powers under the *Town and Country Planning Act 1961* has prepared an amendment to the Shire of Healesville Interim Development Order 1976 for the purpose of rezoning land being lots 3 to 15 (inclusive) and lots 27 to 30 (inclusive) of Lodged Plan 53621 and Consolidated Plan 108616 located on the eastern side of Robin Parade, Healesville from Low Density Residential Zone to Special Study Zone to facilitate the implementation of a Management Plan for the area.

A copy of the amendment has been deposited at the Shire Office, 231 Maroondah Highway, Healesville, at the office of the Upper Yarra Valley and Dandenong Ranges Authority, Old Melbourne Road, Lilydale West and at the office of the Department of Planning (Plan Inspection Section) 5th Floor, 235 Queen Street, Melbourne and will be open for inspection during office hours by any person free of charge.

Any persons affected by the amendment are required to set forth in writing any submission they may wish to make with respect of the amendment addressed to the Shire Secretary, Shire of Healesville, 231 Maroondah Highway, Healesville by 25 June 1983 and state whether you wish to be heard in respect of your submission.

Dated 24 May 1983

6840 G. R. PEACOCK, Shire Secretary

*Town and Country Planning Act 1961*  
SHIRE OF HEALESVILLE  
Form 2.1

*Notice that an amendment has been prepared and is available for inspection*

SHIRE OF HEALESVILLE INTERIM DEVELOPMENT  
ORDER 1976  
Amendment No. 8

Notice is hereby given that the Shire of Healesville in pursuance of its powers under the *Town and Country Planning Act 1961* has

prepared an amendment to the Shire of Healesville Interim Development Order 1976 for the purpose of rezoning land being lots 4 to 8 (inclusive) and lots 15 to 19 (inclusive) of Lodged Plan 1842, which front Smith Street, Healesville, from Township Residential Zone to Industrial Zone.

A copy of the amendment has been deposited at the Shire Office, 231 Maroondah Highway, Healesville, at the office of the Upper Yarra Valley and Dandenong Ranges Authority, Old Melbourne Road, Lilydale West and at the office of the Department of Planning (Plan Inspection Section) 5th Floor, 235 Queen Street, Melbourne and will be open for inspection during office hours by any person free of charge.

Any persons affected by the amendment are required to set forth in writing any submission they may wish to make with respect of the amendment addressed to the Shire Secretary, Shire of Healesville, 231 Maroondah Highway, Healesville by 25 June 1983 and state whether you wish to be heard in respect of your submission.

Dated 24 May 1983

6841

G. R. PEACOCK, Shire Secretary

#### SHIRE OF LILLYDALE

Loan No. 182

##### *Notice of Intention to Borrow the Sum of \$900 000 for Permanent Works and Undertakings*

Notice is hereby given that the Council of the Shire of Lillydale proposes to borrow the principal sum of \$900 000 secured by a charge over the general rates of the municipality, such sum to be raised by a grant of a mortgage in accordance with the provisions of the *Local Government Act 1958*.

1. The maximum rate of interest that may be paid is to be 14 per cent per annum.

2. The purpose for which the loan shall be applied is as follows:

	\$
Construction of Birmingham Road Tennis Pavilion	17 000
Construction of Roadworks — Manchester Road, Mooroolbark	200 000
Provision of Library facilities at Lilydale and Mooroolbark	683 000
	900 000

3. The period of the loan shall be for ten (10) years.

4. The monies borrowed shall be repayable by providing out of the Municipal Fund nineteen (19) half yearly payments of eighty four thousand nine hundred and fifty three dollars and sixty three cents (\$84 953.63) each including principal and interest on 31 December and 30 June during the currency of the loan, and a final payment of six hundred and eighty one thousand, six hundred and thirty two dollars and forty six cents (\$681 632.46). The first instalment shall be payable on 31 December 1983.

5. Such monies shall be payable to the Commonwealth Savings Bank of Australia, 255 Main Street, Lilydale 3140.

6. The plans and specifications and estimates of the costs of the works and a statement showing the proposed expenditure of monies to be borrowed are open for inspection at the Shire Offices, Anderson Street, Lilydale.

6805

S. W. WYATT, Acting Shire Secretary

#### SHIRE OF LOWAN

Loan No. 41

##### *Notice of Intention to Borrow the Sum of \$65,000 for Permanent Works and Undertakings*

The Council of the Shire of Lowan seek approval to borrow the principle sum of \$65,000 secured by a charge over the general rates of the Municipality, such sum to be raised by the grant of a mortgage in accordance with the provisions of the *Local Government Act 1958*.

(1) The maximum rate of interest to be paid is 14 per centum per annum.

(2) The amount of principal money which it is proposed to borrow is 65,000 dollars.

(3) The purpose for which the loan is to be applied is for Permanent Works and Undertakings.

re: Construction of MacDonald Street from Townsend Street to Ryan's Lane, consisting of reconstruction of road pavement including prime and seal; construction of approximately 357 metres of kerb and channel; construction of approximately 300 metres of footpath; and construction of approximately 282 metres of underground drainage and associated pits and.

\$34,000

The reconstruction of road pavement and construction of kerb and channel, footpath and underground drain in Campbell Street, between Macpherson Street and Towns Lane

\$31,000

\$65,000

(4) The term of the loan is to be 4 years repayable by equal half-yearly instalments of Principal and Interest (based on a 10 year term) with a final instalment of the amount outstanding plus interest.

(5) Security over the loan is to be mortgage seal.

(6) The money borrowed shall be repayable by providing out of the Municipal Fund, eight (8) equal half-yearly instalments of \$6,135.54 of principal and interest and a final payment of \$54,868.22.

(7) The first instalment of interest and principal due on 15 January 1984.

(8) Such money shall be repayable to the National Australia Savings Bank Ltd, Melbourne.

The plan, specifications, estimates and details of proposed works and repayment schedules are open for inspection at the Shire Office, Nelson Street, Nhill.

6842

V. J. SMITH, Shire Secretary.

#### SHIRE OF MARONG

Loan No. 54

##### *Notice of Intention to Borrow the Sum of \$70 000 for Permanent Works and Undertakings*

Notice is hereby given that the Council of the Shire of Marong proposes to borrow the principal sum of \$70 000 secured by a charge over the general rates of the municipality, such sum to be raised by the grant of a mortgage in accordance with the provisions of the *Local Government Act 1958*.

1. The maximum rate of interest that may be paid is 15.1% per annum.

2. The purpose for which the loan is to be applied is:

(a) Alterations and additions to Raywood Town Hall (\$35 000).

(b) Contribution towards cost of new Sporting Pavilion at Bridgewater (\$35 000).

3. The period of the loan shall be 10 years.

4. The moneys borrowed shall be repayable by providing out of the Municipal Fund half yearly instalments of approximately \$6892 including principal and interest on 4 July and 4 January during the currency of the loan. The first instalment shall be repayable on 4 January 1984.

5. Such moneys shall be repayable to A.N.Z. Banking Group Ltd., 133 High Street, Kangaroo Flat.

The plans and specifications and the estimate of the cost of the proposed works and a statement showing the proposed expenditure of the moneys to be borrowed are open for inspection at the office of the Council of the Shire of Marong.

Dated 12 May 1983

6806

GRAEME ELVEY, Shire Secretary

SHIRE OF SHERBROOKE

Loan No. 173

Notice of Intention to Borrow the Sum of \$48 000 for Permanent Works and Undertakings

Notice is hereby given that the Council of the Shire of Sherbrooke proposes to borrow the principal sum of \$48 000 secured by a charge over the general rates of the municipality, such sum to be raised by the grant of a mortgage in accordance with the provisions of the *Local Government Act 1958*.

1. The maximum rate of interest that may be paid is 15.1 per centum per annum.

2. The purposes for which the loan is to be applied are:—

	\$
Council's share of Ternes Road private street construction scheme	4 000
Land purchase, Upwey Township Reserve car parking and access	4 000
Purchase of land for public resort and recreation — Sassafra's area	40 000
	48 000

3. The period of the loan shall be ten years.

4. The monies borrowed shall be repayable by providing out of Municipal Funds half yearly instalments of approximately \$4726.35 each including principal and interest on 1 January and 1 July during the currency of the loan. The first instalment shall be payable on 1 January 1984.

5. Such money shall be repayable to the Commissioners of the State Bank of Victoria at the Office of the said Commissioners, 385 Bourke Street, Melbourne.

The plans and specifications and the estimate of the cost of the proposed works and a statement showing the proposed expenditure of the monies to be borrowed are open for inspection at the office of the Council of the Shire of Sherbrooke, Glenferm Road, Upwey.  
6807 K. E. MATSON, General Manager and Shire Secretary

SHIRE OF NUMURKAH

Notice is hereby given that the Numurkah Community Youth Club has applied for a lease under Section 134 of the *Land Act 1958*, for a term of twenty years, in respect of an area of approximately 4 hectares being Allotment 1 Section 16, Township of Numurkah for the purposes of amusement and recreation and social activities connected therewith.

6771 W. J. KENNEDY, Secretary

SHIRE OF TALLANGATTA

Notice of Intention to Take Land Compulsorily

Whereas the Council of the Shire of Tallangatta deems it expedient to exercise its power of taking compulsorily the land delineated and hatched on the map at the foot hereof for the work or undertaking of widening of a road.

And whereas the Council has caused to be prepared a map and details setting out the general description of the work or undertaking for which the land proposed to be taken is to be used the description of the land proposed to be taken and the name of the owner of that land so far as that name is known by the Council.

And whereas the said map and details are deposited at the office of the said Council at Tallangatta and are and shall be open for inspection by all persons interested at all reasonable hours for the space of forty clear days after the publication of this notice in the *Government Gazette*.

Now notice is hereby given to all persons affected by the proposed taking of the said land to set forth in writing addressed to the Council or the Shire Secretary within forty clear days of the publication of this notice in the *Government Gazette* all objections which they may have to the taking of the said land.

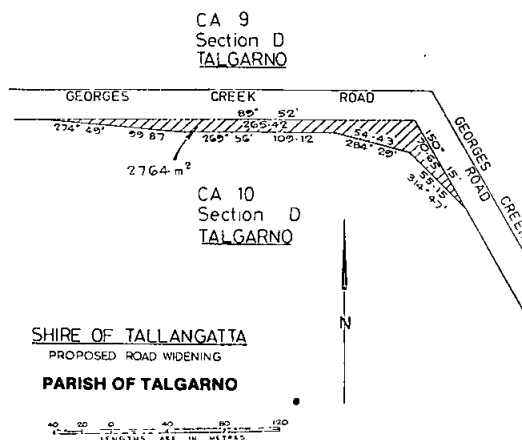

Dated 9 May 1983

By Order of the Council

6772 I. M. BOWMAN, Shire Secretary

GEELONG WATERWORKS AND SEWERAGE TRUST

Pursuant to Section 60 of the *Geelong Waterworks and Sewerage Act 1958* (No. 6263) the Trust has prepared plans to indicate the particulars of sewers and underground works, the construction of which the Trust intends to begin, at a date not less than one month after publication of the notices, in or adjacent to the following localities within the Drainage Area.

Darbin Street, Norlane, Shire of Corio.

Notice is hereby given that the plans indicated are open for public inspection at the Trust's Offices, 61-67 Ryrie Street, Geelong between the hours of 8.10 a.m. and 5.00 p.m. from Monday to Friday (public holidays excepted) by the owners or occupiers of land or premises within the Drainage Area.

6821 L. C. SPITTY, Secretary

Water Act 1958  
DONALD WATERWORKS TRUST  
Water Restrictions

Notice is hereby given that a By-Law for the purpose of restricting the use of water within the Donald Waterworks Trust District has been made by the Donald Waterworks Trust and approved by the Governor in Council on 8 March 1983.

This By-Law empowers the Trust to implement at any time any of the 8 stages of water restriction in any special part or parts of districts as the Trust deems necessary by notice published in a local newspaper.

A copy of the By-Law may be inspected at the office of the Donald Waterworks Trust during office hours.

6808 T. H. BOWLES, Secretary

Water Act 1958  
SMYTHESDALE SCARSDALE WATERWORKS TRUST  
Water Restrictions

Notice is hereby given that By-Law No. 20 for the purpose of restricting the use of water within the Smythesdale Scarsdale Urban and Rural Waterworks Districts has been made by the Smythesdale Scarsdale Waterworks Trust and approved by the Governor in Council on 27 April 1983.

**This By-Law—**

(a) empowers the Trust to implement at any time any of the 8 stages of water restrictions in any special part or parts of districts as the Trust deems necessary by notice published in a local newspaper.

(b) repeals By-Laws 2, 16, 17, 18 and 19.

A copy of By-Law No. 20 may be inspected at the office of the Smythesdale Scarsdale Waterworks Trust, Linton, during normal office hours.

6809 L. OLDHAM, Secretary

**THE BALLARAT SEWERAGE AUTHORITY**

Pursuant to Section 119 (2) of the *Sewerage Districts Act 1958* (No. 6368) notice is hereby given of the intention to construct a sewer for property situated in the vicinity of the following road:—

Cuthberts Road, Alfredton.

More particularly as shown on plans which are open for inspection at this office between the hours of 8.45 a.m. and 4.30 p.m., Monday to Friday inclusive.

Water and Sewerage Offices

Grenville Street South

Ballarat 3350

6790

B. E. LEACH, Secretary

Notice is hereby given that Australian Motor Industries Limited has applied for a Lease pursuant to Section 134 *Land Act 1958* for a term of 10 years in respect of Allotment 8C Section 63A Parish of Melbourne South, City of Port Melbourne for general industrial purposes. 6514

**MARYBOROUGH & DISTRICT PISTOL CLUB**

Notice is hereby given that the Maryborough and District Pistol Club has applied for a lease pursuant to Section 134 *Land Act 1958* for a term of 21 years over an area of Crown Land in Section 4 Parish of Maryborough for the purpose of Amusement and Recreation (Pistol Club) L6-3729. 6818

Notice is hereby given that the partnership subsisting between Alan Rigby Lyon and Margaret Edna Lyon carrying on business as Newsagents at 150 Canterbury Road, Heathmont under the style of A. R. and M. E. Lyon has been dissolved as from 31 December 1982.

RICHARD DUNSTAN & PARTNERS, 473A Whitehorse Road, Mitcham. 6831

**PARTNERSHIP ACT 1958**

Take notice that the partnership between Mr. and Mrs. W. C. and J. Faulker and Mr. and Mrs. J. B. and I. D. Laurie to carry on the business of farming at "Gower Park" Molesworth, Victoria has been dissolved. 6830

**NOTICE OF DISSOLUTION OF PARTNERSHIP**

Notice is hereby given that the partnership previously subsisting between Kevin Thomas Woolnough and Frances Catherine Woolnough, of Perricoota Road, Moama, New South Wales, and Larry Desmond Callaghan and Susan Dorothy Callaghan, of 149 King George Street, Cohuna, Victoria, and Maxwell Clark Dupuy and Carmel Margaret Dupuy, of 30 Queen Street, Rochester, all Insurance Agents carrying on business as Insurance Agents at 46 Mackay Street, Rochester under the style or firm of K. S. Newman & Associates has been dissolved as from 30 April 1982 so far as concerns the said Kevin Thomas Woolnough, the said Francis Catherine Woolnough, the said Larry Desmond Callaghan and the said Susan Dorothy Callaghan all of whom have retired from the said firm.

Dated 16 May 1983

MITCHELL, McKENZIE & CO., solicitors for the retiring parties. 6892

Notice is hereby given that as from 1 July 1982 the only partners in the partnership carrying on business at 60 Albert Road, South Melbourne under the style or firm of John Connell — Mott, Hay & Anderson have been and continue to be Connell Group Holdings Pty. Ltd., Cairncross Pty. Ltd. and Mott, Hay & Anderson International Limited.

Dated 12 May 1983

PHILLIPS, FOX & MASEL, solicitors, 461 Bourke Street, Melbourne, Victoria 3000. 6864

In the Supreme Court of Victoria—Co. No. 13133—In the matter of the Companies (Victoria) Code; and in the matter of Gilbert & Jones Pty. Ltd.

Take notice that on Wednesday, 27 April 1983, a Petition to wind-up the above company was presented and that it shall be heard at the Practice Court, Law Courts, Melbourne, at 10.30 a.m. on Thursday, 2 June 1983. The Petitioners are Edward John Jones and Shirley May Jones both of 6 Como Street, Malvern. Solicitors for the Petitioners are Macpherson & Kelley, of 31st Floor, 140 William Street, Melbourne. Any person who intends to appear at the hearing of the Petition either to oppose or to support must send notice of his intention to the Petitioners or to their Solicitors within the time and in the manner prescribed by rule 24 of the Companies Rules of the Supreme Court of Victoria. 6901

**NOTICE OF WINDING UP ORDER**

In the matter of MALDON DEVELOPMENTS PTY. LTD.

Winding-up Order made 5 May 1983.

Ian Kenneth McKinnon, of 576 St. Kilda Road, Melbourne has been appointed Liquidator.

Dated 10 May 1983

SEWELL KING & HEDSTROM, solicitors for the petitioner. 6774

Companies (Victoria) Code, Section 392 (2) (b)

E. J. DOHERTY (BULLEEN) PTY. LTD.

Notice is hereby given that at an Extraordinary General Meeting of the members of the abovenamed company, held on 6 May 1983 the following resolution was passed as a special resolution:

"That the company be wound up voluntarily and that James Lytft Sabri, Chartered Accountant, of 765 Glenferrie Road, Hawthorn, be appointed Liquidator for the purpose of winding up the affairs of the company with the power to distribute the assets, in specie, to shareholders."

Notice is also given that after twenty-one days from this date, I shall proceed to distribute the assets. All creditors having any claims against the company should furnish particulars of same by that date, otherwise I shall proceed to distribute the assets without regard to their claim.

Dated 10 May 1983

6775 JAMES L. SABRI, Liquidator

Companies (Victoria) Code, Section 392 (2) (b)

E. J. DOHERTY (PROPERTIES) PTY. LTD.

Notice is hereby given that at an Extraordinary General Meeting of the members of the abovenamed company, held on 6 May 1983 the following resolution was passed as a special resolution:

"That the company be wound up voluntarily and that James Lytft Sabri, Chartered Accountant, of 765 Glenferrie Road, Hawthorn, be appointed Liquidator for the purpose of winding up the affairs of the company with the power to distribute the assets, in specie, to shareholders."

Notice is also given that after twenty-one days from this date, I shall proceed to distribute the assets. All creditors having any claims against the company should furnish particulars of same by that date, otherwise I shall proceed to distribute the assets without regard to their claim.

Dated 10 May 1983

6776 JAMES L. SABRI, Liquidator

In the Supreme Court of Victoria—1983 Co. No. 13030—In the matter of the Companies (Victoria) Code; and in the matter of JANOCK PROPERTIES PTY. LTD.—Notice of Winding-Up Order

Winding-Up Order made 12 May 1983.

Name and Address of Liquidator Mr J. M. Walsh of 499 St. Kilda Road, Melbourne.

PSALTIS, DELLIOS & WEST, of 131 Station Street, Fairfield, solicitors for the petitioner 6899

G. V. BROOKE HOLDINGS PTY. LTD.

NOTICE PURSUANT TO SECTION 392 (2) (b) OF THE COMPANIES (VICTORIA) CODE

Notice of Resolution

At an Extraordinary General Meeting of members of G. V. Brooke Holdings Pty. Ltd. held at 27 Lisson Grove, Hawthorn on 16 May 1983 a Special Resolution was passed that the Company be wound up voluntarily and that Mr Donald Alexander Neil McLardy of Smith, Peacock & Henshaw, Chartered Accountants, 5th Floor, 124 Exhibition Street, Melbourne, be appointed liquidator.

Dated 16 May 1983

6900

D. A. N. McLARDY, Liquidator

Companies (Victoria) Code

JARRAH CONSTRUCTIONS PTY. LTD.

Notice is hereby given that a Petition for the winding up of the above Company by the Supreme Court was on 9 May 1983 presented by Peter Charles Sneddon and Patricia Margaret Parmiter, and that the said Petition is directed to be heard before the Court sitting at Melbourne at the hour of 10.30 o'clock in the forenoon on Thursday 16 June 1983 and any creditor or contributory of the Company desiring to support or oppose the making of an Order on the said Petition may appear at the time of hearing by himself or his Counsel for that purpose and a copy of the Petition will be furnished to any creditor or contributory of the said Company requiring the same by the undersigned on payment of the regulated charge for the same.

The Petitioner's address is care of Messrs. Remington & Co., solicitors, 2nd Floor, 60 Albert Road, South Melbourne 3205.

The Petitioner's solicitors are Messrs. Remington & Co., of 2nd Floor, 60 Albert Road, South Melbourne.

Note—Any persons who intend to appear on the hearing of the said Petition must serve on or send by post to the abovenamed solicitors a Notice in writing of his intention so to do. The Notice must state the name and address of the firm and must be signed by the person or firm or his or their solicitor (if any) and must be served or if posted must be sent by post in sufficient time to reach the abovenamed not later than 4 o'clock in the afternoon on 15 June 1983. 6791

Companies (Victoria) Code

PABTRONIC PTY. LTD.

Notice is hereby given that a Petition for the winding up of the above Company by the Supreme Court was on 5 May 1983 presented by Manco Investments Pty. Ltd. (In Liquidation) and that the said Petition is directed to be heard before the Court sitting at Melbourne at the hour of 10.30 o'clock in the forenoon on Thursday 16 June 1983 and any creditor or contributory of the Company desiring to support or oppose the making of an Order on the said Petition may appear at the time of hearing by himself or his Counsel for that purpose and a copy of the Petition will be furnished to any creditor or contributory of the said Company requiring the same by the undersigned on payment of the regulated charge for the same.

The Petitioner's address is care of Messrs. Fordham, Williams Horwath & Co., of 521 Toorak Road, Toorak in the State of Victoria.

The Petitioner's solicitors are Messrs. Remington & Co., of 2nd Floor, 60 Albert Road, South Melbourne.

Note—Any persons who intend to appear on the hearing of the said Petition must serve on or send by post to the abovenamed solicitors a Notice in writing of his intention so to do. The Notice must state the name and address of the firm and must be signed by the person or firm or his or their solicitor (if any) and must be served or if posted must be sent by post in sufficient time to reach the abovenamed not later than 4 o'clock in the afternoon on 15 June 1983. 6792

The Companies Code, 1982

In the matter of Voluntary Winding-up—Notice is hereby given that at a meeting of the members of Westwill Pty. Ltd. on 11 May 1983 the following Special Resolution was passed:

"That the Company be wound up voluntarily and that Joseph Augustine Dobrigh of Lot 1 Maroondah Highway, Lilydale, be appointed as the Liquidator for the purpose of such winding up."

Dated 11 May 1983

6810

J. A. DOBRIGH, Liquidator

THERMALON INSULATION PTY. LTD. (IN LIQUIDATION)

Notice is hereby given that pursuant to section 272 of the Companies Act 1961 a final meeting of Members and Creditors will be held at Victorian Club, 141 Queen Street, Melbourne on 7 July 1983 at 10.30 a.m. for the purpose of laying before it accounts showing how the winding up has been conducted and the assets of the Company disposed of and hearing any explanations of the Liquidator.

Dated 12 May 1983

6811

C. P. STEPHENS, Liquidator

In the Supreme Court of Victoria. C.O. 13130 — In the matter of the Companies (Victoria) Code; and in the matter of Community Newspaper Publishers Proprietary Limited.

Notice is hereby given that a Petition for the winding-up of the abovenamed Company by the Supreme Court was on 21 April 1983 filed by Regal Taxis Limited; and that the said Petition is directed to be heard before the Court sitting at the Supreme Court, Law Courts, William Street, Melbourne at the hour of 10.30 o'clock in the forenoon on 9 June 1983; and any creditor or contributory of the said Company desiring to support or oppose the making of an Order on the said Petition may appear at the time of hearing by himself or his Counsel for that purpose; and a copy of the said Petition will be furnished to any creditor or contributory of the said Company requiring the same by the undersigned on payment of the regulated charge for the same.

The Petitioner's address is: 194-196 Burwood Road, Hawthorn.

The Petitioner's Solicitors are Messrs Home, Wilkinson & Lowry, 80 Collins Street, Melbourne.

HOME, WILKINSON & LOWRY

Note— Any person who intends to appear on the hearing of the said Petition must serve on or send by post to the abovenamed Solicitors, notice in writing of his intention so to do. The notice must state the name and address of the person, or, if a firm, the name and address of the firm and must be signed by the person or firm, or his or their Solicitor (if any) and must be served, or if posted, must be sent by post in sufficient time to reach the abovenamed not later than 4.00 o'clock in the afternoon of 8 June 1983. 6862

In the matter of Philip Hocking Pty. Ltd — Notice of Winding-Up Order.

Winding-Up Order made on 12 May 1983.

Name and address of Liquidator: Everett Thomson Bent of Messrs Bent and Cogle, 144 Jolimont Road, East Melbourne.

HALL & WILCOX, Solicitors for the Petitioner. 6863

*The Companies Act 1961*

## TRAFFORD INVESTMENTS PTY. LTD. (IN VOLUNTARY LIQUIDATION)

## Notice Convening Final Meeting of Members Pursuant to Section 272

Notice is hereby given in pursuance of Section 272 of the *Companies Act 1961*, that the Final Meeting of the Members of the abovenamed Company will be held at the offices of A. H. G. Clarke & Co., First Floor, 460 Bourke Street, Melbourne on Thursday 23 June 1983 at 2.00 p.m. to consider the liquidator's final accounts of the voluntary winding up.

Dated 9 May 1983

6812

A. M. LOCKE, Liquidator

## Companies (Victoria) Code

## ENSTEIN PROPRIETARY LIMITED

Notice is hereby given that a petition for the winding up of the abovenamed company by the Supreme Court was, on 23 December 1982, presented by the said company and that the said Petition is directed to be heard before the Court sitting at Melbourne at the hour of 10.30 o'clock in the forenoon on Thursday 2 June 1983 any creditor or contributory desiring to support or oppose the making of an Order on the said Petition may appear at the time of hearing by himself or his Counsel for that purpose; and a copy of the Petition will be furnished to any creditor or contributory of the said company requiring the same by the undersigned on payment of the regulated charge for the same.

The Petitioner's address is at the office of Messrs. Issac Brott & Co., Solicitors, 274 Brunswick Street, Fitzroy in the State of Victoria.

The Petitioner's Solicitors are Messrs. Issac Brott & Co., 274 Brunswick Street, Fitzroy.

Note—Any person who intends to appear on the hearing of the said Petition must serve or send by post to the abovenamed Solicitors notice in writing of his intention so to do. The notice must state the name and address of the person or if a firm, the name and address of the firm, and must be signed by the person or firm, or his or their Solicitor (if any), and must be served, or if posted must be sent by post in sufficient time to reach the abovenamed Solicitors not later than four o'clock in the afternoon of 1 June 1983.

6893

## Companies (Victoria) Code

## E. N. KNITTING MILLS PROPRIETARY LIMITED

Notice is hereby given that a petition for the winding up of the abovenamed company by the Supreme Court was on 23 December 1982 presented by the said company and that the said Petition is directed to be heard before the Court sitting at Melbourne at the hour of 10.30 o'clock in the forenoon on Thursday 2 June 1983, any creditor or contributory desiring to support or oppose the making of an Order on the said Petition may appear at the time of hearing by himself or his Counsel for that purpose; and a copy of the Petition will be furnished to any creditor or contributory of the said company requiring the same by the undersigned on payment of the regulated charge for the same.

The Petitioner's address is at the office of Messrs. Issac Brott & Co., Solicitors, 274 Brunswick Street, Fitzroy in the State of Victoria.

The Petitioner's Solicitors are Messrs. Issac Brott & Co., 274 Brunswick Street, Fitzroy.

Note—Any person who intends to appear on the hearing of the said Petition must serve or send by post to the abovenamed Solicitors notice in writing of his intention so to do. The notice must state the name and address of the person or if a firm, the name and address of the firm, and must be signed by the person or firm, or his or their Solicitor (if any), and must be served, or if posted

must be sent by post in sufficient time to reach the abovenamed Solicitors not later than four o'clock in the afternoon of 1 June 1983.

6894

*Companies Act 1961, Section 272*

## HAMILTON INSURANCES (SOUTHERN) PTY. LTD. (IN LIQUIDATION)

## NOTICE CONVENING FINAL MEETING OF MEMBERS AND CREDITORS

Notice is hereby given pursuant to Section 272 of the *Companies Act 1961* that a General Meeting of the Members and Creditors of the abovenamed Company will be held at the offices of Ferrier Hodgson & Co., 24th Floor, 459 Collins Street, Melbourne, on Monday 17 June 1983 at 10.00 a.m. for the purpose of having an account laid before them showing the manner in which the winding up has been conducted and the property of the company disposed of and of hearing any explanations that may be given by the Liquidator.

Dated 13 May 1983

6859

A. G. HODGSON, Liquidator

*Companies Act 1961, Section 272 (2)*ROYALE CARPETS PTY. LTD. (IN LIQUIDATION)  
NOTICE OF FINAL MEETING

Notice is hereby given that pursuant to Section 272 (2) of the *Companies Act 1961* a final meeting of the Company and its creditors will be held at the office of Neville Bird, Clark & Co., Accountants, 11th Floor, 499 St. Kilda Road, Melbourne, 3004, on Monday 27 June 1983 at 10.30 a.m. for the purpose of laying before the meeting an account showing how the winding up has been conducted and the property of the Company has been disposed of and giving any explanation thereof.

Dated 13 May 1983

6860

GRAHAM J. CLARK, Liquidator

In the Supreme Court of Victoria, C.O. 13141 — In the matter of the Companies (Victoria) Code; and in the matter of Lyvetta Weaving Mills Proprietary Limited (Receivers and Managers Appointed)

Notice is hereby given that an application by way of Petition for the winding-up of the abovementioned Company by the Supreme Court was on 4 May 1983 presented by Synthetic Dyeworks Industries Pty. Limited and that the Petition is directed to be heard before the Court sitting at the Practice Court, Law Courts, Lonsdale Street, Melbourne at the hour of 10.30 a.m. on Thursday 9 June 1983 and any creditor or contributory of the said Company desiring to support or oppose the making of an order on the said Petition may appear at the time of hearing by himself or his Counsel for that purpose; and a copy of the Petition will be furnished to any creditor or contributory of the said Company requiring the same by the undersigned on payment of the regulated charge for the same.

The Petitioner's Solicitor is Philip E. Fox, Esq., 23rd Floor, 367 Collins Street, Melbourne.

Note—Any person who intends to appear on the hearing of the said Petition must serve or send by post to the abovenamed Solicitor notice in writing of his intention so to do. The notice must state the name and address of the person or if a firm the name and address of the firm and must be signed by the person or firm or his or their solicitors (if any) and must be served or if posted must be sent by post in sufficient time to reach the abovenamed Solicitor not later than 4 o'clock in the afternoon of 8 June 1983.

6861



In the matter of the *Companies Act* 1961; and in the matter of Todic Pty. Ltd. (In Liquidation) — Notice of Final Meeting of Members pursuant to Section 272 and notice to creditors to Lodge Claims.

Notice is hereby given in pursuance of Section 272 of the *Companies Act* 1961 that a General Meeting of the members of the above company will be held at the office of Messrs Coopers & Lybrand, 11th Floor, 460 Bourke Street, Melbourne on 20 June 1983 at 10.00 o'clock in the forenoon for the purpose of having an account laid before them showing the manner in which the winding up has been conducted and the property of the company disposed of, and hearing any explanation that may be given by the liquidator.

Notice is also given that any creditors who have claims which have not yet been satisfied must lodge such claims with me prior to 1 June 1983 or be excluded from settlement.

Dated 18 May 1983

6858

K. J. RUSSELL, Liquidator

Companies (Victoria) Code

L. U. KNITTING MILLS PROPRIETARY LIMITED

Notice is hereby given that a petition for the winding up of the abovenamed company by the Supreme Court was on 23 December 1982 presented by the said company and that the said Petition is directed to be heard before the Court sitting at Melbourne at the hour of 10.30 o'clock in the forenoon on Thursday 2 June 1983, any creditor or contributory desiring to support or oppose the making of an Order on the said Petition may appear at the time of hearing by himself or his Counsel for that purpose; and a copy of the Petition will be furnished to any creditor or contributory of the said company requiring the same by the undersigned on payment of the regulated charge for the same.

The Petitioner's address is at the office of Messrs. Issac Brott & Co., Solicitors, 274 Brunswick Street, Fitzroy in the State of Victoria.

The Petitioner's Solicitors are Messrs. Issac Brott & Co., 274 Brunswick Street, Fitzroy.

Note—Any person who intends to appear on the hearing of the said Petition must serve or send by post to the abovenamed Solicitors notice in writing of his intention so to do. The notice must state the name and address of the person or if a firm, the name and address of the firm, and must be signed by the person or firm, or his or their Solicitor (if any), and must be served, or if posted must be sent by post in sufficient time to reach the abovenamed Solicitors not later than four o'clock in the afternoon of 1 June 1983.

6895

Companies (Victoria) Code

M.E. KNITTING MILLS PROPRIETARY LIMITED

Notice is hereby given that a petition for the winding up of the abovenamed company by the Supreme Court was on 23 December 1982 presented by the said company and that the said Petition is directed to be heard before the Court sitting at Melbourne at the hour of 10.30 o'clock in the forenoon on Thursday 2 June 1983, any creditor or contributory desiring to support or oppose the making of an Order on the said Petition may appear at the time of hearing by himself or his Counsel for that purpose; and a copy of the Petition will be furnished to any creditor or contributory of the said company requiring the same by the undersigned on payment of the regulated charge for the same.

The Petitioner's address is at the office of Messrs. Issac Brott & Co., Solicitors, 274 Brunswick Street, Fitzroy in the State of Victoria.

The Petitioner's Solicitors are Messrs. Issac Brott & Co., 274 Brunswick Street, Fitzroy.

Note—Any person who intends to appear on the hearing of the said Petition must serve or send by post to the abovenamed Solicitors notice in writing of his intention so to do. The notice must state the name and address of the person or if a firm, the name and address of the firm, and must be signed by the person or firm, or his or their Solicitor (if any), and must be served, or if posted must be sent by post in sufficient time to reach the abovenamed Solicitors not later than four o'clock in the afternoon of 1 June 1983.

6896

In the matter of the *Co-operative Housing Societies Act* 1958 and the Companies (Victoria) Code; and in the matter of Ocean Grove and District Co-operative Housing Society Limited (In Liquidation)

NOTICE TO CREDITORS

Notice is hereby given that all persons having any claim against the above Society are required on or before 17 June 1983 to send their names and addresses and particulars of their debts or claims to John Coyle, of 25 Fenwick Street, Geelong, the liquidator of the said Society at his office and if so required by notice in writing from the said Liquidator are personally, or by their Solicitors, to come in and prove their said debts or claims at such time and place as shall be specified in such notice; or, in default thereof, they shall be excluded from the benefit of any distribution made before such debts or claims are so lodged or proved.

Dated at Geelong, 16 May 1983

6829

In the Supreme Court of Victoria, C.O. 13140—In the matter of the Companies (Victoria) Code; and in the matter of Bearwood Pty. Ltd.

Notice is hereby given that a Petition for the winding up of the abovenamed Company by the Supreme Court was on 4 May 1983 presented by Kings Parking Company Pty. Ltd. and that the said Petition is directed to be heard before the Court sitting in the 15th Court, Law Courts, William Street, Melbourne on 9 June 1983 at the hour of 10.30 o'clock in the forenoon, and any creditor or contributory of the said company desiring to support or oppose the making of an Order on the said Petition may appear at the time of hearing by himself or his Counsel for that purpose and a copy of the Petition will be furnished to any creditor or contributory of the said company requiring the same by the undersigned on payment of the regulated charge for the same.

The Petitioner's address is 6th Floor, 136 Exhibition Street, Melbourne.

The Petitioner's solicitors are Corr & Corr, 350 William Street, Melbourne.

CORR & CORR

Note—Any person who intends to appear on the hearing of the said Petition must serve on or send by post to the abovenamed Solicitors, notice in writing of his intention so to do. The Notice must state the name and address of the person, or, if a firm, the name and address of the firm and must be signed by the person or firm, or his or their Solicitor (if any) and must be served, or if posted, must be sent by post in sufficient time to reach the abovenamed not later than 4.00 o'clock in the afternoon on 8 June 1983.

6828

In the Supreme Court of Victoria, C.O. 13151—In the matter of the Companies (Victoria) Code; and in the matter of D. M. R. & P. F. Gerrity Pty. Ltd.

Notice is hereby given that a Petition for the winding up of the abovenamed Company by the Supreme Court was on 6 May 1983 presented by General Energy Company Pty. Ltd. and that the said Petition is now directed to be heard before the Court sitting at Melbourne at the hour of 2.05 p.m. in the afternoon on Thursday 16 June 1983 and any creditor or contributory of the said Company desiring to support or oppose the making of an Order on the said Petition may appear at the time of hearing by himself or his

Counsel for that purpose and a copy of the Petition will be furnished to any creditor or contributory of the Company requiring the same by the undersigned on payment of the regulated charge for the same.

The Petitioner's address is 69 Frederick Street, Northgate in the State of Queensland.

The Petitioner's Solicitors are Messrs. Stephen Maule & Co., of 18th Floor, 500 Collins Street, Melbourne.

STEPHEN MAULE & CO.

Note—Any person who intends to appear on the hearing of the said Petition must serve on or send by post to the abovenamed Solicitors, Stephen Maule & Co., notice in writing of his intention so to do. The notice must state the name and address of the person, or, if a firm, the name and address of the firm, and must be signed by the person or firm, or his or their Solicitors (if any) and must be served or if posted must be sent by post in sufficient time to reach the abovenamed not later than four o'clock in the afternoon of 15 June 1983.

6827

In the matter of the *Co-operative Housing Societies Act 1958* and in the matter of Eaglehawk No. 4 Co-operative Housing Society Limited

#### NOTICE TO CREDITORS

Notice is hereby given that all persons having any claim against the above society are required on or before 13 June 1983 to send their names and addresses and particulars of their debts or claims to Warwick Niven Johanson, Lyric Building, Charing Cross, Bendigo, the liquidator of the said society, at his office and if so required by notice in writing from the said liquidator are personally, or by their solicitors, to come in and prove their said debts or claims at such time and place as shall be specified in such notice; or in default, they shall be excluded from the benefit of any distribution made before such debts or claims are so lodged or proved.

Dated at Bendigo 13 May 1983

6826

W. N. JOHANSON, Liquidator

In the matter of the *Co-operative Housing Societies Act 1958*; and in the matter of Eaglehawk No. 3 Co-operative Housing Society Limited

#### NOTICE TO CREDITORS

Notice is hereby given that all persons having any claim against the above society are required on or before 13 June 1983 to send their names and addresses and particulars of their debts or claims to Warwick Niven Johanson, Lyric Building, Charing Cross, Bendigo, the liquidator of the said society, at his office and if so required by notice in writing from the said liquidator are personally, or by their solicitors, to come in and prove their said debts or claims at such time and place as shall be specified in such notice; or in default, they shall be excluded from the benefit of any distribution made before such debts or claims are so lodged or proved.

Dated at Bendigo 13 May 1983

6825

W. N. JOHANSON, Liquidator

In the Supreme Court of Victoria, C.O. 13112 — In the matter of the Companies (Victoria) Code; and in the matter of Business Control Systems Pty Ltd. — Notice of Winding-Up Order.

Winding-Up Order: Made 12 May 1983.

Name and Address of Liquidator: Robert Molesworth Hobill Cole, c/- Touche Ross & Co., 440 Collins Street, Melbourne, Victoria 3000.

B. J. O'DONOVAN, Crown Solicitor for the Commonwealth and Solicitor for the Petitioner.

6846

#### EAGLEHAWK NO. 4 CO-OPERATIVE HOUSING SOCIETY LIMITED (IN LIQUIDATION) SPECIAL RESOLUTION

At a special general meeting of the abovenamed society duly convened and held at Lyric Building, Charing Cross, Bendigo, at 5.30 p.m. Friday 13 May 1983 the following special resolution was duly passed.

That the Society having successfully completed its objectives ahead of its expected term, be wound up voluntarily, and that Warwick Niven Johanson, of Lyric Building, Charing Cross, Bendigo be appointed Liquidator for the purpose of the winding up.

6824 D. H. R. McCLURE, Chairman of Meeting  
W. N. JOHANSON, Secretary

#### EAGLEHAWK NO. 3 CO-OPERATIVE HOUSING SOCIETY LIMITED (IN LIQUIDATION) SPECIAL RESOLUTION

At a special general meeting of the abovenamed society duly convened and held at Lyric Building, Charing Cross, Bendigo at 5.30 p.m. Friday 13 May 1983 the following special resolution was duly passed.

That the Society having successfully completed its objectives ahead of its expected term, be wound up voluntarily, and that Warwick Niven Johnson, of Lyric Building, Charing Cross, Bendigo be appointed Liquidator for the purpose of the winding up.

6823 D. H. R. McCLURE, Chairman of Meeting  
W. N. JOHANSON, Secretary

In the matter of the *Companies Act 1961*; and in the matter of Holidaywise Koala Pty Limited (In Liquidation)—Members Voluntary Winding-Up

Notice is hereby given that a final meeting of members of the abovenamed company will be held at the offices of Messrs. Hungerford Hancock & Offner, 167 Macquarie Street, Sydney on Wednesday 22 June 1983 at 10.00 a.m. for the purpose of reviewing the Liquidator's account and his report on the winding up.

Dated 6 May 1983

A. R. M. McINTOSH, care of Messrs. Hungerford Hancock & Offner, 167 Macquarie Street, Sydney.

6822

In the Supreme Court of Victoria, C.O. 13114 — In the matter of the Companies (Victoria) Code; and in the matter of Seeforth Computer Systems Pty Ltd — Notice of Winding-Up Order  
Winding-Up Order: Made 12 May 1983.

Name and address of Liquidator: Robert Molesworth Hobill Cole, c/- Touche Ross & Co., 440 Collins Street, Melbourne, Victoria 3000.

B. J. O'DONOVAN, Crown Solicitor for the Commonwealth and Solicitor for the Petitioner.

6847

*Companies Act, 1961, Section 272.*

In the matter of the *Companies Act 1961*; and in the matter of Myldon Pty. Ltd. (In Liquidation)

#### NOTICE CONVENING FINAL MEETING OF MEMBERS AND CREDITORS

Notice is hereby given pursuant to Section 272 of the Act, that the Final Meeting of Members and Creditors of the company will be held at the office of David A. Bradshaw, Public Accountant, 312 Bay Street, Port Melbourne on 15 June 1983 at 10.30 o'clock in the forenoon, for the purpose of the Liquidator laying before the meeting an account of the winding up and the giving of any explanation thereof.

Dated 3 May 1983

6857

D. BRADSHAW, Liquidator

## Unclaimed Moneys Act 1962

## Register of Unclaimed Moneys held by the—

Name of Owner on Books and Last Known Address	Total Amount Due to Owner	Description of Unclaimed Money	Date when Amount first became Payable
\$			
<b>GIBSON CHEMICAL INDUSTRIES LIMITED</b>			
Baker, George S., 150 Maud St, North Balwyn	124.87	Dividend	11.11.81
Hirsch, Rosa, 1st Floor, 294 Little Collins St, Melbourne	88.50	"	18.5.81
McDonald, Alexander S., 3/27 Burraneer Bay Rd, Cronulla, N.S.W. 6727	91.04	"	"
<b>THE KIWI INTERNATIONAL COMPANY LIMITED</b>			
Eilenberg, Wendy A., Ryan Rd, Lancaster	137.50	Dividend	14.8.81
Lane, Alfred G. (estate of), c/o R. S. Daly & Associates, G.P.O. Box 803, Adelaide, S.A.	127.32	"	"
Moloney, Doris B., 2/7 Binnie St, East Brighton	27.50	"	"
Arnold, Ellen, 37 Newton Park, Blackrock, Co. Dublin, Eire	48.13	"	"
Parkin, Malcolm, Elm Grange, Heighington, Darlington, Co. Durham, U.K.	64.29	"	"
Rokeby, Agnes E., Stapeley, 20 The Green Barrow, Bury St. Edmunds, Suffolk, U.K.	11.69	"	"
Sim, Poh K. and Chwee G., 139 Jalan Tun Tan Cheng Lock, Malacca, Malaysia	10.52	"	"
Treadgold, Geoffrey C., 21 Clarendon St, Nottingham NG1 5JA, U.K.	29.21	"	"
Van Gelderen, Karel R. L. (estate of), c/o Andre Dumont, 52 Chantefleur, 1227 Carouge GE, Switzerland	192.50	"	"
Looker, Ernest J. S., 2/208 Alison Rd, Randwick, N.S.W.	27.50	"	"
McKay, Sir Alex B., c/o I. A. McKay, 34 Billyard Ave, Elizabeth Bay, N.S.W.	55.00	"	"
Darugar, Mohamad Hossein (estate of), Kaf S. A. Teheran, Iran	96.25	"	"
Grantham, Norman C., 201 Gladstone Ave, Wood Green, London, U.K.	23.38	"	"
Petersen, Henry E. and Amanda P., 521 Firethorne, Brea, California, U.S.A. 92621	23.38	"	"
Novak, Kinga M. G.	13.75	"	"
Phillips, Constantinos A., 58 Eugene Blvd, South Ambroy, N.J. 08879, U.S.A. 6728	23.38	"	"
<b>W. F. DEACON</b>			
Benning and Hanselle, 5 York St, Brighton	250.00	Trust Account	14.4.80
McCrae, R. A., 48 Blanch St, St. Kilda	150.00	" "	21.4.80
Fokes, 8/25 Clarke St, Elwood	50.00	" "	29.4.81
Donnelly, A. D., 513 Gardenvale Rd, Caulfield 6657	155.68	" "	21.7.80
<b>JOHN FOSTER VALLEY LIMITED</b>			
A. L. B. Investments Pty. Ltd., P. O. Box 179, Geelong	12.50	Dividend	30.10.80
Allmond, Ida, 59A Rose Tce, Wayville, S.A.	13.50	"	"
Brown, Enid Grace, 20 Hillside Ave, Caulfield	33.76	"	"
Henderson, Kenneth John, 62 Margaret St, Petersham, N.S.W.	18.75	"	10.4.81
Irvine, Kim, G.P.O. Box 1821Q, Melbourne	56.25	"	"
Irvine, Rae, G.P.O. Box 1821Q, Melbourne	37.50	"	"
Miller, Alison Jean, 53 Berry St, East Melbourne	67.50	"	30.10.80
Mountford, James Ronald, 346 Little Collins St, Melbourne	19.50	"	"
Ramsay, Jannette Avis, 252 Walsh St, South Yarra	35.63	"	29.10.81
Stewart, Ellen Vena, 24 Winbourne Rd, Mount Waverley 6658	33.76	"	30.10.80
<b>DALGETY AUSTRALIA LIMITED</b>			
Curley, B., Upwey	282.75	Cheque	14.10.81
Fisher, K., Maffra	10.00	Deposit	24.3.81
Cox, Lipson and Tolson, c/o Comstock, Grant Rd, Whittlesea	390.00	Cheque	6.6.80
Patterson, G., 17 Crown St, Flemington	206.00	"	5.6.80
Hayes, A. G. L., 4/3 Dolan St, Werribee	138.00	"	12.9.80
Grant, W., P.O. Box 150, Ferntree Gully	65.00	"	5.6.80
Wilkes, G. K., Balranald	68.14	"	25.3.81
O'Connell, A.	33.25	"	18.9.81
Browns Rd Stud, Browns Rd, Werribee	383.00	"	2.10.81
Unknown Vendor	255.27	Proceeds	16.3.81
Unknown Vendor	14.92	"	24.4.81
Unknown Vendor	73.92	"	21.11.81
Brainwood, C., Long Point, Creswick	18.19	Balance	1.2.80
Unknown Vendor	12.31	Proceeds	17.3.82
6731			

## Unclaimed Moneys Act 1962

## Register of Unclaimed Moneys held by the—

Name of Owner on Books and Last Known Address	Total Amount Due to Owner	Description of Unclaimed Money	Date when Amount first became Payable
\$			
INDUSTRIAL EQUITY LIMITED			
Burrell, Arthur E., P.O. Box 112, Edgecliff, N.S.W.	35.88	dividend	16.5.80
Butcher, Laurence F. and Campbell, Ronald G., 77 Ladd St, Watsonia	55.20	"	"
Green, Edward H., 15 McMillan St, Victoria Park, W.A.	80.64	"	"
Sears, Elizabeth C., 49 Louisa Rd, Birchgrove, N.S.W.	49.92	"	"
Eagle, Cyril J., 26 Taradale Rd, Napier, New Zealand	90.78	"	"
Murray, Douglas Bruce and Jeannette Gertrude, 126 Takahe Rd, Wood Bay, Auckland, N.Z.	96.28	"	"
Cable, James I., 35 Hinemoa St, Kalgoorlie, W.A.	43.36	"	"
Dunning, Leslie F., 27 Spencer St, Bunbury, W.A.	40.64	"	"
Duxfield, Sidney R., P.O. Box 7, Merrylands, N.S.W.	82.40	"	"
Gardener, Gertrude E., 173 Dugan St, Kalgoorlie, W.A.	132.96	"	"
Griffith, A. R., c/o P.O. Box 293 Broken Hill, N.S.W.	86.40	"	"
De Havis, Cicely, 353 Church St, Melbourne	38.88	"	"
Jackson, Charles A., c/o Keogh O'Neill & Co., 179 St. Georges Tce, Perth, W.A.	111.68	"	"
Johnston, Alfred L., 34 Victoria Ave, Claremont, W.A.	38.88	"	"
Nearney, Lorna R., 118 Lesmurdie Rd, Lesmurdie, W.A.	24.08	"	"
Parry, John, 107 Forrest St, Kalgoorlie, W.A.	132.96	"	"
Saunders, Mary J., 11 Vera St, Hamilton, N.S.W.	41.76	"	"
Shorter, Harold Ashton, Ashton Stud, Rosewood, Qld.	89.36	"	"
Stanley, Caroline (estate of), 56 Albert St, Mt. Lawley, W.A.	38.88	"	"
Swans Ltd ACQ Bean Est. P/L, 151 Macquarie St, Sydney, N.S.W.	31.92	"	"
Swans Ltd. Acq N. M. Thompson, 151 Macquarie St, Sydney, N.S.W.	39.68	"	"
Todd, James S. and Cecil, Nelsons Plains via Raymond Tce, N.S.W.	126.24	"	"
Whetham, Elizabeth, P.O. Box 573 Chatswood, N.S.W.	38.88	"	"
Williamson, Isabel M., Roanoke Flats, Francis St, Hyde Park, S.A.	38.88	"	"
Geraghty, Kathleen M., Matamata, N.Z.	36.09	"	"
Kwok, William, 32 Webb St, Wellington, N.Z.	100.81	"	"
McDonald, James G., c/o T. A. McDonald, 143 Otupua Rd, Timaru, N.Z.	34.59	"	"
Potts, Leslie A. (estate of), c/o K. M. Potts, No. 2 Rd, Tampiri, N.Z.	34.59	"	"
Smith, Hilda, 157 Monks Rd, Lincoln, U.K.	34.59	"	"
Clegg, Jean, 603 Glen Ormiston, 22 Doris St, North Sydney, N.S.W.	19.96	"	13.11.80
Lanning, Hugh J. F., Settlement Rd, Swan Marsh	98.08	"	"
Sneddon, Henry Smith, c/o Perpetual Trustee Co. Ltd., Box 4172 G.P.O., Sydney, N.S.W.	13.68	"	"
Beck, Florence Mabel (estate of), c/o RE9 Elcoat & Son, P.O. Box 21 024 Henderson, Auckland, N.Z.	18.16	"	"
Butcher, Laurence F. and Campbell, Ronald G., 77 Ladd St, Watsonia	41.40	"	18.5.79
Sears, Elizabeth Clare, 557 Argyle St, Moss Vale, N.S.W.	16.64	"	"
Eagle, Cyril James, 26 Taradale Rd, Napier, N.Z.	78.08	"	"
Murray, Douglas Bruce and Jeannette Gertrude, 126 Takahe Rd, Wood Bay, Auckland, N.Z.	72.12	"	"
Cable, James I., 35 Hinemoa St, Kalgoorlie, W.A.	40.05	"	"
Dunning, Leslie F., 27 Spencer St, Bunbury, W.A.	30.51	"	"
Duxfield, Sidney R., P.O. Box 7, Merrylands, N.S.W.	61.83	"	"
Gardiner, Gertrude E., 173 Dugan St, Kalgoorlie, W.A.	99.72	"	"
Griffith, A. R., c/o P.O. Box 293 Broken Hill, N.S.W.	64.80	"	"
De Havis, Cicely, 353 Church St, Melbourne	29.16	"	"
Jackson, Charles A., c/o Keogh O'Neill & Co., 179 St. Georges Tce, Perth, W.A.	83.79	"	"
Johnston, Alfred L., 34 Victoria Ave, Claremont, W.A.	29.16	"	"
Nearney, Lorna R., 118 Lesmurdie Rd, Lesmurdie, W.A.	10.05	"	9.11.79
Parry, John, 107 Forrest St, Kalgoorlie, W.A.	99.72	"	18.5.79
Saunders, Mary J., 11 Veda St, Hamilton, N.S.W.	31.32	"	"
Shorter, Harold Ashton, Ashton Stud, Rosewood, Qld.	67.05	"	"
Stanley, Caroline (estate of), 56 Albert St, Mt. Lawley, W.A.	29.16	"	"
Swans Ltd. ACQ Bean Est. P/L, 151 Macquarie St, Sydney, N.S.W.	23.94	"	"
Swans Ltd. ACQ N. M. Thompson, 151 Macquarie St, Sydney, N.S.W.	29.79	"	"
Todd, James S. and Cecil R., Nelsons Plains via Raymond Tce, N.S.W.	94.68	"	"
Whetham, Elizabeth, P.O. Box 573 Chatswood, N.S.W.	29.16	"	"
Williamson, Isabel M., Roanoke Flats, Francis St, Hyde Park, S.A.	29.16	"	"
Geraghty, Kathleen M., Matamata, N.Z.	29.68	"	"
Kwok, William, 32 Webb St, Wellington, N.Z.	82.93	"	"
McDonald, James G., c/o T. A. McDonald, 143 Otupua Rd, Timaru, N.Z.	28.46	"	"
Potts, Leslie A. (estate of), c/o K. M. Potts, No. 2 Rd, Tampiri, N.Z.	28.46	"	"
Smith, Hilda, 157 Monks Rd, Lincoln, U.K.	28.46	"	"
Burrell, Arthur E., 3 Cobby St, Campbell, A.C.T.	29.90	"	9.11.79
Campbell, Jack Dunlop and Janice Maree, 32 Kay St, Carlingford, N.S.W.	16.60	"	"

## Unclaimed Moneys Act 1962

## Register of Unclaimed Moneys held by the—

Name of Owner on Books and Last Known Address	Total Amount Due to Owner	Description of Unclaimed Money	Date when Amount first became Payable
\$			
CADBURY SCHWEPPE AUSTRALIA LIMITED			
Arnot, Bruce, 12 Franklin Rd., East Doncaster	12.30	Dividend	6.5.81
Baird, Robert K., 14 Tweedmouth Av., Rosebery, N.S.W.	20.60	"	"
Beatty, James W., Grunwald, 141 Humphries Rd., Frankston	22.50	"	"
Bernays, Anthony B., 4/15 Winifred St., Clayfield, Qld	25.00	"	"
Chidgey, John and Judith, 10 Jennifer Street, Charlestown, N.S.W.	20.60	"	"
Chisholm, Bruce A., 2/137 Edgevale St, Kew	75.00	"	"
Cowan, Anne R., 15 Windermere Cr, Brighton	10.25	"	"
Day, Cephas, 33 Reserve Rd, Beaumaris	56.25	"	"
Deece, Clarence and Dorothy P., 17 McDougall St, Kensington, N.S.W.	67.50	"	"
Doolan, Norma L., 16 Meadow St, East St Kilda	17.30	"	"
Fewster, Alfred, 26 Barnic Rd, Heathmont	12.30	"	"
Ford, Arthur (estate of)	33.30	"	"
Gallagher, Edward, 3/28 Oxford St, Darlinghurst, N.S.W.	121.85	"	"
Hack, Percy J., 4/539 New South Head Road, Double Bay, N.S.W.	15.65	"	"
Long, Jeffrey (Dr), 11 Bromby Street, South Yarra	29.85	"	"
Long, Michael D., North Star Hotel, Brisbane St, Ipswich, Qld.	51.35	"	"
Lyons, Maxwell A., 37 Princess St, Kew	15.00	"	"
Malcam Holdings Pty Ltd, 303 Collins St, Melbourne	10.65	"	"
Mushin, Rosa, 45 Balaclava Rd, East St Kilda	19.80	"	"
Nickolls, Henry C., 62/90 Blues Point Road, McMahons Point, N.S.W.	10.20	"	"
Nyalla Investments Pty Ltd, Room 2, 28 Oxford St, Darlinghurst, N.S.W.	121.85	"	"
Ord, Stuart D., c/- Lavers Hill Post Office, Lavers Hill	13.75	"	"
Orr, Mabel N., 9/61A Smith St, Wollongong, N.S.W.	59.40	"	"
Pratt, Richard, 1 Eamon Cr, Kew	10.25	"	"
Shankly, Norman J. (estate of), c/- Norman J. Shankly & Shankly, 406 Lonsdale St, Melbourne	19.80	"	"
Textiles Pty Ltd, 282 Collins St, Melbourne	12.00	"	"
Trinca, Alfred J. (Dr), 12 Collins St, Melbourne	74.85	"	"
Twibill, Geoffrey K., 110 Alfred St, Milsons Point, N.S.W.	25.65	"	"
Von Alwyn, Constance, 17 Service St, Caulfield	20.60	"	"
Winham (Aust) Pty Ltd, 292 Galston Road, Galston, N.S.W.	500.00	"	"
Xipell, Mary E., 142 Mont Albert Rd, Canterbury	50.00	"	"
Adam, Raymond D., 75 Walton Rd, Upton Park, London E13 9BW, U.K.	52.49	"	"
Pullan, Jill M., Dreef Naar Huldengerg 178, 1900 Overijse, Belgium	12.75	"	"
Baird, Robert K., 14 Tweedmouth Ave, Rosebery, N.S.W.	16.48	"	14.10.81
Beatty, James W., Grunwald, 141 Humphries Rd, Frankston	18.00	"	"
Borzelli, Adrian, P.O. Box 443, Potts Point, N.S.W.	40.00	"	"
Chidgey, John and Judith, 10 Jennifer St, Charlestown, N.S.W.	16.48	"	"
Chisholm, Bruce A., c/- Price Waterhouse, 11th Floor, 447 Collins St, Melbourne	60.00	"	"
Deece Clarence and Dorothy P., 17 McDougall St, Kensington, N.S.W.	54.00	"	"
Depiazzi, Catherine A., Iona, Dardanup, W.A.	10.20	"	"
Fookes, Eric E., 257 Collins St, Melbourne	23.88	"	"
Ford, Arthur (estate of), c/- Price Waterhouse, Share Department, 11th Floor, 447 Collins Street, Melbourne	26.64	"	"
Frecker, Katherine I., Malabar, Young, N.S.W.	72.00	"	"
Gallagher, Edward, 3/28 Oxford St, Darlinghurst, N.S.W.	97.48	"	"
Goss, Edwin D., 2/18 Macdonald St, Vacluse, N.S.W.	20.00	"	"
Gunner, Robert S., 46 Brooke St, Camperdown	19.80	"	"
Long, Jeffrey (Dr), 11 Bromby St, South Yarra	23.88	"	"
Long, Michael D., North Star Hotel, Brisbane St, Ipswich, Qld.	41.08	"	"
Lyons, Maxwell A., c/- Price Waterhouse, 11th Floor, 447 Collins St, Melbourne	12.00	"	"
Mushin, Rosa, 45 Balaclava Rd, East St Kilda	15.84	"	"
Nyalla Investments Pty Ltd, c/- Price Waterhouse, Share Department, (Address unknown), 447 Collins St, Melbourne	97.48	"	"
Rissanen, Toivo A., 24 Buckmaster Dr, Mill Park	19.80	"	"
Russell, Jennifer M., Swanhill, Blackhall, Qld.	20.00	"	"
Saunders, Nellie L., 2 Lewis St, Epping, N.S.W.	178.20	"	"
Shankly, Norman J., (estate of), c/- Norman J. Shankly & Shankly, 406 Lonsdale St, Melbourne	15.84	"	"
Steeles Hardware Pty Ltd, 67 Puckle St, Moonee Ponds	49.44	"	"
Twibill, Geoffrey K., 110 Alfred St, Milsons Point, N.S.W.	20.52	"	"
Von Alwyn, Constance, c/- Price Waterhouse, Share Department, 11th Floor, 447 Collins St, Melbourne	16.48	"	"
Walter, Margaret M., 4 Auvergne Ave, Newtown, Tas.	39.60	"	"
Wilson, Joan L., 13 Studley Park Rd, Kew	10.24	"	"
Pullan, Jill M., Dreef Naar Huldengerg 178, 1900 Overijse, Belgium	10.20	"	"
6795			
RHEEM AUSTRALIA LIMITED			
Beatty, James W., 2/2 Easton St, Neutral Bay, N.S.W.	37.14	Dividend	28.9.81
Schofield, Thomas W. (estate of), c/o McDermott Sharah & Co., 183 Macquarie St, Sydney, N.S.W.	69.48	"	"

## Unclaimed Moneys Act 1962

## Register of Unclaimed Moneys held by the—

Name of Owner on Books and Last Known Address	Total Amount Due to Owner	Description of Unclaimed Money	Date when Amount first became Payable
\$			
THE MYER EMPORIUM LIMITED			
Wright, Helen Maxwell, 7/200 Wattletree Rd, Malvern	11.46	Interest	31.1.82
Fraser, Donald M., c/o Tayford Motor Co. Ltd., Balfield Rd, Dundee, DD3, 6AH, Scotland, U.K.	10.25	"	"
The Manager, Clydesdale Bank Ltd., A/c Hamish Robertson, Bridge St, Dollar, Clackmannanshire, U.K.	10.56	"	"
Leitch, Nathan J., c/o L. Leitch, 10 Hemmant Street, O'Connor, A.C.T.	35.19	"	"
Cubbin, David R. and Joseph, 9 Inca St, Sunnybank Hills, Q'ld	11.46	"	"
Swift, Michael R. (estate of), c/o S. R. Wallace and Wallace, P.O. Box 733, Mackay North, Q'ld.	12.07	"	"
Dalton, Margaret E., 96 Woodlands St, Woodlands, W.A.	23.33	"	"
Abdullah, Nonadiah, 14/348 Dryburgh St., North Melbourne	12.00	Dividend	"
Aitchison, Roderick McL., 6 Candish Court, Booragon, W.A.	18.00	"	"
Arena, Roma D., 2KA Branksome Gardens, City Beach, W.A.	13.50	"	-1 12.81
Beatty, James W., 2/2 Eaton Street, Neutral Bay, N.S.W.	18.00	"	"
Chong, Chu Fond, 6 Holbeach St., East Brighton	108.00	"	"
Clark, Dolina H., (estate of), c/o Donald C. Clark, 48 Dellfield Drive, Lower Templestowe	18.00	"	"
Crisp, Digby D., 37 Power Street, Balwyn	18.00	"	"
Darken, John H. M., 56 Loughans Road, Ringwood	54.00	"	"
Handbury, Allan J., 46 Kooyongkoot Road, Hawthorn	135.00	"	"
Jason, Phyllis A., c/o Riversdale Private Hospital, 65 Riversdale Road, Hawthorn	18.00	"	"
Johnston, Elisabeth M., 49 View St., Woollahra, N.S.W.	18.00	"	"
Lancefield, ray E., 25 James Cook Island, Sylvanian Waters, N.S.W.	18.00	"	"
Lapin, Margaret, c/o M. Evetts, Lindeman Island, Via Mackay Qld.	18.00	"	11 12.81
Mester, Rita E., 247 Como Parade East, Parkdale	18.00	"	"
Owen, John C., c/o Central Share Registry, Box 45 Collins St., P.O., Melbourne	72.00	"	"
Parkin, William G., 154 Mont Albert Rd., Canterbury	36.00	"	"
Powell, William A., 3/487 Ryrie St., Geelong	15.30	"	"
Singleton, Owen P., 30/202 The Avenue, Parkville	54.72	"	"
Stephens, Heather L. F., Rad Tallygaroopna	13.68	"	"
Stocks Alexander F., 55 Eucalypt Av., Lower Templestowe	27.00	"	"
Theile, Nancy M., Box 11 Mount Waverly	18.00	"	"
Williams, Heather M., 69 Branson Avenue Enfield Heights, S.A.	24.00	"	"
Wong, Mook L., 1/8 Coppin Grv., Hawthorn	30.00	"	"
Anderson, Verna J., c/o Dr. S. G. Andersen, National Institute of Medical Research, London, U.K.	10.20	"	"
Britchford, Anthony G., and Daphne, P.O. Box 5618 Limbe, Malawi, Central Africa	13.68	"	"
Brown, Helen L., 43 Beach Priory Gardens, Southport, Merseyside PR8 2SA, Lancs, U.K.	61.20	"	"
Dallas, James P., P.O. Box 139 Limuru, Kenya	14.62	"	"
Daniels, Peter E., 26 Kings Avenue, Bromley, Kent, U.K.	76.50	"	"
Dennis, Charles W., The Park, Nether Langwith Near Mansfield, Notts, U.K.	19.12	"	"
Evans, Moira C. R., 2 Tahora Av., Remuera, Auckland, N.Z.	306.00	"	"
Fitzgerald Geraldine M. H., c/o A.N.Z. Banking Group Ltd., 71 Cornhill London, NW 11, U.K.	29.53	"	"
Gordon, Mabel P., c/o Central Share Registry, Box 45 Collins St., P.O., Melbourne	30.60	"	"
Jenkins, Rita, 19A 11 Conduit Rd., Hong Kong	17.26	"	"
Norris, Christopher D. H., Flat A/3 Morrison Cres, Melville, Hamilton, N.Z.	15.30	"	"
Page, Christine M., 9-100 Box Hill Scarborough, Yorkshire, U.K.	16.17	"	"
Richardson, Jean M., 16 Richmond Hill Rd, Christchurch 8, N.Z.	13.97	"	"
Slater, Henry Welton and Georgie E., 21 Spinfield Park, Marlow Bucks. SL7, 2DD, U.K.	53.55	"	"
Soutar, John C., P.O. Box 1008 Awali, Bahrain	12.60	"	"
Surtees, Graham N., c/o Central Share Registry, P.O. Box 45 Collins Street, Melbourne	51.00	"	"
Torry, John F. c/o R. C. Greigh & Co., 139 St Vincent St, Glasgow, G2 5JP, U.K.	25.50	"	"
Williams, Edith M., 16 Hillbrow Crt., Esher Surrey, U.K.	63.75	"	"
Ashman, Allan T., c/o Richard Ware, 420 Sydney St, Balgowlah, N.S.W.	30.00	"	"
Benkovic, Joseph F., 8/65-67 Carlisle St, Leichhardt, N.S.W.	18.00	"	"
Browning, Neil G., and Shirle J., 18 Towers St, Arncliffe N.S.W.	12.00	"	"
Edwards, Richard B., Suite 903, 75 Elizabeth St, Sydney, N.S.W.	90.00	"	"
Fitzgerald, Monica M., ANZ Bank Limited, P.O. Box 78, Carnarvon, W.A.	18.00	"	"
Freeman, Arthur D., 29 Murdoch St, Cremorne, N.S.W.	12.60	"	"
King, Eileen M., c/o R. Blake, 16 Mount Ida St, East Gordon, N.S.W.	18.00	"	"
Lanceley, Caroline, (estate of), c/o A. E. Whatmore, G. C. M. Gee & Co., 20 Bridge Street, Sydney, N.S.W.	13.50	"	"
Murphy, Anthony E., 16 Murrays Lane, Adelaide, S.A.	18.00	"	"
Phillips, John W., PO Box 16, Holbrook, N.S.W.	60.00	"	"

## Unclaimed Moneys Act 1962

## Register of Unclaimed Moneys held by the—

Name of Owner on Books and Last Known Address	Total Amount Due to Owner	Description of Unclaimed Money	Date when Amount first became Payable
\$			
THE MYER EMPORIUM LIMITED—continued			
Warner, Edwin A., 103 Springdale Rd, Killara, N.S.W.	30.00	Dividend	11.12.81
Weedon, Howard P., O'Connell House, Grove and O'Connell Sts, Parramatta, N.S.W.	16.92	"	"
Wentworth, Janet M., Lot 1005 Traminar Place, Eagle Vale, N.S.W.	36.00	"	"
Wilson, Brian J., 6 Figtree Rd, Hunters Hill, N.S.W.	15.48	"	"
Wilson, May, 10 Calgorm St, Moree, N.S.W.	24.00	"	"
Holgate, Heathcote B., Anchor Cottage, 11 Old Point Middleton-On-Sea, West Sussex PO22. 7RY, U.K.	76.50	"	"
Teague, Maurice G., P.O. Box 21019, Christchurch, N.Z.	20.96	"	"
Day, Albert A., c/o Inspector Creagh, Railway Station, Cloncurry, Qld.	66.00	"	"
Devlin, Irene M., 38 Crump St, Holland Park, Qld.	135.00	"	"
Kelly, Evan P., 138 Charters Towers Road, Townsville, Qld.	20.16	"	"
Lamont, Norma, 86 Lonerganne St, Garbutt, Townsville, Qld.	12.00	"	"
Mosley, Arthur D., 5 Marlin Street, Boondall, Qld.	12.00	"	"
Nicoll, David A., William St, Beaudesert, Qld.	18.00	"	"
Tickle, George G., and Patricia J., c/o G.P.O. Box 2081, 278 Adelaide St, Brisbane, Qld.	18.00	"	"
Noble, David H., c/o Central Share Registry, Box 45 Collins St, P.O. Melbourne	30.00	"	"
Bungey, Geoffrey S., 5 Gladstone St, Fullarton, S.A.	12.36	"	"
Hicks, Muriel M., 46 Kingston Avenue, Daw Park, S.A.	21.00	"	"
Brennan, Colin K., 18 Gresford St, Chermide West, Brisbane, Qld.	41.63	"	30.11.81
Thomas, Elaine J., 66 Baroda St, Ascot Vale	50.88	"	"
Burgess, Martin, 52 Primrose Chase, Main Road Goostrey, Crewe, Cheshire, U.K.	16.65	"	"
Wright, Helen Maxwell, Flat 7, 200 Wattletree Rd, Malvern	11.46	Interest	31.1.82
Fraser, Donald M., c/o Tayford Motor Co. Ltd. Balfield Rd, Dundee DD3 6AH, Scotland, U.K.	10.25	"	"
The Manager Clydesdale Bank Ltd. a/c Hamish Robertson, Bridge St, Dollar Clackmannanshire, U.K.	10.56	"	"
Leitch, Nathan J., c/o L. Leitch, 10 Hemmant St, O'Connor, A.C.T.	35.19	"	"
Cubbin, David R., and Joseph, 9 Inca St, Sunnybank Hills, Qld.	11.46	"	"
Swift, Michael R. (estate of), c/o S. R. Wallace and Wallace, P.O. Box 733, Mackay North, Qld.	12.07	"	"
Dalton, Margaret E., 96 Woodlands St, Woodlands, W.A.	23.33	"	"
Karn Investments Pty. Ltd., G.P.O. Box 3833, Sydney, N.S.W.	36.00	Dividend	22.7.81
Prousse, Jessie F. D., Queen St, Levin, N.Z.	15.30	"	"
Neil, Irma R., 2/6 Ipswich, Toowoomba, Qld.	20.00	Interest	—9.81
Willis, Alva I. M., 19 Mills St, Hampton	10.40	"	"
Brennan, Colin K., 18 Gresford St, Chermide West, Qld.	41.63	"	31.5.81
Thomas, Elaine J., 66 Baroda St, Ascot Vale	50.88	"	"
Richardson, Winifred C. H., 15 Holborrow St, Croydon, N.S.W.	55.50	"	"
Brennan, Colin K., 18 Gresford St, Chermide West, Qld.	37.00	Account	30.11.80
Gibson, Ella C., 26 Sutherland Rd, Armadale	80.00	"	—3.81
Hishon, Catherine M., Mountjoy Trc, Wynnum, Qld.	19.25	"	"
Neill, Irma R., 2/6 Ipswich, Toowoomba, Qld.	20.00	"	"
Willis, Alva I. M., 19 Mills St, Hampton	10.40	"	"
Gibson, Ella C., 26 sutherland rd, Armadale	80.00	Interest	—9.81
Hishon, Catherine M., Mountjoy Trc, Wynnum, Qld.	19.25	"	"
Webb, Anthony W., 218 Bakersfield, Crayford Rd, Holloway, London N7 OLY, U.K.	21.04	Dividend	16.6.81
White, Amos S., and June Y., c/o 9 Neptune St, Mornington	16.50	"	"
Bank of New South Wales, a/c 35634 W. S. Henderson Wales House Branch, 66 Pitt St, Sydney, N.S.W.	51.89	"	"
O'Neill, Frances E., 71 Westfield Ave, Sanderstead, Surrey, U.K.	28.05	"	"
Page, Christine M., c/o A. Chambers, 14 Raincliff Ave, Yorkshire, U.K.	10.90	"	"
Shaw, Robert A., and Ure, Alan W., c/o Dental Hall and Burgin, 3 Grays Inn Pl, Grays Inn, London WC1R 5EA, U.K.	49.09	"	"
Silverbeck, Rosalie M. S., 202 Queens Dr, Liverpool, U.K.	14.02	"	"
Bray, Marjorie E., 76 Peak Rd, Hong Kong	15.83	"	"
Burgess, Peter F., c/o ASPA, LKPP Building Jalan Gambut Kuantan Pahang, Malaysia	10.52	"	"
Burton, Paul R. W., Radclive Hall Radclive, Buckingham, Buckinghamshire, U.K.	10.28	"	"
Colchester, David M., RD1, Tirau, N.Z.	23.37	"	"
Flatau, Rose E., 60 Eyre Crt, Finchley Rd, London, U.K.	308.55	"	"
Samwell, Moyle M., c/o R. E. Samwell, Samwells Rd, Summertown, S.A.	22.61	"	"
Smith, Stanley J. C. and Olive T. (estate of), 40 Watson Ave, Rose Park, S.A.	22.66	"	"
Ward, Dulcie F. L., 21 Harris Rd, Vale Park, S.A.	82.50	"	"
Tudor, Margaret T., 324a Krukowski Rd, Honolulu 96819, Hawaii	11.69	"	"
Hardy, Frank R., 23 Victoria St, Devonport, Tas.	11.00	"	"
Kingston, Anna M., Forest Range, S.A.	11.00	"	"
Downing, Margaret E., 22 Montrose Ave, Netherby, S.A.	33.00	"	"

## Unclaimed Moneys Act 1962

Register of Unclaimed Moneys held by the—

Name of Owner on Books and Last Known Address	Total Amount Due to Owner	Description of Unclaimed Money	Date when Amount first became Payable
5			
THE MYER EMPORIUM LIMITED—continued			
Forth, Adrienne J., 80 Jutland St, Oxley, Brisbane, Qld.	16.50	Dividend	16.6.81
Moloney, Quenton K., 19 Evans St, Sans Souci, N.S.W.	31.02		
Noble, David H., c/o Central Share Registry of Aust. Pty. Ltd., P.O. Box 45 Collins St, Melbourne	28.05	"	"
Atkinson, Peter J., 37 King St, Prospect, S.A.	22.72	"	"
Bosisto, John Maxwell, 50 Tatiara Dve, Banksia Park, S.A.	44.00	"	"
Hicks, Muriel M., 46 Kingston Ave, Daw Park, S.A.	19.25	"	"
O'Callaghan, Mary C. c/o Central Share Registry of Australia Pty. Ltd., P.O. Box 45 Collins St, Melbourne	22.61	"	"
O'Halloran, Brian, 17 Glengarry St, Lynwood, W.A.	11.00	"	"
Salter, Natasha, 16 Bessie St, Dover Gardens, S.A.	38.50	"	"
Day, Albert A., c/o Inspector Creah Railway Station, Cloncurry, Qld.	60.50	"	"
Devlin, Irene M., 38 Crump St, Holland Park, Qld.	123.75	"	"
Kelly, Evan P., 138 Charters Towers Rd, Townsville, Qld.	18.48	"	"
Lamont, Norma, 86 Lonerganne St, Garbutt, Townsville, Qld.	11.00	"	"
Nicoll, David A., William St, Beaudesert, Qld.	16.50	"	"
Richardson, Kenneth P., c/o R. I. Banks, 37 Rennie St, Indooroopilly, Qld.	90.75	"	"
Tickle, George G., and Patricia J., c/o G.P.O. Box 2081, 278 Adelaide St, Brisbane, Qld.	16.50	"	"
Warner, Edwin A., 103 Springdale Rd, Killara, N.S.W.	27.50	"	"
Weedon, Howard P., O'Connell House, Grose and O'Connell Sts, Parramatta, N.S.W.	15.51	"	"
Wilson, Brian J., 6 Figtree Rd, Hunters Hill, N.S.W.	14.19	"	"
Wilson, May, 10 Calgorm St, Moree, N.S.W.	22.00	"	"
Carpenter, Frederick C. D., c/o Trustee Exec. and Agency Co., G.P.O. Box 2684, Sydney, N.S.W.	322.57	"	"
Holgate, Heathcote B., Anchor Cottage, 11 Old Point Middleton-On-Sea, West Sussex P.O. 22 7RY, U.K.	70.12	"	"
Moriarty, Leo A., 1 Enderley Ave, Surfers Paradise, Qld.	51.05	"	"
James, Eric G., 23/61 Crane Rd, Castle Hill, N.S.W.	181.50	"	"
King, Eileen M., c/o R. Blake, 16 Mount Ida St, East Gordon, N.S.W.	16.50	"	"
Lanceley, Caroline, (estate of), c/o A. E. Whatmore G.C.M. Gee and Co., 20 Bridge St, Sydney, N.S.W.	12.38	"	"
Morgan, Sandra, 21/49-51 Rawson St, Neutral Bay, N.S.W.	11.00	"	"
Murphy, Anthony E., 16 Murrays Lane, Adelaide, S.A.	16.50	"	"
Palmer, Jennifer S., 6 Maroomba Rd, Terrigal, N.S.W.	24.75	"	"
Phillips, John William, Esquire, P.O. Box 16, Holbrook, N.S.W.	55.00	"	"
Seymour, Annabel L., 1 Hertz Pl, Chapman, A.C.T.	13.75	"	"
Williams, Edith M., 16 Hillbrow Cr, Esher Surrey, U.K.	58.44	"	"
Benkovic, Joseph F., 8/65-67 Carlisle St, Leichhardt, N.S.W.	16.50	"	"
Browning, Neil G. and Shirle J., 18 Towers St, Arncliffe, N.S.W.	11.00	"	"
Clark, Anna W., 43 Nelson Rd, Lindfield, N.S.W.	16.50	"	"
Eardley, Aubrey J., Box 387, Griffith, N.S.W.	30.25	"	"
Edwards, Richard B., Suit 903, 75 Elizabeth St, Sydney, N.S.W.	82.50	"	"
Freeman, Arthur D., 29 Murdoch St, Cremorne, N.S.W.	11.55	"	"
Soutar, John C., P.O. Box 1008, Awali, Bahrain	11.55	"	"
Store, Nigel J., The Cedars, 31 Abbey Park Rd, Grimsby, Lincolnshire, U.K.	47.68	"	"
Surtees, Graham N., 43 Richmond Hill Cr, Richmond Hill, Richmond, Sur- rey, U.K.	46.75	"	"
Wade, Robert H., 12 Pleasant Pl, Howick, Auckland, N.Z.	14.02	"	"
Jenkins, Rita, 19A 11 Conduit Rd, Hong Kong	15.83	"	"
Norris, Christopher D. H., flat A/3 Morrison Cres, Melville, Hamilton, N.Z.	14.02	"	"
Page, Christine M., c/o A. Chambers, 14 Raincliff Ave, Scarborough, York- shire, U.K.	14.82	"	"
Richardson, Jean M., 16 Richmond Hill Rd, Christchurch 8, N.Z.	12.81	"	"
Britchford, Anthony G. and Daphne, P.O. Box 5618, Limbe, Malawi, Central Africa	12.70	"	"
Dallas, James P., P.O. Box 139, Limuru, Kenya	13.40	"	"
Daniels, Peter E., 26 Kings Ave, Bromley Kent, U.K.	70.12	"	"
Dennis, Charles W., The Park, Nether Langwith near Mansfield, Notts, U.K.	17.54	"	"
Fitzgerald, Geraldine M. H., c/o A.N.Z. Banking Group Limited, 71 Cornhill, London EC3, U.K.	27.07	"	"
Gordon, Mabel P., c/o Central Share Registry of Aust. Pty. Ltd., P.O. Box 45 Collins St, Melbourne	28.05	"	"
Heaton, Evelyn G., Wstones, Rivock Ave, Utley, Keighley, U.K.	63.11	"	"
Walters, Floyd, 147 Swanston St, South Geelong	16.50	"	"
Webster, Elsie M., c/o The Heights Hotel, 15 Kerferd Rd, Glen Iris	115.50	"	"
Williams, Heather M., 69 Branson Ave, Enfield Heights, S.A.	22.00	"	"
Pickering, Constance A., 1A Ashleigh Gve, Unley Park, S.A.	16.50	"	"
Pitland, Jeanette L., Box 137, P.O. Haberfield, N.S.W.	11.00	"	"
Rose, Rosina O., 4/72 Alfred St, Ramsgate, N.S.W.	45.38	"	"
Rowley, Suzanne, 32 Wentworth Rd, Vaucluse, N.S.W.	66.00	"	"



## Unclaimed Moneys Act 1962

## Register of Unclaimed Moneys held by the—

Name of Owner on Books and Last Known Address	Total Amount Due to Owner	Description of * Unclaimed Money	Date when Amount first became Payable
\$			
THE MYER EMPORIUM LIMITED—continued			
Singleton, Owen P., 30/202 The Avenue, Parkville	50.16	Dividend	16.6.81
Smith, Sybille A. M., c/o P.O. Box 11 Pennant Hills, N.S.W.	16.50	"	"
Stocks, Alexander E., 55 Eucalypt Ave, Lower Templestowe	24.75	"	"
Thiele, Nancy M., Box 11, Mount Waverley	16.50	"	"
Koch, Carol, 2 Gawith Crt, Toorak	55.00	"	"
Lancefield, Ray E., 25 James Cook Island, Sylvanian Waters, N.S.W.	16.50	"	"
Mester, Rita E., 247 Como Parade East, Parkdale	16.50	"	"
Murray, Betty G., c/o E. R. Potts, 46 Mangan St, Tongala	16.50	"	"
O'Connor, Kerry E., and Nola J., c/o Officers Mess Raaf Base, Williamtown, N.S.W.	16.50	"	"
Owen, John C. c/o Central Share Registry of Aust. Pty. Ltd., P.O. Box 45 Collins St, Melbourne	66.00	"	"
Handbury, Alan J., 46 Kooyongkoot Rd, Hawthorn	123.75	"	"
Haworth, Dorothy E., c/o Perpetual Exec. and Trustees, 50 Queen St, Melbourne	55.00	"	"
Keating, Reginald, 17 Koolkuna Ave, Donecaster	11.00	"	"
King, Nancy Mc. A., Hedley Sutton Home, 2 Gascoyne St, Canterbury	49.50	"	"
Aitchison, Roderick McL., 6 Candish Crt, Booragoon, W.A.	16.50	"	"
Arena, Roma D., 2 KA Branksome Gardens, City Beach, W.A.	12.38	"	"
Beatty, James W., 2/2 Eaten St, Neutral Bay, N.S.W.	16.50	"	"
Black, Jenny, Carwin Park, Tarwin Lower	11.00	"	"
Clark, Dolina H. (estate of), c/o Donald C. Clark, 48 Dellfield Dve, Lower Templestowe	16.50	"	"
Crisp, Digby D., 37 Power St, Balwyn	16.50	"	"
Crone, Nina A., P.O. Box 296, East Melbourne	16.50	"	"
Binnie, George, 7 Talbot Ave, East St. Kilda	18.00	"	21.1.82
Bolle, Valerie J., 16 Wood St, Colac	18.00	"	"
Bryant, Hilda M., 1/81 Victoria Cres, Mont Albert	18.00	"	"
Singleton, Owen P., 30/202 The Ave, Parkville	18.00	"	"
Shaw, Robert A., and Ure, Alan W., c/o Denton Hall and Burgin, 3 Grays Inn Place, Grays Inn, London WC1R 5EA, U.K.	53.55	"	11.12.81
Silverbeck, Rosalie M. S., 202 Queens Dve, Liverpool, U.K.	15.30	"	"
Hunter, Robert J. (estate of), J. E. and D. S. Hunter and B. E. S. Cope, c/o Rea Bros. Ltd., Kings House, 6-37 King St, London, EC2V, 8DR, U.K.	25.50	"	"
Page, Christine M., 9-100 Box Hill, Scarborough, Yorks, U.K.	11.88	"	"
Salter, William D., 58 Stuart St, Griffith, A.C.T.	30.00	"	"
Agar, Nicholas F. L., The Turret, 92 Frognal, Hampstead, London, U.K.	33.66	"	"
Allen, Robert E., P.O. Box 826, San Leandro, California U.S.A.	127.50	"	"
Burgess, Peter F., c/o ASPA LKPP Building Jalan Gambutt Kuantan Pahang, Malaysia	11.47	"	"
Burton, Paul R. W., Radclive Hall, Radclive, Buckingham, Bucks, U.K.	11.22	"	"
Elms, Diana J., 80 Hackthorne Rd, Christchurch 2, N.Z.	30.60	"	"
Abbott, Dianne M., c/o 111 Blessington St, South Arm, Tas.	25.50	"	"
Hardy, Frank R., 23 Victoria St, Devonport, Tas.	12.00	"	"
Downing, Margaret E., 22 Montrolse Ave, Netherby, S.A.	36.00	"	"
Forth, Adrienne J., 80 Jutland St, Oxley, Brisbane, Qld.	18.00	"	"
Moloney, Quenton K., 19 Evans St, Sans Souci, N.S.W.	33.84	"	"
McDonald, Mavis, 16 Jarra Pl, Modbury, S.A.	49.44	"	"
O'Callaghan, Mary C., c/o Central Share Registry, Box 45 Collins St, Melbourne	24.66	"	"
O'Halloran, Brian N., 17 Glengarry St, Lynwood, W.A.	12.00	"	"
Retallick, Robin M., 59 Lockwood Rd, Burnside, S.A.	60.00	"	"
Sayer, Walter A., Michael C. C. and John E. Burnett, G.P.O. Box 1221, Adelaide, S.A.	30.00	"	"
Smith, Stanley J. C. and Olive T. (estate of), 40 Watson Ave, Rose Park, S.A.	24.72	"	"
Ward, Dulcie F. L., 21 Harris St, Vale Park, S.A.	90.00	"	"
Tudor, Margaret T., 324A Krukowski Rd, Honolulu 96819, Hawaii	12.75	"	"

6732

## FLEETAYS (HOLDINGS) LIMITED

BJP Investments Pty Ltd, c/- Casper & Casper, Victoria Centre, 2 St. Georges Ter, Perth, W.A.	10.80	Dividend	3.4.81
Brooks, Amy J., 4/1 Glencairn Ave, Burwood	15.12	"	"
O'Brien, Mabel, 35 Russell St, Camberwell	16.20	"	"
Pie, Jean M., c/- P.O. Box 54, Lutwyche, Qld.	20.16	"	"
McWiggan, Charles H. (estate of), c/- J. B. Logan & Co., 56 Claremont St, South Yarra	15.83	"	16.10.81
O'Brien, Mabel, 35 Russell St, Camberwell	13.17	"	"
Pie, Jean M., c/- P.O. Box 54, Lutwyche, Qld.	16.38	"	"
Rennie, Hilda V., 31 Brett Street, Murrumbidgee	10.01	"	"

6794

In the Supreme Court of Victoria, C.O. 12755 — In the matter of the Companies (Victoria) Code; and in the matter of Presha Engineering (Aust.) Pty Ltd — Notice of Winding-Up Order.  
Winding-Up Order: Made 13 May 1983.

Name and address of Liquidator: Geoffrey Ormond Harrison, c/- Touche Ross & Co., 440 Collins Street, Melbourne, Victoria 3000.

B. J. O'DONOVAN, Crown Solicitor for the Commonwealth and Solicitor for the Petitioner. 6848

In the Supreme Court of Victoria, C.O. 13160 — In the matter of the Companies (Victoria) Code, and in the matter of Michaelong Pastoral Company Proprietary Limited.

Notice is hereby given that a petition for the winding up of the abovenamed Company by the Supreme Court was on 12 May 1983 presented by Eric John Unger, Deputy Commissioner of Taxation of the Commonwealth of Australia, and that the said petition is directed to be heard before the Court sitting at the Fifteenth Court, Law Courts, Lonsdale Street, Melbourne at the hour of 10.30 o'clock in the forenoon on 16 June 1983 and any creditor or contributory of the said company desiring to support or oppose the making of an order on the said petition may appear at the time of hearing by himself or his Counsel for the purpose; and a copy of the said petition will be furnished to any creditor or contributory of the said company requiring the same by the undersigned on payment of the regulated charge for the same.

The Petitioner's official address is 350 Collins Street, Melbourne.

The Petitioner's Solicitor is B. J. O'Donovan, Crown Solicitor for the Commonwealth, of 99 Queen Street, Melbourne.

B. J. O'DONOVAN

Note— Any person who intends to appear on the hearing of the said petition must serve on or send by post to the abovenamed B. J. O'DONOVAN notice in writing of his intention so to do. The notice must state the name and address of the person, or, if a firm, the name and address of the firm, and must be signed by the person or firm, or his, or their solicitor (if any), and must be served, or, if posted, must be sent by post in sufficient time to reach the abovenamed not later than 4.00 in the afternoon of 15 June 1983. 6849

In the Supreme Court of Victoria, C.O. 13159 — In the matter of the Companies (Victoria) Code; and in the matter of L. & R. Australian & Continental Butchers Pty Limited.

Notice is hereby given that a petition for the winding up of the abovenamed Company by the Supreme Court was on 12 May 1983 presented by Eric John Unger, Deputy Commissioner of Taxation of the Commonwealth of Australia and that the said petition is directed to be heard before the Court sitting at the Fifteenth Court, Law Courts, Lonsdale Street, Melbourne at the hour of 10.30 o'clock in the forenoon on 16 June 1983 and any creditor or contributory of the said company desiring to support or oppose the making of an order on the said petition may appear at the time of hearing by himself or his Counsel for the purpose; and a copy of the said petition will be furnished to any creditor or contributory of the said company requiring the same by the undersigned on payment of the regulated charge for the same.

The Petitioner's official address is 350 Collins Street, Melbourne.

The Petitioner's Solicitor is B. J. O'Donovan, Crown Solicitor for the Commonwealth, of 99 Queen Street, Melbourne.

B. J. O'DONOVAN

Note— Any person who intends to appear on the hearing of the said petition must serve on or send by post to the abovenamed B. J. O'Donovan notice in writing of his intention so to do. The notice must state the name and address of the person, or, if a firm, the name and address of the firm, and must be signed by the person or firm, or his, or their solicitor (if any), and must be served, or, if posted, must be sent by post in sufficient time to reach the abovenamed not later than 4.00 in the afternoon of 15 June 1983. 6850

In the Supreme Court of Victoria, C.O. 13157 — In the matter of the Companies (Victoria) Code; and in the matter of Corryong Sand & Gravel Pty. Ltd.

Notice is hereby given that a Petition for the Winding up of the abovenamed Company by the Supreme Court was on 11 May 1983, presented by Sun Alliance Insurance Limited of 408-410 Collins Street, Melbourne, in the State of Victoria. And that the said petition is directed to be heard before the Court sitting at Melbourne at the hour of 10.30 o'clock in the forenoon on Thursday 23 June 1983. Any Creditor or Contributory of the said Company desiring to support or oppose the making of an Order on the said Petition may appear at the time of the hearing by himself or by his counsel for the purpose; and a copy of the Petition will be furnished to any creditor or contributory of the said Company requiring the same by the undersigned on payment of the regulated charge for the same.

The Petitioners address is care of Thomas H. Bell & Co., Solicitors, 552 Lonsdale Street, Melbourne.

The Petitioners Solicitors are Thomas H. Bell & Co., 552 Lonsdale Street, Melbourne.

THOMAS H. BELL & CO.

Note— Any person who intends to appear on the hearing of the Petition must serve or send by post to the abovenamed Solicitors, notice in writing of his intention to do so. The Notice must state the name and address of the person or if a firm, the name and address of the firm and must be signed by the person or firm or his or their Solicitors (if any) and must be served or if posted must be sent in sufficient time to reach the abovenamed not later than four o'clock in the afternoon on 22 June 1983. 6844

In the Supreme Court of Victoria, C.O. 13113 — in the matter of the Companies (Victoria) Code; and in the matter of Bercol Constructions Pty Limited — Notice of Winding-Up Order  
Winding-Up Order: Made 12 May 1983.

Name and address of Liquidator: David Carl Christensen, c/- Coopers & Lybrand, 461 Bourke Street, Melbourne, Victoria 3000.

B. J. O'DONOVAN, Crown Solicitor for the Commonwealth and Solicitor for the Petitioner. 6845

In the Supreme Court of Victoria, C.O. 13077 — In the matter of the Companies (Victoria) Code; and in the matter of Trafalgar Financial Corporation Limited.

Notice is hereby given that an Application for the winding up of the abovenamed Company by the Supreme Court of Victoria was on 21 March 1983 presented by George Bowery and that by Order of the Court made 5 May 1983 Bonito Investments Co. Pty. Ltd., Nahini Pty. Ltd. and Peter G. Clarke Consulting Pty. Ltd. were substituted as Applicants for George Bowery and the said Application was directed to be further heard before the Court sitting at Melbourne at the hour of 10.30 a.m. on Thursday 21 July 1983 and any creditor or contributory of the said Company desiring to support or oppose the making of any Order on the said Application may appear at the time of hearing by himself or his counsel for that purpose and a copy of the Application will be furnished to any creditor or contributory of the Company requiring the same by the undersigned on payment of the regulated charge for the same.

The Applicants' addresses are Bonito Investments Co. Pty. Ltd., 6 Shellbank Parade, Cremorne, N.S.W. 2090; Nahini Pty. Ltd., 6 Shellbank Parade, Cremorne, N.S.W. 2090; Peter G. Clarke Consulting Pty. Ltd., Suite 6, 305-309 Kingsway, Caringbah, N.S.W. 2229.

The Applicants' solicitors are Hedderwick Fookes & Alston of 121 William Street, Melbourne.

HEDDERWICK FOOKES & ALSTON (TFY)

Note— Any person who intends to appear on the hearing of the said Application must serve on or send by post to the abovenamed

Solicitors, Hedderwick Fookes & Alston, notice in writing of his intention so to do. The notice must state the name and address of the person or if a firm the name and address of the firm and must be signed by the person or firm or his or their solicitors (if any) and must be served or if posted must be sent by post in sufficient time to reach the abovenamed not later than four o'clock in the afternoon of 20 July 1983. 6851

In the Supreme Court of Victoria at Melbourne, C.O. 13150 — In the matter of the Companies (Victoria) Code 1981; and in the matter of G.A.C. Excavations Pty. Ltd.

Notice is hereby given that an Application for the winding up of the abovenamed company by the Supreme Court was on 6 May 1983 presented by Rowler Trading Company Pty. Ltd. And that the said Application is directed to be heard before the Court sitting in the 15th Court, Law Courts, William Street, Melbourne at the hour of 10.30 o'clock in the forenoon, on 16 June 1983; and any creditor or contributory of the said company desiring to support or oppose the making of an order on the said Application may appear at the time of the hearing by himself or his counsel for that purpose; and a copy of the Application will be furnished to any creditor or contributory of the said company requiring the same by the undersigned on payment of the regulated charge for the same.

The Applicant's address is 2-4 Collins Road, Dromana.

The Applicant's solicitors are Messrs F. J. Orames & Downing, 121 William Street, Melbourne.

F. J. ORAMES & DOWNING

Note— Any person who intends to appear on the hearing of the said Application must serve on or send by post to the abovenamed solicitor notice in writing of his intention so to do. The notice must state the name and address of the person, or if a firm, the name and address of the firm, and must be signed by the person or firm, or his or their solicitors (if any), and must be served, or, if posted, must be sent by post in sufficient time to reach the abovenamed not later than four o'clock in the afternoon on 15 June 1983. 6852

In the Supreme Court of Victoria at Melbourne, C.O. 13149 —

In the matter of the Companies (Victoria) Code 1981; and in the matter of Kynan Dale Consultancy Services Pty. Ltd. formerly Astor Wire Works Pty. Ltd.

Notice is hereby given that an Application for the winding up of the abovenamed company by the Supreme Court was on 6 May 1983 presented by A.R.C. Engineering Pty. Ltd. And that the said Application is directed to be heard before the Court sitting in the 15th Court, Law Courts, William Street, Melbourne at the hour of 10.30 o'clock in the forenoon, on 16 June 1983; and any creditor or contributory of the said company desiring to support or oppose the making of an order on the said Application may appear at the time of the hearing by himself or his counsel for that purpose; and a copy of the Application will be furnished to any creditor or contributory of the said company requiring the same by the undersigned on payment of the regulated charge for the same.

The Applicant's address is 528 Ballarat Road, Sunshine.

The Applicant's solicitors are Messrs F. J. Orames & Downing, 121 William Street, Melbourne.

F. J. ORAMES & DOWNING

Note— Any person who intends to appear on the hearing of the said Application must serve on or send by post to the abovenamed solicitor notice in writing of his intention so to do. The Notice must state the name and address of the person, or if a firm, the name and address of the firm, and must be signed by the person, or firm, or his or their solicitor (if any), and must be served, or, if posted, must be sent by post in sufficient time to reach the abovenamed not later than four o'clock in the afternoon on 15 June 1983. 6853

*The Companies Act 1961*

WUMP PTY. LTD. (IN LIQUIDATION)

NOTICE CONVENING FINAL MEETING OF THE COMPANY PURSUANT TO SECTION 272 (1)

Notice is hereby given that the Final Meeting of Members and Creditors of the abovenamed Company will be held at the offices of Venn Milner & Terracall, Chartered Accountants, Suite 2, 497 Burke Road, Camberwell, Victoria, on Friday 17 June 1983 at 10.30 a.m., for the purpose of laying before the Meeting an account showing how the winding up has been conducted and the property of the Company has been disposed of and giving any explanation thereof.

Dated 13 May 1983

6854

L. A. MILNER, Liquidator

*Companies Act 1961, Section 272*

NORTHCOTE CARPET & TILE CENTRE PTY. LTD. (IN LIQUIDATION)

NOTICE CONVENING FINAL MEETING OF MEMBERS AND CREDITORS

Notice is hereby given pursuant to Section 272 of the *Companies Act 1961* that a General Meeting of the members and creditors of the abovenamed company will be held at the offices of Ferric Hodgson & Co., 24th Floor, 459 Collins Street, Melbourne, on Tuesday 14 June 1983, at 11.00 a.m. for the purpose of having an account laid before them showing the manner in which the winding up has been conducted and the property of the company disposed of and of hearing any explanations that may be given by the Liquidator.

Dated 11 May 1983

6855

A. G. HODGSON, Liquidator

*Companies Act, 1961, Section 271 (1)*

IRONMONGER AND WITHERS PLUMBING SERVICES PTY. LTD. (IN LIQUIDATION)

NOTICE OF GENERAL MEETING OF MEMBERS AND CREDITORS

Notice is hereby given that a Meeting of Members and Creditors of Ironmonger and Withers Plumbing Services Pty. Ltd. will be held at the office of David A. Bradshaw, Public Accountant, 312 Bay Street, Port Melbourne, 3207, on Wednesday 15 June 1983 at 10.00 o'clock in the forenoon.

AGENDA

To lay before the Meeting an account of the acts and dealings of the Liquidator and the conduct of the winding-up during the year ended 7 April 1983.

Dated 9 May 1983

6856

DAVID A. BRADSHAW, Liquidator

ALFRED VICTOR POULTON, formerly of 38 Waratah Street, South Oakleigh, but late of 51 Maygrove Way, Mulgrave, taxi proprietor, deceased

Creditors, next of kin and others having claims in respect of the estate of the deceased who died on 28 January 1983 are required by the executrix, Marion Gwyneth Poulton, of 51 Maygrove Way, Mulgrave, widow, to send particulars to her care of the under-mentioned solicitors by 22 July 1983 after which date the executrix may convey or distribute the assets having regard only to the claims of which she then has notice.

HADEN SMITH & FITCHETT, solicitors, 423 Bourke Street, Melbourne. 6871

ELISABETH PORTUNE, late of 23 Olinda Street, Glen Waverley, formerly married woman but late widow, deceased

Creditors, next of kin and others having claims in respect of the estate of the deceased who died on 28 February 1983 are required by the executors, Herta Djoneff, of 41 Panoramic Grove, Glen

Waverley, home duties, and Paul William Brochie, of 2 Sheringham Drive, Glen Waverley, solicitor, to send particulars to them care of the undermentioned solicitors by 22 July 1983 after which date the executors may convey or distribute the assets having regard only to the claims of which they then have notice.

HADEN SMITH & FITCHETT, solicitors, 423 Bourke Street, Melbourne. 6872

NANCY KATE DUNN, formerly of 188 Highfield Road, Camberwell in the State of Victoria, but late of 119 Mackay Street, Rochester in the said State, widow, deceased

Creditors, next of kin and others having claims in respect of the estate of the deceased (who died on 8 January 1983) are required by The Perpetual Executors and Trustees Association of Australia Limited, of 50 Queen Street, Melbourne to send particulars of their claims to the said company by 22 July 1983 after which date it will convey or distribute the assets having regard only to the claims of which the Company then has notice.

NORMAN SHANKLY & HAMILTON, solicitors, 406 Lonsdale Street, Melbourne. 6873

CATHERINE VICTORIA SUTTON, late of 457 Springvale Road, Springvale in the State of Victoria, widow, deceased

Creditors, next of kin and others having claims in respect of the Estate of the deceased, who died on 16 March 1983 are required by the personal representative Kevin George Cooke, of 128 Exhibition Street, Melbourne in the said State, solicitor, to send particulars to him by 30 July 1983 after which date the personal representative may convey or distribute the assets, having regard only to the claims of which he then has notice.

COOKE & CUSSEN, solicitors, 128 Exhibition Street, Melbourne 3000. 6874

ALEXANDER WYND, late of Lyndoch Home for the Aged, Hopkins Road, Warnambool, pensioner, deceased

Creditors, next of kin and all others having claims in respect of the abovenamed deceased (who died on 20 January 1983) are required to send particulars of their claims in writing to the Executors, Margaret Elizabeth Clewer, of 10 William Street, Warnambool, and Keith Alexander Wynd, of 8 Blake Street, Skipton, care of the undersigned on or before 21 July 1983 after which date they will distribute the assets of the said Estate having regard only to the claims of which they then have notice as aforesaid.

DESMOND DUNNE & DWYER, solicitors, Warnambool. 6835

MERVYN GEORGE THOMAS, formerly of Nullawarre, but late of 202 Moore Street, Warnambool, farmer, deceased

Creditors, next of kin and all others having claims in respect of the abovenamed deceased (who died on 16 February 1983) are required to send particulars of their claims in writing to the Executors, Gweneth Irene Payne, of 202 Moore Street, Warnambool, and John Beynon Dwyer, of 95 Kepler Street, Warnambool, care of the undersigned on or before 21 July 1983 after which date they will distribute the assets of the said Estate having regard only to the claims of which they then have notice as aforesaid.

DESMOND DUNNE & DWYER, solicitors, Warnambool. 6834

Creditors, next of kin and others having claims in respect of the Estate of Phyllis May Armstrong, late of 46 Walsh Street, Coburg, pensioner, deceased, who died on 21 December 1982 are to send particulars of their claims to the Executrix, Alma Lillian Rogers, care of the undermentioned office by 20 July 1983, after which date she will distribute the assets having regard only to claims of which she then has notice.

KLIGER KATZ SCHMIDEG & ROTHFIELD, solicitors, of 6th Floor, 390 Lonsdale Street, Melbourne. 6865

JOAN WINIFRED BATES, late of 115 Kooyong Road, Armadale, married woman, deceased

Creditors, next of kin and others having claims against the Estate of the said deceased who died on 13 January 1983 are to send particulars of their claims to Harold Selwyn Bates and Philip Thomas Bates Kelynack, care of Messrs. Blake & Riggall, solicitors, 140 William Street, Melbourne by 17 August 1983 after which date they will distribute the assets having regard only to the claims of which they then have notice.

BLAKE & RIGGALL, solicitors, 140 William Street, Melbourne. 6866

All persons having claims against the estate of Pamela Margaret Rigby, late of 9 Gould Street, Frankston in the State of Victoria, widow, deceased (who died on 30 January 1983 and Probate of whose Will and Codicil was on 9 May 1983 granted by the Supreme Court of Victoria in its Probate Jurisdiction to The Trustees Executors and Agency Company Limited, of 401 Collins Street, Melbourne in the said State) are hereby required to send particulars of such claims to The Trustees Executors and Agency Company Limited at its address at 401 Collins Street, Melbourne aforesaid, on or before 19 July 1983 after which date it will proceed to transfer, convey or distribute the said Estate to or among the persons entitled thereto having regard only to the claims of which it shall then have had notice and will not be liable for the assets so transferred, conveyed or distributed to any persons of whose claim it shall not then have had notice.

AKEHURST FRIEND & ALLAWAY, solicitors, 10 Queen Street, Melbourne. 6867

DONALD NICOL SIDNEY CARMICHAEL (also known as Donald Nicol Carmichael), late of 13 Kett Street, Nunawading, who died on 5 December 1982

Creditors, next of kin and all others having claims in respect of the said deceased are requested by the Executrix, Wanda Louise Carmichael, of 13 Kett Street, Nunawading to send particulars of such claims addressed to the Executrix care of Ridgeway Clements, 461 Bourke Street, Melbourne by 23 July 1983 after which date the said Executrix will distribute the assets having regard only to the claims of which she then has notice.

RIDGEWAY CLEMENTS, solicitors, 461 Bourke Street, Melbourne. 6868

FRED LATTA, late of 29 Lancaster Street, East Bentleigh, who died on 4 February 1983

Creditors, next of kin and all others having claims in respect of the said deceased are requested by the Executors Frederick Grant Latta, of 28 McGown Road, Mount Eliza and Ian James Latta, of 12 Rubens Court, Scoresby to send particulars of such claims addressed to the Executors care of Ridgeway Clements, 461 Bourke Street, Melbourne by 23 July 1983 after which date the said Executors will distribute the assets having regard only to the claims of which they then have notice.

RIDGEWAY CLEMENTS, solicitors, of 461 Bourke Street, Melbourne. 6869

Lady ETHEL MARIAN SUMNER CASEY, late of "Edrington", Berwick, widow, deceased

Creditors, next of kin and others having claims in respect of the Estate of the deceased, who died on 20 January 1983, are required by the personal representatives, Jack Alpen Richards, of 57 Robinson Road, Hawthorn, Anthony Grenville Hiscock, of 121 William Street, Melbourne and John Christian Robert Sitlington, of 459 Collins Street, Melbourne to send particulars to them care of Officer & Smith, 459 Collins Street, Melbourne by 21 July 1983 after which date the personal representatives may convey or distribute the assets of the Estate, having regard only to the claims of which they then have notice.

HEDDERWICK, FOOKES & ALSTON, 121 William Street, Melbourne. 6870

Creditors, next of kin and others having claims in respect of the Estate of Doris Muriel Smith, late of Bodella Hospital, Walpole Street, Kew in the State of Victoria, retired, who died on 17 September 1982 are to send particulars of their claims to the Executrix care of the undersigned by 23 August 1983 after which date she will commence to distribute the assets having regard only to the claims of which she then has notice.

T. D. ARMSTRONG & GILLMAN, solicitors, 646 Main Street, Belgrave. 6875

Creditors, next of kin and others having claims in respect of the Estate of Charles Reginald Rowe (named in the will Charles Rowe), late of 35 Malane Street, Ormond in the State of Victoria, gentleman, deceased, who died on 22 February 1983 are required to send particulars of their claims to the Executors care of the undermentioned Solicitors by 18 July 1983 after which date they will distribute the assets having regard only to the claims for which notice has been received.

LYTTLETON & GILLARD, solicitors, 51 Marcus Road, Dingley. 6876

Creditors, next of kin or others having claims in respect of the estate of Vincenza Guzzardi, late of 50 North Road, Yallourn North, widow, deceased, who died on 19 April 1983 are to send particulars of their claims to the executors Benito Guzzardi and Cesare Guzzardi, care of the undermentioned solicitors by 27 July 1983 after which date the executors will distribute the assets having regard only to the claims of which they then have notice.

D. C. DAVINE & ASSOCIATES, solicitors, 39 Bred Street, Traralgon. 6877

Creditors, next of kin and others having claims in respect of the Estate of Raymond David Regan, late of 64 Henry Street, Traralgon, pensioner, deceased, who died on 17 February 1973 and Probate of whose Will was granted by the Supreme Court of Victoria on 4 May 1983 to Thelma Beatrice Regan, of 64 Henry Street, Traralgon, widow, are to send particulars of their claims to the said Executrix care of the below mentioned solicitors by 29 July 1983 after which date she will distribute the assets of the deceased having regard only to the claims of which she then has notice.

LITTLETON HACKFORD & MALKIN, solicitors, Law Chambers, 115-119 Hotham Street, Traralgon. 6833

Creditors, next of kin and others having claims in respect of the Estate of Horace Edward Lawson Jones, late of 25 Banks Street, Traralgon, retired, deceased, who died on 23 January 1983 and Probate of whose Will was granted by the Supreme Court of Victoria on 21 April 1983 to Helen Lawson Jones, of 25 Banks Street, Traralgon, physiotherapist, and Edward Richard Jones, of 31 Mercer Street, Castlehill, New South Wales, clerk, are to send particulars of their claims to the said Executors by 29 July 1983 after which date they will distribute the assets of the deceased having regard only to the claims of which they then have notice.

LITTLETON HACKFORD & MALKIN, solicitors, Law Chambers, 115-119 Hotham Street, Traralgon. 6832

Creditors, next of kin and others having claims in respect of the estate of Eadith Lamont Lishman, late of Inala Village, Middleborough Road, South Blackburn, widow, deceased, who died on 24 February 1983 and Probate of whose Will has been granted to Noela Eadith Snell, of 43 Scott Street, Vermont, married woman, are required to send particulars of their claims to the said Executrix care of the undermentioned solicitors by 18 July 1983 after which date she will distribute the assets having regard only to the claims of which she then has notice.

PEARCE & WEBSTER, solicitors, 430 Little Collins Street, Melbourne. 6839

Creditors, next of kin and others having claims in respect of the estate of Jessie Agnes Sutherland, late of 1131 Burwood Highway, Ferntree Gully, widow, deceased, who died on 22 January 1983 and Probate of whose Will has been granted to Laurence James Sutherland, of 1131 Burwood Highway, Ferntree Gully, metallurgical chemist, and Dawn Isobel Sutherland, of 3 Napier Place, South Melbourne, buyer, are required to send particulars of their claims to the said Executors care of the undermentioned solicitors by 18 July 1983 after which date they will distribute the assets having regard only to the claims of which they then have notice.

PEARCE & WEBSTER, solicitors, 430 Little Collins Street, Melbourne. 6838

Creditors, next of kin and others having claims in respect of the Estate of William Keith McKewan, late of Carr Street, Barwon Heads, gentleman, deceased, who died on 21 September 1982 are required to send particulars of their claims to the Executors, Marjorie Diana McKewan and Richard Frank Lloyd Annois, care of the undersigned solicitors before 30 July 1983 after which date the assets of the estate will be distributed having regard only to the claims of which the Executors then have notice.

HARWOOD & PINCOTT, solicitors, 77 Moorabool Street, Geelong. 6837

THOMAS WILLIAM RYAN, late of Buln Buln, retired, deceased

Creditors, next of kin and others having claims in respect of the estate of the deceased, who died on 19 February 1983 are required by the Trustees, John Thomas Archibald Ryan and Hilda Ellen Woolstencroft, to send particulars of their claims to them care of the undersigned solicitors by 29 July 1983 after which date the Trustees may convey or distribute the assets having regard only to the claims of which they then have notice.

GRAY, FRIEND & LONG, solicitors, Warragul. 6836

Creditors, next of kin and others having claims in respect of the estate of Leila Seton Tovey, formerly of 4 Valentine Street, Bendigo, but late of Bendigo Home and Hospital for the Aged, 100 Barnard Street, Bendigo, widow, deceased, are required to send particulars of their claims to the executor, National Trustees Executors and Agency Company of Australasia Limited, of 46 Queen Street, Bendigo and 95 Queen Street, Melbourne care of the undermentioned solicitors by 25 July 1983 after which date it will distribute the assets having regard only to the claims of which it then has notice.

ROGERS & EVERY, solicitors, 71 Bull Street, Bendigo. 6784

VERONICA MICALLEF, late of 62 Molesworth Street, North Melbourne, widow, deceased

Creditors, next of kin and others having claims in respect of the estate of the abovenamed deceased who died on 1 April 1983 are required to send particulars thereof to the Executor of her Will, Phillip Peter Ridgeway, care of the undermentioned solicitors on or before 20 July 1983 after which date he will distribute the assets in the estate having regard only to the claims of which he shall then have notice.

J. M. SMITH & EMMERTON, solicitors, 224 Queen Street, Melbourne. 6785

RUTH GOGOL, late of 16 Carinya Road, Vermont, widow

Creditors, next of kin and others having claims in respect of the Estate of the deceased, who died on 14 February 1983 are required by the Executor, Edward Stuart Musgrave Parker, to send particulars to him, care of Maurice Blackburn & Co., 150 Lonsdale Street, Melbourne, solicitors, by 29 July 1983 after which date he may convey or distribute the assets, having regard only to the claims which he then has notice. 6786

Creditors, next of kin and others having claims in respect of the Estate of Leonard William Smith, late of 653 Princes Highway, Lakes Entrance, retired, deceased, are required by the Executor, Francis George McNamara, of 5 Capes Road, Lakes Entrance, Telecom employee, to send particulars of their claims care of the undermentioned solicitors by 31 July 1983 after which date he will distribute the assets having regard only to the claims to which he shall then have had notice.

WARREN GRAHAM & MURPHY, solicitors, 1/239 Esplanade, Lakes Entrance 3909. 6788

Creditors, next of kin and others having claims against the Estate of Norah Cornehl, late of 310 High Street, Windsor, widow, deceased (who died on 18 March 1983) are required by Patrick Francis Toohey, the Executor of the Will of the said deceased to send to him care of the undersigned solicitors particulars thereof by 31 July 1983 after which date he will distribute the assets having regard only to the claims of which he shall then have notice.

GAVAN DUFFY & KING, solicitors, 95 Queen Street, Melbourne. 6788

Creditors, next of kin and others having claims against the estate of Paul Battlay, deceased, late of 10 Norweena Street, Doncaster in the State of Victoria, pensioner, who died on 29 August 1982 are required to send particulars of their claims to the Executors, Susan Hase and Peter Battlay care of the undermentioned solicitors on or before 16 July 1983 after which date the Executors will distribute the assets of the estate having regard only to the claims of which they shall then have notice.

SACKVILLE, WILKS & CO., solicitors, of 100 Collins Street, Melbourne. 6789

Creditors, next of kin and others having claims in respect of the estate of Elizabeth Fagan, late of 9 Muster Court, South Vermont, married woman, deceased, who died on 24 December 1982 are to send particulars of their claim to the Executrices of the Estate, Patricia Roma Craddock and Heather Euphemia Mason, care of the undersigned by 18 July 1983 after which date they will distribute the assets having regard only to the claims of which they then have notice.

EGAN LOBB & WALKER, solicitors, 5 Hamilton Place, Mount Waverley. 6793

Creditors, next of kin and others having claims against the estate of Bryan McNulty, formerly of 94 Bank Street, Port Fairy, but late of Farmers Road, Dumbalk, pensioner, deceased, who died on 18 November 1982 are requested to send particulars of their claims to the executor, John Kevin McNulty, of 94 Bank Street, Port Fairy, shearer, care of Conlan & Leishman, solicitors, 38 Bank Street, Port Fairy by 30 July 1983 after which date he will distribute the assets having regard only to the claims of which he then has notice.

CONLAN & LEISHMAN, solicitors, 38 Bank Street, Port Fairy. 6813

ANTHONY CHARLES HARDEE, late of 13 Royal Parade, Caulfield in the State of Victoria, pensioner

Creditors, next of kin and others having claims in respect of the estate of the deceased, who died on 21 October 1982 are required by the trustee, the Trustees Executors and Agency Company Limited, of 401 Collins Street, Melbourne, to send particulars to it by 22 July 1983, after which date the trustee may convey or distribute the assets, having regard only to the claims of which he then has notice.

Dated 9 May 1983

DOMINIC TESORIERO & CO., barristers and solicitors, 624 Glenhuntly Road, Caulfield 3162. 6778

CYRIL GEORGE ANGOVE, formerly of Bamawm Extension via Echuca, farmer, but late of 21 Civic Avenue, Echuca, retired farmer, deceased

Creditors, next of kin and others having claims in respect of the estate of the deceased who died on 11 December 1982 are required by the executors, Donald Cyril Angove, of Bamawm Extension, dairy farmer, and Donald Kevin Hicks, of Echuca West, dairy farmer, to send particulars to them care of the undermentioned solicitors by 11 July 1983 after which date they may convey or distribute the assets having regard only to the claims of which they then have notice.

R. H. SCHLEIGER & ASSOCIATES, solicitors, 33-35 Williamson Street, Bendigo; and 59 Brooke Street, Inglewood. 6779

Creditors, next of kin and others having claims in respect of the Estate of William Douglas Anderson, late of "Strathlachlan", Barrabool, farmer, deceased, who died on 9 September 1982 are to send particulars of their claims to The Union Fidelity Trustee Company of Australia Limited, Focus Five Building, Corner Little Malop and Gheringhap Streets, Geelong by 30 June 1983 after which date it will distribute the assets having regard only to the claims of which it then has notice.

HARWOOD & PINCOTT, solicitors, 77 Moorabool Street, Geelong. 6780

ERIC ERNEST HOLMES STORIE, late of 160 Werribee Street, Werribee, gentleman, deceased

Creditors, next of kin and others having claims in respect of the estate of the deceased (who died on 15 October 1982) are required by Lynette Violet Falvey, of 160 Werribee Street, Werribee, married woman, and Robert John Ball, of 430 Little Collins Street, Melbourne, solicitor, to send particulars of their claims to the said Executors care of Henderson & Ball, 430 Little Collins Street, Melbourne, solicitors, by 21 July 1983 after which date they will convey or distribute the assets having regard only to the claims of which they then have notice.

HENDERSON & BALL, 430 Little Collins Street, Melbourne. 6781

Creditors, next of kin and others having claims in respect of the Estate of Georgina Gertrude Austin, late of 36 Dorothy Avenue, Glenhuntly, widow, deceased, who died on 30 March 1983 are required to send particulars of their claims to the Executor David Llewellyn Austin, care of Messrs. Havyatt & Steward, solicitors, 432 William Street, Melbourne, by 21 July 1983 after which date the Executor will distribute the assets of the deceased having regard only to the claims of which he then has notice.

HAVYATT & STEWARD, solicitors, 432 William Street, Melbourne. 6782

Creditors, next of kin and others having claims in respect of the Estate of Gwenneth Emma Hansen, late of 86 Castella Street, Lilydale, widow, deceased, who died on 5 May 1983 are required to send particulars of their claims to the Executrix, Pamela Joy Illingworth, care of Messrs. Havyatt & Steward, solicitors, 432 William Street, Melbourne, by 21 July 1983 after which date the Executrix will distribute the assets of the deceased having regard only to the claims of which she then has notice.

HAVYATT & STEWARD, solicitors, 432 William Street, Melbourne. 6783

MINNIE HOPE METELMANN, late of Allan Street, Nyah West in the State of Victoria, married woman, deceased (who died on 30 December 1982)

Creditors, next of kin and all other persons having claims against the Estate of the deceased are required by the Executors of the Will, David Frederick Metelmann and John Frederick Metelmann, to send particulars to them care of the undersigned on or before 13 July 1983, after which date they will distribute the assets having regard only to the claims of which they then have notice.

GARDEN & GREEN, solicitors, 4 McCallum Street, Swan Hill. 6777

In the Supreme Court of the State of Victoria  
SALE BY THE SHERIFF

On 5th July, 1983 at 12 noon at the Police Station, Shepparton (unless process be stayed or satisfied).

All the Estate and Interest (if any) of G. N. Wellington (shown on Certificate of Title as Gregory Neil Wellington) of Lot 22, Devine Road, Kialla as joint proprietor with Toni Anne Wellington of an estate in fee simple in the land described in Certificate of Title Volume 9115 Folio 313 upon which is erected a single storey brick veneer house known as Lot 22, Devine Road, Kialla. The property is located on the west side of Devine Road, 500 links south of the intersection of Devine Road and Bennett Road, Kialla.

Registered Mortgage Nos. G986992 and H988103 affect the said estate and interest.

Terms—Cash only

6878 J. GREEN, Deputy Sheriff

In the Supreme Court of the State of Victoria  
SALE BY THE SHERIFF

On 28th June, 1983 at 12.00 noon at the Police Station, Ballarat (unless process be stayed or satisfied).

All the Estate and Interest (if any) of Cuthbert John Trice and Evelyn Joyce Trice of Keaneys Road, Snake Valley as joint proprietors of an estate in fee simple in the land described in Crown Grant Volume 4776 Folio 080. The property is located on the northern side of a road unofficially known as Keaneys Road, 711.7 links west of Riley's Road, Snake Valley. A weatherboard dwelling is erected on the property.

6879 R. J. MARTIN, Sheriff's Officer

In the Supreme Court of the State of Victoria  
SALE BY THE SHERIFF

On 29th June, 1983 at 12.00 noon at the Police Station, Bendigo (unless process be stayed or satisfied).

All the Estate and Interest (if any) of Saade Developments Pty. Ltd., Registered Office is 9 Queens Road, South Melbourne in and to:

Firstly: as proprietor of an estate in fee simple in the land described in Certificate of Title Volume 8299 Folio 517 which is vacant land situated on the south-east corner of the intersection of Strathfieldsaye Road and an un-named Government Road, Strathfieldsaye.

Secondly: as proprietor of an estate in fee simple in the land described in Certificate of Title Volume 9160 Folio 667 which is vacant land known as Lot 1 Strathfieldsaye Road, Strathfieldsaye. The property is situated 2859 links south-east of the intersection of Strathfieldsaye Road and an un-named Government Road.

Thirdly: as proprietor of an estate in fee simple in the land described in Certificate of Title Volume 9160 Folio 668 which is vacant land known as Lot 2 Strathfieldsaye Road, Strathfieldsaye. The property is situated 745.239 metres south-east of the intersection of Strathfieldsaye Road and an un-named Government Road.

Terms—Cash only

6880 R. J. MARTIN, Sheriff's Officer

In the Supreme Court of the State of Victoria  
SALE BY THE SHERIFF

On 14th July, 1983 at 2.30 p.m. at the Sheriff's Office, Writs and Warrants Division, 2nd Floor, 241 William Street, Melbourne (unless process be stayed or satisfied).

All the Estate and Interest (if any) of Ronald Lewis (shown on Certificate of Title as Ronald John Lewis) of "Kelmscott", Lot 11 Rutherford Road, Tecoma as joint proprietor with Margaret Grant Lewis of an estate in fee simple in the land described in Certificate of Title Volume 8544 Folio 052 upon which is erected a substantial house known as "Kelmscott", Lot 11 Rutherford Road, Tecoma. The property is located on the western side of

Rutherford Road, 290 feet 11 inches north-west of the intersection of Rutherford Road and Collier Avenue, Tecoma.

Registered Mortgage Nos. J853786 and J853787 and Caveat No. K176007 affect the said estate and interest.

Terms—Cash only

6881 R. J. MARTIN, Sheriff's Officer

In the Supreme Court of the State of Victoria  
SALE BY THE SHERIFF

On 30th June, 1983 at 2.30 p.m. at the Sheriff's Office, Writs and Warrants Division, 2nd Floor, 241 William Street, Melbourne (unless process be stayed or satisfied).

All the Estate and Interest (if any) of Kyriacos Zacharias Varnavas (also known as Jack Varnavas), (shown on Certificate of Title as Kyriacos Varnavas) of 45 Glengyle Street, East Burwood as proprietor of an estate in fee simple in the land described in Certificate of Title Volume 9221 Folio 315 which is vacant land known as No. 5 Andrea Street, Rye.

Registered Mortgage No. G699396 affects the said estate and interest.

Terms—Cash only

6882 R. J. MARTIN, Sheriff's Officer

In the Supreme Court of the State of Victoria  
SALE BY THE SHERIFF

On 23rd June, 1983 at 2.30 p.m. at the Sheriff's Office, Writs and Warrants Division, 2nd Floor, 241 William Street, Melbourne (unless process be stayed or satisfied).

All the Estate and Interest (if any) of Athanasios Basoukos of 9 Kelson Street, Coburg as joint proprietor with Irini Basoukos of an estate in fee simple in the land described in Certificate of Title Volume 5798 Folio 502 upon which is erected a single fronted weatherboard dwelling known as No. 57 Campbell Street, Coburg.

Registered Mortgage No. H879447 affects the said estate and interest.

Terms—Cash only—to be sold to the highest bidder—no reserve set.

6883 R. J. MARTIN, Sheriff's Officer

In the Supreme Court of the State of Victoria  
SALE BY THE SHERIFF

On 30th June, 1983 at 2.30 p.m. at the Sheriff's Office, Writs and Warrants Division, 2nd Floor, 241 William Street, Melbourne (unless process be stayed or satisfied).

All the Estate and Interest (if any) of Graham Ernest D'Ath and Pamela Raye D'Ath of 27 McComas Street, Reservoir as joint proprietors of an estate in fee simple in the land described in Certificate of Title Volume 9488 Folio 417 upon which is erected a dwelling house known as No. 27 McComas Street, Reservoir.

Registered Mortgage No. J658812 affects the said estate and interest and unregistered Caveat No. J676418 may affect the said estate and interest.

Terms—Cash only—to be sold to the highest bidder—no reserve set.

6884 R. J. MARTIN, Sheriff's Officer

In the Supreme Court of the State of Victoria  
SALE BY THE SHERIFF

On 23rd June, 1983 at 2.30 p.m. at the Sheriff's Office, Writs and Warrants Division, 2nd Floor, 241 William Street, Melbourne (unless process be stayed or satisfied).

All the Equitable Estate and Interest (if any) of Raymond Norman Beechey (shown on Contract of Sale as Norman Raymond Beechey) of 14 Everett Street, West Brunswick as joint purchaser with Marie Joan Beechey of the land described in Crown Grant Volume 8534 Folio 327 under a Contract of Sale dated 30th June, 1965 between themselves and the Housing Commission of Victoria as

vendors upon which is erected a brick dwelling known as No. 22 Ebony Parade, Heidelberg.

Caveat Nos. H85236, H418426, H453487 and K50192 affect the said Equitable estate and interest.

Terms—Cash only—to be sold to the highest bidder—no reserve set.

6885 R. J. MARTIN, Sheriff's Officer

In the Supreme Court of the State of Victoria  
**SALE BY THE SHERIFF**

On 30th June, 1983 at 2.30 p.m. at the Sheriff's Office, Writs and Warrants Division, 2nd Floor, 241 William Street, Melbourne (unless process be stayed or satisfied).

All the Estate and Interest (if any) of Saade Developments Pty. Ltd., Registered Office is 9 Queens Road, South Melbourne as proprietor of an estate in fee simple in the land described in Certificate of Title Volume 8498 Folio 867 upon which is erected a single storey shop known as Shop 1, 45 McFarlane Street, East Keilor.

Registered Mortgage No. H892091 and Caveat No. J483543 affect the said estate and interest.

Terms—Cash only  
 6886 R. J. MARTIN, Sheriff's Officer

**NOTICE OF MAKING OF  
 STATUTORY RULES  
 WHICH ARE NOT YET  
 AVAILABLE**

Notice is given of the making of the following Statutory Rules:

- Water Act 1958*  
 100/1983. Water (Recreational Area Penalties) Regulations 1983
- Police Regulation Act 1958*  
 101/1983. Police (Charges Expenses and Allowances) (Provision of Affidavits) Regulations 1983
- Fruit and Vegetables Act 1958*  
 102/1983. Fruit and Vegetables Packing (Amendment No. 1) Regulations 1983
- Warehousemen's Liens Act 1958*  
 103/1983. Warehousemen's Liens (Amendment) Regulations 1983

**NOTICE OF MAKING AND  
 AVAILABILITY OF  
 STATUTORY RULE**

In pursuance of the provisions of the *Subordinate Legislation Act 1962* and the Regulations made thereunder notice is given of the making and availability of the following Statutory Rules:

- | No.                                     | Evidence Act 1958   | Price |
|---|---|-------|
| 93/1983.                                | Evidence (Interpreters Allowances) Amendment) Regulations 1983    | 20c   |
| <i>Police Regulation Act 1958</i>       |   |       |
| 94/1983.                                | Police (Bar to Valour Award) Regulations 1983                     | 20c   |
| <i>Hospitals and Charities Act 1958</i> |   |       |
| 95/1983.                                | Hospitals and Charities (Fees) (Amendment No. 1) Regulations 1983 | 20c   |

- | No.                            | Public Service Act 1974                               | Price |
|--------------------------------|---|-------|
| 96/1983.                       | Public Service Amendment Regulations (No. 5) 1983     | 20c   |
| <i>Public Service Act 1974</i> |   |       |
| 97/1983.                       | Public Service Amendment Regulations (No. 6) 1983     | 20c   |
| <i>Supreme Court Act 1958</i>  |   |       |
| 98/1983.                       | Supreme Court (Interest) Rules 1983                   | 20c   |
| <i>Supreme Court Act 1958</i>  |   |       |
| 99/1983.                       | Supreme Court (Office Hours) Rules 1983               | 20c   |
| <i>Public Service Act 1974</i> |   |       |
| PSD23/1983.                    | Public Service Amendment Determinations (No. 23) 1983 | 20c   |

Copies of these Statutory Rules are available and may be purchased at the Victorian Government Bookshop, located at 41 St. Andrews Place, East Melbourne (formerly 7A Parliament Place, Melbourne, 3002). If ordered by mail, remittance should be addressed to "The Government Printer, Box 203, North Melbourne, 3051", and should include 50c delivery and handling fee.

The annual subscription rates for Statutory Rules for the year commencing 1 January 1982, payable in advance are as follows:

- \*Statutory Rules (other than Public Service Determinations), Pamphlet copies only \$55.00
- Public Service Determinations \$33.00

\* The Bound Volume of Statutory Rules is not included in the subscription rate.

F. D. ATKINSON  
 Government Printer

**CONTENTS**

	Page
Acts of Parliament	1151
Appointments	1170
Bank Holidays	1152
Cemeteries—Scale of Fees	1159
Contracts	1168
Country Roads Board	1161
Estates of Deceased Persons	1169
Government Notices	1152
Lands	1184
Melbourne and Metropolitan Board of Works—Notice	1167
Minerals and Energy	1168
Notice of Making of Statutory Rules	1214
Orders in Council—	
Acts—Local Government; Crown Land (Reserves); Road Traffic; Housing; Soil Conservation and Land Utilization; Land; Coal Mines; Water; Drainage of Land; National Gallery of Victoria; Hospitals and Charities; State Employees Retirement Benefits; Decentralized Industry (Housing)	1171 et seq
Police Sale	1152
Private Advertisements	1187
Proclamations	1151
Public Holidays	1151
Resignations	1171
Tenders	1186
Transport Regulation Board—Public Hearings	1167