



[2745]

PUBLISHED BY AUTHORITY Victoria Government Gazette

No. 86—Wednesday, 31 August 1983

PROCLAMATIONS

Land Act 1958
ROAD PROCLAIMED

PROCLAMATION

By His Excellency the Governor of the State of Victoria and its Dependencies in the Commonwealth of Australia, &c., &c., &c.

I, the Governor of the State of Victoria, in the Commonwealth of Australia, by and with the advice of the Executive Council of the said State, pursuant to the provisions of section 25 (3) (c) of the *Land Act 1958*, doth hereby proclaim as road the Crown land hereinafter described, viz:

Municipal District of the City of Springvale — Parish of Lyndhurst, being the land indicated by hatching on plan hereunder — (L101 (9)) (G-73295).

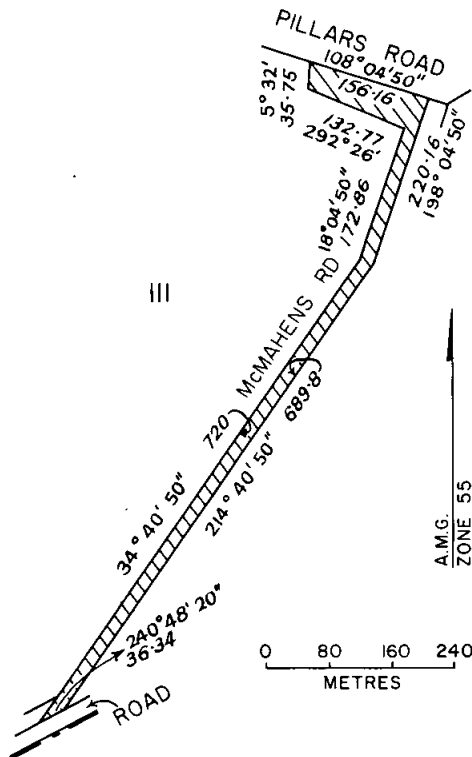

Given under my Hand and the Seal of the State of Victoria aforesaid, at Melbourne, this twenty-third day of August, in the year of Our Lord One thousand nine

hundred and eighty-three, and in the thirty-second year of the reign of Her Majesty Queen Elizabeth the Second, Queen of Australia.

(L.S.)

BRIAN MURRAY

By His Excellency's Command

R. A. MACKENZIE
Minister of Lands

GOD SAVE THE QUEEN!

Lotteries Gaming and Betting (Administration) Act 1983,
No. 9880

DATE OF COMING INTO OPERATION

PROCLAMATION

By His Excellency the Governor of the State of Victoria and its Dependencies in the Commonwealth of Australia, &c., &c., &c.

Whereas by an Act of the Parliament of the State of Victoria passed in the thirty-second year of the reign of Her Majesty Queen Elizabeth the Second, Queen of Australia, entitled the *Lotteries Gaming and Betting (Administration) Act 1983* it is amongst other things enacted that the Act shall come into operation on a day to be fixed by proclamation of the Governor in Council published in the *Government Gazette*.

Now therefore, I, the Governor of the State of Victoria in the Commonwealth of Australia, by and with the advice of the Executive Council therefore, do by this my Proclamation fix Wednesday, 31 August 1983, as the day on which the said *Lotteries, Gaming and Betting (Administration) Act 1983* shall come into operation.

Given under my Hand and the Seal of the State of Victoria aforesaid, at Melbourne, this thirtieth day of August, in the year of Our Lord One thousand nine hundred and eighty-three in the thirty-second year of the reign of Her Majesty Queen Elizabeth the Second, Queen of Australia.

(L.S.)

BRIAN MURRAY

By His Excellency's Command

N. B. TREZISE
Minister for Youth, Sport and Recreation
GOD SAVE THE QUEEN!

GOVERNMENT NOTICES

State Bank Act 1958

Section 30

THE STATE BANK OF VICTORIA CHANGE OF BRANCH NAME

The Commissioners of the State Bank of Victoria hereby give notice that as of 5 September 1983, the branch currently known as Morwell East will be known as Morwell Mid-Valley Branch.

H. E. TORRENS, General Manager

Private Agents Act 1966

NOTICE OF RECEIPT OF APPLICATIONS FOR LICENCES UNDER THE PROVISIONS OF THE PRIVATE AGENTS ACT 1966

The Clerk(s) of the Magistrates' Court(s) as listed hereunder hereby give notice that applications, as under, have been lodged for hearing by the said Court(s) on the date(s) specified.

Any person desiring to object to any of such applications must—

- (a) lodge with the respective Clerk of the Magistrates' Court a notice in the prescribed form of his objection and of the grounds thereof;
- (b) cause a copy of such notice to be served personally or by post upon the applicant at least three days before the hearing of the application; and
- (c) send or deliver—
 - (i) where the objection is not made by the officer in charge of the police district in which the Court is situated—a copy of the notice to such officer; and
 - (ii) where the objection is not made by the Registrar or Deputy Registrar—a copy to the Registrar.

Full Name of Applicant*	Place of Abode of Applicant or Nominee	Name of Firm or Corporation	Address for Registration	Type of Licence	Date of Hearing
MAGISTRATES' COURT, GEELONG					
Culliver, Rhonda Mary	24 Coronation St, Geelong West		24 Coronation St, Geelong West	Inquiry	12.9.83
Dated at Geelong 23 August 1983 A. DUNLOP, Clerk of the Magistrates' Court					
MAGISTRATES' COURT, CHELSEA					
Jones, Russell Douglas	4/32 Golden Ave, Bonbeach		4/32 Golden Ave, Bonbeach	Guard Agent (Ind.)	27.9.83
Dated at Chelsea 22 August 1983 H. McINNES, Clerk of the Magistrates' Court					
MAGISTRATES' COURT, MELBOURNE					
Culhane, Dennis	9 Tennyson St, Moonee Ponds		545 King St, West Melbourne	Inquiry Agent	30.8.83
Rocco, Orlando	15 Lorraine St, Cheltenham		20 Bank Pce, Melbourne	Process Server	"
Boardman, Anthony	19 Edcombe St, Kew		54 Racecourse Rd, North Melbourne	Watchman	"
Gourlay, John	48 Buckley St, Essendon		340 Abbotsford St, North Melbourne	"	"
Lightfoot, Russell	25 Tasman Ave, Deer Park		54 Racecourse Rd, North Melbourne	"	"
McAllester, Ian	115 Park St, Moonee Ponds		" " "	"	"
Oliver, Graeme	17 Sycamore Cres, Boronia		" " "	"	"
Ruthven, Gary	122 Gore St, Fitzroy		340 Abbotsford St, North Melbourne	"	"
Turner, Martin	13 Penshurst Ave, Hastings		54 Racecourse Rd, North Melbourne	"	"
Waldron, Lindsay	6 Arnott St, Ormond		" " "	"	"
Whyte, James	689 High St Rd, Glen Waverley		340 Abbotsford St, North Melbourne	"	"
Dated at Melbourne 18 August 1983 M. QUIRK, Clerk of the Magistrates' Court					
MAGISTRATES' COURT, SUNSHINE					
Szymiczek, Norbert Peter	3 Denham Crt, Kealba		3 Denham Crt, Kealba	Guard Agent	15.9.83
" " "	" " "		" " "	Process Server	"
Dated at Sunshine 18 August 1983 G. G. WILLIAMSON, Clerk of the Magistrates' Court					

*Or in the case of a firm or corporation, of the Nominee

PRIVATE AGENTS—continued

Full Name of Applicant*	Place of Abode of Applicant or Nominee	Name of Firm or Corporation	Address for Registration	Type of Licence	Date of Hearing
MAGISTRATES' COURT, FITZROY					
Rind, Alexander	20 Martin St, St Kilda	Roden Security Services	136 Johnston St, Fitzroy	Watchman	19.9.83
Hill, Stuart	46 Yarralea St, Alphington	" "	" "	"	26.9.83
Spear, Mark	24 Church St, Flemington	" "	" "	"	"
Dated at Fitzroy 19 August 1983 G. SHARKEY, Clerk of the Magistrates' Court					
MAGISTRATES' COURT, RINGWOOD					
Wilde, John Graham	1 Trinian St, Vermont		1 Trinian St, Vermont	Guard Agent	3.10.83
" " "	" " "		" "	Process Server Inquiry Agent	"
Dated at Ringwood 22 August 1983 R. BRUCKNER, Clerk of the Magistrates' Court					
MAGISTRATES' COURT, FITZROY					
Martinovski, Momir	44/56 Derby St, Flemington	Roden Security Services	136 Johnston St, Fitzroy	Watchman	12.9.83
Dated at Fitzroy 15 August 1983 G. SHARKEY, Clerk of the Magistrates' Court					
MAGISTRATES' COURT, FITZROY					
Elliott, Peter Maxwell	4 Derby Pce, Kew	Roden Security Services	136 Johnston St, Fitzroy	Watchman	12.9.83
Dated at Fitzroy 16 August 1983 G. SHARKEY, Clerk of the Magistrates' Court					
MAGISTRATES' COURT, FOOTSCRAY					
Armstrong, Robert Barry	6 Swan St, Werribee	'Armaguard' Mayne Nickless Ltd.	653 Queensberry St, North Melbourne	Watchman	14.9.83
Dated at Footscray 17 August 1983 J. T. FERGUSON, Clerk of the Magistrates' Court					
MAGISTRATES' COURT, FOOTSCRAY					
Vassallo, Joseph	125 St Albans Rd, St Albans	'Armaguard' Mayne Nickless Ltd.	653 Queensberry St, North Melbourne	Watchman	14.9.83
Dated at Footscray 12 August 1983 J. T. FERGUSON, Clerk of the Magistrates' Court					
MAGISTRATES' COURT, SPRINGVALE					
Mapp, Michael John	5 Ruffy Dve, Cranbourne		11 Wardale Rd, South Springvale	Guard Agent	15.9.83
Dated at Springvale 18 August 1983 G. EBERT, Clerk of the Magistrates' Court					
MAGISTRATES' COURT, SPRINGVALE					
Starvaggi, David Henry	21 Clarke Rd, Springvale	Southern Star Security Services	21 Clarke Rd, Springvale	Watchman	9.9.83
Dated at Springvale 16 August 1983 K. B. O'HARE, Clerk of the Magistrates' Court					
MAGISTRATES' COURT, FERNTREE GULLY					
Helms, Peter Charles	9 Sweeney Dve, Narre Warren	Vic. Guard Security	429 Boronia Rd, Bayswater	Watchman	14.9.83
Helms, Bruce William	12 Adelaide St, Dandenong	" " "	" " "	"	"
Dated at Ferntree Gully 19 August 1983 G. J. CONDON, Clerk of the Magistrates' Court					

*Or in the case of a firm or corporation, of the Nominee

PRIVATE AGENTS—*continued*

<i>Full Name of Applicant*</i>	<i>Place of Abode of Applicant or Nominee</i>	<i>Name of Firm or Corporation</i>	<i>Address for Registration</i>	<i>Type of Licence</i>	<i>Date of Hearing</i>
MAGISTRATES' COURT, PRESTON					
Rogan, Anthony John	242 Bulmans Rd, West Melton		30 Maclagan Cres, Reservoir	Watchman	15.9.83
Rogan, Geoffrey William	58 Northumberland Dve, Epping		" " "	"	"
Dated at Preston 16 August 1983 T. J. WILSON, Clerk of the Magistrates' Court					
MAGISTRATES' COURT, LILYDALE					
Moriarty, Michael Raymond	Unit 8/48 Glen Park Rd, Bayswater		26 North Rd, Lilydale	Watchman	8.9.83
Dated at Lilydale 15 August 1983 D. D. REES, Clerk of the Magistrates' Court					
MAGISTRATES' COURT, BOX HILL					
Mudge, Steven Roy	42 Aylmer St, North Balwyn		42 Aylmer St, North Balwyn	Process Server (Ind.)	13.9.83
Dated at Box Hill 16 August 1983 P. O'FARRELL, Clerk of the Magistrates' Court					
MAGISTRATES' COURT, OAKLEIGH					
Hewitt, Ramon R,	2/101 Eskdale Rd, Caulfield North	Kent Security Service	96 Murrumbeena Rd, Murrumbeena	Watchman	9.9.83
Dated at Oakleigh 15 August 1983 A. HARGREAVES, Clerk of the Magistrates' Court					
MAGISTRATES' COURT, SOUTH MELBOURNE					
Pitt, Warren Douglas	1 Nelson Pl, South Melbourne		1 Nelson Pl, South Melbourne	Process Server	13.9.83
Dated at South Melbourne 16 August 1983 R. J. McHUGH, Clerk of the Magistrates' Court					
MAGISTRATES' COURT, FRANKSTON					
Derks, Theoddrus Johannes	6 Excelsior Dve, Frankston		6 Excelsior Dve, Frankston	Inquiry Agent (Ind.)	16.9.83
Dated at Frankston 18 August 1983 B. O'TOOLE, Clerk of the Magistrates' Court					
MAGISTRATES' COURT, MORWELL					
Murphy, Bernard Anthony	14 Banksia Cres, Churchill	Armaguard	14 Driffield Rd, Morwell	Watchman	2.9.83
Dated at Morwell 11 August 1983 K. G. McMAHON, Clerk of the Magistrates' Court					
MAGISTRATES' COURT, ORBOST					
Rees, Maureen Mary	4 Perry St, Marlo		4 Perry St, Marlo	Process Server Commercial Sub-Agent	7.9.83
" " "	" "		" "		"
Dated at Orbost 17 August 1983 I. R. SIGG, Clerk of the Magistrates' Court					
MAGISTRATES' COURT, MILDURA					
Carroll, William Edward	836 15th St, Mildura		836 15th St, Mildura	Guard Agent	14.9.83
Dated at Mildura 16 August 1983 DON GEAR, Clerk of the Magistrates' Court					
MAGISTRATES' COURT, BENDIGO					
Williams, Ian Edward	9 Pitt St, Bendigo		Abel St, Bendigo	Watchman	7.9.83
Dated at Bendigo 17 August 1983 R. HOLLIS, Clerk of the Magistrates' Court					

*Or in the case of a firm or corporation, of the Nominee

PRIVATE AGENTS—continued

Full Name of Applicant*	Place of Abode of Applicant or Nominee	Name of Firm or Corporation	Address for Registration	Type of Licence	Date of Hearing
MAGISTRATES' COURT, HEALESVILLE					
Hardinge, Murray Richard	103 Badger Creek Rd, Healesville		103 Badger Creek Rd, Healesville	Guard Agent (Ind.)	14.9.83
Dated at Healesville 17 August 1983 A. C. GRAY, Clerk of the Magistrates' Court					

*Or in the case of a firm or corporation, of the Nominee

Police Offences Act 1958, No. 6337

DIVISION 1A — STATE CLASSIFICATION OF PUBLICATIONS BOARD

Take note that the State Classification of Publications Board has classified the following publications in accordance with the provisions of Section 180H (1) of the *Police Offences Act 1958*.

Each publication shall be subject to the following restrictions:

- (a) It shall not be offered for sale, sold or delivered to any person under the age of 18 years;
- (b) It shall not be made available for inspection or perusal by any person under the age of 18 years.

Schedule of Publications

Title	Distributor
Gallery, October 1983 Knave, Vol. 15, No. 7 Moist lips	Gordon and Gotch Ltd. Gordon and Gotch Ltd. Melbourne Wholesale Newsagency Pty. Ltd.
One Woman Show	Melbourne Wholesale Newsagency Pty. Ltd.
Tail To Go	Melbourne Wholesale Newsagency Pty. Ltd.
Tongue Tied	Melbourne Wholesale Newsagency Pty. Ltd.

J. ROGERSON, Secretary
State Classification of Publications Board

Police Offences Act 1958, No. 6337

DIVISION 1A — STATE CLASSIFICATION OF PUBLICATIONS BOARD

Take note that the State Classification of Publications Board has classified the following publications in accordance with the provisions of Section 180H (1) of the *Police Offences Act 1958*.

Each publication shall be subject to the following restrictions:

- (a) It shall not be offered for sale, sold or delivered to any person under the age of 18 years;
- (b) It shall not be made available for inspection or perusal by any person under the age of 18 years;
- (c) It shall not be exhibited or displayed in any place to which persons under the age of 18 years have access or so that it is visible from any such place.

Schedule of Publications

Title	Distributor
Razzle, Vol. 1, No. 5 Human Digest, September 1983 Playdames Giant Sampler, 3	Gordon and Gotch Ltd. Gordon and Gotch Ltd. View Productions Pty. Ltd.

J. ROGERSON, Secretary
State Classification of Publications Board

Police Offences Act 1958, No. 6337

DIVISION 1A — STATE CLASSIFICATION OF PUBLICATIONS BOARD

Take note that the State Classification of Publications Board has classified the following publications in accordance with the provisions of Section 180H (1) of the *Police Offences Act 1958*.

Each publication shall be subject to the following restrictions:

- (a) It shall not be offered for sale, sold or delivered to any person under the age of 18 years;
- (b) It shall not be made available for inspection or perusal by any person under the age of 18 years;
- (c) It shall not be exhibited or displayed in any place to which persons under the age of 18 years have access or so that it is visible from any such place;
- (d) It shall not be advertised in any manner whatsoever.

Schedule of Publications

Title	Distributor
New Cunts, No. 36	Undercounter Publications Pty. Ltd.
Dirty, No. 5	Undercounter Publications Pty. Ltd.

J. ROGERSON, Secretary
State Classification of Publications Board

PUBLIC BODIES REVIEW COMMITTEE

Public Hearing on Irrigation Management

7 September 1983 at 9.30 a.m.

The Public Bodies Review Committee will hear evidence from Mr. R. H. Taylor, Assistant Director-General, Planning & Systems Development, Department of Agriculture, on matters dealing with its Inquiry into Management Aspects of Irrigation in Victoria.

The venue for this Hearing will be "Treasury Gate", 2nd Floor, 1-15 Little Collins Street, Melbourne, commencing at 9.30 a.m.

ROBERT H. MILLER, M.P., Chairman

DEPARTMENT OF AGRICULTURE

His Excellency the Governor of the State of Victoria, by and with the advice of the Executive Council thereof has by Order made on 30 August 1983 approved the Victorian Egg Marketing Board to transfer to a reserve fund to be used for any purpose in connection with the operations of the said Victorian Egg Marketing Board the sum of \$1 150 000 from the sale of eggs and egg products during the 1982/83 pool year, in accordance with the provisions of paragraph (i) of sub-section 1 of Section 20 of the *Marketing of Primary Products Act 1958*.

TOM FORRISTAL
Clerk of the Executive Council

At the Executive Council Chamber,
Melbourne, 30 August 1983

FARM PRODUCE MERCHANTS AND COMMISSION
AGENTS ACT 1965 (No. 7274)

List of names and addresses of the licence holders recorded in the register of licensed wholesalers as at 31 July 1983. In accordance with the above Act, those issued with a Merchant's or Commission Agent's licence, have paid the prescribed contribution to the Farm Produce Merchants and Commission Agents Guarantee Fund. All licences, unless earlier surrendered or cancelled, shall continue in force until 30 June 1984.

D. E. HORE

Acting Director-General of Agriculture

MERCHANTS

Name; Principal Place of Business

- Adelaide and Local Tomato Supply: Stores 395-397 Melbourne Wholesale Fruit and Vegetable Market, Footscray, 3011
- Agostino, B. J.: Store 260 Melbourne Wholesale Fruit and Vegetable Market, Footscray, 3011
- Alan Gangelhoff Produce (Nominees) Pty. Ltd.: Stores 198-200 Melbourne Wholesale Fruit and Vegetable Market, Footscray, 3011
- Alexander, E. and Sons; Portland, 3305
- Alfred Millis and Sons Pty. Ltd.: Stores 111-114 Melbourne Wholesale Fruit and Vegetable Market, Footscray, 3011
- Allan P. Dodd and Co.: Rainbow Gully, Basin Road, Olinda, 3788
- Allproduce Traders Pty. Ltd.: Stores 320-322 Melbourne Wholesale Fruit and Vegetable Market, Footscray, 3011
- All States Produce Services Pty. Ltd.: Stores 235-237 Melbourne Wholesale Fruit and Vegetable Market, Footscray, 3011
- Amalfi, J.; 98 Thompsons Road, Bulleen, 3105
- Amarco International Export Company: 103 Stirling Drive, East Keilor, 3033
- Anderson Honey Products Pty. Ltd.: 8 Cameron Parade, Broadford, 3658
- Angelo's Bio-Dynamic and Organic Natureland: 92 South Parade, Blackburn, 3130
- Anguey, R. (Holt and Willey Proprietors): Stores 185-186 Melbourne Wholesale Fruit and Vegetable Market, Footscray, 3011
- Ararat Fruit Supply: 202 Barkly Street, Ararat, 3377
- Archibald Honey Co.: Spring Road, Dingley, 3172
- Ardmona Fresh Fruit Packers Pty. Ltd.: Lenne Road, Ardmona, 3629
- Arnold's CFD Pty. Ltd.; Cnr. Osburn and Wigg Streets, Wodonga, 3690
- Asia Produce Company Pty. Ltd.: Stores 285-286 Melbourne Wholesale Fruit and Vegetable Market, Footscray, 3011
- Austral Produce (Wholesale) Pty. Ltd.: Stores 100-102 Melbourne Wholesale Fruit and Vegetable Market, Footscray, 3011
- Australasian Beeswax and Beeline Products: Jubilee Lake Road, Daylesford, 3460
- Australasian Conference Association Limited trading as Sanitarium Health Food Company; 118 Union Street, Windsor, 3181
- A.V. Fruit Enterprises: Store 257 Melbourne Wholesale Fruit and Vegetable Market, Footscray, 3011
- Avindon Pty. Ltd.: Store 258 Melbourne Wholesale Fruit and Vegetable Market, Footscray, 3011
- Name; Principal Place of Business*
- Bakian, C.: Lot 8 Moores Road, Clyde, 3978
- Barker, Green and Parke Pty. Ltd.: Stores 344-347 Melbourne Wholesale Fruit and Vegetable Market, Footscray, 3011
- Barker-Monaghan Packers Pty. Ltd.: Main Road, Coragulac, 3249
- Basmec Nominees Pty. Ltd., trading as (i) Conga Amalgamated; and (ii) United Continental Grocers; 600 Nicholson Street, North Fitzroy, 3068
- Bayview Orchards; Baynes Road, Red Hill South, 3937
- B.B.A Nominees Pty. Ltd., trading as Addamo Barker Packers: Store 129 Melbourne Wholesale Fruit and Vegetable Market, Footscray, 3011
- Beecher, G. L.; Trafalgar South Road, Trafalgar, 3824
- Bendigo Trading Co-operative Ltd.: Cnr. Breen and Adam Streets, Bendigo, 3550
- Best Fresh Produce Pty. Ltd.: Lot 9 Perry Street, Mildura, 3500
- B.G.P. Produce Pty. Ltd.: Stores 124-129 Melbourne Wholesale Fruit and Vegetable Market, Footscray, 3011
- Blue Dandenong Bulb Farm: Old Emerald Road, Monbulk, 3793
- Bolton, D. N.: 143 Vincent Street, Daylesford, 3460
- Bonneys Farmfoods Pty. Ltd.: 371 Hobart Road, Launceston, 7250
- Border Markets: 407 Wagga Road, Lavington, 2641
- Borwick, P. B. and R. W.; 2 Gravesend Street, Colac, 3250
- Boutsis, T. Pty. Ltd.: Melbourne Wholesale Fruit and Vegetable Market, Footscray, 3011
- Bove, Lee and Russo Pty. Ltd.: Store 276 Melbourne Wholesale Fruit and Vegetable Market, Footscray, 3011
- Bryant and Gourley: 22 Peel Street North, Ballarat, 3350
- Caccaviello, C. and M.: "B" Store, No. 52, Melbourne Wholesale Fruit and Vegetable Market, Footscray, 3011
- Caccaviello, L.: "B" Store, No. 41, Melbourne Wholesale Fruit and Vegetable Market, Footscray, 3011
- Callea, P.: 36 Wannan Road, Highett, 3190
- Camptara Pty. Ltd.: Store 40 Melbourne Wholesale Fruit and Vegetable Market, Footscray, 3011
- Cappiello, John: Tooleybuc, 2739
- Careri Holdings, R., Pty. Ltd.; Store 221 Melbourne Wholesale Fruit and Vegetable Market, Footscray, 3011
- Casamento, J.; 63 Japan Street, Warrnambool, 3280
- Castallana Ira Pty. Ltd.: Store 243 Melbourne Wholesale Fruit and Vegetable Market, Footscray, 3011
- Castelplanio Pty. Ltd., trading as Ernie's Fruit Market; 8-10 Hampstead Road, Maidstone, 3012
- Chandler, B. — A. and D. Horne: Unit 5 Sherwood Court, South Wantirna, 3152
- Chandler Enterprises, A. F., Pty. Ltd., trading as Sparks and Chandler; Main Road, Avonsleigh, 3782
- Chawebb Nominees Pty. Ltd., trading as Charlie Webb and Co.; 1 Anthony Street, Croydon, 3136
- Chelmanpe Pty. Ltd., trading as V. Brancatisano and Sons: Stores 314-316 Melbourne Wholesale Fruit and Vegetable Market, Footscray, 3011
- Chen Holdings, S. and C. Pty. Ltd., trading as W. D. Chen Fruit Distributing Co.: Store 281 Melbourne Wholesale Fruit and Vegetable Market, Footscray, 3011

Name; Principal Place of Business

Chin Bros., S. H., Pty. Ltd.; Stores 289-292 Melbourne Wholesale Fruit and Vegetable Market, Footscray, 3011

Chorley, I. and C. H., and Sons; 18 Railway Crescent, Croydon, 3136

Chris, V.; Main Road, Kinglake, 3763

Cincotta, G. and G. Pty. Ltd.; 209 Main Street, Ballarat, 3350

Cirillo Produce, S. and M.; 56 Lake Road, Woorinen, 3589

Clay, H. and G.; Cnr. Warburton Highway and Gembrook Road, Launching Place, 3139

Clode, L. W. and I. P.; Bahgallah Road, Casterton, 3311

Colac Produce and Company Pty. Ltd.; 67 Bruce Street, Colac, 3250

Cole, A. H. and D. M.; 93 Liebig Street, Warrnambool, 3280

Combined Direct Fruit Supply; 181 Ferntree Gully Road, Mt. Waverley, 3149

Conapak Produce Co.; 512 Main Street, Ballarat, 3350

Con Dwyer Produce Company, Scotts Road, Crossley, 3282

Constas Brothers; Store 148 Melbourne Wholesale Fruit and Vegetable Market, Footscray, 3011

Conti, J. and Co.; Stores 187-188 Melbourne Wholesale Fruit and Vegetable Market, Footscray, 3011

Cook, S. D.; Railway Road, Thorpdale, 3835

Cornish, R., and Sons Pty. Ltd.; Stores 43-45 Melbourne Wholesale Fruit and Vegetable Market, Footscray, 3011

Cornish, R., and Sons (Bananas) Pty. Ltd.; Stores 43-45 Melbourne Wholesale Fruit and Vegetable Market, Footscray, 3011

Costa, T. and Co. Pty. Ltd.; 420 Princes Highway, Corio, 3214

Coulton's Wholesale Fruit Supply; 25-29 Nicholson Street, Orbost, 3888

Country Fruit Distributors; Reid Street, Wangaratta, 3677

Cousins, J.; 5 Malla Avenue, Robinvale, 3549

Crowe, W. I.; Tresco, 3583

Cummaudo, G.; 8 Balding Street, Mirboo North, 3871

Cutbush, J. C. and Co.; Daylesford Road, Dean, 3352

Davis, J., Pty. Ltd.; Stores 307-310 Melbourne Wholesale Fruit and Vegetable Market, Footscray, 3011

De Groot Bulb and Flower Supplies; Silvan Road, Monbulk, 3793

Dellios Bros. Pty. Ltd.; Stores 156-160 Melbourne Wholesale Fruit and Vegetable Market, Footscray, 3011

De Lorenzo, N.; 371 Lonsdale Street, Dandenong, 3175

De Marte, D. and R. A.; Stores 211-213 Melbourne Wholesale Fruit and Vegetable Market, Footscray, 3011

Dennis Hanger Pty. Ltd.; Stores 46-48 Melbourne Wholesale Fruit and Vegetable Market, Footscray, 3011

Dimattina, F., and Co. Pty. Ltd.; Stores 61-69 Melbourne Wholesale Fruit and Vegetable Market, Footscray, 3011

Dimattina-Sabatino Pty. Ltd.; Stores 183-184 Melbourne Wholesale Fruit and Vegetable Market, Footscray, 3011

Direct Produce Pty. Ltd.; Stores 40-42 Melbourne Wholesale Fruit and Vegetable Market, Footscray, 3011

Dobson, K. W. and E. M., Cool Store; 59 Dorset Road, Fern-tree Gully, 3156

Donegan Potato Packers; Sullivan Street, Golden Square, 3555

Downes and Ralph; Portland, 3305

Duiven Voorden Holdings Pty. Ltd.; Old Emerald Road, Monbulk, 3793

Name; Principal Place of Business

Durkin Bros. Produce Pty. Ltd.; Narracan Road, Thorpdale, 3835

E. and S. Pty. Ltd.; 566 St. Kilda Road, Melbourne, 3004

Evelyn and District Fruit Supply; Hunter Road, Wandin, 3139

Exton, J.; Market Street, Trentham, 3458

Fabrizio, M. and C.; Store 210 Melbourne Wholesale Fruit and Vegetable Market, Footscray, 3011

Farm Produce Pty. Ltd.; Bayles Road, Tynong, 3813

Farmers Ltd.; Cnr. Wilson and Wilmot Streets, Burnie, 7320

Ferlazzo, G., and Co. Pty. Ltd.; Stores 173-174 Melbourne Wholesale Fruit and Vegetable Market, Footscray, 3011

Findlay, R. J. and R. H.; Boags Road, Leongatha, 3953

Fiorelli Packing Co. Pty. Ltd.; 11 Ricketts Road, Mt. Waverley, 3149

Freshwater, M. and R.; "Moonmoote", Birregurra, 3242

Gaffney, Ian; 101 Main Street, Drouin, 3818

Gala Fruit; 46 Murphy Street, Wangaratta, 3677

Gallicchio, G.; Store 148 Melbourne Wholesale Fruit and Vegetable Market, Footscray, 3011

Garden City Exporters (Aust.) Pty. Ltd.; 1 Jill Court, Ringwood, 3134

Garro, S., and Sons; Werrill Street, Swan Hill, 3585

Gavin, Con; High Street, Koroit, 3282

Gay, W. R. and J. M.; 194 Rosanna Road, Rosanna, 3084

Geelong Citrus Packers; 24 Leather Street, Breakwater, 3219

Geo. Whaley and Sons Pty. Ltd.; Stores 239-240 Melbourne Wholesale Fruit and Vegetable Market, Footscray, 3011

Geoffrey Thompson Fruit Packing Co. Pty. Ltd.; 20 Wheeler Street, Shepparton, 3630

Geoffrey Thompson and Growers Co-operative Co. Pty. Ltd.; 20 Queen Street, Melbourne, 3000

Geoffrey Thompson (Harcourt) Pty. Ltd.; Leura Orchards, Government Road, Harcourt, 3453

George Banson and Son (Aust.) Pty. Ltd.; Stores 386-389 Melbourne Wholesale Fruit and Vegetable Market, Footscray, 3011

Giampaolo, R.; Woorinen, 3589

Giblin Trading Company; Thirteen Mile Road, Garfield, 3814

Gippsland Bean Cleaners; 7 Forest Road, Orbost, 3888

Goulburn River Producers Co-operative Society Ltd.; Clement Road, Toolamba, 3614

Goulburn Valley Tomatoes; Melbourne Road, Kialla, 3631

Green, N., Australia; Store 190 Melbourne Wholesale Fruit and Vegetable Market, Footscray, 3011

Hall's Fruit Supply; 36 Hopetoun Street, Bendigo, 3550

Hal-Pak Pty. Ltd.; 15 Toolamba Road, Mooroopna, 3629

Hancock, A. W., and Co. Pty. Ltd.; 104 Armstrong Street North, Ballarat, 3350

Handley Produce, G. L.; 41 Harper Street, Wangaratta, 3677

Hanger, H., (Vic.) Pty. Ltd.; Store 140 Melbourne Wholesale Fruit and Vegetable Market, Footscray, 3011

Harold Douglas Pty. Ltd.; Store 347 Melbourne Wholesale Fruit and Vegetable Market, Footscray, 3011

Harris, David C.; "The Gums", Main Road, Sassafras, 3787

Hartwig, D.; 116 Queensville Street, West Footscray, 3012

Hayling Pty. Ltd.; 217-219 Victoria Street, West Melbourne, 3003

<i>Name; Principal Place of Business</i>	<i>Name; Principal Place of Business</i>
Healey, J. and B.: Lot 2 Tootals Road, Dingley, 3172	Loe Bros.; Store 154 Melbourne Wholesale Fruit and Vegetable Market, Footscray, 3011
Hibbii Nominees Pty. Ltd., trading as W. R. Hibbins and Sons; Store 273 Melbourne Wholesale Fruit and Vegetable Market, Footscray, 3011	Lopes, A. and H., and Co. Pty. Ltd.; Store 1 Melbourne Wholesale Fruit and Vegetable Market, Footscray, 3011
Honey Bee Produce Company; 75 Bedford Road, Ringwood East, 3135	Louey Pang, H., and Co. Pty. Ltd.; Stores 338-340 Melbourne Wholesale Fruit and Vegetable Market, Footscray, 3011
Honey Corporation of Australia Limited; Capilano Street, Maryborough, 3465	Louis Citrus; Store 150 Melbourne Wholesale Fruit and Vegetable Market, Footscray, 3011
Hope and Veitch; 67 Bromfield Street, Colac, 3250	Louis Stellato Pty. Ltd.; Stores 132 and 172 Melbourne Wholesale Fruit and Vegetable Market, Footscray, 3011
Horsfield Trading Pty. Ltd.; Railway Yards, Thorpdale, 3835	Lovett, H. L. E., and Co. Pty. Ltd.; Stores 392-394 Melbourne Wholesale Fruit and Vegetable Market, Footscray, 3011
Horsham Fruit Supply; 10 Arthur Street, Horsham, 3400	Luciano, O. and G.; Store 261 Melbourne Wholesale Fruit and Vegetable Market, Footscray, 3011
Hurst and Green; 620 Queensberry Street, North Melbourne, 3051	Mackness Produce Pty. Ltd.; 124 Whitehall Street, Footscray, 3011
Hygiene Packers Pty. Ltd.; Barnshaw Lane, Emerald, 3782	Madafferri, F., and Co.; Stores 311-313 Melbourne Wholesale Fruit and Vegetable Market, Footscray, 3011
Ierianni, A.; Store 220 Melbourne Wholesale Fruit and Vegetable Market, Footscray, 3011	Mansells Transports Pty. Ltd.; 274 Cureton Avenue, Mildura, 3500
Impulse Wholesale Flowers; 943 Dandenong Road, East Malvern, 3145	Marangan Packers Pty. Ltd.; Murray Valley Highway, Nyah, 3594
Interlandi Produce Pty. Ltd.; Stores 121-123 Melbourne Wholesale Fruit and Vegetable Market, Footscray, 3011	Marcheff's Eastern Produce; Stores 398-399 Melbourne Wholesale Fruit and Vegetable Market, Footscray, 3011
Iulianella, C. and N.; 92 Raleigh Street, Westmeadows, 3049	Mark Dykes (Vic.) Pty. Ltd.; Stores 133-138 Melbourne Wholesale Fruit and Vegetable Market, Footscray, 3011
Jackel, G. O., and Sons; 99 Williams Road, Wangaratta, 3677	Mark Wilson Fruit; Store 49 Melbourne Wholesale Fruit and Vegetable Market, Footscray, 3011
J.B. Trading Pty. Ltd.; Stores 92-95 Melbourne Wholesale Fruit and Vegetable Market, Footscray, 3011	Martakis, G., and Sons (Aust.) Pty. Ltd.; 110-112 Bridport Street, Albert Park, 3206
John De Maria; Stores 218-219 Melbourne Wholesale Fruit and Vegetable Market, Footscray, 3011	Mase, G., and Mollo, R.; Piangil, 3597
John Holman and Co. Pty. Ltd.; Stores 116-120 Melbourne Wholesale Fruit and Vegetable Market, Footscray, 3011	Mastrocola, E.; 82 Nicholson Street, Bairnsdale, 3875
J. and S. Fruit Agency; Stores 228-229 Melbourne Wholesale Fruit and Vegetable Market, Footscray, 3011	Materia Bros.; 32 Smith Street, Leongatha, 3953
"K" Brand — S. Kopcheff; Stores 335-337 Melbourne Wholesale Fruit and Vegetable Market, Footscray, 3011	Matthey, N. J., and J. C.; 73-75 Preston Street, Geelong West, 3218
Kapiris Bros. Pty. Ltd.; Stores 1-6 Melbourne Wholesale Fruit and Vegetable Market, Footscray, 3011	M. and B. Fruit Wholesalers; Store 256 Melbourne Wholesale Fruit and Vegetable Market, Footscray, 3011
Kelly, J. and J. M., Pty. Ltd.; Store 400 Melbourne Wholesale Fruit and Vegetable Market, Footscray, 3011	Melbourne Farm Produce; Shop 6, The Mall, West Heidelberg, 3081
Kenney, W. R., and Sons; South Road, Warragul, 3820	Micks and Johns Fruit and Vegetable Supply Pty. Ltd.; 1 Trent Court, East Keilor, 3042
Keogh, Noel; Cosmo Road, Trentham, 3458	Mildura and South Australian Fruit Co.; Stores 390-391 Melbourne Wholesale Fruit and Vegetable Market, Footscray, 3011
King, E. G., Pty. Ltd.; Stores 96-99 Melbourne Wholesale Fruit and Vegetable Market, Footscray, 3011	Ming Green (Wholesale Florist); 117 Bailey Road, Mt. Evelyn, 3796
King, J. L. and Co.; Breen Street, Bendigo, 3550	Mobbs and Co.; 13 Knox Street, Daylesford, 3460
Kinglake Produce Pty. Ltd.; Pheasant Creek, 3757	Morey, J. D., and Sons; Grahamvale Road, Grahamvale, 3631
Knee, H. G. and P. B.; "B" Store No. 152, Melbourne Wholesale Fruit and Vegetable Market, Footscray, 3011	Moser, J.; 250 Campbell Street, Swan Hill, 3585
Lanteri, S.; 170 Main Street, Bairnsdale, 3875	Moss, J., and Sons Pty. Ltd.; Stores 359-361 Melbourne Wholesale Fruit and Vegetable Market, Footscray, 3011
Larizza, D.; 17 Queen Street, Frankston, 3199	Motta, G.; Store 197 Melbourne Wholesale Fruit and Vegetable Market, Footscray, 3011
Latorre, F.; Store 238 Melbourne Wholesale Fruit and Vegetable Market, Footscray, 3011	Mould, A. R., Produce Pty. Ltd.; Store 179 Melbourne Wholesale Fruit and Vegetable Market, Footscray, 3011
Lee, G. W., and Co. Pty. Ltd.; Stores 73-78 Melbourne Wholesale Fruit and Vegetable Market, Footscray, 3011	Mountain Valley Produce; Dalry Road, Healesville, 3777
Legudi, F., Pty. Ltd.; Store 255 Melbourne Wholesale Fruit and Vegetable Market, Footscray, 3011	Mullen, E. M.; Chute Road, Thorpdale, 3835
Liddell, N. J. — Wholesale Florist; 179 Centre Dandenong Road, Cheltenham, 3192	Mullens, G. and W., Pty. Ltd.; Melbourne Wholesale Fruit and Vegetable Market, Footscray, 3011
Lindsay's Orange House; 17 Jacaranda Street, Red Cliffs, 3496	
Lockwood, R. and J., and Son; Stores 356-358 Melbourne Wholesale Fruit and Vegetable Market, Footscray, 3011	

<i>Name; Principal Place of Business</i>	<i>Name; Principal Place of Business</i>
Mumford, J. G., (Wholesale) Pty. Ltd.: Stores 49-52 Melbourne Wholesale Fruit and Vegetable Market, Footscray, 3011	Redpath's Beeline Apiaries: 21 Capella Crescent, Moorabbin, 3189
Mum's Chips Company Pty. Ltd.: 798 Dandenong Road, Springvale, 3171	Reeves, J.: Exton's Road, Kinglake Central, 3757
Muratore, F., Pty. Ltd.: Store 180 Melbourne Wholesale Fruit and Vegetable Market, Footscray, 3011	Rendevski, V., and Sons: Feiglin Lane, Shepparton, 3630
Murray Campaspe Trading Co. Pty. Ltd.: Lot 1 Cohen Street, Rochester, 3561	Riccardi, A., Lot 74 South Gippsland Highway, Tooradin, 3980
M.V.F. Nominees Pty. Ltd., trading as Monvale Flowers: Moxham Road, Monbulk, 3793	Rizzo, P. and V.: 282 Rossiter Road, Koo Wee Rup, 3981
McBeth, J.: 5 Moira Street, East Malvern, 3145	Roberts, L. G.: 120 Thompson Street, Hamilton, 3300
McKay, D.: 450 Murray Street, Colac, 3250	Roderick's Honey: 10 Hosie Street, Bairnsdale, 3875
McLaine, K. W., and Sons Pty. Ltd.: Cherry's Road, Toolangi, 3777	Rose, G. I.: 13 Maury Road, Chelsea, 3196
McMahon Dairy Products Pty. Ltd.: 486 South Road, Moorabbin, 3189	Rose (Orchards) Tatura: Pyke Road, Tatura, 3616
Nar Nar Goon Growers and Packers: Bessie Creek Road, Nar Nar Goon, 3812	Ross, J. W., Pty. Ltd.: Stores 332-334 Melbourne Wholesale Fruit and Vegetable Market, Footscray, 3011
Natoli, G. and C., Pty. Ltd.: Factory 4, 61 Brunel Road, Seaford, 3198	Rossin, G., and Sons: Stores 177-178 Melbourne Wholesale Fruit and Vegetable Market, Footscray, 3011
Nichol, A. and Sons Pty. Ltd.: Stores 323-328 Melbourne Wholesale Fruit and Vegetable Market, Footscray, 3011	Rowse Bros. Pty. Ltd.: Hunters Road, Warragul, 3820
Nichol Produce Pty. Ltd.: Stores 248-250 Melbourne Wholesale Fruit and Vegetable Market, Footscray, 3011	Ruigrok, F. M.: Lot 7 Old Emerald Road, Monbulk, 3793
Nichols, John: Myers Creek Road, Healesville, 3777	Sang Goon and Co. Pty. Ltd.: Store 378 Melbourne Wholesale Fruit and Vegetable Market, Footscray, 3011
Nightingale Bros.: Main Road, Wandiligong, 3744	Santalucia, A., and Sons Pty. Ltd., 47-53 Chapel Street, West Melbourne, 3003
Nine Creeks Fruit Supply: 76 Lloyd Street, Dimboola, 3414	Santarosa, G. and E., Pty. Ltd.: Diggers Road, Werribee South, 3030
Nu-Fruit Pty. Ltd.: 90 Newman Street, Wangaratta, 3677	Santospirito, I. C., and J.: Cheltenham Road, Keysborough, 3175
Orton, J. and A.: Main Road, Colignan, 3494	Sanzaro, Sofio: 116 Fynans Street, South Geelong, 3220
O'Toole, Hugh: Princes Highway, Ilwona, 3282	Scarpari, M. I.: Trotter Road, North Mooroopna, 3629
Pagerton Pty. Ltd.: Stores 88-91 Melbourne Wholesale Fruit and Vegetable Market, Footscray, 3011	Sciarrone, G.: Store 267 Melbourne Wholesale Fruit and Vegetable Market, Footscray, 3011
Pat Lamanna Wholesale Pty. Ltd.: Stores 17-21 Melbourne Wholesale Fruit and Vegetable Market, Footscray, 3011	Scollo, J.: 1420 Heatherton Road, Dandenong, 3175
Peter's Wholesale Fruit Supply: Stores 22-24 Melbourne Wholesale Fruit and Vegetable Market, Footscray, 3011	Scoufos, P. and C.: 84 Nolan Street, Maryborough, 3465
Piccolo, C.: Store 222 Melbourne Wholesale Fruit and Vegetable Market, Footscray, 3011	Sculli, F.: Greta West, 3675
Pirrie Bros.: 8 South Wharf Road, South Melbourne, 3205	Shields Wholesale Florist: Doongallah Road, The Basin, 3154
Ponte, V. and S.: Stores 201-203 Melbourne Wholesale Fruit and Vegetable Market, Footscray, 3011	Silk Bros. (Melb.) Pty. Ltd.: Stores 193-197 Melbourne Wholesale Fruit and Vegetable Market, Footscray, 3011
Ponte Produce, C. and S.: Stores 161-163 Melbourne Wholesale Fruit and Vegetable Market, Footscray, 3011	Skaliotis, L.: 111 Barkly Street, Ararat, 3377
Potter (Melbourne) Pty. Ltd.: Stores 341-343 Melbourne Wholesale Fruit and Vegetable Market, Footscray, 3011	Snowy River Co-operative Limited: Princes Highway, Newmeralla, 3886
Prestia Wholesalers: Stores 224-225 Melbourne Wholesale Fruit and Vegetable Market, Footscray, 3011	Sos, F. and E.: Lot 8 and 9 Karadoc, 3496
Pryde, L. J.: 100 Saxton Street, Numurkah, 3636	Southern Produce: 15 Hinkler Road, Braeside, 3195
Quayle, J. A.: 41-43 Main Street, Ballarat, 3350	Southland Packers Pty. Ltd., trading as A. Venuto & Co.: Stores 56-60 Melbourne Wholesale Fruit and Vegetable Market, Footscray, 3011
Quayle and Hutton: 23-27 Main Street East, Ballarat, 3350	Sperlinga Trading Pty. Ltd.: Stores 53-56 Melbourne Wholesale Fruit and Vegetable Market, Footscray, 3011
Quong Hoong Wah Pty. Ltd.: Stores 103-105 Melbourne Wholesale Fruit and Vegetable Market, Footscray, 3011	Stan Farquhar and Sons Pty. Ltd.: Learmonth Road, Wendouree, 3355
Raciti Holdings Pty. Ltd.: Harewood Park Road, Gembrook, 3783	Star Fruit Co. Pty. Ltd., trading as Banana Marketing Australia: Stores 25-36 Melbourne Wholesale Fruit and Vegetable Market, Footscray, 3011
Rankin, L. and M., Pty. Ltd.: Princes Highway, Trafalgar, 3824	Stephen Chen (Australia) Pty. Ltd., trading as Stephen Chen Fruit Co.: Store 281 Melbourne Wholesale Fruit and Vegetable Market, Footscray, 3011
Red Gem Packers Pty. Ltd.: Main Road, Gembrook, 3783	Stokes and Hammond: 44 Burnett Street, North Hobart, 7002
	Sunzest Pty. Ltd.: Wentworth, 2648
	Tasmanian Local Fruit Merchants: Stores 191-192 Melbourne Wholesale Fruit and Vegetable Market, Footscray, 3011

Name; Principal Place of Business

Tesselaar Nominees Pty. Ltd., trading as Tesselaar's Padua Bulb Nurseries; Monbulk Road, Silvan. 3795

Testarotta, A.; Stores 251-252 Melbourne Wholesale Fruit and Vegetable Market, Footscray. 3011

The Citrus Marketing Company Pty. Ltd.; 58 Pine Avenue, Mildura. 3500

The Committee of Direction of Fruit Marketing; Stores 365-376 Melbourne Wholesale Fruit and Vegetable Market, Footscray. 3011

Tim Young and Co. Pty. Ltd.; Stores 348-351 Melbourne Wholesale Fruit and Vegetable Market, Footscray. 3011

Tony Tripodi Nominees Pty. Ltd.; Lake Boga. 3584

Toolamba Road Produce; Toolamba Road, Toolamba. 3614

Torglen Nominees Pty. Ltd., trading as F. and M. Ponte and Sons; Store 243 Melbourne Wholesale Fruit and Vegetable Market, Footscray. 3011

Tos Tac Trading Company; 5/7 The Grange, East Malvern. 3145

Town and District Fruit Supply; 212c Deakin Avenue, Mildura. 3500

Townley, Ron; Rossiter Road, Koo Wee Rup. 3981

Trainor Bros.; 84 Alma Street, Maryborough. 3465

Trellis, J. G.; Stores 293-295 Melbourne Wholesale Fruit and Vegetable Market, Footscray. 3011

Tripodi, S.; Stores 230-231 Melbourne Wholesale Fruit and Vegetable Market, Footscray. 3011

Tripodi Nominees, R. Pty. Ltd., trading as R.J.T. Fruit; Stores 214-216 Melbourne Wholesale Fruit and Vegetable Market, Footscray. 3011

Trupak Produce Supply; Dean. 3352

Tsourdakis, G. and I.; 281 Camp Road, Broadmeadows. 3047

Tully, G. R., and Sons; Three Chain Road, Moorooduc. 3933

Twin City Fruit Market; 5 Thomas Mitchell Drive, Wodonga. 3690

Uniflora Pty. Ltd.; Monbulk-Seville Road, Silvan. 3795

Valley Pack Pty. Ltd.; Midland Highway, Mooroopna. 3629

Valos, S.; 16 Fanny Street, Moonee Ponds. 3039

Valpied's Fruit; 1773 Sturt Street, Ballarat. 3350

Vear (Fruit) F. W., Pty. Ltd.; Stores 79-84 Melbourne Wholesale Fruit and Vegetable Market, Footscray. 3011

Vear (O'Seas), F. W., Pty. Ltd.; 164 Adderley Street, West Melbourne. 3003

Vear (Providores), F. W., Pty. Ltd.; Stores 79-84 Melbourne Wholesale Fruit and Vegetable Market, Footscray. 3011

Vear (Vegetables), F. W., Pty. Ltd.; Stores 175-176 Melbourne Wholesale Fruit and Vegetable Market, Footscray. 3011

Viva La Fruit Pty. Ltd.; Store 332 Melbourne Wholesale Fruit and Vegetable Market, Footscray. 3011

Vraca, G.; North Murchison. 3610

Western Murray Fruit Supply; 147 Ninth Street, Mildura. 3500

Westmore, F. W., and Son Pty. Ltd.; Store 223 Melbourne Wholesale Fruit and Vegetable Market, Footscray. 3011

Westside Produce; Stores 7-9 Melbourne Wholesale Fruit and Vegetable Market, Footscray. 3011

Whitty Produce Pty. Ltd.; Hume Highway, South Wangaratta. 3678

Whitty Trading Pty. Ltd.; Tone Road, South Wangaratta. 3678

Name; Principal Place of Business

Wiffen, M. J.; Red Cliffs. 3496

Williams, G. R.; 49 Welfare Parade, Burwood. 3125

Wing, R. A., and Co. Pty. Ltd.; Stores 302-306 Melbourne Wholesale Fruit and Vegetable Market, Footscray. 3011

Woodford Produce; Woodford. 3282

Wylie, R. W.; Princes Highway, Boorcan. 3261

Yandell, John Richard; 47 Campbell Street, Castlemaine. 3450

Yarrang Pty. Ltd., trading as F. and I. Baguley Flower and Plant Growers; Heatherston Road, Clayton South. 3169

Young Sang and Co. Pty. Ltd.; Stores 299-301 Melbourne Wholesale Fruit and Vegetable Market, Footscray. 3011

Zagami, J. A.; Esplanade, Lakes Entrance. 3909

Zammicheli, L. and U.; Store 131 Melbourne Wholesale Fruit and Vegetable Market, Footscray. 3011

Zorro Produce; Stores 164-165 Melbourne Wholesale Fruit and Vegetable Market, Footscray. 3011

Zurcas Coolstore and Packing Co. Pty. Ltd.; Benalla Road, Shepparton. 3630

COMMISSION AGENTS

Name; Principal Place of Business

Alberni and Granato; Melbourne Wholesale Fruit and Vegetable Market, Footscray. 3011

Albicini and Franchi Bros.; 19 Talaskia Road, Upper Ferntree Gully. 3156

Aumann, E. G.; Melbourne Wholesale Fruit and Vegetable Market, Footscray. 3011

Aurora Packing Company Pty. Ltd.; Laurel Street, Red Cliffs. 3496

Avalon Fruit Sales; Stores 232-234 Melbourne Wholesale Fruit and Vegetable Market, Footscray. 3011

Condo Bros.; Lot 18 Karadoc. 3496

Craig Mostyn and Growers Packing Co. Pty. Ltd.; 132-136 Albert Road, South Melbourne. 3205

Cutrale, T.; Store 263 Melbourne Wholesale Fruit and Vegetable Market, Footscray. 3011

D'Aloisio, G. and C.; Melbourne Wholesale Fruit and Vegetable Market, Footscray. 3011

Damianopoulos, A., and Sons Pty. Ltd.; Grahamvale Road, Grahamvale. 3631

De Julio Nominees Pty. Ltd.; Melbourne Wholesale Fruit and Vegetable Market, Footscray. 3011

Dennehy, K. J. and A.; Camerons Road, Healesville. 3777

De Vincentis, C., and Sons; Melbourne Wholesale Fruit and Vegetable Market, Footscray. 3011

Di Gregorio, D., and Sons Pty. Ltd.; Thomas Road, Red Hill South. 3937

Dundas Simson Pty. Ltd.; Ardmona. 3629

Feiglin, M., and Sons Nominees Pty. Ltd.; Station Street, Nunawading. 3131

*Frawley, Frank; Bungaree. 3352

Gippsland Fruit Sales Pty. Ltd.; Stores 263-265 Melbourne Wholesale Fruit and Vegetable Market, Footscray. 3011

Goldsworthy, R.; School Road, Wandiligong. 3744

Gregory, R.; Westcott Road, Millbrook. 3352

Harcourt Fruit; Barkers Creek. 3451

Harvey, G. R. and E. R., Pty. Ltd.; Melbourne Wholesale Fruit and Vegetable Market, Footscray. 3011

Name; Principal Place of Business

Hobson, C. C.: Bullarto Road, Koo Wee Rup, 3981
 Holland, D. and G.: Walkers Drain Road, Iona via Bunyip, 3815
 Howell, L. and E.: Melbourne Wholesale Fruit and Vegetable Market, Footscray, 3011
 Jones, J. R.: Main Street, Bacchus Marsh, 3340
 Kalafatis, E.: Old Dookie Road, Lemnos, 3631
 Kolmanic, M., Pty. Ltd.: 77 Springs Road, Drysdale, 3222
 Lane, Patrick Vincent: Lane's Lane, Illowa, 3282
 Lee McKeand and Son Pty. Ltd.: 467-473 Malvern Road, South Yarra, 3141
 Lemnos Fruit Packing Pty. Ltd.: New Dookie Road, Lemnos, 3631
 Micheli, J.: Growers Section, Melbourne Wholesale Fruit and Vegetable Market, Footscray, 3011
 Mildura Growers Sales Co-operative Society Limited: Melbourne Wholesale Fruit and Vegetable Market, Footscray, 3011
 Minutoli, A.: Girgarre East via Tatura, 3624
 Morton, J. R. and A.: Dargo Road, Walpa via Bairnsdale, 3875
 Mould, G. W. and R., Pty. Ltd.: Hunter Road, Wandin, 3139
 McLeod, I. and R.: Melbourne Wholesale Fruit and Vegetable Market, Footscray, 3011
 Neil Forbes International: 120 King Street, Melbourne, 3000
 Parke, T.: Stand 245 Growers Section, Melbourne Wholesale Fruit and Vegetable Market, Footscray, 3011
 Peeler, A. R.: 24 View Street, Castlemaine, 3450
 Peninsula Fruit Sales Pty. Ltd.: Stores 329-331 Melbourne Wholesale Fruit and Vegetable Market, Footscray, 3011
 Peter D'Aloisio Produce Pty. Ltd.: Melbourne Wholesale Fruit and Vegetable Market, Footscray, 3011
 Pettinella, L. and Sons: Melbourne Wholesale Fruit and Vegetable Market, Footscray, 3011
 Piccoli, D. and J., Pty. Ltd.: Store 253 Melbourne Wholesale Fruit and Vegetable Market, Footscray, 3011
 Pignataro, G.: Stand 456 Growers Section, Melbourne Wholesale Fruit and Vegetable Market, Footscray, 3011
 Pignataro, I., Melbourne Wholesale Fruit and Vegetable Market, Footscray, 3011
 Ripepi, R.: Stand 360 Melbourne Wholesale Fruit and Vegetable Market, Footscray, 3011
 Sarnia Packing Pty. Ltd.: Etiwanda Avenue, Mildura, 3500
 Seamer, M. F.: Melbourne Wholesale Fruit and Vegetable Market, Footscray, 3011
 Sesto Nominees Pty. Ltd.: Stores 226-227 Melbourne Wholesale Fruit and Vegetable Market, Footscray, 3011
 Shelton, Ian: Stores 270-271 Melbourne Wholesale Fruit and Vegetable Market, Footscray, 3011
 *Singer Pink and Wilson Pty. Ltd.: "Charteris House," 216-218 Lower Heidelberg Road, East Ivanhoe, 3079
 Somerset Orchard Sales Pty. Ltd.: Stores 206-209 Melbourne Wholesale Fruit and Vegetable Market, Footscray, 3011
 Stacker, J. F. and E. E.: 30 Gardenia Street, Pakenham, 3810
 Stefano, L. and A.: 193 Boundary Road, East Geelong, 3219
 Swift, I. and C.: Melbourne Wholesale Fruit and Vegetable Market, Footscray, 3011
 Taverna, B.: Store 269 Melbourne Wholesale Fruit and Vegetable Market, Footscray, 3011

Name; Principal Place of Business

Taylor, J. A.: Melbourne Wholesale Fruit and Vegetable Market, Footscray, 3011
 The Mildura Co-operative Fruit Company Limited: Eighth Street, Mildura, 3500
 Tully, L. J., and Sons: 31 Victoria Street, Doncaster, 3108
 *Vulcz, L.: Beech Forest, 3237
 Westernport Coolstores: Denham Road, Tyabb, 3913
 Wilson and Hemphill Pty. Ltd.: Tucks Road, Main Ridge, 3928
 Yugalbar Nominees Pty. Ltd., trading as David Hobbs and Co.: Cambus Road, Coldstream, 3770
 Zerbe, L. H., and Co.: "Tathra Vale", Red Hill Road, Red Hill South, 3937

SECONDARY WHOLESALERS

Name; Principal Place of Business

Arceri, G.: New Dookie Road, Shepparton, 3630
 Australian Dried Fruits Sales Pty. Ltd.: 9 Queens Road, Melbourne, 3004
 Bon Food International Pty. Ltd.: 51 Weston Street, Brunswick, 3056
 Curty's Fruit Shop: 31 Main Street, Foster, 3960
 D'Alia, F., and Sons: 180 Commercial Road, Morwell, 3840
 D'Alia Bros.: 1039-41 Nepean Highway, Rosebud, 3939
 Darling, R.: 9 Learmonth Street, Hamilton, 3300
 Dickson, L. M.: 13 Second Avenue, Hepburn Springs, 3461
 Encompass Holdings: Old Emerald Road, Monbulk, 3793
 Foodland Stores Pty. Ltd.: 619 Springvale Road, Glen Waverley, 3150
 Gazis, Z.: 114 Nolan Street, Maryborough, 3465
 Glenferrie Market: 676 Glenferrie Road, Hawthorn, 3122
 Henty Highway Bus Service: 1 Swan Place, Mildura, 3500
 Hoyt Food Manufacturing Industries Pty. Ltd.: 27 Alex Avenue, Moorabbin, 3189
 Kelly Country Fruit Market: Tone Road, Wangaratta, 3677
 Laurie's Fruit Supply: 46 McBride Avenue, Wonthaggi, 3995
 Lazzaro Bros.: 90 York Street, Sale, 3850
 Loricco, A., and Son: 50 Murray Street, Colac, 3250
 Mackaness Prepacking Pty. Ltd.: 124 Whitehall Street, Footscray, 3011
 Marios Fruit Palace: 411 Sturt Street, Ballarat, 3350
 Marsolino's Fruit Supply: Campbell Street, Swan Hill, 3585
 Masciarelli, F. and A., Pty. Ltd.: 91 Myrtle Street, Myrtleford, 3737
 Moe Central Fruit Supply: 13 George Street, Moe, 3825
 McLoughlan, T. W.: 31 Sherwood Street, Birchip, 3483
 North East Fruit Supply: 47 Bridge Street, Benalla, 3672
 Pakenham Fruit Mart: 131 Main Street, Pakenham, 3810
 Penna Sales, A. W., Pty. Ltd.: 151 Rosamond Road, West Maribyrnong, 3032
 Perry, D. J. and K. M.: Stooles Stores, Henty Street, Casterton, 3311
 Plowmans Fruit Supply: 154 Mollison Street, Kyneton, 3444
 Potato Products (Aust.) Pty. Ltd.: 5 Moira Street, East Malvern, 3145
 Presti, L.: 90 Paisley Street, Footscray, 3011

Name: Principal Place of Business

Russo, Tom; 66 Mollison Street, Kyneton, 3444
 Russo's Fruit Supply; 74-80 Mollison Street, Kyneton, 3444
 Sale Fruit Supply; 289 Raymond Street, Sale, 3850
 Schmolling, K. G.; Maroondah Highway, Healesville, 3777
 Sestito, O.; 96 Fryers Street, Shepparton, 3630
 Steve Tripodi Fruit Supply; 88 Princess Street, Traralgon, 3844
 Stonemans Management Pty. Ltd.; 101 Queen Street, Bendigo, 3550
 Symes, Daryl; "Sunnyside", Symes Road, Harcourt, 3453
 Tsakos, M.; 21 Victoria Street, Nhill, 3418
 Van Lier, J. and C.; Myrtlebank via Sale, 3851
 Warrnambool Cool Stores; 179 Drummond Street, Dennington, 3279
 Western District Fruit Supply; Walsh Road, Warrnambool, 3280
 Wong, D. E.; 2 Main Street, Sorrento, 3943
 Wyngaard, B. J.; 44 Maurice Street, Mallacoota, 3889

*Exempt from prescribed contribution to the Guarantee Fund under Regulation 9 (1).

Marketing of Primary Products Act 1958 (No. 6304)

THE VICTORIAN EGG MARKETING BOARD

Section 41C of the *Marketing of Primary Products Act 1958* provides that any person who owns or is entitled to sell or dispose of any eggs may present the same to the Victorian Egg Marketing Board or a person authorized in that behalf by the Board at a place and in such manner as the Board by notice published in the *Government Gazette*, directs for grading and testing and for marking and stamping so as to indicate the grade and quality.

The Victorian Egg Marketing Board, by this public notice, directs that unless the Board otherwise directs, eggs may be presented to the Board or persons duly authorized by the Board in that behalf for grading and testing and for marking and stamping so as to indicate the grade and quality at any one or more of the following places:

1. Metropolitan Grading and Selling Floors
 - Keysborough — Egg Farmers of Victoria, 551 Chandler Road
 - Thomastown — T. J. Neylon & Son Pty. Ltd., 10 Charnfield Court
2. Country Grading and Selling Floors
 - Bendigo — Crystal Egg Company, 21 Garsed Street
 - Mildura — Mildura Co-operative Producers' Egg Floor Pty. Ltd., 155 Seventh Street

The Victorian Egg Marketing Board by this public notice further directs that eggs presented to the Board or a person authorized in that behalf by the Board for grading and testing and for marking and stamping so as to indicate the grade and quality shall be presented in the following manner:

1. All of the provisions of The Victorian Egg Marketing Board Regulations 1979 as amended relating to the manner in which eggs are to be presented as aforesaid shall be observed.
2. All eggs so presented shall be presented properly packed in 2½ dozen trays in a clean and sanitary condition in suitable containers as approved by the Board. "Suitable containers" will normally include only 15 or 30 dozen heavy duty re-usable cardboard cartons and 360 dozen egg trolleys or in bulk on pallets.

3. The person who presents the eggs shall supply to the Board or the person authorized as aforesaid such number of additional empty egg cases or containers and clean and sanitary 2½ dozen trays as the Board or such person may reasonably require for the purpose of re-packing the eggs after grading according to their separate grades.

4. All approved egg containers and egg fillers in which eggs are packed when presented and all additional empty egg containers and egg fillers presented aforesaid shall be clean, uncontaminated and in serviceable condition.

5. There shall be durably and legibly written or marked on each egg case or container in which eggs are so presented or which is supplied as aforesaid, or on a label firmly affixed thereto:

- (a) The name and address of the person by whom the eggs are presented.
 - (b) Any other requirements as notified by the Board from time to time.
 - (c) A clear notification that eggs are presented pursuant to the said Section 41C and not pursuant to Section 21 of the *Marketing of Primary Products Act 1958*.
6. (a) The fee chargeable to persons submitting eggs for grading under Section 41C of the Act will be such rate as fixed by the Board from time to time in accordance with the Act. Currently these rates are:
- (i) 8.5 cents per dozen in 360 dozen trolleys or in bulk on pallets.
 - (ii) 9.5 cents per dozen in 30 dozen containers, and
 - (iii) 10.5 cents per dozen in 15 dozen containers.
- (b) Persons who deliver eggs for grading shall be responsible for costs of delivery to the Grading Floor or such other place as required by the Board.

7. All enquiries regarding the requirements of the Act should be directed to the Board at its Head Office address, 551 Chandler Road, Keysborough, 3173. Telephone 798 7077.

Dated 19 August 1983

C. L. JEFFERSON, Secretary

Marketing of Primary Products Act 1958 (No. 6304)

THE VICTORIAN EGG MARKETING BOARD

By Proclamation published in the *Government Gazette* No. 76 dated 3 August 1983, the Governor in Council of the State of Victoria, provided and declared on 26 July 1983 that all eggs (with certain exceptions) coming into existence within a period of two years from 16 August 1983, shall become vested in and be delivered by producers to The Victorian Egg Marketing Board or its authorized agents.

The Victorian Egg Marketing Board, by this public notice, directs that all eggs (excepting eggs which are exempt from delivery according to Section 21 of the *Marketing of Primary Products Act 1958* (No. 6304) and eggs which in any particular case the Board directs in writing to be delivered at a place or places specified in such direction) shall be delivered to the Board or its authorized agents at any one or more of the following grading and selling floors and/or receiving depots.

1. Grading and Selling Floors

Metropolitan

Keysborough — Egg Farmers of Victoria, 551 Chandler Road
 Thomastown — T. J. Neylon & Son Pty. Ltd., 10 Charnfield Court

Country

Bendigo — Crystal Egg Company, 21 Garsed Street
 Mildura — Mildura Co-operative Producers' Egg
 Floor Pty. Ltd., 155 Seventh Street

2. Receiving and Selling Depots

Ballarat — Egg Farmers of Victoria, 612 Talbot Street
 Dimboola — Nettlebeck & Stalker, 24 Wimmera
 Street
 Euroa — Euroa Co-operative Society Ltd., Railway
 Street
 Geelong South — The Geelong & Cressy Trading Co.
 (1979) Pty. Ltd., 118 Fyans Street
 Hamilton — Grange Dairies Pty. Ltd., 1 Moore Street
 Horsham — Lehmann Distributors, 72 Darlot Street

3. Receiving Depots

Charlton — Crystal Transport Co., 62 High Street
 Stawell — W. J. Barker, 1 Napier Street
 Wangaratta — Wangaratta Dairies, 35 Warby Street
 Warragul — Permewans Pty. Ltd., Princes Highway

The Victorian Egg Marketing Board by this public notice further directs that eggs delivered to the Board or a person authorized in that behalf by the Board for grading and testing and for marking and stamping so as to indicate the grade and quality shall be presented in the following manner:

1. All of the provisions of The Victorian Egg Marketing Board Regulations 1979 as amended relating to the manner in which eggs are to be delivered as aforesaid shall be observed.

2. All eggs so delivered shall be delivered packed in clean, serviceable and uncontaminated egg fillers in containers approved by the Board and legibly marked with the name and registered number allocated by the Board of the producer consigning the eggs. Approved containers will normally include 15 or 30 dozen heavy duty re-usable cardboard cartons and 360 dozen egg trolleys and when presented to the Board shall be clean, uncontaminated and in serviceable condition.

3. Eggs which are fertile shall be clearly identified by labelling each container as "Fertile".

Dated 19 August 1983

C. L. JEFFERSON, Secretary

PUBLIC TRUSTEE ACT 1958, SECTION 17

I hereby give notice that on 9 August 1983, the Public Trustee filed an Election to Administer the following deceased person's estate in accordance with Section 17 of the *Public Trustee Act 1958*:

Orford, Lilian Pearl, formerly of 49 Albert Crescent, North Fitzroy, but late of 45 Munro Street, Coburg, Widow, died 9 April 1983.

I hereby give notice that on 15 August 1983, the Public Trustee filed Elections to Administer the following deceased persons' estates in accordance with Section 17 of the *Public Trustee Act 1958*:

Cheesley, Daisy Elizabeth, formerly of Wodonga, but late of Begonia Private Nursing Home, 207-215 Richards Street, Ballarat East, Pensioner, died 9 December 1982.

Cocks, Marjorie Leila, late of 26 Amaroo Street, Chadstone, Widow, died 17 March 1983.

Fartsalas, Rita Loretto, formerly of Flat 4, First Floor, 150 Victoria Avenue, Albert Park, but late of Parkville, Pensioner, died 8 May 1983.

Flowers, Albert Keith, late of Ballarat, Retired Labourer, died 9 October 1982.

McIntosh, Helen Bryce, late of 142 Sycamore Street, Caulfield, Widow, died 13 June 1983.

Thompson, Robert John, late of 150 Vincent Road, Morwell, Retired Trades Assistant, died 25 September 1982.

Tyzack, Ernest Edward, late of 16 Waterloo Place, Mornington, Retired, died 24 May 1983.

I hereby give notice that on 17 August 1983, the Public Trustee filed Elections to Administer the following deceased persons' estates in accordance with Section 17 of the *Public Trustee Act 1958*:

Chenery, Winifred Charlotte, formerly of Flat 4/5 Travellyn Street, Blackburn South, but late of Strathdon Hostel, 17 Jolimont Road, Forest Hill, Spinster, died 9 July 1983.

Karaot, Mehmet Dogan, late of 821 Centre Road, East Bentleigh, Seaman, died 24 July 1982.

Kos, Joseph, late of Flat 103/12 Holland Street, Flemington, Retired, died 4 December 1978.

Smith, Alice Maude, late of c/- 51 Brinsley Road, Camberwell (in will called Bridesley), Widow, died 29 June 1983.

Stewart, Wallace John Agnew, also known as Wallace John Stewart, formerly of 7 Jenkin Street, East Brunswick, but late of 19 Boston Avenue, Seaford, Retired Cleaner, died 6 July 1983.

Wilson, Allan Harold, late of 1/455 Princes Highway, Noble Park, Purchaser, died between 21 March 1983 and 22 March 1983.

24 August 1983

168 Exhibition Street,
 Melbourne 3000

P. T. SPENCER
 Public Trustee

Creditors, next of kin and others having claims against the estate of any of the under-mentioned deceased persons are required to send particulars of their claims to the Public Trustee, 168 Exhibition Street, Melbourne, Vic. 3000, the personal representative, on or before 7 November 1983, after which date the Public Trustee may convey or distribute the assets having regard only to the claims of which the Public Trustee then has notice:

Cheesley, Daisy Elizabeth, formerly of Wodonga, but late of Begonia Private Nursing Home, 207-215 Richards Street, Ballarat East, Pensioner, died 9 December 1982.

Chenery, Winifred Charlotte, formerly of Flat 4/5 Travellyn Street, Blackburn South, but late of Strathdon Hostel, 17 Jolimont Road, Forest Hill, Spinster, died 9 July 1983.

Cocks, Marjorie Leila, late of 26 Amaroo Street, Chadstone, Widow, died 17 March 1983.

Doble, Thelma Patricia Louise Madden, late of 57 Berry Street, East Melbourne, Retired, died 11 June 1983.

Fartsalas, Rita Loretto, formerly of Flat 4, First Floor, 150 Victoria Avenue, Albert Park, but late of Parkville, Pensioner, died 8 May 1983.

Flowers, Albert Keith, late of Ballarat, Retired Labourer, died 9 October 1982.

Hunter, Maxwell, late of 47 Wood House Street, Invercargill, New Zealand, Freezing Worker, died 28 July 1982.

Jackson, Jessie Maude, formerly of 21 Pattison Street, Moonee Ponds, but late of Unit 6, 234 Dawson Street, West Brunswick, Pensioner, died 6 May 1983.

Karaot, Mehmet Dogan, late of 821 Centre Road, East Bentleigh, Seaman, died 24 July 1982.

Kos, Joseph, late of Flat 103/12 Holland Street, Flemington, Retired, died 4 December 1978.

Linnett, Ada Lily, also known as Lily Ada Linnett, late of Galilee Lodge Nursing Home, 87 Chapel Street, St. Kilda, Widow, died 19 March 1983.

McIntosh, Helen Bryce, late of 142 Sycamore Street, Caulfield, Widow, died 13 June 1983.

Orford, Lilian Pearl, formerly of 49 Albert Crescent, North Fitzroy, but late of 45 Munro Street, Coburg, Widow, died 9 April, 1983.

Rosser, Donald Arthur Lee, late of "Corowa", Eramosa Road, Moorooduc, Retired, died 10 June 1983.

Smith, Alice Maude, late of c/- 51 Brinsley Road, Camberwell (in will called Bridesley), Widow, died 29 June 1983.

Stewart, Wallace John Agnew, also known as Wallace John Stewart, formerly of 7 Jenkin Street, East Brunswick, but late of 19 Boston Avenue, Seaford, Retired Cleaner, died 6 July 1983.

Sutherland, Rupert Hugh, formerly of No. A 32045, Unit HQ, Sup. Com. RAAF Base, Laverton, but late of Lyrebird Hostel, Neerim Street, Drouin, Ex Serviceman, died 17 April 1983.

Thompson, Robert John, late of 150 Vincent Road, Morwell, Retired Trades Assistant, died 25 September 1982.

Tyzack, Ernest Edward, late of 16 Waterloo Place, Mornington, Retired, died 24 May 1983.

Wilson, Allan Harold, late of 1/455 Princes Highway, Noble Park, Purchaser, died between 21 March 1983 and 22 March 1983.

24 August 1983

P. T. SPENCER
Public Trustee

PUBLIC MEETING OF PUBLIC SERVICE BOARD

The next Public Meeting to discuss policy issues will be held at 2.00 p.m. on Tuesday 13 September 1983 in the State Film Theatre, 1 MacArthur Street, Melbourne. The Agenda items for the Meeting are:

- The Points Factor System of Job Evaluation and Classification.
- Proposal to Restructure the Administrative Officer Category.

For the information of persons who may be interested in attending the Meeting, an outline of the matters to be considered at the Meeting is set out below. Full discussion papers will be sent to persons who notify their intention to attend.

1. The Points Factor System of Job Evaluation and Classification.

The Board is adopting a new system for the classification of positions in conjunction with the development of new employment categories. Called a points factor evaluation system, it has been applied extensively throughout the occupational category review program as a systematic, disciplined and quantifiable approach to the assessment of relative job worth, classification and rates of pay. The new system will be applied to all new occupational categories in the future including the Senior Executive Service, Clerical Officer structure and other new structures arising from the category review process.

The discussion paper prepared for this item describes how the new system was developed, how it can be applied to the full range of occupational categories within the Service, and how it is used to establish relativities within each employment category.

2. Proposal to Restructure the Administrative Officer Category.

The Board's occupational category review program has now reached the stage where a proposal has been prepared to restructure the current Administrative Officer category.

Essentially, the proposal is to introduce an eight level structure covering the work currently being performed by Administrative Officers Class E — A1 (2). The proposed structure would complement the new Clerical Officer structure and be subordinate to the Senior Executive Service.

A discussion paper detailing the findings of the review and the proposed new structure has been prepared for consideration at the Public Meeting. While the primary focus of the Administrative Officer review has been to design a new job classification structure and classification process, there are a number of important related issues which have also been addressed in the discussion paper. These include rates of pay, implications for recruitment and staff development, organization design problems, job design and career opportunities for administrators.

At the Meeting a Board Officer will address the policy issues involved; other parties with a major interest will be invited to comment; and the Board will invite those attending to comment on the policy proposals and to raise relevant matters for discussion.

Subsequent to the Meeting the Board will finalize its consideration of the policy issues involved and will publish a statement summarizing its decisions or conclusions.

Public Servants wishing to attend the Meeting should obtain approval for appropriate time off from their Permanent Head.

Permanent Heads are asked to assist interested staff to participate in the Board's Public Meeting.

To ensure that seating is available and that papers can be distributed, those wishing to attend are requested to reserve a place via the Secretary, Public Service Board (telephone notifications and enquiries (03) 651 1139).

A. P. PHILLIPS, Secretary

LOCAL GOVERNMENT DEPARTMENT

ORDER CONFIRMED — SHIRE OF BULN BULN

I, Frank Noel Wilkes, Her Majesty's Minister of the Crown for the time being administering the *Local Government Act 1958*, hereby confirm the Order hereinafter referred to in pursuance of section 514 of the said Act namely:

An Order of the Council of the Shire of Buln Buln made on 25 July 1983 directing the compulsory taking of Crown Allotment 26E, Parish of Noojee East for road purposes.

Dated 19 August 1983

F. N. WILKES
Minister for Local Government

Local Government Department
Melbourne (83/3795)

SHIRE OF COLAC — ROAD DEVIATION

Pursuant to the provisions of Sections 522 and 526 of the *Local Government Act 1958*, the President, Councillors and Ratepayers of the Shire of Colac hereby directs that the land in the Parishes of Ondit and Warrion indicated by hatching on the diagram annexed hereto which has been purchased taken or acquired by it shall be a public highway on and from the

date of publication of this order in the *Government Gazette* and declares that such land shall be a public highway in lieu of the land indicated by cross-hatching on the said diagram.

Dated 15 July 1983

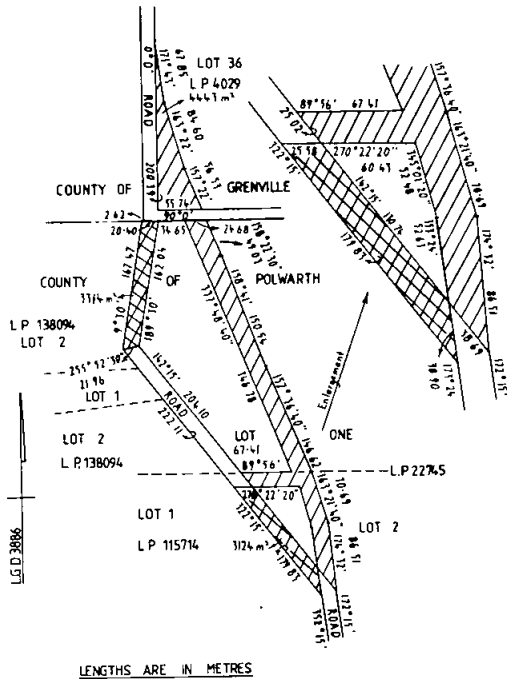

The corporate seal of the President, Councillors and Rate-payers of the Shire of Colac was hereto affixed by order of the Council in the presence of:

(SEAL) C. C. TURNER, President
E. P. CARMODY, Councillor
W. J. MAUNSELL, Secretary

**LOCAL GOVERNMENT DEPARTMENT
ORDER CONFIRMED — TOWN OF STAWELL**

I, Frank Noel Wilkes, Her Majesty's Minister of the Crown for the time being administering the *Local Government Act* 1958, hereby confirm the Order hereinafter referred to in pursuance of section 514 of the said Act namely:

An Order of the Council of the Town of Stawell made on 13 July 1983 directing the compulsory taking of the land described hereunder for the purpose of providing off-street car parking facilities.

All that piece of land being part of Crown Allotment 7, Section 33, Parish of Stawell and commencing at the western angle of the said allotment; thence by a line bearing 38° 10' for 9.91 metres; thence bearing 128° 03' for 12.62 metres; thence bearing 224° 17' for 9.99 metres; and thence bearing 308° 10' for 11.55 metres to the point of commencement.

Dated 19 August 1983

F. N. WILKES
Minister for Local Government

Local Government Department
Melbourne (83/3725)

Cemeteries Act 1958

SCALE OF FEES OF THE TONGALA PUBLIC CEMETERY

In pursuance of the powers conferred upon them by the *Cemeteries Act*, the trustees of the Tongala Public Cemetery hereby make the following scale of fees, which shall come into operation upon publication in the *Government Gazette*, and from and after such publication every scale of fees heretofore made by the said trustees shall be and is hereby rescinded to the extent to which it conflicts with this scale.

Stone Finish Section

	\$
Land, 2.44 m x 1.22 m	250.00
Interment fee	50.00
Reservation of stone finish section (includes right of burial)	300.00

H. W. McLEOD
B. LAMBERT
E. COSTELLO, Trustees

Approved by the Governor in Council, 23 August 1983 —
TOM FORRISTAL, Clerk of the Executive Council

Cemeteries Act 1958

SCALE OF FEES OF THE YARRAM PUBLIC CEMETERY

In pursuance of the powers conferred upon them by the *Cemeteries Act*, the trustees of the Yarram Public Cemetery hereby make the following scale of fees, which shall come into operation upon publication in the *Government Gazette*, and from and after such publication every scale of fees heretofore made by the said trustees shall be and is hereby rescinded to the extent to which it conflicts with this scale.

Private Graves

Land, 2.44 x 1.22 m own selection	\$100.00
-----------------------------------	----------

Lawn Section

Land, 2.44 x 1.22 m	\$200.00
---------------------	----------

W. L. BLAND
R. S. McINTOSH
G. B. CUNNINGHAM, Trustees

Approved by the Governor in Council, 23 August 1983 —
TOM FORRISTAL, Clerk of the Executive Council

Cemeteries Act 1958

RULES AND REGULATIONS OF THE FAWKNER CREMATORIUM AND MEMORIAL PARK

In pursuance of the powers conferred upon them by the *Cemeteries Act*, the trustees of the Fawkner Crematorium and Memorial Park make the following rules and regulations, which shall come into operation upon publication in the *Government Gazette*, and from and after such publication every rule and regulation heretofore made by the said trustees shall be and is hereby rescinded to the extent to which it conflicts with these rules and regulations.

Memorial Work

19A (i) The payment in full of the prescribed fee by a person for a memorial or the reservation of a memorial shall entitle that person or the legal personal representative of that person—

- (a) To the interment of the ashes of one deceased person or in the case of a family memorial to the interment of the ashes of not more than four persons in such memorial.

- (b) To the erection of an inscription in or on such memorial for each such person interred but subject to a charge for the supply engraving and installation of any such inscription—

for a period of twenty-five years from the date of payment of such fee or in the case of a family memorial for a period of twenty-five years from the date of the last interment (hereinafter called "the period of tenure").

(ii) The period of tenure may be renewed for a fee and upon the terms and conditions relating to the reservation of memorials prevailing at the date of the renewal provided a written application for renewal together with the prescribed fee is lodged with the trustees during the final year of the then current reservation period for such memorial.

(iii) Upon the expiration of a period of tenure the reservation of the memorial shall be cancelled and the ashes disposed of by the trustees.

(iv) The trustees reserve the right to relocate the position of any memorial in order to provide for the proper management and ornamentation of the Park.

(v) Notwithstanding anything hereinbefore contained the trustees shall:

- (a) not less than six months prior to the expiration of the period of tenure give notice in writing of the intention of the trustees at the expiration of the period of tenure to cancel the reservation of a memorial and to dispose of any memorial work and cremated remains unless the period of tenure is renewed in accordance with these Regulations;

- (b) give notice in writing of the intention of the trustees at the expiration of two months from the date of the notice to relocate the position of a memorial

and any such notice shall be posted by pre-paid ordinary post to the last known address of the person in whose name a memorial is registered.

76 Cheques to the value of \$5000 or less, plus any cheque payable to the credit of Armaguard Payroll Account, will be signed by any two of the General Manager, Administration Manager, Accountant and Office Manager. Cheques to the value of more than \$5000 will be signed by any one of the trustees plus any two of the General Manager, Administration Manager, Accountant and Office Manager.

K. W. JOYCE
A. J. CORDELL
R. J. COOPER, Trustees

Approved by the Governor in Council, 23 August 1983 —
TOM FORRISTAL, Clerk of the Executive Council

Country Fire Authority Act

PERMISSION TO HOLD FIRE BRIGADE
DEMONSTRATIONS

In pursuance of the provisions of Section 103 of the *Country Fire Authority Act 1958*, the Country Fire Authority has granted approval for the holding of fire brigade demonstrations as under:

Rural Fire Brigades

At Plenty on Sunday, 20 November 1983.

At Swan Hill on Saturday and Sunday, 7 & 8 April 1984.

Dated 24 August 1983

L. A. CRUICKSHANK
Acting Secretary

Community Welfare Services Act 1970

DECLARATION OF SEVERAL ESTABLISHMENTS AS
APPROVED CHILDREN'S HOMES

In pursuance of the powers conferred by Section 29 (1) (b) of the *Community Welfare Services Act 1970*, I do hereby declare the residential units operated by the Anglican Diocesan Mission to Streets and Lanes at:

Unit 64 (Unit 1), 64 Wilson Street, Brighton;

Unit 64 (Unit 2), 64 Wilson Street, Brighton;

St. Faith's, 62 Wilson Street, Brighton;

as Approved Children's Homes for the purposes of the said Act.

22 August 1983

PAULINE TONER, Minister

Community Welfare Services Act 1970

DECLARATION OF SEVERAL ESTABLISHMENTS AS
APPROVED CHILDREN'S HOMES

In pursuance of the powers conferred by Section 29 (1) (b) of the *Community Welfare Services Act 1970*, I do hereby declare the residential areas operated by Kildonan Homes for Children at:

141 Highett Street, Richmond;

149 Highett Street, Richmond;

175 Kent Street, Richmond;

as Approved Children's Homes for the purposes of the said Act.

22 August 1983

PAULINE TONER, Minister

Community Welfare Services Act 1970

DECLARATION OF SEVERAL ESTABLISHMENTS AS
APPROVED CHILDREN'S HOMES

In pursuance of the powers conferred by Section 29 (1) (b) of the *Community Welfare Services Act 1970*, I do hereby declare the residential units operated by the St. Anthony's child care agency at:

18 Leonards Crescent, Ascot Vale;

45 Hedderwick Street, Essendon;

5 Milverton Street, Moonee Ponds;

as Approved Children's Homes for the purposes of the said Act.

22 August 1983

PAULINE TONER, Minister

Community Welfare Services Act 1970

DECLARATION OF SEVERAL ESTABLISHMENTS AS
APPROVED CHILDREN'S HOMES

In pursuance of the powers conferred by Section 29 (1) (b) of the *Community Welfare Services Act 1970*, I do hereby declare the residential units operated by Tally Ho Village at:

131 Canterbury Road, Middle Park;

18 Dickens Street, Elwood;

as Approved Children's Homes for the purposes of the said Act.

22 August 1983

PAULINE TONER, Minister

CONTRACTS ACCEPTED — (Series 1983/84)**PUBLIC WORKS**

His Excellency the Governor of the State of Victoria by and with the advice of the Executive Council thereof has by Order made on 23 August 1983 approved of the acceptance by the Minister of Public Works of the under-mentioned offers without public tenders being invited, viz.:

Offer of MacCallum Gordon & Partners for professional services (Architectural) at Hawthorn West Primary School for the sum of eighteen thousand dollars (\$18 000.00) — 116404.2

The following offers and at the amounts shown for professional services at Mt. Macedon Primary School — New School Building — 122822/0001

	\$
Sofarnos Monsborough & Associates Pty. Ltd. (Architectural)	16 500.00
B.S.C. Consulting Engineers & Surveyors (Structural, Civil, Hydraulics)	22 000.00

The following offers and at the amounts shown for professional services at Ardeer High School, Stage 3 — W.229031P

	\$
Chas. A. Harding Widnell & Trollope (Quantity Surveying)	23 000.00
Bates Smart & McCutcheon Pty. Ltd. (Struct./Civil/Hyd./Elec./Mech.)	49 000.00
Gerner Sanderson Fagetter & Cheeseman (Architectural)	50 000.00

The following offer and at the amount shown for professional services at Wantirna High School, Stage 3 — N.209121P

	\$
Leith Bartlett & Partners Pty. Ltd. (Architectural)	40 000.00

TOM FORRISTAL
Clerk of the Executive Council

At the Executive Council Chamber,
Melbourne, 23 August 1983

CONTRACTS ACCEPTED — (Series 1983/84)**PUBLIC WORKS**

His Excellency the Governor of the State of Victoria by and with the advice of the Executive Council thereof has by Order made on 23 August 1983 approved of the acceptance by the Minister of Public Works of the under-mentioned offers without public tenders being invited, viz.:

Offers at the amounts shown for professional services at Westmeadows Primary School — 52331P

	\$
A. R. Stella & Partners Pty. Ltd. (Architectural)	25 000.00
Scheme Consulting Engineering Group (Structural, Electrical, Mechanical, Hydraulics, Civil)	19 000.00

Offer of Leighton Irwin-Garnet Alsop Pty. Ltd. for professional services (Architectural) at Melton Technical School for the sum of eighty-three thousand dollars (\$83 000.00) — W.120621P

Offer of Robert Grodski & Associates Pty. Ltd. for professional services (Architectural) at the Yarra Glen Primary School for the sum of fifteen thousand dollars (\$15 000.00) — 116117/2

Offer of David M. Breden for professional services (Architectural) at Kangaroo Flat Technical School for the sum of sixteen thousand dollars (\$16 000.00) — N.208737P

Offer of Fraser Mining Construction Pty. Ltd. for the provision of an extra Modular Building for P.A.B.X. Telephone System at Mont Park Psychiatric and Mental Hospital, Bundoora, for the sum of thirty-six thousand dollars (\$36 000) — C.39061/2

TOM FORRISTAL
Clerk of the Executive Council

At the Executive Council Chamber,
Melbourne, 23 August 1983

DEPARTMENT OF MINERALS AND ENERGY**APPLICATION FOR MINING LEASE DECLARED ABANDONED**

No. 612; Western Mining Corporation Limited; 15.1 ha, Parish of Clunes

MINING LEASE GRANTED

No. 178-1; Executor of the Estate of Robert William Bennett; 7.2 ha, Parish of Piangil West

EXPLORATION LICENCE GRANTED

No. 1319; Pan d'Or Mining NL; 132 km², comprising Graticular Blocks Nos. 1356 and 1357, Hamilton Map Sheet

TERMS OF EXPLORATION LICENCES EXTENDED

No. 826; CRA Exploration Pty. Limited; 330 km², comprising Graticular Block Nos. 1150, 1221, 1293, 1363 and 1364 Hamilton Map Sheet

No. 856; CRA Exploration Pty. Limited; 66 km², comprising Graticular Block No. 715 Hamilton Map Sheet

No. 1223; Essex Minerals Company; 198 km², comprising Graticular Blocks Nos. 662, 692 and 693 Melbourne Map Sheet

APPLICATION FOR SEARCH LICENCE DECLARED ABANDONED

No. 2946; Walter Toifi; 39 ha, Parish of Kevington

APPLICATIONS FOR SEARCH LICENCES REFUSED

No. 2717; Frank Evans; 8 ha, Parish of Sandhurst

No. 2856; David George Hurley; 34 ha, Parish of Heathcote

No. 2857; David George Hurley; 38 ha, Parish of Heathcote

No. 2858; David George Hurley; 40 ha, Parish of Heathcote

No. 2888; McNiece-Wright Mining; 6 ha, Parish of Sandhurst

No. 2897; Western Mining Corporation Limited; 3 ha, Parish of Stawell

No. 2898; Western Mining Corporation Limited; 3 ha, Parish of Stawell

No. 2918; Western Mining Corporation Limited; 16 ha, Parish of Stawell

No. 2919; Western Mining Corporation Limited; 8 ha, Parish of Stawell

No. 2920; Western Mining Corporation Limited; 13 ha, Parish of Stawell

No. 2926; Bendigo Gold Associates; 15 ha, Parish of Clarkesdale

No. 2927; Bendigo Gold Associates; 5 ha, Parish of Clarkesdale

- No. 2997: Western Mining Corporation Limited: 30 ha, Parish of Stawell
 No. 2998: Western Mining Corporation Limited: 7 ha, Parish of Stawell
 No. 3024: Bendigo Gold Associates: 20 ha, Parish of Buninyong
 No. 3025: Bendigo Gold Associates: 20 ha, Parish of Buninyong
 No. 3056: St. Arnaud Gold Mines Limited: 3 ha, Parish of St. Arnaud
 No. 3057: St. Arnaud Gold Mines Limited: 8 ha, Parish of St. Arnaud
 No. 3058: St. Arnaud Gold Mines Limited: 13 ha, Parish of St. Arnaud

SEARCH LICENCES GRANTED

- No. 2727: David William Hamilton and Mark William Pitt: 40 ha, Parish of Angora
 No. 2728: David William Hamilton and Mark William Pitt: 40 ha, Parish of Angora
 No. 2787: Swan Resources Limited and Wattle Gully Gold Mines Limited: 40 ha, Parish of Wollonaby
 No. 2853: Graeme McKenzie: 40 ha, Parishes of Moornapa and Bow-Worrung
 No. 2874: Lionel Gross: 40 ha, Parish of Matlock
 No. 2875: Reid Keys: 40 ha, Parish of Matlock
 No. 2894: Stephen Dingwall: 40 ha, Parishes of Moornapa and Bow-Worrung
 No. 2932: Lawrence Reginald Baster and Kevin John Callow: 4 ha, Parishes of Dunolly and Painswick

SEARCH LICENCES EXPIRED

- Nos. 2059, 2060, 2061 and 2062: Peter John Sterling: 40 ha's each, Parish of Whroo
 No. 2332: Raymond James Hille: 8 ha, Parish of Kingower
 No. 2508: Frank Evans: 5 ha, Parish of Sandhurst

APPLICATION FOR EXTRACTIVE INDUSTRY LICENCE DECLARED ABANDONED

- No. 1221: Lindsay Askew and William Thomas Askew: 2 ha, Parish of Brucknell

EXTRACTIVE INDUSTRY LICENCE GRANTED

- No. 791-1: James Alfred Hammill: 7-5263 ha, Parish of Warragul
 No. 801-1: Desmond Michael Sheehan: 16-8425 ha, Parish of Paywit

EXTRACTIVE INDUSTRY LICENCE EXPIRED

- No. 761: Maskell and Gribben Pty. Ltd.: 5-3418 ha, Parish of Kialla

D. R. WHITE
 Minister for Minerals and Energy

MINING LEASE DECLARED VOID

- No. 426: Ronald Clough and Lauris June Clough: 7-9 ha, Parish of Glenalbyn

SEARCH LICENCE DECLARED VOID

- No. 2064: Duncan Robert McLean: 20 ha, Parish of Whitfield South

DR. E. W. RUSSELL
 Secretary for Minerals and Energy

NOTICE TO MARINERS

No. 36 of 1983

AUSTRALIA – VICTORIA

Port Phillip

Beaumaris Bay – Establishment of Mussel Culture Area

Former Notice No. 47 of 1981 is superseded.

Reference Position: Beaumaris Motor Yacht Squadron Light Lat. 38°00'S., Long. 145°03'E (approx).

An area of 6 hectares in Beaumaris Bay is set aside for the cultivation of mussels from floating rafts.

Commencing from a position bearing 177-9° distance 368 metres from the Reference Position, the area is bounded by the lines bearing 98-8° distance 125 metres thence 188-8° distance 480 metres thence 278-8° distance 125 metres thence 008-8° to the commencement point.

Two 3 hectare allotments will be located within this area. The rafts will be marked by yellow light buoys displaying a yellow diagonal cross top-mark and surmounted by a light flashing yellow every 5 seconds (eclipse 4 seconds) height 2 metres.

Mariners are advised to keep well clear of the rafts at all times.

Charts affected: Aus. 143 Aus. 155.

Publication affected: Sailing Directions, Victoria 1970.

This notice should be inserted on Page 286 of these directions.

A. J. WAGGLEN
 Port Officer

Ports and Harbors Division
 168 Exhibition Street
 Melbourne 3000, 24 August 1983

NOTICE TO MARINERS

No. 35 of 1983

AUSTRALIA – VICTORIA

Apollo Bay

Light Re-established

Former Notice No. 15T of 1983 refers and is cancelled.

Reference Position: Front Light (Skene's Creek) (Lat. 38°43'7"S., Long. 143°42'4"E. approx).

Details: Construction work on the Breakwater Head has been completed.

The Breakwater Light has been re-established approximately 15 metres NNW of the old position.

The new position of the light is 215-4°; 4160 metres (2.25 miles) from reference position.

Chart affected: Aus. 350.

Publication affected: Sailing Directions, Victoria 1970. Pages 137 and 594.

A. J. WAGGLEN
 Port Officer

Ports and Harbors Division
 168 Exhibition Street
 Melbourne 3000, 23 August 1983

*Labour and Industry Act 1958*CERTIFICATE OF EXEMPTION UNDER
SECTION 104 (5)

In pursuance of the powers conferred on me by section 104 (5) of the *Labour and Industry Act 1958*, I hereby issue to —
Sunicrust Bakeries Pty. Ltd.

this Certificate exempting it and any person carting or delivering bread on its behalf from the operation of section 104 (4) of the said Act subject to the condition that this Certificate shall apply only to the carting and delivery of bread from —
Ballarat to Ararat

during the period from 19 August to 7 September 1983, both dates inclusive.

Dated 24 August 1983

S. M. CRABB,

Minister of Transport, Acting for and on behalf of the
Minister of Labour and Industry.

EXEMPTION REQUEST

No. 7 OF 1983

On 10 August 1983, the Equal Opportunity Board considered an application by the Salvation Army Western Region Youth and Child Care Service for an exemption to enable it to ensure the presence of residential care workers of each sex at each of its hostels.

The Board hereby grants the exemption requested in respect of advertising for and appointing such workers.

This exemption shall remain in effect until 10 August 1984.

JOAN DWYER, Chairman

IAN G. SHARP, Board Member

DON ROSS, Board Member

Police Regulation Act, Section 122

SALE OF UNCLAIMED MOTOR VEHICLE

An owner is required for an unregistered home-made motor cycle with blue engine casing.

The vehicle came into possession of Police on 11 December 1982, and if not claimed, will be sold by public auction at the Flemington Police Station, 34 Wellington Street, Flemington at 10.00 a.m. on Wednesday, 5 October 1983.

S. I. MILLER

Chief Commissioner of Police

UNCLAIMED MONEYS ACT 1962, No. 6879

Pursuant to the powers conferred on me by Section 10 of the *Unclaimed Moneys Act 1962*, I, Robert Allan Jolly, Treasurer of the State of Victoria, do hereby from and inclusive of 8 August 1983:

- (a) cancel the assignment made on 20 April 1977 of Denise Margaret Alexander to the position of Deputy Registrar of Unclaimed Monies; and
- (b) assign William Lewis Dear, an officer of the Department of Management and Budget, to the position of Deputy Registrar of Unclaimed Monies.

Melbourne, 8 August 1983

R. A. JOLLY
Treasurer

APPOINTMENTS AND
RESIGNATIONS

APPOINTMENTS

His Excellency the Governor of the State of Victoria by and with the advice of the Executive Council thereof has by Orders made on 23 August 1983 been pleased to make the under-mentioned appointments, viz.:

Department of Community Welfare Services

Honorary Probation Officers

Bitaxis, Angela, 36 Davies Street, Brunswick, 3056.
Callander, Stephen James, 7 Victoria Avenue, Albert Park, 3206.
Goring, Laurie, 1 Penleigh Court, Moonee Ponds, 3039.
Top, Johan Albert, WSD48, Kyneton, 3444, to be Honorary Probation Officers for all Adult and Children's Courts in the State of Victoria, as from and inclusive of 16 August 1983, pursuant to the provisions of Section 507 (2) of the *Crimes Act 1958* and Section 9 of the *Children's Court Act 1973*.

Department of Crown Lands and Survey

Bailiffs of Crown Lands

Harold Hasim Adem, Jan William Bos, Bruce Cockroft, Robert Tracy Jones, Anthony William Kellock, Robin Alexander Selkirk Lawson, Alexander Stewart Morgans, Terence John Nicholls, Martin James Sharkey to be bailiffs of Crown Lands, pursuant to the provisions of Section 30 of the *Land Act 1958*, in respect of all Crown lands in the State of Victoria, and with authority to discharge and exercise all the duties and powers of bailiffs of Crown lands.

Health Commission

Trustees of Public Cemeteries

Kenneth John Pata to be an additional Trustee of the Kangaroo Flat Public Cemetery, Bruce Harold Fryer, Frank Patrick Lawless, John Charles McConachy to be additional Trustees of the Jericho & Red Jacket Public Cemeteries, Robert Kenneth Streeter to be a Trustee of the Warracknabeal Public Cemetery, Vice Kenneth Streeter, resigned, Gary Douglas Farrall, Trustee of the Warracknabeal Public Cemetery, Vice Eric Kostoff, resigned, Patrick Moloney, Trustee of the Warracknabeal Public Cemetery, Vice J. McCaffrey, resigned, pursuant to Section 3 (1) of the *Cemeteries Act 1958*.

Law Department

Justices of the Peace

John Henry Bond, 27 Auburn Road, Auburn, Frederick Lindsey Marchingo, 36 Myers Street, Bendigo, John Douglas Perks, Monkey Gully Road, Mansfield to be Justices of the Peace for the State of Victoria.

Commissioners for Taking Declarations, etc.

Catherine Anne Catlow, Caulfield, Carl Ronald Davis, 80 Collins Street, Melbourne, Henry George Elliot, Ferntree Gully Road, Mt. Waverley, Maurice John Foster, 23 Hampton Road, West Essendon, John Michael Green, 11 Bank Place, Melbourne, Michael Meyer Kowadlo, 1125 North Road, South Oakleigh, Dawn Patricia Lumley, Yarra Bend Road, Fairfield, Clive Alexander McKenzie, 114 William Street, Melbourne, Gary John Oliver, 35 Collins Street, Melbourne, Denis Joseph Patmore, Macaulay Road, North Melbourne, John Malcolm Sayer, 37 Wingara Avenue, Keilor East, Peter Francis Schreenan, 360 Collins Street, Melbourne, Elise Jennifer Tamir, 336 Glenferrie Road, Malvern, Stavros Thalasselis, 361 Bay Road, Cheltenham, Gordon Wearing-Smith, Monbulk Road, Kallista, Arnold Leon Wheildon, Yallourn.

Raymond John Williams, Morwell, Kevin Laurance Wynd, 23 Lanyon Street, Dandenong, to be Commissioners for taking declarations and affidavits under the *Evidence Act 1958*.

TOM FORRISTAL
Clerk of the Executive Council

At the Executive Council Chamber,
Melbourne, 23 August 1983

EXPLOSIVES ACT 1960

The Public Service Board, pursuant to the provisions of Section 5 (1) of the *Explosives Act 1960*, hereby appoints John Woods, Keeper of Magazines and Technical Assistant, Third Division, Department of Minerals and Energy, as an Inspector of Explosives, without additional salary.

P. KENNEDY
OIC Secretariat

HIS EXCELLENCY THE GOVERNOR ADVISES THE FOLLOWING AMENDMENT TO THE LIST OF CONSULAR CORPS REPRESENTATIVES RESIDENT IN MELBOURNE.

Nepal

Mr. W. A. Johns has been appointed Honorary Consul-General for Nepal with jurisdiction throughout Victoria with effect from 17 March 1983.

Dated 16 August 1983

JOHN CAIN
Premier

Mental Health Act 1959 Section 26

Notice is hereby given that the following appointments have been made pursuant to Section 26 of the *Mental Health Act 1959*.

Wayne Robert Ralph Dobson — Manager, Mont Park Mental Hospital and Psychiatric Hospital for period 15 August 1983 to 14 September 1983, vice C. E. Norden on leave.

Laurence Edward Reid — Deputy Manager, Mont Park Mental Hospital and Psychiatric Hospital from 15 August 1983, vice W. R. R. Dobson promoted.

Dated 22 August 1983

G. TREVAKS, Chairman

Health Commission of Victoria

Liquor Control Act 1968

APPOINTMENT OF LICENSING INSPECTORS

In accordance with the authority conferred upon me by Section 6 of the *Police Regulation Act 1958*, I, John Roderick Hall, Deputy Commissioner of Police, do hereby appoint under subsection (1) of Section 22 of the *Liquor Control Act 1968*, the following Officers of Police as Licensing Inspectors for the Divisions of the Police Districts as shown:

Division	Number	Police District	Rank and Name
	2	Maroondah	Inspector Brendan Gaffy, No. 13582 (from 14.8.83 to 31.8.83).
	3	Westernport	Inspector Malcolm Wesson, No. 13259 (from 18.9.83 to 15.10.83).

25.8.1983 J. R. HALL
Deputy Commissioner (Administration)

Vermin and Noxious Weeds Act 1958

APPOINTMENT

It is hereby notified that the Public Service Board has appointed Helene J. Ireland, an officer of the Department of Crown Lands and Survey, as Secretary to the Vermin and Noxious Weeds Destruction Board under the provisions of Section 4 of the *Vermin and Noxious Weeds Act* for the period 17 August 1983 to 30 September 1983, without additional salary.

Melbourne, 24 August 1983

J. R. ASHWORTH
Secretary for Lands

DEPARTMENT OF MINERALS AND ENERGY Termination of Appointments

Reginald W. Farrington — Inspector of Explosives — retired on 2 July 1982.

Darrel L. Martin — Inspector of Inflammable Liquids — retired on 25 September 1982.

James Cleghorn — Inspector of Inflammable Liquids, Inspector of Liquefied Gases — retired on 11 May 1982.

P. KENNEDY
Dept. of Minerals and Energy

REVOCATION OF APPOINTMENTS

His Excellency the Governor of the State of Victoria, by and with the advice of the Executive Council thereof, has, by Orders made on 23 August 1983, revoked the appointments of the persons named hereunder to the offices mentioned, viz.:

Department of Community Welfare Services

Honorary Probation Officers

Seied Ahmedi, Leonnard Butcher, Bert Bastrup, Michael Kemmy, as Honorary Probation Officers, pursuant to the provisions of Section 507 (2) of the *Crimes Act 1958* and Section 9 of the *Children's Court Act 1973* for all Adult and Children's Courts in Victoria.

Department of Crown Lands and Survey

Bailiffs of Crown Lands

Leslie George Caulfield, Thomas Henry Taylor, as bailiffs of Crown Lands, made by the Governor in Council on 27 August 1957 (see *Government Gazette* dated 4 September 1957).

Law Department

Justices of the Peace

George Donald Vincent Cheadle, John Ernest Cleary and Alan Edwin Ingram as Justices of the Peace.

Commissioners for Taking Declarations, etc.

John Charles Albress, Peter John Bergin, Steven Colin Burley as Commissioners for taking declarations and affidavits under the *Evidence Act 1958*.

TOM FORRISTAL
Clerk of the Executive Council

At the Executive Council Chamber,
Melbourne, 23 August 1983

RESIGNATIONS

His Excellency the Governor of the State of Victoria by and with the advice of the Executive Council thereof has by Orders made on 23 August 1983 accepted the resignations of the persons named hereunder of the offices mentioned, viz.:

Department of Community Welfare Services

Honorary Probation Officers

Ian Adams, Maureen Blane, Melanie Brand, Diana Charles, Joseph George Cini, Chris Golab, Dale Jennings, Kath Kennedy, Dianne Kirwan, Marie Lambert, Gary Leonard, William Lutterell, Kate McMahon, Kathleen Marshall, Lillian Emily Martin, Chris Powell, Hugh Allan Roche, Margaret Schoonbeek, John Michael Starke, Julie Anne Storey, Brigadier Horace Wishart, as Honorary Probation Officer pursuant to the provisions of Section 507 (2) of the *Crimes Act 1958* and Section 9 of the *Children's Court Act 1973*, for all Adult and Children's Courts in Victoria as from and inclusive of 16 August 1983.

Law Department
Justices of the Peace

Arthur Sydney Thomson as a Justice of the Peace for the State of Victoria.

Commissioners for Taking Declarations, etc.

Norman Bernard, Henri Edmund De Sachau, Geoffrey Alan Guyett, Frederick Linsey Marchingo, John Douglas Perks and Jeffrey Graeme Penberthy as Commissioners for taking declarations and affidavits under the *Evidence Act 1958*.

TOM FORRISTAL
Clerk of the Executive Council

At the Executive Council Chamber,
Melbourne, 23 August 1983

ORDERS IN COUNCIL

LOCAL GOVERNMENT ACT 1958

At the Executive Council Chamber, Melbourne, the twenty-third day of August, 1983

Present:

His Excellency the Governor of Victoria
Mr Mackenzie | Mr Kent
Mr Simpson

ROAD DISCONTINUED — CITY OF COBURG

Whereas it is provided in section 528 (2) of the *Local Government Act 1958*, that where a road (whether or not a public highway but not being a road set out on land of the Crown) or any part thereof is not required for public use, the Governor in Council on the request of the council of the municipality in which such road is situated made not less than one month after publishing in a newspaper generally circulating in the district and posting to the registered proprietor (if any) of the land and the owners and occupiers (if any) of lands abutting or immediately adjacent to the road notice of intention to make such a request may by Order published in the *Government Gazette* direct that such road or part shall be discontinued and thereupon such road or part shall be discontinued accordingly.

And whereas the Council of the City of Coburg has requested that the Governor in Council direct that a road between Livingston Street and Cool Street, Coburg be discontinued and not less than one month previously has published in a newspaper generally circulating in the district and posted to the registered proprietor of the land in the road and to the owners and occupiers of lands abutting or immediately adjacent to the road notice of intention to make such a request.

Now therefore, His Excellency the Governor of the State of Victoria, by and with the advice of the Executive Council thereof, hereby directs:

- (a) that the said road which is shown by hatching on the plan hereunder shall be discontinued;
- (b) that notwithstanding such discontinuance the Melbourne and Metropolitan Board of Works shall continue to have and possess the same right title power authority or interest in or in relation to the whole of the land shown by hatching on the said plan as it had or possessed prior to such discontinuance with respect to or in connection with any drains or pipes laid or erected in on or over such land for the purposes of drainage or sewerage;
- (c) that, subject to any such right title power authority or interest the land in the said road may be sold by the Council of the City of Coburg by agreement.

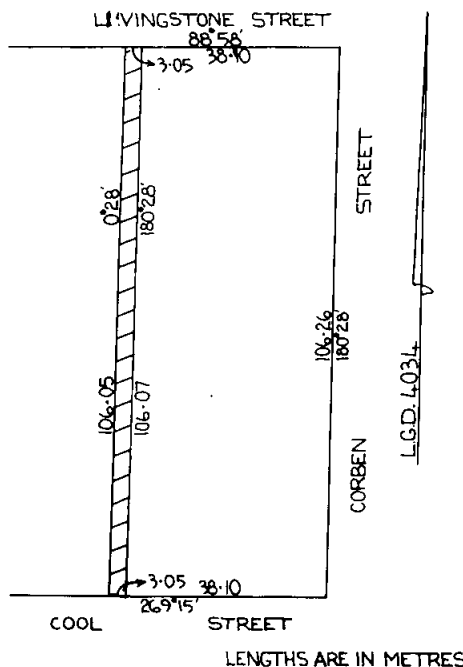

And the Honourable Frank Noel Wilkes, Her Majesty's Minister for Local Government for the State of Victoria, shall give the necessary directions herein accordingly.

TOM FORRISTAL
Clerk of the Executive Council

LOCAL GOVERNMENT ACT 1958

At the Executive Council Chamber, Melbourne, the twenty-third day of August, 1983

Present:

His Excellency the Governor of Victoria
 Mr Mackenzie | Mr Kent
 Mr Simpson

ROAD DISCONTINUED — CITY OF BRUNSWICK

Whereas it is provided in section 528 (2) of the *Local Government Act 1958*, that where a road (whether or not a public highway but not being a road set out on land of the Crown) or any part thereof is not required for public use, the Governor in Council on the request of the council of the municipality in which such road is situated made not less than one month after publishing in a newspaper generally circulating in the district and posting to the registered proprietor (if any) of the land and the owners and occupiers (if any) of lands abutting or immediately adjacent to the road notice of intention to make such a request may by Order published in the *Government Gazette* direct that such road or part shall be discontinued and thereupon such road or part shall be discontinued accordingly.

And whereas the Council of the City of Brunswick has requested that the Governor in Council direct that a road off Taylor Street, Brunswick be discontinued and not less than one month previously has published in a newspaper generally circulating in the district and posted to the registered proprietor of the land in the road and to the owners and occupiers of lands abutting or immediately adjacent to the road notice of intention to make such a request.

Now therefore, His Excellency the Governor of the State of Victoria, by and with the advice of the Executive Council thereof, hereby directs that the said road which is shown by hatching on the plan hereunder, shall be discontinued and the land in the said road may be sold by the Council of the City of Brunswick by agreement

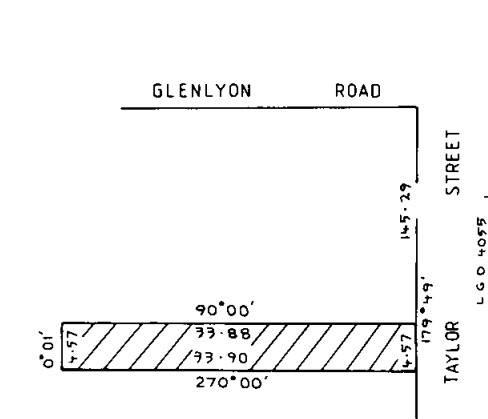

MEASUREMENTS ARE IN METRES

And the Honourable Frank Noel Wilkes, Her Majesty's Minister for Local Government for the State of Victoria, shall give the necessary directions herein accordingly.

TOM FORRISTAL
 Clerk of the Executive Council

LOCAL GOVERNMENT ACT 1958

At the Executive Council Chamber, Melbourne, the twenty-third day of August, 1983.

Present:

His Excellency the Governor of Victoria
 Mr Mackenzie | Mr Kent
 Mr Simpson

ROAD DISCONTINUED — CITY OF ESSENDON

Whereas it is provided in section 528 (2) of the *Local Government Act 1958*, that where a road (whether or not a public highway but not being a road set out on land of the Crown) or any part thereof is not required for public use, the Governor in Council on the request of the council of the municipality in which such road is situated made not less than one month after publishing in a newspaper generally circulating in the district and posting to the registered proprietor (if any) of the land and the owners and occupiers (if any) of lands abutting or immediately adjacent to the road notice of intention to make such a request may by Order published in the *Government Gazette* direct that such road or part shall be discontinued and thereupon such road or part shall be discontinued accordingly.

And whereas the Council of the City of Essendon has requested that the Governor in Council direct that part of a road off Hoddle Street, Essendon be discontinued and not less than one month previously has published in a newspaper generally circulating in the district and posted to the registered proprietor of the land in the road and to the owners and occupiers of lands abutting or immediately adjacent to the road notice of intention to make such a request.

And whereas objections from owners or occupiers of land abutting or immediately adjacent to the road have been received and have been considered;

Now therefore, His Excellency the Governor of the State of Victoria, by and with the advice of the Executive Council thereof, hereby directs:

- (a) that the said part of a road which is shown by hatching on the plan hereunder shall be discontinued;
- (b) that notwithstanding such discontinuance the Melbourne and Metropolitan Board of Works shall continue to have and possess the same right title power authority or interest in or in relation to the whole of the land shown by hatching on the said plan as it had or possessed prior to such discontinuance with respect to or in connection with any drains or pipes laid or erected in on or over such land for the purposes of drainage or sewerage;
- (c) that, subject to any such right title power authority or interest the land in the said part of a road may be sold by the Council of the City of Essendon by agreement.

LOCAL GOVERNMENT ACT 1958

At the Executive Council Chamber, Melbourne, the
twenty-third day of August, 1983

Present:

His Excellency the Governor of Victoria
Mr Mackenzie | Mr Kent
Mr Simpson

ROAD DISCONTINUED – CITY OF BRUNSWICK

Whereas it is provided in section 528 (2) of the *Local Government Act 1958*, that where a road (whether or not a public highway but not being a road set out on land of the Crown) or any part thereof is not required for public use, the Governor in Council on the request of the council of the municipality in which such road is situated made not less than one month after publishing in a newspaper generally circulating in the district and posting to the registered proprietor (if any) of the land and the owners and occupiers (if any) of lands abutting or immediately adjacent to the road notice of intention to make such a request may by Order published in the *Government Gazette* direct that such road or part shall be discontinued and thereupon such road or part shall be discontinued accordingly.

And whereas the Council of the City of Brunswick has requested that the Governor in Council direct that part of a road off Weston Street, Brunswick be discontinued and not less than one month previously has published in a newspaper generally circulating in the district and posted to the registered proprietor of the land in the road and to the owners and occupiers of lands abutting or immediately adjacent to the road notice of intention to make such a request.

Now therefore, His Excellency the Governor of the State of Victoria, by and with the advice of the Executive Council thereof, hereby directs that the said part of a road which is shown by hatching on the plan hereunder, shall be discontinued and the land in the said part of a road may be sold by the Council of the City of Brunswick by agreement.

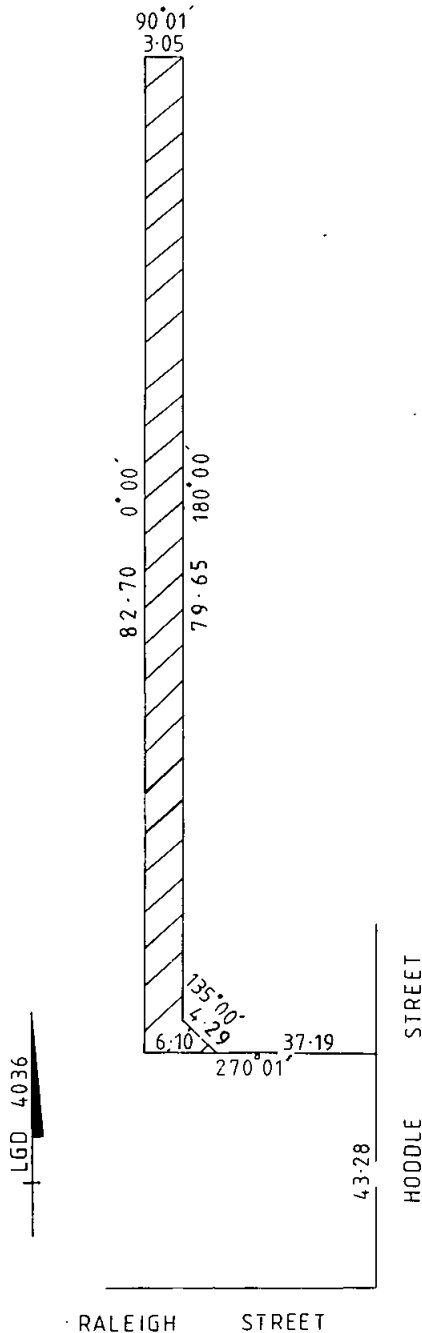

LENGTHS ARE IN METRES

And the Honourable Frank Noel Wilkes, Her Majesty's Minister for Local Government for the State of Victoria, shall give the necessary directions herein accordingly.

TOM FORRISTAL
Clerk of the Executive Council

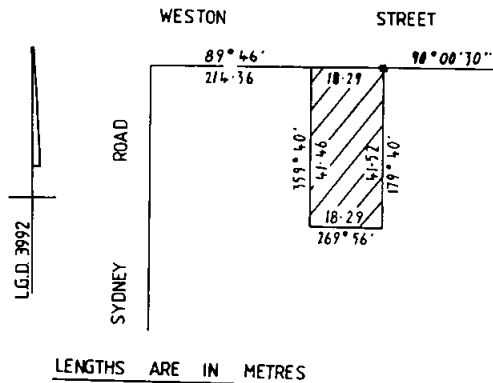

LENGTHS ARE IN METRES

And the Honourable Frank Noel Wilkes, Her Majesty's Minister for Local Government for the State of Victoria, shall give the necessary directions herein accordingly.

TOM FORRISTAL
Clerk of the Executive Council

LOCAL GOVERNMENT ACT 1958

At the Executive Council Chamber, Melbourne, the twenty-third day of August, 1983

Present:

His Excellency the Governor of Victoria
 Mr Mackenzie | Mr Kent
 Mr Simpson

ROAD DISCONTINUED – CITY OF KNOX

Whereas it is provided in section 528 (2) of the *Local Government Act 1958*, that where a road (whether or not a public highway but not being a road set out on land of the Crown) or any part thereof is not required for public use, the Governor in Council on the request of the council of the municipality in which such road is situated made not less than one month after publishing in a newspaper generally circulating in the district and posting to the registered proprietor (if any) of the land and the owners and occupiers (if any) of lands abutting or immediately adjacent to the road notice of intention to make such a request may by Order published in the *Government Gazette* direct that such road or part shall be discontinued and thereupon such road or part shall be discontinued accordingly.

And whereas it is further provided that where a planning scheme under the *Town and Country Planning Act 1961* provides for the closing of a road or part of a road and notice of approval of the planning scheme has been published in the *Government Gazette*, it shall not be necessary for the Council to publish or to post to any person notice of its intention to request the Governor in Council to discontinue such road or part thereof.

And whereas the City of Knox Planning Scheme 1979 provides that a road off Alchester Crescent, Boronia is not required for public use and notice of approval of the planning scheme was published in the *Government Gazette* of 23 September 1981.

Now therefore, His Excellency the Governor of the State of Victoria, by and with the advice of the Executive Council thereof, hereby directs that the said road which is shown by hatching on the plan hereunder shall be discontinued and the land in the said road may be sold by the Council of the City of Knox by agreement.

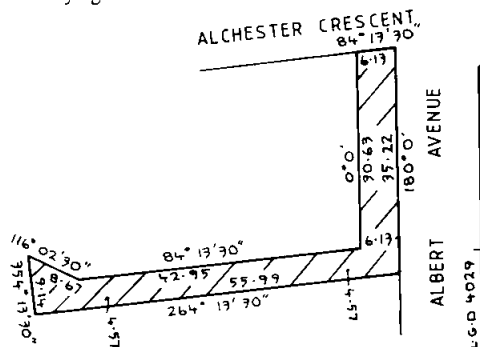

MEASUREMENTS ARE IN METRES

And the Honourable Frank Noel Wilkes, Her Majesty's Minister for Local Government for the State of Victoria, shall give the necessary directions herein accordingly.

TOM FORRISTAL
 Clerk of the Executive Council

LOCAL GOVERNMENT ACT 1958

At the Executive Council Chamber, Melbourne, the twenty-third day of August, 1983

Present:

His Excellency the Governor of Victoria
 Mr Mackenzie | Mr Kent
 Mr Simpson

ROAD DISCONTINUED – CITY OF CAULFIELD

Whereas it is provided in section 528 (2) of the *Local Government Act 1958*, that where a road (whether or not a public highway but not being a road set out on land of the Crown) or any part thereof is not required for public use, the Governor in Council on the request of the council of the municipality in which such road is situated made not less than one month after publishing in a newspaper generally circulating in the district and posting to the registered proprietor (if any) of the land and the owners and occupiers (if any) of lands abutting or immediately adjacent to the road notice of intention to make such a request may by Order published in the *Government Gazette* direct that such road or part shall be discontinued and thereupon such road or part shall be discontinued accordingly.

And whereas the Council of the City of Caulfield has requested that the Governor in Council direct that part of a road bounded by Queens Avenue, Derby Crescent and Epsom Street, Carnegie be discontinued and not less than one month previously has published in a newspaper generally circulating in the district and posted to the registered proprietor of the land in the road and to the owners and occupiers of lands abutting or immediately adjacent to the road notice of intention to make such a request.

Now therefore, His Excellency the Governor of the State of Victoria, by and with the advice of the Executive Council thereof, hereby directs that the said part of a road which is shown by hatching on the plan hereunder, shall be discontinued and the land in the said part of a road may be sold by the Council of the City of Caulfield by agreement.

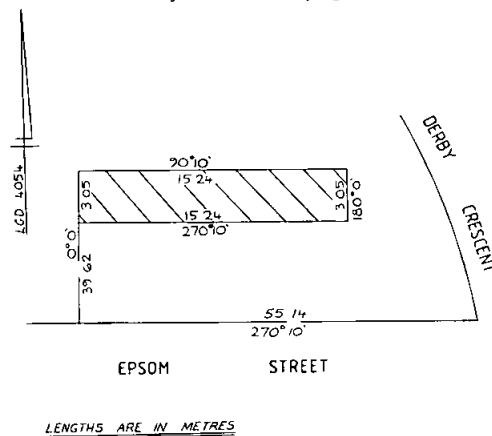

LENGTHS ARE IN METRES

And the Honourable Frank Noel Wilkes, Her Majesty's Minister for Local Government for the State of Victoria, shall give the necessary directions herein accordingly.

TOM FORRISTAL
 Clerk of the Executive Council

LOCAL GOVERNMENT ACT 1958

At the Executive Council Chamber, Melbourne, the
twenty-third day of August, 1983

Present:

His Excellency the Governor of Victoria
Mr Mackenzie Mr Kent
Mr Simpson

VESTING OF A RESERVE IN THE PRESTON CITY COUNCIL

Whereas it is provided by section 569BA of the *Local Government Act 1958*, that where any map or plan has been lodged or deposited with the Registrar of Titles pursuant to section 97 of the *Transfer of Land Act 1958*, or any corresponding previous enactment (whether before or after the commencement of the *Local Government Act 1963*) and any allotment on that map or plan has been transferred the Governor in Council on the request of the council of the municipality may by Order published in the *Government Gazette* direct that the whole or any part of the land comprised in any reserve shown on that map or plan shall vest in the council whereupon such land shall so vest freed and discharged from any mortgage charge lease or sub-lease.

And whereas the Council of the City of Preston has requested that a reserve shown on plan of subdivision be vested in the Council and a lot on that plan has been transferred.

Now therefore, His Excellency the Governor of the State of Victoria, by and with the advice of the Executive Council thereof, and in pursuance of the provisions of sub-section 1 of section 569BA of the *Local Government Act 1958*, doth by this Order vest in the Council of the City of Preston the Reserve for Recreation, Drainage and Sewerage purposes coloured green on Plan of Subdivision No. 42287 lodged in the Office of Titles.

And the Honourable Frank Noel Wilkes, Her Majesty's Minister for Local Government for the State of Victoria, shall give the necessary directions herein accordingly.

TOM FORRISTAL
Clerk of the Executive Council

LOCAL GOVERNMENT ACT 1958

At the Executive Council Chamber, Melbourne, the
twenty-third day of August, 1983

Present:

His Excellency the Governor of Victoria
Mr Mackenzie Mr Kent
Mr Simpson

CONSENT TO VARIATION OF USE OF PART OF A RESERVE — SHIRE OF TAMBO

Whereas pursuant to the provisions of section 569BA of the *Local Government Act 1958*, certain land being the Reserve for Municipal Purposes on Plan of Subdivision No. 131193 lodged in the Office of Titles was vested in the Council of the Shire of Tambo by Order published in the *Government Gazette* on 11 August 1982, and the Council of the Shire of Tambo is now of the opinion that part of the land is no longer required for the purpose for which it was reserved and has requested that consent be given to the use of the land for Road purposes.

And whereas the said Council:

- (a) has published in a newspaper generally circulating in the municipal district a notice describing the land and the proposal for the altered use thereof and stating that at the next ordinary meeting of the Council after

the expiration of forty days after publication of the notice the Council would consider any objection to the proposal.

- (b) has served a copy of the said notice upon any other person whom the Council considered should be so served; and

- (c) has posted a similar notice upon the land in question.

And whereas no objection has been made against the proposal.

Now therefore, His Excellency the Governor of the State of Victoria, by and with the advice of the Executive Council thereof, and in pursuance of the provisions of sub-section 2 of section 569BA of the *Local Government Act 1958* hereby consents to the use of part of the land shown as the Reserve for Municipal Purposes on Plan of Subdivision No. 131193 lodged in the Office of Titles as shown by hatching on the plan hereunder for Road purposes.

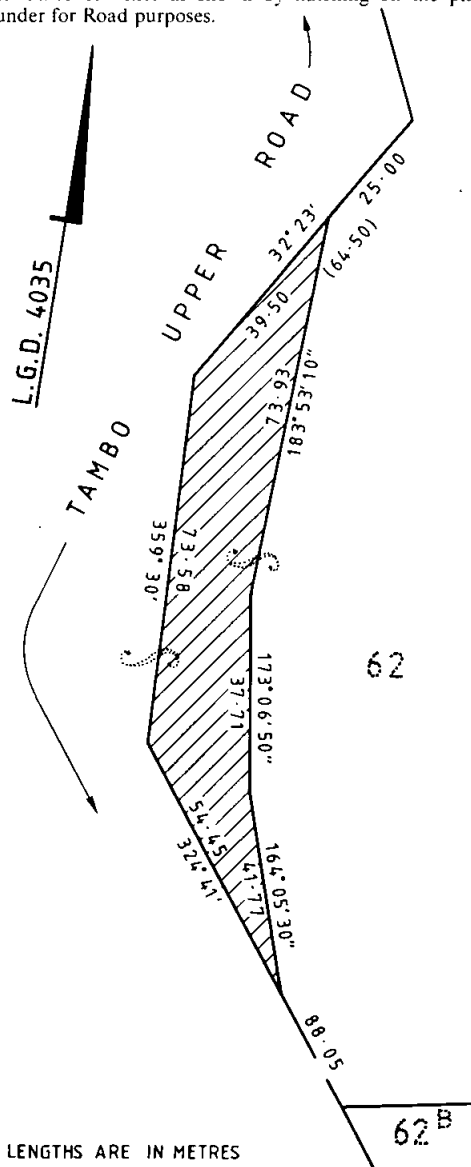

And the Honourable Frank Noel Wilkes, Her Majesty's Minister for Local Government for the State of Victoria, shall give the necessary directions herein accordingly.

TOM FORRISTAL
Clerk of the Executive Council

LOCAL GOVERNMENT ACT 1958

At the Executive Council Chamber, Melbourne, the twenty-third day of August, 1983

Present:

His Excellency the Governor of Victoria
Mr Mackenzie | Mr Kent
Mr Simpson

VESTING OF A RESERVE IN THE FLINDERS SHIRE COUNCIL

Whereas it is provided by section 569BA of the *Local Government Act 1958*, that where any map or plan has been lodged or deposited with the Registrar of Titles pursuant to section 97 of the *Transfer of Land Act 1958*, or any corresponding previous enactment (whether before or after the commencement of the *Local Government Act 1963*) and any allotment on that map or plan has been transferred the Governor in Council on the request of the council of the municipality made by Order published in the *Government Gazette* direct that the whole or any part of the land comprised in any reserve shown on that map or plan shall vest in the council whereupon such land shall so vest freed and discharged from any mortgage charge lease or sub-lease.

And whereas the Council of the Shire of Flinders has requested that a reserve shown on plan of subdivision be vested in the Council and a lot on that plan has been transferred.

Now therefore, His Excellency the Governor of the State of Victoria, by and with the advice of the Executive Council thereof, and in pursuance of the provisions of sub-section 1 of section 569BA of the *Local Government Act 1958*, doth by this Order vest in the Council of the Shire of Flinders the Drainage Reserve on Plan of Subdivision No. 41487 lodged in the Office of Titles as shown by hatching on the attached plan.

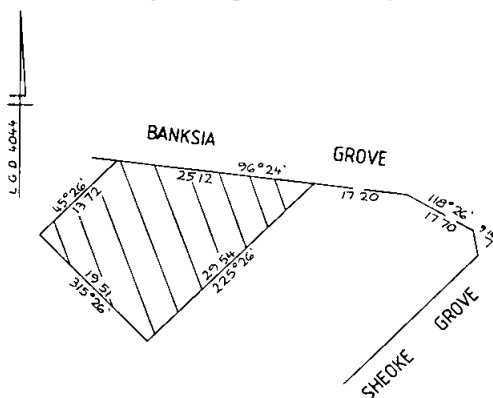

LENGTHS ARE IN METRES

And the Honourable Frank Noel Wilkes, Her Majesty's Minister for Local Government for the State of Victoria, shall give the necessary directions herein accordingly.

TOM FORRISTAL
Clerk of the Executive Council

LOCAL GOVERNMENT ACT 1958

At the Executive Council Chamber, Melbourne, the twenty-third day of August, 1983

Present:

His Excellency the Governor of Victoria
Mr Mackenzie | Mr Kent
Mr Simpson

ROAD DISCONTINUED — CITY OF ST. KILDA

Whereas it is provided in section 528 (2) of the *Local Government Act 1958*, that where a road (whether or not a public highway but not being a road set out on land of the Crown) or any part thereof is not required for public use, the Governor in Council on the request of the council of the municipality in which such road is situated made not less than one month after publishing in a newspaper generally circulating in the district and posting to the registered proprietor (if any) of the land and the owners and occupiers (if any) of lands abutting or immediately adjacent to the road notice of intention to make such a request may by Order published in the *Government Gazette* direct that such road or part shall be discontinued and thereupon such road or part shall be discontinued accordingly.

And whereas the Council of the City of St. Kilda has requested that the Governor in Council direct that a road at the rear of 20-32 Barkly Street, St. Kilda be discontinued and not less than one month previously has published in a newspaper generally circulating in the district and posted to the registered proprietor of the land in the road and to the owners and occupiers of lands abutting or immediately adjacent to the road notice of intention to make such a request.

Now therefore, His Excellency the Governor of the State of Victoria, by and with the advice of the Executive Council thereof, hereby directs that the said road which is shown by hatching on the plan hereunder shall be discontinued and the land in the said road may be sold by the Council of the City of St. Kilda by agreement.

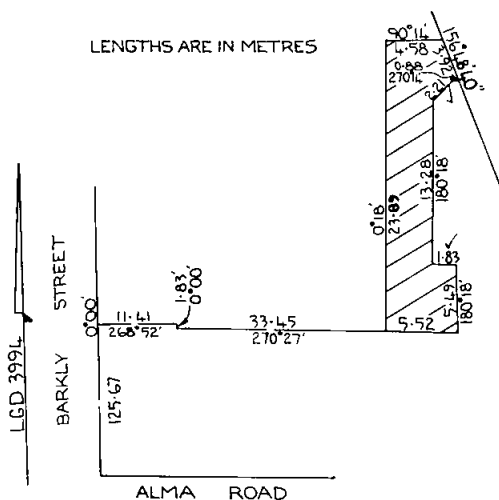

LENGTHS ARE IN METRES

And the Honourable Frank Noel Wilkes, Her Majesty's Minister for Local Government for the State of Victoria, shall give the necessary directions herein accordingly.

TOM FORRISTAL
Clerk of the Executive Council

LOCAL GOVERNMENT ACT 1958

At the Executive Council Chamber, Melbourne, the
twenty-third day of August, 1983

Present:

His Excellency the Governor of Victoria
Mr Mackenzie | Mr Kent
Mr Simpson

VESTING OF RESERVE IN THE FRANKSTON CITY
COUNCIL

Whereas it is provided by section 569BA of the *Local Government Act 1958*, that where any map or plan has been lodged or deposited with the Registrar of Titles pursuant to section 97 of the *Transfer of Land Act 1958*, or any corresponding previous enactment (whether before or after the commencement of the *Local Government Act 1963*) and any allotment on that map or plan has been transferred the Governor in Council on the request of the council of the municipality made by Order published in the *Government Gazette* direct that the whole or any part of the land comprised in any reserve shown on that map or plan shall vest in the council whereupon such land shall so vest freed and discharged from any mortgage charge lease or sub-lease.

And whereas the Council of the City of Frankston has requested that a reserve shown on a plan of subdivision be vested in the Council and an allotment on that plan has been transferred.

Now therefore, His Excellency the Governor of the State of Victoria, by and with the advice of the Executive Council thereof, and in pursuance of the provisions of sub-section 1 of section 569BA of the *Local Government Act 1958*, doth by this Order vest in the Council of the City of Frankston the Drainage Reserve coloured green on Plan of Subdivision No. 50137 lodged in the Office of Titles.

And the Honourable Frank Noel Wilkes, Her Majesty's Minister for Local Government for the State of Victoria, shall give the necessary directions herein accordingly.

TOM FORRISTAL
Clerk of the Executive Council

LOCAL GOVERNMENT ACT 1958

At the Executive Council Chamber, Melbourne, the
twenty-third day of August, 1983

Present:

His Excellency the Governor of Victoria
Mr Mackenzie | Mr Kent
Mr Simpson

VESTING OF A RESERVE IN THE ELTHAM SHIRE
COUNCIL

Whereas it is provided by section 569BA of the *Local Government Act 1958*, that where any map or plan has been lodged or deposited with the Registrar of Titles pursuant to section 97 of the *Transfer of Land Act 1958*, or any corresponding previous enactment (whether before or after the commencement of the *Local Government Act 1963*) and any allotment on that map or plan has been transferred the Governor in Council on the request of the council of the municipality made by Order published in the *Government Gazette* direct that the whole or any part of the land comprised in any reserve shown on that map or plan shall vest in the council whereupon such land shall so vest freed and discharged from any mortgage charge lease or sub-lease.

And whereas the Council of the Shire of Eltham has requested that a reserve shown on plan of subdivision be vested in the Council and a lot on the subdivision has been transferred.

Now therefore, His Excellency the Governor of the State of Victoria, by and with the advice of the Executive Council thereof, and in pursuance of the provisions of sub-section 1 of section 569BA of the *Local Government Act 1958*, doth by this Order vest in the Council of the Shire of Eltham the Drainage Reserve on Plan of Subdivision No. 13612 lodged in the Office of Titles being the land shown by hatching on the attached plan.

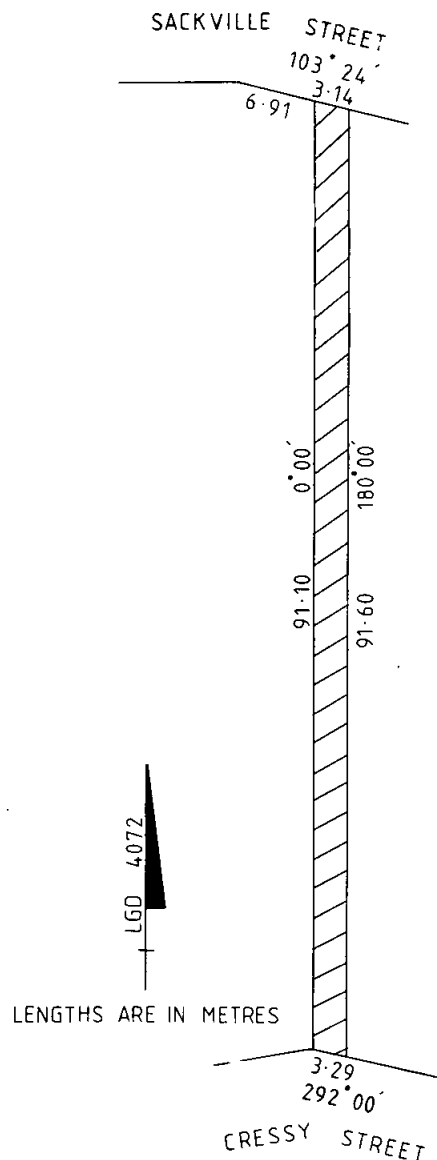

And the Honourable Frank Noel Wilkes, Her Majesty's Minister for Local Government for the State of Victoria, shall give the necessary directions herein accordingly.

TOM FORRISTAL
Clerk of the Executive Council

LOCAL GOVERNMENT ACT 1958

At the Executive Council Chamber, Melbourne, the
twenty-third day of August, 1983

Present:

His Excellency the Governor of Victoria
Mr Mackenzie | Mr Kent
Mr Simpson

ROAD DISCONTINUED — CITY OF ESSENDON

Whereas it is provided in section 528 (2) of the *Local Government Act 1958*, that where a road (whether or not a public highway but not being a road set out on land of the Crown) or any part thereof is not required for public use, the Governor in Council on the request of the council of the municipality in which such road is situated made not less than one month after publishing in a newspaper generally circulating in the district and posting to the registered proprietor (if any) of the land and the owners and occupiers (if any) of lands abutting or immediately adjacent to the road notice of intention to make such a request may by Order published in the *Government Gazette* direct that such road or part shall be discontinued and thereupon such road or part shall be discontinued accordingly.

And whereas the Council of the City of Essendon has requested that the Governor in Council direct that part of a road between Forrester and Mary Streets, Essendon be discontinued and not less than one month previously has published in a newspaper generally circulating in the district and posted to the registered proprietor of the land in the road and to the owners and occupiers of lands abutting or immediately adjacent to the road notice of intention to make such a request.

And whereas objections from owners or occupiers of land abutting or immediately adjacent to the road have been received and have been considered.

Now therefore, His Excellency the Governor of the State of Victoria, by and with the advice of the Executive Council thereof, hereby directs:

- (a) that the said part of a road which is shown by hatching on the plan hereunder shall be discontinued;
- (b) that notwithstanding such discontinuance the Melbourne and Metropolitan Board of Works shall continue to have and possess the same right title power authority or interest in or in relation to the whole of the land shown by hatching on the said plan as it had or possessed prior to such discontinuance with respect to or in connection with any drains or pipes laid or erected in on or over such land for the purposes of drainage or sewerage;
- (c) that, subject to any such right title power authority or interest the land in the said part of a road may be sold by the Council of the City of Essendon by agreement.

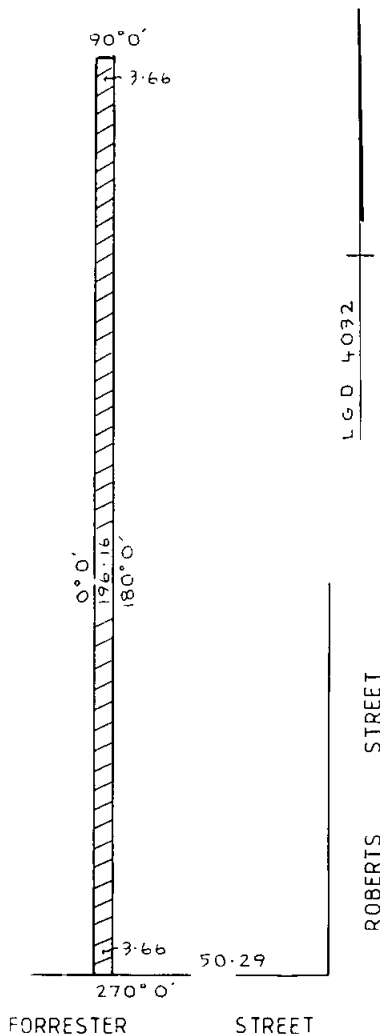

MEASUREMENTS ARE IN METRES

And the Honourable Frank Noel Wilkes, Her Majesty's Minister for Local Government for the State of Victoria, shall give the necessary directions herein accordingly.

TOM FORRISTAL
Clerk of the Executive Council

LOCAL GOVERNMENT ACT 1958

At the Executive Council Chamber, Melbourne, the
twenty-third day of August, 1983

Present:

His Excellency the Governor of Victoria
Mr Mackenzie | Mr Kent
Mr Simpson

And the Honourable Frank Noel Wilkes, Her Majesty's
Minister for Local Government for the State of Victoria, shall
give the necessary directions herein accordingly.

TOM FORRISTAL
Clerk of the Executive Council

ROAD DISCONTINUED — CITY OF BALLAARAT

Whereas it is provided in section 528 (2) of the *Local Government Act 1958*, that where a road (whether or not a public highway but not being a road set out on land of the Crown) or any part thereof is not required for public use, the Governor in Council on the request of the council of the municipality in which such road is situated made not less than one month after publishing in a newspaper generally circulating in the district and posting to the registered proprietor (if any) of the land and the owners and occupiers (if any) of lands abutting or immediately adjacent to the road notice of intention to make such a request may by Order published in the *Government Gazette* direct that such road or part shall be discontinued and thereupon such road or part shall be discontinued accordingly.

And whereas the Council of the City of Ballaarat has requested that the Governor in Council direct that a road off Victoria Avenue, Ballaarat be discontinued and not less than one month previously has published in a newspaper generally circulating in the district and posted to the registered proprietor of the land in the road and to the owners and occupiers of lands abutting or immediately adjacent to the road notice of intention to make such a request.

Now therefore, His Excellency the Governor of the State of Victoria, by and with the advice of the Executive Council thereof, hereby directs that the said road which is shown by hatching on the plan hereunder shall be discontinued and the land in the said road may be sold by the Council of the City of Ballaarat by agreement.

LOCAL GOVERNMENT ACT 1958

At the Executive Council Chamber, Melbourne, the
twenty-third day of August, 1983

Present:

His Excellency the Governor of Victoria
Mr Mackenzie | Mr Kent
Mr Simpson

ROAD DISCONTINUED — CITY OF FOOTSCRAY

Whereas it is provided in section 528 (2) of the *Local Government Act 1958*, that where a road (whether or not a public highway but not being a road set out on land of the Crown) or any part thereof is not required for public use, the Governor in Council on the request of the council of the municipality in which such road is situated made not less than one month after publishing in a newspaper generally circulating in the district and posting to the registered proprietor (if any) of the land and the owners and occupiers (if any) of lands abutting or immediately adjacent to the road notice of intention to make such a request may by Order published in the *Government Gazette* direct that such road or part shall be discontinued and thereupon such road or part shall be discontinued accordingly.

And whereas the Council of the City of Footscray has requested that the Governor in Council direct that a road between Barton and Hope Streets, Footscray West be discontinued and not less than one month previously has published in a newspaper generally circulating in the district and posted to the registered proprietor of the land in the road and to the owners and occupiers of lands abutting or immediately adjacent to the road notice of intention to make such a request.

Now therefore, His Excellency the Governor of the State of Victoria, by and with the advice of the Executive Council thereof, hereby directs:

- (a) that the said road which is shown by hatching on the plan hereunder shall be discontinued;
- (b) that notwithstanding such discontinuance the Melbourne and Metropolitan Board of Works shall continue to have and possess the same right title power authority or interest in or in relation to the whole of the land shown by hatching on the said plan as it had or possessed prior to such discontinuance with respect to or in connection with any drains or pipes laid or erected in on or over such land for the purposes of drainage;
- (c) that, subject to any such right title power authority or interest the land in the said road may be sold by the Council of the City of Footscray by agreement.

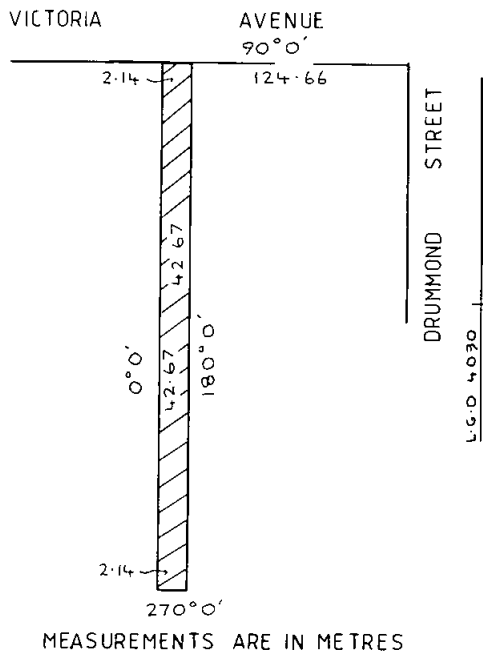

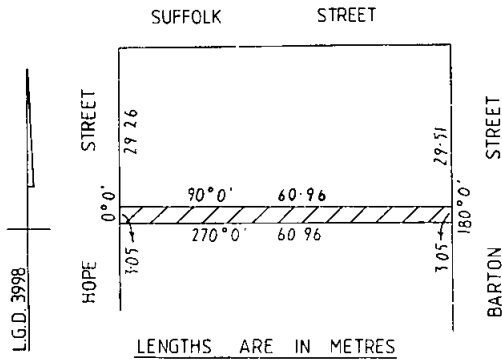

And the Honourable Frank Noel Wilkes, Her Majesty's Minister for Local Government for the State of Victoria, shall give the necessary directions herein accordingly.

TOM FORRISTAL
Clerk of the Executive Council

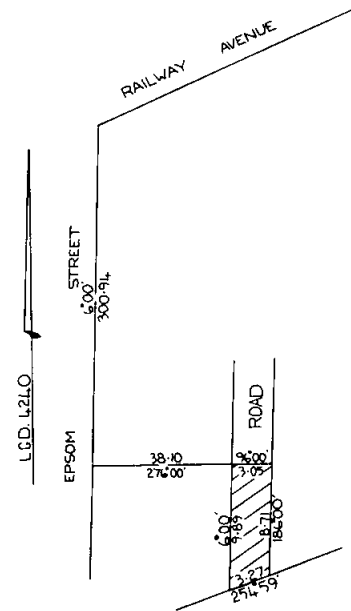

LENGTHS ARE IN METRES

And the Honourable Frank Noel Wilkes, Her Majesty's Minister for Local Government for the State of Victoria, shall give the necessary directions herein accordingly.

TOM FORRISTAL
Clerk of the Executive Council

LOCAL GOVERNMENT ACT 1958

At the Executive Council Chamber, Melbourne, the twenty-third day of August, 1983

Present:

His Excellency the Governor of Victoria
Mr Mackenzie | Mr Kent
Mr Simpson

ROAD DISCONTINUED — SHIRE OF WERRIBEE

Whereas it is provided in section 528 (2) of the *Local Government Act 1958*, that where a road (whether or not a public highway but not being a road set out on land of the Crown) or any part thereof is not required for public use, the Governor in Council on the request of the council of the municipality in which such road is situated made not less than one month after publishing in a newspaper generally circulating in the district and posting to the registered proprietor (if any) of the land and the owners and occupiers (if any) of lands abutting or immediately adjacent to the road notice of intention to make such a request may by Order published in the *Government Gazette* direct that such road or part shall be discontinued and thereupon such road or part shall be discontinued accordingly.

And whereas the Council of the Shire of Werribee has requested that the Governor in Council direct that part of a road off Railway Avenue, Laverton be discontinued and not less than one month previously has published in a newspaper generally circulating in the district and posted to the registered proprietor of the land in the road and to the owners and occupiers of lands abutting or immediately adjacent to the road notice of intention to make such a request.

Now therefore, His Excellency the Governor of the State of Victoria, by and with the advice of the Executive Council thereof, hereby directs that the said part of a road which is shown by hatching on the plan hereunder shall be discontinued and the land in the said part of a road may be sold by the Council of the Shire of Werribee by agreement.

LOCAL GOVERNMENT ACT 1958

At the Executive Council Chamber, Melbourne, the twenty-third day of August, 1983

Present:

His Excellency the Governor of Victoria
Mr Mackenzie | Mr Kent
Mr Simpson

ROAD DISCONTINUED — CITY OF CAMBERWELL

Whereas it is provided in section 528 (2) of the *Local Government Act 1958*, that where a road (whether or not a public highway but not being a road set out on land of the Crown) or any part thereof is not required for public use, the Governor in Council on the request of the council of the municipality in which such road is situated made not less than one month after publishing in a newspaper generally circulating in the district and posting to the registered proprietor (if any) of the land and the owners and occupiers (if any) of lands abutting or immediately adjacent to the road notice of intention to make such a request may by Order published in the *Government Gazette* direct that such road or part shall be discontinued and thereupon such road or part shall be discontinued accordingly.

And whereas it is further provided that where a planning scheme under the *Town and Country Planning Act 1961* provides for the closing of a road or part of a road and notice of approval of the planning scheme has been published in the *Government Gazette*, it shall not be necessary for the Council to publish or to post to any person notice of its intention to request the Governor in Council to discontinue such road or part thereof.

And whereas the City of Camberwell Planning Scheme 1954 provides that a road off Golding Street, Canterbury is not required for public use and notice of approval of the planning scheme was published in the *Government Gazette* of 30 October, 1957.

And whereas the Council of the City of Camberwell has requested that the Governor in Council direct that the said road be discontinued:

Now therefore, His Excellency the Governor of the State of Victoria, by and with the advice of the Executive Council thereof, hereby directs:

- (a) that the said road which is shown by hatching on the plan hereunder shall be discontinued;
- (b) that notwithstanding such discontinuance the Melbourne and Metropolitan Board of Works shall continue to have and possess the same right title power authority or interest in or in relation to the whole of the land shown by cross hatching on the said plan as it had or possessed prior to such discontinuance with respect to or in connection with any drains or pipes laid or erected in on or over such land for the purposes of drainage or sewerage;
- (c) that, subject to any such right title power authority or interest the land in the said road may be sold by the Council of the City of Camberwell by agreement.

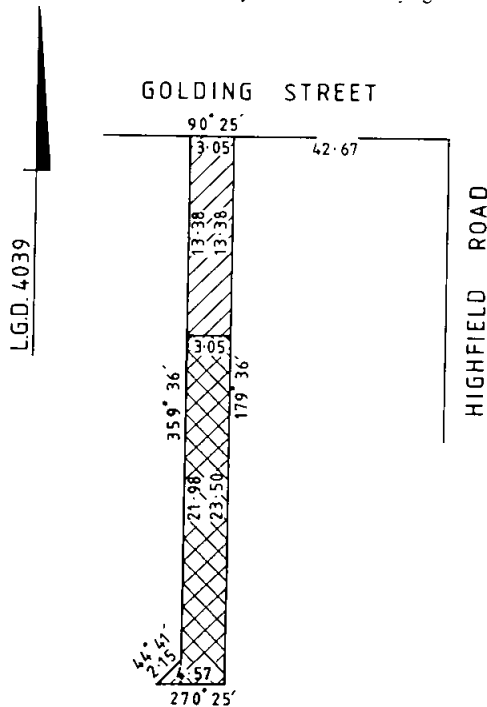

LENGTHS ARE IN METRES

And the Honourable Frank Noel Wilkes, Her Majesty's Minister for Local Government for the State of Victoria, shall give the necessary directions herein accordingly.

TOM FORRISTAL
Clerk of the Executive Council

LOCAL GOVERNMENT ACT 1958

At the Executive Council Chamber, Melbourne, the twenty-third day of August, 1983

Present:

His Excellency the Governor of Victoria
Mr Mackenzie | Mr Kent
Mr Simpson

ROAD DISCONTINUED — CITY OF PRESTON

Whereas it is provided in section 528 (2) of the *Local Government Act* 1958, that where a road (whether or not a public highway but not being a road set out on land of the Crown) or any part thereof is not required for public use, the Governor in Council on the request of the council of the municipality in which such road is situated made not less than one month after publishing in a newspaper generally circulating in the district and posting to the registered proprietor (if any) of the land and the owners and occupiers (if any) of lands abutting or immediately adjacent to the road notice of intention to make such a request may by Order published in the *Government Gazette* direct that such road or part shall be discontinued and thereupon such road or part shall be discontinued accordingly.

And whereas the Council of the City of Preston has requested that the Governor in Council direct that a road off Birch Street, Preston be discontinued and not less than one month previously has published in a newspaper generally circulating in the district and posted to the registered proprietor of the land in the road and to the owners and occupiers of lands abutting or immediately adjacent to the road notice of intention to make such a request.

And whereas objections from owners or occupiers of land abutting or immediately adjacent to the road have been received and have been considered.

Now therefore, His Excellency the Governor of the State of Victoria, by and with the advice of the Executive Council thereof, hereby directs:

- (a) that the said road which is shown by hatching on the plan hereunder shall be discontinued;
- (b) that notwithstanding such discontinuance the Council of the City of Preston shall continue to have and possess the same right title power authority or interest in or in relation to the whole of the land shown by hatching on the said plan as it had or possessed prior to such discontinuance with respect to or in connection with any drains or pipes laid or erected in on or over such land for the purposes of drainage;
- (c) that, subject to any such right title power authority or interest the land in the said road may be sold by the Council of the City of Preston by agreement.

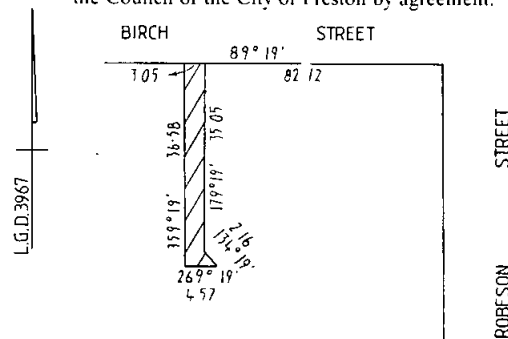

LENGTHS ARE IN METRES

And the Honourable Frank Noel Wilkes, Her Majesty's Minister for Local Government for the State of Victoria, shall give the necessary directions herein accordingly.

TOM FORRISTAL
Clerk of the Executive Council

LOCAL GOVERNMENT ACT 1958

At the Executive Council Chamber, Melbourne, the twenty-third day of August, 1983

Present:

His Excellency the Governor of Victoria
Mr Mackenzie | Mr Kent
Mr Simpson

ROAD DISCONTINUED — CITY OF COBURG

Whereas it is provided in section 528 (2) of the *Local Government Act 1958*, that where a road (whether or not a public highway but not being a road set out on land of the Crown) or any part thereof is not required for public use, the Governor in Council on the request of the council of the municipality in which such road is situated made not less than one month after publishing in a newspaper generally circulating in the district and posting to the registered proprietor (if any) of the land and the owners and occupiers (if any) of lands abutting or immediately adjacent to the road notice of intention to make such a request may by Order published in the *Government Gazette* direct that such road or part shall be discontinued and thereupon such road or part shall be discontinued accordingly.

And whereas the Council of the City of Coburg has requested that the Governor in Council direct that a road off Edna Grove, Coburg be discontinued and not less than one month previously had published in a newspaper generally circulating in the district and posted to the registered proprietor of the land in the road and to the owners and occupiers of lands abutting or immediately adjacent to the road notice of intention to make such a request.

And whereas objections from owners or occupiers of land abutting or immediately adjacent to the road have been received and have been considered.

Now therefore, His Excellency the Governor of the State of Victoria, by and with the advice of the Executive Council thereof, hereby directs:

- (a) that the said road which is shown by hatching and cross hatching on the plan hereunder shall be discontinued;

- (b) that notwithstanding such discontinuance the Melbourne and Metropolitan Board of Works shall continue to have and possess the same right title power authority or interest in or in relation to the whole of the land shown by cross hatching on the said plan as it had or possessed prior to such discontinuance with respect to or in connection with any drains or pipes laid or erected in on or over such land for the purposes of drainage or sewerage;
- (c) that, subject to any such right title power authority or interest the land in the said road may be sold by the Council of the City of Coburg by agreement.

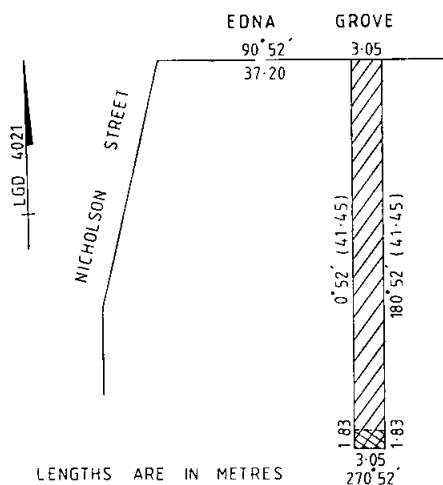

And the Honourable Frank Noel Wilkes, Her Majesty's Minister for Local Government for the State of Victoria, shall give the necessary directions herein accordingly.

TOM FORRISTAL
Clerk of the Executive Council

LOCAL GOVERNMENT ACT 1958

At the Executive Council Chamber, Melbourne, the twenty-third day of August, 1983

Present:

His Excellency the Governor of Victoria
Mr Mackenzie | Mr Kent
Mr Simpson

ROAD DISCONTINUED — CITY OF COBURG

Whereas it is provided in section 528 (2) of the *Local Government Act 1958*, that where a road (whether or not a public highway but not being a road set out on land of the Crown) or any part thereof is not required for public use, the Governor in Council on the request of the council of the municipality in which such road is situated made not less than one month after publishing in a newspaper generally circulating in the district and posting to the registered proprietor (if any) of the land and

the owners and occupiers (if any) of lands abutting or immediately adjacent to the road notice of intention to make such a request may by Order published in the *Government Gazette* direct that such road or part shall be discontinued and thereupon such road or part shall be discontinued accordingly.

And whereas the Council of the City of Coburg has requested that the Governor in Council direct that a road between Jenkin and Kennedy Streets, Coburg be discontinued and not less than one month previously has published in a newspaper generally circulating in the district and posted to the registered proprietor of the land in the road and to the owners and occupiers of lands abutting or immediately adjacent to the road notice of intention to make such a request.

Now therefore, His Excellency the Governor of the State of Victoria, by and with the advice of the Executive Council thereof, hereby directs:

- (a) that the said road which is shown by hatching on the plan hereunder shall be discontinued;

CROWN LAND (RESERVES) ACT 1978

At the Executive Council Chamber, Melbourne, the twenty-third day of August, 1983

Present:

His Excellency the Governor of Victoria
 Mr Mackenzie | Mr Kent
 Mr Simpson |

CROWN LAND TEMPORARILY RESERVED

His Excellency the Governor of the State of Victoria, in the Commonwealth of Australia, by and with the advice of the Executive Council of the said State, pursuant to the provisions of sections 4 and 7 of the *Crown Land (Reserves) Act 1978*, and being of the opinion that the Crown land concerned is required for public purposes, doth hereby temporarily reserve and also except from prospecting or from occupation for mining purposes under any miner's right, the Crown land hereinafter described, viz.:

Municipal District of the Shire of Bass —
 SAN REMO — For Public purposes — 1800 square metres, more or less, being Crown allotment 1^K, section A, Township of San Remo, as indicated by hatching on plan hereunder — (S 463⁽³⁾) (Rs.3972)

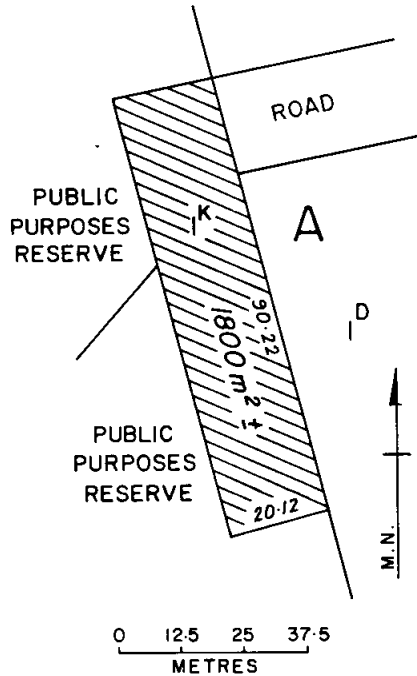

And the Honourable Roderick Alexander Mackenzie, Her Majesty's Minister of Lands for the State of Victoria, shall give the necessary directions herein accordingly.
 TOM FORRISTAL
 Clerk of the Executive Council

CROWN LAND (RESERVES) ACT 1978

At the Executive Council Chamber, Melbourne, the twenty-third day of August, 1983

Present:

His Excellency the Governor of Victoria
 Mr Mackenzie | Mr Kent
 Mr Simpson |

CROWN LANDS PLACED UNDER THE CONTROL AND MANAGEMENT OF THE FORESTS COMMISSION

His Excellency the Governor of the State of Victoria, in the Commonwealth of Australia, by and with the advice of the Executive Council of the said State, pursuant to the provisions of section 18 (1) of the *Crown Land (Reserves) Act 1978*, doth hereby place under the control and management of the Forests Commission, the Crown lands hereinafter described, viz.:

The Crown lands in the Parish of Noonga permanently reserved for Public purposes, being those portions of the frontages to the Broadribb River, and which abut Reserved Forest, shown coloured blue on plan no. VIC. F.C. 18^A lodged in the Central Plan Office — (L9-1427B).

The Crown lands in the Parish of Purgagoolah temporarily reserved for Public purposes, being those portions of the frontages to the Arte River, and which abut Reserved Forest, shown coloured green on plan no. VIC. F.C. 18^A lodged in the Central Plan Office — (L9-1427B).

*This Order is made in lieu of the Order made on 15 June 1983 (see *Government Gazette* dated 22 June 1983, page 1731) in respect of certain Crown lands in the Parishes of Wibenduck and Purgagoolah.

And the Honourable Roderick Alexander Mackenzie, Her Majesty's Minister of Lands for the State of Victoria, shall give the necessary directions herein accordingly.

TOM FORRISTAL
 Clerk of the Executive Council

CROWN LAND (RESERVES) ACT 1978

At the Executive Council Chamber, Melbourne, the twenty-third day of August, 1983

Present:

His Excellency the Governor of Victoria
 Mr Mackenzie | Mr Kent
 Mr Simpson |

CROWN LANDS TEMPORARILY RESERVED

His Excellency the Governor of the State of Victoria, in the Commonwealth of Australia, by and with the advice of the Executive Council of the said State, pursuant to the provisions of sections 4 and 7 of the *Crown Land (Reserves) Act 1978*, and being of the opinion that the Crown lands concerned are required for the purposes respectively mentioned, doth hereby temporarily reserve and also except from prospecting or from occupation for mining purposes under any miner's right, the Crown lands hereinafter described, viz.:

Municipal District of the Shire of Rosedale —
 LONGFORD — For Public Hall — 2023 square metres, being Crown allotment 5^B, Township of Longford, as indicated by hatching on plan hereunder — (L 91⁽⁴⁾) (Rs.12489)

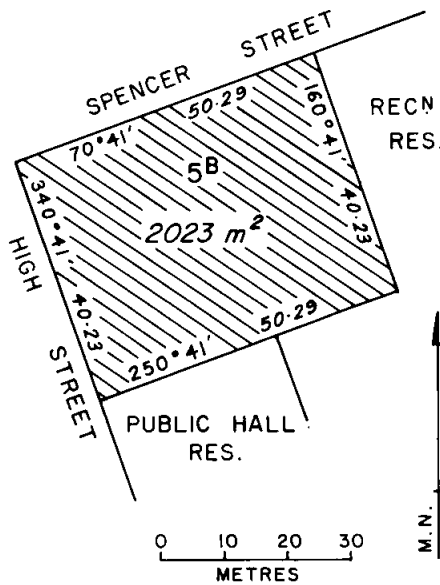

Municipal District of the Borough of Sebastopol —
SEBASTOPOL — For Public Recreation — 11.4 hectares,
 more or less, being Crown allotment 14, section 35, Township
 of Sebastopol, as indicated by hatching on plan hereunder —
 (S 353⁽¹⁰⁾) (Rs.2991)

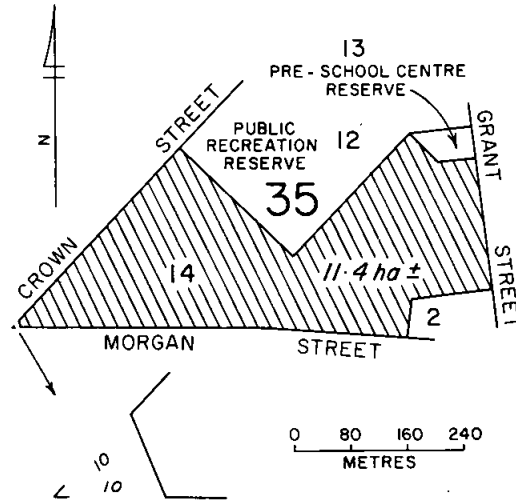

And the Honourable Roderick Alexander Mackenzie, Her
 Majesty's Minister of Lands for the State of Victoria, shall give
 the necessary directions herein accordingly.

TOM FORRISTAL
 Clerk of the Executive Council

Municipal District of the Shire of Sherbrooke —
NARREE WORRAN — For Public Park — 11.67 hectares,
 being Crown allotment 35^H, Parish of Narree Worrان, as indicated
 by hatching on plan hereunder — (N 19⁽¹⁰⁾) (Rs.12501)

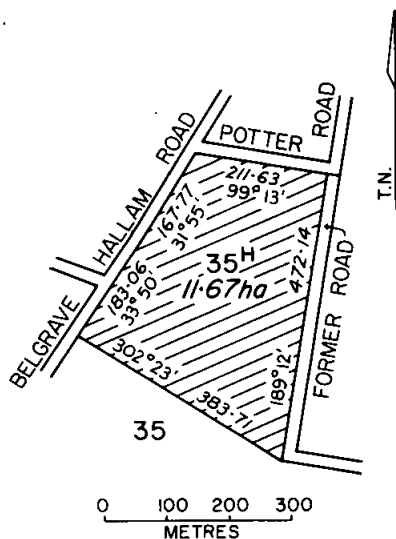

CROWN LAND (RESERVES) ACT 1978

*At the Executive Council Chamber, Melbourne, the
 twenty-third day of August, 1983*

Present:

His Excellency the Governor of Victoria
 Mr Mackenzie | Mr Kent
 Mr Simpson

**CROWN LANDS PLACED UNDER THE CONTROL
 AND MANAGEMENT OF THE FORESTS
 COMMISSION**

His Excellency the Governor of the State of Victoria, in the
 Commonwealth of Australia, by and with the advice of the
 Executive Council of the said State, pursuant to the provisions
 of section 18 (1) of the *Crown Land (Reserves) Act 1978*, doth
 hereby place under the control and management of the Forests
 Commission, the Crown lands hereinafter described, viz.:

The Crown lands in the Parishes of Glenmore, Marroo,
 Mellick-Munjie, Murrindal West, Nappa and Nunningong per-
 manently reserved for Public purposes, being those portions
 of the frontages to the Buchan, Murrindal and Timbarra Rivers,
 and which abut Reserved Forest, shown coloured blue on plan
 no VIC FC 13^A lodged in the Central Plan Office — (L9-2191).

And the Honourable Roderick Alexander Mackenzie, Her
 Majesty's Minister of Lands for the State of Victoria, shall give
 the necessary directions herein accordingly.

TOM FORRISTAL
 Clerk of the Executive Council

CROWN LAND (RESERVES) ACT 1978

At the Executive Council Chamber, Melbourne, the twenty-third day of August, 1983

Present:

His Excellency the Governor of Victoria
 Mr Mackenzie | Mr Kent
 Mr Simpson

CROWN LAND TEMPORARILY RESERVED

His Excellency the Governor of the State of Victoria, in the Commonwealth of Australia, by and with the advice of the Executive Council of the said State, pursuant to the provisions of sections 4 and 7 of the *Crown Land (Reserves) Act 1978*, and being of the opinion that the Crown land concerned is required for the public purpose mentioned, doth hereby temporarily reserve and also except from prospecting or from occupation for mining purposes under any miner's right, the Crown land hereinafter described, viz.:

Municipal District of the City of Dandenong —
DANDENONG — For Health Commission purposes — 697 square metres, being Crown allotment 47A, Parish of Dandenong, as indicated by hatching on plan hereunder — (D 19⁽⁵⁾) (Rs.12372)

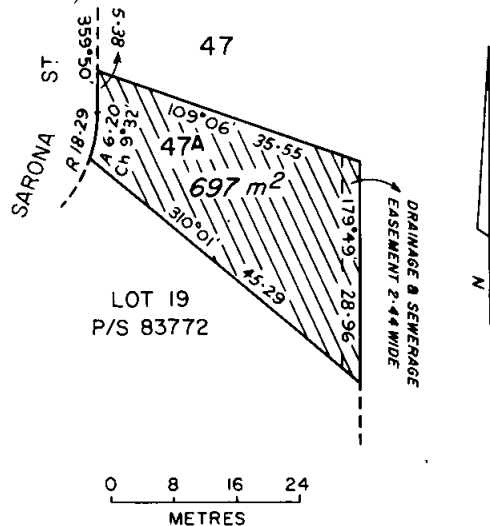

And the Honourable Roderick Alexander Mackenzie, Her Majesty's Minister of Lands for the State of Victoria, shall give the necessary directions herein accordingly.

TOM FORRISTAL
 Clerk of the Executive Council

CROWN LAND (RESERVES) ACT 1978

At the Executive Council Chamber, Melbourne, the twenty-third day of August, 1983

Present:

His Excellency the Governor of Victoria
 Mr Mackenzie | Mr Kent
 Mr Simpson

CROWN LAND PERMANENTLY RESERVED

His Excellency the Governor of the State of Victoria, in the Commonwealth of Australia, by and with the advice of the

Executive Council of the said State, pursuant to the provisions of sections 4 and 7 of the *Crown Land (Reserves) Act 1978*, and being of the opinion that the Crown land concerned is required for the purpose mentioned, doth hereby permanently reserve and also except from prospecting or from occupation for mining purposes under any miner's right, the Crown land hereinafter described, viz.:

Municipal District of the Shire of Swan Hill —
TOLTOL — For Conservation of an Area of Natural Interest — 135 hectares, more or less, being Crown allotments 19A, 19B and 19C, Parish of Toltol, as indicated by hatching on plan hereunder — (T 303⁽³⁾) (Rs.12200)

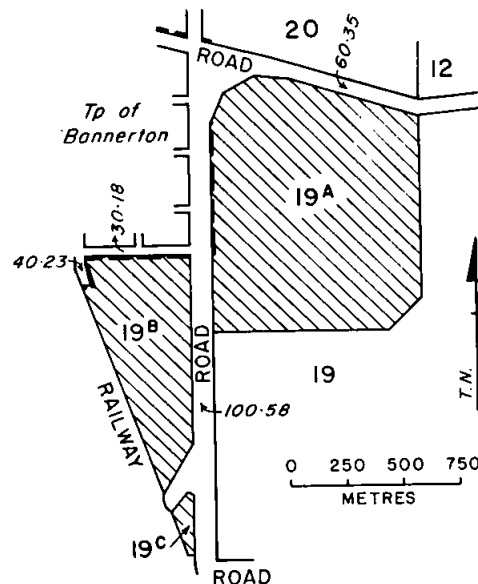

Total area of hatched portions:- 135 ha±

And the Honourable Roderick Alexander Mackenzie, Her Majesty's Minister of Lands for the State of Victoria, shall give the necessary directions herein accordingly.

TOM FORRISTAL
 Clerk of the Executive Council

CROWN LAND (RESERVES) ACT 1978

At the Executive Council Chamber, Melbourne, the twenty-third day of August, 1983

Present:

His Excellency the Governor of Victoria
 Mr Mackenzie | Mr Kent
 Mr Simpson

REVOCATION OF TEMPORARY RESERVATIONS OF LANDS BY ORDERS IN COUNCIL

His Excellency the Governor of the State of Victoria, in the Commonwealth of Australia, by and with the advice of the Executive Council of the said State, pursuant to the provisions

of section 10 of the *Crown Land (Reserves) Act 1978*, do hereby revoke the temporary reservations of lands by Orders in Council hereinafter described, viz.:

CARWARP — The temporary reservation by Order in Council of 31 August 1925 of 2.023 hectares of land in the Parish of Carwarp (being allotment 10^A) for a State School — (Rs.3182).

CARWARP — The temporary reservation by Order in Council of 11 November 1969 of 1.586 hectares of land in the Parish of Carwarp (adjoining allotment 10) for State School purposes — (Rs.3182).

DANDENONG — The temporary reservation by Order in Council of 17 July 1962 of 9.457 hectares of land in the Township of Dandenong for Public Recreation, so far only as the portion thereof containing 2 hectares, more or less, as defined by description and hatching on plan published in the *Government Gazette* dated 3 August 1983, is concerned — (D19C) (Rs.314).

DANDENONG — The temporary reservation by Order in Council of 5 April 1949 of 5058 square metres of land in the Township of Dandenong for a Public Park, so far only as the portion thereof containing 3000 square metres, more or less, as defined by description and hatching on plan published in the *Government Gazette* dated 3 August 1983, is concerned — (D 19⁽⁴⁾) (Rs.314).

DANDENONG — The temporary reservation by Order in Council of 21 August 1962 of 1.315 hectares of land in the Township of Dandenong for Public Park, so far only as the portions thereof containing 9000 square metres, more or less, as defined by description and hatching on plan published in the *Government Gazette* dated 3 August 1983, are concerned — (D19C) (Rs.8153).

EDENHOPE — The temporary reservation by Order in Council of 7 June 1869 of 14.57 hectares of land in the Parish of Edenhope for Public purposes, so far only as the portion thereof containing 1.801 hectares, as defined by description and hatching on plan published in the *Government Gazette* dated 3 August 1983, is concerned — (E 91⁽⁵⁾) (Rs.2365).

EDENHOPE — The temporary reservation by Order in Council of 1 July 1889 of 15.38 hectares, more or less, of land in the Township of Edenhope for Water Supply purposes, revoked as to part by various Orders, so far only as the portions thereof containing 1.706 hectares, as defined by description and hatching on plan published in the *Government Gazette* dated 3 August 1983, are concerned — (E 91⁽⁴⁾) (Rs.10580).

TATURA — The temporary reservation by Order in Council of 25 September 1903 of 14.48 hectares of land in the Township of Tatura for Ornamental Lake and for Public Recreation and the temporary reservation by Order in Council of 20 March 1917 of the same land for the additional purpose of Public Baths, revoked as to part by Order of 22 October 1968, so far as the balance thereof containing 8.134 hectares is concerned — (Rs.1319).

And the Honourable Roderick Alexander Mackenzie, Her Majesty's Minister of Lands for the State of Victoria, shall give the necessary directions herein accordingly.

TOM FORRISTAL
Clerk of the Executive Council

LAND ACT 1958

At the Executive Council Chamber, Melbourne, the
twenty-third day of August, 1983

Present:

His Excellency the Governor of Victoria
Mr Mackenzie | Mr Kent
Mr Simpson

UNUSED ROADS CLOSED

His Excellency the Governor of the State of Victoria, in the Commonwealth of Australia, by and with the advice of the Executive Council of the said State, pursuant to the provisions of section 349 of the *Land Act 1958*, and with the concurrence in writing of the council of the municipality concerned and that of any adjoining land owners, do hereby close the unused roads hereinafter described, viz.:

Municipal District of the City of Echuca —
Township of Echuca, being the road indicated by hatching on plan hereunder — (E 3⁽⁷⁾) (Rs.5756)

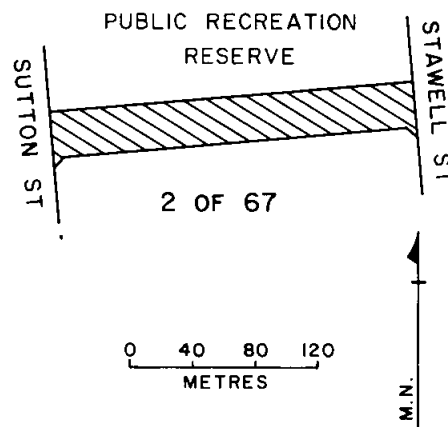

Municipal District of the Shire of Bright —
Parish of Weramatong, being the road indicated by hatching on plan hereunder — (W 350⁽³⁾) (Rs.12511)

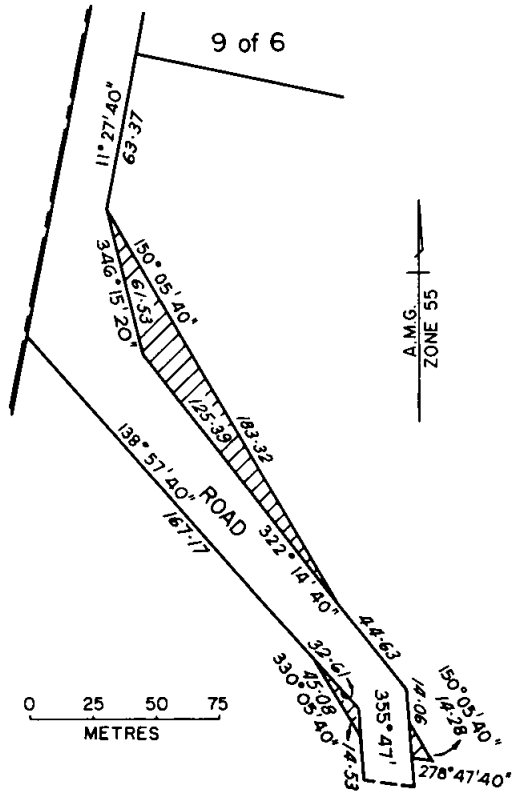

Municipal District of the Shire of Narracan — Parish of Moe, being the road indicated by hatching on plan hereunder — (Parish 3135-3) (L10-370)

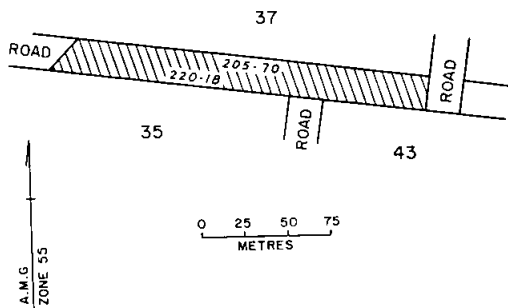

And the Honourable Roderick Alexander Mackenzie, Her Majesty's Minister of Lands for the State of Victoria, shall give the necessary directions herein accordingly.

TOM FORRISTAL
Clerk of the Executive Council

MILDURA URBAN WATER TRUST

At the Executive Council Chamber, Melbourne, the twenty-third day of August, 1983

Present:

His Excellency the Governor of Victoria
Mr Mackenzie | Mr Kent
Mr Simpson

EXTENT OF WATER DISTRICT INCREASED

Under the powers conferred by the Mildura Irrigation and Water Trusts Act and all other powers enabling him in that behalf, His Excellency the Governor of the State of Victoria, by and with the advice of the Executive Council of the said State, doth hereby declare, order and direct that the extent of the Water District of the Mildura Urban Water Trust be increased by adding to the same the areas shown by red colour on the plans approved by the Governor in Council by and with this Order and deposited in the office of the State Rivers and Water Supply Commission, Melbourne (Corr. No. 77/2271/124) and as on and from the date hereof the extent of such District shall be and be deemed to be increased accordingly.

And the Honourable David Ronald White, Her Majesty's Minister of Water Supply for the State of Victoria, shall give the necessary directions herein accordingly.

TOM FORRISTAL
Clerk of the Executive Council

INVERLOCH WATERWORKS TRUST

At the Executive Council Chamber, Melbourne, the twenty-third day of August, 1983

Present:

His Excellency the Governor of Victoria
Mr Mackenzie | Mr Kent
Mr Simpson

Under the powers conferred by the Water Act and all other powers enabling him in that behalf, His Excellency the Governor of the State of Victoria, by and with the advice of the Executive Council of the said State, doth hereby declare that the Commissioners of the Inverloch Waterworks Trust shall from the 27 October 1983, cease to hold office as Commissioners and amend as follows the Order in Council constituting the Inverloch Waterworks Trust made on 8 July 1947 as amended by Order in Council made on 17 May 1960 and 7 November 1973 and published in the *Victoria Government Gazette* on 16 July 1947, 18 May 1960 and 17 November 1973 respectively.

Clause (2) shall be deleted and there shall be substituted the following:

(2) That the Commissioners of the said Trust shall be seven in number of whom:

- (a) six shall be elected by the ratepayers of the said Trust; and
- (b) that one-third of the Commissioners elected by the ratepayers of the said Trust shall retire and be elected annually; and
- (c) the first election of Commissioners under this Order shall be held on Thursday 27 October 1983, between the hours of 8 a.m. and 7 p.m. at the Trust Office, Williams Street, Inverloch.

(d) one other person shall be appointed by the Minister.

And the Honourable David Ronald White, Her Majesty's Minister of Water Supply for the State of Victoria, shall give the necessary directions herein accordingly.

TOM FORRISTAL
Clerk of the Executive Council

LILYDALE SEWERAGE AUTHORITY

*At the Executive Council Chamber, Melbourne, the
twenty-third day of August, 1983*

Present:

His Excellency the Governor of Victoria	
Mr Mackenzie	Mr Kent
Mr Simpson	

AMENDMENT OF ORDER

Under the powers conferred by the Sewerage Districts Act and all other powers enabling him in that behalf, His Excellency the Governor of the State of Victoria, by and with the advice of the Executive Council of the said State, doth hereby amend as follows the Order in Council fixing the annual balance date of the Lilydale Sewerage Authority made on 19 July 1983 and published in the *Victoria Government Gazette* of 27 July 1983.

For the expression "Water Act" substitute the expression "Sewerage Districts Act".

The Honourable David Ronald White, Her Majesty's Minister of Water Supply for the State of Victoria, shall give the necessary directions herein accordingly.

TOM FORRISTAL
Clerk of the Executive Council

MINES ACT 1958

*At the Executive Council Chamber, Melbourne, the
twenty-third day of August, 1983*

Present:

His Excellency the Governor of Victoria	
Mr Mackenzie	Mr Kent
Mr Simpson	

EXCEPTION OF LAND PURSUANT TO SECTION 347 OF THE MINES ACT 1958

Whereas in section 347 of the *Mines Act* 1958, it is amongst other things provided that the Governor in Council may at any time except from occupation for mining purposes under any miner's right or from being leased under a mining lease any specific portions of private lands.

Now therefore, His Excellency the Governor of the State of Victoria, in the Commonwealth of Australia, by and with the advice of the Executive Council of the said State, and in pursuance of the powers conferred by section 347 of the *Mines Act* 1958 and all other powers him thereunto enabling doth by this Order except from occupation for mining purposes under any miner's right or from being leased under a mining lease all that piece of land in the Parish of Bunyip, County of Mornington, being Crown Allotment 83D and being the land described in Certificate of Title Volume 9345 Folio 646.

And the Honourable David Ronald White, Her Majesty's Minister for Minerals and Energy for the State of Victoria, shall give the necessary directions herein accordingly.

TOM FORRISTAL
Clerk of the Executive Council

URBAN LAND AUTHORITY ACT 1979

*At the Executive Council Chamber, Melbourne, the
twenty-third day of August, 1983*

Present:

His Excellency the Governor of Victoria	
Mr Mackenzie	Mr Kent
Mr Simpson	

APPOINTMENT OF MEMBER

Pursuant to the provisions of Section 5 of the *Urban Land Authority Act* 1979, His Excellency the Governor of the State of Victoria, by and with the advice of the Executive Council thereof hereby appoints Arthur Leslie Groves as a member of the Urban Land Authority up to and including 12 July. One thousand nine hundred and eighty-five.

And the Honourable Ian Robert Cathie, Her Majesty's Minister of Housing for the State of Victoria, shall give the necessary directions herein accordingly.

TOM FORRISTAL
Clerk of the Executive Council

METROPOLITAN FIRE BRIGADES ACT 1958

*At the Executive Council Chamber, Melbourne, the
twenty-third day of August, 1983*

Present:

His Excellency the Governor of Victoria	
Mr Mackenzie	Mr Kent
Mr Simpson	

APPOINTMENT OF PRESIDENT OF THE METROPOLITAN FIRE BRIGADES BOARD

His Excellency the Governor of the State of Victoria, in the Commonwealth of Australia, by and with the advice of the Executive Council of the said State, and in pursuance of the powers conferred by the *Metropolitan Fire Brigades Act* 1958, and all other powers him thereunto enabling, doth by this Order appoint Kenneth Norman Fisk to be President of the Metropolitan Fire Brigades Board for a period of four months from and inclusive of 1 September 1983.

And the Honourable Charles Race Thorson Mathews, Her Majesty's Minister for Police and Emergency Services for the State of Victoria, shall give the necessary directions herein accordingly.

TOM FORRISTAL
Clerk of the Executive Council

SUPERANNUATION ACT 1958

*At the Executive Council Chamber, Melbourne, the
twenty-third day of August, 1983*

Present:

His Excellency the Governor of Victoria	
Mr Mackenzie	Mr Kent
Mr Simpson	

Pursuant to the powers conferred by the provisions of paragraph (ja) of subsection (1) of Section 3 of the *Superannuation Act* 1958, His Excellency the Governor of the State of Victoria, by and with the advice of the Executive Council thereof doth by this Order declare that the provisions of the Superannuation Act shall apply to the officers named in the schedule set out hereunder.

Schedule

Stargatt, Vilma Lorraine, Department of Labour and Industry
Crawford, Alan William Eric, Police Reserve

And the Honourable Robert Allen Jolly, Her Majesty's
Treasurer for the State of Victoria, shall give the necessary
directions herein accordingly.

TOM FORRISTAL
Clerk of the Executive Council

PUBLIC SERVICE ACT 1974

*At the Executive Council Chamber, Melbourne, the
twenty-third day of August, 1983*

Present:

His Excellency the Governor of Victoria

Mr. Mackenzie
Mr Simpson

Mr Kent

In pursuance of the powers conferred by sub-section 47 (6)
of the *Public Service Act 1974*, His Excellency the Governor
of the State of Victoria, by and with the advice of the Executive
Council of the said State, and upon the recommendation of the
Public Service Board, doth certify that the following govern-
ment office established under Section 3 of the *Law Reform Act*
1973 is an office substantially similar to an office in the Public
Service.

Law Reform Commissioner

And the Honourable John Cain, Her Majesty's Premier for
the State of Victoria, shall give the necessary directions herein
accordingly.

TOM FORRISTAL
Clerk of the Executive Council

CEMETERIES ACT 1958

*At the Executive Council Chamber, Melbourne, the
twenty-third day of August, 1983*

Present:

His Excellency the Governor of Victoria

Mr Mackenzie
Mr Simpson

Mr Kent

DISCONTINUANCE OF BURIALS IN THE ST. KILDA,
COBURG AND WARRINGAL PUBLIC CEMETERIES

Whereas by section 44 of the *Cemeteries Act 1958*, it is
amongst other things enacted that no cemetery or burial
ground shall be established or opened in Victoria save with the
approval of the Governor in Council; and that in case it shall
appear to the Governor in Council that burials in any cemetery
under any law relating to public cemeteries or in any other
burial ground or place of burial whatsoever should be wholly
discontinued, or should be discontinued subject to any excep-
tion or qualification, the Governor in Council may, by an
Order to be published in the *Government Gazette*, direct that
after a time to be mentioned in such Order, not being less than
three months from the date thereof, burials in such cemetery
or burial ground or place of burial shall be discontinued wholly
or subject to any exceptions or qualifications mentioned in the
same or in any subsequent Order, and may from time to time
postpone the time mentioned in such order, or the discon-
tinuance of burials or otherwise vary any such Order, whether
the time appointed for the discontinuance of burials
thereunder or other operation of such Order shall or shall have
not arrived.

And whereas it appears to the Governor in Council that
burials in the St. Kilda, Coburg and Warringal Public Ceme-
teries should be discontinued, subject to the exceptions and
qualifications hereinafter mentioned.

Now therefore, His Excellency the Governor of the State of
Victoria in the Commonwealth of Australia, by and with the
advice of the Executive Council of the said State hereby directs
that all burials in the said cemeteries shall be discontinued
from and inclusive of 1 August 1983 except burials in allot-
ments of land the right of burial in which has already been pur-
chased from the trustees of such cemeteries and gravesites
recovered by the trustees of such cemeteries pursuant to Sec-
tion 25 of the *Cemeteries Act 1958*.

And the Honourable Thomas William Roper, Her Majesty's
Minister of Health for the State of Victoria, shall give the
necessary directions herein accordingly.

TOM FORRISTAL
Clerk of the Executive Council

CEMETERIES ACT 1958

*At the Executive Council Chamber, Melbourne, the
twenty-third day of August, 1983*

Present:

His Excellency the Governor of Victoria

Mr Mackenzie
Mr Simpson

Mr Kent

DISCONTINUANCE OF BURIALS IN THE RED
JACKET AND JERICHO PUBLIC CEMETERIES AND A
PART OF THE ABERFELDY PUBLIC CEMETERY

Whereas by section 44 of the *Cemeteries Act 1958*, it is
amongst other things enacted that no cemetery or burial
ground shall be established or opened in Victoria save with the
approval of the Governor in Council; and that in case it shall
appear to the Governor in Council that burials in any cemetery
under any law relating to public cemeteries or in any other
burial ground or place of burial whatsoever should be wholly
discontinued, or should be discontinued subject to any excep-
tion or qualification, the Governor in Council may, by an
Order to be published in the *Government Gazette*, direct that
after a time to be mentioned in such Order, not being less than
three months from the date thereof, burials in such cemetery
or burial ground or place of burial shall be discontinued wholly
or subject to any exceptions or qualifications mentioned in the
same or in any subsequent Order, and may from time to time
postpone the time mentioned in such order, or the discon-
tinuance of burials or otherwise vary any such Order, whether
the time appointed for the discontinuance of burials
thereunder or other operation of such Order shall or shall have
not arrived.

Now therefore, His Excellency the Governor of the State of
Victoria in the Commonwealth of Australia, by and with the
advice of the Executive Council of the said State hereby directs
that all burials in that part of the Aberfeldy Public Cemetery
that lies within the boundary of the Thomson River Water
Supply Catchment Area shall be wholly discontinued after the
expiry of a period of three months from the date of this Order.

And further directs that burials in the Red Jacket and Jer-
icho Public Cemeteries be wholly discontinued after the expiry
of a period of three months of this Order.

And the Honourable Thomas William Roper, Her Majesty's
Minister of Health for the State of Victoria, shall give the
necessary directions herein accordingly.

TOM FORRISTAL
Clerk of the Executive Council

POST-SECONDARY EDUCATION ACT 1978

At the Executive Council Chamber, Melbourne, the twenty-third day of August, 1983

Present:

His Excellency the Governor of Victoria
 Mr Mackenzie | Mr Kent
 Mr Simpson

Whereas sub-section (1) of section 38 of the *Post-Secondary Education Act 1978* provides that the Governor in Council on the recommendation of the Victorian Post-Secondary Education Commission may by Order published in the *Government Gazette* confer upon the governing body of a post-secondary education institution the power to award a degree or diploma specified in the Order:

And whereas sub-section (2) of section 38 of the said Act provides that the Governor in Council may in an Order under sub-section (1) make the power to award a specified degree or diploma subject to such terms and conditions as he thinks fit:

And whereas sub-section (3) of section 38 of the said Act provides that the Governor in Council shall not make an Order under this section unless he has received from the Commission a certificate to the effect that the courses of study which lead to the degree are comparable in standard to those which lead to the award of a degree at a university:

And whereas the Victorian Post-Secondary Education Commission recommends that each institution specified in column 1 of the Schedule hereto be given power to award the degree specified in relation to that institution in column 2 of the said Schedule, subject to the condition that the institution does not award the degree to any person whose name is not specified in relation to that degree and that institution in column 3 of the said Schedule:

And whereas the Victorian Post-Secondary Education Commission has certified that the courses of study undertaken by the persons specified in column 3 of the Schedule hereto are comparable in standard to those which lead to the award of a degree at a university:

Now therefore His Excellency the Governor of the State of Victoria by and with the advice of the Executive Council thereof and on the recommendation of the Post-Secondary Education Commission doth by this Order confer upon the governing body of each institution specified in column 1 of the Schedule hereto power to award the degree specified in relation to that institution subject to the condition that the institution does not award the degree to any person whose name is not specified in relation to that degree and that institution in column 3 of the said Schedule:

Column 1	Schedule	
Institution	Column 2	Column 3
	Degree which the Council of the College is to be empowered to award	Person to whom the degree is to be awarded
Swinburne Institute of Technology	Master of Engineering	Algis Juozas KAIRAITIS
Victorian College of Pharmacy	Master of Pharmacy	Carmen LA ROSA

And the Honourable Robert Clive Fordham, Her Majesty's Minister of Education for the State of Victoria, shall give the necessary directions herein accordingly.

TOM FORRISTAL
 Clerk of the Executive Council

WATER ACT 1958

STATE RIVERS AND WATER SUPPLY COMMISSION

At the Executive Council Chamber, Melbourne, the thirtieth day of August, 1983

Present:

His Excellency the Governor of Victoria
 Mr Simpson | Mrs Toner
 Mr Mackenzie | Mr White

GOULBURN-MURRAY IRRIGATION DISTRICT –
 PORTION EXCISED
 SHEPPARTON IRRIGATION AREA – BOUNDARIES
 VARIED

Under the powers conferred by the *Water Act 1958* and all other powers enabling him in that behalf, His Excellency the Governor of the State of Victoria, with the advice of the Executive Council of the said State, on the recommendation of the State Rivers and Water Supply Commission, doth hereby declare order and direct that there shall be excised from the Goulburn-Murray Irrigation District the land shown by green colour on a plan approved by the Governor in Council and deposited in the office of the State Rivers and Water Supply Commission at 590 Orrong Road, Armadale (Corr. No. 82/1931) and that the boundaries of the Shepparton Irrigation Area shall be varied to excise therefrom such land which shall be deemed to be excised from the said Irrigation District and Irrigation Area as on and from 30 September 1983.

And the Honourable David Ronald White, Her Majesty's Minister of Water Supply for the State of Victoria, shall give the necessary directions herein accordingly.

TOM FORRISTAL
 Clerk of the Executive Council

WATER ACT 1958

STATE RIVERS AND WATER SUPPLY COMMISSION

At the Executive Council Chamber, Melbourne, the thirtieth day of August, 1983

Present:

His Excellency the Governor of Victoria
 Mr Simpson | Mrs Toner
 Mr Mackenzie | Mr White

GOULBURN-MURRAY IRRIGATION DISTRICT –
 PORTIONS EXCISED
 RODNEY IRRIGATION AREA – BOUNDARIES
 VARIED

Under the powers conferred by the *Water Act 1958* and all other powers enabling him in that behalf, His Excellency the Governor of the State of Victoria, with the advice of the Executive Council of the said State, on the recommendation of the State Rivers and Water Supply Commission, doth hereby declare order and direct that there shall be excised from the Goulburn-Murray Irrigation District the lands shown by green colour on a plan approved by the Governor in Council and deposited in the office of the State Rivers and Water Supply Commission at 590 Orrong Road, Armadale (Corr. Nos. 78/688, 81/3407) and that the boundaries of the Rodney Irrigation Area shall be varied to excise therefrom such lands which shall be deemed to be excised from the said Irrigation District and Irrigation Area as on and from 30 September 1983.

And the Honourable David Ronald White, Her Majesty's Minister of Water Supply for the State of Victoria, shall give the necessary directions herein accordingly.

TOM FORRISTAL
Clerk of the Executive Council

And the Honourable David Ronald White, Her Majesty's Minister of Water Supply for the State of Victoria, shall give the necessary directions herein accordingly.

TOM FORRISTAL
Clerk of the Executive Council

WATER ACT 1958

At the Executive Council Chamber, Melbourne, the thirtieth day of August 1983

Present:

His Excellency the Governor of Victoria

Mr Simpson		Mrs Toner
Mr Mackenzie		Mr White

MOOROPNA WATERWORKS TRUST – EXTENT OF WATERWORKS DISTRICT AND AREA OF URBAN DISTRICT INCREASED

Under the powers conferred by the *Water Act 1958* and all other powers enabling him in that behalf, His Excellency the Governor of the State of Victoria, with the advice of the Executive Council of the said State, doth hereby declare order and direct that the extent of the Waterworks District of the Mooropna Waterworks Trust and the area of the Urban District of the said Trust be increased by adding to the said Districts the lands shown by blue colour on a plan approved by the Governor in Council and deposited in the office of the State Rivers and Water Supply Commission at 590 Orrong Road, Armadale (Corr. Nos. 78/688, 81/3407) and as on and from 1 October 1983, the extent of the said Waterworks District and the area of the said Urban District shall be deemed to be so increased.

And the Honourable David Ronald White, Her Majesty's Minister of Water Supply for the State of Victoria, shall give the necessary directions herein accordingly.

TOM FORRISTAL
Clerk of the Executive Council

WATER ACT 1958

At the Executive Council Chamber, Melbourne, the thirtieth day of August 1983

Present:

His Excellency the Governor of Victoria

Mr Simpson		Mrs Toner
Mr Mackenzie		Mr White

HURSTBRIDGE WATERWORKS TRUST ABOLISHED

Whereas the Hurstbridge Waterworks Trust is an Authority within the meaning of Section 3 of the *Water Act 1958* and whereas under the provisions of Section 327A of the said Act, the Governor in Council may where an Authority has no further function abolish such an Authority.

And whereas under the provisions of Section 327A of the said Act and by an Order in Council made 28 September 1982, the lands easements works property rights liabilities and obligations of the Hurstbridge Waterworks Trust were transferred to the Melbourne and Metropolitan Board of Works as on and from 1 October 1982.

Now therefore, His Excellency the Governor of the State of Victoria, with the advice of the Executive Council of the said State, in pursuance of the hereinbefore recited powers, doth hereby declare, order and direct that as on and from 1 September 1983, the Hurstbridge Waterworks Trust shall be abolished.

SEWERAGE DISTRICTS ACT 1958

At the Executive Council Chamber, Melbourne, the thirtieth day of August 1983

Present:

His Excellency the Governor of Victoria

Mr Simpson		Mrs Toner
Mr Mackenzie		Mr White

HURSTBRIDGE SEWERAGE AUTHORITY ABOLISHED

Whereas the Hurstbridge Sewerage Authority is an Authority within the meaning of Section 3 of the *Sewerage Districts Act 1958* and whereas under the provisions of Section 19A of the said Act, the Governor in Council may where an Authority has no further function abolish such an Authority.

And whereas under the provisions of Section 19A of the said Act and by an Order in Council made 28 September 1982, the lands easements works property rights liabilities and obligations of the Hurstbridge Sewerage Authority were transferred to the Melbourne and Metropolitan Board of Works as on and from 1 October 1982.

Now therefore, His Excellency the Governor of the State of Victoria, with the advice of the Executive Council of the said State, in pursuance of the hereinbefore recited powers, doth hereby declare, order and direct that as on and from 1 September 1983, the Hurstbridge Sewerage Authority shall be abolished.

And the Honourable David Ronald White, Her Majesty's Minister of Water Supply for the State of Victoria, shall give the necessary directions herein accordingly.

TOM FORRISTAL
Clerk of the Executive Council

LANDS DEPARTMENT NOTICES

APPROACHING LAND SALES

Sale of Crown Land, will be held at the under-mentioned places and dates, viz.:

	No. of Gazette
Colac—Tuesday, 13 September 1983	78
Rochester—Monday, 10 October 1983	80
Vermont—Saturday, 24 September 1983	78
West Meaitan—Tuesday, 13 September 1983	72

SALE OF CROWN LAND BY AUCTION

The land will be offered for sale subject to the provisions of the Land Act and Regulations thereunder.

The upset price is the sum at which bidding will start, and no bid below that sum can be accepted. The highest bidder at or above that sum shall be the purchaser, subject to signature of contract and any necessary payment.

Terms:

A deposit of at least 12½% of the purchase price must be paid at the sale, either in cash or by cheque.

The residue is payable on 7 February 1984 or may be paid off at any earlier time.

Interest at the rate of 14% per annum is payable on arrears after the due date.

Fees, etc.:

Payable with balance of purchase money — Crown Grant fee — \$41.00.

Assurance contribution — One cent in every Five dollars or part thereof of purchase price (this is to guarantee the validity of the Crown Grant).

Transfer of interest prior to completion of payment may be allowed on payment of the prescribed fee and subject to stamp duty.

If unable to attend personally a prospective purchaser may arrange for another person to bid as his agent.

Attention is drawn to section 95, *Land Act* 1958, which provides that the purchaser shall be deemed to be the owner for the purposes of other Acts: also to an amendment to the Local Government Act providing for Government roads, in certain circumstances, to be declared "private streets", thus making the purchaser liable to contribute to the cost of street construction.

R. A. MACKENZIE
Minister of Lands

Department of Crown Land and Survey,
Melbourne

HAMILTON — Sale (No. 12401) of Crown land, by auction, will be held at the Regional Land Office, 17 Thompson Street, Hamilton on Wednesday, 9 November 1983 at 11.00 o'clock a.m. To be conducted by K. C. Gittins, Regional Land Officer, Hamilton.

Lot 1 — Township of Hamilton — Parish of Hamilton North. Fronting Westacott and Craig Streets about 71 metres north-east of Kennedy Street.

Upset price \$6150.00 the lot. Area 898 square metres more or less. Allotment 12 of Section 11 Zoned "Residential" under the City of Hamilton Planning Scheme.

Enquiries: Regional Land Office, Hamilton — Telephone (055) 72 3033 (L2-1298).

BUCHAN CAVES RESERVES

Charges and Visiting Times

In accordance with Regulations 10 and 40 of the Regulations for the care, protection and management of the Buchan Caves Reserves made on 1 December 1976 and published in the *Government Gazette* dated 8 December 1976, I, Roderick Alexander Mackenzie, Her Majesty's Minister of Lands for the State of Victoria, do hereby specify that:

1. The times for inspection and scale of charges which shall be made and taken for the admission of each person to the caves respectively indicated shall be as follows:

Visiting times shall be at 10.00 a.m., 11.00 a.m., 1.15 p.m. and 3.45 p.m. and such times between those times as may be decided by the Supervisor having regard to the number of persons who desire to inspect the caves —

	Scale of Charges
Caves	
Fairy	\$2.00
Royal	\$2.00

Provided, however, that the sum of fifty (50) cents shall be charged and taken for the admission of any person not over the age of sixteen (16) years, and one dollar (\$1.00) for pensioners.

2. The charges for camping shall be as follows:

Up to three (3) persons per night	\$4.20
Each additional person per night	\$1.40
Additional charge for powered site per night	\$2.30

3. The fee for entry to and use of any area set aside for the parking of motor vehicles, bicycles or the tethering of horses shall be twenty (20) cents per day per motor vehicle, bicycle or horse — (Rs.1288).

Given under my hand at Melbourne on 29 August 1983.

R. A. MACKENZIE
Minister of Lands

LICENCE UNDER THE LAND ACT 1958 DECLARED VOID

Notice is hereby given that the licence (issued under the provisions of the *Land Act* 1958), referred to hereunder, has been declared void.

Licence No.: 1387/138

Licenseses: P. A. and A. M. Roder

Locality: Allotment 122H, Parish of Buninyong

Annual Rental: \$2000.00

Reason for voiding: Licence surrendered.

R. A. MACKENZIE
Minister of Lands

Department of Crown Lands and Survey,
Melbourne

23 August 1983

PROPOSED REVOCATION OF TEMPORARY RESERVATION OF LAND BY ORDER IN COUNCIL

In pursuance of the provisions of section 10 of the *Crown Land (Reserves) Act* 1978, notice is hereby given that it is the intention of the Governor in Council to revoke the temporary reservation of land by Order in Council hereunder referred to, viz.:

MELBOURNE SOUTH (ST KILDA) — The temporary reservation by Order in Council of 18 May 1965 of 1189 square metres of land at St Kilda, Parish of Melbourne South, for Public purposes (Police purposes), revoked as to part by Order of 8 November 1966, so far only as the portion thereof containing 3.7 square metres, as indicated by hatching on plan hereunder, is concerned — (M 333(25)) (Rs.8441).

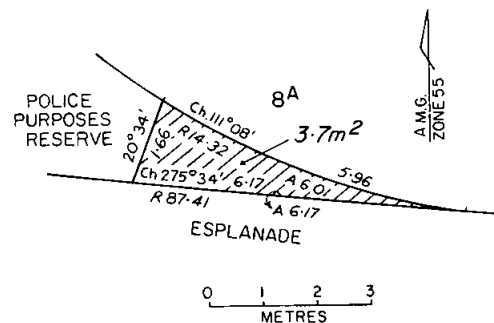

BRUARONG — The temporary reservation by Order in Council of 26 March 1907 of 8094 square metres of land in the Parish of Bruarong (in section 3) for a State School — (C.33557).

R. A. MACKENZIE
Minister of Lands

Department of Crown Lands and Survey,
Melbourne

TENDERS

PUBLIC WORKS DEPARTMENT

Tenders are invited for the purposes indicated hereunder and will be received at 2 Treasury Place, Melbourne, 3002, until **TWO** p.m. on dates shown.

Tenders must be addressed to the Minister of Public Works with the envelope endorsed "Tender for

". Hand-delivered tenders must be placed in the Department's tender box in foyer, Ground Floor, 2 Treasury Place, Melbourne.

Tenders documents are available from the Contracts Office, Room 29, 2 Treasury Place, Melbourne and where indicated, at offices of Inspectors of Works.

* Tenders for works identified with star (*) will only be considered from Contractors qualified for repairs and painting works. Any Tenderers wishing to qualify may obtain the application form from the Contracts Office.

Wednesday, 14 September 1983

Building, Electrical and Mechanical Works

BROADMEADOWS WEST—Floor coverings, Technical School.
FAWKNER NORTH—Gas conversion of furnaces for heating systems, Primary School.

KENSINGTON—Installation of an intruder detection system, Primary School.

NEPEAN—Thermal fire alarm system, Special School

*SOUTHMOOR—(Re-advertisement)—External cyclic maintenance, Primary School.

*STRATHEWEN—Internal and external repairs and painting, Primary School.

THORNBURY—Floor treatment, High School.

TRARALGON—Improvements to cell block and fencing, Police Station, Kay Street. (W.O., Traralgon.)

VARIOUS—Contract 4, 83/84—Supply and delivery of 55 No. modular buildings, F.O.G., P.W.D. storeyard, 69 Salmon Street, Port Melbourne. (W.O., Bendigo, Ballarat and Geelong.)

Siteworks

NARINGAL—New fire services, Primary School. (W.O., Warrnambool.)

SYDENHAM—Connection of town water, Primary School.

Miscellaneous

MALVERN—Maintenance cleaning, C.I.B. offices, Glenferrie Road, Police and Emergency Services.

MELBOURNE—Maintenance cleaning, Public Offices, 49 Spring Street.

MELBOURNE—Supply of carpet, Parliament House—Premiers Department

PORT MELBOURNE—Supply of twenty (20) chain saws, P.W.D. storeyard, 69 Salmon Street.

WESTMEADOWS—Maintenance cleaning, Police Station, Police and Emergency Services.

Wednesday, 21 September 1983

Building, Electrical and Mechanical Services

BAXTER—Installation of an intruder detection system, Technical School.

BONBEACH—Installation of an intruder detection system, High School.

*DALLAS—Internal and external repairs and painting: Electrical upgrade, Primary School.

*PLENTY—Internal and external repairs and painting to Ward "D", Mental Hospital.

RICHMOND WEST—Installation of an intruder detection system, Primary School.

SUNBURY—Renovations to kitchens—Wards F3 and M3, Caloola Training Centre.

TOORA—Re-advertisement: Provision of new relocatable galleries etc., Primary School.

VARIOUS—Supply, deliver and assemble modular building, Warrnambool Area—Naringal and Framlingham Halls. (W.O. Geelong, Ballarat and Bendigo.)

Miscellaneous

FERNTREE GULLY—Maintenance cleaning, Education, Police and Lands Departments. Corner Spring Street and Selmann Avenue. (Police Station, Ferntree Gully.)

NEWPORT—Maintenance cleaning, Police Station. Police and Emergency Services.

WARRNAMBOOL—Maintenance cleaning, Labor and Industry Office, 166c Koroit Street. (W.O. Warrnambool.)

WERRIBEE—Maintenance cleaning, Police Station. Police and Emergency Services.

JACK SIMPSON, M.P.
Minister of Public Works

Public Works Department
Melbourne, 30 August 1983

LATE NOTICES

Transport Act 1983

ROAD TRAFFIC AUTHORITY

Commercial Passenger and Goods Vehicle Applications

Notice is hereby given that the following applications will be considered by the Road Traffic Authority on 20 September 1983.

Notice of any objections should be forwarded to reach the Officer in Charge, Passenger and Goods Division not later than 14 September 1983.

It will not be necessary for interested parties to appear on the hearing date specified, unless advised in writing by the Authority.

Notification of the date for consideration of applications which are objected to and which require determination by the Road Transport Licensing Tribunal will be published by further notice in this *Gazette*.

Dunlop Olympic Ltd., Somerton — Application to license one commercial passenger vehicle with seating capacity for 18 persons, to operate free of charge for the carriage of company employees between their homes and the company's premises in Somerton via the following:

Route: Depart the company's premises on the Hume Highway at Somerton, via the Hume Highway, Barry Road, Blair Street, Camp Road, Pascoe Vale Road, Glenroy Road, West Street, Boundary Road, Sussex Street, Bell Street and the Hume Highway to the company's premises.

Timetable:

<i>Depart Somerton</i>	<i>Arrive Somerton</i>
6.15 a.m.	6.45 a.m.
7.10 a.m.	7.40 a.m.
2.15 p.m.	2.45 p.m.
3.05 p.m.	3.40 p.m.
10.15 p.m.	10.45 p.m.
11.05 p.m.	11.40 p.m.

V. J. McGown & A. J. Broughton, Northcote — Application to license one commercial passenger vehicle with seating capacity for approximately 11 persons, to operate as a Touring Omnibus on the following tours:

(i) *Western Victoria Historical Tour*

Day 1: Depart Melbourne for Ballarat to visit local points of interest and overnight motel accommodation.

Day 2: Depart Ballarat for "Carranballac" homestead via Skipton for inspection and lunch. Then on to Port Fairy via Darlington, Noorat, Terang and Warrnambool. Overnight motel accommodation at Port Fairy.

Day 3: Depart motel accommodation to visit local points of interest at Port Fairy and Tower Hill returning to Port Fairy for overnight motel accommodation.

Day 4: Depart Port Fairy for inspection of Flagstaff Hill Maritime museum at Warrnambool, then on to Halls Gap via Hawkesdale, Peshurst and Dunkeld, to overnight motel accommodation.

Day 5: Depart Halls Gap to inspect Mt Zero Aboriginal Art Caves via Lah-arum, then on to Bunjil's Cave via Stawell by the Western Highway returning to Halls Gap via Pomonal for overnight motel accommodation.

Day 6: Depart Halls Gap for inspection of Seppelts Winery at Great Western and on to Ararat to visit local points of interest. Then return to Melbourne via Ballarat.

(ii) *Wildlife and Wildflower Tour of Western Victoria*

Day 1: Depart Melbourne for Port Campbell, via Stoneyford and Cobden. Cliff top walk and overnight motel accommodation at Port Campbell.

Day 2: Depart Port Campbell for the Twelve Apostles and Loch Ard Gorge, then on to Tower Hill via Warrnambool, stopping at London Bridge, Bay of Islands and Port Fairy. Overnight motel accommodation at Port Fairy.

Day 3: Depart Port Fairy for Cape Nelson State Park via Portland and Swan Lake Flat in Discovery Bay Coastal Park then on to Nelson for overnight motel accommodation.

Day 4: Depart motel accommodation for walks around Nelson and afternoon cruise up the Glenelg River to caves returning to overnight motel accommodation at Nelson.

Day 5: Depart Nelson for Mount Gambier and Naracoorte to visit local points of interest. Overnight motel accommodation at Naracoorte.

Day 6: Depart Naracoorte for Bool Lagoon then on to Nhill via Edenhope and Harrow-Nhill Road stopping at Stringybark Nature Walk. Overnight motel accommodation at Nhill.

Day 7: Depart Nhill for the Little Desert National Park for various walks, returning to Nhill for overnight motel accommodation.

Day 8: Depart Nhill for the Wyperfeld National Park via Jeparit and Rainbow for afternoon walk and tour then on to overnight motel accommodation at Hopetoun.

Day 9: Depart Hopetoun for Halls Gap via Warracknabeal, Rupanyup, Stawell and McKenzie Falls. Overnight motel accommodation at Halls Gap.

Day 10: Depart motel accommodation for the Sundial turntable for various walks then on to Bunjil's Cave via Stawell. Return to Halls Gap via Pomonal for overnight motel accommodation.

Day 11: Depart Halls Gap for Dunkeld then return to Melbourne via Ballarat.

(iii) *West Coast of Victoria Tour*

Day 1: Depart Melbourne for Anglesea. Afternoon walk and overnight motel accommodation at Anglesea.

Day 2: Depart motel accommodation for Wildflower walk and study then on to Lorne and Erskine Falls. Overnight motel accommodation at Lorne.

Day 3: Depart Lorne for Apollo Bay to inspect Paradise treeferns then on to Port Campbell via Laver's Hill stopping at the Twelve Apostles and Loch Ard Gorge. Overnight motel accommodation at Port Campbell.

Day 4: Depart Port Campbell for Warrnambool stopping at London Bridge and Bay of Islands then on to Port Fairy for inspection of Flagstaff Hill. Overnight motel accommodation at Port Fairy.

Day 5: Depart motel accommodation for tour of Port Fairy and Tower Hill returning to overnight motel accommodation at Port Fairy.

Day 6: Depart Port Fairy for Portland for tour and inspection of museum then on to Nelson stopping at Swan Lake Flat in Discovery Bay Coastal Park then on to overnight motel accommodation at Nelson.

Day 7: Depart motel accommodation for walks around Nelson and a cruise up the Glenelg River to caves then return to overnight motel accommodation at Nelson.

Day 8: Depart Nelson for Melbourne via Dartmoor, Digby, Hamilton and Ballarat.

Fares:

Tour (i)	\$450
Tour (ii)	\$796
Tour (iii)	\$596

Note: Cost includes travel, accommodation (shared twin rooms), two meals per day (morning and evening) and admission fees.

Tours are designed specifically for Japanese tourists visiting Victoria and will be promoted in Japan using Japanese language brochures. In addition the hiring party will be accompanied by a guide and an interpreter of Japanese.

K. M., L. & V. C. O'Connor, Bairnsdale — Application for variation of the conditions licences CO 775 and CO 1241, which authorize various tours from Bairnsdale, Lakes Entrance and Sale, to also operate round tours within a 32 km radius of the Lakes Entrance Post Office under an arrangement with the General Manager, Passenger Services Division, V/Line, subject to the condition that passengers shall commence and finish their journey in Melbourne or any other railway station within the State of Victoria.

Passengers to travel to Bairnsdale by rail and the applicant is to provide coach transport from Bairnsdale to Lakes Entrance.

Note: The rights sought in this application are identical to those attached to licence CC 43 in the name of K. M., L. & V. O'Connor and E. C. Dykes.

B. M. Walker's Bus Service Pty. Ltd., Bendigo — Application to license one commercial passenger vehicle with seating capacity for 51 persons, to be purchased, to operate under charter conditions from within a 20 km pick-up radius of Bendigo.

The vehicle to be licensed would hold a 4 star rating for charter purposes.

A. G. D. & K. L. Waterton, Lakes Entrance — Application to license a Ford sedan to operate as a Country Taxi at Lakes Entrance from 1 Orme Street, Lakes Entrance.

P. L. Watson, St Arnaud — Application to license a tow truck, to operate throughout the State of Victoria for the purpose of lifting and carrying or towing damaged and disabled motor vehicles and goods associated with the applicant's panel shop.

Application for renewal of licences as shown by the persons listed hereunder to operate under the same terms and conditions.

- J. M. Ansell, Wood Wood — TO 133.
- J. M. & R. E. Dee, Seymour — CT 231.
- I. S. & J. E. Downs, Beechworth — CC 101.
- C. L. & M. L. Hardeman, Moorabbin — MT 6049.
- E. W. Heinrich, Geelong West — UT 766.
- M. Kokkinaxis, Northcote — SV 103.
- A. M. I. Sanchez Del Rio, Bright — TO 26.
- G. Sanchez, St. Albans — SV 267.
- C. J. Silcock, Herne Hill — UT 862.

31 August 1983

C. J. V. SMITH, Chief General Manager
Registration and Regulation

CONTRACTS ACCEPTED — (Series 1983/84)

PUBLIC WORKS

Ararat — Thermal Detectors, Trade Shops, Ararat Mental Hospital and Training Centre — \$16 285.00 — Wormald Fire Systems, Melbourne.

Byrne — Cyclic maintenance, Byrne Primary School — \$18 577.00 — Rose City Homes Pty. Ltd., Benalla.

Camberwell — Part demolition and alterations, Camberwell Community Mental Health Clinic — \$52 812.00 — E. & R. Roberts Pty. Ltd., Dandenong North.

Dandenong — P.A.B.X. Telephone System installation, Dandenong Psychiatric Centre — \$32 752.00 — Telecom Australia (Commercial Dept.), Melbourne.

Glen Waverley — Hydraulic services, Glen Waverley Police Station — \$11 647.00 — Melbourne and Metropolitan Board of Works, Melbourne.

Glen Waverley — Building work, Glen Waverley Electorate Office — \$12 520.00 — Elecwood Interiors Pty. Ltd., Moorabbin.

Holmesglen — Provision of heating and ventilation in building 3, Holmesglen College of TAFE — \$54 681.00 — Gas and Fuel Corporation of Victoria, Melbourne.

Kingsbury — New footings and brickwork to library, Kingsbury Technical School — \$11 250.00 — R. & B. Schultz Builders Pty. Ltd., Carlton.

Janefield — Replacement of water main, Janefield Training Centre — \$21 747.00 — Vic Territo and Son, Altona North.

Kyabram — Erection of library, Kyabram High School — \$158 300.00 — Crow Constructions Pty. Ltd., Shepparton.

Murchison — Cyclic maintenance, Murchison Primary School — \$59 000.00 — M.D.T. Painting Service Renovation, St. Albans.

Norlane — Cyclic maintenance, Norlane High School — \$67 750.00 — G. K. Marinkovic, Yarraville.

North Melbourne — Mechanical services, Government Printing Office — \$33 970.00 — Belsair, Bayswater.

Tallaroook — Repairs and painting, Tallaroook Primary School — \$18 400.00 — Ballard Painting Services, West Meadows.

Maroondah — Annual services, various schools, Maroondah — \$10 324.00 — Wellcome Australia Ltd., Northcote.

Maroondah — Annual services, various schools, Maroondah — \$12 750.00 — Honeywell Pty. Ltd., Richmond.

Williamstown — Vinyl floor tiles, Williamstown Technical School — \$10 955.00 — C. & S. Flooring, Airport West.

Wonthaggi — Alterations to residence, Wonthaggi Community Residential Unit — \$12 464.00 — W. S. Purvis and Company, Wonthaggi.

D. J. LITTLE, Director General, 26.8.83

**PRIVATE
ADVERTISEMENTS**

CITY OF BALLAARAT

Loan No. 115

Notice of Intention to Borrow

Notice is hereby given that the Council of the City of Ballarat intends to borrow \$100 000 secured by a charge over the general rates of the municipality by the grant of a mortgage in accordance with the provisions of the Local Government Acts.

In connection therewith the following information is stated:

- (a) The amount of the principal monies it is proposed to borrow is \$100 000.
- (b) The maximum rate of interest that may be paid is 15.8 per centum per annum.
- (c) The times which the monies borrowed are to be repayable are 30 September and 30 March during the years 1984-1994. The first payment being due on 30 March 1984. The place such monies shall be repayable is at the Australia and New Zealand Banking Group Limited, Bridge Mall, Ballarat East.
- (d) The purpose for which the loan is to be applied is:

Roadworks:

	\$
Morres Street-Queen Street to Oliver Street	50 000
Doveton Street North-Creswick Road to Clarendon Street (part cont.)	25 000

Drainage:

Alfredton Drainage Scheme	25 000
	100 000

- (e) The manner in which the loan is to be liquidated is by provision out of the Municipal Fund in each half-year the during the currency of the loan of the sum of \$10 109.54 which includes Principal and Interest.

The plans and specifications and the estimate of the cost of the works and a statement showing the proposed expenditure of the monies to be borrowed are open for inspection at the Town Hall, Sturt Street, Ballarat.

Dated 26 August 1983

8584

I. C. SMITH, Town Clerk

CITY OF BENDIGO

Loan No. 132

*Notice of Intention to Borrow the Sum of \$100 000 for
Permanent Works and Undertakings*

Notice is hereby given that the Council of the City of Bendigo proposes to borrow the principal sum of \$100 000 such secured by a charge over the general rates of the municipality, and sum to be raised by the grant of a mortgage in accordance with the provisions of the *Local Government Act 1958*.

- (a) The maximum rate of interest that may be paid is 15.8% p.a.
- (b) The purpose for which that loan is to be applied is: Construction of Regional Library — Hargreaves Street
Headquarters — Central Library — Senior Citizens and Theatre Complex (Part Cost)
- (c) The period of the loan shall be ten (10) years.
- (d) The monies borrowed shall be repayable by providing out of the Municipal Fund Twenty (20) half yearly instalments of principal and interest of \$10 109.54 on 2 May and 2 November during the currency of the loan. The first repayment shall be payable on 2 May 1984.
- (e) Such monies shall be repayable at the Australian and New Zealand Savings Bank Ltd. at 48 Pall Mall, Bendigo or at the nominated office of the said Banking Group.

The plans and specifications and an estimate of the cost of the proposed works and a statement showing the proposed expenditure of the money to be borrowed are open for inspection at the Municipal Offices, Lyttleton Terrace, Bendigo during office hours.

8567 C. K. BEAMISH
Town Clerk and Chief Executive Officer

CITY OF BRUNSWICK
By-Law No. 215

A By-Law of the City of Brunswick made under the provisions of Section 197 of the *Local Government Act 1958* and numbered 215 for prohibiting or regulating the use of motorized vehicles for recreational purposes on any land or any specified part or parts of land not being a highway or private street or road or public land within the meaning of the *Land Conservation Act 1970* and for other purposes.

Pursuant to the powers conferred by the *Local Government Act 1958* and any and every other power it thereunto enabling, the Mayor Councillors and Citizens of the City of Brunswick orders as follows:

Title

1. This By-Law may be known as the Recreational Vehicle By-Law.

Definition

2. In this By-Law "motorized vehicle" includes mini bikes, trail bikes, motor cycles, motor cars, motor scooters, go carts and any other vehicle which may be propelled by internal combustion steam gas or electricity or any other form of power.

"Council" means the Mayor Councillors and Citizens of the City of Brunswick.

"Municipal District" means the Municipal District of the City of Brunswick.

"Council Officer" means a By-Laws Officer, Traffic Officer, Health Surveyor or other Officer or Inspector appointed by the Council.

Written Consent Required

3. A person shall not use any motorized vehicle for recreational purposes on any land within the municipality of the City of Brunswick which is not a highway or private street or road or public land within the meaning of the *Land Conservation Act 1970* without the written consent of the Council first obtained.

Form of Application

4. Any person applying for such written consent from the Council under Clause 3 hereof shall make application in writing to the Council specifying or enclosing the following information:

- (a) state whether the applicant is the owner of the vehicle or vehicles the subject of the application. If the applicant is not the owner the written consent of the owner must be enclosed with the application.
- (b) state each place where such vehicle or vehicles is or are to be used.
- (c) state the times during which such vehicle or vehicles will be used.
- (d) state the names, addresses and age or ages of any person or persons who will be using such vehicle or vehicles at such time.
- (e) describe such vehicle or vehicles stating its make, engine size and whether or not it is registered in accordance with the *Recreational Vehicles Act 1973* and its registration number (if any).
- (f) state whether or not the consent in writing of the owner of the place where such vehicle or vehicles is or are to be used has been obtained and enclose a copy of such consent signed by that owner with the application.
- (g) supply such other or further information as the Council may require.

5. The Council may from time to time prescribe the form or manner in which applications under Clause 4 of this By-Law shall be made.

Consent may be Conditional

6. The Council may grant or refuse the application. If the Council grants its consent under Clause 3 hereof, it may impose any conditions which it considers appropriate to the use of such vehicles.

Names to be Given

7. All persons suspected of or contravening the terms of this By-Law shall give their names and places of abode when asked to do so by a Council Officer.

Operation

8. This By-Law shall apply to and have operation throughout the whole of the Municipal District.

9. Any person guilty of a wilful act or default contrary to the provisions of this By-Law shall be liable to a penalty of not more than \$400.00 and any person guilty of a continuing offence shall be liable to a penalty of not more than \$10.00 for each day on which an offence against this By-Law is continued after a conviction or Order by any Court.

Resolution for passing this By-Law was agreed to by the Council of the City of Brunswick on 1 August 1983, and confirmed on 22 August 1983.

The Corporate Seal of the Mayor, Councillors and Citizens of the City of Brunswick was hereunto affixed in the presence of:

(SEAL)
8568 W. B. MALONEY, Mayor
H. S. V. JURY Councillor
K. D. WILSON, Town Clerk

Form 2.1

Town and Country Planning Act 1961

Section 32 (6) Amendment

Notice that a Planning Scheme has been Prepared and is Available for Inspection

CITY OF TRARALGON PLANNING SCHEME 1957

Amendment No. 39

Notice is hereby given that the City of Traralgon in pursuance of its powers under the *Town and Country Planning Act 1961*, has prepared a scheme for 31-33 Gray Street, Traralgon. Part of lots 17 and 19, lodged plan 6526, Part of Crown Allotments 2, 3 and 4, Section one, Township of Traralgon.

A copy of the scheme has been deposited at the Municipal Offices, Kay Street, Traralgon and at the Regional Office of the Department of Planning, 71 Hotham Street, Traralgon and at the office of the Department of Planning (Plan Inspection Section), 5th Floor, 235 Queen Street, Melbourne, and will be open for inspection during office hours by any person free of charge.

Any persons affected by the scheme are required to set forth in writing any submissions they may wish to make with respect to the scheme addressed to Minister for Planning, P.O. Box 2240T, Melbourne, 3001 by 29 September 1983, and state whether you wish to be heard in respect of your submission.

Dated 26 August 1983

J. L. MITCHELL
Town Clerk/Chief Executive Officer

8585

CITY OF WARRNAMBOOL

Loan No. 166

Notice of Intention to Borrow the Sum of \$50 000 to Assist with Council Contributions to CRB Works

Notice is given that the Council of the City of Warrnambool proposes to borrow the principal sum of \$50 000 secured by a charge over the general rates of the municipality, such sum to be raised by the grant of a mortgage in accordance with the provisions of the *Local Government Act 1958*.

1. The maximum rate of interest that may be paid is 15.5 per cent per annum.

2. The purpose for which the loan is to be applied is:
Council Contributions to CRB Works \$50 000

3. The period of the loan shall be seven (7) years.

4. The monies borrowed shall be repayable by providing out of the Principal Fund half-yearly instalments of \$5 977.06 each including principal and interest on 6 April and 6 October during the currency of the loan. The first instalment shall be payable on 6 October 1983.

5. Such monies shall be repayable to the Australia and New Zealand Banking Group Limited, 55 Collins Street, Melbourne.

The specifications and the estimates of the cost of the contributions and a statement showing the proposed expenditure of the monies to be borrowed are open for inspection at the office of the Council of the City of Warrnambool, Municipal Offices, Liebig Street, Warrnambool, 3280.

8569

V. G. ROBSON, Town Clerk

SHIRE OF ALBERTON

Loan No. 55

Notice of Intention to Borrow the Sum of \$75 000 for the Purpose of Loan Liquidation

Notice is hereby given that the Council of the Shire of Alberton proposes to borrow the principal sum of \$75 000 secured by a charge over the general rates of the municipality, such sum shall be repaid by the granting of a mortgage in accordance with the provisions of the *Local Government Act 1958* (as amended).

1. The maximum rate of interest that shall be paid is 15.8% per annum.

2. The period of the loan shall be 10 years.

3. The purpose which the loan is to be applied is:

Liquidation of Loan No. 38	\$75 000
----------------------------	----------

4. The loan is to be repaid by providing out of the municipal fund twenty half yearly instalments of \$8 509.66 including principal by way of sinking fund and interest on 1 May and 1 November in each year during the currency of the loan and the first instalment being payable on 1 May 1984. The final instalment being redemption in full on 1 November 1993.

5. Interest repayments shall be repayable to the State Insurance Office or such other place as specified by the lender from time to time.

Dated 24 September 1983.

8630

T. J. NEWTON, Shire Secretary

SHIRE OF CRANBOURNE

Loan No. 113

Notice of Intention to Borrow the Sum of \$400 000 for Permanent Works and Undertakings

Notice is hereby given that the Council of the Shire of Cranbourne proposes to borrow the principal sum of \$400 000 secured by a charge over the general rates of the municipality, such sum to be raised by the grant of a mortgage in accordance with the provisions of the *Local Government Act 1958* (as amended).

1. The maximum rate of interest that may be paid is 15.8 per cent per annum.

2. The purposes for which the loan is to be applied are:

	\$
Devon Meadows Community Centre	60 000
S.G. Highway Service Road, Cranbourne	132 000
Off Street Car Park Access, Cranbourne	65 000
Hampton Park Pre-School	110 000
Lloyd Park Pavilion (Part Costs)	33 000
	<u>400 000</u>

3. Period of the loan shall be 15 years.

4. The monies borrowed shall be repayable by providing out of the Municipal Fund half-yearly instalments of approximately \$35 196.78 each including principal and interest on 2 November and 2 May during the currency of the loan. The first instalment shall be payable on 2 May 1984.

5. Such monies borrowed shall be repayable to the Local Authorities Superannuation Board, Rigby House, Queens Road, Melbourne or such other place as the Board may require from time to time.

The plans and specifications and the estimates of the cost of the proposed works and a statement showing the proposed expenditure of the monies to be borrowed are open for inspection at the office of the Council of the Shire of Cranbourne, Sladen Street, Cranbourne.

Dated 29 August 1983

8570 T. VICKERMAN, Shire Secretary

SHIRE OF CRANBOURNE

Loan No. 114

Notice of Intention to Borrow the Sum of \$135 000 for Permanent Works and Undertakings

Notice is hereby given that the Council of the Shire of Cranbourne proposes to borrow the principal sum of \$135 000 secured by a charge over the general rates of the municipality, such sum to be raised by the grant of a mortgage in accordance with the provisions of the *Local Government Act 1958* (as amended).

1. The maximum rate of interest that may be paid is 15.6 per cent per annum.

2. The purpose for which the loan is to be applied is:

\$

• Recreation Reserve Pavilion at Lloyd Park, Langwarrin (Part Costs)	13 000
• Plant Purchases — Track Mounted Excavator	55 000
• Road Construction — Lecky Street, Cranbourne (Russell Street to Cameron Street)	67 000
	<hr/> 135 000

3. Period of the loan shall be 10 years.

4. The monies borrowed shall be repayable by providing out of the municipal funds half-yearly instalments of approximately \$13 546.04 each including principal and interest on 1 November and 1 May during the currency of the loan. The first instalment shall be payable on 1 May 1984.

5. The monies borrowed shall be repayable to the State Bank of Victoria, 385 Bourke Street, Melbourne or such other place as the bank may require from time to time.

The plans and specifications and the estimate of the cost of the proposed works and a statement showing the proposed expenditure of the monies to be borrowed are open for inspection at the office of the Council of the Shire of Cranbourne, Sladen Street, Cranbourne.

Dated 29 August 1983

8586 T. VICKERMAN, Shire Secretary

SHIRE OF LILLYDALE

By-Law No. 170

Brick Areas By-Law

Notice is hereby given that in pursuance to the powers under Clause No. 815 (a) of the Uniform Building Regulations (Victoria), the Local Government Act and the Building Control Act, all other powers it thereunto enables, the Shire of Lillydale has made a By-Law No. 170 for the purposes of:

1. Prescribing in accordance with the Schedules of the By-Law, Brick Areas within the Shire of Lillydale.

2. To provide that all new buildings are erected in accordance with the prescribed materials and in the proportions set out in the By-Law.

3. To provide for exemptions to this By-Law in certain cases.

No. 86—67260/83—4

A copy of the By-Law is open for inspection free of charge during office hours at the Municipal Offices, Anderson Street, Lilydale.

Resolution for passing this By-Law was agreed to by the Council of the Shire of Lillydale on 20 June 1983 and was confirmed on 25 July 1983.

The approval of the Governor in Council was granted on 16 August 1983.

Dated 31 August 1983

8587 G. L. FREEMAN, Shire Secretary

SHIRE OF MANSFIELD WATERWORKS TRUST

Notices to owners of tenements in Dead Horse Lane immediately East of Midland Highway and West of Mansfield-Whitfield Road.

The main pipe in the said lane being laid down, the owners of all tenements situated as above are hereby required on or before 30 September next, to cause a proper pipe and stop cock to be laid so as to supply water within such tenement from the main pipeline.

8572 G. D. PAYNE, Secretary

SHIRE OF MARONG

LOAN No. 55

Notice of Intention to Borrow the Sum of \$34 000 for Permanent Works and Undertakings

Notice is hereby given that the Council of the Shire of Marong proposes to borrow the principal sum of \$34 000 secured by a charge over the general rates of the municipality, such sum to be raised by the grant of a mortgage in accordance with the provisions of the *Local Government Act 1958*.

1. The maximum rate of interest that may be paid is 15.3 per cent per annum.

2. The purpose for which the loan is to be applied is contribution to kerbing and channelling and associated drainage and roadworks.

3. The period of the loan shall be 7 years.

4. The moneys borrowed shall be repayable by providing out of the municipal fund half-yearly instalments of approximately \$4040.64 including principal and interest on 10 April and 10 October during the currency of the loan. The first instalment shall be repayable on 10 April 1984.

5. Such moneys shall be repayable to A.N.Z. Banking Group Ltd., 133 High Street, Kangaroo Flat.

The plans and specifications and the estimate of the cost of the proposed works and a statement showing the proposed expenditure of the moneys to be borrowed are open for inspection at the Office of the Council of the Shire of Marong.

Dated 30 August 1983

8662 GRAEME ELVEY, Shire Secretary

SHIRE OF METCALFE

Loan No. 10

Notice of intention to borrow the sum of \$30 000 for Permanent Works and Undertakings

The Council of the Shire of Metcalfe intends to borrow the sum of \$30 000 on the credit of the general rates of the municipality, such sum to be raised by the grant of a mortgage in accordance with the provisions of the *Local Government Act 1958*.

1. The maximum rate of interest to be paid is 15.2 per cent per annum.

2. The amount to be borrowed is \$30 000.

3. The purpose for which the loan is to be applied is the purchase of a micro-computer system, including software.

4. The period of the loan shall be four years based on a ten year repayment schedule.

5. The monies borrowed shall be repayable by providing out of the Municipal Fund seven half-yearly instalments of approximately \$2 965.18 each including principal and interest, and a final instalment of \$25 781.68.

6. The first instalment shall be payable on 1 April 1984.

7. The monies shall be repayable at the National Australia Savings Bank Limited, Melbourne.

6. The Plans and Specifications and the Estimates and Details of the proposed works and repayment schedules are available for inspection at the Shire Offices, Kyneton Road, Metcalfe.

8626

D. F. DREW, Shire Secretary

SHIRE OF MORNINGTON

Loan No. 137

Notice of intention to borrow \$50 000 for Permanent Works and Undertakings

Notice is hereby given that the Council of the Shire of Mornington proposes to borrow the principal sum of \$50 000 secured by a charge over the general rates of the municipality, such sum to be secured by the grant of a mortgage in accordance with the provisions of the *Local Government Act 1958*.

1. The maximum rate of interest that may be paid is 15.2 per centum per annum.

2. The monies borrowed are to be repaid to the Commonwealth Savings Bank of Australia at the Head Office of the said Bank in Melbourne or such other place or places as the said Bank from time to time may require.

3. The purpose for which the loan is to be applied are:

	\$
Road and easement drain construction — Glenisla Drive, Mount Martha	10 000
Erection of public conveniences and associated works — Mount Martha Commercial Centre	30 000
Drainage works — Hearn Creek, between Esplanade and Ferrero Grove, Mount Martha	10 000

4. The money borrowed shall be repayable by providing out of the Municipal Fund nine equal consecutive half-yearly instalments of \$4 941.97 commencing on 10 April 1984, and concluding on 10 April 1988, with a final tenth instalment on 10 October 1988.

5. The period of the loan shall be 5 years from 10 October 1983.

The Plans and Specifications and the Estimates of the cost of such works and undertakings and a statement of the proposed expenditure of the money to be borrowed are open for inspection at the Office of the Council of the Shire of Mornington, Queen Street, Mornington.

D. G. COLLINGS, Shire Secretary, Civic Centre,
8627 Queen Street, Mornington, 3931.

SHIRE OF OTWAY

Loan No. 34

Notice of Intention to Borrow the Sum of \$110 000 for Permanent Works and Undertakings

Notice is hereby given that the Council of the Shire of Otway proposes to borrow the principal sum of \$110 000 secured by a charge over the general rates of the municipality, such sum to be raised by the grant of a mortgage in accordance with the provisions of the *Local Government Act 1958*.

1. The maximum rate of interest that may be paid is 15 per centum per annum.

2. The purpose for which the loan is to be applied is the purchase of a Grader (part cost) \$110 000. (Total estimated cost \$150 000.)

3. The period of the loan shall be four years, repayments of principal and interest are based on a nine year term.

4. The monies borrowed shall be repayable by providing out of the municipal fund, seven equal half-yearly instalments of \$11 333.18 with a final instalment of \$89 125.11 at the end of four years, each including principal and interest on 29 April and 29 October during the currency of the loan. The first instalment shall be payable on 29 April 1984.

5. Such monies shall be repayable to the Westpac Banking Corporation, Colac Branch, 130-132 Murray Street, Colac.

The plans and specifications and estimate of the cost of the works and a statement showing the proposed expenditure of the monies to be borrowed are open for inspection at the office of the Council of the Shire of Otway, Main Street, Beech Forest and at the Shire Engineer's Office, Nelson Street, Apollo Bay.

8588

T. R. RICHARDSON, Shire Secretary

SHIRE OF WARANGA

Appointment of Prosecuting Officer

Notice is hereby given that Sergeant Geoffrey Robert Durstan, No. 13759 has been appointed as Prosecuting Officer for the Shire of Waranga replacing Sergeant Lewis Reginald Chandler, No. 14300 (retired).

8552

G. A. SHIELL, Shire Secretary

SHIRE OF WARRNAMBOOL

Framlingham Pound

Notice is hereby given that Council has appointed Mr. Allan Maxwell Stuart as pound keeper at Framlingham in lieu of Miss A. McW. Campbell, resigned to be pound keeper at Framlingham.

Notice is further given that Council has appointed Crown Allotment 17, Section 4, Parish of Framlingham West as the pound at Framlingham in lieu of Crown Allotments 11, 11A, 11B, 11C and 11D, Section 5, Parish of Framlingham West, revoked.

By order of the Council

8631

ALAN J. BOWES, Shire Secretary

SHIRE OF WERRIBEE

Loan No. 144

Notice of Intention to Borrow the Sum of \$500 000.00 for Permanent Works and Undertakings.

Notice is hereby given that the Shire of Werribee proposes to borrow the principal sum of \$500 000.00 secured by a charge over the general rates of the municipality, such sum to be raised by the grant of a mortgage in accordance with the provisions of the *Local Government Act 1958*.

1. The maximum rate of interest that may be paid is 15.8% per annum.

2. The purposes for which the loan is to be applied are as follows:

	\$
(i) Construction of pavilion at Galvin Park	160 000
(ii) Construction of Stage I Agars Road/School Road	50 000

(iii)	Construction of footpaths on the North Side of Railway Avenue, between Tarnait and Derrimut Roads and Werribee Street, Werribee	25 000
(iv)	McCormack Park improvements	30 000
(v)	Pannam Drive Pre-School Centre	160 000
(vi)	Heaths Road Stage I	35 000
(vii)	Construction of a toilet block at the Recreation Centre, Bulban Road, Werribee	20 000
(viii)	Part Construction of Greens Road roundabout	20 000
	Total	500 000

3. The period of the loan shall be 15 years.

4. The monies borrowed shall be repayable by providing out of municipal funds half-yearly instalments of approximately \$43 995.35 each including principal and interest, each on 3 April and 3 October during the currency of the loan.

5. The first instalment shall be payable on 3 March 1984.

6. Such monies shall be payable to the Local Authorities Superannuation Board, Rigby House, 15 Queens Road, Melbourne, Victoria, 3004.

The plans and specifications and an estimate of the proposed works and a statement showing the proposed expenditure of the monies to be borrowed are open for inspection at the office of the Council of the Shire of Werribee, Civic Centre, Princes Highway, Werribee, Victoria, 3030.

8543

J. T. KERR, Shire Secretary

WESTERNPORT WATERWORKS TRUST

Notice to owners of tenements in the undermentioned streets and private streets, lanes, courts and alleys opening thereto.

The main pipe in the said street being laid down, the owners of all tenements situated as under are hereby required on or before 1 October 1983, to cause a proper pipe and stop cocks to be laid so as to supply water within such tenements from the main pipe:

Smythe Street, Corinella (east from Baker Street 184 metres)
8573 C. F. BEASLEY, Secretary

MILDURA URBAN WATER TRUST

By-Law No. 3

The Trust's By-Law No. 3 relating to the regulations covering water being supplied for cooling purposes, was approved by the Governor-in-Council on 24 May 1983.

A copy of the By-Law can be viewed free of charge at the Trust Office, 100 7th Street, Mildura.

Dated 26 August 1983

8590

R. E. DUDLEY, Manager/Engineer

BALLAN WATERWORKS TRUST

Extension of Waterworks District, Proclamation of Urban District and Construction of Works for supply of Water to Blackwood

Notice is hereby given that the Ballan Waterworks Trust has made application to the Honourable, the Minister of Water Supply for the extension of its Waterworks Districts, proclamation of the Blackwood Urban District, and for the construction, maintenance and continuance of Water Supply Works within those Districts under the provision of the Water Act.

A general plan and description of the proposed works have been submitted with the application, and copies of same may be seen at the Trust's Office at Steiglitz Street, Ballan, or at the Blackwood Public Hall, Cnr. Golden Point & Byers Roads, Blackwood.

Dated at Ballan, 31 August 1983

8632

JEREMY JOHNSON, Trust Secretary

Water Act 1958

MYRTLEFORD WATERWORKS TRUST

By-Law No. 9

Notice is hereby given that By-Law No. 9 for the purpose of restricting the use of water within the Myrtleford Waterworks district has been made by the Myrtleford Waterworks Trust and approved by the Governor in Council on 9 August 1983.

This By-Law:

- (a) empowers the Trust to implement at any time any of the eight stages of water restrictions in any special part or parts of districts as the Trust deems necessary by notice published in a local newspaper;
- (b) repeals By-Laws 5, 6, 7 and 8.

A copy of By-Law No. 9 may be inspected free of charge at the office of the Trust, Civic Centre, Myrtleford, during normal office hours.

8553

SUZANNE M. WALKER, Secretary

DAYLESFORD SEWERAGE AUTHORITY

Commencement of Works

Notice is hereby given that the Authority intends to construct sewers in the following areas:

(a) Daylesford

In the general area bounded by:

- (i) Raglan Street, Camp Street and Central Springs Road,
- (ii) West Street, Central Springs Road and Bridport Street.

(b) Hepburn

In the general area east of Hepburn Road.

Details of the proposed works are available for inspection at the office of the Authority, 33 Albert Street, Daylesford, during normal office hours.

8633

P. A. INGLE, Secretary

KILMORE SEWERAGE AUTHORITY

By-Law No. 1

Licensing of Plumbers and Drainers

This By-Law outlines the various conditions and requirements pertaining to the licensing of plumbers and drainers in the Kilmore Sewerage District.

By-Law No. 3

Trade Wastes

This By-Law outlines the various conditions under which any property owner shall discharge any trade or manufacturing liquid, refuse or waste into any sewer in the Kilmore Sewerage District.

Copies of the above By-Laws are open for inspection free of charge, during normal office hours at the Kilmore Civic Centre, Sydney Street, Kilmore.

8589

T. K. HAYES, Secretary

THE BALLARAT SEWERAGE AUTHORITY

Pursuant to Section 119 (2) of the *Sewerage Districts Act* 1958 (No. 6368) notice is hereby given of the intention to construct a sewer for property situated in the vicinity of the following street:

Heinz Road, Delacombe

More particularly as shown on plans which are open for inspection at this office between the hours of 8.45 a.m. and 4.30 p.m., Monday to Friday inclusive.

Water and Sewerage Offices
Grenville Street South
Ballarat 3350

8571

B. E. LEACH, Secretary

DISSOLUTION OF PARTNERSHIP

Harry Lioulioukos of 286 Springvale Road, Glen Waverley and Douglas Charles Jensen of 3 McGregor Avenue, Healesville, hereby give notice that they have dissolved their logging business partnership trading as H. Lioulioukos and D. J. Jensen as from 12 August 1983. The business of the former partnership will continue to be carried on by the said Douglas Charles Jensen.

CRILLY & DE GRAAF, solicitors, 234 Maroondah Highway, Healesville, 3777. 8554

Take notice that as from 24 April 1983 the partnership between myself Mr N. Frydman and Mr V. Doran and Mr L. McNally trading as K Mark Marketing or Play Safe Productions from 600 Burke Road, Camberwell has been dissolved.

Further take notice that I will not and have not been responsible for any debts incurred on behalf of the partnership from the above date.

COHENS, FRENKEL, BERKOVITCH KEFFORD, and NEW, solicitors, 114 William Street, Melbourne, 3000. 8555

WODONGA (No. 2) CO-OPERATIVE HOUSING SOCIETY LIMITED (IN LIQUIDATION)

Special Resolution

At a special general meeting of the abovenamed society duly convened and held at 154 High Street, Wodonga on 9 August 1983 at 12 noon, the subjoined special resolution was duly passed:

"That the Society having successfully completed its objectives be wound up voluntarily and that Terence Keith Lyon of 114 Oakover Road, West Preston be appointed liquidator for the purpose of the winding up.

R. F. WILTSHIRE, Chairman
I. M. McNEE, Secretary

8582

Co-operation Act 1981

Part X Section 193 (7)

MARYBOROUGH PRODUCERS AND RECYCLING CO-OPERATIVE LIMITED (IN LIQUIDATION)

On 22 August 1983, the Registrar of Co-operative Societies issued a certificate for winding-up of the abovenamed Co-operative and appointed Colin Stanley Wight, chartered accountant of Arthur Young & Company, 21st Floor, 500 Bourke Street, Melbourne, as the liquidator of the said Co-operative.

Dated 23 August 1983

8583

C. S. WIGHT, Liquidator

Form 125

The Companies (Victoria) Code
Regulation 81

L. R. & K. R. JAMES PTY. LTD.
(IN LIQUIDATION)

TRADING AS "BUNYIP PINE FURNITURE"

Notice of Meeting of Creditors

Notice is hereby given that a meeting of creditors of L. R. & K. R. JAMES PTY. LTD. (In Liquidation) will be held in the meeting room, 3rd Floor, Wallace, McMullin & Smail, 499 St. Kilda Road, Melbourne on 28 September 1983 at 10.30 o'clock in the forenoon.

Agenda

1. To lay before the meeting an account of the acts and dealings of the Liquidator and of the conduct of the winding up during the period ended 18 August 1983.
2. To consider payment of a first and final dividend.
3. To approve and fix the Liquidator's remuneration by Special Resolution.
4. Any other business.

Dated 18 August 1983

A. M. HORSBURGH, Official Liquidator

WALLACE, MCMULLIN & SMAIL, chartered accountants, 499 St. Kilda Road, Melbourne, 3004 8613

Companies Act 1961

Section 272 (2)

LINEAR ELECTRONICS AUSTRALIA PTY. LTD.

Notice of Final Meeting

Notice is hereby given that pursuant to Section 272 (2) of the *Companies Act* 1961, a general meeting of members and creditors of Linear Electronics Australia Pty. Ltd. will be held at Messrs. Duesburys, 19th Floor, 114 William Street, Melbourne, Vic. 3000 on 28 October 1983, at 9.30 a.m.

The purpose of the meeting is to lay accounts before it, showing the manner in which the winding up has been conducted and the property of the company disposed of, and of hearing any explanation that may be given by the liquidator.

Dated August 1983

WARWICK A. LEEMING, Liquidator

DUESBURYS, 114 William Street, Melbourne, Vic. 3000 8614

Companies Act 1961

Rule 99

Regulation 54

In the matter of Economy Exports Pty. Ltd. (In Liquidation)

Take notice that the Liquidator of the abovenamed company has fixed 26 September 1983 as the day on or before which the preferential creditors of the company as defined by Section 292 of the Act, are to prove their debts or claims or be excluded from the first and final dividend made before such debts are proved or as the case may be, from objecting to such dividend.

Dated 19 August 1983

D. A. CRAWFORD, Liquidator

PEAT, MARWICK, MITCHELL & CO., 500 Bourke Street, Melbourne, 3000 8615

Unclaimed Moneys Act 1962

Register of Unclaimed Moneys held by the—

Name of Owner on Books and Last Known Address	Total Amount Due to Owner	Description of Unclaimed Money	Date when Amount first became Payable
\$			
FOODLAND FINANCE LIMITED			
Milchman & Mand, 54 Kilby Rd, East Kew	68.62	Bonus	1.2.82
Hodson, R. & E., 111 Widford St, Glenroy	162.01	"	"
Williamson, B. & K., 4 Florence St, Stawell	214.77	"	"
Tsimbouris & Manzioungas, 20 Victoria St, Richmond	68.93	"	"
Marvonat Pty. Ltd., Cnr. Geelong Rd, & Sproot St, Portarlington	333.78	"	"
8659			
N.K.S. (HOLDINGS) LIMITED			
Blackmore, Colin G., 20 Stanhope Rd, Killara, N.S.W.	287.00	Proceeds	30.9.81
Bushell, Ronald Charles, (estate of), c/o The Public Trustee, Melbourne	4 730.41	"	"
Cameron, Mary P. and Gates, Lorna B., c/o Tyson and Tyson, 59 Cameron St, Launceston, Tas.	575.91	"	"
Christian, Mary Josephine, 71 Wellington St, Kew	2 075.50	"	"
Coy, Thelma E., Mirrmoor Paynes Lane, Kilmore	3 465.00	"	"
Croaker, David H., Coonerang, Wingen, N.S.W.	4 620.00	"	"
Doellinger, Horst R., 2 Kerr St, Camberwell	597.90	"	"
Duntum Pty. Ltd., c/o 7 Stanley St, Elsternwick	3 587.40	"	"
Gibbons, Charles, 12 Goessling Pl, Flynn, A.C.T.	577.50	"	"
Hart, Oscar R., (estate of), c/o Tyson and Tyson, 59 Cameron St, Launceston, Tas.	4 154.50	"	"
Henzell, Colin John, 81 Scott St, Beaumaris	4 929.71	"	"
Hockley, Trevor Richard and Dianne Joy, 2 Addis St, Geelong West	896.85	"	"
Mighell, Frances Mary, 16 Royal Cres, Armadale	3 547.54	"	"
Paterson, Margaret Anne, 42 Kambrook Rd, Caulfield	1 973.07	"	"
Ponton, Arthur Douglas, (estate of), c/o Walter A. Taylor & Co., 41 Warmatta St, Finley, N.S.W.	2 597.00	"	"
Porter, Patricia E., 61 Rose St, Armadale	383.94	"	"
Roberts, Ann Hamilton, c/o P.O. Box 217, Malvern	528.50	"	"
Simpson, Frederick Norman, 2 Epping St, East Malvern	657.69	"	"
Solomons, Catherine Mary, 7/104 Pile St, Marrickville, N.S.W.	2 362.24	"	"
Sprude, Otto, 68 Edinburgh St, Clayton	2 152.44	"	"
Thomas, Marjorie Hester, c/o Gilbert & Rahilly, 130 Graham St, Wonthaggi	5 197.50	"	"
Tune, Sandra, 3 Imala Ave, Tugun, Qld.	84.00	"	"
Underwood, Jennifer Ann, Rosehill Lodge, West Parade, South Guildford, W.A.	266.09	"	"
Unmack, Thelma Clare, 37A Waroonga Rd, Claremont, W.A.	2 590.00	"	"
Weatherly, Katrina Constance, Blythvale, Streatham	2 391.60	"	"
Wilbur-Ham, Brian L., 1 Balfour St, Toorak	57 442.00	"	"
Wilbur-Ham, John Lincoln, 2-449 Glenferrie Rd, Malvern	47 568.50	"	"
Wilson, Jean, 461 Hargreaves St, Bendigo	7 007.00	"	"
Young, William John and Clarke, Noel Francis Dale, c/o 284 Dorset Rd, Boronia	1 890.00	"	"
McRobert, Victor William, 10 Wilsborough Rd, Sanderstead, Surrey, U.K.	2 887.50	"	"
Riddiford, Mark E. J., Kay, David H. and Richard D., c/o Bell Gully & Co., P.O. Box 1291, Wellington, N.Z.	231.00	"	"
Womersley, Walter R., c/o 50 Robinson Rd, 13-02 MNB Building, Singapore	3 115.00	"	"
Campbell, George Alexander, c/o J. Lonsdale, 21 Brawn Ave, Ballarat	3 946.14	"	"
The Equity Trustees Executors & Agency Co. Ltd., & Marie L. Weigall, c/o 472 Bourke St, Melbourne	12 217.00	"	"
Grimwade, Barbara Gaerloch, 8 Cole Crt, Toorak	2 675.43	"	"
Vowez, Jean A., (estate of), c/o Union Fidelity Trustee Co. of Aust. Ltd., 472 Bourke St, Melbourne	3 547.54	"	"
Weigall, Albert, (estate of), c/o The Equity Trustees Executors and Agency Co. Ltd., 472 Bourke St, Melbourne	6 720.00	"	"
8660			
FLETCHER & PARKER PTY. LTD.			
Freeth, L., 69 Tennyson St, Kew	18.52	Proceeds	15.1.54
Owen, E., Pollards Hill Rd, Bransford via Worcester, England	21.00	"	5.5.55
James, H., "Woolverton", 641 Malvern Rd, Toorak	20.00	"	16.8.51
Darragh, B. N., F5/226 Canterbury Rd, St Kilda	17.30	"	29.8.73
7636			

In the Supreme Court of Victoria, C.O. 13381 — In the matter of the Companies (Victoria) Code; and in the matter of Computer Country (Nationwide) Pty. Ltd. — Notice of Appointment of Provisional Liquidator

Order for Appointment of an Official Liquidator as Provisional Liquidator: Made 23 August 1983.

Name and address of Provisional Liquidator: Michael Joseph O'Keeffe of 66 High Street, Glen Iris.

MACNAB & ARCHER, solicitors for the Petitioner 8559

MINERVA CO-OPERATIVE HOUSING SOCIETY
LIMITED (IN LIQUIDATION)

Special Resolution

Passed 22.8.83.

At a Special General Meeting of the abovenamed society duly convened and held at 42 Station Street, Fairfield, on 22 August 1983 at 6.30 p.m. the subjoined special resolution was duly passed:

"That the Society having successfully completed its objectives 127 months ahead of its expected term be wound up voluntarily, and that Mr. Alexander Heteyey, of 93 Banksia Street, Heidelberg, be appointed liquidator for the purposes of the winding up."

DR. A. GALLUS, Chairman of the meeting
8560 A. HETYEY, Secretary

In the matter of the *Co-operative Housing Societies Act 1958* and the *Companies Act 1961*, and in the matter of Minerva Co-operative Housing Society Limited (in liquidation) — Notice to Creditors

Notice is hereby given that all persons having any claim against the above society are required on or before 30 September 1983 to send their names and addresses and particulars of their debts or claims to Mr. A. Heteyey, the liquidator of the said society, at his office, 42 Station Street, Fairfield, 3078, and if so required by notice in writing from the said liquidator are personally, or by their solicitors, to come in and prove their said debts or claims at such time and place as shall be specified in such notice; or, in default thereof, they shall be excluded from the benefit of any distribution made before such debts or claims are so lodged or proved.

Dated at Melbourne, 23 August 1983

A. HETYEY, Liquidator. 8561

Form 92

SCHICK ELECTRONICS AUSTRALIA PTY. LTD. (IN
LIQUIDATION)

Companies Regulations

Notice is hereby given that a meeting of creditors of Schick Electronics Australia Pty. Ltd., will be held at the Settling Room, The Victorian Club, 141 Queen Street, Melbourne, on Monday, 29 August 1983, at 10.30 a.m. in the forenoon.

Agenda

1. To receive the Official Liquidator's Report.
2. To fix the remuneration of the Official Liquidator.
3. To consider, if thought fit, the appointment of members of a Committee of Inspection.

Dated 10 August 1983

R. D. WIDDOWS, Liquidator, 703 South Road, Moorabin, Vic. 3189. Telephone 555 7430 8562

Companies (Victoria) Code

Pursuant to Section 411

IN THE MATTER OF A. J. BORDEN & CO. PTY. LTD.
(IN LIQUIDATION)

Notice of Meeting of Members

Notice is hereby given that pursuant to Section 411 of the Companies (Victoria) Code the final meeting of members of the abovenamed company will be held at the offices of R. J. Spain & Associates, 24 Mason Street, Dandenong on 6 October 1983 at 10.30 a.m. for the purpose of laying before the meeting the liquidators' final account and report and giving any explanation thereof.

Dated 22 August 1983

DONALD WILLIAM CARMODY
8593 ROWAN HARMAN, Joint Liquidators

In the matter of the *Companies Act 1961* and in the matter of D.I.G. Constructions Ltd. (In Liquidation)

Notice is hereby given that pursuant to Section 272 of the *Companies Act 1961*, the final meeting of the members and creditors of the company will be held at the offices of Gary Condon & Co., 6th Floor, 24 Albert Road, South Melbourne on 5 October 1983 at 10.30 a.m., for the purpose of laying before the meeting the account of winding up and any explanation thereof.

Dated 26 August 1983

8594 C. G. CONDON, Liquidator

MCMILLAN CO-OPERATIVE HOUSING SOCIETY
LIMITED (IN LIQUIDATION)

Special Resolution

Passed 10 August 1983

At a special general meeting of the abovenamed society duly convened and held at 4A Commercial Road, Morwell on 10 August 1983 at 8.15 p.m., the subjoined special resolution was passed:

"That the society having successfully completed its objectives forty-five months ahead of its expected term be wound up voluntarily, and that Neville Louis Bond of Lot 20, Ashley Avenue, Morwell be appointed liquidator for the purposes of winding up."

8595 NEVILLE LOUIS BOND, Liquidator

In the matter of the *Co-operative Housing Societies Act 1958* and the Companies (Victoria) Code; and in the matter of M.O.A. Co-operative Housing Society Limited (in liquidation)

NOTICE TO CREDITORS

Notice is hereby given that all persons having any claim against the above Society are required on or before 30 September 1983, to send their names and addresses and particulars of their debts or claims to D. W. McBain of Suite 6, 318 Stephenson Road, Mt. Waverley, 3149, the liquidator of the said Society, at his office and if so required by notice in writing from the said liquidator, are personally, or by their solicitors, to come in and prove their said debts or claims at such time and place as shall be specified in such notice; or, in default thereof, they shall be excluded from the benefit of any distribution made before such debts or claims are so lodged or proved.

Dated at Mount Waverley, 29 August 1983

8629 D. W. McBAIN, Liquidator

The Companies Act 1961

LODHAS (AUSTRALIA) PTY. LTD. (IN LIQUIDATION)

Notice is hereby given that a first dividend is intended to be declared in the above matter. Creditors who have not proved their debts by 12 September 1983 may be excluded from this dividend.

Dated 25 August 1983

G. O. HARRISON, Liquidator

TOUCHE ROSS & CO., 440 Collins Street, Melbourne,
3000 8616

Companies Form 130
Paragraph 577 (1) (f)
Sub-Regulation 120 (2)
Companies (Victoria) Code
Supreme Court Rule 99 (2)

L. R. & K. R. JAMES PTY. LTD. (IN LIQUIDATION)
TRADING AS "BUNYIP PINE FURNITURE"

Notice Inviting Formal Proof of Debt Claim

Take notice that creditors of the company, whose debts or claims have not already been admitted, are required on or before 22 September 1983 to prove their debts or claims and to establish any title they may have to priority by delivering or sending through the post to me at my address a formal Proof of Debt of claim in accordance with Form 131 or 132 containing their respective debts or claims. In default they will be excluded from the benefit of any distribution made before their debts or claims are proved or their priority is established and from objecting to the distribution.

Form of Proof of Debt may be obtained from me.

Dated 18 August 1983

A. M. HORSBURGH, Official Liquidator

WALLACE, McMULLIN & SMAIL, chartered accountants,
499 St. Kilda Road, Melbourne 3004 8617

M.O.A. CO-OPERATIVE HOUSING SOCIETY LIMITED
(IN LIQUIDATION)

Special Resolution

Passed 24 August 1983.

At a special general meeting of the abovenamed Society duly convened and held at 1-3 O'Connell Street, North Melbourne on 24 August 1983, the subjoined resolution was duly passed:

1. That the Society having successfully completed its objectives nineteen months ahead of its expected term be wound up voluntarily, and that Mr. David William McBain of 318-322 Stephenson's Road, Mount Waverley be appointed liquidator for the purpose of the winding-up.

J. A. STONE, Chairman of Meeting
F. J. BEVERIN, Secretary. 8628

In the Supreme Court of Victoria, C.O. 13360 — In the matter of the Companies (Victoria) Code; and in the matter of Beer Bros. Enterprises Pty. Ltd.

Notice is hereby given that an application for the winding up of the abovenamed company by the Supreme Court was on 10 August 1983 presented by D. G. Whelan Rentals Pty. Ltd. and that the said petition is directed to be heard before the Court sitting at Law Courts, William Street, Melbourne at the hour of 10.30 o'clock in the forenoon on 20 October 1983; and any creditor or contributory of the said company desiring to support or oppose the making of an order on the said petition may appear at the time of hearing by himself or his counsel

for that purpose; and a copy of the petition will be furnished to any creditor or contributory of the said company requiring the same by the undersigned on payment of the regulated charge for the same.

The Petitioner's address is 1347 North Road, Huntingdale.

The Petitioner's Solicitors are Messrs. G. D. Burnett & Co., 37-39 Albert Road, Melbourne.

G. D. BURNETT & CO., solicitors for the Petitioner.

Note — Any person who intends to appear on the hearing of the said petition must serve on or send by post to the abovenamed solicitors notice in writing of his intention so to do. The notice must state the name and address of the person, or, if a firm, the name and address of the firm, and must be signed by the person or firm, or his or their solicitors (if any), and must be served, or, if posted, must be sent by post in sufficient time to reach the abovenamed solicitors not later than 4.00 o'clock in the afternoon of 19 October 1983. 8591

In the matter of the *Companies Act 1961*; and in the matter of Denmar Pty. Ltd. (In Liquidation)

Notice is hereby given that pursuant to Section 272 of the *Companies Act 1961*, the final meeting of the members and creditors of the company will be held at the offices of Gary Condon & Co., 6th Floor, 24 Albert Road, South Melbourne on 5 October 1983 at 10.00 a.m., for the purpose of laying before the meeting the account of winding up and any explanation thereof.

Dated 26 August 1983

8592

C. G. CONDON, Liquidator

In the Supreme Court of Victoria, C.O. 13371 — In the matter of the Companies (Victoria) Code; and in the matter of Hamerex Proprietary Limited.

Notice is hereby given that a Petition for the winding-up of the abovenamed company by the Supreme Court was on 15 August 1983 presented by Clive Hall Limited who carries on business at 13-15 O'Connell Street, Sydney in the State of New South Wales and that the said Petition is directed to be heard before the Court sitting at Melbourne at the hour of 10.30 o'clock in the forenoon on 13 October 1983 and any creditor or contributory of the said company desiring to support or oppose the making of an order on the said Petition may appear at the time of hearing by himself or his Counsel for that purpose; and a copy of the Petition will be furnished to any creditor or contributory of the said company requiring the same by the undersigned on payment of the regulated charge for the same.

The Petitioners' official address is 13-15 O'Connell Street, Sydney in the State of New South Wales.

The Petitioners' solicitors are Messrs. Russell, Kennedy & Cook of 257 Collins Street, Melbourne in the State of Victoria.

RUSSELL, KENNEDY & COOK

Note — Any person who intends to appear on the hearing of that said Petition must serve on or send by post to the abovenamed Messrs. Russell, Kennedy & Cook notice in writing of his intention so to do. The notice must state the name and address of the person, or, if a firm, the name and address of the firm, and must be signed by the person or the firm, or his or their solicitor (if any), and must be served, or, if posted, must be sent by post in sufficient time to reach the abovenamed not later than 4.00 o'clock in the afternoon of 12 October 1983.

8605

In the Supreme Court of Victoria, C.O. 13240 — In the matter of the Companies (Victoria) Code; and in the matter of Aubima Pty. Ltd.

Notice of Winding-up Order

Winding-up Order: Made 18 August 1983.

Name and address of Liquidator: Ian Kenneth McKinnon, 4th Floor, 576 St. Kilda Road, Melbourne. 3004.

T. A. SHERMAN, Acting Crown solicitor for the Commonwealth and solicitor for the Petitioner 8606

In the Supreme Court of Victoria, C.O. 13238 — In the matter of the Companies (Victoria) Code; and in the matter of W. G. Bestall Proprietary Limited.

Notice of Winding-up Order

Winding-up Order: Made 18 August 1983.

Name and address of Liquidator: Alan Murray Horsburgh, 499 St. Kilda Road, Melbourne. 3004.

T. A. SHERMAN, Acting Crown solicitor for the Commonwealth and solicitor for the Petitioner 8607

In the Supreme Court of Victoria, C.O. 13239 — In the matter of the Companies (Victoria) Code; and in the matter of Dawn Constructions Pty. Ltd.

Notice of Winding-up Order

Winding-up Order: Made 18 August 1983.

Name and address of Liquidator: Warwick Allen Leeming, 114 William Street, Melbourne. 3000.

T. A. SHERMAN, Acting Crown solicitor for the Commonwealth and solicitor for the Petitioner 8608

In the Supreme Court of Victoria, C.O. 13342 — In the matter of the Companies (Victoria) Code; and in the matter of C.O.A. Pressure Vessels Corporation (Vic.) Pty. Ltd.

Notice is hereby given that a Petition for the winding-up of the abovenamed Company by the Supreme Court was on 1 August 1983 presented by J.M.M.P.L. Pty. Limited whose registered office is situated at 134-166 Wellington Road, Clayton in the State of Victoria and that the said Petition is directed to be heard before the Court sitting at Melbourne at the hour of 10.30 a.m. on Thursday, 15 September 1983 at the Practice Court and any creditor or contributory of the said company desiring to support or oppose the making of an order on the said Petition may appear at the time of hearing by himself or his counsel for that purpose; and a copy of the said Petition will be furnished to any creditor or contributory of the said company requiring the same by the undersigned on payment of the regulated charge for the same.

The Petitioner's address is 134-166 Wellington Road, Clayton in the State of Victoria.

The Petitioner's solicitors are A. E. Wundele & Co., 253 Lonsdale Street, Melbourne.

A. E. WUNDELE & CO., solicitors for the Petitioner.

Note — Any person who intends to appear on the hearing of the said Petition must serve on or send by post to the abovenamed A. E. Wundele & Co., notice in writing of his intention to do so. The notice must state the name and address of the person, or if a firm, the name and address of the firm and must be signed by the person or firm or his or their solicitors (if any) and must be served or, if posted, must be sent by post in sufficient time to reach the abovenamed not later than 4.00 p.m. in the afternoon on 14 September 1983. 8544

MARYBOROUGH AND DISTRICT NO. 3 CO-OPERATIVE HOUSING SOCIETY LIMITED

Take notice that the affairs of the abovenamed Society are now fully wound up and that in pursuance of Section 272 (1) of the Companies Act 1961 and of the Co-operative Housing Societies Act 1958.

A General Meeting of the Society will be held at 95 Nolan Street, Maryborough on 27 September 1983, for the purposes of:

(1) laying before it an account showing how the winding up has been conducted and the property of the Society disposed of and giving any explanations thereof; and

(2) passing a resolution that the books and papers of the said Society and of the liquidator relevant to the affairs of the Society be destroyed after a period of 12 months from the date of the meeting.

Dated 19 August 1983

8545

R. J. WHITMORE, Liquidator

Companies Act 1961

I.O.N. PTY. LTD. (IN LIQUIDATION)

Notice Convening Final Meeting of Members and Creditors pursuant to Section 272

Notice is hereby given, pursuant to Section 272 of the Companies Act 1961, that a meeting of the abovenamed Company and its creditors will be held in the office of Wallace, McMullin & Smail, 499 St. Kilda Road, Melbourne, on Thursday, 6 October 1983, at 11.00 p.m., for the purpose of laying before the meeting an account showing how the winding up has been conducted and the property of the company has been disposed of and of hearing any explanations that may be given by the Liquidators.

Dated 29 August 1983

8546 A. M. HORSBURGH, R. P. NEWMAN, Liquidators

In the Supreme Court of Victoria, C.O. 13396 — In the matter of the Companies (Victoria) Code; and in the matter of Cavallo Pty. Ltd.

Notice is hereby given that a petition for the winding up of the abovenamed company by the Supreme Court was on 25 August 1983 presented by Red Tulip Distribution Services (Vic.) Pty. Ltd. and that the said petition is directed to be heard before the Court sitting at Law Courts, William Street, Melbourne, at the hour of 10.30 o'clock in the forenoon on 20 October 1983; and any creditor or contributory of the said company desiring to support or oppose the making of an order on the said petition may appear at the time of hearing by himself or his counsel for that purpose; and a copy of the petition will be furnished to any creditor or contributory of the said company requiring the same by the undersigned on payment of the regulated charge for the same.

The Petitioners' address is 1 Fennell Street, Port Melbourne.

The Petitioners' solicitors are Messrs. G. D. Burnett & Co., 37-39 Albert Road, Melbourne.

G. D. BURNETT & CO., solicitors for the petitioner.

Note — Any person who intends to appear on the hearing of the said petition must serve on or send by post to the abovenamed solicitors notice in writing of his intention so to do. The notice must state the name and address of the person, or, if a firm, the name and address of the firm, and must be signed by the person or firm, or his or their solicitors (if any), and must be served, or, if posted, must be sent by post in sufficient time to reach the abovenamed solicitors not later than four o'clock in the afternoon on 19 October 1983. 8574

The Petitioners' address is 4-6 Lincoln Street, East Brunswick.

The Petitioners' solicitors are Messrs. G. D. Burnett & Co., 37-39 Albert Road, Melbourne.

G. D. BURNETT & CO., solicitors for the petitioner.

Note — Any person who intends to appear on the hearing of the said petition must serve on or send by post to the abovenamed solicitors notice in writing of his intention so to do. The notice must state the name and address of the person, or, if a firm, the name and address of the firm, and must be signed by the person or firm, or his or their solicitors (if any), and must be served, or, if posted, must be sent by post in sufficient time to reach the abovenamed solicitors not later than four o'clock in the afternoon on 19 October 1983. 8575

COBURG (NO. 7) CO-OPERATIVE HOUSING SOCIETY LIMITED (IN LIQUIDATION)

Special Resolution

Passed 24 August 1983.

At a special general meeting of the abovenamed society duly convened and held at 131 Bell Street, Coburg on 24 August 1983 at 2.30 p.m. the subjoined special resolution was duly passed:

That the Society having successfully completed its objectives 24 months ahead of its expected term be wound up voluntarily, and that Harry Chalmers of 131 Bell Street, Coburg, be appointed liquidator for the purposes of the winding up.

M. J. BRENNAN, Chairman of Meeting
H. CHALMERS, Secretary
8576

Companies (Victoria) Code

C. G. HAYNES HOLDINGS PTY. LIMITED (IN LIQUIDATION)

Notice of Voluntary Liquidation — Section 392 (2)

At a general meeting of the abovenamed Company duly convened and held at 25 Ely Street, Wangaratta on 9 August 1983, the following special resolution was passed:

"That the Company be wound up as a Members Voluntary Liquidation and that the assets of the Company may be distributed in whole or in part to the members in specie should the liquidators so desire."

Dated 9 August 1983

COLIN GEORGE HAYNES and GRAHAM FREDERICK KERR, Liquidators, 25 Ely Street, Wangaratta, Vic. 3677. 8577

Companies Act 1961

ALAN BISHOP IMPORTS PTY. LTD. (IN LIQUIDATION)

Notice Convening Final Meeting of Members and Creditors Pursuant to Section 272 (1)

Notice is hereby given that the final meeting of members and creditors of the abovenamed company will be held at the offices of M. A. Webb & Co., 4th Floor, 286 Toorak Road, South Yarra on Friday, 30 September 1983 at 10.30 a.m. for the purpose of laying before the meeting an account showing how the winding up has been conducted and the property of the Company disposed of and giving any explanation thereof.

Dated 23 August 1983

MICHAEL A. COPPINS, Liquidator
M. A. WEBB & CO., 4th Floor, 286 Toorak Road, South Yarra, Vic. 3141. 8645

Companies Act 1961

LANDER HOME DEVELOPMENTS PTY. LTD. (IN LIQUIDATION)

Notice of Final Meeting of Members and Creditors Pursuant to Section 272

Notice is hereby given that pursuant to Section 272 of the Companies Act 1961, the final meeting of members and creditors of the company will be held at the offices of Messrs. Marquand & Co., Mezzanine Floor, 51 Queen Street, Melbourne on Thursday, 6 October 1983 at 11.30 a.m. for the purpose of laying before the meeting an account showing how the winding up has been conducted and the property of the company has been disposed of and of giving any explanation of the account.

Dated 29 August 1983

D. E. TONKIN, Liquidator
MARQUAND & CO., chartered accountants, 51 Queen Street, Melbourne, 3000. 8646

In the Supreme Court of Victoria, C.O. 13251 — In the matter of the Companies (Victoria) Code; and in the matter of Parkview Catering Pty. Ltd. — Notice of Winding-Up Order
Winding-Up Order: Made 25 August 1983.

Name and address of Liquidator: Kenneth James Russell, 461 Bourke Street, Melbourne.

T. A. SHERMAN, Acting Crown solicitor for the Commonwealth and solicitor for the Petitioner 8641

In the Supreme Court of Victoria, C.O. 13252 — In the matter of the Companies (Victoria) Code; and in the matter of Mayjoy Nominees Pty. Limited — Notice of Winding-Up Order

Winding-Up Order: Made 25 August 1983.

Name and address of Liquidator: Douglas Ewart Tonkin, 51 Queen Street, Melbourne.

T. A. SHERMAN, Acting Crown solicitor for the Commonwealth and solicitor for the Petitioner 8642

In the Supreme Court of Victoria, C.O. 13249 — In the matter of the Companies (Victoria) Code; and in the matter of Mal Clayton Transport Proprietary Limited — Notice of Winding-Up Order

Winding-Up Order: Made 25 August 1983.

Name and address of Liquidator: Douglas Orson Oldfield, 35 Collins Street, Melbourne.

T. A. SHERMAN, Acting Crown solicitor for the Commonwealth and solicitor for the Petitioner 8643

In the Supreme Court of Victoria, C.O. 13397 — In the matter of the Companies (Victoria) Code; and in the matter of Cullsec Pty. Ltd.

Notice is hereby given that a petition for the winding up of the abovenamed company by the Supreme Court was on 25 August 1983 presented by Brunswick Sales Pty. Ltd. and that the said petition is directed to be heard before the Court sitting at Law Courts, William Street, Melbourne at the hour of 10.30 o'clock in the forenoon on 20 October 1983; and any creditor or contributory of the said company desiring to support or oppose the making of an order on the said petition may appear at the time of hearing by himself or his counsel for that purpose; and a copy of the petition will be furnished to any creditor or contributory of the said company requiring the same by the undersigned on payment of the regulated charge for the same.

In the Supreme Court of Victoria, C.O. 13551 — In the matter of the Companies (Victoria) Code; and in the matter of Michaelong Pastoral Company Pty. Ltd.

Advertisement of Application

Notice is hereby given that an application for the winding up of the abovenamed company by the Supreme Court was on 8 August 1983 presented by Amani Pty. Ltd. and that the said application is directed to be heard before the Court sitting at the Practice Court, Law Courts, Lonsdale Street, Melbourne at the hour of 10.30 o'clock in the forenoon on 29 September 1983 and any creditor or contributory of the said company desiring to support or oppose the making of an order on the said application may appear at the time of hearing by himself or his Counsel for the purpose; and a copy of the said application will be furnished to any creditor or contributory of the said company requiring the same by the undersigned on payment of the regulated charge for the same.

The Applicant's official address is Mount Street, South Gundagai, New South Wales.

The Applicant's Solicitors are Messrs. Phillips, Fox & Masel of 461 Bourke Street, Melbourne.

PHILLIPS, FOX & MASEL.

Note — Any person who intends to appear on the hearing of the said application must serve on or send by post to the abovenamed Phillips, Fox & Masel, notice in writing of his intention to do so. The notice must state the name and address of the person, or if a firm the name and address of the firm and must be signed by the person or firm or his or their solicitors (if any) and must be served or if posted, must be sent by post in sufficient time to reach the abovenamed not later than 4.00 o'clock in the afternoon on 28 September 1983. 8556

In the Supreme Court of Victoria, C.O. 13267 — In the matter of the Companies (Victoria) Code; and in the matter of Air Heat Cool Design Pty. Ltd.

Winding-Up Order Made: 18 August 1983.

Name and address of Liquidator: Dennis John Cogle, 144 Jolimont Road, East Melbourne.

Dated 18 August 1983

G. D. BURNETT & CO., solicitors for the Petitioner 8557

Notice is hereby given in accordance with Section 392 of the Companies Act 1981, that at a general meeting of Comoken Court Pty. Ltd. convened and held on 22 August 1983 the following special resolution was duly passed.

"That the company be wound-up voluntarily." 8558

In the Supreme Court of Victoria, C.O. 13237 — In the matter of the Companies (Victoria) Code; and in the matter of Valley Hall Pty. Ltd.

Notice of Winding-up Order

Winding-up Order: Made 18 August 1983.

Name and address of Liquidator: Anthony George Hodgson, 459 Collins Street, Melbourne. 3000.

T. A. SHERMAN, Acting Crown solicitor for the Commonwealth and solicitor for the Petitioner 8609

In the Supreme Court of Victoria, C.O. 13377 — In the matter of the Companies (Victoria) Code; and in the matter of Westcorp Pty. Ltd. — Advertisement of Petition.

Notice is hereby given that a Petition for the winding-up of the abovenamed company by the Supreme Court was on 18 August 1983 presented by Executive Office Interiors Pty. Ltd. and that the said Petition is directed to be heard before the

Court sitting at the 15th Court, Law Courts, William Street, Melbourne on 27 October 1983, at the hour of 10.30 o'clock in the forenoon and any creditor or contributory of the said company desiring to support or oppose the making of an order on the said Petition may appear at the time of hearing by himself or his Counsel for that purpose; and a copy of the Petition will be furnished to any creditor or contributory of the said company requiring the same by the undersigned on payment of the regulated charge for the same.

The Petitioners' address is: 89 Erin Street, Richmond.

The Petitioners' solicitors are: Messrs. Kiddle, Briggs & Willox of 459 Collins Street, Melbourne.

KIDDLE, BRIGGS & WILLOX, solicitors for the Petitioner

Note — Any person who intends to appear on the hearing of that said Petition must serve on or send by post to the abovenamed solicitors notice in writing of his intention to do so. The notice must state the name and address of the person, or if a firm, the name and address of the firm, and must be signed by the person or the firm, or his or their solicitor (if any), and must be served, or, if posted, must be sent by post in sufficient time to reach the abovenamed not later than 4.00 o'clock in the afternoon of Wednesday 26 October 1983 8610

Companies Form 125

Sub-regulation 84 (1) (e)

Companies (Victoria) Code

ADVANCE WARDROBES PTY. LTD.

(IN LIQUIDATION)

Notice of Meeting

1. Notice is given that a meeting of the company and its creditors will be held at the offices of R. G. Dick & Associates at 16 High St., Glen Iris, on 3 October 1983 at 9.45 a.m.

Agenda

2. To lay before the meeting an account showing how the winding up has been conducted and the property of the company has been disposed of, and giving any explanation of the account.

Dated 31 August 1983

R. G. DICK, Liquidator

R. G. DICK & ASSOCIATES, 16 High St., Glen Iris. 3146
8611

Companies (Victoria) Code

Section 411 (2)

ERADISE CONSTRUCTION PTY. LTD.

(IN LIQUIDATION)

Notice is hereby given that pursuant to Section 411 (2) of the Companies (Victoria) Code, a final meeting of the Company and its creditors will be held at the office of Neville Bird, Clark & Co., Public Accountants, 11th Floor, 499 St. Kilda Road, Melbourne, 3004 on Friday, 30 September 1983 at 10.30 a.m., for the purpose of laying before the meeting an account showing how the winding up has been conducted and the property of the company disposed of, and giving any explanation thereof.

Dated 22 August 1983

G. J. CLARK, Liquidator

NEVILLE BIRD, CLARK & CO., public accountants, 11th Floor, 499 St. Kilda Road, Melbourne. 3004 8612

In the matter of the Companies (Victoria) Code 1982; and in the matter of THE AUSTRALIAN WILTON CARPET COMPANY PTY. LTD.

Notice is hereby given that a Petition for the winding up of the abovenamed Company by the Supreme Court was on 19 August 1983 presented by Vempdale Pty. Ltd. and that the said Petition is directed to be heard before the Court sitting at Law Courts, William Street, Melbourne, on 13 October 1983 at 10.30 o'clock in the forenoon and any Creditor or contributory of the said Company desiring to support or oppose the making of an Order on the said Petition may appear at the time of the hearing by himself or his Counsel for that purpose and a copy of the said Petition will be furnished to any Creditor or contributory of the said Company requiring the same by the undersigned on payment of the regulated charge for the same.

The Petitioner's address is 112 James Street, Templestowe in the State of Victoria.

The Petitioner's Solicitors are Messrs. Finkelstein & Lipshutz of 150 Queen Street, Melbourne.

FINKELSTEIN & LIPSHUTZ

NOTE—Any person who intends to appear on the hearing of the said Petition must serve on or send by post to the abovenamed Finkelstein & Lipshutz of 150 Queen Street, Melbourne, notice in writing of his intention to do so. The Notice must state the name and address of the person or if a firm the name and address of the firm and must be signed by the person or firm or his or their Solicitors (if any) and must be served and (if posted) must be sent by post in sufficient time to reach the abovenamed not later than 4 o'clock in the afternoon of 12 October 1983.

8661

In the Supreme Court of Victoria, C.O. 13022 — In the matter of the Companies (Victoria) Code; and in the matter of R. F. M. Continuous Forms (Aust) Pty. Ltd. — Notice of Winding-Up Order

Winding-Up Order: Made 26 July 1983.

Name and address of Liquidator: David Alexander Crawford, 500 Bourke Street, Melbourne.

T. A. SHERMAN, Acting Crown solicitor for the Commonwealth and solicitor for the Petitioner

8644

Companies Act 1981

Notice is hereby given pursuant to Section 411 of the Companies Act that a final meeting of the members of M. Matich & Co. Pty. Ltd. will be held at 131 Queensville Street, West Footscray at 9 a.m. on 30 September 1983.

Business — to receive a final explanation of the Winding-Up of the company from the liquidator.

8551

M. MATICH, Liquidator

EDMUND KNELLER GHRIMES, late of Gerang Gerang, farmer, deceased

Creditors, next of kin and others having claims in respect of the estate of the deceased, who died on 14 August 1982, are required by the personal representatives namely the Union-Fidelity Trustee Company of Australia Limited of 100 Exhibition Street, Melbourne and Nellie Beatrice Cordner of 12 High Street, Dimboola, widow, to send particulars to the said Company at 101 Lydiard Street North, Ballarat by 12 October 1983, after which date the said representatives may convey or distribute the assets having regard only to the claims of which they then have notice.

Dated 31 August 1983

MUNTZ & MARONEY, 48 Victoria Street, Dimboola, solicitors for the personal representatives.

8601

Creditors, next of kin and all others having claims in respect of the will of John Norman Kemp, formerly of 53 Westbourne Road, Kensington, labourer, but late of 7 Forrest Street, Yarraville, retired, deceased, who died on 1 August 1983, are requested to send particulars of their claims to the Executor, Isabel Helen Bates, care of the undermentioned solicitor by 9 November 1983, after which date she will distribute the assets having regard only as to the claims of which she then has notice.

JOHN STEWART, 290 Racecourse Road, Newmarket.

8602

LEONARD ADOLPH SCHUMANN, late of Verdon Street, Inglewood, retired farmer, deceased

Creditors, next of kin and others having claims in respect of the estate of the deceased, who died on 16 April 1983 are required by the Executrix Noela Ann Scanlon of 249 Carpenter Street, Bendigo, home duties, to send particulars to her care of the undermentioned solicitors by 31 October 1983, after which date she may convey or distribute the assets having regard only to the claims of which she then has notice.

R. H. SCHLEIGER & ASSOCIATES, solicitors, 33-35 Williamson Street, Bendigo.

8603

ARTHUR WALLACE KELLY, late of Tarnagulla Road, Inglewood, retired farmer, deceased

Creditors, next of kin and others having claims in respect of the estate of the deceased, who died on 28 April 1983, are required by the Executors Neville William Kelly of 103 Denham Street, Hawthorn, health administrator, and Beverley Jeanette Mumford of 60 Victoria Street, Toora, home duties, to send particulars to them care of the undermentioned solicitors by 31 October 1983, after which date they may convey or distribute the assets having regard only to the claims of which they then have notice.

R. H. SCHLEIGER & ASSOCIATES, solicitors, 33-35 Williamson Street, Bendigo.

8604

Creditors, next of kin and all other persons having claims against the estate of Gertrude Sanders, late of Flat 4, 114 Riversdale Road, Hawthorn in the State of Victoria, widow, deceased, who died on 23 July 1983 and Probate was granted by the Supreme Court of Victoria on 23 August 1983 to Daniel Rechtman of 160 Queen Street, Melbourne solicitor are hereby required to send particulars in writing of such claims to the said Daniel Rechtman care of the undermentioned solicitors on or before 28 October 1983 after which date the said Daniel Rechtman will proceed to distribute the assets of the said Gertrude Sanders having regard only to claims of which he shall then have had notice.

Dated 25 August 1983

PRICE & CHAMBERLIN, BRENT & STEPHENS, solicitors, 160 Queen Street, Melbourne, 3000.

8618

SYLVIA EDITH TOBIN, late of 14 Cassell Street, Hawksburn in the State of Victoria, retired, deceased

Creditors, next of kin and others having claims in respect of the estate of the deceased, who died on 8 June 1983 are required by the Trustee ANZ Executors and Trustee Company Limited of 401 Collins Street, Melbourne in the State of Victoria to send particulars to the Company, care of the undersigned solicitors by 10 October 1983 after which day the Trustee may convey or distribute the assets having regard only to the claims of which it then has notice.

PAVEY WHITING & BYRNE, solicitors, 360 Collins Street, Melbourne.

8619

LEON ROBARTS GILLAM, late of 21 Glen Iris Road, Camberwell in the State of Victoria, chartered accountant, deceased

Creditors, next of kin and others having claims in respect of the deceased, who died on 8 June 1982 are requested to send their claims to Edna Rosa Charlotte Gillam, the Executrix of the estate of Leon Robarts Gillam, care of the undersigned solicitor by 1 November 1983 after which date the Executrix will proceed to distribute the estate having regard only to the claims of which she then has notice.

BARRY KENNA & CO., solicitors, 695 Burke Road, Camberwell. 8620

Creditors, next of kin and all other persons having claims in respect of the estate of Elsie Alice Eaves, late of Hurlingham, 68 Union Street, East Brighton in the State of Victoria, widow, deceased, who died on 23 June 1983, are required to send particulars of their claims to the Executor Ian Hay McGregor Lonie of 60 Market Street, Melbourne in the said state solicitor by 1 November 1983, after which date the Executor will distribute the assets having regard only to the claims of which he shall then have had notice.

MADDOCK LONIE & CHISHOLM, solicitors, 60 Market Street, Melbourne. 8621

JEAN MARGARET CAMPBELL, late of 709 Dana Street, Ballarat, spinster, deceased, who died on 22 December 1982

Creditors, next of kin and all other persons having claims against the estate of the said deceased are required by the Executors, The Union-Fidelity Trustee Company of Australia Limited of 100 Exhibition Street, Melbourne Neil Price Campbell of 1023 Sturt Street, Ballarat, retired and Margaret Alston McArthur of 106 Francis Street, Belmont Home Duties to send details particulars of their claims in respect of the said property to the executors, care of the said company at 101 Lydiard Street, North Ballarat on or before 31 October 1983 after which date they will proceed to distribute the estate having regard only to the claims of which they then have notice.

Dated 31 August 1983

RAMSAY, GAUNT & FRASER, solicitors, 41 Lydiard Street South, Ballarat. 8598

MARY EILEEN DELBRIDGE, late of 18 Newton Street, Thomastown in the State of Victoria, widow, deceased

Creditors, next of kin and others having claims in respect of the estate of the deceased, who died on 10 May 1983 are required by the executor Kenneth Henry Delbridge of 36 Heyington Avenue, Thomastown in the State of Victoria, Cartage Contractor to send particulars to the undermentioned firm by 25 November 1983, after which date the said Kenneth Henry Delbridge may convey or distribute the assets having regard only to the claims of which notice has by then been given.

SETON WILLIAMS & SMYTH, solicitors, 408 Collins Street, Melbourne. 8599

Creditors, next of kin and others having claims against the estate of Reginald Keith Ferber, deceased, late of 45 Browns Road, East Bentleigh in the State of Victoria, retired clerk, who died on 15 July 1983, are required to send particulars of their claims to the Executor, The Equity Trustees Executors and Agency Company Limited of 472 Bourke Street, Melbourne, before 2 November 1983, after which date the Executor will distribute the assets of the estate having regard only to the claims of which it shall then have notice.

SACKVILLE, WILKS & CO., solicitors, 100 Collins Street, Melbourne. 8600

Creditors, next of kin and others having claims in respect of the estate of William Albert Wright, late of 47 Mount Street, Heidelberg, Victoria, gentleman, deceased, who died on 3 June 1983 are required by the applicant for a grant of Representation, Neil Norman Wright of 428 Ringwood-Warrandyte Road South, Warrandyte, Victoria to send particulars to him at the above address by 15 November 1983 after which date the said applicant for a grant of Representation may convey or distribute the whole of the assets of the said deceased having regard only to the claims of which he then has notice.

T. A. RANK & ROBINSON, solicitors, 388 Bourke Street, Melbourne. 8597

STELLA DULCIE EDITH RIDD, late of 5 Cannon Street, Sunshine, widow, deceased

Creditors, next of kin and others having claims in respect of the estate of the deceased (who died on 7 May 1983) are required by the executors Lesley Beall of 7 Cannon Street, Sunshine, retired and Duncan Thomas McGregor of 28 Carathool Street, Bulleen, chartered accountant to send particulars to them, care of the undermentioned solicitors by 16 November 1983 after which date the executors will distribute the assets having regard only to the claims of which they then have notice.

SIEVERS & SIEVERS, solicitors, 17 Sun Crescent, Sunshine. 8578

Creditors, next of kin and others having claims in respect of the estate of Olive Head, formerly of Flat 1, No. 11 Downshire Road, Elsternwick, widow, deceased, who died on 4 June 1983, are to send particulars of their claims to The Equity Trustees Executors and Agency Company Limited, of 472 Bourke Street, Melbourne by 7 November 1983, after which date it will distribute the assets having regard only to the claims of which it then has notice.

AITKEN WALKER & STRACHAN, solicitors, 114 William Street, Melbourne. 3000 8635

OLIVE ESTHER MAY McKENZIE, formerly of Kerang, but late of 504 McIvor Road, Bendigo in the State of Victoria, chiropodist, deceased

Creditors, next of kin and all other persons having claims against the estate of the said deceased are required by Alexander William McKenzie of 115 Victoria Street, Kerang in the State of Victoria and Ronald Neil McKenzie of 54 Fitzroy Street, Kerang aforesaid pensioners, the Executors of the estate of the said deceased to send particulars of such claims to them in care of the undermentioned solicitors on or before 5 November 1983, after which date they will distribute the assets having regard only to the claims to which they then have notice.

BASILE & CO., barristers & solicitors, 46 Wellington Street, Kerang. 3579 8636

EMMANUEL CARUANA, late of 12 Mailey Street, West Sunshine in the State of Victoria, welder, deceased

Creditors, next of kin and others having claims in respect of the estate of the deceased, who died on 29 May 1983, are required by Tessie Caruana of 12 Mailey Street, West Sunshine in the said State, widow, the Executrix to whom probate of the will of the said deceased was granted by the Supreme Court of Victoria to send particulars to her care of the undersigned by 7 November 1983, after which date the said Executrix may convey or distribute the assets having regard only to the claims of which she then has notice.

PATRICK J. CANNON, TESTRO & COBURN, solicitors, 117 Burham Road, Sunshine. 3020 8637

MARIAN BARR, late of Unit 13, "Strathdon", 17 Jolimont Road, Forest Hill in the State of Victoria, widow, deceased

Creditors, next of kin and others having claims in respect of the estate of the deceased, who died on 23 October 1982, are required by the executors Johnnie Hansen of 6 Piccadilly Avenue, Wantirna South, sales manager and Leslie William Edward Charlton of 450 Little Collins Street, Melbourne, chartered accountant to send particulars to them at the office of the said Leslie William Edward Charlton at 450 Little Collins Street, Melbourne by 17 November 1983, after which date they may convey or distribute the assets having regard only to the claim of which they then have notice.

KEITH HERCULES & SONS, solicitors, Suite 3, 456 St. Kilda Road, Melbourne 3004. 8639

Creditors, next of kin and others having claims in the estate of Leo Francis Smith, late of 366 Cardigan Street, Carlton in the State of Victoria, pensioner, now deceased, who died on 8 July 1983, are to send notices of their claims to Brian William Smith of 1 Rautman Street, Sunshine in the said State, clerk, executor of the estate of the said deceased, care of Leo Browne, solicitor of 180 Elgin Street, Carlton in the said State by 5 November 1983, after which date the said Brian William Smith will distribute the estate having regard only for the claims of which he then has notice.

LEO BROWNE, solicitor, 180 Elgin Street, Carlton. 8640

FLORENCE PANSY READ HANTON, late of 37 Davey Street, Frankston, married woman, deceased

Creditors, next of kin, and others having claims in respect of the estate of the deceased, who died on 25 June 1983, are required by The Perpetual Executors and Trustees Association of Australia Limited of 50 Queen Street, Melbourne, to send particulars of their claims to the said company by 3 November 1983, after which date it will convey or distribute the assets, having regard only to the claims of which the company then has notice.

COOK & McCALLUM, solicitors, 60-64 Wells Street, Frankston. 8647

CATHERINE MARY de CARTERET, late of 2a Merriwee Crescent, Toorak, in the State of Victoria, widow, deceased

Creditors, next of kin and others having claims in respect of the estate of the deceased, who died on 4 June 1983, are required by the Trustees, John Michael Haddad of 2a Merriwee Crescent, Toorak, in the said State and Harry Baker of 151 The Parade, Ocean Grove, in the said State, to send particulars to them by 10 November 1983, after which date the Trustees may convey or distribute the assets, having regard only to the claims of which they then have notice.

WHYTE JUST & MOORE, solicitors, 27 Malop Street, Geelong. 8565

HARRY DAYRELL CANNING TANNER, late of 1/8 Mercer Road, Armadale in the State of Victoria, retired merchant, deceased

Creditors, next of kin and others having claims in respect of the estate of the deceased, who died on 7 July 1983, are required by the personal representative Kevin George Cooke of 128 Exhibition Street, Melbourne in the said state solicitor to send particulars to him by 5 October 1983, after which date the personal representative may convey or distribute the assets, having regard only to the claims of which he then has notice.

COOKE & CUSSEN, solicitors, 128 Exhibition Street, Melbourne, 3000. 8625

EMMA ALISON MARTIN, late of 42 Gumnow Street, Swan Hill, in the State of Victoria, married woman, deceased, who died on 30 May 1983

Creditors, next of kin and all other persons having claims against the estate of the deceased, are required by the Executors of the will, Stuart Thomas Martin and Margaret Alison Clark, to send particulars to them care of the undersigned on or before 26 October 1983, after which date they will distribute the assets, having regard only to the claims of which they then have notice.

GARDEN & GREEN, solicitors, 4 McCallum Street, Swan Hill. 8547

Creditors, next of kin and others having claims in respect of the estate of Archibald Kennedy, but known as Arthur Kennedy, late of 13 Edro Avenue, East Brighton, in the State of Victoria, retired engineer, deceased, who died on 22 March 1983 are required to send particulars of their claims to the Executor, care of the undermentioned solicitors by 31 October 1983, after which date he will distribute the assets having regard only to the claims for which notice has been received.

LYTTLETON & GILLARD, solicitors, 51 Marcus Road, Dingley. 8548

Creditors, next of kin and others having claims in respect of the estate of Marjorie Caroline Alice Maddocks, formerly of 21 Yuile Street, Ashburton, in the State of Victoria, but late of 1 Esperance Road, Mount Waverley, in the said State, widow, deceased, who died on 10 May 1983, are required to send particulars of their claims to the Executrices, care of the undermentioned solicitors by 31 October 1983, after which date they will distribute the assets having regard only to the claims for which notice has been received.

LYTTLETON & GILLARD, solicitors, 51 Marcus Road, Dingley. 8549

BETTY STELLA DART, late of Unit 8, 29 Kooyong Road, Armadale, retired, deceased, who died on 19 March 1983

Creditors, next of kin, and all persons having claims against the estate of the above deceased are required to send particulars to the Executor, Cecil George Dart, care of 152 Wattletree Road, Malvern by 5 November 1983, after which date he will distribute the assets, having regard only to claims of which he shall then have notice.

THOMAS BURKE, solicitor, 152 Wattletree Road, Malvern, Vic. 3144 8550

Creditors, next of kin and others having claims in respect of the estate of Colin Russell Franklin, late of Unit 2, 541 Doncaster Road, Doncaster, deceased, who died on 2 April 1983, are to send particulars of their claims to National Trustees Executors and Agency Company of Australasia Limited of 95 Queen Street, Melbourne by 12 November 1983, after which date the said company will distribute the assets, having regard only to the claims of which it then has notice.

STONE LEIGHTON & DAVIS, solicitors, 221 High Street, Kew. 8638

Creditors, next of kin and others having claims in respect of the estate of Doris Mary McRae, late of 17 Cheeseman Avenue, East Brighton, widow, deceased, who died on 28 June 1983, are to send particulars of their claims to ANZ Executors & Trustee Company Limited of 94 Queen Street, Melbourne by 31 October 1983, after which date it will distribute the assets having regard only to the claims of which it then has notice.

MOULES, solicitors, 140 William Street, Melbourne. 8624

Creditors, next of kin and others having claims in respect of the estate of Henry Nelson Parker, late of Oakmoor Private Nursing Home, 352-354 Warrigal Road, South Oakleigh, deceased, who died on 19 June 1983, are requested to send particulars of their claims to the Union Fidelity Trustee Company of Australia Limited, 100 Exhibition Street, Melbourne, the Executor of the will of the deceased by 1 November 1983, after which date the Executor will distribute the assets, having regard only to the claims of which they then have notice.

COLE & CO., solicitors, Oakleigh. 8563

GEORGE ORMOND LESLIE OPIE, late of 35 Dundas Place, Albert Park, gentleman, deceased

Creditors, next of kin and others having claims in respect of the estate of the abovenamed who died on 20 May 1983 are requested to send particulars thereof to the executor of his will James Robins Opie care of the undermentioned solicitors on or before 3 November 1983 after which date he will distribute the assets in the estate having regard only to the claims of which he shall then have notice.

J. M. SMITH & EMMERTON, solicitors, 224 Queen Street, Melbourne. 8579

THELMA BRAME, late of 67 Sydney Parade, East Geelong, widow, deceased

Creditors, next of kin and others having claims in respect of the estate of the deceased who died on 1 July 1983 are required by the personal representatives Mavis Joyce Elsworth and John Henry Elsworth to send particulars to them at the solicitors named below by 10 November 1983 after which date they may convey or distribute the assets having regard only to the claims of which they then have notice.

HODGES HALL & CO, solicitors, 60 Moorabool Street, Geelong. 8580

Creditors, next of kin and others having claims in respect of the estate of John Richard Harland, late of 89 Hope Street, Brunswick, in the State of Victoria, iron moulder, deceased, who died on 13 December 1982 are required by the Executrix of the estate, Ivy Pearl Harland of 89 Hope Street, Brunswick, in the said State, widow, to send particulars to N. C. Gay & Co., solicitors of 136 Sydney Road, Brunswick by 31 October 1983, after which date the said Executrix may distribute the assets having regard only to claims of which she then has notice.

N. C. GAY & CO., solicitors, 136 Sydney Road, Brunswick. 8564

Creditors, next of kin and all other persons having claims in respect of the estate of Florence Niven Smith, late of 19 Grandview Street, Moonee Ponds in the State of Victoria, home duties deceased, who died on 14 November 1982, are required to send particulars of their claims to the Executors Barry MacRae Fry and Jean Alcorn both of 60 Market Street, Melbourne solicitors and Douglas Hardy Hunter of 1169 Riversdale Road, Box Hill South, retired, by 1 November 1983, after which date the Executors will distribute the assets having regard only to the claims of which they shall then have had notice.

MADDOCK LONIE & CHISHOLM, solicitors, 60 Market Street, Melbourne. 8622

MARGARET SHEILA McLAGAN CONNELL, late of 17 Ross Street, Toorak, widow, deceased

Creditors, next of kin and others having claims against the estate of the said deceased, who died on 18 April 1983, are to send particulars of their claims to Bernard Gore Breit, care of Messrs. Blake & Riggall, solicitors, 140 William Street, Melbourne by 30 November 1983, after which date he will distribute the assets, having regard only to the claims of which he then has notice.

BLAKE & RIGGALL, solicitors, 140 William Street, Melbourne. 8648

EWEN DANIEL MACKINNON, late of Langi Willi, Linton, grazier, deceased

Creditors, next of kin and others having claims against the estate of the said deceased who died on 7 June 1983, are to send particulars of their claims to William Russell MacKinnon, care of Messrs. Blake & Riggall, solicitors, 140 William Street, Melbourne by 30 November 1983, after which date he will distribute the assets having regard only to the claims to which he then has notice.

BLAKE & RIGGALL, solicitors, 140 William Street, Melbourne. 8649

FREDERICK ARTHUR CROOK, late of 63 Jasper Road, Moorabbin, widower, deceased

Creditors, next of kin and others having claims against the estate of the said deceased, who died on 22 June 1983, are to send particulars of their claims to Frederic Arthur Crook, care of Messrs. Blake & Riggall, solicitors, 140 William Street, Melbourne, by 30 November 1983, after which date he will distribute the assets having regard only to the claims of which he then has notice.

BLAKE & RIGGALL, solicitors, 140 William Street, Melbourne. 8650

MARIA JANNETTA BONTENBAL, late of 4 Orna Street, Ferntree Gully in the State of Victoria, home duties, deceased

Creditors, next of kin and others having claims in respect of the estate of the deceased who died on 5 February 1983 are required by the trustee Hendricus Marinus Antonius Mathot of 18 Charlotte Street, Blackburn to send particulars to him by 31 October 1983 after which date the trustee may convey or distribute the assets having regard only to the claims of which he then has notice.

A. G. MOORE & ASSOCIATES, solicitors, 5 Court Street, Box Hill. 8581

MARGARET DAVENA GELL, late of 153 Myers Street, Geelong, widow, deceased

Creditors, next of kin, and persons having claims against the estate of the said deceased, who died on 8 August 1983, are required to send particulars of same to the Executrices, Joan Evelyn McGorlick and Lola Davena Benesh in care of the undermentioned, on or before 27 October 1983, after which date they will distribute the assets, having regard only to the claims of which they then have notice.

AINSWORTH & CO., solicitors, 117 Yarra Street, Geelong. 8566

Creditors, next of kin and others having claims in respect of the estate of Horacio Ernest McRae, late of 17 Cheeseman Avenue, East Brighton, retired general manager, deceased, who died on 30 May 1983, are to send particulars of their claims to ANZ Executors & Trustee Company Limited of 94

Queen Street, Melbourne by 31 October 1983, after which date it will distribute the assets having regard only to the claims of which it then has notice.

MOULES, solicitors, 140 William Street, Melbourne. 8623

Creditors, next of kin and others having claims in respect of the estate of Clifford Gordon Baglin, late of Centennial House, Royal Freemasons Homes, 15A Raleigh Street, Windsor, retired public servant, deceased, who died on 31 May 1983, are to send particulars of their claims to The Equity Trustees Executors and Agency Company Limited of 472 Bourke Street, Melbourne by 7 November 1983, after which date it will distribute the assets having regard only to the claims of which it then has notice.

AITKEN WALKER & STRACHAN, solicitors, 114 William Street, Melbourne. 3000 8634

In the Supreme Court of the State of Victoria

SALE BY THE SHERIFF

On 13 October 1983 at 2.30 p.m. at the Sheriff's Office, Writs and Warrants Division, 2nd Floor, 241 William Street, Melbourne (unless process be stayed or satisfied).

All the Estate and Interest (if any) of Alaysha Nominees Pty. Ltd. of 521 Toorak Road, Toorak, as sole proprietor of an estate in fee simple in the land described in Certificate of Title Volume 8987 Folio 732 upon which is erected an Edwardian brick cottage known as No. 61 Victoria Street, Fitzroy.

Registered Mortgage No. J268295 affects the said estate and interest.

Terms — Cash only

8655

J. GREEN, Deputy Sheriff

In the Supreme Court of the State of Victoria

SALE BY THE SHERIFF

On 20 October 1983 at 2.30 p.m. at the Sheriff's Office, Writs and Warrants Division, 2nd Floor, 241 William Street, Melbourne (unless process be stayed or satisfied).

All the Estate and Interest (if any) of Mile Trajkovski and Slavika Trajkovski (shown on Certificate of Title as Slavika Trajkovski) of 36 Sydney Road, Footscray, as joint proprietors of an estate in fee simple in the land described in Certificate of Title Volume 3729 Folio 694 upon which is erected a single fronted weatherboard dwelling known as No. 36 Sydney Road, Footscray.

Registered Mortgage Nos. G528105 and H868433 and Caveat No. G745459 affect the said estate and interest.

Terms — Cash only

8656

L. J. ROUNTREE, Sheriff's Officer

In the Supreme Court of the State of Victoria

SALE BY THE SHERIFF

On 13 October 1983 at 2.30 p.m. at the Sheriff's Office, Writs and Warrants Division, 2nd Floor, 241 William Street, Melbourne (unless process be stayed or satisfied).

All the Estate and Interest (if any) of Patricia Violet Margrie of 57 Amaroo Street, Chadstone, as proprietor of an estate in fee simple in the land described in Certificate of Title Volume 8489 Folio 015 upon which is erected a cement residential dwelling known as No. 57 Amaroo Street, Chadstone.

Registered Mortgage No. J899165 and Caveat No. J841287 affect the said estate and interest.

Terms — Cash only

8657

L. J. ROUNTREE, Sheriff's Officer

In the Supreme Court of the State of Victoria

SALE BY THE SHERIFF

On 18 October 1983 at 12.30 p.m. at the Shepparton Police Station, High Street, Shepparton (unless process be stayed or satisfied).

All the Estate and Interest (if any) of Phil W. Thomson and Pat H. Thomson (shown on Certificate of Title as Phillip William Thomson and Patricia Helen Thomson) of 82 MacIsaac Road, Mooroopna, as joint proprietors of an estate in fee simple in the land described in Certificate of Title Volume 8982 Folio 178 upon which is erected a brick Housing Commission home known as No. 82 MacIsaac Road, Mooroopna.

Registered Mortgage No. J881396 and covenant contained in Transfer J881395 from the Housing Commission affect the said estate and interest.

Terms — Cash only

8651

J. GREEN, Deputy Sheriff

In the Supreme Court of the State of Victoria

SALE BY THE SHERIFF

On 6 October 1983 at 2.30 p.m. at the Sheriff's Office, Writs and Warrants Division, 2nd Floor, 241 William Street, Melbourne (unless process be stayed or satisfied).

All the Estate and Interest (if any) of Ange Ceddia (shown on Certificate of Title as Angelo Ceddia) of 30 Bennett Street, Alphington, as sole proprietor of an estate in fee simple in the land described in Certificate of Title Volume 4956 Folio 149 upon which is erected a weatherboard house known as No. 30 Bennett Street, Alphington.

Registered Mortgage Nos. K55862 and K380806 and Caveat No. 116783 affect the said estate and interest.

Terms — Cash only

8652

J. GREEN, Deputy Sheriff

In the Supreme Court of the State of Victoria

SALE BY THE SHERIFF

On 6 October 1983 at 2.30 p.m. at the Sheriff's Office, Writs and Warrants Division, 2nd Floor, 241 William Street, Melbourne (unless process be stayed or satisfied).

All the Estate and Interest (if any) of Jan Ogon of 90 The Avenue, Spotswood, as sole proprietor of an estate in fee simple in the land described in Certificate of Title Volume 4163 Folio 412 upon which is erected a weatherboard house known as No. 90 The Avenue, Spotswood.

Terms — Cash only

8653

J. GREEN, Deputy Sheriff

In the Supreme Court of the State of Victoria

SALE BY THE SHERIFF

On 13 October 1983 at 2.30 p.m. at the Sheriff's Office, Writs and Warrants Division, 2nd Floor, 241 William Street, Melbourne (unless process be stayed or satisfied).

All the Estate and Interest (if any) of James Oliver Osborne of 41 Mast Gully Road, Upwey, as joint proprietor with Sylvia Joan Osborne of an estate in fee simple in the land described in Certificate of Title Volume 4832 Folio 349 upon which is erected a fibro-cement dwelling known as No. 41 Mast Gully Road, Upwey.

Registered Mortgage No. J995354 affects the said estate and interest.

Terms — Cash only

8654

J. GREEN, Deputy Sheriff

In the Supreme Court of the State of Victoria
SALE BY THE SHERIFF

On 13 October 1983 at 2.30 p.m. at the Sheriff's Office, Writs and Warrants Division, 2nd Floor, 241 William Street, Melbourne (unless process be stayed or satisfied).

All the Estate and Interest (if any) of Frank Hetherton (shown on Certificate of Title as Frank Henry Hetherton) of 12 Riddle Drive, Melton in and to:

Firstly: as proprietor of an estate in fee simple in the land described in Certificate of Title Volume 8368 Folio 495 which is vacant land known as No. 10 Riddle Drive, Melton.

Secondly: as proprietor of an estate in fee simple in the land described in Certificate of Title Volume 8368 Folio 494 upon which is erected a brick dwelling known as No. 12 Riddle Drive, Melton. Registered Mortgage No. J648079 affects the said estate and interest.

Terms — Cash only

8658

L. J. ROUNTREE, Sheriff's Officer

**NOTICE OF MAKING OF
 STATUTORY RULES
 WHICH ARE NOT YET
 AVAILABLE**

Notice is given of the making of the following Statutory Rules:

- Abattoir and Meat Inspection Act 1973*
 202/1983. Abattoir and Meat Inspection (Amendment No. 1) Regulations 1983
- Forests Act 1958*
 203/1983. Forests (William Ricketts Sanctuary) Regulations 1983
- Second-hand Dealers Act 1958*
 204/1983. Second-hand Dealers (Exemption No. 2) Regulations 1983
- Fisheries Act 1968*
 205/1983. Fishing (General) (Amendment No. 1) Regulations 1983
- Hospitals and Charities Act 1958*
 206/1983. Hospitals and Charities (Fees) (Amendment No. 2) Regulations 1983

**NOTICE OF MAKING AND
 AVAILABILITY OF
 STATUTORY RULE**

In pursuance of the provisions of the *Subordinate Legislation Act 1962* and the Regulations made thereunder notice is given of the making and availability of the following Statutory Rules:

- | No. | Forests Act 1958 | Price |
|---|--|-------|
| 198/1983. | Forests (Mount Dandenong Observatory Reserve) Regulations 1983 | 40c |
| <i>Financial Institutions Duty Act 1982</i> | | |
| 199/1983. | Financial Institutions Duty (Further Amendment) Regulations 1983 | 20c |
| <i>Public Service Act 1974</i> | | |
| 200/1983. | Public Service Amendment Regulations (No. 10) 1983 | 20c |

- | <i>Public Service Act 1974</i> | | |
|--------------------------------|--|-----|
| 201/1983. | Public Service Amendment Regulations (No. 11) 1983 | 20c |

- | No. | <i>Public Service Act 1974</i> | Price |
|-------------|---|-------|
| PSD58/1983. | Public Service Amendment Determinations (No. 58) 1983 | 20c |

Copies of these Statutory Rules are available and may be purchased at the Victorian Government Bookshop, located at 41 St. Andrews Place, East Melbourne (formerly 7A Parliament Place, Melbourne, 3002). If ordered by mail, remittance should be addressed to "The Government Printer, Box 203, North Melbourne, 3051", and should include 50c delivery and handling fee.

The annual subscription rates for Statutory Rules for the year commencing 1 January 1982, payable in advance are as follows:

- | | |
|---|---------|
| *Statutory Rules (other than Public Service Determinations), Pamphlet copies only | \$55.00 |
| Public Service Determinations | \$33.00 |

* The Bound Volume of Statutory Rules is not included in the subscription rate.

F. D. ATKINSON
 Government Printer

CONTENTS

	Page
Appointments	2763
Cemeteries—Scale of Fees	2759
Contracts	2761, 2790
Estates of Deceased Persons	2757
Government Notices	2745
Lands	2786
Late Notices	2788
Minerals and Energy	2761
Notice to Mariners	2762
Notice of Making of Statutory Rules	2808
Orders in Council—	
Acts—Local Government; Crown Land (Reserves); Land; Mildura Irrigation and Water Trusts; Water; Sewerage Districts; Mines; Urban Land Authority; Metropolitan Fire Brigades; Superannuation; Public Service; Cemeteries; Post-Secondary Education; Water; Sewerage Districts.	2765 et seq
Police Sale	2763
Private Advertisements	2790
Proclamations	2745
Resignations	2765
Tenders	2788
Transport Regulation Board—Public Hearings	2788