

[1935]

PUBLISHED BY AUTHORITY

# Victoria Government Gazette

No. 67—Wednesday, 20 June 1984

## PROCLAMATIONS

### *Bank Holidays Act 1958* ADDITIONAL BANK HOLIDAYS

#### PROCLAMATION

By His Excellency the Governor of the State of Victoria and its Dependencies in the Commonwealth of Australia, &c., &c., &c.

Whereas by the *Bank Holidays Act 1958* it is amongst other things enacted that the Governor may, in addition to the days specified therein to be observed as bank holidays, appoint any other day or days to be kept as bank holidays in the whole or any part of the State of Victoria.

Now therefore I, the Governor of the State of Victoria, in the Commonwealth of Australia, do by this my Proclamation appoint Monday, 24 December 1984 and Monday, 31 December 1984 to be observed as Bank Holidays throughout the State of Victoria.

Given under my Hand and the Seal of the State of Victoria aforesaid, at Melbourne, this thirteenth day of June in the year of our Lord One thousand nine hundred and eighty-four and in the thirty-third year of the reign of Her Majesty Queen Elizabeth the Second, Queen of Australia.

(L.S.)

B. S. MURRAY

By His Excellency's Command

S. M. CRABB  
Minister for Industrial Affairs

GOD SAVE THE QUEEN!

### *Public Service Act 1974* ADDITIONAL PUBLIC HOLIDAYS

#### PROCLAMATION

By His Excellency the Governor of the State of Victoria and its Dependencies in the Commonwealth of Australia, &c., &c., &c.

Whereas by section 71 of the *Public Service Act 1974* it is amongst other things enacted that the Governor in Council may, in addition to the days specified therein to be observed as holidays in the public offices, appoint any other day or days to be kept as public holidays in the whole or any part of the State of Victoria.

Now therefore I, the Governor of the State of Victoria, in the Commonwealth of Australia, by and with the advice of the Executive Council of the said State, do by this my Proclamation appoint Monday, 24 December 1984 and Monday, 31 December 1984 to be observed as Public Holidays throughout the State of Victoria.

Given under my Hand and the Seal of the State of Victoria aforesaid, at Melbourne, this thirteenth day of June in the year of our Lord One thousand nine hundred and eighty-four and in the thirty-third year of the reign of Her Majesty Queen Elizabeth the Second, Queen of Australia.

(L.S.)

B. S. MURRAY

By His Excellency's Command

S. M. CRABB  
Minister for Industrial Affairs

GOD SAVE THE QUEEN!

### *Soil Conservation and Land Utilization Act 1958* *Land Conservation Act 1970*

#### DIDDAH DIDDAH CREEK (SPRINGHURST) WATER SUPPLY CATCHMENT

#### PROCLAMATION

By His Excellency the Governor of the State of Victoria and its Dependencies in the Commonwealth of Australia, &c., &c., &c.

I, the Governor of the State of Victoria in the Commonwealth of Australia, by and with the advice of the Executive Council of the said State and having considered a recommendation of the Land Conservation Council in pursuance of the provisions contained in section 22 (1) of the *Soil Conservation and Land Utilization Act 1958* (No. 6372) and section 5 (1) (b) of the *Land Conservation Act 1970* (No. 8008) do by this Proclamation define the water supply catchment area to be known as the Diddah Diddah Creek (Springhurst) Water Supply Catchment.

The area proclaimed is the catchment to a storage reservoir controlled by the Springhurst Waterworks Trust, situated on an unnamed tributary to Diddah Diddah Creek and adjacent to Crown Allotment 6B, section 2 and Crown Allotment 15, section 3, Parish of Barambogie.

The use of land within the catchment is subject to specification by notice or by determination made by the Soil Conservation Authority, acting under the provisions of section 22 (2) and section 23 (1) (a) (b) and (c) of the *Soil Conservation and Land Utilization Act 1958*, as amended.

The area described is indicated in Figure 1 (Plan No. S-1324), the original of which is lodged at Head Office of the Soil Conservation Authority, 378 Cotham Road, Kew, 3101.

No. 67—78340/84—Price 80 cents, delivered \$1.40. Subscription rate: \$95 per annum

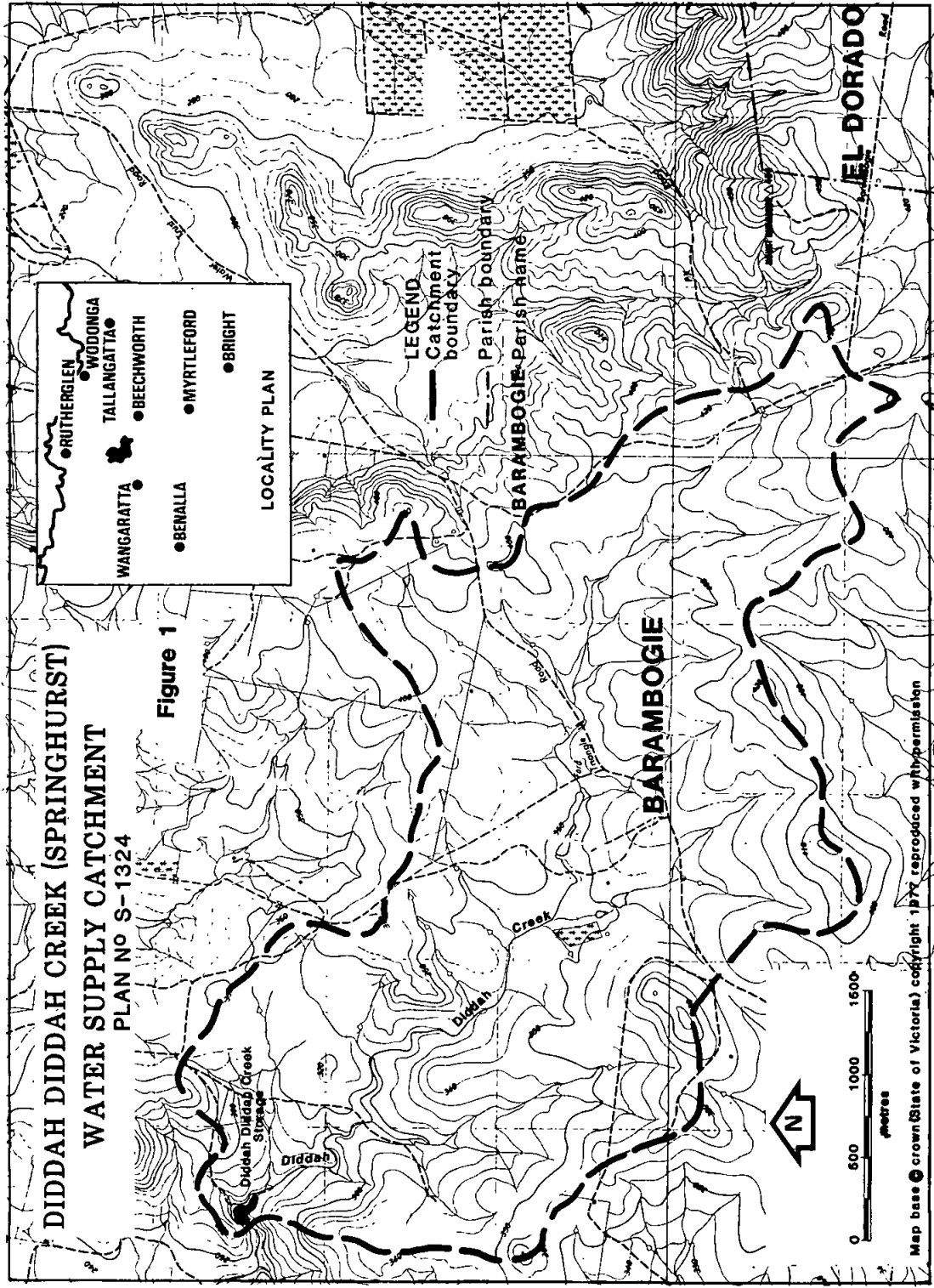

Given under my Hand and the Seal of the State of Victoria aforesaid, at Melbourne, this thirteenth day of June in the year of our Lord One thousand nine hundred and eighty-four and in the thirty-third year of the reign of Her Majesty Queen Elizabeth the Second, Queen of Australia.

(L.S.)

By His Excellency's Command

B. S. MURRAY

EVAN WALKER  
Minister for Planning and Environment

GOD SAVE THE QUEEN!

## MENTAL HEALTH ACT 1959

## PROCLAMATION

By His Excellency the Governor of the State of Victoria and its Dependencies in the Commonwealth of Australia, &c., &c., &c.

Whereas by sub-section (1) of section twenty-four of the *Mental Health Act 1959* it is provided that the Governor in Council may by Proclamation published in the *Government Gazette* proclaim one or more buildings or places provided by the State for the treatment of the mentally ill or the intellectually defective or any part of such building or place to be:

- (a) a psychiatric hospital;
- (b) a mental hospital;
- (c) a training centre; or
- (d) a repatriation mental hospital.

Now therefore I, the Governor of Victoria in the Commonwealth of Australia by and with the advice of the Executive Council of the said State do by this Proclamation declare that as from the Second day of July 1984 the building known as Russell House on land owned by Mildura Base Hospital shown on Plan of Consolidation No. 106385 Parish of Mildura, County of Karkorooc, to be a psychiatric hospital known as Russell House, Mildura.

Given under my Hand and the Seal of the State of Victoria aforesaid, at Melbourne, this thirteenth day of June in the year of our Lord One thousand nine hundred and eighty-four and in the thirty-third year of the reign of Her Majesty Queen Elizabeth the Second, Queen of Australia.

(L.S.)

By His Excellency's Command

J. K. KENNAN  
Acting Minister of Health

GOD SAVE THE QUEEN!

*Water (Central Management Restructuring) Act 1984 No.*  
10081

## DATE OF COMING INTO OPERATION

## PROCLAMATION

By His Excellency the Governor of the State of Victoria and its Dependencies in the Commonwealth of Australia, &c., &c., &c.

Whereas by an Act of Parliament of the State of Victoria passed in the thirty-third year of the reign of Her Majesty Queen Elizabeth the Second, Queen of Australia, entitled the *Water (Central Management Restructuring) Act 1984, No. 10081*, it is amongst other things enacted that the several provisions of the said Act shall come into operation on a day or the respective days to be fixed by proclamation or successive proclamations of the Governor in Council published in the *Government Gazette*.

Now therefore, I, the Governor of the State of Victoria, in the Commonwealth of Australia, by and with the advice of the Executive Council of the said State, do by this Proclamation fix Sunday, 1 July 1984 as the day upon which the whole of the provisions of the said Act shall come into operation.

Given under my Hand and the Seal of the State of Victoria aforesaid, at Melbourne, this nineteenth day of June in the year of our Lord One thousand nine hundred and eighty-four and in the thirty-third year of the reign of Her Majesty Queen Elizabeth the Second, Queen of Australia.

(L.S.)

By His Excellency's Command

D. R. WHITE  
Minister of Water Supply

GOD SAVE THE QUEEN!

*Soil Conservation and Land Utilization Act 1958**Land Conservation Act 1970*

## OVENS RIVER (BRIGHT) WATER SUPPLY CATCHMENT

## PROCLAMATION

By His Excellency the Governor of the State of Victoria and its Dependencies in the Commonwealth of Australia, &c., &c., &c.

I, the Governor of the State of Victoria in the Commonwealth of Australia, by and with the advice of the Executive Council of the said State and having considered a recommendation of the Land Conservation Council in pursuance of the provisions contained in section 22 (1) of the *Soil Conservation and Land Utilization Act 1958* (No. 6372) and section 5 (1) (b) of the *Land Conservation Act* (No. 8008) do by this Proclamation define the water supply catchment area to be known as the Ovens River (Bright) Water Supply Catchment.

The area proclaimed is the catchment to an offtake on the Ovens River controlled by the Bright Waterworks Trust and located in Hawthorn Lane, Township of Bright.

The use of land within this catchment is subject to specification by notice or by determination made by the Soil Conservation Authority, acting under the provisions of section 22 (2) and section 23 (1) (a) (b) and (c) of the *Soil Conservation and Land Utilization Act 1958*, as amended.

The area described is indicated in Figure 1 (Plan S-1371), the original of which is located at Head Office of the Soil Conservation Authority, 378 Cotham Road, Kew, 3101.

### OVENS RIVER (BRIGHT) WATER SUPPLY CATCHMENT

PLAN No. S-1371

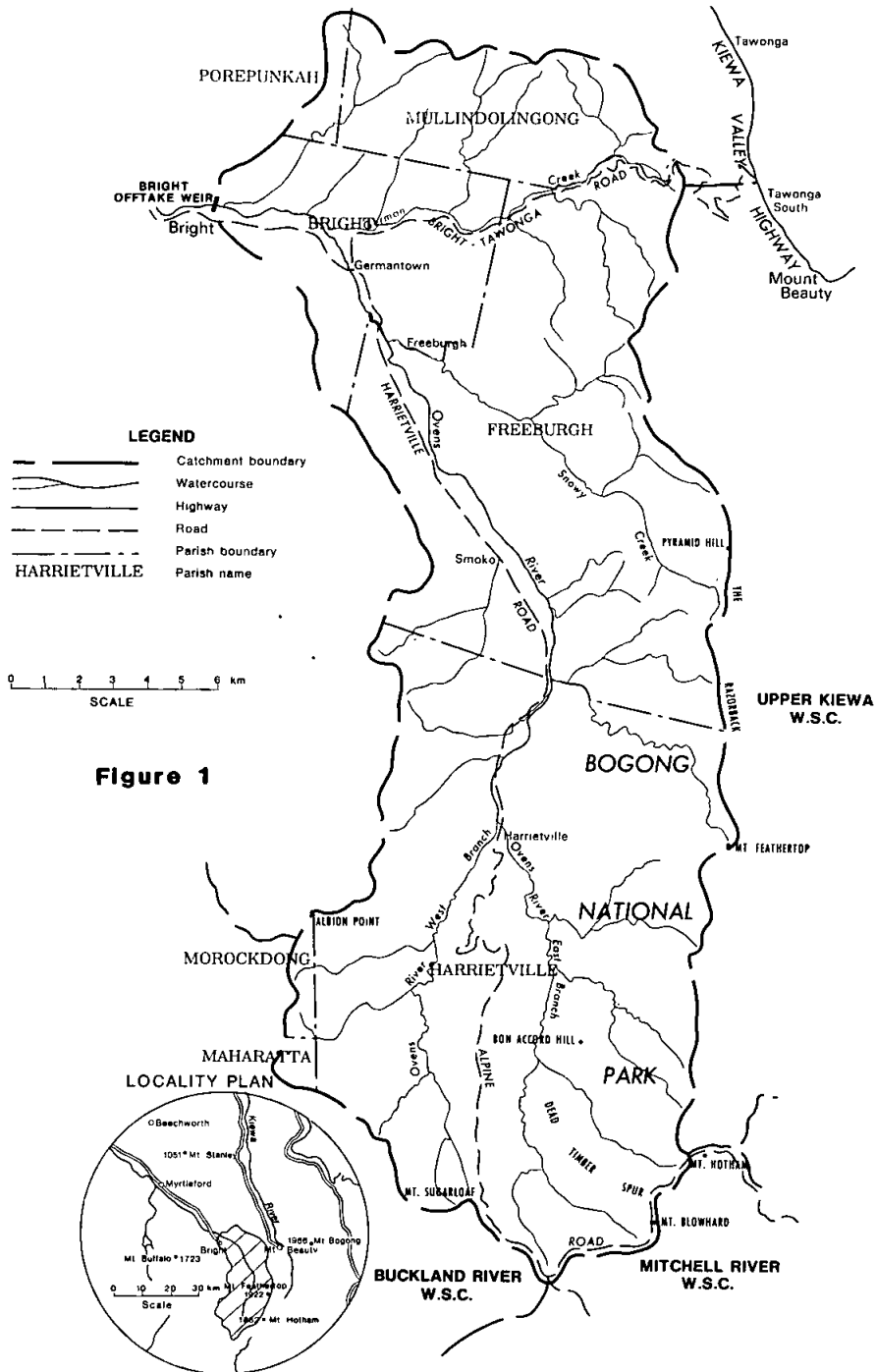

Figure 1

Given under my Hand and the Seal of the State of Victoria aforesaid, at Melbourne, this thirteenth day of June in the year of our Lord One thousand nine hundred and eighty-four and in the thirty-third year of the reign of Her Majesty Queen Elizabeth the Second, Queen of Australia.

(L.S.)

By His Excellency's Command

B. S. MURRAY

EVAN WALKER  
Minister for Planning and Environment

GOD SAVE THE QUEEN!

Soil Conservation and Land Utilization Act 1958

Land Conservation Act 1970

**TOMAHAWK CREEK (GEMBROOK) WATER SUPPLY CATCHMENT**

**PROCLAMATION**

By His Excellency the Governor of the State of Victoria and its Dependencies in the Commonwealth of Australia, &c., &c., &c.

I, the Governor of the State of Victoria in the Commonwealth of Australia, by and with the advice of the Executive Council of the said State and having considered a recommendation of the Land Conservation Council in pursuance of the provisions contained in section 22 (1) of the *Soil Conservation and Land Utilization Act 1958* (No. 8008) do by this Proclamation define the water supply catchment area to be known as the Tomahawk Creek (Gembrook) Water Supply Catchment.

The area proclaimed is the catchment to an offtake weir on Tomahawk Creek controlled by the Gembrook, Cockatoo and Emerald Waterworks Trust and within Crown Allotment 87A, Parish of Beenak.

The use of land within this catchment is subject to specification by notice or by determination made by the Soil Conservation Authority, acting under the provisions of section 22 (2) and section 23 (1) (a) (b) and (c) of the *Soil Conservation and Land Utilization Act 1958*, as amended.

The area described is indicated in Figure 1 (Plan No. S-1368), the original of which is lodged at Head Office of the Soil Conservation Authority, 378 Cotham Road, Kew, 3101.

**TOMAHAWK CREEK (GEMBROOK) WATER SUPPLY CATCHMENT**

PLAN No. S-1368

**Figure 1**

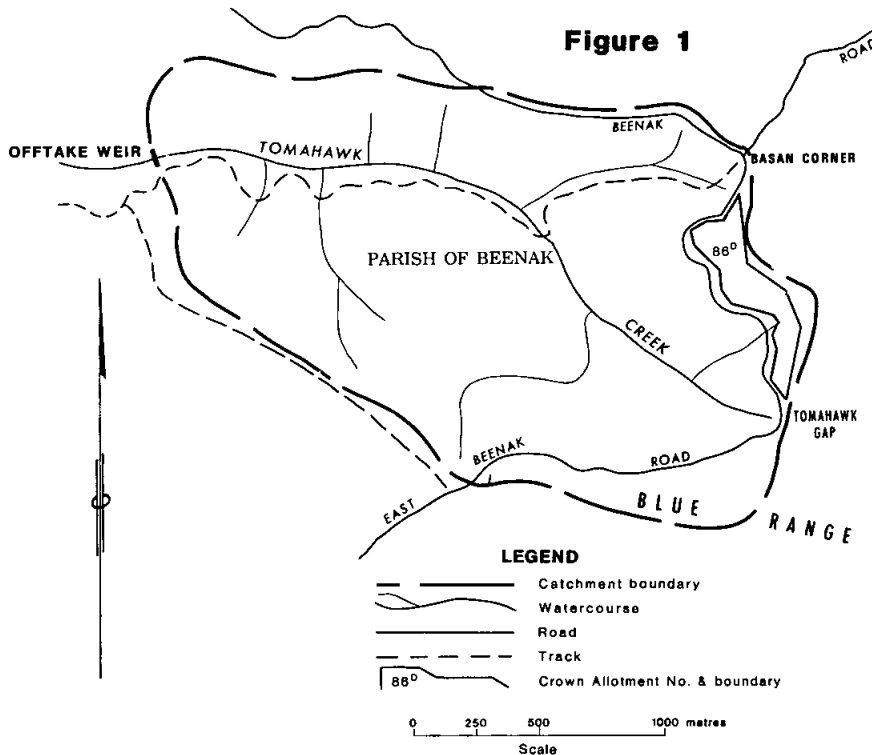

Given under my Hand and the Seal of the State of Victoria aforesaid, at Melbourne, this thirteenth day of June in the year of our Lord One thousand nine hundred and eighty-four and in the thirty-third year of the reign of Her Majesty Queen Elizabeth the Second, Queen of Australia.

(L.S.)

By His Excellency's Command

B. S. MURRAY

EVAN WALKER  
Minister for Planning and Environment

GOD SAVE THE QUEEN!

*Land Act 1958*  
**ROAD PROCLAIMED**

**PROCLAMATION**

By His Excellency the Governor of the State of Victoria and its Dependencies in the Commonwealth of Australia, &c., &c., &c.

I, the Governor of the State of Victoria, in the Commonwealth of Australia, by and with the advice of the Executive Council of the said State, pursuant to the provisions of section 25 (3) (c) of the *Land Act 1958*, do hereby proclaim as road the Crown land hereinafter described, viz:

Parish of Ararat in the Shire of Ararat being the land indicated by hatching on plan hereunder—(L3-3101) (A149 (28)).

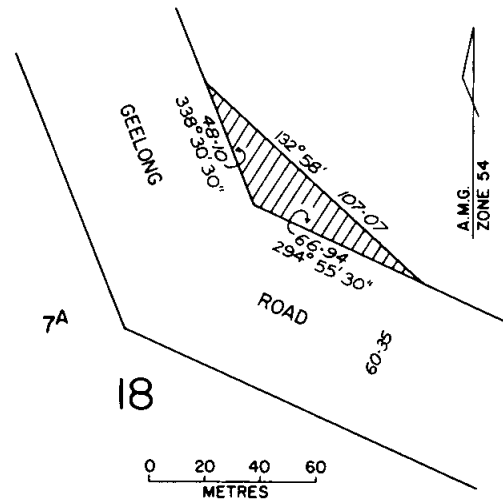

Given under my Hand and the Seal of the State of Victoria aforesaid, at Melbourne, this thirteenth day of June in the year of our Lord One thousand nine hundred and eighty-four and in the thirty-third year of the reign of Her Majesty Queen Elizabeth the Second, Queen of Australia.

(L.S.)

By His Excellency's Command

R. A. MACKENZIE  
Minister for Conservation, Forests and Lands

GOD SAVE THE QUEEN!

*Soil Conservation and Land Utilization Act 1958*

*Land Conservation Act 1970*

**SUNDAY CREEK (BROADFORD-KILMORE) WATER SUPPLY CATCHMENT**

**PROCLAMATION**

By His Excellency the Governor of the State of Victoria and its Dependencies in the Commonwealth of Australia, &c., &c., &c.

I, the Governor of the State of Victoria in the Commonwealth of Australia, by and with the advice of the Executive Council of the said State and having considered a recommendation of the Land Conservation Council in pursuance of the provisions contained in section 22 (1) of the *Soil Conservation and Land Utilization Act 1958* (No. 6372) and section 5 (1) (b) of the *Land Conservation Act 1970* (No. 8008) do by this Proclamation define the water supply catchment area to be known as the Sunday Creek (Broadford-Kilmore) Water Supply Catchment.

The area proclaimed is the catchment to a dam constructed by the Broadford Waterworks Trust on Sunday Creek within Reserved Forest, Parish of Clonbinane.

The use of land within this catchment is subject to specification by notice or by determination made by the Soil Conservation Authority, acting under the provisions of section 22 (2) and section 23 (1) (a) (b) and (c) of the *Soil Conservation and Land Utilization Act 1958*, as amended.

The area described is indicated in Figure 1 (Plan No. S-1370), the original of which is lodged at Head Office of the Soil Conservation Authority, 378 Cotham Road, Kew, 3101.

### SUNDAY CREEK (BROADFORD-KILMORE) WATER SUPPLY CATCHMENT

PLAN No. S-1370

Figure 1

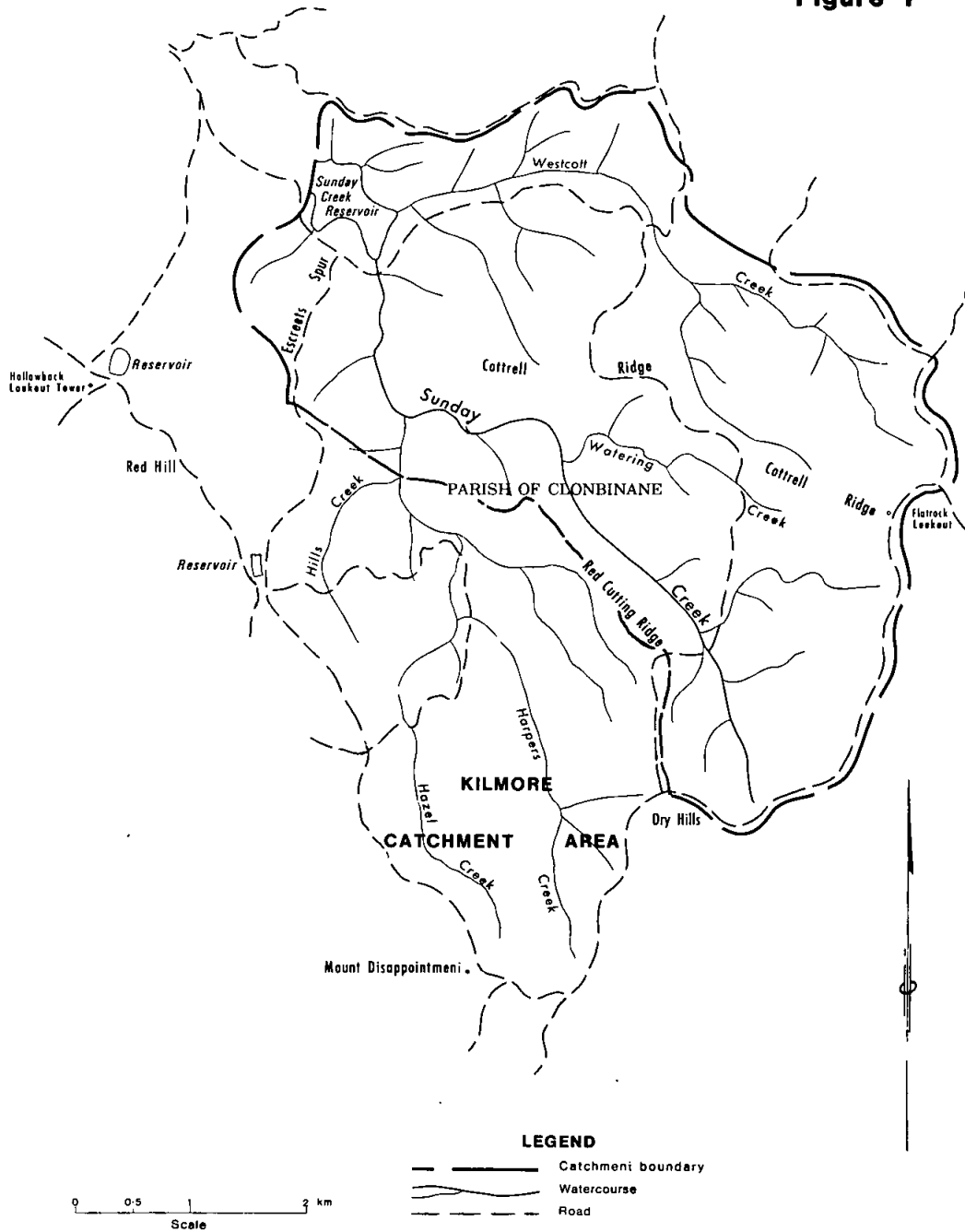

Given under my Hand and the Seal of the State of Victoria aforesaid, at Melbourne, this thirteenth day of June in the year of our Lord One thousand nine hundred and eighty-four and in the thirty-third year of the reign of Her Majesty Queen Elizabeth the Second, Queen of Australia.

(L.S.)

By His Excellency's Command

B. S. MURRAY

EVAN WALKER  
Minister for Planning and Environment

GOD SAVE THE QUEEN!

*Land Act 1958*  
**ROAD PROCLAIMED**

**PROCLAMATION**

By His Excellency the Governor of the State of Victoria and its Dependencies in the Commonwealth of Australia, &c., &c., &c.

I, the Governor of the State of Victoria, in the Commonwealth of Australia by and with the advice of the Executive Council of the said State, pursuant to the provisions of section 25 (3) (c) of the *Land Act 1958*, do hereby proclaim as road the Crown land hereinafter described, viz:

Parish of Frankston in the City of Frankston being the land indicated by hatching on plan hereunder—(L11-3315) (F87 (5)).

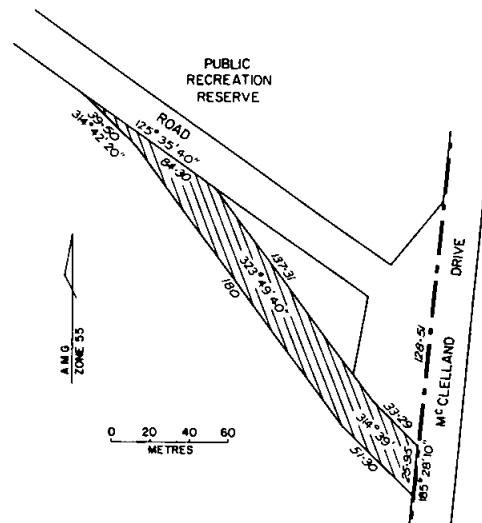

Given under my Hand and the Seal of the State of Victoria aforesaid, at Melbourne, this thirteenth day of June in the year of our Lord One thousand nine hundred and eighty-four and in the thirty-third year of the reign of Her Majesty Queen Elizabeth the Second, Queen of Australia.

(L.S.)

By His Excellency's Command

R. A. MACKENZIE  
Minister for Conservation, Forests and Lands

B. S. MURRAY

GOD SAVE THE QUEEN!

*Soil Conservation and Land Utilization Act 1958*

*Land Conservation Act 1970*

**BUFFALO RIVER (LAKE BUFFALO) WATER SUPPLY CATCHMENT**

**PROCLAMATION**

By His Excellency the Governor of the State of Victoria and its Dependencies in the Commonwealth of Australia, &c., &c., &c.

I, the Governor of the State of Victoria in the Commonwealth of Australia, by and with the advice of the Executive Council of the said State and having considered a recommendation of the Land Conservation Council in pursuance of the provisions contained in section 22 (1) of the *Soil Conservation and Land Utilization Act 1958* (No. 6372) and section 5 (1) (b) of the *Land Conservation Act 1970* (No. 8008) do by this Proclamation define the water supply catchment area to be known as the Buffalo River (Lake Buffalo) Water Supply Catchment.

The area proclaimed is the catchment to Lake Buffalo, a storage constructed by the State Rivers and Water Supply Commission on the Buffalo River adjacent to Crown Allotment 10, section 16, Parish of Dandongadale.

The use of land within this catchment is subject to specification by notice or by determination made by the Soil Conservation Authority, acting under the provisions of section 22 (2) and section 23 (1) (a) (b) and (c) of the *Soil Conservation and Land Utilization Act 1958*, as amended.

The area described is indicated in Figure 1 (Plan No. S-1369), the original of which is lodged at Head Office of the Soil Conservation Authority, 378 Cotham Road, Kew, 3101.



**BUFFALO RIVER(LAKE BUFFALO) WATER SUPPLY CATCHMENT**

PLAN No. S-1369

**Figure 1**

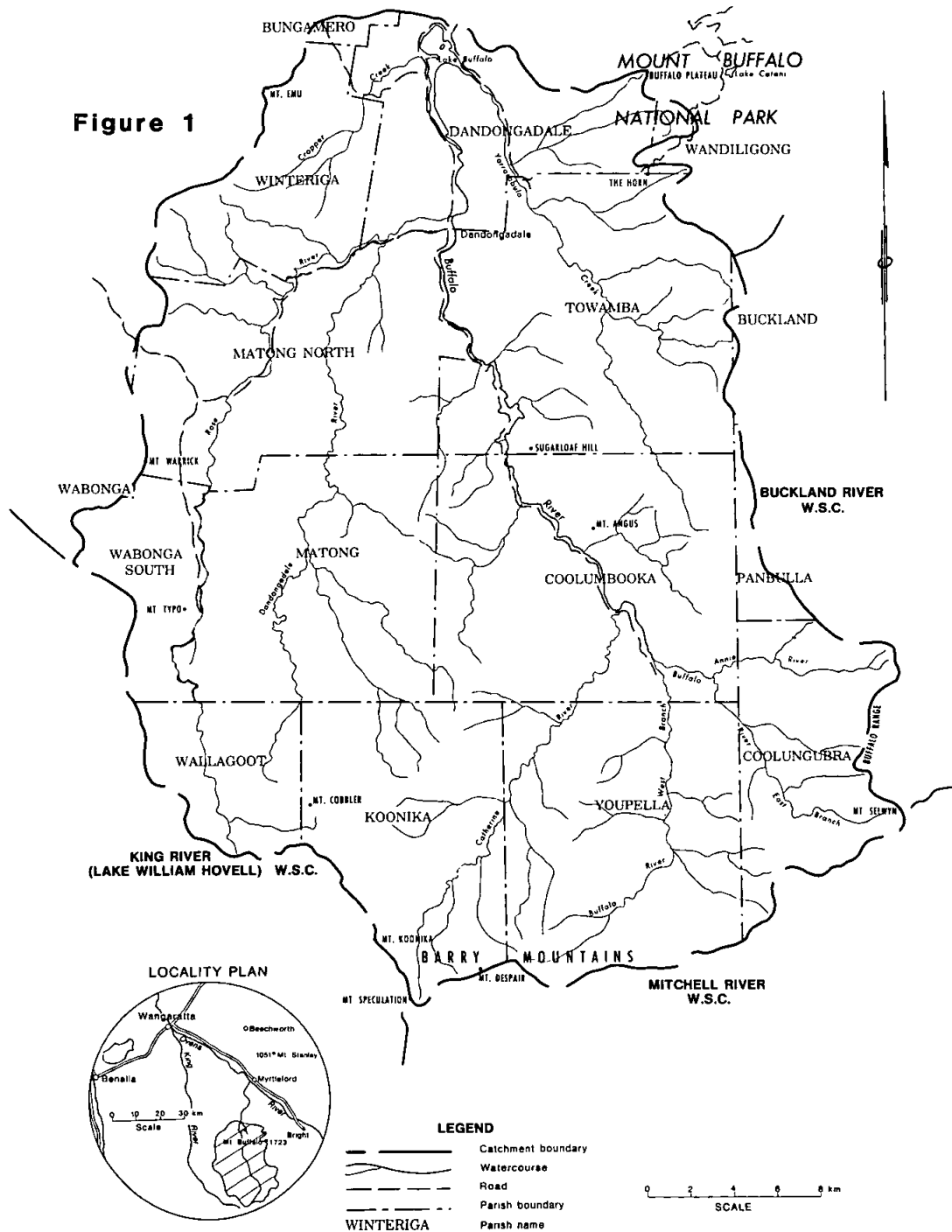

Given under my Hand and the Seal of the State of Victoria aforesaid, at Melbourne, this thirteenth day of June in the year of our Lord One thousand nine hundred and eighty-four and in the thirty-third year of the reign of Her Majesty Queen Elizabeth the Second, Queen of Australia.

(L.S.)

By His Excellency's Command

B. S. MURRAY

EVAN WALKER  
Minister for Planning and Environment

GOD SAVE THE QUEEN!

DRUGS, POISONS AND CONTROLLED SUBSTANCES  
ACT 1981

PROCLAMATION

By His Excellency the Governor of the State of Victoria and its Dependencies in the Commonwealth of Australia, &c., &c.

Whereas by section 9 of the *Drugs, Poisons and Controlled Substances Act 1981* it is amongst other things enacted that the Governor in Council may, by proclamation published in the *Government Gazette* amend any of Schedule One, Two, Three, Four, Five, Six, Seven or Eight or any column in Schedule Eleven to the said Act by adding to any of the said Schedules or removing therefrom any item:

Now therefore, I, the Governor of the State of Victoria in the Commonwealth of Australia, by and with the advice of the Executive Council of the said State do by this my Proclamation:

Amend the Principal Act as follows:

(a) In Schedule Two—

(i) The following items are removed:

“GLYCERYL TRINITRATE except when included in Schedule Four.”

“HEXACHLOROPHANE in substances for skin cleansing purposes containing 3 per centum or less of Hexachlorophane except—

(a) in substances for use on infants; or

(b) in substances for the treatment of animals: provided that the Hexachlorophane substances included within this Schedule entry are labelled with the following three warning statements—

(i) do not use internally or on areas of burnt or damaged skin;

(ii) do not use on infants except under medical direction;

(iii) wash off the skin immediately after use.”

“8-HYDROXYQUINOLINE except—

(a) non-halogenated derivatives containing 1 per centum or less of such derivatives in substances for external use; or

(b) when included in Schedule Four.”

“IODINE (excluding its salts and derivatives) in substances containing more than 2.5 per centum of free Iodine, except preparations for animal treatment only when included in Schedule Six.”

“IODOPHORS containing more than 2.5 per centum free Iodine except when included in Schedule Six.”

“LEAD SALTS and compounds for therapeutic or cosmetic use except substances containing 1 per centum or less for cosmetic use.”

(ii) After the item relating to CLEMIZOLE there shall be inserted the following item:

“CLIOQUINOL and other halogenated derivatives of 8-hydroxyquinoline for topical human therapeutic use.”

(iii) After the item relating to EMBRAMINE there shall be inserted the following item:

“EPHEDRINE except—

(a) when included in Schedule Three; or

(b) in solid dose divided compounded substances containing 10 mg. or less of ephedrine; or

(c) in substances for topical use containing 1 per cent or less of ephedrine; or

(d) in oral liquid substances containing 0.1 per cent or less of ephedrine.”

“ERYTHRITYL TETRANITRATE (See GLYCERYL TRINITRATE).”

(iv) After the item relating to FLUORIDES there shall be inserted the following item:

“GLYCERYL TRINITRATE and other nitrate esters of polyhydric alcohols for human therapeutic use except when included in Schedule Four.”

(v) After the item relating to HALOPYRAMINE there shall be inserted the following item:

“HEXACHLOROPHANE in substances for skin cleansing purposes containing 3 per cent or less of hexachlorophane except—

(a) in substances for use on infants; or

(b) in substances for the treatment of animals: provided that the hexachlorophane substances included within this Schedule entry are labelled with the following four warning statements—

(i) do not use internally or on areas of burnt or damaged skin;

(ii) do not use on infants except under medical direction;

(iii) wash off the skin immediately after use;

(iv) in pregnancy, use only on the advice of a physician.”

(vi) After the item relating to HYDROCYANIC ACID there shall be inserted the following item:

“8-HYDROXYQUINOLINE and its non-halogenated derivatives for human therapeutic use except in substances for topical use containing 1 per cent or less of 8-hydroxyquinoline or its non-halogenated derivatives.”

(vii) After the item relating to IMIDAZOLINE DERIVATIVES there shall be inserted the following items:

“IODINE (excluding its compounds) except—

(a) when included in Schedule Six; or

(b) in iodophors in substances containing 1.5 per cent or less of available iodine; or

(c) in solid or semi-solid substances containing 2.5 per cent or less of available iodine.”

“IRON COMPOUNDS in substances for internal use except—

(a) when included in Schedule Four; or

(b) in solid substances containing 5 mg. or less of iron per unit dose; or

(c) in oral liquid substances containing 0.1 per cent or less of iron.”

(viii) After the item relating to ISOPROPAMIDE there shall be inserted the following items:

“ISORBIDE DINITRATE (See GLYCERYL TRINITRATE).”

“LEAD COMPOUNDS for human therapeutic use.”

(ix) After the item relating to MALDISON there shall be inserted the following item:

MANNITYL HEXANITRATE (See GLYCERYL TRINITRATE).”

(x) After the item relating to METHOXYPHENAMINE there shall be inserted the following item:

“METHYLPROPYLPROPANEDIOL DINITRATE (See GLYCERYL TRINITRATE).”

(xi) After the item relating to PARACETAMOL there shall be inserted the following item:

“PENTAERYTHRITYL TETRANITRATE (See GLYCERYL TRINITRATE).”

(xii) After the item relating to PROPANTHELINE there shall be inserted the following item:

“PROPATYL NITRATE (See GLYCERYL TRINITRATE).”

(xiii) After the item relating to PROPYPHENAZONE there shall be inserted the following item:

“PSEUDOEPHEDRINE except—

(a) in solid dose divided substances containing 20 mg. or less of pseudoephedrine; or

(b) in substances for topical use containing 1 per cent or less of pseudoephedrine; or

(c) in oral liquid substances containing 0.5 per cent or less of pseudoephedrine.”

(xiv) After the item relating to TRIPROLIDINE there shall be inserted the following item:

“TROLNITRATE (See GLYCERYL TRINITRATE).”

(b) In Schedule Three—

(i) The following items are removed:

“EPHEDRINE and PSEUDOEPHEDRINE except—

(a) substances containing 0.5 per centum or less of Ephedrine and Pseudoephedrine; or

(b) substances for external use containing 1 per centum or less of Ephedrine and Pseudoephedrine.”

“ERYTHRITYL TETRANITRATE and other nitric esters of Polyhydric alcohols.”

“GLYCERYL TRINITRATE.”

“IRON salts and complexes in substances intended for human therapeutic use by oral administration, except substances containing 5 milligrams or less of elemental Iron per dose.”

“ISOSORBIDE DINITRATE.”

“MANNITYL HEXANITRATE.”

“PENTAERYTHRITYL TETRANITRATE.”

“PHENYLPROPANOLAMINE in substances containing 50 milligrams or less per dose of Phenylpropanolamine.”

“PSEUDOEPHEDRINE and EPHEDRINE except—

(a) substances containing 0.5 per centum or less of Pseudoephedrine and Ephedrine; or

(b) substances for external use containing 1 per centum or less of Pseudoephedrine and Ephedrine.”

“SALBUTAMOL in metered aerosols delivering 100 micrograms or less of Salbutamol per metered dose.”

“SODIUM CROMOGLYCATE in liquid nasal preparations, topically applied.”

“SODIUM CROMOGLYCATE in substances for topical nasal use.”

(ii) After the item relating to BUTYL NITRATE there shall be inserted the following item:

“CAFFEINE in solid dose divided substances.”

(iii) After the item relating to DOXYLAMINE there shall be inserted the following item:

“ECONAZOLE for cutaneous use in substances containing 1 per cent or less of econazole.”

(iv) After the item relating to EMBRAMINE there shall be inserted the following item:

“EPHEDRINE

(a) when uncompounded; or

(b) in solid divided uncompounded substances.”

(v) After the item relating to FLAVOXATE there shall be inserted the following item:

“FLUOROCARBONS or CHLOROFLUOROCARBONS alone or in combination with other propellants or refrigerants in liquified gas form for therapeutic use.”

(vi) After the item relating to MORANTEL there shall be inserted the following item:

“NAPROXEN, in packs of 12 individual dosage units, tablets or capsules, for treatment of dysmenorrhoea.”

(vii) After the item relating to NITRAZEPAM there shall be inserted the following item:

“NITROFURAZONE, in substances for cutaneous use containing 0.2 per cent or less of nitrofurazone.”

(viii) After the item relating to PHENIRAMINE there shall be inserted the following item:

“PHENYLPROPANOLAMINE in substances containing 50 mg. or less per dose of phenylpropanolamine for relief of coughs and colds.”

(ix) After the item relating to QUININE there shall be inserted the following items:

“SALBUTAMOL—

(a) in metered aerosols delivering 100 micrograms or less of salbutamol per metered dose; or

(b) in dry powders for inhalation capsules delivering 200 micrograms or less of salbutamol per dose.”

“SODIUM CROMOGLYCATE in nasal substances for topical use.”

(c) In Schedule Four—

(i) The following items are removed:

“ECONAZOLE.”

“GLYCERYL TRINITRATE in preparations for injection.”

“8-HYDROXYQUINOLINE for human therapeutic use.”

“IRON complexes in injectable substances intended for human therapeutic use.”

“NITROFURAN for human therapeutic use.”

“SELENIUM, Compounds of, except when included in Schedule Five or Schedule Six.”

(ii) After the item relating to AMINOREX there shall be inserted the following item:

“AMIODARONE.”

(iii) After the item relating to BEMEGRIDE there shall be inserted the following item:

“BENORYLATE.”

(iv) After the item relating to CHOLINE ESTERS there shall be inserted the following item:

“CHYMOPAPAIN.”

(v) After the item relating to CINCHOCAINE there shall be inserted the following items:

“CINOXACIN.”

“CLANOBUTIN by injection for the treatment of animals.”

(vi) After the item relating to DITHIAZANINE there shall be inserted the following item:  
“DOMPERIDONE.”

(vii) After the item relating to DOXYLAMINE there shall be inserted the following item:  
“ECONAZOLE except when included in Schedule Three or Schedule Six.”

(viii) After the item relating to FLUNISOLIDE there shall be inserted the following item:  
“FLUNIXIN MEGLUMINE for animal use.”

(ix) After the item relating to GLUTHETHIMIDE there shall be inserted the following item:  
“GLYCERYL TRINITRATE and other nitrate esters of polyhydric alcohols for human therapeutic use in substances for injection or infusion.”

(x) After the item relating to IMIPRAMINE there shall be inserted the following item:  
“INDAPAMIDE.”

(xi) After the item relating to IPRINDOLE there shall be inserted the following item:  
“IRON COMPOUNDS in injectable substances for human therapeutic use.”

(xii) After the item relating to ISOAMINILE there shall be inserted the following item:  
“ISOCONAZOLE NITRATE.”

(xiii) After the item relating to MORPHINE ANTAGONISTS there shall be inserted the following item:  
“MOXALACTAM.”

(xiv) After the item relating to NALIDIXIC ACID there shall be inserted the following item:  
“NAPROXEN except when included in Schedule Three.”

(xv) After the item relating to NITRAZEPAM there shall be inserted the following item:  
“NITROFURAN and its derivatives for human therapeutic use except when included in Schedule Three.”

(xvi) After the item relating to PIPARDROL there shall be inserted the following item:  
“PIPERACILLIN.”

(xvii) Before the item relating to RAUWOLFIA there shall be inserted the following item:  
“RANITIDINE.”

(xviii) After the item relating to SANTONIN there shall be inserted the following item:

“SELENIUM, compounds of, except—

- (a) when included in Schedule Five or Schedule Six; or
- (b) when included in animal feeds containing 0.1 grams per tonne or less of selenium; or
- (c) in compressed pellets for control of selenium-responsive conditions in sheep; or
- (d) in fertilizers containing 0.02 per cent or less of selenium.”

(xix) After the item relating to SEX HORMONES there shall be inserted the following item:

“SODIUM CALCIUMEDATE for human therapeutic use.”

(xx) After the item relating to TEMAZEPAM there shall be inserted the following item:  
“TENIPOSIDE.”

(xxi) After the item relating to ZERANOL there shall be inserted the following item:

“ZOMERPIRAC SODIUM.”

(d) In Schedule Five—

(i) The following item is removed:

“SELENIUM SULPHIDE in substances containing 2.5 per centum or less of Selenium Sulphide for therapeutic use.”

(ii) After the item relating to CHLOROTHALONIL there shall be inserted the following item:

“CLANOBUTIN for animal use except when included in Schedule Four.”

(iii) After the item relating to PENTACHLOROPHENOL there shall be inserted the following item:

“PERACETIC ACID in concentrations of 10 per cent or less.”

(iv) After the item relating to SECBUMETON there shall be inserted the following item:

“SELENIUM SULPHIDE in substances containing 2.5 per cent or less of selenium sulphide for external therapeutic use.”

(e) In Schedule Six—

(i) The following items are removed:

“BITHIONOL in substances for treatment of animals.”

“DIMETHYL SULPHOXIDE for industrial or laboratory use.”

“IODINE (excluding its salts and derivatives)—

- (a) in Iodophors except those containing 1.5 per centum or less of free Iodine;
- (b) in other liquid preparations containing 2.5 per centum or less of free Iodine;
- (c) in preparations for animal treatment only, except in solid or semi-solid preparations containing 2.5 per centum or less of free Iodine; or
- (d) except when included in Schedule Two.”

(ii) After the item relating to DIMETHYL SULPHATE there shall be inserted the following item:

“DIMETHYL SULPHOXIDE in substances—

- (a) in which dimethyl sulphoxide is the only therapeutically active ingredient and which are prepared, packed and labelled for animal treatment only; or
- (b) in which dimethyl sulphoxide and copper salicylate are the only therapeutically active substances and which are prepared, packed and labelled for animal treatment only; or
- (c) for industrial or laboratory use.”

(iii) After the item relating to HYGROMYCIN B there shall be inserted the following item:

“IODINE (excluding its compounds)—

- (a) in iodophors except in substances containing 1.5 per cent or less of available iodine; or
- (b) in other liquid substances containing 2.5 per cent or less of available iodine; or
- (c) in substances for animal treatment only, except in iodophors containing 1.5 per cent or less of available iodine or in solid or semi-solid substances containing 2.5 per cent or less of available iodine.”

(iv) After the item relating to ISOTHAN there shall be inserted the following item:

“LEAD COMPOUNDS except—

- (a) when included in Schedule Two; or
- (b) in substances for cosmetic use containing 0.025 per cent or less of lead; or

(c) in pencil cores, finger colours, showcard colours, pastels, crayons, poster prints, poster colours, or coloured chalks containing 0.01 per cent or less of lead."

(v) After the item relating to PENTACHLOROPHENOL there shall be inserted the following item:

"PERACETIC ACID except when included in Schedule Five."

(vi) After the item relating to TERPENES, CHLORINATED there shall be inserted the following items:

"TESTOSTERONE CYPIONATE when labelled solely for the treatment and prevention of pizzle and sheath rot in wethers."

(f) In Part 1 of Schedule Seven—

(i) The following items are removed:

"DIBROMOCHLOROPROPANE."

"DITHIONAL for human therapeutic use."

"VINYL CHLORIDE."

(g) In Part 2 of Schedule Seven—

(i) After the item relating to p-BIPHENYLAMINE there shall be inserted the following item:

"BITHIONOL (bis(2-hydroxy-dichlorophenyl)sulphide), bis(2-hydroxy-3,5-dichlorophenyl) sulphoxide, their compounds, and all preparations containing any proportion whatsoever of any one or more of those substances."

(ii) After the item relating to BUNAMIODYL SODIUM there shall be inserted the following item:

"CAMPHECHLOR."

(iii) After the item relating to CINCHOPHEN there shall be inserted the following item:

"CLIOQUINOL and other halogenated derivatives of 8-hydroxyquinoline for internal human therapeutic use."

(iv) After the item relating to CLOMIPHENE CITRATE there shall be inserted the following item:

"COMFREY being the dried and comminutive leaves or dried and powdered root or any part of the dried plant, their preparation, extracts, and mixtures."

(v) After the item relating to DEMETON there shall be inserted the following item:

"1,2-DIBROMO-3-CHLOROPROPANE."

(vi) After the item relating to ETRETINATE there shall be inserted the following item:

"FLUNIXIN MEGLUMINE except when included in Schedule Four."

(vii) After the item relating to VERATRUM there shall be inserted the following item:

"VINYL CHLORIDE MONOMER."

Given under my hand the seal of the State of Victoria aforesaid at Melbourne this thirteenth day of June in the year of Our Lord One thousand nine hundred and eighty-four and in the thirty-third year of the reign of Her Majesty Elizabeth the Second, Queen of Australia.

(L.S.)

B. S. MURRAY

By His Excellency's Command

J. K. KENNAN  
Acting Minister of Health

GOD SAVE THE QUEEN!

## GOVERNMENT NOTICES

### *Drainage Areas Act 1958*

#### SPECIAL MAINTENANCE CHARGE MADE BY THE COUNCIL OF THE SHIRE OF WARRNAMBOOL IN RESPECT OF THE LAKE WANGOOM DRAINAGE AREA

Notice is hereby given that on 13 June 1984, in accordance with the provisions of section 36 of the *Drainage Areas Act 1958*, the Governor in Council approved of the estimate of the cost of proposed maintenance works in the Lake Wangoom Drainage Area submitted by the Council of the Shire of Warrnambool, and of the making by the Council of a Special Maintenance Charge on properties within the said Drainage Area, for the year ending 30 September 1984.

TOM FORRISTAL

Clerk of the Executive Council

### PUBLIC MEETING OF PUBLIC SERVICE BOARD

A Public Meeting of the Public Service Board will be held at 2.00 p.m. on Thursday, 5 July 1984. The location is Meeting Room 2, 1st Floor, Convention Centre, Royal Exhibition Building, Nicholson Street, Carlton (Enter from Entrance 5 off Nicholson Street).

The Agenda item for the Meeting is:

#### *The Public Service (Amendment) Act 1984*

The purpose of the meeting is to outline the major features and operational effects of the amended Public Service Act and revised Regulations and Determinations which were proclaimed on 13 June 1984 with effect from 20 June 1984.

Examples of Significant Changes are:

mobility;  
flexibility;  
wider appointment provisions;  
greater rights.

Public Servants wishing to attend the meeting should obtain appropriate time off from their chief administrator and chief administrators are asked to assist interested staff to participate in the Public Meeting.

To ensure that seating is available those wishing to attend are requested to ring the Board's Office on (03) 651 3761.

### *National Parks Act 1975*

#### AUTHORIZED OFFICERS

In accordance with section 9 (2) of the *National Parks Act 1975*, I, Donald Sydney Saunders, Director of National Parks, hereby appoint the following persons to be Authorized Officers for the purposes of the Act.

These Authorizations are to remain in effect until revoked or until the appointee ceases to be employed by the National Parks Service.

Name	Area of Appointment
John Kneebone	All Parks
Peter D. Jonstone	All Parks
Jonathan C. Day	All Parks
Graeme A. McGregor	Grampians National Park

D. S. SAUNDERS  
Director of National Parks

*Private Agents Act 1966*

## NOTICE OF RECEIPT OF APPLICATIONS FOR LICENCES UNDER THE PROVISIONS OF THE PRIVATE AGENTS ACT 1966

The Clerk(s) of the Magistrates' Court(s) as listed hereunder hereby give notice that applications, as under, have been lodged for hearing by the said Court(s) on the date(s) specified.

Any person desiring to object to any of such applications must—

- (a) lodge with the respective Clerk of the Magistrates' Court a notice in the prescribed form of his objection and of the grounds thereof;
- (b) cause a copy of such notice to be served personally or by post upon the applicant at least three days before the hearing of the application; and
- (c) send or deliver—
  - (i) where the objection is not made by the officer in charge of the police district in which the Court is situated—a copy of the notice to such officer; and
  - (ii) where the objection is not made by the Registrar or Deputy Registrar—a copy to the Registrar.

<i>Full Name of Applicant*</i>	<i>Place of Abode of Applicant or Nominee</i>	<i>Name of Firm or Corporation</i>	<i>Address for Registration</i>	<i>Type of Licence</i>	<i>Date of Hearing</i>
<b>MAGISTRATES' COURT, SPRINGVALE</b>					
Rowlands, George William	2 Lalor Cl, Mulgrave		2 Lalor Cl, Mulgrave	Process Server	29. 6. 84
Dated at Springvale 5 June 1984 B. DOBSON, Clerk of the Magistrates' Court					
<b>MAGISTRATES' COURT, DANDENONG</b>					
McInerney, David Brett	Crossdale 14 Rise, Endeavour Hills		14 Crossdale Rise, Endeavour Hills	Guard Agent (Individual)	28. 6. 84
Dated at Dandenong 6 June 1984 L. T. GOULD, Clerk of the Magistrates' Court					
<b>MAGISTRATES' COURT, BALLARAT</b>					
Davies, Colin Vincent	Victoria St, Creswick		Victoria St, Creswick	Inquiry	27. 6. 84
Dated at Ballarat 6 June 1984 D. CROFT, Clerk of the Magistrates' Court					
<b>MAGISTRATES' COURT, WONTHAGGI</b>					
Brusamarello, Gary Kevin	Korrine, Via Glen Alvie		121 Broome Cres, Wonthaggi	Watchman	9. 7. 84
Dated at Wonthaggi 5 June 1984 A. M. SHINE, Clerk of the Magistrates' Court					
<b>MAGISTRATES' COURT, TRARALGON</b>					
Maskiel, James Gordon	34 Eastern Ave, Newborough		Dunbar Rd, Traralgon	Watchman	25. 6. 84
Dated at Traralgon 31 May 1984 S. WEBSTER, Clerk of the Magistrates' Court					
<b>MAGISTRATES' COURT, PRAHRAN</b>					
Ayers-Berry, Guy	3/51 Delbridge St, North Fitzroy	Mayne Nickless Ltd	390 St Kilda Rd, Melbourne	Watchman	6. 7. 84
Burt, Gregory James	8/23 Domain St, Glenroy	" "	" "	"	"
Durovic, Rudolph	57 Braeswood St, St Albans	" "	" "	"	"
Foulkes, Robert Anthony	8 Northwood St, East Ringwood	" "	" "	"	"
Gough, James Anthony	2/31 Macartney Ave, Kew	" "	28 Stephenson St, Richmond	"	"

\* Or in the case of a firm or corporation, of the Nominee

PRIVATE AGENTS—*continued*

<i>Full Name of Applicant*</i>	<i>Place of Abode of Applicant or Nominee</i>	<i>Name of Firm or Corporation</i>	<i>Address for Registration</i>	<i>Type of Licence</i>	<i>Date of Hearing</i>
Huber, Klaus	5/12 Stewart St, Mt. Waverly	" "	390 St Kilda Rd, Melbourne	"	"
Mullins, Dennis Brian	4/52 Moubay St, Albert Park	" "	76-78 Balmain St, Richmond	"	"
Price, Michael Francis	5 Friar Pl, Melton	" "	390 St Kilda Rd, Melbourne	"	"
Rizzo, Nick	11 Rite St, Vermont	" "	" "	"	"
Saunders, Graeme	32 Livingstone St, East Coburg	" "	" "	"	"
Dated at Prahran 5 June 1984 B. MEEHAN, Clerk of the Magistrates' Court					
MAGISTRATES' COURT, MILDURA					
Pettit, Edward James	111 Magnolia Ave, Mildura		111 Magnolia Ave, Mildura	Guard Agent	4.7.84
Dated at Mildura 8 June 1984 Clerk of the Magistrates' Court					
MAGISTRATES' COURT, SUNSHINE					
Taylor, Mark Douglas	5 Anton Cl, Werribee		254 Ballarat Rd, Sunshine	Inquiry Agent	4.7.84
Dated at Sunshine 5 June 1984 G. WILLIAMSON, Clerk of the Magistrates' Court					
MAGISTRATES' COURT, BROADMEADOWS					
Harding, Philip Gregory	31 Longtown Crt, Craigieburn	Philip Gregory Harding	31 Longtown Crt, Craigieburn	Inquiry Agent	9.7.84
Dated at Broadmeadows 5 June 1984 R. BOURKE, Clerk of the Magistrates' Court					
MAGISTRATES' COURT, BRUNSWICK					
Edwards, Georgina Anne	Rear 136 Koornang Rd, Carnegie	Security Express	104 John St, East Brunswick	Watchman	20.7.84
Iaconis, Vincenzo	62 Rose St, Brunswick	Edward Carlo Fagnani	130 Mitchell St, East Brunswick	Watchman	16.7.84
Dated at Brunswick 6 June 1984 Clerk of the Magistrates' Court					
MAGISTRATES' COURT, PORT MELBOURNE					
Stringer, Clifford James	Flat 9/5 Celeste Crt, East St. Kilda	Armaguard	653 Queer.sberry St, North Melbourne	Watchman	28.6.84
Watts, Raymond William	Riddell Rd, Monegeeta	"	" "	"	"
Wolley, Glenn	1 Brympton Ave, Park Orchards	"	" "	"	12.7.84
Dated at Port Melbourne, 5 June 1984 K. L. HUSSEY, Clerk of the Magistrates' Court					
MAGISTRATES' COURT, PRESTON					
Mein, Norbert George	15 Hendricks Crt, Mill Park		15 Hendricks Crt, Mill Park	Guard Agent	4.7.84
Dated at Preston 5 June 1984 T. WILSON, Clerk of the Magistrates' Court					

\* Or in the case of a firm or corporation, of the Nominee

## PRIVATE AGENTS—continued

Full Name of Applicant*	Place of Abode of Applicant or Nominee	Name of Firm or Corporation	Address for Registration	Type of Licence	Date of Hearing
<b>MAGISTRATES' COURT, BALLARAT</b>					
Crane, Steven Lloyd	87 Camp Pde, Clunes		340 Abbotsford St, North Melbourne	Watchman	26.6.84
Dated at Ballarat, 5 June 1984 D. CROFT, Clerk of the Magistrates' Court					
<b>MAGISTRATES' COURT, OAKLEIGH</b>					
Agriopoulos, Peter	23 Chestnut St, Carnegie	Kent Security Services	96 Murrumbeena Rd, Murrumbeena	Watchman	6.7.84
Dated at Oakleigh, 5 June 1984 W. E. BYRNE, Clerk of the Magistrates' Court					
<b>MAGISTRATES' COURT, RINGWOOD</b>					
Toulson, Dianne Elizabeth	Flat 4, 58 Hemmings St, Dandenong		54 Clarence Rd, Wantirna	Watchman	2.7.84
Dated at Ringwood, 5 June 1984 R. BRUCKNER, Clerk of the Magistrates' Court					

\* Or in the case of a firm or corporation, of the Nominee

**NOTIFICATION OF TRANSFER OF WATER EASEMENT LICENCES**

I, Thomas Cross Read of Goornong, hereby give notice of my intention to transfer two water easement licences to G. R. V. and R. M. Miles of Mitiamo for water supply purposes across land described as part of Crown section 3 and Crown Portion 24, Parish of Ellesmere.

I have obtained the written consent of the Honourable Minister of Water Supply to the said transfer, in accordance with the Regulations.

Dated at Bendigo 15 June 1984

T. C. READ, Goornong, farmer

Department of Minerals and Energy

**APPLICATIONS FOR MINING LEASES REFUSED**

No. 1185; Cosol Pty. Ltd.; 80 ha, Parish of Harrierville.

No. 1186; Adah Dinger; 100 ha, Parish of Harrierville.

**MINING LEASE EXPIRED**

No. 573; Robert Neil Gillingham; 1.2 ha, Parish of Koorangie.

**APPLICATIONS FOR EXPLORATION LICENCES WITHDRAWN**

No. 1386; Marathon Petroleum Aust. Ltd.; 231 km<sup>2</sup>, County of Benambra.

No. 1420; Electrolytic Zinc Co. of Australasia Ltd.; 330 km<sup>2</sup>, comprising Graticular Blocks Nos. 997, 998, 999, 1070 and 1071 Hamilton Map Sheet.

**TERM OF EXPLORATION LICENCE EXTENDED AND AREA RELINQUISHED**

No. 889; CRA Exploration Pty. Ltd.; extended for twelve months. Area relinquished 108.5 km<sup>2</sup>, Area retained 683 km<sup>2</sup>, Counties of Talbot, Rippon, Grenville and Grant.

The above area will become available again for Exploration Licence on 15 December 1984.

**EXPLORATION LICENCE TRANSFERRED IN PART**

No. 1286: From Chemical & Petroleum Industries Pty. Ltd. to Chemical and Petroleum Industries Pty. Ltd. and Resource Technology Pty. Ltd.

**SEARCH LICENCE EXPIRED**

No. 2734; Amber Gem Pty. Ltd.; 4 ha, Parish of Moliagul.

**TAILINGS LICENCE TRANSFERRED**

No. 4773 and 4920; From Mr F. Lockyer to Mrs Doris Lockyer.

**TAILINGS LICENCE EXPIRED**

No. 4670; The United Shire of Beechworth; to remove tailings extending south of Crown Allotment 9 Section B IV upstream to south of Crown Allotment 20 Section B IV known as the "Three Mile Creek" situated in the Parish of Beechworth.

**APPLICATION FOR TAILINGS REMOVAL LICENCE WITHDRAWN**

No. 4931; John Alexander Tehan; to remove tailings from the Old Inglewood Deep Lead situated in the Parish of Glenalby.

**EXTRACTIVE INDUSTRY LEASE GRANTED**

No. 283; William Anthony Donohue; 6.51 ha; Parish of Wonthaggi.

D. R. WHITE

Minister for Minerals and Energy

*Police Regulation Act 1958 Section 122*

**SALE OF UNCLAIMED AND CONFISCATED PROPERTY**

An auction of unclaimed and confiscated property held by Police, will be conducted at the Auction Rooms of Messrs. Fowles Purdy Pty. Ltd., Cnr. of Graham and Plummer Streets, Port Melbourne, at 10.00 a.m. on Tuesday, 24 July 1984.

S. I. MILLER

Chief Commissioner



**ERRATUM**

In *Government Gazette*, No. 56, of 23 May 1984 on page 1598 under the heading *Trustee Act 1958*, concerning Creditors, next of kin etc., the name "Filler, Norman Regionald Tremain", should read "Filler, Norman Reginald Tremain".

**ERRATUM**

In *Government Gazette* No. 59 of 30 May 1984 on page 1728 under the heading 'Notice of Making of Statutory Rules which are not yet available', Rule number 137, where it is shown as "*Industrial Regulations Act 1979*" it should read "*Industrial Relations Act 1979*".

*Transport Act 1983*

**DECLARATION OF ROADS BY THE MINISTER OF TRANSPORT**

The Minister of Transport for the State of Victoria declares the roads or parts of roads or any deviations from or widenings of roads as described below—

**State Highways**

22/84 Declaration of the widening of the Omeo Highway in the Shire of Tambo as shown hatched on plan numbered G.P. 15969B hereunder.

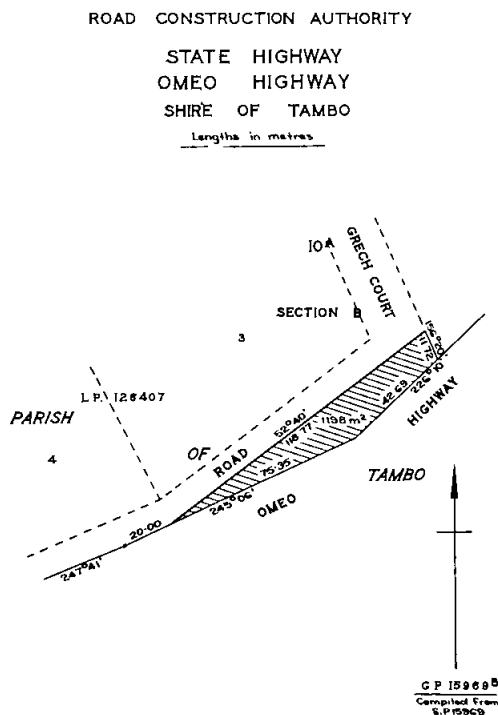

23/84 Declaration of the widening of the Sunraysia Highway in the Town of St. Arnaud as shown hatched on plan numbered G.P. 15512B below.

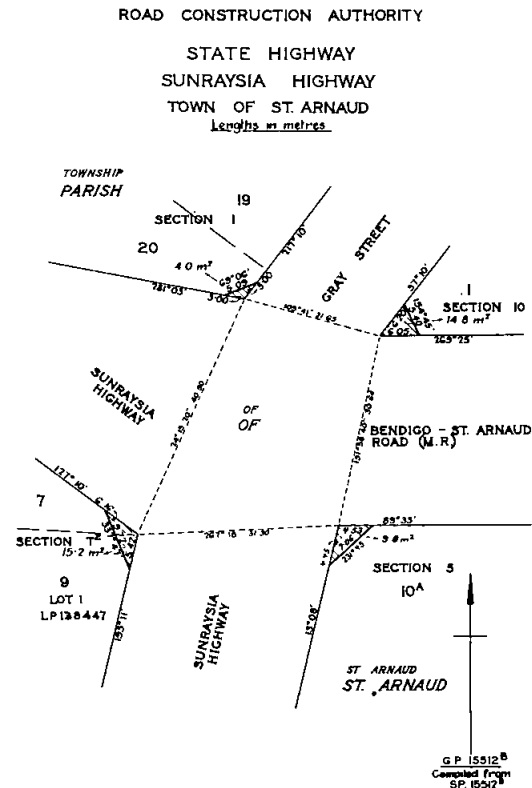



25/84 Declaration of the widening of Stud Road in the City of Knox as shown hatched on plan numbered G.P. 15803B below.

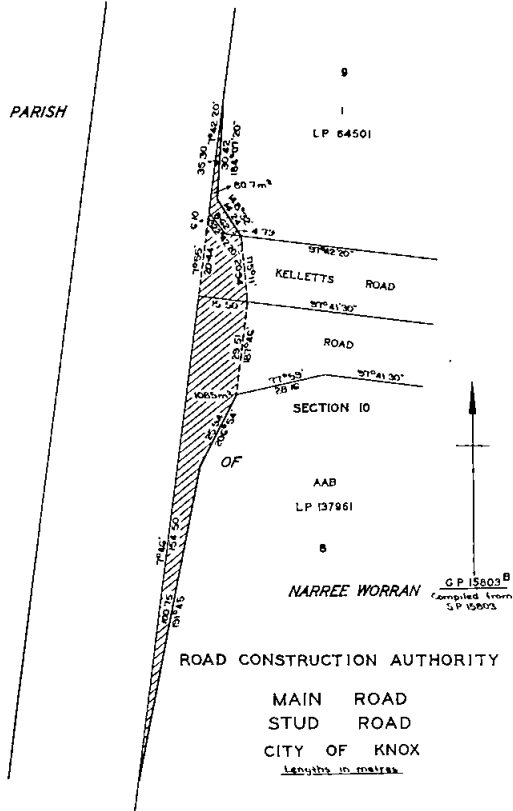

27/84 Declaration of the widening of the Healesville-Koo-wee-rup Road in the Shire of Healesville as shown hatched on plan numbered G.P. 15862 below.

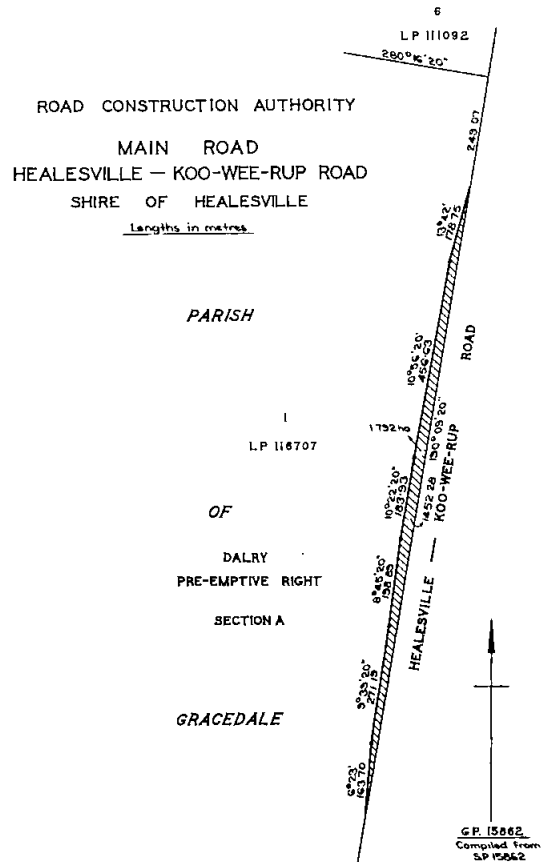

26/84 Declaration of the widening of the Tarwin Lower Road in the Shire of Woorayl as shown hatched on plan numbered G.P. 15776 below.

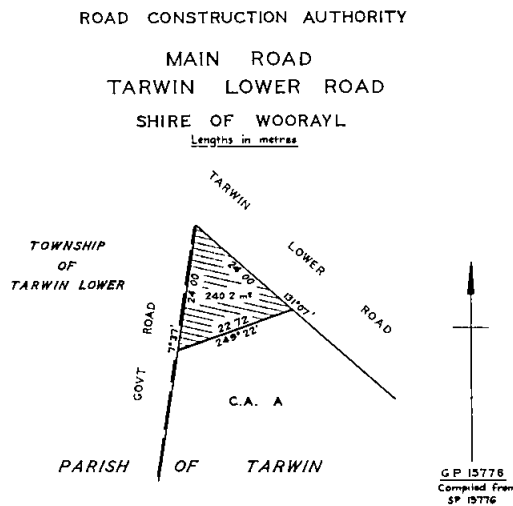

Dated 6 June 1984

J. H. SIMPSON  
Assistant Minister of Transport

Transport Act 1983  
DECLARATION OF ROADS BY THE MINISTER OF TRANSPORT

The Minister of Transport for the State of Victoria declares the roads or parts of roads or any deviations from or widenings of roads as described below—

Main Road

21/84—Declaration of the existing road in the Cities of Berwick, Dandenong, Moorabbin, Oakleigh and Springvale as shown on the plan numbered G.P. 65—M.R. hereunder.

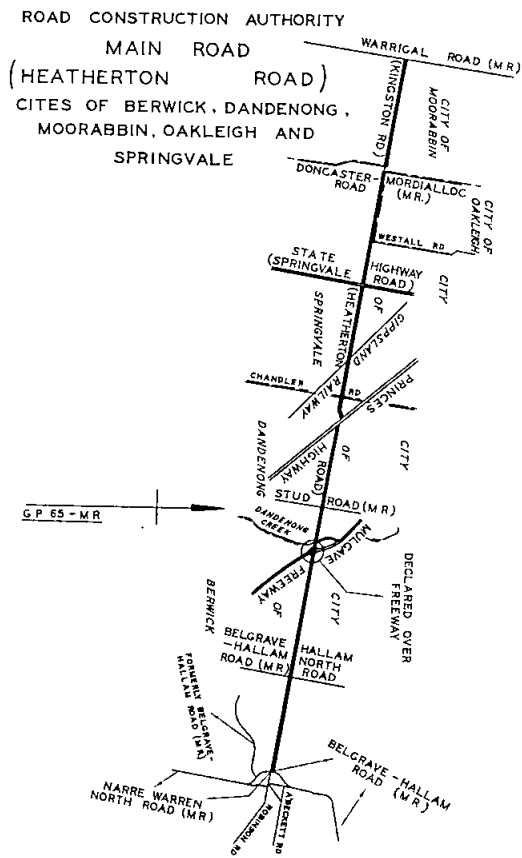

Dated 6 June 1984

J. H. SIMPSON  
Assistant Minister of Transport

*Transport Act 1983*  
**VARIATION OF DECLARATION OF ROADS BY THE MINISTER OF TRANSPORT**

The Minister of Transport for the State of Victoria varies the declarations of roads as described below—

**State Highway**

18/84 By including in the declaration of the Bonang Highway in the Shire of Orbost the land shown hatched on plans numbered G.P. 15784B and G.P. 15785B hereunder, and excluding from the said declaration the land shown cross hatched on the said plans.

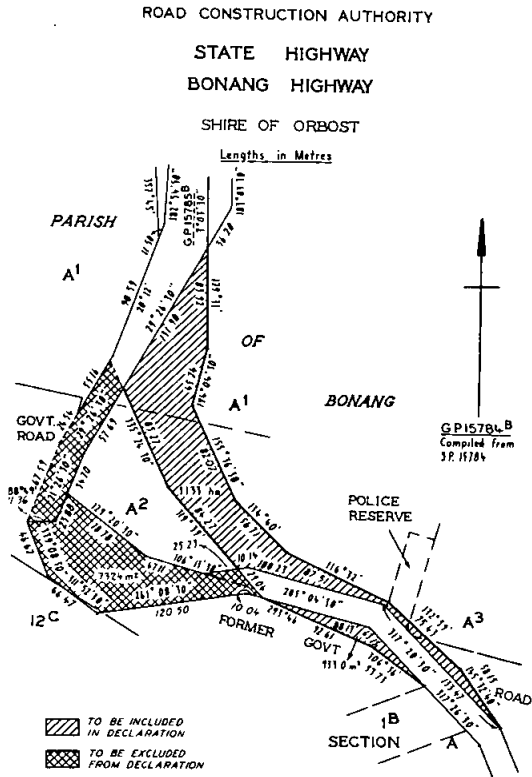

**Main Road**  
 19/84 By including in the declaration of Bengworden Road in the Shire of Bairnsdale the land shown hatched on plans numbered G.P. 15633D, G.P. 15633E and G.P. 15634A hereunder and excluding from the said declaration the land shown cross hatched on plans numbered G.P. 15633D and G.P. 15633E.

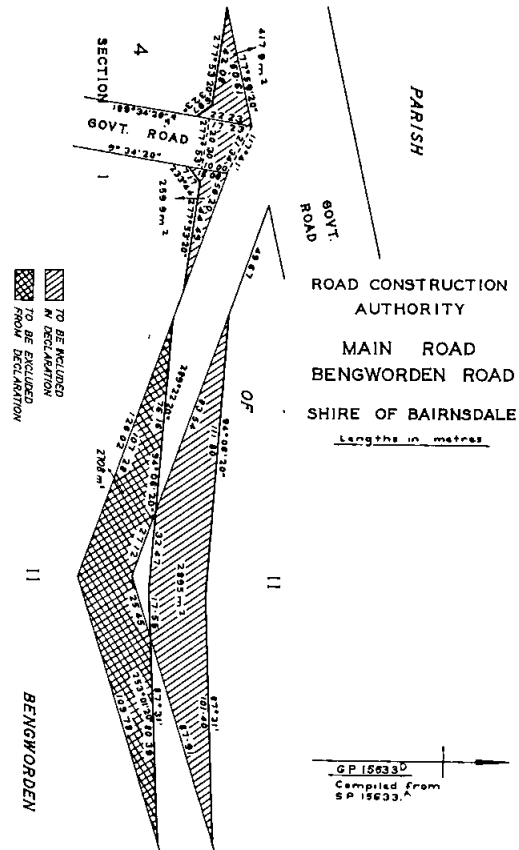
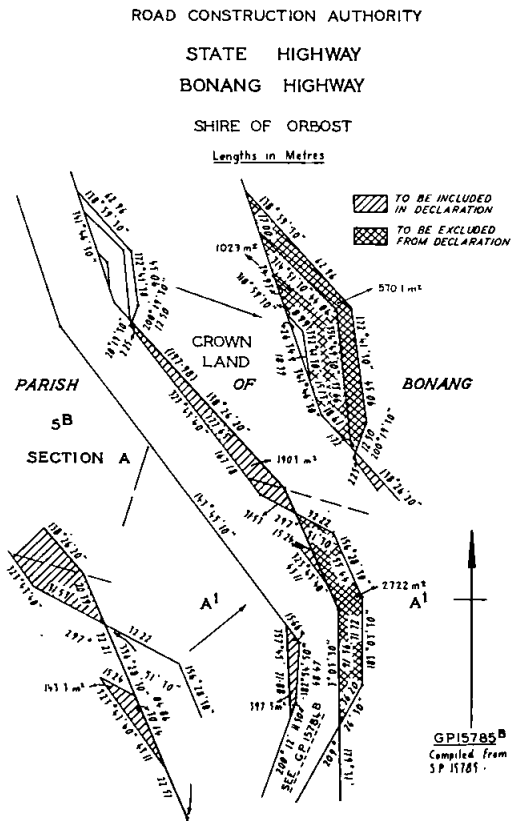

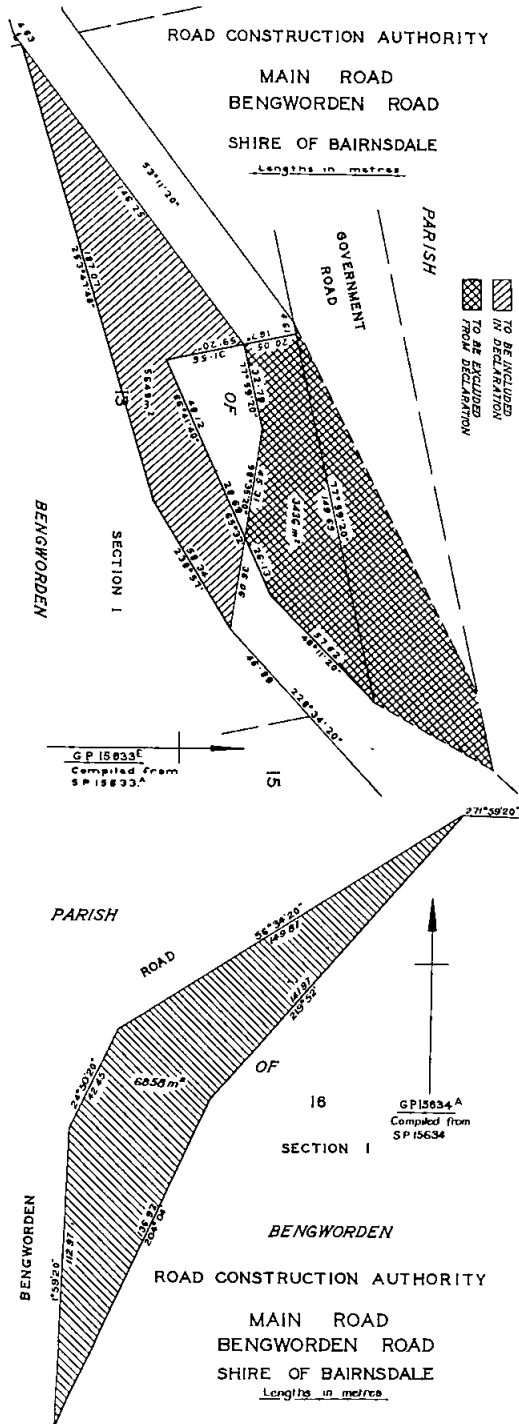

*Transport Act 1983*  
**DECLARATION OF ROADS BY THE MINISTER OF TRANSPORT**

The Minister of Transport for the State of Victoria varies the declarations of roads as described below—

**Main Roads**

16/84—By including in the declaration of the Belgrave-Hallam Road two sections of existing road and excluding from the said declaration a section of road as shown on plan numbered G.P. 66—M.R. hereunder.

ROAD CONSTRUCTION AUTHORITY  
MAIN ROAD  
(BELGRAVE - HALLAM ROAD)  
CITY OF BERWICK

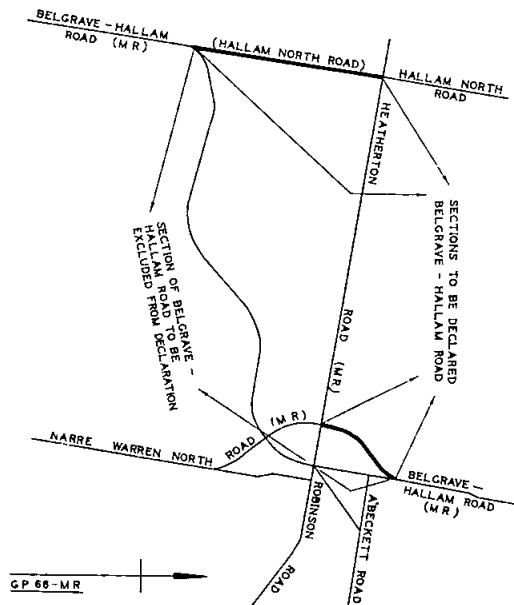

Dated 6 June 1984

J. H. SIMPSON  
Assistant Minister of Transport

17/84—By including in the declaration of the Narre Warren North Road a section of existing road and excluding from the said declaration a section of road as shown on the plan numbered G.P. 67—M.R. hereunder.

ROAD CONSTRUCTION AUTHORITY.  
 MAIN ROAD  
 (NARRE WARREN NORTH ROAD)  
 CITY OF BERWICK

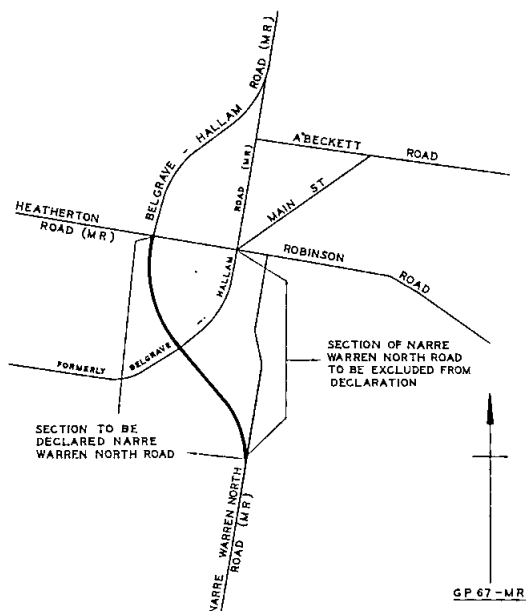

Dated 6 June 1984

J. H. SIMPSON  
 Assistant Minister of Transport

Local Government Department  
**ORDER CONFIRMED—SHIRE OF HASTINGS**  
 I, Frank Noel Wilkes, Her Majesty's Minister of the Crown for the time being administering the *Local Government Act* 1958, hereby confirm the Order hereinafter referred to in pursuance of section 514 of the said Act namely.  
 An Order of the Council of the Shire of Hastings made on 3 April 1984 directing the compulsory taking of the land described in a Conveyance registered in the office of the Registrar General in Book No. 427 by Memorial 412 being the land marked "A" and "B" on the plan hereunder for the purpose of providing a place of public resort and recreation.

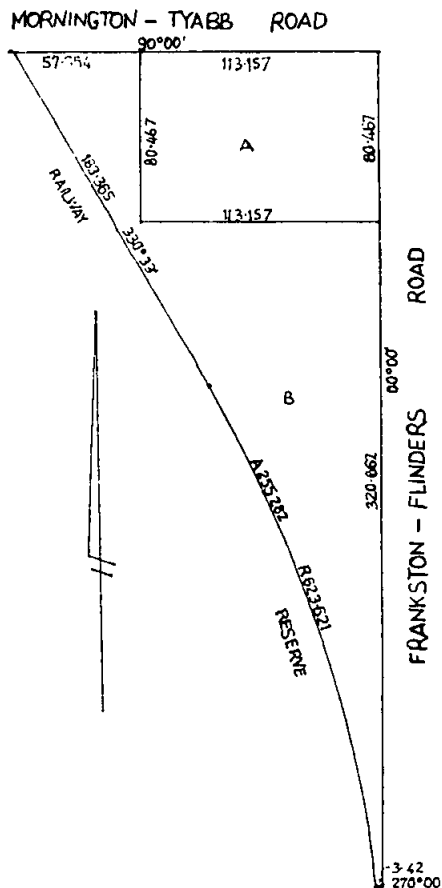

Dated 5 June 1984

F. N. WILKES  
 Minister for Local Government  
 Local Government Department  
 Melbourne (84/2594)

Local Government Department  
**ORDER CONFIRMED—SHIRE OF CORIO**  
 I, Frank Noel Wilkes, Her Majesty's Minister of the Crown for the time being administering the *Local Government Act* 1958, hereby confirm the Order hereinafter referred to in pursuance of section 514 of the said Act namely.

An Order of the Council of the Shire of Corio made on 25 January 1984 directing the compulsory taking of the land described in Memorial No. 43 Book 467 for road purposes.  
 Dated 5 June 1984

F. N. WILKES  
 Minister for Local Government  
 Local Government Department  
 Melbourne (84/1787)

Local Government Department  
**ORDER CONFIRMED—SHIRE OF HASTINGS**  
 I, Frank Noel Wilkes, Her Majesty's Minister of the Crown for the time being administering the *Local Government Act* 1958, hereby confirm the Order hereinafter referred to in pursuance of section 514 of the said Act namely.

An Order of the Council of the Shire of Hastings made on 7 February 1984 directing the compulsory taking of part of the land described in Certificate of Title Volume 8612 Folio 587 being the land shown by hatching on the plan hereunder for the purpose of providing a splay corner for road purposes.

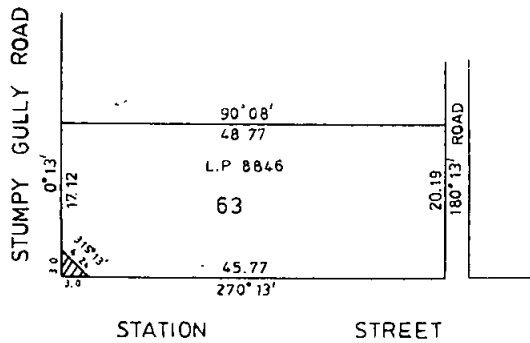

Dated 8 June 1984

F. N. WILKES  
Minister for Local Government

Local Government Department  
Melbourne (84/1670)

The common seal of the President, Councillors and Ratepayers of the Shire of Avon was hereunto affixed 5 December 1983:

(SEAL) M. ROSS, President  
S. JOHNSTON, Councillor  
G. W. BRAYSHAW, Secretary

Confirmed by the Governor in Council 13 June 1984—  
TOM FORRISTAL, Clerk of the Executive Council

Local Government Act 1958

VESTING OF LAND IN THE MUNICIPALITY OF THE SHIRE OF HASTINGS

Whereas it is provided by Division 7 of Part XII of the Local Government Act 1958 that where default has been made in the payment to a municipality of a rate charged on any vacant and unoccupied land and such default has continued for not less than five years and where after the land has been offered for sale by public auction but remains unsold and the Council is of the opinion that the land is unsaleable the Council may apply to the Minister for an Order vesting the land in the municipality.

And whereas default has been made in the payment of rates on certain vacant and unoccupied land in the Shire of Hastings for not less than five years and the land, having been offered for sale by public auction, remains unsold.

And whereas the Council of the Shire of Hastings is of the opinion that the said land is unsaleable and has applied to the Minister for an Order vesting the said land in the municipality.

Now therefore, I, Frank Noel Wilkes, Her Majesty's Minister for Local Government for the State of Victoria, in pursuance of the powers vested in me by the said Division 7, do by this Order, vest in the municipality of the Shire of Hastings the lands described in the schedule hereunder.

SCHEDULE

Lot Nos.	Plan of Subdivision No.
<i>Naval Base Estate</i>	
274, 197, 199, 265, 266, 263, 259, 261, 262.	6936
226, 206	6935
34, 40, 36, 37 section A, 37 section D, 58, 10.	6197
50, 54, 56, 47, 116.	7802
<i>West of Stony Point Railway Line</i>	
545, 540, 119, 122, 123, 124, 125, 127, 128, 527, 528, 488, 501, 504, 493, 495, 455, 456, 457, 458, 423, 424, 434, 393, 394, 399, 367, 361, 366, 136, 187, 188, 232, 228, 291, 292, 302, 303, 304, 305, 317, 174, 176, 99, 106, 81, 90, 77, 78, 84, 85, 72, 73, 60, 61, 52, 25.	8786
<i>East of Stony Point Railway Line</i>	
139, 154, 161.	7219
81, 82.	7218
107.	7220
316, 308, 322, 250, 304, 300, 295.	8749

F. N. WILKES  
Minister for Local Government

Local Government Department  
Melbourne (84/1783)

ROAD DEVIATION ORDER—SHIRE OF AVON

Pursuant to the provisions of sections 522 and 526 of the Local Government Act 1958 the Council of the Shire of Avon hereby directs that the land in the Parish of Nuntin indicated by hatching on the plan hereunder which has been purchased or acquired by it, shall be a Public Highway on and from the date of publication of the Order in the Government Gazette and declares that such land shall be a public highway in lieu of the land indicated by cross hatching on the said plan.

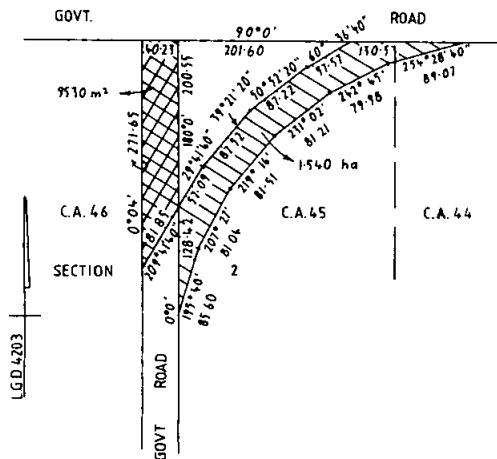

LENGTHS ARE IN METRES



## CONTRACTS ACCEPTED—(Series 1983/84)

## Public Works

- Alberton Shire—External and Internal renovations and painting, Stacey's Bridge Primary School—\$15 050.00—Willem Wilhelm, Morwell.
- Alexandra Shire—Internal and external renovations, Rubicon School Camp—\$83 600.00—M.D.T. Painting Service Renovation, St. Albans.
- Ararat City—Electrical rewire of male wards/F8, Ararat Mental Hospital and Training Centre—\$159 995.00—Cec. Hopper & Sons, Horsham.
- Avoca Shire—Fire services, Avoca Primary School—\$69 820.00—G. K. & L. E. Strange Pty. Ltd., Ballarat East.
- Benalla City—Internal renovations, Benalla Police Residence (No. 1)—\$13 720.00—I. Bulat, Finley, N.S.W.
- Benalla Shire—Toilet upgrade, Swanpool Primary School—\$14 100.00—Alf Richardson Constructions Pty. Ltd., Benalla.
- Benalla Shire—Internal and external renovations, Baddaginnie Primary School—\$14 750.00—Roy O. Tobias, Wangaratta.
- Bendigo City—Restoration of specimen cottage, Bendigo College of T.A.F.E.—\$148 500.00—K. G. Hooker Builders Pty. Ltd., Hawthorn.
- Broadmeadows City—Upgrade roof of trade wing, Fawkner Technical School—\$13 966.00—Steel Deck Industries Pty. Ltd., South Melbourne.
- Broadmeadows City—P.A.B.X. Supply and installation, Fawkner Regional Headquarters (Education)—\$40 536.00—Telecom Australia (Industry Sales) Melbourne.
- Chiltern Shire—Replacement of School, Chiltern Primary School—\$451 906.00—Southwell Constructions, Wangaratta.
- Coburg City—Extension of existing fire alarm system, Coburg H. M. Prison Hospital—\$22 789.00—Wormald Fire Systems, Melbourne.
- Coburg City—2 No. proposed portables for D Division Coburg H. M. Prison Pentridge—\$164 875.00—R. M. & J. C. Hunter, Bendigo.
- Collingwood City—Supply and install electronic A/C Collingwood Police Garage and Gen. Store—\$13 270.00—H. C. Marshall & Company Pty. Ltd., Melbourne.
- Daylesford and Glenlyon Shire—Connection of appliances and boilers, Daylesford Technical High School—\$23 530.00—McLean & Boakes, Ballarat.
- Diamond Valley Shire—Hydraulic services, connection of sewer Watsonia Special School—\$17 350.00—J. R. & B. L. Kendall, Greensborough.
- Footscray City—Replacement of domestic hot water system, Footscray High School—\$10 489.00—S. J. & M. A. & R. A. Rose Pty. Ltd., Coburg North.
- Geelong West City—Construction upgrade stage 2, Manifold Heights Primary School—\$19 969.00—E. J. Lyons & Sons Pty. Ltd., Geelong South.
- Hamilton City—Construction/relocate L.T.C. and alteration, Hamilton North Primary School—\$38 200.00—A. L. Lane, Merino.
- Hawthorn City—Internal painting, Swinburne Technical School—\$13 900.00—R. & M. B. Fredriksson Pty. Ltd., Doncaster East.
- Heidelberg City—Service connection & landscaping, Austin Hospital Special School—\$68 690.00—Florentin Construction Co., Surrey Hills.
- Keilor City—Oval development sprinkler system, Kings Park High School—\$55 250.00—Victorian State School Horticultural Soc., Oakleigh.
- Keilor City—Construction, new school, Kings Park Primary School—\$1 609 538.00—Graham Evans & Co. (Vic.) Pty. Ltd., South Melbourne.
- Knox City—Meter and boiler conversion to gas, Scoresby Horticultural Research Institution—\$19 088.00—Gas & Fuel Corporation of Victoria, Melbourne.
- Kyneton Shire—External and internal repairs and painting, Tylden Primary School—\$17 092.00—Fifth Vemalux Pty. Ltd., Golden Square.
- Malvern City—Diversion of sewer, Holmesglen College of TAFE—\$25 000.00—Melbourne Metropolitan Board of Works, Melbourne.
- Mansfield Shire—Office extension, Woods Point Police Station—\$15 609.00—Ivan Koscuk Painting and Renovating Services Pty. Ltd., Murrumbena.
- Melbourne City—Internal and external repairs and painting, Parkville Baltara Reception Centre (Welfare)—\$10 160.00—S. W. Porter, Melbourne.
- Melbourne City—Internal and external repairs and painting, Parkville Baltara Reception Centre (Welfare)—\$10 535.00—S. W. Porter, Melbourne.
- Melbourne City—Supply and installation of compactus, Melbourne 295 Queen Street (Government Statist)—\$10 925.00—Brownbuilt Ltd., Thornbury.
- Melbourne City—Floor coverings, Parkville Turana Training Centre (Welfare)—\$11 530.00—Frankston Floors Pty. Ltd., Frankston.
- Melbourne City—Upgrade outdoor swimming pool, Turana Youth Training Education Centre—\$13 963.00—Maintain-a-pool Services, Kew.
- Melbourne City—External renovations, Parkville Psychiatric Unit—\$44 500.00—Renovation & Painting Thomastown, Thomastown.
- Melbourne City—Sound proofing to interview rooms, Melbourne 376 Russell Street (Police Complex)—\$48 029.00—W. R. Ajani & Associates Pty. Ltd., Croydon.
- Melton Shire—Sewerage connection, Coburn Primary School—\$25 545.00—A. & A. Di Felice, Chadstone.
- Melton Shire—Construction-outfall drain, Melton Technical School—\$28 347.17—Shire of Melton, Melton.
- Moe City—Building works, Newborough East Primary School—\$102 550.00—W. G. Campbell Constructions Pty. Ltd., Morwell.
- Mornington Shire—Cyclic maintenance, Mount Eliza High School—\$227 112.00—S. S. Sreckovic, Oakleigh.
- Newtown City—Cleaning of Early Childhood Development Program, June 1984-March 1987—\$12 750.00—V. Kukac, Clifton Springs.
- Numurkah Shire—Replacement school, Strathmerton Primary School—\$27 000.00—Alf Richardson Constructions Pty. Ltd., Benalla.
- Oakleigh City—Connection to sewer, Huntingdale Technical School—\$10 800.00—South Melbourne Plumbing Pty. Ltd., South Melbourne.
- Oxley Shire—Transfer of school building architectural, Greta South Primary School—\$12 720.00—Alf Richardson Constructions Pty. Ltd., Benalla.
- Pakenham Shire—Cyclic maintenance, Bunyip Primary School—\$62 696.00—Descolour Pty. Ltd., Murrumbena.
- Port Melbourne City—Various works, Port Melbourne Store and Laboratory (Minerals)—\$23 225.00—Bass Constructions, Northcote.

Port Melbourne City—Extension to core store, Port Melbourne Store and Laboratory (Minerals)—\$72 650.00—P.M.I. Steel Fabrication Co. Pty. Ltd., Williamstown North.

Queenscliffe Borough—Maintenance service, Queenscliff Marine Research Station (Con.)—\$21 376.00—Haden Engineering Pty. Ltd., Moorabbin.

Richmond City—Timber pergola and deck and covered way, Burnley Agriculture Research Institute—\$38 958.00—R. & S. Developments Pty. Ltd., Riddells Creek.

Rodney Shire—Building supply and erection of toilets, Ardmona Primary School—\$15 200.00—Alf Richardson Constructions Pty. Ltd., Benalla.

Shepparton City—Architectural renovations and alterations, Shepparton P.W.D. residence (No. 2)—\$17 430.00—D. W. & M. J. Douglas, Shepparton.

Shepparton City—Internal and external renovations, Shepparton Technical College—\$410 257.00—D. B. & R. E. Robertson, Shepparton.

Sunshine City—Construction building works, St. Albans School for hearing impaired—\$1 453 861.00—Van Driel (Aust.) Pty. Ltd., Caulfield.

Swan Hill City—Building works, Nyah West Police Station—\$14 185.25—J. C. Baird, Nyah.

Tungamah Shire—Building works, Katandra West Primary School—\$14 700.00—Alf Richardson Constructions Pty. Ltd., Benalla.

Waranga Shire—Toilet block, Murchison Primary School—\$14 400.00—Alf Richardson Constructions Pty. Ltd., Benalla.

Warrnambool Shire—Flammable liquid store, Warrnambool Brierly Mental Hospital—\$11 191.00—Paul Slorach, Warrnambool.

Warrnambool City—Fitting out/painting, &c. relocatable, Warrnambool Education Services Centre—\$16 976.00—Paul Slorach, Warrnambool.

Wimmera Shire—Resealing of roads, Longerenong Architectural College—\$10 800.00—Road Construction Authority (Horsham), Horsham.

Wodonga Rural City—Replacement of hot water boiler, Wodonga High School—\$19 682.00—A. G. Coombs, Wodonga.

Dated 14 June 1984

D. J. LITTLE  
Director General of Public Works

#### BUSINESS NAMES ACT 1962

I, James Harley Kennan, Her Majesty's Attorney-General for the State of Victoria, being the Minister for the time being administering the *Business Names Act 1962*, pursuant to the powers conferred by section 9 of the said Act, hereby revoke all directions previously given under the said section and do hereby direct that the Commissioner for Corporate Affairs shall not, except with the consent of the Minister for the time being administering the said Act, accept for registration any business name that is a name or a name of a kind mentioned hereunder, viz.:

1. Names that are likely to be confused with or mistaken for:

- (a) a name that is reserved or registered under Division 2 of Part III of the Companies (Victoria) Code;
- (b) the name of an incorporated association, building society, co-operative company, co-operative society, co-operative housing society, credit union, or friendly society; or
- (c) a registered business name.

2. Names which are misleading in relation to the nature, objects or purposes of the businesses conducted or to be conducted under those names, or in relation to any other matter.

3. Names that are likely to be offensive to members of the public or members of any section of the public.

4. Names containing the following words or phrases or any abbreviation thereof or any words, phrases or abbreviation of like import:

"America's Cup", "Building Society", "Chamber of Commerce", "Chamber of Manufactures", "Chartered", "College of Advanced Education", "Consumer", "Co-operative", "Credit Union", "Executor", "Friendly Society", "Guarantee", "Institute", "Made in Australia", "Oxfam", "Savings", "Starr Bowkett", "Stock Exchange", "Trust", "Trustee", "University".

5. Names which, in the context in which they are proposed to be used, are capable of suggesting:

- (a) connection with a member of the Royal Family when the connection suggested does not exist; or
- (b) that Royal patronage has been received when this is not the case.

6. Names which, in the context in which they are proposed to be used, are capable of suggesting connection with the Crown, the Government of the Commonwealth of Australia, or of a State or Territory or any other part of the Queen's dominions, possessions or territories.

7. Names which include the words "Commonwealth" or "Federal".

8. Names which, in the context in which they are proposed to be used, are capable of suggesting connection with the government of a foreign country.

9. Names which, in the context in which they are proposed to be used, are capable of suggesting connection with a department, authority or instrumentality of the Government of the Commonwealth of Australia or of a State or Territory or with a municipal or other local authority.

10. Names which in the context in which they are proposed to be used, are capable of suggesting:

- (a) connection with ex-servicemen's organizations when the connection suggested does not exist; or
- (b) that the members of an organization are totally or partially incapacitated when this is not the case.

Dated 5 June 1984

J. H. KENNAN  
Attorney-General

Attention is directed to the following additional restrictions on the use of names:

1. Section 9 of the *Business Names Act 1962* provides that, except with the consent of the Attorney-General, a business name shall not be registered under the Act if the business name is a name that in the opinion of the Commissioner is undesirable.

2. The following is a list of some Commonwealth Statutes which contain additional restrictions on the use of names:

- (a) Section 12 of the *International Organization (Privileges and Immunities) Act 1963* provides that, except with the consent in writing of the Minister for the time being administering the Act, a person shall not use in connection with any trade, business, profession, calling or occupation the name or an abbreviation of the name of the United Nations or of any other prescribed international organization.
- (b) Section 66 of the *Banking Act 1959-1973* provides that, except with the consent in writing of the Treasurer of the Commonwealth, a person or body of persons

not being a body corporate in Australia, shall not assume or use, in relation to the business, or any part of the business carried on by the person or body, the word "Bank", "Banker" or "Banking" or any word of like import. Section 67 imposes a similar restriction in respect of the words "savings bank" or any words of like import on any person or body of persons not included among the savings banks specified in Part II of the First Schedule to that Act.

- (c) Protection of word "Anzac" Regulations—(Statutory Rules 1921, No. 2 and No. 216, Statutory Rules 1959, No. 29 and Statutory Rules 1962, No. 79) provide that no person shall, without the authority of the Attorney-General of the Commonwealth, assume or use the word "Anzac" or any word resembling the word "Anzac" in connection with any trade, business, calling or profession or in connection with any entertainment or any lottery or art union.
- (d) Defence (Prohibited Words and Letters) Regulations (Statutory Rules 1957, No. 16) prohibit the use in connection with a trade, business, calling or profession or by an organization or body of persons of the words and letters set out therein (being words and letters indicative of a part of the armed forces of the Commonwealth or of the United Kingdom) without the consent in writing of the Minister for the time being administering the Defence Act.
- (e) The *Boy Scouts' Association Act* 1924: Section 2, places a prohibition on any person using, without authority, the name "The Boy Scouts' Association" or the name of any local branch of the Association or any name implying that any other society or body is the Association or a branch of the Association.
- (f) *Australian Bicentennial Authority Act* 1980: Section 22 provides that, except with the consent in writing of the Australian Bicentennial Authority, a person shall not use the name of the Authority, an abbreviation of the name of the Authority or a prescribed expression (as listed in paragraph 22 (6) (d) of the Australian Bicentennial Authority Act) in connection with a business, trade, profession or occupation.
- (g) *Geneva Conventions Act* 1957: Section 15 prohibits the use of the designation "Red Cross", "Geneva Cross", "Red Crescent" or "Red Lion and Sun", or wording resembling any of those designations, for any purpose whatsoever, without the consent of the Minister for Defence or an authorized person.

3. The following is a list of some Victorian Statutes which contain additional restrictions on the use of names:

*Architects Act* 1958.  
*Building Societies Act* 1976.  
*Chiropodists Act* 1968.  
*Chiropractors and Osteopaths Act* 1978.  
*Co-operation Act* 1958.  
*Dentists Act* 1972.  
*Health Act* 1958.  
*Legal Profession Practice Act* 1958.  
*Medical Practitioners Act* 1970.  
*Nurses Act* 1958.  
*Optometrists Registration Act* 1958.  
*Pharmacists Act* 1974.  
*Physiotherapists Act* 1978.  
*Police Regulation Act* 1958.  
*Second-hand Dealers (Charity Collectors) Act* 1970.  
*Veterinary Surgeons Act* 1958.

#### Melbourne and Metropolitan BOARD OF WORKS

Notice to the Owners and Tenements in the Undermentioned Streets and the Private Streets, Lanes, Courts and Alleys opening thereto.

The main pipe in the said streets being laid down, the owners of all tenements situated as under are hereby required on or before 23 July 1984 to cause a proper pipe and stop cocks to be laid so as to supply water within such tenements from the main pipe.

##### Berwick

- Benalla Close, the total street from Axedale Crescent, southwards.  
 Avenel Place, the total street from Axedale Crescent, southwards.  
 Ensay Court, the total street from Axedale Crescent, southwards.  
 Axedale Crescent, from Heywood Grove to Kennington Park Drive.  
 Heywood Grove, from 30 metres north of Clifton Way further northwards, 180 metres.

##### Broadmeadows

- Sandham Road, from Wright Street eastwards, 154 metres.  
 Gretna Close, the total street from Sandham Road southwards.

##### Croydon

- Burgess Road (Western Arm), from Burgess Close southwards, 105 metres.  
 Morgan Avenue, from 15 metres south of Malseed Street further southwards, 116 metres.  
 Emmerson Street, from Mt Dandenong Road northwards, 126 metres.

##### Dandenong

- 160 Gladstone Road (westside—cluster subdivision 30 metres south of Keenan Court), the total street from Gladstone Road westwards.  
 Weist Court, the total street from Riddell Street southwards.  
 Riddell Street, from Bellbrook Drive north-eastwards and eastwards, 258 metres.  
 Bellbrook Drive, from 50 metres southeast of Ashby Drive further south-eastwards, 183 metres.  
 Bellbrook Drive, from 30 metres north-west of Riddell Street further north-westwards, 190 metres.  
 Ashby Drive, from Bellbrook Drive north-eastwards, 70 metres.

##### Diamond Valley

- Tathra Place, the total street from Pindari Drive north-westwards.  
 Alloo Court, the total street from Pindari Drive northwards.  
 Ellaroo Close, the total street from Allumba Drive northwards.  
 Pindari Drive, from 18 metres west of Beales Lane further westwards, 212 metres.

##### Doncaster and Templestowe

- Warrandyte-Ringwood Road (eastside), from 15 metres south of Wellesely Road further southwards, 410 metres.  
 Drysdale Road, from Leber Street south-westwards, 277 metres.  
 Grandview Road, the total street from Beauty Gully Road northwards.  
 Aloha Gardens, the total street from Bali Hi Boulevard north-westwards and south-westwards.

Bali Hi Boulevard, from 35 metres west of Jenkins Drive further westwards, 50 metres.

Old Warrandyte Road, from 50 metres north of Sandra Court to Tindals Road.

Tindals Road, from Old Warrandyte Road north-eastwards, 368 metres.

#### Keilor

Cromer Place, the total street from Odessa Avenue eastwards then northwards.

Burrowye Crescent, from Rutherglen Way south-eastwards, 197 metres.

Rutherglen Way, from north building line of Tintalra Drive south-westwards, 309 metres.

Willandra Court, the total street from Angourie Crescent south-westwards.

Numinbah Court, the total street from Angourie Crescent northwards.

Angourie Crescent, from 35 metres south of Cocoparra Crescent south-eastwards, 266 metres.

#### Knox

Yellowstone Close, the total street from Superior Avenue south-westwards.

Glenelg Court, the total street from Superior Avenue southwards.

Ladonga Place, the total street from Superior Avenue southwards.

Superior Avenue, from 45 metres southeast of Mississippi Drive south-eastwards, 265 metres.

#### Lillydale

Dorchester Avenue, from Belvedere Drive eastwards, 98 metres.

Norman Berry Drive (northside), from Russell Road to Warburton Highway.

Drummond Road, from Warburton Highway north-eastwards, 159 metres.

Penola Drive, from Norman Berry Drive north-eastwards, 249 metres.

Ducol Court, the total street from Penola Drive south-eastwards.

Hickman Place, the total street from Russell Road eastwards.

Russell Road, from Norman Berry Drive northwards, 84 metres.

Johns Crescent, from Quinn Crescent northwards, 813 metres.

Davey Road, the total street from Johns Crescent northwards.

Marne Road, from Lillydale-Montrose Road to Blue Wren Court, excepting lots 10, 11 and 12.

Blue Wren Court, the total street from Marne Road eastwards, 180 metres.

Commercial Road, from Marne Road northwards, 371 metres.

Quinn Crescent, from Johns Crescent south-westwards, 105 metres.

Imperial Avenue, from 130 metres south-west of Royal Avenue further south-westwards, 104 metres.

Elsie Street, from Royal Avenue south-westwards, 235 metres.

Mary Road, from Beenak Road south-westwards, 197 metres.

Mt Dandenong Road (southside), from Canterbury Road north-westwards, 570 metres.

#### Malvern

Shrewsbury Street, from Rotherwood Drive south-westwards, 28 metres.

#### Preston

Bellevue Crescent, from 56 metres east of Swanston Street eastwards, north-eastwards and westwards, 212 metres.

#### Ringwood

Mundara Drive, from Wonga Road eastwards, 173 metres.

Gilston Way, from Mundara Drive northwards, 41 metres.

Oakleaf Court, the total street from Mundara Drive southwards.

Windarra Court, the total street from Wonga Road eastwards.

Gem Close, the total street from Windarra Court eastwards.

Montanus Court, the total street from Wonga Road north-eastwards.

Marcia Close, the total street from Montanus Court south-eastwards.

Holyrood Crescent, from Montanus Court southwards, 47 metres.

Glendale Road, from Lookover Road northwards, 548 metres.

#### Sherbrooke

Birds Road, from Old Main Road south-westwards and westwards, 292 metres.

Glenfern Close, the total street from Glenfern Road westwards.

George Street, from Albert Street southwards and south-westwards, 220 metres.

#### Springvale

Willow-Glen Court, from 20 metres north of O'Brien Close further northwards, 101 metres.

#### Sunshine

Fitzgerald Road, from Whitesides Avenue southwards, 562 metres.

Hall Street, from Fitzgerald Road eastwards, 155 metres.

#### Waverley

Stanton Court, the total street from Shepherd Road northwards.

Connaught Place, the total street from Shepherd Road northwards.

Torwood Avenue, from 35 metres south of Appletree Drive further southwards, 108 metres.

Roswell Street, from 70 metres south of Eastleigh Drive further southwards then westwards, 207 metres.

Swindon Avenue, from 20 metres east of Vine Court further eastwards, 138 metres.

#### Werribee

Gambier Court, the total street from Morris Road eastwards.

Bayview Crescent, from Vernon Court south-westwards and westwards, 250 metres.

#### Whittlesea

Northumberland Drive, from Buckland Crescent north-westwards, 293 metres.

Asquith Court, the total street from Buckland Crescent north-westwards.

Trafford Way, from Northumberland Drive northwards, 33 metres.

Kempton Court, the total street from Pentland Drive north-westwards.

Pentland Drive, from Northumberland Drive north-eastwards eastwards and south-eastwards, 352 metres.

Stirling Court, the total street from Pentland Drive southwards.

Yorkshire Court, the total street from Pentland Drive south-westwards.

Durban Court, the total street from Pentland Drive north-eastwards.

Manchester Street, from Pentland Drive northwards, 33 metres.

Holburn Way, from Pentland Drive southwards, 81 metres.

Main Street, from Glenburn Street westwards, 23 metres.

Dated 12 June 1984

H. G. FORD  
Director of Administration

**PUBLIC TRUSTEE ACT 1958, SECTION 17**

I hereby give notice that on 27 April 1984 the Public Trustee filed an Election to Administer the following deceased person's estate in accordance with section 17 of the *Public Trustee Act 1958*:

Andreassen, Maxwell Lindsay, late of Kew, pensioner, died 4 November 1983.

Dated 2 May 1984

P. T. SPENCER  
Public Trustee

168 Exhibition Street, Melbourne, 3000

I hereby give notice that on 28 May 1984 the Public Trustee filed an election to administer the following deceased person's estate in accordance with section 17 of the *Public Trustee Act 1958*:

Arnold, Joy Sylvia, late of 51 Alma Road, St. Kilda, widow, died 13 February 1984.

I hereby give notice that on 1 June 1984 the Public Trustee filed elections to administer the following deceased persons' estates in accordance with section 17 of the *Public Trustee Act 1958*:

Clarke, Alma, also known as Sister Gertrude Joseph, late of Little Sisters of the Poor, St. Georges Road, Northcote, Member of Religious Order, died 16 March 1983.

Dunn, Ruby, late of Beechworth, retired, died 22 March 1983.

Hegedus, Maria, late of Hanslope Private Nursing Home, 12 Hanslope Avenue, Alphington, pensioner, died 12 March 1984.

Keating, Mary Eliza, late of 41 King Street, Queenscliff, widow, died 5 March 1984.

McEwen, Elva Mary, formerly of 2 Cain Street, Footscray, but late of 22 Errol Street, Footscray, married woman, died 4 March 1984.

Mitchell, Samuel Thomas, also known as Thomas Smythe, but late of 20 Victoria Avenue, Mitcham, retired public servant, died 12 December 1983.

Perazzo, Gordon Henry, formerly of 44 Cameron Street, Moreland, but late of 39A Investigator Street, Red Hill, A.C.T., retired public servant, died 1 February 1984.

I hereby give notice that on 8 June 1984 the Public Trustee filed an election to administer the following deceased person's estate in accordance with section 17 of the *Public Trustee Act 1958*:

White, George Groves, late of Mont Park, retired farm hand, died 6 April 1984.

Dated 13 June 1984

P. T. SPENCER  
Public Trustee

168 Exhibition Street, Melbourne, 3000

Creditors, next of kin, and others having claims against the estate of any of the under-mentioned deceased persons are required to send particulars of their claims to the Public Trustee, 168 Exhibition Street, Melbourne, Vic. 3000, the personal representative, on or before 27 August 1984 after which date the Public Trustee may convey or distribute the assets having regard only to the claims of which the Public Trustee then has notice:

Arnold, Joy Sylvia, late of 51 Alma Road, St. Kilda, widow, died 13 February 1984.

Clarke, Alma, also known as Sister Gertrude Joseph, late of Little Sisters of the Poor, St. Georges Road, Northcote, Member of Religious Order, died 16 March 1983.

Dunn, Ruby, late of Beechworth, retired, died 22 March 1983.

Hegedus, Maria, late of Hanslope Private Nursing Home, 12 Hanslope Avenue, Alphington, pensioner, died 12 March 1984.

Hooper, Richard Charles, late of 22 Collier Crescent (in the Will called Street), Brunswick, retired ticket checker, died 9 April 1984.

Keating, Mary Eliza, late of 41 King Street, Queenscliff, widow, died 5 March 1984.

Lebicz, Gregory, late of 5 Mulberry Parade, Heidelberg West, invalid pensioner, died 19 March 1984.

Leonard, Gregory James, late of 181 Nicholson Street, Bairnsdale, retired district telephone manager, died 27 October 1983.

McEwen, Elva Mary, formerly of 2 Cain Street, Footscray, but late of 22 Errol Street, Footscray, married woman, died 4 March 1984.

McNeil, Bernice May, late of 5 Duke Street, Kew, widow, died 12 March 1984.

Mitchell, Samuel Thomas, also known as Thomas Smythe, late of 20 Victoria Avenue, Mitcham, retired public servant, died 12 December 1983.

Paterson, James Stephen, formerly of Flat 8, 22 The Esplanade, St. Kilda, but late of Nicholson Caravan Park, Nicholson, clerk, died 23 March 1984.

Perazzo, Gordon Henry, formerly of 44 Cameron Street, Moreland, but late of 39A Investigator Street, Red Hill, A.C.T., retired public servant, died 1 February 1984.

Probert, Luther John, late of Milthorpe Road, Diamond Creek, retired, died 4 January 1983.

White, Edith Emily, formerly of 24 Warley Road, East Malvern, but late of Centennial House, 313 Punt Road, Prahran, widow, died 14 April 1984.

White, George Groves, late of Mont Park, retired farm hand, died 6 April 1984.

Dated 13 June 1984

P. T. SPENCER  
Public Trustee

**VETERINARY SURGEONS ACT 1958 (as Amended)**

The Veterinary Board of Victoria on Wednesday, 9 May 1984, conducted an Inquiry into whether Doctor Jennifer Margaret Nairn, a registered veterinary surgeon of 33 Burwood Road, Hawthorn, Victoria used the business name Burwood Road Clinic for Cats in contravention of Rule 46 (1) of the Veterinary Surgeons Regulations 1969.

In respect of the charge, the Board found the said Dr Nairn guilty as charged and reprimanded Dr Nairn for this act.

B. D. WANSBURY  
Registrar

**VETERINARY SURGEONS ACT 1958 (AS AMENDED)**

Pursuant to section 15A (5) of the *Veterinary Surgeons Act 1958* notice is hereby given by the Veterinary Board of Victoria that an application made under section 15A (4) of the Act has been received from the Animal Welfare League of Victoria seeking the making of an Order declaring that it be a recognized body for the purposes of the Act.

Any persons wishing to make a submission with respect to the application are required to set forth such submission in writing to the Registrar, Veterinary Board of Victoria, 272 Brunswick Road, Brunswick, 3056, by 20 July 1984.

B. D. WANSBURY  
Registrar

*Associations Incorporation Act 1981***DIRECTION BY ATTORNEY-GENERAL**

1. James Harley Kennan, Her Majesty's Attorney-General for the State of Victoria, being the Minister for the time being administering the *Associations Incorporation Act 1981*, pursuant to the powers conferred by section 12 of the said Act hereby direct that the Registrar of Incorporated Associations shall not, except with the consent of the Minister for the time being administering the said Act register under the said Act an association by a name that is a name or a name of a kind mentioned hereunder.

1. Names that are likely to be confused with or mistaken for—

- (a) the name of a company, recognized company, recognized foreign company or registered foreign company to which the provisions of the Companies (Victoria) Code apply; or
- (b) the name of an incorporated association, building society, co-operative company, co-operative society, co-operative housing society, credit union or friendly society; or
- (c) a registered business name.

2. Names which are misleading in relation to the nature, objects or purposes of the business conducted or to be conducted under those names, or in relation to any other matter.

3. Names that are likely to be offensive to members of the public or members of any section of the public.

4. Names containing the following words or phrases or any abbreviation thereof or any words, phrases or abbreviations of like import:

"America's Cup", "Building Society", "Chamber of Commerce", "Chamber of Manufactures", "Chartered", "College of Advanced Education", "Consumer", "Co-operative", "Credit Union", "Executor", "Friendly Society", "Guarantee", "Institute of Advanced Education", "Made in Australia", "Oxfam", "Savings", "Starr Bowkett", "Stock Exchange", "Trust", "Trustee", "University".

5. Names which, in the context in which they are proposed to be used, are capable of suggesting:

- (a) connection with a member of the Royal Family when the connection suggested does not exist; or
- (b) that Royal patronage has been received when this is not the case.

6. Names which, in the context in which they are proposed to be used, are capable of suggesting connection with the Crown, the Government of the Commonwealth of Australia or of a State or Territory or any other part of the Queen's dominions, possessions or territories.

7. Names which include the words "Commonwealth" or "Federal".

8. Names which, in the context in which they are proposed to be used, are capable of suggesting connection with the government of a foreign country.

9. Names which, in the context in which they are proposed to be used, are capable of suggesting connection with a department, authority or instrumentality of the Government of the Commonwealth of Australia or of a State or Territory or with a municipal or other local authority.

10. Names which, in the context in which they are proposed to be used, are capable of suggesting:

- (a) connection with ex-servicemen's organizations when the connection suggested does not exist; or
- (b) that the members of an organization are totally or partially incapacitated when this is not the case.

Dated 4 June 1984

J. H. KENNAN  
Attorney-General

*Hospitals and Charities Act 1958***BROADMEADOWS AND DISTRICTS HELPING HAND ASSOCIATION FOR MENTALLY RETARDED CHILDREN**

## Petition to Incorporate

It is notified in accordance with the provisions of sections 46 and 64 of the *Hospitals and Charities Act 1958* that the Health Commission of Victoria has received a petition signed by twenty-six contributors to an organization known as Broadmeadows and Districts Helping Hand Association for Mentally Retarded Children praying that the organization be incorporated as a benevolent society under the provisions of the said Act.

The organization will have for its objects:

- (a) To establish, manage and maintain educational centres for mentally retarded persons;
- (b) To establish, manage and maintain occupational training centres for the purpose of training over school age mentally retarded persons;
- (c) To establish, manage and maintain a community centre and welfare organization for mentally retarded persons and relatives—
  - to provide activity in leisure hours;
  - to provide avenues of useful citizenship activities;
  - to provide study classes for parents and relatives, and to give assistance on home problems;
- (d) To assist parents of mentally handicapped persons, who are in necessitous circumstances in problems relating to accommodation, transport, psychiatric or medical treatment or other problems of a like nature;
- (e) To arouse, the general public to a greater understanding of the needs of mentally retarded persons, and of mental deficiency;
- (f) To have printed and published any newspapers, periodicals, books or leaflets that the Centre may think desirable for the promotion of its Objects;
- (g) To co-operate with the Government to increase facilities for mentally retarded persons, and to improve the existing facilities for mentally retarded persons;
- (h) To do all such things as are incidental or conducive to the attainment of any, or all, of the above Objects.

If a counter petition signed by an equal or greater number of contributors is not lodged with the aforesaid Commission at 555 Collins Street, Melbourne, within one calendar month of publication of this notice the Governor in Council may, by Order pursuant to the *Hospitals and Charities Act 1958*,

declare the contributors for the time being to Broadmeadows and Districts Helping Hand Association for Mentally Retarded Children to be a body corporate by the name set forth in such order.

Dated 6 June 1984

J. H. KENNAN  
Acting Minister of Health  
Health Commission of Victoria  
Melbourne

*Hospitals and Charities Act 1958*  
DONALD AND DISTRICT NURSING HOME  
Petition to Incorporate

It is notified in accordance with the provisions of section 46 of the *Hospitals and Charities Act 1958* that the Health Commission of Victoria has received a petition signed by twenty-eight contributors to an organization known as Donald and District Nursing Home praying that the organization be incorporated as an institution under the provisions of the said Act.

The organization will have for its objects:

- (a) To provide nursing home care and accommodation for all persons falling within those categories defined under the Aged or Disabled Persons Homes Act 1954-74 and who are assessed as being in need of such care and accommodation.
- (b) To purchase or otherwise acquire any real and or personal property.
- (c) To do such other things which, in the Committee's opinion will provide for the economic, social and recreational well-being of patients.

If a counter petition signed by an equal or greater number of contributors is not lodged with the aforesaid Commission at 555 Collins Street, Melbourne, within one month of publication of this notice the Governor in Council may, by Order pursuant to the *Hospitals and Charities Act 1958*, declare the contributors for the time being to Donald and District Nursing Home to be a body corporate by the name set forth in such order.

Dated 14 June 1984

J. H. KENNAN  
Acting Minister of Health  
Health Commission of Victoria  
Melbourne

*Town and Country Planning Act 1961*  
SHIRE OF BUNGAREE PLANNING SCHEME  
Amendment No. 14  
Notice of Amendment

In pursuance of the powers conferred by the *Town and Country Planning Act 1961*, the Governor in Council on 13 June 1984, amended the abovementioned scheme in respect of the municipal district of the Shire of Bungaree and for which the Shire of Bungaree is the Responsible Authority.

The amendment comes into operation on the date this Notice is published in the *Government Gazette*.

The amendment corrects misspelt words and phrases in the Ordinance.

A copy of the documents may be inspected free of charge, during office hours, at the office of the Ministry for Planning and Environment (Plan Inspection Section), 5th Floor, 235 Queen Street, Melbourne and at the office of the responsible authority Shire of Bungaree, Shire Office, Leigh Creek.

DAVID YENCKEN  
Secretary for Planning and Environment

*Town and Country Planning Act 1961*  
SHIRE OF BUNINYONG PLANNING SCHEME

Amendment No. 23

Notice of Amendment

In pursuance of the powers conferred by the *Town and Country Planning Act 1961*, the Governor in Council on 13 June 1984, amended the abovementioned scheme in respect of the municipal district of the Shire of Buninyong and for which the Shire of Buninyong is the Responsible Authority.

The amendment comes into operation on the date this Notice is published in the *Government Gazette*.

The amendment corrects misspelt words and phrases in the Ordinance.

A copy of the documents may be inspected free of charge, during office hours, at the office of the Ministry for Planning and Environment (Plan Inspection Section), 5th Floor, 235 Queen Street, Melbourne and at the office of the responsible authority Shire of Buninyong, Shire Offices, Learmonth Street, Buninyong.

DAVID YENCKEN  
Secretary for Planning and Environment

*Town and Country Planning Act 1961*  
WANGARATTA SUB-REGIONAL PLANNING  
SCHEME

(Shire of Wangaratta)

Revocation No. 3

Notice of Revocation

Notice of Order Under Section 32 (5)

In pursuance of the powers conferred by the *Town and Country Planning Act 1961*, the Governor in Council on 13 June 1984, revoked in part the abovementioned scheme in respect of land described as Crown Allotment 3, section 2, Parish of Wangaratta North and made an Order pursuant to section 32 (5).

A copy of the Order relating to the revocation may be inspected during office hours at the office of the Ministry for Planning and Environment (Plan Inspection Section) 5th Floor, 235 Queen Street, Melbourne, and Astra House, Jack Hore Place, Wodonga, and at the office of the Shire of Wangaratta, Ely Street, Wangaratta.

DAVID YENCKEN  
Secretary for Planning and Environment

*Town and Country Planning Act 1961*  
SHIRE OF MILDURA PLANNING SCHEME INTERIM  
DEVELOPMENT ORDER

Amendment No. 10

Notice of Amendment

In pursuance of the powers conferred by the *Town and Country Planning Act 1961*, the Governor in Council on the 13 June 1984, amended the abovementioned Order in respect of properties in Irymple Avenue, Irymple described as:

Pt CA 1; Pt CA1; Pts CA 1 and 2; Pt CA 2; Lot 1 Pt CA 4; Lot 2 Pt CA 4; Lots 1-5 LP 56103; Lot 2 and Lot 3 LP 75038, section 41 Block F Parish of Mildura and Pt CA 15; Pt CA 15; Lot 1 LP 135268, section 42 Block F Parish of Mildura—

and for which the Council of the Shire of Mildura is the Responsible Authority.

The amendment comes into operation on the date this Notice is published in the *Government Gazette*.

The amendment includes rezoning said land from Rural Highway and Rural A to Urban zone.

A copy of the documents may be inspected free of charge, during office hours at the office of the Ministry for Planning and Environment (Plan Inspection Section), 5th Floor, 235 Queen Street, Melbourne, and at the office of the Council of the Shire of Mildura at Irymple.

DAVID YENCKEN  
Secretary for Planning and Environment

*Town and Country Planning Act 1961*  
MELBOURNE METROPOLITAN PLANNING SCHEME  
Amendment No. 245  
Notice of Amendment

In pursuance of the powers conferred by the *Town and Country Planning Act 1961*, the Governor in Council on 19 June 1984, amended the abovementioned scheme in respect of the municipal district of the City of Melbourne and for which the Melbourne and Metropolitan Board of Works is the Responsible Authority.

The amendment comes into operation on the date this notice is published in the *Government Gazette*.

The amendment rezones land bounded by Spencer Street, Jeffcott Street, Adderley Street and Latrobe Street, West Melbourne, from Commercial and Industrial to Public Purposes Reservation No. 20—Other Public Uses (Remand Centre).

A copy of the documents may be inspected free of charge, during office hours, at the office of the Ministry for Planning and Environment (Plan Inspection Section), 5th Floor, 235 Queen Street, Melbourne, and at the office of the Melbourne and Metropolitan Board of Works, 625 Little Collins Street, Melbourne.

DAVID YENCKEN  
Secretary for Planning and Environment

*Town and Country Planning Act 1961*  
SHIRE OF MORNINGTON PLANNING SCHEME 1959  
amendment No. 161, 1983  
Notice of Approval

In pursuance of the powers conferred by the *Town and Country Planning Act 1961*, the Governor in Council on 19 June 1984, approved the abovementioned scheme in respect of the municipal district of the Shire of Mornington and for which the Council of the Shire of Mornington is the Responsible Authority.

The Scheme comes into operation on the date this notice is published in the *Government Gazette*.

The Scheme includes the rezoning of land bounded on the north by Wyatt Road, on the east by Racecourse Road and on the south by Tyabb Road, known as Lots 8 and 9 on L.P.6506, from Parkland Industrial 1 to Special Use 1 (in part) and Public Purposes Reservations (Municipal Purposes—Depot and Australia Post/Telecom Australia) in part.

A copy of the documents may be inspected free of charge, during office hours, at the office of the Ministry for Planning and Environment (Plan Inspection Section), 5th Floor, 235 Queen Street, Melbourne and at the Shire of Mornington, Shire Office, Queen Street, Mornington.

DAVID YENCKEN  
Secretary for Planning and Environment

*Town and Country Planning Act 1961*  
CITY OF KNOX PLANNING SCHEME  
Amendment No. 266  
Notice of Amendment

In pursuance of the powers conferred by the *Town and Country Planning Act 1961*, the Governor in Council on 19 June 1984, amended the abovementioned scheme in respect of the municipal district of the City of Knox and for which the Council of the City of Knox is the Responsible Authority.

The Amendment comes into operation on the date this notice is published in the *Government Gazette*.

The amendment includes the rezoning of part of Lot 2, L.P. 8723, Burwood Highway, Wantirna South, from Stream Zone to Special Uses "E" (Car Parking) Zone to provide a parking area for a proposed commercial development. In relation to this amendment an agreement under section 52A of the Act has been entered into between the Mayor, Councillors and Citizens of the City of Knox and Jolu Nominees Pty. Ltd.

A copy of the document may be inspected free of charge, during office hours, at the office of the Ministry for Planning and Environment (Plan Inspection Section), 5th Floor, 235 Queen Street, Melbourne, and at the City of Knox Civic Centre, 511 Burwood Highway, Knoxfield.

DAVID YENCKEN  
Secretary for Planning and Environment

*Town and Country Planning Act 1961*  
MELBOURNE METROPOLITAN PLANNING SCHEME  
Amendment No. 272, Part 1  
Notice of Approval

In pursuance of the powers conferred by the *Town and Country Planning Act 1961*, the Governor in Council on 13 June 1984, approved the abovementioned scheme in respect of the municipal districts of the Shire of Werribee and the City of Knox and for which the Melbourne and Metropolitan Board of Works is the Responsible Authority.

The scheme comes into operation on the date this Notice is published in the *Government Gazette*.

The scheme includes—

- (i) the rezoning of Lots 105–108 and part Lot 109, Neville Avenue, Laverton, to Restricted Business Zone;
- (ii) the rezoning of 8.5 ha of land, being part of Crown section 3 and 4, Parish of Narree Worrana, located generally west of Stud Road and south of Wellington Road, Rowville, to Reserved Living Zone;
- (iii) to include a number of allotments in the "Golden Wattle Ranges Estate," Hurstbridge, in the Table to sub-clause (1) (c) of Clause 11A, to enable the creation of a detached house to be permitted on each allotment; and
- (iv) an amendment to the Table to Sub-clause (2) of Clause 22 of the Planning Scheme Ordinance to provide for a reduction in the number of car spaces required to be provided at the Target Shopping Centre, Plenty Road, Preston, from 923 to 845.

A copy of the documents may be inspected free of charge, during office hours, at the office of the Ministry for Planning and Environment (Plan Inspection Section), 5th Floor, 235 Queen Street, Melbourne and at the office of the Melbourne and Metropolitan Board of Works, 625 Little Collins Street, Melbourne.

DAVID YENCKEN  
Secretary for Planning and Environment



*Town and Country Planning Act 1961*  
**MELBOURNE METROPOLITAN PLANNING SCHEME**  
 Amendment No. 227, Part 2B  
 Notice of Approval

In pursuance of the powers conferred by the *Town and Country Planning Act 1961*, the Governor in Council on 13 June 1984, approved the abovementioned scheme in respect of the municipal district of the City of Coburg and for which the Melbourne and Metropolitan Board of Works is the Responsible Authority.

The scheme comes into operation on the date this Notice is published in the *Government Gazette*.

The scheme includes the rezoning of land generally south-west of Jenkin Street and west of Elizabeth Street to Residential "C" Zone.

A copy of the documents may be inspected free of charge, during office hours, at the office of the Ministry for Planning and Environment (Plan Inspection Section), 5th Floor, 235 Queen Street, Melbourne and at the office of the Melbourne and Metropolitan Board of Works, 625 Little Collins Street, Melbourne.

DAVID YENCKEN  
 Secretary for Planning and Environment

*Town and Country Planning Act 1961*  
**GEELOG REGIONAL PLANNING SCHEME**  
 Amendment No. 87, 1983  
 Notice of Approval

In pursuance of the powers conferred by the *Town and Country Planning Act 1961*, the Governor in Council on 13 June 1984, approved the abovementioned scheme in respect of part of the municipal districts of the Shire of Corio and Bannockburn and for which the Geelong Regional Commission is the Responsible Authority.

The scheme comes into operation on the date this Notice is published in the *Government Gazette*.

The scheme includes the rezoning of land situated on the north-west corner of Friend-in-Hand Road and Hamilton Highway, Stonehaven from Public Purposes Existing—11—Education Department to Rural General Farming, and the rezoning of land situated within Windsor Reserve Norlane fronting Rose Avenue, from Public Open Space (Existing)—B to Residential "A" zone.

A copy of the documents may be inspected free of charge, during office hours, at the office of the Ministry for Planning and Environment (Plan Inspection Section), 5th Floor, 235 Queen Street, Melbourne and at the office of the Geelong Regional Commission, Geelong Public Offices, corner Little Malop and Fenwick Streets, Geelong.

DAVID YENCKEN  
 Secretary for Planning and Environment

*Town and Country Planning Act 1961*  
**GEELOG REGIONAL PLANNING SCHEME**  
 Amendment No. 88  
 Notice of Approval

In pursuance of the powers conferred by the *Town and Country Planning Act 1961*, the Governor in Council on 13 June 1984, approved the abovementioned scheme in respect of the municipal district of the Shire of Corio and for which the Geelong Regional Commission is the Responsible Authority.

The amendment comes into operation on the date this Notice is published in the *Government Gazette*.

No. 67—78340/84—3

The amendment includes an ordinance change to remove out of date Noise Exposure forecast contours from the planning scheme maps in the area around Avalon Airfield, north of Geelong.

A copy of the documents may be inspected free of charge, during office hours, at the office of the Ministry for Planning and Environment (Plan Inspection Section), 5th Floor, 235 Queen Street, Melbourne and at the office of the Geelong Regional Commission, corner Little Malop and Fenwick Streets, Geelong.

DAVID YENCKEN  
 Secretary for Planning and Environment

*Town and Country Planning Act 1961*  
**GEELOG REGIONAL PLANNING SCHEME**  
 Notice that a Planning Scheme (Amending) has been Prepared and is Available for Inspection  
 Amendment No. 101

Notice is hereby given that the Geelong Regional Commission in pursuance of its powers under the *Town and Country Planning Act 1961*, has prepared an Amending Scheme for land within the following area:

Item No. 1. Land at the end of Chaucer and Glengate Streets, Hamlyn Heights. Zone change from Reserved Residential, Residential A and Public Open Space (Proposed) B to the Public Open Space (Existing) B.

A copy of the Amending Scheme has been deposited at this office—Geelong Regional Commission, State Government Offices, corner of Little Malop and Fenwick Streets, Geelong, at the offices of the Corio Shire Council, Osborne House, Swinburne Street, North Geelong (insofar as the Municipality is affected) and at the office of the Ministry for Planning and Environment, (Plan Inspection Section) 5th Floor, 235 Queen Street, Melbourne, and will be open for inspection during office hours by any person, free of charge.

Any persons affected by the Amending Scheme are required to set forth in writing any submissions they may wish to make with respect to the Amending Scheme addressed to the Secretary, Mr G. R. Cowling, Geelong Regional Commission, P.O. Box 770, Geelong, by Thursday 20 September 1984, and to state whether you wish to be heard in respect of your submission.

G. R. COWLING  
 Secretary, Geelong Regional Commission

**APPOINTMENTS AND  
 RESIGNATIONS**

**APPOINTMENT**

His Excellency the Governor of the State of Victoria by and with the advice of the Executive Council thereof has by Order made on 13 June 1984 been pleased to make the undermentioned appointment, viz.:

Health Commission

*Member of the Committee of Management of Hospital*  
 Bryan Hudson to be a member of the Committee of Management of the Queen Victoria Medical Centre pursuant to the provisions of section 63F (2) of the *Hospitals and Charities Act 1958*, for the period of office, 30 June 1984 to 30 September 1986.

TOM FORRISTAL  
 Clerk of the Executive Council

At the Executive Council Chamber  
 Melbourne, 13 June 1984

*Liquor Control Act 1968*

## APPOINTMENT OF LICENSING INSPECTORS

In accordance with the authority conferred upon me by section 6 of the *Police Regulation Act 1958*, I, Eric Archibald Mudge, Deputy Commissioner of Police, do hereby appoint under sub-section (1) of section 22 of the *Liquor Control Act 1968*, the following Officers of Police as Licensing Inspectors for the Divisions of the Police Districts as shown.

Division Number	Police District	Rank and Name
4	Maroondah	Inspector Herbert Schnerring, No. 13324 (from 17.6.84 to 7.7.84).
1	Melbourne	Inspector Robert Keith Rumbold, No. 12795 (from 10.6.84 to 7.7.84).

Dated 14 June 1984

E. A. MUDGE  
Deputy Commissioner (Administration)

*Public Service Act 1974 and Stock Diseases Act 1968*

## APPOINTMENT OF INSPECTOR

The Public Service Board, by certificate dated 28 May 1984, has appointed Susan E. Heath, Agricultural Officer, Temporary, as an Inspector of Stock without additional salary.

DAVID F. SMITH  
Director-General of Agriculture

## RESIGNATION

His Excellency the Governor of the State of Victoria by and with the advice of the Executive Council thereof has by Order made on 13 June 1984 accepted the resignation of the person named hereunder of the office mentioned, viz:

Health Commission

*Member of the Committee of Management of Hospital*

Darcy, Barbara as member of the Committee of Management of the Birregurra and District Community Hospital as from 21 May 1984, in accordance with the provisions of section 63G (1) of the *Hospitals and Charities Act 1958*.

TOM FORRISTAL  
Clerk of the Executive Council

At the Executive Council Chamber  
Melbourne, 13 June 1984

## ORDERS IN COUNCIL

## INDUSTRIAL RELATIONS ACT 1979

*At the Executive Council Chamber, Melbourne, the  
twenty-second day of May 1984*

PRESENT:

His Excellency the Governor of Victoria  
Mr Walker | Mr Crabb  
Mr White | Mrs Toner

## APPOINTMENT OF ACTING CHAIRMAN OF CONCILIATION AND ARBITRATION BOARDS

In pursuance of the powers conferred by the *Industrial Relations Act 1979*, and all other powers him thereunto enabling, His Excellency the Governor of the State of Victoria, by and with the advice of the Executive Council thereof, by this Order appoints James Sam Folino to act as a Chairman

of Conciliation and Arbitration Boards during a period of three months from 24 May 1984 inclusive, while Kenneth Williams, a Chairman of such Boards, is absent from duty.

And the Honourable Steven Marshall Crabb, Her Majesty's Minister for Industrial Affairs for the State of Victoria, shall give the necessary directions herein accordingly.

TOM FORRISTAL  
Clerk of the Executive Council

## INDUSTRIAL RELATIONS ACT 1979

*At the Executive Council Chamber, Melbourne, the  
twenty-second day of May 1984*

PRESENT:

His Excellency the Governor of Victoria  
Mr Walker | Mr Crabb  
Mr White | Mrs Toner

## APPOINTMENT OF ACTING MEMBER OF THE INDUSTRIAL RELATIONS COMMISSION OF VICTORIA

In pursuance of the powers conferred by section 8 (3) of the *Industrial Relations Act 1979*, and all other powers him thereunto enabling, His Excellency the Governor of the State of Victoria, by and with the advice of the Executive Council thereof, by this Order appoints—

Kenneth Williams  
a person who has had extensive experience in the conduct of industrial relations to act as a Member of the Industrial Relations Commission of Victoria during a period of three months from 24 May 1984 inclusive, while Robert John Garlick, a Member of the said Commission, is absent from duty.

And the Honourable Steven Marshall Crabb, Her Majesty's Minister for Industrial Affairs for the State of Victoria, shall give the necessary directions herein accordingly.

TOM FORRISTAL  
Clerk of the Executive Council

*Water and Sewerage Authorities (Restructuring) Act 1983  
Water Act 1958*

## SHIRE OF NUMURKAH

*At the Executive Council Chamber, Melbourne, the  
thirteenth day of June 1984*

PRESENT:

His Excellency the Governor of Victoria  
Mr Walker | Mr Simpson  
Mr Mathews | Mr Simmonds

## APPROVAL OF SITE WORKS FOR EXTENSION TO WATER TREATMENT PLANT

Whereas under the provisions of the *Water and Sewerage Authorities (Restructuring) Act 1983*, and the *Water Act 1958*, and all other powers enabling him in that behalf, His Excellency the Governor of the State of Victoria, by and with the advice of the Executive Council of the said State doth hereby approve of the site of works required for an extension of the water treatment plant for the Shire of Numurkah as shown by red border on the plan approved by the Governor in Council and deposited in the office of the Director of Water Resources, Melbourne (Corr. No. 81/2567/44).

And the Honourable David Ronald White, Her Majesty's Minister of Water Supply for the State of Victoria, shall give the necessary directions herein accordingly.

TOM FORRISTAL  
Clerk of the Executive Council

LAND CONSERVATION ACT 1970 (No. 8008)

At the Executive Council Chamber, Melbourne, the thirteenth day of June 1984

PRESENT:

His Excellency the Governor of Victoria  
 Mr Walker | Mr Simpson  
 Mr Mathews | Mr Simmonds

Pursuant to Section 7 of the Land Conservation Act His Excellency the Governor of the State of Victoria, by and with the advice of the Executive Council thereof, doth hereby approve without modification or alteration, the proposals submitted by the Land Conservation Council to the Minister for Planning and Environment on 4 June 1984 as shown in Appendix A hereunder.

APPENDIX A

On 7 June 1983 the Governor in Council approved the investigation of a number of areas by the Land Conservation Council. The areas approved included the Melbourne Area District 1 Review as shown on plan S25 and the Melbourne Area District 2 Review as shown on plan S26.

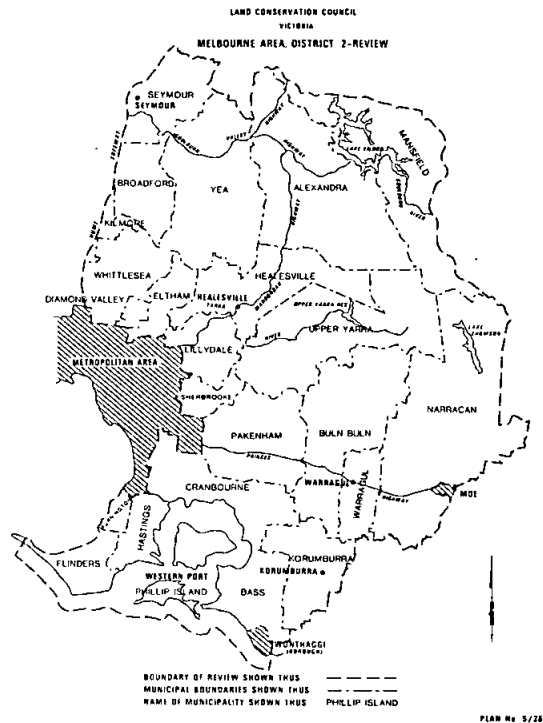
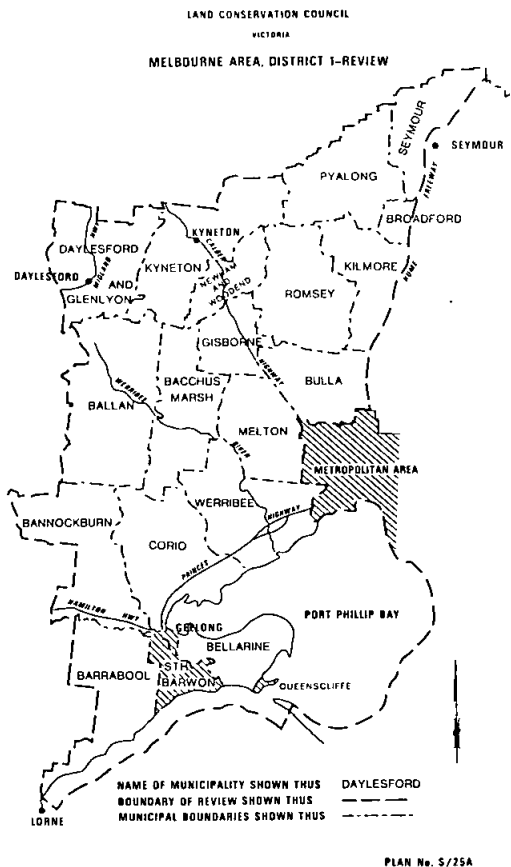

Part of the approved boundary which separates districts 1 and 2 is the Hume Highway. This highway has now been replaced by the Hume Freeway as the major northern traffic route out of Melbourne.

It is therefore considered that the Hume Freeway should form part of the boundary between districts 1 and 2 of the Melbourne Area for the purposes of the Council's review of public land. This boundary is shown on the attached Land Conservation Council plans S25A and S26A.

The coastal boundary has also been extended to include coastal waters.

S. G. McL. DIMMICK  
 Chairman

And the Honourable Evan Walker Her Majesty's Minister for Planning and Environment for the State of Victoria, shall give the necessary directions herein accordingly.

TOM FORRISTAL  
 Clerk of the Executive Council

SUPERANNUATION ACT 1958

At the Executive Council Chamber, Melbourne, the thirteenth day of June 1984

PRESENT:

His Excellency the Governor of Victoria  
 Mr Walker | Mr Simpson  
 Mr Mathews | Mr Simmonds

Pursuant to the powers conferred by the provisions of paragraph (ja) of sub-section (1) of section 3 of the Superannuation Act 1958, His Excellency the Governor of the State of Victoria, by and with the advice of the Executive Council thereof doth by this Order declare that the provisions of the Superannuation Act shall apply to the officers named in the Schedule set out hereunder.

SCHEDULE

Oaten, Peter Joseph	Flagstaff College of Technical and Further Education.
Hopgood, Peter Frederick	Hawthorn Institute of Education
Marshall, Ronald	Hawthorn Institute of Education
Sewell, Christine Anne	Police Reserve
Arnold, Elston Francis	Road Construction Authority
Purchase, Lee David	Road Construction Authority
Abela, Anthony John	Road Traffic Authority
White, Peter James	Victorian Institute of Secondary Education

And the Honourable Robert Allen Jolly, Her Majesty's Treasurer for the State of Victoria, shall give the necessary directions herein accordingly.

TOM FORRISTAL  
Clerk of the Executive Council

LAND ACT 1958

At the Executive Council Chamber, Melbourne, the thirteenth day of June 1984

PRESENT:

His Excellency the Governor of Victoria  
Mr Walker | Mr Simpson  
Mr Mathews | Mr Simmonds

UNUSED ROAD CLOSED

His Excellency the Governor of the State of Victoria, in the Commonwealth of Australia, by and with the advice of the Executive Council of the said State, pursuant to the provisions of section 349 of the *Land Act 1958* and with the concurrence in writing of the council of the municipality concerned and that of any adjoining land owners, doth hereby close the unused road hereinafter described, viz.:

Township of Tatura in the Shire of Rodney being the road indicated by hatching on plan hereunder—(L7-3218) (T252 (3)).

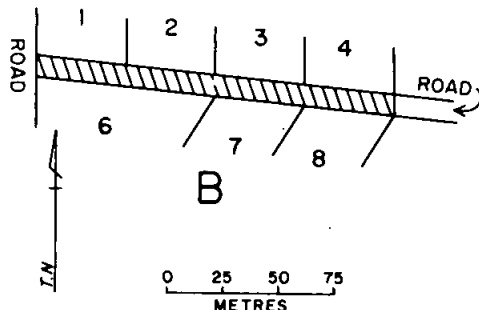

And the Honourable Roderick Alexander Mackenzie, Her Majesty's Minister for Conservation, Forests and Lands for the State of Victoria, shall give the necessary directions herein accordingly.

TOM FORRISTAL  
Clerk of the Executive Council

LAND ACT 1958

At the Executive Council Chamber, Melbourne, the thirteenth day of June 1984

PRESENT:

His Excellency the Governor of Victoria  
Mr Walker | Mr Simpson  
Mr Mathews | Mr Simmonds

UNUSED ROAD CLOSED

His Excellency the Governor of the State of Victoria, in the Commonwealth of Australia, by and with the advice of the Executive Council of the said State, pursuant to the provisions of section 349 of the *Land Act 1958* and with the concurrence in writing of the council of the municipality concerned and that of any adjoining land owners, doth hereby close the unused road hereinafter described, viz:

Parish of Frankston in the City of Frankston being the road indicated by hatching on plan hereunder—(L11-3315) F87 (5).

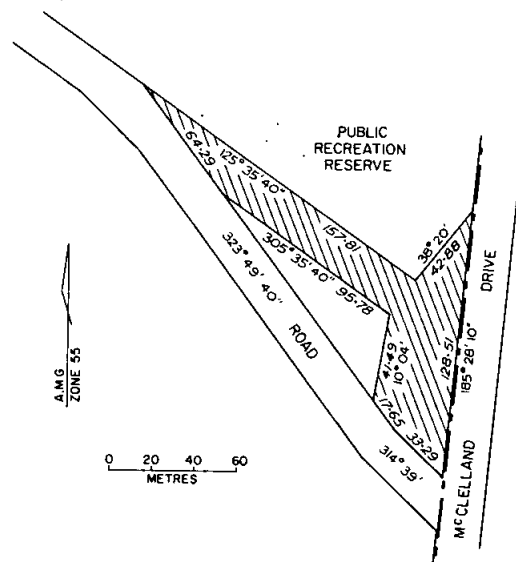

And the Honourable Roderick Alexander Mackenzie, Her Majesty's Minister for Conservation, Forests and Lands for the State of Victoria, shall give the necessary directions herein accordingly.

TOM FORRISTAL  
Clerk of the Executive Council

CROWN LAND (RESERVES) ACT 1978

At the Executive Council Chamber, Melbourne, the thirteenth day of June 1984

PRESENT:

His Excellency the Governor of Victoria  
Mr Walker | Mr Simpson  
Mr Mathews | Mr Simmonds

CROWN LAND PERMANENTLY RESERVED

His Excellency the Governor of the State of Victoria in the Commonwealth of Australia, by and with the advice of the Executive Council of the said State, pursuant to the provisions of sections 4 and 7 of the *Crown Land (Reserves) Act 1978*,

and being of the opinion that the Crown land concerned is required for the purpose mentioned, doth hereby permanently reserve and also except from prospecting or from occupation for mining purposes under any miner's right, the Crown land hereinafter described, viz:

Municipal District—City of Heidelberg

Heidelberg—For Conservation of an Area of Historic Interest

648 square metres, being Crown allotment 10 section 7 Township of Heidelberg, Parish of Keelbundora, as shown on Certified Plan No. 106305 lodged in the Central Plan Office—(Rs. 9274).

And the Honourable Roderick Alexander Mackenzie, Her Majesty's Minister for Conservation, Forests and Lands for the State of Victoria, shall give the necessary directions herein accordingly.

TOM FORRISTAL  
Clerk of the Executive Council

CROWN LAND (RESERVES) ACT 1978

At the Executive Council Chamber, Melbourne, the thirteenth day of June 1984

PRESENT:

His Excellency the Governor of Victoria

Mr Walker	Mr Simpson
Mr Mathews	Mr Simmonds

CROWN LAND TEMPORARILY RESERVED

His Excellency the Governor of the State of Victoria in the Commonwealth of Australia, by and with the advice of the Executive Council of the said State, pursuant to the provisions of sections 4 and 7 of the *Crown Land (Reserves) Act 1978*, and being of the opinion that the Crown land concerned is required for the public purpose mentioned, doth hereby temporarily reserve and also except from occupation for mining purposes under any miner's right, the Crown land hereinafter described; viz:

Municipal District—Shire of Hastings

Crib Point—For a State School

3.907 hectares, being Crown allotment 30, Section 2, Township of Crib Point, Parish of Bittern as shown on Certified Plan No. 106309 lodged in the Central Plan Office—(Rs. 12313).

And the Honourable Roderick Alexander Mackenzie, Her Majesty's Minister for Conservation, Forests and Lands for the State of Victoria, shall give the necessary directions herein accordingly.

TOM FORRISTAL  
Clerk of the Executive Council

CROWN LAND (RESERVES) ACT 1978

At the Executive Council Chamber, Melbourne, the thirteenth day of June 1984

PRESENT:

His Excellency the Governor of Victoria

Mr Walker	Mr Simpson
Mr Mathews	Mr Simmonds

CROWN LAND TEMPORARILY RESERVED

His Excellency the Governor of the State of Victoria, in the Commonwealth of Australia, by and with the advice of the Executive Council of the said State, pursuant to the provisions of sections 4 and 7 of the *Crown Land (Reserves) Act 1978*, and being of the opinion that the Crown land concerned is required for the public purpose mentioned, doth hereby temporarily reserve and also except from occupation for mining purposes under any miner's right, the Crown land hereinafter described, viz:

Act 1978, and being of the opinion that the Crown land concerned is required for the public purpose mentioned, doth hereby temporarily reserve and also except from occupation for mining purposes under any miner's right, the Crown land hereinafter described, viz.:

Municipal District—Shire of Birchip

Birchip—For Public Recreation.

4059 square metres, being Crown allotment 8A section 5, Township of Birchip, Parish of Wirmbirchip, as indicated by hatching on plan hereunder—(B 711 (3)) (Rs. 11644).

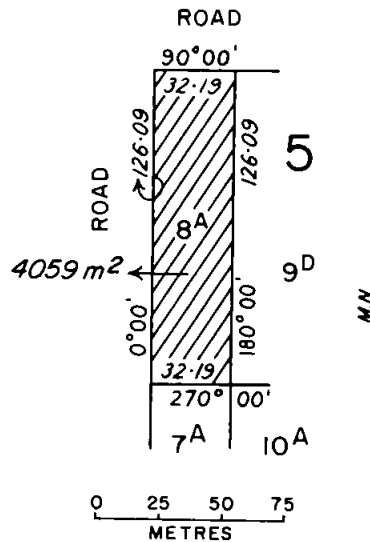

And the Honourable Roderick Alexander Mackenzie, Her Majesty's Minister for Conservation, Forests and Lands for the State of Victoria, shall give the necessary directions herein accordingly.

TOM FORRISTAL  
Clerk of the Executive Council

CROWN LAND (RESERVES) ACT 1978

At the Executive Council Chamber, Melbourne, the thirteenth day of June 1984

PRESENT:

His Excellency the Governor of Victoria

Mr Walker	Mr Simpson
Mr Mathews	Mr Simmonds

REVOCATION OF TEMPORARY RESERVATIONS OF LANDS BY ORDERS IN COUNCIL

His Excellency the Governor of the State of Victoria, in the Commonwealth of Australia, by and with the advice of the Executive Council of the said State, pursuant to the provisions of section 10 of the *Crown Land (Reserves) Act 1978*, doth hereby revoke the temporary reservations of lands by Orders in Council hereinafter described, viz.:

Ouyen—The temporary reservation by Order in Council of 14 August 1979 of 128 hectares of land being Crown allotment 20A, Parish of Ouyen for Public Purposes (Soil Conservation) (Rs.10913).

Wongarra—The temporary reservation by Order in Council of 13 February 1894 of 58 hectares, more or less, of land in the Parish of Wongarra for Public Recreation—(Rs.6353).

Frankston—The temporary reservation by Order in Council of 6 September 1915 of 4034 square metres of land in the Parish of Frankston for Road purposes—(Rs. 1543).

Mirboo North—The temporary reservation by Order in Council of 14 October 1958 of 8600 square metres of land in the Township of Mirboo North for the purposes of the Forests Act so far only as the portion containing 5208 square metres, as defined by description and hatching on plan published in the *Government Gazette* dated 23 May 1984—(Rs.7601).

And the Honourable Roderick Alexander Mackenzie, Her Majesty's Minister for Conservation, Forests and Lands for the State of Victoria, shall give the necessary directions herein accordingly.

TOM FORRISTAL  
Clerk of the Executive Council

#### CROWN LAND (RESERVES) ACT 1978

*At the Executive Council Chamber, Melbourne, the thirteenth day of June 1984*

##### PRESENT:

His Excellency the Governor of Victoria	
Mr Walker	Mr Simpson
Mr Mathews	Mr Simmonds

#### CROWN LAND PERMANENTLY RESERVED

His Excellency the Governor of the State of Victoria in the Commonwealth of Australia, by and with the advice of the Executive Council of the said State, pursuant to the provisions of sections 4 and 7 of the *Crown Land (Reserves) Act 1978*, and being of the opinion that the Crown land concerned is required for the purpose mentioned, doth hereby permanently reserve and also except from prospecting or from occupation for mining purposes under any miner's right, the Crown land hereinafter described, viz:

South Melbourne—For Conservation of an Area of Historic Interest.

1.119 hectares, being Crown allotment 77B, City of South Melbourne, Parish of Melbourne South, as shown on Certified Plan No. 101289 lodged in the Central Plan Office—(Rs 10182).

And the Honourable Roderick Alexander Mackenzie, Her Majesty's Minister for Conservation, Forests and Lands for the State of Victoria, shall give the necessary directions herein accordingly.

TOM FORRISTAL  
Clerk of the Executive Council

#### CROWN LAND (RESERVES) ACT 1978

*At the Executive Council Chamber, Melbourne, the thirteenth day of June 1984*

##### PRESENT:

His Excellency the Governor of Victoria	
Mr Walker	Mr Simpson
Mr Mathews	Mr Simmonds

#### CROWN LAND PERMANENTLY RESERVED

His Excellency the Governor of the State of Victoria in the Commonwealth of Australia, by and with the advice of the Executive Council of the said State, pursuant to the provisions

of sections 4 and 7 of the *Crown Land (Reserves) Act 1978*, and being of the opinion that the Crown land concerned is required for the purpose mentioned, doth hereby permanently reserve and also except from prospecting or from occupation for mining purposes under any miner's right, the Crown land hereinafter described, viz:

Municipal District—Shire of Flinders

Balnarring—For Conservation of an Area of Natural Interest

2.642 hectares, being Crown allotments 66H and 66J, Parish of Balnarring, as shown on Certified Plan No. 106139 lodged in the Central Plan Office—(Rs 7252).

And the Honourable Roderick Alexander Mackenzie, Her Majesty's Minister for Conservation, Forests and Lands for the State of Victoria, shall give the necessary directions herein accordingly.

TOM FORRISTAL  
Clerk of the Executive Council

#### CROWN LAND (RESERVES) ACT 1978

*At the Executive Council Chamber, Melbourne, the thirteenth day of June 1984*

##### PRESENT:

His Excellency the Governor of Victoria	
Mr Walker	Mr Simpson
Mr Mathews	Mr Simmonds

#### CROWN LAND PERMANENTLY RESERVED

His Excellency the Governor of the State of Victoria in the Commonwealth of Australia, by and with the advice of the Executive Council of the said State, pursuant to the provisions of sections 4 and 7 of the *Crown Land (Reserves) Act 1978*, and being of the opinion that the Crown land concerned is required for the purpose mentioned, doth hereby permanently reserve and also except from prospecting or from occupation for mining purposes under any miner's right, the Crown land hereinafter described, viz:

Municipal District—Shire of Hampden

Wilgul North—For Conservation of an Area of Natural Interest

7.7 hectares, being Crown allotment 69A Parish of Wilgul North County of Grenville as shown on Certified Plan No. 106130 lodged in the Central Plan Office—(Rs 11283).

And the Honourable Roderick Alexander Mackenzie, Her Majesty's Minister for Conservation, Forests and Lands for the State of Victoria, shall give the necessary directions herein accordingly.

TOM FORRISTAL  
Clerk of the Executive Council

#### CROWN LAND (RESERVES) ACT 1978

*At the Executive Council Chamber, Melbourne, the thirteenth day of June 1984*

##### PRESENT:

His Excellency the Governor of Victoria	
Mr Walker	Mr Simpson
Mr Mathews	Mr Simmonds

#### CROWN LAND TEMPORARILY RESERVED FOR AN ADDITIONAL PURPOSE

His Excellency the Governor of the State of Victoria in the Commonwealth of Australia, by and with the advice of the Executive Council of the said State, pursuant to the provisions

of sections 4 and 7 of the *Crown Land (Reserves) Act 1978*, and being of the opinion that the Crown land concerned is required for the additional purpose mentioned, doth hereby temporarily reserve and also except from occupation for mining purposes under any miner's right, the Crown land hereinafter described, viz:

Municipal District—Shire of Bairnsdale

Wuk Wuk—For the additional purpose of Public Recreation

2023 square metres in the Parish of Wuk Wuk, being the land temporarily reserved for a Public Hall by Order in Council of 2 November 1949 (see *Government Gazette* dated 9 November 1949)—(Rs. 6453).

And the Honourable Roderick Alexander Mackenzie, Her Majesty's Minister for Conservation, Forests and Lands for the State of Victoria, shall give the necessary directions herein accordingly.

TOM FORRISTAL  
Clerk of the Executive Council

#### CROWN LAND (RESERVES) ACT 1978

*At the Executive Council Chamber, Melbourne, the  
thirteenth day of June 1984*

PRESENT:

His Excellency the Governor of Victoria

Mr Walker	Mr Simpson
Mr Mathews	Mr Simmonds

#### CROWN LAND PLACED UNDER THE CONTROL AND MANAGEMENT OF THE DIRECTOR OF NATIONAL PARKS

His Excellency the Governor of the State of Victoria, in the Commonwealth of Australia, by and with the advice of the Executive Council of the said State, pursuant to the provisions of section 18 (1) of the *Crown Land (Reserves) Act 1978* doth hereby place under the control and management of the Director of National Parks, the Crown land hereinafter described, viz:

Municipal District—Shire of Otway

Aire—The land in the Parish of Aire permanently reserved for the Conservation of an Area of Natural Interest, by Order in Council of 29 November 1983—(see *Government Gazette*, dated 7 December 1983) (Rs. 11208).

And the Honourable Roderick Alexander Mackenzie, Her Majesty's Minister for Conservation, Forests and Lands for the State of Victoria, shall give the necessary directions herein accordingly.

TOM FORRISTAL  
Clerk of the Executive Council

#### LOCAL GOVERNMENT ACT 1958

*At the Executive Council Chamber, Melbourne, the  
thirteenth day of June 1984*

PRESENT:

His Excellency the Governor of Victoria

Mr Walker	Mr Simpson
Mr Mathews	Mr Simmonds

#### AUTHORIZATION OF WORKS OR UNDERTAKINGS IN GREENDALE FOR THE PURPOSES OF DIVISION 5 OF PART X OF THE LOCAL GOVERNMENT ACT 1958—SHIRE OF BALLAN

Whereas it is provided in section 277 (2) of the *Local Government Act 1958* that any works or undertakings not

authorized by that Act (being works or undertakings that are for the special benefit of any particular portion of the municipal district) may, on the application of the council of the municipality, be authorized by Order of the Governor in Council published in the *Government Gazette* and the council may make and levy a rate herein called a "separate rate" in respect of rateable property in such portion exclusively.

And whereas the Council of the Shire of Ballan has made application to have the works or undertakings of electricity reticulation, being works or undertakings that are for the special benefit of a particular portion of the municipal district, in Greendale in the municipal district of the Shire of Ballan to be authorized works or undertakings for the purposes of Division 5 of Part X of the *Local Government Act 1958*.

Now therefore, His Excellency the Governor of the State of Victoria, by and with the advice of the Executive Council thereof and in pursuance of the said section 277 (2) does by this Order authorize the works of electrical reticulation to Lots 1 to 105 inclusive on Plan of Subdivision No. 93708, Lots 1 and 2 on Plan of Subdivision No. 96349 and Crown Allotments 24, 2 and 3 Parish of Blackwood in the municipal district of the Shire of Ballan to be an authorized work or undertaking for the purpose of the said Division 5 of Part X of the *Local Government Act 1958*.

And the Honourable Frank Noel Wilkes, Her Majesty's Minister for Local Government for the State of Victoria, shall give the necessary directions herein accordingly.

TOM FORRISTAL  
Clerk of the Executive Council

#### Water Act 1958

#### MOYHU WATERWORKS TRUST

*At the Executive Council Chamber, Melbourne, the  
thirteenth day of June 1984*

PRESENT:

His Excellency the Governor of Victoria

Mr Walker	Mr Simpson
Mr Mathews	Mr Simmonds

#### EXTENT OF MOYHU WATERWORKS DISTRICT INCREASED, OXLEY URBAN DISTRICT PROCLAIMED, AND SITE OF WORKS APPROVED

Whereas under the provisions of the *Water Act 1958* the Oxley Shire Council has made application for approval of works for the provision of a reticulated water supply for the township of Oxley, and all preliminary procedures under the Act have now been completed.

And whereas the Moyhu Waterworks Trust has agreed to construct and administer the proposed works.

Now therefore, under the powers conferred by the *Water Act* and all other powers enabling him in that behalf, His Excellency the Governor of the State of Victoria, by and with the advice of the Executive Council of the said State, doth hereby—

(a) declare, order and direct that the extent of the Waterworks District of the Moyhu Waterworks Trust be increased by adding thereto the area shown by red border on the accompanying plan approved by the Governor in Council, by and with this Order and deposited in the Office of the Director of Water Resources, Melbourne (Corr. No. 76/1180/57); such lands being wholly within the municipal district of the Shire of Oxley, and as on and from the date hereof the extent of such District shall be and be deemed to be increased accordingly; and

- (b) proclaim that as on and from the date hereof the land shown by green border on the said plan shall be and become an "Urban District" for the purposes of and within the meaning of the said Act and shall be known as Oxley Urban District; and
- (c) state that the principal works to be constructed shall be a pumping station, storage, main pipelines, reticulation mains, and installation of meters on all services; and
- (d) state that the estimated cost of carrying out the proposed works shall be two hundred and sixty-six thousand five hundred dollars (\$266 500); and
- (e) approve of the sites for a pumping station, storage and pipelines as marked (P) and (S) and by yellow line respectively on the said plan; and
- (f) appoint the Moyhu Waterworks Trust to construct, maintain and continue the said works.

And the Honourable David Ronald White, Her Majesty's Minister of Water Supply for the State of Victoria, shall give the necessary directions herein accordingly.

TOM FORRISTAL  
Clerk of the Executive Council

*Geelong Waterworks and Sewerage Act 1958*  
GEELONG WATERWORKS AND SEWERAGE TRUST

*At the Executive Council Chamber, Melbourne, the  
thirteenth day of June 1984*

PRESENT:

His Excellency the Governor of Victoria	
Mr Walker	Mr Simpson
Mr Mathews	Mr Simmonds

CONSENT TO BORROWING \$1 000 000

Under the powers conferred by the Geelong Waterworks and Sewerage Act and all other powers enabling him in that behalf, His Excellency the Governor of the State of Victoria, by and with the advice of the Executive Council of the said State, hereby consents to the Geelong Waterworks and Sewerage Trust borrowing the sum of One million dollars (\$1 000 000) to meet the cost of Loan Nos. L.8, N.8, O.8, T.13, W.13, B.12, and X.13 and water supply works.

And the Honourable David Ronald White, Her Majesty's Minister of Water Supply for the State of Victoria, shall give the necessary directions herein accordingly.

TOM FORRISTAL  
Clerk of the Executive Council

*Geelong Waterworks and Sewerage Act 1958*  
GEELONG WATERWORKS AND SEWERAGE TRUST

*At the Executive Council Chamber, Melbourne, the  
thirteenth day of June 1984*

PRESENT:

His Excellency the Governor of Victoria	
Mr Walker	Mr Simpson
Mr Mathews	Mr Simmonds

CONSENT TO BORROWING \$1 000 000

Under the powers conferred by the Geelong Waterworks and Sewerage Act and all other powers enabling him in that behalf, His Excellency the Governor of the State of Victoria,

by and with the advice of the Executive Council of the said State, hereby consents to the Geelong Waterworks and Sewerage Trust borrowing the sum of One million dollars (\$1 000 000) to meet the cost of conversion of Loan Nos. 163, 164, 165, 222, 224, 289, 292 and 291.

And the Honourable David Ronald White, Her Majesty's Minister of Water Supply for the State of Victoria, shall give the necessary directions herein accordingly.

TOM FORRISTAL  
Clerk of the Executive Council

MOTOR CAR ACT 1958

*At the Executive Council Chamber, Melbourne, the  
nineteenth day of June 1984*

PRESENT:

His Excellency the Governor of Victoria

MOTOR CAR TRIALS OF SPEED WITHIN THE TOWN  
OF CAMPERDOWN

Whereas it is enacted by sub-section (2) of section 83 of the *Motor Car Act 1958* that, if a motor car is used on a highway for purposes of racing or of trial of speed, the driver or the person in charge thereof shall be liable to a penalty of not more than five hundred dollars for the first offence and one thousand dollars for a second or subsequent offence, provided that the said sub-section (2) shall not apply to a motor car used as aforesaid on any highway or portion thereof specified by Order in Council published in the *Government Gazette* and on such days and during such hours as are specified in the Order.

And whereas the Camperdown Motor Sports Club, has requested that such an Order be made to enable motor car trials of speed to be conducted by the said Club on Mt. Leura Lookout Road in the Town of Camperdown on 24 June 1984.

Now therefore, His Excellency the Governor of the State of Victoria, by and with the advice of the Executive Council thereof, and in pursuance of the powers conferred by the *Motor Car Act 1958* and all other powers him thereunto enabling doth by this Order specify Mt. Leura Lookout Road, within the Town of Camperdown, as a highway in respect of which any motor car may, without being subject to the application of the said Act, be used for purposes of trials of speed under the control of the said Camperdown Motor Sports Club on 24 June 1984, between the hours of 11.30 o'clock in the forenoon, and 6.00 o'clock in the afternoon, provided that the Officer-in-Charge of Police in attendance is satisfied that the highway is in a satisfactory condition for racing purposes and that adequate arrangements have been made for the safety of the public.

And the Honourable Steven Marshall Crabb, Her Majesty's Minister of Transport for the State of Victoria, shall give the necessary directions herein accordingly.

TOM FORRISTAL  
Clerk of the Executive Council



## LANDS DEPARTMENT NOTICES

Division of Lands  
DEPARTMENT OF CONSERVATION, FORESTS AND  
LANDS

Sale of Crown Land by Auction  
(No. 12434)

On site, 144 Blair Street, Broadmeadows on Saturday 7 July 1984 at 11 a.m.

Crown description: Allotment B1, Section 11, Parish of Will Will Rook.

Area: 687 square metres more or less.

Terms: Deposit 10%. Residue payable on or before 5 October 1984.

Conducting Officer: Mr B. Clements, Project Manager, Property Sales Group.

Auctioneers: John R. Young Real Estate (Vic.) Pty Ltd—(L11-4246) (Property).

R. A. MACKENZIE  
Minister for Conservation, Forests and Lands

Division of Lands  
DEPARTMENT OF CONSERVATION, FORESTS AND  
LANDS

Sale of Crown Land by Auction  
(No. 12433)

On Site, Corner Ballarat Road and Glen Cairn Avenue, Deer Park on Wednesday, 18 July 1984 at 2.30 p.m.

Crown description: Allotment 2A, Section 22, Parish of Derrimut.

Area: 974 square metres more or less.

Terms: Deposit 10%. Residue payable on or before 16 October, 1984.

Conducting Officer: Mr D. Yurcina, Assistant Regional Land Officer, Melbourne.

Auctioneers: R. Tribe and Associates Pty Ltd—(L11-4260) (Property).

R. A. MACKENZIE  
Minister for Conservation, Forests and Lands

Division of Lands  
DEPARTMENT OF CONSERVATION, FORESTS AND  
LANDS

Sale of Crown Land By Tender  
(No. 12432)

179-197 Napier Street, South Melbourne

Tenders close: 3.00 p.m., Thursday, 12 July 1984.

Terms: Deposit 10%; Residue payable within ninety days of acceptance of the tender offer.

Lot 1: Being Crown Allotment 2, Section 34, City of South Melbourne, Parish of Melbourne South, containing 5352 square metres more or less.

Conducting Officer: Mr B. Clements, Project Manager, Property Sales Group.

Selling Agents: Baillieu Allard Real Estate (S.Y.) Pty. Ltd.—(Rs. 9265B) (Property).

R. A. MACKENZIE  
Minister for Conservation, Forests and Lands

### PROPOSED REVOCATION OF TEMPORARY RESERVATION OF LAND BY ORDER IN COUNCIL

In pursuance of the provisions of section 10 of the *Crown Land (Reserves) Act 1978*, notice is hereby given that it is the intention of the Governor in Council to revoke the temporary reservation of land by Order in Council hereunder referred to, viz.:

**KONGWAK**—The temporary reservation by Order in Council of 2 December 1895 of 4.046 hectares of land in the Parish of Kongwak for a Cemetery, so far only as the portion containing 2.635 hectares as indicated by hatching on plan hereunder—(Parish 2901-2) (Rs.5428).

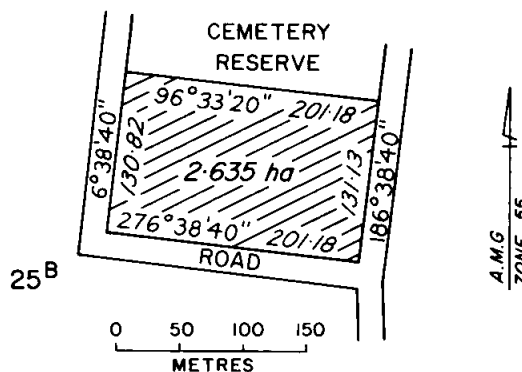
25<sup>B</sup>

**ARCHDALE**—The temporary reservation by Order in Council of 14 January 1936 of 4.2214 hectares of land in the Parish of Archdale for Public Purposes—(Rs.4519).

**ARCHDALE**—The temporary reservation by Order in Council of 28 March 1928 of 1.72 hectares of land in the Parish of Archdale for the Supply of Gravel—(Rs.3608).

**CORINELLA**—The temporary reservation by Order in Council of 16 June 1873 of 8094 square metres of land being Crown allotments 1 and 2 section 20, Township of Corinella, Parish of Corinella for State School purposes—(Rs.7002).

R. A. MACKENZIE  
Minister for Conservation, Forests and Lands  
Department of Crown Lands and Survey  
Melbourne

### REGULATIONS FOR THE CARE PROTECTION AND MANAGEMENT OF "BECKLEY PARK" RACECOURSE AND RECREATION RESERVE

I, Roderick Alexander Mackenzie, Her Majesty's Minister for Conservation, Forests and Lands in and for the State of Victoria, in pursuance of the powers conferred on me by Section 13 of the *Crown Land (Reserves) Act 1978* do hereby make the following Regulations for or with respect to the Crown land in the Parish of Moranghurk (hereinafter referred to as the "Reserve") temporarily reserved for Racecourse and Recreation by Order in Council dated 7 February 1984 (*vide Government Gazette* dated 8 February 1984) in respect of which a Committee of Management (hereinafter referred to as the "Committee") has been appointed.

#### REGULATIONS

1. The Reserve shall be open to the public at all reasonable times, free of charge except on such days as the Reserve may be set apart for maintenance purposes, race meetings, public market, public entertainment, fetes, sports, performance, shows or ceremonies or like purposes on any of which occasions a charge deemed to be reasonable by the Committee may be made and taken for admission to the Reserve, save

that at no time will it be permissible for any person, whether he has paid a charge for admission to the Reserve or whether he has been granted the use thereof, to enter upon any area set aside for harness and greyhound racing tracks or ancillary facilities for racing.

2. No Club, association or person shall hold or take any part in any game of any description, entertainment, performance, public market, show or ceremony in any part of the Reserve without the written authority of the Committee first obtained and then only subject to the payment of such fees and on such terms and conditions as the Committee deems to be reasonable and consistent with these Regulations.

3. No person shall—

- (a) enter or remain in the Reserve who may offend against decency as regards dress, language or conduct, or who may behave in a disorderly or offensive manner, or create or take part in any disturbance;
- (b) enter or remain in the Reserve whilst in a state of intoxication;
- (c) bring into or sell or distribute in the Reserve any intoxicating liquor unless authorized by the Committee and holding a licence or permit as required pursuant to the provisions of the *Liquor Control Act 1968*, and then only in such place or places or portion of the Reserve as may be set apart for the purpose by the Committee;
- (d) climb or jump over the gates or fences in or around the Reserve, stick bills or posters thereon, or cut names on or in any way damage, mark or injure any of the buildings, gates, fences, seats or trees in the Reserve, nor roll or throw stones or any missiles of any kind therein;
- (e) remove, deface or displace any board, plate or fitting, written or printed notice for exhibition of any Regulations or notice fixed or set up by the Committee in the Reserve;
- (f) light a fire in the Reserve except at places as are set apart for such purpose by the Committee;
- (g) do anything whatever in the Reserve for the purpose of making money without the consent of the Committee first obtained;
- (h) play, practise or engage in any organized game, sport or entertainment in the Reserve at any time without the consent of the Committee having been first obtained and then only subject to such conditions as the Committee deems reasonable and consistent with these Regulations;
- (i) take part in any public entertainment of any sort in the Reserve without the permission of the Committee first obtained. All applications for the use of the Reserve must be lodged in writing with the Secretary of the Committee fourteen days before the Reserve or part thereof is required;
- (j) on any portion of the Reserve, cause or permit any outcry sound or noise to be emitted from an amplifier, loud speaker, public address system or like instrument without first obtaining the permission of the Committee, and such permission may be granted subject to such terms, conditions and restrictions as may be imposed by the Committee;
- (k) remain within the Reserve or on any property therein, when lawfully directed to leave the same by any bailiff of Crown lands or member of the Police Force or authorized officer of the Committee;
- (l) dig or remove any sand, soil, stone or other material from the Reserve;

- (m) break glass of any kind or leave or deposit in the Reserve any matter or thing injurious to persons;
- (n) deposit or leave in the Reserve any bottles, glass, tin cans, waste, paper, garbage or litter of any kind except in receptacles provided for the purpose by the Committee;
- (o) play or perform in any band of music, or deliver or read any public speech, lecture, prayer, sermon or address of any kind or sing any sacred or secular song, or enter into any public assemblage on the Reserve except with the consent of the Committee first obtained;
- (p) camp in the Reserve or in any of the buildings therein;
- (q) obstruct, hinder or interfere with any person employed at the Reserve;
- (r) ride a horse, bicycle, motor scooter, motor cycle or trail bike or drive a motor vehicle or any other vehicle within the Reserve recklessly or in a manner which is dangerous to the public, having regard to all the circumstances of the case, or on any area other than that set aside by the Committee for the particular purpose;
- (s) cut, saw, dig, move or displace any trees, bough, live or dead timber, wood or other material which may be in or around the Reserve without the consent of the Committee;
- (t) carry or discharge any firearms or air guns in the Reserve;
- (u) spit or expectorate or commit any nuisance on the paths or in or on any building, structure or erection in the Reserve;
- (v) enter, cross, be on or trespass on any playing ground area, enclosure, course, building, room or structure or any part thereof in the Reserve whilst any sport, game, competition, race, entertainment or amusement is being played, conducted or carried on, or at any time between the commencement and conclusion of such event without the consent of the Committee;
- (w) interfere with or interrupt any game, sports, competition or entertainment or amusement or practise thereat in the Reserve;
- (x) obtain or attempt to obtain admission to any part of the Reserve when not entitled to admission under these Regulations.

4. Any person granted the use of the Reserve or any part thereof for any purpose consistent with the purposes of the reservation shall pay to the Committee such annual or other charge as the Committee considers fair and reasonable and consistent with these Regulations.

5. Persons using, occupying or hiring any stand, building, erection or enclosure in the Reserve on the occasions of any race meetings or other amusements or like activities may be required to deposit a sum which the Committee may at any time determine by way of guarantee that due care shall be taken of such stand, building, erection or enclosure, and such Committee, in its absolute discretion, may make good any loss or damage sustained by such stand, building, erection or enclosure or anything contained therein or by any other property in the Reserve or any losses otherwise sustained by the Committee by reason of such use, occupancy or hiring and deduct the cost of making good such loss or damage from the sum of money deposited by way of guarantee, and all persons so using, occupying or hiring shall abide by these Regulations and by any lawful order or direction which may

be given by the Committee in respect thereof, or for the protection of the property of the Committee or property under its control, or for the safety or the protection of the health of the public therein.

6. All persons using any grandstand or other building or structure in the Reserve shall observe any and every order or direction given by the Committee or any person authorized by the Committee for the prevention of overcrowding or for any other purpose whatsoever.

7. Any person authorized by the Committee may refuse admission to any person to the Reserve or expel any person, from the Reserve if, in the opinion of such authorized person, such refusal or expulsion is conducive to the maintenance of good order therein or to the preservation of the Reserve or is in the interests of other persons resorting thereto.

8. Any person, club, association or other body of persons who has been granted the use of the Reserve or any part thereof pursuant to the provision of Regulations No. (1) and (2) of these Regulations or any person or organization who proposes to use or who uses the Reserve or any part thereof for any organized activity consistent with the purposes of the reservation, including the conduct of stalls, side-shows, or other like activities, shall ensure to the satisfaction of the Committee that a Public Risk Insurance Policy of a nature and to an extent satisfactory to the Committee has been taken out by such persons, club, association, organization or other body of persons prior to the use of the Reserve or any part thereof and remains effective for the duration of such use.

9. Notwithstanding anything else herein contained the Committee may permit any person or persons or community organization, the aims and objects of whom or of which the Committee considers to be generally for the benefit of the Community and consistent with the purposes of the reservation, to use any defined part of the Reserve for the promotion of its objects and for the purpose may—

- (a) grant such a permit either in consideration of payment of such charge as the Committee may determine from time to time or without payment of any charge;
- (b) impose such conditions and/or restrictions on such aforesaid use as the Committee may determine from time to time;
- (c) permit such person or persons or community organization to erect on such aforesaid defined part of the Reserve, such buildings or other structures as the Committee approve for the promotion of the aims and objects of such person or persons or community organizations;
- (d) enter into such written agreements with the person or persons or community organization hereinbefore referred to as the Committee may deem appropriate for more effectively accomplishing the aims and objects of this Regulation.

Given under my Hand at Melbourne on 12 June 1984.

R. A. MACKENZIE

Minister for Conservation, Forests and Lands

Every person who contravenes or fails to comply with these Regulations shall be liable to the penalties prescribed in Section 13 of the *Crown Land (Reserves) Act 1978*.

## T E N D E R S

### PUBLIC WORKS DEPARTMENT

Tenders are invited for the purposes indicated hereunder and will be received at 2 Treasury Place, Melbourne, 3002, until TWO p.m. on dates shown.

Tenders must be addressed to the Minister of Public Works with the envelope endorsed "Tender for

". Hand-delivered tenders must be placed in the Department's tender box in foyer, Ground Floor, 2 Treasury Place, Melbourne.

Tenders documents are available from the Contracts Office, Room 29, 2 Treasury Place, Melbourne and where indicated, at offices of Inspectors of Works.

★Tenders for works identified with star (★) will only be considered from Contractors qualified for repairs and painting works. Any Tenderers wishing to qualify may obtain the application form from the Contracts Office.

### Wednesday, 4 July 1984

#### Building, Electrical and Mechanical Services

FAWKNER—Construction of enclosed link, Tullamarine Regional Office, Education Department.

GLADSTONE VIEWS—Stormwater drainage remedial works, Primary School.

LARUNDEL—Electrical services for engineers workshop, Psychiatric Hospital.

ROYAL PARK—Installation of fire protection system, Psychiatric Hospital.

#### Miscellaneous

DHURRINGILE—Supply of bedside cabinets, H.M. Prison, Office of Corrections, Community Welfare Services.

GLEN WAVERLEY—Maintenance cleaning, Police Station, Police and Emergency Services.

LARUNDEL—(Re-advertised)—Supply and installation of curtains, Psychiatric Hospital.

MELBOURNE—Maintenance cleaning, Coroners' Court, Flinders Street Extension, Law Department.

### Wednesday, 11 July 1984

#### Building, Electrical and Mechanical Services

ESSENDON—Extension to automotive practices workshop, Technical School.

PORT MELBOURNE—Contract 16, 83/84, supply, delivery of 5 No. relocatable modular buildings, F.O.G. Storeyard, 69 Salmon Street. (W.O. Ballarat, Bendigo and Geelong.)

#### Miscellaneous

BARWON HEADS—(Re-advertised)—Maintenance cleaning, Police Station, Police and Emergency Services. (W.O. Geelong.)

EVAN WALKER, M.L.C.  
Minister of Public Works

Public Works Department  
Melbourne, 19 June 1984

**PRIVATE  
ADVERTISEMENTS**

**CITY OF BALLARAT**

**By-Law No. 198  
Victoria Building Regulations By-Law**

Notice is hereby given that at the meeting of the Council held at the Council Chambers, Town Hall, Sturt Street, Ballarat, on Monday 7 May 1984 the Council did agree to a resolution by special order making and passing By-Law No. 198 to be known as the Victoria Building Regulations By-Law for the purposes of—

- (a) repealing By-Laws numbered 154, 167 and 169;
- (b) setting minimum siting and density requirements pursuant to Regulation 11.6 (1) of the Victoria Building Regulations 1983 by adopting a column of Table 11.6 of the said Regulations; and
- (c) prescribed requirements in excess of those specified in the said Table.

A copy of this By-Law is open for inspection free of charge during office hours at the Office of the Council at the Town Hall, Sturt Street, Ballarat.

Dated 7 June 1984

2977 I. C. SMITH, Town Clerk

**Form 2.1**

*Town and Country Planning Act 1961*

**CITY OF CROYDON PLANNING SCHEME 1961**

Notice that a Planning Scheme has been Prepared and is Available for Inspection  
Amendment No. 132

Notice is hereby given that the City of Croydon in pursuance of its powers under the *Town and Country Planning Act 1961* has prepared a scheme for land being Lot 8 on Plan of Subdivision 20449 and known as 328-332 Bayswater Road; and for land being all that land contained in Certificate of Title Volume 9137, Folio 382 and known as 335-343 Dorset Road; and for land being all that land in Plan of Consolidation 150129 and known as 101-109 Maroondah Highway; and for that part of the land contained in Certificate of Title Volume 4515, Folio 744 and zoned Special Uses "B" under the City of Croydon Planning Scheme 1961, and known as 47-51 Maroondah Highway; and to amend the Ordinance.

A copy of the scheme has been deposited at the office of the City of Croydon, Foch Avenue, Croydon 3136, and at the office of the Ministry for Planning and Environment (Plan Inspection Section), 5th Floor, 235 Queen Street, Melbourne 3000, and will be open for inspection during office hours by any person free of charge.

Any persons affected by the scheme are required to set forth in writing any submission they may wish to make with respect to the scheme addressed to the Town Clerk, City of Croydon, P.O. Box 206, Croydon 3136, by 20 July 1984, and state whether you wish to be heard in respect of your submission.

3005

**R. BURTON  
Town Clerk**

**CITY OF WAVERLEY  
Closure of Road to Traffic**

Whereas section 539c of the *Local Government Act 1958* provides that where a Council considers it desirable that any street or road or any part of any street or road be closed to through traffic over the whole or any part of its width may, after preparing a proposal which shall include a plan showing (a) the street or road or part thereof concerned and (b) the points at which barriers are proposed to be erected to prevent the passage of vehicles, the addresses of abutting properties which in the opinion of the Council are properties whose occupiers will be affected by the erection of those barriers and a list of the owners and occupiers of such properties and further after having served notice on the owners and occupiers listed in the proposal, published a public notice in a newspaper generally circulating in the municipal district of its intention to make a resolution adopting the closure of the road to through traffic and having considered a report on the proposal by the Road Traffic Authority, by order published in the *Government Gazette*, adopt the proposal and fix a date on which the order as adopted shall come into operation.

And whereas the Council of the City of Waverley has ordered that Bogong Avenue, east of Kingsway, Glen Waverley, be closed to through traffic by the erection of barriers at the locations shown on the plan hereunder and has served notice on the owners and occupiers listed in the proposal, published a public notice in a newspaper generally circulating in the municipal district and considered all written objections received by it together with the report submitted by the Road Traffic Authority.

Now, therefore, notice is hereby given that the Council of the City of Waverley has resolved that the order as adopted shall come into operation on Monday, 25 June 1984.

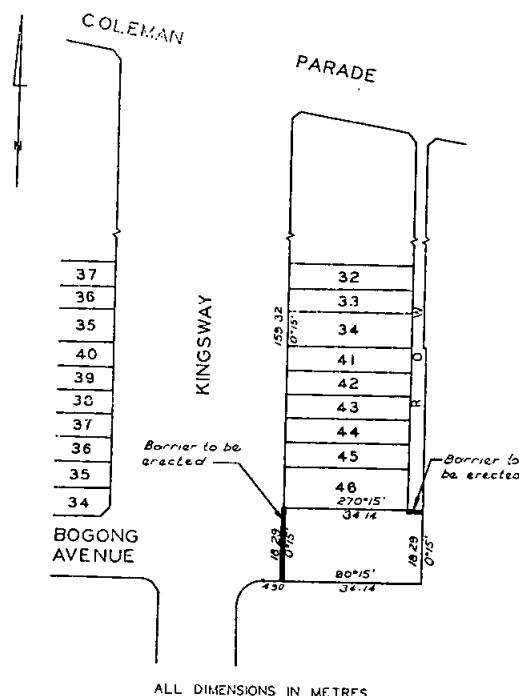

ALL DIMENSIONS IN METRES

3024

**COLIN J. BOCK  
Town Clerk**

*Local Government Act 1958*  
**BOROUGH OF QUEENSCLIFFE**  
 road Discontinuance Resolution

Whereas it is provided in section 528 (2) of the above Act (as amended) that where a road whether or not a public highway (but not being a road set out on Crown land) or any part of that road is not reasonably required as a road for public use, the Council of the municipality in which such road is situated may not less than one month after publishing a public notice in a newspaper generally circulating in the municipal district and giving written notice to the registered proprietor (if any) of the road and to the owners and occupiers (if any) of any land abutting or immediately adjacent to the road of its intention to make a Resolution discontinuing such road or part thereof may by Resolution published in the *Government Gazette* direct that such road or part thereof shall be discontinued and thereupon such road or part of the road shall be discontinued accordingly.

And whereas the Council of the above municipality hereby resolves that an unnamed road off Ward Street, Queenscliff be discontinued and not less than one month previously has published a public notice in a newspaper generally circulating in the municipal district and has given written notice to the registered proprietors of the land in the road and, to the owners and occupiers of lands abutting or immediately adjacent to the road of its intention to make this Resolution and has considered all written objections received by it within fourteen days of the publication of the public notice aforesaid.

Now therefore the Council of the Borough of Queenscliff hereby directs:

- (a) that the said road which is shown by hatching and crosshatching on the plan herewith shall be discontinued (subject to the drainage easement appropriated thereover by Plan of Subdivision No. 22149) upon publication of this Resolution in the *Government Gazette*;

- (b) that notwithstanding such discontinuance Queenscliff Sewerage Authority shall continue to have and possess the same right title power authority or interest in or relation to the part of the land shown by crosshatching on the said plan as it had or possessed prior to such discontinuance with respect to or in connection with any drains or pipes laid or erected in on or over such land for the purposes of drainage or sewerage;

- (c) that subject to the drainage easement aforesaid and to such right title power authority or interest of Queenscliff Sewerage Authority the land in the said road shall vest in the municipality to be retained by it until it is sold by private treaty.

In witness whereof of the common seal of the municipality was affixed hereto 14 June 1984 in the presence of:

K. POTTER, Mayor  
 L. P. WHELAN, Councillor  
 R. T. FORBES, Town Clerk

(SEAL)

3006

*Town and Country Planning Act 1961*  
**SHIRE OF BET BET INTERIM DEVELOPMENT ORDER 1982**

Notice that an Amendment has been Prepared and is Available for Inspection  
 Amendment No. 1

Notice is hereby given that the Shire of Bet Bet, in pursuance of its powers under the *Town and Country Planning Act 1961*, has prepared an Amendment to the Shire of Bet Bet Interim Development Order 1982, for the inclusion of "House" in Column 2 and deletion of Clause 9.4 of the General Farming Zone of the Shire of Bet Bet Interim Development Order 1982.

A copy of the Amendment has been deposited at the Shire Office, 66 Broadway, Dunolly, at the office of the Department of Planning (Plan Inspection Section), 5th Floor, 235 Queen Street, Melbourne, and at the Regional Office of the Department, Hargreaves Street, Bendigo, and will be open for inspection during office hours by any person free of charge.

Any persons affected by the Amendment are required to set forth in writing any submission they may wish to make with respect to the amendment addressed to the Shire Secretary, Shire of Bet Bet, 66 Broadway, Dunolly, 3472, by 20 July 1984, and state whether you wish to be heard in respect of your submission.

Dated 13 June 1984

J. G. KERR  
 Shire Secretary

2984

*Town and Country Planning Authority Act 1961*  
**SHIRE OF BROADFORD PLANNING SCHEME**  
 Notice that a Planning Scheme has been Prepared and is Available for Inspection

Notice is hereby given that the Shire of Broadford in pursuance of its powers under the *Town and Country Planning Act 1961* has prepared a Scheme for the complete Shire, incorporating the existing provisions of the Interim Development Order for the rural areas and including provisions for Residential, Industrial and Local Business Zones within the Township of Broadford.

A copy of the Scheme has been deposited at the Shire Offices, 113 High Street, Broadford and at the Office of the Ministry for Planning and Environment (Plan Inspection Section), 5th Floor, 235 Queen Street, Melbourne and will be open for inspection during office hours by any person free of charge.

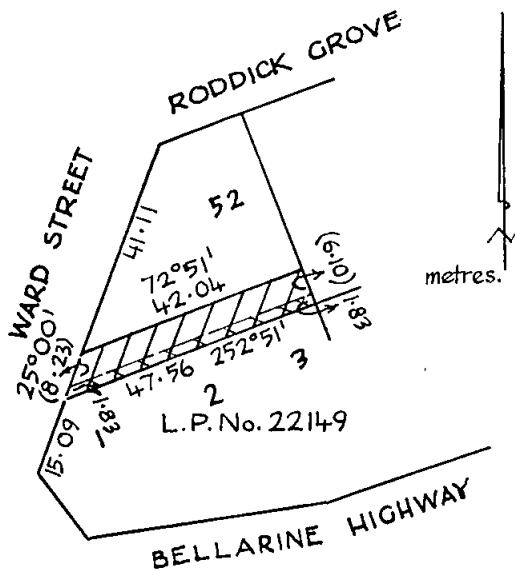

Any persons affected by the Scheme are required to set forth in writing any submission they may wish to make with respect to the Scheme addressed to Shire Secretary, Shire of Broadford, 113 High Street, Broadford, by 20 September 1984 and state whether you wish to be heard in respect of your submission.

Dated 20 June 1984

2976

W. O. TUCKETT, Shire Engineer

#### SHIRE OF CRESWICK

Loan No. 36

Notice of Intention to Borrow the Sum of (\$45 000) for Permanent Works and Undertakings

Notice is hereby given that the Council of the Shire of Creswick proposes to borrow the principal sum of Forty-five Thousand Dollars (\$45 000) secured by a charge over the general rates of the municipality such sum to be raised by the grant of a mortgage in accordance with the provisions of the *Local Government Act 1958*.

The purpose for which the loan is to be applied is:

Refinancing Loan No. 33 which was previously taken up for the construction of municipal offices.

The maximum rate of interest that may be paid is 13.60 per centum per annum.

The period of the loan shall be 4 years notional 6 years.

The moneys borrowed and interest thereon shall be repayable by seven half-yearly instalments of approximately \$5605.35 each on 17 February and 17 August in each year with the final payment of \$19 072.53 being paid on 17 August 1988.

The first instalment shall be repayable on 17 February 1985.

Such moneys shall be repayable at Westpac Banking Corporation Savings Bank Limited, Albert Street, Creswick or such other place as the Bank may nominate from time to time.

As the proposal is to borrow money to liquidate a previous loan the provisions of section 401 (1A) (d) of the *Local Government Act 1958* apply.

2983

B. C. REES  
Shire Secretary

#### SHIRE OF DUNDAS

Notice of Intention to Compulsorily Acquire Land

Take notice that it is the intention of the Council of the Shire of Dundas to compulsorily acquire Crown Allotments 10 and 16, section G, Parish and Township of Cavendish.

A map and papers, indicating the location of the land to be compulsorily acquired, the description of the said land, the purpose for which it is to be compulsorily acquired and the names and addresses of the last known owners/occupiers have been prepared and are available for inspection at the Municipal Offices, corner Pope Street and Market Place, Hamilton, between the hours of 9.30 a.m. and 12.30 p.m., and between 1.30 p.m. and 4.30 p.m. weekdays, for forty clear days from the date of this notice appearing for the first time.

Any person who is affected by the proposed taking of the land and who objects to the said taking should set any objection(s) forth in writing addressed to the Shire Secretary, Shire of Dundas, Post Office Box 425, Hamilton, Victoria, 3300, within forty clear days of this notice appearing for the first time.

2952

J. R. MITCHELL  
Shire Secretary

#### SHIRE OF ELTHAM

Renaming of Street

Notice is hereby given that in accordance with the provisions of the Local Government Act as amended the Council of the Shire of Eltham at its meeting on 4 June 1984 resolved to change the name of a street in the municipality.

*Old name*—Ratray Road East Montmorency

*Old name*—Ratray Road West Montmorency

*New name*—Ratray Road Montmorency

*Location*—That section of Ratray Road East and Ratray Road West between Para Road and Sherbourne Road Montmorency.

2980

R. J. ROSCHOLLER,  
Chief Executive Officer

#### SHIRE OF EUROA

Loan No. 54

Notice of Intention to Borrow the Sum of \$100 000 for Permanent Works and Undertakings

Notice is hereby given that the Council of the Shire of Euroa intends to borrow the sum of One hundred thousand dollars (\$100 000) by the grant of a mortgage secured by a charge over the general rates of the municipality in accordance with the provisions of the Local Government Act.

In connection therewith the following information is stated:

(a) The amount of the principal moneys which it is proposed to borrow is One hundred thousand dollars (\$100 000).

(b) The maximum rate of interest that may be paid is 13.8 per centum per annum.

(c) The period of the loan shall be four (4) years.

(d) The purpose for which the loan is to be applied is for the purchase of plant.

(e) The moneys borrowed shall be repayable by providing out of the municipal fund eight (8) equal half yearly instalments of \$16 681.94 including principal and interest on 1 February and 1 August during the currency of the loan. The first instalment shall be payable on 1 February 1985.

(f) Such moneys shall be repayable at the National Australia Savings Bank Limited Melbourne.

Plans together with estimate of cost of the proposed purchase and a statement showing the proposed expenditure of the moneys to be borrowed are open for inspection at the Shire Office, Euroa.

2951

B. MORAN  
Shire Secretary

*Town and Country Planning Act 1961*

#### SHIRE OF METCALFE—SHIRE OF METCALFE PLANNING SCHEME

Notice that the Shire of Metcalfe Planning Scheme has been Prepared and is Available for Inspection

Notice is hereby given that the Council of the Shire of Metcalfe in pursuance of its powers under the *Town and Country Planning Act 1961* has prepared a scheme for the whole of the municipal district of the Shire of Metcalfe except that part of the North Riding of the Shire which is in the Lake Eppalock Planning Scheme Area. A copy of the scheme has been deposited at the Shire Office, Shire of Metcalfe, Kyneton Road, Metcalfe; at the office of the Loddon—Campaspe Regional Planning Authority, corner Edward and Hargreaves Streets, Bendigo; and at the office of the Department of Planning (Plan Inspection Section), 5th Floor, 235 Queen Street, Melbourne, and will be open for inspection during office hours by any person free of charge.

Any persons affected by the scheme are required to set forth in writing any submission they may wish to make with respect to the scheme addressed to the Shire Secretary, Shire Offices, Metcalfe, Victoria 3448, by Monday, 24 September 1984, and state whether you wish to be heard in support of your submissions.

20 June 1984

DANIEL F. DREW  
Shire Secretary

2982

#### SHIRE OF METCALFE

##### By-Law No. 43

##### Recreational Vehicles By-Law

Please take note that the Council of the Shire of Metcalfe has made a By-Law to prohibit or regulate the use of motorised vehicles for recreational purposes on any land or any specified part or parts of land not being a highway or private street or road or public land within the meaning of the *Land Conservation Act 1970*.

The By-Law was made at the Council meeting held on Tuesday, 17 April 1984, and was submitted for confirmation at the Ordinary Meeting held on Tuesday, 29 May 1984. The By-Law is open for inspection at the Shire Offices, Metcalfe between the hours of 8.30 a.m. and 4.30 p.m.

##### TITLE

The By-Law may be known as the Recreational Vehicles By-Law.

1. A person wishing to use any motorised vehicle for recreational purposes on any land must obtain a written permit from the Council.
2. The owner or occupier of any land shall not permit that land to be used by any motorised vehicle for recreational purposes without a written permit from the Council.
3. The By-Law prescribes that applications for permits shall be in writing and it prescribes information to be supplied with applications.
4. The Council may require the applicant to give notice of the application to persons whom the Council considers may be detrimentally affected or to publish notice of the application.
5. If notice of application has been given, the Council shall not consider the application until a period of 28 days has elapsed since the giving of notice. The Council shall consider all objections to the granting of permit, and the Council may in its discretion grant or refuse to grant a permit with or without conditions.
6. Any permit issued will operate for such period of time as determined by the Council.
7. The By-Law contains general provisions about the construction and maintenance of motorised vehicles used for recreational purposes.
8. The riders of certain types of vehicles will be required to wear approved protective helmets.
9. The Council will have the power to revoke permits for reasons set out in the By-Law.
10. All persons suspected of or contravening the terms of the By-Law shall be required to give their names and addresses to an authorized officer of the Council or to a member of the Victorian Police Force.
11. The By-Law shall operate through the Shire of Metcalfe and shall come into operation the day after publication in the *Government Gazette*.
12. Penalties for offences against the By-Law shall be not less than \$50.00 nor more than \$400.00, and penalties of \$10.00 per day shall apply to continuing offences.

The By-Law was made on Tuesday, 17 April 1984, and confirmed by Special Order passed by the Council at its meeting held on Tuesday, 29 May 1984, when the Common Seal of the President, Ratepayers and Councillors of the Shire of Metcalfe was affixed in the presence of:

J. M. BARTY, President  
E. R. MACTIER, Councillor  
D. F. DREW, Secretary

2981

#### SHIRE OF WOORAYL PLANNING SCHEME

Notice that an Amendment has been Prepared and is Available for Inspection

##### Amendment No. 66

Notice is hereby given that the Shire of Woorayl in pursuance of its powers under the *Town and Country Planning Act 1961* has prepared an amendment for removing a "proposed minor road" through properties between the Esplanade and Hopetoun Street Inverloch.

A copy of the amendment has been deposited at the Shire Office, Smith Street, Leongatha and at the office of the Department of Planning & Environment, 235 Queen Street, Melbourne and will be open for inspection during office hours by any person free of charge.

Any persons affected by the amendment are required to set forth in writing any submissions they wish to make in respect to the scheme addressed to the Minister for Planning & Environment, P.O. Box 2240T, Melbourne 3001, on or by 13 July 1984 and to state whether they wish to be heard in respect of their submissions.

R. G. STANLEY  
Shire Secretary

2949

#### SHIRE OF WOORAYL PLANNING SCHEME

Notice that an Amendment has been Prepared and is Available for Inspection

##### Amendment No. 67

Notice is hereby given that the Shire of Woorayl in pursuance of its powers under the *Town and Country Planning Act 1961* has prepared an amendment for rezoning Nos. 5-17 The Esplanade and 1 Bay Street from commercial A zone to residential B zone and rezoning minor portions of 3 The Esplanade and 14 Hopetoun Street to conform with the major zoning of those allotments.

A copy of the amendment has been deposited at the Shire Office, Smith Street, Leongatha and at the office of the Department of Planning and Environment, 235 Queen Street, Melbourne and will be open for inspection during office hours by any person free of charge.

Any persons affected by the amendment are required to set forth in writing any submissions they wish to make in respect to the scheme addressed to the Shire Secretary, P.O. Box 21, Leongatha, 3953 on or by 20 July 1984 and to state whether they wish to be heard in respect of their submissions.

R. G. STANLEY  
Shire Secretary

2950

#### RUTHERGLEN WATER BOARD

##### Rutherglen Sewerage District

##### Extension to Stage 1 Reticulation

Notice is hereby given that the Board intends to construct sewers in High Street, Rutherglen, west of Church Street in the Police Station property as an extension to previously advertised works.

WALTER J. McQUILLEN  
Secretary/Manager

2988

**CRESWICK SHIRE WATER BOARD****General Notice****Declared Sewerage Area No. 6**

The abovementioned Water Board having made provision for carrying off the sewage from each and every property which or any part of which is within the sewerage area hereinafter described doth hereby declare that on and after 28 May 1984 each and every property which or any part of which is within the said sewerage area shall be deemed to be a sewered property within the meaning of the *Sewerage Districts Act 1958*.

The boundaries of the sewerage area No. 6 hereinbefore referred to are generally as follows:

Government Road and Railway Land to the North;  
Railway Reserve to the East; C.A. 29 and C.A. 47 section 68 to the South and East.

With the exception of the following Lots:

C.A.'s 35, 36 and 38 section 68 Township of Creswick.

By order of the Creswick Shire Water Board

W. H. ROFE, Chairman  
P. R. JACKSON, Secretary

2979

**MOORoopNA WATER BOARD****Notice to Owners of Tenements in the Under-mentioned Streets and Private Streets, Lanes, Courts and Alleys Opening Thereto**

The main pipes in the said streets being laid down, the owners of all tenements situated as under are hereby required on or before 1 August 1984 to cause a proper pipe and stop cocks to be laid so as to supply water within such tenements from the main pipes.

**Mooroopna Waterworks and Urban District**

Norton Drive, Parsons Court, Ducat Court, Hutchins Crescent, Beattie Court, Banfield Avenue, Wilma Court, Helmer Street.

R. F. FORSTER  
Secretary

2986

**MOORoopNA WATER BOARD**

The abovementioned Board, having made provision for carrying off the sewage from each and every property which, or any part of which, is within the sewerage areas hereinafter described, doth hereby declare that on and after 1 August 1984, each and every property which is within the said sewerage areas shall be deemed to be a sewered property within the meaning of the *Sewerage Districts Act*.

The Sewerage Areas hereinafter referred to are:

**Sewerage Area No. 29**

All those pieces of land being Lot Nos. 38 to 75 inclusive on Lodged Plan of Subdivision No. 137587, Part Crown Allotment 7, Parish of Mooroopna. Streets concerned in this area being Norton Drive, Ducat Court and Parsons Court.

**Sewerage Area No. 30**

All those pieces of land being Lots 77 to 87 inclusive on Lodged Plan of Subdivision No. 141947, Part Crown Allotment 6, Parish of Mooroopna. Streets concerned in this area being Hutchins Crescent and Beattie Court.

**Sewerage Area No. 31**

All those pieces of land being Lots 145 to 159 inclusive on Lodged Plan of Subdivision No. 136662 and Lots 160 to 171 inclusive, Part Crown Allotment 25A, Parish of Toolamba. Streets concerned in this area being Banfield Avenue, Wilma Court and Helmer Street.

By order of the Mooroopna Water Board

J. T. GRAHAM, Chairman  
R. F. FORSTER, Secretary

2987

**GEELONG WATERWORKS AND SEWERAGE TRUST**

The abovementioned Trust having made provision for carrying off the sewage from each and every property which or any part of which is within the sewerage area hereinafter described doth hereby declare that on or after 1 July 1984 each and every property which or any part of which is within the said sewerage area shall be deemed and taken to be sewered property within the meaning of the said *Geelong Waterworks and Sewerage Act 1958*.

**Sewerage Area No. 798**

City of South Barwon, Parish of Duneed  
County of Grant

This area comprises all allotments in Raphael Court, Grovedale, allotments Nos. 2525 and 2524 on the west side of Moruya Avenue, allotments Nos. 2517 to 2523 inclusive on the north side of Heyers Road, allotments Nos. 2415 to 2418 inclusive and allotments Nos. 2513 to 2516 inclusive on the south side of Heyers Road.

There are in this area 27 vacant allotments.

**Sewerage Area No. 799**

City of South Barwon, Parish of Conewarre  
County of Grant

This area comprises all allotments in Lansdowne Court, Grovedale, and allotment No. 123 on the west side of Burleigh Drive.

There are in this area:

- (a) 10 houses; and
- (b) 13 vacant allotments.

**Sewerage Area No. 800**

Shire of Corio, Parish of Moorpanyal  
County of Grant

This area comprises allotments Nos. 20 to 36 inclusive Nicholson Crescent, North Geelong.

There are in this area 17 vacant allotments.

**Sewerage Area No. 801**

Shire of Corio, Parish of Moorpanyal  
County of Grant

This area comprises all allotments on the east side of Rennie Street, Lara, between McClelland Avenue and Brunel Close, and those allotments Nos. 2, 15, 16, 17, 18, 27 and 28 on the north side of Brunel Close.

There are in this area:

- (a) 3 houses; and
- (b) 10 vacant allotments.

**Sewerage Area No. 802**

Shire of Corio, Parish of Moorpanyal  
County of Grant

This area comprises allotments 62 to 68 and 71 to 77 in Korakin Street, North Geelong, and allotments Nos. 58 to 61 inclusive on the east side of Nanworen Crescent.

There are in this area 18 vacant allotments.

**Sewerage Area No. 803**

Shire of Corio, Parish of Moorpanyal  
County of Grant

This area comprises allotments Nos. 1 to 3 inclusive on the west side of McCurdy Road, Herne Hill abutting Sewerage Areas Nos. 234, 388 and 504.

There are in this area:

- (a) 1 house; and
- (b) 2 vacant allotments.



Sewerage Area No. 804  
City of South Barwon, Parish of Duneed  
County of Grant

This area comprises allotments Nos. 44, 46 and 47 on the north side of Grove Road, Grovedale abutting Sewerage Areas Nos. 451 and 759.

There are in this area:

- (a) 1 house; and
- (b) 2 vacant allotments.

Sewerage Area No. 805  
Shire of Corio, Parish of Woornyalook  
County of Grant

This area comprises allotments Nos. 1 to 11 inclusive on the north side of Kyema Drive and allotments Nos. 12 to 21 inclusive on the south side of Kyema Drive, Lara, abutting Sewerage Area No. 781.

There are in this area:

- (a) 12 houses; and
- (b) 9 vacant allotments.

Signed under seal of the Geelong Waterworks and Sewerage Trust 13 June 1984.

2985 R. W. WHITESIDE, Chairman  
R. A. JORDAN, Secretary

BRIGHT SEWERAGE AUTHORITY  
Extension of Works Stage 3 Reticulation

Notice is hereby given that the Authority intends to construct Sewers in the area of Showers Avenue and Back Porepunkah Road.

Plans of the proposed works are available for inspection at the Authority Offices, Churchill Avenue, Bright, during office hours.

2948 JAMES F. MARTIN, Secretary

THE BALLARAT SEWERAGE AUTHORITY

Pursuant to section 119 (2) of the *Sewerage Districts Act* 1958 (No. 6368) notice is hereby given of the intention to construct a sewer for property situated in the vicinity of the following streets: 516 Humffray Street South, 41 Bridge Street, Sebastopol, more particularly as shown on plans which are open for inspection at this Office between the hours of 8.45 a.m. and 4.30 p.m., Monday to Friday, inclusive.

B. E. LEACH, Secretary  
Water and Sewerage Offices, Grenville Street South,  
Ballarat, Vic., 3350 2953

THE BALLARAT SEWERAGE AUTHORITY

Pursuant to section 119 (2) of the *Sewerage Districts Act* 1958 (No. 6368) notice is hereby given of the intention to construct a sewer for property situated in the vicinity of the following streets: Mair Street and Pearse Street, more particularly as shown on plans which are open for inspection at this Office between the hours of 8.45 a.m. and 4.30 p.m., Monday to Friday, inclusive.

B. E. LEACH, Secretary  
Water and Sewerage Offices, Grenville Street South,  
Ballarat, Vic., 3350 2962

Notice is hereby given that the Neangar Park Golf Club Incorporated has applied for a lease pursuant to section 134 *Land Act* 1958 for a term of 21 years over allotment 302A section N at Eaglehawk Parish of Sandhurst for the purpose of Amusement and Recreation and Activities Associated Therewith. 2828

Dependants, legal personal representatives and others having claims under the Carlton and United Breweries Limited Employees Superannuation Scheme to the benefit on the life of the abovenamed who died on 1 June 1984 are required by the Trustees of the Scheme, Messrs Timothy Noel Plant, Peter Francis Hosking and Peter Harrie Williamson, all of 16 Bouverie Street, Carlton, Victoria, to send particulars to them by 20 August 1984 after which date the Trustees may distribute the benefit, having regard only to the claims of which they have notice.

"Dependants" within the meaning of the Trust Deed means the wife widow and children of the deceased and any other persons who in the opinion of the Trustees are dependant upon the deceased.

Dated 13 June 1984

2954 J. G. CROSSLAND, Secretary to the Trustees

Notice is hereby given that the partnership previously subsisting between Pandle Harpantidis, Evdokia Keer Harpantidis, Gregorios Rizos and Efstathia Rizos carried on under the name of Greek Educational Supplies at 164 Bridge Road, Richmond was on 21 May 1984 dissolved by mutual consent as far as Pandle Harpantidis and Evdokia Keer Harpantidis are concerned who retired from the said partnership. The retired partners will not be responsible for any debts of the former partnership incurred after that date. 2971

NOTICE OF DISSOLUTION OF PARTNERSHIP

Take notice that from 1 June 1984 the partnership between Colin George O'Brien of 22 Park Road, Kerang and Brian John Reade of 9 Rosalind Street, Cohuna which carried on the business of earthmoving contractors in Kerang has dissolved.

NICHOLAS O'DONOHUE & CO., solicitors of 493 Little Bourke Street, Melbourne 3000 2956

NOTICE OF DISSOLUTION OF PARTNERSHIP

Notice is hereby given that the partnership heretofore subsisting between John Douglas Ricketts, Lynda Christina Ricketts and Graham Howe Stephens carrying on the business of S.C.U.B.A. Diving Retail Sales and Service, Charters and Diving Instruction under the style or firm name of "Geelong Diving Centre" has been dissolved by mutual consent as from 26 May 1984 so far as concerns the said John Douglas Ricketts and Lynda Christina Ricketts who have retired from the firm.

All debts due to and owing by the said firm will be received and paid by the said Graham Howe Stephens who will continue to carry on the said business under the said name of "Geelong Diving Centre".

Dated 1 June 1984

ANDREW SENIA & ASSOCIATES, solicitors and agents for the parties 2957

Notice is hereby given that the partnership heretofore subsisting between Alex Alexandrou and Terry Alexandrou both of 1 Ivanhoe Street, Chadstone, in the State of Victoria and Efthimios Alexandrou of 23 Kalymna Grove, East St. Kilda in the said State carrying on business in partnership as the owners of the racehorse "Emerald River" has been dissolved as from 7 May 1984.

GEORGE KYPRIOS, solicitor, of 491 Malvern Road, South Yarra 2963

Notice is hereby given that the partnership heretofore existing between Con Skapetis and Sia Skapetis and Gary Toronto is dissolved and that Con Skapetis is no longer responsible for any debt, mortgage, encumbrance or any other liability incurred by the partnership.

ISSAC BROTT & TIMOTHY MEPSTEAD, of 113-115  
Victoria Street, Fitzroy 2991

Notice is hereby given that the partnership previously carried on by John Laurence Topp and Ana Topp in a Native Plant Nursery at premises situate at Lot 58 Cranbourne-Frankston Road, Cranbourne South, and elsewhere was dissolved as from 9 April 1984.

R. L. EAGLE, solicitor, 63 High Street, Cranbourne 3977.  
Telephone (059) 96 1600 2978

**ST. ALBANS CO-OPERATIVE HOUSING SOCIETY  
LIMITED**

(In Liquidation)

At a Special General Meeting of the abovenamed Society duly convened and held at St. Mark's Anglican Church Hall, Sunshine on 8 June 1984 at 7.30 p.m. the subjoined Special Resolution was duly passed:

- (a) That having successfully completed its objectives 2 years and 9 months ahead of its expected term the Society be wound up voluntarily and that Mr. Geoffrey Keith Davenport of 53 Wadham Parade, Mount Waverley be appointed Liquidator for the purpose of the winding-up.
- (b) That the remuneration of the liquidator be fixed at \$890.00.
- (c) That the liquidator be empowered to compromise with debtors and/or creditors and/or contributories.

W. J. NEILSON, Chairman of Meeting  
G. K. DAVENPORT, Secretary  
2967

In the matter of the *Co-operative Housing Societies Act 1958* and the *Companies Act 1961* and in the matter of St. Albans Co-operative Housing Society Limited (in Liquidation)—  
Notice to Creditors

Notice is hereby given that all persons having any claim against the above Society are required on or before the 11 July 1984, to send their names and addresses and particulars of their debts or claims to Geoffrey Keith Davenport, the liquidator of the said Society, at his office and if so required by notice in writing from the said liquidator are personally, or by their Solicitors, to come in and prove their said claims at such time and place as shall be specified in such notice, or in default thereof, they shall be excluded from the benefit of any distribution made before such debts or claims are so lodged or proved.

Dated at Mount Waverley 20 June 1984

G. K. DAVENPORT, liquidator, 53 Wadham Parade,  
Mount Waverley 2968

In the Supreme Court of Victoria—Co. No. 141—In the matter of the Companies (Victoria) Code and in the matter of Ninety Eight Wreath Pty Ltd—Notice of Winding-up Order

Winding-up Order made 7 June 1984.

Name and address of liquidator is Ian Kenneth MacKinnon, John MacKinnon and Co., 4th Floor, 576 St Kilda Road, Melbourne, Victoria 3004.

T. A. SHERMAN, Acting Crown Solicitor for the Commonwealth and Solicitor for the Petitioner 3046

Notice Pursuant to Section 392 (2) of the Companies  
(Victoria) Code

C. KNIGHT & SONS PTY. LTD.

Notice of Resolution

At an Extraordinary General Meeting of members of C. Knight & Sons Pty. Ltd. held at 70 City Road, South Melbourne on 8 June 1984, a Special Resolution was passed that the Company be wound up voluntarily and that Donald Alexander Neil McLardy of Smith, Peacock & Henshaw, Chartered Accountants, 5th Floor, 124 Exhibition Street, Melbourne be appointed Liquidator.

Dated 8 June 1984

3016 D. A. N. McLARDY, Liquidator

*Companies Act 1961*, Section 271  
AIC CONSTRUCTIONS PTY. LTD.  
(In Liquidation)

Notice of Annual Meeting of Members and Creditors

Notice is hereby given that a General Meeting of the members and creditors of AIC Constructions Pty. Ltd. (In Liquidation) will be held at the office of V. R. Dye & Co., Chartered Accountants, 159 Springvale Road, Nunawading on Friday 22 June 1984 at 10.30 a.m., to receive an account of my acts and dealings and of the conduct of the winding up during the year ended 23 March 1984.

Dated 7 June 1984

V. R. DYE, Liquidator

V. R. Dye & Co., chartered accountants, 159 Springvale  
Road, Nunawading 3131 3019

FIFTH BELLER HOUSE NOMINEES PTY. LTD.

It was resolved at a General Meeting of members of Fifth Beller House Nominees Pty. Ltd. held on 11 June 1984 that the Company be placed in Voluntary Liquidation and that Edward Kevin Rahill of John H. Donegan & Co., 390 Lonsdale Street, Melbourne be appointed Liquidator.

3020

Edward K. Rahill

Companies Code 1981

PERSEUS PTY. LTD.

Pursuant to Section 392 (2) (b)

Notice is hereby given that at an Extraordinary General Meeting of Members of the above-named company duly convened and held at 459 Collins Street, Melbourne, on 31 May 1984, the following resolution was passed as a Special Resolution:

“That the Company be wound up voluntarily”

and at such last mentioned meeting Alan Ronald Coughlan and Allan John George both of 459 Collins Street, Melbourne, were appointed liquidators for the purposes of the winding up.

Dated at Melbourne 8 June 1984

3022

A. R. COUGHLAN, Liquidator

In the Supreme Court of Victoria—Co. No. 140—In the matter of the Companies (Victoria) Code and in the matter of Bennettswood Freehold Pty Ltd—Notice of Winding-up Order

Winding-up Order made 7 June 1984.

Name and address of liquidator is Warwick Allen Leeming, Duesburys, 114 William Street, Melbourne, Victoria 3000.

T. A. SHERMAN, Acting Crown Solicitor for the Commonwealth and Solicitor for the Petitioner 3045

## Unclaimed Moneys Act 1962

## Register of Unclaimed Moneys held by the—

<i>Name of Owner on Books and Last Known Address</i>	<i>Total Amount Due to Owner</i>	<i>Description of Unclaimed Money</i>	<i>Date when Amount first became Payable</i>
\$			
<b>THE BROKEN HILL PROPRIETARY COMPANY LIMITED</b>			
Adair, Robin, 3 Rycroft Crt, Hatfield Rd. St Albans, Hertfordshire AL4 OSW, U.K.	65.52	Interest	9.11.81
Adams, John S., 80 Parramatta Rd, Homebush, N.S.W.	30.24	"	"
Ahern, Richard P., P.O. Box R172, Royal Exchange, Sydney, N.S.W.	25.20	"	"
Aitken, Dr Ashley M., 155 Highgate, Dunedin, N.Z.	10.08	"	"
Aitken, Jennifer M., 23A Peach Rd, Glenfield, Auckland 10, N.Z.	851.76	"	"
Alexander, Karen M., c/o Karen Witty, 85 Jubilee Rd, Wellington 4, N.Z.	55.44	"	"
Alkin, Ellen M., White Tower, River Rd, Taplow Bucks, U.K.	25.20	"	"
Anderson, Michelle, c/o Mooloolaba Yacht Club, Esplanade, Moo- loolaba, Qld.	30.24	"	"
Andrews, Peter J., Greenacres Stud, One Tree Hill, S.A.	120.96	"	"
Ankudinova, Kera N., 1/43 East Crescent St, McMahons Point, N.S.W.	25.20	"	"
Ansado, Antoine J. (estate of), 51 Rue Mohamed El Quarri, Casa- blanca, Morocco	60.48	"	"
Apted, Sheila M., P.O. Box 179, Armidale, N.S.W.	10.08	"	"
Arber, Phillip N., 805/15 Wyagdon St, North Sydney, N.S.W.	15.12	"	"
Archer-Thomson, Hubert, c/o A. & M. Archer-Thomson, 39 Coombe St, Lyme Regis, Dorset DT7 3PY, U.K.	65.52	"	"
Archibald, Donald G., Old Glengugie, Scone, N.S.W.	20.16	"	"
Armitage, Charles, 4 Bangala St, Warrawee, N.S.W.	10.08	"	"
Armstrong, Capt. John M., c/o Commercial Banking Co. of Sydney, 343 George St, Sydney, N.S.W.	428.40	"	"
Arnold, Georgina D., Willow Cottage, North Stoke, Oxfordshire OX81 SX, U.K.	1013.04	"	"
Ashton, Judith M., 71 Moncur St, Woollahra, N.S.W.	50.40	"	"
Atkins, Judith R., 68 Norrie Ave, Whyalla, S.A.	15.12	"	"
Austin, Andrew T., Myuna, Mortlake,	10.08	"	"
Avery, Margaret I., c/o Brightfields Farm Ltd., Rural Delivery No. 8, Palmerston North, N.Z.	45.36	"	"
Baartz, Robert K. and Elizabeth M., Rowland St, Slacks Creek, Qld.	10.08	"	"
Bagnat, Neville F., P.O. Box 64, Fairy Meadow, N.S.W.	25.20	"	"
Bailey, Margaret, 24 Agamemnon Rd, London NW6, U.K.	161.28	"	"
Bailey, Robert J. M., 23 Belford Gve, Woolwich, London SE18, U.K.	25.20	"	"
Bain, Claude W., 17 Marywil Cres., Takapuna, N.Z.	35.28	"	"
Baker, Colin, 4 Ordnance St, Newcastle, N.S.W.	20.16	"	"
Banach, Heinrich W., 84 Murrarar Rd, Towradgi, N.S.W.	25.20	"	"
Barclay, David R., c/o Capt. J. R. Barclay, 28 Gardiner Pde, Glen Iris	30.24	"	"
Barker, Pamela K., Flat 1, Cnr Markham St and Robina Cres., Armi- dale, N.S.W.	25.20	"	"
Barnes, Graham, 40 Hereford St, Glebe, N.S.W.	95.76	"	"
Barnett, Alaine, 8/20 Hardy St, Dover Heights, N.S.W.	15.12	"	"
Barnett, Jeremy J. D., 9 Heke St, Ngaio, Wellington 4, N.Z.	105.84	"	"
Barnett, Dr. John R., 5 Saint Margarets Dve., Toronto, Ontario 319, Canada	110.88	"	"
Barnett, Peter C., 3 Lawanna Dve, Templestowe,	35.28	"	"
Barrand, Capt. Charles E., c/o J. Apthorpe, 4 Wyndora Ave., Harbord, N.S.W.	25.20	"	"
Barry, John E., 15 Byamee St, Dapto, N.S.W.	20.16	"	"
Barylak, Irena J., c/o Irene Jaroslawa Ho, Flat 7B, 1476 Hospital Rd, Hong Kong	10.08	"	"
Barzoukas, Janet P., Crestwell, 9A Titiro Moana Rd, Korokoro, Wel- lington, N.Z.	110.88	"	"
Bates, Lawrence J., 6 Larch Cres., Mt. Waverley	55.44	"	"
Bath, John S. and Richter-Visser, William F. c/o P.O. Box 1106, Invercargill, N.Z.	75.60	"	"

## Unclaimed Moneys Act 1962

## Register of Unclaimed Moneys held by the—

<i>Name of Owner on Books and Last Known Address</i>	<i>Total Amount Due to Owner</i>	<i>Description of Unclaimed Money</i>	<i>Date when Amount first became Payable</i>
\$			
<b>THE BROKEN HILL PROPRIETARY COMPANY LIMITED—continued</b>			
Baumgarten, Peter, 68 Tivoli Rd, South Yarra	25.20	Interest	9.11.81
Bauwens, Audrey B., 1 Little Pluckett's Way, Buckhurst Hill, Essex, U.K.	695.52	"	"
Bayne-Powell, Philip W. F., Kimbor Cottage, Glaziers Lane, Nor- mandy, NR Guildford, Surrey, U.K.	15.12	"	"
Beaty, Terence I., 37 Acacia Ave North, Campbelltown, S.A.	25.20	"	"
Beckerleg, Peter B., 17 Holbrook Ave, Kirribilla, N.S.W.	20.16	"	"
Beckett, Nathaniel C., c/o Kuwait Airways Corporation, P.O. Box 528, Kuwait, Arabia	10.08	"	"
Bedford, Ian G., 89 Hereford Street, Glebe, N.S.W.	10.08	"	"
Beiser, Hans, Arlberg Ski Centre, Jindabyne Rd, Berridale, N.S.W.	85.68	"	"
Bell, Antonia F., c/o A. F. Skuse, 20 Gledholt Rd, Marsh, Hudders- field, U.K.	20.16	"	"
Bell, Margaret M., c/o Slough Estates Australia Pty. Ltd., 30th Floor, 367 Collins St, Melbourne	25.20	"	"
Bell, Rosemary V., c/o Barclays Bank Limited, 1 Pall Mall East, Lon- don SW1, U.K.	10.08	"	"
Bell, Stephen A., 175 Shakespeare Rd, Milford, Auckland, N.Z.	826.56	"	"
Bell, William M., St Mark's Clinic, 97 Remuera Rd, Remuera, Auck- land 5, N.Z.	10.08	"	"
Bennett, Alison I., 2 Austin St, Winchelsea	20.16	"	"
Bennett, Edna J., 35 Orchard Rise, Papakura, Auckland, N.Z.	131.04	"	"
Benson, Greg K., 2/31 Boyes Crt, Heatley, Qld.	40.32	"	"
Bentley, Michael A., 253 Eastern Valley Way, Middle Cove, N.S.W.	30.24	"	"
Berresford, John D., "Trenance", Penrallt Rd, Trearddur Bay, Holy- head, Anglesey Gwynedd, U.K.	40.32	"	"
Berrill, Rodney G., and Johnson, Gordon, 3 Mackay Cres, Kambah, A.C.T.	60.48	"	"
Bilbie, Patricia A., c/o Patricia A. Plumbley, Flat 3, Little Glencoe St, The Range, Rockhampton, Qld.	45.36	"	"
Bini, Francesco, c/o Joseph Graperlino, 26 Washington St, Essendon	85.68	"	"
Blackwood, Ian L., 18 Grayson Rd, North Epping, N.S.W.	10.08	"	"
Blake, Dennis J., N.T.A. Centre, Gove Bag 36, Darwin, N.T.	50.40	"	"
Blake, Robert B., 65 Blackbutts Rd, Frenchs Forest, N.S.W.	10.08	"	"
Blake-Palmer, Humfrey, P.O. Box 84, Kuala Trengganu, Trengganu Peninsula, Malaysia	40.32	"	"
Blazey, Penelope J., c/o W. R. G. Hiscock, 196 Cecil St, Sth Melbourne	554.40	"	"
Boag, Florance (estate of), c/o Blackmore, 25 Holden St, Ashfield, N.S.W.	35.28	"	"
Boak, Maureen T., 77 Woodland St, Sth Balgowlah Heights, N.S.W.	20.16	"	"
Bolton, James F., c/o Burne Phillips, 41 Spring Gardens, Manchester, M2, 2BS, U.K.	357.84	"	"
Boon, Edwin L., 9160 Edal St, Fort Langley, British Columbia, Vox 1JO, Canada	20.16	"	"
Bosco, Deborah H. and Hagin, Karen L., 20 Dwyer St, Gympie, N.S.W.	342.72	"	"
Boss, Daniel E., SS 2 Box 3-1-7, Harrietsfield, Halifax, Nova Scotia, Canada	10.08	"	"
Bottrell, Thomas B., 25 Delgilbo St, Maryborough, Qld.	40.32	"	"
Bowden, Cynthia M., 75 Victoria Rd, Bellevue Hill, N.S.W.	10.08	"	"
Bowen, Isabel L. (estate of), 6431-20 St, SW, Calgary AB, T3E 5L4, Canada	30.24	"	"
Boyd, Alan R., 119 Frederick St, Dunedin, N.Z.	30.24	"	"
Boyd-Rochfort, Dorothea I. (estate of), c/o McMahon & Tweedy, 9/ 10 Ely Place, Dublin 2, Eire	55.44	"	"
Boydell, Philip G., 42/17 Penkivill St, Willoughby, N.S.W.	30.24	"	"
Brace, David A., 1/27 Stanton Rd, Haberfield, N.S.W.	30.24	"	"
Bradford-Smith, Rachel M., 2 Barnsbury Rd, Balwyn	40.32	"	"

## Unclaimed Moneys Act 1962

## Register of Unclaimed Moneys held by the—

Name of Owner on Books and Last Known Address	Total Amount Due to Owner	Description of Unclaimed Money	Date when Amount first became Payable
\$			
<b>THE BROKEN HILL PROPRIETARY COMPANY LIMITED—continued</b>			
Bradshaw, Gwendoline, 7 Loftus St. Concord, N.S.W.	252.00	Interest	9.11.81
Brahe, Arthur J., 15 Rowland Ave, Wollongong, N.S.W.	25.20	"	"
Bridgford, Judith, 74 Plateau Rd, Avalon, N.S.W.	25.20	"	"
Brigden, David D., c/o Gowrie Private Hotel, Northbourne Ave, Braddon, A.C.T.	131.04	"	"
Briggs, Robert J., 5/473 St Kilda St, Elwood	25.20	"	"
Brock, Felicity, 8 Augusta St, Christchurch 8, N.Z.	25.20	"	"
Bronsdon, Peter, 21 Mimosa Ave, Claremont, W.A.	10.08	"	"
Brooke, Melinda C., Ashbrooke, Brookeborough, Northern Ireland, U.K.	50.40	"	"
Brooks, Alexander, 41 Lanark Rd, Carlisle, Lanarkshire, U.K.	10.08	"	"
Brooks, Stanley C., 29 Pitt St, Coffs Harbour, N.S.W.	10.08	"	"
Brown, Colin V., "Angleview", Thuddungra Rd, Young, N.S.W.	25.20	"	"
Brown, John R. H., Green Lodge, The Severals, Newmarket, Suffolk, U.K.	30.24	"	"
Brown, Leslie T., c/o A. L. Brown, 14 Bindea St, Mt Pritchard, N.S.W.	15.12	"	"
Brown, Robert, 83 Clendon Rd, Toorak	30.24	"	"
Brunstrom, Betty G., c/o Tracy Brunstrom & Hammond Pty. Ltd. 9-15 Blue St, North Sydney, N.S.W.	25.20	"	"
Bryant, John R. and Vicars, Millicent E., 27 Waller Cres, Campbell, A.C.T.	25.20	"	"
Buchanan, Louise M., c/o P.O. Swanpool	20.16	"	"
Buckett, Cyril J., 20 Waldorf Ave, Alvaston, Derby, DE2, 8UE, U.K.	20.16	"	"
Burleigh, Caroline G. R., Blue Waters, Motor-Hotel, Orford, Tasmania	30.24	"	"
Burling, Trevor L., 4 Henley Ave, Wollongong, N.S.W.	20.16	"	"
Burnham, Conlan B., 1 Johnson Ave, Kenthurst, N.S.W.	40.32	"	"
Burrell, Martin H., 11/22 Runnymede St, Battery Point, Tas.	25.20	"	"
Burrows, Winifred M. (estate of), and Richard, Greycot, Madeira Walk, Church Stretton, Salop, U.K.	60.48	"	"
Buxton, George C., 481 Melbourne Rd, Newport	10.08	"	"
Bynon, Paul J., 97 Condamine St, Balgowlah, N.S.W.	25.20	"	"
Cahill, Lawrence A., 13/3 Jones St, Berri, S.A.	10.08	"	"
Cairns, Kevin J., Private Bag 144, Launceston, Tasmania	20.16	"	"
Cameron-Wood, James, Flat 14, Chenies House, Moscow Rd, Lon- don W2, U.K.	10.08	"	"
Campbell, Bruce A., 25 Stanford St, Kurri Kurri, N.S.W.	25.20	"	"
Campbell, Graeme L., 33 Taiyul Rd, Narrabeen, N.S.W.	55.44	"	"
Campbell, Kennedy, 337 Kissing Point Rd, Ermington, N.S.W.	105.84	"	"
Cant, David, Parkview House, Lochgoilhead, Argyll, Scotland, U.K.	60.48	"	"
Carlile, Robert S., c/o Carlile Brothers, Strickland Rd, Bendigo	55.44	"	"
Carlin, Patrick H. (estate of), c/o V. P. McMullin & Son, Ballybofey, Co. Donegal, Eire	55.44	"	"
Carrigan, Louise, Oaklands, Clonmel, Co. Tipperary, Eire	25.20	"	"
Carroll, Geraldine, c/o G. R. Birt, 6 Keira Close, Valentine, N.S.W.	186.48	"	"
Carroll, Jennifer H., c/o Helen Ewart, 3 Alicia St, Hampton	216.72	"	"
Carroll, Veronica, c/o G. R. Birt, 6 Keira Close, Valentine, N.S.W.	156.24	"	"
Carruthers, Avril A., 34 Aitken Ave, Queenscliff, N.S.W.	35.28	"	"
Carruthers, Jaki B., 34 Aitken Ave, Queenscliff, N.S.W.	35.28	"	"
Cartwright, Dianne C., 17 Letchworth Rd, Coorparoo, Qld.	15.12	"	"
Casimir, Anthony J., 11/38 Norman Terrace, Everard Park, S.A.	25.20	"	"
Cator, Penelope A. (Lady), 40 Chester Square, London, SW1, U.K.	10.08	"	"
Cecil, James T. B., 62 Carlton St, Carlton	20.16	"	"
Cecil, Jonathan P. H., 3/5 Fawkner St, Sth. Yarra	50.40	"	"
Cecil, Stephen H., 437 Springvale Rd, Forest Hill	10.08	"	"
Center, Michael and Robert, c/o R. Center, 51 Hawthorn Ave, Chats- wood, N.S.W.	15.12	"	"
Chadwick, Arthur J., 20 Coniston Dve, Holmes Chapel, Crewe, Cheshire, U.K.	85.68	"	"

## Unclaimed Moneys Act 1962

Register of Unclaimed Moneys held by the—

Name of Owner on Books and Last Known Address	Total Amount Due to Owner	Description of Unclaimed Money	Date when Amount first became Payable
\$			
<b>THE BROKEN HILL PROPRIETARY COMPANY LIMITED—continued</b>			
Chadwick, Doris A. (estate of), 1/29 Greenwich Rd, Greenwich, N.S.W.	166.32	Interest	9.11.81
Chambers, Marguerite S., 9 Wiston Gardens, Double Bay, N.S.W.	40.32	"	"
Chambers, Robert E., P.O. Box 498, Healesville	20.16	"	"
Chantrill, David, 3/27 Heath St, Mona Vale, N.S.W.	10.08	"	"
Chapman, Ross, 64 St. Johns Rd, Meadowbank, Auckland, N.Z.	55.44	"	"
Charge, Tiffany J., 42 Alexander St, Smithfield, N.S.W.	10.08	"	"
Charleton, Eileen (estate of), c/o H. P. Brown, 78 Beaconsfield Pde, Albert Park	20.16	"	"
Chatfield Nominees Limited, 13 Elva Rd, Ocean Grove	10.08	"	"
Cher, Yong G., 29B Tanglin Rd, Singapore	10.08	"	"
Chesworth, Michael P., The Manor House, Langham, Holt, Norfolk, NR25 7BT, U.K.	30.24	"	"
Chew, Chee S., c/o Amateur Photo Stores P/L, Chinese Chamber of Commerce Building, Hill St, 6 Singapore	584.64	"	"
Chillingworth, Jennifer, 32 Drury Rd, West Harrow, Middlesex HA1 4BZ, U.K.	40.32	"	"
Christian, William L. (estate of) and Mary M., c/o Porter & Co., Plas Verder Conway, Caernarvonshire, U.K.	15.12	"	"
Clare, Ellen F. E. and Annic, 39 Regent Rd, Surbiton, Surrey, U.K.	10.08	"	"
Clare, Shirley, 3 Grevillea Ave, St. Ives, N.S.W.	30.24	"	"
Clark, Russell, 33 Genoa St, Moorabbin	10.08	"	"
Clarke, Charles A., 17/104 Station Rd, Indooroopilly, Qld.	10.08	"	"
Glasby, Arthur H., 50 Joffre St, Ashgrove, Qld.	302.40	"	"
Cockburn, Graeme D., Rosemount, Grantown-On-Spey, Morayshire, PH26 3JN, U.K.	126.00	"	"
Cole, John S., 362 The Esplanade, Speers Point, N.S.W.	20.16	"	"
Coleman, Wendy F., 637 Toorak Rd, Toorak	25.20	"	"
Collins, Ena, 4/22 Bruce St, Stanmore, N.S.W.	60.48	"	"
Collis, Neil, Alcazar, Te Ore Ore, 6 RD Masterton, N.Z.	10.08	"	"
Combe, Peter J., 17 Sutherland St, Paddington, N.S.W.	20.16	"	"
Connell, Desley W., 11 Diosma Ave, Coromandel Valley, S.A.	20.16	"	"
Cook, Graeme E. and Cecely A., 6 Osborne St, Coocoe, Tasmania	25.20	"	"
Cook, Hamish R. R., P.O. Box 459, Geelong	10.08	"	"
Cooper, Hosie D., 49 Wick Rd, Teddington, Middlesex, U.K.	55.44	"	"
Cooper, Joanna E., 47 Darnley Gve, Mulgrave	10.08	"	"
Cooper, John and Florence H., Kialla Downs, Shepparton	20.16	"	"
Cope, Kenneth C., c/o Innes Hamilton (Comdr.), 10 Haymarket, London, SW1, U.K.	10.08	"	"
Copplestone, Arthur H., and Joyce A., 44 Cynthia St, Morwell	95.76	"	"
Corliss, Ray and Stafford, Kevin, 6 Rawson St, Gilgandra, N.S.W.	10.08	"	"
Cosgrave, Judith M., 402 Wattletree Rd, East Malvern	15.12	"	"
Coupland, Robert D., 33 Lake View Cres, Highbury, S.A.	25.20	"	"
Cowan, Grace D., 25A Manor Rd, Weston-Super-Marc, Avon, B5 23 2SU, U.K.	105.84	"	"
Cowper, Robert E., RD2, Marton, N.Z.	55.44	"	"
Coy, Charles F., 11 Baker Rd, South Oakleigh	10.08	"	"
Coy, Patricia M., 11 Bakers Rd, South Oakleigh	15.12	"	"
Craig, Rosemary E., 18 Orchard Gve, Giffnock, Glasgow, G46 7QU, U.K.	10.08	"	"
Crammond, Mark P., 14 Edward St, Woollahra, N.S.W.	10.08	"	"
Crawford, Carol D., Department of Labour, Private Bag, Wellington, N.Z.	10.08	"	"
Crawford, Deborah E., 12 Northcote Rd, Armadale	15.12	Interest	9.11.81
Crisp, Kenneth P., 174 Ravenhurst Rd, Harborne, Birmingham, U.K.	10.08	"	"
Cromby, Rosemary R., 12A Stevens Rd, 1025 Singapore	50.40	"	"
Crook, Keith T., "Kincora", Campania Tas.	15.12	"	"
Crossley, Robert, 24 Sydney St, Gateshead, N.S.W.	25.20	"	"
Croudis, William A. (Jnr), c/o P.O., Waipu, N.Z.	25.20	"	"

## Unclaimed Moneys Act 1962

Register of Unclaimed Moneys held by the—

Name of Owner on Books and Last Known Address	Total Amount Due to Owner	Description of Unclaimed Money	Date when Amount first became Payable
\$			
<b>THE BROKEN HILL PROPRIETARY COMPANY LIMITED—continued</b>			
Crozier, Barbara S., 12 Juniper Gr, Watford, Herts, U.K.	10.08	Interest	9.11.81
Cunliffe, Jill P., 13 Cranbrook Rd, Rose Bay, N.S.W.	65.52	"	"
Currie, John R., 29 Ashfield St, East Brisbane, Qld.	20.16	"	"
Dabscheck, Gilda M., 10 Hunter Rd, Camberwell	156.24	"	"
Dale, Hilary J., 16 Lois St, East Ringwood	10.08	"	"
Dampney, Mabel J. (estate of), c/o Stagnetto & Co., 186 Main St, Gibraltar	146.16	"	"
D'Aquino, Leo, Box 1022, Griffith, N.S.W.	40.32	"	"
Dargentievil, Camille, (estate of) Chateau de et a Linsmeau Par, Racur, Brapant, Belgium	50.40	"	"
Davey, Victor S. and Nell D., P.O. Box 243, Glenelg, S.A.	65.52	"	"
Davies, John E., 3 Endeavour St, Wahroonga, N.S.W.	20.16	"	"
Davis, Rhonda N., 4 Watson St, Neutral Bay, N.S.W.	25.20	"	"
Dawe, Brian L., 436 Kensington Rd, Wattle Park, S.A.	15.12	"	"
Day, Colin M., Sharp's Cottage, Marden, Maidstone, Kent, U.K.	10.08	"	"
Day, Deborah M., 31 Belgravia Ave, Mont Albert North	10.08	"	"
Deacon, Ann E., 4 Hughes Ave, Ermington, N.S.W.	20.16	"	"
Dearlove, Pamela J., c/o Pamela Mayo Dale, 128 Rosalie St, Shenton Park, W.A.	15.12	"	"
Defries, Hettie, 87 Queenswood Gardens, Wanstead, London E11, U.K.	25.20	"	"
De la Guerrande, Gaston, c/o Jean Lelevier, 22510 Moncontour-De-Bretagne, Cotes du Nord, France	100.80	"	"
Delamain, Alix G., The Old Cottage, Sandford, Nr Woodley, Berkshire, U.K.	10.08	"	"
Delany, Jill C., 2/10 Cheniston Gardens, London W8, U.K.	65.52	"	"
Dell, Lynette R., 8 Adelaide St, Bondi Junction, N.S.W.	10.08	"	"
De Maulde, Lavi (Countess), Rue de Chateau 5, 7721-Ramegnies-Chin, Belgium	357.84	"	"
Denniss, Leslie F., 19 Kilbirmie Pl, Fig Tree, N.S.W.	20.16	"	"
Derinck, Marcel, Boulevard Van Iseghem 76, 8400 Oostende, Belgium	20.16	"	"
Desmarais, Jean, c/o De Ravel Boule Saad and Wyman, 1004 Sanlam Building, Smith St, Durban, South Africa	75.60	"	"
Devlin, Irene M., 38 Crump St, Hollana Park, Qld.	1,038.24	"	"
D'Herwynen, Robert G. (Baron), Chaussee de Jodoigne 71, B-5982 Grez-Doicean, Belgium	206.64	"	"
Dibbs, Stewart J., 50A Epping Ave, Eastwood, N.S.W.	75.60	"	"
Dickinson, Dorothy J., 18 Marlborough St, College Park, S.A.	30.24	"	"
Dijkstra, Gloria E., 26 Westmore Crt, Carlton Dr, Putney, London SW15, U.K.	15.12	"	"
Di Mattei, Eugenio. (Dr), 18 Pitt St, Sydney, N.S.W.	20.16	"	"
Di Micco, Tony, 21 Victoria St, Roseville, N.S.W.	60.48	"	"
Dobson, Isobel, 8 Shaddock Ave, West Pymble, N.S.W.	25.20	"	"
Dobson, Robert J., 1/27 Reynolds St, Cremorne, N.S.W.	10.08	"	"
Docker, Emily M. V., c/o Permanent Trustee Co. Ltd, G.P.O. Box 4270, Sydney, N.S.W.	1,738.80	"	"
Dodd, Peter, c/o National Westminster Bank Limited, 70 Strickland Gate, Kendal, Cumbria, U.K.	756.00	"	"
Dodds-Parker, Peter D., c/o First National City Bank, 17 Bruton Street, London W1, U.K.	15.12	"	"
Dodemaide, Wayne R., 55 Mackay St, Rochester	10.08	"	"
Donaldson, Peter J. H., 13 Norfolk Ave, Budds Beach, Surfers Paradise, Qld.	196.56	"	"
Dorman, Helen E., 20 Hillside Cres, Blackburn	10.08	"	"
Dower, Gail, 1/1 Lemnos St, Red Hill, Qld.	10.08	"	"
Downing, Leonard A., 82 Victoria St, Kings Cross, N.S.W.	20.16	"	"
Downs, Robert A., 27 Fernhill St, Glen Waverley	25.20	"	"
Draper, Stanley R. c/o The Hong Kong and Shanghai Banking Corporation, P.O. Box 64, Hong Kong	40.32	"	"

## Unclaimed Moneys Act 1962

## Register of Unclaimed Moneys held by the—

Name of Owner on Books and Last Known Address	Total Amount Due to Owner	Description of Unclaimed Money	Date when Amount first became Payable
§			
<b>THE BROKEN HILL PROPRIETARY COMPANY LIMITED—continued</b>			
Drummond, Mary B. (estate of), c/o Spencer Thornton and Co., 22 Cousin Lane, London EC4R 3TE, U.K.	55.44	Interest	9.11.81
Duncan, Paul L., 4/8 Bonview Ave, Herne Hill	65.52	"	"
Dunkley, Harry B., Fairmont Cottage, Devonshire, Bermuda	90.72	"	"
Dunolly, Janet, Charlwood Close, Charlwood Lane, Ropley, Alresford, Hants, U.K.	151.20	"	"
Durant, Peter, 6 Cromwell, Swindon, U.K.	20.16	"	"
Dutta, Sisir K. (Dr), 187 Portland Rd, Edgbaston, Birmingham 16 U.K.	105.84	"	"
Dwen, Noyra, 2/74 Curlewis St, Bondi, N.S.W.	15.12	"	"
Eagleton, Edward S., 4/1 Ralston St, Lane Cove, N.S.W.	231.84	"	"
Earlly, Kevin G., 21 Newton Rd, Auckland, N.Z.	15.12	"	"
Economos, Margarete J., 6 Wattle St, Fullarton, S.A.	30.24	"	"
Edwards, Janet L., 109 Broadway, Nedlands, W.A.	25.20	"	"
Elbaum, Simon, 6 Milburn Grove, East St, Kilda	25.20	"	"
Ellery, William H., c/o Naval Mail Redirection Centre, Department of Defence, Russell Offices, Canberra, A.C.T.	10.08	"	"
Elphinstone, Mary S. (estate of), c/o Mowbray and Gray, P.O. Box 1192, Wollongong, N.S.W.	65.52	"	"
Emerson, Benjamin D. G., 27 Dick St, Henley, N.S.W.	20.16	"	"
Emmett, Claire R., 11/352 Toorak Rd, South Yarra	15.12	"	"
Emrik, Michael, 35 Minnegang St, Warrawong, N.S.W.	20.16	"	"
Estoup, Robert, 10 Bld De Suisse, Monte Carlo, Monaco	20.16	"	"
Etheridge, Timothy G., 13/348 Dryburgh St, North Melbourne	10.08	"	"
Evans, Deidre, 27 Kirkwood Ave, Sandringham	25.20	"	"
Evans, Jeremy P. (Dr), Doctors House, Soufriers, St Lucia, West Indies	10.08	"	"
Evans, John D., Farm 607, M/C 333, Morundah, N.S.W.	30.24	"	"
Ewing, Nora C. (estate of), St Helier, Norwood Dr, Whitecraigs, Glas- gow, U.K.	206.64	"	"
Fairley, Hans N. H., 51 Woodcote Rd, Caversham, Reading RG4 7BB, U.K.	246.96	"	"
Fakhouri, Afifa, c/o Afifi Carois, 5 Springfield Ave, Punchbowl, N.S.W.	10.08	"	"
Falla, Peter J., Litchfield	10.08	"	"
Feltham, Richard J., 47 Whitby St, Christchurch 5, N.Z.	110.88	"	"
Fenton, Gary R. (estate of), c/o M. Fenton, 9 Gilbertson Rd, Seacliffe Park, S.A.	10.08	"	"
Fincher, Margaret E., c/o White and Co., 205 Fu House, 7 Ice House St, Hong Kong	10.08	"	"
Findlay, Donald, P.O. Box 1648, Griffith, N.S.W.	20.16	"	"
Finlow, Geoffrey P., 39 Wellington Rd, Nantwich, Cheshire, U.K.	95.76	"	"
Fitam Pty Ltd, P.O. 14, Leichhardt, N.S.W.	105.84	"	"
Fitzgerald, Ian and Nora M., 37 Lindsay St, Ashgrove, Qld.	10.08	"	"
Fitzgerald, Sean, 23 Garnet St, Gore, N.Z.	60.48	"	"
Fitzgibbons, Robert W., Wybalena, Pomona, Qld.	10.08	"	"
Flanagan, Kathleen A., 8/13-15 Kooloora Ave, Harbord, N.S.W.	10.08	"	"
Fleetwood, Elizabeth A. M., c/o Colonel G. M. Fleetwood, P.O. Box 1030, Wisma Damansara, Jalan Semantan, Kuala Lumpur, Malaysia	25.20	"	"
Fleming, Judy A., 4 Kintore Rd, Parkerville, W.A.	115.92	"	"
Fleming, Winifred M., P.O. Box 5522, Boroko, Port Moresby, P.N.G.	25.20	"	"
Flett, Patricia, 44 Middle Rd, Harrow-on-the-Hill, Middlesex, U.K.	25.20	"	"
Flexer, Max, C3 Marine Gate, Marine Dr, Brighton BN2 5TN, U.K.	25.20	"	"
Forde, Margot B., 242 Victoria Ave, Palmerston North, N.Z.	60.48	"	"
Fortune, George D., 11 Douglas Cres, Edinburgh EH12 5BB, U.K.	120.96	"	"
Foster, Georgina P., Flat 5, Woodridge House, Woodridge Close, Bracknell, Berks RG12 3QY, U.K.	115.92	"	"
Foster, Linley R., P.O. Box 7007, Boroko, P.N.G.	126.00	"	"
Foster, Robert, Tayannah, Nambrok	35.28	"	"



## Unclaimed Moneys Act 1962

Register of Unclaimed Moneys held by the—

Name of Owner on Books and Last Known Address	Total Amount Due to Owner	Description of Unclaimed Money	Date when Amount first became Payable
\$			
<b>THE BROKEN HILL PROPRIETARY COMPANY LIMITED—continued</b>			
Fraser, Heatherbelle, c/o H. B. Lewy, 20 O'Connor St, Haberfield, N.S.W.	20.16	Interest	9.11.81
Fraser, Susanne, 85 Quarry Rd, Dural, N.S.W.	287.28	"	"
Frazer, Ewan J. and Joan Marian, Duesden, Tenderden Rd, Bidden- den, Ashford, Kent TN27 8BJ, U.K.	297.36	"	"
Freelander, Selwyn H., 279 The Boulevard, Punchbowl, N.S.W.	75.60	"	"
Freund, Peter E., 4 Avila Crt, Vermont	25.20	"	"
Friedberg, Max E., 77 Breezes Rd, Christchurch 7, N.Z.	10.08	"	"
Froggatt, Ronald B., 77 Beatrice St, Clontarf, N.S.W.	10.08	"	"
Frost, Richard D., 63 Sution Court, Brighton Rd, Sutton, Surrey, U.K.	60.48	"	"
Fuerste, Dietrich, 16 Lakeview Pde, Primbee, N.S.W.	10.08	"	"
Fullford, Gwenda E., 5 Adrian Pl, Balgowlah, N.S.W.	30.24	"	"
Fuller, Kenneth J., 5 Gloucester Ave, Redwood Park, S.A.	25.20	"	"
Gall, Odon, 8 Paper St, Gateshead West, N.S.W.	20.16	"	"
Gale, Royce J., 12 Rigney St, Whyalla Playford, S.A.	25.20	"	"
Gallagher, David P., Flat 2, 50 Pont St, London SW1, U.K.	40.32	"	"
Gallagher Estates Limited, c/o Brian Gallagher, 62 New Beach Road, Darling Point, N.S.W.	15.12	"	"
Gascoigne, G. J., 80 Oswald St, Innaloo, W.A.	156.24	"	"
Gaskell, Jaqueline S., c/o Lloyds Bank Limited, 45 Broadway, London, W5, U.K.	15.12	"	"
Gaywood, Robin, c/o R. L. Howie, 10 Limosa St, Bellbowrie, Qld.	10.08	"	"
Gear, David G., 84 St John Rd, Wattle Gr, W.A.	25.20	"	"
Gee, L. W. (estate of), c/o Paprill Hadfield & Aldous, 79-83 Hereford St, Christchurch, N.Z.	1905.12	"	"
Gibbon, Graham L., 19 Brynteg, Rhiwkina, Cardiff, South Wales, U.K.	20.16	"	"
Gibson, Bruce S., 35 Ford St, Albion, Qld.	10.08	"	"
Gilfillan, Margaret A., 9/488 Toorak Rd, Toorak	20.16	"	"
Gillespie, Robert I., 47 Berry St, Nowra, N.S.W.	10.08	"	"
Glass, Ricki D., 26 Deakin St, East Bentleigh	20.16	"	"
Glencross, Joan H., 55 Cobden St, South Melbourne	20.16	"	"
Glover, Gladys E., 4/537 Broadway, Strathmore, Wellington 3, N.Z.	110.88	"	"
Glovonian Corporation Pty Ltd, 16 Mary Pde, Rydalmere, N.S.W.	15.12	"	"
Golden, Cicely R., Apt 18-Les Palmiers, Rue de la Jalade, Montpellier 34100, France	115.92	"	"
Goldenberg, Donald, and Rita R., 1/14 Cliffbrook Pde, Clovelly, N.S.W.	20.16	"	"
Good, Alfred John., 1A Church St, Bowral, N.S.W.	25.20	"	"
Goodhew, Elizabeth, L., 2 Lownder Cl, London SW1, U.K.	221.76	"	"
Goodman, Jeremy, W., 14/8 Kareela Rd, Cremorne, N.S.W.	55.44	"	"
Goodwin, Barbara A., c/o Barbara Abrahams, 2 Holmes St, Turra- murra, N.S.W.	10.08	"	"
Gopal, Nicky, P.O. Box 3184, Darwin, N.T.	95.76	"	"
Gordon, Adam M., Forest Lodge, Penselwood, Wincanton, Somerset, U.K.	1 391.04	"	"
Gordon, James C., 78 Simpson St, Bondi N.S.W.	30.24	"	"
Gordon, Margaret A., Deils Craig, Mugdock Rd, Strathblane, Glas- gow, U.K.	156.24	"	"
Gordon-Clark, Joanna M., c/o Marine Action Centre, The Bath House, Gwydir St, Cambridge, U.K.	10.08	"	"
Gottlieb, Robert N., c/o Old Essendon Grammarians Association, 57 Hillside Pde, Strathmore	10.08	"	"
Goudes, Nick, 526 Anzac Pde, Kingsford, N.S.W.	65.52	"	"
Goudis, Nicholas, 526 Anzac Pde, Kingsford, N.S.W.	30.24	"	"
Grady, Gordon C., 15 Tanglewood St, St Albans	50.40	"	"
Graefe, Joanne D., 2/66 Gawler St, Salisbury, S.A.	10.08	"	"
Graham, Agnes M., c/o J. Elliott Brooks and Co., Dept 4/G 108, 4 Little Essex St, London WC2R 3LD, U.K.	695.52	"	"

## Unclaimed Moneys Act 1962

## Register of Unclaimed Moneys held by the—

Name of Owner on Books and Last Known Address	Total Amount Due to Owner	Description of Unclaimed Money	Date when Amount first became Payable
<b>S</b>			
<b>THE BROKEN HILL PROPRIETARY COMPANY LIMITED—continued</b>			
Graham, Dorothy, 28 Bauhinia Ave, Earlville, Qld	45.36	Interest	9.11.81
Graham, Edward W., c/o N. J. Morgan, 209 Browning St Bathurst, N.S.W.	15.12	"	"
Granite Investments Ltd, 12 College Lane, Gibraltar	75.60	"	"
Grant, Clare J., 12 Carrick Pl, Mt Eden, Auckland 3, N.Z.	20.16	"	"
Graves, Stephen E., 233 Kooyong Rd, Toorak	10.08	"	"
Gray, Sean W., 11 Morrell St, Woollahra, N.S.W.	40.32	"	"
Gray, Stewart, 6/9 Dunmore Tce, Auchenflower, Qld	65.52	"	"
Greatrex, Charles R., 16240 Ridgecrest Ave, Monte Sereno, California 95030, U.S.A.	383.04	"	"
Green, Arthur, E. (estate of), c/o Woodforde and Drewett, Castle Cary, Somerset BA7 7AB, U.K.	211.68	"	"
Green, Geoffrey A., 78 Couvreur St, Garran, A.C.T	10.08	"	"
Green, Laurence J., 1262 Malvern Rd, Malvern	10.08	"	"
Green, Richard B., 1/9 Hennessy Ave, Elwood	30.24	"	"
Green, Stephen P., 21 Wenke Cres, Yagoona, N.S.W.	10.08	"	"
Greenwood, Anthea, The Barton, Patricxbourne, Canterbury, Kent, U.K.	40.32	"	"
Gregan, Brian M., 26 Wambiri Pl, Cromer, N.S.W.	15.12	"	"
Griesz, George, 19 Reservoir Rd, Pymble, N.S.W.	15.12	"	"
Grillot, Yvonne, 39 Quai Veil-Picard, Besancon, France	20.16	"	"
Grogan, Raymond P., Winnima Way, Berkeley, N.S.W.	20.16	"	"
Gross, Robert E., and Pamela S. G., 9 Gowrie Ave, Glengowrie, S.A.	10.08	"	"
Gunn, Henry A., The Gatehouse, 106 Abinger Rd, Chiswick, London W4, U.K.	10.08	"	"
Gurr, Ian, Box 7, Pam St, Crafers, S.A.	126.00	"	"
Haack, John E., 8 Bathurst St, Woollahra, N.S.W.	10.08	"	"
Haber, Zvi H. (estate of), c/o L. Haber, 301 Dandenong Rd, Windsor	45.36	"	"
Hacker, Paul, 5 Cherry Tree Walk, Horsham, Sussex, U.K.	50.40	"	"
Hafers, Janet M., c/o Janet M. Arnall, 10030-114 St, Apartment 406, Edmonton, Alberta, Canada	10.08	"	"
Hall, Dianne M., c/o Dianne M. Hore, 29 Quirke Ave, Whyalla Stuart, S.A.	20.16	"	"
Hall, Edward T., Gunyerwarildi, Warialda, N.S.W.	55.44	"	"
Hallam, Edgar G., 61 Withers St, West Wallsend, N.S.W.	20.16	"	"
Hallam, Mark, c/o R. D. Agnew, 582 St. Kilda Rd, Melbourne	25.20	"	"
Halls, Eileen M., c/o J. R. Halls, c/o Bank N.S.W., 9-15 Sackville St, London W1, U.K.	105.84	"	"
Hamilton, Donald, M., Monterey, Chanctonbury Dve, Sunningdale, Ascot, Berks SL5 9PT, U.K.	15.12	"	"
Hamilton, William H. (Major), Park View Cottage, Fernhurst, Nr Haslemere, Surrey, U.K.	10.08	"	"
Hancock, Jane A., 130 Blues Point Tower, McMahons Point, N.S.W.	15.12	"	"
Hansen, Danielle O., 56 Suffolk Ave, Collaroy Heights, N.S.W.	45.36	"	"
Hanson, Edward F., Burke Rd, Ferntree Gully	25.20	"	"
Hargreaves, Peter W., 7 Woodlands Ct, Little Eaton, Derby DE2 5DZ, U.K.	15.12	"	"
Harman, Dennis and Fay P., Foster, 31 Haldane Rd, Niddrie	35.28	"	"
Harris, Melissa, 25 Brighton Boulevard, Bondi, N.S.W.	10.08	"	"
Harrison, John J., 35 Archer St, Toowong, Qld	55.44	"	"
Hartman, Claudia N., 23 Catherine Pl, Westminster, London, SW1E 6DX, U.K.	15.12	"	"
Harvey, Doris E., 28 Alnwick Tce, Heathpool, S.A.	10.08	"	"
Hawkins, Jenny, 83 Mitchell St, Bentleigh	95.76	"	"
Hay, Gladys J., 3/5 Mackenzie Ave, Mangerton, N.S.W.	15.12	"	"
Hayes, Annette E., c/o Annette E. Rees, 12 Tango St, Mt Hutton, N.S.W.	10.08	"	"
Haynes, Albert H. (estate of), c/o Public Trust Office, P.O. Box 660, Newcastle, N.S.W.	30.24	"	"

## Unclaimed Moneys Act 1962

## Register of Unclaimed Moneys held by the—

Name of Owner on Books and Last Known Address	Total Amount Due to Owner	Description of Unclaimed Money	Date when Amount first became Payable
\$			
THE BROKEN HILL PROPRIETARY COMPANY LIMITED— <i>continued</i>			
Healey, Timothy C., Apt 8061/1, 80 Cartier St, Ottawa, Ontario K2P 2E7, Canada	40.32	Interest	9.11.81
Heathcote, Martin S., Warrawong, Tambar Springs, N.S.W.	10.08	"	"
Helleur, John M., c/o P. L. Ferrerri, 1147 Pacific Highway, Pymble, N.S.W.	10.08	"	"
Hennessy, Francis J. (estate of), Francis X. and Patrick V., 71 Raglan St, Sale	25.20	"	"
Hepworth, Dudley T., 4 Mt View Rd, Highett	20.16	"	"
Herford, Ian K., 72 Lynbara Ave, St Ives, N.S.W.	10.08	"	"
Hermann, Walter, and Evelyn G. and Hudson, Gladys A., 29 Burke St, Reservoir	30.24	"	"
Heron, Christine, 17/89 Oaks Ave, Dee Why, N.S.W.	10.08	"	"
Hickey, Adrian P., 2 Dobroyd Pde, Haberfield, N.S.W.	10.08	"	"
Hill, Helen E. D., Woodside, Cranham, Gloucester, U.K.	312.48	"	"
Hill, Iris G., 68 Tudor Cl, Brixton Hill, London SW2, U.K.	50.40	"	"
Hill, William, Springwood, Mount Rule Rd, Braddon, Isle of Man	1 819.44	"	"
Hindley, William H. and Olga A. O., P.O. Box 15017, Nairobi, Kenya	30.24	"	"
Hinge, Patricia, 124 Coonanbarra Rd, Wahroonga, N.S.W.	45.36	"	"
Hinings, Peter H., 23 St. Andrews Ave, Thorpe St Andrew, Norwich, Norfolk NR7 ORG, U.K.	10.08	"	"
Hockman, Karen and Brian, 3/6 Hill St, Campsie, N.S.W.	10.08	"	"
Hodgetts, Jill, c/o Jill Rogers, 16 Marcian Ave, Elizabeth Downs, S.A.	20.16	"	"
Holmes, Richard N., Musgrave House, Musgrave Cres, London SW6 4QD, U.K.	30.24	"	"
Van Holst, Joy, 370 Minmurra St, Kiama, N.S.W.	30.24	"	"
Holvik, Patricia A., 14A Sommerset St, Mosman, N.S.W.	20.16	"	"
Holworthy, Crispin, Lymedale, Milford-on-sea, Lymington, Hants, U.K.	10.08	"	"
Holyer, Sheila A., 14 Domaine des Alluets, Rue Montaine, 78 Chambrourly, France	15.12	"	"
Horgan, Everett F., G.P.O. Box 86A, Melbourne	206.64	"	"
Horn, Christopher L. and Partick R., 36 Woonona Rd, Northbridge, N.S.W.	60.48	"	"
Horner, Gisela M., c/o Gisela Moore, 53 Hale Rd, Mosman, N.S.W.	20.16	"	"
Hosie, David, Cairnlea Farm, Balfron Station, Stirlingshire, U.K.	55.44	"	"
Howard, Jeffrey P., 6 Kara St, Lane Cove, N.S.W.	15.12	"	"
Howell, Christopher R., 128 Ryde Rd, Pymble, N.S.W.	25.20	"	"
Hoy, Doreen (estate of), c/o Gaby Hardwicke & Co, 2 Eversley Rd, Bexhill-on-sea, East Sussex TN40 1EY, U.K.	30.24	"	"
Hrouda, Otto, c/o Commonwealth Trading Bank, Barrack St, Sydney, N.S.W.	599.76	"	"
Huckerby, John W., 106 Janet St, Merewether, N.S.W.	25.20	"	"
Hudson, Pamela and Jennifer, 48 Tobruk Ave, Cremorne, N.S.W.	10.08	"	"
Huggett, Lee P., 241 Eighth Ave, Inglewood, W.A.	15.12	"	"
Hughes, Judith A., c/o Judith A. Davis, 333 Park View Tce, No. 9 Oakland, Cal. 94610, U.S.A.	60.48	"	"
Hughey, Kenneth F. D., 12A Crofton Rd, Christchurch 5, N.Z.	30.24	"	"
Hume, Donald H., 23 Sinns Ave, Werribee	15.12	"	"
Hunka, Michael N. R., 45 Pursers Cross Rd, London SW6, U.K.	35.28	"	"
Hunt, David A. (estate of), Burton House, Marsham, Ripon, Yorkshire, U.K.	589.68	"	"
Hunter, John F., 175 Balgowlah Rd, Balgowlah, N.S.W.	15.12	"	"
Hunter, Katherine M., 70 Inderwick Rd, London N8, U.K.	35.28	"	"
Indamaro Pty Ltd, 7 Dillwynia Ave, Lower Templestowe	25.20	"	"
Ings, Susan M., 7 Thornbrough Cl, Hartburn, Stockton-on-Tees, Teesside, U.K.	10.08	"	"
Irwin, Leonard H. and Frederick L., 324 The Esplanade, Speers Point, N.S.W.	25.20	"	"

## Unclaimed Moneys Act 1962

## Register of Unclaimed Moneys held by the—

<i>Name of Owner on Books and Last Known Address</i>	<i>Total Amount Due to Owner</i>	<i>Description of Unclaimed Money</i>	<i>Date when Amount first became Payable</i>
\$			
THE BROKEN HILL PROPRIETARY LIMITED— <i>continued</i>			
James, David R. L., 18 St Clair's Rd, Croydon CRO 5NE, U.K.	15.12	Interest	9.11.81
James, Peter V. (estate of) and Griffiths, Shirley E. F., National Westminster Bank Chambers, Blackheath Village, Blackheath, London SE3, U.K.	428.40	"	"
Jarman, June E., c/o C. Tredinnick, P.O. Box 630, Coffs Harbour, N.S.W.	15.12	"	"
Jasalm Pty Ltd, a/c 2/83 Clendon Rd, Toorak	378.00	"	"
Jay, William H. and Margaret, 63 Tara St, Kangaroo Point, N.S.W.	70.56	"	"
Jenkins, John J., 14 Bay St, Mosman, N.S.W.	40.32	"	"
Jennings, John T., 75 Cliffs Rd, St Claire, Dunedin, N.Z.	30.24	"	"
Jerwood, Valerie A., Greystoke, 18 Waggon Rd, Hadley Wood, Barnet, Herts, U.K.	115.92	"	"
Johnson, Anthony C. R., Hayne Leigh, Blackborough, Cullompton, Devon, U.K.	25.20	"	"
Johnson, Claire I. F., Greta Canyon, Greta Valley Rd, North Canterbury, N.Z.	20.16	"	"
Johnson, Thomas (estate of), c/o T. D. Johnson & Co, 90 Pitt St, Sydney, N.S.W.	45.36	"	"
Johnston, Judith A., 7 Nash St, Daglish, W.A.	25.20	"	"
Johnstone, Michele, 57A Sydney St, Willoughby, N.S.W.	25.20	"	"
Jones, Esme L., 6 Malibu, 29 Wesca Pde, Newcastle, N.S.W.	20.16	"	"
Jones, Frances J., 78 Spit Rd, Spit Junction, N.S.W.	10.08	"	"
Jones, Susan, 10 Henley Rd, Mount Eden, Auckland 3, N.Z.	25.20	"	"
Joseph, David P. and Michael K. (estate of), Snedden, Warwick and Allingham, Wilfred J., c/o Anderson and Snedden, Box 958, Auckland, N.Z.	156.24	"	"
Joseph, Michael K. (estate of) and David P., c/o Snedden Anderson and Co., G.P.O. Box 958, Auckland 1, N.Z.	80.64	"	"
Judd, Noton, 87 Elmwood Dve, Ewell, Surrey, U.K.	10.08	"	"
Kaczanowska, Rachel E., 27 Douglas St, Faulconbridge, N.S.W.	85.68	"	"
Kaczmarowski, Dorothy M., 67 Caloola Ave, Kingswood, N.S.W.	25.20	"	"
Kahn, Phil, c/o N. Sreeivasan, 11 Cedar Place, Woodlands, W.A.	10.08	"	"
Kastrati, Quazim E., 6 Winchester House, 16 Cambridge Park, East Twickenham, Middlesex TW1 2JG, U.K.	40.32	"	"
Kean, Ian M., 5 Astons Rd, Moor Park Road, Northwood, Middlesex, U.K.	25.20	"	"
Keane, Robert M., c/o S. M. Bennett, P.O. Box 258, Coonabarabran, N.S.W.	85.68	"	"
Keddell, Stephen A., P.O. Box 7, Matakana, North Auckland, N.Z.	10.08	"	"
Kelly, Beatrice, 24 Valley Rd, Springwood, N.S.W.	65.52	"	"
Kelman, Simone H. H., 26/28 Rue Rouget de Lisle, 92 Puteaux, France	20.16	"	"
Kendall, Peggy E. and Raymond J., P.O. Box 23-083, Papatoetoe, N.Z.	141.12	"	"
Kengaku, Katsumi, c/o Nippon Steel Corporation, 60 Martin Pl, Sydney, N.S.W.	95.76	"	"
Kennedy, Lord David T., Cassillis House, Maybole, Ayrshire, U.K.	20.16	"	"
Kennedy, John A., 14M, 111 Mt Butler Rd, Hong Kong	40.32	"	"
Kenny, Kevin and Jane, 2 Glenavy Park, Terenure, Dublin 6, Eire	10.08	"	"
Kersey, Sarah J., "Wood Park", Armidale, N.S.W.	10.08	"	"
Khong, Peck W. and Susan M. H., 4/19 Mount St, Coogee, N.S.W.	10.08	"	"
Kilariff, James K., c/o J. W. Gullock, 197 O'Sullivan Rd, Rose Bay, N.S.W.	50.40	"	"
Killen, Hugh W., "Oakhampton", Yarrowitch, N.S.W.	40.32	"	"
Kilpatrick, Susan, c/o Susan Griffin, 101 Leopold St, South Yarra	55.44	"	"
Kinabatangan Development Co. Ltd, P.O. Box 887 Sandakan, Sabah, East Malaysia	20.16	"	"

## Unclaimed Moneys Act 1962

Register of Unclaimed Moneys held by the—

Name of Owner on Books and Last Known Address	Total Amount Due to Owner	Description of Unclaimed Money	Date when Amount first became Payable
\$			
<b>THE BROKEN HILL PROPRIETARY COMPANY LIMITED—continued</b>			
King, Jason 36 Lawson St, Balmain, N.S.W.	15.12	Interest	9.11.81
King, Patricia F., Broadview, Chesswood Rd, Worthing, Sussex, U.K.	10.08	"	"
King, Peter M., 16 Shadforth St, Paddington, N.S.W.	30.24	"	"
King, Roslyn A., 5 Huntingfield Rd, Toorak	509.04	"	"
King, William F., Kingsacre, Kirkhill Rd, Newton Mearns, Renfrewshire, U.K.	60.48	"	"
Kirkby, Valerie, 66 Arthur St, Randwick, N.S.W.	126.00	"	"
Kirkup, Raymond Francis, 13 Almurta Rd, East Bentleigh	40.32	"	"
Klingszot, Charles, 4 Winifred St, Morwell	75.60	"	"
Knight, Wilfred C. and Eileen M. C. and Gotelee, Allan A., White Lodge, Westerfield, Ipswich, Suffolk, U.K.	50.40	"	"
Kong, Neville, 25 Arthur St, Tokoroa, N.Z.	20.16	"	"
Korman, Irving T., c/o Riviera Casuals, Cavill Ave, Surfers Paradise, Qld	20.16	"	"
Kruger, Peter F. W. and Elizabeth, Lot 5, Oxenford Dve, Mount Tamborine, Qld	75.60	"	"
Kwok, Frank W., A401 Tregunter, 14 Tregunter Path, Hong Kong	70.56	"	"
Lambart-John, Edith L. (estate of), c/o Lloyds Bank Limited, 39 Threadneedle St, London EC2R 8AU, U.K.	35.28	"	"
Lammers, John G., 2 Peace Cres, Balgownie, N.S.W.	25.20	"	"
Lamont, Ann F. C., 37 Kirklee Rd, Glasgow W2, U.K.	221.76	"	"
Landsman, Philip, 21 Howard Rd, Tottenham, London N15 6NL, U.K.	126.00	"	"
Lane, Gwenifer B., 11/29 Crows Nest Rd, Waverton, N.S.W.	20.16	"	"
Lane, James E., 129 Gladstone Ave, Mount St Thomas, N.S.W.	20.16	"	"
Lang, Allan A., 51 Corunna Ave, Daw Park, S.A.	20.16	"	"
Laver, James C., 1/112 Wellington St, St. Kilda	10.08	"	"
Lawson, Peter G., Neaskin Farm, Dunmanaway, Co. Cork, Eire	20.16	"	"
Leary, Ida May, Nan Roberts Community, Bourke St, Wagga, N.S.W.	10.08	"	"
Leary, John, c/o Nan Roberts Community, Bourke St, Wagga, N.S.W.	10.08	"	"
Lee, Catherine A., 98 Woodbridge Rd, Rushmere, St Andrew, Ipswich, Suffolk, U.K.	20.16	"	"
Lee, Estella, P.O. Box 6, Bondi Junction, N.S.W.	20.16	"	"
Lee-Steere, Josephine M., c/o Josephine M. White, P.O. Box 433, Manjimup, W.A.	10.08	"	"
Leeden, Alexander G., 16 Dandenong St, Nambour, Qld	126.00	"	"
Lemon, William M., Old Farm Cottage, Ewhurst, Cranleigh, Surrey, U.K.	156.24	"	"
Leonard Dr Edward G., and Nellie Leonard, 47 Chiltern Dve, 13 Singapore	110.88	"	"
Leung, Cee M., 14 Tennyson St, East Malvern	65.52	"	"
Levick, Neville A., c/o Standard Bank Ltd, P.O. Box 7111, Kampala, Uganda	126.00	"	"
Lewis, George H., c/o Texada Mines Pty Ltd, Carnarvon, W.A.	10.08	"	"
Lewis, William R., 8 Parkin Ave, Glen Iris	15.12	"	"
Liesendahl, Gustav P., 3 East Sussex Lane, 10 Singapore	211.68	"	"
Little, Delphine R., c/o Delphine R. Dalziel, 93A Seaforth Cres, Seaforth N.S.W.	35.28	"	"
Littleson, Neil W., 10 Callace St, Brunswick	10.08	"	"
Logan, James J. (estate of), c/o Henry T. Skilton and Logan, P.O. Box 24, Maitland, N.S.W.	20.16	"	"
Logan, Phyllis B., P.O. Box 42, Beechworth	40.32	"	"
Logie, Alan W., 5 Ridge Green Cl, South Nutfield, Surrey, U.K.	10.08	"	"
Lormax, Philip M., Catherine E., and Atison M., c/o Aviemore, Marshdale Rd, Bolton, Lancs. U.K.	10.08	"	"
Long, Ian G., 4 Probate St, Nareburn, N.S.W.	1 128.96	"	"
Lorenzen, Werner C., 49 Branksome Tce, Dover Gardens, S.A.	20.16	"	"
Lorking, Bruce C., 10 Yeo St, Neutral Bay, N.S.W.	25.20	"	"

## Unclaimed Moneys Act 1962

Register of Unclaimed Moneys held by the—

<i>Name of Owner on Books and Last Known Address</i>	<i>Total Amount Due to Owner</i>	<i>Description of Unclaimed Money</i>	<i>Date when Amount first became Payable</i>
\$			
<b>THE BROKEN HILL PROPRIETARY COMPANY LIMITED—continued</b>			
Love, Thomas D. J., 654 King St, Newtown, N.S.W.	257.04	Interest	9.11.81
Lovett-Cameron, Stephen D., P.O. Box 56, Broomehill, W.A.	50.40	"	"
Lowry, Karen M., Oreka, Fernhill, Hastings, Hawkes Bay, N.Z.	20.16	"	"
Lumsdaine, Peter (estate of), and Madigan, Edwin and Taylor, Stanley, c/o Harbord Diggers Club, Harbord, N.S.W.	25.20	"	"
Lyons, Charlotte (estate of), c/o Atkins Jones and Brodie, P.O. Box 1220, Wollongong N.S.W.	403.20	"	"
Macdessi, Amina, 46 Vista St, Sans Souci, N.S.W.	10.08	"	"
Macdessi, Lilly, 2 Berkley Ave, Unandera, N.S.W.	10.08	"	"
McDonald, Dorothy A., (estate of) c/o Wynn Williams and Co, P.O. Box 22-205, Christchurch, N.Z.	110.88	"	"
Macdonell-Scott, Nancy E., 75 Arnold St, Killara, N.S.W.	75.60	"	"
Macgibbon, Bruce R., 20 Grand View Rd, Remuera, Auckland 5, N.Z.	161.28	"	"
MacKenzie, James M. W., 187 Gannons Rd, Caringbah, N.S.W.	10.08	"	"
MacLachlan, Dr Ian, 60 Wilga St, Fairfield, N.S.W.	40.32	"	"
MacMullen, Capt. Timothy W., and Ailene M., 156 Pinnacle Dve, Condon, Qld	30.24	"	"
Magdala Holdings Limited, Northdale, Mont Mado, St John-Jersey, Channel Islands	378.00	"	"
Maier, Prudence, c/o 79 Birdwood St, Hughes, Canberra, A.C.T.	10.08	"	"
Major, Jeffery B., 6/24 Acland St, St Kilda	30.24	"	"
Malhotra, Mangat, c/o John W. A., Meredith, 43/108 Elizabeth Bay Rd, Elizabeth Bay, N.S.W.	10.08	"	"
Maltby, David F., Bargate Farm, Drayton Parslow, Bletchley, Bucks, U.K.	40.32	"	"
Manners, Carol S., 66 Court St, West Wyalong, N.S.W.	20.16	"	"
Margolin, Ronald B., Brambles, 67 Farm Lane North, Barton-on-Sea, Hampshire BH25 7BP, U.K.	10.08	"	"
Marshall, Robert T., 30 Arlington St, Christchurch 5, N.Z.	20.16	"	"
Martin, Allan R., 8/9 Gibbon St, Mosman Park, W.A.	40.32	"	"
Martin, Les, 23 Alexander Pde, Roseville, N.S.W.	15.12	"	"
Martyn, Bruce G., 5 Mentone Rd, Silverfields, Krugersdorp, South Africa	60.48	"	"
Mason, Edward J. H., 3/11 The Avenue, Sneyd Park, Bristol 9, U.K.	15.12	"	"
Mason, Peter J., P.O. Box 3136, Lagos, Nigeria	45.36	"	"
Masuda, Takeo, 1-8-18 Minami-Ogikubo, Suginam-Ku, Tokyo, Japan	20.16	"	"
Materne, Gilbert J., and Mickan, Peter F., 11 Kings Ave, Burnside, S.A.	10.08	"	"
Matheson, Lizzie L., Tidemannsgt 28, Oslo 2, Norway	2 560.32	"	"
May, Barry L., c/o H. Wiltshire Webb, Son and Doyle, P.O. Box 166, Port Vila, Vanuatu	35.28	"	"
McAffer, Keitha M. (estate of), No. 1 Line, 5 R D, Palmerston North, N.Z.	50.40	"	"
McAuliffe, John P., c/o 50 North St, Richmond	15.12	"	"
McBurney, Samuel S., Flat 3 Block 8, Northbourne Flats, Turner, A.C.T.	15.12	"	"
McCallum, Mary P., Dunholme Dalmuir, Dunbartonshire, U.K.	191.52	"	"
McCann, Harvey E., and Florence M., c/o the Equity Trustees, Executor and Agency Co. Ltd, 472 Bourke St, Melbourne	60.48	"	"
McClure, David B., 44 Ferntree Gully Rd, East Oakleigh	10.08	"	"
McCoy, James A., c/o Union Hotel, Tumbarumba, N.S.W.	20.16	"	"
McCoy, James A., and Oxley, Keith W. E. (estate of), c/o Union Hotel, Tumbarumba, N.S.W.	40.32	"	"
McCrossan, Maureen, 28 Woodlawn Park, Churchtown, Dublin 14, Eire	20.16	"	"
McDonald, Patricia M., 3 Millward St, Wanganui East, Wanganui, N.Z.	20.16	"	"
McDowell, Florette, 2/29 Capt Pipers Rd, Vaucluse, N.S.W.	15.12	"	"

## Unclaimed Moneys Act 1962

## Register of Unclaimed Moneys held by the—

Name of Owner on Books and Last Known Address	Total Amount Due to Owner	Description of Unclaimed Money	Date when Amount first became Payable
\$			
<b>THE BROKEN HILL PROPRIETARY COMPANY LIMITED—continued</b>			
McDowell, Margaret R., St Thomas, Whitechurch, Co Dublin 16, Eire	126.00	Interest	9.11.81
McEniery, Dennis M., 33 Buena Vista Ave, Coorparoo, Qld	85.68	"	"
McGovern, Lehane M., 22 Penkivil St, Bondi, N.S.W.	20.16	"	"
McGregor, Peter W., Flat 6/28 Black St, Middle Brighton	20.16	"	"
McIntosh, Dr Ian W., C/o Royal Perth Hospital, Wellington St, Perth, W.A.	20.16	"	"
McJannet, Raynor, 135 Macquarie St, Sydney, N.S.W.	206.64	"	"
McKay, John S., 17A Portland Cres, Thorndon, Wellington, N.Z.	10.08	"	"
McKean, Peter J., 12/23 Pine St, North Randwick, N.S.W.	10.08	"	"
McLaren, Eric S., 44 Illalung Rd, Lambton, N.S.W.	20.16	"	"
McLeod, Vera, Unit 2, Arnold Lodge, 26 Western Rd, Mowll Village, Castle Hill, N.S.W.	70.56	"	"
McLeod, Wellington A., Unit 2, Arnold Lodge, 26 Western Rd, Mowll Village, Castle Hill, N.S.W.	75.60	"	"
McMahon, Henry F. (estate of), and Morton, Peter, P.O. Box 100, Port Douglas, Qld	241.92	"	"
McMahon, Louis M., 2/50-52 Bridge St, Epping, N.S.W.	85.68	"	"
McPherson, Bruce H., 2 Hill St, Mount St Thomas, N.S.W.	20.16	"	"
McTurk, Diane, 300 New Garden St, Queenstown, Georgetown, Guyana, South America	211.68	"	"
Meade, Lynette L. (estate of), C/o B. Corben, 118 Stuart St, Blakehurst, N.S.W.	35.28	"	"
Meagher, John R., 12 Court St, Parkes, N.S.W.	10.08	"	"
Medina, Antonio C., Calle Maipu 924, Buenos Aires, Argentine	10.08	"	"
Medvedeff, Vera N., 86 Restwell St, Bankstown, N.S.W.	15.12	"	"
Megan, Ellen (estate of), C/o Michael B. O'Cleirigh & Co., 5 Lower Hatch St, Dublin 2, Eire	15.12	"	"
Meldrum, Ronald R., 950 Riversdale Rd, Surrey Hills	1093.68	"	"
Mensink, Margaretha, C/o Dunn Strachan & Hardie, 3 Smith St, Warragul	85.68	"	"
Menzies, Alexander S., 10 Hollygreen Dr, Glen Waverley	20.16	"	"
Menzies, Catherine M., 10 Hollygreen Dr, Glen Waverley	20.16	"	"
Menzies, George S., C/o H. G. Menzies, Managord, RD 7, Dannevirke, N.Z.	126.00	"	"
Merlan Investments Pty. Ltd., 474 Victoria St, West Brunswick	141.12	"	"
Michael, Anthony M., 5/321 Dandenong Rd, Prahran	15.12	"	"
Michel, Jane M., C/o National Westminster Bank Ltd., 92 Park Lane, London W1Y 4EJ, U.K.	50.40	"	"
Miller, Douglas B., 3 Cedar Crt, Somerset Rd, Wimbledon SW19, U.K.	10.08	"	"
Miller, James H., Hall Garth, Doncaster Rd, Brayton, Selby YO8 9HD, U.K.	40.32	"	"
Miller, Paul R. (estate of), C/o James P. Donald, P.O. Box 153, Kew	20.16	"	"
Mitchell, Ian J., P.O. Box 23, New Plymouth, N.Z.	95.76	"	"
Mitchell, Janet E., C/o K. G. Gibson, P.O. Box 30-844, Lower Hutt, N.Z.	80.64	"	"
Mo, Raymond and Fletcher, Rodney, C/o R. H. Fletcher, 2/8 Hampton Crt Road, Carlton, N.S.W.	20.16	"	"
Montgomery, Caroline S., 3 Seymour Apartments, 19 Seymour Ave, Kingston 6, Jamaica	80.64	"	"
Moore, Paul L., 31 The Ridge, Canterbury	105.84	"	"
Morley, Lorna K., 3 Boulters Crt, Maidenhead, Berks, U.K.	15.12	"	"
Morrison, Frederick J., 11 Eastern Ave, Mangerton, N.S.W.	60.48	"	"
Morrison, Norman W., P.O. Box 36, Geraldine, South Canterbury, N.Z.	45.36	"	"
Morton, Roderick E., 85 Roslyn St, Brighton	105.84	"	"
Moss, Julie A., 1/87 Ocean St, Woollahra, N.S.W.	20.16	"	"
Munro, Hector H. (estate of), C/o Goldsmith & Musat, 164 High St, Ashburton	10.08	"	"

## Unclaimed Moneys Act 1962

## Register of Unclaimed Moneys held by the—

<i>Name of Owner on Books and Last Known Address</i>	<i>Total Amount Due to Owner</i>	<i>Description of Unclaimed Money</i>	<i>Date when Amount first became Payable</i>
\$			
<b>THE BROKEN HILL PROPRIETARY COMPANY LIMITED—continued</b>			
Murray, William J., 36 Osborne St, Dapto, N.S.W.	25.20	Interest	9.11.81
Murrell, John R., 31 Lings Coppice, Croxted Rd, London SE21 8SY, U.K.	25.20	"	"
Murrowood, George W., P.O. Box 115, Atherton, Qld	55.44	"	"
Mustoe, Brian H., 154 Waldegrave, Kingswood, Basildon, Essex, U.K.	15.12	"	"
Naughton, Claude B., P.O. Box 315, Surfers Paradise, Qld	599.76	"	"
Needs, Dr Ronald E., Sunnybrook Hospital, 2075 Bayview Ave, Toronto, Ontario M4N 3M5, Canada	10.08	"	"
Nekuda, Peter P., 1/14 Reynolds St, Cremorne, N.S.W.	75.60	"	"
Nelson, James H., P.O. Box 1492, Wellington, N.Z.	70.56	"	"
Nelson, Michael, C/o B. C. Humphries, P.O. Box 110B, Newcastle, N.S.W.	20.16	"	"
Neumann, Dr Hans, 1F/15 Onslow Ave, Elizabeth Bay, N.S.W.	40.32	"	"
Neumann, Dr Hans and Leah, 1F Elizabeth Bay Gardens, 15 Onslow Ave, Elizabeth Bay, N.S.W.	45.36	"	"
New, Peter Alan, 3 Broadmeadow Rd, Broadmeadow, N.S.W.	20.16	"	"
Newington, Richard, 49 Orchard Valley, Hythe, Kent, U.K.	15.12	"	"
Ng, David S. C. and Dorothy I. K., C/o Chemfields Inc., P.O. Box 1070 MCC, Makati Metro Manila, Philippines	630.00	"	"
Ng, Meiguin, 28 Edgar Street, Chatswood, N.S.W.	20.16	"	"
Nicholas, Charles V., 102 Gloucester Tce, London W2, U.K.	40.32	"	"
Nicholls, Susan, 94 Maude St, Shepparton	40.32	"	"
Nicholson, Robert McW., 24 Tulip St, Daisy Hill, Qld	30.24	"	"
Nicoll, Ross F., 7 Little Selwyn St, Paddington, N.S.W.	10.08	"	"
Nixon, David E. and Wood, Kenneth and Goddard, Eileen D., C/o Dawson & Co, 2 New Square, Lincolns Inn, London WC2A 3RZ, U.K.	362.88	"	"
Nixon, Roger R., C/o 35 Arthur St, Doncaster	45.36	"	"
Nixon-Smith, Audrey Felicia, Turnstones, Perrancombe, Perranporth, Cornwall, U.K.	50.40	"	"
Northcote Stock Nominees Ltd., 119-125 Finsbury Pavement, London EC2A 1JJ, U.K.	156.24	"	"
Oakly, Warren T., 7 Macara St, Masterton, N.Z.	50.40	"	"
O'Dwyer, Patrick J., 10 Lamrock St, Cobar, N.S.W.	65.52	"	"
O'Farrell, John R., C/o Manager, Bank of N.S.W., Manuka, A.C.T.	15.12	"	"
O'Keeffe, Howard J., C/o Beacon Tyre Service, Hornibrook Esplanade, Clontarf Beach, Qld	10.08	"	"
Olden, Herbert J., 16 Morwell St, London WC1, U.K.	55.44	"	"
Olderoid, Toby and Tia, C/o Ruth Center, 51 Hawthorn Ave, Chatswood, N.S.W.	15.12	"	"
Oldfield, Lynne C., C/o Lynne Lowe, 12 Keiran St, Bondi Junction, N.S.W.	10.08	"	"
O'Neill, Ian H., 71 Westfield Ave, Sanderstead, Surrey, U.K.	65.52	"	"
Ord, Grace E. (estate of), C/o John M. Rothery, Freehill Hollingdale & Page, 60 Martin Pce, Sydney, N.S.W.	10.08	"	"
O'Reilly, Elizabeth, 19 Chepstow Villas, London W11 3DZ, U.K.	176.40	"	"
Osborne, George M., Waihemo, Murringo, N.S.W.	231.84	"	"
Osmond, Ronald T., P.O. Box 3, Cambridge, N.Z.	246.96	"	"
O'Sullivan, Bernard J. (estate of), C/o V. J. O'Sullivan, 30 Amaral Ave, Dapto, N.S.W.	20.16	"	"
O'Sullivan, Terence E., 38 Geisel St, Dalby, Qld	15.12	"	"
O'Sullivan, Terence J., 44 Gipps St, Nanango, Qld	45.36	"	"
Overton, Paul E., 36 St Johns Rd, Glebe, N.S.W.	15.12	"	"
Paddle, Jill P., C/o Jill P. Jones, 1/4 Louisa St, Birchgrove, N.S.W.	20.16	"	"
Page, Christine M., C/o Barclays Bank Limited, 19 Great Cumberland Pce, London, W1, U.K.	35.28	"	"
Page-Sharp, Rosalie G., 3 Russell St, Ballarat	25.20	"	"
Parnell, The Hon. John P. C., West End Farm, Ebbesbourne Wake, Salisbury, Wilts, U.K.	126.00	"	"



## Unclaimed Moneys Act 1962

Register of Unclaimed Moneys held by the—

Name of Owner on Books and Last Known Address	Total Amount Due to Owner	Description of Unclaimed Money	Date when Amount first became Payable
\$			
<b>THE BROKEN HILL PROPRIETARY COMPANY LIMITED—continued</b>			
Patel, Arvindrai R., P.O. Box 12283, Nairobi, Kenya	30.24	Interest	9.11.81
Patel, Shantaben N., 365 Gander Green Lane, North Cheam, Sutton, Surrey SM3 9QX, U.K.	241.92	"	"
Paul, Ian H. and Elizabeth H., Minimi, Thallon, Qld	65.52	"	"
Paul, Myra J., 20 Alfred St, Heidelberg	10.08	"	"
Paul, Carmel R., 32B Freeman Rd, Kuala Lumpur, Malaysia	65.52	"	"
Paul, Edward A. N., 111 Caledonian Ave, Maylands, W.A.	10.08	"	"
Peacock, Matthew J., P.O. Box 38, Kings Cross, N.S.W.	146.16	"	"
Pearce, Kevin R., 50 Dawson St, Cooks Hill, N.S.W.	20.16	"	"
Pearson, Antoni, 7 Ellen St, Randwick, N.S.W.	10.08	"	"
Pearson, John Ford, C/o 34 Helen St, Merewether, N.S.W.	20.16	"	"
Pegrum, Frances J., 3/137 Darling Point Rd, Darling Point, N.S.W.	10.08	"	"
Pelling, Deborah E., 263 Banyule Rd, Rosanna	30.24	"	"
Pender, Margaret M. and Warner, Anne E., C/o M. M. Pender, 27 Hinaiu St, Christchurch, N.Z.	20.16	"	"
Penman, Keith (estate of) and Ebbott, Terence P., C/o Fibremakers Ltd., Canterbury Rd, Bayswater	25.20	"	"
Perry, Grace Z., 14 Wongneichong Gap Rd, APT 2A, Hong Kong	20.16	"	"
Peter, Nicholas, 33 Osborne Ave, McKinnon	10.08	"	"
Petrie, Andrew H., C/o Post Office, Eneabba, W.A.	10.08	"	"
Philp, James C. P., C/o Ellis Peirs & Young Jackson, 17 Albemarle St, London W1, U.K.	40.32	"	"
Phippard, Lorna L., 2/21 Manning Rd, Double Bay, N.S.W.	2016.00	"	"
Pill, Leslie, 13 Picton St, Mascot, N.S.W.	55.44	"	"
Piper, Dorothy E. (estate of), C/o C. E. Piper and D. I. Dence, 20 High St, Epping, N.S.W.	493.92	"	"
Pitman, Jenifer F., 31 Fulready Rd, London E10, U.K.	20.16	"	"
Pitt, Herbert W., C/o Westminster Bank Ltd., 14 Sloane Sq, London SW1, U.K.	1249.92	"	"
Player, Anthony J. F., 91 Factory Rd, Mosgiel, Otago, N.Z.	20.16	"	"
Plint, Colin W., 30 Wait St, Newcastle, N.S.W.	55.44	"	"
Podberscek, Boris and Gail H., 85 Tooth Ave, Paddington, Qld	10.08	"	"
Polito, John P., The Qld Queen House, Melbourne, Market Harborough, Leicestershire LE16 8EB, U.K.	10.08	"	"
Ponsonby, Sarah V. T., Helsett Farm, Lesnewth, Roscastle, Cornwall, U.K.	15.12	"	"
Pook, Robert D., Larkswood, Oakfield Close, Weybridge, Surrey, U.K.	10.08	"	"
Poole, Edward R., 88 Billing St, Whyalla Playford, S.A.	20.16	"	"
Pope, Patricia Mary C., 58 Victoria Ave, Claremont, W.A.	20.16	"	"
Porter, Irene, Flat 1, 54 Warren Rd, Marrickville, N.S.W.	10.08	"	"
Porter, Susan M., 3 Sandhurst Crt, Wheelen Hill	75.60	"	"
Potts, Heather J., Box 9, Quairading, W.A.	50.40	"	"
Powell, Jocelyn F. B. and Beer, Charles G. A., 28 Estria Rd, Edgbaston, Birmingham 15, U.K.	141.12	"	"
Poynter, William G., 5 Minard St, The Gap, Qld	25.20	"	"
Price, Marion F., 53 Carranya Rd, Lane Cove, N.S.W.	25.20	"	"
Friday, Brian C. E. and Elsie H. M., 31 The Fairways, Leamington Spa, Warks, U.K.	10.08	"	"
Prowse, Leonie M., c/o Leonie Maree Nolan, 8 Carbost Cres, Macleod	45.36	"	"
Puelmans, Florimand (estate of), Societe Generale De Banque, 3 Montagne Du Parc, 1000-Brussels, Ref. 210/ADM/TIT/OS/LDV/ 75011/, Belgium	25.20	"	"
Punnett, Betty (estate of), Penison Estates Ltd, Peniston, St. Vincent, West Indies	15.12	"	"
Pyne, John Charles and Patricia, 15 Scott St, Narrabundah, A.C.T.	105.84	"	"
Quayle, Jack D., 111 Oroua St, Eastbourne, N.Z.	10.08	"	"
Quiggin, Peter Edwin, 4 Helmsdale Dve, Valentine, N.S.W.	25.20	"	"
Quine, Peter Croxton, c/o M. White, 269 Fig Tree Pocket Rd, Fig Tree Pocket, Qld.	25.20	"	"

## Unclaimed Moneys Act 1962

## Register of Unclaimed Moneys held by the—

<i>Name of Owner on Books and Last Known Address</i>	<i>Total Amount Due to Owner</i>	<i>Description of Unclaimed Money</i>	<i>Date when Amount first became Payable</i>
\$			
<b>THE BROKEN HILL PROPRIETARY COMPANY LIMITED—continued</b>			
Quinn, John Joseph, 28 King St, Lorn, N.S.W.	20.16	Interest	9.11.81
Radford, Eric R. and Joy F., Pender Lodge, 6 Oakleigh Park Noth, Whetstone, London NZO 9AR, U.K.	55.44	"	"
Radford, Prudence W., 139 Livingstone Ave, Pymble, N.S.W.	15.12	"	"
Ralston, Mary, c/o Allen K. Rost, 55 Clarence St, Sydney, N.S.W.	302.40	"	"
Ramanathan, Kandasamy, c/o Federal Ministry of Works and Housing, Jebba Bridge Project, PM Bag 571, Jebba Kwara, State Nigeria	10.08	"	"
Ray, Clare Alice, St. Annes Hospital, 19 Marian St, Killara, N.S.W.	25.20	"	"
Read, Ethel Gladys (estate of), c/o Phillips & Co., P.O. Box 256, Yass, N.S.W.	131.04	"	"
Redding, Garry, 5/303 Clovelly Rd, Clovelly, N.S.W.	10.08	"	"
Reed, Dane B. and Turner, John B., 62/64 Moorgate, London, E C 2, U.K.	131.04	"	"
Reed, Maxwell Peter, 4 Flintoff Ave, Toorak	10.08	"	"
Reilly, Duncan Neil, 1/187 Prospect Rd, Prospect, S.A.	10.08	"	"
Remfry, Kenneth R. M. and Joyce H., 4 Dell Close, Roman Rd, Broadstone, Dorset, U.K.	10.08	"	"
Rengger, Janice Anne (Bundarra), Cumberland Rd, Ingleburn, N.S.W.	25.20	"	"
Renowden, Janice Elizabeth, 149 Dare St, Ocean Grove	25.20	"	"
Frederic, Ove Ditlev, Reventlow-Mourier, Brahetrolleborg, 5783 Korinith, Denmark	50.40	"	"
Reynard, Edward, 52 High Rd, Gardens, Johannesburg, South Africa	206.64	"	"
Richards, Henry T., Bruce Highway, Rothwell, Qld.	166.32	"	"
Ricker, Beverley, 38 Hetherington St, Herston, Qld.	30.24	"	"
Ridsdale, Gregory William, 10 Pearson St, Bairnsdale	10.08	"	"
Rima Wholesale Limited, 49/50 Great Marlborough St, London W1, U.K.	45.36	"	"
Ritchie, Ruth Mary, Creagan Farm, Appin, Argyll, U.K.	10.08	"	"
Roberts, Andrew Kingsley, Lot 32, Woodfull Rd, Lower Plenty	483.84	"	"
Roberts, Florence M. (Brookside), Mill St, Bradenham, Norfolk, U.K.	105.84	"	"
Roberts, Norman Eric, 1230 Sutton Place, West Vancouver BC, Canada	40.32	"	"
Roberts, Terrance Brian, 4 Kirkland Circuit, Macgregor, A.C.T.	25.20	"	"
Robertson, Ian Blair, P.O. Box 274, Kerikeri, Bay of Islands, N.Z.	30.24	"	"
Robertson, John F., 20 Birnam Cres, Bearsden, Dunbartonshire, U.K.	30.24	"	"
Robertson, Stephen D., Erodisi, Broomehill, W.A.	50.40	"	"
Robill Pty. Ltd., 5 Huntingfield Rd, Toorak	1174.32	"	"
Robinson, Geoffrey, Alfred St, Glendale, N.S.W.	20.16	"	"
Robinson, John Phillip, Trustee Estate Haywood, 88 Boundary St, East Roseville, N.S.W.	962.64	"	"
Rodgers, Stephen A., 76 Rockbourne Tce, Bardon, Qld.	10.08	"	"
Roe, Barbara Kennedy, 146 Latrobe Tce, Paddington, Qld.	756.00	"	"
Roe, Molly Diana, Fir Crest, Rye Hill, Rye, East Sussex, U.K.	236.88	"	"
Rogers, Catherine Marie, 32 Patterson St, Concord, N.S.W.	10.08	"	"
Rohan, Bridget J., 5A Hayes St, Neutral Bay, N.S.W.	10.08	"	"
Rome, Nora Lorimer, 19 Church St, Ellesmere, Shropshire, U.K.	554.40	"	"
Rosen, Isidore Isaac, 3 St. Johns Square, Cardiff CF1 2SD, U.K.	131.04	"	"
Ross, David J., Apt 304 Jockey Club, 11111 Biscayne Building, Miami, 33161 Florida, U.S.A.	15.12	"	"
Ross, Donald Martin, Ben Mhor Hotel, Grantown-On-Spey, Morayshire, U.K.	50.40	"	"
Ross, John Prentice, 1 Rectory Lane, Capenhurst, Chester, U.K.	146.16	"	"
Ross, Scott Lawson B., Retreat, Manilla, N.S.W.	15.12	"	"
Rowland, Kathleen M., West Haven, Widemouth Bay, Bude, Cornwall, U.K.	25.20	"	"
Rowley, Gillian, 85 Saunder St, Wynyard, Tas.	10.08	"	"
Roy, Hugh, P.O. Box N7899, Nassau, Bahamas	65.52	"	"

## Unclaimed Moneys Act 1962

Register of Unclaimed Moneys held by the—

<i>Name of Owner on Books and Last Known Address</i>	<i>Total Amount Due to Owner</i>	<i>Description of Unclaimed Money</i>	<i>Date when Amount first became Payable</i>
\$			
<b>THE BROKEN HILL PROPRIETARY COMPANY LIMITED—continued</b>			
Russell, Dwayne H. W., c/o D. E. Russell, Minden Heights, RD2, Tauranga, N.Z.	10.08	Interest	9.11.81
Russell, Gilbert Lewis, 2/3 Hall St, Whyalla Stuart, S.A.	25.20	"	"
Russell, John Howard T., 15 Stoneleigh Road, Gibbet Hill, Conventry, U.K.	95.76	"	"
Russell, Raymond E., c/o Staff Mess, Mt. Isa Mines Ltd., Mt. Isa, Qld.	70.56	"	"
Ryan, John (estate of), c/o 27 Morehampton Tce, Donnybrook, Dublin, Eire	10.08	"	"
Ryan, Kathleen, 9 Menzies St, Sumner, Christchurch, N.Z.	105.84	"	"
Ryan, Veronica, c/o Bell Branigan, O'Donnell and O'Brien, 22 Lower Baggot St, Dublin 2, Eire	45.36	"	"
Sallman, Doris, c/o A. F. Sallman, 60 Collins St, Melbourne	30.24	"	"
Salter, William D., 76 Groom St, Hughes, A.C.T.	65.52	"	"
Sampson, Lionel B. and Kennett, Elizabeth A., Hazelhome, Pinnacle Rd, Orange, N.S.W.	20.16	"	"
Samways, Cyril L., Superannuation Fund, c/o W. Kohn, 235 Elizabeth St, Sydney, N.S.W.	25.20	"	"
Sanders, Beryl M. I. F., 11 Carlyle St, Moonsee Ponds	529.20	"	"
Santos, Teodoro V., Suite 406, Midland Mansions, 839 Pasay Rd, Makati Metro Manila, Philippines	115.92	"	"
Saunders, Phillip C. H., 8 Allamanda St, Fairfield, Qld.	40.32	"	"
Savage, Peter, c/o John M. Savage and Son, 126 Oxford St, Collingwood	30.24	"	"
Scheeren, Willem B., 93 Cygnet Cres, Redhill, A.C.T.	15.12	"	"
Scheunert, Ruth I., "Domanda,, Hayes Garden, Navan, Co Meath, Eire	30.24	"	"
Schouten, Alexander J., c/o Police Headquarters, Hong Kong	30.24	"	"
Schwarz, Erna, 96 Brighton Blvd, North Bondi, N.S.W.	85.68	"	"
Scott, Alexander J., Surrey Downs, Rd 2, Kati Kati, Bay of Plenty, N.Z.	25.20	"	"
Scott, Allan K., 12/6 Rockley Rd, South Yarra	25.20	"	"
Scott, Hugh C. and Barr-Hamilton, Hugh P., 25/1 Cook Rd, Centennial Park, N.S.W.	10.08	"	"
Scott, Michael G., 34 Erasmus St, Surrey Hills	20.16	"	"
Scott, Richard A., c/o Graham Miller and Co, Europe, 46 Butzbacher Strasse, 6 Frankfurt Am Main, Germany	35.28	"	"
Scotting, Cyril R., 13 Old Belmont Rd, Belmont North, N.S.W.	25.20	"	"
Seears, Brian J., Booroola, Cooma, N.S.W.	30.24	"	"
Seears, John H. M., Booroola, Cooma, N.S.W.	25.20	"	"
Sellars, Kenneth S., c/o J. S. Sellars, Shell Company of Aust. Ltd., Finance and Information Division, 155 William St, Melbourne	20.16	"	"
Sepic, Valentin, 2/27 Harrison St, Rockingham, W.A.	20.16	"	"
Setright, David R. and Etkind, Gordon L. M., 8 The Ridings, Ealing, London W5 U.K.	60.48	"	"
Seymour-Collins, Susan L., 28 Scarsdale Villas, London W8 6PR, U.K.	60.48	"	"
Shane, Gai R., 4/10 Commodore St, North Sydney, N.S.W.	10.08	"	"
Shannon, Dennis I., Flat 19 Orange-Tree Grove, Bennetts La, Paddington, N.S.W.	10.08	"	"
Shaw, Maureen M., c/o Maureen M. Thompson, 2 Brooks St, Macquarie Fields, N.S.W.	10.08	"	"
Shaw, Veronica M., c/o Shell B. P. PMB 2418, 20-20 Marina, Lagos, Nigeria	20.16	"	"
Sheldon, Philip W. E. (Dr), Rockley House Farm, Cumnor, Oxford, U.K.	10.08	"	"
Shepherd, Donald M., P.O. Box 196, Mount Isa Qld	20.16	"	"
Sibley, Neville V., 45 Greenbank St, Marrickville, N.S.W.	771.12	"	"
Silbermann, Zinaina, 68 Wentworth Ave, Sydney, N.S.W.	15.12	"	"

Unclaimed Moneys Act 1962

Register of Unclaimed Moneys held by the—

Name of Owner on Books and Last Known Address	Total Amount Due to Owner	Description of Unclaimed Money	Date when Amount first became Payable
\$			
<b>THE BROKEN HILL PROPRIETARY COMPANY LIMITED—continued</b>			
Silverton, John A., c/o ANZ Banking Group Ltd, 385 New South Head Rd, Double Bay, N.S.W.	55.44	Interest	9.11.81
Sinclair, Bruce A., 5 Repton Crt, The Avenue, Beckenham, Kent, U.K.	10.08	"	"
Skinner, Elisabeth, 12/17 Grasmere Rd, Cremorne, N.S.W.	20.16	"	"
Slatter, Kevin, 8/8 Louisa Rd, Birchgrove, N.S.W.	10.08	"	"
Sleigh, Gordon F., c/o The Clydesdale Bank Ltd., 10 Exchange St, Aberdeen, U.K.	423.36	"	"
Slooman, Alistair J., 9/276 Domain Rd, South Yarra	10.08	"	"
Smith, Kenneth H., Norwood, Cliff Rd R.D. 1, Marton, N.Z.	226.80	"	"
Smith, Marjorie K. (estate of), c/o Vivian Gray and Co, Ling House, 10/13 Dominion St, London EC2, U.K.	15.12	"	"
Smith, Raymond F. K., P.O. Box No. 121, Manuka P.O., A.C.T.	115.92	"	"
Smylie, Marion Y., Flat 1, Block 9, 6 Edmondson St, Campbell, A.C.T.	20.16	"	"
Snell, Thomas J., 9/257 Blaxland Rd, Ryde, N.S.W.	10.08	"	"
Sonter, Mark J., P.O. Box 10, Mary Kathleen, Qld	25.20	"	"
Souter, Margaret A., P.O. Box 550, Double Bay, N.S.W.	60.48	"	"
Southern, Guy Hugo and Knoller, Rudolf D., c/o E. S. Townley, Acre House, 69/76 Long Acre, London WC2E 9JW, U.K.	378.00	"	"
Spargo, Peter E., P.O. Box 211, Rondebosch 7700, South Africa	20.16	"	"
Speers, John C., 5 Trinity Cres, London SW 177A G, U.K.	20.16	"	"
Spence, Mary Helen, 935 Bexhill Rd, Port Credit, Ontario, Canada	20.16	"	"
Spencer, Archie D., 1882 Weaver Pl, South Headland, W.A.	20.16	"	"
Spilva, Andrew, 1/160 Cumberland Rd, Pascoe Vale	20.16	"	"
Spink, Hugh M. S., 3/19 Morden Rd, Blackheath, London SE3 OAD, U.K.	10.08	"	"
Stace, Helen M., 5/19 Sheehy St, Glebe, N.S.W.	25.20	"	"
Stanley, Trevor A. and Brian T., Post Office, Smithfield, Qld	10.08	"	"
Stanton, John W. and Ball, Edward S., 9 Queen Anne St, London W1M 0BQ, U.K.	40.32	"	"
Stanton, Judith A., 20 Banambila St, Aranda, A.C.T.	25.20	"	"
Steele, Judith M., 40 Ellington St, London N7, U.K.	10.08	"	"
Steer, Stafford E. and Carol, 33 Parklands Ave, Lane Cove, N.S.W.	10.08	"	"
Stephens, Brian W. H., 170 The White, Albany St, London NW1, U.K.	15.12	"	"
Stephens, Geoffrey F., 4 Merrilong Ave, Mt Kuring-Gai, N.S.W.	20.16	"	"
Stephens, Olwen G. L., 4 Millbank, Kintbury, Newbury, Berks, U.K.	312.48	"	"
Stevenson, Lyal M., 44 Lynden Ave, Glenfield, Auckland 10, N.Z.	75.60	"	"
Stevenson, Newberry, 180 Beaumont St, Hamilton, N.S.W.	10.08	"	"
Steward, Susan J., c/o Susan J. Jenks, Apt 207B, 3939 Ocean Dr, Vero Beach, Florida 32960, USA.	10.08	"	"
Stewart, Charles G., P.O. Box 305, Matamata, N.Z.	80.64	"	"
Stewart, Craig K., 3 Shakespeare Ave, Yorkine, W.A.	60.48	"	"
Stewart, Murray J., 10 Tui Pl, Tokoroa, N.Z.	10.08	"	"
Stewart, Stanley T. and Teresa Z., 103 Holland Rd, 10 Singapore	25.20	"	"
Stichbury, Thelma F., 202 Davies St, Hastings, N.Z.	20.16	"	"
Stitt, Angus B., 1/66 Prospect St, Rosehill, N.S.W.	282.24	"	"
Stoker, Sonia, Woodlands, Horsham Rd, Bramley, Surrey, U.K.	70.56	"	"
Stone, Anthony Lee, 2/21 Royden St, Moorabbin	10.08	"	"
Stone, Peter J., 15 Somers Rd, Warrnambool	105.84	"	"
Stoop, Michael, Old Cottage, Hare Hatch, Twyford, Berks, U.K.	95.76	"	"
Stovell, Hugh V., 18 Bellbird Cres, Woodlands, Waikanae, N.Z.	20.16	"	"
Strachan, David C., Flat E, 8 Compton Rd, Islington, London N1, U.K.	221.76	"	"
Strang, Elizabeth A., 31 Northcote Rd, Armadale	25.20	"	"
Strauss, Paul, c/o Ernest L. Davis and Co., Room 705 Fu House, 7 Ice House Street, Central, Hong Kong	40.32	"	"
Stritzel, Leo, 26 Alexandra Crt, Empire Way, Wembley Park, Middlesex, U.K.	30.24	"	"

## Unclaimed Moneys Act 1962

## Register of Unclaimed Moneys held by the—

Name of Owner on Books and Last Known Address	Total Amount Due to Owner	Description of Unclaimed Money	Date when Amount first became Payable
\$			
<b>THE BROKEN HILL PROPRIETARY COMPANY LIMITED—continued</b>			
Stuart, Christina, c/o Radio Hong Kong, 6th Floor, Sutherland House, Hong Kong	30.24	Interest	9.11.81
Stuart, Ruth Marie, c/o International House, University of Sydney, Sydney, N.S.W.	25.20	"	"
Stubbs, Iris Regina, Penn Crt, Hollingbourne, Maidstone, Kent, U.K.	15.12	"	"
Sundarjee, Jethalal, Bhagwanjee, Puran and Murji, 157 Renwick Rd, Suva, Fiji	10.08	"	"
Sundquist, Barbara J., 11 Carlow Cres, Killarney Heights, N.S.W.	10.08	"	"
Sweeney, Margaret J., P.O. Box 229, Mermaid Beach, Qld	25.20	"	"
Sweeny, John W., 64 Phillip St, Thirroul, N.S.W.	20.16	"	"
Sweetland, Gillian N, c/o Shell Co. of Aust. Ltd, 155 William St, Melbourne	10.08	"	"
Tararin, George A., c/o E. Mitchell, 399 Liverpool St, Darlinghurst, N.S.W.	50.40	"	"
Tatters, Barbara, 110 Northcote St, Kurri Kurri, N.S.W.	25.20	"	"
Taverner, Browyn M., c/o Bronwyn M. Tuckwell, 8 Napier St, Engadine, N.S.W.	136.08	"	"
Taylor, Fiona Margaret, 4 Pindari Ave, St. Ives, N.S.W.	156.24	"	"
Taylor, Geoffrey D., P.O. Box 96, Queenstown, N.Z.	60.48	"	"
Taylor, George Leighton and Atkinson, William H. L. (trustees for) Christopher George Taylor, c/o C. G. Taylor, 3 Park St, Frankston	25.20	"	"
Taylor, George Leighton and Atkinson, William H. L., c/o C. G. Taylor, 3 Park St, Frankston	20.16	"	"
Taylor, Graham B., 71 Glennie Rd, West Norwood, London SE27, U.K.	15.12	"	"
Taylor, Gwendoline N., Eton Rd, Cambridge Park, N.S.W.	90.72	"	"
Taylor, Jill, 71 Glennie Rd, West Norwood, London SE27, U.K.	30.24	"	"
Taylor, Lynton G., 24 Mandalong Rd, Mosman, N.S.W.	45.36	"	"
Taylor, Mark E., 12/294 Pacific Hwy, Artarmon, N.S.W.	191.52	"	"
Taylor, Myron E. and Witt, Warren R., c/o Chase N. B. A. Group Ltd., G.P.O. Box 5469 C.C., Melbourne	15.12	"	"
Taylor, Peter Syme, 35 Netherby Ave, Netherby, S.A.	10.08	"	"
Taylor, Ronald Frederick, 9 Northcott Ave, Singleton Heights, N.S.W.	20.16	"	"
Thomas, Denise Frances, 2/2 McKye St, Waverton, N.S.W.	10.08	"	"
Thompson, Marjorie B., 11 Quinton Rd, Manly, N.S.W.	1 839.60	"	"
Thompson, William T. M., 523 Maitland Rd, Mayfield West, N.S.W.	20.16	"	"
Throsby, Peter W., G.P.O. Box 290, Sydney, N.S.W.	141.12	"	"
Throssell, Philippa, 13 Lupton St, London NW1, U.K.	75.60	"	"
Throssell, Robin, Fellover, St. Breward, Bodmin, Cornwall, U.K.	75.60	"	"
Tibballs, Joan F., c/o Post Office, South Wagga Wagga, N.S.W.	40.32	"	"
Timson, Julie E., c/o Julie E. Hankin, 2/56 Balmoral St, Waitara, N.S.W.	55.44	"	"
Tindall, Margaret N., Blacksmith's Cottage, Denham, Bucks, U.K.	282.24	"	"
Tober, John T., 100 Wellington Rd, Portland	20.16	"	"
Toovey, Rosemary W., 95 Windsor Dr, Amersham Hill, High Wycombe, Bucks, U.K.	50.40	"	"
Tottenham, George W. L., Innish, Blaney Enniskillen, Fermanagh, Northern Ireland, U.K.	30.24	"	"
Townsend, Clive A., c/o Post Office, St Kilda West	20.16	"	"
Travers, Jean C., c/o Jean C. Harman, P.O. Box 351, Strathfield, N.S.W.	95.76	"	"
Tree, Frances O., 58 Princes Highway, Albion Park Rail, N.S.W.	20.16	"	"
Trunchion, Beryl J. (estate of), c/o Williams Kingston and Trunchion, 4 Castilian St, Northampton NN1 1LA, U.K.	30.24	"	"
Tuckerman, Marjorie I. (estate of), c/o E. B. Tuckerman, 302 Pitt St, Sydney, N.S.W.	388.08	"	"
Turnbull, John (estate of), c/o W. G. Broadbent and Co., P.O. Box 28, Paeroa, N.Z.	997.92	"	"

## Unclaimed Moneys Act 1962

## Register of Unclaimed Moneys held by the—

<i>Name of Owner on Books and Last Known Address</i>	<i>Total Amount Due to Owner</i>	<i>Description of Unclaimed Money</i>	<i>Date when Amount first became Payable</i>
<b>§</b>			
<b>THE BROKEN HILL PROPRIETARY COMPANY LIMITED—continued</b>			
Turner, Beatrice K., 32 Eastwell Rd, Australind, W.A.	10.08	Interest	9.11.81
Turner, Gordon K., Gregholm Barr Near Giruan, Ayrshire KA26 9TT, U.K.	40.32	"	"
Turner, Margaret H., 7 Wright Rd, North Blackburn	740.88	"	"
Twigg, Nicholas S., 58 Rowe St, Ballarat	25.20	"	"
Twinn, John R., Cobbs Farm, Pebmarsh, Halstead, Essex, U.K.	30.24	"	"
Ulliyett, Patricia, 21 Elm Bank Cl, Lillington, Leamington SPA Warks, U.K.	20.16	"	"
Van Angeren, Cornelia P. M., 72 Van Montfoort Laan, The Hague, Holland	10.08	"	"
Van-Den-Ende, Isabella J., 18 Rawson Rd, Fairfield West, N.S.W.	10.08	"	"
Vander, Peter J., 45 Home Park Rd, London SW19, U.K.	15.12	"	"
Vasey, Lucienne Majorie, 37 Blair St, North Bondi, N.S.W.	317.52	"	"
Vehicle and Finance Insurance, c/o E. R. Serruya, 3/28 South Barrack Rd, Gibraltar	85.68	"	"
Vetch, Grahame F. H., 8/20 Yuille St, Brighton	75.60	"	"
Vine, Alan, 119 Granadilla St, Macgregor, Qld	120.96	"	"
The Virginia Estate Company, Estate Office, Kells Co. Meath, Eire	166.32	"	"
Virili, David A. and Salkeld, Fulgenzio L., c/o P.O. Box 43, Dampier, W.A.	10.08	"	"
Vogel, Geoffrey J., 17 Everest St, Khandallah, Wellington, N.Z.	30.24	"	"
Vokes, Bruce Stanley, 9 Cleverton Cl, Warners Bay, N.S.W.	25.20	"	"
Vora, Dalichand J. and Pranvanti D., P.O. Box 1674, Nakuru, Kenya	60.48	"	"
Vuysteke-Janssens, Monique, Kortrijkse, Steenweg 391, Ghent, Belgium	35.28	"	"
Wade, Graeme H., c/o ANZ Bank Ltd, 337 Anzac Pde, Kingsford, N.S.W.	45.36	"	"
Wakefield, Alan, 115 Preston-New-Road, Marton, Blackpool, Lancs, U.K.	35.28	"	"
Walker, James C., 40 Ravelston Dykes, Edinburgh EH4 3EB, U.K.	85.68	"	"
Walsh, Graham A., 4 Wallaroy Cres, Double Bay, N.S.W.	50.40	"	"
Walsh, Peter J., 114 Argyll St, Chadstone	25.20	"	"
Walters, Barbara, c/o C. Kerry, G.P.O. Box 4652, Sydney, N.S.W.	191.52	"	"
Walters, Peter Ernest, Cornells, Widdington, Saffron Walden, Essex, U.K.	30.24	"	"
Wannan, Alison D., 260 Bobbin Head Rd, Turramurra, N.S.W.	15.12	"	"
Ward, Karimah F., c/o Georgia Ward, 2 Durley Cl, Frankston	80.64	"	"
Warner, Abe, 55 Glenmore Rd, Paddington, N.S.W.	10.08	"	"
Warner, Edwin A., 103 Springdale Rd, Killara, N.S.W.	1 033.20	"	"
Watson, May (estate of), c/o Stock Exchange Systems Qld Pty. Ltd, G.P.O. Box 1887, Brisbane, Qld.	10.08	"	"
Way, Lewis M. (estate of), c/o Northcote and Co., P.O. Box 548, Cophthall Cl, London EC2P 2JJ, U.K.	710.64	"	"
Weatherill, Margaret R., 32 Hubbard Way, Medina, W.A.	25.20	"	"
Webb, Helen, 57 Kuroki St, Penshurst, N.S.W.	10.08	"	"
Webster, Stephen, Ragbir St. St. Augustine, Trinidad	55.44	"	"
Weeks, Forster B., Tanga House, 5 Princes Rd, Tamavua, Fiji	30.24	"	"
Wellard, Kevin Arthur, 2 Seaview Ave, Ballina, N.S.W.	20.16	"	"
Wells, Evelyn J., Tahuroa Rd Rd1, Morrinsville, N.Z.	115.92	"	"
Wellwood, Margaret G., P.O. Box 1214, Hastings, N.Z.	40.32	"	"
West, Christopher John R., and Patricia A., The Old Inn House, Cromer, near Stevenage, Hertfordshire U.K. SG2 7QA	10.08	"	"
Westenra, Barbara C. A., Camla, Dunsandel, Canterbury, N.Z.	80.64	"	"
Whately, Leslie, Yampi, W.A.	20.16	"	"
Wheat, Robert S., and Dorothy E., 554 Darling St, Rozelle, N.S.W.	15.12	"	"
White, Timothy J., P.O. Box 199, Werribee	181.44	"	"
White, William (estate of), c/o W. J. Whiting, P.O. Box 146, Corrimal, N.S.W.	25.20	"	"

## Unclaimed Moneys Act 1962

## Register of Unclaimed Moneys held by the—

<i>Name of Owner on Books and Last Known Address</i>	<i>Total Amount Due to Owner</i>	<i>Description of Unclaimed Money</i>	<i>Date when Amount first became Payable</i>
\$			
<b>THE BROKEN HILL PROPRIETARY COMPANY LIMITED—continued</b>			
White, Wiliam D., 56 Lock Ave, P.O. Box 199, Werribee	40.32	Interest	9.11.81
Whiteacre, John D., c/o ANZ Bank Limited, Customers Mail, G.P.O. Box 2520, Sydney, N.S.W.	10.08	"	"
Whitehouse, Hazel, 13 Ostend Crt, Cleveland, Qld.	65.52	"	"
Whiting, Ernest L., 382 Wattletree Rd, East Malvern	10.08	"	"
Wickson, John L., 83 Stoke Rd, Linslade, Leighton Buzzard, Beds, U.K.	15.12	"	"
Wilbur-Ham, Brian Lincoln, 3 Balfour St, Toorak	156.24	"	"
Wilcox, Thomas L., 97 Elgin St, Carlton	448.56	"	"
Williams, Barrie Margaret, 23/46 Rainbow St, Kingsford, N.S.W.	10.08	"	"
Williams, Christine I., 7 Swallow St, Slade Pt, via Mackay, Qld	20.16	"	"
Williams, Elisabeth A., White Lane, Middle Assendon, Henley-on-Thames Oxon, U.K.	10.08	"	"
Williams, Mark, c/o G.P.O. Box 4251, Darwin, N.T.	20.16	"	"
Williams, Matilda L. (estate of), c/o Clive Lougher, 10 Kelvin Rd, Cardiff, U.K.	85.68	"	"
Williams, Peter, 9 Stapleton Pl, Pymble, N.S.W.	70.56	"	"
Williams, Phillip J., 2/11 Harbour St, Wollongong, N.S.W.	25.20	"	"
Williams, Rachel W. (estate of), c/o Kitson and Trotman, Beaminster, Dorset DT8 3AN, U.K.	141.12	"	"
Williamson, Maxwell R., 12 Sapphire Cres, Merimbula, N.S.W.	15.12	"	"
Wilson, Daniel J., 4 Standing Rd, Lesmurdie, W.A.	20.16	"	"
Winy, Maurice A., 20 Burnett St, Mooloolaba, Qld.	30.24	"	"
Wong, Hsiung-Zee, c/o Hoare Govett, Far East Limited, 3401 Connaught Centre, Connaught Rd, Central Hong Kong	630.00	"	"
Wood, Leonard G., 41 Goddington Rd, Bourne End, Bucks, U.K.	10.08	"	"
Woodcock, Louis D. (estate of), c/o R. Spence, 5 Rose Cl, Caves Beach, N.S.W.	20.16	"	"
Woods, Leo Frederick and Margaret E., 11 The Wallaby Run, Lilydale	10.08	"	"
Woodward, Warren, 13 Fullers Rd, Chatswood, N.S.W.	25.20	"	"
Woolley, John L., and Julie L., 124 Hill Rd, North Balwyn	25.20	"	"
Woolton, Madeleine, S., 2 Spencer Dr, Hampstead Garden Suburb, London N2, U.K.	20.16	"	"
Working Holiday Bureau Ltd., P.O. Box 1382, Christchurch, N.Z.	30.24	"	"
Worrall, Ross R., 5/217 Anzac Pde, Kensington, N.S.W.	141.12	"	"
Wright, Errol V., 94 Addison Ave, Lake Illawarra, N.S.W.	20.16	"	"
Wright, Peter B., 48 Fairfield Rd, Broadstairs, Kent, U.K.	10.08	"	"
Wyatt, Charles E. N., and Fawcus, Charles R., a/c M. Knowle, Mayfield, Sussex, U.K.	433.44	"	"
Wyber, Donald S., c/o Bank of NSW, 368-374 Collins St, Melbourne	131.04	"	"
Wynnot Holdings Limited, Wellington House, 17 Union St, St. Helier, Jersey, Channel Islands	1 134.00	"	"
Yamakado, Katsuko, 4/26 Toorak Rd West, South Yarra	10.08	"	"
Yang, Thien Siung, 8 Binda St, Mt. Ousley, N.S.W.	20.16	"	"
Yates, Frank W. G., 10/3 The Esplanade, Balmoral Beach, N.S.W.	45.36	"	"
Yeung, Frances, 23 Netherby Ave, Mulgrave	40.32	"	"
Yeung, Thomas, 23 Netherby Ave, Mulgrave	20.16	"	"
Young, Duncan Mark, Mansard House, First Ave, Frinton on Sea, Essex, U.K.	110.88	"	"
Young, Jean, 44 Constitution Rd, Dulwich Hill, N.S.W.	1 013.04	"	"
Zair, Alfred H. (estate of), c/o Greens, Ludlow, Shropshire, U.K.	10.08	"	"
Zoltak, Agnes, 7 Crestmont Crt, Toorak	15.12	"	"
2160			
<b>SEATAINER TERMINALS LTD.</b>			
Keefe, Edward J., 49 York Ave, East Ivanhoe	1509.00	Wages	12.7.81
2665			

## Unclaimed Moneys Act 1962

## Register of Unclaimed Moneys held by the—

<i>Name of Owner on Books and Last Known Address</i>	<i>Total Amount Due to Owner</i>	<i>Description of Unclaimed Money</i>	<i>Date when Amount first became Payable</i>
<b>\$</b>			
<b>INDUSTRIAL ENGINEERING LIMITED</b>			
Clencie, G. K., 26 Carlton St, Braybrook	11.80	Interest	31.3.82
Piniki, R. J., 35 Elizabeth St, St. Albans	79.99	"	"
Beardmore, E., Lot 34, Lancebarn Rd, Jimboomba, Qld	80.34	"	"
Landy, H. M., 3 Scock St, North Ipswich, Qld	26.66	"	"
Melvold, S. J., 103 Poinciana St, Inala, Qld	17.44	"	"
Neale, B. J., 11 Centoukas St, Inala, Qld	16.87	"	"
Norman, G., 9 Sherbert St, Sunnybank, Qld	24.75	"	"
Turnbull, R., 41 Clipper St, Inala, Qld	11.03	"	"
Bond, K., 21 Glenda Rd, Durack, Qld	10.88	"	"
Ives, E., 82 Greenmount Ave, Holland Park, Qld	67.89	"	30.9.82
Landy, H., 3 Scock St, North Ipswich, Qld	15.38	"	"
Melvold, S. J., 103 Poinciana St, Inala, Qld	14.75	"	"
Norman, G., 9 Sherbert St, Sunnybank, Qld	13.28	"	"
Norris, A., 9 Fenton Rd, Fairfield, Qld 2649	91.45	"	"
<b>CUSTOM CREDIT HOLDINGS LIMITED</b>			
Ang, Anne Cik Heong	16.00	Overpayment	10.6.81
Brown, M. C., 58 Aspinall St, Leichardt, Qld	121.00	"	6.10.82
Lotocki, W., 8 Woomeera Ave, Noble Park	62.00	"	1.4.81
Mathews, G. A., 9 Arizona Dr, Clontarf, Qld	70.00	"	8.2.82
Milgram and Schwartz Pty. Ltd., 24 Peel St, Collingwood	48.00	"	9.4.81
Williams, A. D., Needham Rd, Willow Grove 2650	34.36	Balance of Loan	27.4.82
<b>PHILLIP MORRIS (AUSTRALIA) LIMITED</b>			
Atkinson, Robert David, 15 Rocklyn Pl, Launceston, Tas.	124.80	Dividend	11.10.82
Boon, Nicola, C/o AWL Hewett, 90 Pitt St, Sydney, N.S.W.	66.30	"	"
Brandon, Jack and Rose, 5/757 Old South Rd, Vacluse, N.S.W.	40.20	"	"
Browning, Eileen C., 14 Bangalla Rd, Rose Bay, N.S.W.	19.95	"	11.3.83
Cheerose Pty. Ltd., GPO Box 2213, Sydney, N.S.W.	32.70	"	11.10.82
Cobwebb Pty. Ltd., C/o Michael Boyce & Co., 15 Bent St, Sydney, N.S.W.	30.00	"	"
Creed, Jennifer J., P.O. Box 148, Camperdown	33.30	"	11.3.83
Douglas, Shirley May, 474 Glenferrie Rd, Hawthorn	19.95	"	11.10.82
Evans, Caroline Ross, C/o Protective Commissioner, P.O. Box 466, North Sydney, N.S.W.	48.00	"	"
Falkenberg, Paul T., 8 Sobels St, Tanunda, S.A.	50.55	"	11.3.83
Godwin, Joan Annette, 8 Brown St, Darwin, N.T.	90.00	"	11.10.82
Hespe, John Henry McA. (estate of), C/o B. J. Hickey, Adelaide St, East Gosford, N.S.W.	249.60	"	"
Holloway, Jean M., 22 Gerald St, Nunawading	26.55	"	11.3.83
Horton, Margaret Elizabeth and Frances Margaret, 26 Murdoch St, Cremorne, N.S.W.	31.80	"	11.10.82
Mills, Majorie R., 16 Khartoun Ave, Gordon, N.S.W.	48.75	"	11.3.83
Shaw, Alexander Elliot, 4 Glades Ave, Gladesville, N.S.W.	39.90	"	11.10.82
Turner, Leslie V. (estate of), C/o R. J. Darton & Co., 471 Marrickville Rd, Dulwich Hill, N.S.W. 2651	30.60	"	11.3.83
<b>HERALD EMPLOYEES CREDIT CO-OPERATIVE LIMITED</b>			
Briggs, M., 6 Laura St, Clayton	47.13	Interest	15.7.81
Ralph, C. R., 7 Linca St, West Meadows	20.00	Cheque	25.7.81
Valentine, E. 2668	250.00	"	"



## Unclaimed Moneys Act 1962

## Register of Unclaimed Moneys held by the—

<i>Name of Owner on Books and Last Known Address</i>	<i>Total Amount Due to Owner</i>	<i>Description of Unclaimed Money</i>	<i>Date when Amount first became Payable</i>
\$			
<b>RHEEM AUSTRALIA LIMITED</b>			
Brosnan, Kathleen J., 140 Simpson St, East Melbourne	20.60	Dividend	1.4.83
Drayton, Ronald C., Bellevue, Pokolbin, N.S.W.	26.78	"	1.10.82
Esplin, Yvonne B., 28 Belgravia Gardens, 60 Darling Point Rd, Darling Point, N.S.W.	13.75	"	1.4.83
Johnson, Anthony G., 30 Epacris Ave, Forestville, N.S.W.	116.00	"	"
Pate, John W., 438 Avoca St, Kingsford, N.S.W.	30.95	"	1.4.82
Pate, John W., 438 Avoca St, Kingsford, N.S.W.	40.23	"	1.10.82
Schofield, Thomas W. (estate of), C/o McDermott Sharah & Co., 183 Macquarie St, Sydney, N.S.W.	57.90	"	1.4.82
Schofield, Thomas W. (estate of), C/o McDermott Sharah & Co., 183 Macquarie St, Sydney, N.S.W.	75.27	"	1.10.82
Schofield, Thomas W. (estate of), C/o McDermott Sharah & Co., 183 Macquarie St, Sydney, N.S.W.	57.90	"	1.4.83
2669			
<b>COCA-COLA BOTTLERS, MELBOURNE</b>			
Shannon, J., 63 Denver St, East Bentleigh	35.00	Wages	21.10.81
Saba, N., 1/17 Phillip St, Lakemba, Sydney	20.17	Unpresented Cheque	9.1.81
2404			
<b>S.P.C. LIMITED</b>			
Williams, M., Victoria Lake Caravan Park, Shepparton	74.00	Wages	15.2.82
King, J., Oasis Caravan Park, Mooroopna	23.30	"	4.5.82
Norman, D., Oasis Caravan Park, Mooroopna	20.00	"	"
Brady, R., Victoria Lake Caravan Park, Shepparton	11.40	"	"
Flatman, M., Victoria Lake Caravan Park, Shepparton	58.60	"	"
Mazzarol, A., Strayleaves Caravan Park, Shepparton	44.30	"	"
Lidfors, I., c/o Post Office Atherton, North Queensland	31.40	"	"
Hargreaves, T., c/o Post Office Nathalia	28.50	"	"
Francis, S., 43 Knight St, Shepparton	56.70	"	"
Russell, D., Poplar Ave, Orrvale	75.00	"	"
Urus, S., 6 Grace Crt, Shepparton	52.50	"	"
Halsall, G., Victoria Lake Caravan Park, Shepparton	33.80	"	"
O'Flynn, T., c/o Midland Caravan Park, Mooroopna	37.10	"	"
Smith, K., c/o Midland Caravan Park, Mooroopna	37.10	"	"
Harbridge, S., Vara Ville Caravan Park, Mooroopna	11.70	"	"
Mills, R., Pine Lodge Caravan Park, Shepparton	11.70	"	"
James, A., Corio St, Shepparton	11.70	"	"
Cassar, J., Grieves Caravan Park, Shepparton	12.30	"	"
Crawford, K., Grieves Caravan Park, Shepparton	12.30	"	"
Abraham, P., Strayleaves Caravan Park, Shepparton	78.20	"	"
Rodgers, J., 81 Erons St, Brunswick	79.00	"	"
O'Brien, P., Victoria Lake Caravan Park, Shepparton	39.40	"	"
Bone, G., 16 McDonald St, Shepparton	63.00	"	"
Gatenyo, M., c/o Post Office Atherton, Qld	28.50	"	"
Brown, C., Victoria Lake Caravan Park, Shepparton	24.40	"	"
Parkinson, K., Victoria Lake Caravan Park, Shepparton	24.40	"	"
Poulson, J., 8 Fryers St, Shepparton	28.40	"	"
Phillips, E., Post Office, Undera	13.40	"	"
Lea, M., Post Office, Undera	20.90	"	"
Debus, T., South Shepparton Caravan Park, Shepparton	10.30	"	"
Kennedy, C., 5/22 Welsford St, Shepparton	71.20	"	"
Layton, J., Victoria Lake Caravan Park, Shepparton	34.40	"	"
Lancaster, V., 6/8 Tyquin Crt, Shepparton	59.90	"	"
Moss, J., Strayleaves Caravan Park, Shepparton	137.70	"	25.3.83
Whelehan, H., 3/2 Monash St, Shepparton	11.80	"	"

Unclaimed Moneys Act 1962

Register of Unclaimed Moneys held by the—

Name of Owner on Books and Last Known Address	Total Amount Due to Owner	Description of Unclaimed Money	Date when Amount first became Payable
	\$		
<b>FLEETWAYS (HOLDINGS) LIMITED</b>			
Allen, Dorothy J., 1/24 White St, Glen Iris	14.40	Dividend	2.4.82
Angel, John A. M., Glencarry, Marimal, Qld	44.00	"	"
Duff, Margaret, 50A Schnapper Rd, Ettalong Beach, N.S.W.	32.50	"	"
Gibson, Julene S., 2 McPhail Ave, Kingscliff, N.S.W.	32.18	"	"
Glanfield, Gavin A., and Caroline F., 21 Pearce St, South Coogee, N.S.W.	14.63	"	"
Jennings, Edwin B., 1 Ethel St, Traralgon	240.00	"	"
Jenkins, Nettie J., 201 Waterdale Rd, Ivanhoe	10.73	"	"
O'Brien, Mabel, 35 Russell St, Camberwell	29.37	"	"
Payne, Edward J. B., 11/16 Tintern Ave, Toorak	11.08	"	"
Phipps, Amy U., 39 Murphy St, Elsternwick	14.63	"	"
Pie, Jean M., c/o Price Waterhouse, 447 Collins St, Melbourne	36.54	"	"
Rennie, Hilda V., 31 Brett St, Murrumbidgee	22.33	"	"
Ward, Thomas G. S. (Capt), 18 Jenner St, Seaforth, N.S.W.	17.88	"	"
2884			
<b>LUKE LIMITED</b>			
Battersby, Brian Stewart, 11 Elouera St, Ashgrove, Qld.	34.32	Dividend	8.4.82
Bloom, Alan, 26 Fyfe Drv, Lower Templestowe	41.60	"	"
Bolton, Donald A., P.O. Box 169 Kingswood, S.A.	14.00	"	25.10.82
Fleming, John M., 15 Smith St, Hamilton	34.84	"	6.4.82
Highett, Graeme C., 203 Century Building, 129 Swanson St, Mel- bourne	28.60	"	8.4.82
Hipwell, Freda G., 4 Casey Ave, Sunbury	58.50	"	"
Kenworthy, Dorothea, 4/594 Inkerman Rd, Caulfield North 2406	24.78	"	25.10.82
<b>HUMES LIMITED</b>			
Baird, John H., 28 Woolwich Rd, Hunters Hill, N.S.W.	441.70	Dividend	31.3.82
Paynter, Rosemary, 325 High Street, Kew	46.40	"	"
Scott, Adrian R., c/o Box 39218, Winnellie, N.T.	41.10	"	"
Baird, Moira J., 28 Woolwich Rd, Hunters Hill, N.S.W.	123.40	"	"
Coombe, Rodney, 21 Matheson Rd, Applecross, W.A.	10.26	"	28.10.82
Hudson, Martin, 9 Ellesmore Rd, Windsor	10.32	"	"
Ryan, Rosemary, 46/211 Waterloo Rd, Marsfield, N.S.W.	13.44	"	"
Van Der Draai, Bernhard and Mechtilda, 23 Bursaria, Cres, Frank- ston North	12.30	"	"
Bower, Roderick St. C., 48 Christie St, St. Leonards, N.S.W.	24.36	"	31.3.82
McDecker, Ronald, Centreway Pharmacy, P.O. Box 164 Willetton, W.A.	48.00	"	"
English, Kevin and Ellen, 77 Mayne St, Gulgong, N.S.W.	78.76	"	"
Glastone, Susan, 9 Hibble St, Meadowbank	12.06	"	28.10.82
Lovett, Alan, 98 The Esplanade, French's Forest, N.S.W.	30.70	"	31.3.82
Lovett, Alan and Marietta, 98 The Esplanade, French's Forest, N.S.W.	154.50	"	"
Mitchell, Alan, 6 Hood St, Mont Albert	61.60	"	"
Paterson, David, Pebbly Hill Rd, Cattai, N.S.W.	20.00	"	"
Measom, Patricia, 22 km Peg, Wanneroo Rd, Wanneroo, W.A.	82.44	"	"
Podbury, Murray, 5 Vanessa Crt, Frankston	235.50	"	28.10.82
Purkis, Kenneth, 24 Wood St, Eastwood, N.S.W.	17.76	"	31.3.82
Robinson, Emily J., 14B Clark St, Nedlands, W.A.	52.50	"	"
Stossel, Frederick M., 260 Bridge St, Glebe, N.S.W.	32.00	"	"
Foster, William, c/o Australian Broadcasting Commission, Box 293E, G.P.O., Brisbane	30.30	"	28.10.82
Kyritsis, Fotios, 11 Somerton Cres, East Moonah, Tas.	12.30	"	"
Smith, Leslie and Cheryl, 8 Westward St, Burrendah, W.A.	27.78	"	"
2407			

## Unclaimed Moneys Act 1962

## Register of Unclaimed Moneys held by the—

<i>Name of Owner on Books and Last Known Address</i>	<i>Total Amount Due to Owner</i>	<i>Description of Unclaimed Money</i>	<i>Date when Amount first became Payable</i>
\$			
<b>AUSTRALIAN MOTOR INDUSTRIES LIMITED</b>			
A.G.W. Pty. Ltd., c/o Walker and Walker, 20th Fl, 1-3 Alfred St, Sydney Cove, N.S.W.	66.00	Dividend	16.4.82
Anthony, Elsie M., 11 Mansfield St, Thornbury	15.60	"	20.9.82
Blain, Eric S., 139 Bromfield St, Warrnambool	15.40	"	11.10.82
Cohen, Hyman L., 6 Nicholson St, Balwyn	11.55	"	"
Dare, Peter, 4 Nicholas St, Colac	11.55	"	"
Dean, Constance E., 385 Union St, Albury North, N.S.W.	17.50	"	"
Hammond, Roy, 11 Miller Avenue, Bexley North, N.S.W.	10.26	"	"
Jenkins, Elsie M., 41 Jefferson Close, Grants Hill, Ilford, Essex, U.K.	32.72	"	"
Kidd, Margaret W., 1/24 Wolseley Grove, Brighton Beach	48.40	"	16.4.82
Kench, Ronda M., 21 Truro Ave, Kingswood, S.A.	15.40	"	11.10.82
Lew, William H. C., 24 Nicholson St, Fitzroy	15.40	"	"
Linwar Nominees Pty. Ltd., 20 O'Connell St, Sydney, N.S.W.	77.00	"	"
Philon, Margritt (estate of), c/o Campbell, Hooper, Wright & Supper- stone, Boundary House, London Road, Sunningdale, Berks, SL5 OKJ, U.K.	65.45	"	"
Roach, Janice, Pierce, Yvonne and Sidney Kosky, c/o 22 Aubin St, Neutral Bay, N.S.W.	44.00	"	16.4.82
Taylor, Elaine A., 21 Twycross Rd, Burbage, Leicestershire, U.K.	13.09	"	16.4.82
Turner, Leonard T., 22 Bandon St, Forbes, N.S.W.	77.00	"	11.10.82
Watchorn, Helen M., 10 Nyora St, Killara, N.S.W.	19.25	"	"
Welsh, Alfred J., 10 Doherty Ave, Morwell	11.55	"	"
2405			
<b>DALGETY FARMERS LIMITED</b>			
Connley, J., Bairnsdale	97.64	Sale Proceeds	26.5.82
Delston, A. J. and M. E., Robinvale	21.35	Cheque	10.2.81
Grundy, G., Riversea via Maffra	79.01	"	11.12.81
Fitzgibbon, H., Corowa	16.89	Sale Proceeds	1.9.80
Kelly, D., Shaw St, Mortlake	10.00	Cheque	14.8.81
McKenzie, G., Camperdown	11.09	"	16.6.82
2625			
<b>GENERAL MOTORS—HOLDEN'S LTD DANDENONG</b>			
Sanders, D. A., 7 Cerberus Rd, Baxter	56.84	Wages	30.8.82
Donald, K., 11/116 Princes Hwy, Dandenong	203.06	Holiday Pay	29.7.82
Villella, A., 92 James St, Dandenong	93.49	"	2.2.83
Lay, I. V. A., 3/34 Madden Ave, Carnegie	972.16	"	20.9.82
2443			
<b>GIBSON CHEMICAL INDUSTRIES LIMITED</b>			
Burrows, Miles P. and Susanne E., 17 Harris St, Paddington, N.S.W.	14.70	Dividend	10.11.82
Burrows, Miles P. and Susanne E., 17 Harris St, Paddington, N.S.W.	14.70	"	17.5.82
Foletta, Henry G., 34 St. Georges Rd, Toorak	1201.05	"	10.11.82
Hirsch, Rosa, 1st Floor, 294 Little Collins St, Melbourne	53.10	"	"
Hirsch, Rosa, 1st Floor, 294 Little Collins St, Melbourne	53.10	"	17.5.82
Mills, Warren F., 208 Jasper Rd, Bentleigh	29.55	"	10.11.82
McDonald, Alexander S., 3/27 Burraneer Bay Rd, Cronulla, N.S.W.	54.60	"	"
McDonald, Alexander S., 3/27 Burraneer Bay Rd, Cronulla, N.S.W.	54.60	"	17.5.82
Veal, Edgar J. B., 52 Napier St, Maryborough	432.15	"	10.11.82
2666			

## Unclaimed Moneys Act 1962

## Register of Unclaimed Moneys held by the—

Name of Owner on Books and Last Known Address	Total Amount Due to Owner	Description of Unclaimed Money	Date when Amount first became Payable
\$			
<b>COSTAIN AUSTRALIA LIMITED</b>			
Coogan, Clive K., 15 Irillbarra Rd, Canterbury	125.00	Dividend	15.10.82
Foletta, Henry G., 34 St. Georges Rd, Toorak	46.85	"	"
Jeffery, Janice D., 2/71 Crisp St, Hampton	13.85	"	"
Maluga, August L., 34 Woods Rd, Sefton, N.S.W.	32.85	"	"
Pitt, William A., 17A Yanderloo St, Croydon Park, N.S.W.	15.00	"	18.5.82
Pitt, William A., 17A Yanderloo St, Croydon Park, N.S.W.	15.00	"	15.10.82
Sanders, P. J. and M. A.	32.85	"	"
Sang, William Lew, 480 Tooronga Rd, Hawthorn 2667	49.35	"	"
<b>ROYAL MELBOURNE INSTITUTE OF TECHNOLOGY</b>			
Abdulnour, I., 5 O'Grady St, West Brunswick	16.00	Chemistry Refund	22.10.82
Bailey, K., 3/20 Royal Ave, Glenhuntly	20.00	"	"
Low, G. S., 4/6 Beaconsfield Rd, East Hawthorn	20.60	Salaries	6.9.82
Chester, L., 552 Station St, North Carlton	13.14	"	20.9.82
Dennis, J. E., 55 Argyle St, Fitzroy	84.88	"	9.11.82
Bryce, M., 3/1 Mosman St, Mosman, N.S.W.	20.34	"	23.11.82
Lee, Y. C., 7/31 Fulton St, East St. Kilda	16.74	"	14.12.82
Wilkinson, P. R., 47 Hampton Rd, West Essendon	66.00	"	9.11.82
Kaegi, H. W., 10 Laave Ave, Rosanna	14.98	"	15.2.83
Dance, C., 20 Liddiard St, Hawthorn	42.94	"	26.4.83
Arnold, L. M., 3/1 Barkly Ave, Armadale	20.00	Chemistry Refund	15.12.82
Lu, B. U., 104 Paper St, Burwood	18.00	"	"
Toywant, D., 9/5 Solly Ave, North Carlton	18.00	"	"
Ball, S., 12/21 Martin St, Thornbury	20.00	"	"
Rose, B., 61 Holden St, North Fitzroy	15.00	Biology Refund	19.1.83
Bruce, R., 119 Westbury St, East St. Kilda	10.00	"	"
Kyval, J., 9A Miller St, Essendon	15.00	"	"
Pek, P. L., 8/486 Drummond St, Carlton	16.00	Chemistry Refund	3.2.83
Chan, A., 1/25 Gardiner Rd, Clayton	20.00	"	16.2.83
Tan, C., 12/778 Drummond St, North Carlton	30.00	"	"
Coogan, C., c/o CSIRO, 9 Queens Rd, Melbourne 2511	75.00	Honorarium	31.3.83

In the Supreme Court of Victoria—No. Co. 235—In the matter of the Companies (Victoria) Code; and in the matter of Estate Co-ordination Pty. Ltd.

Notice is hereby given that a Petition for the winding up of the abovenamed Company by the Supreme Court was on 15 May 1984 presented by T. D. Clements and Associates Pty. Ltd.; and that the said Petition is directed to be heard before the Court sitting at the Supreme Court, Law Courts, William Street, Melbourne at the hour of 10.30 o'clock in the forenoon on 2 August 1984; and any creditor or contributory of the said Company desiring to support or oppose the making of an Order on the said Petition may appear at the time of hearing by himself or his Counsel for that purpose; and a copy of the said Petition will be furnished to any creditor or contributory of the said Company requiring the same by the undersigned on payment of the regulated charge for the same.

Petitioner's address is 114 Dryburgh Street, North Melbourne, Victoria.

Petitioner's Solicitors are Messrs. Phillips & Wilkins of 823 High Street, Thornbury.

PHILLIPS & WILKINS, Solicitors for the Petitioner

Note: Any person who intends to appear on the hearing of the said Petition must serve on or send by post to the abovenamed Solicitors, notice in writing of his intention so to do. The notice must state the name and address of the person, or if a firm, the name and address of the firm and must be signed by the person, or firm, or his or their Solicitor (if any) and must be served, or if posted, must be sent by post in sufficient time to reach the abovenamed not later than 4.00 o'clock in the afternoon on 1 August 1984. 2996

**GLENFINE PTY. LTD.**  
(in Voluntary Liquidation)

Notice is hereby given that at a general meeting of members of Glenfine Pty. Ltd. on 4 June 1984 the following special resolution was passed:

That the company be wound up as a members voluntary liquidation and that Robert John Evans of 23 Armstrong Street North, Ballarat, be appointed liquidator.

Dated 8 June 1984

2955

R. J. EVANS, liquidator

DERRIMUT CO-OPERATIVE HOUSING SOCIETY  
LIMITED

(In Liquidation)

At a Special General Meeting of the abovenamed Society duly convened and held at St. Mark's Anglican Church Hall, Sunshine on 8 June 1984 at 7.30 p.m. the subjoined Special Resolution was duly passed:

- (a) That having successfully completed its objectives 3 years and 3 months ahead of its expected term the Society be wound up voluntarily and that Mr. Geoffrey Keith Davenport of 53 Wadham Parade, Mount Waverley be appointed Liquidator for the purpose of the winding up.
- (b) That the remuneration of the liquidator be fixed at \$800.00.
- (c) That the liquidator be empowered to compromise with debtors and/or creditors and/or contributories.

W. J. NELSON, Chairman of Meeting  
G. K. DAVENPORT, Secretary

2969

In the matter of the *Co-operative Housing Societies Act 1958* and the *Companies Act 1961* and in the matter of Derrimut Co-operative Housing Society Limited (in Liquidation)—  
Notice to Creditors

Notice is hereby given that all persons having any claim against the above Society are required on or before the 11 July 1984 to send their names and addresses and particulars of their debts or claims to Geoffrey Keith Davenport, the liquidator of the said Society, at his office and if so required by notice in writing from the said liquidator are personally, or by their Solicitors, to come in and prove their said claims at such time and place as shall be specified in such notice, or in default thereof, they shall be excluded from the benefit of any distribution made before such debts or claims are so lodged or proved.

Dated at Mount Waverley 20 June 1984

G. K. DAVENPORT, liquidator, 53 Wadham Parade,  
Mount Waverley 2970

Companies (Victoria) Code 1981

NIVLA PTY. LTD.

Notice is hereby given that at a general meeting of the abovenamed company on 30 May 1984, the members passed a Special Resolution that the company be wound up voluntarily.

Dated 30 May 1984

R. G. TREGEAR, Liquidator

Tregear Nolch McBain, 535 Whitehorse Road, Mitcham,  
Vic. 3132 2990

SUNNY INVESTMENTS PTY.

Liquidation—Members Voluntary Winding Up

By Special Resolution passed on 14 June 1984 it was resolved that Sunny Investments Pty. be liquidated and that Mr H. G. Stevens, Suite 4, 2nd Floor, 300 Burwood Road, Hawthorn 3122, be appointed liquidator. 2992

DEAKIN & MORRIS INDUSTRIES PTY. LTD.

(In Voluntary Liquidation)

Notice is hereby given of a meeting of Shareholders to be held at 63 Henderson Road, North Clayton on 18 July 1984 at 5.30 p.m. in order to receive the Liquidators Account of Receipts and Payments and Statement of the position of winding up. 3002

In the Supreme Court of Victoria—No. Co. 233 of 1984—In the matter of the Companies (Victoria) Code and in the matter of Inglewood Gold Mines N. L. (Provisional Liquidator Appointed)—Advertisement of Petition

Notice is hereby given that a petition for the winding up of the above-named company by the Supreme Court was on 14 May 1984, presented by Kenneth Alfred Evans. And that the said petition is directed to be heard before the Court sitting at Melbourne at the hour of 10.30 o'clock in the forenoon on Thursday, 26 July 1984; and any creditor or contributory of the said company desiring to support or oppose the making of an order on the said petition may appear at the time of hearing by himself or his counsel for that purpose; and a copy of the petition will be furnished to any creditor or contributory of the said company requiring the same by the undersigned on payment of the regulated charge for the same.

The Petitioner's address is 1/97 Chomley Street, Prahran in the State of Victoria.

The Petitioner's solicitors are Messrs. Irlicht & Broberg of 450 Little Collins Street, Melbourne.

IRLICHT & BROBERG, solicitors for the abovenamed petitioner.

Note: Any person who intends to appear on the hearing of the said petition must serve on or send by post to the abovenamed solicitors notice in writing of his intention so to do. The notice must state the name and address of the person, or if a firm, the name and address of the firm, and must be signed by the person or firm, or his or their solicitor (if any), and must be served or, if posted must be sent by post in sufficient time to reach the above-named not later than four o'clock in the afternoon of Wednesday, 25 July 1984. 2989

Registered No. 109923 Paragraph 577 (1) (f), Sub-regulation 120 (2)

Companies Form No. 130

Companies (Victoria) Code

Supreme Court Rule 99 (2)

MATCHBOX PTY. LTD. (In Liquidation)

Notice Inviting Formal Proof of Debt or Claim

Take notice that creditors of the company, whose debts or claims have not already been admitted, are required on or before 25 July 1984 to prove their debts or claims and to establish any title they may have to priority by delivering or sending through the post to me at my address a formal proof of debt or claim in accordance with Form 131 or 132 containing their respective debts or claims. In default they will be excluded from the benefit of any distribution made before their debts or claims are proved or their priority is established and from objecting to the distribution.

Form of proof may be obtained from me.

Dated 15 June 1984

J. M. WALSH, Official Liquidator

Wallace, McMullin & Smail, Chartered Accountants, 499  
St Kilda Road, Melbourne 3010

Notice of Winding Up Order

IN THE MATTER OF PETER AUBIN (LIVESTOCK)  
PTY. LTD.

Winding Up Order made 14 June 1984

Arthur Robert Waters of Messrs. Orr, Martin & Waters, 460 Bourke Street, Melbourne has been appointed liquidator.  
Dated 15 June 1984

ROGERS & GAYLARD, 31 Queen Street, Melbourne,  
Solicitors for the applicant 3012

## Form 142

Companies (Victoria) Code

ROTEX THEATRE CO-OPERATIVE LIMITED

Notice of Intention to Declare a Dividend

A final dividend is to be declared on 10 July 1984 in respect of the company.

Creditors whose debts or claims have not already been admitted are required on or before 10 July 1984 formally to prove their debts or claims. In default, they will be excluded from the benefit of the dividend.

Dated 14 June 1984

T. BENT, Liquidator

Bent & Cogle, Chartered Accountants, 144 Jolimont Road,  
East Melbourne 2993

## COMPANIES (VICTORIA) CODE 1981

Notice of Meeting of Members Pursuant to Section 411—  
In the Matter of Melma Investments Pty. Ltd. (In Voluntary Liquidation)

Notice is hereby given that pursuant to section 411 of the Companies (Victoria) Code 1981, the Final Meeting of Members of the abovenamed company will be held at the offices of Evans and Metcalfe, 23 Armstrong Street North, Ballarat on 29 July 1984 at 10.00 a.m. for the purpose of laying before the meeting the liquidation final account and report and giving any explanation thereof.

Dated 12 June 1984

3007

B. K. METCALFE, Liquidator

In the Supreme Court of Victoria—Co. 144—In the matter of the Companies (Victoria) Code; and in the matter of Swain's Wholesale Distributors (Vic) Pty. Ltd.

Notice of Appointment of Liquidator. Order for appointment of a liquidator made 7 June 1984.

Name and address of Liquidator: Robert Arthur Waters, 460 Bourke Street, Melbourne 3001.

Messrs CORNWALL STODART & CO., solicitors, 63 Exhibition Street, Melbourne, solicitors for the Applicant.

3008

Companies (Victoria) Code

HOVELL PARK INVESTMENT COMPANY LIMITED

(In Voluntary Liquidation)

Notice is hereby given that a General Meeting of the Company will be held at 42 Aberdeen Street, Geelong West, on Monday, 30 July 1984 at 10.00 a.m. for the purpose of laying before the meeting the accounts of the Liquidator showing how the voluntary winding up has been conducted and the assets disposed of, and giving any explanations thereof.

Dated 15 June 1984

3047

R. J. COLENZO, Liquidator

MOE CITY REPORTER PTY. LTD. (in Liquidation)

We act on behalf of Mr Neville Bird of Messrs Neville Bird, Clark & Co., Public Accountants, the liquidator of the above Company having been appointed by an Order of the Supreme Court of Victoria on 13 October 1983.

We are instructed that you are indebted to the above Company in the sum of \$99.00.

Take notice that failing payment of the said sum of \$99.00 together with our costs of \$20.00 to this office within the next seven (7) days, proceedings are to be issued for the recovery of the debt.

2959

RICHARDSON CULBARD JONES &amp; CO.

## WARREN GRANT NOMINEES PROPRIETARY LIMITED (in Liquidation)

Notice of Order for Examination, Pursuant to Section 541 of the Companies (Victoria) Code

Order made 6 June 1984 requiring Warren John Grant, Allan Raymond Dalton and Geoffrey Owen Tancred to attend before the Judge in Chambers, Practice Court, 15th Court, Law Courts, 459 Lonsdale Street, Melbourne on 18 June 1984 at 10.30 o'clock in the forenoon to be publicly examined on oath or affirmation on any matters relating to the promotion, formation, management, administration or winding up of or otherwise relating to the affairs of Warren Grant Nominees Proprietary Limited (in liquidation) and to produce any books in their possession or under their control relevant to the promotion, formation, management, administration or winding up of or otherwise relating to the affairs of the said Warren Grant Nominees Proprietary Limited (in liquidation) pursuant to section 541 of the Companies (Victoria) Code.

2958

J. M. SMITH & EMMERTON  
solicitors for the liquidator*The Companies Act 1961*

P. J. SELETTO &amp; COMPANY PTY. LTD. (In Liquidation)

Notice is hereby given that a second and final dividend is intended to be declared in the above matter. Creditors who have not proved their debts by 29 June 1984 may be excluded from this dividend.

Dated 14 June 1984

R. M. H. COLE, Liquidator

Touche Ross &amp; Co., 440 Collins Street, Melbourne 3014

Pursuant to the *Trustee Act* 1958 notice is hereby given that all persons having claims against the estate of Mary Jane Polinelli late of 19 Yuille Street Brighton in the State of Victoria, widow, deceased, who died on 12 July 1981 and probate of whose will was granted by the Supreme Court of the said State in its Probate Jurisdiction on 28 February 1983 to National Trustees Executors and Agency Company of Australasia Limited of 95 Queen Street Melbourne in the said State are hereby required to send particulars in writing of such claims to the said National Trustees Executors and Agency Company of Australasia Limited at its abovementioned address on or before 31 August 1984 after which date the said National Trustees Executors and Agency Company of Australasia Limited will proceed to distribute the assets of the said Mary Jane Polinelli deceased which shall have come to its hands amongst the persons entitled thereto, having regard only to the claims of which it shall then have had notice. And notice is hereby further given that the said National Trustees Executors and Agency Company of Australasia Limited will not be liable for the assets so distributed or any part thereof to any person of whose claim it shall not have had notice as aforesaid.

FRANK CURTAIN & CO., solicitors, 143 Queen Street,  
Melbourne. 67 7541 3011

Creditors next of kin and others having claims in respect of the estate of Charles George Morley Hamilton late of Staffa Private Hotel, 70 Nicholson Street, Fitzroy, retired labourer, deceased, who died on 11 March 1984 are to send particulars of their claims to The National Trustees Executors and Agency Company of Australasia Limited of 95 Queen Street, Melbourne the Executor by 22 August 1984 after which date the Executor will commence to distribute the assets having regard only to the claims of which it then has notice.

RENNICK & GAYNOR, solicitors of 427 Riversdale  
Road, Hawthorn East 3021

Creditors, next of kin and others having claims against the estate of Doris Elizabeth Keller late of 867 Sydney Road, Coburg, widow deceased (who died on 2 April 1984) are to send particulars of their claims to National Trustees Executors and Agency Company of Australasia Limited of 95 Queen Street, Melbourne, before 25 August 1984 after which date it will distribute the assets of the estate having regard only to the claims for which it then has notice.

JOHN F. CARROLL, solicitor, 95 Queen Street,  
Melbourne 3029

Creditors, next of kin and others having claims against the estate of Anne O'Connor late of 14 King Street, Glen Iris, widow deceased (who died on 13 January 1984) are to send particulars of their claims to National Trustees Executors and Agency Company of Australasia Limited of 95 Queen Street, Melbourne, before 25 August 1984 after which date it will distribute the assets of the estate having regard only to the claims of which it then has notice.

JOHN F. CARROLL, solicitor, 95 Queen Street,  
Melbourne 3030

CROCETTO BABORE late of 47 Madden Street, Maidstone, Pastrycook, deceased, died on 1 December 1983. Claims to the Executrix Margery Agnes Babore of 47 Madden Street, Maidstone by the 29 August 1984.

JOHN F. CARROLL, LL.B., Solicitor, 4 Paisley Street,  
Footscray 3031

Creditors, next of kin and others having claims in respect of the estate of Else David late of 34 Snowdon Avenue, Caulfield, in the State of Victoria, married woman deceased who died on 3 April 1984 are required to send particulars of their claims to the Equity Trustees Executors and Agency Company Limited of 472 Bourke Street, Melbourne, on or before 21 August 1984 after which date it will distribute the assets, having regard to the claims of which it then has notice.

COHENS, FRENKEL BERKOVITCH KEFFORD &  
NEW, solicitors, 114 William Street, Melbourne 3054

JOHN EDWARD RYAN, late of Cohuna, in the State of Victoria, plumber, deceased

Creditors, next of kin and all other persons having claims against the estate of the said deceased are required by Mathew Thomas Ryan of Cohuna aforesaid plant operator and Leo Ronald Ryan of Cohuna aforesaid contractor the Executors of the estate of the said deceased to send particulars of such claims to them in care of the under-mentioned Solicitors on or before 30 August 1984 after which date they will distribute the assets having regard only to the claims of which they then have notice.

WILLAN & MCKENZIE, solicitors, Box 299, Cohuna  
3055

LILLIAN MAY THRUM, formerly of Macorna, but late of Cohuna, in the State of Victoria, widow, deceased

Creditors, next of kin and all other persons having claims against the estate of the said deceased are required by Henry Harwood Thrum and William Edward Thrum both of Macorna farmers the Executors of the estate of the said deceased to send particulars of such claims to them in care of the under-mentioned Solicitors on or before 30 August 1984 after which date they will distribute the assets having regard only to the claims of which they then have notice.

WILLAN & MCKENZIE, solicitors, Box 299, Cohuna  
3056

Creditors, next of kin and others having claims against the estate of Trian Peters, late of 115 Ivanhoe Parade, Ivanhoe, in the State of Victoria, gentleman, deceased who died 9 July 1981 are required by Paraskevoula Koraitzas of 115 Ivanhoe Parade, Ivanhoe, in the State of Victoria, the Executrix, to forward particulars of their claims to the said Executrix care of the undermentioned solicitors by 22 August 1984 after which date the Executrix will distribute the assets having regard only to the claims of which she will then have had notice.

F. J. ORAMES & DOWNING, 121 William Street,  
Melbourne, solicitors for the Executrix 3015

WILMA MARGARET ISLES CUMING, late of 29  
Stonnington Place, Toorak, married woman, deceased

Creditors, next of kin and others having claims against the estate of the said deceased who died on 15 March 1984 are to send particulars of their claims to Mariannus Adrian Cuming, David Cuming and John Adrian Cuming c/o Messrs. Blake & Riggall solicitors, 140 William Street, Melbourne by 20 September 1984 after which date they will distribute the assets having regard only to the claims of which they then have notice.

BLAKE & RIGGALL, solicitors, 140 William Street,  
Melbourne, 3017

Creditors, next of kin and others having claims in respect of the estate of Thomas George Payne, late of 100 Domain Street, South Yarra, architect, deceased, who died on 31 October 1983 are required to send particulars of their claim to Marjory Dowd care of the undermentioned solicitors by 23 August 1984 after which date the administratrix will distribute the assets having regard only to the claims of which she then has notice.

MAHONY & GALVIN, solicitors, 85 Queen Street,  
Melbourne 3018

RUBY LILLIAN MULLINS, late of 8 Evan Street, Box Hill  
North, in the State of Victoria, widow

Creditors, next of kin and others having claims in respect of the estate of the deceased, who died on 22 January 1984 are required by the Trustees the Union-Fidelity Trustee Company of Australia Limited of 100 Exhibition Street, Melbourne in the State of Victoria and Fay Bedford of 8 Evan Street, Box Hill North in the State of Victoria Home Duties and Brian Charles Mullins of Warraiedar Station P.M.B., Wubin in the State of Western Australia, Farmer, to send particulars to them by 22 August 1984 after which date the trustees may convey or distribute the assets, having regard only to the claims of which they then have notice.

OAKLEY THOMPSON & CO., solicitors, 205 King Street,  
Melbourne 2964

Creditors, next of kin and others having claims in respect of the estate of Norman William Ikin formerly of Coronation Court Traralgon late of Stawell Street, Sale, carpenter, deceased who died on 8 February 1984 and Probate of whose Will was granted by the Supreme Court of Victoria on 31 May 1984 to Isabel Mavis Ikin of Stawell Street, Sale widow are to send particulars of their claims to the said executor care of the below mentioned solicitors by 31 August 1984 after which date she will distribute the assets of the deceased having regard only to the claims of which she then has notice.

LITTLETON HACKFORD & MALKIN, solicitors, Law  
Chambers, 115-119 Hotham Street, Traralgon 2965

**HUGH TERENCE O'REILLY**, late of 362 Hampshire Crescent, Sunshine, in the State of Victoria, retired storeman, deceased

Creditors, next of kin and others having claims in respect of the Estate of the Deceased who died 21 February 1984 are required by Sandra Rosemary Paul of 9 Langtree Court, Blackburn, Teacher the Executor to whom Probate of the Will of the said Deceased was granted by the Supreme Court of Victoria to send particulars care of the undersigned by 27 August 1984 after which date the said Executor may convey or distribute the assets having regard only to the claims of which she then has notice.

**PATRICK J. CANNON, TESTRO & COBURN**, solicitors,  
of 117 Durham Road, Sunshine 2972

Creditors, next of kin and others having claims against the estate of Hilda May Dowell, deceased, late of 12 Austin Street, Oakleigh in the State of Victoria, widow, who died 5 May 1984, are required to send particulars of their claims to the Executor Wayne Douglas McDonald care of the undermentioned solicitors on or before 27 August 1984, after which date the Executor will distribute the assets of the estate having regard only to the claims of which he shall then have notice.

**SACKVILLE, WILKS & CO.**, solicitors, of 100 Collins Street, Melbourne 2973

Creditors, next of kin and others having claims in respect of the Estate of Joseph Antonio L'Aimable formerly of 4 Dingley Court Dingley in the State of Victoria, but late of Sundowner Caravan Park, Tootals Road, Dingley, in the said State, retired deceased who died 19 September 1983 are required to send particulars of their claims to the Executors care of the undermentioned solicitors by 20 August 1984 after which date will distribute the assets having regard only to the claims for which notice has been received.

**LYTTLETON & GILLARD**, solicitors, 51 Marcus Road, Dingley 2974

**JOAN ANNETTE WYER**, late of Unit 44, No. 330 Springvale Road, Donvale, widow, deceased

Creditors, next of kin and others having claims in respect of the estate of the deceased, who died 29 April 1984 are required by the personal representatives Paul Anthony Jester Wyer of 3 Badgerly Street, Macquarie Australian Capital Territory and Peter Hugh Wyer of 142 Canterbury Road Middle Park to send particulars to them care of the undermentioned solicitors by 28 August 1984 after which date the personal representatives may convey or distribute the assets having regard only to the claims of which they then have notice.

**AITKEN, WALKER & STRACHAN**, solicitors, 114 William Street, Melbourne 2975

**FRANK CLOUGH**, late of 36 Dowding Street, Eaglehawk, in the State of Victoria, retired shed hand, deceased

Creditors, next of kin and others having claims in respect of the estate of the deceased who died on 27 November 1983 are required by the Trustee, National Trustees Executors and Agency Company of Australasia Limited, 46 Queen Street, Bendigo in the State of Victoria to send particulars to it by 31 August 1984 after which date the Trustee may convey or distribute the assets having regard only to the claims of which it then has notice.

Dated 6 June 1984

**MESSRS BECK SHEAHAN QUINN & CO.**, solicitors, of  
238 Hargreaves Street, Bendigo 2960

**LILIAN ELIZABETH CRADDOCK**, late of 53 Suffolk Road, North Sunshine, widow, deceased

Creditors, next of kin and others having claims in respect of the Estate of the deceased who died on 12 December 1983 are required by Bert Lawrence Craddock of 61 Suffolk Road, North Sunshine Motor Mechanic the Executor to whom Probate of the Will of the said deceased was granted by the Supreme Court of Victoria to send particulars care of the undersigned by 27 August 1984 after which date the said Executor may convey or distribute the assets having regard only to the claims of which he then has notice.

**PATRICK J. CANNON, TESTRO & COBURN**, solicitors,  
117 Durham Road, Sunshine 2998

**EDWARD HENRY CABLE**, late of Boort in the State of Victoria, retired farmer, deceased

Creditors, next of kin and other persons having claims against the Estate of the said deceased who died on 15 December 1983 are required to send particulars of same to thej Executrix Adelaide Dorothy Cable in care of the undersigned on or before 8 August 1984 after which date they will distribute the assets having regard only to the claims of which they then have notice.

**HERCULES & WORLAND**, barristers & solicitors, 130 Godfrey Street, Boort 2999

**JOHANNES LORENZ BORKOWSKI** (also known as Johannes Borkowski, also known as John Borkowski) late of 17 Dumphries Street, Deer Park in the State of Victoria, inspector, deceased

Creditors next of kin and others having claims in respect of the estate of the deceased who died on 17 September 1983 are required by the Trustee Alicja Lila Borkowski of 79 Billingham Road, Deer Park in the State of Victoria, Home Duties, to send particulars to her by 21 August 1984 after which date, the Trustee may convey or distribute the assets having regard only to the claims of which she then has notice.  
Dated 14 June 1984

**MESSRS. BOUGHTONS**, barristers & solicitors, 15 Market Street, Nunawading, 3131 3000

**RUTH ALLISON STUBBS** late of 59 Serpells Road Templestowe, retired nursing sister, deceased

Creditors, next of kin and others having claims against the estate of the said deceased who died on 11 February 1984 are to send particulars of their claims to Henry William Stubbs c/o Messrs. Blake & Riggall solicitors, 140 William Street, Melbourne by 20 September 1984 after which date he will distribute the assets having regard only to the claims of which he then has notice.

**BLAKE & RIGGALL**, solicitors, 140 William Street, Melbourne 3009

Creditors, next of kin and others having claims in respect of the estate of Frederick Stanley Dickinson, late of 10 Aileen Avenue, Montrose in the State of Victoria, pensioner, deceased who died on 18 March 1984 are required by the Executrix of his Will, Linda Julie Miller, of 43 Edgerton Road, Mitcham in the said State, married woman, to send particulars of such claims to such Executrix care of her solicitor, G. S. Baker of 325 Collins Street, Melbourne in the said State by 15 August 1984, after which date the said Executrix will distribute or convey the assets having regard only to the claims of which she then has notice.

**G. S. BAKER**, solicitor, 325 Collins Street, Melbourne 3013



<b>LATE NOTICES</b>
---------------------

*Transport Act 1983*  
ROAD TRAFFIC AUTHORITY

## Commercial Passenger and Goods Vehicle Applications

Notice is hereby given that the following applications will be considered by the Road Traffic Authority on 10 July 1984.

Notice of any objections should be forwarded to reach the Manager, Licensing and Driver Certification Division not later than 4 July 1984.

It will not be necessary for interested parties to appear on the hearing date specified, unless advised in writing by the Authority.

Notification of the date for consideration of applications which are objected to and which require determination by the Road Transport Licensing Tribunal will be published by further notice in this Gazette.

Burleigh, B. L., South Caulfield. Application to license a four wheel drive passenger vehicle with a seating capacity for 10 persons, to be purchased, to operate for the carriage of bush walkers, canoeists, cross country skiers and persons participating in similar outdoor recreational activities and associated supplies and equipment, on round tours as follows:

		<i>Fare</i>
(a) (i)	Between Bairnsdale and Ensay South	25.00
	Mt. Delusion	35.00
	Benambra	40.00
	Sassafras Gap	51.00
	Glen Valley	46.00
	Cobungra	40.00
	Flourbag Plain	43.00
	Mt. Hotham	46.00
	McKillop Bridge	39.00
	Suggan Buggen	41.00
(ii)	Between Eildon and Howqua Track	36.00
	Sheepyard Flat	45.00
	Mt. Stirling	51.00
	Catherine Saddle	55.00
	Mt. Skene	33.00
	Mt. Shillinglaw	33.00
	Mt. Singleton	36.00
(iii)	Between Moe and Walhalla	24.00
	Mt. St. Gwinear	25.00
	Stronachs Gap	28.00
(iv)	Between Traralgon and Tidal River	38.00
	Ben Cruachen	14.00
	Wellington River	32.00
	McFarlane Saddle	26.00
	Moroka Gorge	29.00
	Howitt Plains	27.00
	King Billy	29.00
(v)	Between Stratford and Waterford	18.00
	Crooked River	23.00
	Eaglevale	25.00
	Dargo	20.00

Treasures Plain	29.00
Mt. St. Bernard	31.00

Note: Passengers are to be set down within a 10 km radius of the above destinations.

(b) Between Bairnsdale, Eildon, Moe, Traralgon or Stratford and other uninhabited destinations located in that part of Victoria, South and East of Wangaratta.

Fares: \$40.00 plus 25 cents per kilometre for the first 200 km plus 15 cents per kilometre thereafter.

Note: For the return journey passengers may need to be conveyed to a different transport interchange depending on the schedule of connecting services.

De Petri, J. M., Camberwell. Application for one Metropolitan Taxi licence to be issued subject to the cancellation of Metropolitan Hire car licence No. MH 2454.

Hurstbridge Bus and Taxi Service Pty. Ltd., Hurstbridge. Application to license two commercial passenger vehicles one with a seating capacity for 48 persons, and one with a seating capacity for 45 persons, to operate as Metropolitan Special Service Omnibuses.

Torrance, C. M. and McConnell, H. J., Tongala. Application for variation of the conditions of licence TS 66 which authorizes an Education Department school contract service between Deakin and Tongala, to operate under charter conditions from within a 20 km pick-up radius of Tongala. The licensed vehicle would hold a 3 star rating for charter purposes.

Note: This application is subject to the cancellation of the charter rights attached to licence TS 1615, which authorize charter operations from within a 20 km pick-up radius of Tongala.

Wren, D. S., Bairnsdale. Application for variation of the conditions of licence CC 108 which authorizes charter operations from within a 20 km radius of Bruthen Post Office, to delete the clause which states: "Management and operation of the vehicle under licence shall be from a depot situated within a 20 km radius of Bruthen Post Office approved by the Road Traffic Authority"; and instead insert the following clause: "Management and operation of the vehicle under licence shall be from a depot situated within a 20 km radius of Bairnsdale Post Office, approved by the Road Traffic Authority".

Note: The vehicle licensed by CC 108 holds a 4 star rating for charter purposes.

Application for renewal of licences as shown by the persons listed hereunder to operate under the same terms and conditions.

Alvarez, J. E., East Brighton, ST 6513.
Apostolopoulos, K. and E., St. Albans, MT 6792.
Avramopoulos, A., Prahran, ST 5726.
Axiotis, G. & T., Coburg, St 6473.
Barta, T., Bulleen, St 5912.
Battista, G., Vermont South, MT 4552.
Bolebrand (International) Investment Pty. Ltd. Bundoora, MT 6782.
Bolling, M. B. & D. Y., East Brighton, MT 1948.
Bullen, R. J., Essendon, MT 2684.
Caprez Pty. Ltd., Sandringham, Mt 6729.
Chidiac, I., Vermont South, MT 4305.
Cole, J. S. T., Melton, ST 6689.
Constantopoulos, S., East Malvern, ST 6427, ST 6566 and ST 6468.
Cox, J. E., Mulgrave, MT 4591.

Dikeos, A., Ashburton, MT 4420.  
 Dwyer, B. P., Mount Waverley, MT 5145.  
 Edmunds, R. A., Karingal, ST 6472.  
 El-Hallal, B., Preston, MT 6544.  
 Feldheim, I. S., Caulfield, ST 7596.  
 Fragiadakis, M., Dingley, MT 5906.  
 Franklin, P. F., Ballarat, UT 6.  
 Frosh, H. & H., Elsternwick, MT 6698.  
 Gamble, C. S., Wangaratta, CT 709.  
 Groves, H. F., Clayton, ST 5995.  
 Henley, K. J. & J. E., Cheltenham, ST 6402.  
 Howard, P. N., East Bentleigh, ST 6703.  
 Hurstbridge Bus & Taxi Service Pty. Ltd., Hurstbridge, MC 518.  
 Jesensek, L. & E. A., Sunshine, MT 6786.  
 Kelada, B. A. & G. A., Bentleigh, MT 6572.  
 Kery, K., St. Kilda, MT 3032.  
 Kouvarakis, C., Lalor, MT 6014.  
 Lane, R. J., Wendouree, UT 1018.  
 Langford, M. A., Glenroy, ST 7544.  
 Lilikakis, N. & K., Vermont South, ST 6742.  
 W. J. Lock's Taxi Service Pty. Ltd., East Brunswick, MT 5236.  
 Low, D. R., Greensborough, ST 22 and MT 6798.  
 Marescaux, R. G., & K. E., Mulgrave, MT 6836.  
 Margi, J. E., Hawthorn, ST 6608 and MT 4158.  
 Markopoulos, G., East Doncaster, MT 5350.  
 Mavromatis, A., West Brunswick, MT 6774.  
 Moerman, J., Pascoe Vale, MT 5869.  
 Moreland Bus Lines Pty. Ltd., Brunswick, MC 48 and MC 692.  
 Moore, R. N., Heatherton, ST 6743.  
 Motylski, W., North Coburg, MT 4054.  
 Muir, J. P., Dandenong, ST 6571.  
 McKenna, B. D., Mornington, MT 4534.  
 McNamara, P. T., Warrnambool, CT 637.  
 Nolan, L. G., Bentleigh, ST 5100.  
 Norster, G. & S., Essendon, ST 6510.  
 Pace, J. & M. B., Airport West, MT 5490.  
 Perkov, E., Fairfield, MT 6444.  
 Peterson, T., Chadstone, ST 6396.  
 Phillips, R. G. & D. L., South Caulfield, MT 6788.  
 Pitruzzello, M., Broadmeadows, ST 5830.  
 Polychronopoulos, C., Seaford, MT 4516.  
 Ramec Nominees Pty. Ltd., South Caulfield, MT 6818.  
 Ransom, G. R., Scoresby, ST 6771.  
 Rivana Nominees Pty. Ltd., East St. Kilda, MT 4131.  
 Sakoulas, P., Abbotsford, MT 6756.  
 Salata, R. & A., Northcote, MT 5528.  
 Sellars, M. C., Bayswater, ST 6248.  
 Shafirovich, Y., East St. Kilda, MT 6845.  
 Sheahan, D. M., Yarraville, MT 4700 and MT 5284.  
 Sheppard, F. X., Elwood, MT 6724.  
 Sideris, A. N., Broadmeadows, ST 6385.  
 Sierak, R. M., Noble Park, MT 4988.  
 Smythe, M. J. & McAteer, C. M., Northcote, MT 6594.  
 Spitalnic, M., East Brighton, MT 4663.  
 Stednick, W., Wesburn, MT 6358.

Stewart, D. M. & V. J., Braybrook, ST 6247.  
 Tsakalofas, J. & K., Yarraville, MT 4376.  
 Tuck, M. H., Glen Waverley, ST 5683.  
 Tuckerman, B. T., Lower Templestowe, ST 6515.  
 Twenty Fifth Monga Nominees Pty. Ltd., Springvale South, ST 6461.  
 Vagenas, A., East Doncaster, MT 5992.  
 Weinstein, M., Doncaster, MT 5036.  
 Woodman, W. H., Gardenvale, MT 5039.  
 Dated 20 June 1984

C. J. V. SMITH  
 Chief General Manager  
 Regulation & Registration

STATE TENDER BOARD—CONTRACTS ACCEPTED  
 AMENDMENTS

Schedule Number	Item Number	New Rate	Effective Date
		\$	
	<i>Antiseptics, Disinfectants, Deodorants and Insecticides</i>		
1/01		*	
	* Change of Address:		
	Tredmar Chemicals (Aust.) Pty. Ltd.		
	Delete: 14 Ardena Court, East Bentleigh, Phone No. 579-5222		
	Add: 135-137 Keys Road, Moorabbin, 3189, Phone No. 555-3688		
	<i>Cleaning and Polishing Requirements</i>		
1/04		*	
	* Change of Address:		
	Tredmar Chemicals (Aust.) Pty. Ltd.		
	Delete: 14 Ardena Court, East Bentleigh, Phone No. 579-5222		
	Add: 135-137 Keys Road, Moorabbin, 3189, Phone No. 555-3688		
	<i>Electrical Goods</i>		
1/05	27	430.48	1.7.84
		419.72	*
	28	391.00	
		381.22	#
	* Minimum order lots of 20		
	# Minimum order lots of 25		
	<i>Paints and Painters' Sundries</i>		
1/13	1	7.72	18.6.84
	2	2.45	
	3	8.25	
	4	2.58	
	5	9.48	
	6	2.90	
	7	13.80	
	8	4.05	
	9	9.48	
	10	2.90	
	11	7.66	
	12	2.43	
	13	9.67	
	15	7.66	
	16	2.43	

17	8.46		
18	2.67		
19	8.25		
20	2.58		
21	10.18		
22	3.09		
23	9.32		
24	2.87		
25	10.14		
26	3.08		
27	8.46		
28	2.67		
31	8.85		
32	2.76		
33	7.80		
34	2.50		
35	9.00		
36	2.81		
41	7.39		
42	2.36		
45	11.83		
46	3.52		
59	6.91		
60	2.24		
67	8.88		
68	2.75		
<i>Motor Spirit, Kerosene, Fuel Oils and Lubricants</i>			
		1/53B	30 * # 1.4.84
		* Delete:	0.4236
		Add:	0.4247
			31 * # 1.4.84
		* Delete:	0.4318
		Add:	0.4329
		#	The State Fuels Tax of \$0.0498 is included in these amended rates
			Petrol Outlets Add:
		Wonthaggi Shell	1. E. & T. Dowson, 215 White Road, 7 a.m.—7 p.m. Diesel
		Epsom B.P.	Northern Gate, Midland Highway, 8 a.m.—6 p.m.
<i>Hand Tools (General)</i>			
		1/56	45 Frost List * 28.5.84
			84/1
			Jobbers
			Less 50%
			M.T.S. and
			Others Less
			42.5%
			65 10.91 * 1.6.84
			66 12.91 *
			68 15.28 *
			70 19.55 *
			71 7.10 *
			72 8.53 *
			74 11.07 *
			76 14.74 *
			123 1.28 28.5.84
			124 1.28
			125 1.28
			126 2.59
			127 3.98
		* Delete:	Purchase Regulation 84
		Add:	Brand "Cyclone"
			New Contractor: Eliza Tinsley (Aust.) Pty. Ltd.
			J. M. PAWSON
			Secretary to the Tender Board
<i>Soaps and Soap Mixtures</i>			
		1/15	*
		* Change of Address:	
		Tredmar Chemicals (Aust.) Pty. Ltd.	
		Delete:	14 Ardena Court, East Bentleigh, Phone No. 579-5222
		Add:	135-137 Keys Road, Moorabbin, 3189, Phone No. 555-3688
<i>Toilet Requirements</i>			
		1/16	*
		* Change of Address:	
		Tredmar Chemicals (Aust.) Pty. Ltd.	
		Delete:	14 Ardena Court, East Bentleigh, Phone No. 579-5222
		Add:	135-137 Keys Road, Moorabbin, 3189, Phone No. 555-3688
<i>Fasteners</i>			
			<i>Discounts</i>
		1/26	39 Less 47-7% 28.5.84
			40 Less 47-7%
			49 Less 50%
			50 Less 50%
			51 Less 49%
<i>Liquid Petroleum Gas—Bulk</i>			
		1/52A	1 334.37 1.5.84
			2 340.30
			3 358.07
			4 368.89
			5 388.53
			6 22.48
Police Regulation Act Section 122			
SALE OF UNCLAIMED MOTOR VEHICLE			
An owner is required for an unregistered Blue Kawasaki motor cycle, engine No. G4E000024.			
The vehicle came into possession of Police on 14 November 1983, and if not claimed, will be sold by public auction at the Fitzroy Police Station, Cnr. Young and Condell Streets, Fitzroy, on Tuesday, 7 August 1984, at 9.00 a.m.			
S. I. MILLER Chief Commissioner of Police			
Police Regulation Act Section 122			
SALE OF UNCLAIMED MOTOR VEHICLE			
An owner is required for a green 1968 model Chrysler Sedan, previous Registration No. AEG365, engine No. VF134760C.			
The vehicle came into possession of Police on 18 January 1983, and if not claimed, will be sold by public auction at the Fitzroy Criminal Investigation Branch, Cnr. Young and Condell Streets, Fitzroy, on Tuesday, 7 August 1984 at 9.30 a.m.			
S. I. MILLER Chief Commissioner of Police			







*Tobacco Leaf Industry Stabilization Act 1966*  
TOBACCO QUOTAS

In pursuance of the provisions of the *Tobacco Leaf Industry Stabilization Act 1966* the Tobacco Quota Committee appointed under the said Act hereby makes it known that during the seasonal year ending 30 September 1984 the Growers Basic Quotas set out below have been issued for the first time, cancelled or altered in the manner shown.

G.B.Q.	Name	Final Amount Kg.	Land Description			Change	Authority
			Allotment	Section	Parish		
004	S. and C. Adamo	0	A17 (1), A27 (D) A27, A17		Everton	Cancelled	T.Q.C.
036	I. and E. Baveresco	24 100	3B, 3	31	Barwidgee	Name	T.Q.C.
059	Blackbird Nominees Pty. Ltd.	45 000	1B, 2A	17	Eurandelong	Amount	T.Q.C.
061	N. and I. and S. and S. Bojanic	0	6	7	Eurandelong	Cancelled	T.Q.C.
081	Estate of G. Bonato and A. Bonato	0	72F, 72G, Parts 72E, 72D		Whorouly	Cancelled	T.Q.C.
097	G. M. and P. M. and P. M. Burrowes	19 000	4B, 4C, 5A, 5B	5	Wabonga	Name and amount	T.Q.C.
112	L. and P. Camillo	0	Part 63B		Whorouly	Cancelled	T.Q.C.
119	A. and M. Cardamone	0	31C, 32B, Part 32, 32A		Whorouly	Cancelled	T.Q.C.
129	N. and C. Cavallin	0	Part 5 and 5B	A	Myrthee	Cancelled	T.Q.C.
143	G. Cerminara	0	9B, 10A, 10B	3	Myrtleford	Cancelled	T.Q.C.
152	D. and C. and P. Ciccone	33 200	13, 14, 15	5	Wematong	Name and amount	T.Q.C.
155	A. and K. W. Clemens	17 400	2, 3, 4	16	Eurandelong	Amount	T.Q.C.
167	Cooper Downs Tobacco Pty. Ltd.	0	3, 3A, 4, 4A, Parts 1A, 2 2, 4	5 6	Wematong	Cancelled	T.Q.C.
192	V. and R. Crispo	0	Part 7	19	Edi	Cancelled	T.Q.C.
197	P. and A. Cunico	20 000	3B, 3C, 3D	17	Eurandelong	Amount	T.Q.C.
231	E. De Fazio and Sons	0	11B and Part 11A		Tatong	Cancelled	T.Q.C.
243	A. and M. Del Mastro	21 400	1A, 1B, 1D	A	Oxley	Amount	T.Q.C.
245	P. and J. M. Del Mastro	0	1A, 1B, 1D	A	Oxley	Cancelled	T.Q.C.
285	G. and F. and F. Fiumara	33 800	Parts 15, 15A, 15B	2	Whitfield South	Name and amount	T.Q.C.
294	A. and M. Folino and A. and M. Gallo	24 500	6, 6A, 6B, Parts 5A, 5B	7	Wandiligong	Land	T.Q.C.
295	G. Fota, P. Vaccaro and A. Fota	0	3	4	Whorouly	Cancelled	T.Q.C.
298	Formelo Pty. Ltd.	30 000	8, 8A, 4A, 4B 5E, 7A, 7	1 2	Wabonga Wabonga	New Quota	T.Q.C.
306	G. and G. Frasca and A. and R. La Spina and G. and M. Volo	45 300	10	A	Myrthee	Name and amount	T.Q.C.
325	A. S. Garoni	40 000	Part 1, 4A, 4B, 7	1	Mullagong	Amount	T.Q.C.
333	L. F. and M. Gigliotti	7 000	Part 1	4	Wematong	Amount	T.Q.C.
336	A. and B. and U. and G. Gioffredi	22 900	6, 10, 10A, Part 9A	C	Buckland	Amount	T.Q.C.
344	L. and F. Groppo	0	2, Part 7	19	Edi	Cancelled	T.Q.C.
392	F. Iaria	0	2A, 2B, 2C	M	Bright	Cancelled	T.Q.C.
393	A. and C. Iaria	29 500	5, Parts 3, 4	18	Mullindoligong	Amount	T.Q.C.
395	S. F. Ivone	18 200	Part 11, 14, 14A, 14B		Oxley	Name	T.Q.C.
413	F. G. Johnson	0	3A, 3B, 4A, 6, 8 2B, 3A, Part 1A	12 17	Eurandelong Eurandelong	Cancelled	T.Q.C.
415	R. D. and A. G. Johnson	15 000	2B, 3A, Parts 1B, 1B, 2A	17	Eurandelong	Amount	T.Q.C.
421	M. Jursich	0	11, 12	8	Eurandelong	Cancelled	T.Q.C.
459	S. and M. La Spina	0	4A, 6A, 6B, 6C		Whorouly	Cancelled	T.Q.C.
477	Lunardi and Co.	10 500	7B, Part 7A	J	Myrtleford	Land	T.Q.C.
481	V. and B. Lyons and Co.	22 200	71C		Whorouly	Amount	T.Q.C.
500	McCormack Bros.	23 600	4, 6, 12A	11	Porepukah	Amount	T.Q.C.
506	T. and W. McCormack	12 800	6A, 6B, 6C, 12 8A	20 12	Barwidgee Myrtleford	Land	T.Q.C.
509	C. and S. L. MacDonald	2 000	1, 2, 3, Part 4A	P	Myrtleford	Amount	T.Q.C.
515	W. R. and M. R. McGuffie	67 900	1, 2, 3, and 33 Parts 4A, 30, 31, 32 168A	P	Myrtleford Whorouly	Amount	T.Q.C.
552	A. and S. Marchese	0	2A, 2B, 2C, 2D, 3B, 3C		Oxley	Cancelled	T.Q.C.
563	C. and E. Martinelli	15 900	1A, 1B, 1C, 1D, Part 9	2	Whitfield South	Land	T.Q.C.
575	C. and M. Megalogenis and S. and M. Vlassis	20 700	Lots 1, 2, 4, Part Allot. 6	A	Myrthee	Land	T.Q.C.
579	R. and E. and R. Micheli	0	8, 8A, 4A, 4B 5E, 7A, 7	1 2	Wabonga Wabonga	Cancelled	T.Q.C.
587	Estate of A. Michelini and I. and F. Michelini	28 000	8, 12, 13, 13A, 14, 15, 16, 16A	19	Eurandelong	Amount	T.Q.C.





## APPOINTMENT

His Excellency the Governor of the State of Victoria by and with the advice of the Executive Council thereof has by order made on 19 June 1984 been pleased to make the under-mentioned appointment, viz:

Law Department

*Member of the Legal Aid Commission*

Andrew John Kirkham, Q.C., a nominee of the Victorian Bar Council, to be a member of the Legal Aid Commission pursuant to the provisions of section 4 (1) (d) of the *Legal Aid Commission Act 1978* for the period 19 June 1984 to 13 February 1986.

TOM FORRISTAL  
Clerk of the Executive Council

At the Executive Council Chamber  
Melbourne, 19 June 1984

## RESIGNATION

His Excellency the Governor of the State of Victoria by and with the advice of the Executive Council thereof has by order made on 19 June 1984 accepted the resignation of the person named hereunder of the office mentioned, viz.:

Law Department

*Member of the Legal Aid Commission*

Douglas Graham, Q.C., as a member of the Legal Aid Commission, pursuant to the provisions of section 5 (2) of the *Legal Profession Practice Act 1958*.

TOM FORRISTAL  
Clerk of the Executive Council

At the Executive Council Chamber  
Melbourne, 19 June 1984

*Water Act 1958*

## STATE RIVERS AND WATER SUPPLY COMMISSION

*At the Executive Council Chamber, Melbourne, the  
thirteenth day of June 1984*

PRESENT:

His Excellency the Governor of Victoria

Mr Walker	Mr Simpson
Mr Mathews	Mr Simmonds

Under the powers conferred by the *Water Act 1958* and all other enabling powers, His Excellency the Governor of the said State of Victoria, with the advice of the Executive Council hereby declares, orders and directs as follows:

1. That as on and from 1 July 1984, the Urban Districts shown on the schedule hereto be united to form one District to be known as the Northern Mallee Urban District.

2. The said Northern Mallee Urban District so formed shall comprise the lands which were within the boundaries of the Urban Districts shown in the said schedule on 1 July 1984.

3. That all property, income, assets, rights and liabilities standing in the name of the Urban Districts shown in the said schedule shall upon the union of those districts as hereinbefore provided stand in the name of the Northern Mallee Urban District so formed. (Corr. No. 83/1532.)

## SCHEDULE

Beulah Urban District  
Chinkapook Urban District  
Hopetoun Urban District  
Lascelles Urban District  
Nandaly Urban District

Ouyen Urban District  
Patchewollock Urban District  
Speed Urban District  
Tempy Urban District  
Walpeup Urban District  
Yaapeet Urban District

And the Honourable David Ronald White, Her Majesty's Minister of Water Supply for the State of Victoria, shall give the necessary directions herein accordingly.

TOM FORRISTAL  
Clerk of the Executive Council

*Water Act 1958*

## STATE RIVERS AND WATER SUPPLY COMMISSION

*At the Executive Council Chamber, Melbourne, the  
thirteenth day of June 1984*

PRESENT:

His Excellency the Governor of Victoria

Mr Walker	Mr Simpson
Mr Mathews	Mr Simmonds

## WIMMERA AND MALLEE WATERWORKS DISTRICTS BE UNITED TO FORM WIMMERA MALLEE WATERWORKS DISTRICT

Under the powers conferred by the *Water Act 1958* and all other enabling powers, His Excellency the Governor of the said State of Victoria, with the advice of the Executive Council on the recommendation of the State Rivers and Water Supply Commission, hereby declares, orders and directs as follows:

1. That as on and from 1 July 1984 the Wimmera and Mallee Waterworks Districts be united so as to form one District to be known as the Wimmera Mallee Waterworks District.

2. The said Wimmera Mallee Waterworks District so formed shall comprise the lands which were within the boundaries of the aforesaid Wimmera and Mallee Waterworks Districts on 1 July 1984.

3. That all property, income, assets, rights and liabilities standing in the name of the Wimmera and Mallee Waterworks Districts shall upon the union of those districts as hereinbefore provided stand in the name of the Wimmera Mallee Waterworks District. (Corr. No. 81/2210.)

And the Honourable David Ronald White, Her Majesty's Minister of Water Supply for the State of Victoria, shall give the necessary directions herein accordingly.

TOM FORRISTAL  
Clerk of the Executive Council

*Water Act 1958*

## STATE RIVERS AND WATER SUPPLY COMMISSION

*At the Executive Council Chamber, Melbourne, the  
thirteenth day of June 1984*

PRESENT:

His Excellency the Governor of Victoria

Mr Walker	Mr Simpson
Mr Mathews	Mr Simmonds

Under the powers conferred by the *Water Act 1958* and all other enabling powers, His Excellency the Governor of the said State of Victoria, with the advice of the Executive Council hereby declares, orders and directs as follows:

1. That as on and from 1 July 1984, the Urban Districts shown on the schedule hereto be united to form one District to be known as the Southern Mallee Urban District.

2. The said Southern Mallee Urban District so formed shall comprise the lands which were within the boundaries of the Urban Districts shown in the said schedule on 1 July 1984.

3. That all property, income, assets, rights and liabilities standing in the name of the Urban Districts shown in the said schedule shall upon the union of those districts as hereinbefore provided stand in the name of the Southern Mallee Urban District so formed. (Corr. No. 83/1532.)

## SCHEDULE

Berriwillock Urban District  
Birchip Urban District  
Culgoa Urban District  
Nullawil Urban District  
Sea Lake Urban District  
Watchem Urban District  
Woomelang Urban District  
Wycheproof Urban District

And the Honourable David Ronald White, Her Majesty's Minister of Water Supply for the State of Victoria, shall give the necessary directions herein accordingly.

TOM FORRISTAL  
Clerk of the Executive Council

*Water Act 1958*

## STATE RIVERS AND WATER SUPPLY COMMISSION

*At the Executive Council Chamber, Melbourne, the  
thirteenth day of June 1984*

## PRESENT:

His Excellency the Governor of Victoria  
Mr Walker                      |                      Mr Simpson  
Mr Mathews                     |                     Mr Simmonds

Under the powers conferred by the *Water Act 1958* and all other enabling powers, His Excellency the Governor of the said State of Victoria, with the advice of the Executive Council hereby declares, orders and directs as follows:

1. That as on and from 1 July 1984, the Urban Districts shown on the schedule hereto be united to form one District to be known as the Western Wimmera Urban District.

2. The said Western Wimmera Urban District so formed shall comprise the lands which were within the boundaries of the Urban Districts shown in the said schedule on 1 July 1984.

3. That all property, income, assets, rights and liabilities standing in the name of the Urban Districts shown in the said schedule shall upon the union of those districts as hereinbefore provided stand in the name of the Western Wimmera Urban District so formed. (Corr. No. 83/1532.)

## SCHEDULE

Antwerp Urban District  
Dimboola Urban District  
Dooen Urban District  
Jeparit Urban District  
Natimuk Urban District  
Pimpinio Urban District  
Rainbow Urban District

And the Honourable David Ronald White, Her Majesty's Minister of Water Supply for the State of Victoria, shall give the necessary directions herein accordingly.

TOM FORRISTAL  
Clerk of the Executive Council

*Water Act 1958*

## STATE RIVERS AND WATER SUPPLY COMMISSION

*At the Executive Council Chamber, Melbourne, the  
thirteenth day of June 1984.*

## PRESENT:

His Excellency the Governor of Victoria  
Mr Walker                      |                      Mr Simpson  
Mr Mathews                     |                     Mr Simmonds

Under the powers conferred by the *Water Act 1958* and all other enabling powers, His Excellency the Governor of the said State of Victoria, with the advice of the Executive Council hereby declares, orders and directs as follows:

1. That as on and from 1 July 1984, the Urban Districts shown on the schedule hereto be united to form one District to be known as the Eastern Mallee Urban District.

2. The said Eastern Mallee Urban District so formed shall comprise the lands which were within the boundaries of the Urban Districts shown in the said schedule on 1 July 1984.

3. That all property, income, assets, rights and liabilities standing in the name of the Urban Districts shown in the said schedule shall upon the union of those districts as hereinbefore provided stand in the name of the Eastern Mallee Urban District so formed—(Corr. No. 83/1532.)

## SCHEDULE

Chillingollah Urban District  
Lalbert Urban District  
Manangatang Urban District  
Quambatook Urban District  
Ultima Urban District  
Waitchie Urban District  
Woorinen Urban District

And the Honourable David Ronald White, Her Majesty's Minister of Water Supply for the State of Victoria, shall give the necessary directions herein accordingly.

TOM FORRISTAL  
Clerk of the Executive Council

*Water Act 1958*

## STATE RIVERS AND WATER SUPPLY COMMISSION

*At the Executive Council Chamber, Melbourne, the  
thirteenth day of June 1984.*

## PRESENT:

His Excellency the Governor of Victoria  
Mr Walker                      |                      Mr Simpson  
Mr Mathews                     |                     Mr Simmonds

Under the powers conferred by the *Water Act 1958* and all other enabling powers, His Excellency the Governor of the said State of Victoria, with the advice of the Executive Council hereby declares, orders and directs as follows:

1. That as on and from 1 July 1984, the Urban Districts shown on the schedule hereto be united to form one District to be known as the Southern Wimmera Urban District.

2. The said Southern Wimmera Urban District so formed shall comprise the lands which were within the boundaries of the Urban Districts shown in the said schedule on 1 July 1984.

3. That all property, income, assets, rights and liabilities standing in the name of the Urban Districts shown in the said schedule shall upon the union of those districts as hereinbefore provided stand in the name of the Southern Wimmera Urban District so formed—(Corr. No. 83/1532.)

## SCHEDULE

Brim Urban District  
 Jung Jung Urban District  
 Marnoo Urban District  
 Minyip Urban District  
 Rupanyup Urban District

And the Honourable David Ronald White, Her Majesty's Minister of Water Supply for the State of Victoria, shall give the necessary directions herein accordingly.

TOM FORRISTAL  
 Clerk of the Executive Council

## PUBLIC SERVICE ACT 1974

At the Executive Council Chamber, Melbourne, the nineteenth day of June 1984

## PRESENT:

His Excellency the Governor of Victoria  
 Mr White | Mr Kent  
 Mrs Toner

## AMENDMENTS TO SCHEDULE TWO OF THE PUBLIC SERVICE ACT 1974

Whereas it is provided by section 2 of the *Public Service (Amendment) Act 1984* that the several provisions of the Act shall come into operation on a day or on the respective days to be fixed by proclamation or successive proclamations of the Governor in Council published in the *Government Gazette*:

And whereas it is provided by section 27 of the said Act that for Schedule Two and Schedule Three of the *Public Service Act 1974* there shall be substituted the Schedule Two, the Schedule Three and the Schedule Three A set out in the said section:

And whereas it is provided by sub-section 10 (1) of the *Public Service (Amendment) Act 1984* that in Part III of the *Public Service Act 1974* for Division 1 there shall be substituted the Division set out in that certain provisions empowering the Governor in Council by Order to amend Schedule Two:

And whereas by a Proclamation of the Governor in Council dated 13 June 1984 and made pursuant to section 2 of the *Public Service (Amendment) Act 1984*, Wednesday, 20 June 1984 has been fixed as the day on which certain provisions including sub-section 10 (1) and section 27 of that Act shall come into operation:

Now therefore, His Excellency the Governor of the State of Victoria, by and with the advice of the Executive Council of the said State, in exercise of all the powers thereunto enabling, doth by this Order amend Schedule Two to the *Public Service Act 1974* as substituted by sub-section 10 (1) of the *Public Service (Amendment) Act 1984* by—

- (i) removing the administrative unit of "Ministry of Water Resources and Water Supply" from column one;
- (ii) removing the office of "Director of Water Resources" from column two;
- (iii) removing the unit of "Office of the State Rivers and Water Supply Commission" from Column three;
- (iv) removing the office "Chairman, State Rivers and Water Supply Commission" from column four;
- (v) adding immediately after the administrative unit of "Victorian Tourism Commission" in column one, the administrative unit of "Department of Water Resources" to column one;

- (vi) adding, immediately after the office of "Chairman, Victorian Tourism Commission" and in relation to the administrative unit of "Department of Water Resources" in column one, the office of "Director-General of Water Resources" in column two;
- (vii) adding, in relation to the administrative unit of "Department of Water Resources" in column one, the unit of "Rural Water Commission of Victoria" in column three; and
- (viii) adding, in relation to the unit of "Rural Water Commission of Victoria" in column three, the office of "General Manager, Rural Water Commission of Victoria" to column four.

This order shall have effect from and inclusive of 1 July 1984.

And the Honourable John Cain, Her Majesty's Premier for the State of Victoria, shall give the necessary directions herein accordingly.

TOM FORRISTAL  
 Clerk of the Executive Council

## CITY OF ARARAT

## Bylaw No. 133

The Council of the City of Ararat has made a Bylaw, under the provisions of section 197 and 198 of the *Local Government Act 1958*, and section 93 of the *Health Act 1958*, for or with respect to:

- (a) Regulating the keeping of animals within the Municipal District of the City of Ararat.
- (b) Fixing the distance from any dwelling within which it shall be unlawful to keep any animal within the Municipal District of the City of Ararat.
- (c) Providing for the use and control of receptacles used for the deposit and collecting of refuse and rubbish and prescribing the size and shape of the materials to be used in the construction of such receptacles.

The resolution for passing this Bylaw was agreed to by the Council of the City of Ararat on 15 August 1983, and confirmed on 12 September 1983.

A copy of this Bylaw is open for inspection, free of charge, at the Municipal Offices, Vincent Street, Ararat, during office hours.

3041

I. A. KEITH  
 Town Clerk

## CITY OF MALVERN

## Closure of Right-of-way to Through Traffic

Notice is hereby given pursuant to the provisions of section 539C of the *Local Government Act 1958* that the Council of the City of Malvern having considered a report by the Road Traffic Authority on a proposal for the closure to through traffic of the right-of-way connecting Malvern Road with Woodmason Street, in the City of Malvern and having advertised the proposal pursuant to the provisions of sections 539C and 193A of the *Local Government Act*, and having received no objections to the proposal, has by Order adopted the proposal to permanently close to through traffic the right-of-way connecting Malvern Road with Woodmason Street, in the City of Malvern as shown on the plan below and that such Order shall come into effect on Monday, 25 June 1984.

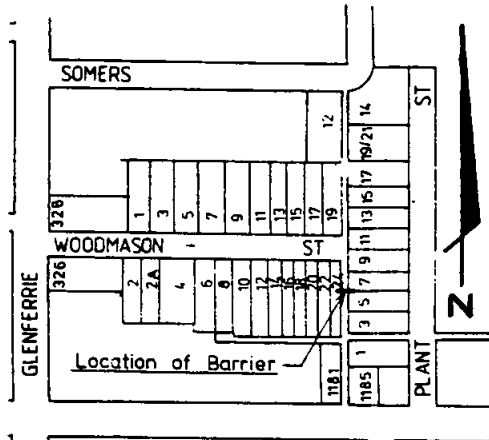

**CITY OF NUNAWADING**  
Road Discontinuance

Pursuant to section 528 (2) of the *Local Government Act* 1958, the Council of the City of Nunawading, after consultation with Public Authorities and the advertising of its intention and notification to the registered proprietor of the land and owners and occupiers of any land abutting or as immediately adjacent to the road, has by resolution of its Ordinary Meeting held on 28 May 1984, as follows:

- (a) That part of the unused Right of Way between No. 6 and No. 8 Clarke Street, Blackburn shown by hatching on the plan hereunder shall be discontinued.
- (b) That the land in the discontinued road shall be sold and transferred to the abutting owners by private treaty.

PART OF CROWN ALLOTMENT 82  
PARISH OF NUNAWADING  
COUNTY OF BOURKE

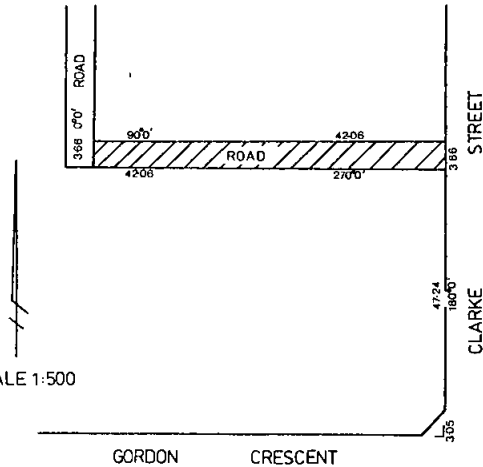

3032

P. A. BIRRELL  
City Manager & Town Clerk

**CITY OF MALVERN**

Closure of Road to Through Traffic

Notice is hereby given pursuant to the provisions of section 539C of the *Local Government Act* 1958, that the Council of the City of Malvern having advertised a proposal for the permanent closure to through traffic of Milton Parade, Malvern, immediately east of Toorong Road and having considered all objections received in accordance with Section 193A of the *Local Government Act* 1983 and having considered a report on the proposal by the Road Traffic Authority, has by Order adopted the proposal for the permanent closure to through traffic of Milton Parade, Malvern immediately east of Toorong Road as shown below, without modification, and that such Order shall come into operation on Monday, 25 June 1984.

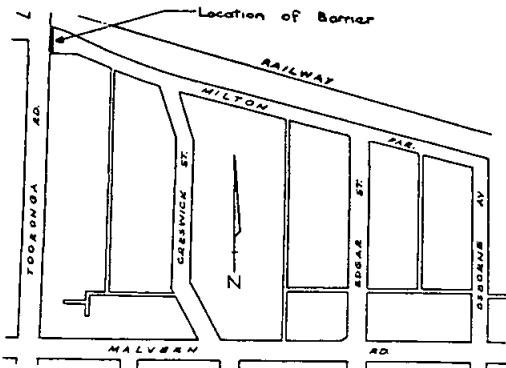

3033

P. A. BIRRELL  
City Manager & Town Clerk

3038

L. FELL  
Chief Executive

**CITY OF SANDRINGHAM**

Notice of Intention to Acquire Land Compulsorily

Whereas the Council of the City of Sandringham deems it expedient to exercise its powers of taking compulsorily the land for Municipal purposes being the whole of Lot No. 3 on Plan of Subdivision No. 131451 being part of Crown Portion 29, Parish of Moorabbin and being that section of the footway located between properties known as 330 and 331 Beach Road, Black Rock, and whereas the Council has caused to be prepared maps and other papers setting out a general description of the work or undertaking for which the land is proposed to be taken and the names of the owners or reputed owners, lessees or reputed lessees, mortgagees and occupiers of that land so far as those names are known or can be ascertained by the Council and whereas the said maps and other papers are deposited at the office of the said Council at Royal Avenue, Sandringham and are and shall be open for inspection by all person interested at all reasonable hours for the space of forty clear days after the publication of this notice in the *Government Gazette*. Now notice is hereby given to all persons affected by the proposed taking of the said land

to set forth in writing addressed to the Council or the Town Clerk at the address aforesaid within forty clear days of the publication of this notice in the *Government Gazette* all objections which they may have to the taking of the said land. At the Ordinary Meeting of the Council next after the expiration of the said forty clear days the Council will consider any such objection and any person so objecting as aforesaid may appear before the Council in support of such objection. By Order of the Council.

2966 P. S. SHERMAN, Town Clerk

CITY OF WARRNAMBOOL

Loan No. 172

Notice of Intention to Borrow the Sum of \$100 000

Notice is given that the Council of the City of Warrnambool proposes to borrow the principal sum of \$100 000 secured by a charge over the general rates of the municipality, such sum to be raised by the grant of a Mortgage in accordance with the provisions of the *Local Government Act 1958*.

1. The maximum rate of interest that may be paid is 15.5 per cent per annum.

2. The purpose for which the Loan is to be applied is:

Council's contribution to Road  
Construction Authority roadworks \$100 000

3. The period of the Loan shall be ten (10) years.

4. The moneys borrowed shall be repayable by providing out of the Principal Fund, half-yearly instalments of \$9 996.47 each including principal and interest on 25 July and 25 January during the currency of the loan. The first instalment shall be payable on 25 January 1985.

5. Such moneys shall be repayable to the National Commercial Banking Corporation of Australia Limited, 257 Collins Street, Melbourne.

The specifications and the estimates of the cost of the contributions and a statement showing the proposed expenditure of the moneys to be borrowed are open for inspection at the office of the Council of the City of Warrnambool, Municipal Offices, Liebig Street, Warrnambool 3280.

3036 V. G. ROBSON  
Town Clerk

CITY OF WARRNAMBOOL

Loan No. 174

Notice of Intention to Borrow the Sum of \$250 000

Notice is given that the Council of the City of Warrnambool proposes to borrow the principal sum of \$250 000 secured by a charge over the general rates of the municipality, such sum to be raised by the grant of a Mortgage in accordance with the provisions of the *Local Government Act 1958*.

1. The maximum rate of interest that may be paid is 15.2% per annum.

2. The purpose for which the loan is to be applied is:

	\$
Kerb and Channel and Drainage— Younger Street	30 000
Kerb and Channel and Drainage—Grafton Road	56 000
Road Construction—Mickle Crescent (Part Cost)	8 000
Road Construction—Dennys Street	95 000
Council proportion—R.C.A. Grant Works	26 000
Footpath Construction—Various Streets	35 000
	250 000

3. The period of the loan shall be ten (10) years.

4. The moneys borrowed shall be repayable by providing out of the Principal Fund, half-yearly instalments of \$24 709.85 each including principal and interest on 25 July and 25 January during the currency of the loan. The first instalment shall be payable on 25 January 1985.

5. Such moneys shall be repayable to the National Commercial Banking Corporation of Australia Limited, 257 Collins Street, Melbourne.

The specifications and the estimates of the cost of the contributions and a statement showing the proposed expenditure of the moneys to be borrowed are open for inspection at the office of the Council of the City of Warrnambool, Municipal Offices, Liebig Street, Warrnambool 3280.

3035 V. G. ROBSON, Town Clerk

SHIRE OF BUNINYONG

By-Law No. 30

Meeting Procedure by Law

For the purpose of regulating the proceedings of the Council meetings and meetings of Council Committees and for other purposes.

Notice is hereby given that the abovementioned By-Law has been passed by the Council and is available for perusal at the office of the Council, Municipal Chambers, Buninyong during office hours.

3039 A. F. HELYAR  
Shire Secretary

SWAN HILL WATERWORKS TRUST

Notice to owners of tenements in the undermentioned Streets and the Private Streets, Lanes, Courts and Alleys opening thereto.

The main pipe in the said Street being laid down the owners of all tenements situated as under are hereby required on or before 30 September 1984, to cause a proper pipe and stop cock to be laid so as to supply water within such tenements from the main pipe.

*Swan Hill Urban District*

- Area No. 55—Wilkins Grove
- Area No. 56—Murlong Street
- Area No. 57—Werril Street, Murray Valley Highway
- Area No. 58—Back Saleyard Road, Murray Valley Highway
- Area No. 59—Gray Street

3040 G. J. MENNIE, Secretary

DROMANA-ROSEBUD SEWERAGE AUTHORITY

Notice of Intention to Commence Works

The Dromana-Rosebud Sewerage Authority advise that that sewer construction works will soon be carried out in the following areas:

Sewer Reticulation 7D:

This stage serving approximately 280 properties is bounded by Seaview Avenue, Buckley Street, Rymer Avenue and Patterson Street, Safety Beach.

Sewer Reticulation 4G:

This stage serving approximately 200 properties is bounded by Bayview Road, Navigator Street and Parkes Street, McCrae.

Any interested person may inspect the plan of works at the Office of the Authority, Nepean Highway, Dromana between 9.00 a.m. and 4.00 p.m. Monday to Friday.

3037 J. O. WILLIAMS  
Secretary

## DANDENONG SEWERAGE AUTHORITY

## By-Law No. 7

Notice is hereby given that By-law No. 7—relating to fees for house connection design plans, amending plans, penalties for non-compliance with Authority's By-Laws, and to licence fees—was passed by the Dandenong Sewerage Authority on the 12 April 1984, confirmed on the 17 May 1984, and has been approved by the Governor in Council.

A copy of the said By-Law No. 7 may be inspected, free of charge, during office hours at the Authority's office, 205 Thomas Street, Dandenong.

3034

A. L. FOSTER  
Secretary/Manager

Would Brendan Thompson please collect his bay mare and bay foal from R. & A. J. Smith, South Valley Road, Highton, 3216. 3059

In the Supreme Court of Victoria—Co. 303—In the matter of the Companies (Victoria) Code and in the matter of Australian Modern Products Proprietary Limited

Notice is hereby given that a petition for the winding up of the abovenamed Company by the Supreme Court was on 14 June 1984, presented by Interglobal Commodities Proprietary Limited. And that the said petition is directed to be heard before the Court sitting at the Fifteenth Court, Supreme Court, cnr. William and Lonsdale Streets, Melbourne at the hour 10.30 o'clock in the forenoon on 19 July 1984; and any creditor or contributory of the said Company Australian Modern Products Proprietary Limited desiring to support or oppose the making of an order on the said petition may appear at the time of hearing by himself or his counsel for that purpose; and a copy of the petition will be furnished to any creditor or contributory of the said company Australian Modern Products Proprietary Limited requiring the same by the undersigned on payment of the regulated charge for the same.

The Petitioner's address is 70 Stephenson Street, Richmond.

The Petitioner's Solicitor is Mr Simon Feingold of the Law Offices of Simon Feingold, 207 Balaclava Road, Caulfield.

SIMON FEINGOLD

Note: Any person who intends to appear on the hearing of the said petition must serve on or send by post to the abovenamed Simon Feingold notice in writing of his intention so to do. The notice must state the name and address of the person, or, if a firm, the name and address of the firm, and must be signed by the person or firm, or his or their solicitor (if any) and must be served, or if posted, must be sent by post in sufficient time to reach the abovenamed not later than 4.00 in the afternoon of Wednesday 18 July 1984. 3048

Companies (Queensland) Code  
IOLANDA INVESTMENTS PTY. LTD.  
(in Liquidation)

Notice of Voluntary Liquidation, Section 392 (2)

At a General Meeting of the abovenamed company, duly convened and held at 278 Church Street, Richmond, on 12 June 1984 the following Special Resolution was passed:

"That the company be wound up as a Members' Voluntary Liquidation and that the assets of the company may be distributed in whole or in part to the members *in specie* should the Liquidators so desire."

Dated 12 June 1984

JAMES REGOS, 278 Church Street, Richmond, 3121

3025

Companies Form 130

Companies (Queensland) Code

IOLANDA INVESTMENTS PTY. LTD.

(in Liquidation)

Notice Inviting Formal Proof of Debt or Claim

Take notice that creditors of the company are required on or before 10 July 1984 to prove their debts or claims and to establish any title they may claim in accordance with Form 131 or 132 containing their respective debts or claims. In default they will be excluded from the benefit of any distribution made before their debts or claims are proved or their priority is established and from objecting to the distribution.

Form of proof may be obtained from the Liquidator.

Dated 12 June 1984

JAMES REGOS, 278 Church Street, Richmond, 3121

3026

Companies (Victoria) Code

A. F. &amp; M. H. WHITEHEAD PTY. LTD.

(in Liquidation)

Notice of Voluntary Liquidation, Section 392 (2)

At a General meeting of the abovenamed company, duly convened and held at 278 Church Street, Richmond, on 8 June 1984, the following Special Resolution was passed:

"That the company be wound up as a Members' Voluntary Liquidation and that the assets of the company may be distributed in whole or in part to the members *in specie* should the Liquidators so desire."

Dated 12 June 1984

JAMES REGOS, 278 Church Street, Richmond, 3121

3027

In the Supreme Court of Victoria—Co. 137—In the matter of the Companies (Victoria) Code and in the matter of Candela Ira Nominees Pty. Ltd.—Notice of Winding-Up Order

Winding-Up Order made 7 June 1984.

Name and Address of Liquidator: Geoffrey Ormond Harrison, Touche Ross and Co., 440 Collins Street, Melbourne, Vic. 3000.

T. A. SHERMAN, Acting Crown Solicitor for the Commonwealth and Solicitor for the Petitioner 3042

In the Supreme Court of Victoria—Co. 138—In the matter of the Companies (Victoria) Code and in the matter of Kallis Holdings Pty. Ltd.—Notice of Winding-Up Order

Winding-Up Order made 7 June 1984.

Name and Address of Liquidator: Anthony George Hodgson, Ferrier Hodgson and Co., 459 Collins Street, Melbourne, Vic. 3000.

T. A. SHERMAN, Acting Crown Solicitor for the Commonwealth and Solicitor for the Petitioner 3043

In the Supreme Court of Victoria—Co. 139—In the matter of the Companies (Victoria) Code and in the matter of Sixteenth Zulu Pty. Ltd.—Notice of Winding-Up Order

Winding-Up Order made 7 June 1984.

Name and Address of Liquidator: Alan Murray Horsburgh, Wallace McMullin and Smail, 499 St Kilda Road, Melbourne, Vic. 3004.

T. A. SHERMAN, Acting Crown Solicitor for the Commonwealth and Solicitor for the Petitioner 3044

The Companies (Victoria) Code—In the matter of Seref Pty. Ltd.

(In Voluntary Liquidation).

Notice is hereby given that at an Extraordinary Meeting of the members of the above-named Company held on 14 June 1984 it was resolved that the company be wound up voluntarily and that for such purpose Mr David W. Jones of 1 Yarra Street, South Yarra be appointed Liquidator.

Notice is also given that after twenty-one days from this date I shall proceed to distribute the assets. All creditors having any claim against the company shall furnish particulars of same by that date, otherwise I shall proceed to distribute the assets without regard to their claim.

Dated 14 June 1984.

DAVID W. JONES, Liquidator

Cook, Jones and Co., Chartered Accountants, 1 Yarra Street, South Yarra 3049

Companies Form 130  
Companies (Victoria) Code

A. F. & M. H. WHITEHEAD PTY. LTD.  
(in Liquidation)

Notice Inviting Formal Proof of Debt or Claim

Take notice that creditors of the company are required on or before 10 July 1984 to prove their debts or claims and to establish any title they may claim in accordance with Form 131 or 132 containing their respective debts or claims. In default they will be excluded from the benefit of any distribution made before their debts or claims are proved or their priority is established and from objecting to the distribution.

Form of proof may be obtained from the Liquidator.

Dated 12 June 1984

JAMES REGOS, 278 Church Street, Richmond, 3121

3028

WILKINSON and JARMYN INVESTMENTS PTY. LTD.  
(In Voluntary Liquidation)

Notice is hereby given that at an Extraordinary General Meeting of the abovenamed Company held on 14 June 1984 the following Special Resolution was duly passed:

"That the company be wound up voluntarily".

3050

P. J. HARRINGTON, Liquidator

SPRYDIA INVESTMENTS PTY. LTD.  
(In Liquidation)

Notice is hereby given of the final meeting of members to be held at 660 Bridge Road, Richmond on 27 July 1984 at 10.00 a.m.

3051

P. J. HARRINGTON, Liquidator

In the Supreme Court of Victoria—1984 Co. No. 215—In the matter of the Companies (Victoria) Code and in the matter of Dorm Investments Pty. Ltd.—Advertisement of Application

Notice is hereby given that an application for the winding up of the abovenamed company by the Supreme Court was on 4 May 1984 presented by David Jones and the said application is directed to be heard before the court sitting at the Practice Court, Law Courts, Lonsdale Street, Melbourne at the hour of 10.30 o'clock in the forenoon of 19 July 1984 and any creditor or contributory of the said company desiring to support or oppose the making of an order on the said Application may appear at the time by himself or by his Counsel for the purpose; and a copy of the said Application will be furnished to any creditor or contributory of the said company requiring same by the undersigned on payment of the regulated charge for the same.

The Applicant's official address is 1 Yarra Street, South Yarra, Victoria.

The Applicant's solicitors are Messrs Cooper Korbl & Co., of 361 Queen Street, Melbourne.

COOPER, KORBL & Co.

Note: Any person who intends to appear on the hearing of the said Application must serve on or send by post to the abovenamed Cooper, Korbl & Co., notice in writing of his intention to do so. The notice must state the name and address of the person, or, if a firm, the name and address of the firm and must be signed by the person or the firm, or his, or their Solicitors (if any), and must be served, or, if posted, must be sent by post in sufficient time to reach the abovenamed not later than 4.00 o'clock in the afternoon of 18 July 1984. 3064

Creditors next of kin and others having claims in respect of the Estate of Gary Gordon Decker late of Hamilton Road, Horsham in the State of Victoria, carrier, deceased, who died on 4 June 1984 are requested to send particulars of their claims to Messrs Denis J. O'Brien & Co., solicitors of 64 McLachlan Street, Horsham the solicitors for the Executor of the Will of the said deceased before 13 July 1984 after which date they will distribute the assets having regard only to the claims they then have had notice.

DENIS J. O'BRIEN & CO., solicitors, Horsham 2994

LAVINIA MAY SMITH, late of Cohuna in the State of Victoria, widow, deceased

Creditors next of kin and all other persons having claims against the Estate of the said deceased are required by Beverley Dorothea Miller and Jack Richard Smith the Executors of the Estate of the said deceased to send particulars of such claims to them in care of the undermentioned Solicitors on or before 21 August 1984 after which date they will distribute the assets having regard only to the claims of which they then have had notice.

WILLAN & McKENZIE, solicitors, Box 299, Cohuna, Victoria 3568 2995

AGNES CHRISTINA BARNETT, late of Benlynn Nursing Home, 4/6 Killara Street, West Sunshine, spinster, deceased

Creditors, next of kin and others having claims in respect of the Estate of the deceased who died on 3 February 1984 are required by Robert George Barnett of 20 Couch Street, Sunshine, retired, the Executor to whom Probate of the Will of the said deceased was granted by the Supreme Court of Victoria to send particulars care of the undersigned by 27 August 1984 after which date the said Executor may convey or distribute the assets having regard only to the claims of which he then has notice.

PATRICK J. CANNON, TESTRO & COBURN, solicitors, 117 Durham Road, Sunshine 2997

Creditors, next of kin and others having claims in respect of the estate of Nigel Shaw Scott-Branagan late of Flat 12, 17 Armadale Street, Armadale in the State of Victoria, marketing manager, deceased, who died on 23 October 1983 are required to send particulars of their claims to the executor care of the undermentioned solicitors by 20 August 1984 after which date will distribute the assets having regard only to the claims for which notice has been received.

LYTTLETON & GILLARD, solicitors, 51 Marcus Road, Dingley 2961

In the Will of ELSA GERTRUDE LEAROYD formerly of 38 Falkingham Road, Mount Evelyn in the State of Victoria but late of Eastern Districts Private Nursing Home at 124 Maroondah Highway, Croydon in the said State, widow deceased

Creditors, next of kin and others having claims in respect of the estate of the deceased who died on 29 February 1984 are required by the Perpetual Executors and Trustees Association of Australia Limited of 50 Queen Street, Melbourne, to send particulars of their claims to the said Company by 21 August 1984 after which date it will convey or distribute the assets, having regard only to the claims of which the Company then has notice.

McCOLL HAWTHORNE & WILLIAMS, solicitors of 246 Main Street, Lilydale 3001

MINNIE EFFIE ROLLINSON late of Boort in the State of Victoria, widow, deceased

Creditors, next of kin and other persons having claims against the estate of the said deceased who died on 4 June 1984 are required to send particulars of same to the executors Lindsay Alexander Rollinson and Ian Alexander Rollinson in care of the undersigned on or before 14 August 1984 after which date they will distribute the assets having regard only to the claims of which they then have notice.

HERCULES & WORLAND, barristers & solicitors, 130 Godfrey Street, Boort 3003

IVAN LYLE MYHILL late of Castlemaine Caravan Park, Walker Street, Castlemaine, retired, deceased

Creditors next of kin and others having claims in respect of the estate of the abovenamed deceased who died on 7 March 1984 are to send particulars of their claims to the Executor Perpetual Executors & Trustees Association of Australia Limited, C/o O'Brien & Galante, 44 Pascoe Vale Road, Moonee Ponds by 23 August 1984 after which date the said Executor will distribute the assets having regard only to the claims of which it then has notice.

O'BRIEN & GALANTE, solicitors, 44 Pascoe Vale Road, Moonee Ponds 3004

MARION LLOYD ENTWISLE formerly of Lake Boga in the State of Victoria, but late of Unit 1, 69 Splatt Street, Swan Hill in the said State, Married Woman, deceased (who died on 28 March 1984)

Creditors, next of kin and all other persons having claims against the Estate of the deceased are required by the Executors of the Will, Geoffrey Hindhaugh Entwisle and Suzanne Lloyd McKenzie, to send particulars to them care of the undersigned on or before the 22 August 1984, after which date they will distribute the assets having regard only to the claims of which they then have notice.

GARDEN & GREEN, solicitors, 4 McCallum Street, Swan Hill 3057

IVY LILIAN CHRISTMAS, late of 2 Gardiner Street, Lilydale, Married Woman, deceased

Creditors, next of kin and others having claims in respect of the estate of the deceased who died 28 February 1984, are required by the Executor Arthur Benjamin Christmas of 2 Gardiner Street, Lilydale, Widower to send particulars to the undermentioned firm by 15 September 1984, after which date the said Arthur Benjamin Christmas may convey or distribute the assets having regard only to the claims of which notice has by then been given.

SETON WILLIAMS & SMYTH, solicitors, 408 Collins Street, Melbourne 3058

GWENDOLINE MURIEL REILLY, late of Unit 12, 8 Parring Road, Balwyn, secretary, deceased

Creditors, next of kin and others having claims in respect of the estate of the abovenamed deceased who died on 24 January 1984, are required by Bruce Roderick James Hallows and Ian Fraser Bult both of 257 Collins Street, Melbourne, solicitors, the executors of the Will of the deceased to send particulars of their claims to the said executors care of the undernamed solicitors by 24 August 1984, after which date they will convey or distribute the assets having regard only to the claims of which they then have notice.

RUSSELL, KENNEDY & COOK, solicitors, 257 Collins Street, Melbourne 3052

THELMA MAY GLEW, late of Unit 2, 44 Sherwood Avenue, Chelsea, retired veterinary nurse, deceased

Creditors, next of kin and others having claims in respect of the estate of the abovenamed deceased who died on 12 February 1984 are required by James Kenneth Aitken and Nancy Beatrice Dowdle both of 257 Collins Street Melbourne, solicitors, the proving executors of the Will of the deceased to send particulars of their claims to the said executors care of the undernamed solicitors by 24 August 1984, after which date they will convey or distribute the assets having regard only to the claims of which they then have notice.

RUSSELL, KENNEDY & COOK, solicitors, 257 Collins Street, Melbourne 3053

Creditors next of kin or others having claims in respect of the estate of Dorothy Isabelle Keane late of 31 Gordon Street, West Newport, deceased, who died on 2 March 1984 are to send particulars of their claims to the executor John Francis Keane care of the undermentioned solicitors by 20 August 1984 after which date the executor will distribute the assets having regard only to the claims of which he then has notice.

N. F. WILCKENS & ROCHE, solicitors, 43 Ferguson Street, Williamstown 3023

In the Supreme Court of the State of Victoria  
SALE BY THE SHERIFF

On 23 July 1984 at 2.30 p.m. at the Police Station, Cobram (unless process be stayed or satisfied).

All the estate and interest (if any) of Ezio Bruni of 48 Warkil Street, Cobram, Nazareno Bisogni (shown on Certificate of Title as Nazzareno Bisogni) c/o North Victorian Builders Supplies, Broadway Street, Cobram and Francesco Bisogni of corner Wondah and Churr Street, Cobram in and to:

Firstly: as proprietors as Tenants in Common in equal shares of an estate in fee simple in the land described in Certificate of Title Volume 9318 Folio 227 which is vacant land known as Lot 5 Catona Crescent, Cobram.

Registered Mortgage No. K180834 and Caveat No. K117944 affect the said estate and interest.

Secondly: as proprietors as Tenants in Common in equal shares of an estate in fee simple in the land described in Certificate of Title Volume 9318 Folio 239 which is vacant land known as Lot 17 Catona Crescent, Cobram.

Registered Mortgage No. K180834 and Caveat No. K117944 affect the said estate and interest.

Thirdly: as proprietors as Tenants in Common in equal shares of an estate in fee simple in the land described in Certificate of Title Volume 9318 Folio 242 which is vacant land known as Lot 20 Catona Crescent, Cobram.

Registered Mortgage No. K180834 and Caveat No. K117944 affect the said estate and interest.



In the Supreme Court of the State of Victoria  
SALE BY THE SHERIFF

On 26 July 1984 at 2.30 p.m. at the Police Station, Morwell (unless process be stayed or satisfied).

All the estate and interest (if any) of Deborah V. Lock (shown on Certificate of Title as Deborah Verna Lock) of 5 Budge Street, Morwell as proprietor of an estate in fee simple in the land described in Certificate of Title Volume 8489 Folio 383 upon which is erected an aluminium clad dwelling house known as No. 5 Budge Street, Morwell.

Terms—Cash only

Dated 20 June 1984

3060

J. BALDWINSON, Sheriff's Officer

In the Supreme Court of the State of Victoria  
SALE BY THE SHERIFF

On 26 July 1984 at 2.30 p.m. at the Sheriff's Office, Writs and Warrants Division, 2nd Floor, 241 William Street, Melbourne (unless process be stayed or satisfied).

All the estate and interest (if any) of Anthony James Webb and Tessa Gay Webb of 4 Old Mill Park Road, Chirnside Park as joint proprietors of an estate in fee simple in the land described in Certificate of Title Volume 8757 Folio 782 upon which is erected a mud-brick house known as Lot 4 Nyora Road, Healesville.

Registered Mortgage No. H549312 affects the said estate and interest.

Terms—Cash only

Dated 20 June 1984

3062

J. BALDWINSON, Sheriff's Officer

In the Supreme Court of the State of Victoria  
SALE BY THE SHERIFF

On 26 July 1984 at 2.30 p.m. at the Sheriff's Office, Writs and Warrants Division, 2nd Floor, 241 William Street, Melbourne (unless process be stayed or satisfied).

All the estate and interest (if any) of Mervyn Keith Struthers-Gee of 24 Gillard Street, Burwood as joint proprietor with Marjorie Helen Struthers-Gee of an estate in fee simple in the land described in Certificate of Title Volume 6721 Folio 144 upon which is erected a brick-clad house known as No. 24 Gillard Street, Burwood. The property is situated at the corner of Gillard and Coppard Streets, Burwood on the west side of Gillard Street and the north side of Coppard Street; that it has a boundary of 135 feet on Coppard Street a frontage of 42 feet on Gillard Street a display corner of 21 ft. 2.5 in. on the south-east corner of the property a northern boundary of 150 feet and a western boundary of 56 ft. 7 in.

Registered Mortgage No. K383108 affects the said estate and interest.

Terms—Cash only

Dated 20 June 1984

3063

J. BALDWINSON, Sheriff's Officer

Fourthly: as proprietors as Tenants in Common in equal shares of an estate in fee simple in the land described in Certificate of Title Volume 9318 Folio 245 which is vacant land known as Lot 23 Catona Crescent, Cobram.

Registered Mortgage No. K180834 and Caveat No. K117944 affect the said estate and interest.

Fifthly: as proprietors as Tenants in Common in equal shares of an estate in fee simple in the land described in Certificate of Title Volume 9318 Folio 255 which is vacant land known as Lot 33 Catona Crescent, Cobram.

Registered Mortgage No. K180834 and Caveat No. K117944 affect the said estate and interest.

Sixthly: as proprietors as Tenants in Common in equal shares of an estate in fee simple in the land described in Certificate of Title Volume 9318 Folio 256 which is vacant land known as Lot 34 Catona Crescent, Cobram.

Registered Mortgage No. K180834 and Caveat No. K117944 affect the said estate and interest.

Seventhly: as proprietors as Tenants in Common in equal shares of an estate in fee simple in the land described in Certificate of Title Volume 5271 Folio 159 which is vacant land known as Crown Allotment 45 Murray Valley Highway, Cobram.

Registered Mortgage No. G467819 affects the said estate and interest.

Eighthly: All the Estate and Interest (if any) of Ezio Bruni of 48 Warkil Street, Cobram and Nazareno Bisogni (shown on Certificate of Title as Nazzareno Bisogni) c/o North Victorian Builders Supplies, Broadway Street, Cobram as proprietors as Tenants in Common in equal shares of an estate in fee simple in the land described in Certificate of Title Volume 85535 Folio 185 which is vacant land known as Lot 1 Broadway Street, Cobram.

Registered Mortgage No. J282990 affects the said estate and interest.

Terms—Cash only

3061

J. BALDWINSON, Sheriff's Officer

**NOTICE OF MAKING OF  
STATUTORY RULES  
WHICH ARE NOT YET  
AVAILABLE**

Notice is given of the making of the following Statutory Rules:

No.

*Melbourne and Metropolitan Board of Works Act 1958*  
153/1984. By-law No. 202 Plumbing Code and Sewerage Regulations 1984

*Weights and Measures Act 1958*

160/1984. Weights and Measures Regulations 1984

*Housing Act 1983*

170/1984. Housing (Standard of Habitation) Regulations 1984

*Motor Boating Act 1961*

171/1984. Motor Boating (Lake Mokoan) Regulations 1984

*Supreme Court Act 1958*

176/1984. Supreme Court (Sheriff's Fees) (Amendment) Regulations 1984

*Magistrates' Courts Act 1971*

177/1984. Magistrates' Courts (Amendment) Rules 1984

*Reference Areas Act 1978*

178/1984. Reference Areas (Advisory Committee—Remuneration and Allowances) (Amendment No. 2) Regulations 1984

*Country Fire Authority Act 1958*

179/1984. Country Fire Authority (Members' Expenses) Regulations 1984

No.		Price
	<i>Melbourne and Metropolitan Board of Works Act 1958</i>	
180/1984.	Special By-law No. 27: Fees for Water Supply and Sewerage Services to Non-Rateable Property and Cultural and Recreational Lands	
	<i>Public Authorities Marks Act 1958</i>	
181/1984.	By-law No. 206: Approving and Stamping of Materials	
	<i>Transport Act 1983</i>	
182/1984.	Road Construction Authority (Amendment) Regulations 1984	
	<i>National Parks Act 1975</i>	
183/1984.	National Parks (Amendment No. 2) Regulations 1984	
	<i>Zoological Parks and Gardens Act 1981</i>	
184/1984.	Zoological Parks and Gardens (Admission of Children) Regulations 1984	
	<i>Transport Act 1983</i>	
185/1984.	Transport (Public Rail and Road Vehicle) Regulations 1984	
	<i>Transport Act 1983</i>	
186/1984.	Transport (Timber on Declared Roads) Regulations 1984	
	<i>Transport Act 1983</i>	
187/1984	Transport (Commercial Goods Vehicles) Regulations 1984	
	<i>Transport Act 1983</i>	
188/1984	Transport (Road Transport Licensing Tribunal) Regulations 1984	
	<i>Transport Act 1983</i>	
189/1984	Transport (Recreation Vehicles) Regulations 1984	
	<i>Transport Act 1983</i>	
190/1984	Transport (West Gate Bridge) Regulations 1984	
	<i>Health Act 1958</i>	
191/1984	Health (Radiation Safety) Regulations 1984	
<div style="border: 1px solid black; padding: 5px; width: fit-content; margin: 0 auto;"> <p><b>NOTICE OF MAKING AND AVAILABILITY OF STATUTORY RULES</b></p> </div>		
<p>In pursuance of the provisions of the <i>Subordinate Legislation Act 1962</i> and the Regulations made thereunder notice is given of the making and availability of the following Statutory Rules:</p> <p>The following Statutory Rules are obtainable from the Victorian Government Bookshop, 41 St Andrews Place, East Melbourne.</p>		
No.	<i>Extractive Industries Act 1966</i>	Price
135/1984.	Extractive Industries (Board of Examiners Fees) Regulations 1984	20c
	<i>Marketing of Primary Products Act 1958</i>	
156/1984.	The Tobacco Leaf Marketing Board (Charges) Regulations 1984	20c
	<i>Fisheries Act 1984</i>	
157/1984.	Fishing (General) (Amendment No. 2) Regulations 1984	20c
	<i>Survey Co-ordination Act 1958</i>	
162/1984.	Place Names Committee (Members' Fees) Regulations 1984	20c
	<i>Lifts and Cranes Act 1967</i>	
163/1984.	Lifts and Cranes (Appeals) (Fees and Expenses) (Amendment No. 2) Regulations 1984	20c
	<i>Scaffolding Act 1971</i>	
164/1984.	Scaffolding (Board of Examiners Fees and Travelling Expenses) (Amendment No. 2) Regulations 1984	20c
	<i>Boilers and Pressure Vessels Act 1970</i>	
165/1984.	Boilers and Pressure Vessels (Steam Engine Drivers and Boiler Attendants) (Amendment No. 2) Regulations 1984	20c
	<i>Boilers and Pressure Vessels Act 1970</i>	
166/1984.	Boilers and Pressure Vessels (Board of Examiners for Welders of Boilers and Pressure Vessels Fees and Travelling Allowances) (Amendment No. 2) Regulations 1984	20c
	<i>Construction Industry Long Service Leave Act 1983</i>	
167/1984.	Construction Industry Long Service Leave (Construction Industry Long Service Leave Board Fees and Allowances) (Amendment No. 2) Regulations 1984	20c
	<i>Environment Protection Act 1970</i> (No. 8056)	
169/1984.	Environment Protection (Motor Vehicle Emission Control) (Amendment) Regulations 1984	20c
	<i>Environment Protection Act 1970</i> (No. 8056)	
172/1984.	Environment Protection (Insulated Wire Burning) Regulations 1984	20c
	<i>Forests Act 1958</i>	
173/1984.	Forests (Mt Buller Alpine Reserve) (Amendment) Regulations 1984	20c
	<i>Post-Secondary Education Act 1978</i>	
174/1984.	Technical and Further Education Board (Chairman and Members' Terms and Conditions) (Amendment No. 1) Regulations 1984	20c
	<i>Post-Secondary Education Act 1958</i>	
175/1984.	Post-Secondary Education Commission (Terms and Conditions) (Amendment No. 17) Regulations 1984	20c

**Agents**

The following have been appointed agents to receive advertisements for the Victoria Government Gazette:

- Armstrong's Communications Pty Ltd 191 Queen Street Melbourne Victoria 3000
- Arnall and Jackson 390 Barkly Street Brunswick Victoria 3056
- Blane's Authorized Newsagents 162 Murray Street Colac Victoria 3250
- Cornell R G 126 Eighth Street Mildura
- Franks H and Co 184 Ryrie Street Geelong Victoria 3220
- Gordon and Gotch Australasia Ltd 25-37 Huntingdale Road Burwood Victoria 3125
- Harston, Partridge & Co. Pty Ltd 455 Little Collins Street Melbourne Victoria 3000
- Kyneton Guardian Pty Ltd PO Box 18 Kyneton Victoria 3444
- Lonsdale Newsagency 250 Lonsdale Street Dandenong Victoria 3175
- The Mercantile Exchange 50 Queen Street Melbourne Victoria 3000
- McDonald's Newsagency 88 Bridge Street Ballarat Victoria 3350
- McGill's Authorised Newsagency 183-185 Elizabeth Street Melbourne Victoria 3000
- McNaughton P R and L A 112-114 Gray Street Hamilton Victoria 3300
- Powney's Authorized Newsagency 293 Hargreaves Street Bendigo Victoria 3550
- Purdie J & Co. 138 Moorabool Street Geelong Victoria 3220
- Vernons of Richmond 261 Bridge Road Richmond Victoria 3121

**Publications Availability**

Publications may be purchased from the **Victorian Government Bookshop**  
41 St Andrews Place East Melbourne  
(PO Box 203 North Melbourne 3051)  
Telephone Inquiries (03) 651 2754, 651 2759

**Mail Orders and Postage**

A postage and packaging fee must be added to the cost of the requested publication using the table of rates below. Remittances should be made payable to the 'Victorian Government Printing Office'.

Total Price of Publications	Postage Packaging Fee
\$ 0.10 to \$ 2.00 .....	\$ 0.60
\$ 2.05 to \$ 5.00 .....	\$ 1.00
\$ 5.05 to \$25.00 .....	\$ 1.50
\$25.05 to \$75.00 .....	\$ 2.00
\$75.00 and over .....	\$ 3.00

**Bankcard**

Purchases may be made using Bankcard facilities in the Bookshop and by mail order. Bankcard mail orders require the Bankcard number, expiry date, name, address and signature of customer to be supplied. (Minimum purchase of \$5.00 applies).

**Publication Details**

The Victoria Government Gazette is published every Wednesday, unless otherwise advertised.

**Copy Deadline**

Private advertisements will be accepted by: Gazette Advertising  
**Victorian Government Printing Office**  
PO Box 203 North Melbourne 3051, no later than 1 pm on the day before publication.

**Advertising Rates**

Single column X cm/part cm .....	\$3.20
Double column X cm/part cm .....	\$6.40
Full page .....	\$150.00

Ordinary rates will apply to material submitted for publication before 1 pm Tuesday. Double rates will apply for material submitted between 1 pm and 3.30 pm Tuesday.

**Advertisers should note:**

- There are approximately 30 words to each column centimetre depth;
- Signatures (in particular) and proper names must be written clearly in the text;
- Advertising material should be double-spaced and confined to ONE SIDE ONLY of each sheet of paper.
- Documents NOT CLEARLY PREPARED will be returned to the sender, unpublished.

**Correspondence**

All correspondence should be addressed to: Gazette Advertising  
**Victorian Government Printing Office**  
PO Box 203 North Melbourne 3051  
Telephone Inquiries (03) 328 2141

**General information**

The following guidelines should be followed for the publication of official material in the Victoria Government Gazette.

**Publication of official material**

- Duplicate copies should be submitted for the use of the Gazette Officer.
- Material submitted to the Executive Council for Gazettal will normally be published in the next week's issue.
- Where urgent gazettal is required, special arrangements should be made with the: Gazette Officer  
Department of the Premier  
3rd Floor 1 Treasury Place  
Melbourne  
Telephone Inquiries (03) 651 2440

**Publication of other material**

- All other material authorised by a responsible officer should be forwarded to the Gazette Officer no later than 9.30 am on Tuesday.
- Lengthy or complicated notices should be forwarded several days before publication.
- Proofs will be supplied only when requested or at the direction of the Gazette Officer. They should be returned quickly to avoid delay in publication.
- No additions or amendments to material for publication will be accepted by telephone.

**Notice to Advertisers: Late Copy**

Copy received after 3.30 p.m. on the day prior to publication at the Victorian Government Printing Office will be placed in the following issue of the *Government Gazette*, irrespective of any date/s mentioned in the copy.

<b>CONTENTS</b>
-----------------

	Page
Appointments	1967
Bank Holidays	1935
Contracts	1959
Estates of Deceased Persons	1963
Government Notices	1947
Lands	1975
Late Notices	2015
Melbourne and Metropolitan Board of Works— Notice	1961
Minerals and Energy	1950
Notice of Making of Statutory Rules	2031
Orders in Council—	
Acts—Industrial Relations; Water and Sewerage Auth- orities (Restructuring); Land Conservation; Super- annuation; Land; Crown Land (Reserves); Local Government; Water; Geelong Waterworks and Sewerage; Motor Car	1968 et seq
Police Sale	1950
Private Advertisements	1978
Proclamations	1935
Public Holidays	1935
Resignation	1968
Tenders	1977
Transport	2015