

[4335]

PUBLISHED BY AUTHORITY



Victoria Government Gazette

No. 96—Wednesday, 12 November 1986

PROCLAMATION

Mental Health Act 1959
PROCLAMATION

I, J. Davis McCaughey, Governor of Victoria, acting with the advice of the Executive Council and under section 24 of the *Mental Health Act 1959* declare that as from 17 November 1986 the buildings known as Ward G7 form part of the Mental Hospital, Kew.

Given under my Hand and the Seal of Victoria
on 3 November 1986—

(L.S.) J. DAVIS McCAUGHEY

By His Excellency's Command

D. R. WHITE
Minister for Health

GOVERNMENT NOTICES

ERRATUM

Gazette No. 125—18 December, 1985—Page 4698.

Notice read: Castlemaine

Merrifield Street, from end of existing main (opposite Lot 11A) to a point opposite Lot 1 about 15 metres westerly.

Notice should read: Castlemaine

Merrifield Street, from end of existing main (opposite CA 11A) to a point opposite Lot 1 about 15 metres westerly.

Gazette No. 125—18 December 1985—Page 4699.

Notice read: Harcourt

Eagles Road: (i) from end of existing main (opposite CA 8) to a point opposite CA 7 about 18 metres northerly; (ii) from end of existing main (opposite Lots 3 and 3) to a point opposite Lots 4 and 4 about 22 metres southerly.

Notice should read: Harcourt

Eagles Roads, (i) from end of existing main (opposite CA 7 about 18 metres northerly; (ii) from end of existing main (opposite CA 3, Sec. 2) to a point opposite CA 4, Sec. 2 about 22 metres southerly.

Gazette No. 60—16 July 1986—Page 2710.

Notice read: Kangaroo Flat

Robert Street, (western side only) from end of existing main (opposite Lot 26 LP 91121) to a point opposite Lot 1, LP 6880 about 24 metres northerly.

Notice should read: Kangaroo Flat

Robert Street, from Archer Street to a point opposite Lot 14, LP 93753 about 34 metres westerly.

Gazette No. 60—16 July 1986—Page 2710.

Notice read: Taradale

Pennus Road from end of existing main (opposite CA 30G) to a point opposite Lot 1 part CA 30E about 30 metres westerly.

Notice should read: Taradale

Pennos Road from end of existing main (opposite CA 30G) to a point opposite lot 1 part CA 30E about 30 metres westerly.

Gazette No. 80—1 October 1986—Page 3759.

Groundwater (Border Agreement) Act 1985—
Declaration Under Sub-clause 28 (2) of the Border Groundwaters Agreement.

The last line of the Schedule read:

Zone	Permissible Annual Volume (M1)
	varied
4B	from 4500 to 5700

Notice should read:

Zone	Permissible Annual Volume (M1)
	varied
7B	from 4500 to 5700

ERRATUM

In *Government Gazette* No. 92 of 5 November 1986 on page 4243, the title "Appointment of Royal Commission into Grain Storage, Handling and Transport" should read "Appointment of Royal Commission into Grain Storage, Handling and Transport".

GERD GASPARS
Gazette Officer

ERRATUM

In *Government Gazette* No. 83 of 8 October 1986 on page 3924, under the "*Health (Contraceptives) Act 1974*" the date 16.9.85 should read 16.9.86.

GERD GASPARS
Gazette Officer

Private Agents Act 1966

NOTICE OF RECEIPT OF APPLICATIONS FOR LICENCES UNDER THE PROVISIONS OF THE PRIVATE AGENTS ACT 1966

The Clerk(s) of the Magistrates' Court(s) as listed hereunder hereby give notice that applications, as under, have been lodged for hearing by the said Court(s) on the date(s) specified.

Any person desiring to object to any of such applications must—

- (a) lodge with the respective Clerk of the Magistrates' Court a notice in the prescribed form of his objection and of the grounds thereof;
- (b) cause a copy of such notice to be served personally or by post upon the applicant at least three days before the hearing of the application; and
- (c) send or deliver—
 - (i) where the objection is not made by the officer in charge of the police district in which the Court is situated—a copy of the notice to such officer; and
 - (ii) where the objection is not made by the Registrar or Deputy Registrar—a copy to the Registrar.

<i>Full Name of Applicant*</i>	<i>Place of Abode of Applicant or Nominee</i>	<i>Name of Firm or Corporation</i>	<i>Address for Registration</i>	<i>Type of Licence</i>	<i>Date of Hearing</i>
MAGISTRATES' COURT, NORTHCOTE					
Briggs, Cecil	56 Drinkwater Cres, Sunshine	Alun Dauncey	54 Wingrove St, Fairfield	Watchman	15.12.86
Dated at Northcote, 30 October 1986 R. J. MALONEY, Clerk of the Magistrates' Court					
MAGISTRATES' COURT, RINGWOOD					
Macartney, Allan Lawrence	4 Leicester Crt, Wantirna South		4 Collins Pl, Kilsyth	Guard Agent	25.11.86
Dated at Ringwood, 29 October 1986 D. D. REES, Clerk of the Magistrates' Court					
MAGISTRATES' COURT, BROADMEADOWS					
Graham, Elizabeth	38 Margaret St, Oak Park		38 Margaret St, Oak Park	Process Server Inquiry Agent	8.12.86
" "	" "	" "	" "	" "	" "
Dated at Broadmeadows, 28 October 1986 J. ISAACS, Clerk of the Magistrates' Court					
MAGISTRATES' COURT, RINGWOOD					
Smith, Jeffrey Parker	18 Cumberland Ave, Bayswater	Vic State Security	17 Picadilly Crt, Kilsyth	Watchman	20.11.86
Dated at Ringwood, 30 October 1986 D. REES, Clerk of the Magistrates' Court					
MAGISTRATES' COURT, BALLARAT					
Lewis, Peter Leslie Francis	115 Lonsdale St, Ballarat		653 Queensberry St, North Melbourne	Watchman	25.11.86
Frowd, Keith Ernest	R.M.B. 505, Ballan		390 St. Kilda Rd, Melbourne	" "	24.11.86
Dated at Ballarat, 31 October 1986 D. J. CROFT, Clerk of the Magistrates' Court					

* Or in the case of a firm or corporation, of the Nominee

PRIVATE AGENTS—continued

Full Name of Applicant*	Place of Abode of Applicant or Nominee	Name of Firm or Corporation	Address for Registration	Type of Licence	Date of Hearing
MAGISTRATES' COURT, BEECHWORTH					
Edwards, Kenneth Robert	Crawford St, Beechworth		Crawford St, Beechworth	Process Server	4.12.86
" " "	" "		" "	Inquiry Agents	"
" " "	" "		" "	Commercial Agents	"
Dated at Beechworth, 30 October 1986 R. W. MUNRO, Clerk of the Magistrates' Court					
MAGISTRATES' COURT, PRESTON					
Vella, Joseph	51 Northumberland Dve, Epping		51 Northumberland Dve, Epping	Process Server	27.11.86
" "	" "		" "	Guard Agent	"
Dated at Preston, 31 October 1986 R. McHUGH, Clerk of the Magistrates' Court					
MAGISTRATES' COURT, FERNTREE GULLY					
Crawford, Richard Hales	7 Norris Cr, Healesville		40 Cavendish Ave, Wantirna	Watchman	2.12.86
McLean, Shane Edwin	53 Jumping Creek Rd, Wonga Park		429 Boronia Rd, Bayswater	"	5.12.86
Quain, Adrian	9 Dixon St, Croydon		"	"	"
Dated at Ferntree Gully, 7 November 1986 M. CALDWELL, Clerk of the Magistrates' Court					
MAGISTRATES' COURT, SPRINGVALE					
Husband, Neil Douglas	13 Russell St, Surrey Hills	MSS Patrol Services	41 Fairview St, Springvale	Watchman	26.11.86
Dated at Springvale, 27 October 1986 B. LAWRENCE, Clerk of the Magistrates' Court					
MAGISTRATES' COURT, SPRINGVALE					
McGregor, Glen Andrew	102 Mackie Rd, East Bentleigh		11 Wardale Rd, Springvale	Commercial Sub-Agent	8.1.87
" "	" "		"	Inquiry Agent	"
" "	" "		"	Process Server	"
Dated at Springvale, 3 November 1986 B. LAWRENCE, Clerk of the Magistrates' Court					
MAGISTRATES' COURT, FRANKSTON					
Binns, Michael	10 Hilton Ave, Springvale		6 Telopea Ct, North Frankston	Watchman	15.12.86
Dated at Frankston, 6 November 1986 S. MERBACH, Clerk of the Magistrates' Court					

* Or in the case of a firm or corporation, of the Nominee

PRIVATE AGENTS—continued

<i>Full Name of Applicant*</i>	<i>Place of Abode of Applicant or Nominee</i>	<i>Name of Firm or Corporation</i>	<i>Address for Registration</i>	<i>Type of Licence</i>	<i>Date of Hearing</i>
MAGISTRATES' COURT, SUNSHINE					
Zampaglione, John Andrew	252 McKean St, North Fitzroy		4 Rayner St, Footscray	Inquiry Agent	25.11.86
Dated at Sunshine, 30 October 1986 G. G. WILLIAMSON, Clerk of the Magistrates' Court					
MAGISTRATES' COURT, WODONGA					
Gehrig, Graham Charles	24 Sapphire Circuit, Wodonga		24 Sapphire Circuit, Wodonga	Process Server	25.11.86
" "	" "		" "	Guard Agent	"
Dated at Wodonga, 31 October 1986 Clerk of the Magistrates' Court					
MAGISTRATES' COURT, OAKLEIGH					
Whitehead, Christopher Mark	46 Alexandra Pde, Clifton Hill		96 Murrumbeena Rd, Murrumbeena	Watchman	4.12.86
Dated at Oakleigh, 6 November 1986 S. JANSON, Clerk of the Magistrates' Court					
MAGISTRATES' COURT, BRUNSWICK					
Lapierre, Patrick Dario	168 Dalton Rd, Thomastown		7 Lt Miller St, East Brunswick	Inquiry Agent (Individual)	17.12.86
Dated at Brunswick, 3 November 1986 R. W. COOK, Clerk of the Magistrates' Court					
MAGISTRATES' COURT, PORT MELBOURNE					
Ferro, Domenic	633 Whitehorse Rd, Mont Albert	Armaguard	Cnr Graham & Turner Sts, Port Melbourne	Watchman	4.12.86
Josevski, Zoranco	181 Charles St, Footscray	"	"	"	"
Dated at Port Melbourne, 6 November 1986 K. HUSSEY, Clerk of the Magistrates' Court					
MAGISTRATES' COURT, BOX HILL					
Deriboillou, Nicolas	66 Crow Street, East Burwood		66 Crow Street, East Burwood	Guard Agent	1.12.86
Dated at Box Hill, 31 October 1986 D. J. HALPIN, Clerk of the Magistrates' Court					

* Or in the case of a firm or corporation, of the Nominee

PRIVATE AGENTS—continued

Full Name of Applicant*	Place of Abode of Applicant or Nominee	Name of Firm or Corporation	Address for Registration	Type of Licence	Date of Hearing
MAGISTRATES' COURT, OAKLEIGH					
Smith, Paul Aron	1/76 Kennedy St, Sth Oakleigh		96 Murrumbeena Rd, Murrumbeena	Watchman	26.11.86
Dated at Oakleigh, 31 October 1986 S. JANSON, Clerk of the Magistrates' Court					
MAGISTRATES' COURT, SUNSHINE					
Demetriou, Jim	1 Pine Crt, St. Albans		2 Ikara Cl, St. Albans	Watchman	2.12.86
Dated at Sunshine, 3 November 1986 ADRIAN R. MCGIRR, Clerk of the Magistrates' Court					

* Or in the case of a firm or corporation, of the Nominee

HEALTH ACT 1958

Supplement to the Register of Contraceptives published in the *Government Gazette* in accordance with the provisions of section 270H (5) of the *Health Act 1958*.

Serial No.	Date of Registration	Distinctive Name	Name and Address of Applicant	Proprietary Medicine Reg. No.
C219	17.10.86	R3 Med Condoms	Engelander Imports 632 Bourke Street Melbourne Vic. 3000	

G. J. ROUCH, Health Department, Victoria

COUNTY COURT ACT 1958

COUNTY COURT SITTINGS 1986

Notice is hereby given that an additional sitting of the County Court at Ballarat will commence on Monday, 17 November 1986.

Dated 6 November 1986

G. R. D. WALDRON
Chief Judge of the County Court of Victoria

Education Act 1958

NOTICE OF THE MAKING OF AN ORDER UNDER SECTION 13 (4) OF THE ACT

Pursuant to section 13 of the *Education Act 1958* I hereby give notice that an Order of the Governor in Council was made on 5 November 1986 under sub-section (4) of the said Act amending certain provisions relating to the Paynesville Primary School Council.

IAN CATHIE
Minister for Education

LOCAL GOVERNMENT DEPARTMENT

Order Confirmed—Shire of Tullaroop

I, James Lionel Simmonds, Her Majesty's Minister of the Crown for the time being administering the *Local Government Act 1958*, hereby confirm the Order hereinafter referred to in pursuance of section 514 of the said Act namely.

An Order of the Council of the Shire of Tullaroop made on 8 July 1986 directing the compulsory taking of the land described as Crown Allotments 1, 1A, 2A, 3, 4, 4A, 7A, 8 and 8A Township of Bet Bet, Parish of Talbot for the purpose of providing a place of public resort and recreation.

Dated 3 November 1986

J. L. SIMMONDS
Minister for Local Government
Local Government Department
Melbourne (86/1114)

LOCAL GOVERNMENT DEPARTMENT

Order Confirmed—Shire of Barrabool

I, James Lionel Simmonds, Her Majesty's Minister of the Crown for the time being administering the *Local Government Act 1958*, hereby confirm the Order hereinafter referred to in pursuance of section 514 of the said Act namely.

An Order of the Council of the Shire of Barrabool made on 17 September 1986, directing the compulsory taking of the land described in a conveyance registered in the Office of the Registrar General in Book No. 141 by Memorial No. 320 for the purpose of extending its works depot at Mt. Moriac.

Dated 3 November 1986

J. L. SIMMONDS

Minister for Local Government

Local Government Department

Melbourne (86/1576)

Subordinate Legislation Act 1962

MINISTRY OF EDUCATION

Notice of Preparation of a Regulatory Impact Statement

Notice is hereby given, in accordance with the provisions of the *Subordinate Legislation Act 1962*, of the proposal to make regulations to be known as the Education Department (Amendment) Regulations 1986 (Amendment No. 65).

The objective of the proposed regulations is to restructure the school year in a manner which retains the number of school days, allows some public holidays to occur in school vacations, minimizes the potential for absenteeism and achieves conformity with other States.

A regulatory impact statement has been prepared in accordance with the provisions of the *Subordinate Legislation Act 1962*.

The statement advises that a working party formed to consider the organization of the school year recommended a four-term year in which the number of school days would not be reduced; would have minimal impact on industry and government; would provide the community with greater choice of vacation times and would ease congestion associated with school holiday periods.

Comments and submissions are invited from interested members of the public. Three weeks will be allowed from the date of this advertisement for such comments to be made.

Copies of the regulatory impact statement are available from the Executive Services, Ministry of Education, Level 16, Rialto Towers, 525 Collins Street, Melbourne (Telephone 628 2917). Written comments may be addressed to the Executive Officer, Ministry of Education, G.P.O. Box 4367, Melbourne, 3001.

G. J. ALLEN
Chief ExecutiveCOMPANIES (AUDITORS AND
LIQUIDATORS DISCIPLINARY BOARD)
(AMENDMENT) REGULATIONS 1986

I, Jim Kennan, Her Majesty's Attorney-General for the State of Victoria, give notice that after consideration of the submissions and comments received in response to the regulatory impact statement issued in relation of the proposed Companies (Auditors and Liquidators Disciplinary Board) (Amendment) Regulations 1986 that I intend to proceed with the making of the proposed regulations.

J. H. KENNAN
Attorney-General

CONTRACTS ACCEPTED

Public Works

His Excellency the Governor of the State of Victoria by and with the advice of the Executive Council thereof has by Order made on 5 November 1986 approved of the acceptance by the Minister of Public Works of the under-mentioned offer without public tenders being invited, viz:

Offers of Able Demolitions and Excavations Pty. Ltd. for the demolition of buildings and clearing of certain sites at South Melbourne for the total sum of Eighty two thousand five hundred dollars (\$82 500).

L. G. HOUSTON
Clerk of the Executive CouncilAt the Executive Council Chamber
Melbourne, 5 November 1986

CONTRACTS ACCEPTED—(Series 1986-87)

Ballarat City—Construction, architectural, Ballarat School of Mines and Industries, \$1 185 600.00—S. J. Weir Pty. Ltd. (Wendouree), Wendouree.

Keilor City—Provide 1 No. relocatable (Part B2), Western Institute of T.A.F.E., \$172 699.00—Cemac Associated Ltd.—Construction, Reservoir.

Keilor City—Provide 4 No. relocatables (Part B1), Western Institute of T.A.F.E., \$298 290.00—Mod Kon Constructions Pty. Ltd., Ballarat.

Mildura Shire—Construction, architectural, Sunraysia College of T.A.F.E., \$8 837 050.00—Thiess Contractors Pty. Ltd., Mount Waverley.

Wangaratta City—Construction, architectural, Wangaratta College of T.A.F.E., \$4 077 704.00—Lionel H. Brown Pty. Ltd., Wangaratta.

D. J. LITTLE
Director-General of Public WorksPublic Works Department
Melbourne, 12 November 1986

LAND ACT 1958

Under section 98 of the *Land Act 1958* I, Joan Elizabeth Kirner, Her Majesty's Minister for Conservation, Forests and Lands for the State of Victoria, hereby declare void the contract of sale with Joseph John English for the undermentioned Crown land.

Sale No.—12223

Date of Sale—14 February 1977

Place of Sale—Castlemaine

Lot—2

Allotment—11E

Section—A1

Township—Castlemaine

Parish—Castlemaine

County—Talbot—(W 82074)

Dated 6 November 1986

J. E. KIRNER

Minister for Conservation, Forests and Lands

DEPARTMENT OF CONSERVATION,
FORESTS AND LANDS

Sale of Crown Property by Auction

No. 12489

On Site: 52 Miller Street, Tongala, on Friday, 5 December 1986 at 12.15 p.m.

Crown Description: Crown Allotment 2A, Section C, Township and Parish of Tongala.

Area: 737 square metres more or less.

Terms: Deposit 10 per cent, residue payable in 90 days.

Officer Conducting Sale: Mr M. Christofas, Property Officer, Department of Property and Services.

Auctioneer: Gippsland & Northern Company Limited Real Estate Agency, Tongala

J. E. KIRNER

Minister for Conservation, Forests and Lands

MELBOURNE ST. KILDA-ROAD
UNDERPASS) LANDS ACT 1969 (No. 7832)

Whereas pursuant to section 3 of the *Melbourne (St. Kilda-road Underpass) Lands Act 1969* (No. 7832), that upon submission to the Minister for Conservation, Forests and Lands of a plan or plans of survey signed by the Surveyor-General showing areas of lands on which the Melbourne and Metropolitan Board of Works has carried out the works required in the construction of the St. Kilda-road underpass and associated works reserved as aforesaid and corresponding as nearly as practicable with the areas indicated approximately by black hatching and cross-hatching on the plans in the First, Second, Third and Fourth Schedules (to the said Act), and upon the Minister for Conservation, Forests and Lands being satisfied that the lands

described in the plan or plans of survey do so correspond the Minister may cause a description of the lands shown in the plan or plans of survey to be published in the *Government Gazette*.

Now, therefore, I, Joan Elizabeth Kirner, Her Majesty's Minister for Conservation, Forests and Lands in and for the State of Victoria, do hereby certify I am satisfied that the lands described in the plan of survey No. 107413 (hereunder) does correspond as nearly as practicable with the area indicated by black hatching on the plan in part of the Fourth Schedule, to the said Act (No. 7832)—(Corres. No. C.100242).

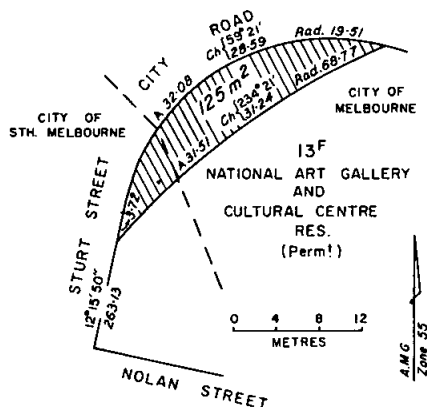

Given under my hand, at Melbourne, 8 August 1986.

JOAN ELIZABETH KIRNER

Minister for Conservation, Forests and Lands

FIREARMS (EXEMPTION NO. 5)
REGULATIONS 1986

Pursuant to the Subordinate Legislation Act, the Ministry for Police and Emergency Services invites written comments from members of the public on the proposed Firearms (Exemption No. 5) Regulations 1986.

The objective of these regulations is to facilitate the conduct of "survival" or "war" games by exempting the participants from the requirement to hold a shooter's licence whilst participating in the games.

A regulatory impact statement has been prepared which indicates that there are no financial costs involved for the promoters of, or participants in, the games; the benefit of granting the exemption is to increase the viability of a new enterprise which involves outdoor physical exertion, and a possible disadvantage is a diminished responsibility in the safe use of firearms.

Copies of the regulatory impact statement and the regulations are available from the Ministry for Police and Emergency Services, Room 6, 1st Floor, Old Treasury Building, Spring Street, Melbourne, 3000, or by phone 651 1337.

Written submissions should be received by the Ministry within three weeks from today.

R. L. KING, Secretary

STATE TENDER BOARD
CONTRACTS ACCEPTED
Amendments

Schedule Number	Item Number	New Rate	Effective Date
\$			
<i>Chemicals, Agricultural, etc.</i>			
1/03	51	14.63*	15.10.86
*For pallet lots of 32 × 20 litre containers the rate is \$14.00 per litre			
<i>Electrical Goods</i>			
1/05	41	31.67	21.10.86
<i>Paints and Painters Sundries</i>			
1/13	100	0.90	3.11.86
	101	1.81	
	102	1.26	
<i>LPG (Bulk and Cylinders)</i>			
1/52A	1	329.00	1.11.86
	2	336.26	
	3	367.70	
	4	385.03	
	5	406.63	
	6	23.67	
<i>Motor Spirit, Kerosene, Fuel Oils and Lubricants</i>			
1/53B	23	0.5659	16.10.86
	24	0.5029	
	25	0.5238	
	32	0.3891	
Petrol Outlets: Add: Epsom, Epsom Service Centre, Midland Highway			
<i>Hand Tools</i>			
1/56	22 (6 mm)	5.35*	1.11.86
	(10 mm)	5.35*	
	(13 mm)	5.35*	
	(15 mm)	6.00*	
	(19 mm)	6.30*	
	(25 mm)	6.65*	
	(31 mm)	8.95*	
	(38 mm)	10.70*	
	74 (50 mm)	2.75*	
	75 (63 mm)	3.85*	
	188	58.94*	

*Change of Name:

Delete: A. J. Calder Industrial Supplies

Add: Dunlop Industrial Sales

General Stationery

1/64	138	4.65	22.10.86
	139	4.65	
	140	4.65	
	141	4.65	

Provisions—Melbourne and Metropolitan District			
2/01	76	5.23	24.10.86
	78	10.74	
	165	5.05	
	166	2.13	
	169	1.89	

J. M. PAWSON
Secretary to the Tender Board



REVIEW OF AGRICULTURAL BODIES

Public Hearing

The Public Bodies Review Committee is currently conducting a review of a number of Victoria's Agricultural Bodies. As part of this review, the Committee will hold a Public Hearing on Monday, 17 November 1986 commencing at 3.00 p.m.

At this Hearing, the Committee will hear evidence from Professor Allan Fels, Prices Commissioner, in relation to his review of egg prices and to respond to criticisms received in relation to his recent Report.

The venue for this Hearing will be the Committee's Offices situated at "Treasury Gate", 2nd Floor, 1-15 Little Collins Street, Melbourne.

Further information regarding this Hearing is available from Mr David Ali on telephone number 654 3099.

PAULINE TONER, M.P.
Chairman

MELBOURNE AND METROPOLITAN
BOARD OF WORKS

General Notice

The Melbourne and Metropolitan Board of Works having made provision for carrying off the sewage of each and every property which or any part of which is situate in the sewerage areas hereinafter described doth hereby declare that on and after 17 November 1986, each and every property so situate shall be deemed to be a sewered property within the meaning of the *Melbourne and Metropolitan Board of Works Act 1958*.

The sewerage areas hereinbefore referred to are:

Sewerage Area No. 5600

City of Croydon—This area comprises lots 122 to 125 Merrill Crescent.

Sewerage Area No. 5645

City of Croydon—This area comprises lots 25 to 12, part lot 11, that piece of land described on Plan of Consolidation No. 102429, lots 8 and 9, a reserve and lots 17 to 31 Alice Street, lots 7 to 5, a reserve, lots 2 to 4 and a further lot 4 Rustic Rise, lots 1, 3 and 47 Richardson Road (in lieu of approval given by the Board on 19 August 1986).

Sewerage Area No. 5670

Shire of Lillydale—This area comprises lots 1 and 2 Taylor Road and lots 3 to 6 Cardigan Road.

Sewerage Area No. 5676

City of Knox—This area comprises lots 405 to 409 Spruce Drive, lots 410 to 416 Dandelion Drive.

Sewerage Area No. 5679

City of Knox—This area comprises all lots in Seban Court and Border Close, lots 13, 12, 7 and 6 George Street, a Tree Reserve abutting Stud Road.

Sewerage Area No. 5680

City of Croydon—This area comprises lots 1 to 4, that piece of land described on Letter Plan No. S-578 and lot 5 Trawalla Road.

Sewerage Area No. 5682

Shire of Lillydale—This area comprises part lot 7, a further part lot 7, lots 1 to 5 Canterbury Road, portion of the Melbourne and Metropolitan Board of Works Pipe Track abutting Canterbury Road and Montrose Road.

Sewerage Area No. 5696

Shire of Lillydale—This area comprises lots 1 to 4 Durham Road.

Sewerage Area No. 5708

City of Doncaster and Templestowe—This area comprises lot 2 Andersons Creek Road.

Sewerage Area No. 5713

City of Doncaster and Templestowe—This area comprises lot 2 Warrandyte Road.

Sewerage Area No. 5718

City of Doncaster and Templestowe—This area comprises lots 4 and 5 Waites Court.

Sewerage Area No. 6610

Shire of Werribee—This area comprises all lots in Hope Place, Ester Court and Ann Place, lots 228 to 218 and 240 to 229 Shane Avenue, lots 151 to 141 Aviation Road.

Sewerage Area No. 6612

Shire of Werribee—This area comprises all lots in De Garis Place, lots 582 to 584, 598, 599 and 600 to 602 Riverbend Crescent.

Sewerage Area No. 6613

Shire of Werribee—This area comprises lots 6 to 3, 7 and 1 Morris Road, lots 2, 9 and 10 Heaths Road, lot 8 Old Geelong Road.

Sewerage Area No. 6614

City of Keilor—This area comprises lots 791 to 794, 801 and 802 Marriot Road, lots 798 to 800 Stutz Close, lots 843 and 920 Lady Nelson Way, lots 831 to 828, 803, 918, 850 to 844, 827, 826 and 812 to 809 Darracq Drive, lots 813 to 817 and 818 to 825 Winton Court, lots 853 to 861 and 867 to 870 Tarrant Court, lots 851, 852 and 871 to 877 Minerva Crescent, lots 905 to 902 Vinct Close, portion of a Tree Reserve abutting Lady Nelson Way and Sunshine Avenue.

Sewerage Area No. 6616

City of Keilor—This area comprises all lots in Kindale Court, lots 204, 193 to 191, 185, 184, 183 to 179, 178 to 171, 186 and 190 to 187 Monte Carlo Drive, a Reserve abutting Madeline Court and Monte Carlo Drive, a further Reserve abutting Monte Carlo Drive, Kilee Place and Venice Court.

Sewerage Area No. 6619

City of Keilor—This area comprises all lots in Salisbury Street and Argyll Street, lots 7 to 1, 9 to 1 and 9 to 5 Albert Road, lots 4 to 1, a further lots 4 to 1, a further lots 4 to 1, a further lots 4 to 1, a further lots 4 to 1 and a further lots 4 to 1, lots 14 to 5 and those pieces of land described on Letter Plan No. S-1283 Keilor-Melton Road, lots 21 to 25 The Esplanade, lots 30 to 26, 1 to 17 and 1 to 13 Victoria Road.

Sewerage Area No. 6620

Shire of Werribee—This area comprises all lots in Milton Drive, Downham Way, Sawley Grove and Zircon Street, lots 1009 to 1003 and 1021 to 1013 Topaz Avenue, lots 965 to 957, 1075 to 1073 and 1038 to 1033 Marne Avenue, lots 1030 to 1024 and 983 to 980 Black Forest Road, lots 979 to 968, 966 and 967 Olive Way, lots 1078 to 1086 Yando Place, lots 1087 to 1092 and 1187 to 1193 Ribblesdale Avenue, lots 1194 to 1196, 1151 to 1155, 1124, 1106, 1105, 1077, 1076, 947 to 956, 1042 to 1047 and 1346 Brougham Avenue, lot 1352 Penole Way, lots 1351 to 1347 and 1048 Clitheroe Drive, lots 1185 to 1171 and 1209 to 1207 Oxford Way, lots 1210 and 1186 to 1197 Brett Place.

Sewerage Area No. 6622

Shire of Werribee—This area comprises lots 213 to 206 Melia Court, lots 258 to 261 Tamarind Crescent.

Sewerage Area No. 6623

City of Keilor—This area comprises lots 294 to 296 and 297 to 304 Eddie Street, lots 305 to 312, 313 to 317, 361, 362, 389 to 393 and 457 to 453 Power Street, lots 470 to 468 Joan Court, lots 462 to 458 Michael Avenue, lots 397 to 394, 318 to 322 and 323 to 326 Grace Street, lots 328 and 327 Fox Street, lots 385 to 388 and 363 to 372 Lois Street, lots 374 and 373 Taylors Road, lot part 1, lots 2 to 11 and 12 to 16 Leslie Street, a Reserve abutting Fox Street, Grace Street, Power Street and Eddie Street.

Sewerage Area No. 6625

Shire of Werribee—This area comprises lot 1 Ridge Drive, lots 2 and 3 Honour Avenue.

Sewerage Area No. 7504

City of Chelsea—This area comprises lots 39 to 61 Beachcomber Court.

Sewerage Area No. 7506

City of Berwick—This area comprises lots 6 to 12, 13, 14 and 15 to 17 Anaconda Road, a Municipal Reserve abutting Bosco Close and Anaconda Road.

Sewerage Area No. 7509

City of Springvale—This area comprises lots 1 to 5 Westall Road, lots 6 to 10 Centre Road.

Sewerage Area No. 7510

City of Waverley—This area comprises all lots in Narrabri Court, lots 682 to 684 and 685 Grantchester Road, lots 664, 665, 677 to 681, 686, 687, 713 to 719, an Electrical Reserve and lot 720 Grandview Road, a municipal reserve abutting Merran Court, Fayette Court and Grandview Road.

Sewerage Area No. 7511

City of Moorabbin—This area comprises lots 45 to 60 and 153 to 138 Hunt Crescent, lots 61 to 63 Elder Street.

Sewerage Area No. 7512

City of Berwick—This area comprises all lots in Warrock Court, lots 12 to 24 Marida Court, lots 27, 28, an Electrical Reserve.

Sewerage Area No. 7514

City of Berwick—This area comprises lots 184 to 188, 181 to 183 and 189 to 192 Lunn Court, lots 179, 180, 193, 194, an Electrical Reserve and lots 195 to 198 Shiraz Crescent.

Sewerage Area No. 3999

City of Coburg—This area comprises lots 1 to 3 and portion of lot 1 Mitchell Parade.

Sewerage Area No. 5610

Shire of Eltham—This area comprises lots 54 and 55 Hillcrest Road.

Sewerage Area No. 8420

City of Broadmeadows—This area comprises all lots in Rex Place, The Loop and Maria Court, lots 59 to 55 and 6 to 1 North Street, a Reserve abutting North Street and The Loop.

Sewerage Area No. 8423

Shire of Whittlesea—This area comprises lot 28 Blaxland Avenue.

By order of the Board

Dated 11 November 1986

H. G. FORD
Director of Administration and Services

I hereby give notice that on 24 October 1986 the Public Trustee filed Elections to Administer the following deceased persons' estates in accordance with section 17 of the *Public Trustee Act 1958*:

Blosfelds, Nikolais, late of "Windways", Murray Valley Highway, Ebdon, retired farmer, died 6 July 1986.

Hombergen, Antonius Aloysius Johannes, late of Room 2, 78 Riversdale Road, Hawthorn, pensioner, died 21 July 1986.

Jandora, Marta, late of Essendon Private Nursing Home, 10 Fletcher Street, Essendon, home duties, died 6 September 1986.

Narvik, Doreen Lillian, also known as Doris Narvik, late of Edgelea Private Nursing Home, 87 Chapel Street, East St. Kilda, pensioner, died 9 August 1986.

Pham, Mai Thi Tuyet, late of Flat 5, 76 Dundas Street, Thornbury, married woman, died 8 or 9 February 1985.

Richardson, Vivian, late of Mont Park, pensioner, died 13 August 1986.

Williams, William James, late of 434 Gore Street, Fitzroy, pensioner, died 14 August 1986.

I hereby give notice that on 28 October 1986 the Public Trustee filed Elections to Administer the following deceased persons' estates in accordance with section 17 of the *Public Trustee Act 1958*:

Howard, Gerald Joseph, late of 43 Mitchell Street, West Footscray, pensioner, died 27 July 1986.

Werner, Boleslaw, late of 31 Glenlyon Road, Brunswick, retired, died 20 October 1984.

I hereby give notice that on 30 October 1986 the Public Trustee filed Elections to Administer the following deceased persons' estates in accordance with section 17 of the *Public Trustee Act 1958*:

Clark, Myrtle, late of 74 Erskine Street, Middle Park, home duties, died 6 May 1986.

Kiely, Thomas, also known as Thomas Keily, late of Mont Park, pensioner died 10 May 1986.

Llopis, Richard, formerly of 341 Burnley Street, Burnley, but late of 8 Johnston Street, Collingwood, retired panel beater, died 25 June 1986.

Paull, Gwenyth Rosa, late of Surrey Hills Private Nursing Home, 18 Florence Road, Surrey Hills, died 23 June 1986.

Tognazzini, Frank Vaughan, 119 Station Street Bennettswood, but late of Caritas Christi Hospice, 104 Studley Park Road, Kew, retired, died 13 August 1986.

Veverka, Jerry, late of 7/21 Spenser Street, St. Kilda, retired chef, died 10 September 1986.

Dated 5 November 1986

W. J. KILPATRICK
Public Trustee

Creditors, next of kin and others having claims against the estate of any of the under-mentioned deceased persons are required to send particulars of their claims to the Public Trustee, 168 Exhibition Street, Melbourne, Vic. 3000, the personal representative, on or before 15 January 1987 after which date the Public Trustee may convey or distribute the assets having regard only to the claims of which the Public Trustee then has notice:

Blosfelds, Nikolais, late of "Windways" Murray Valley Highway, Ebdon, retired farmer, died 6 July 1986.

Clark, Myrtle, late of 74 Erskine Street, Middle Park, home duties, died 6 May 1986.

Hombergen, Antoius Aloysius Johannes, late of Room 2, 78 Riversdale Road, Hawthorn, pensioner, died 21 July 1986.

Howard, Gerald Joseph, late of 43 Mitchell Street, West Footscray, pensioner, died 27 July 1986.

Jandova, Marta, late of Essendon Private Nursing Home, 10 Fletcher Street, Essendon, home duties, died 6 September 1986.

Judasiewski, Alojzy also known as Les Judasewski, late of 6 St. Leonards Avenue, St. Kilda, pensioner, died 2 February 1986.

Kiely, Thomas, also known as Thomas Keily, late of Mont Park, pensioner, died 10 May 1986.

Llopis, Richard, formerly of 341 Burnley Street, Burnley, but late of 8 Johnston Street, Collingwood, retired panel beater, died 25 June 1986.

Macdivitt, Archibald Frank, late of 72 Alamein Road, West Heidelberg, retired, died 3 July 1986.

Missen, Amy Elena Ada, late of 31 Bishop Street, Kingsville, widow, died 24 August 1986.

Moore, Thomas Parker, late of Flat 8, 49 Robert Street, Bentleigh, retired postal worker, died 6 April 1986.

Narvik, Doreen Lillian also known as Doris Narvik, late of Edgelea Private Nursing Home, 87 Chapel Street, East St. Kilda, pensioner, died 9 August 1986.

Negrello, Augusto, late of 11 Reno Road, Sandringham, pensioner, died 4 July 1986.

Norton, Alice Margaret, formerly of 32 Peter Street, Springvale, but late of "Aberdeen Lodge", Walton Street, Dandenong, pensioner, died 5 January 1986.

Paull, Gwenyth Rosa, late of Surrey Hills Private Nursing Home, 18 Florence Road, Surrey Hills, pensioner, died 23 June 1986.

Pham, Mai Thi Tuyet, late of Flat 5, 76 Dundas Street, Thornbury, married woman, died 8 or 9 February 1985.

Richardson, Vivian, late of Mont Park, pensioner, died 13 August 1986.

Secomb, Ada Pearl, late of 4 McFarlane Crescent, Dandenong, home duties, died 12 June 1986.

Tognazzini, Frank Vaughan, formerly of 119 Station Street, Bennettswood, but late of Caritas Christi Hospice, 104 Studley Park Road, Kew, retired, died 13 August 1986.

Tolmie, Ena Loreto, late of 68 Downshire Road, Elsternwick, widow, died 2 July 1986.

Veverka, Jerry, late of 7/21 Spenser Street, St. Kilda, retired chef, died 10 September 1986.

Werner, Boleslaw, late of 31 Glenlyon Road, Brunswick, retired, died 20 October 1984.

Williams, William James, late of 434 Gore Street, Fitzroy, pensioner, died 14 August 1986.

Wood, Elizabeth Dorothy, late of Alba Villa, 76 Carnarvon Road, Strathmore, widow, died 5 August 1986.

Dated 5 November 1986

P. T. SPENCER
Public Trustee

Cemeteries Act 1958

SCALE OF FEES OF THE KANIVA AND
LILLIMUR PUBLIC CEMETERY

In pursuance of the powers conferred upon them by the Cemeteries Act the trustees of the Kaniva and Lillimur Public Cemetery hereby make the following scale of fees, which shall come into operation upon publication in the *Government Gazette*, and from and after such publication every scale of fees heretofore made by the said trustees shall be and is hereby rescinded to the extent to which it conflicts with this scale.

	\$
Sinking grave 1.83 m deep	195.00
Sinking grave 2.13 m deep	220.00
Sinking grave for children under 12 years	60.00
Removal of slab or monument	10.00
Land, 2.44 m × 1.22 m	75.00
Interment fee	35.00
Burials on Saturdays, Sunday and Public Holidays:	
Sinking grave 1.83 m deep (extra)	85.00
Sinking grave 2.13 m deep (extra)	110.00
Memorial Wall	80.00
(Additional lines in inscription remain \$3.00)	

S. L. HAWKER, Trustee
G. G. SIBSON, Trustee
R. G. COUTTS, Trustee

Approved by the Governor in Council, 5 November 1986—L. G. HOUSTON, Clerk of the Executive Council

Cemeteries Act 1958

SCALE OF FEES OF THE DOWLING FOREST
PUBLIC CEMETERY

In pursuance of the powers conferred upon them by the Cemeteries Act the trustees of the Dowling

Forest Public Cemetery hereby make the following scale of fees, which shall come into operation upon publication in the *Government Gazette*, and from and after such publication every scale of fees heretofore made by the said trustees shall be and is hereby rescinded to the extent to which it conflicts with this scale.

	\$
Land	75.00
Sinking	110.00
Interment fee	35.00
Reopen (no cover)	110.00
Reopen (with cover)	120.00
Permission to erect a headstone or monument—5 per cent of cost with a minimum of \$15.00	
Exhumation charge (when authorized)	300.00

A. WILSON, Trustee
T. FORD, Trustee
J. DAVEY, Trustee
A. MCCOLL, Trustee

Approved by the Governor in Council, 5 November 1986—L. G. HOUSTON, Clerk of the Executive Council

Cemeteries Act 1958

SCALE OF FEES OF THE GREAT WESTERN PUBLIC CEMETERY

In pursuance of the powers conferred upon them by the Cemeteries Act the trustees of the Great Western Public Cemetery hereby make the following scale of fees, which shall come into operation upon publication in the *Government Gazette*, and from and after such publication every scale of fees heretofore made by the said trustees shall be and is hereby rescinded to the extent to which it conflicts with this scale.

	\$
Land, 2.44 m × 1.22 m	40.00
Reservation of Land	20.00
Reopening of grave	40.00
Interment of ashes	40.00

T. BRADY, Trustee
I. MCKAY, Trustee
M. BRUMBY, Trustee

Approved by the Governor in Council, 5 November 1986—L. G. HOUSTON, Clerk of the Executive Council

Cemeteries Act 1958

SCALE OF FEES OF THE DOOKIE PUBLIC CEMETERY

In pursuance of the powers conferred upon them by the Cemeteries Act the trustees of the Dookie Public Cemetery hereby make the following scale of fees, which shall come into operation upon

publication in the *Government Gazette*, and from and after such publication every scale of fees heretofore made by the said trustees shall be and is hereby rescinded to the extent to which it conflicts with this scale.

Sinking Charges for Private Graves

Sinking grave 1.83 m deep \$150.00

T. RYAN, Trustee

J. KINGSTON, Trustee

F. PETSCHACK, Trustee

Approved by the Governor in Council, 5 November 1986—L. G. HOUSTON, Clerk of the Executive Council

Cemeteries Act 1958

SCALE OF FEES OF THE YAN YEAN PUBLIC CEMETERY

In pursuance of the powers conferred upon them by the Cemeteries Act the trustees of the Yan Yeon Public Cemetery hereby make the following scale of fees, which shall come into operation upon publication in the *Government Gazette*, and from and after such publication every scale of fees heretofore made by the said trustees shall be and is hereby rescinded to the extent to which it conflicts with this scale.

Private Graves

Land, 2.44 m × 1.22 m \$120.00

L. RUSSELL, Trustee

V. BARRETT, Trustee

P. JOHNSON, Trustee

Approved by the Governor in Council, 5 November 1986—L. G. HOUSTON, Clerk of the Executive Council

Town and Country Planning Act 1961

MELBOURNE METROPOLITAN INTERIM DEVELOPMENT ORDER

Bayside Interim Height Areas

Notice of Extension of Operation

In pursuance of the powers conferred by the *Town and Country Planning Act 1961*, the Governor in Council on 20 November 1985 approved the above mentioned order for which the Minister for Planning and Environment is the responsible authority.

In pursuance of the powers conferred by the *Town and Country Planning Act 1961*, the Governor in Council on 11 November 1986 extended the operation of the aforementioned order for a further twelve-month period expiring on 20 November 1987.

The operation of the order is extended on the date this notice is published in the *Government Gazette*.

The order controls the construction of buildings and works which exceed specified height limits.

A copy of the documents may be inspected free of charge, during office hours at the office of the Ministry for Planning and Environment, The Olderfleet Buildings, 477 Collins Street, Melbourne, and at the office of the councils of the Cities of St Kilda, Brighton, Sandringham, Mordialloc, Chelsea and Frankston.

DAVID YENCKEN
Secretary for Planning and Environment

Town and Country Planning Act 1961
GEE LONG REGIONAL PLANNING SCHEME
Amendment No. 168
Notice of Approval

In pursuance of the powers conferred by the *Town and Country Planning Act 1961*, the Governor in Council on 11 November 1986, approved the abovementioned scheme in respect of the municipal districts of the Shires of Bellarine and Barrabool and the City of South Barwon and for which the Geelong Regional Commission is the responsible authority.

The scheme comes into operation on the date this notice is published in the *Government Gazette*.

The scheme includes land at Mount Duneed and Drysdale in Schedule 1 to the scheme; includes a new definition "Mineral Working" in the scheme, and rezones land in Burdoo Drive, Grovesdale from a Residential A zone to a Local Business zone.

A copy of the documents may be inspected free of charge, during office hours, at the office of the Ministry for Planning and Environment (Planning Information Services), The Olderfleet Buildings, 477 Collins Street, Melbourne and at the office of the Geelong Regional Commission, State Offices, Little Malop Street, Geelong.

DAVID YENCKEN
Secretary for Planning and Environment

Town and Country Planning Act 1961
SHIRE OF OTWAY (OCEAN ROAD)
Interim Development Order
Amendment No. 2
Notice of Amendment

In pursuance of the powers conferred by the *Town and Country Planning Act 1961*, the Governor in Council on 11 November 1986 amended the abovementioned order in respect of the Shire of Otway and for which the Minister for Planning and Environment is the responsible authority.

The amendment comes into operation on the date this notice is published in the *Government Gazette*.

The amendment varies the ordinance to allow the responsible authority to consider variations to lot size and dimensions in the Township and Village zones.

A copy of the documents may be inspected free of charge, during office hours at the office of the Ministry for Planning and Environment (Plan Inspection Section), The Olderfleet Buildings, 477 Collins Street Melbourne, and at the office of the Council of Shire of Otway, Nelson Street, Apollo Bay.

DAVID YENCKEN
Secretary for Planning and Environment

Town and Country Planning Act 1961
CITY OF COLAC PLANNING SCHEME 1963
Amendment No. 26
Notice of Amendment

In pursuance of the powers conferred by the *Town and Country Planning Act 1961*, the Governor in Council on 11 November 1986 amended the abovementioned scheme in respect of the municipal district of the City of Colac and for which the City of Colac is the responsible authority.

The amendment comes into operation on the date this notice is published in the *Government Gazette*.

The amendment includes provisions enabling discretionary reduction in the required setback of buildings from the frontage of properties.

A copy of the documents may be inspected free of charge, during office hours, at the office of the Ministry for Planning and Environment (Planning Information Services), The Olderfleet Buildings, 477 Collins Street, Melbourne and at the office of the City of Colac, 4-6 Rae Street, Colac.

DAVID YENCKEN
Secretary for Planning and Environment

Transport Act 1983
ROAD TRAFFIC AUTHORITY

Commercial Passenger Vehicle Applications

Notice is hereby given that the following applications will be considered by the Road Traffic Authority on 2 December 1986.

Notice of any objections should be forwarded to reach the Manager, Vehicle Licensing Branch or any Regional Office of the Road Traffic Authority not later than 26 November 1986.

It will not be necessary for interested parties to appear on the hearing date specified, unless advised in writing by the Authority.

Notification of the date for consideration of applications which are objected to and which require determination by the Road Transport Licensing Tribunal will be published by further notice in this *Gazette*.

Hoys Roadlines Pty. Ltd., Wangaratta. Application for variation of the conditions of licences TS 434, TS 1056, TS 1096, TS 1373, TS 1463 and TS 1777 which authorize various Ministry of Education contract services to operate under charter conditions within a 20 km pick-up radius of the Wangaratta Post Office.

Hoys Roadlines Pty. Ltd., Wangaratta. Application for variation of the conditions of licence TS 1567 which authorizes a Ministry of Education contract service between O'Keefe Road and Boorhaman Primary School to operate under charter conditions from within a 20 km pick-up radius of the Tangambalanga Post Office.

Hoys Roadlines Pty. Ltd., Wangaratta. Application to license one commercial passenger vehicle with seating capacity for 18 passengers to operate under charter conditions from within a 20 km pick-up radius of the St. James Post Office.

Note: (i) The vehicle to be licensed currently operates a Ministry of Education contract service between Yundool and St James Primary School. (ii) The vehicle to be licensed holds a 2 Star rating for charter purposes.

R. B. Pankowski, Upper Plenty. Application to license one commercial passenger vehicle to be purchased to operate for the carriage of students of Assumption College, Kilmore between the College, sporting and other venues associated with College activities and their homes.

Timetable: As and when required.

Fares: \$2.50 per student.

Note: The vehicle to be licensed will have a small seating capacity of approximately 18 persons.

N. Soliman, Essendon. Application to license one commercial passenger vehicle in respect of a 1986 Ford LTD with seating capacity for 4 passengers to operate as a metropolitan hire car from EPHS Ltd. of 547 Spencer Street, West Melbourne.

Note: Notice of this application replaces a notice which appeared in the *Victoria Government Gazette* number 83 dated 8 October 1986.

Previous objections to the granting of this application are invalid and interested parties are advised that a new notice of objection must be submitted.

Dated 12 November 1986

G. SHANKS, Group Manager
Vehicle and Licensing and Regulation Strategies

Country Fire Authority Act 1958

DECLARATION OF FIRE DANGER PERIOD

Under the powers conferred by section 4 of the *Country Fire Authority Act 1958*, I, Charles Race Thorson Mathews, Minister for Police and Emergency Services, after consultation with the Minister for Conservation, Forests and Lands, hereby declare the following periods to be the fire danger periods in the municipalities or parts of municipalities specified commencing on the date shown and, unless varied by subsequent declaration, ending at midnight on Thursday, 30 April 1987:

To commence from and inclusive of Saturday, 15 November 1986:

Shire of Bairnsdale

Town of Bairnsdale
Shire of Orbost
Shire of Tambo.

To commence from and inclusive of Monday, 17 November 1986:

City of Mildura
Shire of Mildura.

Dated 11 November 1986

C. R. T. MATHEWS

Minister for Police and Emergency Services

Police Offences Act 1958, No. 6337

DIVISION 1A—STATE CLASSIFICATION OF PUBLICATIONS BOARD

Take note that the State Classification of Publications Board has classified the following publications in accordance with the provisions of section 180H (1) of the *Police Offences Act 1958*.

Each publication shall be subject to the following restrictions:

- (a) It shall not be offered for sale, sold or delivered to any person under the age of 18 years;
- (b) It shall not be made available for inspection or perusal by any person under the age of 18 years;
- (c) It shall not be exhibited or displayed in any place to which persons under the age of 18 years have access or so that it is visible from any such place.

<i>Title</i>	<i>Distributor</i>
Club International—December 1986—Vol. 10 Issue 12 (U.S.A.)	Gordon & Gotch Ltd.
Hot Dreams—January 1987—Vol. 3 No. 1	Gordon & Gotch Ltd.
Live—January 1987—Vol. 6 No. 8	Gordon & Gotch Ltd.
Soldiers of Glory—November 1986—Vol. 1 No. 2	Gordon & Gotch Ltd.
Velvet Special—No. 14	Gordon & Gotch Ltd.
Three-way Lovers—February 1986	Gordon & Gotch Ltd.

R. V. DOOLEY

Acting Secretary

State Classification of Publications Board

Police Offences Act 1958, No. 6337

DIVISION 1A—STATE CLASSIFICATION OF PUBLICATIONS BOARD

Take note that the State Classification of Publications Board has classified the following publications in accordance with the provisions of section 180H (1) of the *Police Offences Act 1958*.

Each publication shall be subject to the following restrictions:

(a) It shall not be offered for sale, sold or delivered to any person under the age of 18 years;

(b) It shall not be made available for inspection or perusal by any person under the age of 18 years.

<i>Title</i>	<i>Distributor</i>
American Survival Guide—November 1986—Vol. 8 No. 11	Gordon & Gotch Ltd.
Australian Hot Talk—No. 5	Gordon & Gotch Ltd.
Australian Forum—Vol. 1 No. 7	Gordon & Gotch Ltd.
Best of Club International, The — No. 11	Gordon & Gotch Ltd.
Club International—Vol. 15 No. 12	Gordon & Gotch Ltd.
Escort—Vol. 6 No. 11	Gordon & Gotch Ltd.
Gallery—December 1986—Vol. 14 No. 12	Gordon & Gotch Ltd.
Men Only—Vol. 51 No. 12	Gordon & Gotch Ltd.
Razzle—Vol. 4 No. 22	Gordon & Gotch Ltd.

R. V. DOOLEY
Acting Secretary
State Classification of Publications Board

Department of Industry, Technology and Resources

INTENTION TO GRANT MINING LEASES

- No. 760; G. R. Bates and Drummond Ridge Pty. Ltd.; 25 ha, Parish of Wedderburn.
No. 988; E. L. & M. L. Smith; 5-255 ha, Parish of Terrick Terrick West.
No. 1331; D. J. Renowden; 11-75 ha, Parish of Moolpah.

APPLICATION FOR MINING LEASES TRANSFERRED

- No. 827; From Dubranson Pty. Ltd. to Southern Continental Mining Ltd.
Nos. 999 and 1342; From Whirrakee Mining Company to Golden Phoenix NL.
Nos. 1201 and 1203; From Lyzen Pty. Ltd. to Golden Phoenix NL.
No. 1214; From Jetsew Pty. Ltd. to Golden Phoenix NL.

MINING LEASES TRANSFERRED

- Nos. 315, 581, 979, 981, 1051 and 1082; From Ando Gold NL to Ando Minerals NL.
Nos. 545-1, 723, and 9196; From Australian Gypsum Ltd. to Mildura Plaster Mills Pty. Ltd.

VARIATION OF MINING LEASE COVENANTS

- Nos. 635 and 1005; A. C. P. Webb, the Lessee may in lieu of employing labour expend in each half year a minimum of \$30 000 on operations authorized by the lease and shall continue to expend the aforesaid amount for each additional 6 month period, unless otherwise determined by the Minister, who may increase or decrease the amount as he thinks fit.

MINING LEASES EXPIRED

- No. 617; E. D. Moore; 1-99 ha, Parish of Koorangie.
No. 675; J. A. & S. F. Hannic; 61-66 ha, Parish of Moortwoora.

APPLICATION FOR DEVELOPMENT LEASE DECLARED ABANDONED

- No. 89; Centaur Mining and Exploration Ltd.; 100 ha, Parishes of Burrumbeep and Ararat.

VARIATION OF DEVELOPMENT LEASE COVENANT

- No. 14; CRA Exploration Pty. Ltd.; the expenditure covenant to be reduced to \$40 000 for the first two years and \$50 000 per year thereafter.

APPLICATIONS FOR DEVELOPMENT LEASES TRANSFERRED

- Nos. 152 and 153; from Zyne Pty. Ltd. to Golden Phoenix NL.
Nos. 274, 275 and 276; From Whirrakee Mining Co. to Golden Phoenix NL.

INTENTION TO GRANT A PROSPECTING AREA LICENCE

- No. 112; L. J. Austin; 5-52 ha, Parish of Buninyong.

PROSPECTING AREA LICENCES GRANTED

- Nos. 145, 146 and 147; Walhalla Mining Company NL; 248, 255 and 244 has respectively, Parish of Knowsley.
No. 123; Lyzen Pty. Ltd.; 25-74 ha, Parish of Whirrakee.

PROSPECTING AREA LICENCES RENEWED

- No. 6-1; F. J. Mordey; 2-4948 ha, Parish of Redbank.

APPLICATIONS FOR PROSPECTING AREA LICENCE TRANSFERRED

- Nos. 90 and 92; From Lyzen Pty. Ltd. to Golden Phoenix NL.
Nos. 99 and 100; From Lyzen Pty. Ltd. to Golden Phoenix NL.
No. 97; From Jetsew Pty. Ltd. to Golden Phoenix NL.
No. 116; From Whirrakee Mining Company to Golden Phoenix NL.
No. 40; From Dubranson Pty. Ltd. to Southern Continental Mining Limited.

TAILINGS REMOVAL LICENCES GRANTED

No. 5165; General Gold Resources NL; to remove tailings from the "Lord Nelson Dump" between Miller Street, Showground and Recreation Reserve in the Parish of St Arnaud.

No. 5183; Bendigo Gold Associates Pty. Ltd.; to remove tailings from the "Nuggetty Atax Dump" situated in the Parish of Wombat.

No. 5202; Cunneen Excavations Pty. Ltd.; to remove tailings from the Bracewell and James Street Dumps situated in the Parish of Nerring.

TAILINGS REMOVAL LICENCES EXPIRED

No. 4890; G. R. & M. Bird; to remove tailings from the "Blow Mine" situated in the Parish of Tarrngower.

No. 4906; Shire of Creswick; to remove tailings from the "O'Keefes Dump" situated in the Parish of Creswick.

No. 4915; J. V. Wallace; to remove tailings from the "Central Ajax Mine" situated in the Parish of Wombat.

No. 4930; Forest Commission of Victoria; to remove tailings from an area of reserved forest situated in the Parish of Stanley.

INTENTION TO GRANT TAILINGS TREATMENT LICENCES

No. 312; K. A. White; 4.5 ha, Parish of Langi-Logan.

No. 210; Minax Giselle Pty. Ltd.; 1.092 ha, Parish of Carisbrook.

TAILINGS TREATMENT LICENCES GRANTED

No. 248; Coemo Kirsten Pty. Ltd.; 5.398 ha, Parish of Bet Bet.

No. 264; Ando Mineral NL; 8.1464 ha, Parish of Tchuterr.

APPLICATION FOR TAILINGS TREATMENT LICENCE WITHDRAWN

No. 314; K. A. White; 8.1 ha, Parish of Burrumbeep.

APPLICATION FOR TAILINGS TREATMENT LICENCE REFUSED

No. 310; K. A. White; 16.4 ha, Parish of Nerring.

INTENTION TO GRANT AN EXPLORATION LICENCE

No. 1825; Kinglake Resources Pty. Ltd.; approximately 2 km², County of Grenville.

EXPLORATION LICENCES GRANTED AND AREAS REFUSED

No. 1604; Mincomp Pty. Ltd.; area retained 16 km² area refused 0.5 km², County of Bogon and Benambra.

No. 1623; D. R. & B. R. McLean; area retained 15 km², area refused nil, County of Talbot.

No. 1630; General Gold Resources NL, 189 km², County of Kara Kara.

No. 1641; Aberfoyle Resources Ltd. and Balmoral Resources NL; area retained 249.5 km², area refused 0.5 km², Counties of Borung and Karkaroc.

No. 1647; B. R., D. R. & I. G. McLean; area retained 50 km², area refused nil, County of Delatite.

No. 1660; Mumbil Mines NL; area retained 89 km², area refused nil, Parishes of Angora and Yambulla.

INTENTION TO EXTEND EXPLORATION LICENCES

No. 1326-3; Kinglake Resources Pty. Ltd. and Eastern Copper Mines NL; 88 km², County of Wonnangatta.

No. 1327-2; Kinglake Resources Pty. Ltd. and Eastern Copper Mines NL; 200.5 km², County of Wonnangatta.

EXPLORATION LICENCES EXTENDED

No. 1233-4; Western Mining Corporation Ltd. and BP Mining Development Australia Pty. Ltd.; 135 km², County of Benambra.

No. 1234-4; Western Mining Corporation Ltd. and BP Mining Development Australia Pty. Ltd.; 252.5 km², Counties of Dargo and Tambo.

No. 1235-4; Western Mining Corporation Ltd. and BP Mining Development Australia Pty. Ltd.; 126 km², Counties of Dargo and Tambo.

No. 1236-4; Western Mining Corporation Ltd. and BP Mining Development Australia Pty. Ltd.; 194.5 km², Counties of Benambra and Tambo.

No. 1237-4; Western Mining Corporation Ltd. and BP Mining Development Australia Pty. Ltd.; 157.5 km², Counties of Omeo and Benambra.

No. 1238-4; Western Mining Corporation Ltd. and BP Mining Development Australia Pty. Ltd.; 67 km², Counties of Corryong and Benambra.

No. 1239-4; Western Mining Corporation Ltd. and BP Mining Development Australia Pty. Ltd.; 141 km², Counties of Corryong and Benambra.

EXPLORATION LICENCE AREAS EXTENDED PURSUANT TO SECTION 519B (6) OF THE MINES ACT 1958 AS AMENDED

No. 1513; Interactive Process Services Pty. Ltd., Clive Willman and Associates & A. D. Garrett; 1.25 km², County of Talbot.

No. 1589; Western Mining Corporation Ltd.; 0.75 km², County of Grenville.

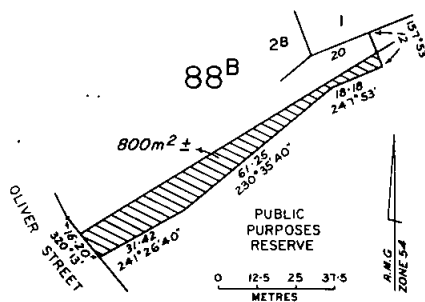
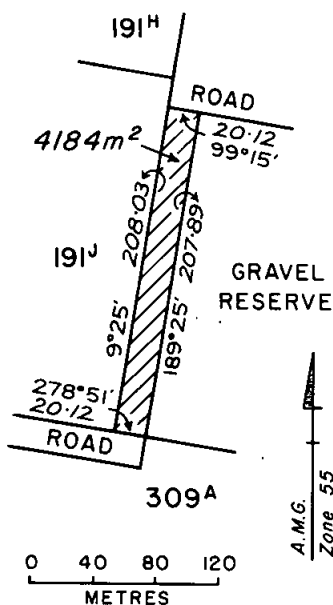

J. E. KIRNER
Minister for Conservation, Forests and Lands

APPOINTMENTS

APPOINTMENTS

His Excellency the Governor of the State of Victoria by and with the advice of the Executive Council thereof has by order made on 7 October 1986 been pleased to make the under-mentioned appointments, viz:

Department of Health

Trustee of Public Cemetery

Gregory John DIXON

to be Trustee of the Brim Cemetery Trust, pursuant to section 3 (1) of the *Cemeteries Act 1958*.

L. G. HOUSTON

Clerk of the Executive Council

At the Executive Council Chamber
Melbourne, 7 October 1986

APPOINTMENTS

His Excellency the Governor of the State of Victoria by and with the advice of the Executive Council thereof has by order made on 5 November 1986 been pleased to make the under-mentioned appointments, viz:

Department of Conservation, Forests and Lands

Bailiffs of Crown Land

Warren Peter BARNES

for the Crown land within the municipal district of the Shire of Orbost, and

Gary R McCORKELL and

Kaye C McCORKELL

for the Genoa River Bridge Reserve

to be bailiffs of Crown land pursuant to section 30 of the *Land Act 1958*.

L. G. HOUSTON

Clerk of the Executive Council

At the Executive Council Chamber

Melbourne, 5 November 1986

Tyntynder West—The temporary reservation by Order in Council of 5 March 1946 of 4.760 hectares north of Crown Allotment 39s, Parish of Tyntynder West as a site for Public Recreation Purposes so far only as the portion containing 8555 square metres being Crown Allotment 39x, Parish of Tyntynder West as shown on Certified Plan No. 108053 lodged in the Central Plan Office—(Rs 5745).

Warrnambool—The temporary reservation by Order in Council of 16 March 1960 of 50.226 hectares of land in the Township of Warrnambool as a site for Public Park and Public Recreation, revoked as to part by various Orders so far only as the portion containing 3 hectares being Crown Allotment 187A Township of Warrnambool as shown on Certified Plan No. 108040 lodged in the Central Plan Office—(Rs 283).

Warrnambool—The temporary reservation by Order in Council of 15 March 1949 of 4.047 hectares of land in the Township of Warrnambool as a site for a Quarry so far only as the portion containing 1158 square metres as shown on Certified Plan No. 108039 lodged in the Central Plan Office—(Rs 6332).

Ballarat East—The temporary reservation by Order in Council of 5 April 1892 of 12.14 hectares of land in the Township of Ballarat East, as a site for Public Purposes, revoked as to part by various orders, so far only as regards the portion containing 800 square metres more or less, as indicated by hatching on plan hereunder—(B128(42))(Rs 5114).

REVOCACTION OF APPOINTMENTS

2 Wimmera Senior Sergeant Peter John Mintern-Lane, 14738 (from 26.10.86 to 27.12.86)

His Excellency the Governor of the State of Victoria, by and with the advice of the Executive Council thereof, has, by Orders made on 5 November 1986, revoked the appointments of the persons named hereunder to the office mentioned, viz:

Dated 10 November 1986

E. A. MUDGE
Deputy Commissioner (Administration)

Department of Conservation, Forests and Lands

Bailiffs of Crown Land

Paul John FLINT
Jeanette SEVERS
Murray Johnson TANNER
Catherine Agnes TANNER
June Estelle EDLINGTON
Robert Joseph DENNIS and Daphne Kathleen DENNIS
as bailiffs of Crown land.

L. G. HOUSTON
Clerk of the Executive Council

At the Executive Council Chamber
Melbourne, 5 November 1986

Liquor Control Act 1968

APPOINTMENT OF LICENSING INSPECTORS

In accordance with the authority conferred upon me by section 6 of the *Police Regulation Act 1958*, I, Eric Archibald Mudge, Deputy Commissioner of Police, do hereby appoint under sub-section (1) of section 22 of the *Liquor Control Act 1968*, the following Officers of Police as Licensing Inspectors for the Divisions of the Police Districts as shown:

<i>Division Number</i>	<i>Police District</i>	<i>Rank and Name</i>
4	Dandenong	Chief Inspector Frederick Maxwell Elliott, 11354 (from 30.11.86 to 28.12.86).
1	Malvern	Inspector Richard Ellis Gray, 13185 (from 26.10.86 to 22.11.86).
2	Malvern	Chief Inspector Brian Brown, 13217 (from 28.9.86 to 4.10.86).
4	Malvern	Chief Inspector Brian Brown, 13217 (from 5.10.86 to 18.10.86).
4	Malvern	Inspector Peter Geoffrey Kemp, 14542 (from 19.10.86 to 22.11.86).
2	Prahran	Chief Inspector Brian Brown, 13217 (from 19.10.86 to 1.11.86).
2	Prahran	Inspector Quentin Andrew Pritchard, 14485 (from 2.11.86 to 30.11.86).

Liquor Control Act 1968

APPOINTMENT OF LICENSING INSPECTORS

In accordance with the authority conferred upon me by section 6 of the *Police Regulation Act 1958*, I, Eric Archibald Mudge, Deputy Commissioner of Police, do hereby appoint under sub-section (1) of section 22 of the *Liquor Control Act 1968*, the following Officers of Police as Licensing Inspectors for the Divisions of the Police Districts as shown:

<i>Division Number</i>	<i>Police District</i>	<i>Rank and Name</i>
2	Cheltenham	Inspector James Patrick McCaffrey, 15004 (from 19.10.86 to 29.11.86)
1	Gippsland	Inspector Maurice Leonard Lindsay, 13280 (from 16.11.86 to 29.11.86)
2	Ivanhoe	Inspector Richard Alfred Henry Ellis, 15490 (from 9.11.86 to 6.12.86)

Dated 3 November 1986

E. A. MUDGE
Deputy Commissioner (Administration)

ORDERS IN COUNCIL

State Electricity Commission Act 1958
STATE ELECTRICITY COMMISSION OF
VICTORIA

*At the Executive Council Chamber, Melbourne, the
twenty-first day of October 1986*

PRESENT:

His Excellency the Governor of Victoria
Mr Kennan | Mr Walsh
Mrs Hogg |

His Excellency the Governor of the State of Victoria in the Commonwealth of Australia by and with the advice of the Executive Council of the said State, pursuant to the provisions of section 65 (3) and (4) of the *State Electricity Commission Act 1958*, does hereby declare that those areas of the State described in the schedules A and B hereunder and are "declared areas" for the purposes of section 60 (3) of the *State Electricity Commission Act 1958*.

Copies of plans defining declared areas referred to in Schedule B are held by the Secretary, State Electricity Commission of Victoria.

SCHEDULE A—DEFINITION BY
BOUNDARY

1. The Total Areas of the following Cities

Altona	Malvern
Brighton	Moorabbin
Broadmeadows	Mordialloc
Camberwell	Newtown
Caulfield	Oakleigh
Colac	Prahran

Collingwood	Richmond
Essendon	Sandringham
Fitzroy	South Melbourne
Geelong	St Kilda
Geelong West	Traralgon
Hawthorn	Wangaratta
Kew	Waverley

2. The Area of the City of Croydon Except—
that area commencing at the intersection of the northern side of Mt Dandenong Road and the western boundary of the City, then generally easterly by the northern boundary of Mt Dandenong Road to the extension of the easterly boundary of Bayswater Road, thence southerly by that extension and the easterly boundary of Bayswater Road to the southerly boundary of Eastfield Road, thence westerly by the southerly boundary of Eastfield Road to the western boundary of the City, thence by that boundary back to the point of commencement.

3. That Area of the City of Port Melbourne—
commencing at the intersection of the southern boundary of Lorimer Street with the common boundary of the Cities of Port Melbourne and South Melbourne, thence generally westerly and south westerly by the southern boundary of Lorimer Street to the point of intersection with the north eastern boundary of the Westgate Freeway, thence north westerly by the Freeway boundary to the north westerly boundary of Lorimer Street, thence generally north easterly and easterly by that boundary to the common boundary of the Cities of Port Melbourne and South Melbourne, then by that boundary back to the point of commencement.

SCHEDULE B—DEFINITION BY PLAN

Cities	<i>Drawing Series Numbers Both Inclusive</i>	<i>Number of Sheets</i>
Ararat	VB6/174 to VB6/174/3	4
Ballaarat	VB6/160 to VB6/160/14	15
Benalla	VH6/814	1
Bendigo	VC6/530 to VC6/530/1	2
Berwick	VE6/1015 to VE6/1015/2	3
Castlemaine	VC6/531 to VC6/531/2	3
Dandenong	VE6/1018 to VE6/1018/2	3
Doncaster and Templestowe	VE6/1020 to VE6/1020/1	2
Frankston	VE6/1023 to VE6/1023/3	4
Hamilton	VJ6/501	1
Horsham	VN6/333 to VN6/333/6	7
Keilor	VA6/802 to VA6/802/4	5
Knox	VE6/1026/1 to VC6/1026/3	3
Maryborough	VC6/537 to VC6/537/2	3
Melbourne	VA6/803	1
Mildura	VL6/1860	1
Moe	VK6/1011	1

Portland	VJ6/502	1
Sale	VK6/1013	1
Shepparton	VH6/810 to VH6/810/2	3
South Barwon	VD6/301 to VD6/301/8	9
Springvale	VE6/1032 to VE6/1032/2	3
Sunshine	VA6/805 to VA6/805/3	4
Swan Hill	VC6/541 to VC6/541/1	2
Warrnambool	VJ6/500 to VJ6/500/4	5
Williamstown	VA6/807	1
Wodonga (Rural City)	VH6/808 to VH6/808/4	5
<i>Towns</i>		
Bairnsdale	VK6/1002	1
Camperdown	VJ6/503	1
Kyabram	VH6/800 to VH6/800/1	2
St Arnaud	VC6/539	1
<i>Boroughs</i>		
Eaglehawk	VC6/532	1
Kerang	VC6/534 to VC6/534/1	2
Queenscliffe	VD6/302 to VD6/302/3	4
Sebastopol	VB6/159 to VB6/159/6	7
Wonthaggi	VK6/1015 to VK6/1015/1	2
<i>Shires</i>		
Bacchus Marsh	VB6/175 to VB6/175/6	7
Ballarat	VB6/162 to VB6/162/11	12
Beechworth	VH6/812 to VB6/812/1	2
Bellarine	VD6/300 to VD6/300/13	14
Bulla	VA6/801 to VAG/801/4	5
Buln Buln	VK6/1004	1
Cobram	VH6/804 to VH6/804/1	2
Corio	VD6/303 to VD6/305/5	6
Cranbourne	VE6/1016 to VE6/1016/3	4
Diamond Valley	VE6/1019/1 to VE6/1019/2	2
Eltham	VE6/1021 to VE6/1021/1	2
Euroa	VH6/801	1
Flinders	VE6/1022 to VE6/1022/4	5
Gisborne	VE6/533	1
Hastings	VE6/1024 to VE6/1024/4	5
Korumburra	VK6/1007	1
Kyneton	VC6/535 to VC6/535/1	2
Maffra	VK6/1010	1
	VK6/1005	1
Marong	VC6/536 to VC6/536/1	2
Melton	VA6/804 to VA6/804/3	4
Morwell	VK6/1012 to VK6/1012/1	2
	VK6/1003	1
Myrtleford	VH6/817	1
Numurkah	VH6/803	1
	VH6/802	1
Pakenham	VE6/1029 to VE6/1029/1	2
Rochester	VC6/538 to VC6/538/1	2
Rodney	VH6/807 to VH6/807/1	2
	VH6/811	1
Seymour	VH6/816	1
	VH6/818 to VH6/818/1	2
	VH6/813	1
Strathfieldsaye	VC6/540 to VC6/540/1	2
Tambo	VK6/1008 to VK6/1008/1	2
Warragul	VK6/1014 to VK6/1014/1	2
Werribee	VA6/806 to VA6/806/5	6
Whittlesea	VE6/1033/1 to VE6/1033/3	3

Woorayl	VK6/1009	1
	VK6/1006	1
Yarrawonga	VH6/815	1
<i>Special Areas</i>		
Bandiana Army Camp Area	VH6/821	1
Falls Creek Alpine Reserve	VH6/820	1
Mt Buller Alpine Reserve	VH6/819	1
Puckapunyal Army Camp Area	VH6/805	1

And the Honourable Robert Clive Fordham, Her Majesty's Minister for Industry, Technology and Resources, shall give the necessary directions herein accordingly.

L. G. HOUSTON
Clerk of the Executive Council

Foreign Judgments Act 1962
Section 4

EXTENSION OF PART II TO ANGUILLA

The Governor in Council under Section 4 (2) of the *Foreign Judgments Act 1962*, directs that Part II of the Act be extended to Anguilla and that the Eastern Caribbean Supreme Court be deemed the superior court of that Country.

Dated 28 October 1986

Responsible Minister:

J. H. KENNAN

Attorney-General

L. G. HOUSTON
Clerk of the Executive Council

Crown Land (Reserves) Act 1978

CROWN LANDS TEMPORARILY RESERVED

The Governor in Council under sections 4 and 7 of the *Crown Land (Reserves) Act 1978* temporarily reserves for the purposes mentioned and also excepts from prospecting or from occupation for mining purposes under any miners right the following Crown lands:

Municipal District of the Shire of Bungaree

Ballarat North—Public Park, 1.3 hectares, more or less, being Crown Allotment 8, Section 23, Township of Ballarat North, Parish of Ballarat as indicated by hatching on plan hereunder—(B128(93))(Rs 13336).

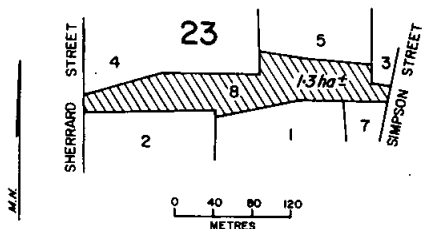

Municipal District of the Town of Bairnsdale

Bairnsdale—Public Park, 8094 square metres being Crown Allotment 3A, section D, Township of Bairnsdale, Parish of Bairnsdale as indicated by hatching on plan hereunder—(B66(12))(Rs 13352).

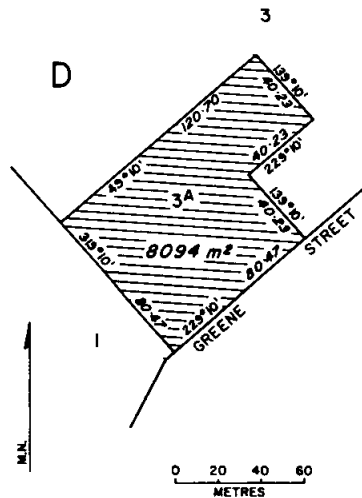

Municipal District of the Shire of Bulla

Buttlejorrk—Community Purposes, 989 square metres being Crown Allotment 63c, Parish of Buttlejorrk formerly being Lot 33 on Plan of Subdivision No. 88472 lodged in the Office of Titles—(Rs 13306).

Municipal District of the City of Springvale

Dandenong—Community Purposes, 2400 square metres, more or less, being Crown Allotment 22F, Parish of Dandenong, formerly Lot 60, Block A, on Plan of Subdivision No. 6870 lodged in the Office of Titles—(Rs 13300).

Municipal District of the Shire of Otway
 Skenes Creek—Public Purposes (Camping and Public Park), 2.022 hectares being Crown Allotment 17, Section 3A, Township of Skenes Creek, Parish of Krambruk as shown on Certified Plan No. 107407 lodged in the Central Plan Office—(Rs 13009).

Municipal District of the Shire of Kara Kara
 Rich Avon East—Water Supply, 2795 square metres being Crown Allotment 7C, Parish of Rich Avon East as indicated by hatching on plan hereunder—(R75(8)) (Rs 13323).

Municipal District of the Shire of Violet Town
 Violet Town—Public Recreation, 3300 square metres, more or less, being Crown Allotments 2A, 3A and 5A, Section 22, Crown Allotment 1, Section 23 and Crown Allotment 2, Section 25, Township of Violet Town, Parish of Shadforth as indicated by hatching on plan hereunder—(V7(4)) (Rs 13328).

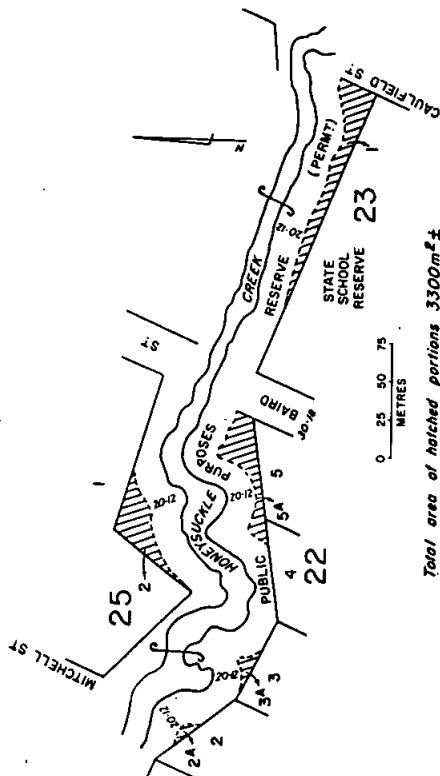
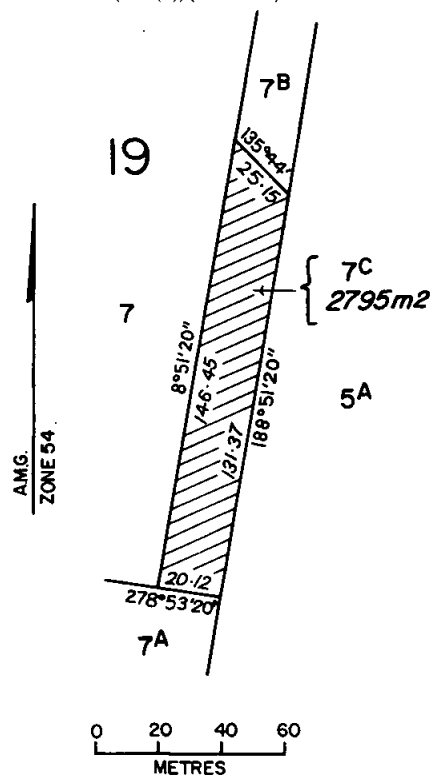

Municipal District of the Shire of Leigh
 Teesdale—Public Recreation, 25.80 hectares being Crown Allotment 1, Section B, Township of Teesdale, Parish of Carrah as shown on Certified Plan No. 103867 lodged in the Central Plan Office—(Rs 13314).

Municipal District of the City of Altona
 Truganina—Public Recreation, 1 hectare being Crown Allotment 4, Section 5, Parish of Truganina as shown on Certified Plan No. 101729 lodged in the Central Plan Office—(Rs 10322).

Dated: 5 November 1986

Responsible Minister:

JOAN E. KIRNER

Minister for Conservation, Forests and Lands

L. G. HOUSTON
 Clerk of the Executive Council

Crown Land (Reserves) Act 1978

CROWN LAND TEMPORARILY RESERVED

The Governor in Council under sections 4 and 7 of the *Crown Land (Reserves) Act 1978* temporarily reserves for the purposes mentioned and also excepts from prospecting or from occupation for mining purposes under any miners right the following lands:

Municipal District of the Shire of Karkaroc

Cambacanya—Water Supply, 2.023 hectares being Crown Allotment 23B, Parish of Cambacanya as indicated by hatching on plan hereunder—(C468(3))(Rs 13167).

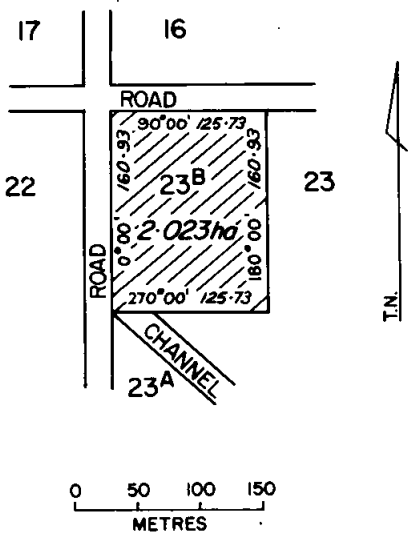

Municipal District of the Shire of Tullaroop
Maryborough—Conservation of an area of historic interest, 5.4 hectares, more or less being Crown Allotment 25A, Section 2, Parish of Maryborough as indicated by hatching on plan hereunder—(M66(17))(Rs 13168).

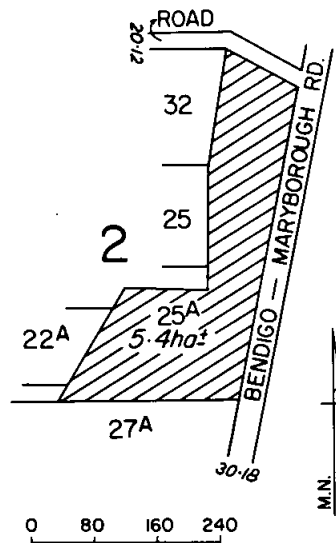

Subject to Survey

Municipal District of the Shire of Swan Hill and the Shire of Walpeup

Kulwin and Wagant—Conservation of an area of natural interest, 262.1 hectares being Crown Allotment 31, Parish of Kulwin and Crown Allotment 20A, Parish of Wagant as shown on Certified Plan No. 107561 lodged in the Central Plan Office—(Rs 13136).

Municipal District of the Shire of Karkaroc

Kurdgweechee—Water Supply, 1.214 hectares being Crown Allotment 8B, Parish of Kurdgweechee as indicated by hatching on plan hereunder—(K179(4))(Rs 13166).

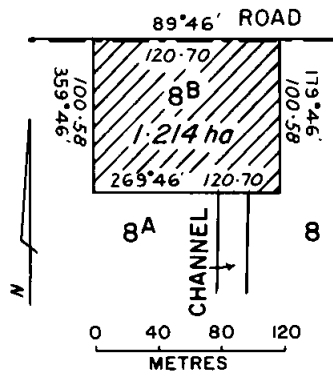

Municipal District of the Shire of Strathfieldsaye
 Mandurang—Conservation of an area of natural interest, 10 hectares, more or less, being Crown Allotment 88k, Section D, Parish of Mandurang as indicated by hatching on plan hereunder—(M29(10)) (Rs 13142).

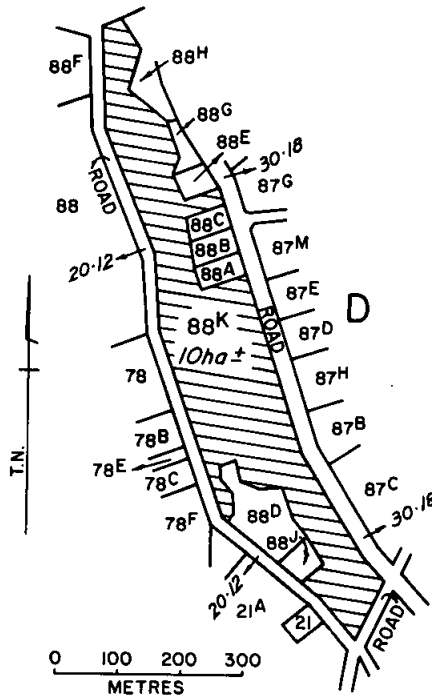

Municipal District of the Shire of Glenelg
 Dergholm—State School Forest Plantation, 2.7 hectares, more or less, being Crown Allotment 39, Township of Dergholm, Parish of Roseneath as indicated by hatching on plan hereunder—(D177(5)) (Rs 13141).

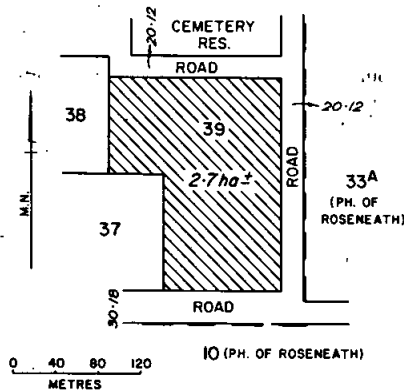

Municipal District of the City of Frankston
 Frankston—Community Welfare Purposes, 805 square metres being Crown Allotment 49A, Parish of Frankston formerly being Lot 3 on Plan of Subdivision No. 75196 lodged in the Office of Titles—(Rs 13189).

Municipal District of the Shire of Walpeup
 Baring North—Conservation of an area of natural interest, 20.18 hectares being Crown Allotments 13A and 13C, parish of Baring North as indicated by hatching on plan hereunder—(B784(3)) (Rs 13126).

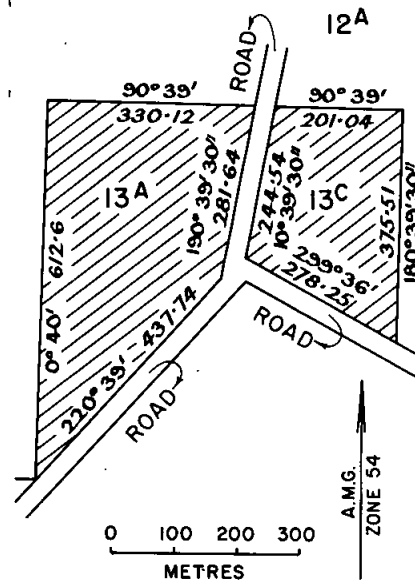

Total area of hatched portions 20.18 ha

Municipal District of the Shire of Walpeup
 Patchewollock North—Conservation of an area of natural interest, 84 hectares being Crown Allotment 43B. Parish of Patchewollock North as shown on Certified Plan No. 105920 lodged in the Central Plan Office—(Rs 13101).

Municipal District of the Shire of Swan Hill
 Turoar—Conservation of an area of natural interest, 2.644 hectares being Crown Allotment 54A, Parish of Turoar as shown on Certified Plan No. 107274 lodged in the Central Plan Office—(Rs 13367).

Municipal District of the Shire of Charlton
 Charlton—Public Purposes (Children's Playground), 1508 square metres being Crown Allotment 1, Section 14, Township of Charlton, Parish of Charlton East as shown on Certified Plan No. 107527 lodged in the Central Plan Office—(Rs 13174).

Municipal District of the Shire of Warragul
 Drouin East—Public Purposes (Departmental Residence), 692 square metres being Crown Allotment 8A, Section A, Parish of Drouin East formerly being Lot 51 on Plan of Subdivision No. 134893 lodged in the Office of Titles—(Rs 13016).

Municipal District of the City of Frankston
 Frankston—Health Purposes, 783 square metres being Crown Allotment 4A, Section 4, Parish of Frankston, formerly being Lot 9 on Lodged Plan of Subdivision No. 98154 lodged in the Office of Titles—(Rs 13014).

Municipal District of the Shire of Werribee
 Truganina—Health Purposes, 673 square metres being Crown Allotment 7A, Section A, Parish of Truganina as indicated by hatching on plan hereunder—(3651) (Rs 13032).

Municipal District of the Shire of Flinders
 Wannaeue—Health Purposes, 824 square metres being Crown Allotment 13F, Section A, Parish of Wannaeue formerly being Lot 122 on Plan of Subdivision No. 14475 lodged in the Office of Titles—(Rs 13031).

Municipal District of the Shire of Marong
 Kangaroo Flat—Public Recreation, 1390 square metres being Crown Allotment 79F, Township of Kangaroo Flat, Parish of Sandhurst as indicated by hatching on plan hereunder—(5403) (Rs 13098).

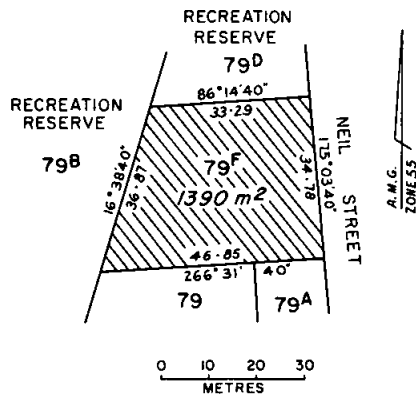

Dated: 5 November 1986
 Responsible Minister:
 JOAN E. KIRNER
 Minister for Conservation, Forests and Lands
 L. G. HOUSTON
 Clerk of the Executive Council

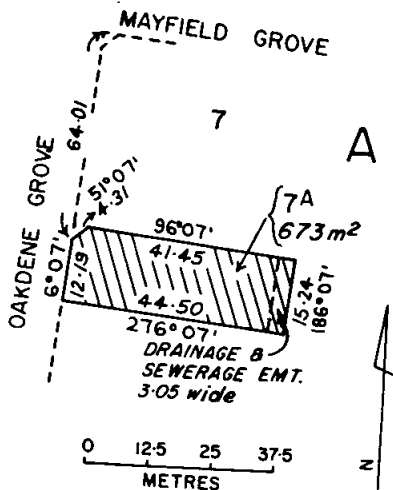

CROWN LAND (RESERVES) ACT 1978

At the Executive Council Chamber, Melbourne, the fifth day of November 1986

PRESENT:

His Excellency the Governor of Victoria
 Mr Trezise | Mr Roper

CROWN LAND PERMANENTLY RESERVED

His Excellency the Governor of the State of Victoria, in the Commonwealth of Australia, by and with the advice of the Executive Council of the said State, pursuant to the provisions of sections 4 and 7 of the *Crown Land (Reserves) Act 1978*, and being of the opinion that the Crown land concerned is required for the purposes mentioned, hereby permanently reserves and also excepts from prospecting or from occupation for mining purposes under any miner's right, the Crown land hereinafter described, viz:

Municipal District of the Shire of Tallangatta
 Wagra—for Conservation of an Area of Natural Interest, 160 ha more or less being Crown Allotment 7, Section 10 in the Parish of Wagra as indicated by hatching on plan hereunder—(Parish 3698-1) (Rs 12717).

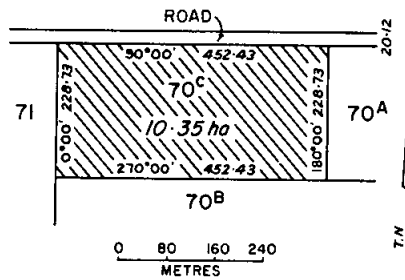
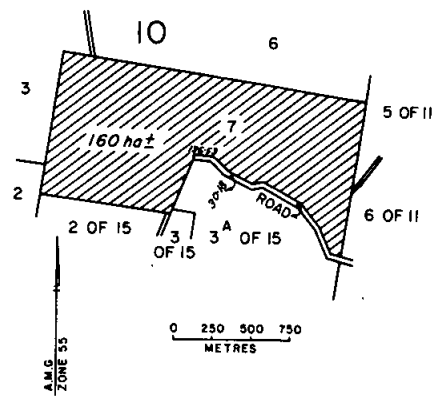

Municipal District of the Shire of Ripon
 Carngham—for Conservation of an Area of Natural Interest, 5.2 ha more or less being Crown Allotment 28c, Section 31 in the Parish of Carngham as indicated by hatching on plan hereunder—(Parish 2351) (Rs 12807).

Municipal District of the Shire of Kowree
 Kout Narin—for Conservation of an Area of Natural Interest, 31 ha more or less being Crown Allotment 100 in the Parish of Kout Narin as indicated by hatching on plan hereunder—(K123(2)) (Rs 12849).

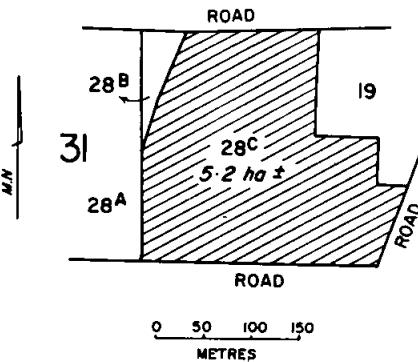
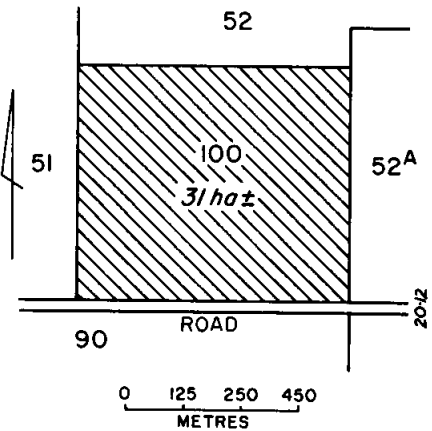

Municipal District of the Shire of Dundas
 Wookurkook—for Conservation of an Area of Natural Interest, 10.35 ha being Crown Allotment 70c in the Parish of Wookurkook as indicated by hatching on plan hereunder—(W258(3)) (Rs 12847).

Municipal District of the Shire of Daylesford and Glenlyon
 Holcombe—for Conservation of an Area of Natural Interest, 24 ha more or less being Crown Allotment 3b, Section A and Crown Allotment 20k in the Parish of Holcombe as indicated by hatching on plan hereunder—(Parish 2760) (Rs 12481).

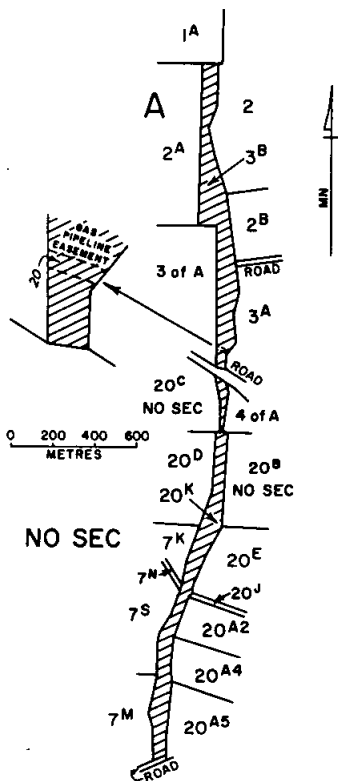

Total area of hatched portions 24 ha ±

Municipal District of the Shire of Lexton
 Lexton—for Conservation of an Area of Natural Interest, 17.44 ha being Crown Allotment 34E, Section B1 in the Parish of Lexton as indicated by hatching on plan hereunder—(L49(4)) (Rs 12868).

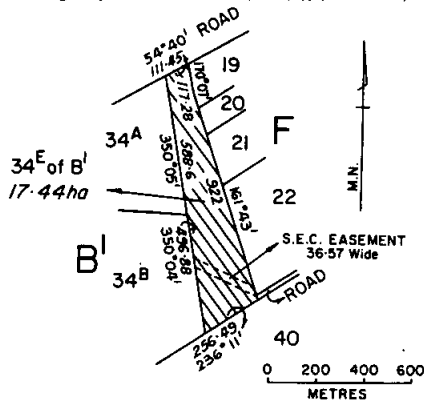

Municipal District of the Shire of Lexton
 Lexton—for Conservation of an Area of Natural Interest, 8.103 ha being Crown Allotment 28, Section F in the Parish of Lexton as indicated by hatching on plan hereunder—(L49(4)) (Rs 12958).

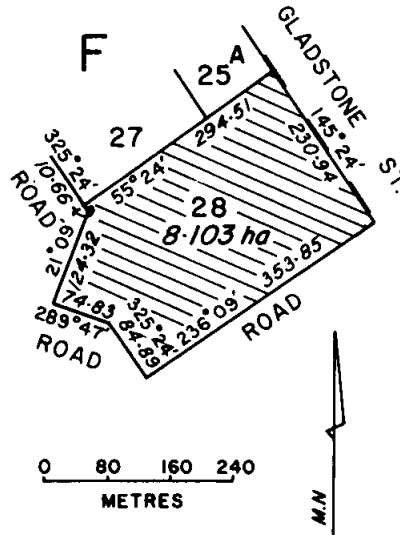

Municipal District of the Shire of Lexton
 Lexton—for Conservation of an Area of Natural Interest, 8.4 ha more or less being Crown Allotment 13A, Section B1 in the Parish of Lexton as indicated by hatching on plan hereunder—(L49(4)) (Rs 12959).

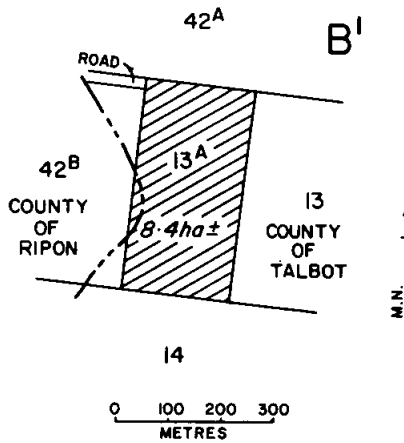

Municipal District of the Shire of Ripon
 Raglan—for Conservation of an Area of Natural Interest, 14.82 ha being Crown Allotment 24A, Section 1 in the Parish of Raglan as indicated by hatching on plan hereunder—(R3(12)) (Rs 12941).

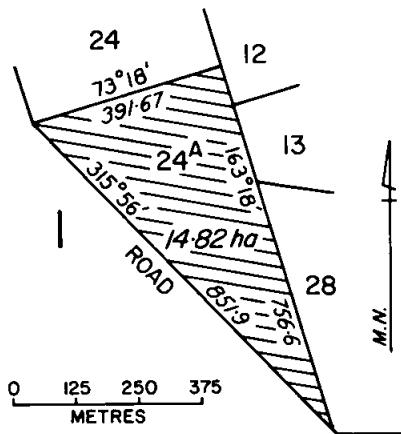

Municipal District of the Shire of Warrnambool
 Nullawarre—for Conservation of an Area of Natural Interest, 1.012 ha being Crown Allotment 36B in the Parish of Nullawarre as indicated by hatching on plan hereunder—(Parish 3333) (Rs 12439).

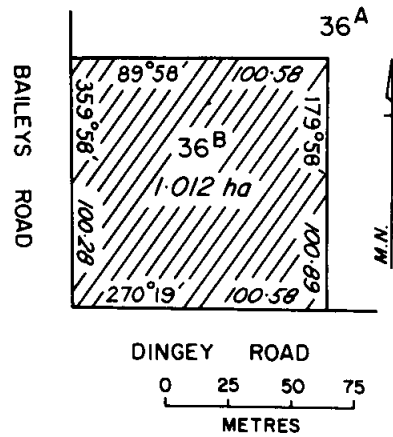

Municipal District of the Shire of Ripon
 Beaufort—for Conservation of an Area of Natural Interest, 12.4 ha more or less being Crown Allotment 5, Section G in the Parish of Beaufort as indicated by hatching on plan hereunder—(B305(7)) (Rs 12836).

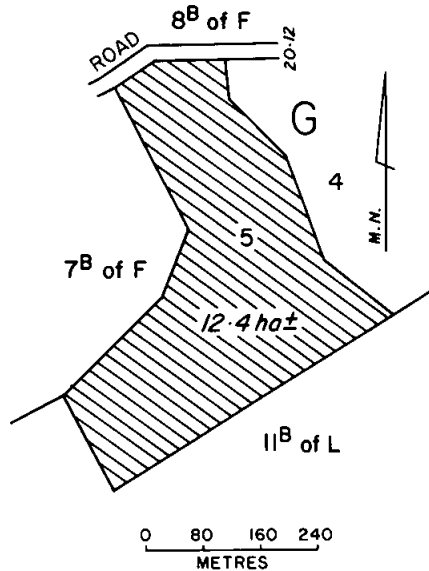

Municipal District of the Shire of Leigh
 Dereel—for Conservation of an Area of Natural Interest, 7 ha more or less being Crown Allotments A66B and A70 in the Parish of Dereel as indicated by hatching on plan hereunder—(D172(7)) (Rs 12950).

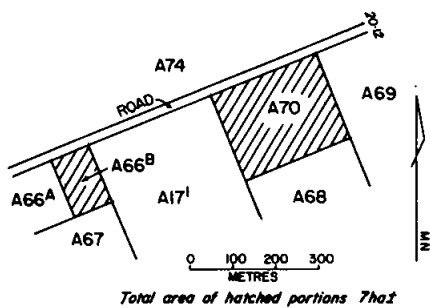

Municipal District of the Shire of Ballarat
 Tourello—for Conservation of an Area of Natural Interest, 7.5 ha more or less being Crown Allotment 9A, Section 3 in the Parish of Tourello as indicated by hatching on plan hereunder—(T92(3)) (Rs 12863).

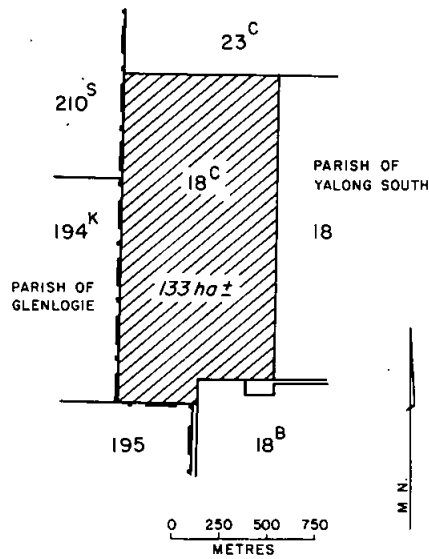
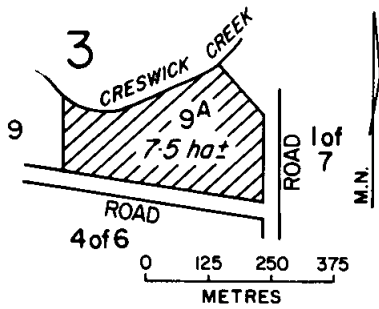

Municipal District of the Shire of Maffra
 Glenmaggie—for Conservation of an Area of Natural Interest, 1.841 ha being Crown Allotment 90B in the Parish of Glenmaggie as indicated by hatching on plan hereunder—(G178(10)) (Rs 12921).

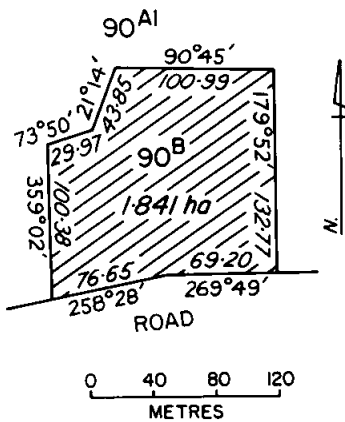

Municipal District of the Shire of Arapiles
 Connangorach—for Conservation of an Area of Natural Interest, 126 ha more or less being Crown Allotment 65A in the Parish of Connangorach as indicated by hatching on plan hereunder—(C438(3)) (Rs 12850).

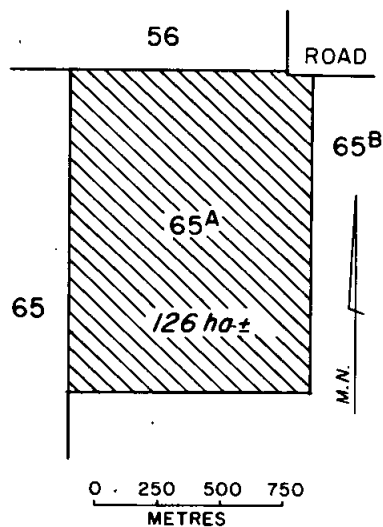

Municipal District of the Shire of Lexton
 Yalong South—for Conservation of an Area of Natural Interest, 133 ha more or less being Crown Allotment 18C in the Parish of Yalong South as indicated by hatching on plan hereunder—(Y93(4)) (Rs 12924).

Municipal District of the Shire of Maffra
 Glenmaggie—for Conservation of an Area of Natural Interest, 8708 square metres being Crown Allotment 38E in the Parish of Glenmaggie as indicated by hatching on plan hereunder—(G178(10)) (Rs 12999).

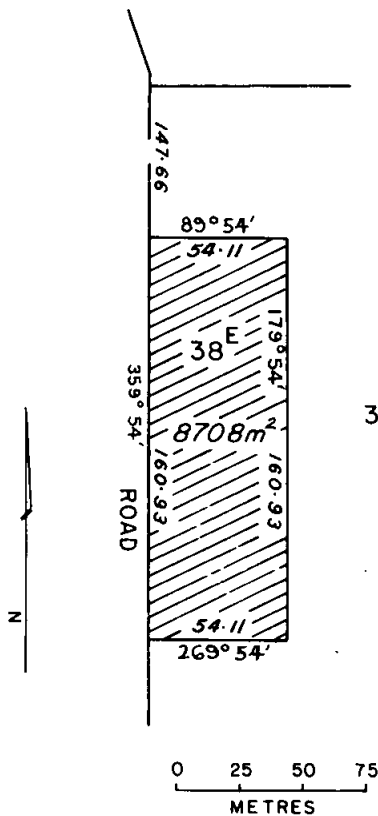

Municipal District of the Shire of Grenville
 Mannibadar—for Conservation of an Area of Natural Interest, 5.5 ha more or less being Crown Allotment 44A in the Parish of Mannibadar as indicated by hatching on plan hereunder—(M90(2)) (Rs 12838).

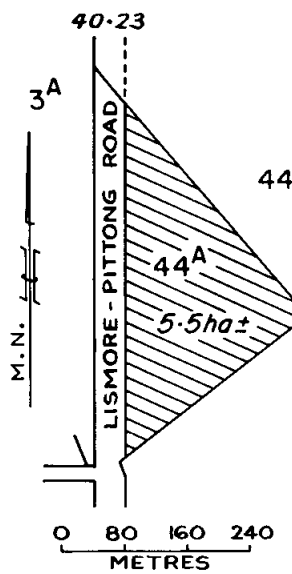

38^D Municipal District of the Shire of Buninyong
 Buninyong—for Conservation of an Area of Natural Interest, 68 ha more or less being Crown Allotment 34C in the Parish of Buninyong as indicated by hatching on plan hereunder—(B489(10)) (Rs 12995).

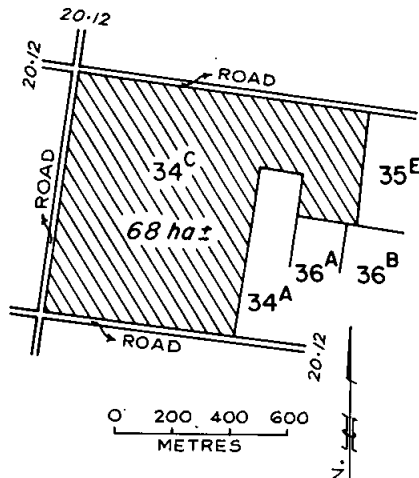

Municipal District of the Shire of Avon
 Meerlieu—for Conservation of an Area of Natural Interest, 130 ha more or less being Crown Allotment 12A, Section 3 in the Parish of Meerlieu as indicated by hatching on plan hereunder—(Parish 3082-1) (Rs 12946).

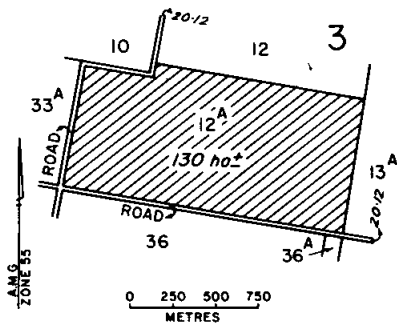

Municipal District of the Shire of Ararat
 Moyston West—for Conservation of an Area of Natural Interest, 7.275 ha being Crown Allotment 17A, Section A in the Parish of Moyston West as indicated by hatching on plan hereunder—(M299(5)) (Rs 12964).

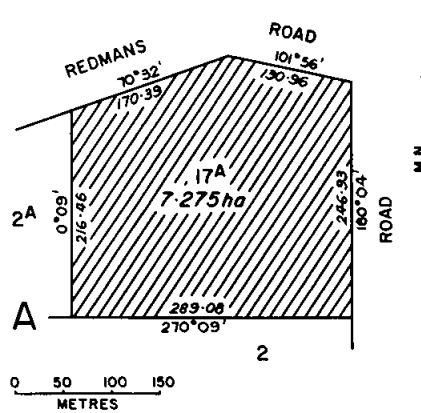

Municipal District of the Shire of Ararat
 Jallukar—for Conservation of an Area of Natural Interest, 5.5 ha more or less being Crown Allotment 11D, Section 2 in the Parish of Jallukar as indicated by hatching on plan hereunder—(Parish 2778) (Rs 12830).

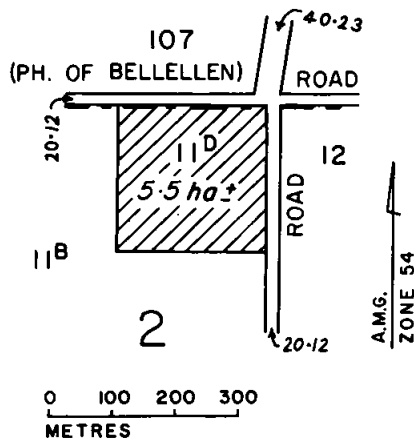

Municipal District of the Shire of Lexton
 Glenpatrick—for Conservation of an Area of Natural Interest, 13 ha more or less being Crown Allotment 30A, Section 2 in the Parish of Glenpatrick as indicated by hatching on plan hereunder—(G74(5)) (Rs 13137).

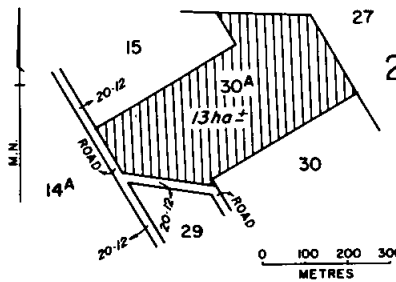

Municipal District of the Shire of Grenville

Smythesdale—for Conservation of an Area of Natural Interest, 4.048 ha being Crown Allotment 2J, Section 49 in the Parish of Smythesdale as indicated by hatching on plan hereunder—(S297 (8)) (Rs 13054).

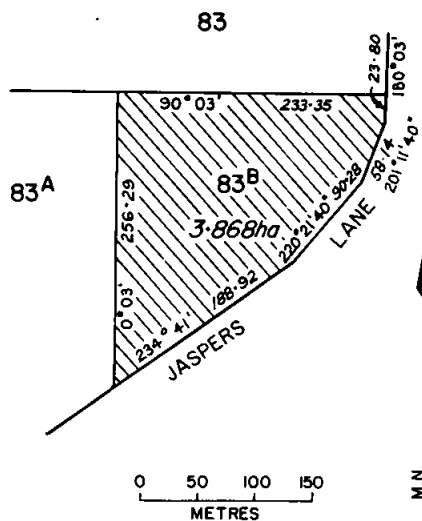
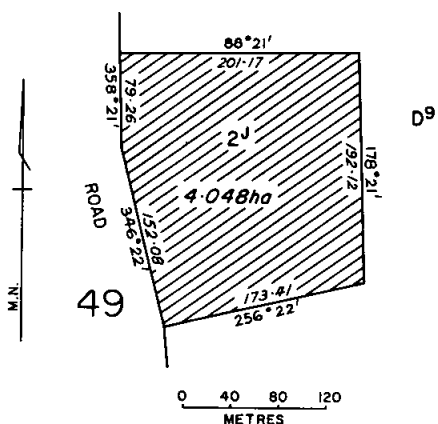

And the Honourable Joan Elizabeth Kirner, Her Majesty's Minister for Conservation, Forests and Lands for the State of Victoria, shall give the necessary direction herein accordingly.

L. G. HOUSTON
Clerk of the Executive Council

Municipal District of the Shire of Bet Bet

Dunolly—for Conservation of an Area of Natural Interest, 7.389 ha being Crown Allotment 5E, Section 1B in the Parish of Dunolly as indicated by hatching on plan hereunder—(D125(10)) (Rs 13068).

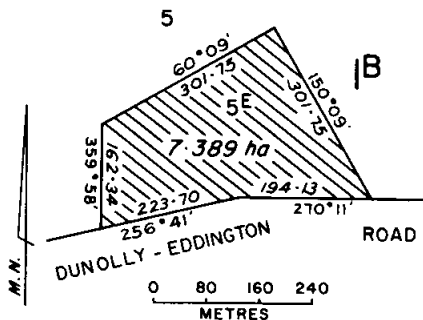

Municipal District of the Shire of Kowree
Telangatuk—for Conservation of an Area of Natural Interest, 3.868 ha being Crown Allotment 83B in the Parish of Telangatuk as indicated by hatching on plan hereunder—(T195(6)) (Rs 13193).

CROWN LAND (RESERVES) ACT 1978

At the Executive Council Chamber, Melbourne, the fifth day of November 1986

PRESENT:

His Excellency the Governor of Victoria
Mr Trezise | Mr Roper

CROWN LAND PERMANENTLY RESERVED

His Excellency the Governor of the State of Victoria, in the Commonwealth of Australia, by and with the advice of the Executive Council of the said State, pursuant to the provisions of sections 4 and 7 of the *Crown Land (Reserves) Act 1978*, and being of the opinion that the Crown land concerned is required for the purposes mentioned, hereby permanently reserves and also excepts from prospecting or from occupation for mining purposes under any miner's right, the Crown land hereinafter described, viz.:

Municipal District of the Shire of Arapiles

Carchap—for Conservation of an Area of Natural Interest 3.2 ha more or less being Crown Allotment 61A in the Parish of Carchap as indicated by hatching on plan hereunder—(C421(4)) (Rs 13119).

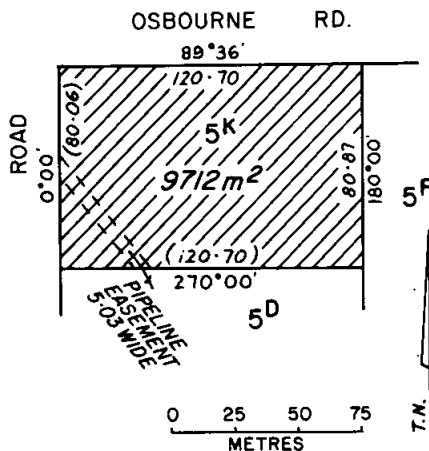
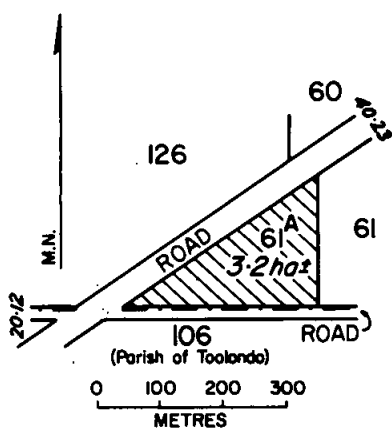

Municipal District of the Shire of Kowree
 Charam—for Management of Wildlife 75 ha more or less being Crown Allotment 47B in the Parish of Charam as indicated by hatching on plan hereunder—(C387(3)) (Rs 12831).

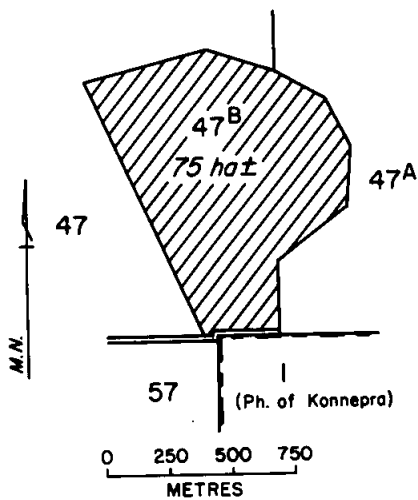

Municipal District of the Shire of Kowree
 Gymbowen—for Conservation of an area of Natural Interest 68.12 ha being Crown Allotments 74C and 74D in the Parish of Gymbowen as indicated by hatching on plan hereunder—(G230(2)) (Rs 13235).

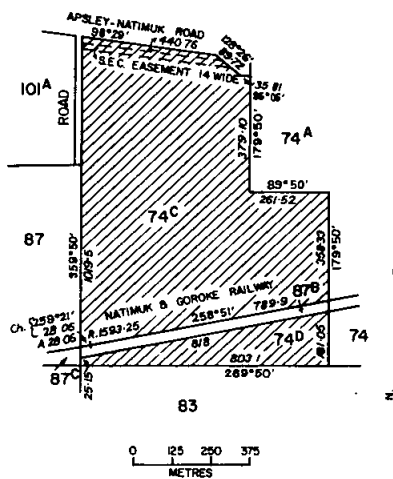

Municipal District of the Shire of Wimmera
 Horsham—for Water Supply 9712 square metres being Crown Allotment 5K in the Parish of Horsham as indicated by hatching on plan hereunder—(H95(4)) (Rs 7517).

Total area of hatched portions 68.12ha

Municipal District of the Shire of Bairnsdale

Coongulmerang—for the preservation of species of native plants 10.2 ha more or less being Crown Allotment 21A, Section A in the Parish of Coongulmerang as indicated by hatching on plan hereunder—(Parish 2436-1)(Rs 13339).

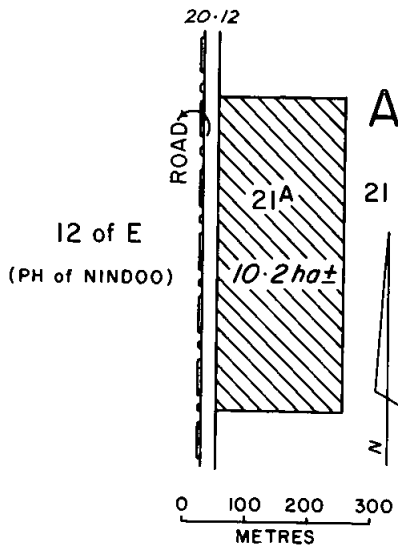

Municipal District of the Shire of Pyalong

Baynton—for Conservation of an Area of Natural Interest 4900 square metres more or less being Crown Allotment 1A, Section 2 in the Parish of Baynton as indicated by hatching on plan hereunder—(B24(2))(Rs 12451).

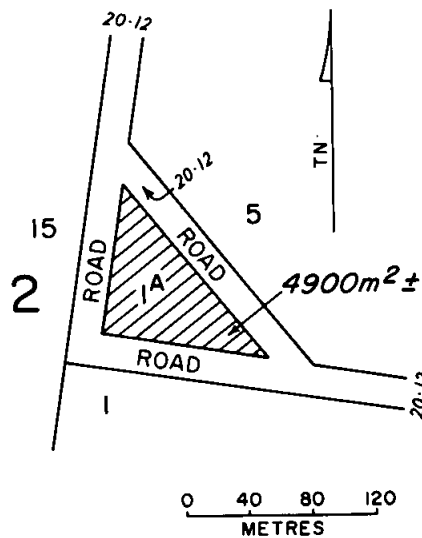

Municipal District of the Shire of Dundas

Murndal—for the protection of the bed and banks of a lake 10 ha more or less being Crown Allotment 7, Section 5 in the Parish of Murndal as indicated by hatching on plan hereunder—(M283(2)) (Rs 13118).

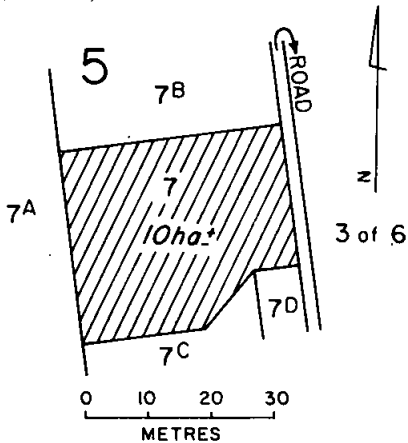

Municipal District of the Shire of Eltham

Queenstown—for Conservation of an Area of Natural Interest 143.1 ha being Crown Allotments 13A and 23D, Section A in the Parish of Queenstown as indicated on Certified Plan No. 103907 lodged in the Central Plan Office—(Q22(7)) (Rs 12888).

Municipal District of the Shire of Kyneton

Baynton—for Conservation of an Area of Natural Interest 2.909 ha being Crown Allotment 32A in the Parish of Baynton as indicated on Certified Plan No. 107573 lodged in the Central Plan Office—(B24(2)) (Rs 12433).

Municipal District of the Shire of Ararat

Moyston—for Conservation of an Area of Natural Interest 4.026 ha being Crown Allotment N1 in the Parish of Moyston as indicated on Certified Plan No. 107955 lodged in the Central Plan Office—(M299(F3)) (Rs 12791).

Municipal District of the Shire of Ararat

Watgania—for Management of Wildlife 635.1 ha being Crown Allotment 91A in the Parish of Watgania as indicated on Certified Plan No. 107724 lodged in the Central Plan Office—(W263(3)) (Rs 12844).

Municipal District of the shire of Kowree
 Toolondo—for Conservation of an Area of Natural Interest 1.531 ha being Crown Allotment 19A in the Parish of Toolondo as indicated on Certified Plan No. 107804 lodged in the Central Plan Office—(T187(5)) (Rs 13212).

Municipal District of the Shire of Hastings
 Bittern—for Conservation of an Area of Natural Interest 5.624 ha being Crown Allotment 34D, in the Parish of Bittern as indicated on Certified Plan No. 107435 lodged in the Central Plan Office—(B397(9)) (Rs 13255).

Municipal District of the Shire of Dundas
 Cavendish—for Conservation of an Area of Natural Interest 17.45 ha being Crown Allotments 13, 14 and 15, Section 12 in the Township of Cavendish as indicated on Certified Plan No. 107544 lodged in the Central Plan Office—(C181(5)) (Rs 13102).

Municipal District of the Shire of Pakenham
 Pakenham—for Conservation of an Area of Natural Interest 11.14 ha being Crown Allotments 149A and 149B in the Parish of Pakenham as indicated on Certified Plan No. 107263 lodged in the Central Plan Office—(P5(5)) (Rs 13110).

And the Honourable Joan Elizabeth Kirner, Her Majesty's Minister for Conservation, Forests and Lands for the State of Victoria, shall give the necessary directions herein accordingly.

L. G. HOUSTON
 Clerk of the Executive Council

Crown Land (Reserves) Act 1978
CROWN LAND TEMPORARILY RESERVED

The Governor in Council under sections 4 and 7 of the *Crown Land (Reserves) Act 1978* temporarily reserves for the purpose mentioned and also excepts from prospecting or from occupation for mining purposes under any miners right the following land:

Municipal District of the Shire of Werribee
 Deutgam—Police Purposes, 1.376 hectares more or less, being Crown Allotment 1a, Section C, Parish of Deutgam as shown by hatching on the plan hereunder—(D42-6) (Rs 13373).

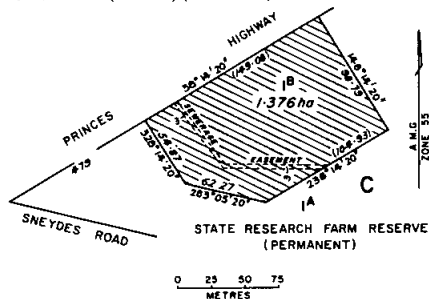

Dated: 5 November 1986

Responsible Minister:
 JOAN E. KIRNER
 Minister for Conservation, Forests and Lands
 L. G. HOUSTON
 Clerk of the Executive Council

Crown Land (Reserves) Act 1978
CROWN LAND PERMANENTLY RESERVED

The Governor in Council, under section 4 of the *Crown Land (Reserves) Act 1978* permanently reserves for the purpose mentioned the following Crown land:

Municipal District of the Shire of Stawell
 Illawarra—Conservation of an area of historic interest, 8.393 hectares being Crown Allotment 232A, Parish of Illawarra as indicated by hatching on plan hereunder—(2771) (Rs 12973).

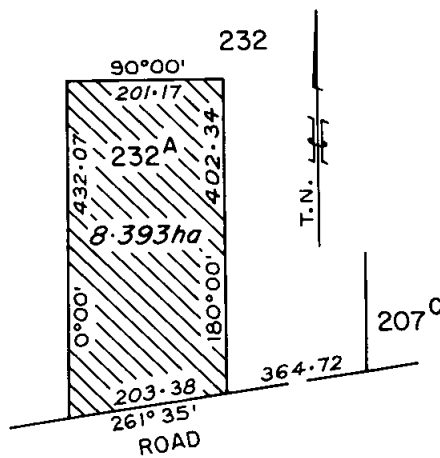

Dated: 5 November 1986
 Responsible Minister:
 JOAN E. KIRNER
 Minister for Conservation, Forests and Lands
 L. G. HOUSTON
 Clerk of the Executive Council

Crown Land (Reserves) Act 1978
VESTING OF LAND IN THE CITY OF WANGARATTA

The Governor in Council under section 16 (1) of the *Crown Land (Reserves) Act 1978* directs that the Crown land described in the Schedule hereunder be vested in the Corporation of the City of Wangaratta on trust for the purposes for which the land has been reserved and, under section 16 (2) of the Act, empowers the Corporation to grant leases or licences for a term not exceeding 21 years in respect of the land for the purposes of the reservation.

Schedule

Wangaratta—An area of 32 hectares more or less in the Township of Wangaratta shown by hatching on plan hereunder being the lands permanently reserved as a site for Public Recreation Purposes by Order in Council of 15 July 1875 and temporarily reserved as a site for Public Recreation by Order in Council of 22 April 1986—(W85(8)) (Rs 2441) (Rs 3185).

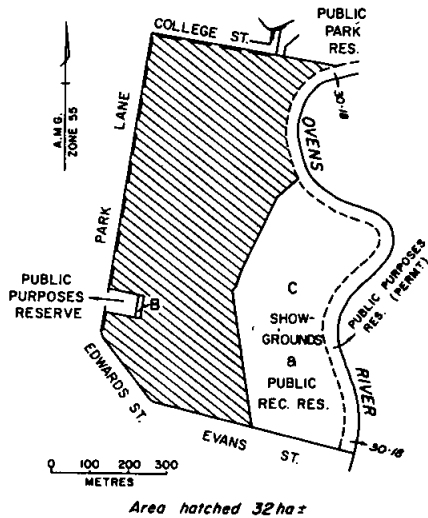

Dated: 5 November 1986
 Responsible Minister:
JOAN E. KIRNER
 Minister for Conservation, Forests and Lands
L. G. HOUSTON
 Clerk of the Executive Council

Land Act 1958
UNUSED ROADS CLOSED

The Governor in Council under section 349 of the *Land Act 1958* and with the consent of the municipalities concerned, closes the following unused roads.

Municipal district of the Shire of Avoca, Parish of Yehrip being the road indicated by hatching on plan hereunder—(Y83(3)) (Rs 13172).

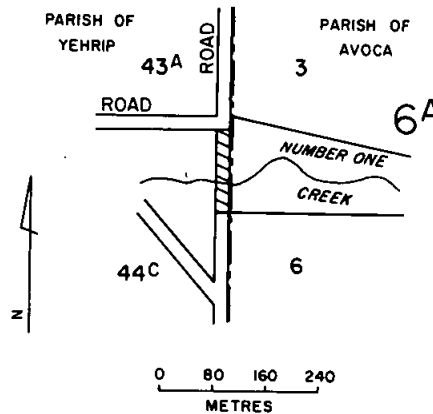

Municipal district of the Shire of Kowree, Parish of Tallageira being the road indicated by hatching on plan hereunder—(T279(3)) (Rs 13353).

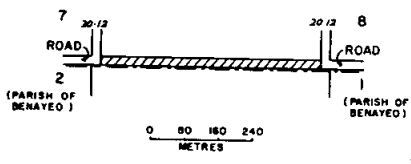

Dated: 5 November 1986
 Responsible Minister:
JOAN E. KIRNER
 Minister for Conservation, Forests and Lands
L. G. HOUSTON
 Clerk of the Executive Council

Land Act 1958

UNUSED ROAD CLOSED

The Governor in Council under section 349 of the *Land Act 1958* and with the consent in writing of the municipality concerned and the adjoining owners closes the following unused road.

Municipal District of the Shire of Kaniva, Township of Kaniva, Parish of Kaniva, being the road indicated by hatching on plan hereunder—(K147(7)) (L4-3297).

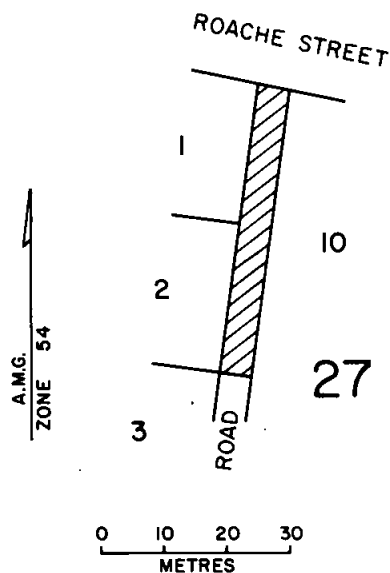

Dated: 5 November 1986

Responsible Minister:

JOAN E. KIRNER

Minister for Conservation, Forests and Lands

L. G. HOUSTON

Clerk of the Executive Council

MOTOR CAR ACT 1958

At the Executive Council Chamber, Melbourne, the fifth day of November 1986

PRESENT:

His Excellency the Governor of Victoria

Mr Trezise

Mr Roper

MOTOR CAR TRIALS OF SPEED IN THE SHIRE OF MALDON

Whereas it is enacted by sub-sections (1) and (2) of section 83A of the *Motor Car Act 1958* that, if a motor car is used on a highway for purposes of

racing or of trial of speed, and if a race or trial of speed is organized or managed, the driver or the person in charge thereof and the person organizing or managing the race or trial of speed, shall be liable to a penalty of not more than Five hundred dollars for the first offence and One thousand dollars for the second offence, provided that the said sub-sections (1) and (2) shall not apply to a motor car used as aforesaid or to a race or trial of speed on any highway or portion thereof specified by Order in Council published in the *Government Gazette*, on such days and during such hours as are specified in the order.

And whereas the Vintage Sports Car Club of Australia has requested that such an order be made to enable an event known as the "Mt Tarrangower Hill Climb" to be conducted by the said club on 23 November 1986.

Now therefore, His Excellency the Governor of the State of Victoria, by and with the advice of the Executive Council thereof, and in pursuance of the powers conferred by the *Motor Car Act 1958* and all other powers him thereunto enabling, doth order that the provisions of sub-sections (1) and (2) of section 83A of the *Motor Car Act 1958* and of the regulations made under Part VI. of the *Transport Act 1983* shall not apply with respect to the event known as the Mt Tarrangower Hill Climb to be held on Mt Tarrangower Tourist Road within the Shire of Maldon between the hours of 9.00 in the forenoon and 6.00 in the afternoon on Sunday, 23 November 1986.

And the Honourable Thomas William Roper, Her Majesty's Minister for Transport for the State of Victoria, shall give the necessary directions herein accordingly.

L. G. HOUSTON

Clerk of the Executive Council

Public Service Act 1974

REVOCATION OF DELEGATION OF PUBLIC SERVICE BOARD POWERS, DUTIES AND FUNCTIONS

Alpine Resorts Commission is an administrative unit specified in Schedule Three of the Public Service Act. Delegation of Public Service Board powers to a Schedule Three unit occurs through Order by Governor in Council.

The Public Service Board has recommended revocation of delegations at present extended to the Commission.

Pursuant to section 23(7) of the Act, the Governor in Council by this Order revokes Orders made on 10 September 1985, 10 December 1985 and 3 June 1986 in relation to the Alpine Resorts Commission constituted by the *Alpine Resorts Act 1983*.

Dated: 6 November 1986

Responsible Minister:

JOHN CAIN

Premier

L. G. HOUSTON

Clerk of the Executive Council

TENDERS

PUBLIC WORKS DEPARTMENT

Tenders are invited for the purposes indicated hereunder and will be received at 2 Treasury Place, Melbourne, 3002, until TWO p.m. on the dates shown.

Tenders must be addressed to the Minister for Public Works with the envelope endorsed "Tender for

Tenders forwarded either by mail, telegram or telex which arrive after the closing time will be accepted provided that the official Telecom or Australia Post time and date stamping indicates dispatch prior to the closing time. (TIME AND DATE STAMPING MUST BE REQUESTED AT SOME POST OFFICES.)

(TELEX No. AA152039)

Hand-delivered tenders must be placed in the Department's tender box, in foyer, Ground Floor, 2 Treasury Place, Melbourne.

Tender documents are available from the Contracts Office, Room 29, Ground Floor, 2 Treasury Place, Melbourne and where indicated at offices of Inspector of Works.

Wednesday, 19 November 1986

Building, Electrical and Mechanical Services

EPPING—Connection to sewer, Primary School.

TERANG—External and internal painting and repairs, High School. (W.O. Warrnambool).

Miscellaneous

HOPPERS CROSSING—Supply of milling machine, T1300, Post Primary School.

MELBOURNE—Workstations for CADD installations, T3062, 2 Treasury Place—Public Works Department.

PORT MELBOURNE—Purchase of two (2) transportable ablation units, P.W.D. storeyard—69 Salmon Street.

PORT MELBOURNE—Purchase of two (2) only transportable office units, P.W.D. storeyard—69 Salmon Street.

PORT MELBOURNE—Purchase of two (2) only transportable change units, P.W.D. storeyard—69 Salmon Street.

PORT MELBOURNE—Purchase of four (4) only transportable amenities units, P.W.D. storeyard—69 Salmon Street.

WARRNAMBOOL—Supply of automotive equipment, T1298, College of T.A.F.E.

WARRNAMBOOL—Supply of welding equipment, T1293, College of T.A.F.E.

Wednesday, 26 November 1986

Building, Electrical and Mechanical Services

BARWON HEADS—New cavity—Brickwork building for student toilets, Primary School. (W.O. Geelong).

CRAIGIEBURN—Connection to sewer, Primary School.

SOUTH MELBOURNE—Supply and installation of carpet, Coronial Services Centre—Law Department.

ST. ALBANS—Hydraulic services, Western Institute, T.A.F.E.

ST. ALBANS—Covered walkway—framing and decking, Western Institute, T.A.F.E.

ST. ALBANS—Covered walkway—roof decking and screens, Western Institute, T.A.F.E.

Wednesday, 3 December 1986

Building, Electrical and Mechanical Services

GEELONG—Internal building alterations to provide toilets, Regional Headquarters—Education Department. (W.O. Geelong).

GLEN WAVERLEY—Supply and install HF radio system, Sheriff's Office—287 Springvale Road—Law Department.

YARRAWONGA—Internal and external repairs and painting, Primary School. (W.O. Benalla, Shepparton and Wangaratta).

RONALD WALSH

Minister for Public Works

Public Works Department
Melbourne, 10 November 1986

PRIVATE ADVERTISEMENTS

CITY OF BENALLA

Town and Country Planning Act 1961

CITY OF BENALLA PLANNING SCHEME

Notice that a Planning Scheme has been Prepared
and is Available for Inspection

Amendment No. 44

Notice is hereby given that the City of Benalla, in pursuance of its powers under the *Town and Country Planning Act 1961*, has prepared a scheme for inclusion in the Planning Scheme, the rezoning of the following lands:

- (a) Part Crown allotments 6 and 11, Section 7, Samaria Road, Benalla, from Light Industrial to Residential 'B' Zone;
- (b) Crown allotment 10 and part Crown Allotments 5, 6, 7, 8 and 12, Section 7, Samaria Road, Benalla, from Rural to Residential 'B' Zone.

A copy of the scheme has been deposited at the Civic Offices, Fawckner Drive, Benalla, and at the office of the Ministry for Planning Environment (Plan Inspection Section), Ground Floor, Olderfleet Buildings, 477 Collins Street, Melbourne, and will be open for inspection during office hours by any person free of charge.

Any persons affected by the scheme are required to set forth in writing any submission they may wish to make with respect to the scheme, addressed to the Town Clerk, Civic Offices, Fawckner Drive, Benalla, by 15 December 1986, and state whether they wish to be heard in respect of their submission.
5062 W. S. JABOOR, Town Clerk

- (b) the City of Camberwell continuing to have and possess the same right title power authority or interest in or in relation to the whole of the land shown by hatching on the said plan as it had or possessed prior to such discontinuance with respect to or in connection with any drains or pipes laid or erected in or over such land for the purposes of drainage; and
- (c) the land in the said road subject to any such right title power authority or interest vesting in the municipality to be retained by it until it is sold by private treaty.

MARTIN VERHOEVEN
Chief Executive Officer

4984

CITY OF CAMBERWELL
Road Discontinuance

Pursuant to section 528 (2) of the *Local Government Act 1958*, the Council of the City of Camberwell has resolved that part of a road abutting 12 Norbert Street, Balwyn, which is shown by hatching on the plan herewith, and which has been closed under the Melbourne Metropolitan Planning Scheme Amendment 408, gazetted on 25 June 1986 be discontinued subject to—

- (a) the Melbourne and Metropolitan Board of Works continuing to have and possess the same right title power authority or interest in or in relation to the whole of the land shown by hatching on the said plan as it had or possessed prior to such discontinuance with respect to or in connection with any drains or pipes laid or erected in on or over such land for the purposes of drainage or sewerage;

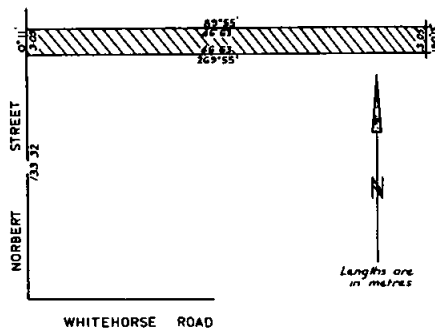

R.O.W. to be discontinued with the M.M.B.W. and Council retaining existing rights.

CITY OF CAMBERWELL
Road Discontinuance

Pursuant to section 528 (2) of the *Local Government Act 1958*, the Council of the City of Camberwell has resolved that part of a road abutting Nos 33 and 35 Aylmer Street, Balwyn which is shown by hatching on the plan herewith, and which has been closed per Amendment 408, Melbourne Metropolitan Planning Scheme, gazetted 25 June 1986 be discontinued subject to—

- (a) the land in the said road subject to any such right, title, power, authority or interest vesting in the municipality to be retained by it until sold by private treaty.

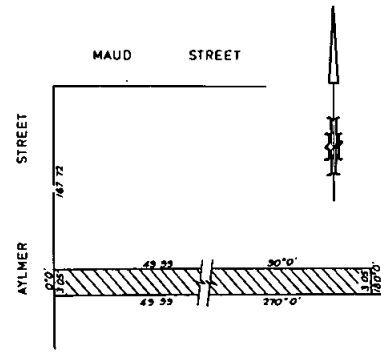

Section of R.O.W. to be discontinued with Council retaining existing rights.

MARTIN VERHOEVEN
Chief Executive Officer and Town Clerk

4985

CITY OF FRANKSTON

Closure of an Unnamed Road, Seaford

Notice is hereby given pursuant to the provisions of section 539c of the *Local Government Act 1958* (as amended) that the Council of the City of Frankston at a meeting held on Monday, 27 October 1986, formally ordered the closure of an unnamed road between Nos. 84 and 85 Nepean Highway, Seaford, to through vehicular traffic at points 6 m and 18 m from its intersection with Beach Grove shown on the plan hereunder.

The closure will come into effect on Monday, 1 December 1986.

Dated 28 October 1986.

CITY OF FRANKSTON
CLOSURE OF AN UN-NAMED R.O.W.
TO THROUGH TRAFFIC
PART OF CROWN ALLOTMENTS 5 & 6 SECTION A
PARISH OF FRANKSTON
COUNTY OF MORNINGTON
 SCALE 1:1000 METRES

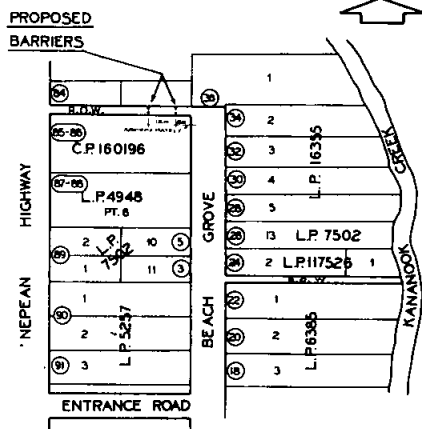

5052 A. H. BUTLER, Chief Executive Officer

Town and Country Planning Act 1961
CITY OF MOE—CITY OF MOE PLANNING
SCHEME 1966

Notice that a Planning Scheme has been Prepared and is Available for Inspection

Amendment No. 98

The City of Moe has prepared a Planning Scheme for the—

- (i) re-zoning of Lots 1, 2, 3 and 4, L.P. 64269 (at the intersection of George and Kirk Streets)

- and Part C.A. 8, section 2, Township of Moe (in Kirk Street) from Commercial "A" zone to Commercial "B" zone;
- (ii) re-zoning of Lots 1, 2, 3, 4 and 5, L.P. 112246 (street Nos. 16 to 30 inclusive) Kirk Street from Commercial "A" zone to Commercial "B" zone;
- (iii) re-zoning of all shops within V/Line lands on the south side of George Street (street Nos. 1 to 29 inclusive) opposite the intersection of Moore Street, from Commercial "A" zone to Commercial "B" zone; and
- (iv) re-zoning of the land bounded by Saviges Road, Albert Street and Clifton Street and the projection of the southern boundary of Clifton Street to Saviges Road from a Light Industrial zone to Commercial "B" zone.

A copy of the scheme may be inspected during office hours, free of charge, at the City Offices, Albert Street, Moe, the office of the Ministry for Planning and Environment, The Olderfleet Buildings, 477 Collins Street, Melbourne, the Ministry's Local Office located at 71 Hotham Street, Traralgon and at the Latrobe Regional Commission's Offices, 43 Grey Street, Traralgon.

Persons affected by the scheme may lodge written submissions, to reach the Town Clerk, City of Moe, P.O. Box 189 Moe, 3825, on or before Friday, 12 December 1986 stating whether they wish to be heard personally by the council.

5017 P. G. LERSTANG, Town Clerk

CITY OF RINGWOOD

Notice of Adoption of Order of Partial Closure of Street

Pursuant to section 539c of the *Local Government Act 1958* the Council of the City of Ringwood at its meeting held on 28 July 1986, adopted an order for the partial closure of Haig Street between Nos. 15 and 21.

The council resolved that such order shall come into operation on and from 17 November 1986.

5018 ALAN C. ROBERTSON, Chief Executive

CITY OF PRESTON

Road Discontinuance

Pursuant to section 528 (2) of the *Local Government Act 1958*, the Council of the City of Preston at its Ordinary Meeting of Council held on 13 October 1986, resolved that the road shown hatched on the plan below, be discontinued and sold by private treaty.

"That notwithstanding such discontinuance the Melbourne and Metropolitan Board of Works shall continue to have and possess the same right, title, power, authority or interest in or in relation to the whole of the land shown by hatching on the said

plan as it had or possessed prior to such discontinuance with respect to or in connection with any drains or pipes laid or erected in on or over such land for the purposes of drainage or sewerage."

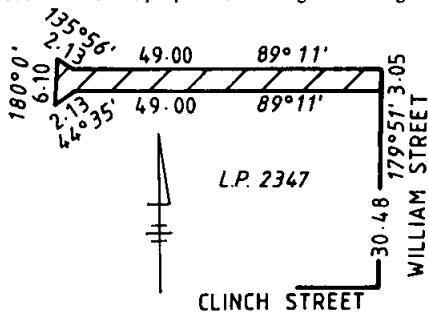

4986 D. O. McLEAN, Chief Executive Officer

CITY OF PRESTON
Road Discontinuance

Pursuant to section 528 (2) of the *Local Government Act 1958*, the Council of the City of Preston at its Ordinary Meeting of Council held on 17 November 1985, resolved that the road shown hatched on the plan below, be discontinued and sold by private treaty.

"That notwithstanding such discontinuance the Council and the Melbourne and Metropolitan Board of Works shall continue to have and possess the same right, title, power, authority or interest in or in relation to the whole of the land shown by crosshatching on the said plan as it had or possessed prior to such discontinuance with respect to or in connection with any drains or pipes laid or erected in on or over such land for the purposes of drainage or sewerage."

CITY OF PRESTON
Road Discontinuance

Pursuant to section 528 (2) of the *Local Government Act 1958*, the Council of the City of Preston at its Ordinary Meeting of Council held on 13 October 1986, resolved that the road shown hatched on the plan below, be discontinued and sold by private treaty.

"That notwithstanding such discontinuance the Melbourne and Metropolitan Board of Works and the Gas and Fuel Corporation shall continue to have and possess the same right, title, power, authority or interest in or in relation to the whole of the land shown by hatching on the said plan as it had or possessed prior to such discontinuance with respect to or in connection with any drains or pipes laid or erected in on or over such land for the purposes of drainage or sewerage."

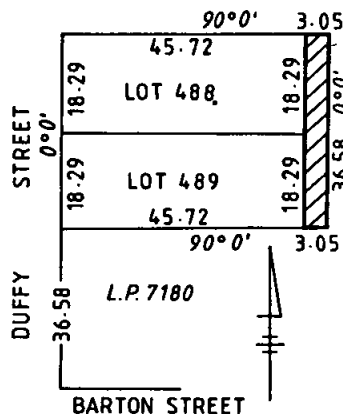

4987 D. O. McLEAN, Chief Executive Officer

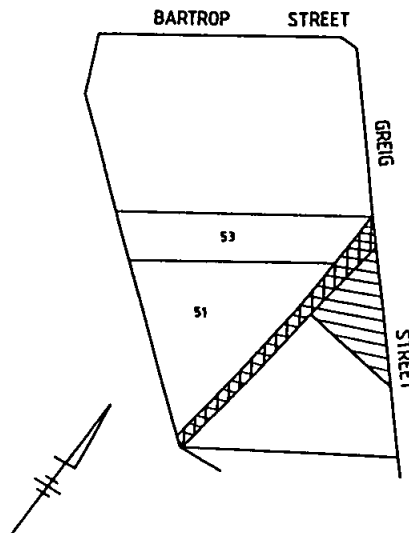

4988 D. O. McLEAN, Chief Executive Officer

Form 2.1
Town and Country Planning Act 1961
CITY OF SHEPPARTON PLANNING SCHEME
1953

Notice that a Planning Scheme has been Prepared and is Available for Inspection
Amendment No. 108, 1986

Notice is hereby given that the Council of the City of Shepparton, in pursuance of its powers under the *Town and Country Planning Act 1961*, has prepared a Scheme for the purpose of amending the Town Planning Scheme to allow the rezoning of

properties on the north side of Nixon Street, from Corio Street to Railway Parade, from Residential "A" to Residential "A1".

A copy of the Scheme has been deposited at the office of the Council, Municipal Offices, Welsford Street, Shepparton, and at the office of the Ministry for Planning and Environment (Plan Inspection Section), Ground Floor, The Olderfleet Buildings, 477 Collins Street, Melbourne, and will be open for inspection during office hours by any person, free of charge.

Any persons affected by the Scheme are required to set forth, in writing, any submission they may wish to make with respect to the Scheme addressed to the City Manager/Town Clerk, City of Shepparton, P.O. Box 989, Shepparton, 3630, by Friday, 5 December 1986, and state whether you wish to be heard in respect of the submission.

Dated 31 October 1986

4989 I. L. GILBERT, City Manager/Town Clerk

SHIRE OF CRESWICK

Naming of Road

Notice is hereby given that in pursuance of the powers conferred by section 535 (4) of the *Local Government Act 1958*, as amended, the Council of the Shire of Creswick has allocated the following road name:

Old Name—Government Road.

New Name—Spittle Road.

Locality—Commencing at the south-west corner of Crown Allotment 9, Section N, Parish of Creswick; thence northerly to the north-west corner of Crown Allotment 3b, Section L, Parish of Creswick.

4990 B. C. REES, Shire Secretary

Town and Country Planning Act 1961

SHIRE OF MORNINGTON PLANNING SCHEME 1959 (AS AMENDED)

Notice that a Planning Scheme has been Prepared and is Available for Inspection

Amendment No. 186

Notice is hereby given that the Shire of Mornington in pursuance of its powers under the *Town and Country Planning Act 1961*, has prepared a Scheme for the land at 53-55 Barkly Street, Mornington, being occupied by the old Mornington Restaurant, to rezone the land to Sub-Regional Business and include the building as being of Historic Interest.

A copy of the Scheme has been deposited at the Council Offices, Queen Street, Mornington, and at the office of the Ministry for Planning and Environment, Ground Floor, 477 Collins Street, Melbourne, and will be open for inspection during office hours by any person free of charge.

Any persons affected by the Scheme are required to set forth in writing any submission they may wish to make with respect to the Scheme addressed to Shire Secretary, P.O. Box 78, Mornington, 3931, by 13 December 1986, and state whether you wish to be heard in respect of your submission.

Dated 30 October 1986

4991 D. G. COLLINGS, Shire Secretary

Form 2.1

Town and Country Planning Act 1961

SHIRE OF SHEPPARTON—SHIRE OF SHEPPARTON PLANNING SCHEME 1983

Notice that a Planning Scheme has been Prepared and is Available for Inspection

Amendment No. 7, 1986

Notice is hereby given that the Council of the Shire of Shepparton, in pursuance of its powers under the *Town and Country Planning Act 1961*, has prepared a Scheme for the rezoning of Crown Allotment 51, Section C, Parish of Shepparton from the Rural D Zone to the Low Density Residential Zone.

A copy of the Scheme has been deposited at the Council Offices, corner of Nixon and Welsford Streets, Shepparton, and at the office of the Ministry for Planning and Environment, The Olderfleet Buildings, 477 Collins Street, Melbourne, and will be open for inspection during office hours by any person, free of charge.

Any persons affected by the Scheme are required to set forth, in writing, any submission they may wish to make with respect to the Scheme addressed to the Shire Secretary, Shire of Shepparton, P.O. Box 606, Shepparton, 3630, by Friday, 19 December 1986, and state whether you wish to be heard in respect of the submission.

Dated 12 November 1986

4993 I. W. MARTIN, Shire Secretary

Form 2.1

Town and Country Planning Act 1961

SHIRE OF SHEPPARTON—SHIRE OF SHEPPARTON PLANNING SCHEME 1983

Notice that a Planning Scheme has been Prepared and is Available for Inspection

Amendment No. 8, 1986

Notice is hereby given that the Council of the Shire of Shepparton, in pursuance of its powers under the *Town and Country Planning Act 1961*, has prepared a Scheme for the rezoning of Part Crown Allotment 5, Section A, Parish of Congupna from the Rural C Zone to the Village Zone.

A copy of the Scheme has been deposited at the Council Offices, corner of Nixon and Welsford Streets, Shepparton, and at the office of the Ministry for Planning and Environment, The Olderfleet

Buildings, 477 Collins Street, Melbourne, and will be open for inspection during office hours by any person, free of charge.

Any persons affected by the Scheme are required to set forth, in writing, any submission they may wish to make with respect to the Scheme addressed to the Shire Secretary, Shire of Shepparton, P.O. Box 606, Shepparton, 3630, by Friday, 19 December 1986, and state whether you wish to be heard in respect of the submission.

Dated 12 November 1986

4994 I. W. MARTIN, Shire Secretary

Form 2.1

Town and Country Planning Act 1961

SHIRE OF SHEPPARTON—SHIRE OF SHEPPARTON PLANNING SCHEME 1983

Notice that a Planning Scheme has been Prepared and is Available for Inspection

Amendment No. 9, 1986

Notice is hereby given that the Council of the Shire of Shepparton, in pursuance of its powers under the *Town and Country Planning Act 1961*, has prepared a Scheme for the rezoning of Lot 2, L.P. 132988, Parish of Kialla from the Rural Residential and Rural E Zones (not including the area zoned Special Use (Motel)) to the Low Density Residential Zone.

A copy of the Scheme has been deposited at the Council Offices, corner of Nixon and Welsford Streets, Shepparton, and at the office of the Ministry for Planning and Environment, The Olderfleet Buildings, 477 Collins Street, Melbourne, and will be open for inspection during office hours by any person, free of charge.

Any persons affected by the Scheme are required to set forth, in writing, any submission they may wish to make with respect to the Scheme addressed to the Shire Secretary, Shire of Shepparton, P.O. Box 606, Shepparton, 3630, by Friday, 19 December 1986, and state whether you wish to be heard in respect of the submission.

Dated 12 November 1986

4995 I. W. MARTIN, Shire Secretary

Form 2.1

Town and Country Planning Act 1961

SHIRE OF SHEPPARTON—SHIRE OF SHEPPARTON PLANNING SCHEME 1983

Notice that a Planning Scheme has been Prepared and is Available for Inspection

Amendment No. 10, 1986

Notice is hereby given that the Council of the Shire of Shepparton, in pursuance of its powers under the *Town and Country Planning Act 1961*, has prepared a Scheme for the rezoning of Part Crown Allotment 54A, Parish of Kialla from the Rural C Zone to the Rural Residential Zone.

A copy of the Scheme has been deposited at the Council Offices, corner of Nixon and Welsford Streets, Shepparton, and at the office of the Ministry for Planning and Environment, The Olderfleet Buildings, 477 Collins Street, Melbourne, and will be open for inspection during office hours by any person, free of charge.

Any persons affected by the Scheme are required to set forth, in writing, any submission they may wish to make with respect to the Scheme addressed to the Shire Secretary, Shire of Shepparton, P.O. Box 606, Shepparton, 3630, by Friday, 19 December 1986, and state whether you wish to be heard in respect of the submission.

Dated 12 November 1986

4996 I. W. MARTIN, Shire Secretary

SHIRE OF SHERBROOKE

Notice of Road Closure

The Council of the Shire of Sherbrooke, being of the opinion that the portion of Grey Street, Belgrave, situated between Lot 31 and Lot 32 LP 12055 Grey Street/Best Street, Belgrave (as depicted in the plan hereunder) is not reasonably required as a road for public use, has resolved to close the said road pursuant to section 528 (2) of the *Local Government Act 1958* and retain same for municipal purposes.

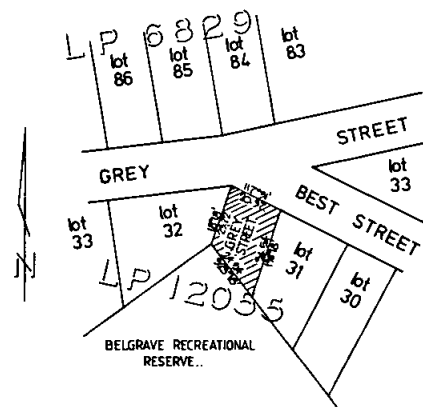

ROAD TO BE CLOSED.

5053 K. E. MATSON
General Manager and Shire Secretary

Town and Country Planning Act 1961
**SHIRE OF TAMBO (LAKES ENTRANCE)
 PLANNING SCHEME**

Notice that a Planning Scheme Amendment has been Prepared and is Available for Inspection
 Amendment No. 73

Notice is hereby given that the Shire of Tambo in pursuance of its powers under the *Town and Country Planning Act 1961*, has prepared a planning scheme amendment for the following:

That area situated north of Lake Tyers Beach Road and south of Bream Road, Lake Tyers, located at the intersection of these two streets, being Lot 25 LP 51134 to be rezoned from Residential B to Commercial General and which is to include a 'Site Specific' amendment to clause 28 (c) of the ordinance to allow a service station to be developed on a site having an area of less than 1000m².

A copy of the scheme has been deposited at the Shire Offices, Main Street, Bruthen, and at the office of the Ministry for Planning and Environment (Plan Inspection Section) Ground Floor, 477 Collins Street, Melbourne, and will be open for inspection during office hours by any person free of charge.

Any persons affected by the Scheme are required to set forth in writing any submissions they may wish to make addressed to the Chief Executive, Shire of Tambo, P.O. Box 10, Bruthen, 3885, by 15 December 1986, and state whether they wish to be heard in respect of their submission.

4998 W. J. HOBSON, Chief Executive

SHIRE OF WOORAYL

By-Law No. 68

Footway Advertising By-Law

Notice is hereby given that the Council of the Shire of Woorayl has made a By-law entitled the Footway Advertising By-law.

The By-law is for the purpose of—

- (a) regulating the placing of goods for sale on the footway; and
- (b) regulating the placing of advertising signs on the footway.

A copy of the By-law is available for inspection, free of charge, during office hours at the Shire Office, Smith Street, Leongatha.

Dated 31 October 1986

4992 R. G. STANLEY, Shire Secretary

Notice is hereby given that Frederick George Kingston, Alan James Egan and Morris John May, Trustees of the Stawell Harness Racing Club have applied for a lease under section 134 of the *Land Act 1958* for a term of 21 years of allotment 14A section 59A Parish of Stawell, containing 9.262 hectares for amusement and recreation. (Harness Racing and Drive-In Theatre.) 4870

BALLARAT WATER BOARD

Pursuant to section 119 (2) of the *Sewerage Districts Act 1958* (No. 6368) notice is hereby given of the intention to construct a sewer for property situated in the vicinity of the following streets:

SHIRE OF BALLAARAT

Midland Highway

CITY OF BALLAARAT

Lydiard Street North

Duggan Street

Morres Street

SHIRE OF GRENVILLE

Glenelg Highway

more particularly as shown on plans which are open for inspection at this Office between the hours of 8.45 a.m. and 4.30 p.m., Monday to Friday, inclusive.

4999 B. E. LEACH, Secretary

GEELONG AND DISTRICT WATER BOARD

Pursuant to section 60 of the *Geelong Waterworks and Sewerage Act 1958* (No. 6263) the Board has prepared plans to indicate the particulars of sewers and underground works, the construction of which the Board intends to begin at a date not less than one month after publication of the notices, in or adjacent to the following locality within the Drainage Area.

Wiltons Road, Ocean Grove—Shire of Bellarine

Notice is hereby given that the plans indicated are open for public inspection at the Board's Offices, 61-67 Ryrie Street, Geelong between the hours of 8.10 a.m. and 5.00 p.m. from Monday to Friday (public holidays excepted) by the owners or occupiers of land or premises within the Drainage Area.

5000 R. A. JORDAN, Secretary

GEELONG AND DISTRICT WATER BOARD

Pursuant to section 60 of the *Geelong Waterworks and Sewerage Act 1958* (No. 6263) the Board has prepared plans to indicate the particulars of sewers and underground works, the construction of which the Board intends to begin at a date not less than one month after publication of the notices, in or adjacent to the following locality within the Drainage Area.

Oxford Street, Stanford Court, Yale Court, Whittington, Shire of Bellarine

Notice is hereby given that the plans indicated are open for public inspection at the Board's Offices, 61-67 Ryrie Street, Geelong between the hours of 8.10 a.m. and 5.00 p.m. from Monday to Friday (public holidays excepted) by the owners or occupiers of land or premises within the Drainage Area.

5054 R. A. JORDAN, Secretary

OTWAY COAST WATER BOARD

By-Law No. 2
Trade Wastes

Notice is hereby given that By-Law No. 2 of the Otway Coast Water Board was passed by resolution on 5 June 1986.

By-Law No. 2 provides that no person shall cause, or permit to be discharged into any sewer of the Water Board, excepting by agreement with the Board, any trade or manufacturing liquid refuse or waste other than domestic sewage.

By-Law No. 2 also provides that no person shall cause or permit to flow or pass or be carried from any manufactory of business or other premises of any such person into any sewer of the Water Board or any drain or pipe communicating therewith, any wastes, liquid or refuse which does not comply with By-Law No. 2 as detailed.

Notice is hereby given that a copy of By-Law No. 2 is open for inspection by any person without charge at the office of the Board, 5 Pascoe Street, Apollo Bay, during normal office hours.

5019 J. SEYMOUR, Secretary

Notice is hereby given that Dimboola Golf Club Inc. has applied for a lease pursuant to section 134 of the *Land Act* 1958 for a term of 21 years of Allotments 61 and 78 Section B Parish of Dimboola containing 52.91 hectares for Amusement and Recreation (Golf Club). 5061

Notice is given that the business "Heritage Read Funerals Ferntree Gully" conducted by Robert Frank Heritage, Keith Heritage and Ronald Eldridge Read was dissolved on 20 October 1986, 4950

Leo Charles Bates and Lorraine May Bates, trading as partners in the business known as Bates Cycles and operated from 271 Gower Street and 346 High Street, Preston, hereby give notice that they have ceased to trade as partners of that business as of 1 November 1986 and will no longer accept liability for debts incurred by said business operated from those addresses. 5020

Take notice that the partnership between Gaetano Guiseppe Crocilla and David Alan Barlow and Margaret Josephine Meeham as trustees of the Meeham Investment Trust has been dissolved as from 2 November 1986 and Gaetano Guiseppe Crocilla will continue to conduct the business as from 2 November 1986 under the business of Gaetano of Toorak from 60 Ross Street, Toorak. 5021

Notice is hereby given that the partnership between Martyn Lionel Hubbard and Haydn Trevor Holloway who carry on business as Advance Garden Tidy at 78 Leon Avenue, Rosebud was dissolved on 1 November 1986. The business will be continued by Martyn Lionel Hubbard.

WRIGHT SMITHS, solicitors, 13 Rosebud Parade, Rosebud 5022

Notice is hereby given that the partnership hereto subsisting between Ian Andrew Ness, John Frederick Henry and Carlo Anthony Massola carrying on business as solicitors at 12 Batman Street, Melbourne, 3003 under the style or firm of Turner Ness and Davis has been dissolved by mutual consent as from 13 October 1986.

Dated 6 November 1986

IAN ANDREW NESS
JOHN FREDERICK HENRY
5038 CARLO ANTHONY MASSOLA

On 15 October 1986 the partnership previously carried on under the registered business name "House of Polly" between Coral Carlyle McCreadie of 20 Chaucer Crescent, Bundoora and Skocco Nominees Pty. Ltd. of 1st Floor, 98 Fletcher Street, Essendon was dissolved. The business operated by Skocco Nominees Pty. Ltd. is continuing under the registered business name "House of Polly". 5039

Take notice that the partnership hitherto existing between Lucas Xiros, Valda Renate Xiros, George Theleritis and Eftihia Theleritis under the business name of Eckero is hereby dissolved by mutual consent as from 31 October, 1986. All debts of the partnership are to be presented to George Theleritis and Eftihia Theleritis who will continue to carry on the business under the name of Eckero.

APTED & WILLIAMSON, solicitors, 63 Yarra Street, Geelong 5055

Companies (Victoria) Code, Section 392 (2)
HALSTEAD HOLDINGS PTY. LTD. (In
Liquidation)

Notice of Voluntary Liquidation

At a General Meeting of the abovenamed Company duly convened and held on 24 October 1986 the following Special Resolution was passed:

"It was resolved that Mr Brian Allan Rudy of 19A Fosbery Avenue, Caulfield North be appointed liquidator of the Company, and that the assets of the company be distributed in specie to the shareholders".

Dated 24 October 1986

5003 B. A. RUDY, Liquidator

Unclaimed Moneys Act 1962

Register of Unclaimed Moneys held by the—

<i>Name of Owner on Books and Last Known Address</i>	<i>Total Amount Due to Owner</i>	<i>Description of Unclaimed Money</i>	<i>Date when Amount first became Payable</i>
\$			
ASSOCIATED DAIRIES LIMITED			
Pritchard, P	171.40	Wages	16.10.84
Morfea, S	218.80	"	1.1.85
Bedson, J	632.66	"	2.4.85
Norazmi, M 5034	55.70	"	27.12.84
FARM PRODUCE PTY. LTD.			
Armstrong, D C, 5 Wirilda Crt, Springvale	109.50	Payment	7.3.85
Kikstra, T J, 1 Main St, Garfield 5035	190.80	"	28.10.83

In the Supreme Court of Victoria—1986 Co. No. 822—In the matter of the Companies (Victoria) Code; and in the matter of Famous Fine Furniture Pty. Ltd.

Notice is hereby given that an application for the winding up of the abovenamed company by the Supreme Court of Victoria was on 20 October 1986 filed by Lawrie Arthur's Place Pty. Limited. The application is to be heard before the Court in the Seventh Court, Law Courts, Lonsdale Street, Melbourne, at 10.30 a.m. on 3 December 1986.

The Liquidator whose appointment is sought is Robert Eastaugh Ramsay of the firm Bird Cameron Insolvency of 7th Floor, 128 Exhibition Street, Melbourne.

Any creditor or contributory of the company desiring to support or oppose the making of an order on the application may appear at the time of hearing by himself or his Counsel for that purpose. A copy of the application will be furnished by the undersigned to any creditor or contributory of the company requiring it on payment of the regulated charge.

The Applicant's address is 5-13 Mentmore Avenue, Rosebery, New South Wales.

The applicant's solicitors are Arthur Phillips & Just of 394 Collins Street, Melbourne.

N. J. JUST OF ARTHUR PHILLIPS & JUST, solicitors for the applicant.

Note—Any person who intends to appear on the hearing of the application must serve on or send by post to the abovenamed solicitors, Arthur Phillips & Just, notice in writing of his intention to do so. The notice must state the name and address of the person or, if a firm, the name and address of the firm, and must be signed by the person or firm or

his or their solicitor (if any), and must be served or, if posted, must be sent by post in sufficient time to be received not later than 4.00 p.m. of 2 December 1986.

In the Supreme Court of Victoria—1986 Co. No. 821—In the matter of the Companies (Victoria) Code; and in the matter of H. A. Hare Agencies Pty. Ltd.

Notice is hereby given that an application for the winding up of the abovenamed company by the Supreme Court of Victoria was on 20 October 1986 filed by Lawrie Arthur's Place Pty. Limited. The application is to be heard before the Court in the Seventh Court, Law Courts, Lonsdale Street, Melbourne, at 10.30 a.m. on 3 December 1986.

The Liquidator whose appointment is sought is Kenneth James Russell, of the firm of Coopers & Lybrand, 29th Floor, 385 Bourke Street, Melbourne.

Any creditor or contributory of the company desiring to support or oppose the making of an order on the application may appear at the time of hearing by himself or his Counsel for that purpose. A copy of the application will be furnished by the undersigned to any creditor or contributory of the company requiring it on payment of the regulated charge.

The applicant's address is 5-13 Mentmore Avenue, Rosebery, New South Wales.

The applicant's solicitors are Arthur Phillips & Just of 394 Collins Street, Melbourne.

N. J. JUST OF ARTHUR PHILLIPS & JUST, solicitors for the applicant.

Note—Any person who intends to appear on the hearing of the application must serve on or send by post to the abovenamed solicitors, Arthur Phillips

& Just, notice in writing of his intention to do so. The notice must state the name and address of the person or, if a firm, the name and address of the firm, and must be signed by the person or firm or his or their solicitor (if any), and must be served or, if posted, must be sent by post in sufficient time to be received not later than 4.00 p.m. of 2 December 1986. 5037

In the matter of Penny Food Stores Pty. Limited (in Liquidation) and in the matter of the Companies (New South Wales) Code

Notice is hereby given that a final meeting of the members of the abovenamed company will be held in pursuance of the Companies (New South Wales) Code 1981, section 411, at the offices of Widin & Company, 11th Floor, 2 Castlereagh Street, Sydney, on Tuesday, 17 December 1986, at 10.30 a.m., for the purpose of having laid before it by the liquidator an account showing how the winding up has been conducted and the property of the company disposed of and of hearing an explanation of the account by the liquidator.

Dated 14 November 1986

W. J. WIDIN, Liquidator
Widin & Company, 11th Floor, 2 Castlereagh Street, Sydney, N.S.W., 2000 5025

Companies (Victoria) Code, Paragraph 392 (2) (b)
DANE (AUSTRALIA) PTY. LTD.
(in Voluntary Liquidation)

Notice is hereby given that at an extraordinary general meeting of the members of the above named company held on 17 November 1986, it was resolved that the company be wound up voluntarily and that Alan Boyd of Lot 10 Eloca Court, Wallington, be appointed Liquidator. Notice is also given that after 21 days from this date, I shall proceed to distribute the assets. All creditors having any claims against the company should furnish particulars of same by that date, otherwise I shall proceed to distribute the assets without regard to their claim.

Dated 18 November 1986

5023 A. BOYD, Liquidator

Companies (Victoria) Code
J. J. & D. McQUEEN PTY. LTD.
(in Voluntary Liquidation)
Notice of Final Meeting

Notice is hereby given that pursuant to section 411 of the Companies (Victoria) Code, the final meeting of the members of the Company will be held at the office of A. E. Dredge, 2nd Floor 286 Toorak Road, South Yarra, on 15 December 1986 at 10 a.m. for the purpose of having an account laid before them showing the manner in which the

winding up has been conducted and hearing any explanation that may be given by the liquidator.

Dated 5 November 1986

A. E. DREDGE, Liquidator, 2nd Floor, 286 Toorak Road, South Yarra 5024

B.W.I.U. (CARPENTERS & JOINERS) No. 3
CO-OPERATIVE HOUSING SOCIETY
LIMITED
(in Liquidation)

Take notice that the affairs of the above-named Society are now fully wound-up and that in pursuance of section 411 (2) of the Companies (Victoria) Code and of the *Co-operative Housing Societies Act 1958*, a General Meeting of the Society will be held at 1st Floor, 1 Lygon Street, Carlton South on Wednesday, 17 December 1986 at 2.00 p.m. for the purposes of:

1. Laying before it an account showing how the winding-up has been conducted and the property of the Society disposed of and giving any explanations thereof; and

2. Passing a resolution that the books and papers of the said Society and of the Liquidator relevant to the affairs of the Society be destroyed after a period of twelve months from the date of the meeting.

Dated 5 November 1986

5026 K. E. PALMER, Liquidator

Pursuant to section 411 of the Companies (Victoria) Code a General Meeting of the Members of Elphickdale Pty. Ltd. is hereby convened for 9 December 1986 at the offices of Houghton & Eddy Pty., 6th Floor, 20 Collins Street, Melbourne at 5.00 p.m.

The purpose of the meeting is to present and explain to members the Liquidator's account of how the winding up has been conducted and the property of the company disposed of. 5001

In the Supreme Court of Victoria—1986 No. Co. 856—In the matter of the Companies (Victoria) Code: and in the matter of Nomad Tours of Australia Proprietary Limited—Advertisement of Application for Winding-Up

Notice is hereby given that an application for the winding up of the abovenamed company by the Supreme Court of Victoria was on 29 October 1986 filed by Ansett Transport Industries (Operations) Pty. Ltd. The application is to be heard before the Court in the Seventh Court, Law Courts, Lonsdale Street, Melbourne at 10.30 a.m. on 10 December 1986. The liquidator whose appointment is sought is Owen Jenkins of 88 Myers Street, Geelong. Any creditor or contributory of the Company desiring to support or oppose the making of an order on the application may appear at the time of hearing by himself or his Counsel for that purpose. A copy of

the application will be furnished to any creditor or contributory of the Company requiring the same by the undersigned on payment of the regulated charge for the same.

The Applicant's official address is 501 Swanston Street, Melbourne.

The Applicant's Solicitor is Jeffrey P. Salinger and Associates, 320 Toorak Road, South Yarra.

JEFFREY P. SALINGER & ASSOCIATES

NOTE: Any person who intends to appear on the hearing of the application must serve on or send by post to the said Jeffrey P. Salinger and Associates, notice in writing of his intention to do so. The notice must state the name and address of the person, or, if a firm, the name and address of the firm, and must be signed by the person or firm, or his or their solicitor (if any), and must be served, or, if posted, must be sent by post in sufficient time to be received not later than 4.00 p.m. on 9 December 1986. 5002

CHARLES JOHN FENN, late of Leitchville, in the State of Victoria, farmer, deceased

Creditors, next of kin and all other persons having claims against the estate of the said deceased are required by Edward John Fenn and Barry Lindsay Fenn both of Leitchville aforesaid, farmers, the executors of the estate of the said deceased to send particulars of such claims to them in care of the undermentioned solicitors on or before 31 December 1986, after which date they will distribute the assets having regard only to the claims to which they then have notice.

EMBLETON & ASSOCIATES, barristers and solicitors, 77 King George Street, Cohuna 5008

JEAN ROBERTA JOHNSTON, late of 4 Ophir Road, Mount Waverley, widow, deceased

Creditors, next of kin and others having claims in respect of the estate of the abovenamed Jean Roberta Johnston, deceased, who died on 7 September 1986, are required by National Trustees Executors & Agency Company of Australasia Limited of 95 Queen Street, Melbourne, which has made application to the Registrar of Probates for a grant of representation, to send particulars of their claims to the said company at its abovementioned address by 14 January 1987, after which date the said company will convey or distribute the assets of the estate of the said deceased having regard only to the claims of which it then has notice.

BONELLA, CUTLER & CO., of 110 Hawthorn Road, Caulfield, solicitors for the said company 5009

Creditors, next of kin and others having claims in respect of the estate of Frederick Thomas Moore, late of 25 Roy Street, Wangaratta, deceased, who died on 20 April 1986, are to send particulars of

their claims to the executor care of the undermentioned solicitors by 8 December 1986 after which date the executor will distribute the assets having regard only to the claims of which he then has notice.

McSWINEYS, solicitors, 57 Reid Street, Wangaratta 5010

DONALD DAVID HUNTER NEWELL, late of Fairfield Hospital, but formerly of "Dreelburn Stud", Sunbury, studmaster, deceased

Creditors, next of kin and others having claims in respect of the deceased who died on 16 July 1984 are required by the trustees Martin John O'Connor of 5 Coromandel Crescent, Knoxfield, chartered accountant, and Thelma Jane Ethel Newell of Flat 2, 6 Lake Street, Glenhuntly, gentlewoman, and Laurence Clifford Scott now of 3 Wicklow Street, Ormond, butcher, and Raymond Whittaker of 7 Bellevue Terrace, Pascoe Vale, company representative, to send particulars to Greening Johnson & Gilbert of 37 Queen Street, Melbourne by 30 January 1987 after which date the trustees may convey or distribute the assets having regard only to claims of which they then have notice.

Dated 30 October 1986 5011

Creditors, next of kin and others having claims in respect of the estate of Alan Robert Semple, late of 20 Dawson Street, Rosedale, council employee, deceased intestate, who died on 29 July 1986 and letters of administration of whose estate were granted by the Supreme Court of Victoria on 30 October 1986 to Raymond Langley Semple of 20 Dawson Street, Rosedale, driver, are to send particulars of their claims to the said administrator, care of the below mentioned solicitors by 19 January 1987 after which date he will distribute the assets of the deceased having regard only to the claims of which he then has notice.

LITTLETON HACKFORD & MALKIN, solicitors, Law Chambers, 115-119 Hotham Street, Traralgon 5012

MAURICE JAMES BRUCE STEVENSON, late of 24 Renown Street, Burwood, gentleman, deceased

Creditors, next of kin and others having claims in respect of the estate of the deceased who died on 23 September 1986 are required by the Equity Trustees Executors and Agency Company Limited of 472 Bourke Street, Melbourne, the applicant for a grant of probate of the deceased's Will, to send particulars of their claims to the applicant at the address aforesaid by 15 January 1987 after which date the company will convey or distribute the assets having regard only to the claims of which it then has notice.

ALAN WAINWRIGHT, J. OKNO & CO., solicitors, 213 Lonsdale Street, Melbourne 5013

Creditors, next of kin and others having claims in respect of the estate of Euphemia Rachel Rintoull, late of 23 Hazelwood Road, Morwell, widow, deceased, who died on 20 February 1986 and probate of whose Will was granted by the Supreme Court of Victoria on 30 October 1986 to Mary Zenna Marion of "Mowbray" Mons School Road, Buderim, Queensland, widow and Nancy Margaret Gordon of 51 Tarwin Street, Morwell, married woman, are to send particulars of their claims to the said executors, care of the below mentioned solicitors by 19 January 1987 after which date they will distribute the assets of the deceased having regard only to the claims of which they then have notice.

LITTLETON HACKFORD & MALKIN,
solicitors, Law Chambers, 115-119 Hotham Street,
Traralgon 5014

EILEEN WARNE, late of 23 Evelina Road, Toorak,
deceased, who died on 20 July 1986

Creditors, next of kin and others having claims in respect of the said deceased are requested to send particulars of their claims to the executrix, Bessie Bell Gadd, care of the undermentioned solicitors by 10 January 1987 after which date the executrix will distribute the assets having regard only to the claims of which she then has notice.

RIDGEWAY CLEMENTS, solicitors, 221
Glenhuntly Road, Elsternwick 5015

DONALD FREDERICK WELSH, late of 121
Murlong Street, Swan Hill, in the State of Victoria,
Road Construction Authority patrolman,
deceased

Creditors, next of kin and other persons having claims against the estate of the said deceased, who died on 16 September 1986 are required to send particulars of same to Myra Ruth Welsh, the widow of the deceased, in care of the undersigned on or before 5 January 1987 after which date she will distribute the assets having regard only to the claims of which she then has notice.

DWYER, BENNETT & MAHON, barristers and
solicitors, 194-208 Beveridge Street, Swan Hill
5016

DENISE RICHARDS, late of 33 Kinkora Road,
Hawthorn, in the State of Victoria, widow,
deceased

Creditors, next of kin and others having claims in respect of the estate of the deceased (who died on 31 August 1986) are required by The Perpetual Executors and Trustees Association of Australia Limited of 50 Queen Street, Melbourne to send particulars of their claims to the said Company by 15 January 1987 after which date it will convey or distribute the assets, having regard only to the claims of which the Company then has notice.

BEST HOOPER, solicitors, 400 Little Collins
Street, Melbourne 5046

PHOEBE CAROLINE SMITH, late of Unit 4, 68
Riversdale Road, Hawthorn, in the State of
Victoria, widow, deceased

Creditors, next of kin and others having claims in respect of the estate of the deceased (who died on 29 April 1986) are required by the administrator Horrie Edgar William Gordon Foster of Flat 3, 4 Murphy Avenue, Heme Hill in the said State, retired, to send particulars of their claims to him at the office of the undermentioned solicitors on or before 15 January 1987 after which date he will convey or distribute the assets having regard only to the claims of which he then has notice.

BEST HOOPER, solicitors, 400 Little Collins
Street, Melbourne 5047

Creditors, next of kin and others having claims in respect of the estate of Gavin Donaldson Wilkins, late of Flat 2, 117 Caroline Street, South Yarra, medical practitioner, deceased, who died on 15 May 1986 are to send particulars of their claims to The Equity Trustees Executors and Agency Company Limited of 472 Bourke Street, Melbourne by 13 January 1987 after which date it will distribute the assets having regard only to the claims of which it then has notice.

MARTIN & MARTIN, solicitors, of 37 Queen
Street, Melbourne 5048

After 14 clear days application will be made to the Supreme Court that Probate of the Will dated 21 September 1977 of Gemma Rigutto, late of 36 Robinson Street, East Brighton in the State of Victoria, housewife, deceased be granted to Luigi Rigutto of 36 Robinson Street, East Brighton, retired, the executor appointed by the said Will.

5049

Creditors, next of kin and others having claims in respect of the estate of Michele Carrara, late of 379 Albion Street, Brunswick in the State of Victoria, shoeman, deceased, who died on 14 May 1984 are to send particulars of their claims to the administratrix Maria Rachele Parissi care of the undermentioned solicitors by 12 January 1987 after which date the administratrix will distribute the assets having regard only to the claims of which she then has notice.

LE GRAND, RANGLES, ADAMS & CO., 636
Sydney Road, Brunswick, 3056, the solicitors acting
herein 5031

Creditors, next of kin and others having claims in respect of the estate of Warren William Davy, late of 18 Lahona Avenue, East Bentleigh in the State of Victoria, salesman, deceased, who died on 12 August 1986 are to send particulars of their claims to Merl Lynette Young of 14 Dion Road, Glen Waverley in the said State, the executrix appointed by the Will of the said deceased by 12 January 1987.

J. & S. SHATIN & BERNSTEIN, solicitors of
114 William Street, Melbourne 5032

JOYCE AMELIA SLOANE, late of 14 Denning Court, Rosebud, married woman, deceased

Creditors, next of kin and others having claims in respect of the deceased, who died on 15 June 1986, are required by the personal representatives William Sloane of 14 Denning Court, Rosebud and Julie Marcelle Pacher of 20 Stephen Street, Croydon to send particulars to them care of the undermentioned solicitors within 2 months of the date of publication of this notice after which date the personal representatives may convey or distribute the assets having regard only to the claims of which they then have notice.

WRIGHT SMITHS, solicitors, 13 Rosebud Parade, Rosebud 5033

Supreme Court of Victoria on 23 October 1986 to Joan Esmee Christie of Flat 7/35-37 Nolan Street, Frankston now are hereby required to send particulars in writing of such claims to the said Joan Esmee Christie on or before 2 January 1987 after which date the said Joan Esmee Christie will proceed to distribute the assets of the said Ruth Dorothy Christie deceased having regard only to the claims of which she shall then have had notice and will not be liable for the assets so distributed or any part thereof to any person of whose claim she shall not have had notice as aforesaid.

HUNT, McCULLOUGH, DANIELS & KOLLIAS, of 1 Railway Grove, Mornington, solicitors for the said Joan Esmee Christie 5006

Creditors, next of kin and others having claims in respect of the estate of Gertrude Annie Alberry (also known as Gertrude Alberry) late of Ellesmere Avenue, Croydon, widow, deceased, who died on 23 February 1985 are to send particulars of their claims to the executor Michael Joseph Mornane of 118 Queen Street, Melbourne by 15 January 1987 after which date he will distribute the assets having regard only to the claims of which he shall then have had notice.

M. MORNANE, solicitor, 118 Queen Street, Melbourne 5040

Creditors, next of kin and others having claims against the estate of Claude Wellesley Daykin, late of 3 Merlyn Avenue, South Clayton, retired, deceased (who died on 17 August 1986) are required by Patrick Francis Toohey, the executor of the Will of the said deceased to send to him care of the undersigned solicitors particulars thereof by 15 January 1987 after which date he will distribute the assets of the deceased having regard only to the claims of which he shall then have notice.

GAVAN DUFFY & KING, solicitors, 95 Queen Street, Melbourne 5007

Creditors, next of kin and others having claims in respect of the estate of Charles Bates late of 24 Hanley Street, Avondale Heights in the State of Victoria, pensioner, deceased who died on 18 August 1986 are to send particulars of their claims to Emanuel Bates of 1 Gordon Crescent, Romsey in the said State the substituted executor appointed by the Will of the said deceased Kate Bates the instituted executrix having predeceased the deceased, by 9 January 1987.

J. & S. SHATIN & BERNSTEIN, solicitors, of 114 William Street, Melbourne 5004

Creditors, next of kin and others having claims in respect of the estate of Danetta McVicar Evans, late of 288 Pakington Street, Newtown, widow, deceased, who died on 24 October 1986, are to send particulars of their claims to D. R. James, LL.M., solicitor, 145 Whitehorse Road, Ringwood by 12 January 1987, after which date he will distribute the assets having regard only to the claims of which he then has notice.

D. R. JAMES, LL.M., solicitor, 145 Whitehorse Road, Ringwood 5056

Creditors, next of kin and others having claims in respect of the estate of Mary Elizabeth Boyd late of 44 Glenthorne Drive, Keysborough in the State of Victoria, widow, deceased who died on 15 July 1986 are required to send particulars of their claims to the executors care of the undermentioned solicitors by 9 January 1987 after which date they will distribute the assets having regard only to the claims for which notice has been received.

BORCHARD & MOORE, solicitors, of 44 Douglas Street, Noble Park 5005

Creditors, next of kin and others having claims in respect of the estate of Robert Henry Gardiner, late of 2A Erica Street, Pascoe Vale, gentleman, deceased, who died on 18 June 1986, are to send particulars of their claims to the executrix of the estate, Mavis Helen Reeves care of the undermentioned solicitors by 14 January 1987, after which date she will distribute the assets having regard only to the claims of which she then has notice.

LLOYD P. GOODE & CO., solicitors, 390 Lonsdale Street, Melbourne 5057

Notice is hereby given that all persons having claims against the estate of Ruth Dorothy Christie late of 21 Victoria Street, Hastings in the State of Victoria, widow, deceased who died on 28 May 1986 and probate of whose Will was granted by the

NOTICE TO CREDITORS

Pursuant to the *Trustees Act 1958*

Notice is hereby given that all persons having claims against the estate of the late Reginald Henry Goldsworthy also known as Henry Reginald

Goldsworthy, late of Amberley Lodge, 10 Union Street, Armadale, in the State of Victoria, retired public servant, deceased who died on 2 September 1986, and letters of administration of whose estate, with the Will annexed, was granted by the Supreme Court of the said State in its probate jurisdiction on 30 October 1986 to John Maxwell Goldsworthy of 55-57 Landsdowne Street, Traralgon in the said State, are hereby required to send particulars in writing of such claims to the undersigned at his office hereunder mentioned on or before 31 January 1987, after which date the said John Maxwell Goldsworthy will proceed to distribute the assets of the said deceased of the said Reginald Henry Goldsworthy which shall have come to his hands amongst the persons entitled thereto, having regard only to the claims of which he shall then have had notice.

And notice is hereby further given that the said John Maxwell Goldsworthy will not be liable for the assets so distributed or any part thereof to any person of whose claim he shall not have had notice as aforesaid.

Dated 6 November 1986

HARRISON BRAUN & CO. of Suite C, 414 Toorak Road, Toorak, in the State of Victoria, solicitors and proctors for the said John Maxwell Goldsworthy 5058

LEONARD MALCOM McWATTIE, late of 380 Ryrie Street, Geelong, retired bank manager, deceased

Creditors, next of kin and others having claims in respect of the abovenamed deceased (who died on 8 December 1985) are required to send particulars of their claims to the Executors John Welford Stubbs of 56 North Valley Road, Highton and Geoffrey Robert Reeve of 27 Malop Street, Geelong, care of the undermentioned solicitors by 21 January 1987 after which date they may convey or distribute the assets having regard only to the claims of which they then have notice.

WHYTE JUST & MOORE, solicitors, 27 Malop Street, Geelong 5059

ERIC RAYMOND WILLIAMS, late of 16 Willesden Road, Hughesdale, in the State of Victoria, retired stereotyper, deceased

Creditors, next of kin and others having claims in respect of the estate of the above-named deceased who died on 29 June 1986 are required by the applicant for a Grant of Probate of the Will of the said deceased, namely Maud Doris Williams of 16 Willesden Road, Hughesdale, aforesaid widow, to send particulars to her solicitors, Messrs. N. D. Kelly & Associates, of 437 Centre Road, Bentleigh by 16 January 1987 after which date the Applicant for the

Grant of Probate may convey or distribute the assets of the deceased having regard only to claims of which she then has notice.

Dated 12 November 1986

N. D. KELLY & ASSOCIATES, solicitors, 437 Centre Road, Bentleigh 5060

Creditors, next of kin and others having claims in respect of the estate of Thomas Stephen Hobson, late of 235 Hawthorn Road, Caulfield, gentleman, who died on 23 September 1986 are to send the particulars of their claims to National Trustees Executors and Agency Company of Australasia Limited of 95 Queen Street, Melbourne by 13 January 1987 after which date it will distribute the assets having regard only to the claims of which it then has notice.

RYLAH & RYLAH, solicitors, 337 La Trobe Street, Melbourne 5041

ROY JAMES McARTHUR, late of 66 Finch Street, East Malvern, Victoria, solicitor, deceased

Creditors, next of kin and others having claims in respect of the estate of the deceased (who died on 22 June 1986) are required by Reginald Frederick Williams of 7 Brunel Street, East Malvern, Victoria, estate agent the sole executor appointed by the Will to send particulars of their claims to the estate's solicitors Messrs Mallesons of Level 28, North Tower, Rialto, 525 Collins Street, Melbourne, Victoria by 21 January 1987 after which date it will convey or distribute the assets, having regard only to the claims of which the Company then has notice. 5042

Creditors, next of kin and others having claims against the estate of Douglas Frank Naunton, late of Unit 3, 10 Westminster Street, Balwyn in the State of Victoria, clerk, deceased, who died on 7 July 1986 are required by the Executor, Arthur James Downing of 422 Collins Street, Melbourne in the State of Victoria, to forward particulars of their claim to the said executor care of the undermentioned solicitors by 21 January 1987 after which date the executor will distribute the assets having regard only to the claims of which he will then have had notice.

READ & READ, 422 Collins Street, Melbourne, solicitors for the executor 5043

DOROTHY WINIFRED NEIL, late of Unit 1/20 Seymour Road, Elsternwick, widow, deceased

Creditors, next of kin and others having claims in respect of the estate of the said deceased who died on 15 May 1986 are to send particulars of their claims to the executor The Equity Trustees Executors and Agency Company Limited of 472 Bourke Street, Melbourne by 16 January 1987 after

which date it will distribute the assets having regard only to the claims of which it then has notice.

ARTHUR ROBINSON & HEDDERWICKS,
solicitors, 535 Bourke Street, Melbourne 5044

NORMAN EDITH NEWCOMEN, late of Flat 7,
42 Edgar Street, Glen Iris, spinster, deceased

Creditors, next of kin and others having claims in respect of the estate of the deceased who died on 24 June 1986 are required by Jack Just, solicitor of 394 Collins Street, Melbourne the proving executor of the Will of the said deceased to whom probate has been granted to send particulars to him by 15 February 1987, after which date he may convey or distribute the assets having regard only to the claims of which he then has notice.

ARTHUR PHILLIPS & JUST, solicitors, 394
Collins Street, Melbourne 5045

JOHN BUCKLEY, late of Australian Staff College
Queenscliff in the State of Victoria, retired
steward, deceased

Creditors, next of kin and others having claims in respect of the estate of the abovenamed deceased who died on 9 January 1986 are required by the Trustee George Rhynchart of 30 Kite Street Orange in the State of New South Wales, retired, to send particulars of their claims to the Trustee care of the undermentioned Solicitors by 12 January 1987 after which date the Trustee may convey or distribute the assets having regard only to the claims of which he then has notice.

INGPEN & BENT, solicitors for the trustee, 95
Yarra Street, Geelong 5027

IVAN ALEXANDER CAMERON, late of 136
Queen Street, Altona, pensioner deceased

Creditors, next of kin and others having claims in respect of the Estate of the abovenamed deceased who died on 22 August 1986 are required by the administrator Marjory Fay Love of 17 Autumn Gully Road, Bendigo, married woman to send particulars to her care of the undermentioned Solicitors by 16 January 1987 after which date she may distribute the assets having regard only to the claims of which she then has notice.

COHEN KIRBY & ISER, solicitors, 90 Pall Mall,
Bendigo 5028

FRANCIS CARROLL, late of Unit 2, 2 Foster
Street, South Geelong, retired reservoir keeper,
deceased

Creditors, next of kin and others having claims in respect of the estate of the deceased who died on 23 December 1985 are requested to send particulars of their claims to the Executrix Margaret Joyce Connors and the Executor James Leslie Carroll care of the undermentioned Solicitors by 22 January 1987

after which date the Executrix and Executor will proceed to distribute the estate having regard only to the claims of which they then have notice.

BURKE COX & CO., solicitors, 111 Yarra Street,
Geelong 5029

ELIZABETH MAY HEPPELL, late of Unit 1, 42
Park Crescent, South Geelong, retired retailer,
deceased intestate

Creditors, next of kin and others having claims in respect of the estate of the deceased who died on 12 September 1986, are requested to send particulars of their claims to the Administratrix Elvie Agnes Crawford care of the undermentioned Solicitors by 22 January 1987, after which date the Administratrix will proceed to distribute the estate having regard only to the claims of which she then has notice.

BURKE COX & CO., solicitors, 111 Yarra Street,
Geelong 5030

In the Supreme Court of the State of Victoria
SALE BY THE SHERIFF

On 18 December 1986 at 1.00 p.m. at the
Wodonga Police Station (unless process be stayed
or satisfied).

All the Estate and Interest (if any) of Roger Parry
Leake of 307 Lawrence Street, Wodonga as Joint
Proprietor with Gay Leake of an estate in fee simple
in the Land described in Certificate of Title Volume
8957 Folio 964 upon which is erected a dwelling
and known as No. 307 Lawrence Street, Wodonga.

Registered Mortgage K591751 and Caveat
M463724M affects the said Estate and Interest.

Terms—Cash only

Dated 12 November 1986

5050 A. STANLEY, Sheriff's Officer

**NOTICE OF MAKING OF
STATUTORY RULES
WHICH ARE NOT YET
AVAILABLE**

Notice is given of the making of the following
Statutory Rules:

Marine Act 1958

268/1986 Port Phillip Pilot Sack and
Superannuation Fund
(Amendment) Regulations
1986

	<i>Metropolitan Fire Brigades Superannuation Act 1976</i>				<i>Registration of Births Deaths and Marriages Act 1959</i>	
284/1986	Metropolitan Fire Brigades Superannuation (Board Scheme) (Further Amendment) Regulations 1986			273/1986	Births Deaths and Marriages (Prescribed Forms and Procedures) Regulations 1986	\$1.90
				11 November 1986		
	<i>Lotteries Gaming and Betting Act 1966</i>				<i>Country Fire Authority Act 1986</i>	
285/1986	Lotteries Gaming and Betting (Gaming Machines) (Further Amendment) Regulations 1986			274/1986	Country Fire Authority (Physical Standards) Regulations 1986	\$0.40
				11 November 1986		
	<i>Supreme Court Act 1958</i>				<i>Liquor Control Act 1968</i>	
286/1986	Supreme Court (Chapter I Amendment) Rules 1986			275/1986	Liquor Control (Amendment No. 1) Regulations 1986	\$0.40
				11 November 1986		
<p>NOTICE OF MAKING AND AVAILABILITY OF STATUTORY RULES</p>					<i>Motor Car Act 1958</i>	
				276/1986	Motor Car (Amendment) Regulations 1986	\$0.40
				11 November 1986		
					<i>Marine Act 1958</i>	
				277/1986	Marine (Pilots and Pilotage) (Retirement) Regulations 1986	\$0.40
				11 November 1986		
					<i>Transport Act 1983</i>	
				278/1986	Transport (West Gate Bridge) (Amendment) Regulations 1986	\$0.40
				11 November 1986		
					<i>Water Act 1958</i>	
				279/1986	Water (Kimbolton Recreational Area) Amendment Regulations 1986	\$0.40
				11 November 1986		
					<i>Industrial Relations Act 1979</i>	
				280/1986	Industrial Relations (Industrial Relations Commission) (Salaries Expenses and Allowances) (Further Amendment) Regulations 1986	\$0.40
				11 November 1986		
					<i>Fisheries Act 1968</i>	
				281/1986	Fishing (Scallop) (Amendment No. 4) Regulations 1986	\$0.40
				11 November 1986		

In pursuance of the provisions of the *Subordinate Legislation Act 1962* and the Regulations made thereunder notice is given of the making and availability of the following Statutory Rules:

Note: The date specified after each Statutory Rule is the date it was first obtainable from the Victorian Government Bookshop, 41 St Andrew's Place, East Melbourne.

	<i>Superannuation Benefits Act 1977</i>		<i>Registration of Births Deaths and Marriages Act 1959</i>	
282/1986	Superannuation Benefits Regulations (No. 4) 1986	283/1986	Births Deaths and Marriages (Prescribed Fees) (No. 2) Regulations 1986	
11 November 1986	\$0.40	11 November 1986		\$0.40
			<i>Public Service Act 1974</i>	
		PSD37/1986	Public Service Amendment Determinations (No. 37) 1986	40c

Publications Availability

Publications may be purchased from the
Victorian Government Bookshop
41 St Andrews Place East Melbourne
(PO Box 203 North Melbourne 3051)
Telephone Inquiries (03) 320 0299

Mail Orders and Postage

A postage and packaging fee must be added to the cost of the requested publication using the table of rates opposite. Remittances should be made payable to the 'Victorian Government Printing Office'.

Bankcard

Purchases may be made using Bankcard facilities in the Bookshop and by mail order.

Bankcard mail orders require the Bankcard number, expiry date, name, address and signature of customer to be supplied.
(Minimum purchase of \$5.00 applies).

<i>Total Price of Publications</i>	<i>Postage Packaging Fee</i>
\$ 0.00 to \$ 2.00.....	\$ 0.80
\$ 2.05 to \$ 5.00.....	\$ 1.10
\$ 5.05 to \$ 25.00.....	\$ 2.50
\$ 25.05 to \$ 75.00.....	\$ 3.00
\$ 75.05 to \$125.00.....	\$ 3.50
\$125.05 to \$200.00.....	\$ 4.00
\$200.05 and over.....	at cost

General Information

The following guidelines should be followed for the publication of official material in the *Victoria Government Gazette*.

Publication of official material

- Duplicate copies should be submitted for the use of the Gazette Officer.
- Material submitted to the Executive Council for Gazettal will normally be published in the next week's issue.
- Where urgent gazettal is required, special arrangements should be made with the:
Gazette Officer
Department of the Premier and Cabinet
Government Branch
2nd Floor, 1 Treasury Place
Melbourne 3000
Telephone Inquiries (03) 651 5153

Publication of other material

- All other material authorized by a responsible officer should be forwarded to the Gazette Officer no later than 9.30 a.m. on Tuesday.
- Lengthy or complicated notices should be forwarded several days before publication.
- Proofs will be supplied only when requested or at the direction of the Gazette Officer. They should be returned quickly to avoid delay in publication.
- No additions or amendments to material for publication will be accepted by telephone.

Late Copy

Copy received after 3.30 p.m. on the day prior to publication at the Victorian Government Printing Office will be placed in the following issue of the *Victoria Government Gazette*, irrespective of any date/s mentioned in the copy.

Publication Details

The *Victoria Government Gazette* is published every Wednesday, unless otherwise advertised.

Copy Deadline

Private advertisements will be accepted by:

Gazette Advertising

Victorian Government Printing Office

PO Box 203 North Melbourne 3051, no

later than 11 a.m. on the day before

publication.

Advertising Rates

Single column × cm/part cm \$3.60

Double column × cm/part cm \$7.20

Full page..... \$151.00

Ordinary rates will apply to material submitted for publication before 11 a.m. Tuesday. Double rates will apply for material submitted between 11 a.m. and 3.30 p.m. Tuesday.

Advertisers should note:

- There are approximately 30 words to each column centimetre depth;
- Signatures (in particular) and proper names must be written clearly in the text;
- Advertising material should be double-spaced and confined to ONE SIDE ONLY of each sheet of paper
- Documents NOT CLEARLY PREPARED will be returned to the sender, unpublished.

Correspondence

All correspondence should be addressed to:

Gazette Advertising

Victorian Government Printing Office

PO Box 203 North Melbourne 3051

Telephone Inquiries (03) 320 0100

Agents

The following have been appointed agents to receive advertisements for the *Victoria Government Gazette* :

- Armstrong's Communications Pty Ltd
191 Queen Street Melbourne 3000
- Blane's Authorized Newsagents 162
Murray Street Colac 3250
- Cornell R G 126 Eighth Street Mildura
3500
- Franks H and Co 184 Ryrie Street Geelong
3220
- Gordon and Gotch Australasia Ltd
25-37 Huntingdale Road Burwood 3125
- Harston, Partridge & Co. Pty Ltd 455
Little Collins Street Melbourne 3000
- Kyneton Guardian Pty Ltd PO Box 18
Kyneton 3444
- The Mercantile Exchange 108 Queen
Street Melbourne 3000
- Bridgemall Newsagency 63 Bridgemall
Road Ballarat 3350
- McGill's Authorized Newsagency
183-185 Elizabeth Street Melbourne 3000
- McNaughton P R and L A 112-114
Gray Street Hamilton 3300
- Powney's Authorized Newsagency 293
Hargreaves Street Bendigo 3550
- Purdie J & Co. 138 Moorabool Street
Geelong 3220
- Vernons of Richmond 261 Bridge Road
Richmond 3121

CONTENTS

	Page
Appointments	4352
Cemeteries—Scale of Fees	4345
Contracts	4340
Contracts Accepted—Amendments	4342
Courts	4339
Estates of Deceased Persons	4344
Government Notices	4335
Melbourne and Metropolitan Board of Works	4342
Notice of Making of Statutory Rules	4388
Orders in Council—	
Acts—State Electricity Commission;	4334
Foreign Judgments; Crown Land	et
(Reserves); Land; Motor Car;	seq
Public Service	
Private Advertisements	4374
Proclamation	4335
Tenders	4374

[4395]

PUBLISHED BY AUTHORITY



Victoria Government Gazette

No. 97—Wednesday, 19 November 1986

PUBLICATION OF THE "VICTORIA GOVERNMENT GAZETTE"

Christmas and New Years Holidays

The Victoria Government Gazette for the remainder of 1986 will be published on Wednesdays as usual except for the period around Christmas and New Years Day when there will be no Gazette published on the last two Wednesdays in December i.e. 24 and 31 December 1986.

The first issue of the Gazette for 1987 will be published on Wednesday, 7 January 1987, and thereafter on each Wednesday.

Where urgent gazettal is required on days other than those mentioned above, special arrangements should be made with the Gazette Officer, Department of the Premier and Cabinet, Second Floor, 1 Treasury Place, Melbourne, 3002. Telephone: (03) 651 5153

G. GASPARS
Gazette Officer

**Department of the Premier
and Cabinet,
10 November 1986**

PROCLAMATIONS

Public Service Act 1974
PUBLIC HALF HOLIDAY

PROCLAMATION

By His Excellency the Governor of the State of Victoria and its Dependencies in the Commonwealth of Australia, &c., &c., &c.

In pursuance of the powers conferred by section 71 (2) of the *Public Service Act 1974*, I, the Governor of the State of Victoria, in the Commonwealth of Australia, by and with the advice of the Executive Council of the said State, do by this my Proclamation appoint the day and date mentioned hereunder to be observed as a Public Half-Holiday at the place respectively specified:

Public Half-Holiday from the Hour of Twelve Noon

Friday, 28 November 1986, within the City of Ararat.

Given under my Hand and the Seal of the State of Victoria aforesaid, at Melbourne, this eighteenth day of November in the year of our Lord One thousand nine hundred and eighty-six and in the thirty-fifth year of the reign of Her Majesty Queen Elizabeth the Second, Queen of Australia.

(L.S.) J. DAVIS McCAUGHEY

By His Excellency's Command

R. W. WALSH
Acting Minister for Labour

GOD SAVE THE QUEEN!

Public Service Act 1974
ADDITIONAL PUBLIC HOLIDAY

PROCLAMATION

By His Excellency the Governor of the State of Victoria and its Dependencies in the Commonwealth of Australia, &c., &c., &c.

Whereas by section 71 of the *Public Service Act 1974* it is amongst other things enacted that the Governor in Council may, in addition to the days specified therein to be observed as holidays in the public offices, appoint any other day or days to be kept as public holidays in the whole or part of the State of Victoria:

Now therefore, I, the Governor of the State of Victoria, in the Commonwealth of Australia, by and with the advice of the Executive Council of the said State, do by this my Proclamation appoint Friday, 2 January 1987, to be observed as a Public Holiday throughout the State of Victoria.

Given under my Hand and the Seal of the State of Victoria aforesaid, at Melbourne, this eighteenth day of November in the year of our Lord One thousand nine hundred and eighty-six and in the thirty-fifth year of the reign of Her Majesty Queen Elizabeth the Second, Queen of Australia.

(L.S.) J. DAVIS McCAUGHEY

By His Excellency's Command

R. W. WALSH
Acting Minister for Labour

GOD SAVE THE QUEEN!

Bank Holidays Act 1958
ADDITIONAL BANK HOLIDAY

PROCLAMATION

By His Excellency the Governor of the State of Victoria and its Dependencies in the Commonwealth of Australia, &c., &c., &c.

Whereas by the *Bank Holidays Act 1958* it is amongst other things enacted that the Governor may, in addition to the days specified therein to be observed as bank holidays, appoint any other day or days to be kept as bank holidays in the whole or any part of the State of Victoria.

Now therefore I, the Governor of the State of Victoria, in the Commonwealth of Australia, do by this my Proclamation appoint Friday, 2 January 1987, to be observed as a Bank Holiday throughout the State of Victoria.

Given under my Hand and the Seal of the State of Victoria aforesaid, at Melbourne, this eighteenth day of November in the year of our Lord One thousand nine hundred and eighty-six and in the thirty-fifth year of the reign of Her Majesty Queen Elizabeth the Second, Queen of Australia.

(L.S.) J. DAVIS McCAUGHEY

By His Excellency's Command

R. W. WALSH
Acting Minister for Labour

GOD SAVE THE QUEEN!

Films Act 1971

EXEMPTION PURSUANT TO SECTION 11 (2)

Under the powers found in section 11 (2) of the *Films Act 1971*, the Governor in Council exempts the films set out in the Schedule below from the provisions of Part II of the *Films Act 1971*, subject to the following conditions:

- (i) That the films be exhibited only by DCF Film Distribution at a Festival at Melbourne, commencing on 12 December 1986, an event approved by the Attorney-General of the Commonwealth for the purposes of Part III

- of the Customs (Cinematograph Films) Regulations of the Commonwealth of Australia;
- (ii) That the films are screened not more than three times in the course of the approved event;
- (iii) In respect of imported films, that the films be exported or delivered to the holder of a permission in respect of the films, within the period of 6 weeks after the conclusion of the approved event;
- (iv) That the films are not screened other than before a subscription audience; and
- (v) That no person under the age of 18 years is admitted to screening of the films.

Schedule

Police.
 Bars De Fer.
 Black Mic Mac.
 Inspecteur Lavardin.
 Chronique Des Annes De Braise.
 La Dernière Image.
 L'Effrontee.
 Parole De Flic.
 Le Bon Plaisir.
 On Ne Meurt Que Deux fois.
 La Puritaine.
 Flagrant Desir.
 L'Éte Prochain.
 Le Lieu Du Crime.
 Miss Mona/No Woman's Land.
 La Memoire Tatouee.
 Je Hais Les Acteurs.
 Le Rayon Vert.
 Saraounia.

Given under my Hand and the Seal of Victoria
 on 11 November 1986.
 (L.S.) J. DAVIS McCAUGHEY
 By His Excellency's Command

J. H. KENNAN
 Attorney-General

Motor Boating Act 1961
 PROCLAMATION

I, J. Davis McCaughey, Governor of Victoria, acting with the advice of the Executive Council and under section 6A of the *Motor Boating Act 1961*, name the State of New South Wales, the State of South Australia, the State of Queensland, the State of Tasmania, the State of Western Australia and the Territory of Northern Territory and the Territory of the Australian Capital Territory to be named States and Territories for the purposes of that Act.

Given under my Hand and the Seal of Victoria
 on 11 November 1986.

(L.S.) J. DAVIS McCAUGHEY
 By His Excellency's Command

T. W. ROPER
 Minister for Transport

GOVERNMENT NOTICES

Port Phillip Coastal Planning and Management Act 1966

NOTICE OF EXEMPTION

I, Jim Kennan, Minister for Planning and Environment am of the opinion that the proposal to:

Change the use of that part of the Port Phillip Area within and adjacent to the Shire of Corio as shown on Plan No. 861262A to Submarine Fabrication Facility—

should be exempted from the provisions of section 6 of the *Port Phillip Coastal Planning and Management Act 1966* and hereby so exempt the said change of use pursuant to section 6 (4), subject to the conditions that:

1. The subject land shall only be used and developed for "Submarine Fabrication Facility".
2. Any development or works on the subject land shall not proceed unless in accordance with an endorsed plan approved by the Secretary for Planning and Environment or his nominee.
3. Use and development of purposes not consistent with the use and development of the area for "Submarine Fabrication Facility" must be approved under the provisions of the *Port Phillip Coastal Planning and Management Act 1966*.

Dated 12 November 1986

JIM KENNAN
 Minister for Planning and Environment

ASSOCIATIONS INCORPORATIONS ACT
 1981

Notice is hereby given that in accordance with sub-section 36 (2) of the *Associations Incorporations Act 1981*, the incorporation of Access Studio Gallery Inc., Dandenong Youth Theatre Project Inc., Hellenic Cultural Centre of Egialians Inc., Heatherdale Training Centre Inc., North Fawkner Football Social Club Inc., Templestowe Baptist Community Centre Inc., XXVIII World Modern Pentathlon Championships 1985 Inc., Wellington Fleet Sailboard Club Inc. and Yarrowonga Croquet Club Inc. was cancelled on 29 October 1986.

GORDON LEWIS
 Registrar of Incorporated Associations

Private Agents Act 1966

NOTICE OF RECEIPT OF APPLICATIONS FOR LICENCES UNDER THE PROVISIONS OF THE PRIVATE AGENTS ACT 1966

The Clerk(s) of the Magistrates' Court(s) as listed hereunder hereby give notice that applications, as under, have been lodged for hearing by the said Court(s) on the date(s) specified.

Any person desiring to object to any of such applications must—

- (a) lodge with the respective Clerk of the Magistrates' Court a notice in the prescribed form of his objection and of the grounds thereof;
- (b) cause a copy of such notice to be served personally or by post upon the applicant at least three days before the hearing of the application; and
- (c) send or deliver—
 - (i) where the objection is not made by the officer in charge of the police district in which the Court is situated—a copy of the notice to such officer; and
 - (ii) where the objection is not made by the Registrar or Deputy Registrar—a copy to the Registrar.

<i>Full Name of Applicant*</i>	<i>Place of Abode of Applicant or Nominee</i>	<i>Name of Firm or Corporation</i>	<i>Address for Registration</i>	<i>Type of Licence</i>	<i>Date of Hearing</i>
MAGISTRATES' COURT, DROMANA					
Millar, David Henry	222 Dundas St, Rye	Royal Security Services P/L	5 Boundary Rd, Dromana	Watchman	8.12.86
Dated at Dromana, 7 November 1986 M. LEA, Clerk of the Magistrates' Court					
MAGISTRATES' COURT, LILYDALE					
Brown, Gary James	15 Dorrigo Dve, Boronia		26 North Rd, Lilydale	Watchman	19.12.86
Dated at Lilydale, 7 November 1986 R. O'KEEKE, Clerk of the Magistrates' Court					
MAGISTRATES' COURT, ST KILDA					
Weerasinghe, Nihal Dias	4/24 Vale St, St Kilda	Sinha Security Service	4/24 Vale St, St Kilda	Individual Guard Agents	22.12.86
Dated at St Kilda, 10 November 1986 T. DWYER, Clerk of the Magistrates' Court					
MAGISTRATES' COURT, CASTLEMAINE					
Green, Lyle James	Coolstore Rd, Harcourt		Coolstore Rd, Harcourt	Process Server	11.12.86
Dated at Castlemaine, 11 November 1986 P. KELLOW, Clerk of the Magistrates' Court					
MAGISTRATES' COURT, FRANKSTON					
Baker, David William	20A Violet St, Frankston		20A Violet St, Frankston	Inquiry Agent	8.12.86
Binns, Michael	"	"	"	"	"
Dated at Frankston, 10 November 1986 S. MERBACH, Clerk of the Magistrates' Court					

* Or in the case of a firm or corporation, of the Nominee

PRIVATE AGENTS—continued

<i>Full Name of Applicant*</i>	<i>Place of Abode of Applicant or Nominee</i>	<i>Name of Firm or Corporation</i>	<i>Address for Registration</i>	<i>Type of Licence</i>	<i>Date of Hearing</i>
MAGISTRATES' COURT, PRAHRAN					
Face, Brian	20 Dulcie St, Sunshine	Mayne Nickless P/L	390 St Kilda Rd, Melbourne	Watchman	12.12.86
Somerville, Gordon	4 Fehon St, Yarraville	"	"	"	"
Cumming, Leslie Robert John	55 Jamieson St, St Albans	"	"	"	"
Rossino, Luigi	527 Lygon St, Carlton	"	"	"	"
Harris, Peter Wayne	3/39 Tooronga Rd, Malvern	Alef Security Services P/L	271A Carlisle St, Balaclava	"	"
Karavas, William	36 Ireland Ave, Doncaster East	"	"	"	"
Hartopitsos, Kiriakos	18 Dyer Crt, South Clayton	"	"	"	"
Sandstom, Guy Christopher	95 Noone St, Clifton Hill	"	"	"	"
Hopkins, Adrien Edward Jeffrey	32/64 Auburn Rd, Hawthorn	"	"	"	"
Dickman, Beverley	78 York Rd, Mt Evelyn	Mayne Nickless Ltd	390 St Kilda Rd, Melbourne	Watchman	"
Morrish, Geoffrey William	1/5 Kelly St, Chadstone	"	"	"	"
Mai, Quang Minh	36 Droop St, Footscray	"	"	"	"
Humnh, Phi Hung	39 Mackay St, Yarraville	"	"	"	"
Hartley, Wayne George	3 Hurst Crt, Croydon	"	"	"	"
Lovell, Bradley John Francis	100 Madeline St, East Preston	"	"	"	"
McNamara, Peter Grant	5 Turner Cres, Brambrook	"	"	"	"
Bennett, Mandy Lee	9 Cameron St, Reservoir	"	"	"	"
Ford, John	29 Cormorant Cres, Werribee	"	"	"	"
Azidis, Theo Harris	41/20 Elgin St, Carlton	Alef Security Services P/L	271A Carlisle St, Balaclava	"	"
Maskell, Kenneth William	10 Riley St, Thornbury	"	"	"	"

Dated at Prahran, 13 November 1986
Clerk of the Magistrates' Court

MAGISTRATES' COURT, BOX HILL

Rutter, Thomas Arthur	52 Station St, Nunawading		Suite 8/20 Lygon St, Brunswick East	Inquiry Agent	12.1.87
"	"		"	Guard Agent	"
"	"		"	Process Server	"

Dated at Box Hill, 11 November 1986
Clerk of the Magistrates' Court

* Or in the case of a firm or corporation, of the Nominee

PRIVATE AGENTS—continued

Full Name of Applicant*	Place of Abode of Applicant or Nominee	Name of Firm or Corporation	Address for Registration	Type of Licence	Date of Hearing
	MAGISTRATES' COURT, BROADMEADOWS				
Peterson, Howard John	9 Cleeland Cl, Epping		390 St Kilda Rd, Melbourne	Watchman	8.1.86
	Dated at Broadmeadows, 13 November 1986 Clerk of the Magistrates' Court				
	MAGISTRATES' COURT, RINGWOOD				
Bourke, Peter Leslie	10 The Ridge, Kinglake		14A Thornton Cres, Mitcham	Provisional Watchman	13.1.87
	Dated at Ringwood, 10 November 1986 D. REES, Clerk of the Magistrates' Court				
	MAGISTRATES' COURT, MOONEE PONDS				
Pilli, Giuseppe	15 Fitzgerald Rd, Essendon	Patrick Oswald Pilli	15 Fitzgerald Rd, Essendon	Watchman	12.1.87
	Dated at Moonee Ponds, 11 November 1986 J. DOLLING, Clerk of the Magistrates' Court				
	MAGISTRATES' COURT, PORT MELBOURNE				
Burns, Stephen	3/68 Shaftesbury Pde, Thornbury	Armaguard	Cnr Graham and Turner Sts, Port Melbourne	Watchman	11.12.86
Lawton, Thomas	6 Mt Barron St, Balnarring	"	"	"	"
Lehne, Peter Charles	38 Woodward St, Springvale	"	"	"	"
McGhie, Robert James	143 Empress Ave, West Footscray	"	"	"	"
Rae, Herbert George	175 Boundary Rd, Narre Warren Nth	"	"	"	"
Reardon, Brian James	39 Allenby Ave, Reservoir	"	"	"	"
Wheat, Robert John	24A Two Bays Rd, Mt Eliza	"	"	"	"
	Dated at Port Melbourne, 12 November 1986 K. HUSSEY, Clerk of the Magistrates' Court				

* Or in the case of a firm or corporation, of the Nominee

Police Regulation Act, Section 122
SALE OF UNCLAIMED MOTOR VEHICLE
 An owner is required for an unregistered white Holden Commodore, which has no identifying numbers.
 The vehicle came into possession of Police on 5 April 1986 and if not claimed, will be sold by public auction at the Dandenong Police Station, 50 Langhorne Street, Dandenong, on Wednesday, 4 February 1987, at 2.00 p.m.

S. I. MILLER
 Chief Commissioner of Police

Summary Offences Act, Section 33 (4)
SALE OF UNCLAIMED MOTOR VEHICLE
 An owner is required for an unregistered bronze Ford Fairmont sedan, Engine No. JG 35MY 42902K.
 The vehicle came into possession of Police on 23 June 1982, and if not claimed, will be sold by public auction at the Police Traffic Branch, 20 Dawson Street, Brunswick, on Wednesday, 4 February 1987, at 10.00 a.m.

S. I. MILLER
 Chief Commissioner of Police

Transport Act 1983

ROAD TRAFFIC AUTHORITY

Commercial Passenger Vehicle Applications

Notice is hereby given that the following applications will be considered by the Road Traffic Authority on 9 December 1986.

Notice of any objections should be forwarded to reach the Manager, Vehicle Licensing Branch or any Regional Office of the Road Traffic Authority not later than 3 December 1986.

It will not be necessary for interested parties to appear on the hearing date specified, unless advised in writing by the Authority.

Notification of the date for consideration of applications which are objected to and which require determination by the Road Transport Licensing Tribunal will be published by further notice in this Gazette.

Aarjent Towing & Salvage Pty. Ltd., North Melbourne. Application for variation of the conditions of tow truck licence 673, presently operating from 187 Abbotsford Street, North Melbourne, to delete that operational address and instead include operations from a depot located at 178 Whitehorse Road, Blackburn.

Note: (i) The Authority has under consideration an application to transfer this licence to Hillman Spares and Repairs Pty. Ltd. of 178 Whitehorse Road, Blackburn. (ii) This licence is a restricted licence and does not authorize operations from the scene of a motor car accident.

W. Christian (Terang) Pty. Ltd., Terang. Application to license one commercial passenger vehicle, to be purchased, with seating capacity for 45 passengers to operate under charter conditions from within a 20 km pick-up radius of the Chief Post Office at Warrnambool.

Note: The vehicle to be licensed would hold a 4 star rating for charter purposes.

R. R. & M. A. Hayes, Tooborac. Application for variation of the conditions of licence TS 1910 which authorizes a Ministry of Education contract service between Emu Flat and Tooborac Primary School to operate under charter conditions from within a 20 km pick-up radius of the Pyalong Post Office.

B. M. Jessop and H. M. Komesaroff, Balaclava. Application to license one commercial passenger vehicle in respect of a 1974 Rolls Royce sedan with seating capacity for four passengers to operate as a metropolitan hire car from Suite 13, 285 Carlisle Street, Balaclava.

D. W. & R. I. Raeburn, Stawell. Application to license one commercial passenger vehicle, with seating capacity for 7 passengers to operate for the carriage of guests of the Fyans Lodge Host Farm to places of interest within a 80 kilometre radius of the Fyans Lodge Host Farm.

Timetable: As and when required.

Fares: Included in overall charge to guests.

N. S. & P. M. Reid, Stawell. Application to license one commercial passenger vehicle with seating capacity for 8 passengers to operate for the carriage of guests of the Bellarine Rise Host Farm to places of interest within a 80 kilometre radius of the Bellarine Rise Host Farm.

Timetable: As and when required.

Fares: Included in overall charge to guests.

G. Zovko, Bell Park. Application for variation of the conditions of licence SV 537 which authorizes the carriage of farm labourers between the City of Geelong and surrounding areas and farms located within the Shires of Ballan, Bannockburn, Buninyong and Corio to include the Shires of Werribee, Bellarine, South Barwon, Barrabool, Winchelsea, Otway, Heytesbury, Hampden and Leigh.

Timetable: As and when required.

Fares: To be determined.

Dated 19 November 1986

G. SHANKS
Group Manager
Vehicle Licensing and Regulation Strategies

NOTICE OF VARIATION OF CONDITIONS
OF A PIPELINE LICENCE

Whereas sub-section (3) of section 30 of the *Pipelines Act 1967* provides that the Minister may by notice published in the *Government Gazette* amend vary add to or revoke any conditions stated or included in a licence, I, Robert Clive Fordham, Minister for Industry, Technology and Resources, do now hereby vary the conditions of Pipeline Licence No. 7 in the manner indicated in the Schedule hereto.

Schedule

1. Delete line in Clause 1 (A) (iii) of the Schedule to the Licence and replace with:

"A maximum allowable operating pressure of 9650 kPa (1400 psi)".

2. Replace Clause 1 (D) of the Schedule to the Licence with:

"(D) Pressure Control

(i) The inlet pressure of the liquid hydrocarbons in the pipeline shall not at any time, unless otherwise approved in writing by the Director, Petroleum Division of the Department of Industry, Technology and Resources, exceed 9.65 MPa (1400 psi);

(ii) All pressure control systems associated with the pipeline shall be maintained in accordance with Rule 7.2 of the Australian Standard 2018-1981: SAA Liquid Petroleum Pipeline Code."

3. Replace sub-Clause 2 (B) (i) of the Schedule to the Licence with:

“(i) *Pressure Test*

Unless otherwise approved by the Director, Petroleum Division of the Department of Industry, Technology and Resources, the pipeline shall be subjected to pressure tests at intervals not exceeding 5 years and be in compliance with Rule 6.4 of Australian Standard 2018-1981: SAA Liquid Petroleum Pipeline Code and the requirements of Australian Standard 1978-1977: SAA Code for Field Pressure Testing of Pipelines and also in accordance with a program having the prior approval of the said Director.

The licensee shall give the Director, Petroleum Division of the Department of Industry, Technology and Resources, seven days notice of intention to test, and shall within fourteen days of completion of a pressure test, forward to the said Director a test report covering as applicable the strength and leak test components of that pressure test, and supported by graphs of pipeline pressure and pipeline and ground temperature with test fluid volume and time as appropriate, all duly interpreted and verified by the licensee's testing engineer.

No other pressure testing of the pipeline portions thereof shall be carried out by the licensee without prior notice in writing to and approval of the said Director.”

Dated 11 November 1986

ROBERT CLIVE FORDHAM
Minister for Industry, Technology and Resources

NOTICE OF VARIATION OF CONDITIONS OF A PIPELINE LICENCE

Whereas sub-section (3) of section 30 of the *Pipelines Act 1967* provides that the Minister may by notice published in the *Government Gazette* amend vary add to or revoke any conditions stated or included in a licence, I, Robert Clive Fordham, Minister for Industry, Technology and Resources, do now hereby vary the conditions of Pipeline Licence No. 8 in the manner indicated in the Schedule hereto.

Schedule

1. Replace Clause 1 (D) of the Schedule to the Licence with:

“(D) *Pressure Control*

(i) The inlet pressure of the liquid hydrocarbons in the pipeline shall not at any time, unless otherwise approved in writing by the Director, Petroleum Division of the Department of Industry, Technology and Resources, exceed 9.65 MPa (1400 psi);

(ii) All pressure control systems associated with the pipeline shall be maintained in accordance with Rule 7.2 of the Australian Standard 2018-1981: SAA Liquid Petroleum Pipeline Code.”

2. Replace sub-Clause 2 (B) (i) of the Schedule to the Licence with:

(i) *Pressure Test*

Unless otherwise approved by the Director, Petroleum Division of the Department of Industry, Technology and Resources, the pipeline shall be subjected to pressure tests at intervals not exceeding 5 years and be in compliance with Rule 6.4 of Australian Standard 2018-1981: SAA Liquid Petroleum Pipeline Code and the requirements of Australian Standard 1978-1977: SAA Code for Field Pressure Testing of Pipelines and also in accordance with a program having the prior approval of the said Director.

The licensee shall give the Director, Petroleum Division of the Department of Industry, Technology and Resources, seven days notice of intention to test, and shall within fourteen days of completion of a pressure test, forward to the said Director a test report covering as applicable the strength and leak test components of that pressure test, and supported by graphs of pipeline pressure and pipeline and ground temperatures with test fluid volume and time as appropriate, all duly interpreted and verified by the licensee's testing engineer.

No other pressure testing of the pipeline portions thereof shall be carried out by the licensee without prior notice in writing to and approval of the said Director.”

Dated 11 November 1986

ROBERT CLIVE FORDHAM
Minister for Industry, Technology and Resources

Town and Country Planning Act 1961 SHIRE OF LILLYDALE PLANNING SCHEME 1958

Amendment No. 206 Notice of Approval

In pursuance of the powers conferred by the *Town and Country Planning Act 1961*, the Governor in Council on 11 November 1986 approved the abovementioned scheme in respect of the municipal district of the Shire of Lillydale and for which the Lillydale Shire Council is the responsible authority.

The scheme comes into operation on the date this notice is published in the *Government Gazette*.

The scheme includes the rezoning of land on the north-west corner of Mt Dandenong Tourist Road and Swansea Road, Montrose from Public Open Space (Recreation) Reserve to Public Purposes No. 5 (Municipal Purposes) Reserve to more accurately

reflect the use of the land for public library and multi-purpose recreation hall purposes.

A copy of the documents may be inspected free of charge, during office hours, at the office of the Ministry for Planning and Environment, The Olderfleet Buildings, 477 Collins Street, Melbourne, and at the office of the Council of the Shire of Lillydale at Lillydale.

DAVID YENCKEN
Secretary for Planning and Environment

Town and Country Planning Act 1961
CITY OF MILDURA PLANNING SCHEME
Amendment No. 70
Notice of Approval

In pursuance of the powers conferred by the *Town and Country Planning Act 1961*, the Governor in Council on 11 November 1986 approved the abovementioned scheme in respect of the municipal district of the City of Mildura and for which the Council of the City of Mildura is the responsible authority.

The scheme comes into operation on the date this notice is published in the *Government Gazette*.

The scheme includes rezoning part Lot 7, Plan of Subdivision No. 2168, Block F, Section 30, Parish of Mildura, situated at the north-east corner of San Mateo Avenue and Fourteenth Street, Mildura, from reserve for Public Purpose—Existing No. 10 (Mildura Urban Water Trust) to Residential "A" zone.

A copy of the documents may be inspected free of charge, during office hours, at the office of the Ministry for Planning and Environment, The Olderfleet Buildings, 477 Collins Street, Melbourne, and at the office of the responsible authority, Deakin Avenue, Mildura.

DAVID YENCKEN
Secretary for Planning and Environment

Town and Country Planning Act 1961
SHIRE OF MORWELL PLANNING SCHEME
1977

Amendment No. 31
Notice of Approval

In pursuance of the powers conferred by the *Town and Country Planning Act 1961*, the Governor in Council on 11 November 1986 approved the abovementioned scheme in respect of the municipal district of the Shire of Morwell and for which the Shire of Morwell is the responsible authority.

The scheme comes into operation on the date this notice is published in the *Government Gazette*.

The scheme includes the reservation of part of 48–50 Church Street, Morwell from Commercial A Zone to Public Purposes Existing—9 (Country Fire Authority).

A copy of the documents may be inspected free of charge, during office hours, at the office of the Ministry for Planning and Environment, The Olderfleet Buildings, 477 Collins Street, Melbourne, and at the office of the responsible authority, Shire of Morwell, Princes Highway, Morwell.

DAVID YENCKEN
Secretary for Planning and Environment

Town and Country Planning Act 1961
SHIRE OF SWAN HILL—ROBINVALE
PLANNING SCHEME 1958

Amendment No. 7
Notice of Approval

In pursuance of the powers conferred by the *Town and Country Planning Act 1961*, the Governor in Council on 11 November 1986 approved the abovementioned scheme in respect of the municipal district of the Shire of Swan Hill and for which the Council of the Shire of Swan Hill is the responsible authority.

The scheme comes into operation on the date this notice is published in the *Government Gazette*.

The scheme includes incorporating "ancillary buildings or works" and "indoor sports centre" as permissible uses or developments in the Industrial zone.

A copy of the documents may be inspected free of charge, during office hours, at the office of the Ministry for Planning and Environment, The Olderfleet Buildings, 477 Collins Street, Melbourne, and at the office of the responsible authority, Beveridge Street, Swan Hill.

DAVID YENCKEN
Secretary for Planning and Environment

Town and Country Planning Act 1961
SHIRE OF ROSEDALE PLANNING SCHEME

Amendment No. 50
Notice of Approval

In pursuance of the powers conferred by the *Town and Country Planning Act 1961*, the Governor in Council on 11 November 1986 approved the abovementioned scheme in respect of the municipal district of the Shire of Rosedale and for which the Shire of Rosedale is the responsible authority.

The scheme comes into operation on the date this notice is published in the *Government Gazette*.

The scheme includes the rezoning of part Crown Allotment 124A Parish of Toongabbie North from "Rural B" to "Rural Residential B".

A copy of the documents may be inspected free of charge, during office hours, at the office of the Ministry for Planning and Environment, The Olderfleet Buildings, 477 Collins Street, Melbourne and at the office of the responsible authority, Shire of Rosedale, Cansick Street, Rosedale.

DAVID YENCKEN
Secretary for Planning and Environment

Town and Country Planning Act 1961
SHIRE OF COBRAM PLANNING SCHEME
1979

Amendment No. 20, 1986
Notice of Approval

In pursuance of the powers conferred by the *Town and Country Planning Act 1961*, the Governor in Council on 11 November 1986 approved the abovementioned scheme in respect of the municipal district of the Shire of Cobram and for which the Council of the Shire of Cobram is the responsible authority.

The scheme comes into operation on the date this notice is published in the *Government Gazette*.

The scheme provides for the removal of mandatory building setback provisions in the Planning Scheme Ordinance in so far as they relate to Mookarii Street, Cobram.

A copy of the documents may be inspected free of charge, during office hours, at the office of the Ministry for Planning and Environment, The Olderfleet Buildings, 477 Collins Street, Melbourne and at the office of the responsible authority, the Shire of Cobram, Shire Offices, Station Street, Cobram.

DAVID YENCKEN
Secretary for Planning and Environment

Town and Country Planning Act 1961
SHIRE OF CHILTERN PLANNING SCHEME
1982

Amendment No. 2, 1986
Notice of Approval

In pursuance of the powers conferred by the *Town and Country Planning Act 1961*, the Governor in Council on 11 November 1986 approved the abovementioned scheme in respect of the municipal district of the Shire of Chiltern and for which the Council of the Shire of Chiltern is the responsible authority.

The scheme comes into operation on the date this notice is published in the *Government Gazette*.

The scheme has several parts to it in that it allows the erection of houses on six separate parcels of land, the alteration of a Public Purpose Reservation to Residential A zone, and the extension of the Historic Area special control, all in the Chiltern township area.

A copy of the documents may be inspected free of charge, during office hours, at the office of the Ministry for Planning and Environment, The Olderfleet Buildings, 477 Collins Street, Melbourne and at the office of the responsible authority, the Shire of Chiltern, Main Street, Chiltern.

DAVID YENCKEN
Secretary for Planning and Environment

Town and Country Planning Act 1961
SHIRE OF LILLYDALE PLANNING SCHEME
1958

Amendment No. 210
Notice of Approval

In pursuance of the powers conferred by the *Town and Country Planning Act 1961*, the Governor in Council on 11 November 1986 approved the abovementioned scheme in respect of part of the municipal district of the Shire of Lillydale and for which the Lillydale Shire Council is the responsible authority.

The scheme comes into operation on the date this notice is published in the *Government Gazette*.

The scheme includes the rezoning of land on the south-east corner of Manchester Road and Winyard Drive, Mooroolbark from Residential "G" zone to Commercial (General) zone to allow the development of the land for offices comprising 1830 square metres floor area and 29 car parking spaces.

A copy of the documents may be inspected free of charge, during office hours, at the office of the Ministry for Planning and Environment, The Olderfleet Buildings, 477 Collins Street, Melbourne and at the office of the Council of the Shire of Lillydale at Lillydale.

DAVID YENCKEN
Secretary for Planning and Environment

Town and Country Planning Act 1961
MELBOURNE METROPOLITAN PLANNING
SCHEME

Revocation No. 53
Notice of Revocation

Notice of Order Under Section 32 (5)

In pursuance of the powers conferred by the *Town and Country Planning Act 1961*, the Governor in Council on 11 November 1986 made an order revoking in part the abovementioned scheme in respect of part Lot 25 LP 4802 Mount Pleasant Road, Research, Shire of Eltham and made an order pursuant to section 32 (5). The order provides that the subject land may be subdivided into two allotments and the vacant allotment created to be used for the purpose of a detached house.

A copy of the orders relating to the revocation may be inspected during office hours at the office of the Ministry for Planning and Environment, The Olderfleet Buildings, 477 Collins Street, Melbourne, and at the office of the Shire of Eltham, 895 Main Road, Eltham.

DAVID YENCKEN
Secretary for Planning and Environment

Town and Country Planning Act 1961
SHIRE OF CRANBOURNE (WESTERN PORT)
PLANNING SCHEME

Revocation No. 7

Notice of Revocation

Notice of Order Under Section 32 (5)

In pursuance of the powers conferred by the *Town and Country Planning Act 1961*, the Governor in Council on 11 November 1986 made an order revoking in part the abovementioned scheme in respect of Lot 1, LP 26269, South Gippsland Highway, Tooradin, and made an order pursuant to section 32 (5). The order provides that the land so revoked may be used or developed as if it were within the General Farming B zone with the Highway Policy Area overlay of the scheme and the provisions of the scheme do not apply insofar as they would prevent the grant of a permit by the responsible authority for the subdivision of the land into two lots of approximately 2090 m² each.

A copy of the orders relating to the revocation may be inspected during office hours at the office of the Ministry for Planning and Environment, The Olderfleet Buildings, 477 Collins Street, Melbourne, and at the office of the responsible authority, Shire of Cranbourne Council, Shire Offices, Sladen Street, Cranbourne.

DAVID YENCKEN
Secretary for Planning and Environment

Town and Country Planning Act 1961
SHIRE OF KORUMBURRA PLANNING
SCHEME

Amendment No. 35A

Notice of Amendment

In pursuance of the powers conferred by the *Town and Country Planning Act 1961*, the Governor in Council on 11 November 1986, amended the abovementioned scheme in respect of the municipal district of the Shire of Korumburra and for which the Shire of Korumburra Council is the Responsible Authority.

The amendment comes into operation on the date this Notice is published in the *Government Gazette*.

The amendment includes Pt CA 35A, Parish of Jumbunna East, Lynn St, Jumbunna in the Residential A Zone.

A copy of the documents may be inspected free of charge, during office hours, at the office of the Ministry for Planning and Environment (Plan Inspection Section), The Olderfleet Buildings, 477 Collins Street, Melbourne and at the office of the Responsible Authority, Shire of Korumburra Council, Shire Offices, Cnr Commercial and King Streets, Korumburra.

DAVID YENCKEN
Secretary for Planning and Environment

Town and Country Planning Act 1961
CRANBOURNE PLANNING SCHEME 1960

Amendment No. 57

Notice of Approval

In pursuance of the powers conferred by the *Town and Country Planning Act 1961*, the Governor in Council on 11 November 1986 approved the above mentioned scheme in respect of the municipal district of the Shire of Cranbourne and for which the Shire of Cranbourne Council is the Responsible Authority.

The scheme comes into operation on the date this Notice is published in the *Government Gazette*.

The scheme includes Lots 1-4 (inclusive), LP 7319, Parish of Lyndhurst, in Stevensons Road, south of Cranbourne-Frankston Road, Cranbourne, within the Reserved Living Zone and makes additional control provisions within this zone to specifically apply to the subject area limiting any subdivision allotment sizes to between 2000 and 4000 m² or larger where encumbered by an S.E.C. transmission line easement.

A copy of the documents may be inspected free of charge, during office hours, at the office of the Ministry for Planning and Environment (Plan Inspection Section), The Olderfleet Buildings, 477 Collins Street, Melbourne and at the office of the Responsible Authority, Shire of Cranbourne Council, Shire Offices, Sladen Street, Cranbourne.

DAVID YENCKEN
Secretary for Planning and Environment

Town and Country Planning Act 1961
SHIRE OF LILLYDALE PLANNING SCHEME
1958

Amendment No. 202

Notice of Approval

In pursuance of the powers conferred by the *Town and Country Planning Act 1961*, the Governor in Council on 11 November 1986, approved the abovementioned scheme in respect of the municipal district of the Shire of Lillydale and for which the Lillydale Shire Council is the Responsible Authority.

The scheme comes into operation on the date this Notice is published in the *Government Gazette*.

The scheme includes the rezoning of part No. 17, part CA 2, section 4, Monash Avenue, Olinda from Ridge Residential to Special Use Zone No. 14 (Place of Worship) to enable the subdivision of part of an allotment containing a church from the remainder of the allotment containing a vicarage which is no longer required.

A copy of the documents may be inspected free of charge, during office hours, at the office of the Ministry for Planning and Environment, The Olderfleet Buildings, 477 Collins Street, Melbourne and at the office of the Council of the Shire of Lillydale at Lillydale.

DAVID YENCKEN
Secretary for Planning and Environment

*Upper Yarra Valley and Dandenong Ranges
Authority Act 1976*

UPPER YARRA VALLEY AND DANDENONG
RANGES REGIONAL STRATEGY PLAN

Amendment No. 14

Notice of Amendment

In pursuance of the powers conferred by the Upper Yarra Valley and Dandenong Ranges Authority Act, the Governor in Council on 11 November 1986, amended the abovementioned Strategy Plan in respect of land situated at part No. 17, part CA 2, section A, Monash Avenue, Olinda, and for which the Upper Yarra Valley and Dandenong Ranges Authority is the responsible body.

The amendment comes into operation on the date this Notice is published in the *Government Gazette*.

The amendment designates that the above land may, subject to the grant of a permit, be subdivided into two allotments.

A copy of the documents may be inspected free of charge, during office hours, at the office of the Ministry for Planning and Environment, The Olderfleet Buildings, 477 Collins Street, Melbourne, and at the office of the Upper Yarra Valley and Dandenong Ranges Authority, Old Melbourne Road, Lilydale West.

DAVID YENCKEN

Secretary for Planning and Environment

Town and Country Planning Act 1961
SHIRE OF ROCHESTER (ROCHESTER
TOWNSHIP) PLANNING SCHEME

Amendment No. 15

Notice of Approval

In pursuance of the powers conferred by the *Town and Country Planning Act 1961*, the Governor in Council on 11 November 1986, approved the abovementioned scheme in respect of the area subject to the Shire of Rochester (Rochester Township) Planning Scheme for which the Shire of Rochester is the Responsible Authority.

The scheme comes into operation on the date this Notice is published in the *Government Gazette*.

The scheme provides for the prohibition of the use "Adult Book Shop" in all zones in the Planning Scheme.

A copy of the documents may be inspected free of charge, during office hours, at the office of the Ministry for Planning and Environment, The Olderfleet Buildings, 477 Collins Street, Melbourne and at the office of the Responsible Authority, the Shire of Rochester, Mackay Street, Rochester.

DAVID YENCKEN

Secretary for Planning and Environment

Town and Country Planning Act 1961

GEELONG REGIONAL PLANNING SCHEME

Amendment No. 104, Part 2b

Notice of Approval

In pursuance of the powers conferred by the *Town and Country Planning Act 1961*, the Governor in Council on 11 November 1986, approved the abovementioned scheme in respect of the municipal district of the Shire of Bannockburn and for which the Geelong Regional Commission is the Responsible Authority.

The scheme comes into operation on the date this Notice is published in the *Government Gazette*.

The scheme includes land at Fyansford in a Reserved Industrial and Rural Residential zone.

A copy of the documents may be inspected free of charge, during office hours, at the office of the Ministry for Planning and Environment (Planning Information Services), The Olderfleet Buildings, 477 Collins Street, Melbourne and at the office of the Geelong Regional Commission, State Offices, Little Malop Street, Geelong.

DAVID YENCKEN

Secretary for Planning and Environment

Town and Country Planning Act 1961

SHIRE OF LILLYDALE PLANNING SCHEME

Amendment No. 228

Notice of Amendment

In pursuance of the powers conferred by the *Town and Country Planning Act 1961*, the Governor in Council on 11 November 1986, amended the abovementioned scheme in respect of part of the municipal district of the Shire of Lillydale and for which the Lillydale Shire Council is the Responsible Authority.

The amendment comes into operation on the date this Notice is published in the *Government Gazette*.

The amendment enables buildings and works to be erected closer than 7.5 metres to the eastern boundary of Lot 9, part CA 8, Section 30, No. 58 John Street, Lillydale.

A copy of the documents may be inspected free of charge, during office hours, at the office of the Ministry for Planning and Environment, The Olderfleet Buildings, 477 Collins Street, Melbourne and at the office of the Council of the Shire of Lillydale at Lillydale.

DAVID YENCKEN

Secretary for Planning and Environment

Town and Country Planning Act 1961

GEELONG REGIONAL PLANNING SCHEME

Amendment No. 165

Notice of Amendment

In pursuance of the powers conferred by the *Town and Country Planning Act 1961*, the Governor in Council on 11 November 1986, amended the

abovementioned scheme in respect of the municipal district of the City of South Barwon and for which the Geelong Regional Commission is the Responsible Authority.

The amendment comes into operation on the date this Notice is published in the *Government Gazette*.

The amendment includes land in Bell Street, Torquay adjacent to the Torquay Community Health Centre in a Public Purposes (Existing)—24—State Government Other reservation.

A copy of the documents may be inspected free of charge, during office hours, at the office of the Ministry for Planning and Environment (Planning Information Services), The Olderfleet Buildings, 477 Collins Street, Melbourne and at the office of the Geelong Regional Commission, State Offices, Little Malop Street, Geelong.

DAVID YENCKEN
Secretary for Planning and Environment

Town and Country Planning Act 1961
GEELONG REGIONAL PLANNING SCHEME
Amendment No. 170
Notice of Approval

In pursuance of the powers conferred by the *Town and Country Planning Act 1961*, the Governor in Council on 11 November 1986, approved the abovementioned scheme in respect of the municipal district of the Shire of Barrabool and for which the Geelong Regional Commission is the Responsible Authority.

The scheme comes into operation on the date this Notice is published in the *Government Gazette*.

The scheme includes land on the west side of Torquay-Geelong Road, north of Beach Street from Rural General Farming to a Reserved Residential zone.

A copy of the documents may be inspected free of charge, during office hours at the office of the Ministry for Planning and Environment (Planning Information Services), The Olderfleet Buildings, 477 Collins Street, Melbourne and at the office of the Geelong Regional Commission, Little Malop Street, Geelong.

DAVID YENCKEN
Secretary for Planning and Environment

Town and Country Planning Act 1961
CITY OF SALE PLANNING SCHEME
Amendment No. 30
Notice of Approval

In pursuance of the powers conferred by the *Town and Country Planning Act 1961*, the Governor in Council on 11 November 1986, approved the abovementioned scheme in respect of the municipal district of the City of Sale and for which the City of Sale is the Responsible Authority.

The scheme comes into operation on the date this Notice is published in the *Government Gazette*.

The scheme includes a number of rezonings at Warruk to bring the Scheme into line with the adopted development plan for the area and an Ordinance amendment to the definition of "Home Occupation" to bring it into line with most other Schemes in the region.

A copy of the documents may be inspected free of charge during office hours, at the office of the Ministry for Planning and Environment, The Olderfleet Buildings, 477 Collins Street, Melbourne and at the office of the Responsible Authority, City of Sale, Macalister Street, Sale.

DAVID YENCKEN
Secretary for Planning and Environment

Town and Country Planning Act 1961
TOWN OF BAIRNSDALE PLANNING
SCHEME
Amendment No. 57
Notice of Approval

In pursuance of the powers conferred by the *Town and Country Planning Act 1961*, the Governor in Council on 11 November 1986 approved the abovementioned scheme in respect of the municipal district of the Town of Bairnsdale and for which the Town of Bairnsdale is the Responsible Authority.

The Scheme comes into operation on the date this Notice is published in the *Government Gazette*.

The Scheme includes the rezoning of Part of Crown Pre-Emptive, section A, Township of Lucknow, Parish of Wy Yung, from "Minor Road" to "Residential A".

A copy of the documents may be inspected free of charge, during office hours, at the office of the Ministry for Planning and Environment, The Olderfleet Buildings, 477 Collins Street, Melbourne and at the office of the Responsible Authority, Town of Bairnsdale, 8 Pearson Street, Bairnsdale.

DAVID YENCKEN
Secretary for Planning and Environment

Town and Country Planning Act 1961
CITY OF SALE PLANNING SCHEME
Amendment No. 25
Notice of Approval

In pursuance of the powers conferred by the *Town and Country Planning Act 1961*, the Governor in Council on 11 November 1986 approved the abovementioned scheme in respect of the municipal district of the City of Sale and for which the City of Sale is the Responsible Authority.

The Scheme comes into operation on the date this Notice is published in the *Government Gazette*.

The scheme includes rezoning land at No. 123 Cunninghame Street, Sale, from "Residential High Density" to "Highway Commercial".

A copy of the documents may be inspected free of charge, during office hours, at the office of the Ministry for Planning and Environment, The Olderfleet Buildings, 477 Collins Street, Melbourne and at the office of the Responsible Authority, City of Sale, Macalister Street, Sale.

DAVID YENCKEN
Secretary for Planning and Environment

Town and Country Planning Act 1961
SHIRE OF PAKENHAM PLANNING
SCHEME—PART 1

Amendment No. 49
Notice of Approval

In pursuance of the powers conferred by the *Town and Country Planning Act 1961*, the Governor in Council on 11 November 1986 approved the above mentioned scheme in respect of the municipal district of the Shire of Pakenham and for which the Shire of Pakenham Council is the responsible authority.

The scheme comes into operation on the date this Notice is published in the *Government Gazette*.

The scheme includes Part CA 61, Parish of Nar Nar Goon, Healesville/Koo Wee Rup Road, Pakenham within the Public Purposes — 3 — Sewerage Authority Reservation.

A copy of the documents may be inspected free of charge, during office hours, at the office of the Ministry for Planning and Environment, Ground Floor, The Olderfleet Buildings, 477 Collins Street, Melbourne and at the office of the responsible authority, Shire of Pakenham Council, Municipal Offices, Henty Way, Pakenham.

DAVID YENCKEN
Secretary for Planning and Environment

Town and Country Planning Act 1961
SHIRE OF KORUMBURRA PLANNING
SCHEME

Amendment No. 34 (Part 1)
Notice of Approval

In pursuance of the powers conferred by the *Town and Country Planning Act 1961*, the Governor in Council on 11 November 1986 approved the above mentioned scheme in respect of the municipal district of the Shire of Korumburra and for which the Shire of Korumburra Council is the responsible authority.

The scheme comes into operation on the date this Notice is published in the *Government Gazette*.

The scheme includes Part C.A. 15A, Parish of Kongwak, being Lots 7, 8 and 9, LP 4610, Korumburra-Wonthaggi Road, Kongwak

Township in the Village zone, and modifies ordinance provisions to allow, subject to permit, excision of less area than specified in the rural zone for specific cases warranted for Rural Service Industry.

A copy of the documents may be inspected free of charge, during office hours, at the office of the Ministry for Planning and Environment, Ground Floor, The Olderfleet Buildings, 477 Collins Street, Melbourne and at the office of the responsible authority, Shire of Korumburra Council, Shire Offices, Corner Commercial and King streets, Korumburra.

DAVID YENCKEN
Secretary for Planning and Environment

Town and Country Planning Act 1961
SHIRE OF BASS PLANNING SCHEME

Amendment No. 19
Notice of Approval

In pursuance of the powers conferred by the *Town and Country Planning Act 1961*, the Governor in Council on 11 November 1986 approved the abovementioned scheme in respect of the municipal district of the Shire of Bass and for which the Council of the Shire of Bass is the responsible authority.

The scheme comes into operation on the date this Notice is published in the *Government Gazette*.

The scheme includes a prohibition on the establishment of brothels in the municipal district.

A copy of the documents may be inspected free of charge, during office hours, at the office of the Ministry for Planning and Environment, Ground Floor, The Olderfleet Buildings, 477 Collins Street, Melbourne and at the office of the responsible authority, Shire of Bass, Main Road, Archies Creek.

DAVID YENCKEN
Secretary for Planning and Environment

Town and Country Planning Act 1961
SHIRE OF HASTINGS PLANNING SCHEME

Amendment No. 15
Notice of Approval

In pursuance of the powers conferred by the *Town and Country Planning Act 1961*, the Governor in Council on 11 November 1986 approved the above mentioned scheme in respect of the municipal district of the Shire of Hastings and for which the Council of the Shire of Hastings is the responsible authority.

The scheme comes into operation on the date this Notice is published in the *Government Gazette*.

The scheme includes provisions to provide for the establishment of a refuse disposal depot at 19 McKirdys Road, Tyabb.

A copy of the documents may be inspected free of charge, during office hours, at the office of the

Ministry for Planning and Environment (Plan Inspection Section), The Olderfleet Buildings, 477 Collins Street, Melbourne and at the office of the responsible authority, the Council of the shire of Hastings, Marine Parade, Hastings.

DAVID YENCKEN
Secretary for Planning and Environment

Town and Country Planning Act 1961

SHIRE OF GISBORNE PLANNING SCHEME
Amendment No. 21
Notice of Approval

In pursuance of the powers conferred by the *Town and Country Planning Act 1961*, the Governor in Council on 11 November 1986, approved the abovementioned scheme in respect of the municipal district of the Shire of Gisborne and for which the Shire of Gisborne is the Responsible Authority.

The scheme comes into operation on the date this Notice is published in the *Government Gazette*.

The scheme includes an Ordinance amendment that changes the minimum size of car parking space required to accord with the Melbourne Metropolitan Planning Scheme standards and also alters the width of access lanes for angle parking.

A copy of the documents may be inspected free of charge, during office hours, at the office of the Ministry for Planning and Environment, The Olderfleet Buildings, 477 Collins Street, Melbourne and at the office of the Responsible Authority, the Shire of Gisborne, Robertson Street, Gisborne.

DAVID YENCKEN
Secretary for Planning and Environment

Town and Country Planning Act 1961

CITY OF SHEPPARTON PLANNING SCHEME
1953

Amendment No. 99, 1986
Notice of Approval

In pursuance of the powers conferred by the *Town and Country Planning Act 1961*, the Governor in Council on 11 November 1986 approved the abovementioned scheme in respect of the municipal district of the City of Shepparton and for which the Council of the City of Shepparton is the Responsible Authority.

The scheme comes into operation on the date this Notice is published in the *Government Gazette*.

The scheme rezones land on the east side of Mitchell Street, from Old Dookie Road to Williams Road in the City of Shepparton from Industrial "B" to Industrial "A".

A copy of the documents may be inspected free of charge, during office hours, at the office of the Ministry for Planning and Environment, The Olderfleet Buildings, 477 Collins Street, Melbourne, and at the office of the Responsible Authority, the City of Shepparton, Civic Centre, Shepparton.

DAVID YENCKEN
Secretary for Planning and Environment

Town and Country Planning Act 1961

TOWN OF KYABRAM PLANNING SCHEME
Amendment No. 35, 1986
Notice of Approval

In pursuance of the powers conferred by the *Town and Country Planning Act 1961*, the Governor in Council on 11 November 1986 approved the abovementioned scheme in respect of the municipal district of the Town of Kyabram and for which the Council of the Town of Kyabram is the Responsible Authority.

The scheme comes into operation on the date this Notice is published in the *Government Gazette*.

The scheme allows the rezoning of the Druids Hall at No. 25 Saleyards Road Kyabram from Special Use Zone No. 2 to Residential Zone.

A copy of the documents may be inspected free of charge, during office hours, at the office of the Ministry for Planning and Environment, The Olderfleet Buildings, 477 Collins Street, Melbourne, and at the office of the Responsible Authority, the Town of Kyabram, Lake Road, Kyabram.

DAVID YENCKEN
Secretary for Planning and Environment

Town and Country Planning Act 1961

CITY OF BENALLA PLANNING SCHEME
Amendment No. 42
Notice of Approval

In pursuance of the powers conferred by the *Town and Country Planning Act 1961*, the Governor in Council on 11 November 1986 approved the abovementioned scheme in respect of the municipal district of the City of Benalla and for which the Council of the City of Benalla is the Responsible Authority.

The scheme comes into operation on the date this Notice is published in the *Government Gazette*.

The Scheme allows the rezoning of land in Carrier Street Benalla between Mackellar and Church Streets from Residential "B" zone to Commercial "B" zone.

A copy of the documents may be inspected free of charge, during office hours, at the office of the Ministry for Planning and Environment, The Olderfleet Buildings, 477 Collins Street, Melbourne, and at the office of the Responsible Authority, the City of Benalla, Civic Centre, Fawckner Drive, Benalla.

DAVID YENCKEN
Secretary for Planning and Environment

Town and Country Planning Act 1961

GEELONG REGIONAL PLANNING SCHEME
Notice that a Planning Scheme (Amending) has
been Prepared and is Available for Inspection
Amendment No. 179

Notice is hereby given that the Geelong Regional Commission in pursuance of its powers under the *Town and Country Planning Act 1961*, has prepared

an amending scheme for land located on the north side of Barwon Terrace between Crown and Wood Streets, South Geelong. The amendment proposes to remove the land liable to flooding designation from the subject land.

A copy of the amending scheme has been deposited at this office, Geelong Regional Commission, State Government Offices, corner of Little Malop and Fenwick Streets, Geelong, at the Offices of the City of Geelong, Town Hall, Geelong (insofar as the municipalities are affected) and at the Offices of the Ministry for Planning and Environment, The Olderfleet Buildings, 477 Collins Street, Melbourne, and will be open for inspection during office hours by any person free of charge.

Any persons affected by the amending scheme are required to set forth in writing any submissions they wish to make with respect to the amending scheme addressed to the Secretary, Mr G. R. Cowling, Geelong Regional Commission, P.O. Box 770, Geelong, by Friday, 19 December 1986, and state whether you wish to be heard in respect of your submission.

G. R. COWLING, Secretary
Geelong Regional Commission

Town and Country Planning Act 1961

GEELONG REGIONAL PLANNING SCHEME
Notice that a Planning Scheme (Amending) has been Prepared and is Available for Inspection
Amendment No. 180

Notice is hereby given that the Geelong Regional Commission in pursuance of its powers under the *Town and Country Planning Act 1961*, has prepared an amending scheme for land located on the south side of Clifford Parade east of Grove Road, Barwon Heads. The proposed zoning change is from Special Uses—4—Recreation Club to Public Purposes (Existing)—2—Local Government.

A copy of the amending scheme has been deposited at this office, Geelong Regional Commission, State Government Offices, corner of Little Malop and Fenwick Streets, Geelong, at the Offices of the City of South Barwon, 2 Colac Road, Belmont (insofar as the municipalities are affected) and at the Offices of the Ministry for Planning and Environment, The Olderfleet Buildings, 477 Collins Street, Melbourne, and will be open for inspection during office hours by any person free of charge.

Any persons affected by the amending scheme are required to set forth in writing any submissions they wish to make with respect to the amending scheme addressed to the Secretary, Mr G. R. Cowling, Geelong Regional Commission, P.O. Box 770, Geelong, by Thursday, 19 February 1987, and state whether you wish to be heard in respect of your submission.

G. R. COWLING, Secretary
Geelong Regional Commission

Town and Country Planning Act 1961
CITY OF MOE PLANNING SCHEME

Amendment No. 95
Notice of Approval

In pursuance of the powers conferred by the *Town and Country Planning Act 1961*, the Governor in Council on 18 November 1986 approved the abovementioned scheme in respect of the municipal district of the City of Moe and for which the City of Moe is the Responsible Authority.

The scheme comes into operation on the date this Notice is published in the *Government Gazette*.

The scheme includes the rezoning of land from "Agricultural A" to "Residential D" for the purpose of creating four house lots.

A copy of the documents may be inspected free of charge, during office hours, at the office of the Ministry for Planning and Environment, The Olderfleet Building, 477 Collins Street, Melbourne and at the office of the Responsible Authority City of Moe, 46 Albert Street, Moe.

DAVID YENCKEN
Secretary for Planning and Environment

Department of Industry, Technology and
Resources

PROSPECTING AREA LICENCES EXPIRED
No. 1; D. R. Brown and Cuffley; 12.5 ha, Parish of Stanley.

No. 9; C. H. Hainsworth; 17.3 ha, Parish of Waanyarra.

No. 27; Allison Banner Pty. Ltd.; 47.2 ha, Parish of Morri Morri.

TAILINGS REMOVAL LICENCE EXPIRED
No. 5082; Shire of Bet Bet; to remove tailings situated at Mitchell's Pit approximately 1.5 km from the township of Tarnagulla.

**APPLICATION FOR EXTENSION OF
EXPLORATION LICENCE DECLARED
ABANDONED**

No. 1437-1; G. Black; 1 km², County of Anglesea.
The above area will become available again for Exploration Licence on 19 May 1987.

EXPLORATION LICENCES EXPIRED
No. 1394-1; D. R. Brown and B. W. Cuffley; 4 km², Parishes of Beechworth and Everton.

No. 1444; Balmoral Resources NL; 103 km², Parish of Bitchigal.

The above areas will become available again for Exploration Licences on 29 April 1986.

**EXTRACTIVE INDUSTRY LICENCE
ASSIGNED**

No. 603; From J. H. Robins to Oupan Resources Pty. Ltd.

ROBERT FORDHAM
Minister for Industry, Technology and Resources

MELBOURNE AND METROPOLITAN
BOARD OF WORKS

General Notice

Notice to the Owners of Tenements in the Undermentioned Streets and the Private Streets, Lanes, Courts and Alleys opening thereto. The main pipe in the said streets being laid down, the owners of all tenements situated as under are hereby required on or before 22 December 1986 to cause a proper pipe and stop cocks to be laid so as to supply water within such tenements from the main pipe.

Berwick

Ruby Place, the total street from Howell Drive northwards. Kerry Close, the total street from Howell Drive northwards. Howell Drive, from Buchanans Road eastwards 258 metres. Marida Court, the total street from County Drive westwards. Warrock Court, the total street from County Drive westwards. County Drive, from 40 metres north of Marida Court further northwards 85 metres. Heyington Circle, the total street from Magid Drive south-eastwards. Magid Drive, from the Plantation Reserve adjoining Narre Warren North Road westwards and south-westwards 191 metres. Jonathan Court, the total street from Allison Avenue southwards. Halcyon Way, from Shrikes Road southwards 468 metres. Beaumont Road, from 125 metres north of Gardiner Street further northwards 212 metres.

Broadmeadows

Knight Court, the total street from Buchan Street northwards. Castella Court, from 110 metres south-west of Taggerty Crescent further south-westwards 125 metres. Kim Close, the total street from Garvoc Court westwards. Nourell Court, the total street from Barry Road northwards and eastwards.

Bulla

Fleetwood Drive, from Bridlington Drive north-westwards 40 metres. Glasson Court, the total street from Fleetwood Drive westwards and southwards. Greenvale Drive, from 100 metres west of Fleetwood Drive further westwards 85 metres. Greenvale Drive, from 14 metres east of Fleetwood Drive further eastwards 48 metres.

Chelsea

Beachcomber Court, from 45 metres east of Myola Street further eastwards 204 metres.

Cranbourne

Beckington Crescent, from Narellan Drive westwards 169 metres. Narellan Drive, from Pound Road northwards 134 metres. Robbins Way, from Ivan Crescent southwards 53 metres. Ivan Crescent, from Campbell Drive eastwards 340 metres. Campbell Drive, from 153 metres north of Cairns Road further northwards 101 metres.

Croydon

Langdale Drive, from 18 metres west of Coniston Close, further north-eastwards 162 metres. Bowness Court, from Langdale Drive, westwards northward and southwards 288 metres.

Dandenong

Red Gum Drive, from Cahill Street northwards and eastwards 330 metres. Cahill Street, from Ordish Road eastwards 557 metres. Ordish Road, from 1240 metres south of Greens Road further southwards 410 metres.

Diamond Valley

Edmund Rice Parade, from Binnak Drive westwards and southwards 322 metres. Selwood Court, the total street from Edmund Rice Parade westwards. Chappell Drive, from Edmund Rice Parade northwards 34 metres. Stallard Court, the total street from Binnak Drive westwards.

Doncaster and Templestowe

Ruby Street, from 10 metres north of Murrindal Drive, further northwards and westwards 92 metres. Flannery Court, from Tindals Road eastwards 100 metres. Porter Street, from 206 metres west of Church Road, further westwards 90 metres. Niland Rise, total street from Porter Street southwards and westwards. Wakefield Place, total street from Niland Rise westwards and southwards. Beale Court, from 68 metres north of Stradmore Avenue further northwards and westwards 95 metres.

Annette Place, total street from Edwin Road southwards. Glendenning Rise, from Edwin Road northwards 130 metres. Edwin Road, from 56 metres west of Read Street, further westwards 134 metres.

Fitzroy

Westgarth Street, from Smith Street westwards 35 metres.

Keilor

Tennyson Drive, from Taylors Road northeastwards 42 metres. Amis Crescent, from North Road northwards 122 metres. Kingsley Place, from Tennyson Drive eastwards 49 metres. Burns Way, the total street from Tennyson Drive to Shakespeare Drive. Shakespeare Drive, from 62 metres east of Kipling Place further eastwards and north-eastwards 160 metres. Tennyson Drive, from 38 metres north of Taylors Road further northwards 160 metres.

Knox

Gregory Road, the total street from Valerie Street eastwards. Gideon Close, the total street from Gregory Road southwards. Bradley Place, the total street from Gregory Road southwards. Daraio Court, the total street from Allora Avenue north-westwards. Nunana Court, the total street from Allora Avenue northwards. Allora Avenue, from Daraio Court (west side) further eastwards and south-eastwards 138 metres. Inverness Avenue,

from Claremont Avenue southwards 72 metres. Max Close, the total street from Balladonia Road south-westwards. Murrindal Drive, from Balladonia Road north-westwards 55 metres.

Lillydale

Water Supply Easement from Edinburgh Road, 200 metres south of Beaulieu Avenue, westwards 4 metres. Water Supply Easement from Edinburgh Road, 404 metres south of Beaulieu Avenue, westwards 36 metres. Mount Dandenong Road, from 70 metres north-west of Balmoral Street, further north-westwards 83 metres. Tamworth Road, from 95 metres south of Derby Road, further southwards and northwards 63 metres. Stan Brae Court, from Jumping Creek Road north-westwards 557 metres.

Malvern

Talbot Crescent, from Toorak Road north-westwards 170 metres.

Sherbrooke

Baynes Park Road, from 720 metres south-west of Centre Road, further south-westwards 165 metres.

Springvale

Australis Court, the total street from Kingston Drive eastwards. Kingston Drive, from 55 metres south west of Attenborough Court further south-westwards 90 metres. Dorrington Court, the total street from Rowan Road south-eastwards.

Werribee

Elliot Court, the total street from Burke Crescent south-westwards. McCormack Crescent, from Burke Crescent southwards 38 metres. Merrett Avenue, from Burke Crescent southwards 42 metres. Burke Crescent, from Cameron Drive southwards, south-eastwards, eastwards and north-eastwards 658 metres. Cameron Drive, from Derrimut Road eastwards 116 metres. Nicholas Street, the total street from Maplehurst Avenue to Bellbridge Drive. Bellbridge Drive, from 170 metres north of Macedon Street further northwards 67 metres. Melia Court, the total street from Tamarind Crescent southwards. Rhus Court, the total street from Tamarind Crescent southwards. Argyle Crescent, from Tamarind Crescent north-eastwards 31 metres. Osprey Street, from Tamarind Crescent eastwards 33 metres. Tamarind Crescent, from 60 metres east of Argyle Crescent further eastwards, south-eastwards and southwards 314 metres.

Whittlesea

Roycroft Avenue, from 8 metres south-east of Protea Court further south-eastwards 139 metres. Figtree Court, the total street from Roycroft Avenue south-westwards. Chestnut Road, from Roycroft Avenue north-eastwards 324 metres. Ribbon Court, the total street from Chestnut Road north-westwards. Woodvale Court, the total street from Norwood Drive westwards. Norwood Drive, from Woodvale Court southwards 30 metres. Norwood Drive, from Woodvale Court northwards 49 metres.

Rainbird Court, the total street from Baystone Road westwards. Arsenal Court, the total street from Foxzami Crescent westwards. Foxzami Crescent, from Baystone Road southwards 105 metres. Banker Court, the total street from Baystone Road southwards. Baystone Road, from Foxzami Crescent eastwards 119 metres. Baystone Road, from Foxzami Crescent north-westwards 70 metres. Carrington Boulevard, from 30 metres west of Madera Drive further westwards 125 metres. Dakota Drive, from Carrington Boulevard southwards 133 metres. Sladen Close, the total street from Dakota Drive westwards. Emma Court, the total street from Dakota Drive north-eastwards. Heals Road, from Schotters Lane eastwards 300 metres. Elm Street, from 50 metres east of Church Street further eastwards 80 metres. Fir Street, from 50 metres east of Church Street further eastwards 70 metres. Sherwin Street, from Hill Street westwards 70 metres. Hill Street, from Evelyn Street northwards 237 metres. Bourke Street, from Hill Street eastwards 103 metres. Evelyn Street, from Hill Street eastwards 107 metres. Paddock Street, from west building line of Mason Street further westwards 30 metres. Paddock Street, from west building line of Mason Street eastwards 19 metres. Ridge Road, from Whittlesea-Yea Road eastwards and south-eastwards 204 metres.

Dated 11 November 1986

H. G. FORD

Director of Administration and Services

Seeds Act 1982

REGISTERED SEED CLEANING PLANTS 1986-87

The following list of registered seed cleaning plants is published pursuant to section 17 of the *Seeds Act* 1982 (Registration effective 1 October 1986 to 30 September 1987).

Register Number	Name and Address	Purpose for which Seed Cleaning Plant is Registered
V10	Smyth & Murphy Aust. Pty. Ltd. (PO Box 192), Benalla 3672	All kinds of seed
V14	J F Roberts, RMB 8320, Warncoort 3243	All kinds of pasture seed
V15	Lidgerwood Seeds, RMB 1097, Birregurra 3242	All kinds of seed
V16	L J & S E Whitehead, Colac Road, Birregurra 3242	All kinds of seed
V17	Camberley Farms, "Camberley", Mt Mercer, R792, Ballarat 3352	All kinds of clover seed
V18	W Mizzeni & Sons, RMB 336, Creswick 3362	All kinds of seed
V19	Hedonelle P/L, c/o F E S, B M & P F Kinnersey, "Pine View", RMB 904, Mt Beckworth via Creswick 3363	All kinds of seed
V21	A, M D & L Toose, "Highgate", Smeaton 3364	All kinds of seed
V23	Gordon Hendy & Partners, Kokoda Road, Naring (RMB 3303, Numurkah 3636)	All kinds of seed

V24	W J & W L Ryan, RMB 2365, Katamatite Road, Yarrowonga 3730	All kinds of seed	VM77	G Byron, PO Box 92, Numurkah 3636	Cereals and grain legumes
V25	D E & J A Roberts, Byrne Street, Moyhu (RMB 9200, Wangaratta 3678)	All kinds of seed	VM78	I Bridgewater, 55 Victoria Street, Dimboola 3414	Cereals and grain
V26	Sutherland Seed Co., Gobur Road, RMB 1025, Yarck 3719	All kinds of seed	VM79	G P Cummins, RMB 2345, Yarrowonga 3730	Cereals and grain
V27	G E Taft & Son, PO Box 55, Rutherglen 3685	All kinds of seed	VM80	Daldy Grading, "Hibanks" Karamomus Road, Arcadia 3613	Cereals and grain legumes
V28	Valley Seeds Pty Ltd, Mansfield Road, Cathkin (RMB 1480, Alexandra 3714)	All kinds of seed	V81	B L & K M Grosser, Emu Plains Road, Major Plains (P O Box 10, Devenish 3726)	Cereals and grain legumes
V29	E B H James & Co., Yarrowalla Road, (PO Box 27, Pyramid Hill 3575)	All kinds of seed	VM83	L F & L J Kearney, 1 Dingwell Street, Beulah 3395	Cereals and grain legumes
V30	B W May, "Grassmere", RMB 314, Creswick 3363	All kinds of seed	VM84	L & M Grading, 11 George Street, Rochester 3561	Cereals and grain legumes
V31	Master Seeds of Mansfield, "Kooyong", Mansfield 3722	All kinds of pasture seeds	VM85	R Wellington, 7 Exhibition Street, Numurkah 3636	Cereals and grain legumes
V32	May Park Seed & Grain, St James Road, RMB 1010, Dookie 3646	All kinds of seed	VM87	P Stewart, Wanatta, RMB via Rushworth 3612	Cereals, grain legumes and oilseeds
V33	C H Elliott, Rathscar West, (RMB 2314, Maryborough 3465)	All kinds of seed	V88	N D & M E Mundy, 43 Scott Street, (PO Box 86), Orbst 3888	Beans
V34	Parkseeds, "Parkdale", Olivers Road, Mansfield 3722	All kinds of seed	VM89	W D Seeds Pty Ltd, RMB 314, Creswick 3363	Cereals and grain legumes
V35	Baker Seed Co., Springhurst Road, (PO Box 76), Rutherglen 3685	All kinds of seed			
V36	G M Crocker, "Woodlands", Murchison Road, (PO Box 33), Violet Town 3669	All kinds of pasture seed and cereals			
V37	Lumar Seeds, Ludeman Road, RMB 1060, Dookie 3646	All kinds of seed			
V38	F E & V R Hendy, Naring, (RMB 3100, Numurkah 3636)	All kinds of pasture seeds			
V40	T & F Grain Handling, PO Box 122, Koondrook 3580	Millet			
V42	Seedland Producers, Mt Buller Road, (PO Box 245), Mansfield 3722	All kinds of seed			
V43	Victorian Outgrowers Pool & Marketing Co Ltd (Lismore), PO Box 132, Newport 3015	All kinds of seed			
V45	Melcann Holdings Ltd, Hume Highway, Benalla 3672 (PO Box 236, West Footscray 3012)	All kinds of seed			
V50	Magnus Kahl, "Belvedere", Kahis Road, Gnarwarre 3221	Vegetable seeds			
V51	R G Mayfield, "Lucernedale", Ninth Street, Kerang 3579	All kinds of seed			
V53	Buchholz Brothers, "Coore", Lismore 3324	All kinds of pasture seeds			
V55	Marquands Produce, Benalla Saleyards Road, (PO Box 251), Benalla 3672	Cereals			
VM57	Alf Hannaford & Co Pty Ltd, Box 238, Dimboola 3414	Cereals, grain legumes			
V60	K J & B K Crawford, Mountajup via Dunkeld 3294	All kinds of seed			
V62	Henderson Seed Co Pty Ltd, 165 Templestowe Road, Lower Templestowe, (PO Box 118, Bulleen 3105)	Vegetable seeds			
VM66	Darkim Holding Pty Ltd, Mitchell Road, (PO Box 71), Echuca 3625	Millet			
V73	Snowy River Co-op Ltd, Newmerella, (PO Box 510, Orbst 3888)	French beans, sweet corn, popcorn, maize			
V74	B C & V Byrne, Benalla Road, (PO Box 127), Mansfield 3722	All kinds of seed			
V75	Rothleigh Past. Co, "Rothleigh", Yarck 3719	All kinds of seed			

J. J. WRIGHT, Chief General Manager
Department of Agriculture and Rural Affairs

PROPOSED REVOCATION OF TEMPORARY RESERVATION OF LAND BY ORDER IN COUNCIL

In pursuance of the provisions of section 10 of the *Crown Land (Reserves) Act 1978*, notice is hereby given that it is the intention of the Governor in Council to revoke the temporary reservation of land by Order in Council hereunder referred to, viz.:

Sutton—The temporary reservation by Order in Council of 14 September 1874 of 8734 square metres of land west of Crown allotment 8, Parish of Sutton as a site for State School Purposes—(Rs.13269).

Maryborough—The temporary reservation by Order in Council of 26 July 1906 of 2-0234 square metres of land south of Crown allotment 9, section 15, Parish of Maryborough as a site for Water Supply Purposes—(C.38832).

Briagolong—The temporary reservation by Order in Council of 18 March 1902 of 10-945 hectares of land adjoining Crown allotments 125A and 125E, Parish of Briagolong as a site for the Supply of Gravel—(C.14526).

Balmoral—The excepting from occupation for residence or business under any miners right or business licence and withholding from sale, leasing and licensing of 74-66 hectares of land in the Parish of Balmoral by Order in Council of 5 November 1877, revoked as to part by various orders, so far as the balance remaining of 36-14 hectares, more or less—(C.65556).

Krambruk—The temporary reservation by Order in Council of 25 October 1966 of 16-187 hectares of land, more or less, east of allotment 8A, section 2A, Parish of Krambruk as a site for Public Recreation—(Rs.8685).

J. E. KIRNER

Minister for Conservation, Forests and Lands

Melbourne, within one month of publication of this notice the Governor in Council may, by order pursuant to the *Hospitals and Charities Act 1958*, declare the contributors for the time being to Cranbourne Shire Community Health Service to be a body corporate by the name set forth in such order.

D. R. WHITE
Minister for Health

Health Department of Victoria
Melbourne

Community Welfare Services Act 1970
DECLARATION OF AN INSTITUTION AS AN
APPROVED CHILDREN'S HOME

In pursuance of the powers conferred by section 29 (1) (b) of the *Community Welfare Services Act 1970*, I do hereby declare the premises at 6 Coral Avenue, Warracknabeal as an approved children's home for the purpose of the said Act effective from 6 November 1986.

Dated 12 November 1986

CAROLINE HOGG
Minister

Community Welfare Services Act 1970
DECLARATION OF AN INSTITUTION AS AN
APPROVED CHILDREN'S HOME

In pursuance of the powers conferred by section 29 (1) (b) of the *Community Welfare Services Act 1970*, I do hereby declare the premises at 20 Grantham Street, West Brunswick as an approved children's home for the purpose of the said Act effective from 6 November 1986.

Dated 12 November 1986

CAROLINE HOGG
Minister

Community Welfare Services Act 1970
DECLARATION OF SEVERAL
ESTABLISHMENTS AS APPROVED
CHILDREN'S HOME

In pursuance of the powers conferred by section 29 (1) (b) of the *Community Welfare Services Act 1970*, I do hereby declare the premises at—

13 Mountfield Road, Mitcham;

347 Gladstone Road, North Dandenong; and

55 Folkstone Crescent, Ferntree Gully,

as approved children's home for the purpose of the said Act, effective from 6 November 1986.

Dated 12 November 1986

CAROLINE HOGG
Minister

Delegation of Authority under the *Freedom of Information Act 1982* (Section 26)

THE VICTORIAN EGG MARKETING BOARD
POULTRY FARMER LICENSING
COMMITTEE

General Authority

The officer occupying for the time being (whether on a permanent, acting or temporary basis) the position of Legal Officer of the Victorian Egg Marketing Board or the Poultry Farmer Licensing Committee is, pursuant to section 26 of the *Freedom of Information Act 1982*, authorized to make all decisions on behalf of the said agency that are necessary to be made in order to comply with and give effect to the provisions of the *Freedom of Information Act 1982* in respect of requests made to the said agency.

Principal Officer
Chairman
Victorian Egg Marketing Board
Poultry Farmer Licensing Committee

Delegation of Authority under the *Freedom of Information Act 1982* (Section 26)

OFFICE OF THE AUDITOR-GENERAL

General Authority

The officer occupying for the time being (whether on a permanent, acting or temporary basis) the position of Manager, Administrative Services in the Office of the Auditor-General is, pursuant to section 26 of the *Freedom of Information Act 1982*, authorized to make all decisions on behalf of the said agency that are necessary to be made in order to comply with and give effect to the provisions of the *Freedom of Information Act 1982* in respect of requests made to the said agency.

Principal Officer
Auditor-General

Revocation of Delegation of Authority under the *Freedom of Information Act 1982* (Section 26)

OFFICE OF THE AUDITOR-GENERAL

I hereby revoke the authority delegated to the officer occupying the position of Editorial and Reports Officer to make decisions on behalf of the said agency in respect of requests made under the *Freedom of Information Act 1982*.

Principal Officer
Auditor-General

Delegation of Authority under the *Freedom of Information Act 1982* (Section 26)

VICTORIAN ETHNIC AFFAIRS
COMMISSION

General Authority

The officer occupying for the time being (whether on permanent, acting or temporary basis) the position of Deputy Chairperson, Research and

Policy and Management Services is, pursuant to section 26 of the *Freedom of Information Act 1982*, authorized to make all decisions on behalf of the said agency that are necessary to be made in order to comply with and give effect to the provisions of the *Freedom of Information Act 1982* in respect of requests made to the Commission.

Principal Officer
Chairman
Victorian Ethnic Affairs Commission

Delegation of Authority under the *Freedom of Information Act 1982* (Section 26)
MINISTRY OF TRANSPORT

The officer occupying for the time being (whether on a permanent, acting or temporary basis), the position of Deputy Director-General in the Ministry of Transport is, pursuant to section 26 of the *Freedom of Information Act 1982*, authorized to make all decisions to give effect to the *Freedom of Information Act 1982* for all Ministry of Transport records.

Principal Officer
Director-General of Transport

Revoking Delegation of Authority under the *Freedom of Information Act 1982* (Section 26)
MINISTRY OF TRANSPORT

Subject to section 26 of the *Freedom of Information Act 1982*, I hereby revoke the delegation to D. Coulson, administrative officer, Ministry of Transport, to make decisions on behalf of the Ministry in respect of requests made to the Ministry pursuant to the Act.

Principal Officer
Director-General of Transport

Delegation of Authority under the *Freedom of Information Act 1982* (Section 26)
MINISTRY OF TRANSPORT

The officers occupying for the time being (whether on a permanent acting or temporary basis), the position of ADM-4 Secretariat—Corporate Services in the Ministry of Transport is, pursuant to section 26 of the *Freedom of Information Act 1982*, authorized to make decisions in respect of allowing access and calculating charges for all M.O.T. records.

Principal Officer
Director-General of Transport

Delegation of Authority under the *Freedom of Information Act 1982* (Section 26)
MINISTRY OF TRANSPORT

The officers occupying for the time being (whether on a permanent acting or temporary basis), the position of ADM-5 Secretariat—Corporate Services in the Ministry of Transport is, pursuant to section 26 of the *Freedom of Information Act 1982*,

authorized to make decisions in respect of allowing access and calculating charges for all M.O.T. records.

RUSSEL INGERSOLL
Director-General of Transport

Delegation of Authority under the *Freedom of Information Act 1982* (Section 26)
WARRNAMBOOL INSTITUTE OF
ADVANCED EDUCATION
General Authority

The officer occupying for the time being (whether on permanent, acting or temporary basis) the position of Registrar in the Warrnambool Institute of Advanced Education is, pursuant to section 26 of the *Freedom of Information Act 1982*, authorized to make all decisions on behalf of the said agency that are necessary to be made in order to comply with and give effect to the provisions of the *Freedom of Information Act 1982* in respect of the requests made to this Institute.

Principal Officer
Director

Warrnambool Institute of Advanced Education

Delegation of Authority under the *Freedom of Information Act 1982* (Section 26)
LATROBE REGIONAL COMMISSION
General Authority

The officer occupying for the time being (whether on permanent, acting or temporary basis) the position of Records and F.O.I. Officer in the Latrobe Regional Commission is, pursuant to section 26 of the *Freedom of Information Act 1982*, authorized to make all decisions on behalf of the said agency that are necessary to be made in order to comply with and give effect to the provisions of the *Freedom of Information Act 1982* in respect of requests made to the Commission.

Principal Officer
Chief Executive Officer
Latrobe Regional Commission

Delegation of Authority under the *Freedom of Information Act 1982* (Section 26)
CRIMES COMPENSATION TRIBUNAL
General Authority

The officer occupying for the time being (whether on permanent, acting or temporary basis) the position of Secretary of the Crimes Compensation Tribunal is, pursuant to section 26 of the *Freedom of Information Act 1982*, authorized to make all decisions on behalf of the said agency that are necessary to be made in order to comply with and give effect to the provisions of the *Freedom of Information Act 1982* in respect of requests made to the Tribunal.

Principal Officer
Crimes Compensation Tribunal

Delegation of Authority under the *Freedom of Information Act 1982* (Section 26)

HOLMESGLEN COLLEGE OF TAFE

The officer occupying for the time being, the position of Freedom of Information Manager in the Holmesglen College of TAFE is, pursuant to section 26 of the *Freedom of Information Act 1982*, authorized to make all decisions on behalf of the said agency that are necessary to be made in order to comply with and give effect to the provisions of the *Freedom of Information Act 1982* in respect of requests made to the said agency.

B. MacKENZIE
Principal Officer

8) Co-operative Housing Society Limited, Heidelberg District (No. 9) Co-operative Housing Society Limited, Heidelberg District (No. 10) Co-operative Housing Society Limited, Heidelberg District (No. 11) Co-operative Housing Society Limited, Heidelberg District (No. 12) Co-operative Housing Society Limited and Heidelberg District (No. 13) Co-operative Housing Society Limited were amalgamated into one society under the name of Heidelberg Amalgamated Co-operative Housing Society Limited on 1 November 1986.

Dated at Melbourne, 1 November 1986

GORDON D. LEWIS
Registrar of Co-operative Housing Societies

Delegation of Authority under the *Freedom of Information Act 1982* (Section 26)

SWINBURNE INSTITUTE OF TECHNOLOGY
AND COLLEGE OF TAFE

General Authority

The officer occupying for the time being (whether on permanent, acting or temporary basis) the position of Freedom of Information Officer of Swinburne is, pursuant to section 26 of the *Freedom of Information Act 1982*, authorized to make all decisions on behalf of the said agency that are necessary to be made in order to comply with and give effect to the provisions of the *Freedom of Information Act 1982* in respect of requests made to the Institute.

Principal Officer
Swinburne

Victoria
Co-operative Housing Societies Act 1958
NOTICE OF AMALGAMATION OF
SOCIETIES

Notice is hereby given that pursuant to the provisions of the *Co-operative Housing Societies Act 1958*, Charter (No. 2) Co-operative Housing Society Limited, Charter (No. 6) Co-operative Housing Society Limited, Exhibition (No. 1) Co-operative Housing Society Limited, Kew (No. 3) Co-operative Housing Society Limited and SENTRY Co-operative Housing Society Limited were amalgamated into one society under the name of Charter (No. 22) Co-operative Housing Society Limited on 1 November 1986.

Dated at Melbourne, 1 November 1986

GORDON D. LEWIS
Registrar of Co-operative Housing Societies

CONTRACTS ACCEPTED—(Series 1986-87)

PUBLIC WORKS

Prahran City—Internal cyclic maintenance, Trelowarren Mental Health Hostel—\$228 720.00—S. S. Sreckovic, Oakleigh.

Ringwood City—Construction building, Norwood High School—\$837 931.00—Ralph Mackie & Staff (Vic.) Pty Ltd, Frankston.

Shepparton City—Internal and external repairs and painting, Shepparton Primary School 4666—\$71 800.00—J. & S. Crawford Painting & Decorating, 101 Batman Avenue.

Dated 14 November 1986

D. J. LITTLE
Director-General of Public Works

Victoria
Co-operative Housing Societies Act 1958
NOTICE OF AMALGAMATION OF
SOCIETIES

Notice is hereby given that pursuant to the provisions of the *Co-operative Housing Societies Act 1958*, M.J.C.C. (No. 1) Co-operative Housing Society Limited, M.J.C.C. (No. 2) Co-operative Housing Society Limited, Saxon Co-operative Housing Society Limited, Stalbridge Co-operative Housing Society Limited, Stedman (No. 1) Co-operative Housing Society Limited and Winton Co-operative Housing Society Limited were amalgamated into one society under the name of Charter (No. 23) Co-operative Housing Society Limited on 1 November 1986.

Dated at Melbourne, 1 November 1986

GORDON D. LEWIS
Registrar of Co-operative Housing Societies

Victoria
Co-operative Housing Societies Act 1958
NOTICE OF AMALGAMATION OF
SOCIETIES

Notice is hereby given that pursuant to the provisions of the *Co-operative Housing Societies Act 1958*, Heidelberg District (No. 6) Co-operative Housing Society Limited, Heidelberg District (No.

Victoria
Co-operative Housing Act 1958
NOTICE OF AMALGAMATION OF SOCIETIES

Notice is hereby given that pursuant to the provisions of the *Co-operative Housing Societies Act 1958*, Charter (No. 13) Co-operative Housing Society Limited and Charter (No. 14) Co-operative Housing Society Limited were amalgamated into one society under the name of Charter (No. 24) Co-operative Housing Society Limited on 1 November 1986.

Dated at Melbourne, 1 November 1986

GORDON D. LEWIS
 Registrar of Co-operative Housing Societies

Victoria
Co-operative Housing Societies Act 1958
NOTICE OF AMALGAMATION OF SOCIETIES

Notice is hereby given that pursuant to the provisions of the *Co-operative Housing Societies Act 1958*, Charter (No. 7) Co-operative Housing Society Limited, Charter (No. 9) Co-operative Housing Society Limited and J.P.S. (No. 1) Co-operative Housing Society were amalgamated into one society under the name of Charter (No. 25) Co-operative Housing Society Limited on 1 November 1986.

Dated at Melbourne, 1 November 1986

GORDON D. LEWIS
 Registrar of Co-operative Housing Societies

Victoria
Co-operative Housing Societies Act 1958
NOTICE OF AMALGAMATION OF SOCIETIES

Notice is hereby given that pursuant to the provisions of the *Co-operative Housing Societies Act 1958*, Charter (No. 4) Co-operative Housing Society Limited, Kew (No. 2) Co-operative Housing Society Limited, Selborne (No. 2) Co-operative Housing Society Limited, Selborne (No. 5) Co-operative Housing Society Limited and Selborne (No. 7) Co-operative Housing Society Limited were amalgamated into one society under the name of Charter (No. 26) Co-operative Housing Society Limited on 1 November 1986.

Dated at Melbourne, 1 November 1986

GORDON D. LEWIS
 Registrar of Co-operative Housing Societies

Victoria
Co-operative Housing Societies Act 1958
NOTICE OF AMALGAMATION OF SOCIETIES

Notice is hereby given that pursuant to the provisions of the *Co-operative Housing Societies Act 1958*, Eastern (No. 2) Co-operative Housing

Society Limited, Eastern (No. 3) Co-operative Housing Society Limited, Eastern (No. 4) Co-operative Housing Society Limited, Eastern (No. 5) Co-operative Housing Society Limited, Kew (No. 5) Co-operative Housing Society Limited, Kew (No. 6) Co-operative Housing Society Limited, Viewbank Co-operative Housing Society Limited and Whitehorse (No. 1) Co-operative Housing Society Limited were amalgamated into one society under the name of Charter (No. 27) Co-operative Housing Society Limited on 1 November 1986.

Dated at Melbourne, 1 November 1986

GORDON D. LEWIS
 Registrar of Co-operative Housing Societies

Victoria
Co-operative Housing Societies Act 1958
NOTICE OF AMALGAMATION OF SOCIETIES

Notice is hereby given that pursuant to the provisions of the *Co-operative Housing Societies Act 1958*, Bellevue (No. 1) Co-operative Housing Society Limited, Eastern Co-operative Housing Society Limited and Eastern (No. 6) Co-operative Housing Society Limited were amalgamated into one society under the name Charter (No. 28) Co-operative Housing Society Limited on 1 November 1986.

Dated at Melbourne, 1 November 1986

GORDON D. LEWIS
 Registrar of Co-operative Housing Societies

**STATE TENDER BOARD
 CONTRACTS ACCEPTED
 AMENDMENTS**

<i>Schedule Number</i>	<i>Item Number</i>	<i>New Rate</i>	<i>Effective Date</i>
		\$	
	<i>Toilet Requirements</i>		
1/16	4	24.75*	3.11.86
	5	25.28	
	6	25.63	
	7	27.19	
	8	27.19	
	9	16.59	
	10	17.26	
	11	18.62	
	12	19.38	
	13	19.57	
	14	19.92	
	15	20.69	
	16	22.13	
	17	22.84	
	18	23.06	
	21	15.88	
	22	16.55	
	23	17.90	
	24	18.62	
	25	18.79	

Light Commercial Motor Vehicles			
1/59A	3A	8590.00	12.11.86
	3C	9566.00	
	4A	8285.00	
	4C	9301.00	
	5A	9999.00	
	5C	11084.00	

Optional Equipment—
Automatic Transmission

	3A	811.00	
	4A	810.00	
	5A	810.00	
1/59c	1A	11672.00	12.11.86
	1C	12707.00	
	2A	11320.00	
	2C	12264.00	
	3A	13585.00	
	3C	14673.00	
	5A	18154.00	
	6A	14718.00	
	6C	17528.00	
	7A	18994.00	
1/59D	3	33720.00	12.11.86
1/59E	B	13528.00*	12.11.86
		10888.00+	
		13789.00#	
		16896.00φ	

* D/Cab 2 tonne
+ S/Cab 2-25 tonne
S/Cab 3 tonne
φ S/Cab 3-6 tonne

General Stationery		
1/64	41	0.98*
	45	0.84+
	84	0.75#
	97	2.65φ
	128	..

Model/ Brand	Packaging	Contractor
*Advance	Box of 10	Esselte Dymo Aust. P/L
+Leviathan	Pkt. of 10	Garnet Manufacturing Co. 93 Bayfield Rd., Bayswater, 3153. Phone: 729-1022
#Micador	Pkt. of 10	Michael A. Dortheimer Pty. Ltd.
φLiquicryl	4 bottles per carton	Reeves Educational Products Purchase (Regulation 84)

With the exception of Garnet, the other three are current contractors and therefore their existing settlement discounts, minimum quantities etc. are applicable to these additional items.

Provisions—Melbourne and Metropolitan District
2/01 48 9.44 4.9.86

Refer *Victoria Government Gazette* No. 92,
5 November, 1986.

Delete: Item No. 276
Add: Item No. 271

As of 10 November 1986, all items held by Epic Food Services will be supplied by Kevin Rose Wholesalers.

J. M. PAWSON
Secretary to the Tender Board

Exemption

APPLICATION No. 14 of 1986

On 30 October 1986, the Equal Opportunity Board considered an application under section 40 (1) of the *Equal Opportunity Act* 1984 by It's A Pleasure Pty. Ltd. for renewal of an exemption from the provisions of the Act to enable it to employ women only as fashion consultants to sell on commission the Company's range of lingerie, bras and sleepwear.

The Board had regard to the fact that the applicant had informed the Board that the duties of a fashion consultant include taking measurements for, and the fitting of, bras.

The Board determined that in these circumstances it is desirable that the Company's fashion consultants be female.

The Board hereby grants an exemption from the operation of sections 21 (1) and 59 of the *Equal Opportunity Act* 1984 to permit the applicant to employ women only as fashion consultants to sell on commission the Company's range of lingerie, bras and sleepwear.

This exemption shall remain in force until 30 October 1989.

JAN WADE, President
LEANNA DARVALL, Member
WILLIAM CHERREY, Member
CON GEORGE, Member

Exemption

APPLICATION No. 16 of 1986

On 30 October 1986, the Equal Opportunity Board considered an application under section 40 (1) of the *Equal Opportunity Act* 1984 by Rentokil Pty. Limited for exemption from the provisions of the Act to enable it to employ women only in two positions in the Company's Sanitact Division, namely sales consultants and service drivers.

The Board had regard to the fact that—

- (i) the Sanitact Division provides a sanitary disposal service to offices, schools, clubs, hotels, entertainment centres, etc.;
- (ii) the duties of a sales consultant involve selling the service which includes surveying the areas to be serviced;

- (iii) the duties of a service driver include changing the sanitary units in toilet areas; and
- (iv) the duties of both sales consultant and service driver require the holders of those positions to enter female toilets during business hours.

The Board determined that in these circumstances it is desirable that sales consultants and service drivers employed in the Company's Sanitact Division be female.

The Board hereby grants an exemption from the operation of sections 21 (1) and 59 of the *Equal Opportunity Act 1984* to permit the applicant to employ women only as sales consultants and service drivers in the Company's Sanitact Division.

This exemption shall remain in force until 30 October 1989.

JAN WADE, President
LEANNA DARVALL, Member
WILLIAM CHERREY, Member
CON GEORGE, Member

Police Offences Act 1958, No. 6337

DIVISION 1A—STATE CLASSIFICATION OF PUBLICATIONS BOARD

Take note that the State Classification of Publications Board has classified the following publications in accordance with the provisions of section 180H (1) of the *Police Offences Act 1958*.

Each publication shall be subject to the following restrictions:

- (a) It shall not be offered for sale, sold or delivered to any person under the age of 18 years;
- (b) It shall not be made available for inspection or perusal by any person under the age of 18 years.

Title	Distributor
Advocate, The—November 11, 1986—Issue 459	Publisher Services International Pty Ltd
Buns of Playguy—Vol. 1 No. 1	Gordon & Gotch Ltd.
Inches—December 1986—Vol. 2 No. 10	Gordon & Gotch Ltd.
Penthouse—December 1986—Vol. 18 No. 4	Gordon & Gotch Ltd.
Soldier of Fortune—December 1986 Vol. 11 No. 12	Gordon & Gotch Ltd.

R. V. DOOLEY,
Acting Secretary
State Classification of Publications Board

Police Offences Act 1958, No. 6337

DIVISION 1A—STATE CLASSIFICATION OF PUBLICATIONS BOARD

Take note that the State Classification of Publications Board has classified the following

publications in accordance with the provisions of section 180H (1) of the *Police Offences Act 1958*.

Each publication shall be subject to the following restrictions:

- (a) It shall not be offered for sale, sold or delivered to any person under the age of 18 years;
- (b) It shall not be made available for inspection or perusal by any person under the age of 18 years;
- (c) It shall not be exhibited or displayed in any place to which persons under the age of 18 years have access or so that it is visible from any such place.

Title	Distributor
Erotic X-Film Guide—January 1987 Vol. 5 No. 1	Gordon & Gotch Ltd.
Manscape—January 1987—Vol. 2 No. 8	Gordon & Gotch Ltd.
Manscape—February 1987—Vol. 3 No. 3	Gordon & Gotch Ltd.
Sex Guide—January 1987	Gordon & Gotch Ltd.

R. V. DOOLEY,
Acting Secretary

State Classification of Publications Board

ADOPTION ACT 1984

Pursuant to section 5 of the *Adoption Act 1984*, the Manager of Adoption Section, Delegate of the Director-General of Community Services has approved the following person as Counsellor:

Lynn, Patricia Grace
Marriage Counselling Centre
123 Neil Street
Toowoomba, Queensland 4350
Nominating Agency: Catholic Family Welfare Bureau.

Dated 14 November 1986

GERARD McPHEE
Acting Manager, Adoption Section

ADOPTION ACT 1984

Pursuant to section 5 of the *Adoption Act 1984*, the Manager of Adoption Section, Delegate of the Director-General of Community Services has approved the following person as Counsellor.

Cheng, Robert Kum Leng
Community Services Victoria,
55 Swanston Street,
Melbourne 3000.

Nominating Agency: Community Services Victoria.

Dated 6 November 1986

GERARD McPHEE
Acting Manager, Adoption Section

Public Service Act 1974

NOTICE

Pursuant to section 70 (2) of the *Public Service Act 1974*, the Public Service Board declares that the title of the office of Deputy Director, Industrial Relations Division, Senior Executive Service, Level I (Position No. 39/05/0065/8) has been changed to Principal Industrial Officer.

Dated 27 October 1986

M. L. RUSH
Secretary

SHIRE OF ROCHESTER

Road Deviation Order

Pursuant to the provisions of sections 522 and 526 of the *Local Government Act 1958* the Council of the Shire of Rochester hereby directs that the land in the Parish of Terrick Terrick East indicated by hatching on the plan hereunder, which has been purchased taken or acquired by it, shall be a public highway on and from the date of publication of this order in the *Government Gazette* and declares that such land shall be a public highway in lieu of the land indicated by cross hatching on the said diagram.

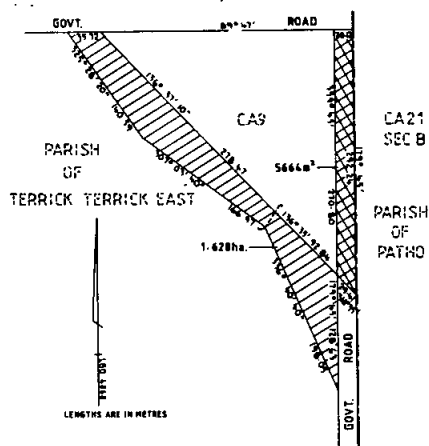

The common seal of President, Councillors and Ratepayers of the Shire of Rochester was hereunto affixed, 2 October 1986—

REGINALD C. MUNZEL, Councillor
F. B. DULLARD, Councillor
K. JACKEL, Secretary

Confirmed by the Governor in Council, 11 November 1986—L. G. HOUSTON, Clerk of the Executive Council

Local Government Act 1958

NOTICE OF INTENTION TO MAKE AN ORDER FOR THE RESUBDIVISION OF THE MUNICIPAL DISTRICT OF THE SHIRE OF OTWAY

Under the provisions of Part II of the *Local Government Act 1958*, notice is given of my intention to make a recommendation to the Governor in Council with respect to a proposal for the resubdivision of the internal boundaries of the municipal district of the Shire of Otway.

Dated 10 November 1986

JIM SIMMONDS

Minister for Local Government

Local Government Department
Melbourne (83/5723)

Local Government Act 1958

NOTICE OF INTENTION TO MAKE AN ORDER FOR THE RESUBDIVISION OF THE MUNICIPAL DISTRICT OF THE CITY OF FITZROY

Under the provisions of Part II of the *Local Government Act 1958*, notice is given of my intention to make a recommendation to the Governor in Council with respect to a proposal for the resubdivision of the internal boundaries of the municipal district of the City of Fitzroy.

Dated 17 November 1986

JIM SIMMONDS

Minister for Local Government

Local Government Department
Melbourne (84/5562)

Local Government Act 1958

NOTICE OF INTENTION TO MAKE AN ORDER FOR THE RESUBDIVISION OF THE MUNICIPAL DISTRICT OF THE SHIRE OF KORUMBURRA

Under the provisions of Part II of the *Local Government Act 1958*, notice is given of my intention to make a recommendation to the Governor in Council with respect to a proposal for the resubdivision of the internal boundaries of the municipal district of the Shire of Korumburra.

Dated 10 November 1986

JIM SIMMONDS

Minister for Local Government

Local Government Department
Melbourne (84/0237)

APPOINTMENTS AND RESIGNATIONS

APPOINTMENTS

His Excellency the Governor of the State of Victoria by and with the advice of the Executive Council thereof has by Order made on 11 November 1986 been pleased to make the undermentioned appointments, viz.:

Department of Conservation, Forests and Lands
Bailiffs of Crown Land

Charles ABREHART,

Ronald Phillip BENBOW,

Eric Anton CICER,

Lindsay Warren EDGERTON, and

Clive Anthony REDDECLIFFE,

to be bailiffs of Crown land, under section 30 of the *Land Act 1958*, for the ocean foreshore reserves within the municipal district of the Shire of Flinders.

Law Department

Member, Victorian Prison Industries Commission

Peter Bruce HARMSWORTH,

to be a Member of the Victorian Prison Industries Commission, pursuant to section 8 (2) (c) of the *Victorian Prison Industries Commission Act 1983* from 11 November 1986 to 1 February 1987.

Acting Director of Public Prosecutions

Leonard FLANAGAN, Q.C.,

to be Acting Director of Public Prosecutions pursuant to section 7 (1) of the *Director of Public Prosecutions Act 1982* from 17 November 1986 to 15 December 1986, inclusive, during the absence of the Director of Public Prosecutions.

Coroner

Alan John SPILLANE,

to be a Coroner pursuant to section 8 of the *Coroners Act 1985*.

L. G. HOUSTON
Clerk of the Executive Council

At the Executive Council Chamber
Melbourne, 11 November 1986

National Parks Act 1975

AUTHORIZED OFFICERS

In accordance with section 9 (2) of the *National Parks Act 1975*, I, Donald Sydney Saunders, Director of National Parks, hereby appoint the following persons to be authorized officers for the purposes of the Act.

These authorizations are to remain in effect until revoked or until the appointee ceases to be employed by the Department of Conservation, Forests and Lands.

<i>Name</i>	<i>Area of Appointment</i>
Hawker, Peter Charles	All Parks
Morley, Michael Joseph	All Traralgon Region Parks
Bray, Peter Leslie	All Traralgon Region Parks
Penrose, Neville Arthur	All Traralgon Region Parks
Jackson, Robert William	All Portland Region Parks
Wilkinson, Donald	All Traralgon Region Parks
Lachlan	All Portland Region Parks
Priest, Roger Patrick	All Portland Region Parks
Cooper, Charles	All Portland Region Parks
Galbraith	All Portland Region Parks
O'Bryan, Leslie Charles	All Horsham Region Parks
Evans, Stewart Thomas	All Yarram Region Parks
King, Kenneth William	All Yarram Region Parks
Niggel, Robert Godfrey	All Yarram Region Parks
Ward, Brian Colin	All Parks

D. S. SAUNDERS
National Parks and Wildlife Division

APPOINTMENT OF TRUSTEE OF THE MELBOURNE CRICKET GROUND

His Excellency the Governor of the State of Victoria by and with the advice of the Executive Council thereof has by order made on 11 November 1986, pursuant to the provisions of section 5A (1) (d) of the *Melbourne Cricket Ground Act 1933* appointed the undermentioned person as a Trustee of the land in the City of Melbourne permanently reserved by Order in Council of 20 February 1934 (and extended by Acts Nos. 5614, 6854 and 9990) for the Melbourne Cricket Ground viz.:

the Honourable Robert Clive FORDHAM, M.P.,
in the place of the Honourable John William Galbally, Q.C.

L. G. HOUSTON
Clerk of the Executive Council
At the Executive Council Chamber
Melbourne, 11 November 1986

Liquor Control Act 1968

APPOINTMENT OF LICENSING INSPECTORS

In accordance with the authority conferred upon me by section 6 of the *Police Regulation Act 1958*, I, Eric Archibald Mudge, Deputy Commissioner of Police, do hereby appoint under sub-section (1) of section 22 of the *Liquor Control Act 1968*, the following Officers of Police as Licensing Inspectors for the Divisions of the Police Districts as shown:

<i>Division Number</i>	<i>Police District</i>	<i>Rank and Name</i>
1	Broad-meadows	Inspector Norman Thomas McGill, 13683 (from 9.11.86 to 29.11.86).
1	Goulburn	Chief Inspector Brian Brown, 13217 (from 3.11.86 to 13.12.86).

Dated 14 November 1986

E. A. MUDGE
Deputy Commissioner (Administration)

RESIGNATIONS

His Excellency the Governor of the State of Victoria by and with the advice of the Executive Council thereof has by Orders made on 11 November 1986 accepted the resignations of the persons named hereunder of the offices mentioned, viz.:

Law Department

Honorary Probation Officers.

Susan LINCOLN.

Phillip STEWART,

as Honorary Probation Officers pursuant to section 507 (2) of the *Crimes Act* 1958 for all adult Courts.

L. G. HOUSTON
Clerk of the Executive Council

At the Executive Council Chamber
Melbourne, 11 November 1986

ORDERS IN COUNCIL

Marine Act 1958

REVOCAATION OF APPOINTMENTS

The Administrator in Council under section 7 of the *Marine Act* 1958 revokes the following appointments:

- Order in Council made on 22 September 1983 appointing Richard Michael Perry as Port Officer for the Ports of Anderson's Inlet, Apollo Bay, Barwon Heads, Corner Inlet and Port Albert, Gippsland Lakes, Lorne, Mallacoota, Port Campbell, Port Fairy, Port Phillip, Snowy River, Warrnambool and Westernport.
- Order in Council made on 31 May 1983 appointing Keith Harold Dann as Deputy Port Officer for the Ports of Anderson's Inlet, Apollo Bay, Barwon Heads, Corner Inlet and Port Albert, Gippsland Lakes, Lorne, Mallacoota, Port Campbell, Port Fairy, Port Phillip, Snowy River, Warrnambool and Westernport.

- Order in Council made on 10 March 1982 appointing Charles Paulusz as Harbor Master for the Ports of Mallacoota, Snowy River, Gippsland Lakes, Corner Inlet and Port Albert, Anderson's Inlet, Barwon Heads, Lorne, Apollo Bay, Port Campbell, Warrnambool and Port Fairy.

Dated 28 October 1986

Responsible Minister:

TOM ROPER

Minister for Transport

L. G. HOUSTON

Clerk of the Executive Council

Marine Act 1958

APPOINTMENT OF PORT OFFICERS

The Administrator in Council under section 7 of the *Marine Act* 1958 appoints—

Captain Alastair Stewart Bolles

as Port Officer for the Ports of Port Phillip, Westernport, Anderson's Inlet, Corner Inlet and Port Albert, Gippsland Lakes, Snowy River and Mallacoota;

Mr Noel Patrick O'Donnell

as Port Officer for the Ports of Port Fairy, Port Campbell and Warrnambool;

Mr Max Bom

as Port Officer for the Ports of Apollo Bay, Lorne and Barwon Heads.

Dated 28 October 1986

Responsible Minister:

TOM ROPER

Minister for Transport

L. G. HOUSTON

Clerk of the Executive Council

Marine Act 1958

APPOINTMENT OF DEPUTY PORT OFFICERS

The Administrator in Council under section 7 of the *Marine Act* 1958 appoints—

Captain Keith Harold Dann,

Captain William Schofield Gent,

Mr Royston Kilford

as Deputy Port Officers for the Ports of Port Phillip, Westernport, Anderson's Inlet, Corner Inlet and Port Albert, Gippsland Lakes, Snowy River and Mallacoota;

Mr Ian deCerjat Forsyth Baird

as Deputy Port Officer for the Ports of Port Campbell, Port Fairy and Warrnambool;

Mr Christopher Pike Coleridge Gordon
as Deputy Port Officer for the Ports of Apollo Bay,
Lorne and Barwon Heads.
Dated 28 October 1986
Responsible Minister:
TOM ROPER
Minister for Transport

L. G. HOUSTON
Clerk of the Executive Council

Ian Scott Edwards
as Assistant Harbor Master for the Ports of Apollo
Bay, Lorne and Barwon Heads.

Dated 28 October 1986
Responsible Minister:
TOM ROPER
Minister for Transport

L. G. HOUSTON
Clerk of the Executive Council

Marine Act 1958

APPOINTMENT OF OFFICERS UNDER
SECTION 7 OF THE MARINE ACT 1958

The Administrator in Council under section 7 of
the *Marine Act 1958* appoints—

Thomas Joseph Pritchett,
Richard Ernest Rowland,
Bryan William Pinder,
Kieran McManus,
Noel Patrick O'Donnell,
Ian Scott Edwards,
William Gent

as officers for the purpose of carrying out and
enforcing the rules and regulations made under
section 7 of the Act.

Dated 28 October 1986
Responsible Minister:
TOM ROPER
Minister for Transport

L. G. HOUSTON
Clerk of the Executive Council

Marine Act 1958

APPOINTMENT OF HARBOR MASTERS,
DEPUTY HARBOR MASTER AND
ASSISTANT HARBOR MASTER

The Administrator in Council under section 7 of
the *Marine Act 1958* appoints—

Noel Patrick O'Donnell
as Harbor Master for the Ports of Port Fairy, Port
Campbell and Warrnambool;

Max Bom

as Harbor Master for the Ports of Apollo Bay, Lorne
and Barwon Heads;

Charles Paulusz

as Harbor Master for the Ports of Mallacoota, Snowy
River, Gippsland Lakes, Corner Inlet and Port
Albert, and Anderson's Inlet.

Christopher Pike Gordon

as Deputy Harbor Master for the Ports of Apollo
Bay, Lorne and Barwon Heads.

Land Act 1958
UNUSED ROAD CLOSED

The Governor in Council under section 349 of
the *Land Act 1958* and with the consent in writing
of the municipality concerned closed the following
unused road.

Municipal District of the Shire of Ararat, Parish
of Lexington being the road indicated by hatching
on plan hereunder—(L39 (7)) (Rs. 12929).

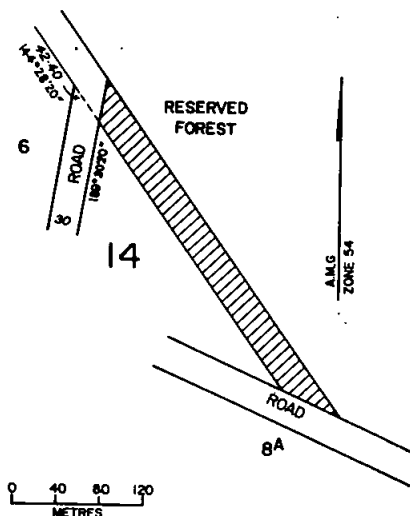

Dated: 1 November 1986

Responsible Minister:
JOAN E. KIRNER
Minister for Conservation, Forests and Lands

L. G. HOUSTON
Clerk of the Executive Council

Crown Land (Reserves) Act 1978
**REVOCATION OF TEMPORARY
 RESERVATION**

The Governor in Council under section 10 of the *Crown Land (Reserves) Act 1978* revokes the following temporary reservations:

Ballarat—The temporary reservation by Order in Council of 6 February 1951 of 2.023 hectares of land adjoining Crown Allotment E, section 17, Parish of Ballarat as a site for a Rubbish Depot—(Rs 6625).

Burnewang—The temporary reservation by Order in Council of 6 February 1893 of 12.14 hectares of land adjoining Crown Allotments 2 and 3 Parish of Burnewang as a site for Public Purposes so far only as the portion containing 4 hectares more or less as indicated by hatching on the plan published in the *Government Gazette* of 15 October 1986, Page 3971—(B636 (2)) (Rs 8359).

Jindivick—The temporary reservation by Order in Council of 21 August 1923 of portion of the Island in the Tarago River, Parish of Jindivick as a site for Recreation Purposes—(Parish 2801-1) (Rs 2807).

Dated: 11 November 1986

Responsible Minister:

JOAN E. KIRNER

Minister for Conservation, Forests and Lands

L. G. HOUSTON
 Clerk of the Executive Council

Crown Land (Reserves) Act 1978
**REVOCATION OF TEMPORARY
 RESERVATIONS**

The Governor in Council under section 10 of the *Crown Land (Reserves) Act 1978* revokes the following temporary reservations:

Yulecart—The temporary reservation by Order in Council of 18 May 1869 of 8094 square metres of land in the Parish of Yulecart (adjoining south-west of Crown Allotment 4, section 7) as a site for a Common School—(Parish 4001-2) (Rs 1654).

Yulecart—The temporary reservation by Order in Council of 31 July 1917 of 683 square metres of land in the Parish of Yulecart (adjoining south-east of Crown Allotment 4, section 7) as a site for a State School—(Parish 4001-2) (Rs 1654).

Dated: 11 November 1986

Responsible Minister:

JOAN E. KIRNER

Minister for Conservation, Forests and Lands

L. G. HOUSTON
 Clerk of the Executive Council

**STATE EMPLOYEES RETIREMENT
 BENEFITS ACT 1979 No. 9363**

The Governor in Council under section 2 (c) (ii) of the *State Employees Retirement Benefits Act 1979*, declares that the provisions of the Act shall apply

to the employees of the Road Traffic Authority from 11 November 1986.

Dated: 11 November 1986

Responsible Minister:

R. A. JOLLY
 Treasurer

L. G. HOUSTON
 Clerk of the Executive Council

Land Act 1958
**APPOINTMENT OF BAILIFFS OF CROWN
 LAND**

The Governor in Council, under section 30 of the *Land Act 1958*, appoints the persons named below to be bailiffs of Crown land, without salary, for the designated regions of the Department of Conservation, Forests and Lands:

Traralgon Region

Bennett, Noel William.
 Booth, John Samuel.
 Bray, Peter Leslie.
 Broome, Peter Thomas.
 Browning, James Arthur.
 Chatto, Raymond Eric.
 Dowler, Peter Geoffrey.
 Hastings, Ian.
 Kennedy, Darryl William.
 Lawrence, Peter James.
 Madigan, Brian Patrick.
 Manning, Neil Victor.
 McIntyre, Graeme Douglas.
 Morley, Michael Joseph.
 Moulton, Philip Sullivan.
 Noble, Frank William.
 O'Brien, Shane William.
 Penrose, Neville Arthur.
 Philip, Alexander.
 Price, Robert John.
 Rawson, Richard Peter.
 Ridgeway, Mark John.
 Rule, Leonard Robert.
 Sharp, Ronald Brian John.
 Slorach, John Andrew.
 Smith, Alexander Evan.
 Speekman, Paul Anthony.
 Stuart, Maxwell Albert.
 Waller, Alan Baden.
 Wilkinson, Donald Lachlan Fraser.
 Woollan, Robert Edward.

Mildura Region

Fleet, Anthony Joseph.

All Regions

Warren, Rodney Philip.

Dandenong Region

Courtney, Peter Grant.

Warragul Region

Bowley, David Graeme.

Portland Region

Garden, Andrew Munro.

*Yarram Region*Beech, Graeme Keith.
Carroll, Ian Keith.
Mason, Alan James.
Parmigiani, Errol Malko.
Voros, Stephen.*Wodonga Region*Cox, Trevor Wayne.
Morsby, Geoffrey.*Benalla Region*

Brumley, Richard Arthur.

Dated: 11 November 1986

Responsible Minister:

JOAN E. KIRNER

Minister for Conservation, Forests and Lands

L. G. HOUSTON

Clerk of the Executive Council

Water Act 1958
RURAL WATER COMMISSION OF
VICTORIA*At the Executive Council Chamber, Melbourne, the
eleventh day of November 1986*

PRESENT:

His Excellency the Governor of Victoria

Mr McCutcheon | Mr Wilkes

MERBEIN IRRIGATION DISTRICT—
PORTION EXCISED

Under the powers conferred by the *Water Act 1958* and all other powers enabling him in that behalf, His Excellency the Governor of the State of Victoria, with the advice of the Executive Council of the said State, on the recommendation of the Rural Water Commission of Victoria, doth hereby declare order and direct that there shall be excised from the Merbein Irrigation District the land shown by green colour on a plan approved by the Governor in Council and deposited in the office of the Rural Water Commission of Victoria, at 590 Orrong Road, Armadale (Corr. No. 67/332) and as on and from 30 November 1986, such portion shall be deemed to be excised accordingly.

And the Honourable Andrew McCutcheon, Her Majesty's Minister for Water Resources for the State of Victoria, shall give the necessary directions herein accordingly.

L. G. HOUSTON
Clerk of the Executive Council

MOTOR CAR ACT 1958

*At the Executive Council Chamber, Melbourne, the
eleventh day of November 1986*

PRESENT:

His Excellency the Governor of Victoria

Mr McCutcheon | Mr Wilkes

MOTOR CAR TRIALS OF SPEED WITHIN
THE SHIRES OF BRIGHT, MYRTLEFORD,
BEECHWORTH, OXLEY AND THE
WANGARATTA REGION OF THE
DEPARTMENT OF CONSERVATION,
FORESTS AND LANDS

Whereas it is enacted by sub-sections (1) and (2) of section 83A of the *Motor Car Act 1958* that, if a motor car or motor cycle is used on a highway for purposes of racing or of trial of speed, and if a race or trial of speed is organised or managed, the driver or the person in charge thereof and the person organising or managing the race or trial of speed, shall be liable to a penalty of not more than Five hundred dollars for the first offence and One thousand dollars for the second offence, provided that the said sub-sections (1) and (2) shall not apply to a motor car or motor cycle used as aforesaid or to a race or trial of speed on any highway or portion thereof specified by Order in Council published in the *Government Gazette* and on such days and during such hours as are specified in the Order.

And whereas the Light Car Club of Australia (Melbourne) has requested that such an Order be made to enable an event known as the "DP Visco/Bright Alpine Rally" to be conducted by the said Club on 22 and 23 November 1986.

Now therefore, His Excellency the Governor of the State of Victoria, by and with the advice of the Executive Council thereof, and in pursuance of the powers conferred by the *Motor Car Act 1958* and all other powers him thereunto enabling, doth Order that the provisions of sub-sections (1) and (2) of section 83A of the *Motor Car Act 1958* and of the regulations made under Part VI of the *Transport Act 1983* shall not apply with respect to the event known as the "BP Visco/Bright Alpine Rally" to be held on sections of road within the Shires of Bright, Myrtleford, Beechworth and the Wangaratta Region of the Department of Conservation Forests and Lands under the control of Light Car Club of Australia (Melbourne) between the hours of 9.00 a.m. on Saturday, 22 November 1986 and 7.30 p.m. on Sunday, 23 November 1986.

And the Honourable Thomas William Roper, Her Majesty's Minister for Transport for the State of Victoria, shall give the necessary directions herein accordingly.

L. G. HOUSTON
Clerk of the Executive Council

CROWN LAND (RESERVES) ACT 1978

At the Executive Council Chamber, Melbourne, the eleventh day of November 1986

PRESENT:

His Excellency the Governor of Victoria
Mr McCutcheon | Mr Wilkes

His Excellency the Governor of the State of Victoria in the Commonwealth of Australia, by and with the advice of the Executive Council of the said State pursuant to the provisions of section 18 (1) of the *Crown Land (Reserves) Act 1978* does by this Order hereby place the land described as Allotment 9B of section 58 and Allotments 8D, 8E and 8F of section 57, City of Port Melbourne, Parish of Melbourne South temporarily reserved for Public Recreation by Orders in Council of 22 July 1980 and 9 September 1986 respectively under the control of the Melbourne and Metropolitan Board of Works.

And the Honourable Joan Elizabeth Kirner, Her Majesty's Minister for Conservation, Forests and Lands for the State of Victoria shall give the necessary directions herein accordingly.

L. G. HOUSTON
Clerk of the Executive Council

MOTOR CAR ACT 1958

At the Executive Council Chamber, Melbourne, the eighteenth day of November 1986

PRESENT:

His Excellency the Governor of Victoria
Mr Kennan | Mr Spyker
Mr Jolly

MOTOR CAR TRIALS OF SPEED IN THE SHIRE OF ARARAT

Whereas it is enacted by sub-sections (1) and (2) of section eighty-three A of the *Motor Car Act 1958* that, if a motor car is used on a highway for purposes of racing or of trial of speed, and if a race or trial of speed is organized or managed, the driver or the person in charge thereof and the person organizing or managing the race or trial of speed shall be liable to a penalty of not more than five hundred dollars for the first offence and one thousand dollars for the second offence, provided that the said sub-sections (1) and (2) shall not apply to a motor car used as aforesaid or to a race or trial of speed on any highway or portion thereof specified by Order in Council published in the *Government Gazette* on such days and during such hours as are specified in the order;

And whereas the Ford Four Car Club Incorporated has requested that such an order be made to enable an event known as the "1986 Golden Mile Hillclimb" to be conducted by the said club on 29 and 30 November 1986.

Now therefore, His Excellency the Governor of the State of Victoria, by and with the advice of the Executive Council thereof, and in pursuance of the powers conferred by the *Motor Car Act 1958* and all other powers him thereunto enabling, doth order that the provisions of sub-sections (1) and (2) of section eighty-three A of the *Motor Car Act 1958* and of the regulations made under Part VI. of the *Transport Act 1983* shall not apply with respect to the event known as the 1986 Golden Mile Hillclimb to be held on One Tree Hill Road and Picnic Road within the Shire of Ararat between the hours of 12.00 noon and 5.00 in the afternoon on Saturday, 29 November 1986, and 10.00 in the forenoon and 5.00 in the afternoon on Sunday, 30 November 1986.

And the Honourable Thomas William Roper, Her Majesty's Minister for Transport for the State of Victoria, shall give the necessary directions herein accordingly.

L. G. HOUSTON
Clerk of the Executive Council

T E N D E R S**PUBLIC WORKS DEPARTMENT**

Tenders are invited for the purposes indicated hereunder and will be received at 2 Treasury Place, Melbourne, 3002, until TWO p.m. on the dates shown.

Tenders must be addressed to the Minister for Public Works with the envelope endorsed "Tender for "

Tenders forwarded either by mail, telegram or telex which arrive after the closing time will be accepted provided that the official Telecom or Australia Post time and date stamping indicates dispatch prior to the closing time. (TIME AND DATE STAMPING MUST BE REQUESTED AT SOME POST OFFICES.)

(TELEX No. AA152039)

Hand-delivered tenders must be placed in the Department's tender box, in foyer, Ground Floor, 2 Treasury Place, Melbourne.

Tender documents are available from the Contracts Office, Room 29, Ground Floor, 2 Treasury Place, Melbourne and where indicated at offices of Inspector of Works.

Wednesday, 26 November 1986**Building, Electrical and Mechanical Services**

BARWON HEADS—New cavity—Brickwork building for student toilets, Primary School (W.O. Geelong).

CRAIGIEBURN—Connection to sewer, Primary School.

SOUTH MELBOURNE—Supply and installation of carpet: Coronial Services Centre—Law Department.

ST. ALBANS—Hydraulic services, Western Institute, T.A.F.E.

ST. ALBANS—Covered walkway—framing and decking, Western Institute, T.A.F.E.

ST. ALBANS—Covered walkway—roof decking and screens, Western Institute, T.A.F.E.

Wednesday, 3 December 1986

Building, Electrical and Mechanical Services

BAIRNSDALE—Replacement of roof, Primary School (W.O. Bairnsdale).

GEELONG—Internal building alterations to provide toilets, Regional Headquarters—Education Department (W.O. Geelong).

GLEN WAVERLEY—Supply and install HF radio system, Sheriff's Office, 287 Springvale Road—Law Department.

ST. ALBANS—(Re-advertised) Manufacture and erection of covered walkway—steelworks, Western Institute, T.A.F.E.

YARRAWONGA—Internal and external repairs and painting, Primary School (W.O. Benalla, Shepparton and Wangaratta).

Wednesday, 10 December 1986

Building, Electrical and Mechanical Services

PORT MELBOURNE—Contract 4, 86/87: Supply and delivery of relocatable modular buildings, at rates, F.O.G., P.W.D. storeyard, 69 Salmon Street (W.O. Ballarat and Bendigo).

RED CLIFFS—Internal and external renovations to main building, Primary School (W.O. Mildura).

SHEPPARTON—External and part internal renovations, Primary School (W.O. Benalla, Shepparton and Wangaratta).

RONALD W. WALSH
Minister for Public Works

Public Works Department
Melbourne, 17 November 1986

DEPARTMENT OF PROPERTY AND SERVICES

Tenders are invited for the services indicated hereunder and will be received at the Property Division, Department of Property and Services, 3rd Floor, 35 Spring Street, Melbourne 3000 until TWO p.m. on the dates shown.

Specifications and Tender documents are available from the Property Division Office at the above address (Phone 651 3581) or, where indicated, at other locations.

Late tenders will not be considered.

Wednesday, 3 December 1986

BALLARAT—Maintenance cleaning, period 1 January 1987 to 31 December 1989, Health Department, Gillies Street. (Documents available from the Caretaker, State Offices, Cnr Mair and Doveton Streets, Ballarat.)

COLAC—Maintenance cleaning, period 1 January 1987 to 31 December 1988, Police Station and Court House, Queen Street. (Documents available from the Caretaker, State Offices, Gellibrand Street, Colac.)

DONALD—Maintenance cleaning, period 1 January 1987 to 30 November 1988, Police Station, Woods Street. (Documents available from Donald Police Station.)

MILDURA—Maintenance cleaning, period 1 January 1987 to 31 December 1988, Police Station Cells, Madden Avenue. (Documents available from the Caretaker, State Offices, Mildura.)

FOOTSCRAY—Security Patrol Service, period 1 January 1987 to 31 December 1987, Dental Centre, 2 Geelong Road.

Dr E. W. RUSSELL
Director-General of Property and Services

STATE TENDER BOARD

Schedule No. 1/53A

MOTOR SPIRIT (BULK) STATE PETROL CENTRE

Tenders will be received until 8.30 a.m. on Friday, 28 November 1986 from persons willing to supply motor spirit etc. in such quantities as may be ordered by the Victorian Government during 1 January 1987 to 31 December 1987 and 1 January 1987 to 31 December 1988.

Full particulars and information may be obtained from the office of the Tender Board (Telephone 651 3266).

Tenders enclosed in the envelope provided, must be deposited in the tender-box at the Tender Board Offices, 3rd Floor, 49 Spring Street, Melbourne, 3000, or, if sent by post, postage must be prepaid and the tenders addressed to the Chairman of the Tender Board, Tender Board Offices, 49 Spring Street, Melbourne, 3000, which office they must reach not later than by first post on the date of closing of tenders. Under no circumstances will tender details be accepted by telephone.

J. M. PAWSON
Secretary to the Tender Board

**PRIVATE
ADVERTISEMENTS**

Form 2.1

Town and Country Planning Act 1961

CITY OF BALLAARAT PLANNING SCHEME

Notice that a Planning Scheme has been Prepared and is Available for Inspection

Amendment No. 93

Notice is hereby given that the City of Ballaarat in pursuance of its powers under the *Town and Country Planning Act 1961* has prepared a scheme to allow the use "Tourist Facility Restaurant" in a Residential "A" zone on C.A. 18b, 21, 22, 23, 24 and Part C.A. 20 Section Q, Township of Ballarat East (217 Main Road, Ballarat) subject to a permit.

A copy of the scheme has been deposited at the Town Hall, Sturt Street, Ballarat; the Central Highlands Regional Office, Ministry for Planning and Environment, State Offices, corner Mair and Doveton Streets, Ballarat; Ministry for Planning and Environment, The Olderfleet Buildings, 477 Collins Street, Melbourne and will be open for inspection during office hours to any person free of charge.

Any persons affected by the scheme are required to be set forth in writing any submission they may wish to make with respect to the scheme addressed to the Town Clerk, City of Ballaarat, Town Hall, Sturt Street, Ballarat, 3350 by 19 December 1986 and state whether you wish to be heard in respect of the submission.

Dated 19 November 1986

R. J. NUTTALL

5063 City Engineer and Planning Officer

CITY OF COBURG

Vesting of Reserve

Notice is hereby given pursuant to section 569BA of the *Local Government Act 1958*, as amended, that the Council of the City of Coburg at its ordinary meeting on 29 September 1986, resolved that the drainage reserve bounded by Davern, Magdalen, O'Heas and Westgate Streets and shown hatched on the plan hereunder be vested in Council.

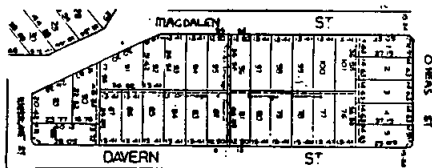

5117

J. R. DIFFEN, City Manager

CITY OF COBURG

Road Discontinuance

Pursuant to section 528 (2) of the *Local Government Act 1958*, the Council of the City of Coburg at its Ordinary Meeting of Council held on 10 November 1986, resolved that the road bounded by Bruce, Rose, Munro and Bell Streets and shown hatched on the plan hereunder, be discontinued and sold by private treaty.

Notwithstanding such discontinuance the Council of the City of Coburg and the Melbourne and Metropolitan Board of Works shall continue to have and possess the same right, title, power, authority or interest in or in relation to the whole of the land shown hatched on the said plan as it had possessed prior to such discontinuance.

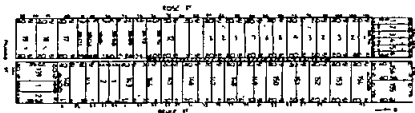

5118

J. R. DIFFEN, City Manager

CITY OF COBURG

Road Discontinuance

Pursuant to section 528 (2) of the *Local Government Act 1958*, the Council of the City of Coburg at its Ordinary Meeting of Council held on 18 August 1986, resolved that the road bounded by Shedden, Sussex, Waratah and Derby Streets and shown hatched on the plan hereunder, be discontinued and sold by private treaty.

Notwithstanding such discontinuance the Council of the City of Coburg and the Melbourne and Metropolitan Board of Works shall continue to have and possess the same right, title, power, authority or interest in or in relation to the whole of the land shown hatched on the said plan as it had possessed prior to such discontinuance.

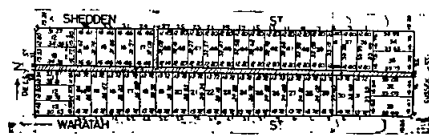

5119

J. R. DIFFEN, City Manager

CITY OF COLLINGWOOD

Notice of Intention to Compulsorily Take Land

Whereas:

A. The Council of the City of Collingwood deems it expedient to exercise its power of taking compulsorily the land delineated on the map at the foot hereof and designated by the symbol A (being part of the land described in Memorial No. 653 Book 133 and being part of Crown Portion 66 County of Bourke Parish of Jika Jika) for providing same as a place for the future development of Municipal Offices.

B. The Council has caused to be prepared a map and other papers setting out the general description of the work or undertaking for which the land proposed to be taken is to be used the description of the land proposed to be taken and the names of the owners or reputed owners, lessees or reputed lessees, mortgagees and occupiers of that land so far as those names are known to or can be ascertained by the Council.

C. The said map and other papers are deposited at the Office of the said Council at Town Hall, 140 Hoddle Street, Abbotsford and are and shall be open for inspection by all persons interested at all reasonable hours for the space of 40 clear days after the publication of this notice in the *Government Gazette*.

Notice is hereby given to all persons affected by the proposed taking of the said land to set forth in writing addressed to the Council or Town Clerk within 40 clear days of the publication of this notice in the *Government Gazette* all objections which they may have to the taking of the said land.

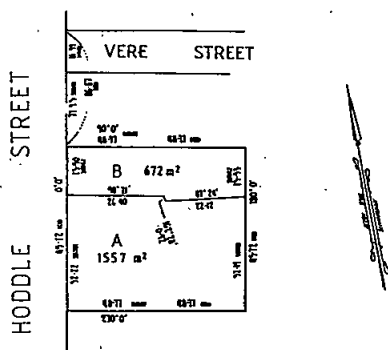

Dated 10 November 1986

By Order of the Council
5091 L. D. COOK, Town Clerk

CITY OF ECHUCA

By-law No. 94

Animal and Bird By-law

A By-law of the City of Echuca made under the provisions of section 93 of the *Health Act* 1958 and sections 197 and 198 of the *Local Government Act* 1958 for the purposes of—

- (a) repealing By-law numbered 85;
- (b) suppressing nuisances;
- (c) regulating the keeping of animals, birds, reptiles and bees;
- (d) limiting the number of animals, birds and reptiles kept on any property;
- (e) the regulating or prohibiting of the keeping of any place or the storage of any things which in the opinion of the council may be offensive, injurious to health or dangerous;
- (f) fixing the distance from any dwelling within which it shall be unlawful to keep any animal, bird or reptile or store any such thing;
- (g) the provision use and control of receptacles for the deposit and storage of food for consumption by animals or poultry;
- (h) providing for the health of residents in the municipal district and against the spreading of contagious or infectious diseases;
- (i) maintaining the good rule and government of the municipality

and for other purposes.

In pursuance of the powers conferred by the *Health Act* 1958 and by the *Local Government Act* 1958, and in pursuance of all other powers it thereunto enabling, the Mayor, Councillors and Citizens of the City of Echuca order as follows:

Short Title

1. This by-law may be cited as the Animal and Bird By-law.

Commencement and Area of Operation

2. This by-law shall operate from the date of publication of notice of its making in the *Government Gazette* and shall apply to and have operation throughout the whole of the municipal district of the City of Echuca, which is hereby declared to be a populous or residential area, save and except for those areas zoned rural A within the meaning of the City of Echuca Planning Scheme.

3. By-law No. 85 is hereby repealed.

PART I.—GENERAL

1. In this by-law unless inconsistent with the context or subject-matter—

“Animal” means and includes cow, heifer, bull, bullock, horse, goat, swine, ferret, pig and sheep and the young thereof.

“Approved materials” means materials approved by the Health Inspector of the Municipality.

“Area” in relation to a poultry house means the superficial area of a horizontal section thereof made at ground level.

“Battery laying cage” means a wire and metal mesh cage divided into one or more compartments in which laying fowls are kept.

“Cat” means and includes a cat of either sex over the age of three months.

“Council” means the Council of the City of Echuca.

“Dog” means and includes a dog of either sex over the age of six months.

“Dwelling” includes a living room sleep-out or tent and all rooms for sleeping living and cooking.

“Frontage” means the boundary line between any land and the street on which such land abuts or where such land abuts on more than one street then the boundary line between such land and the street to which the main building fronts or where there is no building on the said land then the shortest boundary line between such land and any street on which land abuts.

“Horse” means and includes any stallion, mare, gelding, pony, colt or foal, ass or mule or any animal used for burden or draft or for carrying persons.

“Litter” includes wood shavings, tan bark, straw or dry grass clippings or other similar suitable clean material.

“Municipality” means the Municipality of the City of Echuca.

“Poultry” means and includes any fowl, chicken, turkey, goose, gander, duck, duckling, pigeon, squab, any caged bird or the young thereof.

“Premises” means any building land or allotment whether singularly or jointly owned and whether occupied or vacant.

“Stable” means and includes any building or erection used or intended to be used for the purpose of confining, protecting or sheltering any horse.

“Town Clerk” means Town Clerk of the City of Echuca, appointed at that time.

2. Any premises where poultry or animals are kept for trade, such premises being registered with Council under the Health Act, are exempt from the provisions of this by-law.

3. A person shall not permit any animal or bird kept by him to create or cause such an amount or volume of noise as to be a nuisance to any person residing in the neighbourhood.

PART II.—ANIMALS

1. A person shall not keep or cause or permit or suffer to be kept any horse on land zoned Residential A or Commercial A or Commercial B as defined in the approved City of Echuca Planning Scheme in force for the time being.

2. A person shall only keep or cause or permit or suffer to be kept any horse on land within any other zone provided it is a minimum of 1 hectare, with the exception of those areas zoned Rural A, unless either—

- (a) such horse is stabled in an approved stable on those premises; or
- (b) such person has a written permit from the council issued in accordance with clause 3 of this by-law to keep that horse on those premises, and such permit has not been revoked.

3. Any person desiring a permit from the council to keep any horse (other than in an approved stable) or any other animal on any premises shall deliver to the Town Clerk a written application for such permit setting out a full and detailed description of the premises concerned and of the animal in respect of which the application is made. The council shall not be required to grant any such applications unless—

- (a) the premises concerned in which any horse is intended to be kept shall provide at all times an unrestricted area for the keeping of such horse of at least 500 square metres;
- (b) the premises concerned have an adequate water supply;
- (c) the premises concerned are properly and securely fenced on all sides and provision made to prevent any horse from coming closer to any boundary than 3 metres or 6 metres from any dwelling;
- (d) proper provision is made for the storage of feed and the dispensing thereof;
- (e) the situation and drainage of the premises is such that the animal may be properly kept;
- (f) the keeping of such animal in all the circumstances would not in the opinion of the council be likely to constitute a nuisance, be dangerous or offensive or injurious to the health of any person;
- (g) The name and the address of the owner of the horse is to be clearly displayed on the fence or gate surrounding the paddock in which the horse is kept;
- (h) all gates to the paddock in which the horse is kept are to be securely locked.

4. For the purpose of clause 2 hereof an approved stable shall be a stable which complies with the Victoria Building Regulations for the construction of stables or it being a stable which was erected prior to the commencement of this by-law and not complying with the requirements thereof has been approved in writing by the council for the purpose of this by-law.

5. Any person seeking the approval of the council to build a stable for the purpose of the preceding clause shall deliver to the Town Clerk a written request for such approval setting out a full and detailed description of the premises and the stable concerned showing in particular the provisions made for drainage and sanitation and such approval shall not be given unless the council is satisfied that the keeping of a horse in such a stable will not constitute a nuisance or be dangerous or offensive or injurious to the health of any person.

6. The owner or occupier of any premises on which a stable is erected shall—

- (a) cause all manure, refuse and rubbish therein to be placed in a properly constructed receptacle with brickwork walls at least 20 centimetres in thickness or concrete walls at least 10 centimetres in thickness with brick or concrete floor at least 15 centimetres in thickness and lined throughout internally with cement rendering composed of two-and-a-half parts sand to one part cement;
- (b) maintain such receptacle at all times in such good state of repair as is necessary to prevent any escape or leakage of the contents thereof;
- (c) keep such receptacle wholly covered with an effective cover at all times except when manure, refuse or rubbish is actually being deposited therein or being taken therefrom;
- (d) effectively deodorize such receptacle and the contents thereof from time to time as may be necessary to prevent its becoming a nuisance, offensive or injurious or dangerous to health;
- (e) cause all the contents of such receptacle to be removed from such premises at least once every week;
- (f) cause the floor of such stable to be constructed of impervious material approved by the council, such impervious material to be graded and drained to a silt trap connected to the sewer in accordance with the requirements of the Echuca Water Board;
- (g) keep such stable at all times effectively and thoroughly repaired and cleansed in such a manner as may be necessary to prevent its constituting a nuisance or becoming dangerous or offensive or injurious to the health of any resident in the municipality.

PART III.—DOGS AND CATS

1. A person shall not keep or permit or suffer to be kept more than two (2) dogs as defined in Part I. hereof on any premises without being the holder of a permit in writing from the council.

2. A person shall not keep or cause or permit or suffer to be kept on any premises more than two (2) cats as defined in Part I. hereof without being the holder of a permit in writing from the council.

3. Any person desiring the consent of the council pursuant to any of the preceding clauses of this Part shall deliver to the Town Clerk a written request for such consent and every request shall set out a full description of the premises concerned showing in particular the provisions made for drainage and sanitation and shall also set out the number and description of the dogs or cats (as the case may be) intended to be kept thereon and such consent shall not be given unless the council is satisfied that the keeping of the dogs or cats (as the case may be) as described in the request on the premises therein referred to as will not constitute a nuisance or be dangerous or offensive or injurious to the health of any person.

4. Any consent given by the council pursuant to the previous clause may be given subject to such conditions if any as the council in the particular case considers advisable; such conditions shall be stated in the consent and if they are not complied with the council may withdraw the consent.

PART IV.—POULTRY

1. A person shall not keep or cause or permit to be kept on any premises more than twenty (20) head of poultry or fifty (50) head of pigeons without the written consent of council.

2. A person shall not keep or cause or permit to be kept on any premises any poultry in a battery laying cage or battery laying cage system without the written consent of council.

3. A person shall not keep or cause or permit to be kept in any premises any poultry except in a poultry house constructed in accordance with this by-law provided that a poultry house may have attached thereto for the use of the poultry a poultry run.

4. A person shall not keep or cause or permit to be kept in any poultry house a number of poultry greater than the number produced by multiplying the area in square metres of such poultry house by 3.5.

5. A person shall not on any premises keep or cause or permit to be kept any poultry within a distance of—

- (a) 18 metres from any street or road to which such land has a frontage;
- (b) 3 metres from any other street or road;

- (c) 1.5 metres from the boundary of any adjoining land;
- (d) 7.5 metres from any dwelling.

6. A person shall not keep or cause or permit to be kept at any one premises more than two (2) turkeys, ducks or geese without the written consent of council.

7. Every poultry house situated in a populous or residential zone shall—

- (a) be roofed with galvanized iron or other approved impervious material and such roof shall be provided with guttering and spouting leading to adequate storm water drain;
- (b) have all external walls constructed of approved rat-proof material;
- (c) be rendered rat proof by placing galvanized iron, jointed brickwork or concrete around the foundation to a depth of at least fifty centimetres below ground level;
- (d) be paved with approved impervious material the surface level of which shall be at all points at least ten centimetres above the level of the ground;
- (e) be constructed so as to be capable of holding litter to a depth of least twenty centimetres.

8. Any person desiring the consent of the council pursuant to any of the preceding clauses of this Part shall deliver to the Town Clerk a written request for such consent and every request shall set out a full description of the premises concerned showing in particular provisions made for drainage and sanitation and shall also set out the number and description of poultry intended to be kept thereon and such consent will not be given unless the council is satisfied that the keeping of the poultry as described in the request on the premises therein referred to will not constitute a nuisance or be dangerous or offensive or injurious to the health of any person.

9. Any consent given by the council pursuant to the previous clause may be given to such conditions if any as the council in the particular case considers advisable; such conditions shall be stated in the consent and if they are not complied with the council may withdraw the consent.

10. Save as herein provided the provisions of this Part shall not apply to any poultry farm which was in existence as a poultry farm at the date on which this by-law comes into operation as long as the number of mature birds kept thereon is not greater than the number usually kept thereon immediately before the coming into operation of this by-law and so long as any poultry house or similar structure or enclosed poultry run or battery cage system thereon is kept in as good order and condition as at the date on which this by-law comes into operation.

PART V.—REPTILES AND BEES

1. A person shall not keep or cause or permit to be kept on any premises any reptile without the written consent of council.

2. A person shall not keep or cause or permit to be kept on any premises any bees without the written consent of council.

PART VI.—CLEANLINESS

1. The ground surrounding any stable receptacle for manure or poultry house shall be well drained.

2. The occupier of any land shall cause any stable, poultry house and poultry run thereon to be thoroughly cleansed from time to time as often as may be necessary and shall keep the same at all times in a clean, wholesome and sanitary condition.

3. A person shall not keep or store or cause or permit to be kept or stored on any land where animals or poultry are kept any food for consumption by such animals or poultry unless such food is kept or stored in rat-proof receptacles or rat-proof buildings.

4. The occupier of any land on which any animal or poultry is kept shall cause any animal or poultry kept thereon which suffers from any infectious disease communicable to man to be forthwith destroyed and disposed of to the satisfaction of the Health Surveyor of the Municipality.

5. The occupier of any land on which any stable or poultry house is erected shall keep the area of land within 1.5 metres of such stable or poultry house free from all dry grass, weeds, refuse, rubbish or other materials capable of harbouring rats or vermin.

6. The owner or occupier shall ensure that all poultry droppings, litter and refuse are disposed of in such a manner so as to not create offensive conditions or permit the breeding of flies at any stage of the life cycle.

7. The Health Surveyor of the Municipality may by written notice delivered or posted to the owner or occupier of any premises direct that the provisions of this by-law be complied with.

PART VII.—PENALTIES

Any person doing any act forbidden to be done or failing to do any act directed to be done by this by-law shall be liable for any such offence to a penalty of not more than One hundred dollars and in the case of a continuing offence to a further daily penalty of not more than Ten dollars per day for each day on which the offence is continued after a conviction or order by any Court.

Resolution for the passing of this by-law was agreed to by the Council of the City of Echuca on 18 February 1985 and confirmed on 25 March 1985.

The Common Seal of the Mayor, Councillors and Citizens of the City of Echuca was hereunto affixed in the presence of—

R. B. SNOW, Mayor
A. E. ROSENDALE, Councillor
K. E. McCARTNEY, Town Clerk

Form 2.1

Town and Country Planning Act 1961

CITY OF HORSHAM PLANNING SCHEME

Notice that a Planning Scheme has been Prepared and is Available for Inspection

Amendment No. 116

Notice is hereby given that the Council of the City of Horsham in pursuance of its powers under the *Town and Country Planning Act 1961* has prepared a scheme:

1. To amend the Planning Scheme Ordinance to introduce a new zone titled Residential Development, and to insert an additional table to clause 6 page 21 (a) after Rural Steamway Zone to incorporate the Residential Development Zone.
2. To amend the Planning Scheme Ordinance to introduce under part 6—Special Provisions a new clause 22A relating to the provisions which shall apply to the subdivision of land in the Residential Development Zone.
3. To rezone land with a frontage to Williams Road being part of Crown Allotment 5, and section 7 Parish of Horsham to be rezoned from Rural A to Residential Development and Rural C Streamway in the Municipal District of the City of Horsham, shown enclosed within the black borders on the Planning Scheme Map.
4. To rezone land which forms the centre of land on the corner of Riley Road and Florence Street, Part Crown Allotments 1 and 2, section 2 to be rezoned from Rural A to Residential Development Zone within the Municipal District of the City of Horsham shown enclosed within the black borders on the Planning Scheme Map.

A copy of the scheme has been deposited at the Office of the Council of the City of Horsham, Civic Centre, Roberts Avenue, Horsham and at the Office of the Ministry for Planning and Environment (Plan Inspection Section), The Olderfleet Buildings, 477 Collins Street, Melbourne, and will be open for inspection during office hours by any person free of charge.

Any persons affected by the scheme are required to set forth in writing any submission they may wish to make with respect to the scheme addressed to the Town Clerk, City of Horsham, P.O. Box 511, Horsham by 19 December 1986 and state whether they wish to be heard in respect of their submission.

5084 R. A. MARSHALL, Town Clerk

CITY OF MELBOURNE

Notice of Intention to Borrow Money

Notice is hereby given in accordance with the provisions of the Melbourne and Geelong Debentures Inscribed Stock and Mortgages Act, that the Melbourne City Council has Australian Loan Council approval to borrow the sum of \$4 700 000 to provide funds for permanent works and

undertakings for the year ending 30 June 1987 for the purposes of carrying into effect the provisions of the several Acts of Parliament relating to the City of Melbourne.

D. N. BETHKE

5098 Chief Executive Officer and Town Clerk

CITY OF MILDURA

Notice pursuant to Section 528 (2) of the *Local Government Act 1958*

Permanent Road Closure

That the City of Mildura having, in accordance with section 528 (2) of the *Local Government Act 1958*—

- (a) consulted all relevant authorities;
- (b) advertised its intention;
- (c) served notice on the adjoining owners of that portion of the road to be closed;
- (d) and received no objections to the proposal,

is of the opinion that that part of the road located at the corner of Sixth Street and Ontario Avenue is no longer required as a road for public use and by this resolution hereby directs that the said part of the road (as hatched on the plan hereunder) be discontinued and dealt with as follows:

1. In respect to that area of land marked "A" on the plan hereunder shall vest in the Council to be retained for municipal purposes for consolidation with Lot 1 on Plan of Subdivision No. 121285 being property more commonly known as 2 Ontario Avenue, Mildura.

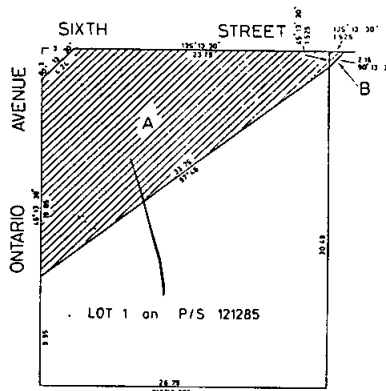

ROAD TO BE CLOSED

SCALE 1:250

2. In respect to that area of land marked "B" on the plan hereunder, to be sold by private treaty to the owners of the adjoining property more commonly known as 237 Seventh Street, Mildura.

Further, that upon publication of this Notice in the *Government Gazette*, the said part of the road shall be discontinued and shall vest and be sold as aforesaid.

The above resolution was adopted by the Council at its ordinary meeting held on 30 October 1986.

DAMIAN B. GOSS
5085 Town Clerk and Chief Executive

CITY OF RICHMOND
Road Discontinuance

Pursuant to section 528 (2) of the *Local Government Act 1958* notice is hereby given that the Council of the City of Richmond at its ordinary meeting held on Monday, 8 September 1986 passed the following resolution:

- (a) That council discontinue the right-of-way at the rear of 143 Bridge Road (more accurately described by hachure on the plan below), such right-of-way being, in the opinion of council, not reasonably required for public use;
- (b) That notwithstanding such discontinuance, the Melbourne and Metropolitan Board of Works shall continue to have and possess the same right, title, power, authority or interest in or in relation to the whole of the land as it had or possessed prior to such discontinuance with respect to or in connection with any drains or pipes laid in, on or over such land;
- (c) That such lands resulting from the discontinued right-of-way be sold by private treaty to an abutting owner.

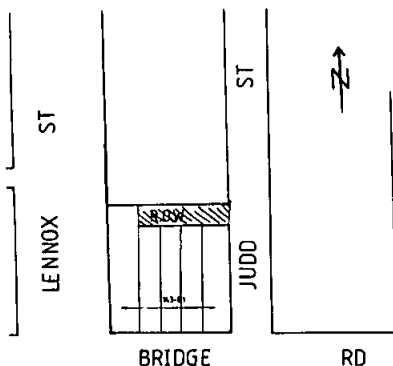

5099 D. G. WILLIAMS, Town Clerk

Erratum

CITY OF SHEPPARTON PLANNING SCHEME
1953

Amendment No. 108, 1986

In *Government Gazette* No. 96 dated 12 November 1986 on pages 4377/4378 the date for submissions should read "Friday 12 December 1986" not 5 December 1986 as stated.

CITY OF WANGARATTA

By-Law No. 85

Animals and Birds By-Law

Notice is hereby given that in pursuance of powers conferred by section 197 (1) (X1a) and (XXX1) (f) of the *Local Government Act 1958* and section 93 of the *Health Act 1958* the Council of the City of Wangaratta has made By-Law No. 85 for the purpose of—

- (a) regulating the keeping of animals and birds;
- (b) suppressing nuisances;
- (c) prescribing penalties for breaches of this By-Law.

A copy of the By-Law is open for inspection, free of charge, during office hours, at the Municipal Offices, Ovens Street, Wangaratta.

Resolution for passing this By-Law was adopted by the Council on 29 September 1986 and confirmed on 10 November 1986.

5064 J. W. ELWARD, Town Clerk

Upper Yarra Valley and Dandenong Ranges
Authority Act 1976

NOTICE OF INTENTION TO RE-
INVESTIGATE THE UPPER YARRA VALLEY
AND DANDEONG RANGERS REGION

Sub-section 21 (2) of the *Upper Yarra Valley and Dandenong Ranges Authority Act 1976* states that the Authority shall re-investigate the region between four and six years after the approval of a Regional Strategy Plan for the region or part of the region and shall if necessary prepare and submit to the Minister an amending Regional Strategy Plan for the region.

The current Regional Strategy Plan was approved by the Governor in Council in October 1982. The Authority has therefore resolved to re-investigate the region pursuant to sub-section 21 (2) of the *Upper Yarra Valley and Dandenong Ranges Authority Act 1976*.

Any person who wishes to make representation on the re-investigation of the region may do so in writing addressed to: Director, Upper Yarra Valley and Dandenong Ranges Authority, P.O. Box 104, Lilydale, Vic. 3140

Such representation should reach the above address not later than the 13 February 1987.

12 November 1986

5097 GEORGE WRIGHT, Director

Form 2.1

*Town and Country Planning Act 1961***TOWN OF KYABRAM—TOWN OF
KYABRAM PLANNING SCHEME 1963**

Notice that a Planning Scheme has been Prepared
and is Available for Inspection

Amendment No. 36

Notice is hereby given that the Town of Kyabram in pursuance of its powers under the *Town and Country Planning Act 1961* has prepared a scheme for the rezoning of land described as Lot 11 L.P. B-582, Parish of Kyabram East (7-9 Church Street) from Residential Zone to Commercial A Zone.

A copy of the scheme has been deposited at the Municipal Offices, Lake Road, Kyabram and at the office of the Ministry for Planning and Environment, The Olderfleet Buildings, 477 Collins Street, Melbourne and will be open for inspection during office hours by any person free of charge.

Any persons affected by the scheme are required to set forth in writing any submission they may wish to make with respect to the scheme, addressed to the Chief Executive Officer, P.O. Box 426, Kyabram 3620, by 19 December 1986 and state whether you wish to be heard in respect of your submission.

5088 F. J. SULTANA, Town Engineer

Form 2.1

*Town and Country Planning Act 1961***SHIRE OF BACCHUS MARSH**

Notice that a Planning Scheme has been Prepared
and is Available for Inspection

Amendment No. 42

Notice is hereby given that the Shire of Bacchus Marsh in pursuance of its powers under the *Town and Country Planning Act 1961* has prepared a scheme to provide for an increase in the minimum size of allotments created by subdivision in the Residential A zoned land located between Maddingley Boulevard, Griffith Street, Crown Allotment A—Township of Bacchus Marsh, Bacchus Street and Meikle Street, Maddingley, as shown.

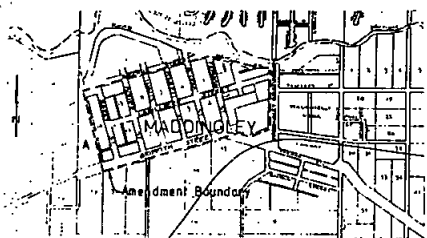

A copy of the scheme has been deposited at the Shire Offices, Shire of Bacchus Marsh, 197 Main Street, Bacchus Marsh and at the office of the Ministry for Planning and Environment, The Olderfleet Buildings, 477 Collins Street, Melbourne, and will be open for inspection during office hours by any person free of charge.

Any persons affected by the scheme are required to set forth in writing any submission they may wish to make with respect to the scheme addressed to Shire Secretary, Shire of Bacchus Marsh, P.O. Box 216, Bacchus Marsh 3340 by 19 December 1986 and state whether they wish to be heard in respect of their submission.

Dated 11 November 1986

5086 D. L. MURPHY, Shire Engineer

Schedule 1

Form 2.1

*Town and Country Planning Act 1961***SHIRE OF CRANBOURNE (WESTERN PORT)
PLANNING SCHEME**

Notice that a Planning Scheme has been Prepared
and is Available for Inspection

Amendment No. 41—1986

Notice is hereby given that the Shire of Cranbourne in pursuance of its powers under the *Town and Country Planning Act 1961*, has prepared a Scheme:

To amend the Principal Scheme by rezoning land being—

part CA 28, Parish of Yallock, Caldermeade Road, Primary School No. 4271 (1.1 hectares)

part CA 40, Parish of Lang Lang East, Westernport Road, Yannathan South, Primary School No. 3225 (1.2 hectares)

part CA 77, Parish of Yallock, School Road, Bayles, Primary School No. 3420 (0.8 hectares)

from Public Purposes Reservation No. 8 (Primary School) to General Farming B Zone.

A copy of the Scheme has been deposited at the Shire Offices, Cranbourne and at the office of the Ministry for Planning and Environment, The Olderfleet Buildings, 477 Collins Street, Melbourne and will be open for inspection during office hours by any person free of charge.

Any persons affected by the Scheme are required to set forth in writing any submissions they may wish to make with respect to the Scheme addressed to the Shire Secretary, Shire of Cranbourne, Shire Offices, Cranbourne, by 19 February 1986 and to state whether you wish to be heard in respect of your submissions.

5065

A. J. HOBAN, Town Planner

Town and Country Planning Act 1961
SHIRE OF KILMORE PLANNING SCHEME
 1973

Notice that a Planning Scheme has been Prepared and is Available for Inspection
 Amendment No. 67, 1986

Notice is hereby given that the Shire of Kilmore, in pursuance of its powers under the *Town and Country Planning Act 1961* has prepared a Planning Scheme for land known as Lot 1 and Lot 2, LP89322, Parish of Wallan Wallan, corner Duke and Windham Streets, Wallan from its present zoning of Rural A1 to Residential Development.

A copy of the Scheme has been deposited at the office of the Shire of Kilmore, Civic Centre, Sydney Street, Kilmore and at the office of the Ministry for Planning and Environment, The Olderfleet Buildings, 477 Collins Street, Melbourne and will be open for inspection during office hours to any person free of charge.

Any persons affected by the Scheme are required to set forth in writing any submission they may wish to make with respect to the Scheme addressed to the Shire Secretary, Shire of Kilmore, P.O. Box 187, Kilmore, Victoria: 3764, on or before 19 December 1986 and state whether they wish to be heard in respect of their submission.

Dated 7 November 1986

5066 T. K. HAYES, Shire Secretary

SHIRE OF MIRBOO
 Road Deviation Order

Pursuant to the provisions of section 522 of the *Local Government Act 1958* the Council of the Shire of Mirboo hereby directs that the land in the Township of Mirboo North and the Parish of Mirboo indicated by hatching on the Plan hereunder which has been purchased, taken or acquired by it, shall be a Public Highway on and from the date of publication of this Order in the *Government Gazette*.

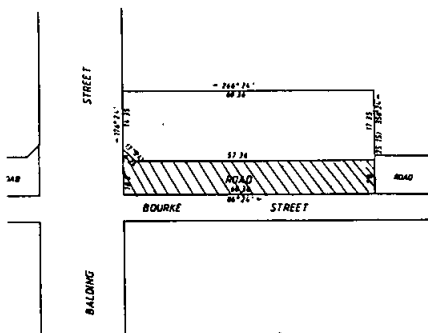

The common seal of the President, Councillors and Ratepayers of the Shire of Mirboo was hereto affixed on 22 May 1986 in the presence of:

J. R. AUSTIN, President
 N. L. MARTYN, Councillor
 R. L. GREGG, Secretary

5120

SHIRE OF PHILLIP ISLAND

Reserves on Plan of Subdivision No. 75476 to Vest in Shire

Pursuant to section 569BA of the *Local Government Act 1958* the Council of the Shire of Phillip Island has on 17 September 1986 resolved as follows:

Whereas Plan of Subdivision No. 75476 has been lodged with the Registrar of Titles pursuant to section 97 of the *Transfer of Land Act 1958* and allotments on that Plan of Subdivision have been transferred the Council of the Shire of Phillip Island hereby directs that the whole of the land comprised in the recreation drainage and sewerage reserve and the drainage reserve set out on the said Plan of Subdivision No. 75476 shall vest in the said Shire of Phillip Island.

5087 B. D. HAYES, Chief Executive Officer

Town and Country Planning Act 1961
SHIRE OF SHERBROOKE PLANNING
 SCHEME 1979 (RURAL AREAS)

Notice that a Planning Scheme has been Prepared and is Available for Inspection
 Amendment No. 38

Notice is hereby given that the Shire of Sherbrooke in pursuance of its powers under the *Town and Country Planning Act 1961* has prepared a scheme for the purpose of permitting the use of a Community Integration Facility on the Chandler Co-Operative land at Lot 1, L.P.134475, Moroney Crescent, Menzies Creek.

A copy of the scheme has been deposited at the Shire Offices, Glenfern Road, Upwey and at the Office of the Ministry for Planning and Environment, The Olderfleet Buildings, 477 Collins Street, Melbourne and will be open for inspection during office hours by any person free of charge.

Any persons affected by the Scheme are required to set forth in writing any submissions they may wish to make with respect to the scheme, addressed to the Shire Secretary, Shire of Sherbrooke, Glenfern Road, Upwey by 19 December 1986 and state whether they wish to be heard in respect of their submission.

5121 K. E. MATSON
 General Manager and Shire Secretary

SHIRE OF SHERBROOKE
Vesting of Reserves

Whereas it is provided by section 569BA of the *Local Government Act 1958* that where any map or plan has been deposited with the Registrar of Titles pursuant to section 97 of the *Transfer of Land Act 1958*, whether before, on or after the commencement of this section and any allotment on that map or plan has been transferred the Council may by a resolution direct that the whole or any part of the land comprised in any reserve shown on that map or plan shall vest in the Council and upon the publication of that resolution in the *Government Gazette*, that land shall vest in the municipality freed and discharged from any mortgage, charge, lease or sub-lease.

And whereas the Council of the Shire of Sherbrooke has resolved that reserves shown on plans of subdivision be vested in the Council and allotments on these plans have been transferred.

Now therefore in pursuance of the provisions of sub-section 1 of section 569BS of the *Local Government Act 1958* this order vests in the Council of the Shire of Sherbrooke the following reserve:

Plantation Reserve created on Plan of Subdivision No. 127587, Volume 8781, Folio 135 Thompson Avenue, Olinda, as identified in the plan hereunder—

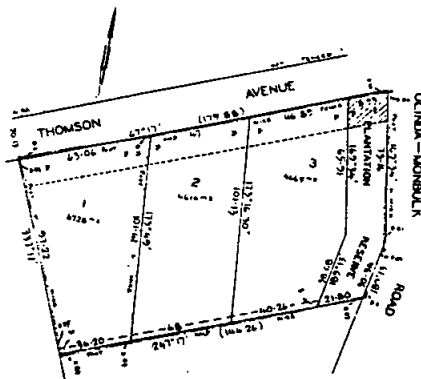

K. E. MATSON
5067 General Manager and Shire Secretary

SHIRE OF SHERBROOKE
Vesting of a Reserve

Whereas it is provided by section 569BA (1) of the *Local Government Act 1958*, that where any map or plan has been lodged or deposited with the Registrar of Titles pursuant to section 97 of the *Transfer of Land Act 1958*, whether before, on or after the commencement of this section and any allotment on that map or plan has been transferred,

the council may by resolution direct that the whole or any part of the land comprised in any reserve shown on that map or plan shall vest in the council and upon the publication of that resolution in the *Government Gazette*, that land shall vest in the municipality freed and discharged from any mortgage, charge, lease or sub-lease.

Pursuant to section 569BA (1) of the *Local Government Act 1958*, the Council of the Shire of Sherbrooke hereby directs that the whole of the land comprised in the drainage and recreation reserve contained in Plan of Subdivision No. 55855 and as depicted in the plan hereunder, shall vest in the Council of the Shire of Sherbrooke.

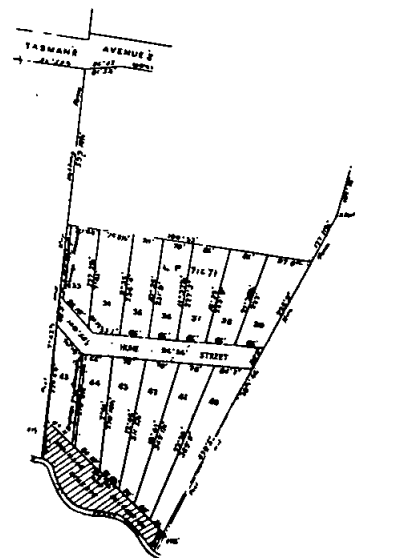

K. E. MATSON
5068 General Manager and Shire Secretary

SHIRE OF SHERBROOKE
Notice of Road Closure—Walnut Avenue,
Emerald

The Council of the Shire of Sherbrooke, being of the opinion that the portion of Walnut Avenue, Emerald, as shown in the plan hereunder, is not reasonably required as a road for public use and having consulted the relevant statutory authorities, resolved pursuant to section 528 (2) of the *Local Government Act* that the portion of Walnut Avenue, Emerald abutting Lot 22-26 LP 11181 be discontinued and part be sold by private treaty to adjoining land owners and part be retained for municipal purposes.

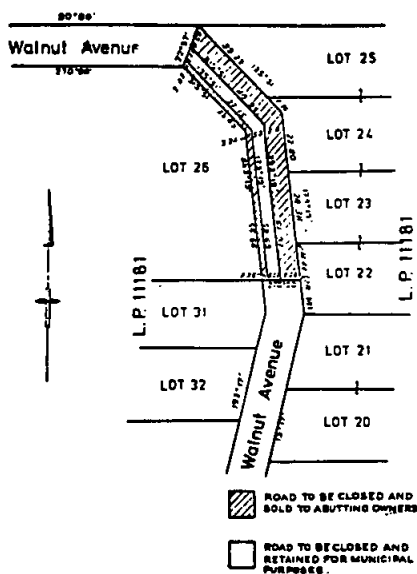

Tambo, P.O. Box 10, Bruthen, 3885, by 22 December, 1986 and state whether they wish to be heard in respect of their submission.

Dated 13 November 1986

5104 W. J. HOBSON, Chief Executive

SHIRE OF SHERBROOKE

Closure of Road to Through Traffic—Logan Park Road, at the Wellington Road Intersection, Lysterfield

The Council of the Shire of Sherbrooke, having considered all objections received and a report on the proposal by the Road Traffic Authority at a Special Meeting of Council held on 28 October 1986, by order adopted the proposal to close Logan Park Road, at the Wellington Road intersection, Lysterfield to through traffic pursuant to section 539c of the Local Government Act; with the proposal thus becoming part of the order.

The closure as adopted is identified in the plan hereunder:

5069 K. E. MATSON
General Manager and Shire Secretary

Town and Country Planning Act 1961
SHIRE OF TAMBO (BALANCE OF SHIRE)
PLANNING SCHEME—INTERIM
DEVELOPMENT ORDER 1985

Notice that an Interim Development Order Amendment has been Prepared and is Available for Inspection
Amendment No. 10

Notice is hereby given that the Shire of Tambo in pursuance of its powers under the Town and Country Planning Act 1961, has prepared an Interim Development Order Amendment for the following:

That area situated and abutting the eastern boundary of Broadlands Road adjacent to the Brolga Grove intersection, Metung being CP 160599 and which is to encompass a "Site Specific" amendment to allow the erection of a house to exceed 4.5 m in height above the natural surface.

A copy of the order has been deposited at the Shire Offices, Main Street, Bruthen, and at the office of the Ministry for Planning and Environment (Plan Inspection Section) Ground Floor, 477 Collins Street, Melbourne, and will be open for inspection during office hours by any person free of charge.

Any persons affected by the Order are required to set forth in writing any submissions they may wish to make addressed to the Chief Executive, Shire of

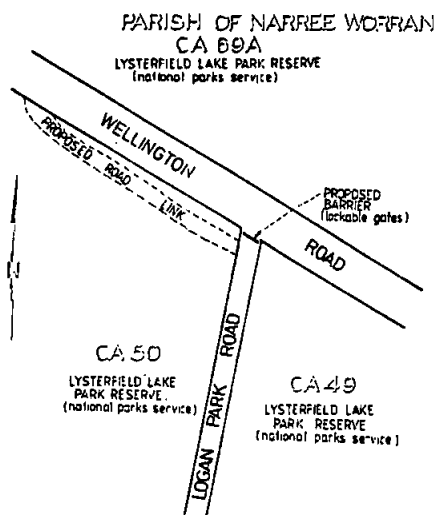

This order as adopted shall come into operations as from 24 November 1986.

5100 K. E. MATSON
General Manager/Shire Secretary

Town and Country Planning Act 1961
SHIRE OF TAMBO (LAKES ENTRANCE)
PLANNING SCHEME

Notice that a Planning Scheme Amendment has been Prepared and is Available for Inspection
Amendment No. 72

Notice is hereby given that the Shire of Tambo in pursuance of its powers under the *Town and Country Planning Act 1961*, has prepared a Planning Scheme Amendment for the following:

That area situated east of the Princes Highway and north of Beveridges Road and being part of Crown allotment 17A Township of Cunninghame to be rezoned from Residential C to Tourist zone.

A copy of the scheme has been deposited at the Shire Offices, Main Street, Bruthen, and at the office of the Ministry for Planning and Environment (Plan Inspection Section) Ground Floor, 477 Collins Street, Melbourne, and will be open for inspection during office hours by any person free of charge.

Any persons affected by the scheme are required to set forth in writing any submissions they may wish to make addressed to the Chief Executive, Shire of Tambo, P.O. Box 10 Bruthen, 3885, by 22 December, 1986 and state whether they wish to be heard in respect of their submission.

Dated 13 November, 1986

5101 W. J. HOBSON, Chief Executive

Town and Country Planning Act 1961
SHIRE OF TAMBO (BALANCE OF SHIRE)
PLANNING SCHEME—INTERIM
DEVELOPMENT ORDER 1985

Notice that an Interim Development Order Amendment has been Prepared and is Available for Inspection

Amendment No. 5

Notice is hereby given that the Shire of Tambo in pursuance of its powers under the *Town and Country Planning Act 1961*, has prepared an Interim Development Order Amendment for the following:

That area situated east of King Street and west of Moorhouse Street, Metung, being lots 24 and 26 LP 479, Part Lots 23 and 25 LP 479, and part of a government road, Parish of Bumberrah rezone from Rural A and Special Investigation Area to Residential and Special Investigation Area.

A copy of the order has been deposited at the Shire Offices, Main Street, Bruthen, and at the office of the Ministry for Planning and Environment (Plan Inspection Section), Ground Floor, 477 Collins Street, Melbourne, and will be open for inspection during office hours by any person free of charge.

Any persons affected by the order are required to set forth in writing any submissions they may wish to make addressed to the Chief Executive, Shire of Tambo, P.O. Box 10, Bruthen, 3885, by 22

December, 1986 and state whether they wish to be heard in respect of their submission.

Dated 13 November 1986

5102 W. J. HOBSON, Chief Executive

Town and Country Planning Act 1961
SHIRE OF TAMBO (BALANCE OF SHIRE)
PLANNING SCHEME—INTERIM
DEVELOPMENT ORDER 1985

Notice that an Interim Development Order Amendment has been Prepared and is Available for Inspection

Amendment No. 6

Notice is hereby given that the Shire of Tambo in pursuance of its powers under the *Town and Country Planning Act 1961*, has prepared an Interim Development Order Amendment for the following:

That area situated north of Engineers Road and south of Old Engineers Road, Bruthen being part of Crown allotment 16B Section A Parish of Tambo and which is to encompass a "Site Specific" amendment to allow a two-lot subdivision with the minimum allotment size being two hectares.

A copy of the order has been deposited at the Shire Offices, Main Street, Bruthen, and at the office of the Ministry for Planning and Environment (Plan Inspection Section), Ground Floor, 477 Collins Street, Melbourne, and will be open for inspection during office hours by any person free of charge.

Any persons affected by the order are required to set forth in writing any submissions they may wish to make addressed to the Chief Executive, Shire of Tambo, P.O. Box 10, Bruthen, 3885, by 22 December, 1986 and state whether they wish to be heard in respect of their submission.

Dated 13 November 1986

5103 W. J. HOBSON, Chief Executive

SHIRE OF TAMBO

Pursuant to section 535 of the *Local Government Act 1958*, the Council of the Shire of Tambo resolved at a meeting held on 3 November 1986, that the name of the following street or road as set out hereunder be changed—

Old Name—Macrae Street.

New Name—Macrae Court.

Locality—Lakes Entrance.

5070 W. J. HOBSON, Chief Executive

SHIRE OF YEA

Declaration of Silver Creek Road to be Dedicated as a Public Highway

Pursuant to section 587 (3) of the *Local Government Act* and application having been made, the Council of the Shire of Yea at its meeting on 6 October 1986 declared Silver Creek Road (between Yea-Whittlesea Road and the municipal boundary) to be dedicated as a public highway.

5071 JIM ELVEY, Shire Secretary

**MORNINGTON PENINSULA AND DISTRICT
WATER BOARD**

Notice of Commencement of Works
Cranbourne Area

Notice is hereby given that the Board intends to construct reticulation sewers, rising mains and pump stations in the area of Cranbourne comprising generally South Gippsland Highway, Craig Road, Glendoon Road and Ballarto Road.

Plans of the proposed works are available for inspection at the Board Branch Office, No. 178 Sladen Street, Cranbourne during normal office hours.

It is anticipated that the works will commence in November.

5072 J. O. WILLIAMS, Secretary

**MORNINGTON PENINSULA AND DISTRICT
WATER BOARD**

Notice of Commencement of Works
Rosebud Area

Notice is hereby given that the Board intends to construct reticulation sewers in the area of Rosebud comprising generally, Waterfall Gully Road, Jetty Road, Duells Road, Goolgowie Street, Wakool Avenue, Sylvan Drive and Sherwood Avenue.

Plans of the proposed works are available for inspection at the Board Branch Office, corner of Verdon Street and Nepean Highway, Dromana during normal office hours.

It is anticipated that the works will commence in November.

5073 J. O. WILLIAMS, Secretary

STAWELL WATER BOARD

General Notice—Sewered Area No. 39

The Stawell Water Board having made provision for carrying off the sewage from each and every property which or any part of which is within the sewerage area hereinafter described doth hereby declare that on and after 1 December 1986 each and every property which or any part of which is within the said sewerage area shall be deemed to be a seweraged property within the meaning of the *Sewerage Districts Act 1958*.

The sewerage area hereinbefore referred to is that area contained in Crown Allotments 16 and 17 section 81A Parish of Stawell.

By order of the Stawell Water Board.

5074 E. F. JEFFERY, Chairman
N. R. ILLIG, Secretary

STAWELL WATER BOARD

Notice to owners of tenements in the undermentioned streets, lanes, courts and alleys opening thereto.

The main pipe in the said streets being laid down, the owners of all tenements situated as under are hereby required on, or before 1 December 1986 to cause a proper pipe and stop cock to be laid so as to supply water within such tenements from the main pipe.

D'Arcy Street—Crown Allotment 14, 15 Section 128 Township and Parish of Stawell.

Henderson Street—Lot 1 Lodge Plan 132016 Parish of Stawell.

5075 N. R. ILLIG, Secretary

GEELONG AND DISTRICT WATER BOARD

Pursuant to section 60 of the *Geelong Waterworks and Sewerage Act 1958* (No. 6263) the Board has prepared plans to indicate the particulars of sewers and underground works, the construction of which the Board intends to begin at a date not less than one month after publication of the notices, in or adjacent to the following locality within the Drainage Area.

Carramar Court, Highton, City of South Barwon
Murradoc Road, Drysdale, Shire of Bellarine

Notice is hereby given that the plans indicated are open for public inspection at the Board's Offices, 61-67 Ryrie Street, Geelong between the hours of 8.10 a.m. and 5.00 p.m. from Monday to Friday (public holidays excepted) by the owners or occupiers of land or premises within the Drainage Area.

5122 R. A. JORDAN, Secretary

**NOTICE OF DISSOLUTION OF
PARTNERSHIP**

Notice is hereby given that the partnership hitherto subsisting between William Vincent Hogan of 50 Hesse Street, Winchelsea in the State of Victoria of the one part and William Joseph Hogan of Lorne Road, Winchelsea in the said State of the other party carrying on business of W. Hogan and Son Partnership has been dissolved as and from 30 June 1986. The said business shall be continued by the continuing partner William Joseph Hogan together with the new partner Suzanne Margaret Hogan.

Dated 28 July 1986

WILLIAM VINCENT HOGAN
WILLIAM JOSEPH HOGAN
SUZANNE MARGARET HOGAN

Phillip Considine & Co., barristers and solicitors,
40 Myers Street, Geelong 5089

Notice is hereby given that the partnership heretofore subsisting between Peter Warner Foster and Marion Boyce Foster carrying on business as market gardeners at Upper Tambo Road Nicholson has been dissolved as from 1 July 1986. 5123

Take notice that the partnership formerly carried on under the name Peter Hinds Body Repairs at 186 Kingsway, South Melbourne and/or 20 George Street, Spotswood has been dissolved and Cheryl Anne Hinds is no longer responsible for any debts in respect to such business formerly carried on as from 17 November 1986.

CHERYL ANNE HINDS, by her solicitors,
Tisher, Liner & Co., of 317-319 La Trobe Street,
Melbourne 5124

Notice is hereby given that the partnership heretofore subsisting between Wladyslaw Kamusinski, Zbigniew Szypnicki, Marek Sykurski and Krzysztof Marek Wrzesinski carrying on business at 3-5 Patrona Street, Dandenong under the style or firm of "Baltic Stonemason Professionals" has been dissolved by mutual consent as from 22 October 1986 so far as concerns the said Wladyslaw Kamusinski and Marek Sykurski who retire from the said firm.

Dated 22 October 1986

WLADYSLAW KAMUSINSKI
ZBIGNIEW SZYPNICKI
MAREK SYKURSKI
5125 KRZYSZTOF MAREK WRZESINSKI

Notice is hereby given that the partnership heretofore subsisting between Lionel Harrison Browne of 1 Baystone Drive, Cranbourne and Jean Elizabeth Browne of Unit 3, 7 Fairfield Street, Cranbourne in the State of Victoria, carrying on the business in the name of L. H. & J. E. Browne Builders, from premises at 1 Baystone Drive, Cranbourne, has been dissolved by mutual consent as from 1 April 1986.

All debts due to and owing by the said late partnership shall be received and paid by the said Lionel Harrison Browne who will continue to carry on the business under the same name and from the same premises. 5141

Notice is hereby given that the partnership between William John Davies of Flat 4, Venice Street, Mentone and Kay Lesley Davies of 16 Brigado Court, Keysborough and Donald Haworth and Barbara Haworth both of 12 Leslie Grove, Noble Park, who carried on business under the style or firm name of Keysborough Video Library at 293 Corrigan Road, Keysborough has been dissolved as from 15 November 1986.

Dated 19 November 1986

WILLIAM JOHN DAVIES
KAY LESLEY DAVIES
Baring Heath, solicitors, 2nd Floor, 582 St Kilda
Road, Melbourne 5142

**Mt. WAVERLEY No. 2 CO-OPERATIVE
HOUSING SOCIETY LIMITED**

Take notice that the affairs of the abovenamed society are now fully wound up and that in pursuance to section 272 (1) of the *Companies Act 1961* and of the *Co-operative Housing Societies Act 1958* a general meeting of the society will be held at First Floor, 54 McCrae Street, Dandenong on Tuesday, 16 December 1986, at 12.30 p.m. for the purposes of—

- (i) laying before it an account showing how the winding up has been conducted and the property of the society disposed of and giving an explanation thereof; and
- (ii) passing a resolution that the books and papers of the said society and of the liquidator relevant to the affairs of the society be destroyed after a period of twelve months from the date of the meeting.

Dated 10 November 1986

5133 R. K. O'NEILL, Liquidator

Re: HARRY KINGSTON & CO. PTY. LTD.
Notice of Liquidators Final Meeting per S411
Companies Code (Victoria)

Members are advised that a final meeting of the company will be held at the office of McLean Delmo & Partners, Second Floor, 300 Burwood Road, Hawthorn, at 10 a.m. on 22 December 1986 to consider the liquidators account of the winding up.

5134 A. D. McLEAN, Liquidator

The Companies Act 1961
AUSTREX OVERSEAS PTY. LTD.
(in Liquidation)

**Notice Convening Final Meeting of Members and
Creditors Pursuant to Section 272**

Notice is hereby given pursuant to section 272 of the *Companies Act 1961*, that a meeting of the abovenamed company and its creditors will be held in the office of James Romanis & Co., 2nd Floor, 270 Queen Street, Melbourne, on Monday, 22 December 1986, at 10.30 a.m., for the purpose of laying before the meeting an account showing how the winding up has been conducted and the property of the company has been disposed of and of hearing any explanations that may be given by the liquidator.

Dated 17 November 1986

JAMES SCOTT ROMANIS, Liquidator
James Romanis & Co., chartered accountant, 2nd
Floor, 270 Queen Street, Melbourne 5143

Unclaimed Moneys Act 1962

Register of Unclaimed Moneys held by the—

Name of Owner on Books and Last Known Address	Total Amount Due to Owner	Description of Unclaimed Money	Date when first became Payable
\$			
ASSOCIATED BROADCASTING SERVICES LIMITED			
Auld, James P, 35A Smyth St, Benalla	11.76	Dividend	23.3.84
Bloom, Elsie (estate of), c/o Leon Bloom, 1/21 Anderson St, Caulfield	39.20	"	"
Bloom, Leon Unit 1, 21 Anderson St, Caulfield	39.20	"	"
Bonwick, Ian G, 22 Churchill Ave, Cheltenham	19.60	"	"
Cole, Patrick K, Millawa, RMB 117 Deniliquin, NSW	39.20	"	"
Coote, Sidney W and Nancy M, P.O. Box 139 Nunawading	39.20	"	"
Glass, Jessie, c/o G. D. Stevenson, 5 E1 Ramleh Ave, Wendouree	156.80	"	"
Hogg, Marie J, 34 Arthur St, Prospect, SA	19.60	"	"
Homering, Gus, c/o Lotus Lily Restaurant, 332 New South Head Rd, Double Bay NSW	98.00	"	"
Kershaw, Keith R, P.O. Box 515, Orbost	19.50	"	"
Knight, Carole B, 11A Omama Rd, Murrumbena	54.88	"	"
Knott, Roy M, c/o Coastal Holdings, P.O. Cape Rodney, Papua New Guinea	133.28	"	"
Layther, Norma D, 51 Pine Lodge Cres, Seaton, SA	52.22	"	"
McPherson, Neil C, New Dookie Rd, Shepparton	19.60	"	"
Millar, Maureen I, Undera, via Mooroopna	78.40	"	"
Rimes, Graeme W, 4 Princes Cres, Shepparton	19.60	"	"
Thuan, Elizabeth A, Lot 46 Spring Rd, South Belgrave	78.40	"	"
Trevaskis, Jean G, Kerferd St, Tatura	156.80	"	"
Turpie, Stephen G, c/o Marine Auto-Port, Nepean Hwy, Dromana	19.60	"	"
Waterson, Dawn L, 234 South Rd, East Brighton	19.60	"	"
Wickes, Brian H, 38 Orr St, Shepparton	19.60	"	"
5082			
PASSIONA BOTTLING CO. (PERTH) LTD			
Gollow, Ian J, 131 Hale Rd, Wembley Downs, WA	12.50	Dividend	1977
Harcourt, A O,	27.20	"	1978
Hitchins, F E,	134.96	"	1978
Lalor, Mildred R, 28 Oakdale St, Floreat Park, WA	15.00	"	1977
Owen, Theresa E, 416 Stirling Hwy, Cottesloe, WA	43.68	"	1978
Raison, Doris G, 31 Evandale St, Floreat WA	163.80	"	1979
Thompson, Richard H, 370 Norket Rd, Mandogalup, WA	25.00	"	1976
Trotter, Richard W, 2/85 Beresford Rd, Rose Bay, NSW	138.30	"	1970
Owen, Theresa E, 416 Stirling Hwy, Cottesloe, WA	624.00	Cheques	
Trotter, Richard W, 2/85 Beresford Rd, Rose Bay, NSW	390.00	"	
5083			

Companies (Victoria) Code

NOTICE CONVENING FINAL MEETING
PURSUANT TO SECTION 411

Notice is hereby given that a general meeting of the members and creditors of the companies mentioned below will be held at the office of R. D. Widdows, Suite 4, 703 South Road, Moorabbin, on Friday, 19 December 1986, for the purpose of having an account laid before them showing the manner in which the winding-up has been conducted and the

property of the company disposed of, and of hearing any explanation that may be given by the liquidator.

9.15 a.m. Maurice Hudson Industries (Aust.) Pty. Ltd.

9.30 a.m. Freeway Retreads Pty. Ltd.

9.45 a.m. Charles F. Cutler Pty. Ltd.

10.00 a.m. Progress Windows Pty. Ltd.

Dated 13 November 1986

BAIRNSDALE AND DISTRICT (No. 4) CO-OPERATIVE HOUSING SOCIETY LIMITED

Take notice that the affairs of the abovenamed Society are now fully wound up and that in pursuance to section 272 (1) of the *Companies Act 1961* and of the *Co-Operative Housing Societies Act 1958* a General Meeting of the Society will be held at the Bairnsdale Library Meeting Room, Service Street, Bairnsdale, on Tuesday, 23 December 1986, at 12.30 p.m. for the purposes of—

- (i) Laying before it an account showing how the winding up has been conducted and the property of the Society disposed of and giving an explanation thereof; and
- (ii) Passing a Resolution that the books and papers of the said Society and of the liquidator relevant to the affairs of the Society be destroyed after a period of twelve months from the date of the meeting.

Dated 10 November 1986

5130 R. K. O'NEILL, Liquidator

BAIRNSDALE AND DISTRICT (No. 5) CO-OPERATIVE HOUSING SOCIETY LIMITED

Take notice that the affairs of the abovenamed Society are now fully wound up and that in pursuance to section 272 (1) of the *Companies Act 1961* and of the *Co-Operative Housing Societies Act 1958* a General Meeting of the Society will be held at the Bairnsdale Library Meeting Room, Service Street, Bairnsdale, on Tuesday, 23 December 1986, at 12.30 p.m. for the purposes of—

- (i) Laying before it an account showing how the winding up has been conducted and the property of the Society disposed of and giving an explanation thereof; and
- (ii) Passing a Resolution that the books and papers of the said Society and of the liquidator relevant to the affairs of the Society be destroyed after a period of twelve months from the date of the meeting.

Dated 10 November 1986

5131 R. K. O'NEILL, Liquidator

MT. ELIZA CO-OPERATIVE HOUSING SOCIETY LIMITED

Take notice that the affairs of the abovenamed Society are now fully wound up and that in pursuance to section 272 (1) of the *Companies Act 1961* and of the *Co-Operative Housing Societies Act 1958* a General Meeting of the Society will be held at First Floor, 54 McCrae Street, Dandenong on Tuesday, 16 December 1986, at 12.30 p.m. for the purposes of—

- (i) Laying before it an account showing how the winding up has been conducted and the property of the Society disposed of and giving an explanation thereof; and

- (ii) Passing a Resolution that the books and papers of the said Society and of the liquidator relevant to the affairs of the Society be destroyed after a period of twelve months from the date of the meeting.

Dated 10 November 1986

5132 R. K. O'NEILL, Liquidator

BAIRNSDALE AND DISTRICT CO-OPERATIVE HOUSING SOCIETY LIMITED

Take notice that the affairs of the abovenamed Society are now fully wound up and that in pursuance to section 272 (1) of the *Companies Act 1961* and of the *Co-Operative Housing Societies Act 1958* a General Meeting of the Society will be held at the Bairnsdale Library Meeting Room, Service Street, Bairnsdale, on Tuesday, 23 December 1986, at 12.30 p.m. for the purposes of—

- (i) laying before it an account showing how the winding up has been conducted and the property of the Society disposed of and giving an explanation thereof; and
- (ii) passing a Resolution that the books and papers of the said Society and of the Liquidator relevant to the affairs of the Society be destroyed after a period of twelve months from the date of the meeting.

Dated 10 November 1986

5127 R. K. O'NEILL, Liquidator

BAIRNSDALE AND DISTRICT (No. 2) CO-OPERATIVE HOUSING SOCIETY LIMITED

Take notice that the affairs of the abovenamed Society are now fully wound up and that in pursuance to section 272 (1) of the *Companies Act 1961* and of the *Co-Operative Housing Societies Act 1958* a General Meeting of the Society will be held at the Bairnsdale Library Meeting Room, Service Street, Bairnsdale, on Tuesday, 23 December 1986, at 12.30 p.m. for the purposes of—

- (i) laying before it an account showing how the winding up has been conducted and the property of the Society disposed of and giving an explanation thereof; and
- (ii) passing a Resolution that the books and papers of the said Society and of the Liquidator relevant to the affairs of the Society be destroyed after a period of twelve months from the date of the meeting.

Dated 10 November 1986

5128 R. K. O'NEILL, Liquidator

BAIRNSDALE AND DISTRICT (No. 3) CO-OPERATIVE HOUSING SOCIETY LIMITED

Take notice that the affairs of the abovenamed Society are now fully wound up and that in pursuance to section 272 (1) of the *Companies Act*

1961 and of the *Co-operative Housing Societies Act 1958* a General Meeting of the Society will be held at the Bairnsdale Library Meeting Room, Service Street, Bairnsdale, on Tuesday, 23 December 1986, at 12.30 p.m. for the purposes of—

- (i) laying before it an account showing how the winding up has been conducted and the property of the Society disposed of and giving an explanation thereof; and
- (ii) passing a Resolution that the books and papers of the said Society and of the Liquidator relevant to the affairs of the Society be destroyed after a period of twelve months from the date of the meeting.

Dated 10 November 1986

5129 R. K. O'NEILL, Liquidator

ROBERT ALLAN McLEAN late of 15 Agnes Street, Beaumaris in the State of Victoria, retired public servant, deceased

Creditors, next of kin and others having claims in respect of the estate of the abovenamed deceased who died on 12 June 1986 are required to send particulars of their claims to the executor, John Desmond Taubman of 374 Beach Road, Beaumaris by 25 January 1987 after which date he may convey or distribute the assets having regard only to the claims of which he then has notice.

WISEWOULD SCHILLING, solicitors, 459 Little Collins Street, Melbourne 5113

FLORENCE LOGAN, late of Harold McCracken Nursing Home, 6 Church Street, Fitzroy North, widow, deceased

Creditors, next of kin and others having claims against the estate of the said deceased who died on 29 August 1986 are to send particulars of their claims to Wendy Yvonne Nance c/o Messrs. Blake & Riggall, solicitors, 140 William Street, Melbourne by 19 February 1987 after which date she will distribute the assets having regard only to the claims of which she then has notice.

BLAKE & RIGGALL, solicitors, 140 William Street, Melbourne 5114

MOLLY THIRL (sometimes spelt "THURL") **RAYMOND LELEU** formerly of Flat 2, 9A Fordholm Road, Hawthorn but late of 31 Chrystobel Crescent, Hawthorn in the State of Victoria, widow, deceased

Creditors, next of kin and others having claims in respect of the estate of the abovenamed deceased who died on 8 July 1986 are required to send particulars of their claims to the executor, Ian Andrew Ness now of 459 Little Collins Street, Melbourne by 25 January 1987 after which date he may convey or distribute the assets having regard only to the claims of which he then has notice.

WISEWOULD SCHILLING, solicitors, 459 Little Collins Street, Melbourne 5115

IAN JEFFREYS WOOD, late of 1/27 Tintern Avenue, Toorak, retired medical practitioner, deceased

Creditors, next of kin and others having claims against the estate of the said deceased who died on 1 September 1986 are to send particulars of their claims to Edith Mary Wood and The Union-Fidelity Trustee Company of Australia Limited, c/o Messrs. Blake & Riggall, solicitors, 140 William Street, Melbourne by 19 February 1987 after which date they will distribute the assets having regard only to the claims of which they then have notice.

BLAKE & RIGGALL, solicitors, 140 William Street, Melbourne 5116

GERALDINE BERRY, late of 21 Railway Parade, Murrumbeena, widow, deceased

Creditors, next of kin and others having claims in respect of the deceased who died on 14 March 1986 are required by the administrator, Ian William Cox of 405 Little Bourke Street, Melbourne, solicitor, to send particulars to him care of the below mentioned solicitors by 21 January 1987 after which date he may convey or distribute the assets having regard only to the claims of which he then has notice.

FREDERICK W. COX & SON, solicitors, 405 Little Bourke Street, Melbourne 5076

JAMES STOREY, late of 10 Blamey Street, East Bentleigh, retired, deceased

Creditors, next of kin and others having claims in respect of the deceased who died on 8 April 1986 are required by the executor, John Ian Grahame of 16 Brownfield Street, Cheltenham to send particulars to him care of the below mentioned solicitors by 21 January 1987 after which date he may convey or distribute the assets regard only to the claims of which he then has notice.

FREDERICK W. COX & SON, solicitors, 405 Little Bourke Street, Melbourne 5077

Creditors, next of kin and others having claims against the estate of Vincent Curran late of 11 Salisbury Grove, Hawthorn, retired, deceased, are required to send particulars of their claims to the executors, Kenneth Henry Paul Hamilton and Gregory Gray in care of the undermentioned solicitors on or before 22 January 1987 after which date the executors will distribute the assets having regard only to the claims of which they have notice.

GREGORY GRAY & CO., solicitors, 17 Launder Street, Hawthorn 5078

LIONEL GEORGE DEAN, late of 11 Beamish Street, Werribee, in the State of Victoria, truck driver, deceased

Creditors, next of kin and other persons having claims against the estate of the said deceased who died on 11 June 1979 are required to send particulars

of same to the executrix Mabel Lillian Dean in care of the undersigned on or before 20 January 1987 after which date she will distribute the assets having regard only to the claims of which she then has notice.

PETER W. BURKE & DELANY, 3 Wedge Street,
Werribee 5079

LESLIE FREDERICK DEAN, late of 434 Teddy Bear Lane, Cowes, in the State of Victoria, retired, deceased

Creditors, next of kin and other persons having claims against the estate of the said deceased who died on 17 May 1979 are required to send particulars of same to the administratrix Mabel Lillian Dean in care of the undersigned on or before 20 January 1987 after which date she will distribute the assets having regard only to the claims of which she then has notice.

PETER W. BURKE & DELANY, 3 Wedge Street,
Werribee 5080

Creditors, next of kin and others having claims in respect of the estate of Margaretta Scobie Moffat late of 40 Normanby Street, Brighton in the State of Victoria, widow, deceased who died on 25 July 1986 are requested to send particulars of their claims to the executors Robin Edward Clements and Robert Wilson Bett care of the undermentioned solicitors by 1 February 1987 after which date the executors will distribute the assets having regard only to the claims of which they then have notice.

RIDGEWAY CLEMENTS, solicitors, of 221
Glenhuntly Road, Elsternwick 5081

Creditors, next of kin and others having claims in respect of the estate of William Francis Brady, late of 124 Victoria Parade, Albert Park, retired public servant deceased, who died on 14 October 1986 are to send the particulars of their claims to ANZ Executors & Trustee Company Limited of 94 Queen Street, Melbourne by 20 January 1987 after which date it will distribute the assets having regard only to the claims of which it then has notice. 5109

MARIE PICOIR CARLYON, late of 82/390
Toorak Road, South Yarra, widow, deceased

Creditors, next of kin and others having claims against the estate of the said deceased who died on 16 August 1986 are to send particulars of their claims to Margaret Scott Low and Norman Murdoch Carlyon care of Messrs Blake & Riggall, solicitors, 140 William Street, Melbourne by 19 February 1987 after which date they will distribute the assets having regard only to the claims of which they then have notice.

BLAKE & RIGGALL, solicitors, 140 William
Street, Melbourne 5110

Creditors, next of kin and others having claims in respect of the estate of Adele Clarence Johnson, late of Duretta Private Nursing Home, 60 The Avenue, Windsor in the State of Victoria, spinster, deceased who died on 19 June 1986 are required to send particulars of their claims to the executor National Trustees Executors and Agency Company of Australasia Limited of 95 Queen Street, Melbourne by 22 January 1987 after which date it will distribute the assets having regard only to the claims for which notice has been received. 5111

TERRY STEPHEN JONES, late of Flat 9, 8
Cardigan Street, East St. Kilda, assistant manager,
deceased who died on 29 April 1985

Creditors, next of kin and others having claims in respect of the estate of the deceased are required by the legal personal representative of his estate Bryan David Connor of 20 Bond Street, Sydney, New South Wales, trust manager to send particulars thereof to him care of the New Zealand Insurance Company Ltd., 6th Floor, 20 Bond Street, Sydney, New South Wales before 23 January 1987 after which date he may distribute the assets of the deceased having regard only to the claims of which he then has notice.

FREDERICK OWEN & ASSOCIATES,
solicitors, 450 Little Collins Street, Melbourne
5112

BETTY HILDA GUTHRIE late of 1/19 Herbert
Street, St Kilda, home duties, deceased

Creditors, next of kin and others having claims in respect of the estate of the deceased who died on 15 September 1986 are required by the trustees National Trustees Executors and Agency Company of Australasia Limited of 95 Queen Street, Melbourne and Donald Alfred Guthrie of 1/19 Herbert Street, St Kilda, laboratory assistant to send particulars of their claims to them care of the abovementioned company by 30 January 1987 after which date the trustees may convey or distribute the assets having regard only to the claims of which they then have notice.

D. L. McNAMARA LL.B., solicitor, 19 Grey
Street, St Kilda 5105

Creditors, next of kin and others having claims against the estate of Mary Martin, late of 76 Kangaroo Road, Murrumbena, widow, deceased who died on 17 August 1986 are required to send particulars of their claims to the executors Arthur David Powell Martin of 14 Kenilworth Crescent, Glen Waverley, and Edward Frederick Martin of 115 Carpenter Street, Brighton by 27 January 1987 after which date the executors will distribute the assets having regard only to the claims of which they then have notice. 5106

Creditors, next of kin and others having claims in respect of the estate of Daisy Catherine O'Brien formerly of 22 Weir Street, Balwyn but late of 10 Wandsworth Road, Surrey Hills, widow, who died on 9 July 1986 are to send particulars of their claims to National Trustees Executors and Agency Company of Australasia Limited of 95 Queen Street, Melbourne on or before 19 January 1987 after which date it will distribute the assets having regard only to the claims of which it then has notice.

R. P. BARRETT & SON, solicitors, 472 Bourke Street, Melbourne 5107

Creditors, next of kin and others having claims in respect of the estate of Elli Alter late of 520 Dandenong Road, Caulfield, widow, who died on 20 September 1986 are to send the particulars of their claims to The Equity Trustees Executors and Agency Company Limited of 472 Bourke Street, Melbourne by 20 January 1987 after which date it will distribute the assets having regard only to the claims of which it then has notice.

RYLAH & RYLAH, solicitors, 337 La Trobe Street, Melbourne 5108

Creditors, next of kin and other persons having claims against the estate of Frank Alexander Speed late of 37 Halliday Street, Mount Waverley, retired public servant, deceased, who died on 13 June 1986 are required by the executors, Beatrice Lempriere Speed and Ronald Albern Eggleston, to send particulars of their claims to them at 37 Halliday Street, Mount Waverley 3149, by 31 January 1987 after which date they will distribute the assets having regard only to the claims of which they then have notice.

Creditors, next of kin and others having claims in respect of the estate of Thomas Murray Arnott late of 13 Coster Street, Benalla, gentleman (who died on 31 August 1986) are requested to send particulars of their claims in writing to the undermentioned solicitors for William Jackson Arnott and David Murray Arnott, the executors by 2 February 1987 after which date the executors will distribute the assets of the deceased having regard only to the claims of which they then have notice.

HAMILTON CLARKE & BALKIN, solicitors, 81-83 Nunn Street, Benalla 5092

Creditors, next of kin and others having claims in respect of the estate of Norman Le Pelley Brown late of 34 Thomas Street, East Brighton in the State of Victoria, retired gentleman, deceased, who died on 20 September 1986 are to send particulars of their claims to Christina Muriel Brown of 34 Thomas Street, East Brighton in the said State, widow, care of the undermentioned solicitors by 19 January 1987 after which date she will distribute the assets having regard only to the claims to which she has notice.

REGINALD C. BUTLER & CO., solicitors, 312 Centre Road, Bentleigh 5093

Creditors, next of kin and others having claims against the estate of Marion Elizabeth Davies late of Unit 10, 43 Armadale Street, Armadale, spinster, deceased, who died on 2 October 1986 are required by the proving executor, Norman Buick Wilson of 46 South Road, Brighton Beach, retired, to send particulars of their claims to him care of the undermentioned solicitors by 31 December 1986 after which date he will distribute the assets of the deceased having regard only to the claims of which he then shall have notice.

THOMAS BURKE & ASSOCIATES, solicitors, 152 Wattletree Road, Malvern 5094

ANNIE GRACE FIDGE, late of 9 Hastings Square, Warragul, widow, deceased

Creditors, next of kin and others having claims in respect of the estate of the deceased who died on 6 August 1986 are required by the trustee, Evelyn Doris Cole, to send particulars of their claims to her care of the undersigned solicitors by 30 January 1987 after which date the trustee may convey or distribute the assets having regard only to the claims of which she then has notice.

GRAY, FRIEND & LONG, solicitors, Warragul 5095

PATRICK O'LOUGHLAN, formerly of 88 McCallum Street, Swan Hill, but late of 1 Cockerell Court, Swan Hill, in the State of Victoria, plumber, deceased

Creditors, next of kin and other persons having claims against the estate of the said deceased who died on 14 October 1986 are required to send particulars of same to the executrix, Patricia Mary O'Loughlan, in care of the undersigned on or before 5 January 1987 after which time she will distribute the assets having regard only to the claims of which she then has notice.

DWYER, BENNETT & MAHON, barristers and solicitors, 194-208 Beveridge Street, Swan Hill 5096

MARION ETHEL ELIZABETH CROCKER late of Hume Court, Lara, married woman deceased

Creditors, next of kin and others having claims in respect of the estate of the deceased, who died on 29 July 1986 are required by Patrick John Cannon of 205 Hampshire Road, Sunshine, solicitor and Ronald Frederick Stewart Crosbie of 9 Maryvale Street, Sunshine, the executors to whom probate was granted by the Supreme Court of Victoria to send particulars care of the undersigned by 26 January 1987 after which date the said executors may convey or distribute the assets having regard only to the claims of which they then have notice.

PATRICK J. CANNON, COBURN & ASSOCIATES, solicitors, 205 Hampshire Road, Sunshine 5135

Creditors, next of kin and others having claims in respect of the estate of Eliza Grace Eaton, late of Dickens Lodge, McKean Street, North Fitzroy in the State of Victoria, widow, deceased, who died on 23 July 1986 are to send particulars of their claims to Ruth Rushton of 3 Bradford Avenue, Preston in the said State, married woman, care of the undermentioned solicitors by 19 January 1987 after which date she will distribute the assets having regard only to the claims to which she then has notice.

REGINALD C. BUTLER & CO., solicitors, 312 Centre Road, Bentleigh 5136

Creditors, next of kin and others having claims in respect of the estate of Gilbert Horace Hodson, late of 5/142 Barrow Street, East Coburg, gentleman, deceased, who died on 18 September 1986 are required to send particulars of their claims to the deceased's executors, Joseph Butera and George John Strugnell, care of the undermentioned solicitors by 27 January 1987 after which date they will distribute the assets thereof having regard only to the claims of which they then have notice.

STRUGNELL DEAKIN DUNCAN, solicitors, 106 Bell Street (P.O. Box 62), Coburg 5137

Creditors, next of kin and others having claims against the estate of Frances Catherine Howell, late of Flat 3, 7 Hopetoun Road, Toorak, gentlewoman, deceased, are required to send particulars of their claims to the executors, Agnes Helen Lambie and Anthony David Cooke, care of the undermentioned solicitors on or before 1 February 1987 after which date the executors will distribute the assets of the deceased having regard only to the claims of which they then have had notice.

KEARNEY'S, solicitors, 140 Queen Street, Melbourne 5138

GEORGE DAVID JOKOVICH known as George David Jakovich (deceased) late of 104 Sydney Street, Mackay, Queensland, died on 14 April 1986. Any persons claiming to be dependent upon the deceased are requested to send particulars of their claims to "Life Claims Department, Australian Eagle Ins. Co. Ltd., G.P.O. Box 1883R, Melbourne 3001" within two months from the date of this notice, after which date the deceased's entitlement will be distributed in accordance with the provisions of the Eagle Retirement Fund Trust Deed, having regard only to the claims which have been notified. 5139

Creditors, next of kin and others having claims in respect of the estate of Ernest James Jordon, late of 333 Gaffney Street, Pascoe Vale, investor, deceased, who died on 10 September 1986 are to send particulars of their claims to the executor of

the estate, Leslie Fredrick Best, care of the undermentioned solicitors by 20 January 1987 after which date he will distribute the assets having regard only to the claims of which he then has notice.

LLOYD P. GOODE & CO., solicitors, 390 Lonsdale Street, Melbourne 5140

ETHEL MAY BANNERMAN, late of Nazareth House, Ballarat, home duties, deceased

Creditors, next of kin and others having claims against the estate of the said deceased, who died on 17 July 1986, are to send particulars of their claims to Kenneth Albert Richards, care of Messrs Blake & Riggall, solicitors, 140 William Street, Melbourne by 19 February 1987, after which date he will distribute the assets having regard only to the claims of which he then has notice. 5144

Creditors, next of kin and others having claims against the estate of Leslie Thomas Drury, late of Flat 2, 14 Markham Avenue, Ashburton, clerk, deceased, who died on 9 July 1986 are required to send particulars of their claims to The Equity Trustees Executors and Agency Company Limited of 472 Bourke Street, Melbourne, the administrator of the said deceased on or before 14 January 1987 after which date the company will distribute the assets having regard only to the claims of which it then has notice.

TOLHURST DRUCE & EMMERSON, solicitors, 389 Lonsdale Street, Melbourne 5145

All persons having claims against the estate of Angela Mary Filliponi, late of 81 Burke Road, Malvern East in the State of Victoria, widow, deceased (who died on 2 August 1986 and probate of whose Will was on 12 November 1986 granted by the Supreme Court of Victoria in its probate jurisdiction to Patricia Johnson of 184 Tooronga Road, Glen Iris in the said State, widow, and Peter James Mapleback of 10 Queen Street Melbourne in the said State, solicitor) are hereby required to send particulars of such claims to Patricia Johnson at her address at 184 Tooronga Road, Glen Iris aforesaid and to Peter James Mapleback of 10 Queen Street, Melbourne aforesaid on or before 20 January 1987 after which date they will proceed to transfer, convey or distribute the said estate to or among the persons entitled thereto having regard only to the claims of which they shall then have had notice and will not be liable for the assets so transferred, conveyed or distributed to any persons of whose claim they shall not then have had notice.

AKEHURST FRIEND & ALLAWAY, solicitors, 10 Queen Street, Melbourne 5146

EDITH MAUDE McDONALD, late of 440 Camberwell Road, Camberwell, in the State of Victoria, widow, deceased

Creditors, next of kin and others having claims in respect of the estate of the deceased who died on 4 September 1986 are required by the legal personal representative Keith Ernest Reynolds of 4 Athelstan Road, Camberwell in the said State, Salvation Army Officer, to send particulars to him by 24 January 1987 after which date he will distribute the assets having regard only to the claims of which he has notice.

E. P. JOHNSON & DAVIES, of 257 Collins Street, Melbourne 5147

ALFRED HILDEBRAND STEVENS, late of "Stamford Park", Stud Road, Rowville, in the State of Victoria, grazier, deceased

Creditors, next of kin and others having claims in respect of the estate of the deceased (who died on 10 April 1986) are required by the Executors Keith Vannan Rintoul of 13 Bluff Avenue, Flinders in the said State, retired solicitor, and Norman Ryder Stevens of 23 Findon Street, East Malvern in the said State, chartered accountant, to send particulars of their claims to them at the office of the undermentioned solicitors on or before Friday, 30 January 1987 after which date they will convey or distribute the assets having regard only to the claims of which they then have notice.

BEST HOOPER, solicitors, 400 Little Collins Street, Melbourne 5148

ISOBEL ELVA STOCKIGT, late of 250 Domain Road, South Yarra, in the State of Victoria, musician, deceased

Creditors, next of kin and others having claims in respect of the estate of the abovenamed deceased, who died on 12 September 1986 are required to send particulars thereof to the Executor care of the undermentioned solicitors on or before 12 January 1987 after which date the Executor may convey or distribute the assets having regard only to the claims of which he then has notice.

REES, BECKWITH & CO., solicitors, 118 Queen Street, Melbourne 5149

**NOTICE OF MAKING OF
STATUTORY RULES
WHICH ARE NOT YET
AVAILABLE**

Notice is given of the making of the following Statutory Rules:

Valuation of Land Act 1960
287/1986 Valuer's Qualification Board
(Amendment) Rules 1986

Marine Act 1958

288/1986 Marine (Inspection Fees for 'Hire and Drive Yourself' Motor Boats and Rowing Boats) Regulations 1986

Marine Act 1958

289/1986 Marine (Survey, Plans and Compass) Fees Regulations 1986

Marine Act 1958

290/1986 Marine (Examination Fees for Pilot Licences) Regulations 1986

Marine Act 1958

291/1986 Marine (Fees for Certificates of Service) Regulations 1986

Marine Act 1958

292/1986 Marine (Examination Fees for Pilotage Exemption Certificates) Regulations 1986

Marine Act 1958

293/1986 Marine (Fees for Examinations Certificates of Competency) Regulations 1986

Business Franchise (Tobacco Act) 1974

Business Franchise (Petroleum Products) Act 1979

294/1986 Business Franchise (Tobacco and Petroleum Products) (Miscellaneous Amendment) Regulations 1986

**NOTICE OF MAKING
AND AVAILABILITY OF
STATUTORY RULES**

In pursuance of the provisions of the *Subordinate Legislation Act 1962* and the Regulations made thereunder notice is given of the making and availability of the following Statutory Rules:

Note: The date specified after each Statutory Rule is the date it was first obtainable from the VGPO Bookshop Information Victoria Centre 318 Lt. Bourke Street Melbourne.

Marine Act 1958

268/1986 Port Phillip Pilot Sick and Superannuation Fund (Amendment) Regulations 1986

19 November 1986

\$0.90

	<i>Metropolitan Fire Brigades Superannuation Act 1976</i>	
284/1986	Metropolitan Fire Brigades Superannuation (Board Scheme) (Further Amendment) Regulations 1986	
13 November 1986		\$0.40
	<i>Lotteries Gaming and Betting Act 1966</i>	
285/1986	Lotteries Gaming and Betting (Gaming Machines) (Further Amendment) Regulations 1986	
13 November 1986		\$0.40
	<i>Supreme Court Act 1958</i>	
286/1986	Supreme Court (Chapter I Amendment) Rules 1986	
19 November 1986		\$1.30
	<i>Public Service Act 1974</i>	
PSD42/1986	Public Service Determinations (No. 42) 1986	40c

CONTENTS

		Page
Appointments		4422
Bank Holidays		4396
Contracts		4417
Contracts Accepted—Amendments		4418
Government Notices		4397
Melbourne and Metropolitan Board of Works		4411
Notice to Matiners		4414
Notice of Making of Statutory Rules		4449
Orders in Council—		
Acts—Marine; Land; Crown Land (Reserves); State Employees Retirement Benefits; Land; Water; Motor Car; Crown Land (Reserves); Motor Car		4423 et seq
Police Sale		4400
Private Advertisements		4429
Proclamation		4396
Public—Half Holiday		4396
Public Holidays		4396
Resignations		4423
Tenders		4427

Publications Availability

Publications may be purchased from the **VGPO Bookshop**
 Information Victoria Centre
 318 Lt. Bourke Street Melbourne
 (PO Box 203 North Melbourne 3051)
 Telephone Inquiries (03) 663 3760

Mail Orders and Postage
 A postage and packaging fee must be added to the cost of the requested publication using the table of rates below. Remittances should be made payable to the 'VGPO'.

Bankcard
 Purchases may be made using Bankcard facilities in the VGPO Bookshop and by mail order.
 Bankcard mail orders require the Bankcard number, expiry date, name, address and signature of customer to be supplied. (Minimum purchase of \$5.00 applies).

<i>Total Price of Publications</i>	<i>Postage Packaging Fee</i>
\$ 0.00 to \$ 2.00.....	\$ 0.80
\$ 2.05 to \$ 5.00.....	\$ 1.10
\$ 5.05 to \$ 25.00.....	\$ 2.50
\$ 25.05 to \$ 75.00.....	\$ 3.00
\$ 75.05 to \$125.00.....	\$ 3.50
\$125.05 to \$200.00.....	\$ 4.00
\$200.05 and over.....	at cost