

- Documents NOT CLEARLY PREPARED will be returned to the sender, unpublished.

Late Copy

Copy received after 3.30 pm one day prior to publication at the VGPO will be placed in the following issue of the *Victoria Government Gazette*, irrespective of any date/s mentioned in the copy.

CORRESPONDENCE

All correspondence should be addressed to:

Gazette Advertising
 VGPO
 PO Box 203
 North Melbourne 3051
 Telephone Inquiries (03) 320 0100
 Fax No. (03) 329 2696

AVAILABILITY

All gazettes may be purchased over the counter from VGPO Bookshop Information Victoria Centre 318 Lt Bourke Street, Melbourne. Telephone (03) 663 3760.

Cost for individual copies is \$1.10.

Mail orders may be sent to VGPO PO Box 203 North Melbourne 3051. A postage and packaging fee must be added to the cost of the gazettes required using the table of rates below:

Total Price of Publications	Postage Packaging Fee
\$0.00 to \$2.00.....	\$0.80
\$2.05 to \$5.00.....	\$1.10
\$5.05 to \$25.00.....	\$2.50
\$25.05 to \$75.00.....	\$3.00
\$75.05 to \$125.00.....	\$3.50
\$125.00 to \$200.00.....	\$4.00
\$200.05 and over.....	at cost

Bankcard purchases may be made using Bankcard facilities in the VGPO Bookshop and by mail orders.

Bankcard mail orders require the Bankcard number, expiry date, name, address and signature of customer to be supplied.

(Minimum purchase of \$5.00 applies).

SUBSCRIPTIONS

Subscribers to the *Victoria Government Gazette* have three subscription services to choose from:

- General Special and Periodical;
- General and Special;
- Periodical.

Subscriptions are payable in advance and accepted for a period of one year. All subscriptions are on a firm basis and refunds for cancellations will not be given.

Subscription rates for 1987 are as follows:

General Special and Periodical	\$115
General and Special	\$100
Periodical	\$60

Prices include postage.

All remittances should be made payable to VGPO.

OTHER ISSUES OF THE GAZETTE

Special issues of the Gazette are published on specific days when required.

They are provided at no extra charge with weekly general issues.

Special issues are not available on separate subscription.

Periodical issues of the Gazette are published on each Monday when required. Listings such as Dentist's Register, Pharmacy Register are examples.

Subscription may be made separately at a cost of \$60.00 per annum including postage.

PROCLAMATIONS

ACT OF PARLIAMENT

PROCLAMATION

By His Excellency the Governor of the State of Victoria and its Dependencies in the Commonwealth of Australia, &c., &c., &c.

I, the Governor of the State of Victoria, in the Commonwealth of Australia, do hereby declare that I have this day assented, in Her Majesty's name, to the Bill passed by the Parliament of the said State the title whereof is hereunder set forth, together with the short title, that is to say:

No. 1/1987 *Grocery Prices Act 1987*

Given under my Hand and the Seal of the State of Victoria aforesaid, at Melbourne, this twenty-fourth day of March, in the year of our Lord One thousand nine hundred and eighty-seven and in the thirty-sixth year of the reign of Her Majesty Queen Elizabeth II.

(L.S.) J. DAVIS McCAUGHEY

By His Excellency's Command

JOHN CAIN
Premier

GOD SAVE THE QUEEN!

No. 1/1987. This Act comes into operation on a day or days to be proclaimed.

Grocery Prices Act 1987

PROCLAMATION OF COMMENCEMENT

I, the Governor of Victoria, acting with the advice of the Executive Council and under section 2 of the *Groceries Prices Act 1987*, fix 25 March 1987 as the day on which that Act comes into operation.

Given under my Hand and Seal of Victoria on 24 March 1987.

(L.S.) J. DAVIS McCAUGHEY

By His Excellency's Command

JOHN CAIN
Premier

Land Act 1958

PROCLAMATION OF ROADS

I, J. Davis McCaughey, Governor of Victoria acting with the advice of the Executive Council and under section 25 (3) (c) of the *Land Act 1958* proclaim as road the following lands:

Municipal District of the City of Melbourne
Doutta Galla—Crown Allotment 28M, section 2, Parish of Doutta Galla as shown on Certified Plan No. 108221 lodged in the Central Plan Office—(L11-1905).

Municipal District of the Shire of Portland
Malanganee—The land in the Parish of Malanganee shown by hatching on plan hereunder—(M507 (4)) (L2-3587).

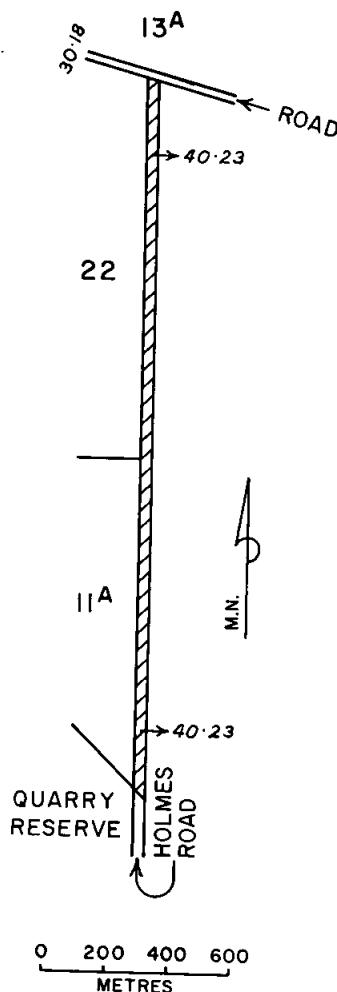

Municipal District of the City of Mildura
 Mildura—The land in the Parish of Mildura
 shown by hatching on plan hereunder—(M556(14))
 (L5-665).

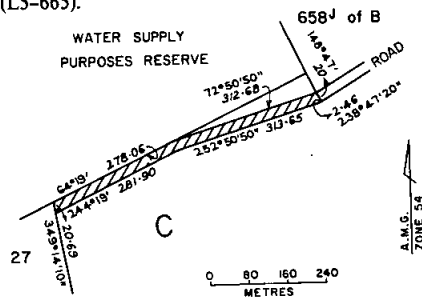

Municipal District of the Shire of Walpeup
 Wymlet—The land in the Parish of Wymlet
 shown by hatching on plan hereunder—(W425(1))
 (3629/155).

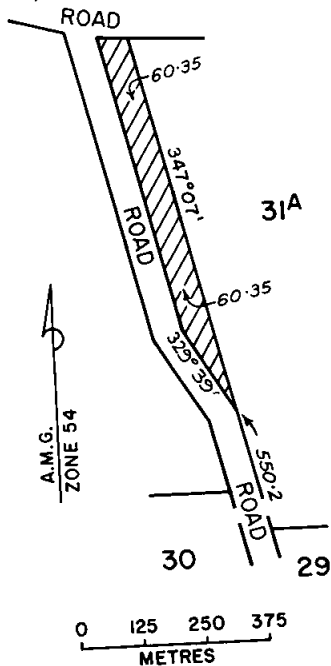

Given under my hand and the seal of Victoria
 on 17 March 1987.

(L.S.) J. DAVIS McCAUGHEY
 By His Excellency's Command

JOAN E. KIRNER
 Minister for Conservation, Forests and Lands

GOVERNMENT NOTICES

Department of Conservation, Forests and Lands
SALE OF CROWN LAND BY AUCTION

No. 12507

On Site Corryong Road, Koetong, 1 May 1987 at
 2.30 p.m.

Crown Description: Crown Allotments 51J and
 51L, County of Benambra, Parish of Keotong.

Terms: Deposit 10%, residue payable in 60 days.

Officer Conducting Sale: A. Burford, Property &
 Consultant, Property Sales Group.

Auctioneers: Drummond Real Estate Pty. Ltd.,
 Licenced Estate Agents, Wodonga (S.9050—
 Property).

J. E. KIRNER

Minister for Conservation, Forests and Lands

Department of Conservation, Forests and Lands
**SALE OF CROWN LAND BY PUBLIC
 AUCTION**

No. 12512

City of Port Melbourne on Wednesday, 15 April
 1987 at 11.00 a.m. at Phillip Room, Windsor
 Hotel, Melbourne

Property Address: 525 Graham Street, Port
 Melbourne.

Crown Description: Allotment 12, section 67D.

Crown Lease Particulars: Volume 1208, Folio
 232.

Terms: Deposit 10% of purchase price. Balance
 payable on 10 June 1987.

Selling Agent: Richard Stanton (Vic.) Pty. Ltd.,
 351 Collins Street, Melbourne 3000.

J. E. KIRNER

Minister for Conservation, Forests and Lands

Department of Conservation, Forests and Lands
**SALE OF CROWN LAND BY PUBLIC
 AUCTION**

No. 12512

City of South Melbourne on Wednesday, 15 April
 1987 at 11.00 a.m. at Phillip Room, Windsor
 Hotel, Melbourne

Property Address: 56-58 Boundary Street, South
 Melbourne.

Crown Description: Allotment 8, section 104.

Crown Lease Particulars: Volume 1212, Folio
 219.

Terms: Deposit 10% of purchase price. Balance
 payable on 10 June 1987.

Selling Agent: Richard Stanton (Vic.) Pty. Ltd.,
 351 Collins Street, Melbourne 3000.

J. E. KIRNER

Minister for Conservation, Forests and Lands

Department of Conservation, Forests and Lands
**SALE OF CROWN LAND BY PUBLIC
 AUCTION**

No. 12512

City of Port Melbourne on Wednesday, 15 April
 1987 at 11.00 a.m. at Phillip Room, Windsor
 Hotel, Melbourne

Property Address: 195 Williamstown Road, Port
 Melbourne.

Crown Description: Allotments 10 and 10b,
 section 67E.

Crown Lease Particulars: Volume 1206, Folio
 440.

Terms: Deposit 10% of purchase price. Balance
 payable on 10 June 1987.

Selling Agent: Richard Stanton (Vic.) Pty. Ltd.,
 351 Collins Street, Melbourne 3000.

J. E. KIRNER
 Minister for Conservation, Forests and Lands

Department of Conservation, Forests and Lands
**SALE OF CROWN LAND BY PUBLIC
 AUCTION**

No. 12512

City of South Melbourne on Wednesday, 15 April
 1987 at 11.00 a.m. at Phillip Room, Windsor
 Hotel, Melbourne

Property Address: 93 Montague Street, South
 Melbourne.

Crown Description: Allotment 10b, section 57A.

Terms: Deposit 10% of purchase price. Balance
 payable on 10 June 1987.

Selling Agent: Richard Stanton (Vic.) Pty. Ltd.,
 351 Collins Street, Melbourne 3000.

J. E. KIRNER
 Minister for Conservation, Forests and Lands

Department of Conservation, Forests and Lands
**SALE OF CROWN LAND BY PUBLIC
 AUCTION**

No. 12512

City of Port Melbourne on Wednesday, 15 April
 1987 at 11.00 a.m. at Phillip Room, Windsor
 Hotel, Melbourne

Property Address: 128 Salmon Street, Port
 Melbourne.

Crown Description: Allotment 6C, section 59.

Crown Lease Particulars: Volume 1207, Folio
 532.

Terms: Deposit 10% of purchase price. Balance
 payable on 10 June 1987.

Selling Agent: Richard Stanton (Vic.) Pty. Ltd.,
 351 Collins Street, Melbourne 3000.

J. E. KIRNER
 Minister for Conservation, Forests and Lands

Department of Conservation, Forests and Lands
SALE OF CROWN LAND BY AUCTION

No. 12501

On Site: Richardson Avenue, Red Cliffs on 9
 April 1987 at 2.00 p.m.

Terms: Deposit 10%. Residue payable in 60 days.

Crown Description: Crown Allotments 222B, C,
 D, E, F, G, H, J and K, section B, Parish of Mildura.

Officer Conducting Sale: A. Burford, Property
 Consultant, Property Sales Group.

Auctioneer: Collie & Tierney Pty. Ltd., Licensed
 Estate Agents, Mildura. (S248-Property.)

J. E. KIRNER
 Minister for Conservation, Forests and Lands

Department of Conservation, Forests and Lands
SALE OF CROWN LAND BY AUCTION

No. 12505

On Site: Kline Street, Ballarat East on Wednesday,
 22 April 1987 at 3.00 p.m.

Crown Description: Crown Allotment 15, section
 50, Township of Ballarat East, Parish of Ballarat.

Area: 3085 square metres.

Terms: Deposit 10%. Residue due 22 June 1987.

Officer Conducting Sale: Geoff Hines,
 Department of Property and Services.

Auctioneer: Edgar Bartrop, Real Estate Pty. Ltd.,
 Licensed Estate Agents, Ballarat.

J. E. KIRNER
 Minister for Conservation, Forests and Lands

Department of Conservation, Forests and Lands
SALE OF CROWN LAND BY AUCTION

No. 12506

On Site: Webb Drive, Wonthaggi on Friday, 24
 April 1987 at 12.00 noon.

Crown Description: Crown Allotment 14A, section
 107, Township of Wonthaggi, Parish of Wonthaggi.

Area: 1-755 hectares.

Terms: Deposit 10%. Residue due 24 June 1987.

Officer Conducting Sale: Geoff Hines,
 Department of Property and Services.

Auctioneer: P.B.E. Real Estate Pty. Ltd., Licensed
 Estate Agents, Wonthaggi.

J. E. KIRNER
 Minister for Conservation, Forests and Lands

Department of Conservation, Forests and Lands
**SALE OF CROWN LAND BY PUBLIC
 AUCTION**

No. S25

On site: City of Melbourne on Thursday, 16 April
 1987 at 3.00 p.m. by Public Auction

Property Address: 632 Footscray Road, West
 Melbourne

Crown Description: Crown Allotment 15, section 1A, Parish of Dousta Galla

Crown Lease Particulars: Volume 1211 Folio 570

Terms: Deposit 10% of purchase price. Balance payable 15 June 1987.

Selling Agent: Hendersons The Property People (Vic.) Pty. Ltd., 303 Collins Street, Melbourne 3000. Telephone: 614 4055

J. E. KIRNER
Minister for Conservation, Forests and Lands

Department of Conservation, Forests and Lands
SALE OF CROWN LAND BY AUCTION
No. 12504

On site: Delgany Avenue, Portsea on Saturday, 2 May 1987 at 2.00 p.m.

Terms: 10% Deposit. Residue payable in 30 days.

Crown Description: Crown Allotments 29B and 29C, Parish of Nepean, County of Mornington.

Area: 1184M² + 1185M² respectively.

Officer Conducting sale: A. Burford, Property Consultant, Asset Sales Group.

Auctioneer: Edgar E. Johnston & Associates, Licensed Estate Agents, Sorrento—(S433-Property).

J. E. KIRNER
Minister for Conservation, Forests and Lands

Department of Conservation, Forests and Lands
SALE OF CROWN LAND BY AUCTION
No. 12509

On site: 16 Old Eltham Road, Lower Plenty on Saturday, 11 April 1987 at 2.30 p.m.

Terms: Deposit 10% Residue payable in 60 days.

Crown Description: Crown Allotment 2A, Portion 2, Parish of Nillumbik.

Department of Property and Services Consultant: M. Tutchener.

Auctioneers: Nicholas Lauder Pty. Ltd., Estate Agents, 951 Main Road, Eltham.

J. E. KIRNER
Minister for Conservation, Forests and Lands

Department of Conservation, Forests and Lands
SALE OF CROWN PROPERTY BY AUCTION
No. 12598

On site: 156 Beaconsfield Parade, Middle Park on Wednesday, 29 April 1987 at 2.00 p.m.

Crown Description: Crown Allotment 23A, section 43R, Parish of Melbourne South, County of Bourke.

Area: 3451 square metres.

Terms: 10% deposit, residue payable in 60 days.

Officer Conducting Sale: A. Burford, Property Consultant, Asset Sales Group.

Auctioneer: Hocking Stuart, Licensed Estate Agents, Albert Park.

J. E. KIRNER
Minister for Conservation, Forests and Lands

Department of Conservation, Forests and Lands
SALE OF CROWN PROPERTY BY AUCTION
No. 12503

On Site: 26 Cambridge Street, Wendouree on Wednesday, 15 April 1987 at 1.00 p.m.

Terms: 10% deposit. Residue payable in 60 days.

Crown Description: Crown Allotment 7A, Parish of Ballarat, County of Grenville.

Area: 703 m².

Officer Conducting Sale: A. Burford, Property Consultant, Property Sales Group.

Auctioneer: Neville J. Richards Pty. Ltd., Licensed Estate Agents, Ballarat (S1142—Property).

J. E. KIRNER
Minister for Conservation, Forests and Lands

Department of Conservation, Forests and Lands
SALE OF CROWN LAND BY AUCTION
No. 12502

On Site: Victoria Lane, Daylesford on Saturday, 9 May 1987 at 11.30 a.m.

Crown Description: Crown Allotment 10, section 21A, Township of Daylesford West.

Area: 5798 m².

Terms: Deposit 10%. Balance payable in 30 days.

Auctioneer: John Kontek & Son (Aust.) Pty. Ltd., 50 Vincent Street, Daylesford, Victoria 3460 (Ref: L1-1729).

J. E. KIRNER
Minister for Conservation, Forests and Lands

MITTA MITTA RIVER IMPROVEMENT
TRUST

By-Law Number 33

The Mitta Mitta River Improvement Trust in pursuance and exercise of the powers conferred by the *River Improvement Act 1958*, doth hereby make the By-Law following:

1. The following rate, to be called the "Mitta Mitta River Improvement District River Improvement Rate" is hereby made and shall be levied upon the occupiers or owners of all properties within the Mitta Mitta River Improvement Trust District which are rateable to any municipality.

A rate of nineteen hundredths of a cent in the dollar on the site value of all those properties in the First Division, as determined by the Order in Council made on 1 February 1961, and published in the *Government Gazette* on 18 February 1961.

A rate of ninety five thousandths of a cent in the dollar on the site value of all those properties within

the Second Division, as determined by the said Order in Council.

No rate on all those properties within the Third Division, as determined by the said Order in Council.

2. The minimum rate in the First and Second Divisions shall be four dollars.

3. Such rates are made and shall be levied for the period beginning with 1 January 1987 and ending with 31 December 1987, and shall be payable on 1 July 1987 at the office of the Mitta Mitta River Improvement Trust, Tallangatta.

4. Such person or persons as the Mitta Mitta River Improvement Trust may from time to time appoint for that purpose shall be and is or are authorised to demand, receive, collect and recover the said rate.

5. Interest will be charged on all rates remaining unpaid after 31 October 1987.

The foregoing By-Law was made by the Mitta Mitta River Improvement Trust on 12 February 1987, and the common seal of the Trust was hereunto affixed, on 12 February 1987, in the presence of—

R. FRASER PATON, Chairman
DONALD J. E. PETERS, Commissioner
H. R. CRAIG, Secretary

Approved, 6 March 1987—A. McCUTCHEON,
Minister for Water Resources

ASSOCIATIONS INCORPORATION ACT 1981

Notice is hereby given that in pursuance of subsection 10 (4) of the *Associations Incorporation Act 1981* a Certificate of Incorporation was granted to the Melbourne Tenpin Bowling Association Limited on 23 February 1987.

GORDON LEWIS
Registrar of Incorporated Associations

ELECTRICAL APPROVALS BOARD

Pursuant to Regulation 17 of the Approval of Electrical Equipment Regulations 1984, the State Electricity Commission of Victoria hereby gives notice that it has withdrawn approval of the undermentioned article:

Applicant: A. Genovese & Sons

Article and Reference Number: Electric Kettle (Coffee Maker) Trade Name "Genovese" or "Eterna" Cat. No. EDY or Lady Moka Ref. No. V78393.

Date of Certificate of Approval: 24.7.79.

Date of Withdrawal of Approval: 17.2.87.

Approvals Marking: V/78393/EDY or V/78393/Lady Moka.

State Electricity Commission of Victoria
Dated: 16 March 1987

L. R. FOSTER
Secretary

Regulations

RESERVE FOR CONSERVATION OF AN AREA OF NATURAL INTEREST

I, Joan Elizabeth Kirner, Her Majesty's Minister for Conservation, Forests and Lands in and for the State of Victoria under the powers conferred on me by section 13 of the *Crown Land (Reserves) Act 1978* do make the following regulations for or with respect to Crown allotment 58, section B, Parish of Bumbang temporarily reserved by order in council of 25 November 1986 for conservation of an area of natural interest (hereinafter referred to as "the reserve").

The reserve has been placed under the control of a Committee of Management (herein after referred to as the "Committee") with full power to enforce these regulations.

Regulations

1. The reserve shall be open to the public at all times free of charge.

2. In the reserve no person shall—

(a) enter or remain who may offend against decency as regards dress, language or conduct or who may behave in a disorderly, unseemly or offensive manner, or create or take part in any disturbance;

(b) carry, use or discharge any firearm, air rifle or any other weapon;

(c) carry or use any trap, snare, net or other device for the capture of animals;

(d) disturb, interfere with or destroy any bird or other animal or its lair or nest;

(e) interfere with, mark, deface, or damage any buildings, gates, fences, barriers, seats, signs or other improvements;

(f) leave or deposit any glass bottle, tin can, waste paper, refuse or any other rubbish except in receptacles provided for the purpose;

(g) erect buildings, nor sell or offer to sell or hire any article or commodity;

(h) bring any dog, unless controlled by a chain, cord or leash.

3. In the Reserve no person shall, unless authorised by consent in writing of the Committees:

(a) interfere with, mark, deface or damage, pick or injure any tree, shrub, flower, plant or any other vegetation;

(b) light or cause to be lit any fire except in any properly constructed fireplace provided for that purposes;

(c) camp;

(d) drive any vehicle other than on a formed road or car park open to the public;

(e) put or allow to remain any sheep, horses, cattle, pigs or other animals;

- (f) organise or take part in any public entertainment game or sport;
 (g) disturb or remove any soil, sand, humus, gravel or rock.

Given under my hand at Melbourne on 12 March 1987

JOAN E. KIRNER

Minister for Conservation, Forests and Lands

Every person who contravenes or fails to comply with these Regulations shall be liable to the penalties prescribed in section 13 of the *Crown Land (Reserves) Act 1978*.

RETIREMENT VILLAGES (FEES FOR EXEMPTIONS) REGULATIONS 1987

I, Jim Kennan, Her Majesty's Attorney-General for the State of Victoria give notice that after consideration of the submissions and comments received in response to the Regulatory Impact Statement issued in relation to the proposed Retirement Village (Fees for Exemption) Regulations 1987 that I intend to proceed with the making of the proposed regulations.

J. KENNAN
 Attorney-General

Police Regulation Act, Section 122

SALE OF UNCLAIMED MOTOR VEHICLE

An owner is required for a 1971 Datsun Homer van, Engine No. R133684.

The vehicle came into possession of Police on 2 November 1985, and if not claimed, will be sold by public auction at the Caulfield Police Compound, 289 Hawthorn Road, Caulfield, on 7 March 1987, at 10 a.m.

S. I. MILLER
 Chief Commissioner of Police

Co-operation Act 1981

FIERY CREEK CO-OPERATIVE LIMITED LAVERTON BOWLING CLUB CO-OPERATIVE LIMITED MIRBOO NORTH PRIMARY SCHOOL CO-OPERATIVE LIMITED

Notice is hereby given in pursuance of section 192 (8) of the *Co-operation Act 1981* and section 459 (2) of the Companies (Victoria) Code that, at the expiration of three months from the date hereof, the names of the aforementioned societies will, unless cause is shown to the contrary, be struck off the register and the societies will be dissolved.

Dated at Melbourne 12 March 1987

D. F. HENRY
 Acting Deputy Registrar of Co-operative Societies

CONTRACTS ACCEPTED—(Series 1986/87)

Public Works

Bendigo City—Renovations, Golden Square High School, \$89 375.00—Ferguson & Phillips, Bendigo.

Corio Shire—Flood damaged carpet, Rosewall Primary School—\$72 706.50—Myer Teale, Thornbury.

Geelong City—Internal and External Repairs and Painting, Geelong Primary School 4398—\$383 982.00—P. H. & C. K. Kleiss, Geelong.

Melbourne City—Building Works, Melbourne, 2 Treasury Place (Property and Services)—\$64 835.00—Harris Maintenance Consultants Pty. Ltd., 148 Little Lonsdale Street.

Werribee Shire—A/c Security/Vital Records Room, Laverton Public Records Office Repository—\$51 152.00—A. & V. Hart Pty. Ltd., Greensborough.

Whittlesea Shire—Internal and External Repairs and Painting, Lalor North Primary School—\$156 000.00—T. & B. Radosavljevic, Gladstone Park.

Various—Maintenance of Gas Appliances, Annual Services, Western Metropolitan—\$77 818.40—Gas & Fuel Corp. (Commercial Sales), 171 Flinders Street.

Various—Supply and delivery of Office seating, period ending 30 June 1987, various locations—@ Rates—Stem Tubular Industries, Boronia.

Dated: 19 March 1987

Public Works Department
 Melbourne 3002

J. R. DEVENISH
 Acting Director-General

Labour and Industry Act 1958

CERTIFICATE OF EXEMPTION UNDER SECTION 104 (5)

In pursuance of the powers conferred on me by section 104 (5) of the *Labour and Industry Act 1958*, I, Steven Marshall Crabb, Minister for Labour, hereby issue to—

Alex Reich, Trading as Dandenong Ranges Bakery of 20A Alchester Crescent, Boronia

this certificate exempting him and any person carting or delivering bread on his behalf from the operation of section 104 (4) of the said Act, subject to the condition that this certificate shall apply only to the carting and delivery of

Wuppertaler—Bread, Rolls and Fruit Loaf

Hypo Glycemia—Bread, Rolls and Herbed Vegetable Breads

from Boronia throughout Victoria until 31 December 1987.

Dated 4 March 1987

S. M. CRABB
 Minister for Labour

Private Agents Act 1966

NOTICE OF RECEIPT OF APPLICATIONS FOR LICENCES UNDER THE PROVISIONS OF THE PRIVATE AGENTS ACT 1966

The Clerk(s) of the Magistrates' Court(s) as listed hereunder hereby give notice that applications, as under, have been lodged for hearing by the said Court(s) on the date(s) specified.

Any person desiring to object to any of such applications must—

- (a) lodge with the respective Clerk of the Magistrates' Court a notice in the prescribed form of his objection and of the grounds thereof;
- (b) cause a copy of such notice to be served personally or by post upon the applicant at least three days before the hearing of the application; and
- (c) send or deliver—
 - (i) where the objection is not made by the officer in charge of the police district in which the Court is situated—a copy of the notice to such officer; and
 - (ii) where the objection is not made by the Registrar or Deputy Registrar—a copy to the Registrar.

Full Name of Applicant*	Place of Abode of Applicant or Nominee	Name of Firm or Corporation	Address for Registration	Type of Licence	Date of Hearing
MAGISTRATES' COURT, WERRIBEE					
Ryan, Patrick Gerald	35 Fitzroy St, Laverton		35 Fitzroy St, Laverton	Guard Agent	16.4.87
Dated at Werribee, 13 March 1987 IAN J. SIMMONS, Clerk of the Magistrates' Court					
MAGISTRATES' COURT, OAKLEIGH					
Taruingaro, Arthur	37 Burlington St, Oakleigh		37 Burlington St, Oakleigh	Guard Agent	2.4.87
Poa					
Quattrochi, Peter	13 Liverpool Dr, Keysborough		13 Liverpool Dr, Keysborough	Inquiry Agent	"
Dated at Oakleigh, 11 March 1987 S. JANSON, Clerk of the Magistrates' Court					
MAGISTRATES' COURT, DROMANA					
Frijo-Orlando, Mark	12 Killara St, Rosebud		Royal Security Services P/L, 5 Boundary R, Dromana	Watchman	13.4.87
Julian					
Dated at Dromana, 12 March 1987 M LEA, Clerk of the Magistrates' Court					
MAGISTRATES' COURT, BROADMEADOWS					
Kelly, James Francis	83 Banfield Rd, Heidelberg Heights	Mayne Nickless Ltd.	390 St Kilda Rd, Melbourne	Watchman	29.5.87
Dated at Broadmeadows, 10 March 1987 J. ISAACS, Clerk of the Magistrates' Court					
MAGISTRATES' COURT, HEIDELBERG					
Hill, Donald Max	15 Tarakan St, West Heidelberg	Alex Ibbotson Security Services	15 Tarakan St, West Heidelberg	Watchman	15.4.87
Dated at Heidelberg, 11 March 1987 D. GEAR, Clerk of the Magistrates' Court					

*Or in the case of a firm or corporation, of the Nominee

PRIVATE AGENTS—continued

Full Name of Applicant*	Place of Abode of Applicant or Nominee	Name of Firm or Corporation	Address for Registration	Type of Licence	Date of Hearing
MAGISTRATES' COURT, BOX HILL					
Hall, Andrew Mark	39 Banool Quadrant, East Doncaster		19 Jeffery St., Blackburn	Watchman	27.4.87
Dated at Box Hill 18 March 1987 D. COVENTRY, Clerk of the Magistrates' Court					
MAGISTRATES' COURT, TRARALGON					
Humphrys, Brent Alexander	34 Bayley Dr, Traralgon		34 Bayley Dr, Traralgon	Watchman	24.4.87
Molloy, Gary Vincent	11 Cedar Crt., Traralgon		11 Cedar Crt., Traralgon	Process Server	"
" " Leonard William	51 High St., Traralgon		10 Kay St., Traralgon	Watchman	"
Dated at Traralgon 17 March 1987 H. WOODROFFE, Clerk of the Magistrates' Court					
MAGISTRATES' COURT, SUNSHINE					
Maher, Alan Raymond	28 Thrusby Cres., Deer Park		28 Thrusby Cres., Deer Park	Process Server	1.5.87
Walker, Peter Richard	10 Slough St., Deer Park		10 Slough St., Deer Park	"	23.1.87
" "	" "		" "	Inquiry Agent	"
Dated at Sunshine 17 March 1987 R. NIEMER, Clerk of the Magistrates' Court					
MAGISTRATES' COURT, BROADMEADOWS					
Papageorgiou, Chris	30 Middle St, Glenroy		30 Middle St, Glenroy	Guard Agent	23.4.87
Dated at Broadmeadows, 16 March 1987 J. ISAACS, Clerk of the Magistrates' Court					
MAGISTRATES' COURT, FRANKSTON					
Osborne, Neville James	131 Casuarina Dve, Frankston		131 Casuarina Dve, Frankston	Process Server	15.4.87
Dated at Frankston, 16 March 1987 S. MERBACH, Clerk of the Magistrates' Court					
MAGISTRATES' COURT, PRESTON					
Cravaritis, Vasilios	15 Robeson St, West Preston		15 Robeson St, West Preston	Inquiry Agent	8.4.87
Dated at Preston, 6 March 1987 R. McHUGH, Clerk of the Magistrates' Court					
MAGISTRATES' COURT, SPRINGVALE					
Hogan, Gary	3/41 Ardagower Rd, Noble Park		29 Wonganella Dve, East Keilor	Watchman	2.4.87
Dated at Springvale, 12 March 1987 M. J. BOURKE, Clerk of the Magistrates' Court					

*Or in the case of a firm or corporation, of the Nominee

PRIVATE AGENTS—continued

Full Name of Applicant*	Place of Abode of Applicant or Nominee	Name of Firm or Corporation	Address for Registration	Type of Licence	Date of Hearing
MAGISTRATES' COURT, PRAHRAN					
O'Neil, Brian Edward	1 Barnes Gr, Chelsea	Mayne Nickless	390 St Kilda Rd, Melbourne	Watchman	27.3.87
O'Sullivan, Paul Anthony	17 Cheviot Ave, Coldstream	ALEF Security	271A Carlisle St, Balaclava	"	"
Rae, Kelley Francis	21 Mac Cres, Parkdale	Mayne Nickless	390 St Kilda Rd, Melbourne	"	"
Watson, Roy	2 Queen St, West Coburg	"	"	"	"
Wetter, Bernt	8/223 Canterbury Rd, St Kilda	"	"	"	"
Wilkinson, Stephen	29 Bliburg St, Jacana	"	"	"	"
Castleton, Deanne Beryl	6 Penola Pl, Mulgrave	"	"	"	"
Croavolo, Adam Frederick	41 Monash St, Ascot Vale	"	"	"	"
Inglis, Keith Grant	7/1260 Glenhuntly Rd, Glenhuntly	"	"	"	"
Jarvis, Darrin Paul	10 Alexander St, Avondale Heights	"	"	"	"
Lamont, Rodney	Majestic Hotel, Fitzroy St, St Kilda	"	"	"	"
Lee, Geoffrey James	9 Lantana Crt, Dandenong	ALEF Security	271A Carlisle St, Balaclava	"	"
Ogiannakis, Emmanuel Mark	38 Orloff Cl, South Clayton	"	"	"	"
Marsden, Gary	2/53 Graham St, Sunshine	Mayne Nickless	390 St Kilda Rd, Melbourne	"	"
Mathiesen, Carol	5 Ferntree Crt, Ferntree Gully	ALEF Security	271A Carlisle St, Balaclava	"	"
Abraham, Clayton John	1 Bruce Cres, Ferntree Gully	Chadstone Shopping Centre	1341 Dandenong Rd, Chadstone	Guard Agent	"
Angelone, Paula	22/48 Cromwell Rd, South Yarra	"	22/48 Cromwell Rd, South Yarra	Inquiry Agent	"
Huitfeust, Andrew McKenzie	2/198 Cotham Rd, Kew	"	2/198 Cotham Rd, Kew	Guard Agent	"
Love, David Timothy	18 Holmbury Blvd, Mulgrave	Accident Assesors M.S.S.	128 Bridge Rd, Richmond	Inquiry Agent	"
Schoevers, Evert Cornelious	27 Olive St, Caulfield South	"	6 Bowen Cres, South Melbourne	Inquiry Agent	"
Van Bevge, Hans Anton	3 Derby Pl, Kew	Asguard Security	3 Derby Pl, Kew	Process Server	"
"	"	"	"	Inquiry Agent	"
"	"	"	"	Guard Agent	"
Brady, Michael Patrick	17 Eildon Rd, Ashwood	ALEF Security	271A Carlisle St, Balaclava	Watchman	"

Dated at Prahran, 12 March 1987
Clerk of the Magistrates' Court

*Or in the case of a firm or corporation, of the Nominee

PRIVATE AGENTS—continued

Full Name of Applicant*	Place of Abode of Applicant or Nominee	Name of Firm or Corporation	Address for Registration	Type of Licence	Date of Hearing
Hedges, Barbara Dawne	MAGISTRATES' COURT, SOUTH MELBOURNE 23 Fonteyn Dve, Wantirna South		Suite 4, 320 St Kilda Rd, Melbourne	Commercial Sub-Agent	24.4.87
Dated at South Melbourne, 18 March 1987 DENNIS SCULLY, Clerk of the Magistrates' Court					
Miller, Eric Campbell	MAGISTRATES' COURT, SEYMOUR Lot 7, Highlands Rd, Seymour		18 Rupert St, Broadford	Watchman	27.4.87
Dated at Seymour, 19 March 1987 T. J. SMALLEY, Clerk of the Magistrates' Court					
Rapson, Robert	MAGISTRATES' COURT, PRESTON 3 Cooma St, Preston		3 Cooma St, Preston	Guard Agent	14.4.87
Dated at Preston, 12 March 1987 R. McHUGH, Clerk of the Magistrates' Court					
Hitchens, Glenn Patrick	MAGISTRATES' COURT, BROADMEADOWS 73 Tadsten Dve, Tullamarine			Inquiry Agent	1.5.87
Dated at Broadmeadows, 13 March 1987 J. ISAACS, Clerk of the Magistrates' Court					
Terrill, Bruce Andrew	MAGISTRATES' COURT, BALLARAT 7 Locksley St, Ballarat		7 Locksley St, Ballarat	Process Server	6.4.87
Dated at Ballarat, 16 March 1987 D. L. CROFT, Clerk of the Magistrates' Court					
Warnest, Peter John	MAGISTRATES' COURT, MILDURA Flat 3, 1 Cameron Ave, Mildura		3/1 Cameron Ave, Mildura	Guard Agent	7.4.87
Dated at Mildura, 16 March 1987 K. E. CROTTY, Clerk of the Magistrates' Court					

*Or in the case of a firm or corporation, of the Nominee

Transport Act 1983

DECLARATIONS AND DEDICATIONS OF ROADS

The Road Construction Authority, in pursuance of the powers conferred by the *Transport Act 1983*, declares the roads or parts of roads or any deviations from or widenings of roads to be as described below; and further declares that any such new roads, deviations or widenings made by the Authority are fit to be used as public highways—

Freeway

16/87 The new road (Hume Freeway) in the Shire of Benalla and Shire of Violet Town as shown hatched and cross hatched on plans numbered GP 15662C, GP 15666E, GP 15668E, GP 15671D, GP 15675B, GP 16133A, GP 16135 and GP 16142.

State Highways

17/87 The deviation from the Midland Highway in the Shire of Benalla as shown hatched and cross hatched on plan numbered GP 15668F.

18/87 The deviation from the Hume Highway in the Shire of Benalla as shown hatched and cross hatched on plan numbered GP 16133B.

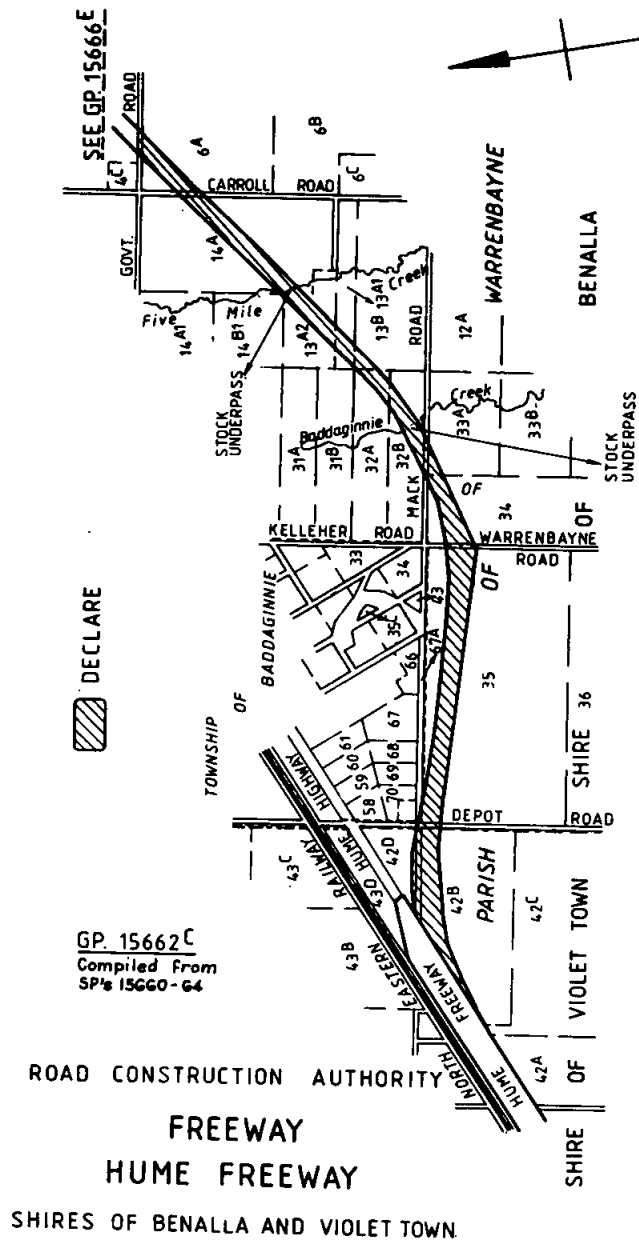

HEAVY LINE INDICATES

- 1. The limits of the freeway reservation.
- 2. A restriction of access.

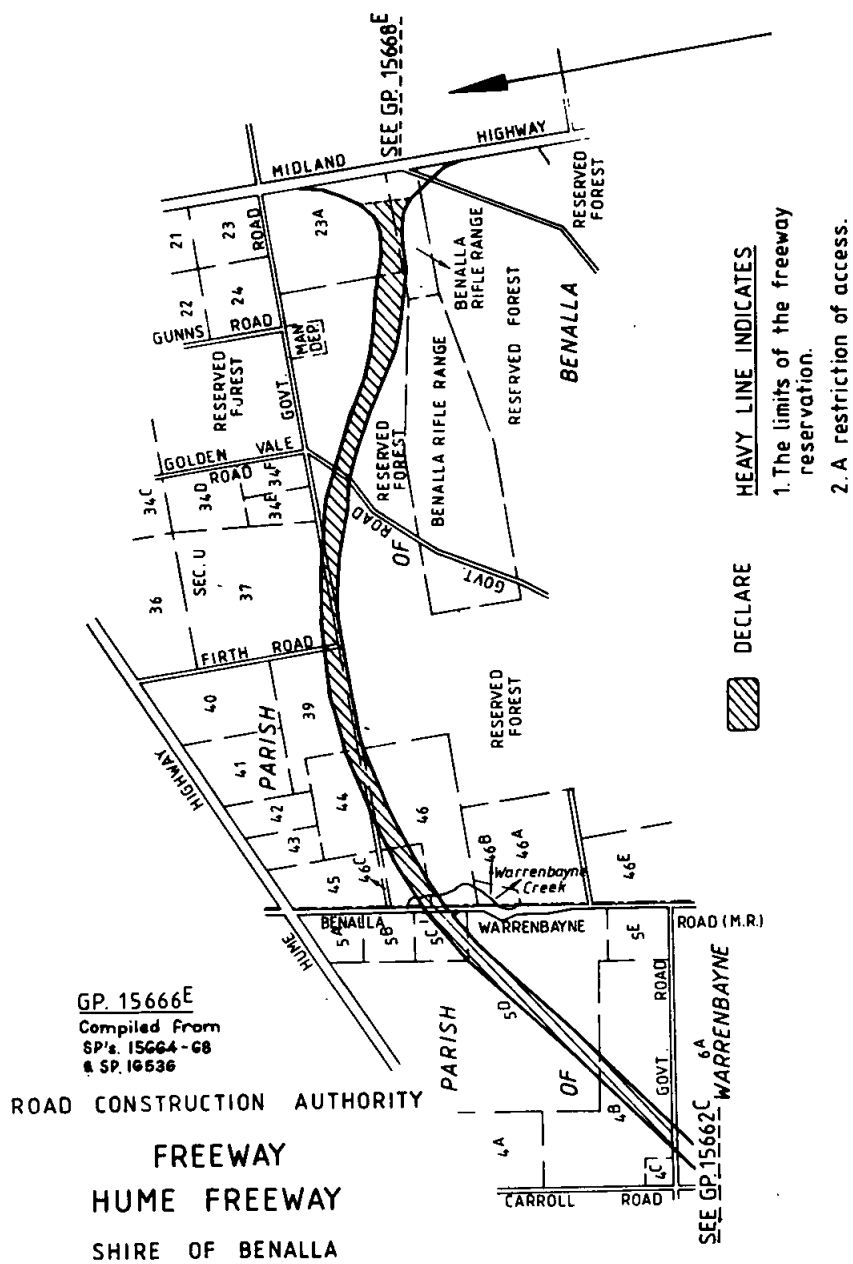

GP. 15666E
 Compiled From
 SP's 15664-C8
 & SP. 16536

ROAD CONSTRUCTION AUTHORITY

FREWAY
HUME FREEWAY
 SHIRE OF BENALLA

SEE GP. 15662C 6A
 WARRENBAYNE

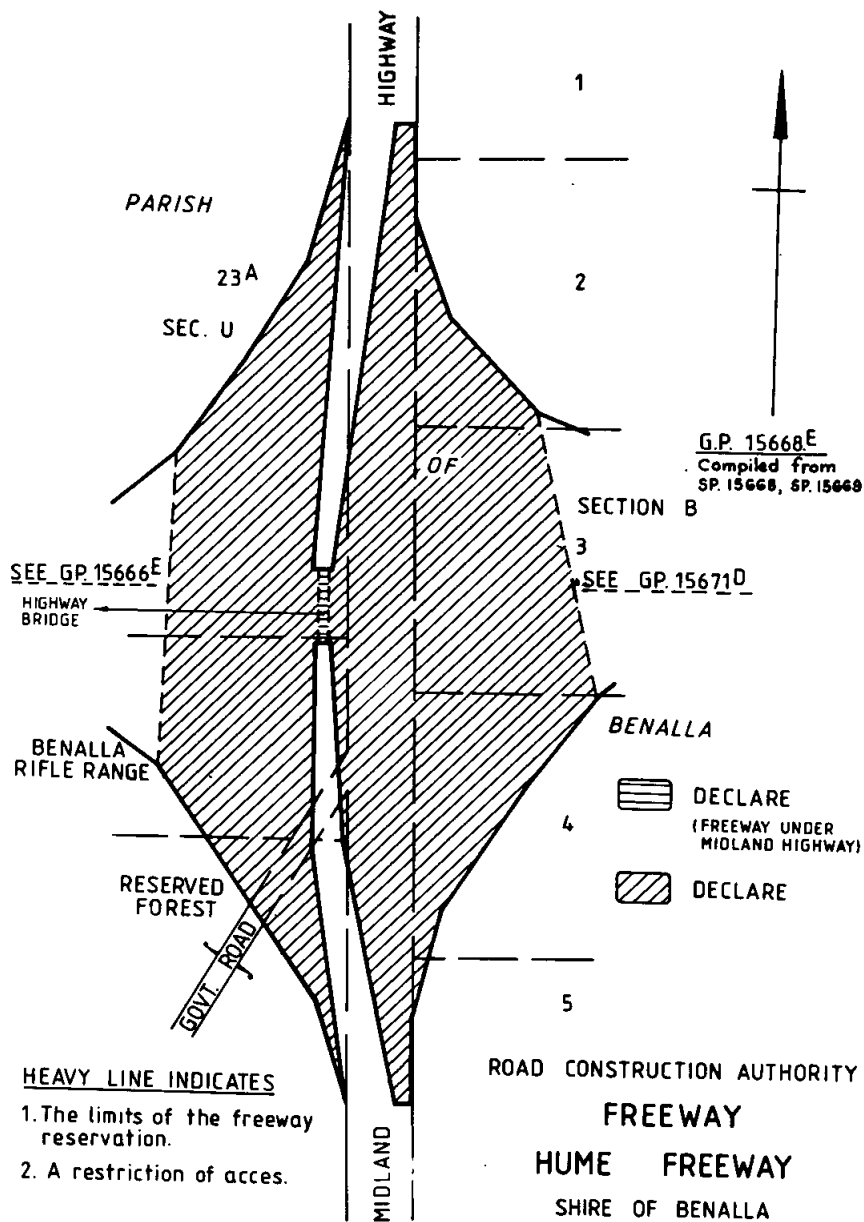

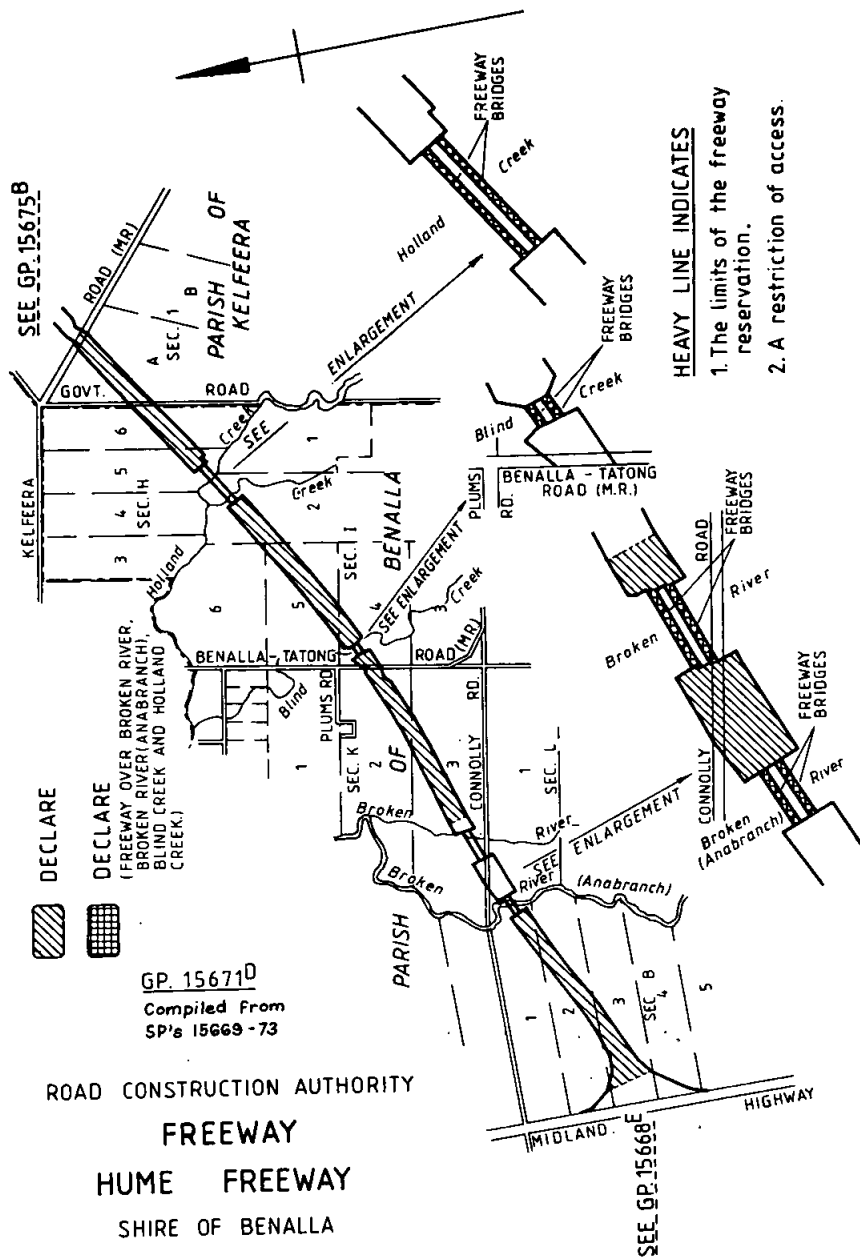

SEE GP. 15675B

KELFEERA

GOVT. ROAD

DECLARE



DECLARE
(FREEWAY OVER BROKEN RIVER,
BROKEN RIVER (ANABRANCH),
BLIND CREEK AND HOLLAND
CREEK.)

GP. 15671D

Compiled From
SP's 15669 - 73

ROAD CONSTRUCTION AUTHORITY

FREEWAY

HUME FREEWAY

SHIRE OF BENALLA

HEAVY LINE INDICATES

- 1. The limits of the freeway reservation.
- 2. A restriction of access.

SEE GP. 15668E

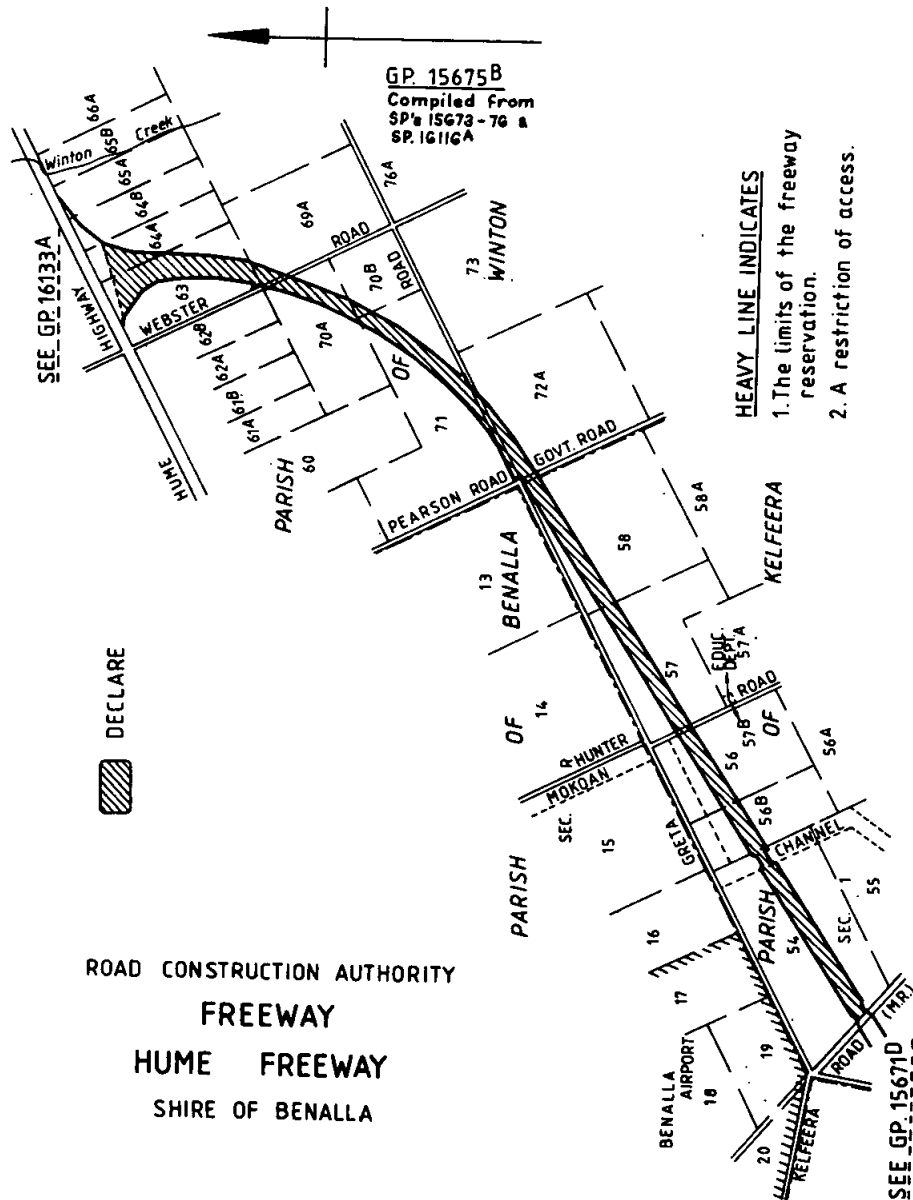

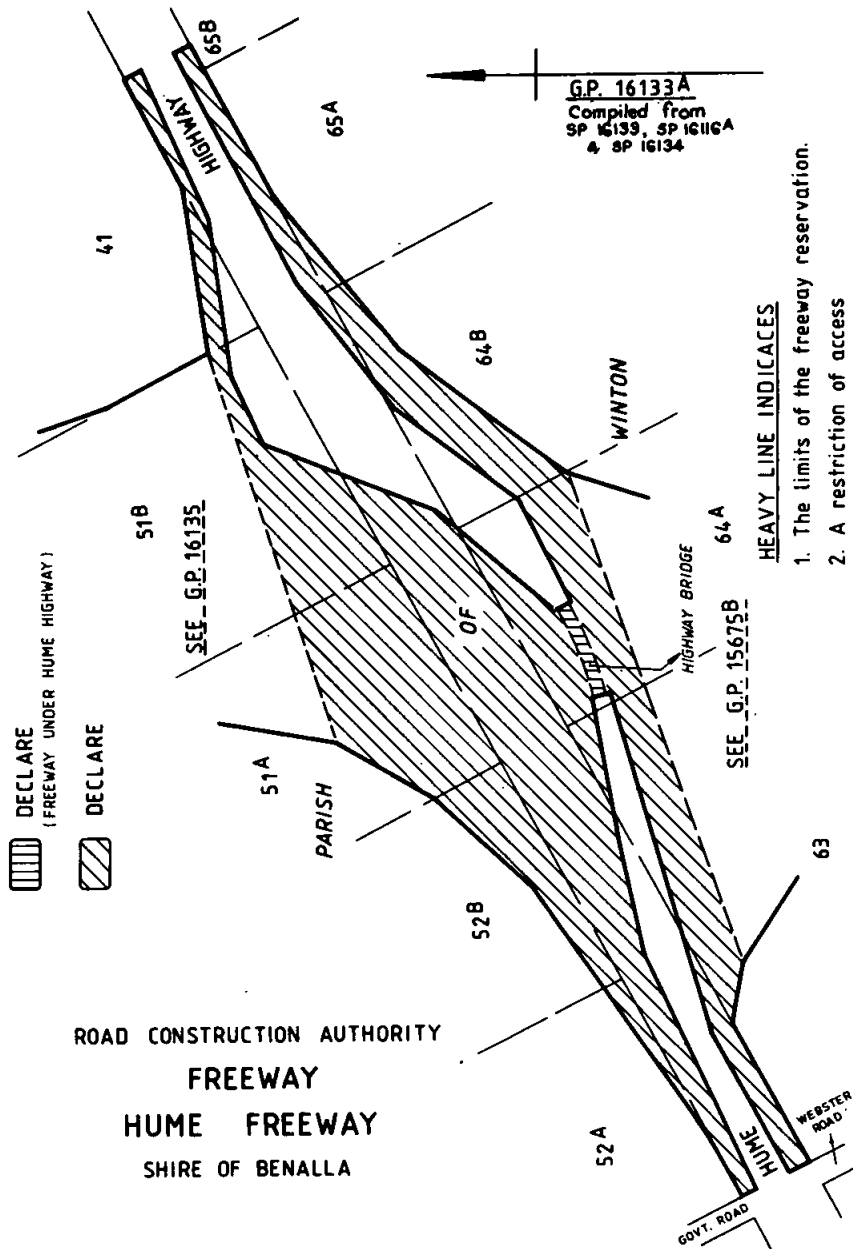

DECLARE
(FREEWAY UNDER HUME HIGHWAY)

DECLARE

ROAD CONSTRUCTION AUTHORITY
FREEWAY
HUME FREEWAY
SHIRE OF BENALLA

G.P. 16133A
Compiled from
SP 16133, SP 16134
& SP 16134

HEAVY LINE INDICATES

1. The limits of the freeway reservation.
2. A restriction of access

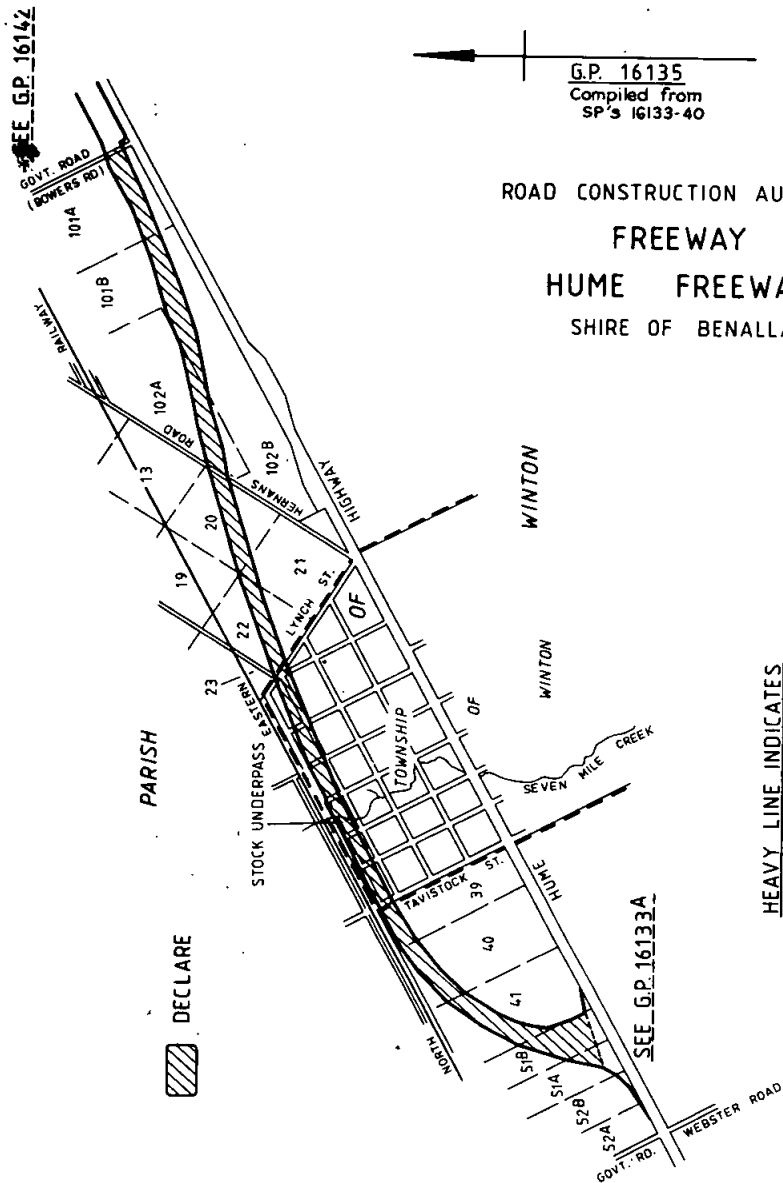

ROAD CONSTRUCTION AUTHORITY
FREEWAY
HUME FREEWAY
 SHIRE OF BENALLA

↑
 G.P. 16135
 Compiled from
 SP'S 16133-40

HEAVY LINE INDICATES

1. The limits of the freeway reservation.
2. A restriction of access

▨ DECLARE

SEE G.P. 16133A

SEE G.P. 16142

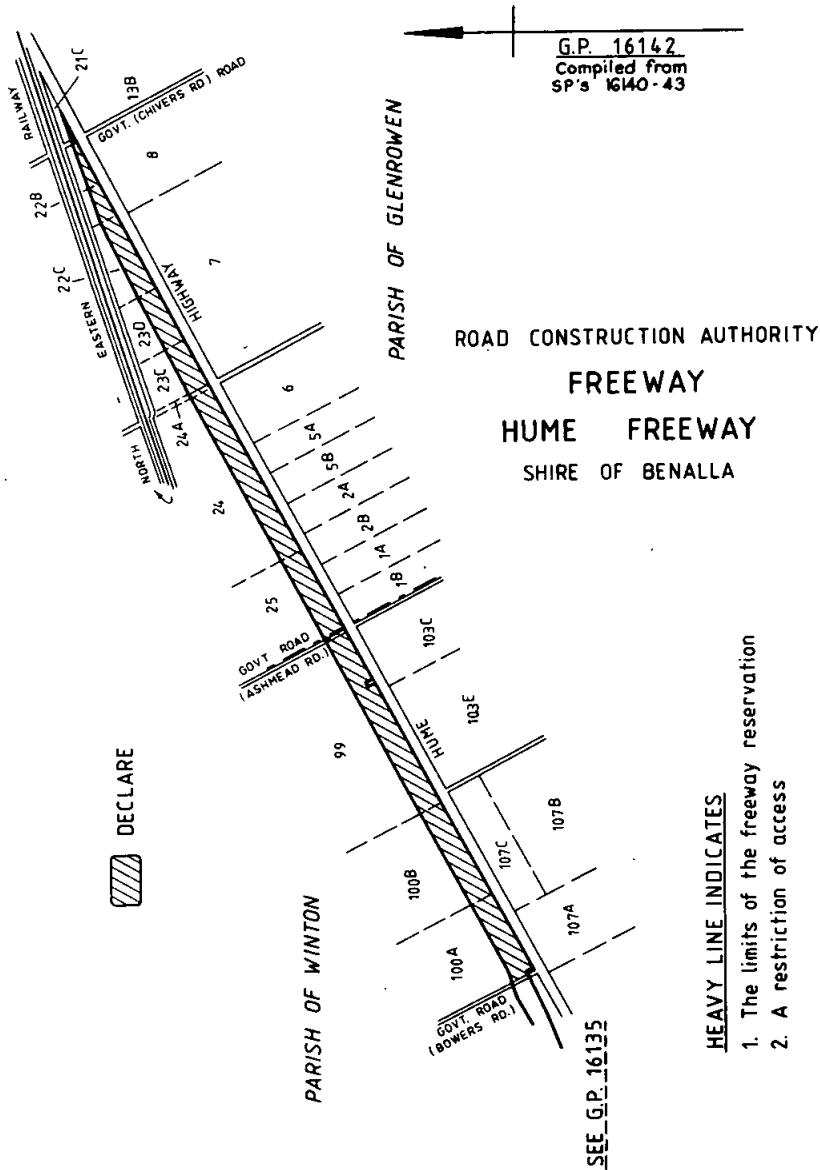

DECLARE

HEAVY LINE INDICATES

- 1. The limits of the freeway reservation
- 2. A restriction of access

SEE G.P. 16135

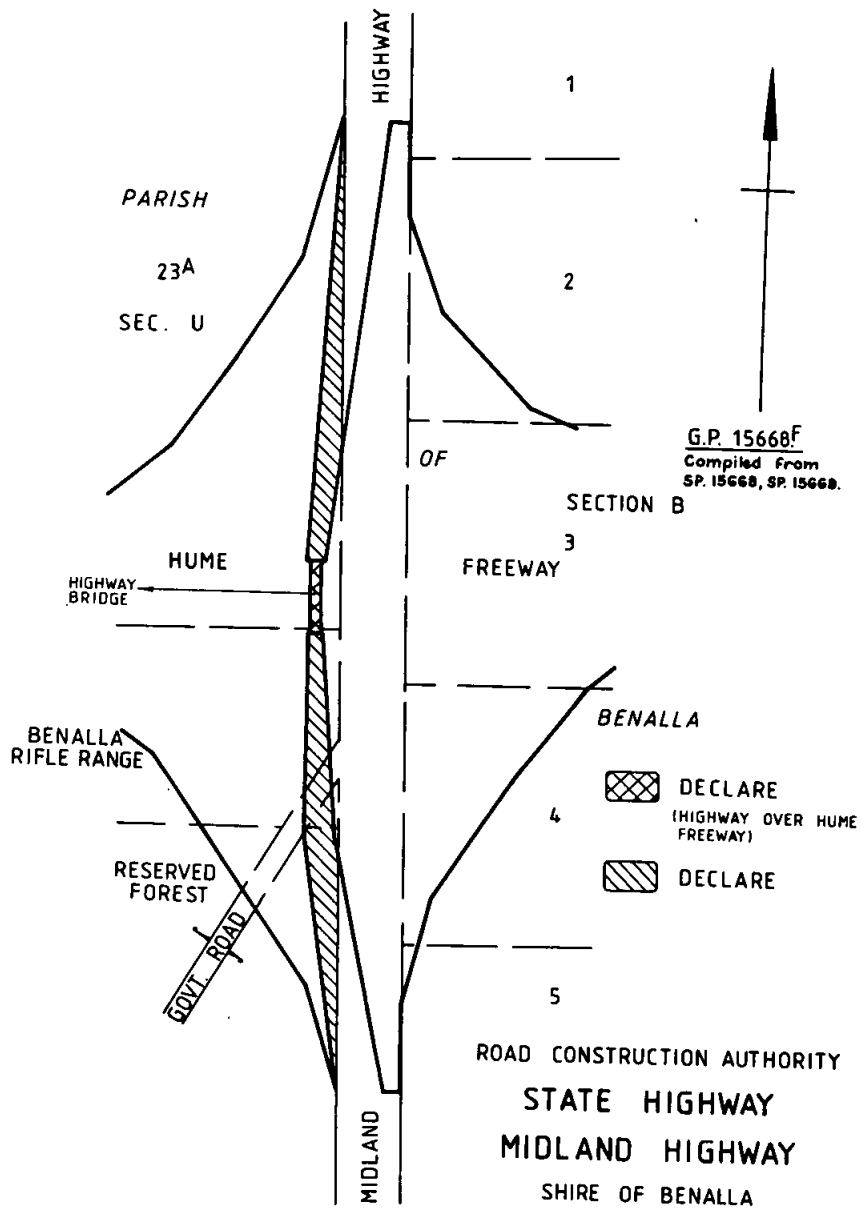

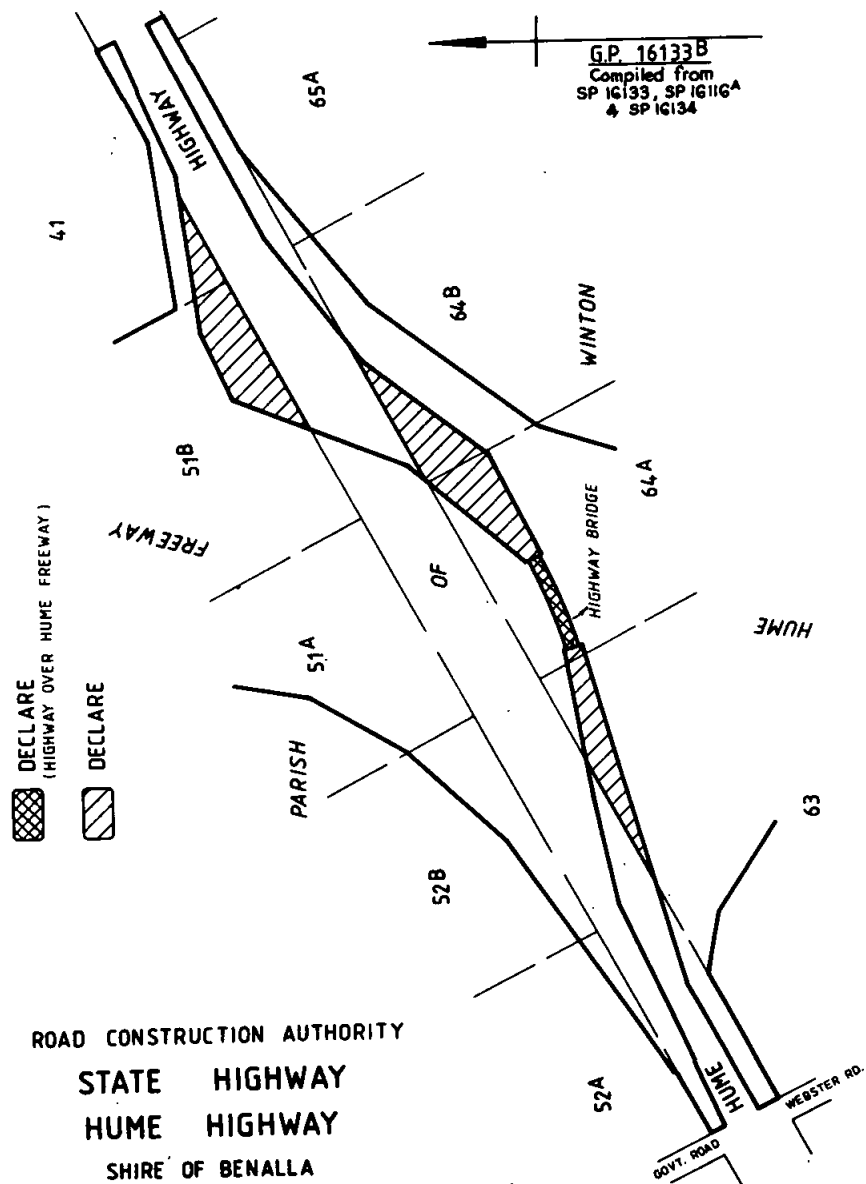

ROAD CONSTRUCTION AUTHORITY
STATE HIGHWAY
HUME HIGHWAY
 SHIRE OF BENALLA

In accordance with the provisions of Clause 2 (2), Schedule 5 of the *Transport Act 1983*, the new roads, deviations or widenings made by the Authority shall, upon the publication of this notice in the *Government Gazette*, become and be absolutely dedicated to the public as a public highway within the meaning of any law now or hereafter in force.

IAN F. X. STONEY

16 March 1987

Managing Director, Road Construction Authority

TAFE Teaching Service
ELECTION FOR MEMBERS OF THE TAFE
TEACHING SERVICE REGISTRATION
BOARD

An election for members of the above Board is to be conducted viz.:

Two selected members from within any classification.

Three selected deputies from within any classification.

Nominations are called in for the above. Such nominations are to be in the hands of the Returning Officer by 12 noon on Wednesday, 15 April 1987.

Close of poll for elections for the above will be 4.00 p.m. Friday, 29 May 1987. Nominations and ballot papers are to addressed to:

MARIANA BRKICH
Returning Officer

TAFE Teaching Service
9th Floor
420 St Kilda Road
Melbourne 3004

Kowree, Kyneton, Leigh, Lexton, Newham and Woodend, Melton, Ripon, Romsey, Stawell, Wimmera.

Dated 23 March 1987

JOAN E. KIRNER
Minister for Conservation, Forests and Lands

HOSPITALS AND CHARITIES ACT 1958 (No. 6274)

It is notified for general information that the Department of Community Services Victoria has, under the provisions of Section 50 of the Act, approved the corporate name of "Melbourne Family Care Organization" being changed to "Family Action".

Dated 8 April 1987

P. JOHNSTONE
Director-General Community Services

PENTAL ISLAND RIVER MANAGEMENT
BOARD

By-Law No. 31

The Pental Island River Management Board, in pursuance and exercise of the powers conferred by the *River Improvement Act 1958*, doth hereby make the By-Law following:

1. The following rate to be called the Pental Island River Improvement District River Improvement Rate is hereby made and shall be levied upon the occupiers or owners of all the properties within the Pental Island River Improvement District which are rateable in the municipality, the rate of two and one half cents in the dollar on the net annual municipal value of such properties. Provided that the sum of two dollars shall be the minimum amount of rate in respect of any property liable to be rated in the said district.

2. Such rate is made and shall be levied for the period beginning with 1 January 1987 and ending with 31 December 1987 and shall be payable on 1 July 1987, at the office of the Pental Island River Management Board, at Swan Hill.

3. Such person or persons as the Pental Island River Management Board may from time to time appoint for that purpose is or are hereby authorized to demand, receive, collect and recover the said rate.

The foregoing By-Law was made by the Pental Island River Management Board on 3 February 1987 and the common seal of the said Board was hereunto affixed on 3 February 1987.

K. JAMES, Chairman
R. BURNS, Secretary

Approved, 18 March 1987—A. McCutcheon,
Minister for Water Resources

Forests Act 1958 No. 6254

REVOCATION OF PROHIBITED PERIOD

In pursuance of the powers conferred by section 3 of the *Forests Act 1958*, I, Joan E. Kirner, Her Majesty's Minister for Conservation, Forests and Lands in the State of Victoria hereby vary the Declarations of a Prohibited Period previously made by me in the *Victoria Government Gazette* No. 94 dated 7 November 1986, No. 102 dated 10 December 1986, and No. 104 dated 17 December 1986, insofar as they refer to the municipalities specified hereunder, and by this notice declare that in the specified municipalities the prohibited period in respect to any fire protected area (other than a State forest, National Park or protected public land) shall end as specified hereunder.

Schedule 1

The prohibited period shall end at midnight between 27 and 28 March 1987 in the following municipalities:

The Shires of Alberton, Avon, Buln Buln, Maffra, Mirboo, Morwell, Narracan, Rosedale, South Gippsland, Traralgon, Warragul and Woorayl.

Cities of Sale and Traralgon.

Schedule 2

The prohibited period shall end at midnight between 29 and 30 March 1987 in the following municipalities:

The Shires of Arapiles, Ararat, Avoca, Bacchus Marsh, Ballan, Ballarat, Bannockburn, Barrabool, Bungaree, Buninyong, Corio, Creswick, Daylesford and Glenlyon, Dundas, Gisborne, Grenville,

Industrial Relations Act 1979
**COMMERCIAL TRAVELLERS
 CONCILIATION AND ARBITRATION
 BOARD AND THE GENERAL BOARD**

Notice is hereby given that an application has been lodged on behalf of the United Sales Representatives and Commercial Travellers Guild of Australia (Victorian Branch) for variation of the jurisdiction of the General Board and the Commercial Travellers Conciliation and Arbitration Board—

To deprive the General Board of its powers in relation to:

- Door to door sales persons selling services, and
- Market researchers

And to increase the powers of the Commercial Travellers Conciliation and Arbitration Board in such manner:

- To include commercial travellers soliciting orders for and promoting sales of advertising space or time,
- To include commercial travellers soliciting orders for and promoting sales of articles, goods, services, wares, merchandise or materials to be used by the purchaser or by the person from whom the order was solicited for his personal use, or disposal,
- To include commercial travellers soliciting orders for, promoting and selling services,
- To delete the phrase "persons employed outside the employer's place of business" and insert "persons employed away from or substantially away from the employer's place of business" in its place,
- To insert after "soliciting orders", where that appears in the Jurisdiction clause, the additional words "and promoting sales of",
- To include persons employed soliciting orders for or promoting sales, via telephone or other electronic means, of articles, goods, services, wares, merchandise or advertising of any kind,
- To include Market Researchers, being persons employed by a firm in the occupation of gathering information about the preferences, and/or purchasing powers of members of the public, and
- To include Merchandisers, being persons employed substantially away from the employer's place of business in the work of promoting the employer's products, re-ordering stock and the preparation of display units and gondola ends.

Notice is also given that this matter is listed for mention before the Industrial Relations Commission of Victoria in Full Session at 9.45 a.m. on Wednesday, 1 April 1987 in Hearing Room No. 1, Level 18, Nauru House, 80 Collins Street, Melbourne.

A. S. DOWLING
 Deputy Registrar
 Industrial Relations Commission of Victoria

Education Act 1958

Notice of the making of an Order under section 13 (4) of the Act

Pursuant to section 13 of the *Education Act 1958* I hereby give notice that Orders of the Governor in Council were made on 17 March 1987 under subsection (4) of the said Act amending certain provisions relating to the State Schools listed below:

- 615 Tarraville Primary School
- 1652 Nullawarre Primary School
- 7060 Broadmeadows Technical School

IAN CATHIE
 Minister for Education

Crown Land (Reserves) Act 1978

NOTICE OF INTENTION

Recommended under section 10 of the *Crown Land (Reserves) Act 1978* that notice be published in the *Government Gazette* of the intention of the Governor in Council to revoke the following reservations:

Ballarat—The temporary reservation by Order in Council of 31 October, 1938 of 3-909 hectares of land in the Township of Ballarat as a site for Public Recreation, revoked as to part by various Orders, so far only as the portion containing 728 square metres being Crown Allotment 23, Section 93, Township of Ballarat as shown on Certified Plan No. 107452 lodged in the Central Plan Office. (Rs 3420)

Cranbourne—The area of 94.5 hectares, more or less, of land deemed to be temporarily reserved for the purposes of Racecourse, Botanical Gardens and Public Recreation under Section 5 of the *Crown Land (Reserves) Act 1978* being part of Crown portion 17, Parish of Cranbourne transferred to the Crown by Transfer No. L831767 registered in the Office of Titles on 14 August, 1985 and by Memorial of Conveyance No. 925, Book 838 lodged in the Office of the Registrar General on 14 August 1985. (Rs 13133)

Mowamba—The temporary reservation by order in Council of 19 April, 1887 of 105.2 hectares, more or less, of land adjoining Crown Allotment 17, Parish of Mowamba as a site for Watering Purposes. (C 40173)

Sunbury—The temporary reservation by Order in Council of 23 November 1868 of land for railway purposes within the line of railway from Melbourne to Echuca so far only as the balance remaining within the boundaries of the Township of Sunbury. (Rs 13233)

Warrak—The temporary reservation by Order in Council of 3 December, 1866 of 2023 square metres of land in Section 4, Township of Warrak, as a site for Common School Purposes. (Rs 445)

Warrak—The temporary reservation by Order in Council of 21 November, 1933 of 1164 square metres of land in Section 4, Township of Warrak as

a site for a State School in addition to and adjoining the site temporarily reserved therefor by Order in Council of 3 December, 1866. (Rs 445)

Warrak—The temporary reservation by Order in Council of 21 February, 1935 of 1012 square metres of land in Section 4, Township of Warrak as a site for a State School in addition to and adjoining the site temporarily reserved therefor by Order in Council of 3 December, 1866. (Rs 445)

Warrak—The temporary reservation by Order in Council of 22 May, 1956 of 1012 square metres of land in Section 4, Township of Warrak as a site for State School Purposes in addition to and adjoining the site temporarily reserved therefor by Order in Council of 21 February, 1935. (Rs 445)

JOAN E. KIRNER

Minister for Conservation, Forests and Lands

Town and Country Planning Act 1961
CITY OF BALLAARAT PLANNING SCHEME
Amendment No. 88
Notice of Approval

In pursuance of the powers conferred by the *Town and Country Planning Act 1961*, the Governor in Council on 17 March 1987, amended the abovementioned scheme in respect of the municipal district of the City of Ballaarat and for which the City of Ballaarat is the Responsible Authority.

The scheme comes into operation on the date this Notice is published in the *Government Gazette*.

The scheme includes rezoning of the land generally bounded by Winter, Valentine, Latrobe and Pleasant Streets from Residential/Light Industrial to Residential "A". This rezoning recognises the emerging type of land use in the area and protects its corresponding amenity.

A copy of the documents may be inspected free of charge, during office hours, at the office of the Ministry for Planning and Environment, (Plan Inspection Section), The Olderfleet Buildings, 477 Collins Street, Melbourne and at the office of the responsible authority City of Ballaarat, Town Hall, Sturt Street, Ballarat.

DAVID YENCKEN

Secretary for Planning and Environment

MELBOURNE AND METROPOLITAN
BOARD OF WORKS

Notice to the owners of tenements in the undermentioned streets and the private streets, lanes, courts and alleys opening thereto.

The main pipe in the said streets being laid down, the owners of all tenements situated as under are hereby required on or before 27 April 1987 to cause a proper pipe and stock cocks to be laid so as to supply water within such tenements from the main pipe.

Berwick

Strathavan Drive, from 25 metres southeast of Earlston Square further southeastwards 245 metres.

Fisher Close, the total street from Strathavan Drive southwards.

Bruce Court, the total street from Strathavan Drive southwards.

Progress Street, from Princes Highway southwards 287 metres.

Heatherton Road, from 48 metres east of Fairmont Court further eastwards 190 metres.

Carolyn Close, the total street from Heatherton Road southwards and westwards.

Melanie Close, from Carolyn Crescent southeastwards, southwards and southwestwards 443 metres.

Narre Warren—Cranbourne Road, from Centre Road southwards 175 metres Centre Road, from 20 metres of Narre Warren—Cranbourne Road further southeastwards 692 metres.

Kilgerron Court, the total street from Centre Road southwards.

Andrew Court, the total street from Denise Court westwards.

Denise Court, from Andene Drive southwards 123 metres.

Andene Drive, from Denise Court westwards and northwards 128 metres.

Warrington Close, the total street from Green Ridge Avenue eastwards.

Weeden Crescent, from 36 metres southeast of Elder Close further southeastwards 184 metres.

Basil Close, the total street from Weeden Crescent southwards.

Mace Rise, the total street from Weeden Crescent southwestwards.

Spice Rise, the total street from Weeden Crescent southwestwards.

Hyssop Drive, from Weeden Crescent northwards 60 metres.

Terry Close, the total street from Maramba Drive westwards, northwards and southwards.

Maramba Drive, from 28 metres northwest of Van Court further northwestwards and northwards 162 metres.

Glasgow Court, the total street from Straun Avenue southwards.

Dalry Close, the total street from Straun Avenue southwards.

Irvine Close, the total street from Straun Avenue southwards.

Straun Avenue, from Shetland Street northwestwards 325 metres.

Shetland Street, from 85 metres southeast of Dornie Mews further southwards 124 metres.

Winnie Court, the total street from Song Street northwestwards.

Elizabeth Court, the total street from Song Street southeastwards and southwards.

Song Street, from 20 metres northeast of Elizabeth Court further northeastwards 66 metres.

Broadmeadows

Derby Street, from Springbank Street southeastwards 210 metres.

Bulla

Barrymore Road, from Dunbar Court northeastwards 378 metres.

Lamark Court, the total street from Barrymore Road northwestwards.

Dundee Court, the total street from Barrymore roadsoutheastwards.

Cranbourne

Kooyong Close, the total street from Hallam Road westwards and northwards.

South Gippsland Highway, from opposite Olive Road further northwestwards 145 metres.

Dandenong

Llewellyn Court, the total street from Hanna Street southwards.

Heidelberg

Casey Crescent, from Martins Lane southwards 131 metres.

Casey Crescent, from Casey Crescent westwards and southwestwards 148 metres.

Mill Court, the total street from Casey Crescent northwestwards.

Knox

Meaghan Court, the total street from Burchall Crescent northwards.

Cowin Close, the total street from Burchall Crescent southwards.

Burchall Crescent, from Dandelion Drive westwards 132 metres.

Gill Court, the total street from Dandelion Drive eastwards.

Kemp Court, the total street from Dandelion Drive eastwards.

Dandelion Drive, from 138 metres south of Spruce Drive further southwards 180 metres.

Hilson Close, the total street from Bemboka Court westwards.

Bemboka Court, from Jenola Parade southwards 155 metres.

Jenola Parade, from 110 metres northeast of Julie Close further northeastwards and eastwards 278 metres.

Argyle Way, from 80 metres north of Fewster Drive further northwards 48 metres.

Kirrum Close, the total street from Witken Avenue westwards.

Witken Avenue, from Riddell Road westwards, southwestwards and southwards 124 metres.

Reita Avenue, from 165 metres northwest of Witken Avenue further northwestwards and westwards 155 metres.

Candlebark Quadrant, from Timbertop Drive southwards and eastwards 239 metres.

Clondara Drive, from Timbertop Drive northwestwards 50 metres.

Incana Place, the total street from Timbertop Drive northwards.

Timbertop Drive, from 90 metres west of Rupicola Court further southwestwards 173 metres.

Jessica Close, the total street from Cathies Lane westwards and northwards.

Moorabbin

Glenda Court, the total street from Hunt Crescent southwards.

Hunt Crescent, from 278 metres east of Elder Street further eastwards and northwards 213 metres.

Preston

Amery Street, from Mahoneys Road to Alcock Street.

Alcock Street, the total street from Amery Street to Hughes Parade.

Ross Street, the total street from Alcock Street to Barrow Street.

Ballan Street, the total street from Alcock Street to Barrow Street.

Springvale

Nyala Court, the total street from Luanda Street northwards.

Luanda Street, from Malmo Court southeastwards 106 metres.

Malmo Court, the total street from Luanda Street northwards, southwards and eastwards.

Flinders Street, from Corrigan Road northwestwards 263 metres.

Teralba Close the total street from Spring Road northeastwards, northwards and northwestwards.

Spring Road, from 42 metres southeast of Harley Street further southeastwards 160 metres.

Whittlesea

Medlar Court, the total street from Telopea Crescent southwards.

Olea Court, from Telopea Crescent northwards 39 metres.

Manuka Court, from 40 metres southwest of Telopea Crescent further westwards 123 metres.

Telopea Crescent, from 44 metres northwest of Manuka Court further westwards and northwestwards 232 metres.

Kinlora Avenue, from Findon Road southwards 210 metres.

Dransfield Way, from 20 metres west of Longwood Drive further westwards 154 metres.

Paulka Court, the total street from Dransfield Way northwards.

Pratt Court, the total street from Dransfield Way northwards.

Longwood Drive, from Findon Road northwards and northeastwards 215 metres.

Findon Road (north side), from Glendale Avenue eastwards 144 metres.

Findon Road (south side), from Glendale Avenue eastwards 183 metres.

Glendale Avenue, from 44 metres north of Dean Court further northwards and eastwards 185 metres.

Dransfield Way, from Longwood Drive northwestwards 28 metres.

Dransfield Way, from Longwood Drive northwards 20 metres.

Basil Court, from Longwood Drive eastwards 30 metres.

Findon Road, from Kinlora Avenue eastwards 141 metres.

Dated 17 March 1987

H. G. FORD

Director of Administration and Services

Department of Labour
LIQUIFIED GASES (TRANSPORTATION
AND GAS TRANSFER) (SELF-SERVICE OF LP
GAS) REGULATIONS 1987

Notice of Preparation of a Regulatory Impact
Statement

In accordance with the provisions of the *Subordinate Legislation Act 1962*, notice is given of the proposal to make regulations to be known as the Liquefied Gases (Transportation and Gas Transfer) (Self-service of LP Gas) Regulations 1987.

A Regulatory Impact Statement has been prepared as required by the *Subordinate Legislation Act*.

The objectives of the proposed regulations are—

- (i) to make provision for refuelling operations at certain LP Gas Motorfuel Stations to be carried out by self-service;
- (ii) to ensure that the self-service operations carried out at those LP Gas Motorfuel Stations are conducted in a safe manner; and
- (iii) to make it optional at all Motorfuel Stations for a person to wear protective gloves while filling LP Gas into vehicle fuel containers.

The statement concludes that amendment of the Liquefied Gases (Transportation and Gas Transfer) Regulations 1980 is the most appropriate way to introduce self-service of LP Gas. It further concludes that the measures specified by the proposed regulations are the most appropriate way to ensure the safety of the public.

Comments and submissions are invited from interested parties.

Copies of the Regulatory Impact Statement Regulations may be obtained either by writing to, The Acting Manager, Dangerous Goods Branch, Department of Labour, Level 3, 500 Bourke Street, Melbourne Vic. 3000 or by phoning Mrs Anderson or Mrs South during business hours on 602 8338.

Written submissions on the Regulatory Impact Statement should be sent to the above address no later than 21 days from the date of publication of this notice.

MELBOURNE CRICKET GROUND ACT 1984

Recommended pursuant to the provisions of section 3 (3) of the *Melbourne Cricket Ground Act 1984* that the Governor in Council approve the floodlights affixed to the floodlight towers of the Melbourne Cricket Ground being operated on Friday nights for the playing of football matches with the senior game commencing at 8.00 p.m. after a reserves curtain-raiser at 5.15 p.m. on the following eight (8) occasions:

Friday, 27 March 1987, North Melbourne v Brisbane; 3 April 1987, North Melbourne v Melbourne; 24 April 1987, North Melbourne v St Kilda; 22 May 1987, Richmond v North Melbourne; 12 June 1987, North Melbourne v Essendon; 17 July 1987, North Melbourne v Geelong; 21 August 1987, Melbourne v West Coast; 28 August 1987, Richmond v Brisbane—(Rs. 3197)

JOAN E. KIRNER

Minister for Conservation, Forests and Lands

Approved by the Governor in Council 24 March 1987—L. G. HOUSTON, Clerk of the Executive Council

Subordinate Legislation Act 1962

PROPOSED REGULATION TO INCREASE
THE FEE FOR AN ABALONE LICENCE

I, Joan Elizabeth Kirner, Minister for Conservation, Forests and Lands, give notice under the *Subordinate Legislation Act 1962* as follows:

The proposed Fishing (Abalone Licence Fee) Regulations 1987 have been the subject of a Regulatory Impact Statement.

Public comment and submissions have been invited and received and have been duly considered as required by section 12 of the *Subordinate Legislation Act 1962*.

I have decided that the proposed Fishing (Abalone Licence Fee) Regulations 1987 should be made.

JOAN E. KIRNER

Minister for Conservation, Forests and Lands

STATE TENDER BOARD
CONTRACTS ACCEPTED

Schedule Number	Item Number	Amendments	
		New Rate	Effective Date
			\$
<i>Motor Spirit—State Petrol Centre</i>			
1/53A	1	0-4822	14.3.87
	2	0-4778	
<i>Motor Spirit, Kerosene, Fuels, Oils and Lubricants</i>			
1/53B	1	0-4778	14.3.87
	2	0-4877	
	5	0-4822	
	6	0-4921	
	7	0-5448	
	8	0-5348	
	10	0-5154	
	12	0-5209	
	14	0-5126	
	16	0-5176	
	17	0-5125	
	18	0-5125	
	26	0-4728	
	27	0-4803	
	28	0-5380	
	29	0-5330	
<i>Tyres and Tubes Pneumatic</i>			
1/57	3	G-Year 13.3.87 List T69	16.3.87
		Discounts unchanged	
	3 (b)	56.75	
		J. M. PAWSON Secretary to the Tender Board	

Industrial Relations Commission of Victoria
*Industrial Relations Act 1979*APPLICATION FOR APPROVAL OF AN
INDUSTRIAL AGREEMENT

Notice is hereby given that an application has been made by the Pastrycooks, Bakers, Biscuitmakers and Allied Trades Union for approval and registration of an industrial agreement to be known as the "Parka Pantry Superannuation Agreement".

Notice is also given that this matter is listed for investigation and report by Acting Deputy President Garlick at 10.00 a.m. on Friday, 27 March 1987 in Hearing Room No. 2, Level 18, Nauru House, 80 Collins Street, Melbourne.

A. S. DOWLING
Deputy Registrar
Industrial Relations Commission of VictoriaIndustrial Relations Commission of Victoria
*Industrial Relations Act 1979*APPLICATION FOR APPROVAL OF AN
INDUSTRIAL AGREEMENT

Notice is hereby given that an application has been made by the Pastrycooks, Bakers, Biscuitmakers and Allied Trades Union for approval and registration of an industrial agreement to be known as the "Tip Top [Victoria] Bakers and Pastrycooks Superannuation Agreement".

Notice is also given that this matter is listed for investigation and report by Acting Deputy President Garlick at 10.30 a.m. on Friday, 27 March 1987 in Hearing Room No. 2, Level 18, Nauru House, 80 Collins Street, Melbourne.

A. S. DOWLING
Deputy Registrar
Industrial Relations Commission of Victoria

APPOINTMENTS

APPOINTMENTS

His Excellency the Governor of the State of Victoria by and with the advice of the Executive Council thereof has by Order been pleased to make the undermentioned appointment, viz.:

Department of Health
*Psychiatrist Superintendent*David John HICKINGBOTHAM, M.B.B.S, D.P.M.,
F.R.A.N.Z.C.P.

to be Psychiatrist Superintendent, Bundoora Repatriation Mental Hospital, pursuant to the provisions of section 26 (1) of the *Mental Health Act 1959*, from 2 March 1987, *vice* A. Stoller.

L. G. HOUSTON
Clerk of the Executive Council
At the Executive Council Chamber
Melbourne, 11 March 1987

APPOINTMENTS

The Governor in Council has made the following appointments:

Attorney-General's Department
Commissioners for taking AffidavitsCyril Ronald SAUNDERS, 45 Poplar Road,
Parkville.Ross Wolstencroft ODEN, 55 Swanston St,
Melbourne.Alexander Jamie WOOD, 55 Swanston St,
Melbourne, andRobert Eric Thomas OLDFIELD, Westfield
Shopping Town, Airport West.

to be Commissioners for taking Affidavits under section 114 (1) of the *Evidence Act 1958*.

Commissioner—Law Reform Commission

Gary Daniel SULLIVAN to be part-time Commissioner of the Law Reform Commission pursuant to section 8 (1) of the *Law Reform Commission Act 1984* for a period of 3 years from 17 March 1987.

L. G. HOUSTON
Clerk of the Executive Council

National Parks Act 1975
AUTHORISED OFFICERS

In accordance with section 9 (2) of the National Parks Act, I Donald Sydney Saunders, Director of National Parks, hereby appoint the following persons to be authorised officers for the purposes of the Act.

These authorisations are to remain in effect until revoked or until the appointee ceases to be employed by the Department of Conservation Forests and Lands.

Name	Area of Appointment
Newman, Anthony John	Phillip Island Penguin Reserve
McKechnie, Anthony Peter	Phillip Island Penguin Reserve
Speedie, Claire Dianne	Phillip Island Penguin Reserve
Kirby, Roderick Duffus	Phillip Island Penguin Reserve
Alexander, Robert John	Phillip Island Penguin Reserve
Newman, Scott	Phillip Island Penguin Reserve
Callander, Robert Scott	Phillip Island Penguin Reserve
Jeffrey, Robert James	Phillip Island Penguin Reserve
Scrase, David	Phillip Island Penguin Reserve
Newton, Maryanne Therese	All Parks
Laffy, Robert John	All Portland Region Parks
Miller, Geoffrey Lloyd	All Portland Region Parks
Summerfield, Alan Joseph	All Portland Region Parks
Morgan, Gary William	All Wodonga Region Parks
Ross, Jeffrey Frederick	All Wodonga Region Parks
Gow, James Carmichael	All Horsham Region Parks
Cobb, Peter Barrett	All Alexandra Region Parks
Black, Peter Rodney	All Portland Region Parks

Godfrey-Smith, Alexander Peter	All Portland Region Parks
Hogan, Michael Henry	All Portland Region Parks
Hoog-Antink, Marchel	All Portland Region Parks
Martin, Neil Arthur	All Portland Region Parks
Musgrove, Peter Richard	All Portland Region Parks
Pollock, John Munro	All Portland Region Parks
Robinson, Ian Arthur	All Portland Region Parks
Scott, Peter James	All Portland Region Parks
Varcoe, Anthony John	All Parks
Schofield, Annmarie	All Parks
Millar, Paul Edmond	All Parks
Scott, Barry Robert	All Parks
Williamson, Ross	All Parks
Johnston, Laurence Samuel	All Parks
Costello, Russell Thomas	All Parks
Hanel, Graeme Leslie	All Parks
Reichelt, Phillip John	All Parks
Doyle, Peter	Haining Farm
Bairstow, Kenneth	Haining Farm
Houlihan, Richard John	All Parks

D. S. SAUNDERS
Director of National Parks

ORDERS IN COUNCIL

Crown Land (Reserves) Act 1978
REVOCATION OF TEMPORARY
RESERVATION

The Governor in Council under section 10 of the *Crown Lands (Reserves) Act 1978* now revokes the following temporary reservations:

Dowling Forest—The temporary reservation by Order in Council of 27 February 1973 of 4730 square metres of land in section 4, Parish of Dowling Forest as a site for Municipal Purposes so far only as the portion containing 2290 square metres as indicated by hatching on plan published in the *Government Gazette* of 18 February 1987, page 356—(Rs.7786).

Dated: 17 March 1987

Responsible Minister:

JOAN E. KIRNER
Minister for Conservation, Forests and Lands

L. G. HOUSTON
Clerk of the Executive Council

Crown Land (Reserves) Act 1978

CROWN LANDS TEMPORARILY RESERVED

The Governor in Council under sections 4 and 7 of the *Crown Land (Reserves) Act 1978* temporarily reserves for the purposes mentioned and also excepts from prospecting or from occupation for mining purposes under any miners right the following Crown lands.

Municipal District of the City of Ararat

Ararat—Municipal Purposes, 1895 square metres being Crown Allotment 6A section 115, Township of Ararat, Parish of Ararat as indicated by hatching on plan hereunder—(A148(9)) (Rs.6651).

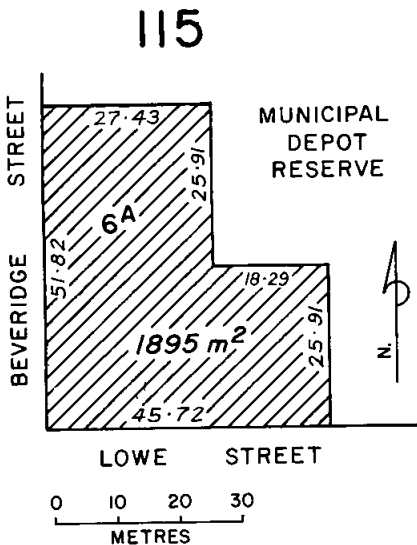

Municipal District of the Shire of Mount Rouse
Dunkeld—Departmental Purposes (Residence) 1200 square metres being Crown Allotment 4, section 24, Township of Dunkeld, Parish of Dunkeld is shown on Certified Plan No. 107671 lodged in the Central Plan Office—(Rs.13416).

Dated: 17 March 1987
Responsible Minister:

JOAN E. KIRNER
Minister for Conservation, Forests and Lands
L. G. HOUSTON
Clerk of the Executive Council

Crown Land (Reserves) Act 1978

CROWN LAND TEMPORARILY RESERVED

The Governor in Council under sections 4 and 7 of the *Crown Land (Reserves) Act 1978* temporarily reserves for the purpose mentioned and also excepts

from prospecting or from occupation for mining purposes under any miners right the following Crown land.

Municipal District of the Shire of Swan Hill

Piangil West—For Conservation of an Area of Natural Interest 84.53 hectares being Crown Allotment 5A in the Parish of Piangil West as shown on Certified Plan No. 107633 lodged in the Central Plan Office—(Rs.13426).

Dated: 17 March 1987

Responsible Minister:

JOAN E. KIRNER
Minister for Conservation, Forests and Lands
L. G. HOUSTON
Clerk of the Executive Council

Crown Land (Reserves) Act 1978

REVOCATION OF TEMPORARY RESERVATION

The Governor in Council under section 10 of the *Crown Land (Reserves) Act 1978* now revokes the following temporary reservations:

Annuelo—The temporary reservation by Order in Council of 1 July 1930 of 5.68 hectares of land in the Parish of Annuelo as a site for Public Recreation—(Rs.4018).

Carapugna—The temporary reservation by Order in Council of 17 December 1888 of 52.13 hectares of land in the Parish of Carapugna as a site for Water Supply purposes, revoked as to parts by Orders of 22 September 1908 and 15 February 1977, so far as the balance remaining of 10.898 hectares—(Rs.13354).

Castle Donnington—The temporary reservation by Order in Council of 26 September 1972 of 759 square metres of land in section 7A, Parish of Castle Donnington as a site for Public Purposes (Departmental Residence)—(Rs.9670).

Coleraine—The temporary reservation by Order in Council of 6 November 1865 of 2023 square metres of land in section 2, Township of Coleraine, Parish of Coleraine as a site for a Court House—(Rs.6298).

Creswick—The temporary reservation by Order in Council of 23 January 1979 of 8 hectares of land being Crown Allotment 35E, section 48A, Township of Creswick, Parish of Creswick as a site for State School purposes—(Rs.10576).

Creswick—The temporary reservation by Order in Council of 24 July 1951 of 1.0117 hectares, more or less, of land in the Township of Creswick, Parish of Creswick as a site for a Rubbish Depot and Supply of Gravel—(Rs.6684).

Deutgam—The temporary reservation by Order in Council of 21 July 1981 of 212.6 hectares being Crown Allotment 3, section 5, Parish of Deutgam and Crown Allotment 6, section A, Parish of Mambourin as a site for Public Recreation, Public Park, Gardens and Ornamental Plantations,

Conservation of an area of Historic Interest, Museums and Galleries, Educational Purposes, Conference Centre and the Promotion of Tourism, so far only as the area of 2530 square metres in the Parish of Deutgam shown by hatching on plan published in the *Government Gazette* of 18 February 1987, page 356—(Rs.11425).

Dowling Forest—The temporary reservation by Order in Council of 16 December 1958 of 2.43 hectares of land in section 4, Parish of Dowling Forest as a site for Municipal Purposes so far only as the portion containing 197 square metres as indicated by hatching on plan published in the *Government Gazette* of 18 February 1987, page 356—(Rs.7786).

Langi-Kal-Kal—The temporary reservation by Order in Council of 21 August 1917 of 2.93 hectares adjoining Crown Allotment 12A, section C, Parish of Langi-Kal-Kal as a site for Gravel Supply—(Rs.1673).

Langley—The temporary reservation by Order in Council of 20 June 1933 of 46.54 hectares, more or less, of land in the Parish of Langley as a site for Public Purposes and the Supply of Gravel—(Rs.4310).

Merrymbuella—The temporary reservation by Order in Council of 25 May 1886 of 12.55 hectares, more or less, of land in the Parish of Merrymbuella as a site for Watering Purposes—(Rs.12802).

Nuntin—The temporary reservation by Order in Council of 26 September 1961 of 1.821 hectares, more or less of land south of Crown Allotments 85E and 85G, section 2, Parish of Nuntin as a site for Drainage purposes—(Rs.6725).

Sale—The temporary reservation by Order in Council of 24 February 1931 of 1.416 hectares, more or less, of land east of Crown Allotment 65, section 2, Parish of Sale, as a site for Bathing and Recreation—(Rs.4114).

Walmer—The temporary reservation by Order in Council of 23 January 1912 of 17.06 hectares of land adjoining Crown Allotment 22, section 7, Parish of Walmer as a site for Supply of Gravel, revoked as to part by Order of 30 October 1923, so far as the balance remaining of 13.01 hectares, more or less—(Rs.2407).

Weerangourt—The temporary reservation by Order in Council of 25 August 1873 of 8094 square metres of land adjoining Crown Allotment 2B, section 9, Parish of Weerangourt as a site for State School Purposes, revoked as to part by Order of 16 March 1951, so far as the balance remaining of 6374 square metres—(L2-3864).

Dated: 17 March 1987

Responsible Minister:

JOAN E. KIRNER

Minister for Conservation, Forests and Lands

L. G. HOUSTON

Clerk of the Executive Council

Crown Land (Reserves) Act 1978

CROWN LANDS PERMANENTLY RESERVED

The Governor in Council under sections 4 and 7 of the *Crown Land (Reserves) Act 1978* permanently reserves for the purposes mentioned and also excepts from prospecting or from occupation for mining purposes under any miners right the following Crown lands.

Municipal District of the Shire of Arapiles

Arapiles—Management of Wildlife, 94 hectares more or less being Crown allotment 115C, Parish of Arapiles as indicated by hatching on plan hereunder. (A169(6)) (Rs.13418)

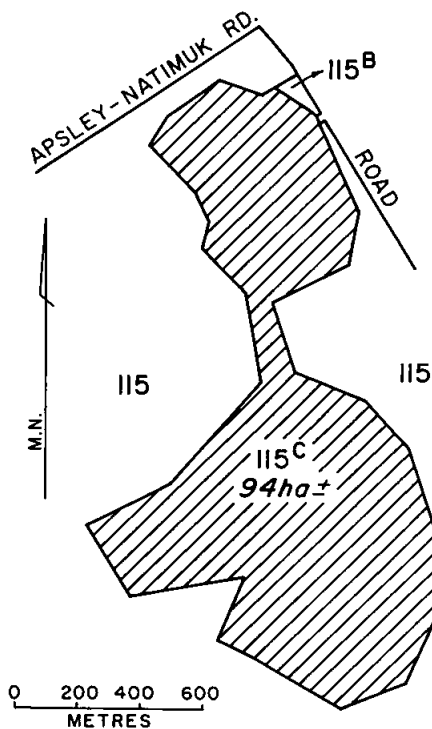

Municipal District of the Shire of Dundas

Geerak—Conservation of an area of natural interest, 3.986 hectares being Crown Allotment 4D, Parish of Geerak as shown on Certified Plan No. 107713 lodged in the Central Plan Offices. (Rs. 12691).

Municipal District of the Shire of Kowree

Harrow—Water Supply, 1.9 hectares more or less, being Crown Allotment 23B, Parish of Harrow as indicated by hatching on plan hereunder. (H49(3)) (Rs.13419)

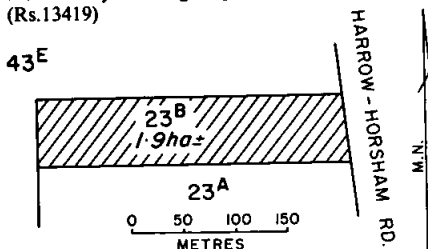

Dated: 17 March 1987
 Responsible Minister:
 JOAN E. KIRNER
 Minister for Conservation, Forests and Lands
 L. G. HOUSTON
 Clerk of the Executive Council

Land Act 1958

UNUSED ROADS CLOSED

The Governor in Council under section 349 of the *Land Act 1958* and with the consent in writing of the municipality concerned and the adjoining owners closes the following unused roads:

Municipal District of the City of Doncaster and Templestowe

Bulleen—The road in the Parish of Bulleen indicated by hatching on plan hereunder. (B526(3)) (Rs.13420)

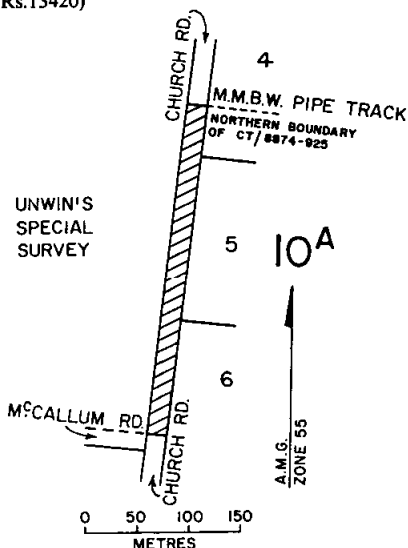

Municipal District of the City of Geelong

Geelong—The road in the City of Geelong, Parish of Corio as indicated by hatching on plan hereunder. (5311-3) (L1-984)

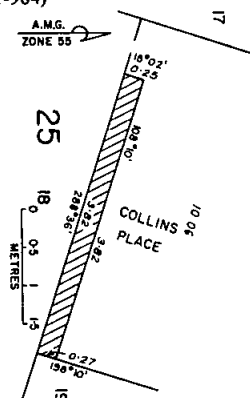

Dated: 17 March 1987
 Responsible Minister:
 JOAN E. KIRNER
 Minister for Conservation, Forests and Lands
 L. G. HOUSTON
 Clerk of the Executive Council

Land Act 1958

UNUSED ROAD CLOSED

The Governor in Council under section 349 of the *Land Act 1958* and with the consent of the municipality concerned closes the following unused road:

Municipal District of the Shire of Orbost

Bendock—The road in the Parish of Bendock shown by hatching on plan hereunder. (B644(9)) (L9-3715)

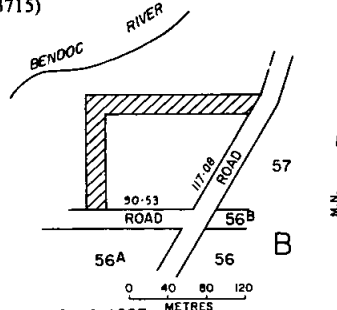

Dated: 17 March 1987
 Responsible Minister:
 JOAN E. KIRNER
 Minister for Conservation, Forests and Lands
 L. G. HOUSTON
 Clerk of the Executive Council

HISTORIC BUILDINGS ACT 1981 (No. 9667)

At the Executive Council Chamber, Melbourne, the seventeenth day of March 1987

PRESENT:

His Excellency the Governor of Victoria	
Mr Mathews	Mr Walker
Mr Walsh	Mr Simmonds

AMENDMENT OF REGISTER OF HISTORIC BUILDINGS

Whereas it is provided by section 14 of the *Historic Buildings Act 1981* that the Governor in Council, on the recommendation of the Minister, may by notice published in the *Government Gazette*, amend the Register of Historic Buildings established under the said Act—

- (a) by adding any specified building;
- (b) by removing any specified building; or
- (c) by altering any item.

And whereas the Minister has recommended that the Register be amended.

Now therefore His Excellency the Governor of the State of Victoria, by and with the advice of the Executive Council thereof, doth hereby amend the Register of Historic Buildings in the manner and to the extent shown as follows, by adding—Historic Buildings No. 650—Former Post Office, Day Avenue, Omeo (to the extent of the whole of the building and the whole of the land Certificate of Title Vol. 5784 Fol. 770).

And the Honourable James Harley Kennan, Her Majesty's Minister for Planning and Environment for the State of Victoria, shall give the necessary directions herein accordingly.

L. G. HOUSTON
Clerk of the Executive Council

HISTORIC BUILDINGS ACT 1981 (No. 9667)

At the Executive Council Chamber, Melbourne, the seventeenth day of March 1987

PRESENT:

His Excellency the Governor of Victoria	
Mr Mathews	Mr Walker
Mr Walsh	Mr Simmonds

AMENDMENT OF REGISTER OF HISTORIC BUILDINGS

Whereas it is provided by section 14 of the *Historic Buildings Act 1981* that the Governor in Council, on the recommendation of the Minister, may by notice published in the *Government Gazette*, amend the Register of Historic Buildings established under the said Act—

- (a) by adding any specified building;
- (b) by removing any specified building; or

(c) by altering any item.

And whereas the Minister has recommended that the Register be amended.

Now therefore His Excellency the Governor of the State of Victoria, by and with the advice of the Executive Council thereof, doth hereby amend the Register of Historic Buildings in the manner and to the extent shown as follows, by adding—Historic Building No. 652—"Ballam Park", Cranbourne Road, Frankston (to the extent of the homestead and its extension, the garden, the watertank, the two weatherboard stores, the blacksmith's shop and the caretaker's residence and all the land indicated in red on the plan held by the Historic Buildings Council (Part of Certificate of Title, Vol. 8505 Fol. 023) but excluding the garage, the two shops and the new shed).

And the Honourable James Harley Kennan, Her Majesty's Minister for Planning and Environment for the State of Victoria, shall give the necessary directions herein accordingly.

L. G. HOUSTON
Clerk of the Executive Council

Hospitals and Charities Act 1958

INCORPORATION OF PENINSULA COMMUNITY HEALTH SERVICE

The Governor in Council under sections 46 and 64 of the *Hospitals and Charities Act 1958* declares to be a body corporate a benevolent society by the name of Peninsula Community Health Service.

Dated: 24 March 1987

Responsible Minister:

DAVID WHITE
Minister for Health

L. G. HOUSTON
Clerk of the Executive Council

TENDERS

PUBLIC WORKS DEPARTMENT

Tenders are invited for the purposes indicated hereunder and will be received at 2 Treasury Place, Melbourne, 3002, until TWO p.m. on the dates shown.

Tenders must be addressed to the Minister for Public Works with the envelope endorsed "Tender for _____".

Tenders forwarded either by mail, telegram or telex, which arrive after the closing time, will be accepted provided that the official Telecom or Australia Post time and date stamping indicates dispatch prior to the closing time. (TIME AND DATE STAMPING MUST BE REQUESTED AT SOME POST OFFICES.)

(TELEX No. AA152039)

Hand-delivered tenders must be placed in the Department's tender box, in foyer, Ground Floor, 2 Treasury Place, Melbourne.

Tender documents are available from the Contracts Office, Room 29, Ground Floor, 2 Treasury Place, Melbourne and where indicated, at offices of Inspector of Works.

Wednesday, 1 April 1987

Building, Electrical and Mechanical Services etc.

HORSHAM—Construction of caretakers residence, Crops Research Institute—Department of Agriculture. (W.O. Horsham.)

Wednesday, 8 April 1987

Building, Electrical and Mechanical Services etc.

CARLTON—New student toilets, Primary School.

CRESSY—Internal and external repairs and painting, Primary School. (W.O. Geelong.)

FLEMINGTON—External repairs and painting to all buildings, Travencore centre.

LAVERS HILL—Siteworks, Consolidated School. (W.O. Geelong and Warrnambool.)

MELBOURNE—Fit-out works to 4th floor, 450 St. Kilda Road—T.A.F.E. Board.

MORTLAKE—Alterations and additions, High School. (W.O. Geelong and Warrnambool.)

MORTLAKE—Siteworks, High School. (W.O. Geelong and Warrnambool.)

PORT MELBOURNE—Modernise existing Drilling Unit Office, Industry Technology and Resources—Minerals Group.

SHEPPARTON—Renovations and extensions, Regional Office of Corrections. (W.O. Benalla, Shepparton and Wangaratta.)

SHERBOURNE—Internal and external repairs and painting, Primary School.

WARRNAMBOOL—*Re-advertised and amended:* Internal and external repairs and painting, Primary School. (W.O. Warrnambool.)

Wednesday, 15 April 1987

Building, Electrical and Mechanical Services etc.

CAULFIELD—*Re-advertised and Amended:* Roof repairs, High School.

KURUNJANG—Supply and Installation of Aluminium Windows and Doors, Stage 2—Blocks 1 and 2, Post Primary School.

KURUNJANG—Brickwork and Blockwork, Stage 2—Blocks 1 and 2, Post Primary School.

KURUNJANG—Roofing and Roof Plumbing, Stage 2—Blocks 1 and 2, Post Primary School.

MACROBERTSON—Internal Repairs and Painting to Hall, Girls' High School.

MELBOURNE—Fit-out works, 1st Floor, 406 Lonsdale Street, Department of Youth, Sport and Recreation.

RONALD W. WALSH
Minister for Public Works

Public Works Department
Melbourne, 23 March 1987

**PRIVATE
ADVERTISEMENTS**

CITY OF BRUNSWICK

Road Discontinued

Whereas it is provided in section 528 (2) of the *Local Government Act 1958* that where a road (whether or not a public highway, but not being a road set out on land of the Crown) or any part thereof is not required for public use, the Council of the Municipality in which such a road is situated may, not less than one month after publishing in a newspaper generally circulating in the district and posting to the registered proprietor (if any) of the land and the owners and occupiers (if any) of lands abutting or immediately adjacent to the road notice of intention to resolve that such road or part shall be discontinued.

And whereas the Council of the City of Brunswick having published or posted such notice of intention as aforesaid and having not received any objections to the proposal, has resolved that the road at the rear of 1 to 21 Culloden Street, West Brunswick, be discontinued.

Now therefore the Council of the City of Brunswick hereby directs that—

- (a) the said road which is shown by hatching on the plan hereunder shall be discontinued;
- (b) the publication of this resolution be effected in the *Government Gazette*, and
- (c) thereafter subject to any such right, title, power, authority, or interest, the said part to be sold to the abutting owners by private treaty;
- (d) the Melbourne and Metropolitan Board of Works shall continue to have and possess the same right power authority or interest in or in relation to the whole of the land shown by hatching on the said plan as it had or possessed prior to such discontinuance with respect to or in relation to any drains or pipes laid or erected in or over such land for the purposes of drainage or sewerage.

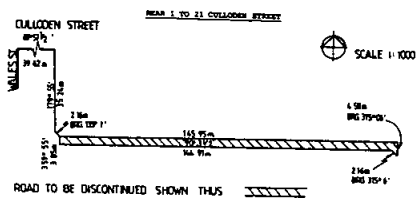

6413

K. D. WILSON
Town Clerk

CITY OF BERWICK
Public Notice
Change of Road Name

The Council of the City of Berwick in accordance with the provisions of section 535 of the *Local Government Act 1958* (as amended) resolved on Tuesday, 3 March 1987 to the following road name change:

Old Name: Berwick-Cranbourne Road, Berwick
New Name: Clyde Road, Berwick

Description: The road shown on the plan hereunder marked thus extending in a northerly direction from the south western boundary of Crown Allotment 34A Parish of Berwick (Grices Road) to High Street (Princes Highway), Berwick Village.

Effective: 1 May 1987

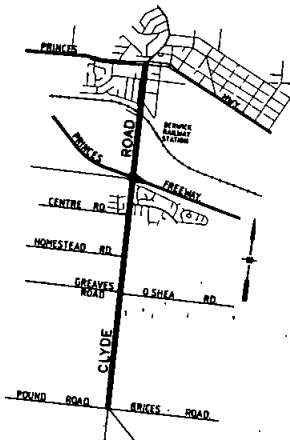

Dated: 18 March 1987

P. J. NORTHEAST
City Manager

6377

CITY OF CAMBERWELL
By-Law 213

Notice is hereby given that a By-law under sections 197 and 228 of the *Local Government Act 1958*, for the purpose of amending By-law 202 which regulates all meetings of the Council or of Standing Committees or Occasional Committees appointed by Council, has been made and sealed by the City of Camberwell.

Briefly, By-law No. 213 amends By-law 202 in regard to the manner in which deputations are received by Standing Committees of Council; in addition minor procedural changes have been made for the purpose of clarity and/or to reflect changes in the titles and operation of various Standing Committees of Council.

The Resolution for passing this By-law was agreed to by Council on 1 December 1986 and confirmed on 9 February 1987.

A copy of the abovementioned By-law is available for inspection without fee by any person during office hours 8.30 a.m.-5.00 p.m. Monday to Friday, at the Office Services Division counter of the Municipal Offices, Inglesby Road, Camberwell.

MARTIN VERHOEVEN
6419 Chief Executive Officer and Town Clerk

CITY OF COLLINGWOOD
Road Discontinuance

Pursuant to section 528 (2) of the *Local Government Act 1958*, the Council of the City of Collingwood, after consultation with Public Authorities and the advertising of its intention and notification to the registered proprietor of the land and owners and occupiers of any land abutting or as immediately adjacent to the road, has by resolution of its Ordinary Meeting held on 24 November 1986, resolved that the road between 17 and 19 Hotham Street, as shown hatched on the plan attached is:

- (a) in the opinion of Council, not reasonably required for public use, and shall be discontinued;
- (b) notwithstanding such discontinuance, the Melbourne and Metropolitan Board of Works shall continue to have and possess the same rights, title, power, authority or interest in or in relation to the road as it had or possessed prior to such discontinuance with respect to or in connection with any drain or pipes laid or erected in or over such land, for the purposes of drainage and sewerage; and,
- (c) that the land in the discontinued road be sold and transferred to the abutting owners by private treaty.

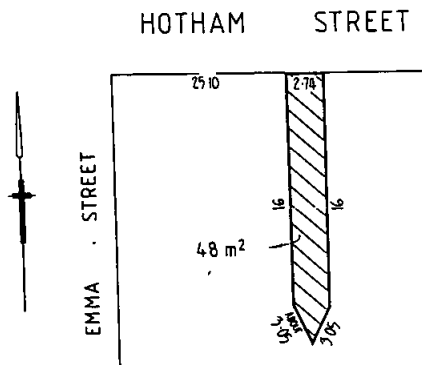

6459

L. D. COOK, Town Clerk

CITY OF ESSENDON

**Discontinuance of Right-of-Way Bounded by
Cooper, Roberts, Mary and Spencer Streets
Essendon R.O.W. 141**

Whereas it is provided in section 528 (2) (a) of the *Local Government Act 1958*, that where a road (whether or not a public highway but not being a road set out on land of the Crown) or any part hereof is not required for public use of the Council of the municipality in which such road is situated made not less than one month after publishing in a newspaper generally circulating in the district and posting to the registered proprietor (if any) of the land and to the owners and occupiers (if any) of lands abutting or immediately adjacent to the road notice of intention to pass such a resolution published in the *Government Gazette* direct that such a road or part shall be discontinued and thereupon such road or part shall be discontinued accordingly.

And whereas the Council of the City of Essendon on 23 February 1987, resolved that the road be discontinued and not less than one month previously has published in a newspaper generally circulating in the district and posted to the registered proprietors of the land in the roads and to the owners and occupiers of lands abutting or immediately adjacent to the roads notice of intention to make such a resolution.

Now therefore the Mayor, Councillors and Citizens of the City of Essendon by resolution dated 23 February 1987, hereby directs:

(a) that the said road which is shown by hatching on the plan hereunder, shall be discontinued:

- (b) that notwithstanding such discontinuance the Melbourne and Metropolitan Board of Works and the Mayor, Councillors and Citizens of the City of Essendon shall continue to have and possess the same right, title, power, authority or interest in or in relation to the whole of the land shown by hatching on the said plan as they had or possessed prior to such discontinuance with respect to or in connection with any drains or pipes laid or erected in or over such land for the purposes of drainage or sewerage; and
- (c) that, subject to any such right, title, power, authority, interest in the land in the said road may be sold by Council of the City of Essendon by agreement.

SPENCER ST.

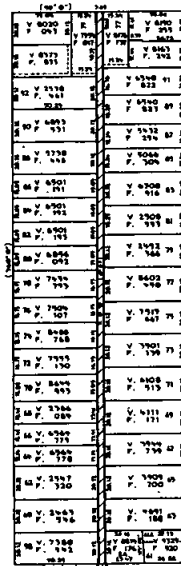

Civic Centre
Moonee Ponds

6400

P. R. SEAMER
City Manager

CITY OF SHEPPARTON

By-Law No. 75

Meeting Procedure (Amendment) By-Law

A By-Law of the City of Shepparton made under section 197 of the *Local Government Act 1958*, and numbered 75 for the purpose of amending By-Law No. 63 (Meeting Procedure By-Law).

In pursuance of the powers contained in the *Local Government Act 1958*, the Mayor, Councillors and Citizens of the City of Shepparton order as follows:

By-Law No. 63 is hereby amended as follows:

(1) After Clause 39 insert Clause 39A:

'39A. *Limit to Speaking Time When Presenting Standing Committee Reports*

Notwithstanding anything contained in Clause 39 of this By-Law the Chairman, or in the Chairman's absence, the Deputy Chairman or some other person acting in their place, shall have ten minutes in which to present Standing Committee Reports.;

(2) Delete Clause 25 as it presently stands and substitute the following:

'25. *Moving Motions or Amendments*

(a) Any Councillor may propose or second an amendment to a motion, save that the mover or seconder of the original motion shall not propose or second an amendment unless or until the original motion has been amended and the amended motion is the motion before the meeting.

(b) Each amendment shall be dealt with separately and no subsequent amendment proposed, seconded or accepted for discussion until the vote on the amendment before the meeting has been taken and debate resumed on the motion (either in the form previously before the meeting if the amendment was lost or in the amended form if carried).

(c) Unless otherwise provided in this clause there shall be no limit on the number of amendments which any one Councillor may propose or second to the original motion or the motion amended.;

(3) Delete Clause 36 as it presently stands and substitute the following:

'36. *Speaking Twice*

No Councillor shall speak a second time on the same motion except—

- (a) As provided in clauses 26 and 27 hereof;
- (b) In explanation when he or she has been misrepresented or misunderstood;
- (c) When the motion in the form to which the Councillor last spoke has been amended and the motion as amended is the motion then under discussion before the meeting.' "

Resolution for passing this By-Law was adopted by the Council on 9 February 1987, and confirmed on 10 March 1987.

The Common Seal of the Mayor, Councillors and Citizens of the City of Shepparton was hereunto affixed in the presence of—

W. B. HUNTER, Mayor
K. F. RIORDAN, Councillor
I. L. GILBERT, Town Clerk

CITY OF SHEPPARTON

Naming of Street

Pursuant to the provisions of section 535 (4) of the *Local Government Act 1958*, the Council at a meeting on 10 March 1987, resolved to name the previously unnamed section of street, westerly from Adams Avenue, as "Andrew Fairley Avenue".

Dated 18 March 1987

I. L. GILBERT

6414

City Manager/Town Clerk

CITY OF SOUTH BARWON

Discontinuance of Road

Notice is hereby given that in accordance with section 528 (2) of the *Local Government Act 1958*, the City of South Barwon has resolved that the road shown hatched below, known as part Lot 35 Crows Road is not reasonably required as a road for public use and that the Council has resolved to discontinue and sell the said road by private treaty to owners.

Now therefore the Council of the City of South Barwon hereby directs:

- (a) That the said road which is shown by hatching on the plan herewith shall be discontinued upon publication of Resolution in the *Government Gazette*;
- (b) That notwithstanding the discontinuance, the Geelong and District Water Board shall continue to have and possess the same access rights over that part of the said road as they possessed prior to such discontinuance;
- (c) That subject to any such right, title, power, authority or interest in the land the said road shall vest in the municipality until it is sold by private treaty.

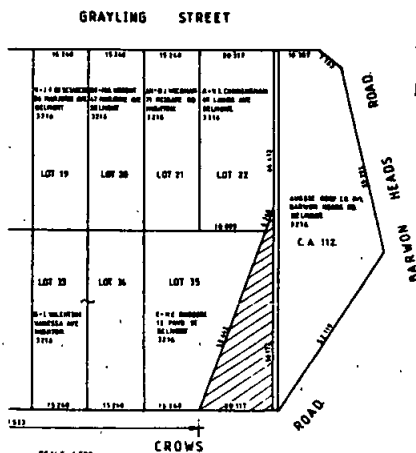

6401

K. B. McDONALD
Town Clerk

Town and Country Planning Act 1961

CITY OF WANGARATTA

Notice that a Planning Scheme has been Prepared and is Available for Inspection

Wangaratta Sub-Regional Planning Scheme—
(City of Wangaratta)
Amendment No. 20

Notice is hereby given that the Council of the City of Wangaratta in pursuance of its powers under the *Town and Country Planning Act 1961*, has prepared a scheme for rezoning land at the corner of Mather and Shadforth Streets Wangaratta, described in Certificate of Title, Volume 8535, Folios 468 through to 473, from Commercial "B" to Residential "A".

A copy of the scheme has been deposited at the Council Offices, Ovens Street, Wangaratta, the Ministry for Planning and Environment (Plan Inspection Section), The Olderfleet Buildings, 477 Collins Street, Melbourne and at the Regional Office of the Ministry for Planning and Environment, Astra House, Jack Hore Place, Wodonga and will be open for inspection during office hours by any person free of charge.

Any persons affected by the Scheme are required to set forth in writing any submission they may wish to make with respect to the Scheme addressed to the Town Clerk, City of Wangaratta, P.O. Box 238, Wangaratta, 3677, by 27 April 1987, and state whether they wish to be heard in respect of their submission.

J. W. ELWARD
Town Clerk

6378

Form 2.1

Town and Country Planning Act 1961

SHIRE OF ARARAT (WILLAURA) PLANNING
SCHEME

Notice that a Planning Scheme has been Prepared and is Available for Inspection
Amendment No. 5, 1987

Notice is hereby given that the Council of the Shire of Ararat in pursuance of its powers under the *Town and Country Planning Act 1961* has prepared a Scheme to allow "Home Industries" and "Home Occupation" within the residential district of the Township of Willaura.

A copy of the scheme has been deposited at the office of the Council of the Shire of Ararat, Barkly Street, Ararat, at the office of the Ministry for Planning and Environment, The Olderfleet Buildings, 477 Collins Street, Melbourne and at the regional office of the Ministry for Planning and Environment, corner Mair and Doverton Streets, Ballarat and will be open for inspection during office hours by any person free of charge.

Any persons affected by the scheme are required to set forth in writing any submission they may

wish to make with respect to the scheme addressed to the Shire Secretary, Shire of Ararat, P.O. Box 90, Ararat 3377 by 27 April 1987 and state whether they wish to be heard in respect of their submission.
Dated 18 March 1987

BARRY J. SERTORI
Shire Secretary

6402

SHIRE OF BELLARINE

Order for Dedication of a Public Highway

Pursuant to the provisions of section 522 of the *Local Government Act 1958* the Council of the Shire of Bellarine hereby directs that the land with frontage of 10.33 metres to the southern side of Dorothy Street, Leopold by depth of 36.58 metres along the eastern side of Simons Road being the land described in Certificate of Title Volume 9406 Folio 008 and in Transfer No. M742939B lodged in the Titles Office which land has been purchased, taken or acquired by it, shall be a public highway on and from the date of publication of this Order in the *Government Gazette*.

The common seal of the President, Councillors and Ratepayers of the Shire of Bellarine was affixed hereto this 19 March 1987 in the presence of:

V. ROBINSON, President
KEVIN J. BELL, Councillor
P. L. WIGNALL, Shire Secretary

6421

SHIRE OF CRESWICK

Notice of Intention to Take Land Compulsorily

Whereas the Council of the Shire of Creswick deems it expedient to exercise the powers of taking land compulsorily and whereas in the opinion of the Council such compulsory taking of land is necessary and desirable notice is hereby given:

1. That the Council of the Shire of Creswick has deemed it expedient to exercise its power of taking compulsorily the lands described hereunder for road reserve purposes.

2. The said Council has caused to be prepared and has approved maps and other papers showing the general description of the work or undertaking for which the lands proposed to be taken are to be used, the description of the lands proposed to be so taken and the names of the owners or reputed owners lessees or reputed lessees, mortgagees and occupiers of the said lands so far as those names are known to or can be ascertained by the Council.

3. Such maps and other papers have been deposited at the office of the Council, Shire Hall, Creswick and are open for inspection by all persons interested at all reasonable hours for 40 clear days after the publication of this notice in the *Government Gazette*.

4. The lands proposed to be taken are:

- (a) All that piece of land being Allotment 1 of section 51, Township of Creswick, Parish of Creswick, County of Talbot and being the land described in Crown Grant Number 24 Folio 4614;
- (b) All that piece of land being Allotment 3B, section 10, Township of Creswick, Parish of Creswick, County of Talbot and being the land described in Crown Grant Volume 6562 Folio 279;
- (c) All that piece of land being Allotment 1, section 63, Township of Creswick, Parish of Creswick, County of Talbot and being the land described in Crown Grant Volume 280 Folio 816;
- (d) All that piece of land containing 2 roods more or less being Allotment A3, Parish of Creswick, County of Talbot being the land described in Crown Grant Volume 2525 Folio 944.

5. All persons affected by the proposed taking of the said land are required to set forth in writing, addressed to the Council or the Shire Secretary of the Shire of Creswick within 40 clear days from the publication of this notice in the *Government Gazette*, all objections which they may have to the taking of the said land.

6403

B. C. REES
Shire Secretary

SHIRE OF CRESWICK

Notice of Intention to Take Land Compulsorily

Whereas the Council of the Shire of Creswick deems it expedient to exercise the powers of taking land compulsorily and whereas in the opinion of the Council such compulsory taking of land is necessary and desirable notice is hereby given:

1. That the Council of the Shire of Creswick has deemed it expedient to exercise its power of taking compulsorily the lands described hereunder for recreation reserve purposes.

2. The said Council has caused to be prepared and has approved maps and other papers showing the general description of the work or undertaking for which the lands proposed to be taken are to be used, the description of the land proposed to be so taken and the names of the owners or reputed owners, lessees or reputed lessees, mortgages and occupiers of the said land so far as those names are known to or can be ascertained by the Council.

3. Such maps and other papers have been deposited at the office of the Council, Shire Hall, Creswick and are open for inspection by all persons interested at all reasonable hours for 40 clear days after the publication of this notice in the *Government Gazette*.

4. The lands proposed to be taken are:

- (a) All that piece of land being Allotment 6 of section 52, Township of Creswick, Parish of Creswick, County of Talbot and being the land described in Crown Grant Number 4611 Folio 1863;
- (b) All that piece of land being Allotment 3 of section 56A, in the Township of Creswick, Parish of Creswick, County of Talbot and being the land described in Crown Grant Volume 2177 Folio 328.

5. All persons affected by the proposed taking of the said land are required to set forth in writing addressed to the Council or the Shire Secretary of the Shire of Creswick within 40 clear days from the publication of this notice in the *Government Gazette* all objections which they may have to the taking of the said land.

6404

B. C. REES
Shire Secretary

SHIRE OF GISBORNE

Abolishment and Establishment of Pounds

The Council of the Shire of Gisborne determined to abolish and re-establish its pound facilities as follows:

1. To abolish the pound currently located in Bacchus Marsh Road and more particularly described as Reserve, *Gazette* 1872, page 373, being part of section E, Parish of Gisborne.

2. To reserve the following areas for the purposes of the Pound Act pursuant to section 4 of the said Act:

- (a) The land comprising some 8.5 hectares on the corner of Hamilton and Barringo Roads, New Gisborne, and more particularly described as Lots 8 and 9, LP 91979.
- (b) The land described as Lot 25 Ladd Road, New Gisborne, being part of Crown Allotment C, section 4, Parish of Gisborne.

Further information is available from the undersigned if required.

6427

T. H. LARKINS, Shire Secretary

SHIRE OF KILMORE

Wallan Sewerage Scheme

Reticulation Stage 1

Notice is hereby given in accordance with section 119 of the Sewerage Districts Act of the Councils intention after a period of 30 days to commence construction of sewers and associated works.

The area of construction is generally bounded by Queen Street (south side), Windham Street (east side) and Watson Street (north side). This land is generally known as the Wedding Drive Estate.

C. Definitions

3. In this By-Law unless the context or matter subject otherwise indicates or requires—

- (a) "Council" means the Council of the Shire of Wangaratta; and its delegated officers;
- (b) "permit" means a permit in writing issued by or given by or under the authority of the Council or its authorised officer pursuant to the provisions of this By-Law and in accordance with the form specified in Schedule 1, or to the like effect and subject to the conditions as specified in Schedule 1 as may be applicable;
- (c) "Road Reservation" means any street or road situated in the municipality;
- (d) "Timber" means any tree or shrub, whether it be dead or alive, standing or fallen, and includes firewood.

D. General Provisions

4. No person shall remove any timber from a road reservation within the municipality—

- (a) without previously obtaining a permit from the Council; and
- (b) complying with the conditions contained in the permit.

5. Any person who contravenes or fails to comply with the provisions of this By-Law shall be guilty of an offence and shall be liable to a penalty of not more than five penalty units.

E. Operation of By-Law

This By-Law shall come into operation on the day after the day of publication thereof in the *Government Gazette*.

Schedule 1

as Referred to in—C. Definitions clause 3 (b) hereinbefore

SCHEDULE 1

SHIRE OF WANGARATTA

Permit Issued Pursuant to the

Collection of Firewood By-Law No. 34

I..... of.....
is hereby permitted to remove green/dry* timber from..... Road reservation adjacent to Allotment/s..... Section..... Parish of.....
within the Shire of Wangaratta for a period of 30 days from the date hereof, subject to compliance with the provisions of the said By-Law and the conditions as follows:

- 1. No obstruction shall be caused to traffic.
- 2. All stumps shall be *grubbed/cut off at..... mm *above/below ground level and any resultant holes shall be filled with soil, leaving same 150mm. above surrounding surface.

3. All debris resulting from operations shall be removed from the road reserve, and clear of water tables and drains.

4. All precautions shall be taken to prevent damage to the road, and in the event of damage, such damage shall be made good at the applicant's expense, and to the satisfaction of Council.

5. Applicants shall be liable for, and shall indemnify the Council against all actions claims and demands whatsoever arising out of any damage caused by the exercise of powers conferred by the granting of approval to this application.

6. The applicant shall lodge a deposit of \$..... with the Council and such deposit may be forfeited in the event of any non-compliance with the above conditions.

Dated day of 19.....
.....
Authorised Officer of the Shire of Wangaratta

Note to: Forests Officer,
I hereby certify that the above conditions will be complied with

.....
Applicant, Nominated Agent

NOTICE TO APPLICANT

Subject to payment in advance, of royalties assessed at \$..... you will be issued with a Licence granting authority to remove timber as defined in application. You *are/are not hereby granted Authority to remove timber as defined in application, authority valid until.....

.....
Forest Officer

*Strike out words/conditions not applicable.

Resolution for having this By-Law was agreed to by the Council on Wednesday, 18 February 1987 and confirmed on Wednesday, 18 March 1987.

The By-Law becomes effective on the day after this notice is published in the *Victoria Government Gazette*—namely, 25 March 1987.

A copy of the By-Law is available for inspection, free of charge, during office hours at the Shire Office, 23 Ely Street, Wangaratta.

Dated 18 March 1987

B. J. HALLINAN
Shire Secretary

6406

SHIRE OF WOORAYL

Closure of Road to through Traffic

Whereas the Council of the Shire of Woorayl:

- 1. is of the opinion that it is desirable that the right of way between Mary Rogers Crescent and

A'Beckett Street, Leongatha should be closed to through traffic by the erection of barriers pursuant to section 539c of the *Local Government Act 1958*;

2. has consulted and received a report by the Road Traffic Authority referred to in section 539c (5);

3. has served notice of the proposal on the owners and the occupiers listed in the proposal being the owners and occupiers of all properties in Mary Rogers Crescent, A'Beckett Street and Millicent Street abutting the right of way, in accordance with section 539c (2);

4. has considered the one objection received to the proposal;

Now the Council does hereby direct—

- (a) that the proposal to close the right of way to through traffic by the erection of barriers as shown on the plan below, be adopted without modification;
- (b) that public notice of the adoption of this Order be placed in the *Government Gazette* and specify that the Order as adopted shall come into operation on Monday 6 April 1987.

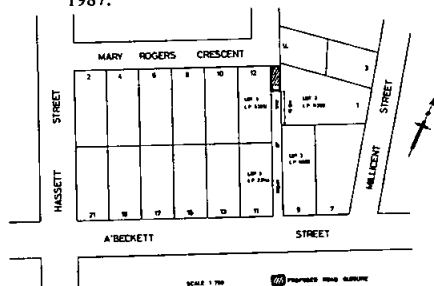

6428 R. G. STANLEY, Shire Secretary

GEELONG AND DISTRICT WATER BOARD

Pursuant to section 60 of the *Geelong Waterworks and Sewerage Act 1958* (No. 6263) the Board has prepared plans to indicate the particulars of sewers and underground works, the construction of which the Board intends to begin at a date not less than one month after publication of the notices, in or adjacent to the following locality within the Drainage Area.

Bailey Street, Belmont, City of South Barwon

Notice is hereby given that the plans indicated are open for public inspection at the Board's offices, 61-67 Ryrie Street, Geelong between the hours of 8.10 a.m. and 5.00 p.m. from Monday to Friday (public holidays excepted) by the owners or occupiers of land or premises within the Drainage Area.

R. A. JORDAN
Secretary

6461

**Sixth Schedule
MORNINGTON PENINSULA AND DISTRICT
WATER BOARD
General Notice**

Declaration of Sewerage Area

The abovementioned Board having made provision for carrying off the sewage from each and every property which, or any part of which, is within the Sewerage Area hereinafter described, doth hereby declare that on or after 1 May 1987 each and every property which, or any part of which, is within the said Sewerage Area shall be deemed to be a sewered property within the meaning of the *Sewerage Districts Act 1958*.

The boundaries of the Sewerage areas hereinafter referred to are:

**Shire of Cranbourne Sewerage District
Sewerage Area No. 135**

The boundaries of all that piece of land comprising Lot No. 529 on Lodged Plan of Subdivision No. 202803, such allotment having an abuttal to Hornsby Drive, Langwarrin, Lot Nos. 536 to 538 inclusive on Lodged Plan of Subdivision No. 202803 such allotments having an abuttal to Casuarina Close, Langwarrin, Lot No. 549 on Lodged Plan of Subdivision No. 202803, such allotment having an abuttal to Hornsby Drive, Langwarrin, Lot Nos. 552, 553 on Lodged Plan of Subdivision No. 202803 such allotments having an abuttal to Correa Court, Langwarrin

By Order of the said Water Board

J. K. BUCHANAN, Chairperson
J. O. WILLIAMS, Secretary

6462

**Sixth Schedule
MORNINGTON PENINSULA AND DISTRICT
WATER BOARD
General Notice
Declaration of Sewerage Area**

The abovementioned Board having made provision for carrying off the sewage from each and every property which, or any part of which, is within the Sewerage Area hereinafter described, doth hereby declare that on or after 1 May 1987 each and every property which, or any part of which, is within the said Sewerage Area shall be deemed to be a sewered property within the meaning of the *Sewerage Districts Act 1958*.

The boundaries of the Sewerage areas hereinafter referred to are:

**Shire of Mornington Sewerage District
Sewerage Area No. 193**

The boundaries of all that piece of land comprising Lot Nos. 21 to 23 inclusive on Lodged Plan of Subdivision No. 23815 such allotments having an abuttal to Kilburn Grove, Mount Martha.

By Order of the said Water Board

J. K. BUCHANAN, Chairperson
J. O. WILLIAMS, Secretary

6463

STAWELL WATER BOARD**Notice of Commencement of Construction of Sewerage Works**

Pursuant to section 119 (2) of the *Sewerage Districts Act 1958* notice is hereby given of the intention to construct sewers for properties situated in the following areas, at least 30 days after the date of this notice.

D'Arcy Street—Lots, 16, 17, 18, 19, 26, 27, 28, 29, 30 and 31 on Plan of Subdivision 42980 Township and Parish of Stawell and Crown Allotments 6 section 129 Township and Parish of Stawell, and more particularly as shown on plans which are open for inspection at the office of the Stawell Water Board between the hours of 8.30 a.m. and 5.15 p.m. Monday to Friday inclusive.

N. R. ILLIG
Secretary

6380

Sixth Schedule

MORNINGTON PENINSULA AND DISTRICT WATER BOARD**General Notice****Declaration of Sewerage Area**

The abovementioned Board having made provision for carrying off the sewage from each and every property which, or any part of which, is within the Sewerage Area hereinafter described, doth hereby declare that on or after 1 May 1987 each and every property which, or any part of which, is within the said Sewerage Area shall be deemed to be a sewerage property within the meaning of the *Sewerage Districts Act 1958*.

The boundaries of the Sewerage Areas hereinafter referred to are:

Shire of Flinders Sewerage District
Sewerage Area No. 113

The boundaries of all that piece of land comprising Lot Nos. 5 to 20 inclusive, 27 to 38 inclusive 40 to 43 inclusive on Lodged Plan of Subdivision No. 43632 such allotments having an abuttal to Burunda Road, Rosebud, Lot Nos. 37, 38 on Lodged Plan of Subdivision No. 39191, Lot Nos. 35, 36 on Lodged Plan of Subdivision No. 43202, Lot Nos. 21, 22, 25, 26 on Lodged Plan of Subdivision No. 43632, Lot No. 1 on Lodged Plan of Subdivision No. 111103 such allotments having an abuttal to Troon Road, Rosebud, Lot Nos. 6, 7 on Lodged Plan of Subdivision No. 62053 such allotments having an abuttal to Wilgah Road, Rosebud, Lot Nos. 281 to 300 inclusive on Lodged Plan of Subdivision No. 40098, Lot No. 2 on Lodged Plan of Subdivision No. 79489 such allotments having an abuttal to Austin Avenue, Rosebud, Lots Nos. 1 to 8 inclusive, 14 to 21 inclusive on Lodged Plan of Subdivision No. 53552, Lot Nos. 4 to 34 inclusive on Lodged Plan of Subdivision No. 43202, Lot Nos. 9 to 13 inclusive, 22 to 26 inclusive on Lodged Plan of Subdivision No. 57338 such allotments having an

abuttal to Sunningdale Road, Rosebud, Lot No. 32 to 40 inclusive on Lodged Plan of Subdivision No. 53552, Lot Nos. 27, 28, 30, 31 on Lodged Plan of Subdivision No. 57338 such allotments having an abuttal to Fairway Grove, Rosebud, Lot Nos. 302 to 316 inclusive, 325 to 331 inclusive on Lodged Plan of Subdivision No. 40098, Lot No. 1 on Lodged Plan of Subdivision No. 78489, such allotments having an abuttal to Fairway Crescent, Rosebud, Lot No. Part 3 on Lodged Plan of Subdivision No. 15787, Lot Nos. 2, 3, 5 on Lodged Plan of Subdivision No. 44313, Lot Nos. 1, 2 on Lodged Plan of Subdivision No. 71538, lot Nos. 1, 2 on Lodged Plan of Subdivision No. 113604, Lot No. 1 on Lodged Plan of Subdivision No. 114472, Lot Nos. 1, 2 on Lodged Plan of Subdivision No. 140323, Lot Nos. 1 to 4 inclusive on Lodged Plan of Subdivision No. 141800 such allotments having an abuttal to Hove Road, Rosebud. Lot Nos. 11 to 20 inclusive, on Lodged Plan of Subdivision No. 27639, such allotments having an abuttal to Armstrong Road, Rosebud, Lot Nos. 21 to 25 inclusive, 40 on Lodged Plan of Subdivision No. 27639, Lot Nos. 26, 27, 32, 180 to 190 inclusive, 192 to 202 inclusive on Lodged Plan of Subdivision No. 31231 such allotments having an abuttal to Hillman Avenue, Rosebud, Lot Nos. 28 to 30 inclusive 33, 34 on Lodged Plan of Subdivision No. 31231, such allotments having an abuttal to Morgan Court, Rosebud, Lot Nos. 203 to 215 inclusive, 220-232 inclusive on Lodged Plan of Subdivision No. 31231, Lot No. 1 on Lodged Plan of Subdivision No. 82559 such allotments having an abuttal to Riley Street, Rosebud, Lot Nos. 191, 216-218 inclusive on Lodged Plan of Subdivision No. 31231, Lot Nos. 279, 280 on Lodged Plan of Subdivision No. 40098, Lot Nos. 1, 2 on lodged plan of Subdivision No. 44473, Lot No. 2 on lodged plan of subdivision 82559 such allotments having an abuttal to Talbot Grove, Rosebud, Lot Nos. 317, 318, 321 to 324 inclusive on Lodged Plan of Subdivision No. 40098, Lot No. 3 on Lodged Plan of Subdivision No. 44473, such allotments having an abuttal to Daimler Court, Rosebud.

Sewerage Area No. 114

The boundaries of all that piece of land comprising Lot Nos. 62 to 64 inclusive on Lodged Plan of Subdivision No. 10775, such allotments having an abuttal to Latrobe Parade, McCrae, Lot Nos. 71 to 75 inclusive on Lodged Plan of Subdivision No. 10775, such allotments having an abuttal to Rudduck Street, McCrae, Lot Nos. 54 to 56 inclusive on Lodged Plan of Subdivision No. 16394, Lot Nos. 1, 2, on Lodged Plan of Subdivision No. 124553, Lot Nos. 144 to 146 inclusive Part 157, Part 158 159 to 162 inclusive on Lodged Plan of Subdivision No. 15265, Lot Nos. 2, 3, on Lodged Plan of Subdivision No. 41498, Lot Nos. 147, 148 on Lodged Plan of Subdivision No. 30122, such allotments having an abuttal to Outlook Road, McCrae, Lot Nos. 5 to 10 inclusive, 19, 26, 27, on

Lodged Plan of Subdivision No. 53282, such allotments having an abuttal to Alexander Parade, McCrae, Lot Nos. 20 to 25 inclusive on Lodged Plan of Subdivision No. 53282 such allotments having an abuttal to Timara Court, McCrae, Lot Nos. 1 to 7 inclusive on Lodged Plan of Subdivision No. 114055, Lot Nos. 32 to 45 inclusive, 57 to 63 inclusive on Lodged Plan of Subdivision No. 57637, such allotments having an abuttal to Arthurs Avenue, McCrae, Lot Nos. 28 to 31 inclusive, 56 on Lodged Plan of Subdivision No. 57637, Lot Nos. 1 to 4 inclusive, 28 to 34 inclusive on Lodged Plan of Subdivision No. 53282, Lot Nos. 149 to 151 inclusive, 154 to 156 inclusive, on Lodged Plan of Subdivision No. 15265, Lot No. 61 on Lodged Plan of Subdivision No. 16394, Lot Nos. 76 to 80 inclusive on Lodged Plan of Subdivision No. 10775, Lot Nos. 1 to 3 inclusive on Lodged Plan of Subdivision No. 114593, such allotments having an abuttal to Bayview Road, McCrae, Lot Nos. 1 to 18 inclusive, 21 to 27 inclusive on Lodged Plan No. 57637, such allotments having an abuttal to The Boulevard, McCrae. Consolidation Plan No. 100900 such allotment having an abuttal to The Boulevard, McCrae.

Sewerage Area No. 115

The boundaries of all that piece of land comprising Lot Nos. 16 to 24 inclusive on Lodged Plan of Subdivision No. 44943, Lot Nos. 1 to 3 inclusive on Lodged Plan of Subdivision No. 44944, Lot Nos. 90, 91, 116, 117 on Lodged Plan of Subdivision No. 50763, Lot No. 1 on Lodged Plan of Subdivision No. 113118, such allotments having an abuttal to Elizabeth Street, Rosebud, Lot Nos. 25 to 30 inclusive on Lodged Plan of Subdivision No. 44944, Lot Nos. 118, 125 to 127 inclusive, 142 to 145 inclusive, 148 to 151 inclusive on Lodged Plan of Subdivision No. 51302, Consolidation Plan No. 152708, such allotments having an abuttal to Old Cape Schanck Road, Rosebud, Lot Nos. 33 to 36 inclusive on Lodged Plan of Subdivision No. 34277, Lot Nos. 137 to 141 inclusive on Lodged Plan of Subdivision No. 51302, on Lodged Plan of Subdivision Nos. 52, 53, 72 to 75 inclusive on Lodged Plan of Subdivision No. 44936, such allotments having an abuttal to Waterfall Gully Road, Rosebud, Lot Nos. 4 to 6 inclusive on Lodged Plan of Subdivision No. 44944, Lot Nos. 6 to 15 on Lodged Plan of Subdivision No. 44943, such allotments having an abuttal to Bayview Road, Rosebud, Lot Nos. 27 to 35 inclusive, 54, 57, 60 to 66 inclusive, Consolidation Plan Nos. 161602, 161907, such allotments having an abuttal to Leura Crescent, Rosebud, Lot Nos. 92 to 103 inclusive, 113 to 115 inclusive on Lodged Plan of Subdivision No. 50763, Lot Nos. 20 to 24 inclusive, 41 to 44 inclusive, 61 to 64 inclusive on Lodged Plan of Subdivision No. 44936, Lot Nos. 119 to 124 on Lodged Plan of Subdivision No. 51302 such allotments having an abuttal to Anne Street, Rosebud, Lot Nos. 65 to 71 inclusive on Lodged

Plan of Subdivision No. 44936 such allotments having an abuttal to Caroline Court, Rosebud, Lot Nos. 128 to 136 inclusive on Lodged Plan of Subdivision No. 51302 such allotments having an abuttal to Devon Court, Rosebud, Lot Nos. 19, 45 to 51 inclusive, 54 to 60 inclusive on Lodged Plan of Subdivision No. 44936, Lot Nos. 7 to 14 inclusive, 17, 18 31 to 40 inclusive on Lodged Plan of Subdivision No. 44944, Consolidation Plan No. 108472 such allotments having an abuttal to Leisure Way, Rosebud.

By Order of the said Water Board

6464 J. K. BUCHANNAN, Chairperson
J. O. WILLIAMS, Secretary

Take notice that as at 1 March 1987 the partnership of Lewis Walker & Robinson was dissolved and David Meredith Robinson will re-establish the practice of David M. Robinson & Associates of 84 Station Street, Fairfield and will not be responsible for any liabilities incurred by Lewis Walker & Robinson from that date.

D. M. ROBINSON, solicitor 6381

Notice is hereby given that the partnership heretofore subsisting between Sigmar Proebstl, Melita Proebstl, Arthur Endres and Honilori Endres carrying on business of scallop fishing under the name or style of South Esk Fisheries has been dissolved as from 24 February 1987. 6407

Take notice that Christopher John Pietsch has retired from the partnership of David Charles Pietsch, Lola Dorothy Pietsch and Christopher John Pietsch all of Kewell East, farmers and as between Christopher John Pietsch of the first part and David Charles Pietsch and Lola Dorothy Pietsch of the second part the partnership will be dissolved as and from 1 February 1987.

THOMPSON, FRANCIS & COMPANY,
solicitors, Horsham 6465

Notice is hereby given that the partnership until now subsisting between Michael Muirhead and Desmond John Reynolds carrying on business as suppliers of welding alloys at 85 Hudson Road, Spotswood under the style or firm of Alloy Supplies Australia has been dissolved as from 20 March 1987.
Dated 18 March 1987

RUSSELL, KENNEDY & COOK, solicitors of
257 Collins Street, Melbourne for and on behalf of
Michael Muirhead 6444

Notice is hereby given that partnership heretofore subsisting between Reginald Mervyn Friend, Colin John Daniels, Peter Godfrey Allaway and Peter James Mapleback, carrying on business as solicitors at 10 Queen Street, Melbourne and 20 Russell Street, Essendon under the name of Akehurst, Friend & Allaway, has been dissolved as from 1 February 1987 so far as concerns the said Reginald Mervyn Friend, who retired from the said firm. 6443

CHATHAM DIXON PTY. LTD.

Notice of Liquidators Final Meeting per S 411
Companies Code (Victoria)

Members are advised that a final meeting of the company will be held at the office of McLean Delmo & Partners, second floor, 300 Burwood Road, Hawthorn, at 10 a.m. on 30 April 1987 to consider the liquidators account of the winding up.

6382 A. D. McLEAN, Liquidator

Companies (Victoria) Code, Section 411
J. HAYAT & CO. PTY. LTD.

(In Voluntary Liquidation)

Notice is hereby given that a final meeting of members of the company will be held at 8 Aberdeen Road, Prahran, on 27 April 1987 at 9.00 a.m. for the purpose of laying before it the liquidators financial accounts and to finalise the liquidation, and dissolution of the company.

Dated 17 March 1987

BARRY HODSON & JACOB STAINMAGEN,
liquidators, 8 Aberdeen Road, Prahran 6383

Notice is hereby given that the partnership heretofore subsisting between Gloria Lorraine Ring and George Walter Ring carrying on business at Lot 53 Ring's Road, Daylesford (also known as Tipperary Springs Road, Daylesford) as Plant Operators, under the style or firm name of "G. W. & G. Ring" has been dissolved as from 5 March 1987.

Dated 5 March 1987

6416 GLORIA L. RING

Unclaimed Moneys Act 1962

Register of Unclaimed Moneys held by the—

Name of Owner on Books and Last Known Address	Total		Date when Amount first became Payable
	Amount Due to Owner	Description of Unclaimed Money	

\$

KRAFT FOODS LIMITED

Bouzos, N, 43 Tribe St, Richmond	2070.60	Wages	21.7.85
Barnes, D J, 84 Roden St, West Melbourne 6313	525.00	"	14.7.85

E J LOVE & CO

Dunn, P. A., 3 Lansell Crt, Thomastown	170.00	Deposit	30.1.85
Mouriston, M and W, 64 Winter Cres, Reservoir	168.32	"	23.6.82
Ward, D M, 6/27 Cash St, Kingsbury	113.42	"	24.8.82
Hooper, J, 1/8 Pratt St, Reservoir	17.50	"	4.11.82
Grubb, S, 4/23 Ashley St, Reservoir	160.00	"	24.1.83
Senn, M S, 4/1 Frankston St, Reservoir	100.00	"	9.2.83
Smart, D and D, 5/6 Storey Rd, Reservoir	25.71	"	7.4.83
Tsalikis, A and P, 9 Shand Rd, Reservoir	36.70	"	16.12.83
Heerah, E and M, 1/27 Grimwade St, Reservoir	21.14	"	9.5.84
Gamblin, R G and C, 8 Sheffield St, Preston	82.86	"	12.12.84
Church, L. E., 5/178 Dunne St, Kingsbury 6392	26.03	"	18.2.86

ARNOTT BROCKHOFF GUEST

Neill, J G, 3/34A Arundel Ave, Glenroy 6309	102.60	Wages	6.11.84
--	--------	-------	---------

Unclaimed Moneys Act 1962

Register of Unclaimed Moneys held by the—

<i>Name of Owner on Books and Last Known Address</i>	<i>Total Amount Due to Owner</i>	<i>Description of Unclaimed Money</i>	<i>Date when Amount first became Payable</i>
\$			
EMPEROR MINES LIMITED			
Atkinson, Mary G, 9 Bella Vista Rd, Caulfield	41.76	Dividend	7.11.85
Balderstone, Michael T, Rhinds Rd, Wallington	27.36	"	"
Bartlett, Leslie R, Ringwood Farm, Cooperstown, New York, 133326, USA	29.58	"	"
Bathgate, I F & B F, 13 Godfrey Rd, Artarmon, NSW	20.88	"	"
Betancourt, Sergid E, 923 Herberton St, Pittsburg, Pennsylvania, USA	28.36	"	"
Binsted, William J, 22 St. Kevin's Arcade, Karangahape Rd, Auckland, NZ	70.99	"	"
Black, Paul S, 5 Fossey St, Holder, ACT	13.50	"	"
Bonda, Gerrit, 178 Konina Rd, Titirangi, NZ	46.21	"	"
Booth, Malcolm J, 14/2 Corriami St, Wollongong, NSW	41.76	"	"
Braddick, Kenneth J, 46 Knox St, Watson, ACT	41.76	"	"
Brown, Craig F, 41/321 Windsor Rd, Baulkam Hills, NSW	13.02	"	"
Brown, Desmond M, c/o N M Rothschild & Sons Ltd, 9 Battery Road, 01-02 Straits Trading Building 0104, Singapore	98.53	"	"
Brown, Lotitia F, 3/312 Wattletree Rd, East Malvern	20.28	"	"
Brown, Patrick A, 25 Orana Ave, Pymble, NSW	13.92	"	"
Brunsdon, John D, 26A Hillside Cres, Mt Eden, Auckland, N.Z.	23.66	"	"
Cairns, W C & F, executors, estate of William Cairns, 5 Amelia St, South Caulfield	48.78	"	"
Cassar, Dr C & D, 13 Jersey Rd, Matraville, NSW	34.98	"	"
Cathles, Cheryl J, The Sheepskin Factory, 19 Corben St, Surry Hills, NSW	60.72	"	"
Catt, Mavis C, 1 Niobe Crt, Lower Templestowe	20.22	"	"
Coastal Nominees Ltd, Garrard House, 31-45 Gresham St, London, EC2V 7LH, UK	28.66	"	"
Dall, Edna M, 115 Elizabeth St, Rosalie, Qld	41.76	"	"
Dawson, Jodie R, 15 Dorking Place, Morley, WA	21.06	"	"
Dawson, Raymond A, 15 Dorking Place, Morley, WA	21.06	"	"
Dempsey, Mary L, c/o Mr R G McElroy, 119 St Stephens Ave, Parnell, Auckland, NZ	286.01	"	"
Dempster, Elizabeth G, 23A Rangitoto View Rd, Howick, Auckland, NZ	35.50	"	"
Djerf, Sonia, 30 Lucinda Ave, Wahroonga, NSW	29.70	"	"
Donnelly, Peter, 8 Westland Ave, Londonderry, Northern Ireland	14.62	"	"
Duigan, John L, 558 Drummond St, Carlton	27.84	"	"
Dyer, John R, c/o Stand Nominees, A/c Bert, 18/20 York Buildings, London, WC2, UK	125.20	"	"
Eady, Olaf C, 46A Tohunga Cres, Parnell, Auckland 1, NZ	378.68	"	"
Earl, John G, 5/245 Esplanade, Cairns, Qld	16.86	"	"
Eddies, Robin L, 13 Venise Crt, Glen Waverley	13.50	"	"
Edgar, Peggy M, 5 Bell Street, Malvern	105.06	"	"
Egan, John, 1st Floor, Rural Bank Building, Town Centre, Mount Druitt, NSW	20.22	"	"
Egan, Maureen, 1st Floor, Rural Bank Building, Town Centre, Mount Druitt, NSW	20.22	"	"
Eichman, Noel E, PO Box 3210, Port Moresby, TP. New Guinea	35.50	"	"
Filippini, Douglas J, PO Box 89, Wellington, NZ	12.60	"	"
Filippini, Margaret F, 47 Whites Line West, Lower Hutt, NZ	25.70d	"	"
Fisher, Stephen B, 18 Seymour St, Herne Bay, Auckland, NZ	11.83	"	"
Fogarty, Winifred G, 8A Field St, South Caulfield	41.76	"	"
Forster, Patricia, 12 Nickol Rd, Karratha, WA	18.54	"	"

Unclaimed Moneys Act 1962

Register of Unclaimed Moneys held by the—

<i>Name of Owner on Books and Last Known Address</i>	<i>Total Amount Due to Owner</i>	<i>Description of Unclaimed Money</i>	<i>Date when Amount first became Payable</i>
\$			
EMPEROR MINES LIMITED—continued			
Fox-Male, Dennis H & Walker, Bruce H, 2 Raymond Buildings, Grays Inn, London, WC 1, UK	53.35	Dividend	7.11.85
Frank, Dr G F & T H, 65 Beaumont Ave, San Francisco, California, 94118, USA	15.76	"	"
Friedman, Ruth E, 7418 Monita Rd, Baltimore, Maryland, 21208, USA	30.86	"	"
Gellerstein, Gerome, Fox Hall St, Mohegan Lake, New York, 10547, USA	23.66	"	"
Goddard, Madeline, 214 Duke Place, East Patchogue, New York, 11772, USA	23.66	"	"
Goh, Hock H, 361 Nepean Highway, Mordialloc	29.70	"	"
Gorenstein, Danny, 34 Swan St, Richmond	130.44	"	"
Gosselin, Doris, 29 Eastern Rd, Turramurra, NSW	41.76	"	"
Gould, Charles S, 2081 Pittwater Rd, Church Point, NSW	18.54	"	"
Graham, Dorothy H, 3702 Greenway, Baltimore 18, Maryland, U.S.A.	96.85	"	"
Gray, Euphemia A D, 30 Norfolk St, St. Clair, Dunedin, NZ	17.75	"	"
Griffin, Brian, 10 Traves St, West Chermiside, Qld	57.90	"	"
Grogan, P F & Wheatley, H J, c/o The Commercial Bank of Australia, Victoria Park, WA	27.84	"	"
Gunn, Robert, 6 Tritton Ave, Mt Albert, Auckland, NZ	15.76	"	"
Gunphil Pty Ltd, c/o P M J Fitzgerald, 38 Warruga Ave, Bayswater	185.58	"	"
Guys Investments Pty Ltd, Suite 11, 178-186 Queen St, St. Marys, NSW	34.80	"	"
Hahn, Dorothy R, 52 Clark Rd, North Sydney, NSW	20.88	"	"
The Hawkshead Trust Ltd, 23 Austin Friars, London, EC2N 2BU, UK	16.63	"	"
Haywood, H C, PO Box 311, Morley, WA	42.18	"	"
Hegarty, Shirley, 17 Musseri Ave, Dingley	37.08	"	"
Hemingway, M D & A L, 2 Cole St, Elwood	41.76	"	"
Heng, Terence A L, 1/129 Francis St, Clayton	33.72	"	"
Highley, Jocelyn R, 13 Old Lake Rd, Narrow Neck, Auckland, NZ	23.66	"	"
Higson, Jillian W, Pincop, Kilve, Bridgewater, Somerset, TA5 1EA, UK	71.71	"	"
Hill, Michael, 21 College St, Hawthorn	18.54	"	"
Hollifield, William C, Custodian for R C Hollifield, Rte 1, Moore, JC, USA 29369	14.79	"	"
Hollis, W S & N, 9513 Ashburton Dve, Burke (Fairfax), VA 22015 USA	70.99	"	"
Johansen, Armin T, c/o Remuera Motor Lodge, 16 Minto Rd, Auckland 5, NZ	111.84	"	"
John A Thompson & Son Pty Ltd, 2 Moonga Rd, Toorak	33.72	"	"
Jordan, Alfred W, 179 Pacific Hwy, Roseville, NSW	41.76	"	"
Kas, Gerard, 5/31 Dolphin St, Randwick, NSW	20.88	"	"
Kennaway, Bronwyn D, c/o R Kennaway, RDI Maungaruroto, NZ	24.53	"	"
Kerrison, Irene A, Garden Flat, 4 Avoca Rd, Black Rock, Co Dublin, Ireland	24.82	"	"
Killy, W J E, 1851 Finch Crt, North West Roseburg, Oregon, 97470, USA	12.90	"	"
Lambert, Margaret M, c/o Registry Managers, 150 Queen St, Melbourne	20.88	"	"
Lambeth, William, Box 441, New Plymouth, NZ	11.83	"	"
Le, Chui E, 34 Jalan SS 1.28, Petaling Jaya Selangor, Malaysia	14.33	"	"

Unclaimed Moneys Act 1962

Register of Unclaimed Moneys held by the—

Name of Owner on Books and Last Known Address	Total Amount Due to Owner	Description of Unclaimed Money	Date when Amount first became Payable
\$			
EMPEROR MINES LIMITED— <i>continued</i>			
Lee, Ainslee S, 250 Schonnell Dve, St. Lucia, Qld	105.42	Dividend	7.11.85
Leggett, Mirium L, 25 North Terrace East, Mt Gambier, SA	42.18	"	"
Leggett, Robert M, 25 North Terrace East, Mt Gambier, SA	42.18	"	"
Leow, Chong J, 1/29 Francis St, Clayton	33.72	"	"
Levy, R & Jacobs, E, PO Box 11, Vaucluse, NSW	101.22	"	"
Alexander Liddell (estate of), c/o J Addis, 45 Llaneast St, Malvern	20.88	"	"
Liddell, Dana G, 349 Philip Ave, North Rockhampton, Qld	20.22	"	"
Lindsey, Peter, 16 St. Vincents Rd, Greenwich, NSW	13.50	"	"
Ling, Walter, 195 Fischer St, Malvern, SA	14.82	"	"
Lo-Nano, Patricia, PO Box 547, South Main St, Sheffield, MQ 1257, USA	11.83	"	"
McCutchan, Edith E, 2/17 Sherwood Rd, Ivanhoe	20.88	"	"
McDonald, Enid, PO Box 107, Wanaka, Otago, NZ	462.26	"	"
McElroy, Roy G, 119 St. Stephens Ave, Parnell, Auckland 1, NZ	29.58	"	"
McElroy, R G & R H Duncan, as Executors (estate of) J E Snell, PO Box 5947, Auckland, NZ	159.27	"	"
McGowan, Lennard A, 3/17 Alana Pl, Mount Wellington, Auckland, NZ	19.32	"	"
McGraw, Nathan P, 1444 7th Ave 206, San Francisco, California, 94122, USA	11.83	"	"
MacMahon, Sheila E, PO Box 876, Bichend, Tas	13.50	"	"
Magyar, Michael, 15 Cousins St, Southport, New York 11768, USA	11.83	"	"
Manyana Beach Development Pty Ltd, 9th Floor, 53 Martin Pl, Sydney, NSW	16.86	"	"
Marron, Annie R, c/o Mrs Mulcahy, 29 Irving Rd, Toorak	20.88	"	"
Martin, Leslie R, PO Box 331, Suva, Fiji	14.62	"	"
Martin, Ralph M, 1 William St, Holmesglen, NSW	33.72	"	"
Mawson, Ellen, c/o Commonwealth Trading Bank of Australia, Glebe, NSW	68.10	"	"
Meehan, William G, PO Box 3, Bonalbo, NSW	26.10	"	"
Meier, Eric, 22 Norman Rd, New Plymouth, NZ	17.75	"	"
Moher, Michael B, 15 Perth St, Toowoomba, Qld	27.84	"	"
Murphy, Roy G, "Walhallow Station", Tennant Creek, NT	20.22	"	"
O'Mara, William R, 839 South Lorraine Blvd, Los Angeles, California, USA	35.50	"	"
Orny, Roland, 64 Berry St, Wagga, NSW	32.52	"	"
Phillips, Richard F, 17 Bishops Pl, Kensington, SA	41.76	"	"
Pither, Patricia A, 165 McKinnon Rd, McKinnon	17.70	"	"
Plichka, Michael A, c/o D Blades, 169 Marion Rd, West Richmond, SA	13.50	"	"
Pliitt & Company (52-6034576), c/o Trust Department, 1st National Bank of Maryland, Baltimore, Maryland, 21203, USA	355.01	"	"
Pomeroy, Ira L, Garden Gve, California, 92641, USA	59.21	"	"
Poutsma, J A & M L, 21 Park St, South Yarra	12.66	"	"
Pulham, J R, Bloomfield, P J & Morgan H D, PO Box 7033, Auckland, NZ	35.50	"	"
Pulham, J R, Bloomfield, P J, Carrach-Hopewell, J & Morgan, c/o 19 Omana Ave, Epsom, Auckland, NZ	17.75	"	"
Read, Ingrid, No. 5 Rd, Main South Rd, Ashburton, NZ	11.83	"	"
Rintoul, R H, PO Box 256, Newborough	20.22	"	"
Rombay Pty Ltd, c/o 2/23 Oaks Ave, Dee Why, NSW	42.18	"	"
Rowley, Laurence E, PO Box 82, Wickham, WA	27.84	"	"
Ryan, Margaret, 40 The Avenue, Randwick, NSW	10.38	"	"

Unclaimed Moneys Act 1962

Register of Unclaimed Moneys held by the—

<i>Name of Owner on Books and Last Known Address</i>	<i>Total Amount Due to Owner</i>	<i>Description of Unclaimed Money</i>	<i>Date when Amount first became Payable</i>
\$			
EMPEROR MINES LIMITED— <i>continued</i>			
Saint, Harold F, 22 Greenhill Rd, Wayville, SA	32.52	Dividend	7.11.85
Sauer, Ann, c/o PO Box 80, Belmont, WA	50.58	"	"
Sheil, Elizabeth G, 12 Dalmeny Rd, Northbridge, NSW	41.76	"	"
Siegmund, Dorothea, Eberleinstrasse 20, 62 Wiesbaden, West Germany	29.23	"	"
Singh, Ganga (estate of), c/o P Ragg, Box 29, Ba, Fiji	19.32	"	"
Smith, Harold S, Exec. (estate of), A. Whipps, 2 Hunter St, Sydney, NSW	16.26	"	"
Snorroson, Jennifer, 5 Elgin St, Hawthorn	33.72	"	"
Stewart, Blair D, 16 Langan St, Earlville, Qld	41.76	"	"
Stewart, Robyn E, 16 Langan St, Earlville, Cairns, Qld	41.76	"	"
Szczygielski, Corinne D, 9 Becker Crt, Padbury, WA	33.72	"	"
Tanner, A, 478 Valencia Dve, Los Altos, California 94022, USA	11.83	"	"
Townsend, Dorothy, Townsend Plaza, Howells, N.Y. 10932, USA	23.66	"	"
Troon, Dianne Margaret, 622 Sandy Bay Rd, Sandy Bay, Tas	106.68	"	"
Ullock, Raymond, 35 Wentworth St, Randwick, NSW	13.50	"	"
Uren, June D, PO Box 15, Ringwood	13.50	"	"
Vyle, Joanne V, PO Box 9090, Newmarket, Auckland, NZ	15.76	"	"
Wall, Molly S, 8 King Edward Pde, Devonport, Auckland, NZ	35.50	"	"
Weaver, Eric R, 24 Umere Cres, Ellerslie, Auckland, NZ	35.50	"	"
Weil, John L, 2705 Chestnut St, New Orleans, Louisiana 70115, USA	17.75	"	"
Whitehead, Edgar J, Dress Circle Rd, Avalon, NSW	14.22	"	"
Willman, Viola F, 5 Sunray Dve, Highland Illinois 62249, USA	59.21	"	"
Wolf, Hermina B, 266 Valley Road NW, Atlanta, Georgia, 30305, USA	21.47	"	"
Wood Grundy Ltd (London), 30 Finsbury Sq, London EC2A 1SB, UK	17.19	"	"
Wright, Edward F La B, Stable Cottage, Chiddingfold, Surrey, England	17.75	"	"
Wyman, Philip R, 24 Mortley Ave, Mt Waverley	40.50	"	"
Zorn Nominees Ltd CM A/C, 10 Throngmorton Ave, London, EC2N 2dp, UK	25.86	"	"
Betheras, R A G (estate of), V M Betheras, 93 Brunel Rd, East Malvern	10.62	"	"
Bullivani, Prudence, Gregadod, Wagga, NSW	10.38	"	"
Cairns, William F (estate of), c/o T Cairns, 5 Amelia St, South Caulfield	13.92	"	"
The Hawkshead Trust Ltd, 23 Austin Friars, London EC2N, UK	57.38	"	"
Kennaway, Jacqueline W, c/o R H Kennaway, RDI Maungaturoto, Northland, NZ	10.20	"	"
Quayle, Frank L, 49 Fir St, Waterview, Auckland, NZ	15.76	"	"
6312			
TRANSPORT DEVELOPMENT AUSTRALIA LIMITED			
Finney, Victor C, 39 Edwards Ave, Moranda, NSW	18.49	Dividend	18.7.85
Trebral Investments Pty Ltd, 207 Glen Osmond Rd, Frewville, SA	11.14	"	"
Finney, Victor C, 39 Edwards Ave, Moranda, NSW	26.10	"	25.2.86
Trebral Investments Pty Ltd, 207 Glen Osmond Rd, Frewville, SA	15.72	"	"
6314			
SMITH & MILES HOLDINGS LTD			
March, Mary B., c/o T. Mason, Templeton St, Wantirna	60.00	Dividend	23.5.85
6390			

Unclaimed Moneys Act 1962

Register of Unclaimed Moneys held by the—

Name of Owner on Books and Last Known Address	Total	Description of Unclaimed Money	Date
	Amount Due to Owner		when Amount first became Payable
\$			
W. J. TROTTER PTY LTD			
Armstrong, S. and F.	500.00	Deposit	9.1.82
Needham, C. R.	530.00	„	4.5.82
6438			

The Companies Act 1961—In the matter of Highlands Road Proprietary Limited (In Liquidation)—Members winding up

Notice is hereby given that at the Extraordinary General Meeting Highlands Road Proprietary Limited duly convened and held at the office of M. D. Crew at 124 Johnston Street, Fitzroy 3065, in the State of Victoria on 23 March 1987.

The following Resolution was proposed and passed as a Special Resolution.

That the Company be wound up voluntarily.

Dated: 23 March 1987

6466 M. D. CREW, Liquidator

Creditors, next of kin and others having claims in respect of the Estate of John Edwin Barnett late of 3 Davis Court, Traralgon, retired gentleman, deceased, who died on 12 December 1986 and Probate of whose Will was granted by the Supreme Court of Victoria on 27 February 1987 to Terrence John Dowling of 7 Roger Street, Morwell, retired gentleman are to send particulars of their claims to the said Executors care of the below mentioned solicitors by 29 May 1987 after which date they will distribute the assets of the deceased having regard only to the claims of which they then have notice.

LITTLETON, HACKFORD & MALKIN, solicitors, Law Chambers, 115-119 Hotham Street, Traralgon 6384

ROSE ANN ELIZABETH DAW, late of 8 Chapman's Road, Trafalgar, in the State of Victoria, widow, deceased

Creditors, next of kin and others having claims in respect of the estate of the deceased who died on 27 October 1986 are required by the Executors Francis Xavier O'Halloran of Trafalgar retired solicitor and Arthur John Francis Davis of Trafalgar solicitor to send particulars to their solicitors Messrs F. X. O'Halloran, Davis & Co., Kirk Street, Moe by 25 May 1987 after which date the Executors may convey or distribute the assets having regard only to the claims of which they then have notice.

Dated 11 March 1987 6385

Creditors, next of kin and others having claims in respect of the estate of Edward Graham Farquharson late of 8 Melville Avenue, Frankston gentleman deceased who died on 21 November 1986 are to send particulars of their claims to The Equity Trustees Executors and Agency Company Limited of 472 Bourke Street, Melbourne by 27 May 1987 after which date the said Company will distribute the assets having regard only to the claims of which it then has notice.

MIDDLETONS OSWALD BURT, solicitors, of 140 William Street, Melbourne 6386

In the estate of Alan Ronald McDonald, late of "Rosevale", Koondrook, in the State of Victoria, farmer, deceased

Creditors, next of kin and all other persons having claims against the estate of the said deceased are required by Tessa Lesley McDonald of "Rosevale", Koondrook aforesaid widow the Executrix of the estate of the said deceased to send particulars of such claims to her in care of the undermentioned solicitors on or before 17 May 1987 after which date she will distribute the assets having regard only to the claims to which she then has notice.

BASILE & CO., barristers and solicitors, 46 Wellington Street, Kerang 6387

Creditors, next of kin and others having claims against the estate of Miriam Kreemilda Beecher McKay formerly of Unit 50, 466 Burwood Highway, Wantirna South in the State of Victoria but late of Bassendean Nursing Home, 27 Hamilton Street, Bassendean in the State of Western Australia, pensioner, deceased who died on 11 March 1986 are required by the executors National Trustees Executors and Agency Company of Australasia Limited of 95 Queen Street, Melbourne in the State of Victoria and Clifton Graham McKay of 4 Spotted Gum Way, Willetton in the State of Western Australia to send particulars of their claims to the said executors by 27 May 1987 after which date the

said executors will distribute the assets having regard only to the claims of which the said executors then have notice.

POWER & CO., solicitors, of 452 Burwood Highway, Wantirna South 6388

Creditors, next of kin and others having claims in respect of the estate of Archibald Templeton late of 107 Kay Street, Traralgon, retired gentleman deceased who died on 10 January 1987 and Probate of whose Will was granted by the Supreme Court of Victoria on 27 February 1987 to Florence Jean Templeton of 107 Kay Street, Traralgon, home duties are to send particulars of their claims to the said Executors care of the below mentioned solicitors by 29 May 1987 after which date they will distribute the assets of the deceased having regard only to the claims of which they then have notice.

LITTLETON, HACKFORD & MALKIN, solicitors, Law Chambers, 115-119 Hotham Street, Traralgon 6389

Creditors, next of kin and others having claims in respect of the estate of Emily Teresa Leumont, late of 13 Patterson Street, Coburg, widow, deceased who died on 25 October 1986 are required to send particulars of their claims to the Equity Trustees Executors and Agency Company Limited of 472 Bourke Street, Melbourne the deceased's Executor by 27 May 1987 after which date it will distribute the assets thereof having regard only to the claims of which it then has notice.

STRUGNELL DEAKIN DUNCAN, solicitors, 106 Bell Street (P.O. Box 62) Coburg 6467

ERNEST JOHN OLIVER, late of Ultima in the State of Victoria, farmer, deceased (who died on 3 November 1986)

Creditors, next of kin and all other persons having claims against the estate of the deceased are required by the Executors of the Will, Susan Jane Oliver, Alfred John Oliver and Elsie Mavis Ingram, to send particulars to them care of the undersigned on or before 20 May 1987, after which date they will distribute the assets having regard only to the claims of which they then have notice.

GARDEN & GREEN, solicitors, 4 McCallum Street, Swan Hill 6468

Pursuant to the *Trustee Act* 1958 notice is hereby given that all persons having claims against the estate of Alice Constance Raines late of 27 Grandview Road, Preston, in the State of Victoria, widow, deceased, who died on 1 January 1987 and Probate of whose Will was granted by the Supreme Court of the said State in its Probate Jurisdiction, on 27 February 1987 to Donald James Raines, of 152 Clarendon Street, Thornbury, in the State of Victoria, retired accountant, are hereby required to

send particulars in writing of such claims to the said Executor care of the undersigned firm of solicitors at its office, 8th Floor, 150 Queen Street, Melbourne, in the said State, before the expiration of two months from the date of publication of this notice, after which date the said Executor will proceed to distribute the assets of the said Alice Constance Raines (deceased) which shall have come to his hands amongst the persons entitled thereto, having regard only to the claims of which he then shall have had notice.

Notice is hereby further given that the said Donald James Raines, will not be liable for the assets so distributed or any part thereof to any persons of whose claim he shall not have had notice as aforesaid.

Dated: 3 March 1987

HAINES & POLITES, solicitors for the said Donald James Raines 6469

GEOFFREY ALFRED KAYE, late of 78A Cromwell Road, South Yarra, in the State of Victoria, graduate in medicine, deceased

Creditors, next of kin and others having claims in respect of the estate of the deceased who died on 27 October 1986 are required by the Union—Fidelity Trustee Company of Australia Limited of 100 Exhibition Street, Melbourne aforesaid the applicant for a Grant of Administration, to send particulars of their claims to the said applicant in the care of the said Company by 15 June 1987 after which date it will convey or distribute the assets having regard only to the claims of which it then has notice.

FREEHILL, HOLLINGDALE & PAGE, solicitors, 140 William Street, Melbourne 6452

Creditors, next of kin and others having claims in respect of the estate of Agnes Adelaide Marshall, late of Strathdon Community Hostel, 9 Jolimont Road, Forest Hill, widow, deceased, who died on 5 February, 1987 are to send the particulars of their claims to ANZ Executors & Trustee Company Limited of 94 Queen Street, Melbourne by 15 June 1987 after which date it will distribute the assets having regard only to the claims of which it then has notice.

LOUIS MOHR, late of Schoolhouse Road, Woori Yallock in the State of Victoria, engineer, deceased

Creditors, next of kin and others having claims in respect of the estate of the deceased who died on or about 14 January 1987 are required by the Executrices Elizabeth Marion Erswell of 127 Napoleon Street, Eltham, widow and Janice Allen of Schoolhouse Road, Woori Yallock, married woman to send particulars to the undermentioned firm by 1 June 1987 after which date the said Executrices may convey or distribute the assets

having regard only to the claims of which notice has by then been given.

SETON WILLIAMS & SMYTH, solicitors, 900 Main Road, Eltham 6454

JAMES EDWARD SWEENEY, formerly of Unit 4, 66 Wilson Street, Cheltenham, but late of Lot 24 Williams Road, Launching Place, in the State of Victoria, gentleman, deceased

Creditors, next of kin and others having claims in respect of the estate of the deceased who died on 2 January 1987 are required by ANZ Executors and Trustee Company Limited of 94 Queen Street, Melbourne aforesaid the applicant for a Grant of Administration to send particulars of their claims to the said applicant in the care of the said Company by 15 June 1987 after which date it will convey or distribute the assets having regard only to the claims of which it then has notice.

FREEHILL, HOLLINGDALE & PAGE, solicitors, 140 William Street, Melbourne 6455

MARY LINDA BOURKE, late of Unit 2, 60 Railway Road, Carnegie, widow, deceased

Creditors, next of kin and others having claims in respect of the Estate of Mary Linda Burke late of Unit 2, 60 Railway Road, Carnegie, widow deceased who died on 14 March 1986 are required to send particulars of their claims to the Executor William Thomas Bateman c/o Robert A. Green, Solicitor, 549 Hampton Street, Hampton by 30 June 1987 after which date the said William Thomas Bateman may convey or distribute the assets, having regard only to the claims of which he then has notice.

6408

Creditors, next of kin and others having claims in respect of the will of Harry Arthur Stanley Cox late of 62 Outlook Drive, Glenroy, invalid pensioner, deceased who died on 9 February 1987 are requested to send particulars of their claims to the Executors John Eudes Stewart and John Douglas McPherson, c/o the undermentioned solicitor by 3 June 1987 after which date they will distribute the assets having regard only as to the claims of which they then have notice.

JOHN STEWART, solicitor, 290 Racecourse Road, Newmarket 6409

Creditors, next of kin and others having claims in respect of the estate of Margaret Yvonne Smith late of Maskrey Street, Traralgon, married woman, deceased, intestate who died on 23 May 1985 are requested to send particulars of their claims to the Administrator, Lindsay John Smith c/o the undermentioned solicitor by 1 June 1987 after which date he will distribute the assets having regard only as to the claims of which he then has notice.

JOHN STEWART, solicitor, 290 Racecourse Road, Newmarket 6410

IVY MAY WILSON, late of 28 Park Grove, Burnley, in the State of Victoria, retired book-keeper, deceased

Creditors, next of kin and others having claims in respect of the estate of the abovenamed deceased who died on 16 December 1986, are required by Janet Iris Davis of 63 Lochiel Avenue, Edithvale the Executrix of the deceased's Will to send particulars of their claim to the said Executrix care of the undermentioned solicitor by 29 May 1987, after which date he will convey or distribute the assets having regard only to the claims which he then has notice.

A. B. NATOLI LL.B., solicitor, of 24 Cotham Road, Kew 6411

ALICE MAUD ELIZABETH PATRONI, late of Unit 15, 41 Park Street, South Yarra, widow

Creditors, next of kin and others having claims in respect of the estate of the deceased, who died on 8 February 1986, are required by the trustee Michael John Hannah, solicitor of 372 Lonsdale Street, Melbourne, to send particulars to him by 20 May 1987 after which date the trustee may convey or distribute the assets, having regard only to the claims of which he then has notice.

WM. MURRAY & SON, solicitors, 372 Lonsdale Street, Melbourne 6412

BERTHA FLORENCE STRICKLAND, late of 102 Ascot Street South, Ballarat, widow, deceased.

Creditors, next of kin and others having claims in respect of the estate of the deceased who died on 4 June 1986 are required by the Applicant for grant of administration The Union-Fidelity Trustee Company of Australia Limited of 100 Exhibition Street Melbourne to send particulars to it by 25 May 1987 after which date the applicant for grant of administration may convey or distribute the assets having regard only to the claims of which it then has notice.

CUTHBERTS, solicitors, 101 Lydiard Street North, Ballarat 6417

Creditors, next of kin and others having claims in respect of the estate of Ernest Herbert Thomas late of Circle Mission Church, Kallista-Emerald Road, The Patch, retired, deceased, who died on 16 January 1987, are required to send particulars of their claims to the Executors, Herbert Ernest Thomas, Ralph Waldo Crouch and Faith Willmott, care of the undersigned solicitors by 27 May 1987, after which date the said executors will proceed to distribute the estate having regard only to the claims of which they then have notice.

ARMSTRONG SINGER & ROSS, solicitors, Suite 1, 647A Main Street, Belgrave 6418

In the Supreme Court of the State of Victoria
SALE BY THE SHERIFF

On 7 May 1987 at 2.30 p.m. at the Sheriff's Office,
287 Springvale Road, Glen Waverley (unless process
be stayed or satisfied)

All the estate and interest (if any) of Yvonne
Louisa Demetrious (now Chalmers-Alexander) of
506 Main Road, Tecoma shown on Certificate of
Title as Yvonne Louise Chalmers-Alexander, Joint
Proprietor with Peter Chalmers-Alexander of an
estate in fee simple in the land described in
Certificate of Title Volume 5363 Folio 579 upon
which is erected a dwelling and known as 506 Main
Road, Tecoma.

Registered Mortgages L73831Y, L457026K and
Caveats L418545B and M323829E affect the said
estate and interest.

Terms—Cash only
6456 A. STANLEY, Sheriff's Officer

In the Supreme Court of the State of Victoria
SALE BY THE SHERIFF

On 30 April 1987 at 2.00 p.m. at Kerang Police
Station (unless process be stayed or satisfied)

All the estate and interest (if any) of Ian William
Findlay of 88 Bendigo Road, Kerang as proprietor
of an estate in fee simple in the land described in
Certificate of Title Volume 8700 Folio 515 upon
which is erected a dwelling and known as No. 37
Bendigo Road, Kerang.

Registered Mortgages L247115M, L836720M and
Caveats M533512X and M666989W affect the said
Estate and Interest.

Terms—Cash only
6457 A. STANLEY, Sheriff's Officer

In the Supreme Court of the State of Victoria
SALE BY THE SHERIFF

On 7 May 1987 at 2.30 p.m. at the Yea Police
Station (unless process be stayed or satisfied)

All the estate and interest (if any) of Ronald
Alexander Mathew of 22 Field Street, Shepparton
as Joint Proprietor with Elizabeth Jean Mathew of
an estate in fee simple in the land described in
Certificate of Title Volume 4433 Folio 429 which is
vacant land of approximately 2 acres being part of
Crown Allotment 56 and known as Kanumbra
Primary School, Kanumbra.

Registered Caveat L898248M affects the said
Estate and Interest.

Terms—Cash only
6458 A. STANLEY, Sheriff's Officer

NOTICE OF MAKING OF
STATUTORY RULES
WHICH ARE NOT YET
AVAILABLE

Notice is given of the making of the following
Statutory Rules:

- Associations Incorporation Act*
1981
- 45/1987 Associations Incorporation
(Fees Amendment)
Regulations 1987
- Business Names Act 1962*
- 46/1987 Business Names (Fees
Amendment) Regulations
1982
- Marketing of Primary Products*
Act 1958
- 47/1987 The Victorian Egg Marketing
Board (Amendment No. 2)
Regulations 1987
- Marketing of Primary Products*
Act 1958
- 48/1987 The Victorian Egg Marketing
Board (Amendment)
Regulations 1987
- Road Safety Act 1986*
- 49/1987 Road Safety (Procedures) (Fees
Amendment) Regulations
1987

NOTICE OF MAKING
AND AVAILABILITY OF
STATUTORY RULES

In pursuance of the provisions of the *Subordinate
Legislation Act 1962* and the Regulations made
thereunder notice is given of the making and
availability of the following Statutory Rules:

Note: The date specified after each Statutory Rule
is the date it was first obtainable from the VGPO
Bookshop Information Victoria Centre 318 Lt
Bourke Street Melbourne.

- Wildlife Act 1975*
- 39/1987 Wildlife (Game) (No. 1)
Regulations 1987

20 March 1987

	<i>Superannuation Benefits Act 1977</i>	
40/1987	Superannuation Benefits Regulations (No. 2) 1987	40c
20 March 1987		
	<i>Credit (Administration) Act 1984</i>	
41/1987	Credit (Administration) (Licencing) (Fees Amendment) Regulations 1987	40c
20 March 1987		
	<i>Weights and Measures Act 1958</i>	
42/1987	Weights and Measures (Fees Amendment) Regulations 1987	70c
20 March 1987		
	<i>Finance Brokers Act 1969</i>	
43/1987	Finance Brokers (Licencing and General) (Fees Amendment) Regulations 1987	40c
20 March 1987		
	<i>Water Act 1958</i>	
44/1987	Water (Green's Lake Recreational Area) (Amendment) Regulations 1987	40c
20 March 1987		
	<i>Fisheries Act 1968</i>	
50/1987	Fishing (Scallop) (Amendment No. 2) Regulations 1987	40c
25 March 1987		

Guardianship and Administration Board Act 1986
PROCLAMATION OF COMMENCEMENT

I, J. Davis McCaughey, Governor of Victoria, acting with the advice of the Executive Council and under the power found in section 2 of the *Guardianship and Administration Board Act 1986*, fix 1 April 1987 as the day on which Part 1, sections 5 and 6, all remaining sections of Part 3, sections 75 to 82 inclusive, Schedule 1 and Schedule 3 of that Act shall come into operation.

Given under my Hand and the Seal of Victoria on 24 March 1987.

(L.S.) J. DAVIS McCAUGHEY
 By His Excellency's Command
 J. H. KENNAN
 Attorney-General

Note: Section 14 in Part 3 of this Act was proclaimed to commence on 8 July 1986.
 Other sections not covered in this Proclamation are yet to be proclaimed.

Lotteries Gaming and Betting Act 1966

PROCLAMATION OF COMMENCEMENT

I, J. Davis McCaughey, Governor of Victoria, acting with the advice of the Executive Council, fix Wednesday, 1 April 1987, as the day on which sections 5 (6), 5 (7) and 8 of the *Lotteries Gaming and Betting (Amendment) Act 1986* come into operation.

Given under my Hand and the Seal of Victoria on 24 March 1987.

(L.S.) J. DAVIS McCAUGHEY
 By His Excellency's Command
 N. B. TREZISE
 Minister for Sport and Recreation

Country Fire Authority Act 1958

VARIATION OF FIRE DANGER PERIOD

In pursuance of the powers conferred by section 4 of the *Country Fire Authority Act 1958*, I, Charles Race Thorson Mathews, Minister for Police and Emergency Services, after consultation with the Minister for Conservation, Forests and Lands hereby vary the declaration of fire danger periods previously published in the *Government Gazette* by declaring that such fire danger periods shall end in respect of the undermentioned municipalities or parts of municipalities specified.

To terminate from and inclusive of Monday, 30 March 1987

City of Warrnambool	Borough of Port Fairy
Shire of Belfast	Shire of Minhamite
Shire of Mount Rouse	Shire of Warrnambool
	C. R. T. MATHEWS
Ministry for Police and Emergency Services	
Melbourne, 24 March 1987	

LATE NOTICES

State Concessions Act 1986

PROCLAMATION OF COMMENCEMENT

I, J. Davis McCaughey, Governor of Victoria, acting with the advice of the Executive Council and under section 2 of the *State Concessions Act 1986*, fix 30 March 1987 as the day on which sections 1 to 6 and items 3, 7, 8 and 11 of the schedule of the Act come into operation.

Given under my hand and the seal of Victoria on 24 March 1987.

(L.S.) J. DAVIS McCAUGHEY
 By His Excellency's Command
 C. J. HOGG
 Minister for Community Services

Country Fire Authority Act 1958

VARIATION OF FIRE DANGER PERIOD

In pursuance of the powers conferred by section 4 of the *Country Fire Authority Act 1958*, I, Charles Race Thorson Mathews, Minister for Police and Emergency Services, after consultation with the Minister for Conservation Forests and Lands hereby vary the declaration of fire danger periods previously published in the *Government Gazette* by declaring that such fire danger periods shall end in respect of the undermentioned municipalities or parts of municipalities specified.

To Terminate from and inclusive of Saturday, 28 March 1987

Shire of Alberton

To Terminate from and inclusive of Monday, 30 March 1987

City of Ballarat	Borough of Sebastopol
Shire of Grenville	Shire of Ballarat
Shire of Bungaree	Shire of Buninyong
City of Maryborough	Shire of Ballan
Shire of Creswick	Shire of Daylesford and Glenlyon
Shire of Kyneton	Shire of Newstead
Shire of Talbot and Clunes	Shire of Tullaroop
City of Ararat	Town of Stawell
Shire of Ararat	Shire of Avoca
Shire of Lexton	Shire of Ripon
Shire of Stawell	

C. R. T. MATHEWS

Ministry for Police and Emergency Services
Melbourne, 24 March 1987

Co-operation Act 1981

CHANGE OF NAME OF A SOCIETY

Notice is hereby given that The Circle Credit Co-operative Limited which was incorporated as a Credit Society under the abovenamed Act on 1 April 1972, has registered a change of its name and is now incorporated under the name of Circle Credit Co-operative Limited under the said Act.

Dated 18 March 1987

A. M. SARSFIELD

Deputy Registrar of Co-operative Societies

Freedom of Information Act 1982

NOTICE OF REGULATORY IMPACT STATEMENT

Proposed Statutory Rule exempting certain offices from the operation of the Act

The Attorney-General has made available a regulatory impact statement about a proposed statutory rule exempting the following offices from the provisions of the Freedom of Information Act.

Auditor-General
Victorian Government Solicitor (formerly Crown Solicitor)
Director of Public Prosecutions
Lay Observer to Barristers and Solicitors Disciplinary Tribunals
Ombudsman
Police Complaints Authority
Solicitor-General
Public Advocate

Reasons for the Proposed Rule

The objectives to be achieved by the Rule are to exempt the eight offices mentioned from the requirements of the Freedom of Information Act so that each can function without the constraint of having to respond to requests to access to documents.

The Auditor-General, Ombudsman Public Advocate and Police Complaints Authority have a primary responsibility to report to Parliament on their investigations and it is considered that the release of documents prior to making their reports could significantly prejudice their ability to conduct confidential investigations, obtain further information in the future and compromise their reporting to Parliament. A similar reason exists in respect of the Lay Observer who reports to the Law Institute and the Attorney-General.

The Victorian Government Solicitor, Director Public Prosecutions and Solicitor-General generate documents in the course of their role as legal advisers to Ministers, Government departments and agencies. Those documents are considered to be protected by legal professional privilege and as such it is the Client Minister, Department or Agency which has the sole right to determine any question of access.

Summary of Impact Statement

The statement concludes that in the case of the Victorian Government Solicitor, Director of Public Prosecutions and Solicitor-General, the public's ability to obtain documents will be largely unaltered if the Rule is passed because access to documents can still be sought from the Client Minister, Department or Agency.

In respect of the other offices proposed for exemption, the statement assess the relative merits of exempting the offices to allow them an unfettered ability to investigate with complete confidentiality, to provide reports on their findings and to retain public confidence, against any social cost arising from the denial of access to documents held by those offices.

Obtaining a Copy of the Statement

A copy of the Regulatory Impact Statement is available from the Law Department, 221 Queen Street, Melbourne (telephone: 603 6833). Submissions about the proposed Rule will be accepted by the Department until 22 April 1987.

Constitution Act 1975
Local Government Act 1958
MUNICIPAL COUNCIL ELECTIONS TO BE
HELD ON 1 AUGUST 1987

Fixing of Dates

The Governor in Council acting under section 74AB of the *Constitution Act 1975* and sections 82 (2), 83 (2), 85 (4) and 85 (5) of the *Local Government Act 1958* fixes the following dates in relation to the Municipal Council Elections to be held on 1 August 1987—

Wednesday, 6 May 1987—"Entitlement date" for the purposes of section 74B of the *Constitution Act 1975*.

Tuesday, 9 June 1987—The date for the purposes of section 82 (2) of the *Local Government Act 1958*.

Tuesday, 16 June 1987—The date for the purposes of section 83 (2) of the *Local Government Act 1958*.

Thursday, 16 July 1987—The date in respect of the City of Melbourne for the purposes of section 85 (4) and (5) of the *Local Government Act 1958*.

Dated 24 March 1987

J. L. SIMMONDS
Minister for Local Government
L. G. HOUSTON
Clerk of the Executive Council

Transport Act 1983

ROAD TRAFFIC AUTHORITY

Commercial Passenger Vehicle Applications

Notice is hereby given that the following applications will be considered by the Road Traffic Authority on 28 April 1987.

Notice of any objections should be forwarded to reach the Manager, Vehicle Licensing Branch or any Regional Office of the Road Traffic Authority not later than 22 April 1987.

It will not be necessary for interested parties to appear on the hearing date specified, unless advised in writing by the Authority.

Notification of the date for consideration of applications which are objected to and which require determination by the Road Transport Licensing Tribunal will be published by further notice in this Gazette.

Black Forest Bus Service Pty. Ltd., Gisborne. Application for variation of the conditions of license TS 1412 which authorises a Ministry of Education school contract service between Romsey and Sunbury, to operate under charter conditions from within a 20 km pick-up radius of the Post Office at Gisborne.

Note: The licensed vehicle holds a 3 star rating for charter purposes.

R. Cameron, Horsham. Application to license one commercial passenger vehicle with seating capacity for 5 passengers to operate a 3 day tour as follows:

Day 1. Depart Horsham and travel to South Vectis property on Wimmera River for sightseeing and overnight accommodation at the property.

Day 2. Depart South Vectis property and travel to Toolondo via Nooradjua and Black Range to the Grampians National Park for sightseeing and return to Toolondo for overnight accommodation on farm property.

Day 3. Travel within the boundaries of local farm property at Toolondo then travel to Mt Arapiles for sightseeing and return to Horsham via Wimmera Highway.

Timetable: As and when required.

Fares: To be determined.

Note: This application is made in conjunction with a similar application by A. I. Pelchen.

G. R. Fleet, Whittington. Application to license one commercial passenger vehicle in respect of a 1974 Statesman sedan with seating capacity for 5 passengers to operate as a special purpose vehicle from 8 Durran Street, Whittington for the carriage of passengers for wedding parties within a 35 km radius of the Chief Post Office in the City of Geelong.

K. F. Long, Rosanna. Application for variation of a commercial passenger vehicle licence granted by the Road Transport Licensing Tribunal on 28 November 1986 in respect of a 1959 Austin Sheerline or Princess sedan to delete the existing description of the vehicle and insert in its place a 1949 Austin Sheerline or Princess sedan.

P. Milosevic, Coburg. Application to license one commercial passenger vehicle with seating capacity for 2 passengers to convey pets accompanied by owners of pets, or pets alone to or from destinations as directed by owners or others throughout the State of Victoria.

Timetable: As and when required.

Fares:

(i) Monday to Friday 9.00 a.m. to 6.00 p.m. \$1.00 per mile and \$5.00 per 15 minutes detention time.

(ii) Monday to Friday 6.00 p.m. to 9.00 p.m. and on Saturday and Sunday 9.00 a.m. to 8.00 p.m. \$1.30 per mile and \$6.00 per 15 minute detention time.

(iii) Monday to Friday 9.00 p.m. to 9.00 a.m. and on Saturday and Sunday 8.00 p.m. to 9.00 a.m. and public holidays all day and night (24 hrs.). \$1.70 per mile and \$7.00 per 15 minute detention time.

Note:

(i) 10 per cent discount for unemployed people, pensioners and regular customers at all times;

(ii) All fares are calculated at the above rate for the first 25 miles and less 75 per cent every mile thereafter extra long distances are subject to negotiation; and

(iii) All trips are quoted from Coburg Post Office to the required destination and return to the post office.

A. I. Pelchen, Horsham. Application to license one commercial passenger vehicle to be purchased with seating capacity for 4 passengers to operate a 3 day tour as follows:

Day 1. Depart Horsham and travel to South Vectis property on Wimmera River for sightseeing and overnight accommodation at the property.

Day 2. Depart South Vectis property and travel to Toolondo via Nooradju and Black Range to the Grampians National Park for sightseeing and return to Toolondo for overnight accommodation on farm property.

Day 3. Travel within the boundaries of local farm property at Toolondo then travel to Mt Arapiles for sightseeing and return to Horsham via Wimmera Highway.

Timetable: As and when required.

Fares: To be determined.

Note: This application is made in conjunction with a similar application by R. Cameron.

A. & L. Taylor, Dixons Creek. Application for variation of the conditions of licence TO 204 which authorises four day tours of the north-eastern regions of Melbourne to:

(a) include additional tour departure and return points as follows: (i) Melbourne Airport; (ii) Yarra Glen Railway Station; (iii) Healesville Railway Station; (iv) Healesville Tourist Railway (when available); and (b) provide varied accommodation in Healesville.

M. Tron, Gardenvale. Application to license one commercial passenger vehicle in respect of a 1976-1986 stretched Ford sedan to be purchased with seating capacity for 7 passengers to operate as a metropolitan hire car from 3 Gardenia Road, Gardenvale.

Dated 25 March 1987

M. KENT
Group Manager
Vehicle Licensing and Regulation Strategies

Transport Act 1983

ROAD TRANSPORT LICENSING TRIBUNAL
Commercial Passenger Vehicle and Tow Truck
Applications

Notice is hereby given that the following applications, previously gazetted and objected to, will be considered by the Road Transport Licensing Tribunal as follows:

<i>Applicant</i>	<i>Previous Gazette No.</i>	<i>Date</i>
(i) On Wednesday, 13 May 1987 in the City of Bendigo Council Chambers, Lytton Terrace, Bendigo: commencing at 9.30 a.m.		
A. E. E. McEwan	60	16.7.86
T. M. & M. L. Witham	86	15.10.86

commencing at 10.30 a.m.

A. W. Tierney	72	27.8.86
F. J. McEvoy	90	29.10.86
O. V. Flynn	90	29.10.86
N. F. Talbot	102	10.12.86
N. F. Hayes	102	10.12.86
(ii) On Wednesday, 20 May 1987 in the Korumburra Court House, Bridge Street, Korumburra, commencing at 11.00 a.m.		
J. D. & M. I. Mackie	74	10.9.86
J. E. Felsovary	99	26.11.86
(iii) On Tuesday, 26 May 1987 in the Ballarat Shire Offices, Learmonth Road, Wendouree, commencing at 10.30 a.m.		
Lashandra Pty. Ltd.	87	22.10.86
Shuttlebus, Ballarat Pty. Ltd.	87	22.10.86
L. E. Turner	86	15.10.86

Dated 25 March 1987

G. S. HUGHES
Registrar

Department of Industry, Technology and
Resources

MINING LEASE GRANTED

No. 760; G. R. Bates and Drummond Ridge Pty Ltd; 13.96 ha, Parish of Wedderburn.

APPLICATION FOR MINING LEASE

TRANSFERRED

No. 1112; From P. O'Donnell and G. Taylor to United and Commercial Holdings Ltd.

APPLICATION FOR DEVELOPMENT LEASE

WITHDRAWN

No. 9, 10 and 11; CRA Exploration Ltd; approximately 100, 130 and 120 ha respectively, Parish of Walhalla.

INTENTION TO GRANT PROSPECTING
AREA LICENCES

No. 183; Associated Gold Mines of Victoria Ltd; 62.4 ha, Parish of Butgulla.

No. 188; Pyrenees Mining Company Pty Ltd; 25.6 ha, Parish of Kingower.

No. 197; Planet Resources Group NL; 7 ha, Parish of Craigie.

No. 198; Planet Resources Group NL; 10 ha, Parish of Maryborough.

No. 199; Planet Resources Group NL; 260 ha, Parish of Craigie.

No. 201; Planet Resources Group NL; 28.5 ha, Parish of Maryborough.

PROSPECTING AREA LICENCES EXPIRED

No. 2; D. R. Brown and B. W. Cuffley; 12.5 ha, Parish of Stanley.

No. 43; B. Prothero; 15 ha, Parishes of Goulburn and Lauraville.

TAILINGS REMOVAL LICENCE GRANTED

No. 5225; Western Mining Corporation Ltd; to remove tailings from Crown land north of Albion Road, Stawell.

TAILINGS REMOVAL LICENCES EXPIRED

No. 4920; D. Lockyer, to remove tailings from the "William Fancy Dump" situated at Berringa in the Parish of Clarkesdale.

No. 4937; Shire of Tullaroop, to remove alluvial tailings from Crown land west of Crown Allotment 15 section 19 situated in the Parish of Maryborough.

APPLICATION FOR TAILINGS TREATMENT LICENCE WITHDRAWN

No. 392; Gaffney's Creek Gold Mines NL; 1.709 ha, Parish of Lauraville.

TAILINGS TREATMENT LICENCE CONDITION VARIED

No. 300; Clarke Bros, A. F. Campbell, Automake Pty Ltd and Eaglehawk Gold Pty Ltd condition 5 is altered in that the words "cyanided sands" should read "non-cyanided sands".

INTENTION TO GRANT EXPLORATION LICENCES

No. 1668; T. F. Croft; 7 km², Parish of Glenpatrick.
No. 1819; CRA Exploration Pty Ltd; 267 km², Shire of Swan Hill.

INTENTION TO EXTEND EXPLORATION LICENCES

No. 954-3; CRA Exploration Pty Ltd; 59 km², County of Talbot.

No. 1316-3; Roscraft Minerals Pty Ltd; 48 km², Counties of Dalhousie and Bourke.

EXPLORATION LICENCE EXTENDED

No. 1326-3; Eastern Copper Mines NL and Kinglake Resources Pty Ltd; 88 km², County of Wonnangatta.

EXPLORATION LICENCES EXPIRED

No. 1409; Ashton Mining Ltd; 130 km², County of Bogong.

The above expired area will become available again for Exploration Licence on 24 August 1987.

No. 1493-1; P. S. and K. M. Forwood; 136.5 km², County of Dundas.

The above expired area will become available again for Exploration Licence on 7 September 1987.

EXTRACTIVE INDUSTRY LICENCE GRANTED

No. 1179; Marafield Pty Ltd and Telleano Pty Ltd; 3.946 ha, Parish of Buninyong.

APPLICATIONS FOR EXTRACTIVE INDUSTRY LICENCES REFUSED

No. 1337; F. and M. F. Lane; 57 ha, Parish of Yangery.

No. 1339; R. E. and P. E. Neave; 5.6 ha, Parish of Boola Boola.

EXTRACTIVE INDUSTRY LICENCES RENEWED

No. 747-2; H. J. Tulloch; 13.2306 ha, Parish of Tanjil.

No. 882-1; C. and C. Hall; 7.2376 ha, Parish of Yanakie.

No. 1087-1; G. R. Farley; 21.1178 ha, Parish of Rosedale.

EXTRACTIVE INDUSTRY LICENCES EXPIRED

No. 917-1; B. W. James; 144.8 ha, Parishes of Marong and Leichardt.

No. 184; F. G. Hams & Sons Pty Ltd; 4.9 ha, Parish of Bunyip.

No. 972-1; CSR Ltd; 18.373 ha; Parish of Rosedale.

No. 784; R. F. and V. M. Dowel; 2.2627 ha, Parish of Drumdlemara.

EXTRACTIVE INDUSTRY LEASES RENEWED

No. 139-1; Boral Resources Pty Ltd; 12.3929 ha, Parish of Merrimu.

No. 208-1; Rochester Shire Council; 20.3068 ha, Parish of Nanneella.

EXTRACTIVE INDUSTRY LICENCE ASSIGNED

No. 430; From CSR Ltd to Monier Ltd.

ROBERT FORDHAM

Minister for Industry, Technology and Resources

Police Offences Act 1958, No. 6337

DIVISION 1A—STATE CLASSIFICATION OF PUBLICATIONS BOARD

Take note that the State Classification of Publications Board has classified the following publications in accordance with the provisions of section 180H (1) of the *Police Offences Act 1958*.

Each publication shall be subject to the following restrictions:

- (a) It shall not be offered for sale, sold or delivered to any person under the age of 18 years;
- (b) It shall not be made available for inspection or perusal by any person under the age of 18 years;
- (c) It shall not be exhibited or displayed in any place to which persons under the age of 18 years have access or so that it is visible from any such place.

Title	Distributor
Adult Movies—Swank Gold Press—Vol. 5	Gordon & Gotch Ltd.
No. 2—May 1987	Gordon & Gotch Ltd.
Chic—Vol. 10 No. 12 October 1986	Gordon & Gotch Ltd.
Erotic Encounters—May 1987—Vol. 1 No. 2	Gordon & Gotch Ltd.

Family Letters—June 1987	Gordon & Gotch Ltd.	Escort—Vol. 7 No. 1	Gordon & Gotch Ltd.
Family Secrets—June 1987	Gordon & Gotch Ltd.	Gung-Ho—November 1986—Vol. 6 No. 55	Gordon & Gotch Ltd.
First Class—May 1987	Gordon & Gotch Ltd.	Gung-Ho—March 1987—Vol. 7 No. 57	Gordon & Gotch Ltd.
Forbidden Acts—June 1987	Gordon & Gotch Ltd.	In the Wind—No. 26—Winter 1987	Gordon & Gotch Ltd.
Human Digest—April 1987—Vol. 11 No. 4	Gordon & Gotch Ltd.	Knave—Vol. 19 No. 3	Gordon & Gotch Ltd.
Kinky Letters—Intimate Acts—April 1987 Vol. 7 No. 2	Gordon & Gotch Ltd.	Pocketfox—Summer 1987—Vol. 3 No. 3	Gordon & Gotch Ltd.
Letters Magazine—May 1987	Gordon & Gotch Ltd.	Special Weapons and Tactics—February 1987—Vol. 6 No. 2	Gordon & Gotch Ltd.
Letters Magazine—June 1987	Gordon & Gotch Ltd.	Penthouse Erotic Pets 1987	Gordon & Gotch Ltd.
Partner—May 1987—No. 95	Gordon & Gotch Ltd.	Razzle—Vol. 5 No. 1	Gordon & Gotch Ltd.
Penthouse Variations—April 1987	Gordon & Gotch Ltd.	Razzle—Vol. 5 No. 2	Gordon & Gotch Ltd.
Real Letters—June 1987			
Sexual Response—May 1987—Vol. 1 No. 1	Gordon & Gotch Ltd.		
Shameless Tales—May 1987—Vol. 1 No. 1	Gordon & Gotch Ltd.		
True Letters—June 1987	Gordon & Gotch Ltd.		
X-Letters—May 1987—Vol. 4 No. 4	Gordon & Gotch Ltd.		

R. DOOLEY
Acting Secretary,
State Classification of Publication Board

Police Offences Act 1958, No. 6337

DIVISION 1A—STATE CLASSIFICATION OF PUBLICATIONS BOARD

Take note that the State Classification of Publications Board has classified the following publications in accordance with the provisions of section 180H (1) of the *Police Offences Act 1958*.

Each publication shall be subject to the following restrictions:

- (a) It shall not be offered for sale, sold or delivered to any person under the age of 18 years;
- (b) It shall not be made available for inspection or perusal by any person under the age of 18 years.

<i>Title</i>	<i>Distribution</i>
Australian Playgirl for Men—Pinups	Overseas Periodicals (Aust.) Pty. Ltd.
Best of Genesis—Sexiest Girls—Summer 87	Gordon & Gotch Ltd.
Club International—Vol. 16 No. 1	Gordon & Gotch Ltd.

R. DOOLEY
Acting Secretary,
State Classification of Publications Board

Town and Country Planning Act 1961

PHILLIP ISLAND PLANNING SCHEME

Amendment No. 25

Notice of Approval

In pursuance of the powers conferred by the *Town and Country Planning Act 1961*, the Governor in Council on 24 March 1987, approved the abovementioned scheme in respect of the municipal district of the Shire of Phillip Island and for which the Council of the Shire of Phillip Island is the responsible authority.

The scheme comes into operation on the date this Notice is published in the *Government Gazette*.

The scheme includes provisions relating to car parking in the Cowes commercial area, modifies some definitions and the uses which may be permitted in the Commercial A and Commercial B zones and introduces provisions relating to Overall Development Plans.

A copy of the documents may be inspected free of charge during office hours, at the office of the Ministry for Planning and Environment (Plan Inspection Section), The Oldfleet Buildings, 477 Collins Street, Melbourne and at the office of the responsible authority, Shire of Phillip Island, Civic Centre, Thompson Avenue, Cowes.

DAVID YENCKEN
Secretary for Planning and Environment

Town and Country Planning Act 1961

PHILLIP ISLAND PLANNING SCHEME

Amendment No. 27

Notice of Amendment

In pursuance of the powers conferred by the *Town and Country Planning Act 1961*, the Governor in Council on 24 March 1987, amended the

abovementioned scheme in respect of the municipal district of the Shire of Phillip Island and for which the Council of the Shire of Phillip Island is the responsible authority.

The amendment comes into operation on the date this Notice is published in the *Government Gazette*.

The amendment includes modification to the Tables to Clause 6 of the Ordinance to note that house is subject to Clause 20 in the Rural Residential, Residential A and Residential B Zones.

A copy of the documents may be inspected free of charge during office hours, at the office of the Ministry for Planning and Environment, The Olderfleet Buildings, 477 Collins Street, Melbourne and at the office of the responsible authority, Council of the Shire of Phillip Island, Civic Centre, Thompson Avenue, Cowes.

DAVID YENCKEN
Secretary for Planning and Environment

Town and Country Planning Act 1961
PHILLIP ISLAND PLANNING SCHEME
Interim Development Order
Amendment No. 23
Notice of Revocation

In pursuance of the powers conferred by the *Town and Country Planning Act 1961*, the Governor in Council on 24 March 1987 made an Order revoking the abovementioned Order in respect of all affected land generally bound by Chapel Street, Warley Avenue, The Esplanade and Thompson Avenue, Cowes.

This order provides that the whole of the Phillip Island Planning Scheme Amendment No. 23 Interim Development Order is revoked.

A copy of the documents may be inspected free of charge during office hours, at the office of the Ministry for Planning and Environment, The Olderfleet Buildings, 477 Collins Street, Melbourne and at the office of the responsible authority, Shire of Phillip Island, Civic Centre, Thompson Avenue, Cowes.

DAVID YENCKEN
Secretary for Planning and Environment

Town and Country Planning Act 1961
CITY OF WARRNAMBOOL INTERIM
DEVELOPMENT ORDER (BUILDING
CONTROL) 1987
Amendment No. 1
Notice of Amendment

In pursuance of the powers conferred by the *Town and Country Planning Act 1961*, the Governor in Council on 24 March 1987, amended the abovementioned Order in respect of the City of Warrnambool and for which the Minister for Planning and Environment is the responsible authority.

The amendment comes into operation on the date this Notice is published in the *Government Gazette*.

This amendment is required to reinstate the provisions of the City of Warrnambool (Historic Buildings) Interim Development Order which ceased upon gazettal of City of Warrnambool Interim Development Order (Building Control) 1987.

A copy of the documents may be inspected free of charge during office hours, at the office of the Ministry for Planning and Environment, The Olderfleet Buildings, 477 Collins Street, Melbourne.

DAVID YENCKEN
Secretary for Planning and Environment

Motor Car Act 1958
MOTOR CAR TRIALS OF SPEED WITHIN
THE TOWN OF CAMPERDOWN

The Governor in Council under section 83A (4) of the *Motor Car Act 1958*, declares that sub-sections (1) and (2) of section 83A of the Act and any regulations made under Part VI of the *Transport Act 1983* shall not apply with respect to the following events known as "Victorian Hillclimb Championship 1987, Round 1" on 28 and 29 March 1987; "Mt Leura Hillclimb 1987" on 21 June 1987 and "Victorian Hillclimb Championship 1987, Round 3" on 26 and 27 September 1987, to be conducted by the Ford Four Car Club on Mt Leura Lookout Road within the Town of Camperdown between the hours of 10.30 am and 5.30 pm on each day.

Dated: 24 March 1987

Responsible Minister:
TOM ROPER
Minister for Transport

L. G. HOUSTON
Clerk of the Executive Council

Crown Land (Reserves) Act 1978
REVOCATION OF TEMPORARY
RESERVATIONS

The Governor in Council under section 10 of the *Crown Land (Reserves) Act 1978* revokes the following temporary reservations.

Deutgam—The temporary reservation by Order in Council of 6 June, 1974 of 6591 square metres of land being Crown Allotment 17G, section E, Parish of Deutgam as a site for Public Purposes (Police Purposes). (Rs 9883)

Jika Jika—The temporary reservation by Order in Council of 8 July, 1953 of 2782 square metres more or less, of land in the Parish of Jika Jika, (City of Brunswick) as a site for Road and Public Purposes. (Rs 6086)

Keelbundora—The temporary reservation by Order in Council of 7 September, 1976 of 9085 square metres of land being Crown Allotment 6A,

Parish of Keelbundora (at Heidelberg) as a site for Public Purposes (National Gallery). (Rs 10219)

Lancefield—The temporary reservation by Order in Council of 21 October, 1867 of 7664 square metres of land in the Township of Lancefield as a site for Police Purposes, revoked as to part by various Orders, so far only as the portion containing 903 square metres being Crown Allotment 12b, section 66, Township of Lancefield as shown on Certified Plan No. 108224 lodged in the Central Plan Office. (Rs 9467)

Moorabool West—The temporary reservation by Order in Council of 19 January, 1874 of 4856 square metres of land adjoining Crown Allotment 4, section 20, Parish of Moorabool West as a site for State School Purposes. (LI 3199)

Rokewood—The temporary reservation by Order in Council of 9 March, 1869 of 1-897 hectares of land in the Township of Rokewood, Parish of Corindhap as a site for watering purposes, revoked as to part by Order of 7 March 1911, so far as the balance thereof containing 1-492 hectares. (Rs 5230)

Scoresby—The temporary reservation for Horticultural Research Station purposes by Orders in Council of 4 February 1969 and 15 October 1946, revoked as to part by various Orders, so far only as the portion containing 60-81 hectares being Crown Allotment 41c Parish of Scoresby as shown on Certified Plan No. 108172 lodged in the Central Plan Office. (Rs 5885)

Warrnambool—The temporary reservation by Order in Council of 26 October, 1914 of 1-0042 hectares of land in the Township of Warrnambool, Parish of Wangoom as a site for a High School so far only as the area of 183 square metres being Crown Allotment 4A, section 61A, Township of Warrnambool shown on Certified Plan No. 108234 lodged in the Central Plan Office. (Rs 268)

Dated: 24 March 1987

Responsible Minister:

JOAN E. KIRNER

Minister for Conservation, Forests and Lands

L. G. HOUSTON
Clerk of the Executive Council

Alpine Resorts Commission Act 1983

ALPINE RESORTS COMMISSION

Notice of Appointed Day Under Section 24 (2)

The Governor in Council under section 24 (2) of the *Alpine Resorts Act 1983* does by this Notice fix Wednesday, 25 March 1987 as the "appointed day" on which the Alpine Resorts Commission shall take over the administration, control and management of the alpine resort at Lake Mountain.

Dated: 24 March 1987

Responsible Minister:

R. C. FORDHAM

Minister for Industry, Technology and Resources

L. G. HOUSTON
Clerk of the Executive Council

CITY OF ST. KILDA

By-Law No. 214

Unsolicited Material By-Law

A By-Law of the City of St. Kilda under the provisions of the *Local Government Act 1958* and numbered 214 for the purposes of—

- (a) Suppressing nuisances.
- (b) Regulating traffic and processions.
- (c) Generally for maintaining the good rule and government of the municipality.

In pursuance of the powers conferred by section 197 of the *Local Government Act 1958* and of any and every other power it thereunto enabling the Mayor Councillors and Citizens of the City of St Kilda order as follows:

1. This By-Law may be known as the Unsolicited Material By-Law.

2. In this By-Law unless inconsistent with the context or subject matter:

"Authorized Officer" means the Municipal Clerk or a By-Laws Officer or a Health Surveyor of the City of St Kilda.

"Council" means the Council of the City of St Kilda.

"Land" includes property.

"Municipal District" means the municipal district of the City of St Kilda.

"Occupier" includes the person in actual occupation, his agent or the person for the time being in charge of any property.

"Owner" bears the same meaning as is ascribed to it in the *Local Government Act 1958*.

"Permit" means a written permit issued pursuant to the authority of the Council under the hand of an Authorized Officer.

"Person" includes the owner or occupier or the person in charge of any property, and includes an incorporated or unincorporated body or society.

"Prescribed Item" means an item package or article which does not contain on it the address of the premises it is to be or has been delivered to.

"Property" means any land dwelling or flat in separate ownership or separate occupation within any area set forth in this By-Law.

"Public Place" has the same meaning as ascribed to it in the *Summary Offences Act 1966*.

"Restricted Letterbox" means a letterbox serving residential premises which has attached on it or placed nearby thereto in such a way as to be visible to any person placing an item package or article therein a sign inscribed with the words "No Unsolicited Material" or words to that or a similar effect.

"Vehicle" includes motor cars, trucks, motor cycles, pedal cycles, motor scooters whether registered or not.

3. Any land, dwelling or flat shall, until the contrary is proved be deemed to be in separate ownership or separate occupation for the purposes of this By-Law if it is rated separately and distinctly as one piece of land in the Rate Book of the Council.

Distribution of Notices, Advertisements, Pamphlets, Goods or Gifts

4. No person upon any street, footway or other public place shall without first obtaining a permit nor otherwise in accordance with the conditions of any such permit give out or distribute to bystanders or passers-by or place in or upon any vehicle standing or parked in on or upon any street, footway or public place any handbills, placards, notices, advertisements, books, pamphlets or papers.

5. No person shall litter or cause or permit or suffer to be littered any streets, footway or public place by scattering, throwing down, placing or otherwise depositing or permitting or suffering to be scattered thrown down, placed or otherwise deposited upon such street, footway or public place any handbill, placard, notice advertisement, book, pamphlet or paper.

6. Any person giving out distributing or placing or causing, permitting or allowing to be given out or distributed to any passers-by or bystanders or vehicles or placed on any vehicles any handbills, placards, notices, advertisements, books, pamphlets or papers shall ensure at all times that the street, footway, or public place within fifty metres from the place where such items are given out distributed or placed is at all times kept clean and free from such items.

7. No person upon any street footway or other public place shall without first obtaining a permit nor otherwise than in accordance with the conditions of any such permit give out distribute place upon offer or make available to by-standers, passers-by or vehicles any goods, gifts, or things whatsoever whether by way of gift, sample or otherwise or offer or agree to make such goods, gifts or things available or to deliver the same to such by-stander or passer-by at his place of residence or work.

Permit Applications

8. Any person applying for a written permit from the Council pursuant to Clause 4 of this By-Law shall:

- (a) Make application in writing therefore to the Council stating his name, address and age, and the name and address of the organization or association by which he is employed or which he represents.
- (b) State precisely to which footways, streets or other public places within the municipality the applicant desires the permit to relate.
- (c) Specify the nature and content of the bills, placards, notices, advertisements, books, pamphlets or papers to be given out, distributed or placed.

(d) State precisely between what hours and on what day or days the applicant desires permission pursuant to this Clause.

(e) Furnish such further and other information as the Council may require.

9. Any person applying for a written permit from the Council pursuant to Clause 7 of this By-Law shall:

(a) Make application in writing therefor to the Council, stating his name, address and age, and the name and address of the organization or association by which he is employed or which he represents.

(b) State precisely to which foot-ways streets or other public places within the municipality the applicant desires the permit to relate.

(c) Specify precisely the goods gifts or other things to which the applicant requests the permit relate.

(d) State precisely between what hours and on what day or days the applicant desires permission pursuant to this Clause.

(e) State whether the goods, gifts or things are to be given out distributed offered or made available (stating which) to by-standers or passers-by.

(f) State whether the goods gifts or things will be made available by way of gift sample or otherwise (stating which).

(g) State whether any offer will be made to whether agreement will be sought (stating which) to make such goods gifts or things available to or to deliver the same to such by-stander or passer-by at his place of residence or work.

(h) Furnish such further and other information as the Council may require.

10. The Council may from time to time, prescribe the form or manner in which applications under Clauses 4 and 7 of this By-Law shall be made.

Council Permits

11. (1) The Council may in its discretion grant any such application pursuant to this By-Law with or without conditions or may refuse to grant the same.

(2) Where a form of permit is prescribed by this By-Law or by Council Resolution substantial compliance therewith or the issue of a permit to the like effect shall be sufficient for the purposes of this By-Law.

(3) Any such permit shall continue in force for a period of twelve (12) months from its issue or renewal or until the Council in its absolute discretion shall revoke the same and shall thereafter become null and void and of no effect unless renewed by the Council on the application in writing of the holder made prior to its expiry.

(4) No permit shall be transferrable by the holder to any other person.

Revocation of Permits

12. If at any time the holder of any permit shall in the opinion of the Council fail to comply with all the terms and conditions of this By-Law and of such permit and the conditions thereof or if at any time in the opinion of the Council any obstruction shall be caused or the orderly flow of traffic shall be interfered with by the exercise of any rights granted by such permit or by any assemblage of persons caused thereby or in the absolute discretion of the Council, the Council considers it otherwise appropriate the Council may revoke such permit and the same shall thereafter become null and void and of no effect.

General Clauses

13. No person shall give out distribute or place or cause, permit, or allow or suffer to be given out or distributed to by-standers or passers-by or placed upon any vehicles any hand bills, placards, advertisements, notices, books, pamphlets or papers:

- (1) So as to unduly obstruct the street, road, footway or public place.
- (2) So as to cause, permit or suffer any nuisance or other condition liable to be dangerous to health or offensive to exist at or contiguous thereto.
- (3) So as to cause, permit or suffer any littering of such street, road, footway or public place.
- (4) Any person who gives out or distributes to by-standers or passers-by or places upon any vehicles any handbills, placards, notices, advertisements, books, pamphlets or papers as aforesaid shall at all times—
 - (i) state his name and place of abode when asked to do so by an Authorised Officer or a By-Laws Officer of the Council.
 - (ii) produce any permit granted by the Council pursuant to this By-Law to any Officer of the Council or any member of the Police Force on demand.
 - (iii) comply with and observe all other Statutes, Regulations, By-Laws or Laws applicable and in particular relating to the sale of such goods.
 - (iv) shall not exhibit erect or display any advertisement thereat or in the vicinity thereof without first obtaining the necessary consents and authorities from the Council or any other Responsible Authority.
 - (v) shall not without first obtaining a permit nor otherwise than in accordance with the conditions of any such permit shout or cry out or otherwise advertise (whether by using a public address system or otherwise) the contents of such hand bills, placards, notices, advertisements, books, pamphlets or papers.

Letterbox Distributions

14. (1) In this Clause 14 unless inconsistent with the context or subject matter—

“Council” means the Council of the Mayor Councillors and Citizens of the City of St. Kilda.

“Person” includes an incorporated or unincorporated body or society.

“Prescribed item” means an item package or article which does not contain on it the address of the premises it is to be or has been delivered to.

“Restricted letter box” means a letterbox serving residential premises which has attached on it or placed nearby thereto in such a way as to be visible to any person placing an item package or article therein a sign inscribed with the words “No Unsolicited Material” or words to that or a similar effect.

- (2) No person shall deposit place or insert or cause permit or suffer to be deposited placed or inserted into any restricted letterbox an unsolicited prescribed item.
- (3) No person shall engage direct or authorise a person to deposit place or insert into any restricted letterbox an unsolicited prescribed item.
- (4) This By-Law does not apply to any statutory body or any services or deliveries provided or made by that body.
- (5) An item package or article shall not be deemed to be a prescribed item within the meaning of that phrase in this By-Law if it contains any electoral or political material advertising a candidate in an approaching federal state or municipal election.

15. All persons suspected of or contravening the terms of this By-Law or any permit issued thereunder or the conditions thereof shall give their names and places of abode when asked to do so by an Authorised Officer or By-Laws Officer of the Council.

Penalty

16. Any person guilty of any wilful act or default contrary to this By-Law or any permit issued thereunder or any condition thereof shall be liable to a penalty of not less than 1 penalty unit nor more than 10 penalty units and in addition a further penalty of not more than one penalty unit for each day on which an offence against this By-Law is continued after notice has been given to the offender by the Council of the commission of the offence or after a conviction or order of any Court, as the case may be.

17. In addition to any penalties any expense incurred by the Council in consequence of a breach of its By-Law shall be paid by the person committing such breach.

18. This By-Law shall apply to and have operation throughout the whole of the municipal district.

Resolution for passing this By-Law agreed to by the Council of the City of St. Kilda on 16 February 1987 and confirmed on 16 March 1987.

The common seal of the Mayor, Councillors and Citizens of the City of St. Kilda was hereunto affixed on 16 March 1987 in the presence of—

K. N. M. McGREGOR, Mayor
T. S. COLLISON, Councillor
6420 B. JONES, Town Clerk/City Manager

Town and Country Planning Act 1961

SHIRE OF BRIGHT PLANNING SCHEME 1983

Notice that a Planning Scheme has been Prepared and is Available for Inspection

Amendment No. 6

Notice is hereby given that the Shire of Bright in pursuance of its powers under the *Town and Country Planning Act 1961* has prepared a Scheme to rezone Pt Lot 9, LP 4378, Section O, Township of Bright, Mt Porepunkah Road from a Low Density Residential Zone to a Residential Zone (Normal Density).

A copy of the Scheme has been deposited at the Shire Office, Churchill Avenue, Bright, the Ministry for Planning and Environment Regional Office, Astra House, Jack Hore Place, Wodonga and at the Ministry for Planning and Environment (Plan Inspection Section), The Olderfleet Buildings, 477 Collins Street, Melbourne and will be open for inspection during office hours by any person free of charge.

Any persons affected by the Scheme are required to set forth in writing any submission that they may wish to make with respect to the Scheme, addressed to the Shire Secretary, Shire of Bright, PO Box 139, Bright 3741, by Monday, 27 April 1987 and state whether they wish to be heard in respect of their submission.

Dated 25 March 1987

6422 W. R. WARNE, Shire Secretary

Town and Country Planning Act 1961

SHIRE OF BRIGHT PLANNING SCHEME 1983

Notice that a Planning Scheme has been Prepared and is Available for Inspection

Amendment No. 7

Notice is hereby given that the Shire of Bright in pursuance of its powers under the *Town and Country Planning Act 1961* has prepared a Scheme to rezone Pt Lot 9, LP 4378, Section O, Township of Bright, Mt Porepunkah Road from a Rural Zone to a Low Density Residential Zone and to permit a Tourist Establishment in a Low Density Residential Zone.

A copy of the Scheme has been deposited at the Shire Office, Churchill Avenue, Bright, the Ministry for Planning and Environment Regional Office, Astra House, Jack Hore Place, Wodonga and at the Ministry for Planning and Environment (Plan Inspection Section), The Olderfleet Buildings, 477 Collins Street, Melbourne and will be open for inspection during office hours by any person free of charge.

Any persons affected by the Scheme are required to set forth in writing any submission that they may wish to make with respect to the Scheme, addressed to the Shire Secretary, Shire of Bright, PO Box 139, Bright 3741, by Monday, 27 April 1987 and state whether they wish to be heard in respect of their submission.

Dated 25 March 1987

6423 W. R. WARNE, Shire Secretary

Town and Country Planning Act 1961

SHIRE OF BRIGHT PLANNING SCHEME 1983

Notice that a Planning Scheme has been Prepared and is Available for Inspection

Amendment No. 8

Notice is hereby given that the Shire of Bright in pursuance of its powers under the *Town and Country Planning Act 1961* has prepared a Scheme to rezone Lots 3, 6 and 7, LP 4378, Section O, Township of Bright, Mt Porepunkah Road from a Rural Zone to a Low Density Residential Zone and to restrict subdivision on the subject land to minimum lot sizes of 4000 square metres.

A copy of the Scheme has been deposited at the Shire Office, Churchill Avenue, Bright, the Ministry for Planning and Environment Regional Office, Astra House, Jack Hore Place, Wodonga and at the Ministry for Planning and Environment (Plan Inspection Section), The Olderfleet Buildings, 477 Collins Street, Melbourne and will be open for inspection during office hours by any person free of charge.

Any persons affected by the Scheme are required to set forth in writing any submission that they may wish to make with respect to the Scheme, addressed to the Shire Secretary, Shire of Bright, PO Box 139, Bright 3741, by Monday, 27 April 1987 and state whether they wish to be heard in respect of their submission.

Dated 25 March 1987

6424 W. R. WARNE, Shire Secretary

Town and Country Planning Act 1961

SHIRE OF BRIGHT PLANNING SCHEME 1983

Notice that a Planning Scheme has been Prepared and is Available for Inspection

Amendment No. 9

Notice is hereby given that the Shire of Bright in pursuance of its powers under the *Town and Country Planning Act 1961* has prepared a Scheme to rezone

Lot 1, LP 115418, Section O, Township of Bright, Toorak Road, from a Low Density Residential Zone to a Residential Zone (Normal Density).

A copy of the Scheme has been deposited at the Shire Office, Churchill Avenue, Bright, the Ministry for Planning and Environment Regional Office, Astra House, Jack Hore Place, Wodonga and at the Ministry for Planning and Environment (Plan Inspection Section), The Olderfleet Buildings, 477 Collins Street, Melbourne and will be open for inspection during office hours by any person free of charge.

Any persons affected by the Scheme are required to set forth in writing any submission that they may wish to make with respect to the Scheme, addressed to the Shire Secretary, Shire of Bright, PO Box 139, Bright 3741, by Monday, 27 April 1987 and state whether they wish to be heard in respect of their submission.

Dated 25 March 1987

6425 W. R. WARNE, Shire Secretary

Town and Country Planning Act 1961

SHIRE OF BRIGHT PLANNING SCHEME 1983

Notice that a Planning Scheme has been Prepared and is Available for Inspection

Amendment No. 10

Notice is hereby given that the Shire of Bright in pursuance of its powers under the *Town and Country Planning Act 1961* has prepared a Scheme to rezone Part C.A.5, Section O, Township of Bright, Mt Porepukah Road from Low Density Residential Zone (Normal Density) and to rezone Lot 10, LP 4378, Pt C.A.5, Section O, and C.A.10, section O, Township of Bright, Mt Porepukah Road and Back Germantown Road from Rural Zone to a Low Density Residential Zone.

A copy of the Scheme has been deposited at the Shire Office, Churchill Avenue, Bright, the Ministry for Planning and Environment Regional Office, Astra House, Jack Hore Place, Wodonga and at the Ministry for Planning and Environment (Plan Inspection Section), The Olderfleet Buildings, 477 Collins Street, Melbourne and will be open for inspection during office hours by any person free of charge.

Any persons affected by the Scheme are required to set forth in writing any submission that they may wish to make with respect to the Scheme, addressed to the Shire Secretary, Shire of Bright, PO Box 139, Bright 3741, by Monday, 27 April 1987 and state whether they wish to be heard in respect of their submission.

Dated 25 March 1987

6426 W. R. WARNE, Shire Secretary

BALLARAT WATER BOARD

Pursuant to section 119 (2) of the *Sewerage Districts Act 1958*, (No. 6368) notice is hereby given of the intention to construct a sewer for property situated in the vicinity of the following streets:

Shire of Buninyong
Rodney Avenue
Shire of Grenville
Panorama Drive
Shire of Ballarat
Norman Street
City of Ballarat
Edwardes Street
Clayton Street

more particularly as shown on plans which are open for inspection at this office between the hours of 8.45 a.m. and 4.30 p.m., Monday to Friday, inclusive.

6429

P. A. POLLARD, Secretary

ASSOCIATED TOBACCO COMPANIES

Co-operative Housing Society No. 11 Limited
(in Liquidation)

Take notice that the affairs of the above-named society are now fully wound up and that in pursuance of section 272 (1) of the *Companies Act 1961* and of the *Co-operative Housing Societies Act 1958*, a general meeting of the society will be held at the Training Room, W. D. & H. O. Wills (Australia) Limited, 246 East Boundary Road, East Bentleigh at 4.00 p.m. on Tuesday, 28 April 1987 for the purposes of—

- (i) laying before it an account showing how the winding up has been conducted and the property of the society disposed of and giving any explanations thereof; and
- (ii) passing a resolution that the books and papers of the said society and of the liquidator relevant to the affairs of the society be destroyed after a period of twelve months from the date of the meeting.

Dated: 18 March 1987

6430

R. J. STROUD, Liquidator

ASSOCIATED TOBACCO COMPANIES

Co-operative Housing Society No. 12 Limited
(in Liquidation)

Take notice that the affairs of the above-named society are now fully wound up and that in pursuance of section 272 (1) of the *Companies Act 1961* and of the *Co-operative Housing Societies Act 1958*, a general meeting of the society will be held at the Training Room, W. D. & H. O. Wills (Australia) Limited, 246 East Boundary Road, East Bentleigh at 4.00 p.m. on Tuesday, 28 April 1987 for the purposes of:

- (i) laying before it an account showing how the winding up has been conducted and the property of the society disposed of and giving any explanations thereof; and
- (ii) passing a resolution that the books and papers of the said society and of the liquidator relevant to the affairs of the society be destroyed after a period of twelve months from the date of the meeting.

Dated: 18 March 1987

6431 R. T. STROUD, Liquidator

Companies Forms 102

Sub-section 421 (i)

MORWELL MANAGEMENT SERVICES
PTY LTDNotice of Appointment and of Address of Office of
Liquidator

(Members Voluntary Winding Up)

I, Bernd Wilhelm Ritzer of 16 Kirk Street, Moe
give notice that—

- (a) I was appointed liquidator of the company by a resolution of the company passed on 16 March 1987;
- (b) the address of my office is care of Ritzer Gallagher Morgan, 16 Kirk Street, Moe.

Dated: 19 March 1987

6432 B. W. RITZER, Liquidator

TYRONE JOHN BRAHAM (deceased) late of 161
Bishop Road, Beachmore, Qld. died on 21
January 1987

Any persons claiming to be dependent upon the deceased are requested to send particulars of their claims to "Life Claims Department, Australian Eagle Ins. Co. Ltd., G.P.O. Box 1883R, Melbourne 3001", within two months of the date of this notice, after which date the deceased's entitlement will be distributed in accordance with the provisions of the Eagle Retirement Fund Trust Deed, having regard only to the claims which have been notified. 6433

JAMES WILLIAM DAVIDSON (deceased) late of
125 Pohlman Street, Southport, Qld. died on 8
February 1987

Any persons claiming to be dependent upon the deceased are requested to send particulars of their claims to "Life Claims Department, Australian Eagle Ins. Co. Ltd., G.P.O. Box 1883R, Melbourne 3001", within two months of the date of this notice, after which the deceased's entitlement will be distributed in accordance with the provisions of the Eagle Retirement Fund Trust Deed, having regard only to the claims which have been notified. 6434

Creditors, next of kin and others having claims in respect of the estate of William John Davis formerly of 2 Etzel Street Airport West in the State of Victoria but late of 43 Jellicoe Street Noble Park in the said State, retired warehouseman, deceased, who died on 8 December 1986 are required to send particulars of their claims to the administrator care of the undermentioned solicitors by 29 May 1987, after which date he will distribute the assets having regard only to the claims for which notice has been received.

BORCHARD & MOORE, solicitors, of 44
Douglas Street, Noble Park 6435

ROBERT CLARENCE SIMS late of Bendigo Home
and Hospital for the Aged 100-104 Barnard Street,
Bendigo, retired, deceased

Creditors, next of kin and others having claims in respect of the estate of the deceased who died on 6 February 1987 are required by the trustee, Ian Bentley Still to send particulars of their claims to him care of the undersigned solicitors by 29 May 1987 after which time the trustee may convey or distribute the assets having regard only to the claims of which he then has notice.

IAN B. STILL & CO., solicitors, 32 Sydney Street,
Kilmore 6436

Creditors next of kin and others having claims against the estate of Caterina Brotto late of 24 Dorset Road, Ferntree Gully in the State of Victoria, widow, deceased (who died on 20 November 1986) are required by Patrick Francis Toohey the executor of the will of the said deceased to send to him care of the undersigned solicitors particulars thereof by 3 June 1987 after which date he will distribute the assets of the deceased having regard only to the claims of which he shall then have notice.

GAVAN DUFFY & KING, solicitors, 95 Queen
Street, Melbourne 6437

Creditors, next of kin and others having claims in respect of the estate of Francis Charles Biggins late of 221 Como Parade East, Parkdale, retired purchasing officer deceased who died on 2 July 1986, and probate of whose will has been granted to National Trustees Executors and Agency Company of Australasia Limited of 95 Queen Street, Melbourne are requested to send particulars of their claims to the said company by 4 June 1987 after which date it will distribute the assets having regard only to the claims of which it then has notice. 6445

Creditors, next of kin and others having claims in respect of the estate of Phyllis Gertrude Charles late of Maidstone Private Nursing Home, 41 Thomson Street, Maidstone, widow deceased who died on 18 December, 1986 are to send particulars of their claims to The Equity Trustees Executors and Agency Company Limited of 472 Bourke Street, Melbourne by 26 May 1987 after which date it will distribute the assets having regard only to the claims which it then has notice.

MARTIN & MARTIN, solicitors of 37 Queen Street, Melbourne 6446

FLORENCE EVANS late of Colton Close, 1-19 York Street, Glenroy, widow, deceased

Creditors next of kin and others having claims in respect of the estate of the deceased who died on 2 February 1987 are required by The Perpetual Executors and Trustees Association of Australia Limited of 50 Queen Street, Melbourne to send particulars of their claims to the said company by 26 May 1987 after which date it will convey or distribute the assets having regard only to the claims of which the company has notice.

MARTIN & MARTIN, solicitors of 37 Queen Street, Melbourne 6447

Creditors, next of kin and others having claims in respect of the estate of Kevin Thomas O'Neill, late of 46 Ward Grove, Pascoe Vale South, driver, deceased who died on 14 November 1986 are requested to send particulars of their claims to the executors National Trustees Executors and Agency Company of Australasia Limited and Mary Alice O'Neill care of the Company's registered office, 95 Queen Street, Melbourne by 3 June 1987 after which date the Executors will distribute the assets having regard only to the claims of which they then have notice.

PETER J. WALSH, solicitor, 95 Queen Street, Melbourne 6448

NINA RUBEL late of Flat 7, No. 9 Meadow Street, East St. Kilda, widow, deceased

Creditors, next of kin and others having claims in respect of the estate of the deceased who died on 24 November 1986 are required by the executors to send particulars of their claims to S. Rogozinski, solicitor of 281 Alma Road, North Caulfield, 3161 by 30 June 1987 after which date the executors may convey or distribute the assets having regard only to the claims of which they then have notice.

6449

Creditors, next of kin and others having claims in respect of the estate of Haydee Janet Witt, late of Alton Court, 2 McIntyre Drive, Altona, widow, deceased who died on 28 November 1986 are to send the particulars of their claims to ANZ Executors & Trustee Company Limited of 94 Queen Street, Melbourne by 26 May 1987 after which date it will distribute the assets having regard only to the claims of which it then has notice.

6451

JAMES EDWARD SWEENEY formerly of Unit 4, 66 Wilson Street, Cheltenham but late of Lot 24 Williams Road, Launching Place in the State of Victoria, gentlemen, deceased

Creditors, next of kin and others having claims in respect of the estate of the deceased who died on 2 January 1987 are required by ANZ Executors & Trustee Company Limited of 94 Queen Street, Melbourne aforesaid the applicant for a Grant of Administration to send particulars of their claims to the said applicant in the care of the said Company by 31 May 1987 after which date it will convey or distribute the assets having regard only to the claims of which it then has notice.

FREEHILL, HOLLINGDALE & PAGE, solicitors, 140 William Street, Melbourne 6450

A Guide to the Freshwater Fish of Victoria

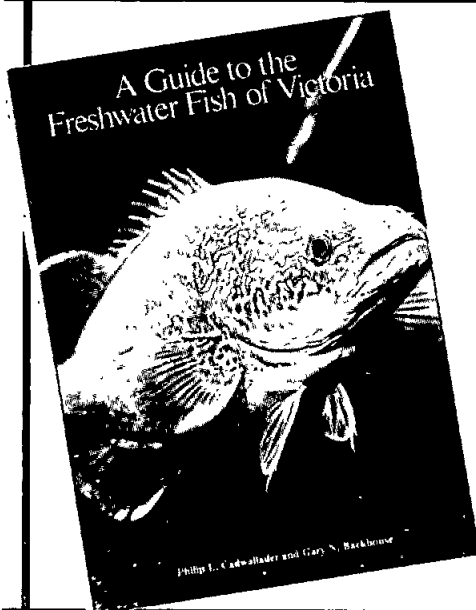

This detailed guide is now available.

The Guide features:
58 full-colour photographs of live specimens for all species of fish found in the fresh waters of Victoria; Introductory Sections on the Inland waters of Victoria and Man's impact on our native freshwater fish, plus more; A Key (with line drawings) to the families of freshwater fish in Victoria; details of each fish species; and an extensive Index and Glossary.

With over 240 pages, this authoritative and easy to read text will appeal to anglers, students, naturalists and a far wider audience. Price: \$13.50 (\$16.50 posted)

VGPO Bookshop Information Victoria Centre
318 Lt Bourke-St Melbourne PO Box 203 North Melbourne 3051
Telephone (03) 663 3760

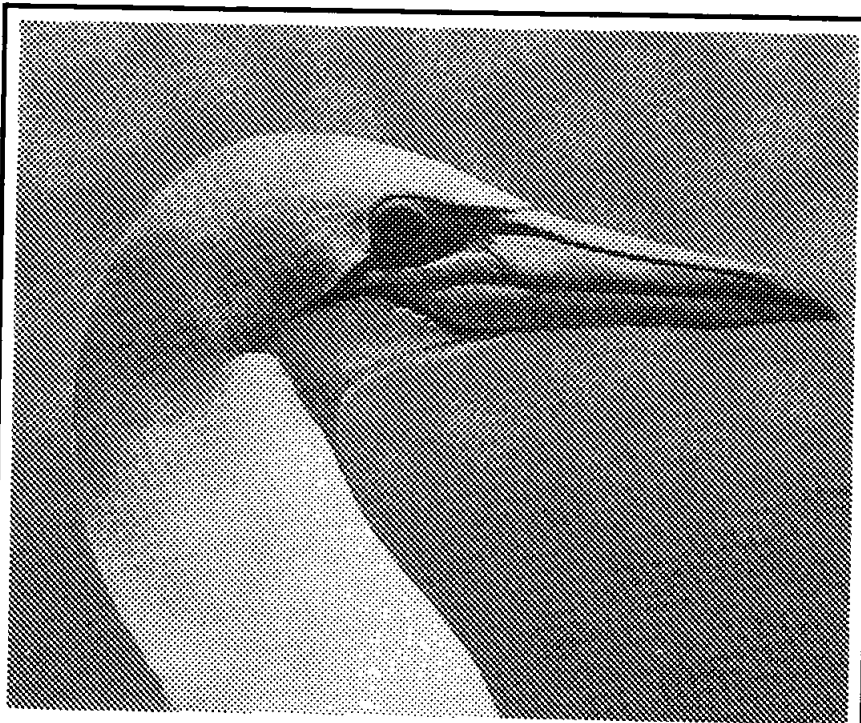

**BIRDS OF PORT PHILLIP
BAY**

Available now from the VGPO Bookshop
Information Victoria Centre
318 Lt Bourke St Melbourne
Telephone inquiries 663 3760

Price—\$6.95
Postage—\$2.50

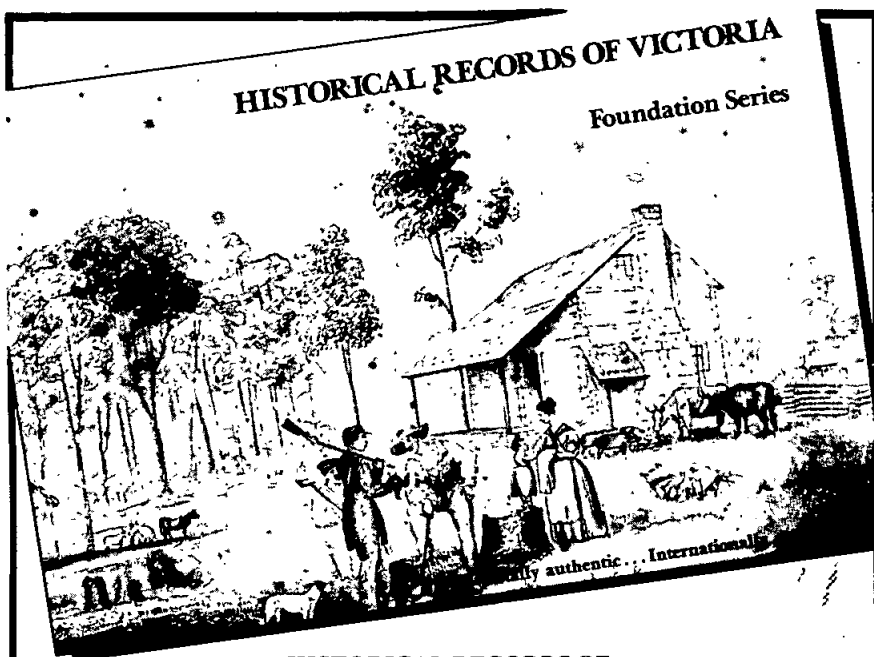

HISTORICAL RECORDS OF VICTORIA Volume 3

The Early Development of Melbourne

Historical Records of Victoria unfolds and unravels the grand schemes, ideas and intrigues that shaped and flavoured the infant community of Melbourne, and offers new insights into the initial development of other important centres.

Volume 3 in the series, *The Early Development of Melbourne*, tells the often dramatic and exciting story of the first years of permanent settlement at Port Phillip in the words of the pioneers themselves. Most of the documents presented, and many of the accompanying illustrations, have never been published before.

The Early Development of Melbourne contains beautiful color reproductions of contemporary paintings, and more than a hundred portraits, views and maps. It is fully indexed for ease of reference, and is available in paperback and clothbound editions as well as a special Deluxe edition, handbound in full leather.

The volumes have been painstakingly designed for optimum legibility, reading pleasure and durability. Typesetting, printing and binding are of the very highest order. Special Archival paper — to last at least 500 years — has been utilised.

This is the revealing history of early Melbourne and Victoria you have long awaited, at a very affordable price . . .

Act now and participate in the historical experiences of your State and its people.

This is a series no Victorian can afford to miss.

Prices: Paperback \$19.50 (\$22.00 Posted)
Clothbound \$28.50 (\$31.50 Posted)
Deluxe
Leatherbound \$110.00 (\$113.50 Posted)

Available now from the VGPO Bookshop
Information Victoria Centre
318 Lt Bourke St Melbourne
Telephone inquiries 663 3760

Historical Records of Victoria Communications, Trade and Transport

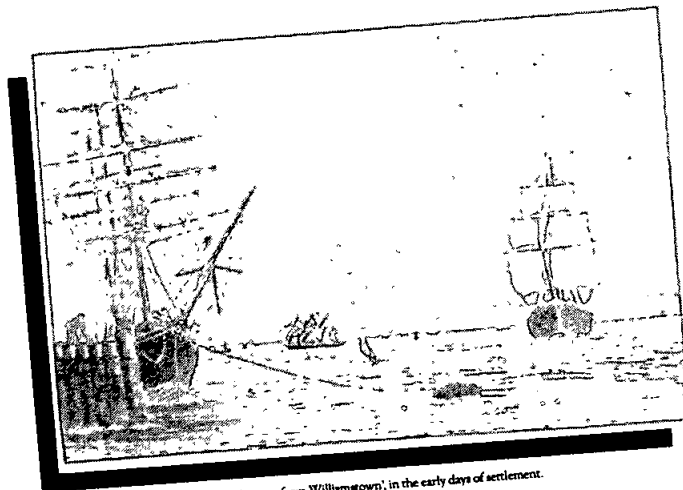

'Melbourne from Williamstown', in the early days of settlement.

Historical Records of Victoria - Volume 4 Communications, Trade and Transport.

The eagerly awaited and much sought after *Historical Records of Victoria - Volume 4* is now available. In keeping with previously published volumes the quality of volume 4 is first class. Titled COMMUNICATIONS, TRADE AND TRANSPORT, this volume of *Historical Records of Victoria* brings together all official documents which could be located in the important areas of communications, shipping, trade and transport, during the founding years of settlement.

The volume is divided into five main parts. Part I contains a good deal of previously unpublished information on early shipping, charting and Customs activities around Port Phillip Bay.

Part II outlines the first Government-controlled immigration schemes involving Port Phillip. Passenger lists and other details have been included wherever available.

Part III deals with the growth and control of the liquor trade, which was of great importance to Customs and other civil authorities.

Part IV depicts problems encountered by the first newspaper publishers, who had to contend with Government licensing in addition to other pioneering difficulties.

Part V shows the attempts made to organise satisfactory postal services, at a time when the district's need for better communications was increasing with remarkable speed.

To date there are four volumes in the HRV series and all have been painstakingly designed for optimum legibility, reading pleasure and durability. Typesetting, printing and binding are of the very highest order. Special Archival paper—to last at least 500 years—has been utilised.

Whether this is your first introduction to *Historical Records of Victoria* or you have the previously released splendid volumes there is no doubt you will be impressed with the quality of this publication and its contents. An impression so lasting you will await the future volumes with great anticipation.

Act now and participate in the historical experiences of your State and its people.

This is a series no Victorian can afford to miss.

Prices:
Paperback \$19.50 (\$22.00 Posted)
Clothbound \$28.50 (\$31.50 Posted)
Deluxe
Leatherbound \$110.00 (\$113.50 Posted)

Available from VGPO Bookshop
Information Victoria Centre
318 Lt Bourke Street, Melbourne
Telephone inquiries (03) 663 3760.