

Search advice notice: This page number 1153 duplicated - see also renumbered page 1423

VICTORIA GOVERNMENT G A Z E T T E

No. G 19 Wednesday 20 May 1987

By Authority F D Atkinson Government Printer Melbourne

GENERAL

GENERAL INFORMATION

The General edition of the *Victoria Government Gazette* is published on each Wednesday and provides information on tenders for the State Government as well as other matters of general interest such as public and private notices.

Special issues of the *Victoria Government Gazette* when published will be made available automatically to subscribers of the General edition.

NOTICES TO BE PUBLISHED

GOVERNMENT NOTICES The following guidelines should be followed to ensure publication of official material in the *Victoria Government Gazette*.

Publication of official material

- Duplicate copies should be submitted for the use of the Gazette officer.
- Material submitted to the Executive Council for gazettal will normally be published in the following week's issue.
- Where urgent gazettal is required, special arrangements should be made with
Mr Gerd Gaspars
Gazette Officer
Department of the Premier and Cabinet
Government Branch
2nd Floor, 1 Treasury Place
Melbourne, 3002
Telephone Inquiries
(03) 651 5153

Publication of other material

- All other material authorised by a responsible officer should be forwarded to the Gazette Office no later than 9.30 am on Tuesday.
- Lengthy or complicated notices should be forwarded several days before publication.

- Proofs will be supplied only when requested or at the direction of Gazette Officer. They should be returned quickly to avoid delay in publication.
- No additions or amendments to material for publication will be accepted by telephone.

PRIVATE NOTICES

Copy Deadline. Private advertisements will be accepted by:

Gazette Advertising
VGPO
PO Box 203
North Melbourne Vic 3051

no later than 11 am one day before publication.

Advertising Rates

Single column × cm/part cm \$3.85
Double column × cm/part cm \$7.70
Full page \$161.70
Ordinary rates will apply to material submitted for publication before 11 am Tuesday. Double rates will apply for special gazettes and for material submitted between 11 am and 3.30 pm Tuesday.

Advertisers should note:

- There are approximately 30 words to each column centimetre depth;
- Signatures (in particular) and proper names must be written clearly in the text;
- All material submitted for publication should be double-spaced and confined to ONE SIDE ONLY of each sheet of paper
- Documents NOT CLEARLY PREPARED will be returned to the sender, unpublished.

Late Copy

Copy received after 3.30 pm one day prior to publication at the VGPO will be placed in the following issue of the *Victoria Government Gazette*, irrespective of any date/s mentioned in the copy.

Search advice notice: This page number 1154 duplicated - see also renumbered page 1424

1154 G 19 20 May 1987

Victoria Government Gazette

CORRESPONDENCE

All correspondence should be addressed to:
Gazette Advertising
VGPO
PO Box 203
North Melbourne 3051
Telephone Inquiries (03) 320 0100
Fax No. (03) 329 2696

AVAILABILITY

All gazettes may be purchased over the counter from VGPO Bookshop Information Victoria Centre 318 Lt Bourke Street, Melbourne. Telephone (03) 663 3760.

Cost for individual copies is \$1.10.

Mail orders may be sent to VGPO PO Box 203 North Melbourne 3051. A postage and packaging fee must be added to the cost of the gazettes required using the table of rates below:

| Total Price of Publications | Postage Packaging Fee |
|-----------------------------|-----------------------|
| \$0.00 to \$2.00..... | \$0.80 |
| \$2.05 to \$5.00..... | \$1.10 |
| \$5.05 to \$25.00..... | \$2.50 |
| \$25.05 to \$75.00..... | \$3.00 |
| \$75.05 to \$125.00..... | \$3.50 |
| \$125.00 to \$200.00..... | \$4.00 |
| \$200.05 and over..... | at cost |

Bankcard purchases may be made using Bankcard facilities in the VGPO Bookshop and by mail orders. Bankcard mail orders require the Bankcard number, expiry date, name, address and signature of customer to be supplied.

(Minimum purchase of \$5.00 applies).

SUBSCRIPTIONS

Subscribers to the *Victoria Government Gazette* have three subscription services to choose from:

General Special and Periodical;
General and Special;
Periodical.

Subscriptions are payable in advance and accepted for a period of one year. All subscriptions are on a firm basis and refunds for cancellations will not be given.

Subscription rates for 1987 are as follows:

| | |
|--------------------------------|-------|
| General Special and Periodical | \$115 |
| General and Special | \$100 |
| Periodical | \$60 |

Prices include postage.

All remittances should be made payable to VGPO.

OTHER ISSUES OF THE GAZETTE

Special issues of the Gazette are published on specific days when required.

They are provided at no extra charge with weekly general issues.

Special issues are not available on separate subscription.

Periodical issues of the Gazette are published on each Monday when required. Listings such as Dentist's Register, Pharmacy Register are examples.

Subscription may be made separately at a cost of \$60.00 per annum including postage.

PROCLAMATIONS

Fire Authorities Act 1987

PROCLAMATION OF COMMENCEMENT

I, J. Davis McCaughey, Governor of Victoria, acting with the advice of the Executive Council and under section 2 of the *Fire Authorities Act 1987*, fix Wednesday, 20 May 1987, as the day on which sections 1, 2, 4, 6, 7, 9 and 13 of the Act come into operation, and fix Wednesday, 1 July 1987 as the day on which sections 3, 5, 8, 10, 11, 12 and 14 of that Act come into operation.

Given under my hand and the seal of Victoria on 19 May 1987.

(L.S.) J. DAVIS McCAUGHEY
By His Excellency's Command

C. R. T. MATHEWS
Minister for Police and Emergency Services

Mental Health Act 1959, No. 6605

PROCLAMATION

I, J. Davis McCaughey, Governor of Victoria, acting with the advice of the Executive Council and under section 24 (2) of the *Mental Health Act 1959*, do by this Proclamation, vary as from 21 May 1987, the Proclamation dated 5 January 1983, adding the building known as Ward N4 to the mental hospital known as Mental Hospital, Larundel, and delete the said Ward N4 from the mental hospital and add the said Ward N4 to the psychiatric hospital known as Psychiatric Hospital, Larundel.

Given under my Hand and Seal of the State of Victoria, at Melbourne on 12 May 1987.

(L.S.) J. DAVIS McCAUGHEY
By His Excellency's Command

D. R. WHITE
Minister for Health

Land Act 1958

PROCLAMATION OF ROADS

I, J. Davis McCaughey, Governor of Victoria acting with the advice of the Executive Council and under section 25 (3) (c) of the *Land Act 1958* proclaim as roads the following lands:

MUNICIPAL DISTRICT OF THE SHIRE OF BULN BULN

DROUIN WEST—Crown Alloment 73A, Parish of Drouin West as shown on Certified Plan No. 108312 lodged in the Central Plan Office—(Rs 12766).

MUNICIPAL DISTRICT OF THE SHIRE OF SWAN HILL

PIANGIL WEST—The land in the Parish of Piangil West as indicated by hatching on plan hereunder—(P148 (4)) (L5-2055).

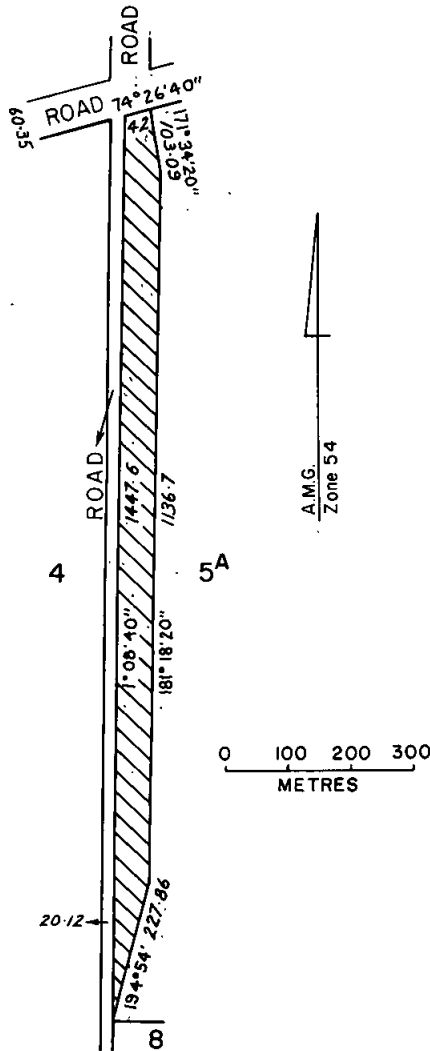

Given under my hand and the seal of Victoria on 12 May 1987.

(L.S.) J. DAVIS McCAUGHEY
By His Excellency's Command

J. E. KIRNER
Minister for Conservation, Forests and Lands

Search advice notice: This page number 1156 duplicated - see also renumbered page 1426

1156 G 19 20 May 1987

Victoria Government Gazette

Environment Protection (Amendment) Act 1987
(No. 22 of 1987)

PROCLAMATION OF COMMENCEMENT

Section 2 of the *Environment Protection (Amendment) Act 1987* provides that section 23 of the Act comes into operation on 10 December 1985 (the date of Royal Assent of the *Environment Protection (Industrial Waste) Act 1985*) and for the remainder to come into operation on a day or days to be proclaimed.

I, J. Davis McCaughey, Governor of Victoria, acting with the advice of the Executive Council and under section 2 of the *Environment Protection Amendment Act 1987*, fix 1 June 1987 as the day on which the remainder of the Act comes into operation.

Given under my hand and the seal of
Victoria on 19 May 1987

(L.S.) J. DAVIS McCAUGHEY
By His Excellency's Command

JIM KENNAN
Minister for Planning and Environment

Motor Spirit—State Petrol Centre

| | | | |
|-------|---|--------|---------|
| 1/53A | 1 | 0.4801 | 16.5.87 |
| | 2 | 0.4752 | |

Motor Spirit, Kerosene, Fuel Oils and Lubricants

| | | | |
|-------|----|--------|---------|
| 1/53B | 1 | 0.4756 | 16.4.87 |
| | 2 | 0.4855 | |
| | 5 | 0.4801 | |
| | 7 | 0.5427 | |
| | 8 | 0.5327 | |
| | 10 | 0.5132 | |
| | 12 | 0.5187 | |
| | 14 | 0.5105 | |
| | 16 | 0.5155 | |
| | 17 | 0.5104 | |
| | 18 | 0.5104 | |
| | 26 | 0.4707 | |
| | 27 | 0.4782 | |
| | 28 | 0.5359 | |
| | 29 | 0.5309 | |

Light Commercial Motor Vehicles

Refer *Government Gazette*, No. G10, 11 March 1987.

| | | | |
|-------|----|---------|--------|
| 1/59D | 1B | 1455.24 | 5.3.87 |
|-------|----|---------|--------|

Provisions—Melbourne and Metropolitan District

| | | | |
|------|-----|--------|--------|
| 2/01 | 144 | 0.6054 | 1.5.87 |
| | 145 | 0.6384 | |
| | 146 | 1.2597 | |
| | 147 | 0.6054 | |
| | 148 | 0.2833 | |
| | 149 | 0.4223 | |
| | 150 | 0.6384 | |
| | 151 | 1.2597 | |
| | 152 | 2.4799 | |
| | 153 | 0.4223 | |
| | 154 | 0.6384 | |
| | 155 | 1.2597 | |
| | 156 | 0.4223 | |
| | 158 | 0.6054 | |
| | 159 | 0.6054 | |
| | 160 | 0.6384 | |
| | 161 | 1.2597 | |
| | 162 | 1.2597 | |
| | 163 | 0.6054 | |

Overload Data Preparation Work

5/05 Refer *Victoria Government Gazette*, No. G18, 13 May 1987

The new rates are for Davies Computer Services

J. M. PAWSON
Secretary to the Tender Board

GOVERNMENT NOTICES

County Court Act 1958

COUNTY COURT SITTINGS 1987

Notice is hereby given that an additional sitting of the County Court at Shepparton will commence on Monday, 18 May 1987.

Dated 6 May 1987

G. R. D. WALDRON
Chief Judge of the County Court of Victoria

STATE TENDER BOARD
CONTRACTS ACCEPTED
Amendments

| Schedule Number | Item Number | New Rate | Effective Date |
|-----------------|-------------|----------|----------------|
|-----------------|-------------|----------|----------------|

| | | | |
|-----------|-------------|----|---------|
| | | \$ | |
| | | . | |
| Fasteners | | | |
| 1/26 | 31-38,73,74 | * | 23.4.87 |

* Delete: The British United Shoe Machinery Company of Australia Pty. Ltd.

Add: Otter Nails Pty. Ltd., 1808 Princes Highway, Clayton, 3168.

Telephone No. 544 2622

All discounts remain unchanged.

Search advice notice: This page number 1157 duplicated - see also renumbered page 1427

Victoria Government Gazette

G 19 20 May 1987 1157

Private Agents Act 1966

NOTICE OF RECEIPT OF APPLICATIONS FOR LICENCES UNDER THE PROVISIONS OF
THE PRIVATE AGENTS ACT 1966

The Clerk(s) of the Magistrates' Court(s) as listed hereunder hereby give notice that applications, as under, have been lodged for hearing by the said Court(s) on the date(s) specified.

Any person desiring to object to any of such applications must—

- (a) lodge with the respective Clerk of the Magistrates' Court a notice in the prescribed form of his objection and of the grounds thereof;
- (b) cause a copy of such notice to be served personally or by post upon the applicant at least three days before the hearing of the application; and
- (c) send or deliver—
 - (i) where the objection is not made by the officer in charge of the police district in which the Court is situated—a copy of the notice to such officer; and
 - (ii) where the objection is not made by the Registrar or Deputy Registrar—a copy to the Registrar.

| <i>Full Name of Applicant*</i> | <i>Place of Abode of Applicant or Nominee</i> | <i>Name of Firm or Corporation</i> | <i>Address for Registration</i> | <i>Type of Licence</i> | <i>Date of Hearing</i> |
|--------------------------------------|---|------------------------------------|---|------------------------|------------------------|
| MAGISTRATES' COURT, MELBOURNE | | | | | |
| Beljulji, Daniel Stephan | 11/10 Murray St, West Brunswick | Wormald Security | 87 Racecourse Rd, North Melbourne | Watchman | 27.4.87 |
| Jeffery, Tony | 4 Barwon Crt, Rowville | " | " | " | " |
| Allen, John Maxwell | 5/301 Heidelberg Rd, Northcote | T.N.T. Group 4 P/L | 54 Racecourse Rd, North Melbourne | " | 29.4.87 |
| Fairfax, Mark William | 4 Eram Rd, Box Hill | " | " | " | " |
| Brown, Allan John | 3/262 Moreland Rd, Brunswick | Wormald Security | 87 Racecourse Rd, North Melbourne | " | 7.5.87 |

Dated at Melbourne 12 May 1987
Clerk of the Magistrates' Court

| | | | | | |
|---|--------------------------------|--|-----------------------------------|-------------------|---------|
| MAGISTRATES' COURT, MOONEE PONDS | | | | | |
| Magdalani, George | 59 Odessa Ave, Keilor Downs | | 59 Odessa Ave, Keilor Downs | Process Server | 15.6.87 |

Dated at Moonee Ponds 12 May 1987
Clerk of the Magistrates' Court

| | | | | | |
|-------------------------------------|----------------------------|--|----------------------------|----------------|---------|
| MAGISTRATES' COURT, ST KILDA | | | | | |
| Moser, Roman | 22 Thackeray St, Elwood | | 22 Thackeray St, Elwood | Guard Agent | 10.6.87 |

Dated at St Kilda 11 May 1987
Clerk of the Magistrates' Court

*Or in the case of a firm or corporation, of the Nominee

Search advice notice: This page number 1158 duplicated - see also renumbered page 1428

1158 G 19 20 May 1987

Victoria Government Gazette

PRIVATE AGENTS—continued

| Full Name of Applicant* | Place of Abode of Applicant or Nominee | Name of Firm or Corporation | Address for Registration | Type of Licence | Date of Hearing |
|---|--|-----------------------------|-----------------------------------|-----------------|-----------------|
| MAGISTRATES' COURT, FERNTREE GULLY | | | | | |
| Goold, Phillip Ray | 10 Austral Ave, Upwey | Goold Investigation Agency | 10 Austral Ave, Upwey | Inquiry Agent | 4.6.87 |
| Dated at Ferntree Gully 6 May 1987 A. J. CALDWELL, Clerk of the Magistrates' Court | | | | | |
| MAGISTRATES' COURT, WERRIBEE | | | | | |
| Mason, Anthony Peter | 5/27 Clarendon Pde, West Footscray | | 85 Bindowan Dve, Hoppers Crossing | Watchman | 4.6.87 |
| Locke, John | Caravan Park, Werribee South | | Caravan Park, Werribee South | Process Server | " |
| " " | " " | | " " | Guard Agent | " |
| " " | " " | | " " | Inquiry Agent | " |
| Bradley, Robert William | 6 O'Neill Ave, Hoppers Crossing | | 6 O'Neill Ave, Hoppers Crossing | Inquiry Agent | " |
| Dated at Werribee 6 May 1987 Clerk of the Magistrates' Court | | | | | |
| MAGISTRATES' COURT, SUNSHINE | | | | | |
| Deltglio, Angelo | 3 Buna Way, Keilor Downs | | 3 Buna Way, Keilor Downs | Process Server | 19.6.87 |
| Dated at Sunshine 8 May 1987 R. NIEMER, Clerk of the Magistrates' Court | | | | | |

*Or in the case of a firm or corporation, of the Nominee

Notice is hereby given that in accordance with sub-section 36 (2) of the *Associations Incorporations Act 1981*, the incorporation of St Therese's Bendigo Netball Club Inc., Port Fairy and District Community Youth Support Scheme Inc., Shepparton City Soccer Club Inc., Osterreichischer Enzian Volkstanz Klub Ballarat Inc., Preston Basketball Association Inc., Diamond Creek Squash Club Inc., Carisbrook Community Youth Club Inc., Bunurong Aboriginal Culture Association Inc., Lal Lal Youth Club Association Inc. and Collingwood Community Youth Clubs Inc., was cancelled on 27 April 1987.

GORDON LEWIS
Registrar of Incorporated Associations

Subordinate Legislation Act 1962
TRANSPORT (ROAD TRAFFIC) (SPEED
LIMIT AMENDMENT) REGULATIONS
1987

I, Thomas William Roper, Minister for Transport, give notice that after consideration of the submissions and comments received in response to the regulatory impact statement issued in relation to the proposed Transport (Road Traffic) (Speed Limit Amendment) Regulations 1987 I intend to proceed with the making of the proposed regulations.

T. W. ROPER
Minister for Transport

ADOPTION ACT 1984

Pursuant to section 5 of the *Adoption Act 1984* the manager adoption section, delegate of the Director-General Community Services Victoria, has revoked the approval of all previously gazetted counsellors and hereby approves the following persons as counsellors:

| | |
|----------------------------|---------------------------|
| Adam, Judith Mary | Cussen, Bryan |
| Aitken, Jeanette | Davey, Louise |
| Alleyne, Jane | De Laps, Debra |
| Alway, Ray | Debenham, David |
| Andrews, Kathleen | Dillion, Helen |
| Atkinson, Anne | Dodge, Sandra |
| Badenach, Annette Lorraine | Drager, Susan |
| Barber, Dorothy Anne | Dwyer, John |
| Barker, George | Embry, Dianne |
| Barnard, Amanda | Erikson, James Patrick |
| Barton, Margaret | Ervin, Sharene |
| Bates, Carolyn | Evans, William |
| Benger, Marilyn | Farrugia, Diane |
| Benjamin, Ronald | Feldman, Susan Lilo |
| Benward, Jean | Fielding, Peter |
| Bieske, Maria Lidwina | Finlay, Susan |
| Black, Margaret Grace | Fleming, Helen |
| Boyle, Desley | Frees, Anne |
| Brady, Jan | Gardner, Jennifer |
| Brisbane, Julie | Garland, Leilani |
| Britton, Denise | Gavan, Susan |
| Burke, Margaret | Gorfine, Loretta Margaret |
| Burns, Valerie | Goy, Margaret |
| Calder, Margaret Helen | Graham-Higgs, Elizabeth |
| Cameron, Margaret | Grant, Kathleen |
| Campbell, Helen Diana | Gray, Martha Lynn |
| Campi, Margaret | Gregory, Graeme |
| Care, Carmel | Gross, Eva |
| Carrig, Helen | Guy, Rodney Hamilton |
| Carter, Maree | Hadwin, Diane |
| Cauchi, Joseph | Hancock, Graham |
| Chandler, Margaret | Haralson, Vickie |
| Chapman, Philippa | Harrison, Robyn |
| Cheek, Mary | Hill, Loyietta |
| Cicchini, Mercurio | Hindhaugh, Janet |
| Clancy, Mary | Howell, Peter |
| Clarkson, Donald | Humfrey, Donna |
| Clayton, Christine | Iacovino, Michael |
| Cleary, Raymond | Ibbs, Walter Henry |
| Cohen, Penelope | Jaeche, Maureen |
| Coogan, Carol | Jarius, Margaret |
| Cooper, Gary | Johnson, Rosemary |
| Croft, Alison | Johnston, Janet |
| Cummings, Kenneil | Jones, Katie |
| | Kane, Helen |
| | Kelly-Evans, Gretta |
| | Kerry, Simon |
| | Kilkenny, Helen Margaret |
| | King, Elaine |
| | Larkin, Steven |

Search advice notice: This page number 1160 duplicated - see also renumbered page 1430

1160 G 19 20 May 1987

Victoria Government Gazette

| | |
|------------------------------|-------------------------|
| Laughlan, John | Preston, Eileen |
| Levy, Mina | Ralph, Mary |
| Lindeman, Melissa | Redwood, Kenneth |
| Lindner, Stuart David | Renkin, Peter |
| Linehan, Michael | Ri, Joseph |
| Linke, Pamela | Riley, Robyn |
| Linsell, Kym | Riminton, Jacqueline |
| Linton, Nicole | Roberts, Cyndia |
| Lipman, Betty | Robertson, Constance |
| Lippman, Marion | Rogers, Noel |
| Lock, Marion | Sawbridge, Phillida |
| Loughry, Mary | Scapin, Gary |
| Macaitis, Ingeborg Rosemarie | Schoemakers, Christina |
| Maciburko, Helen | Sebesfi, Nora |
| MacPherson, Eileen | Shaw, Moya |
| Mann, Michell | Simpson, Margaret |
| Martin, Margaret | Smith, Angela |
| Marwood, Jennifer | Snijders, G. |
| Maxwell, Jeanine | Spencer, Joan |
| May, Felicity | Stevenson, Bethia |
| McCarthy, Geralyn | Stewart, Joan |
| McClung, Florence | Storer, Shane |
| McCrory, Margaret | Strays-Campbell, Louise |
| McGough, Kerry | Struthers, Karen |
| McGregor, Janet | Suss, Miriam |
| McGregor, Margaret | Swain, Phillip |
| McLellan, Elizabeth | Taylor, Helen |
| McPhee, Gerard | Tynan, Patricia |
| Medford, Sue | Urban, Kuata |
| Miiler, Sandy | Van Keppel, Margaret |
| Millar, Sue | Wall, Josephine |
| Moore, Mary | Westfold, Joan |
| Morris, Jullian | Whelan, Janet |
| Mulders, Anthony | Whelan, Sally |
| Newman, Mary | White, Karen |
| Newton, Mary | Whyoon, Ethel |
| Nicholls, Lynette Joy | Williams, Sharon |
| Norris, Jennifer | Wilson, Alice |
| Norton, Denise | Wilson, Roslyn |
| O'Brien, Terence | Wimpole, Helena |
| O'Neil, Caroline | Winston, Megan |
| Oosterhoff, Robert | Wolstenholme, Enid |
| Parker, Cecily | Wood, Eileen |
| Parker, Patricia | Young, Marilyn |
| Parsons, Susan | Young, Pauline |
| Pascoe, Carmel | |
| Paxton, Thomas | |
| Payne, Vivienne | |
| Peel, Robyn | |
| Povey, Susan | |

Dated 4 May 1987

MICHAEL BERESFORD-SMITH
Acting Manager
Adoption Section

Town and Country Planning Act 1961
MELBOURNE METROPOLITAN
PLANNING SCHEME

Notice that a Planning Scheme has been
Prepared and is Available for Inspection
Amendment No. 431

Notice is hereby given that the Minister for
Planning and Environment in pursuance of the
powers under the *Town and Country Planning
Act 1961* has prepared a planning scheme
which—

(A) proposes to rezone land situated at—

1. Various areas generally west of Tinks Road, City of Berwick.
2. No. 99 Bay Street and rear of No. 1 Berwick Street, City of Brighton.
3. No. 589 Glenhuntly Road, Elsternwick, City of Caulfield.
4. Nos. 306-310 Hawthorn Road, City of Caulfield.
5. 651-653 Victoria Street, Abbotsford, City of Collingwood.
6. Various areas of land in the City of Essendon.
7. Nos. 36-72 Napier Street, City of Essendon.
8. 332-338 Frankston-Cranbourne Road, Karingal, City of Frankston.
9. North of Klauer Street and south-west corner Seaford-Hartnett Road, Seaford, City of Frankston.
10. West of Parmelia Drive and east of the northern railway line, Taylors Lakes, City of Keilor.
11. Various areas of land in the City of Prahran.
12. Swan Street, Richmond.
13. Various areas of land in the City of Richmond.
14. Various areas of land in the City of St. Kilda.
15. Various areas of land in the City of South Melbourne.
16. Aitken and Ann Streets, City of Williamstown.
17. 28-32 Parker Street, City of Williamstown.
18. South of Minns Road between Melton-Gisborne Road and the Toolern Creek, Shire of Melton.
19. Coburns Road, Shire of Melton.
20. Lot 3 Old Geelong Road, Hoppers Crossing, Shire of Werribee.

21. North-east corner of Bulban and Balls Roads, Shire of Werribee.
22. South-west corner of Alma and Kiora Streets, Laverton South, Shire of Werribee.
23. Eynesbury Road, Shire of Werribee.

(B) proposes to amend the scheme Ordinance by—

1. Including Ordinance provisions relating to rezoning (A) 5 above.
2. Including Ordinance provisions relating to rezoning (A) 17 above.
3. Including Ordinance provisions relating to rezoning (A) 20 above.
4. Inclusion of land referred (A) 8 above in a new zone to be known as Frankston Business B3 Zone.
5. Amending Clause 25G (5) to enable the responsible authority to have discretion to permit buildings and works to exceed the height limits which apply under the Clause.
6. Amending Clause 5AAA.
7. Including the purpose "Caretaker's House" in Column 5 of the Table to Clause 7 for the Stream and Floodway Zone.
8. Including new Clause 20CE (6) and including the purpose "Shop provided the conditions of Clause 20CE (6) are complied with" in Column 4 of the Table to Clause 7 for the Special Use Zone No. 16.

A copy of the scheme will be deposited at the offices of the Ministry for Planning and Environment, The Olderfleet Buildings, 477 Collins Street, Melbourne from 20 May 1987 to 22 June 1987.

A copy of the scheme Ordinance and so much of the scheme map which affects land within the area administered by the regional office of the Ministry or within the municipal district has been deposited at—

- City Offices, City of Berwick, Princes Highway, Narre Warren.
Town Hall, City of Brighton, Boxshall Street, Brighton.
City Offices, City of Caulfield, cnr. Hawthorn and Glen Eira Roads, Caulfield.
Municipal Offices, City of Collingwood, 140 Hoddle Street, Abbotsford.
Civic Centre, City of Essendon, Pascoe Vale Road, Essendon.
Civic Centre, City of Frankston, Davey Street, Frankston.

Search advice notice: This page number 1162 duplicated - see also renumbered page 1432

1162 G 19 20 May 1987

Victoria Government Gazette

Municipal Offices, City of Keilor, Calder Highway, Keilor.

Town Hall, City of Prahran, Greville Street, Prahran.

Town Hall, City of Richmond, Bridge Road, Richmond.

Town Hall, City of St. Kilda, Brighton Road, St. Kilda.

Town Hall, City of South Melbourne, Bank Street, South Melbourne.

Municipal Offices, City of Williamstown, 104 Ferguson Street, Williamstown.

Shire Offices, Shire of Melton, cnr. High and Yuille Streets, Melton.

Civic Centre, Shire of Werribee, 45 Princes Highway, Werribee.

A copy of the scheme Ordinance only has been deposited at—

Civic Offices, City of Altona, 115 Civic Parade, Altona.

Town Hall, City of Box Hill, 1022 Whitehorse Road, Box Hill.

Municipal Offices, City of Broadmeadows, Pascoe Vale Road, Broadmeadows.

Municipal Offices, City of Brunswick, 233 Sydney Road, Brunswick.

Civic Centre, City of Camberwell, 350 Camberwell Road, Camberwell.

Municipal Offices, City of Chelsea, 312 Station Street, Chelsea.

City Offices, City of Coburg, Bell Street, Coburg.

City Offices, City of Croydon, Civic Square, Croydon.

Municipal Offices, City of Dandenong, 205 Thomas Street, Dandenong.

Municipal Offices, City of Doncaster and Templestowe, 695 Doncaster Road, Doncaster.

Municipal Offices, City of Fitzroy, 201 Napier Street, Fitzroy.

Town Hall, City of Footscray, Napier Street, Footscray.

Town Hall, City of Hawthorn, 360 Burwood Road, Hawthorn.

Civic Centre, City of Heidelberg, Upper Heidelberg Road, Ivanhoe.

Municipal Offices, City of Kew, Charles Street, Kew.

Civic Centre, City of Knox, 511 Burwood Highway, Knoxfield.

Civic Centre, City of Malvern, cnr. Glenferrie Road and High Street, Malvern.

Town Hall, City of Melbourne, Council House, 200 Little Collins Street, Melbourne.

Municipal Offices, City of Moorabbin, 977 Nepean Highway, Moorabbin.

Council Chambers, City of Mordialloc, Mentone Parade, Mentone.

Municipal Offices, City of Northcote, 189 High Street, Northcote.

Civic Centre, City of Nunawading, 379 Whitehorse Road, Nunawading.

Municipal Offices, City of Oakleigh, Atherton Road, Oakleigh.

Town Hall, City of Port Melbourne, Bay Street, Port Melbourne.

City Hall, City of Preston, High Street, Preston.

Civic Centre, City of Ringwood, Maroondah Highway, Ringwood.

Municipal Offices, City of Sandringham, Royal Avenue, Sandringham.

Civic Centre, City of Springvale, 397 Springvale Road, Springvale.

Municipal Offices, City of Sunshine, Alexandra Avenue, Sunshine.

Municipal Offices, City of Waverley, Springvale Road, Glen Waverley.

Municipal Offices, Shire of Bulla, Macedon Street, Sunbury.

Shire Offices, Shire of Cranbourne, Sladen Street, Cranbourne.

Civic Centre, Shire of Diamond Valley, Civic Drive, Greensborough.

Shire Offices, Shire of Eltham, 895 Main Road, Eltham.

Municipal Offices, Shire of Whittlesea, High Street, Epping.

Municipal Offices, Shire of Pakenham, Henty Way, Pakenham.

* A copy of the scheme or relevant part thereof referred to above will be open for inspection during office hours by any person, free of charge.

Any persons affected by the scheme are required to set forth in writing any submissions they wish to make with respect to the scheme, addressed to the Secretary, Ministry for Planning and Environment, Box 2240T, Melbourne, 3001, by 22 June 1987 and state whether they wish to be heard in respect of their submission.

5 May 1987

DAVID YENCKEN
Secretary for Planning and Environment

Victoria Government Gazette

G 19 20 May 1987 1163

Town and Country Planning Act 1961
GEELONG REGIONAL PLANNING
SCHEME

Notice that a Planning Scheme (Amending) has been Prepared and is Available for Inspection
Amendment No. 196

Notice is hereby given that the Geelong Regional Commission in pursuance of its powers under the *Town and Country Planning Act 1961*, has prepared an Amending Scheme to the Geelong Regional Planning Scheme Map.

This amendment proposes to rezone land located on the south east corner of Lower Duneed Road and Horseshoe Bend Road, Mr Duneed from Rural General Farming to Rural Residential.

A copy of the Amending Scheme has been deposited at this office—Geelong Regional Commission, State Government Offices, corner of Little Malop and Fenwick Streets, Geelong; at the Offices of the City of South Barwon (insofar as the municipalities are affected) and at the Offices of the Ministry for Planning and Environment, The Olderfleet Buildings, 477 Collins Street, Melbourne, and will be open for inspection during office hours by any person free of charge.

Any persons affected by the Amending Scheme are required to set forth in writing any submissions they wish to make with respect to the Amending Scheme, addressed to the Secretary, G. R. Cowling, Geelong Regional Commission, P.O. Box 770, Geelong 3220, by Saturday, 20 June 1987, and state whether you wish to be heard in respect of your submission.

G. R. COWLING, Secretary
Geelong Regional Commission

Town and Country Planning Act 1961
GEELONG REGIONAL PLANNING
SCHEME

Notice that a Planning Scheme (Amending) has been Prepared and is Available for Inspection
Amendment No. 195

Notice is hereby given that the Geelong Regional Commission in pursuance of its powers under the *Town and Country Planning Act 1961*, has prepared an Amending Scheme to the Geelong Regional Planning Scheme Map.

This amendment proposes to rezone land located on the north east corner of Leather and Tanner Streets, Breakwater, from part public purposes (existing)—17—Mental Health

Authority and part Residential A to part Industrial A and part public open space (existing)—B—public park.

A copy of the Amending Scheme has been deposited at this office—Geelong Regional Commission, State Government Offices, corner of Little Malop and Fenwick Streets, Geelong; at the Offices of the City of Geelong (insofar as the municipalities are affected) and at the Offices of the Ministry for Planning and Environment, The Olderfleet Buildings, 477 Collins Street, Melbourne, and will be open for inspection during office hours by any person free of charge.

Any persons affected by the Amending Scheme are required to set forth in writing any submissions they wish to make with respect to the Amending Scheme, addressed to the Secretary, G. R. Cowling, Geelong Regional Commission, P.O. Box 770, Geelong 3220, by Thursday, 20 August 1987, and state whether you wish to be heard in respect of your submission.

G. R. COWLING, Secretary
Geelong Regional Commission

Town and Country Planning Act 1961
GEELONG REGIONAL PLANNING
SCHEME

Amendment No. 171

Notice of Approval

In pursuance of the powers conferred by the *Town and Country Planning Act 1961*, the Governor in Council on 19 May 1987 approved the abovementioned scheme in respect of the municipal districts of the Borough of Queenscliffe, Shire of Bellarine, and City of South Barwon and for which the Geelong Regional Commission is the responsible authority.

The amendment comes into operation on the date this notice is published in the *Government Gazette*.

The amendment includes addition of three items to Schedule 1 of the Scheme, being land at Burnt Point, Curlewis and Marshall.

A copy of the documents may be inspected free of charge, during office hours, at the office of the Ministry for Planning and Environment, The Olderfleet Buildings, 477 Collins Street, Melbourne and at the office of the Geelong Regional Commission, State Offices, Little Malop Street, Geelong

DAVID YENCKEN
Secretary for Planning and Environment

Search advice notice: This page number 1164 duplicated - see also renumbered page 1434

1164 G 19 20 May 1987

Victoria Government Gazette

Town and Country Planning Act 1961
TOWN OF STAWELL PLANNING SCHEME
Amendment No. 5
Notice of Approval

In pursuance of the powers conferred by the *Town and Country Planning Act 1961*, the Governor in Council on 19 May 1987 amended the abovementioned scheme in respect of the municipal district of the Town of Stawell and for which the Town of Stawell is the responsible authority.

The scheme comes into operation on the date this notice is published in the *Government Gazette*.

The scheme proposes to amend provisions in the Town of Stawell Planning Scheme relating to the use of the Big Hill Reserve, Stawell, to permit mining activities. The reserve is already being mined by Western Mining Corporation and this amendment will facilitate an extension to current activity on the site.

A copy of the documents may be inspected free of charge, during office hours, at the office of the Ministry for Planning and Environment (Plan Inspection Section), The Olderfleet Buildings, 477 Collins Street, Melbourne and at the office of the responsible authority Town of Stawell, Town Hall, Stawell 3380.

DAVID YENCKEN
Secretary for Planning and Environment

Town and Country Planning Act 1961
**MELBOURNE METROPOLITAN
PLANNING SCHEME**

Notice of a Proposed Amendment to the
Melbourne Metropolitan Planning Scheme
Amendment No. 457

Notice is hereby given that, pursuant to subsection 7 of section 32 of the *Town and Country Planning Act 1961*, the Minister has required that the Minister for Planning and Environment give notice of and deposit for inspection by the public, for a period of one month a proposed amendment to the Melbourne Metropolitan Planning Scheme.

The amendment, known as Amendment No. 457 is to rezone land at the Rosedale Estate, Chartwell, Boundary Road, Shire of Melton to General Farming B—Restructure Area.

The proposed amendment is available for inspection free of charge during office hours at the offices of the Shire of Melton, corner of Yuille and High Streets, Melton and at the office of The Ministry for Planning and Environment, the Olderfleet Buildings, 477 Collins Street, Melbourne.

Any persons affected by the proposed amendment are required to set forth in writing any submissions they may wish to make with respect to the proposed amendment addressed to the Minister for Planning and Environment, 500 Collins Street, Melbourne, by 22 June 1987.
Dated 19 May 1987

DAVID YENCKEN
Secretary for Planning and Environment

Town and Country Planning Act 1961
SHIRE OF EUROA PLANNING SCHEME
1984

Amendment No. 1
Notice of Amendment

In pursuance of the powers conferred by the *Town and Country Planning Act 1961*, the Governor in Council on 19 May 1987 amended the abovementioned scheme in respect of the municipal district of the Shire of Euroa and for which the Shire of Euroa is the responsible authority.

The amendment comes into operation on the date this notice is published in the *Government Gazette*.

The amendment includes provisions relating to the subdivision and construction of houses in the Rural A and Rural B Zones of the Shire.

A copy of the documents may be inspected free of charge, during office hours, at the office of the Ministry for Planning and Environment, The Olderfleet Buildings, 477 Collins Street, Melbourne and at the office of the responsible authority Shire Offices, Binney Street, Euroa.

DAVID YENCKEN
Secretary for Planning and Environment

State Electricity Commission Act 1958
**ELECTION OF EMPLOYEES'
REPRESENTATIVE OF THE STATE
ELECTRICITY COMMISSION**

Pursuant to Regulation 13 of the State Electricity Commission Employees' Representative Regulations 1985 I declare:

Kevin James Flynn, Projects Engineer, Mid Western Electricity Supply Region, Ballarat,

duly elected to be the Employees' Representative of the State Electricity Commission for the period of two years, commencing from 3 July 1987.

Kevin James Flynn was the only candidate for the election to the position specified.

CLIVE RAYMOND ANSON
Returning Officer

Search advice notice: This page number 1165 duplicated - see also renumbered page 1435

Victoria Government Gazette

G 19 20 May 1987 1165

Cemeteries Act 1958
SCALE OF FEES OF THE FOSTER PUBLIC CEMETERY

In pursuance of the powers conferred upon them by the Cemeteries Act the trustees of the Foster Public Cemetery hereby make the following scale of fees, which shall come into operation upon publication in the *Government Gazette*, and from and after such publication every scale of fees heretofore made by the said trustees shall be and is hereby rescinded to the extent to which it conflicts with this scale.

| | |
|--|--------|
| <i>Private Graves</i> | \$ |
| Land 2.44 m × 1.22 m | 75.00 |
| Sinking grave | 100.00 |
| Re-opening grave including sinking | 125.00 |
| <i>Extra Charges</i> | |
| Permission to erect headstone or monument | 10.00 |
| Interment of ashes in private grave | 25.00 |
| <i>Lawn Section</i> | |
| Land 2.44 m × 1.22 m. First interment including plaque and sinking | 400.00 |
| Re-opening—2nd interment and plaque and sinking | 325.00 |
| Ashes buried in main Lawn Section including plaque | 300.00 |
| Ashes buried in Ashes Section including plaque | 80.00 |

H. PARAGREEN, Trustee
 J. R. McDONALD, Trustee
 A. F. BALDWIN, Trustee

Approved by the Governor in Council, 12 May 1987—L. G. HOUSTON, Clerk of the Executive Council

Cemeteries Act 1958
SCALE OF FEES OF THE NHILL PUBLIC CEMETERY

In pursuance of the powers conferred upon them by the Cemeteries Act the trustees of the Nhill Public Cemetery hereby make the following scale of fees, which shall come into operation upon publication in the *Government Gazette*, and from and after such publication every scale of fees heretofore made by the said trustees shall be and is hereby rescinded to the extent to which it conflicts with this scale.

| | |
|----------------------------------|-------|
| <i>Private Graves</i> | \$ |
| Land 2.438 m × 1.219 m (8' × 4') | 30.00 |
| Own land selection (extra) | 5.00 |

Public Graves

| | |
|--|-------|
| Interment in grave without exclusive right—stillborn child | 10.00 |
| Interment in grave without exclusive right—others | 15.00 |

Sinking Charges for Private Graves

| | |
|---|--------|
| Sinking grave 1.828 m (6') deep | 120.00 |
| Each additional 0.304 m (1') | 30.00 |
| Sinking oversize grave (extra) | 30.00 |
| Sinking oversize grave for American type casket (extra) | 30.00 |
| Cancellation of order to sink (if commenced) | 30.00 |

Re-opening Charges

| | |
|---------------------------------------|--------|
| Re-opening grave (no cover) | 100.00 |
| Re-opening grave (with cover or kerb) | 120.00 |

Extra Charges

| | |
|---|-------|
| Interment not in the prescribed hours or on Saturday, Sunday or Public Holidays | 50.00 |
|---|-------|

Miscellaneous Charges

| | |
|---|--------|
| Interment fee | 25.00 |
| Certificate of right of burial | 2.00 |
| Inspection of plan or register | 5.00 |
| Permission to erect a headstone or monument—5 per cent of cost with a minimum of \$10.00 | |
| Permission to erect a brick grave or to erect any stone kerb, brick, tilework or concrete | 10.00 |
| Exhuming the remains of a body (when authorised) | 150.00 |
| Interment of ashes in a private grave | 25.00 |

J. E. CURKPATRICK, Trustee
 L. H. MULHALLEN, Trustee
 M. L. LYNCH, Trustee

Approved by the Governor in Council, 12 May 1987—L. G. HOUSTON, Clerk of the Executive Council

Cemeteries Act 1958
SCALE OF FEES OF THE DUNKELD PUBLIC CEMETERY

In pursuance of the powers conferred upon them by the Cemeteries Act the trustees of the Dunkeld Public Cemetery hereby make the following scale of fees, which shall come into operation upon publication in the *Government Gazette*, and from and after such publication every scale of fees heretofore made by the said trustees shall be and is hereby rescinded to the extent to which it conflicts with this scale.

Search advice notice: This page number 1166 duplicated - see also renumbered page 1436

1166 G 19 20 May 1987

Victoria Government Gazette

| | |
|---|--------|
| | \$ |
| Reserved site | 20.00 |
| Grave site | 40.00 |
| Grave digging 6' | 120.00 |
| Grave digging 7' | 140.00 |
| Interment fee | 20.00 |
| Permission to erect headstone monument—5% of total cost with a minimum of \$15.00 | |
| Stillborn and child under 10 | 10.00 |
| Search fee | 5.00 |

HEATHER M. MACGUGAN, Trustee
HEATHER M. FUNK, Trustee
W. A. FITZPATRICK, Trustee

Approved by the Governor in Council, 12 May 1987—L. G. HOUSTON, Clerk of the Executive Council

Cemeteries Act 1958

SCALE OF FEES OF THE BARNAWARTHA PUBLIC CEMETERY

In pursuance of the powers conferred upon them by the Cemeteries Act the trustees of the Barnawartha Public Cemetery hereby make the following scale of fees, which shall come into operation upon publication in the *Government Gazette*, and from and after such publication every scale of fees heretofore made by the said trustees shall be and is hereby rescinded to the extent to which it conflicts with this scale.

| | |
|--|--------|
| | \$ |
| Land | 55.00 |
| Sinking grave 1.83 m | 250.00 |
| Re-open (no cover) | 250.00 |
| Re-open (with cover) | 250.00 |
| Interment fee | 40.00 |
| Permission to erect headstone (single) | 20.00 |
| (double) | 30.00 |
| Interment of ashes in private grave | 30.00 |

E. T. FISHER, Trustee
G. J. POOLEY, Trustee
R. A. WELSH, Trustee

Approved by the Governor in Council, 12 May 1987—L. G. HOUSTON, Clerk of the Executive Council

Police Offences Act 1958, No. 6337

DIVISION 1A—STATE CLASSIFICATION OF PUBLICATIONS BOARD

Take note that the State Classification of Publications Board has classified the following publications in accordance with the provisions

of section 180H (1) of the *Police Offences Act 1958*.

Each publication shall be subject to the following restrictions:

- (a) It shall not be offered for sale, sold or delivered to any person under the age of 18 years;
- (b) It shall not be made available for inspection or perusal by any person under the age of 18 years.

| Title | Distributor |
|--|---------------------|
| Australian Variations—No. 6 | Gordon & Gotch Ltd. |
| Club International—Vol. 16 No. 5 | Gordon & Gotch Ltd. |
| Escort—Vol. 7 No. 5 | Gordon & Gotch Ltd. |
| Genesis—July 1987—Vol. 14 No. 12 | Gordon & Gotch Ltd. |
| Hustler Humor—July 1987—Vol. 10 Issue 3 | Gordon & Gotch Ltd. |
| Knave—Penpower Special—1987 | Gordon & Gotch Ltd. |
| Penthouse Forum—July 1987—Vol. 16 No. 10 | Gordon & Gotch Ltd. |
| Penthouse Letters—No. 11 | Gordon & Gotch Ltd. |

R. V. DOOLEY
Acting Secretary

State Classification of Publications Board

Police Offences Act 1958, No. 6337

DIVISION 1A—STATE CLASSIFICATION OF PUBLICATIONS BOARD

Take note that the State Classification of Publications Board has classified the following publications in accordance with the provisions of section 180H (1) of the *Police Offences Act 1958*.

Each publication shall be subject to the following restrictions:

- (a) It shall not be offered for sale, sold or delivered to any person under the age of 18 years;
- (b) It shall not be made available for inspection or perusal by any person under the age of 18 years;
- (c) It shall not be exhibited or displayed in any place to which persons under the age of 18 years have access or so that it is visible from any such place.

Search advice notice: This page number 1167 duplicated - see also renumbered page 1437

Victoria Government Gazette

G 19 20 May 1987 1167

| Title | Distributor |
|--|---------------------|
| Chic—April 1987— Vol. 11 No. 8 | Gordon & Gotch Ltd. |
| Erotic X-Film Guide—August 1987—Vol. 5 No. 8 | Gordon & Gotch Ltd. |
| Leg Show—March 1987—Vol. 4 No. 5 | Gordon & Gotch Ltd. |
| Velvet—August 1987—Vol. 10 No. 12 | Gordon & Gotch Ltd. |

R. V. DOOLEY
Acting Secretary
State Classification of Publications Board

SHIRE OF DUNDAS
Road Deviation Order

Pursuant to the provisions of sections 522 and 526 of the *Local Government Act 1958*, as amended, the Council of the Shire of Dundas hereby directs that the land in the Shire of Dundas being part of Crown Allotments 5B and 7B Parish of Mokanger County of Dundas which is shown hatched on the plan hereunder, which has been taken, purchased or acquired by it, shall be a Public Highway from and after the Date of Publication of this Order in the *Government Gazette*, and declares that such land shall be a Public Highway in lieu of land in the said Parish shown cross-hatched on the said plan.

CITY OF BALLAARAT
Road Deviation Order

Pursuant to the provisions of sections 522 and 526 of the *Local Government Act 1958* the Council of the City of Ballarat hereby directs that the land in the Parish of Ballarat indicated by hatchure on the plan hereunder which has been purchased, taken or acquired by it, shall be a public highway on and from the date of publication of this Order in the *Victoria Government Gazette* and declares that such land shall be a public highway in lieu of the land indicated by cross hatchure on the said plan.

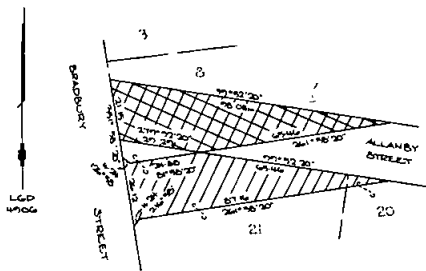

The Common Seal of the Corporation styled the Mayor, Councillors and Citizens of the City of Ballarat was hereunto affixed 17 February 1987 in the presence of:

J. E. REEVES, Mayor
W. V. CHAPMAN, Councillor
I. C. SMITH, Town Clerk

Confirmed by the Governor in Council, 12 May 1987—L. G. HOUSTON, Clerk of the Executive Council

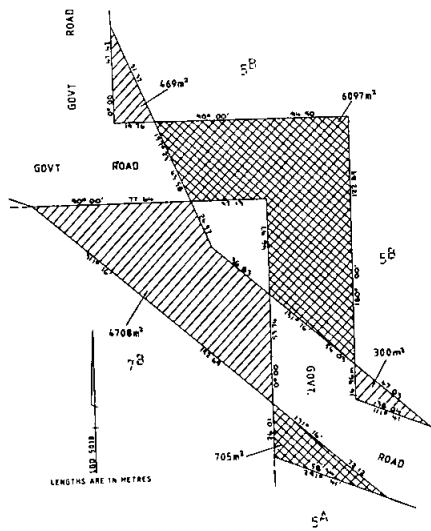

Dated 5 March 1987.

The Common Seal of the President Councillors an Ratepayers of the Shire of Glenelg was hereunto affixed in the presence of:

S. J. LEWIS, President
IAN L. HERRMANN, Councillor
J. R. MITCHELL, Secretary

Confirmed by the Governor in Council, 12 May 1987—L. G. HOUSTON, Clerk of the Executive Council

Search advice notice: This page number 1168 duplicated - see also renumbered page 1438

1168 G 19 20 May 1987

Victoria Government Gazette

CONTRACTS ACCEPTED—(Series 1986/87)

Colac City—Internal and external painting and repairs, Cressy Primary School—\$95 554.00—K. J. & L. J. & D. F. & M. J. Whitehead, Colac.

Eltham Shire—Repairs and painting, Sherbourne Primary School—\$147 800.00—Polycolor Painting Services, Ascot Vale.

Kew City—Building works, Kew Children's Cottages—\$568 467.00—W. L. Cody & Quinn Pty Ltd, Heidelberg West.

Melbourne City—Electrical works, Melbourne, 328 Swanston Street (State Library)—\$252 325.00—E. H. Waldron Pty Ltd, Bulleen.

Melton Shire—Construction brickwork and blockwork, Kurunjang Post Primary School—\$79 089.00—N. J. & L. J. Cartledge Pty Ltd, O'Learys Road.

Melton Shire—Construction metal roofing and plumbing, Kurunjang Post Primary School—\$122 480.00—Lodaton Pty Ltd, Northcote.

Traralgon City—Electrical contract, Traralgon High School—\$163 345.00—A. K. C. Electrics Pty Ltd, Northcote.

Dated 13 May 1987

JOHN DEVENISH
Director General of Public Works

Contracts Accepted
PUBLIC WORKS

His Excellency the Governor of the State of Victoria by and with the advice of the Executive Council thereof has by Order made on 12 May 1987 approved of the acceptance by the Minister of Public Works of the undermentioned offer without public tenders being invited, viz:

Offer of Berkeley Building Services Pty Ltd for asbestos removal works at the Plenty Psychiatric Hospital for the sum of One Hundred and Eleven Thousand Eight Hundred and Sixty Five Dollars (\$111 865.00).

L. G. HOUSTON
Clerk of the Executive Council

I hereby give notice that on 11 May 1987, the Public Trustee filed an Election to Administer the following deceased person's estate in accordance with section 17 of the *Public Trustee Act 1958*:

Sanchez-Rivas, Antonio, but late of 72 Pigdon Street, North Carlton, tram conductor, died 19 June 1986.

Dated 13 May 1987

W. J. KILPATRICK
Public Trustee

Creditors, next of kin and others having claims against the estate of any of the under-mentioned deceased persons are required to send particulars of their claims to the Public Trustee, 168 Exhibition Street, Melbourne, Vic. 3000, the personal representative, on or before 23 July 1987 after which date the Public Trustee may convey or distribute the assets having regard only to the claims of which the Public Trustee then has notice:

Armstrong, Frederick, but late of 7 Francis Avenue, Drouin, retired storekeeper, died 16 December 1986.

Burrows, Marion Margaret, but late of 24 Verdon Street, Maidstone, widow, died on or about 3 January 1987.

Connelly, Thomas Alfred, formerly No. V501476 of the Australian Military Forces, but late of Bundoora, pensioner, died 1 January 1987.

Coulthard, John Neville, but late of Brighton House, 139 New Street, Brighton, retired, died 19 December 1986.

Deucjar, Marjorie St. Clair, but late of Southern Memorial Hospital, 294 Kooyong Road, Caulfield, widow, died 17 September 1984.

Gribble, Evan Edward, but late of Mont Park, pensioner, died 17 March 1987.

Milnes, Linda May, but late of 30 Saunders Street, West Coburg, home duties, died 5 March 1987.

Sanchez-Rivas, Antonio, but late of 72 Pigdon Street, North Carlton, tram conductor, died 19 June 1986.

Melbourne 13 May 1987

W. J. KILPATRICK
Public trustee

Crown Land (Reserves) Act 1978

NOTICE OF INTENTION

Recommended under section 10 of the *Crown Land (Reserves) Act 1978* that notice be published in the *Government Gazette* of the intention of the Governor in Council to revoke the following temporary reservations:

BEEAC—The temporary reservation by Order in Council of 25 May 1937 of 2428.1 square metres more or less in the Township of Beeac, Parish of Ondit as a site for a Rubbish Depot—(Rs.4699).

ONDIT—The temporary reservation by Order in Council of 12 November 1872 of 34.4 hectares more or less in the Parish of Ondit as a site for Public purposes—(Rs.11444).

JOAN E. KIRNER
Minister for Conservation, Forests and Lands

Search advice notice: This page number 1169 duplicated - see also renumbered page 1439

Victoria Government Gazette

G 19 20 May 1987 1169

Crown Land (Reserves) Act 1978

NOTICE OF INTENTION

Recommended under section 10 of the *Crown Land (Reserves) Act 1978* that notice be published in the *Government Gazette* of the intention of the Governor in Council to revoke the following temporary reservations:

NEWBRIDGE—The temporary reservation by Order in Council of 9 May 1906 of 1.24 hectares of land in section 14, Township of Newbridge, Parish of Tarnagulla as a site for a State School—(Rs.5006).

NEWBRIDGE—The temporary reservation by Order in Council of 20 November 1939 of 3693 square metres in section 14, Township of Newbridge, Parish of Tarnagulla in addition to and adjoining the site temporarily reserved therefor by Order in Council of 9 May 1906—(Rs.5006).

KANGDERAAR—The temporary reservation by Order in Council of 22 September 1880 of 4.05 hectares of land in section 5, Parish of Kangderaar as a site for Watering Purposes—(Rs.13436).

HAMILTON SOUTH—The temporary reservation by Order in Council of 15 December 1981 of 587 square metres of land being Crown Allotment 4B, section 1, Parish of Hamilton South as a site for Departmental Residence—(Rs.11971).

JOAN E. KIRNER

Minister for Conservation, Forests and Lands

Road Safety Act 1986

MOTOR CAR TRIALS OF SPEED WITH THE EAST GIPPSLAND FOREST AREA BETWEEN BULUMWAAL AND BUCHAN, AND THE TOWN OF BAIRNSDALE

Under section 68 (3) of the *Road Safety Act 1986*, I declare that sub-sections (1) and (2) of section 68 of the Act and any regulations made under Part IV of the *Transport Act 1983* shall not apply with respect to the event known as "Marsh Seats Akademos Rally 1987" to be conducted by the Melbourne University Car Club on sections of road within the East Gippsland Forest Area Between Bulumwaal and Buchan and the Town of Bairnsdale between the hours of 10.00 a.m. on Saturday, 23 May 1987 and 1.00 a.m. on Sunday, 24 May 1987.

Dated 18 May 1987

TOM ROPER
Minister for Transport

Department of Industry, Technology and Resources

MINING LEASE GRANTED

No 1354; Ando Minerals; 9.348 ha, Parish of Moolerr

INTENTION TO GRANT A DEVELOPMENT LEASE

No 305; Tallangalook P/L & Strategic Finance P/L; 200 ha, Parish of Tallangalook

PROSPECTING AREA LICENCE GRANTED
No 241; Planet Resources Group NL; 156.7ha, Parish of Avoca

INTENTION TO GRANT AN EXPLORATION LICENCE

No 1807; Poolette Holdings Ltd; 3.75 km², Parish of Rutherglen

EXPLORATION LICENCES GRANTED AND AREAS REFUSED

No 1658; BHP Minerals Ltd; area retained 167.25 km², area refused 77.25 km², Parish of Buchan

No 1659; BHP Minerals Ltd; area retained 349 km², area refused 8 km², County of Tambo

No 1721; BHP Minerals Ltd; area retained 419 km², area refused nil, County of Dundas

EXPLORATION LICENCE EXTENDED

No 1308-2; Bendigo Mining NL; 48.5 km², County of Gladstone

EXTRACTIVE INDUSTRY LICENCES RENEWED

No 908-2; D. A. Drysdale; 3.3407 ha, Parish of Wyndham

No 970-1; F. N. Pitt; 5.2009 ha, Parish of Jeparit

ROBERT FORDHAM

Minister for Industry, Technology and Resources

Electric Light and Power Act 1958

ORDER GRANTED BY THE GOVERNOR IN COUNCIL

It is hereby notified that Orders (Nos. 394 and 395) have been granted by His Excellency the Governor in Council under section 10 of the *Electric Light and Power Act 1958* (No. 6241) to the City of Footscray enabling the supply of electricity to the Kingsville and South Kingsville areas respectively.

ROBERT FORDHAM

Minister for Industry, Technology and Resources

1170 G 19 20 May 1987

Victoria Government Gazette

**VICTORIAN GOVERNMENT MAJOR
PROJECTS UNIT**

I, Evan Walker, Minister Responsible for Major Projects, hereby state that:

1. In relation to Major Project Control as referred to in the Administration of Acts Supplement to the General Order of 29 April 1986 dated 13 February 1987 and published in the *Government Gazette* of 18 February 1987, the following major State projects are the responsibility of the independent major projects unit known as the Victorian Government Major Projects Unit:

- (i) Bayside Project
- (ii) Convention Centre Project
- (iii) Southbank Project
- (iv) Lynch's Bridge Project
- (v) Jolimont Project

2. For the purposes of section 4 (1) (c) of the *Urban Land Authority Act 1979*, I have directed Richard William Parker, as delegate of the Urban Land Authority in relation to Major Project Control, and his successors, to assist in the implementation of State urban planning policies and major State projects through the acquisition development and sale of land relating to the said projects.

Dated 14 May 1987

EVAN WALKER
Minister responsible for Major Projects

Alpine Resorts Act 1983
ALPINE RESORTS COMMISSION
Declaration of 1987 Snow Season

In pursuance of the powers conferred on it under the provisions of the *Alpine Resorts Act 1983* and the Regulations made thereunder the Alpine Resorts Commission declares that the 1987 Snow Season shall be as follows:

| <i>Alpine Resort</i> | <i>Opening Date</i> | <i>Closing Date</i> |
|----------------------|---------------------|---------------------|
| Mount Hotham | 5 June 1987 | 5 October 1987 |
| Falls Creek | 5 June 1987 | 5 October 1987 |
| Mount Buller | 5 June 1987 | 5 October 1987 |
| Mount Stirling | 5 June 1987 | 5 October 1987 |
| Mount Baw Baw | 5 June 1987 | 5 October 1987 |
| Mount Donna Buang | 5 June 1987 | 5 October 1987 |
| Lake Mountain | 5 June 1987 | 5 October 1987 |

6 May 1987

R. J. GROSE, General Manager

MEDICAL BOARD OF VICTORIA

Notice

The Medical Board of Victoria having conducted an inquiry pursuant to the provisions of section 17 of the *Medical Practitioners Act 1970* on Wednesday, 6 May 1987 found that Dr. James Alexander Miller Coles had been convicted and found guilty in New South Wales of an offence which if committed in Victoria would have been an indictable offence under section 17 (4) (a) of the *Medical Practitioners Act 1970*.

In accordance with section 17 (4) (h) of the *Medical Practitioners Act 1970* the Medical Board of Victoria ordered that the name of Dr. John Alexander Miller Coles be removed from the Medical Register of Victoria.

J. H. SMITH, Secretary
The Medical Board of Victoria

Building Control Act 1981
**BUILDING CONTROL ACCREDITATION
AUTHORITY**

Pursuant to Part V of the *Building Control Act 1981* a Certificate of Accreditation (Number V86/14) has been issued to Exclusive Metal Pty. Ltd, of 319 Pascoe Vale Road Essendon the Building Control Accreditation Authority has determined that the installation method for Heatcharm Models C600, C500 and C400 with regard to the distance between the appliance and a combustible rear or side wall and the extent and construction of the hearth complies with the requirements of Regulation 25.4 of the Victoria Building Regulations subject to those conditions of use and identification details contained in the said certificate.

E. KAROL
Registrar, Building Accreditation Authority

Co-operation Act 1981
**DONVALE PRIMARY SCHOOL CO-
OPERATIVE LIMITED**
**SKYE COMMUNITY CO-OPERATIVE
LIMITED**

Notice is hereby given in pursuance of section 192 (8) of the *Co-operation Act 1981* and section 459 (2) of the Companies (Victoria) Code, that, at the expiration of three months from the date hereof, the names of the aforementioned societies will, unless cause is shown to the contrary, be struck off the register and the societies will be dissolved.

Dated at Melbourne 8 May 1987

D. F. HENRY
Acting Deputy Registrar of Co-operative
Societies

Co-operation Act 1981

CHANGE OF NAME OF A SOCIETY

Notice is hereby given that Correct Line Graphics Co-operative Limited which was incorporated as a Trading Society under the above-named Act on 21 May 1987, has registered a change of its name and is now incorporated under the name of Art Thieves Design Co-operative Limited under the said Act.
Dated at Melbourne 11 May 1987.

D. F. HENRY
Acting Deputy Registrar of Co-operative Societies

VETERINARY SURGEONS ACT 1958 (AS AMENDED)

The Veterinary Board of Victoria on Thursday, 23 April 1987 conducted an Inquiry into the conduct of Dr. Peter Jellinek, a registered veterinary surgeon of Cathedral Lane, Taggerty, Victoria to ascertain whether:

1. On 9 April 1986 at St. Kilda not being authorised by or licenced under the *Drugs Poisons and Controlled Substances Act 1981*, No. 9719 he did traffick in a drug of dependance.
2. On 9 April 1986 at St. Kilda not being authorised by or licenced under the *Drugs Poisons and Controlled Substances Act 1981*, No. 9719 he did introduce a drug of dependance into a body of another person.
3. On 9 April 1986 he did in a public place namely Grey Street, St. Kilda, solicit Donna Maree Jones to prostitute herself for pecuniary reward with himself.

The Board found charges 1, 2 and 3 to be proven and ordered that Dr. Peter Jellinek's registration as a veterinary surgeon be cancelled and that his name be removed from the Veterinary Register of Victoria. The Board further ordered that Dr. Jellinek pay the sum of \$2500 towards the cost of and incidental to the inquiry by the Board.

B. D. WANSBURY, Registrar

EXEMPTION

Application No. 2 of 1987

On 8 May 1987 the Equal Opportunity Board considered an application under section 40 (1) of the *Equal Opportunity Act 1984* by Western Region Health Centre Ltd for an exemption from the provisions of the Act to enable the company to ensure the availability of an obstetrician and gynaecologist of each sex at the Western Region Health Centre Ltd.

The Board had regard to the applicant's submission which informed the Board that:

- (i) the Centre engages a male obstetrician and gynaecologist for one session per week;
- (ii) a greater number of patients require to see an obstetrician and gynaecologist each week than the male obstetrician and gynaecologist can see in one session;
- (iii) many patients specifically request referral to a female obstetrician and gynaecologist.

In addition, the Board noted that in 1982 an exemption had been granted to Western Region Health Centre Ltd. in relation to somewhat similiar needs for a female medical practitioner. On that occasion the Board had weighed the relative advantages of breaking down conflicting stereotypes. On this occasion the Board believed the issues still exist and this gave additional support to its decision to grant the exemption sought.

The Board hereby grants an exemption from the operation of section 21 (1) (a) and (c) and section 59 of the *Equal Opportunity Act 1984* to permit Western Region Health Centre Ltd. to advertise for and employ a female obstetrician and gynaecologist.

This exemption shall remain in force until 8 May 1990.

IAN SHARP, Acting President
PATRICIA CLANCY, Member
LEANNA DARVALL, Member
WILLIAM CHERREY, Member
CON GEORGE, Member

MITCHELL RIVER IMPROVEMENT TRUST

Rating By-Law No. 29

The Mitchell River Improvement Trust, in pursuance and exercise of the powers conferred by the *River Improvement Act 1958* doth hereby make a By-Law following:

1. The following rate to be called the "Mitchell River Improvement District River Improvement Rate" is hereby made and shall be levied upon the occupiers or owners of all properties within the Mitchell River Improvement District which are rateable to any municipality.

A rate of 1.0 cents in the dollar on the Net Annual Municipal value of all those properties within the First Division as determined by Order in Council made on 14 January 1964, being those lands shown coloured green on the plan titled "Mitchell River Improvement Trust Proposed Ratings Divisions" approved by the Governor in Council and deposited at the office of the State Rivers and Water Supply Commission at Melbourne—(Corr. 60/263/25).

Provided that the sum of Two Dollars shall be the minimum amount payable in respect of any property liable to be rated in the said Division.

A rate of 0.75 cents in the dollar on the Net Annual Municipal value of all these properties within the Second Division, being those lands shown coloured brown on the said plan.

Provided that the sum of Two Dollars shall be the minimum amount payable in respect of any property liable to be rated in the said Division.

A rate of 0.5 cents in the dollar on the Net Annual Municipal value of all properties within the Third Division being those lands shown coloured yellow on the said plan.

Provided that the sum of Two Dollars shall be the minimum amount payable in respect of any property liable to be rated in the said Division.

2. Such rates are made and shall be levied for the period beginning on 1 January 1987 and ending with 31 December 1987 and shall be payable on 10 April 1987.

Such persons as the Mitchell River Improvement Trust may from time to time appoint for the purpose shall be and is or are hereby authorised to demand, receive, collect and recover the said rate.

The foregoing By-LAW was made by the Mitchell River Improvement Trust on 30 March 1987, and the common seal of the said Trust was hereunto affixed, 30 March 1987.

W. J. COUNIHAN, Chairman
J. E. JOHNSTON, Commissioner
D. J. ROBERTS, Secretary

Approved 30 April 1987, A. McCUTCHEON,
Minister for Water Resources

APPOINTMENTS

APPOINTMENTS

His Excellency the Governor of the State of Victoria by and with the advice of the Executive Council thereof has by Order made on 12 May 1987 been pleased to make the undermentioned appointments, viz:

Department of Health
Psychiatrist Superintendent

Thomas Mathew PEYTON, M.B., Ch.B.,
M.R.A.N.Z.C.P.

to be Psychiatrist Superintendent of the Royal Park Psychiatric Hospital, pursuant to the provisions of section 26 (1) of the *Mental Health Act 1959*, from 27 April 1987, vice J. Stevenson, sick leave.

David Yap Hiong CHONG, M.B., B.S., D.P.M.
to be Deputy Psychiatrist Superintendent of the Royal Park Psychiatric Hospital, pursuant to the provisions of section 26 (1) of the *Mental Health Act 1959*, from 27 April 1987, vice T. M. Peyton, higher duties.

Terrence Mark HARDIKER, M.B., Ch.B., D. Obst., R.C.O.G., D.C.H., D.P.M.,
M.R.A.N.Z.C.P.

to be Psychiatrist Superintendent of the Dandenong Psychiatric Centre, pursuant to the provisions of section 26 (1) of the *Mental Health Act 1959*, for period 25 April 1987 to 10 May 1987, vice D. Leonard on leave.

Lois Phillipa HARMS, M.B., B.S., D.P.M.
to be Deputy Psychiatrist Superintendent of the Dandenong Psychiatric Centre, pursuant to the provisions of section 26 (1) of the *Mental Health Act 1959*, for period 25 April 1987 to 10 May 1987, vice T. M. Hardiker, higher duties.

Trustees of Public Cemeteries

Geoffrey John LEWIS and

Edward Victor START

to be Trustees of the Crowlands Public Cemetery

Donne James RAMAGE

to be Trustee of the Violet Town Public Cemetery

Mabel RENNIE

to be Trustee of the Boolarra Public Cemetery,

All appointments were made pursuant to section 3 (1) of the *Cemeteries Act 1958*.

L. G. HOUSTON

Clerk of the Executive Council

At the Executive Council Chamber

Melbourne, 12 May 1987

Public Service Act 1958

ACTING SUPERINTENDENT OF VERMIN AND NOXIOUS WEEDS DESTRUCTION Notice of Appointment

Notice is given that Mr Kenneth Christopher McNeill is appointed under the *Public Service Act 1958* to be the person for the time being performing the duties of the Superintendent of Vermin and Noxious Weeds Destruction pursuant to section 4 of the *Vermin and Noxious Weeds Act 1958* from 1 January 1985 to 30 June 1987.

GERRY GRIFFIN

Acting Director-General, Department of
Conservation, Forests and Lands

APPOINTMENT OF INSPECTORS UNDER
THE OCCUPATIONAL HEALTH AND
SAFETY ACT 1985

Pursuant to section 38 of the *Occupational Health and Safety Act 1985* the following people have been appointed as Occupational Health and Safety Inspector.

James Graham EDGAR
John Leslie CARVER
Mary Ann HAYES
Frederick Mark THOMAS
Bryan BOTTOMLEY
Allan Kevin KEMP
Ronald LENARD
Cesare DICHIERA
Peter Edward PHAIR
Michael Frances EVANS
Trevor Charles McDEVITT
Evan Maxwell MCGREGOR

S. M. CRABB
Minister for Labour

APPOINTMENT OF INSPECTORS UNDER
THE INFLAMMABLE LIQUIDS ACT 1966

Pursuant to section 3 (1) of the *Inflammable Liquids Act 1966* the following people have been appointed as Dangerous Goods Inspector.

James Graham EDGAR
John Leslie CARVER
Mary Ann HAYES
Frederick Mark THOMAS
Bryan BOTTOMLEY
Allan Kevin KEMP
Ronald LENARD
Cesare DICHIERA
Peter Edward PHAIR
Michael Frances EVANS
Trevor Charles McDEVITT
Evan Maxwell MCGREGOR

S. M. CRABB
Minister for Labour

APPOINTMENT OF INSPECTORS UNDER
THE LIQUEFIED GASES ACT 1968

Pursuant to section 4 (1) of the *Liquefied Gases Act 1968* the following people have been appointed as Dangerous Goods Inspector.

James Graham EDGAR
John Leslie CARVER
Mary Ann HAYES
Frederick Mark THOMAS

Bryan BOTTOMLEY
Allan Kevin KEMP
Ronald LENARD
Cesare DICHIERA
Peter Edward PHAIR
Michael Frances EVANS
Trevor Charles McDEVITT
Evan Maxwell MCGREGOR

S. M. CRABB
Minister for Labour

APPOINTMENT OF INSPECTORS UNDER
THE EXPLOSIVES ACT 1960

Pursuant to section 5 (1) of the *Explosives Act 1960* the following people have been appointed as Dangerous Goods Inspector.

James Graham EDGAR
John Leslie CARVER
Mary Ann HAYES
Frederick Mark THOMAS
Bryan BOTTOMLEY
Allan Kevin KEMP
Ronald LENARD
Cesare DICHIERA
Peter Edward PHAIR
Michael Frances EVANS
Trevor Charles McDEVITT
Evan Maxwell MCGREGOR

S. M. CRABB
Minister for Labour

APPOINTMENT OF INSPECTORS UNDER
THE DANGEROUS GOODS ACT 1985

Pursuant to section 11 of the *Dangerous Goods Act 1985* the following people have been appointed as Dangerous Goods Inspector.

James Graham EDGAR
John Leslie CARVER
Mary Ann HAYES
Frederick Mark THOMAS
Bryan BOTTOMLEY
Allan Kevin KEMP
Ronald LENARD
Cesare DICHIERA
Peter Edward PHAIR
Michael Frances EVANS
Trevor Charles McDEVITT
Evan Maxwell MCGREGOR

S. M. CRABB
Minister for Labour

1174 G 19 20 May 1987

**APPOINTMENT OF INSPECTORS UNDER
THE INDUSTRIAL RELATIONS ACT 1979**

Pursuant to section 87 of the *Industrial Relations Act 1979* the following people have been appointed as Inspector.

James Graham EDGAR
John Leslie CARVER
Mary Ann HAYES
Frederick Mark THOMAS
Bryan BOTTOMLEY
Allan Kevin KEMP
Ronald LENARD
Cesare DICHIERA
Peter Edward PHAIR
Michael Frances EVANS
Trevor Charles McDEVITT
Evan Maxwell McGREGOR

S. M. CRABB
Minister for Labour

**APPOINTMENT OF INSPECTORS UNDER
THE LABOUR AND INDUSTRY ACT 1958**

Pursuant to section 186 (1) of the *Labour and Industry Act 1958* the following people have been appointed as Factories and Shops Inspector.

James Graham EDGAR
John Leslie CARVER
Mary Ann HAYES
Frederick Mark THOMAS
Bryan BOTTOMLEY
Allan Kevin KEMP
Ronald LENARD
Cesare DICHIERA
Peter Edward PHAIR
Michael Frances EVANS
Trevor Charles McDEVITT
Evan Maxwell McGREGOR

S. M. CRABB
Minister for Labour

ORDERS IN COUNCIL

State Employees Retirement Benefits Board
1979

**APPOINTMENT OF DEPUTY MEMBER OF
THE STATE EMPLOYEES RETIREMENT
BENEFITS BOARD**

The Governor in Council under section 5 of the *State Employees Retirement Benefits Act 1979* appoints Peter Leonard-Kanevsky Deputy Chairman of the State Employees Retirement

Victoria Government Gazette

Benefits Board during the absence of Neal Douglas Duke from the date of this Order until 29 May 1987, inclusive, and appoints Elizabeth Sandra Findlay Deputy Member of the Board in place of Peter Leonard-Kanevsky for the same period.

Dated: 12 May 1987
Responsible Minister:
R. A. JOLLY
Treasurer

L. G. HOUSTON
Clerk of the Executive Council

Crown Land (Reserves) Act 1978

**REVOCATION OF TEMPORARY
RESERVATIONS**

The Governor in Council under section 10 of the *Crown Land (Reserves) Act 1978* revokes the following temporary reservations:

MOOROODUC—The temporary reservation by Order in Council of 1 July 1969 of 910.5 square metres more or less in section 22 of the Parish of Moorooduc as a site for public purposes (Departmental Residence)—(Rs. 9188).

GISBORNE—The temporary reservation by Order in Council of 15 December 1899 of 5033 square metres of land in section 23, Township of Gisborne as a site for Court House and Police Purposes—(Rs. 6088).

Dated 12 May 1987
Responsible Minister:

JOAN E. KIRNER
Minister for Conservation, Forests and Lands
L. G. HOUSTON
Clerk of the Executive Council

Crown Land (Reserves) Act 1978

**CROWN LAND PERMANENTLY
RESERVED**

The Governor in Council under sections 4 and 7 of the *Crown Land (Reserves) Act 1978* permanently reserves for the purpose mentioned and also excepts from prospecting or from occupation for mining purposes under any miners right the following Crown land:

MUNICIPAL DISTRICT OF THE SHIRE OF
KOWREE

AWONGA.—Management of Wildlife, 74.5 hectares, more or less, being Crown Allotment 46, Parish of Awonga as indicated by hatching on plan hereunder—(Rs. 13421).

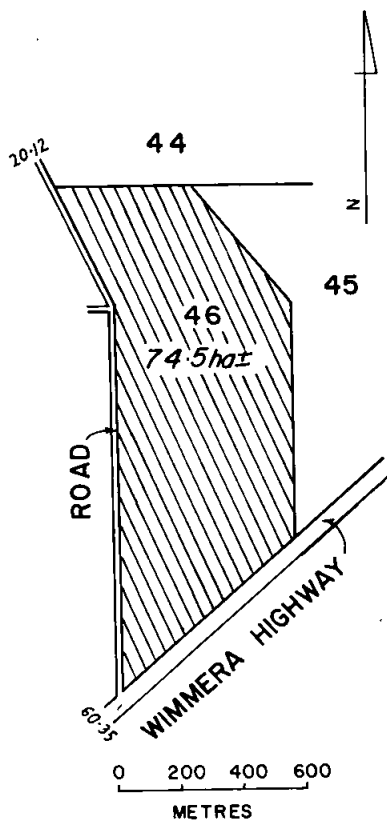

Dated 12 May 1987
 Responsible Minister:
 JOAN E. KIRNER
 Minister for Conservation, Forests and Lands
 L. G. HOUSTON
 Clerk of the Executive Council

Crown Land (Reserves) Act 1978
**CROWN LANDS TEMPORARILY
 RESERVED**

The Governor in Council under sections 4 and 7 of the *Crown Land (Reserves) Act 1978* temporarily reserves for the purposes mentioned and also excepts from prospecting or from occupation for mining purposes under any miners right the following Crown lands.

**MUNICIPAL DISTRICT OF THE SHIRE OF
 KYNETON**

LANCEFIELD—Conservation of an area of historic interest, 903 square metres being Crown Allotment 12B, section 66, Township of Lancefield, Parish of Lancefield shown on Certified Plan No. 108224 lodged in the Central Plan Office—(Rs 13437).

**MUNICIPAL DISTRICT OF THE SHIRE OF
 SWAN HILL**

TYNTYNDER WEST—Public Purposes, (Plantation), 4367 square metres being Crown Allotment 1k, section 1, Parish of Tyntynder West shown on Certified Plan No. 108260 lodged in the Central Plan Office—(Rs 13435).

Dated: 12 May 1987

Responsible Minister:

JOAN E. KIRNER

Minister for Conservation, Forests and Lands

L. G. HOUSTON

Clerk of the Executive Council

Crown Land (Reserves) Act 1978
**CROWN LAND PERMANENTLY
 RESERVED**

The Governor in Council under sections 4 and 7 of the *Crown Land (Reserves) Act 1978* permanently reserves for the purpose mentioned and also excepts from prospecting or from occupation for mining purposes under any miners right the following Crown land:

**MUNICIPAL DISTRICT OF THE
 BOROUGH OF PORT FAIRY**

BELFAST—For conservation of an area of Historic Interest 2393 square metres being Crown Allotment 7U in the Parish of Belfast as shown on Certified Plan No. 108198 lodged in the Central Plan Office—(Rs. 12894).

Dated 12 May 1987

Responsible Minister:

JOAN E. KIRNER

Minister for Conservation, Forests and Lands

L. G. HOUSTON

Clerk of the Executive Council

Local Government Act 1958
**VARIATION OF SEPARATE RATE, CITY
 OF COBURG**

The Governor in Council acting under section 294A of the *Local Government Act 1958* varies a separate rate made by the Council of the City of Coburg on 11 January 1983 for the purpose of providing off-street parking facilities for the

Sydney Road Shopping Centre by deleting the properties known as Nos. 25 and 27 Victoria Street Coburg.

Dated: 12 May 1987

Responsible Minister:

J. L. SIMMONDS

Minister for Local Government

L. G. HOUSTON
Clerk of the Executive Council

Local Government Act 1958
SHIRE OF COLAC

Authorisation of works or undertakings for the purposes of Division 5 of Part X of the *Local Government Act 1958*

The Governor in Council acting under section 277 (2) of the *Local Government Act 1958* authorises the provision of electrical reticulation by the Council of the Shire of Colac to Lots 38-41, 45-47, 49, 60-69 and 72-74 on Plan of Subdivision No. 125752 to be an authorised work or undertaking for the purpose of Division 5 of Part X of the *Local Government Act 1958*.

Dated: 12 May 1987

Responsible Minister:

J. L. SIMMONDS

Minister for Local Government

L. G. HOUSTON
Clerk of the Executive Council

Hospitals and Charities Act 1958
INCORPORATION OF FLEMINGTON
COMMUNITY HEALTH CENTRE

The Governor in Council under sections 46 and 64 of the *Hospitals and Charities Act 1958* declares to be a body corporate a benevolent society by the name of Flemington Community Health Centre.

Dated 12 May 1987

Responsible Minister:

DAVID WHITE

Minister for Health

L. G. HOUSTON
Clerk of the Executive Council

Hospitals and Charities Act 1958
INCREASE IN CAPITAL WORKS
EXPENDITURE LIMITS FOR CERTAIN
HOSPITALS

The Governor in Council under section 63A (1) of the *Hospitals and Charities Act 1958* determines that while a Health Services Agreement is in force between the Chief General Manager and a scheduled hospital or the

committee of a scheduled hospital which is listed in the following table the amount of expenditure involved or likely to be involved on a capital project which must not be exceeded in an agreement entered into by such hospital or committee without the approval of the Chief General Manager shall be the amount indicated in the table opposite the name of the hospital.

Table

| Hospital | Amount |
|---|------------|
| Austin Hospital—Heidelberg | \$ 100 000 |
| The Bendigo and Northern District Base Hospital | 100 000 |
| Maribyrnong Medical Centre | 100 000 |
| Wangaratta District Base Hospital | 100 000 |

Dated 12 May 1987

Responsible Minister:

D. R. WHITE

Minister for Health

L. G. HOUSTON
Clerk of the Executive Council

OFFICE OF THE MINISTER FOR WATER
RESOURCES

Latrobe Valley Act 1958

Term of Office of Members of Latrobe Valley Water and Sewerage Board

The Governor in Council under the powers conferred by the *Latrobe Valley Act 1958* hereby fixes the term of office of Members other than the Chairman and the Manager of the Latrobe Valley Water Board as one year from and inclusive of 1 July 1987.

Dated: 12 May 1987

Responsible Minister:

ANDREW McCUTCHEON

Minister for Water Resources

L. G. HOUSTON
Clerk of the Executive Council

Stock Diseases Act 1968
DECLARATION OF A FOOTROT
CONTROL AREA

The Governor in Council, acting under section 4 of the *Stock Diseases Act 1968*—

(1) declares that—

(a) all land enclosed within the boundaries of the Shires of Swan Hill, Wycheproof, Birchip, Donald, Charlton, Dunmunkle, Kara Kara, Stawell, Ararat, Mount Rouse, Minhamite, Mortlake, Belfast and Warrnambool, the Borough of Port Fairy,

the Towns of St Arnaud and Stawell, and the Cities of Swan Hill, Ararat and Warrnambool;

- (b) land on which sheep, goats or deer are introduced or kept which is held in the same ownership as any land within the boundaries described in paragraph (a) and run as one property with that land—

to be a control area in respect of footrot in sheep, goats and deer.

(2) specifies the requirements which are to operate in respect of the declared footrot control area to be the provisions in Division 2 of Part II of the *Stock Diseases Act 1968*; and

(3) specifies that this Order shall come into operation on 21 May 1987.

Dated: 19 May 1987

Responsible Minister:

EVAN WALKER, MLC

Minister for Agriculture and Rural Affairs

L. G. HOUSTON

Clerk of the Executive Council

TENDERS

PUBLIC WORKS DEPARTMENT

Tenders are invited for the purposes indicated hereunder and will be received at 2 Treasury Place, Melbourne, 3002, until **TWO** p.m. on the dates shown.

Tenders must be addressed to the Minister for Public Works with the envelope endorsed "Tender for ...".

Tenders forwarded either by mail, telegram or telex, which arrive after the closing time, will be accepted provided that the official Telecom or Australia Post time and date stamping indicates dispatch prior to the closing time. (TIME AND DATE STAMPING MUST BE REQUESTED AT SOME POST OFFICES.)

(TELEX No. AA152039)

Hand-delivered tenders must be placed in the Department's tender box, in foyer, Ground Floor, 2 Treasury Place, Melbourne.

Tender documents are available from the Contracts Office, Room 29, Ground Floor, 2 Treasury Place, Melbourne and where indicated, at offices of Inspector of Works.

Wednesday, 27 May 1987

Building, Electrical and Mechanical Services etc.

KURUNJANG—Plasterboards and ceilings, post primary school.

KURUNJANG—Joinery fittings, post primary school.

KURUNJANG—Siteworks, post primary school.

KURUNJANG—General carpentry, post primary school.

MALDON—Construction of accommodation buildings, Tarrengower Prison. (W.O. Bendigo.)

MELBOURNE—Fit out works to 6th and 7th Floors, 500 Bourke Street, Department of Local Government.

MELBOURNE—Fit out works to 9th and 10th Floors, 500 Collins Street, Ministry for Planning and Environment.

NOBLE PARK—Upgrading of existing L.T.C. Building, High School.

STUDFIELD—Internal and external repairs and painting, Primary School.

WESTMEADOWS—Extension to Brucellosis Wing, Attwood Veterinary Research Laboratory.

Wednesday, 3 June 1987

Building, Electrical and Mechanical Services etc.

BALLAN—External alterations and repairs to existing single storey brick building, Primary School. (W.O. Ballarat.)

CARLTON—Office fit out, 221 Drummond Street, Law Department.

FERNTREE GULLY—*Re-advertised and re-amended*: Upgrade of existing toilet facilities, Technical School.

FITZROY—Provision of toilets, Primary School.

SOUTH YARRA—Design and installation of fire sprinklers and detection system, National Herbarium, Botanical Gardens.

MELBOURNE—Cleaning masonry facade to western elevation, State Library and Museum Complex, 328 Swanston Street,

WARRNAMBOOL—*Re-advertised and Amended*: Internal and external repairs and painting, Primary School. (W.O. Warrnambool.)

WARRNAMBOOL EAST—Internal and external repairs and painting, Primary School. (W.O. Warrnambool.)

Miscellaneous

MACLEOD—Supply of tractor, Police Forensic Science Laboratory

RONALD W. WALSH
Minister for Public Works

Public Works Department
Melbourne, 11 May 1987

**PRIVATE
ADVERTISEMENTS**

CITY OF BOX HILL

Notice of Adoption by Order of a Proposal for Closure of Young Street to Through Traffic.

Notice is hereby given that the council, having prepared a proposal to close part of Young Street, from Whitehorse Road, Box Hill, pursuant to section 539 (c) of the *Local Government Act 1958* and having considered written objections to the proposal and heard persons who stated in their written objections that they wished to be heard before council and having considered a report from the Road Traffic Authority, has resolved to formally adopt by order the proposal.

Such Order shall come into operation from 30 June 1987.

The location of the partial closure is shown in the diagram below.

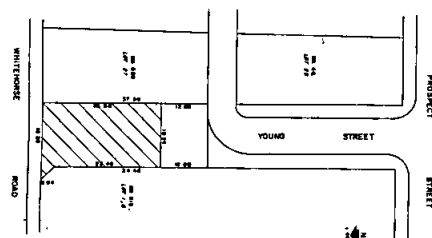

7142

I. G. PORT
Town Clerk

CITY OF FOOTSCRAY

Road Discontinuance

Whereas the Council of the City of Footscray has, pursuant to section 528 (2) of the *Local Government Act 1958*, formed the opinion that the road—

rear of 126 Stephen Street and adjacent to 2 Simpson Street, Yarraville, is not reasonably required as a road for public use and has, not less than one month before formally directing by resolution that the said road be discontinued, published a public notice in a newspaper generally circulating in the municipal district, and given written notice to the last registered owner of the land in the road and the owners and occupiers of lands abutting or immediately adjacent to the road of the proposed discontinuance, and has considered all (if any) written objections to the proposal.

Now therefore the Council of the City of Footscray by resolution on 9 February 1987, has directed that the said road which is shown by hatching on the plan hereunder be discontinued and the land being the road so discontinued shall vest in the municipality until it is sold by private treaty.

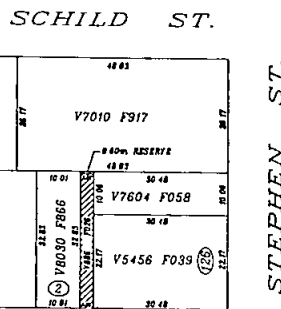

SIMPSON ST.

AREA OF RIGHT OF WAY SHOWN HATCHED IS TO BE CLOSED & SOLD TO ABUTTING OWNERS UNDER SECTION 528(2) OF THE LOCAL GOVERNMENT ACT PROVIDED STORMWATER & SEWERAGE EASEMENT RIGHTS ARE MAINTAINED.

Notwithstanding such discontinuance the Melbourne and Metropolitan Board of Works shall continue to have and possess the same right title power authority or interest in or in relation to the whole of the land shown by hatching on the said plan as it had or possessed prior to such discontinuance with respect to or in connection with any drains or pipes laid or erected in on or over such land for the purpose of drainage and sewerage.

7143

R. T. DOWNES
Acting Town Clerk

CITY OF FOOTSCRAY

Road Discontinuance

Whereas the Council of the City of Footscray has, pursuant to section 528 (2) of the *Local Government Act 1958*, formed the opinion that the road at the rear of 47 Moore Street and 36 Donald Street, Footscray—

is not reasonably required as a road for public use and has, not less than one month before formally directing by resolution that the said road be discontinued, published a public notice in a newspaper generally circulating in the municipal district, and given written notice to the last registered owner of the land in the road and the

owners and occupiers of lands abutting or immediately adjacent to the road of the proposed discontinuance, and has considered all (if any) written objections to the proposal.

Now therefore the Council of the City of Footscray by resolution on 15 December 1986, has directed that the said road which is shown by hatching on the plan hereunder be discontinued and the land being the road so discontinued shall vest in the municipality until it is sold by private treaty.

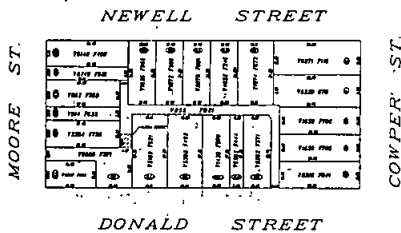

AREA OF RIGHT OF WAY SHOWN HATCHED IS TO BE CLOSED & SOLD TO ABUTTING OWNERS UNDER SECTION 528(2) OF THE LOCAL GOVERNMENT ACT PROVIDED STORMWATER & SEWERAGE EASEMENT RIGHTS ARE MAINTAINED.



Notwithstanding such discontinuance the Melbourne and Metropolitan Board of Works shall continue to have and possess the same right title power authority or interest in or in relation to the whole of the land shown by hatching on the said plan as it had or possessed prior to such discontinuance with respect to or in connection with any drains or pipes laid or erected in on or over such land for the purpose of drainage and sewerage.

7144

R. T. DOWNES
Acting Town Clerk

CITY OF FOOTSCRAY
Road Discontinuance

Whereas the Council of the City of Footscray has, pursuant to section 528 (2) of the *Local Government Act 1958*, formed the opinion that the road—

rear of and adjacent to 26-34 Wembley Avenue, Spotswood, is not reasonably required as a road for public use and has, not less than one month before formally directing by resolution that the said road be discontinued, published a public notice in a newspaper generally circulating in the municipal district, and given written notice to the last registered owner of the land in the road and the owners and occupiers of lands abutting or immediately adjacent to the road of the proposed discontinuance, and has considered all (if any) written objections to the proposal.

Now therefore the Council of the City of Footscray by resolution on 24 February 1987, has directed that the said road which is shown by hatching and cross-hatching on the plan hereunder be discontinued and the land being the road so discontinued shall vest in the municipality until it is sold by private treaty.

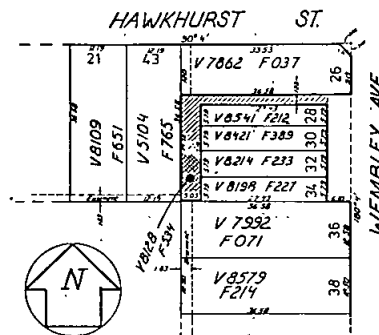

AREA SHOWN HATCHED IS TO BE FORMALLY CLOSED TO FORM PART OF THE ADJUTING PROPERTIES IN ACCORDANCE WITH THE PROVISIONS OF SECTION 528 (2) OF THE LOCAL GOVERNMENT ACT. PROVISION OF AN 183M WIDE EASEMENT FOR SEWERAGE AND DRAINAGE IN FAVOR OF COUNCIL IS TO BE CREATED AT REAR OF ALL 26-34 WEMBLEY AVE. AREA SHOWN CROSS HATCHED TO BE RETAINED FOR MUNICIPAL PURPOSES.

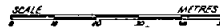

FILE 25 / 76 / 10
DRAWN A 305105/11
DRAWING NO. X 39351/10
DATE 14-5-86/4

Notwithstanding such discontinuance the Melbourne and Metropolitan Board of Works shall continue to have and possess the same right title power authority or interest in or in relation to the whole of the land shown by hatching and cross-hatching on the said plan as it had or possessed prior to such discontinuance with respect to or in connection with any drains or pipes laid or erected in on or over such land for the purpose of drainage and sewerage.

7145

R. T. DOWNES
Acting Town Clerk

CITY OF SALE

Appointment of Prosecuting Officer

Notice is hereby given that Senior Sergeant Daniel Patrick McIlwaine, No. 15776, has been appointed Prosecuting Officer for the City of Sale in lieu of Senior Sergeant Norman Lewis Baker, No. 11718, transferred.

7093

JOHN L. LOW
Town Clerk

CITY OF WAVERLEY
By-Law No. 116

A By-law of the City of Waverley made under section 197 of the *Local Government Act 1958* and numbered 116 being for the purpose of amending By-Law No. 114 known as the Incinerator By-Law.

In pursuance of the powers conferred by the *Local Government Act 1958*, the Mayor, Councillors and Citizens of the City of Waverley order as follows:

By-Law No. 114 shall be amended by:

1. Substituting for Clause 5 thereto the following clause:

5. No person shall burn or cause or allow to be burned any matter, material or substance whatsoever on any land or premises or suffer any fire to remain alight within the Municipal District otherwise than in—

- (a) a properly constructed fireplace housed inside a building; or
- (b) an incinerator constructed, erected or installed in accordance with the provisions of this By-Law; or
- (c) a properly constructed barbeque;

without the prior consent in writing of the Council given under the hand of an Authorised Officer with any conditions set out in such consent.

2. Substituting for Clause 10 (a) thereto the following clause:

- (a) on any Sunday, Monday, Tuesday or Wednesday; or

3. Substituting for Clause 12 thereto the following clause:

12. Any person guilty of a breach of this By-Law shall be liable to a penalty of not more than 10 penalty units and to a further penalty of not more than 1 penalty unit for each day on which such offence is continued after a conviction or Order by any Court.

Resolution for passing this By-Law agreed to by Council on 24 March 1987; and confirmed on 5 May 1987.

The common seal of the Mayor, Councillors and Citizens of the City of Waverley was hereunto affixed in the presence of:

T. M. HEFFERMAN, Mayor
G. B. FRECKER, Councillor
COLIN J. BOCK, Town Clerk

Town and Country Planning Act 1961
CITY OF WARRNAMBOOL PLANNING
SCHEME

Notice that a Planning Scheme Amendment has been Prepared and is Available for Inspection

Amendment No. 22

Notice is hereby given that the Council of the City of Warrnambool, in pursuance of its powers under the *Town and Country Planning Act 1961*, has prepared a scheme for the following areas, as illustrated on the following plans:

1. Re-zoning of land at Lots 20 and 21, C.A. 25 and 27, section A, Balmoral Road, from Rural "2" to part Residential "2" and part Special Use (Church).
2. Re-zoning of land at Lots 2-6 Saywell Court, from Light Industry to Residential "2".
3. Re-zoning of land at 128 Rooney's Road, from Special Use (Church) to Special Use 12 Dance School.
4. Re-zoning of land at 293 Timor Street, from Commercial "1" to Residential "1".

A copy of the scheme has been deposited at the Municipal Offices, Liebig Street, Warrnambool, at the Regional Offices of the Ministry for Planning and Environment, 1st Floor, Victorian Savings and Loan Society Building, Liebig Street, Warrnambool; Plan Inspection Section, The Olderfleet Buildings, 477 Collins Street, Melbourne, and will be open for inspection during office hours by any person free of charge.

Any persons affected by the scheme are required to set forth in writing any submission they may wish to make with respect to the scheme addressed to the Town Clerk, City of Warrnambool, P.O. Box 198 Warrnambool, 3280, by Thursday 25 June 1987, and state whether they wish to be heard in respect of their submission.

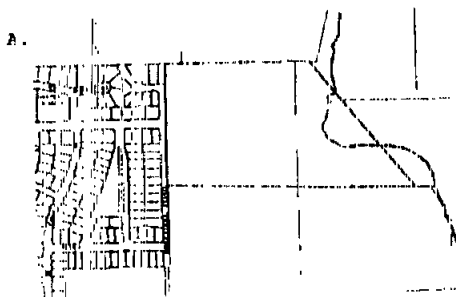

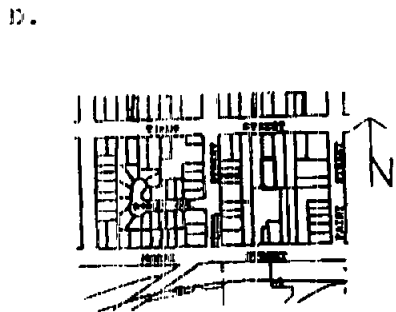
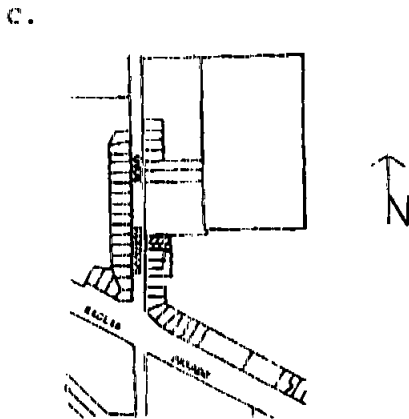
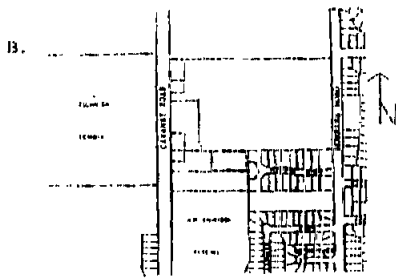

Form 2.1
Town and Country Planning Act 1961
**BOROUGH OF SEBASTOPOL PLANNING
 SCHEME**

Notice that a Planning Scheme has been
 Prepared and is Available for Inspection
 Amendment No. 43

Notice is hereby given that the Council of the
 Borough of Sebastopol in pursuance of its powers
 under the *Town and Country Planning Act 1961*
 has prepared a scheme for the following area:

Land being Lot 1, LP 205477U, Township of
 Sebastopol located at 54 Hertford Street,
 Sebastopol. The Planning Scheme proposes to
 rezone the land from Residential "A" to
 Commercial "B".

A copy of the scheme has been deposited at
 the Town Hall, 181 Albert Street, Sebastopol, at
 the Regional Office of the Ministry for Planning
 and Environment, Corner Mair and Doveton
 Streets, Ballarat and at The Olderfleet Buildings,
 477 Collins Street, Melbourne, and will be open
 for inspection during office hours to any persons
 free of charge.

Any persons affected by the scheme are
 required to set forth in writing any submissions
 they may wish to make with respect to the scheme
 addressed to the Town Clerk, Borough of
 Sebastopol, Town Hall, 181 Albert Street,
 Sebastopol, by Monday, 22 June 1987, and state
 whether you wish to be heard in respect of your
 submission.

G. A. CHRISTIE
 7095 Borough Engineer, Planning Officer

BOROUGH OF WONTHAGGI
 Change of Name of Street

Notice is hereby given that at a meeting of the
 Council of the Borough of Wonthaggi held on 27
 April 1987, it was resolved to change the names
 of the following streets:

1. The western section of Henry Street
 (between Wentworth Road and George Street),
 North Wonthaggi to be named Henry Street
 West.
2. The eastern section of Henry Street
 (between Korumburra Road and George Street),
 North Wonthaggi to be named Henry Street
 East.

7146 V. G. ROBSON
 Town Clerk

7096 A. A. N. DEED
 Town Clerk

BOROUGH OF WONTHAGGI

Change of Name of Street

Notice is hereby given that at a meeting of the Council of the Borough of Wonthaggi held on 16 March 1987, it was resolved to change the name of the court section of Dickson Street, between Hagelthorn and King Streets, Wonthaggi, to Tilley Court.

A. A. N. DEED
Town Clerk

7097

and Crown Allotments 1, 21 and 22, section 15, Township of Bealiba.

Dated 5 May 1987

J. A. THOMPSON
Shire Secretary

7098

SHIRE OF CRANBOURNE

Road Name Change—Tooradin

Notice is hereby given, pursuant to the provisions of section 535 of the *Local Government Act 1958*, the Council of the Shire of Cranbourne, at Meetings held on 5 November 1986 and 8 April 1987, resolved to change the name of the section of Baxter-Tooradin Road, Tooradin, east of Warneet Road, to "Nursery Lane", as shown on the plan hereunder.

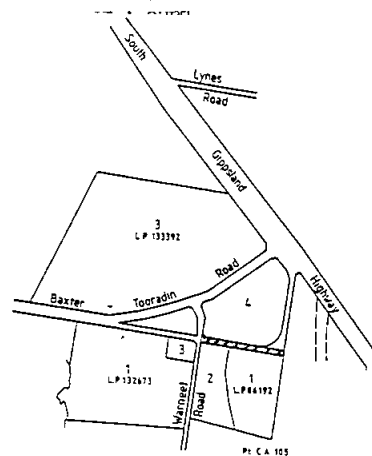

7147

T. VICKERMAN
Shire Secretary

SHIRE OF BET BET

Naming of Streets and Roads

Notice is hereby given pursuant to the provisions of the *Local Government Act 1958*, as amended, that the Council of the Shire of Bet Bet resolved at its meeting held on 29 April 1987 to assign the following names to the various un-named Government Roads, as stated hereunder:

| Name | Location |
|-----------------|---|
| Burrows Lane | Un-named road/lane located between Crown Allotments 1 and 8, section G, Parish of Donolly and Crown Allotment 28, section F, Parish of Barp. |
| Karingal Road | Un-named road/lane located between Crown Allotments 19, 29, 36, 37, section A, Parish of Barp and Crown Allotments 9-11, 5, 7 and 8, section E, Parish of Barp. |
| Allens Road | Un-named road/lane located between Crown Allotments 45, 85 and 86, section F, Parish of Tarnagullä. |
| Lummis Lane | Un-named road/lane located between Crown Allotments 5, 6, 15 and 16, section 5, Parish of Painswick. |
| Apple Jack Road | Un-named road/lane located between Crown Allotments 29, 35 and 40, section A, Parish of Barp. |
| Watts Road | Un-named road/lane located between Crown Allotments 7 and 10, section 39, Township of Dunolly, Lot 1, LP 203002, section 39, Township of Dunolly. |
| Queripels Road | Un-named road/lane located between Crown Allotments 1A, 3A, 9A, 36, 36A, 42-45, section B, Parish of Bealiba |

SHIRE OF CRANBOURNE

Road Name Change—Pearcedale

Notice is hereby given, pursuant to the provisions of section 535 of the *Local Government Act 1958*, the Council of the Shire of Cranbourne, at Meetings held on 14 January 1987 and 8 April 1987, resolved to change the name of the road between Baxter-Tooradin Road, and the Shire Boundary, commonly known

as Queen Street-Queens Road, Pearcedale, to "Queens-Road", as shown hatched on the plan hereunder.

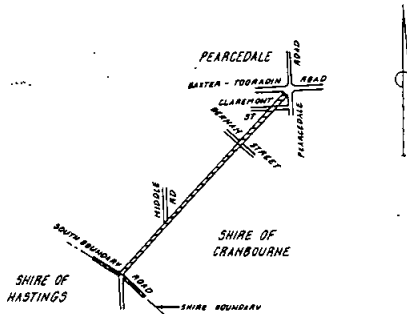

▨ To be known as Queens Road

T. VICKERMAN
Shire Secretary

7148

SHIRE OF DAYLESFORD AND
GLENLYON
Road Naming

Notice is hereby given that pursuant to section 535 (4) of the *Local Government Act 1958*, Council at a Meeting held on 7 April 1987 resolved to make the following Street/Road name change:—

Old Name: Unnamed Government Road
New Name: Tierney's Lane

Location: Government Road, Daylesford, running off Central Springs Road, between Table Hill Road and Fulcher Street.

G. K. TREVASKIS
Shire Secretary

7149

SHIRE OF DIAMOND VALLEY
Vesting of recreational reserve

The Council of the Shire of Diamond Valley at its meeting held on 24 April 1987, has hereby resolved that pursuant to section 569BA (1) of the *Local Government Act* the recreational reserve shown hatched on the plan below shall vest in Council.

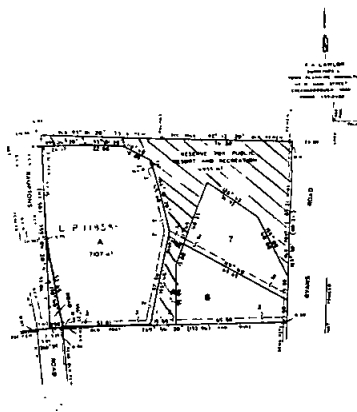

W. M. BALKIN
Shire Secretary

7103

SHIRE OF DIAMOND VALLEY
Vesting of recreational reserve

The Council of the Shire of Diamond Valley at its meeting held on 24 April 1987, has hereby resolved that pursuant to section 569BA (1) of the *Local Government Act* the recreational reserve shown hatched on the plan below shall vest in Council.

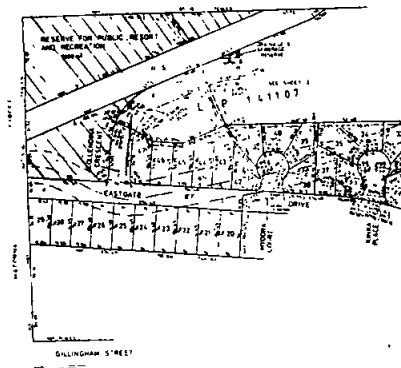

W. M. BALKIN
Shire Secretary

7104

SHIRE OF DIAMOND VALLEY

Vesting of recreational reserve

The Council of the Shire of Diamond Valley at its meeting held on 24 April 1987, has hereby resolved that pursuant to section 569BA (1) of the Local Government Act the recreational reserve shown hatched on the plan below shall vest in Council.

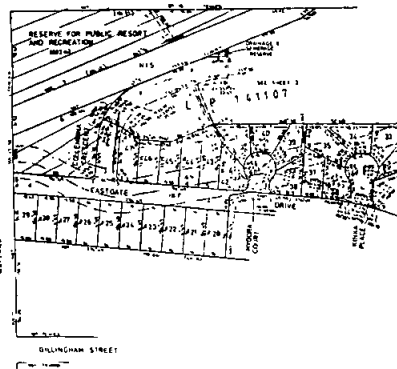

7105

W. M. BALKIN
Shire Secretary

considered all objections, resolved to change the name of the following streets in Hastings, west of the railway line, and as shown cross-hatched on the plan hereunder.

| <i>Old Names</i> | <i>New Names</i> |
|------------------|------------------|
| Elizabeth Street | Phillip Court |
| Spring Street | Autumn Court |

W. R. FEATHERSTON

Shire Secretary

Municipal Offices, Hastings 7151

SHIRE OF HASTINGS

**Discontinuance of Roads and Rights of Way
Natural Bushland Reserve, South Beach Road/
Disney Street, Crib Point**

At its meeting held on 7 April 1987, the Council of the Shire of Hastings, being of the opinion that the roads and rights of way identified in the plan hereunder, are not reasonably required as roads and rights of way for public use, and having complied with the provisions of sections 528 (2) (a) (ii) and (iii) of the *Local Government Act 1958* (as amended), resolved that the roads and rights of way be discontinued, and upon the publication of its resolution in the *Government Gazette*, the land being the roads and rights of way is to be retained by the Council of the Shire of Hastings for municipal purposes.

CLOSURE OF UNNECESSARY ROADS

Part Crown Allotment 123
Parish of Bittern
County of Mornington

ROADS TO BE CLOSED AND RETAINED FOR MUNICIPAL PURPOSES SHOWN SHADDED

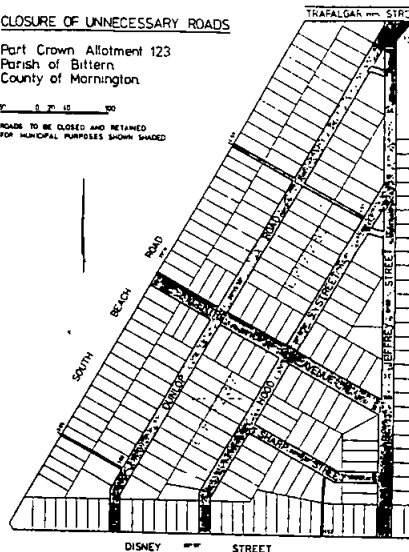

7150

W. R. FEATHERSTON
Shire Secretary

SHIRE OF HASTINGS

Street Name Changes

Pursuant to section 535 (4) of the *Local Government Act 1958* (as amended), on 5 May 1987, the Council of the Shire of Hastings having undertaken the necessary procedures and

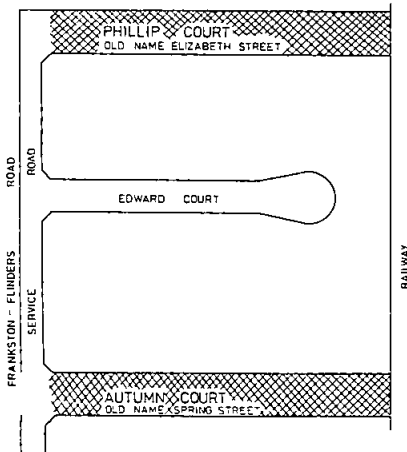

SHIRE OF KYNETON

Acquisition of CA 22, Section A Township of Lauriston

Take notice that this council proposes to construct a 50 m long, three-span concrete bridge over the Coliban River at Lauriston.

The existing road is to be realigned and the new alignment will pass through CA 22 Section A, Township of Lauriston which is owned by J. Stringer, Draper.

It will therefore be necessary for the council to acquire this entire property for roadmaking purposes.

The relevant maps and papers are deposited for inspection at the Shire Office, Kyneton.

Council calls upon all persons affected by the proposed taking of the land to set forth in writing addressed to the Shire Secretary, Shire of Kyneton within forty (40) clear days of the publication of this notice, all objections that they may have to the taking of the land.

D. J. PARKINSON
Shire Secretary

7152

SHIRE OF MILDURA

Naming of Road

Notice is hereby given that in pursuance of the powers conferred by section 535 (4) of the Local Government Act, the Council of the Shire of Mildura has formally resolved to name the road hatched on the plan below "Johns Road".

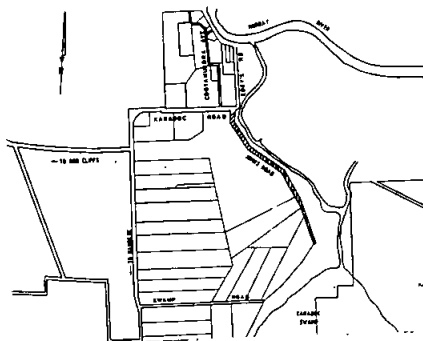

DAVID McMILLAN
Shire Secretary

7100

SHIRE OF LEXTON

Order Changing Name of Road

Notice is hereby given that the Council of the Shire of Lexton at a meeting held on 6 May 1987, made an order pursuant to section 535 (4) of the Local Government Act 1958 (as amended) changing the name of the Road set out hereunder:

Old Name: Settlement Road

New Name: Gallagher's Road

ANTHONY A. McCABE
Shire Secretary

7099

SHIRE OF RODNEY

In accordance with section 535 (4) of the Local Government Act 1958, the Council of the Shire of Rodney at the meeting of Council held on 4 May 1987, resolved to change the name of Main Street, Toolamba to Wren Street.

R. L. JAMES
Shire Secretary

7102

SHIRE OF NUMURKAH

Road Naming

Notice is hereby given that pursuant to section 535 (4) of the Local Government Act 1958, Council at a meeting held on 28 April 1987, resolved to make the following road name change.

Old Name: Goulburn Valley Highway.

New Name: Numurkah Road.

Location—From Naring Road, Numurkah northerly to the Murray Valley Highway at Strathmerton.

L. G. MITCHELL
Shire Secretary

7101

Form 2.1

Town and Country Planning Act 1961

SHIRE OF SHEPPARTON PLANNING SCHEME 1983

Notice That a Planning Scheme Has Been Prepared and is Available for Inspection
Amendment No. 18, 1986

Notice is hereby given that the Council of the Shire of Shepparton, in pursuance of its powers under the *Town and Country Planning Act 1961*, has prepared a scheme for the rezoning from the Rural D Zone to the Low Density Residential Zone land comprising all of Crown Allotment 43, Parish of Shepparton. The rezoning affects 20.5 hectares of land fronting New Dookie Road and lying to the north of the Dobson Road low density residential estate.

A copy of the scheme has been deposited at the council offices, corner of Nixon and Welsford Streets, Shepparton, and at the office of the

Ministry for Planning and Environment, The Olderfleet Buildings, 477 Collins Street, Melbourne, and will be open for inspection during office hours by any person, free of charge.

Any persons affected by the scheme are required to set forth, in writing, any submission they may wish to make with respect to the scheme addressed to the Shire Secretary, Shire of Shepparton, P.O. Box 606, Shepparton, 3630, by Friday, 3 July 1987, and state whether you wish to be heard in respect of the submission.

Dated 20 May 1987

I. W. MARTIN
Shire Secretary

7153

Form 2.1

Town and Country Planning Act 1961
SHIRE OF SHEPPARTON PLANNING
SCHEME 1983

Notice That a Planning Scheme Has Been Prepared and is Available for Inspection
Amendment No. 19, 1987

Notice is hereby given that the Council of the Shire of Shepparton, in pursuance of its powers under the *Town and Country Planning Act 1961*, has prepared a scheme for the rezoning from the Rural A Zone to the Village Zone, of part of Crown Allotment 144, Parish of Dookie, comprising an area of land 16 hectares in area fronting Ryans Road to a depth of 250 metres.

A copy of the scheme has been deposited at the council offices, corner of Nixon and Welsford Streets, Shepparton, and at the office of the Ministry for Planning and Environment, The Olderfleet Buildings, 477 Collins Street, Melbourne, and will be open for inspection during office hours by any person, free of charge.

Any persons affected by the scheme are required to set forth, in writing, any submission they may wish to make with respect to the scheme addressed to the Shire Secretary, Shire of Shepparton, P.O. Box 606, Shepparton, 3630, by Friday, 3 July 1987, and state whether you wish to be heard in respect of the submission.

Dated 20 May 1987

I. W. MARTIN
Shire Secretary

7154

Form 2.1

Town and Country Planning Act 1961
SHIRE OF SHEPPARTON PLANNING
SCHEME 1983

Notice That a Planning Scheme Has Been Prepared and is Available for Inspection
Amendment No. 20, 1987

Notice is hereby given that the Council of the Shire of Shepparton, in pursuance of its powers

under the *Town and Country Planning Act 1961*, has prepared a scheme for the rezoning from the Rural (Future Urban) Zone to the Residential Zone of all of Lot 8, L.P. 115007, Part Crown Allotment 77, Parish of Kialla. The land has a frontage to Raftery Road and the Goulburn Valley Highway.

A copy of the scheme has been deposited at the council offices, corner of Nixon and Welsford Streets, Shepparton, and at the office of the Ministry for Planning and Environment, The Olderfleet Buildings, 477 Collins Street, Melbourne, and will be open for inspection during office hours by any person, free of charge.

Any persons affected by the scheme are required to set forth, in writing, any submission they may wish to make with respect to the scheme addressed to the Shire Secretary, Shire of Shepparton, P.O. Box 606, Shepparton, 3630, by Friday, 3 July 1987, and state whether you wish to be heard in respect of the submission.

Dated 20 May 1987

I. W. MARTIN
Shire Secretary

7155

SHIRE OF WOORAYL

Change of street names

Notice is hereby given that the Council of the Shire of Woorayl at its meeting held on Friday, 8 May 1987 made the following name changes:

1. Marian Street, Inverloch to Marion Court; and
2. Nation Street, Inverloch to Nation Court.

7106 R. G. STANLEY, Shire Secretary

SHIRE OF WARRAGUL

By-Law No. 91

Notice is hereby given that the Council of the Shire of Warragul has made a By-Law No. 91, under the provisions of section 228 of the *Local Government Act, 1958* for the purpose of repealing By-Laws numbered—

10, 11, 17, 19, 20, 21, 23, 24, 25, 31, 32, 36, 50, 52, 57, 58, 59, 61, 62, 64, 67, 68, 75, 78, 80.

A copy of this By-Law is available for public inspection free of charge, during office hours at the Municipal Offices, Civic Place, Warragul.

The resolution approving this By-Law was carried by the Council on 14 April 1987 and confirmed on 12 May 1987.

V. B. DAVIDSON
Shire Secretary

7179

GEELONG AND DISTRICT WATER BOARD

Pursuant to section 60 of the *Geelong Waterworks and Sewerage Act 1958* (No. 6263) the Board has prepared plans to indicate the particulars of sewers and underground works, the construction of which the Board intends to begin at a date not less than one month after publication of the notices, in or adjacent to the following localities within the Drainage Area.

Thompsons Road, Kelly Court, North Geelong, Shire of Corio.

Patrick Street, Whittington, Shire of Bellarine.

Notice is hereby given that the plans indicated are open for public inspection at the Board's Offices, 61-67 Ryrie Street, Geelong between the hours of 8.10 a.m. and 5.00 p.m. from Monday to Friday (public holidays excepted) by the owners or occupiers of land or premises within the Drainage Area.

R. A. JORDAN
Secretary

7180

**SIXTH SCHEDULE
YACKANDANDAH WATER BOARD
General Notice**

Declaration of Sewerage Area

The abovenamed Board having made provision for carrying off the sewage from each and every property which, or any part of which, is within the Sewerage Area hereinafter described, doth hereby declare that on or after 1 July 1987 each and every property which, or any part of which, is within the said Sewerage Area shall be deemed to be a seweraged property within the meaning of the *Sewerage Districts Act 1958*.

The boundaries of the sewerage areas hereinafter referred to are:

Shire of Yackandandah Sewerage Authority
Yackandandah Township Sewerage District

All of that area gazetted as the Yackandandah Township Sewerage District

By Order of the said Yackandandah Water Board

R. P. ADAMS, Chairman
D. M. HOLWERDA, Secretary

7181

**PAKENHAM WATER BOARD
General Notice**

The Pakenham Water Board, having made provision for carrying off the sewage from each and every property which, or any part of which, is within the Sewerage Area hereinafter described, doth hereby declare that on, or after 1 June 1987, each and every property which, or any part of

which, is within the said Sewerage Area, shall be deemed to be a seweraged property within the meaning of the *Sewerage Districts Act 1958*.

Sewerage Area No. 21

Comprising Lots 1-2, 18-31, 33-36 Eagle Drive, Lots 3-17 Andrew Court, Lots 37-40, 47-49, 55-59 Deed Drive, Lots 41-46 Malcolm Court, Lots 50-54 Horne Court and Lot 32 The Avenue, Pakenham.

By order of the said water board

D. J. BOURKE, Chairman

B. J. WALLIS, Secretary

7107

SHEPPARTON WATER BOARD

Pursuant to section 119 (2) of the *Sewerage Districts Act 1958* (No. 6368) notice is hereby given of the intention to construct sewers for properties situated in the following streets:

City of Shepparton

Orchard Circuit

Fitzgerald Street

Pine Road

Verney Road

Lightfoot Street

more particularly as shown on plans which are open for inspection at this office between the hours of 9.00 a.m. and 4.30 p.m. Monday to Friday inclusive.

L. J. GLEESON
General Manager

7108

NOTICE OF DISSOLUTION

Notice is hereby given that the partnership heretofore subsisting between John Geoffrey Newton, Adam Fligeman, Mushtaq Ahmad Khan, Elsie Koadlow, Margaret Louise Murdoch, Ian George Murdoch and Sam Salcman carrying on the business of primary production on a property in New South Wales known as "Sturt's Billabong" under the style or firm of "Yewahplain Pastoral Co." has been dissolved as from 5 September 1986 so far as concerns Sam Salcman who retired from the said partnership.

Dated 28 April 1987

SAM SALCMAN

7115

**Companies (Victoria) Code, Section 392 (2) (b)
RONARDEN PROPRIETARY LIMITED**

Notice is hereby given that at a general meeting of the members of the abovenamed company held on 12 May 1987, it was resolved that the company be wound up voluntarily and that Ian Milton Nisbet, of 143 Queen Street, Melbourne, be appointed liquidator.

Notice is also given that after 21 days from this date, I shall proceed to distribute the assets. All creditors having any claims against the company should furnish particulars of same by that date, otherwise I shall proceed to distribute the assets without regard to their claim.

Dated 13 May 1987

7159

I. M. NISBET

YUILLE No. 3 CO-OPERATIVE HOUSING SOCIETY LIMITED

(In Liquidation).

Notice of Final Meeting in Voluntary Winding Up

Take notice that the affairs of the abovenamed society are now fully wound up and that in pursuance of section 272 (1) of the *Companies Act 1961* and of the *Co-operative Housing Societies Act 1958*, a general meeting of the society will be held at 54 Lydiard Street South, Ballarat, on 27 May 1987 at 5.00 p.m. for the purposes of—

- (i) laying before it an account showing how the winding up has been conducted and the property of the society disposed of and giving any explanations thereof; and
- (ii) passing a resolution that the books and papers of the said society and of the liquidator relevant to the affairs of the society be destroyed after a period of twelve months from the date of the meeting.

Dated 11 May 1987

7160 BRUCE E. BARTROP, Liquidator

In the matter of the Companies (Victoria) Code; and in the matter of Ern Mackie Victorian Distributors Pty. Limited (in Liquidation)

Notice is hereby given pursuant to section 392 (2) of the Companies (Victoria) Code that at an extraordinary general meeting of members of the abovenamed company held on 6 May 1987 it was resolved—

- (a) that the company be wound up voluntarily;
- (b) that John Stafford, of 5th Floor, 14 Paul Street, Milsons Point, N.S.W. 2061, be appointed liquidator and that his remuneration for his duties as liquidator be determined in accordance with time spent.

Dated 7 May 1987

7178 J. E. STAFFORD, Liquidator

CARLISLE DRY CLEANERS PTY. LTD.

Notice of Voluntary Liquidation—Section 392

At a general meeting of the abovenamed company duly convened and held at 23 Ringwood Street, Ringwood on 10 May 1987, the following resolution was passed as a special resolution.

That the company be wound up as a members voluntary liquidation and that the assets of the company may be distributed in whole or in part to the members in specie should the liquidator so desire.

Dated 12 May 1987

7111

BRUCE ROSS, Liquidator

KARDINIA (No. 9) CO-OPERATIVE HOUSING SOCIETY LIMITED

Notice of Final Meeting in Voluntary Winding Up

Take notice that the affairs of the above-named Society are now fully wound up and that in pursuance of section 272 (1) of the *Companies Act 1961* and of the *Co-operative Housing Societies Act 1958* a General Meeting of the Society will be held at Aberdeen Chateau, 115 Aberdeen Street, Newtown on 15 June 1987 at 7.30 p.m. for the purpose of:

(1) Laying before it an account showing how the winding up has been conducted and the property of the Society disposed of and giving any explanations thereof; and

(2) Passing a Resolution that the Books and Papers of the said Society and of the Liquidator relevant to the affairs of the Society be destroyed after a period of twelve months from the date of the meeting.

Dated 30 April 1987

7112

A. R. QUICK, Liquidator

**Companies (Victoria) Code, Section 411
FRANK VARALLO & ASSOCIATES PTY.
LTD.**

(in Voluntary Liquidation)

Notice is hereby given that a final meeting of members of the company will be held at 8 Aberdeen Road, Prahran, on 23 June 1987 at 9 a.m. for the purpose of laying before it the liquidators financial accounts and to finalise the liquidation, and dissolution of the company.

Dated 15 May 1987

BARRY HODSON & JACOB
STAINMAGEN, liquidators, 8 Aberdeen Road,
Prahran 7156

Unclaimed Moneys Act 1962

Register of Unclaimed Moneys held by the—

| <i>Name of Owner on Books and Last Known Address</i> | <i>Total Amount Due to Owner</i> | <i>Description of Unclaimed Money</i> | <i>Date when Amount first became Payable</i> |
|--|--|---|--|
| \$ | | | |
| ACI INTERNATIONAL LIMITED | | | |
| Aldrick, Peter L, 1 Hopetoun St, Dandenong | 12.24 | Dividend | 28.2.86 |
| Aldridge, Edna E, 91 Stevenson St, Kew | 111.35 | " | " |
| Allan, Barbara, c/o Perp T/Tee Co Ltd, 39 Hunter St, Sydney, NSW | 535.50 | " | " |
| Allan, Pamela G, 45 Albert St, Harden, NSW | 43.36 | " | " |
| Allsopp, Rosemary E, 30 Huntleys Point Rd, Huntleys Pt, NSW | 102.00 | " | " |
| Alston, Thomas D D, Yanrey Station, Carnarvon, WA | 586.16 | " | " |
| Altimira, J, PO Box 276, Bunbury, WA | 74.93 | " | " |
| Antoniesen, Herman P, 86 Fitzpatrick Cres, Casula, NSW | 25.50 | " | " |
| Appelboom, Doreen J, 14 Linlithgow Rd, Toorak | 51.00 | " | " |
| Arnott, Gwennyth V, 4 Russell St, Balgowlah, NSW | 29.08 | " | " |
| Arthur, Peta M, Trailee, Temora, NSW | 26.52 | " | " |
| B & G Securities Pty Ltd, Shellshear Trust, PO Box 44, Albury, NSW | 73.44 | " | " |
| Baker, John W, 7 Binda Pl, Yowie Bay, NSW | 13.43 | " | " |
| Baker, Rosemary A, 7/31 Hampstead Rd, Homebush, NSW | 42.50 | " | " |
| Baker, Ian H, 66 Chelmsford Ave, Epping, NSW | 21.26 | " | " |
| Baragwaneth, Janette C, 78 George St, East Melbourne | 62.90 | " | " |
| Bardon, Ines E, 117 East Tamaki, Papatoetoe, NZ | 18.80 | " | " |
| Barnett, Peter, 2/91 Mathoura Rd, Toorak | 43.36 | " | " |
| Barry, Alice R, 113 Studley Rd, Heidelberg | 51.00 | " | " |
| Baty, Donald E, Lot 20 Clementson Dve, West Huxton, NSW | 34.00 | " | " |
| Baty, Leanne F, Lot 20 Clementson Dve, West Huxton, NSW | 34.00 | " | " |
| Bayldon, Grant R, c/o Harold J Bayldon, 6 Lucerne Rd, Remuera, Auckland, NZ | 54.20 | " | " |
| Bayldon, Stephen J, c/o Harold J Bayldon, 6 Lucerne Rd, Remuera, Auckland, NZ | 27.10 | " | " |
| Bell, Stephen A, Oak Lodge, Alfriston Rd, Manurewa, Auckland, NZ | 173.40 | " | " |
| Bellshaw, John A, New Zealand | 18.08 | " | " |
| Bennett, James W, 9/22 Salisbury St, North Unley, SA | 170.00 | " | " |
| Berlei Staff Prov. Fund Mge P/L, 30 O'Dea Ave, Waterloo, NSW | 4250.00 | " | " |
| Bernera Hogs Pty Ltd, 756 New South Head Rd, Rose Bay, NSW | 46.92 | " | " |
| Berney, Hilda (estate of), c/o J W Rice, 25-27 Sping St, Chatswood, NSW | 45.90 | " | " |
| Berry, Walter H, PO Box 56004, Linden Tawa, NZ | 158.96 | " | " |
| Biddles, P R, PO Box 403, Kebayoran Baru, Jakarta, Indonesia | 95.20 | " | " |
| Blackman, Shona, c/o PO Wangarei, NZ | 27.04 | " | " |
| Blackmore, Donald G, c/o R'dale Hotel, Riversdale Rd, Hawthorn | 68.00 | " | " |
| Blyth, Peter, 160 Centaurus Rd, Christchurch 2, NZ | 29.63 | " | " |
| Bolling, Fred, 15/7 Dowling St, Kensington, NSW | 21.26 | " | " |
| Bossong, Hans, 72 Melbourne Hill Rd, Warrandyte | 15.13 | " | " |
| Brennan, Eileen, 311 Kent St, Falls Church, Virginia, USA | 12.65 | " | " |
| Bromberg, John, 4/3 Balston St, East St Kilda | 170.00 | " | " |
| Brooker, Reinald, 5 Pitt St, Redland Bay, Qld | 68.00 | " | " |
| Brookes, Richard J, 5 Hopetoun Rd, Toorak | 510.00 | " | " |
| Brooks, A H (estate of), c/o Lindsey, R, Adelphi Farm, Westbury, Tas | 17.00 | " | " |
| Brown, David G, 1/48 Albert St, Hornsby, NSW | 29.76 | " | " |
| Brown, Stuart S, 12 Broadmeadow Dve, Forest Hill, SA | 42.50 | " | " |
| Bruham Properties Ltd, 32 Eaton Cres, Matau, Tauranga, NZ | 17.34 | " | " |
| Brush, John A, 30 Club Cres, Ballarat | 34.00 | " | " |
| Buckle, Jean B, 9 Owen St, Lindfield, NSW | 202.30 | " | " |
| Burne, Robert D, 7/11 Harriette St, Neutral Bay, NSW | 25.50 | " | " |
| Burnside, Nora M, 110 WattleValley Rd, Camberwell | 102.00 | " | " |
| Burton, Kevin H, 64 Manton Rd, Clayton | 34.00 | " | " |
| Burton, Shayne, 3 Parish Crt, Millswood, SA | 61.72 | " | " |

Unclaimed Moneys Act 1962

Register of Unclaimed Moneys held by the—

| Name of Owner on Books and Last Known Address | Total Amount Due to Owner | Description of Unclaimed Money | Date when Amount first became Payable |
|---|------------------------------------|--------------------------------------|--|
| \$ | | | |
| ACI INTERNATIONAL LIMITED—continued | | | |
| Butler, Cynthia A, 52 Torroodun St, Mt Waverley | 15.30 | Dividend | 28.2.86 |
| Byrne, Arthur J, GPO Box 4830, Sydney, NSW | 20.40 | " | " |
| Cameron, Kenneth V B, Esmeralda, via Croydon, Qld | 163.97 | " | " |
| Cameron, Allen C, Rockwood, Chinchilla, Qld | 179.10 | " | " |
| Canning, George C, 18 Selbourne St, Hawthorn | 21.26 | " | " |
| Carman, Evelyn H, Onaero Beach, No 43 Rd, Waikanae, NZ | 316.62 | " | " |
| Caswell, Peter R, 90 Pembroke Rd, Coorparoo, Qld | 53.04 | " | " |
| Catlow, W R and M E, 10 Baudelaire Ave, Wantirna | 42.50 | " | " |
| Cauciau, Virginio, 117 Miller St, North Fitzroy | 30.26 | " | " |
| Chapman, Martha, 11 Frisram Rd, Beacon Hill, NSW | 204.00 | " | " |
| Chariston, Shelly, 39 Cambridge St, Paddington, NSW | 61.20 | " | " |
| Chiam, Heng Foo, 116 Mt Pleasant Rd, Forest Hill | 51.00 | " | " |
| Chong, Barry T, 7 Casey St, Grovley, Qld | 34.00 | " | " |
| Churchland, M T and D M, 36 Renway Ave, Lugarno, NSW | 10.20 | " | " |
| Clark, Roger W, 18 Grant St, Dandenong | 68.00 | " | " |
| Clarke, Ashley J, 55 Baratta St, South Blackburn | 10.20 | " | " |
| Cleaver, Bryan J, 141 Sulphide St, Broken Hill, NSW | 122.40 | " | " |
| Cohen, Jonathan, 305 Miller St, Hastings, NZ | 26.01 | " | " |
| Coleman, Paul A, Flat 8/15 Greenlands Ave, Sandy Bay, Tas | 68.00 | " | " |
| Collins, Heather L, 48 Tuxen St, North Balwyn | 21.26 | " | " |
| Connelly, Angela M, 8 Bayview Ave, Ballina, NSW | 15.39 | " | " |
| Connolly, Gerald V, 95A Englefield Rd, Christchurch, NZ | 144.50 | " | " |
| Conway, John F, 32 Trafalgar Crs, Bundoora | 17.00 | " | " |
| Coombes, Leslie L, & Alkoomie Ave, Forestville, NSW | 40.80 | " | " |
| Copland, Patricia M, c/o M Donohoe, 2/11 Osborne Rd, Manly, NSW | 25.50 | " | " |
| Coulin, Raymond G, 12 Carmichael St, Tamworth, NSW | 136.00 | " | " |
| Cox, Terence J, 2/58 Princes Hwy, Doveton | 68.00 | " | " |
| Cox, John T, 604/8 Broughton Rd, Artarmon, NSW | 20.40 | " | " |
| Cross G C & Beighley J G, 342 Cascades Dve, Fairfax, California, USA | 27.04 | " | " |
| Croxton, Leonard W, PO Box 270, Burleigh Heads, Qld | 170.00 | " | " |
| Dalton, David P, EPS Invest. Club, PO Box 623, Neutral Bay, NSW | 10.03 | " | " |
| Darby, John J, 131 Armagh St, Christchurch, NZ | 18.08 | " | " |
| Davey, John J, 5 Bucknell St, Christchurch, NZ | 21.68 | " | " |
| Davies, Margaret A, 15 Carroll St, North Melbourne | 10.63 | " | " |
| Dawson, Nora, PO Box 21, Warilla, NSW | 34.00 | " | " |
| Dixon, Bruce C, New Zealand | 13.02 | " | " |
| Donald, David W, 4/7 Fisher St, Cabramatta, NSW | 85.00 | " | " |
| Dowling, Dianne B, PO Box 118, Collingwood | 340.00 | " | " |
| Downing M E & N W Forrester, c/o N W Forrester, 22 Gilies Rd, Woodley, SA | 144.16 | " | " |
| Dreverman, Peter C, c/o Nobles Nob Mine, Tennant Creek, NT | 44.20 | " | " |
| Duggan, Francis J, Candlebark Captains Flat Rd, Queanbeyan, NSW | 28.39 | " | " |
| Dunen, Richard, 110 Boronia St, Wentworthville, NSW | 34.00 | " | " |
| Dunn, Gwenda, Stonehaven, via Geelong | 18.70 | " | " |
| Edward, David W, 2523 Lake St, San Francisco, California, USA | 36.14 | " | " |
| Edwards, George O, 11 Ramahana Rd, Christchurch, NZ | 13.01 | " | " |
| Ellis, Thomas R, 2A Haig St, Netherby, SA | 428.40 | " | " |
| English, K J & E T, 77 Mayne St, Gulgong, NSW | 313.48 | " | " |
| Evans, Caroline R, c/o Prot. Comm. PO Box 466, North Sydney, NSW | 274.38 | " | " |

Unclaimed Moneys Act 1962

Register of Unclaimed Moneys held by the—

| <i>Name of Owner on Books and Last Known Address</i> | <i>Total Amount Due to Owner</i> | <i>Description of Unclaimed Money</i> | <i>Date when Amount first became Payable</i> |
|---|--|---|--|
| \$ | | | |
| ACI INTERNATIONAL LIMITED— <i>continued</i> | | | |
| Evatts, Barry H, 35 Outlook Rd, Mount Waverley | 149.10 | Dividend | 28.2.86 |
| Farlow, Colin, 2 Cometrowe St, Drummoyne, NSW | 21.26 | " | " |
| Farrington, Edward P, 12 Jessie St, Preston | 31.79 | " | " |
| Fiancee Pty. Limited, 5th Floor, 99 Creeks Rd, Brisbane, Qld | 344.25 | " | " |
| Fleders, Dianne, 2/46 Munto Rd, Queanbeyan, ACT | 34.00 | " | " |
| Fleming, John M, Four Steel Rd, Hamilton | 21.26 | " | " |
| Foster, John E, Flat 10, 4 Marei Rd, One Tree Hill, Auckland, NZ | 28.90 | " | " |
| Fry, William H, Lower Wonga, via, Woolooga, Qld | 115.60 | " | " |
| Gardiner, Paul J, 24 Harold St, Largs Bay, SA | 34.00 | " | " |
| Gibby, Joan T, c/o 54 Gracedale Ave, North Bayswater | 10.20 | " | " |
| Gillet, Margaret A, Unit 1, 9 Bindaring Pde, Claremont, WA | 168.39 | " | " |
| Goodall, Donald G W, Mossburn No. 2 Rd, Southland, NZ | 104.04 | " | " |
| Gottsche, Pamela B, c/o P B Breen, 1053 Douglas Cres, Vancouver, BC Canada | 10.86 | " | " |
| Goulden, Wendy M E, c/o Mrs Mathers, 6 Tarella Dr, Mount Waverley | 38.60 | " | " |
| Gow, Alan J, Lot 54, Wonga Rd, Millgrove | 10.20 | " | " |
| Graham, Laurel C, 5/21 Bridge St, Epping, NSW | 26.52 | " | " |
| Graham, Maion L, 27 Victoria St, Epping NSW | 13.44 | " | " |
| Grant, Peter D & Malcolm J, c/o Berry Alty & Neil, PO Box 10, Damaru, NZ | 41.89 | " | " |
| Gray, Zena H (estate of), 195 Adelaide Tce, Perth WA | 71.18 | " | " |
| Greenland, David G, 54 Vincent Rd, Lake Albert, NSW | 68.00 | " | " |
| Griffiths, G M, O E & Gregg Gra, c/o Braham & Priani, 521 Toorak Rd, Toorak | 11.06 | " | " |
| Gullaren Pty. Limited, PO Box 262, Collingwood | 85.00 | " | " |
| Gupta, Ram R, 16 Tagore Rd, Cantonment, Kampur, India | 312.40 | " | " |
| Halse, Dorothy C, 7 Reserve St, Smithfield, NSW | 195.59 | " | " |
| Hamer, Robert E, 10 Coromdale Cres, Mairangi Bay, NZ | 14.45 | " | " |
| Hancock, Gordon R, 42 Fairburn Cres, Koorngal, NSW | 68.00 | " | " |
| Hanney, David J, c/o 8 Awoonga St, Wynnum North, Qld | 20.40 | " | " |
| Hanney, Kelly A, c/o 8 Awoonga St, Wynnum North, Qld | 20.40 | " | " |
| Hansen, David T, 13 The Oval, Seletar Airbase, Singapore | 18.08 | " | " |
| Harder, Ethel (estate of), c/o Peter Hassett & Co, PO Box 64, Burwood | 17.00 | " | " |
| Harris, Keith R, 10 Hearthside Crt, Ringwood | 42.50 | " | " |
| Hausmann, Rodney G, 11 Hillsdale Cres, Strathpine, Qld | 68.00 | " | " |
| Hay, Thelma M (estate of), c/o Pennington & Pennington, 263 George St, Sydney, NSW | 12.76 | " | " |
| Henderson, Judith A, 226 Hamilton, Rd, Chermside, Qld | 34.00 | " | " |
| Hewitt, Graeme R, 20 Edgar St, Wendouree | 136.00 | " | " |
| Hill, John D, Yandaran, Qld | 34.00 | " | " |
| Hill, Barbara, 322 Military Rd, Vaucluse, NSW | 42.50 | " | " |
| Hill, Margaret L, 32 Grenfell St, Adelaide, SA | 76.76 | " | " |
| Hinds, Phillipa A, 29/48 Khartoum Rd, North Ryde, NSW | 15.90 | " | " |
| Hipwell, Freda G, 4 Casey Ave, Sunbury | 12.75 | " | " |
| Hoad, Mark W, 188 Oxley Rd, Graceville, Qld | 34.00 | " | " |
| Hobby, Janice, 37 Bushlands Ave, Gordon, NSW | 340.00 | " | " |
| Hodges, Neil R, 10 Dalkeith Cl, Wheelers Hill | 136.00 | " | " |
| Holstein, Lesley A, 12A Napper St, Coogee South, NSW | 10.54 | " | " |
| Hoppe, A V and P A, PO Box 195, Hawthorn | 183.60 | " | " |
| Hopton, Hilary, 64 Haslam Cres, Elizabethvale, SA | 34.00 | " | " |
| Horrocks, Elizabeth, 204 Tillyard Ave, Fraser, ACT | 17.00 | " | " |

Unclaimed Moneys Act 1962

Register of Unclaimed Moneys held by the—

| <i>Name of Owner on Books and Last Known Address</i> | <i>Total Amount Due to Owner</i> | <i>Description of Unclaimed Money</i> | <i>Date when Amount first became Payable</i> |
|---|--|---|--|
| \$ | | | |
| ACI INTERNATIONAL LIMITED—continued | | | |
| Howell, John R N A, 14 Elmore St, Charlestown, NSW | 22.78 | Dividend | 28.2.86 |
| Howie, Sheila M, 32 River Rd, Brentwood, Essex, England, UK | 22.78 | " | 1.6.85 |
| Hughes, Helena M, c/o Aust. Devel. Ass. Bureau, PO Box 884, Canberra, ACT | 29.07 | " | 28.2.86 |
| Hughes, Douglas W, 152 Church Rd, Northfield, Birmingham, England, UK | 86.70 | " | " |
| Hunt, Guy A P, PO Box 117, Woolloogabba, Qld | 34.00 | " | " |
| Ingersoll, John K, c/o 46 Terrace Rd, Dulwich Hill, NSW | 42.50 | " | " |
| Inns, Jeff, 3/55 Blackwood Ave, Mentone | 34.00 | " | " |
| Ismailovski, Nafis, 14 Willis Cl, Hampton Park | 34.00 | " | " |
| Jack, Joyce E, 6 Seabank La, Southport, Qld | 36.22 | " | " |
| Jack, Joyce E, 6 Seabank La, Southport, Qld | 10.80 | " | 1.12.85 |
| Jackson, P A, Drive R F, c/o McIntosh & Henderson 185 Elizabeth St, Sydney, NSW | 21.26 | " | 28.2.86 |
| Jeffers, Roy H, 2/45 Maurice St, Herne Hill | 12.76 | " | " |
| Jessop, Christine M, PO Box 48-065 Blockhouse Bay, Auckland, NZ | 16.99 | " | " |
| Job, Philip J, 5 Kawana Pl, Menai, NSW | 136.00 | " | " |
| Johnson, Margaret A, Toomah Split Rock Rd, Upper Beaconsfield | 44.38 | " | " |
| Johnson, Grace I, 52A Dyers Pass Rd, Christchurch, NZ | 144.50 | " | " |
| Johnson, Virginia N, Mt. Torlesse, Springfield, NZ | 32.23 | " | " |
| Jordan, Gwen L, 1 Granthan Rd, Somerton Park, SA | 25.67 | " | " |
| Joseph, T H and Rea B S, 12 Mirang Ave, Mount Eliza | 38.25 | " | " |
| Judd, David C, 640 Yambula Ave, Albury, NSW | 34.00 | " | " |
| Kaia P, Tamont K, Warep, B, c/o A E Cooke, Dept. of District Admin, Sub District Office, PNG | 31.52 | " | " |
| Kaia, Phillip, c/o A E Cooke, Dept. of District Admin, Sub District Office, PNG | 36.14 | " | " |
| Keenan, Judith R, 44 Leonard St, Upwey | 29.76 | " | " |
| Keeves Josephine M, 235 Ward St, North Adelaide, SA | 32.14 | " | " |
| Kelly, Martin, 310 Payneham Rd, Marsden, SA | 21.26 | " | " |
| Kielar, Juliusz, 274 Kent St, New Farm, Qld | 68.00 | " | " |
| Kilroe-Smith, Angelique 1/111 Kooyong Koot Rd, Hawthorn | 17.00 | " | " |
| Kilroe-Smith, Noel, 72 Glyndon Rd, Camberwell | 4 250.00 | " | " |
| Kilroe-Smith, Russell, 1/111 Kooyong Koot Rd, Hawthorn | 27.20 | " | " |
| King, Rae, 55 Ann St, Dandenong | 30.60 | " | " |
| Kite, Paul F, 14 Cassia Cres, Queanbeyan, ACT | 34.00 | " | " |
| Larson, Neil C, 80 Kensington Rd, Summer Hill, NSW | 34.00 | " | " |
| Lawson, Phillip D, 9/8 Bowen St, Chatswood, NSW | 75.14 | " | " |
| Leddin, Lillian, 47 Highfield Rd, Lindfield, NSW | 140.08 | " | " |
| Lee, Chin L, The Prince Henry Hospital Unit 9, Anzac Pde, Little Bay, NSW | 170.00 | " | " |
| Levy, Victoria S, 17/205 Birrell St, Waverley, NSW | 230.27 | " | " |
| Lewis, Colin H, 14 Rayment Ave, Kingsgrove, NSW | 224.06 | " | " |
| Liao, Christine M, 37 Wandin Rd, Camberwell | 122.40 | " | " |
| Lind, Paula, The Garrison, 13 Spit Rd, Mosman, NSW | 233.16 | " | " |
| Lindwall, James R, 13 Hoadley St, Mawson, ACT | 136.00 | " | " |
| Llewlyn, Gillian A, c/o Lawrence Milton & Howarth, PO Box 90, Christchurch, NZ | 232.15 | " | " |
| Lockhart, Thomas F, PO Box 1025, Hastings, NZ | 82.51 | " | " |
| Loroma Pty. Limited, c/o William Holdsworth & Ass., Box 58, Camberwell | 127.50 | " | " |

Unclaimed Moneys Act 1962

Register of Unclaimed Moneys held by the—

| <i>Name of Owner on Books and Last Known Address</i> | <i>Total Amount Due to Owner</i> | <i>Description of Unclaimed Money</i> | <i>Date when Amount first became Payable</i> |
|---|--|---|--|
| \$ | | | |
| ACI INTERNATIONAL LIMITED— <i>continued</i> | | | |
| Low, Mei W, Flat 12A 8 Hudson St, North Caulfield | 137.70 | Dividend | 28.2.86 |
| Luck, Ronald K, 34 Isaac St, Peakhurst, NSW | 88.40 | " | " |
| Luke, Rosemary D, 10 Myrning Cres, Toorak | 14.54 | " | " |
| Mackay, Hecor J, Barr Creek, via Jandowae, Qld. | 31.80 | " | " |
| Macphillamy, Helen P, 3 Simpson St, Mosman, NSW | 37.83 | " | " |
| Mahlstedt, Leslie R, Temple Crt, 422 Collins St, Melbourne | 11.22 | " | " |
| Mantle, John S, 48 Clackmannan Rd, Winston Hills, NSW | 25.50 | " | " |
| Markham, Peter J, 4/1 Gillies St, Wollstonecraft, NSW | 136.00 | " | " |
| Marsden, Arnold, 4 Murray St, Mentone | 26.52 | " | " |
| Marshall, Doreen A, c/o Perp T/Tee Co Ltd, 33-39 Hunter St, Sydney, NSW | 557.52 | " | " |
| Maskell, Harold J M, Flat 5, 27 Billyard Avenue, Elizabeth Bay, NSW | 34.00 | " | " |
| Matthews, A T (estate of), 67 Lennox St, Rockdale, NSW | 27.54 | " | " |
| Maunsell, John, Albion Hotel, Parramatta, NSW | 53.04 | " | " |
| May, Peter G, 3/11 Clarendon Street, Frankston | 34.00 | " | " |
| Maynes, Edwin G, 59 Cambridge St, Paddington, NSW | 24.82 | " | " |
| McBrien, David (estate of), c/o R Shacklock, 9520 via Salerno, Burbank, California, USA | 144.50 | " | " |
| McCormack, Liam C, c/o Legal Dept, Central Government Offices, Hong Kong | 40.11 | " | " |
| McCrae, Shirley E, Unit 34, 8 O'Shaugnessy St, Kew | 43.36 | " | " |
| McDonald, Caroline M, PO Box 596, Queanbeyan, NSW | 14.71 | " | " |
| McGifford, Noelene M, 101 Daffodil St, Titirangi, Auckland, NZ | 34.68 | " | " |
| McGuire, Hugh H (estate of), c/o Trustees, H McGuire, 18 Grange Rd, Mount Eden, Auckland, NZ | 63.23 | " | " |
| McJannet, Alan H D, 45 Drumalbyn Rd, Sellevue Hill, NSW | 38.26 | " | " |
| McLennan, Iain A, c/o Manion McCosker, 75 Elizabeth St, Sydney, NSW | 38.76 | " | " |
| McLeod, Judith L, Corriedale, 4 Crd Camaru, NZ | 35.01 | " | " |
| Messina, Salvatore, 1383 Heatherton Rd, Dandenong | 34.00 | " | " |
| Mikanos Pty Limited, c/o J Bennett, 34 Aroona Rd, North Caulfield | 394.40 | " | " |
| Montgomery-Clarke, 22 Ponticello St, Whitfield, Qld | 26.70 | " | " |
| Montgomery-Clarke, A J, 22 Ponticello St, Whitfield, Qld | 26.70 | " | " |
| Morgan, Bruce A, Box 68 Collinsville, Qld | 25.50 | " | " |
| Morgan, Charles F E, Geeron Forbes, NSW | 204.00 | " | " |
| Morton, Alexandrina R, PO Box 241, Cleveland, Qld | 76.50 | " | " |
| Mrocki, Harry, 11 St Johns Rd, Mount Waverley | 136.00 | " | " |
| Murphy, Valda E, 11 St Johns Rd, Mount Waverley | 83.39 | " | " |
| Need, John F, 40 Rosserdale Cres, Mount Eliza | 24.48 | " | " |
| New Zealand Cons Noms Ltd, c/o PO Box 36, Christchurch, NZ | 360.39 | " | " |
| Newbiggin, Richard L, 11 Henwood St, Blackburn South | 38.88 | " | " |
| Ng, A W, 18/350 Bronte Rd, Bronte, NSW | 85.00 | " | " |
| Ngo, H P, 8/1 Hampden Rd, Artarmon, NSW | 34.00 | " | " |
| Nockolos, David J, 33 Tynan St, Orange, NSW | 34.00 | " | " |
| Norman, Jennifer J, c/o D S Scott, Roadside Delivery, Casterton | 52.28 | " | " |
| Normandy Grace Pty Limited, Flat 8, 321 Beaconsfield Pde, St. Kilda | 255.00 | " | " |
| Obara, Mary P, 7/16 Bellevue St, North Parramatta, NSW | 30.78 | " | " |
| Obradovic, V, 18 Ronald Ave, Bulleen | 15.13 | " | " |
| O'Brien, Vincent (estate of), c/o Gillis & Co, 12th Floor, Kindersley House, 33 Bligh St, Sydney, NSW | 10.20 | " | " |
| O'Conner, Brian T, 18 Larool Cres, West Sunshine | 68.00 | " | " |

Unclaimed Moneys Act 1962

Register of Unclaimed Moneys held by the—

| <i>Name of Owner on Books and Last Known Address</i> | <i>Total Amount Due to Owner</i> | <i>Description of Unclaimed Money</i> | <i>Date when Amount first became Payable</i> |
|--|--|---|--|
| \$ | | | |
| ACI INTERNATIONAL LIMITED—continued | | | |
| Oram, Dione, 50 Elliot Ave, Balwyn | 21.42 | Dividend | 28.2.86 |
| Parer, Sarita H, c/o 5 Morella Rd, Clifton Gardens, NSW | 19.04 | " | " |
| Parker, Dennis J, 11 Courallie Dve, Orange, NSW | 34.00 | " | " |
| Parkinson, Peter C H, 4/20 Union St, North Sydney, NSW | 10.63 | " | " |
| Parry, Frank, 1 Greenwich Pl, Viewbank | 136.00 | " | " |
| Pasterczyk, Joseph G, 7 Balsa St, Marsden, Qld | 34.00 | " | " |
| Payne, C L (estate of), 25 Bowen St, New Farm, Qld | 36.89 | " | " |
| Peach, Ivor A, 3 Walter St, Mitcham | 51.30 | " | " |
| Pearson, Dawn E, 1 Brewster Pl, Duffy, ACT | 25.50 | " | " |
| Pellow, Kevin C, 3 Acacia Dr, Briar Hill, ACT | 136.00 | " | " |
| Perkins, Patricia H, 44 Elizabeth St, Melbourne | 52.54 | " | " |
| Perry, N C and C T, 22 Austral Ave, Upwey | 68.00 | " | " |
| Petrovic, D, 16 George St, Brunswick | 21.68 | " | " |
| Pilcher, Norman C (estate of), 25 Westbourne Rd, Remuera, Auckland, NZ | 117.92 | " | " |
| Plimmer, Ian R, 30 Orchard St, Wadestown, Wellington, NZ | 10.86 | " | " |
| Plummer, Sally, 39 John St, Eastwood, SA | 42.50 | " | " |
| Powell, Rosemary J, PO Box 21240, Henderson, NZ | 40.90 | " | " |
| Power, Matthew J, Wyndham Park, Bergins Rd, Rowville | 25.50 | " | " |
| Porcuier in the Straits, c/o Bain & Co, 1004 Bank of America Tw, Harcourt Rd, Hong Kong | 3570.00 | " | " |
| Putt, Harry, 65 Burdett St, Hornsby, NSW | 20.40 | " | " |
| Ranginui Holdings Limited, c/o Stone & Co, PO Box 1334, Auckland NZ | 1118.44 | " | " |
| Rasidovski, Nevzat, 206 Outlook Dvc, North Dandenong | 68.00 | " | " |
| Rawlings, John N, 8 Knox Rd, Manurewa, Auckland, NZ | 28.90 | " | " |
| Read, James W, 28 Kalang Rd, Elanora Heights, NSW | 17.00 | " | " |
| Read, Scott A, 28 Kalang Rd, Elanora Heights, NSW | 17.00 | " | " |
| Rex, Pamela J, 37 Roebuck St, Red Hill, ACT | 25.50 | " | " |
| Richardson, Barry A, 9 Talune St, Lindisfarne, Tas | 64.26 | " | " |
| Ritchie, Phillip L, 3/67 Ocean Ave, Double Bay, NSW | 116.46 | " | " |
| Robertson, Irene M, 515 Glenferrie Rd, Hawthorn | 212.50 | " | " |
| Robertson, Ernest B, 8 Holly Cr, Mitcham | 61.80 | " | " |
| Robertson, John E G, 23 John Watson Dve, Mount Gambier, SA | 153.00 | " | " |
| Robinson, June, 98 Hamilton Rd, Fairfield, NSW | 61.20 | " | " |
| Rogers, Peter H, 32 Patterson St, Concord, NSW | 26.52 | " | " |
| Ross, Dorothy, 111 Forest Rd, Miranda, NSW | 34.00 | " | " |
| Routley Noms (NSW) Pty Ltd, c/o Duesburys, GPO Box 4331, Sydney, NSW | 59.50 | " | " |
| Rowley, Lynsy M, c/o The Esplanade Hotel, PO Box 32-002 Devonport, Auckland, NZ | 19.73 | " | " |
| Rowse, Anthony I, Rumson Rd, Rumson, NJ, USA | 81.08 | " | " |
| Ruddock, Dennis, 26 Carolyn Cres, Bundoora | 43.86 | " | " |
| Russell, Walter A, c/o 5 Hortense St, Burwood | 34.18 | " | " |
| Sander, William I, 43 First Ave, Sawtell, NSW | 11.56 | " | " |
| Sangwell, Rodney J, 163 Wigram Rd, Forest Lodge, NSW | 213.02 | " | " |
| Schithman, Albert M, 18 Marlton St, Tarragindi, Qld | 34.00 | " | " |
| Schramko, Zolta G, 6 Stratham Pl, Belrose, NSW | 61.20 | " | " |
| Scott, Andrew D H, Kiekstyle Coalgate, Canterbury, NZ | 45.17 | " | " |
| Scott, Robert H, 75 Brisbane St, East Maitland, NSW | 25.50 | " | " |
| Sculley, Edward S, 8th Floor, 23 Berry St, North Sydney, NSW | 22.10 | " | " |
| Selwyn, Susan, 5 Homebush Rd, Putney, London, UK | 65.04 | " | " |

Unclaimed Moneys Act 1962

Register of Unclaimed Moneys held by the—

| <i>Name of Owner on Books and Last Known Address</i> | <i>Total Amount Due to Owner</i> | <i>Description of Unclaimed Money</i> | <i>Date when Amount first became Payable</i> |
|--|--|---|--|
| § | | | |
| ACI INTERNATIONAL LIMITED— <i>continued</i> | | | |
| Sharp, Gladys (estate of), c/o Royds Sharp, 104 East Kilbridge Rd, Busby, Glasgow, Scotland | 42.64 | Dividend | 28.2.86 |
| Sheaffe, Roger W, Box 23, Boougal, NSW | 139.40 | | |
| Simpson, Warwick E, Clarkesville, Milton, NZ | 13.66 | | |
| Singleton, Owen P, 15 Cass Ave, Croydon | 178.00 | | |
| Sleigh, Decima M, Flat 6, Austinlea, 765 Punt Rd, South Yarra | 25.50 | | |
| Smibert, Margaret, 8 Blackfriars Cl, Toorak | 76.50 | | |
| Smith, G W and N R, 1/129 Burns Bay Rd, Lane Cove, NSW | 26.52 | | |
| Smith, Raymond L, 41 Tunstall Sq, East Doncaster | 42.50 | | |
| Snare, Anthony C, 16 Eloise Ave, Hallett Grove, SA | 34.00 | | |
| Spall, James G, Flat 65, 4 Macleay St, Potts Point, NSW | 860.38 | | |
| Stafford, Phillip J, 2 Fts RAAF Base, Pearce, WA | 37.13 | | |
| Standage, Bretel C, 1 Maramanui Way, Mirimar, Wellington, NZ | 30.35 | | |
| Stasiw, Wasyl, 88 Vincent St, Mount Waverley | 10.54 | | |
| Statham, Roslyn M, 14 Hammond St, Mysterton Estate, Townsville, Qld | 85.00 | | |
| Stephenson, Winsome L, 21 Huthwaite St, Wagga Wagga, NSW | 96.56 | | |
| Stuart, Christopher C, 30 Wright Ave, Swanbourne, WA | 42.50 | | |
| Surridge, Josephine, P.O. Box 22, Wellington, NZ | 27.03 | | |
| Swain, Ross B, 5 Harmony Rd, Huntingdon, USA | 28.90 | | |
| Szintal, Peter D, c/o Tedmal Administrators Pty Ltd, 10 Queens St, Melbourne | 188.36 | | |
| Tan, Cheng G, 28 Malcolm Rd, Singapore | 17.86 | | |
| Taylor, Carolyn E, 62 Bruce St, Nedlands, WA | 91.80 | | |
| Temelkovski, Tomislav, 75 Salty St, South Kingsville | 34.00 | | |
| Thackeray, Gail, 55 Wikirwhi Cres, Palmerston North, NZ | 10.92 | | |
| Thackeray, Graham, 55 Wikirwhi Cres, Palmerston North, NZ | 10.92 | | |
| Thackeray, Rosie, 55 Wikirwhi Cres, Palmerston North, NZ | 33.53 | | |
| Thackerton, Donna, 55 Wikirwhi Cres, Palmerston North, NZ | 10.92 | | |
| Thomas Leight Pty Limited, 726 Doncaster Rd, Doncaster | 31.88 | | |
| Thomas, Anthony R, 14 Gladstone Rd, North Brighton, SA | 85.00 | | |
| Thompson, Roger B, 129 Campbell St, Collingwood | 68.00 | | |
| Thornycroft, Robert, 62 Wilson St, North Carlton | 21.26 | | |
| Tim So D M, 158 Dublin Rd, Singapore | 10.70 | | |
| Todoka Pty Limited, c/o 4 Loloma Crt, Burwood | 127.16 | | |
| Todorovski, Svetozar, Flat 4, 214 Dawson St, West Brunswick | 42.93 | | |
| Torrance, Clifford, 183 Muller Rd, Boondall Heights, Qld | 60.02 | | |
| Tretter, Anna M, Hotel Elizabeth Park Alt Aussee Steermark, Austria | 37.14 | | |
| Trust, Betty and A Loréttia, Newman Rd, Wavell Heights, Qld | 45.56 | | |
| Trustray, John R P, c/o Barclays Bank Ltd, 43 South End Rd, London, UK | 19.51 | | |
| Tyler, Henry J, 79 Kellys Rd, St. Albans, Christchurch, NZ | 418.78 | | |
| Umney, Derrick, c/o 109 Northwood Rd, Northwood, NSW | 94.86 | | |
| Von Nida, Edward, c/o E. Von Nida & Co (Qld) Pty Ltd, P.O. Box 173 Clayfield, Qld | 184.12 | | |
| Van Impelen, Helen M G, P.O. Box 22-205 Otahuhu, NZ | 40.34 | | |
| Wadson, Thonda K, 58 Jardine St, Rockhampton, Qld | 51.00 | | |
| Waldie, Ian H, 32 Boundary St, Roseville, NSW | 69.02 | | |
| Walker, Michael A, 6/24 Wilmoth Ave, Murrumbena | 158.19 | | |
| Walter, Kenneth G, 4 Auvergne Ave, Newtown, Tas | 24.66 | | |
| Warne, Peter H, 18 Robert St, Willoughby, NSW | 102.00 | | |
| Warren No, LASF and HS, 2 Lurling St, Maroubra, NSW | 40.80 | | |

Unclaimed Moneys Act 1962

Register of Unclaimed Moneys held by the—

| <i>Name of Owner on Books and Last Known Address</i> | <i>Total Amount Due to Owner</i> | <i>Description of Unclaimed Money</i> | <i>Date when Amount first became Payable</i> |
|--|--|---|--|
|--|--|---|--|

\$

ACI INTERNATIONAL LIMITED—continued

| | | | |
|---|--------|----------|---------|
| Waters, Naomi A, 1 Jean St, Greenacre, NSW | 10.63 | Dividend | 28.2.86 |
| Waters, Wilfred F (estate of), c/o W Carew Hardham & Co, 337 La Trobe St, Melbourne | 47.86 | " | " |
| Wearne, Albert A, 6 Hunter St, Yarralumla, ACT | 34.34 | " | " |
| Webber, Albert R, 1/587 Glenferrie Rd, Hawthorn | 51.00 | " | " |
| West, Sally P, 4/17 Cookes Rd, Windsor Gardens, SA | 68.00 | " | " |
| Whitehorn, Elelore H, 117 Hargrave St, Peterhead, SA | 34.00 | " | " |
| Whiteoak-Smith, Alan K, 11 Dagonet St, Strathmore | 34.00 | " | " |
| Whyte, William F A, 87 Woodhouse Gve, North Box Hill | 132.10 | " | " |
| Wilkinson, Henrietta, 17 Willow Gve, Waipukway, Hawkes Bay, NZ | 10.64 | " | " |
| Williamson, Ann, 6 Claret St, Doveton | 34.00 | " | " |
| Wilson, David L, Yarraman Station, Quirindi, NSW | 31.80 | " | " |
| Wilson, Lawrence F, 5 Asaph Cl, Hornsby Heights, NSW | 10.54 | " | " |
| Wilson, Ian, P.O. Box 956, Banff, Alberta, Canada | 41.62 | " | " |
| Wilson, Kevin F, 107 Calliope Rd, Auckland, NZ | 10.84 | " | " |
| Wing, Barbara M, 11 York Dve, Flagstaff Hill, SA | 46.08 | " | " |
| Winter, Ruth M, 41A Tomes Rd, Christchurch, NZ | 62.44 | " | " |
| Withers, Ian L, 46 Middle Cres, Middle Brighton | 17.00 | " | " |
| Wong, Stephen, 15 William St, Roseville, NSW | 17.00 | " | " |
| Woolcock, Neil, 14 Vera St, South Oakleigh | 42.50 | " | " |
| Zannis, Con, 144 Williams St, Norwood, SA | 38.08 | " | " |

6895

WESTERN MINING CORPORATION HOLDINGS LTD

| | | | |
|--|--------|----------|---------|
| Abbadini, Santo, 70 McDonald St, Kalgoorlie, WA | 14.00 | Dividend | 2.12.85 |
| Aitken, James K, 194 Wattle St, Bendigo | 31.04 | " | 13.5.85 |
| Akeroyd, Christopher J, 4 Darmody St, Weetangera, ACT | 14.20 | " | " |
| Alcock, Amanda, 34 Eastview Rd, Church Point, NSW | 11.04 | " | 2.12.85 |
| Aliaz, Shlomo, c/o Raymond K Elias, 70/29 Main St, Kew Garden Hills, New York, USA | 153.00 | " | 13.5.85 |
| Annear, Ian A, PO Box 58, Lucindale, SA | 30.00 | " | " |
| Argyle, Albert E, 24 Hillcrest Dve, Union Missouri, USA | 39.78 | " | " |
| Arvidson, Lawrence J, 36 Sasse Ave, Bayswater | 14.00 | " | " |
| Ayers, Frank and Helen, Yen San Building, 268 Orchard Rd, Singapore | 16.32 | " | " |
| Bannanlyne, Elizabeth A, 28 Grandview Ave, Wagga Wagga, NSW | 11.04 | " | 2.12.85 |
| Banos, James, SR3 Box 3109, Iron Mountain, Michigan, USA | 10.20 | " | " |
| Barbera, Maria R, 2/5 East Crescent St, McMahons Point, NSW | 38.64 | " | " |
| Barnett, Madeline S, 104 Thompson Rd, Napier, NZ | 14.96 | " | " |
| Baron, John, c/o Nathan Baron, 613 Toorak Rd, Toorak | 228.78 | " | 13.5.85 |
| Barratt, Brett J, 68 Pine Ave, Nova Gardens, SA | 13.20 | " | 2.12.85 |
| Barrie, Lynette B, 3 Glebe Ave, Cheltenham | 42.00 | " | 13.5.85 |
| Barry, Jeffrey, 113 Studley Rd, Heidelberg | 20.00 | " | " |
| Bates, Robin E, 3-14-26 Hiroo Shibuya KU, Tokyo, Japan | 17.00 | " | 2.12.85 |
| Beddoes, Ann L, 142 Beecroft Rd, Beecroft, NSW | 24.74 | " | 13.5.85 |
| Bedgood, Peter H, Lot 29 Angus Ave, East Ringwood | 11.04 | " | 2.12.85 |
| Belcredi, Marie, 66 Simmat Ave, Condell Park, NSW | 72.00 | " | 13.5.85 |
| Bell, Steven, 167 Wigram Rd, Glebe, NSW | 30.00 | " | " |
| Bensemman, Erle W, 119A Rugby St, Christchurch, NZ | 16.32 | " | " |

Unclaimed Moneys Act 1962

Register of Unclaimed Moneys held by the—

| <i>Name of Owner on Books and Last Known Address</i> | <i>Total Amount Due to Owner</i> | <i>Description of Unclaimed Money</i> | <i>Date when Amount first became Payable</i> |
|---|--|---|--|
| \$ | | | |
| WESTERN MINING CORPORATION HOLDINGS LTD— <i>continued</i> | | | |
| Benson, Joseph E, 1328 Leighton Rd, Peterborough, Ontario, Canada | 33.66 | Dividend | 13.5.85 |
| Berns, Beryl E M, and Peter W McGee, c/o 8-18 Bent St, Sydney, NSW | 69.00 | " | " |
| Black, Anthony R, c/o Utah Development, 266 Hay St, Subiaco, WA | 12.00 | " | 2.12.85 |
| Boaz, Robert C, PO Box 146, Dana Point, California USA | 10.20 | " | " |
| Booth, Malcolm J, 7/42 Cliff Rd, Wollongong, NSW | 24.00 | " | " |
| Bracken, Simon W, 1 Molong St, Curl Curl North, NSW | 16.00 | " | " |
| Bradbury, Peter, 285 Forest Rd, Hurstville, NSW | 11.04 | " | " |
| Brookfield, Muriel, c/o Dept Human Geography, RS PAC S ANU, GPO Box 4, Canberra, ACT | 21.00 | " | " |
| Brosnan, Kevin G, Flat 3 391 South Rd, Brighton South | 14.40 | " | " |
| Brown, Donald F, Jnr with Mr Bhaguanjee Bhula Rama, 18 Fyvie Ave, Linden Wellington, NZ | 48.96 | " | " |
| Brown, Patricia R, PO Box 2246, Cairns, QLD | 68.28 | " | " |
| Brown, Stanley B, c/o Turner Hopkins & Co, PO Box 1627, Auckland, NZ | 10.20 | " | 13.5.85 |
| Brunstrom, Betty G, c/o Tracey Brunstrom & Hammond Pty Ltd, 20 Bank Pl, Melbourne | 43.20 | " | 2.12.85 |
| Buchanan, Andrew J C, 509 Glenferrie Road, Hawthorn | 33.12 | " | " |
| Buckley, Edwin D, with Isabel Buckley and Errol M Gordon, Box 140 Bordertown, SA | 55.20 | " | " |
| Buckley, Keith, PO Box 55, Cottesloe, WA | 17.60 | " | " |
| Burrows, Noel A, 86 Yabba St, Ascot | 13.80 | " | 13.5.85 |
| Burton, Donald J, 13 Victoria Ave, Claremont, WA | 13.00 | " | 2.12.85 |
| Busch, Neville J G, 66 Anzac Pde, Toronto, NSW | 10.00 | " | 13.5.85 |
| Callan, Terence and Desmond, PO Box 60, Belmont | 59.76 | " | 2.12.85 |
| Camalich, Eleen G, Il Poggio, 46 Corso Cuneo, S Margherita Ligure, Prov Di Genoa, Italy | 37.80 | " | 13.5.85 |
| Campbell, Ray, PO Box 5295, Fort Worth, Texas 76108, USA | 71.40 | " | 2.12.85 |
| Canty, Vincent, c/o Dr A Canty, Wickham House, 155 Wickham Tce, Brisbane, QLD | 60.00 | " | " |
| Cargill, Thomas, Maple House, Rue De Lavista, St Lawrence, Jersey | 19.44 | " | 13.5.85 |
| Carman, George, 5 Essex Ct, The Temple, London | 22.10 | " | 2.12.85 |
| Carroll, Geoffrey R, PO Box 31, Laverton, WA | 10.04 | " | " |
| Carroll, John L and Diana J, 254 La Perouse St, Red Hill, ACT | 18.72 | " | " |
| Carter, Margaret E, 434 Como Pde, Mordialloc | 36.00 | " | " |
| Cassidy, Kevin, 10 Haig St, Burwood | 11.88 | " | " |
| Cestaro, Corrado, 43 Rickard Rd, Strathfield | 19.20 | " | 15.5.85 |
| Chan, Bing Fun, 110 Austin Rd, 2/F Kowloon Hong Kong | 25.34 | " | 2.12.85 |
| Chapman Hay Ltd, 37 Park St, South Melbourne | 20.00 | " | " |
| Chatham Pastoral Co Pty Ltd, Flat 4, 113 Darling Point Rd, Darling Point, NSW | 10.00 | " | " |
| Chaytor, Anthony D C, Marshlands Blenheim, RD 3 NZ | 10.20 | " | " |
| Chen, Keng Beng, c/o Bank of NSW 60 Martin Pl, Sydney, NSW | 60.00 | " | " |
| Cheung, Ned W, 2 Pillars Pl, Matraville, NSW | 36.00 | " | " |
| Chong-Kwan, Liliane, 1145 Osborne Ave, Verdun, Canada | 21.66 | " | 2.12.85 |
| Christophers, Dorothy, 170 Joseph Banks Dve, Kings Langley, NSW | 23.76 | " | " |
| Chua, Gladys L, 2 Jalan Penggawa (off Jalan U Thant), Kuala Lumpur, Malaysia | 40.80 | " | " |
| Citinational Nominees Pty Limited, 1 Margaret St, Sydney, NSW | 11.04 | " | " |
| Clark, Alexander M, 2 Kurrajong La, Kambalda, WA | 21.84 | " | " |

Unclaimed Moneys Act 1962

Register of Unclaimed Moneys held by the—

| Name of Owner on Books and Last Known Address | Total Amount Due to Owner | Description of Unclaimed Money | Date when Amount first became Payable |
|--|------------------------------------|--------------------------------------|--|
| \$ | | | |
| WESTERN MINING CORPORATION HOLDINGS LTD— <i>continued</i> | | | |
| Clark, Ian M, c/o L. J. Clark, 8 Braeside St, Launceston, Tas | 28.56 | Dividend | 2.12.85 |
| Clifton, Jennifer, 14 Curtin La, North Adelaide, SA | 180.00 | " | " |
| Clinkscale, Martin M, Flat A/384 Toorak Rd, South Yarra | 16.00 | " | " |
| Cocks, Donald (estate of), c/o John J Austin, 12th Floor, Wynyard House, 291 George St, Sydney, NSW | 73.44 | " | " |
| Collins, Marie A, Flat 1/4 Maylands Ave, North Balwyn | 11.00 | " | " |
| Condon, Gweneth D, 20 Monaro Rd, Kooyong | 105.58 | " | 13.5.85 |
| Coogan, Clive K, 15 Irlbarra Rd, Canterbury | 37.60 | " | 2.12.85 |
| Cook, Graeme E and Cicely A, 6 Osborne St, Cooe, Tas | 11.04 | " | " |
| Cooper, Maureen K, 35 Arthur St, Wellington, NSW | 12.00 | " | " |
| Cooper Park Apartments Pty Ltd, Suite 922, Manchester Unity Building, 160 Castlereagh St, Sydney, NSW | 19.20 | " | " |
| Corcoran, Owen F, 11 Burke St, Blaxland, NSW | 20.00 | " | " |
| Corke, Dennis, 61 Barmah St, Mt Eliza | 34.50 | " | 13.5.85 |
| Cox, George P, 97 Splatt St, Swan Hill | 44.16 | " | 2.12.85 |
| Craig, David R, 15 Torrington Rd, Strathfield | 16.56 | " | " |
| Cranford, Roland, 20 52nd St, Gulfport, Mississippi, USA | 10.61 | " | " |
| Crompton, Annemarie, 104 Brougham Pl, North Adelaide, SA | 14.24 | " | 13.5.85 |
| Cropley, Graeme H, 156 Amelia St, Toronto, Canada | 20.44 | " | 2.12.85 |
| Croudis, Betty, Harrisville R, RD2, Pukekohe, NZ | 22.51 | " | " |
| Cuthbert, William B, 20 Abercorn Rd, Forrestfield, WA | 24.00 | " | " |
| D. G. Moore & Associates Pty Limited, 86A Grant St, Cottesloe, WA | 14.40 | " | " |
| Dadlani, Harkishin L, 313 North Bridge Rd, Singapore | 51.00 | " | 13.5.85 |
| Dass, Dwarka, 9 Simson Pl, Kambah, ACT | 12.00 | " | " |
| Davenport, Poppy K, 2 Minnow Dve, Glenalta, SA | 12.00 | " | 2.12.85 |
| Davies, Joy, c/o John J. Hilton Pty Limited, 253 Parramatta Rd, Broadway, NSW | 69.00 | " | 13.5.85 |
| Davison Farm Enterprises, Pty Ltd, c/o Packham Tavani & Associates, PO Box 354, West Perth, WA | 48.00 | " | " |
| Delfin Securities Pty Limited, No. 2 Acc, 16 O'Connell St, Sydney, NSW | 40.00 | " | 2.12.85 |
| Dewhurst, Roger H, PO Box 2142, Rotorua, NZ | 26.93 | " | " |
| Diaz, Jose V, 3/5 Abbott St, Coogee, NSW | 12.00 | " | " |
| Dick, Mary L, 37 Shadforth St, Mosman | 13.14 | " | 13.5.85 |
| Dickinson, Jack, 229 New Rd, Middlestown UK | 20.40 | " | " |
| Dinon, Dino, PO Box 802, Main Office, Youngstown, Ohio, USA | 38.25 | " | " |
| Dixon, Oliver F, 40A View St, Peppermint Grove, WA | 27.60 | " | 2.12.85 |
| Dowling, Dianne B, PO Box 118, Collingwood | 20.00 | " | 13.5.85 |
| Doyle, Alexandra, 15 Burrabirra Ave, Vaucluse, NSW | 19.20 | " | " |
| Doyle, James, 15 Burrabirra Ave, Vaucluse, NSW | 19.20 | " | " |
| Doyle, Joanna, 15 Burrabirra Ave, Vaucluse, NSW | 19.20 | " | 13.5.85 |
| Dranreb Holdings Sdn Bhd; 3rd Floor Wisma Socfin, Jalan Semantan, Damansara Heights, Kuala Lumpur 23-03 Malaysia | 61.20 | " | 2.12.85 |
| Dubois, Leonie, 9/94 Alfred St, Milsons Point, NSW | 11.04 | " | " |
| Duffy, Charles A, 1 Vivian St, Boulder, WA | 12.00 | " | " |
| Dunn, Joyce L, 6 Almond Gve, Brighton, SA | 20.00 | " | " |
| Duxbury, Judith M, 12 Rydal St, Hoon Hay, Christchurch, NZ | 11.67 | " | " |
| Dyball, Pamela J, 18 Darwin St, Carlingford, NSW | 11.04 | " | " |
| Easterbrook, Stella, 5 Barbara St, Box Hill North | 26.48 | " | 13.5.85 |
| Edan Pty Limited, c/o S M Munnings c/o Regency Travel 6/263 Alfred St, North Sydney, NSW | 97.50 | " | " |

Unclaimed Moneys Act 1962

Register of Unclaimed Moneys held by the—

| Name of Owner on Books and Last Known Address | Total Amount Due to Owner | Description of Unclaimed Money | Date when Amount first became Payable |
|--|------------------------------------|--------------------------------------|--|
| \$ | | | |
| WESTERN MINING CORPORATION HOLDINGS LTD— <i>continued</i> | | | |
| Edgeworth, Neville R, PO Box 5608, Wellesley St, Auckland, NZ | 76.95 | Dividend | 2.12.85 |
| Elek, Anthony P, Flat 4, 179 Kennigo St, Springhill, Qld | 11.04 | " | " |
| Ephraums, Anandi M, 20 Torino St, Zillmere, Qld | 10.00 | " | 13.5.85 |
| Equity Holdings Pty Limited, c/o 626 Bourke St, Melbourne | 13.80 | " | 2.12.85 |
| Evans, Maldwyn, Grove Cottage, Pickering St, Loose NR Maidstone, Kent, UK | 13.71 | " | " |
| Evans, Mary A, 2 Hunter Rd, Wimbledon London, UK | 13.60 | " | 13.5.85 |
| Fack, John R, Ashley Cottage, 27 Fairfield Rd, Montpelier Bristol, UK | 17.00 | " | " |
| Fairfoul, Albert Mc B (estate of), c/o Russell N Boughton with John W N James, 400 Little Collins St, Melbourne | 100.00 | " | 2.12.85 |
| Fancourt, Dr Michael W and Robin F, Noradene, 85 Vivian St, New Plymouth, NZ | 16.39 | " | " |
| Faulkner, Wilfred L, 16 Gibraltar Dve, Isle of Capri, Qld | 13.80 | " | " |
| Fenton, William J J, 36 Cordelia St, South Brisbane, Qld | 41.40 | " | 13.5.85 |
| Findlay, David, 30 Parkhill Rd, Howick, Auckland, NZ | 11.26 | " | 2.12.85 |
| Firmager, Jennifer R, "Roughters" Watermill La, Icklesham Winchelsea, East Sussex, UK | 14.08 | " | 13.5.85 |
| Fletcher, Nigel J, 3 Helmet Row, London, UK | 17.00 | " | " |
| Forbes, Anne M, 13 Marine St, Somerton Park, SA | 36.00 | " | " |
| Foster, Brian, 17 Woolcott Ave, Wahroonga, NSW | 14.00 | " | " |
| Fox, George A, 331 Buderim Garden Village, Mooloolaba Rd, Buderim, Qld | 20.00 | " | 2.12.85 |
| Fraser, Neil A, Elgin Takamatua, Akaroa, NZ | 58.65 | " | " |
| Freymark, Sylvia, 5 Brett Ct, Port Augusta West, SA | 12.00 | " | " |
| Frost, Brian J, Flat 6, 29 Coogee St, Randwick, NSW | 12.00 | " | " |
| Gaston, Fiona, Nee Smith "Ballymena" Booroorban, NSW | 11.04 | " | " |
| Gaston, John R, "Ballymeena" Booroorban, NSW | 48.00 | " | " |
| Gay, Keith, Unit 4, 14 York St, Coorparoo, Qld | 25.80 | " | " |
| Gay, Keith, and Adams, John D, c/o United Investment Club, 4/14 York St, Coorparoo, Qld | 38.40 | " | " |
| Gentles, Alison M, 9 Seaview Rd, Remuera, Auckland, NZ | 82.11 | " | " |
| Gentles, Dorothy C, 9 Seaview Rd, Remuera, NZ | 41.06 | " | 13.5.85 |
| Geraghty, Margaret M, Morris Towers, 149 Wickham Tce, Brisbane Qld | 14.40 | " | 2.12.85 |
| Geraghty, James S, 8/59 Howard St, Randwick, NSW | 33.12 | " | " |
| Gilder, Catherine, Glenfallach, Licola | 20.00 | " | 13.5.85 |
| Gillingham, Diana M, Flat 8, 128 Glenhuntly Rd, Elwood | 10.00 | " | 2.12.85 |
| Giustino, David A, Flat 5, 26 Simpsons Rd, Bardon, Qld | 12.00 | " | " |
| Glendinning, Donald S, 3 Chippendale Cres, Palmerston North, NZ | 18.30 | " | " |
| Golinger, Mark P, 38 Learoyd St, Mount Lawley, WA | 12.00 | " | 13.5.85 |
| Gopal, Nicky, PO Box 3184, Darwin, NT | 12.00 | " | 2.12.85 |
| Gorr, Janet, Flat 2, Toolanba Rd, Mooroopna | 10.00 | " | 13.5.85 |
| Gould, George, 98 Piesse St, Boulder, WA | 11.04 | " | " |
| Grabbe, Robin, PO Box 192, Mount Magnet, WA | 34.56 | " | " |
| Graham, Charles E, The Paddock, Kinsale, Co Cork, Eire | 28.98 | " | " |
| Gray, Juliet, 7 Ashley Gve, Malvern | 67.50 | " | " |
| Green, Rosemary J, 4 Johnson Ave, Armidale, NSW | 11.40 | " | 2.12.85 |
| Green, Vera M, Box 1287, GPO Brisbane, Qld | 55.56 | " | 13.5.85 |
| Greenwood, Nicholas J, 11/25 Thirza St, Mitchell Park, SA | 10.00 | " | " |
| Grinston, Michael, c/o Michael Grinston, Sudek & Co, 155 King St, Sydney, NSW | 24.00 | " | " |

1200 G 19 20 May 1987

Victoria Government Gazette

Unclaimed Moneys Act 1962

Register of Unclaimed Moneys held by the—

| Name of Owner on Books and Last Known Address | Total Amount Due to Owner | Description of Unclaimed Money | Date when Amount first became Payable |
|---|------------------------------------|--------------------------------------|--|
| § | | | |
| WESTERN MINING CORPORATION HOLDINGS LTD— <i>continued</i> | | | |
| Groves, Peter D, 5 Brett Crt, Port Augusta West, SA | 12.00 | Dividend | 2.12.85 |
| Gupta, Bina, 26 Wentworth Rd, Vaucluse, NSW | 11.05 | " | 13.5.85 |
| Hagan, Marion, 52 Boronia Ave, Cheltenham, NSW | 20.00 | " | 2.12.85 |
| Haites, Binnert R, 32 Cairn Rd, Aberdeen, Scotland | 12.24 | " | " |
| Hakala, Esa, PO Box 989, Darwin, NT | 33.12 | " | 13.5.85 |
| Hall, Mervyn, 69 Ranelagh Cres, South Perth WA | 13.80 | " | 2.12.85 |
| Halstead, Kathleen G, Box 5965, Boroko, PNG | 17.00 | " | " |
| Hamilton, Richard A, 84 Wittenoom St, Kalgoorlie, WA | 15.60 | " | " |
| Harrington, Brian F, 17 Park St, Clovelly, NSW | 16.08 | " | " |
| Harris, Robin, PO Box 32, Seville | 48.30 | " | 13.5.85 |
| Hart, Nicholas and Eva, Flat 2, 275 Edgecliff Rd, Woollahra, NSW | 24.00 | " | " |
| Hartnett, Fiona M, 18 Hornsby St, Malvern | 10.00 | " | " |
| Hartshorne, Greg T and Dianne Y, 28 Gears Ave, Drummoyne, NSW | 20.00 | " | 2.12.85 |
| Harvey Drew Pty Limited, 21 Binda Pl, Sorrento, Surfers Paradise, Qld | 120.00 | " | 13.5.85 |
| Hedigan, Helen M, Springfields, Rosehill Rd, Lower Plenty | 11.20 | " | 2.12.85 |
| Hellein, Reginald H, Unit 5, 10 Avonmore Tce, Mosman Park, WA | 10.00 | " | 13.5.85 |
| Herden, Richard A, PO Box 623, Toowoomba, Qld | 28.80 | " | 2.12.85 |
| Herlisha Pty Ltd, c/o Neal & Partners, 5th Floor, 160 Clarence St, Sydney, NSW | 34.60 | " | " |
| Hesketh, Robert W, Haselgrove, Colin P (estate of) and Auld, Michael, c/o Stevens Searcy Hill & Co, 191 Flinders St, Adelaide, SA | 19.20 | " | " |
| Hill, Mabel A, Flat 4, 4 Yarra St, Hawthorn | 27.60 | " | " |
| Hird, Joan M, c/o Department of Trade, Edmund Barton Building, Kings Ave, Canberra, ACT | 15.00 | " | " |
| Holm, Alexander B, 9 Walbeck Rd, Kalamunda, WA | 17.52 | " | 13.5.85 |
| Holyoak, Harry C (estate of), c/o Jean S Holyoak, 5 Waterdale Rd, Ivanhoe | 30.00 | " | " |
| Hope, Gerda, 2344 Maria-Enzersdorf, Donaustasse 108/7, Vienna, Austria | 28.00 | " | 2.12.85 |
| Hopkins, David E, Gary L and Steven E, PO Box 341, Auburn, USA | 29.35 | " | " |
| Horsley, Emily W, PO Box 656, Tamworth, NSW | 72.66 | " | 13.5.85 |
| Horvat, Karl, 21 Beaumont Cl, Chapman, ACT | 10.60 | " | 2.12.85 |
| Hubbard, Frederick T, c/o McIntosh Griffin Hamson Wallace Smith & Co, 360 Collins St, Melbourne | 96.00 | " | " |
| Hudson, Peter R and Graeme A, 20 Fermoy Ave, Bayview, NSW | 48.00 | " | 2.12.85 |
| Hunt, Christopher B, c/o M E Thomas, 50 Wellington Sq, North Adelaide, SA | 30.00 | " | 13.5.85 |
| J N I Investments Pty Ltd, c/o T P Fowler, GPO Box 2449, Adelaide, SA | 28.06 | " | " |
| Jackson, Murray E, PO Box 876, Sale | 36.00 | " | " |
| Jacon Nominees Pty Ltd, c/o G Gayland, 90 Maude St, Shepparton | 144.00 | " | 2.12.85 |
| Johnson, George R, PO Box 198, Collins St, Melbourne | 13.24 | " | 13.5.85 |
| Jollow, Frederick C, 217 Burwood Rd, Burwood, NSW | 12.96 | " | " |
| Jones, Albion B, 200 Gilbert St, Adelaide, SA | 66.00 | " | " |
| Jordan Holdings Pty Ltd, c/o Maurico Secretarial Services, 3rd Floor, 400 Lonsdale St, Melbourne | 49.08 | " | " |
| Kalb, Bernard, c/o CBS News, Flat 3A, 2 Kennedy Tce, Hong Kong | 11.20 | " | 2.12.85 |
| Kater, Evelyn, Mumblebone, Warren, NSW | 11.04 | " | 13.5.85 |
| Keating, Geoffrey R, Saiala, Quambone, NSW | 11.04 | " | 2.12.85 |
| Keleher, Thomas H, c/o J Greathead, 296 Buckland Rd, Wavell Heights, Qld | 11.04 | " | " |

Unclaimed Moneys Act 1962

Register of Unclaimed Moneys held by the—

| <i>Name of Owner on Books and Last Known Address</i> | <i>Total Amount Due to Owner</i> | <i>Description of Unclaimed Money</i> | <i>Date when Amount first became Payable</i> |
|---|--|---|--|
| \$ | | | |
| WESTERN MINING CORPORATION HOLDINGS LTD— <i>continued</i> | | | |
| Keller, Victoria, c/o Robert B Elliott, 4th Floor, 71 Archer St, Chatswood, NSW | 37.20 | Dividend | 13.5.85 |
| Kelly, Gordon R, 2 Saltbush Rd, Kambalda West, WA | 42.76 | " | 2.12.85 |
| Kelly, Winifred L and John R, 6/209 Kooyong Rd, Toorak | 2020.00 | " | " |
| Keynes, June S, Curbur Station, via Mullewa, WA | 12.00 | " | 13.5.85 |
| Khan, Saeed Ullah, PO Box 72, Farrer Road Post Office, Singapore | 14.08 | " | 2.12.85 |
| Kimmel, Keith W, 6037 Fox Chase Trail, Shreveport, Louisiana, USA | 10.65 | " | 13.5.85 |
| Kingsland, Kathleen J, 36 Vasey Cres, Campbell, ACT | 96.08 | " | 2.12.85 |
| Knight, Christopher N, "Tannabah", Coonabarabran, NSW | 17.60 | " | " |
| Koedyk, Francis M and Ruth J, 79B Bluebush Rd, Kambalda, WA | 30.00 | " | 13.5.85 |
| Kolyos, Nicholas, 1252 11St Apt 101, Santa Monica, California, USA | 161.99 | " | " |
| Kong, Claire, c/o Bobby Kong, 126 Lancaster Dve, St Louis, Mo, USA | 18.77 | " | 2.12.85 |
| Kwei, Ling, 29 Savaris Crt, Donvale | 10.00 | " | 13.5.85 |
| Kwo, Seng M, Flat A 5th Floor, 303 Prince Edward Rd, Kowloon, Hong Kong | 94.13 | " | " |
| Kwok, Philip C, Wing On Life Assurance Company, 2nd Floor, Wing On Life Building, Des Voeux Rd, Central Hong Kong | 24.50 | " | " |
| Lads Investment Co Pty Ltd, Nelson Rd, Lilydale | 40.00 | " | 2.12.85 |
| Lahey, Mary (estate of), c/o 26 Branch Ave, Fig Tree, NSW | 15.40 | " | " |
| Lau, Ting W (estate of), c/o Betty B Lau, 220 Blackburn Rd, Doncaster East | 33.12 | " | 13.5.85 |
| Lau, Yu M, Braemar Hill Mansions, 23 Braemar Hill Rd, 9th Floor Flat A, North Point, Hong Kong | 14.00 | " | 2.12.85 |
| Lavin, James, PO Box 60 Coober Pedy, SA | 40.00 | " | 13.5.85 |
| Lawson, Dora G, 10 Elizabeth Rise, Castletown, Isle of Man | 64.40 | " | 2.12.85 |
| Le Mercier, Emile, 151 E Kings Rd, 02-19 Farrer Crt, Singapore | 20.40 | " | " |
| Lee, Dr Joseph, 1st Floor, 245 Forest Rd, Hurstville, NSW | 15.24 | " | 13.5.85 |
| Leigh, Dr Noel P, c/o National Westminster Bank, Chancery Lane & Holborn Branch, 332 High St, Holborn, London, UK | 11.43 | " | 2.12.85 |
| Lester, Robert G, Nyang South Rd, Torrita | 27.60 | " | " |
| Levis, Richard A, Box 101, Bairnsdale | 11.52 | " | " |
| Lewis, Karen, 32 Russell St, Cleveland, Qld | 40.00 | " | " |
| Liew, Teck F, 6/101 Desa Aman, Jalan Cheras, Kuala Lumpur, Malaysia | 10.08 | " | 2.12.85 |
| Lightbourn, Michael E, PO Box 4039, Nassau, Bahamas | 11.20 | " | " |
| Lillicrap, Norma E, (estate of), c/o P W Lillicrap, 136 Sexton St, Ekibin, Qld | 12.00 | " | " |
| Lipschutz, Eugenie, 13 Howard St, Homebush, NSW | 29.50 | " | 13.5.85 |
| Little, Alan N, 6 Oroya St, Kalgoorlie, WA | 40.26 | " | " |
| Little, Archibald, Patons Rd, Hope, Nelson, NZ | 40.40 | " | 2.12.85 |
| Little, Archibald, Patons Rd, Hope, Nelson, NZ | 20.20 | " | 13.5.85 |
| Lloyd, Roberta J, 1-26-7 Minami Azabu, Minato-Ku, Tokyo 106, Japan | 15.30 | " | 2.12.85 |
| Long, Adrian L, 14 Longstaff St, Lyneham, ACT | 12.00 | " | " |
| Lowe, Lolita J, 32 Anderson Rd, East Hawthorn | 41.10 | " | 13.5.85 |
| Luscombe, Lucia L, 14 Richmond Avenue East, St Ives, NSW | 49.68 | " | " |
| Lynch, Peter E, 12 Pictavia St, Toowong, Qld | 14.40 | " | 2.12.85 |
| Ma, Leong-on, PO Box K149, Kowloon Central PO, Hong Kong | 14.00 | " | " |
| Mac's Pty Ltd, 33 Rohini St, Turramurra, NSW | 274.00 | " | 13.5.85 |
| MacDonald, John D, Sub-Editors, The Star, Shortland St, Auckland, NZ | 13.60 | " | 2.12.85 |

1202 G 19 20 May 1987

Victoria Government Gazette

Unclaimed Moneys Act 1962

Register of Unclaimed Moneys held by the—

| <i>Name of Owner on Books and Last Known Address</i> | <i>Total Amount Due to Owner</i> | <i>Description of Unclaimed Money</i> | <i>Date when Amount first became Payable</i> |
|---|--|---|--|
| \$ | | | |
| WESTERN MINING CORPORATION HOLDINGS LTD— <i>continued</i> | | | |
| Machado, Anthony L, and Quinie J, 5 Bowater Cl, Wahoonga, NSW | 62.80 | Dividend | 13.5.85 |
| MacKenzie, Colin D, c/o Department of Foreign Affairs, Administrative Buildings, Parkes, ACT | 13.24 | " | 2.12.85 |
| MacKenzie, Robert, c/o Ian Thorpeolo, 6th Floor, 185 Elizabeth St, Sydney, NSW | 90.00 | " | 13.5.85 |
| MacLaurin, Barbara A, "Petwyn Vale", Wingen, NSW | 57.60 | " | 2.12.85 |
| Mahlstedt, Leslie R, 422 Collins St, Melbourne | 14.80 | " | " |
| Maluna Investments Pty Ltd, 13 Undelcarra Rd, Burnside, SA | 324.52 | " | " |
| Mandl, Kamilla, 3 Boden Ave, Strathfield, NSW | 63.48 | " | " |
| Manning, Lorna E, Flat 5, 166 New South Head Rd, Edgecligg, NSW | 33.00 | " | 13.5.85 |
| Manton, Marion L, 20 College St, Balmain, NSW | 15.84 | " | 2.12.85 |
| Marchant, Mary T, 56 Hawken Dve, St Lucia, Qld | 10.08 | " | " |
| Mashburn, Mandel L, 11180 Windrow Dve, Eden Prairie, Minnesota 55344, USA | 35.19 | " | 13.5.85 |
| Mason, Lorna E, 8 Middle Rd, Camberwell | 20.00 | " | " |
| Matchett, Richard L, Talbingo, NSW | 30.48 | " | " |
| Maurey, Kenneth L, PO Box 719, Carson City, Nevada 89702, USA | 34.00 | " | 2.12.85 |
| Mavromattes, Kathleen and Maria, 139 New South Head Rd, Vaucluse, NSW | 16.56 | " | " |
| Mayer, Franz, PO Box 1160, Boroko, PNG | 111.44 | " | 13.5.85 |
| McRae Investments Pty Ltd, 96 Pymont Bridge Rd, Camperdown, NSW | 74.22 | " | " |
| McAlister, Gweneth D, 20 Monaro Rd, Kooyong | 13.20 | " | 2.12.85 |
| McAuliffe, PO Box 2, Kambalda, WA | 12.00 | " | " |
| McCarthy, Margaret M, 26 Myrtle St, Murillumbah, NSW | 14.40 | " | " |
| McCarthy, Rosanne M, 55 Clifton Hill, St Johns Wood, London NW8 0JN, UK | 16.32 | " | 13.5.85 |
| McCormack, Ann D, 7 Michael St, North Fitzroy | 13.76 | " | 2.12.85 |
| McDonald, Hector L, 28 Hourigan Ave, Clayton | 47.52 | " | " |
| McNamara, Kevin F, PO Box 11, Wundowie, WA | 11.04 | " | " |
| McNeil, Terry, 193 Capricorn, Ave, Paraburdoo, WA | 30.00 | " | 13.5.85 |
| McNicoll, Ruth, Flat 7, 52 Pasley St, South Yarra | 138.00 | " | 13.5.85 |
| Mensink, Margaret, PO Box 274, Warragul | 55.98 | " | " |
| Merrindav Pty Ltd, 25 Norfolk Rd, Longueville, NSW | 69.00 | " | " |
| Milner, Noel R, GPO Box 2322, Adelaide, SA | 15.08 | " | 2.12.85 |
| Molony, Charles, Ave Des Tilleuls 8, Brussels 1180, Belgium | 38.25 | " | 13.5.85 |
| Momberger, Adolf, c/o Civil Aviation Agencies, Konedobu, Papua New Guinea | 17.00 | " | " |
| Moore, George W, 133 Labouchere Rd, Como, WA | 12.00 | " | " |
| Moore, Vera, c/o Alfred T Day & Co, 327 Collins St, Melbourne | 201.24 | " | 2.12.85 |
| Morgan, Colleen W, 40 Wattle Valley Rd, Canterbury | 192.00 | " | " |
| Morgan, David, 15 Chisholm Ave, Burnside, SA | 48.00 | " | " |
| Morgan, Kenneth F, PO Box 107, Palm Beach, Qld | 25.20 | " | 13.5.85 |
| Morris, Evan B and Jill, M S 889, Dalby, Qld | 20.00 | " | " |
| Morrow, Ewan C, Wakere, No 8 R D, Ashburton 8300, NZ | 25.50 | " | " |
| Mortiss, Rita, 511 Honour Ave, Sherwood, Qld | 12.00 | " | 2.12.85 |
| Munn, Paul R and Aileen F, 29 Broadway, South Brighton, SA | 32.00 | " | " |
| Murrinui Pty Ltd, c/o E J Whitehead Leighton & Co, 20 Loftus St, Sydney, NSW | 48.00 | " | " |
| Mustey, Haydn M, Old Gippsland Rd, Lilydale | 464.00 | " | " |
| Nagano, Setsu, 34 4 4 Chome, Matsubara Setagaya KU, Tokyo, Japan | 28.73 | " | 13.5.85 |
| Nanayakkara, Asoka, 8/13 Drummond St, Belmore, NSW | 10.00 | " | " |

Unclaimed Moneys Act 1962

Register of Unclaimed Moneys held by the—

| Name of Owner on Books and Last Known Address | Total Amount Due to Owner | Description of Unclaimed Money | Date when Amount first became Payable |
|--|------------------------------------|--------------------------------------|--|
| \$ | | | |
| WESTERN MINING CORPORATION HOLDINGS LTD—continued | | | |
| Newton, Suzanne R, 21 Darley St, Forestville, NSW | 40.80 | Dividend | 13.5.85 |
| Ng, James P, 88 Ramsay St, Haberfield, NSW | 32.00 | " | 2.12.85 |
| Nicholas, Carol O, 2 Frethey Gve, Nae Nae, Lower Hutt, NZ | 93.84 | " | " |
| Nichols, Cyril, PO Box 91, 86-88 Sekama Rd, Kuching, Sarawak Malaysia | 19.55 | " | " |
| Nienaber, Janet H, c/o Moffat, 27 Allen Dve, Mount Eliza | 165.60 | " | " |
| Norase Pty Limited, 26 Montague Rd, Cremorne, NSW | 17.44 | " | 13.5.85 |
| Northey, Peter J, 121 Purpur Ave, Lake Illawarra, NSW | 14.40 | " | 2.12.85 |
| Norton, Judith A, 2 Dalwood Crt, Rosslyn Park, SA | 24.00 | " | 13.5.85 |
| O'Brien, Judith M, 10 View St, Hawthorn | 16.00 | " | 2.12.85 |
| O'Brien, Phillip W, Flat 11, 7 Mooltan St, Flemington | 39.60 | " | 13.5.85 |
| O'Keefe, Brian, 27 Leura Gve, Hawthorn | 46.00 | " | 2.12.85 |
| O'Neill, Dermot J, 17/693 Malvern Rd, Toorak | 74.64 | " | 13.5.85 |
| Ogilvy, Cheryl P, 6 Hislop St, Keilor | 60.00 | " | " |
| Olsson, Anthony S, 133 Park St, South Melbourne | 17.24 | " | " |
| Ong, Charmaine, 7 Cairns St, Riverwood, NSW | 90.24 | " | 2.12.85 |
| Opic, Paul, 7 Brigalow St, O'Connor, ACT | 28.80 | " | " |
| Opik, Hilja, 7 Brigalow St, O'Connor, ACT | 38.40 | " | " |
| Orny, Roland, 44 Warrawong St, Wagga Wagga, NSW | 22.08 | " | " |
| Oztukel, Nihal, c/o Woodside Petroleum, 77 St George's Tce, Perth, WA | 36.00 | " | 13.5.85 |
| Pacey, Maureen E, 18 Sandalwood St, Blackwater, Qld | 108.00 | " | " |
| Packer, John S, c/o The Manager, ANZ Banking Group Ltd, 293 Collins St, Melbourne | 13.80 | " | 2.12.85 |
| Palafia Pty Limited, Little Boree, Borenore, NSW | 12.40 | " | 13.5.85 |
| Palmer, Robert M, 31 Hopetoun St, Paddington, NSW | 85.20 | " | 2.12.85 |
| Patfram Pty Ltd, c/o J C Gibb & Co, 39 Martin Pl, Sydney, NSW | 96.00 | " | " |
| Patterson, Noel M, 20 Drumskea Rd, Enagh Upper, Ballymoney, Co Antrim, UK | 20.95 | " | " |
| Penman, Dr Andrew G, PO Box 166, Halls Creek, WA | 30.00 | " | 13.5.85 |
| Pigdon, Marjorie, PO Box 19, Yarrowonga | 291.50 | " | " |
| Plumley, Harold C F, 6 Pranglely Ave, Mangere Central, Auckland, NZ | 57.80 | " | " |
| Plumridge, Desma E, 248 Wonga Rd, Warranwood | 16.34 | " | " |
| Popkin, Michael, 27 Deneland Dve, Hawthorndene, SA | 11.04 | " | 2.12.85 |
| Porter, Hilda V M, 50 Beach Rd, Mentone | 11.04 | " | " |
| Powell, Cheryl K, PO Box 2518, South Hedland, WA | 16.00 | " | " |
| Powell, Margaret F, PO Box 1, Yass, NSW | 12.00 | " | 13.5.85 |
| Prendiville, Caroline, 12 Cygnet Cres, Dalkeith, WA | 14.40 | " | 2.12.85 |
| Pritchard, Timothy S, 174 Booran Rd, Caulfield South | 27.60 | " | " |
| Projo Investments Pty Ltd, 12A/17 Shellcove Rd, Neutral Bay, NSW | 22.00 | " | 13.5.85 |
| Prytz, Ian E, c/o Box 35 Dunkeld | 48.30 | " | " |
| Purcell, Felix M and Kathleen T, 14 Pinoak Pl, Howitt St, Kingston, ACT | 25.28 | " | 2.12.85 |
| R A Richards Investment Company Limited, 3R D, Hororata, NZ | 14.93 | " | " |
| R S & E M Thompson Pty Ltd, Unit 23 'Roseview', 1919 Brunswick St, New Farm, Qld | 16.56 | " | 13.5.85 |
| Radom, Janna, 11 Marsh Pl, Lane Cove, NSW | 13.66 | " | " |
| Rajeon Pastoral Company Proprietary Limited, Wickliffe | 57.00 | " | " |
| Rajendran, Gloriosa, 2188 Jalan Ampang, Kuala Lumpur, Malaysia | 51.00 | " | " |
| Rajendran, Thuraiappah (estate of), c/o Shearn Delamore & Co, PO Box 10138, Kuala Lumpur 01-02, Benteng, Malaysia | 68.00 | " | 2.12.85 |

Unclaimed Moneys Act 1962

Register of Unclaimed Moneys held by the—

| Name of Owner on Books and Last Known Address | Total Amount Due to Owner | Description of Unclaimed Money | Date when Amount first became Payable |
|--|------------------------------------|--------------------------------------|--|
| \$ | | | |
| WESTERN MINING CORPORATION HOLDINGS LTD— <i>continued</i> | | | |
| Rayner, Joan H, 23 Terrara Rd, Vermont | 200.00 | Dividend | 13.5.85 |
| Rennie, Francis B, 66 Hallett Rd, Burnside, SA | 18.40 | " | 2.12.85 |
| Renouf Equities Limited, Level 17, Prudential Building, 33-39 Martin Pl, Sydney, NSW | 540.00 | " | " |
| Renshaw, Dr Peter K, PO Box 12-014, Maori Hill, Dunedin, NZ | 216.11 | " | " |
| Rhodes, Ronald D, 6 Waitarua Rd, Remuera, Auckland, NZ | 16.32 | " | " |
| Richardson, Thomas W, 132 Toorong Rd, Glen Iris | 14.08 | " | " |
| Ripley, William T, 23 Aralia St, Nightcliff, NT | 12.00 | " | " |
| Robinson, John C, PO Box 1213, Kota Kinabalu, Sabah, East Malaysia | 30.96 | " | 13.5.85 |
| Robinson, Mary (estate of), c/o Lempriere Abbott McLeod, 86 Gawler Pl, Adelaide, SA | 13.08 | " | 2.12.85 |
| Rochlin, Gregory P, 48 Howitt St, South Yarra | 14.72 | " | " |
| Rogers, Carolyn J, 24 Byron St, Coogee, NSW | 20.00 | " | 13.5.85 |
| Row, David J and Heather J, 15 Armstrong Tce, Paddington, Qld | 36.00 | " | " |
| Rowley, Suzanne, 10 Etha Ave, Darling Point, NSW | 17.28 | " | 2.12.85 |
| Rumpf, Roma E, 2 Hepburn Rd, Doncaster | 27.60 | " | " |
| Rusman, Johannes W, 85A Beach Rd, Bondi, NSW | 30.00 | " | 13.5.85 |
| S U Nominees Pty Ltd, 3 Cypress Crt, Greenwood, WA | 50.00 | " | " |
| Salmon, Maria, c/o Landings Inc, 1001A West Ave, Austin, Texas, USA | 10.20 | " | 2.12.85 |
| Saltbush Pty Limited, c/o E M Ritchie, 251 Barrenjoey Rd, Newport Beach, NSW | 14.60 | " | 13.5.85 |
| Saltmarsh, Ian C, 125 Channel Hwy, Taroona, Tas | 15.00 | " | 2.12.85 |
| Sanders, Robert J, 5 Cochrane St, Camira, Qld | 12.00 | " | " |
| Sauer, Ann, c/o Graham Joseph Sauer, 9 Boord St, Dernancourt, SA | 24.00 | " | " |
| Schubert, Wilfred, 11 Highland Ave, Balwyn | 11.04 | " | " |
| Scotis, Peter J, 4 Daniell Pl, Kew | 26.40 | " | " |
| Semel, Jacob, 106-108 Bakers Rd, Coburg | 107.64 | " | 13.5.85 |
| Sewell, Patricia M, 21 High St, Bildeston, Ipswich, Suffolk, UK | 31.68 | " | " |
| Sexton, Robin P, 50 Railway La, Eden Hills, SA | 12.00 | " | 2.12.85 |
| Sharpe, Geoffrey A, 27 Palermo St, South Yarra | 30.00 | " | 13.5.85 |
| Shellene, Kent, 12430 Pinerock La, Houston, Texas, USA | 13.60 | " | 2.12.85 |
| Shelley, Maxwell N, 1 Teddington Rd, Hampton | 22.08 | " | 13.5.85 |
| Silbermann, Theodor J, 23 Orr St, Bondi, NSW | 48.00 | " | " |
| Simmons, Gordon McK, 1 Basedow St, Fannie Bay, NT | 43.56 | " | 2.12.85 |
| Simpson, Elizabeth R, GPO Box 1784N, Adelaide, SA | 426.42 | " | 13.5.85 |
| Sinfield, Keith H, 34 Birubi Cres, Bilgola Plateau, NSW | 13.80 | " | 2.12.85 |
| Siou, George, 6 Staddon Cl, St Ives, NSW | 33.12 | " | 13.5.85 |
| Skinner, Rupert G B, 111 Charles St, Prahran | 12.60 | " | 2.12.85 |
| Small, Joy M, 33 Fifth Ave, Apt. 9-D, USA | 13.69 | " | 13.5.85 |
| Smith, Dudley W, PO Box 2, Rotorua, NZ | 17.14 | " | " |
| Smith, John M, c/o Tallow Products Pty Ltd, PO Box 47, Botany, NSW | 12.00 | " | 2.12.85 |
| Smith, Raymond L, 41 Tunstall Sq, East Doncaster | 13.60 | " | " |
| Sommer & Co Pty Ltd, 30 Fitzroy Ave, Camden Park, SA | 82.80 | " | 13.5.85 |
| Soo, Siu Ming, Door Fook Mansion, Apt 9A, 126 Pokjulam Rd, Hong Kong | 33.60 | " | " |
| Spicer, Janet D, 98 Greencroft Gardens, London, UK | 20.40 | " | 2.12.85 |
| St. Leger, John S, 7 Latin Heights, Kellner Rd, Bloemfontein, South Africa | 67.20 | " | 13.5.85 |
| Stalley, Joseph W (estate of), c/o William F Stalley and Andrew Stalley, "Rossmore", Bourke, NSW | 118.80 | " | " |

Unclaimed Moneys Act 1962

Register of Unclaimed Moneys held by the—

| <i>Name of Owner on Books and Last Known Address</i> | <i>Total Amount Due to Owner</i> | <i>Description of Unclaimed Money</i> | <i>Date when Amount first became Payable</i> |
|--|--|---|--|
| \$ | | | |
| WESTERN MINING CORPORATION HOLDINGS LTD— <i>continued</i> | | | |
| Steele, Georgina, 8 Cambridge Ave, Dee Why West, NSW | 16.00 | Dividend | 2.12.85 |
| Stewart, Thomas D, 87 Boneo Rd, Rosebud | 11.04 | " | " |
| Stoker, Sonia, Woodlands, Horsham Rd, Bramley, Surrey, UK | 59.78 | " | " |
| Storie, Roderick, 32 Burrawong Ave, Mosman, NSW | 11.04 | " | " |
| Stott, Brian K, 22 Jolly St, Clayfield, Qld | 10.72 | " | " |
| Stribling, Helen A, 17 Kent Crt, Toorak | 15.76 | " | " |
| Stuart, Iain M, 37 Castlemaine St, Yarraville | 19.36 | " | " |
| Suckling, John W, Korweinguboora | 15.44 | " | " |
| Sundman, John G, 24 Nix St, West End, Townsville, Qld | 48.00 | " | " |
| Sutton, Beverley A, 92 Arthur Circle, Forrest, ACT | 30.00 | " | 13.5.85 |
| Swales, Ronald T, Hong Kong & Shanghai Banking Corporation, Peninsula Crt, Kowloon, Hong Kong | 11.60 | " | 2.12.85 |
| Sweeney, Anne, c/o Riordan Sweeney, 462 Burwood Rd, Hawthorn | 20.00 | " | " |
| Swordfish Pty Ltd, PO Box 409, Burleigh Heads, Qld | 30.00 | " | 13.5.85 |
| Szczerbiak, Mikola, 66 Uriarra Rd, Queanbeyan, NSW | 11.52 | " | 2.12.85 |
| Tan, Beng L, 233 Racecourse Bukit Timah, Singapore 1128 | 20.40 | " | 13.5.85 |
| Tattersfield, John W, c/o R J Wallace, 25 The Tor Walk, Castlecrag, NSW | 11.52 | " | 2.12.85 |
| Telepix Pty Limited, c/o R L Laphorne, 1/155 Alexander St, Crows Nest, NSW | 13.24 | " | " |
| Thomas, Robert W, PO Box 507, North Sydney, NSW | 33.12 | " | 13.5.85 |
| Thompson, Elizabeth J, 110 Arabella St, Longueville, NSW | 40.00 | " | " |
| Thompson, Nora, 101 Eastwood Ave, Epping, NSW | 57.60 | " | 2.12.85 |
| Thompson, Terry (estate of), c/o Elizabeth J H Thompson, 110 Arabella St, Longueville, NSW | 13.34 | " | 13.5.85 |
| Thomsett, Lena P (estate of), c/o Gay L Leaker, 25 Rayleigh Rd, Wimbledon, London, UK | 13.47 | " | 2.12.85 |
| Thomson, Wilfred B, 94 Waddell Rd, Bicton, WA | 13.80 | " | " |
| Thornton, Michaela V, c/o P B Thornton Ebsworth & Ebsworth, GPO Box 713, Sydney, NSW | 20.00 | " | " |
| Tindale, Tracey E, Flat 5, 31 Fleming Rd, Herston, Qld | 12.00 | " | " |
| Tipping, Herbert J, 366 Pease St, Cairns, Qld | 20.00 | " | 13.5.85 |
| Trikeriotis, John and Beverley A, 280 Young St, Wayville, SA | 93.60 | " | " |
| Tucker, Liga, 5 Brodrick St, Karrinyup, WA | 14.40 | " | 2.12.85 |
| Tuckwell, Graham, 6/18 Thrupp St, Neutral Bay, NSW | 20.00 | " | 13.5.85 |
| Turnbull, Sarah J, Mannerim, R S D, Drysdale | 20.00 | " | " |
| Turner, Frank (estate of), c/o E R Stack & Sons, 17 Wharf St, Forster, NSW | 45.90 | " | " |
| Vereecken, Erik, 66 Park Ryvissche, Zwynaarde 9710, Belgium | 27.70 | " | 2.12.85 |
| Vial, Amanda J, 20 Rosslyn St, Hawthorn East | 38.28 | " | 13.5.85 |
| Vinecombe, Marie F D and Robert F, Devonlea, Talbot | 37.08 | " | " |
| W & B Investments Pty Ltd Provident Fund, 11/12 Homedale Cres, Connells Point, NSW | 48.00 | " | 2.12.85 |
| WA Fritze & Company Australia Pty Ltd, 604/20 Loftus St, Sydney, NSW | 20.00 | " | " |
| Waggoner, Ross (estate of), c/o Rawles Hinkle Carter Brigham Gaustad & Behnke, PO Box 720, Ukiah, California, USA | 91.80 | " | " |
| Wake, Geoffrey St. A, 20 Chatsworth Rd, East Prahran | 13.32 | " | " |
| Walch, Anna L, "Southlea", Proctors Rd, Dynnyrne, Tas | 16.00 | " | " |
| Walker, Rosemary, 13A Inkerman St, Mosman, NSW | 60.00 | " | 13.5.85 |
| Walmsley, Ina M, 39 Channell St, Swansea, NSW | 29.12 | " | 2.12.85 |
| Ward, William P, "Carinya", Rochester | 23.88 | " | 13.5.85 |

Unclaimed Moneys Act 1962

Register of Unclaimed Moneys held by the—

| Name of Owner on Books and Last Known Address | Total Amount Due to Owner | Description of Unclaimed Money | Date when Amount first became Payable |
|---|------------------------------------|--------------------------------------|--|
| \$ | | | |
| WESTERN MINING CORPORATION HOLDINGS LTD—continued | | | |
| Wardle, Susan, 267 Flinders La, Melbourne | 20.00 | Dividend | 13.5.85 |
| Waterman, Karen D, Apt 2A, 131 East Hartsdale Ave, Hartsdale, NY, USA | 40.67 | " | 2.12.85 |
| Waters, Morris W, 2nd Floor, 969 Burke Rd, Camberwell | 13.80 | " | " |
| Watson, Pauline, 17/31 Wharf Rd, Gladesville, NSW | 17.04 | " | " |
| Watson, Romola L, 8 Horgan St, Mosman Park, WA | 19.20 | " | " |
| Weber, Lawrence J, c/o Kinhill Stearns, 645 Harris St, Ultimo, NSW | 68.00 | " | 13.5.85 |
| Wehl, Carl A, PO Box 42, Stawell | 14.52 | " | 2.12.85 |
| Wellwood, Margaret G, PO Box 1214, Hastings, Hawkes Bay, NZ | 12.52 | " | " |
| Welsh, Barry F, c/o Dunhill Morgan & Macready, 34 Hunter St, Sydney, NSW | 14.40 | " | 13.5.85 |
| Western Line Electric Pty Limited, PO Box 71, Strathfield, NSW | 14.40 | " | 2.12.85 |
| White, Anne M, 57 Bay St, Mosman, NSW | 16.24 | " | " |
| White, Cecil A, PO Box 260, Geelong | 17.60 | " | " |
| White, Kevin R, PO Box 814, Panguna, North Solomons Province | 39.99 | " | 13.5.85 |
| White, Vera E, 5 Stawell St, East Prahran | 13.24 | " | 2.12.85 |
| Wiese, Neville C, PO Box 50, Mundulla, SA | 24.00 | " | " |
| Wilce, Michael, PO Box 21, Tiaro, Qld | 34.00 | " | 13.5.85 |
| Wilkinson, Henry L, 10 Malcolm St, North Beach, WA | 14.68 | " | " |
| Williamson, Ronald F, 4 St Georges Ave, East Benteleigh | 26.48 | " | 2.12.85 |
| Willington, Valerie L, 67 Raglan St, Sale | 10.00 | " | 13.5.85 |
| Wiryasaputra, Rudy, 11/61 Kensington Rd, Kensington, NSW | 30.00 | " | " |
| Withell, Edward R, Montevideo #14A Fracc, El Paraiso, Tijuana B C, Mexico | 14.00 | " | 2.12.85 |
| Withers, Zoe D, 40 Denison St, Rozelle, NSW | 20.00 | " | " |
| Wolfert-Mulder, Andrea M, 11 Belhaven Ave, Taroom, Tas | 36.00 | " | 13.5.85 |
| Wolsing, Ben and Bengta, 223 Sutherland St, Paddington, NSW | 44.94 | " | " |
| Wolsing, Bengta, 223 Sutherland St, Paddington, NSW | 45.06 | " | " |
| Wood, Andrew H, Flat B, 408 Stirling Hwy, Cottlesloe, WA | 13.80 | " | 2.12.85 |
| Wood, Jillian F, Racecourse Rd, Morningson | 25.08 | " | 13.5.85 |
| Woodridge, John, 1/8A Reed St, Cremorne, NSW | 12.00 | " | " |
| Woodwind Nominees Pty Limited, 333 Punt Rd, Richmond | 59.40 | " | " |
| Wren, Gavin F, 31 Joynt St, Hamilton, Qld | 12.00 | " | 2.12.85 |
| Yeap, Rosemary, c/o Kee Yeap Associates, 163A Goldhill Centre, Thomsom Rd, Singapore | 11.73 | " | " |
| Young, John R, Gap St, Springsure, Qld | 151.20 | " | " |
| Zonneveld, Pieter C, c/o Voorwerf 2, 1027 AG Zunderdorp, Amsterdam (N), Holland | 34.00 | " | " |
| Zwarthoed, John, Randenbrocherweg 32, Amersfoort, Holland 7002 | 11.05 | " | " |
| JOHN HOLLAND HOLDINGS LIMITED | | | |
| Aubrey-Sloccock, Margaret A, 10th Floor, 492 St Kilda Rd, Melbourne | 70.60 | Dividend | 29.3.85 |
| Begg, Virginia, 19 Epping Rd, Double Bay, NSW | 53.50 | " | " |
| Cleine, Douglas K, 3/8 Barkly St, Ringwood | 25.00 | " | 25.10.85 |
| Daly, Phyllis N, 38 Walsh St, Balwyn | 89.40 | " | 29.3.85 |
| Dore, Dorothy J, 39 Loch St, Camberwell | 42.80 | " | 25.10.85 |
| Gove, William R, 17 St Georges Rd, Armadale | 37.50 | " | 29.3.85 |
| Growse, Jocelyn, 88 Bellevue Ave, Rosanna | 66.65 | " | " |
| Jacobs, Cyril W, 77 William St, Greensborough | 33.20 | " | 25.10.85 |
| Jeffrey, Carla R, 147 Glenferrie Rd, Malvern | 26.75 | " | 29.3.85 |
| Josephs, David C, 41 Sheringham Dve, Glen Waverley | 22.30 | " | " |

Unclaimed Moneys Act 1962

Register of Unclaimed Moneys held by the—

| <i>Name of Owner on Books and Last Known Address</i> | <i>Total Amount Due to Owner</i> | <i>Description of Unclaimed Money</i> | <i>Date when Amount first became Payable</i> |
|--|--|---|--|
| \$ | | | |
| JOHN HOLLAND HOLDINGS LIMITED—continued | | | |
| Kay, Edwina, 99 Bay Rd, Sandringham | 42.80 | Dividend | 29.3.85 |
| MacDougall, Margot, 9/107 Williams Rd, Prahran | 43.20 | " | 25.10.85 |
| McCarthy, Desmond R, 211 Holden St, Nth Fitzroy | 39.80 | " | " |
| Meyer, Jonathon G, 1 Huntingtower Rd, Armadale | 32.70 | " | 29.3.85 |
| Murphy, Anthony E, 6/25 Maxwell St, Adelaide, SA | 44.70 | " | " |
| Pitts, Michael J, 41 Branksome Gve, Blackburn South | 66.65 | " | " |
| Reid, Mary, 39 Sandford St, Highett | 32.10 | " | " |
| Ribbands, John A, 18 McCulloch St, Bairnsdale | 39.80 | " | 25.10.85 |
| Round, Jennifer M, 16 South Rd, Brighton Beach | 66.65 | " | " |
| Russell-Smith, Margaret E, 639 Nepean Highway, Frankston | 268.65 | " | 29.3.85 |
| Stark, Helen B, Bream Creek, Tas | 46.13 | " | " |
| Syme, Irene N, 6 Gascoyne St, Canterbury | 180.00 | " | 25.10.85 |
| Thornton, John M, 18 Wilson St, Braidwood NSW | 66.40 | " | 29.3.85 |
| Tozer, Peter, 5 Martin Cres, Glen Iris | 89.45 | " | 25.10.85 |
| Varkulevicius, Elizabeth, 4 Aintree Rd, Glen Iris | 27.80 | " | 29.3.85 |
| 7005 | | | |
| DALGETY FARMERS LIMITED | | | |
| Doyle, C, RSD 531, Kimberley, Tas | 195.00 | Cheque | 31.5.85 |
| Wong, S T, c/o R G Chapman, PO Box 5, Caulfield South | 1379.05 | " | 8.8.85 |
| Old, T, 12 Terrigal Cl, North Richmond | 293.90 | Proceeds | —2.83 |
| Augustine, J L, PO Box 69, Pearcevale | 163.69 | " | —4.84 |
| Woods, R | 349.34 | " | 20.2.86 |
| Details not known | 63.65 | Cheque | 11.7.85 |
| 7009 | | | |
| ICI AUSTRALIA LIMITED | | | |
| Thornton, Patricia A, Flat 3, 11 Vincent St, Surrey Hills | 2 000.00 | Cheque | 30.11.80 |
| Towe, Blanche M, PO Box 114, Wauchope, NSW | 200.00 | " | 31.5.82 |
| Brown, Ralph (estate of), c/o M Linkenbagh, 126 The Mall, Leura, NSW | 3 600.00 | " | 30.11.83 |
| Burrett, Thelma M, c/o Arthur Phillips & Just, PO Box 261, Collins St Post Office, Melbourne | 500.00 | " | " |
| Holdenson, Harvey R (estate of), c/o James A Murray, GPO Box 22820, Melbourne | 1 000.00 | " | " |
| McLauchlan, Lorraine A and MacDonald, Beryl E, 41 Eitel St, Airport West | 400.00 | " | " |
| Ramsey, Una D and Brian F, 24 Third St, Cleve, SA | 200.00 | " | " |
| Tieli, Salvatore, 26 Aubrey Cres, Coffs Harbour, NSW | 1 000.00 | " | " |
| Whittakers, Wanda G (estate of), c/o Alison A Christie, 18 Dwyer St, Macleod | 300.00 | " | " |
| McAlister, William A (estate of), c/o Raves Marsh Morck & Hill, 11th Floor, 70 Castlereagh St, Sydney, NSW | 200.00 | " | " |
| Rowley, Stephanie M, 14 Regency Rd, Kilkenny, SA | 400.00 | " | 31.5.84 |
| Brattle, Deborah K, 4 Islop Pl, Woodlands, WA | 200.00 | " | " |
| Cumberland, Harry C (estate of), c/o M A Kent & Associates, 14 Ellenborough St, Ipswich, Qld | 400.00 | " | " |
| Herschell, Hoarce D, 41 Elizabeth St, Elsternwick | 1 200.00 | " | " |
| Lambert, Mary M (estate of) | 200.00 | " | " |
| Smith, Graham J, 16 Poole St, Deer Park | 200.00 | " | " |
| Tie, Edmund G, 32 Barry St, Northcote | 3 200.00 | " | " |

Unclaimed Moneys Act 1962

Register of Unclaimed Moneys held by the—

| Name of Owner on Books and Last Known Address | Total Amount Due to Owner | Description of Unclaimed Money | Date when Amount first became Payable |
|---|------------------------------------|--------------------------------------|--|
| \$ | | | |
| ICI AUSTRALIA LIMITED—continued | | | |
| Akers, Agnes, 916 Pittwater Rd, Dee Why, NSW | 400.00 | Cheque | 31.5.85 |
| Cox, Barbara E J, c/o Conwell Busch & Lilley, GPO Box 67, Brisbane, Qld | 10 000.00 | " | " |
| Forward, Charles A, Unit 12, Lot 553, Merriwa Rd, Sheidow Park, SA | 100.00 | " | " |
| Knapp, Bernard M, Unit 3, 5 Carruth Rd, Torrens Park, SA | 800.00 | " | " |
| Meers, Mary I (estate of), c/o National Trustees, GPO Box 2819AA, Melbourne | 1 000.00 | " | " |
| Richardson, Joyce W, 132 Tooronga Rd, Glen Iris | 200.00 | " | " |
| Thompson, John C, 14 Denmark Hill Rd, Camberwell | 1 000.00 | " | " |
| Cocks, Donald (estate of), c/o D Graham, 4 Gannon Ave, Dolls Point, NSW | 200.00 | " | 31.1.86 |
| Crew, Philomena M, 51 Kamerunga Rd, Stratford, via Cairns, Qld | 300.00 | " | " |
| Elliott, Barbara M, 62 Byng St, Orange, NSW | 2 000.00 | " | " |
| Gifford, Alfred S (estate of), c/o Arthur Robinson & Hedderwicks, GPO Box 1776Q, Melbourne | 1 000.00 | " | " |
| Griffith, Glen W, 53 North Rd, Elwood | 5 000.00 | " | " |
| Peterson, John, 5 Amaral St, Narraweena, NSW 7007 | 1 600.00 | " | " |
| JENNINGS INDUSTRIES LIMITED | | | |
| Alt, Beverley A, 19 Bayswater Rd, Lindfield, NSW | 37.13 | Interest | 30.6.85 |
| Ashwin, William, 9 McRostie Cl, Whyalla, Stuart, SA | 21.00 | Dividend | 27.3.85 |
| Barnes, Keith D, "Keswick Lodge", Ridge Rd, Kallista | 31.15 | " | " |
| Bassett, Deborah, 2/6 Mosman St, Mosman, NSW | 12.00 | " | " |
| Beauchamp, Colin C, 23 Ashburton St, Bentley, WA | 35.75 | " | 23.10.85 |
| Bell, John A, 8/6 Carr St, Waverton, NSW | 21.00 | " | 27.3.85 |
| Berg, Colin R, 7 Findlay St, Blacktown, NSW | 15.00 | " | " |
| Bird, Doris M, 7 Scott St, Mitcham | 12.00 | " | " |
| Blair, Richard A, 18 Andrew Pl, North Rocks, NSW | 47.85 | " | " |
| Boal, Heather M and McLachlan, Colin, "Alcheringa", Grubb Rd, Drysdale | 29.25 | " | 23.10.85 |
| Bradley, Brian M, 61 Amherst St, Cammeray, NSW | 50.40 | " | 27.3.85 |
| Burney, John H, c/o Gaffney Cline Regent Ctr, Regent Rd, Aberdeen, UK | 42.50 | " | " |
| Burns, John, Box 771, Geraldton, WA | 13.23 | Interest | 31.12.85 |
| Butcher, Ronald, c/o Jennings Industries Ltd, 66 River Tce, Brisbane, Qld | 28.95 | Dividend | 27.3.85 |
| Casey, John J, c/o Dillingham Corporation, Suite 1600, Two Embarcadero Centre, San Francisco, USA | 46.75 | " | 23.10.85 |
| Casey, John J, PO Box 3468, Honolulu, USA | 42.50 | " | 27.3.85 |
| Chapman, Bruce L and Valma, 274 Springvale Rd, Glen Waverley | 42.00 | " | " |
| Clark, Kevin W, 7/23 Genoa St, Surfers Paradise, Qld | 26.46 | Interest | 30.6.85 |
| Cole, Katrina H, 14 Parslow St, Malvern | 10.05 | Dividend | 23.10.85 |
| Coles, Maureen R, 260 Penshurst St, Willoughby, NSW | 25.00 | " | 27.3.85 |
| Coles, Pamela G, "The Old Oaks", Eastworth Rd, Verwood, Wimborne, Dorset, UK | 100.98 | " | 23.10.85 |
| Coogan, Clive K, 15 Iribarra Rd, Canterbury | 55.70 | Interest | 30.6.85 |
| Coongie Nominees Pty Ltd, 4 Laura Ave, St Marys, SA | 119.08 | Dividend | 27.3.85 |
| Cranch, Terence G, Pacific General Store, Jacobs Well, Qld | 30.00 | " | " |
| Crouch, Linda E, 16 Viscount Dve, Doncaster | 18.57 | Interest | 30.6.85 |
| Cumine, Ian J, 67 Winmalee Dve, Glen Waverley | 333.90 | Dividend | 27.3.85 |

Unclaimed Moneys Act 1962

Register of Unclaimed Moneys held by the—

| <i>Name of Owner on Books and Last Known Address</i> | <i>Total Amount Due to Owner</i> | <i>Description of Unclaimed Money</i> | <i>Date when Amount first became Payable</i> |
|--|--|---|--|
| \$ | | | |
| JENNINGS INDUSTRIES LIMITED—continued | | | |
| Dalziell, Peter R, 19 Goonang Rd, City Beach, WA | 28.65 | Dividend | 27.3.85 |
| Davenport, Gary I, 2/1 Robert Cres, Wodonga | 25.20 | " | " |
| Devlin, Francis J, "Oakdale", Main Rd, Mt Dandenong | 28.95 | " | " |
| Duckitt, Graham, 28 Eucalyptus Dve, Westleigh, NSW | 13.00 | " | 23.10.85 |
| Dudley, Alan C, c/o AMP Society, GPO Box 4134, Sydney, NSW | 28.05 | " | " |
| Dunkinson, Valentine J and Brenda, Coolibah St, Dalby, Qld | 52.50 | " | 27.3.85 |
| Eaves, John H and Ostenfeld, John Alexander, 51 Mosley St, Manchester, UK | 192.78 | " | " |
| Eden, Alfred R, PO Box 313, Port Lincoln, SA | 21.38 | Interest | 30.6.85 |
| Emsley, Gordon L, PO Box 282, South Melbourne | 418.12 | " | " |
| Emsley, Graham T, PO Box 282, South Melbourne | 37.13 | " | " |
| Eyeglass Envelopes Pty Ltd, 34 Leicester St, Carlton South | 82.50 | Dividend | 23.10.85 |
| Fothergill, Bernard H, 1 Preston La, Barton-on-Humber, UK | 40.54 | Interest | 30.6.85 |
| Fraillon, Eva A, c/o P. Strasser, 7 Georgian Crt, Balwyn | 29.15 | Dividend | 27.3.85 |
| Galea, Charlie P, 26 Elm Gve, Springvale | 56.70 | " | " |
| Godwin, Marjorie G, PO Box No. 67 Patutahi, nr Gisborne, NZ | 168.30 | " | 23.10.85 |
| Grant, Lynette M, 42 Bamboore Cres, Wanneroo, WA | 21.45 | " | " |
| Green, John C, 22 Ainslie Pde, Carlingford, NSW | 52.54 | " | 27.3.85 |
| Grinter, Alison M and William, Swifts Creek | 24.75 | " | 23.10.85 |
| Guy, Natalie H, 40 Burra Rd, Artarmon, NSW | 68.92 | Interest | 31.12.85 |
| Hart, Roger C, 12 Ash St, Kirwan, Townsville, Qld | 208.00 | Dividend | 27.3.85 |
| Hawkes, Raymond, 3 Ulva Pl, Macquarie, ACT | 13.20 | " | 23.10.85 |
| Henderson, Leslie C, 57 Sanders St, Upper Mt Gravatt, Qld | 42.00 | " | 27.3.85 |
| Hindmarsh, Nellie D, c/o Coopers & Lybrand SRD, 385 Bourke St, Melbourne | 68.65 | " | " |
| Hinkley, Walter M, 11 Stacey St, Cronulla, NSW | 48.30 | " | " |
| Hinkley, Walter M, 14307 Apple Tree, Houston, Texas, USA | 23.38 | " | 23.10.85 |
| Hosch, Gerhard, 48 Recreation Rd, Kalamunda, WA | 54.00 | " | " |
| Hosch, Gerhard, 6/36 Gardner St, Como, WA | 15.00 | " | " |
| Hoskin, Michael F, PO Box 391 Dapto, NSW | 44.00 | " | " |
| Hoskin, Michael F, 4 Lorne Crt, Howrah, Tas | 13.00 | " | " |
| Jackson, Vincent B, 20 Ridge Circuit, Leppington, NSW | 31.50 | " | " |
| Jenkins, Thomas W, 24 Andromeda Cres, Engadine, NSW | 35.00 | " | " |
| Jenkinson, James A, 21 Chambers St, South Yarra | 175.95 | " | " |
| Johnston, Peter A, 13 Amaroo Ave, Georges Hall, NSW | 19.50 | " | 23.10.85 |
| Johnstone, Geoff, 73 George St, Inglewood, Qld | 39.00 | " | 27.3.85 |
| Jones, Catherine I, 33 Gerald St, Nunawading | 100.00 | " | " |
| Jones, Karen E, 7/227 Onslow Rd, Shenton Park, WA | 21.00 | " | " |
| Kang, Diana Nance Ee-Lin, 14 Burton St, Concord, NSW | 18.57 | Interest | 30.6.85 |
| Kelly, Paul A, 9 Glenburn Pl, Papakura Auckland, NZ | 28.05 | Dividend | 27.3.85 |
| Lanser, Ian N, 73 Headland Rd, Dee Why, NSW | 15.00 | " | " |
| Latham, Stanley R and June L, 5 Venus St, Bateman, WA | 55.00 | " | 23.10.85 |
| Lawrance, Margaret R, 32 Chelford St, Alderley, Qld | 27.85 | Interest | 31.12.85 |
| Leone, Priscilla M, 74 Fordham Ave, Camberwell | 49.50 | Dividend | 23.10.85 |
| Lever, Allan, 29 Knockator Cres, Toowoomba, Qld | 160.00 | " | 27.3.85 |
| Macadam, Robert Douglas, 34 Lee Rd, North Springwood, NSW | 22.50 | " | " |
| Mackey, Anthony, c/o Coopers & Lybrand S/Reg, 460 Bourke St, Melbourne | 29.72 | " | " |
| Mackinnon, Colin C, RD3, Whakatane, NZ | 28.05 | " | 23.10.85 |
| Maclachlan, Sarah H, Leewood House, Dunblan, Perthshire, UK | 99.67 | " | " |
| Maguire, Bernard (estate of), c/o Ray Johnson, PO Box 91, Chelsea | 42.00 | " | 27.3.85 |

Unclaimed Moneys Act 1962

Register of Unclaimed Moneys held by the—

| <i>Name of Owner on Books and Last Known Address</i> | <i>Total Amount Due to Owner</i> | <i>Description of Unclaimed Money</i> | <i>Date when Amount first became Payable</i> |
|--|--|---|--|
| \$ | | | |
| JENNINGS INDUSTRIES LIMITED— <i>continued</i> | | | |
| Maher, Edwina, c/o Michael Mayer, Carlingford Aust Ins Pty Ltd, GPO Box 2420, Sydney, NSW | 82.50 | Dividend | 23.10.85 |
| Marsden, Diana Marion, c/o M T Cash, 216 Markham St, Armidale, NSW | 55.00 | " | " |
| McCarthy, Benjamin J, GPO Box 935, Brisbane, QLD | 10.00 | " | 27.3.85 |
| McConnell, Frederick, 118 Shaftsbury Ave, Bedford, WA | 58.35 | " | " |
| McCreanor, Gerald T, 41 Honeyeater Dr, Burleigh Waters, QLD | 83.85 | " | " |
| McLeod, Roderick A, 7/9 Shell Cove, Neutral Bay, NSW | 11.00 | " | 23.10.85 |
| Moran, John P, PO Box 215, Kingston, ACT | 26.45 | Interest | 30.6.85 |
| Morris, David J, 1A/80 Shirley Rd, Wollstonecraft, NSW | 16.50 | Dividend | 23.10.85 |
| Mosur, Joseph, 3/23-25 The Trongate, Granville, NSW | 12.00 | " | 27.3.85 |
| Nicholas, Richard H, 6 Fellows St, Latham, ACT | 17.20 | " | " |
| Nicholls, Frank G and Yvonne I, 61/4 Sydney St, Prahran | 22.52 | Interest | 30.6.85 |
| North, Sylvia M, 3 Brentford Crt, Noble Park | 27.95 | Dividend | 23.10.85 |
| O'Connor, Patrick, c/o Coopers & Lybrand S/Reg, 460 Bourke St, Melbourne | 43.75 | " | 27.3.85 |
| O'Donnell, Kieran V, 673 Burke Rd, Camberwell | 16.50 | " | 23.10.85 |
| O'Keefe, Dennis A, 66 Greenaway Dr, Ferntree Gully | 13.00 | " | " |
| Palmer, Valma M, 5-19 Elphinstone St, West Footscray | 13.23 | Interest | 31.12.85 |
| Parker, Alfred W, c/o Lewis & Howitt, PO Box 386, Mt Waverley | 17.45 | Dividend | 27.3.85 |
| Phillips, Maxwell F, PO Box 36, Clarence Gardens, SA | 25.00 | " | 23.10.85 |
| Plant, Donald G, 10 Sevenoaks Av, Croydon | 55.00 | " | " |
| Plowman, Gail, Lot 11, Bradley La, Warrandyte | 11.90 | " | 27.3.85 |
| Rabsweet Pty Ltd, 23 London Rd, Clayfield, Qld | 50.00 | " | " |
| Richardson, Barry A, 9 Talune St, Lindsfarne, Tas | 119.48 | " | " |
| Robinson, Neil J, 15 Primrose Pl, Farmborough Heights, NSW | 50.15 | " | 23.10.85 |
| Rogers, Margaret E, 139 Raglan St, Mosman, NSW | 43.25 | " | 27.3.85 |
| Rouse, Edmund D, c/o B. J. Clark, 37 Watchorn St, Launceston, Tas | 15.91 | Interest | 30.6.86 |
| Roxburgh, Clive W, c/o Coopers & Lybrand, 461 Bourke St, Melbourne | 187.50 | Dividend | 27.3.85 |
| Ruhle, Ashley J, 9/128 Marine Pde, Southport, Qld | 15.00 | " | " |
| Salmon, David J, 48 Lindsay St, Ashgrove, Qld | 20.00 | " | " |
| Scott-Warren, David N, Mont Du Quaisne, St Brelade, Jersey, C.I. | 42.00 | " | 23.10.85 |
| Simmons, Daryl Edwin, 12 Lambrigg St, Farrer, ACT | 106.00 | " | 27.3.85 |
| Smith, Albert T, 3 Boona Court, Karawara, WA | 25.20 | " | " |
| Smith, Mark, 16 Rogers St, Everton Park, Qld | 13.20 | " | 23.10.85 |
| Sommer, Walter, c/o Coopers & Lybrand S/Reg, 461 Bourke St, Melbourne | 437.50 | " | 27.3.85 |
| Steele, Olive Margaret, 56 Albert Ave, Springvale | 42.00 | " | " |
| Stephens, Raymond K, 7 Kilian St, Winston Hills, NSW | 88.20 | " | " |
| Stone, Richard Llewellyn and Beverley K, c/o R G Halverson, 7 Bayswater Rd, Croydon | 120.00 | " | " |
| Symons, Eric, 9 Burnfort Rd, Newport, Gwent, UK | 76.03 | " | " |
| Thompson, Roland C, 4 Marriage Rd, Brighton | 30.00 | " | " |
| Tregea, Patricia A, 3 West St, Nerang, Qld | 13.23 | Interest | 31.12.85 |
| Trifkovic, Michael, Block B, Room 18, Ainslie Hostel, Ainslie, ACT | 31.25 | " | " |
| Trimby, Glen G, 3 Salicina Crt, Endeavour Hills | 24.00 | " | " |
| Tristian Investment Co Ltd, PO Box N 1612, Nassau, Bahamas | 514.26 | " | 27.3.85 |
| Tymons, Hilda, "Warburton", Berrick Prior, near Benson, Oxon, UK | 25.50 | " | " |
| Viggers, Josephine, 3 31-35 Water Rd, Cremorne, NSW | 50.40 | " | " |
| Viking Limited, Exchange House, 54-58 Athol St, Douglas, Isle of Man | 37.59 | " | " |
| Wade, Terry E, 235 Hyde St, Yarraville | 18.57 | Interest | 31.12.85 |

Unclaimed Moneys Act 1962

Register of Unclaimed Moneys held by the—

| Name of Owner on Books and Last Known Address | Total Amount Due to Owner | Description of Unclaimed Money | Date when Amount first became Payable |
|---|------------------------------------|--------------------------------------|--|
| \$ | | | |
| JENNINGS INDUSTRIES LIMITED—continued | | | |
| Ward, Cynthia D, 27 Brooklands Crt, Rochdale, Lancashire, UK | 30.56 | Dividend | 27.3.85 |
| Warman, Malcolm R, 27 Valiant St, West Chermiside, Qld | 16.50 | " | 23.10.85 |
| Warribri Investments Pty Ltd, 1D Mistral Ave, Mosman, NSW | 143.00 | " | " |
| Webb, Bruce C, 2/96 Severn St, Box Hill North | 15.00 | " | " |
| White, James E, 75 Copeland Rd, Beecroft, NSW | 58.35 | " | 27.3.85 |
| Wilfred Cohen & Associates Pty Ltd, Suite 5, Level 5, Ryrie House, 15-19 Boundary St, Rushcutters Bay, NSW | 27.85 | Interest | 30.6.85 |
| Wilkinson, Murray A, 9/106 Bayview Tce, Clayfield, Qld | 50.00 | Dividend | 23.10.85 |
| Wilson Bishop Tolley & Co Pty Ltd, 628-630 Bourke St, Melbourne | 76.90 | " | " |
| Wilson, Judith A, "Murdeduke", Winchelesa | 19.21 | Interest | 30.6.85 |
| Wilson, Stephen A, 46 Loinsdale Ave, Berowra, NSW | 21.40 | Dividend | 27.3.85 |
| Yates, Gordon, 283 Hindmarsh Dve, Rivett, ACT | 20.00 | " | 23.10.85 |
| 7006 | | | |
| STIRLING PROPERTIES LIMITED | | | |
| Brown, Margerat I, Fawknor Park Residence, Slater St, Melbourne | 45.00 | Dividend | 1.11.85 |
| Burteluis, Gary H | 30.00 | " | 30.4.85 |
| Heat, Harold R | 36.00 | " | " |
| Ninth Nabula Pty Ltd, "Woodside", Bonds Rd, Lower Plenty | 252.00 | " | " |
| Powell, I | 21.60 | " | " |
| Seventh Hibreeze Pty Ltd, "Woodside", Bonds Rd, Lower Plenty | 360.00 | " | " |
| Storey, L | 36.00 | " | " |
| 7003 | | | |
| McILWRAITH McEACHARN LIMITED | | | |
| Antipodes Nominees Pty Ltd, c/o Muecke Pickering & Co, 198 Greenhill Rd, Adelaide, SA | 236.25 | Dividend | 11.11.85 |
| Arit, Wolchard, c/o 17 Wilfred St, Lota, Qld | 27.00 | " | 26.4.85 |
| Bowman, Eric R, 405 Bronte Rd, Waverley, NSW | 25.00 | " | " |
| Cameron, Jessie D (estate of), 34 Haldane St, Beaumaris | 41.64 | " | " |
| Catchlove, John C, 325A Bamba Rd, Caulfield South | 33.84 | " | " |
| Catchlove, Louise A, c/o Coopers & Lybrand S/Reg. GPO Box 1331L Melbourne | 10.50 | " | 11.11.85 |
| Danehurst Pty Ltd, Box 3996 GPO, Sydney, NSW | 54.00 | " | 26.4.85 |
| Dimelow, John B, 66 Union Rd, Surrey Hills | 118.09 | " | 11.11.85 |
| Drinkwater, Peter C, c/o Coopers & Lybrand S/Reg. 461 Bourke St, Melbourne | 54.00 | " | 26.4.85 |
| Dunlop, William R, 64 Neerim Dr, Mooloolaba, Qld | 11.62 | " | 11.11.85 |
| Fratz, Beverley, 21 Bellevue Rd, East Bentleigh | 81.00 | " | 26.4.85 |
| Green, Martin J, 1/4 Kandanga Gr, Bulleen | 23.59 | " | 11.11.85 |
| Jordan, Rose A, 33 Farleigh St, Ashfield, NSW | 15.00 | " | 26.4.85 |
| Lapthorne, Athol D, 17 Salisbury St, Balwyn | 45.00 | " | " |
| Levine, Caroline A, 38 Woodlands Rd, East Lindfield, NSW | 236.25 | " | 11.11.85 |
| Martin, Alfred H, 10 Challis Ave, Turrumurra, NSW | 202.44 | " | 26.4.85 |
| Potts, Brandon J, 4 Kintor St, Wahroonga, NSW | 420.00 | " | 11.11.85 |
| Potts, Jason C, 4 Kintor St, Wahroonga, NSW | 420.00 | " | " |
| Potts, Timothy B, Kintor St, Wahroonga, NSW | 420.00 | " | " |
| Ross, Margaret A, PQ Box 95, Corrimal, NSW | 105.00 | " | " |
| Sinclair, Anne M, Unit 16, 48 Austin St, Shenton Park, WA | 70.00 | " | " |

Unclaimed Moneys Act 1962

Register of Unclaimed Moneys held by the—

| <i>Name of Owner on Books and Last Known Address</i> | <i>Total Amount Due to Owner</i> | <i>Description of Unclaimed Money</i> | <i>Date when Amount first became Payable</i> |
|---|--|---|--|
| \$ | | | |
| McILWRAITH McEACHARN LIMITED —continued | | | |
| Sinclair, Anne M, 13/36 Megalong St, Nedlands, WA | 50.00 | Dividend | 26.4.85 |
| Tepper, Helen J, 1/4 Kandanga Gve, Bulleen | 23.59 | " | 11.11.85 |
| Thompson, Edward L, 111 Victoria St, Potts Point, NSW | 81.00 | " | 26.4.85 |
| Wright, Leonard L, 8 Alexander Ave, Ashford, SA 7004 | 168.75 | " | " |
| ESANDA FINANCE | | | |
| Campbell, B F and T J | 116.78 | Payment | 1.5.85 |
| Carriers, A J | 44.69 | " | 14.5.85 |
| Falls, Kendall | 349.68 | " | 17.1.85 |
| Hoare, W M | 138.83 | " | 6.5.85 |
| Booth, J L | 55.76 | " | 10.5.85 |
| Archibald, R J | 152.94 | " | 7.3.85 |
| Comma Typewriters | 22.05 | " | 20.5.85 |
| Hunt, R E and E P | 32.39 | " | 2.5.85 |
| Milne Lighting | 214.12 | " | 2.5.85 |
| Glasgow, G M | 392.48 | " | 24.1.85 |
| Yang, J, (Aust) Pty Ltd | 28.96 | " | 7.5.85 |
| NADJ Office Products | 273.67 | " | " |
| Forty Third Janalux Pty Ltd | 298.13 | " | 20.5.85 |
| Burger, L E | 276.85 | " | 18.4.85 |
| Kincade, S | 226.44 | " | 3.5.85 |
| 310178816 | 1680.14 | " | 1.7.85 |
| Wrobel, R J | 232.08 | " | 20.2.85 |
| Mitchell, J | 39.90 | " | 15.2.85 |
| Vitale, J D | 88.00 | " | 21.3.85 |
| McNaughton, K J | 203.07 | " | 22.3.85 |
| Tellacman, D L | 199.38 | " | 18.2.85 |
| Fielder, A | 406.58 | " | 23.1.85 |
| Linnet, L J | 263.72 | " | 14.2.85 |
| Cameron, D A | 65.60 | " | 1.4.85 |
| Collett, Eliza | 87.59 | " | 7.8.85 |
| Banks, K L, | 223.95 | " | 7.8.85 |
| TDW Software | 46.63 | " | 20.8.85 |
| Cottageware | 419.03 | " | " |
| M A Mandel Pty Ltd | 12.41 | " | " |
| Unknown | 20.00 | " | 31.10.85 |
| Muellen, S | 30.00 | " | 17.10.85 |
| Hambling, MA and Jensen, D L | 144.93 | " | unknown |
| Peebles, J M | 492.29 | " | " |
| Khale, I and S | 198.17 | " | " |
| Budget Deli | 352.65 | " | " |
| Barneveld, C | 60.51 | " | " |
| Blakey, N C | 1265.33 | " | " |
| Gooding, L V | 101.84 | " | " |
| Comber, G V | 94.17 | " | " |
| Ruiz, A, | 65.18 | " | " |
| Waratah Press | 181.29 | " | " |
| Gillis, J E and S A | 16.67 | " | " |
| Bell, K W and D B | 51.98 | " | " |
| Hartzenberg, M | 33.16 | " | " |

Unclaimed Moneys Act 1962

Register of Unclaimed Moneys held by the—

| <i>Name of Owner on Books and Last Known Address</i> | <i>Total Amount Due to Owner</i> | <i>Description of Unclaimed Money</i> | <i>Date when Amount first became Payable</i> |
|--|----------------------------------|---------------------------------------|--|
| \$ | | | |
| ESANDA FINANCE—continued | | | |
| Unknown | 135.74 | Payment | unknown |
| Topello Pty Ltd | 23.85 | " | " |
| Vital Data | 50.11 | " | 9.85 |
| Unknown | 484.50 | " | 2.5.85 |
| Wilson, N W, 7 Linda Ave, Bacchus Marsh | 959.49 | " | 4.3.85 |
| Chan, Peter K F, 3/16 Mitchell St, Bairnsdale | 591.98 | " | 13.2.86 |
| Russo, A R and J, 27A Lytton St, Glenroy | 454.10 | " | 20.2.86 |
| Luke, D J, 114/12 Wall St, Maylands, WA | 292.36 | " | 13.1.86 |
| Challis, E, 28 Edward St, Burwood | 303.00 | " | 11.2.86 |
| Basso, D A, 2 Fakeham Rd, Ashburton | 32.14 | " | " |
| Clarke, A E, 86 Third Rd, Rosebud | 248.64 | " | 4.2.86 |
| Firth T, 56 Albert Rd, Hallam | 158.65 | " | 23.12.85 |
| Cooke, R A, 40 Coonans Rd, Bendigo | 66.20 | " | 20.12.85 |
| Arms and Childs, 52 Story St, Parkville | 61.74 | " | 11.12.85 |
| Bunting, Maxwell I, 1 Delany Ave, Bright | 204.45 | " | 31.10.85 |
| Polttock, M J, 30 James Pde, Traralgon | 211.50 | " | 18.11.85 |
| Hong Lee Constructions, 17 Bolton Crt, Greensborough | 63.20 | " | 19.12.85 |
| Distributors Aust., 19/21 Robinson St, Dandenong | 455.70 | " | 25.11.85 |
| Head Guard Blinds, 20 Wickham Rd, Moorabbin | 233.43 | " | 25.11.85 |
| Gleeson & Power Management, 79 Mahoneys Rd, Forest Hills | 24.96 | " | 15.11.85 |
| Peters, P W and D G, 6/76 Athol Rd, Springvale South | 64.37 | " | 14.11.85 |
| Brown, N R, 544 Burwood Hwy, Ferntree Gully | 119.08 | " | 6.11.85 |
| J G L Mitchell Family Trust, 7 Mary St, Blackburn | 98.06 | " | 11.11.85 |
| McFaddon, I F and P, 78 The Fairway, Kingsbury | 50.46 | " | 23.10.85 |
| Mitchell, John, 19th St, Cardross | 54.74 | " | 22.10.85 |
| Guivercivius Family Trust, 7 Davis St, Doncaster | 157.01 | " | 4.7.85 |
| Loats, B, 2/43 Maud St, Geelong | 45.87 | " | 13.8.84 |
| Western Communications, 2nd Floor, 31 Coventry St, South Melbourne | 625.60 | " | 29.1.86 |
| York, F J, 7/19 Wyuna Rd, North Caulfield | 200.00 | " | 17.1.86 |
| Sidebottom. G G, 9 Brigalo Crt, Noble Park | 814.44 | " | 20.1.86 |
| Tyskin, V, 5th Floor, 259 Collins St, Melbourne | 118.40 | " | 21.1.86 |
| ESANDA LIMITED | | | |
| Bradbury, Morris I, 4 Cook Pl, Wandong | 40.00 | Interest | 30.7.85 |
| Crevar, Alfred (estate of), c/o Geoffrey R Crevar, Flat 24/89 Denham St, Hawthorn | 35.00 | " | 26.11.85 |
| Clucas, Charles W, 3/21 Alan St, Noble Park | 102.69 | " | 31.1.86 |
| Meilak, Charles and Tessie, 6 Larlac St, Glenroy | 28.77 | " | 3.2.86 |
| Ackland, Denis A, 15 Guildford Ln, Melbourne | 471.78 | " | 16.10.85 |
| Affleck, James H and Dorothy, 25 Timor Pde, West Heidelberg | 63.75 | " | 15.7.85 |
| Allnut, Lindsey M, 10 Parkview Pde, Benalla | 175.00 | " | 11.10.85 |
| Ameit, Anna M, Larpent RMB 8145, Colac | 48.75 | " | 13.8.85 |
| Armstrong, Lawrence J (estate of), Judith Eleanor Armstrong, 30 Warrigal Rd, Surrey Hills | 83.22 | " | 15.3.85 |
| Ashton, Robyn S, 6 Shrimpton Crt, Mont Albert North | 30.54 | " | 4.12.85 |
| Auguste, Brigitte, 18 Hansworth St, Mulgrave | 97.50 | " | 22.7.85 |
| Authorised Nominees Proprietary Limited, c/o H Byron Moore, Day & Journeaux, 257 Collins St, Melbourne | 700.00 | " | 14.12.85 |
| Barratt, Dorothy, Unit 7/242 Balcombe Rd, Mentone | 81.25 | " | 3.3.85 |
| Bartlett, Doris May, Alma | 846.58 | " | 27.2.86 |
| Benincasa, Enza E, 57 Rainer St, Pascoe Vale South | 55.58 | " | 12.8.85 |
| Bennett William L and Dorothy M, 60 Lawson Pde, Highett | 147.50 | " | 15.8.85 |
| Bennets, Elizabeth R, 39 Stewart St, Brunswick | 34.34 | " | 13.2.86 |

Unclaimed Moneys Act 1962

Register of Unclaimed Moneys held by the—

| Name of Owner on Books and Last Known Address | Total Amount Due to Owner | Description of Unclaimed Money | Date when Amount first became Payable |
|---|------------------------------------|--------------------------------------|--|
| \$ | | | |
| ESANDA LIMITED—continued | | | |
| Bernardi, Mario C and Nicastro, Sebastiano, 107 Holmes St, Brunswick | 14.00 | Interest | 27.11.85 |
| Beasley, Edna M, 12A Lithgow St, Burwood | 51.40 | " | 28.2.86 |
| Blackwood, Corona J, 146 The Boulevard, Ivanhoe | 31.25 | " | 15.12.85 |
| Blaikie, Florence M (estate of), c/o Robertson McKean & O'Neill, 142 Manifold St, Camperdown | 512.85 | " | 2.9.85 |
| Bradbury, Morris I, 4 Cook Pl, Wandong | 40.00 | " | 15.10.85 |
| Brereton, Jessie O, Woolsthorpe | 59.45 | " | 27.2.87 |
| Brown, Dorothy E, 8 Small St, Ryde | 67.50 | " | 15.5.85 |
| Buntine, Mary A, c/o R H Dunn, 31 Winston Dve, Doncaster | 125.00 | " | 15.12.85 |
| Chamberlain, Jillian A and Taylor, Garry W, Trustees for Samantha Taylor, 2 Lascelles Ave, Manifold Heights | 140.00 | " | 13.5.85 |
| Chan, Andrew T K (estate of), c/o Septimus Jones & Lee, 7th Floor, 257 Collins St, Melbourne | 156.25 | " | 21.12.85 |
| Clemens, Justin D, Flat 1/8 Cromwell Rd, South Yarra | 31.88 | " | 15.11.85 |
| Clifford, Septimus D and Gutha D, 28 Wright St, Essendon | 325.00 | " | 15.10.85 |
| Coleman, Sarah, 108 Railway Pde, Pascoe Vale | 512.74 | " | 6.1.86 |
| Corbet, Boyd M, 1/9 Mont Albert Rd, Canterbury | 357.92 | " | 31.1.86 |
| Crerar, Alfred (estate of), c/o Geoffrey R Crerar, Flat 24/89 Denham St, Hawthorn | 35.00 | " | 15.7.85 |
| Hungerforddarton, Richard, 1 Bonavista Ave, Surry Hills | 18.03 | " | 12.1.86 |
| Davy, Lindellah E J, 2/33 Latrobe St, Mentone | 95.03 | " | " |
| Delbridge, Sharon L, 12 Burnley St, Laverton | 15.00 | " | 19.2.86 |
| Demasi, Francesco, PO Box 17, Cororooke | 71.89 | " | 1.1.86 |
| De Rouffignac, Isabel, Trustee for Valmai Isabel Mouser, 26 Spring Rd, Springvale South | 15.44 | " | 21.6.85 |
| Dicocco, Giovanni, 58 Victoria Rd, Hawthorn | 18.90 | " | 28.2.86 |
| Dicocco, Giovanni, 58 Victoria Rd, Hawthorn | 15.44 | " | " |
| Dicocco, Giovanni, 58 Victoria Rd, Hawthorn | 16.82 | " | " |
| Donnellan, Paul R, 44 Walnut Rd, North Balwyn | 61.75 | " | 29.8.85 |
| Dundas, Henry, 44 Langdon Rd, Caulfield | 39.81 | " | 15.2.86 |
| Finlay, Anthony, Cororooke | 198.75 | " | 1.8.85 |
| Finlay, Anthony, Cororooke | 198.75 | " | 1.11.85 |
| Finlay, Anthony, Cororooke | 65.00 | " | 2.9.85 |
| Finlay, Anthony, Cororooke | 249.38 | " | 3.8.85 |
| Finlay, Anthony, Cororooke | 249.38 | " | 3.11.85 |
| Finlay, Anthony, Cororooke | 71.25 | " | 7.11.85 |
| Finlay, Anthony, Cororooke | 140.00 | " | 15.2.86 |
| Finlay, Anthony, Cororooke | 106.88 | " | 17.2.86 |
| Finlay, Anthony, Cororooke | 260.00 | " | 22.12.85 |
| Foote, Victoria F, Imlay Nursing Home, Pambula | 13.25 | " | 31.1.86 |
| Fullerton, Shirley J, 5/12 Maroona Rd, Carnegie | 36.25 | " | 14.6.85 |
| Garrett, Allan W, 2A Hill St, Hawthorn | 90.00 | " | 20.9.85 |
| Gilbert, Adele, 230 Grant St, Ballarat | 66.25 | " | 5.11.85 |
| Gilmore, John G, Trustee for Evelyn May Gilmore, c/o Laverton High School, Bladin St, Laverton | 30.62 | " | 15.12.85 |
| Glass, Jessie, c/o G D Stevenson, 5 El-Ramleh Ave, Wendouree | 21.25 | " | 15.5.85 |
| Goullet, Wendy P, 1 Langdon Rd, Caulfield | 11.02 | " | 15.1.86 |
| Grace, Elizabeth M, 620 Warrigal Rd, South Oakleigh | 13.87 | " | 7.3.85 |
| Grace, Elizabeth M, 620 Warrigal Rd, South Oakleigh | 15.29 | " | 7.6.85 |
| Grace, Elizabeth M, 620 Warrigal Rd, South Oakleigh | 15.44 | " | 7.9.85 |
| Grace, Elizabeth M, 620 Warrigal Rd, South Oakleigh | 17.00 | " | 7.12.85 |
| Hallenstein, Janet B, 3 Farleigh Gye, Middle Brighton | 32.50 | " | 3.12.85 |

Unclaimed Moneys Act 1962

Register of Unclaimed Moneys held by the—

| <i>Name of Owner on Books and Last Known Address</i> | <i>Total Amount Due to Owner</i> | <i>Description of Unclaimed Money</i> | <i>Date when Amount first became Payable</i> |
|--|--|---|--|
| \$ | | | |
| ESANDA LIMITED—continued | | | |
| Harry, Dean D, 342 High St, Lower Templestowe | 71.25 | Interest | 13.2.86 |
| Harry, Dean D, 342 High St, Lower Templestowe | 71.25 | " | 13.11.85 |
| Hatton, Percy E, 38 Rosebud Pde, Rosebud | 93.75 | " | 15.4.85 |
| Hatton, Percy E, 38 Rosebud Pde, Rosebud | 93.75 | " | 15.7.85 |
| Henderson, Len C, 126 Burrows St, Mildura | 34.37 | " | 17.10.85 |
| Hill, Peter, Raymond Hamment and Roger Biddleston, 16 Mitchell Ave, Warrandyte | 158.08 | " | 24.10.85 |
| Hintz, Shirley J, RMB 7526 Coulston Dve, Wangaratta South | 12.45 | " | 30.9.85 |
| Hood, Phillip M, 18 Coral Ave, Footscray | 32.50 | " | 16.2.86 |
| Hodges, Thomas P, 16 Gurner St, St. Kilda | 65.00 | " | 5.1.86 |
| Honey, Ada, Trustee for Michelle, Mark, Gavin and Christine Honey, 6/74 Serrell St, East Malvern | 30.62 | " | 15.2.86 |
| Hursey, Pauline, 37 Munich Dve, Keilor Downs | 97.50 | " | 22.8.85 |
| Hursey, Pauline, 37 Munich Dve, Keilor Downs | 97.50 | " | 22.11.85 |
| Ireland, George L, 2917 Nepean Hwy, Blairgowrie | 32.33 | " | 11.12.85 |
| James, Ann M, Flagstaff Hill Henty, RSD 305 Casterton | 33.75 | " | 15.10.85 |
| Jamison, Elaine, 38 Allambee Ave, Camberwell | 112.50 | " | 20.2.86 |
| Joyce, John, 64 High St, Ararat | 525.00 | " | 15.4.85 |
| Kelly, Barbara I, 32 Blair St, Coburg | 26.12 | " | 15.5.85 |
| Keane, Beverley J, 78 Manton Rd, Clayton | 22.30 | " | 23.3.85 |
| Keane, Beverley J, 78 Manton Rd, Clayton | 24.70 | " | 23.6.85 |
| Keane, Beverley J, 78 Manton Rd, Clayton | 24.78 | " | 23.9.85 |
| Keane, Beverley J, 78 Manton Rd, Clayton | 28.08 | " | 23.12.85 |
| Kendrick, Ross P, 215 Lawrence Rd, Mt. Waverley | 44.63 | " | 15.6.85 |
| Kendrick, Ross P, 215 Lawrence Rd, Mount Waverley | 44.63 | " | 15.12.85 |
| Kneebone, Emelie A, Nevin Lenne Gross & Bennett, PO Box 234, Myrtleford | 103.79 | " | " |
| Kosky, Elsa, 1/740 Orrong Rd, Toorak | 85.00 | " | 9.3.85 |
| Kyabram Rotaract Club, PO Box 415, Kyabram | 15.44 | " | 18.6.85 |
| Lee, George C and Jane, 1/45 Regent St, Mount Waverley | 215.75 | " | 20.6.85 |
| Leblanc, Elsie and Victoria I, 35 Mary St, St Kilda | 34.93 | " | 20.12.85 |
| Legg, Eunice, 77 Station St, Port Melbourne | 350.00 | " | 15.2.86 |
| Lear, Maisie, Trustee for Steffan Vaivars and Keiran Vaivars, 34 Rosalind St, Maroopna | 10.55 | " | 13.6.85 |
| Loft, Sheralyn B, 12 Singleton Rd, North Balwyn | 16.25 | " | 15.1.86 |
| Lord, Ella R, 240 Flinders/Frankston Rd, Frankston | 14.05 | " | 17.2.86 |
| Lovejoy, Jean E, 4 Shenandoah Drive, Coronet Bay | 175.00 | " | 4.1.86 |
| Mallac, Eileen, 3 Knight St, Elwood | 44.06 | " | 27.7.85 |
| Malvern Grammarians, c/o Mr Neat, 183 Hawthorn Rd, Vermont South | 76.51 | " | 8.6.85 |
| Maroney, Ronald, Trustee for Amy Maroney, Eildon Rd, Thornton | 18.90 | " | 9.2.86 |
| Maroney, Ronald, Trustee for Amy Maroney, Eildon Rd, Thornton | 15.44 | " | 9.8.85 |
| Massing, Natham I, 22 Coleman Ave, East Kew | 162.50 | " | 14.1.86 |
| Matthews, Herbert N and Betty P, 15 Leslie Rd, Essendon | 506.25 | " | 7.2.86 |
| McAuliffe, Paul A, 1029 Wellington St, West Perth | 18.49 | " | 20.1.86 |
| McLaine, Patricia, 11 Brooklyn Ave, South Caulfield | 101.25 | " | 15.2.86 |
| McLaine, Patricia, 11 Brooklyn Ave, South Caulfield | 101.25 | " | 15.11.85 |
| McMorrison, Jennifer V, Trustee for A C McMorrison Family Trust, 9 Riversdale Crt, Hawthorn | 70.83 | " | 7.2.86 |
| McPherson, Donald H (estate of), c/o Beard Dawbard & Ongarellio, 411 Nepean Hwy, Frankston | 22.68 | " | 23.2.86 |
| Mellor, James B, Trustee for Michelle McDonald, c/o 24 Higgins Ave, Sunbury | 37.81 | " | 4.2.86 |

Unclaimed Moneys Act 1962

Register of Unclaimed Moneys held by the—

| <i>Name of Owner on Books and Last Known Address</i> | <i>Total Amount Due to Owner</i> | <i>Description of Unclaimed Money</i> | <i>Date when Amount first became Payable</i> |
|---|--|---|--|
| S | | | |
| ESANDA LIMITED— <i>continued</i> | | | |
| Menyweather, Ellis R and Joyce R, 19 Webster Cres, Watsonia | 214.37 | Interest | 30.8.85 |
| Millsom, Vallance H and Joan M, 36 Maltravers Rd, Ivanhoe | 28.53 | " | 20.6.85 |
| Milne, Harold M A, 37 Patrick St, Stawell | 16.88 | " | 27.9.85 |
| Mimis, Leslie G, 36 Brock St, Euroa | 52.00 | " | 23.5.85 |
| Moulton, Peter J, 13 Black St, Brighton | 290.50 | " | 15.9.85 |
| Monahan, Ann M, 138 Hawdon St, Heidelberg | 27.00 | " | 31.8.85 |
| Morris, Shane F, 10 Cumming St, Burwood | 15.50 | " | 24.9.85 |
| Morris, Shane F, 10 Cumming St, Burwood | 17.57 | " | 24.12.85 |
| Morwell Urban Fire Brigade, 44/48 Church St, Morwell | 30.62 | " | 22.1.86 |
| Morwell Urban Fire Brigade, 44/48 Church St, Morwell | 30.62 | " | 22.10.85 |
| Moylan, Anthony J, c/o Esanda Registry, 1 Collins St, Melbourne | 27.74 | " | 2.3.85 |
| Moylan, Anthony J, c/o Esanda Registry, 1 Collins St, Melbourne | 30.44 | " | 2.6.85 |
| Moylan, Anthony J, c/o Esanda Registry, 1 Collins St, Melbourne | 30.88 | " | 2.9.85 |
| Moylan, Anthony J, c/o Esanda Registry, 1 Collins St, Melbourne | 33.62 | " | 2.12.85 |
| Munro, Leslie J (estate of), 25 North Rd, Brighton | 435.00 | " | 15.11.85 |
| Murphy, Betty J, 15 Newington Gve, Caulfield | 13.96 | " | 24.3.85 |
| Murrumbidgee Districts Junior Football Club, Social Committee, 9 Beauville Ave, Murrumbidgee | 13.87 | " | 2.3.85 |
| Murrumbidgee Districts Junior Football Club, Social Committee, 9 Beauville Ave, Murrumbidgee | 15.44 | " | 2.9.85 |
| Nikkelson, Gwenda P, 36 Glenshan La, Mount Eliza | 67.50 | " | 15.10.85 |
| Northcote, Marguerite M (estate of), c/o Fleming Henderson and Gardiner, PO Box 44, Albury | 76.56 | " | 15.5.85 |
| O'Brien, Margaret I, 26 McGregor St, Fairfield | 280.00 | " | 29.7.85 |
| O'Brien, Margaret I, 26 McGregor St, Fairfield | 127.50 | " | 15.6.85 |
| Ogden, Maisie, 20 Breadlebaine St, Newcomb | 37.40 | " | 5.2.86 |
| Paul, Lorraine S (estate of), c/o D B Paul, 694 Nepean Hwy, Carrum | 67.50 | " | 15.6.85 |
| Pearce, Jean A, PO Box 84, Toorak | 340.00 | " | 4.1.86 |
| Petschel, Elfreda M, 54 Rippon Rd, Hamilton | 101.51 | " | 6.2.86 |
| Pettigrew, James B, RSD, Wunghno | 42.50 | " | 8.4.85 |
| Phillips, Hilda J (estate of) and Arthur A, c/o Meloyne Barnett, PO Box 58, Box Hill | 88.13 | " | 15.12.85 |
| Powell, Wilfred A G (estate of), c/o Madden Butler Elder & Grah, 500 Collins St, Melbourne | 437.50 | " | 15.7.85 |
| Preston, Noel B, Trustee for James Harley Preston, 64 Heatherdale Rd, Mitcham | 12.75 | " | 15.11.85 |
| Przibella, Craig L, 238 Wirraway St, Albury | 37.81 | " | 12.2.86 |
| Pugh, Vera M, 5 Hassall St, Port Melbourne, NSW | 37.81 | " | 6.2.86 |
| Rawlings, Malcolm S, Trustee for Nathon R & Joel S Rawlings, 37 Clark St, Hamilton | 15.62 | " | 26.3.85 |
| Rawlings, Malcolm S, Trustee for Nathon R & Joel S Rawlings, 37 Clark St, Hamilton | 15.62 | " | 26.6.85 |
| Rawlings, Malcolm S, Trustee for Nathon R & Joel S Rawlings, 37 Clark St, Hamilton | 15.62 | " | 26.9.85 |
| Rawlings, Malcolm S, Trustee for Nathon R & Joel S Rawlings, 37 Clark St, Hamilton | 15.62 | " | 26.12.85 |
| Richardson, Marjory D, Glenallan PB, Swan Hill | 33.75 | " | 30.11.85 |
| Riley, Erin M, Flat 2/37 Breaker St, Mainbeach | 16.88 | " | 17.11.85 |
| Rousset, Marc A F and Marie D, c/o Bundoora Hotel Plenty, Bundoora | 13.56 | " | 5.7.85 |
| Saunders, Henry A, 196 Hope St, Brunswick | 49.00 | " | 15.2.86 |
| Smith, Martin, 1 Jessie St, Blackburn North | 17.19 | " | 17.1.86 |
| Steel, Howard J, Trustee for David James Keswick Steel, 4 Beale St, Templestowe | 15.62 | " | 15.3.85 |

Unclaimed Moneys Act 1962

Register of Unclaimed Moneys held by the—

| <i>Name of Owner on Books and Last Known Address</i> | <i>Total Amount Due to Owner</i> | <i>Description of Unclaimed Money</i> | <i>Date when Amount first became Payable</i> |
|---|--|---|--|
| \$ | | | |
| ESANDA LIMITED— <i>continued</i> | | | |
| Steel, Howard J, Trustee for David James Keswick Steel, 4 Beale St, Templestowe | 15.62 | Interest | 15.6.85 |
| Steel, Howard J, Trustee for David James Keswick Steel, 4 Beale St, Templestowe | 15.62 | ,, | 15.9.85 |
| Steel, Howard J, Trustee for David James Keswick Steel, 4 Beale St, Templestowe | 15.62 | ,, | 15.12.85 |
| Stevens, Hope, 40 Myrtle St, Clifton Hill | 37.05 | ,, | 25.7.85 |
| Tate, Valerie A, Hilden King Rd, Harkaway | 123.51 | ,, | 15.8.85 |
| Taylor, Robert W, 101 Sparks Rd, Norlane | 10.47 | ,, | 19.12.85 |
| Thompson, Mary G, Unit 8/330 Springvale Rd, Donvale | 21.38 | ,, | 14.10.85 |
| Thornley, Susanne M, 2 Teresa St, Greensborough | 15.12 | ,, | 8.2.86 |
| Threnoworth, Gordon W and Alma P, 29 Bournian Ave, Strathmore | 18.90 | ,, | 15.2.86 |
| Tilley, Margaret C, 22 Mervin Cres, Ivanhoe | 160.00 | ,, | 15.3.85 |
| Toohey, Sylvia A, 3 Bryant St, Warrnambool | 25.00 | ,, | 15.12.85 |
| Tragear, Dorothy E, 19 Elizabeth St, Doncaster East | 44.38 | ,, | 30.12.85 |
| Trewartha, Roy R C, 3/49 Victoria St, Box Hill | 439.18 | ,, | 20.2.86 |
| Tsui, Charles, 8 Myrning St, Burwood | 33.75 | ,, | 14.2.86 |
| Turner, Iris C A, 8 Carman Crt, Ringwood | 12.50 | ,, | 15.5.85 |
| Turner, Veronica A, PO Box 60, Robinvale | 35.00 | ,, | 16.1.86 |
| Vegar, Helen J, c/o R Ferguson, 230 Dendy St, East Brighton | 21.25 | ,, | 4.3.85 |
| Vella, Michael, 10 Rangeview Ave, Chadstone | 130.00 | ,, | 27.5.85 |
| Vella, Michael, 10 Rangeview Ave, Chadstone | 130.00 | ,, | 27.8.85 |
| Vinnicombe, Thea, 75 Hovell St, Echuca | 15.44 | ,, | 26.9.85 |
| Vlahandreas, Tony, 210 Bridge St, Port Melbourne | 116.20 | ,, | 16.5.85 |
| Walter Hazel S and K, (estate of) G H Walter, c/o Turner Ness & Davis, 8/12 Batman Ave, Melbourne | 544.00 | ,, | 15.3.85 |
| Walter, Hazel S and K, (estate of) G H Walter, c/o Turner Ness & Davis, 8/12 Batman Ave, Melbourne | 544.00 | ,, | 15.6.85 |
| Walter, Hazel S and K, (estate of) G H Walter, c/o Turner Ness & Davis, 8/12 Batman Ave, Melbourne | 544.00 | ,, | 15.9.85 |
| Warner, Stephen P, c/o Bairnsdale Tourist Caravan Park | 233.26 | ,, | 7.1.86 |
| Wathen, Norma C, 10 Dellas Ave, Templestowe | 72.55 | ,, | 7.1.86 |
| Wathen, Norma C, 10 Dellas Ave, Templestowe | 56.57 | ,, | 7.4.85 |
| Wathen, Norma C, 10 Dellas Ave, Templestowe | 61.08 | ,, | 7.7.85 |
| Wathen, Norma C, 10 Dellas Ave, Templestowe | 62.53 | ,, | 7.10.85 |
| Watson, Herbert W and Myrtle A E, c/o Esanda Ltd, 5/1 Collins St, Melbourne | 31.25 | ,, | 15.9.85 |
| Watson, Herbert W and Myrtle A E, c/o Esanda Ltd, 5/1 Collins St, Melbourne | 31.25 | ,, | 15.12.85 |
| Whitehead, Gilbert E, 45 Strathmore St, Bentleigh | 125.00 | ,, | 15.12.85 |
| Wilson, Jessica L, Murdeduke Cressy Rd, Winchelsea | 65.00 | ,, | 5.9.85 |
| Wilton, Lylie L, c/o R Sill, 15 Leindon Crt, Mt Eliza | 103.13 | ,, | 17.11.85 |

WORKMANS No. 26 CO-OPERATIVE
HOUSING SOCIETY LIMITED
Draft Notice of Final Meeting in Voluntary
Winding Up

Take notice that the affairs of the abovernamed Society are now fully wound up and that in pursuance of section 411 (2) of the Victorian Companies Code and the *Co-operative Housing Societies Act 1958*, A general meeting of the society will be held on 2nd Floor, 33 Princes Highway, Dandenong on Monday, 22 June 1987 at 5.30 p.m. for the purpose of:

- (i) laying before it an account showing how the winding up has been conducted and the property of the society disposed of and giving any explanation thereof; and
- (ii) passing a resolution that the books and papers of the said society and of the liquidator relevant to the affairs of the society be destroyed after a period of twelve months from the date of the meeting.

Dated 14 May 1987

7157 L. S. EVA, Liquidator

WORKMANS No. 8 CO-OPERATIVE
HOUSING SOCIETY LIMITED
Draft Notice of Final Meeting in Voluntary
Winding Up

Take notice that the affairs of the above-named Society are now fully wound up and that in pursuance of section 411 (2) of the Victorian Companies Code and of the *Co-operative Housing Societies Act 1958*, a general meeting of the society will be held on 2nd Floor, 33 Princes Highway, Dandenong on Monday, 22 June 1987 at 5.30 p.m. for the purpose of:

- (i) laying before it an account showing how the winding up has been conducted and the property of the society disposed of and giving any explanations thereof; and
- (ii) passing a resolution that the books and papers of the said society and of the liquidator relevant to the affairs of the society be destroyed after a period of twelve months from the date of the meeting.

Dated 14 May 1987

7158 L. S. EVA, Liquidator

Notice of final meeting in voluntary winding up
KARDINIA (No. 11) CO-OPERATIVE
HOUSING SOCIETY LIMITED

Take notice that the affairs of the abovenamed Society are now fully wound up and that in pursuance of section 272 (1) of the *Companies*

Act 1961 and of the *Co-operative Housing Societies Act 1958* a General Meeting of the Society will be held at Aberdeen Chateau, 115 Aberdeen Street, Newtown on 15 June 1987 at 7.30 p.m. for the purpose of:

- (1) Laying before it an account showing how the winding up has been conducted and the property of the Society disposed of and giving any explanations thereof; and
- (2) Passing a Resolution that the Books and Papers of the said Society and of the Liquidator relevant to the affairs of the Society be destroyed after a period of twelve months from the date of the meeting.

Dated 30 April 1987

7112 A. R. QUICK, Liquidator

SUNBURY PRINTING & PUBLISHING Co.
PTY. LTD. (in Liquidation)

Companies (Victoria) Code—Section 411 (2)

Notice is hereby given of a meeting of the Members of Sunbury Printing & Publishing Co. Pty. Ltd. (In Liquidation) to be held at 133 Rose Street, Essendon, 3040 on 20 June 1987 at 9.00 a.m.

The object of the Meeting is to report on the progress and completion of the liquidation of the Company.

Dated 12 May 1986

THOMAS D. WOODLOCK, Liquidator, 133
Rose Street, Essendon 7114

Advertising Winding up Resolution
THE CAMPERDOWN-TERANG CO-
OPERATIVE HOUSING SOCIETY LIMITED

(in Liquidation)

Special Resolution

Passed 5 May 1987

At a Special General Meeting of the abovenamed Society duly convened and held at 8 Church Street Camperdown on 5 May 1987 at 7.30 p.m. the subjoined special resolution was duly passed:

1. That the Society having successfully completed its objectives 35 months ahead of its expected term be wound up voluntarily, and that John Patrick Sinnott of 70 Bowen Street Camperdown be appointed liquidator for the purposes of winding up.

A. J. ARUNDELL

Chairman of Meeting

P. J. Sinnott & Associates, public accountants,
8 Church Street, Camperdown 7109

In the Supreme Court of Victoria—1987 Co. No. 266—In the matter of the Companies (Victoria) Code; and in the matter of Wildtrek Limited—Advertisement of application

Notice is hereby given that an application for the winding up of the abovenamed company by the Supreme Court was on 29 April 1978 filed by Australian World Expedition Pty. Ltd. The application is to be heard before the Court in the 7th Court, Law Courts, Lonsdale Street, Melbourne at 10.30 a.m. on 24 June 1987.

The liquidator whose appointment is sought is Robert Eastaugh Ramsay of the firm of Bird Cameron Insolvency, 7th Floor, 128 Exhibition Street, Melbourne.

Any creditor or contributory of the company desiring to support or oppose the making of an order on the application may appear at the time of hearing by himself or his Counsel for that purpose. A copy of the application will be furnished by the undersigned to any creditor or contributory of the company requiring it on payment of the regulated charge.

The applicant's address is 377 Sussex Street, Sydney.

The applicant's solicitor is Trumble & Szanto of 5th Floor, Pran Central, 325 Chapel Street, Prahran.

TRUMBLE & SZANTO

Note: Any person who intends to appear on the hearing of the application must serve on or send by post to the abovenamed solicitors, Trumble & Szanto notice in writing of his intention so to do. The notice must state the name and address of the person or, if a firm, the name and address of the firm, and must be signed by the person or firm, or his or their solicitor (if any), and must be served or, if posted, must be sent by post in sufficient time to be received not later than 4 o'clock in the afternoon of Tuesday, 23 June 1987. 7110

JAMES McEWAN, late of 65 Comans Street, Morwell, in the State of Victoria, retired, deceased

Creditors, next of kin and others having claims in respect of the estate of the deceased (who died on 1 May 1986) are required by the administratrix Noreen Myrtle McEwan 65 Comans Street, Morwell in the said State, widow to send particulars to her care of the undermentioned solicitors by 21 July 1987 after which date the administratrix may convey or distribute the assets having regard only to the claims of which she then has notice.

SLATER & GORDON, solicitors, of 636 Bourke Street, Melbourne 7185

DORIS ROSETTA ELIZABETH GRAY, late of 99 Paisley Street, Footscray, widow

Creditors, next of kin and others having claims in respect of the estate of the deceased (who died on 2 March 1987) are required by the Perpetual Executors and Trustees Association of Australia Ltd of 150 Queen Street, Melbourne to send particulars of their claims to the said company by 15 July 1987 after which date it will convey or distribute the assets, having regard only to the claims of which the company then has notice. 7186

MINNIE IRENE AMY TAYLOR, late of Caulfield Hospital, 294 Kooyong Road, Caulfield, spinster, deceased

Creditors, next of kin and others having claims in respect of the estate of the deceased (who died on 13 November 1986) are required by the Perpetual Executors and Trustees Association of Australia Limited of 50 Queen Street, Melbourne, to send particulars of their claims to the said company by 22 July 1987 after which date it will convey or distribute the assets, having regard only to the claims of which the company then has notice.

WM. R. HUNT, M.A., LL.B., 358 Lonsdale Street, Melbourne 7187

FAY BROOKS, late of 317 Orrong Road, East St. Kilda, in the State of Victoria, widow, deceased

Creditors, next of kin and others having claims in respect of the estate of the deceased (who died on 1 April 1987) are required by the executrices Golda Mehlman of 3/11 Sorrett Avenue, Malvern, married woman and Jean Ronea of 9A Fenwick Street, Kew, widow, to send particulars of their claims to them at the office of the undermentioned solicitors on or before Friday, 24 July 1987, after which date they will convey or distribute the assets, having regard only to the claims of which they then have notice.

BEST HOOPER, solicitors, 400 Little Collins Street, Melbourne 7182

Creditors, next of kin and others having claims in respect of the estate of the deceased, William Joseph Bevan who died on 12 November 1986 are required by the Executor Jeffrey Gordon Bland (in the Will named Geoffrey Bland) to send particulars of their claims in writing to the said Executor care of the undermentioned firm of solicitors by 28 July 1987 after which date the executor will distribute the assets having regard only to the claims of which they then have notice.

MAL. RYAN, JACKSON & GLEN, solicitors, 81 Grant Street, Alexandra 7183

Creditors, next of kin and others having claims in respect of the estate of Ethel Mary Podger, late of 14/6 Mitchell Street, Mentone, spinster deceased who died on 12 January 1987, are to send the particulars of their claims to ANZ Executors and Trustee Company Limited of 94 Queen Street, Melbourne by 1 September 1987 after which date it will distribute the assets having regard only to the claims of which it then has notice.

7184

GRACE MARY FENELON, late of Vincenpaul Hostel for the Aged, 13 Strabane Avenue, Box Hill North in the State of Victoria, widow, deceased

Creditors, next of kin and others having claims in respect of the estate of the abovenamed deceased who died on 14 January 1987 are required by National Trustees Executors and Agency Company of Australasia Limited of 419 Collins Street, Melbourne, the Executors of the deceased's Will to send particulars of their claims to it by 29 July 1987, after which date it will convey or distribute the assets having regard only to the claims which it then has notice.

A. B. NATOLI, LL.B., solicitor of 24 Cotham Road, Kew

7128

HETTY FAIGEL MEISSNER, late of Flat 3, 4 Kireep Road, Balwyn, in the State of Victoria, widow, deceased

Creditors, next of kin and others having claims in respect of the estate of the deceased, who died on 25 October 1986 are required by the trustees, Jonathan Michael Meissner, of 17 Davis Street, Kew, in the said State, and Michael William Caraher, of 140 William Street, Melbourne, in the said State, to send particulars to them by 22 July 1987, after which date the trustees may convey or distribute the assets, having regard only to the claims of which the trustees then have notice.

HALL & WILCOX, solicitors, 140 William Street, Melbourne

7173

PENTTI KALEVI KALLBACKA, deceased, late of 21 George Street, Hartwell, Victoria, died on 3 March 1987

Any persons claiming to be dependent upon the deceased are requested to send particulars of their claims to "Life Claims Department, Australian Eagle Ins. Co. Ltd., G.P.O. Box 1883R, Melbourne 3001", within two months of the date

of this notice, after which date the deceased's entitlement will be distributed in accordance with the provisions of the Eagle Retirement Fund Trust Deed, having regard only to the claims which have been notified.

7177

ARTHUR GEORGE ARNOTT, late of Rymers Road, Gladysdale, retired printer, deceased

Creditors, next of kin and others having claims in respect of the estate of the deceased, who died on 1 January 1987, are required by the executor Thomas Herbet Harman, of 47 Humber Road, Croydon, estate agent, to send particulars to him care of the undermentioned solicitors by 25 July 1987, after which date the executor may convey or distribute the assets having regard only to the claims of which he then has notice.

RATNER McPHEE, solicitors, of 199 Stud Road, Wantirna South

7175

HENRY ROBERT WILLGOSS JONES, late of 2/35 Rose Street, Altona, retired company director, deceased

Creditors, next of kin and others having claims in respect of the estate of the deceased, who died on 26 April 1986, are required by Mary Jones, of 1/39 Ligar Street, Sunbury, widow, the executrix to whom probate of the will of the said deceased, was granted by the Supreme Court of Victoria, to send particulars to her care of the undermentioned solicitors by 1 August 1987, after which date the said executrix may convey or distribute the assets having regard only to claims of which she then has notice.

MESSRS PATRICK J. CANNON, COBURN & ASSOCIATES, solicitors, of 205 Hampshire Road, Sunshine

7174

Creditors, next of kin and others having claims in respect of the estate of Dorothy Jean Reynoldson, late of 5 Glenferrie Street, Caulfield North, spinster, deceased, who died on 19 February 1987, are required by the executrix of the estate to send particulars of their claims to the executrix, in the care of the undermentioned solicitors by 20 July 1987, after which date the said executrix will distribute the assets having regard only to the claims of which they then have notice.

VERA FOWLER & CO., solicitors, of 1 Evandale Road, Malvern

7176

In the intestate estate of URBANO ALBERTO SEGAFREDO, late of 12 Putnam Avenue, Bendigo in the State of Victoria, retired, deceased, intestate

Creditors, next of kin and all other persons having claims against the estate of the said deceased are required by Antonietta Segafredo of 12 Putnam Avenue, Bendigo aforesaid widow the next of kin of the said deceased to send particulars of such claims to her in care of the undermentioned solicitors on or before 15 July 1987 after which date she will distribute the assets having regard only to the claims to which she then has notice.

BASILE & CO, barristers and solicitors, 46 Wellington Street, Kerang 7161

HELEN KING, late of 324 Beveridge Street, Swan Hill, in the State of Victoria, widow, deceased (who died on 4 January 1987)

Creditors, next of kin and all other persons having claims against the estate of the deceased are required by the executors of the will, James Horatio King, William Dunstan King and Roma Grace Nalder, to send particulars to them care of the undersigned on or before 15 July 1987, after which date they will distribute the assets having regard only to the claims of which they then have notice.

GARDEN & GREEN, solicitors, 4 McCallum Street, Swan Hill 7162

ALFRED THOMAS HALL WHITEHEAD, late of "The Meadows", Towong, in the State of Victoria, farmhand, deceased

Creditors, next of kin and others having claims in respect of the estate of the deceased who died on 19 December 1986, are required by the executor Clive Francis Daly of "Coolangatta", Khancoban, New South Wales to send particulars to him care of Hood & Braham, solicitors, PO Box 7, Corryong, 3707 by 12 August 1987 after which date the executor may convey or distribute the assets, having regard only to the claims of which he then has notice.

Dated 8 May 1987 7163

WINIFRED MAY HOGARTH FISHER, late of 3 McDonald Street, Mansfield, spinster, deceased

Creditors, next of kin and others having claims in respect of the deceased who died on 9 October 1986 are required by her trustees Hugh David Boyd Norman of 17 Lord Street, Roseville, engineer and Robert John Ritchie of Beolite, Mansfield, grazier to send particulars to them care of the undermentioned firm of solicitors by

5 August 1987 after which date the trustees may convey and distribute the assets having regard only to the claims of which they then have notice.

MESSRS MAL. RYAN, JACKSON & GLEN, 9 High Street, Mansfield, solicitors for the trustees 7164

WALTER ARTHUR BASTERFIELD, late of 20 Valkstone Street, East Bentleigh, retired, deceased

Creditors, next of kin and others having claims in respect of the estate of the deceased who died on 5 November 1986 are required by the executors Linda Leigh Basterfield, home duties and Daryl Walter Basterfield, technical officer, both of 20 Valkstone Street, East Bentleigh to send particulars to them by 22 July 1987 after which date the executors may convey or distribute the assets, having regard only to the claims of which they then have notice.

COHENS FRENKEL KEFFORD NEW, solicitors, of 114 William Street, Melbourne 7116

JOHN MALCOLM TAYLOR, late of Boga Street, Lake Boga, in the State of Victoria, pensioner, deceased

Creditors, next of kin and other persons having claims against the estate of the said deceased who died on 5 January 1987 are required to send particulars of same to the executors John Taylor and Leonard Thomas Taylor in care of the undersigned on or before 20 July 1987 after which date they will distribute the assets having regard only to the claims of which they then have notice.

DWYER BENNETT & MAHON, barristers and solicitors, 194-208 Beveridge Street, Swan Hill 7117

KATIE LAVINIA MCKENZIE, late of Sea Lake, in the State of Victoria, married woman, deceased

Creditors, next of kin and other persons having claims against the estate of the said deceased who died on 14 March 1987 are required to send particulars of same to the executors Henry Joseph Watson and Lynette Joyce Schodde, in care of the undersigned on or before 20 July 1987 after which date they will distribute the assets having regard only to the claims of which they then have notice.

DWYER BENNETT & MAHON, barristers and solicitors, 194-208 Beveridge Street, Swan Hill 7118

THOMAS CLIVE BULL, late of 12 Boys Street, Swan Hill, in the State of Victoria, farmer, deceased (who died on 9 January 1987)

Creditors, next of kin and all other persons having claims against the estate of the deceased are required by the executors of the Will, Donald Charles Henderson and Gordon Oppenlander, to send particulars to them care of the undersigned on or before 15 July 1987, after which date they will distribute the assets having regard only to the claims of which they then have notice.

GARDEN & GREEN, solicitors, 4 McCallum Street, Swan Hill 7119

EDITH MAUDE ELIZABETH HUGHSON, late of Greensborough Private Nursing Home, 226 Elder Street, Greensborough, widow, deceased

Creditors, next of kin and others having claims in respect of the estate of the deceased who died on 14 January 1987 are required by the Trustee, Philip Edington Rhoden, solicitor of 376 Collins Street, Melbourne to send particulars to him care of John P. Rhoden, 376 Collins Street, Melbourne by 31 July 1987 at which date the Trustee may convey or distribute the assets having regard only to the claims of which he then has notice.

Dated 15 May 1987 7169

FLORENCE MAY MONISH, late of 16 Naroon Road, Alphington, in the State of Victoria, widow, deceased

Creditors, next of kin and others having claims in respect of the deceased who died on 21 April 1987 are required by the Executor, Brian Redmond Smyth of 900 Main Road, Eltham, solicitor, to send particulars to the undermentioned firm by 23 July 1987 after which date the said Executor may convey or distribute the assets having regard to the claims of which notice has by then been given.

SETON WILLIAMS & SMYTH, solicitors, 900 Main Road, Eltham 7170

JANET ELIZABETH KING, late of 1175 Main Road, Eltham, in the State of Victoria, home duties, deceased

Creditors, next of kin and others having claims in respect of the estate of the deceased who died on 17 April 1987 are required by the Executor, Brian Redmond Smyth of 900 Main Road, Eltham, solicitor and executrices Lorraine Shields of 103 Bible Street, Eltham, married woman and Eileen Jenkins of 123 Brougham Street, Eltham, married women, to send particulars to the undermentioned firm by 23 July 1987 after which

date the said Executor may convey or distribute the assets having regard to the claims of which notice has by then been given.

SETON WILLIAMS & SMYTH, solicitors, 900 Main Road, Eltham 7171

Creditors, next of kin and others having claims against the estate of Vincent Ernest Atyeo late of 405 Beach Road, Beaumaris in the State of Victoria, retired, who died on 15 March 1987 are required by the Executors Mark Vincent Atyeo of 25 Wilsmore Crescent, Chifley in the Australian Capital Territory, public servant, George Francis Atyeo of Crossakeil Court, Hawthorn in the State of Victoria, retired and Robert Owen Church of 15 Bundoran Parade, Box Hill North in the State of Victoria, accountant to send particulars of their claims to them care of the undersigned by 20 July 1987 after which date they may convey or distribute the estate having regard only to the claims of which they then have notice.

JOHN D. MUSTOW & CO., solicitors, 105 Queen Street, Melbourne 7172

LILLIAN CURZON, late of 3 Oulton Street, Caulfield

Creditors, next of kin and others having claims in respect of the deceased, who died on 9 December 1986 are required by the trustee Damian Kevin Kelly of Old Melbourne Road, Millbrook, Ballarat to send particulars to him by 31 July 1987 after which date the trustee may convey or distribute the assets having regard only to the claims of which he then has notice.

Dated 11 May 1987 7120

ARTHUR GEORGE RITCHIE, late of 375 Station Street, Box Hill, retired plumber, deceased

Creditors, next of kin and others having claims in respect of the estate of the deceased, who died on 14 March 1984 are required by the executors Arthur Maxwell Ritchie and Faye Maree Kirkup to whom probate was granted by the Supreme Court of Victoria on 29 April 1986 to send particulars of their claims to the said executors care of Hicks & Oakley, solicitors, 217 Blackburn Road, Mount Waverley by 27 July 1987 after which date they will convey or distribute the assets having regard only to the claims of which they then have notice.

7121

Creditors, next of kin or others having claims in respect of the estate of Kevin Timothy Carr, late of Harold McCracken Nursing Home of 6 Church Street, North Fitzroy, retired driver, deceased, who died on 16 July 1986 are to send particulars of their claims to the administratrix care of the undermentioned solicitors by 20 July 1987 after which date the administratrix will distribute the assets having regard only to the claims of which she then has notice.

D. C. DAVINE EDMUNDS & CO., solicitors,
39 Breed Street, Traralgon 7123

Park, toolmaker and Czeslaw Wojcik of 22 Campbell Street, Glen Waverley, railway employee the executors to whom Probate of the Will of the said deceased was granted by the Supreme Court of Victoria to send particulars care of the undersigned by 27 July 1987 after which date the said executors may convey or distribute the assets having regard only to the claims of which they then have notice.

PATRICK J. CANNON, COBURN &
ASSOCIATES, solicitors, 205 Hampshire Road,
Sunshine 7126

Creditors, next of kin and others having claims in respect of the Will of Moira Bible, late of 30 Grace Street, Malvern, widow, deceased, who died on 20 March 1987 are requested to send particulars of their claims to the executors Janice Moira Bible and Peter Julian Bible care of the undermentioned solicitor by 22 July 1987 after which date they will distribute the assets having regard only as to the claims of which they then have notice.

JOHN STEWART, solicitor, 290 Racecourse
Road, Newmarket 7123

Creditors, next of kin and others having claims against the estate of Patrick Martin O'Brien formerly of 10 Arthur Street, South Yarra in the State of Victoria but late of 36 Andrew Street, Oakleigh in the said State, retired electrician, deceased, who died on 11 February 1987 probate of whose estate was granted to Terence Michael O'Brien (in the Will called Terrence O'Brien) of 6 Munro Avenue, Mount Waverley in the said State, gentleman, are to send particulars of such claims to the undersigned at his office hereunder mentioned by 20 July 1987, after which date the said Terence Michael O'Brien will distribute the assets having regard only to the claims of which he shall then have had notice.

JOHN KEATING & ASSOCIATES, solicitors,
191 Greville Street, Prahran 7127

Creditors, next of kin and others having claims in respect of the Will of Sebastiano Buccheri late of 27 Shields Street, Flemington, gentleman, deceased who died on 2 April 1987 are requested to send particulars of their claims to the Executrix Sebastiana Buccheri c/o the undermentioned solicitor by 22 July 1987 after which date she will distribute the assets having regard only as to the claims of which she then has notice.

JOHN STEWART, solicitor, 290 Racecourse
Road, Newmarket 7124

ENID LENORE FISKE, late of 5/2 Rodney
Street, Bendigo, widow, deceased

Creditors, next of kin and others having claims against the estate of the said deceased, who died on 31 January 1987, are to send particulars of their claims to George Huntly Gordon and Charles Bernard Gore Brett, care of Messrs Blake & Riggall, solicitors, 140 William Street, Melbourne, by 20 August 1987, after which date they will distribute the assets having regard only to the claims of which they then have notice.

7165

Creditors, next of kin and others having claims in respect of the estate of Sydney McCure late of 15 Fairbairn Road, Toorak, gentleman, deceased are requested to send notices of their claims to the Executrix Diana Florence Lilian Sonenberg care of Messrs Middletons Oswald Burt, 140 William Street, Melbourne by 22 July 1987 after which date the Executrix will distribute the estate having regard only to the claims of which she then has notice.

MIDDLETONS OSWALD BURT, solicitors,
140 William Street, Melbourne 7125

JOSEF KUCZYNSKI late of 32 Blanche Street,
Ardeer, labourer, deceased

Creditors, next of kin and others having claims in respect of the estate of the deceased who died on 12 November 1986 are required by Edward Henry Kuczynski of 39 Chester Crescent, Deer

Creditors, next of kin and others having claims in respect of the estate of Cecil Simeon Lord Gerahty, late of 1/110 Stradbroke Avenue, Swan Hill, retired seed merchant, deceased, who died on 15 January 1987, are to send the particulars of their claims to ANZ Executors & Trustee Company Limited, of 94 Queen Street, Melbourne, by 17 August 1987, after which date it will distribute the assets having regard only to the claims of which it then has notice. 7166

Creditors, next of kin and others having claims in respect of the estate of James Kirkpatrick Elliott, late of Unit 3, 125 Thomas Street, Hampton, retired, deceased, who died on 18 February 1987, are to send particulars of their claims to ANZ Executors & Trustee Company Limited, of 94 Queen Street, Melbourne, by 1 August 1987, after which date it will distribute the assets having regard only to the claims of which it then has notice. 7167

ADA BEVERLEY RAINES, late of Unit 3/98 Bruce Street, Preston, married woman, deceased

Creditors, next of kin and others having claims in respect of the estate of the deceased, who died on 25 October 1986, are requested to send particulars of their claims to the executor, Arnold Russell Raines, care of the undesignated solicitor, by 21 July 1987, after which date the said executor will proceed to distribute the estate having regard only to the claims of which he then has notice.

MARJORY C. COATES, 422 Collins Street, Melbourne 7168

LATE NOTICES

Transport Act 1983

ROAD TRAFFIC AUTHORITY

Commercial Passenger Vehicle Applications

Notice is hereby given that the following applications will be considered by the Road Traffic Authority on 23 June 1987.

Notice of any objections should be forwarded to reach the Manager, Vehicle Licensing Branch or any Regional Office of the Road Traffic Authority not later than 17 June 1987.

It will not be necessary for interested parties to appear on the hearing date specified, unless advised in writing by the Authority.

Notification of the date for consideration of applications which are objected to and which require determination by the Road Transport Licensing Tribunal will be published by further notice in this Gazette.

R. Carr, East Ringwood. Application for variation of the conditions of licence SV 626 which authorises a tour within a 55 km pick-up radius of GPO Melbourne to an area bounded by Castlemaine, Avoca, St Arnaud, Wedderburn and Bendigo to operate an additional tour to pick-up within a 55 km radius of GPO Melbourne to vineyards and wineries within the Yarra Valley bounded by Wonga Park, Yarra Glen, Dixon's Creek, Healesville and Yarra Junction.

Timetable: Depart 9.00 a.m. Return 4.30 p.m.

Fares: \$35.00 per person.

Note: Cost of tour includes admission charges and a 3 course luncheon at winery.

A. Crammond, Kilsyth. Application to license one commercial passenger vehicle in respect of a 1968 Pontiac sedan with seating capacity for 5 passengers to operate as a special purpose vehicle from 15 Ruskin Avenue, Croydon for the carriage of passengers for wedding parties.

Note: This application is made in conjunction with similar applications by C. Sikavitsas, L. Scott, S. Woodman, J. M. Flynn, B. Crammond, E. Goudswaard, I. R. Farrow and F. Fazio.

B. Crammond, Kilsyth. Application to license one commercial passenger vehicle in respect of a 1968 Pontiac sedan with seating capacity for 5 passengers to operate as a special purpose vehicle from 15 Ruskin Avenue, Croydon for the carriage of passengers for wedding parties.

Note: This application is made in conjunction with similar applications by C. Sikavitsas, L. Scott, S. Woodman, A. Crammond, J. M. Flynn, E. Goudswaard, I. R. Farrow and F. Fazio.

G. V. Crawley, Huntingdale. Application to license one commercial passenger vehicle in respect of a 1979 Ford LTD sedan with seating capacity for 4 passengers to operate as a special purpose vehicle from 39 Hargreaves Street, Huntingdale for the carriage of passengers for wedding parties.

Note: Notice of this application replaces a notice which appeared in *Victoria Government Gazette* No. G 15, dated 15 April 1987.

Previous objections to the granting of this application are invalid and interested parties are advised that a new notice of objection must be submitted.

Denver Point Pty. Ltd., Ringwood East. Application to license one commercial passenger vehicle with seating capacity for 14 passengers to operate free of charge for the carriage of residents of Achill Lodge on day tours within a 40 km radius of Achill Lodge located at Ringwood East.

Timetable: As and when required.

I. R. Farrow, Clayton North. Application to license one commercial passenger vehicle in respect of a 1967 Chevrolet sedan with seating capacity for 6 passengers to operate as a special purpose vehicle from 15 Ruskin Avenue, Croydon for the carriage of passengers for wedding parties.

Note: This application is made in conjunction with similar applications by C. Sikavitsas, L. Scott, S. Woodman, A. Crammond, B. Crammond, E. Goudswaard, J. M. Flynn and F. Fazio.

F. Fazio, Dandenong. Application to license one commercial passenger vehicle in respect of a 1929 Chevrolet Tourer with seating capacity for 4 passengers to operate as a special purpose vehicle from 15 Ruskin Avenue, Croydon for the carriage of passengers for wedding parties.

Note: This application is made in conjunction with similar applications by C. Sikavitsas, L. Scott, S. Woodman, A. Crammond, B. Crammond, E. Goudswaard, I. R. Farrow and J. M. Flynn.

J. M. Flynn, Croydon. Application to license one commercial passenger vehicle in respect of a 1966 Chevrolet sedan with seating capacity for 5 passengers to operate as a special purpose vehicle from 15 Ruskin Avenue, Croydon for the carriage of passengers for wedding parties.

Note: This application is made in conjunction with similar applications by C. Sikavitsas, L. Scott, S. Woodman, A. Crammond, B. Crammond, E. Goudswaard, I. R. Farrow and F. Fazio.

E. Goudswaard, Croydon. Application to license one commercial passenger vehicle in respect of a 1957 Chevrolet sedan with seating capacity for 5 passengers to operate as a special purpose vehicle from 15 Ruskin Avenue, Croydon for the carriage of passengers for wedding parties.

Note: This application is made in conjunction with similar applications by C. Sikavitsas, L. Scott, S. Woodman, A. Crammond, B. Crammond, J. M. Flynn, I. R. Farrow and F. Fazio.

Gray Blakey Motors Pty. Ltd., Koo Wee Rup. Application to license one class 2 tilt tray tow truck to operate within an 80 km radius from a depot situated at Station, Koo Wee Rup for the purpose of:

- (a) Lifting and carrying or towing damaged or disabled motor cars, excluding the ability to attend the scene of a motor car accident in the "Controlled Area"; and
- (b) Undertaking trade towing.

L. J. Grealy, Wodonga. Application to license one class 2 tow truck to operate within a 100 km radius from a depot situated at 12 Reid Street, Wodonga for the purpose of lifting and carrying or towing damaged or disabled motor cars, excluding the ability to attend the scene of a motor car accident in the "Controlled Area".

Kangaroo Flat Bus Lines Pty. Ltd., Kangaroo Flat. Application to license four commercial passenger vehicles to be purchased, three with seating capacity for 49 passengers and one with seating capacity for 21 passengers to operate as follows:

| (A) Tour No. 1 | Duration |
|---|----------|
| 1. Talking Tram, Central Deborah Mine, Central area of Bendigo, Victoria Hill and Sacred Heart College. | 3 hrs |
| 2. City Sights, Bendigo Pottery, White Hills Cemetery and Chinese Joss House. | 3 hrs |
| 3. Sandhurst Town and Maiden Gully. | 3 hrs |
| 4. Cherry Berry Farm | 2 hrs |
| 5. Arakoon Resort | 2-4 hrs |
| 6. Bendigo Goldfields | 2-3 hrs |
| 7. Wineries near Bendigo | 2-3 hrs |
| 8. Mohair Farm, Carmens Tunnel, Maldon, Mt Tarrangower and Castlemaine. | 7 hrs |
| 9. Echuca, Alambee Auto Museum and Cruise on the Murray River. | 7 hrs |
| 10. Inglewood, Wedderburn returning via Melville Caves. | 7 hrs |

Fares:

| Tour No. | Adult | Pens. | Students |
|----------|---------------------------|-----------------------|----------|
| 1 | \$11.00 | \$11.00 | \$ 8.00 |
| 2 | \$ 6.00 | \$ 4.00 | \$ 4.00 |
| 3 | \$ 8.00 | \$ 7.00 | \$ 5.00 |
| 4 | \$ 5.00 | \$ 5.00 | \$ 3.00 |
| | Adult and Pens. | Student | |
| | (Include Devonshire tea) | (Include Water Slide) | |
| 5 | \$ 4.00 | \$ 4.00 | \$ 4.00 |
| | (All include water slide) | | |
| 6 | \$ 6.00 | \$ 6.00 | \$ 5.00 |
| 7 | \$ 4.00 | \$ 4.00 | \$ 2.00 |
| 8 | \$12.00 | \$ 9.00 | \$ 9.00 |
| 9 | \$16.00 | \$15.00 | \$11.00 |
| 10 | \$10.00 | \$ 9.00 | \$ 7.00 |

Timetable: As and when required.

Note:

- (i) All tours depart Bendigo
- (ii) Cost of each tour includes entrance fees.

ACCOMMODATED PACKAGE TOURS TO BENDIGO

(B) Tours of Educational value and tourist interest.

All tours to commence within 200 km radius of Bendigo. The cost of the tour would include accommodation, all meals (except lunch first day) and entrance fees. All entrance fees are based on the current rate as at 1.4.87. All accommodation rates are based on the current rate as at 1.4.87. All coach rates are based on the current rate as

at 1.4.87. The package tours include any day or half day tours numbered from 1 to 10, which can be included in the itinerary.

| No. of Days | 2 | 3 |
|--|---------|----------|
| Motel Accom. (Adult) | \$78.00 | \$110.00 |
| Motel Accom. (Student) | \$68.00 | \$93.00 |
| Cabins or on-site vans (Student) | \$57.00 | \$72.00 |
| Tents with camp cook (Student) (or other arrangements) | \$46.00 | \$57.00 |

| No. of Days | 4 | 5 |
|--|----------|----------|
| Motel Accom. (Adult) | \$148.00 | \$195.00 |
| Motel Accom. (Student) | \$132.00 | \$174.00 |
| Cabins or on-site vans (Student) | \$108.00 | \$143.00 |
| Tents with camp cook (Student) (or other arrangements) | \$84.00 | \$107.00 |

All the rates quoted are based on 30 or more passengers.

A loading of 20% on groups 22-29 passengers.

A loading of 30% on groups 15-21 passengers.

A loading of 50% on groups or individuals 1-14 passengers.

The student rates are based on one leader per 10 students free of charge.

Note:

(i) Tours packaged by V/Line to and from various venues as directed by State Transport Authority.

(ii) Tours packaged by Travel Agents, groups or other persons.

(C) Under charter conditions from within a 20 km pick-up radius of the Chief Post Office in the City of Bendigo.

Note:

(i) The vehicles to be licensed would hold a minimum 3 star rating for charter purposes.

(ii) Notice of this application replaces a notice which appeared in *Victoria Government Gazette* No. 17 dated 6 May 1987.

Previous objections to the granting of this application are invalid and interested parties are advised that a new notice of objection must be submitted.

K. G. Martin, Nandally. Application to license one commercial passenger vehicle to be purchased with seating capacity for 22 passengers to operate for the carriage of students and groups of the Nandally Community to and from sporting and social activities.

Timetable: As and when required.

Fares: 28 cents per kilometre plus running expenses for school usage. 33 cents per kilometre plus running expenses for community usage.

Note: Notice of this application replaces a notice which appeared in *Victoria Government Gazette*, No. G 17 dated 6 May 1987.

Previous objections to the granting of this application are invalid and interested parties are advised that a new notice of objection must be submitted.

K. M. L. & V. C. O'Connor, Bairnsdale. Application to license one commercial passenger vehicle with seating capacity for 45 passengers to operate for the carriage of school children attending St Annes Grammar School, Sale to the exclusive of all other passengers excepting duly authorised teachers between Paynesville and the school, via Bairnsdale and Eagle Point.

Note: Service to operate under contract to St Annes Grammar School, Sale.

K. M. L. & V. C. O'Connor, Bairnsdale. Application to license two commercial passenger vehicles to be purchased, one with seating capacity for 15-35 passengers and one with seating capacity for 40-45 passengers to operate:

(a) Day and five day tours as follows:

1. Lakes Entrance or Bairnsdale to Buchan Caves.

2. Lakes Entrance or Bairnsdale to Marlo.

3. Lakes Entrance or Bairnsdale to Metung.

4. Lakes Entrance or Bairnsdale to Shelly Beach and the Bluff.

5. Lakes Entrance or Bairnsdale to Tambo Valley.

6. Lakes Entrance or Bairnsdale to Lake Tyers Aboriginal Station.

7. Bairnsdale town tour and surrounding districts.

8. Bairnsdale to Glenaladale National Park.

9. Bairnsdale to Golvinda Winery and Mount Taylor.

10. Bairnsdale to Buchan.

11. Bairnsdale to Bruthen and Swan Reach.

12. Sale, Stratford, Bairnsdale and Lakes Entrance to Mt. Hotham Ski Resort.

13. Day 1 Bairnsdale and the Lakes;

Day 2 Caves and Lakes Entrance;

Day 3 Omeo and Mt Hotham;

Day 4 Beechworth Gold and Strawberry Wine;

Day 5 Kelly Country and Home.

14. On round tours on any route or routes within a radius of thirty two (32) kilometres from the Post Office at Lakes Entrance but only under

an arrangement with V/Line whereby passengers are to be carried by road on the vehicles to be licensed as part of a round tour commenced and completed by rail at Melbourne or at some other railway station within Victoria.

Timetable: As and when required.

Fares: To be determined.

(b) Under charter conditions from within a 20 km pick-up radius of the Post Office at Bairnsdale.

Note: The licensed vehicles would hold 3 star ratings for charter purposes.

K. M. L. & V. C. O'Connor, Bairnsdale. Application to license one commercial passenger vehicle to be purchased with seating capacity for 45 passengers to operate for the carriage of passengers employed with J. Ray McDermott (Aust.) Pty. Ltd., between Lakes Entrance and Longford.

Note: Service to operate under contract to J. Ray McDermott (Aust.) Pty. Ltd.

K. M. L. & V. C. O'Connor, Bairnsdale. Application for variation of the conditions of licence CC123 which authorises charter operations from within a 20 km pick-up radius of the Post Office at Bairnsdale to operate one day and five day tours as follows:

1. Lakes Entrance or Bairnsdale to Buchan Caves.
2. Lakes Entrance or Bairnsdale to Marlo.
3. Lakes Entrance or Bairnsdale to Metung.
4. Lakes Entrance or Bairnsdale to Shelly Beach and the Bluff.
5. Lakes Entrance or Bairnsdale to Tambo Valley.
6. Lakes Entrance or Bairnsdale to Lake Tyers Aboriginal Station.
7. Bairnsdale town tour and surround districts.
8. Bairnsdale to Glenaladale National Park.
9. Bairnsdale to Golvinda Winery and Mount Taylor.
10. Bairnsdale to Buchan.
11. Bairnsdale to Bruthen and Swan Reach.
12. Sale, Stratford, Bairnsdale and Lakes Entrance to Mt Hotham Ski Resort.
13. Day 1 Bairnsdale and The Lakes;
Day 2 Caves and Lakes Entrance;
Day 3. Ormeo and Mt Hotham;
Day 4 Beechworth Gold and Strawberry Wine;
Day 5 Kelly Country and Home.
14. On round tours on any route or routes within a radius of thirty two (32) kilometres from the Post Office at Lakes Entrance but only under an arrangement with V/Line whereby passengers

are to be carried by road on the vehicles to be licensed as part of a round tour commenced and completed by rail at Melbourne or at some other railway station within Victoria.

Timetable: As and when required.

Fares: To be determined.

K. M. L. & V. C. O'Connor, Bairnsdale. Application for variation of the conditions of licence TO 206 which authorises various one day and five day tours to operate under charter conditions from within a 20 km pick-up radius of the Post Office at Bairnsdale.

Note: The licensed vehicle holds a 5 star rating for charter purposes.

L. Scott, Mooroolbark. Application to license one commercial passenger vehicle in respect of a 1968 Chevrolet sedan with seating capacity for 5 passengers to operate as a special purpose vehicle from 15 Ruskin Avenue, Croydon for the carriage of passengers for wedding parties.

Note: This application is made in conjunction with similar applications by C. Sikavitsas, J. M. Flynn, S. Woodman, A. Crammond, B. Crammond, E. Goudswaard, I. R. Farrow and F. Fazio.

Shuttle Bus Ballarat Pty. Ltd., Ballarat. Application for variation of the conditions of licences TO 149 and TO 150 which authorise various day, half day, two and three day tours of Ballarat to operate the vehicles in substitution for but not in addition to existing CO licences in the name of the applicant.

C. Sikavitsas, Keilor. Application to license one commercial passenger vehicle in respect of a 1962 Chevrolet Convertible with seating capacity for 3 passengers to operate as a special purpose vehicle from 15 Ruskin Avenue, Croydon for the carriage of passengers for wedding parties.

Note: This application is made in conjunction with similar applications by J. M. Flynn, L. Scott, S. Woodman, A. Crammond, B. Crammond, E. Goudswaard, I. R. Farrow and F. Fazio.

C. Stavropoulos, Lower Templestowe. Application to license two commercial passenger vehicles, one to be purchased, in respect of 1979 Jaguar sedans with seating capacity for 5 passengers to operate as special purpose vehicles from 4 Wren Court, Lower Templestowe for the carriage of passengers for wedding parties.

Note: Notice of this application replaces a notice which appeared in *Victoria Government Gazette*, No. G 15 dated 15 April 1987.

Previous objections to the granting of this application are invalid and interested parties are advised that a new notice of objection must be submitted.

R. J. Stewart & R. A. Maskell, Korumburra. Application to license one class 1 tow truck (tray with ramps) to operate within a 60 km radius from a depot situated at 38 Bridge Street, Korumburra in the course of business as motor vehicle repairers and farm machinery distributor:

- (i) For the purpose of lifting and carrying or towing damaged or disabled motor cars, excluding the ability to attend the scene of a motor car accident; and
- (ii) For the carriage of general goods within the prescribed area referred to above.

S. Woodman, Croydon. Application to license one commercial passenger vehicle in respect of a 1962 Chevrolet sedan with seating capacity for 5 passengers to operate as a special purpose vehicle from 15 Ruskin Avenue, Croydon for the carriage of passengers for wedding parties.

Note: This application is made in conjunction with similar applications by C. Sikavitsas, L. Scott, J. M. Flynn, A. Crammond, B. Crammond, E. Goudswaard, I. R. Farrow and F. Fazio.
Dated 20 May 1987

M. KENT
Group Manager
Vehicle Licensing and Regulation Strategies

Mount Donna Buang—The Acheron Way north of Cement Creek and the Healesville-Warburton Road between Pantom Gap and the Summit.

Mount Saint Gwinear—The Thompson Valley Road from the Thompson Dam Road intersection to Rocky Knob and the Mount Saint Gwinear Road from Rocky Knob to the Mount Saint Gwinear car park.

Mount Stirling—The Mount Stirling Road from the intersection of the Mount Buller Alpine Road at Mirimbah to Telephone Box junction.

Mount Torbreck—The Mount Torbreck Road.

Mount Tamboritha—The Mount Tamboritha Road between the last crossing of the Wellington River and Mount Tamboritha (currently is the end of sealed road surface).

Licola Area—The Target Creek Road between Licola and Glencairn and the Jamieson/Licola/Heyfield Road between Licola and Violet Hill.

Dated 20 May 1987

MICHAEL J. ROUX
Chairman and Managing Director

Road Traffic Authority

Transport Act 1983

TRANSPORT (PASSENGER VEHICLES) REGULATIONS 1984

Determination of Hazardous Areas

Notice is hereby given that the Road Traffic Authority has determined the undermentioned areas to be hazardous areas for the purposes of conditions of licences, permits and certificates for the period 4 June 1987 to 5 October 1987 inclusive:

Mount Buller—The Mount Buller Alpine Road from the junction of the Mount Stirling Road the Mount Buller Alpine Village.

Mount Hotham—The Alpine Way from Harrierville over Mount Hotham to Omeo.

Falls Creek—The Bogong High Plains Road from the Bogong Village exit road via Falls Creek to the Omeo Highway.

Mount Buffalo—The road from the National Parks Service Control Gate situated at the base of Mount Buffalo to the top of Mount Buffalo.

Mount Baw Baw—The Mount Baw Baw Road from Tanjil Bren to Mount Baw Baw.

Lake Mountain—The Marysville-Woods Point Tourist Road from Cumberville to the Lake Mountain turnoff.

Town and Country Planning Act 1961

MELBOURNE METROPOLITAN PLANNING SCHEME

Notice of a Proposed Amendment to the Melbourne Metropolitan Planning Scheme Amendment No. 455

Notice is hereby given that, pursuant to subsection 7 of section 32 of the *Town and Country Planning Act 1961*, the Minister has required that the Minister for Planning and Environment give notice of and deposit for inspection by the public, for a period of one month, a proposed amendment to the Melbourne Metropolitan Planning Scheme.

The amendment, known as Amendment No. 455 is to rezone land at High Street, Kew to Office "A" together with Ordinance provisions.

The proposed amendment is available for inspection free of charge during office hours at the offices of the City of Kew, Charles Street, Kew, and at the office of the Ministry for Planning and Environment, The Olderfleet Buildings, 477 Collins Street, Melbourne.

Any persons affected by the proposed amendment are required to set forth in writing any submissions they may wish to make with respect to the proposed amendment addressed

to the Minister for Planning and Environment,
500 Collins Street, Melbourne, by 22 June 1987.
Dated 19 May 1987

DAVID YENCKEN
Secretary for Planning and Environment

Town and Country Planning Act 1961
**MELBOURNE METROPOLITAN INTERIM
DEVELOPMENT ORDER**

Urban Conservation Areas (May 1987)
Notice of Approval

The Interim Development Order which was made by the Minister for Planning and Environment was approved by the Governor in Council on 19 May 1987.

The Order provides controls designed to conserve and enhance certain areas of architectural or historic character within the Cities of Essendon, St Kilda, South Melbourne and Richmond and encourage development which is in harmony with the existing character and appearance of the designated areas pending the processing of an amendment to the Melbourne Metropolitan Planning Scheme.

The Order comes into operation on the date this Notice is published in the *Government Gazette*.

A copy of the documents may be inspected free of charge, during office hours at the office of the Ministry for Planning and Environment, The Olderfleet Buildings, 477 Collins Street, Melbourne, and at the offices of the relevant Councils.

DAVID YENCKEN
Secretary for Planning and Environment

Town and Country Planning Act 1961
**MELBOURNE METROPOLITAN INTERIM
DEVELOPMENT ORDER**

Urban Conservation Areas (May 1987)
Notice of Execution of Delegation

The Minister for Planning and Environment has delegated to the Councils of the Cities of Essendon, St Kilda, South Melbourne and Richmond, all necessary authority to administer and enforce the interim development order.

The delegation begins on 20 May 1987.

Copies of the notice of delegation may be inspected during office hours at the office of the Ministry for Planning and Environment, The Olderfleet Buildings, 477 Collins Street, Melbourne and at the offices of the relevant Councils.

DAVID YENCKEN
Secretary for Planning and Environment

**NOTICE OF MAKING
AND AVAILABILITY OF
STATUTORY RULES**

In pursuance of the provisions of the *Subordinate Legislation Act 1962* and the Regulations made thereunder notice is given of the making and availability of the following Statutory Rules:

Note: The date specified after each Statutory Rule is the date it was first obtainable from the VGPO Bookshop Information Victoria Centre 318 Lt Bourke Street Melbourne.

| | | |
|-------------|--|--------|
| | <i>Abattoir and Meat Inspection Act 1973</i> | |
| 92/1987 | Abattoir and Meat Inspection (Amendment) Regulations 1987 | |
| 13 May 1987 | | 40c |
| | <i>Fisheries Act 1968</i> | |
| 93/1987 | Fishing (Scallop) (Amendment No. 4) Regulations 1987 | |
| 13 May 1987 | | 40c |
| | <i>Transport Act 1983</i> | |
| 94/1987 | Transport (Road Traffic) (Fairways Amendment) Regulations 1987 | |
| 13 May 1987 | | 40c |
| 95/1987 | Transport (Road Traffic) (Emergency Vehicles Amendment) Regulations 1987 | |
| 13 May 1987 | | 40c |
| | <i>County Court Act 1958</i> | |
| 96/1987 | County Court (Amendment) Rules 1987 | |
| 19 May 1987 | | \$1.30 |
| | <i>Fishing Act 1968</i> | |
| 97/1987 | Fishing (Scallop) Amendment (No. 5) Regulations 1987 | |
| 20 May 1987 | | 40c |
| | <i>Pharmacists Act 1974</i> | |
| 98/1987 | Pharmacists (Fees) Regulations 1987 | |
| 20 May 1987 | | 40c |

1230 G 19 20 May 1987

Victoria Government Gazette

Victoria Government Gazette

G 19 20 May 1987 1231

1232 G 19 20 May 1987

Victoria Government Gazette

| |
|-----------------|
| CONTENTS |
|-----------------|

| | Page |
|--|------|
| Appointments | 1172 |
| Cemeteries—Scale of Fees | 1165 |
| Contracts | 1168 |
| Contracts Accepted—Amendments | 1156 |
| Courts | 1156 |
| Estates of Deceased Persons | 1168 |
| Government Notices | 1156 |
| Late Notices | 1224 |
| Notice of Making Statutory Rules | 1229 |
| Orders in Council— | |
| Acts—State Employees Retirement Benefits Board; Crown Land (Reserves); Local Government; Hospitals and Charities; Latrobe Valley; Stock Diseases | 1174 |
| Private Advertisements | 1178 |
| Proclamations | 1155 |
| Tenders | 1177 |

No. G 19—Government Gazette

A Victorian Government Publication

Published by VGPO

Melbourne Victoria Australia

© State of Victoria

This publication is copyright. No part may be reproduced by any process except in accordance with the provisions of the Copyright Act

Address all inquiries to the Government Printer for the State of Victoria

PO Box 203 North Melbourne 3051 Victoria Australia

ISSN 0819—548X

Further copies of this publication can be obtained from VGPO Bookshop

Information Victoria Centre

318 Lt Bourke Street Melbourne

(PO Box 203 North Melbourne 3051)

By Authority F D Atkinson Government Printer Melbourne

Recommended Retail Price \$1.10