

VICTORIA GOVERNMENT
G A Z E T T E

No. G 23 Wednesday 17 June 1987
By Authority F D Atkinson Government Printer Melbourne

GENERAL

GENERAL INFORMATION

The General edition of the *Victoria Government Gazette* is published on each Wednesday and provides information on tenders for the State Government as well as other matters of general interest such as public and private notices.

Special issues of the *Victoria Government Gazette* when published will be made available automatically to subscribers of the General edition.

- Proofs will be supplied only when requested or at the direction of Gazette Officer. They should be returned quickly to avoid delay in publication.
- No additions or amendments to material for publication will be accepted by telephone.

PRIVATE NOTICES

NOTICES TO BE PUBLISHED

GOVERNMENT NOTICES The following guidelines should be followed to ensure publication of official material in the *Victoria Government Gazette*.

Publication of official material

- Duplicate copies should be submitted for the use of the Gazette officer.
- Material submitted to the Executive Council for gazettal will normally be published in the following week's issue.
- Where urgent gazettal is required, special arrangements should be made with
Mr Gerd Gaspar
Gazette Officer
Department of the Premier and Cabinet
Government Branch
2nd Floor, 1 Treasury Place
Melbourne, 3002
Telephone Inquiries
(03) 651 5153

Publication of other material

- All other material authorised by a responsible officer should be forwarded to the Gazette Office no later than 9.30 am on Tuesday.
- Lengthy or complicated notices should be forwarded several days before publication.

Copy Deadline. Private advertisements will be accepted by:

Gazette Advertising
VGPO
PO Box 203
North Melbourne Vic 3051

no later than 11 am one day before publication.

Advertising Rates

Single column × cm/part cm\$3.85
Double column × cm/part cm\$7.70
Full page\$161.70

Ordinary rates will apply to material submitted for publication before 11 am Tuesday. Double rates will apply for special gazettes and for material submitted between 11 am and 3.30 pm Tuesday.

Advertisers should note:

- There are approximately 30 words to each column centimetre depth;
- Signatures (in particular) and proper names must be written clearly in the text;
- All material submitted for publication should be double-spaced and confined to ONE SIDE ONLY of each sheet of paper
- Documents NOT CLEARLY PREPARED will be returned to the sender, unpublished.

Late Copy

Copy received after 3.30 pm one day prior to publication at the VGPO will be placed in the following issue of the *Victoria Government Gazette*, irrespective of any date/s mentioned in the copy.

CORRESPONDENCE

All correspondence should be addressed to:
 Gazette Advertising
 VGPO
 PO Box 203
 North Melbourne 3051
 Telephone Inquiries (03) 320 0100
 Fax No. (03) 329 2696

AVAILABILITY

All gazettes may be purchased over the counter from VGPO Bookshop Information Victoria Centre
 318 Lt Bourke Street, Melbourne. Telephone (03) 663 3760.
 Cost for individual copies is \$1.10.

Mail orders may be sent to VGPO PO Box 203 North Melbourne 3051. A postage and packaging fee must be added to the cost of the gazettes required using the table of rates below:

Total Price of Publications	Postage Packaging Fee
\$0.00 to \$2.00.....	\$0.80
\$2.05 to \$5.00.....	\$1.10
\$5.05 to \$25.00.....	\$2.50
\$25.05 to \$75.00.....	\$3.00
\$75.05 to \$125.00.....	\$3.50
\$125.00 to \$200.00.....	\$4.00
\$200.05 and over.....	at cost

Bankcard purchases may be made using Bankcard facilities in the VGPO Bookshop and by mail orders.

Bankcard mail orders require the Bankcard number, expiry date, name, address and signature of customer to be supplied.

(Minimum purchase of \$5.00 applies).

SUBSCRIPTIONS

Subscribers to the *Victoria Government Gazette* have three subscription services to choose from:
 General Special and Periodical;
 General and Special;
 Periodical.

Subscriptions are payable in advance and accepted for a period of one year. All subscriptions are on a firm basis and refunds for cancellations will not be given.

Subscription rates for 1987 are as follows:

General Special and Periodical	\$115
General and Special	\$100
Periodical	\$60

Prices include postage.

All remittances should be made payable to VGPO.

OTHER ISSUES OF THE GAZETTE

Special issues of the Gazette are published on specific days when required.

They are provided at no extra charge with weekly general issues.

Special issues are not available on separate subscription.

Periodical issues of the Gazette are published on each Monday when required. Listings such as Dentist's Register, Pharmacy Register are examples.

Subscription may be made separately at a cost of \$60.00 per annum including postage.

PROCLAMATIONS

Post-Secondary Education Act 1978 PROCLAMATION OF DATE OF OPERATION

I, Sir John McIntosh Young, Administrator of Victoria acting with the advice of the Executive Council fix Sunday, 21 June 1987, as the day from which the provisions of section 66 of the *Post Secondary Education Act 1978*, will operate in respect of teaching positions which exist at the undermentioned Technical and Further Education Colleges:

Holmesglen College of TAFE

Yallourn College of TAFE

Given under my hand and the seal of
Victoria on 16 June 1987.

(L.S.) J. McI. YOUNG
By His Excellency's Command

I. R. CATHIE
Minister for Education

Local Government Act 1958 SHIRE OF NATHALIA

Proclamation of Public Highways

I, J. Davis McCaughey, Governor of Victoria acting with the advice of the Executive Council and under section 519 of the *Local Government Act 1958* proclaim Nicholson, Martin and North Streets, Nathalia coloured brown on Plan of Subdivision No. 29282 and bounded by Railway and Frazer Streets and Muntz Avenue to be public highways.

Given under my hand and the seal of
Victoria on 10 June 1987.

(L.S.) J. DAVIS McCAUGHEY

By His Excellency's Command

J. L. SIMMONDS
Minister for Local Government

Vegetation and Vine Diseases Act 1958 PROCLAMATION DEFINING THE BOUNDARY OF THE NAGAMBIE VINE DISEASE DISTRICT

I, J. Davis McCaughey, Governor of Victoria, acting with the advice of the Executive Council and under section 33 of the *Vegetation and Vine Diseases Act 1958* amend the Proclamation made on 4 March 1986 and published in the *Government Gazette* on 5 March 1986 by substituting for item (2) the following item:

(2) The Nagambie Vine Disease District the boundary of which is defined as follows:

Commencing at the point where the northern boundary of the Parish of Bailieston joins the western boundary of that parish; thence easterly along the northern boundary of that parish and easterly north easterly and generally south westerly along the northern boundary of the Parish of Noorilim to the intersection with the northern boundary of the Parish of Warring; thence easterly along the northern boundary of that parish to the eastern boundary of that parish; thence southerly along the eastern boundary of that parish and the eastern boundary of the Parish of Wormangal to the southern boundary of that parish; thence westerly along the southern boundary of that parish and part of the southern boundary of the Parish of Tabilk to the intersection with the Seymour to Shepparton railway line; thence southerly along that railway line to the intersection with the southern boundary of the Parish of Avenel; thence westerly along that boundary to the intersection with the eastern boundary of the Parish of Northwood; thence southerly along that boundary to the southern boundary of that parish; thence generally westerly along that boundary to the western boundary of that parish; thence northerly along that boundary and the western boundaries of the Parishes of Mitchell and Bailieston to the point of commencement.

Given under my hand and the seal of
Victoria on 10 June 1987.

(L.S.) J. DAVIS McCAUGHEY

By His Excellency's Command

EVAN WALKER
Minister for Agriculture and Rural Affairs

Land Act 1958 PROCLAMATION

I, J. Davis McCaughey, Governor of Victoria acting with the advice of the Executive Council and under section 22c (2) of the *Land Act 1958* and upon receipt of certification of the Clerk of the municipality of the Shire of Tallangatta that the land is or has been used for a public hall, do hereby declare part of Crown Allotments 84 and 85, Parish of Wagra being the land more particularly described in Certificate of Title Volume 4621, Folio 096, to be land to which section 22c of the said Act applies.

Given under my hand and the seal of
Victoria on 10 June 1987.

(L.S.) J. DAVIS McCAUGHEY

By His Excellency's Command

J. E. KIRNER
Minister for Conservation, Forests and Lands

Land Act 1958

PROCLAMATION OF ROAD

I, J. Davis McCaughey, Governor of Victoria acting with the advice of the Executive Council and under section 25 (3) (c) of the *Land Act 1958* proclaim as road the following land:

MUNICIPAL DISTRICT OF THE SHIRE OF BUNINYONG

BUNINYONG—Crown Allotment 123N, Parish of Buninyong as shown on Certified Plan No. 108403 lodged in the Central Plan Office—(L3-3718).

Given under my hand and the seal of Victoria on 10 June 1987.

(L.S.) J. DAVIS McCAUGHEY

By His Excellency's Command

J. E. KIRNER

Minister for Conservation, Forests and Lands

Land Act 1958

PROCLAMATION OF ROAD

I, J. Davis McCaughey, Governor of Victoria acting with the advice of the Executive Council and under section 25 (3) (c) of the *Land Act 1958* proclaim as road the following land:

MUNICIPAL DISTRICT OF THE SHIRE OF GRENVILLE

BERRINGA—Crown Allotment 3A, Township of Berringa, Parish of Clarksdale as shown on Certified Plan No. 108400 lodged in the Central Plan Office—(L3-1474).

Given under my hand and the seal of Victoria on 10 June 1987.

(L.S.) J. DAVIS McCAUGHEY

By His Excellency's Command

J. E. KIRNER

Minister for Conservation, Forests and Lands

Mental Health Act 1986

PROCLAMATION OF COMMENCEMENT

I, Sir John McIntosh Young, Administrator of Victoria, acting with the advice of the Executive Council and under section 2 of the *Mental Health Act 1986*, fix 19 June 1987 as the day on which the following provisions of that Act come into operation:

Sections 1, 2, 3, 21 and 23, and Schedule 1.

Given under my hand and the seal of Victoria on 16 June 1987.

(L.S.) J. McI. YOUNG

By His Excellency's Command

D. R. WHITE

Minister for Health

GOVERNMENT NOTICES

INCORRECT PAGE NUMBERING IN GOVERNMENT GAZETTES

Please note that there has been an error in the numbering sequence of the pages in *Government Gazette* Numbers G21 and G22 of 3 and 10 June 1987 respectively.

In order to prevent gross confusion it has been decided to leave the page numbering "as is" since there is sufficient differentiation with the Gazette number and date.

Consequently, Gazette number G23 of 17 June 1987 will continue on from page 1535.

Any inconvenience which may have been caused in this regard is regretted.

Dated: 15 June 1987

Gerd Gaspars
Gazette Officer

Transport Act 1983

ROAD TRAFFIC AUTHORITY

Commercial Passenger Vehicle Applications

Notice is hereby given that the following applications will be considered by the Road Traffic Authority on 21 July 1987.

Notice of any objections should be forwarded to reach the Manager, Vehicle Licensing Branch or any Regional Office of the Road Traffic Authority not later than 15 July 1987.

It will not be necessary for interested parties to appear on the hearing date specified, unless advised in writing by the Authority.

Notification of the date for consideration of applications which are objected to and which require determination by the Road Transport Licensing Tribunal will be published by further notice in this Gazette.

Ninth Janalux Pty Ltd, Lang Lang. Application for variation of the conditions of licence CC76 which authorises spare vehicle operations on Ministry of Education contract services and charter rights of Pakenham to operate a service under contract to the Parents Association of Belgrave South for the carriage of school children to the exclusion of all other passengers excepting duly authorised teachers between Belgrave South Primary School and Berwick High School.

Tarenberg Pty Ltd, Garfield. Application for variation of the conditions of licence TS.1540 which authorises various school contract services to operate under charter conditions from within a 20 km pick-up radius of the Post Office at Garfield.

A. J. Todd, Goon Nure. Application to license one commercial passenger vehicle with seating capacity for 4 passengers to operate a service free of charge for the carriage of guests to The Wattle Point Farm Guest House between the guest house and the Bairnsdale Railway Station.

Timetable: As and when required.

D. C. L. Bryan Chelsea. Application to license one commercial passenger vehicle with seating capacity for 11 passengers to operate for the carriage of children between the Brownies Child Minding Centre, 71 Blantyne Avenue, Chelsea and the following schools:

- (i) Bonbeach Primary School.
- (ii) St Joseph's Primary School.
- (iii) Chelsea Heights Primary School.
- (iv) Edithvale Primary School; and
- (v) St Louis de Montfort Primary School.

Timetable:

8.15 a.m.—9.00 a.m.

3.00 p.m.—4.00 p.m.

Fares:

Included in the overall charge of child minding fees.

Dated: 17 June 1987

M. KENT
Group Manager

Vehicle Licensing and Regulation Strategies

MELBOURNE AND METROPOLITAN
BOARD OF WORKS
General Notice

The Melbourne and Metropolitan Board of Works having made provision for carrying off the sewage of each and every property which or any part of which is situate in the Sewerage Areas hereinafter described doth hereby declare that on and after 22 June 1987 each and every property so situate shall be deemed to be a sewered property within the meaning of the *Melbourne and Metropolitan Board of Works Act 1958*.

The Sewerage Areas hereinbefore referred to are:

Sewerage Area No. 5804

City of Knox—This area comprises lots 62 to 60 Murrindal Drive, lots 59 and 58 Balladonia Road and lots 57 to 55 Max Close.

Sewerage Area No. 5815

Shire of Sherbrooke—This area comprises lots 1 and 2 Sandells Road.

Sewerage Area No. 5816

City of Nunawading—This area comprises all lots in Pine Drive, Village Walk and Kara Walk,

lots 5 to 8 and 9 to 13 Morack Road, a Reserve abutting Kara Walk and Morack Road, a further Reserve abutting Canowindra Close and Village Walk.

Sewerage Area No. 5817

Shire of Lillydale—This area comprises all lots in Drysdale Place, Westall Court and Olsen Close, lots 319, 320, 326 to 329, 384 to 382, 371, 370 and 356 to 352 Landscape Drive and a portion of a Tree Reserve abutting Mooroolbark Road.

Sewerage Area No. 6609

City of Altona—This area comprises lot 1 Chambers Road

Sewerage Area No. 6649

City of Sunshine—This area comprises lot 1 Market Road.

Sewerage Area No. 6665

City of Keilor—This area comprises all lots in Winchester Court and Palace Court, lots 467 to 472, 808 to 800, 783, 782, 765 and 454 to 459 Unicorn Way.

Sewerage Area No. 5726

City of Doncaster and Templestowe—This area comprises lot 32 and lot A Deep Creek Drive, a Tree Reserve abutting Heidelberg—Warrandyte Road and Deep Creek Drive, a Drainage and Recreation Reserve abutting lot A and Mullum Mullum Creek and Heidelberg—Warrandyte Road.

Sewerage Area No. 5762

City of Doncaster and Templestowe—This area comprises lot 2 Reynolds Road, lots 1, 2, 1 and 2 Chivers Road and portion of a Tree Reserve abutting Reynolds Road.

Sewerage Area No. 5763

City of Knox—This area comprises lot 2 Burwood Highway and lot 4 Lewis Road.

Sewerage Area No. 5765

City of Knox—This area comprises all lots in Hi-Tech Place, lots 3 to 8, 97 to 100, 112 and 113 Laser Drive, lots 1 and 2 Kelletts Road, a Tree Reserve abutting Kelletts Road and a portion of a Tree Reserve abutting Taylors Lane.

Sewerage Area No. 5767

City of Box Hill—This area comprises all lots in Livingstone Close and Varcoe Close and lots 4 and 5 Elgar Road.

Sewerage Area No. 5800

City of Knox—This area comprises lots 128 to 132 and 145 to 143 Candlebark Quadrant.

Sewerage Area No. 5801

City of Knox—This area comprises all lots in Meaghan Court, Cowin Close, Kemp Court and Gill Court, lots 445, 444, 428 to 426, 460 to 458

and 446 Burchall Crescent, lots 465 to 461, 425, 424, 541, 542, 551 to 554, 563 and 564 Dandelion Drive, an Electrical Reserve abutting Burchall Crescent and a portion of a Tree Reserve abutting Napoleon Road.

Sewerage Area No. 6670

City of Sunshine—This area comprises lots 1 and 2 Whitesides Avenue.

Sewerage Area No. 6671

City of Keilor—This area comprises lots 373 to 359 Harmon Avenue and lots 353 to 339 Errington Road.

Sewerage Area No. 6672

City of Werribee—This area comprises lots 2, 1 and 10 Little Boundary Road.

Sewerage Area No. 6673

City of Keilor—This area comprises lots 1605 to 1608, portion of a Walkway and lots 1609 to 1611 Yacht Court.

Sewerage Area No. 6674

City of Keilor—This area comprises all lots in Ivy Tower Court and Courageous Street, lots 1525 to 1528 and 1559 to 1567 Solent Crescent, lots 1519 to 1515 and 2177 to 2182 Fastnet Drive, lots 2175 and 2176 Remus Way.

Sewerage Area No. 6675

City of Werribee—This area comprises all lots in Hilden Close, lots 380, 379 and 363 to 355 Fernwood Drive.

Sewerage Area No. 6676

City of Werribee—This area comprises all lots in Glendale Court, lots 78, 44 to 38 and 101 Lyall Drive, portion of a Plantation Reserve abutting Galvin Road and a further portion of a Plantation Reserve abutting Princes Highway.

Dated 16 June 1987

By order of the Board

H. G. FORD

Director of Administration and Services

Cemeteries Act 1958

SCALE OF FEES OF THE GREEN LAKE PUBLIC CEMETERY

In pursuance of the powers conferred upon them by the Cemeteries Act the trustees of the Green Lake Public Cemetery hereby make the following scale of fees, which shall come into operation upon publication in the *Government Gazette*, and from and after such publication every scale of fees heretofore made by the said trustees shall be and is hereby rescinded to the extent to which it conflicts with this scale.

Land, 2.44 m × 1.22 m	\$ 75.00
Sinking grave 1.83 m deep	110.00

Interment fee	35.00
Reopening grave (no cover)	110.00
Reopening grave (with cover)	120.00
Permission to erect a headstone or monument—5 per cent of cost with a minimum of \$15.00	
Exhumation charge (when authorised)	300.00
Search fee per request	15.00

R. D. KUHNE, Trustee
R. L. PELICKER, Trustee
B. R. GROSS, Trustee

Approved by the Governor in Council, 10 June 1987—E. M. MILLER, Acting Clerk of the Executive Council

Cemeteries Act 1958

SCALE OF FEES OF THE BRANXHOLME PUBLIC CEMETERY

In pursuance of the powers conferred upon them by the Cemeteries Act the trustees of the Branxholme Public Cemetery hereby make the following scale of fees, which shall come into operation upon publication in the *Government Gazette*, and from and after such publication every scale of fees heretofore made by the said trustees shall be and is hereby rescinded to the extent to which it conflicts with this scale.

	\$
Land	45.00
Interment fee	30.00
Reopen grave with cover (extra)	10.00
Permission to erect a headstone or monument—5 per cent of cost with minimum \$15.00	
Exhumation charge (when authorised)	300.00

C. S. MACGUGIN, Trustee
W. F. FLETCHER, Trustee
J. R. READ, Trustee
C. HANKS, Trustee
D. N. BLACK, Trustee
J. D. MOON, Trustee
C. GORRIE, Trustee

Approved by the Governor in Council, 10 June 1987—E. M. MILLER, Acting Clerk of the Executive Council

Cemeteries Act 1958

SCALE OF FEES OF THE INVERLOCH PUBLIC CEMETERY

In pursuance of the powers conferred upon them by the Cemeteries Act the trustees of the Inverloch Public Cemetery hereby make the following scale of fees, which shall come into operation upon publication in the *Government Gazette*, and from and after such publication

every scale of fees heretofore made by the said trustees shall be and is hereby rescinded to the extent to which it conflicts with this scale.

Public Graves

	\$
Interment in grave without exclusive right—still born child	45.00
Interment in grave without exclusive right—child up to 3 years	45.00
Interment in grave without exclusive right—others	100.00

Private Graves

Lawn grave 2.44 m × 1.22 m	220.00
Monumental section grave 2.44 m × 1.22 m	220.00
Each interment in monumental or lawn grave	130.00
Each interment in monumental or lawn grave for child under 3 years	85.00
Bronze plaque 382 × 280 cm	130.00

Miscellaneous Charges

Sinking grave for an oversize casket	40.00
Interment of cremated remains	50.00
Interment on Saturday	70.00
Permission to construct a brick, stone or concrete grave	40.00
Permission to erect a headstone or monument	40.00
Exhuming the remains of a body (when authorised)	250.00

M. RILEY, Trustee

T. EVANS, Trustee

A. SNOW, Trustee

Approved by the Governor in Council, 10 June 1987—E. M. MILLER, Acting Clerk of the Executive Council

**CONTRACTS ACCEPTED
PUBLIC WORKS**

His Excellency the Governor of the State of Victoria by and with the advice of the Executive Council thereof has by order made on 10 June 1987 approved of the acceptance by the Minister of Public Works of the under-mentioned offer without public tenders being invited, viz:

Offer of Gryffin Pty. Ltd. for the provision of security works at B Division, Pentridge Gaol for the sum of Seventy Seven Thousand, Seven Hundred and Sixty Eight Dollars (\$77 768.00).

E. M. MILLER

Acting Clerk of the Executive Council

At the Executive Council Chamber
Melbourne, 10 June 1987

Education Act 1958
**NOTICE OF THE MAKING OF AN ORDER
UNDER SECTIONS 13 (1), (4) & (5) OF THE
ACT**

Under section 13 of the *Education Act 1958*, I hereby give notice that an Order of the Governor in-Council was made on 16 June 1987 under sub-section (1) constituting a council for:

7850 Bell Park High School and 7170 Geelong West Technical School

7705 Caulfield High School and 7079 Caulfield Technical School

1567 Richmond Primary School and 2798 Richmond North Primary School;

and under sub-section (4) dissolving the school council for

7850 Bell Park High School

and the school council for

7170 Geelong West Technical School

and the school council for

7705 Caulfield High School

and the school council for

7079 Caulfield Technical School

and the school council for

1567 Richmond Primary School

and the school council for

2798 Richmond North Primary School;

and under sub-section (5) directing the disposal of any assets of the council for the

7850 Bell Park High School

and of the council for

7170 Geelong West Technical School

and of the council for

7705 Caulfield High School

and of the council for

7079 Caulfield Technical School

and of the council for

1567 Richmond Primary School

and of the council for

2798 Richmond North Primary School.

I. R. CATHIE

Minister for Education

Town and Country Planning Act 1961

**MELBOURNE METROPOLITAN
PLANNING SCHEME**

Notice of Repealing of Revocation No. 57

Under the powers of the Act, the Governor in Council on 10 June 1987, repealed the revocation and Order approved on 20 January 1987, notice of which was published in the *Government Gazette* dated 21 January 1987.

A copy of the documents may be inspected free of charge, during office hours, at the office of the Ministry for Planning and Environment, The Olderfleet Buildings, 477 Collins Street, Melbourne.

DAVID YENCKEN
Secretary for Planning and Environment

Town and Country Planning Act 1961
MELBOURNE METROPOLITAN PLANNING SCHEME
Amendment No. 446
Notice of Amendment

In pursuance of the powers conferred by the *Town and Country Planning Act 1961*, the Governor in Council on 10 June 1987, amended the abovementioned scheme for which the Minister for Planning and Environment is the Responsible Authority.

The amendment comes into operation on the date this Notice is published in the *Government Gazette*.

The amendment includes minor amendments to the Ordinance provisions relating to Dual Occupancy in Residential C Zones, to clarify the interpretation of the existing controls.

A copy of the documents may be inspected free of charge, during office hours, at the office of the Ministry for Planning and Environment, The Olderfleet Buildings, 477 Collins Street, Melbourne.

DAVID YENCKEN
Secretary for Planning and Environment

Town and Country Planning Act 1961
MELBOURNE METROPOLITAN PLANNING SCHEME
Amendment No. 465
Notice of Amendment

In pursuance of the powers conferred by the *Town and Country Planning Act 1961*, the Governor in Council on 10 June 1987, amended the abovementioned scheme in respect of the municipal district of the City of Frankston and for which the Minister for Planning and Environment is the Responsible Minister.

The amendment comes into operation on the date this Notice is published in the *Government Gazette*.

The amendment introduces detailed planning controls in the Frankston District Centre, including several sub-zones, in conformity with the Frankston District Centre Physical Framework Plan.

A copy of the documents may be inspected

free of charge, during office hours, at the office of the Ministry for Planning and Environment, The Olderfleet Buildings, 477 Collins Street, Melbourne.

DAVID YENCKEN
Secretary for Planning and Environment

SHIRE OF HEALESVILLE
Road Deviation Order

Pursuant to the provisions of sections 522 and 526 of the *Local Government Act 1958*, the Council of the Shire of Healesville, hereby directs that the land in the Parish of Tarrawarra indicated by hatching on the plan hereunder, shall be a public highway on and from the date of publication of this Order in the *Government Gazette* and declares that such land shall be a public highway in lieu of the land indicated by cross-hatching on the said plan.

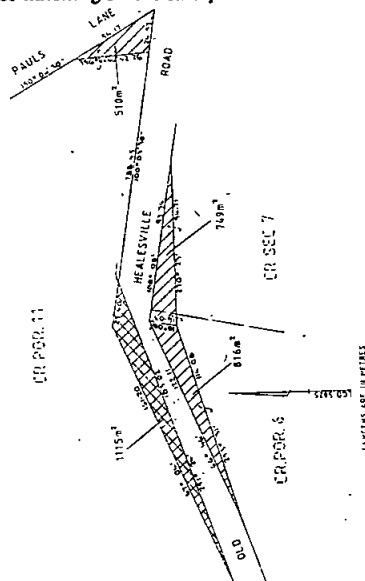

The common seal of the President, Councillors and Ratepayers of the Shire of Healesville was hereunto affixed 31 March 1987, in the presence of—

G. B. STEPHENS, Shire President

J. C. MELROSE, Councillor

G. R. PEACOCK, Shire Secretary

Confirmed by the Governor in Council, 10 June 1987—E. M. MILLER, Acting Clerk of the Executive Council

Industrial Relations Act 1979
NOTICE OF APPLICATION FOR
RECOGNITION AS AN ASSOCIATION

Notice is hereby given that the Victorian Association of Bakers has filed applications to be recognised as an association under the *Industrial Relations Act 1979* with respect to trades for which the Food Shops and Pastrycooks Conciliation and Arbitration Boards have been appointed.

Pursuant to Regulation 33 (5) of the Industrial Relations Regulations any recognised association or person interested may on or before 16 July 1987, file in the Registry (Level 18, Nauru House, 80 Collins Street, Melbourne) an objection to the application.

The objection shall be in, or to the effect of Form 9 prescribed by the Regulations.

A. S. DOWLING
Deputy Registrar

Industrial Relations Commission of Victoria

ERRATUM

Notice of Making and Availability of Statutory Rules

In *Government Gazette* No G19 of 20 May 1987 on page 1229, Statutory Rule No. 95/1987 should be headed by the words "*Transport Act 1983*". With regards to Statutory Rule No. 97/1987, the words "*Fishing Act 1968*" should read "*Fisheries Act 1968*".

Notice of Making of Statutory Rules Which Are Not Yet Available

In *Government Gazette* No G21 of 3 June on page 1166, Statutory Rule No. 104/1987 the words "*Stock Diseases Act 1968*" should read "*Stock Diseases Act 1958*", Statutory Rule No. 106/1987 the words "*Co-operative Housing Societies Act 1968*" should read "*Co-operative Housing Societies Act 1958*".

Hospitals and Charities Act 1958
NOTICE OF PETITION TO INCORPORATE
Stonehaven Nursing Home

The Chief General Manager of the Department of Health Victoria has received a petition signed by twenty-five contributors to an institution known as Stonehaven Nursing Home praying that the institution be incorporated under section 46 of the *Hospitals and Charities Act 1958*.

The organisation will have for its objects:

- (a) To provide nursing home care and accommodation for all persons falling within those categories defined under the *Aged or Disabled Persons Homes Act 1954*

and who are assessed as being in need of such care and accommodation;

- (b) To purchase or otherwise acquire any real and/or personal property;
- (c) To do such other things which, in the Committee's opinion will provide for the economic, social and recreational well-being of patients.

If no counter-petition signed by an equal or greater number of contributors is lodged with the Chief General Manager at 555 Collins Street, Melbourne within one month after the date of publication of this notice the Governor in Council may by Order published in the *Government Gazette* declare the contributors for the time being to the institution to be a body corporate by the name set forth in the Order.

D. R. WHITE
Minister for Health

Hospitals and Charities Act 1958
NOTICE OF PETITION TO INCORPORATE
Frankston Community Health Service

The Chief General Manager of the Department of Health Victoria has received a petition signed by twenty-seven contributors to a benevolent society known as Frankston Community Health Service praying that the benevolent society be incorporated under sections 46 and 64 of the *Hospitals and Charities Act 1958*.

The organisation will have for its objects:

- (a) To manage and maintain a Community Health Service in the City of Frankston which will provide facilities for all persons in Frankston, including those in necessitous circumstances;
- (b) To promote co-operation with other health and welfare services;
- (c) To purchase or acquire any real and/or personal property and other buildings to be used for the above purpose;
- (d) To do all such other things as are incidental or conducive to the attainment of the above objects.

If no counter-petition signed by an equal or greater number of contributors is lodged with the Chief General Manager at 555 Collins Street, Melbourne within one month after the date of publication of this notice the Governor in Council may by Order published in the *Government Gazette* declare the contributors for the time being to the institution to be a body corporate by the name set forth in the Order.

D. R. WHITE
Minister for Health

Creditors, next of kin and others having claims against the estate of any of the under-mentioned deceased persons are required to send particulars of their claims to the Public Trustee, 168 Exhibition Street, Melbourne, Vic. 3000, the personal representative, on or before 20 August 1987 after which date the Public Trustee may convey or distribute the assets having regard only to the claims of which the Public Trustee then has notice:

Leith, Harry, but late of 14 Devon Street, Box Hill South, gentleman, died 8 May 1987.

Quattrone, Domenico Antonio, also known as Domenic Quattrone, formerly of 42 Moonee Street, Ascot Vale, but late of Mont Park, retired labourer, died 9 February 1986.

Skelton, Edward Leslie, but late of 157 Raglan Street, Preston, retired carpenter, died 24 March 1987.

Stubbs, Philip Edwin, but late of 17 Clive Street, Alphington, retired foreman, died 14 April 1987.

Melbourne, 10 June 1987

W. J. KILPATRICK
Public Trustee

Department of Labour
PROPOSED LIQUEFIED GASES
(TRANSPORTATION AND GAS
TRANSFER) (SELF-SERVICE OF LP GAS)
REGULATIONS 1987

The comments received on the Regulatory Impact Statement for the above proposed regulations have been considered by the Department.

In accordance with the provisions of the *Subordinate Legislation Act 1962*, I give notice that the proposed regulations will be made.

S. M. CRABB
Minister for Labour

TAMBO RIVER IMPROVEMENT TRUST
Rating By-Law No. 30

The Tambo River Improvement Trust, in pursuance and exercise of the powers conferred by the *River Improvement Act 1958*, doth hereby make the By-Law following:

1. The following rate to be called the "Tambo River Improvement District River Improvement Rate" is hereby made and shall be levied upon the occupiers or owners of all properties within the Tambo River Improvement District which are rateable to any Municipality.

A rate of 4-01 cents in the dollar on the nett annual value of all those properties within Divisions 1-9 inclusive as determined by the

Order in Council made on 17 March 1964, and published in the *Government Gazette* on 18 March 1964.

The minimum rate shall be \$4.00.

2. Such rates are made and shall be levied for the period beginning with 1 January 1987, and ending with 31 December 1987, and shall be payable on 10 January 1987 at the Office of the Tambo River Improvement Trust, Bruthen.

3. Such person or persons as the Tambo River Improvement Trust may from time to time be appointed for that purpose shall be and is or are hereby authorised to demand, receive, collect and recover the said rate.

The foregoing By-Law was made by the Tambo River Improvement Trust on 9 April 1987 and the common seal of the Trust was hereunto affixed on 9 April 1987 in the presence of—

A. J. NEAL, Chairman
J. D. McKAY, Commissioner
W. J. HOBSON, Secretary

Approved 29 April 1987—A.
McCUTCHEON, Minister for Water Resources

CONTRACTS ACCEPTED—(Series 1986-87)
Public Works

Benalla City—Building works, Benalla Regional Headquarters (Education)—\$107 250.00—Alf Richardson Constructions Pty Ltd, Benalla.

Bulla Shire—Building works, Craigieburn Primary School—\$80 650.00—West Footscray Building Renovating, 134 Cross Street.

Corio Shire—Pavement failure of tennis courts, Geelong North High School—\$64 512.00—John Bartolo, North Geelong.

Healesville Shire—Building works, all in Yarra Glen Police Station—\$240 000.00—E. Osinski Building Company Pty Ltd, Kingsbury.

Melton Shire—Construction aluminium windows and doors, Kurunjang Post Primary School—\$161 992.00—H. Troon Pty Ltd, Wendouree.

Melton Shire—Construction structural—concrete, Kurunjang Post Primary School—\$234 127.00—R. & A. Benedet Pty Ltd, Bell Post Hill.

Mortlake Shire—Cyclic maintenance—mechanical, Mortlake High School—\$58 065.00—Ted Finchett Pty Ltd, Hamilton.

Nunawading City—Reinstate and painting of fire damaged area, Burwood Heights Primary School—\$93 376.00—B. & D. Eastern Contractors, Kilsyth.

Otway Shire—Mechanical services, Lavers Hill Consolidated School—\$59 424.55—K. J. & F. V. Ayers & Sons Pty Ltd, Moolap.

Shepparton City—Office fit-out, A Shepparton Regional Office (Corrections)—\$52 012.00—Hansen & Yuncken Pty Ltd (Shepparton), Shepparton.

Sunshine City—Electrical services, St. Albans High School—\$86 445.00—AKC Electrics Pty Ltd, Nothcote.

Dated: 10 June 1987

JOHN DEVENISH
Director-General of Public Works

Electric Light and Power Act 1958
ORDER GRANTED BY THE GOVERNOR
IN COUNCIL

It is hereby notified that an Order (No. 396) has been granted by His Excellency the Governor in Council under section 10 of the *Electric Light and Power Act 1958* (No. 6241) to Carlton and United Breweries Limited enabling the installation and operation of an 11kv underground cable across Southampton Crescent, Abbotsford.

R. FORDHAM
Minister for Industry, Technology and
Resources

PROPOSED MOTOR CAR TRADERS
REGULATION 1987

Notice of Preparation of a Regulatory Impact
Statement

Notice is hereby given in accordance with the provisions of the *Subordinate Legislation Act 1962* of the proposal to make regulations to be known as the Motor Car Traders Regulations 1987.

The objective of the proposed regulations is to implement the purposes of the *Motor Car Traders Act 1986*, that is, to facilitate the efficient licensing of motor car traders and to ensure that the rights of purchasers of motor vehicles are adequately protected.

A regulatory impact statement has been prepared in accordance with the provisions of the *Subordinate Legislation Act 1962*.

The results of the impact statement are that the preferred course of action is make the proposed regulations.

Copies of the regulatory impact statement are available from the Ministry of Consumer Affairs, 500 Bourke Street, Melbourne (telephone 602 8330).

Comments and submissions are invited from interested parties.

Written submissions should be sent to the Director of Consumer Affairs at the above address within 21 days of the date of publication of this notice.

DAVID HALL
Director of Consumer Affairs

STATE TENDER BOARD
CONTRACTS ACCEPTED
Amendments

Schedule Number	Item Number	New Rate	Effective Date
\$			
<i>Light Commercial Motor Vehicles</i>			
1/59A	3A	9530.00	15.6.87
	3B	9685.00	16.6.87
	3C	10769.00	15.6.87
	3D	11097.00	16.6.87
	4A	9191.00	15.6.87
	4B	9217.00	16.6.87
	4C	10458.00	15.6.87
	4D	10620.00	16.6.87
	5A	11208.00	15.6.87
	5B	11211.00	16.6.87
1/59B	5C	12421.00	15.6.87
	5D	12476.00	16.6.87

Optional Equipment—

Automatic Transmission

1/59B	3B	889.00	
	3D	756.00	
	4B	893.00	
	4D	757.00	
	2B	9125.00	16.6.87
	3A	10574.00	15.6.87
	3B	11561.00	16.6.87
	3C	12986.00	
	4A	13049.00	15.6.87
	4C	14362.00*	15.6.87
1/59C	4D	13899.00	16.6.87

Optional Equipment—

Auto Transmission 941.00

All other optional equipment pricing is the same as the petrol model.

*Delete: VYGE23SFVMW

Add: VRGE24DFVMY

Optional Equipment—

Automatic Transmission

1/59C	3B	993.00	
	3C	897.00	
	4D	891.00	
	1A	12998.00	15.6.87
	1C	14086.00	

	2A	12596.00	
	2C	13587.00	
	3A	14767.00	
	3C	15933.00	
	4A(3)	17503.00	16.6.87
	4A(11)	17856.00	
	4B(3)	19934.00	
	4B(11)	20288.00	
	5A	19779.00	15.6.87
	5B	18952.00	16.6.87
	6A	16035.00	15.6.87
	6B	15764.00	16.6.87
	6C	19092.00	15.6.87
	6D	18121.00	16.6.87
	7A	20740.00	15.6.87
1/59D	1B	12227.00	16.6.87
	2B	16130.00	
	2C	17324.00*	15.6.87
	2D	17398.00	16.6.87
	3	37084.00	15.6.87

*Delete: DYG23SFMW
Add: WRGE24DFMY
Optional Equipment—
Automatic Transmission

	1B	943.00	
1/59E	B	18078.00*	15.6.87
		14162.00+	
		15052.00#	
	C	15034.00†	16.6.87
		12508.00§	
		12376.00φ	
		13511.00×	
		15440.00>	
		17910.00<	

*Delete: FGH40XNAM Single cab diesel
Add: SGH40XNFAM Single cab turbo diesel
+Delete: KMH40LRM Dual cab diesel
Add: KAH40LM6 Dual cab diesel
#Delete: MGH40WGFAM Single cab diesel
Add: SGH40WNFAM Single cab diesel
†Dual cab diesel
§C/C D/W diesel
φC/C D/W petrol
×C/C D/W diesel
>C/C D/W diesel auto
<Dual Cab/Chass.

Police Offences Act 1958, No. 6337
DIVISION 1A—STATE CLASSIFICATION
OF PUBLICATIONS BOARD

Take note that the State Classification of Publications Board has classified the following publications in accordance with the provisions of section 180H (1) of the *Police Offences Act 1958*.

Each publication shall be subject to the following restrictions:

- (a) It shall not be offered for sale, sold or delivered to any person under the age of 18 years;
- (b) It shall not be made available for inspection or perusal by any person under the age of 18 years;
- (c) It shall not be exhibited or displayed in any place to which persons under the age of 18 years have access or so that it is visible from any such place.

<i>Title</i>	<i>Distributor</i>
Exclusive—No. 71	Gordon & Gotch Ltd.
New Direction—No. 181	Gordon & Gotch Ltd.
Journal of Love, The—No. 100	Gordon & Gotch Ltd.
Adam Film World Guide—Directory of Adult Films—Vol. 3 No. 5—March 1987	Gordon & Gotch Ltd.
Best of Erotic X-Film Guide—No. 4	Gordon & Gotch Ltd.
X-Video Review	Gordon & Gotch Ltd.
Best of Real Letters—Fall 1987	Gordon & Gotch Ltd.
Best of Sensuous Letters—Fall 1987	Gordon & Gotch Ltd.
Best of Touch—Fall 1987	Gordon & Gotch Ltd.
Erotic X-Film Guide Spotlights—September 1987—X-Rated Stars in Action	Gordon & Gotch Ltd.
Forbidden Acts—August 1987	Gordon & Gotch Ltd.
True Letters—August 1987	Gordon & Gotch Ltd.
Velvet's Letters—Fall 1987	Gordon & Gotch Ltd.

J. M. PAWSON
Secretary to the Tender Board

R. V. DOOLEY
Acting Secretary
State Classification of Publications Board

Police Offences Act 1958, No. 6337

**DIVISION 1A—STATE CLASSIFICATION
OF PUBLICATIONS BOARD**

Take note that the State Classification of Publications Board has classified the following publications in accordance with the provisions of section 180H (1) of the *Police Offences Act 1958*.

Each publication shall be subject to the following restrictions:

- (a) It shall not be offered for sale, sold or delivered to any person under the age of 18 years;
- (b) It shall not be made available for inspection or perusal by any person under the age of 18 years.

<i>Title</i>	<i>Distributor</i>
Australian Pillow Talk—Vol. 1 No. 4	Gordon & Gotch Ltd.
Journal of Love, The—No. 98	Gordon & Gotch Ltd.
Parade—Vol. 3 No. 7	Gordon & Gotch Ltd.
Australian Penthouse—July 1987—Vol. 8 No. 7	Gordon & Gotch Ltd.
Club International—Vol. 16 No. 4	Gordon & Gotch Ltd.
Club International—Vol. 16 No. 6	Gordon & Gotch Ltd.
Escort—Vol. 7 No. 6	Gordon & Gotch Ltd.
Fiesta—Vol. 21 No. 6	Gordon & Gotch Ltd.
Knave—Vol. 19 No. 6	Gordon & Gotch Ltd.
New Breed—May 1987—No. 31	Gordon & Gotch Ltd.
Outlaw Biker—June 1987—Vol. 3 No. 5	Gordon & Gotch Ltd.
Penthouse—July 1987—Vol. 18 No. 11	Gordon & Gotch Ltd.
Penthouse Variations—July 1987	Gordon & Gotch Ltd.
Razzle—Vol. 5 No. 11	Gordon & Gotch Ltd.
Soldier of Fortune—July 1987—Vol. 12 No. 7	Gordon & Gotch Ltd.
Special Weapons and Tactics—May 1987	Gordon & Gotch Ltd.

R. V. DOOLEY
Acting Secretary

State Classification of Publications Board

Department of Industry, Technology and
Resources

APPLICATIONS FOR MINING LEASES
REFUSED

Nos. 1403–1410 (incl.); Planet Resources Group
N. L. and B. Riley Investments P/L;
260 ha each, Creswick.

**APPLICATION FOR DEVELOPMENT
LEASE WITHDRAWN**

No. 294; Bonanza Syndicate; 100 ha, Parish of
Cabanandra.

**APPLICATION FOR TAILINGS REMOVAL
LICENCE WITHDRAWN**

No. 5186; Bendigo Gold Associates P/L; to
remove tailings from an area adjacent
to Brittain Street, situated in the
Parish of Ballarat.

**INTENTION TO GRANT EXPLORATION
LICENCES**

No. 1690; Pan Australian Mining Ltd; 20 km²,
Shire of Korong.

No. 1691; Pan Australian Mining Ltd; 44 km²,
Parishes of Bealiba and Archdale.

No. 1692; Pan Australian Mining Ltd; 19 km²,
Parish of Moliagul.

No. 1768; Tihele P/L; 36.75 km², County of
Gladstone.

No. 1826; CRA Exploration P/L; 98 km², Shires
of Stawell and Kara Kara.

**EXPLORATION LICENCES GRANTED
AND AREAS REFUSED**

No. 1638; Bonanza Syndicate; area retained 12.5
km², area refused 9 km², Shire of
Orbost.

No. 1670; Pan Australian Mining Ltd; area
retained 21 km², area refused nil,
Shire of Omeo.

No. 1725; BHP Minerals Ltd; area retained 49.75
km², area refused 6 km², Parishes of
Painswick and Moliagul.

No. 1786; Bendigo Gold Associates P/L; area
retained 74.25 km², area refused 15.25
km², Shire of Orbost.

No. 1788; Bendigo Gold Associates P/L; area
retained 39.5 km², area refused nil,
Shire of Orbost.

No. 1808; M. Robinson & P. Gillard; area
retained 4 km², area refused 8 km²,
Parish of Panbulla.

**INTENTION TO EXTEND AN
EXPLORATION LICENCE**

No. 1506–1; Carlton Textiles (Export) P/L; 29
km², County of Talbot.

EXPLORATION LICENCE EXTENDED

No. 1221–4; Ashton Mining Ltd; 571 km²,
Counties of Borung and Kara Kara.

**APPLICATION FOR EXPLORATION
LICENCE WITHDRAWN**

No. 1952; P. N. Bierwirth, 122 km², Shires of Dundas and Wannon.

EXPLORATION LICENCES CANCELLED

No. 1378-1; CRA Exploration P/L; 562 km², Counties of Borung and Ripon.

No. 1379-1; CRA Exploration P/L; 550.5 km², Shire of Ararat.

No. 1532-1; CRA Exploration P/L; 12 km², Shire of Ararat.

The above cancelled areas will become available again for Exploration Licence on 9 December 1987.

EXPLORATION LICENCE EXPIRED

No. 1593; Poolette Holdings (Vic.) Pty Ltd; 39.5 km², County of Grant.

The above expired area will become available again for Exploration Licence on 23 November 1987.

EXTRACTIVE INDUSTRY LICENCES GRANTED

No. 1200; Robertson Industries P/L; 8.5825 ha, Parish of Scoresby.

No. 1257; K. R. & M. P. Broadbent; 8.553 ha, Parish of Warrion.

APPLICATION FOR EXTRACTIVE INDUSTRY LICENCE REFUSED

No. 1350; M. F. Lane; 14.3 ha, Parish of Yangery.

EXTRACTIVE INDUSTRY LICENCES RENEWED

No. 235-1; Boral Resources (Vic.) P/L; 24.9314 ha, Parish of Merrimu.

No. 545-1; Shire of Buln Buln; 10.3275 ha, Parish of Jindivick.

No. 687-2; Aidan J. Graham Pty 12-0073 ha, Parish of Langwarrin.

No. 778-2; P. A. Mount; 19.4831 ha, Parish of Holey Plains.

No. 833-2; W. A. Molan & Sons; 5.0255 ha, Colongulac.

No. 873-2; J. M. Kilpatrick; 2.52 ha, Parish of Werribee.

ROBERT FORDHAM
Minister for Industry, Technology and Resources

Transport Act 1983

ROAD TRAFFIC AUTHORITY
Determination of Fees

In accordance with section 147B of the *Transport Act 1983* the Road Traffic Authority with the approval of the Minister for Transport has revoked the Determination of Fees published in *Government Gazette* No. G.21 dated 3 June

1987 and has determined that the fee payable in respect to an application under section 143A for a licence to operate a taxi-cab within a proclaimed taxi-cab zone shall be \$100.

MICHAEL J. ROUX
Chairman and Managing Director
Road Traffic Authority

Town and Country Planning Act 1961
SHIRE OF ALBERTON (COASTAL)
PLANNING SCHEME 1962

Amendment No. 29

Notice of Approval

In pursuance of the powers conferred by the *Town and Country Planning Act 1961*, the Administrator in Council on 16 June 1987, approved the abovementioned scheme in respect of the municipal district of the Shire of Alberton and for which the Shire of Alberton is the Responsible Authority.

The scheme comes into operation on the date this Notice is published in the *Government Gazette*.

The scheme includes ordinance amendment to transfer the use 'Shop' from not requiring a planning permit, to requiring a planning permit in the Commercial A Zone.

A copy of the documents may be inspected free of charge, during office hours, at the office of the Ministry for Planning and Environment, The Olderfleet Buildings, 477 Collins Street, Melbourne and at the office of the Responsible Authority, Shire of Alberton, Shire Office, Commercial Road, Yarram.

DAVID YENCKEN
Secretary for Planning and Environment

Town and Country Planning Act 1961
LATROBE REGION (COMMERCIAL DEVELOPMENTS) INTERIM DEVELOPMENT ORDER 1984

Amendment No. 5

In pursuance of the powers conferred by the *Town and Country Planning Act 1961*, the Administrator in Council on 16 June 1987, amended the abovementioned scheme in respect of the municipal district of the Shire of Alberton and for which the Shire of Alberton is the Responsible Authority.

The amendment comes into operation on the date this Notice is published in the *Government Gazette*.

The amendment includes ordinance changes to allow consideration of a commercial development on land bounded by James and Nicol Streets, and Commercial Lane, Yarram.

A copy of the documents may be inspected free of charge, during office hours, at the office of the Ministry for Planning and Environment, The Olderfleet Buildings, 477 Collins Street, Melbourne, and at the office of the responsible authority, Shire of Alberton, Commercial Road, Yarram.

DAVID YENCKEN
Secretary for Planning and Environment

Private Agents Act 1966

NOTICE OF RECEIPT OF APPLICATIONS FOR LICENCES UNDER THE PROVISIONS OF THE PRIVATE AGENTS ACT 1966

The Clerk(s) of the Magistrates' Court(s) as listed hereunder hereby give notice that applications, as under, have been lodged for hearing by the said Court(s) on the date(s) specified.

Any person desiring to object to any of such applications must—

- (a) lodge with the respective Clerk of the Magistrates' Court a notice in the prescribed form of his objection and of the grounds thereof;
- (b) cause a copy of such notice to be served personally or by post upon the applicant at least three days before the hearing of the application; and
- (c) send or deliver—
 - (i) where the objection is not made by the officer in charge of the police district in which the Court is situated—a copy of the notice to such officer; and
 - (ii) where the objection is not made by the Registrar or Deputy Registrar—a copy to the Registrar.

<i>Full Name of Applicant*</i>	<i>Place of Abode of Applicant or Nominee</i>	<i>Name of Firm or Corporation</i>	<i>Address for Registration</i>	<i>Type of Licence</i>	<i>Date of Hearing</i>
MAGISTRATES' COURT, PRESTON					
Cravaritis, Billy Vasilios	15 Robeson St, West Preston		15 Robeson St, West Preston	Guard Agent Process Server	1.7.87
" "	" "		" "	" "	"
Dated at Preston 5 June 1987 P. WISE, Clerk of the Magistrates' Court					
MAGISTRATES' COURT, DANDENONG					
Turner, Simon John	31 Wansworth Ave, Mulgrave		71 Kooyong Rd, Caulfield	Inquiry Agent Commercial Sub-Agent	6.7.87
" "	" "		" "	" "	"
Dated at Dandenong 9 June 1987 R. O'KEEFE, Clerk of the Magistrates' Court					
MAGISTRATES' COURT, YARRAM					
Cook, Barry Howard	12 Duke St, Yarram		47 Union St, Sale	Watchman	
G. O'CONNOR, Clerk of the Magistrates' Court					
MAGISTRATES' COURT, LILYDALE					
Boilean, John Edward	35 Lindsay Ave, Murrumbidgee	Kellerman Mercantile	Lot 18 Montrose-Lilydale Rd, Montrose	Commercial Sub-Agent	26.6.87
Dated at Lilydale 1 June 1987 M. DAVIS, Clerk of the Magistrates' Court					

*Or in the case of a firm or corporation, of the Nominee

PRIVATE AGENTS—continued

<i>Full Name of Applicant*</i>	<i>Place of Abode of Applicant or Nominee</i>	<i>Name of Firm or Corporation</i>	<i>Address for Registration</i>	<i>Type of Licence</i>	<i>Date of Hearing</i>
MAGISTRATES' COURT, FRANKSTON					
Hargreaves, Jeffrey Michael	143 Ballarto Rd, Carrum Downs		143 Ballarto Rd, Carrum Downs	Guard Agent	1.7.87
Dated at Frankston 1 June 1987 K. YOUNG, Clerk of the Magistrates' Court					
MAGISTRATES' COURT, CAMBERWELL					
Henderson, Keith George	30 Nathan St, Donscaster		143 Auburn Rd, Auburn	Inquiry Agent	8.7.87
" "	" "	Loss Assessors Vic. Pty. Ltd.	" "	Inquiry Agent Corporation	"
Dated at Camberwell 12 June 1987 Clerk of the Magistrates' Court					
MAGISTRATES' COURT, ALEXANDRA					
Hauser, Bruce John	51 Steavenson Rd, Buxton		51 Steavenson Rd, Buxton	Guard Agent	10.7.87
Dated at Mansfield 5 June 1987 W. F. FROUDE, Clerk of the Magistrates' Court					
MAGISTRATES' COURT, SHEPPARTON					
Henry, Robin Leo	5 Devine Rd, Kialla West		5 Devine Rd, Kialla West	Commercial Agent	14.7.87
Dated at Shepparton 12 June 1987 D DRUMMOND, Clerk of the Magistrates' Court					
MAGISTRATES' COURT, BROADMEADOWS					
Smith, Geoffrey Graham	75 Alston St, Thornbury		3 Fern Cl, Broadmeadows	Guard Agent	2.7.87
Dated at Broadmeadows 12 June 1987 J. ISAACS, Clerk of the Magistrates' Court					
MAGISTRATES' COURT, BRUNSWICK					
Menay, Berdan,	17 Clifton Gve, Lalor		20 Lygon St, East Brunswick	Inquiry Agent	1.7.87
" "	" "		" "	Guard Agent	"
Dated at Brunswick 3 June 1987 B. P. REGAN, Clerk of the Magistrates' Court					
MAGISTRATES' COURT, SPRINGVALE					
Hogan, Gary	8 Edney Crt, Noble Park		8 Edney Crt, Noble Park	Inquiry Agent	2.7.87
" "	" "		" "	Guard Agent	"
Dated at Springvale 3 June 1987 M. BOURKE, Clerk of the Magistrates' Court					

*Or in the case of a firm or corporation, of the Nominee

PRIVATE AGENTS—continued

Full Name of Applicant*	Place of Abode of Applicant or Nominee	Name of Firm or Corporation	Address for Registration	Type of Licence	Date of Hearing
MAGISTRATES' COURT, WODONGA					
Jones, Russell William	4 Schubert Crt, Wodonga		390 St. Kilda Rd, Melbourne	Watchman	7.7.87
Dated at Wodonga 12 June 1987 Clerk of the Magistrates' Court					
MAGISTRATES' COURT, BROADMEADOWS					
Beardsworth, Garry Michael	176 Beverley Rd, Rosanna	Mayne Nickless Ltd	390 St. Kilda Rd, Melbourne	Watchman	15.5.87
Dated at Broadmeadows 10 June 1987 Clerk of the Magistrates' Court					
MAGISTRATES' COURT, WANGARATTA					
Overton, Stephen	23 O'Leary St, Wangaratta	N.E.S.S. Escorts	28 Rangeview St, Wangaratta	Watchman	13.7.87
Dated at Wangaratta 11 June 1987 J. KENNEDY, Clerk of the Magistrates' Court					
MAGISTRATES' COURT, BRUNSWICK					
Rouda, Maha	1 Breamlea Crt, Coolaroo	Rofvena Pty Ltd, Trading as: J. & F. Investigations	20 Lygon St, East Brunswick	Guard Agent	1.7.87
" "	" "		" "	Inquiry Agent	"
Dated at Brunswick 5 June 1987 B. P. REGAN, Clerk of the Magistrates' Court					
MAGISTRATES' COURT, SPRINGVALE					
Vargo, John Z.	2/15 Close Ave, Dandenong		634 St Kilda Rd, Melbourne	Watchman	2.7.87
Dated at Springvale 5 June 1987 M. J. BOURKE, Clerk of the Magistrates' Court					
MAGISTRATES' COURT, FRANKSTON					
Snip, Hendrik Pieter	1072 Nepean Hwy, Mornington	Security Incorporated Services	10 North Gateway Langwarrin	Watchman	9.7.87
Dated at Frankston 9 June 1987 K. YOUNG, Clerk of the Magistrates' Court					
MAGISTRATES' COURT, RINGWOOD					
Girvan, Mark James	13 Glen Dhu Rd, Kilsyth		19 Gladys Gve, Groydon West	Commercial Sub-Agent	7.7.87
Dated at Ringwood 9 June 1987 D. D. REES, Clerk of the Magistrates' Court					

*Or in the case of a firm or corporation, of the Nominee

PRIVATE AGENTS—continued

Full Name of Applicant*	Place of Abode of Applicant or Nominee	Name of Firm or Corporation	Address for Registration	Type of Licence	Date of Hearing
MAGISTRATES' COURT, MELBOURNE					
Hamilton, David J.	16 Clancys La, Doncaster	T.N.T. Group 4 Pty Ltd	54 Racecourse Rd, North Melbourne	Watchman	1.6.87
Shepherd, Brian Ernest	1A Suemar St, Mulgrave	T.N.T. Security	"	"	"
Ryan, Bruce Anthony	204 Haughton Rd, South Oakleigh	Bruce Anthony Ryan	5th Floor, 358 Lonsdale St, Melbourne	Process Server	2.6.87
Doll, Dennis John	139 Gillespie Rd, St. Albans	T.N.T. Group 4 Pty Ltd	54 Racecourse Rd, North Melbourne	Watchman	3.6.87
Beckingham, Glenn Michael	H.M.A.S. Lonsdale, Rouse St, Port Melbourne	Wormald Security	87 Racecourse Rd, North Melbourne	"	4.6.87
Keating, Leonard James	14 McGrath Cl, Kealba	T.N.T. Security	54 Racecourse Rd, North Melbourne	"	"
Marsh, Shane Andrew	5 Wungaro Crt, Greensborough	Wormald Security	87 Racecourse Rd, North Melbourne	"	"
Newton, William	11 Hoffman St, Cheltenham	"	"	"	"
Nichols, Paul John	37 Bailey Rd, Cockatoo	"	"	"	"
Stirrup, Raymond	39 Woodland Dr, St. Albans	"	"	"	"
Jones, Stephen Lance	10 Robinson Dr, Mornington	T.N.T. Security	54 Racecourse Rd, North Melbourne	"	5.6.87
Pannu, Satjit Singt	10/7 Empire St, Footscray	T.N.T. Group 4 Pty Ltd	"	"	"
White, Norman John	56 Mitchell St, Mornington	T.N.T. Security	"	"	"
Zharkov, Ivan	8/1A Spray St, Parkdale	"	"	"	"

Dated at Melbourne 9 June 1987
Clerk of the Magistrates' Court

MAGISTRATES' COURT, SPRINGVALE

Smith, Patricia Margaret	75 Kambara Dve, Mulgrave	Danimote Pty Ltd	75 Kambara Dve, Mulgrave	Inquiry Agent Corporation	1.7.87
Parker, Jeanette Grace	" "	"	"	"	"

Dated at Springvale 2 June 1987
M. HALADJIAN, Clerk of the Magistrates' Court

*Or in the case of a firm or corporation, of the Nominee

PRIVATE AGENTS—continued

Full Name of Applicant*	Place of Abode of Applicant or Nominee	Name of Firm or Corporation	Address for Registration	Type of Licence	Date of Hearing
Vandenham, John	MAGISTRATES' COURT, FERNTREE GULLY 117 Narr Mean Dve, Ringwood North		117 Narr Mean Dve, Ringwood North	Watchman	3.7.87
			Dated at Ferntree Gully 5 June 1987 A. J. CALDWELL, Clerk of the Magistrates' Court		
Maskell, Ernest Hedley	MAGISTRATES' COURT, PORT MELBOURNE 148 Derrimut Rd, Hoppers Crossing		152 Turner St, Port Melbourne	Watchman	2.7.87
			Dated at Port Melbourne 10 June 1987 T. B. TORPY, Clerk of the Magistrates' Court		
Turnbull, Alan George	MAGISTRATES' COURT, SOUTH MELBOURNE 9 Lincoln St, Burwood East		Suite 3, 1st Floor, 424 St. Kilda Rd, Melbourne	Inquiry Agent	3.7.87
			Dated at South Melbourne 10 June 1987 D. SCULLY, Clerk of the Magistrates' Court		

*Or in the case of a firm or corporation, of the Nominee

Town and Country Planning Act 1961
CITY OF MELBOURNE (CENTRAL CITY)
INTERIM DEVELOPMENT ORDER
Amendment No. 41
Notice of Amendment

In pursuance of the powers conferred by the *Town and Country Planning Act 1961*, the Administrator in Council on 31 March 1987, amended the abovementioned Order in respect of land in the Museum Station area, Melbourne and for which the Minister for Planning and Environment is the responsible authority.

The amendment comes into operation on the date this notice is published in the *Government Gazette*.

The amendment includes a proposal for the use and development of land within the Museum Station precinct described as—

- (a) all that land bounded by Elizabeth Street, LaTrobe Street, Swanston Street, and Little Lonsdale Street; and
- (b) all that land situate at and known as 284 to 310 Lonsdale Street; St. Francis Street south of Little Lonsdale Street; all properties abutting the east side of that

part of St. Francis Street being south of Little Lonsdale Street; 273 to 307 Little Lonsdale Street; Patrick Street; and all properties abutting Patrick Street.

A copy of the documents may be inspected free of charge, during office hours, at the office of the Ministry for Planning and Environment, The Olderfleet Buildings, 477 Collins Street, Melbourne and at the office of the responsible authority.

DAVID YENCKEN
Secretary for Planning and Environment

Town and Country Planning Act 1961
SHIRE OF FLINDERS PLANNING SCHEME
Amendment No. 223
Notice of Amendment

In pursuance of the powers conferred by the *Town and Country Planning Act 1961*, the Administrator in Council on 16 June 1987, amended the abovementioned scheme in respect of the municipal district of the Shire of Flinders and for which the Shire of Flinders is the responsible authority.

The amendment comes into operation on the

date this notice is published in the *Government Gazette*.

The amendment rezones Lots 2064 and 2063, LP43381 Summoner Street, Blairgowrie and Lots a071 and 2072, LP43381, Dana Avenue, Blairgowrie from Public Open Space Reserve to Wildcoast Residential Zone. It also rezones Lots 1878 and 1879, LP43378, Summoner Street, Blairgowrie and Lots 1886 and 1887, LP43378, Dana Avenue, Blairgowrie from Wildcoast Residential zone to Public Open Space Reserve—Public Park.

A copy of the documents may be inspected free of charge, during office hours, at the office of the Ministry for Planning and Environment, The Olderfleet Buildings, 477 Collins Street, Melbourne and at the office of the Shire of Flinders, Boneo Road, Rosebud.

DAVID YENCKEN
Secretary for Planning and Environment

Town and Country Planning Act 1961
SHIRE OF ALBERTON (COASTAL)
PLANNING SCHEME 1962

Amendment No. 28
Notice of Approval

In pursuance of the powers conferred by the *Town and Country Planning Act 1961*, the Administrator in Council on 16 June 1987, approved the abovementioned scheme in respect of the municipal district of the Shire of Alberton and for which the Shire of Alberton is the responsible authority.

The scheme comes into operation on the date this notice is published in the *Government Gazette*.

The scheme includes the rezoning of land bounded by James, Nicol and Yarram Streets and Commercial Lane, Yarram, from Industrial A Zone to Commercial A Zone, to allow expansion of Yarram's main shopping centre.

A copy of the documents may be inspected free of charge, during office hours, at the office of the Ministry for Planning and Environment, The Olderfleet Buildings, 477 Collins Street, Melbourne, and at the office of the responsible authority, Shire of Alberton, Shire Office, Commercial Road, Yarram.

DAVID YENCKEN
Secretary for Planning and Environment

APPOINTMENTS

APPOINTMENTS

His Excellency the Governor of the State of Victoria by and with the advice of the Executive Council thereof has by Order made on 10 June 1987 been pleased to make the undermentioned appointments, viz.:

Department of Health
Official Visitors

M. GRAVE
P. MCLOUGHLIN
E. M. SHRADER
M. CROTHERS
W. R. HAMMOND and
R. PHILPOTT

to be Official Visitors to Brierly Hospital Warrnambool, pursuant to the provisions of section 66 of the *Mental Health Act 1959*, for the period ending 30 June 1988.

Trustees of Public Cemeteries

Phillip Robert BENSON
to be a Trustee of the Meeniyan Public Cemetery.
George Robert BUNDETT,
Garry Robin John MCINNES and
Peter Kenneth EORST
to be Trustees of the Wickliffe Public Cemetery.
Trenfield James FISHER
to be a Trustee of the Rainbow Public Cemetery.
Maxwell Thomas MANNING
to be a Trustee of the Trentham Public Cemetery.
John William BEVERLY
to be a Trustee of the Poowong Public Cemetery.
Donald Neil POYNER and
Susan Joy MCDUGALL
to be Trustees of the Boort Public Cemetery.
All appointments were made pursuant to section 3 (1) of the *Cemeteries Act 1958*.

E. M. MILLER
Acting Clerk of the Executive Council

At the Executive Council Chamber
Melbourne, 10 June 1987

Mental Health Act 1959
SECTION 26

Notice is hereby given that the following appointment has been made pursuant to section 26 of the *Mental Health Act 1959*.

Bernard John GROSE

Deputy Manager, Mental Hospital and Training Centre, Warrnambool, and LEWANA CLINIC, Warrnambool, from 1 June 1987, *vice* D. J. Duffy.

T. J. DALY, Director
Office of Psychiatric Services

Appointments
MINISTRY OF EDUCATION—TECHNICAL
TEACHERS REGISTRATION BOARD

His Excellency, the Administrator in Council, by order made on 16 June 1987, appointed William Edward Loughnan, who is a member of the teaching service, as a member of the Technical Teachers Registration Board to replace Douglas van Reein Alkemade, who has retired from the teaching service, for the period 16 June 1987 to 30 June 1987.

E. M. MILLER
Acting Clerk of the Executive Council

3	Malvern	Inspector Graham James Brown, 15349 (from 10.5.87 to 30.5.87).
4	Malvern	Inspector Peter Geoffrey Kemp, 14542 (<i>vice</i> Chief Inspector Roberts, 10936).
4	Malvern	Inspector Richard Ellis Gray, 13185 (from 12.4.87 to 23.5.87).
4	Malvern	Inspector Neil Francis Phipps, 14769 (from 24.5.87 to 23.6.87).
1	Maroondah	Inspector Lawrence Colin Beet, 15803 (from 20.5.87 to 30.6.87).
4	Maroondah	The appointment of Inspector Lawrence Colin Beet, 15803 in <i>Police Gazette</i> 4 June 1987 is withdrawn.

Dated 12 June 1987

P. DELIANIS
Deputy Commissioner (Administration)

Liquor Control Act 1968
APPOINTMENT OF LICENSING
INSPECTORS

In accordance with the authority conferred upon me by section 6 of the *Police Regulation Act 1958*, I, Paul Delianis, Deputy Commissioner of Police, do hereby appoint under sub-section (1) of section 22 of the *Liquor Control Act 1968*, the following Officers of Police as Licensing Inspectors for the Divisions of the Police Districts as shown:

<i>Division</i>	<i>Police</i>	
<i>Number</i>	<i>District</i>	<i>Rank and Name</i>
1	Broadmeadows	Inspector Douglas Hilton, 13737 (from 24.5.87 to 18.6.87).
4	Cheltenham	Inspector Edward Arthur Hart, 16720 (from 1.6.87 to 15.7.87).
4	Dandenong	Inspector Kenneth Herbert Blay, 13750 (<i>vice</i> Chief Inspector Stafferton, 12247).
3	Essendon	Inspector Richard Maxwell Joyce, 14243 (<i>vice</i> Chief Inspector MacLennan, 13056).
3	Malvern	Inspector Mervyn Russell McCallum, 13650 (<i>vice</i> Chief Inspector Cartwright, 12303).

ORDERS IN COUNCIL

Superannuation Act 1958
**DECLARATION OF AN APPROVED
 SUPERANNUATION SCHEME**

The Governor in Council, on the recommendation of the Treasurer, under section 36B of the *Superannuation Act 1958* declares the Port of Melbourne Authority Superannuation Scheme to be an approved superannuation scheme for the purposes of that section of the Act.

Dated: 2 June 1987

Responsible Minister:

R. A. JOLLY
 Treasurer

E. M. MILLER
 Acting Clerk of the Executive Council

Swan Hill Pioneer Settlement Act 1974
**APPROVAL OF REGULATIONS TO BE
 MADE BY THE SWAN HILL PIONEER
 SETTLEMENT AUTHORITY**

The Governor in Council under section 39 of the *Swan Hill Pioneer Settlement Act 1974* approves the making of the Regulations set out hereunder by the Swan Hill Pioneer Settlement Authority:

Dated: 5 May 1987

Responsible Minister:

R. C. FORDHAM,
 Minister for Industry, Technology and Resources

L. G. HOUSTON
 Clerk of the Executive Council
 The Swan Hill Pioneer Settlement Authority makes the following Regulations:

1. These Regulations may be cited as the Swan Hill Pioneer Settlement (Amendment) Regulations 1987 No. 2.

2. In these Regulations the Swan Hill Pioneer Settlement Regulations 1975 are called the Principal Regulations.

3. In Regulation 5 of the Principal Regulations, there shall be added the following:

(2) The following charges are prescribed for admission to the Art Gallery:

For persons under 15 years and over	\$1.00
For persons below 15 years of age	Free of charge

Major Exhibitions—Persons 15 years and over \$1.00 to a maximum of \$4.00

Made by the Swan Hill Pioneer Settlement Authority.

Date:

- : Chairman
- : Member
- : Member
- : Member
- : Member
- : Member
- : Member
- : Member
- : Member

Land Act 1958
COMMON TO BE DIMINISHED
 Notice of Intention

The Governor in Council under section 184 of the *Land Act 1958* gives notice of intention to diminish the following common:

DOWLING FOREST—The Ballarat West Town Common proclaimed as such by the Governor in Council on 28 January 1861 so far only as regards the area of 3.3 hectares, more or less, in the Parish of Dowling Forest as shown by hatching on plan hereunder—(C 91998).

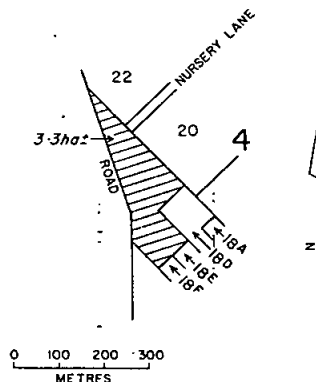

Dated: 10 June 1987

Responsible Minister:

JOAN E. KIRNER
 Minister for Conservation, Forests and Lands

E. M. MILLER
 Acting Clerk of the Executive Council

Land Act 1958

APPOINTMENT OF BAILIFF OF CROWN LAND

The Governor in Council, under section 30 of the *Land Act 1958* appoints Douglas Henry Hardie to be a bailiff of Crown land, without salary, for the Crown reserves within the municipality of Keilor under the control of the Corporation of the City of Keilor with authority to enforce the regulations made with respect to the care protection and management of the reserves and revokes the appointment as a bailiff of Crown lands of John Thomas Bayliss—(Rs.6433).

Dated: 10 June 1987

Responsible Minister:

JOAN E. KIRNER

Minister for Conservation, Forests and Lands

E. M. MILLER

Acting Clerk of the Executive Council

Crown Land (Reserves) Act 1978

REVOCATION OF TEMPORARY RESERVATIONS

The Governor in Council under section 10 of the *Crown Land (Reserves) Act 1978* revokes the following temporary reservations:

NEWBRIDGE—The temporary reservation by Order in Council of 9 May 1906 of 1.24 hectares of land in section 14, Township of Newbridge, Parish of Tarnagulla as a site for a State School—(Rs.5006).

NEWBRIDGE—The temporary reservation by Order in Council of 20 November 1939 of 3693 square metres in section 14, Township of Newbridge, Parish of Tarnagulla in addition to and adjoining the site temporarily reserved therefor by Order in Council of 9 May 1906—(Rs.5006).

KANGDERAAR—The temporary reservation by Order in Council of 22 September 1880 of 4.05 hectares of land in section 5, Parish of Kangderaar as a site for Watering Purposes—(Rs.13436).

HAMILTON SOUTH—The temporary reservation by Order in Council of 15 December 1981 of 587 square metres of land being Crown Allotment 4B, section 1, Parish of Hamilton South as a site for Departmental Residence—(Rs.11971).

Dated 10 June 1987

Responsible Minister:

JOAN E. KIRNER

Minister for Conservation, Forests and Lands

E. M. MILLER

Acting Clerk of the Executive Council

CROWN LAND (RESERVES) ACT 1978

Under section 7 (2) of the *Crown Land (Reserves) Act 1978* the Governor in Council revokes the exception from prospecting or from occupation for mining purposes under any miners right for the following land:

CRESWICK—The land comprising 26.3 hectares in the Township and Parish of Creswick temporarily reserved by Order in Council of 17 January 1967 for Public Purposes (Scenic Purposes)—(Rs.8749).

Dated: 10 June 1987

Responsible Minister:

JOAN E. KIRNER

Minister for Conservation, Forests and Lands

E. M. MILLER

Acting Clerk of the Executive Council

Crown Land (Reserves) Act 1978

REVOCATION OF TEMPORARY RESERVATIONS

The Governor in Council under section 10 of the *Crown Land (Reserves) Act 1978* revokes the following temporary reservations:

BEEAC—The temporary reservation by Order in Council of 25 May 1937 of 2428.1 square metres more or less in the Township of Beeac, Parish of Ondit as a site for a Rubbish Depot—(Rs.4699).

ONDIT—The temporary reservation by Order in Council of 12 November 1872 of 34.4 hectares more or less in the Parish of Ondit as a site for Public purposes—(Rs.11444).

Dated 10 June 1987

Responsible Minister:

JOAN E. KIRNER

Minister for Conservation, Forests and Lands

E. M. MILLER

Acting Clerk of the Executive Council

Crown Land (Reserves) Act 1978

NOTICE OF INTENTION

The Governor in Council under section 10 of the *Crown Land (Reserves) Act 1978* gives notice of intention to revoke the following temporary reservation:

TAHARA—The temporary reservation by Order in Council of 10 March 1914 of 39.93 hectares of land in the Township of Tahara, Parish of Tahara as a site for Public Recreation so far only as the portion containing 419 square metres being Crown Allotment 1, section 4, Township of Tahara as shown on Certified Plan No. 108396 lodged in the Central Plan Office—(Rs.832).

Dated 10 June 1987

Responsible Minister:
JOAN E. KIRNER

Minister for Conservation, Forests and Lands
E. M. MILLER
Acting Clerk of the Executive Council

Crown Land (Reserves) Act 1978
CROWN LAND PERMANENTLY
RESERVED

The Governor in Council under sections 4 and 7 of the *Crown Land (Reserves) Act 1978* permanently reserves for the purpose mentioned and also excepts from prospecting or from occupation for mining purposes under any miners right the following Crown land:

MUNICIPAL DISTRICT OF THE SHIRE OF
GISBORNE

GISBORNE—Public purposes, 1.2 hectares, more or less, of land in the Parish of Gisborne as indicated by hatching on plan hereunder—(2662-1)(Rs.5224).

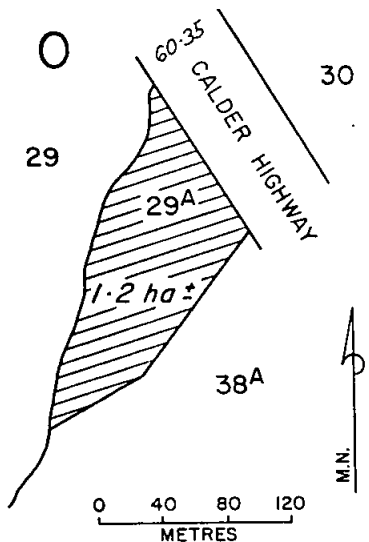

Dated: 10 June 1987

Responsible Minister:
JOAN E. KIRNER

Minister for Conservation, Forests and Lands
E. M. MILLER
Acting Clerk of the Executive Council

Crown Land (Reserves) Act 1978
CROWN LAND TEMPORARILY
RESERVED

The Governor in Council under sections 4 and 7 of the *Crown Land (Reserves) Act 1978* temporarily reserves for the purpose mentioned and also excepts from prospecting or from occupation for mining purposes under any miners right the following Crown land:

MUNICIPAL DISTRICT OF THE CITY OF
ARARAT

ARARAT—Public Recreation, 1.6 hectares, more or less, of land being Crown allotment 13, section 42, Township of Ararat, Parish of Ararat as indicated by hatching on plan hereunder—(A148 (8)) (Rs.8890).

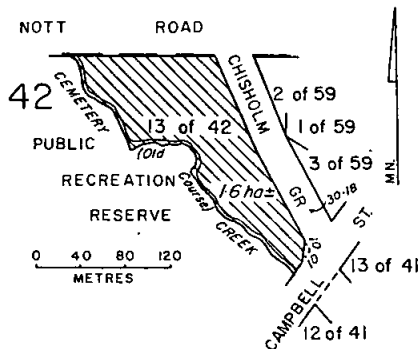

Dated: 10 June 1987

Responsible Minister:
JOAN E. KIRNER

Minister for Conservation, Forests and Lands
E. M. MILLER
Acting Clerk of the Executive Council

Crown Land (Reserves) Act 1978
CROWN LANDS TEMPORARILY
RESERVED

The Governor in Council under sections 4 and 7 of the *Crown Land (Reserves) Act 1978* temporarily reserves for the purposes mentioned and also excepts from prospecting or from occupation for mining purposes under any miners right the following Crown lands:

MUNICIPAL DISTRICT OF THE SHIRE OF
WIMMERA

QUANTONG—For Crop Research purposes 44.5 hectares more or less being Crown Allotment 21G, Parish of Quantong as indicated by hatching on plan hereunder—(Q36 (3)) (Rs.13497).

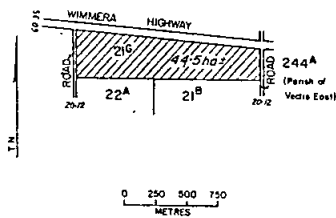

MUNICIPAL DISTRICT OF THE SHIRE OF WIMMERA

VECTIS EAST—For Crop Research purposes 560 hectares more or less being Crown Allotments 235A and 252A, Parish of Vectis East as indicated by hatching on plan hereunder—(V12 (6)) (Rs.13497).

DEPARTMENT OF PROPERTY AND SERVICES
DIVISION OF SURVEY AND MAPPING

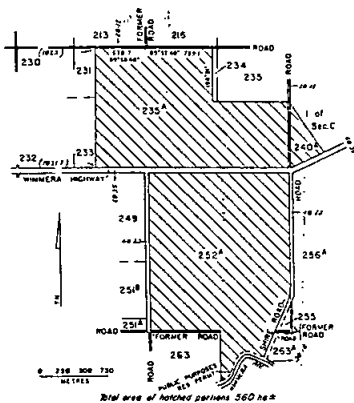

Dated: 10 June 1987
 Responsible Minister:
JOAN E. KIRNER
 Minister for Conservation, Forests and Lands
E. M. MILLER
 Acting Clerk of the Executive Council

**Crown Land (Reserves) Act 1978
 NOTICE OF INTENTION**

The Governor in Council under section 10 of the *Crown Land (Reserves) Act 1978* gives notice of intention to revoke the following temporary reservation:

YACKANDANDAH—The temporary reservation by Order in Council of 10 June, 1891 of 1.04 hectares of land in the Parish of

Yackandandah as a site for a State School—(L8-1794).

Dated 10 June 1987
 Responsible Minister:
JOAN E. KIRNER
 Minister for Conservation, Forests and Lands
E. M. MILLER
 Acting Clerk of the Executive Council

CHILDREN'S COURT ACT 1973

The Governor in Council, pursuant to the provisions of section 9 of the *Children's Court Act 1973*, hereby appoints the undermentioned to be Honorary Probation Officers for Children's Courts in the State of Victoria for a period ending 31 December 1989.

Inner Urban Region

- Jennifer Arnott
- Dorothy Campbell
- Margaret Crosbie
- Anna Curtis
- Maureen Fagan
- Diana James

to be Honorary Probation Officers for Children's Courts in the State of Victoria, pursuant to the provisions of section 9 of the *Children's Court Act 1973* for a period ending 31 December 1989.

North-Eastern Region

- Keith Von Baer
- Gregory Bech
- David Bongiorno
- Paul Cacioli
- Ralph Perry Comodo
- Janette Edgar
- Pauline Gibbs
- Corinna Jennifer Haigh
- Kim Kathryn Hibbert
- Douglas Hibbert
- Brian Kinloch
- Ian Roy McFadyen
- Gary Marchant
- Colin Milnes
- Meredith Mitskinis
- Mark Andrew Mulcahy
- Paul Oppy
- Joan Pollock
- Donald Ramsay
- Peter John Richardson
- Robyn June Skerry
- Sharon Leanne Smith
- Damian Toes
- Marianne Therese Tome

to be Honorary Probation Officers for Children's Courts in the State of Victoria, pursuant to the provisions of section 9 of the *Children's Court Act 1973* for a period ending 31 December 1989.

Southern Suburbs Region

Donna Andrew
Kathleen Arentz
Beryl Bartacok
Geoff Birbeck
Robert Bromley
Karl Buetiner
Jennifer Cumming
Jenny Dickson
Martin Dixon
Luano Doko
Jim Drysdale
Herbert Dunne
Emmy Elbaum
Leanne Maxine Gillett
Mary Gilligan
Michael Gcurly
Lisa Rose Gunther
Noela Haines
Faye Haskins
Elaine Henshaw
Leanne Jemmerson
Des Kealy
Andrew Lefebure
John Mahoney
Stanley Mangalson
Clifford McAliece
Alister McLeish
Jim Miller
David Mills
Joan Mullumby
Jacqueline Nixon
Roma O'Connor
Catherine Pocknee
Lynette Richards
Colleen Rolls
Christopher Ryan
Enid Sheehy
Claire Timloch
Jan Warren
Marshall White
Lorraine Williams
Marcia Williams
Sheryl Wilson
Lois Wintle

to be Honorary Probation Officers for Children's Courts in the State of Victoria, pursuant to the provisions of section 9 of the *Children's Court Act 1973* for a period ending 31 December 1989.

Westernport Region

Barbara Jeanette Black
Evelyn Chetland
Terry Holman
Ria Neil

to be Honorary Probation Officers for Children's Courts in the State of Victoria, pursuant to the provisions of section 9 of the *Children's Court Act 1973* for a period ending 31 December 1989.

East Gippsland Region

Rita Iy Hood
Rhonda Malvina Mahomet
Kerry Mills
Helen Morgan
to be Honorary Probation Officers for Children's Courts in the State of Victoria, pursuant to the provisions of section 9 of the *Children's Court Act 1973* for a period ending 31 December 1989.

Central Gippsland Region

Laurie Briggs
Charmaine Teresa Birchfield
Ross David Cadby
Enid Patricia Cassells
Graham Dickinson
Keith Raymond Dyer
Kaye Maree Ford
Jennifer Ann Gardiner
Julie Ann Hardy
Ann Lorraine Hibbert
Janice Johnson
Miriam Ann Johnston
Perry Martin Lepetit
Lorraine Ann Lockwood
Rex McGowen
Mary Elizabeth Pallot
Edna Dawn Reid
Margaret Lillian Schonberger
Elaine Stafford
Glenda Kim Stanislaw
Gregory Norman Smith
Leslie George Watson
Tom Errol Webster
Mary Ann Willis
Geoffrey Ronald Wilson
Robert Woszezeiko
Sandra Viotto

to be Honorary Probation Officers for Children's Courts in the State of Victoria, pursuant to the provisions of section 9 of the *Children's Court Act 1973* for a period ending 31 December 1989.

Goulburn Region

Colin Bruce Beaton
Eric Burchett
Valerie Kathleen Downie
Nikki Frampton
Francis Michael Graham
Rosamund Mary Henning
Raelene Johnson
Roger Davis Lafontaine
Barbara Davis McCrabb
Carolyn Dawn McCullough
Elizabeth Moore
Leigh Pye
Gayle Maree Roach
Patsy Irene Sidebottom
Don Thickens
Ivan Thompson
Bob Turner
Sandra Turner

to be Honorary Probation Officers for Children's Courts in the State of Victoria, pursuant to the provisions of section 9 of the *Children's Court Act 1973*, for a period ending 31 December 1989.

Loddon Campaspe Region

Ronald Adams
Frank Caird
Frank Cooper
Helen Huntley
Marlene Mailer
Paul McGaskell
Petra Velda
Geneen Polean Wright
Nola Wright
Peter Wright
David Young

to be Honorary Probation Officers for Children's Courts in the State of Victoria, pursuant to the provisions of section 9 of the *Children's Court Act 1973*, for a period ending 31 December 1989.

Mallee Region

Veysel Algin

to be Honorary Probation Officers for Children's Courts in the State of Victoria, pursuant to the provisions of section 9 of the *Children's Court Act 1973*, for a period ending 31 December 1989.

Wimmera Region

Phillip Laurence Atkinson

Ross William Barnes
Rhonda Gail Brunt
Bruce Charles
Allan Campbell Forrester
Shirley Annette Glover
Neil William Fryer
Marion McConchie
Leonie Ellen McClelland
Raelene Patricia Mitchell
Shirley Jeanette Mitchell
Arlene Jean Parker
Christine Ann Phipps
Leslie Victor Power
Mary Joseph Rooney
Carole Irene Smith
Dianne Gail Thomas
Shirley Wilson

to be Honorary Probation Officers for Children's Courts in the State of Victoria, pursuant to the provisions of section 9 of the *Children's Court Act 1973* for a period ending 31 December 1989.

Dated 10 June 1987

Responsible Minister:

CAROLINE HOGG
Minister for Community Services

E. M. MILLER
Acting Clerk of the Executive Council

CHILDREN'S COURT ACT 1973

The Governor in Council, pursuant to the provisions of section 9 of the *Children's Court Act 1973*, hereby revokes the appointment of the undermentioned persons to be Honorary Probation Officers for Children's Courts in the State of Victoria.

Barwon Region

Neville Funston
Evan Jones

North West Region

Betty Allois
Elizabeth Durbridge
Loretta Hogan
Joanna McLeay
Robert Mussen

Outer East Region

Peter Hannon

Southern Region

Andrew Lefebure
Geoffrey Birbank
Clifford McAhlicce
Ian Jensen

Susan Lincoln
Lynn Cochrane
Inner Urban Region
Yvonne Phillips
Central Gippsland Region

Lorraine Hodge
Dianne Merry
Rick Tipping
George Braun
Rene Robertson
Carole Mann
Delma Dean
Kevin Merry
Elaine Stratford
Angela Dyson
Margaret Miller
Henk Harberts
Tim Buttle

Dated 10 June 1987

Responsible Minister:

CAROLINE HOGG
Minister for Community Services

E. M. MILLER
Acting Clerk of the Executive Council

CHILDREN'S COURT ACT 1973

The Governor in Council, pursuant to section 165 (1) of the *Community Welfare Services Act 1970* (as amended) and section 8 (2) of the *Children's Court Act 1973* hereby appoints the undermentioned persons to be Stipendiary Youth Parole and Stipendiary Probation Officers.

Westernport Region

Rosalie Fleur Freadman

Glenelg Region

Grace Annette Brown

Gail Maree Reid

Outer East Region

Beverley Jean Atkinson

Southern Region

Mano Ponnusamy

Dated 10 June 1987

Responsible Minister:

CAROLINE HOGG
Minister for Community Services

E. M. MILLER
Acting Clerk of the Executive Council

CHILDREN'S COURT ACT 1973

The Governor in Council, pursuant to the provisions of section 9 of the *Children's Court*

Act 1973, hereby appoints all current Honorary Probation Officers to be Honorary Probation Officers for all Children's Courts in the State of Victoria for a period ending 31 December 1989.

Dated 10 June 1987

Responsible Minister:

CAROLINE HOGG
Minister for Community Services

E. M. MILLER
Acting Clerk of the Executive Council

Hospitals and Charities Act

**INCORPORATION OF JOHN CURTIN
MEMORIAL HOSTEL**

The Governor in Council under section 46 of the *Hospitals and Charities Act 1958* declares to be a body corporate an institution in Creswick by the name of John Curtin Memorial Hostel.

Dated 10 June 1987

Responsible Minister:

DAVID WHITE
Minister for Health

E. M. MILLER
Acting Clerk of the Executive Council

Hospitals and Charities Act

VARIATION OF OBJECTS

The Governor in Council under section 52 of the *Hospitals and Charities Act 1958* varies the objects of Dunmunkle Health Services and the objects of the institution shall be:

1. (a) To provide for provision of preventive health services and provide facilities for diagnosis and treatment of illness for all persons.

(b) To manage and maintain community health services so as to provide facilities for family physicians, specialists, district nurses, physiotherapists, occupational therapists, social workers, psychiatric nurses and other medical and/or paramedical personnel as required.

(c) To manage and maintain acute hospital facilities so as to afford relief, including maintenance and the treatment or cure of, or attention to, any disease or ailment, or any injury consequent on any accident, medical and/or surgical attendance, medicine, nursing assistance, support or such of any kind or in any form to such persons as are entitled under the Act.

(d) The acute hospital facilities provided will be for both public and private patients or either of them.

(e) To manage and maintain nursing home facilities so as to provide nursing home care and accommodation for all persons falling within those categories defined under the

Commonwealth Aged or Disabled Persons Homes Act 1954 and who are assessed as being in need of such care and accommodation.

2. To do other such things which, in the Board's opinion, will provide for the economic, social and recreational well-being of patients and residents.

3. To purchase or acquire any real and/or personal property and other buildings to be used for the above purpose.

4. To do all such other items as are incidental or conducive to the attainment of the above objects.

Dated 10 June 1987

Responsible Minister:

DAVID WHITE
Minister for Health

E. M. MILLER
Acting Clerk of the Executive Council

Racing Act 1958

APPOINTMENT OF A MEMBER TO THE
RACECOURSES LICENCES BOARD

The Governor of Victoria acting with the advice of the Executive Council and pursuant to the powers conferred by section 34 (3) of the *Racing Act 1958* appoints Trevor S. Craddock as a Member of the Racecourses Licences Board for the period 25 June 1987 to 21 May 1990.

Dated 10 June 1987

Responsible Minister:

NEIL B. TREZISE
Minister for Sport and Recreation

E. M. MILLER
Acting Clerk of the Executive Council

Forests Act 1958

DECLARATION OF PROTECTED PUBLIC
LAND

Botanic Gardens Annex, Cranbourne

The Governor in Council under section 62 (1) of the *Forests Act 1958* declares to be protected public land, the following Crown lands:

CRANBOURNE AND SHERWOOD—An area of 160.15 hectares of land in the Parishes of Cranbourne and Sherwood permanently reserved for the purposes of a Botanic Gardens and Research Institute devoted to the growing, display and study of Australian native plants and for the enjoyment of the people of Victoria by Order in Council of 1 December 1970—(Rs.9375).

LANGWARRIN—An area of 2.374 hectares of land being Crown Allotments 2A and 2B, Parish of Langwarrin temporarily reserved for the

purposes of Botanic Gardens Research Institute and Public Recreation by Order in Council of 7 February 1984—(Rs.9375).

SHERWOOD—An area of 22.28 hectares of land being Crown Allotment 22c, Parish of Sherwood permanently reserved as a site for the purposes of a Botanic Gardens and Research Institute devoted to the growing, display and study of Australian native plants and for the enjoyment of the people of Victoria by Order in Council of 12 July 1977—(Rs.9375).

SHERWOOD—An area of 6.1943 hectares of land deemed to be temporarily reserved for the purposes of the preservation of an area of ecological significance; the conservation of an area of natural interest or beauty or of scientific historic interest; the preservation of species of native plants and the propagation or management of wildlife or the preservation of wildlife habitat under section 5 of the *Crown Land (Reserves) Act 1978* being part of Crown Allotment 22A, Parish of Sherwood transferred to the Crown by Transfer No. L844423Q registered in the Office of Titles on 21 August 1985—(Rs.9375).

SHERWOOD—An area of 65.23 hectares, more or less, of land deemed to be temporarily reserved for the purposes of Botanic Gardens and Public Recreation under section 5 of the *Crown Land (Reserves) Act 1978* being part of Crown allotments 22B and 23B, Parish of Sherwood transferred to the Crown by Transfer No. L929302G registered in the Office of Titles on 26 August 1985—(L11-3335).

Dated: 10 June 1987

Responsible Minister:

JOAN E. KIRNER
Minister for Conservation, Forests and Lands

E. M. MILLER
Acting Clerk of the Executive Council

Local Government Act 1958

SHIRE OF BROADFORD
Confirmation of Separate Rate

The Governor in Council acting under section 287 of the *Local Government Act 1958* confirms a separate rate made by the Council of the Shire of Broadford on 12 February 1987 for the purpose of providing electricity reticulation in the Parish of Kerrisdale.

Dated 10 June 1987

Responsible Minister:

J. L. SIMMONDS
Minister for Local Government

E. M. MILLER
Acting Clerk of the Executive Council

Local Government Department
SHIRE OF KORUMBURRA

Retention of land for municipal purposes

The Governor in Council acting under section 526 (2) of the *Local Government Act 1958* approves of the Council of the Shire of Korumburra retaining the land shown by cross-hatching on the plan hereunder for municipal purposes.

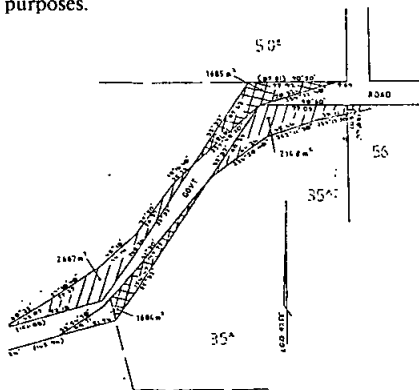

Dated 10 June 1987
Responsible Minister:
J. L. Simmonds
Minister for Local Government

E. M. MILLER
Acting Clerk of the Executive Council

Urban Land Authority Act 1979
CITY OF MOORABBIN

Transfer of Land

The Governor in Council under section 19 (1) of the *Urban Land Authority Act 1979* transfers to the Urban Land Authority the land described in the Schedule.

Schedule
Parish of Mordialloc
County of Bourke

1. Lot 5 Block H on Plan of Subdivision No. 1499 and being the whole of the land in Certificate of Title Volume 9142 Folio 092.
2. Lot 8 Block H on Plan of Subdivision No. 1499 and being the whole of the land in Certificate of Title Volume 9142 Folio 093.
3. Crown Allotment One A Section Seven and being the whole of the land in Certificate of Title Volume 7038 Folio 515.

Dated 10 June 1987

Responsible Minister:
FRANK NOEL WILKES
Minister for Housing

E. M. MILLER
Acting Clerk of the Executive Council

Urban Land Authority Act 1979
VERMONT SOUTH

Transfer of Land

The Governor in Council under section 19 (1) of the *Urban Land Authority Act 1979* transfers to the Urban Land Authority the land described in the Schedule.

Schedule
Parish of Nunawading
County of Bourke

Lot No.	Plan of Subdivision	Certificate of Title	
		Volume	Folio
69	99763	9093	252
275	112571	9201	596

Dated 10 June 1987

Responsible Minister:
FRANK NOEL WILKES
Minister for Housing

E. M. MILLER
Acting Clerk of the Executive Council

Retirement Villages Act 1986

Section 6

DECLARATION OF EXEMPTION

Under the powers found in section 6 of the *Retirement Villages Act 1986*, the Governor in Council on the recommendation of the Attorney-General, declares:

the Anglican Homes for Elderly People of 12 Wyuna Avenue, Hawthorn to be an exempt organisation to which none of the provisions of the *Retirement Villages Act 1986* apply.

upon condition that no ingoing contribution is sought nor a donation solicited from prospective residents.

Dated 2 June 1987

Responsible Minister:
J. H. KENNAN
Attorney-General

E. M. MILLER
Acting Clerk of the Executive Council

Retirement Villages Act 1986

Section 6

DECLARATION OF EXEMPTION

Under the powers found in section 6 of the *Retirement Villages Act 1986*, the Governor in Council on the recommendation of the Attorney-General, declares:

the Cumberland View Retirement Village of Whalley Drive, Wheelers Hill to be an exempt village to which the following provisions of the *Retirement Villages Act 1986* ("the Act") do not apply:

- (i) Sections 16, 25, 29 (7) and 34 of the Act, Upon condition that:

the requirements of the sections are complied with by the manager for the time being of the village as if the expression "manager" were substituted for the expression "owner" in the sections; and

- (ii) Section 38, upon condition that the maintenance charge payable by a resident is increased only by the same percentage increase made from time to time in the single age pension payable by the Commonwealth.

The above are conditional upon a copy of this exemption being given to each prospective resident at the same time such residents are given the residence documents relating to the village.

Dated 2 June 1987

Responsible Minister:

J. H. KENNAN
Attorney-General

E. M. MILLER
Acting Clerk of the Executive Council

Retirement Villages Act 1986

Section 6

DECLARATION OF EXEMPTION

Under the powers found in section 6 of the *Retirement Villages Act 1986*, the Governor in Council on the recommendation of the Attorney-General, declares:

the Glendale Aged Care Hostel of Heaths Road, Hoppers Crossing, to be an exempt village to which the following provisions of the *Retirement Villages Act 1986* ("the Act") do not apply:

- (i) Sections 16, 25, 29 (7) and 34 of the Act, Upon condition that:

the requirements of the sections are complied with by the manager for the time being of the village as if the expression "manager" were substituted for the expression "owner" in the sections; and

- (ii) Section 38, upon condition that the maintenance charge payable by a resident is increased only by the same percentage increase made from time to time in the single age pension payable by the Commonwealth.

The above are conditional upon a copy of this exemption being given to each prospective resident at the same time such residents are given the residence documents relating to the village.

Dated 2 June 1987

Responsible Minister:

J. H. KENNAN
Attorney-General

E. M. MILLER
Acting Clerk of the Executive Council

Retirement Villages Act 1986

Section 6

DECLARATION OF EXEMPTION

Under the powers found in section 6 of the *Retirement Villages Act 1986*, the Governor in Council on the recommendation of the Attorney-General, declares:

Forty Dorking Road of 40 Dorking Road, Box Hill to be an exempt village to which the following provisions of the *Retirement Villages Act 1986* (the Act) do not apply;

- (i) Part 5 of the Act upon condition that the obligation (whether enforceable or not) to refund any part of the ingoing contribution is made between the City of Box Hill and the resident, and is subject to the terms and conditions contained in clause 3 of the Residency Agreement lodged in support of the application for exemption.

- (ii) Section 38 of the Act upon condition that the maintenance charge levied on a resident of the village shall not exceed a total equal to 85% of the Commonwealth Aged Pension and 50% of any other income of such a pensioner resident (if any).

The above are conditional upon a copy of this exemption being given to each prospective resident at the same time such residents are given the residence documents relating to the village.

Dated 2 June 1987

Responsible Minister:

J. H. KENNAN
Attorney-General

E. M. MILLER
Acting Clerk of the Executive Council

Retirement Villages Act 1986

Section 6

DECLARATION OF EXEMPTION

Under the powers found in section 6 of the *Retirement Villages Act 1986*, the Governor in Council on the recommendation of the Attorney-General, declares:

the Kirkbrae Presbyterian Homes for the Aged of 794 Mt Dandenong Road, Kilsyth to be an exempt village to which the following provisions of the *Retirement Villages Act 1986* (the Act) do not apply:

Sections 36 (7), 37 (4) and 38 of the Act,

Upon condition that:

- (i) the maintenance charge levied on a resident of the village shall not exceed a total equal to 85% of the Commonwealth Aged Pension and 50% of any other income of such a pensioner resident (if any); and
- (ii) that a copy of this exemption be given to each prospective resident at the same time such residents are given the residence documents relating to the village.

Dated 2 June 1987

Responsible Minister:

J. H. KENNAN
Attorney-General

E. M. MILLER

Acting Clerk of the Executive Council

Retirement Villages Act 1986

Section 6

DECLARATION OF EXEMPTION

Under the powers found in section 6 of the *Retirement Villages Act 1986*, the Governor in Council on the recommendation of the Attorney-General, declares:

Lionsbrae, of Everard Road, Ringwood East to be an exempt village to which the following provisions of the *Retirement Villages Act 1986* (the Act) do not apply:

Sections 13, 16, 19, 21, 24, 25, 34 and 38 of the Act,

Upon condition that:

- (i) the requirements of the sections are complied with by the manager for the time being of the village as if the expression "manager" were substituted for the expression "owner" in the sections; and
- (ii) that a copy of this exemption be given to each prospective resident at the same time such residents are given the residence documents relating to the village.

Dated 2 June 1987

Responsible Minister:

J. H. KENNAN
Attorney-General

E. M. MILLER

Acting Clerk of the Executive Council

Retirement Villages Act 1986

Section 6

DECLARATION OF EXEMPTION

Under the powers found in section 6 of the *Retirement Villages Act 1986*, the Governor in Council on the recommendation of the Attorney-General, declares:

the Overseas Missionary Fellowship of 14 Grange Road, Kew to be an exempt organisation to which none of the provisions of the *Retirement Villages Act 1986* apply.

Upon condition that no ingoing contribution is sought nor a donation solicited from prospective residents.

Dated 2 June 1987

Responsible Minister:

J. H. KENNAN
Attorney-General

E. M. MILLER

Acting Clerk of the Executive Council

Retirement Villages Act 1986

Section 6

DECLARATION OF EXEMPTION

Under the powers found in section 6 of the *Retirement Villages Act 1986*, the Governor in Council on the recommendation of the Attorney-General, declares:

The Royal Freemasons Homes of Victoria of 313 Punt Road, Prahran to be an exempt organisation to which the following provisions of the *Retirement Villages Act 1986* (the Act) do not apply:

- (i) Section 19 of the Act in relation to residents moving between retirement villages owned by the organisation.
- (ii) Section 25 (5) and (6) of the Act upon condition that monies which would have been required to be dealt with pursuant to those sub-sections are paid into a trust account in the name of the person for the time being who is the manager of a retirement village conducted by the organisation and the requirements of section 25 (6) of the Act complied with as if they applied to such an account.

(iii) Part V of the Act upon condition that the organisation does not encumber any land upon which a retirement village is located.

(iv) Section 34 (4)

(v) Section 37 (4) in relation to the by-laws set out in the residence documents lodged with the application for exemption,

and upon condition that a copy of this exemption be given to each prospective resident at the same time such residents are given the residence documents relating to the village.

Dated 2 June 1987

Responsible Minister:

J. H. KENNAN
Attorney-General

E. M. MILLER
Acting Clerk of the Executive Council

Retirement Villages Act 1986
Section 6

DECLARATION OF EXEMPTION

Under the powers found in section 6 of the *Retirement Villages Act 1986*, the Governor in Council on the recommendation of the Attorney-General, declares:

Tullamore, a retirement village situated at 991 Mt Dandenong Tourist Road, Montrose to be an exempt village to which the following provisions of the *Retirement Villages Act 1986* (the Act) do not apply;

Section 25 (5) and (6) upon condition that the monies which would have been required to be dealt with pursuant to those subsections are paid into a trust account in the name of the manager for the time being of the retirement village and the requirements of sub-section 25 (6) of the Act are complied with as if they applied to such an account;

and upon condition that a copy of this exemption be given to each prospective resident at the same time such residents are given the residence documents relating to the village.

Dated 2 June 1987

Responsible Minister:

J. H. KENNAN
Attorney-General

E. M. MILLER
Acting Clerk of the Executive Council

Retirement Villages Act 1986
Section 6

DECLARATION OF EXEMPTION

Under the powers found in section 6 of the *Retirement Villages Act 1986*, the Governor in

Council on the recommendation of the Attorney-General, declares:

the Warramunda Village Inc., Kyabram, to be an exempt village to which the following provisions of the *Retirement Villages Act 1986* (the Act) do not apply:

(i) Section 34 (4) of the Act; and

(ii) Section 37 (4) in relation to the by-laws set out in the residence documents lodged with the application for exemption—

upon condition that a copy of this exemption be given to each prospective resident at the same time such residents are given the residence documents relating to the village.

Dated 2 June 1987

Responsible Minister:

J. H. KENNAN
Attorney-General

E. M. MILLER
Acting Clerk of the Executive Council

Retirement Villages Act 1986
Section 6

DECLARATION OF EXEMPTION

Under the powers found in section 6 of the *Retirement Villages Act 1986*, the Governor in Council on the recommendation of the Attorney-General, declares:

Woorayl Lodge, Leongatha, to be an exempt village to which the following provisions of the *Retirement Villages Act 1986* (the Act) do not apply:

(i) Section 25 (5) of the Act, upon condition that any monies comprising all or any part of an ingoing contribution are within 7 days of receipt paid into a trust account maintained by the secretary for the time being of the Woorayl Lodge;

(ii) Section 37 (4) of the Act—

and upon condition that a copy of this exemption be given to each prospective resident at the same time such residents are given the residence documents relating to the village.

Dated 2 June 1987

Responsible Minister:

J. H. KENNAN
Attorney-General

E. M. MILLER
Acting Clerk of the Executive Council

TENDERS

WARRNAMBOOL—Intruder detection system, College of T.A.F.E.

RONALD W. WALSH

Minister for Public Works

Public Works Department
Melbourne, 9 June 1987

PUBLIC WORKS DEPARTMENT

Tenders are invited for the purposes indicated hereunder and will be received at 2 Treasury Place, Melbourne, 3002, until TWO p.m. on the dates shown.

Tenders must be addressed to the Minister for Public Works with the envelope endorsed "Tender for".

Tenders forwarded either by mail, telegram or telex, which arrive after the closing time, will be accepted provided that the official Telecom or Australia Post time and date stamping indicates dispatch prior to the closing time. (TIME AND DATE STAMPING MUST BE REQUESTED AT SOME POST OFFICES.)

(TELEX No. AA152039)

Hand-delivered tenders must be placed in the Department's tender box, in foyer, Ground Floor, 2 Treasury Place, Melbourne.

Tender documents are available from the Contracts Office, Room 29, Ground Floor, 2 Treasury Place, Melbourne and where indicated, at offices of Inspector of Works.

Wednesday, 1 July 1987

Building, Electrical and Mechanical Services etc.

ABERFELDIE—Cyclic maintenance, Primary School.

KNOX—*Re-advertised and amended*: Repairs and painting, Technical School.

KURUNJANG—Floor finishes—Stage 2, Blocks 1 & 2, Post Primary School.

KURUNJANG—Painting—Stage 2, Blocks 1 & 2, Post Primary School.

KURUNJANG—Operable walls—Stage 2, Blocks 1 & 2, Post Primary School.

MELBOURNE—Fit out to Floors 16–21 inclusive, A.C.I. House—200 Queen Street.

Miscellaneous

MELBOURNE—Supply of ergonomic desks, T1408, P.W.D.—2 Treasury Place.

Wednesday, 8 July 1987

Building, Electrical and Mechanical Services etc.

NORTH MELBOURNE—Accommodation reorganisation to computer/office area, Victorian Government Printing Office.

SEBASTOPOL—Alterations and additions to Police Premises, Police Traffic Operations Group. (W.O. Ballarat).

PRIVATE ADVERTISEMENTS

CITY OF ARARAT
Closure of Road to Traffic

Notice is hereby given that the City of Ararat has adopted an order pursuant to the Local Government Act, section 539C for the closure of Maude Street, Ararat shown hatched on the plan, to vehicular traffic by the erection of barriers and further that the order shall come into operation on Thursday, 18 June 1987.

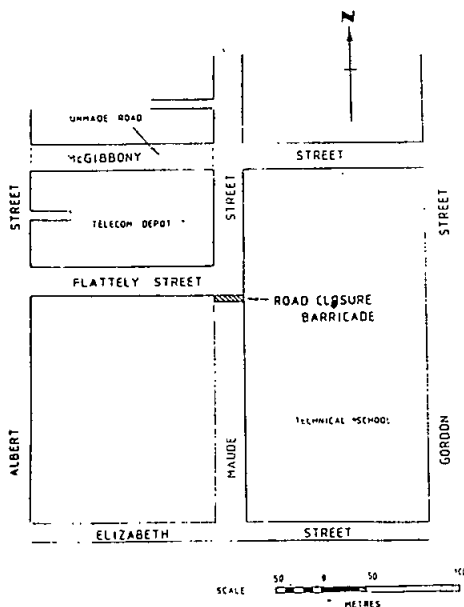

LYNDEN J. SMITH
 Town Clerk

7497

CITY OF CHELSEA

Road Discontinuance—Programme A16/84

Pursuant to section 528 (2) of the *Local Government Act 1958*, as amended, the Council of the City of Chelsea after consultation with public authorities and the advertising of its intention and notification to the registered

proprietor of the land and owners and occupier of any land abutting or is immediately adjacent to the road (right-of-way) has by resolution of its Ordinary Meeting held 18 May 1987 resolved that such part of the road (right-of-way) bounded by Berry Avenue, Elsie Grove and Hazel Avenue, Edithvale as shown hatched on the plan attached is:

- (a) not required as a road for public use; and
- (b) that notwithstanding such discontinuance the Melbourne and Metropolitan Board of Works shall continue to have and possess the same rights title power authority or interest in or in relation to the whole of the land shown by hatching on the said plan as it had or possessed prior to such discontinuance with respect to or in connection with any drains or pipes laid or erected in or over such land for the purpose of drainage or sewerage; and
- (c) such part of the road be discontinued and sold by agreement.

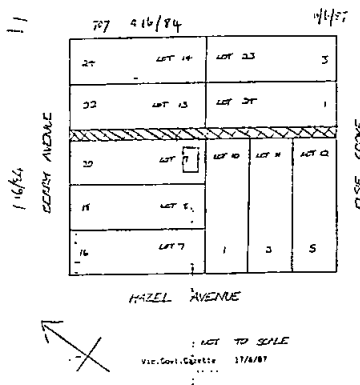

Dated 17 June 1987

7524

J. J. DRINAN, Town Clerk

CITY OF FITZROY

Discontinuance of Road

Notice is hereby given that in accordance with section 528 (2) of the *Local Government Act*, the City of Fitzroy has resolved that the road shown hatched on the plan below, known as right-of-way adjacent to 182 Napier Street and rear 32-42 Condell Street, is not reasonably required as a road for public use and be discontinued and sold by private treaty.

Now therefore, the Council of the City of Fitzroy hereby directs:

- (a) that the said road which is shown by hatching on the plan herewith shall be discontinued upon publication of this resolution in the *Government Gazette*;
- (b) that notwithstanding the discontinuance the Melbourne and Metropolitan Board of Works shall continue to have the same access rights over the land as they possessed prior to such discontinuance;
- (c) that subject to any such right title power authority or interest in the land the said road shall vest in the municipality until it is sold by private treaty.

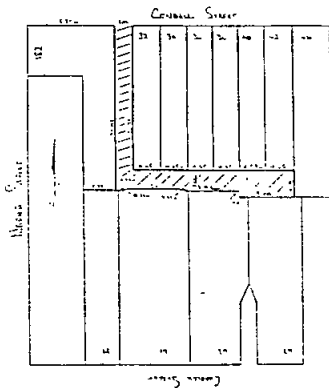

7466 **DAVID PEILE**
Chief Executive Officer

CITY OF HEIDELBERG
Road Discontinuance

Pursuant to section 528 (2) of the *Local Government Act 1958*, the Council of the City of Heidelberg, after consultation with Public Authorities and the advertising of its intention and notification to the registered proprietor of the land and owners and occupiers of any land abutting or as immediately adjacent to the road, has by resolution of its Ordinary Meeting on 6 April 1987 resolved that such part of the road adjoining Lot 18 Ivanhoe Parade and Lot 23 St Elmo Road, Ivanhoe, as shown hatched on the plan attached is—

- (a) in the opinion of Council nor reasonably required for public use, and shall be discontinued;
- (b) that the land in the discontinued road be retained by Council for municipal purposes.

ROAD SHOWN HATCHED TO BE DISCONTINUED SUBJECT TO RIGHTS OF EASEMENT FOR DRAINAGE, SEWERAGE AND GAS PURPOSES.

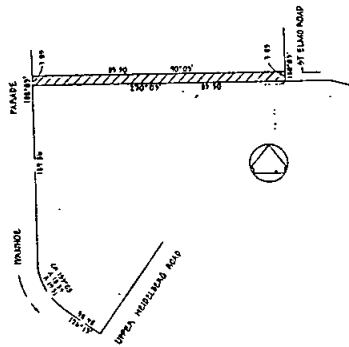

CITY OF HEIDELBERG
MAY 1987

Civic Centre, Ivanhoe
G. BRENNAN, Chief Executive Officer 7499

CITY OF HEIDELBERG
Vesting of Reserve

The Council of the City of Heidelberg in accordance with the provisions of section 569BA (1) of the *Local Government Act 1958*, the provisions of that section having been complied with at its meeting on 1 June 1987, ordered and directed that such part of the drainage reserve adjoining Lot 58 Prospect Road, Rosanna, on Lodged Plan No. 4923, Parish of Keelbundora,

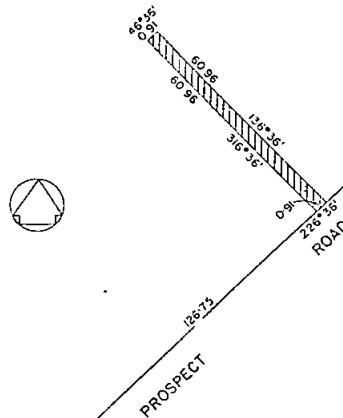

ST. JAMES ROAD

County of Bourke, and shown hatched on the attached plan shall be vested in the Council. On the publication of this resolution in the *Government Gazette*, that land shall vest in the municipality freed and discharged from any mortgage, charge, lease or sub-lease.

Dated 9 June 1987

7474 G. BRENNAN, Chief Executive Officer

CITY OF FRANKSTON
Permanent Closure of Outlook Road,
Frankston

Notice is hereby given that the Council of the City of Frankston, having considered the proposal for closure of Outlook Road, Frankston, to through vehicular traffic at its point of intersection with Heatherhill Road in accordance with the provisions of section 539c of the *Local Government Act 1985*, as amended, adopts the proposal without modifications, as shown on Council Plan No. M392 hereunder.

CITY OF FRANKSTON
CLOSURE OF
OUTLOOK ROAD
TO THROUGH TRAFFIC
PART OF CROWN ALLOTMENT 6R
PARISH OF FRANKSTON
COUNTY OF MORNINGTON

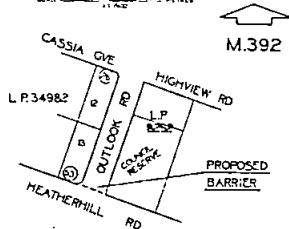

This Order was made at a Meeting of the Council held on 18 May 1987, and will come into operation on 24 June 1987.

7467 A. H. BUTLER
Chief Executive Officer

CITY OF HAWTHORN
Road Discontinuance

Pursuant to section 528 (2) of the *Local Government Act 1958*, the Council of the City of Hawthorn after consultation with Public Authorities and the advertising of its intention and notification to the registered proprietor of the land, owners and occupiers of any land abutting or immediately adjacent to the road has resolved at an ordinary meeting held on 22 April

1986 that part of the road abutting 390-392 Riversdale Road, Hawthorn and contained in Certificate of Title, Volume 1892, Folio 286, and as shown by hatching on the plan hereunder is not reasonably required as a road for public use be discontinued and sold by private treaty.

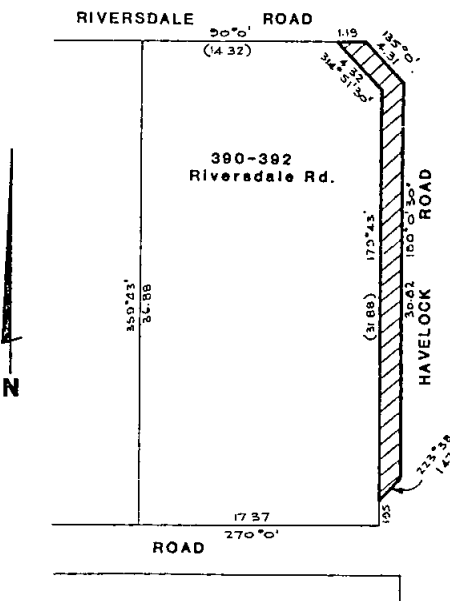

7473 B. C. SMITH, Town Clerk

Form 2.1
Town and Country Planning Act 1961
CITY OF MOE PLANNING SCHEME 1966
Notice that a Planning Scheme has been
Prepared and is Available for Inspection

Amendment No. 89
Notice is hereby given that the City of Moe in pursuance of its powers under the *Town and Country Planning Act 1961* has prepared a scheme to cause an amendment to the Ordinance of the Principal Scheme.

The Amendment proposes to provide controls relating to the following:

- (a) to include matters which are needed to eliminate some ambiguities that exist in the present Planning Scheme Ordinance, more specifically to clarify the meaning of words like "site" and "curtilage" when used in certain circumstances and what works can be constructed in building line setback areas;

- (b) to include matters that will allow Council, as the Responsible Authority, to widen the scope of some activities and more specifically, to enable applications to be considered for planning "Moveable Units" in more zones and for building some dwellings in certain non-residential circumstances;
- (c) to replace controls related to residential developments that were partly lost through a recent change to the Health Act, more specifically, in relation to minimum width of streets to which residential allotments can have a frontage;
- (d) to include controls for commercial developments with frontages to streets less than 15 m wide; and
- (e) to include controls specifying the minimum width of all new streets in industrial zones and the minimum width of the industrial zone streets to which building developments may have frontages.

- (b) That the said portion of the road be discontinued and upon publication of the said resolution in the *Government Gazette* the said portion of the road shall be deemed to be discontinued and the land being the said portion of the road shall vest in the municipality and may be sold by agreement.

Dated 17 June 1987

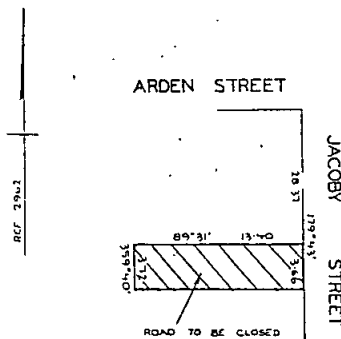

D. N. BETHKE

7525 Chief Executive Officer and Town Clerk

CITY OF NORTHCOTE

Notice of Road Discontinuance

Pursuant to Paragraph 528 (2) (a) of the *Local Government Act 1958* ("the Act")

The Council of the City of Northcote ("the Council") at its meeting on 18 May 1987, made the following resolution:

- (a) the Council, being of the opinion that the road ("the Road") delineated and hatched on the plan hereunder being Volume 2556 Folio 194 is not reasonably required as a road for public use, hereby directs that the road be discontinued and sold by public auction, public tender or private treaty;

A copy of the scheme has been deposited at the Municipal Offices, Albert Street, Moe and at the Regional Office of the Ministry for Planning and Environment, 71 Hotham Street, Traralgon and at the office of the Ministry for Planning and Environment, The Olderfleet Buildings, 477 Collins Street, Melbourne, and will be open for inspection during office hours by any person free of charge.

Any persons affected by the scheme are required to set forth in writing any submissions they may wish to make with respect to the scheme addressed to Economic Development and Planning Officer, City of Moe, Municipal Offices, Albert Street, Moe 3825 by 17 July 1987 and state whether you wish to be heard in respect of your submission.

Dated 5 June 1987

B. PEACH

7475 Economic Development and Planning Officer

CITY OF MELBOURNE

Discontinuance of Road

Take notice that in accordance with the provision of section 528 (2) of the *Local Government Act 1958*, the Council of the City of Melbourne on 18 May 1987, resolved as follows:

- (a) That a portion of lane, located off the western side of Jacoby's Lane, North Melbourne, at the rear of Nos. 117-119 Arden Street, North Melbourne, as shown hatched on the plan hereunder, are not required for public use; and

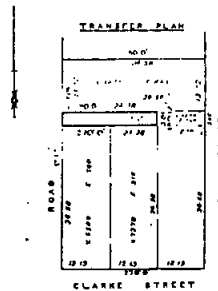
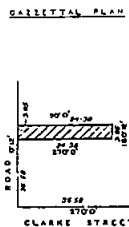

- (b) notwithstanding the discontinuance of the Road, the City of Northcote shall continue to have and possess the same right, title, power and authority or interest in or in relation to the Road or any part of the Road with respect to or in connection with any "drains" laid or erected in, on or over the Road or part of the Road for the purpose of "drainage" or other like purpose as existed prior to the discontinuance of the Road in accordance with paragraph 528 (2) (e) of the *Local Government Act 1958*.

P. J. BLACK
Chief Executive Officer

7468

CITY OF RICHMOND
Road Discontinuance

Pursuant to section 528 (2) of the *Local Government Act 1958*, the Council of the City of Richmond, after consultation with Public Authorities, the advertising of its intention, and notification to the registered proprietor of the land, owners and occupiers of any land abutting or immediately adjacent to the road has resolved at an ordinary meeting held on 15 June 1987.

- (a) That Council discontinue the Right-of-Way at the rear of 21-33 Cubitt Street, Richmond (more accurately described by hachure on the plan below) such Right-of-Way being in the opinion of Council not reasonably required for public use;
- (b) That notwithstanding such discontinuance, the Melbourne and Metropolitan Board of Works and the Council shall continue to have and possess the same right, title, power, authority or interest in or in relation to the whole of the land as it had, or possessed prior to such discontinuance with respect to or in connection with any drains or pipes laid in on or over such land;
- (c) That such lands resulting from the discontinued Right-of-Way be sold by private treaty.

ENG. G. BEHN, SURV.

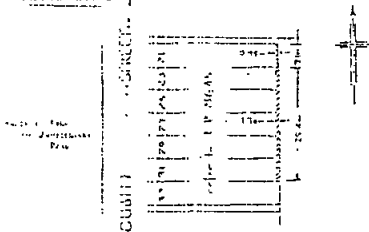

7526

D. G. WILLIAMS, Clerk

CITY OF SPRINGVALE

Vesting of Reserve for Electrical Sub-Station
Purposes Being Part Lot 142 Gladesville
Boulevard, Patterson Lakes

The Council of the City of Springvale in accordance with the provisions of section 569BA (1) of the *Local Government Act 1958* (as amended), resolved at its meeting on June 9 1987 that the Reserve for Electrical Sub-station purposes, being part of Lot 142 Gladesville Boulevard, Patterson Lakes and contained in Certificate of Title Volume 9422 Folio 144 as shown hatched on the plan below be vested in the name of the mayor, councillors and citizens of the City of Springvale and by this notice such land in the Reserve shall so be vest free and discharged of any mortgage, charge, lease or sub-lease.

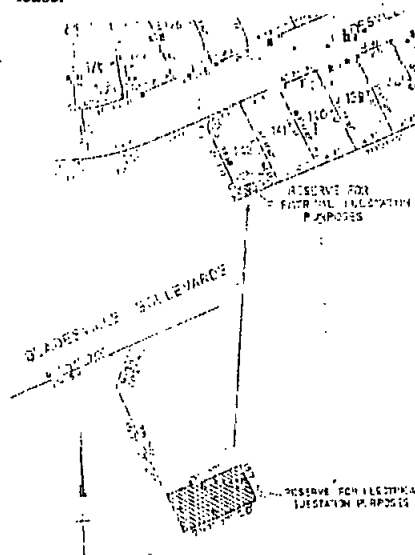

I. J. TATTERSON
Chief Executive Officer

7546

CITY OF SWAN HILL
By-Law No. 44
By-Law Repeal By-Law

Notice is given that at a meeting of the Council of the City of Swan Hill held on 14 April 1987 a resolution confirming the adoption of a resolution dated 10 March 1987 for making By-Law No. 44 to be known as the By-Law Repeal By-Law was passed. The By-Law was confirmed by the Governor in Council on 27 May 1987. The purpose of By-Law No. 44 are for—

Repealing By-Laws of the City of Swan Hill in force prior to the date of publication of By-Law No. 44 and namely By-Laws numbered 1, 11, 17, 18, 21, 22, 26 and 28.

A copy of this By-Law is open for inspection free of charge during office hours of the Council at the Municipal Offices, Nyah Road, Swan Hill. Dated 9 June 1987

G. J. MENNIE
Town Clerk

7500

Form 2.1

Town and Country Planning Act 1961
CITY OF TRARALGON PLANNING
SCHEME 1957

Notice that a Planning Scheme has been Prepared and is Available for Inspection
Amendment No. 87

Notice is hereby given that the City of Traralgon in pursuance of its powers under the *Town and Country Planning Act 1961* has prepared a scheme for the whole of the Municipal District of the City of Traralgon.

The Amendment proposes to insert ordinance provisions making 'Sunday Markets' consent uses in Rural, Rural Residential, Residential 'A', Residential 'B', Residential Development, Industrial 'A', Industrial 'B' and Special Uses Zones.

A copy of the scheme has been deposited at the Municipal Offices, Kay Street, Traralgon and at the Regional Office of the Ministry for Planning and Environment, 71 Hotham Street, Traralgon and at the office of the Ministry for Planning and Environment, The Olderfleet Buildings, 477 Collins Street, Melbourne, and will be open for inspection during office hours by any person free of charge.

Any persons affected by the scheme are required to set forth in writing any submissions they may wish to make with respect to the scheme addressed to Chief Executive/Town Clerk, City of Traralgon, Municipal Offices, Kay Street, Traralgon, 3844 by 17 July, 1987 and state whether you wish to be heard in respect of your submission.

Dated 15 June 1987

K. L. MITCHELL
Chief Executive/Town Clerk

7540

BOROUGH OF WONTHAGGI
Change of Street Name

Notice is hereby given that at a meeting of the Council of the Borough of Wonthaggi held on 18 May 1987, it was resolved to change the name of

the court section of Dickson Street, between Hagelthorn and Hunter Street, to Robertson Court.

7487

A. A. N. DEED, Town Clerk

Form 2.1

Town and Country Planning Act 1961
SHIRE OF BACCHUS MARSH PLANNING
SCHEME

Notice that a Planning Scheme Amendment has been Prepared and is Available for Inspection
Amendment No. 47

Notice is hereby given that the Shire of Bacchus Marsh in pursuance of its powers under the *Town and Country Planning Act 1961* has prepared a scheme for land being part of Crown Allotments 37 and 38, Parish of Parwan (Title Vol. 4350, Folio 946 and Conveyance Book 424, Memorial 186) owned by the State Transport Authority and located north of the Ballarat to Melbourne Railway line and east of Vallences Road.

The scheme re-zones this land from Railway Reservation to Rural A.

A copy of the scheme has been deposited at the Shire Offices of Bacchus Marsh, 197 Main Street, Bacchus Marsh and at the office of the Ministry for Planning and Environment, The Olderfleet Buildings, 477 Collins Street, Melbourne and will be open for inspection during office hours, by any person, free of charge.

Any persons affected by the scheme are required to set forth in writing any submission they may wish to make with respect to the scheme, addressed to the Shire Secretary, Shire of Bacchus Marsh, P.O. Box 216, Bacchus Marsh 3340 by 17 September 1987 and state whether you wish to be heard in respect of your submission.

Dated 16 June 1987

D. L. MURPHY
Shire Engineer

7527

SHIRE OF DIAMOND VALLEY

Notice is hereby given that in pursuance of the powers conferred on it by the *Local Government Act 1958* the Council of the Shire of Diamond Valley did on 25 May 1987 rename Grevillea Court to St. Andrews Court.

W. M. BALKIN, Shire Secretary
P.O. Box 115, Greensborough, 3088 7476

SHIRE OF DIAMOND VALLEY

Vesting of Reserve for Municipal Purposes
The Council of the Shire of Diamond Valley at its meeting of 25 May 1987 has hereby resolved

that pursuant to section 569BA (1) of the *Local Government Act 1958* the reserve for municipal purposes shown hatched on the plan below shall vest in Council.

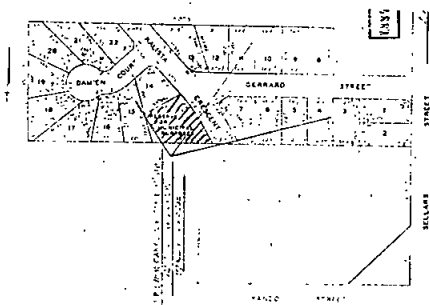

W. M. BALKIN, Shire Secretary
P.O. Box 115, Greensborough, 3088 7477

SHIRE OF DIAMOND VALLEY
Vesting of Road Reserve

The Council of the Shire of Diamond Valley at its meeting of 25 May 1987 has hereby resolved that pursuant to section 569BA (1) of the *Local Government Act 1958* the road reserve shown hatched on the plan below shall vest in Council.

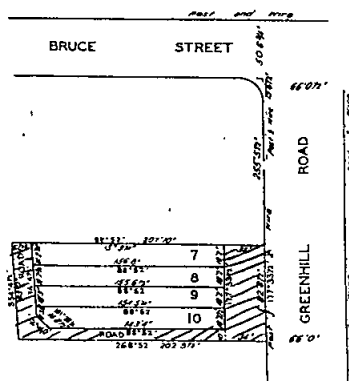

W. M. BALKIN, Shire Secretary
P.O. Box 115, Greensborough, 3088 7480

SHIRE OF DIAMOND VALLEY
Vesting of Reserve for Municipal Purposes
The Council of the Shire of Diamond Valley at its meeting of 25 May 1987 has hereby resolved that pursuant to section 569BA (1) of the *Local Government Act 1958* the reserve for municipal purposes shown hatched on the plan below shall vest in Council.

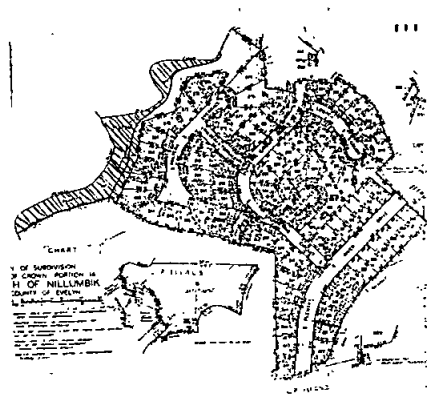

W. M. BALKIN, Shire Secretary
P.O. Box 115, Greensborough, 3088 7478

SHIRE OF DIAMOND VALLEY
Vesting of Reserve for Municipal Purposes
The Council of the Shire of Diamond Valley at its meeting of 25 May 1987 has hereby resolved

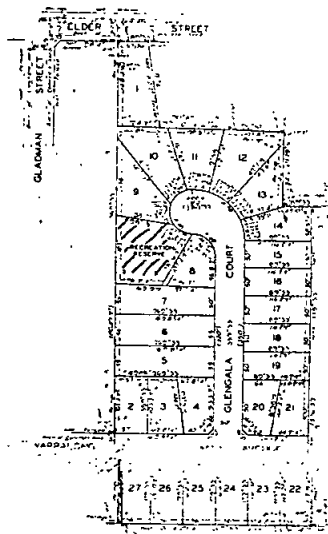

1576 G 23 17 June 1987

Victoria Government Gazette

that pursuant to section 569BA (1) of the *Local Government Act 1958* the reserve for municipal purposes shown hatched on the plan below shall vest in Council.

W. M. BALKIN, Shire Secretary
P.O. Box 115, Greensborough, 3088 7481

SHIRE OF DIAMOND VALLEY

Reserve for Public Resort and Recreation

The Council of the Shire of Diamond Valley at its meeting of 25 May 1987 has hereby resolved that pursuant to section 569BA (1) of the *Local Government Act 1958* the reserve for public resort and recreation shown hatched on the plan below shall vest in Council.

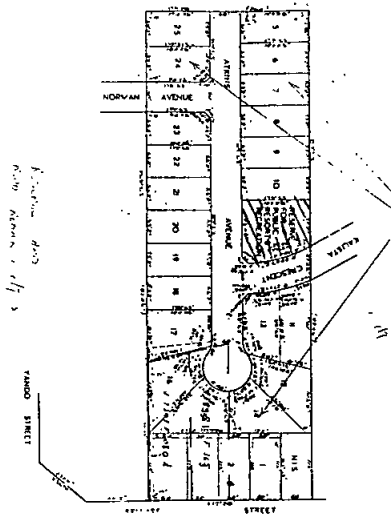

W. M. BALKIN, Shire Secretary
P.O. Box 115, Greensborough, 3088 7479

SHIRE OF DIAMOND VALLEY

Vesting of Drainage and Sewerage Reserve

The Council of the Shire of Diamond Valley at its meeting of 25 May 1987 has hereby resolved that pursuant to section 569BA (1) of the *Local Government Act 1958* the reserve for drainage and sewerage purposes shown hatched on the plan below shall vest in Council.

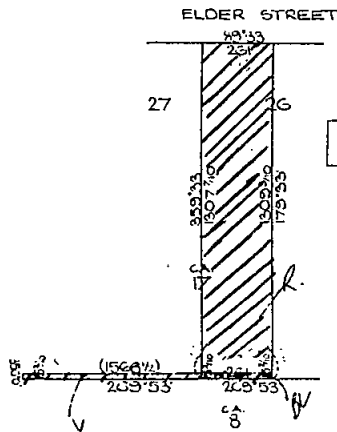

W. M. BALKIN, Shire Secretary
P.O. Box 115, Greensborough, 3088 7482

SHIRE OF GLENELG

Road Discontinuance

Whereas the Council of the Shire of Glenelg has pursuant to section 528 (2) of the *Local Government Act 1958* and—

- (a) being of the opinion that portions of Hansen's Road, Parish of Casterton, County of Follett, are not reasonably required as a road for public use and having consulted with any public statutory authority referred to in sub-section 2 (b) and having published a public notice in a newspaper giving details of the proposal, by resolution pursuant to section 528 of the *Local Government Act 1958* directs that the parts of the road as shown on Licensed Surveyor's Plan Ref. C0735 shall

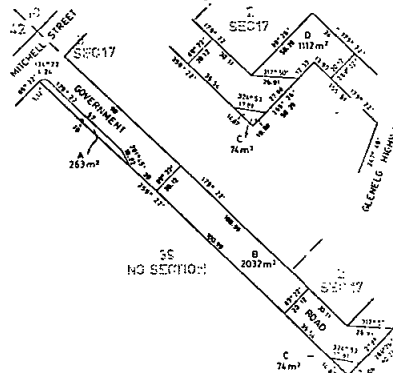

be discontinued and the land being part of the road discontinued shall vest in the municipality;

- (b) the purpose of the land being portion of the road to be discontinued shall be retained by the Shire of Glenelg for municipal purposes; and
- (c) such road is shown by hatching on the plan hereunder.

7483

V. J. SMITH, Shire Secretary

SHIRE OF LILLYDALE

Discontinuance of Part Forge Road, Mt. Evelyn

Whereas section 528 (2) of the *Local Government Act 1958* provides that where a road, whether or not a public highway (but not being a road set out on Crown Land) or any part of that road is not reasonably required for public use, the Council of the municipality in which such road is situated, may not less than one (1) month after publishing a public notice in a newspaper circulating generally in the municipal district and giving written notice to the registered proprietor (if any) of the road and to the owners and occupiers (if any) of any land abutting or immediately adjacent to the road of its intention to make a resolution discontinuing such road or part thereof, may by resolution published in the *Government Gazette* direct that such road or part thereof, shall be discontinued and thereupon such road or part of the road shall be discontinued accordingly.

And whereas the Council of the Shire of Lillydale resolved that the unused portion of Forge Road between Lot 4 on LP.90308, Lot 1 on LP.21990 and extending to the southern bank of the Stringybark Creek be discontinued and not less than one (1) month previously has

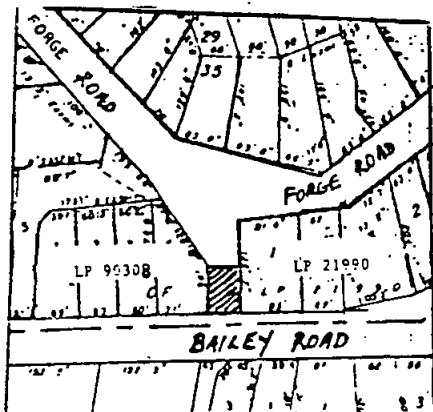

published a public notice in a newspaper generally circulating in the municipal district and has given notice to the last registered owners of the land in the road and the owners or occupiers of the land abutting and immediately adjacent to the road of the proposed discontinuance and no objections having been received.

Now therefore, the Council of the Shire of Lillydale hereby directs that the portion of the road concerned as shown by hatching on the plan herewith shall be discontinued and shall vest in the municipality.

7528

W. I. HEINE
Chief Executive Officer

SHIRE OF SHERBROOKE

By-Law No. 169

(Noise By-Law)

Notice is given in accordance with section 207 (a) (ii) of the *Local Government Act 1958*, as amended, that the Council of the Shire of Sherbrooke has made By-Law No. 169 for the purpose of:

- (i) Controlling and regulating the use of premises with a view to preventing objectionable noises at unreasonable times.
- (ii) Suppressing nuisances.
- (iii) Prohibiting, or minimising noises in public highways.
- (iv) Generally for maintaining the good rule and government of the municipality.

A copy of the By-Law may be inspected at the Shire Offices, Glenfern Road, Upwey. 7484

SHIRE OF SWAN HILL

By-Law No. 75—Garbage Collection

Notice is hereby given that in pursuance of powers conferred by section 197 of the *Local Government Act 1958*, the Council of the Shire of Swan Hill has made a By-Law numbered 75 for the purpose of:

- (i) (a) The provision, use and control of receptacles for the deposit and collection of refuse and rubbish.
- (b) Preventing or regulating the deposit of refuse upon the streets and other lands and places under the control of Council.
- (c) The removal, replacement, cleansing and disinfectant of receptacles for refuse.
- (ii) The By-Law shall be made under the Health Act.
- (iii) By-Law No. 57 shall be repealed.

- (iv) The By-Law shall include the urban areas of Robinvale, Lake Boga, Nyah/Nyah West, Manangatang, Ultima, Woorinen South and rural areas generally known as Robinvale Irrigation District, Tol Tol Road area, Kenley, Nyah Irrigation District, Beverford Irrigation District, Woorinen Irrigation District, Murraydale Irrigation District, Murrawee Irrigation District, Murray Valley highway south of Swan Hill, Lake Boga area and the eastern end of Lake boga/Tresco Irrigation District.
- (v) The By-Law shall require the occupier to keep clean and maintain the receptacle which will remain Council property.
- (vi) The By-Law shall require only the 240 litre bins to be used for garbage collection.
- (vii) The By-Law requires the occupier to place the receptacle adjacent to curtilage for garbage collection or in an approved area if flats.
- (viii) The By-Law shall require the occupier, to whom the receptacle was issued, to keep it in good order and shall report in seven days to the Council any loss or damage.
- (ix) The By-Law shall require occupiers not to place in the receptacle, live ashes, oils, paints, solvents or inflammable materials or any object which may damage the receptacle, or putrescent material.
- (x) The By-Law will require the receptacle to be numbered for identification.
- (xi) The By-Law requires the receptacles to only be placed on the curtilage on collection days and to be removed immediately following collection.
- (xii) The By-Law requires refuse to be left in the curtilage only in the approved receptacles.
- (xiii) The By-Law requires any authorisations to be given under this By-Law to be signed by the Shire Secretary or Health Surveyor.
- (xiv) The By-Law penalties shall be a maximum of \$400, and \$10 per day for any continuing offence.

A copy of the By-Law is open for inspection, free of charge, during office hours at the Municipal Offices, Beveridge Street, Swan Hill.

A resolution approving the By-Law was carried at a meeting of Council held on 8 May 1985, and was confirmed at a meeting of Council held on 14 May 1986.

7485 N. L. NOELKER, Shire Secretary

SHIRE OF WYCHEPROOF

By-Law No. 37

Notice is hereby given that pursuant to section 93 of the *Health Act* 1958 and section 197 of the *Local Government Act* 1958; the Council of the Shire of Wycheproof has made By-Law No. 37 to control the keeping of animals and repeal By-Law No. 30.

Dated 10 June 1987

G. R. DRYDEN

7529

Shire Secretary

SHIRE OF YEA

Naming of Roads

Notice is hereby given that, pursuant to section 535 (4) of the *Local Government Act*, the Council of the Shire of Yea, at its meeting held on 1 June 1987, formally resolved to allocate the name Brigadoon Road to the road reserve between Crown Allotment 12, Parish of Koby Boyn, Crown Allotments 36 and 36A, Parish of Switzerland, and Crown Allotments 16 and 16A, Parish of Dropmore.

NICK ZANDBERGS

7486

Acting Shire Secretary

Form 2.2

Town and Country Planning Act 1961

SHIRE OF TALLANGATTA RURAL AREA INTERIM DEVELOPMENT ORDER 1980

Notice that an Interim Development Order Amendment has been Prepared and is Available for Inspection

Amendment No. 10

Notice is hereby given that the Shire of Tallangatta in pursuance of its powers under the *Town and Country Planning Act* 1961 has prepared an amendment for the subdivision of Crown Allotment 7, Section B, L.P. 34549/7, Parish of Wagra.

A copy of the Amendment has been deposited at the Shire of Tallangatta Municipal Offices, Towong Street, Tallangatta; the Regional Office of the Ministry for Planning and Environment, Astra House, Jack Hore Place, Wodonga; and at the Office of the Ministry for Planning and Environment, The Olderfleet Buildings, 477 Collins Street, Melbourne, and will be open for inspection during office hours by any person free of charge.

Any persons effected by the Amendment are required to set forth in writing any submission they may wish to make with respect to the Amendment, addressed to the Shire Secretary, Shire of Tallangatta, P.O. Box 55, Tallangatta

3700, by Friday 17 July, 1987 and is required to state whether you wish to be heard in respect of the submission.

7539 W. S. GILL
Shire Secretary

CITY OF BROADMEADOWS

Section 569BA (1) Local Government Act

Notice is hereby given that the Council of the City of Broadmeadows at its meeting of 11 May 1987 resolved pursuant to section 569BA of the Local Government Act to vest to Council freed and discharged from any mortgage, charge, lease or sublease the whole of the land shown on Lodged Plan of Subdivision No. 82509, Parish of Tullamarine, as a Reserve, it being part of the land remaining untransferred in Certificate of Title Volume 8749 Folio 696. The land in question is situated in Freight Road, Tullamarine.

7498 K. G. DOUGLAS, Acting Town Clerk

CITY OF BROADMEADOWS

Section 569BA—Local Government Act

Notice is hereby given that the Council of the City of Broadmeadows at its meeting of 21 May 1987, resolved pursuant to section 569BA (1) of the Local Government Act to vest to Council freed and discharged from any mortgage, charge, lease or sub-lease the whole of the land shown as a Water Reserve on Lodged Plan No. 4286, it being part of the land described in Certificate of Title Volume 6772, Folio 376. The land in question abuts the Merri Creek.

7523 K. DOUGLAS, Acting Town Clerk

Notice is hereby given that the partnership heretofore subsisting between Kenneth Westfield Cormick and Francis Cormick, formerly carrying on a business of an authorised newsagency at 343 Gilbert Road, West Preston, has been dissolved by mutual consent as from this date.

Gill, Kane & Co., solicitors, 422 Collins Street,
Melbourne 3000. 7530

Water Act 1958

**MORNINGTON PENINSULA AND
DISTRICT WATER BOARD**

Mornington Peninsula Urban District

Notice to owners of tenements in the undermentioned streets in the Mornington Peninsula Urban District and the private streets, lanes and alleys opening thereto.

Rosebud

Street; Section

Mt Arthur Avenue; From Waterfall Gully Road to a point opposite Lot 5 about 136 metres southerly.

Somerville

Street; Section

Crofters Hill Road; Full Length

The main pipe in the said street being laid down, the owners of all tenements situated as above are hereby required, on or before 27 July 1987 to cause proper pipes and stop cocks to be laid so as to supply water within such tenements from the main pipes.

Dated at Frankston 17 June 1987

J. O. Williams
Secretary

Mornington Peninsula and District Water
7501 Board

PORT OF MELBOURNE AUTHORITY

To: Mr Michael J. Lockwood, 60 Bulleen Road,
North Balwyn, Vic. 3104.

Take notice that the fishing vessel "Noulabelle" owned by you and currently moored at Gem Street Pier, Williamstown within the Port of Melbourne Authority is considered by the Port of Melbourne to be an obstruction to the safe and convenient navigation and use of the Port.

And further take notice that pursuant to section 87 of the *Port of Melbourne Authority Act 1958* the Authority requires you to remove the said vessel from the Port of Melbourne within 14 days after the date of this notice.

And further take notice that prior to removal of the said vessel from the Port of Melbourne you are required to pay to Authority all mooring and other charges payable to the Authority in respect of the mooring of the vessel.

And further take notice that if the acts required by this notice are not performed within the time prescribed the Authority may, at your expense, sell or otherwise dispose of the said vessel and the materials or goods recovered therefrom.

Dated 10 June 1987

7512

Captain W. GENT
Harbor Master

Notice is hereby given that the partnership heretofore subsisting between Diana Cooper and Christine Anne Lewis, carrying on business being a crafts business at Unit 6, 53 Rattray Road, Montmorency under the firm name of Dorcas Cottage Crafts has been dissolved as from 1 June 1987 so far as concerns the said Christine Anne Lewis who retires from the said firm.

PHILLIP G. SPARK, solicitor, 25 Were Street,
Montmorency 7490

Take notice that the partnership hereto existed between Chris Nicolaidis of 30 A Beckett Street, Coburg, and Vouli Oplopiadis of 118 O'Heas Street, Coburg, as proprietors of the business of Lighting Sales at 30 Holmes Road, Moonee Ponds, was dissolved on 29 May 1987, and further, the said business shall continue to be carried on by the said Chris Nicolaidis. All accounts and claims against the dissolved partnership are to be sent to Chris Nicolaidis, at 30 Holmes Road, Moonee Ponds. 7469

CONQUEST AVIATION

Notice of Dissolution of Partnership

The persons heretofore comprising the members of the partnership known as "Conquest Aviation" ("The Partnership") established pursuant to Deed of Partnership dated 25 June 1980 hereby publicly notify, for the purposes of section 42 of the Partnership Ordinance 1963 (as amended) of the Australian Capital Territory and Clause 34 of the said Deed of Partnership, that the Partnership was dissolved on 31 March 1987.

WILLOUGHBY & DUNNE
PARRAMATTA, chartered accountants, 4/426
Church Street, North Parramatta, N.S.W. 7488

Public notice is hereby given that Christopher John Cogdon of 342 Neerim Road Carnegie 3163, is as of 8 April 1987 no longer a partner in the business known as Bentleigh Trivia, 175 Centre Road, Bentleigh 3204. And is therefore not responsible for any debts or business dealings thereafter. 7489

Notice is hereby given that as from 28 May 1987, Shirley Jean Kolcze shall retire from the partnership of "Duets Restaurant" and the business shall continue to be conducted by Jeanette Freshwater. 7401

Companies Act 1961 EKISTICS PTY. LTD.

Notice is hereby given in pursuance of section 411 of the Companies (Victoria) Code that a general meeting of members of the above named company will be held at the offices of E. P. Taylor & Co., 220 Chesterville Road, Moorabbin, on 5 July 1987, at 9.30 in the forenoon, for the purpose of having the liquidator's accounts laid before them showing the manner in which the winding up has been conducted and the property of the company disposed of and hearing of any explanations that may be given by the liquidator.

R. L. MALE
Liquidator 7504

Companies (Victoria) Code

A.H.B. PTY. LTD.

(in Voluntary Liquidation)

Notice Convening Final Meeting of Members

Notice is hereby given that pursuant to section 411 (1) a general meeting of members of A.H.B. Pty. Ltd will be held at the office of G. C. Andrews, 153 Wellington Parade South, Jolimont on 20 July 1987 at 10.30 in the forenoon. The purpose of the meeting is to lay accounts before it showing the manner in which the winding up has been conducted and the property of the company has been disposed of and of hearing any explanation that may be given by the liquidator.

Dated 10 June 1987.

G. C. ANDREWS
Liquidator 7502

In the matter of the *Co-operation Act* 1981—and
in the matter of Clontarf Co-operative Society
Limited (in voluntary liquidation).

At a special general meeting of the abovenamed society duly convened and held at the registered office, 16 James Street, Geelong on Friday, 12 June 1987, the subjoined special resolution was duly passed:

That the society having successfully completed its objectives, be wound up voluntarily and that Michael Wayne Lindsay of 16 James Street, Geelong be appointed liquidator for the purpose of winding up.

Dated 12 June 1987

R. J. VAGUE
Chairman of the Meeting
R. W. McI. FARROW
Secretary 7503

P. P. JAY PTY. LTD.

Notice is hereby given that at an extraordinary general meeting of the members of the abovenamed company duly convened and held on 10 June 1987 it was resolved that the company be wound up as a members voluntary winding up and that Charles D. A. McInnes of 4th Floor, 17 Queen Street, Melbourne be appointed liquidator.

C. D. A. McINNES
Liquidator 7535

For the service of notices to the Travel Compensation Fund, the address for mailing purposes is: Travel Compensation Fund, Room 205, 2nd Floor, 150 Queen Street, Melbourne.

7538

In the matter of the Companies (Victoria) Code (Section 411 (2)) and in the matter of K. G. Goodsall Brokering Pty. Limited (in Voluntary Liquidation)

Notice is hereby given that the final meeting of members of the company will be held at the office of Charles M. Harvey & Co., 24th Floor, 31 Market Street, Sydney on 23 June 1987 at 10.00 a.m. for the purpose of the Liquidator laying before the meeting an account showing how the winding up has been conducted and the property of the company has been disposed of, and to giving any explanation thereof.

Dated 1 June 1987

7534

F. E. MOODY
Liquidator

Form 102
Companies (Victoria) Code
Sub-Section 421 (1)
A. & K. ROBERTS PROPRIETARY
LIMITED
Notice of Appointment and Address of Office of
Liquidator

Members Voluntary Winding-Up
I, Dennis, Michael Gridley of 8 Stringybark
Court, North Ringwood give notice that—

(a) I was appointed liquidator of the
company—by a resolution of the company
passed on 11 June, 1987;

(b) The address of my office is—6 Oaklands
Avenue, Ferntree Gully 3156.

Dated 11 June 1987

7505

DENNIS M. GRIDLEY
Liquidator

C89945—In the matter of Adromage
Constructions Pty Ltd (in Voluntary
Liquidation)—Members Winding Up

Notice is hereby given that at a General
Meeting of the above company duly convened
and held at Lot 9, Longully Road, Healesville on
29 May 1987 the following resolution was
proposed and passed as a special resolution:

That the company be wound up voluntarily
and that Garry B. Purchase of 2 Ashley Court,
Research be appointed liquidator for the purpose
of such winding up.

Dated 29 May 1987

7492

Companies (Victoria) Code
AUSTAG PTY. LTD.
(in Voluntary Liquidation)
Notice Convening Final Meeting, Pursuant to
Section 411

Notice is hereby given that a general meeting
of members of the above-named Company will
be held at the offices of the Liquidator on Friday,
24 July 1987, at 9.00 a.m. for the purpose of
having an account laid before them showing the
manner in which the winding up has been
conducted and the property of the Company
disposed of and of having any explanation that
may be given by the Liquidator.

Dated 17 June 1987

R. W. VANCE, Liquidator
Bentley & Co., chartered accountants, 5th floor,
636 St. Kilda Road, Melbourne 7511

NAVIDA PTY. LTD. (In Voluntary
Liquidation) Special
Resolution to Wind Up

At an extraordinary general meeting of the
abovenamed company duly convened and held
at 47A O'Shannassy Street, Sunbury on 12 June
1987 the following resolution was passed as a
special resolution:

"That the company be wound up
voluntarily."

At the abovementioned meeting Timothy
Newman was appointed Liquidator for the
purpose of the winding up.

Notice is also given that after 30 days from
this date, I shall proceed to distribute the assets.
All creditors having any claims against the
company should furnish particulars of same by
that date, otherwise I shall proceed to distribute
the assets without regard to their claim.

Dated 12 June 1987

7545

TIMOTHY NEWMAN
Liquidator

NOTICE THAT A MEMBERS' WINDING
UP RESOLUTION PASSED

Notice is hereby given in accordance with
section 392 of the Companies Act 1981, that at a
general meeting of Belina Pty. Ltd., duly
convened and held on 2 June 1987 the following
special resolution was duly passed:

That the company be wound up voluntarily.

BENVENUTO MICHAEL MOLINARO
7531 Director

Notice is hereby given in accordance with
section 392 of the Companies Code 1981, that at
a general meeting of Kinnara Pty. Ltd., duly
convened and held on 13 May 1987, the following
special resolution was duly passed—

That the company be wound up voluntarily.

D. L. ACKLAND
7533 Liquidator

Unclaimed Moneys Act 1962

Register of Unclaimed Moneys held by the—

Name of Owner on Books and Last Known Address	Total Amount Due to Owner	Description of Unclaimed Money	Date when Amount first became Payable
RALPH McKAY LIMITED			
	\$		
Barraclough, Ruth, 3 Garrison Gve, Wantirna	37.17	Dividend	29.3.85
Barry, Rachael B, 34 Balyarta Cres, Mooloolaba, Qld	96.32	"	"
Bickley Pty Limited, c/o Thompson Douglass & Co, GPO Box 3997, Sydney, NSW	77.00	"	"
Blackman, Grant R and Meryl A and Pollock, Pamela M, 11 Smith St, Bentleigh	265.16	"	"
Bort, Edwin B (estate of), Bull Plain, Corowa, NSW	54.25	"	"
Camm, Lorna B, 38 Through Rd, Burwood	117.65	"	"
Campbell, Eleanor B, Unit 1, 17-19 Wilson St, Berwick	93.03	"	4.10.85
Carroll, Merle (estate of), c/o Moules, 28th Floor, BHP House, 140 William St, Melbourne	320.18	"	29.3.85
Cormack, Florence, 29 Rynie St, Mosman, NSW	74.41	"	"
Crouch, George E and Joan I, Lovett Bay, Church Point, NSW	21.56	"	"
Currie, Susan J, 10 Peel St, Kirribilli, NSW	154.00	"	"
Daley, Hilda J, 43 Beacon Rd, Garden City	279.30	"	"
De-La-Cruz, Gualberto, 18/50 Middle Rd, Maribyrnong	14.00	"	"
Djakulovic, Ivan, 51 Fawkner Cres, East Keilor	14.00	"	"
Fayle, Hedley R (estate of), c/o Hamer & Hamer, Suite 7, Level 1, Glenrose Shopping Centre, Glen St, Belrose, NSW	32.48	"	"
Gallia, Marie, 78 Bath Rd, Burwood	74.41	"	"
Galvin, Ivy P, c/o Registry Manager, 3rd Floor, 150 Queen St, Melbourne	86.80	"	"
Geofwardet Pty Ltd, c/o 69 High St, Queanbeyan, NSW	13.51	"	"
Gibson, Ian D, RMB 8006, South Wangaratta	36.96	"	"
Gillon & Sharp Nominees Pty Ltd, 351 Collins St, Melbourne	66.90	"	"
Griffin, Oonagh M, 13 Currajong Ave, Camberwell	29.66	"	"
Holuigue, Beverley D, 3 Avondale Rd, Armadale	186.20	Dividend	29.3.85
Leitch, James W, 21 Kitchener Pde, Newcastle, NSW	38.50	"	4.10.85
Love, Richard, 34 Cecil St, Gordon, NSW	18.48	"	29.3.85
McClymont, William J, GPO Box 385, Sydney, NSW	15.89	"	4.10.85
McLeod, Ursula L, c/o Public Trust Office, PO Box 1461N Melbourne	62.02	"	29.3.85
McPherson, Alexander M (estate of), 40 Galibal St, Waramanga, ACT	372.40	"	"
MacPherson, Carrie A, 40 Galibal St, Waramanga, ACT	74.34	"	"
Marsh, Robert R (estate of), c/o Robert J Marsh, PO Box 289, Toorak	263.83	"	4.10.85
Metcalf, Rodney J, 33 Howley Cres, Amila, NT	93.03	"	29.3.85
Mitchell, Stamo, 6 Gullsway, Frankston	372.40	"	"
Mortimer, Ian, 11 Higgins St, Penrith, NSW	14.00	"	"
Munro, Iris J, 612 Murray Rd, West Preston	10.78	"	"
Odd Lot Nominees Pty Limited, Box 4423 GPO, Sydney, NSW	12.46	"	"
Penny, Janet L, 30 McCormack St, Curtin, ACT	154.00	"	"
Pilla, Maria, 4/80 Mason St, Newport	14.00	"	"
Polywog Nominees Pty Ltd, c/o Sackville Wilks & Co, 100 Collins St, Melbourne	385.00	"	"
Poolman, Deborah, 2 Gahan Crt, Toorak	563.01	"	"
Richards, Phyllis J, 20 Howard St, Glen Iris	74.34	"	"
Scotch Australian Investments Ltd, Farmers Bagots Acc Services, 15 Bentham St, Adelaide, SA	289.52	"	"
Scott, Colin W, Hinnomunjie Station, Omeo	46.69	"	"
Smith, Henry C (estate of), c/o MacKay Taylor & Smith, 131 Kepler St, Warrnambool	38.92	"	"
Storey, Margaret E, Flat 1, 17 Arthur Ave, Cronulla, NSW	120.32	"	"
Walker, Kelvin D, 73 Ridge Rd, Wantirna	92.98	"	"
Woodruff, Anthony P, 51 Verdon St, Williamstown	539.00	"	"

Unclaimed Moneys Act 1962

Register of Unclaimed Moneys held by the—

<i>Name of Owner on Books and Last Known Address</i>	<i>Total Amount Due to Owner</i>	<i>Description of Unclaimed Money</i>	<i>Date when Amount first became Payable</i>
\$			
THE UNION-FIDELITY TRUSTEE COMPANY OF AUSTALIA LIMITED			
Adam, Henry, 65 Roden St, West Melbourne	19.00	Dividend	21.6.85
Andrews, Judith N, 11 Park Ave, Gordon, NSW	150.00	"	"
Crawford, Caroline M, Police Station, Whittlesea	47.50	"	"
Farmer, William, c/o H. A. Farmer, 171 Ferguson St, Williamstown	23.75	"	"
Forbes, David (address unknown)	14.25	"	"
Harbeck, A, Jarrah Forest Sawmills, Green Bushes, WA	14.25	"	"
Hill, John F, 11 The Strand, Bendigo	225.00	"	6.11.85
Kaleph Investments Pty Ltd, c/o A Kirkwood, 86 Chelmsford Ave, Lindfield, NSW	250.00	"	21.6.85
Martyn, John (address unknown)	47.50	"	"
McLeod, Evelyn M L, 32 Commercial Rd, North Hobart, Tas	900.00	"	6.11.85
Moore, Francis T, GPO Box 1150, Brisbane, Qld	225.00	"	"
Reid, George S, 53 High St, Waratah, NSW	90.00	"	"
Robertson, Alex B and M & D Hinsley, c/o Louis A Sallman, 100 Exhibition St, Melbourne	675.00	"	"
Sutton, George K, c/o Pirie & Sutton, PO Box 162, Ballarat	40.00	"	21.6.85
Toplis, John R, Daily Telegraph, Sydney, NSW	23.75	"	"
Tulloch, Harry (address unknown)	23.75	"	"
Walker, Thelma M, 800 Mair St, Ballarat	690.00	"	"
White, Russell, 12 Malua St, Ormond	40.00	"	"
7472	EDWARD M. ASHTON, REAL ESTATE		
Simpson, T, 11/43 Buckley St, Essendon	174.30	Refund	7.12.83
Taylor, K, 8/50 Richardson St, Essendon	145.00	"	22.11.83
Cox, D, 17 Richardson St, Essendon	16.90	"	2.11.83
7470			

BLACKBURN COOL STORES PTY. LTD.
(In Voluntary Liquidation)

Special Resolution to Wind Up

At an extraordinary general meeting of the abovementioned company duly convened and held at 50 Springfield Road, Blackburn, on 10 June 1987, the following resolution was passed on as a special resolution:

That the company be wound up voluntarily.

At the abovementioned meeting K. J. Moylan was appointed Liquidator for the purpose of the winding up.

Notice is also given that after 30 days from this date, I shall proceed to distribute the assets. All creditors having any claim against the company should furnish particulars of same by that date, otherwise I shall proceed to distribute the assets without regard to their claim.

Dated 11 June 1987

7532

GWYNETH MURIEL LOFTUS, late of 18 Marlborough Avenue, Camberwell, in the State of Victoria, widow, deceased.

Creditors, next of kin and other having claims in respect of the estate of the abovementioned deceased who died 24 October 1986 are required by James Kenneth Aitken of 257 Collins Street Melbourne in the State of Victoria Solicitor and Edith Melva Thompson of 76 Athelsten Road Camberwell, in the State of Victoria, home duties, the executors of the will of the said deceased to send particulars of their claims to the said executors in the care of the undermentioned solicitors, by 21 August 1987 after which date the executors will convey or distribute the assets having regard only to the claims of which they then have notice.

RUSSELL, KENNEDY & COOK, solicitors,
257 Collins Street, Melbourne

7517

Creditors, next of kin and others having claims in respect of the estate of Eleanor Doreen Anderson, late of 9 Banks Street, Traralgon, married woman, deceased, who died on 19 April 1987 and probate of whose will was granted by the Supreme Court of Victoria on 9 June 1987 to Marie Janet Anderson, of 9 Banks Street, Traralgon, home duties, are to send particulars of their claims to the said executrix by 26 August 1987, after which date she will distribute the assets of the deceased having regard only to the claims of which she then has notice.

LITTLETON, HACKFORD & MALKIN,
solicitors, Law Chambers, 115-119 Hotham
Street, Traralgon 7547

EMILY KATE HUTTON, late of 281 Kooyong Road, Elsternwick, in the State of Victoria, gentlewoman, deceased

Creditors, next of kin and all others having claims in respect of the deceased, who died on 6 September 1986, are required by the executors James Hutton, of 281 Kooyong Road, Elsternwick and Andrew Hutton of 21 Wilson Street, Berwick, in the said State, to send particulars of such claims to the said executors by 25 August 1987 after which date the executors will distribute the assets having regard only to the claims of which they then have notice.

Dated 12 June 1987

ARONI & COLMAN, solicitors, of 394-396
Glenhuntly Road, Elsternwick 7548

Creditors, next of kin and others having claims in respect of the Estate of Elsie Grace Petterson, late on 4/27 Range Street, Camberwell, spinster, deceased who died 6 April 1987 are to send the particulars of their claims to ANZ Executors & Trustee Company Limited of 94 Queen Street, Melbourne by 24 August 1987 after which date it will distribute the assets having regard only to the claims of which it then has notice. 7520

KEVIN THOMAS RICKWOOD, deceased, late of 4 Hadfield Avenue, Busselton, W.A. died on 25 January 1987.

Any person claiming to be dependant upon the deceased are requested to send particulars of their claims to "Life Claims Department, Australian Eagle Ins. Co. Ltd., G.P.O. BOX 1883R, Melbourne 3001", within two months of the date of this notice, after which date the deceased's entitlement will be distributed in accordance with the provisions of the Eagle Self-Employed Superannuation Fund having regard only to the claims which have been notified. 7522

Creditors, next of kin and others having claims in respect of the Estate of Olive Eveline Woolcott McGregor, late of Queen Elizabeth Geriatric Centre, Ballarat, widow, deceased who died 22 January 1987 are required to send particulars to the Executor Charles Keith Geer care of the address mentioned hereunder by 18 August 1987 after which date the Executor shall convey or distribute the assets having regard only to the claims of which he then has notice.

HERBERT, GEER & RUNDLE, 385 Bourke
Street, Melbourne. 7521

Creditors, next of kin and others having claims in respect of the estate of the deceased, Alex Ernest McLaren, formerly of 66 Raleigh Street, Middle Footscray, but late of 18 Hull Road, Croydon, retired Groundsman, who died on 12 April 1986 are requested to send particulars of their claims to the Executors Colin James Gibson and John Patrick Spillane care of the undermentioned solicitors by 20 August 1987 after which date they will convey or distribute the assets having regard only to the claims of which they then have notice.

SECOMB MCDONALD SMITH JONES & KENNEDY, 59-63 Irving Street Footscray.

7518

Creditors, next of kin and others having claims in respect of the Estate of Kaete Muncheberg, (also known as Kate Muncheberg), late of 4 Meadow Lane, Mount Eliza, married woman deceased, who died 25 March, 1987 are to send the particulars of their claims to ANZ Executors & Trustee Company Limited of 94 Queen Street, Melbourne by the 9 September, 1987 after which date it will distribute the assets having regard only to the claims of which it then has notice. 7519

Pursuant to the provisions of the *Trustee Act*
1958

Creditors, next of kin and all other persons having claims in respect of the estate of Alfred Stanley Gillies, late of Pine Lane, Heatherton, market gardener, deceased, who died on 14 May 1987 are required to send particulars of their claims to the executors, Victor Roy Higgins of 11 Meppel Drive, Clayton, market gardener and Donald Lyston Chisholm, of 440 Collins Street, Melbourne, solicitor, by 12 August 1987 after which date the Executors will distribute the assets having regard only to the claims of which they shall then have notice.

MADDOCK LONIE & CHISHOLM,
solicitors, 440 Collins Street, Melbourne 7515

MARIA STODOLSKI, late of 49 Lilleys Road, Warragul, home duties, deceased

Creditors, next of kin and others having claims in respect to the estate of the deceased, who died on 29 March 1987, are required by the trustees, Irena Christina Davis and Richard Edmund Stodolski, to send particulars of their claims to them care of the undersigned solicitors by 29 August 1987, after which date the trustees may convey or distribute the assets having regard only to the claims of which they then have notice.

GRAY, FRIEND & LONG, solicitors, Warragul 7536

WILLIAM WAGNER, late of Neerim South, retired, deceased

Creditors, next of kin and others having claims in respect to the estate of the deceased, who died on 7 March 1987, are required by the Trustees Valma Joy Cook and Robert John Cook, to send particulars of their claims to them care of the undersigned solicitors by 23 August 1987, after which date the trustees may convey or distribute the assets having regard only to the claims of which they then have notice.

GRAY, FRIEND & LONG, solicitors, Warragul 7537

Creditors, next of kin and others having claims in respect of the estate of Bridget Eileen Linahan, 306 Errard Street South, Ballarat, late of 208 Drummond Street South, Ballarat in the State of Victoria, widow, deceased who died on 18 December 1986 are to send particulars of their claims to Anna Patrica McInnes and Agnus McInnes the executors after which date the executors will distribute the assets having regard only as to the claims of which he then has notice.

T. W. BRENNAN & CO., & F. P. WILLIAMS, solicitors, 118 Queen Street, Melbourne 7516

Creditors, next of kin and others having claims in respect of the estate of Rachel Alice Geddes, late of 11A Elizabeth Crescent Glenhuntly widow deceased who died 24 April 1987, are required by the executors James Alexander Geddes of 11A Elizabeth Crescent, Glenhuntly, public servant and Gordon Alistair Geddes of 5 Bayview Road, McCrae, public servant to send particulars of their claims to them in care of the undermentioned solicitor by 31 August 1987, after which date they will distribute the assets having regard only to the claims of which they then have notice.

W. ANDREW THWAITES, solicitor, 10/416 Collins Street, Melbourne 7514

Creditors, next of kin and others having claims in respect of the Estate of Alma Ruby Conlon (also known as Alma Ruby Jean Conlon), late of 12 Weir Street, Kew who died 27 March 1987 are to send the particulars of their claims to ANZ Executors & Trustee Company Limited of 94 Queen Street, Melbourne by 9 September 1987 after which date it will distribute the assets having regard to the claims of which it then has notice.

7513

In the Will of Julia Guscott, late of 9 Merricks Close, Fern Tree Gully, in the State of Victoria, widow, deceased

Creditors, next of kin and others having claims in respect of the estate of the abovenamed deceased who died on 2 March 1987 are required by the Executors, Ronald Boden of 30 Fairydale Road, Monbulk in the State of Victoria, nurseryman and David Lucas of 26 Station Street, Fern Tree Gully in the State of Victoria, solicitor to send particulars of their claims to them care of the undermentioned Solicitors by 15 September 1987 after which date they will distribute the assets having regard only to the claims of which they then have notice.

DAVID LUCAS & CO., solicitors, of 26 Station Street, Fern Tree Gully 7493

ANTONIO VINCENZO MARGARITI, late of Unit 2, 14 Brennand Street, North Fitzroy, in the State of Victoria, labourer, deceased

Creditors, next of kin and others having claims in respect of the estate of the abovenamed deceased who died on 1 February 1987, are required by Angelo Basilio Natoli and John Francis Natoli both of 24 Cotham Road, Kew, the Executors of the deceased's Will to send particulars of their claims to the said Executors care of the undermentioned Solicitor by 26 August 1987, after which date he will convey or distribute the assets having regard only to the claims which he then has notice.

A. B. NATOLI, LL.B., solicitor, of 24 Cotham Road, Kew 7494

Creditors, next of kin or others having claims in respect of the estate of Josephine Julie Binks, late of 4 Shandford Avenue, Brighton, deceased, who died on 2 August 1986, are requested to send particulars of their claims to the executrix, care of the undermentioned solicitors by 19 August 1987, after which date the executrix will distribute the assets having regard only to the claims of which she then has notice.

RIDGEWAY CLEMENTS, solicitors, 221 Glenhuntly Road, Elsternwick. 7506

Creditors, next of kin and others having claims in respect of the estate of Sophie Kathleen Murphy, late of 45 Donald Street, Prahran, formerly of 64 Dundas Street, Rye, widow, deceased who died on 12 December 1986 are required by the executors of the estate to send particulars of their claims to the executors in the care of the undermentioned Solicitors by 15 August 1987 after which date the said executors will distribute the assets having regard only to the claims of which they then have notice.

VERA FOWLER & CO., solicitors, of 1
Evandale Road, Malvern 7496

Creditors, next of kin and others having claims in respect of the estate of Dora Elizabeth Munro, late of 11 Lytton Street, Kew, retired, deceased who died on 1 August 1986 are required by the executors of the estate to send particulars of their claims to the executors in the care of the undermentioned Solicitors by 15 August 1987 after which date the said executors will distribute the assets having regard only to the claims of which they then have notice.

VERA FOWLER & CO., solicitors, of 1
Evandale Road, Malvern 7495

NEIL MELVILLE GRANT, formerly of
Chinkapook in the State of Victoria, but late
of 97 Murlong Street, Swan Hill, in the said
State, retired farmer, deceased.

Creditors, next of kin and other persons having claims against the estate of the said deceased, who died on 28 February 1987, are required to send particulars of same to the executors, Gary Melville Grant, Wayne John Grant, Graeme Robert Grant and Maureen Anne Champion, in care of the undersigned on or before 24 August 1987, after which date they will distribute the assets having regard only to the claims of which they then have notice.

DWYER BENNETT & MAHON, barristers
and solicitors, 194-208 Beveridge Street, Swan
Hill. 7507

Creditors, next of kin, and others having claims in respect of the estate of Isabel Maron Neilson, late of Flat 15, 401 Alma Road, Caulfield, chiropodist, deceased, who died 6 February 1987, are required by the executors of the estate to send particulars of their claims to the executors in the care of the undermentioned solicitors by 21 August 1987, after which date the said executors will distribute the assets having regard only to the claims of which they then have notice.

VERA FOWLER & CO., solicitors, of 1
Evandale Road, Malvern 7510

In the Will of VERA JANE HINDSON, late of 1
Lawton Avenue, Geelong West, Widow,
deceased.

Creditors, next of kin and others having claims in respect of the estate of the abovenamed deceased, who died on 13 July 1986, are required by Evelyn Joyce Hirst, married woman, and Eric Hirst, gentleman, both of 77 Clarke Street, Newtown, the executors of the said deceased's will, dated 28 April 1980, to send particulars to them care of Messrs. Apted & Williamson, solicitors, 63 Yarra Street, Geelong, by 17 August 1987, after which date the said executors may convey or distribute the assets having regard only to the claims of which they then have notice.

7508

Creditors, next of kin and others having claims in respect of the estate of Hamilton Mackenzie, late of 27 Mason Avenue, Elwood, in the State of Victoria, retired labourer, deceased, who died on 27 February 1987, are required by the executor Burns Philp Trustee Company Limited, of 356 Collins Street, Melbourne, in the said State, to send particulars to it by 17 August 1987, after which date the executor may convey or distribute the assets having regard only to the claims of which it then has notice.

J. M. SMITH & EMMERTON, solicitors, 385
Bourke Street, Melbourne 7509

DOROTHY WOODFULL HEATHCOTE,
formerly of Mecwa House, 6 Warner Street,
Malvern, but late of Garthowen Nursing
Home, 10 Keneally Street, Surrey Hills in the
State of Victoria, widow, deceased.

Creditors, next of kin and others having claims in respect of the estate of the deceased, who died on 29 April 1987 are required by the trustees William James Heathcote of 34 Christowell Street, Camberwell and John Keith Heathcote of 62 Argyle Road, Kew to send particulars to them care of the undersigned solicitors by 17 August 1987 after which date the trustees may convey or distribute the assets having regard only to the claims of which they then have notice.

COLTMANS, solicitors, 367 Collins Street,
Melbourne 7541

Pursuant to the provisions of the *Trustee Act* 1958, creditors, next of kin and all other persons having claim in respect of the estate of Sinclair Lowe, late of 30 Gray Street, South Caulfield, retired, deceased, who died on 8 May 1987 are required to send particulars of their claims to the executors, Donald Lyston Chisholm and John Lyston Chisholm both of 440 Collins Street,

Melbourne, solicitors by 12 August, 1987 after which date the executors will distribute the assets having regard only to the claims of which they shall then have had notice.

MADDOCK LONIE & CHISHOLM,
solicitors, 440 Collins Street, Melbourne 7542

FRANCES AUSTIN SHEPHERD, late of 35A Bruce Street, Toorak in the State of Victoria, gentlewoman, deceased

Creditors, next of kin and others having claims in respect of the estate of the deceased, who died on 6 April 1987, are required by the trustees Desmond Harold Dodds and David York Syme both of 367 Collins Street, Melbourne, solicitors to send particulars to them care of the undersigned solicitors by 17 August 1987 after which date the trustees may convey or distribute the assets having regard only to the claims of which they then have notice.

COLTMANS, solicitors, 367 Collins Street,
Melbourne 7543

ROBERTA ALMA VILLIGER, late of 3 Flowers Street, South Caulfield in the State of Victoria, widow, deceased

Creditors, next of kin, and others having claims in respect of the estate of the deceased, who died on 4 April 1987 are required by the trustee Judith Ann Best of 367 Collins Street, Melbourne solicitor to send particulars to her care of the undersigned solicitors by 17 August 1987 after which date the trustee may convey or distribute the assets having regard only to the claims of which she then has notice.

COLTMANS, solicitors, 367 Collins Street,
Melbourne 7544

NOTICE OF MAKING OF
STATUTORY RULES
WHICH ARE NOT YET
AVAILABLE

134/1987 Credit (Amendment)
Regulations 1987
Credit Act 1984

Notice is given of the making of the following
Statutory Rules:

Teaching Service Act 1981
127/1987 Teaching Service (Appeals
Boards, Chairman and
Members—Terms and
Conditions)
(Amendment No. 22)
Regulations 1987

*Post-Secondary Education
Act 1978*
128/1987 Post-Secondary Education
Commission (Terms and
Conditions)
(Amendment No. 23)
Regulations 1987

*Post-Secondary Education
Act 1978*
129/1987 Post-Secondary Education
(Chairman and Members
Of Boards)
(Remuneration and
Allowance) (Amendment
No. 4)

*Occupational Health and
Safety Act 1985*
130/1987 Dangerous Substances
(Placarding of Work
Places) (Amendment)
Regulations 1987

*Emergency Services
Superannuation Act 1986*
131/1987 Emergency Services
Superannuation (Police
Recruits) Regulations
1987

Supreme Court Act 1986
132/1987 Supreme Court (Court
Fees) (Amendment)
Regulations 1987

National Parks Act 1975
133/1987 National Parks
(Amendment No. 1)
Regulations 1987

**NOTICE OF MAKING
AND AVAILABILITY OF
STATUTORY RULES**

In pursuance of the provisions of the *Subordinate Legislation Act 1962* and the Regulations made thereunder notice is given of the making and availability of the following Statutory Rules:

Note: The date specified after each Statutory Rule is the date it was first obtainable from—
VGPO Bookshop
Information Victoria Centre
318 Lt Bourke Street, Melbourne

			<i>Transport Act 1983</i>	
109/1987	Transport (Road Traffic) (Speed Limit Amendment) Regulations 1987	11 June 1987		40c
			<i>Melbourne and Metropolitan Board of Works Act 1958</i>	
110/1987	By-Law No. 228 Fees for Restriction and Restoration of Water Supply	11 June 1987		40c
			<i>Melbourne and Metropolitan Board of Works Act 1958</i>	
103/1987	<i>Seeds Act 1982</i> Seeds (Fees) Regulations 1987	11 June 1987		40c
			<i>Stock Diseases Act 1968</i>	
104/1987	Stock Diseases (Fees) Regulations 1987	11 June 1987		40c
			<i>Magistrates' Courts Act 1971</i>	
105/1987	Magistrates Court (Fees, Costs and Charges) (Amendment) Regulations 1987	11 June 1987		40c
			<i>Co-operative Housing Societies Act 1958</i>	
106/1987	Co-operative Housing Societies (General) (Amendment) Regulations 1987	11 June 1987		40c
			<i>Health Act 1958</i>	
107/1987	Health (Private Hospitals—Notification of Interest) Regulation 1987	16 June 1987		40c
			<i>Medical Practitioners Act 1970</i>	
108/1987	Medical Practitioners (Private Hospitals— Notification of Interest) Regulations 1987	15 June 1987		70c
			<i>Road Safety Act 1986</i>	
113/1987	By-Law No. 232 Water Supply	15 June 1987		40c
			<i>Road Safety (Procedures) (Further Amendment) Regulations 1987</i>	
116/1987	Road Safety (Procedures) (Further Amendment) Regulations 1987	15 June 1987		40c
			<i>Hospital and Charities Act 1958</i>	
117/1987	Hospitals and Charities (Amendment No. 1) Regulations 1987	11 June 1987		40c
			<i>Agricultural Chemicals Act 1958</i>	
118/1987	Agricultural Chemicals (Fees) Regulations 1987	12 June 1987		40c
			<i>Agricultural Chemicals Act 1958</i>	
119/1987	Pesticides (Fees) Regulations 1987	12 June 1987		40c
			<i>Farm Produce Merchants and Commission Agents Act 1965</i>	
120/1987	Farm Produce Merchants and Commission Agents (Fees) Regulations 1987	12 June 1987		40c
			<i>Companies (Application of Laws) Act 1981</i>	

1590 G 23 17 June 1987

Victoria Government Gazette

121/1987	Companies (Application of Laws) (Retirement Villages Exemption) Regulations 1987	
12 June 1987		40c
	<i>Retirement Villages Act 1986</i>	
122/1987	Retirement Villages Regulations 1987	
12 June 1987		40c
	<i>Transport Act 1983</i>	
123/1987	Victoria Transport Borrowing Agency (Bonded Stocks) (Revocation) Regulations 1987	
12 June 1987		40c
	<i>Transport Act 1986</i>	
124/1987	Transport Accident (Charges Amendment) Regulations 1987	
15 June 1987		40c
	<i>Public Authorities Marks Act 1958</i>	
125/1987	By-Law No. 229 Approving and Stamping of Materials	
16 June 1987		40c
	<i>Melbourne and Metropolitan Board of Works Act 1958</i>	
126/1987	Special By-Law 31 Fees for Water Supply and Sewerage Services to Non-Rateable Property and Cultural and Recreational Lands	
16 June 1987		40c

Victoria Government Gazette

G 23 17 June 1987 1591

1592 G 23 17 June 1987

Victoria Government Gazette

Victoria Government Gazette

G 23 17 June 1987 1593

1594 G 23 17 June 1987

Victoria Government Gazette

Victoria Government Gazette

G 23 17 June 1987 1595

1596 G 23 17 June 1987

Victoria Government Gazette

Victoria Government Gazette

G 23 17 June 1987 1597

CONTENTS

	Page
Appointments	1554
Cemeteries—Scale of Fees	1540
Contracts	1541, 1544
Contracts Accepted—Amendments	1545
Estates of Deceased Persons	1544
Government Notices	1538
Melbourne and Metropolitan Board of Works	1539
Notice of Making Statutory Rules	1588
Orders in Council—	
Acts—Superannuation; Swan Hill Pioneer Settlement; Land; Crown Land (Reserves); Children's Court; Hospitals and Charities; Racing; Forests; Local Government; Urban Land Authority; Retirement Villages	1556
Private Advertisements	1569
Proclamations	1537
Tenders	1568

No. G 23—General Government Gazette

A Victorian Government Publication

Published by VGPO
Melbourne Victoria Australia

© State of Victoria

This publication is copyright. No part may be reproduced by any process except in accordance with the provisions of the Copyright Act

Address all inquiries to the Government Printer
for the State of Victoria
PO Box 203 North Melbourne 3051 Victoria Australia
ISSN 0819—5471

Further copies of this publication can be obtained from
VGPO Bookshop
Information Victoria Centre
318 Lt Bourke Street Melbourne
(PO Box 203 North Melbourne 3051)

By Authority F D Atkinson Government Printer Melbourne
Recommended Retail Price \$1.10