

VICTORIA GOVERNMENT GAZETTE

No. G 42 Wednesday 2 November 1988
By Authority Jean Gordon Government Printer Melbourne

GENERAL

Gazette Services

The *Victoria Government Gazette* (VGG) is published by VGPO for the State of Victoria and is produced in three editions.

VGG General is published each Wednesday and provides information regarding Acts of Parliament and their effective date of operation; Government notices; requests for tenders; as well as contracts and contracts accepted. Private notices are also published.

VGG Special is published any day when required for urgent or special Government notices. VGG Special is made available automatically to subscribers of VGG General.

VGG Periodical is published on Monday when required and includes specialised information eg. Medical, Dental, Pharmacist's Registers, etc.

Government Advertising

Publishing Details

The following Guidelines should be followed to ensure publication of Government material in the *Victoria Government Gazette*.

- Duplicate copies should be submitted for use by the Gazette Officer.
- Material submitted to the Executive Council for gazettal will normally be published in the following week's issue.
- Where urgent gazettal is required, contact:
Gerd Gaspar
Gazette Officer
Department of the Premier and Cabinet
2nd Floor 1 Treasury Place
Melbourne 3000
Telephone Inquiries (03) 651 5153
- Government advertising other than material for the consideration of the Executive Council should be forwarded to the Gazette Office no later than 9.30 am on Tuesday.
- Lengthy or complicated notices should be forwarded several days before publication.
- Proofs will be supplied only when requested or at the direction of the Gazette Officer.
- No additions or amendments to material for publication will be accepted by telephone.
- Double rates for advertising in the Special Gazette will apply.

Private Advertising

Publishing Details. Send copy to:

VGG Coordinator
Gazette Advertising
VGPO
66-112 Macaulay Road
North Melbourne
(PO Box 203 North Melbourne 3051)
Telephone inquiries (03) 320 0100
Fax No. (03) 329 2696

Advertising Rates and Payment

Single column × cm/part cm \$3.85
Double column × cm/part cm \$7.70
Full page \$161.70

All private advertising **MUST** be paid for in advance, prior to any gazettal. Cheques should be made payable to 'VGPO'.

Advertisers should note:

- There are approximately 20 words to each column centimetre depth.
- Signatures (in particular) and proper names must also be in block letters.
- All material should be double spaced.
- Advertisements can be faxed, and a cover sheet should be used, marked to the attention of the Gazette Coordinator.
- Documents not clearly prepared and in the exact format for gazettal will be returned to the sender unpublished.
- Late copy received at VGPO after 3.30 pm Tuesday will be placed in the following issue of VGG, irrespective of any date/s mentioned in the copy (unless otherwise advised).

Copy Deadline

11.00 am Tuesday (Normal Rates)
3.30 pm Tuesday (Double Rates)

Subscriptions

VGG is available by three subscription services:

General and Special—\$106 each year
General, Special and Periodical—\$122 each year
Periodical—\$64 each year

Subscriptions are payable in advance and accepted for a period of one year. All subscriptions are on a firm basis and refunds for cancellations will not be given.

All payments should be made payable to VGPO.

Subscription inquiries: (03) 320 0217

Bookshop Inquiries: (03) 663 3760

PROCLAMATION

MUNICIPAL DISTRICT OF THE SHIRE OF ARARAT

ARARAT—The land in the Parish of Ararat as indicated by hatching on plan hereunder—(A149(29)) (L3-3190).

Land Act 1958

PROCLAMATION OF ROADS

I, J. Davis McCaughey, Governor of Victoria, with the advice of the Executive Council and under section 25 (3) (c) of the *Land Act 1958* proclaim as roads the following lands.

MUNICIPAL DISTRICT OF THE CITY OF ARARAT

ARARAT—The land in the Township of Ararat, Parish of Ararat as indicated by hatching on plan hereunder—(A148(9)) (L3-929).

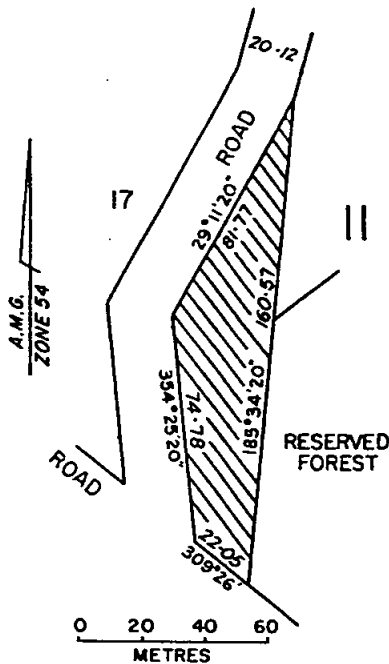
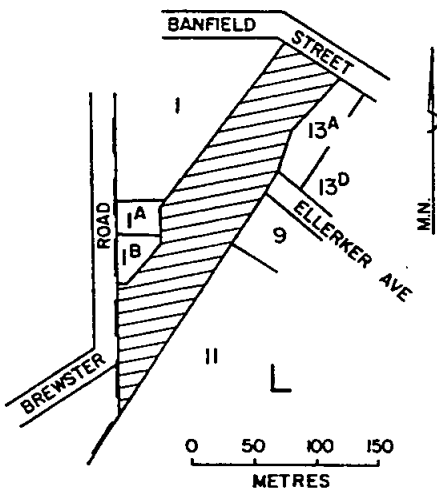

MUNICIPAL DISTRICT OF THE SHIRE OF BUNGAREE

BALLARAT—Crown Allotment 26a, section 5, Parish of Ballarat as shown on Certified Plan No. 108412 lodged in the Central Plan Office—(L3-3971).

MUNICIPAL DISTRICT OF THE SHIRE OF BUNINYONG

BALLARAT—Crown Allotment 3A, section 4A1, Parish of Ballarat as shown on Certified Plan No. 108461 lodged in the Central Plan Office—(L3-3756).

MUNICIPAL DISTRICT OF THE SHIRE OF DUNDAS

BEPCHA—Crown Allotment 10D, Parish of Bepcha as shown on Certified Plan No. 108127 lodged in the Central Plan Office—(L2-3158).

MUNICIPAL DISTRICT OF THE SHIRE OF STAWELL

ILLAWARRA—Crown Allotment 37G, Parish of Illawarra as shown on Certified Plan No. 108521 lodged in the Central Plan Office—(L4-597).

MUNICIPAL DISTRICT OF THE SHIRE OF MALDON

MALDON—Crown Allotment 15c, section 10, Parish of Maldon as shown on Certified Plan No. 109116 lodged in the Central Plan Office—(L6-4119).

MUNICIPAL DISTRICT OF THE SHIRE OF WARRAGUL

WARRAGUL—The lands in the Township of Warragul, Parish of Drouin East as indicated by hatching on plans hereunder—(W313(10)) (C82243).

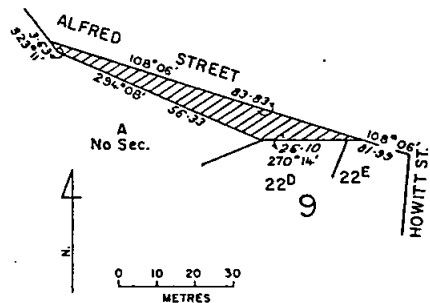
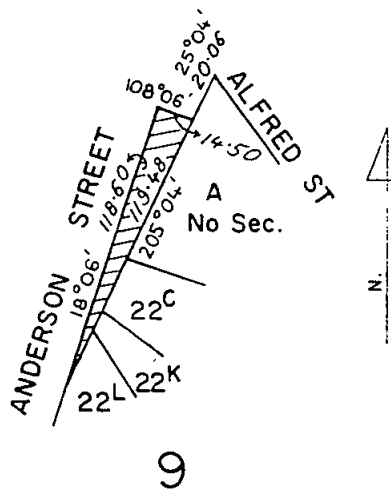

Given under my hand and the seal of
Victoria on 25 October 1988
(L.S.) J. DAVIS McCAUGHEY
By His Excellency's Command
KAY SETCHES
Minister for Conservation, Forests and Lands

GOVERNMENT NOTICES

Private Agents Act 1966

NOTICE OF RECEIPT OF APPLICATIONS FOR LICENCES UNDER THE PROVISIONS OF THE PRIVATE AGENTS ACT 1966

The Clerk(s) of the Magistrates' Court(s) as listed hereunder hereby give notice that applications, as under, have been lodged for hearing by the said Court(s) on the date(s) specified.

Any person desiring to object to any of such applications must—

- (a) lodge with the respective Clerk of the Magistrates' Court a notice in the prescribed form of his objection and of the grounds thereof;
- (b) cause a copy of such notice to be served personally or by post upon the applicant at least three days before the hearing of the application; and
- (c) send or deliver—
 - (i) where the objection is not made by the officer in charge of the police district in which the Court is situated—a copy of the notice to such officer; and
 - (ii) where the objection is not made by the Registrar or Deputy Registrar—a copy to the Registrar.

Full Name of Applicant*	Place of Abode of Applicant or Nominee	Name of Firm or Corporation	Address for Registration	Type of Licence	Date of Hearing
MAGISTRATES' COURT, MELBOURNE					
Walton, Kenneth Alexander	2 Paproth Gve, North Altona	Wormald Security	87 Racecourse Rd, North Melbourne	Watchman	18.10.88
Vaughan, Robert Francis	115 Altona St, West Heidelberg	" "	" "	"	"
Beckwith, Peter Norman	4 Leigh Crt, Dallas	" "	" "	"	"
Horton, Steven Maurice	478 St. Kilda Rd, Melbourne	TNT Security	54 Racecourse Rd, North Melbourne	"	19.10.88
Hatty, Mary Elizabeth	16 Corrish St, Sunbury	" "	" "	"	"
Bugeja, Carol	3/14 Forrest St, Sunshine	" "	" "	"	"
Brent, Arthur Frederick	5 Judith Cl, Narre Warren	" "	" "	"	"
Dated at Melbourne, 19 October 1988 Clerk of the Magistrates' Court					
McCormick, Daniel John	24 Cook St, West Brunswick	Wormald	57 Racecourse Rd, North Melbourne	Watchman	24.10.88
Daley, Gillian Ann	36 Leithead St, Brunswick	" "	" "	"	"
Rivers, Andrew	10 Cohuna Crt, East Burwood	" "	" "	"	"
Kerry, Attila Lajos	99 Lyon Rd, Rosanna East	" "	" "	"	"
Buccuss, Ernest John	9 Ethel St, Boronia	" "	" "	"	"
Young, Mark Anthony	5/5 Spray St, Elwood	" "	" "	"	"
Cunningham, Michael James Richard	10 Killeen St, West Sunshine	" "	" "	"	"
Dated at Melbourne, 24 October 1988 Clerk of the Magistrates' Court					
MAGISTRATES' COURT, SPRINGVALE					
Dick, David Alexander	42 Regent Ave, Springvale	David Alexander Dick	42 Regent Ave, Springvale	Inquiry Agent	30.11.88
Dated at Springvale, 25 October 1988 W. WARD, Clerk of the Magistrates' Court					
MAGISTRATES' COURT, OAKLEIGH					
Bronson, Brian	37 Carlton St, McKinnon		96 Murrumbeena Rd, Murrumbeena	Watchman	24.11.88
Dated at Oakleigh, 24 October 1988 B. BOLTON, Clerk of the Magistrates' Court					

*Or in the case of a firm or corporation, of the Nominee

PRIVATE AGENTS—continued

Full Name of Applicant*	Place of Abode of Applicant or Nominee	Name of Firm or Corporation	Address for Registration	Type of Licence	Date of Hearing
MAGISTRATES' COURT, BENDIGO					
Abley, Christopher Grant	2/10 Lawson St, Spring Gully		2/10 Lawson St, Spring Gully	Commercial Sub-Agent	14.11.88
Abley, Wendy Jane	2/10 Lawson St, Spring Gully		2/10 Lawson St, Spring Gully	Process Server	"
Dated at Bendigo, 24 October 1988 T. J. NIHILL, Clerk of the Magistrates' Court					
MAGISTRATES' COURT, BROADMEADOWS					
Reid, Alan	1 Latrobe Crt, Sunbury		5 Lily St, Coburg	Watchman	24.11.88
Orchard, John	16 Pickett St, Reservoir		29 Catalina Dve, Tullamarine	Watchman	25.11.88
Carr, Darren John	20 Pascoe St, Pascoe Vale			Watchman	29.11.88
Dated at Broadmeadows R. MALONEY, Clerk of the Magistrates' Court					
MAGISTRATES' COURT, BRUNSWICK					
Keech, Cameron Derek	29 Parkhill Dve, Ashwood	City Watch Security Services	409 Albert St, Brunswick	Watchman	23.11.88
Dated at Brunswick, 24 October 1988 B. P. REGAN, Clerk of the Magistrates' Court					
MAGISTRATES' COURT, FERNTREE GULLY					
Seychell, Anthony	9 Lovell Ct, Rowville		9 Lovell Ct, Rowville	Guard Agent	24.11.88
de Kroon, Frank	125 Duff St, Cranbourne		34 Margot St, Ferntree Gully	Watchman	"
Dated at Ferntree Gully, 24 October 1988 IAN R. SIGG, Clerk of the Magistrates' Court					
MAGISTRATES' COURT, RINGWOOD					
Pudney, Roger Lionel	2 Nandina St, Nunawading		2 Nandina St, Nunawading	Watchman	30.11.88
Girvan, Glenda May	19 Gladys Gve, Croydon West		6 Oaklands Ave, Ferntree Gully	Commercial Sub-Agent	28.11.88
Dated at Ringwood, 21 October 1988 Clerk of the Magistrates' Court					
MAGISTRATES' COURT, OAKLEIGH					
Jacobson, Frank John	5 Boston Ave, Seaford		167 McKinnon Rd, McKinnon	Watchman	30.11.88
Rivelli, Michael	198 O'Heas Rd, Coburg		13 Warrigal Rd, Oakleigh	"	1.12.88
Ainsworth, Phillip John	4 Naroo Crt, Glen Waverley		4 Naroo Crt, Glen Waverley	Commercial Sub-Agent	23.11.88
Dated at Oakleigh, 26 October 1988 B. BOLTON, Clerk of the Magistrates' Court					

*Or in the case of a firm or corporation, of the Nominee

EXEMPTION

Application No. 5 of 1988

On 7 October 1988, the Equal Opportunity Board considered an application made under section 40 (1) of the *Equal Opportunity Act 1984* by the Steering Committee of the Outer Eastern Women's Health Service for an exemption from the provisions of the Act to enable the Outer Eastern Women's Health Service to advertise for and appoint women only in two positions of a Project Co-ordinator and a Project Officer in order to co-ordinate and assist in the establishment and development of the Outer Eastern Women's Health Service.

The Board has regard to the applicant's submission and job descriptions which informed the Board that—

- (i) both positions will be responsible to the Steering Committee which comprises representatives from the Maroondah Hospital Advisory Group on Women's Health and representatives from the Outer Eastern Women's Health Network;
- (ii) the State Government has allocated funds to establish an Outer Eastern Women's Health Service, which will be in premises already secured adjacent to the Maroondah Hospital in Ringwood East. The successful submission was prepared jointly by the Maroondah Hospital Advisory Group on Women's Health and the Outer Eastern Women's Health Network;
- (iii) the Maroondah Hospital Advisory Group on Women's Health was formed in September 1987 and its role is to advise the Maroondah Hospital Committee of Management on matters pertaining to women's health. It includes female members of the Hospital's Committee of Management, Ringwood City Council, District Health Council Program, Medical and Nursing professions and Hospital Administrative Staff. The Outer Eastern Women's Health Network is a group of women who live in the outer eastern suburbs. It was formed in May 1987 through local Neighbourhood Houses, Maternal and Child Health, Education Department, Medical and Nursing professions, and has a membership of 75 women;
- (iv) The service will work with existing health and community services to address women's health needs in such areas as—cervical cancer and breast cancer; stages of life, family planning; contraception; premenstrual tension; menopause; menstrual

Victoria Government Gazette

pain; pelvic problems; endometriosis; ageing; osteoporosis; emotional health and determined that the exemption requested was desirable to assist in the establishment and development of the Outer Eastern Women's Health Service.

The Board hereby grants an exemption from the operation of section 21 (1) (a) and (c) and section 59 of the *Equal Opportunity Act 1984* to permit the Steering Committee of the Outer Eastern Women's Health Service to advertise for and appoint women to the following positions with the Outer Eastern Women's Health Service:

1. Project Co-ordinator;
2. Project Officer.

The granting of this exemption does not guarantee any extension of exemption will be granted nor does it imply that any other positions other than those specified are exempt.

This exemption shall remain in force until 31 July 1989.

M. RIZKALLA, President
C. GEORGE, Member
J. MURPHY, Member
D. RECHTMAN, Member
S. CHARLESWORTH, Member

Transport Act 1983

ROAD TRAFFIC AUTHORITY

Commercial Passenger Vehicle Applications

Notice is hereby given that the following applications will be considered by the Road Traffic Authority on 6 December 1988.

Notice of any objections should be forwarded to reach the Manager, Vehicle Licensing Branch or any Regional Office of the Road Traffic Authority not later than 30 November 1988.

It will not be necessary for interested parties to appear on the hearing date specified, unless advised in writing by the Authority.

Notification of the date for consideration of applications which are objected to and which require determination by the Road Transport Licensing Tribunal will be published by further notice in this *Gazette*.

Cobb and Co. Coaches Pty. Ltd., Preston. Application to license one commercial passenger vehicle to be purchased in respect of a 1989 Centurion coach with seating capacity for 29 passengers to operate as a metropolitan special service omnibus.

Note: The vehicle to be licensed would hold a 4 star rating for charter purposes.

D. A. Elliot, Croydon. Application to license two commercial passenger vehicles to be purchased in respect of two 1958-1965 Mercedes

Victoria Government Gazette

Benz sedans each with seating capacity for 5 passengers to operate as special purpose vehicles from 29 Homer Avenue, Croydon for the carriage of passengers for wedding parties.

M. J. Kerrigan, Richmond. Application to license one commercial passenger vehicle to be purchased in respect of a 1980-1988 Ford LTD (air-conditioned) stretched limousine with seating capacity for 8 passengers to operate as a special purpose vehicle from 16 Flamingo Drive, Mildura for the carriage of passengers for the following purposes: weddings, engagements, birthday celebrations, processions (e.g. Mardi Gras), as a supplementary mourning coach for funeral hirings when the hiring has been pre-booked by a funeral director.

M. J. Kerrigan, Richmond. Application to license one commercial passenger vehicle to be purchased in respect of a 1980-1988 Ford LTD (air-conditioned) stretched limousine with seating capacity for 8 passengers to operate as a country hire care from 16 Flamingo Drive, Mildura.

F. M. McKenzie, Anglesea. Application to license one commercial passenger vehicle in respect of a 1928 Riley Nine Tourer sedan with seating capacity for 3 passengers to operate as a special purpose vehicle from Lot 3, Great Ocean Road, Anglesea for the carriage of passengers for the following purposes: wedding parties; and one or two day trips as and when required to places of interest between Geelong and Warrnambool via Geelong/Bellarine Peninsula and Great Ocean Road.

S. Nathan, Essendon. Application for variation of the conditions of two SV licences granted by the Road Transport Licensing Tribunal subject to the conditions set out in its Memorandum of Determination dated 15 October 1986 and not yet taken up to amend the condition that the vehicles to be licensed shall be a 1938 La Salle sedan and a 1975-1978 Mercedes Benz sedan to a 1938 Chevrolet sedan and a 1965 Rolls Royce sedan.

A. Peko, Narre Warren. Application to license one commercial passenger vehicle in respect of a 1977 Statesman Caprice sedan with seating capacity for 4 passengers to operate as a special purpose vehicle from 24 Lancaster Avenue, Narre Warren for the carriage of passengers for wedding parties.

M. Tron, Moorabbin. Application to license four commercial passenger vehicles to be purchased in respect of two 1981 or later model Mercedes Benz sedans each with seating capacity for 4 passengers, one 1982 or later model Ford Lincoln sedan and one 1985 or later model Cadillac sedan each with seating capacity for 5

G 42 2 November 1988 3271

passengers to operate as metropolitan hire cars from 64 Mortimore Street, Moorabbin.

Dated 2 November 1988

G. SHANKS

Group Manager

Commercial Road User Programs

DEPARTMENT OF PROPERTY AND SERVICES

Sale of Crown Land by Public Auction

Reference No. S9242

On Saturday, 3 December 1988 at 11 a.m. on site.

Property Address: 21 Pinnacle Drive, Rawson.

Crown Description: CA 9G of B.

Terms of Sale: 10% deposit with balance due in 60 days.

Officer Co-ordinating Sale: Helen Mcvius, Property Consultant, Government Land Bureau, Department of Property and Services.

Selling Agent: King & Heath, corner Moore and Albert Streets, Moe.

R. W. WALSH

Minister for Property and Services

DEPARTMENT OF PROPERTY AND SERVICES

Sale of Crown Land by Public Auction

Reference No. S9243

On Saturday, 3 December 1988 at 11.30 a.m. on site.

Property Address: 10 St. Gwinear Court, Rawson.

Crown Description: CA 9F of B.

Terms of Sale: 10% deposit, balance due in 60 days.

Officer Co-ordinating Sale: Helen Mcvius, Property Consultant, Government Land Bureau, Department of Property and Services.

Selling Agent: King & Heath, corner Moore and Albert Streets, Moe.

R. W. WALSH

Minister for Property and Services

Co-operation Act 1981

FERNTREE GULLY CREDIT UNION
CO-OPERATIVE LIMITED

I hereby notify that I have this day registered the dissolution of the abovenamed society and cancelled its registration under the abovenamed Act.

Dated at Melbourne 20 October 1988.

A. M. SANSFIELD

Deputy Registrar of Co-operative Societies

3272 G 42 2 November 1988

Co-operation Act 1981

NOTICE OF MERGER OF SOCIETIES

Notice is hereby given that, pursuant to the provisions of the *Co-operation Act 1981*, Ferntree Gully Credit Union Co-operative Limited and Eastern Community Credit Union Co-operative Limited were merged into one society under the name of Eastern Community Credit Union Co-operative Limited on 1 July 1988.
Dated at Melbourne 20 October 1988

A. M. SANSFIELD

Deputy Registrar of Co-operative Societies

ERRATUM

In *Government Gazette*, No. G36 of 21 September 1988 on page 2852 under Sale of Crown Land by Public Auction Reference GL10171 in Crown description read "Section 14" instead of "Section 24".

**STATE TENDER BOARD
CONTRACTS ACCEPTED
Amendments**

<i>Schedule Number</i>	<i>Item Number</i>	<i>New Rate</i>	<i>Effective Date</i>
		\$	
Provisions/Groceries 2/01A	24	"Phoenix" Cake List 7.11.88	7.11.88
	39	23.00	24.10.88

J. M. PAWSON

Secretary to the Tender Board

**OPTOMETRISTS REGISTRATION BOARD
(VIC)**

Pursuant to the *Optometrists Registration Act 1958* and the *Optometrists Regulations* notice is hereby given that an election for four certified optometrists to be nominated by certified optometrists for appointment as members of the Optometrists Registration Board as from 29 January 1989 will be held on Friday, 16 December 1988 and notice is further given that Wednesday, 16 November 1988 has been fixed as the date for receiving nominations for elections. All nominations must be in the form or to the effect of the form prescribed by the Regulations and must be lodged with the Registrar of the Board before 12 noon on the said 16 November 1988. Nomination forms may be obtained from the Registrar.

NORMAN L. BROCKLEY
Registrar

Optometrists Registration Board, 19th Floor,
555 Collins Street, Melbourne.

Victoria Government Gazette

Police Regulation Act 1958, Section 122

SALE OF UNCLAIMED PROPERTY

An owner is required for a pink coloured 1960 Pontiac Sedan, Engine No. PV153315 which came into the possession of Police on 17 May 1988.

In accordance with an order issued by the Warracknabeal Magistrates' Court on 3 June 1988, the vehicle will be sold by public auction at 10 a.m. on Monday, 12 December 1988, at Minyip Police Station, 106 Main Street, Minyip.

K. GLARE

Chief Commissioner

Police Offences Act 1958, No. 6337

**DIVISION 1A—STATE CLASSIFICATION
OF PUBLICATIONS BOARD**

Take note that the State Classification of Publications Board has classified the following publications in accordance with the provisions of section 180H (1) of the *Police Offences Act 1958*.

Each publication shall be subject to the following restrictions:

- (a) It shall not be offered for sale, sold or delivered to any person under the age of 18 years;
- (b) It shall not be made available for inspection or perusal by any person under the age of 18 years.

<i>Title</i>	<i>Distributor</i>
Supercycle, October 1988	Gordon & Gotch Ltd.
American Survival Guide, September 1988	Gordon & Gotch Ltd.
Soldier of Fortune, September 1988	Gordon & Gotch Ltd.
Special Weapons and Tactics, September 1988	Gordon & Gotch Ltd.
Penthouse Letters, November 1988	Gordon & Gotch Ltd.
Fiesta, Vol. 22 No. 11	Gordon & Gotch Ltd.
Gallery, December 1988	Gordon & Gotch Ltd.
Genesis, Girls/Girls, Winter 1988	Gordon & Gotch Ltd.

D. J. FREEMAN

Acting Secretary

State Classification of Publications Board

Police Offences Act 1958, No. 6337

DIVISION 1A—STATE CLASSIFICATION OF PUBLICATIONS BOARD

Take note that the State Classification of Publications Board has classified the following publications in accordance with the provisions of section 180H (1) of the *Police Offences Act 1958*.

Each publication shall be subject to the following restrictions:

- (a) It shall not be offered for sale, sold or delivered to any person under the age of 18 years;
- (b) It shall not be made available for inspection or perusal by any person under the age of 18 years;
- (c) It shall not be exhibited or displayed in any place to which persons under the age of 18 years have access or so that it is visible from any such place.

Title	Distributor
Juggs, November 1988	Gordon & Gotch Ltd.
Harvey, December 1988	Gordon & Gotch Ltd.
Penthouse Variations, November 1988	Gordon & Gotch Ltd.
Letters Magazine, December 1988	Gordon & Gotch Ltd.
Human Digest, November 1988	Gordon & Gotch Ltd.

D. J. FREEMAN
Acting Secretary
State Classification of Publications Board

ORDERS IN COUNCIL

Crown Land (Reserves) Act 1978
CROWN LANDS TEMPORARILY RESERVED

The Governor in Council under sections 4 and 7 of the *Crown Land (Reserves) Act 1978* temporarily reserves for the purposes mentioned and also excepts from prospecting or from occupation for mining purposes under any miners right the following Crown lands:

MUNICIPAL DISTRICT OF THE SHIRE OF BUNINYONG

BALLARAT—Water Supply, 9105 square metres being Crown Allotment Z9, Parish of Ballarat as shown on Certified Plan No. 107739 lodged in the Central Plan Office—(Rs. 13922).

MUNICIPAL DISTRICT OF THE CITY OF BALLAARAT

BALLARAT EAST—Water Supply, 1.081 hectares being Crown Allotment 1, section 128A, Township of Ballarat East, Parish of Ballarat, as shown on Certified Plan No. 107740 lodged in the Central Plan Office—(Rs. 13921).

MUNICIPAL DISTRICT OF THE CITY OF CRESWICK

CRESWICK—Water Supply, 6026 square metres being Crown Allotment 20, section S, Parish of Creswick as shown on Certified Plan No. 104727 lodged in the Central Plan Office—(Rs. 13920).

MUNICIPAL DISTRICT OF THE CITY OF WERRIBEE

DEUTGAM—Public purposes, 1.3 hectares, more or less, being Crown Allotment 95A, section D, Parish of Deutgam as indicated by hatching on plan hereunder—(D42(6)) (Rs. 7964).

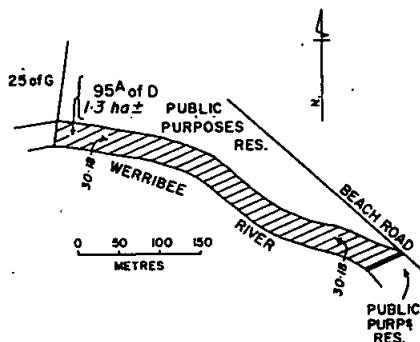

3274 G 42 2 November 1988

MUNICIPAL DISTRICT OF THE SHIRE OF KOWREE

DING-A-DING—Management of Wildlife, 16.19 hectares, being Crown Allotment 21A, Parish of Ding-a-ding as indicated by hatching on plan hereunder—(D175(2)) (Rs. 13911).

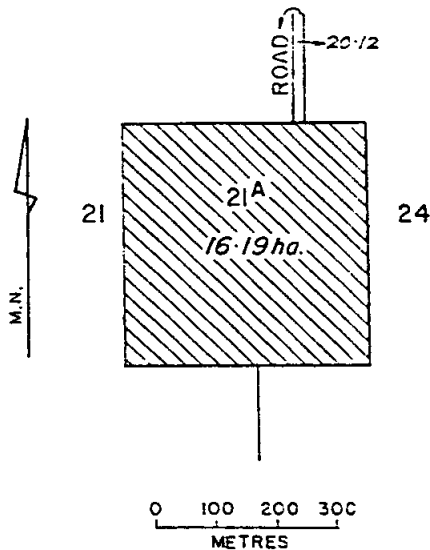

MUNICIPAL DISTRICT OF THE SHIRE OF WINCHELSEA

LORNE—Cricket and other purposes of Public Recreation, 1434 square metres being Crown Allotment 1c, Township of Lorne, Parish of Lorne as shown on Certified Plan No. 108940 lodged in the Central Plan Office—(Rs. 90).

MUNICIPAL DISTRICT OF THE SHIRE OF MILDURA

MILDURA—Kindergarten, 1933 square metres, being Crown Allotment 232A, section B, Parish of Mildura as shown on Certified Plan No. 106976 lodged in the Central Plan Office—(Rs. 13857).

MUNICIPAL DISTRICT OF THE SHIRE OF MILDURA

MILDURA—Infant Welfare Centre, 858 square metres being Crown Allotment 232B, section B, Parish of Mildura as shown on Certified Plan No. 106976 lodged in the Central Plan Office—(Rs. 13858).

MUNICIPAL DISTRICT OF THE CITY OF MILDURA

MILDURA—Sewerage Purposes, 37.35 hectares being Crown Allotment 1, section 6,

Victoria Government Gazette

Block E, Parish of Mildura as shown on Certified Plan No. 106730 lodged in the Central Plan Office—(Rs. 13923).

MUNICIPAL DISTRICT OF THE SHIRE OF KORONG

WOOSANG—Preservation of native flora and fauna, 1250 hectares more or less, being Crown Allotments 60E and 60F, section B, Parish of Woosang as indicated by hatching on plan hereunder—(W312(8)), (W312(7)) (Rs. 12992).

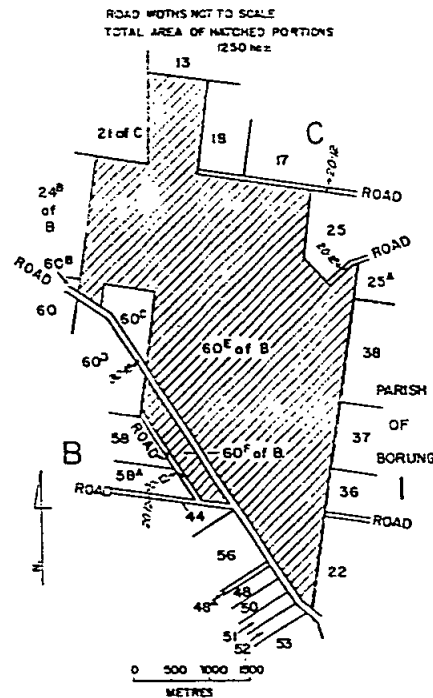

Dated 25 October 1988

Responsible Minister:

KAY SETCHES

Minister for Conservation, Forests and Lands

KATHY OUZOUNIS

Acting Clerk of the Executive Council

Crown Land (Reserves) Act 1978
CROWN LAND PERMANENTLY RESERVED

The Governor in Council under sections 4 and 7 of the *Crown Land (Reserves) Act 1978* permanently reserves for the purposes mentioned and also excepts from prospecting or from

Victoria Government Gazette

occupation for mining purposes under any miners right the following Crown lands.

MUNICIPAL DISTRICT OF THE SHIRE OF KOWREE

BENAYEO—Management of Wildlife, 31 hectares more or less, being Crown allotment 47C, Parish of Benayeo as shown by hatching on plan hereunder—(B601 (4)) (Rs.13766).

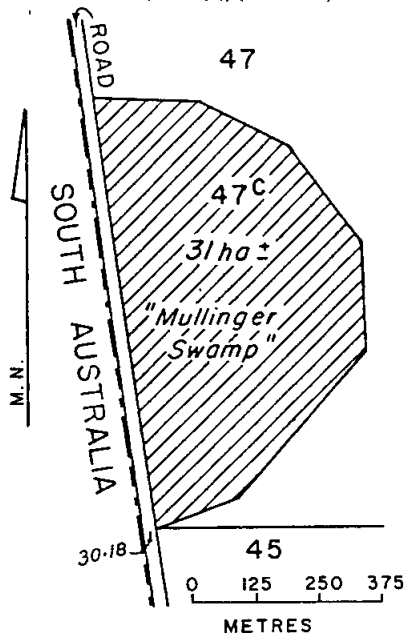

MUNICIPAL DISTRICT OF THE SHIRE OF KOWREE

KOUT NARIN—Conservation of an Area of Natural Interest, 8.3 hectares, more or less, being Crown allotment 29B, Parish of Kout Narin as shown by hatching on plan hereunder—(K 123 (2)) (Rs.13740).

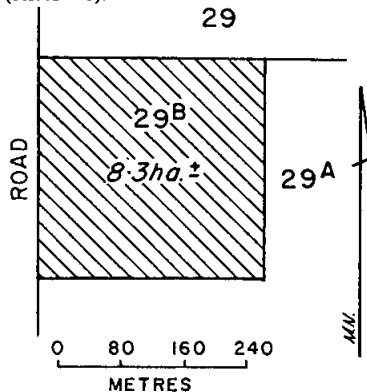

G 42 2 November 1988 3275

MUNICIPAL DISTRICT OF THE SHIRE OF KOWREE

YALLAKAR—Conservation of an Area of Natural Interest, 7 hectares, more or less, being Crown allotment 29A, section A, Parish of Yallakar as shown by hatching on plan hereunder—(Y 91(6)) (Rs.13791).

30

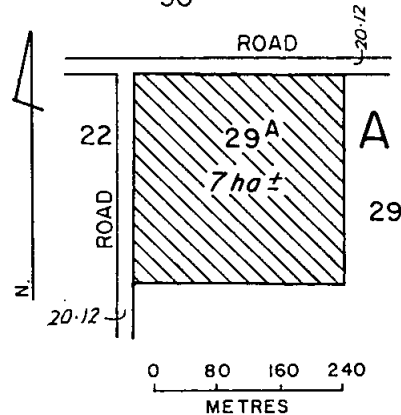

Dated 25 October 1988

Responsible Minister:

KAY SETCHES

Minister for Conservation Forests and Lands

KATHY OUZOUNIS

Acting Clerk of the Executive Council

Crown Land (Reserves) Act 1978

NOTICE OF INTENTION

The Governor in Council under section 10 of the *Crown Land (Reserves) Act 1978* gives notice of intention to revoke the following temporary reservations:

BRITANNIA CREEK—The temporary reservation by Order in Council of 21 November 1927 of 1.816 hectares of land being Crown Allotments 1, 2, 3 and 4, section 4, Township of Britannia Creek (formerly Township of Tarrango), Parish of Warburton as a site for a State School, revoked as to part by Order in Council of 28 January 1941, so far as the balance remaining of 1.411 hectares—(Rs. 3573).

BULLUMWAAL AND NUNGATTA—The temporary reservation by Order in Council of 27 May 1947 of 97.12 hectares, more or less, of land in the Township of Bullumwaal and the Parishes of Bullumwaal and Nungatta as a site for the growth of timber for the purpose of the manufacture or production of eucalyptus oil—(80A/141).

KUNAT KUNAT—The temporary reservation by Order in Council of 29 May 1979 of 7964 square metres of land being Crown Allotment 7, section 3A, Parish of Kunat Kunat as a site for public buildings—(Rs. 10727).

LINTON—The temporary reservation by Order in Council of 10 August 1982 of 1988 square metres of land being Crown Allotment 10, section 15, Township of Linton as a site for public buildings—(Rs. 11619).

MOLYULLAH—The temporary reservation by Order in Council of 4 August 1884 of 2-023 square metres of land in the Parish of Tatong (now in the Township of Molyullah) as a site for Public Purposes (State School)—(Rs. 12860).

NERRING—The temporary reservation by Order in Council of 9 June 1873 of 4047 square metres, of land in the Parish of Nerring as a site for State School purposes—(L6-2141).

WARRACKNABEAL—The temporary reservation by Order in Council of 9 December 1969 of 2023 square metres, more or less, of land in the Township of Warracknabeal, Parish of Werrigar as a site for Public Purposes (Public Building) so far only as the portion containing 1196 square metres being Crown Allotments 1D and 1E, section 12, Township of Warracknabeal, Parish of Werrigar as shown on sheets 1 and 2 of Certified Plan No. 108861 lodged in the Central Plan Office—(Rs. 9244).

Dated 25 October 1988

Responsible Minister:

KAY SETCHES

Minister for Conservation, Forests and Lands

KATHY OUZOUNIS

Acting Clerk of the Executive Council

Crown Land (Reserves) Act 1978
**REVOCAION OF TEMPORARY
 RESERVATIONS**

The Governor in Council under section 10 of the *Crown Land (Reserves) Act 1978* revokes the following temporary reservations:

BALLARAT EAST—The temporary reservation by Order in Council of 13 January 1976 of 684 square metres of land being Crown Allotment 20A, section 108, Township of Ballarat East, Parish of Ballarat as a site for public purposes (Departmental Residence)—(Rs. 10091).

CASTLE DONNINGTON—The temporary reservation by Order in Council of 25 February 1969 of 632 square metres of land in section 7A, Parish of Castle Donnington as a site for public purposes (Public Works Department)—(Rs. 9123).

CASTLE DONNINGTON—The temporary reservation by Order in Council of 18 December 1973 of 630 square metres of land being Crown Allotment J, section 7A, Parish of Castle Donnington as a site for public purposes (Departmental Residence)—(Rs. 9821).

CASTLE DONNINGTON—The temporary reservation by Order in Council of 19 October 1982 of 778 square metres of land being Crown Allotment 10A, section A, Parish of Castle Donnington as a site for Departmental Residence—(Rs. 12083).

COLERAINE—The temporary reservation by Order in Council of 19 July 1960 of 1-72 hectares, more or less, of land in the Township of Coleraine, Parish of Coleraine as a site for Tourist Camping purposes—(Rs. 7080).

CORINDHAP—The temporary reservation by Order in Council of 17 November 1874 of 2-023 hectares of land in section 6, Township of Corindhap as a site for State School purposes—(Rs. 6945).

DIMBOOLA—The temporary reservation by Order in Council of 28 June 1966 of 8094 square metres of land (in four parcels) in the Parish of Dimboola for public purposes (for use of the Forests Department)—(Rs. 8387).

DOWLING FOREST—The temporary reservation by Order in Council of 15 August 1972 of 179-4 hectares of land in the Parish of Dowling Forest as a site for a Racecourse so far only as the portions containing 4-67 hectares, more or less, as indicated by hatching on plan published in the *Victoria Government Gazette*, on 28 September 1988, page 2948—(Rs. 1233).

DOWLING FOREST—5-276 hectares of land being part of Crown Allotment A, Parish of Dowling Forest transferred to the Crown by Transfer No. H35201 registered in the office of Titles on 13 April 1978 and deemed to be temporarily reserved for the purposes of a racecourse under section 127 (3) of the *Racing Act 1958* so far only as the portion containing 1900 square metres, more or less, as indicated by hatching on plan published in the *Victoria Government Gazette* on 28 September 1988, page 2948—(Rs. 1233).

ECHUCA WEST—The temporary reservation by Order in Council of 26 February 1889 of 13-14 hectares of land in the Township of Echuca West as a site for Camping and Watering purposes, revoked as to part by Order in Council of 2 December 1964 so far as the balance remaining of 12-42 hectares—(Rs. 7195).

MORTLAKE—The temporary reservation by Order in Council of 18 April 1864 of 1012 square metres of land being the southern half of Crown Allotment 1, section 10 in the Township of

Mortlake as a site for a Shire Hall—(L2-4008).

MORTLAKE—The temporary reservation by Order in Council of 23 July 1877 of 607 square metres of land being part of Crown Allotment 1, section 10 in the Township of Mortlake as site for a Shire Hall in addition to and adjoining the site temporarily reserved therefor by Order in Council of 18 April 1864—(L2-4008).

QUEENSCLIFF—The temporary reservation by Order in Council of 2 July 1940 of 1619 square metres of land in section 43 at Queenscliff (formerly Borough of Queenscliff) Parish of Paywit as a site for the use of the State Rivers and Water Supply Commission—(Rs. 5058).

QUEENSCLIFF—The temporary reservation by Order in Council of 5 November 1941 of 3237 square metres of land in section 43 at Queenscliff (formerly Borough of Queenscliff) Parish of Paywit as a site for the use of the State Rivers and Water Supply Commission in addition to and adjoining the site temporarily reserved therefor by Order in Council of 2 July 1940—(Rs. 5058).

RED CLIFFS—The temporary reservation by Order in Council of 16 November 1971 of 835 square metres of land in section 12 at Red Cliffs, Parish of Mildura as a site for public purposes (Departmental Residence)—(Rs. 9504).

SWAN HILL—The temporary reservation by Order in Council of 23 November 1976 of 544 square metres of land being Crown Allotment M, section 6A, Township of Swan Hill, Parish of Castle Donnington as site for public purposes (Ministry for Conservation purposes)—(Rs. 10172).

Dated 25 October 1988

Responsible Minister:

KAY SETCHES

Minister for Conservation, Forests and Lands

KATHY OUZOUNIS

Acting Clerk of the Executive Council

Crown Land (Reserves) Act 1978
REVOCATION OF TEMPORARY
RESERVATIONS

The Governor in Council under section 10 of the *Crown Land (Reserves) Act 1978* revokes the following temporary reservations:

BALLAN—The temporary reservation by Order in Council of 1 August 1870 of 5.06 hectares of land in the Township of Ballan as a site for the purposes of public recreation so far only as the portion containing 1200 square metres shown as Crown Allotment 10A, section 37, Township of Ballan, Parish of Ballan as shown on Certified Plan No. 108987 lodged in the Central Plan Office—(Rs. 4832).

BARKLY—The temporary reservation by Order in Council of 7 January 1878 of 2.023 hectares of land in section D Parish of Barkly as a site for public purposes (State School)—(Rs. 13398).

BUNINYONG—The temporary reservation by Order in Council of 3 August 1868 of 8094 square metres of land adjoining Crown Allotment 126A, Parish of Buninyong as a site for Manure Depot—(87/0540).

EDENHOPE—The temporary reservation by Order in Council of 16 February 1874 of 7461 square metres of land in section 4, Township of Edenhope, Parish of Edenhope as a site for State School purposes revoked as to part by Order in Council of 19 March 1968 so far as the balance remaining of 6247 square metres—(Rs. 6844).

MARMA—The temporary reservation by Order in Council of 22 August 1881 of 12.14 hectares of land in the Parish of Marma as a site for affording access to water, revoked as to part by Order in Council of 11 July 1932 so far as the balance remaining of 2.25 hectares—(Rs. 4947).

SWAN HILL—The temporary reservation by Order in Council of 8 July 1980 of 539 square metres of land being Crown Allotment E1, section 6A, Township of Swan Hill as a site for Departmental Residence—(Rs. 10963).

Dated 25 October 1988

Responsible Minister:

KAY SETCHES

Minister for Conservation, Forests and Lands

KATHY OUZOUNIS

Acting Clerk of the Executive Council

Crown Land (Reserves) Act 1978
INCORPORATION OF COMMITTEE OF
MANAGEMENT OF CORRINGLE
FORESHORE RESERVE

The Governor in Council, under section 14A (1) of the *Crown Land (Reserves) Act 1978*, being satisfied that it is in the public interest to declare to be a corporation the Committee of Management appointed under section 14 (2) of the Act of the land described in the Schedule hereunder—

(a) declares that the Committee of Management shall be a corporation;

(b) assigns the name "Corringle Foreshore Reserve Committee of Management Incorporated" to the corporation; and

under section 14B (3) of the Act, appoints Allan Norman Holmes to be chairperson of the corporation.

3278 G 42 2 November 1988

SCHEDULE

Those parts of the lands in the Parish of Newmerella temporarily reserved for public recreation by Orders in Council of 11 August 1879 and 12 September 1898 as shown bordered red on the plan marked "N/2-9-1988" attached to Department of Conservation, Forests and Lands Correspondence No. Rs. 9079.

Dated 25 October 1988

Responsible Minister:

KAY SETCHES

Minister for Conservation, Forests and Lands

KATHY OUZOUNIS

Acting Clerk of the Executive Council

Crown Land (Reserves) Act 1978
REVOCATION OF TEMPORARY
RESERVATIONS

The Governor in Council under section 10 of the *Crown Land (Reserves) Act 1978* revokes the following temporary reservations:

BALLARAT—The temporary reservation by Order in Council of 6 April 1965 of 1138 square metres of land in section 65, Township of Ballarat, Parish of Ballarat, as a site for public purposes (use of Police Department)—(Rs. 8425).

MILDURA—The temporary reservation by Order in Council of 30 August 1977 of 1900 square metres of land being Crown Allotment 12, section 30, Block D, Parish of Mildura as a site for public purposes (Social Welfare Department purposes)—(Rs. 10261).

POREPUNKAH—The temporary reservation by Order in Council of 21 January 1941 of 2.479 hectares, more or less, of land in the Township of Porepukah, Parish of Porepukah as a site for Camping purposes so far only as the portion containing 2781 square metres shown as parcel 2 on Road Construction Authority plan No. SP 16789—(Rs. 5158).

Dated 25 October 1988

Responsible Minister:

KAY SETCHES

Minister for Conservation, Forests and Lands

KATHY OUZOUNIS

Acting Clerk of the Executive Council

Land Act 1958
UNUSED ROADS CLOSED

The Governor in Council under section 349 of the *Land Act 1958* and with the consent in writing of the municipalities concerned and the adjoining owners closes the following unused roads:

Victoria Government Gazette

MUNICIPAL DISTRICT OF THE SHIRE OF
BULN BULN

DROUIN WEST—The road in the Parish of Drouin West shown as Crown Allotment 8, section 9 on Certified Plan No. 108797 lodged in the Central Plan Office—(L10-1129).

DROUIN WEST—The road in the Parish of Drouin West shown as Crown Allotment 9, section 9 on Certified Plan No. 108796 lodged in the Central Plan Office—(L10-1129).

MUNICIPAL DISTRICT OF THE SHIRE OF
KARKAROOC

GOYURA—The road in the Parish of Goyura shown as Crown Allotment 30A on Certified Plan No. 109011 lodged in the Central Plan Office—(L5-3022).

MUNICIPAL DISTRICT OF THE CITY OF
MARYBOROUGH

MARYBOROUGH—The road in the Parish of Maryborough as indicated by hatching on plan hereunder—(M66(17)) (87/0539).

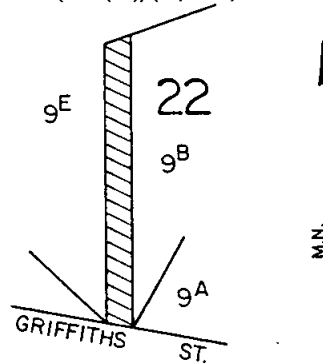

0 50 100 150
METRES

Dated 25 October 1988

Responsible Minister:

KAY SETCHES

Minister for Conservation, Forests and Lands

KATHY OUZOUNIS

Acting Clerk of the Executive Council

Land Act 1958
UNUSED ROADS CLOSED

The Governor in Council under section 349 of the *Land Act 1958* and with the consent in writing of the municipalities concerned closes the following unused roads:

Victoria Government Gazette

MUNICIPAL DISTRICT OF THE SHIRE OF KORONG

BORUNG—The roads in the Parish of Borung as indicated by hatching on plan hereunder—(B89(8)) (Rs. 13210).

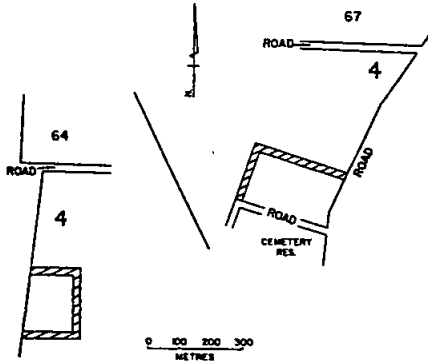

MUNICIPAL DISTRICT OF THE SHIRE OF BUNINYONG

ENFIELD—The road in the Parish of Enfield as indicated by hatching on plan hereunder—(E52(4)), (E52(5)) (L3-1378).

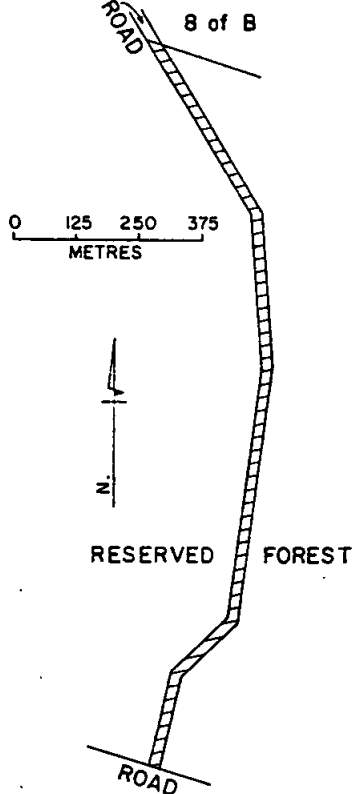

G 42 2 November 1988 3279

MUNICIPAL DISTRICT OF THE SHIRE OF BUNINYONG

LYNCHFIELD—The road in the Parish of Lynchfield as indicated by hatching on plan hereunder—(L164(4)) (L3-1378).

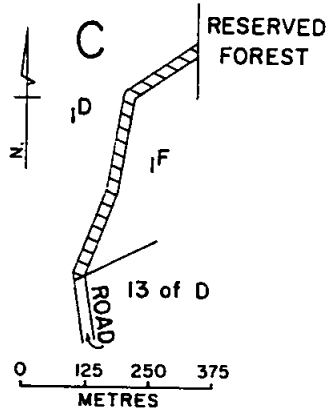

Dated 25 October 1988

Responsible Minister:

KAY SETCHES

Minister for Conservation, Forests and Lands

KATHY OUZOUNIS

Acting Clerk of the Executive Council

Retirement Villages Act 1986

Section 6

DECLARATION OF EXEMPTION

Under the powers found in section 6 of the *Retirement Villages Act 1986*, the Governor in Council on the recommendation of the Attorney-General, declares:

The retirement village owned by Australian Retirement Communities Pty. Ltd., and situated at 870 Plenty Road, Reservoir, to be an exempt village for the purposes of the *Retirement Villages Act 1986* (the Act) to which—

- (i) the provisions of section 25 (2) (d) of the Act do not apply upon condition that the obligation to repay the refundable ingoing contribution to any resident (or their legal personal representative) is secured by a written guarantee as required in the conditions of the Repurchase Agreement annexed to the application;
- (ii) the provisions of section 37 (4) of the Act do not apply to any by-laws contained in the model documents entitled Service Agreement and Agreement to Purchase annexed to the application; which may be or have been entered into by a resident of the village—

3280 G 42 2 November 1988

and upon condition that a copy of this exemption be given to each prospective resident at the same time such residents are given the residence documents relating to the village.

Dated 25 October 1988

Responsible Minister:

ANDREW McCUTCHEON
Attorney-General

KATHY OUZOUNIS
Acting Clerk of the Executive Council

Retirement Villages Act 1986
Section 6

DECLARATION OF EXEMPTION

Under the powers found in section 6 of the *Retirement Villages Act 1986*, the Governor in Council on the recommendation of the Attorney-General, declares:

All retirement villages owned by Australian Retirement Communities Pty. Ltd., of 26-34 Church Street, Middle Brighton, and located on land the subject of a strata title or cluster title sub-division, where the resident will acquire a legal interest, or an equitable interest in a unit of the sub-division, to be a class of exempt retirement villages to which the following provisions of the *Retirement Villages Act 1986* (the Act), do not apply:

Section 9 (4) of the Act;

Upon condition that any encumbrance (other than those mentioned in section 42 (2) of the *Transfer of Land Act 1958*) affecting the unit to which the resident is entitled to possession, is discharged on or before the resident is entitled to take possession.

Dated 25 October 1988

Responsible Minister:

ANDREW McCUTCHEON
Attorney-General

KATHY OUZOUNIS
Acting Clerk of the Executive Council

Retirement Villages Act 1986
Section 6

DECLARATION OF EXEMPTION

Under the powers found in section 6 of the *Retirement Villages Act 1986*, the Governor in Council on the recommendation of the Attorney-General, declares:

That all retirement villages situated on land held by the Anglican Trusts Corporation for the Anglican Diocese of Gippsland be declared exempt villages to which none of the provisions of the *Retirement Villages Act 1986*, (the Act) apply up to and including 30 November 1988,

Victoria Government Gazette

but thereafter all of the provisions of the Act apply other than:

- (i) Part 2 of the Act;
- (ii) Part 3 of the Act except for section 16 thereof;
- (iii) Section 19 of the Act, in relation to residents moving between retirement villages conducted by the Anglican Diocese of Gippsland and in relation to any resident seeking admission into the villages where it is impractical to comply with the section because of the resident's urgent need for care, accommodation, or services, upon condition that the resident is provided with an opportunity to terminate all contracts relating to the village and receive a full refund of any ingoing contribution for a period of not less than 21 days after occupancy commences;
- (iv) Section 25 upon condition that any moneys which would have been required to be paid into a trust account or special purpose bank account are held on deposit in a trust account operated by a person authorised by the Anglican Diocese of Gippsland and the provisions of section 25 are otherwise observed as if the money was held in a special purpose bank account under section 25 (5);
- (v) Part 5 of the Act;
- (vi) Section 34 (4);
- (vii) Section 37 of the Act upon condition that a change to the by-laws will not be implemented if the Commissioner for Corporate Affairs so directs after receipt of a written request to do so by more than 50 per cent of the residents of a village;

upon condition that—

- (a) the property upon which the retirement village is situated remains unencumbered;
- (b) any ingoing contributions received do not exceed \$25 000;
- (c) the owner of the property upon which the retirement villages are situated does not sell or part with possession of the land except to residents of the village without prior approval of the Commissioner for Corporate Affairs; and
- (d) a copy of this exemption be given to each prospective resident at the same time such residents are given the residence documents relating to a village.

Victoria Government Gazette

Dated 25 October 1988

Responsible Minister:

ANDREW McCUTCHEON

Attorney-General

KATHY OUZOUNIS
Acting Clerk of the Executive Council

Retirement Villages Act 1986

Section 6

DECLARATION OF EXEMPTION

Under the powers found in section 6 of the Retirement Villages Act 1986, the Governor-in-Council on the recommendation of the Attorney-General, declares:

The Independent Living Units and the Lodge at Forest Hills Retirement Village operated by Forest Hills Pty. Ltd. situated at 264 Springvale Road, Nunawading, to be exempt villages to which the following provisions of the Retirement Villages Act 1986 ("the Act") do not apply:

Section 38 (2) of the Act upon condition that residents are not required to pay a maintenance charge which exceeds the product derived from the following formula:

$$\frac{A \times B}{C}$$

Where:

A is the maintenance charge payable for the quarter ending on 31 December 1986;

B is the quarterly consumer price index number last published at the time the adjusted maintenance charge needs to be determined;

C is the quarterly consumer price index number published in April 1986 in respect of the quarter ending on 31 March 1986;

unless the provisions of sub-section 38 (4) and 38 (5) apply;

and upon condition that a copy of this exemption be given to each prospective resident at the same time such residents are given the residence documents relating to the villages.

Dated 25 October 1988

Responsible Minister:

ANDREW McCUTCHEON

Attorney-General

KATHY OUZOUNIS
Acting Clerk of the Executive Council

Note: This declaration is in addition to an earlier declaration made on 25 August 1987 in respect to the Lodge.

G 42 2 November 1988 3281

Health Services Act 1988

AMENDMENT TO SCHEDULE ONE

The Governor-in-Council under section 8 (1) (b) of the Health Services Act 1988 removes the name Springvale and District Community Hospital from Schedule One of Act.

Dated 25 October 1988

Responsible Minister:

DAVID WHITE

Minister for Health

KATHY OUZOUNIS

Acting Clerk of the Executive Council

Cemeteries Act 1958

SCALES OF FEES FOR PUBLIC
CEMETERIES

The Governor in Council under section 17 of the Cemeteries Act 1958 consents to the making of the Scales of Fees in respect of:

Cemeteries Act 1958

SCALE OF FEES FOR THE YEA PUBLIC
CEMETERY

In pursuance of the powers conferred upon them by the Cemeteries Act the trustees of the Yea Public Cemetery hereby make the following scale of fees, which shall come into operation upon publication in the Government Gazette, and from and after such publication every scale of fees heretofore made by the said trustees shall be and is hereby rescinded to the extent to which it conflicts with this scale.

	\$
<i>Public and General Cemetery</i>	
Purchase of land (2.44 m x 1.22 m)	170.00
Private selection of site (at time of burial)	75.00
Sinking of grave charge—1.37 metres	170.00
1.83 metres	210.00
2.13 metres	260.00
Child's grave	130.00
Oversize grave (width or length) extra	60.00
Interment fee	80.00
Interment on Saturday, Sunday and Public Holidays	120.00
Reopening of grave (no cover)	170.00
Reopening of grave with cover	190.00
Permission to erect monument—10% of cost—minimum \$50.00	
Reservation and Certificate of Right of Burial (includes purchase of land and private selection of site)	265.00

Columbarium

Purchase of niche and plaque	180.00
Private selection of niche (at time of interment)	75.00
Interment fee	80.00
Reservation (includes purchase of niche and plaque and private selection of niche)	255.00

S. FLEMING, Trustee
D. R. LAWSON, Trustee
L. M. GUNTER, Trustee

Cemeteries Act 1958

SCALE OF FEES FOR THE WERRIBEE PUBLIC CEMETERY

In pursuance of the powers conferred upon them by the Cemeteries Act the trustees of the Werribee Public Cemetery hereby make the following scale of fees, which shall come into operation upon publication in the *Government Gazette*, and from and after such publication every scale of fees heretofore made by the said trustees shall be and is hereby rescinded to the extent to which it conflicts with this scale.

	\$
<i>Lawn Cemetery (Non-Denominational)</i>	
Lawn grave 2.44 m × 1.22 m	500.00
Sinking of grave	300.00
Bronze plaque—380 mm × 280 mm (single) (15" × 11")	190.00
Bronze plaque—380 mm × 280 mm (double) (15" × 11")	230.00
Flower container	70.00
Interment fee	100.00
Detachable plate 2nd interment	70.00
<i>Private Graves (Denominational)</i>	
Land 2.44 m × 1.22 m	400.00
Own selection of site	55.00
Sinking grave	300.00
Cancellation of order to sink (if commenced)	120.00
Vaults	2000.00
Sealing vault	180.00
<i>Re-opening Charges (for above)</i>	
Re-opening grave (with cover or kerb)	300.00
Interment fee	100.00
<i>Memorials</i>	
Niche wall	180.00
Niche plate 136 mm × 102 mm	70.00
Rose garden	230.00
Bronze plaque—203 mm × 152 mm	100.00

Extra Charges

Interment not in the prescribed hours or on Saturdays, Sundays or Public Holidays	175.00
Interment in private grave without due notice	120.00
After 4.00 p.m.—Monday to Friday	120.00

Miscellaneous Charges

Certificate of Right of Burial	10.00
Inspection of plan or register	10.00
Annual maintenance (single grave) if required by holder of Right of Burial	100.00
Permission to erect headstone or monument 10% of cost with a minimum of	60.00
Permission to construct a brick grave or to erect any stone kerb, brick tilework or concrete	40.00
Grave renovations or additional inscription	40.00
Exhuming the remains of a body (when authorised)	600.00
Interment of ashes in a private grave	150.00

R. B. COMBEN, Trustee
S. G. FLYNN, Trustee
F. X. PURCELL, Trustee

Cemeteries Act 1958

SCALE OF FEES FOR THE TRUGANINA PUBLIC CEMETERY

In pursuance of the powers conferred upon them by the Cemeteries Act the trustees of the Truganina Public Cemetery hereby make the following scale of fees, which shall come into operation upon publication in the *Government Gazette*, and from and after such publication every scale of fees heretofore made by the said trustees shall be and is hereby rescinded to the extent to which it conflicts with this scale.

	\$
<i>Private Graves</i>	
Land 2.44 m × 1.22 m	300.00
Own selection of land	55.00
<i>Sinking charges for private graves</i>	
Sinking grave (any depth)	300.00
Cancellation or order to sink (if commenced)	120.00
<i>Re-opening Charges</i>	
Re-opening grave	300.00
Interment fee	100.00

Extra Charges

Interment outside prescribed hours, or on Saturdays, Sundays or Public Holidays	175.00
Interment in a private grave without due notice	120.00

Miscellaneous Charges

Interment fee	100.00
Certificate of Right of Burial	10.00
Permission to erect a headstone or monument—10% of cost with a minimum of \$60.00	
Permission to construct a brick grave or to erect any stone kerb, brick tile-work or concrete	40.00
Exhumating the remains of a body (when authorised)	600.00
Interment of ashes in a private grave	150.00

R. B. COMBEN, Trustee
S. G. FLYNN, Trustee
F. X. PURCELL, Trustee

Cemeteries Act 1958

SCALE OF FEES FOR THE WINTON PUBLIC CEMETERY

In pursuance of the powers conferred upon them by the Cemeteries Act the trustees of the Winton Public Cemetery hereby make the following scale of fees, which shall come into operation upon publication in the *Government Gazette*, and from and after such publication every scale of fees heretofore made by the said trustees shall be and is hereby rescinded to the extent to which it conflicts with this scale.

	\$
Land, 2.44 m × 1.22 m	50.00
Sinking grave 1.83 m deep	110.00
Interment fee	20.00
Reopening grave (no cover)	110.00
Reopening grave (with cover)	120.00
Permission to erect a headstone or monument—5% of cost with a minimum of \$15.00	
Exhumation charge (when authorised)	300.00

WILLIAM JOYCE, Trustee
RALPH LEE, Trustee
GARY ASHMEAD, Trustee

Cemeteries Act 1958

SCALE OF FEES FOR THE TRARALGON PUBLIC CEMETERY

In pursuance of the powers conferred upon them by the Cemeteries Act the Trustees of the

Traralgon Public Cemetery hereby make the following scale of fees, which shall come into operation upon publication in the *Government Gazette*, and from and after such publication every scale of fees heretofore made by the said trustees shall be and is hereby rescinded to the extent to which it conflicts with this scale.

Scale of Fees \$

Monumental Section

Land 2.44 m × 1.22 m	155.00
Land 1.22 m × 0.61 m	55.00
Sinking to 2.0 metres	155.00
Reopening grave	135.00

Extra Charges

Sinking on Saturdays	75.00
Sinking Sundays or Public Holidays	110.00

Miscellaneous Charges

Certificate of Right of Burial	6.00
Annual maintenance charge (optional)	45.00
Interment of cremated remains	55.00

Monumental Fees

On all monuments erected (5% of cost of materials with a minimum fee of \$25.00)

Lawn Section

Land 2.44 m × 1.22 m	210.00
Sinking and plaque for each opening	275.00
Land 1.22 m × 0.61 m including sinking and plaque for infant burial	155.00

Extra Charges

Sinking Saturdays	80.00
Sinking Sundays or Public Holidays	110.00

Interment of cremated remains plus plaque

135.00

Certificate for Right of Burial

6.00

J. F. ALLCORN, Trustee
A. E. M. NIELSEN, Trustee
R. L. PATRICK, Trustee
D. DUNBAR, Secretary

Cemeteries Act 1958

SCALE OF FEES FOR THE ENSAY PUBLIC CEMETERY

In pursuance of the powers conferred upon them by the Cemeteries Act the trustees of the Ensay Public Cemetery hereby make the following scale of fees, which shall come into operation upon publication in the *Government Gazette*, and from and after such publication every scale of fees heretofore made by the said trustees shall be and is hereby rescinded to the extent to which it conflicts with this scale.

\$

Private Graves

Land 2.44 m × 1.22 m × 2.13 m deep	100.00
Own selection of land (extra)	50.00
Sinking grave 1.83 m deep	200.00
Each additional 0.3 m (double)	30.00
Sinking oversize grave (extra)	40.00
Cancellation of Order to sink	50.00
Reopening grave (no cover)	200.00
Reopening grave (with cover)	225.00

Miscellaneous Charges

Interment fee	70.00
Interment fee outside prescribed hours	100.00
Permission to erect headstone	30.00

Lawn Cemetery

Grave 2.44 m × 1.22 m × 2.13 m deep	230.00
Interment fee	70.00
Sinking grave	230.00
Bronze plaque and vase—Supplied at moderate cost	
Mini slab, plaque and headstone for monumental section—at moderate cost	

BEVERLEY COOK, Trustee
THOMAS COOK, Trustee
BERNARD DUGGAN, Trustee

Cemeteries Act 1958
SCALE OF FEES FOR THE PHILLIP ISLAND PUBLIC CEMETERY

In pursuance of the powers conferred upon them by the Cemeteries Act the trustees of the Phillip Island Public Cemetery hereby make the following scale of fees, which shall come into operation upon publication in the *Government Gazette*, and from and after such publication every scale of fees heretofore made by the said trustees shall be and is hereby rescinded to the extent to which it conflicts with this scale.

\$

Lawn Section

Land 2.44 m × 1.22 m first interment (includes plaque)	525.00
Second interment	300.00

Monumental Section

First interment	330.00
Second interment	250.00
Second interment where concrete slab needs to be removed	300.00

Garden of Remembrance

Interment of ashes—	
Including plaque	110.00
Without plaque	80.00
Reservations all sections	50.00
Search fees	10.00

EDITH JEFFREY, Trustee
PETER FORREST, Trustee
MICHAEL DIXON, Trustee

Cemeteries Act 1958
SCALE OF FEES FOR THE BEECHWORTH PUBLIC CEMETERY

In pursuance of the powers conferred upon them by the Cemeteries Act the trustees of the Beechworth Public Cemetery hereby make the following scale of fees, which shall come into operation upon publication in the *Government Gazette*, and from and after such publication every scale of fees heretofore made by the said trustees shall be and is hereby rescinded to the extent to which it conflicts with this scale.

\$

Land fee 8 × 4 ft	225.00
Sinking fee—single interment	225.00
Sinking fee—double interment	250.00
Reopen fee	225.00

E. B. COLLINS, Trustee
E. J. HAWKINS, Trustee
K. McINTOSH, Trustee
J. M. TOLLEY, Trustee

Cemeteries Act 1958
SCALE OF FEES FOR THE NORTH BYADUK PUBLIC CEMETERY

In pursuance of the powers conferred upon them by the Cemeteries Act the trustees of the North Byaduk Public Cemetery hereby make the following scale of fees, which shall come into operation upon publication in the *Government Gazette*, and from and after such publication every scale of fees heretofore made by the said trustees shall be and is hereby rescinded to the extent to which it conflicts with this scale.

\$

Land, 2.44 m × 1.22 m	80.00
Sinking grave 1.83 m deep (Contract price plus 10% as administrative charge)	—
Interment fee	40.00
Reopening grave (no cover)	110.00
Reopening grave (with cover)	120.00

Victoria Government Gazette

G 42 2 November 1988 3285

Permission to erect a headstone or monument—10% of cost with a minimum of \$40.00

Exhumation charge (when authorised) 400.00
Search fee per request 15.00

KEVIN HARMAN, Trustee
JOHN DUYNSTYN, Trustee
ROBERT STEWART, Trustee

Dated 18 October 1988

Responsible Minister:

DAVID RONALD WHITE
Minister for Health

KATHY OUZOUNIS
Acting Clerk of the Executive Council

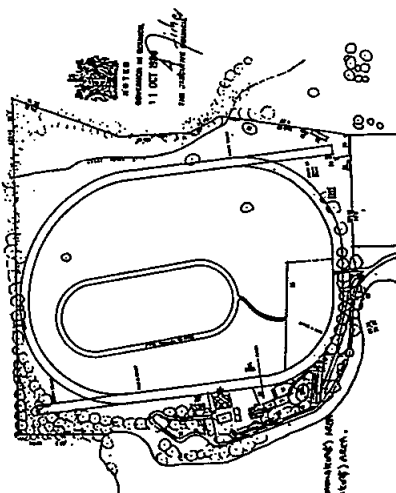

RACING ACT 1958

The Governor in Council approves the making of the following Rule by the Committee of the Kyneton District Racing Club:

Dated 11 October 1988

Responsible Minister:

NEIL B. TREZISE
Minister for Sport and Recreation

LAWRENCE A. FISHER
Clerk of the Executive Council

The Committee of the Kyneton District Racing Club makes the following Rule:

Dated 17 October 1988

G. F. O'BRIEN
President
G. D. BUCKLEY
Secretary

RULE ALLOWING AREAS TO BE SET ASIDE FOR BOOKMAKERS AT KYNETON RACECOURSE

Citation

1. This Rule may be cited as a Rule made by the Kyneton District Racing Club regarding the setting aside of areas by the Kyneton Racecourse as an area in which persons may carry on the business or vocation of bookmaking.

Authorising Provision

2. This Rule is made under section 5 of the *Racing Act 1958*.

Schedule

3. That part of the plan in the Schedule delineated and cross-hatched and numbered 33 and 34 represents new betting areas of Kyneton.

**PRIVATE
ADVERTISEMENTS**

**CITY OF BENDIGO
Street Closure**

Notice is hereby given that the Council of the City of Bendigo, pursuant to the provisions of section 539C of the *Local Government Act 1958*, adopted by order a proposal for the closure of Pine Street between Pyke Street and Palmerston Street to through traffic by the construction of kerbing and barriers at Pyke Street.

The Council has resolved that the Order as adopted shall come into operation on 24 October 1988. The location of the road closure is shown on the diagram below.

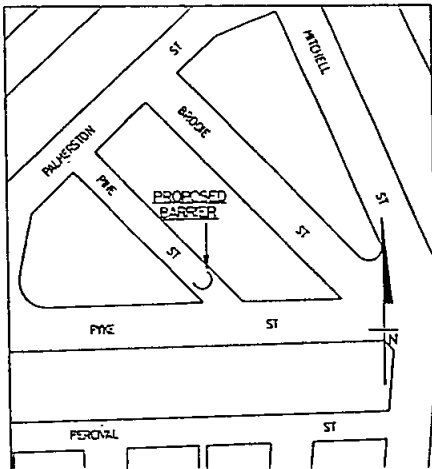

3130 **R. J. BURTON**
Chief Executive Officer

**CITY OF CAMBERWELL
Road Discontinuance**

Pursuant to section 528 (2) of the *Local Government Act 1958*, the Council of the City of Camberwell has resolved that part of a road abutting 31 and 33 Milverton Street, Burwood which is shown by hatching on the plan herewith, and which has been closed per Amendment 408, Melbourne Metropolitan Planning Scheme, gazetted 25 June 1986, be discontinued subject to—

- (a) the Melbourne and Metropolitan Board of Works continuing to have and possess the same right, title, power, authority or interest in or in relation to the whole of

Victoria Government Gazette

the land shown by hatching on the said plan as it had or possessed prior to such discontinuance with respect to or in connection with any drains or pipes laid or erected in on or over such land for the purposes of drainage or sewerage;

- (b) the land in the said road subject to any such right, title, power, authority or interest vesting in the municipality to be retained by it until sold by private treaty.

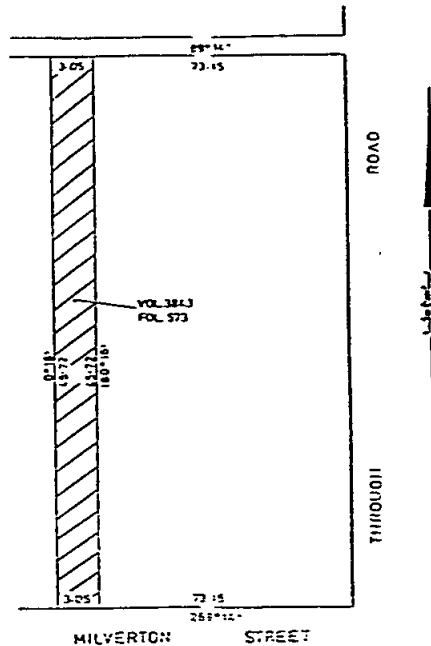

 ROAD TO BE DISCONTINUED WITH M.P.W.B. RETAINING EXISTING RIGHTS.

3136 **BRUCE S. MANKS**
Acting Town Clerk

**CITY OF FOOTSCRAY
Road Discontinuance**

Whereas the Council of the City of Footscray has, pursuant to section 528 (2) of the *Local Government Act 1958*, formed the opinion that the road rear of Donald and Moore Streets, Footscray, is not reasonably required for public use and has, not less than one month before formally directing by resolution that the said road be discontinued, published a public notice in a newspaper generally circulating in the Municipal district, and given written notice to the last

Victoria Government Gazette

registered owner of the land in the road and the owners and occupiers of lands abutting or immediately adjacent to the road of the proposed discontinuance, and has considered all (if any) written objections to the proposal.

Now therefore the Council of the City of Footscray by resolution on 10 February 1988, has directed the said road which is shown by hatching on the plan hereunder be discontinued and the land being the road so discontinued shall vest in and shall be retained in part by the Municipality for Municipal purposes.

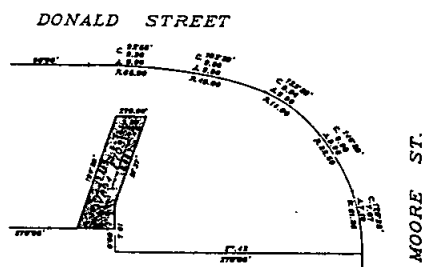
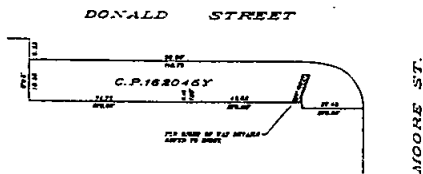

AREA OF ROUST OF WAY SHOWN HATCHED IS TO BE DISCONTINUED & RETAINED FOR MUNICIPAL PURPOSES UNDER SECTION 52A(2) OF THE LOCAL GOVERNMENT ACT PROVIDED STORMWATER & SEWERAGE EASEMENT RIGHTS ARE MAINTAINED



Notwithstanding such discontinuance the Melbourne and Metropolitan Board of Works shall continue to have and possess the same right title power authority or interest in or relation to the whole of the land shown by hatching on the said plan as it had or possessed prior to such discontinuance with respect to or in connection with any drains or pipes laid or erected in or on or over such land for the purpose of drainage or sewerage.

G. L. PEARCE
3153 Chief Executive Officer and Town Clerk

CITY OF GEELONG

Notice is hereby given that at meetings of Council held on 27 September and 25 October,

G 42 2 November 1988 3287

1988 the Council made, passed and confirmed the following By-Law:

By-Law No. 180 (Cattle Market)

Made under the provisions of section 6 of 6 Victoria No. 18 extended to the City of Geelong pursuant to section 6 of 13 Victoria No. 40 for imposing the rates tolls and dues to be levied in the cattle market of the City.

A copy of the By-Law has been deposited at the City Hall, Gheringhap Street, Geelong, and is open for inspection during the hours of 8.30 a.m. and 5.15 p.m. each day Monday to Friday.

T. J. T. NEAL
Town Clerk and Chief
Administrative Officer

3124

Planning and Environment Act 1987
NOTICE OF AMENDMENT
Amendment No. RL22, 1988

The City of Knox has prepared an amendment which proposes to amend the Regional Section (Ordinance Provisions) in respect of the Knox Garden Industrial and Knox Light Industrial zones to include site specific provisions applicable to Jells Park Industrial Estate at the north-west corner of Ferntree Gully Road/Cathies Lane, Scoresby.

The Amendment can be inspected at:

1. City of Knox, Civic Centre, 511 Burwood Highway, Knoxfield.
2. The Ministry for Planning and Environment, Olderfleet Buildings, 477 Collins Street, Melbourne.

Any person affected by the Amendment may make a submission in writing, which must be sent to the City of Knox Civic Centre, 511 Burwood Highway, Knoxfield 3180, by 3 December 1988.

Dated 28 October 1988

3123

A. P. ATKINS
Town Planner

Planning and Environment Act 1987
NOTICE OF AMENDMENT TO A
PLANNING SCHEME
Amendment L3

The City of Preston has prepared Amendment L3 to the Local Section of the Preston Planning Scheme.

The amendment affects land at Nos. 465-475 and Nos. 499-505 Bell Street, Preston.

The amendment proposes to change the planning scheme by rezoning the land from Local Business zone to Residential C zone.

3288 G 42 2 November 1988

The amendment can be inspected at: City of Preston, Building and Planning Department, Town Hall, 350 High Street, Preston and Ministry for Planning and Environment, Ground Floor, 477 Collins Street, Melbourne.

Submissions about the amendment must be sent to: City of Preston, P.O. Box 91, Preston 3072 by 5 December 1988.

D. O. McLEAN
Chief Executive Officer
3122

Planning and Environment Act 1987
NOTICE OF AMENDMENT TO A
PLANNING SCHEME

The City of Shepparton has prepared Amendment No. L11 to the Shepparton City Planning Scheme.

The Amendment affects land between Callister, Watson and Gilchrist Streets, Shepparton being:

Callister Street—Nos. 15-33

Gilchrist Street—Nos. 18, 35-37

Watson Street—Part Crown Allotment 13 Section E Lots 1 and 3, LP 88283; Lot 4, LP 58360; Lot 1, LP 120087, RP 18250.

The Amendment proposes to change the Planning Scheme by rezoning the above land from Industrial "B" (General Industrial) to Commercial "E".

The Amendment can be inspected at the City of Shepparton, Municipal Offices, 90 Welsford Street, Shepparton, and at the Ministry for Planning and Environment, 477 Collins Street, Melbourne.

Submissions about the amendment must be sent to the City of Shepparton, P.O. Box 989, Shepparton by 2 December 1988.

Dated 2 November 1988

I. L. GILBERT
City Manager
3146

CITY OF SPRINGVALE

Road (Right-of-Way) Discontinuance

Pursuant to section 528 (2) (a) of the *Local Government Act 1958* (as amended) the Council of the City of Springvale after consultation with public authorities and the advertising of its intention and notification to the registered proprietors of the land and the owners and occupiers of any land abutting or immediately adjacent to the road (Right-of-Way) has by resolution at its Ordinary Meeting held on October 25, 1988, resolved that the road (Right-of-Way) at the rear of allotments No. 4 and 5 Springvale Road, Springvale, contained in Certificate of Title Volume 8241 Folio 945 shown

Victoria Government Gazette

hatched on the plan hereunder be discontinued and sold by private treaty.

Notwithstanding such discontinuation the Dandenong-Springvale Water Board shall continue to have and possess the same right, title, power, authority or interest in or in relation to the section of land shown hatched on the said plan as it had or possessed prior to such discontinuation with respect to or in connection with any drain or pipes laid or erected in or over such land for the purpose of sewerage.

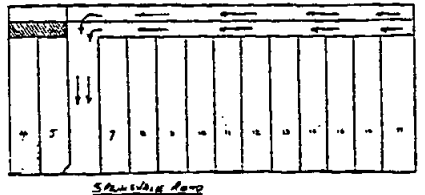

SPRINGVALE ROAD
Proposed Closing
Existing R.O.W.

I. J. TATTERSON
Chief Executive Officer
3139

Planning and Environment Act 1987
NOTICE OF AMENDMENT TO A
PLANNING SCHEME

The United Shire of Beechworth has prepared Amendment No. L9 to the Beechworth Planning Scheme, Chapter One: Rural Area.

The amendment proposes to change the Planning Scheme by amending the provisions which apply to the Rural A zone to remove the requirement for subdivision to comply with the tenement provisions included in the scheme. Where a subdivision proposal does not comply, an agreement will be entered into which will state that no dwelling is possible on the lots affected and this agreement will be registered on title to the land.

The amendment can be inspected at the Shire Office, United Shire of Beechworth, Ford Street, Beechworth; Ministry for Planning and Environment, Plan Inspection Section, 5th Floor, 235 Queen Street, Melbourne; or Regional Office, Ministry for Planning and Environment, Astra House, Jack Hore Place, Wodonga.

Submissions about the amendment must be sent to the United Shire of Beechworth, Ford Street, Beechworth by 5 December 1988.

D. W. POPE
Shire Engineer
3134

Victoria Government Gazette

SHIRE OF BIRCHIP

By-Law No. 36

Keeping of Animals

Notice is hereby given that the Council, at its meeting held on 15 June 1987, confirmed by special order a resolution passed at its meeting held on 18 May 1987, to make and adopt By-law No. 36 for the purposes of:

- (a) Repealing By-law No. 32—Keeping of Animals;
- (b) The regulating of the keeping of animals or birds (including poultry and pigeons) and the regulating or prohibiting of the keeping of any place or the storage of any things which in the opinion of the Council may be offensive, injurious to health or dangerous;
- (c) Fixing the distance from any dwelling within which it shall be unlawful to keep any animals or birds or store any such thing;
- (d) Providing for the health of the residents in the municipal district against the spreading of contagious or infectious diseases;
- (e) Suppressing nuisances;
- (f) Regulating the keeping of animals, birds, reptiles and bees with power to limit the number of animals, birds and reptiles kept on any property within an area within the municipal district set forth in the By-law and declared therein to be a populous or residential area and to prohibit the keeping of any specified kind of animal, bird or reptile in such area.

This By-law shall apply to and have operation throughout the whole of the municipal district of the Shire of Birchip.

A copy of this By-law is open for inspection free of charge during office hours at the Shire Offices, Cumming Avenue, Birchip.

G. P. NOONAN
Shire Secretary

3135

Planning and Environment Act 1987
**NOTICE OF AN AMENDMENT TO A
PLANNING SCHEME**

The Council of the Shire of Gisborne has prepared Amendment No. L3 to the Gisborne Planning Scheme. The amendment affects the land at No. 80 Station Road, New Gisborne.

The amendment proposes to include the land in a Special Residential zone in order to allow its subdivision into 3 allotments.

The amendment and supporting documentation can be inspected at Municipal

G 42 2 November 1988 3289

Offices, Robertson Street, Gisborne; Office of the Ministry for Planning and Environment, The Olderfleet Buildings, 477 Collins Street, Melbourne.

Submissions about the amendment must be sent to The Shire Secretary, Shire of Gisborne, P.O. Box 63, Gisborne, 3437 by 2 December 1988

G. LUSH

3132 Director of Planning and Building

SHIRE OF HASTINGS

Street Name Changes

Council, at its meeting held on October 4, 1988, having complied with all statutory procedures pursuant to section 535 (4) of the *Local Government Act 1956* (as amended) resolved to change the names of Highview Road and Campbell Crescent (northern section) to Highview Court, Balnarring, and Reserve Road and Campbell Crescent (western section) to Campbell Court, Balnarring.

The carriageways concerned are depicted as hatched on the plan below.

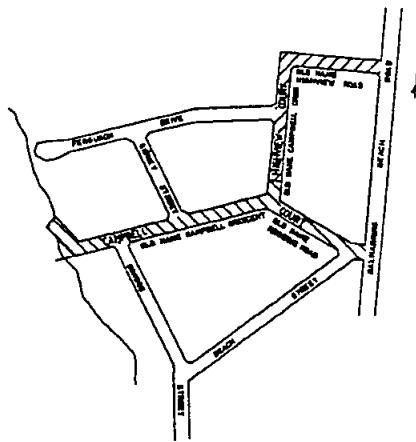

W. R. FEATHERSTON,
Chief Executive Officer

3145

Planning and Environment Act 1987
**NOTICE OF AMENDMENT TO A
PLANNING SCHEME**

The Shire of Lillydale has prepared Amendment No. L.39 to the Lillydale Planning Scheme.

The amendment affects land bounded by Main Street, Anderson Street, Chapel Street and the Olinda Creek in Lillydale.

3290 G 42 2 November 1988

The Amendment proposes to change the Planning Scheme by rezoning part of the land to Commercial (General) and part Special Uses 15—Restaurant with an Overall Plan of Development applicable to the area zoned Commercial (General).

The amendment can be inspected at: 1. Upper Yarra Valley and Dandenong Ranges Authority, John Street, Lilydale, Vic. 2. Shire of Lilydale, Anderson Street, Lilydale, Vic. 3. Ministry for Planning and Environment, The Olderfleet Buildings, 477 Collins Street, Melbourne Vic.

Submissions about the amendment must be sent to the Shire of Lilydale, Shire Offices, Anderson Street, Lilydale, P.O. Box 105, Lilydale, by 9 December 1988.

3140 W. I. HEINE
Chief Executive Officer

Planning and Environment Act 1987
NOTICE OF AMENDMENT TO A
PLANNING SCHEME

The Shire of Lilydale has prepared Amendment No. L.42 to the Lilydale Planning Scheme.

The amendment affects land at lot 9 L.P. 26169 at the north-west corner of Maroondah Highway and Victoria Road, Lilydale.

The Amendment proposes to change the Planning Scheme by varying subclause (d) of the Residential "G" zone to remove the present limitation of 3 years operation of any permit for professional offices within the existing office building.

The amendment can be inspected at: 1. Upper Yarra Valley and Dandenong Ranges Authority, John Street, Lilydale, Vic. 2. Shire of Lilydale, Anderson Street, Lilydale, Vic. 3. Ministry for Planning and Environment, The Olderfleet Buildings, 477 Collins Street, Melbourne Vic.

Submissions about the amendment must be sent to the Shire of Lilydale, Shire Offices, Anderson Street, Lilydale, P.O. Box 105, Lilydale, by 9 December 1988.

3141 W. I. HEINE
Chief Executive Officer

Planning and Environment Act 1987
NOTICE OF AMENDMENT TO A
PLANNING SCHEME

The Shire of Lilydale has prepared Amendment No. L.43 to the Lilydale Planning Scheme.

The amendment affects land at C.A. 12, Lots 1 and 2 L.P. 94627, Lots 1-3 L.P./ 87091, Warburton Highway, Seville.

Victoria Government Gazette

The Amendment proposes to change the Planning Scheme by rezoning the land Service Industrial and amending the scheme to make the uses retail plant nursery and sand soil and screenings yard permissible within the prescribed area.

The amendment can be inspected at: 1. Upper Yarra Valley and Dandenong Ranges Authority, John Street, Lilydale, Vic. 2. Shire of Lilydale, Anderson Street, Lilydale, Vic. 3. Ministry for Planning and Environment, The Olderfleet Buildings, 477 Collins Street, Melbourne Vic.

Submissions about the amendment must be sent to the Shire of Lilydale, Shire Offices, Anderson Street, Lilydale, P.O. Box 105, Lilydale, by 9 December 1988.

3142 W. I. HEINE
Chief Executive Officer

Planning and Environment Act 1987
SHIRE OF LILLYDALE

Notice of Amendment to a Planning Scheme
The Shire of Lilydale has prepared Amendment No. L.44 to the Lilydale Planning Scheme.

The amendment affects land at lot part CA3A Parish of Wandin Yallock, County of Evelyn on Warburton Highway between Henderson Road and Wallace Road, Seville.

The Amendment proposes to change the Planning Scheme by rezoning the land for a Major Tourist Development.

The amendment can be inspected at: 1. Upper Yarra Valley and Dandenong Ranges Authority, John Street, Lilydale, Vic. 2. Shire of Lilydale, Anderson Street, Lilydale, Vic. 3. Ministry for Planning and Environment, The Olderfleet Building, 477 Collins Street, Melbourne Vic.

Submissions about the amendment must be sent to the Shire of Lilydale, Shire Offices, Anderson Street, Lilydale, P.O. Box 105, Lilydale, by 9 December 1988.

3143 W. I. HEINE
Chief Executive Officer

Planning and Environment Act 1987
SHIRE OF LILLYDALE

Notice of Amendment to a Planning Scheme
The Shire of Lilydale has prepared Amendment No. L.45 to the Lilydale Planning Scheme.

The amendment affects land at lot 1 LP16001 O'Connor Avenue, Mt Evelyn.

The Amendment proposes to change the Planning Scheme by varying the Rural

Victoria Government Gazette

(Residential) Zone to allow subdivision of the property and construction of a house on each of the allotments so created.

The amendment can be inspected at: 1. Upper Yarra Valley and Dandenong Ranges Authority, John Street, Lilydale, Vic. 2. Shire of Lilydale, Anderson Street, Lilydale, Vic. 3. Ministry for Planning and Environment, The Olderfleet Building, 477 Collins Street, Melbourne Vic.

Submissions about the amendment must be sent to the Shire of Lilydale, Shire Offices, Anderson Street, Lilydale, P.O. Box 105, Lilydale, by 9 December 1988.

3144

W. I. HEINE
Chief Executive Officer

Planning and Environment Act 1987

NOTICE OF AMENDMENT TO A
PLANNING SCHEME

The Shire of Marong has prepared Amendment No. L9 to the Marong Planning Scheme.

The amendment affects land at CA 9, Section 7 and Crown land, including land described as Railway Lot 10, Township of Marong, fronting the Calder Highway.

The amendment proposes to change the Planning Scheme by changing the designation of Railway Reservation to Public Purposes (local

G 42 2 November 1988 3291

government) Reservation to enable the construction of Shire Offices, associated on-site parking, driveways and landscaping for the Shire of Marong.

The amendment can be inspected at the Shire of Marong, Shire Office, Marong 3515; Ministry for Planning and Environment, 477 Collins Street, Melbourne 3000; Loddon-Campaspe Regional Planning Authority, 391 Hargreaves Street, Bendigo 3550.

Submissions about the amendment must be sent to the Shire of Marong, Shire Office, Marong 3515, by 5 December 1988.

Dated 28 October 1988

3155

R. G. CAMPBELL
Director of Technical Services
Shire Engineer

NOTICE TO MUNICIPALITIES

I hereby consent on behalf of Olive Mary Hines and Geoffrey Douglas Hines to the Municipality complying with any Notice issued under section 695 *Local Government Act 1958* and/or section 41B *Fire Authority Act 1958* to remove any fire hazard at reasonable cost from lands held solely or jointly. This consent is valid to 1 February 1989.

3154

G. D. HINES

EDITION

18

MELWAY
STREET DIRECTORY

EDITION

18

LARGE SIZE BOOK

- Size 357 mm × 269 mm
- Hard Cover with fitted clear plastic jacket
- Scale 1:16 000
(Standard Melway is 1:20 000)
- Dramatically larger and clearer
- For desk use

SPECIAL OFFER

* \$39.00 postage FREE
within Australia

ORDER FROM:

Melway Publishing Pty. Ltd.
19 High Street, Glen Iris, Vic. 3146

* If exempt Sales Tax, less \$2.36

2910

3292 G 42 2 November 1988

DANDENONG VALLEY AUTHORITY
Declaration of Arterial Drains

The Dandenong Valley Authority, in pursuance and exercise of the powers conferred by the *Dandenong Valley Authority Act 1963*, doth hereby declare that the rivers, creeks, watercourses and drains, and new arterial drains proposed within the district of the Authority as set out and described in the Schedule hereto, shall be arterial drains under and for the purposes of the Act.

Schedule—Declaration of Arterial Drains
New Declarations

Hydes Drain—1309/0005

Commencing near a point within C.A. 3, Sec. D, Parish of Gembrook, approximately 50 m southerly and 80 metres easterly of the most northern corner of the said C.A. 3, then generally northerly through the said C.A. 3, lot 1, L.P. 30459, C.A. 41 Sec. D, a Municipal Purposes Reserve, across Sutherland Road and through a Creek Reserve, then generally northerly and westerly through C.A.'s 59, 22, 23 and 25, Sec. D in the said Parish, and the Baden Powell Park Scout Camp to its junction with existing declared Stoney Creek No. 6050 all in the Shire of Pakenham.

Upper Beaconsfield Drain—1309/0006

Commencing near a point on the northern boundary of Harris Road near the south-western corner of lot 23, L.P. 1137, Parish of Gembrook, then generally northerly through the said lot 23, lot 3, L.P. 75335, lots 24 and 21, L.P. 1137, across Tower Road, then further northerly through lots 1, 2 and 3, L.P. 99435, across Beaconsfield—Emerald Road, then further northerly through C.A. 57 Sec. D in the said Parish, lots 1 to 6 inclusive, L.P. 57656 and then through a Public Purposes Reserve to its junction with existing declared Stoney Creek No. 6050, all in the Shire of Pakenham. 3121

WONTHAGGI-INVERLOCH WATER BOARD

Construction of Sewer Reticulation Mains

Notice is hereby given of intention to construct sewers and related works in the following areas:

- (i) Florida Rise Stage 2—Capt 3, section 1, Township of Inverloch.
- (ii) Cuttriss Street Stage 4—Capt 1, section 5, Township of Inverloch.
- (iii) Beachway Estate Stages 2 & 3—Capt 3, section 1, Township of Inverloch.

Details of the proposed works are available for

Victoria Government Gazette

inspection at the Board Office, 11 Williams Street, Inverloch, during normal office hours.

3125 **K. F. O'HALLORAN**
Manager/Secretary

WARRACKNABEAL WATER BOARD

Ministry of Housing Sewer Extension

Notice of Commencement of Construction of Sewerage Works

Pursuant to Clause 119 (2) of the *Sewerage Districts Act 1958*, Notice is hereby given that construction of a sewerage works will commence in the area of properties bounded by Jamouneau, Gardiner, Anderson and Werrigar Streets at least 30 days after this notice.

A map showing the locations of the works is open for inspection and may be inspected at the Shire Offices in Scott Street, Warracknabeal, from Monday to Friday during the hours of 9.00 a.m. to 5.00 p.m.

3126 **G. J. INKSTER**
Acting Secretary

ROBINA BURTON, late of Pheasant Creek, widow, deceased

Creditors, next of kin and others having claims in respect of the estate of the deceased, who died on 26 July 1988, are required by the trustees, Arthur Thomas Burton of Pheasant Creek, cartage contractor, and Elwyn Sarah Wesley of 20 Gooch Street, Thornbury, married woman, to send particulars to them care of the undermentioned solicitors by 10 January 1989, after which date the trustees may convey or distribute the assets having regard only to the claims of which they then have notice.

PHILLIPS & WILKINS, solicitors, 823 High Street Thornbury 3147

ANNIE VERONICA D'ARCY, late of 61 Church Street, Geelong West in the State of Victoria, home duties, deceased

Creditors, next of kin and others having claims in respect of the estate of the deceased, who died on 2 August 1988, are required by the trustees, Maureen Patricia Bates of Unit 2, 10 Fairway, North Geelong, Margaret June McDonald of 24 Barwon Boulevard, Highton and Eileen Frances Ball of 3 Hodgson Street, Geelong West to send particulars to them by 30 December 1988, after which date the trustees may convey or distribute the assets having regard only to the claims of which they then have notice.

Dated 24 October 1988.

AINSWORTH & CO., solicitors, 117 Yarra Street, Geelong 3148

Victoria Government Gazette

BETTINE MARGARET PEART, late of Unit 1,
2 Wellington Street, Mornington, widow,
deceased

Creditors, next of kin and others having claims in respect of the estate of the deceased (who died on 11 June 1988) are required by The Perpetual Executors and Trustees Association of Australia Limited of 50 Queen Street, Melbourne, to send particulars of their claims to the said company by 19 February 1989, after which date it will convey or distribute the assets, having regard only to the claims of which the company then has notice.

3138

Creditors, next of kin and others having claims against the estate of Margaret Lillian Easterby, late of 6/393 Toorak Road, South Yarra in the State of Victoria, gentlewoman, deceased, who died on 24 July 1988 are requested to send particulars of their claims to Elaine Margaret Easterby of 626 Whitehorse Road, Mitcham in the said State, gentlewoman, the executrix of the said estate care of the belowmentioned solicitors by 11 January 1989 after which date she will then distribute the assets having regard only to the claims at which date she then has notice.

PURVES CLARKE RICHARDS, solicitors,
121 William Street, Melbourne 3128

Creditors, next of kin or others having claims in respect of the estate of Vera Isabel Speakman, late of Unit 25 Maranoa Close, Balwyn, deceased, who died on 10 March 1988 are requested to send particulars of their claims to the executor care of the undermentioned solicitors by 15 November 1988 after which date the executor will distribute the assets having regard only to the claims of which he then has notice.

RIDGEWAY CLEMENTS, solicitors, 575
Bourke Street, Melbourne 3129

Creditors, next of kin or others having claims in respect of the estate of Abraham Needleman, late of Flat 24, 27 Fulton Street, East St. Kilda, who died on 18 August 1988 are required to send particulars of the claims, to the executors Manuel Gershon Needleman of 19 Powderham Road, North Caulfield and Cicely Smith of 19 Octavius Avenue, Caulfield, in care of the undersigned solicitors on or before 13 January 1989 after which date they will distribute the assets of the estate having regard only to the claims of which they then have notice.

DOBSON & GILES, solicitors, 79 Hawthorn
Road, Caulfield 3131

G 42 2 November 1988 3293

Creditors, next of kin and others having claims in respect of the estate of Percy Douglas Payne, late of 12 Victor Avenue, Cheltenham in the State of Victoria, gentleman, deceased, who died on 24 June 1988 and probate of whose will was granted by the Supreme Court of Victoria in its probate jurisdiction on 11 October 1988 to Jean Payne are required to send particulars of their claims to the executrix care of Minter Ellison of 40 Market Street, Melbourne in the said State by 4 January 1989, after which date the executrix will distribute the assets of the estate having regard only to the claims of which she shall then have had notice.

MINTER ELLISON, solicitors, 40 Market
Street, Melbourne 3133

Creditors, next of kin or others having claims in respect of the estate of Peter Mark Wilson, late of R.M.B. 8838 Wangaratta, deceased, who died on 16 April 1988, are to send particulars of their claims to the executrix, Helen Harmer, care of the undermentioned solicitors by 24 January 1989, after which date the executrix will distribute the assets having regard only to the claims of which she then has notice.

McSWINEYS, solicitors, 57 Reid Street,
Wangaratta 3149

Creditors, next of kin or others having claims in respect of the estate of Eric Eilson Newth late of Milawa in the State of Victoria, farmer, deceased, who died on 1 September 1988 are to send particulars of their claims to the executor Thomas Hugh Newth care of the undermentioned solicitors by 25 January 1988 after which date the executor will distribute the assets having regard only to the claims of which he then has notice.

McSWINEYS, solicitors, 57 Reid Street,
Wangaratta 3120

IAN KEITH VALENTINE, late of 6 Bute Street,
Murrumbidgee, parts manager, deceased,
intestate

Creditors, next of kin and others having claims in respect of the estate of the deceased, who died on 17 July 1988, are required by the trustee, Beryl Valentine of 90 Glenroy Road, Glenroy, to send particulars to her care of John P. Rhoden, solicitors, 414 Bourke Street, Melbourne, by 15 January 1989, after which date the trustees may convey or distribute the assets having regard only to the claims of which she then has notice. 3137

3294 G 42 2 November 1988

VAUGHAN HASTINGS GODDARD, late of 7 Holyrood Street, Camberwell, gentleman, deceased.

Creditors, next of kin and others having claims in respect of the estate of the abovenamed deceased, who died on 15 May 1988, are required by the executors of his will, Susan Mae Sonenberg and The Equity Trustees Executors and Agency Company Limited to send particulars of their claims to the executors at the office of The Equity Trustees Executors and Agency Company Limited, 472 Bourke Street, Melbourne, by 5 January 1988, after which date they will distribute the assets in the estate having regard only to the claims of which they then have notice.

J. M. SMITH & EMMERTON, solicitors, 385 Bourke Street, Melbourne 3150

In the Supreme Court of the State of Victoria
SALE BY THE SHERIFF

On 8 December 1988 at 2.30 p.m. at the Sheriff's Office, 287 Springvale Road, Glen Waverley (unless process be stayed or satisfied).

All the Estate and Interest (if any) of Judith Elfreda Lungu of 37 Smithacres Road, Montrose as joint proprietor with Roy Aurel Lungu of an estate in fee simple in the land described in Certificate of Title Volume 9376, Folio 222 upon which is erected a part brick veneer, part weatherboard dwelling known as 37 Smithacres Road, Montrose.

Registered Mortgage No. M597450V and unregistered dealing No. N710898V effect the said estate and interest.

Terms—Cash only.

3127 H. BUETTNER, Sheriff's Officer

Creditors, next of kin or others having claims in respect of the estate of Henry Borrow Gale late of 220 Middleborough Road, Blackburn South, retired, deceased, who died on 13 January 1988, are required by the executors of his will, Robert Henry Gale of 6/11 Dean Street, Kew, production manager and Ian William Gale of 5 Verdant Court, Glen Waverley, manager, to send particulars to them care of the undermentioned solicitors by 22 December 1988, after which date the executors may convey or distribute the assets having regard only to the claims of which they then have notice.

Dated 25 October 1988

ANDERSON RICE, solicitors, 51 Queen Street, Melbourne 3151

Victoria Government Gazette

Creditors, next of kin and other persons having claims against the estate of Winifred Emily Ridler-Spence, late of 1/2A Avoca Avenue, Elwood in the State of Victoria, retired, manageress, who died on 20 August 1988, are required by the executors, John Duncan Mustow, solicitor, Geoffrey John Mustow, solicitor and Robin Elizabeth Mayhew Mustow, solicitor, all of 105 Queen Street, Melbourne in the said State, to send particulars of their claims to them care of the undersigned by 2 January 1989, after which date they may convey or distribute the estate having regard only to the claims of which they then have notice. 3152

NOTICE OF MAKING OF
STATUTORY RULES
WHICH ARE NOT YET
AVAILABLE

Notice is given of the making of the following Statutory Rules:

- Mines Act 1958*
- 399/1988 Mines (Mining Titles)
(Eductor Dredge)
Regulations 1988
- Firearms Act 1958*
- 400/1988 Firearms (Transactions)
Regulations 1988
- Private Agents Act 1966*
- 401/1988 Private Agents (Fees)
Regulations 1988
- Police Regulations Act 1958*
- 402/1988 Police (Charges, Expenses
and Allowances)
(Amendment of Fees)
Regulations 1988

**NOTICE OF MAKING
AND AVAILABILITY OF
STATUTORY RULES**

In pursuance of the provisions of the *Subordinate Legislation Act 1962* and the Regulations made thereunder notice is given of the making and availability of the following Statutory Rules:

Note: The date specified after each Statutory Rule is the date it was first obtainable from—
VGPO Bookshop
Information Victoria Centre
318 Lt Bourke Street, Melbourne

	<i>Public Service Act 1974</i>		
PSD51/1988	Public Service	Determinations (No. 51) 1988	Code 1
	<i>Public Service Act 1974</i>		
PSD52/1988	Public Service	Determinations (No. 52) 1988	Code 1
	<i>Public Service Act 1974</i>		
PSD53/1988	Public Service	Determinations (No. 53) 1988	Code 1

	<i>House</i>	<i>Contract</i>	
	<i>Guarantee Act 1987</i>		
395/1988	House	Contract's	
	Guarantee		
	(Amendment)		
	Regulations 1988		
28 October 1988			Code 1
	<i>Nurses Act 1958</i>		
396/1988	Nurses' Agents (Fees)		
	Regulations 1988		
28 October 1988			Code 1
	<i>Drugs, Poisons and</i>		
	<i>Controlled Substances Act</i>		
	1981		
397/1988	Drugs, Poisons and	Controlled Substances	
	(Miscellaneous		
	Amendment No. 6)		
	Regulations 1988		
28 October 1988			Code 1
	<i>Firearms Act 1958</i>		
398/1988	Firearms (Exemption No. 8)	Regulations 1988	
28 October 1988			Code 1

Price Code	No. of Pages (Including cover and blank pages)	Price
1	1-4	\$0.42
2	5-8	\$0.75
3	9-12	\$1.05
4	13-16	\$1.50
5	17-24	\$1.80
6	25-32	\$2.25
7	33-40	\$2.55
8	41-48	\$2.85
9	49-56	\$3.20
10	57-64	\$3.50
11	65-72	\$3.80
12	73-80	\$4.00
13	81-88	\$4.45
14	89-96	\$4.80
Each additional 16 pages or part thereof		\$0.63

	<i>Public Service Act 1974</i>		
PSD49/1988	Public Service	Determinations (No. 49) 1988	Code 1
	<i>Public Service Act 1974</i>		
PSD50/1988	Public Service	Determinations (No. 50) 1988	Code 1

3296 G 42 2 November 1988

Victoria Government Gazette

CONTENTS

	Page
Government Notices	3268
Orders in Council— Acts—Crown Lands (Reserves); Land; Retirement Villages; Health Services; Cemeteries; Racing	3273
Private Advertisements	3286
Proclamation	3266

No. G 42—General Government Gazette

A Victorian Government Publication

Published by VGPO
Melbourne Victoria Australia

© State of Victoria

This publication is copyright. No part may be reproduced by
any process except in accordance with the provisions
of the Copyright Act

Address all inquiries to the Government Printer
for the State of Victoria
PO Box 203 North Melbourne 3051 Victoria Australia
ISSN 0819—5471

Further copies of this publication can be obtained from
Bookshop
Information Victoria
318 Lt Bourke Street Melbourne

Bookshop Inquiries: (03) 663 3760

By Authority Jean Gordon Government Printer Melbourne
Recommended Retail Price \$1.15