

# VICTORIA GOVERNMENT G A Z E T T E

No. G 5 Wednesday 10 February 1988  
By Authority Jean Gordon Government Printer Melbourne

**GENERAL**

## Gazette Services

The *Victoria Government Gazette* (VGG) is published by VGPO for the State of Victoria and is produced in three editions.

VGG **General** is published each Wednesday and provides information regarding Acts of Parliament and their effective date of operation; Government notices; requests for tenders; as well as contracts and contracts accepted. Private notices are also published.

VGG **Special** is published any day when required for urgent or special Government notices. VGG **Special** is made available automatically to subscribers of VGG **General**.

VGG **Periodical** is published on Monday when required and includes specialised information eg. Medical, Dental, Pharmacist's Registers, etc.

## Government Advertising

### Publishing Details

The following Guidelines should be followed to ensure publication of Government material in the *Victoria Government Gazette*.

- Duplicate copies should be submitted for use by the Gazette Officer.
- Material submitted to the Executive Council for gazettal will normally be published in the following week's issue.
- Where urgent gazettal is required, contact:  
Gerd Gaspar  
Gazette Officer  
Department of the Premier and Cabinet  
2nd Floor 1 Treasury Place  
Melbourne 3000  
Telephone Inquiries (03) 651 5153
- Government advertising other than material for the consideration of the Executive Council should be forwarded to the Gazette Office no later than 9.30 am on Tuesday.
- Lengthy or complicated notices should be forwarded several days before publication.
- Proofs will be supplied only when requested or at the direction of the Gazette Officer.
- No additions or amendments to material for publication will be accepted by telephone.
- Double rates for advertising in the Special Gazette will apply.

## Private Advertising

### Publishing Details. Send copy to:

VGG Coordinator  
Gazette Advertising  
VGPO  
66-112 Macaulay Road  
North Melbourne  
(PO Box 203 North Melbourne 3051)  
Telephone inquiries (03) 320 0100  
Fax No. (03) 329 2696

### Advertising Rates and Payment

Single column × cm/part cm \$3.85  
Double column × cm/part cm \$7.70  
Full page \$161.70

All private advertising **MUST** be paid for in advance, prior to any gazettal. Cheques should be made payable to 'VGPO'.

### Advertisers should note:

- There are approximately 20 words to each column centimetre depth.
- Signatures (in particular) and proper names must also be in block letters.
- All material should be double spaced.
- Advertisements can be faxed, and a cover sheet should be used, marked to the attention of the Gazette Coordinator.
- Documents not clearly prepared and in the exact format for gazettal will be returned to the sender unpublished.
- Late copy received at VGPO after 3.30 pm Tuesday will be placed in the following issue of VGG, irrespective of any date/s mentioned in the copy (unless otherwise advised).

### Copy Deadline

11.00 am Tuesday (Normal Rates)  
3.30 pm Tuesday (Double Rates)

## Subscriptions

VGG is available by three subscription services:

General and Special—\$100 each year  
General, Special and Periodical—\$115 each year  
Periodical—\$60 each year

Subscriptions are payable in advance and accepted for a period of one year. All subscriptions are on a firm basis and refunds for cancellations will not be given.

All payments should be made payable to VGPO.

Subscription inquiries: (03) 320 0217

VGPO Bookshop Inquiries: (03) 663 3760

## PROCLAMATIONS

### Land Act 1958

#### PROCLAMATION OF ROAD

I, J. Davis McCaughey, Governor of Victoria acting with the advice of the Executive Council and under section 25 (3) (c) of the *Land Act 1958* proclaim as road the following land:

#### MUNICIPAL DISTRICT OF THE SHIRE OF OXLEY

WHOROULY—The land in the Township of Whorouly, Parish of Whorouly as shown by hatching on plan hereunder—(L8-4241).

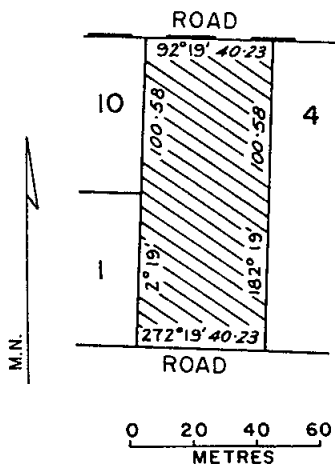

Given under my hand and the seal of Victoria on 2 February 1988

(L.S.) J. DAVIS McCAUGHEY

By His Excellency's Command

J. E. KIRNER

Minister for Conservation, Forests and Lands

### Loddon-Campaspe Regional Planning Authority Act 1987

(No. 59)

#### PROCLAMATION OF COMMENCEMENT

I, J. Davis McCaughey, Governor of Victoria, acting with the advice of the Executive Council and under section 2 of the *Loddon-Campaspe Regional Planning Authority Act 1987*, fix 15 February 1988 as the day on which the Act, other than section 14, comes into operation.

Section 14 shall come into operation on the day on which Item 81 of the Schedule to the *Planning and Environment Act 1987* comes into operation.

Given under my hand and the seal of Victoria on 2 February 1988

(L.S.) J. DAVIS McCAUGHEY

By His Excellency's Command

T. W. ROPER

Minister for Planning and Environment

### Planning and Environment Act 1987

(No. 45)

#### PROCLAMATION OF COMMENCEMENT

I, J. Davis McCaughey, Governor of Victoria, acting with the advice of the Executive Council and under section 2 (2) of the *Planning and Environment Act 1987*, fix 16 February 1988 as the day on which the remainder of the Act, except Items 118 and 119 of the Schedule, comes into operation.

Given under my hand and the seal of Victoria on 2 February 1988

(L.S.) J. DAVIS McCAUGHEY

By His Excellency's Command

T. W. ROPER

Minister for Planning and Environment

### Prostitution Regulation Act 1986

#### PROCLAMATION OF COMMENCEMENT

I, J. Davis McCaughey, Governor of Victoria, acting with the advice of the Executive Council and under section 2 of the *Prostitution Regulation Act 1986*, fix 16 February 1988 as the day on which section 82 of the Act shall come into operation.

Given under my hand and the seal of Victoria on 2 February 1988

(L.S.) J. DAVIS McCAUGHEY

By His Excellency's Command

J. H. KENNAN

Attorney-General

Note: By Proclamation made on 11 August 1987, the following provisions of this Act came into operation from 16 August 1987:

Sections 1-11, 50-52, 54-60, 67, 68 excluding paragraphs (a), (b), (c), (g) and (h) of sub-section (1), 69, 71, 72, 73 excluding sub-section (1), paragraph (a) of sub-section (2) and sub-section (3), 74 excluding paragraph (c), 75, 76, 77 excluding paragraph (b), and 78-81.

*Health (Amendment) Act 1987*

**PROCLAMATION OF COMMENCEMENT**

I, Sir John McIntosh Young, the Lieutenant-Governor, as Deputy for the Governor of Victoria, acting with the advice of the Executive Council, and under section 2 (2) of the *Health (Amendment) Act 1987* fix 14 February 1988 as the day on which sections 5, 6 and 7 of the Act shall come into operation.

Given under my hand and the seal of Victoria on 9 February 1988.

(L.S.) J. McI. YOUNG  
By His Excellency's Command

D. R. WHITE  
Minister for Health

**GOVERNMENT NOTICES**

**ASSOCIATIONS INCORPORATION ACT  
1981**

Notice is hereby given that in pursuance of sub-section 10 (4) of the *Associations Incorporation Act 1981* a certificate of incorporation was granted to Melbourne International Shooting Co-operative Limited on 21 January 1988.

RON TREVTHAN  
Registrar of Incorporated Associations

**POLICE GAOLS REGULATIONS 1988**

Under the provisions of the Subordinate Legislation Act, the Ministry for Police and Emergency Services invites comments from members of the public on the Police Gaols Regulations 1988, made under the *Corrections Act 1986*.

The objective of these Regulations is to provide for the management, administration, and security of police gaols and for the safe custody and welfare of persons held in them.

A copy of the regulatory impact statement is available from the Manager, Executive Services, Ministry for Police and Emergency Services, Old Treasury Building, Spring Street, Melbourne 3000 or by telephoning 651 6121.

Comments in writing should be received at the Ministry within three weeks of this date.

W. J. McCANN, Secretary

**Regulations**

**MURRAY RIVER FRONTAGE PARK**

I, Joan Elizabeth Kirner, Her Majesty's Minister for Conservation, Forests and Lands for the State of Victoria in pursuance of the powers conferred on me by section 13 of the *Crown Land (Reserves) Act 1978*, do hereby apply the regulations made on 19 March 1952 (vide *Government Gazette* of 26 March 1952) for or with respect to the care, protection and management of the Murray River Frontage Park, Mildura to the land in the Parish of Mildura as indicated by purple colour on the plan marked M/18.12.50 attached to Department of Conservation, Forests and Lands correspondence No. Rs 9912.

Dated 21 January 1988

J. E. KIRNER  
Minister for Conservation, Forests and Lands

Regulations  
BALCOMBE ESTUARY PUBLIC  
RECREATION RESERVE

I, Joan Elizabeth Kirner, Her Majesty's Minister for Conservation, Forests and Lands in and for the State of Victoria in pursuance of the powers conferred on me by section 13 of the *Crown Land (Reserves) Act 1978*, do hereby apply the Regulations for and with respect to the reserved Crown Land in the Township of Osborne, Parish of Moorooduc, temporarily reserved for Public Recreation purposes by Order in Council of 6 May 1986 (vide *Government Gazette* dated 14 May 1986) being the land indicated by red colour on plan attached to Departmental correspondence Rs4898 and known as the "Balcombe Estuary Public Recreation Reserve".

The Reserve has been placed under the control of the Corporation of the Shire of Mornington as Committee of Management (hereinafter referred to as the "Committee") with full power and authority to enforce these Regulations.

Regulations

Title

1. These Regulations may be cited as the Balcombe Estuary Public Recreation Reserve Regulations 1988.

Application

2. These Regulations shall apply to the whole of the Reserve.

Definitions

3. In these Regulations, unless inconsistent with the context or subject matter—

"Minister" means Minister for Conservation, Forests and Lands.

"Act" means the *Crown Land (Reserves) Act 1978*, as amended.

"Authorised Officer" means any person appointed, in writing, by the Committee as an authorised officer for the purposes of these Regulations and (except for the purpose of receipt of any fees or the grant variation or revocation of any permit) also includes any member of the Police Force and any Bailiff of Crown Lands.

"Camp" without limiting the generality of the verb, includes:

(a) Erect, occupy or use any tent, or any temporary, makeshift or similar form of accommodation, or

(b) Park, occupy or use any caravan or other movable form of accommodation.

"Firearm" includes any rifle, gun, pistol, air pistol, gun or like thing using gas cartridges, catapult, bow and arrow or cross bow, and any

other implement designed to discharge missiles capable of injuring or destroying animal life.

"Permit" includes any authority, approval, consent, permission, receipt, ticket or the like given, granted or issued under the Act of these Regulations.

"Vehicle" includes any motor car, motor cycle, bicycle, cart, horse drawn vehicle, trailer or water craft.

Behaviour

4. No person shall:

(a) Enter or remain in the Reserve who may offend against decency as regards dress, language or conduct;

(b) Commit or create or knowingly permit or allow to continue any public or private nuisance or any annoyance to the public or any person lawfully in the Reserve whether such nuisance or annoyance takes place in a public or private building, tent or other structure or in any enclosed or unenclosed space in the Reserve or do or suffer to be done any act which in the opinion of an authorised officer is, or is likely to be to the annoyance or disturbance of any persons using the Reserve;

(c) Except within any area set apart for the purpose, play any game in which a hard ball is used or engage in any game or sport likely to cause interference, disturbance or danger to others using the Reserve.

Shooting &c

5. No person shall in the Reserve, except in accordance with a written permit:

(a) Shoot, trap, maim, injure, kill or destroy any bird or animal;

(b) Have in his possession, carry or use any firearm, poison, trap or snare.

Firearms &c

6.

(a) Any person carrying or using any firearm, poison, trap or snare in the Reserve, without a permit shall surrender the same on demand to any authorised officer who shall issue a receipt therefor.

(b) The person apparently entitled to any such article may collect it from the office of the Committee after completion of investigations and legal proceedings (if any) by the Committee in relation to any offence alleged against the person who surrendered the same.

## Damage

7.

- (a) No person, except with a permit, shall in the Reserve, remove, cut, damage, displace, deface or interfere with any rock, timber, tree, shrub, plant, wild flower or other vegetation, or any sign, notice board, seat, table, gate, post, fence, bridge, building, structure, or any other thing of like nature to any of the foregoing.
- (b) No person shall dig or remove from or take into the Reserves any gravel, stone, shell-grit, sand, soil or loam.

## Missiles

8. No person shall roll or throw any stone or any other substance or missile within the Reserve.

## Camping

9. No person shall camp in any part of the Reserve.

## Refuse and Litter

10. No person shall within the Reserves deposit or cause to be deposited (except in a receptacle provided for the purpose) any bottle, glass object, vessel or other container, broken glass, tins, waste paper, foodstuff, vegetable matter, offal or other refuse or litter.

## Glass &amp;c

11. No person shall intentionally break any glass, bottle or other container within the Reserve.

## General

12. No person shall in any part of the Reserves, except in accordance with and upon the terms of a permit in writing—

- (a) Sell or offer for sale any article whatsoever;
- (b) Give out, distribute, erect, leave, set-up or display any handbills, placards, notices, pamphlets, books, papers, advertising matter or any like thing;
- (c) Occupy use or enter any building, booth, shed, stand or enclosure, unless the same is set aside for public use;
- (d) Erect or place therein any building, booth, shed, or other structure;
- (e) Solicit or collect money or orders for goods or services;
- (f) Take part in or advertise any entertainment for gain;
- (g) Preach, declaim, harangue or deliver any address of any kind or use any amplifier, public address system, loud hailer or similar device;
- (h) Let for hire any article, device or thing;
- (i) Take photographs for gain or commercial purposes;

(j) Ply any vehicle for hire or carry passengers for fee or reward;

(k) Conduct any school or provide any form of instruction for gain;

(l) Advertise for sale or trade or hire any article, device, service or thing.

## Dogs

13. No person shall cause, suffer or permit any dog belonging to him or in his charge:

(a) To be brought into or to enter or to remain in any camping area or any portion of the Reserve except where and when permitted by notice; and

(b) To be brought into or to enter or remain in the Reserve unless such dog is and continues to be at all times under proper control on a chain, cord or leash, and unless such dog be effectively restrained from causing annoyance to any person and from damaging or interfering in any way with any property in the Reserve.

## Horses

14. No person shall, except in accordance with a written permit from the Committee, ride, drive or lead any horse upon the Reserve.

## Animals Generally

15.

(a) Save aforesaid, no person shall cause or suffer or knowingly permit any animal belonging to him or in his charge to be brought into or enter or remain in the Reserve without a permit;

(b) Any animal found in the Reserve contrary to these Regulations may be seized by an authorised officer and impounded or destroyed, and the owner or custodian thereof shall be liable to pay compensation for any damage done by such animals to the property of the Committee.

## Enclosures

16. No person shall, except where and upon conditions authorised by the Committee, enter any areas in the Reserve which is enclosed for plantation of young trees, shrubs or grass plots or for the growth or preservation of native flora.

## Fires and Solid Fuel Barbeques

17. No person shall without permit light a fire or solid fuel barbeque within the Reserves, except in a fireplace provided by the Committee for the purpose, and any person who lights a fire in the Reserve shall take all reasonable and proper precautions to ensure that the fire does not escape from control; nor shall any person wilfully, carelessly, or negligently do make or permit any act or omission which may result or be likely to

result in damage by fire or hot coals to anything growing or being thereon.

#### Roadways &c

18. No person shall unless authorised by the Committee drive, ride, push, pull, place or leave any vehicle in or on the Reserve except in or upon such roadways or areas as are set aside for the purpose, and no person shall allow any vehicle to remain stationary in any position where it may cause undue or unreasonable obstruction to the lawful passage of others.

#### Parking

19. No person shall park any vehicle within the Reserve except—

- (a) in an area set apart for the purpose and clearly defined by signs, or
- (b) as and where directed or authorised by the Committee or an authorised officer,
- (c) upon payment of such fees (if any) as may be prescribed.

#### Stranded Vehicles

20. An authorised officer may remove or cause to be removed or order the removal of any parked, stranded or broken down vehicle from any roadway or area within the Reserve:

Provided that the removal of any vehicle:

- (a) Shall be at the sole risk of the owner of the vehicle who shall be deemed to have accepted such risk as a condition of entry to the Reserve, and
- (b) May be effected in such manner as the authorised officer deems fit.

#### Abandoned Vehicles

21. Any vehicle left unattended within the Reserve for a continuous period exceeding 48 hours may be removed by the Committee at the risk and expense of the owner.

#### Use of Facilities

22. No person shall:

- (a) Use any kitchen, laundry, change-room, shower, toilet or other convenience or any part thereof in the Reserve except for its proper and upon payment of such fees (if any) as may be prescribed;
- (b) Enter or use or permit any child under his care or control to enter or use any place, room, convenience, or structure set apart for the use of the opposite sex: Provided that this Regulation shall not apply to a child under the age of six years, when accompanied by an adult of the opposite sex.

#### Directions by Sign

23.

- (a) The Committee may, by clear notices or signs establish in such prominent position or positions as the case requires, prohibit or regulate any act, matter or thing within the Reserve or any part thereof.
- (b) No person shall erect or remove any such notice or sign except with the authority of the Committee.
- (c) No person shall disobey the directions indicated in any such notice or sign.

#### Permits

24.

- (a) The holder of any permit shall observe and comply with all conditions thereof.
- (b) Any person purporting to hold any permit shall produce the same on demand by any authorised officer, and unless such permit is thereupon produced that person shall not be entitled to claim the benefit of any such permit.

#### Direction to Leave

25.

- (a) Any authorised officer may direct a person who in his opinion offends against any of these Regulations forthwith to leave the Reserve or any place therein.
- (b) Every person who fails to comply forthwith with any such direction shall be guilty of an offence and may be removed from the Reserves or such place.

#### Giving of Name

26. If, in the opinion of an authorised officer, any person has contravened or failed to comply with any provision of these Regulations then such officer may demand and receive the name and address of such person and any person who refuses to furnish his name and address or who then furnishes an incorrect name and address shall be deemed to have committed an offence.

#### Obstruction of Officers

27. No person shall obstruct, hinder or interfere with any authorised officer or any employee of the Committee in the execution of his duty in the Reserve.

#### General Powers

28. The Committee may—

- (a) Provide and maintain conveniences, facilities and amenities of any description in any part of the Reserves, or arrange for the provision and maintenance thereof and may from time to time determine or vary the conditions of entry or use thereof.

- (b) Make such arrangements as it deems necessary or desirable for or in connection with the proper and efficient management and operation of the Reserves or any portion thereof.

#### Permits

29. The Committee may issue permits for purposes provided for in these Regulations which are not otherwise provided for in the Act.

- (a) Any permit may be granted for such period and subject to such terms, conditions and fees consistent with these Regulations as the Committee may from time to time determine, either generally or in the particular case.
- (b) No permit shall be transferable.
- (c) Any permit (other than a permit granted by or pursuant to a document under seal) may be revoked or withdrawn at the discretion of the Committee or at the direction of the Minister (Rs 4898).

These Regulations are made in lieu of all previous Regulations made for or with respect to the abovementioned Reserves, which are hereby revoked.

Given under my hand at Melbourne on 29 January 1988.

J. E. KIRNER  
Minister for Conservation, Forests and Lands

Every person who contravenes or fails to comply with these Regulations shall be liable to the penalties prescribed in section 13 of the *Crown Land (Reserves) Act 1978*.

#### Regulations

##### MORNINGTON FORESHORE RESERVE

I, Joan Elizabeth Kirner, Her Majesty's Minister for Conservation, Forests and Lands in and for the State of Victoria in pursuance of the powers conferred on me by section 13 of the *Crown Land (Reserves) Act 1978*, do hereby apply the Regulations for and with respect to the reserved Crown Land in the Township of Mornington, Parish of Moorooduc, being the land indicated by red colour on plans marked M/27.4.31 and M/22.4.36 attached to Departmental correspondence Rs5207 and known as the "Mornington Foreshore Reserve".

The Reserve has been placed under the control of the Corporation of the Shire of Mornington as Committee of Management (hereinafter referred to as the "Committee") with full power and authority to enforce these Regulations.

#### Regulations

##### Title

1. These Regulations may be cited as the Mornington Foreshore Reserve Regulations 1988.

##### Application

2. These Regulations shall apply to the whole of the Reserves.

##### Definitions

3. In these Regulations, unless inconsistent with the context or subject matter—

"Minister" means Minister for Conservation, Forests and Lands.

"Act" means the *Crown Land (Reserves) Act 1978*, as amended.

"Authorised Officer" means any person appointed, in writing, by the Committee as an authorised officer for the purposes of these Regulations and (except for the purpose of receipt of any fees or the grant variation or revocation of any permit) also includes any member of the Police Force and any Bailiff of Crown Lands.

"Camp" without limiting the generality of the verb, includes:

- (a) Erect, occupy or use any tent, or any temporary, makeshift or similar form of accommodation, or
- (b) Park, occupy or use any caravan or other movable form of accommodation.

"Firearm" includes any rifle, gun, pistol, air pistol, gun or like thing using gas cartridges, catapult, bow and arrow or cross bow, and any other implement designed to discharge missiles capable of injuring or destroying animal life.

"Permit" includes any authority, approval, consent, permission, receipt, ticket or the like given, granted or issued under the Act of these Regulations.

"Vehicle" includes any motor car, motor cycle, bicycle, cart, horse drawn vehicle, trailer or water craft.

##### Behaviour

4. No person shall:

- (a) Enter or remain in the Reserves who may offend against decency as regards dress, language or conduct;
- (b) Commit or create or knowingly permit or allow to continue any public or private nuisance or any annoyance to the public or any person lawfully in the Reserves whether such nuisance or annoyance takes place in a public or private building, tent or other structure or in any enclosed or unenclosed space in the Reserves or do or suffer to be done any act which in the

opinion of an authorised officer is, or is likely to be to the annoyance or disturbance of any persons using the Reserves;

- (c) Except within any area set apart for the purpose, play any game in which a hard ball is used or engage in any game or sport likely to cause interference, disturbance or danger to others using the Reserves.

#### Shooting &c

5. No person shall in the Reserves, except in accordance with a written permit:

- (a) Shoot, trap, maim, injure, kill or destroy any bird or animal;  
 (b) Have in his possession, carry or use any firearm, poison, trap or snare.

#### Firearms &c

6. (a) Any person carrying or using any firearm, poison, trap or snare in the Reserves, without a permit shall surrender the same on demand to any authorised officer who shall issue a receipt therefore.  
 (b) The person apparently entitled to any such article may collect it from the office of the Committee after completion of investigations and legal proceedings (if any) by the Committee in relation to any offence alleged against the person who surrendered the same.

#### Damage

7. (a) No person, except with a permit, shall in the Reserves, remove, cut, damage, displace, deface or interfere with any rock, timber, tree, shrub, plant, wild flower or other vegetation, or any sign, notice board, seat, table, gate, post, fence, bridge, building, structure, or any other thing of like nature to any of the foregoing.  
 (b) No person shall dig or remove from or take into the Reserves any gravel, stone, shell-grit, sand, soil or loam.

#### Missiles

8. No person shall roll or throw any stone or any other substance or missile within the Reserves.

#### Camping

9. No person shall camp in any part of the Reserves.

#### Refuse and Litter

10. No person shall within the Reserves deposit or cause to be deposited (except in a receptacle provided for the purpose) any bottle, glass object, vessel or other container, broken

glass, tins, waste paper, foodstuff, vegetable matter, offal or other refuse or litter.

#### Glass &c

11. No person shall intentionally break any glass, bottle or other container within the Reserves.

#### General

12. No person shall in any part of the Reserves, except in accordance with and upon the terms of a permit in writing—

- (a) Sell or offer for sale any article whatsoever;  
 (b) Give out, distribute, erect, leave, set-up or display any handbills, placards, notices, pamphlets, books, papers, advertising matter or any like thing;  
 (c) Occupy, use or enter any building, booth, shed, stand or enclosure, unless the same is set aside for public use;  
 (d) Erect or place therein any building, booth, shed, or other structure;  
 (e) Solicit or collect money or orders for goods or services;  
 (f) Take part in or advertise any entertainment for gain;  
 (g) Preach, declaim, harangue or deliver any address of any kind or use any amplifier, public address system, loud hailer or similar device;  
 (h) Let for hire any article, device or thing;  
 (i) Take photographs for gain or commercial purposes;  
 (j) Ply any vehicle for hire or carry passengers for fee or reward;  
 (k) Conduct any school or provide any form of instruction for gain;  
 (l) Advertise for sale or trade or hire any article, device, service or thing.

#### Dogs

13. No person shall cause, suffer or permit any dog belonging to him or in his charge:

- (a) To be brought into or to enter or to remain in any camping area or any portion of the Reserves except where and when permitted by notice; and  
 (b) to be brought into or to enter or remain in the Reserves unless such dog is and continues to be at all times under proper control on a chain, cord or leash, and unless such dog be effectively restrained from causing annoyance to any person and from damaging or interfering in any way with any property in the Reserve.



Horses

14. No person shall, except in accordance with a written permit from the Committee, ride, drive or lead any horse upon the Reserves.

Animals Generally

15.

(a) Save aforesaid, no person shall cause or suffer or knowingly permit any animal belonging to him or in his charge to be brought into or enter or remain in the Reserves without a permit.

(b) Any animal found in the Reserve contrary to these Regulations may be seized by an authorised officer and impounded or destroyed, and the owner or custodian thereof shall be liable to pay compensation for any damage done by such animals to the property of the Committee.

Enclosures

16. No person shall, except where and upon conditions authorised by the Committee, enter any areas in the Reserves which is enclosed for plantation of young trees, shrubs or grass plots or for the growth or preservation of native flora.

Fires and Solid Fuel Barbeques

17. No person shall without permit light a fire or solid fuel barbeque within the Reserves, except in a fireplace provided by the Committee for the purpose, and any person who lights a fire in the Reserve shall take all reasonable and proper precautions to ensure that the fire does not escape from control; nor shall any person wilfully, carelessly, or negligently do make or permit any act or omission which may result or be likely to result in damage by fire or hot coals to anything growing or being thereon.

Roadways &c

18. No person shall unless authorised by the Committee drive, ride, push, pull, place or leave any vehicle in or on the Reserve except in or upon such roadways or areas as are set aside for the purpose, and no person shall allow any vehicle to remain stationary in any position where it may cause undue or unreasonable obstruction to the lawful passage of others.

Parking

19. No person shall park any vehicle within the Reserve except—

- (a) in an area set apart for the purpose and clearly defined by signs, or
- (b) as and where directed or authorised by the Committee or an authorised officer,
- (c) upon payment of such fees (if any) as may be prescribed.

Stranded Vehicles

20. An authorised officer may remove or cause to be removed or order the removal of any parked, stranded or broken down vehicle from any roadway or area within the Reserve:

Provided that the removal of any vehicle:

- (a) Shall be at the sole risk of the owner of the vehicle who shall be deemed to have accepted such risk as a condition of entry to the Reserve, and
- (b) May be effected in such manner as the authorised officer deems fit.

Abandoned Vehicles

21. Any vehicle left unattended within the Reserves for a continuous period exceeding 48 hours may be removed by the Committee at the risk and expense of the owner.

Use of Facilities

22. No person shall:

- (a) Use any kitchen, laundry, change-room, shower, toilet or other convenience or any part thereof in the Reserve except for its proper and upon payment of such fees (if any) as may be prescribed;
- (b) Enter or use or permit any child under his care or control to enter or use any place, room, convenience, or structure set apart for the use of the opposite sex: Provided that this Regulation shall not apply to a child under the age of six years, when accompanied by an adult of the opposite sex.

Directions by Sign

23.

- (a) The Committee may, by clear notices or signs establish in such prominent position or positions as the case requires, prohibit or regulate any act, matter or thing within the Reserve or any part thereof.
- (b) No person shall erect or remove any such notice or sign except with the authority of the Committee.
- (c) No person shall disobey the directions indicated in any such notice or sign.

Permits

24.

- (a) The holder of any permit shall observe and comply with all conditions thereof.
- (b) Any person purporting to hold any permit shall produce the same on demand by any authorised officer, and unless such permit is thereupon produced that person shall not be entitled to claim the benefit of any such permit.

## Direction to Leave

25.

- (a) Any authorised officer may direct a person who in his opinion offends against any of these Regulations forthwith to leave the Reserves or any place therein.
- (b) Every person who fails to comply forthwith with any such direction shall be guilty of an offence and may be removed from the Reserves or such place.

## Giving of Name

26. If, in the opinion of an authorised officer, any person has contravened or failed to comply with any provision of these Regulations then such officer may demand and receive the name and address of such person and any person who refuses to furnish his name and address or who then furnishes an incorrect name and address shall be deemed to have committed an offence.

## Obstruction of Officers

27. No person shall obstruct, hinder or interfere with any authorised officer or any employee of the Committee in the execution of his duty in the Reserves.

## General Powers

28. The Committee may—

- (a) Provide and maintain conveniences, facilities and amenities of any description in any part of the Reserves, or arrange for the provision and maintenance thereof and may from time to time determine or vary the conditions of entry or use thereof.
- (b) Make such arrangements as it deems necessary or desirable for or in connection with the proper and efficient management and operation of the Reserves or any portion thereof.

## Permits

29. The Committee may issue permits for purposes provided for in these Regulations which are not otherwise provided for in the Act.

- (a) Any permit may be granted for such period and subject to such terms, conditions and fees consistent with these Regulations as the Committee may from time to time determine, either generally or in the particular case.
- (b) No permit shall be transferable.
- (c) Any permit (other than a permit granted by or pursuant to a document under seal) may be revoked or withdrawn at the discretion of the Committee or at the direction of the Minister (Rs 5207).

These Regulations are made in lieu of all previous Regulations made for or with respect to the abovementioned Reserves, which are hereby revoked.

Given under my hand at Melbourne on  
29 January 1988.

J. E. KIRNER

Minister for Conservation, Forests and Lands

Every person who contravenes or fails to comply with these Regulations shall be liable to the penalties prescribed in section 13 of the *Crown Land (Reserves) Act 1978*.

REGULATIONS FOR THE CARE,  
PROTECTION AND MANAGEMENT OF  
CROWN LANDS PLACED UNDER THE  
CONTROL OF THE HISTORIC BUILDINGS  
MANAGEMENT COMMITTEE

The Minister for Conservation, Forests and Lands, acting under section 13 of the *Crown Land (Reserves) Act 1978*, makes the following Regulations for the Crown lands (called the "Reserve") listed in Schedule 1, which have been placed under the control of the Historic Buildings Management Committee (called the "Committee").

## Regulations

## 1. Definitions:

"Authorised Officer" means any person appointed by the Committee to be its agent and includes all Regional Managers for the time being of the Department of Conservation, Forests and Lands and their delegates.

2. The Reserve shall be open to the public on such days and hours and at such admission charges as are determined by the Committee.

## 3. No person shall—

- (a) enter or remain in the Reserve who, in the opinion of an Authorised Officer may offend against decency as regards dress, language or conduct;
- (b) place any advertisement, placard or notice upon any tree, structure or path in the Reserve without the consent of the Committee;
- (c) sell or offer for sale any article or solicit or gather money or hand out literature within the Reserve without the permission of the Committee;
- (d) interfere with any person lawfully using the Reserve;
- (e) interfere with or damage any building, structure or other property or any tree, shrub or plant within the Reserve;

- (f) leave or deposit any rubbish in the Reserve except in receptacles provided for the purpose;
- (g) light a fire in the Reserve except at such places as are set aside for the purpose by the Committee or any Authorised Officer and at such times as allowed by the Country Fire Authority;
- (h) carry or discharge any weapon within the Reserve without the written consent of an authorised officer;
- (i) snare or destroy any animal or bird within the Reserve without the consent of an Authorised Officer;
- (j) transmit by radio or television from within the Reserve without the permission of the Committee;
- (k) occupy any building within the Reserve for any private or public activity without the written permission of the Committee;
- (l) camp in the Reserve or erect any structure within the Reserve without the permission of the Committee or any Authorised Officer;
- (m) except on lawful occasions, enter any enclosed area or building, or any other structure within the Reserve;
- (n) remain within the Reserve or in any property therein when lawfully directed to leave the same by any member of the Police Force or an Authorised Officer;
- (o) bring into the Reserve any dog, unless securely held;
- (p) bring in or allow to remain in the Reserve any other animal, without the permission of the Committee.
4. The Committee shall have authority to impound any cattle found trespassing on the Reserve. For the purpose of this clause "cattle" shall mean cattle as defined by the *Pounds Act 1958*.
5. The owner of any animals found wandering in the Reserve, except with permission of the Committee, shall be guilty of an offence against these Regulations.
6. (i) No motor car or other vehicle shall be taken onto the Reserve, except—
- (a) with the permission of the Committee or an Authorised Officer; or
- (b) for the purpose of using an area specially set aside by the Committee as a car park.
- (ii) The use of any car park shall be subject to such conditions and arrangements as the Committee may determine.

7. No alterations, additions or other works shall be undertaken on the Reserve or any structures thereon without the written approval of the Committee.

8. Any person may take still or moving photographs or films in the Reserve for private use, but if for publication or sale, the written consent of the Committee must be obtained prior to publication or sale and, a fee may be charged and conditions imposed, including acknowledgement of the source.

9. Every person within the Reserve shall comply with any lawful direction of any member of the Police Force or officer or employee of the Committee or an Authorised Officer.

10. Any officer or employee of the Committee or an Authorised Officer may remove or exclude from the Reserve any person who commits a breach of these Regulations.

11. Any permit, agreement or licence issued by the Committee may be for such period and subject to such terms, conditions and fees consistent with these Regulations as the Committee may determine.

12. The foregoing Regulations shall not restrict any servants, agents or workmen of the Committee in the proper execution of their duty or work in the Reserve.

Given under my hand on 29 January 1988

J. E. KIRNER

Minister for Conservation, Forests and Lands

Every person who contravenes or fails to comply with these Regulations shall be liable to the penalties prescribed in section 13 of the *Crown Land (Reserves) Act 1978*.

#### Schedule 1

Drysdale Free Library, permanently reserved by Order in Council of 10 August 1885.

Toongabbie Mechanics Institute Reserve, permanently reserved by Orders in Council of 23 December 1884 and 30 September 1895.

#### INVERLEIGH FLORA RESERVE

Rs. 6570

I, Joan Elizabeth Kirner, Her Majesty's Minister for Conservation, Forests and Lands, in and for the State of Victoria, in pursuance of the powers conferred on me by section 13 of the *Crown Land (Reserves) Act 1978*, do hereby make the following Regulations for or with respect to the Crown Land in the Parish of Carrah (hereinafter referred to as the "Reserve") temporarily reserved for the purpose of Preservation of Species of Native Plants (vide *Government Gazette 1983, P 261*).

## Regulations

1. The Reserve shall be open to the public at all times free of charge.
2. A person shall not, in the Reserve—
  - (a) be either unclothed, or clothed in an indecent manner;
  - (b) use any profane, indecent or obscene language;
  - (c) use any threatening, abusive or insulting words, or
  - (d) behave in a riotous, indecent, offensive, threatening or insulting manner.
3. A person shall not, in the Reserve, roll or throw a stone or other substance or missile.
4. (a) A person shall not, in the Reserve, shoot, trap, catch or otherwise destroy or interfere with wildlife.
  - (b) A person shall not, in the Reserve, use any poison, trap, snare or net.
5. A person shall not, in the Reserve—
  - (a) damage, deface, remove or otherwise interfere with any rock or any natural feature; or
  - (b) dig or remove from, or take into the Reserve gravel, stone, shell, grit, sand, soil or loam; or
  - (c) remove, cut, damage, displace, deface or interfere with a memorial, sign, notice, board, seat, table, gate, post, fence, bridge, building or any other thing constructed or erected in the Reserve.
6. A person shall not, in the Reserve, leave or deposit any glass, bottle, tin, carton, package, food, paper or any other refuse or rubbish except in receptacles provided for the purpose in the Reserve.
7. A person shall not, in the Reserve, erect or construct a building (other than a building erected or constructed in accordance with a tenancy or permit granted under the Act or a tent erected in accordance with these Regulations).
8. A person shall not, in the Reserve, occupy, use or enter a building—
  - (a) unless the building is set aside for public use the occupation, use or entry is in the building in accordance with the purposes for which it is so set aside; or
  - (b) except in accordance with a tenancy or permit held under the Act.
9. A person shall not—
  - (a) bring a dog into the Reserve or allow a dog under his control to enter or remain in the Reserve except in accordance with this clause.

- (b) Nothing in this clause prohibits a blind person having in the Reserve a dog that is bona fide used as a guide dog.
- (c) A person may have a dog in the Reserve if the dog is kept under control, is on a leash, chain or cord and is restrained from causing annoyance to persons or damage to property.

10. Subject to the Act, a person shall not, in the Reserve, pick remove, destroy or otherwise damage any wildflower, plant shrub, tree or other vegetation.

11. A person shall not, in the Reserve, excavate, remove, deface, damage or otherwise interfere with any archaeological or aboriginal remains or relics.

12. A person shall not, in the Reserve, light a fire except in accordance with the *Forests Act* 1958.

13. A person shall not, in the Reserve, drive a vehicle except on roadways or in areas set aside for driving vehicles of that class.

14. A person shall not bring cattle or poultry or a sheep, goat, pig, ferret or pet bird into the Reserve.

15. (a) A person shall not bring a horse, donkey, or mule into the Reserve, or allow a horse, donkey or mule under his control to enter the Reserve except in accordance with this clause.

(b) A person may ride, drive or lead a horse, donkey or mule in the Reserve on roads, trails or other areas set aside for riding.

(c) A person shall not ride a horse, donkey, or mule in the Reserve, in a manner that may endanger a person or animal.

(d) A person shall not, in the Reserve, leave a horse, donkey or mule unattended.

16. A person shall not bring a cat into the Reserve or allow a cat under his control to enter or remain in the Reserve.

17. A person shall not, in the Reserve, play a game or take part in an activity likely to cause inconvenience, disturbance or annoyance to other persons.

18. A person shall not, in the Reserve, camp or erect a tent or use a caravan or other mobile structure for camping except in a place set aside for camping and in accordance with a permit under the Act.

Every person infringing these Regulations in any respect shall be liable to expulsion from the Reserve in addition to any other penalty to which such person may be liable.

Given under my hand at Melbourne on 29  
January 1988.

J. E. KIRNER

Minister for Conservation, Forests and Lands  
Every person who contravenes or fails to comply  
with these Regulations shall be liable to the  
penalties prescribed in section 13 of the *Crown  
Land (Reserves) Act 1978*.

REGULATIONS FOR THE CARE,  
PROTECTION AND MANAGEMENT OF  
CERTAIN CROWN RESERVE IN THE  
TOWNSHIP OF DAYLESFORD

I, Joan Elizabeth Kirner, Her Majesty's  
Minister for Conservation, Forests and Lands in  
and for the State of Victoria, in pursuance of the  
powers conferred on me by section 13 of the  
*Crown Land (Reserves) Act 1978* do hereby make  
the following Regulations for or with respect to  
the Crown Land in the Township of Daylesford,  
Parish of Wombat temporarily reserved as a site  
for Public Recreation by Order in Council of 25  
November 1986 in respect of which a Committee  
of Management (hereinafter referred to as the  
"Committee") has been appointed.

Regulations

1. The Reserve shall be open to the public  
from sunrise to sunset, free of charge, except as  
hereinafter provided.

2. No person shall:

- (a) Enter or remain in the Reserve, who may  
offend against decency as regards dress,  
language or conduct, or who may behave  
in a disorderly, unseemly or offensive  
manner, or create or take part in any  
disturbance.
- (b) Enter or remain in the Reserve whilst in a  
state of intoxication.
- (c) Use indecent or offensive language in the  
Reserve.
- (d) Offer any article of food or drink, or any  
other commodity whatsoever, for sale, or  
bring intoxicating liquor into the Reserve  
without the consent of the Committee first  
being obtained.
- (e) Obstruct, hinder or interfere with any  
person employed at the Reserve.
- (f) Climb, jump, get on or over any of the  
gates or fences in or around the Reserve,  
or stick bills or advertisements or cut  
names thereon, or in any way damage or  
injure any of the buildings, furniture or  
fittings, gates, fences, seats, or other  
structures in the Reserve.
- (g) Interfere with, break, or damage in any  
way, any of the trees, shrubs or plants, or

pluck any of the flowers, or walk on the  
beds or borders in the Reserve.

- (h) Leave or deposit any bottles, broken glass,  
paper, orange peel, banana skins, refuse  
or rubbish whatsoever therein, nor roll or  
throw stones or missiles of any kind  
therein, or leave anything therein that  
might injure any person.
  - (i) Light a fire in the Reserve, except at such  
places as are set apart for the purpose by  
the Committee.
  - (j) Carry or discharge any firearms or air-  
guns in the Reserve or shoot, snare or  
destroy any game or birds therein without  
the consent of the Committee.
  - (k) Bet publicly in the Reserve without the  
consent of the Committee.
  - (l) Erect any buildings, tent or structure or  
camp on any portion of the Reserve  
without permission in writing of  
Committee first obtained, and then only  
under such conditions as may be  
determined by the said Committee.
  - (m) Bring into the Reserve any dog without  
the permission of the Committee.
  - (n) Do anything whatsoever in the Reserve  
for the purpose of producing a commercial  
or monetary return without the consent  
in writing of the Committee first obtained.
3. For the purpose of maintaining good order,  
any person authorised by the Committee, may  
refuse admission to the Reserve to any person.
4. No person shall remain in the Reserve at  
any time when lawfully directed by any officer or  
employee of the Committee to leave the same.
5. The Committee may enter into Agreements  
for the use of any portion or portions of the  
Reserve by any Club, Association or person for  
the purpose of holding football, cricket, or other  
matches, fetes, carnivals, entertainments, musical  
performances, shows or sports, or for playing  
football, cricket, lacross, hockey or other athletic  
games, or for athletic training or other physical  
recreation, subject to payment of such fees, and  
on such terms and conditions as it may deem  
reasonable and consistent with these Regulations  
and may authorise any Club, Association or  
person to make a charge for admission thereto.
6. No person shall engage in any organised  
sport or game or training in relation thereto  
within the Reserve on Sundays, Anzac Day or  
Good Friday without obtaining consent of  
Committee.
7. No Club, Association or person shall hold  
or take part in any organised sport,  
entertainment, performance, show or ceremony

in any part of the Reserve without the written authority of the Committee first obtained.

8. No Club or Association of any kind having for its objects physical recreation, or any member or members of any club or association, nor any other person shall play, practice or train or engaged in any game or sport or athletic exercise within the Reserve, without the permission in writing of the Committee first obtained, unless any person is, at the time of playing, a member of any Club which is duly authorised by the said Committee to play in the said Reserve at such time.

9. No person except the Committee or its officers and employees on duty shall enter any part of the Reserve when a charge is made for admission, without first paying the fees chargeable for admission.

10. No person shall drive or park a motor car or motor cycle within the Reserve except at such places as are set apart for the purpose; and on such days a charge is being levied for admission to that part of the Reserve, an additional charge of an amount as is from time to time determined by the Committee shall be payable for the parking of motor cars and motor cycles.

11. No person shall take or put, or allow to be taken or put in the Reserve, any horses, cattle, sheep, goats, pigs, or other animals or, being the owner or having the possession, care, custody, control or supervision thereof, shall suffer or allow such horses, cattle, sheep, goats, pigs, or other animals to be in or graze or wander upon the Reserve without the permission in writing of the Committee.

12. The owner of any horses, cattle, sheep, goats, pigs or other animals that are found wandering upon any part of the Reserve shall be guilty of an offence against the Regulations.

13. All animals and all poultry entering the Reserve must be under proper control, and the owner of any animal or poultry that causes damage within the Reserve shall be responsible therefor.

14. No person shall take or drive any carriage, cart, or any other vehicle drawn by a horse or other animal, into the Reserve without the permission of the Committee, and no horse or other animal drawing any such carriage, cart, or other vehicle shall, whilst in the Reserve, be detached or unharnessed therefrom, or left without a person in charge.

15. No person shall drive, push, pull or place on the Reserve any motor car or motor cycle, trailer or other vehicle except in such places as are set aside for such purposes by the Committee

unless such person obtains the permission in writing of the Committee.

16. No person shall enter any building in the Reserve without the permission of the Committee, and any person having entered such building shall leave the same on being requested so to do by any member or employee of the Committee, or by any member of the Police Force.

17. No persons except labourers and workmen employed on the Reserve shall enter any plots therein which may be enclosed for plantations of young trees, shrubs or flowers.

18. Every person to whom a ticket has been issued authorising such person to enter upon the Reserve shall upon demand produce and, if required, surrender such ticket to any gatekeeper or other person duly authorised to demand such production or surrender of tickets.

19. Any person found in a state of intoxication, or behaving in a disorderly manner, or creating or taking part in any disturbance or committing any act of indecency in the Reserve, or refusing to obey those authorised by the Committee or by any Club, Association, or persons renting or having been granted the use of the Reserve for the time being to keep order, shall be liable to be forthwith removed therefrom, notwithstanding that such persons may have purchased a ticket for admission thereto, and shall also be liable to prosecution for an offence against these Regulations.

20. No person shall camp in the Reserve other than at the specified camping area and after having duly paid the fees as may be determined by the Committee from time to time.

Every person infringing these Regulations in any respect shall be liable to expulsion from the Reserve in addition to any other penalty to which such person may be liable.

Given under my hand at Melbourne on 29 January 1988.

J. E. KIRNER

Minister for Conservation, Forests and Lands

Every person who contravenes or fails to comply with these Regulations shall be liable to the penalties prescribed in section 13 of the *Crown Land (Reserves) Act 1978*.

I hereby give notice that on 3 December 1987, the State Trust Corporation of Victoria filed an Election to Administer the following deceased person's estate in accordance with section 22 of the *State Trust Corporation Act 1987*.

Papkovs, Alexander, also known as Papkovs, Aleksander and Papkovs, Alek, late of

"Windways", Murray Valley Highway, Ebden, pensioner, died between 5 and 10 June 1987.

I hereby give notice that on 19 January 1988, the State Trust Corporation of Victoria filed Elections to Administer the following deceased person's estate in accordance with section 22 of the *State Trust Corporation Act 1987*.

Carroll, Ernest Roy, formerly of 44 Union Street, Malvern, but late of 88 Edsall Street, Malvern, retired fibrous plasterer, died 17 October 1987.

Stephens, Reginald, late of 7 Paterson Street, Abbotsford, pensioner, died 9 November 1987.

I hereby give notice that on 20 January 1988, the State Trust Corporation of Victoria filed an Election to Administer the following deceased person's estate in accordance with section 22 of the *State Trust Corporation Act 1987*.

Harrison, Ada Josephine, formerly of 17 Mack Street, Reservoir, but late of 4/130 Spensley Street, Clifton Hill, widow, died 3 December 1987.

I hereby give notice that on 21 January 1988, the State Trust Corporation of Victoria filed an Election to Administer the following deceased person's estate in accordance with section 22 of the *State Trust Corporation Act 1987*.

Hill, Frank Lindsay, late of 34 Seaview Road, Frankston, retired technical teacher, died 7 October 1987.  
3 February 1988

W. J. KILPATRICK

Managing Director, State Trust Corporation

Creditors, next of kin and others having claims against the estate of any of the undermentioned deceased persons are required to send particulars of their claims to the State Trust Corporation of Victoria, 168 Exhibition Street, Melbourne, Vic, 3000 the personal representative, on or before 14 April 1988 after which date the State Trust Corporation may convey or distribute the assets having regard only to the claims of which the State Trust Corporation then has notice:

Baxter, William, 316 Gordon Street, Maidstone, retired, died 22 September 1987.

Berg, Alison Gael, late of Kars Street, Beechworth, sales assistant, died 7 November 1987.

Black, Walter Paterson, late of Unit 1, 2 Wattle Avenue, Glenhuntly, retired jeweller, died 13 November 1987.

Bradford, Gwendoline May, formerly known as Gwendoline May Denis, formerly of Lot 16, Cairnview Court, Launching Place but late of 8 Boonah Court, Lower Templestowe, widow, died 16 September 1987.

Carroll, Ernest Roy, formerly of Union Street, Malvern but late of 58 Edsall Street, Malvern, retired fibrous plasterer, died 17 October 1987.

Cook, Beryl Caroline, late of Unit 1, 137 Centenary Avenue, Melton, home duties, died 21 September 1987.

Daly, Mary Pauline, formerly of 60 Rennie Street, Coburg, Mount Royal, spinster, died 10 August 1987.

Daldy, Monica Mary, formerly of Flat 15/178 Power Street, Hawthorn but late of 353A Upper Heidelberg Road, Ivanhoe, invalid pensioner, died 19 December 1986.

Dickenson, Lilla Maude, late of 3 Mary Street, Spotswood, widow, died 7 September 1987.

Evans, Gladys Mary Victoria, formerly of Flat 45, 23 Wattle Road, Hawthorn but late of Rumbalara Nursing Home, 17 Church Street, Brighton, widow, died 6 September 1987.

Harrison, Ada Josephine, formerly of 17 Mack Street, Reservoir but late of 4/130 Spensley Street, Clifton Hill, widow, died 3 December 1987.

Hill, Frank Lindsay, late of 34 Seaview Road, Frankston, retired technical teacher, died 7 October 1987.

Hinde, Marjorie Isobel, late of Flat 4, 2 Brookfield Court, East Hawthorn, retired secretary, died 10 August 1987.

Hirst, Elsie May, late of 3 Graham Avenue, McKinnon, married woman, died 3 December 1987.

Hogg, Ada Evelyn, also known as Ada Hogg, formerly of Flat 1, 6/8 Glen Eira Road, Elsternwick but late of Bambra House Private Nursing Home, 5 Bambra Road, Caulfield, widow, died 17 November 1986.

Knight, Joyce Adele, late of 20 Grattan Street, Seymour, spinster, died 10 June 1987.

McKnight, Eileen Elizabeth Mary, late of 129 Chirside Street, West Footscray, widow, died 1 October 1987.

Mills, Reginald Nelson, late of 50 Oakbank Street, Newport, retired bus driver, died 20 November 1987.

Papkovs, Alexander, also known as Papkovs, Alexander and Papkovs, Alek, late of "Windways", Murray Valley Highway, Ebden, pensioner, died between 5 and 10 June 1987.

Reade, Maud Revell, late of 360 New Street, Brighton, pensioner, died 25 September 1987.

Richardson, Joseph Kevin, formerly No. 148719, Unit I.R.O., Shepparton, Royal Australian Air Force and 1031 Punt Road, East Melbourne but late of 4 Hilda Street, Balwyn, carpenter, died 18 June 1987.

Soloduhin, Penehas, also known as Paul Soloduhin, late of 5 Clarke Avenue, Caulfield, retired surveyor, died 12 August 1987.

Steele, George Patrick, late of 7 Spicer Street, Beaumaris, pensioner, died 8 December 1987.

Stephens, Reginald, late of 7 Paterson Street, Abbotsford, pensioner, died 9 November 1987.

Witcombe, Edna Mavis, late of 37 Howard Street, Brunswick, home duties, died 5 November 1987.

Melbourne, 3 February 1988

W. J. KILPATRICK  
Managing Director  
State Trust Corporation

*Cemeteries Act 1958*

SCALE OF FEES OF THE SPRING HILL  
(COLIBAN) PUBLIC CEMETERY

In pursuance of the powers conferred upon them by the Cemeteries Act the trustees of the Spring Hill (Coliban) Public Cemetery hereby make the following scale of fees, which shall come into operation upon publication in the *Government Gazette*, and from and after such publication every scale of fees heretofore made by the said trustees shall be and is hereby rescinded to the extent to which it conflicts with this scale.

	\$
Land 2.44m x 1.22m	80.00
Sinking grave 1.83m deep—Contract price +10% as administrative charge	
Interment fee	40.00
Re-opening grave (no cover)	110.00
Re-opening grave (with cover)	120.00
Permission to erect a headstone or monument—10% of cost with a minimum of \$40.00	
Exhumation Charge (when authorised)	400.00
Search fee per request	15.00

C. WILSON, Trustee  
G. BUTLIN, Trustee  
R. MCGREGGOR, Trustee

Approved by the Governor in Council, 2 February 1988—LAWRENCE A. FISHER, Clerk of the Executive Council

*Cemeteries Act 1958*

SCALE OF FEES OF THE GEELONG  
CEMETERIES TRUST

In pursuance of the powers conferred upon them by the Cemeteries Act the trustees of the Geelong Cemeteries Trust hereby make the following scale of fees, which shall come into operation upon publication in the *Government Gazette*, and from and after such publication every scale of fees heretofore made by the said trustees shall be and is hereby rescinded to the extent to which it conflicts with this scale.

1. *Pre-need purchases*

Administration fees will apply as follows:

*Right of Burial	\$100 additional
*Cremation Fee	\$50 additional
*Memorial Position for cremated remains (limited tenure)	\$50 additional

2. *Cremation Fee* \$325

I. F. APTED, Trustee

G. F. HIGGINS, Trustee

I. D. MacDONALD, Trustee

Approved by the Governor in Council, 2 February 1988—LAWRENCE A. FISHER, Clerk of the Executive Council

*Cemeteries Act 1958*

SCALE OF FEES OF THE TOWANINNIE  
PUBLIC CEMETERY

In pursuance of the powers conferred upon them by the Cemeteries Act the trustees of the Towaninnie Public Cemetery hereby make the following scale of fees, which shall come into operation upon publication in the *Government Gazette*, and from and after such publication every scale of fees heretofore made by the said trustees shall be and is hereby rescinded to the extent to which it conflicts with this scale.

	\$
Land 2.44m x 1.22m	80.00
Sinking grave 1.83m deep—Contract price +10% as administrative charge	
Interment fee	40.00
Re-opening grave (no cover)	110.00
Re-opening grave (with cover) (advised against)	120.00
Permission to erect a headstone or monument—10% of cost with a minimum of \$40.00	
Exhumation Charge (when authorised)	400.00
Search fee per request	15.00



R. SUMMERHAYES, Trustee  
G. R. KELLY, Trustee  
G. J. McLEAN, Trustee

Approved by the Governor in Council, 2  
February 1988—LAWRENCE A. FISHER, Clerk  
of the Executive Council

*Cemeteries Act 1958*

SCALE OF FEES OF THE GISBORNE  
PUBLIC CEMETERY

In pursuance of the powers conferred upon  
them by the Cemeteries Act the trustees of the  
Gisborne Public Cemetery hereby make the  
following scale of fees, which shall come into  
operation upon publication in the *Government  
Gazette*, and from and after such publication  
every scale of fees heretofore made by the said  
trustees shall be and is hereby rescinded to the  
extent to which it conflicts with this scale.

	\$
<i>Public Graves</i>	
Interment in grave without exclusive right—stillborn child	50.00
Interment in grave without exclusive right—child	75.00
<i>Private Graves</i>	
Memorial Area	
Land 2.44 m × 1.22 m (selected by Trust)	280.00
<i>Lawn Section</i>	
land grave site 2.44 m × 1.22 m (selected by trust)	280.00
Bronze plaque, flower container and concrete mould	310.00
<i>Interment Fee</i>	
Interment Fee (includes sinking grave 1.83 m deep and administration costs)	200.00
Interment in existing grave (Owner to arrange removal and replacement of any cover)	170.00
<i>Miscellaneous Charges</i>	
Oversize grave	55.00
Additional depth (per .3 m)	35.00
Cancellation of order to sink (if commenced)	100.00
Late fee (per half hour or part thereof after 15 minutes)	30.00
Interment other than between 9 a.m. and 5 p.m. on normal working days or without due notice	150.00
Permission to erect a headstone, monument, stone, tile or concrete surround—5% of cost min.	50.00
Grave renovations or additional inscriptions	30.00

Exhuming the remains of a body (when authorised)	400.00
Interment of ashes in a private grave	50.00
Search Fee (per request)	15.00
Memorial Wall and Garden	
Wall niche and plaque (or reservation)	180.00
Wall vase	20.00
Ashes in memorial garden with plaque	150.00

A. McKIMM, Trustee  
G. E. YOUNG, Trustee  
K. GOSSIP, Trustee

Approved by the Governor in Council, 2  
February 1988—LAWRENCE A. FISHER, Clerk  
of the Executive Council

*Cemeteries Act 1958*

SCALE OF FEES OF THE ROTHWELL  
PUBLIC CEMETERY

In pursuance of the powers conferred upon  
them by the Cemeteries Act the trustees of the  
Rothwell Public Cemetery hereby make the  
following scale of fees, which shall come into  
operation upon publication in the *Government  
Gazette*, and from and after such publication  
every scale of fees heretofore made by the said  
trustees shall be and is hereby rescinded to the  
extent to which it conflicts with this scale.

	\$
<i>Public Graves</i>	
Interment in grave without exclusive right—stillborn child	50.00
Interment in grave without exclusive right—others	80.00
Number peg or label	20.00
<i>Private Graves</i>	
Land 2.44 m × 1.22 m	120.00
Own selection of land (extra)	60.00
Sinking grave 1.83 m deep	140.00
Each additional 0.3 m	35.00
Sinking oversize grave	40.00
Cancellation of order to sink (if commenced)	25.00
Reopening grave (no cover)	140.00
Reopening grave (with cover)	160.00
Interment Fee	50.00
Interment outside prescribed hours, or on Saturdays, Sundays or Public Holidays or without due notice	50.00
Certificate of Right of Burial	10.00
Number plate or brick	10.00
Permission to erect a headstone or monument—5% of cost with a minimum of \$50.00	

Exhuming the remains of a body (when authorised)	400.00
Interment of ashes in a private grave	50.00
Search Fee	15.00

T. McLEAN, Trustee  
A. REES, Trustee  
R. REES, Trustee

Approved by the Governor in Council, 2 February 1988—LAWRENCE A. FISHER, Clerk of the Executive Council

*Cemeteries Act 1958*

SCALE OF FEES OF THE ELTHAM PUBLIC CEMETERY

In pursuance of the powers conferred upon them by the Cemeteries Act the trustees of the Eltham Public Cemetery hereby make the following scale of fees, which shall come into operation upon publication in the *Government Gazette*, and from and after such publication every scale of fees heretofore made by the said trustees shall be and is hereby rescinded to the extent to which it conflicts with this scale.

<i>Lawn and Monumental Sections</i>	
Land 2.44 m × 1.22 m—at need	500.00
Land 2.44 m × 1.22 m—preneed	600.00
<i>Sinking Charges</i>	
Sinking grave to 2 m	375.00
Sinking grave to 2.5 m	450.00
Sinking oversized grave—American type casket—(extra)	125.00
<i>Reopening Charges</i>	
Reopen grave for interment	375.00
Removal of concrete top to sink or reopen grave	100.00
Removal of ledger or slab top to sink or reopen grave	100.00
Interment of Ashes	80.00
<i>Children's Section</i>	
Land	200.00
Sinking charges for one child	150.00
<i>Ashes Walk</i>	
Interment of Ashes "Ashes Walk" including (143 mm × 115 mm) bronze plaque (period of tenure is 25 years from date of purchase)	200.00
<i>Miscellaneous Charges</i>	
Saturday interments (extra)	250.00
Permission to erect a monument to grave up to \$500 (plus \$10 per \$100 or part thereof over \$500)	50.00
For additional inscription of Headstone	25.00

For inspecting plan or copy of Register	20.00
Exhumation of body from grave (when authorised)	700.00
Cancellation of order	50.00

B. HOLLAND, Trustee  
G. WATT, Trustee  
F. HARRINGTON, Trustee

Approved by the Governor in Council, 2 February 1988—LAWRENCE A. FISHER, Clerk of the Executive Council

*Cemeteries Act 1958*

SCALE OF FEES OF THE BOX HILL PUBLIC CEMETERY

In pursuance of the powers conferred upon them by the Cemeteries Act the trustees of the Box Hill Public Cemetery hereby make the following scale of fees, which shall come into operation upon publication in the *Government Gazette*, and from and after such publication every scale of fees heretofore made by the said trustees shall be and is hereby rescinded to the extent to which it conflicts with this scale.

<i>Land for Private Graves</i>		\$
Plots 2.44 m × 1.22 m	600.00	
<i>Sinking or Reopening Private Graves</i>		
Sinking grave 2.13 m or 2.44 m deep (Standard measurement 0.68 m wide at shoulder)	450.00	
Reopening grave (without slab or cover)	450.00	
Reopening grave (with slab or cover)	530.00	
Lined graves (incl. land and 1st interment)	3 500	
<i>Extra Charges</i>		
Sinking grave over standard width (where permitted)—over 0.68 m at shoulder	100.00	
For a square casket	100.00	
Interment not in usual hours (i.e. before 9 a.m. or after 4 p.m.) excluding Saturday, Sunday or Public Holiday (where permitted)	100.00	
Interment on Saturday, Sunday or Public Holiday (where permitted) (plus labour)	250.00	
<i>Burial of Ashes</i>		
Interment of ashes in private grave (earth top)	125.00	
Interment of ashes in private grave (pebble top)	165.00	
Interment of ashes in private grave (with slab)	205.00	

Interment of ashes in lawn plot including container and plaque	300.00
Interment of ashes in Columbarium	100.00
<i>Miscellaneous Charges</i>	
Exhumation of body (when authorised)	1 000.00
Exhumation of ashes	100.00
<i>Grave Maintenance Charge (Optional)</i>	
<i>Monumental</i>	
First Year	40.00
Each succeeding year	40.00
Removal of screening on grave	40.00

J. COEN, Trustee  
J. HUGHES, Trustee  
N. LANGLEY, Trustee

Approved by the Governor in Council, 2 February 1988—LAWRENCE A. FISHER, Clerk of the Executive Council

*Cemeteries Act 1958*

**SCALE OF FEES OF THE MELTON PUBLIC CEMETERY**

In pursuance of the powers conferred upon them by the Cemeteries Act the trustees of the Melton Public Cemetery hereby make the following scale of fees, which shall come into operation upon publication in the *Government Gazette*, and from and after such publication every scale of fees heretofore made by the said trustees shall be and is hereby rescinded to the extent to which it conflicts with this scale.

<b>§</b>	
<i>Public Graves</i>	
Interment in grave without exclusive right—stillborn child	45.00
Interment in grave without exclusive right (others)	90.00
Number peg or label	20.00
<i>Private Graves</i>	
Land, 2.44m × 1.22m	200.00
Own selection of site (extra)	60.00
Land Lawn section 2.44m × 1.22m	360.00
<i>Sinking Charges for Private Graves</i>	
Sinking grave 1.83m deep	160.00
Each additional 0.3m	30.00
Sinking oversize grave (extra)	50.00
Cancellation of order to sink (if commenced)	50.00
<i>Sinking Charges</i>	
Reopening grave (no cover)	160.00
Reopening grave (with cover)	170.00

*Extra Charges*

Interment not in the prescribed hours or on Saturdays, Sundays or Public Holidays	80.00
Late fee (per half-hour or part thereof in excess of first fifteen minutes)	15.00
Interment fee	90.00
Certificate of Right of Burial	10.00
Number plate or brick	12.00
Late fee where less than 8 hours (working hours) notice is given	50.00
<i>Miscellaneous Charges</i>	
Inspection of plan or register	20.00
Annual maintenance (single grave)—Optional	70.00
Permission to construct a brick grave or to erect any stone kerb, brick tilework or concrete	25.00
Grave renovations or additional inscription	25.00
Exhuming the remains of a body (when authorised)	400.00
Interment of ashes in a private grave	50.00
Search Fee (up to ten names, \$5.00 each item, \$3.00 each item thereafter).	

R. HERBERT, Trustee  
J. McELLROY, Trustee  
M. WOOD, Trustee

Approved by the Governor in Council, 2 February 1988—LAWRENCE A. FISHER, Clerk of the Executive Council

**VICTORIAN DAIRY INDUSTRY AUTHORITY**

Notice Pursuant to Section 42 of the *Dairy Industry Act 1984*

Pursuant to the provisions of the *Dairy Industry Act 1984* the Victorian Dairy Industry Authority does, by this notice, hereby amend on the specified day the notice published in *Government Gazette*, No. G11 of 18 March 1987 as follows:

(1) From the Second Schedule of the said notice—Under the heading North Central Milk District, the following shall be deleted—

Gane, E. & E., 55 Rutherford Street, Avoca.

Under the heading Northern Milk District, the following shall be deleted—

Griffiths, J. J. (T/A Summerhill Dairy), Roe Street, Benalla.

Under the heading Western Milk District, the following shall be deleted—

Wright, T. & L. F. (T/A Kooler Dairy), 3 Adams Street, Cobden.

(2) To the Second Schedule of the said notice—Under the heading North Central Milk District, the following shall be inserted—

McMahon International Foods Pty. Ltd.,  
Wallace/Bungaree Road, Wallace.

Gane, E. & E., 87 High Street, Avoca.

Under the heading Northern Milk District, the following shall be inserted—

McNeill Health & Bulk Foods Pty. Ltd., Roe  
Street, Benalla.

Under the heading Western Milk District, the following shall be inserted—

Wright, T. & L. F. (T/A Kooler Dairy), Terang  
Road, Cobden.

For the purpose of this notice, the "specified day" shall be the day upon which the amendments made pursuant to this notice come into effect by virtue of section 42 (2) of the *Dairy Industry Act 1984*.

By order of the Victorian Dairy Industry  
Authority.

J. F. HOGAN, Secretary

#### ERRATUM

##### *Parliamentary Committees Act 1968* REFERENCE TO THE PARLIAMENTARY LEGAL AND CONSTITUTIONAL COMMITTEE ON THE FREEDOM OF INFORMATION ACT 1982

In *Government Gazette* No. G4 of 3 February 1988 on pages 181 and 182 with reference to the abovementioned matter, paragraphs (a) and (b), which appeared on page 182 were incorrectly set out and should have appeared as:

(a) examination of

—whether certain statutory officers are being adversely affected in the proper performance of their public duties by the accessibility of the documents of their agencies, and

—whether, there should be provision for exemption of agencies from the application of the Act and if so, which agencies,

(b) problems posed by voluminous and expensive applications and in particular whether limits need to be placed on such applications and especially

—whether access charges should be related to the cost of providing that access

—whether members of Parliament should continue to have free access,

—whether the Act should provide a power to agencies to limit

unreasonably voluminous requests, and

—the extent to which departmental priorities are being affected by Freedom of Information requests

including relevant comparisons with the Commonwealth Freedom of Information Act.

GERD GASPARS, Gazette Officer  
4 February 1988

#### LANDS ACT 1958

Notice is hereby given that the Yarwangle Cultural Learning Resource Centre Co-operative Society Ltd has applied for a lease pursuant to section 134 of the *Land Act 1958* for a term of 99 years over the land described as 24.66 hectares of Crown land being Allotment 18C, section C, Parish of Woornyalook.

J. E. KIRNER

Minister for Conservation, Forests and Lands

#### *Industrial Relations Act 1987*

##### NATIONAL WAGE CASE FEBRUARY 1988

Notice is hereby given that in accordance with the provisions of section 19 of the *Industrial Relations Act 1979* the Minister for Labour has referred the Awards in the Schedule hereunder to the Industrial Relations Commission of Victoria for its consideration having regard to claims which have been or may be lodged in respect to such Awards seeking a flow-on of the effect of the decision by the Australian Conciliation and Arbitration Commission in the National Wage Case February 1988 (Print H0900).

#### Schedule

Actors Television Programmes and Feature Film; Adult Education Professional Administrative Clerical Computing and Technical Staff; Adult Education Tutor Staff; Adult Units (Day Training Centres) Instructors; Aerated Water Trade; Agricultural and Pastoral Workers; Agricultural Implements; Ambulance Services; Ambulance Superintendents and Senior Administrative Officers; Animal Manure; Architects; Bagmakers; Biscuit; Boarding School Employees; Bread Carters; Bread Trade; Bricklayers; Brick Trade; Brushmakers; Builders' Labourers; Building Contracts Salesmen's; Building Sheets (Compressed Straw); Bulk Grain Workers; Business Equipment (Technical Services); Butchers; Butchers (Supermarkets); Butter Factories and Condenseries; Canteen

Workers; Caretakers; Carpenters; Carters and Drivers; Cement; Cement Articles; Cemetery Employees; Chemists Shops; Cigar Trade; Cleaners; Cleaners and Domestic Arts Assistants (Government Schools); Clerks (Building and Housing Societies); Clerks (Credit Societies); Clothing Trades; Clothing and Footwear Shops; Colleges of Advanced Education Academic and Teaching Staff Salaries; Colleges of Advanced Education Professional Administrative Clerical Computing and Technical Staff Salaries; Colleges of Advanced Education Senior and Chief Librarians Salaries; Commercial Artists; Commercial Clerks; Commercial Travellers; Confectioners; Cordage; Cork Trade; Country Fire Authority Officers; Country Fire-Fighters; Country Printers; Dairy Farm Workers; Day Child Care Workers; Dental Technicians; Dockmens; Draughtsmens; Dyers and Clothes Cleaners; Education Service (Catholic Schools); Electorate Officers; Electrical, Furniture and Hardware Shops; Electrical Trade; Entertainment Employees (Performers); Excavation or Roadwork; Factory Engine-Drivers; Fibre Cement Workers; Fibrous Plasterers; Fire Brick and Refractories; Fire Brigades Operational Staff; Fire Brigades Service Staff; Fish; Flock; Floor Coverings (Printed Felt Base); Food Shops; Footwear; Footwear Repairers; Frozen Goods; Fruit Growers; Fruit Packing; Furnishing Trades; Garden Employees; General; General Shops; Glassworkers; Glue and Gelatine; Grain Elevators Board Administrative, Clerical, Supervisory, Professional, Technical and Maintenance Employees; Graphic Arts; Grocers' Sundries; Hairdressers and Beauty Industry; Health and Sports (Centre) Employees; Health Professional Services; Horsehair; Hospital Administrative Officers; Hospital and Benevolent Homes; Hospital Dental Officers; Hospital Managers; Hospital Pharmacists; Hospital Resident Medical Officers; Hospital Scientists; Hospital Senior Medical Officers; Hotel, Restaurant and Boarding Houses; Ice; Ice Cream; Jam Trade; Jewellers; Journalists; Kindergarten and Play Centre Assistants; Kindergarten Teachers; Land Surveyors; Laundry Workers; Law Clerks; Lift; Licensed Clubs Employees; Limeburners; Mannequins and Models; Manufacturing Chemists; Marine Stores; Meat Preservers and Vegetable Oil Processors; Metal Industry (Non Trades); Metal Industry (Skilled); Metalliferous Mining; Mineral Earths; Mineral Prospecting and Exploration; Mining Engine Drivers; Mothercraft Nurses; Motor Drivers; Motor Requisites; Musicians; Newsvendors; Non-Ferrous Metals; Nurserymen's; Off-Course Totalizator Employees; Optical Workers; Paint and Colour; Painters; Pastrycooks; Pest Control; Photographers; Photographic Goods; Plasterers; Plaster of Paris; Plastic Moulding; Plumbers; Port Emergency Service; Port Security Officers; Pottery; Poultry; Poultry Farm Workers; Premixed Concrete; Pre-School Play Leaders; Principals (Catholic Primary Schools); Production Planning; Professional Engineers; Psychologists; Quarry; Rabbit Processing; Racecallers; Radio; Real Estate Salesmens; Registered Nurses; Residential Child Care Workers; Retail Dairy; Road Patrolmen's; Road Traffic Authority; Roofing Tiles; Rubber Trade; Saddlery, Leather and Canvas Workers; Saltworker's; Sand Pit; Sausage Casings; Scientific and Technical Workers; Seamen's; Security Employees; Sewage Distribution; Sewer Builders; Shearing Industry; Slaters and Tilers; Slaughtering for Export; Social and Community Services; Softgoods-Wholesale; Sports Ground Maintenance; State Government Schools Professional, Administrative, Clerical, Computing and Technical Staff; Stonecutters; Storemen, Packers and Sorters; Sugar Refiners; TAFE Professional Administrative Clerical Computing and Technical Staff Salaries; Tanners; Tanners (Furred Skins); Tar and Bitumen; Teacher Aides (Government Schools); Teachers (Day Training Centres); Teachers' (Independent Schools); Tea Packing; Television Performers and Session Singers; Tennis Strings; Textile Industry; Tilelayers; Totalizator Employees; Tow Truck Drivers; Transport Accident Commission Employees; Underground Clay Mining; Undertakers; Universities Academic Staff; Universities General Staff; Vegetable Growers; Vehicle Building Industry; Veterinary Assistants and Animal Attendants; Victorian College of Agriculture and Horticulture Non Academic Staff Salaries; Victorian College of Agriculture and Horticulture (Tradesmen/Instructors) Salaries; Victorian College of Agriculture and Horticulture Academic and Teaching Staff Salaries; Victorian Fire Services Administrative and Clerical Officers; Watch Cases; Watchmakers; Waterfront Watchmen's; Wharfs and Jetties; Wholesale Grocers; Wholesale Wine and Spirit Stores; Wireworking (Australian Wire Industries Pty. Ltd. Bekaert-BHP Steel Cord); Woodworkers; Zoological Board Salaried Staff.

Notice is also given that this matter is listed for hearing before the Industrial Relations Commission of Victoria in Full Session at 10.30 a.m. on Monday, 15 February 1988 in Hearing Room No. 1, Level 18, Nauru House, 80 Collins Street, Melbourne.

E. E. RAKUSZ  
Acting Deputy Registrar  
Industrial Relations Commission of Victoria

*Transport Act 1983*  
**ROAD TRAFFIC AUTHORITY**  
 Commercial Passenger Vehicle and Tow Truck  
 Applications

Notice is hereby given that the following applications will be considered by the Road Traffic Authority on 15 March 1988.

Notice of any objections should be forwarded to reach the Manager, Vehicle Licensing Branch or any Regional Office of the Road Traffic Authority not later than 9 March 1988.

It will not be necessary for interested parties to appear on the hearing date specified, unless advised in writing by the Authority.

Notification of the date for consideration of applications which are objected to and which require determination by the Road Transport Licensing Tribunal will be published by further notice in this *Gazette*.

O. Boscacci, Lower Templestowe. Application to license two commercial passenger vehicles, in respect of a 1951 Mercedes Benz sedan with seating capacity for 4 passengers and a 1950-60 Mercedes Benz limousine to be purchased with seating capacity for 5 passengers to operate as special purpose vehicles from 30 Feathertop Avenue, Lower Templestowe for the carriage of passengers for wedding parties.

*Note:* This application is made in conjunction with a similar application by R. Pegoraro.

Heath-Sallwyn Investments Pty. Ltd., Clyde. Application to license one commercial passenger vehicle with seating capacity for 28 passengers to operate as a metropolitan special service omnibus.

*Note:* The vehicle to be licensed would hold a 2-star rating for charter purposes.

Heath-Sallwyn Investments Pty. Ltd., Clyde. Application to license one commercial passenger vehicle with seating capacity for 45 passengers to operate a service for the carriage of school children attending Maranatha Christian School, Endeavour Hills to the exclusion of all other passengers excepting duly authorised teachers between Frankston, Carrum Downs and Maranatha Christian School, Endeavour Hills.

*Note:* Service to operate under contract to Maranatha Christian School.

Heath-Sallwyn Investments Pty. Ltd., Clyde. Application to license one commercial passenger vehicle with seating capacity for 45 passengers to operate a service for the carriage of school children attending Maranatha Christian School, Endeavour Hills to the exclusion of all other passengers excepting duly authorised teachers between Ferntree Gully, Boronia, Narre Warren

North and Maranatha Christian School, Endeavour Hills.

*Note:* Service to operate under contract to Maranatha Christian School.

M. J. Palframan, Patterson Lakes. Application to license two class 1 tow trucks, to be purchased, to operate throughout the State of Victoria, from a depot situated at Main Street, Lang Lang, for the purpose of lifting and carrying or towing damaged or disabled motor cars, but excluding the ability to attend the scene of a motor car accident in the "Controlled Area".

R. Pegoraro, Bulleen. Application to license one commercial passenger vehicle in respect of a 1959 Mercedes Benz limousine with seating capacity for 5 passengers to operate as a special purpose vehicle from 83 Thompsons Road, Bulleen, for the carriage of passengers for wedding parties.

*Note:* This application is made in conjunction with a similar application by O. Boscacci.  
 Dated 10 February 1988

M. McQUILLEN  
 Group Manager

Vehicle Licensing and Regulation Strategies

**TRAFFIC AUTHORITY**

Mass Limits Increase Permits

In accordance with section 505 (2) of the *Local Government Act 1958* and sections 38 and 39 of the *Transport Act 1983*, the Councils of the Municipalities listed below have authorised the Road Traffic Authority to act on behalf of the Councils in extending permits issued by the Authority under section 35 of the *Motor Car Act 1958*, or regulations under the *Road Safety Act 1986* which replaces that section, to any road within the Municipality which is not a State Highway, Main Road, Tourists' Road, Forest Road or Freeway within the meaning of the Transport Act, subject to the conditions that—

travel shall not be authorised over any roads specified in this notice or those signposted with lower limits than allowed under these permits; and

permit issue shall be limited to the Option A limits described by the Review of Road Vehicle Limits.

Municipalities

Shire of Dundas—excluding Kerrs Road, Deerhurst Road, Burgers Road, Twomeys Bridge Road, Macarthur Cemetery Road, Chrome Road, Morgiana Road, Partridges Road, Moodies Road, Murrays Road, Tarrington-Strathkellar Road, Robsons Road—from the Glenelg Highway to Depot Lane.

Shire of Marong  
Shire of Myrtleford  
City of Warrnambool—excluding Hopkins  
River Bridge, Stanley Street Bridge, and Pertobe  
Road Bridge.  
Shire of Wycheproof.

MICHAEL J. ROUX  
Chairman and Managing Director

Department of Industry, Technology and  
Resources

**MINING LEASES GRANTED**

- No. 1153; D. R. Brown & B. W. Cuffley; 154.32  
ha, Parishes of Yackandandah and Stanley.  
No. 1845; Goldquest NL; 150.27 ha, Parishes of  
Glenalbyn and Inglewood.

**APPLICATIONS FOR MINING LEASE  
REFUSED**

- No. 1416; B. R., I. J. & D. R. McLean; 58.9 ha,  
Parish of Franklin.  
No. 1420; Kinex P/L; 260 ha, Parishes of Bet Bet  
and Maryborough.  
No. 1480; Kinex P/L; 203 ha, Parish of Barkly.  
No. 1505; Planet Resources Group NL; 219 ha,  
Parish of Ballarat.  
No. 1507; Planet Resources Group NL; 241 ha,  
Parish of Ballarat.  
No. 1646; L. D. Bayly; 294 ha, Parish of Spring  
Hill.  
No. 1647; L. D. Bayly; 500 ha, Parish of Spring  
Hill.  
No. 1649; L. D. Bayly; 800 ha, Parish of Spring  
Hill.  
No. 1650; L. D. Bayly; 289 ha, Parish of Spring  
Hill.  
No. 1692; L. D. Bayly; 775 ha, Parishes of  
Smeaton and Spring Hill.  
No. 1688; Minico P/L; 240 ha, Parish of Jallukar.

**APPLICATION FOR MINING LEASE  
WITHDRAWN**

- No. 1799; Jenso P/L; Parish of Lockwood.  
**APPLICATION FOR MINING LEASE  
TRANSFERRED**  
No. 1390; From Walhalla Mining Co. NL to  
Aymleg P/L.  
**MINING LEASE EXPIRED**  
No. 443; K. & M. Dunstall; 13.5 ha, Parish of  
Everton.

**APPLICATIONS FOR DEVELOPMENT  
LEASES REFUSED**

- No. 623; Thirty Seventh Shako P/L; 180 ha,  
Parish of Bung Bong.

- No. 665; Tathorn P/L; 228 ha, Parish of  
Blackwood.

- No. 749; B. R. Hochwimmer & T. E. Johnston;  
265 ha, Parish of Panbulla.

- No. 846; Casevill P/L; approx 297 ha, Parishes  
of Wedderburn and Barrakee.

**APPLICATIONS FOR DEVELOPMENT  
LEASES WITHDRAWN**

- No. 265; Base Exploration P/L; 230.4 ha, Parish  
of Moliagul.

- No. 773; D. Bentley; 196 ha, Parishes of Craigie  
and Amherst.

- No. 775; B. C. Burton; 80 ha, Parish of Yarraberb.

**APPLICATIONS FOR DEVELOPMENT  
LEASES TRANSFERRED**

- Nos. 15 & 149; From Walhalla Mining Co. NL  
to Aymleg P/L.

**APPLICATIONS FOR PROSPECTING AREA  
LICENCES REFUSED**

- No. 182; Sandhurst Mining NL; Parishes of  
Tourello, Creswick and Ascot.

- No. 265; Kinex P/L; 232.75 ha, Parishes of Bet  
Bet & Maryborough.

- No. 272; Bendigo Mining NL; approx 232 ha,  
Parish of Inglewood.

- No. 354; Planet Resources Group NL; 219 ha,  
Parish of Ballarat.

- No. 356; Planet Resources Group NL; 241 ha,  
Parish of Ballarat.

- No. 486; Broadcast Holdings P/L; 278 ha, Parish  
of Gorong.

- No. 488; Tathorn P/L; 228 ha, Parish of  
Blackwood.

**APPLICATION FOR PROSPECTING AREA  
LICENCE DECLARED ABANDONED**

- No. 343; N. M. Higgins & T. G. Kornell; 250 ha,  
Parish of Langi-Kal-Kal.

**APPLICATION FOR PROSPECTING AREA  
LICENCE WITHDRAWN**

- No. 200; Planet Resources Group NL; 111.2 ha,  
Parishes of Wareek and Bung Bong.

**APPLICATIONS FOR PROSPECTING AREA  
LICENCE TRANSFERRED**

- Nos. 193 & 204; From Walhalla Mining Co NL  
to Aymleg P/L.

**APPLICATION FOR RENEWAL OF  
PROSPECTING AREA LICENCE REFUSED**

- Nos. 71-1; C. Hider and D. R. McLean; 256 ha,  
Parish of Ballark.

**PROSPECTING AREA LICENCES EXPIRED**

- Nos. 145, 146 & 147; Walhalla Mining Co. NL;  
248, 255 and 244 ha respectively, Parish of  
Knowsley.

**TAILINGS REMOVAL LICENCES EXPIRED**

No. 4940; Bendigo Gold Associates, to remove tailings from the "Old and New Specimen Hill Mines" dumps situated in the Parish of Wombat.

No. 5068; D. A. Clinton; to remove tailings from an area north east of allotment 62J situated in the Parish of Woori Yallock.

**TAILINGS TREATMENT LICENCE GRANTED**

No. 280; Bendigo Gold Associates P/L; 79.01 ha, Parishes of Nerring and Huntly.

**APPLICATIONS FOR TAILINGS TREATMENT LICENCES REFUSED**

No. 356; Planet Resources Group NL; 30 ha, Parishes of Carisbrook and Craigie.

No. 490; Village Mines NL; 2 ha, Parish of Maldon.

**APPLICATIONS FOR EXPLORATION LICENCES REFUSED**

No. 1949; Tarmeta P/L; 77 km<sup>2</sup>, Shire of Broadford.

No. 2214; Noble Resources NL; 22 km<sup>2</sup>, Bendigo.  
**APPLICATION FOR EXPLORATION LICENCE DECLARED ABANDONED**

No. 2162; T. F. Croft; 95 km<sup>2</sup>, Shires of Kara Kara and Avoca.

**INTENTION TO EXTEND AN EXPLORATION LICENCE**

No. 1370-2; Epoch Mining NL; 150.25 km<sup>2</sup>, County of Grenville.

**EXPLORATION LICENCE EXTENDED AND AREA RELINQUISHED**

No. 1370-1; Epoch Mining NL; area retained 143.25 km<sup>2</sup>, area relinquished 196.25 km<sup>2</sup>, County of Grenville.

The above relinquished area became available again for Exploration Licence on 12 June 1987.

**EXPLORATION LICENCE EXTENDED PURSUANT TO SECTION 519B (6) OF THE MINES ACT 1958 AS AMENDED**

No. 1370-1; Epoch Mining NL; 3.75 km<sup>2</sup>, County of Grenville.

**APPLICATION FOR EXTRACTIVE INDUSTRY LICENCE DECLARED ABANDONED**

No. 1352; P. S. Hocking; 60 ha, Parish of Carlyle.  
**EXTRACTIVE INDUSTRY LICENCES RENEWED**

No. 68-1; The Standard Brick Works (Box Hill) P/L; 6.986 ha, Parish of Nunawading.

No. 146-1; The President, Councillors and Ratepayers of the Shire of Buln Buln; 36.26 ha, Parish of Jindivick.

No. 549-1; G. F. & G. M. Coffey; 11.15 ha, Parish of Wa-De-Lock.

No. 776-1; Little River Sand Co. P/L; 230.7 ha, Parish of Wurdi Youang.

**APPLICATION FOR RENEWAL OF EXTRACTIVE INDUSTRY LICENCE REFUSED**

No. 368-1; I. Beer; 7.8 ha, Parish of Yarroweyah.  
**EXTRACTIVE INDUSTRY LICENCE EXPIRED**

No. 790-1; Chuck Drainage P/L; 14.8 ha, Parish of Koo-wee-rup.

**EXTRACTIVE INDUSTRY LEASES RENEWED**

No. 73-1; Victoria Portland Cement Co. P/L; 2.45 ha, Parish of Duned.

No. 258-1; J. & R. Turner Industries P/L; 22 ha, Parish of Langwarrin.

**ROBERT FORDHAM**  
Minister for Industry, Technology and Resources

**Town and Country Planning Act 1961  
SHIRE OF BUNINYONG INTERIM  
DEVELOPMENT ORDER****Amendment No. 7  
Notice of Amendment**

In pursuance of the powers conferred by the *Town and Country Planning Act 1961*, the Lieutenant-Governor as deputy for the Governor in Council on 9 February 1988 amended the abovementioned Order in respect of the municipal district of the Shire of Buninyong and for which the Shire of Buninyong is the responsible authority.

The amendment comes into operation on the date this notice is published in the *Government Gazette*.

The amendment allows for the use and development of Crown Allotments 4A, 4c and part of 4b, section 12A, Parish of Lal Lal for the extraction of kaolin clay, in accordance with the schedules and conditions forming part of the amendment.

A copy of the documents may be inspected free of charge, during office hours, at the office of the Ministry for Planning and Environment, The Olderfleet Buildings, 477 Collins Street, Melbourne, and at the office of the Council of the Shire of Buninyong, Learmonth Street, Buninyong.

**CAROLYN MATHER**  
Acting Secretary for Planning and Environment



## Private Agents Act 1966

## NOTICE OF RECEIPT OF APPLICATIONS FOR LICENCES UNDER THE PROVISIONS OF THE PRIVATE AGENTS ACT 1966

The Clerk(s) of the Magistrates' Court(s) as listed hereunder hereby give notice that applications, as under, have been lodged for hearing by the said Court(s) on the date(s) specified.

Any person desiring to object to any of such applications must—

- (a) lodge with the respective Clerk of the Magistrates' Court a notice in the prescribed form of his objection and of the grounds thereof;
- (b) cause a copy of such notice to be served personally or by post upon the applicant at least three days before the hearing of the application; and
- (c) send or deliver—
  - (i) where the objection is not made by the officer in charge of the police district in which the Court is situated—a copy of the notice to such officer; and
  - (ii) where the objection is not made by the Registrar or Deputy Registrar—a copy to the Registrar.

Full Name of Applicant*	Place of Abode of Applicant or Nominee	Name of Firm or Corporation	Address for Registration	Type of Licence	Date of Hearing
<b>MAGISTRATES' COURT, HEIDELBERG</b>					
Curran, Neville Stafford	15 Eurolie St, North Balwyn	Barnett Curran and Associates	15 Eurolie St, North Balwyn	Firm (Inquiry Agent)	3.3.88
" "	"	"	"	Inquiry Agent	"
Dated at Heidelberg, 2 February 1988 R. W. COOK, Clerk of the Magistrates' Court					
<b>MAGISTRATES' COURT, BOX HILL</b>					
Bibic, Peter	9 Barcelona St, Box Hill		9 Barcelona St, Box Hill	Guard Agent	7.3.88
Judd, Paul Wayne	1 Gawler Crt, Mont Albert	Mont Albert Security Services	1 Gawler Crt, Mont Albert	Guard Agent (Firm)	"
McOrmond, Dennis Noel	1 Ursula St, Box Hill North	D N & F L McOrmond Security	1 Ursula St, Box Hill North	Guard Agents (Corp.)	24.2.88
Reynen, Laurence John	32 Linden St, Blackburn	Nenyer Security Officer Training Academy	32 Linden St, Blackburn	Guard Agent (Firm)	1.3.88
Carr, Luke Thomas	704 Macedon St, Keilor		1 Mt. Pleasant Rd, Nunawading	Watchman	2.3.88
Nelson, Paul John	11 Halley St, Blackburn		"	"	"

Dated at Box Hill, 2 February 1988  
Clerk of the Magistrates' Court

\*Or in the case of a firm or corporation, of the Nominee

## PRIVATE AGENTS—continued

<i>Full Name of Applicant*</i>	<i>Place of Abode of Applicant or Nominee</i>	<i>Name of Firm or Corporation</i>	<i>Address for Registration</i>	<i>Type of Licence</i>	<i>Date of Hearing</i>
<b>MAGISTRATES' COURT, PRAHRAN</b>					
Beckman, Geoffrey Michael	Flat 2/250 Glenlyon Rd, East Reservoir	Mayne Nickless Ltd.	390 St. Kilda Rd, Melbourne	Watchman	28.3.88
Beer, Rodney Norman	10 Caroline St, Essendon	" "	" "	"	"
Brilliant, Adrian John	35 Werder St, Box Hill	" "	" "	"	"
Brown, Scott Geoffrey	49 Centre Dandenong Rd, Dingley	Alef Security Services P/L	271A Carlisle St, Balaclava	"	"
Busk, Terry Victor	31 Gabonia Ave, Watsonia	Mayne Nickless Ltd.	390 St. Kilda Rd, Melbourne	"	"
Cain, Michael William	16 Keys Crt, Narre Warren	" "	" "	"	"
Campbell, Ian Thomas	57 Buckingham St, Richmond	" "	" "	"	"
Cannon, Mark Anthony	Simpson Barracks, Watsonia	" "	" "	"	"
Chambers, Edward	32 Shoring Rd, Diggers Rest	" "	" "	"	"
Collie, Peter Robert	4 Frye St, Watsonia	" "	" "	"	"
Cotroneo, Claude	56 Purinuan Rd, Reservoir	Alef Security Services P/L	271A Carlisle St, Balaclava	"	"
Croot, Philip Rex	13 Black Springs Rd, Chirnside Park	Mayne Nickless Ltd.	390 St. Kilda Rd, Melbourne	"	"
Day, Kevin Campbell	11 Rosewall St, Sunshine	" "	" "	"	"
Deans, Anthony James	89 Great Pyrie St, Heathmont	" "	" "	"	"
Donaldson, Garry	32 Wackett St, Laverton	Alef Security Services P/L	271A Carlisle St, Balaclava	"	"
Draper, Russell Allan	32A York St, Bon Beach	Mayne Nickless Ltd.	390 St. Kilda Rd, Melbourne	"	"
Drilos, Peter	1/77 Harold St, Hawthorn	" "	" "	"	"
Efthimiadis, Nick	2 Selkirk Ave, Wantirna	Alef Security Services P/L	271A Carlisle St, Balaclava	"	"
Ferreira, Rodney Claude	2/488 Springvale Rd, Springvale	Mayne Nickless Ltd.	390 St. Kilda Rd, Melbourne	"	"
Ford, Winston Peter James	52 Durcell Ave, Portsea	" "	" "	"	"
Godden, Andrew Mark	3 Nutwood St, Reservoir	Alef Security Services P/L	271A Carlisle St, Balaclava	"	"

\*Or in the case of a firm or corporation, of the Nominee

## PRIVATE AGENTS—continued

Full Name of Applicant*	Place of Abode of Applicant or Nominee	Name of Firm or Corporation	Address for Registration	Type of Licence	Date of Hearing
MAGISTRATES' COURT, PRAHRAN—continued					
Hallas, Shaun	194 Cardigan Rd, Mooroolbark	Alef Security Services P/L	271A Carlisle St, Balaclava	Watchman	28.3.88
Hartinger, Karolina	21/7 Eldridge St, Footscray	Mayne Nickless Ltd.	390 St. Kilda Rd, Melbourne	"	"
Hatzipanagiotis, Dimitrios	39 Richard St, East Bentleigh	" "	" "	"	"
Hubbard, Maxwell Edmond	66 Kevin Ave, Ferntree Gully	" "	" "	"	"
Huddle, Edward Basil	14 Henderson St, Laverton	" "	" "	"	"
Jackson, Frederick Charles	32 Embankment Gve, Chelsea	" "	" "	"	"
Jensz, Wayne Ronald	2/10 Hatfield Crt, West Footscray	" "	" "	"	"
Kennedy, James Patrick	40 Roycroft Ave, Mill Park	" "	" "	"	"
Lee-Tet, Richard John	18 Anglers Dve, East Warburton	" "	" "	"	"
Lindsay, Thomas Martin	26 Maxweld St, Ardeer	" "	" "	"	"
Lobley, Robert Mark	1/77 Middles St, Glenroy	" "	" "	"	"
Looney, Tim Noel	19 Melba Ave, Sunbury	Mayne Nickless Ltd.	390 St. Kilda Rd, Melbourne	"	"
Marmarou, Basil	10 Monash St, Box Hill Sth.	" "	" "	"	"
Martin, Julie Anne	1A St. Neots Ave, Northcote	" "	" "	"	"
Michael, Michael	4 Arundel Crt, Box Hill Sth.	" "	" "	"	"
Murphy, Kevin	21 Hughes Cres, Dandenong	" "	" "	"	"
McCann, Andrew David	1 Cobby St, Laverton	" "	" "	"	"
McDonald, Donald Campbell	70 Princes Hwy, Dandenong	" "	" "	"	"
McDonald, Vernon Russell	6 Ironbark St, St. Albans	" "	" "	"	"
McFarland, Ian John	26 Churchill St, East Doncaster	" "	" "	"	"
Omelogullari, Zafer Victor	8 Bournemouth Ave, Springvale	" "	" "	"	"
Omerogullar, Ismail	8 Bournemouth Ave, Springvale	" "	" "	"	"
Parr, Steven Gary	7/14 Kingston Dve, Dingley	" "	" "	"	"
Pepi, Lawrence	44 Pardy St, Pascoe Vale	" "	" "	"	"

\*Or in the case of a firm or corporation, of the Nominee

## PRIVATE AGENTS—continued

Full Name of Applicant*	Place of Abode of Applicant or Nominee	Name of Firm or Corporation	Address for Registration	Type of Licence	Date of Hearing
<b>MAGISTRATES' COURT, PRAHRAN—continued</b>					
Phillips, Barry John	20/28 Canterbury St, Flemington	Mayne Nickless Ltd.	390 St. Kilda Rd, Melbourne	Watchman	28.3.88
Pollock, Alan Leslie	13 Sierra Crt, Hoppers Crossing	" "	" "	" "	" "
Rooney, Kevin Barry	21 Hermoine Ave, Oak Park	" "	" "	" "	" "
Roslaniac, Peter Witold	142 Mossfiel Dve, Hoppers Crossing	" "	" "	" "	" "
Rubigny, Emile Louis	31 Nicklause Dve, Hoppers Crossing	" "	" "	" "	" "
Russell, James	13 Apsley Rd, Belgrave	" "	" "	" "	" "
Skenderis, John	41 Talbot Ave, Thomastown	" "	" "	" "	" "
Stojkovski, John	1 Peppermint Crt, Altona Meadows	" "	" "	" "	" "
Sutton, Brian Joseph	50 Rissall St, Broadmeadows	" "	" "	" "	" "
Szabo, Charlie Frank	2 Grosvenor St, Balaclava	" "	" "	" "	" "
Theodoridis, Catherine Dorothy	19 Judkins Ave, Hoppers Crossing	" "	" "	" "	" "
Weatherhead, Geoffrey Alan	98 Lea Rd, Mulgrave	" "	" "	" "	" "
Welch, Brian Frederick	45 Browns Rd, Devon Meadows	" "	" "	" "	" "
Welsh, John Gordon	Lot 14, Markham Rd, Riddells Creek	" "	" "	" "	" "
White, Scott Norman	8 Pecan Crt, Frankston	" "	" "	" "	" "
Winnett, Robert John	12 Johnston St, Reservoir	" "	" "	" "	" "
Brown, Graeme Maxwell	18 Matlock Ave, Mulgrave	Specialized Attendance Service Pty. Ltd.	298 Victoria St, Richmond	Guard Agent	" "
Connally, Terence John	63 Rainier Ave, Dromana	" "	" "	" "	" "
Constanti, Sodorri	3 Parker Ave, Boronia	Boronia Investigations and Security Services	3 Parker Ave, Boronia	" "	" "
Michel, Albert	89 Kamrook Rd, Sth. Caulfield	United Security (Aust.)	89 Kamrook Rd, Sth. Caulfield	" "	" "

\*Or in the case of a firm or corporation, of the Nominee

## PRIVATE AGENTS—continued

Full Name of Applicant*	Place of Abode of Applicant or Nominee	Name of Firm or Corporation	Address for Registration	Type of Licence	Date of Hearing
MAGISTRATES' COURT, PRAHRAN—continued					
Brown, Graeme Maxwell	18 Matlock Ave, Mulgrave	Specialized Attendance Services Pty. Ltd.	298 Victoria St, Richmond	Inquiry Agent	28.3.88
Doan, Don Hung Do	7 Maidstone Ave, East Burwood		128 Bridge Rd, Richmond	"	"
Feather, Craig Hartley	14/73 Shoobra Rd, Elsternwick	Craig Feather Enterprises	14/73 Shoobra Rd, Elsternwick	"	"
Fellows, David John	98 Peel St, Windsor	Amalgamated Special Services	Suit 506, 5th Floor, 325 Chapel St, Prahran	"	"
Doan, Don Hung Do	7 Maidstone Ave, East Burwood		128 Bridge Rd, Richmond	Process Server	"
Dated at Prahran 20 February 1988 Clerk of the Magistrates' Court					
MAGISTRATES' COURT, WODONGA					
Fellowes, Ian James	569 David St, Albury, NSW	MSS Patrol Services	634 Graham St, Port Melbourne	Watchman	8.3.88
Rowe, Lionel George	10 George St, Seven Hills, NSW		2nd Floor, 222 Latrobe St, Melbourne	Process Server	"
Dated at Wodonga, 4 February 1988 P. DODGSON, Clerk of the Magistrates' Court					
MAGISTRATES' COURT, BROADMEADOWS					
Hansen, Gary Robert	24 Finchley Ave, Glenroy		390 St. Kilda Rd, Melbourne	Watchman	8.3.88
Dated at Broadmeadows, 2 February 1988 J. ISAACS, Clerk of the Magistrates' Court					
MAGISTRATES' COURT, BROADMEADOWS					
Anticevic, Ronald Victor	53 Stuart St, Moonee Ponds	Northside Security	191 Roberts Rd, Keilor	Watchman	9.3.88
Bacher, Knud Peter	174 Epsom Rd, Ascot Vale	MSS	5 Lily St, Coburg	"	18.2.88
Barry, Peter John	59 Westborne Gve, Northcote	"	" "	"	9.3.88
Lang, Edwin	7/241 Gower St, Preston	"	" "	"	"
Webb, Michael	13 Thomas St, Thomastown	"	" "	"	"
Dated at Broadmeadows, 27 January 1988 R. MALONEY, Clerk of the Magistrates' Court					

\*Or in the case of a firm or corporation, of the Nominee

## PRIVATE AGENTS—continued

Full Name of Applicant*	Place of Abode of Applicant or Nominee	Name of Firm or Corporation	Address for Registration	Type of Licence	Date of Hearing
<b>MAGISTRATES' COURT, BROADMEADOWS</b>					
Spriggs, Michael Kenneth	71 Marlborough St, Fawkner	D & C Security	4/128 Parks St, Moonee Ponds	Watchman	17.3.88
Stevens, Mark Peter	1/98 Rathmines St, Fairfield	M.S.S. Patrol Services	5 Lily St, Coburg	"	10.3.88
Dated at Broadmeadows 4 February 1988 R. MALONEY, Clerk of the Magistrates' Court					
<b>MAGISTRATES' COURT, RINGWOOD</b>					
Fradley, Derek	28 Avalon St, Mooroolbark		28 Avalon St, Mooroolbark	Inquiry Agent	26.2.88
" "	"		"	Guard Agent	"
Egdell, Andrew Robson	11 Bincit Dr, Bangholme		634 Graham St, Port Melbourne	Watchman	28.2.88
Dated at Ringwood 29 January 1988 D. D. REES, Clerk of the Magistrates' Court					
<b>MAGISTRATES' COURT, RINGWOOD</b>					
Dusting, Bruce Robert	35 Bungalook Rd, Bayswater		35 Bungalook Rd, Bayswater	Guard Agent	25.2.88
" "	"		"	Guard Agent Firm	"
Ward, John Victor	58 Andrew Cres, Croydon		"	Guard Agent	"
Dated at Ringwood 28 January 1988 D. D. REES, Clerk of the Magistrates' Court					
<b>MAGISTRATES' COURT, RINGWOOD</b>					
Myors, David Leslie	Lot 10A, Sayle St, Yarra Glen		634 Graham St, Port Melbourne	Watchman	1.3.88
Willoughby, Kenneth McKenzie	9 Tanunda St, Vermont South		"	"	"
Dated at Ringwood 2 February 1988 D. D. REES, Clerk of the Magistrates' Court					
<b>MAGISTRATES' COURT, SANDRINGHAM</b>					
Boisen, Donald Allen	1 Harry St, Moorabbin	D. A. Boisen & Associates	1 Harry St, Moorabbin	Inquiry Agent	4.3.88
Mackechnie, Ian Murray	20 Arranmore Ave, Black Rock	Imac Investigation & Security Service	20 Arranmore Ave, Black Rock	"	"
" "	"	"	"	Guard Agent	"
Dated at Sandringham 3 February 1988 HELEN L. MITCHELL, Clerk of the Magistrates' Court					

\*Or in the case of a firm or corporation, of the Nominee

## PRIVATE AGENTS—continued

Full Name of Applicant*	Place of Abode of Applicant or Nominee	Name of Firm or Corporation	Address for Registration	Type of Licence	Date of Hearing
<b>MAGISTRATES' COURT, SPRINGVALE</b>					
Ryan, Edward William	44 Government Rd, The Basin		390 St. Kilda Rd, Melbourne	Watchman	2.3.88
Dated at Springvale 3 February 1988 R. O'KEEFE, Clerk of the Magistrates' Court					
<b>MAGISTRATES' COURT, MOONEE PONDS</b>					
Handford, Mark Ian	13 Lyon St, Essendon		13 Lyon St, Essendon	Inquiry Agent	15.3.88
Dated at Moonee Ponds, 1 February 1988 Clerk of the Magistrates' Court					
<b>MAGISTRATES' COURT, BROADMEADOWS</b>					
De Pauli, Andrew	577 Rae St, North Fitzroy		390 St Kilda Rd, Melbourne	Watchman	16.3.88
Dated at Broadmeadows 4 February 1988 J. ISAACS, Clerk of the Magistrates' Court					
<b>MAGISTRATES' COURT, RINGWOOD</b>					
Laurens, Peter Alan	17 Piedmont St, Box Hill	M.S.S. Patrol Services	634 Graham St, Port Melbourne	Watchman	1.3.88
Dated at Ringwood 1 February 1988 D. D. REES, Clerk of the Magistrates' Court					

\*Or in the case of a firm or corporation, of the Nominee

## TAMBO RIVER IMPROVEMENT TRUST

## Rating By-law No. 31

The Tambo River Improvement Trust, in pursuance and exercise of the powers conferred by the *River Improvement Act 1958*, doth hereby make the By-law following:

1. The following rate to be called the "Tambo River Improvement District River Improvement Rate" is hereby made and shall be levied upon the occupiers or owners of all properties within the Tambo River Improvement District which are rateable to any Municipality.

A rate of 4.01 cents in the dollar on the nett annual value of all those properties within Divisions 1-9 inclusive as determined by the Order in Council made on 17 March 1964, and published in the *Government Gazette* on 18 March 1964.

The minimum rate shall be \$4.00.

2. Such rates are made and shall be levied for the period beginning with 1 January 1988, and ending with 31 December 1988, and shall be payable on 10 January 1988, at the Office of the Tambo River Improvement Trust, Bruthen.

3. Such person or persons as the Tambo River Improvement Trust may from time to time be appointed for that purpose shall be and is or are hereby authorised to demand, receive, collect and recover the said rate.

The foregoing By-law was made by the Tambo River Improvement Trust, on 2 December 1987, and the common seal of the trust was hereunto affixed on 2 December 1987, in the presence of:

A. J. NEAL, Chairman  
J. D. McKAY, Commissioner  
W. J. HOBSON, Secretary

Approved 23 December 1987—F. N. WILKES,  
Minister for Water Resources.

**AVON-MACALISTER RIVERS  
MANAGEMENT BOARD**

**Rating By-law No. 2, 1988**

The Avon-Macalister Rivers Management Board in pursuance of the powers conferred by the *River Improvement Act 1958*, doth hereby make the following By-law:

1. The rate to be called the "Avon-Macalister Rivers Management Board Rate" is hereby made and shall be levied upon the occupiers or owners of all properties within the Avon-Macalister Rivers Management District rateable to any Municipality:

(a) a rate of 0.95 cents in the Dollar of the Net Annual Value of those properties which were by an Order in Council made on 13 February 1979, deemed to be within the First and Second Divisions of the district of the former Avon River Improvement Trust (which district was, by an Order in Council made on 17 December 1985, included in the district of the Avon-Macalister Rivers Management Board).

(b) a rate of 0.95 cents in the Dollar of the Net Annual Value of those properties which were within the district of the former Macalister River Improvement Trust (which district was, by an Order in Council made on 17 December 1985, included in the district of the Avon-Macalister Rivers Management Board).

2. No rate is made or levied in respect of those properties which were by an Order in Council made on 13 February 1979, deemed to be within the Third Division of the district of the former Avon River Improvement Trust (which district was by an Order in Council made on 17 December 1985, included in the district of the Avon-Macalister Rivers Management Board).

3. The sum of four dollars (\$4.00) shall be the minimum amount of rate in respect of any property liable to be rated in the Avon-Macalister Rivers Management District.

4. Such rate is made and shall be levied for the year beginning 1 January 1988, and ending with 31 December 1988, and shall be payable on 1 January 1988, at the Office of the Avon-Macalister Rivers Management Board at Maffra.

5. Such person or persons as the Avon-Macalister Rivers Management Board may from time to time appoint for that purpose shall be and is or are hereby authorised to demand, collect and recover the said rate.

6. The foregoing By-law was made by the Avon-Macalister Rivers Management Board on 16 December 1987 and the Common Seal of the said Board was hereunto affixed on 16 December 1987.

J. S. DWYER, Chairman  
P. J. STEWART, Commissioner  
M. L. MOORE, Secretary

Approved 7 January 1988—F. N. WILKES,  
Minister for Water Resources

**Industrial Relations Commission of Victoria  
*Industrial Relations Act 1979***

**ADULT UNITS (DAY TRAINING  
CENTRES) INSTRUCTORS  
CONCILIATION AND ARBITRATION  
BOARD**

Notice is hereby given that an application has been lodged by the Victorian Teachers' Union for variation of the jurisdiction of the Adult Units (Day Training Centres) Instructors Conciliation and Arbitration Board to encompass the:

"occupation of instructors/assistants in sheltered workshops in the State of Victoria"

Notice is also given that this matter is listed for mention before the Industrial Relations Commission of Victoria in Full Session at 10.00 a.m. on Wednesday, 17 February 1988 in Hearing Room No. 1, Level 18, Nauru House, 80 Collins Street, Melbourne.

E. E. RAKUSZ  
Acting Deputy Registrar

**Industrial Relations Commission of Victoria**

**Industrial Relations Commission of Victoria  
*Industrial Relations Act 1979***

**TEACHERS (DAY TRAINING CENTRES)  
CONCILIATION AND ARBITRATION  
BOARD**

Notice is hereby given that an application has been lodged by the Victorian Teachers' Union for variation of the jurisdiction of the Teachers (Day Training Centres) Conciliation and Arbitration Board to include the words:

"teachers in early intervention programs associated, or previously associated, with Day Training Centres"

Notice is also given that this matter is listed for mention before the Industrial Relations Commission of Victoria in Full Session at 10.00 a.m. on Wednesday, 17 February 1988 in Hearing Room No. 1, Level 18, Nauru House, 80 Collins Street, Melbourne.

E. E. RAKUSZ  
Acting Deputy Registrar

**Industrial Relations Commission of Victoria**



*Co-operation Act 1981*

**CHANGE OF NAME OF A SOCIETY**

Notice is hereby given that Turkish Child Care Co-operative Limited which was incorporated as a Community Advancement Society under the above-named Act on 17 June 1976 has registered a change of its name and is now incorporated under the name of Turkish Community Services Co-operative Limited under the said Act.

Dated at Melbourne 20 January 1988

L. G. HOPKINS

Deputy Registrar of Co-operative Societies

*Co-operation Act 1981*

**ARTSMAN CO-OPERATIVE LIMITED  
MOYHU AND DISTRICT PRE-SCHOOL  
CO-OPERATIVE LIMITED  
6TH AND 7TH NORTH MOORABBIN BOY  
SCOUT CO-OPERATIVE LIMITED  
STAWELL SPORTS STADIUM CO-  
OPERATIVE SOCIETY LIMITED**

Notice is hereby given in pursuance of section 192 (8) of the *Co-operation Act 1981* and section 459 (2) of the *Companies (Victoria) Code*, that, at the expiration of three months from the date hereof, the names of the aforementioned societies will, unless cause is shown to the contrary, be struck off the register and the societies will be dissolved.

Dated at Melbourne 4 February 1988.

L. G. HOPKINS

Deputy Registrar of Co-operative Societies

**APPOINTMENTS AND  
RESIGNATIONS**

**APPOINTMENTS**

His Excellency the Governor of the State of Victoria by and with the advice of the Executive Council thereof has by Order made on 2 February 1988 been pleased to make the undermentioned appointments, viz:

Department of Health

*Trustee of Public Cemeteries*

Geoffrey Albert WILKINSON

to be a Trustee of the Crowlands Public Cemetery

John Ngi Chong KONG

to be a Trustee of the Horsham Cemetery

Councillors for the Shire of Bright

—Cr. Patrick Kelvin DICKENS

—Cr. Stuart HARGRAVES

—Cr. Gerard H. VAN-DINTER

—Cr. Ian Roberts ROPER

—Cr. Stephan SVARE

—Cr. Graham Ronald COOPER

—Cr. Heinz Karl Johannes WEISSENBOECK

—Cr. Brian Henry GOSS

—Cr. Leslie Norman PEART

—Cr. Roderick Leigh LUMSDEN

—Cr. Patrick Thomas COX and

—Cr. Sid DAL BOSCO

to be Trustees of the Harrietville Cemetery

Alan Gordon HUDSON

to be a Trustee of the Goornong Cemetery

Cuthbert Oswald HARRY

to be a Trustee of the The Necropolis

Geoffrey Neil KLIMECK

to be a Trustee of the Chewton Public Cemetery Trust

Alan Maxwell MORROW

Norm ROBERTS

Ronald Russell PLANT and

Allan MILLAR

to be Trustees of the Koondrook Public Cemetery Trust

Appointments were made pursuant to section 3 (1) of the *Cemeteries Act 1958*.

*Food Standards Committee*

Joan MACEWAN

to be a Member of the Foods Standards Committee, under section 62 (h) of the *Food Act 1984* vice, C. Sims, resigned, for the period ending 14 April 1990.

Attorney General's Department  
Crimes Compensation Tribunal

Mary Monica O'CALLAGHAN, a Barrister and Solicitor of not less than 7 years standing to be a Crimes Compensation Tribunal pursuant to Schedule 1 of the *Criminal Injuries Compensation Act 1983* for a period of office from 1 February 1988 to 27 May 1988.

*Legal Aid Commission*

Mary Anne NOONE, nominee of the Federation of Community Legal Centres to be an Alternative Member of the Legal Aid Commission for Caroline Ryan pursuant to section 4A (1) of the *Legal Aid Commission Act 1978*, for the remainder of the term of office of Caroline Ryan.

*Administrative Appeals Tribunal*

John ATKINSON  
Judith ATKINSON and

Val HEAP to be part-time Members of the Planning Division of the Administrative Appeals Tribunal pursuant to section 6A of the *Administrative Appeals Tribunal Act 1984* for a period of office from 2 February 1988 to 2 May 1988.

John ALDER to be a full-time Member of the Planning Division of the Administrative Appeals Tribunal pursuant to section 6A of the *Administrative Appeals Tribunal Act 1984* for the period ending 30 June 1988.

LAWRENCE A. FISHER

Clerk of the Executive Council

At the Executive Council Chamber  
Melbourne, 2 February 1988

REVOCATION OF APPOINTMENTS

His Excellency the Governor of the State of Victoria, by and with the advice of the Executive Council thereof, has, by Orders made on 2 February 1988, revoked the appointments of the persons named hereunder to the offices mentioned, viz:

Attorney General's Department  
*Justice of the Peace*

PASCOE-WEBBE, Marguerite Mary as Justice of the Peace pursuant to Part III of the *Magistrates' Courts Act 1971*.

*Commissioner for Taking Affidavits*

MERCER, Jeffrey John as Commissioner for taking Affidavits pursuant to section 114 (2) of the *Evidence Act 1958*.

LAWRENCE A. FISHER

Clerk of the Executive Council

At the Executive Council Chamber  
Melbourne, 2 February 1988

*Liquor Control Act 1968*  
APPOINTMENT OF LICENSING  
INSPECTORS

In accordance with the authority conferred upon me by section 6 of the *Police Regulation Act 1958*, I, Noel Ronald Newnham, Deputy Commissioner of Police, do hereby appoint under sub-section (1) of section 22 of the *Liquor Control Act 1968*, the following Officers of Police as Licensing Inspectors for the Divisions of the Police Districts as shown:

<i>Division Police Number District</i>	<i>Rank and Name</i>
3 Malvern	Inspector Graham James Brown, 15349 (from 7 February 1988 to 27 February 1988).
4 Malvern.	Inspector Graham James Brown, 15349 (from 10 January 1988 to 30 January 1988).

Dated 5 February 1988

N. R. NEWNHAM

Deputy Commissioner (Administration)

*Forests Act 1958*  
APPOINTMENT OF MEMBER AND  
CHAIRMAN OF THE TIMBER  
PROMOTION COUNCIL

Under the powers of the Forests (Part V—Timber Promotion) Regulations 1975, I hereby appoint Gerald Griffin as a member of and as chairman (vice Robert Smith resigned as chairman only) of the Timber Promotion Council until 31 October 1988.

J. E. KIRNER

Minister for Conservation, Forests and Lands

RESIGNATIONS

His Excellency the Governor of the State of Victoria by and with the advice of the Executive Council thereof has by Orders made on 2 February 1988 accepted the resignations of the persons named hereunder of the offices mentioned, viz:

Attorney-General's Department

*Justices of the Peace*

AINSWORTH, John Norman  
BRENCHLEY, Leonard John  
CHESHER, Albert George  
CONGRAM, William Maxwell  
FALCONER, Keith Angus

FINLAYSON, Alexander Terris  
GODWIN, James Hubert  
HUNTER, Maxwell John  
KNIGHT, Richard Carlile  
LARKIN, Thomas Francis  
MONCRIEFF, Eric John  
RITCHIE, Robert Arnold  
ROSEL, Gerald Kevin  
SHEPPERBOTTOM, Percival Charles  
SMITH, James Ralston  
STEVENS, Gordon Ralph  
THOMPSON, Alfred Ernest and  
TWEED, Justine Constance Broughton as  
Justices of the Peace, pursuant to Part III of the  
*Magistrates' Courts Act 1971.*

*Commissioners for Taking Affidavits*

AINSCOW, Robert Ian  
ALLAN, Robert George  
ALLEN, Malcolm William  
BAPTIST, Sheila Rose  
BEARD, Peter Bruce  
BENNETT, Rodney Phillip  
BENNETT-YULES, Margaret Helen  
BICKNELL, Lynette  
BLUNT, David Frederick Gresley  
BOWER, Lindsay Ray  
BROADWAY, Heather Christina  
BULMER, Patricia Eileen  
BURDETT, Allan Hugh  
BURNS, Stewart Norman  
CAFARELLA, Robert  
CERDOR, Joseph Marie Geo  
CHAPMAN, Pamela Janne  
CHUBB, Ronald James  
COLLINS, Wallace Arnold  
COUNSEL, Adrian Bernard  
CROCOS, Alan Edward Henry  
CROFT, Stanley James  
CULLEN, Douglas James  
DALTON, Jeffrey Clive  
DAVIES, Kenneth Albert  
DELAHUNT, Brendan John  
DILLON, Robert Charles  
DOLLING, David Frederick  
DOWNES, Kevin Michael  
EHMS, Alan Andrew  
FLANAGAN, John Stephen  
FLOYD, Eoin Melville  
FLYNN, John Joseph

FRENCH, Ronald Anthony  
GERVASONI, Rex Kelvin  
GIBNEY, Leo  
GRAY, Francis Walter  
GREENAWAY, Peter James  
HAMBLY, Loretta Joy  
HAYES, John Gerard  
HIGGINS, Eileen Josephine Patricia  
HOUGH, Alan David  
JEFFS, Zane Byron  
JILLARD, Kenneth Alan  
JOEL, Francis Clayton  
KAHAN, Leon Alexander  
KIELY, Stephen Robert  
KNOP, Ian Milton  
LINDREA, Frances  
MAY, John Leslie  
MCCOLL, Vincent  
MCDONALD, John  
MCHARDY, James Patrick  
MCLACHLAN, Ian  
MCLAREN, Alexander John  
MOLLOY, John Anthony  
MORRISH, Margaret May  
NOLAN, Francis  
O'CALLAGHAN, Brian Frederick  
O'CONNOR, John Francis  
O'DAY, Paul Joseph  
O'NEILL, Brian Edward  
PETERSON, Robert Banks  
PINDER, Rock John  
REID, Lynette Anne  
RENTZIS, Elias  
RICHARDS, Michael Allen  
ROBERTS, Francis Reginald  
SHACKLETON, Janet Elizabeth  
SHELTON, Arthur Trevis  
SHERRY, James Francis  
SINCLAIR, Allan Lance  
SLAGTMAN, Bernard Theodore  
SPANDIDEAS, Stavtos  
SUTHERLAND, Derek Bowman  
TEMPLETON, Robert William  
THEODOS, Chris  
THOMAS, John  
TITTERELL, Kevin Rodney  
TWOMEY, Mathew Aidan  
TYLER, Sydney Lawrence  
VAN NOOTEN, David John

WHITFIELD, David Norman and  
YOUNG, Michael John as Commissioners for  
Taking Affidavits pursuant to section 114 (3) of  
the *Evidence Act 1958*.

LAWRENCE A. FISHER  
Clerk of the Executive Council  
At the Executive Council Chamber  
Melbourne, 2 February 1988

## ORDERS IN COUNCIL

*Local Government Act 1958*

### RESUBDIVISION OF THE MUNICIPAL DISTRICT OF THE SHIRE OF UPPER MURRAY

The Governor in Council, acting under Part II  
of the *Local Government Act 1958*, orders—

1. that on and from 1 April 1988 the municipal district of the Shire of Upper Murray shall be resubdivided into three ridings whose names and boundaries are described hereunder;
2. that the number of councillors shall be nine.

Corryong Riding

Reduced and Re-defined

Previous Gazettal 1982.172

Commencing at the eastern angle of the Township of Corryong; thence south-westerly by the township boundary to Parish Lane; thence north-westerly by that lane and Briggs Gap Road to the north-western boundary of the Township; thence north-easterly by that boundary and south-easterly by the north-eastern boundary of the Township to the point of commencement.

Tintaldra Riding

Enlarged and Re-defined

Previous Gazettal 1982.172

Commencing at the junction of the northern boundary of the Parish of Cudgewa with the western boundary of the Parish of Tintaldra, being a point on the Shire boundary; thence generally southerly by the western boundary of the Parish of Tintaldra to the road forming the north-western boundary of allotment 9, Section 5, Parish of Cudgewa; thence south-westerly by that road to the southern angle of allotment 4, Section 5; thence further south-westerly by a line to the eastern angle of allotment 4, Section 6, being a point on the western boundary of allotment 7; thence south-westerly and south-easterly by that boundary and further south-easterly by a line to the northern angle of allotment 13A; thence south-easterly and south-westerly by the north-eastern and south-eastern boundaries of that allotment to the north-eastern boundary of allotment 11, Section 7; thence south-easterly by that boundary and south-westerly by the road forming the south-eastern boundary of the said allotment to the northern angle of allotment A, section B, Parish of Colac Colac; thence south-easterly and north-easterly by a road to the northern angle of allotment 2, Section A; thence south-easterly by a road to the north-western boundary of the Township of Corryong; thence north-easterly, south-easterly

and south-westerly by the Township boundary to the western angle of allotment 4, Section Z, Parish of Colac Colac; thence south-easterly by a road to the most northern angle of allotment 10, Section Z; thence south-westerly and generally south-easterly by a road to the eastern boundary of allotment 2, Section 1; thence southerly by that boundary and westerly by a road to the western boundary of allotment 8, Section 2; thence southerly by that boundary and the western boundary of allotment 10 and further southerly, westerly and northerly by the eastern, southern and western boundaries of allotment 12A, Section 1 to the road forming the northern boundary of the said allotment; thence south-westerly by that road to the north-eastern angle of allotment 7c, Section 4; thence southerly and westerly by the eastern and southern boundaries of that allotment to the road forming the western boundary of the said allotment; thence generally southerly by that road to the north-western angle of allotment 12, Section 6; thence further southerly by the range dividing the watersheds of the Nariel and Thougla Creeks to Mount Gibbo, being a point on the Shire boundary; and thence south-easterly, generally northerly and southerly by the Shire boundary to the point of commencement.

Cudgewa Riding  
Enlarged and Re-defined  
Previous Gazettal 1982.172

Commencing at the junction of the northern boundary of the Parish of Cudgewa with the western boundary of the Parish of Tintaldra, being a point on the Shire boundary; thence generally southerly by the western boundary of the Parish of Tintaldra to the road forming the north-western boundary of allotment 9, Section 5, Parish of Cudgewa; thence south-westerly by that road to the southern angle of allotment 4, Section 5; thence further south-westerly by a line to the eastern angle of allotment 4, Section 6 being a point on the western boundary of allotment 7; thence south-westerly and south-easterly by that boundary and further south-easterly by a line to the northern angle of allotment 13A; thence south-easterly and south-westerly by the north-eastern and south-eastern boundary of that allotment to the north-eastern boundary of allotment 11, Section 7; thence south-easterly by that boundary and south-westerly by the road forming the south-eastern boundary of the said allotment to the northern angle of allotment A, Section B, Parish of Colac Colac; thence south-easterly and north-easterly by a road to the northern angle of allotment 2, Section A; thence south-easterly by a road to the south-eastern boundary of the Township of

Corryong; thence south-westerly by the Township boundary to the western angle of allotment 4, Section Z, Parish of Colac Colac; thence south-easterly by a road to the most northern angle of allotment 10, Section Z; thence south-westerly and generally south-easterly by a road to the eastern boundary of allotment 2, Section 1; thence southerly by that boundary and westerly by a road to the western boundary of allotment 8, Section 2; thence southerly by that boundary and the western boundary of allotment 10 and further southerly, westerly and northerly by the eastern, southern and western boundaries of allotment 12A, Section 1 to the road forming the northern boundary of the said allotment; thence south-westerly by that road to the north-eastern angle of allotment 7c, Section 4; thence southerly and westerly by the eastern and southern boundaries of that allotment to the road forming the western boundary of the said allotment; thence generally southerly by that road to the north-western angle of allotment 12, Section 6; thence further southerly by the range dividing the watersheds of the Nariel and Thougla Creeks to Mount Gibbo, being a point on the Shire boundary; and thence generally north-westerly and generally north-easterly by the Shire boundary to the point of commencement.

Dated 2 February 1988

Responsible Minister:

J. L. SIMMONDS  
Minister for Local Government

LAWRENCE A. FISHER  
Clerk of the Executive Council

*Local Government Act 1958*

RESUBDIVISION OF THE MUNICIPAL  
DISTRICT OF THE SHIRE OF  
SHERBROOKE

The Governor in Council, acting under Part II of the *Local Government Act 1958*, orders—

1. that on and from 1 April 1988 the municipal district of the Shire of Sherbrooke shall be resubdivided into four ridings whose names and boundaries are described hereunder;
2. that all councillors shall go out of office on the day appointed for the election of councillors next after this Order takes effect; and
3. that the number of councillors shall be twelve.

South Riding  
Re-defined

Previous Gazettal 1963.3152

Commencing on the western boundary of the Shire where Lysterfield Road is intersected by Monbulk Creek; thence south-easterly by that

creek and easterly by the northern boundary of the Monbulk Creek Retarding Basin to the eastern boundary of the Lysterfield Postal District; thence northerly by that boundary and the eastern boundary of the Upwey Postal District to the Ferntree Gully-Belgrave Railway; thence generally easterly by that railway and the Emerald Tourist Railway to the Belgrave-Gembrook Road, being a point on the southern boundary of the Dandenong Ranges National Park as shown on plan N.P. 86 lodged in the Central Plan Office; thence generally easterly by that boundary to the Belgrave-Gembrook Road; thence southerly by that road to Boyce Road; thence south-easterly by that road to Johns Road; thence northerly and south-easterly by that road to Black Hill Road; thence easterly by that road to School Road; thence south-westerly and south-easterly by that road and further south-easterly by Menzies Road to the Belgrave-Gembrook Road; thence south-easterly by that road to Wellington Road; thence south-westerly by that road to Glenbrook Road; thence southerly by that road and a line in continuation thereof to the northern boundary of the Melbourne and Metropolitan Board of Works land surrounding the Cardinia Reservoir; thence generally easterly and south-easterly by that boundary to the south-eastern boundary of the Shire, and thence generally south-westerly, westerly and northerly by the Shire boundary to the point of commencement.

**Centre Riding  
Re-defined**

Previous Gazettal 1963.3152

Commencing on the western boundary of the Shire where Lysterfield Road is intersected by Monbulk Creek; thence south-easterly by that creek and easterly by the northern boundary of the Monbulk Creek Retarding Basin to the eastern boundary of the Lysterfield Postal District; thence northerly by that boundary and the eastern boundary of the Upwey Postal District and westerly by the northern boundary of that district to Hughes Street; thence north-westerly by a direct line to the junction of Birdwood Avenue with Himalaya Road, being a point on the western boundary of the Shire, and thence southerly by the Shire boundary to the point of commencement.

**East Riding  
Reduced and Re-defined**

Previous Gazettal 1963.3152

Commencing on the northern boundary of the Shire at the junction of Holden Road with the Olinda-Monbulk Road; thence south-westerly by Holden Road to the eastern boundary of allotment 65, Section C, Parish of Monbulk;

thence south-easterly by that boundary and a line in continuation thereof to Monbulk Road; thence south-westerly by that road to the eastern boundary of allotment 20, Section H; thence south-westerly by that boundary to the Kallista-Emerald Road; thence south-easterly by that road to the eastern boundary of allotment 33; thence southerly by that boundary and the eastern boundary of allotment 35 to Ward Road; thence westerly by that road to Grantulla Road being a point on the eastern boundary of the Dandenong Ranges National Park as shown on plan N.P. 86 lodged in the Central Plan Office; thence generally southerly and westerly by the park boundary to the Emerald Tourist Railway; thence generally westerly by that railway and the Ferntree Gully-Belgrave Railway to the eastern boundary of the Upwey Postal District; thence northerly by that boundary and westerly by the northern boundary of that Postal District to Hughes Street; thence north-westerly by a direct line to the junction of Birdwood Avenue with Himalaya Road, being a point on the western boundary of the Shire, and thence northerly generally easterly and south-easterly by the Shire boundary to the point of commencement.

**Emerald Riding  
Enlarged and Re-defined**

Previous Gazettal 1963.3152

Commencing on the northern boundary of the Shire at the junction of Holden Road with the Olinda-Monbulk Road; thence south-westerly by Holden Road to the eastern boundary of allotment 65, Section C, Parish of Monbulk; thence south-easterly by that boundary and a line in continuation thereof to Monbulk Road; thence south-westerly by that road to the eastern boundary of allotment 20, Section H; thence south-westerly by that boundary to the Kallista-Emerald Road; thence south-easterly by that road to the eastern boundary of allotment 33; thence southerly by that boundary and the eastern boundary of allotment 35 to Ward Road; thence westerly by that road to Grantulla Road being a point on the eastern boundary of the Dandenong Ranges National Park as shown on plan N.P. 86 lodged in the Central Plan Office; thence generally southerly by that boundary to the eastern boundary of allotment 5A, Section A, Parish of Narree Worrان, being a point on the Belgrave-Gembrook Road; thence southerly by that road to Boyce Road; thence south-easterly by that road to Johns Road; thence northerly and south-easterly by that road to Black Hill Road; thence easterly by that road to School Road; thence south-westerly and south-easterly by that road and further south-easterly by Menzies Road to the Belgrave-Gembrook Road; thence south-

easterly by that road to Wellington Road; thence south-westerly by that road to Glenbrook Road; thence southerly by that road and a line in continuation thereof to the northern boundary of the Melbourne and Metropolitan Board of Works land surrounding the Cardinia Reservoir; thence generally easterly and south-easterly by that boundary to the south-eastern boundary of the Shire, and thence generally north-easterly, north-westerly, south-westerly and north-westerly by the Shire boundary to the point of commencement.

Dated 2 February 1988

Responsible Minister:

J. L. SIMMONDS

Minister for Local Government

LAWRENCE A. FISHER  
Clerk of the Executive Council

*Local Government Act 1958*  
**AMENDMENT OF AN ORDER MADE FOR  
THE RESUBDIVISION OF THE  
MUNICIPAL DISTRICT OF THE SHIRE OF  
TULLAROOP**

By an Order published in the *Government Gazette* on 16 December 1987 the Governor of Victoria acting with the advice of the Executive Council and under Part II of the *Local Government Act 1958* ordered that on and from 1 April 1988 the municipal district of the Shire of Tullaroop be subdivided into four ridings and described the boundaries of the Norwood, Rodborough, Charlotte Plains and Carisbrook Ridings.

The Governor of Victoria acting with the advice of the Executive Council and pursuant to section 28 (3) (f) of the Act hereby amends the Order by deleting from the Order the described boundaries for the Charlotte Plains and Carisbrook Ridings and substituting the following descriptions:

**Charlotte Plains Riding  
Constituted**

Commencing on the western boundary of the Shire at the south-western angle of allotment 4, section 5A, Parish of Bet Bet; thence easterly by the southern boundary of that allotment and northerly by the road forming the eastern boundary of that allotment to the southern boundary of allotment 1A; thence easterly by that boundary, further easterly and northerly by the southern and eastern boundaries of allotment 1B and easterly by the road forming the southern boundary of allotment 8, section 1A to the western boundary of allotment 32 being the eastern boundary of the reserved forest; thence generally

southerly by that boundary to the north-western boundary of the Municipal District of the City of Maryborough; thence north-easterly and south-easterly by the City boundary to the Castlemaine and Maryborough Railway, thence easterly by that railway to the western boundary of allotment 5C, section A<sup>1</sup>, Parish of Maryborough, thence northerly by that boundary and the western boundaries of allotments 2D and 2E to Old Tullaroop Road; thence south-easterly by that road to the western boundary of allotment 2A; thence northerly by that boundary and easterly by the northern boundary of that allotment to the western boundary of the Parish of Carisbrook, thence northerly by that parish boundary to the road forming the southern boundary of allotment 6A, Parish of Carisbrook, thence easterly by that road and the road forming the southern boundary of section 22 to the road forming the western boundary of allotment 20, no section, thence southerly by that road and the western boundary of allotment 18, no section, to the Tullaroop Creek; thence generally south-easterly by that creek and the eastern shore of Tullaroop Reservoir to the southern boundary of the Shire, and thence generally easterly, northerly, north-westerly and south-westerly by the Shire boundary to the point of commencement.

**Carisbrook Riding  
Constituted**

Commencing on the north-eastern boundary of the Municipal District of the City of Maryborough where it is intersected by the Castlemaine and Maryborough Railway; thence easterly by that railway to the western boundary of allotment 5C, section A<sup>1</sup>, Parish of Maryborough, thence northerly by that boundary and the western boundaries of allotments 2D and 2E to Old Tullaroop Road; thence south-easterly by that road to the western boundary of allotment 2A; thence northerly by that boundary and easterly by the northern boundary of that allotment to the western boundary of the Parish of Carisbrook, thence northerly by that parish boundary to the road forming the southern boundary of allotment 6A, Parish of Carisbrook; thence easterly by that road and the road forming the southern boundary of section 22 to the road forming the western boundary of allotment 20, no section, thence southerly by that road and the western boundary of allotment 18, no section, to the Tullaroop Creek; thence southerly by that creek to the western boundary of allotment 1, section 2, thence southerly by that boundary to Freehold Lane, thence westerly by that lane to McCallum Creek, thence generally southerly by that creek to a road forming the southern boundary of allotment 13, no section, thence

westerly by that road and Williams Road to the south-western angle of allotment 13D, section A, being a point on the eastern boundary of the reserved forest, thence generally northerly and westerly by that boundary to the north-eastern boundary of the Municipal District of the City of Maryborough, and thence north-westerly by that boundary to the point of commencement.

Dated 2 February 1988

Responsible Minister:

J. L. SIMMONDS  
Minister for Local Government

LAWRENCE A. FISHER  
Clerk of the Executive Council

*Local Government Act 1958*

**RESUBDIVISION OF THE MUNICIPAL DISTRICT OF THE SHIRE OF BALLARAT**

The Governor in Council, acting under Part II of the *Local Government Act 1958*, orders—

1. that on and from 1 April 1988 the municipal district of the Shire of Ballarat shall be resubdivided into four ridings whose names and boundaries are described hereunder;

2. that all councillors shall go out of office on the day appointed for the election of councillors next after this Order takes effect; and

3. that the number of councillors shall be twelve.

**Showgrounds Riding  
Constituted**

Commencing on the Shire boundary at the intersection of Gregory Street and Forest Street; thence northerly by Forest Street to Olliers Road; thence easterly by that road to the Shire boundary, and thence south-easterly and westerly by the Shire boundary to the point of commencement.

**Central Riding  
Constituted**

Commencing on the Shire boundary at the intersection of Gregory Street and Forest Street; thence northerly by Forest Street to Olliers Road; thence westerly by that road to Gillies Street; thence southerly by that street to the Burrumbeet Creek; thence westerly, north-westerly and south-westerly by that creek to the road forming the southern boundary of allotment 63C, Parish of Dowling Forest; thence westerly by that road to the Ballarat-Maryborough Road; thence southerly by that road to the Sunraysia Highway; thence southerly by that highway and south-easterly by Learmonth Road to Grevillea Road; thence north-easterly by that road to Gillies

Street; thence southerly by that street to the Shire boundary at Gregory Street, and thence easterly by the Shire boundary to the point of commencement.

**Alfredton Riding  
Constituted**

Commencing at the intersection of the Ballarat-Carngham Road and Finchs Road being a point on the southern boundary of the Shire; thence northerly by Finchs Road to Carngham No. 2 Road; thence westerly by that road to Finchs Road; thence again northerly by that road to the Western Highway; thence north-westerly by that highway to Dowling Road; thence northerly by that road to McCartneys Road; thence easterly by that road and further easterly by the road forming the southern boundary of allotment 64, Parish of Dowling Forest to the Ballarat-Maryborough Road; thence southerly by that road to the Sunraysia Highway; thence southerly by that highway and south-easterly by Learmonth Road to Grevillea Road; thence north-easterly by that road to Gillies Street; thence southerly by that street to the Shire boundary at Gregory Street; and thence southerly, north-westerly, again southerly and westerly by the Shire boundary to the point of commencement.

**Rural Riding  
Constituted**

Commencing at the intersection of the Ballarat-Carngham Road and Finchs Road being a point on the southern boundary of the Shire; thence northerly by Finchs Road to Carngham No. 2 Road; thence westerly by that road to Finchs Road; thence again northerly by that road to the Western Highway; thence north-westerly by that highway to Dowling Road; thence northerly by that road to McCartneys Road; thence easterly by that road and further easterly by the road forming the southern boundaries of allotments 64, 63, 63A, 63B and 63C, Parish of Dowling Forest to the Burrumbeet Creek, thence north-easterly, south-easterly and easterly by that creek to Gillies Street; thence northerly by that street to Olliers Road; thence easterly by that road to the Shire boundary, and thence northerly, westerly, southerly and easterly by the Shire boundary to the point of commencement.

Dated 2 February 1988

Responsible Minister:

J. L. SIMMONDS  
Minister for Local Government

LAWRENCE A. FISHER  
Clerk of the Executive Council



*Local Government Act 1958*

**RESUBDIVISION OF THE MUNICIPAL DISTRICT OF THE SHIRE OF SEYMOUR**

The Governor in Council, acting under Part II of the *Local Government Act 1958* orders—

1. that on and from 1 April 1988 the municipal district of the City of Seymour shall be resubdivided into four ridings whose names and boundaries are described hereunder;

2. that all councillors of the Avenel and Seymour North Ridings shall go out of office on the day appointed for the election of councillors next after this Order takes effect; and

3. that the number of councillors shall be twelve.

**Avenel Riding**

**Enlarged and Re-defined**

**Previous Gazettal 1966.1885**

Commencing on the Shire boundary at the south-western angle of allotment 33A, Section A, Parish of Worrour; thence north-westerly by a road to the north-western angle of allotment 31, Section A; thence northerly by a road to Kobyboyn Road; thence westerly by that road to Telegraph Road; thence south-westerly by that road to the Goulburn Valley Highway; thence north-westerly by that highway to Delatite Road; thence northerly by that road to Whiteheads Creek; thence north-westerly by that creek to the Goulburn River; thence generally northerly by that river to a point in line with the road forming the southern boundary of allotment 10, Parish of Northwood; thence westerly by a line and a road to the south-western angle of allotment 16A, Section B; thence due west by a line to the Shire boundary, and thence generally north-easterly, south-easterly and south-westerly by the Shire boundary to the point of commencement.

**Seymour North Riding**

**Reduced and Re-defined**

**Previous Gazettal 1966.1885**

Commencing at the junction of Whiteheads Creek with the Goulburn River; thence south-easterly by Whiteheads Creek to Delatite Road; thence south-westerly by that road to Anzac Avenue; thence north-westerly by that avenue to the North Eastern Railway; thence south-westerly by that railway to the Goulburn River, and thence generally north-westerly and generally north-easterly by that river to the point of commencement.

**Seymour South Riding**

**Reduced and Re-defined**

**Previous Gazettal 1966.1885**

Commencing on the Goulburn River where it is crossed by the North Eastern Railway; thence

north-easterly by the North Eastern Railway to Anzac Avenue; thence south-easterly by that avenue and the Goulburn Valley Highway to the south-eastern angle of allotment 52A, Parish of Tallarook; thence westerly by the southern boundary of that allotment and allotment 51 and further westerly by a line in continuation thereof to the Goulburn River, and thence generally north-westerly by that river to the point of commencement.

**Tallarook Riding**

**Reduced and Re-defined**

**Previous Gazettal 1966.1885**

Commencing on the Shire boundary at the south-western angle of allotment 33A, Section A, Parish of Worrour; thence north-westerly by a road to the north-western angle of allotment 31, Section A; thence northerly by a road to Kobyboyn Road; thence westerly by that road to Telegraph Road; thence south-westerly by that road to the Goulburn Valley Highway; thence north-westerly by that highway to the south-eastern angle of allotment 52A, Parish of Tallarook; thence westerly by the southern boundary of that allotment and allotment 51 and further westerly by a line in continuation thereof to the Goulburn River; thence generally north-westerly, north-easterly and northerly by that river to a point in line with the road forming the southern boundary of allotment 10, Parish of Northwood; thence westerly by a line and a road to the south-western angle of allotment 16A, Section B; thence due west by a line to the Shire boundary, and thence southerly, easterly and north-easterly by the Shire boundary to the point of commencement.

Dated 2 February 1988

Responsible Minister:

J. L. SIMMONDS

Minister for Local Government

LAWRENCE A. FISHER  
Clerk of the Executive Council

*Local Government Act 1958*

**AMENDMENT OF AN ORDER MADE FOR THE RESUBDIVISION OF THE MUNICIPAL DISTRICT OF THE SHIRE OF BULN BULN**

By an Order published in the *Government Gazette* on 16 December 1987 the Governor of Victoria acting with the advice of the Executive Council and under Part II of the *Local Government Act 1958* ordered that on and from 1 April 1988 the municipal district of the Shire of Buln Buln be subdivided into four ridings and described the boundaries of the Neerim, South Drouin, North Drouin and Longwary Ridings.

The Governor of Victoria acting with the advice of the Executive Council and pursuant to section 28 (3) (f) of the Act hereby amends the Order by deleting from the Order the described boundaries for the South Drouin, North Drouin and Longwarry Ridings and substituting the following descriptions:

South Drouin Riding  
Constituted

Commencing at a point on the eastern boundary of the Shire where it is intersected by the Gippsland Railway, thence generally north-westerly by that railway to Viaduct Place, thence northerly by that place to Princes Highway (Drouin-Warragul Road), thence generally north-westerly by that highway to Wellwood Road (Longwarry-Drouin Road), thence westerly by that road to the Longwarry Road, thence southerly by that road, the western boundary of allotment 67D, Parish of Drouin West and a line in continuation thereof to the road forming the northern boundary of allotment 68, thence westerly by that road to the road forming the western boundary of allotment 69A, thence southerly by that road and Box Road to the northern boundary of allotment 104, thence south-westerly and southerly by the north-western and western boundaries of that allotment and further southerly by the eastern boundary of allotment 105 to David Lane, thence easterly by that lane to Gardner and Holman Road, thence south-westerly by that road to Ringin Road, thence generally south-easterly by that road to the Main South Road, thence southerly by that road to the southern boundary of the Parish of Drouin West, thence easterly, southerly and easterly by that boundary to the Shire boundary, and thence northerly by that boundary to the point of commencement.

North Drouin Riding  
Constituted

Commencing at the junction of the northern boundary of allotment 25A Parish of Drouin West with the eastern boundary of the Shire, thence westerly by the northern boundary of that allotment, Lockwood Road, the southern boundaries of allotment 7A and allotment 6B and Walton Road to the Main Neerim Road, thence southerly by that road to the Princes Freeway, thence generally north-westerly by that freeway and the Princes Highway to McGlone Road, thence southerly by that road to Cook Road, thence westerly by that road to the Longwarry-Drouin Road, thence south-easterly and easterly by that road to the Drouin-Warragul Road, thence generally south-easterly by that road to Viaduct Place, thence southerly by that place to the Gippsland Railway, thence generally south-

easterly by that railway to the Shire boundary, and thence northerly by that boundary to the point of commencement.

Longwarry Riding  
Constituted

Commencing at the junction of the northern boundary of the Parish of Jindivick with the western boundary of the Shire, thence easterly by the northern boundary of that parish to a point in line with the eastern boundary of allotment 106C Parish of Jindivick, thence southerly by a line, the eastern boundaries of allotment 106D and allotment 106C to the northern boundary of allotment 110F, thence easterly and southerly by the northern and eastern boundaries of that allotment and further southerly by the eastern boundaries of allotment 110G and allotment 110E to the north-western angle of allotment 111, thence easterly and southerly by the northern and eastern boundaries of that allotment to the north-western angle of allotment 111A, thence easterly by the northern boundary of that allotment to Forest Road, thence generally easterly by that road to the northern boundary of allotment 111B, thence generally south-easterly by that boundary to the western boundary of allotment 69, thence northerly by that boundary and easterly by the northern boundaries of allotment 69, allotment 69B and again allotment 69 to the road forming the eastern boundary of that allotment, thence southerly by that road to Jacksons Track, thence south-westerly by that track to Fisher Road, thence easterly and southerly by that road to the Princes Highway, thence westerly by that highway to McGlone Road, thence southerly by that road to Cook Road, thence westerly by that road to the Longwarry-Drouin Road, thence south-easterly and southerly by that road and the western boundary of allotment 67D, Parish of Drouin West and a line in continuation thereof to the road forming the northern boundary of allotment 68, thence westerly by that road to the road forming the western boundary of allotment 69A, thence southerly by that road and Box Road to the northern boundary of allotment 104, thence south-westerly and southerly by the north-western and western boundaries of that allotment and further southerly by the eastern boundary of allotment 105 to David Lane, thence easterly by that lane to Gardner and Holman Road, thence south-westerly by that road to Ringin Road, thence generally south-easterly by that road to the Main South Road, thence southerly by that road to the southern boundary of the Parish of Drouin West, thence easterly, southerly and easterly by that boundary to the Shire boundary,

and thence southerly, westerly and generally northerly by that boundary to the point of commencement.

Dated 2 February 1988

Responsible Minister:

J. L. SIMMONDS

Minister for Local Government

LAWRENCE A. FISHER

Clerk of the Executive Council

*Local Government Act 1958*

**ALTERATION OF THE NAME OF THE SUBDIVISIONS OF THE MUNICIPAL DISTRICT OF THE SHIRE OF WHITTLESEA**

Whereas by an Order published in the *Government Gazette* on 16 December 1987 the Governor in Council under Part II of the *Local Government Act 1958* ordered that on and from 1 April 1988 the municipal district of the Shire of Whittlesea be subdivided into four ridings viz. South West, Central, South East and Whittlesea and Yan Yean Ridings.

Now, the Governor in Council acting with the advice of the Executive Council and pursuant to section 24B (1) of the Act, hereby alters the names of the respective subdivisions to be known as West, Central, East and North Ridings on and from 1 April 1988.

Dated 2 February 1988

Responsible Minister:

J. L. SIMMONDS

Minister for Local Government

LAWRENCE A. FISHER

Clerk of the Executive Council

*Crown Land (Reserves) Act 1978*  
**CROWN LANDS TEMPORARILY RESERVED**

The Governor in Council under sections 4 and 7 of the *Crown Land (Reserves) Act 1978* temporarily reserves for the purposes mentioned and also excepts from prospecting or from occupation for mining purposes under any miners right the following Crown lands:

**MUNICIPAL DISTRICT OF THE SHIRE OF SWAN HILL**

**ANNUELLO**—Preservation of species of native plants and animals, 325 hectares, more or less, being Crown Allotments 47B, 50D and 55A, Parish of Annuello as indicated by hatching on plan hereunder—(Rs. 13700).

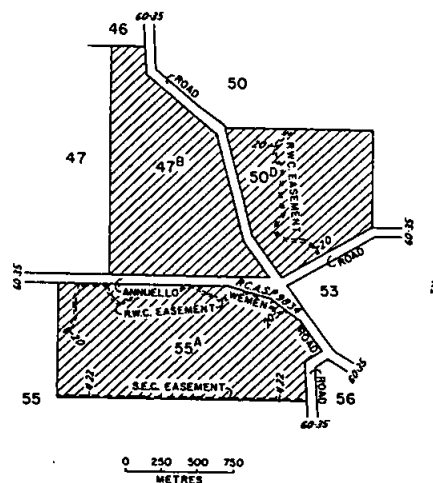

Total area of hatched portions 325 ha.

**MUNICIPAL DISTRICT OF THE SHIRE OF WALPEUP**

**WYMLET**—Conservation of an area of natural interest, 37 hectares, more or less being Crown Allotments 7 and 7A, Parish of Wymlet as indicated by hatching on plan hereunder—(Rs. 13698).

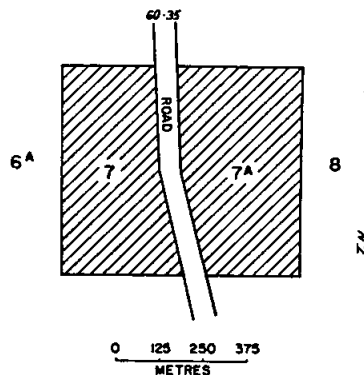

Total area of hatched portions 37 ha.

Dated 2 February 1988

Responsible Minister:

JOAN E. KIRNER

Minister for Conservation, Forests and Lands

LAWRENCE A. FISHER

Clerk of the Executive Council

**Crown Land (Reserves) Act 1978  
CROWN LANDS TEMPORARILY  
RESERVED**

The Governor in Council under sections 4 and 7 of the *Crown Land (Reserves) Act 1978* temporarily reserves for the purposes mentioned and also excepts from prospecting or from occupation for mining purposes under any miners right the following Crown lands:

**MUNICIPAL DISTRICT OF THE SHIRE OF  
TULLAROOP**

**CARISBROOK**—Municipal Purposes 1-341 hectares being Crown Allotment 10b, Parish of Carisbrook as shown on Certified Plan No. 108750 lodged in the Central Plan Office—(Rs 8301).

**MUNICIPAL DISTRICT OF THE CITY OF  
CASTLEMAINE**

**CASTLEMAINE**—Conservation of an area of historic interest, 1695 square metres being Crown Allotment 10, section 118b, Township of Castlemaine as shown on Certified Plan No. 25594 lodged in the Central Plan Office—(Rs 12562).

**MUNICIPAL DISTRICT OF THE SHIRE OF  
ALEXANDRA**

**EILDON**—Public Purposes (Police Purposes), 1922 square metres being Crown Allotment 5E, Parish of Eildon as indicated by hatching on plan hereunder—(Rs 13692).

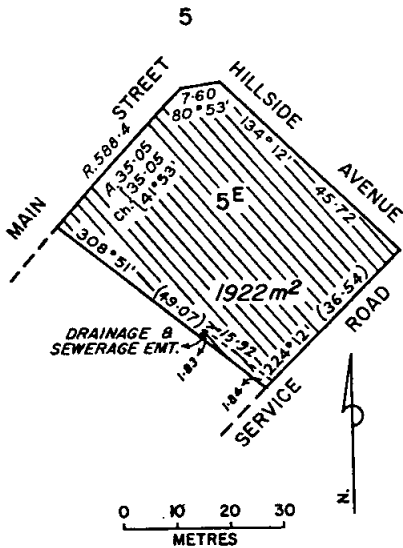

**MUNICIPAL DISTRICT OF THE CITY OF  
GEE LONG**

**GEE LONG**—Public Recreation, 4020 square metres being Crown Allotment 2A, section 4C, City of Geelong, Parish of Corio as indicated by hatching on plan hereunder—(Rs 13694).

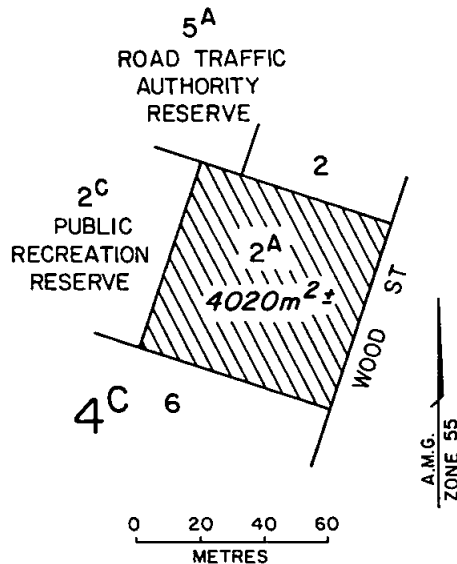

**MUNICIPAL DISTRICT OF THE SHIRE OF  
McIVOR**

**GLENHOPE**—Conservation of an area of natural interest, 4.6 hectares, more or less, being Crown Allotment 2b, section A, Parish of Glenhope as indicated by hatching on plan hereunder—(Rs 13554).

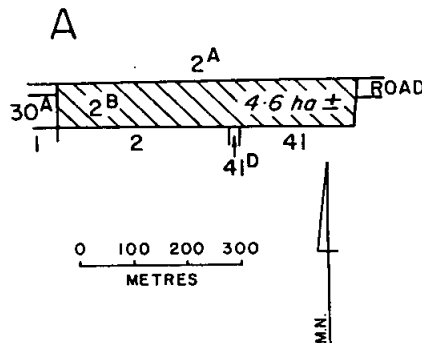

**MUNICIPAL DISTRICT OF THE SHIRE OF WALPEUP**

**KATTYOONG**—Water Supply, 7.259 hectares being Crown Allotment 1A, Parish of Kattoyong as indicated by hatching on plan hereunder—(Rs 13173).

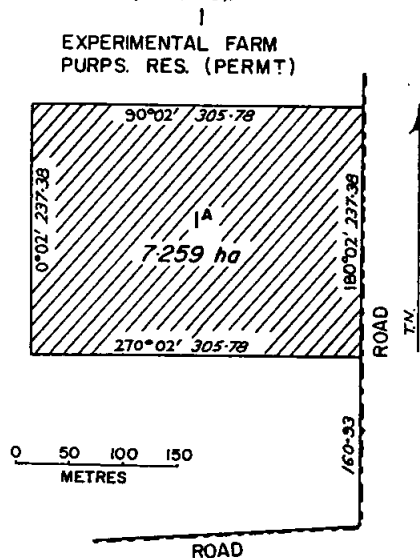

**MUNICIPAL DISTRICT OF THE SHIRE OF OXLEY**

**OXLEY**—Municipal Purposes and Public Hall, 3035 square metres being Crown Allotment 8, section 9, Township of Oxley, Parish of Oxley as indicated by hatching on plan hereunder—(Rs 10624).

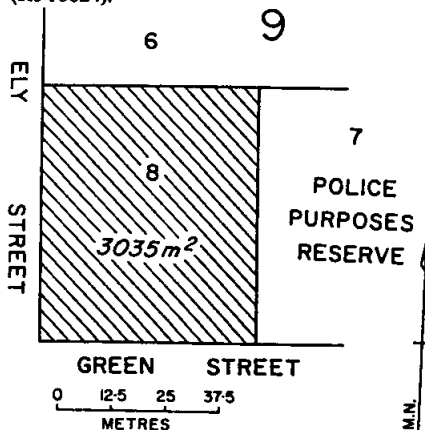

**MUNICIPAL DISTRICT OF THE SHIRE OF KERANG**

**QUAMBATOOK**—Conservation of an area of natural interest, 30.7 hectares more or less, being Crown Allotment 11A, section 1, Parish of Quambatook as indicated by hatching on plan hereunder—(Rs 11731).

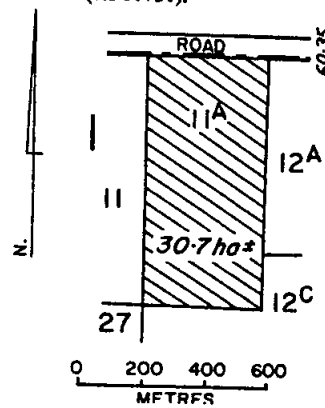

**MUNICIPAL DISTRICT OF THE SHIRE OF DIMBOOLA**

**TULLYVEA**—Conservation of an area of historic interest, 8090 square metres, more or less, being Crown Allotment 37A, Parish of Tullyvea as indicated by hatching on plan hereunder—(Rs 3512).

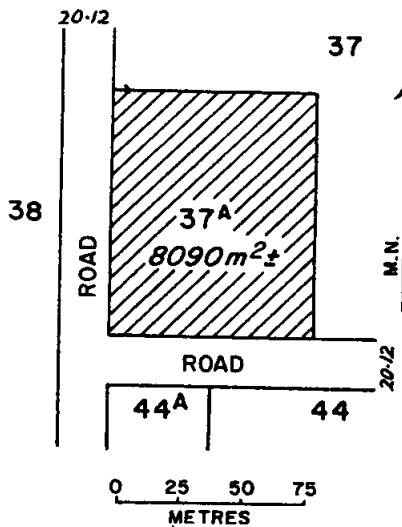

**MUNICIPAL DISTRICT OF THE SHIRE OF YACKANDANDAH**

**YACKANDANDAH**—Conservation of an area of historic interest, 1065 square metres being Crown Allotment 11, section 10, Township of Yackandandah, Parish of Yackandandah as shown on Certified Plan No. 107058 lodged in the Central Plan Office—(Rs 13672).

**MUNICIPAL DISTRICT OF THE SHIRE OF WARRACKNABEAL**

**WARRACKNABEAL**—Water Supply Purposes, 1338 square metres being Crown Allotment 5, section 32, Township of Warracknabeal, Parish of Werrigar as shown on Certified Plan No. 108707 lodged in the Central Plan Office—(Rs 13693).

Dated 2 February 1988

Responsible Minister:

**JOAN E. KIRNER**

Minister for Conservation, Forests and Lands

**LAWRENCE A. FISHER**

Clerk of the Executive Council

*Crown Land (Reserves) Act 1978*

**NOTICE OF INTENTION**

The Governor in Council under section 10 of the *Crown Land (Reserves) Act 1978* gives notice of intention to revoke the following temporary reservation:

**TYABB**—The temporary reservation by Order in Council of 14 August 1963 of 189.4 hectares, more or less, of land in the Parish of Tyabb as a site for Public purposes so far only as the area of 4.5 hectares, more or less, as indicated by hatching on plan hereunder—(Rs 8228).

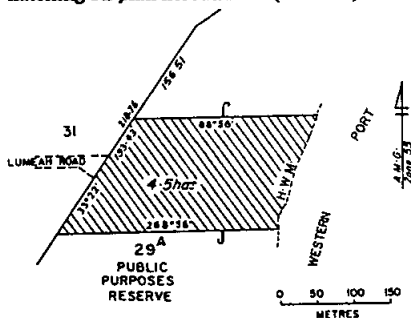

Dated 2 February 1988

Responsible Minister:

**JOAN E. KIRNER**

Minister for Conservation, Forests and Lands

**LAWRENCE A. FISHER**

Clerk of the Executive Council

*Crown Land (Reserves) Act 1978*  
**REVOCATION OF TEMPORARY RESERVATIONS**

The Governor in Council under section 10 of the *Crown Land (Reserves) Act 1978* revokes the following temporary reservations:

**AREEGRA**—The temporary reservation by Order in Council of 18 April 1902 of 8094 square metres of land adjoining Crown Allotment 27, Parish of Areegra as a site for a State School—(L4-4682).

**BELFAST**—The temporary reservation by Order in Council of 23 October 1951 of 556 square metres of land in the Parish of Belfast as a site for State School purposes—(Rs 6712).

**BELFAST**—The temporary reservation by Order in Council of 13 June 1944 of 2175 square metres of land in the Parish of Belfast as a site for a Public Park so far only as the area of 205 square metres as indicated by hatching on plan published in the *Government Gazette* of 30 December 1987 on page 3559—(Rs 5503).

**JAMIESON**—The temporary reservation by Order in Council of 17 March 1959 of 984 square metres, more or less of land in section 12, Township of Jamieson, Parish of Jamieson as a site for Public Buildings in addition to and adjoining the site temporarily reserved therefore by Order in Council of 8 August 1864—(Rs 7806).

**MELBOURNE EAST**—The temporary reservation by Order in Council of 8 June 1874 of 3136 square metres of land in section 19A, at East Melbourne, City of Melbourne, Parish of Melbourne North as a site for State School so far only as the portion containing 33.7 square metres as indicated by hatching on plan published in the *Government Gazette* of 30 December 1987 on pages 3559 and 3560—(Rs 13616).

**WOORNYALOOK**—The temporary reservation by Order in Council of 11 April 1962 of 251.97 hectares more or less of land in the Parish of Woornyalook as a site for the Preservation of Wildlife so far only as the area of 24.66 hectares being Crown Allotment 18C, section C, Parish of Woornyalook as shown on Certified Plan No. 108726 lodged in the Central Plan Office—(Rs 8126).

Dated 2 February 1988

Responsible Minister:

**JOAN E. KIRNER**

Minister for Conservation, Forests and Lands

**LAWRENCE A. FISHER**

Clerk of the Executive Council

*Crown Land (Reserves) Act 1978*

## NOTICE OF INTENTION

The Governor in Council under section 10 of the *Crown Land (Reserves) Act 1978* gives notice of intention to revoke the following temporary reservations:

**ARAPILES**—The temporary reservation by Order in Council of 12 September 1905 of 1644 square metres of land being Crown Allotment 5, section 5, Township of Arapiles as a site for a Public Hall—(Rs 3221).

**BALLARAT**—The temporary reservation by Order in Council of 18 November 1986 of 7.5 hectares, more or less, of land being Crown Allotment 19D, section 3, Parish of Ballarat as a site for Public Recreation so far only as the portion containing 298 square metres being Crown Allotment 19E, section 3, Parish of Ballarat as shown on Certified Plan No. 108743 lodged in the Central Plan Office—(Rs 1333).

**BALLARAT EAST**—The temporary reservation by Order in Council of 8 March 1983 of 202 square metres of land being Crown Allotment 77F, section 102, Township of Ballarat East as a site for State School purposes so far only as the portion containing 137 square metres being Crown Allotment 77K, section 102, Township of Ballarat East as shown on Certified Plan No. 108714 lodged in the Central Plan Office—(Rs 2427).

**BALMATTUM**—The temporary reservation by Order in Council of 31 October 1881 of 6.07 hectares of land in the Parish of Balmattum as a site for the Supply of Gravel and Stone revoked as to part by Order of 19 July 1928 so far as the balance remaining of 5.23 hectares—(Rs 3691).

**DUDDO**—The temporary reservation by Order in Council of 31 July 1923 of 4.05 hectares of land in the Parish of Duddo as a site for Recreation purposes—(Rs 208).

**DUDDO**—The temporary reservation by Order in Council of 17 June 1924 of 2023 square metres of land in the Parish of Duddo as a site for Recreation purposes in addition to and adjoining the site temporarily reserved therefore by Order in Council of 31 July 1923—(Rs 208).

**DUDDO**—The temporary reservation by Order in Council of 17 June 1924 of 2023 square metres of land in the Parish of Duddo as a site for a Public Hall—(Rs 209).

**GHIN GHIN**—The temporary reservation by Order in Council of 26 February 1958 of 6.15 hectares of land in section 7, Township of Ghin Ghin, Parish of Ghin Ghin as a site for Public purposes so far only as the portion containing 1.55 hectares, more or less, as indicated by hatching on plan hereunder—(Rs 7693).

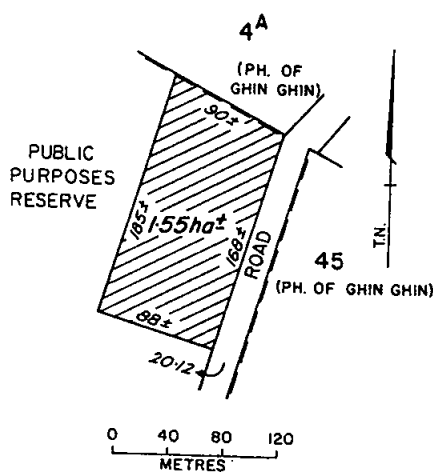

**GRANT**—The temporary reservation by Order in Council of 31 July 1865 of 4603 square metres of land in the Township of Grant as a site for Church of England purposes—(C 82553).

**JILWAIN**—The temporary reservation by Order in Council of 12 July 1960 of 3.64 hectares, more or less, of land in the Parish of Jilwain as a site for Public purposes—(Rs 7950).

**KERANG**—The temporary reservation by Order in Council of 1 August 1972 of 739 square metres of land in section 1, Parish of Kerang as a site for Public Purposes (Departmental Residence)—(Rs 9620).

**KERRIE**—The temporary reservation by Order in Council of 4 August 1908 of 1.568 hectares of land in the Parish of Kerrie as a site for a Quarry—(C 84278).

**RAGLAN**—The temporary reservation by Order in Council of 1 June 1914 of 8094 square metres of land in section 7, Township of Raglan, Parish of Raglan as a site for a State School—(C 57826).

Dated 2 February 1988

Responsible Minister:

JOAN E. KIRNER

Minister for Conservation, Forests and Lands

LAWRENCE A. FISHER

Clerk of the Executive Council

*Crown Land (Reserves) Act 1978*  
INCORPORATION OF COMMITTEE OF  
MANAGEMENT OF HAPPY VALLEY HALL  
AND RECREATION RESERVE

The Governor in Council under section 14A  
(1) of the *Crown Land (Reserves) Act 1978*, being

satisfied that it is in the public interests to declare to be a corporation the Committee of Management appointed under section 14 (2) of the Act of the land described in the schedule hereunder:

- (a) declares that the Committee of Management shall be a corporation;
- (b) assigns the name "Happy Valley Hall Committee" to the corporation; and
- under section 14b (3) of the Act, appoints David William McDonald to be Chairperson of the corporation.

**Schedule**

Crown Allotment 3C, section 22, Parish of Barwidgee temporarily reserved as a site for Public Hall and Public Recreation by Order in Council of 16 April 1986—(Rs.13091).

Dated 2 February 1988

Responsible Minister:

JOAN E. KIRNER

Minister for Conservation, Forests and Lands

LAWRENCE A. FISHER

Clerk of the Executive Council

*Crown Land (Reserves) Act 1978*  
**CROWN LANDS TEMPORARILY  
RESERVED**

The Governor in Council under sections 4 and 7 of the *Crown Land (Reserves) Act 1978* temporarily reserves for the purposes mentioned and also excepts from prospecting or from occupation for mining purposes under any miners right the following Crown Lands:

**MUNICIPAL DISTRICT OF THE CITY OF  
WANGARATTA**

WANGARATTA—For Public Purposes (Police Purposes) 8103 square metres being Crown Allotment 6A, section 71A in the Township of Wangaratta Parish of Wangaratta North as shown on Certified Plan No. 108675 lodged in the Central Plan Office—(Rs.11816).

**MUNICIPAL DISTRICT OF THE CITY OF  
WANGARATTA**

WANGARATTA—For Public Park and Public Recreation 3-226 hectares being Crown Allotment 5A, section 71A in the Township of Wangaratta Parish of Wangaratta North as shown on Certified Plan No. 108675 lodged in the Central Plan Office—(Rs.11818).

Dated 2 February 1988

Responsible Minister:

JOAN E. KIRNER

Minister for Conservation, Forests and Lands

LAWRENCE A. FISHER

Clerk of the Executive Council

*Crown Land (Reserves) Act 1978*

**NOTICE OF INTENTION**

The Governor in Council under section 10 of the *Crown Land (Reserves) Act 1978* gives notice of intention to revoke the following temporary reservations:

ECHUCA NORTH—The temporary reservation by Order in Council of 17 September 1974 of 593 square metres of land being Crown Allotment 51b, section A, Parish of Echuca North as a site for Public Purposes (Departmental Residence)—(Rs.9965).

KOOLOMERT—The temporary reservation by Order in Council of 6 July 1897 of 4047 square metres of land in the Parish of Koolomert as a site for a State School—(L2-1419).

KOOLOMERT—The temporary reservation by Order in Council of 26 May 1902 of 7664 square metres of land in the Parish of Koolomert as a site for a State School in addition to and adjoining the site temporarily reserved therefore by Order of 6 July 1897—(L2-1419).

LAKES ENTRANCE—The temporary reservation by Order in Council of 6 August 1974 of 604 square metres of land being Crown Allotment 52A, Township of Lakes Entrance, Parish of Colquhoun as a site for Public Purposes (Departmental Residence)—(Rs.9927).

Dated 2 February 1988

Responsible Minister:

JOAN E. KIRNER

Minister for Conservation, Forests and Lands

LAWRENCE A. FISHER

Clerk of the Executive Council

*The Constitution Act Amendment Act 1958*

**APPOINTMENT OF RETURNING  
OFFICERS**

The Governor in Council, under section 145 of *The Constitution Act Amendment Act 1958*, appoints the following persons to be Returning Officers for the electorates indicated against their respective names.

<i>Returning Officer</i>	<i>Electoral Province</i>
Neil Robert Manning	Monash
<i>Returning Officer</i>	<i>Electoral District</i>
Neil Robert Manning	Albert Park
Denise Veronica Applebee	Oakleigh
Frank Coleman	Ringwood

Dated 2 February 1988

Responsible Minister:

PETER SPYKER, M.P.

Minister for Property and Services

LAWRENCE A. FISHER

Clerk of the Executive Council



**Land Act 1958  
UNUSED ROAD CLOSED**

The Governor in Council under section 349 of the *Land Act 1958* and with the consent in writing of the municipality concerned and the adjoining owner closes the following unused road:

**MUNICIPAL DISTRICT OF THE SHIRE OF SEYMOUR**

**WORROUGH**—The road in the Parish of Worrough as indicated by hatching on plan hereunder—(L7-4082).

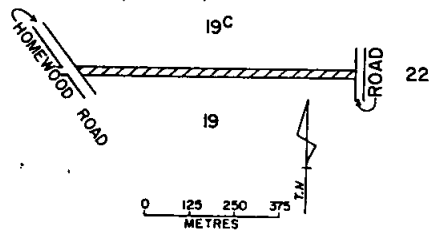

Dated 2 February 1988

Responsible Minister:

**JOAN E. KIRNER**

Minister for Conservation, Forests and Lands

**LAWRENCE A. FISHER**

Clerk of the Executive Council

**Land Act 1958  
UNUSED ROADS CLOSED**

The Governor in Council under section 349 of the *Land Act 1958* closes the following unused roads:

**MUNICIPAL DISTRICT OF THE SHIRE OF ALBERTON**

**DARRIMAN**—The roads in the Parish of Darriman as indicated by hatching on plan hereunder.

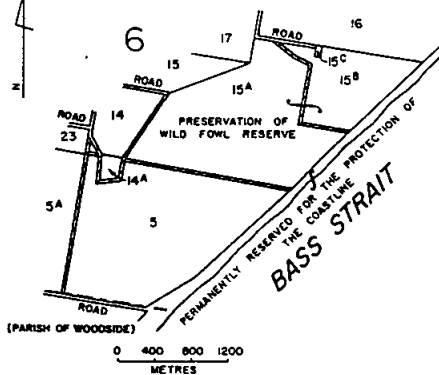

**WOODSIDE**—The roads in the Parish of Woodside as indicated by hatching on plan hereunder—(Rs. 7767).

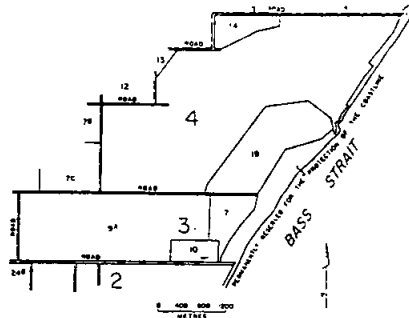

Dated 2 February 1988

Responsible Minister:

**JOAN E. KIRNER**

Minister for Conservation, Forests and Lands

**LAWRENCE A. FISHER**

Clerk of the Executive Council

**Retirement Villages Act 1986**

**Section 6**

**DECLARATION OF EXEMPTION**

Under the powers found in section 6 of the *Retirement Villages Act 1986*, the Governor in Council on the recommendation of the Attorney-General, declares:

Eastwood Park of Guthridge Parade, Sale and Northwood Park of Stead Street, Sale, to be exempt villages to which the following provision of the *Retirement Villages Act 1986* (the Act) do not apply:

Section 38 of the Act upon condition that the maintenance charge levied on a resident of a village shall not exceed a total equal to 85% of the Commonwealth single aged pension, and in the case of a resident in receipt of a part pension, 85% thereof and 50% of any other income of such a pensioner resident (if any);

and upon condition that a copy of this exemption be given to each prospective resident at the same time such residents are given the residence documents relating to a village.

Dated 2 February 1988

Responsible Minister:

**A. McCUTCHEON**

Attorney-General

**LAWRENCE A. FISHER**

Clerk of the Executive Council

*Retirement Villages Act 1986*

## Section 6

## DECLARATION OF EXEMPTION

Under the powers found in section 6 of the *Retirement Villages Act 1986*, the Governor in Council on the recommendation of the Attorney-General, declares:

The Canterbury Memorial Home Units of 154-162 Canterbury Road, Canterbury, to be an exempt village to which the following provisions of the *Retirement Villages Act 1986* (the Act) do not apply:

- (i) Section 25 (5) and (6) of the Act upon condition that monies which would have been required to be dealt with pursuant to those sub-sections are paid into a trust account in the name of the person for the time being who is the Secretary of the Committee of Management of the village and the requirements of section 25 (6) of the Act are complied with as if they applied to such an account.
- (ii) Section 38 of the Act upon condition that the maintenance charge levied on a resident of the village shall not exceed a total equal to 85% of the Commonwealth single aged pension, and in the case of a resident in receipt of a part pension, 85% thereof and 50% of any other income of such a pensioner resident (if any);

and upon condition that a copy of this exemption be given to each prospective resident at the same time such residents are given the residence documents relating to the village.

Dated 2 February 1988.

Responsible Minister:

A. McCUTCHEON  
Attorney-General

LAWRENCE A. FISHER  
Clerk of the Executive Council

*Hospitals and Charities Act 1958*INCORPORATION OF KING VALLEY  
COMMUNITY HEALTH SERVICE

The Governor in Council under sections 46 and 64 of the *Hospitals and Charities Act 1958* declares to be a body corporate a benevolent society by the name of King Valley Community Health Service.

Dated 2 February 1988

Responsible Minister:

J. E. KIRNER  
Acting Minister for Health

LAWRENCE A. FISHER  
Clerk of the Executive Council

*Hospitals and Charities Act 1958*INCORPORATION OF COLERAINE AND  
DISTRICT HOMES FOR THE AGED

The Governor in Council under section 46 of the *Hospitals and Charities Act 1958* declares to be a body corporate an institution by the name of Coleraine and District Homes for the Aged.

Dated 2 February 1988

Responsible Minister:

J. E. KIRNER  
Acting Minister for Health

LAWRENCE A. FISHER  
Clerk of the Executive Council

*Hospitals and Charities Act 1958*INCORPORATION OF JOHN PICKFORD  
GERIATRIC CENTRE

The Governor in Council under section 46 of the *Hospitals and Charities Act 1958* declares to be a body corporate an institution by the name of John Pickford Geriatric Centre.

Dated 2 February 1988

Responsible Minister:

J. E. KIRNER  
Acting Minister for Health

LAWRENCE A. FISHER  
Clerk of the Executive Council

*Planning and Environment Act 1987*DIRECTION THAT PLANNING SCHEMES  
SHALL NOT BE BINDING UPON CERTAIN  
MINISTERS

In accordance with section 16 of the *Planning and Environment Act 1987*, the Governor in Council directs that:

1. Planning schemes shall not be binding on the use and development of land carried out by or on behalf of the Minister for Conservation, Forests and Lands, the Minister for Health or the Minister for Education except where:

- (a) The land is within the Yarra and Maribyrnong Area as defined in this Order; or
- (b) The land is within the Port Phillip Area as defined in this Order.

2. The Yarra and Maribyrnong Area means those areas of land in the vicinity of the Yarra and Maribyrnong Rivers shown on the plans endorsed as forming part of this Order and lodged with the Ministry for Planning and Environment.

3. The Port Phillip Area means:

- (a) All those portions of land or land covered with water which abut the waters of Port Phillip Bay and are between low water mark and an imaginary line following the

course of high water mark at a distance of 200 metres landward from high water mark; and which are—

- (i) unalienated land of the Crown whether reserved for any purpose or not;
  - (ii) vested in the Crown or any public authority; or
  - (iii) occupied or controlled by the Crown or by any other public authority; and
- (b) All the waters and the sea-bed under those waters which are between high water mark of Port Phillip Bay and an imaginary line following the course of low water mark at a distance of 600 metres seaward from low water mark.

Dated 2 February 1988

Responsible Minister:

T. W. ROPER

Minister for Planning and Environment

LAWRENCE A. FISHER  
Clerk of the Executive Council

*Environment Protection Act 1970*  
AMENDMENT TO THE STATE  
ENVIRONMENT PROTECTION POLICY  
(CONTROL OF NOISE FROM  
COMMERCIAL, INDUSTRIAL AND  
TRADE PREMISES WITHIN THE  
MELBOURNE METROPOLITAN AREA)  
N-1

The Governor in Council makes the following amendment under section 16 (2):

1. Wherever the terms 'Melbourne and Metropolitan Planning Scheme' or 'Melbourne and Metropolitan Planning Scheme Ordinance' appear, substitute 'Planning Scheme applying to the area under consideration'.

2. For Clause 5, Part II— Boundaries of Area Affected, substitute 'the Policy shall be observed within the area defined below:

- (a) The municipal districts of the Cities of Altona, Berwick, Box Hill, Brighton, Broadmeadows, Brunswick, Camberwell, Caulfield, Chelsea, Coburg, Collingwood, Croydon, Dandenong, Doncaster and Templestowe, Essendon, Fitzroy, Footscray, Frankston, Hawthorn, Heidelberg, Keilor, Kew, Knox, Malvern, Melbourne, Moorabbin, Mordialloc, Northcote, Nunawading, Oakleigh, Port Melbourne, Prahran, Preston, Richmond, Ringwood, Sandringham, South Melbourne, Springvale, St Kilda, Sunshine, Waverley, Werribee and Williamstown.

- (b) The municipal districts of the Shires of Bulla, Diamond Valley, Eltham, Melton, and Whittlesea; and that portion of the Shire of Cranbourne commencing at a point on the municipal boundary at the north-eastern angle of Allotment 71C, Parish of Cranbourne; then southerly by a road on the eastern boundary of that allotment to Ballarto Road; then westerly by that road to the north-eastern angle of the Parish of Langwarrin; then southerly by a road on the eastern boundary of that parish to the south-eastern angle of allotment 11; then westerly by a road to the north-western angle of allotment 58; then southerly by a road to the south-eastern angle of allotment 62; then westerly to a road to the north-western angle of allotment 81; then southerly by a road to the southern boundary of the parish being a point on the municipal boundary; and then generally westerly, generally northerly and generally south-easterly by that boundary to the point of commencement.

- (c) All areas deemed by section 55 of the *Port of Melbourne Authority Act 1958* to be severed from the municipal districts of the Cities of Footscray, Melbourne, Port Melbourne and Williamstown'.

Dated 2 February 1988

Responsible Minister:

T. W. ROPER

Minister for Planning and Environment

LAWRENCE A. FISHER  
Clerk of the Executive Council

*Education Act 1978*

AMENDING OF AN ORDER MADE  
UNDER SECTION 12A (1) OF THE ACT

The Governor in Council, under section 12A (2) of the *Education Act 1958*, varies the Order made on 8 December 1987 by amending the Local Government Area of Lilydale shown under the Local Government Areas comprising the Eastern Metropolitan Education Region, to the Local Government Area of Lilydale.

Dated 2 February 1988

Responsible Minister:

CAROLINE HOGG

Minister for Education

LAWRENCE A. FISHER  
Clerk of the Executive Council

*Urban Land Authority Act 1979*  
TRANSFER OF LAND

## Churchill

The Governor in Council under section 19 (1) of the *Urban Land Authority Act 1979* transfers to the Urban Land Authority the land described in the Schedule.

Schedule  
Parish of Maribyrnong  
County of Bourke

Lot No.	Plan of Subdivision	Certificate of Title	
		Volume	Folio
N	139395	9651	239
433	138362	9651	234

Dated 2 February 1988

Responsible Minister:

R. W. WALSH

Minister for Housing and Construction

LAWRENCE A. FISHER

Clerk of the Executive Council

## TENDERS

MINISTRY OF HOUSING AND  
CONSTRUCTION

(formerly Public Works Department)

Tenders are invited for the purposes indicated hereunder and will be received at 2 Treasury Place, Melbourne, 3002, until TWO p.m. on the dates shown.

Tenders must be addressed to the Minister for Housing and Construction with the envelope endorsed "Tender for \_\_\_\_\_".

Tenders forwarded either by mail, telegram, telex or fax, which arrive after the closing time, will be accepted provided that the official Telecom or Australia Post time and date stamping indicates dispatch prior to the closing time.

(TIME AND DATE STAMPING MUST BE REQUESTED AT SOME POST OFFICES.)

(TELEX No. AA152039)

(FAX No. 6511738)

Hand-delivered tenders must be placed in the Ministry's tender box, on First Floor, 2 Treasury Place, Melbourne.

Tender documents are available from the Contracts Office, Room 29, Ground Floor, 2 Treasury Place, Melbourne and where indicated, at offices of Inspector of Works.

Wednesday, 17 February 1988

Building, Electrical and Mechanical Services etc.

ARMADALE—External repairs and painting, Frank Tate House—373 Dandenong Road—Ministry of Education.

BALMORAL—Cyclic maintenance—alterations and additions, Primary School. (W.O. Warrnambool and Hamilton.)

BEEAC—Cyclic maintenance, Primary School. (W.O. Geelong.)

HAMILTON—Welding bay upgrade, Technical School. (W.O. Hamilton.)

OBERON SOUTH—Staff/Administration up-grade, Primary School. (W.O. Geelong.)

WERRIBEE—Upgrade of fire and general service—Hydraulics, Animal Research Institute—Department of Agriculture and Rural Affairs.

Wednesday, 24 February 1988

Building, Electrical and Mechanical Services etc.

JANEFIELD—Supply and install dishwashing machines to Wards MF2, MF3 and MF4 and associated kitchen renovations, Training Centre.

KURUNJANG—Hydraulic services—Block 4, Post Primary School.

**KURUNJANG**—Excavation and concrete—Block 4, Post Primary School.

**KURUNJANG**—Bulk earthworks—Block 4, Post Primary School.

**SNOBS CREEK**—Installation of aquarium/fish tanks in visitors centre, Snobs Creek Fish Hatchery. (W.O. Alexandra).

**SOUTH MELBOURNE**—Internal repairs and painting, Police Station.

**EAST MELBOURNE**—Construction of quiet zone, Government Computing Services—33 St. Andrews Place. Department of Property and Services.

**VARIOUS**—Annual maintenance of gas appliances, Western Metropolitan Region—Ministry of Education.

**Miscellaneous**

**PORT MELBOURNE**—Purchase of one (1) only skid steer loader, M.O.H.C. Storeyard—69 Salmon Street.

**SOUTH MELBOURNE**—Supply of foyer chairs, T1530, Coronial Services Centre, 57–83 Kavanagh Street.

**Wednesday, 2 March 1988**

**Building, Electrical and Mechanical Services etc.**

**BROWNHILL**—New toilet block extension, Primary School. (W.O. Ballarat.)

**SYNDAL**—Fire re-instatement, High School.

**RONALD W. WALSH**

Minister for Housing and Construction

Ministry of Housing and Construction  
Melbourne, 1 February 1988

**PRIVATE  
ADVERTISEMENTS**

**CITY OF ARARAT  
Closure of Road to Traffic**

Notice is hereby given that the City of Ararat has adopted an order pursuant to the Local Government Act, section 539c, for the closure of Vanstan Street at Gossip Avenue, Ararat, shown hatched on the plan, to vehicular traffic by the erection of barriers and further that the order shall come into operation on Monday, 15 February 1988.

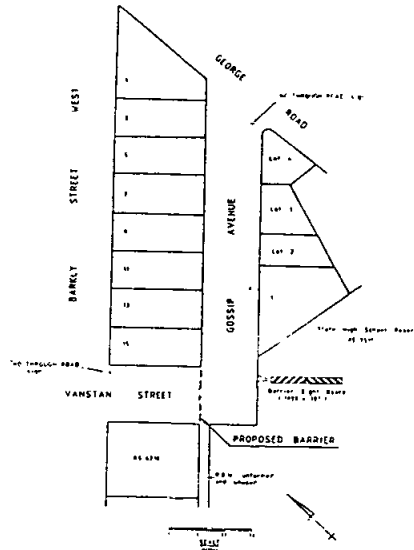

**CITY OF ALTONA**

**Vesting of a Reserve for Municipal Purposes**

The Council of the City of Altona, at its meeting held on Tuesday, 9 February 1988, resolved that pursuant to section 569BA (1) of the *Local Government Act 1958*, the Reserve for Municipal Purposes shown hatched on the plan below shall vest in the Council.

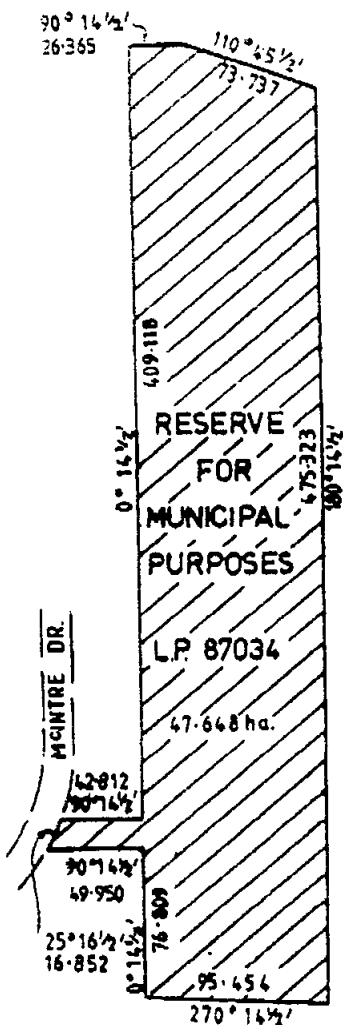

a public notice in a newspaper generally circulating in the municipal district and given written notice to the registered proprietor of the land and the owners and occupiers of abutting land as required by section 528 (2) (a) (iii) of the *Local Government Act 1958* (as amended); and

2. Having received no objections: resolved at its Ordinary Meeting held on 21 December 1987—

The the Council, being of the opinion that the road commencing at Campaspe Street and bearing 78 degrees 00' for 21.92m thence 168 degrees 00' for 10.01m and being located on Crown Allotment 3, section 4, Township of Echuca, is not required as a road for public use, that it be discontinued as a road and the land be sold by private treaty after publication of this notice in the *Government Gazette*.

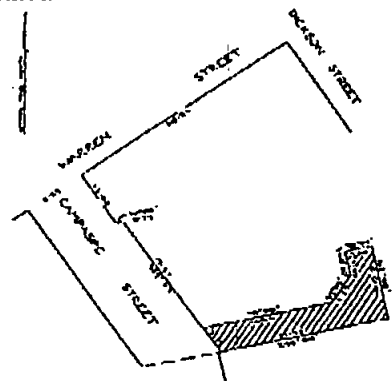

K. F. McCARTNEY  
Chief Executive Officer

134

**CITY OF FRANKSTON**

**Discontinuance of Part of an Unmade Right of Way off Beach Street, Frankston**

Notice is hereby given that the Council of the City of Frankston being of the opinion that the part of the unmade right of way off Beach Street between Lewis Street and Dandenong Road East on Plan of Subdivision No. LP 1007 and shown hatched on Council Plan M. 398 is not required for public use and having complied with the provisions of section 528 (2) of the *Local Government Act* (as amended) has resolved that the part of the unmade right of way be discontinued and that:

The Mornington Peninsula and District Water Board continue to have and possess the same power, authority and interest in or in relation to the road with respect to pipes laid in the land for

JOHN F. SHAW

Chief Executive Officer/Town Clerk

136

**CITY OF ECHUCA**  
**Road Discontinuance**

The Council of the City of Echuca, pursuant to section 528 (2) of the *Local Government Act 1958* (as amended)—

1. Having, not less than one month before the date of the meeting at which the resolution to discontinue the road was considered, published

sewerage purposes that it had or possessed prior to the discontinuance.

Notice is hereby given that the Council has directed that the land be retained by the City of Frankston for municipal purposes.

Minister for Local Government and will be subject to such conditions as the Treasurer may impose.

4 February 1988

T. J. T. NEAL  
Town Clerk and Chief  
Administrative Officer

118

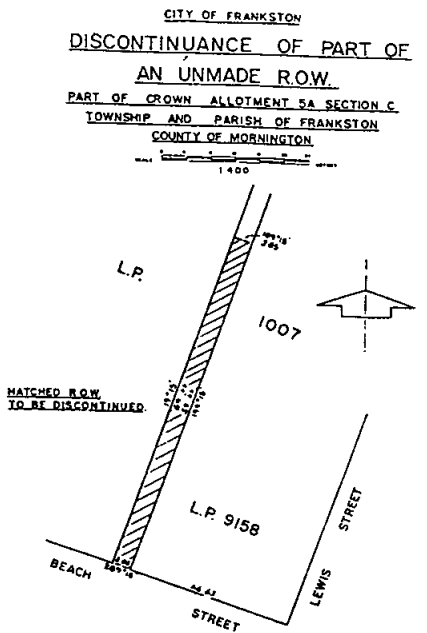

M.398

A. H. BUTLER  
Chief Executive Officer

137

**CITY OF GEELONG**

**Notice of Intention to Borrow Money**

Pursuant to the Melbourne and Geelong Debentures Inscribed Stock and Mortgages Acts and the Geelong Market Site Act 1983 notice is hereby given that the Council of the City of Geelong intends to borrow the sum of \$31 700 000 for the purpose of repaying loans totalling that amount. The period of the loan shall be five years due 7 March 1993.

The Loan raised pursuant to this notice will require the consent of the Treasurer and the

**CITY OF MARYBOROUGH**

**Prosecuting Officer**

Notice is hereby given that the City of Maryborough has appointed Senior Sergeant James David Edwards, Number 16988, as its Prosecuting Officer for the City to take legal proceedings on behalf of the Council for and in connection with breaches and non-observance of the Local Government Act or any other Act which the Council from time to time is empowered to enforce and any By-laws, rules or regulations made under such Acts.

117 RICHARD J. PEKIN, Town Clerk

**CITY OF PORTLAND**

**Road Discontinuance**

Notice is hereby given that pursuant to section 528 (2) of the Local Government Act 1958, the Council of the City of Portland having formed the opinion that the right of way, shown hatched on the plan below, is no longer reasonably required for private use and after consultation with public authorities and the advertising of its intention and notification to the registered proprietor of the land and the owners and occupiers of the land abutting or immediately adjacent to the right of way, has by resolution at its Ordinary Meeting held on 2 February 1988, directed the discontinuance of such right of way shown by hatching and for the retention of such land for municipal purposes.

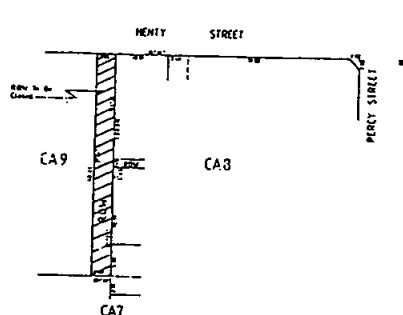

138

G. K. TREVASKIS, Chief Executive

**SHIRE OF BELLARINE**

Pursuant to section 535 of the *Local Government Act 1958*, the Council of the Shire of Bellarine resolved at a meeting held on 16 December 1987, that the name of the following street or road as set out hereunder be changed:

*Old Name*—Bonnyvale Lane

*New Name*—Bonnyvale Road

*Locality*—Ocean Grove

P. L. WIGNALL

140 Deputy Shire Manager/Shire Secretary

Exempting Class Xb buildings constructed on farmland and used for farming purposes from complying with certain of the requirements of the *Victoria Building Regulations 1983* (as amended).

This By-Law shall apply to and have operation throughout the whole of the Municipal District of the Shire of Buninyong.

A copy of the said By-Law is open for inspection free of charge during office hours at the Municipal Offices, Learmonth Street, Buninyong.

A. F. HELYAR  
Shire Secretary

139

**SHIRE OF BULN BULN**

Discontinuance of part of Wolff Street, Drouin

Notice is hereby given that pursuant to section 528(2) of the *Local Government Act 1958*, the Council of the Shire of Buln Buln, after consultation with public authorities, and the advertising of its intention and notification to the registered proprietors of the land and the owners and occupiers of any land abutting or immediately adjacent to the road, has by resolution at its Ordinary Meeting, held on 27 January 1988 having resolved that the road abutting Lots 5 and 49 on Lodged Plan No. 1863 being Part of Crown Allotment 6 and 7, section 15, Township of Drouin, being part of Wolff Street, Drouin, as shown crosshatched on the plan hereunder, be discontinued and the parcel of land be sold by private treaty.

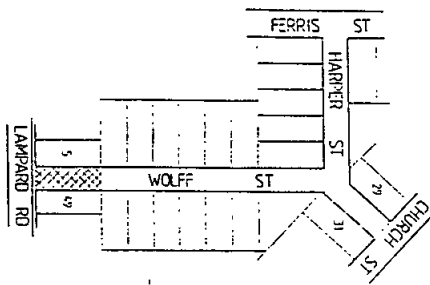

92

**SHIRE OF BUNINYONG**

By-Law No. 33

Farm Outbuilding By-Law

Notice is hereby given that the Council at its meeting held on 3 December 1987, confirmed by Special Order a resolution passed at its meeting held on 21 January 1988 to make and adopt By-Law No. 33 for the purpose of:

**SHIRE OF FLINDERS**

Street Name Change

Hillview Drive, Dromana to Hillview Quarry Drive

The Council of the Shire of Flinders having undertaken the appropriate procedure in accordance with section 535 of the *Local Government Act 1958*, and invited objection in accordance with section 193A of the said Act, has at the meeting of 3 February 1988, determined to change the name Hillview Drive, Dromana to Hillview Quarry Drive.

Dated 10 February 1988

123 LARRY M. JONES, Chief Executive

**SHIRE OF KILMORE**

Wallan Sewerage Scheme Reticulation—Stage 2

Notice is hereby given in accordance with section 119 of the *Sewerage Districts Act 1958* of the Council's intention after a period of thirty (30) days to commence construction of sewers and associated works due to realignment of sewers.

The areas affected by the realignment are CA's 17, section 9; C/A's 1-12, section 16; C/A's 3-17, section 15; Lot 5 LP99873, Lots 1 and 3 LP99290 and LP99291 respectively and C/A's 16 and 17, section 6 and C/A's 16 and 17, section 5 all in the Parish of Wallan Wallan.

Plans have been prepared showing the revised location of the sewers and associated works and are available for inspection at the Civic Centre, Kilmore or the Wallan Post Office during normal business hours.

P. ANDERSON  
Chief Executive Officer

119



**RUTHERGLEN WATER BOARD**

**By-Law No. 101**

Notice is hereby given that By-law No. 101 titled Trade Waste has been adopted by the Board and approved by the Governor in Council.

The general purport of the By-law covers:

Chapter 1—Title and Definition

Chapter 2—Discharge of Waste

Chapter 3—Acceptance of Waste

Chapter 4—General Provisions

Appendix A—Standards and Requirements for Acceptance of Waste Discharge.

A copy of the By-law is open for inspection by any person without charge at the Shire Office, 153 High Street, Rutherglen during normal office hours.

**WALTER J. McQUILLEN**

Secretary/Manager

98

**GEELONG AND DISTRICT WATER BOARD**

Pursuant to section 60 of the *Geelong Waterworks and Sewerage Act 1958* (No. 6263) the Board has prepared plans to indicate the particulars of sewers and underground works, the construction of which the Board intends to begin at a date not less than one month after publication of the notices, in or adjacent to the following locality within the Drainage Area.

Great Ocean Road, Anglesea, Shire of Bellarine  
Nelson Road/Edgewater Close, Point Lonsdale, Shire of Bellarine

Glenburn Street/Coulter Street/ Helms Street/  
Coppards Road/ Lindel Street, Newcomb, Shire of Bellarine

Grosvenor Drive/Wandana Drive/Pall Mall/  
Scenic Road, Highton, Shire of Barrabool.

Notice is hereby given that the plans indicated are open for public inspection at the Board's Offices, 61-67 Ryrie Street, Geelong between the hours of 8.10 a.m. and 5.00 p.m. from Monday to Friday (public holidays excepted) by the owners or occupiers of land or premises within the Drainage Area.

116

**R. A. JORDAN, Secretary**

**WONTHAGGI-INVERLOCH WATER BOARD**

**Eighth Schedule**

Notice to owners of tenements in the undermentioned streets and the Private Streets, Lanes, Courts and Alleys opening thereto:

Lots 84-106 Youll Grove, Inverloch

Lots 9-16 Glendale Court, Inverloch

Lots 1-6, 10-12 and 13-21 Loughran Drive, Wonthaggi

Lots 7-9 Elkin Court, Wonthaggi

Lots 1-6 Wyeth Place, Inverloch

Lots 7-9 Ramsay Boulevard, Inverloch

Lots 1-4 St. Kilda Street, Inverloch

Lots 5-6 Ramsay Boulevard, Inverloch

The main the said street being laid down, the owners of all tenements situated as above are hereby required, on or before 1 February 1988 to cause proper pipes and stop cocks to be laid so as to supply water within such tenements from the main pipe.

120

**K. F. O'HALLORAN, Secretary**

**SIXTH SCHEDULE**

**Wonthaggi-Inverloch Water Board**

**General Notice**

The Wonthaggi-Inverloch Water Board having made provision for carrying off sewage from each and every property which or any part of which is in the sewerage areas hereinafter described doth hereby declare that on or after 1 February 1988 each and every property which any or part of which is within the said sewerage areas shall be deemed to be a seweraged property within the meaning of the *Sewerage Districts Act 1958*:

The boundaries of the sewerage area hereinbefore referred to are as follows:

Inverloch District—Declared Area No. 8

Wonthaggi District—Declared Area No. 11

The boundaries of the said Sewerage Area is delineated on a plan which may be inspected at the Inverloch Office of the Board.

By Order of the said Board

121

**K. F. O'HALLORAN, Secretary**

To be sold under the Livery and Agistment Act, two ponies owned by Mr Kevin O'Grady, 32 Grandview Road, Torquay. 1 Buckskin Mare, 1 dappled Grey Gelding. (053) 67 1984. 122

**SELECT PANEL AND GAS SERVICES**

**Withdrawal of Partner**

Creditors of the firm of Select Panel and Gas Services take notice that as from 1 October 1985 Robert Keith Wheildon ceased to be a partner in the above firm all the debts and liabilities of which arising after that date being the sole responsibility of the continuing partner Stephen Robert Cadman 113

**PRESTON & NORTHCOTE NO. 2  
CO-OPERATIVE HOUSING SOCIETY  
LIMITED (In Liquidation)**

Take notice that the affairs of the above-named Society are now fully wound up and that in pursuance of section 411 (1) of the Companies (Victoria) Code 1981 and of the *Co-Operative Housing Societies Act 1958*, a General Meeting of the Society will be held at the Society's Office, 4/414 Lonsdale Street, Melbourne on the 16 March 1988 at 5.30 p.m. for the purpose of:—

- (i) laying before it an account showing how the winding up has been conducted and the property of the Society disposed of and giving any explanations thereof; and
- (ii) passing a resolution that the books and papers of the said Society and of the Liquidator relevant to the affairs of the Society be destroyed after a period of twelve months from the date of the meeting.

Dated 10 February 1988.

H. C. HOLMES, R. J. ANDERSON AND P. L.  
HARRISON  
141 Joint/Several Liquidators.

**MARGARET ANN KNELL, deceased**

Creditors, next of kin and others having claims in respect of the estate of the deceased who died on 1 August 1987 are required by the executor, Herbert Stanley Knell, to send particulars to the undermentioned firm by 2 May 1988 after which date the said executor may convey or distribute the assets having regard only to the claims of which notice has by then been given.

O'HAIRE & O'HAIRE, solicitors, 627 Chapel  
Street, South Yarra 125

**JESSIE WHEELER, late of Prestonia Nursing  
Home, 10 Hotham Street, Preston,  
gentlewoman, deceased**

Creditors, next of kin and others having claims in respect of the estate of the deceased who died on 16 November 1987 are required by Alfred Bruce Anderson of 67 Walsh Street, South Yarra, the Executor of the Will of the said deceased to send particulars to him care of his solicitors, Ford and Company of 400 Lonsdale Street, Melbourne, by 27 April 1988 after which date he may convey or distribute the assets having regard only to the claims of which he then has notice.

FORD AND COMPANY, 400 Lonsdale  
Street, Melbourne 142

Creditors, next of kin and others having claims in respect of the estate of Amy Garland, late of Athol Lodge, 41 Acland Street, St. Kilda, spinster, deceased, who died on 12 August 1987 are to send the particulars of their claims to ANZ Executors & Trustee Company Limited of 94 Queen Street, Melbourne by 11 April 1988 after which date it will distribute the assets having regard only to the claims of which it then has notice. 151

Creditors, next of kin and others having claims in respect of the estate of Peter Kenworthy Clark, late of 10 Tara Drive, Frankston, gentleman, deceased, who died on 1 October 1987 are to send the particulars of their claims to ANZ Executors & Trustee Company Limited of 94 Queen Street, Melbourne by 11 April 1988 after which date it will distribute the assets having regard only to the claims of which it then has notice. 152

ERIC MALCOLM GASHLER, late of Flat 3,  
263 Beach Road, Black Rock in the State of  
Victoria, company director, deceased

Creditors, next of kin and others having claims in respect of the estate of the deceased, who died on 15 August 1987 are required by the Executors of the Estate, Susan Leigh Cato of Flat 9, 44 Murphy Street, South Yarra, Victoria, actress and John Alexander Hampton Lewis of 28 Lavender Park Road, Eltham, Victoria, solicitor to send particulars to them by 22 April 1988 after which date the Executors may convey or distribute the assets, having regard only to the claims of which they then have notice.

CORRS PAVEY WHITING & BYRNE,  
solicitors, 350 William Street, Melbourne 149

**CHRISTINA MARIE MISELL, late of 43 Maud  
Street, North Balwyn, retired librarian,  
deceased**

Creditors, next of kin and others having a claim in respect of the estate of the deceased who died on 24 November 1987 are required by the Executors of her Will Damien Morrell Smith and John Damien Misell to send particulars to them at the office of the undermentioned Solicitor by 12 April 1988 after which date the Executors will distribute the assets of the deceased having regard only to claims of which they will then have had notice.

Wm. R. HUNT M.A. LL.B., 358 Lonsdale  
Street, Melbourne, solicitor for the Executors 144

Creditors, next of kin and others having claims in respect of the estate of Myles Sylvester Hallissy late of 12 Halifax Street, North Box Hill, deceased who died on 6 July 1987 are requested to send particulars of their claims to the executrix care of the undermentioned solicitors by 8 April 1988 after which date the executrix will distribute the assets having regard only to the claims of which she then has notice.

**RIDGEWAY CLEMENTS**, solicitors, 575 Bourke Street, Melbourne 153

Creditors, next of kin and others having claims in respect of the estate of Dorothy Elanor Anderson formerly of 1 Sytheny Court, Surrey Hills in the State of Victoria, married woman but late of Unit 3, 9 Hedgeley Avenue, East Malvern in the State of Victoria, widow, deceased, who died on 16 November 1987 are to send the particulars of their claims to Susan-Gaye Boisjoux, Barbara Diane McClelland and Desmond Harold Dodds the Executors of the said estate whose address is care of Coltmans, solicitors of 575 Bourke Street, Melbourne 3000 by 30 April 1988 after which date the said Executors will distribute the assets having regard only to the claims of which they then have notice 154

Creditors, next of kin and others having claims against the estate of Jean Murrells late of 16 Vista Grove, Toorak in the State of Victoria, gentlewoman, deceased who died on 15 November 1987 are requested to send particulars of their claims to Kenneth George McClure of 6 Mount View Road, Malvern in the said State, company director, the executor named in the said Will care of the belowmentioned solicitors by 14 April 1988 after which date he will distribute the assets having regard only to the claims at which date he then has notice.

**PURVES & PURVES**, solicitors of 121 William Street, Melbourne 155

**GEOFFREY IAN FEUTRILL**, late of 1A David Street, Surrey Hills, lecturer, deceased

Creditors, next of kin and others having claims in respect of the estate of the deceased who died on 4 July 1987 are required by the personal representative Helen Louise Feutrill of 1A David Street, Surrey Hills to send particulars to her care of the undermentioned solicitors by 19 April 1988 after which date the personal representative may convey or distribute the assets having regard only to the claims of which she then has notice.

**AITKEN WALKER & STRACHAN**, solicitors, 114 William Street, Melbourne 156

**ELIZABETH GOURLAY CARTWRIGHT**, formerly of 891 Mount Dandenong Road, Montrose but late of 27 The Greenway, Heathmont, widow, deceased

Creditors, next of kin and others having claims in respect of the estate of the deceased who died on 18 July 1979 are required by the legal personal representative, Keith Earl, of 39 Park Street, South Melbourne, Salvation Army officer, to send particulars to him by 17 April 1988 after which date he will distribute the assets having regard only to the claims of which he then has notice.

**E. P. JOHNSON & DAVIES** of 257 Collins Street, Melbourne 124

**GEORGE WEBB**, late of 27 Pinnacle Crescent, Bulleen, retired printer, deceased

Creditors, next of kin and others having claims in respect of the estate of the abovenamed deceased who died on 5 October 1987 are required by Equity Trustees Executors and Agency Company Limited of 472 Bourke Street, Melbourne, the executor appointed by the will of the said deceased to send particulars of their claims to the said Company by 12 April 1988 after which date it will convey or distribute the assets having regard only to the claims of which it then has notice.

**DOMINIC M. LALLO**, solicitor, 27 Flinders Lane, Melbourne 135

**JOAN SUTHERLAND**, late of 23 Eva Street, Malvern, married woman, deceased

Creditors, next of kin and others having claims in respect of the estate of the deceased (who died on 28 September 1987) are required by The Union-Fidelity Trustee Company of Australia Limited of 100 Exhibition Street, Melbourne, to send particulars of their claims to the said Company by 19 April 1988 after which date it will convey or distribute the assets, having regard only to the claims of which the Company then has notice. 132

**EDNA MARION MALING**, late of 830 Canterbury Road, Box Hill, married woman, deceased

Creditors, next of kin and others having claims in respect of the estate of the deceased (who died on 21 October 1987) are required by The Perpetual Executors and Trustees Association of Australia Limited of 50 Queen Street, Melbourne, to send particulars of their claims to the said Company by 19 April 1988 after which date it will convey or distribute the assets, having regard only to the claims of which the Company then has notice. 133

**MAUD ILLEAN PARKES**, late of 55 Harold Street, Sandringham, widow, deceased

Creditors, next of kin and others having claims against the estate of the said deceased who died on 8 September 1987 are to send particulars of their claims to Albert Egerton Parkes care of Messrs. Blake & Riggall, solicitors, 140 William Street, Melbourne by 10 May 1988 after which date he will distribute the assets having regard only to the claims of which he then has notice.

131

**STEPHEN JOHN PARISH**, late of Nyah in the State of Victoria, retired farmer, deceased (who died on 15 June 1987)

Creditors, next of kin and all other persons having claims against the estate of the deceased are required by the Executors of the Will, Frederick Alan Parish and Donald John Athorn, to send particulars to them care of the undersigned on or before 5 April 1988, after which date they will distribute the assets having regard only to the claims of which they then have notice.

**GARDEN & GREEN**, solicitors, 4 McCallum Street, Swan Hill 110

In the Will of **MAURICE JOSEPH DUFFY**, late of 230 Rosanna Road, Rosanna in the State of Victoria, Catholic priest, deceased

Creditors, next of kin and others having claims in respect of the estate of the deceased, who died on 31 July 1987 are required by the executors National Mutual Trustees Limited, Mary Bernadette Duffy and Desmond Francis Welladsen of 46 Queen Street, Bendigo to send particulars to the Executors by 20 April 1988 after which date the Executors may convey or distribute the assets, having regard only to the claims of which the Executors then have notice.

**MESSRS ROGERS & EVERY**, solicitors, 71 Bull Street, Bendigo 111

In the Will of **LESLIE VICTOR GOODING**, late of Main Road, Epsom in the State of Victoria, public servant, deceased

Creditors, next of kin and others having claims in respect of the estate of the deceased, who died on 23 July 1987 are required by the executors National Mutual Trustees Limited and Dorothy Edith Archibald of 46 Queen Street, Bendigo to send particulars to the executors by 20 April 1988 after which date the Executors may convey or distribute the assets, having regard only to the claims of which the Executors then have notice.

**MESSRS ROGERS & EVERY**, solicitors, 71 Bull Street, Bendigo 112

**IVAN JOHN DONOVAN**, late of 95 Market Street, Essendon, clerk, deceased

Creditors, next of kin and others having claims in respect of the estate of the abovenamed deceased who died on 29 October 1987 are to send particulars of their claims to the Executors Jillian Clare Reilly and Suzanne Margaret Evelyn Ronksley care of the undermentioned solicitors by 21 April 1988 after which date the said Executor will distribute the assets having regard only to the claims of which he then has notice.

**O'BRIEN & GALANTE**, solicitors, 27 Norwood Crescent, Moonee Ponds 108

**FRANCES MARY NALDER**, late of 5 Ultima Road, Swan Hill in the State of Victoria, widow, deceased (who died on 10 May 1987)

Creditors, next of kin and all other persons having claims against the estate of the deceased are required by the Executors of the Will, Graeme William Nalder, Helen Mary Frame and Judith Frances Rowling, to send particulars to them care of the undersigned on or before 5 April 1988, after which date they will distribute the assets having regard only to the claims of which they then have notice.

**GARDEN & GREEN**, solicitors, 4 McCallum Street, Swan Hill 109

Creditors, next of kin and others having claims in respect of the estate of Frederick Joseph Sullivan formerly of 485 Gilbert Street, West Preston and late of 17 Montpellier Drive, Highton in the State of Victoria, shop proprietor, who died on 14 January 1985, are requested to send particulars of their claims in writing to the National Mutual Trustees Limited the executor of the said estate by 12 April 1988 after which date the executor will distribute the assets of the deceased having regard only to the claims of which it then has notice.

**DOYLE CONSIDINE**, solicitors, 73 Moorabool Street, Geelong 101

Creditors, next of kin and others having claims in respect of the estate of Vida Finetta McEacharn late of 8A Trawalla Avenue, Toorak, widow, deceased who died on 24 September 1987 are to send particulars of their claims to Ian Malcolm McEacharn, Merran Kathleen Clark, Jencie Merlyn Toakley and Russell McDonald Brown at 20th Floor, 140 William Street, Melbourne by 13 April 1988 after which date they will distribute the assets having regard only to the claims of which they then have notice.

**MIDDLETONS OSWALD BURT**, solicitors, 140 William Street, Melbourne 102

**ELIZABETH MYRTLE BROWN**, late of Hamer Court, 523 High Street, Kew in the State of Victoria, widow deceased

Creditors, next of kin, and others having claims in respect of the estate of the deceased, who died on 17 October 1987 are required by the personal representative Donald Brown of 27 Jacka Street, North Balwyn in the said State, retired gentleman, to send particulars to him by 12 April 1988 after which date the personal representative may convey or distribute the assets, having regard only to the claims of which he then has notice.

**COOKE & CUSSEN**, solicitors, 128 Exhibition Street, Melbourne 93

**JOAN CLARISSA WORSNOP**, late of 10 Cumberland Avenue, Bayswater, in the State of Victoria, widow, deceased

Creditors, next of kin and others having claims in respect of the estate of the deceased who died on 1 September 1987 are required by the personal representative Linda Mary Worsnop to send particulars to her care of the undersigned solicitors by 11 April 1988 after which date the personal representative may convey or distribute the assets having regard only to the claims of which she then has notice.

**TESTART, ROBINSON & PITTS**, solicitors, 942-946 Whitehorse Road, Box Hill 94

**NEIL BARCLAY ALLEN**, late of 1 Boorahman Street, North Balwyn, leather merchant, deceased

Creditors, next of kin and others having claims in respect of the estate of the abovenamed deceased who died on 20 October 1987 are to send particulars of their claims to the executors, Gail Marilyn Cornelius and Noel Raymond Allen care of the undermentioned solicitors by 14 April 1988 after which date the said executor will distribute the assets having regard only to the claims of which he then has notice.

**O'BRIEN & GALANTE**, solicitors, 27 Norwood Crescent, Moonee Ponds 95

**ALMA FLORENCE RAMSAY**, late of 1/31 Yeovil Road, Burwood, widow, deceased

Creditors, next of kin and others having claims against the estate of the said deceased who died on 23 November 1987 are to send particulars of their claims to Bette Anne Lovelace, care of Messrs. Blake & Riggall, solicitors, 140 William Street, Melbourne by 10 May 1988 after which date she will distribute the assets having regard only to the claims of which she then has notice.

130

**ISABELLA ADELAIDE SEIDENSTICKER**, late of Queenscliff Nursing Home, 20 Hesse Street, Queenscliff in the State of Victoria, gentlewoman, deceased

Creditors, next of kin and others having claims in respect of the estate of the abovenamed deceased who died on 6 October 1987 are required by the Trustee, John David Sumpter of Queenscliff Manor, 11 Learmonth Street, Queenscliff in the said State, retired, to send particulars of their claims to the Trustee care of the undermentioned solicitors by 20 March 1988 after which date the Trustee may convey or distribute the assets having regard only to the claims of which he then has notice.

**INGPEN & BENT**, solicitors, 95 Yarra Street, Geelong, Solicitors for the Trustee 99

**MARY AGNES KINSELLA**, late of 5/8 Westbury Street, East St. Kilda, spinster, deceased

Creditors, next of kin and others having a claim in respect of the estate of the deceased who died on 1 October 1987 are required by the executor of her will James Kinsella Robertson to send particulars to him at the office of the undermentioned solicitor by 12 April 1988 after which date the executor will distribute the assets of the deceased having regard only to the claims of which he will then have had notice.

**Wm. R. HUNT, M.A. LL.B.**, 358 Lonsdale Street, Melbourne, solicitor for the executors 145

Creditors, next of kin and others having claims in respect of the estate of Nancy Hamilton Baird late of 4/20 Lisson Grove, Hawthorn in the State of Victoria, spinster, deceased who died on 11 November 1987 are required by the executor The Union-Fidelity Trustee Company of Australia Limited of 100 Exhibition Street, Melbourne in the said State to send particulars to it by the 11 April 1988 after which date the executor may convey or distribute the assets, having regard only to the claims of which it then has notice.

**J. M. SMITH & EMMERTON**, solicitors, 385 Bourke Street, Melbourne 146

Creditors, next of kin and others having claims in respect of the estate of Shirley Joan Charlton, late of Preston and District Nursing Home, Benambra Street, Preston, home duties, deceased, who died on 24 September 1987, are to send the particulars of their claims to ANZ Executors & Trustee Company Limited of 94 Queen Street, Melbourne, by 11 April 1988, after which date it will distribute the assets having regard only to the claims of which it then has notice.

128

**MARJORIE JOY BEASY**, late of 39 Thurlia Street, Swan Hill in the State of Victoria, married woman, deceased

Creditors, next of kin and other persons having claims against the estate of the said deceased who died on 15 January 1988 are required to send particulars of same to the executors Donald James Pope and Vallereen Joy Lindsay in care of the undersigned on or before 10 April 1988 after which date they will distribute the assets having regard only to the claims of which they then have notice.

**DWYER, BENNETT & MAHON**, barristers and solicitors, 194-208 Beveridge Street, Swan Hill 147

Creditors, next of kin and others having claims in respect of the estate of Kathe (also known as Kaethe) Mosheim late of 7 Gardiner Road, Hawthorn in the State of Victoria, widow, deceased, who died on 22 November 1987 are requested to send particulars of their claims to the executor Daniel Rechtman, solicitor of 160 Queen Street, Melbourne by 9 May 1988 after which date he will distribute the assets having regard only as to the claims of which he then has notice.

**PRICE BRENT**, solicitors, 160 Queen Street, Melbourne 148

**DOROTHY ANNE COSTELLO**, late of 5 Walter Crescent, Warrnambool in the State of Victoria, widow, deceased

Creditors, next of kin and all others having claims in respect of the estate of the abovenamed deceased (who died on 19 October 1987) are required to send particulars of their claims in writing to the executors John Patrick Costello of 24 Outram Avenue, Kyabram and Alfred Anthony Grigg of Orrvale Road, Shepparton East care of the undersigned on or before 20 April 1988 after which date they will distribute the assets of the said deceased's estate having regard only to the claims of which they then have notice as aforesaid.

**DESMOND DUNNE & DWYER**, solicitors, Warrnambool 103

Creditors, next of kin and others having claims in respect of the estate of Florence Lovelock Breidahl of 23 Chatsworth Avenue, North Brighton, widow, deceased, who died on 28 October 1987, are to send the particulars of their claims to ANZ Executors & Trustee Company Limited of 94 Queen Street, Melbourne, by 11 April 1988, after which date it will distribute the assets having regard only to the claims of which it then has notice. 129

**GERTRUDE SHERRY**, late of Kenilworth Private Nursing Home, 3 Kenilworth Parade, Ivanhoe in the State of Victoria, widow, deceased

Creditors, next of kin and others having claims in respect of the estate of the deceased, who died on 9 September 1987 are required by the executor David John Dethridge, solicitor, of 43 Ryrie Street, Geelong, to send particulars to him by 30 April 1988 after which date he may convey or distribute the assets having regard only to the claims of which he then has notice.

**DAVID DETHRIDGE LL.B.**, solicitor, of 43 Ryrie Street, Geelong 100

Creditors, next of kin and others having claims against the estate of George Richard Jago late of 13 Jeffrey Street, Blackburn in the State of Victoria, retired are required by the Administrator of the Will of the deceased to send particulars of their claims to her solicitors Messrs. G. W. P. Aarons & Co., of 262 Queen Street, Melbourne, on or before 16 April 1988 after which date the Administrator will distribute the assets having regard only to the claims of which she will then have had notice.

**G. W. P. AARONS & CO.**, solicitors for the Administrator, 262 Queen Street Melbourne 105

Creditors, next of kin and others having claims in respect of the estate of Robert Schoenfeld late of Flat 12, 35 Powlett Street, East Melbourne in the State of Victoria, scientific editor, deceased who died on 24 November 1987 are required by the executor The Equity Trustees Executors and Agency Company Limited of 472 Bourke Street, Melbourne in the said State to send particulars to it by 11 April 1988 after which date the executor may convey or distribute the assets, having regard only to the claims of which it then has notice.

**J. M. SMITH & EMMERTON**, solicitors, 385 Bourke Street, Melbourne 106

Creditors, next of kin and others having claims in respect of the estate of Geoffrey Stuart Baker, late of Unit 5, 33-35 Franklin Road, Doncaster East in the State of Victoria, retired, deceased who died on 7 March 1987 are to send particulars of their claims to the Executors, Barrie John Young and Graeme Leslie Hubbard care of the undermentioned solicitors by 18 April 1988 after which date they will distribute the assets having regard only to the claims of which they then have notice.

**YOUNG HUBBARD & CO.**, solicitors of 825 Burke Road, Camberwell, 3124 143

Creditors, next of kin and others having claims against the estate of Lindsay William Bolden formerly of 143 Ascot Vale Road, Ascot Vale but late of 261 The Boulevard, East Ivanhoe in the State of Victoria, retired engineer, deceased who died on 6 November 1987 are required by the executor National Mutual Trustees Limited of 419 Collins Street, Melbourne in the said State, to send particulars of their claims to the said executor by 11 April 1988 after which date the said executor will distribute the assets having regard only to the claims of which the said executor then has notice.

POWER & Co., solicitors of 452 Burwood Highway, Wantirna South 104

GLADYS ELIZABETH THALLON, late of 18 Parlington Street, Canterbury, widow, deceased

Creditors, next of kin and others having claims in respect of the estate of the deceased who died on 2 November 1987 are required by the personal representatives Robert Jack Thallon of 18 Parlington Street, Canterbury and Gladys Joan Thallon of 125 Rutland Avenue, Mount Eliza to send particulars to them care of the undermentioned solicitors by 19 April 1988 after which date the personal representatives may convey or distribute the assets having regard only to the claims of which they then have notice.

AITKEN WALKER & STRACHAN, solicitors, 114 William Street, Melbourne 107

ANNIE AMELIA AKERMAN, late of Milpara Park Hostel, Ebdale Street, Frankston in the State of Victoria, widow, deceased

Creditors, next of kin and others having claims in respect of the estate of the deceased who died on 30 September 1987 are required by the executor, The Equity Trustees Executors and Agency Company Limited of 472 Bourke Street, Melbourne in the said State to send particulars of their claims to the said company by 11 April 1988 after which date it will convey or distribute the assets having regard only to the claims of which the company then has notice.

WELSH MAJOR & PRESTON, solicitors, 439A Nepean Highway, Frankston 96

Creditors, next of kin and others having claims in respect of the estate of Stanley Proctor Thomas of 66 Regent Street, Belmont, retired house decorator, deceased, who died on 25 September 1987, are to send the particulars of their claims to ANZ Executors & Trustee Company Limited of 94 Queen Street, Melbourne by 11 April 1988, after which date it will distribute the assets having regard only to the claims of which it then has notice. 127

Creditors, next of kin and others having claims in respect of the estate of Winifrid Ledgard, also known as Winifred Ledgard, late of Eastern Districts Private Nursing Home, 124 Maroondah Highway, Croydon, widow, deceased, who died on 18 September 1987, are to send the particulars of their claims to ANZ Executors & Trustee Company Limited of 94 Queen Street, Melbourne, by 11 April 1988, after which date it will distribute the assets having regard only to the claims of which it then has notice. 126

Estate WILLIAM ROBERT MILLER, deceased

Creditors, next of kin and others having claims in respect of the estate of the deceased who died on 20 May 1986 are required by the surviving Executrix Gwenda Mary Miller to send particulars to the undermentioned firm by 4 May 1988 after which date the said Executrix may convey or distribute the assets having regard only to the claims of which notice has by then been given.

O'HAIRE & O'HAIRE, solicitors, 627 Chapel Street, South Yarra 150

**LATE NOTICES***Local Government Act 1958***RESUBDIVISION OF THE MUNICIPAL DISTRICT OF THE SHIRE OF ROMSEY**

The Lieutenant-Governor, as deputy for the Governor in Council, acting under Part II of the *Local Government Act 1958*, orders—

1. that on and from 1 April 1988 the municipal district of the Shire of Romsey shall be resubdivided into four ridings whose names and boundaries are described hereunder;
2. that all councillors shall go out of office on the day appointed for the election of councillors next after this Order takes effect; and
3. that the number of councillors shall be twelve.

**Lancefield Riding**  
Enlarged and Re-defined  
Previous Gazettal 1919-1295

Commencing on the western boundary of the Shire where it is intersected by the Lancefield-Woodend Road; thence easterly by that road to Boundary Road; thence easterly by that road and Forbes Road to Tickawarra Road; thence northerly by that road to Grahams Road; thence north-easterly by that road to the Lancefield-Kilmore Road; thence south-easterly by that road to the Shire boundary; and thence generally northerly, westerly and southerly by the Shire boundary to the point of commencement.

**Romsey Riding**  
Reduced and Re-defined  
Previous Gazettal 1919-1295

Commencing on the western boundary of the Shire where it is intersected by the Lancefield-Woodend Road; thence easterly by that road to Boundary Road; thence easterly by that road and Forbes Road to Tickawarra Road; thence southerly by that road to the Woodend-Wallan Road; thence easterly by that road to Portingales Lane; thence southerly by that lane to Greens Lane; thence westerly by that lane to the Melbourne-Lancefield Road; thence northerly by that road to Knox Road; thence north-westerly by that road to the Woodend-Wallan Road; thence generally westerly by that road to the Shire boundary; and thence generally north-easterly by the Shire boundary to the point of commencement.

**Central Riding**  
Constituted

Commencing on the western boundary of the Shire where it is intersected by the Woodend-Wallan Road; thence easterly by that road to Knox Road; thence south-easterly by that road to the Melbourne-Lancefield Road; thence southerly by that road to Greens Lane; thence easterly by Greens Lane to Portingales Lane; thence northerly by that lane to the Woodend-Wallan Road; thence westerly by that road to Tickawarra Road; thence northerly by that road to Grahams Road; thence north-easterly by that road to the Lancefield-Kilmore Road; thence south-easterly by that road to the Shire boundary; thence generally south-easterly, southerly and westerly by the Shire boundary to the junction of Riddell Creek with Jackson Creek; thence generally north-westerly by Riddell Creek to Sandy Creek; thence generally north-westerly by Sandy Creek to the Gisborne-Kilmore Road; thence south-westerly by that road to Sandy Creek Road; thence north-westerly by that road to the northern angle of allotment 76, Parish of Kerrie; thence southerly by the western boundary of that allotment to Gap Road; thence north-westerly by that road to the Shire boundary; and thence generally northerly by the Shire boundary to the point of commencement.

**Riddells Creek Riding**  
Constituted

Commencing at the junction of Riddell Creek with Jackson Creek being a point on the southern boundary of the Shire; thence generally north-westerly by Riddell Creek to Sandy Creek; thence generally north-westerly by Sandy Creek to the Gisborne-Kilmore Road; thence south-westerly by that road to Sandy Creek Road; thence north-westerly by that road to the northern angle of allotment 76, Parish of Kerrie; thence southerly by the western boundary of that allotment to Gap Road; thence north-westerly by that road to the Shire boundary; and thence southerly and generally easterly by the Shire boundary to the point of commencement.

Dated 9 February 1988.

Responsible Minister:  
J. L. SIMMONDS  
Minister for Local Government

LAWRENCE A. FISHER  
Clerk of the Executive Council



*Local Government Act 1958*  
**RESUBDIVISION OF THE MUNICIPAL  
DISTRICT OF THE SHIRE OF AVON**

The Lieutenant-Governor, as deputy for the Governor in Council, acting under Part II of the *Local Government Act 1958*, orders—

1. that on and from 1 April 1988 the municipal district of the Shire of Avon shall be resubdivided into three ridings whose names and boundaries are described hereunder;

2. that all councillors of the North and Central Ridings shall go out of office on the day appointed for the election of councillors next after this Order takes effect; and

3. that the number of councillors shall be nine.

**South Riding**  
Enlarged and Re-defined  
Previous Gazettal 1967-1948

Commencing on the shore of Lake Wellington at the mouth of the Avon River being a point on the Shire boundary; thence generally north-westerly by the Avon River to the western boundary of the Shire; and thence generally southerly, south-easterly and north-easterly by the Shire boundary to the point of commencement.

**North-Central Riding**  
Constituted

Commencing on the shore of Lake Wellington at the mouth of the Avon River being a point on the Shire boundary; thence generally north-westerly by the Avon River to the eastern boundary of the Township of Stratford; thence northerly by that boundary and westerly by the northern boundary of the township to the Princes Highway; thence westerly by a line to the most eastern angle of allotment 36B, Parish of Stratford; thence north-westerly by that allotment to the Heyfield-Bairnsdale Railway; thence north-easterly by that railway to the southern boundary of allotment 30; thence westerly by that boundary and the southern boundary of allotment 31 to Dargo Road; thence southerly by that road to Wyndham Street; thence westerly by that street to the south-western angle of allotment 27; thence northerly by the western boundary of that allotment and further northerly by a line in continuation thereof to Llowalong Road; thence westerly by that road to Blackall Creek; thence southerly by that creek to the Avon River; thence north-westerly by that river to the western boundary of the Shire; thence generally northerly, easterly and southerly by the Shire boundary to the point of commencement.

**Stratford Township Riding**  
Constituted

Commencing on the Avon River at the south-eastern angle of the Township of Stratford; thence northerly by the eastern boundary and westerly by the northern boundary of the Township of Stratford to the Princes Highway; thence westerly by a line to the most eastern angle of allotment 36B, Parish of Stratford; thence north-westerly by that allotment to the Heyfield-Bairnsdale Railway; thence north-easterly by that railway to the southern boundary of allotment 30; thence westerly by that boundary and the southern boundary of allotment 31 to Dargo Road; thence southerly by that road to Wyndham Street; thence westerly by that street to the south-western angle of allotment 27; thence northerly by the western boundary of that allotment and further northerly by a line in continuation thereof to Llowalong Road; thence westerly by that road to Blackall Creek; thence southerly by that creek to the Avon River; and thence south-easterly by that river to the point of commencement.

Dated 9 February 1988

Responsible Minister:

J. L. SIMMONDS

Minister for Local Government

LAWRENCE A. FISHER  
Clerk of the Executive Council

*Local Government Act 1958*  
**RESUBDIVISION OF THE MUNICIPAL  
DISTRICT OF THE SHIRE OF DEAKIN**

The Lieutenant-Governor, as deputy for the Governor in Council, acting under Part II of the *Local Government Act 1958*, orders—

1. that on and from 1 April 1988 the municipal district of the Shire of Deakin shall be resubdivided into three ridings whose names and boundaries are described hereunder;

2. that the number of councillors shall be nine.

**Central Riding**  
Constituted

Commencing on the eastern boundary of the Shire at Wilson Road; thence westerly by that road to Watson Road; thence southerly by that road to Graham Road; thence easterly by that road to McEwen Road, being a point on the Shire boundary; and thence easterly and northerly by the Shire boundary to the point of commencement.

**North Riding**  
Constituted

Commencing on the eastern boundary of the Shire at Wilson Road; thence westerly by that road to McDonald Road; thence northerly by

that road to Rowe Road; thence westerly by that road to the Echuca-Kyabram Road; thence further westerly by a road, a line in continuation thereof and a road forming the northern boundary of allotment 153, Parish of Echuca South to the Shire boundary; and thence generally northerly, north-easterly, south-easterly and southerly by the Shire boundary to the point of commencement.

**South Riding  
Constituted**

Commencing on the Shire boundary at the intersection of Graham Road and McEwen Road; thence westerly by Graham Road to Watson Road; thence northerly by that road to Wilson Road; thence westerly by that road to McDonald Road; thence northerly by that road to Rowe Road; thence westerly by that road to the Echuca-Kyabram Road; thence further westerly by a road, a line in continuation thereof and a road forming the northern boundary of allotment 153, Parish of Echuca South to the Shire boundary; and thence generally southerly, easterly and northerly by the Shire boundary to the point of commencement.

Dated 9 February 1988

Responsible Minister:

J. L. SIMMONDS

Minister for Local Government

LAWRENCE A. FISHER  
Clerk of the Executive Council

*Local Government Act 1958*

**RESUBDIVISION OF THE MUNICIPAL  
DISTRICT OF THE SHIRE OF KORONG**

The Lieutenant-Governor, as deputy for the Governor in Council, acting under Part II of the *Local Government Act 1958*, orders—

1. that on and from 1 April 1988, the municipal district of the Shire of Korong shall be resubdivided into three ridings whose names and boundaries are described hereunder;

2. that the number of councillors shall be nine.

**Central Riding**

Reduced and Re-defined

Previous Gazettal 1895-3293

Commencing at a point on the Shire boundary where it is intersected by the western boundary of the Parish of Moliagul; thence northerly by that boundary and the western boundary of the Parish of Kangeraar to the southern boundary of the Parish of Brenanah; thence easterly and northerly by the southern and eastern boundaries of that parish and further northerly by the eastern boundary of the Parish of Korong to the Calder Highway; thence north-westerly by that highway

to the eastern boundary of the Parish of Wedderburne; thence northerly, westerly and southerly by the eastern, northern and western boundaries of that parish and further southerly by the western boundaries of the Parish of Kurraca and the Parish of Wehla to the Logan-Wehla-Rheola Road; thence south-westerly by that road to the St. Arnaud-Bendigo Road; thence south-easterly by that road to the road forming the northern boundary of allotment 9, Parish of Kooreh; thence south-westerly by that road to the Shire boundary; and thence generally southerly and generally easterly by the Shire boundary to the point of commencement.

**South Riding  
Reduced and Re-defined  
Previous Gazettal 1961-217**

Commencing at a point on the Shire boundary where it is intersected by the western boundary of the Parish of Moliagul; thence northerly by that boundary and the western boundary of the Parish of Kangeraar to the southern boundary of the Parish of Brenanah; thence easterly and northerly by the southern and eastern boundaries of that parish and further northerly by the eastern boundaries of the Parish of Korong and the Parish of Kinypanial to the northern boundary of the Parish of Powlett; thence easterly by that boundary to the Shire boundary; and thence south-easterly, generally southerly and generally south-westerly by the Shire boundary to the point of commencement.

**North Riding  
Enlarged and Re-defined  
Previous Gazettal 1895-1979**

Commencing at a point on the Shire boundary being the north-eastern angle of the Parish of Powlett; thence westerly and southerly by the northern and western boundaries of that parish and further southerly by the western boundary of the Parish of Kurting to the Calder Highway; thence north-westerly by that highway to the eastern boundary of the Parish of Wedderburne; thence northerly, westerly and southerly by the eastern, northern and western boundaries of that parish and further southerly by the western boundaries of the Parish of Kurraca and the Parish of Wehla to the Logan-Wehla-Rheola Road; thence south-westerly by that road to the St. Arnaud-Bendigo Road; thence south-easterly by that road to the road forming the northern boundary of allotment 9, Parish of Kooreh; thence south-westerly by that road to the Shire boundary; and thence generally north-westerly,

generally northerly, generally easterly and southerly by the Shire boundary to the point of commencement.

Dated 9 February 1988

Responsible Minister:

J. L. SIMMONDS

Minister for Local Government

LAWRENCE A. FISHER

Clerk of the Executive Council

*Local Government Act 1958*

**RESUBDIVISION OF THE MUNICIPAL DISTRICT OF THE SHIRE OF LOWAN**

The Lieutenant-Governor, as deputy for the Governor in Council, acting under Part II of the *Local Government Act 1958*, orders—

1. that on and from 1 April 1988 the municipal district of the Shire of Lowan shall be resubdivided into four ridings whose names and boundaries are described hereunder;
2. that all councillors shall go out of office on the day appointed for the election of councillors next after this Order takes effect; and
3. that the number of councillors shall be twelve.

**South Riding**

**Reduced and Re-defined**

Previous Gazettal 1956-578

Commencing at a point on the eastern boundary of the Shire where it is intersected by the Western Highway, thence westerly by that highway to George Street, thence southerly and westerly by that street to Glenferness Street, thence northerly by that street to Nelson Street, thence westerly by that street to Victoria Street, thence south-westerly by that street and the Western Highway to Kinimakatka Road, thence southerly by that road, K. Clarks Road and a line in continuation thereof to the Shire boundary, and thence easterly and generally northerly by the Shire boundary to the point of commencement.

**South-West Riding**

**Constituted**

Commencing on the western boundary of the Shire at the Diapur-Miram Road, thence easterly by that road, the Diapur-Nhill Road, Yanac Road and Nelson Street to Victoria Street, thence south-westerly by that street and the Western Highway to Kinimakatka Road, thence southerly by that road, K. Clarks Road and a line in continuation thereof to the Shire boundary, and thence westerly, generally northerly, westerly and northerly by the Shire boundary to the point of commencement.

**East Riding**

**Enlarged and Re-defined**

Previous Gazettal 1956-578

Commencing at a point on the Shire boundary being the north-western angle of the Parish of Warraquil, thence southerly by the western boundaries of that parish and the Parish of Propodollah Extension Road, thence easterly by that road and Propodollah Road to Lacey's Road, thence further easterly by that road to the western boundary of the Parish of Woorak, thence southerly by that boundary to Propodollah Road, thence further southerly by that road and McKenzie Avenue to Park Street, thence easterly by that street to Dart Street, thence northerly by that street to Ramsay Street, thence easterly by that street to Davis Avenue, thence southerly by that avenue to Nelson Street, thence easterly by that street to Glenferness Street, thence southerly by that street to George Street, thence easterly and northerly by that street to the Western Highway, thence easterly by that highway to the Shire boundary, and thence generally northerly and westerly by the Shire boundary to the point of commencement.

**West Riding**

**Enlarged and Re-defined**

Previous Gazettal 1956-578

Commencing at a point on the Shire boundary being the north-western angle of the Parish of Warraquil, thence southerly by the western boundaries of that parish and the Parish of Propodollah to the Propodollah Extension Road, thence easterly by that road and Propodollah Road to Lacey's Road, thence further easterly by that road to the western boundary of the Parish of Woorak, thence southerly by that boundary to Propodollah Road, thence further southerly by that road and McKenzie Avenue to Park Street, thence easterly by that street to Dart Street, thence northerly by that street to Ramsay Street, thence easterly by that street to Davis Avenue, thence southerly by that avenue to Nelson Street, thence westerly by that street and Yanac Road to the Diapur-Nhill Road, thence further westerly by that road and the Diapur-Miram Road to the Shire boundary, thence northerly, westerly, generally northerly, easterly, southerly and easterly by the Shire boundary to the point of commencement.

Dated 9 February 1988

Responsible Minister:

J. L. SIMMONDS

Minister for Local Government

LAWRENCE A. FISHER

Clerk of the Executive Council

*Local Government Act 1958*  
**RESUBDIVISION OF THE MUNICIPAL  
DISTRICT OF THE SHIRE OF  
DAYLESFORD AND GLEN LYON**

The Lieutenant-Governor, as deputy for the Governor in Council, acting under Part II of the *Local Government Act 1958*, orders—

1. that on and from 1 April 1988 the municipal district of the Shire of Daylesford and Glenlyon shall be resubdivided into four ridings whose names and boundaries are described hereunder;
2. that all councillors shall go out of office on the day appointed for the election of councillors next after this Order takes effect; and
3. that the number of councillors shall be twelve.

**Daylesford Riding**  
**Reduced and Re-defined**  
**Previous Gazettal 1966-1404**

Commencing on the western boundary of the Shire where it is intersected by the Midland Highway; thence north-easterly by that highway to Albert Street; thence easterly by that street to Howe Street; thence north-easterly by that street to Raglan Street; thence easterly by that street to East Street; thence southerly by that street to Stanbridge Street; thence westerly by that street to Vincent Street; thence southerly by that street, King Street and Ballan Road to the Shire boundary; and thence south-westerly and generally northerly by the Shire boundary to the point of commencement.

**Hepburn Riding**  
**Reduced and Re-defined**  
**Previous Gazettal 1966-1404**

Commencing on the western boundary of the Shire where it is intersected by the Midland Highway; thence north-easterly by that highway to Albert Street; thence easterly by that street to Vincent Street; thence northerly by that street and Vincent Street North to Westwood Street; thence easterly by that street to Jamison Street; thence northerly by that street to Kidds Gully at the southern boundary of allotment 51R, section 2, Parish of Wombat; thence northerly by that gully to its junction with Spring Creek; thence northerly by a direct line to a point on the northern boundary of the Parish of Wombat at the south-western angle of the Parish of Holcombe; thence westerly by the northern boundary of the Parish of Wombat to the Shire boundary; thence south-easterly by the Shire boundary to the point of commencement.

**Franklin Riding**  
**Enlarged and Re-defined**  
**Previous Gazettal 1966-1404.5**

Commencing on the eastern boundary of the Shire at Spring Hill Road; thence generally westerly by that road to Malmsbury Road; thence south-westerly by that road to Back Glenlyon Road; thence south-westerly by that road to Woolnoughs Road; thence north-westerly by that road to Porcupine Ridge Road; thence generally southerly by that road to the Daylesford-Glenlyon Road; thence south-westerly by that road to the Midland Highway; thence south-westerly by that highway to Raglan Street; thence westerly by that street to Howe Street; thence south-westerly by that street to Vincent Street; thence northerly by that street and Vincent Street North to Westwood Street; thence easterly by that street to Jamison Street; thence northerly by that street to Kidds Gully at the southern boundary of allotment 51R, section 2, Parish of Wombat; thence northerly by that gully to its junction with Spring Creek; thence northerly by a direct line to a point on the northern boundary of the Parish of Wombat at the south-western angle of the Parish of Holcombe; thence westerly by the northern boundary of the Parish of Wombat to the Shire boundary; thence generally northerly, generally easterly and generally southerly by the Shire boundary to the point of commencement.

**Glenlyon Riding**  
**Enlarged and Re-defined**  
**Previous Gazettal 1966-1405**

Commencing on the eastern boundary of the Shire of Spring Hill Road; thence generally westerly by that road to Malmsbury Road; thence south-westerly by that road to Back Glenlyon Road; thence south-westerly by that road to Woolnoughs Road; thence north-westerly by that road to Porcupine Ridge Road; thence generally southerly by that road to the Daylesford-Glenlyon Road; thence south-westerly by that road to the Midland Highway; thence south-westerly by that highway to East Street; thence southerly by that street to Stanbridge Street; thence westerly by that street to Vincent Street; thence southerly by that street, King Street and Ballan Road to the Shire boundary; and thence generally easterly and north-easterly by the Shire boundary to the point of commencement.

Dated 9 February 1988

Responsible Minister:  
J. L. SIMMONDS  
Minister for Local Government

LAWRENCE A. FISHER  
Clerk of the Executive Council

*Local Government Act 1958*

**RESUBDIVISION OF THE MUNICIPAL DISTRICT OF THE SHIRE OF GISBORNE**

The Lieutenant-Governor, as deputy for the Governor in Council, acting under Part II of the *Local Government Act 1958*, orders—

1. that on and from 1 April 1988 the municipal district of the Shire of Gisborne shall be resubdivided into three ridings whose names and boundaries are described hereunder;

2. that the number of councillors shall be nine:

Bullengarook Riding

Enlarged and Re-defined

Previous Gazettal 1982-1512

Commencing at a point on the western boundary of the Shire where it is intersected by Blackwood Road; thence generally south-easterly and easterly by that road to Wiltshire Road; thence further easterly by that road to the Calder Highway; thence south-easterly and southerly by that highway to Aitken Street; thence southerly by that street to Willowbank Road; thence easterly by that road to the Calder Highway; thence south-easterly by that highway to the Shire boundary; and thence south-easterly, westerly, northerly and north-easterly by the Shire boundary to the point of commencement.

Gisborne Riding

Reduced and Re-defined

Previous Gazettal 1982-1512

Commencing at a point on the eastern boundary of the Shire where it is intersected by Hamilton Road; thence westerly by that road to the Mt. Macedon Road, thence southerly by that road to the Calder Highway; thence south-easterly and southerly by that highway to Aitken Street; thence southerly by that street to Willowbank Road; thence easterly by that road to the Calder Highway; thence south-easterly by that highway to the Shire boundary; and thence northerly, easterly, generally northerly and generally westerly by the Shire boundary to the point of commencement.

Macedon Riding

Re-defined

Previous Gazettal 1982-1512

Commencing at a point on the western boundary of the Shire where it is intersected by Blackwood Road; thence generally south-easterly and easterly by that road to Wiltshire Road; thence further easterly by that road to the Calder Highway; thence south-easterly by that highway to Mount Macedon Road; thence northerly by that road to Hamilton Road; thence easterly by that road to the Shire boundary; and thence

generally northerly, north-westerly, westerly and south-westerly by that boundary to the point of commencement.

Dated 9 February 1988

Responsible Minister:

J. L. SIMMONDS

Minister for Local Government

LAWRENCE A. FISHER

Clerk of the Executive Council

*Local Government Act 1958*

**ALTERATION OF THE NAME OF THE SUBDIVISIONS OF THE MUNICIPAL DISTRICT OF THE SHIRE OF WYCHEPROOF**

Whereas by an Order published in the *Government Gazette* on 9 December 1987, the Governor in Council under Part II of the *Local Government Act 1958*, ordered that on and from 1 April 1988 the municipal district of the Shire of Wycheproof be subdivided into four ridings viz.: Riding One, Riding Two, Riding Three and Riding Four.

Now, the Lieutenant-Governor as deputy for the Governor in Council acting with the advice of the Executive Council and pursuant to section 24B (1) of the Act, hereby alters the names of the respective subdivisions to be known as Thalia, Bunguluke, Myall and Tyrrell Ridings on and from 1 April 1988.

Dated 9 February 1988

Responsible Minister:

J. L. SIMMONDS

Minister for Local Government

LAWRENCE A. FISHER

Clerk of the Executive Council

*Local Government Act 1958*

**RESUBDIVISION OF THE MUNICIPAL DISTRICT OF THE SHIRE OF HEALESVILLE**

The Lieutenant-Governor as deputy for the Governor in Council, acting under Part II of the *Local Government Act 1958*, orders

1. that on and from 1 April 1988 the municipal district of the Shire of Healesville shall be resubdivided into three ridings whose names and boundaries are described hereunder;

2. that all councillors shall go out of office on the day appointed for the election of councillors next after this Order takes effect; and

3. that the number of councillors shall be nine.

Watts Riding

Constituted

Commencing at a point on the Shire boundary being the junction of the Watts River with the Yarra River; thence north-easterly by the Watts River to the Yarra Glen-Healesville Road; thence north-westerly by that road to Chum Creek Road; thence northerly by that road to Kinglake Road; thence north-westerly and south-westerly by that road to the Old Toolangi-Mount Slide Road; thence generally westerly by that road to Kinglake Road; thence north-westerly by that road to the Shire boundary; thence generally northerly, generally easterly and generally south-easterly by the Shire boundary to the Maroondah Highway; thence generally south-westerly by that highway to the Watts River; thence south-westerly by that river to the northern shore of the Maroondah Reservoir; thence south-westerly by that shore and westerly and southerly by the Watts River to Wilson Street; thence south-easterly by that street and generally south-easterly by Badger Creek Road to Badger Avenue; thence south-westerly by that avenue to Toolebewong Road; thence westerly by that road to the Healesville-Koo Wee Rup Road; thence northerly by that road to Badger Creek; thence generally south-westerly by that creek to the Shire boundary; and thence generally north-westerly by the Shire boundary to the point of commencement.

**Badger Riding  
Constituted**

Commencing at a point on the Shire boundary being the junction of Badger Creek with the Yarra River; thence generally north-easterly by that creek to the Healesville-Koo Wee Rup Road; thence southerly by that road to Toolebewong Road; thence easterly by that road to Badger Avenue; thence north-easterly by that avenue to Badger Creek Road; thence generally north-westerly by that road and north-westerly by Wilson Street to the Watts River; thence northerly and easterly by that river, north-easterly by the northern shore of the Maroondah Reservoir and further north-easterly by the Watts River again to the Maroondah Highway; thence generally north-easterly by that highway to the Shire boundary; and thence south-easterly, generally south-westerly and north-westerly by the Shire boundary to the point of commencement.

**Sugarloaf Riding  
Constituted**

Commencing at a point on the Shire boundary being the junction of the Watts River with the Yarra River; thence north-easterly by the Watts River to the Yarra Glen-Healesville Road; thence north-westerly by that road to Chum Creek Road;

thence northerly by that road to Kinglake Road; thence north-westerly and south-westerly by that road to the Old Toolangi-Mount Slide Road; thence generally westerly by that road to Kinglake Road; thence north-westerly by that road to the Shire boundary, and thence generally south-westerly, southerly, further south-westerly, generally southerly, generally north-easterly and generally easterly by the Shire boundary to the point of commencement.

Dated 9 February 1988

Responsible Minister:

J. L. SIMMONDS

Minister for Local Government

LAWRENCE A. FISHER  
Clerk of the Executive Council

*Local Government Act 1958*

**RESUBDIVISION OF THE MUNICIPAL  
DISTRICT OF THE CITY OF WERRIBEE**

The Lieutenant-Governor, as deputy for the Governor in Council, acting under Part II of the *Local Government Act 1958*, orders—

1. that on and from 1 April 1988, the municipal district of the City of Werribee shall be resubdivided into four wards whose names and boundaries are described hereunder;
2. that all councillors shall go out of office on the day appointed for the election of councillors next after this Order takes effect; and
3. that the number of councillors shall be twelve.

**West Ward  
Constituted**

Commencing on the City boundary at the mouth of the Werribee River; thence north-westerly by the Werribee River to the Melbourne-Geelong Railway; thence south-westerly by that railway to a point in line with the prolongation of Walls Road; thence northerly by a line and Walls Road to Cambridge Crescent; thence northerly by that crescent to Ballan Road; thence south-easterly by that road to Hooker Road; thence north-easterly by that road to Greaves Street; thence north-westerly by that street to the western angle of the Werribee West Primary School Site; thence north-easterly by the north-western boundary of that site and further north-easterly by a line in continuation thereof to the Werribee River; thence north-westerly by that river to a point in line with the prolongation of Shaws Road; thence easterly by a line and Shaws Road to Cemetery Road; thence southerly by that road to Railway Avenue; thence north-easterly by that avenue to Derrimut Road; thence northerly by that road to Heaths Road; thence

westerly by that road to Tarneit Road; thence northerly by that road to Hogans Road; thence westerly by that road and a line in continuation thereof to the Werribee River; thence north-westerly by that river to the City boundary; and thence further north-westerly, southerly, westerly, south-easterly and north-easterly by the City boundary to the point of commencement.

## North Ward

## Reduced and Re-defined

## Previous Gazettal 1982-1512

Commencing at the junction of Palmers Road with Boundary Road, being a point on the northern boundary of the City; thence southerly by Palmers Road to Sayers Road; thence westerly by that road to Forsyth Road; thence southerly, south-westerly and south-easterly by that road to the Old Geelong Road; thence further south-easterly by the Laverton RAAF Base boundary and a line in continuation thereof to the Melbourne-Geelong Railway; thence south-westerly by that railway to the Old Geelong Road; thence northerly by that road to Morris Road; thence northerly by that road to Heaths Road; thence westerly by that road to Tarneit Road; thence northerly by that road to Hogans Road; thence westerly by that road and a line in continuation thereof to the Werribee River; thence north-westerly by that river to a point in line with the prolongation of Boundary Road being a point on the City boundary; and thence easterly by the City boundary to the point of commencement.

## East Ward

## Enlarged and Re-defined

## Previous Gazettal 1982-1512

Commencing at the junction of Palmers Road with Boundary Road being a point on the northern boundary of the City; thence southerly by Palmers Road to Sayers Road; thence westerly by that road to Forsyth Road; thence southerly, south-westerly and south-easterly by that road to the Old Geelong Road; thence further south-easterly by the Laverton RAAF Base boundary and a line in continuation thereof to the Melbourne-Geelong Railway; thence south-westerly by that railway to the MMBW Outfall Sewer; thence southerly and south-westerly by that outfall sewer to the Werribee River; thence south-easterly by that river to the City boundary; and thence north-easterly, generally northerly and westerly by the City boundary to the point of commencement.

## Central Ward

## Reduced and Re-defined

## Previous Gazettal 1982-1512

Commencing on the Werribee River where it

is crossed by the Melbourne-Geelong Railway; thence south-westerly by that railway to a point in line with the prolongation of Walls Road; thence northerly by a line and Walls Road to Cambridge Crescent; thence northerly by that crescent to Ballan Road; thence south-easterly by that road to Hooker Road; thence north-easterly by that road to Greaves Street; thence north-westerly by that street to the western angle of the Werribee West Primary School Site; thence north-easterly by the north-western boundary of that site and further north-easterly by a line in continuation thereof to the Werribee River; thence north-westerly by that river to a point in line with the prolongation of Shaws Road; thence easterly by a line and Shaws Road to Cemetery Road; thence southerly by that road to Railway Avenue; thence north-easterly by that avenue to Derrimut Road; thence northerly by that road to Heaths Road; thence easterly by that road to Morris Road; thence southerly by that road to Old Geelong Road; thence further southerly by that road to the Melbourne-Geelong Railway; thence north-easterly by that railway to the MMBW Outfall Sewer; thence southerly and south-westerly by that outfall sewer to the Werribee River; and thence north-westerly and north-easterly by that river to the point of commencement.

Dated 9 February 1988

Responsible Minister:

J. L. SIMMONDS

Minister for Local Government

LAWRENCE A. FISHER

Clerk of the Executive Council

*Local Government Act 1958*

## RESUBDIVISION OF THE MUNICIPAL DISTRICT OF THE SHIRE OF BARRABOOL

The Lieutenant-Governor, as deputy for the Governor in Council, acting under Part II of the *Local Government Act 1958*, orders—

1. that on and from 1 April 1988, the municipal district of the Shire of Barrabool shall be resubdivided into three ridings whose names and boundaries are described hereunder;
2. that all councillors shall go out of office on the day appointed for the election of councillors next after this Order takes effect; and
3. that the number of councillors shall be nine.

## Moriac Riding

## Enlarged and Re-defined

## Previous Gazettal 1958-450

Commencing on the eastern boundary of the Shire at the north-eastern angle of Portion 71

Parish of Puebla; thence westerly by the road forming the northern boundary of that portion and by Coombes Road and Hendy Main Road to Brushfields Road; thence southerly by that road to the northern boundary of the Parish of Jan Juc; thence westerly by that Parish boundary to Forest Road; thence south-westerly by that road to the western boundary of the Shire; thence northerly, westerly, further northerly, generally easterly, southerly, further easterly, and further southerly by the Shire boundary to the point of commencement.

Jan Juc Riding  
Constituted

Commencing on the eastern boundary of the Shire at the north-eastern angle of Portion 71, Parish of Puebla; thence westerly by the road forming the northern boundary of that portion and by Coombes Road and Hendy Main Road to Brushfields Road; thence southerly by that road to the northern boundary of the Parish of Jan Juc; thence westerly by that Parish boundary to Forest Road; thence south-westerly and south-easterly by that road to the Great Ocean Road; thence generally southerly by that road to the northern boundary of the Township of Anglesea; thence westerly by that township boundary to the Anglesea River; thence generally southerly by that river to the Shire boundary, and thence generally north-easterly and northerly by the Shire boundary to the point of commencement.

Coast Riding  
Reduced and Re-defined  
Previous Gazettal 1958-450

Commencing on the Shire boundary at the mouth of the Anglesea River; thence northerly by that river to the northern boundary of the Township of Anglesea; thence easterly by that township boundary to the Great Ocean Road; thence generally northerly by that road to Forest Road; thence generally north-westerly by that road to the Shire boundary (near the north-western angle of allotment 57, Parish of Jan Juc); and thence southerly, generally south-westerly and generally north-easterly by the Shire boundary to the point of commencement.

Dated 9 February 1988

Responsible Minister:  
J. L. SIMMONDS  
Minister for Local Government

LAWRENCE A. FISHER  
Clerk of the Executive Council

*Historic Buildings Act 1981 (No. 9667)*  
AMENDMENT OF REGISTER OF  
GOVERNMENT BUILDINGS

Under section 32A of the *Historic Buildings Act 1981* the Governor in Council amends the Register by adding

Former Court House, corner of High and Heckfield Streets, Macarthur to the extent of the whole of the building and land as shown on the plan held by the Ministry for Planning and Environment.

Dated 15 December 1987

Responsible Minister:  
T. W. ROPER  
Minister for Planning and Environment

LAWRENCE A. FISHER  
Clerk of the Executive Council

*Historic Buildings Act 1981 (No. 9667)*  
AMENDMENT OF REGISTER OF  
GOVERNMENT BUILDINGS

Under section 32A of the *Historic Buildings Act 1981* the Governor in Council amends the Register by adding

Court House, Forest Street, Woodend to the extent of the whole of the building and land contained in Court House Reserve Rs. 7091 and shown on the plan held by the Ministry for Planning and Environment.

Dated 15 December 1987

Responsible Minister:  
T. W. ROPER  
Minister for Planning and Environment

LAWRENCE A. FISHER  
Clerk of the Executive Council

*Historic Buildings Act 1981 (No. 9667)*  
AMENDMENT OF REGISTER OF  
GOVERNMENT BUILDINGS

Under section 32A of the *Historic Buildings Act 1981* the Governor in Council amends the Register by adding

Court House, Glendinning Street, Balmoral to the extent of the whole of the buildings and part of the Police Reserve Rs. 6649 as shown on the plan held by the Ministry for Planning and Environment.

Dated 15 December 1987

Responsible Minister:  
T. W. ROPER  
Minister for Planning and Environment

LAWRENCE A. FISHER  
Clerk of the Executive Council



*Historic Buildings Act 1981 (No. 9667)*  
**AMENDMENT OF REGISTER OF  
GOVERNMENT BUILDINGS**

Under section 32A of the *Historic Buildings Act 1981*, the Governor in Council amends the Register by adding—

Former School, Three Chain Road, Cobaw to the extent of the whole of the buildings and land contained in the Public Recreation Reserve RS 8002 and shown on the plan held by the Ministry for Planning and Environment.

Dated 15 December 1987

Responsible Minister:

**T. W. ROPER**  
Minister for Planning and Environment

**LAWRENCE A. FISHER**  
Clerk of the Executive Council

---

*Historic Buildings Act 1981 (No. 9667)*  
**AMENDMENT OF REGISTER OF  
HISTORIC BUILDINGS**

Under section 14 of the *Historic Buildings Act 1981*, the Governor in Council amends the Register by adding Historic Building No. 676—

Mandeville Hall, 10 Mandeville Crescent, Toorak—

to the extent of the whole of Mandeville Hall, and its forecourt, St. George's (the original house), the stables and men's quarters and the whole of the land in Certificate of Title Volume 9567, Folio 959 as shown on the plan held by the Ministry for Planning and Environment.

Dated 15 December 1987

Responsible Minister:

**T. W. ROPER**  
Minister for Planning and Environment

**LAWRENCE A. FISHER**  
Clerk of the Executive Council

---

*Historic Buildings Act 1981 (No. 9667)*  
**AMENDMENT OF REGISTER OF  
GOVERNMENT BUILDINGS**

Under section 32A of the *Historic Buildings Act 1981*, the Governor in Council amends the Register by adding—

South Channel Fort, Port Phillip Bay— to the extent of the whole of the structure and works and the whole of the land described as Certificate of Title Volume 6665, Folio 905.

Dated 15 December 1987

Responsible Minister:

**T. W. ROPER**  
Minister for Planning and Environment

**LAWRENCE A. FISHER**  
Clerk of the Executive Council

*Historic Buildings Act 1981 (No. 9667)*  
**AMENDMENT OF REGISTER OF  
HISTORIC BUILDINGS**

Under section 14 of the *Historic Buildings Act 1981*, the Governor in Council amends the Register by adding Historic Building No. 682—

Melbourne University Boat Club Shed, Yarra Bank, off Jeffries Parade, Melbourne—

to the extent of the whole of the building and land as shown on the plan held by the Ministry for Planning and Environment.

Dated 15 December 1987

Responsible Minister:

**T. W. ROPER**  
Minister for Planning and Environment

**LAWRENCE A. FISHER**  
Clerk of the Executive Council

---

*Historic Buildings Act 1981 (No. 9667)*  
**AMENDMENT OF REGISTER OF  
GOVERNMENT BUILDINGS**

Under section 32A of the *Historic Buildings Act 1981* the Governor in Council amends the Register by adding

HMVS Cerebus, Half Moon Bay to the extent of the whole of the surviving fabric but excluding the jetty.

Dated 15 December 1987

Responsible Minister:

**T. W. ROPER**  
Minister for Planning and Environment

**LAWRENCE A. FISHER**  
Clerk of the Executive Council

---

*Historic Buildings Act 1981 (No. 9667)*  
**AMENDMENT OF REGISTER OF  
GOVERNMENT BUILDINGS**

Under section 32A of the *Historic Buildings Act 1981* the Governor in Council amends the Register by adding

Former Court House, Lancefield to the extent of the whole of the building and land as shown on the plan held by the Ministry for Planning and Environment.

Dated 15 December 1987

Responsible Minister:

**T. W. ROPER**  
Minister for Planning and Environment

**LAWRENCE A. FISHER**  
Clerk of the Executive Council

*Historic Buildings Act 1981 (No. 9667)*  
**AMENDMENT OF REGISTER OF  
 HISTORIC BUILDINGS**

Under section 14 of the *Historic Buildings Act 1981* the Lieutenant-Governor as deputy for the Governor in Council amends the Register by adding Historic Buildings No. 667.

Massey Ferguson Complex, Devonshire Road, Sunshine to the extent of the whole of the site and all of the buildings shown hatched on the plan held by the Ministry for Planning and Environment on the land comprising all of (A) Lot 2 and (B) Lots 11 and 12 on the Plan of Subdivision prepared by the Licensed Surveyor D. C. Hann (Ref 862B/6A), Certificates of Title Volume 9644 Folio 028 and 029.

Dated 9 February 1988

Responsible Minister:

**T. W. ROPER**

Minister for Planning and Environment

**LAWRENCE A. FISHER**

Clerk of the Executive Council

*Historic Buildings Act 1981 (No. 9667)*  
**AMENDMENT OF REGISTER OF  
 GOVERNMENT BUILDINGS**

Under section 32A of the *Historic Buildings Act 1981* the Governor in Council amends the Register by adding

Former School of Mines, 27 Lyttleton Street, Castlemaine

to the extent of the exterior of the building to the depth of the front wing.

Dated 15 December 1987

Responsible Minister:

**T. W. ROPER**

Minister for Planning and Environment

**LAWRENCE A. FISHER**

Clerk of the Executive Council

*Historic Buildings Act 1981 (No. 9667)*  
**AMENDMENT OF REGISTER OF  
 GOVERNMENT BUILDINGS**

Under section 32A of the *Historic Buildings Act 1981* the Governor in Council amends the Register by adding

Former Police Stables, rear of Police Station, High Street, Mansfield to the extent of the stable buildings on part of Court House and Police Building Reserve Rs. 8549.

Dated 15 December 1987

Responsible Minister:

**T. W. ROPER**

Minister for Planning and Environment

**LAWRENCE A. FISHER**

Clerk of the Executive Council

*Water and Sewerage Authorities (Restructuring) Act 1983*

*Water Act 1958*

**MORNINGTON PENINSULA AND  
 DISTRICT WATER BOARD**

Extension of Mornington Peninsula Urban District Approved

The Governor in Council, under the provisions of the *Water and Sewerage Authorities (Restructuring) Act 1983* and the *Water Act 1958*, approves of the extension to the Mornington Peninsula Urban District as shown in red on the accompanying plans Corr. No. L86/573/28 (Plans Nos. 1-5).

Dated 2 February 1988

Responsible Minister:

**STEVE CRABB**

Acting Minister for Water Resources

**LAWRENCE A. FISHER**

Clerk of the Executive Council

*Water and Sewerage Authorities (Restructuring) Act 1983*

**SUNRAYSIA WATER BOARD**

Extent of Sunraysia Urban District Increased

The Governor in Council, under the provisions of the *Water and Sewerage Authorities (Restructuring) Act 1983*, approves of the extension of the Sunraysia Urban District of the Sunraysia Water Board as shown by the lands coloured pink on the accompanying plans marked "D" and "H" (Corr. No. 007583/25 and 26).

Dated 2 February 1988

Responsible Minister:

**STEVE CRABB**

Acting Minister for Water Resources

**LAWRENCE A. FISHER**

Clerk of the Executive Council

*Water and Sewerage Authorities (Restructuring) Act 1983*

*Water Act 1958*

**PAKENHAM WATER BOARD**

Township of Pakenham

Extension of Sewerage District Approved

The Governor in Council, under the provisions of the *Water and Sewerage Authorities (Restructuring) Act 1983* and the *Water Act 1958*, approves of the extension to the township of Pakenham Sewerage District as shown in red on

the accompanying plans (Corr. No. 79/2176/87  
(Plan No. 1)).

Dated 2 February 1988

Responsible Minister:

**STEVE CRABB**

Acting Minister for Water Resources

**LAWRENCE A. FISHER**  
Clerk of the Executive Council

*Water and Sewerage Authorities (Restructuring)  
Act 1983*

*Sewerage Districts Act 1958*

**CITY OF MARYBOROUGH**

Extension of Maryborough Sewerage District  
Approved

The Governor in Council, under the provisions  
of the *Water and Sewerage Authorities  
(Restructuring) Act 1983* and the *Sewerage  
Districts Act 1958*, approves of the extension to  
the Maryborough Sewerage District as shown in  
pink on the accompanying plan (Corr. No.  
003096/67).

Dated 2 February 1988

Responsible Minister:

**STEVE CRABB**

Acting Minister for Water Resources

**LAWRENCE A. FISHER**  
Clerk of the Executive Council

*Local Government Act 1958*

**NOTICE OF INTENTION TO MAKE AN  
ORDER FOR THE RESUBDIVISION OF  
MUNICIPAL DISTRICTS**

Under the provisions of Part II of the *Local  
Government Act 1958*, I give notice of my  
intention to make a recommendation to the  
Governor in Council about proposals for the  
resubdivision of the municipal districts of the  
following municipalities:

City of Box Hill  
Shire of Bungaree  
Shire of Buninyong  
Shire of Creswick  
City of Heidelberg  
Shire of Kowree  
City of Shepparton  
Shire of Strathfieldsaye

**J. L. SIMMONDS**

Minister for Local Government

Local Government Department  
Melbourne

**TO THE HONOURABLE THE MINISTER FOR PROPERTY AND SERVICES**

I hereby give you notice that it is my intention, on Friday next 12 February 1988, to issued a  
Writ for the Election of a member to serve in the Legislative Assembly of Victoria for the Electoral  
District of Kew.

Dated 9 February 1988

**C. T. EDMUNDS**  
Speaker

**NOTICE OF MAKING OF  
STATUTORY RULES  
WHICH ARE NOT YET  
AVAILABLE**

Notice is given of the making of the following Statutory Rules:

	<i>Marine Act 1958</i>		<i>Post-Secondary Education Act 1978</i>
9/1988	Marine (Certificates of Service) (Fees Amendment) Regulations 1988	18/1988	Post-Secondary Education Commission (Terms and Conditions) (Amendment No. 24) Regulations 1988
	<i>Marine Act 1958</i>		<i>Health Act 1958</i>
10/1988	Marine (Examinations and Certificates of Competency) (Fees Amendment) Regulations 1988	19/1988	Health (Proprietary Medicines) (Members Fees) Regulations 1988
	<i>Marine Act 1958</i>		<i>Transport Act 1983</i>
11/1988	Marine (Pilotage Exemption) (Fees Amendment) Regulations 1988	21/1988	Transport (Public Rail and Road Vehicle) (Amendment) Regulations 1988
	<i>Marine Act 1958</i>		<i>Transport Act 1983</i>
12/1988	Marine (Pilots and Pilotage) (Fees Amendment) Regulations 1988	22/1988	Transport (Metropolitan Transit Authority) (Amendment) Regulations 1988
	<i>Marine Act 1958</i>		<i>Transport Act 1983</i>
13/1988	'Hire and Drive Yourself' Motor Boat and Rowing Boat (Fees Amendment) Regulations 1988	23/1988	Transport (State Transport Authority) (Amendment) Regulations 1988
	<i>Marine Act 1958</i>		
14/1988	Marine (Survey, Plans and Compass) (Fees Amendment) Regulations 1988		
	<i>Construction Industry Long Service Act 1983</i>		
16/1988	Construction Industry Long Service Leave (Contribution Amendment) Regulations 1988		
	<i>Supreme Court Act 1986</i>		
17/1988	Supreme Court (Court Fees No. 2) (Amendment) Regulations 1988		

**NOTICE OF MAKING  
AND AVAILABILITY OF  
STATUTORY RULES**

In pursuance of the provisions of the *Subordinate Legislation Act 1962* and the Regulations made thereunder notice is given of the making and availability of the following Statutory Rules:

Note: The date specified after each Statutory Rule is the date it was first obtainable from—

VGPO Bookshop  
Information Victoria Centre  
318 Lt Bourke Street, Melbourne

	<i>Supreme Court Act 1986</i>	
15/1988	Solicitors' Remuneration Order 1988	
10 February 1988		\$1.70
	<i>Planning and Environment Act 1987</i>	
20/1988	Planning and Environment Regulations 1988	
10 February 1988		\$1.70
	<i>Public Service Act 1974</i>	
PSD62/1987	Public Service Determinations (No. 62) 1987	40c
	<i>Public Service Act 1974</i>	
PSD63/1987	Public Service Determinations (No. 63) 1987	40c
	<i>Public Service Act 1974</i>	
PSD64/1987	Public Service Determinations (No. 64) 1987	40c
	<i>Public Service Act 1974</i>	
PSD65/1987	Public Service Determinations (No. 65) 1987	40c
	<i>Public Service Act 1974</i>	
PSD66/1987	Public Service Determinations (No. 66) 1987	40c
	<i>Public Service Act 1974</i>	
PSD1/1988	Public Service Determinations (No. 1) 1988	40c

294 G 5 10 February 1988

*Victoria Government Gazette*



## CONTENTS

	Page
Appointments	249
Cemeteries—Scale of Fees	232
Estates of Deceased Persons	230
Government Notices	219
Late Notices	280
Notice of Making of Statutory Rules	292
Orders in Council—	
Acts—Local Government; Crown Land (Reserves); The Constitution Act Amendment; Land; Retirement Villages; Hospitals and Charities; Planning and Environment; Environment Protection; Education; Urban Land Authority	252
Private Advertisements	269
Proclamations	218
Resignations	250
Tenders	268

### No. G 5—General Government Gazette

A Victorian Government Publication

Published by VGPO  
Melbourne Victoria Australia  
© State of Victoria

This publication is copyright. No part may be reproduced by any process except in accordance with the provisions of the Copyright Act

Address all inquiries to the Government Printer  
for the State of Victoria  
PO Box 203 North Melbourne 3051 Victoria Australia  
ISSN 0819—5471

Further copies of this publication can be obtained from  
VGPO Bookshop  
Information Victoria Centre  
318 Lt Bourke Street Melbourne  
(PO Box 203 North Melbourne 3051)

VGPO Bookshop Inquiries: (03) 663 3760

By Authority Jean Gordon Government Printer Melbourne

Recommended Retail Price \$1.10