

# VICTORIA GOVERNMENT GAZETTE

No. G22 Wednesday 10 June 1992

By Authority L. V. North, Government Printer Melbourne

GENERAL

## Gazette Services

The *Victoria Government Gazette* (VGG) is published by THE LAW PRINTER (PPSV) for the State of Victoria and is produced in three editions.

**VGG General** is published each Wednesday and provides information regarding Acts of Parliament and their effective date of operation; Government notices; requests for tenders; as well as contracts and contracts accepted. Private notices are also published.

**VGG Special** is published any day when required for urgent or special Government notices. VGG special is made available automatically to subscribers of VGG General.

**VGG Periodical** is published on Monday when required and includes specialised information eg. Medical, Dental, Pharmacist's Registers, etc.

## Government Advertising

### Publishing Details

The following Guidelines should be forwarded to ensure publication of Government material in the *Victoria Government Gazette*.

- Duplicate copies should be submitted for use by the Gazette Officer.
- Material submitted to the Executive Council for gazettal will normally be published in the following week's issue.
- Where urgent gazettal is required, contact:  
Gerd Gasparis  
Gazette Officer  
Department of the Premier and Cabinet  
Ground Floor 1 Treasury Place  
Melbourne 3000  
Telephone inquiries (03) 651 5153
- Government advertising other than material for the consideration of the Executive Council should be forwarded to the Gazette Office no later than 9.30 a.m. on Tuesday.
- Lengthy or complicated notices should be forwarded several days before publication.
- Proofs will be supplied only when requested or at the direction of the Gazette Officer.
- No additions or amendments to material for publication will be accepted by telephone.

### Advertising Rates and Payment

#### General Gazette

Single column x cm/part cm \$2.65  
Double column x cm/part cm \$5.30  
Full page \$111.00

#### Periodical Gazette

Full page \$115.50

#### Special Gazette

Full page \$233.00.

## Private Advertisements

### Publishing Details: Send copy to:

VGG Coordinator  
Gazette Advertising  
THE LAW PRINTER  
28 Queensbridge Street, South Melbourne  
(PO Box 292 South Melbourne 3205)  
Telephone inquiries (03) 2424600  
Fax No. (03) 2424699

### Advertising Rates and Payment

#### General Gazette

Single column x cm/part cm \$4.10  
Double column x cm/part cm \$8.20  
Full page \$171.50

#### Periodical Gazette

Full page \$180.00

#### Special Gazette

Full page \$360.00

Cheques should be made payable to 'THE LAW PRINTER'.

These rates apply to advertisements printed on or after 14 February 1990.

### Advertisers should note:

- There are approximately 20 words to each column centimetre depth.
- Signatures (in particular) and proper names must also be in block letters.
- All material should be double spaced.
- Advertisements can be faxed, and a cover sheet should be used, marked to the attention of the Gazette Coordinator.
- Documents not clearly prepared and in the exact format for gazettal will be returned to the sender unpublished.
- Late copy received at THE LAW PRINTER after 11.00 a.m. Monday will be placed in the following issue of VGG, irrespective of any date/s mentioned in the copy (unless otherwise advised).

### Copy Deadline

11.00 a.m. Monday

## Subscriptions

VGG is available by three subscription services:

General and Special—\$160.00 each year  
General, Special and Periodical—\$212.00 each year  
Periodical—\$106.00 each year

Subscriptions are payable in advance and accepted for a period of one year. All subscriptions are on a firm basis and refunds for cancellations will not be given.

All payments should be made payable to THE LAW PRINTER.  
Subscription inquiries (03) 2424600  
Fax (03) 2424699

**PROCLAMATIONS**

*Land Act 1958*

**PROCLAMATION OF ROADS**

I, Richard E. McGarvie, Governor of Victoria, acting with the advice of the Executive Council and under section 25 (3) (c) of the *Land Act 1958* proclaim as roads the following lands:

**MUNICIPAL DISTRICT OF THE SHIRE OF OMEO**

**BINDI**—The land in the Parish of Bindi as indicated by hatching on plan hereunder—(B 612[3]) (L9-4602).

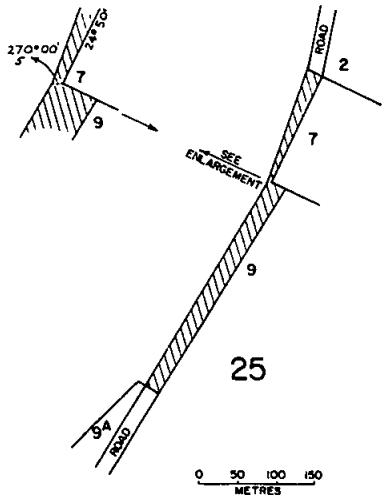

**MUNICIPAL DISTRICT OF THE CITY OF DONCASTER AND TEMPLESTOWE**

**NUNAWADING**—Crown Allotment 140B, Parish of Nunawading as shown on Certified Plan No. 111144 lodged in the Central Plan Office—(GL/15675).

Given under my hand and the seal of Victoria on 10 June 1992

(L.S.) R. E. McGARVIE  
By His Excellency's Command

**BARRY PULLEN**  
Minister for Conservation and Environment

20090

*Land Act 1958*

**PROCLAMATION OF ROAD**

I, Richard E. McGarvie, Governor of Victoria, acting with the advice of the Executive Council and under section 25 (3) (c) of the *Land Act 1958* proclaim as road the following land:

**MUNICIPAL DISTRICT OF THE SHIRE OF CRESWICK**

**SMEATON**—The land in the Township of Smeaton, Parish of Smeaton shown as Crown Allotment 7c on Certified Plan No. 108415 lodged in the Central Plan Office—(Rs 21019).

Given under my hand and the seal of Victoria on 10 June 1992

(L.S.) R. E. McGARVIE  
By His Excellency's Command  
**BARRY PULLEN**  
Minister for Conservation and Environment

20090

*Crimes (Culpable Driving) Act 1992*  
**PROCLAMATION**

I, Richard E. McGarvie, Governor of Victoria, acting with the advice of the Executive Council and under section 2 of the *Crimes (Culpable Driving) Act 1992*, fix Saturday, 13 June 1992 as the day on which the Act shall commence.

Given under my hand and the seal of Victoria on 10 June 1992

(L.S.) R. E. McGARVIE  
By His Excellency's Command

**JIM KENNAN**  
Deputy Premier and Attorney-General

20430

**GOVERNMENT NOTICES**

*Survey Co-ordination Act 1958*

**PLACE NAMES COMMITTEE**

**1. Notice of Assignment of Place Names**

The Place Names Committee hereby gives notice that it has assigned the undermentioned place names in respect of which no objections to the previously published proposals were received.

<i>Place Name</i>	<i>Location</i>
Wattle Bank	Shire of Korumburra. Locality whose boundaries are shown on the plan on display at the Shire Offices.
Wattle Heights School	Department of School Education to take away the names of Balwyn and Doncaster Special Schools and to assign the name Wattle Heights School.
Tragowel Plains Primary School	Department of School Education to take away the names of Tragowel, Macorna and Mincha West Primary Schools and to assign the name Tragowel Plains Primary School.
Rowellyn Park Primary School	Department of School Education to name a new school in Rowellyn Drive, Carrum Heights.
Sid Baker Reserve	Shire of Flinders. A reserve located between Summoner Street and Dana Avenue, Blairgowrie.
Luke Polkinghorne Memorial Reserve	Shire of Lillydale. A reserve in Taylor Road, Mooroolbark.

**2. Notice of Alteration of Place Names**

The Place Names Committee hereby gives notice that it altered the undermentioned place names in the manner indicated and in respect of which no objections to previously published proposals were received.

<i>Former Name</i>	<i>New Name</i>
Falls Creek (Variant Name—Ferris Creek)	Traawool Creek (Variant Name—Falls Creek)
Smythesdale Cricket and Recreation Reserve	Smythesdale Equestrian Reserve
Bacchus Marsh Secondary College	Bacchus Marsh Secondary College— Darley Campus
Bacchus Marsh Secondary College	Bacchus Marsh Secondary College— Maddingley Campus
Preston East Technical School	Northland Secondary College
Redcliffs High School	Redcliffs Secondary College
Wodonga Technical School	Mitchell Secondary College, Wodonga
Kiewa Valley Consolidated School	Kiewa Valley Primary School
Lavers Hill Consolidated School	Lavers Hill P-12 College
Bogong School Camp	Bogong Outdoor Education Centre
Gardenvale Central School	Gardenvale Primary School
Knoxbrooke Special Developmental School	Ferntree Gully Special Developmental School

PLACE NAMES COMMITTEE, care of Survey and Mapping Victoria, 2 Treasury Place, Melbourne 3000.

## Private Agents Act 1966

## NOTICE OF RECEIPT OF APPLICATIONS FOR LICENCES

Any objections to the applications below should be in accordance with the *Private Agents Act 1966* s. 12 and *Private Agents Regulations 1988*, reg. 16

Full name of Applicant/Nominee	Residential Address	Name of Firm or Corporation	Address for Registration	Licence Type	Hearing Date and Court
Farrell, Raymond Neville	22 Harold Street, Shepparton		34 Sobroan Street, Shepparton	CS	7.7.92 Seymour

20620

\*Licence Type: CA—Commercial Agent; CS—Commercial Sub-Agent; P—Process Server; IA—Inquiry Agent; G—Guard Agent; W—Watchman

## Police Regulation Act 1958

## VICTORIA POLICE FORCE

## Determination No. 544 of the Police Service Board

The Police Service Board, in pursuance of the powers in that behalf conferred by the *Police Regulation Act 1958*, hereby makes the following Determination (that is to say):

1. The Determination No. 179 of the Police Service Board of 14 December 1971, and published in the *Government Gazette* of 25 January 1972, as amended, is hereby further amended as follows:

1.1 By deleting paragraph 45 (1) and substituting therefor the following new paragraph:

"45. (1) Members travelling on duty and *required to stay overnight* shall be granted the following relevant allowances:

	Capital Cities including Canberra	All other places within Australia
	\$	\$
Breakfast	12.60	8.05
Lunch	21.40	16.30
Dinner	30.15	23.05
Bed (accommodation)	92.60	48.00
Incidentals	11.85	11.85
	<u>168.60</u>	<u>107.25"</u>

1.2 In paragraph 45 (5) (a) by deleting the amounts "\$8.10" and "\$11.65" where appearing and substituting therefor the following new amounts "\$9.80" and "\$11.85".

1.3 In paragraph 47 by deleting the amount "\$8.10" where appearing and substituting therefor the following new amount "\$9.80".

1.4 In paragraph 50 (a) by deleting the amount "\$8.10" where appearing and substituting therefor the following new amount "\$9.80".

1.5 In paragraph 51 by deleting the amounts "\$11.65", "\$14.40", "\$17.70" and "\$20.05" and substituting therefor the following new amounts "\$11.85", "\$14.60", "\$17.95" and "\$20.35".

2. This Determination shall come into operation on and from 29 May 1992.

Dated 29 May 1992

B. D. LAWRENCE  
A Deputy President of the Industrial  
Relations Commission of Victoria  
Chairman and Member of the  
Police Service Board

L. P. DOYLE  
Member of the Police Service Board

F. J. LESLIE  
Member of the Police Service Board

## Police Regulation Act 1958

## PROTECTIVE SERVICES OFFICERS

## Determination No. 33 of the Police Service Board

The Police Service Board, pursuant to the powers conferred on it under section 69 (2) (d) of the *Police Regulation Act 1958*, hereby makes the following Determination with respect to Protective Services Officers employed under the provisions of Part VIa of the Act:

1. The Determination No. 1 of the Police Service Board of 18 December 1987, and published in the *Government Gazette* of 2 March 1988, is hereby further amended as follows:

1.1 In paragraph 75 by deleting the amount "\$8.10" where appearing and substituting therefor the following new amount "\$9.80".

1.2 By deleting paragraph 81 and substituting therefor the following new paragraph:

"81. Officers travelling on duty and required to stay overnight shall be granted the following relevant allowances:

	<i>Capital Cities including Canberra</i>	<i>All other places within Australia</i>
	\$	\$
Breakfast	12.60	8.05
Lunch	21.40	16.30
Dinner	30.15	23.05
Bed (accommodation)	92.60	48.00
Incidentals	11.85	11.85
	<u>168.60</u>	<u>107.25</u>

1.2 In paragraph 85 (a) by deleting the amounts "\$8.10" and "\$11.65" where appearing and substituting therefor the following new amounts "\$9.80" and "\$11.85".

This Determination shall come into operation on and from 29 May 1992.

Dated 29 May 1992

B. D. LAWRENCE

A Deputy President of the Industrial  
Relations Commission of Victoria  
Chairman and Member of the  
Police Service Board

L. P. DOYLE

Member of the Police Service Board

F. J. LESLIE

Member of the Police Service Board

20620

*Police Regulation Act 1958—Section 122*  
SALE OF UNCLAIMED PROPERTY

An owner is required for an unregistered partly stripped 1972 model Yamaha trail bike with engine No. 12-510448.

The vehicle came into the possession of Police on 12 November 1991, and, if not claimed, it will be sold at public auction at 11 a.m. on Tuesday, 28 July 1992 at the Knox Police Station, 420 Burwood Highway, Wantirna South.

K. GLARE

Chief Commissioner

20620

*Planning and Environment Act 1987*  
HEYTESBURY PLANNING SCHEME  
Notice of Approval of Amendment  
Amendment L11

The Minister for Planning and Housing has approved Amendment L11 to the Shire of Heytesbury Planning Scheme.

The amendment comes into operation on the date this notice is published in the *Government Gazette*.

The amendment will enable Council to consider applications for an additional house on rural land required to accommodate either a

1422 G 22 10 June 1992

family member or sharefarmer without the excision of the land by subdivision.

A copy of the amendment can be inspected free of charge during office hours at the Department of Planning and Housing, Ground Floor, 477 Collins Street, Melbourne and the offices of the Shire of Heytesbury, Municipal Offices, 26 Silvester Street, Cobden.

GEOFF CODE  
Manager

20600 Planning Co-ordination Branch

*Planning and Environment Act 1987*  
TAMBO PLANNING SCHEME  
Notice of Approval of Amendment  
Amendment L48

The Minister for Planning and Housing has approved Amendment L48 to Chapter 2, Local Section of the Tambo Planning Scheme.

The amendment comes into operation on the date this notice is published in the *Government Gazette*.

The amendment—

Changes the planning scheme by rezoning lands in the Sarsfield, Nicholson, Tambo Upper and Swan Reach areas of the Shire from Rural B to Rural A.

Rezones a small area of land bounded by Mulhollands Road and Riches Road from "Rural A" to "Rural B" to develop Sarsfield as a node for hobby farm type development and infill zoning.

Introduces a new "Rural Residential zone" and concurrently rezones Crown Allotment 123 Blairs Road, Lakes Entrance from "Rural A" to the new "Rural Residential zone".

Introduces new subdivision density provisions and tenement provisions into the Rural A zone and changes the full name of the "Rural B" zone from "Rural B—Rural Residential" to "Rural B—Hobby Farm".

A copy of the amendment can be inspected free of charge during office hours at the offices of the Shire of Tambo, 55 Palmers Road, Lakes Entrance and at the Department of Planning and Housing, 477 Collins Street, Melbourne.

GEOFF CODE  
Manager

20600 Planning Co-ordination Branch

*Victoria Government Gazette*

*Planning and Environment Act 1987*  
TAMBO PLANNING SCHEME  
Notice of Approval of Amendment  
Amendment L45

The Minister for Planning and Housing has approved Amendment L45 to the Tambo Planning Scheme.

The amendment comes into operation on the date this notice is published in the *Government Gazette*.

The amendment allows a permit to be granted for land at Lot 2 Lodged Plan 215156 Omeo Highway, Sarsfield to be used for a shop and associated residence with off-street car parking and landscaping.

A copy of the amendment can be inspected free of charge during office hours at the offices of the Shire of Tambo, 55 Palmers Road, Lakes Entrance and at the Department of Planning and Housing, 477 Collins Street, Melbourne.

GEOFF CODE  
Manager

20600 Planning Co-ordination Branch

*Planning and Environment Act 1987*  
GEELONG REGIONAL PLANNING  
SCHEME

Notice of Amendment to a Planning Scheme  
Amendment L106

The Geelong Regional Commission has prepared Amendment L106 to the Geelong Regional Planning Scheme.

The amendment proposes to change the Local Section of the Planning Scheme by inserting a clause into the Ordinance to allow, subject to a permit issued by the City of Geelong, the development and use of an office on the land to the south of the existing Target Head office.

The amendment can be inspected at Geelong Regional Commission, State Government Offices, corner Little Malop and Fenwick Streets, Geelong; Ministry for Planning and Housing, The Olderfleet Buildings, 477 Collins Street, Melbourne; the offices of City of Geelong, Town Hall, Gheringhap Street, Geelong.

Submissions about the amendment must be sent to the Secretary, Geelong Regional Commission, PO Box 770, Geelong 3220 by 10 July 1992.

G. R. COWLING  
Secretary

20340 Geelong Regional Commission

Victoria Government Gazette

*Planning and Environment Act 1987*  
WARRAGUL PLANNING SCHEME  
Notice of Approval of Amendment  
Amendment L22

The Minister for Planning and Housing has approved Amendment L22 to the Local Section of the Warragul Planning Scheme.

The amendment comes into operation on the date this notice is published in the *Government Gazette*.

The amendment allows a permit to be granted for a reduction in the required building setback in the Residential B Zone.

A copy of the amendment can be inspected free of charge during office hours at the Department of Planning and Housing, Ground Floor, 477 Collins Street, Melbourne and at the offices of the Rural City of Warragul, Civic Place, Warragul.

GEOFF CODE  
Manager  
20600 Planning Co-ordination Branch

*Planning and Environment Act 1987*  
PAKENHAM PLANNING SCHEME  
Notice of Approval of Amendment  
Amendment L59

The Minister for Planning and Housing has approved Amendment L59 to the Pakenham Planning Scheme.

The amendment comes into operation on the date this notice is published in the *Government Gazette*.

The amendment exempts from the notification requirements of section 52 (a) of the *Planning and Environment Act 1987*, proposed developments within—

100 metres of an existing or proposed freeway or highway reserve; or  
any other reserve apart from a road.

Notice must still be given to any authority which may be affected by a reduced setback.

A copy of the amendment can be inspected free of charge during office hours at the offices of the Shire of Pakenham, Municipal Offices, Henty Way, Pakenham and at the Department of Planning and Housing, 477 Collins Street, Melbourne.

GEOFF CODE  
Manager  
20600 Planning Co-ordination Branch

G 22 10 June 1992 1423

*Planning and Environment Act 1987*  
BROADMEADOWS PLANNING SCHEME  
Notice of Approval of Amendment  
Amendment L29

The Minister for Planning and Housing has approved Amendment L29 to the Local Section of the Broadmeadows Planning Scheme.

The amendment comes into operation on the date this notice is published in the *Government Gazette*.

The amendment rezones land at 1059 Pascoe Vale Road, Broadmeadows, from Road—Existing Main Reservation to District Centre Broadmeadows Zone.

A copy of the amendment can be inspected, free of charge, during office hours, at the Department of Planning and Housing, Ground Floor, 477 Collins Street, Melbourne and at the offices of the City of Broadmeadows, Pascoe Vale Road, Broadmeadows.

GEOFF CODE  
Manager  
20600 Planning Co-ordination Branch

*Planning and Environment Act 1987*  
DIAMOND VALLEY PLANNING SCHEME  
Notice of Approval of Amendment  
Amendment L10

The Minister for Planning and Housing has approved Amendment L10 to the Local Section of the Diamond Valley Planning Scheme.

The amendment comes into operation on the date this notice is published in the *Government Gazette*.

The amendment introduces the new Diamond Valley Neighbourhood Business No. 1 Zone into the Diamond Valley Planning Scheme.

The amendment also rezones land at 15–29 Civic Drive, Greensborough, from part Reserved Living and part Residential C zones to part Diamond Valley Neighbourhood Business No. 1 Zone and part Open Space—Public Proposed Reservation.

A copy of the amendment can be inspected, free of charge, during office hours, at the Department of Planning and Housing, Ground Floor, 477 Collins Street, Melbourne and at the offices of the Shire of Diamond Valley, Civic Drive, Greensborough.

GEOFF CODE  
Manager  
20600 Planning Co-ordination Branch

1424 G 22 10 June 1992

*Planning and Environment Act 1987*  
ALTONA PLANNING SCHEME  
Notice of Approval of Amendment  
Amendment L21

The Minister for Planning and Housing has approved Amendment L21 to the Local Section of the Altona Planning Scheme.

The amendment comes into operation on the date this notice is published in the *Government Gazette*.

The amendment modifies the control over parking provision at the Altona Gate shopping centre.

A copy of the amendment can be inspected, free of charge, during office hours, at the Department of Planning and Housing, Ground Floor, 477 Collins Street, Melbourne and at the offices of the City of Altona, Civic Parade, Altona.

GEOFF CODE  
Manager  
20600 Planning Co-ordination Branch

*Planning and Environment Act 1987*  
BUNINYONG PLANNING SCHEME  
Notice of Approval of Amendment  
Amendment L16

The Minister for Planning and Housing has approved Amendment L16 to the Buninyong Planning Scheme.

The amendment comes into operation on the date this notice is published in the *Government Gazette*.

The amendment introduces a new zone and relevant provisions entitled the Technology Park zone and rezones approximately 28 hectares of land fronting the east side of Geelong Road bounded by Gear Avenue and Vincent Drive, Mt. Helen from Rural (Residential 1) to Technology Park.

A copy of the amendment can be inspected free of charge during office hours at the offices of the Shire of Buninyong, Municipal Centre, 309 Learmonth Street, Buninyong, at the Department of Planning and Housing, 477 Collins Street, Melbourne and at the Department of Planning and Housing, Regional Office, State Government Offices, Ballarat.

GEOFF CODE  
Manager  
20600 Planning Co-ordination Branch

*Victoria Government Gazette*

*Planning and Environment Act 1987*  
BUNINYONG PLANNING SCHEME  
Notice of Approval of Amendment  
Amendment L7A

The Minister for Planning and Housing has approved Amendment L7A to the Buninyong Planning Scheme.

The amendment comes into operation on the date this notice is published in the *Government Gazette*.

The amendment introduces a Highway Policy Area special planning control over land adjoining the southern boundary of the Western Highway, between Reidy's Road and west of Greene Road, Warrenheip. The Highway Policy Area prohibits the use and development of land incompatible with a Highway frontage.

A copy of the amendment can be inspected, free of charge, during office hours, at the offices of the Shire of Buninyong, 309 Learmonth Street, Buninyong, at the Department of Planning and Housing, 477 Collins Street, Melbourne and at the Department of Planning and Housing, Regional Office, State Government Offices, Ballarat.

GEOFF CODE  
Manager  
20600 Planning Co-ordination Branch

*Planning and Environment Act 1987*  
CROYDON PLANNING SCHEME  
Notice of Approval of Amendment  
Amendment L37

The Minister for Planning and Housing has approved Amendment L37 to the Croydon Planning Scheme.

The amendment comes into operation on the date this notice is published in the *Government Gazette*.

The amendment rezones land at 59-63 (Lot 1 LP 96376) Plymouth Road, Croydon North (the former SEC Terminal Site) from Public Purposes 13—State Electricity Commission to Croydon Residential Development.

A copy of the amendment can be inspected, free of charge, during office hours, at the offices of the City of Croydon, Civic Square, Croydon and at the Department of Planning and Housing, 477 Collins Street, Melbourne.

GEOFF CODE  
Manager  
20600 Planning Co-ordination Branch



Victoria Government Gazette

*Planning and Environment Act 1987*  
DIAMOND VALLEY PLANNING SCHEME  
Notice of Approval of Amendment  
Amendment L13

The Minister for Planning and Housing has approved Amendment L13 to the Diamond Valley Planning Scheme.

The amendment comes into operation on the date this notice is published in the *Government Gazette*.

The amendment—

incorporates a Diamond Valley Rural Residential Zone into the Diamond Valley Planning Scheme;

reserves land in Ironbark Road, Yarrambat as "Open Space—Public Existing" Reservation;

rezones land generally bounded by Kurrak Road to the south, the Diamond Valley Conservation Zone boundary to the west, Yarrambat Park and Bannons Lane to the north and parts of Yan Yean Road, Youngs Road and Eisemans Road to the east to Diamond Valley Rural Residential Zone.

A copy of the amendment can be inspected, free of charge, during office hours, at the offices of the Shire of Diamond Valley, Civic Drive, Greensborough and at the Department of Planning and Housing, 477 Collins Street, Melbourne.

GEOFF CODE  
Manager  
20600 Planning Co-ordination Branch

*Planning and Environment Act 1987*  
HASTINGS PLANNING SCHEME  
Notice of Lapsing of Amendment  
Amendment L10 Part 3

The Minister for Planning and Housing has refused the above amendment.

The amendment proposed to rezone approximately 2.25 hectares of land on the south-east corner of Frankston—Flinders Road and Baxter—Tooradin Road, Baxter from a Medium Density 1 zone to a Special Use No. 4 (Baxter Village) zone.

The amendment lapses on the date this notice is published in the *Government Gazette*.

GEOFF CODE  
Manager  
20600 Planning Co-ordination Branch

G 22 10 June 1992 1425

*Planning and Environment Act 1987*  
PAKENHAM PLANNING SCHEME  
Notice of Approval of Amendment  
Amendment L61 Part 2

The Minister for Planning and Housing has approved Amendment L61 Part 2 to the Pakenham Planning Scheme.

The amendment comes into operation on the date this notice is published in the *Government Gazette*.

The amendment rezones 2 parcels of land at Pakenham:

1. north of the reservation for the Princes Freeway between McGregor Road and Koo Wee Rup Road from part Agriculture 1 Zone and part Existing Public Purposes 7 Reservation to a Highway 1 Zone;

2. between Bald Hill Road and the Gippsland Railway, west of the reservation for the Princes Freeway, from an Agriculture 1 Zone to a Highway 1 Zone.

A copy of the amendment can be inspected, free of charge, during office hours, at the offices of the Shire of Pakenham, Municipal Offices, Henty Way, Pakenham and at the Department of Planning and Housing, 477 Collins Street, Melbourne.

GEOFF CODE  
Manager  
20600 Planning Co-ordination Branch

*Planning and Environment Act 1987*  
WONTHAGGI PLANNING SCHEME  
Notice of Approval of Amendment  
Amendment L13

The Minister for Planning and Housing has approved Amendment L13 to the Wonthaggi Planning Scheme.

The amendment comes into operation on the date this notice is published in the *Government Gazette*.

The amendment allows rural zoned land below 1000 square metres in area to have buildings constructed at least 6 metres from a road alignment.

A copy of the amendment can be inspected free of charge during office hours at the offices of the Borough of Wonthaggi, McBride Avenue, Wonthaggi and at the Department of Planning and Housing, 477 Collins Street, Melbourne.

GEOFF CODE  
Manager  
20600 Planning Co-ordination Branch

1426 G 22 10 June 1992

*Planning and Environment Act 1987*  
KORUMBURRA PLANNING SCHEME  
Notice of Approval of Amendment  
Amendment L36

The Minister for Planning and Housing has approved Amendment L36 to the Korumburra Planning Scheme.

The amendment comes into operation on the date this notice is published in the *Government Gazette*.

The amendment introduces new definitions for Abattoir, Medical Centre, Premises, Professional Consulting Room, Private Open Space and Site Coverage and rectifies an error in Clause 26 (1).

A copy of the amendment can be inspected free of charge during office hours at the offices of the Shire of Korumburra, 165 Commercial Street, Korumburra and at the Department of Planning and Housing 477 Collins Street, Melbourne.

GEOFF CODE  
Manager  
20600 Planning Co-ordination Branch

*Planning and Environment Act 1987*  
CRANBOURNE PLANNING SCHEME  
Notice of Approval of Amendment  
Amendment L66

The Minister for Planning and Housing has approved Amendment L66 to the Cranbourne Planning Scheme.

The amendment comes into operation on the date this notice is published in the *Government Gazette*.

The amendment affects land at Crown Allotment A, South Gippsland Highway, Tooradin, allowing, subject to permit, a limited range of small scale low key commercial activities at the historic residence and associated gardens known as "Harewood".

A copy of the amendment can be inspected free of charge during office hours at the offices of the Shire of Cranbourne, Sladen Street, Cranbourne and at the Department of Planning and Housing, 477 Collins Street, Melbourne.

GEOFF CODE  
Manager  
20600 Planning Co-ordination Branch

*Victoria Government Gazette*

*Planning and Environment Act 1987*  
MIRBOO PLANNING SCHEME  
Notice of Approval of Amendment  
Amendment L10

The Minister for Planning and Housing has approved Amendment L10 to the Mirboo Planning Scheme.

The amendment comes into operation on the date this notice is published in the *Government Gazette*.

The amendment rezones part Crown Allotment 7b, Parish of Marden, Castle Street, Mirboo North from 'Rural' to 'Rural Residential'.

A copy of the amendment can be inspected free of charge during office hours, at the offices of the Shire of Mirboo, Ridgeway, Mirboo North and at the Department of Planning and Housing, 477 Collins Street, Melbourne.

GEOFF CODE  
Manager  
20600 Planning Co-ordination Branch

*Planning and Environment Act 1987*  
BERWICK PLANNING SCHEME  
Notice of Approval of Amendment  
Amendment L46 Part 1

The Minister for Planning and Housing has approved Amendment L46 Part 1 to the Berwick Planning Scheme.

The amendment comes into operation on the date this notice is published in the *Government Gazette*.

The amendment:

Rezones land occupied by a former quarry located to the north-east of the intersection of King and Robinson Roads, Harkaway from Special Extractive—Berwick Zone to Landscape Interest A and allows a permit to be granted for a two lot subdivision of lot 5 LP 129056.

Reserves for Public Purposes 19A Local Government Municipal Purposes, Berwick, the Narre Warren North Regional Landfill site, Narre Warren North.

A copy of the amendment can be inspected free of charge during office hours at the offices of the City of Berwick, Princes Highway, Narre Warren and at the Department of Planning and Housing, 477 Collins Street, Melbourne.

GEOFF CODE  
Manager  
20600 Planning Co-ordination Branch

*Planning and Environment Act 1987*  
HORSHAM PLANNING SCHEME  
Notice of Approval of Amendment  
Amendment L31 (Part 1)

The Minister for Planning and Housing has approved Amendment L31 (Part 1) to the Horsham Planning Scheme.

The amendment comes into operation on the date this notice is published in the *Government Gazette*.

The amendment is basically threefold—

- (a) introduces provisions for the establishment of a Dual Occupancy within the Residential A and Residential B zones and prohibits a Dual Occupancy within the remaining zones;
- (b) introduces new car parking provisions in Table to Clause 42;
- (c) Reserves land (Part CA 5, Section B, Parish of Horsham) fronting Davis Drive, Horsham of approximately 0.8 hectares for Public Purposes—19—Cemetery.

The amendment inserts definitions for the terms "General Store" and "Dual Occupancy" and redefines the term "Flat".

The amendment introduces the term "General Store" as a prohibited use within the Rural A, Residential B, Service Business, Highway Use, General Industrial and Garden Industrial zones.

A copy of the amendment can be inspected free of charge during office hours at the offices of the City of Horsham, Civic Centre, Roberts Avenue, Horsham; at the Department of Planning and Housing, 477 Collins Street, Melbourne and at the Department of Planning and Housing, Regional Office, State Government Offices, Ballarat.

GEOFF CODE  
Manager  
20600 Planning Co-ordination Branch

*Planning and Environment Act 1987*  
BULN BULN PLANNING SCHEME  
Notice of Approval of Amendment  
Amendment L13

The Minister for Planning and Housing has approved Amendment L13 to the Buln Buln Planning Scheme.

The amendment comes into operation on the date this notice is published in the *Government Gazette*.

The amendment makes various changes to improve the Planning Scheme; they include—

1. Revision of the authorities from which information must be sought in respect of the Catchment Policy Areas and the Drainage or Flooding Problem Policy Area.
2. New definitions of slope, display home and veterinary clinic and consequential changes to the Table of Uses.
3. To allow consolidation of land without a permit.
4. To require a permit for rather than prohibit a house on a tenement landholding of less than 0.4 or 0.5 hectares as the case may be for particular zones.
5. To delete the subdivision rectangle controls of the Rural Hills zone.

A copy of the amendment can be inspected free of charge during office hours at the offices of the Shire of Buln Buln, 33 Young Street, Drouin and at the Department of Planning and Housing, 477 Collins Street, Melbourne.

GEOFF CODE  
Manager  
20600 Planning Co-ordination Branch

*Planning and Environment Act 1987*  
MIRBOO PLANNING SCHEME  
Notice of Approval of Amendment  
Amendment L9

The Minister for Planning and Housing has approved Amendment L9 to the Mirboo Planning Scheme.

The amendment comes into operation on the date this notice is published in the *Government Gazette*.

The amendment changes the planning scheme to allow an existing shed at part Crown Allotment 46A, Parish of Mirboo, Grand Ridge Road, Mirboo North to be used for light industry, subject to a permit being issued.

A copy of the amendment can be inspected free of charge during office hours at the offices of the Shire of Mirboo, Ridgeway, Mirboo North and at the Department of Planning and Housing, 477 Collins Street, Melbourne.

GEOFF CODE  
Manager  
20600 Planning Co-ordination Branch

1428 G 22 10 June 1992

*Planning and Environment Act 1987*  
ESSENDON PLANNING SCHEME  
Notice of Approval of Amendment  
Amendment L34

The Minister for Planning and Housing has approved Amendment L34 to the Local Section of the Essendon Planning Scheme.

The amendment comes into operation on the date this notice is published in the *Government Gazette*.

The amendment—

rezones land bounded by Alexandra Avenue, Coats and McPherson Streets and Pascoe Vale Road, from Restricted Business and Residential C Zones to Moonee Ponds District Centre No. 7, Office Park Zone and Multi-Unit Residential Zone;

introduces the Moonee Ponds District Centre No. 7, Office Park Zone and the Multi-Unit Residential Zone into the Ordinance; and

imposes height controls over the areas contained in the new zones.

A copy of the amendment can be inspected, free of charge, during office hours, at the Department of Planning and Housing, Ground Floor, 477 Collins Street, Melbourne, and at the offices of the City of Essendon, corner Pascoe Vale Road and Kellaway Avenue, Moonee Ponds.

GEOFF CODE  
Manager  
20600 Planning Co-ordination Branch

*Planning and Environment Act 1987*  
BERWICK PLANNING SCHEME  
Notice of Approval of Amendment  
Amendment L45

The Minister for Planning and Housing has approved Amendment L45 to the Berwick Planning Scheme.

The amendment comes into operation on the date this notice is published in the *Government Gazette*.

The amendment—

- (i) allows payment of cash-in-lieu of open space for subdivision in the Berwick—Normal Density Zone and the Berwick Residential—Berwick Township Zone;
- (ii) makes as-of-right Movable Dwelling Unit in the following zones:

*Victoria Government Gazette*

Berwick Residential—Berwick Township;  
Berwick Residential-Low Density;  
Berwick Residential-Normal Density;  
(iii) rezones lot D PS 312460A and lot B PS 312886N within the Hampton Park East Flood Plain from part Stream and Floodway and part Berwick Residential—Normal Density to Proposed Public Purposes 20 Reservation.

A copy of the amendment can be inspected free of charge during office hours at the offices of the City of Berwick, Princes Highway, Narre Warren and at the Department of Planning and Housing, 477 Collins Street, Melbourne.

GEOFF CODE  
Manager  
20600 Planning Co-ordination Branch

*Planning and Environment Act 1987*  
ECHUCA PLANNING SCHEME  
Notice of Approval of Amendment  
Amendment L14

The Minister for Planning and Housing has approved Amendment L14 to the Echuca Planning Scheme.

The amendment comes into operation on the date this notice is published in the *Government Gazette*.

The amendment replaces the existing color maps with black and white maps.

A copy of the amendment can be inspected free of charge during office hours at the City of Echuca Offices, Heygarth Street, Echuca, the Loddon—Campaspe Regional Planning Authority, 261 Hargreaves Street, Bendigo and at the Department of Planning and Housing, The Olderfleet Buildings, 477 Collins Street, Melbourne.

GEOFF CODE  
Manager  
20600 Planning Co-ordination Branch

*Planning and Environment Act 1987*  
BERWICK PLANNING SCHEME  
Notice of Approval of Amendment  
Amendment L47

The Minister for Planning and Housing has approved Amendment L47 to the Berwick Planning Scheme.

The amendment comes into operation on the date this notice is published in the *Government Gazette*.

Victoria Government Gazette

G 22 10 June 1992 1429

The amendment allows lots 10 and 11, LP 1847, Nos. 67-69 Webb Street, Narre Warren, to be used for a Youth Welfare Service, subject to a permit being granted.

A copy of the amendment can be inspected free of charge during office hours at the offices of the City of Berwick, Princes Highway, Narre Warren and at the Department of Planning and Housing, 477 Collins Street, Melbourne.

GEOFF CODE  
Manager  
20600 Planning Co-ordination Branch

*Planning and Environment Act 1987*  
CROYDON PLANNING SCHEME  
Notice of Approval of Amendment  
Amendment L43

The Minister for Planning and Housing has approved Amendment L43 to the Croydon Planning Scheme.

The amendment comes into operation on the date this notice is published in the *Government Gazette*.

The amendment closes a three metre wide portion of Cecil Circuit, abutting Montana Parade, Croydon.

A copy of the amendment can be inspected, free of charge, during office hours at the offices of the City of Croydon, Civic Centre, Civic Square, Croydon and at the Department of Planning and Housing, 477 Collins Street, Melbourne.

GEOFF CODE  
Manager  
20600 Planning Co-ordination Branch

*Planning and Environment Act 1987*  
BERWICK PLANNING SCHEME  
Notice of Approval of Amendment  
Amendment L48

The Minister for Planning and Housing has approved Amendment L48 to the Berwick Planning Scheme.

The amendment comes into operation on the date this notice is published in the *Government Gazette*.

The amendment increases the maximum allowable floor space for offices in the Special Use Zone No. 9A from 2500 square metres to 12 000 square metres.

A copy of the amendment can be inspected, free of charge, during office hours, at the offices of the City of Berwick, Princes Highway, Narre

Warren and at the Department of Planning and Housing, 477 Collins Street, Melbourne.

GEOFF CODE  
Manager  
20600 Planning Co-ordination Branch

*Planning and Environment Act 1987*  
HEALESVILLE PLANNING SCHEME  
Notice of Lapsing of Amendment  
Amendment L39

On 31 March 1992 the Council of the Shire of Healesville resolved to abandon the above amendment.

The amendment proposed to rezone part Lot 2 LP 71807 Melba Highway being part of Crown Allotment 15u, Parish of Tarrawarra North to Referred Development zone.

The amendment lapses on the date this notice is published in the *Government Gazette*.

GEOFF CODE  
Manager  
20600 Planning Co-ordination Branch

CORRIGENDUM  
ALL PLANNING SCHEMES IN VICTORIA  
Amendment S23

In *Special Government Gazette* S15 dated 15 May 1992, in the notice for the above amendment, after the fourth paragraph, include the following:

Submissions about the amendment must be sent to the Minister for Planning and Housing, Attention: Planning Co-ordination Branch, P.O. Box 2240T, Melbourne 3001 by 31 July 1992.

GEOFF CODE  
Manager  
20600 Planning Co-ordination Branch

CORRIGENDUM  
METROPOLITAN REGION PLANNING  
SCHEMES  
Amendment R113

In *Special Government Gazette* S15 dated 15 May 1992, in the notice for the above amendment, before the last paragraph, include the following:

Submissions about the amendment must be sent to the Minister for Planning and Housing, Attention: Planning Co-ordination Branch, P.O. Box 2240T, Melbourne 3001 by 31 July 1992.

GEOFF CODE  
Manager  
20600 Planning Co-ordination Branch



Victoria Government Gazette

G 22 10 June 1992 1431

Schedule Number	Item Number	New Rate	Effective Date
		\$	
* Options Available—	Air Conditioning	5 756.00	

N. L. JORDAN  
20790 Secretary to the Tender Board

Transport Act 1983

ROADS CORPORATION

Commercial Passenger Vehicle and Tow Truck Applications

Notice is hereby given that the following applications will be considered by the Roads Corporation on 14 July 1992.

Notice of any objection to the granting of an application should be forwarded to reach the Section Leader, Vehicle Licensing or any District Office of the Roads Corporation not later than 8 July 1992.

It will not be necessary for interested parties to appear on the date specified, unless advised in writing by the Corporation.

Notification of the date for consideration of applications which are objected to and which require determination by the Road Transport Licensing Tribunal will be published by further notice in this Gazette.

Arica Pty. Ltd., Yarrowonga. Application to license one commercial passenger vehicle in respect of a 1983 Denning bus with seating capacity for 46 passengers to operate as a country special service omnibus from within a 20 km pick-up radius of the Yarrowonga Post Office.

*Note:* The vehicle to be licensed would hold a 5 star rating for charter purposes.

M. J. P. Bristow, Glen Iris. Application for variation of conditions of licence SV 642 which authorises the licensed vehicle to operate as a special purpose vehicle in respect of a 1958 Rolls Royce sedan with seating capacity for 4 passengers to change the vehicle to a 1950 Rolls Royce sedan with seating capacity for 4 passengers.

R. D. Hickman, Vermont. Application for variation of the conditions of licence SV 840 which authorises the licensed vehicle to operate as a special purpose vehicle in respect of a

1955–1965 Rolls Royce Silver Cloud sedan to change the vehicle to a 1955 or later model Rolls Royce sedan with seating capacity for 4–5 passengers.

Phil Munday's Panel Works (Croydon) Pty. Ltd., Croydon. Application for variation of the conditions to tow truck licence number 026 which authorises the licensed vehicle to be managed, controlled and operated from a depot situated at 4 Newman Street, Ringwood to change the depot address to 16 Windsor Road, Croydon.

P. Psychogios, East Doncaster. Application for variation of the conditions of licence MH 4259 which authorises the licensed vehicle to operate as a metropolitan hire car in respect of a 1980–1983 Ford LTD sedan to change the vehicle to a 1981 or later model Mercedes Benz sedan with seating capacity for 7–9 passengers.

V. A. Vescio, Moonee Ponds. Application to license one commercial passenger vehicle in respect of a 1983 Ferrari coupe with seating capacity for 3 passengers to operate as a special purpose vehicle from 44 Ngarveno Street, Moonee Ponds for the carriage of passengers for wedding parties.

Dated 10 June 1992

RAY DONNELLEY  
20703 Section Leader—Vehicle Licensing

Transport Act 1983

ROADS CORPORATION

Commercial Passenger Vehicle Application

Amendment to Previous Notice

This notice corrects a previous notice which appeared in the *Victoria Government Gazette* No. 20 dated 27 May 1992. Closing date for objections and the consideration dated specified in that notice shall remain the same.

R. B. Hodgkinson, North Ringwood. Application for variation of the conditions of licences MH 4347 and MH 4351 which authorise the licensed vehicles to operate as metropolitan hire cars in respect of 1982–83 or later model Mercedes Benz sedans to change the vehicles to "unrestricted modern luxurious vehicles".

Dated 10 June 1992

RAY DONNELLEY  
20703 Section Leader—Vehicle Licensing

1432 G 22 10 June 1992

Land Acquisition and Compensation Act 1986  
Transport Act 1983

NOTICE OF ACQUISITION

Compulsory Acquisition of Interest in Land

The Roads Corporation declares that by this notice it acquires the following interests in the land described hereunder:

*Owners' Names:* Ninth Martor Pty. Ltd. and Werona Pty. Ltd.

*Description of Interest in Land:* Part of Lot One on Plan of Subdivision No. 204758r, Parish of Maribymong.

*Area:* 7424 square metres.

*Title Details:* Part of land contained in Certificate of Title Volume 9721 Folio 277.

*Survey Plan No.:* 18479 (parcel one).

The survey plan referred to in this notice may be viewed at Property Services Department, Vic Roads, 2nd Floor, 3 Prospect Hill Road, Camberwell.

Published with the authority of the Roads Corporation and the Minister for Transport.

DEREK TREWARNE

Manager Property Operations  
Roads Corporation

20703

Victoria Government Gazette

Land Acquisition and Compensation Act 1986  
Transport Act 1983

NOTICE OF ACQUISITION

Compulsory Acquisition of Interest in Land

The Roads Corporation declares that by this notice it acquires the following interests in the land described hereunder:

*Owner's Name:* Dampp Nominees Pty. Limited.

*Description of Interest in Land:* Being part of Lot 2 on Plan of Subdivision No. 94266 in the Parish of Holden.

*Area:* 2.309 hectares.

*Title Details:* Land contained in Certificate of Title Volume 8968 Folio 221.

*Survey Plan No.:* 18131 (Parcel Nos 2 and 8).

The survey plan referred to in this notice may be viewed at Property Services, Vic Roads, 3 Prospect Hill Road, Camberwell.

Published with the authority of the Roads Corporation and the Minister for Transport.

DEREK TREWARNE

Manager Property Operation  
Roads Corporation

20703

Land Acquisition and Compensation Act 1986  
Transport Act 1983

NOTICE OF ACQUISITION

Compulsory Acquisition of Interest in Land

The Roads Corporation declares that by this notice it acquires the following interest in the land described hereunder:

*Owners' Names:* Allen Frederick Henry Cook and the Executors of the Estate of Maude Eveline Cook.

*Description of Interest in Land:* Part of Lot 2 on Plan of Subdivision No. 54879, Parish of Cut-paw-paw.

*Area:* 3.645 hectares.

*Title Details:* Part of land contained in Certificate of Title Volume 8340 Folio 163.

*Survey Plan No.:* 18474b (parcel 2).

The survey plan referred to in this notice may be viewed at Property Services Department, Vic Roads, 2nd Floor, 3 Prospect Hill Road, Camberwell.

Published with the authority of the Roads Corporation and the Minister for Transport.

DEREK TREWARNE

Manager Property Operations  
Roads Corporation

20703

Land Acquisition and Compensation Act 1986  
Transport Act 1983

NOTICE OF ACQUISITION

Compulsory Acquisition of Interest in Land

The Roads Corporation declares that by this notice it acquires the following interests in the land described hereunder:

*Owner's Name:* Maddocks Excavations Pty. Ltd.

*Description of Interest in Land:* Being part of Lot 11 on Plan of Subdivision No. 94266 in the Parish of Holden.

*Area:* 1079 square metres.

*Title Details:* Land contained in Certificate of Title Volume 8968 Folio 230.

*Survey Plan No.:* 18129 (Parcel No. 6).

The survey plan referred to in this notice may be viewed at Property Services, Vic Roads, 3 Prospect Hill Road, Camberwell.

Published with the authority of the Roads Corporation and the Minister for Transport.

DEREK TREWARNE

Manager Property Operation  
Roads Corporation

20703



Victoria Government Gazette  
Land Acquisition and Compensation Act 1986  
Transport Act 1983

**NOTICE OF ACQUISITION**

**Compulsory Acquisition of Interest in Land**

The Roads Corporation declares that by this notice it acquires the following interests in the land described hereunder:

*Owners' Names:* Rocco Tripodi, Caterina Tripodi, Frank Tripodi, Patty Tripodi and Connie Tripodi.

*Description of Interest in Land:* Being part of Lot 4 on Plan of Subdivision No. 94266 in the Parish of Holden.

*Area:* 1577 square metres.

*Title Details:* Land contained in Certificate of Title Volume 8968 Folio 223.

*Survey Plan No.:* 18130 (Parcel No. 3).

The survey plan referred to in this notice may be viewed at Property Services, Vic Roads, 3 Prospect Hill Road, Camberwell.

Published with the authority of the Roads Corporation and the Minister for Transport.

DEREK TREWARNE  
Manager Property Operation  
Roads Corporation

20703

Land Acquisition and Compensation Act 1986  
Transport Act 1983

**NOTICE OF ACQUISITION**

**Compulsory Acquisition of Interest in Land**

The Roads Corporation declares that by this notice it acquires the following interests in the land described hereunder:

*Owners' Names:* Jack Harrison and Winifred Harrison.

*Description of Interest in Land:* Part of Lot 7 on Plan of Subdivision No. 94266 in the Parish of Holden.

*Area:* 1665 square metres.

*Title Details:* Land contained in Certificate of Title Volume 9153 Folio 674.

*Survey Plan No.:* 18130.

The survey plan referred to in this notice may be viewed at Property Services, Vic Roads, 3 Prospect Hill Road, Camberwell.

Published with the authority of the Roads Corporation and the Minister for Transport.

DEREK TREWARNE  
Manager, Property Operations  
Roads Corporation

20703

G 22 10 June 1992 1433

Petroleum (Submerged Lands) Act 1982

STATE OF VICTORIA

**DECLARATION OF LOCATION**

I, David Ronald White, Minister for Manufacturing and Industry Development for the State of Victoria in respect of the area specified as being adjacent to the State of Victoria, hereby declare the blocks described hereunder, being blocks that are the subject of a permit of which Bridge Exploration Pty Ltd of 255 Elizabeth Street, Sydney; Gas and Fuel Exploration NL of 151 Flinders Street, Melbourne, and State Electricity Commission of Victoria of 15 William Street, Melbourne, are the registered holders, to be a location for the purposes of section 37 of the Act under which this instrument is made.

**DESCRIPTION OF BLOCKS**

Block Nos. 1913 (part), 1914 (part), 1985 (part) and 1986 (part) on the Melbourne Sheet SJ55 prepared and published for the purposes of the *Petroleum (Submerged Lands) Act 1982*, and shown below.

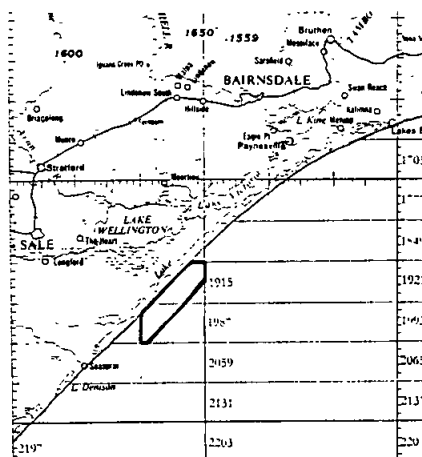

Made under the *Petroleum (Submerged Lands) Act 1982* of the State of Victoria.

Dated 4 June 1992

DAVID WHITE  
Minister for Manufacturing and  
Industry Development

20400

1434 G 22 10 June 1992

**ADOPTION ACT 1984**

Under the functions and powers assigned to me by the Director-General of Community Services under section 10 (2) of the *Community Welfare Services Act 1970* in relation to section 5 of the Adoption Act.

I, Robyn Clark, approve the following person under section 5 (1) and section 5 (2) (a) of the Adoption Act as approved Counsellor for the purpose of section 35 of the Act.

Leenaerts, Kathy, Community Services Victoria, Adoption and Permanent Care, 104 Mount Street, Heidelberg 3084.

ROBIN CLARK  
Regional Director  
Family Youth and Children Services  
North East Region  
20080

*Building Control Act 1981*  
**BUILDING CONTROL ACCREDITATION  
AUTHORITY**

Pursuant to Part V of the *Building Control Act 1981* a Certificate of Accreditation (Number V92/03) has been issued to Renouf Industries Pty Ltd, 7 Corr Street, Moorabbin, 3189, by the Building Control Accreditation Authority for the accreditation of Standard Grade (Nos. 301 and 303), Roof Tiling Grade (Nos. 311 and 313) and Super Grade (Nos. 350 and 353) of TECO Aluminium Foil Insulation.

The Building Control Accreditation Authority appointed under Part V of the *Building Control Act 1981* has examined the application and determined that Standard Grade, Roof Tiling Grade and Super Grade of TECO Aluminium Foil Insulation complies with the requirements of Clause B1.1 and Part F1 of the *Building Code of Australia 1990* as adopted by the Victoria Building Regulations 1983. Conditions of use and identification details are provided in the three (3) data sheets attached to the Certificate.

STUART McLENNAN  
Registrar, Building Control  
Accreditation Authority  
20600

*Building Control Act 1981*  
**BUILDING CONTROL ACCREDITATION  
AUTHORITY**

Pursuant to Part V of the *Building Control Act 1981* a Certificate of Accreditation (Number V92/03) has been issued to Renouf Industries Pty. Ltd., 7 Corr Street, Moorabbin 3189, by the

*Victoria Government Gazette*

Building Control Accreditation Authority for the accreditation of Standard Grade (Nos 301 and 303), Roof Tiling Grade (Nos 311 and 313) and Super Grade (Nos 350 and 353) of TECO Aluminium Foil Insulation.

The Building Control Accreditation Authority appointed under Part V of the *Building Control Act 1981* has examined the application and determined that Standard Grade, Roof Tiling Grade and Super Grade of TECO Aluminium Foil Insulation complies with the requirements of Clause B1.1 of the Building Code of Australia 1990 as adopted by the Victoria Building Regulations 1983. Conditions of use and identification details are provided in the three (3) data sheets attached to the Certificate.

STUART McLENNAN  
Registrar  
Building Control Accreditation  
Authority  
20600

Health Department Victoria  
**PROPOSED HEALTH (INFECTIOUS  
DISEASES) (RATS AND MICE)  
REGULATIONS 1992**

Notice is given as required by the *Subordinate Legislation Act 1962* of the intention to make the above Regulations under the *Health Act 1958*.

The reason for, and the objective of, the proposed Regulations is to protect the public health through the prevention of the spread of infectious diseases by the implementation of directed proactive measures to minimise the harbourage and breeding of rats and mice in identified problem areas.

A Regulatory Impact Statement has been prepared and concludes that the potential benefits of the proposed Regulations outweigh the potential costs.

Comments and submissions are invited from the public and will be received up to 21 days from the date of publication of this notice.

Copies of the Regulatory Impact Statement are available from, and submissions should be lodged with, the Manager, Statutory Services, Health Department Victoria, 555 Collins Street, Melbourne 3000. Telephone (03) 616 7278.

T. J. DALY  
Chief General Manager  
20370

Department of Food and Agriculture  
STOCK (ARTIFICIAL BREEDING OF  
STOCK) REGULATIONS 1992

In accordance with the provisions of the *Subordinate Legislation Act 1962* notice is given of the proposal to make regulations to be known as the Stock (Artificial Breeding of Stock) Regulations 1992.

A Regulatory Impact Statement has been prepared as required by the Subordinate Legislation Act.

The objectives of these Regulations are to implement the *Stock (Artificial Breeding) Act 1962* and to facilitate an efficient, economical and convenient service to farmers in relation to artificial breeding of stock and efficient and adequate supervision and control of such breeding in order to prevent the transmission of disease during artificial insemination of stock.

In summary the Regulatory Impact Statement concludes that the net benefit of the proposed regulations exceeds that for any other possible alternative.

Copies of the Regulatory Impact Statement and the proposed regulations may be obtained from Mr Kevin Pagon, Legal Branch, Department of Food and Agriculture, "The Mill", 165 Hargreaves Street, Bendigo 3550. Telephone: (054) 30 4476. Fax: (054) 30 4499.

Comments and submissions are invited from interested parties.

Written submissions should be sent to the above address by no later than 21 days from the publication of this notice.

MICHAEL BLAMEY  
20020 Director-General

Creditors, next of kin and others having claims against the estate of any of the under-mentioned deceased persons are required to send particulars of their claims to the State Trust Corporation of Victoria, 168 Exhibition Street, Melbourne Vic. 3000 the personal representative, on or before 11 August 1992 after which date the State Trust Corporation may convey or distribute the assets having regard only to the claims of which the State Trust Corporation then has notice:

Brown, Dorothy, late of 47 Adelaide Street, St. Albans, sheltered workshop employee, died 26 February 1992.

Campbell, Charles Owen, late of 17 Kingsley Road, Reservoir, retired, died 7 March 1992.

Colenso, Margaret Alice Lillias, late of Hallam Private Nursing Home, 47 Belgrave-Hallam Road, Hallam, pensioner, died 20 December 1991.

Drain, Joseph Patrick, late of 61 Hamilton Street, Niddrie, invalid pensioner, died 11 March 1992.

Hanley, John William, formerly of 99 Park Street, South Yarra, late of 24 Pakington Street, Kew, retired, died 20 March 1992.

Matuszynski, Michael, late of Arden Lodge, 214 Arden Street, North Melbourne, pensioner, died 24 January 1992.

O'Brien, Cyril James, late of Lewisham Nursing Home, Lewisham Road, Windsor, pensioner, died 19 March 1992.

Powderham, Maude Vera, formerly of 8 Joffie Street, Burwood, late of "Bodella", 32 Walpole Street, Kew, widow, died 14 January 1992.

Price, Robert Leslie, formerly of Foster North, Gippsland, late of RMB 5945, Cooriemungle, Timboon 3268, farmer, died 3 February 1992.

Reynolds, Edward Albert, late of 5 Tallowood Street, Frankston North, truck driver, died 29 December 1991.

Sampson, Anne Olivia, also known as Anne Olive, formerly of Flat 5/K3 Henry Street, Windsor, late of Amaroo Nursing Home, 294 Maroondah Highway, Ringwood, pensioner, died 17 September 1991.

Spooner, William John, late of 161 Spensley Street, Clifton Hill, widower, died 24 March 1992.

Storey, John Alfred, late of Unit 3, 2 Clive Street, Mount Waverley, retired, died 3 April 1992.

Dated at Melbourne 2 June 1992

B. F. CARMODY  
20434 Managing Director  
State Trust Corporation

Notice is hereby given that Mildura Co-operative Producers Grading Floor Society Ltd. of 55 Seventh Avenue, Mildura will cease to be an agent of the Board pursuant to section 94 of the *Egg Industry Act 1989* effective 31 May 1992.

J. VIPADI  
20940 Corporate Secretary

1436 G 22 10 June 1992

WATER ACT 1989

I, Steve Crabb, Minister for Water Resources, make the following Order:

AMENDMENT TO THE APPOINTMENT  
OF THE COLIBAN REGION WATER  
AUTHORITY ORDER 1992

1. This Order is called the Amendment to the Appointment of the Coliban Region Water Authority Order 1992.

2. This Order is made under the powers conferred by Division 2 of Part 6 of the *Water Act* 1989 and all other available powers.

3. This Order is to take effect on and from 1 July 1992.

4. This Order amends the Appointment of the Coliban Region Water Authority Order 1992 published in the *Government Gazette*, No. S9 of 26 March 1992 ("the Original Order").

5. Paragraph 3 of the Original Order is amended by omitting paragraph 3 and substituting the following paragraph:

"3. This Order takes effect on and from 15 December 1992."

STEVE CRABB

21210 Minister for Water Resources

WATER ACT 1989

I, Steve Crabb, Minister for Water Resources, make the following Order:

AMENDMENT TO THE CONSTITUTION  
OF THE COLIBAN REGION WATER  
AUTHORITY (No. 2) ORDER 1992

1. This Order is called the Amendment to the Constitution of the Coliban Region Water Authority (No. 2) Order 1992.

2. This Order is made under the powers conferred by Division 2 of Part 6 of the *Water Act* 1989 and all other available powers.

3. This Order is to take effect on and from 1 July 1992.

4. This Order amends the Constitution of the Coliban Region Water Authority Order 1992 published in the *Government Gazette*, No. G12 of 25 March 1992 ("the Original Order").

5. Paragraph 3 of the Original Order is amended by omitting paragraph 3 and substituting the following paragraph:

"3. This Order takes effect on and from 1 July 1992."

Victoria Government Gazette

6. Paragraph 7 (b) (i) of the Original Order shall be amended by adding after "Longlea" and before "and"—

"Expedition Pass Reservoir".

7. Paragraph 7 (g) of the Original Order shall be amended by—

(1) deleting from the list of officers and employees the following names—

"Arnett, K. G.

Chisholm, R.

Davis, K.

Langtry, C.M.

Miller, B. J.

Mou, A. M.

Noonan, K. W.

Poassalaqua, S. W."

(2) adding to the list of officers and employees the following names—

"Arnett, H. G.

Mason, R. H.

Noone, J. P.

Wallis, D.N.

Passalaqua, S. W."

8. Paragraph 8 of the Original Order shall be amended by omitting paragraph 8 and substituting the following paragraph:

"8 (1) for a period of 12 months commencing on the date of this Order the membership of the Coliban Region Water Authority constituted by Order entitled Constitution of the Coliban Region Water Authority Order 1992 published in the *Government Gazette*, No. G12 of 25 March 1992 shall be the three interim members specified below—

(a) Elaine McNamara;

(b) Brian Thomas; and

(c) Larry O'Toole.

(2) In the event that during the said period of 12 months any interim member ceases to be a member of the Coliban Region Water Authority the Minister may appoint another interim member in his or her place.

(3) An interim member appointed pursuant to sub-clause (2) shall be appointed by the Minister in writing in accordance with the following criteria—

(a) the appointee is not to be over 72 years of age;

(b) the appointee is to reside in the Coliban Area;

(c) the appointee is to have been a member of any Authority abolished by the "Constitution of the Coliban Region Water Authority Order".

STEVE CRABB

21210 Minister for Water Resources

*Water Act 1989*

MINISTERIAL ORDER PURSUANT TO SECTION 104 (3) (b)

I, Steve Crabb, Minister for Water Resources, by this Order, diminish the extent of the Tyntynder North Waterworks District by excising therefrom the land shown by green colour on Plan No. 6237 (21) lodged in the Plan Room of the Rural Water Commission of Victoria, 590 Orrong Road, Armadale (Corres. No. 91/08491) pursuant to section 104 (3) (b) of the *Water Act 1989*.

This Order shall have effect from 30 June 1992.

Dated 2 June 1992

STEVE CRABB

20720 Minister for Water Resources

STATE TENDER BOARD, VICTORIA  
Dictation Equipment  
Schedule No. 1/73

Tenders will be received until 8.30 a.m. on Friday, 26 June 1992 from persons willing to provide the Victorian Government with Dictation equipment during the period from 1 September 1992 to 31 August 1994.

Tender documents may be obtained from the State Tender Board, 1st Floor, 555 Collins Street, Melbourne 3000. Telephone No. 616 8666.

Tenders must be deposited in the Tender Box at the Tender Board Office, 1st Floor, 555 Collins Street, Melbourne 3000, or, if sent by post, postage must be prepaid and the tenders addressed to the Chairman of the Tender Board, Tender Board Offices, 555 Collins Street, Melbourne 3000, which office they must reach not later than by first post on the date of the closing of tenders. Under no circumstances will tender details be accepted by telephone.

N. L. JORDAN

20790 Secretary to the Tender Board

*Education Act 1958*

NOTICE OF THE MAKING OF AN ORDER UNDER SECTION 13 (4) OF THE ACT

Pursuant to section 13 of the *Education Act 1958* I hereby give notice that an Order of the Governor in Council was made on 2 June 1992 under sub-section (4) of the said Act amending certain provisions of the constitution of the school council listed below—

4794 Winlaton Youth Training Education Centre Council

NEIL POPE

20160 Minister for School Education

*Education Act 1958*

NOTICE OF THE MAKING OF ORDERS UNDER SECTION 13 (4) OF THE ACT

Pursuant to section 13 of the *Education Act 1958* I hereby give notice that Orders of the Governor in Council were made on 2 June 1992 under sub-section (4) of the said Act amending certain provisions of the constitutions of the school councils listed below—

4661 Tootgarook Primary School Council  
5113 Livingstone Primary School Council  
5120 Silvertown Primary School Council  
7255 Moorabbin City Secondary College Council

NEIL POPE

20160 Minister for School Education

*Education Act 1958*

NOTICE OF THE MAKING OF ORDERS UNDER SECTION 13 (4) OF THE ACT

Pursuant to section 13 of the *Education Act 1958* I hereby give notice that Orders of the Governor in Council were made on 2 June 1992 under sub-section (4) of the said Act amending certain provisions of the constitutions of the school councils listed below—

5325 Mill Park Heights Primary School Council  
5336 Monmia Primary School Council

NEIL POPE

20160 Minister for School Education

DE-REGISTRATION OF POLITICAL PARTY

In accordance with section 148p (1) (b) of *The Constitution Act Amendment Act 1958* the Nuclear Disarmament Party (Victorian Division) is hereby de-registered.

Dr G. P. LYONS

20673 Electoral Commissioner

1438 G 22 10 June 1992

*Industrial Relations Act 1979*

**ADULT UNITS (DAY TRAINING CENTRES) INSTRUCTORS AWARD**

Notice is hereby given that the Federated Teachers Union of Victoria has lodged an application for a declaration as to the true intent and effect of the Adult Units (Day Training Centres) Instructors Award made on 9 November 1988 in relation to the following:

"Clause 2 (c): *Experience*

- (v) For casual hours instructors an equivalent full instruction year shall comprise 1484 hours. An increment shall be paid for every 1484 hours completed.
- (vi) An instructor, who completes a recognised base qualification subsequent to employment, shall be advanced to the first step on the subdivision range appropriate to that qualification. Provided that an instructor shall advance two incremental levels on completion of ACHE or ACHE equivalent."

Notice is also given that this matter is listed for mention before the Industrial Relations Commission of Victoria in Court Session at 10.00 a.m. on Thursday, 18 June 1992 at Nauru House, 80 Collins Street, Melbourne.

J. TSOUTSOULIS  
Deputy Registrar

Industrial Relations Commission  
of Victoria  
21292

*Industrial Relations Act 1979*  
**BRICK TRADE CONCILIATION AND ARBITRATION BOARD AND FIRE BRICK AND REFRACTORIES CONCILIATION AND ARBITRATION BOARD**

Notice is hereby given that the Federated Brick Tile and Pottery Industrial Union of Australia has lodged an application for the abolition of the Fire Brick and Refractories Conciliation and Arbitration Board and variation to the jurisdiction of the Brick Trade Conciliation and Arbitration Board as follows:

"To the whole of the State of Victoria to any person or persons or classes of persons employed in the process, trade or business of—

- (a) brickmaking (including clay digging);
- (b) sand and lime brickmaking;

*Victoria Government Gazette*

- (c) the manufacture of fire bricks and refractories, but not including the making of insulators of refractory or semi-refractory materials for use in goods or appliances operated by gas, oil or electricity; and
- (d) digging clay in connection with the manufacture of fire bricks and refractories, but not including the mining of clay in underground mines."

Notice is also given that this matter is listed for mention before the Industrial Relations Commission of Victoria in Full Session at 9.30 a.m. on Tuesday, 23 June 1992 at Nauru House, 80 Collins Street, Melbourne.

J. TSOUTSOULIS  
Deputy Registrar

Industrial Relations Commission  
of Victoria  
21292

*Industrial Relations Act 1979*  
**APPOINTMENT OF A CONCILIATION AND ARBITRATION BOARD**

Notice is hereby given that the State Public Service Federation Victoria has lodged an application for the appointment of a Conciliation and Arbitration Board for professional, administrative, clerical, computing and technical staff employed by the State Insurance Office.

Notice is also given that this matter is listed for mention before the Industrial Relations Commission of Victoria at 10.00 a.m. on Monday, 29 June 1992 at Nauru House, 80 Collins Street, Melbourne.

J. TSOUTSOULIS  
Deputy Registrar

Industrial Relations Commission  
of Victoria  
21292

*Delegation of Authority under the Freedom of Information Act 1982 (Section 26)*

**VICTORIAN ACCIDENT REHABILITATION COUNCIL  
General Authority**

The officer occupying for the time being (whether on a permanent, acting or temporary basis), the position of Manager—Administrative Services in the Victorian Accident Rehabilitation Council is authorised to make all necessary decisions on behalf of the Council, in order to comply with and give effect to the

*Victoria Government Gazette*

provisions of the Freedom of Information Act in respect to requests made to the Council.

Any previous notice of authorisation of this FOI function is hereby revoked.

Dated 5 June 1992

GAVIN A. ROBINS  
Chief Executive Officer  
Victorian Accident Rehabilitation  
Council

20890

ADMINISTRATION OF ACTS  
Supplement to the General Order of  
7 April 1992

I, Joan Elizabeth Kirner, Premier of Victoria state that the following administrative arrangements for the following Acts and functions will operate in addition to the arrangements specified in the Administration of Acts General Order of 7 April 1992 and subsequent Supplementary Orders:

MINISTER FOR COMMUNITY SERVICES  
Community Services Act 1970

Excluding:

Sections 201 and 202 in so far as they relate to the administration of Division 9 of Part III and of section 203 where it relates to the administration of that Division (these provisions are administered by the Minister for Labour).

MINISTER FOR LABOUR  
Community Services Act 1970

Sections 201 and 202 in so far as they relate to the administration of Division 9 of Part III and of section 203 where it relates to the administration of that Division.

From and inclusive of the date of this order.  
Dated 10 June 1992

JOAN E. KIRNER  
Premier

20660

ADMINISTRATION OF ACTS  
Supplement to the General Order of 7 April  
1992

I, Joan Elizabeth Kirner, Premier of Victoria state that the following administrative arrangements for the following Acts and functions will operate in addition to and where necessary in substitution for the arrangements specified in the Supplementary Order dated 4

G 22 10 June 1992 1439

February 1992 and the Administration of Acts General Order of 7 April 1992 and subsequent Supplementary Orders:

MINISTER FOR MAJOR PROJECTS  
Crown Land (Reserves) Act 1978

Only in so far as it relates to the land shown as Crown Allotments 4A, 4B on Certified Plan 111284 lodged with Central Plan Office and to be known as the Old Treasury Building Reserve. (The remaining provisions are administered by the Minister for Conservation and Environment.)

MINISTER FOR CONSERVATION AND  
ENVIRONMENT

Crown Land (Reserves) Act 1978

Except in so far as it relates to the land shown as Crown Allotments 4A, 4B on Certified Plan 111284 lodged with Central Plan Office and to be known as the Old Treasury Building Reserve (these provisions are administered by the Minister for Major Projects).

From and inclusive of the date of this Order.  
Dated 4 June 1992

JOAN E. KIRNER  
Premier

20660

*Legal Profession Practice Act 1958*  
SOLICITORS' (PROFESSIONAL  
CONDUCT AND PRACTICE)  
(AMENDMENT No. 1) RULES 1992

In pursuance of the powers conferred by the *Legal Profession Practice Act 1958* and all other powers thereunto enabling the Council of the Law Institute of Victoria hereby makes the following Rules:

1. These Rules may be cited as the Solicitors' (Professional Conduct and Practice) (Amendment No. 1) Rules 1992 and shall come into operation on the date of their publication in the *Victoria Government Gazette*.

2. The Solicitors' (Professional Conduct and Practice) Rules 1984 are in these Rules referred to as the Principal Rules.

3. That the following Rule 14 be inserted into the Principal Rules:

*Conducting Separate Business*

14. (1) A solicitor may conduct a separate business from the same premises as the solicitor's legal practice provided that the solicitor ensures that all clients of the separate business are informed that the separate business





APPOINTMENT

*Constitution Act 1975*

APPOINTMENT

Under the powers found in sub-section (4) of section 80A of the *Constitution Act 1975*, on the declaration of the Chief Justice, I appoint Mr Justice Peter Murphy to perform the duties and exercise the powers of a Judge of the Supreme Court for the period of six months commencing 2 June 1992.

JIM KENNAN  
Deputy Premier and  
Attorney-General

20430

**ORDERS IN COUNCIL**

**GOVERNMENT EMPLOYEE HOUSING AUTHORITY ACT 1981**

The Governor in Council under section 12 of the *Government Employee Housing Authority Act 1981*—

1. transferring properties held by the Minister for Water Resources to the Government Employee Housing Authority, as specified in the attached Schedule; and
2. fixing 2 June 1992 as the day on which this Order comes into effect.

**SCHEDULE OF PROPERTIES HELD BY THE MINISTER FOR WATER RESOURCES FOR  
TRANSFER TO GEHA**

Ardmona	McIsaac Road	63R
Bacchus Marsh	8 Malcolm Street	852
Bacchus Marsh	22 Malcolm Street	853
Ballendella		43R
Bamawm		42R
Baulkamaugh	Corner Boals and Fuzzards Roads	612
Baulkamaugh	Fuzzards Road	437
Bears Lagoon		85R
Beverford	Cottman Road	763
Beverford	Cottman Road	163R
Birchip	21 Campbell Street	431
Birchip	68 Cumming Avenue	621R
Birchip	32 Duncan Street	322
Birchip	34 Duncan Street	405
Birchip	13 Morrison Street	290R
Boort	13 Holloway Street	911
Boort	6 Kiniry Street	169
Boort	79 Lakeview Street	878
Boort	9 Lakeview Street	939
Broken/Hollands Weir		864
Burramine	Murray Valley Highway	223
Cairn Curran Reservoir		298
Cairn Curran Reservoir		708R
Camperdown	54 Manifold Street	788
Camperdown	23 Wright Street	868
Cardross	Montana Avenue	314
Cardross	Montana Avenue	390
Carlisle River	Carlisle and Kennedy's Creek	258
Cobram	18 Churr Street	
Cobram	8 Hovell Court	
Cobram	39 Karook Street	931
Cobram	86 Queen Street	257
Cobram	14 Thompson Street	730
Cobram	68 William Street	222
Cobram East	Murray Valley Highway	233
Cohuna	11 Kerang Road	338
Cohuna	5 Kerang Street	676
Cohuna	86 King Edward Street	406
Cohuna	161 King George Street	122R
Cohuna	165 King George Street	123R
Congupna	Goulburn Valley Highway	266
Cowwarr Weir		717
Cowwarr Weir		919
Cullulleraine	Government Road	375
Cullulleraine	Government Road	180R
Denison	Sale-Heyfield Road	629

Denison	Sale-Heyfield Road	613
Dennison		614
Dimboola	6 Church Street	191
Dingee		133R
Dingee	Government Road	935
Durham Ox		146R
Echuca West		47R
Elphinstone	Gilbert Street	4R
Fulham		674
Glenmaggie Lake		26R
Goulburn Weir		15R
Goulburn Weir		635
Gunbower	Treacy Street	934
Hamilton	28 White Avenue	810
Hopetoun	14 Hope Street	641
Hopetoun	93 Toole Street	211
Horefield		136R
Horsham	19 Francis Street	197R
Horsham	44 Kalkee Road	413
Horsham	4 Natimuk Road	189
Katamatite	Foy Street	944
Katunga	Centenary Way	428
Kerang	110 Boundary Street	837
Kerang	112 Boundary Street	143
Kerang	7 Dunlop Street	125R
Kerang	14 Keats Street	805
Kerang	Koondrook Road	744
Kerang	Lake Meran RSD	379
Kerang	95 Lilac Avenue	742
Kerang	91 Lilac Avenue	743
Kerang	Loddon Valley Highway	912
Kerang	26 Lyall Avenue	714
Kerang	48 Marne Street	492
Kerang	37 Nolan Street	260R
Kerang	6 Nugget Street	
Kerang	12 Wellington Street	296
Kerang	211 Westslade Avenue	139
Kerang East	Old Echuca Road	961
Koroop via Cohuna		130R
Ky-Valley	Everard Road	270
Kyabram	Graham Road	84R
Laanecoorie		23R
Laanecoorie		921
Lake Bellfield	2 Sundial Avenue	828
Lake Boga	Murray Valley Highway (Depot)	168
Lake Boga	Murray Valley Highway (Depot)	808
Lake Buffalo		820
Lake Buffalo		879
Lake Eildon	25 Second Street	684
Lake Eildon	1 Seventh Street	699
Lake Eildon	7 South Crescent	980
Lake Eppalock		761
Lake Eppalock		848
Lake Glenmaggie		716
Lake Mokoan		847
Lake Mokoan		855
Lake Nillahcootie		839
Lake Nillahcootie		954
Lake Wartook		196
Lake Wartook		854

1444 G 22 10 June 1992

Victoria Government Gazette

Lake William Hovell		872
Leitchville	Murray Valley Highway	126R
Leitchville	Queen Mary Avenue	131R
Leongatha	4 Jeffrey Street	861
Lockington	Lucas Crescent	925
Lubeck East		195R
Maffra	35A King Street	773
Maffra	23 McLean Street	834
Maffra	5 Parkinson Street	875
Maffra	11 Powerscourt Street	733
Maffra	15 Powerscourt Street	28R
Maffra	44 Princess	770
Maffra	42 Princess	772
Maffra	83 Queen Street	301
Melton Reservoir		172R
Merbein	Channel Road	179R
Merbein	117 Commercial Street	117R
Merbein	249 Commercial Street	121R
Merbein	McEdwards Street	120R
Merbein	McEdwards Street	729
Merbein	11 Railway Avenue	119R
Merrimu Reservoir		910
Merrimu Reservoir		951
Mildura	199 Tenth Street	66
Minyip	123 Main Street	371
Mitiamo		932
Mitiamo		933
Mooroopna	30 Graeme Street	955
Murrabit		914
Murrabit	Murrabit-Kerang Road	140R
Murtoa	18 Lloyd Street	192
Murtoa	7 Marma Street	427
Murtoa	3 Marma Street	392
Murtoa	61 McDonald Street	306
Myall	Murrabit-Kondrook Road	142R
Nambrok		628
Nanneella		49R
Nathalia	111 Blake Street	229
Nathalia	21 Federation Street	701
Nathalia	10 Veldt Street	938
Nathalia	31 Veldt Street	946
Murchison	36 Robinson Street	
Newlyn Reservoir		846
Newry	Summerlea Road	457
Newry	Summerlea Road	458
Numurkah	Alberts Road	601
Nuntin	Brewers Hill	31R
Nyah	Church Street	157R
Nyah	Murray Valley Highway	271
Nyah	Murray Valley Highway	156R
Nyah West	Allan Street	219
Orbost	Boundary Road	823
Ouyen	12 Britt Street	323
Ouyen	18 Cooper Street	289
Ouyen	14 William Street	241
Prairie	RSD	153
Pykes Creek Reservoir		173R
Pykes Creek Reservoir		424R
Pyramid Hill	26 Barber Street	417
Pyramid Hill	30 Barber Street	419

Pyramid Hill	28 Barber Street	423
Pyramid Hill	18 Durham Ox Road	486
Pyramid Hill	12 Durham Ox Road	144R
Pyramid Hill	36 Gladfield Road	616R
Pyramid Hill	66 Kelly Street	252
Pyramid Hill	Mincha RSD	384
Quantong	Lanes Avenue	432R
Red Cliffs	Block 174B	100R
Red Cliffs	Boobok Avenue	115R
Red Cliffs	48 Fitzroy Avenue	345
Red Cliffs	50 Fitzroy Avenue	98R
Red Cliffs	83 Ilex Street	330
Red Cliffs	85 Ilex Street	735
Red Cliffs	43 Kiewa Avenue	336
Red Cliffs	45 Kiewa Avenue	342
Red Cliffs	1 Melia Avenue	748
Red Cliffs	Pumps Road	110R
Red Cliffs	Pumps Road	111R
Red Cliffs	Pumps Road	112R
Red Cliffs	Scout Hall Road	104R
Robinvale	Lot 77B B Relift	372
Robinvale	Corner Carrington and Old Streets	460
Robinvale	Happy Valley Road	660
Robinvale	4 Latje Road	363
Robinvale	16 Leonora Street	636
Robinvale	Pumps Road	718
Robinvale	Pumps Road	462
Rochester	17 Edwards Street	671
Rochester	133 Mackay Street	800R
Rocklands Reservoir		403
Rocklands Reservoir		877
Sale	4 Howard Street	923
Shepparton	8 Bouchier Street	964
Shepparton	40 Dunrobin Street	950
Shepparton	14 Gillies Street	858
Shepparton	52 St Georges Road	451
Stanhope	10 Ross Street	915
Stanhope	23 Steele Street	874
Strathmerton	45 Patrick Street	942
Swan Hill	25 Marrabor Street	886
Swan Hill	Miloo Street (North End)	416
Swan Hill	1 Murlong Street	762
Swan Hill	43 Murlong Street	821
Swan Hill	Murraydale Road	164
Swan Hill	75 Thurla Street	782
Tatura	7 Bartlett Street	58R
Tatura	32 Casey Street	606
Tatura	4 Dhurringile Road	653
Tatura	7 Edgar Street	974
Tatura	19 Hanlon Street	57
Tatura	13 Hanlon Street	55
Tatura	Harston Road	67R
Tatura	Harston Road	70R
Tatura	2 Hastie Street	647
Tatura	298 Hogan Street	672
Tatura	26 Park Street	969
Tatura	29 Ponting Street	930
Tatura	33 Ross Street	473
Tatura	31 Ross Street	474
Tatura	80 Ross Street	664

1446 G 22 10 June 1992

Victoria Government Gazette

Tatura	29 Service Street	652R
Tatura	4 Williams Street	969
Teal Point	Kondrook Road	615
Tennyson		48R
Tinamba	Maffra-Tinambra Road	212
Tinamba	Maffra-Tinambra Road	213
Tongala	Curr Road	681
Tongala	53 Miller Street	214
Tongala	6 Miller Street	873
Tongala	6 Morris Court	963
Tongala	48 Torney Street	953
Tullaroop Reservoir		734
Tullaroop Reservoir		952
Undera	Madill Road	617
Undera	Sellwood Road	273
Undera	Sellwood Road	949
Underbool	Fasham Street	453R
Waaia	Waaia-Bearii Road	488
Wangaratta	14 Dixon Street	819
Wangaratta	5 Evelyn Court	899
Waranga Basin		18
Werribee	4 Cattanach Crescent	380
Werribee	15 Minogue Crescent	945
Werribee South	15 Cavleys Road	90R
Winnindo	Denison Road	675
Wycheproof	4 Prospect Street	412
Wyelangta	207r Lavers Hill-Beech Forest Road	
Wyuna	Murray Valley Highway	255
Yarrowalla		151R
Yielima	Murray Valley Highway	661
Yielima	Vales Road	611

Dated 26 May 1992

Responsible Minister:

TONY SHEEHAN

Treasurer

DAMIEN O'SHEA

Acting Clerk of the Executive Council

20470

ADMINISTRATIVE ARRANGEMENTS ACT 1983

The Governor in Council makes the following Order:

Dated 2 June 1992

Responsible Minister:

JOAN E. KIRNER

Premier

DAMIEN O'SHEA

Acting Clerk of the Executive Council

ADMINISTRATIVE ARRANGEMENTS ORDER (No. 110) 1992

1. This Order is called the Administrative Arrangements Order (No. 110) 1992.

2. This Order is made under the powers conferred by section 3 of the *Administrative Arrangements Act 1983* and under every other available power.

3. This Order takes effect on and after the date on which it is published in the *Government Gazette*.

4. In respect of an item in the Schedule a reference to an Old Body in any provision of an Act specified in Column 2 or in any statutory or other instrument made under any provision of an Act specified in Column 2 shall be construed as a reference to the New Body.

5. Where—

- (a) before this Order takes effect a transaction happened in relation to an Old Body; then—
- (b) this Order does not affect the validity or continuity of the transaction, and the transaction shall continue and may be completed in relation to the New Body in the same way as it would have been continued and may have been completed in relation to the Old Body if this Order had not been made.

6. In this Order—

“The Act” means the *Administrative Arrangements Act 1983*.

“Body” means Minister, Administrative Unit or Officer.

“Instrument” includes contract and agreement.

“Old Body” and “New Body” mean respectively the Bodies specified in Column 1 and Column 3 of each item in the Schedule.

“Schedule” means the Schedule to this Order.

“Transaction” includes—

- (a) agreement, bond, contract, deed or other consensual arrangement whatsoever;
- (b) action, appeal, arbitration, prosecution or other legal proceeding whatsoever;
- (c) assignment, charge, lease, mortgage, transfer or other dealing with property whatsoever;
- (d) loan, guarantee, indemnity or other dealing with money whatsoever;
- (e) approval, consent, delegation, direction, licence, Order, permit, requirement or other authority whatsoever;
- (f) notice; and
- (g) any other act, entitlement or liability in the law whatsoever.

#### SCHEDULE

Item	Column 1 (Old Body)	Column 2 (Legislation)	Column 3 (New Body)
1.	Officer	<i>Community Services Act 1970</i> , section 79 (1)	Officer of the Department of Labour
2.	Director-General of Community Services	<i>Community Services Act 1970</i> , section 201 in so far as it relates to the administration of Division 9 of Part III and of section 203 where it relates to the administration of that Division	Director-General of Labour
3.	Officer of the Department	<i>Community Services Act 1970</i> , section 201 in so far as it relates to the administration of Division 9 of Part III and of section 203 where it relates to the administration of that Division	Officer of the Department of Labour

## ADMINISTRATIVE ARRANGEMENTS ACT 1983

The Governor in Council makes the following Order:

Dated 2 June 1992

Responsible Minister:  
JOAN E. KIRNER  
Premier

DAMIEN O'SHEA  
Acting Clerk of the Executive Council

## ADMINISTRATIVE ARRANGEMENTS ORDER (No. 109) 1992

1. This Order is called the Administrative Arrangements Order (No. 109) 1992.
2. This Order is made under the powers conferred by section 3 of the *Administrative Arrangements Act 1983* and under every other available power.
3. This Order takes effect in respect of each item in the Schedule on and after the date specified in Column 4.
4. In respect of each item in the Schedule a reference to the Old Body in any provision of an Act specified in Column 2 or in any statutory or other instrument made under any provision of an Act specified in Column 2 shall be construed as a reference to the New Body.
5. Where—
  - (a) before this Order takes effect a transaction happened in relation to an Old Body; then—
  - (b) this Order does not affect the validity or continuity of the transaction, and the transaction shall continue and may be completed in relation to the New Body in the same way as it would have been continued and may have been completed in relation to the Old Body if this Order had not been made.
6. In this Order—
 

“The Act” means the *Administrative Arrangements Act 1983*.

“Body” means Minister, Administrative Unit or Officer.

“Instrument” includes contract and agreement.

“Old Body” and “New Body” mean respectively the Bodies specified in Column 1 and Column 3 of each item in the Schedule.

“Schedule” means the Schedule to this Order.

“Transaction” includes—

  - (a) agreement, bond, contract, deed or other consensual arrangement whatsoever;
  - (b) action, appeal, arbitration, prosecution or other legal proceeding whatsoever;
  - (c) assignment, charge, lease, mortgage, transfer or other dealing with property whatsoever;
  - (d) loan, guarantee, indemnity or other dealing with money whatsoever;
  - (e) approval, consent, delegation, direction, licence, Order, permit, requirement or other authority whatsoever;
  - (f) notice; and
  - (g) any other act, entitlement or liability in the law whatsoever.

## SCHEDULE

Item	Column 1 (Old Body)	Column 2 (Legislation)	Column 3 (New Body)	Column 4 (Commencement)
1.	Executive Director, Occupational Training Board	All Acts	Executive Director, Occupational Training Bureau	1 July 1991
2.	Executive Director, Occupational Training Bureau	All Acts	Executive Director, Vocational Training Bureau	26 February 1992







**Crown Land (Reserves) Act 1978  
REVOCATION OF PERMANENT  
RESERVATION**

The Governor in Council under section 13 (3) of the *Land (Miscellaneous Matters) Act 1988* revokes the following Order in Council of the permanent reservation of land:

**DEUTGAM**—The Order in Council of 6 July 1927 of the permanent reservation of 472.6 hectares of land being Crown Allotments 1 and 1A, Section C, Parish of Deutgam and Crown Allotment 9, Section B, Parish of Tarneit as a site for State Research Farm (Agricultural) revoked as to part by various Acts, so far only as the portion containing 8.840 hectares being Crown Allotment 1H, Section C, Parish of Deutgam and the portion containing 1571 square metres shown as Crown Allotment 1J, Section C, Parish of Deutgam as shown on the plan hereunder—(Rs 3465).

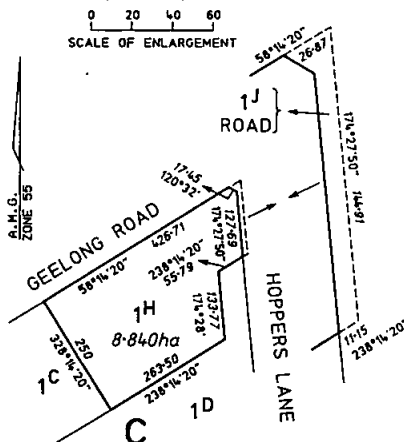

Dated 10 June 1992  
Responsible Minister:  
**BARRY PULLEN**  
Minister for Conservation and Environment  
**DAMIEN O'SHEA**  
20090 Acting Clerk of the Executive Council

**Crown Land (Reserves) Act 1978  
CROWN LANDS TEMPORARILY  
RESERVED**

The Governor in Council under sections 4 and 7 of the *Crown Land (Reserves) Act 1978* temporarily reserves for the purposes mentioned and also nominates as areas for which consent of the person or manager administering or

managing the lands is required before work may be done on those lands in accordance with the *Mineral Resources Development Act 1990*, the following Crown lands:

**MUNICIPAL DISTRICT OF THE CITY OF  
BERWICK**

**BERWICK**—Show Grounds and Public Recreation, 2 hectares, more or less, being Crown Allotment 27, Township of Berwick, Parish of Berwick as indicated by hatching on plan hereunder—(B 317(5)) (Rs 6654).

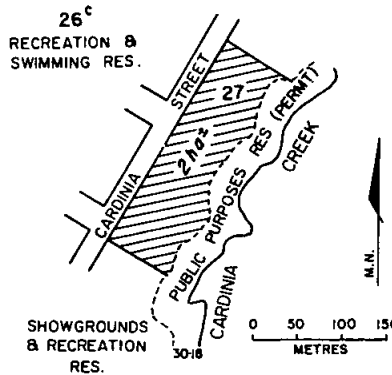

**MUNICIPAL DISTRICT OF THE SHIRE OF  
CRESWICK**

**SMEATON**—Conservation of an area of historic interest, 8000 square metres, more or less, being Crown Allotments 5 and 5A, Section 4, Township of Smeaton, Parish of Spring Hill as indicated by hatching on plan hereunder—(S 302(3)) (Rs 21019).

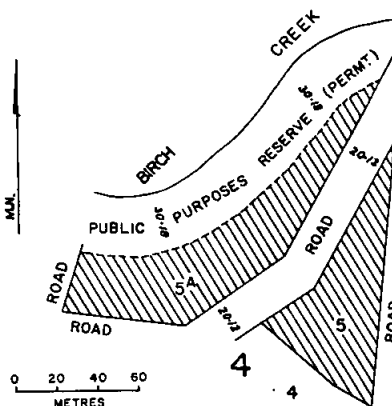

TOTAL AREA OF HATCHED PORTIONS 8000m<sup>2</sup>

1452 G 22 10 June 1992

**MUNICIPAL DISTRICT OF THE SHIRE OF CRESWICK**

**SMEATON**—Conservation of an area of historic interest, 1.692 hectares being Crown Allotment 7A, Section 3, Township of Smeaton, Parish of Smeaton as shown on Certified Plan No. 108415 lodged in the Central Plan Office—(Rs 21019).

**MUNICIPAL DISTRICT OF THE SHIRE OF BET BET**

**TARNAGULLA**—Public Park, 1.3 hectares, more or less, being Crown Allotment 12, Section 27, Township of Tarnagulla, Parish of Tarnagulla as indicated by hatching on plan hereunder—(T 173[9]) (Rs 2566).

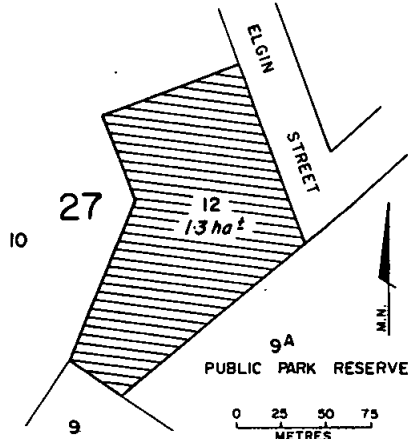

Dated 10 June 1992  
Responsible Minister:  
**BARRY PULLEN**  
Minister for Conservation and Environment  
**DAMIEN O'SHEA**  
20090 Acting Clerk of the Executive Council

**Crown Land (Reserves) Act 1978  
CROWN LAND PERMANENTLY  
RESERVED**

The Governor in Council under sections 4 and 7 of the *Crown Land (Reserves) Act 1978* permanently reserves for the purpose mentioned and also nominates as an area for which consent of the person or manager administering or managing the land is required before work may be done on that land in accordance with the *Mineral Resources Development Act 1990*, the following Crown land:

Victoria Government Gazette

**MUNICIPAL DISTRICT OF THE SHIRE OF NEWHAM AND WOODEND**

**ROCHFORD**—Water Supply, 9.43 hectares, more or less being Crown Allotment 66E, Parish of Rochford as indicated by hatching on plan hereunder—(R 22[3]) (Rs 3596).

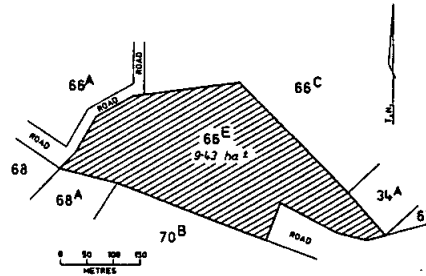

Dated 10 June 1992  
Responsible Minister:  
**BARRY PULLEN**  
Minister for Conservation and Environment  
**DAMIEN O'SHEA**  
20090 Acting Clerk of the Executive Council

**Crown Land (Reserves) Act 1978  
CROWN LAND PERMANENTLY  
RESERVED**

The Governor in Council under sections 4 and 7 of the *Crown Land (Reserves) Act 1978* permanently reserves for the purpose mentioned and also nominates as an area for which consent of the person or manager administering or managing the land is required before work may be done on that land in accordance with the *Mineral Resources Development Act 1990*, the following Crown land:

**MUNICIPAL DISTRICT OF THE CITY OF ELTHAM**

**NILLUMBIK**—Preservation of habitat for native fauna, 2.113 hectares being Crown Allotment 14A, Section 5, Parish of Nillumbik, formerly being Lot K on Plan of Subdivision No. 112913 lodged in the Office of Titles—(Rs 37007).

Dated 10 June 1992  
Responsible Minister:  
**BARRY PULLEN**  
Minister for Conservation and Environment  
**DAMIEN O'SHEA**  
20090 Acting Clerk of the Executive Council

*Crown Land (Reserves) Act 1978*  
REVOCATION OF TEMPORARY  
RESERVATIONS

The Governor in Council under section 10 of the *Crown Land (Reserves) Act 1978* revokes the following temporary reservations:

**MALDON**—The temporary reservation by Order in Council of 4 November 1987 of 2370 hectares, more or less, of land in the Township of Maldon and the Parishes of Maldon, Muckleford and Walmer as a site for the preservation of an area of natural and historic interest, so far only as the portion in the Township of Maldon containing 6643 square metres as indicated by hatching on plan published in the *Victoria Government Gazette* on 13 May 1992, pages 1156-7—(M 449[11]) (Rs 12778).

**WONTHAGGI**—The temporary reservation by Order in Council of 4 August 1970 of 1012 square metres of land in Section 8, Township of Wonthaggi, Parish of Wonthaggi as a site for Public Purposes (Public Offices)—(Rs 9353)  
Dated 10 June 1992

Responsible Minister:

**BARRY PULLEN**

Minister for Conservation and Environment  
**DAMIEN O'SHEA**  
20090 Acting Clerk of the Executive Council

*Crown Land (Reserves) Act 1978*  
REVOCATION OF TEMPORARY  
RESERVATIONS

The Governor in Council under section 10 of the *Crown Land (Reserves) Act 1978* revokes the following temporary reservations:

**DOWLING FOREST**—The temporary reservation by Order in Council of 29 November 1966 of 4047 square metres of land in Section 4, Parish of Dowling Forest as a site for Public purposes (Police purposes)—(Rs 8746).

**PEECHEMBER and YANAC-A-YANAC**—The temporary reservation by Order in Council of 25 November 1889 of 17-185 hectares of land in the Parishes of Peecheember and Yanac-a-yanac, in two separate portions, as a site for water supply purposes, revoked as to part by Order in Council of 7 April 1964, so far as the balance remaining containing 16-78 hectares, more or less—(Rs 5600).

**PEECHEMBER and YANAC-A-YANAC**—The temporary reservation by Order in Council of 24 March 1890 of 36-16 hectares of land in the Parishes of Peecheember and Yanac-a-yanac,

in two separate portions, as a site for water supply purposes in addition to and adjoining the site temporarily reserved therefor by Order in Council of 25 November 1889, revoked as to part by Order in Council of 12 November 1930, so far as the balance remaining containing 19-97 hectares, more or less—(Rs 5600).

**SHEPPARTON**—The temporary reservation by Order in Council of 25 July 1950 of 611 square metres of land in Section 22, Township of Shepparton, Parish of Shepparton as a site for Police purposes—(Rs 6564).

**SMEATON**—The temporary reservation as a site for the conservation of an area of historic interest of 5-580 hectares of land being Crown Allotments 1, 2, 3 and 5 and part of Crown Allotments 4, 6, 7 and 8, Section 3, Township of Smeaton and part of Crown Portions 46 and 64, Parish of Smeaton transferred to the Crown by Transfer No. M998449E registered in the Office of Titles on 20 August 1987 so far only as that portion containing 1-494 hectares being Crown Allotments 1, 2, 3 and 5 and part of Crown Allotments 4, 6, 7 and 8, Section 3, Township of Smeaton—(Rs 21019).

Dated 10 June 1992

Responsible Minister:

**BARRY PULLEN**

Minister for Conservation and Environment  
**DAMIEN O'SHEA**  
20090 Acting Clerk of the Executive Council

*Crown Land (Reserves) Act 1978*  
REVOCATION OF TEMPORARY  
RESERVATION

The Governor in Council under section 10 of the *Crown Land (Reserves) Act 1978* revokes the following temporary reservation:

**MELBOURNE**—The temporary reservation by Order in Council of 11 August 1936 of 3-237 hectares more or less of land in the Parish of Melbourne North as a site for public offices and approaches, so far only as the portion shown as Crown Allotments 4A and 4B, Section 5, City of Melbourne, Parish of Melbourne North on Certified Plan No. 111284 lodged in the Central Plan Office—(Rs 4588).

Dated 10 June 1992

Responsible Minister:

**JIM KENNAN**

Minister for Major Projects  
**DAMIEN O'SHEA**  
20022 Acting Clerk of the Executive Council

1454 G 22 10 June 1992

*Crown Land (Reserves) Act 1978*  
REVOCATION OF TEMPORARY  
RESERVATIONS

The Governor in Council under section 10 of the *Crown Land (Reserves) Act 1978* revokes the following temporary reservations:

ASHENS—The temporary reservation by Order in Council of 18 February 1878 of 2.023 hectares of land in the Parish of Ashens (formerly part of Allotment 67) as a site for a State School—(Rs 4318).

ASHENS—The temporary reservation by Order in Council of 10 July 1933 of 8802 square metres of land in the Parish of Ashens as a site for a State School in addition to and adjoining the site temporarily reserved therefor by Order in Council of 18 February 1878—(Rs 4318).

CAMBRIAN HILL—The temporary reservation by Order in Council of 6 September 1886 of 2.719 hectares of land in the Parish of Yarrowee (now in the Township of Cambrian Hill) as a site for the supply of material for road making purposes, revoked as to part by Orders in Council of 29 August 1905 and 19 June 1962 so far as the balance remaining containing 2.155 hectares—(Rs 13655).

DROUIN—The temporary reservation for railway purposes by Order in Council of 23 November 1868 of the Crown lands comprised within the limits of deviation of the surveyed line of railway from Melbourne to Sale so far only as the portions containing 3.186 hectares, more or less, shown as Crown Allotments 19B, 19C, 19D and 19E, Section A, Township of Drouin, Parish of Drouin West as shown on Certified Plan No. 111054—(GL 14826).

KEELBUNDORA—The temporary reservation by Order in Council of 22 July 1980 of 18.46 hectares of land being Crown Allotment 28D, Parish of Keelbundora as a site for Multiple Handicapped Children—(Rs 10247).

KEELBUNDORA—The temporary reservation by Order in Council of 11 December 1979 of 7.881 hectares of land being Crown Allotment 10F, Parish of Keelbundora as a site for State School Purposes—(Rs 7832).

LITTLE RIVER—The temporary reservation for railway purposes by Order in Council of 23 November 1868 of the land comprised within the line of railway from Melbourne to Ballarat so far only as the portions containing 1.6455 hectares shown as Crown Allotments 36D, 36E, 36F, 36G, 36H, 36I, 36K and 36L, Section 1,

*Victoria Government Gazette*

Township of Little River, Parish of Bulban on Certified Plan No. 111141 lodged in the Central Plan Office—(GL 16166).

MULGRAVE—The temporary reservation by Order in Council of 21 July 1987 of 1404 square metres of land being Crown Allotment 88B, Parish of Mulgrave as a site for the Department of Community Services—(Rs 9220).

PYRAMID HILL—The temporary reservation by Order in Council of 22 July 1908 of 42.56 hectares of land in the Township of Pyramid Hill, Parish of Terrick Terrick West as a site for a Racecourse and other purposes of Public Recreation, revoked as to part by Order in Council of 25 May 1971, so far only as the portion containing 10.16 hectares shown as Crown Allotment 6, Section 4, Township of Pyramid Hill on Certified Plan No. 111121 lodged in the Central Plan Office—(Rs 1295).

TYLDEN—The temporary reservation by Order in Council of 18 November 1889 of 8094 square metres of land in the Township of Tylden (formerly Allotment 3, Section A, Parish of Tylden) as a site for Police Purposes, revoked as to part by Orders in Council of 9 January 1893, 21 November 1938 and 13 September 1966, so far as the balance remaining containing 2327 square metres—(Rs 8660).

Dated 10 June 1992

Responsible Minister:

BARRY PULLEN

Minister for Conservation and Environment

DAMIEN O'SHEA

20090 Acting Clerk of the Executive Council

*Crown Land (Reserves) Act 1978*  
NOTICE OF INTENTION

The Governor in Council under section 10 of the *Crown Land (Reserves) Act 1978* gives notice of intention to revoke the following temporary reservations:

CORINDHAP—The temporary reservation by Order in Council of 14 May 1968 of 10.60 hectares of land in the Township of Corindhap, Parish of Corindhap as a site for water supply purposes—(Rs 8990).

JIKA JIKA—The temporary reservation by Order in Council of 23 January 1968 of 1366 square metres of land in Section 24 at Carlton, Parish of Jika Jika as a site for Public Purposes (Department of Health purposes)—(Rs 8902).

MERRYMBUELA—The temporary reservation by Order in Council of 18 November 1986 of 16.2 hectares, more or less, of land being Crown Allotment 2A, Parish of Merrymbuela as a site for the supply of stone—(Rs 13319).

ST. ARNAUD—The temporary reservation by Order in Council of 2 November 1977 of 1012 square metres of land being Crown Allotment 5, Section 13, Township of St. Arnaud, Parish of St. Arnaud as a site for public purposes (Departmental residence)—(Rs 10413).

TRAWALLA—The temporary reservation by Order in Council of 3 November 1890 of 41.65 hectares of land in the Parish of Trawalla as a site for water supply purposes and for public recreation, revoked as to part by Orders in Council of 18 August 1908, 12 July 1966 and 20 June 1967, so far as the balance remaining containing 11.12 hectares, more or less—(Rs 295).

TRAWALLA—The temporary reservation by Order in Council of 3 March 1915 of 5.618 hectares of land in the Parish of Trawalla as a site for water supply purposes and for public recreation in addition to and adjoining the site temporarily reserved therefor by Order in Council of 3 November 1890, revoked as to part by Orders in Council of 12 July 1966 and 20 June 1967, so far as the balance remaining containing 5.489 hectares, more or less—(Rs 295).

TRAWALLA—The temporary reservation by Order in Council of 27 June 1961 of 2656 square metres of land in the Parish of Trawalla as a site for water supply purposes and public recreation in addition to and adjoining the site temporarily reserved therefor by Order in Council of 3 November 1890—(Rs 295).

Dated 10 June 1992

Responsible Minister:

BARRY PULLEN

Minister for Conservation and Environment

DAMIEN O'SHEA

20090 Acting Clerk of the Executive Council

*Crown Land (Reserves) Act 1978*

NOTICE OF INTENTION

The Governor in Council under section 10 of the *Crown Land (Reserves) Act 1978* gives notice of intention to revoke the following temporary reservations:

DANDENONG—The temporary reservation by Order in Council of 5 April 1977 of 232 square metres of land being Crown Allotment 43A, Parish of Dandenong as a site for Public Purposes (Mental Health Authority purposes)—(Rs 10230).

DANDENONG—The temporary reservation by Order in Council of 7 December 1968 of 1543 square metres of land in the Parish of Dandenong as a site for Public Purposes (Mental Health Authority purposes)—(Rs 9094).

DANDENONG—The temporary reservation by Order in Council of 5 December 1978 of 798 square metres of land being Crown Allotment 43B, Parish of Dandenong as a site for Public Purposes (Mental Health Authority purposes)—(Rs 9094).

MINIMAY—The temporary reservation by Order in Council of 13 November 1956 of 6070 square metres of land in the Township of Minimay, Parish of Minimay as a site for a Rubbish Depot—(Rs 7508).

NI NI—The temporary reservation by Order in Council of 4 November 1966 of 1.214 hectares of land in the Parish of Ni Ni (formerly part of Allotment 95) as a site for a Cemetery—(02-6161).

Dated 10 June 1992

Responsible Minister:

BARRY PULLEN

Minister for Conservation and Environment

DAMIEN O'SHEA

20090 Acting Clerk of the Executive Council

*Crown Land (Reserves) Act 1978*

REVOCATION OF TEMPORARY RESERVATIONS

The Governor in Council under section 10 of the *Crown Land (Reserves) Act 1978* revokes the following temporary reservations:

DANDENONG—The temporary reservation by Order in Council of 7 October 1867 of 8094 square metres of land in Section 8, Township of Dandenong, Parish of Dandenong as a site for Police purposes—(Rs 4806).

KONGWAK—The temporary reservation by Order in Council of 2 December 1895 of 4.047 hectares of land in the Parish of Kongwak (formerly part of Allotment 25B) as a site for a Cemetery—(Rs 5428).

MELBOURNE—The temporary reservation by Order in Council of 22 February 1977 of 2012 square metres of land being Crown

1456 G 22 10 June 1992

Allotment 7A, Section 31, City of Melbourne, Parish of Melbourne North as a site for Public Purposes (Public Buildings)—(Rs 10301).

Dated 10 June 1992

Responsible Minister:

BARRY PULLEN

Minister for Conservation and Environment

DAMIEN O'SHEA

20090 Acting Clerk of the Executive Council

*Crown Land (Reserves) Act 1978*  
RESERVED CROWN LAND PLACED  
UNDER THE CONTROL AND  
MANAGEMENT OF THE RURAL WATER  
COMMISSION

The Governor in Council under section 18 (1) of the *Crown Land (Reserves) Act 1978* places under the control and management of the Rural Water Commission the following Crown land—

VECTIS EAST—An area of 29 hectares, more or less, being Crown Allotment 258r, Parish of Vectis East temporarily reserved as a site for water supply purposes by Order in Council of 30 July 1991 (see *Victoria Government Gazette* of 31 July 1991)—(Rs 13746).

Dated 10 June 1992

Responsible Minister:

BARRY PULLEN

Minister for Conservation and Environment

DAMIEN O'SHEA

20090 Acting Clerk of the Executive Council

*Crown Land (Reserves) Act 1978*  
INCORPORATION OF COMMITTEE OF  
MANAGEMENT OF ROKEBY PUBLIC  
HALL AND RECREATION RESERVES

The Governor in Council under section 14A (1) of the *Crown Land (Reserves) Act 1978*, being satisfied that it is in the public interests to declare to be a corporation the Committee of Management appointed under section 14 (2) of the Act of the land described in the schedule hereunder—

(a) declares that the Committee of Management shall be a corporation;

(b) assigns the name "Rokeby Community Reserves and Hall Committee Incorporated" to the corporation; and

under section 14B (3) of the Act, appoints Timothy Stoll to be Chairperson of the Corporation.

*Victoria Government Gazette*

SCHEDULE

The land in the Township of Rokeby temporarily reserved as a site for a Public Hall by Order in Council of 18 September 1916 together with the remaining lands in the said Township temporarily reserved as sites for Public Recreation by Orders in Council of 5 December 1911 and 17 October 1923—(Rs 1193) (Rs 1182).

Dated 10 June 1992

Responsible Minister:

BARRY PULLEN

Minister for Conservation and Environment

DAMIEN O'SHEA

20090 Acting Clerk of the Executive Council

*Crown Land (Reserves) Act 1978*  
INCORPORATION OF COMMITTEE OF  
MANAGEMENT OF YARRA GLEN  
SHOWGROUNDS AND RECREATION  
RESERVE

The Governor in Council, under section 14A (1) of the *Crown Land (Reserves) Act 1978*, being satisfied that it is in the public interests to declare to be a corporation the Committee of Management appointed under section 14 (2) of the Act of the land described in the schedule hereunder—

(a) declares that the Committee of Management shall be a corporation;

(b) assigns the name "Yarra Glen Public Recreation and Showgrounds Reserve Incorporated" to the corporation; and

under section 14B (3) of the Act, appoints Leonard James Olney to be Chairperson of the corporation.

SCHEDULE

The reserved Crown lands in the Parish of Tarrawarra as are indicated by red colour on plan marked T/12.4.47 attached to Department of Conservation and Environment correspondence No. Rs 934—(Rs 934).

Dated 10 June 1992

Responsible Minister:

BARRY PULLEN

Minister for Conservation and Environment

DAMIEN O'SHEA

20090 Acting Clerk of the Executive Council



Victoria Government Gazette

Land Act 1958

UNUSED ROADS CLOSED

The Governor in Council under section 349 of the *Land Act 1958* and with the consents in writing of the municipalities concerned closes the following unused roads:

MUNICIPAL DISTRICT OF THE SHIRE OF GRENVILLE

SMYTHESDALE—The road in the Township of Smythesdale, Parish of Smythesdale shown as Crown Allotment 8, Section 40 on Certified Plan No. 111172 lodged in the Central Plan Office—(90-1290).

MUNICIPAL DISTRICT OF THE SHIRE OF SOUTH GIPPSLAND

WONGA WONGA SOUTH—The road in the Parish of Wonga Wonga South as indicated by hatching on plan hereunder—(W 353[11]) (Rs 13950).

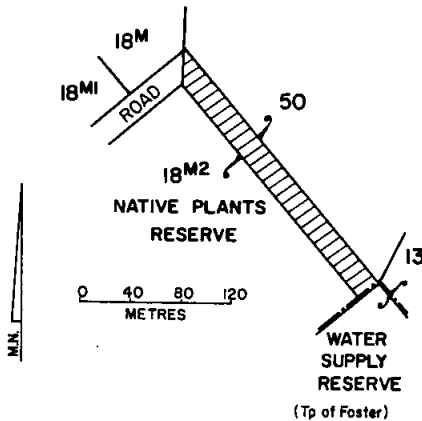

Dated 10 June 1992  
Responsible Minister:  
BARRY PULLEN  
Minister for Conservation and Environment  
DAMIEN O'SHEA  
20090 Acting Clerk of the Executive Council

Land Act 1958

UNUSED ROADS CLOSED

The Governor in Council under section 349 of the *Land Act 1958* and with the consents in writing of the municipalities concerned and the adjoining owners closes the following unused roads:

G 22 10 June 1992 1457

MUNICIPAL DISTRICT OF THE CITY OF WILLIAMSTOWN

CUT-PAW-PAW—The road in the Parish of Cut-paw-paw as indicated by hatching on plan hereunder—(C 345[20]) (GL/14049).

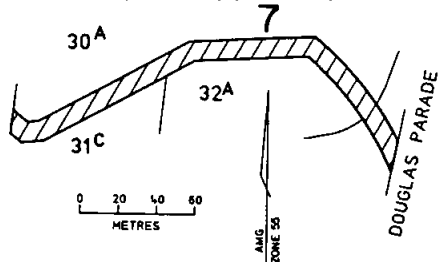

MUNICIPAL DISTRICT OF THE SHIRE OF COLAC

NALANGIL—The road in the Parish of Nalangil shown as Crown Allotment 4, Section 24A on Certified Plan No. 111266 lodged in the Central Plan Office—(GL/14552).

MUNICIPAL DISTRICT OF THE SHIRE OF KILMORE

WALLAN WALLAN—The road in the Parish of Wallan Wallan shown as Crown Allotment 52A on Certified Plan No. 110344 lodged in the Central Plan Office—(L7-4061).

Dated 10 June 1992  
Responsible Minister:  
BARRY PULLEN  
Minister for Conservation and Environment  
DAMIEN O'SHEA  
20090 Acting Clerk of the Executive Council

Land Act 1958

LAND VESTED IN THE CITY OF GEELONG

The Governor in Council under section 22A of the *Land Act 1958* vests in the City of Geelong 278 square metres of land in the City of Geelong, Parish of Corio described in an instrument of surrender dated 20 March 1992 by the Public Transport Corporation and attached to Department of Conservation and Environment correspondence number LI 4144.

Dated 10 June 1992  
Responsible Minister:  
BARRY PULLEN  
Minister for Conservation and Environment  
DAMIEN O'SHEA  
20090 Acting Clerk of the Executive Council

1458 G 22 10 June 1992

*Land Act 1958*

**ABOLITION OF COMMON**

The Governor in Council under section 184 of the *Land Act 1958* gives notice of intention to abolish the following Common:

CARAMUT—The remaining portions of the Caramut Town Common in the Township of Caramut proclaimed on 20 November 1865 and 14 October 1869—(Rs 417).

Dated 10 June 1992

Responsible Minister:

BARRY PULLEN

Minister for Conservation and Environment

DAMIEN O'SHEA

20090 Acting Clerk of the Executive Council

*Land Act 1958*

**UNUSED ROADS CLOSED**

The Governor in Council under section 349 of the *Land Act 1958* and with the consents in writing of the municipalities concerned and the adjoining owners closes the following unused roads:

**MUNICIPAL DISTRICT OF THE CITY OF  
GEELONG**

GEELONG—The road in the City of Geelong, Parish of Corio shown as Crown Allotment 1A, Section 107 on Certified Plan No. 110883 lodged in the Central Plan Office—(L1-3858).

**MUNICIPAL DISTRICT OF THE SHIRE OF  
WARANGA**

GIRGARRE—The road in the Parish of Girgarre shown as Crown Allotment 32E, Section G on Certified Plan No. 111028 lodged in the Central Plan Office—(P 132874).

Dated 10 June 1992

Responsible Minister:

BARRY PULLEN

Minister for Conservation and Environment

DAMIEN O'SHEA

20090 Acting Clerk of the Executive Council

*Victoria Government Gazette*

which an exemption under section 137NB of the *Stamps Act 1958* applies.

**SCHEDULE**

Documents relating to the National Mortgage (Debt) Bonds Program:

A. A Trust Deed between National Mortgage Market Corporation Limited ("NMMC") and Permanent Trustee Australia Limited ("Trustee");

B. Debenture Charge Deeds between the Trustee and Permanent Custodians Limited ("Security Trustee");

C. Security Trust Deeds between the Trustee, NMMC and the Security Trustee;

D. Originator Agreements between NMMC, the Trustee and a third party ("Originator");

E. Bank Guarantees and Indemnities in favour of the Trustee in respect of Originators' obligations under Originator Agreements;

F. Guaranteed Investment Contracts between Prudential Global Funding, Inc ("Prudential"), Macquarie Bank Limited ("Macquarie"), NMMC, the Trustee and the Security Trustee;

G. Registry Services Agreement between National Registries Pty Ltd, the Trustee and NMMC;

H. Underwriting Agreement between NMMC, the Trustee, Macquarie and others;

I. Unit Holder's Covenants and Acknowledgements in favour of the Trustee;

J. Investment Facility Agreement between NMMC, the Trustee and National Australia Bank Limited;

K. Loan Deed between NMMC and the Trustee; and

L. ISDA Agreements and Schedules between Prudential and the Trustee.

Dated 10 June 1992

Responsible Minister:

TONY SHEEHAN

Treasurer

DAMIEN O'SHEA

20470 Acting Clerk of the Executive Council

**STAMPS ACT 1958**

Pursuant to paragraph (e) (ii) of section 137NB of the *Stamps Act 1958*, the Governor in Council declares that instruments referred to in the following Schedule (those instruments to be substantially in the form attached to this Order marked "A" to "L" inclusive) are instruments to

**STAMPS ACT 1958**

Pursuant to paragraph (c) of the definition of "mortgage-backed security" contained in section 137NA of the *Stamps Act 1958*, the Governor in Council declares that Bonds to be issued under a Trust Deed to be entered into by National Mortgage Market Corporation Limited as Manager and Permanent Trustee Australia

*Victoria Government Gazette*

Limited as Trustee/Issuer (that Trust Deed to be substantially in the form attached to this Order marked "A") are mortgage-backed securities for the purposes of Sub-Division (17A) of Division 3 of Part II of the *Stamps Act* 1958.

Dated 10 June 1992

Responsible Minister:

TONY SHEEHAN

Treasurer

DAMIEN O'SHEA

20470 Acting Clerk of the Executive Council

*Historic Buildings Act* 1981 (No. 9667)  
AMENDMENT OF REGISTER OF  
HISTORIC BUILDINGS

Under section 14 of the *Historic Buildings Act* 1981 the Governor in Council amends the Register by adding Historic Building No. 927—Williamstown Dressing Pavilion, The Esplanade, Williamstown.

To the extent of:

1. All the buildings known as the Williamstown Dressing Pavilion marked B-1 on Plan 862127K (A) endorsed by the Chairperson, Historic Buildings Council and held by the Director, Historic Buildings Council; and

2. All the land described as 9<sup>B</sup> of 22 (excision from public park reserve) on map CP 108352 Department of Property and Services, County of Bourke, Parish of Cut-paw-paw, Township of Williamstown and marked L-1 on Plan 862127K (A), endorsed by the Chairperson, Historic Buildings Council and held by the Director, Historic Buildings Council.

Dated 10 June 1992

Responsible Minister:

ANDREW McCUTCHEON

Minister for Planning and Housing

DAMIEN O'SHEA

20604 Acting Clerk of the Executive Council

*Historic Buildings Act* 1981 (No. 9667)  
AMENDMENT OF REGISTER OF  
HISTORIC BUILDINGS

Under section 14 of the *Historic Buildings Act* 1981 the Governor in Council amends the Register by adding Historic Building No. 926—

Banyule Homestead, Buckingham Drive, Heidelberg.

To the extent of:

1. All the buildings known as Banyule Homestead, Buckingham Drive, Heidelberg; and

G 22 10 June 1992 1459

2. All the land marked L-1 on Plan 601859B, contained in Volume 1212, Folio 311, signed by the Chairperson, Historic Buildings Council and held by the Director, Historic Buildings Council.

Dated 10 June 1992

Responsible Minister:

ANDREW McCUTCHEON

Minister for Planning and Housing

DAMIEN O'SHEA

20604 Acting Clerk of the Executive Council

*Shop Trading Act* 1987  
EXEMPTION FROM CLOSING HOURS  
PROVISIONS

Public Exhibition of Work of Industry or Art

Under section 8 (3) of the *Shop Trading Act* 1987, the Governor in Council exempts shops taking part in the Malvern Doll Show, Malvern Town Hall, from any part of the provisions of section 7 on the following days—

Saturday, 13 June 1992 between the hours of 10.00 a.m. and 5.00 p.m.; and

Sunday, 14 June 1992 between the hours of 10.00 a.m. and 5.00 p.m.

Dated 10 June 1992

Responsible Minister:

THEO THEOPHANOUS

Minister for Consumer Affairs

DAMIEN O'SHEA

20110 Acting Clerk of the Executive Council

*Shop Trading Act* 1987  
EXEMPTION FROM CLOSING HOURS  
PROVISIONS  
Festivals

Under section 8 (3) of the *Shop Trading Act* 1987, the Governor in Council exempts shops taking part in the Peninsula Winter Festival from any part of the provisions of section 7 on—

Sunday, 14 June 1992 between the hours of 9.00 a.m. and 5.00 p.m.

Dated 10 June 1992

Responsible Minister:

THEO THEOPHANOUS

Minister for Consumer Affairs

DAMIEN O'SHEA

20110 Acting Clerk of the Executive Council

1460 G 22 10 June 1992

Victoria Government Gazette

*Health Services Act 1988*  
BAIRNSDALE REGIONAL HEALTH  
SERVICES  
Exemption

The Governor in Council, acting under section 11 of the *Health Services Act 1988*, and on the recommendation of the Minister for Health, by this Order declares that section 34 (1) of the Act does not have effect in relation to—

Terence Christian Bartels  
Donald Robert Hannington  
James Damien O'Connor  
Linda Kaye Twite

in their capacities as members of the Board of the Bairnsdale Regional Health Service.

This Order and declaration cease to have effect on 1 November 1995, or in relation to a person referred to above who resigns, or who is removed from office, or whose office otherwise becomes vacant, before that date.

Dated 10 June 1992

Responsible Minister:

MAUREEN LYSTER  
Minister for Health

DAMIEN O'SHEA  
20370 Acting Clerk of the Executive Council

---

*Drainage Areas Act 1958*  
SHIRE OF SOUTH GIPPSLAND  
Consent to Make Special Improvement Charge  
The Governor in Council acting under section 31 (2) of the *Drainage Areas Act 1958* consents to the Council of the Shire of South Gippsland making a special improvement charge in respect of works carried out in the Hedley Drainage Area.

Dated 2 June 1992

Responsible Minister:

CAROLINE HOGG  
Minister for Ethnic, Municipal  
and Community Affairs

DAMIEN O'SHEA  
20460 Acting Clerk of the Executive Council

---

**PRIVATE  
ADVERTISEMENTS**

**CITY OF FOOTSCRAY**  
Road Discontinuance  
Road (Right of Way) Rear 4-6 Cecil Street and  
adjacent 240-242 Williamstown Road,  
Yarraville

File Reference 25/78/282

Pursuant to section 528 (2) of the *Local Government Act 1958* the Council of the City of Footscray by resolution on 8 July 1991 resolved that the road shown hatched on the plan set out hereunder be discontinued and sold by private treaty.

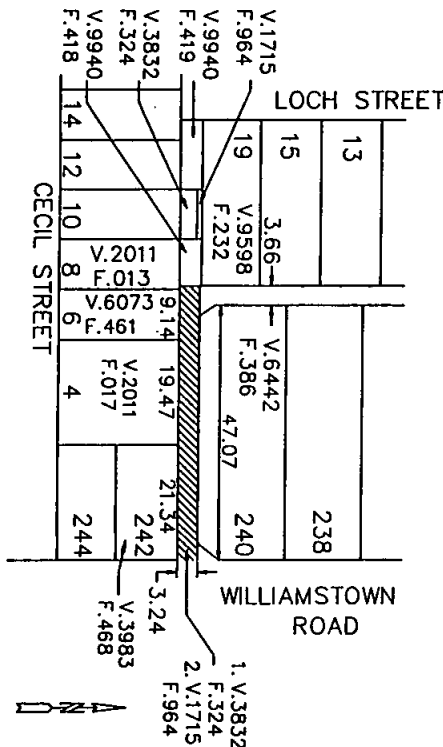

Notwithstanding such discontinuance Melbourne Water shall continue to have and possess the same right title power authority or interest in or in relation to the whole of the land shown by hatching on the said plan as it had or possessed prior to such discontinuance with respect to or in connection with any drains or

pipes laid or erected in on or over such for the purposes of drainage, sewerage or for the supply of water.

18666 **ROB SPENCE**  
Chief Executive

*Planning and Environment Act 1987*  
**CITY OF BROADMEADOWS**  
Notice of Amendment to Planning Scheme  
Amendment L33

The City of Broadmeadows has prepared Amendment L33 to the Local Section of the Broadmeadows Planning Scheme.

The amendment affects all Industrial Zones (except Extractive Industrial) and the Service Business Zone within the City of Broadmeadows.

The amendment proposes to replace current ambiguous provisions relating to Video Hire with provisions requiring a planning permit for Video Hire subject to the minimum size of the premises being 1000 square metres.

The amendment can be inspected at City of Broadmeadows, Municipal Offices, Pascoe Vale Road, Broadmeadows; Department of Planning and Housing, Ground Floor, 477 Collins Street, Melbourne.

Submissions about the amendment must be sent to City of Broadmeadows, P.O. Box 119, Broadmeadows 3047 by 10 July 1992.

18636 **STEVE GORE**  
Acting Chief Executive Officer

*Planning and Environment Act 1987*  
**HORSHAM PLANNING SCHEME—**  
**LOCAL SECTION**

Notice of Amendment to a Planning Scheme  
Amendment L37

The City of Horsham has prepared Amendment L37 to the Horsham Planning Scheme.

The amendment proposes the following:

1. To introduce a new definition for the term "Home Occupation" and deletes the term "Home Industry". The new term "Home Occupation" shall require a planning permit in most zones.

1462 G 22 10 June 1992

2. Correct an anomaly to the Horsham Planning Scheme by deleting the term "Motel" in Column 5 "Prohibited Use" of the Service Business zone.

The amendment can be inspected at Horsham City Council Offices, Roberts Avenue, Horsham; Department of Planning and Housing, corner Mair and Doveton Streets, Ballarat; and Department of Planning and Housing, The Oldfleet Buildings, 477 Collins Street, Melbourne.

Submissions about the amendment must be sent to Horsham City Council, PO Box 511, Horsham 3402 by 5 August 1992.

L. S. CAMPBELL  
City Engineer  
18650

CITY OF KEILOR

Environmental Control Local Law No. 6  
(Amending Local Law No. 2)

Notice is hereby given that it is the intention of the Council of the City of Keilor to make a new Local Law entitled "Environmental Control Local Law No. 6".

The proposed Local Law No. 6 amends certain provisions of Council's Local Law No. 2.

The general purpose of these amendments is to provide more effective control over fire hazards on vacant land.

Any person affected by the proposed Local Law may make a written submission regarding the proposal Local Law by lodging such submissions within 14 days of this notice.

Any person having lodged such submission may request to appear either in person or be represented before Council in support of such submission in accordance with the provisions of section 223 of the *Local Government Act 1989*.

A copy of the draft Local Law may be obtained from the Municipal Offices between the hours of 8.30 a.m. to 4.30 p.m. Monday to Wednesday and Friday, extended to 8.00 p.m. on Thursdays.

J. R. CASTLE  
18631 Director, Finance and Administration

CITY OF MALVERN

Extension of Exhibition Period

The City of Malvern has prepared an Amendment L14 to the Local Section of the Malvern Planning Scheme.

The amendment proposes to change the Malvern Planning Scheme by altering the

Victoria Government Gazette

existing Residential C Zoning to Residential Zone 1 and Residential Zone 2.

The purposes of the two new zones are—

to ensure that all new development is more compatible with the identified Urban Characters of the municipality;

to preserve and enhance areas largely homogenous in character and individual building, individual trees identified as worthy of preservation;

to identify areas for residential development and use;

to facilitate the establishment of community facilities compatible with community needs;

to provide an opportunity for a variety of residential dwelling types; and

to encourage diversity of residential densities in appropriate areas.

A copy of the amendment, explanatory statement and supporting reports can be inspected free of charge during office hours at the City of Malvern Planning Department, corner Glenferrie Road and High Street, Malvern, Monday to Friday between the hours of 9 a.m.—12 noon and 4 p.m.—5 p.m.; the Offices of the Department of Planning and Housing, 477 Collins Street, Melbourne and the Department of Planning and Housing, 1st Floor, 33–39 High Street, Cranbourne.

Submissions relating to the amendment must be sent to City of Malvern, PO Box 100, Malvern 3144 by 10 July 1992.

P. A. AKERS  
18664 Chief Executive Officer

CITY OF NORTHCOTE

Notice of Road Discontinuance pursuant to section 528 (2) (a) of the *Local Government Act 1958* ("The Act")

The Council of the City of Northcote ("the Council") at its meeting of 18 November 1991 made the following resolution:

- (a) Council being of the opinion that the road ("the road") delineated and hatched on the plan hereunder being part of Volume 3391 Folio 161 is not reasonably required as a road for public use, hereby directs that the road be discontinued and sold by public auction, public tender or private treaty;
- (b) Notwithstanding the discontinuance of the road the City of Northcote and the

Melbourne and Metropolitan Board of Works shall continue to have and possess the same right, title, power and authority or interest in or in relation to the road or any part of the road with respect to or in connection with any drains and pipes laid or erected in, on or over the road or part of the road for the purpose of drainage or sewerage or for the supply of water or other like purpose as existed prior to the discontinuance of the road in accordance with paragraph 528 (2) (e) of the *Local Government Act 1958*.

*Planning and Environment Act 1997*  
**SALE PLANNING SCHEME**

Notice of Amendment to a Planning Scheme  
 The Sale City Council has prepared Amendment No. L20 to the Sale Planning Scheme.

The amendment affects land at Crown Allotment 3, Otway and Prince Streets, Sale.

The amendment proposes to change the Planning Scheme by rezoning the land from "Residential Low Density B" to "Highway Commercial".

The amendment can be inspected at the Sale Council Chambers, 82-88 Macalister Street, Sale; the Office of The Department of Planning and Housing (Plan Inspection Section), Ground Floor of The Olderfleet Buildings, 477 Collins Street, Melbourne and at the Office of the Latrobe Regional Commission, 43 Grey Street, Traralgon.

Submissions about the amendment must be sent to the City Engineer, City of Sale, PO Box 506, Sale, Victoria 3850 by 13 July 1992.

R. J. GILBERT  
 18640 City Engineer/Town Planner

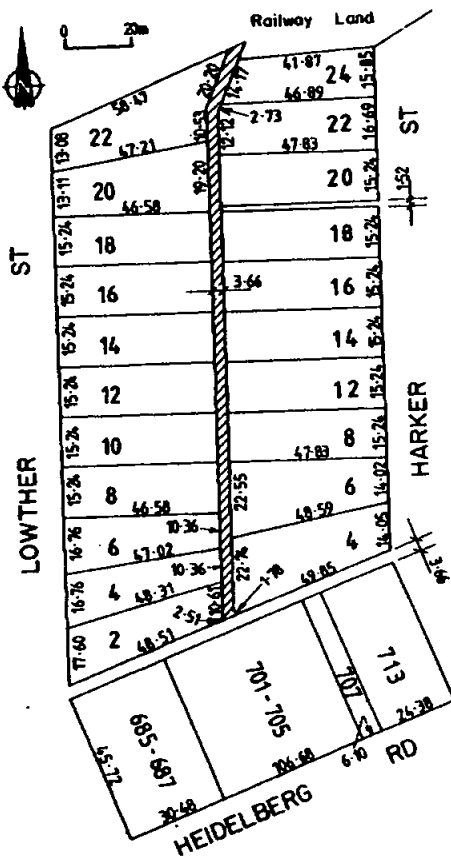

**CITY OF SANDRINGHAM**

Proposed Environment Local Law No. 2

Notice is hereby given that the Council has decided to extend the period for receiving submissions on the above proposed Local Law from 3 June to 17 June 1992.

Details of the proposed Local Law were published in the *Government Gazette* of 20 May 1992 (refer pages 1214 and 1215).

The proposed Local Law, among other things, will—

- Place a total ban on the use of incinerators; and
- Require a person in charge of a dog or other animal to remove its droppings from any road, street, nature strip, reserve or public or Council land.

A copy of the proposed Environment Local Law can be inspected or obtained at the Municipal Offices, Royal Avenue, Sandringham. It is also on public exhibition at Council's Libraries in Sandringham, Beaumaris, and Hampton.

Any person affected by the proposed Local Law may make a submission to the Council by 17 June 1992.

1464 G 22 10 June 1992

Submissions must be in writing and addressed to the Chief Executive Officer, City of Sandringham, PO Box 27, Sandringham 3191. Persons lodging submissions should indicate whether or not they wish to appear before the Council in support of their submission.

JOHN L. PURDEY  
Chief Executive Officer  
18627

*Planning and Environment Act 1987*  
SPRINGVALE PLANNING SCHEME  
Notice of Amendment

The City of Springvale has prepared Amendment No. L51 to the Local Section of the Springvale Planning Scheme.

The amendment affects land at Part Crown Allotment 116 Soden Road, Bangholme.

The amendment proposes to change the Planning Scheme by including a site specific control to allow a detached house.

The amendment can be inspected at the City of Springvale, Civic Centre, 397 Springvale Road, Springvale, or Department of Planning and Housing, 477 Collins Street, Melbourne and 33 High Street, Cranbourne.

Submissions about the amendment must be sent to the City of Springvale, PO Box 109, Springvale 3171 by 10 July 1992.

I. J. TATTERSON  
Chief Executive Officer  
18626

CITY OF SUNSHINE  
Change of Street Names

Notice is hereby given that pursuant to subsection 4 of section 535 of the *Local Government Act 1958* the Council of Sunshine has resolved to change the following street names in the suburb of Deer Park.

Old Name	New Name
1. Station Road (between Tilburn and Boundary Road) Part of Crown Allotment 22 Section 7, Parish of Derrimut, County of Bourke	Mt Derrimut Road
2. Porter Road, Lodged Plan 87003 and 52670	Porter Court

JOHN P. JAMES  
Chief Executive Officer/Town Clerk  
18638

*Victoria Government Gazette*

BOROUGH OF PORT FAIRY  
Proposed Local Laws

Notice is hereby given of the intention of the Council of the Borough of Port Fairy to make the following Local Laws in accordance with the provisions of the *Local Government Act 1989*.

Local Law No. 1—The Common Seal

The purpose of this Local Law is to regulate the use of the Common Seal of the Municipality.

Local Law No. 2—Council Meeting Procedure

The purpose of this Local Law is to regulate proceedings of Council and Committee Meetings including the election of Mayor and Deputy Mayor.

A copy of the proposed Local Law can be obtained from the Municipal Offices, 10 Cox Street, Port Fairy during office hours, Monday to Friday.

Any person affected by the proposed Local Law may make a written submission. Any submission must be lodged with the Town Clerk within 14 days after the date of the publication of this notice.

In making a submission an effective person may request to be heard in support of the submission and appear in person or by some other person acting on his or her behalf before the Council.

Persons making written submissions should clearly state if they wish to be heard in support of their submission.

Every written submission received within the prescribed period will be considered by the Council in accordance with section 223 of the *Local Government Act 1989* and will be notified of the time and date of the hearing.

J. W. TIPPETT  
Town Clerk  
18647

*Planning and Environment Act 1987*  
BULLA PLANNING SCHEME  
Notice of Amendment  
Amendment No. L62

The Shire of Bulla has prepared Amendment L62 to the Local Section of the Bulla Planning Scheme.

The amendment proposes to increase the maximum allowable floorspace at the Greenvale Shopping Centre from 2400m<sup>2</sup> to 3000m<sup>2</sup>.

The amendment can be inspected at Shire of Bulla, Municipal Offices, Town Planning Section, Sunbury; Shire of Bulla, Branch Office,



*Victoria Government Gazette*

Craigieburn Road West, Craigieburn; Department of Planning and Housing, Ground Floor, The Olderfleet Buildings, 477 Collins Street, Melbourne; Department of Planning and Housing, Metropolitan North Western Region, Level 3, 235 Queen Street, Melbourne.

Submissions about the amendment must be sent to Shire Secretary, Shire of Bulla, PO Box 42, Sunbury (attention: Town Planner) by Monday, 13 July 1992.

18625 JOHN WATSON  
Shire Secretary

*Planning and Environment Act 1987*  
NOTICE OF AMENDMENT TO A  
PLANNING SCHEME

The Shire of Hastings has prepared Amendment L70 to the Hastings Planning Scheme.

The amendment affects land:

1. Generally located at Nos. 17, 61, 67 and 83 Eramosa Road West and 16 Graf Road, Somerville; and
2. Nos. 21 to 31 (inclusive) Eramosa Road East and 243 to 251 (inclusive) Frankston-Flinders Road, Somerville.

The amendment proposes to change the Hastings Planning Scheme by rezoning the subject land from—

- (a) District Business Zone, Low Intensity Commercial Zone and Public Purposes—Existing 2 (Commonwealth Government) Reservation to Residential 2;
- (b) Residential 2 and Public Purposes—Existing 1 (c) (Municipal—Other) to Somerville Commercial Expansion Area Zone; and
- (c) The introduction of new provisions into the Planning Scheme Ordinance, relating to the Somerville Commercial Expansion Area Zone.

The amendment can be inspected at the Shire Offices, Marine Parade, Hastings; the Department of Planning and Housing, 33-39 High Street, Cranbourne; and the Department of Planning and Housing, The Olderfleet Buildings, 477 Collins Street, Melbourne.

Submissions about the amendment must be sent to the Manager—Planning and Development, Shire of Hastings, P.O. Box 55, Hastings 3915 by 13 July 1992.

18662 W. R. FEATHERSTON  
Chief Executive Officer

G 22 10 June 1992 1465

*Planning and Environment Act 1987*  
SHIRE OF KILMORE

Notice of Amendment to a Planning Scheme

The Shire of Kilmore has prepared Amendment L52 to the Kilmore Planning Scheme—Local Section.

The amendment proposes to rezone land contained within the wedge bounded by Mill Road to the west, Gehreys Lane to the south and the Northern Highway to the east. This area contains approximately 55 hectares and is currently zoned General Farming. The land is proposed to be rezoned Rural Residential 1 to allow for subdivision and development consistent with the current controls within the Kilmore Planning Scheme, namely lots of minimum size of 0.4 hectares.

The amendment is available for public inspection free of charge during office hours at the Department of Planning and Housing, The Olderfleet Buildings, 447 Collins Street, Melbourne; Shire of Kilmore, Civic Centre, Sydney Street, Kilmore.

Submissions about the amendment must be sent to Shire of Kilmore, PO Box 187, Kilmore 3764 by Friday, 10 July 1992.

18629 P. ANDERSON  
Shire Secretary

SHIRE OF LILLYDALE  
Quotation No. 588

Bulk Supply of Liquid Pool Chlorine (Sodium Hypochlorite)

Offers are invited for the bulk supply of Liquid Pool Chlorine. Specifications are available from Pauline Clark, telephone 735 8289. Closing date for quotations 5.00 p.m. Friday, 19 June 1992.

18632 W. HEINE  
Chief Executive

SHIRE OF LOWAN  
Notice of Proposed Local Law  
Local Law No. 1

The Lowan Shire Council proposes to make a Local Law for the purposes of regulating—

1. Proceedings at meetings of Council and Committees;
2. The election of Shire President; and
3. The use of the Council Common Seal.

The general purport of the proposal includes a specification of the laws which will govern the general order of business, rules of debate,

1466 G 22 10 June 1992

procedure, public access, conduct at meetings, procedure for the election of Shire President, use and safekeeping of the Council's Common Seal, and penalties for non-compliance with such laws as they relate to such meetings and procedures.

If made, the Local Law also will replace and repeal the existing Meetings Procedure By-law, By-law No. 72.

A copy of the proposed Local Law can be obtained from the Council Office at 92 Nelson Street, Nhill.

Any person affected by the proposed Local Law may make a submission relating to it to Council.

Submissions received by the Council within 14 days of the publication of this notice will be considered by the Council in accordance with section 223 of the *Local Government Act 1989*.

Any person requesting that she or he be heard in support of the written submission is entitled to appear before a meeting of the Council either personally or by a person acting on her or his behalf and will be notified of the time and date of the hearing.

R. J. FOSTER  
Shire Secretary

18639

SHIRE OF WOORAYL  
Road Declaration

Pursuant to section 203 (3) of the *Local Government Act 1989* the Council of the Shire of Woorayl hereby declares the section of road hatched on the plan hereunder, and as shown on Plan of Subdivision No. 311320X, to be a public highway.

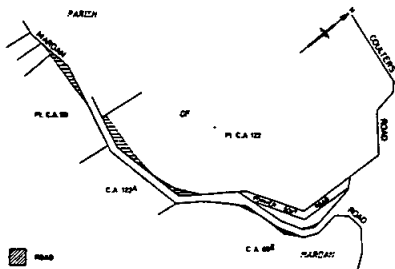

JOHN F. DYER  
Chief Executive Officer

18642

Victoria Government Gazette

In the High Court of Australia sitting as the Court of Disputed Returns—No. M25 of 1992—Filed 28 May 1992

In the matter of the *Commonwealth Electoral Act 1918* and in the matter of the election of one member of the House of Representatives for the Electoral Division of Wills in the Commonwealth of Australia.

Between Ian Sykes*	The Petitioner
and Philip Cleary	First Respondant
John Delacretaz	Second Respondant
'Bill' Kardamitsis	Third Respondant
Geraldine Rawson	Fourth Respondant

\* Address for service, 324A Bell Street, Coburg, Victoria

Petitioning the High Court sitting as the Court of Disputed Returns

Ian Sykes hereby disputes the poll declared on 23 April 1992 for Wills.

On the grounds that section 44 of the Constitution was breached by Candidates incapable of being chosen:

CLEARY, Philip, who was declared elected yet who held both pecuniary interests with the Public Service of the Commonwealth and offices of profit under the Crown in the Australian Broadcasting Commission, the Education Department and Community Services Victoria; and

DELACRETAZ, John, who was under acknowledgement of a foreign power, namely Switzerland; and

KARDAMITSIS 'Bill', who was under acknowledgement of a foreign power namely Greece and being an officer of the Greek Orthodox Church is disqualified from office in a secular States' Parliament; and

RAWSON, Geraldine, who being a paid councillor of The City of Coburg held an office of profit under the Crown; and

SYKES, Ian, who held a passport for the United Kingdom until 19 May 1991; And prays jointly and severally for relief:

From Unallowable Candidates, costs;

From Cleary, section 46 monies\* and that the preferences of unallowable candidates be redistributed or the election be voided.

Ian Sykes candidate in this election.

Donald Bernard, Chartist, 10/12 Trawalla Avenue, Toorak

*Victoria Government Gazette*

Jennifer Salmon, Secretary, 560 Park Street,  
North Carlton.

\*Due under *The Common Informers  
(Parliamentary Disqualifications) Act 1975*  
18634

*Police Regulation Act 1958—Section 122*  
**SALE OF UNCLAIMED AND  
CONFISCATED PROPERTY**

Auction of unclaimed and confiscated  
property held by Police will be conducted at the  
Auction Rooms of the Sheriff's Southern  
Regional Headquarters, 8–20 King Street,  
Oakleigh, commencing from 11.00 a.m. on 11  
June 1992.

K. GLARE  
18667 Chief Commissioner

**WATER ACT 1989**

I, Mark Anderson, Director, Water Industry  
Management, as delegate of the Minister for  
Water Resources make the following order:

**EXTENSION OF THE SHIRE OF DEAKIN  
WATERWORKS DISTRICT AND THE  
CHANGING OF THE DISTRICT'S NAME  
TO TONGALA WATER DISTRICT ORDER  
1992**

1. This Order is called the Extension of the  
Shire of Deakin Waterworks District and the  
Changing of the District's Name to Tongala  
Water District Order 1992.

2. This Order is made under section 96 (11)  
(b) and 99 (8) (b) of the *Water Act 1989*.

3. This Order takes effect from the date on  
which it appears in the *Government Gazette*.

4. The proposal for the extension of the Shire  
of Deakin Waterworks District submitted to me  
by the Deakin Water Board on 28 February 1992  
is approved.

5. The Shire of Deakin Waterworks District  
of the Deakin Water Board is extended to  
include the area bordered in red on the  
accompanying Plan Number OIC/11, a copy of  
which may be inspected at the offices of the  
Deakin Water Board situated at the Shire  
Offices, Tongala.

6. I have agreed to the application made by  
the Deakin Water Board on 28 February 1992  
that the name of the Shire of Deakin Waterworks  
District be changed to the Tongala Water  
District.

G 22 10 June 1992 1467

7. The name of the Shire of Deakin  
Waterworks District is changed to the Tongala  
Water District.

Dated 20 May 1992

MARK ANDERSON  
Director, Water Industry Management  
as Delegate of the Minister for Water  
Resources  
18633

Take notice that the Partnership of Thomas  
William Hayes and Angela Louise Hayes  
conducted at 14 High Street, Eaglehawk under  
the name of Eaglehawk Pizza Parlour has been  
dissolved by consent as at 13 May 1992, the  
business is continuing to be conducted by  
Thomas William Hayes.

PETER CAHILL, solicitor, 66 Bull Street,  
Bendigo 18624

HAROLD GORDON CLEEVE, late of 7/11  
Park Street, St. Kilda, retired gentleman,  
deceased

Creditors, next of kin and others having  
claims in respect of the estate of the deceased,  
who died on 4 March 1992 are required by the  
trustee Kenneth John Boyd of 13 Rae Street,  
Hawthorn, insurance agent, to send particulars  
to him by 11 August 1992 after which date the  
trustee may convey or distribute the assets,  
having regard only to the claims of which he  
then has notice.

STEDMAN CAMERON, 455 Bourke Street,  
Melbourne, solicitors for the said Kenneth John  
Boyd 18659

ALBERT GRAYSON FIRTH, late of 33  
Armstrong Court, Traralgon in the State of  
Victoria, pensioner, deceased

Creditors, next of kin and others having  
claims in respect of the estate of the deceased,  
who died on 25 October 1991, are required by  
the executor Ian Phillip Cooper of 1 Blackwood  
Court, Drouin in the said State and John Thomas  
Glover of 9 Lafayette Street, Traralgon in the  
said State to send particulars to them care of the  
undermentioned solicitors by 10 August 1992  
after which date the executors may convey or  
distribute the assets having regard only to the  
claims of which they then have notice.

SLATER & GORDON, solicitors of 37 Elgin  
Street, Morwell 18660

## Unclaimed Moneys Act 1962

## Register of Unclaimed Moneys held by the—

Name of Owner on Books and Last Known Address	Total Amount Due to Owner	Description of Unclaimed Money	Date when Amount first became Payable
\$			
AUSTRALIAN GUARANTEE CORPORATION LIMITED			
Beaumont, Heather, 3/20 Severn St, Box Hill	823.47	Interest	23.11.90
Boatman, John H, 9 Smythe Street, Wodonga	144.53	"	31.1.90
Bradley, J, 5 Arthur St, Inglewood	67.53	Refund	8.3.91
Brown, Anthony J, 14 Campbells, Cres, Ballarat	115.85	Interest	9.8.90
Bruce, Robert J, 9 Kolonga Crt, Vermont South	318.73	"	2.3.90
Bunyan Kelley, 2/14 Ballater St, Essendon	174.15	"	30.4.90
Clarke, Joyce M, 54 Churchill St, Port Albert	725.62	"	31.1.90
Fisher, Edwin J, 38 Main St, Greensborough	83.35	Refund	22.3.91
Gumpold, Anna, Unit 2/23 Henderson Rd, Keysborough	129.64	Interest	31.10.90
Hee, B S/of Kevin, NPO Box 89 Lilydale	150.99	"	30.6.90
Holborn, Peter J, 30 Ireland St, Bright	72.56	"	31.1.90
Holroyd, C D/of L, M46 Rathmines Rd, East Hawthorn	355.46	"	9.11.90
Holroyd, J D/of L, M46 Rathmines Rd, East Hawthorn	355.46	"	"
Holroyd, J S/of L, M46 Rathmines Rd, East Hawthorn	355.46	"	"
Holroyd, M S/of L, M46 Rathmines Rd, East Hawthorn	355.46	"	"
Kemp, Elaine M, 3/24 Alma Rd, East St. Kilda	29.01	"	31.1.90
Litchfield, B D, 25 Clive St, Shepparton	215.06	"	30.6.90
Moloney, Gwyneth M, 100 Latrobe St, Mentone	43.55	"	31.1.90
Oldehaber, H C, 251 Tooranga Rd, Glen Iris	30.00	Refund	5.3.91
Penny, Rae N, 225 Bluff Rd, Sandringham	87.06	Interest	31.1.90
Rickards, M, 731 Glenhuntley Rd	272.00	Refund	22.3.91
Risstrom, Donald, c/o 5 Mitchell St, Colbinabbin	40.60	Interest	30.6.90
Robinson, Gwenneth, Ingws Rd, Berwick	7297.13	"	8.7.90
Rouse, E GD/of Levyc/ 12 Dalmonte Gr, Kallista	2033.71	"	31.3.90
Rouse, G GD/of Levyc/ 12 Dalmonte Gr, Kallista	2033.71	"	"
Scott, Heather J, 18 Mowbray St, East Hawthorn	46.99	"	31.1.90
Silver, Barry, 10 Short St, Southport, Qld	949.22	"	1.10.90
Smith, Hazel M, 14 Frederick St, Yarraville	725.15	Interest	16.10.90
Tomaszewski, Rar, Unit 2/1266 Toorak Rd, Burwood	23.77	Refund	14.1.91
Whitlock, MFVD, Flat 2/115 Northumberland Rd, Pascoe Vale	889.28	Interest	14.8.90
Younie, G C, Unknown	99.28	Refund	21.3.91
Zhao, Yi X, 1 Atlantic St, Clayton	138.21	Interest	30.1.90

Creditors, next of kin or others having claims in respect of the estate of Ilma Hazel Cameron, late of St. Winifred's Private Nursing Home, 41 Coppin Street, East Malvern, deceased who died on 11 April 1992 are to send particulars of their claims to the executor care of the undermentioned solicitors by 21 August 1992 after which date the executor will distribute the assets having regard only to the claims of which he then has notice.

REDMOND, ROWAN, MARTIN & CAMERON, solicitors, 472 Bourke Street, Melbourne 18628

GRAHAM PETER YOUNG, late of 38 Elisabeth Street, Springvale South, process worker, deceased

Creditors, next of kin and others having claims in respect of the estate of the abovenamed deceased are required to send particulars of their claims to the executor Rex Becroft Young care of the undernoted solicitor by 20 August 1992 after which date he will convey or distribute the assets having regard only to the claims of which he then has notice.

JAMES HOPPER, solicitor, 409 Whitehorse Road, Balwyn 18630

ROY MURDOCH HARDY, late of 9 Sturrock Court, Berwick, retired, deceased

Creditors, next of kin and others having claim in respect of the estate of the deceased who died on 6 April 1992 are required by ANZ Executors & Trustee Company Limited (A.C.N. 006 132 332) of 91 William Street, Melbourne, the applicant for a grant of administration to send particulars of their claims to the said company by 12 August 1992 after which date it will convey or distribute the assets having regard only to the claims of which the company then has notice.

BOOTHBY & BOOTHBY, solicitors, 883 Dandenong Road, Caulfield East 18658

CLIFFORD WILLIAM HARDEN (also known as Mark William Harden), late of 48 Melville Road, West Brunswick, Victoria, pet shop proprietor, deceased, who died on 24 February 1992

Creditors, next of kin and others having claims in respect of the estate of the deceased are required by the executor of his will Ross Allan Gray of 48 Melville Road, West Brunswick, Victoria, pet shop proprietor to send particulars thereof to him care of the undermentioned solicitors before 12 August 1992 after which date he may distribute the assets of the deceased having regard only to the claims of which he then has notice.

FREDERICK OWEN & ASSOCIATES PTY., solicitors, 424 St. Kilda Road, Melbourne 18655

Creditors, next of kin and others having claim in respect of the estate of Mary Gertrude Lane formerly of Mathoura House, 51 Mathoura Road, Toorak but late of Canterbury Private Nursing Home, 14 Balwyn Road, Canterbury, spinster deceased who died on 14 April 1992 are requested to send particulars of their claims to the executor National Mutual Trustees Limited of 65 Southbank Boulevard, South Melbourne, formerly and in the will described as National Trustees Executors and Agency Company of Australasia Limited of 95 Queen Street, Melbourne, by 14 August 1992 after which date the executor will distribute the assets having regard only to the claims of which it then has notice.

PETER J. WALSH & JOHN F. CARROLL, solicitors, 83 William Street, Melbourne 18656

FLORENCE GERTRUDE DYSON, late of 15 Coppin Avenue, Rushall Crescent, North Fitzroy in the State of Victoria, widow deceased

Creditors, next of kin and others having claims in respect of the estate of the abovenamed deceased who died on 22 November 1991, are required by the executor and trustee, Desmond Mark Niall of 99 William Street, Melbourne in the said State, solicitor to send particulars to him by 14 August 1992, after which date the executor and trustee may convey or distribute the assets having regard only to the claims of which he has notice.

RIGBY COOKE, solicitors, 99 William Street, Melbourne 18637

FLORENCE ERICA TALBOT ROWE, late of Perpetua Private Nursing Home, 300 Springvale Road, Donvale, gentlewoman deceased

Creditors, next of kin and others having claims in respect of the estate of the deceased (who died on 1 January 1992) are required by the executor Perpetual Trustees Victoria Limited of 50 Queen Street, Melbourne to send particulars of their claims to the said executor by 31 August 1992, after which date it will convey or distribute the assets having regard only to the claims of which it then has notice.

BEST HOOPER, solicitors, 563 Little Lonsdale Street, Melbourne 18641

ALMA ALEXANDRA HUTCHESON, late of Hostel Apartment No. 34, Cumberland View Retirement Community, Whalley Drive, Mulgrave, widow deceased

Creditors, next of kin and others having claims in respect of the estate of the deceased who died on 20 January 1992 are required by Leslie John Hicks the executor to whom probate was granted by the Supreme Court of Victoria on 1 April 1992 to send particulars of their claims to the said executor care of Hicks & Oakley, solicitors, 260A Blackburn Road, Mount Waverley by 17 August 1992 after which date he will convey or distribute the assets having regard only to the claims of which he then has notice.

HICKS & OAKLEY, solicitors, 260A Blackburn Road, Mount Waverley 18643

1470 G 22 10 June 1992

AMELIA BEECHER, formerly of Sunny Creek Road, Thorpdale but late of Gibson Road, Trafalgar, widow deceased

Creditors, next of kin and others having claims in respect of the estate of the deceased who died on 4 January 1992 are required by the trustees Joan Margaret Hull and Spencer Russell Beecher to send particulars of their claims to them care of the undersigned solicitors by 16 August 1992 after which date the trustees may convey or distribute the assets having regard only to the claims of which they then have notice.

GRAY, FRIEND & LONG, solicitors,  
Warragul 18644

DAVID ARTHUR BARBER, late of 10 Hamilton Highway, Inverleigh in the State of Victoria, scientist deceased

Creditors, next of kin and others having claims in respect of the estate of the abovenamed deceased who died between 3 and 6 March 1992 are required by Evelyn Agnes Barber of 10 Hamilton Highway, Inverleigh in the said State, of home duties the widow of the deceased to send particulars of their claims to the trustee care of the undermentioned solicitors by 5 July 1992 after which date the trustee may convey or distribute the assets having regard only to the claims of which she then has notice.

INGPEN & BENT, solicitors, 95 Yarra Street, Geelong, solicitors for the trustee 18645

Creditors, next of kin and others having claims in respect of the estate of Lila May Hanrahan, deceased, late of 37 Cave Hill Road, Lilydale, widow deceased who died on 6 March 1992, are required to send particulars thereof to National Mutual Trustees Limited the executor of the will of the said deceased addressed to the said company at its registered office at 65 Southbank Boulevard, South Melbourne by 24 August 1992, after which date the said company will distribute the assets of the deceased having regard only to the claims of which it shall then have notice.

GAVAN DUFFY & KING, solicitors, 83 William Street, Melbourne 18646

Creditors, next of kin and others having claims in respect of the estate of Felicity Veronica Rhodes, late of Flat 8, 43 Church Street, West Footscray, home duties deceased who died on 19 February 1992 are requested to

Victoria Government Gazette

send particulars of their claims to the executor National Mutual Trustees Limited of 65 Southbank Boulevard, South Melbourne, formerly and in the will described as National Trustees Executors and Agency Company of Australasia Limited of 95 Queen Street, Melbourne by 14 August 1992 after which date the executor will distribute the assets having regard only to the claims of which it then has notice.

PETER J. WALSH & JOHN F. CARROLL,  
solicitors, 83 William Street, Melbourne 18657

Creditors, next of kin and others having claims in respect of the estate of Sheila Augustus Boucher late of 42 Yuille Street, Frankston in the State of Victoria, widow who died on 5 February 1992 are required by the executor of the estate to send particulars of their claims to the executor in the care of the undermentioned solicitor by 5 August 1992 after which date the said executor will distribute the assets having regard only to the claims of which he then has notice.

R. F. M. HOLLOW, barrister and solicitor  
395-399 Nepean Highway, Frankston 18648

MURIEL ANN PARSONS, late of 3 Dudley Street, North Essendon

Creditors, next of kin and others having claims in respect of the estate of the deceased who died on 21 March 1992 in Parkville are required by the executor National Mutual Trustees Limited to send particulars to it by 11 August 1992 after which date the executor may convey or distribute the assets having regard only to the claims of which it then has notice.

Dated 10 June 1992

NATIONAL MUTUAL TRUSTEES  
LIMITED, 65 Southbank Boulevard, South  
Melbourne 18649

Next of kin having claims in respect of the estate of Charles Rupert Clifford Nelson, late of 29 Grace Street, White Hills, Victoria, retired, deceased who died on 20 February 1992 are to send particulars of their claims to Wendy Margaret Smith and Pamela Ann Davis care of the undersigned by 15 August 1992 after which they shall distribute the estate having regard only to the claims of which they have notice.

BECK SHEAHAN QUINN & KIRKHAM,  
110 Pall Mall, Bendigo 18622

Creditors, next of kin and others having claims in respect of the estate of Evelyn Alice Watson, late of Eliza Lodge, Nepean Highway, Frankston in the State of Victoria, widow who died on 24 March 1992 are required by the executors of the estate to send particulars of their claims to the executors in the care of the undermentioned solicitor by 10 August 1992, after which date the said executors will distribute the assets having regard only to the claims of which he then has notice.

R. F. M. HOLLOW, barrister and solicitor,  
395-399 Nepean Highway, Frankston 18671

PERCY WILLIAM LAWRENCE, late of Cowangie in the State of Victoria, farmer deceased

Creditors, next of kin and others having claims in respect of the estate of the deceased, who died on 19 April 1992 are required by the trustee, Trust Company of Australia Limited of 151 Rathdowne Street, Carlton South in the said State to send particulars to it by 31 August 1992, after which date the trustee may convey or distribute the assets having regard only to the claims of which the trustee then has notice.

HALL & WILCOX, solicitors, 27th Floor,  
140 William Street, Melbourne 18668

Creditors, next of kin or others having claims in respect of the estate of Margaret Antionette Bond, late of East Gippsland Centre, McKean Street, Bairnsdale in the State of Victoria, pensioner deceased who died on 5 October 1991 are required to provide details of such claims to her executor, The Equity Trustees Executors and Agency Company Limited, of 472 Bourke Street, Melbourne in the said State by 10 August 1992, after which date the executor may convey or distribute the assets of the estate having regard only to the claims of which it then has notice.

WILDER MOSES BENGASINO, solicitors,  
Suite 8, 233 Cardigan Street, Carlton 18665

Creditors, next of kin or others having claims in respect of the estate of Florence Rita Duffy, late of Unit 4, 81-83 Dobson Street, Ferntree Gully Victoria, gentlewoman deceased who died on 16 April 1992 are to send particulars of their claims to the administratrix Joan Maree Jackson care of the undermentioned solicitors by 10 September 1992 after which date the

administratrix will distribute the assets having regard only to the claims of which she then has notice.

BRENDAN H. HARDIMAN &  
ASSOCIATES, solicitors, 108 Railway Avenue,  
Ringwood East 18672

Creditors, next of kin and others having claims against the estate of June Evelyn Paxton late of 8/49 Kooyong Road, Armadale in the State of Victoria, retired movement recorder, who died on 30 April 1992 probate of whose will was granted to Peter Damian Moon of 191 Greville Street, Prahran in the said State, solicitor, are to send particulars to the undersigned at their office hereunder mentioned by 8 August 1992 after which date the said Peter Damian Moon will distribute the assets having regard only to the claims of which he shall then have had notice.

JOHN KEATING & ASSOCIATES,  
solicitors, 191 Greville Street, Prahran 18635

ELSIE VIOLET SMITH, late of 2 Hardie Terrace, East Ivanhoe, Victoria, widow deceased

Creditors, next of kin and others having claims against the estate of the said deceased who died on 4 February 1992 are to send particulars of their claims to Perpetual Trustees Victoria Limited of 50 Queen Street, Melbourne, Victoria by 12 August 1992 after which date it will distribute the assets having regard only to the claims of which it then has notice.

BLAKE DAWSON WALDRON, solicitors,  
101 Collins Street, Melbourne 18653

Creditors, next of kin or others having claims in respect of the estate of June Alice Cinciruk formerly of 52 Marlborough Street, East Bentleigh, but late of Unit 5, 57 Milan Street, Mentone, Victoria, deceased who died on 9 September 1991 are to send particulars of their claims direct to the executor The Equity Trustee Executors and Agency Company Limited at 472 Bourke Street, Melbourne by 10 July 1992 after which date the executor will distribute the assets having regard only to the claims of which they then have notice.

TAYLOR SPLATT & PARTNERS,  
solicitors, 40 Young Street, Frankston 18623

1472 G 22 10 June 1992

Creditors, next of kin and others having claim in respect of the estate of Alice Kingsley late of Flat 2/24 Gertrude Street, Windsor, widow deceased who died on 5 March 1992 are requested to send particulars of their claims to the executor National Mutual Trustees Limited of 65 Southbank Boulevard, South Melbourne, by 14 August 1992 after which date the executor will distribute the assets having regard only to the claims of which it then has notice.

PETER J. WALSH & JOHN F. CARROLL,  
solicitors, 83 William Street, Melbourne 18654

The County Court of the State of Victoria  
SALE BY THE SHERIFF

On 9 July 1992 at 2.30 p.m. at the Sheriff's Office, 8-20 King Street, Oakleigh (unless process be stayed or satisfied).

All the estate and interest (if any) of John Ioannou of 2 Tamar Drive, Deer Park joint proprietor with Maria Ioannou of an estate in fee simple in the land described on Certificate of Title Volume 9209 Folio 046 upon which is erected a brick veneer home known as 2 Tamar Drive, Deer Park.

Registered Mortgage No. N990389K affects the said estate and interest.

Terms—Cash only

18669

E. SMIRL  
Sheriff's Officer

The Supreme Court of the State of Victoria  
SALE BY THE SHERIFF

To the Highest Bidder at the Best Price Offered

On 9 July 1992 at 2.30 p.m. at the Sheriff's Office, 8-20 King Street, Oakleigh (unless process be stayed or satisfied).

All the estate and interest (if any) of Maxwell Bell of 9 Fernwood Drive, Hoppers Crossing as shown on Certificate of Title as Max Bruce Bell joint proprietor with Wanda Bell of an estate in fee simple in the land described on Certificate of Title Volume 9734 Folio 327 upon which is erected a dwelling known as 9 Fernwood Drive, Hoppers Crossing.

Registered Mortgage Nos. P905249Y, Caveat Nos. P514991Y and P344937A affect the said estate and interest.

No Reserve Set. Terms—Cash only

18670

E. SMIRL  
Sheriff's Officer

Victoria Government Gazette

The Supreme Court of the State of Victoria  
SALE BY THE SHERIFF

On 16 July 1992 at 2.30 p.m. at the Sheriff's Office, 8-20 King Street, Oakleigh (unless process be stayed or satisfied).

All the estate and interest (if any) of Arnold Crest Pty. Ltd. of Registered Office, 25th Floor, Nauru House, 80 Collins Street, Melbourne as registered proprietor of an estate in fee simple in the land described in Certificates of Title Volume 2326 Folio 196, Volume 4144 Folio 707, Volume 8782 Folio 404, Volume 8783 Folio 146, Volume 5792 Folio 386 and Volume 9887 Folio 212 upon which is erected an office building known as 115 Victoria Parade, East Melbourne.

Registered Mortgage Nos. N821314M, P495517C, P492782W, Caveat No. P781501J and the right title power authority or interest of Melbourne and Metropolitan Board of Works and State Electricity Commission of Victoria saved by section 528 (2) (e) of the *Local Government Act 1958* affect the said estate and interest of Title Volume 5792 Folio 386.

Terms—Cash only

18661

E. SMIRL  
Sheriff's Officer



**NOTICE OF MAKING OF STATUTORY  
RULES WHICH ARE NOT YET  
AVAILABLE**

Notice is given of the making of the following  
Statutory Rules:

- |         |  |          |  |
|---------|--|----------|--|
|         | <i>Transfer of Land Act</i><br>1958  |          |  |
| 90/1992 | Transfer of Land (General)<br>(Amendment)<br>Regulations 1992  | 96/1992  | Special By-law No. 37:<br>Water Supply and<br>Sewerage Services to<br>Non-Rateable Property<br>and Cultural and<br>Recreational Lands<br>(Amendment) |
|         | <i>Magistrates' Court Act</i><br>1989  |          | <i>Supreme Court Act</i><br>1986   |
| 91/1992 | Magistrates' Court<br>General (Amendment)<br>Regulations 1992  | 97/1992  | Supreme Court (Chapter I<br>Amendment No. 24)<br>Rules 1992  |
|         | <i>Health Act 1958</i>   |          | <i>Supreme Court Act</i><br>1986   |
| 92/1992 | Children's Services<br>Centre (Fees<br>Amendment)<br>Regulations 1992  | 98/1992  | Supreme Court<br>(Corporations) Rules<br>1992  |
|         | <i>Finance Brokers Act</i><br>1969   |          | <i>Surveyors Act 1978</i>  |
| 93/1992 | Finance Brokers<br>(Licensing and<br>General) (Fees<br>Amendment)<br>Regulations 1992                            | 99/1992  | Surveyors (Registration)<br>Regulations 1992   |
|         | <i>Drugs, Poisons and<br/>Controlled Substances<br/>Act 1981</i>   |          | <i>Surveyors Act 1978</i>  |
| 94/1992 | Drugs, Poisons and<br>Controlled Substances<br>(Amendment)<br>(Uniform Standards)<br>(No. 1) Regulations<br>1992 | 100/1992 | Surveyors (Surveyors<br>Board) Regulations<br>1992   |
|         | <i>State Superannuation<br/>Act 1988</i>   |          |  |
| 95/1992 | State Superannuation<br>(Amendment)<br>Regulations 1992  |          |  |

**NOTICE OF MAKING AND AVAILABILITY  
OF STATUTORY RULES**

In pursuance of the provisions of the *Subordinate Legislation Act 1962* and the Regulations made thereunder notice is given of the making and availability of the following Statutory Rules:

Note: The date specified after each Statutory Rule is the date it was first obtainable from—

The Law Printer  
28 Queensbridge Street, South Melbourne, 3205  
Tel: 242 4600

76/1992 *County Court Act 1958*  
County Court (Chapter I  
Amendment No. 13)  
Rules 1992  
5 June 1992 Code B

77/1992 *Building Control Act*  
1981  
Victoria Building  
(General Amendment)  
Regulations 1992  
5 June 1992 Code A

78/1992 *State Electricity*  
*Commission Act 1958*  
State Electricity  
Commission (Energy  
Efficiency Labelling)  
(Amendment)  
Regulations 1992  
5 June 1992 Code A

79/1992 *State Electricity*  
*Commission Act 1958*  
State Electricity  
Commission (Energy  
Efficiency Labelling)  
(Clothes Washing  
Machines)  
(Amendment)  
Regulations 1992  
5 June 1992 Code A

The retail prices and price codes below will apply from 1 October 1991 to the following products: Acts (New, Reissue and Reprint), Statutory Rules (New, Reissue and Reprint), Parliamentary Papers, Bills and Reports, Special and Periodical Gazettes, and Industrial Awards.

Price Code	No. of Pages (Including cover and blank pages)	Price
A	1-16	\$2.60
B	17-32	\$3.90
C	33-48	\$5.25
D	49-96	\$7.85
E	97-144	\$10.50
F	145-192	\$12.60
G	193-240	\$14.50
H	241-288	\$15.25
I	289-352	\$16.80
J	353-416	\$20.00
K	417-480	\$23.00
L	481-544	\$26.25

A set retail price per issue will apply from 1 October 1991 to:

Government Gazette (General) \$1.60 per issue  
Hansard (Weekly) \$2.60 per issue



.

.

.

.



1476 G 22 10 June 1992

*Victoria Government Gazette*



1

2

3

4





.

.

.

.



1478 G 22 10 June 1992

Victoria Government Gazette



:

:

:

:





.

.

.

.



### CONTENTS

	Page
Appointment	1441
Contracts Accepted—Amendments	1430
Estates of Deceased Persons	1435
Government Notices	1419
Notice of Making of Statutory Rules	1473
Orders in Council—	
Acts—Government Employee Housing Authority; Administrative Arrangements; Public Account; Housing; Crown Land (Reserves); Land; Stamps; Historic Buildings; Shop Trading; Health Services; Drainage Areas	1442
Police Sale	1421
Private Advertisements	1461
Proclamations	1418
Tenders	1437

A Victorian Government Publication

Published by

THE LAW PRINTER

a business unit of

Printing and Publishing Services Victoria (PPSV)

Melbourne Victoria Australia

© State of Victoria 1992

This publication is copyright. No parts may be reproduced by any process except in accordance with the provisions of the Copyright Act.

Address all inquiries to the Government Printer for the State of Victoria

PO Box 292 South Melbourne 3205 Victoria Australia

ISSN 0819—5471

L. V. North, Government Printer Melbourne

**Mail and Bulk Order Sales**

The Law Printer

PO Box 292 South Melbourne 3205

28 Queensbridge Street, South Melbourne

Telephone inquiries (03) 242 4600

Fax (03) 242 4699

**Counter Sales**

Information Victoria Bookshop

318 Lt. Bourke Street Melbourne 3000

Telephone inquiries (03) 651 4100

**Recommended Retail Price \$1.60**