

# VICTORIA GOVERNMENT GAZETTE

No. G27 Wednesday 15 July 1992

By Anthony L. V. North, Government Printer Melbourne

GENERAL

## Gazette Services

The *Victoria Government Gazette* (VGG) is published by THE LAW PRINTER (PPSV) for the State of Victoria and is produced in three editions.

VGG General is published each Wednesday and provides information regarding Acts of Parliament and their effective date of operation; Government notices; requests for tenders; as well as contracts and contracts accepted. Private notices are also published.

VGG Special is published any day when required for urgent or special Government notices. VGG special is made available automatically to subscribers of VGG General.

VGG Periodical is published on Monday when required and includes specialised information eg. Medical, Dental, Pharmacist's Registers, etc.

## Government Advertising

### Publishing Details

The following Guidelines should be forwarded to ensure publication of Government material in the *Victoria Government Gazette*.

- Duplicate copies should be submitted for use by the Gazette Officer.
- Material submitted to the Executive Council for gazettal will normally be published in the following week's issue.
- Where urgent gazettal is required, contact:  
Gerd Gaspar  
Gazette Officer  
Department of the Premier and Cabinet  
Ground Floor 1 Treasury Place  
Melbourne 3000  
Telephone inquiries (03) 651 5153
- Government advertising other than material for the consideration of the Executive Council should be forwarded to the Gazette Office no later than 9.30 a.m. on Tuesday.
- Lengthy or complicated notices should be forwarded several days before publication.
- Proofs will be supplied only when requested or at the direction of the Gazette Officer.
- No additions or amendments to material for publication will be accepted by telephone.

### Advertising Rates and Payment General Gazette

Single column x cm/part cm \$2.65  
Double column x cm/part cm \$5.30  
Full page \$111.00

### Periodical Gazette

Full page \$115.50

### Special Gazette

Full page \$233.00.

## Private Advertisements

### Publishing Details: Send copy to:

VGG Coordinator  
Gazette Advertising  
THE LAW PRINTER  
28 Queensbridge Street, South Melbourne  
(PO Box 292 South Melbourne 3205)  
Telephone inquiries (03) 2424600  
Fax No. (03) 2424699

### Advertising Rates and Payment

**General Gazette**  
Single column x cm/part cm \$4.10  
Double column x cm/part cm \$8.20  
Full page \$171.50

### Periodical Gazette

Full page \$180.00

### Special Gazette

Full page \$360.00  
Cheques should be made payable to 'THE LAW PRINTER'.  
These rates apply to advertisements printed on or after 14 February 1990.

### Advertisers should note:

- There are approximately 20 words to each column centimetre depth.
- Signatures (in particular) and proper names must also be in block letters.
- All material should be double spaced.
- Advertisements can be faxed, and a cover sheet should be used, marked to the attention of the Gazette Coordinator.
- Documents not clearly prepared and in the exact format for gazettal will be returned to the sender unpublished.
- Late copy received at THE LAW PRINTER after 11.00 a.m. Monday will be placed in the following issue of VGG, irrespective of any date/s mentioned in the copy (unless otherwise advised).

### Copy Deadline

11.00 a.m. Monday

## Subscriptions

VGG is available by three subscription services:

General and Special—\$160.00 each year  
General, Special and Periodical—\$212.00 each year  
Periodical—\$106.00 each year

Subscriptions are payable in advance and accepted for a period of one year. All subscriptions are on a firm basis and refunds for cancellations will not be given.

All payments should be made payable to THE LAW PRINTER.  
Subscription inquiries (03) 2424600  
Fax (03) 2424699

**PROCLAMATIONS**

*Land Act 1958*

**PROCLAMATION OF ROADS**

I, Richard E. McGarvie, Governor of Victoria, acting with the advice of the Executive Council and under section 25 (3) (c) of the *Land Act 1958*, proclaim as roads the following lands:

**MUNICIPAL DISTRICT OF THE SHIRE OF COLAC**

**ONDIT**—The land in the Parish of Ondit as indicated by hatching on plan hereunder—(06[3], 06[4]) (L1-1357).

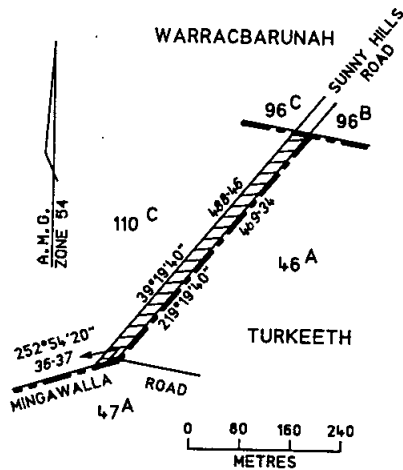

**MUNICIPAL DISTRICT OF THE SHIRE OF COLAC**

**ONDIT and WARRACBARUNAH**—The land in the Parishes of Ondit and Warracbarunah as indicated by hatching on plan hereunder—(06[3], 06[4], W 41[2]), (L1-1357).

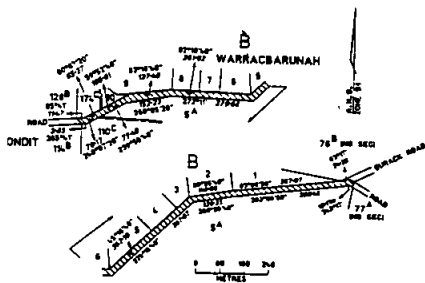

Given under my hand and the seal of Victoria on 15 July 1992

(L.S.) R. E. MCGARVIE  
By His Excellency's Command

BARRY PULLEN  
Minister for Conservation and Environment

20090

*Land Act 1958*

**PROCLAMATION OF ROADS**

I, Richard E. McGarvie, Governor of Victoria, acting with the advice of the Executive Council and under section 25 (3) (c) of the *Land Act 1958*, proclaim as roads the following lands:

**MUNICIPAL DISTRICT OF THE CITY OF BENDIGO**

**BENDIGO**—Crown Allotments 2c and 2d, Section 124c, at Bendigo, Parish of Sandhurst as shown on Certified Plan No. 111279 lodged in the Central Plan Office—(GL 16602).

**MUNICIPAL DISTRICT OF THE SHIRE OF KOWREE**

**CHARAM**—The Crown land in the Parish of Charam as indicated by hatching on plan hereunder—(C 387[3]) (Rs 35049).

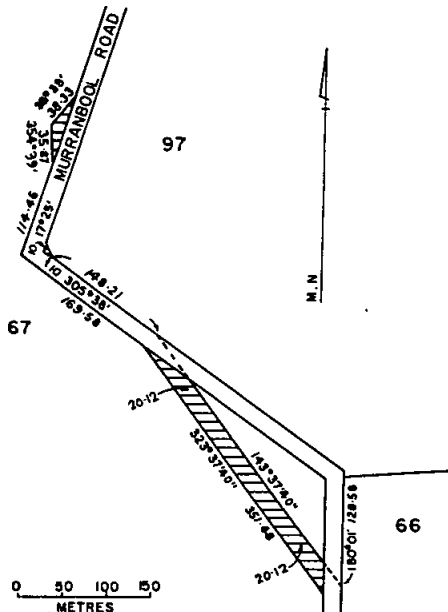

MUNICIPAL DISTRICT OF THE SHIRE OF  
MILDURA

MILDURA—Crown Allotment 17c, Section  
6, Block F, Parish of Mildura as shown on  
Certified Plan No. 111136 lodged in the Central  
Plan Office—(011309/134).

Given under my hand and the seal of  
Victoria on 15 July 1992

(L.S.) R. E. McGARVIE  
By His Excellency's Command

BARRY PULLEN  
Minister for Conservation and  
Environment

20090

*Environment Protection (Resource Recovery)  
Act 1992*

(No. 53 of 1992)

PROCLAMATION OF COMMENCEMENT

I, Richard E. McGarvie, Governor of  
Victoria, acting with the advice of the Executive  
Council and under section 2 of the *Environment  
Protection (Resource Recovery) Act 1992*, fix 16  
July 1992 as the day on which that Act comes  
into operation.

Given under my hand and the seal of  
Victoria at Melbourne on 15 July 1992

(L.S.) R. E. McGARVIE  
By His Excellency's Command

BARRY PULLEN  
Minister for Conservation and  
Environment

20210

*Agricultural Industry Development (Tomato  
Processing) Act 1992*

PROCLAMATION OF COMMENCEMENT

I, Richard E. McGarvie, Governor of  
Victoria, acting with the advice of the Executive  
Council and under section 2 of the *Agricultural  
Industry Development (Tomato Processing) Act  
1992*, fix 15 July 1992 as the day on which that  
Act comes into operation.

Given under my hand and the seal of  
Victoria on 15 July 1992

(L.S.) R. E. McGARVIE  
By His Excellency's Command

IAN BAKER  
Minister for Food and Agriculture

20020

**GOVERNMENT NOTICES**

*Planning and Environment Act 1987*  
**BALLAARAT (CITY) PLANNING SCHEME**  
Notice of Approval of Amendment  
Amendment L29

The Minister for Planning and Housing has approved Amendment L29 to the Ballaarat (City) Planning Scheme.

The amendment comes into operation on the date this notice is published in the *Government Gazette*.

The amendment deletes Schedule III provisions from the Ballaarat (City) Planning Scheme.

A copy of the amendment can be inspected, free of charge, during office hours, at the offices of the City of Ballaarat, Town Hall, Ballarat, at the Department of Planning and Housing, 477 Collins Street, Melbourne and at the Department of Planning and Housing, Regional Office, State Government Offices, Ballarat.

GEOFF CODE  
Manager

20600 Planning Co-ordination Branch

*Planning and Environment Act 1987*  
**CAMBERWELL PLANNING SCHEME**  
Notice of Approval of Amendment  
Amendment L28

The Minister for Planning and Housing has approved Amendment L28 to the Local Section of the Camberwell Planning Scheme.

The amendment comes into operation on the date this notice is published in the *Government Gazette*.

The amendment corrects an error in the Camberwell Planning Scheme by including opposite Convenience Shop, Cafe, Petrol Station and Restaurant in the Camberwell Residential zone a condition which makes it clear that the requirements of Clause 110-4 must be complied with.

A copy of the amendment can be inspected free of charge during office hours at the Department of Planning and Housing, Ground Floor, 477 Collins Street, Melbourne, and at the offices of the City of Camberwell, Inglesby Road, Camberwell.

GEOFF CODE  
Manager

20600 Planning Co-ordination Branch

*Planning and Environment Act 1987*  
**LEIGH PLANNING SCHEME**  
Notice of Approval of Amendment  
Amendment L5

The Minister for Planning and Housing has approved Amendment L5 to the Leigh Planning Scheme.

The amendment comes into operation on the date this notice is published in the *Government Gazette*.

The amendment changes the planning scheme by replacing the existing ordinance and maps with a new planning scheme which is written in plain English and incorporates revised planning objectives and controls for the whole of the Shire of Leigh.

A copy of the amendment can be inspected free of charge, during office hours at Department of Planning and Housing, The Olderfleet Buildings, 477 Collins Street, Melbourne; Shire of Leigh, Shire Offices, Aitchison Street, Rokewood.

GEOFF CODE  
Manager

20600 Planning Co-ordination Branch

*Planning and Environment Act 1987*  
**BACCHUS MARSH PLANNING SCHEME**  
Notice of Approval of Amendment  
Amendment L27 Part 2

The Minister for Planning and Housing has approved Amendment L27 Part 2 to the Local Section of the Bacchus Marsh Planning Scheme.

The amendment comes into operation on the date this notice is published in the *Government Gazette*.

The amendment rezones land located on the north side of Holts Lane, east of Beresford Crescent, Bacchus Marsh, from Rural B to Residential C Zone.

A copy of the amendment can be inspected, free of charge, during office hours, at the Department of Planning and Housing, Ground Floor, 477 Collins Street, Melbourne and at the offices of the Shire of Bacchus Marsh, 197 Main Street, Bacchus Marsh.

GEOFF CODE  
Manager

20600 Planning Co-ordination Branch

Victoria Government Gazette

*Planning and Environment Act 1987*  
ELTHAM PLANNING SCHEME  
Notice of Approval of Amendment  
Amendment L27 Part 3

The Minister for Planning and Housing has approved Amendment L27 Part 3 to the Eltham Planning Scheme.

The amendment comes into operation on the date this notice is published in the *Government Gazette*.

The amendment deletes the existing site specific controls which allowed, for a twelve month period, the use of the property at 1420 Heidelberg-Kinglake Road, Cottlesbridge, for winery sales, and introduces a new provision to enable a permit to be granted for the use subject to conditions.

A copy of the amendment can be inspected, free of charge, during office hours, at the offices of the Shire of Eltham, 895 Main Road, Eltham and at the Department of Planning and Housing, 477 Collins Street, Melbourne.

GEOFF CODE  
Manager  
20600 Planning Co-ordination Branch

*Planning and Environment Act 1987*  
NUNAWADING PLANNING SCHEME  
Notice of Approval of Amendment  
Amendment L21

The Minister for Planning and Housing has approved Amendment L21 to the Nunawading Planning Scheme.

The amendment comes into operation on the date this notice is published in the *Government Gazette*.

The amendment rezones land on the north east corner of Burwood Highway and Livingstone Road, Vermont South from Proposed Public Purposes (Local Government) Reservation to Restricted Business Zone. It will enable the land to be developed for a range of retail and commercial purposes subject to the grant of a permit by the Council.

A copy of the amendment can be inspected, free of charge, during office hours, at the offices of the City of Nunawading, Civic Centre, 379 Whitehorse Road, Nunawading and at the Department of Planning and Housing, 477 Collins Street, Melbourne.

GEOFF CODE  
Manager  
20600 Planning Co-ordination Branch

G 27 15 July 1992 1781

*Planning and Environment Act 1987*  
GEELONG REGIONAL PLANNING  
SCHEME

Notice of Approval of Amendment  
Amendment R77

The Minister for Planning and Housing has approved Amendment R77 to the Geelong Regional Planning Scheme.

The amendment comes into operation on the date this notice is published in the *Government Gazette*.

The amendment changes the Regional Section of the Scheme by rezoning land situated between Forest Road and the Geelong-Melbourne railway, North Corio, from Rural General Farming Zone to Reserved Industrial Zone.

A copy of the amendment can be inspected, free of charge, during office hours, at the offices of the Department of Planning and Housing, Ground Floor, 477 Collins Street, Melbourne, the offices of the Geelong Regional Commission, 5th Floor, State Offices, corner Fenwick and Little Malop Streets, Geelong, and at the offices of each of the following Councils: City of Geelong, City of Newtown, City of Geelong West, Borough of Queenscliffe, Bellarine Rural City, City of South Barwon, Shire of Barrabool, Shire of Bannockburn, Shire of Corio.

GEOFF CODE  
Manager  
20600 Planning Co-ordination Branch

*Planning and Environment Act 1987*  
GEELONG REGIONAL PLANNING  
SCHEME

Notice of Lapsing of Amendment  
Amendment R91 Part 1

On 28 May 1992 the Geelong Regional Commission resolved to abandon the above amendment.

The amendment proposed to rezone land in McMahon Avenue, Anglesea, from Special Uses—3—Golf Links Zone to Residential A Zone.

The amendment lapses on the date this notice is published in the *Government Gazette*.

GEOFF CODE  
Manager  
20600 Planning Co-ordination Branch

1782 G 27 15 July 1992

*Planning and Environment Act 1987*  
CAMBERWELL PLANNING SCHEME  
Notice of Approval of Amendment  
Amendment L4

The Minister for Planning and Housing has approved Amendment L4 to the Camberwell Planning Scheme.

The amendment comes into operation on the date this notice is published in the *Government Gazette*.

The amendment introduces Urban Conservation Controls in the area east of Camberwell Junction, generally bounded by Canterbury Road to the north, Boroondara Park and the Alamein Railway line to the east and Riversdale Road to the south.

A copy of the amendment can be inspected free of charge during office hours at the offices of the City of Camberwell, Inglesby Road, Camberwell and at the Department of Planning and Housing, Ground Floor, 477 Collins Street, Melbourne.

GEOFF CODE  
Manager  
20600 Planning Co-ordination Branch

*Planning and Environment Act 1987*  
COBURG PLANNING SCHEME  
Notice of Approval of Amendment  
Amendment L28

The Minister for Planning and Housing has approved Amendment L28 to the Coburg Planning Scheme.

The amendment comes into operation on the date this notice is published in the *Government Gazette*.

The amendment rezones the Coburg Post Office at 185 Moreland Road, Coburg from Public Purposes 1 Commonwealth Government Reservation to a Restricted Business zone to reflect recent legislative changes and the changing role of Australia Post.

A copy of the amendment can be inspected free of charge during office hours at the offices of the City of Coburg, Municipal Offices, Bell Street, Coburg and at the Department of Planning and Housing, 477 Collins Street, Melbourne.

GEOFF CODE  
Manager  
20600 Planning Co-ordination Branch

*Victoria Government Gazette*

*Planning and Environment Act 1987*  
GEELONG REGIONAL PLANNING  
SCHEME

Notice of Approval of Amendment  
Amendment R98

The Minister for Planning and Housing has approved Amendment R98 to the Geelong Regional Planning Scheme.

The amendment comes into operation on the date this notice is published in the *Government Gazette*.

The amendment changes the Regional Section of the Geelong Regional Planning Scheme by rezoning land at numbers 11 to 15 Clarence Street, Geelong West, from Commercial Office Zone to Public Purposes (Existing) 2—Local Government.

A copy of the amendment can be inspected, free of charge, during office hours, at Department of Planning and Housing, The Olderfleet Buildings, 477 Collins Street, Melbourne; Geelong Regional Commission, 5th Floor, State Offices, corner Fenwick and Little Malop Streets, Geelong; City of Geelong, City of Newtown, City of Geelong West, Borough of Queenscliffe, Bellarine Rural City, City of South Barwon, Shire of Barrabool, Shire of Bannockburn, Shire of Corio.

GEOFF CODE  
Manager  
20600 Planning Co-ordination Branch

*Planning and Environment Act 1987*  
RINGWOOD PLANNING SCHEME  
Notice of Approval of Amendment  
Amendment L18

The Minister for Planning and Housing has approved Amendment L18 to the Ringwood Planning Scheme.

The amendment comes into operation on the date this notice is published in the *Government Gazette*.

The amendment rezones land at 2, 4 and 6 Bond Street from Residential C to District Centre Peripheral Office Zone.

A copy of the amendment can be inspected, free of charge, during office hours, at the offices of the City of Ringwood, Civic Centre, Braeside Avenue, Ringwood and at the Department of Planning and Housing, 477 Collins Street, Melbourne.

GEOFF CODE  
Manager  
20600 Planning Co-ordination Branch

*Victoria Government Gazette*

*Planning and Environment Act 1987*  
KYNETON PLANNING SCHEME  
Notice of Approval of Amendment  
Amendment L3

The Minister for Planning and Housing has approved Amendment L3 to the Kyneton Planning Scheme.

The amendment comes into operation on the date this notice is published in the *Government Gazette*.

The amendment alters the location of the Proposed Local Access Road reserve for the deviation of Mollison Street, Kyneton, in connection with the Kyneton Bypass.

A copy of the amendment can be inspected free of charge during office hours at the Shire of Kyneton, Shire Office, Mollison Street, Kyneton, the Loddon-Campaspe Regional Planning Authority, 261 Hargreaves Street, Bendigo and at the Department of Planning and Housing, The Olderfleet Buildings, 477 Collins Street, Melbourne.

GEOFF CODE  
Manager  
20600 Planning Co-ordination Branch

*Planning and Environment Act 1987*  
FLINDERS PLANNING SCHEME  
Notice of Approval of Amendment  
Amendment L101

The Minister for Planning and Housing has approved Amendment L101 to the Flinders Planning Scheme.

The amendment comes into operation on the date this notice is published in the *Government Gazette*.

The amendment affects land at the Dromana Recreation Reserve being Part CA 4 Section 1, Parish of Kangerong situated at the north-east corner of Charles and Pier Streets, Dromana. The amendment removes a covenant which prevented the sale of intoxicating liquor on the land.

A copy of the amendment can be inspected, free of charge, during office hours, at the offices of the Shire of Flinders, Municipal Offices, Boneo Road, Dromana and at the Department of Planning and Housing, 477 Collins Street, Melbourne.

GEOFF CODE  
Manager  
20600 Planning Co-ordination Branch

G 27 15 July 1992 1783

*Planning and Environment Act 1987*  
CRANBOURNE PLANNING SCHEME  
Notice of Approval of Amendment  
Amendment L72

The Minister for Planning and Housing has approved Amendment L72 to the Cranbourne Planning Scheme.

The amendment comes into operation on the date this notice is published in the *Government Gazette*.

The amendment affects the Stream and Floodway Zone located south of the Kilberry Park Estate at Hampton Park by reserving part of this land for Public Purposes 20—Other Public Uses and rezoning other parts to Reserved Living Zone.

A copy of the amendment can be inspected, free of charge, during office hours, at the offices of the Shire of Cranbourne, Sladen Street, Cranbourne and at the Department of Planning and Housing, 477 Collins Street, Melbourne.

GEOFF CODE  
Manager  
20600 Planning Co-ordination Branch

*Planning and Environment Act 1987*  
SOUTH MELBOURNE PLANNING  
SCHEME

Notice of Approval of Amendment  
Amendment L51

The Minister for Planning and Housing has approved Amendment L51 to the Local Section of the South Melbourne Planning Scheme.

The amendment comes into operation on the date this notice is published in the *Government Gazette*.

The amendment enables the land specified for shops and restaurants on the Southgate Concept Plan to be used for any use for which a General Licence may be granted under the *Liquor Control Act 1987*.

A copy of the amendment can be inspected free of charge during office hours at the Department of Planning and Housing, Ground Floor, 477 Collins Street, Melbourne, and at the offices of the City of South Melbourne, Bank Street, South Melbourne.

GEOFF CODE  
Manager  
20600 Planning Co-ordination Branch

1784 G 27 15 July 1992

*Planning and Environment Act 1987*  
GEELONG REGIONAL PLANNING  
SCHEME

Notice of Approval of Amendment  
Amendment R99

The Minister for Planning and Housing has approved Amendment R99 to the Geelong Regional Planning Scheme.

The amendment comes into effect on the day this notice is published in the *Government Gazette*.

The amendment includes additional provisions in Clause 91—Motor Vehicle and Boat Sales or Hire—of the Regional Section of the Geelong Regional Planning Scheme to ensure that the visual amenity of abutting roads is protected and that the effects of noise from such premises does not affect residential properties.

A copy of the amendment can be inspected free of charge during office hours at Department of Planning and Housing, The Olderfleet Buildings, 477 Collins Street, Melbourne; Geelong Regional Commission, 5th Floor, State Offices, corner Fenwick and Little Malop Streets, Geelong; City of Geelong, City of Geelong West, Bellarine Rural City, Shire of Barrabool, Shire of Corio, City of Newtown, Borough of Queenscliffe, City of South Barwon, Shire of Bannockburn.

GEOFF CODE  
Manager  
20600 Planning Co-ordination Branch

*Planning and Environment Act 1987*  
BASS PLANNING SCHEME  
Notice of Lapsing of Amendment  
Amendment L21

On 1 June 1992 the Shire of Bass resolved to abandon the above amendment.

The amendment proposed to give Council the discretion to consider advertising signs greater than two square metres in all zones of the Shire.

The amendment lapses on the date this notice is published in the *Government Gazette*.

GEOFF CODE  
Manager  
20600 Planning Co-ordination Branch

*Victoria Government Gazette*

*Planning and Environment Act 1987*  
PAKENHAM PLANNING SCHEME  
Notice of Approval of Amendment  
Amendment L69

The Minister for Planning and Housing has approved Amendment L69 to the Local Section of the Pakenham Planning Scheme.

The amendment comes into operation on the date this notice is published in the *Government Gazette*.

The amendment rezones 1.876 hectare of land, being former Cora Lynn State School Reserve, from Public Purposes Reservation (Education Department) to Agriculture 1 zone.

A copy of the amendment can be inspected, free of charge, during office hours, at the Department of Planning and Housing, Ground Floor, 477 Collins Street, Melbourne and the office of the Shire of Pakenham, Henty Way, Pakenham.

GEOFF CODE  
Manager  
20600 Planning Co-ordination Branch

*Planning and Environment Act 1987*  
YACKANDANDAH PLANNING SCHEME  
Notice of Approval of Amendment  
Amendment L4

The Minister for Planning and Housing has approved Amendment L4 to the Yackandandah Planning Scheme.

The amendment comes into operation on the date this notice is published in the *Government Gazette*.

The amendment rezones land on the western corner of Railway Avenue and Station Streets, Yackandandah from Public Purposes Reservation (Local Government) to Public Purposes, Reservation (DCE) and Residential zone.

A copy of the amendment can be inspected free of charge during office hours at the offices of the Shire of Yackandandah, High Street, Yackandandah and at the Department of Planning and Housing, 477 Collins Street, Melbourne.

GEOFF CODE  
Manager  
20600 Planning Co-ordination Branch



Victoria Government Gazette

Planning and Environment Act 1987  
PORT FAIRY PLANNING SCHEME  
Notice of Approval of Amendment  
Amendment L8 Part 1

The Minister for Planning and Housing has approved Amendment L8 Part 1 (Items 5 and 7) to the Port Fairy Planning Scheme.

The amendment comes into operation on the date this notice is published in the *Government Gazette*.

The amendment changes the Local Section of the Port Fairy Planning Scheme as follows:

Item 5: By rezoning approximately 1600 square metres of land on the north side of Bank Street, west of James Street and occupied by a former drill hall and residence from Special Uses 3 Reserve (Municipal Purposes), to Historic Commercial zone; and

Item 7: By rezoning approximately 750 square metres of land on the north side of Bank Street, west of Sackville Street and occupied by the former Borough Chambers, from Public Purposes 3 Reserve (Municipal Purposes) to Historic Commercial zone.

The properties were formerly owned by the Borough of Port Fairy and have subsequently been sold. The rezoning reflects the proper and appropriate zone for the respective parcels of land.

A copy of the amendment can be inspected free of charge during office hours at the Department of Planning and Housing, The Olderfleet Buildings, 477 Collins Street, Melbourne; Borough of Port Fairy, Borough Chambers, Bank Street, PO Box 51, Port Fairy.

GEOFF CODE  
Manager  
20600 Planning Co-ordination Branch

Planning and Environment Act 1987  
BULN BULN PLANNING SCHEME  
Notice of Approval of Amendment  
Amendments L16 and L18

The Minister for Planning and Housing has approved Amendments L16 and L18 to the Local Section of the Bacchus Marsh Planning Scheme.

The amendment comes into operation on the date this notice is published in the *Government Gazette*.

The amendments make the following changes to the Scheme:

G 27 15 July 1992 1785

1. Include the Deep Creek and Loch River Water Supply Catchment Policy Area, as proclaimed in August 1990 under the *Soil Conservation and Land Utilisation Act 1958*, into the maps and Ordinance.
2. Insert new clauses into the Ordinance to:  
(a) require a permit for any buildings or works in the Catchment Policy Area; (b) designate the Tarago Water Board and the Department of Conservation and Environment as referral authorities; and (c) exempt the construction of power lines of less than 200 000 volts including the installation of 22kV substations, meters and public lighting from controls applying to the Local Section.
3. Change the classification of the following roads:  
Declare Willowgrove Road, Loch Valley Road and Main Neerim North Road to Main Road status;  
Downgrade Neerim East Road, Main South Road and Lardner Road.

A copy of the amendment can be inspected, free of charge, during office hours, at the offices of the Shire of Buln Buln, 33 Young Street, Drouin and at the Department of Planning and Housing, 477 Collins Street, Melbourne.

GEOFF CODE  
Manager  
20600 Planning Co-ordination Branch

Planning and Environment Act 1987  
UPPER YARRA PLANNING SCHEME  
Notice of Approval of Amendment  
Amendment L23

The Minister for Planning and Housing has approved Amendment L23 to the Local Section of the Upper Yarra Planning Scheme.

The amendment comes into operation on the date this notice is published in the *Government Gazette*.

The amendment allows the subdivision of land at 10-14 Carter Street, Launching Place into lots of not less than 0.5 hectare and each lot to be used for one house.

A copy of the amendment can be inspected, free of charge, during office hours, at the offices of the Shire of Upper Yarra, Main Street, Yarra Junction and at the Department of Planning and Housing, 477 Collins Street, Melbourne.

GEOFF CODE  
Manager  
20600 Planning Co-ordination Branch

1786 G 27 15 July 1992

*Planning and Environment Act 1987*  
**FOOTSCRAY PLANNING SCHEME**  
Notice of Approval of Amendment  
Amendment L32 Part 1

The Minister for Planning and Housing has approved Amendment L32 Part 1 to the Local Section of the Footscray Planning Scheme.

The amendment comes into operation on the date this notice is published in the *Government Gazette*.

The amendment rezones land at 56 Paisley Street to Public Purposes 19—Local Government, to enable construction of a new central library.

A copy of the amendment can be inspected free of charge during office hours at the Department of Planning and Housing, Ground Floor, 477 Collins Street, Melbourne, and at the offices of the City of Footscray, Napier Street, Footscray.

GEOFF CODE  
Manager  
20600 Planning Co-ordination Branch

*Planning and Environment Act 1987*  
**WHITTLESEA PLANNING SCHEME**  
Notice of Lapsing of Amendment  
Amendment L59

On 6 April 1992, the City of Whittlesea resolved to abandon the above amendment.

The amendment proposed to allow the sale and hire of video cassettes and associated items at Unit 1, Lot 5 LP137225, Settlement Road, Thomastown.

The amendment lapses on the date this notice is published in the *Government Gazette*.

GEOFF CODE  
Manager  
20600 Planning Co-ordination Branch

*Planning and Environment Act 1987*  
**GEELONG REGIONAL PLANNING SCHEME**

Notice of Approval of Amendment  
Amendment R97

The Minister for Planning and Housing has approved Amendment R97 to the Geelong Regional Planning Scheme.

The amendment comes into operation on the date this notice is published in the *Government Gazette*.

*Victoria Government Gazette*

The amendment rezones land at 1-3 Paul Street, Hamlyn Heights, Shire of Corio, from Public Open Space (Existing)—B—Public Park to Residential A; rezones land at 5 Cowan Street, Fairhaven, Shire of Barrabool, from District Business to part Local Business and part Residential A.

A copy of the amendment can be inspected, free of charge during office hours at Department of Planning and Housing, The Olderfleet Buildings, 477 Collins Street, Melbourne; Geelong Regional Commission, 5th Floor, State Offices, corner Fenwick and Little Malop Streets, Geelong; City of Geelong, City of Newtown, City of Geelong West, Borough of Queenscliffe, Bellarine Rural City, City of South Barwon, Shire of Barrabool, Shire of Bannockburn, Shire of Corio.

GEOFF CODE  
Manager  
20600 Planning Co-ordination Branch

*Planning and Environment Act 1987*  
**WHITTLESEA PLANNING SCHEME**  
Notice of Lapsing of Amendment  
Amendment L23

On 13 December 1991 the above amendment lapsed.

The amendment proposed to rezone land bounded by Dalton Road, Cumberland Crescent, the MMBW Yan Yean pipetrack and the proposed future F5 freeway reservation, Thomastown, from Proposed Main Road Reservation to Reserved Light Industrial Zone.

GEOFF CODE  
Manager  
20600 Planning Co-ordination Branch

*Planning and Environment Act 1987*  
**CRANBOURNE PLANNING SCHEME**  
Notice of Approval of Amendment  
Amendment L68

The Minister for Planning and Housing has approved Amendment L68 to the Cranbourne Planning Scheme.

The amendment comes into operation on the date this notice is published in the *Government Gazette*.

The amendment changes the zoning of 17.31 hectares being portion of Lot 2, LP 127289 (proposed Lot 1 PS 308279) Evans Road, Cranbourne, from Corridor B to Reservation, Other Public Uses—Proposed.



*Victoria Government Gazette*

A copy of the amendment can be inspected, free of charge, during office hours, at the offices of the Shire of Cranbourne, Shires Offices, Sladen Street, Cranbourne and at the Department of Planning and Housing, 477 Collins Street, Melbourne.

GEOFF CODE  
Manager  
20600 Planning Co-ordination Branch

*Planning and Environment Act 1987*  
BRIGHT PLANNING SCHEME  
Notice of Approval of Amendment  
Amendment L19

The Minister for Planning and Housing has approved Amendment L19 to the Bright Planning Scheme.

The amendment comes into operation on the date this notice is published in the *Government Gazette*.

The ordinance amendment alters the Second Schedule of the Ordinance—Control of Outdoor Advertising—to enable special circumstances to be considered when evaluating applications for advertising signs.

A copy of the amendment can be inspected free of charge during office hours at the offices of the Shire of Bright, Churchill Avenue, Bright and at the Department of Planning and Housing, 477 Collins Street, Melbourne.

GEOFF CODE  
Manager  
20600 Planning Co-ordination Branch

*Land Acquisition and Compensation Act 1986*  
*Transport Act 1983*  
Section 21, Regulation 16  
NOTICE OF ACQUISITION

Compulsory Acquisition of Interest in Land

The Roads Corporation declares that by this notice it acquires the following interests in the land described as 963.4 square metres being part of Crown Allotment 92, Section C, Parish of Shepparton, being part of the land contained in Certificate of Title Volume 9595 Folio 045 and Crown Grant Book 454 Memorial 790. The land is shown as parcel one on Roads Corporation Survey Plan No. 18366B.

*Interested Parties:* V. C. Rendeovski and V. Rendeovski.

The survey plan referred to in this notice may be viewed at the Roads Corporation's Office located at 3 Prospect Hill Road, Camberwell.

G 27 15 July 1992 1787

Published with the authority of the Roads Corporation and the Minister for Transport.

TIM HOLDEN  
Manager, Property Services  
Roads Corporation  
20703

*Land Acquisition and Compensation Act 1986*  
*Transport Act 1983*

NOTICE OF ACQUISITION

Compulsory Acquisition of Interest in Land  
The Roads Corporation declares that by this notice it acquires the following interest in the land described hereunder:

*Owner:* The Church of England Trusts Corporation for the Diocese of Melbourne.

*Description of Interest in Land:* Being part of Lot 13 on Plan of Subdivision No. 2459, Parish of Jika Jika.

*Area:* 47.2 square metres.

*Title Details:* Contained in Certificate of Title Volume 5786 Folio 067.

*Survey Plan:* 18190.

The survey plan referred to in this notice may be viewed at 3 Prospect Hill Road, Camberwell.

Published with the authority of the Roads Corporation and the Minister for Transport.

DEREK TREWARNE  
Manager, Property Operations  
20703

*Land Acquisition and Compensation Act 1986*  
*Transport Act 1983*

NOTICE OF ACQUISITION

Compulsory Acquisition of Interest in Land  
The Roads Corporation declares that by this notice it acquires the following interest in the land described hereunder:

*Owner:* D., E. and V. Sambanis.

*Description of Interest in Land:* Being part of Lot 14 on Plan of Subdivision No. 2459, Parish of Jika Jika.

*Area:* 98.1 square metres.

*Title Details:* Contained in Certificate of Title Volume 3199 Folio 670.

*Survey Plan:* 18190.

The survey plan referred to in this notice may be viewed at 3 Prospect Hill Road, Camberwell.

Published with the authority of the Roads Corporation and the Minister for Transport.

DEREK TREWARNE  
Manager, Property Operations  
20703

1788 G 27 15 July 1992

*Land Acquisition and Compensation Act 1986*  
*Transport Act 1983*  
Section 21, Regulation 16  
NOTICE OF ACQUISITION

Compulsory Acquisition of Interest in Land

The Roads Corporation declares that by this notice it acquires the following interest in the land described as 2000 square metres being part of Lot One on Plan of Subdivision No. 65529, Parish of Kialla, being part of the land contained in Certificate of Title Volume 8531 Folio 883. The land is shown as parcel one on Roads Corporation Survey Plan No. 18562.

*Interested Parties as Joint Proprietors:* Cosimo Aloï, Angelina Aloï, Giovanni Aloï and Maria Theresa Aloï.

The survey plan referred to in this notice may be viewed at the Roads Corporation's Office located at 3 Prospect Hill Road, Camberwell.

Published with the authority of the Roads Corporation and the Minister for Transport.

DEREK TREWARNE  
Manager, Property Operations  
Roads Corporation

20703

*Victoria Government Gazette*

*Land Acquisition and Compensation Act 1986*  
*Transport Act 1983*  
Section 21, Regulation 16  
NOTICE OF ACQUISITION

Compulsory Acquisition of Interest in Land

The Roads Corporation declares that by this notice it acquires the following interest in the land described as 47.2 square metres of land being part of Lot 10 on Plan of Subdivision No. 2459, Parish of Jika Jika, being part of the land contained in Certificate of Title Volume 6262 Folio 317. The land is shown as parcel one on Roads Corporation Survey Plan No. 18190.

*Interested Party as Registered Proprietor:* Giovanni Pilla.

The survey plan referred to in this notice may be viewed at the Roads Corporation's Office located at 3 Prospect Hill Road, Camberwell.

Published with the authority of the Roads Corporation and the Minister for Transport.

TIM HOLDEN  
Manager, Property Services  
Roads Corporation

20703

*Land Acquisition and Compensation Act 1986*  
*Transport Act 1983*  
Section 21, Regulation 16  
NOTICE OF ACQUISITION

Compulsory Acquisition of Interest in Land

The Roads Corporation declares that by this notice it acquires the following interest in the land described as 47.2 square metres of land being part of Lot 11 on Plan of Subdivision No. 2459, Parish of Jika Jika, being part of the land contained in Certificate of Title Volume 6370 Folio 846. The land is shown as parcel 2 on Roads Corporation Survey Plan No. 18190.

*Interested Parties as Joint Proprietors:* Silvio Di Santedicola and June Di Santedicola.

The survey plan referred to in this notice may be viewed at the Roads Corporation's Office located at 3 Prospect Hill Road, Camberwell.

Published with the authority of the Roads Corporation and the Minister for Transport.

TIM HOLDEN  
Manager, Property Services  
Roads Corporation

20703

*Transport Act 1983*  
ROADS CORPORATION

Commercial Passenger Vehicle Application  
Amendment to Previous Notice

This notice corrects a previous notice which appeared in the *Victoria Government Gazette* No. 23 dated 17 June 1992. Closing date for objections and the consideration date specified in that notice shall remain the same.

J. B. P. Phillips, Thornbury. Application to license two commercial passenger vehicles to be purchased in respect of the following:

<i>Make</i>	<i>Year of Manu- facture</i>	<i>Seating Capacity</i>
1 Chrysler sedan	1959	5
1 Chrysler sedan	1960	5

to operate as special purpose vehicles from Lot 16 Markhams Road, Riddells Creek for the carriage of passengers for wedding parties.

Dated 15 July 1992

RAY DONNELLEY  
Section Leader—Vehicle Licensing

20703

**Transport Act 1983  
ROAD DECLARATIONS AND  
DEDICATIONS**

The Roads Corporation, pursuant to the *Transport Act 1983*, upon publication of this notice declares the, or varies the declaration of, roads as described below and on the plans attached and further declares that such roads are fit to be used as a public highway and are now absolutely dedicated to the public for use as public highways within the meaning of any law now or hereafter in force.

**Main Roads**

- R398/92 Glengower Road, in the Shires of Creswick and Talbot and Clunes, shown by heavy line on plan numbered GP 81-MR.
- R399/92 By renaming part Talbot-Avooca Road as Lexton-Talbot Road and excluding the balance of Talbot-Avooca Road, in the Shire of Talbot and Clunes shown by heavy line and heavy broken line on plan numbered GP 80-MR.
- R400/92 Ardmona Road, in the Shire of Rodney, shown by heavy line on plan numbered GP 91-MR.
- R401/92 Cressy Road, in the Shire of Grenville, shown by heavy line on plan numbered GP 84-MR.

ROADS CORPORATION  
MAIN ROADS  
TALBOT-AVOCCA ROAD  
LEXTON-TALBOT ROAD  
SHIRE OF TALBOT AND CLUNES

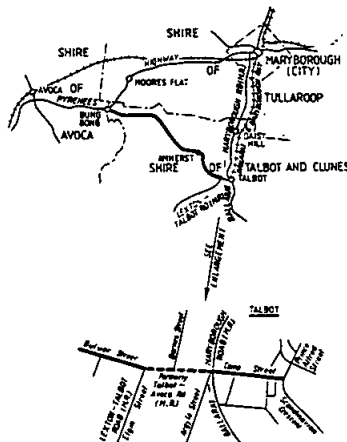

LEGEND:  
TALBOT-AVOCCA ROAD ——— EXCLUDE  
LEXTON-TALBOT ROAD - - - - - RENAME

ROADS CORPORATION  
MAIN ROAD  
GLENGOWER ROAD  
SHIRES OF CRESWICK &  
TALBOT AND CLUNES

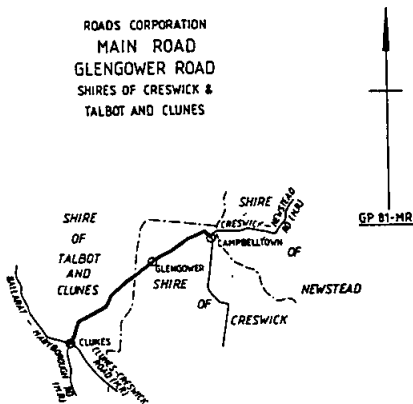

EXCLUDE ———

ROADS CORPORATION  
MAIN ROAD  
ARDMONA ROAD  
SHIRE OF RODNEY

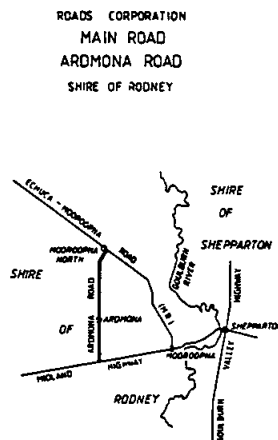

EXCLUDE ———

1790 G 27 15 July 1992

ROADS CORPORATION  
MAIN ROAD  
CRESSY ROAD  
SHIRE OF GRENVILLE

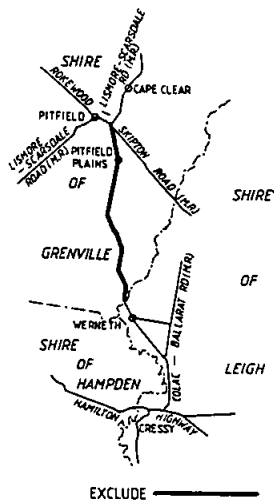

Victoria Government Gazette

*Main Roads*

- 19/92 Morwell-Thorpdale Road in the Shire of Narracan shown hatched on plan numbered GP17587.
- 20/92 Korumburra-Warragul Road in the Shire of Warragul, shown hatched and cross-hatched on plans numbered GP16930 and GP16931.
- 21/92 Lancefield-Tooborac Road in the Shire of Romsey, shown hatched and cross-hatched on plans numbered GP17428A and GP17429.

*Roads*

- 22/92 Burke and Wills Track in the Shire of Romsey, shown hatched on plan numbered GP17428B.
- 23/92 Drummond-Vaughan Road in the Shire of Daylesford and Glenlyon, shown hatched and cross-hatched on plans numbered GP17565A and GP17566A.

Dated 9 July 1992

REG PATTERSON  
Chief Executive  
Roads Corporation

20701

*Transport Act 1983*  
ROAD DECLARATIONS AND  
DEDICATIONS

The Roads Corporation, pursuant to the *Transport Act 1983*, upon publication of this notice declares the, or varies the declaration of, roads as described below and on the plans attached and further declares that such roads are fit to be used as a public highway and are now absolutely dedicated to the public for use as public highways within the meaning of any law now or hereafter in force.

*Highways*

- 17/92 Midland Highway in the Shire of Ballarat, shown by heavy line and heavy broken line on plan numbered GP 25-SH.
- 18/92 Princes Highway in the Shire of Orbost, shown hatched and cross-hatched on plans numbered GP17989, GP17990, GP17991, GP17992, GP17993 and GP17994.

ROADS CORPORATION  
STATE HIGHWAY  
MIDLAND HIGHWAY  
SHIRE OF BALLARAT

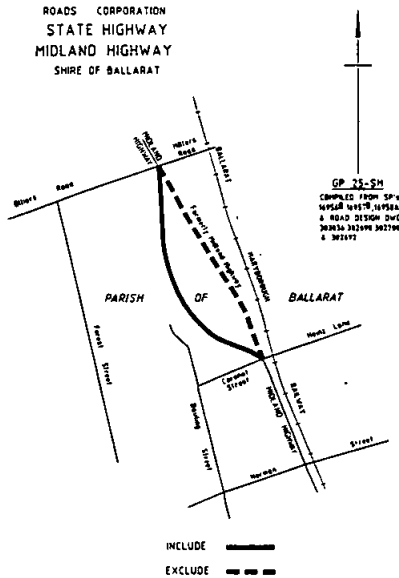



1792 G 27 15 July 1992

Victoria Government Gazette

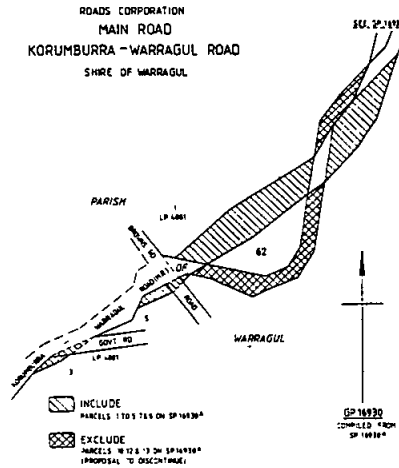
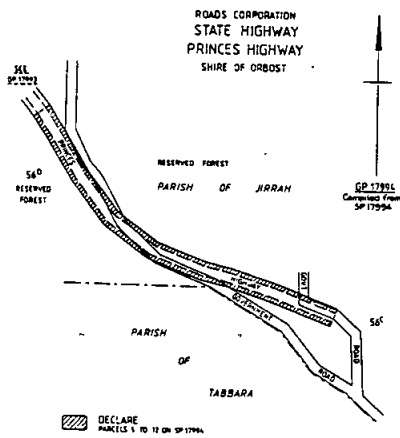
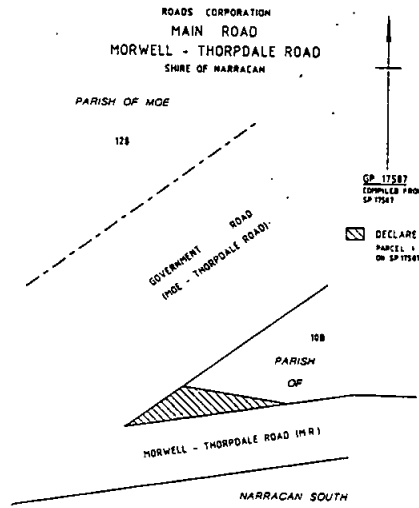
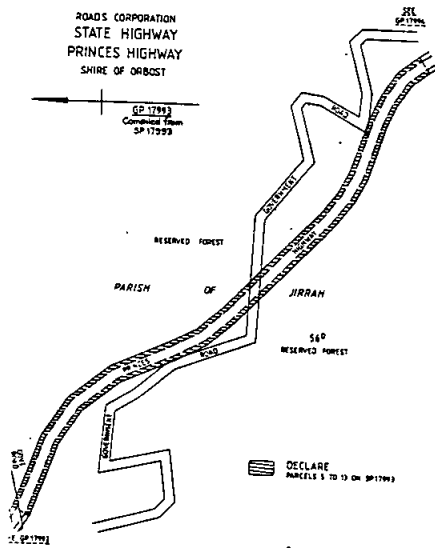



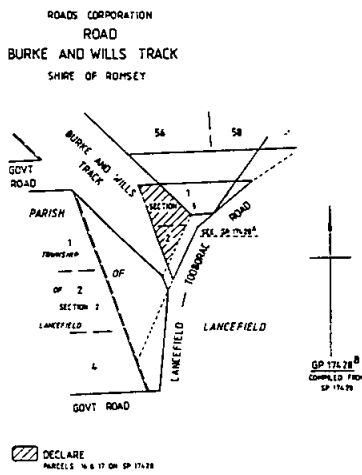
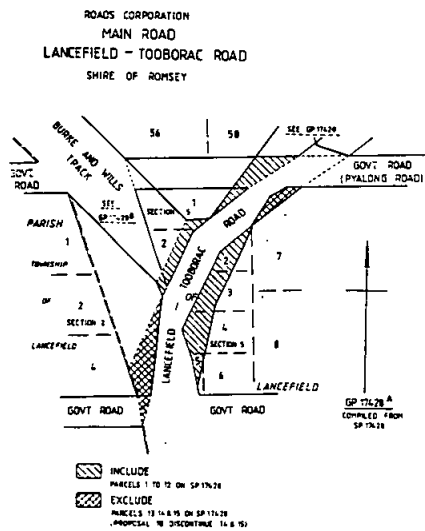
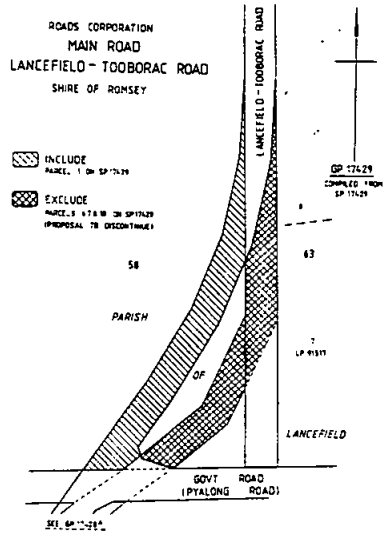
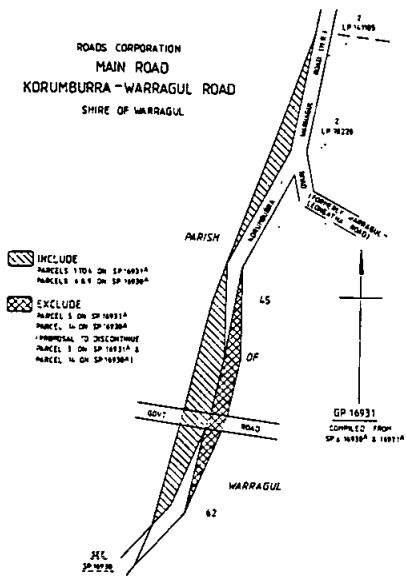

1794 G 27 15 July 1992

ROADS CORPORATION  
ROAD  
SHIRE OF DAYLESFORD AND GLENLILTON

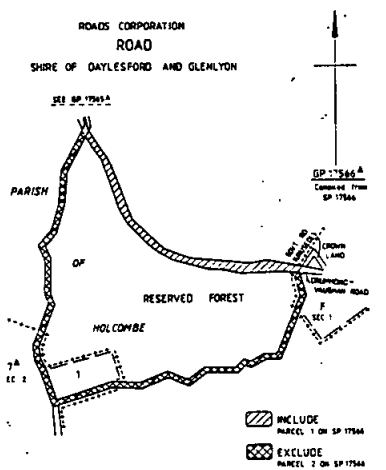
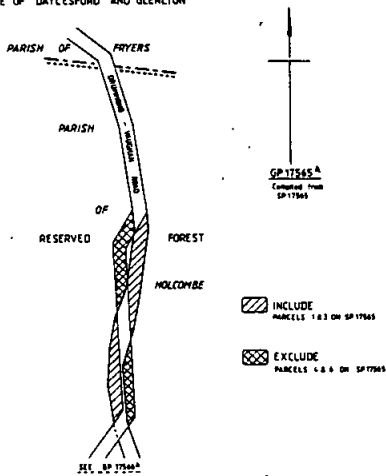

Dated 9 July 1992

20701

REG PATTERSON  
Chief Executive  
Roads Corporation

Victoria Government Gazette

Transport Act 1983

ROADS CORPORATION

Commercial Passenger Vehicle Application  
Amendment to Previous Notice

This notice corrects a previous notice which appeared in the *Victoria Government Gazette* No. 24 dated 24 June 1992.

The application in the name of W.B.L. Pty. Ltd., Warragul was Gazetted in error.

Dated 15 July 1992

RAY DONNELLEY  
20703 Section Leader—Vehicle Licensing

Transport Act 1983

ROAD TRANSPORT LICENSING

TRIBUNAL

Commercial Passenger Vehicle and Tow Truck  
Applications

Notice is hereby given that the applications to the following parties previously gazetted and objected to will be considered by the Road Transport Licensing Tribunal on the following days:

Applicant	Previous Gazette No.	Date
(i) On Monday, 17 August 1992 in the Public Hearing Theatre, Ground Floor, North Building, Roads Corporation, corner Lygon and Princes Streets, Carlton commencing at 9.30 a.m.		
M. R. Fialla	G.17	6.5.92
G. P. A. Nominees Pty. Ltd.	G.18	13.5.92
A. J. Comelli	G.15	15.4.92
T. Kalyvas	G.18	13.5.92
(ii) On Wednesday, 19 August 1992 in the Public Hearing Theatre, Ground Floor, North Building, Roads Corporation, corner Lygon and Princes Streets, Carlton commencing at 9.30 a.m.		
Beacon Heights Pty. Ltd.	G.17	6.5.92
Berwick Motor Body Repairers Pty. Ltd.	G.15	15.4.92

Dated 15 July 1992

20703

A. BARDEN  
Registrar

Transport Act 1983  
ROAD TRANSPORT LICENSING  
TRIBUNAL

Commercial Passenger Vehicle Applications

Notice is hereby given that the applications to the following parties previously gazetted and objected to will be considered by the Road Transport Licensing Tribunal on the following days:

<i>Applicant</i>	<i>Previous Gazette No.</i>	<i>Date</i>
(i) On Monday, 10 August 1992 in the Public Hearing Theatre, Ground Floor, North Building, Roads Corporation, corner Lygon and Princes Streets, Carlton commencing at 9.30 a.m.		
D. G. McKinall	G.16	29.4.92
R. J. Risely	G.16	29.4.92
P. and J. Apostolopoulos	G.16	29.4.92
I. Drakopoulos	G.15	15.4.92
(ii) On Wednesday, 12 August 1992 in the Public Hearing Theatre, Ground Floor, North Building, Roads Corporation, corner Lygon and Princes Streets, Carlton commencing at 9.30 a.m.		
J. H. and B. C. Masterton	G.6	12.2.92
Corsage Wedding Car Service Pty. Ltd.	G.18	13.5.92
P. Kasimatis	G.15	15.4.92
A. Todaro	G.18	13.5.92

Dated 8 July 1992

20703

A. BARDEN  
Registrar

Transport Act 1983  
ROADS CORPORATION  
Commercial Passenger Vehicle and Tow Truck Applications

Notice is hereby given that the following applications will be considered by the Roads Corporation on 18 August 1992.

Notice of any objection to the granting of an application should be forwarded to reach the Section Leader, Vehicle Licensing or any District Office of the Roads Corporation not later than 12 August 1992.

It will not be necessary for interested parties to appear on the date specified, unless advised in writing by the Corporation.

Notification of the date for consideration of applications which are objected to and which require determination by the Road Transport

Licensing Tribunal will be published by further notice in this Gazette.

P. G. Amos, Wodonga. Application to license one class 1 tow truck to be purchased to operate from a depot situated at 1/20 Queen Street, Wodonga for the purpose of lifting and carrying or towing damaged or disabled motor cars from any place within a 100 km radius of the applicant's depot at Wodonga to any place throughout the State of Victoria including the ability to attend the scene of an accident outside the "Controlled Area".

M. J. Barton, Wodonga. Application to license one commercial passenger vehicle to be purchased in respect of a 1982-1984 Denning bus with seating capacity for 49 passengers to operate as a country special service omnibus from within a 20 km pick-up radius of the Kergunyah Post Office.

*Note:* The vehicle to be licensed would hold a 4 star rating for charter purposes.

Bendal Pty. Ltd., North Sunshine. Application for variation of the conditions of licence SV 607 which authorises the licensed vehicle to operate as a special purpose vehicle in respect of a 1977-1979 Jaguar sedan with seating capacity for 4 passengers to change the vehicle to a 1982 Mercedes Benz sedan with seating capacity for 4 passengers.

T. J. Doyle, Werribee. Application for variation of the conditions of tow truck licence 644 which authorises the licensed vehicle to be managed, controlled and operated from a depot situated at 9 Lock Avenue, Werribee to change the depot address to 60-62 Lock Avenue, Werribee.

G. Jones, Spotswood. Application to license one class 1 tow truck to operate throughout the State of Victoria from a depot situated at 90 Hudson Road, Spotswood for the purpose of lifting and carrying or towing damaged or disabled motor cars excluding the ability to attend the scene of a motor car accident.

Lilydale Motors Pty. Ltd., Lilydale. Application to license one class 1 tow truck to be purchased to operate from a depot situated at 68 Cavehill Road, Lilydale for the purpose of lifting and carrying or towing damaged or disabled motor cars from any place within a 80 km radius of the applicant's depot at Lilydale to any place within a 80 km radius of the applicant's depot at Lilydale excluding the ability to attend the scene of a motor car accident.

1796 G 27 15 July 1992

Longbuild Pty. Ltd., Adelaide. Application for variation of the conditions of tow truck licence number 844 which authorises the licensed vehicle to—

- (i) be managed, controlled and operated from a depot situated at Hamilton Highway, Cressy; and
- (ii) used as a tow truck for the purpose of lifting and carrying or lifting and towing damaged or disabled motor cars—
  - (a) from the scene of an accident occurring within a 30 km radius of the Cressy Post Office to any place in Victoria; and
  - (b) from any place other than the scene of an accident to any place in Victoria—

to instead—

- (i) change the depot address to Farras Street, Rokewood; and
- (ii) operate as a tow truck for the purpose of lifting and carrying or lifting and towing damaged or disabled motor cars—
  - (a) from the scene of an accident occurring within a 20 km radius north of the east/west line and a 30 km radius south of the east/west line drawn through the Rokewood Post Office; and
  - (b) from any place other than the scene of an accident to any place in Victoria.

*Note:* This licence is currently under consideration for transfer to L. A. & C. A. Parrot, Rokewood.

Nationwide Towing Pty. Ltd., Blackburn. Application to license three class 2 tow trucks and one class 1 tow truck all to be purchased to operate from a depot situated at 40 Alfred Street, Blackburn for the purpose of lifting and carrying or towing damaged or disabled motor cars from any place within a 50 km radius of the applicant's depot at Blackburn to any place within a 150 km radius of the applicant's depot at Blackburn excluding the ability to attend the scene of a motor car accident.

Nationwide Towing Pty. Ltd., Blackburn. Application for variation of the conditions of tow truck licence number 777 which authorises the licensed vehicle to be managed, controlled and operated from a depot situated at 38 Alfred

Victoria Government Gazette

Street, Blackburn to change the depot address to 449 Bridge Road, Richmond.

*Note:* This licence is currently under consideration for transfer to J. Cusmano, Richmond.

J. H. Oliver, Seymour. Application to license one commercial passenger vehicle to be purchased in respect of a 1982 Ford Lincoln stretched limousine with seating capacity for 7 passengers to operate as a special purpose vehicle from 7 Darcy Street, Seymour for the carriage of passengers for—

- (i) any of the following purposes: weddings, anniversaries, debutante balls;
- (ii) tours to various wineries situated within a 100 km radius of the Seymour Post Office.

*Note:* Passengers will be picked up/set down within a 100 km radius of the Seymour Post Office.

J. Procopiou, Braybrook. Application for variation of the conditions of licence SV 544 which authorises the licensed vehicle to operate as a special purpose vehicle in respect of a 1977-1979 Jaguar sedan with seating capacity for 4 passengers to change the vehicle to a 1981 Mercedes Benz sedan with seating capacity for 4 passengers.

B. J. Street, Lalor. Application to license two commercial passenger vehicles in respect of one 1986-87 Jaguar sedan to be purchased and one 1984 Jaguar sedan each with seating capacity for 4 passengers to operate as metropolitan hire cars from 87 Kingsway Drive, Lalor.

W. Tagg, Reservoir. Application to license four commercial passenger vehicles in respect of the following:

Make	Year of Manufacture	Seating Capacity
Jaguar Sedan	1980	4
Ford Fairlane Sedan	1985	4
Ford LTD Sedan	1986	4
Ford LTD Sedan (To be purchased)	1989	4

to operate as metropolitan hire cars from 16 Liston Avenue, Reservoir.

C. D. Taylor & K. Karn, Prahran. Application to license one commercial passenger vehicle to be purchased in respect of a 1985 Toyota Hi-Ace bus with seating capacity for 12 passengers to operate a courtesy service for the carriage of guests of the applicants "Lords Lodge" Tourist

*Victoria Government Gazette*

Hostel situated at 204 Punt Road, Prahran between Melbourne Airport, Tullamarine, Flinders Street Station and Melbourne, Australia Coachline Bus Terminal, Franklin Street Melbourne and the Hostel.

Verlay Pty. Ltd., Glen Waverley. Application for variation of the conditions of tow truck licence 730 which authorises the licensed vehicle to be managed, controlled and operated from a depot situated at 41 Ricketts Road, Mount Waverley to change the depot address to 504 Neerim Road, Murrumbeena.

A. F. Whatmore, Glen Iris. Application to license one commercial passenger vehicle in respect of a 1980 Daimler sedan with seating capacity for 4 passengers to operate as a metropolitan hire car from 63 Gardiner Parade, Glen Iris.

J. A. Whiting, Werribee. Application for variation of the conditions of tow truck licence 645 which authorises the licensed vehicle to be managed, controlled and operated from a depot situated at 9 Lock Avenue, Werribee to change the depot address to 60-62 Lock Avenue, Werribee.

Winter and Taylor (Sales) Pty. Ltd., Geelong. Application for variation of the conditions of tow truck licence 803 which authorises the licensed vehicle to be managed, controlled and operated from a depot situated at 4 Baxter Road, North Geelong to change the depot address to 23 Cavendish Street, Geelong.

Dated 15 July 1992

RAY DONNELLEY  
20703 Section Leader—Vehicle Licensing

*Transport Superannuation Act 1988*  
ELECTION OF ONE MEMBER OF THE  
TRANSPORT SUPERANNUATION BOARD

Notice is hereby given that no nominations were received by the close of nominations for the election of a member of the fund to be appointed as a member of the Transport Superannuation Board, pursuant to Regulation 4 (2) (a) of the Transport Superannuation Board Election Regulations 1988.

R. J. MILLAR  
20673 Returning Officer

Creditors, next of kin and others having claims against the estate of any of the under-mentioned deceased persons are required to send particulars of their claims to the State Trust Corporation of Victoria, 168 Exhibition Street,

G 27 15 July 1992 1797

Melbourne Vic. 3000, the personal representative, on or before 15 September 1992 after which date the State Trust Corporation may convey or distribute the assets having regard only to the claims of which the State Trust Corporation then has notice:

Bielski, Blodwen Patricia, late of Unit 1, 21A Barkly Street, Mordialloc, home duties, died 10 April 1992.

Birch, Mignonette, formerly of 41 Kerferd Street, Coburg, late of Llandysill Nursing Home, 4 Scott Street, Essendon, widow, died 5 May 1992.

Calleja, Michael, formerly of 30 Hampshire Road, Sunshine, late of Benlynn Park Private Nursing Home, 2 Killara Street, West Sunshine, pensioner, died 18 April 1992.

Chrisfield, William Dudley, late of 50 Jackson Street, Anglesea, retired, died 7 April 1992.

Connelly, Mary Theresa, late of 1 Deakin Street, Hampton, pensioner, died 16 April 1992.

Evans, Charles James, also known as Charlie James Evans, late of Jumbuk Road, Yinnar South, pensioner, died 7 April 1992.

Harrigan, Ruby Elizabeth, late of 262 Victoria Road, Thornbury, widow, died 5 April 1992.

Hewson, Alice, formerly of Unit 1/65 Abbott Street, Sandringham, late of Unit 2, 946 Nepean Highway, Mornington, retired registered nurse, died 2 May 1992.

Hinsley, Janet Lydell, late of 34 Golf View Road, Heatherton, widow, died 13 December 1988.

Paul, Frank, late of Brynmawr Road, Camberwell, pensioner, died 16 April 1992.

Potter, Valda Marie, late of 4 Larcombe Street, Highton, home duties, died 11 April 1992.

Renfrey, Roy Elliott, also known as Roy Elliott Anderson, late of 76 Pentland Parade, Seddon, retired, died 13 December 1991.

Roylance, Alan, late of 15 Lantana Avenue, Thomastown, pensioner, died 18 February 1992.

Samuel, Patrick Dionysius, late of 14 Fortuna Avenue, North Balwyn, retired, died 3 April 1992.

Dated at Melbourne 7 July 1992

B. F. CARMODY  
20434 Managing Director  
State Trust Corporation

1798 G 27 15 July 1992

STATE TENDER BOARD  
CONTRACTS ACCEPTED  
Amendments

Schedule Number	Item Number	New Rate	Effective Date
		\$	
<i>Agricultural Chemicals</i>			
1/03	38	63.00	10.7.92
	39	287.00	
	40	1 082.00	
<i>Motor Spirit, Fuel Oils, Lubricants and Kerosene</i>			
1/53	5	0-6217	26.6.92
	6	0-6217	
	7	0-6217	
	8	0-6217	
	9	0-5964	
	10	0-5964	
	1	0-5881	1.7.92
	2	0-5889	
	3	0-5951	
	4	0-5969	
	12	0-5754	
	13	0-5762	
	5	0-6242	1.7.92
	6	0-6247	
	7	0-6242	
	8	0-6242	
	9	0-5981	
	10	0-5981	
	5	0-6262	1.7.92
	6	0-6262	
	7	0-6262	
	8	0-6262	
	9	0-6003	
	10	0-6003	
<i>Light Commercial Vehicles</i>			
1/59	2.1	11 071.07	9.7.92
	2.2	11 974.98	
	5.1	*	
	11.1	16 792.72	
	12.1	17 658.25	
	15.1	14 365.17	
	17.1	19 908.27	
	32.1	+	
* Delete: "Navara BMD21FMY Utility"			
+ Delete: "Urvan WRGE24DFMY Bus"			
	4.1	14 207.00~	7.7.92
	5.1	16 154.00~	
	9.1	12 417.00~	
<i>~ Options Available—</i>			
	Tow pack	223.00	
	Air-conditioning	1 067.00	
	Tonneau cover	216.00	
	11.1	16 280.00^	
	12.1	18 001.00^	
	15.1	13 620.00^	
	16.1	15 716.00^	

Victoria Government Gazette

Schedule Number	Item Number	New Rate	Effective Date
		\$	
<i>^ Options Available—</i>			
	Tow pack	223.00	
	Air-conditioning	1 067.00	
	Tonneau cover	216.00	
<i>Provisions</i>			
2/01	143	7-6133	1.7.92
	144	8-5956	
N. L. JORDAN			
20790	Secretary to the Tender Board		
Department of Manufacturing and Industry Development			
MINING LICENCE RENEWED			
No. 4040-1; A. I. and J. S. Baker; 33-93 ha, Parish of Boulka.			
No. 4546-2; D. Laube; 1-0 ha, Parish of Ballarat.			
APPLICATION FOR MINING LICENCE WITHDRAWN			
No. 4150; Geosurvey; 254-54 ha, Parish of Boorgunyah.			
No. 4512; Cluff Minerals (Aust.) P/L; 66 ha, Parish of Castlemaine.			
MINER'S RIGHT CLAIM EXPIRED			
No. 3400; G. T. Guy and M. D. Sefton; 0-14 ha, Parish of Butgulla.			
APPLICATION FOR RENEWAL OF EXTRACTIVE INDUSTRIES LICENCE WITHDRAWN, LICENCE EXPIRED			
No. 1145; C. W. and G. P. Winkler; 8-146 ha, Parish of Wormbete.			
DAVID WHITE			
20400	Minister for Manufacturing and Industry Development		
Notice is hereby given that the Victorian Aboriginal Education Association has applied for a lease under section 137AA (3) of the <i>Land Act 1958</i> for a term of 99 years in respect of 445 square metres of Crown land being Allotment 100b, Parish of Jika Jika for the purposes of Education and Administration.			
MARY J. ATKINSON			
20090	President		

Victoria Government Gazette

MELBOURNE WATER  
General Notice

Melbourne Water having made provision for carrying off the sewage of each and every property which or any part of which is situated in the Sewerage Areas hereinafter described both hereby declare that on and after 7 August 1992 each and every property so situated shall be deemed to be seweraged property within the meaning of the *Melbourne and Metropolitan Board of Works Act 1958*.

The Sewerage Areas hereinbefore referred to are:

Sewerage Area No. 8884  
(360/291/0072)

Shire of Diamond Valley—This area comprises all lots Grevillea Close and contains 11 lots.

Sewerage Area No. 8885  
(360/291/0072)

Shire of Diamond Valley—This area comprises lots 1, 2A and 2B Hurstbridge Road and contains 3 lots.

Sewerage Area No. 8886  
(360/291/0072)

Shire of Diamond Valley—This area comprises all lots Maldon Place and Colgoa Court, lots 92 to 95, 84, 61 and 42 Kamarooka Drive and contains 32 lots.

Sewerage Area No. 8887  
(360/291/0072)

Shire of Diamond Valley—This area comprises all lots Darwinia Place, Honey Myrtle Rise and Blackwood Close, lots 121 to 126, 114 and lot 115 Glen Gully Road and contains 29 lots.

Sewerage Area No. 8888  
(360/291/0072)

Shire of Diamond Valley—This area comprises lots 182 to 189 and lot 1 Sherbrooke Street, lots 3 to 5 and a reserve Gum Glade, lots 1 to 3, 1, 2 and a further lot 1, lots 117 to 114, 3 to 1, 112 to 108, lot 2, lots 123 to 145, 147 to 152, 3 to 1 and 155 to 161 Scenic Crescent and contains 69 lots.

Sewerage Area No. 8889  
(360/291/0072)

Shire of Bulla—This area comprises all lots Medstead Court and Tedburn Court, lots 352 to

G 27 15 July 1992 1799

364 Bridgewater Road, lots 312 to 317 Surrey Court, lots 223 to 226 Yarcombe Crescent, lots 243 to 239 and 287 to 291 Newlyn Drive, lots 292 to 300, 310 to 312, 331 to 336 and lots 344 to 351 Pembroke Crescent and contains 74 lots.

Sewerage Area No. 8890  
(360/291/0072)

Shire of Bulla—This area comprises lots 54 to 60 Queensberry Place, lot 53, a reserve and lot 73 Dumfries Terrace, lots 46 and 47 Elphington Boulevard and contains 11 lots.

Sewerage Area No. 8891  
(360/291/0072)

City of Whittlesea—This area comprises lots 1 to 8 and 25 to 33 Kalman Road and contains 17 lots.

By Order of Melbourne Water

R. SKINNER  
Regional Manager  
Yarra Region

20492

REVOCATION OF DIRECTION UNDER  
SECTION 247 (3) OF THE WATER ACT 1989  
AND ALL OTHER ENABLING  
POWERS—CITY OF SALE

I, John Harrowfield, Acting Minister for Water Resources hereby revoke the direction made under section 247 (3) of the *Water Act 1989* and all other enabling powers in regard to the City of Sale published in *Government Gazette S46* of 17 September 1991.

Dated 8 July 1992

JOHN HARROWFIELD  
21210 Acting Minister for Water Resources

*Water Act 1989*  
NOTICE OF DIRECTION GIVEN UNDER  
SECTION 307

I, David Downie, Director-General of Water Resources on behalf of the Minister for Water Resources give notice under section 307 (3) of the *Water Act 1989* that on 8 July 1992, John Harrowfield, Acting Minister for Water Resources gave a direction under section 307 of the *Water Act 1989* and all other enabling powers to the City of Sale.

Summary of Contents of the Direction given on  
8 July 1992

The City of Sale shall not, directly or indirectly—

1800 G 27 15 July 1992

- (a) expend any fees paid to it by any owner of property for the development of services by the City of Sale pursuant to the *Water Act 1989*;
- (b) expend any fees paid to it by any owner of property in respect of works or services provided by the City of Sale pursuant to the *Water Act 1989*;
- (c) expend any proceeds of the sale or other disposition of any works vested in the City of Sale by or under the *Water Act 1989*—

for or in connection with the construction of any building on any land owned or acquired by the City of Sale including the area bounded by Cunninghame, Macalister, Marley and York Streets without the prior consent in writing of the Director-General of the Department of Water Resources.

Dated 10 July 1992

DAVID DOWNIE  
Director-General

21210

Department of Water Resources

### SURVEYORS BOARD OF VICTORIA Surveyors (Fees) Regulations 1992

The Minister for Finance proposes the above regulations under the *Surveyors Act 1978* to amend the *Surveyors (Fees) Regulations 1980*.

The objective of the regulations is to prescribe fees as set down in the *Surveyors Act 1978* and the *Surveyors (Registration) Regulations 1992*.

A Regulatory Impact Statement has been prepared setting out the new Schedule of Fees. These fees seek to recover the costs of the training and registrations aspects of the Board's operations.

The Regulatory Impact Statement may be obtained from the Surveyors Board of Victoria, 2nd Floor, 2 Treasury Place, Melbourne 3002 by writing or telephoning the Secretary on (03) 651 2855.

Written submissions are invited from interested parties regarding the proposed regulations. These should be addressed to the Chairman, Surveyors Board of Victoria at the above address not later than 12 August 1992.

J. R. PARKER  
Chairman

20678

### Victoria Government Gazette

### Petroleum (Submerged Lands) Act 1967 COMMONWEALTH OF AUSTRALIA

#### Declaration of Location

I, David Ronald White, Minister for Manufacturing and Industry Development, the Designated Authority in respect of the area specified as being adjacent to the State of Victoria, hereby declare the blocks described hereunder, being blocks that are the subject of a permit of which The Shell Company of Australia Limited, 1 Spring Street, Melbourne, Ampolex Limited, Level 15, 580 George Street, Sydney, New South Wales, and Santos Limited, Santos House, 39 Grenfell Street, Adelaide, South Australia are the registered holders, to be a location for the purposes of section 37 of the Act under which this instrument is made.

#### Description of Blocks

Block Nos. 1789, 1860 and 1861 on the Melbourne Sheet SJ55 prepared and published for the purposes of the Petroleum (Submerged Lands) Act 1967, and shown below.

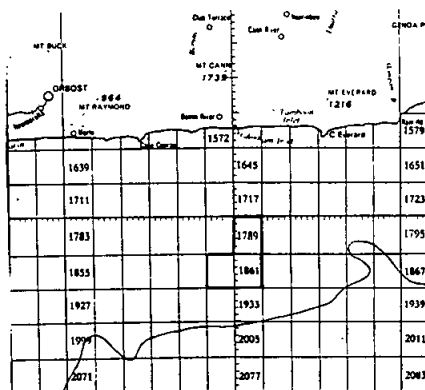

Made under the Petroleum (Submerged Lands) Act 1967 of the Commonwealth of Australia on behalf of the Commonwealth-Victoria Offshore Petroleum Joint Authority.

Dated 10 July 1992

DAVID WHITE  
Designated Authority

20400



Victoria Government Gazette

SHIRE OF OXLEY

Pursuant to the provisions of sections 522 and 526 of the *Local Government Act 1958* the Council of the Shire of Oxley hereby directs that the land in the Parish of Greta indicated by hatching on the plan hereunder which has been purchased taken or acquired by it, shall be a public highway on and from the date of publication of this Order in the *Government Gazette* and declares that such land shall be a public highway in lieu of the land indicated by cross hatching on the said plan.

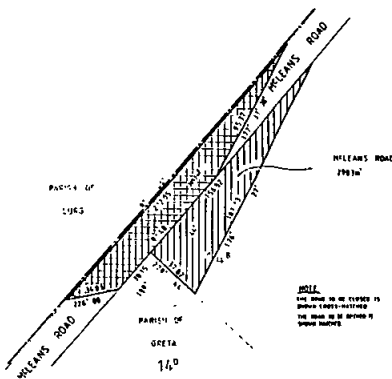

The common seal of the President, Councillors and Ratepayers of the Shire of Oxley was hereunto affixed on 5 June 1992

R. K. GIBB,  
President  
P. F. DELANEY,  
Councillor  
D. MONTGOMERY,  
Shire Secretary

20460

*Subordinate Legislation Act 1962*  
*Historic Buildings Act 1981*  
HISTORIC BUILDINGS (FEES)  
REGULATIONS 1992

I, Andrew McCutcheon, Minister for Planning and Housing, give notice that as no public comments and submission were received in response to the Regulatory Impact Statement on the proposed Historic Buildings (Fees) Regulations 1992, I intend to proceed with the making of the proposed regulations.

ANDREW McCUTCHEON  
20600 Minister for Planning and Housing

G 27 15 July 1992 1801

*County Court Act 1958*

ADDITIONAL COUNTY COURT SITTINGS  
1992

Notice is given that the additional sittings of the County Court of Victoria will be held at Bairnsdale to commence on Monday, 27 July 1992.

G. R. D. WALDRON  
Chief Judge of the  
County Court of Victoria

20430

*County Court Act 1958*

ADDITIONAL COUNTY COURT SITTINGS  
1992

Notice is given that the additional sittings of the County Court of Victoria will be held at Morwell to commence on Monday, 3 August 1992.

G. R. D. WALDRON  
Chief Judge of the  
County Court of Victoria

20430

MINISTRY FOR THE ARTS

*Subordinate Legislation Act 1962*

Notice of the Preparation of a Regulatory  
Impact Statement

In accordance with the provisions of the *Subordinate Legislation Act 1962*, notice is given of a proposal to replace the Public Records Regulations 1973 with new regulations to be known as Public Records Regulations 1992. The objectives of the regulations are to provide conditions for the inspection of public records, the use of facilities provided by the Public Record Office and to prescribe fees for the making and supplying of copies of public records.

A Regulatory Impact Statement has been prepared as required by the *Subordinate Legislation (Review and Revocation) Act 1984* which provides details of the fees charged for copies of public records, identifies the main user groups who are affected, in what manner and to what degree and considers alternate methods of achieving the objectives of the Regulations. Copies of the statement are available from Darryl O'Callaghan, Archival Heritage, 3rd Floor, 176 Wellington Parade, East Melbourne 3002.

Interested members of the public are invited to forward comments and submissions within 21 days from the publication of this advertisement.

20672

1802 G 27 15 July 1992

**INDEMNITY**

1. Whereas it is alleged that Crown Lease registered in the Office of Titles under Volume 1211 Folio 767 and being a Lease of Crown Allotments 33, 34, 35 and 36, Section O, Parish of French Island, County of Mornington is liable to forfeiture for breaches of the Lessee's covenants and conditions therein.

2. And whereas for the purpose of allowing the Lessee and all other persons interested in the Lease to show cause to the Minister for Conservation and Environment ("the Minister") against such forfeiture, the Minister has appointed a Local Land Board to publicly hear reasons against the forfeiture of the said Lease.

3. And whereas the said Local Land Board so constituted is inter alia required to publicly hear any evidence which may be tendered to it with respect to such reasons against forfeiture of the said Lease and thereafter to report thereon to the Minister.

4. And whereas the said Local Land Board has sought to be indemnified with respect to any loss or damage arising from Legal proceedings being brought against the Local Land Board for defamation or negligence by reason of it holding the said Public Hearing and/or the making of the said Report.

5. And whereas in the event of legal proceedings being brought against the said Local Land Board for defamation or negligence by reason of it holding the said Public Hearing and/or by the making of the said Report, the State of Victoria will have the right to conduct the defence of such legal proceedings and the right to determine the terms and conditions of settlement thereof and that the Local Land Board will do such things, or refrain from doing such things as the Minister deems necessary for the conduct of the defence to such legal proceedings and to the settlement thereof.

6. And whereas it appears to be the undersigned Barry Thomas Pullen to be appropriate that such indemnity be granted.

Now I the undersigned Barry Thomas Pullen, in my capacity as Minister for Conservation and Environment of the State of Victoria that in the event of legal proceedings being brought against the Local Land Board for defamation or negligence by reason of it holding the said Public Hearing and/or by the making of the said Report the State of Victoria shall indemnify the said Local Land Board with respect to any loss or damages or costs for which

*Victoria Government Gazette*

the said Local Land Board may be held liable. Such indemnity is to be subject to the State of Victoria having the right to determine the terms and conditions to the settlement thereof and further subject to the said Local Land Board doing such things or refraining from doing such things to the satisfaction of the Minister that the Minister deems necessary for the conduct of the defence of such legal proceedings and the settlement thereof.

Dated 9 July 1992

**BARRY PULLEN**  
Minister for Conservation  
and Environment

20090

*Co-operation Act 1981*  
**MELBOURNE UNIVERSITY INSTITUTE  
OF EDUCATION CHILD CARE CENTRE  
CO-OPERATIVE SOCIETY LTD.  
3RD WODONGA BOY SCOUT  
CO-OPERATIVE LIMITED**

Notice is hereby given in pursuance of section 192 (8) of the *Co-operation Act 1981* and section 572 (2) of the *Corporations Act 1989* that, at the expiration of three months from the date hereof, the names of the aforementioned societies will, unless cause is shown to the contrary, be struck off the register and the societies will be dissolved.

Dated at Melbourne 1 July 1992

**D. F. HENRY**  
Deputy Registrar of  
Co-operative Societies

20430

**NOTICE OF AVAILABILITY OF  
STATUTORY RULES**  
Accident Compensation (Further Amendment)  
Regulations 1992

Notice is given that the above Regulations were made by the Governor in Council on 15 July 1992 and come into operation on that date.

In accordance with the provisions of the *Subordinate Legislation Act 1962*, copies of the Regulations are available for inspection by any member of the public without charge during normal office hours at the Department of Labour, Level 23, Nauru House, 80 Collins Street, Melbourne.

Dated 15 July 1992

**JOHN HARROWFIELD**  
Minister for Finance as Minister  
assisting the Minister for Labour

20290

*Victoria Government Gazette*

**APPOINTMENT OF PERSON TO BE A  
LOCAL LAND BOARD**

1. Whereas it is alleged that Crown Lease registered in the Office of Titles under Volume 1211 Folio 767 and being a Lease of Crown Allotments 33, 34, 35 and 36, Section O, Parish of French Island, County of Mornington, is liable to forfeiture for breaches of the Lessee's covenants and conditions therein.

2. And whereas pursuant to the provisions of section 34 of the *Land Act* 1958 the Lessee and all other persons interested in the Lease are entitled to show cause to the Minister for Conservation and Environment ("the Minister") against such forfeiture.

3. And whereas the reasons against such forfeiture of the Lease are to be publicly heard by the Minister or by a Local Land Board consisting of one or more persons appointed by the Minister.

Now I the undersigned Barry Thomas Pullen, in my capacity as Minister for Conservation and Environment of the State of Victoria pursuant to section 34 of the *Land Act* 1958 hereby appoint Raymond Lawrence Leivers of 240 Victoria Parade, East Melbourne to be a Local Land Board and to publicly hear reasons against forfeiture of the said Lease. The Hearing will take place on Tuesday, 28 July 1992 at 10.00 a.m. at Council Chambers, Shire of Hastings, Marine Parade, Hastings and notification of such hearing will be published in appropriate newspapers in accordance with Land Act Regulations 3 (1) (a) (i).

Dated 9 July 1992

**BARRY PULLEN**  
Minister for Conservation  
and Environment

20090

**Regulations  
INVERLEIGH FLORA RESERVE**

*Title*

1. These Regulations may be cited as the Inverleigh Flora Reserve (Extension) Regulations 1992.

*Principal Regulations*

2. In these Regulations the regulations made on 29 January 1988 and published in the *Victoria Government Gazette* on 10 February 1988, for or in respect to the Inverleigh Flora Reserve are called the Principal Regulations.

*G 27 15 July 1992 1803*

*Authorising Provisions*

3. These Regulations are made under section 13 of the *Crown Land (Reserves) Act* 1978.

*Commencement*

4. These Regulations come into operation on the day they are published in the *Victoria Government Gazette*.

*Extension of Principal Regulations*

5. The Principal Regulations are extended to Crown Allotment 15D, Parish of Carrah temporarily reserved as a site for preservation of species of native plants by Order in Council of 28 April 1992—(Rs 6570).

Dated 8 July 1992

**BARRY PULLEN**  
Minister for Conservation  
and Environment

20090

**PUBLIC NOTICE**

Notice is hereby given that the State Bank of Victoria (a business name of Commonwealth Bank of Australia) will reduce the rate of interest paid for new applications to its Fixed Deposit Stock Account to 2.25% from 1 August 1992. The current rate for existing holders on 1 August 1992 will continue until 1 September 1992.

50385

**ATTORNEY-GENERAL'S DEPARTMENT  
VICTORIA**

**Business Names Regulations (No. 2) 1992**

In accordance with the requirements of the *Subordinate Legislation Act* 1962 I hereby give notice that I intend that the above regulations which have been the subject of a Regulatory Impact Statement be made.

**J. H. KENNAN**  
20430 Deputy Premier and Attorney-General

*Trustee Act* 1958—  
**SECTION 3AE**

I hereby declare the Class of Mortgage Backed Securities known as Prime Asset Vehicle Limited Promissory Notes, issued on 2 July 1992, to be Approved Mortgage-Backed Securities for the purpose of Part 1c of the *Trustee Act* 1958.

Given under my hand and seal on 10 July 1992

**H. M. WALTER**  
Acting Commissioner for  
Corporate Affairs

20430

1804 G 27 15 July 1992

*Trustee Act 1958*  
Section 3AE

I hereby declare the class of Mortgage-Backed Securities known as Fanmac Premier Trust No. 24 Bonds issued by Fanmac Limited to be an approved Mortgage-Backed Security for the purpose of Part 1c of the *Trustee Act 1958*.

Given under my hand and seal on 8 July 1992

H. M. WALTER  
Acting Commissioner for  
Corporate Affairs  
20430

*Trustee Act 1958*  
Section 3AE

I hereby declare the class of Mortgage-Backed Securities known as Fanmac Premier Trust No. 25 Bonds issued by Fanmac Limited to be an approved Mortgage-Backed Security for the purpose of Part 1c of the *Trustee Act 1958*.

Given under my hand and seal on 8 July 1992

H. M. WALTER  
Acting Commissioner for  
Corporate Affairs  
20430

*Police Regulation Act 1958*—Section 122  
SALE OF UNCLAIMED PROPERTY

An owner is required for an unregistered yellow and white Yamaha XT 250 motor cycle with Chassis No. 3Y4 031183.

This vehicle came into the possession of Police on 1 April 1992 and if not claimed it will be sold at public auction at 11 a.m. on Wednesday, 12 August 1992 at the St. Albans Police Station, corner Main Road West and Mitchell Street, St. Albans.

K. GLARE  
Chief Commissioner  
20620

VICTORIA POLICE

*T.358—Corporate Policy, Planning and Review*  
Supply of a Legislation and Update Service for the period ending 30 June 1994.

Anstat Pty. Ltd., 9 Stewart Street, Richmond 3121—At rates.

DAVID G. DETTMANN  
Chief Inspector  
Acting Supply Officer  
20620

*Victoria Government Gazette*

VICTORIA POLICE

*T.350—Supply Division*

Supply of caps and hats for the period ending 30 June 1995.

M. Reiner & Co. Pty. Ltd., 137 Sydney Road, Coburg 3058—At rates.

DAVID G. DETTMANN  
Chief Inspector  
Acting Supply Officer  
20620

*Education Act 1958*

NOTICE OF THE MAKING OF AN ORDER  
UNDER SECTION 13 (4) OF THE ACT

Pursuant to section 13 of the *Education Act 1958*, I hereby give notice that an Order of the Deputy Governor in Council was made on 7 July 1992 under sub-section (4) of the said Act amending certain provisions of the constitution of the school council listed below—

7720 Cheltenham Secondary College  
Council

NEIL POPE  
Minister for School Education  
20160

*Education Act 1958*

NOTICE OF THE MAKING OF AN ORDER  
UNDER SECTION 13 (4) OF THE ACT

Pursuant to section 13 of the *Education Act 1958*, I hereby give notice that an Order of the Deputy Governor in Council was made on 7 July 1992 under sub-section (4) of the said Act amending certain provisions of the constitution of the school council listed below—

7585 Belmont High School Council

NEIL POPE  
Minister for School Education  
20160

*Education Act 1958*

NOTICE OF THE MAKING OF ORDERS  
UNDER SECTION 13 (4) OF THE ACT

Pursuant to section 13 of the *Education Act 1958*, I hereby give notice that Orders of the Deputy Governor in Council were made on 7 July 1992 under sub-section (4) of the said Act amending certain provisions of the constitutions of the school councils listed below—

3892 Wandin North Primary School Council  
5139 Movelle Primary School Council

NEIL POPE  
Minister for School Education  
20160

*Education Act 1958*

NOTICE OF THE MAKING OF AN ORDER  
UNDER SECTIONS 13 (1), (4) AND (5) OF  
THE ACT

Under section 13 of the *Education Act 1958*, I hereby give notice that an Order of the Deputy Governor in Council was made on 7 July 1992 and under sub-section (1) constituting the—

Traralgon Heights Secondary College and the  
Traralgon High School Council  
and under sub-section (4) dissolving the—

Traralgon Heights Secondary College  
Council and the

Traralgon High School Council  
and under sub-section 5 directing the disposal  
of any assets of the—

Traralgon Heights Secondary College  
Council and the

Traralgon High School Council.

NEIL POPE

20160 Minister for School Education

---

*Education Act 1958*

NOTICE OF THE MAKING OF ORDERS  
UNDER SECTION 13 (4) OF THE ACT

Pursuant to section 13 of the *Education Act 1958*, I hereby give notice that Orders of the Deputy Governor in Council were made on 7 July 1992 under sub-section (4) of the said Act amending certain provisions of the constitutions of the school councils listed below—

3967 Yallourn North Primary School  
Council

7870 Golden Square Secondary College  
Council

NEIL POPE

20160 Minister for School Education

---

**APPOINTMENTS**

*Children and Young Persons Act 1989*  
**APPOINTMENT OF HONORARY  
PROBATION OFFICERS**

I, Heather Scovell, Regional Director of North West Region of Community Services, under section 34 (4) of the *Children and Young Persons Act 1989* appoint the undermentioned persons as Honorary Probation Officers in the State of Victoria for the period ending 31 December 1992:

Antoinette Louise Patamisi  
Janelle Louise Thomson  
Megan Stanton

Dated 5 June 1992

20080 **HEATHER SCOVELL**  
Regional Director

*Children and Young Persons Act 1989*  
**REVOCATION OF APPOINTMENT OF  
HONORARY PROBATION OFFICERS**

I, Heather Scovell, Regional Director of North West Region of Community Services, under section 34 (4) of the *Children and Young Persons Act 1989* revoke the appointment of the undermentioned persons as Honorary Probation Officers in the State of Victoria.

Christine Anne Jacobson  
Dianne Louise Kannegiesser  
Stephen John Kannegiesser  
David Lloyd Hughes

Dated 9 June 1992

20080 **HEATHER SCOVELL**  
Regional Director

*Children and Young Persons Act 1989*  
**APPOINTMENT OF HONORARY YOUTH  
PAROLE OFFICERS**

I, Heather Scovell, Regional Director of North West Region of Community Services, under section 226 of the *Children and Young Persons Act 1989* appoint the undermentioned persons as Honorary Parole Officers in the State of Victoria for the period ending 31 December 1992:

Antoinette Louise Patamisi  
Janelle Louise Thomson  
Megan Stanton

Dated 25 May 1992

20080 **HEATHER SCOVELL**  
Regional Director

*Children and Young Persons Act 1989*  
**REVOCATION OF APPOINTMENT OF  
HONORARY PROBATION OFFICER**

I, Heather Scovell, Regional Director of North West Region of Community Services, under section 34 (4) of the *Children and Young Persons Act 1989* revoke the appointment of the undermentioned person as Honorary Probation Officer in the State of Victoria:

Christine Ann Laurie  
Dated 20 May 1992

20080 **HEATHER SCOVELL**  
Regional Director

## ORDERS IN COUNCIL

*Cemeteries Act 1958*  
SCALE OF FEES

Under section 17 of the *Cemeteries Act 1958* and on the recommendation of the Minister for Health, the Governor in Council consents to the making of the Scale of Fees in respect of the following Public Cemeteries:

*Cemeteries Act 1958*  
SCALE OF FEES OF THE HAWKESDALE  
PUBLIC CEMETERY

In pursuance of the powers conferred upon them by the *Cemeteries Act* the trustees of the Hawkesdale Public Cemetery hereby make the following scale of fees, which shall come into operation upon publication in the *Government Gazette*, and from and after such publication every scale of fees heretofore made by the said trustees shall be and is hereby rescinded to the extent to which it conflicts with this scale.

	\$
Land 2.44 m x 1.22 m	60.00
Sinking grave 1.83 m	220.00
Each additional 30 cm	50.00
Weekends and public holidays (extra)	40.00
Child/Baby	80.00
Monument Fee	30.00
Re-opening of grave	120.00
Exhumation of body (where authorised)	200.00
Reinterment	200.00

F. J. CARLIN, Trustee  
A. G. GOW, Trustee  
R. E. NAGORCKA, Trustee

*Cemeteries Act 1958*  
SCALE OF FEES OF THE NYAH PUBLIC  
CEMETERY

In pursuance of the powers conferred upon them by the *Cemeteries Act* the trustees of the Nyah Public Cemetery hereby make the following scale of fees, which shall come into operation upon publication in the *Government Gazette*, and from and after such publication every scale of fees heretofore made by the said trustees shall be and is hereby rescinded to the extent to which it conflicts with this scale.

	\$
Land 2.44 m x 1.22 m	80.00

Administrative fee per interment	40.00
Grave digging	170.00

J. W. PIERCE, Trustee  
R. W. SUTTON, Trustee  
T. O'LOUGHLAN, Trustee

*Cemeteries Act 1958*  
SCALE OF FEES OF THE MAFFRA  
PUBLIC CEMETERY

In pursuance of the powers conferred upon them by the *Cemeteries Act* the trustees of the Maffra Public Cemetery hereby make the following scale of fees, which shall come into operation upon publication in the *Government Gazette*, and from and after such publication every scale of fees heretofore made by the said trustees shall be and is hereby rescinded to the extent to which it conflicts with this scale.

*General Cemetery*

	\$
Land 2.44 m x 1.22 m—Trustees selection	
For two interments	550.00
Re-open grave	345.00
Extra with ledger	45.00

*Lawn Cemetery*

Grave 2.44 m x 1.22 m—includes plaque and flower container	805.00
Re-open grave—includes plaque	680.00

*Baby's Lawn Section*

Interment, digging and plaque	200.00
-------------------------------	--------

*Monumental Rose Garden*

Rose bush and interment of ashes and plaque	285.00
---	--------

*Columbarium*

Single niche, plaque and flower container	210.00
Double niche, plaque and flower container	280.00

*Miscellaneous Charges*

Interment on Saturdays, Sundays or Public Holidays (Extra)	120.00
Sinking of oversize grave	100.00

C. J. SEMMENS, Trustee  
P. NYE, Trustee  
C. JOHNSTON, Trustee

1808 G 27 15 July 1992

*Cemeteries Act 1958*  
SCALE OF FEES OF THE KILMORE  
PUBLIC CEMETERY

In pursuance of the powers conferred upon them by the Cemeteries Act the trustees of the Kilmore Public Cemetery hereby make the following scale of fees, which shall come into operation upon publication in the *Government Gazette*, and from and after such publication every scale of fees heretofore made by the said trustees shall be and is hereby rescinded to the extent to which it conflicts with this scale.

*Public Graves*

	\$
Interment in grave without exclusive right—stillborn child	20.00
Interment in grave without exclusive right—others	25.00

*Private Graves*

Land 2.44 m x 1.22 m	500.00
----------------------	--------

*Sinking Charges for Private Graves*

Sinking grave 1.83 m	300.00
Each additional 0.3 m	25.00
Sinking oversize grave (extra)	30.00
Cancellation of order to sink (if commenced)	20.00

*Reopening Charges*

Reopening grave (no cover)	200.00
Reopening grave (with cover)	220.00

*Miscellaneous Charges*

Interment fee	30.00
Permission to erect a headstone or monument (maximum height from beam 0.6 m)—10% of cost with a minimum of \$100.00	
Exhuming the remains of a body (when authorised)	750.00
Interment of ashes in a private grave	100.00
Interment on Saturdays, Sundays or Public Holidays (extra)	30.00
Removal of slab (extra)	30.00

C. D. BERRY, Trustee  
A. E. RAGLUS, Trustee  
R. E. HANNAM, Trustee

*Cemeteries Act 1958*  
SCALE OF FEES OF THE TOORA  
PUBLIC CEMETERY

In pursuance of the powers conferred upon them by the Cemeteries Act the trustees of the

*Victoria Government Gazette*

Toora Public Cemetery hereby make the following scale of fees, which shall come into operation upon publication in the *Government Gazette*, and from and after such publication every scale of fees heretofore made by the said trustees shall be and is hereby rescinded to the extent to which it conflicts with this scale.

*Lawn Section*

	\$
1st interment including plaque	650.00
Re-opening	375.00

*General Section*

1st interment	400.00
Re-opening	300.00

*Miscellaneous Charges*

Interment of ashes, including land and plaque	650.00
Permission to erect headstone/monument—10% of cost with minimum of \$50.00	
Search fee	25.00

R. UNWIN, Trustee  
N. EVERITT, Trustee  
P. C. BEALE, Trustee

*Cemeteries Act 1958*

SCALE OF FEES OF THE FERNTREE  
GULLY PUBLIC CEMETERY

In pursuance of the powers conferred upon them by the Cemeteries Act the trustees of the Ferntree Gully Public Cemetery hereby make the following scale of fees, which shall come into operation upon publication in the *Government Gazette*, and from and after such publication every scale of fees heretofore made by the said trustees shall be and is hereby rescinded to the extent to which it conflicts with this scale.

	\$
Re-opening	420.00
Rose garden (perpetual)	430.00
Ashes in private grave	90.00
Oversize grave (extra)	125.00
Rectangular opening	245.00
Additional digging (3 interments)	100.00
Removal of chip top/ledger	100.00
Exhumation	1200.00



Monumental Fees

Monuments (other than vaults)	8%
Vault memorials	9.5%

COUNCILLORS FOR THE CITY OF KNOX,  
Trustees

Cemeteries Act 1958

SCALE OF FEES OF THE NAGAMBIE  
PUBLIC CEMETERY

In pursuance of the powers conferred upon them by the Cemeteries Act the trustees of the Nagambie Public Cemetery hereby make the following scale of fees, which shall come into operation upon publication in the *Government Gazette*, and from and after such publication every scale of fees heretofore made by the said trustees shall be and is hereby rescinded to the extent to which it conflicts with this scale.

	\$
Interment in grave without exclusive right—stillborn child	50.00
Interment in grave without exclusive right—others	70.00
Number peg or label	25.00
<i>Private Graves</i>	
Land 2.44 m x 1.22 m	130.00
<i>Lawn Section</i>	
Land 2.44 m x 1.22 m	270.00
<i>Sinking Charges</i>	
Sinking grave 1.83 m deep	165.00
Each additional 0.3 m	30.00
Sinking oversize grave	30.00
Sinking grave Saturday, Sunday or Public Holidays or without due notice, extra	40.00
Cancellation of order to sink (if commenced)	60.00
Re-opening grave (no cover)	165.00
Re-opening grave (with cover)	180.00
<i>Miscellaneous Charges</i>	
Interment fee	45.00
Interment outside prescribed hours or Saturdays, Sundays or Public Holidays or without due notice, extra	40.00
Concrete beam (lawn section)	120.00
Permission to erect a headstone or monument—10% of cost with a minimum of \$40.00	

Permission to construct a brick grave or to erect a stone kerb, brick tilework or concrete—10% of cost with a minimum of \$40	
Exhuming the remains of a body (when authorised)	500.00
Interment of ashes in a private grave	40.00
Memorial tree	70.00
Search fee per request	25.00

D. E. TOME, Trustee  
J. RITCHIE, Trustee  
R. H. PONTING, Trustee

Cemeteries Act 1958

SCALE OF FEES OF THE LOCHIEL  
PUBLIC CEMETERY

In pursuance of the powers conferred upon them by the Cemeteries Act the trustees of the Lochiel Public Cemetery hereby make the following scale of fees, which shall come into operation upon publication in the *Government Gazette*, and from and after such publication every scale of fees heretofore made by the said trustees shall be and is hereby rescinded to the extent to which it conflicts with this scale.

	\$
Land, 2.44 m x 1.22 m	80.00
Own selection of land (extra)	40.00
Land, 1.22 m x 0.9 m (for child's grave)	40.00
<i>Sinking Charges for Private Graves</i>	
Sinking child's grave—stillborn	40.00
Sinking child's grave—other	70.00
Sinking grave 1.83 m deep	150.00
Each additional 0.3 m	20.00
Sinking oversize grave	35.00
Cancellation of order to sink (if commenced) (plus any other cost if commenced)	25.00
Re-opening grave (no cover)	150.00
Re-opening grave (with cover) (advised against)	165.00
Sinking—Saturdays, Sundays, Public Holidays	30.00
<i>Miscellaneous Charge</i>	
Administrative fee for interment—adult	30.00
Administrative fee for interment—baby	20.00

1810 G 27 15 July 1992

Interment outside prescribed hours, or on Saturdays, Sundays or Public Holidays or without due notice	40.00
Certificate of right of burial	5.00
Number plate or brick	15.00
Permission to erect a headstone or monument—7½% of cost with a minimum of \$10.00	
Permission to construct a brick grave or to erect any stone kerb, brick tile-work or concrete—7½% of cost with a minimum of \$10.00	
Exhuming the remains of a body (when authorised)	400.00
Interment of ashes in a private grave	60.00
Memorial wall niche and plaque	150.00
Search fee per request	15.00

IVAN WERNER, Trustee  
C. W. BOEHM, Trustee  
M. L. WUNDERSITZ, Trustee

*Cemeteries Act 1958*  
SCALE OF FEES OF THE MADDINGLEY  
PUBLIC CEMETERY

In pursuance of the powers conferred upon them by the Cemeteries Act the trustees of the Maddingley Public Cemetery hereby make the following scale of fees, which shall come into operation upon publication in the *Government Gazette*, and from and after such publication every scale of fees heretofore made by the said trustees shall be and is hereby rescinded to the extent to which it conflicts with this scale.

*Lawn Cemetery*  
(non-Denominational)

	\$
Lawn grave (2.44 m x 1.22 m) purchase	600.00
Sinking of grave—up to 2.12 m depth	350.00
Sinking of oversize grave (extra)	75.00
Interment fee—first or second	100.00
Lawn cemetery standardised headstone—Quotation + 10%	
Lawn cemetery plaque (not permitted without headstone)—quotation + 10%	

*Private Graves*  
(Denominational)

Land (2.44 m x 1.22 m) purchase	450.00
Sinking of grave—up to 2.12 m depth	350.00

*Victoria Government Gazette*

Sinking of oversize grave (extra)	75.00
Interment fee—first or second	100.00

*Re-opening Charges*  
(for both Lawn and Private)

Re-opening grave	350.00
Removal of slab or concrete (extra)	75.00
Interment fee	100.00
Sinking of oversize grave (extra)	75.00

*Public Graves*

Interment in grave, without exclusive right—stillborn child	50.00
Interment in grave, without exclusive right—other	70.00

*Placement of Ashes*

Purchase of niche in wall	375.00
Interment of ashes—in niche	25.00
Interment of ashes—in any grave	150.00
Purchase of additional adjacent niche for family member	275.00
Wall plaque—Quotation + 10%	

*Extra Charges*

Sinking of grave on weekend or public holidays	75.00
Interment not in the prescribed hours of 8.00 a.m.—5.00 p.m. or on weekends or public holidays	150.00
Interment in private or lawn grave without due notice (24 hours)	150.00
Interment after 4.00 p.m. Monday to Friday inclusive	150.00

*Miscellaneous Charges*

Search of cemetery records	25.00
Maintenance (single grave) if required by holder of right of burial—per annum	100.00
Permit to erect headstone or monument—private graves—on submission of plans and specifications—10% of cost with a minimum of \$50	Fee
Permit to construct—a brick grave, or to erect any stone kerb, brick, tile or concrete surround	50.00
Grave renovations or additional inscription	50.00

Exhumation of any remains of a body  
when authorised 450.00

A. E. CONNE, Trustee  
K. WERNER, Trustee  
W. SCOTT, Trustee  
M. BLACKIE, Trustee  
A. HUTCHINSON, Trustee  
G. STEWART, Trustee

Gazette, and from and after such publication every scale of fees heretofore made by the said trustees shall be and is hereby rescinded to the extent to which it conflicts with this scale.

	\$
Land, 2.44 m x 1.22 m	385.00
Sinking grave	275.00
Saturday morning burial (extra)	130.00
Interment of ashes in niche wall	110.00
Interment of ashes in rose garden	140.00
Monumental fees	50.00
Search fee	10.00

*Cemeteries Act 1958*  
SCALE OF FEES OF THE CASTLEMAINE  
PUBLIC CEMETERY

In pursuance of the powers conferred upon them by the Cemeteries Act the trustees of the Castlemaine Public Cemetery hereby make the following scale of fees, which shall come into operation upon publication in the *Government*

GEORGE E. SHILL, Trustee  
C. KUHLE, Trustee  
A. A. HALL, Trustee  
J. W. HARRIS, Trustee

*Cemeteries Act 1958*

SCALE OF FEES OF THE TRUSTEES OF THE GEELONG CEMETERIES TRUST

In pursuance of the powers conferred upon them by the Cemeteries Act the Trustees of the Geelong Cemeteries Trust hereby make the following scale of fees, which shall come into operation upon publication in the *Government Gazette*, and from and after such publication every scale of fees heretofore made by the said Trustees shall be and is hereby rescinded to the extent to which it conflicts with this scale.

\$

1. *Fee for Right of Burial*

In graves measuring 2.4 m x 1.2 m approximately

(a) Lawn areas, non-denominational

\* limit of 2 adult burials per grave, or 3 burials subject to the prior agreement of the Trust

\* interment fee is additional

In approved bronze plaque memorial areas	650.00
In approved headstone memorial areas	650.00
In preferred position, selected by the applicant from those offered by the Trust	675.00

(b) Monument (non-lawn) areas, denominational

\* limit of 2 adult burials per grave

\* interment fee is additional

Eastern and Barrabool Hills Cemeteries	435.00
Western Cemetery	535.00

(c) Concrete-lined graves

\* Eastern Cemetery only and subject to availability

\* limit of 2 interments per grave

\* interment fee and sand are additional

In Children's Lawn areas

\* graves of reduced dimensions

\* interment fee is included

Child to 3 months (including stillborn)	235.00
Child over 3 months and under 11 years	335.00
* second interment	50.00

2. *Interment Fees*

(a) Sinking or reopening to 2.3 m	
Weekdays, to 4.00 p.m.	525.00
Saturday mornings or public holidays (when permitted)	700.00
(b) Public graves	
* there is no exclusive Right of Burial	
* memorials or other markers are not permitted	
Child under 11 years (including stillborn)	35.00
All others	80.00
(c) Additional charges	
Sand or loam for backfilling grave	60.00
Insufficient notice	80.00
Late fee: after 4.00 p.m., Monday to Friday	120.00
after 11.00 a.m., Saturday	120.00
Sinking to 2.7 m (when permitted) additional	125.00
Removal of ledger	90.00
Casket fee (or oversize coffin)	80.00
Interment of cremated remains in a grave	120.00
Interment of cremated remains with mourners in attendance—additional	30.00
Exhumation (when approved)	1 200.00

3. *Miscellaneous Cemetery Charges*

(a) Certificate of Right of Burial (optional)	20.00
(b) Replacement copy of Certificate of Right of Burial	20.00
(c) Search fee	5.00
(d) Monument Permit Fees:	
* including renovation work	
Headstone up to \$1000 value—10% of cost	
Headstone over \$1000 value—7% of cost, minimum \$100	
Additional inscription	20.00
(e) Installation of an approved bronze plaque purchased other than through the Trust	140.00

4. *Crematorium*

(a) Cremation Fee:	
* there is no additional charge for use of the chapel at the crematorium	
* there are no concession rates for pensioners or ex-service personnel	
Weekdays—Adult	550.00
—Child under 5 years (including stillborn)	220.00
Prepaid cremation fee (weekday)	570.00
Saturday mornings and public holidays (subject to special arrangement only)	
child or adult	725.00
(b) Miscellaneous Charges:	
Collection of cremated remains	
* notice required, available 24 hours after cremation	30.00
Packaging and despatch of cremated remains	
* within Australia	60.00
* outside Australia	90.00

5. *Memorialisation of Cremated Remains*

All new positions provided by the Trust for the memorialisation of cremated remains are subject to a tenure of 50 years from the date on which application is made for each such position. Positions arranged pre-need are subject to the same tenure period of 50 years, irrespective of the length of time cremated remains occupy a position. The Trust will not accept money for bronze memorial plaques until the time each plaque is ordered.

All memorials are offered subject to availability.

Some existing Niche Walls at the Eastern and Western cemeteries have provision to accept only a token amount of cremated remains in each niche.

Type of Memorial	Cemetery	No. of Positions per Memorial	Cost of Memorial without Plaque
			\$
Niche wall (token remains only)	Eastern and Western	1	150.00
Memorial Cross	Western	1	185.00
Rose, per position: Total of 4 positions at each rose	Eastern, Western and B/Hills	1	265.00
Tree, shrub or boulder	Memorial Park, Eastern and Western		By negotiation
Niche wall	Memorial Park, Western and B/Hills	1	From \$200.00 to \$600.00
Niche wall	Western and B/Hills	2	From \$300.00 to \$500.00
Memorial wall with remains placed at unmarked location	Memorial Park	1	165.00
Shrub garden, border position	Memorial Park	1	265.00
Strewing of cremated remains			
* in an unmarked position at the discretion of the Trustees			No charge
* at a specified location but unmarked position			40.00
Removal of cremated remains from a memorial for collection or transfer to another position within the cemetery			40.00

#### 6. Other

- \* Bronze memorial plaques
- \* Flower containers and plaque stands
- \* Entries in a Book of Remembrance

are all available from the Trust at moderate cost.

I. F. APTED, Trustee  
G. F. HIGGINS, Trustee  
I. D. MACDONALD, Trustee

Dated 7 July 1992

Responsible Minister:  
MAUREEN LYSTER  
Minister for Health

DAMIEN O'SHEA  
Acting Clerk of the Executive Council

20370

#### Cemeteries Act 1958 SCALE OF FEES

Under section 17 of the *Cemeteries Act 1958* and on the recommendation of the Minister for Health, the Governor in Council consents to the making of the Scales of Fees in respect of the following Public Cemeteries:

#### Cemeteries Act 1958 SCALE OF FEES OF THE BARINGHUP PUBLIC CEMETERY

In pursuance of the powers conferred upon them by the *Cemeteries Act*, the trustees of the Baringhup Public Cemetery hereby make the following scale of fees, which shall come into

1814 G 27 15 July 1992

operation upon publication in the *Government Gazette*, and from and after such publication every scale of fees heretofore made by the said trustees shall be and is hereby rescinded to the extent to which it conflicts with this scale.

	\$
Land 2.44 m x 1.22 m	110.00
Sinking grave 1.83 m deep—Contract price plus 10% administrative charge	
Interment fee	60.00
Re-opening grave (no cover)	150.00
Re-opening grave (with cover)	170.00
Permission to erect a headstone or monument—10% of cost with a minimum of \$50.00	
Exhumation charge (when authorised)	500.00
Search fee per request	15.00

ALISON THOMAS, Trustee  
 SALLY E. BRYANT, Trustee  
 BRIAN THOMAS, Trustee  
 JOHN R. LILLIE, Trustee  
 GWEN E. HOGAN, Trustee  
 HELEN ARTHUR, Trustee  
 MARR BOYD-GRAHAM, Trustee

*Cemeteries Act 1958*  
**SCALE OF FEES OF THE KOONDRUCK PUBLIC CEMETERY**

In pursuance of the powers conferred upon them by the *Cemeteries Act*, the trustees of the Koondruck Public Cemetery hereby make the following scale of fees, which shall come into operation upon publication in the *Government Gazette*, and from and after such publication every scale of fees heretofore made by the said trustees shall be and is hereby rescinded to the extent to which it conflicts with this scale.

*Lawn Section*

	\$
New grave	595.00
Re-open	290.00

ALLAN MILLAR, Trustee  
 ALLAN MORROW, Trustee  
 RONALD R. PLANT, Trustee

*Victoria Government Gazette*

*Cemeteries Act 1958*

**SCALE OF FEES OF THE MELBOURNE CHEVRA KADISHA PUBLIC CEMETERY**

In pursuance of the powers conferred upon them by the *Cemeteries Act*, the trustees of the Melbourne Chevra Kadisha Public Cemetery hereby make the following scale of fees, which shall come into operation upon publication in the *Government Gazette*, and from and after such publication every scale of fees heretofore made by the said trustees shall be and is hereby rescinded to the extent to which it conflicts with this scale.

*Fee for Right of Burial*

	\$
Standard position fee	650.00
Preferred position fee—additional 50% of right of burial fee	
Preferred position fee in new section	1200.00

*Interment Fee*

Interment fee	650.00
---------------	--------

JOSEPH MILLER, Trustee  
 MOSES RABI, Trustee  
 MEYER HERSZBERG, Trustee

*Cemeteries Act 1958*

**SCALE OF FEES OF THE GEMBROOK PUBLIC CEMETERY**

In pursuance of the powers conferred upon them by the *Cemeteries Act*, the trustees of the Gembrook Public Cemetery hereby make the following scale of fees, which shall come into operation upon publication in the *Government Gazette*, and from and after such publication every scale of fees heretofore made by the said trustees shall be and is hereby rescinded to the extent to which it conflicts with this scale.

	\$
Concrete lined graves	1750.00

W. D. BEER, Trustee  
 J. A. WILLIAMS, Trustee  
 R. LEA, Trustee

*Cemeteries Act 1958*

**SCALE OF FEES OF THE KIALLA WEST PUBLIC CEMETERY**

In pursuance of the powers conferred upon them by the *Cemeteries Act*, the trustees of the Kialla West Public Cemetery hereby make the following scale of fees, which shall come into

*Victoria Government Gazette*

operation upon publication in the *Government Gazette*, and from and after such publication every scale of fees heretofore made by the said trustees shall be and is hereby rescinded to the extent to which it conflicts with this scale.

	\$
Grave site	280.00
Interment fee	340.00
Interment fee (weekends and public holidays) extra	150.00
Re-opening (no cover)	340.00
Re-opening (with cover)	400.00
Exhumation fee (when authorised)	1 000.00

E. F. HARMER, Trustee  
C. N. HAZELMAN, Trustee  
I. E. KLEIN, Trustee

*Cemeteries Act 1958*  
SCALE OF FEES OF THE PINE LODGE  
PUBLIC CEMETERY

In pursuance of the powers conferred upon them by the *Cemeteries Act*, the trustees of the Pine Lodge Public Cemetery hereby make the following scale of fees, which shall come into operation upon publication in the *Government Gazette*, and from and after such publication every scale of fees heretofore made by the said trustees shall be and is hereby rescinded to the extent to which it conflicts with this scale.

*Lawn Cemetery*

	\$
Lawn grave site	540.00
Interment fee	340.00
Interment fee (weekends and public holidays) extra	180.00
Interment fee (ashes)	60.00
Bronze plaques (380 mm x 215 mm)—	
single	200.00
dual conversion	250.00
tree or shrub	140.00
Flower container	20.00
Ceramic tiles (5 cm x 7 cm)—	
black and white	130.00
colour	150.00
Memorial shrub	250.00
Memorial tree	250.00
Exhumation fee (when authorised)	1000.00

E. F. HARMER, Trustee  
C. N. HAZELMAN, Trustee  
I. E. KLEIN, Trustee

G 27 15 July 1992 1815

Dated 7 July 1992

Responsible Minister:  
MAUREEN LYSTER  
Minister for Health

DAMIEN O'SHEA  
20370 Acting Clerk of the Executive Council

*Cemeteries Act 1958*  
APPOINTMENT OF TRUSTEES

Under sections 3 (1) and 3 (2) of the *Cemeteries Act 1958* and on the recommendation of the Minister for Health, the Governor in Council makes the following appointments of trustees of the following Public Cemeteries—

Name	Public Cemetery
Ross Archibald Blain	Rye
Stuart Geoffrey Weir	Rye
Marilyn Joy Reid	Trafalgar
James Walter Simpkins	Chiltern
John Robert Roulston	Runnymede

Dated 7 July 1992

Responsible Minister:  
MAUREEN LYSTER  
Minister for Health

DAMIEN O'SHEA  
20370 Acting Clerk of the Executive Council

*Cemeteries Act 1958*  
APPOINTMENT OF TRUSTEES

Under sections 3 (1) and 3 (2) of the *Cemeteries Act 1958* and on the recommendation of the Minister for Health, the Governor in Council makes the following appointments of trustees of the following Public Cemeteries—

Name	Public Cemetery
Phillip Graham	Clear Lake
Wegener	Clear Lake
Donald Arthur Hobbs	Clear Lake
Patricia Kalms	Murrayville
Peter Murnane	Hawkesdale
Desmond Thomas	
McGrath	Koondrook
Ian Bruce Campbell	Koondrook
Frederick Henry	Geelong Cemeteries
Freijah	Trust
Raelene Jones	Lake Boga

Dated 7 July 1992

Responsible Minister:  
MAUREEN LYSTER  
Minister for Health

DAMIEN O'SHEA  
20370 Acting Clerk of the Executive Council

1816 G 27 15 July 1992

*Crown Land (Reserves) Act 1978*  
**CROWN LANDS PERMANENTLY RESERVED**

The Governor in Council under sections 4 and 7 of the *Crown Land (Reserves) Act 1978* permanently reserves for the purposes mentioned and also nominates as areas for which consent of the person or manager administering or managing the lands is required before work may be done on those lands in accordance with the *Mineral Resources Development Act 1990*, the following Crown lands:

**MUNICIPAL DISTRICT OF THE SHIRE OF KOWREE**

**CHARAM**—Management of wildlife, 160 hectares, more or less, being Crown Allotment 22c, Parish of Charam as indicated by hatching on plan hereunder—(C 387[3]) (Rs 13129).

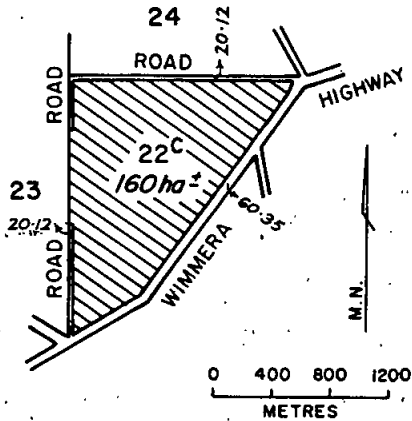

**MUNICIPAL DISTRICT OF THE SHIRE OF KOWREE**

**KARNAK**—Management of wildlife, 163 hectares, more or less, being Crown Allotment 5, Section 4, Township of Karnak and Crown Allotment 8d, Parish of Karnak as indicated by hatching on plan hereunder—(K 132[4], [3]) (Rs 497).

Victoria Government Gazette

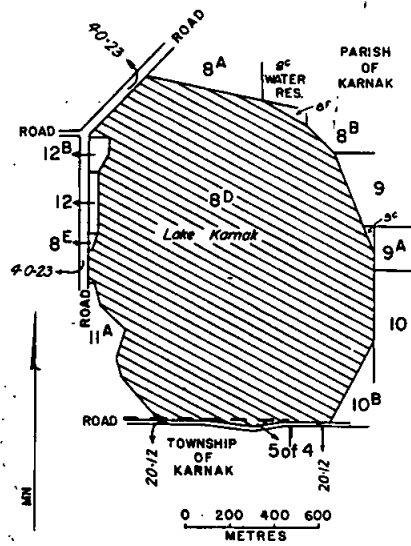

AREA HATCHED 163 ha±

**MUNICIPAL DISTRICT OF THE SHIRE OF ROMSEY**

**KERRIE**—Conservation of an area of natural interest, 13.5 hectares, more or less, being Crown Allotment 188A, Parish of Kerrie as indicated by hatching on plan hereunder—(K 26[8]) (Rs 33001).

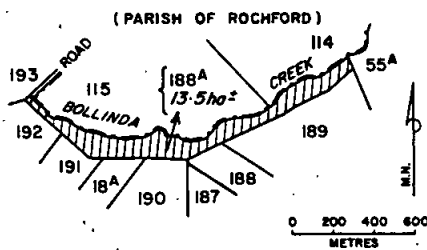

**MUNICIPAL DISTRICT OF THE SHIRE OF LOWAN**

**WARRAQUIL**—Conservation of an area of natural interest, 29.56 hectares being Crown Allotment 15F, Parish of Warraquil as shown on Certified Plan No. 110598 lodged in the Central Plan Office—(Rs 8098).



Victoria Government Gazette

MUNICIPAL DISTRICT OF THE SHIRE OF  
KANIVA

YEARINGA—Conservation of an area of natural interest, 33 hectares, more or less, being Crown Allotment 32E, Parish of Yearinga as indicated by hatching on plan hereunder—(Y 110[2]) (Rs 5431).

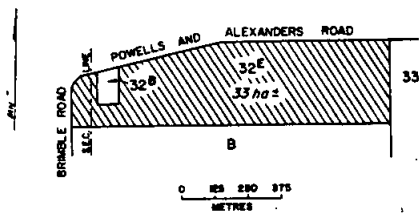

Dated 15 July 1992

Responsible Minister:

BARRY PULLEN

Minister for Conservation and Environment

DAMIEN O'SHEA

20090 Acting Clerk of the Executive Council

*Crown Land (Reserves) Act 1978*  
CROWN LANDS TEMPORARILY  
RESERVED

The Governor in Council under sections 4 and 7 of the *Crown Land (Reserves) Act 1978* temporarily reserves for the purposes mentioned and also nominates as areas for which consent of the person or manager administering or managing the lands is required before work may be done on those lands in accordance with the *Mineral Resources Development Act 1990*, the following Crown lands:

MUNICIPAL DISTRICT OF THE SHIRE OF  
WALPEUP

BOULKA—Conservation of an area of natural interest, 33.47 hectares being Crown Allotments 1B and 1C, Parish of Boulka as shown on Certified Plan No. 110634 lodged in the Central Plan Office—(Rs 14357).

MUNICIPAL DISTRICT OF THE SHIRE OF  
TALBOT AND CLUNES

BUNG BONG—Conservation of an area of natural interest, 27 hectares, more or less, being Crown Allotment 37F, Parish of Bung Bong as indicated by hatching on plan hereunder—(B 539[4]) (Rs 1632).

G 27 15 July 1992 1817

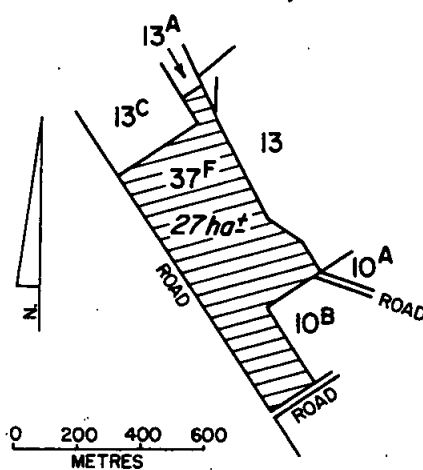

MUNICIPAL DISTRICT OF THE SHIRE OF  
MILDURA

MILDURA—Kindergarten, 653 square metres being Crown Allotment 232b, Section B, Parish of Mildura as shown on Certified Plan No. 111204 lodged in the Central Plan Office—(Rs 13857).

Dated 15 July 1992

Responsible Minister:

BARRY PULLEN

Minister for Conservation and Environment

DAMIEN O'SHEA

20090 Acting Clerk of the Executive Council

*Crown Land (Reserves) Act 1978*  
CROWN LAND PERMANENTLY  
RESERVED

The Governor in Council under sections 4 and 7 of the *Crown Land (Reserves) Act 1978* permanently reserves for the purpose mentioned and also nominates as an area for which consent of the person or manager administering or managing the land is required before work may be done on that land in accordance with the *Mineral Resources Development Act 1990*, the following Crown land:

MUNICIPAL DISTRICT OF THE SHIRE OF  
ALBERTON

WON WRON—Preservation of species of native plants, 128 hectares, more or less, being Crown Allotment 1A, Section A, Parish of Won Wron as indicated by hatching on plan hereunder—(W 248 [3]) (Rs 14002).

1818 G 27 15 July 1992

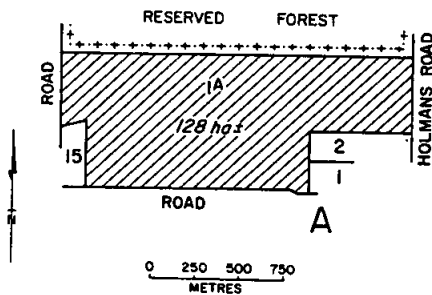

Dated 15 July 1992  
 Responsible Minister:  
**BARRY PULLEN**  
 Minister for Conservation and Environment  
**DAMIEN O'SHEA**  
 20090 Acting Clerk of the Executive Council

Victoria Government Gazette

**GATUM GATUM**—The temporary reservation by Order in Council of 1 September 1970 of 6070 square metres of land in the Parish of Gatum Gatum as a site for Public Purposes (Trigonometrical Survey Station) revoked as to part by Order in Council of 4 September 1984 so far only as the portion containing 55 square metres as indicated by hatching on plan hereunder—(G 148[3]) (Rs 9308).

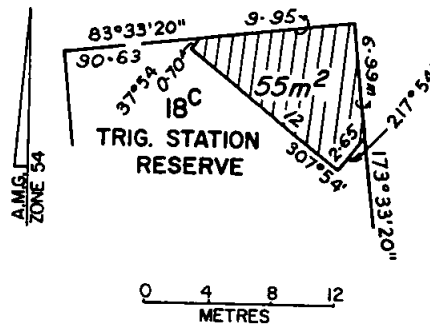

*Crown Land (Reserves) Act 1978*  
**NOTICE OF INTENTION**

The Governor in Council under section 10 of the *Crown Land (Reserves) Act 1978* gives notice of intention to revoke the following temporary reservations:

**DARTMOOR**—The temporary reservation by Order in Council of 12 January 1954 of 1695 square metres, more or less, of land in the Township of Dartmoor, Parish of Dartmoor as a site for a Baby Health Centre so far only as the portion containing 484 square metres as indicated by hatching on plan hereunder—(D 32[6])—(Rs 7207).

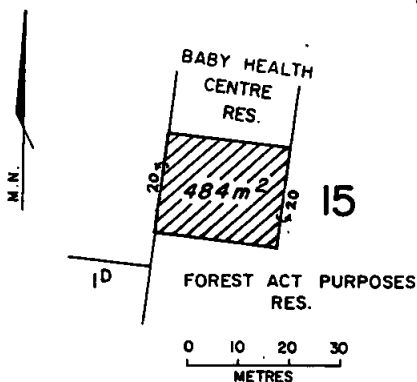

**HORSHAM**—The temporary reservation by Order in Council of 19 February 1877 of 784 square metres of land in the Township of Horsham, Parish of Horsham as a site for a Court House so far only as the portion containing 72 square metres, more or less, as indicated by hatching on plan hereunder—(H 91[3]) (Rs 1713).

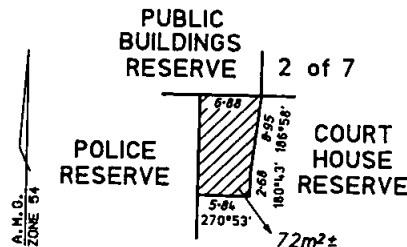

**STAWELL**—The temporary reservation by Order in Council of 24 October 1978 of 6.489 hectares of land being Crown Allotment 3, Section 117, Parish of Stawell as a site for Public Purposes (Home for the Aged)—(Rs 10635).

**YANAC-A-YANAC**—The temporary reservation by Order in Council of 15 November 1988 of 205 hectares, more or less, of land in the Parish of Yanac-A-Yanac as a site for the management of wildlife—(Rs 13965).

*Victoria Government Gazette*

Dated 15 July 1992

Responsible Minister:

BARRY PULLEN

Minister for Conservation and Environment

DAMIEN O'SHEA

20090 Acting Clerk of the Executive Council

*Crown Land (Reserves) Act 1978*  
INCORPORATION OF COMMITTEE OF  
MANAGEMENT OF SASSAFRAS  
MECHANICS' INSTITUTE RESERVE

The Governor in Council, under section 14A (1) of the *Crown Land (Reserves) Act 1978*, being satisfied that it is in the public interests to declare to be a corporation the Committee of Management appointed under section 14 (2) of the Act of the land described in the schedule hereunder:

- (a) declares that the Committee of Management shall be a corporation;
- (b) assigns the name "Sassafras Mechanics Institute Reserve Committee of Management Incorporated" to the corporation; and

under section 14B (3) of the Act, appoints Sue Lowery to be Chairperson of the corporation.

SCHEDULE

The remaining land in the Parish of Monbulk temporarily reserved as a site for a Mechanics' Institute by Order in Council of 6 August 1894 and 24 August 1948—(Rs 2710).

Dated 15 July 1992

Responsible Minister

BARRY PULLEN

Minister for Conservation and Environment

DAMIEN O'SHEA

20090 Acting Clerk of the Executive Council

*Crown Land (Reserves) Act 1978*  
INCORPORATION OF COMMITTEE OF  
MANAGEMENT OF BANNOCKBURN  
PUBLIC HALL RESERVE

The Governor in Council, under section 14A (1) of the *Crown Land (Reserves) Act 1978*, being satisfied that it is in the public interests to declare to be a corporation the Committee of Management appointed under section 14 (2) of the Act of the land described in the schedule hereunder—

- (a) declares that the Committee of Management shall be a corporation;

G 27 15 July 1992 1819

- (b) assigns the name "Bannockburn Public Hall Reserve Committee of Management Incorporated" to the corporation; and

under section 14B (3) of the Act, appoints Reginald James Smith to be Chairperson of the corporation.

SCHEDULE

The remaining land in the Township of Bannockburn, Parish of Wabdallah, temporarily reserved as a site for a Public Hall by Order in Council of 26 June 1962—(Rs 2121).

Dated 15 July 1992

Responsible Minister:

BARRY PULLEN

Minister for Conservation and Environment

DAMIEN O'SHEA

20090 Acting Clerk of the Executive Council

*Crown Land (Reserves) Act 1978*  
INCORPORATION OF COMMITTEE OF  
MANAGEMENT OF THE KEAST PARK  
PUBLIC PURPOSES RESERVE

The Governor in Council, under section 14A (1) of the *Crown Land (Reserves) Act 1978*, being satisfied that it is in the public interests to declare to be a corporation the Committee of Management appointed under section 14 (2) of the Act of the land described in the schedule hereunder—

- (a) declares that the Committee of Management shall be a corporation;
- (b) assigns the name "Keast Park Committee of Management" to the corporation; and—

under section 14B (3) of the Act, appoints Roy Alexander Dore B.E.M. to be Chairperson of the corporation.

SCHEDULE

The reserved Crown land in the Parish of Lyndhurst as is shown by red colour on plan marked KP/4.2.76 attached to Department of Conservation and Environment correspondence—(Rs 5549).

Dated 15 July 1992

Responsible Minister:

BARRY PULLEN

Minister for Conservation and Environment

DAMIEN O'SHEA

20090 Acting Clerk of the Executive Council

1820 G 27 15 July 1992

*Crown Land (Reserves) Act 1978*  
REVOCATION OF TEMPORARY  
RESERVATIONS

The Governor in Council under section 10 of the *Crown Land (Reserves) Act 1978* revokes the following temporary reservations:

**BENDIGO**—The temporary reservation by Order in Council of 20 January 1981 of 1026 square metres of land being Crown Allotment 559c, Section K, at Bendigo, Parish of Sandhurst as a site for Teacher Housing Authority purposes—(Rs 11429).

**BENDIGO**—The temporary reservation by Order in Council of 17 February 1925 of 2327 square metres of land adjoining Crown Allotment 4, Section F17, at Bendigo, Parish of Sandhurst as a site for Public Purposes—(Rs 3072).

**MILDURA**—The temporary reservation by Order in Council of 25 May 1965 of 12.14 hectares of land in Section B, Parish of Mildura as a site for Public Purposes (Sewerage purposes)—(Rs 8448).

**QUAMBATOOK**—The temporary reservation by Order in Council of 5 December 1978 of 638 square metres of land being Crown Allotment 23, Township of Quambatook, Parish of Quambatook as a site for Public Purposes (Teacher Housing Authority Purposes)—(Rs 10660).

**ROCHESTER WEST**—The temporary reservation for railway purposes by Order in Council of 23 November 1868 of the land comprised within the line of railway from Melbourne to Echuca, as fenced, so far only as the portion containing 1087 square metres being Crown Allotment 91f, Parish of Rochester West as shown on Certified Plan No. 111133 lodged in the Central Plan Office—(GL/16338).

**TRARALGON**—The temporary reservation by Order in Council of 11 October 1977 of 895 square metres of land being Crown Allotment 22c, Parish of Traralgon as a site for Public Purposes (Departmental Residence)—(Rs 10461).

Dated 15 July 1992

Responsible Minister:

**BARRY PULLEN**

Minister for Conservation and Environment

**DAMIEN O'SHEA**

20090 Acting Clerk of the Executive Council

*Victoria Government Gazette*

*Crown Land (Reserves) Act 1978*  
NOTICE OF INTENTION

The Governor in Council under section 10 of the *Crown Land (Reserves) Act 1978* gives notice of intention to revoke the following temporary reservations:

**FERNIHURST**—The temporary reservation by Order in Council of 14 November 1887 of 8094 square metres of land in the Township of Fernihurst, Parish of Mysia as a site for a State School—(E.13252).

**JIKA JIKA**—The temporary reservation by Order in Council of 27 June 1967 of 2656 square metres of land in the Parish of Jika Jika as a site for Public Purposes (Car Park), revoked as to part by Order in Council of 11 February 1986, so far as the balance remaining containing 1608 square metres, more or less—(Rs 8815).

**KATUNGA**—The temporary reservation by Order in Council of 5 November 1975 of 893 square metres of land being Crown Allotment 17c, Section C, Parish of Katunga as a site for Public Purposes (Police Purposes)—(Rs 10089).

**MOORABBIN**—The temporary reservation by Order in Council of 16 September 1889 of 3035 square metres of land in the Parish of Moorabbin as a site for Railway Purposes—(Rs 37009).

**NAR NAR GOON**—The temporary reservation by Order in Council of 28 August 1962 of 3060 square metres, more or less, of land in the Parish of Nar Nar Goon as a site for Police purposes, so far only as the portion containing 1031 square metres being Crown Allotment 43e, Parish of Nar Nar Goon as shown on Certified Plan No. 111353 lodged in the Central Plan Office—(Rs 8159).

Dated 15 July 1992

Responsible Minister:

**BARRY PULLEN**

Minister for Conservation and Environment

**DAMIEN O'SHEA**

20090 Acting Clerk of the Executive Council

*Crown Land (Reserves) Act 1978*  
CROWN LANDS TEMPORARILY  
RESERVED

The Governor in Council under sections 4 and 7 of the *Crown Land (Reserves) Act 1978* temporarily reserves for the purposes mentioned and also nominates as areas for which consent of

*Victoria Government Gazette*

the person or manager administering or managing the lands is required before work may be done on those lands in accordance with the *Mineral Resources Development Act 1990*, the following Crown lands:

**MUNICIPAL DISTRICT OF THE SHIRE OF  
KOWREE**

**GOROKE**—Public Recreation, 6199 square metres being Crown Allotment 9C, Parish of Goroce as shown on Certified Plan No. 76421 lodged in the Central Plan Office—(Rs 1575).

**MUNICIPAL DISTRICT OF THE SHIRE OF  
WIMMERA**

**WALLUP**—Public Recreation, 162 square metres being Crown Allotment 118c, Parish of Wallup as shown on Certified Plan No. 102893 lodged in the Central Plan Office—(Rs 6285).

Dated 15 July 1992

Responsible Minister:

**BARRY PULLEN**

Minister for Conservation and Environment

**DAMIEN O'SHEA**

20090 Acting Clerk of the Executive Council

*Crown Land (Reserves) Act 1978*

**SCOTTS CREEK MECHANICS INSTITUTE  
RESERVE**

**Appointment of Trustees**

The Governor in Council under section 12 of the *Crown Land (Reserves) Act 1978* appoints:

Colin Spokes

Peter Baker

as trustees of the land being Crown Allotment 5, Section 2, Township of Cooriejong (now Township of Scotts Creek) permanently reserved as a site for a Mechanics Institute and Free Library by Order in Council of 19 March 1889 in the place of—

Charles Henry Nunn

William John Neal

Robert Jones

Robert Louis Ashmore—(Rs 2837).

Dated 15 July 1992

Responsible Minister:

**BARRY PULLEN**

Minister for Conservation and Environment

**DAMIEN O'SHEA**

20090 Acting Clerk of the Executive Council

G 27 15 July 1992 1821

**TOMATO PROCESSING INDUSTRY  
DEVELOPMENT ORDER**

**1. Citation**

This industry development order may be cited as the Tomato Processing Industry Development Order 1992.

**2. Order made under the Agricultural Industry Development Act 1990.**

This Order is made under Part 4A of the *Agricultural Industry Development Act 1990*.

**3. Purposes of Order**

The purposes of this Order are—

(a) to set up a Committee—

(i) to recommend prices to be paid by processors to producers for processing tomatoes grown in the State;

(ii) to recommend the terms and conditions of payment;

(iii) to recommend grade standards and grading procedures for tomatoes purchased by processors;

(b) to determine provisions to be included in contracts between producers and processors for the supply or purchase of tomatoes for processing; and

(c) to provide a means of settling disputes between producers and processors about the grading of tomatoes purchased by processors.

**4. Definitions**

In this Order—

“Act” means the *Agricultural Industry Development Act 1990*.

“Committee” means the Tomato Industry Negotiating Committee.

“Processor” includes a person who purchases tomatoes from a producer for resale to a processor.

“Producer” means—

(a) a person by whom, or on whose behalf, tomatoes are grown; and

(b) if tomatoes are grown or produced for sale by a partnership or under a share farming agreement, the partnership or the parties to that agreement—

but does not include a person engaged as an employee on wages or salary or piece work rates.

“Tomatoes” means any tomatoes grown in the State and used or intended to be used for processing.

1822 G 27 15 July 1992

*5. Term of Order*

This order comes into operation on its publication in the *Government Gazette* and remains in force for four years from that date.

*6. Establishment of a Committee*

There shall be a "Tomato Industry Negotiating Committee".

*7. Members*

The Committee shall consist of nine members appointed by the Minister being—

- (a) the chairperson who is an officer of the public service employed in the Department of Food and Agriculture; and
- (b) the four producer members of the Tomato Processing Industry Negotiating Committee as constituted immediately before the repeal of the *Tomato Processing Industry Act 1976*; and
- (c) the four processor members of the Tomato Processing Industry Negotiating Committee as constituted immediately before the repeal of the *Tomato Processing Industry Act 1976*.

*8. Chairpersons voting rights*

The Chairperson has a casting vote on the question of recommended prices, if the Committee does not otherwise agree on that question. The Chairperson is not entitled to vote on any other question arising at a meeting of the Committee.

*9. Function to recommend prices*

- (1) The Committee must recommend prices for tomatoes purchased by a processor.
- (2) The Committee may recommend different prices for tomatoes according to—
  - (a) the grade of the tomatoes; or
  - (b) the purpose of which they are used or intended to be used.
- (3) The Committee may adjust a recommended price if it is of the opinion that it is appropriate to do so because of changed circumstances.

*10. Function to recommend terms and conditions of payment*

- (1) The Committee must recommend the terms and conditions of payment by processors for tomatoes.
- (2) The terms and conditions of payment recommended by the Committee may include all or any of the following—

*Victoria Government Gazette*

- (a) maximum amounts which should be deducted from the price otherwise payable for tomatoes;
  - (b) times of payment;
  - (c) interest penalties for non-compliance with times of payment.
- (3) If the Committee fails to make a recommendation about the terms and conditions of payment, the Committee must recommend the terms and conditions recommended by it for the previous year.
- (4) In the case of the first recommendation made by the Committee after its appointment, if the Committee fails to make that recommendation, the terms and conditions fixed under the *Tomato Processing Industry Act 1976* (as in force immediately before the commencement of this Schedule) for the 1992 harvest are to be recommended.

*11. Function to recommend grade standards and grading procedures*

- (1) The Committee must recommend grade standards and grading procedures for tomatoes purchased by processors.
- (2) The grade standards may include permissible levels of material other than tomatoes, ripeness and total soluble solids content.
- (3) The grading procedures may include sampling methods and analytical techniques to measure total soluble solids.
- (4) If the Committee fails to make a recommendation about the grade standards and grading procedures for tomatoes purchased by processors, the Committee must recommend the terms and conditions recommended by it for the previous year.
- (5) In the case of the first recommendation made by the Committee after its appointment, if the Committee fails to make that recommendation, the grade standards and grading procedures fixed under the *Tomato Processing Industry Act 1976* (as in force immediately before the commencement of this Schedule) for the 1992 harvest are to be recommended.

*12. Market report*

The Committee must prepare a report on the market outlook for the industry at least once in every year and must prepare such a report whenever a recommendation is made about prices or terms and conditions of payment.

13. *Publication of market outlook, prices and terms and conditions*

The Committee must publish any report prepared on the market outlook and any recommended prices or terms and conditions of payment at the same time and in the same manner being in a newspaper or other publication which circulates throughout the State.

14. *Meetings*

(1) The Committee must meet in a timely manner to enable it to recommend prices, terms and conditions of payment, quality standards and grading procedures before planting and no later than 1 September.

(2) A meeting of the Committee may be convened by notice in writing given by the chairperson, the four producer members or the four processor members.

(3) Such a notice must be given to all other members at least seven days before the proposed meeting.

15. *Provisions to be included in contracts*

Contracts between producers and processors for the supply or purchase of tomatoes must include provisions for—

- (a) the quantity of tomatoes;
- (b) the price to be paid for particular grades of tomatoes;
- (c) the terms and conditions of payment;
- (d) grade standards;
- (e) the point and method of delivery of tomatoes to the processor;
- (f) weighing, sampling and grading requirements;
- (g) the time after delivery before which processors are to advise producers on results of grade determinations which result in price discounting;
- (h) a delivery schedule specifying the time periods during which specified quantities of tomatoes are to be delivered to the processor.

16. *Resolution of disputes*

If there is a dispute between a producer and a processor about the grade of tomatoes delivered for processing or grading procedures an authorised officer may determine the dispute if he or she is requested to do so by both the producer and the processor within 24 hours after the tomatoes have been delivered to the processor.

17. *Powers of an authorised officer*

For the purpose of resolving a dispute between a producer and a processor an authorised officer may enter the premises of a processor or a producer used for the purpose of processing or producing tomatoes but not a place of residence.

18. *Financial year*

The financial year of the Committee is the period from 1 July to 30 June.

19. *Voting*

For the purpose of voting at a future poll on the making of a new Order, a producer who delivered tomatoes to a processor in the immediate preceding year is eligible to vote.

20. *Codes of Practice*

(1) Where a code of practice has been prepared for the tomato processing industry by the Australian Tomato Processors Association and the Victorian Farmers Federation (Tomato Section), the Committee must review that code of practice at its first meeting for each year.

(2) Upon reviewing a code of practice, the Committee may make recommendations to the bodies who made the code about amendments to the code.

(3) If amendments are made to the code, the bodies who made those amendments must cause them to be published in a newspaper circulating generally throughout the State or in a publication circulating generally to growers and processors in the State within 30 days of having been made.

Dated 15 July 1992

Responsible Minister:

IAN BAKER

Minister for Food and Agriculture

DAMIEN O'SHEA

20020 Acting Clerk of the Executive Council

*Land Act 1958*

UNUSED ROAD CLOSED

The Governor in Council under section 349 of the *Land Act 1958* and with the consent in writing of the municipality concerned closes the following unused road:

MUNICIPAL DISTRICT OF THE SHIRE OF  
KOWREE

KARNAK—The road in the Township of Karnak, Parish of Karnak as indicated by hatching on plan hereunder—(K 132[3]) (Rs 497).

1824 G 27 15 July 1992

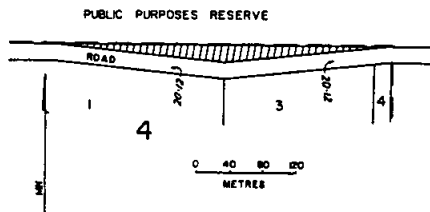

Dated 15 July 1992  
 Responsible Minister:  
**BARRY PULLEN**  
 Minister for Conservation and Environment  
**DAMIEN O'SHEA**  
 20090 Acting Clerk of the Executive Council

*Land Act 1958*  
**UNUSED ROADS CLOSED**

The Governor in Council under section 349 of the *Land Act 1958* and with the consents in writing of the municipalities concerned and the adjoining owners closes the following unused roads:

**MUNICIPAL DISTRICT OF THE SHIRE OF KOWREE**

**CHARAM**—The road in the Parish of Charam as indicated by hatching on plan hereunder—(C 387[3]) (Rs 35049).

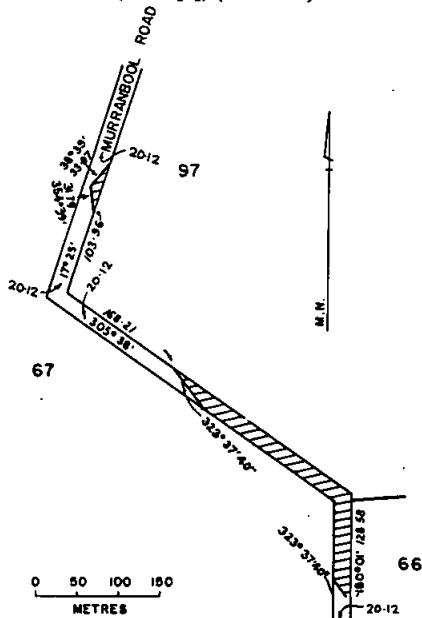

*Victoria Government Gazette*  
**MUNICIPAL DISTRICT OF THE SHIRE OF DAYLESFORD AND GLENLYON**

**HEPBURN**—The road in the Township of Hepburn, Parish of Wombat shown as 'Crown Allotment 18a, Section 13 on Certified Plan, No. 110938 lodged in the Central Plan Office—(L1-3768).

Dated 15 July 1992  
 Responsible Minister:  
**BARRY PULLEN**  
 Minister for Conservation and Environment  
**DAMIEN O'SHEA**  
 20090 Acting Clerk of the Executive Council

**LAND ACT 1958**

The Governor in Council under section 22A (4) of the *Land Act 1958* amends the metes and bounds described in Part 1 (a) of the Second Schedule to the *Port of Geelong Authority Act 1958* by excision therefrom of the lands in the Parish of Moolap bordered red on plans marked A Corio 5000/7-06, and B Corio 5000/8-06 attached to Department of Conservation and Environment correspondence No. L1-4164—(L1-4164).

Dated 15 July 1992  
 Responsible Minister:  
**BARRY PULLEN**  
 Minister for Conservation and Environment  
**DAMIEN O'SHEA**  
 20090 Acting Clerk of the Executive Council

*Land Act 1958*  
**ABOLITION OF COMMON**

The Governor in Council under section 184 of the *Land Act 1958* abolishes the following Common:

**CARAMUT**—The remaining portions of the Caramut Town Common in the Township of Caramut proclaimed on 20 November 1865 and 14 October 1869—(Rs 417).

Dated 15 July 1992  
 Responsible Minister:  
**BARRY PULLEN**  
 Minister for Conservation and Environment  
**DAMIEN O'SHEA**  
 20090 Acting Clerk of the Executive Council



**EXCHANGE OF RESERVED FOREST FOR CROWN LAND**

The Governor in Council under section 49 of the *Forests Act 1958* authorises, in exchange for the Crown land described in Dedication Schedule No. 304 hereunder, the excision of the land described in Excision Schedule No. 222 hereunder from Reserved Forest.

**DEDICATION SCHEDULE No. 304**

An area of 1.004 hectares of Crown land in the Parish of Winyangung as indicated by hatching on plan hereunder—(W 250[9]) (L2/559).

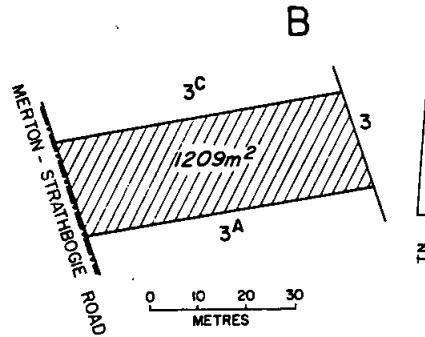

Dated 15 July 1992  
 Responsible Minister:  
**BARRY PULLEN**  
 Minister for Conservation and Environment  
**DAMIEN O'SHEA**  
 20090 Acting Clerk of the Executive Council

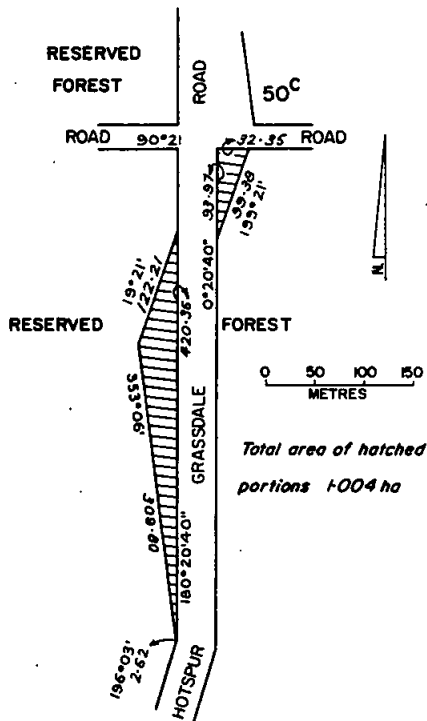

**FARM PRODUCE WHOLESALE ACT 1990**

The Governor in Council, acting under section 31 of the *Farm Produce Wholesale Act 1990* authorises and requires wholesalers—

- (a) to deduct from a payment to a producer of Queensland produce marketed in Victoria an amount which is calculated at the rate specified in the Schedule below, such amount being the marketing levy which is payable by a producer to the Queensland Fruit and Vegetable Growers under the Fruit Marketing Organisation Act 1923–1980 (Queensland);
- (b) to remit any amount so deducted to the Queensland Fruit and Vegetable Growers.

**SCHEDULE**

Produce	Unit	Rate of Marketing Levy
Papaw	per package	31 cents

Dated 15 July 1992  
 Responsible Minister:  
**IAN BAKER**  
 Minister for Food and Agriculture  
**DAMIEN O'SHEA**  
 20020 Acting Clerk of the Executive Council

**EXCISION SCHEDULE No. 222**

An area of 1209 square metres of Reserved Forest in the Parish of Strathbogie as indicated by hatching on plan hereunder—(S 444[3]) (L7/4204).

1826 G 27 15 July 1992

*Dairy Industry Act 1984*  
VICTORIAN DAIRY INDUSTRY  
AUTHORITY

The Governor in Council under section 44 (15) of the *Dairy Industry Act 1984* approves the following Determination of milk prices made by the Victorian Dairy Industry Authority.

Dated 15 July 1992

Responsible Minister:

IAN BAKER

Minister for Food and Agriculture

DAMIEN O'SHEA

Acting Clerk of the Executive Council

DETERMINATION

This Determination is made by the Victorian Dairy Industry Authority under the powers conferred by section 44 of the *Dairy Industry Act 1984* after consultation with the Prices Commissioner and shall come into operation on 1 August 1992.

The Determination of milk prices made by the Victorian Dairy Industry Authority and published in the *Government Gazette* dated 29 April 1992, 27 May 1992 and 24 June 1992, is amended as follows:

For Part 3 of the Determination substitute:

Part 3

PRICES PAYABLE FOR MILK SUPPLIED  
TO PROCESSORS BY THE AUTHORITY

The Authority has determined that the following prices must be paid for milk sold by the Authority to milk processors:

- (a) Standardised raw milk for processing as daily pasteurised milk for sale in Victoria will be—
  - (i) for flavoured milk and low fat flavoured milk marketed under processor (non VDIA) brands—48.25 cents per litre;
  - (ii) for all other milk—49.01 cents per litre.
- (b) Standardised raw milk for processing as daily pasteurised milk for sale in Australia but outside Victoria will be—
  - (i) for flavoured milk and low fat flavoured milk marketed under processor (non VDIA) brands—47.73 cents per litre;
  - (ii) for all other milk—47.73 cents per litre.

*Victoria Government Gazette*

- (c) Standardised raw milk for processing as daily pasteurised milk for sale by export will be 26.17 cents per litre where the milk is appropriated in accordance with section 37 (4) (c) of the *Dairy Industry Act 1984* and 28.52 cents per litre when delivered by the Authority to milk processing premises.
- (d) Standardised raw milk for processing as daily pasteurised ultra filtered milk for sale in Victoria will be 37.71 cents per litre.
- (e) Standardised raw milk for processing as daily pasteurised ultra filtered milk for sale in Australia but outside Victoria will be 37.33 cents per litre.
- (f) Standardised raw milk for processing as daily pasteurised reverse osmosis milk "Challenge" for sale in Victoria will be 40.10 cents per litre.
- (g) Standardised raw milk for processing as daily pasteurised reverse osmosis milk "Challenge" for sale in Australia but outside Victoria will be 39.69 cents per litre.
- (h) Standardised raw milk for processing as ultra heat treated milk for sale in Australia will be 30.39 cents per litre where the milk is appropriated in accordance with section 37 (4) (c) of the *Dairy Industry Act 1984* and 32.74 cents per litre when delivered by the Authority to milk processing premises.
- (i) Standardised raw milk for processing as ultra heat treated milk for sale by export will be 26.17 cents per litre where the milk is appropriated in accordance with section 37 (4) (c) of the *Dairy Industry Act 1984* and 28.52 cents per litre when delivered by the Authority to milk processing premises.
- (j) Standardised raw milk for processing as reverse osmosis ultra heat treated milk "Challenge" for sale in Australia will be 28.76 cents per litre where the milk is appropriated in accordance with section 37 (4) (c) of the *Dairy Industry Act 1984*.
- (k) Standardised raw milk for processing as sterilised milk for sale by export will be 26.17 cents per litre where the milk is appropriated in accordance with section 37 (4) (c) of the *Dairy Industry Act 1984* and 28.52 cents per litre when

*Victoria Government Gazette*

delivered by the Authority to milk processing premises.

- (l) Standardised raw milk for processing as daily pasteurised organic and bio-dynamic milk for sale in Victoria will be 53.03 cents per litre.
- (m) Standardised raw milk for processing as daily pasteurised organic and bio-dynamic milk for sale in Australia but outside Victoria will be 51.63 cents per litre.

I. D. SAULWICK  
Chairman

20020

*Environment Protection Act 1970*  
VARIATION OF STATE ENVIRONMENT  
PROTECTION POLICY (SITING AND  
MANAGEMENT OF LANDFILLS  
RECEIVING MUNICIPAL WASTES)

The Governor in Council under section 16 (2) of the *Environment Protection Act 1970* and on the recommendation of the Environment Protection Authority, the State Environment Protection Policy (Siting and Management of Landfills Receiving Municipal Wastes) as follows:

Dated 15 July 1992

Responsible Minister:  
BARRY PULLEN

Minister for Conservation and Environment  
DAMIEN O'SHEA  
Acting Clerk of the Executive Council

For clause 19 (e) substitute—

19 (e) Pneumatic automotive tyres (including any tyre which is made either wholly or partly of natural or synthetic rubber or similar material)—

- (i) on and from 1 August 1992 must not be deposited for disposal onto land at any landfill site which serves more than 50 000 persons unless the tyres have been shredded into pieces not exceeding 250 millimetres in size in any dimension;
- (ii) on and from 1 July 1993 must not be deposited for disposal onto land at any landfill site which serves 50 000 persons or less unless the tyres have been shredded into pieces not exceeding 250 millimetres in size in any dimension.

20210

G 27 15 July 1992 1827

ROYAL BOTANIC GARDENS ACT 1991

The Governor in Council under section 17 (1) of the *Royal Botanic Gardens Act 1991* places under the management of the Royal Botanic Gardens Board the area of 2.614 hectares being Crown Allotment F, City of Melbourne, Parish of Melbourne South permanently reserved as a site for Public Park, Gardens and Herbarium by Order in Council of 9 October 1979 (see *Victoria Government Gazette* of 17 October 1979, page 3230)—(Rs 1041).

Dated 15 July 1992

Responsible Minister:  
BARRY PULLEN

Minister for Conservation and Environment  
DAMIEN O'SHEA

20090 Acting Clerk of the Executive Council

*Murray Darling Basin Act 1992*

APPOINTMENT OF A DEPUTY  
COMMISSIONER FOR VICTORIA TO THE  
MURRAY DARLING BASIN COMMISSION

The Governor in Council under section 5 of the *Murray Darling Basin Act 1982* and Clause 9 of the River Murray Waters Agreement as amended by the Murray Darling Basin Agreement, appoints David James Dole as a Deputy Commissioner of the Murray Darling Basin Commission, for a period of three years from 1 July 1992 to 30 June 1995.

Dated 30 June 1992

Responsible Minister:  
STEVE CRABB

Minister for Water Resources

DAMIEN O'SHEA

20720 Acting Clerk of the Executive Council

*Local Government Act 1958*

CITY OF HEIDELBERG  
Confirmation of Separate Rate

The Governor in Council acting under section 287 of the *Local Government Act 1958* confirms a separate rate made by the Council of the City of Heidelberg on 23 March 1992 for the purpose of providing funds for the revitalisation of The Mall, West Heidelberg.

Dated 15 July 1992

Responsible Minister:  
CAROLINE HOGG

Minister for Ethnic,  
Municipal and Community Affairs

DAMIEN O'SHEA

20460 Acting Clerk of the Executive Council

**PRIVATE  
ADVERTISEMENTS**

**BELLARINE RURAL CITY COUNCIL**  
Notice of adoption of proposal under section  
539c (9) of the *Local Government Act 1958*  
Whereas—

1. The Council at its meeting on 15 April 1992, resolved to approve a proposal for the closure of Moonaree Road, Leopold (or part thereof) to through traffic by the erection of barriers.
2. The Council served notice of the proposal and the owners and occupiers listed in the proposal and sought and obtained a report on the proposal from the Roads Corporation.
3. No objections to the proposal were received.

Now notice is hereby given that the Council has by Order adopted the proposal without modification and resolved that the Order come into operation on 20 July 1992.  
Dated 10 July 1992

19043 P. L. WIGNALL  
Municipal Clerk

*Planning and Environment Act 1987*  
**CITY OF CROYDON**  
Notice of Amendment to a Planning Scheme  
Amendment L52

The Council of the City of Croydon has prepared Amendment L52 to the Croydon Planning Scheme.

The amendment proposes to rezone Lot 31, Plymouth Road from Croydon Residential Low/Croydon Residential Development Zone to Road—Proposed Widening to enable acquisition of the land by Vic Roads.

The amendment can be inspected at Municipal Offices, City of Croydon, Civic Square, Croydon; Department of Planning and Housing, The Oldfleet Buildings, 477 Collins Street, Melbourne.

Submissions about the amendment must be sent to City of Croydon, P.O. Box 206, Croydon 3136 by Monday, 17 August 1992  
Dated 7 July 1992

19044 T. L. MAHER  
Chief Executive Officer

*Planning and Environment Act 1987*  
**CITY OF CROYDON**  
Notice of Amendment to a Planning Scheme  
Amendment L36

The Council of the City of Croydon has prepared Amendment L36 to the Croydon Planning Scheme.

The amendment proposes to rezone Nos. 51 and 58–66 Bayfield Road from Croydon Residential Low Zone to Croydon Light Industrial Zone.

The amendment can be inspected at Municipal Offices, City of Croydon, Civic Square, Croydon; Department of Planning and Housing, The Oldfleet Buildings, 477 Collins Street, Melbourne.

Submissions about the amendment must be sent to City of Croydon, P.O. Box 206, Croydon 3136 by Friday, 14 August 1992

Dated 6 July 1992  
19048 T. L. MAHER  
Chief Executive Officer

*Planning and Environment Act 1987*  
**DANDENONG PLANNING SCHEME**  
Notice of Amendment to a Planning Scheme  
Amendment L17

The City of Dandenong has prepared Amendment No. L17 to the Dandenong Planning Scheme.

The amendment changes the Local Section of the Dandenong Planning Scheme.

The amendment will—

- rezone the area generally bounded by Foster, Langhorne, Wilson and Pultney Streets from Residential "C" zone to Dandenong Legal Precinct zone;
- insert a new clause into the planning scheme to control the use and development of land within this zone;
- enable the redevelopment and expansion of the existing Dandenong Police and Law Courts facilities to occur subject to an approved development plan without the need for a planning permit;
- ensure any redevelopment protects the amenity of adjoining residential land.

The amendment can be inspected at City of Dandenong Town Planning Department, Municipal Offices, 39 Clow Street, Dandenong;

*Victoria Government Gazette*

Department of Planning and Housing, Ground Floor, The Olderfleet Buildings, 477 Collins Street, Melbourne; Department of Planning and Housing, Metropolitan South and Westernport Region, 33-39 High Street, Cranbourne.

Submissions about the amendment must be sent to: City Manager, City of Dandenong, P.O. Box 333, Dandenong 3175; attention: Manager Planning and Development, by Monday, 17 August 1992.

Dated 10 July 1992

JEREMY S. WOOD  
19070 Manager Planning and Development

CITY OF MALVERN

Making of Local Law 7/92—Keeping of Caravans, Trailers and Boats

Notice is hereby given that at its meeting held on 29 June 1992, the Council of the City of Malvern made a Local Law for the purpose of regulating and prohibiting the leaving or standing of caravans, trailers or boats on streets or roads and the placing of caravans on property within the municipality of the City of Malvern.

A copy of this Local Law is available for inspection at the Municipal Offices corner High Street and Glenferrie Road, Malvern, between the hours of 9.00 a.m. and 5.00 p.m. Monday to Friday.

D. A. CARTLEDGE  
19042 Town Clerk

CITY OF MALVERN  
Making of Local Law 8/92  
Keeping of Bees

Notice is hereby given that at its meeting held on 29 June 1992, the Council of the City of Malvern made a Local Law for the purpose of regulating the keeping of bees within the City of Malvern.

A copy of this Local Law is available for inspection at the Municipal Offices, corner High Street and Glenferrie Road, Malvern between the hours of 9.00 a.m. and 5.00 p.m. Monday to Friday.

D. A. CARTLEDGE  
19091 Town Clerk

CITY OF MELBOURNE  
Proposed Local Law  
Queen Victoria Market Local Law

Notice is hereby given that at a meeting of the Council of the City of Melbourne held on 13 July 1992 the Council resolved to propose to

G 27 15 July 1992 1829

make a Local Law titled "Queen Victoria Market Local Law 1992" pursuant to the provisions of the *Local Government Act* 1989.

The objectives of this Local Law are to—

- (a) provide for the regulation and government of the Market;
- (b) regulate the activities of persons in the Market; and
- (c) regulate the sale of goods and services in the Market.

The Local Law is necessary to re-enact the provisions of the existing Queen Victoria Market By-law and subsequent amending By-laws which are scheduled to be repealed on 1 October 1992.

The Local Law is a substantially reformatted version of the existing By-law and Market rules which have been in place since 1983, and entitled "Conditions Effecting Stallholders Open Standings". The Local Law enables the full introduction of the new trader payments system, the licensing of traders, the power to issue infringement notices and to seize goods.

The Local Law provides for the Council to determine Rules governing the Market. These Rules will be made concurrently with the Local Law and follow the same submission process. The Rules govern conduct of persons within the Market, including the various types of Market users such as stallholders, stallholders' employees, public, box hire operators and the table and trestle hire operators.

A copy of the Local Law and Rules may be obtained from the Management Services Division, 3rd Floor, Town Hall, Swanston Street, Melbourne free of charge during office hours (i.e. 8.00 a.m. to 5.00 p.m. daily from Monday to Friday).

Any person affected by the proposed Local Law or Rules may make a submission relating to the proposed Local Law and Rules under section 233 of the *Local Government Act* 1989. Only submissions received by the Council within 14 days of publication of this notice shall be considered.

The Council has determined that the Economic and Corporate Services Committee will consider any written submissions received within the designated period of time, and hear any persons who may wish to be heard in support of their written submission, at a meeting to be held at 5.30 p.m. Wednesday, 3 August 1992 on the 2nd Floor, Town Hall, Swanston Street, Melbourne. Persons making written

1830 G 27 15 July 1992

submissions should clearly state whether they wish to be heard in support of their submission.

Submissions should be addressed to the Town Clerk, Town Hall, Swanston Street, Melbourne, 3000 and must be lodged at the Town Hall no later than 5.00 p.m. Wednesday, 20 July 1992.

Persons making submissions will be notified in writing of the Council's decision following consideration of these submissions.

19051 Town Clerk J. A. YOUNG

CITY OF MELBOURNE  
Parking Local Law 1992  
No. 12 of 1992

Notice is given that at a meeting of the Council of the City of Melbourne held on 13 July 1992, the Council made a Local Law titled "Parking Local Law 1992" pursuant to the provisions of the *Local Government Act 1989*.

The objectives of the Local Law are—

- (a) in relation to fixed items for parking areas—
  - (i) to establish for fixed items—
    - (a) how they may vary and are to be sufficiently indicated; and
    - (b) when they are to come into operation;
  - (ii) to stipulate how parking fees are to be paid;
  - (iii) to state requirements for tickets obtained from ticket-dispensing machines to be valid; and
  - (iv) to constitute offences for contraventions of restrictions and requirements imposed by fixed items;
- (b) to constitute offences for other actions in parking areas; and
- (c) to provide generally for the control and management of parking areas.

The Local Law replaces the provisions of section 555A of the *Local Government Act 1958* for erection and enforcement of "green" parking signs for time limits and fees. It will come into operation upon the repeal of the section 555A scheduled for 1 October 1992.

A copy of the Local Law can be inspected at or purchased from the Management Services Division, 3rd Floor, Town Hall, Swanston Street, Melbourne, during office hours (i.e. 8.00 a.m. to 5.00 p.m. daily from Monday to Friday).

19052 Town Clerk J. A. YOUNG

Victoria Government Gazette

CITY OF MELBOURNE

Permits Services and Fees (Amendment) Local Law

No. 13 of 1992

Notice is given that at a meeting of the Council of the City of Melbourne held on 13 July 1992, the Council made a Local Law titled "Permits Services and Fees (Amendment) Local Law 1992" pursuant to the provisions of the *Local Government Act 1989*.

The objective of the Local Law is to amend the Permits Services and Fees Local Law 1990 (No. 4 of 1990) to provide for fees for the Council's Parks and Gardens Division and Melbourne Electricity.

The Local Law further amends the original Local Law by the addition of a Schedule 2.

A copy of the Local Law may be inspected at or purchased from the Management Services Division, 3rd Floor, Town Hall, Swanston Street, Melbourne, during office hours (i.e. 8.00 a.m. to 5.00 p.m. daily from Monday to Friday).

19053 J. A. YOUNG  
Town Clerk

*Planning and Environment Act 1987*  
MELBOURNE PLANNING SCHEME  
Notice of Amendment  
Amendment L93

The City of Melbourne has prepared Amendment L93 to the Melbourne Planning Scheme.

The amendment introduces a new clause in the Local Section Part 1 of the Scheme affecting the Melbourne Residential 1R2 Zone to facilitate the use, development and subdivision of land at 400-410 Racecourse Road, Flemington for the purposes of a 24 hour police station.

The land is to be developed in accordance with the plan named "Flemington 24 Hour Police Station 400-410 Racecourse Road, Flemington" sheet TP1-TP4 inclusive.

The amendment is available for inspection at the Department of Planning and Housing, The Oldfleet Buildings, 477 Collins Street, Melbourne; the City of Melbourne, Council House, 200 Little Collins Street, Melbourne.

Submissions must be lodged by 10 August 1992 with the City of Melbourne, Strategic Planning Branch, GPO Box 1603M, Melbourne.

19054

*Victoria Government Gazette*  
**CITY OF MILDURA**  
**Road Discontinuance**

Pursuant to section 528 (2) of the *Local Government Act 1958* ("the Act"), the Council of the City of Mildura ("the Council") at its Ordinary Meeting held on 29 June 1992, resolved that the road (laneway) between the west boundary of 67 Cureton Avenue and the east boundary of 59 Cureton Avenue, Mildura (shown hatched on the plan set out hereunder) be discontinued and the land shall vest in the municipality until it is sold by private treaty.

Notwithstanding such discontinuance, the Council, Sunraysia Water Board and the State Electricity Commission of Victoria shall continue to have and possess the same right, title, power, authority or interest in or in relation to the whole of the land as they had or possessed prior to such discontinuance with respect or in connection with drainage, sewerage or the supply of electricity and the land involved shall be encumbered for sewerage purposes.

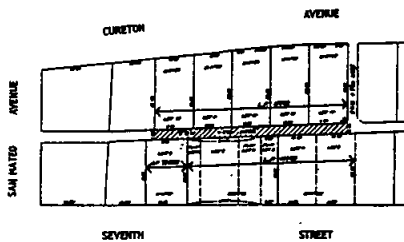

Dated 1 July 1992

19066

**CHRIS GILLARD**  
Municipal Clerk

**CITY OF MOORABBIN**  
**Dedication of Public Highway**

In accordance with section 522 of the *Local Government Act 1958* the Council of the City of Moorabbin at a Special Meeting on 6 July, 1992 by order has hereby directed that the land known as Lot 53 Hall Street, McKinnon on Plan of Subdivision 9559 and contained in Certificate of Title Volume 5458 Folio 536 acquired by the Council and shown by hatching below shall be a public highway and deemed to be dedicated to the public accordingly from date of publication of this notice in the *Government Gazette*.

G 27 15 July 1992 1831

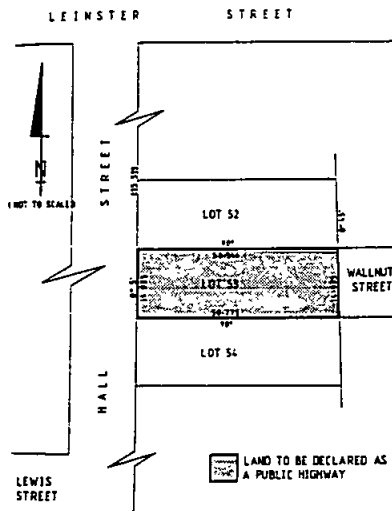

19079

**DOUG OWENS**  
City Manager

*Planning and Environment Act 1987*  
**CITY OF PRESTON**

**Notice of Amendment to a Planning Scheme**  
**Amendment L23**

The City of Preston has prepared Amendment L23 to the Local Section of the Preston Planning Scheme.

The amendment affects land at No. 7-15 Radford Road, Reservoir.

The amendment proposes to change the Planning Scheme by rezoning part of the land from Proposed Public Open Space to General Industrial Zone.

The amendment can be inspected at City of Preston, Planning Section, 1st Floor, 350 High Street, Preston; Ministry of Planning and Housing, Ground Floor, 477 Collins Street, Melbourne.

Submissions about the amendment must be sent to City of Preston, PO Box 91, Preston 3072 by 15 August 1992.

19065

**K. SPILLER**  
General Manager

1832 G 27 15 July 1992

CITY OF PRESTON

Notice is hereby given that the Council of the City of Preston proposes to make a Local Law pursuant to Part 5 of the *Local Government Act 1958* ("the Act").

This Local Law is:

No. 2 of 1992—Council Land (Obstructions and Behaviour).

The purpose of this Local Law is to:

- (a) Enable people to enjoy the use of Council Land without nuisance and disturbance from other people.
- (b) Regulate the use of Council Land.

A copy of the proposed Local Law can be obtained from Council's Municipal Offices, 350 High Street, Preston during normal office hours.

Any affected person may in relation to the proposed Local Law make a submission which will be considered in accordance with section 223 of the Act. 19098

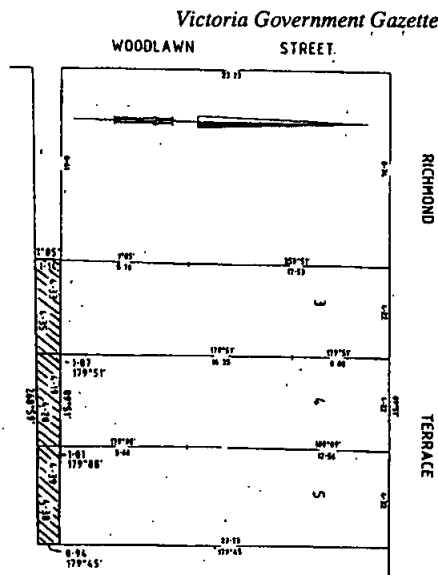

DAVID G. WILLIAMS  
Chief Executive Officer/  
Town Clerk

19058

CITY OF RICHMOND  
Road Discontinuance

Pursuant to section 528 (2) of the *Local Government Act 1958* (as amended), the Council of the City of Richmond, at its Ordinary Meeting of Council, held on 6 July 1992, resolved that section of the road, at the rear of Nos 56-60 Richmond Terrace, Richmond, which is shown by hatching on the plan herewith, be discontinued subject to:

- (a) Melbourne Water and the Mayor, Councillors and Citizens of the City of Richmond continuing to have and possess the same right, title, power, authority or interest in or in relation to the whole of the land shown by hatching on the said plan as it had or possessed prior to such discontinuance with respect to or in connection with any drains or pipes laid or erected in on or over such land for the purpose of drainage or sewerage.
- (b) The land in the said road subject to any such right, title, power, authority or interest vesting in the municipality to be retained by it until sold by private treaty.

CITY OF WILLIAMSTOWN

Notice of Proposed Local Law No. 3

The Council of the City of Williamstown has drafted a Processes of Municipal Government (Procedures for Meetings) Local Law.

This Local Law is made for the purposes of—

- (a) providing a mechanism to facilitate the good government of the City of Williamstown through its formal meeting procedure to ensure effective and efficient Council decisions are made in a manner which acknowledges the role of Local Government within the Australian system of Government;
- (b) to promote and encourage community participation in the system of local government by providing mechanisms for the Council to ascertain the communities view and expectations;
- (c) to regulate and control the election of Mayor;
- (d) to regulate and control the procedures governing the conduct of meetings including—
  - (i) the notice required for meetings;
  - (ii) the keeping of minutes;



- (e) to regulate and control the use of Council's seal;
- (f) to provide for the administration of the Council's powers and functions; and
- (g) to provide generally for peace, order and good government of the municipal district.

If made, this Local Law will replace and repeal Local Law No. 1 and By Laws 146 and 152.

A copy of the proposed Local Law can be obtained from the City of Williamstown, 104 Ferguson Street, Williamstown.

Any person affected by the proposed Local Law may make a submission relating to the proposed Local Law in accordance with section 223 of the *Local Government Act 1989* within 14 days of the publication of this notice.

Any person requesting to be heard in support of a written submission is entitled to appear before a meeting of the Council (or Committee) either personally or by a person acting on his or her behalf and will be notified of the time and date of the hearing.

R. A. McCLEAN  
19064 Chief Executive Officer

SHIRE OF ALBERTON  
Proposed Local Laws

Notice is hereby given that the Council of the Shire of Alberton at its meeting held on 29 June 1992 resolved to commence the procedure to make Local Laws pursuant to the *Local Government Act 1989*.

The purpose and general purport of the proposed Local Laws are—

- (a) to make provision for the use of the common seal;
- (b) to provide for the election of the Shire President and Deputy Shire President;
- (c) to regulate and control the meetings of Council and Council Committees;
- (d) to provide for the protection of Council land;
- (e) to provide for people to enjoy the use of Council land without nuisance or disturbance and to regulate the use of Council land including—
  - (i) Yarram Swimming Pool;
  - (ii) Municipal Library Service;
  - (iii) Municipal reserves and recreation lands;

- (iv) Port Albert Foreshore Reserve;
- (f) to control shopping trolleys on Council land and other public places;
- (g) to control advertising signs, display of goods and the placing of chairs and tables on footpaths in the commercial area of the Shire;
- (h) to prevent repairing of vehicles on roads;
- (i) to control the issue of special parking permits for disabled persons;
- (j) to regulate the selling of goods, other than from shops and to regulate house collections and house to house distributions of materials;
- (k) to protect the amenity of the municipal district—
  - (i) to control unsightly or dangerous land and to regulate the use of land for storage of old or secondhand motor vehicles and machinery;
  - (ii) to control trees and plants at intersections and trees overhanging roads;
- (l) to regulate camping and caravans on private property;
- (m) to regulate the use of incinerators;
- (n) to regulate the keeping of horses and cattle using roads;
- (o) to regulate the collection of night soil and the use of septic tanks;
- (p) to regulate the use of premises for keeping animals;
- (q) to regulate drains on private property;
- (r) to provide for minimum siting requirements for buildings in the Shire and minimum allotments sizes;
- (s) to allow for erection of outbuildings prior to dwellings in certain cases;
- (t) to set a maximum number of class one dwellings to be constructed on any allotment;
- (u) to regulate the construction of farm buildings;
- (v) to provide generally for the peace, order and good government of the municipal district;
- (w) to repeal By-laws 52, 56; 57, 58, 59, 61, 64, 65 and 66.

A copy of the proposed Local Laws can be obtained from the Shire of Alberton Municipal Office, 161 Commercial Road, Yarram.

1834 G 27 15 July 1992

Any person affected by the proposed Local Laws may make a submission relating to the proposed Local Laws, in accordance with section 223 of the *Local Government Act 1989*, within fourteen days of the publication of this notice.

Any person requesting to be heard in support of the written submission is entitled to appear before a meeting of the Council (or Committee) either personally or by a person acting on his or her behalf and will be notified of the time and date of the hearing.

G. J. STEPHENS  
19038 Chief Executive Officer

**SHIRE OF DUNMUNKLE**  
Local Laws Nos 2 and 3

Notice is hereby given that the Council of the Shire of Dunmunkle at its meeting on 7 July 1992, made the following two Local Laws.

**Local Law No. 2**  
Processes of Municipal Government

The purposes and general purport of Local Law No. 2 are to facilitate good government in the Shire of Dunmunkle, to encourage community participation, to regulate Council Meeting Procedures, to control use of the Council Seal and to provide for the administration of Council's powers and functions.

**Local Law No. 3**  
Library and Community Information

The purposes and general purport of Local Law No. 3 are to regulate access to, conduct within and membership and use of Council's Libraries, and to define the rights and obligations of members.

Copies of Local Laws Nos 2 and 3 are available, or may be inspected, at the Shire Office, 59 Cromie Street, Rupanyup during business hours.

E. N. WIDDICOMBE  
19097 Shire Secretary

**SHIRE OF ELTHAM**

**Order for Dedication of a Public Highway**

Pursuant to the provisions of section 203 (3) of the *Local Government Act 1989* the Council of the Shire of Eltham hereby directs that all pieces of land being delineated and shown hatched on the Plan drawn hereunder being part of the land described in Certificate of Titles

*Victoria Government Gazette*

Volume 7481 Folio 089 and Volume 7481 Folio 088 shall be a Public Highway on and from the due date of the publication of this order in the *Government Gazette*.

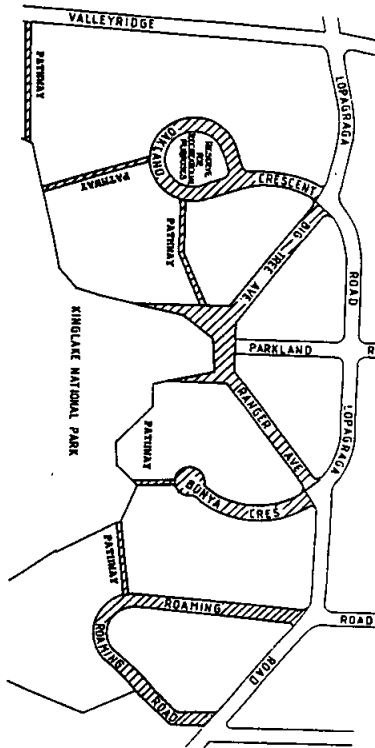

19041  
RODNEY J. ROSCHOLLER  
Chief Executive Officer

*Planning and Environment Act 1987*

**SHIRE OF HASTINGS**

**Notice of Amendment to a Planning Scheme  
Amendment L52**

The Shire of Hastings has prepared Amendment L52 to the Hastings Planning Scheme.

The amendment affects land at 114 Grants Road, Baxter, and proposes to change the Planning Scheme by rezoning part of the land from Intensive Farming to Public Purpose—Primary School.

The land proposed to be rezoned is approximately 0.57 hectares in area and is located immediately to the south of the existing Baxter East Primary School. It has a frontage of 35 metres to Grants Road and a depth of approximately 164 metres.

The proposed rezoning will allow the land to be acquired and developed for use by the Primary School.

The amendment can be inspected at the Shire Offices, Marine Parade, Hastings; the Department of Planning and Housing, 33–39 High Street, Cranbourne; and the Department of Planning and Housing, The Olderfleet Buildings, 477 Collins Street, Melbourne.

Submissions about the amendment must be sent to the Manager—Planning and Development, Shire of Hastings, P.O. Box 55, Hastings 3915 by 17 August 1992

19062 W. R. FEATHERSTON  
Chief Executive Officer

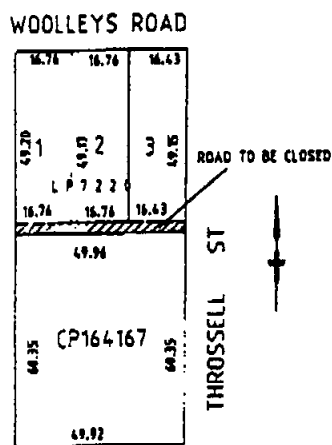

The road closure shall become effective upon publication of this resolution in the *Government Gazette*.

19074 W. R. FEATHERSTON  
Chief Executive Officer

SHIRE OF HASTINGS  
Closure of Road Abutting 54 Throssell Street,  
Bittern

The Council of the Shire of Hastings, having complied with the provisions of section 528 (2) of the *Local Government Act 1958* (as amended), passed the following resolution at its Council Meeting on 23 June 1992:

That Council, being of the opinion that the road abutting 54 Throssell Street, Bittern, as shown hatched on the diagram hereunder, is not reasonably required as a road for public use, having consulted with the relevant public statutory authorities, having published and given notice pursuant to section 528 (2) of the *Local Government Act 1958* (as amended), hereby resolves and directs that the road abutting 54 Throssell Street, Bittern, be discontinued and the land so discontinued shall vest in the municipality and shall be sold by private treaty.

The diagram below illustrates which section is to be closed.

Planning and Environment Act 1987  
SHIRE OF HEALESVILLE

Notice of Amendment to a Planning Scheme  
The Shire of Healesville has prepared Amendment No. 136 to the Healesville Planning Scheme.

The amendment affects land at Lots 25, 26, 53, 54 and 55, LP 1056 Francis Avenue, Yarra Glen.

The amendment proposes designating the above allotments as a Flood Fringe Policy Area.

The amendment can be inspected at the Shire of Healesville, 231 Maroondah Highway, Healesville; Upper Yarra Valley and Dandenong Ranges Authority, 7 John Street, Lilydale, and Ministry for Planning and Housing, Suite 4, 38–40 Prospect Street, Box Hill and at Ground Floor, 477 Collins Street, Melbourne.

Submissions about the amendment must be sent to the Shire of Healesville Private Bag No. 3, Healesville by 16 August 1992.

19050 STUART BOWRAN  
Manager, Local Development

1836 G 27 15 July 1992

SHIRE OF HEALESVILLE

Notice is hereby given that the Council of the Shire of Healesville at a meeting held on 28 April 1992, resolved in accordance with section 535 (4) of the *Local Government Act 1958* (as amended) to make the following road name change:

*Old Name:* Bakers Road.

*New Name:* Barkers Road.

For further enquiries please contact Stuart Chisholm on (059) 624777.

19059

G. R. PEACOCK  
Shire Secretary

SHIRE OF MELTON  
Proposed Local Laws

Notice is hereby given that Council intends to make Local Laws which are titled—

- Local Law No. 2 Camping
- Local Law No. 3 Streets and Roads (Traffic)
- Local Law No. 4 Control of Vehicles
- Local Law No. 5 Impounding of Stray Animals
- Local Law No. 6 Street Traders and Collectors
- Local Law No. 7 Open Air Burning and Incinerators

The proposed Camping Local Law provides for:

Regulation of camping on roads and land.

It would require a permit to be held before a tent, caravan or annex was occupied on any land. This would cover the common situation where owner/occupiers wish to live on their land for the duration of their homes construction. This Local Law would revoke our existing By-law 70 which deals with caravans and camping.

The proposed Streets and Roads (Traffic) Local Law provides for:

incorporation of some provisions of the *Local Government Act 1958* which are to be repealed including traffic diversions, road closures etc.

The proposed Control of Vehicles Local Law provides for:

regulation and control of the abandonment of vehicles within the municipal district;  
regulation and control of the unlawful obstruction, parking and standing of vehicles within the municipal district;  
the amenity of roads within the municipal district.

Victoria Government Gazette

It would create an offence for a person to leave an unregistered vehicle or abandon a vehicle in a street or on Council land. This Local Law will replace soon to be repealed sections of the *Local Government Act 1958*.

The proposed Impounding of Stray Animals Local Law provides for:

prohibiting owners of animals from permitting those animals to stray; and  
to provide for the impounding of stray animals.

It will make it an offence to allow animals such as horses, cows etc. to stray onto roads or land owned or occupied by another person. It would give Council's authorised officers or other persons the power to remove an animal from the road if it has strayed there and take it to our pound.

This will repeal Clause 306 of our existing Local Laws and will cover some of the areas currently legislated through the *Local Government Act 1958* and the *Pounds Act 1958*.

The proposed Street Traders and Collectors Local Law provides for:

regulation of use of streets and other places by persons dealing in goods and services; and  
regulation of practice of soliciting and collecting gifts of money and subscriptions.

It would require a permit to be held by a person prior to them dealing in goods on streets, vacant land, land not normally occupied by that person or on public places. Exceptions would be where a planning permit has been issued for a particular activity.

It would also require a street collector or service provider to obtain a permit. This would mean permits would be required for the sale of raffle tickets, provision of services for rewards (door-to-door selling) and collection of money for various purposes or causes e.g. charities.

This proposed Local Law will repeal Clauses 501 and 502 of our existing Local Laws, which deal with hawkers and peddlers and street appeals.

Open Air Burning and Incinerators (Internal) Local Law:

This is a re-draft of the existing Local Law which has operated since 1990 which provided for:

fire prevention and protection;  
the prohibition or regulation of the lighting of fires in the open air or in an incinerator;

minimising airborne particle pollution;  
environmental control protection and  
authorisation.

Copies of the proposed Local Laws are  
available on enquiry at the Civic Centre during  
office hours. Any person affected by this  
proposal may make a written submission to  
Council under section 223 of the *Local  
Government Act* 1989. Such submission should  
be submitted within 14 days of this notice.

Any person making a written submission may  
request to be heard in person or by a person  
acting on his or her behalf in support of their  
submission by appearing before the Council at a  
meeting scheduled to be held on Thursday, 27  
July 1992.

LINDSAY A. MERRITT  
19039 Chief Executive

*Planning and Environment Act* 1987  
RIPON PLANNING SCHEME—LOCAL  
SECTION, CHAPTER 2

Notice of Amendment to a Planning Scheme  
Amendment No. L9

The Shire of Ripon has prepared Amendment  
No. L9 to the Ripon Planning Scheme, Local  
Section, Chapter 2.

The amendment proposes to change the  
Planning Scheme by requiring the Responsible  
Authority, when considering whether or not to  
grant or refuse a permit, to have regard to the  
publication entitled "Beaufort Business Area  
Strategy".

The amendment and the publication entitled  
"Beaufort Business Area Strategy" can be  
inspected at the Offices of the Shire of Ripon,  
Lawrence Street, Beaufort and the Offices of the  
Department of Planning and Housing, State  
Government Offices, corner of Doveton and  
Mair Streets, Ballarat and The Olderfleet  
Buildings, 477 Collins Street, Melbourne.

Submissions about the amendment must be  
sent to the Shire of Ripon, Shire Offices,  
Lawrence Street, Beaufort by 2 September 1992.

PETER C. HUMPHRIES  
19055 Shire Engineer

*Planning and Environment Act* 1987  
RODNEY PLANNING SCHEME  
Notice of Amendment to a Planning Scheme  
Amendment No. L52

The Shire of Rodney has prepared  
Amendment No. L52 to the Rodney Planning  
Scheme.

The amendment affects land at the  
intersection of Echuca Road, Northgate Street  
and O'Brien Street, Mooroopna. The land is  
described as being Lots 1 and 2 LP 82264  
Section N, Parish of Mooroopna, Echuca Road  
and O'Brien Street, Mooroopna.

The amendment proposes to change the  
Planning Scheme by rezoning 1124.03 m<sup>2</sup> of  
land from Residential to Commercial A. The  
purpose of this amendment is to correct a  
clerical error made by staff during the execution  
of an earlier amendment to the Rodney Planning  
Scheme. This being Amendment L11 to the  
Rodney Planning Scheme.

The amendment can be inspected at Shire of  
Rodney, Shire Office, Casey Street, Tatura;  
North East/Goulburn Region, Ministry for  
Planning and Housing, North Eastern Office,  
State Offices, 1 McKoy Street, West Wodonga;  
Ministry for Planning and Housing, The  
Olderfleet Buildings, 477 Collins Street,  
Melbourne.

Submissions about the amendment must be  
sent to Shire of Rodney, Shire Offices, Casey  
Street, Tatura 3616 by 12 August 1992

TERRY W. ALFORD  
19056 Shire Engineer/Town Planner

DIOCESAN SYNOD 1992

Notice is hereby given that the Archbishop of  
Melbourne has convened the Second Session of  
the meeting of the Synod of the Anglican  
Church of Australia within the Diocese of  
Melbourne, Victoria, for Thursday, 8 October  
1992 at 7.00 p.m. at the Cathedral Church of St  
Paul in the State of Victoria.

JOHN M. LESTER  
19072 Registrar of the Diocese of Melbourne

*Livery and Agistment Act* 1958  
Section 8 (3)

To Mrs Emelinee Smith, c/o Post Office,  
Tooradin 3980—Take notice that on Sunday, 2  
August 1992 at the Royal Melbourne  
Showgrounds, cattle described as Thoroughbred  
Horse Un-named 1990 bay filly by Star  
Pyramul ex Give'N'Take (DOB 7-9-90) will be  
auctioned pursuant to the *Livery and Agistment  
Act* 1958 for settlement of amounts to 10 July  
1992 totalling \$2860.00 by Victorian  
Bloodstock Sales Pty. Ltd. 19073

## Effective Writing

### A Three Day Course

A training program structured in accordance with the provisions of the Commonwealth Training Guarantee Act, 1990

The Faculty of Education offers an intensive three day EFFECTIVE WRITING course which aims at providing the course participants with individual writing development. The course is suitable for people who currently write briefs, letters or reports as part of their duties, or who will soon be required to.

The topics covered include grammar problems, style, sentence and document construction, briefs, job applications and reports.

Training techniques will include exercises, discussions, lectures and films. Participants will receive feedback on the strengths and weakness of their writing skills from the course presenter, and other participants. A University certificate will be presented to each participant on completion of the course.

**Venue:** Downtowner Motel, Carlton

**Dates:** 7, 10, 11 August

**Times:** 9.00am - 4.30pm

**Cost:** \$600 (includes course handbook, a copy of Eagleson's book WRITING IN PLAIN ENGLISH, University certificate and morning and afternoon tea).

For further details and registration please contact:

**Val Oliver, Faculty of Education**

**Phone: (06) 201 2470**

**Fax: (06) 201 5065**

The University of Canberra is a member of the Unified National System and is sponsored by Monash University

1992

UNIVERSITY OF CANBERRA



UCB 148

- (d) The erection of buildings and subdivision;
- (e) Other potential developments and changes on the land in order to ensure its conservations.

Submissions with respect to the proposed Covenant may be made within one month of the publication of this notice in the *Government Gazette* to the Minister for Conservation and Environment (att. Mr N. Wale, Manager Environmental Planning) P.O. Box 41, East Melbourne 3002. Enquiries may be made direct to the Victorian Conservation Trust—Tel. (03) 651 4040. 19060

### NOTICE OF COVENANT

#### Section 3A—Victorian Conservation Trust Act

The owners of approximately 260 ha of land off the Harrow-Jullumba Road, Douglas being Allotment 112A, Parish of Toolongrook in the Shire of Kowree propose to enter into a Covenant with the Victorian Conservation Trust of 49 Spring Street, Melbourne with regard to for the purpose of:

Protecting the native trees, wildlife and other special features by regulating:

- (a) The introduction of flora and fauna not indigenous to the area;
- (b) The grazing of stock;
- (c) The keeping of domestic animals;
- (d) The erection of buildings and subdivision;
- (e) Other potential developments and changes on the land in order to ensure its conservation.

Submissions with respect to the proposed Covenant may be made within one month of the publication of this notice in the *Government Gazette* to the Minister for Conservation and Environment (att. Mr N. Wale, Manager Environmental Planning) P.O. Box 41, East Melbourne 3002. Enquiries may be made direct to the Victorian Conservation Trust—Tel. (03) 651 4040. 19061

### NOTICE OF COVENANT

#### Section 3A—Victorian Conservation Trust Act

The owner of approximately 160 ha of land off Coliban Road, Trentham being Crown Portion 29 and Crown Allotments 27B, 30, 31A, 41, 42B and 43, Parish of Coliban in the Shire of Kyneton proposes to enter into a Covenant with the Victorian Conservation Trust of 49 Spring Street, Melbourne with regard to for the purpose of:

Protecting the native trees, wildlife and other special features by regulating:

- (a) The introduction of flora and fauna not indigenous to the area;
- (b) The grazing of stock;
- (c) The keeping of domestic animals;

### NOTICE OF DISSOLUTION OF PARTNERSHIP

Notice is hereby given that the partnership subsisting between Eleftherios Halikias and Mary Halikias and Haralambos Lambrakis and Tonia Lambrakis carrying on business as fruit and vegetable retailers at 21 Moore Street, Moe

*Victoria Government Gazette*

and 64 Moore Street, Moe under the name and style of Moe Fruit Market and Moe Plaza Fruit Mart was dissolved as from 18 March 1991, so far as the business concerns Eleftherios Halikias and Mary Halikias who have both retired from the said firm.

E. HALIKIAS  
M. HALIKIAS  
19078

Corporations Law  
ROBERTOL PROPRIETARY LIMITED  
(In Liquidation)  
Notice of Meeting of Members  
Pursuant to Section 509  
A.C.N. 004 214 797

Notice is hereby given that pursuant to section 509 of the Corporations Law, the final meeting of members of the abovenamed company will be held at the office of Allford Shugg of 152 Lime Avenue, Mildura on 20 August 1992 at eleven o'clock in the forenoon for the purpose of laying before the meeting the liquidator's final account and report and giving any explanation thereof.

Dated: 10 July 1992

P. J. SHUGG, Liquidator  
Allford Shugg, 152 Lime Avenue, Mildura  
19076

B. T. SOLUTIONS PTY. LTD.  
Notice of Application  
Notice of Application Under Section 460 of the  
Corporations Law  
A.C.N. 003 715 437

In Proceedings No. VG3179 of 1992 commenced on 16 June 1992, ACA Pacific Pty. Ltd. will apply to the Federal Court of Australia at 2.15 p.m. on 28 July 1992 at 450 Little Bourke Street, Melbourne for an order that B. T. Solutions Pty. Ltd. ("the Company") be wound up.

The Applicant's address for service is Hardham Dalton & Sundberg, solicitors, 12/271 William Street, Melbourne 3000.

Any contributory, member or creditor of the Company may appear at the hearing in person or by counsel or by a solicitor to support or oppose the making of an order to wind up the Company.

Subject to the Rules, the Registrar of the Court will permit a contributory, member, creditor or officer of the Company to inspect the application and any affidavit in relation to the application and will provide a copy of the

G 27 15 July 1992 1839

application and of any affidavit in relation to the application to a contributory, member, creditor or officer of the Company on payment of the prescribed fee.

Any person intending to appear at the Directions Hearing must comply with Order 71, sub-rule 37 (8) of the Federal Court Rules by filing a Notice of Appearance in Form 79 and serving that Notice of Appearance on the Applicant at its address for service shown above not later than 2 days before the date appointed for Directions under Order 4, rule 8. This notice is inserted by Hardham Dalton & Sunberg of 12/271 William Street, Melbourne, solicitors for the Applicant. 19100

EDWIN ALEXANDER WILKINS, late of Natya in the State of Victoria, farmer, deceased

Creditors, next of kin and other persons having claims against the estate of the said deceased who died on 31 October 1991 are required to send particulars of same to the executrix Elaine Joan Wilkins in care of the undersigned on or before 21 September 1992 after which date she will distribute the assets having regard only to the claims of which she then has notice.

DWYER MAHON & ROBERTSON,  
barristers and solicitors, 194-208 Beveridge  
Street, Swan Hill 19096

Creditors, next of kin and others having claims in respect of the estate of Alan William McFarlane late of 7 Fiddes Street, Moorabbin Victoria, retired public accountant, deceased, are required by the Applicant for Letters of Administration with the will annexed, namely Joan Hazel Funston of 10 Hastings Street, Wendouree, Victoria, home duties, to send particulars of any such claims to the estate solicitors, Messrs N. D. Kelly & Associates of 437 Centre Road, Bentleigh, Victoria, by 18 September 1992, after which date the said applicant in her capacity as administratrix as aforesaid may convey or distribute the assets of the deceased, having regard only to the claims of which she or the said solicitors then have notice.  
Dated 15 July 1992

N. D. KELLY & ASSOCIATES, solicitors,  
437 Centre Road, Bentleigh, solicitors for the  
said applicant for administration 19101

## Unclaimed Moneys Act 1962

## Register of Unclaimed Moneys held by the—

Name of Owner on Books and Last Known Address	Total Amount Due to Owner	Description of Unclaimed Money	Date when Amount first became Payable
\$			
VAMGAS LTD			
265 Elizabeth Street Pty Ltd, c/o Reginald V McFadzean, GPO Box 4910, Sydney, NSW	256.00	Dividend	3.6.88
Abisaab, George, c/o Joseph Dahdah & Company, 266 Cleveland St, Sydney, NSW	25.60	"	"
Abrahams, Anthony M, 6 Rue Teodule Ribot 75017, Paris, France	25.60	"	"
Adams, Patricia N, 16 Monomeath Ave, Canterbury	25.60	"	"
Aiderson, Robert W, 76 Hawkestone St, North Cottesloe, WA	12.80	"	"
Allen, Christopher J, 38 Hughes St, Woodville, SA	12.80	"	"
Anderson, Ann P, 32 Cope St, Lane Cove, NSW	25.60	"	"
Andrews, Grahame P, c/o Merz Clennan & Partners, Goldsworthy, WA	25.60	"	"
Barock, Peter, 37 Guruwa St, Woomera, SA	12.80	"	"
Barker Holdings Pty Ltd, 20 Ewing St, Garden Suburb, NSW	51.20	"	"
Barker, John W, Flat 4, 1 Bates St, East Malvern	51.20	"	"
Barlow, John R, 11/29 Gannons Ave, Dolls Point, NSW	12.80	"	"
Bateson, Don M, c/o Commonwealth Bank of Aust, Mitchell, Qld	12.80	"	"
Bayley, Clive S, c/o M J Hobbs & Co, GPO Box 4914, Sydney, NSW	128.00	"	"
Beattie, Robert, PO Box 106, Woomera, SA	12.80	"	"
Beaver, Norman L, Mount Ida via Menzies, WA	12.80	"	"
Bills, Meredith M, 7 Hazelmere Rd, Glengowrie, SA	25.60	"	"
Birkelund, John R, 15 Bosworth St, Hamersley, WA	25.60	"	"
Black, Lynette R, 11/230 Glebe Point Rd, Glebe, NSW	51.20	"	"
Booth, Betty J, 645 South Rd, Moorabbin	64.00	"	"
Borelli, Jules J, 108 Martin St, Gardenvale	25.60	"	"
Braithwaite, Margaret M, PO Box 43, Rose Bay, NSW	12.80	"	"
Brandli, Walter, 65/59 Malcolm St, West Perth, WA	12.80	"	"
Broad, Allen J, 10 McPherson Ave, Carnegie	25.60	"	"
Brown, David T and Gladys, 6/37 Osborne St, Wollongong, NSW	12.80	"	"
Brown, Roslyn M, 26 Byron St, Wyong, NSW	12.80	"	"
Brown, Sheila M, 26 Byron St, Wyong, NSW	12.80	"	"
Bruce, Eileen A, 10/42 Alfred St, Prahran	12.80	"	"
Bull, Audrey, 85 Carrington Rd, Wahroonga, NSW	24.00	"	"
Cameron, Margot (estate of) and Kenneth McD, PO Box 57, Mermaid Beach, Qld	25.60	"	"
Campbell, Robin E, Woden, Queanbeyan, NSW	25.60	"	"
Canning, Robert E, c/o Kamwala Secondary School, P.O. Box 30505, Lusaka, Zambia	19.20	"	"
Capper, Vera Kezia, 1 Station St, Pymble, NSW	38.40	"	"
Carpenter, Alwyn J, 6 Ellen St, Harbord, NSW	25.60	"	"
Carr, Jeffrey Keston (estate of), c/o Eric D Elwing, Commercial Bank Chambers, Mary St, Gympie, Qld	25.60	"	"
Carter, Agnes, 115 Hawken Dve, St. Lucia, Qld	102.40	"	"
Carter, Edward S, Victoria House, 175 Goderich St, East Perth, WA	128.00	"	"
Challenor, Graham M, PO Box 62, Roebourne, WA	25.60	"	"
Chang, Phyllis (estate of), c/o Gillis Delaney, 75 Elizabeth St, Temple Crt, Sydney, NSW	12.80	"	"
Chmeliauskas, Stanley T, 42 Dickson Ave, Artarmon, NSW	51.20	"	"
Clifford, Neal D, 264 Burraneer Bay Rd, Caringbah, NSW	20.00	"	"
Clough, Robert L, Epenarra Station, Alice Spring, NT	38.40	"	"
Coombes, Robert M, GPO Box 1936, Bangkok, Thailand	25.60	"	"
Corne Sybil, 18/20 Warwick Ave, Cammeray, NSW	25.60	"	"
Cornfeld Investment Services Pty Ltd, 341 Military Rd, Mosman, NSW	128.00	"	"
Cruickshank, Robert G, 4 Manorvale Pde, Werribee	19.20	"	"



## Unclaimed Moneys Act 1962

## Register of Unclaimed Moneys held by the—

Name of Owner on Books and Last Known Address	Total Amount Due to Owner	Description of Unclaimed Money	Date when Amount first became Payable
\$			
VAMGAS LTD—continued			
Cudmore, Peter J, c/o J. W. Cudmore, 22 Pearce St, Caulfield	20.00	Dividend	3.6.88
Cudmore, Robert J, c/o J. W. Cudmore, 22 Pearce St, Caulfield	120.00	"	"
Curnow, Colin M, 18 Beta Cres, Panorama, SA	12.80	"	"
Curtis, Thomas J, 10 Violet St, Balgowlah, NSW	12.80	"	"
De Feu, Barry J, GPO Box H560, Perth, WA	12.80	"	"
Deloose, Odessa, 195 O'Sullivan Rd, Bellevue Hill, NSW	38.40	"	"
Delves, Sandra E, 71 Hotham St, East Melbourne	25.60	"	"
Dewar, Graham J, 11 Warandoo St, Gordon, NSW	25.60	"	"
Dodd, David, Keperra Drive-in Theatre, PO Box 102, Alderley, Qld	12.80	"	"
Doherty, Brian J (estate of), c/o C B H Rowlandson & Company, Suite, 1st Floor, Old Purser Bldg, 268 Old Northern Rd, Castle Hill, NSW	89.60	"	"
Doherty, Ross A, 8 Bilberry Ave, Bilgola Plateau, NSW	25.60	"	"
Donnelly, Benedict J, Box 717, Esperance, WA	25.60	"	"
Donoghoe, Michael L, 75 Proctor Pde, Chester Hill, NSW	25.60	"	"
Drane, Francis H, Unit 55, 29-35 Gerard St, Cremorne, NSW	25.60	"	"
Driver, Peter J and Janis S, c/o ANZ Banking Group Ltd, Lae, TPNG	25.60	"	"
Economos, Margarette J, 6 Wattle St, Fullarton, SA	102.40	"	"
Edwards, Alyson B, PO Box 172, Newcastle, NSW	25.60	"	"
Farrell, Gregory K, 75 Cowper St, Randwick, NSW	12.80	"	"
Fearnley, James R and Cecily L, Main Rd, Upper Brookfield, Qld	25.60	"	"
Ferguson, Joanna, 10 Coonil Cres, Malvern	12.00	"	"
Filip, Nikola, c/o Quantas Engineering, PO Box 126, Darwin, NT	12.80	"	"
Flanagan, William K, c/o Patrick & Co, 43 Northbourne Ave, Canberra, ACT	12.80	"	"
Fletcher, Lynette K, c/o 80 Banksia Tce, South Perth, WA	12.80	"	"
Foley, Margaret A, 43 Teele Ave, Somerville, Massachusetts, USA	12.80	"	"
Friems, Willi and Christine, Flat 4, 6 Albenca St, Mentone	64.00	"	"
Fuller, Stephen R, 95 Brook St, Muswellbrook, NSW	12.80	"	"
Gardiner, Don, c/o Maxdon Developments, PO Box 104, Beaconsfield, NSW	128.00	"	"
Gaskin, John H, 19 Albert St, Claremont, WA	12.80	"	"
Geegan, Ellen A, 68 Ryeland St, Miller, NSW	128.00	"	"
Geikie, Nancy J, 6/393 Pacific Hwy, Lindfield, NSW	38.40	"	"
George, David O, 37 Wolsley Tce, Ascot Park, SA	12.80	"	"
Gibson, Frederick R, 22 Bushwood Rd, Kew Garden, Richmond, Surrey, UK	12.00	"	"
Goderson, Neil K and Magdalena, Box 183, West Perth, WA	12.80	"	"
Goldman, Wera, c/o 33 Onslow St, Rose Bay, NSW	153.60	"	"
Goodwin, Reginald, 42 Harvey Ave, Netley, SA	12.80	"	"
Gosselin, Doris, 29 Eastern Rd, Turramurra, NSW	25.60	"	"
Graham, Charles E, The Paddock, Kinsale, Co Cork, Ireland	76.80	"	"
Greenhill, Aloisia, 10 Idmiston St, Elizabeth Centre, SA	25.60	"	"
Guy, John L, 44 Tupil Cres, Boronia	12.80	"	"
Haber, Harry F, 14 Liverpool Rd, Croydon, NSW	51.20	"	"
Haage, Paul D, 2/1A Marathon Rd, Darling Point, NSW	12.80	"	"
Hall, Clive G, 41A Arkana Rd, Balga, WA	76.80	"	"
Hallowes, Mary L, Flat 2, 21 Grange Rd, Toorak	12.80	"	"
Harper, Reginald H, 2/112 Old South Rd, Bondi Junction, NSW	12.80	"	"
Harris, Michele, c/o E S & A Bank Ltd, 365 George St, Sydney, NSW	12.80	"	"
Herbert, Jeffrey and Coombes, John, c/o P Berney, 21 Sycamore Dve, Duncraig, WA	12.80	"	"
Herrmann, Richard P, 100 Grandview Dve, Newport, NSW	51.20	"	"

## Unclaimed Moneys Act 1962

## Register of Unclaimed Moneys held by the—

Name of Owner on Books and Last Known Address	Total Amount Due to Owner	Description of Unclaimed Money	Date when Amount first became Payable
\$			
VAMGAS LTD—continued			
Hickey, Aileen A, 35 Elizabeth St, Mentone	12.80	Dividend	3.6.88
Holberton, John A, 14 Monaro Cres, Red Hill, NSW	12.80	"	"
Holden, Roger R, 638-11 Street, Evanston, Michigan, USA	12.80	"	"
Hope, Carol M, c/o Bechtel Pacific, PO Box 61, Port Hedland, WA	12.80	"	"
Humeniuk, Tadeuz and Dorniak, Bohdan and Chawter, Myrosiaw, 7 The Grove, Woodville, SA	25.60	"	"
Humphries, Mavis E, 33 Fishing Point Rd, Rathmines, NSW	12.80	"	"
Hunt, Peter A, 39 The Boulevard, Lilyfield, NSW	51.20	"	"
Irwin, Samuel E, 14/1 Wando Gve, East St Kilda	25.60	"	"
Jackel Nominees Pty Ltd, c/o Morien & Co, 201 Balaclava Rd, Caulfield	51.20	"	"
Jackson, Peter M, 30 Wahroonga Ave, Wattle Park, SA	12.80	"	"
Johnston, Frederick S, 13 Canning Rd, Kalamunda, WA	12.80	"	"
Johnston, Joan, c/o Redden & Murtagh, PO Box 572, Geelong	12.80	"	"
Jones, Alan C, Hawkesbury Agric College, Richmond, NSW	12.80	"	"
Kandaiya, Kulaseragham, Flat 2, 5 Hardy St, Hollywood, WA	12.80	"	"
Kasinowski, Lubow, 2 Glenview St, Paddington, NSW	51.20	"	"
Keddie, Peter McK, PO Box 59, Port Kembla, NSW	64.00	"	"
Kelen, George, c/o Residents Quarters, Royal Prince Alfred Hospital, Camperdown, NSW	38.40	"	"
Kelly, Maurice Q, 12/63 Moray St, New Farm Qld	25.60	"	"
Kemp, Elvie V, Flat 8, 27 Ormond Rd, Elwood	25.60	"	"
Kimpton, Janice E, 56 Peacock Pde, Belrose, NSW	51.20	"	"
Kiosoglous, Antonie M (estate of), c/o Lewis Abbott & Company, 8 Greenhill Rd, Wayville, SA	64.00	"	"
Kipluks, John P, 10-15 Palmer St, Jolimont	64.00	"	"
Knuckey, Trevor J, 34 Barton Ave, Haberfield, NSW	12.80	"	"
Krishnasamy, Pragasamoorthi, Flat 2, 5 Hardy St, Nedlands, WA	12.80	"	"
Layton, Brian (estate of), c/o W & H Alker, 15 Caunce St, Blackpool, UK	64.00	"	"
Lee, Anthony, c/o Wolff Dunlop & Co, 23 Hamilton St, Sydney, NSW	12.80	"	"
Leggett, Vera J, 50 Francis St, Carlton, NSW	25.60	"	"
Leigh, Jack, 155 Swanston St, Melbourne	12.80	"	"
Leinweber, Joseph, 368 Dowling St, Paddington, NSW	25.60	"	"
Levy, Jillian B, PO Box 1604, Chatswood, NSW	20.00	"	"
Long, Lee J, 30/7 Gilbert St, Rose Bay, NSW	12.80	"	"
Lory, Damian, 3 Quandolain Cl, Ivanhoe East	25.60	"	"
Manojlovic, Peter, 64 Gourlay St, Balaclava	12.80	"	"
Martin, Elsinore M, 23 Astelot Dve, Donvale	25.60	"	"
Mason, Lionel J, PO Box 958, Mount Isa, Qld	51.20	"	"
McElhinney, Adrian J, 1 Blackwood Ave, Morningside, Qld	19.20	"	"
McKellar, Kenneth S, Unit 4, 8 Macleay St, Potts Point, NSW	40.00	"	"
McLeish, Stuart, 4/33 Dalley St, Queenscliff, NSW	12.80	"	"
McMahon, Russell T and Cecelia M, 5 Winifred St, Mosman Park, WA	25.60	"	"
McMaster, Helen M, 44 Ruby St, West Essendon	25.60	"	"
McNeill, Ronald W, PO Box 76, Redfern, NSW	12.80	"	"
McPherson, Alexander, Unit 5 "Fourwinds", 22 Buderim Ave, Alexnadra Headland, Qld	32.00	"	"
Morris, Dennis P, 7/23 Shirley Rd, Wollstonecraft, NSW	25.60	"	"
Morton, Alvin R, PO Box 116, Tennant Creek, SA	25.60	"	"
Moss, Edwin R and Mary MacD, PO Box 73, Southport, Qld	25.60	"	"
Murdoch, Patricia J, 40 Franklin Rd, Doncaster East	12.80	"	"
Musche, Joseph (estate of), 12 Acorn Rd, Dundrum, Dublin, Eire	25.60	"	"

## Unclaimed Moneys Act 1962

## Register of Unclaimed Moneys held by the—

Name of Owner on Books and Last Known Address	Total Amount Due to Owner	Description of Unclaimed Money	Date when Amount first became Payable
\$			
VAMGAS LTD—continued			
Nash, Robert M, 342 Victoria Ave, Chatswood, NSW	12.80	Dividend	3.6.88
Ngongataha Limited, GPO Box 4910, Sydney, NSW	256.00	"	"
Oftrowski, Cecil A, 50 Bruce Ave, Belfield, NSW	38.40	"	"
Osk Nominees SDN BHD, Berhad Lee Wah Bank Building, 2nd Floor, Room 207, Kuala Lumpur, Malaysia	38.40	"	"
OSullivan, Peter D, 101 Palmer St, Woolloomooloo, NSW	25.60	"	"
Owen, John M, c/o Unit 6, 1328 Dandenong Rd, Chadstone	12.80	"	"
Packer, Geoffrey A, 7 King Edward St, Pymble, NSW	12.80	"	"
Parry, Gwendoline R, 39 Wybalena Rd, Hunters Hill, NSW	64.00	"	"
Paynter, Julie, 3 Marne St, Surrey Hills	12.80	"	"
Peryman, Lyane, 27 Carrol St, Kogarah, NSW	12.80	"	"
Peters, James, 36 Neil St, Kangaroo Flat	51.20	"	"
Ping, Lee Ching, c/o Wah Tin Co Ltd, 29 Tai Yip St, Kwun Tong, Kowloon, Hong Kong	16.00	"	"
Porteus, Robert D and Clune, Vincent P, 7 Third Ave, Applecross, WA	25.60	"	"
Preiss, Vera, 93 Whitby Rd, Kings Langley, NSW	25.60	"	"
Quaill, Barry W and Lambert, Arnold G, 58 Griffith St, Coolangatta, Qld	38.40	"	"
Ralston, Martin K, 44/9-11 Corrimal St, Wollongong, NSW	38.40	"	"
Rice, Ian G, 14 Western Pde, Brooklyn Park, SA	19.20	"	"
Roberts, Ian R and Anthony C, 3 Lakewood Crt, West Lakes, SA	51.20	"	"
Roberts, Ronald J, 125 Guildford Rd, Bassendean, WA	12.80	"	"
Robinson, Phillip, Flat 3, 7 Railway Ave, Armadale	64.00	"	"
Robson, Annie D, 8 Adderstone Ave, North Sydney, NSW	25.60	"	"
Rohen, Bridie, 59 Hayes St, Neutral Bay, NSW	89.60	"	"
Ross, Jack, PO Box 56, Nunawading	12.80	"	"
Rudski, Shaw, 315 Hawthorn Rd, Caulfield	12.80	"	"
Runciman, Heather M, 56 Ronald Ave, Greenwich, NSW	38.40	"	"
Ryne, Dennis, c/o Meda Station via Derby, WA	10.88	"	"
Schultz, Dorothy M, 10 Cartledge Way, Sale	25.60	"	"
Schwarz, Angioletta, 31 Wallace Ave, Toorak	102.40	"	"
Shankly, Elizabeth A, 16 St Georges Rd, Toorak	25.60	"	"
Skipper, John, PO Box 242, Dannevirke, NZ	128.00	"	"
Smith, Arthur J, c/o Central Share Registry, GPO Box 505H, Melbourne	25.60	"	"
Spencer, John W, 16 Farnan St, Westgarth	12.80	"	"
Steele, Sandra, c/o Nurses Home, Prince Henrys Hospital, Melbourne	12.80	"	"
Stewart, Raymond D, 6a Norton Ave, Riverview, Qld	25.60	"	"
Sutton, John M and Joan C, 14 Burunda St, Como, NSW	128.00	"	"
Tapperell, Geoffrey Q, c/o ANZ Bank Ltd, Strand, London, UK	25.60	"	"
Teakle, Patricia, 5 Omaha St, Belfield, NSW	12.80	"	"
Thompson, Clive E, Bowen, Ernest C and Gardner, Frank A, 49/53 Wentworth Ave, Sydney, NSW	12.80	"	"
Thoroughgood, Terresse, 177 Doncaster Ave, Kensington, NSW	128.00	"	"
Tiernam, Lesley M, 2/22 Lamrock Ave, Bondi, NSW	12.80	"	"
Todd, Ronald, PO Box 39, Winton, NZ	12.80	"	"
Tyson, Gregory C, 92A Main St, Leehan, Tas	12.80	"	"
Wall, Geoffrey, 3 Burrabirra Ave, Vaulcluse, NSW	12.80	"	"
Wallace, James L, 19 Pile St, Marrickville, NSW	25.60	"	"
Wang, Sweding, 243 Carrington Rd, Coogee, NSW	38.40	"	"
Ward, Denis K, 19 Rabbitt St, Frenchs Forest, NSW	51.20	"	"
Watkins, John E and Jennifer C, PO Box 1556, Boroko, TPNG	25.60	"	"
Watson, Andrew W, 15 Stanhope Rd, Killara, NSW	12.80	"	"

## Unclaimed Moneys Act 1962

## Register of Unclaimed Moneys held by the—

<i>Name of Owner on Books and Last Known Address</i>	<i>Total Amount Due to Owner</i>	<i>Description of Unclaimed Money</i>	<i>Date when Amount first became Payable</i>
\$			
VAMGAS LTD—continued			
Weingott, Frances H, 24 Deakin St, Auburn, NSW	12.80	Dividend	3.6.88
Welch, Jean F, 85 Alexandria Pde, Wahroonga, NSW	38.40	"	"
Wenck, Brian, 45 Hillsdon Rd, Taringa, Qld	25.60	"	"
West, Ronald I, Commercial Bank of Australia, Canberra, ACT	12.80	"	"
William Mackay Pty Ltd, 30 Powell St, Killara, NSW	25.60	"	"
Wilson, Julia M and Nicholas C, 17 Hoseason St, Mawson, NSW	128.00	"	"
Winks, Rupert W, c/o GPO Box 505H, Melbourne	25.60	"	"
Witherspoon, John c/o Hawkesbury Agricultural, College, Richmond, NSW	25.60	"	"
Wyllie, William A, 8 Blenheim Rd, Lindfield, NSW	25.60	"	"
Yates, Michael, Flat 1, 282 New St, Brighton	12.80	"	"
Zammit, Bernard, c/o Consolidated Milk Ind, PO Box 22, Redfern, NSW	38.40	"	"
265 Elizabeth Street Pty Ltd, c/o Reginald V McFadzean, GPO Box 4910, Sydney, NSW	256.00	"	14.11.88
Abisaab, George, c/o Joseph Dahdah & Company, 266 Cleveland St, Sydney, NSW	25.60	"	"
Aiderson, Robert W, 76 Hawkestone St, North Cottesloe, WA	12.80	"	"
Allen, Christopher J, 38 Hughes St, Woodville, SA	12.80	"	"
Anderson, Ann P, 32 Cope St, Lane Cove, NSW	25.60	"	"
Andrews, Grahame P, c/o Merz Clennan & Partners, Goldsworthy, WA	25.60	"	"
Barcock, Peter, 37 Guruwa St, Woomera, SA	12.80	"	"
Barker Holdings Pty Ltd, 20 Ewing St, Garden Suburb, NSW	51.20	"	"
Barker, John W, Flat 4, 1 Bates St, East Malvern	51.20	"	"
Barlow, John R, 11/29 Gannons Ave, Dolls Point, NSW	12.80	"	"
Bateson, Don M, c/o Commonwealth Bank of Aust, Mitchell, Qld	12.80	"	"
Bayley, Clive S, c/o M J Hobbs & Co, GPO Box 4914, Sydney, NSW	128.00	"	"
Beattie, Robert, PO Box 106, Woomera, SA	12.80	"	"
Beaumont, Frederick G, 2 Sarah Crs, Templestowe	25.60	"	"
Beaver, Norman L, Mount Ida via Menzies, WA	12.80	"	"
Bills, Meredith M, 7 Hazelmere Rd, Glengowrie, SA	25.60	"	"
Birkelund, John R, 15 Bosworth St, Hamersley, WA	25.60	"	"
Black, Lynette R, 11/230 Glebe Point Rd, Glebe, NSW	51.20	"	"
Borelli, Jules J, 108 Martin St, Gardenvale	25.60	"	"
Braithwaite, Margaret M, PO Box 43, Rose Bay, NSW	12.80	"	"
Brandli, Walter, 65/59 Malcolm St, West Perth, WA	12.80	"	"
Brinawa Investments Pty Ltd, c/o T. F. W. M. Heath, 33 Curlew St, Toowong, Qld	256.00	"	"
Brown, David T and Gladys, 6/37 Osborne St, Wollongong, NSW	12.80	"	"
Brown, Roslyn M, 26 Byron St, Wyong, NSW	12.80	"	"
Brown, Sheila M, 26 Byron St, Wyong, NSW	12.80	"	"
Bruce, Eileen A, 10/42 Alfred St, Prahran	12.80	"	"
Bull, Audrey, 85 Carrington Rd, Wahroonga, NSW	24.00	"	"
Burns, Fiona, 25 Hall St, Moreland	12.80	"	"
Cameron, Margot (estate of) and Kenneth McD, PO Box 57, Mermaid Beach, Qld	25.60	"	"
Campbell, Robin E, Woden, Queanbeyan, NSW	25.60	"	"
Canning, Robert E, c/o Kamwala Secondary School, P.O. Box 30505, Lusaka, Zambia	19.20	"	"
Capper, Vera K, 1 Station St, Pymble, NSW	38.40	"	"
Carpenter, Alwyn J, 6 Ellen St, Harbord, NSW	25.60	"	"
Carr, Jeffrey K (estate of), c/o Eric D Elwing, Commercial Bank Chambers, Mary St, Gympie, Qld	25.60	"	"

## Unclaimed Moneys Act 1962

## Register of Unclaimed Moneys held by the—

<i>Name of Owner on Books and Last Known Address</i>	<i>Total Amount Due to Owner</i>	<i>Description of Unclaimed Money</i>	<i>Date when Amount first became Payable</i>
\$			
VAMGAS LTD—continued			
Carter, Aletha A, 25 Anthony St, Ascot, Qld	128.00	Dividend	14.11.88
Carter, Edward S, Victoria House, 175 Goderich St, East Perth, WA	128.00	"	"
Challenor, Graham M, PO Box 62, Roebourne, WA	25.60	"	"
Chang, Phyllis (estate of), c/o Gillis Delancy, 75 Elizabeth St, Temple Crt, Sydney, NSW	12.80	"	"
Chmeliauskas, Stanley T, 42 Dickson Ave, Artarmon, NSW	51.20	"	"
Clough, Robert L, Epenarra Station, Alice Springs, NT	38.40	"	"
Coombes, Robert M, GPO Box 1936, Bangkok, Thailand	25.60	"	"
Corne, Sybil, 18/20 Warwick Ave, Cammeray, NSW	25.60	"	"
Cornfeld Investment Services Pty Ltd, 341 Military Rd, Mosman, NSW	128.00	"	"
Cudmore, Peter J, c/o J. W. Cudmore, 22 Pearce St, Caulfield	20.00	"	"
Curnow, Colin M, 18 Beta Cres, Panorama, SA	12.80	"	"
Curtis, Thomas J, 10 Violet St, Balgowlah, NSW	12.80	"	"
De Feu, Barry J, GPO Box H560, Perth, WA	12.80	"	"
Deloose, Odessa, 195 O'Sullivan Rd, Bellevue Hill, NSW	38.40	"	"
Delves, Sandra E, 71 Hotham St, East Melbourne	25.60	"	"
Dent, Jean M, 5 Zoocoli St, Coonamble, NSW	25.60	"	"
Dewar, Graham J, 11 Warandoo St, Gordon, NSW	25.60	"	"
Dodd, David, Keperra Drive-in Theatre, PO Box 102, Alderley, Qld	12.80	"	"
Doherty, Brian J (estate of), c/o C B H Rowlandson & Company, Suite 1st Floor, Old Purser Bldg, 268 Old Northern Rd, Castle Hill, NSW	89.60	"	"
Doherty, Ross A, 8 Bilberry Ave, Bilgola Plateau, NSW	25.60	"	"
Donnelly, Benedict J, Box 717, Esperance, WA	25.60	"	"
Donoghoe, Michael L, 75 Proctor Pde, Chester Hill, NSW	25.60	"	"
Drane, Francis H, Unit 55, 29-35 Gerard St, Cremorne, NSW	25.60	"	"
Driver, Peter J and Janis S, c/o ANZ Banking Group Ltd, Lae, TPNG	25.60	"	"
Economos, Margarette J, 6 Wattle St, Fullarton, SA	102.40	"	"
Edwards, Alyson B, PO Box 172, Newcastle, NSW	25.60	"	"
Farrell, Gregory K, 75 Cowper St, Randwick, NSW	12.80	"	"
Fearnley, James R and Cecily L, Main Rd, Upper Brookfield, Qld	25.60	"	"
Filip, Nikola, c/o Qantas Engineering, PO Box 126, Darwin, NT	12.80	"	"
Flanagan, William K, c/o Patrick & Co, 43 Northbourne Ave, Canberra, ACT	12.80	"	"
Fletcher, Lynette K, c/o 80 Banksia Tce, South Perth, WA	12.80	"	"
Foley, Margaret A, 43 Teele Ave, Somerville, Massachusetts, USA	12.80	"	"
French, Mary T, PO Box 314, Locust Valley, Long Island, New York, USA	25.60	"	"
Friems, Willi and Christine, Flat 4, 6 Albenca St, Mentone	64.00	"	"
Fuller, Stephen R, 95 Brook St, Muswellbrook, NSW	12.80	"	"
Gardiner, Don, c/o Maxdon Developments, PO Box 104, Beaconsfield, NSW	128.00	"	"
Gaskin, John H, 19 Albert St, Claremont, WA	12.80	"	"
Geegan, Ellen A, 68 Ryeland St, Miller, NSW	128.00	"	"
George, David O, 37 Wolseley Tce, Ascot Park, SA	12.80	"	"
Gibson, Frederick R, 22 Bushwood Rd, Kew Garden, Richmond, Surrey, UK	12.00	"	"
Goderson, Neil K and Magdalena, Box 183, West Perth, WA	12.80	"	"
Goodwin, Reginald, 42 Harvey Ave, Netley, SA	12.80	"	"
Gosselin, Doris, 29 Eastern Rd, Turrumurra, NSW	25.60	"	"
Greenhill, Aloisia, 10 Idmiston St, Elizabeth Centre, SA	25.60	"	"
Guy, John L, 44 Tulip Cres, Boronia	12.80	"	"
Haber, Harry F, 14 Liverpool Rd, Croydon, NSW	51.20	"	"

## Unclaimed Moneys Act 1962

## Register of Unclaimed Moneys held by the—

<i>Name of Owner on Books and Last Known Address</i>	<i>Total Amount Due to Owner</i>	<i>Description of Unclaimed Money</i>	<i>Date when Amount first became Payable</i>
\$			
VAMGAS LTD— <i>continued</i>			
Haegge, Paul D, 2/1A Marathon Rd, Darling Point, NSW	12.80	Dividend	14.11.88
Hall, Chive G, 41A Arkana Rd, Balga, WA	76.80	"	"
Hallowes, Mary L, Flat 2, 21 Grange Rd, Toorak	12.80	"	"
Hammond, Stanley R, 161 Sixth Avenue, Inglewood, WA	17.60	"	"
Harper, Reginald H, 2/112 Old South Rd, Bondi Junction, NSW	12.80	"	"
Harris, Michele, c/o E S & A Bank Ltd, 365 George St, Sydney, NSW	12.80	"	"
Henchman, Peter H, 48 Chisholm St, Greenwich, NSW	12.80	"	"
Herbert, Jeffrey and Coombes, John, c/o P Berney, 21 Sycamore Dve, Duncraig, WA	12.80	"	"
Herrmann, Richard P, 100 Grandview Dve, Newport, NSW	51.20	"	"
Hickey, Aileen A, 35 Elizabeth St, Mentone	12.80	"	"
Hirst, Ronald G, 72 Moverly Rd, Kingsford, NSW	76.80	"	"
Holberton, John A, 14 Monaro Cres, Red Hill, NSW	12.80	"	"
Holden, Roger R, 638-11 Street, Evanston, Michigan, USA	12.80	"	"
Hope, Carol M, c/o Bechtel Pacific, PO Box 61, Port Hedland, WA	12.80	"	"
Humphries, Mavis E, 33 Fishing Point Rd, Rathmines, NSW	12.80	"	"
Hunt, Peter A, 39 The Boulevard, Lilyfield, NSW	51.20	"	"
Ienace, Ivor, 2 Welby St, Coral Gable, Qld	38.40	"	"
Irwin, Samuel E, 14/1 Wando Gve, East St Kilda	25.60	"	"
Jackel Nominees Pty Ltd, c/o Morlen & Co, 201 Balaclava Rd, Caulfield	51.20	"	"
Jackson, Peter M, 30 Wahroonga, Ave, Wattle Park, SA	12.80	"	"
Jewel, Raymond, P, 359 Dowling St, Darlinghurst, NSW	25.60	"	"
Johnston, Joan, c/o Redden & Murtagh, PO Box 572, Geelong	12.80	"	"
Johnston, Rodger S, 14J 15-19 Onslow Ave, Elizabeth Bay, NSW	20.00	"	"
Jones, Alan C, Hawkesbury Agric College, Richmond, NSW	12.80	"	"
Kandaiya, Kulasseragham, Flat 2, 5 Hardy St, Hollywood, WA	12.80	"	"
Kasinowski, Lubow, 2 Glenview St, Paddington, NSW	51.20	"	"
Keddie, Peter McK, PO Box 59, Port Kembla, NSW	64.00	"	"
Kelen, George, c/o Residents Quarters, Royal Prince Alfred Hospital, Camperdown, NSW	38.40	"	"
Kelly, Maurice Q, 12/63 Moray St, New Farm, Qld	25.60	"	"
Kemp, Elvie V, Flat 8, 27 Ormond Rd, Elwood	25.60	"	"
Kimpton, Janice E, 56 Peacock Pde, Belrose, NSW	51.20	"	"
Kiosoglous, Antonie M (estate of), c/o Lewis Abbott & Company, 8 Greenhill Rd, Wayville, SA	64.00	"	"
Kipluks, John P, 10-15 Palmer St, Jolimont	64.00	"	"
Knuckey, Trevor J, 34 Barton Ave, Haberfield, NSW	12.80	"	"
Krishnasamy, Pragasamoorthi, Flat 2, 5 Hardy St, Nedlands, WA	12.80	"	"
Layton, Brian (estate of), c/o W & H Alker, 15 Caunce St, Blackpool, UK	64.00	"	"
Lee, Anthony, c/o Wolfe Dunlop & Co, 23 Hamilton St, Sydney, NSW	12.80	"	"
Leggett, Vera J, 50 Francis St, Carlton, NSW	25.60	"	"
Leigh, Jack, 155 Swanston St, Melbourne	12.80	"	"
Leinweber, Joseph, 368 Dowling St, Paddington, NSW	25.60	"	"
Levy, Jillian B, PO Box 1604, Chatswood, NSW	20.00	"	"
Leyden, Thais L, 4320 Tarpen La, Alexandria, Virginia, USA	12.80	"	"
Long, Lee J, 30/7 Gilbert St, Rose Bay, NSW	12.80	"	"
Lory, Damian, 3 Quandolan Cl, Ivanhoe East	25.60	"	"
Manojlovic, Peter, 64 Gourlay St, Balaclava	12.80	"	"
Martin, Elsinore M, 23 Astelot Dve, Donvale	25.60	"	"
Mason, Lionel J, PO Box 958, Mount Isa, Qld	51.20	"	"
McElhinney, Adrian J, 1 Blackwood Ave, Morningside, Qld	19.20	"	"

## Unclaimed Moneys Act 1962

## Register of Unclaimed Moneys held by the—

Name of Owner on Books and Last Known Address	Total Amount Due to Owner	Description of Unclaimed Money	Date when Amount first became Payable
§			
VAMGAS LTD—continued			
McLeish, Stuart, 4/33 Dalley St, Queenscliff, NSW	12.80	Dividend	14.11.88
McMahon, Russell T and Cecelia M, 5 Winifred St, Mosman Park, WA	25.60	"	"
McMaster, Helen M, 44 Ruby St, West Essendon	25.60	"	"
McNeill, Ronald W, PO Box 76, Redfern, NSW	12.80	"	"
McShane, Robert, 13 Macquarie St, Bolton Point, NSW	25.60	"	"
Morris, Dennis P, 7/23 Shirley Rd, Wollstonecraft, NSW	25.60	"	"
Morton, Alvin R, PO Box 116, Tennant Creek, SA	25.60	"	"
Moss, Edwin R and Mary MacD, PO Box 73, Southport, Qld	25.60	"	"
Musche, Joseph (estate of), 12 Acorn Rd, Dundrum, Dublin, Eire	25.60	"	"
Nash, Robert M, 342 Victoria Ave, Chatswood, NSW	12.80	"	"
Ngongataha Limited, GPO Box 4910, Sydney, NSW	256.00	"	"
Ofrowski, Cecil A, 50 Bruce Ave, Belfield, NSW	38.40	"	"
Osk Nominees SDN BHD, Berhad Lee Wah Bank Building, 2nd Floor, Room 207, Kuala Lumpur, Malaysia	38.40	"	"
O'Sullivan, Peter D, 101 Palmer St, Woolloomooloo, NSW	25.60	"	"
Owen, John M, c/o Unit 6, 1328 Dandenong Rd, Chadstone	12.80	"	"
Paynter, Julie, 3 Marne St, Surrey Hills	12.80	"	"
Peryman, Lynne, 27 Carrol St, Kogarah, NSW	12.80	"	"
Peters, James, 36 Neil St, Kangaroo Flat	51.20	"	"
Ping, Lee Ching, c/o Wah Tin Co Ltd, 29 Tai Yip St, Kwun Tong, Kowloon, Hong Kong	16.00	"	"
Porteus, Robert D and Clune, Vincent P, 7 Third Ave, Applescross, WA	25.60	"	"
Quail, Barry W and Lambert, Arnold G, 58 Griffith St, Coolangatta, Qld	38.40	"	"
Ralston, Martin K, 44/9-11 Corrimal St, Wollongong, NSW	38.40	"	"
Roberts, Ronald J, 125 Guildford Rd, Bassendean, WA	12.80	"	"
Robinson, Phillip, Flat 3, 7 Railway Ave, Armadale	64.00	"	"
Robson, Annie D, 8 Adderstone Ave, North Sydney, NSW	25.60	"	"
Rohen, Bridie, 59 Hayes St, Neutral Bay, NSW	89.60	"	"
Ross, Jack, PO Box 56, Nunawading	12.80	"	"
Rudski, Shaw, 315 Hawthorn Rd, Caulfield	12.80	"	"
Runciman, Heather M, 56 Ronald Ave, Greenwich, NSW	38.40	"	"
Ryne, Dennis, c/o Meda Station via Derby, WA	10.88	"	"
Schultz, Dorothy M, 10 Cartledge Way, Sale	25.60	"	"
Shankly, Elizabeth A, 16 St Georges Rd, Toorak	25.60	"	"
Skipper, John, PO Box 242, Dannevirke, NZ	128.00	"	"
Smith, Arthur J, c/o Central Share Registry, GPO Box 505H, Melbourne	25.60	"	"
Spalding, Dorothy M (estate of) and Shellman, Augustus W (estate of), c/o T W Biggs & Biggs, GPO Box 1388, Brisbane, Qld	12.80	"	"
Spencer, John W, 16 Farnan St, Westgarth	12.80	"	"
Steele, Sandra, c/o Nurses Home, Prince Henrys Hospital, Melbourne	12.80	"	"
Stewart, G W, M L and Sean G, c/o G W Stewart, 21 Alice St, Beau Destert, Qld	12.80	"	"
Stewart, Raymond D, 68 Norton Ave, Riverview, Qld	25.60	"	"
Tapperell, Geoffrey Q, c/o ANZ Bank Ltd, Strand, London, UK	25.60	"	"
Teakle, Patricia, 5 Omaha St, Belfield, NSW	12.80	"	"
Thompson, Clive E and Bowen, Ernest C and Gardner, Frank A, 49/53 Wentworth Ave, Sydney, NSW	12.80	"	"
Thompson, Ian D and Janice H, 3 Newton Rd, Strathfield, NSW	12.80	"	"
Thoroughgood, Terresse, 177 Doncaster Ave, Kensington, NSW	128.00	"	"
Tiernam, Lesley M, 2/22 Lamrock Ave, Bondi, NSW	12.80	"	"
Tyson, Gregory C, 92A Main St, Leehan, Tas	12.80	"	"

## Unclaimed Moneys Act 1962

## Register of Unclaimed Moneys held by the—

<i>Name of Owner on Books and Last Known Address</i>	<i>Total Amount Due to Owner</i>	<i>Description of Unclaimed Money</i>	<i>Date when Amount first became Payable</i>
\$			
VAMGAS—continued			
Wall, Geoffrey, 3 Burrabirra Ave, Vacluse, NSW	12.80	Dividend	3.7.89
Wallace, James L, 19 File St, Marrickville, NSW	25.60	"	"
Wang, Sweding, 243 Carrington Rd, Coogee, NSW	38.40	"	"
Ward, Denis K, 19 Rabbitt St, French's Forest, NSW	51.20	"	"
Watkins, John E and Jennifer C, PO Box 1556, Boroko, TPNG	25.60	"	"
Watson, Andrew W, 15 Stanhope Rd, Killara, NSW	12.80	"	"
Weingott, Frances H, 24 Deakin St, Auburn, NSW	12.80	"	"
Welch, Jean F, 85 Alexandria Pde, Wahroonga, NSW	38.40	"	"
Wenck, Brian, 45 Hillsdon Rd, Taringa, Qld	25.60	"	"
West, Ronald I, Commercial Bank of Australia, Canberra, ACT	12.80	"	"
William Mackay Pty Ltd, 30 Powell St, Killara, NSW	25.60	"	"
Wilson, Julia M and Nicholas C, 17 Hoseason St, Mawson, NSW	128.00	"	"
Winks, Rupert W, c/o GPO Box 505H, Melbourne	25.60	"	"
Witherspoon, John c/o Hawkesbury Agricultural, College, Richmond, NSW	25.60	"	"
Wyllie, William A, 8 Blenheim Rd, Lindfield, NSW	25.60	"	"
Yates, Michael, Flat 1, 282 New St, Brighton	12.80	"	"
Zammnit, Bernard, c/o Consolidated Milk Ind, PO Box 22, Redfern, NSW	38.40	"	"
265 Elizabeth Street Pty Ltd, c/o Reginald V McFadzean, GPO Box 4910, Sydney, NSW	256.00	"	"
Abisaab, George, c/o Joseph Dahdah & Company, 266 Cleveland St, Sydney, NSW	25.60	"	"
Aiderson, Robert W, 76 Hawkestone St, North Cottesloe, WA	12.80	"	"
Allen, Christopher J, 38 Hughes St, Woodville, SA	12.80	"	"
Anderson, Ann P, 32 Cope St, Lane Cove, NSW	25.60	"	"
Andrews, Grahame P, c/o Merz Clennan & Partners, Goldsworthy, WA	25.60	"	"
Anthony, Mary R, 100 Cunningham St, Dalby, Qld	25.60	"	"
Ashton, Mary R, 13/2 Lindsay St, Neutral Bay	25.60	"	"
Barcock, Peter, 37 Guruwa St, Woomera, SA	12.80	"	"
Barker Holdings Pty Ltd, 20 Ewing St, Garden Suburb, NSW	51.20	"	"
Barker, John W, Flat 4, 1 Bates St, East Malvern	51.20	"	"
Barlow, John R, 11/29 Gannons Ave, Dolls Point, NSW	12.80	"	"
Bateson, Don M, c/o Commonwealth Bank of Aust, Mitchell, Qld	12.80	"	"
Bayley, Clive S, c/o M J Hobbs & Co, GPO Box 4914, Sydney, NSW	128.00	"	"
Beattie, Robert, PO Box 106, Woomera, SA	12.80	"	"
Beaver, Norman L, Mount Ida via Menzies, WA	12.80	"	"
Bills, Meredith M, 7 Hazelmere Rd, Glengowrie, SA	25.60	"	"
Birkelund, John R, 15 Bosworth St, Hamersley, WA	25.60	"	"
Black, Lynette R, 11/230 Glebe Point Rd, Glebe, NSW	51.20	"	"
Borelli, Jules J, 108 Martin St, Gardenvale	25.60	"	"
Braithwaite, Margaret M, PO Box 43, Rose Bay, NSW	12.80	"	"
Brandli, Walter, 65/59 Malcolm St, West Perth, WA	12.80	"	"
Brown, David T and Gladys, 6/37 Osborne St, Wollongong, NSW	12.80	"	"
Brown, Roslyn M, 26 Byron St, Wyong, NSW	12.80	"	"
Brown, Sheila M, 26 Byron St, Wyong, NSW	12.80	"	"
Bruce, Eileen A, 10/42 Alfred St, Prahran	12.80	"	"
Brunwiler, Marcel, c/o Ivo Brunwiler, St. Gallerstr 62, Switzerland	25.60	"	"
Bull, Audrey, 85 Carrington Rd, Wahroonga, NSW	24.00	"	"
Burns, Fiona, 25 Hall St, Moreland	12.80	"	"
Cameron, Margot (estate of) and Kenneth McD, PO Box 57, Mermaid Beach, Qld	25.60	"	"



## Unclaimed Moneys Act 1962

## Register of Unclaimed Moneys held by the—

Name of Owner on Books and Last Known Address	Total Amount Due to Owner	Description of Unclaimed Money	Date when Amount first became Payable
\$			
VAMGAS LTD—continued			
Campbell, Robin E, Woden, Queanbeyan, NSW	25.60	Dividend	3.7.89
Capper, Vera Kezia, 1 Station St, Pymble, NSW	38.40	"	"
Carpenter, Alwyn J, 6 Ellen St, Harbord, NSW	25.60	"	"
Carr, Jeffrey Keston (estate of), c/o Eric D Elwing, Commercial Bank Chambers, Mary St, Gympie, Qld	25.60	"	"
Carter, Edward S, Victoria House, 175 Goderich St, East Perth, WA	128.00	"	"
Challenor, Graham M, PO Box 62, Roebourne, WA	25.60	"	"
Chang, Phyllis (estate of), c/o Gillis Delaney, 75 Elizabeth St, Temple Crt, Sydney, NSW	12.80	"	"
Chmeliauskas, Stanley T, 42 Dickson Ave, Artarmon, NSW	51.20	"	"
Coombes, Robert M, GPO Box 1936, Bangkok, Thailand	25.60	"	"
Corne Sybil, 18/20 Warwick Ave, Cammeray, NSW	25.60	"	"
Cornfeld Investment Services Pty Ltd, 341 Military Rd, Mosman, NSW	128.00	"	"
Cudmore, Peter J, c/o J. W. Cudmore, 22 Pearce St, Caulfield	20.00	"	"
Curnow, Colin M, 18 Beta Cres, Panorama, SA	12.80	"	"
Curtis, Thomas J, 10 Violet St, Balgowlah, NSW	12.80	"	"
Davis, Esmac R (estate of), c/o Grahame Goldberg Partners, 1st Floor, 181 Elizabeth St, Sydney, NSW	38.40	"	"
De Feu, Barry J, GPO Box H560, Perth, WA	12.80	"	"
Deloose, Odessa, 195 O'Sullivan Rd, Bellevue Hill, NSW	38.40	"	"
Delves, Sandra E, 71 Hotham St, East Melbourne	25.60	"	"
Dewar, Graham J, 11 Warandoo St, Gordon, NSW	25.60	"	"
Dodd, David, Keperra Drive-in Theatre, PO Box 102, Alderley, Qld	12.80	"	"
Doherty, Brian J (estate of), c/o C B H Rowlandson & Company, Suite, 1st Floor, Old Purser Bldg, 268 Old Northern Rd, Castle Hill, NSW	89.60	"	"
Doherty, Ross A, 8 Bilberry Ave, Bilgola Plateau, NSW	25.60	"	"
Donnelly, Benedict J, Box 717, Esperance, WA	25.60	"	"
Donoghoe, Michael L, 75 Proctor Pde, Chester Hill, NSW	25.60	"	"
Drane, Francis H, Unit 55, 29-35 Gerard St, Cremorne, NSW	25.60	"	"
Driver, Peter J and Janis S, c/o ANZ Banking Group Ltd, Lae, TPNG	25.60	"	"
Economos, Margaret J, 6 Wattle St, Fullarton, SA	102.40	"	"
Edwards, Alyson B, PO Box 172, Newcastle, NSW	25.60	"	"
Evans, Esha, 49 Paddington St, Paddington, NSW	128.00	"	"
Farrell, Gregory K, 75 Cowper St, Randwick, NSW	12.80	"	"
Fearnley, James R and Cecily L, Main Rd, Upper Brookfield, Qld	25.60	"	"
Filip, Nikola, c/o Quantas Engineering, PO Box 126, Darwin, NT	12.80	"	"
Flanagan, William K, c/o Patrick & Co, 43 Northbourne Ave, Canberra, ACT	12.80	"	"
Fletcher, Lynette K, c/o 80 Banksia Tce, South Perth, WA	12.80	"	"
Foley, Margaret A, 43 Teele Ave, Somerville, Massachusetts, USA	12.80	"	"
Fong, Kin, Block G 9th Floor, Hop Hing Ind Building, 702 Castle Peak Rd, Kowloon, Hong Kong	25.60	"	"
Friems, Willi and Christine, Flat 4, 6 Albenca St, Mentone	64.00	"	"
Fuller, Stephen R, 95 Brook St, Muswellbrook, NSW	12.80	"	"
Gardiner, Don, c/o Maxdon Developments, PO Box 104, Beaconsfield, NSW	128.00	"	"
Gaskin, John H, 19 Albert St, Claremont, WA	12.80	"	"
Geegan, Ellen A, 68 Ryeland St, Miller, NSW	128.00	"	"
George, David O, 37 Wolseley Tce, Ascot Park, SA	12.80	"	"
Gibson, Frederick R, 22 Bushwood Rd, Kew Garden, Richmond, Surrey, UK	12.00	"	"
Gill, John, 5 McIvor St, Reservoir	40.00	"	"

## Unclaimed Moneys Act 1962

## Register of Unclaimed Moneys held by the—

Name of Owner on Books and Last Known Address	Total Amount Due to Owner	Description of Unclaimed Money	Date when Amount first became Payable
\$			
VAMGAS—continued			
Goddard, Ronald I, 7 Lilac Cl, Taree, NSW	12.80	Dividend	3.7.89
Goderson, Neil K and Magdalena, Box 183, West Perth, WA	12.80	"	"
Goodwin, Reginald, 42 Harvey Ave, Netley, SA	12.80	"	"
Gosselin, Doris, 29 Eastern Rd, Turramurra, NSW	25.60	"	"
Greenhill, Aloisia, 10 Idmiston St, Elizabeth Centre, SA	25.60	"	"
Guy, John L, 44 Tulip Cres, Boronia	12.80	"	"
Haber, Harry F, 14 Liverpool Rd, Croydon, NSW	51.20	"	"
Hall, Clive G, 41A Arkana Rd, Balga, WA	76.80	"	"
Hallowes, Mary L, Flat 2, 21 Grange Rd, Toorak	12.80	"	"
Hammond, Stanley R, 161 Sixth Ave, Inglewood, WA	17.60	"	"
Harper, Reginald H, 2/112 Old South Rd, Bondi Junction, NSW	12.80	"	"
Harris, Michele, c/o ES & A Bank Ltd, 365 George St, Sydney, NSW	12.80	"	"
Harrison, Jeffrey E, c/o Jardine Fleming Aust. Securities Ltd, 9th Floor, 19 Pitt St, Sydney, NSW	64.00	"	"
Herrmann, Richard P, 100 Grandview Dve, Newport, NSW	51.20	"	"
Hickey, Aileen A, 35 Elizabeth St, Mentone	12.80	"	"
Holberton, John A, 14 Monaro Cres, Red Hill, NSW	12.80	"	"
Holden, Roger R, 638-11 Street, Evanston, Michigan, USA	12.80	"	"
Hope, Carol M, c/o Bechtel Pacific, PO Box 61, Port Hedland, WA	12.80	"	"
Humphries, Mavis E, 33 Fishing Point Rd, Rathmines, NSW	12.80	"	"
Hunt, Peter A, 39 The Boulevard, Lilyfield, NSW	51.20	"	"
Hutchison, Peter, 9/58 Florence St, Hornsby, NSW	40.00	"	"
Ienace, I, 2 Welby St, Coral Gable, Qld	38.40	"	"
Irwin, Samuel E, 14/1 Wando Gve, East St Kilda	25.60	"	"
Jackel Nominees Pty Ltd, c/o Morien & Co, 201 Balaclava Rd, Caulfield	51.20	"	"
Jackson, Peter M, 30 Wahroonga Ave, Wattle Park, SA	12.80	"	"
Jewel, Raymond P, 359 Dowling St, Darlinghurst, NSW	25.60	"	"
Johnston, Joan, c/o Redden & Murtagh, PO Box 572, Geelong	12.80	"	"
Johnston, Rodger S, 14/ 15-19 Onslow Ave, Elizabeth Bay, NSW	20.00	"	"
Jones, Alan C, Hawkesbury Agric College, Richmond, NSW	12.80	"	"
Kandaiya, Kulaseragham, Flat 2, 5 Hardy St, Hollywood, WA	12.80	"	"
Kasinowski, Lubow, 2 Glenview St, Paddington, NSW	51.20	"	"
Keddie, Peter McK, PO Box 59, Port Kembla, NSW	64.00	"	"
Kelen, George, c/o Residents Quarters, Royal Prince Alfred Hospital, Camperdown, NSW	38.40	"	"
Kelly, Maurice Q, 12/63 Moray St, New Farm Qld	25.60	"	"
Kemp, Elvie V, Flat 8, 27 Ormond Rd, Elwood	25.60	"	"
Kimpton, Janice E, 56 Peacock Pde, Belrose, NSW	51.20	"	"
Kiosoglous, Antonie M (estate of), c/o Lewis Abbott & Company, 8 Greenhill Rd, Wayville, SA	64.00	"	"
Kipluks, John P, 10-15 Palmer St, Jolimont	64.00	"	"
Knuckey, Trevor J, 34 Barton Ave, Haberfield, NSW	12.80	"	"
Krishnasamy, Pragasamoorthi, Flat 2, 5 Hardy St, Nedlands, WA	12.80	"	"
Layton, Brian (estate of), c/o W & H Alker, 15 Counce St, Blackpool, UK	64.00	"	"
Lee, Anthony, c/o Wolff Dunlop & Co, 23 Hamilton St, Sydney, NSW	12.80	"	"
Leggett, Vera J, 50 Francis St, Carlton, NSW	25.60	"	"
Leigh, Jack, 155 Swanston St, Melbourne	12.80	"	"
Leinweber, Joseph, 368 Dowling St, Paddington, NSW	25.60	"	"
Levy, Jillian B, PO Box 1604, Chatswood, NSW	20.00	"	"
Long, Lee J, 30/7 Gilbert St, Rose Bay, NSW	12.80	"	"
Lory, Damian, 3 Quandolan Cl, Ivanhoe East	25.60	"	"

## Unclaimed Moneys Act 1962

## Register of Unclaimed Moneys held by the—

Name of Owner on Books and Last Known Address	Total Amount Due to Owner	Description of Unclaimed Money	Date when Amount first became Payable
\$			
VAMGAS LTD—continued			
Lough, John C (Junior), 49 Manning Rd, Double Bay, NSW	25.60	Dividend	3.7.89
Manojlovic, Peter, 64 Gourlay St, Balaclava	12.80	"	"
Martin, Elsinore M, 23 Astelot Dve, Donvale	25.60	"	"
Mason, Lionel J, PO Box 958, Mount Isa, Qld	51.20	"	"
McElhinney, Adrian J, 1 Blackwood Ave, Morningside, Qld	19.20	"	"
McLeish, Stuart, 4/33 Dalley St, Queenscliff, NSW	12.80	"	"
McMahon, Russell T and Cecelia M, 5 Winifred St, Mosman Park, WA	25.60	"	"
McMaster, Helen M, 44 Ruby St, West Essendon	25.60	"	"
McNeill, Ronald W, PO Box 76, Redfern, NSW	12.80	"	"
Morris, Dennis P, 7/23 Shirley Rd, Wollstonecraft, NSW	25.60	"	"
Morton, Alvin R, PO Box 116, Tennant Creek, SA	25.60	"	"
Moss, Edwin R and Mary MacD, PO Box 73, Southport, Qld	25.60	"	"
Musche, Joseph (estate of), 12 Acorn Rd, Dundrum, Dublin, Eire	25.60	"	"
Nash, Robert M, 342 Victoria Ave, Chatswood, NSW	12.80	"	"
Ngongataha Ltd, GPO Box 4910, Sydney, NSW	256.00	"	"
Oftrowski, Cecil A, 50 Bruce Ave, Belfield, NSW	38.40	"	"
Osk Nominees SDN BHD, Lee Wah Bank Building, 2nd Floor, Room 207, Kuala Lumpur, Malaysia	38.40	"	"
O'Sullivan, Peter D, 101 Palmer St, Woolloomooloo, NSW	25.60	"	"
Owen, John M, c/o Unit 6, 1328 Dandenong Rd, Chadstone	12.80	"	"
Paynter, Julie, 3 Marne St, Surrey Hills	12.80	"	"
Peryman, Lynne, 27 Carrol St, Kogarah, NSW	12.80	"	"
Peters, James, 36 Neil St, Kangaroo Flat	51.20	"	"
Ping, Lee Ching, c/o Wah Tin Co Ltd, 29 Tai Yip St, Kwun Tong, Kowloon, Hong Kong	16.00	"	"
Porteus, Robert D and Clune, Vincent P, 7 Third Ave, Applecross, WA	25.60	"	"
Quaill, Barry W and Lambert, Arnold G, 58 Griffith St, Coolangatta, Qld	38.40	"	"
Ralston, Martin K, 44/9-11 Corrimal St, Wollongong, NSW	38.40	"	"
Roberts, Ronald J, 125 Guildford Rd, Bassendean, WA	12.80	"	"
Robinson, Phillip, Flat 3, 7 Railway Ave, Armadale	64.00	"	"
Robson, Annie D, 8 Adderstone Ave, North Sydney, NSW	25.60	"	"
Rohan, Bridie, 59 Hayes St, Neutral Bay, NSW	89.60	"	"
Ross, Jack, PO Box 56, Nunawading	12.80	"	"
Rudski, Shaw, 315 Hawthorn Rd, Caulfield	12.80	"	"
Runciman, Heather M, 56 Ronald Ave, Greenwich, NSW	38.40	"	"
Ryne, Dennis, c/o Meda Station via Derby, WA	10.88	"	"
Schultz, Dorothy M, 10 Cardledge Way, Sale	25.60	"	"
Shankly, Elizabeth A, 16 St Georges Rd, Toorak	25.60	"	"
Skipper, John, PO Box 242, Dannevirke, NZ	128.00	"	"
Smith, Arthur J, c/o Central Share Registry, GPO Box 505H, Melbourne	25.60	"	"
Smith Beverley R, c/o GPO Box 101, Sydney, NSW	40.00	"	"
Spencer, John W, 16 Farnan St, Westgarth	12.80	"	"
Steele, Sandra, c/o Nurses Home, Prince Henry's Hospital, Melbourne	12.80	"	"
Stewart, Raymond D, 68 Norton Ave, Riverview, Qld	25.60	"	"
Tapperell, Geoffrey Q, c/o ANZ Bank Ltd, Strand, London, UK	25.60	"	"
Tate, Monica M, 2/361 Cornwall St, Greenslopes, Qld	25.60	"	"
Teakle, Patricia, 5 Omaha St, Belfield, NSW	12.80	"	"
Thompson, Clive E, Bowen, Ernest C and Gardner, Frank A, 49/53 Wentworth Ave, Sydney, NSW	12.80	"	"
Thompson, Ian D and Janice H, 3 Newton Rd, Strathfield, NSW	12.80	"	"
Thoroughgood, Terresse, 177 Doncaster Ave, Kensington, NSW	128.00	"	"

## Unclaimed Moneys Act 1962

## Register of Unclaimed Moneys held by the—

Name of Owner on Books and Last Known Address	Total Amount Due to Owner	Description of Unclaimed Money	Date when Amount first became Payable
\$			
VAMGAS—continued			
Tiernam, Lesley M, 2/22 Lamrock Ave, Bondi, NSW	12.80	Dividend	3.7.89
Tyson, Gregory C, 92A Main St, Leehan, Tas	12.80	"	"
Wall, Geoffrey, 3 Burrabirra Ave, Vaucluse, NSW	12.80	"	"
Wallace, James L, 19 Pile St, Marrickville, NSW	25.60	"	"
Wang, Sweding, 243 Carrington Rd, Coogee, NSW	38.40	"	"
Ward, Denis K, 19 Rabbitt St, French's Forest, NSW	51.20	"	"
Watkins, John E and Jennifer C, PO Box 1556, Boroko, T PNG	25.60	"	"
Watson, Andrew W, 15 Stanhope Rd, Killara, NSW	12.80	"	"
Weingott, Frances H, 24 Deakin St, Auburn, NSW	12.80	"	"
Welch, Jean F, 85 Alexandria Pde, Wahroonga, NSW	38.40	"	"
Wenck, Brian, 45 Hillsdon Rd, Taringa, Qld	25.60	"	"
West, Ronald I, Commercial Bank of Australia, Canberra, ACT	12.80	"	"
William Mackay Pty Ltd, 30 Powell St, Killara, NSW	25.60	"	"
Wilson, Julia M and Nicholas C, 17 Hoseason St, Mawson, NSW	128.00	"	"
Winks, Rupert W, c/o GPO Box 505H, Melbourne	25.60	"	"
Witherspoon, John, c/o Hawkesbury Agricultural, College, Richmond, NSW	25.60	"	"
Wyllie, William A, 8 Blenheim Rd, Lindfield, NSW	25.60	"	"
Yates, Michael, Flat 1, 282 New St, Brighton	12.80	"	"
Zammit, Bernard, c/o Consolidated Milk Ind, PO Box 22, Redfern, NSW	38.40	"	"
265 Elizabeth Street Pty Ltd, c/o Reginald V McFadzean, GPO Box 4910, Sydney, NSW	736.00	"	30.10.89
Aiderson, Robert W, 76 Hawkstone St, North Cottesloe, WA	36.80	"	"
Allen, Christopher J, 38 Hughes St, Woodville, SA	36.80	"	"
Allen, David W, 21/41 De fiance Rd, Woodridge, Qld	110.40	"	"
Allen, Norman, 38 Dominic Dve, Bate Haven, NSW	57.50	"	"
Anderson, Ann P, 32 Cope St, Lane Cove, NSW	73.60	"	"
Andrews, Grahame P, c/o Merz Clennan & Partners, Goldsworthy, WA	73.60	"	"
Barcock, Peter, 37 Guruwa St, Woomera, SA	36.80	"	"
Barker Holdings Pty Ltd, 20 Ewing St, Garden Suburb, NSW	147.20	"	"
Barker, John W, Flat 4, 1 Bates St, East Malvern	147.20	"	"
Bariow, John R, 11/29 Gannons Ave, Dolls Point, NSW	36.80	"	"
Bateson, Don M, c/o Commonwealth Bank of Aust, Mitchell, Qld	36.80	"	"
Bayley, Clive S, c/o M J Hobbs & Co, GPO Box 4914, Sydney, NSW	368.00	"	"
Beattie, Robert, PO Box 106, Woomera, SA	36.80	"	"
Beaver, Norman L, Mount Ida via Menzies, WA	36.80	"	"
Betros, Christine, 514 Elizabeth St, Surrey Hills, NSW	73.60	"	"
Betros, Katherine, 514 Elizabeth St, Surrey Hills, NSW	110.40	"	"
Betros, Therese, 514 Elizabeth St, Surrey Hills, NSW	73.60	"	"
Bills, Meredith M, 7 Hazelmere Rd, Glengowrie, SA	73.60	"	"
Birkelund, John R, 15 Bosworth St, Hamersley, WA	73.60	"	"
Black, Lynette R, 11/230 Glebe Point Rd, Glebe, NSW	147.20	"	"
Booth, Betty J, 645 South Rd, Moorabbin	184.00	"	"
Borelli, Jules J, 108 Martin St, Gardenvale	73.60	"	"
Braithwaite, Margaret M, PO Box 43, Rose Bay, NSW	36.80	"	"
Brandli, Walter, 65/59 Malcolm St, West Perth, WA	36.80	"	"
Brewster, Charles A, 53 Fisher Ave, Sandy Bay, Tas	11.50	"	"
Brown, David T and Gladys, 6/37 Osborne St, Wollongong, NSW	36.80	"	"
Bruce, Eileen A, 10/42 Alfred St, Prahran	36.80	"	"
Bull, Audrey, 85 Carrington Rd, Wahroonga, NSW	69.00	"	"
Burns, Fiona, 25 Hall St, Moreland	36.80	"	"

## Unclaimed Moneys Act 1962

## Register of Unclaimed Moneys held by the—

<i>Name of Owner on Books and Last Known Address</i>	<i>Total Amount Due to Owner</i>	<i>Description of Unclaimed Money</i>	<i>Date when Amount first became Payable</i>
\$			
VAMGAS LTD—continued			
Cameron, Margot (estate of) and Kenneth McD, PO Box 57, Mermaid Beach, Qld	73.60	Dividend	30.10.89
Campbell, Robin E, Woden, Queanbeyan, NSW	73.60	"	"
Capper, Vera Kezia, 1 Station St, Pymble, NSW	110.40	"	"
Carpenter, Alwyn J, 6 Ellen St, Harbord, NSW	73.60	"	"
Carr, Jeffrey Keston (estate of), c/o Eric D Elwing, Commercial Bank Chambers, Mary St, Gympie, Qld	73.60	"	"
Carter, Edward S, Victoria House, 175 Goderich St, East Perth, WA	368.00	"	"
Challenor, Graham M, PO Box 62, Roebourne, WA	73.60	"	"
Chang, Phyllis (estate of), c/o Gillis Delaney, 75 Elizabeth St, Temple Crt, Sydney, NSW	36.80	"	"
Chmeliauskas, Stanley T, 42 Dickson Ave, Artarmon, NSW	147.20	"	"
Clothier, Judith A, 3 Batley Ave, Hawthorndene, SA	55.20	"	"
Coombes, Robert M, GPO Box 1936, Bangkok, Thailand	73.60	"	"
Corne Sybil, 18/20 Warwick Ave, Cammeray, NSW	73.60	"	"
Cornfeld Investment Services Pty Ltd, 341 Military Rd, Mosman, NSW	368.00	"	"
Cruikshank, Robert G, 4 Manorvale Pde, Werribee	55.20	"	"
Cudmore, Peter J, c/o J. W. Cudmore, 22 Pearce St, Caulfield	57.50	"	"
Curtis, Paul A, 119A Chapel St, East St Kilda	11.50	"	"
Curtis, Thomas J, 10 Violet St, Balgowlah, NSW	36.80	"	"
Davis, Esmac R (estate of), c/o Grahame Goldberg Partners, 1st Floor 181 Elizabeth St, Sydney, NSW	110.40	"	"
De Feu, Barry J, GPO Box H560, Perth, WA	36.80	"	"
Deloose, Odessa, 195 O'Sullivan Rd, Bellevue Hill, NSW	110.40	"	"
Delves, Sandra E, 71 Hotham St, East Melbourne	73.60	"	"
Dewar, Graham J, 11 Warandoo St, Gordon, NSW	73.60	"	"
Dodd, David, Keperra Drive-in Theatre, PO Box 102, Alderley, Qld	36.80	"	"
Doberty, Brian J (estate of), c/o C B H Rowlandson & Company, Suite, 1st Floor, Old Purser Bldg, 268 Old Northern Rd, Castle Hill, NSW	257.60	"	"
Doherty, Ross A, 8 Bilberry Ave, Bilgola Plateau, NSW	73.60	"	"
Donnelly, Benedict J, Box 717, Esperance, WA	73.60	"	"
Donoghoe, Michael L, 75 Proctor Pde, Chester Hill, NSW	73.60	"	"
Drane, Francis H, Unit 55, 29-35 Gerard St, Cremorne, NSW	73.60	"	"
Driver, Peter J and Janis S, c/o ANZ Banking Group Ltd, Lae, TPNG	73.60	"	"
Economos, Margarette J, 6 Wattle St, Fullarton, SA	294.40	"	"
Edwards, Alyson B, PO Box 172, Newcastle, NSW	73.60	"	"
Esson, Michael H, 8/25 Park St, Richmond	11.50	"	"
Farrell, Gregory K, 75 Cowper St, Randwick, NSW	36.80	"	"
Fearnley, James R and Cecily L, Main Rd, Upper Brookfield, Qld	73.60	"	"
Filip, Nikola, c/o Quantas Engineering, PO Box 126, Darwin, NT	36.80	"	"
Flanagan, William K, c/o Patrick & Co, 43 Northbourne Ave, Canberra, ACT	36.80	"	"
Fletcher, Lynette K, c/o 80 Banksia Tce, South Perth, WA	36.80	"	"
Foley, Margaret A, 43 Teele Ave, Somerville, Massachusetts, USA	36.80	"	"
Friems, Wilh and Christine, Flat 4, 6 Albenca St, Mentone	184.00	"	"
Fuller, Stephen R, 95 Brook St, Muswellbrook, NSW	36.80	"	"
Gardiner, Don, c/o Maxdon Developments, PO Box 104, Beaconsfield, NSW	368.00	"	"
Gaskin, John H, 19 Albert St, Claremont, WA	36.80	"	"
Geegan, Ellen A, 68 Ryeland St, Miller, NSW	368.00	"	"
George, David O, 37 Wolseley Tce, Ascot Park, SA	36.80	"	"
Gibson, Frederick R, 22 Bushwood Rd, Kew Garden, Richmond, Surrey, UK	34.50	"	"

## Unclaimed Moneys Act 1962

## Register of Unclaimed Moneys held by the—

<i>Name of Owner on Books and Last Known Address</i>	<i>Total Amount Due to Owner</i>	<i>Description of Unclaimed Money</i>	<i>Date when Amount first became Payable</i>
\$			
VAMGAS LTD—continued			
Goddard, Ronald I, 7 Lilac Close, Taree, NSW	36.80	Dividend	30.10.89
Goderson, Neil K and Magdalena, Box 183, West Perth, WA	36.80	"	"
Goodwin, Reginald, 42 Harvey Ave, Netley, SA	36.80	"	"
Gosselin, Doris, 29 Eastern Rd, Turramurra, NSW	73.60	"	"
Greenhill, Aloisia, 10 Idmiston St, Elizabeth Centre, SA	73.60	"	"
Guy, John L, 44 Tupil Cres, Boronia	36.80	"	"
Haber, Harry F, 14 Liverpool Rd, Croydon, NSW	147.20	"	"
Haggerston, Peter J, 46 Watt St, Newcastle, NSW	73.60	"	"
Hall, Clive G, 41A Arkana Rd, Balga, WA	220.80	"	"
Hallowes, Mary L, Flat 2, 21 Grange Rd, Toorak	36.80	"	"
Hammond, Stanley R, 161 Sixth Ave, Inglewood, WA	50.60	"	"
Hannaford, Charles G, 8 Victoria St, Douglas, Isle of Man, UK	23.00	"	"
Harper, Reginald H, 2/112 Old South Rd, Bondi Junction, NSW	36.80	"	"
Harris, Michele, c/o E S & A Bank Ltd, 365 George St, Sydney, NSW	36.80	"	"
Herrmann, Richard P, 100 Grandview Dve, Newport, NSW	147.20	"	"
Hickey, Aileen A, 35 Elizabeth St, Mentone	36.80	"	"
Holberton, John A, 14 Monaro Cres, Red Hill, NSW	36.80	"	"
Holden, Roger R, 638-11 Street, Evanston, Michigan, USA	36.80	"	"
Hope, Carol M, c/o Bechtel Pacific, PO Box 61, Port Hedland, WA	36.80	"	"
Huejar Pty Ltd, 20 Hillcrest Ave, Mona Vale, NSW	368.00	"	"
Humphries, Mavis E, 33 Fishing Point Rd, Rathmines, NSW	36.80	"	"
Hunt, Peter A, 39 The Boulevard, Lilyfield, NSW	147.20	"	"
Ienace, Ivor, 2 Welby St, Coral Gable, Qld	110.40	"	"
Ipkendanz, Jean R, 122 Bellevue Rd, Bellevue Hill, NSW	11.50	"	"
Irwin, Samuel E, 14/1 Wando Gve, East St Kilda	73.60	"	"
Jackel Nominees Pty Ltd, c/o Morlen & Co, 201 Balaclava Rd, Caulfield	147.20	"	"
Jackson, Peter M, 30 Wahroonga Ave, Wattle Park, SA	36.80	"	"
Jewel, Raymond P, 359 Dowling St, Darlinghurst, NSW	73.60	"	"
Johnston, Joan, c/o Redden & Murtagh, PO Box 572, Geelong	36.80	"	"
Johnston, Rodger S, 14/ 15-19 Onslow Ave, Elizabeth Bay, NSW	57.50	"	"
Jones, Alan C, Hawkesbury Agric College, Richmond, NSW	36.80	"	"
Kandaiya, Kulaseragam, Flat 2, 5 Hardy St, Hollywood, WA	36.80	"	"
Kasinowski, Lubow, 2 Glenview St, Paddington, NSW	147.20	"	"
Keddie, Peter McK, PO Box 59, Port Kembla, NSW	184.00	"	"
Kelen, George, c/o Residents Quarters, Royal Prince Alfred Hospital, Camperdown, NSW	110.40	"	"
Kelly, Maurice Q, 12/63 Moray St, New Farm Qld	73.60	"	"
Kemp, Elvie V, Flat 8, 27 Ormond Rd, Elwood	73.60	"	"
Kimpton, Janice E, 56 Peacock Pde, Belrose, NSW	147.20	"	"
Kiosoglous, Antonie M (estate of), c/o Lewis Abbott & Company, 8 Greenhill Rd, Wayville, SA	184.00	"	"
Kipluks, John P, 10-15 Palmer St, Jolimont	184.00	"	"
Knuckey, Trevor J, 34 Barton Ave, Haberfield, NSW	36.80	"	"
Ko, Yen C, 17 Grant Ville St, Burwood	11.50	"	"
Krishnasamy, Pragasamoorthi, Flat 2, 5 Hardy St, Nedlands, WA	36.80	"	"
Kutyla, Helen A, 51 Inskip St, Rocklea, Qld	27.60	"	"
Layton, Brian (estate of), c/o W & H Alker, 15 Caunce St, Blackpool, UK	184.00	"	"
Lee, Anthony, c/o Wolff Dunlop & Co, 23 Hamilton St, Sydney, NSW	36.80	"	"
Leggett, Vera J, 50 Francis St, Carlton, NSW	73.60	"	"
Leigh, Jack, 155 Swanston St, Melbourne	36.80	"	"
Leinweber, Joseph, 368 Dowling St, Paddington, NSW	73.60	"	"

## Unclaimed Moneys Act 1962

## Register of Unclaimed Moneys held by the—

<i>Name of Owner on Books and Last Known Address</i>	<i>Total Amount Due to Owner</i>	<i>Description of Unclaimed Money</i>	<i>Date when Amount first became Payable</i>
\$			
VAMGAS LTD—continued			
Levy, Jillian B, PO Box 1604, Chatswood, NSW	57.50	Dividend	30.10.89
Long, Lee J, 30/7 Gilbert St, Rose Bay, NSW	36.80	"	"
Lory, Damian, 3 Quandolan Cl, Ivanhoe East	73.60	"	"
Lough, John C, 49 Manning Rd, Double Bay, NSW	73.60	"	"
Manojlovic, Peter, 64 Gourlay St, Balaclava	36.80	"	"
Martin, Elsinore M, 23 Astelot Dve, Donvale	73.60	"	"
Mason, Lionel J, PO Box 958, Mount Isa, Qld	147.20	"	"
McElhinney, Adrian J, 1 Blackwood Ave, Morningside, Qld	55.20	"	"
McLeish, Stuart, 4/33 Dalley St, Queenscliff, NSW	36.80	"	"
McMahon, Russell T and Cecelia M, 5 Winifred St, Mosman Park, WA	73.60	"	"
McMaster, Helen M, 44 Ruby St, West Essendon	73.60	"	"
McNeill, Ronald W, PO Box 76, Redfern, NSW	36.80	"	"
Mills, Jacquilyn F, c/o PO Box 345, Unley, SA	11.50	"	"
Morris, Dennis P, 7/23 Shirley Rd, Wollstonecraft, NSW	73.60	"	"
Morton, Alvin R, PO Box 116, Tennant Creek, SA	73.60	"	"
Moss, Edwin R and Mary M, PO Box 73, Southport, Qld	73.60	"	"
Nash, Robert M, 342 Victoria Ave, Chatswood, NSW	36.80	"	"
Ngongataha Limited, GPO Box 4910, Sydney, NSW	736.00	"	"
Oftrowski, Cecil A, 50 Bruce Ave, Belfield, NSW	110.40	"	"
Orme, Mark, c/o Meda Station via Derby, WA	18.40	"	"
Osk Nominees SDN BHD, Lee Wah Bank Building, 2nd Floor, Room 207, Kuala Lumpur, Malaysia	110.40	"	"
O'Sullivan, Peter D, 101 Palmer St, Woolloomooloo, NSW	73.60	"	"
Owen, John M, c/o Unit 6, 1328 Dandenong Rd, Chadstone	36.80	"	"
Payne, Peter J, 23 Pacific Way, Tura Beach, NSW	36.80	"	"
Paynter, Julie, 3 Marne St, Surrey Hills	36.80	"	"
Peryman, Lynne, 27 Carrol St, Kogarah, NSW	36.80	"	"
Peters, James, 36 Neil St, Kangaroo Flat	147.20	"	"
Ping, Lee Ching, c/o Wah Tin Co Ltd, 29 Tai Yip St, Kwun Tong, Kowloon, Hong Kong	46.00	"	"
Porteus, Robert D and Clune, Vincent P, 7 Third Ave, Applecross, WA	73.60	"	"
Quaill, Barry W and Lambert, Arnold G, 58 Griffith St, Coolangatta, Qld	110.40	"	"
Ralston, Martin K, 44/9-11 Corrimal St, Wollongong, NSW	110.40	"	"
Rich, Diana M and Brownrigg, Margaret R, 86 Norfolk Rd, Epping, NSW	36.80	"	"
Roberts, Ronald J, 125 Guildford Rd, Bassendean, WA	36.80	"	"
Robinson, Phillip, Flat 3, 7 Railway Ave, Armadale	184.00	"	"
Robson, Annie D, 8 Adderstone Ave, North Sydney, NSW	73.60	"	"
Rohan, Bridie, 59 Hayes St, Neutral Bay, NSW	257.60	"	"
Rollond, Anne M, 11 Broadway, Glenelg, SA	73.60	"	"
Ross, Jack, PO Box 56, Nunawading	36.80	"	"
Rudski, Shaw, 315 Hawthorn Rd, Caulfield	36.80	"	"
Runciman, Heather M, 56 Ronald Ave, Greenwich, NSW	110.40	"	"
Ryne, Dennis, c/o Meda Station via Derby, WA	31.28	"	"
Schultz, Dorothy M, 10 Cardledge Way, Sale	73.60	"	"
Shankly, Elizabeth A, 16 St Georges Rd, Toorak	73.60	"	"
Silbermann, Theodore, 68 Wentworth Ave, Sydney, NSW	27.60	"	"
Skipper, John, PO Box 242, Dannevirke, NZ	368.00	"	"
Smith, Arthur J, c/o Central Share Registry, GPO Box 505H, Melbourne	73.60	"	"
Spencer, John W, 16 Farnan St, Westgarth	36.80	"	"
Steele, Sandra, c/o Nurses Home, Prince Henrys Hospital, Melbourne	36.80	"	"

## Unclaimed Moneys Act 1962

## Register of Unclaimed Moneys held by the—

<i>Name of Owner on Books and Last Known Address</i>	<i>Total Amount Due to Owner</i>	<i>Description of Unclaimed Money</i>	<i>Date when Amount first became Payable</i>
\$			
VAMGAS LTD—continued			
Stewart, Raymond D, 6a Norton Ave, Riverview, Qld	73.60	Dividend	30.10.89
Sweaney, Ronald D, c/o High School, Bombala, NSW	184.00	"	"
Tam, Man S, 119 Tower St, Panania, NSW	11.50	"	"
Tapperell, Geoffrey Q, c/o ANZ Bank Ltd, Strand, London, UK	73.60	"	"
Teakle, Patricia, 5 Omaha St, Belfield, NSW	36.80	"	"
Thompson, Clive E and Bowen, Ernest C and Gardner, Frank A, 49/53 Wentworth Ave, Sydney, NSW	36.80	"	"
Thompson, Ian D and Janice H, 3 Newton Rd, Strathfield, NSW	36.80	"	"
Thoroughgood, Terresse, 177 Doncaster Ave, Kensington, NSW	368.00	"	"
Thring, John D, Long Island, Avenue Range, SA	368.00	"	"
Tiernam, Lesley M, 2/22 Lamrock Ave, Bondi, NSW	36.80	"	"
Tyson, Gregory C, 92A Main St, Leehan, Tas	36.80	"	"
Wall, Geoffrey, 3 Burrabirra Ave, Vaucluse, NSW	36.80	"	"
Wood, Harriet E and Laura C, 66 Crosby Rd, Albion, Qld	23.00	"	"
Wyllie, William A, 8 Blenheim Rd, Lindfield, NSW	73.60	"	"
Yates, Michael, Flat 1, 282 New St, Brighton	36.80	"	"
Zammit, Bernard, c/o Consolidated Milk Ind, PO Box 22, Redfern, NSW	110.40	"	"
1035			
POTTER WARBURG ASSET MANAGEMENT LTD			
Gorman, Ann, c/o Potter Warburg Asset Management, 1 Collins St, Melbourne	24.19	Redemption	18.12.90
O'Halloran, Kathryn M, 64 Gladstone Rd, Briar Hill	23.69	"	"
Read, Glenn M, c/o Potter Warburg Asset Management, 1 Collins St, Melbourne	40.11	"	"
McCutchan, Noel J and Denise G, 34 Sanford Pl, Kaleen, ACT	15.97	"	19.12.90
Trousdell, Alexander I and Alison N, c/o Potter Warburg Asset Management, 1 Collins St, Melbourne	118.70	"	"
Westwood, Larry, 5/124 Rowe St, Eastwood, NSW	14.60	"	"
Bryant, John, c/o Potter Warburg Asset Management, 1 Collins St, Melbourne	58.62	Distribution	21.1.91
Meynell, Brown J, c/o 50 Suffolk Rd, Hawthorndene, SA	11.92	"	"
Richardson, Karl B, 1069 South Pine Rd, Everton Hills, Qld	94.85	"	"
Black, Ernest J, 42 Curlew St, Toowong, Qld	85.72	Distribution	26.2.91
Craft, Henry C, c/o Potter Warburg Asset Management, 1 Collins St, Melbourne	123.90	"	"
Dixon, Ivy V (estate of), Attention Executors, Flat 3, 45 Fuller St, Walkerville, SA	73.03	"	"
Belsey, Carmel, c/o Potter Warburg Asset Management, 1 Collins St, Melbourne	14.85	Redemption	26.1.91
1066			
HAWKER DE HAVILLAND VICTORIA LIMITED			
Gibbard, R, 24 Bennett St, West Sunshine	22.94	Wages	4.9.89
Peltonen, E, 7/25 Hope St, Spotswood	198.77	"	"
Stewart, G, 3/82 Dickens St, Elwood	21.69	"	"
McIntyre, J, 597 Brunswick St, North Fitzroy	126.25	"	"
1021			



## Unclaimed Moneys Act 1962

## Register of Unclaimed Moneys held by the—

Name of Owner on Books and Last Known Address	Total Amount Due to Owner	Description of Unclaimed Money	Date when Amount first became Payable
§			
HALLMARK GENERAL INSURANCE COMPANY LTD			
Looker, W, PO Box 174, Merbein	24.66	Refund	28.7.88
Howden, P, 31 Derwent Dve, Long Gully	25.73	"	14.11.89
Avery, J, Mt Herbert Estate, Ravenswood	21.77	"	"
Kelly, J, 7 Illingworth St, Golden Square	24.11	"	"
King, D, Lot 3 Ballarat Rd, Skye	27.18	"	"
Bourke, W, 3 Adelyn St, East Doncaster	21.50	"	"
Laws, P, 5 Edward St, Glen Waverley	28.84	"	"
Davis, J, 5/182 Weatherall Rd, Cheltenham	21.59	"	"
Hall, K, 104 White Rd, Wonthaggi	29.81	"	"
Rosbergen, R, 11/451 Princes Hwy, Noble Park	23.44	"	"
Edge, N, Willow Lodge Caravan Park, Dandenong	23.59	"	"
Duncan, B, 45 Coolivan Crt, Noble Park	25.44	"	"
McAlphine, C, 4/11 Irving St, Windsor	20.82	"	"
Jennings, R, Lot 1, Christians Gve, Kallista	24.48	"	"
Lizza, P, 75 Busaria Ave, Ferntree Gully	21.16	"	"
Barnes, K, 29 Third St, Blackrock	21.22	"	"
Bright, B, 6/93 Eastwood St, Kensington	24.73	"	"
Davis, L, 3/11 Lucas St, Mitcham	25.44	"	"
Surigao, S, 2 Tucker Rd, Clyde	22.61	"	"
Ryschka, H, 5 Considine Crt, Corio	26.52	"	"
Berrie, D, 8 Coonara Cres, Whittington	29.24	"	"
Wilson, S, A.S.C. Fort, Queenscliff	22.49	"	"
Clarke, J, 13 Jubilee Ave, Frankston	20.27	"	"
Opie, L, 27 Normanby Rd, Sorrento	29.61	"	"
Fenn, R, 38 Griffiths St, West Heidelberg	25.57	"	"
Harris, A, 1 Cornilio, Wandin	19.79	"	"
Foster, F, 3/14 Marys St, Hawthorn	25.39	"	"
Gardam, G, c/o P.O. Tooradin	23.34	"	"
Ambier, P, 9 Dawson St, Rosedale	24.90	"	"
Poole, W, 3 Cooper Crt, Moe	26.99	"	"
Gittos, G, 6 Joel Crt, Leongatha	29.26	"	"
Sheehan, T, 2/2 Willow Gve, Coburg	21.85	"	"
Stumpo, G, 56-58 Lambeth St, Kensington	28.28	"	"
Smith, C, 4/170 Cumberland Rd, Pascoe Vale	24.43	"	"
Paxton, D, 2 Ferney Rd, Upwey	21.75	"	"
Lazzard, R, 841 High St, Glen Waverley	20.57	"	"
Davies, R, 3/39 Bond St, Ringwood	23.28	"	"
Farley, T, 92 Duke St, Rosedale	21.61	"	"
Wilson, J, c/o RAAF Base, East Sale	23.65	"	"
Harcourt, A, 213 St Georges Rd, Shepparton	24.36	"	"
Patten, R, 32 Rowe St, Euroa	21.98	"	"
Vandyke, D, 10 Evans Crt, Shepparton	24.74	"	"
Koener, K, 180 Clarinda Rd, Heatherton	21.97	"	"
Brebon, S, 21 Riveria Rd, Avondale Heights	20.57	"	"
Laffey, N, 40 Yaralla Cres, Greensborough	26.21	"	"
Ivens, D, 34 Bailey Dve, Traralgon	19.23	"	"
Rhodes, C, 21 Inchbold St, Wangaratta	25.08	"	"
Hodges, P, 12 Brooks St, Bright	20.07	"	"
Dumesny, W, 12 Varsity Crt, St Albans	19.63	"	"
Walko, J, 32 Nightingale Ave, Werribee	25.95	"	"
Rudall, M, 44 Galvin St, Altona	25.81	"	"

## Unclaimed Moneys Act 1962

## Register of Unclaimed Moneys held by the—

<i>Name of Owner on Books and Last Known Address</i>	<i>Total Amount Due to Owner</i>	<i>Description of Unclaimed Money</i>	<i>Date when Amount first became Payable</i>
§			
HALLMARK GENERAL INSURANCE COMPANY LTD—continued			
Jervics, M, 17/18-20 Glen St, Werribee	23.91	Refund	14.11.89
Johnson, K, 12 Bradley St, Newport	23.33	"	"
Riley, D, 21 Belgrade Ave, Wodonga	20.45	"	"
Mooney, N, Omeo Hwy, Swifts Creek	25.27	"	"
Mcllverna, K, 5 Davies Crt, Bendigo	30.22	"	"
Haliano, W, 1 Eric St, East Brighton	21.81	"	"
Matthews, L, 1717 Sturt St, Ballarat	24.03	"	"
Elliot, A, North Rd, Pearcedale	18.79	"	"
Dawkins, P, 47 Normancy St, Cranbourne	24.66	"	"
Wiltshire, D, 2 Brucevale Cres, Park Orchards	20.72	"	"
Adams, S, 4/5 Kincumber Rd, Croydon	26.03	"	"
Bullard, A, 24 Bryants Rd, Dandenong	23.21	"	"
Hilder, K, 28 Alvina St, Ferntree Gully	21.56	"	"
Angelevski, R, 41 Stook St, West Yarraville	26.89	"	"
Dinh, V, 16/108 Elizabeth St, Richmond	24.19	"	"
Wilde, J, 1/532 Highbury Rd, Glen Waverley	23.33	"	"
Hill, J, 1/132 Evell St, Glenroy	22.63	"	"
Edwards, R, Hastings Caravan Park, Site 18, Hastings	19.75	"	"
Hill, J, 12 Roslyn Rd, Rye	23.79	"	"
Phillips, R, 13 Culliver St, Horsham	28.81	"	"
Ferguson, L, 17 Lower Main St, Stawell	23.25	"	"
Symons, S, 11 Elphin Crt, Hawthorn	23.82	"	"
Thoene, D, 13 Valencia Rd, Lilydale	22.20	"	"
Csimma, T, 21 Amaroo Dve, Churchill	26.87	"	"
Walton, W, 90 Feathertop Dve, Werribee	19.75	"	"
Grossi, M, 2/282 Union Rd, Moonee Ponds	23.82	"	"
Camberth, K, 282 Paper Rd, Airport West	27.29	"	"
Alpuvan, M (Address Unknown)	21.48	"	"
Hale, D, 5/328 Rosella St, Murrumbeena	20.64	"	"
Kennedy, S, 4/94 May St, North Fitzroy	19.63	"	"
Joyce, G, 27 Annerley Ave, Shepparton	27.52	"	"
Quigg, M, 6 Vivi St, Puckapunyal	24.26	"	"
Smith, A, 28 Railway Pde, Highett	23.18	"	"
Hammond, S, 14 Strezledci Crt, Cranbourne	19.18	"	"
Varney, C, 251 Ash Gve, Springvale	23.22	"	"
May, K, Parklane Caravan Park, Traralgon	25.71	"	"
Miller, R, 10 Donald St, Wangaratta	19.14	"	"
Rogers, E, Lot 60 Dohertys Rd, Tarneit	21.52	"	"
Shannon, P, 7 Blaxland Dve, Sunbury	27.59	"	"
Woods, D, 3/13 Stapley Cres, Altona	23.94	"	"
Lawson, L, 8/20 Dene St, East Malvern	19.54	"	"
Patynek, H, 25 Elizabeth St, Fawkner	20.91	"	"
McCourt, M, 17/311 Royal Pde, Parkville	23.49	"	"
Usher, D, 15 Bourke Rd, Cranbourne	21.54	"	"
Allen, G, 672 Drummona St, North Carlton	23.53	"	"
Bastow, I, 2 Taree St, St Albans	32.02	"	"
Cottier, T, 1/13 Loch St, Beechworth	28.93	"	"
Piggott, B, 94 Roberts St, West Footscray	24.21	"	"
Drohasky, A, 18 Earnest St, Bayswater	20.39	"	"
Kildey, L, 7/1A Davidson St, South Yarra	23.29	"	"
Dimaggio, A, 14 Tanner Ave, Kew	19.94	"	"

## Unclaimed Moneys Act 1962

## Register of Unclaimed Moneys held by the—

<i>Name of Owner on Books and Last Known Address</i>	<i>Total Amount Due to Owner</i>	<i>Description of Unclaimed Money</i>	<i>Date when Amount first became Payable</i>
\$			
HALLMARK GENERAL INSURANCE COMPANY LTD—continued			
Wright, D, 10 Yew St, Wendouree	31.87	Refund	14.11.89
Horne, R, 16 Hialview Ave, Cranbourne	20.80	"	"
Possingham-Ball, S (Address Unknown)	25.03	"	"
Chernysh, V, 9 Blair St, Broadmeadows	22.35	"	"
Buxton, M, 13 The Avenue, Mt Waverley	23.12	"	"
Klen-Boonschate, E, 70 Brockley St, Wodonga	22.92	"	"
Smart, K, 4 Cretel Crt, Croydon	19.26	"	"
Sikorski, P, 4/1 Quandong St, Thomastown	25.13	"	"
Ewart, M, 139 Station St, Carlton	27.15	"	"
Marshall, D, 26 Lesney St, Richmond	20.01	"	"
Sowa, H, 1441 Sturt St, Ballarat	24.70	"	"
Roumeloitis, J, 23/364 Bayswater Rd, Bayswater	22.47	"	"
McCormack, B, 349 Springvale Rd, Forest Hills	26.92	"	"
Asaladi, R, 6/51 Glen Park Rd, Bayswater	23.50	"	"
Prsa, J, 9 Dumfries Way, Wantirna	23.11	"	"
Ledwidge, R, 395 Scoresby Rd, Ferntree Gully	24.33	"	"
Naylor, R, 25 Stuart St, Bayswater	24.15	"	"
Ganterton, P, 1 Avonside Rd, Belgrave Heights	23.70	"	"
Gurkin, D, 1/24 Thune St, Box Hill North	20.66	"	"
Pearson, M, 816 Doncaster Rd, Doncaster	23.55	"	"
Richards, F, 59 Box Hill Cres, Box Hill	26.85	"	"
Brett, B, 7 Nattia Crt, Keysborough	28.14	"	"
Berryman, M, 5 Dactyl St, Moorabbin	21.07	"	"
Hamilton, L, 12 Delmont Crt, Cranbourne	24.66	"	"
Delong, D, 1/13 Hawthorn Rd, Kilsyth	21.80	"	"
Miller, R, 37 Tristanig St, Doveton	28.69	"	"
O'Neill, H, 20 Power St, Dandenong	22.60	"	"
Augustus, K, 29 Scolsburn Way, Endeavour Hills	26.03	"	"
Mesrobian, P, 2 Filmore Rd, Dandenong	24.25	"	"
Chevalier, R, 51 Kidd Rd, Doveton	23.53	"	"
Doumis, N, 6/211 Hotham St, Elsternwick	26.07	"	"
McNamara, T, 27 Loretto Ave, Ferntree Gully	21.45	"	"
Robertson, S, 4/20 Close Ave, Dandenong	20.63	"	"
Hancock, T, 1/7 Berkley Crt, Altona	20.04	"	"
Gwynne, S, 47 Hedwig Cres, Mooroolbark	27.08	"	"
Bain, S, 1 Oakfield Crt, Bayswater	19.71	"	"
Jarvis, K, 15 Jessie St, Blackburn North	23.80	"	"
Partridge, B, 21 Curtain Cres, Dandenong North	24.47	"	"
Wallis, J, 55 Highfield Ave, Mulgrave	25.50	"	"
Glazebrook, T, 63 Campbell St, Glen Waverley	24.84	"	"
Taricani, F, 32 Koonalda Ave, Glen Waverley	20.59	"	"
Marshall, K, 23 Willow Crt, Bell Park	19.60	"	"
Lowe, J, 30 Rocklea Dve, Torquay	19.92	"	"
Uwland, H, 13 Charlotte Ave, Newcombe	23.86	"	"
Rawling, W, 6 Rosebud Cres, Broadmeadows	26.68	"	"
Sawdy, K, Lot 17 Larch St, Langwarrin	24.84	"	"
Grubber, B, 2/5 King St, Hastings	19.62	"	"
Wall, P, 7 Imre Cres, Baxter	19.93	"	"
Evans, D, 14 Collin Ave, Frankston	23.53	"	"
Mallard, C, 2 Amberly Cres, Frankston	20.79	"	"
Fuller, S, 9 Perversi Rd, Diamond Creek	25.16	"	"

## Unclaimed Moneys Act 1962

## Register of Unclaimed Moneys held by the—

<i>Name of Owner on Books and Last Known Address</i>	<i>Total Amount Due to Owner</i>	<i>Description of Unclaimed Money</i>	<i>Date when Amount first became Payable</i>
§			
HALLMARK GENERAL INSURANCE COMPANY LTD— <i>continued</i>			
Headreck, D, 2 Oak Crt, Horsham	19.15	Refund	14.11.89
Purchase, P, RMB 7417, Horsham	24.78		
Lyons, J, 8/7 College Pde, Kew	24.10	"	"
Cigana, D, 457 Tooroonga Rd, East Hawthorn	23.29	"	"
Woodall, M, 11 Cherry Ave, Mildura	18.94	"	"
Page, N, 11 Giloa St, Mornington	20.85	"	"
Lawler, G, 16 King St, Hastings	23.67	"	"
McGregor, P, 65 Moore St, Moe	27.28	"	"
Adams, J, 23 Aldmeia St, Morwell	21.07	"	"
Dellbridge, G, 78 Corrons St, Morwell	28.45	"	"
Twite, U, 3 Londrew Ave, Springvale	18.47	"	"
Abbey, E, 7 Packer St, Murrumbena	20.03	"	"
Zeven, J, 29 Oaklands St, Maribyrnong	22.83	"	"
Vongkham, K, 2/269 Albion St, Brunswick	22.45	"	"
Ryan, K, 17 Armstrong St, Coburg	23.61	"	"
Colbourne, R, 5 Carbine St, Mill Park	24.50	"	"
Evans, R, Lot 7, Old Mill Place, Chirnside Park	30.53	"	"
Dalton, M, 21 New St, Ringwood	18.84	"	"
Collins, T, 101 Albert St, Boronia	20.27	"	"
Joiner, D, 7 McAlister St, Sale	24.14	"	"
Holding, P, 10 Neil St, Startford	23.80	"	"
Johnson, G, RMB 1015 Edwards Rd, Tallygaroopna	23.62	"	"
O'Hara, P, 5 Tullaroop Crt, St Albans	24.02	"	"
White, D, 163 Kidds Rd, Doveton	21.96	"	"
Palewandren, R, 1/15 Adelaide St, St Albans	22.00	"	"
Schoenfelder, W, 13 Hancock St, Altona	24.35	"	"
Hoare, L, 1/8 Munroe St, Lalor	18.94	"	"
Smythe, R, 5 Lansell Crt, Thomastown	20.29	"	"
White, J, 57 Alamein Rd, West Heidelberg	28.70	"	"
Armit, K, 49 Taylor St, Hurstbridge	24.74	"	"
Lont, H, 20 Little Cres, Traralgon	24.37	"	"
Emms, M, 10 Brandy Creek Rd, Warragul	19.15	"	"
Perry, D, 1/78 Dixon St, Wangaratta	20.36	"	"
Pritchard, B, 2/51 Diane Cres, Croydon	20.40	"	"
Taylor, B, 6 End Ave, North Altona	20.34	"	"
Campbell, C, 77 Third Ave, North Altona	25.35	"	"
Davis, J, 4 Mill St, Wodonga	20.33	"	"
Simpson, P	29.81	"	10.2.89
Nelson, G, PO Box 498, School of Radio, Lakes Entrance	23.16	"	14.11.89
Jamieson, R, Hampshire Rd, Sunshine	20.00	"	23.4.90
Manzone, T, 33 Windsor Cres, Bundoora	20.00	"	"
Cottle, D, 14 Cherrington Square, Wantirna	20.00	"	28.4.90
Upston, F, 178 Van Ness Ave, Mornington	20.00	"	23.4.90
McDonald, R, 8 Celtic Crt, Wodonga	27.07	"	4.4.91
Garbutt, T, 21 Greave Pde, Altona	196.00	"	6.6.91
Peeters, M, 46 Stud Rd, Dandenong	297.40	"	5.3.91

## Unclaimed Moneys Act 1962

## Register of Unclaimed Moneys held by the—

<i>Name of Owner on Books and Last Known Address</i>	<i>Total Amount Due to Owner</i>	<i>Description of Unclaimed Money</i>	<i>Date when Amount first became Payable</i>
\$			
HALLMARK LIFE INSURANCE COMPANY LTD			
Neilson, Ruth, 8 Barnett St, Yarraville	478.00	Refund	1.3.83
Marston, Michelle, 39 Fenton St, Ascot Vale	367.00	"	23.8.83
Francis, J, 54 Livingston St, Avernell	261.00	"	15.9.84
Perri, A, 12 Wirbill St, Cobram	1873.00	"	19.9.84
Geake, S, 3/21 Pitt St, Ringwood	253.00	"	1.11.84
Suares, R, 167 Buckley St, Footscray	279.00	"	14.11.84
Miller, W, 2/1 Shakespeare St, Traralgon	157.00	"	1.3.86
Martin, K, 22 Emma St, Collingwood	533.00	"	"
Rae, S, 3/87 Ontario Ave, Mildura	143.00	"	"
Romao, c/o AFS, Footscray	483.00	"	20.3.86
Dell, J, 13 Keane St, Coburg	157.00	"	10.10.86
La Ruffa, Antonio, c/o AFS, Oakleigh	127.00	"	1.12.86
McDonald, Glenys, 52 Looker Rd, Montmorency 1081	28.00	"	20.12.89
\$NZ			
COMALCO LIMITED			
Allison, Roland (estate of) and Butts, Thomas McD, c/o Watts & Patterson, PO Box 10-249, Wellington, NZ	268.21	Dividend	11.5.90
Andrews, Pamela, c/o Touche Ross Share Registry, GPO Box 2975EE, Melbourne	67.05	"	"
Baird, Denis W, 161 Washington Ave, Brooklyn, Wellington, NZ	89.18	"	"
Ball, Nita C, Springston RD 4, Christchurch, NZ	121.37	"	"
Bamford, Graeme, Ward, Alan and Kemp, Michael, 82 Castor Cres, Porirua, NZ	23.39	"	"
Bellamy, Geoffrey M, 4 Potter Rd (off Norwood Rd), North East Valley, Dunedin, NZ	67.05	"	"
Bickerstaff, Marian C, 51 Goodwood Dve, Manakau City, Auckland, NZ	23.39	"	"
Botherway, David W, 18 Barossa Ave, Vermont South	67.05	"	"
Broughton, Warren G, PO Box 1745, Invercargill, NZ	23.39	"	"
Clement, Joseph McI, Kaiwera RD 2, Gore, NZ	37.93	"	16.11.90
Coles, Francis E, 27 Dallington Toe, Christchurch, NZ	67.05	"	11.5.90
Cox, Gregory N, 10 Weku Rd, Pukerua Bay, Wellington, NZ	96.22	"	"
Dillon, Richard J, Ardlussa, 6 RD, Gore, NZ	13.10	"	"
Dore, Theodore C, 385 Barbadoes St, Christchurch, NZ	15.41	"	16.11.90
Dowell, Monica R, 50 Rock Isle Rd, Torbay, Auckland, NZ	14.27	"	11.5.90
Doyle, Michael D, 15 Ostend Rd, Waiheke Is, Auckland, NZ	23.39	"	"
Fairbrother, Monty C, 4 Rahiwi Pl, Masterton, NZ	43.40	"	16.11.90
George, Francis J, 56 Matai Rd, Hataitai, Wellington, NZ	47.90	"	11.5.90
Gore, Joyce A, RD 10, Frankston Junction, NZ	143.49	"	"
Hamilton, Christopher L, PO Box 211, Katikati, NZ	25.86	"	16.11.90
Hebenton, Janice M, Unit 3, 136 Karori Rd, Wellington, NZ	26.66	"	11.5.90
Hilton, Katherine A, 75 Elizabeth St, Wellington, NZ	115.67	"	"
H W Couldrey Holdings Ltd, PO Box 675, Auckland, NZ	223.29	"	"
Ivan, Yee, PO Box 139, Masterton, NZ	111.64	"	"
Jardine, Philippa M, 4 Poronui St, Mt Eden, Auckland, NZ	26.89	"	"
Jones, Frank and Doreen, 5 Grande Ave, Auckland, NZ	96.20	"	"
Kearns, Brian E, 28 Teviot St, Oamaru, NZ	16.60	"	"
Kemp, Ruth, Green Valley 3 RD, Palmerston, Otago, NZ	13.49	"	16.11.90

## Unclaimed Moneys Act 1962

## Register of Unclaimed Moneys held by the—

<i>Name of Owner on Books and Last Known Address</i>	<i>Total Amount Due to Owner</i>	<i>Description of Unclaimed Money</i>	<i>Date when Amount first became Payable</i>
\$NZ			
COMALCO LIMITED— <i>continued</i>			
Kingscote, Robert A, 10 Stratford St, Christchurch, NZ	50.29	"	11.5.90
Langtry, William S, Maginness, Eiffelton RD 4, Ashburton, NZ	67.05	"	"
McConnell, Daphne M, 44 Dawson St, New Plymouth, NZ	67.05	"	"
McLeod, Jessie M, Block Rd, Otahuti RD 4, Invercargill, NZ	107.62	"	"
Meale, Jeanne M, 12 Seaview Rd, Remuera, NZ	30.40	"	"
Nelson, Francis R, PO Box 16-327, Hornby, Christchurch, NZ	89.18	"	"
Pickles, Doris P, c/o Share Department, GPO Box 2975EE, Melbourne	102.57	"	"
Pirie, David S, 21 Brockhall La, Christchurch, NZ	49.58	"	"
Plumley, Harold C, 6 Prangley Ave, Mangere, Auckland, NZ	89.10	"	"
Polson, Raymond S and Mayman, Michael N, c/o R S Burnside, Waihaorunga, Waimate RD 7, NZ	95.88	"	"
Rao, Runa S, 13 Ninth Ave, Tauranga, NZ	20.28	"	16.11.90
Risk, William H, Flora Road East, Makarewa, Invercargill Rd, NZ	21.50	"	"
Robertson, Peter A, 6 Ferry Rd, Days Bay, Wellington, NZ	34.88	"	"
Robinson, Rowena J, 18A Bongard St, Tauranga, NZ	67.05	"	11.5.90
Ryan, Michael T, 122 Cavendish Rd, Christchurch, NZ	38.35	"	"
Scandrett, Beverley G, Fairfax RD 8, Invercargill, NZ	134.10	"	"
Smeaton, David, Orawia RD 1, Otautau, Southland, NZ	77.11	"	"
Stevens, John D, Cave, South Canterbury, NZ	21.50	"	16.11.90
Surgenor, Maurice J, PO Box 61, Picton, NZ	60.33	"	11.5.90
Treloar, Joan O, 64 Wai-Iti Cres, Lower Hutt, NZ	59.22	"	16.11.90
Woodham, Jennifer M, RD 1, Ngatarawa Rd, Bridge, PA Hastings, NZ	57.66	"	11.5.90
Wright, Margaret P, Te Mara, Mt Bruce, Masterton, NZ	95.88	"	"
Young, Lionel A, 6 Te Kowhai Pl, Remuera, Auckland, NZ	43.40	"	16.11.90

1080

LILIAN CATHERINE ETHEL VAUGHAN, late of 14 Walbundry Avenue, North Balwyn in the State of Victoria, who died on 23 March 1992

Creditors, next of kin and all others having claims in respect of the said deceased are requested by the executor, The Equity Trustees Executors and Agency Company Limited of 472 Bourke Street, Melbourne to send particulars of such claims addressed to the executor, The Equity Trustees Executors and Agency Company Limited of 472 Bourke Street, Melbourne by 23 September 1992 after which date the said executor will distribute the assets having regard only to the claims of which it then has notice.

GARDENS RIDGEWAY, lawyers, 535  
Bourke Street, Melbourne 19086

KATHRYN JOY NEILAN, late of Old Sale Road, Drouin West, manager, deceased

After fourteen (14) clear days from today, Elizabeth Ann Dance of 221 Bleasby Road, Eight Mile Plains, Queensland, housewife, the lawfully constituted guardian of Sheridan Collette Louise Neilan of 221 Bleasby Road, Eight Mile Plains, Queensland, infant, daughter of the said deceased, will apply to the Supreme Court, Brisbane, for a grant of administration of the estate of the abovenamed deceased who died intestate. Any person interested who desires to object to the application, or to be heard upon it, may file a caveat in the registry at any time before the grant is made, and all notices may be served at the undermentioned address.

BOWDENS, solicitors, Level 35, Central Plaza One, 345 Queen Street, Brisbane, Queensland 19037

GLADYS MARGARET COLQUHOUN, late of Andrina Nursing Home, 4 Orchard Road, Brighton, Victoria, spinster, deceased

Creditors, next of kin and others having claims in respect of the estate of the deceased (who died on 29 March 1992) are required by Perpetual Trustees Victoria Limited (in the will called The Perpetual Executors and Trustees Association of Australia Limited) of 50 Queen Street, Melbourne to send in particulars of their claims to the said company by 22 September 1992 after which date it will convey or distribute the assets having regard only to the claims of which the company then has notice.

CORRS CHAMBERS WESTGARTH,  
solicitors, Bourke Place, 600 Bourke Street,  
Melbourne 19081

Creditors, next of kin and others having claims in respect of the estate of Dorothy Melba Greville late of 1/12 Kingsnorth Street, Doncaster, married woman, deceased who died on 17 May 1992 are requested to send particulars of their claims to the executors Lorne Henry Greville and Dawn Margaret Bladin care of the undermentioned solicitors by 18 September 1992 after which date the executors will distribute the assets having regard only to the claims of which they then have notice.

PETER J. WALSH & JOHN F. CARROLL,  
solicitors, 83 William Street, Melbourne 19082

Creditors, next of kin and others having claims in respect of the estate of Bonnie Patricia Thomas, late of Flat 2, 21 Chusan Street, Balaclava in the State of Victoria, home duties, deceased who died on 1 May 1992 are required to send particulars of their claims to the Equity Trustees Executors and Agency Company Limited of 472 Bourke Street, Melbourne by 9 September 1992 after which date it will distribute the assets having regard only to the claims of which it then has notice. 19083

Creditors, next of kin and others having claims in respect of the estate of John Patrick Kenney deceased who died on 18 March 1992 are required by the executor to send particulars of their claim to the undermentioned firm by 15 September 1992, after which date the trustee will convey or distribute assets having regard only to the claims of which the trustee then has notice.

LOMBARD & GILLARD, solicitors, 26-28  
Station Road, Cheltenham 19049

Creditors, next of kin and others having claims in respect of the estate of Dorothy May Hosking, formerly of 24 Knaith Road, Ringwood East but late of Croydon Park Nursing Home, 18 Hyton Crescent, Croydon in the State of Victoria, married woman, deceased who died on 7 May 1992 are required by the trustee company National Mutual Trustees Limited of 65 Southbank Boulevard, South Melbourne in the said State to send particulars of their claims to the said company by 16 September 1992, after which date it will convey or distribute the assets having regard only to the claims of which the company then has notice. 19084

Creditors, next of kin and others having claims in respect of the estate of Marjory Isabel Orton late of "Moorfields", 20-26 Manningtree Road, Hawthorn, Victoria, deceased who died on 3 April 1992, are to send particulars of their claims to The Equity Trustees Executors and Agency Co. Ltd. of 472 Bourke Street Melbourne, by 20 September 1992, after which date it will distribute the assets having regard only to the claims of which it then has notice. 19085

MARJORIE JANE MILLER, late of 13 Haigh Street, South Oakleigh in the State of Victoria, widow, deceased

Creditors, next of kin and others, having claims against the estate of the abovenamed deceased who died on 12 June 1992 should send particulars to the executor, Loch Neish Adams and John Garde care of the undermentioned solicitors by 14 September 1992, after which date the executor will distribute the assets having regard only to the claims of which it then has notice.

ADAMS & GARDE, solicitors, 11A Central Avenue, Moorabbin 19057

Creditors, next of kin and others having claims in respect of the estate of Ella Amelia Chapman, late of 85 MacPherson Street, Footscray, widow, deceased who died on 3 April, 1992 are requested to send particulars of their claims to the executor, The Equity Trustees Executors and Agency Company Limited of 472 Bourke Street, Melbourne by 19 August 1992 after which date they will convey or distribute the assets having regard only to the claims of which they then have notice.

SECOMBS, solicitors, 100 Paisley Street,  
Footscray 19094

1864 G 27 15 July 1992

Victoria Government Gazette

DOROTHEA RUTH O'LOUGHLIN, late of Tara Private Nursing Home, 398 Ryrie Street, Geelong, widow, deceased

Creditors, next of kin and others having claims in respect of the estate of the deceased who died on 5 April 1992 are required by the executors Vincent Joseph O'Loughlin and Patrick Francis Burke to send particulars of their claims to the executors care of the undermentioned solicitors by 25 September 1992 after which date the executors will proceed to distribute the estate having regard only to the claims of which they then have notice.

BURKE COX & CO., solicitors, 111 Yarra Street, Geelong 19063

GRAHAM ARTHUR MILLS, late of 17 Beringa Avenue, Grovedale in the State of Victoria, production worker, deceased

Creditors, next of kin and others having claims in respect of the estate of the abovenamed deceased, who died on 12 January 1992 are required by the trustees Kevin Malcolm Mills and Leanne Mills to send particulars of their claims to the trustees care of the undermentioned solicitors by 30 September 1992 after which date the trustees may convey or distribute the assets having regard only to the claims of which they then have notice.

INGPEN & BENT, solicitors, 95 Yarra Street, Geelong, solicitors for the trustees 19045

DOROTHY JOAN BISSELL, late of 6 Chisholm Street, Swan Hill in the State of Victoria, married woman, deceased

Creditors, next of kin and others having claims against the estate of the said deceased who died on 6 April 1992 are required to send particulars of same to the executor Hugh Melville Bissell in care of the undersigned on or before 11 September 1992 after which date they will distribute the assets of the estate having regard only to the claims of which they then have notice.

DWYER, MAHON & ROBERTSON, barristers and solicitors, 194-208 Beveridge Street, Swan Hill 19046

DORIS VERA HAYNES, late of Glandore Nursing Home, 194 Alma Road, East St Kilda, widow, deceased, who died on 8 January 1992

Creditors, next of kin and others having claims in respect of her estate are to send the

particulars of their claims to the executors, Permanent Trustee Company Limited of 294-296 Collins Street, Melbourne by 11 September 1992 after which date they will distribute the assets having regard only to the claims of which they then have notice.

ALPASS & ASSOCIATES, solicitors, 511 Mt. Dandenong Road, Kilsyth 19047

NELLIE IRENE LYONS, late of Unit 1, 7 Olinda Avenue, Beaumaris, Victoria, widow, deceased

Creditors, next of kin and others having claims in respect of the estate of the deceased who died on 24 May 1992 are required by the executors Shirley Winifred May McAdam of 31 Ashwood Avenue, Highett, Victoria, home duties and Desmond Lawrence Lyons of 39 Paul Street, Cheltenham, Victoria builder to send particulars to them by 13 September 1992 after which date they may convey or distribute the assets having regard only to the claims of which they then have notice.

NICHOLAS O'DONOHUE & CO., solicitors, 180 Queen Street, Melbourne 19075

Creditors, next of kin and others having claims against the estate of Sheila Maria McClure late of 1/16A Cromwell Road, South Yarra in the State of Victoria who died on 2 May 1992 are required by the executor The Equity Trustees Executors and Agency Company Limited of 472 Bourke Street, Melbourne to send detailed particulars of their claims to the said executor c/o Hassall & Byrne, solicitors of 308 Highett Road, Highett, 3190 by 15 September 1992 after which date it will proceed to distribute the said estate having regard only to the claims of which it then has notice.

HASSALL & BYRNE, solicitors, 308 Highett Road, Highett 19077

Creditors, next of kin and others having claims in respect of the estate of Doris Le Lievre late of Mayflower Nursing Home, 7 Centre Road, East Brighton, Victoria, spinster, deceased who died on 7 June 1992 are required by the executors Edward Graeme Henry and Campbell Craven Paine both of 80 Collins Street, Melbourne, Victoria, solicitors to send particulars of their claims to the executors care of the undermentioned address by 16 September 1992 after which date the said executors will convey or distribute the assets having regard



*Victoria Government Gazette*

only to the claims of which the said executors then have notice.

DARVALL McCUTCHEON, solicitors, 80  
Collins Street, Melbourne 19092

DORIS GWENDOLINE MACGREGOR, late  
of 4 Bennett Street, North Richmond in the  
State of Victoria, widow, deceased

Creditors, next of kin and others having  
claims in respect of the estate of the deceased  
who died on 13 March 1992 are required by the  
legal personal representatives Margaret Anne  
Pallant, shop assistant and James Harold  
Douglas Pallant, manager both of 27 Juniper  
Avenue, Glen Waverley to send particulars to  
them by 30 September 1992 after which date  
they will distribute the assets of the deceased  
having regard only to the claims of which they  
then have notice.

E. P. JOHNSON & DAVIES, of 257 Collins  
Street, Melbourne 19087

Creditors, next of kin and others having  
claims in respect of the estate of Evelyn  
Gertrude Moffatt late of 719 Hampton Street,  
Brighton, retired school principal, deceased who  
died on 2 May 1992 and Probate of whose will  
was granted by the Supreme Court of Victoria  
on 30 June 1992 to Peter James Weiss of 421A  
Church Street, Richmond are to send particulars  
of their claims to the said executor care of the  
below-mentioned solicitor by 21 September  
1992 after which date the executor will  
distribute the assets of the deceased having  
regard only to the claims of which the executor  
then has notice.

PETER J. WEISS LL.B., solicitor, 421A  
Church Street, Richmond 19088

LESLIE NORMAN POUND, late of 24 Wilfred  
Road, East Ivanhoe, Victoria, deceased

Creditors, next of kin, and all other persons  
having claims against the estate of the said  
deceased are required by Robert James Pound of  
24 Palm Beach Drive, Patterson Lakes, Victoria,  
managing director one of the executors to send  
particulars of such claims to the undermentioned  
solicitors on or before 18 September 1992 after  
which date they will distribute the assets having  
regard only to those claims of which they then  
have notice.

SAM STIDSTON & CO., solicitors, Suite 4,  
307 Main Street, Mornington 19080

G 27 15 July 1992 1865

GLADYS IRENE DUNNE, late of 355  
Springvale Road, Donvale, Victoria, widow,  
deceased

Creditors, next of kin and others having  
claims in respect of the deceased (who died on 9  
June 1992) are required to send particulars of  
their claims to Graham Joseph McCarten and  
Robert James McCarten care of Walsh, Johnston  
& Co., Solicitors of 452 High Street, Northcote  
before 23 September 1992 after which date they  
may convey or distribute the assets having  
regard only to the claims of which they then  
have notice.

WALSH, JOHNSTON & CO., solicitors, 452  
High Street, Northcote 19095

The Supreme Court of the State of Victoria  
SALE BY THE SHERIFF

On 20 August 1992 at 2.30 p.m. at the  
Sheriff's Office, 8-20 King Street, Oakleigh  
(unless process be stayed or satisfied).

All the estate and interest (if any) of Thomas  
John Muir of 15 Wimbourne Court, Wantirna as  
joint proprietor with Mardie Lamont of an estate  
in fee simple in the land described on Certificate  
of Title Volume 904 F Folio 835 upon which is  
erected a dwelling known as 15 Wimbourne  
Court, Wantirna.

Registered Mortgage Nos H827331,  
P172673U and Caveat No. R145245G affects  
the said estate and interest.

Terms—Cash only

19089 E. SMIRL  
Sheriff's Officer

The Supreme Court of the State of Victoria  
SALE BY THE SHERIFF

On 20 August 1992 at 2.30 p.m. at the  
Sheriff's Office, 8-20 King Street, Oakleigh  
(unless process be stayed or satisfied).

All the estate and interest (if any) of John Soer  
of 1 Daniel Solander Drive, Endeavour Hills as  
registered proprietor of an estate in fee simple in  
the land described on Certificate of Title  
Volume 9046 Folio 951 upon which is erected a  
brick veneer dwelling known as 1 Daniel  
Solander Drive, Endeavour Hills.

Registered Mortgage No. J505488 and the  
Covenant contained in transfer G212190 affects  
the said estate and interest.

Terms—Cash only

19090 E. SMIRL  
Sheriff's Officer

1866 G 27 15 July 1992

**NOTICE OF MAKING OF STATUTORY  
RULES WHICH ARE NOT YET  
AVAILABLE**

Notice is given of the making of the following  
Statutory Rules:

	<i>Supreme Court Act</i> 1986
216/1992	Admiralty Rules 1992
	<i>County Court Act 1958</i>
217/1992	County Court (Chapter II Amendment No. 5) Rules 1992

Victoria Government Gazette

**NOTICE OF MAKING AND AVAILABILITY  
OF STATUTORY RULES**

In pursuance of the provisions of the  
*Subordinate Legislation Act 1962* and the  
Regulations made thereunder notice is given of the  
making and availability of the following Statutory  
Rules:

Note: The date specified after each Statutory  
Rule is the date it was first obtainable from—  
The Law Printer  
28 Queensbridge Street, South Melbourne, 3205  
Tel: 242 4600

	<i>Police Regulation Act</i> 1958	
118/1992	Police Regulations 1992	Code C
8 July 1992		
	<i>Petroleum Act 1958</i>	
120/1992	Petroleum Regulations 1992	Code D
9 July 1992		
	<i>Marketing of Primary Products Act 1958</i>	
121/1992	Tobacco Leaf Marketing (Producers) Regulations 1992	Code A
8 July 1992		
	<i>Survey Co-ordination Act 1958</i>	
122/1992	Survey Co-ordination (Surveys) Regulations 1992	Code B
8 July 1992		
	<i>Audit Act 1958</i>	
123/1992	Treasury Regulations 1992	Code D
9 July 1992		
	<i>Residential Tenancies Act 1980</i>	
125/1992	Residential Tenancies Regulations 1992	Code C
9 July 1992		
	<i>Small Claims Tribunals Act 1973</i>	
126/1992	Small Claims Tribunals Regulations 1992	Code A
8 July 1992		

<i>Victoria Government Gazette</i>		<i>G 27 15 July 1992 1867</i>	
	<i>Business Franchise Tobacco Act 1974</i>	156/1992	<i>Fisheries Act 1968 (Abalone)</i>
132/1992	Business Franchise (Tabacco and Petroleum Products) Regulations 1992	13 July 1992	Fishing (Amendment) Regulations 1992
			Code A
9 July 1992		Code C	<i>Conservation, Forests and Lands Act 1987</i>
	<i>Melbourne and Metropolitan Board of Works Act 1958</i>	164/1992	Conservation, Forests and Lands (Infringement Notice) Regulations 1992
137/1992	By-law No. 303: Melbourne and Metropolitan Board of Works Employees Superannuation Fund (Amendment) Regulations	14 July 1992	
			Code A
9 July 1992		Code B	<i>Sunday Entertainment Act 1967</i>
	<i>Subordinate Legislation Act 1962</i>	171/1992	Sunday Entertainment Regulations 1992
139/1992	Subordinate Legislation Regulations 1992	13 July 1992	
			Code A
9 July 1992		Code A	<i>State Employees Retirement Benefits Act 1979</i>
	<i>Property Law Act 1958</i>	179/1992	State Employees Retirement Benefits Board Election Regulations 1992
140/1992	Property Law (Registration of Instruments) Regulations 1992	13 July 1992	
			Code A
9 July 1992		Code A	<i>Finance Brokers Act 1969</i>
	<i>Evidence Act 1958</i>	184/1992	Finance Brokers Regulations 1992
144/1992	Evidence (Interpreters Allowances) Regulations 1992	14 July 1992	
			Code B
	<i>Annual Reporting Act 1983</i>	186/1992	<i>Health Act 1958 (Seizure)</i>
146/1992	Annual Reporting (Public Sector Superannuation Schemes) (Amendment) Regulations 1992	13 July 1992	Health (Seizure) Regulations 1992
			Code A
13 July 1992		Code A	<i>Police Regulation Act 1958</i>
	<i>State Electricity Commission Act 1958</i>	187/1992	Police (Charges) Regulations 1992
147/1992	State Electricity Commission (Licensing of Electrical Mechanics Exemptions) Regulations 1992	13 July 1992	
			Code A
13 July 1992		Code A	<i>Forests Act 1958</i>
		188/1992	Fire Protection Regulations 1992
		14 July 1992	
			Code B
		189/1992	<i>Land Conservation (Vehicle Control) Act 1972</i>
13 July 1992		13 July 1992	Land Conservation (Vehicle Control) Regulations 1992
			Code A

1868 G 27 15 July 1992

Victoria Government Gazette

	<i>Forests Act 1958</i>	
191/1992	Forests (Miscellaneous) (Amendment) Regulations 1992	
14 July 1992		Code A
	<i>Supreme Court Act</i> 1986	
210/1992	Supreme Court (Chapter II Amendment No. 9) Rules 1992	
14 July 1992		Code A
	<i>Supreme Court Act</i> 1986	
211/1992	Supreme Court (Chapter I Amendment No. 25) Rules 1992	
14 July 1992		Code A
	<i>Motor Car Traders Act</i> 1986	
215/1992	Motor Car Traders (Fees) (Amendment) Regulations 1992	
14 July 1992		Code A

The retail prices and price codes below will apply from 1 October 1991 to the following products: Acts (New, Reissue and Reprint), Statutory Rules (New, Reissue and Reprint), Parliamentary Papers, Bills and Reports, Special and Periodical Gazettes, and Industrial Awards.

<i>Price Code</i>	<i>No. of Pages (Including cover and blank pages)</i>	<i>Price</i>
A	1-16	\$2.60
B	17-32	\$3.90
C	33-48	\$5.25
D	49-96	\$7.85
E	97-144	\$10.50
F	145-192	\$12.60
G	193-240	\$14.50
H	241-288	\$15.25
I	289-352	\$16.80
J	353-416	\$20.00
K	417-480	\$23.00
L	481-544	\$26.25

A set retail price per issue will apply from 1 October 1991 to:

Government Gazette (General)	\$1.60 per issue
Hansard (Weekly)	\$2.60 per issue



1870 G 27 15 July 1992

*Victoria Government Gazette*





## CONTENTS

	Page
Appointments	1806
Contracts	1804
Contracts Accepted—Amendments	1798
Courts	1801
Estates of Deceased Persons	1797
Government Notices	1780
Melbourne Water	1799
Notice of Making of Statutory Rules	1866
Orders in Council—	
Acts—Cemeteries; Crown Land (Reserves); Order; Land; Forests; Farm Produce Wholesale; Dairy Industry; Environment Protection; Royal Botanic Gardens; Murray Darling Basin; Local Government	1807
Police Sale	1804
Private Advertisements	1828
Proclamations	1778

A Victorian Government Publication

Published by

THE LAW PRINTER

a business unit of

Printing and Publishing Services Victoria (PPSV)

Melbourne Victoria Australia

© State of Victoria 1992

This publication is copyright. No parts may be reproduced  
by any process except in accordance with the provisions  
of the Copyright Act.

Address all inquiries to the Government Printer  
for the State of Victoria

PO Box 292 South Melbourne 3205 Victoria Australia

ISSN 0819—5471

L. V. North, Government Printer Melbourne

**Mail and Bulk Order Sales**

The Law Printer

PO Box 292 South Melbourne 3205

28 Queensbridge Street, South Melbourne

Telephone inquiries (03) 242 4600

Fax (03) 242 4699

**Counter Sales**

Information Victoria Bookshop

318 Lt. Bourke Street Melbourne 3000

Telephone inquiries (03) 651 4100

**Recommended Retail Price \$1.60**