



VICTORIA GOVERNMENT GAZETTE.

Published by Authority.

[Registered at the General Post Office, Melbourne, for transmission by post as a newspaper.]

No. 140]

WEDNESDAY, OCTOBER 31.

[1945

PUBLIC HOLIDAYS.

PROCLAMATION

By His Excellency the Governor of the State of Victoria and its Dependencies in the Commonwealth of Australia, &c., &c., &c.

IN pursuance of the provisions contained in Part VII. of the *Public Service Act 1928* (19 Geo. V. No. 3757), I, the Governor of the State of Victoria, in the Commonwealth of Australia, by and with the advice of the Executive Council of the said State, do by this my Proclamation appoint the days and dates hereunder mentioned to be observed as Public Holidays or Public Half-Holidays (as the case may be) at the places respectively specified, viz:—

Public Holidays:—

TUESDAY, THE 6TH DAY OF NOVEMBER, 1945, throughout the Shire of Mildura.
TUESDAY, THE 6TH DAY OF NOVEMBER, 1945, throughout the City of Mildura.
WEDNESDAY, THE 14TH DAY OF NOVEMBER, 1945, throughout the Borough of Shepparton.
WEDNESDAY, THE 14TH DAY OF NOVEMBER, 1945, throughout the Borough of Eaglehawk.
SATURDAY, THE 24TH DAY OF NOVEMBER, 1945, throughout the North Riding of the Shire of Buln Buln.

Public Half-Holidays from the Hour of Twelve o'clock noon:—

WEDNESDAY, THE 31ST DAY OF OCTOBER, 1945, throughout the Shire of Cohuna.*
THURSDAY, THE 15TH DAY OF NOVEMBER, 1945, throughout the Borough of Sebastopol.*

* Agricultural Show.

Given under my Hand and the Seal of the State of Victoria aforesaid, at Melbourne, this thirtieth day of October, in the year of Our Lord One thousand nine hundred and forty-five, and in the ninth year of the reign of His Majesty King George VI.

(L.S.)

WINSTON DUGAN.

By His Excellency's Command,

T. K. MALTBY,
Chief Secretary.

GOD SAVE THE KING!

BANK HOLIDAYS.

PROCLAMATION

By His Excellency the Governor of the State of Victoria and its Dependencies in the Commonwealth of Australia, &c., &c., &c.

IN pursuance of the provisions contained in Part III. of the *Banks and Currency Act 1928*, I, the Governor of the State of Victoria, in the Commonwealth of Australia, do by this my Proclamation appoint the days and dates named hereunder special days to be observed as Bank Holidays or Bank Half-Holidays (as the case may be) at the places respectively mentioned, that is to say:—

Bank Holidays:—

SATURDAY, THE 3RD DAY OF NOVEMBER, 1945, at Horsham.
WEDNESDAY, THE 7TH DAY OF NOVEMBER, 1945, at Murtoa.

Bank Half-Holidays from the Hour of Twelve o'clock noon:—

THURSDAY, THE 1ST DAY OF NOVEMBER, 1945, at Warrnambool.
THURSDAY, THE 15TH DAY OF NOVEMBER, 1945, at Sale.
WEDNESDAY, THE 31ST DAY OF OCTOBER, 1945, at Cohuna.

Given under my Hand and the Seal of the State of Victoria aforesaid, at Melbourne, this thirtieth day of October, in the year of Our Lord One thousand nine hundred and forty-five, and in the ninth year of the reign of His Majesty King George VI.

(L.S.)

WINSTON DUGAN.

By His Excellency's Command.

T. K. MALTBY,
Chief Secretary.

GOD SAVE THE KING!

MELBOURNE CUP HOLIDAY.

It is hereby notified that on

TUESDAY, THE 6TH NOVEMBER, 1945,

the Public Offices throughout the Cities of Box Hill, Brighton, Brunswick, Camberwell, Caulfield, Chelsea, Coburg, Collingwood, Essendon, Fitzroy, Footscray, Hawthorn, Heidelberg, Kew, Malvern, Melbourne, Moorabbin, Mordialloc, Northcote, Nunawading, Oakleigh, Port Melbourne, Prahran, Preston, Richmond, St. Kilda, Sandringham, South Melbourne, and Williamstown, the Borough of Ringwood, and the Shires of Baccus Marsh, Berwick, Braybrook, Broadmeadows, Bulla, Cranbourne, Dandenong, Doncaster and Templestowe, Eltham, Ferntree Gully, Frankston and Hastings, Gisborne, Keilor, Lillydale, Melton, Mornington, Mulgrave, Romsey, Werribee, and Whittlesea will be closed, that date having been proclaimed by the Governor in Council, under the powers conferred by the *Public Service Act 1928*, to be observed as a Holiday in the Public Offices.

T. K. MALTBY,
Chief Secretary.

Chief Secretary's Office.

Melbourne, 13th October, 1945.

APPOINTMENTS.

HIS Excellency the Governor of the State of Victoria, by and with the advice of the Executive Council thereof, has, by Orders made on the 23rd day of October, 1945, been pleased to make the following appointments, viz.:—

DEPARTMENT OF CHIEF SECRETARY.

Electoral Registrars (Acting).

WILLIAM EWART DUNSTAN

to be Electoral Registrar (Acting) for the Clunes Subdivision of the Electoral District of Allendale; for the Bannockburn, Beacoe, Camperdown, Linton, and Smythesdale Subdivisions of the Electoral District of Hampden; for the Avoca, Carisbrook, Maldon, and Maryborough Subdivisions of the Electoral District of Midlands; for the Beech Forest, Birregurra, Cobden, Colac, Krambruk, and Port Campbell Subdivisions of the Electoral District of Polwarth; for the Penhurst Subdivision of the Electoral District of Portland; for the Ararat, Beaufort, Landsborough, and Willaura Subdivisions of the Electoral District of Ripon; and for the Allansford, Mortlake, and Terang Subdivisions of the Electoral District of Warrnambool, to take effect on and from 5th November, 1945, during the absence on leave of Francis Peter Mills;

LEONARD FOSTER MURRAYLEE

to be Electoral Registrar (Acting) for the Blyth and Brunswick West Subdivisions of the Electoral District of Brunswick; for the Brunswick South and Edward Subdivisions of the Electoral District of Carleton; for the Coburg and Mitchell Subdivisions of the Electoral District of Coburg; and for the Coburg West Subdivision of the Electoral District of Essendon, to take effect on and from 29th October, 1945, during the absence on leave of William Bushby; and

ALAN CARLYLE VEREY

to be Electoral Registrar (Acting) for the Burwood Subdivision of the Electoral District of Camberwell; for the Dandenong Subdivision of the Electoral District of Dandenong; for the Berwick, Drouin, Koo-wee-rup, Pakenham, and Warragul Subdivisions of the Electoral District of Gippsland West; for the Burwood South Subdivision of the Electoral District of Glen Iris; for the Carrum and Mentone Subdivisions of the Electoral District of Mentone; for the Promana and Frankston Subdivisions of the Electoral District of Mornington; for the Oakleigh East Subdivision of the Electoral District of Oakleigh; for the Cranbourne and Ferntree Gully Subdivisions of the Electoral District of Scoresby; and for the Loch Subdivision of the Electoral District of Wonthaggi, to take effect on and from 5th November, 1945, during the absence on leave of John William Pette.

Superintendents (Acting) of Reformatory Prisons.

THOMAS MORRISSEY

to be Superintendent (Acting) of the Beechworth Reformatory Prison, from the 24th October, 1945, to the 13th November, 1945, both dates inclusive, during the absence on leave of William Callaghan; and

ALBERT AUSTIN SPALL

to be Superintendent (Acting) of the Castlemaine Reformatory Prison, from the 5th November, 1945, to the 25th November, 1945, both dates inclusive, during the absence on leave of James Edwards.

DEPARTMENT OF LANDS AND SURVEY.

Inspectors of Vermin and Noxious Weeds.

CHARLES HERBERT GREEN and

COLIN HERBERT WHEELER,

Inspectors, Department of Lands and Survey,

to act also as Inspectors under the *Vermin and Noxious Weeds Act 1928*, without additional salary, as from and inclusive of the 17th September, 1945.

DEPARTMENT OF LAW.

Magistrates.

ROYAL IRVINE MCKAY, 476 Whitehorse-road, Surrey Hills,
GERALD FRANCIS WRAITH, 307 Wattletree-road, Malvern,
and

ALEXANDER GEDDES, corner of Bank-place and Little
Collins-street, Melbourne.

to Keep the Peace in the Central Bailiwick of the State of
Victoria;

CHARLES MORTIMER LUCKOCK, Dundonnell, and
HAROLD THOMAS MCCONNELL, Kolora,

to Keep the Peace in the Western Bailiwick of the State of
Victoria;

WILLIAM ARCHIBALD PURCELL SNODGRASS, Balmattum
East,

to Keep the Peace in the Northern Bailiwick of the State of
Victoria; and

ALBERT GEORGE PENNELL, Burke-street, Braybrook.

to Keep the Peace in the Central Bailiwick of the State of
Victoria.

Commissioners for Taking Declarations, &c.

HENRY ALBERT LINDSAY, Peel-street, Quarry Hill,

ALBERT ERNEST RICHARDSON, Secretary, Trades Hall,
Bendigo,

ARTHUR BAILEY PEAKE, Mt. Korong-road, Eaglehawk,

JOSEPH PATRICK KELLETT, 2 Hilton-street, Clifton Hill,

RAYMOND JAMES JOSEPH PAGET, 12 Roading-street,
Brighton,

HARRY GOODWIN, 155 Thomas-street, Brighton,

ROBERT GEORGE GOLDRING, 18 Fergie-street, North Fitzroy.

SARIE MCKILLOP, 16 Woodside-crescent, Toorak,

JESSIE ELIZABETH MCARTHUR, 820 Malvern-road, Toorak,

CHARLES VINCENT BLYTH, 35 Excelsior-street, Regent,

JOSEPH NAZARETH WINTER, 13 Leaming-street, Reservoir,

JOHN HAYES, "Belvedere," North-road, Reservoir,

ANNIE LLOYD BITTLES, 44 Pine-street, Reservoir,

CLIVE ERNEST SANDY, 38 Fletcher-street, Essendon,

LEIGH BLEARS, 25 Balmanno-avenue, North Essendon,

STANISLAUS TERENCE CORRIGAN, 110 Ingles-street, Port
Melbourne,

MARY ANN ANDERSON, Lloyd-street, Dimboola,

ALBERT WARD ADAMS, 72 William-street, Brighton,

ROBERT LAURENCE DYER, 20 New-street, Brighton Beach,

CLIFFORD CHARLES DENTEX, 3 Villeroi-street, Hampton,
and

JAMES LIONEL GILLIES, 846 Hampton-street, Brighton,

to be Commissioners for taking Declarations and Affidavits,
pursuant to the provisions of Division 8 of Part IV. of the
Evidence Act 1928, to resign upon removing from the neigh-
bourhood of the addresses stated.

Bailiff of County Court.

JOHN THOMPSON, Senior Constable of Police, Dimboola.

to be a Bailiff of the County Court at Horsham, in the place
of L. D. Dean, resigned (fees).

DEPARTMENT OF PUBLIC WORKS.

Chairman of Country Roads Board.

WILLIAM LESLIE DALE,

pursuant to the provisions of section 4 of the *Country Roads
Act 1928*, to be Chairman of the Country Roads Board for
a term of twelve months from and inclusive of the second
day of January, 1946.

Wharf Manager, &c.

First Constable ROBERT JAMES LEES, No. 8096,

to be Wharf Manager at Tooradin, to carry out that portion
of Part II. of the *Marine Act 1928* which relates to the
management of Public Wharves, and to be an officer under
section 19 of such Act to levy and collect wharfage rates
thereat.

C. W. KINSMAN,

Clerk of the Executive Council.

At the Executive Council Chamber,
Melbourne, the 23rd October, 1945.

RESIGNATIONS.

HIS Excellency the Governor of the State of Victoria, by and with the advice of the Executive Council thereof, has, by Orders made on the 23rd day of October, 1945, accepted the resignations of the persons named hereunder of the offices mentioned, viz.:—

DEPARTMENT OF AGRICULTURE.

GEORGE HENRY WRIGHT, Veterinary Stock Inspector, Class "C," Professional Division, as an officer of the Public Service of Victoria, to date from and inclusive of the 25th October, 1945.

DEPARTMENT OF LAW.

ALFRED CHARLES PARKINSON, from the Commission of the Peace for the Eastern Bailiwick of Victoria.

RAY TASSIE, as a Commissioner for taking Declarations and Affidavits, pursuant to the provisions of the *Evidence Act 1928*.

RICHARD HAMLIN PETHYBRIDGE and HERBERT JOHN HEAVEY, as Probation Officers, pursuant to the provisions of the *Children's Court Act 1928*, for the Children's Courts at Morwell and Shepparton, respectively.

LEO DOMINIC DEAN, as a Bailiff of the County Court at Horsham.

C. W. KINSMAN,
Clerk of the Executive Council.

At the Executive Council Chamber,
Melbourne, the 23rd October, 1945.

GARDENER, REPATRIATION MENTAL HOSPITAL, BUNDOORA, MENTAL HYGIENE BRANCH, DEPARTMENT OF HEALTH.

APPPLICATIONS will be received by the Public Service Board up to Friday, the 16th November, 1945, from officers of the Public Service of Victoria, who are qualified, for appointment to the above-mentioned position.

Yearly Salary.—£312, minimum; £325, maximum, plus £30 cost of living allowance. The rates are subject to variation in accordance with the rise or fall in the index numbers of the cost of living.

Duties.—To be in charge of ornamental and vegetable gardens.

Qualifications.—To possess a thorough knowledge of ornamental gardening, with ability to design and plant out new ground; a sound knowledge of vegetable gardening; an appreciation of gardening as a means to helping patients toward recovery, and capacity for enlisting their co-operation.

By order,

E. F. FITZGIBBON,
Acting Secretary.

Office of the Public Service Board,
Melbourne, 30th October, 1945.

PUBLIC SERVICE OF VICTORIA.—VACANCIES, PROFESSIONAL DIVISION.

APPPLICATIONS will be received by the Public Service Board from persons, who are qualified, for appointment to the under-mentioned positions:—

Ethnologist, Class "C," Public Library, National Gallery, and National Museums Branch, Department of Chief Secretary.

Yearly Salary.—£449, minimum; £527, maximum.

Duties.—To be curator of the ethnological and anthropological collections of the Museum; to undertake scientific research on the collections and in the field, and to advise the public and scientific organizations on all matters relating to ethnology.

Qualifications.—To have a University degree with Anthropology as a major subject, ability to act as a curator, and experience in ethnological research work.

Assistant Works Manager, Class "C," Government Cool Stores, Department of Agriculture.

Yearly Salary.—£449, minimum; £501, maximum.

Duties.—As directed, to assist in the management of the Victoria Dock Cool Stores, including preparation of daily works programme of storage chambers and labour required, placing of railway trucks, &c.

Qualifications.—To possess a sound knowledge of refrigeration practices, with special knowledge of the problems of the storage of dairy products. Business experience is essential.

Assistant Plant Pathologist, Classes "D" and "C," Department of Agriculture.

Yearly Salary.—£436, minimum; £540, maximum.

Duties.—As directed, to conduct research into the plant pathological problems of Victoria, to investigate and report on plant disease outbreaks, to diagnose plant disease specimens, to deliver lectures and conduct field demonstrations on the control of plant diseases.

Qualifications.—To possess a Degree in Agricultural Science, or its equivalent, experience in the conduct of research in plant pathology, and a general knowledge of agricultural and horticultural practice.

Inspector of Works, Class "D," Department of Public Works.

Yearly Salary.—£351, minimum; £436, maximum.

Duties.—To generally supervise and inspect works and buildings carried out and erected under contract.

Qualifications.—To possess ability to make reports and estimates of repairs with sketch plans when required, and training in subjects relating to buildings, &c.

Conchologist (Female), Class "D," Public Library, National Gallery, and National Museums Branch, Department of Chief Secretary.

Yearly Salary.—£364, minimum; £423, maximum.

Duties.—To be curator of the museum collection of mollusca; to undertake research on the collections and in the field; to advise the public and scientific associations on all matters relating to this group; and to assist with other collections as required.

Qualifications.—To have a University degree or equivalent training in Science, with Zoology as a major subject, ability to act as a curator, and to arrange public exhibitions of museum collections, and proved ability to conduct research and prepare scientific papers.

NOTE.—In addition to the salary rates quoted, a cost of living allowance at the rate of £20 in the case of females and £30 in the case of males is payable. The rates are subject to variation in accordance with the rise or fall in the index numbers of the cost of living.

Applications (which should be accompanied by evidence of experience and qualifications, and a statement of date and place of birth) should be lodged at this office not later than Friday, the 9th November, 1945.

By order,

E. F. FITZGIBBON,
Acting Secretary.

Office of the Public Service Board,
Melbourne, 30th October, 1945.

PUBLIC SERVICE OF VICTORIA.—VACANCIES.

APPPLICATIONS will be received by the Public Service Board up to Friday, the 9th November, 1945, from officers of the Public Service of Victoria, who are eligible and qualified, for appointment to the under-mentioned positions:—

PROFESSIONAL DIVISION.

Entomologist, Class "C," Department of Agriculture.

Yearly Salary.—£449, minimum; £579, maximum.

Duties.—To undertake, as directed, entomological research and advisory work, and to prepare reports on entomological matters.

Qualifications.—To hold a degree of Bachelor of Agricultural Science, together with proved experience and capacity in the conduct of entomological research work.

Forest Economist, Class "C," Department of State Forests.

Yearly Salary.—£449, minimum; £579, maximum.

Duties.—To make stumpage appraisals, including determination of production costs, market values, and royalty values, economic surveys in connexion with the practicability of establishment of new forest industries, sawmill studies, embracing mill lay-out, and grading and efficiency studies, and to maintain liaison between the Forests Commission and the sawmilling industry.

Qualifications.—To be the holder of a degree in Forestry, or a graduate of a recognized School of Forestry; to have a sound knowledge of, and experience in, timber assessment, logging, and sawmilling practice, and the economics of industries connected with forest products in general; to be thoroughly conversant with the Forests Act and Regulations, and with Victorian forestry practice and procedure.

CLERICAL DIVISION.

Third Class Clerk, Taxation (Probate Duties) Branch, Department of Treasurer.

Duties.—To examine wills, settlements, and statements for duty, and raise any necessary requisitions thereon; to calculate life and remainder interests under wills; to check assessments for duty, and to exercise supervision over staff generally.

Qualifications.—To possess a sound knowledge of the Administration and Probate Acts and decisions of Courts relevant to assessment of probate duty, and ability to control a staff.

Fourth Class Clerk, Department of Health.

Duties.—To be responsible for the purchase of medical, technical, and general stores of the General Health Branch of the Department, and to supervise the clerical staff engaged in recording receipts and disposals of such stores.

Qualifications.—To possess specialized knowledge of and experience in sanatoria and clinic requirements, particularly in regard to medical stores and equipment, ability to organize methods of stock control, and a thorough knowledge of Stores and Transport and Public Accounts regulations.

NOTE.—In addition to the salary rates quoted, a cost of living allowance at the rate of £30 a year is payable. The rates are subject to variation in accordance with the rise or fall in the index numbers of the cost of living.

By order,
E. F. FITZGIBBON,
Acting Secretary.

Office of the Public Service Board,
Melbourne, 30th October, 1945.

PUBLIC SERVICE OF VICTORIA.—VACANCIES, GENERAL DIVISION.

APPPLICATIONS will be received by the Public Service Board from persons, who are qualified, for appointment to the under-mentioned positions:—

Orchard Supervisor, Grade II, Department of Agriculture.

Yearly Salary.—£298, minimum: £363, maximum.

Duties.—To inspect orchards, nurseries, and markets; to advise growers regarding treatment of diseases, mixing and applying of spray materials, pruning, cultivation, packing, manuring, draining, and all work necessary in the orchard; to direct irrigation as applied to fruit trees, scientific planning of orchards for growers, renovation of old orchards; to report on different phases of horticulture and to carry out necessary duties under the *Vegetation and Vine Diseases Act 1928* and the *Fruit and Vegetables Act 1928*.

Qualifications.—To have a thoroughly practical knowledge of fruit growing, suitability of soils, pruning, packing, budding, grafting, working stock, &c., irrigation of orchards, spraying and use of spray pump; to be conversant with the life history of insect and fungi pests and treatment for suppression; and to have a knowledge of the *Vegetation and Vine Diseases Act 1928*, the *Fruit and Vegetables Act 1928*, and all of the regulations under these Acts, and the regulations under the Commonwealth Customs Act and Commerce (Trading Description) Act.

Assistant Gardener, Mental Hospital, Mont Park, Department of Health.

Salary.—£300 a year.

Duties.—To carry out gardening operations, and to assist in the nursery under the supervision of the Curator.

Qualifications.—To possess a knowledge of general ornamental gardening, ability to propagate plants from seeds and cuttings, and to prune trees and shrubs. Ability to control mental patients, and a knowledge of glass-house work are desirable. (This advertisement is in lieu of that which appeared in the *Government Gazette* on the 17th October, 1945.)

NOTE.—In addition to the salary rates quoted, a cost of living allowance at the rate of £30 a year is payable. The rates are subject to variation in accordance with the rise or fall in the index numbers of the cost of living.

Applications (which should be accompanied by evidence of experience and qualifications, and a statement of date and place of birth) should be lodged at this office not later than Friday, the 16th November, 1945.

By order,
E. F. FITZGIBBON,
Acting Secretary.

Office of the Public Service Board,
Melbourne, 30th October, 1945.

Act No. 3757, Section 66 (VIII).

REGULATIONS.—CLASSIFICATION OF GENERAL DIVISION.

CHAPTER VII.

THE Public Service Board, in pursuance of the powers vested in it, hereby amends Chapter VII. of the Public Service Regulations as shown below, and submits the same for the approval of the Governor in Council:—

Department and Office.	Yearly Rate of Salary.	
	Minimum.	Maximum.
DEPARTMENT OF CHIEF SECRETARY.	£	£
PUBLIC LIBRARY.		
<i>Repeal—</i> Caretaker	247	299*
<i>Add—</i> Supervisor, Assistant .. .	304	317

Department and Office.	Additional Yearly Rate.
DEPARTMENT OF TREASURER.	£
<i>Government Printing Office.</i>	
<i>For</i> Security Officer .. .	120
<i>Read—</i> Security Officer .. .	133
<i>To take effect as from and inclusive of the 1st October, 1945.</i>	

Department and Office.	Yearly Rate of Salary.	
	Minimum.	Maximum.
DEPARTMENT OF HEALTH.		
GENERAL HEALTH.	£	£
<i>For—</i> Housekeeper, Cresswell Sanatorium .. .	195	210†
<i>Read—</i> Housekeeper, Cresswell Sanatorium	226†
<i>To date from and inclusive of the 1st September, 1945.</i>		

* Less deduction of £30 a year for quarters, fuel, light, and water.
† With a deduction of £32 a year for quarters and rations.

D. D. PAINE, Chairman.
E. F. FITZGIBBON, Acting Secretary.

Office of the Public Service Board,
Melbourne, 26th September and 1st October, 1945.

Approved by the Governor in Council,
23rd October, 1945.

C. W. KINSMAN,
Clerk of the Executive Council.

Public Service Act 1928.

REGULATIONS.—CHAPTER XIII.—LEAVE OF ABSENCE.

CORRIGENDUM.

IN the Regulations appearing in the *Gazette* of the 24th October, 1945, at page 2661, amending clauses 4 and 6 of Chapter XIII. of the Public Service Regulations, the date appearing after the words "Office of the Public Service Board" should read "25th October, 1944" and not "25th October, 1945" as shown therein.

Gazette Office,
Melbourne.

Public Service Act 1928 (No. 3757). Sections 90 and 91.
EXEMPTIONS.

HIS Excellency the Governor of the State of Victoria, by and with the advice of the Executive Council thereof, and upon the recommendation of the Public Service Board, has, by Orders made on the 23rd day of October, 1945, exempted the officers specified hereunder from the provisions of sections 90 and 91 of the *Public Service Act 1928* (No. 3757):—

DEPARTMENT OF AGRICULTURE.

One (1) officer of the Dairying Division, and one (1) Officer of the Live Stock Division, who are required to work overtime—such exemption to be operative for the period from the 11th August, 1945, to the 15th September, 1945, both dates inclusive.

DEPARTMENT OF MINES.

Drill Hands who are required to work overtime at the Deep Drilling Plant at Nelson—such exemption to be operative for the period from 8th September, 1945, to the 17th December, 1945, both dates inclusive.

C. W. KINSMAN,
Clerk of the Executive Council.

At the Executive Council Chamber,
Melbourne, the 23rd October, 1945.

AIDE-DE-CAMP, ETC.

HIS Excellency the Governor of Victoria has been pleased to make the following appointments:—

Lieutenant JOHN ATTERILL TEMPLETON, R.N.V.R., to be Aide-de-Camp to His Excellency, to date from the 22nd October, 1945; and

ROBERT GIBBES, to be Assistant Private Secretary to His Excellency, to date from the 20th August, 1945.

By order,
C. W. KINSMAN,
Official Secretary.

The Governor's Office,
Melbourne, 24th October, 1945.

SHIRE OF OMEO.

ROAD DEVIATION CONFIRMED.

IN pursuance of the powers conferred by sections 521 and 525 of the *Local Government Act 1928*, the Council of the Shire of Omeo doth hereby order that the land hereinafter described shall be a public highway from the publication of this Order in the *Government Gazette*, namely:—All that piece of land being part of Crown allotment 11 of section 11, Parish of Hinmumunjie, County of Benambra, commencing at a point on the southern boundary south 81 deg. 16 min. east 570½ links from the south-eastern angle of Crown allotment 8 of section 11; thence north 50 deg. 38 min. east 1,019 links, south 83 deg. 40 min. east 472 links, south 17 deg. 47 min. east 870 links, north 81 deg. 16 min. west 112 links, north 17 deg. 47 min. west 755 links, north 83 deg. 40 min. west 365 links, south 50 deg. 38 min. west 887 links, north 81 deg. 16 min. west 134½ links to the point of commencement.

And the said Council doth hereby further declare that the said land above described shall from the date of publication in the said *Government Gazette* be a public highway in lieu of the land hereinafter described, namely:—All that piece of land being part of a Government road on the southern side of Crown allotment 11 of section 11, Parish of Hinmumunjie, County of Benambra, commencing at a point on the southern boundary of the said allotment south 81 deg. 16 min. east 705 links from the south-eastern angle of Crown allotment 8 of section 11; thence south 81 deg. 16 min. east 1,294 links, south 17 deg. 47 min. east 112 links, north 81 deg. 16 min. west 1,434 links, north 50 deg. 38 min. east 134½ links to the point of commencement.

Dated the fifteenth day of August, 1945.

The common seal of the President, Councillors, and Rate-payers of the Shire of Omeo was hereto affixed in the presence of—

(SEAL) J. M. POULSON, Councillor.
A. M. PEARSON, Councillor.
P. J. McMAFON, Secretary.

Confirmed by the Governor in Council,
the 23rd day of October, 1945.

C. W. KINSMAN,
Clerk of the Executive Council.

DEPARTMENT OF LAW.

SITTINGS OF SUPREME COURT, MELBOURNE.—
ADDITIONAL DAY.

HIS Excellency the Governor of the State of Victoria, by and with the advice of the Executive Council thereof, doth, by Order made on the 30th day of October, 1945, appoint Wednesday, the 7th day of November, 1945, as a day for the sittings of the Supreme Court for the hearing of Criminal Trials at Melbourne in addition to the days heretofore appointed.

C. W. KINSMAN,
Clerk of the Executive Council.

At the Executive Council Chamber,
Melbourne, 30th October, 1945.

DEPARTMENT OF LAW.

CHILDREN'S COURTS—DAYS ALTERED.

HIS Excellency the Governor of the State of Victoria, by and with the advice of the Executive Council thereof and in pursuance of the provisions of section 12 of the *Children's Court Act 1928*, doth on the 30th day of October, 1945, hereby order that the days and hours heretofore appointed for the holding of Children's Courts named in the schedule below be altered to the days and hours indicated—to take effect as from and inclusive of the dates shown.

SCHEDULE.

Court.	Days and Hours.
Melvern ..	Every second Tuesday at 10 o'clock a.m., as from and inclusive of the 6th November, 1945
Hawthorn ..	Every second Thursday at 10 o'clock a.m., as from and inclusive of the 8th November, 1945

C. W. KINSMAN,
Clerk of the Executive Council.

At the Executive Council Chamber,
Melbourne, 30th October, 1945.

Melbourne and Metropolitan Board of Works Acts.

MELBOURNE AND METROPOLITAN BOARD OF WORKS.

NOTICE DECLARING THAT A PROPOSED NEW MAIN DRAIN WITHIN THE CITY OF SANDBRINGHAM AND WITHIN THE METROPOLIS SHALL BE AND BE DEEMED TO BE A MAIN DRAIN (AREA No. 51).

MELBOURNE and Metropolitan Board of Works, under the powers conferred upon it by the Melbourne and Metropolitan Board of Works Acts, and otherwise, doth by this Notice declare that the new main drain within the metropolis, as the same is defined and described hereunder, and which it is proposed to construct under the Melbourne and Metropolitan Board of Works Acts, shall be a main drain under and for the purposes of the said last-mentioned Acts.

Proposed New Drain above Referred to.

The following is a description of the course of and a specification of the points of commencement and termination of the said proposed New Main Drain, that is to say:—

Commencing at a manhole near the south building line of Raynes Park-road, on the new main drain described in *Victoria Government Gazette* No. 428, dated 27th December, 1940, pages 4449 and 4450; thence easterly along Raynes Park-road to Earlsfield-road, southerly along Earlsfield-road to Fewster-road, easterly along Fewster-road, and southerly to and terminating at a point on the south building line of Fewster-road, 20 feet east of the west building line of Glamis-avenue.

Dated this 16th day of October, 1945.

The common seal of the Melbourne and Metropolitan Board of Works was affixed hereto, in the presence of—

(SEAL) J. C. JESSOP, Chairman.
GEO. A. ROGERS, J.P., Member.
CHAS. J. W. BRIGGS, Secretary.

(Published in lieu of Notice appearing in the *Gazette* of 24th October, 1945, page 2602.)

STATE RIVERS AND WATER SUPPLY COMMISSION.

BY-LAW No. 4199.—RATES AND CHARGES FOR WATER.—URBAN DISTRICTS AND URBAN DIVISIONS.

THE State Rivers and Water Supply Commission, in pursuance and exercise of the powers conferred by the Water Acts, doth hereby make the By-law following:—

1. The following rates for the supply of water for domestic purposes are hereby made, and shall be levied upon the occupiers or owners of lands and tenements within the respective Urban Districts and Urban Divisions as set out hereunder:—

Lands or tenements situate in a street in which a pipe for the supply of water has been laid down—a rate of such amount in the pound of the annual municipal valuation of such lands or tenements as is set down in column 2 opposite the name of the respective Urban District and Urban Division in column 1 of the Schedule hereto: Provided that the total amount of the rate payable annually in respect of any such lands or tenements (other than land on which there is no building) shall be not less than the sum set down in column 3 opposite the name of the respective Urban District and Urban Division in column 1 of the said Schedule and in respect of any such lands or tenements on which there is no building shall be not less than the sum set down in column 4 opposite the name of the respective Urban District and Urban Division in column 1 of the said Schedule.

2. Such rates are made and shall be levied for the year beginning with the 1st day of July, 1945, and ending with the 30th day of June, 1946, and shall be payable on the 2nd day of November, 1945, at the office of the State Rivers and Water Supply Commission, at the place set down in column 6 opposite the name of the respective Urban District and Urban Division in column 1 of the said Schedule.

3. The maximum quantity of water to be supplied per annum without further charge to properties rated by the Commission shall be the quantity which, if charged for at the amount per 1,000 gallons set down in column 5 opposite the name of the respective Urban District and Urban Division in column 1 of the said schedule, would give an amount equal to that payable per annum in respect of the properties so supplied under the provisions of any By-law of the Commission for making and levying rates.

4. For all water supplied per annum in excess of the maximum quantity referred to in clause 3 of this By-law the charge shall be one shilling per 1,000 gallons.

Such charge shall be payable on demand at the office of the State Rivers and Water Supply Commission at the place mentioned in column 6 opposite the name of the respective Urban District and Urban Division in column 1 of the said Schedule.

5. For the supply of water by measure from the pipes of the Commission to lands and tenements (within the respective Urban Districts and Urban Divisions as set out hereunder) which are not liable to any rate made under any By-law of the Commission—

The charge to be paid for water so supplied shall, except in cases of special agreements with the Commission, be such amount per 1,000 gallons as is set down in column 5 opposite the name of such Urban District or Urban Division in column 1 of the schedule hereto: Provided that where any minimum annual charge has been fixed by the Commission, the quantity of water to be supplied for such minimum annual charge in each case shall, except in cases of special agreements with the Commission, be the quantity which, if charged for at the amount per 1,000 gallons set down in column 5 opposite the name of such Urban District or Urban Division in column 1 of the said schedule, would give an amount equal to that payable in respect of such minimum annual charge, and for all water supplied in excess of such quantity the charge shall be 1s. per 1,000 gallons.

6. The charges as set out in clause 5 of this By-law are made and shall be levied for the year beginning with the 1st day of July, 1945, and ending with the 30th day of June, 1946, and shall be payable on demand at the office of the State Rivers and Water Supply Commission at the place mentioned in column 6 opposite the name of the respective Urban District and Urban Division in column 1 of the said schedule.

7. Such person or persons as the State Rivers and Water Supply Commission may from time to time appoint for that purpose shall be and is or are hereby authorized to demand, receive, collect, and recover the said rates and charges for water.

SCHEDULE.

Name of Respective Urban District and Urban Division.	Amount of Rate in the £1 of the Annual Municipal Valuation of Tenements (other than Lands on which there is no Building) and in Respect of Lands on which there is no Building.	Minimum Amount of Rate per Year in Respect of Tenements (other than Lands on which there is no Building).	Minimum Amount of Rate per Year in Respect of Lands on which there is no Building.	Amount per 1,000 Gallons on which Maximum Quantity of Water to be Supplied per Annum under Rate Payable Annually is to be Based or for Water supplied by Measure.	Places at which Rates and Charges shall be Payable.
Column 1.	Column 2.	Column 3.	Column 4.	Column 5.	Column 6.
<i>Urban Districts.</i>					
	<i>s. d.</i>	<i>s. d.</i>	<i>s. d.</i>	<i>s. d.</i>	
Allansford	2 0	40 0	10 0	1 0	Camperdown
Anglesea	1 8	33 4	10 0	1 0	Geelong
Antwerp	2 4	46 8	10 0	1 4	Horsham
Barwon Heads and Ocean Grove	1 8	33 4	10 0	1 0	Geelong
Berriwillock	2 4	15 0	..	1 0	Birehip
Berwick	1 5	20 0	7 6	1 0	Pakenham East
Beulah	2 0	15 0	..	1 0	Hopetoun
Birehip	1 4	15 0	..	1 0	Birehip
Bittern	2 1	20 0	7 6	1 0	Frankston
Brim	2 4	40 0	10 0	1 0	Murton
Bunyip	1 7	33 4	10 0	1 0	Pakenham East
Camperdown	2 0	40 0	10 0	1 0	Camperdown
Carwarp	2 4	46 8	10 0	1 4	Werrimull
Chelsea—Frankston	1 4	20 0	7 6	1 0	Chelsea or Frankston
Chillingollah	2 4	46 8	10 0	1 4	Nyah West
Chinkapook	2 4	46 8	10 0	1 4	Ouyen
Cobden	2 0	40 0	10 0	1 0	Camperdown
Cranbourne	1 4	20 0	7 6	1 0	Cranbourne
Crib Point	2 1	33 4	10 0	1 0	Frankston
Culgoa	2 4	15 0	..	1 0	Birehip
Dandenong	1 3	20 0	7 6	1 0	Dandenong
Dimboola	1 4	15 0	..	1 0	Horsham
Doon	1 4	26 8	5 0	1 0	Horsham
Dromana—Portsea	2 2	40 0	10 0	1 0	Frankston
Drysdale	1 8	33 4	10 0	1 0	Geelong
Gasfield	1 7	33 4	10 0	1 0	Pakenham East
Hastings	2 0	26 8	10 0	1 0	Frankston
Hopetoun	2 0	15 0	..	1 0	Hopetoun
Jeparit	1 5	15 0	..	1 0	Horsham

SCHEDULE—continued.

Name of Respective Urban District and Urban Division.	Amount of Rate in the £1 of the Annual Municipal Valuation of Tenements (other than Lands on which there is no Building) and in Respect of Lands on which there is no Building.	Minimum Amount of Rate per Year in Respect of Tenements (other than Lands on which there is no Building).	Minimum Amount of Rate per Year in Respect of Lands on which there is no Building.	Amount per 1,000 Gallons on which Maximum Quantity of Water to be Supplied per Annum under Rate Payable Annually is to be Based or for Water supplied by Measure.	Places at which Rates and Charges shall be Payable.
Column 1.	Column 2.	Column 3.	Column 4.	Column 5.	Column 6.
<i>Urban Districts—continued.</i>					
	<i>s. d.</i>	<i>s. d.</i>	<i>s. d.</i>	<i>s. d.</i>	
Jung Jung	2 0	20 0	7 6	1 0	Horsham
Koondrook	1 10	15 0	..	1 0	Kerang
Lake Boga	2 0	15 0	..	1 0	Swan Hill
Lalbert	2 4	46 8	10 0	1 0	Nyah West
Lascelles	2 4	15 0	..	1 0	Hopetoun
Longwarry	1 8	33 4	10 0	1 0	Pakenham East
Manangatang	2 4	46 8	10 0	1 4	Nyah West
Marnoo	2 4	33 4	10 0	1 0	Murtoa
Marong	2 0	26 8	10 0	1 0	Bendigo
Merbein	1 10	15 0	..	1 0	Red Cliffs
Meringur	2 4	46 8	10 0	1 8	Werrimull
Minyip	1 10	15 0	..	1 0	Murtoa
Mitiamo	2 8	15 0	..	1 0	Pyramid Hill
Mornington	1 4	20 0	7 6	1 0	Frankston
Nandaly	2 4	46 8	10 0	1 4	Ouyen
Natimuk	1 4	15 0	..	1 0	Horsham
Newstead	2 0	40 0	10 0	1 0	Castlemaine
Nullawil	2 4	46 8	10 0	1 4	Birchip
Nyah	1 10	36 8	..	1 0	Nyah West
Nyah West	1 10	40 0	10 0	1 0	Nyah West
Ouyen	2 0	15 0	..	1 4	Ouyen
Pakenham	1 5	33 4	10 0	1 0	Pakenham East
Patchewollock	2 4	46 8	10 0	1 4	Hopetoun
Piangil	2 4	40 0	10 0	1 0	Nyah West
Portarlington	1 8	33 4	10 0	1 0	Geelong
Pyramid Hill	1 6	30 0	10 0	1 0	Pyramid Hill
Quambatook	1 11	15 0	..	1 0	Birchip
Queenscliff and Point Lonsdale	1 8	33 4	10 0	1 0	Geelong
Rainbow	1 4	15 0	..	1 0	Hopetoun
Rupanyup	1 11	15 0	..	1 0	Murtoa
Sea Lake	1 4	15 0	..	1 0	Birchip
Somerville	1 8	20 0	7 6	1 0	Frankston
South Frankston	1 6	66 8	13 4	1 0	Frankston
Speed	2 4	46 8	10 0	1 4	Hopetoun
Springvale	1 3	20 0	7 6	1 0	Dandenong
Tempy	2 4	46 8	10 0	1 4	Hopetoun
Terang	2 0	40 0	10 0	1 0	Camperdown
Torquay	1 8	33 4	10 0	1 0	Geelong
Ultima	2 0	15 0	..	1 0	Nyah West
Waitechie	2 4	46 8	10 0	1 4	Nyah West
Walpeup	2 4	46 8	10 0	1 4	Ouyen
Watchem	2 2	15 0	..	1 0	Birchip
Werrimull	2 4	46 8	10 0	1 8	Werrimull
Wonthaggi	1 4	15 0	..	1 0	Wonthaggi
Woomelang	2 4	15 0	..	1 0	Birchip
Woorinen	2 4	46 8	10 0	1 0	Nyah West
Wycheproof	1 4	15 0	..	1 0	Birchip
Yaapeet	2 4	46 8	10 0	1 4	Hopetoun
<i>Urban Divisions.</i>					
Bacchus Marsh	1 4	15 0	..	1 0	Bacchus Marsh
Cohuna	1 4	15 0	..	1 0	Cohuna
Corop	1 8	15 0	..	1 0	Tongala
Dingee	2 4	26 8	10 0	1 0	Pyramid Hill
Heyfield	1 11	33 4	10 0	1 0	Maffra
Leitchville	2 4	26 8	10 0	1 0	Cohuna
Lockington	2 0	40 0	10 0	1 0	Rochester
Murrabit	2 4	46 8	10 0	1 4	Kerang
Red Cliffs	1 4	20 0	10 0	1 0	Red Cliffs
Stanhope	1 6	30 0	10 0	1 0	Tongala

The foregoing By-law was made by the State Rivers and Water Supply Commission on the 22nd day of October, 1945, and the common seal of the said Commission was hereunto affixed the 29th day of October, 1945, in the presence of—

L. R. EAST, Chairman.

(SEAL) H. HANSLOW, Commissioner.

H. W. McCAY, Commissioner.

Approved by the Governor in Council,
30th October, 1945.

C. W. KINSMAN,
Clerk of the Executive Council.

STATE RIVERS AND WATER SUPPLY COMMISSION.

BY-LAW No. 4200.—FLOOD PROTECTION RATE.—LOWER KOO-WEE-RUP FLOOD PROTECTION DISTRICT.

THE State Rivers and Water Supply Commission, in pursuance and exercise of the powers conferred by the Water Acts, doth hereby make the By-law following:—

1. The following Flood Protection Rate is hereby made under the provisions of the Water Acts, and shall be levied upon the occupiers or owners of all lands within the Lower Koo-wee-rup Flood Protection District:—

For the service rendered to such district by the flood protection works constructed for such service—

- (1) Of all lands in the First Division, being the lands included within the red border on the plan of such district, signed and sealed by the State Rivers and Water Supply Commission, and lodged at the office of such Commission, at Melbourne, excepting and excluding all lands in the Second Division as shown coloured pink on the aforesaid plan, excepting and excluding all lands in the Third Division as shown coloured green on the aforesaid plans, and excepting and excluding all lands in the Fourth Division as shown coloured brown on the aforesaid plan—a Flood Protection Rate of Twenty-four pence in the pound of the rateable value of such lands.
- (2) Of all lands in the Second Division as shown coloured pink on the aforesaid plan—a Flood Protection Rate of Eighteen pence in the pound of the rateable value of such lands.
- (3) Of all lands in the Third Division as shown coloured green on the aforesaid plan—a Flood Protection Rate of Twelve pence in the pound of the rateable value of such lands.
- (4) Of all lands in the Fourth Division as shown coloured brown on the aforesaid plan—a Flood Protection Rate of Six pence in the pound of the rateable value of such lands.

2. Such Flood Protection Rate is made and shall be levied for the year beginning with the 1st day of July, 1945, and ending with the 30th day of June, 1946, and shall be payable on the 2nd day of November, 1945, at the office of the State Rivers and Water Supply Commission at Koo-wee-rup.

3. For making and levying such Flood Protection Rate the value of the lands set out in the valuations made in accordance with the provisions of the Water Acts, and adopted by the said Commission on the 22nd day of October, 1945, shall be deemed and taken to be the rateable value of such lands.

4. Such person or persons as the State Rivers and Water Supply Commission may from time to time appoint for that purpose shall be, and is, or are, hereby authorized to demand, receive, collect, and recover the said rate.

The foregoing By-law was made by the State Rivers and Water Supply Commission on the 22nd day of October, 1945, and the common seal of the said Commission was hereunto affixed the 29th day of October, 1945, in the presence of—

(SEAL) L. R. EAST, Chairman.
H. HANSLOW, Commissioner.
H. W. McCAY, Commissioner.

Approved by the Governor in Council,
30th October, 1945.

C. W. KINSMAN,
Clerk of the Executive Council.

STATE RIVERS AND WATER SUPPLY COMMISSION.
BY-LAW No. 4201.—FLOOD PROTECTION CHARGES.—CARDINIA FLOOD PROTECTION DISTRICT.

THE State Rivers and Water Supply Commission, in pursuance and exercise of the powers conferred by the Water Acts, doth hereby make the By-law following:—

1. The following Flood Protection Charge is hereby made under the provisions of the Water Acts, and shall be levied upon the occupiers or owners of all lands within the Cardinia Flood Protection District:—

For the service rendered to such district by the flood protection works constructed for such service—

- (1) Of all lands in the First Division, being the lands included within the red border on the plan of such district, signed and sealed by the State Rivers and Water Supply Commission, and lodged at the office of such Commission, at Melbourne, excepting and excluding all lands in the Second Division as shown coloured pink on the aforesaid plan, excepting and excluding all lands in the Third Division as shown coloured green on the aforesaid plan and excepting and excluding all lands in the Fourth Division as shown coloured brown on the aforesaid plan—a charge of Thirty-eight pence for each and every acre of such lands.

(2) Of all lands in the Second Division as shown coloured pink on the aforesaid plan—a charge of Twenty-eight and one half pence for each and every acre of such lands.

(3) Of all lands in the Third Division as shown coloured green on the aforesaid plan—a charge of Nineteen pence for each and every acre of such lands.

(4) Of all lands in the Fourth Division as shown coloured brown on the aforesaid plan—a charge of Nine and one half pence for each and every acre of such lands.

2. Such charge is made and shall be levied for the year beginning with the 1st day of July, 1945, and ending with the 30th day of June, 1946, and shall be payable on the 2nd day of November, 1945, at the office of the State Rivers and Water Supply Commission at Koo-wee-rup.

3. Such person or persons as the State Rivers and Water Supply Commission may from time to time appoint for that purpose shall be, and is, or are, hereby authorized to demand, receive, collect, and recover the said charge.

The foregoing By-law was made by the State Rivers and Water Supply Commission on the 22nd day of October, 1945, and the common seal of the said Commission was hereunto affixed the 29th day of October, 1945, in the presence of—

(SEAL) L. R. EAST, Chairman.
H. HANSLOW, Commissioner.
H. W. McCAY, Commissioner.

Approved by the Governor in Council,
30th October, 1945.

C. W. KINSMAN,
Clerk of the Executive Council.

STATE RIVERS AND WATER SUPPLY COMMISSION.
BY-LAW No. 4202.—FLOOD PROTECTION CHARGES.—FLOOD PROTECTION DISTRICTS.

THE State Rivers and Water Supply Commission, in pursuance and exercise of the powers conferred by the Water Acts, doth hereby make the By-law following:—

1. The following Flood Protection Charges are hereby made under the provisions of the Water Acts, and shall be levied upon the occupiers or owners of all lands within the Loch Garry Flood Protection District, and within the respective Divisions of the Kanyapella Flood Protection District:—

For the service rendered to such districts by the flood protection works constructed for such service—

(1) Of all lands in the Loch Garry Flood Protection District—a Flood Protection Charge of Two pence for each and every acre of such lands.

(2a) Of all lands in the First Division of the Kanyapella Flood Protection District, being the lands included within the red border on a plan of such District, signed and sealed by the State Rivers and Water Supply Commission and lodged at the office of such Commission at Melbourne, excepting and excluding all lands in the Third Division of the said Flood Protection District, as shown coloured brown on the aforesaid plan—a Flood Protection Charge of Three pence for each and every acre of such lands.

(2b) Of all lands in the Third Division of the said Kanyapella Flood Protection District, as shown coloured brown on the aforesaid plan—a Flood Protection Charge of One and one-half pence for each and every acre of such lands.

2. Such Flood Protection Charges are made and shall be levied for the year beginning with the 1st day of July, 1945, and ending with the 30th day of June, 1946, and shall be payable on the 2nd day of November, 1945, at the office of the State Rivers and Water Supply Commission at Shepparton in the case of the Loch Garry Flood Protection District, and at Tongala in the case of the Kanyapella Flood Protection District.

3. Such person or persons as the State Rivers and Water Supply Commission may from time to time appoint for that purpose shall be, and is, or are, hereby authorized to demand, receive, collect and recover the said Flood Protection Charges.

The foregoing By-law was made by the State Rivers and Water Supply Commission on the 22nd day of October, 1945, and the common seal of the said Commission was hereunto affixed the 29th day of October, 1945, in the presence of—

(SEAL) L. R. EAST, Chairman.
H. HANSLOW, Commissioner.
H. W. McCAY, Commissioner.

Approved by the Governor in Council,
30th October, 1945.

C. W. KINSMAN,
Clerk of the Executive Council.

STATE RIVERS AND WATER SUPPLY COMMISSION.

BY-LAW No. 4203.—DRAINAGE RATES.—CARRUM DRAINAGE DISTRICT.

THE State Rivers and Water Supply Commission, in pursuance and exercise of the powers conferred by the Water Acts, doth hereby make the By-law following:—

1. The following Drainage Rates are hereby made under the provisions of the Water Acts, and shall be levied upon the occupiers or owners of all lands within the respective Divisions of the Carrum Drainage District for the drainage of such lands:—

- (1) Of all lands in the First Division, being the lands included within the red border on the plans of such district, signed and sealed by the State Rivers and Water Supply Commission, and lodged at the office of such Commission at Melbourne, excepting and excluding all lands in the Second Division as shown coloured red on the aforesaid plans, excepting and excluding all lands in the Third Division as shown coloured green on the aforesaid plans, and excepting and excluding all lands in the Fourth Division as shown coloured brown on the aforesaid plans—a Drainage Rate of Three pence in the pound of the unimproved capital value of such lands.
- (2) Of all lands in the Second Division as shown coloured red on the aforesaid plans—a Drainage Rate of Two and one-fourth pence in the pound of the unimproved capital value of such lands.
- (3) Of all lands in the Third Division as shown coloured green on the aforesaid plans—a Drainage Rate of One and one-half pence in the pound of the unimproved capital value of such lands.
- (4) Of all lands in the Fourth Division as shown coloured brown on the aforesaid plans—a Drainage Rate of Three-fourths of a penny in the pound of the unimproved capital value of such lands.

Provided that the sum of Two shillings shall be the minimum amount of rate in respect of any land or tenement liable to be rated in the said district.

2. Such Drainage Rates are made and shall be levied for the year beginning with the 1st day of July, 1945, and ending with the 30th day of June, 1946, and shall be payable on the 2nd day of November, 1945, at the office of the State Rivers and Water Supply Commission, at Chelsea.

3. For making and levying such Drainage Rates the unimproved capital values of the lands set out in the valuations made in accordance with the provisions of the Water Acts, and adopted by the said Commission on the 22nd day of October, 1945, shall be deemed and taken to be the rateable value of such lands.

4. Such person or persons as the State Rivers and Water Supply Commission may from time to time appoint for that purpose shall be and is or are hereby authorized to demand, receive, collect, and recover the said Drainage Rates.

The foregoing By-law was made by the State Rivers and Water Supply Commission on the 22nd day of October, 1945, and the common seal of the said Commission was hereunto affixed the 29th day of October, 1945, in the presence of—

(SEAL) L. R. EAST, Chairman.
H. HANSLAW, Commissioner.
H. W. McCAY, Commissioner.

Approved by the Governor in Council,
30th October, 1945.

C. W. KINSMAN,
Clerk of the Executive Council.

Water Acts.

STATE RIVERS AND WATER SUPPLY COMMISSION.

SPRINGVALE URBAN DISTRICT.

NOTICE to owners of tenements in the under-mentioned street in the Springvale Urban District and the private streets, lanes, courts, and alleys opening thereto:—

Clarke-road, from Heatherton-road to a point about 10 chains south-easterly.

The main pipe in the said street being laid down, the owners of all tenements situated as above are hereby required, on or before the 1st day of December next, to cause proper pipes and stop cocks to be laid, so as to supply water within such tenements from the main pipe.

L. DUGGAN, Secretary,
State Rivers and Water Supply Commission.
Melbourne, 29th October, 1945.

Dairy Products Acts.

QUOTAS FOR BUTTER AND CHEESE.

BUTTER QUOTA.

I. WILLIAM RONALD CUMMING, Minister of Agriculture in the State of Victoria, after consultation with the Victorian Dairy Products Board, and after ascertaining that the supply and distribution of butter at reasonable prices to consumers thereof in Victoria will be ensured, hereby determine a quota for butter as follows:—

The proportion shall be Forty-eight point two seven per cent. The period for which this quota is to operate shall be the month of November, 1945.

CHEESE QUOTA.

I. WILLIAM RONALD CUMMING, Minister of Agriculture in the State of Victoria, after consultation with the Victorian Dairy Products Board, and after ascertaining that the supply and distribution of cheese at reasonable prices to consumers thereof in Victoria will be ensured, hereby determine a quota for cheese as follows:—

The proportion shall be Forty point eight two per cent. The period for which this quota is to operate shall be the month of November, 1945.

RONALD CUMMING,

Minister of Agriculture.

29th October, 1945.

APPLICATIONS FOR MINING LEASES.

SUBJECT to any necessary excisions, &c., it is proposed to grant the following lease:—

8986: Castlemaine; Wilfred Albert Clayton; 2a. 1r.; Parish of Morang.

APPLICATION FOR MINING LEASE ABANDONED.

6915: Mineral; Gardiner and Warner Pty. Ltd.; 323a. 2r. 16p.; Parish of Woolamai.

APPLICATIONS FOR MINING LEASES REFUSED.

9063: Ballarat; C. J. Freeman and R. H. Kingston; 15 acres; at Berringa.

9064: Ballarat; D. F. Nolan; 80 acres; at Berringa.

TAILINGS LICENCES GRANTED.

1873: Tailings Licence; W. L. Rewell (in lieu of Tailings Licence No. 1544, expired).
1882: Tailings Licence; E. A. Waller (in lieu of Tailings Licence No. 1816, expired).
1883: Tailings Licence; E. A. Waller (in lieu of Tailings Licence No. 1832, expired).
1884: Tailings Licence; S. W. James (in lieu of Tailings Licence No. 1534, expired).
1885: Tailings Licence; E. C. Parker (in lieu of Tailings Licence No. 1535, expired).
1887: Tailings Licence; W. B. Wilkinson.
1891: Tailings Licence; L. A. Akers.
1892: Tailings Licence; J. T. Farquhar.
1893: Tailings Licence; D. J. Hastings.

LICENCES EXPIRED.

1537: Tailings Licence; M. P. Denyer.
1549: Tailings Licence; W. R. Rehe and A. J. H. Rehe.
1561: Tailings Licence; T. H. Hocking.
1592: Tailings Licence; The New Warden Gold Mining Co. N. L.

TERM OF LICENCES EXTENDED.

The terms of the under-mentioned licences have been extended for further periods from 1st October and 1st November, 1945, respectively:—

137: Petroleum Prospecting Licence; Western Petroleum No Liability; 198 square miles; Parishes of Palpara, Wanwin, Glenelg, &c.
139: Petroleum Prospecting Licence; Austral Oil Drilling Syndicate N. L.; 8.25 square miles; Parish of Colquhoun.

J. S. DISNEY,
Minister of Mines.

TAILINGS LICENCES DECLARED VOID.

1858: Tailings Licence; Victorian Railways Commissioners.
1699: Tailings Licence; C. W. Nash and W. J. Nicol.

GEO. BROWN,
Secretary for Mines.

REAL ESTATE AGENTS ACTS.

IN accordance with the provisions of the above-mentioned Acts, the following is published for general information:—

(a) List of Persons to whom Real Estate Agents' Licences have been issued for the year 1945 during the month of September:—

Name.	Principal Place of Business (Registered Address).	Name of Firm or Partnership.	Date from which Licence is Effective.
Beamish, W. A.	Korumburra		6.9.45
Corbet, J. H.	Camp-street, Ballarat		11.9.45
Fagan, J. J.	29 Fletcher-street, Essendon		8.9.45
Fletcher, H. D.	40 Cotham-road, Kew	Fletcher and Parker	19.9.45
Garage Brokers Pty. Ltd. (E. H. Christian, nominee)	422 Collins-street, Melbourne		20.9.45
Holden, W. M.	Tatura		19.9.45
O'Neill, W.	279 Bridge-road, Richmond	Patrick Burke and Co.	7.9.45
Robinson, G. E.	28 Wilgah-street, St. Kilda		17.9.45

(b) List of Persons to whom Sub-Agents' Licences under the Real Estate Agents Acts have been issued for the year 1945 during the month of September:—

Name.	Registered Address.	Date from which Licence is Effective.	Name.	Registered Address.	Date from which Licence is Effective.
Appleton, N. B.	77 Wattle-tree-road, Armadale	28.9.45	Roberts, W. P.	24 Grey-street, St. Kilda	17.9.45
Burke, V. M.	412 Bell-street, West Coburg	13.9.45	Rodger, S.	348 Beaconsfield-parade, St. Kilda	11.9.45
Crone, W. H. W.	11 Palmer-street, Jolimont	26.9.45	Roger, A. S.	395 Collins-street, Melbourne	4.9.45
Klemm, R. J.	176 Williams-road, Toorak	18.9.45	Thewlis, E. H.	Benalla	20.9.45
Long, I. A.	69 New-street, Brighton Beach	7.9.45	Thomson, J. B.	14 Glenbrook-avenue, East Malvern	24.9.45
Murphy, P. J.	25 Flower-street, Essendon	24.9.45	Thornycroft, W. J.	Romsey	17.9.45
O'Brien, A. T.	12A Acland-street, St. Kilda	3.9.45	West, E. J.	12 Sylvester-grove, Preston	5.9.45
Rhodes, H.	Main-road, Selby	14.9.45			

The Treasury,
Melbourne, 23rd March, 1945.

F. MADDERN,
Registrar.

BUSINESS AGENTS ACT 1930.

IN accordance with the provisions of the above-mentioned Act, the following is published for general information:—

(a) List of Persons to whom Business Agents' Licences have been issued for the year 1945 during the month of September:—

Name.	Principal Place of Business (Registered Address).	Name of Firm or Partnership.	Date from which Licence is Effective.
Fagan, J. J.	29 Fletcher-street, Essendon		14.9.45
Garage Brokers Pty. Ltd. (E. H. Christian, nominee)	422 Collins-street, Melbourne		20.9.45
Heeps, B. M.	144 Toorak-road, South Yarra	D. P. Heeps and Co.	25.9.45
Heeps, D. P.	144 Toorak-road, South Yarra	D. P. Heeps and Co.	25.9.45
O'Neill, W.	279 Bridge-road, Richmond	Patrick Burke and Co.	7.9.45
Robinson, G. E.	28 Wilgah-street, St. Kilda		17.9.45
Sinn, J. J.	230 Hawthorn-road, Caulfield		15.9.45

(b) List of Persons to whom Sub-Agents' Licences under the Business Agents Act have been issued for the year 1945 during the month of September:—

Name.	Registered Address.	Date from which Licence is Effective.	Name.	Registered Address.	Date from which Licence is Effective.
Appleton, N. B.	77 Wattle-tree-road, Armadale	28.9.45	Roberts W. P.	24 Grey-street, St. Kilda	17.9.45
Crone, W. H. W.	11 Palmer-street, Jolimont	26.9.45	Rodger, S.	348 Beaconsfield-parade, St. Kilda	11.9.45
Gerlach, M. H.	9 Lurnea-road, Glen Iris	15.9.45	Thewlis, E. H.	Benalla	20.9.45
Harman, F. T.	225 Princes-street, Port Melbourne	24.9.45	West, E. J.	12 Sylvester-grove, Preston	5.9.45
Klemm, R. J.	176 Williams-road, Toorak	18.9.45			

The Treasury,
Melbourne, 23rd October, 1945.

F. MADDERN,
Registrar.

AUCTION SALES ACT 1928.

KERANG.—Notice is hereby given that the Annual Meeting of Justices for the Licensing of Auctioneers will be held at the Court House, Kerang, on Tuesday, the 27th day of November, 1945, at Ten o'clock in the forenoon.—L. S. GALAGHER, Clerk of Petty Sessions.

WARRNAMBOOL.—Notice is hereby given that the Annual Meeting of Justices for the licensing of auctioneers will be held at the Court House, Timor-street, Warrnambool, on Tuesday, the 27th day of November, 1945, at Ten o'clock in the forenoon.—R. L. PAIG, Clerk of Petty Sessions.

AUCTION SALES ACT 1928.

LIST of Persons to whom Auctioneers' Licences have been issued for the year 1945 during the month of September:—

Name.	Registered Address.	Date of Issue.
Bow, R. V.	Swan Hill	13.9.45
Dexter, W. R.	58 Skene-street, Newtown	18.9.45
Hippisley, F.	Ringwood-road, Bayswater	28.9.45
Joel, L.	362 Little Collins-street, Melbourne	28.9.45
McMichael, W. J.	4 Ferncroft-avenue, East Malvern	15.9.45
*Robinson, K. J.	5 Columban-avenue, North Essendon	10.9.45
†Stewart, R. M.	Hamilton	27.9.45
Turner, H. J.	Portland	21.9.45
Woodard, W. R. G.	481 Riversdale-road, Hawthorn East	29.9.45

* Licence transferred from S. Shallard.—† Licence transferred from R. H. Stewart.

The Treasury,
Melbourne, 23rd October, 1945.

A. T. SMITHERS,
Director of Finance.

Transport Regulation Acts.

TRANSPORT REGULATION BOARD.

NOTICES OF PUBLIC HEARINGS.

NOTICE is hereby given that the applications made by the persons named below for licences to operate the commercial passenger vehicles on the route or routes, or in the manner set out opposite their names, will be heard at the Exhibition Buildings, Rathdown-street, Carlton, at 10.15 a.m., on Wednesday, the 21st November, 1945:—

Name of Applicant.—Nature of Application.

- REYNOLDS, A. A.—Application for variation of licences A.1141 and A.1123 to include the ability to operate under charter conditions:—(a) within a radius of 20 miles of Cressy and to Ballarat, Geelong, Lorne, and Apollo Bay, (b) within a radius of 20 miles of Lismore, Derrinalum, and Foxhow and to Ballarat, Geelong, Lorne, and Apollo Bay.
- MARK, A. E.—Two commercial passenger vehicles, with seating capacity for 20 persons each, to operate as follows:—(a) for the carriage of passengers otherwise than at separate and distinct fares within a radius of 50 miles from the Post Office at Ballarat, (b) as a touring omnibus on round tours on the following routes:—(1) from Ballarat to Three Lakes and return, (2) from Ballarat to Moorabool Reservoir, Wilson Reservoir, also Gong Reservoir, (3) a round tour of 40 miles to places of local scenic attraction, (4) from Ballarat to Lal Lal and return, (5) from Ballarat to Kooweinguboora Springs and return, (6) from Ballarat to the Devil's Kitchen and return, (7) from Ballarat to Black Hill, The Botanical Gardens, Golden Mount, The Arch of Victory, and Eureka Stockade and return, (8) from Ballarat to the Creswick Swimming Pool and return.
- DUGINS, J. F.—Application for permit from 28th December, 1945, to 6th February, 1946, to enable vehicle A.98 to operate between Lakes Entrance and Lake Tyers daily, at separate and distinct fares.
- LORNE TOURIST BUREAU.—Two commercial passenger vehicles, with seating capacity for 11 and 14 persons respectively, to operate as follows:—(a) day and half-day tours from Lorne to Apollo Bay (two routes), Erskine Falls, Cora Lynn Falls, Cumberland River and Cave, Stoney Creek and Paradise, Wymboliel, Allanvale. (b) general local tour, (c) the ability to operate for Fletcher's Motor Services for peak loading as required. NOTE.—This replaces the application published in the *Government Gazette* of the 17th October, 1945.

NOTICE is hereby given that the applications made by the persons named below for licences to operate the commercial goods or passenger vehicles on the route or routes, or in the manner set out opposite their names, will be heard at a time and place to be communicated to the parties:—

Name of Applicant.—Nature of Application.

- EWING, J. W.—One commercial goods vehicle for the carriage of—(a) general goods within a radius of 20 miles of Penshurst, (b) from and to Hamilton, Warrnambool, and Mortlake to and from places within 20 miles Penshurst—general goods, (c) from places within 25 miles Penshurst to Warrnambool, Hamilton, Camperdown, Terang, and Mt. Gambier—live stock.
- HANLON, M.—One commercial passenger vehicle, with seating capacity for 5 persons—(a) for the carriage of passengers at separate and distinct fares for each passenger within 5 miles Bairnsdale, (b) private hire 20 miles Bairnsdale.

- MARK, A. E.—Application for variation of licences A.361, C.146, C.147, and C.151—(1) to delete "Haddon" from the route as prescribed in the present conditions of licence A.361; (2) to enlarge the present licensed route under licence A.361 so as to read "between Skipton and Ballarat" via the following routes and on the days mentioned, viz:—(a) Mondays to Fridays inclusive—via Pittong, Snake Valley, Carngham, Canico, Smythesdale, and Nintingbool; (b) Saturdays—via Pittong, Linton, Snake Valley, Carngham, Canico, Smythesdale, and Nintingbool—on the following time-table:—Mondays to Fridays—Leave Skipton 7.20 a.m. Arrive Ballarat 9.15 a.m. Leave Ballarat 4 p.m. Arrive Skipton 5.50 p.m. Saturdays—Leave Skipton 7.20 a.m. Arrive Ballarat 9.15 a.m. Leave Linton 7.50 a.m. Arrive Ballarat 9.15 a.m. Leave Ballarat 12.30 p.m. Arrive Linton 1.50 p.m. Arrive Skipton 2.20 p.m.; (3) To substitute and add the following fares on licence A.361:—Skipton to Ballarat 5s. single, Linton to Ballarat 4s. single, Snake Valley to Ballarat 3s. 6d. single, Carngham to Ballarat 3s. 6d. single, Smythesdale to Ballarat 2s. single, Nintingbool to Ballarat 1s. 6d. single; (4) to allow any licensed vehicle to be registered interchangeably with any other licensed vehicle.
- ROUT, A., AND T. D. WOOD.—One commercial passenger vehicle, with seating capacity for 23 persons, to be purchased, to operate as follows:—Between Edithvale Railway Station and Blackburn Railway Station, via Springvale-road, Dandenong-road, May-road, Blackburn-road.
- HEWITT, W. H. D.—One commercial passenger vehicle, with seating capacity for 7 persons, for the carriage of school children as follows:—Commencing at Panitya, then north for 2 miles, then east for 1 mile, then return to Panitya, then east on main Pinnaroo-Ouyen road for 1 mile, then to Panitya, and then 4 miles south to Nuski's bore on the Ngallo bus route.
- MANSFIELD-YEA PASSENGER SERVICE PTY. LTD.—Application for variation of all "A" licences to add the following time-table:—Tuesdays and Thursdays in each week—Leave Lilydale 9 a.m., arrive Yea 11 a.m., arrive Mansfield, 1.15 p.m. Leave Mansfield 2 p.m., arrive Yea 4 p.m., arrive Lilydale 6.29 p.m.
- WALTERS, J. E.—One commercial goods vehicle to operate as follows:—(a) general goods within 20 miles Warrnambool. (b) new furniture from Maples, Warrnambool, within a radius of 50 miles of Warrnambool.
- REID'S MOTOR SERVICE.—One commercial passenger vehicle, with seating capacity for 20 persons, to operate as follows:—Between Bendigo and Warracknabeal, via Kangaroo Flat, Lanecoerie, Eddington, Dunolly, Bealiba, St. Arnaud, Marnoo, Ripanyup, Minyip.
- LITTLEHALES, J. H.—One commercial passenger vehicle, with seating capacity for 32 persons to operate as a stage omnibus between Colac and Ballarat, via Cressy, Werneth, Rokewood, Dereel, Napoleons.
- THOMPSON, E. N. & E. F.—Application for variation of all "A" licences to extend present route from terminus at the Basin P.O. to the corner of Mountain Highway and Toorak-avenue.
- SANDLANT, H. I.—One commercial goods vehicle for the carriage of general goods and two passengers between Navarre and Ararat, via Glendhu and Crowlands.
- SOUTAR BROS.—One commercial passenger vehicle to operate as a stage omnibus between Melbourne, Daylesford, and Hepburn Springs.
- Notice of any objection should be forwarded to reach the Acting Secretary to the Board not later than Wednesday, the 7th November, 1945.

E. V. FIELD,
Acting Secretary.

Exhibition Buildings, Rathdown-street, Carlton, 30th October, 1945.

CONTRACTS ACCEPTED.—(Series 1945-46.)

Contract No.	Particulars.	Amount.	Name of Contractor.	Charge against Vote or Fund.
	GOVERNMENT PRINTER—			
	Supply and delivery of Printing Paper, Writing Paper, &c., required by the Government Printer for the year 1945-46—			
789	Schedule No. 1.—Printing Paper, Writing Paper, &c.	Rates as per annex	Gordon and Gotch (Australasia) Ltd.	} Contingencies, 1945-46
790	Wiggins, Teape, and Alex. Pirie (Export) Ltd.	
791	B. J. Ball Pty. Ltd.	
792	Spicers and Detmold Ltd.	
793	Sands & McDougall Pty. Ltd.	
794	P. Rowe Pty. Ltd.	
795	Alex. Cowan and Sons Ltd.	
796	L. A. Wade Pty. Ltd.	
797	Edwards, Dunlop & Co. Ltd.	
798	Max Wurcker (1930) Pty. Ltd.	

Approved—A. A. DUNSTAN, Treasurer. 17.9.45.

ANNEX TO CONTRACTS NOS. 1945/789 TO 1945/798.
Schedule No. 1.

PRINTING PAPER, WRITING PAPER, ETC.

- 1945/789—*Gordon and Gotch (Australasia) Ltd.* Security, £35.
- 1945/790—*Wiggins, Teape, and Alex. Pirie (Export) Ltd.* Security, £168.
- 1945/791—*B. J. Ball Pty. Ltd.* Security, £85.
- 1945/792—*Spicers and Detmold Ltd.* Security, £254.
- 1945/793—*Sands and McDougall Pty. Ltd.* Security, £19.
- 1945/794—*P. Rowe Pty. Ltd.* Security, £23.
- 1945/795—*Alex. Cowan and Sons Ltd.* Security, £73.
- 1945/796—*L. A. Wade Pty. Ltd.* Security, £34.
- 1945/797—*Edwards, Dunlop and Co. Ltd.* Security, £366.
- 1945/798—*Max Wurcker (1930) Pty. Ltd.* Security, £12.

ADJUSTMENT OF CONTRACT RATES.

With the exception of Items 152 and 248A, all rates are subject to adjustment in accordance with the special conditions of the respective contracts.
Notification of such adjustments will be published in the *Government Gazette* as required.
Contracts for a number of items are subject to special conditions regarding availability of supplies, delivery dates, priority certificates, export and import licences, &c.

AGREEMENTS.

Where the name of the supplier opposite any item is shown in italics, with the sign (A), no contract has been executed nor security lodged; requirements of such items are to be purchased from the supplier named, under Tender Board Agreement.

B. British. C. Commonwealth.

Item No.	Description.	Quantity.	Rate.	Country of Origin.	Name of Contractor.
	WHITE PRINTING PAPER.		£ s. d.		
	<i>Sample No. 1—</i>		per ream.		
4	Double Royal, 38 lb., 25 in. x 40 in.	1,500 reams	0 19 6½	C.	Alex. Cowan and Sons Ltd.
	COLOURED PRINTING PAPER.		£ s. d.		
	<i>Sample No. 3—</i>		per ream.		
13	Yellow Quadruple Foolscap, 45 lb., 27 in. x 34 in.	100 ..	1 15 4½	B.	} Edwards, Dunlop and Co. Ltd.
13A	Green Quadruple Foolscap, 45 lb., 27 in. x 34 in.	50 ..	1 15 4½	B.	
16	Pink, Double Royal, 48 lb., 25 in. x 40 in.	100 ..	1 17 9½	B.	
	SUPER-CALENDERED PAPER.				
	<i>Sample No. 6—</i>				
38	Reels, 39 in.	150,000 lb.	57 11 11½	C.	Spicers & Detmold Ltd.
38A	Sup. Cal. Double Imperial, 79½ lb., 30 in. x 44 in.	1,500 reams	2 0 9-05	C.	Edwards, Dunlop & Co. Ltd.

§ Rate subject to surcharge of £2 10s. 4½d. per ton for packing in crates or, alternatively, 10s. per reel for packing with metal end rings and plywood discs, to be credited on return.

CONTRACTS ACCEPTED—continued.

Item No.	Description.	Quantity.	Rate.	Country of Origin.	Name of Contractor.
BLUE WOVE WRITING PAPER (STATIONERY).			£ s. d.		
46	Sample No. 9— Quadruple Foolscap, 44 lb., 27 in. x 34 in.	750 reams	per ream 1 6 3 85†	C.	Wiggins, Teape, and Alex. Pirie (Export) Ltd.
LEDGER PAPER.					
65	Sample No. 14— Double Medium, 68 lb., 22 in. x 35 in.	50 reams	per ream 6 0 6	B.	} Wiggins, Teape, and Alex. Pirie (Export) Ltd.
67	Quadruple Foolscap, 60 lb., 27 in. x 34 in.	350 „	5 6 4	B.	
67A	Buff Machine Posting, 25½ in. x 30¼ in., 82 lb.	25 „	6 9 9	B.	
CREAM WOVE BOND WRITING PAPER (STATIONERY).					
83	Sample No. 18— Double Foolscap, 36 lb., 17 in. x 27 in.	150 reams	2 16 7	B.	Edwards, Dunlop and Co. Ltd.
LOAN PAPER (STATIONERY).					
87	Sample No. 19— Double Foolscap, 20 lb., 17 in. x 27 in.	100 reams	4 11 0	B.	Spicers and Detmold Ltd.
REINFORCED PAPER (STATIONERY).					
91	Sample No. 20— Reinforced Paper, 50 lb., 17 in. x 27 in., watermarked "J. R. Jones"	50 reams	14 11 11½	B.	Edwards, Dunlop and Co. Ltd.
CREAM WOVE BANK PAPER (STATIONERY).					
96	Sample No. 22— Quadruple Foolscap, 29 lb., 27 in. x 34 in.	1,000 reams	1 12 11	B.	Edwards, Dunlop and Co. Ltd.
COLOURED BANK PAPER (STATIONERY).					
98	Sample No. 23— Blue Quadruple Foolscap, 29 lb., 27 in. x 34 in.	100 reams	1 14 8	B.	} Edwards, Dunlop and Co. Ltd.
100	Green Quadruple Foolscap, 29 lb., 27 in. x 34 in.	100 „	1 14 8	B.	
CARTRIDGE PAPER (STATIONERY).					
107	Sample No. 26— Quadruple Foolscap, 60 lb., rough, 27 in. x 34 in.	200 reams	1 15 3 15	C.	Gordon and Gotch (Asia.) Ltd.
108	Imperial, 60 lb., smooth, 22 in. x 30 in.	500 „	1 14 0 04	C.	B. J. Ball Pty. Ltd.
109	Royal, 45½ lb., smooth, 20 in. x 25 in.	100 „	1 5 9 42	C.	} L. A. Wade Pty. Ltd.
110	Doubly Denny, 76½ lb., smooth, 22½ in. x 35 in.	100 „	2 3 2 55	C.	
COVER PAPER (STATIONERY).					
135	Sample No. 32— Royal Blue, Double Medium, 80 lb., 23 in. x 36 in.	50 reams	per ton 75 10 0	C.	Australian Paper Manufacturers Ltd. (A)
COPYING TISSUE (STATIONERY).					
141	Sample No. 33— Double Crown White, 7½ lb., 20 in. x 30 in.	100 reams	per ream 1 7 8§	B.	Spicers and Detmold Ltd.
DRAWING PAPER (STATIONERY).					
145	Sample No. 34— Antiquarian (hot pressed), 31 in. x 53 in., Whatman's (all insides)	2 reams	per ream 73 12 5‡	B.	Spicers and Detmold Ltd.
TRACING CLOTH (STATIONERY).					
152	Sample No. 37— Dull Back, 42 in. (25 yards), "Sapphire"	50 rolls	per yard 0 3 9	B.	P. Rowe Pty. Ltd.

† Rate subject to surcharge of £3 0s. 5 4d. per ton for packing in cases.—|| Rate subject to 2 per cent. discount.—§ Rate subject to packing charge.—‡ Plus packing charge approximately £1 6s. per ream.

CONTRACTS ACCEPTED—continued.

Item No.	Description.	Quantity.	Rate.	Country of Origin.	Name of Contractor.
PASTEBOARDS (STATIONERY).					
<i>Sample No. 38—</i>					
156	Mottled, 4-sheet, 25½ in. x 30½ in., 44 lb. per gross	1,750 gross	per ton 79 10 0	C.	Australian Paper Manufacturers Ltd. (A)
SYSTEM BOARDS (STATIONERY).					
<i>Sample No. 42—</i>					
167	Buff, 25½ in. x 30½ in., 6-sheet, 44 lb. per 100 boards (bale packed) ..	1,000 boards	per 100 2 3 4	B.	} Edwards, Dunlop, and Co. Ltd.
172A	White, 25½ in. x 30½ in., 6-sheet, 44 lb. per 100 boards (bale packed) ..	2,000 "	2 3 4	B.	
180	White, 25½ in. x 30½ in., 4-sheet, 28 lb. per 100 boards (bale packed) ..	30,000 "	1 7 7	B.	
181	White, 27 in. x 34 in., 3-sheet, 28 lb. per 100 boards (bale packed) ..	10,000 "	1 7 7	B.	
183	Green, 25½ in. x 30½ in., 3-sheet, 22 lb. per 100 boards (bale packed)	5,000 "	1 1 8	B.	
STRAWBOARDS.					
<i>Sample No. 43—</i>					
185	Imperial, 12 oz., 22½ in. x 32 in., 76 boards, 56 lb.	40 bundles	per ton 24 5 0*	C.	} Australian Paper Manufacturers Ltd. (A)
186	" 16 oz., 22½ in. x 32 in., 56 boards, 56 lb.	250 "	28 10 0*	C.	
188	" 24 oz., 22½ in. x 32 in., 38 boards, 56 lb.	40 "	28 10 0*	C.	
189	" 36 oz., 22½ in. x 32 in., 25 boards, 56 lb.	50 "	28 10 0*	C.	
189A	" 64 oz., 22½ in. x 32 in., boards 56 lb.	40 "	37 10 0*	C.	
193	Extra Royal, 20 oz., 21½ in. x 28½ in., 52 boards, 56 lb. ..	150 "	28 10 0*	C.	
197	Royal, 12 oz., 20½ in. x 26½ in., 95 boards, 56 lb.	75 "	24 5 0†*	C.	
200	" 24 oz., 20½ in. x 26½ in., 47 boards, 56 lb.	40 "	28 10 0†*	C.	
201	" 36 oz., 20½ in. x 26½ in., 32 boards, 56 lb.	40 "	28 10 0†*	C.	
203	Large Middle, 12 oz., 18½ in. x 23½ in., 122 boards, 56 lb. ..	40 "	24 5 0†*	C.	
204	" 16 oz., 18½ in. x 23½ in., 92 boards, 56 lb.	50 "	28 10 0†*	C.	
207	" 36 oz., 18½ in. x 23½ in., 40 boards, 56 lb.	100 "	28 10 0†*	C.	
215	Double Foolscap, 12 oz., 18 in. x 27 in., 111 boards, 56 lb. ..	50 "	24 5 0†*	C.	
216	" 16 oz., 18 in. x 27 in., 80 boards, 56 lb.	50 "	28 10 0†*	C.	
217	" 20 oz., 18 in. x 27 in., 68 boards, 56 lb.	50 "	28 10 0†*	C.	
218	" 24 oz., 18 in. x 27 in., 56 boards, 56 lb.	50 "	28 10 0†*	C.	
219	" 36 oz., 18 in. x 27 in., 41 boards, 56 lb.	40 "	28 10 0†*	C.	
STATIONERY.					
248A	Tracing Paper, 30 in. x 50 yards, "Arcus" No. 1959, Matt. ..	100 rolls	per roll 1 4 6	B.	Max Wurcker (1930) Pty. Ltd.
ENVELOPES.					
per 1,000					
257	10½ in. x 7½ in., Pocket, gummed, Kraft Brown	75,000	1 5 6	C.	} Spicers and Detmold Ltd.
259	15 in. x 11 in., Kraft Brown	8,000	4 0 0	C.	
261A	9 in. x 4 in., Pocket, gummed, Manilla	50,000	0 13 0	C.	
261B	5½ in. x 3½ in., Window Face, Bankers, secretivo, gummed ..	350,000	0 11 0	C.	
261C	5½ in. x 3½ in., Pocket, gummed, Manilla	150,000	0 9 3	C.	Sands & McDougall Pty. Ltd. Spicers and Detmold Ltd.
BOOKBINDERS' LEATHER.					
per skin					
281	Calf, Super Royal, rough, 36 in. x 24 in.	60 skins	} Purchase (Clause 4)
283	Red Glazed Basil, 30 in. x 27 in.	144 "	
292	Roan, Purple, straight-grained, 30 in. x 27 in.	60 "	
per foot					
307	Banding, Vellum, white, 32 in. x 22 in.	12 "	
MANILLA TAGS.					
per 1,000					
314	5N (in gangs of 4)	150,000	4 9	C.	} Spicers and Detmold Ltd.
315	6N (in gangs of 4)	150,000	5 4	C.	

|| Rate subject to 2 per cent. discount.—* Rate less maximum rebate of £1 5s. per ton, less 2 per cent.—† Rate plus cutting charge of £1 5s. per ton.

CONTRACTS ACCEPTED.—(Series 1945-46.)**GENERAL STORES.**

Gazette No. 86, 28th June, 1945, Schedule No. 67, Soap-makers' Materials, Dry salteries, &c.—For the rate shown for Item No. 1 substitute £12 3s. 6d. per ton as from 2nd July, 1945.

PROVISIONS.—CEREALS.

Requirements under Sub-schedule No. 5 of Schedule No. 1 for the month of November, 1945, are to be purchased under agreement from the under-mentioned firms at the rates per cwt. indicated, viz.:—Moran and Cato Pty. Ltd.—Granulated Wheat, 12s. 6d. net; Robert Harper & Co. Pty. Ltd.—Oatmeal, plain, 22s. 6d.; Barley Kernels, 24s.; Rice, dressed and unpolished, 24s.; Rycena, 21s. Rates less 3 per cent. 14 days, or 2½ per cent. 30 days. H. S. K. Ward Pty. Ltd.—Barley, Pearl, 19s. 6d., rate less 3 per cent. 14 days, or 2½ per cent. 30 days. Split peas are not available.

PROVISIONS.

Gazette No. 84, 25th June, 1945, Schedule No. 2, Sub-schedule No. 2, Item No. 30—Rice, ground, add 4½d. lb. Schedule No. 3, Sub-schedule No. 2, Item No. 38—Oatmeal, flaked, add 28s. cwt. Schedule No. 12, Sub-schedule No. 2, Item No. 6—Camp Pie, add 7s. 6d. per dozen, 12-oz. tins. Item No. 32—Macaroni, add 7s. 9d. box, 22 lb. Item No. 35—Oatmeal, flaked, add 28s. cwt. To date from 1st November, 1945.

W. H. RUTHERFORD, Secretary to the Tender Board.
20.10.45.

ORDERS IN COUNCIL.—(Series 1945-46.)**DEPARTMENT OF PUBLIC INSTRUCTION.**

785. Renovations at Lyric Building, Prahran, £472.—G. T. Cahlan, East Malvern.

786. Renovations at Gordon Institute of Technology, £109 15s.—C. P. Hornsey, Geelong.

787. Removal of flax mill buildings at Donnybrook to North Melbourne and re-erection of buildings, £451.—Axton and Wigraff, Alphington.

Approved by the Governor in Council, 23rd October, 1945.—
C. W. KINSMAN, Clerk of the Executive Council.

FORESTS COMMISSION.

Loan Act No. 5049, Item 5—

788. To the purchase of allotment 60n, Parish of Bingin-warri, County of Buln Buln, containing 199 acres 0 roods 21 perches, for forest purposes, £100.—VX126604, Pte. E. J. Littlejohn, Welshpool.

Approved by the Governor in Council, 17th July, 1945.—
C. W. KINSMAN, Clerk of the Executive Council.

STATE ELECTRICITY COMMISSION.

799. For the supply of motor generator sets and field rheostats, to Quotation No. 138.—Hodson and Gault Pty. Ltd.

800. For the supply of rubber conveyor belts for briquette works, Yallourn, to Quotation No. 851.—Hopkins, Odlum Pty. Ltd.

801. For the supply of rubber conveyor belts for briquette works, Yallourn, to Quotation No. 851.—Dunlop Rubber Australia Limited.

802. For the supply of two portable air compressor units.—
Department of the Army.

803. For the supply of mild steel, cast steel, and cast iron pipework and fittings for turbo-generator mains, Newport "C" Power Station, to Specification No. 45-46/40.—Stewarts and Lloyds (Aust.) Pty. Ltd.

804. For the supply and installation of 7 cubic yard heavy duty steel tipping bodies for truck chassis, to Quotation Nos. 502 and 502a.—Engineering Products Pty. Ltd.

Approved by the Governor in Council, 23rd October, 1945.—
C. W. KINSMAN, Clerk of the Executive Council.

Farmers' Debts Adjustment Act 1935.**CANCELLATION OF STAY ORDER.**

NOTIFICATION is hereby given that the Stay Order issued to the under-mentioned farmer has been cancelled by the Farmers' Debts Adjustment Board, such cancellation to take effect on 31st October, 1945:—

No. of Stay Order; Name; Address.

881; Murdoch, Alexander Evette; Lismore.

W. R. MANN, Secretary,
Farmers' Debts Adjustment Board.

30th October, 1945.

4 GEORGE VI. No. 4755, SECTION 6.

I HEREBY give notice that, on the 15th October, 1945, I filed an election to administer the following deceased person's estate, in accordance with section 6 of the *Public Trustee Act 1940*:—

DAVIS, JAMES, late of Caritas Christi Home, Kew, pensioner, died 24th May, 1945, intestate.

I HEREBY give notice that, on the 22nd October, 1945, I filed elections to administer the following deceased persons' estates, in accordance with section 6 of the *Public Trustee Act 1940*:—

*COURTNEY, PHILLIP WILLIAM, also known as William Courtney, late of 10 Macquarie-street, Williamstown, retired shipwright, died 10th June, 1945.

JAEREL, CARL PAUL, late of No. 4 Forest Camp, Mount Disappointment, labourer, died 19th March, 1945, intestate.

*JENNER, ANNIE, formerly of Middleborough-road, Box Hill, but late of 4 Bruce-street, Box Hill, widow, died 11th September, 1945.

*LETHBORG, HENRIETTA ANNIE, late of 17 Stokes-street, Preston, married woman, died 9th August, 1945.

*MARSHALL, GEORGINA ANN, formerly of 50 Richard-street, Coburg, but late of 25 Egremont-street, North Fitzroy, spinster, died 26th June, 1945.

MILLERSHIP, EDWARD HERBERT, late of 46 Blyth-street, Brunswick, Commonwealth peace officer, died 4th August, 1945, intestate.

MORRISON, GEORGE GRANT, late of 108 Rosslyn-street, West Melbourne, clerk, died 7th September, 1929, intestate.

*WILLIAMS, ANNIE, late of Cheltenham, widow, died 11th December, 1939.

YEOMANS, HILDA HAMILTON, late of 723 High-street, Thornbury, widow, died 1st August, 1945, intestate.

* According to the provisions of the will.

J. E. DON,
Public Trustee.

412 Collins-street, Melbourne, C.1, 24th October, 1945.

NOTICE.

ADMINISTRATION of the estate of each of the under-mentioned deceased persons has been granted to me, and creditors, next of kin, and all others having claims against the estate of any of the persons so mentioned are required to send particulars of their claims to the Public Trustee, No. 412 Collins-street, Melbourne, on or before the 2nd January, 1946, or they will be excluded from the distribution of the estate when the assets are being distributed:—

† BRIGGS, SARAH PHELPS, formerly of Christchurch, New Zealand, but late of Paeroa, New Zealand, widow, died 29th March, 1945.

† BROOK, RUPERT HAROLD, formerly of 38 Hopper-street, Quarry Hill, Bendigo, but late of R.A.N. (H.M.A.S. *Yarra*), sailor, died 4th March, 1942.

BURNETT, LAURISTON WRIGHT, late of 24 Park-street, St. Kilda, clerk, died 24th July, 1945, intestate.

* COURTNEY, PHILLIP WILLIAM, also known as William Courtney, late of 10 Macquarie-street, Williamstown, retired shipwright, died 10th June, 1945.

DAVIS, JAMES, late of Caritas Christi Home, Kew, pensioner, died 24th May, 1945, intestate.

† DEMPSTER, ANDREW, late of 263 Jasper-road, McKinnon, gentleman, died 28th August, 1945.

ELLIS, CHARLES FREDERICK, late of 4 Monash-street, Footscray, munition inspector, died 22nd June, 1945, intestate.

† FRY, VICTOR MORWICK, formerly of 117 Charles-street, Northcote, and Australian Imperial Forces, VX55307, but late of Royal Australian Air Force, sergeant, died 24th June, 1945.

JAEKEL, CARL PAUL, late of No. 4 Forest Camp, Mount Disappointment, labourer, died 19th March, 1945, intestate.

*JENNER, ANNIE, formerly of Middleborough-road, Box Hill, but late of 4 Bruce-street, Box Hill, widow, died 11th September, 1945.

†KEYSTON, JESSIE ANN, late of 22 Waterloo-street, Carlton, married woman, died 14th August, 1945.

†LEGG, ISABELLA MAUD, late of 17 Ashley-grove, Malvern, spinster, died 17th August, 1945.

*LETHBRG, HENRIETTA ANNIE, late of 17 Stokes-street, Preston, married woman, died 9th August, 1945.

*MARSHALL, GEORGINA ANN, formerly of 50 Richard-street, Coburg, but late of 25 Egrement-street, North Fitzroy, spinster, died 26th June, 1945.

†MILLER, ALFRED CHARLES, late of 35 Cochrane-street, Camberwell, retired station manager, died 26th August, 1945.

MILLERSHIP, EDWARD HERBERT, late of 46 Blyth-street, Brunswick, Commonwealth peace officer, died 4th August, 1945, intestate.

MORRISON, GEORGE GRANT, late of 108 Rosslyn-street, West Melbourne, clerk, died 7th September, 1929, intestate.

O'DONNELL, JOHN JOSEPH, late of 93 Delbridge-street, North Fitzroy, foreman clobber, died 29th August, 1945, intestate.

†SEYMOUR, CECIL WHITING, late of Auckland, New Zealand, retired boot importer, died 24th February, 1945.

*WILLIAMS, ANNIE, late of Cheltenham, widow, died 11th December, 1939.

YEOMANS, HILDA HAMILTON, late of 723 High-street, Thornbury, widow, died 1st August, 1945, intestate.

* According to the provisions of the will.
 † With the will annexed.

J. E. DON,
 Public Trustee.

Melbourne, 24th October, 1945.

DEPARTMENT OF LANDS AND SURVEY.

At the Executive Council Chamber, Melbourne, the twenty-third day of October, 1945.

PRESENT:

His Excellency the Governor of Victoria.

Mr. Malthby	Mr. McBrien
Mr. Disney	Mr. Michaelis.

UNUSED AND UNMADE ROADS CLOSED.

HIS Excellency the Governor of the State of Victoria, by and with the advice of the Executive Council thereof, doth hereby direct that, in pursuance of the provisions of section 304 of the Land Act 1928 (No. 3709), the unused and unmade roads referred to hereunder be closed, viz.:

Township of Koondrook, Parish of Murrabit, County of Gambowee, being the road indicated by hachure on plan hereunder.

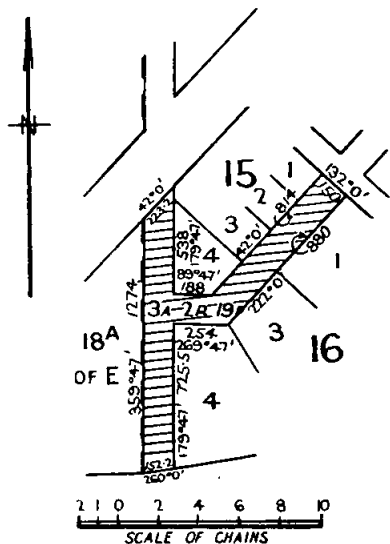

Parish of Olangolah, County of Polwarth, being the road indicated by hachure on plan hereunder.—(O.241(1) (Rs.518).

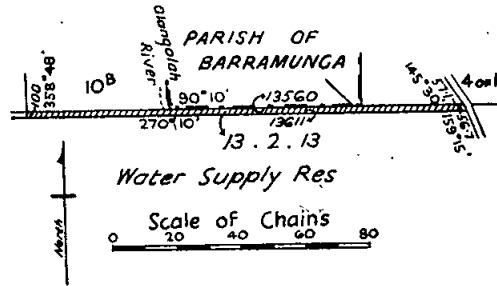

Parish of Wangoom, County of Villiers, being the road indicated by hachure on plan hereunder.

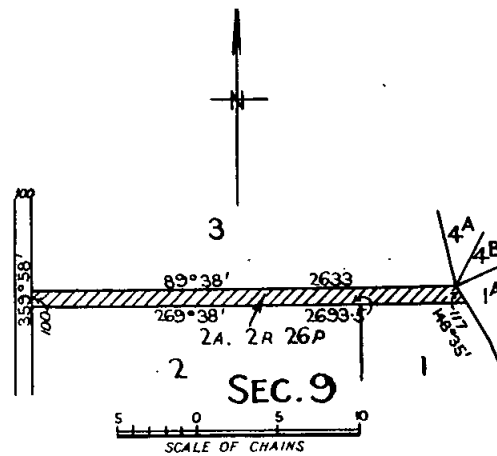

LANDS TEMPORARILY RESERVED FROM SALE.

HIS Excellency the Governor of the State of Victoria, by and with the advice of the Executive Council thereof, doth hereby, in pursuance of the provisions of the Land Act 1928, reserve, temporarily, and also except from occupation for mining purposes under any miner's right, the lands hereinafter described:—

Town of SHELFORD.—Site for Mechanics' Institute in addition to and adjoining the site temporarily reserved therefor by Order of the 1st August, 1864—1 road, Town of Shelford, Parish of Dorog, County of Grenville, as indicated by hachure on plan hereunder.—(S.270(1) (Rs.2561).

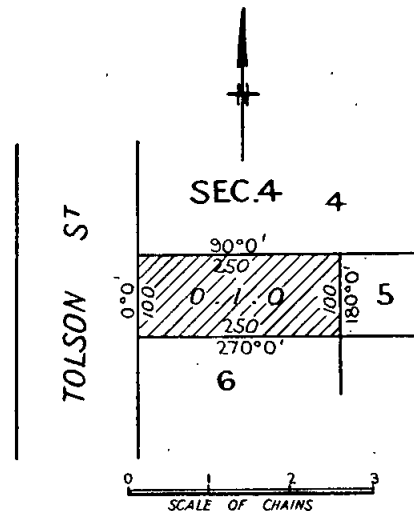

OLANGOLAH.—Site for Water Supply purposes in addition to and adjoining the site temporarily reserved therefor by Order in Council of the 29th May, 1945—13 acres 2 roods 13 perches. Parish of Olangolah, County of Polwarth, as indicated by hachure on plan hereunder.—(O.24L(1) (Rs.518).

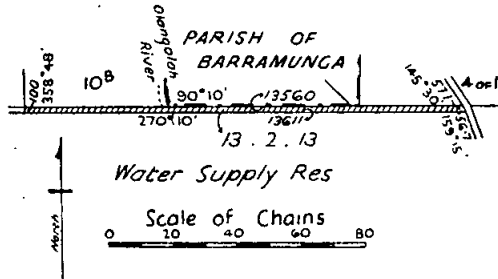

WINCHELSEA.—Site for Police purposes—2 roods 1 perch, Town of Winchelsea, Parish of Mirnee, County of Grenville, as indicated by hachure on plan hereunder.—(W.168(2) (Rs.5708).

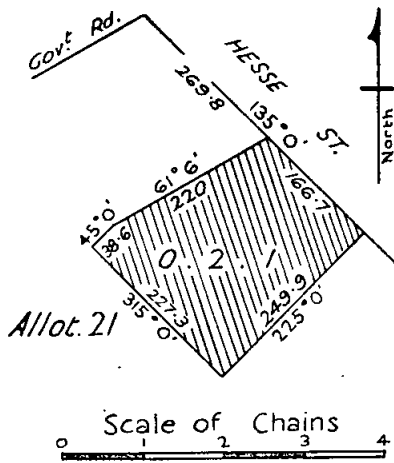

And the Honorable William Hugh Everard, His Majesty's Commissioner of Crown Lands and Survey for the State of Victoria, shall give the necessary directions herein accordingly.

C. W. KINSMAN,
Clerk of the Executive Council.

DAIRY PRODUCE ACT 1935 (No. 4349).

At the Executive Council Chamber, Melbourne, the twenty-third day of October, 1945.

PRESENT:

His Excellency the Governor of Victoria.
Mr. Maltby | Mr. McBrien
Mr. Disney | Mr. Michaelis.

DECLARATION OF SUFFICIENT FACTORIES, SHIRE OF RODNEY.

IN pursuance of section 3 of the Dairy Produce Act 1935 (No. 4349), His Excellency the Governor of the State of Victoria, by and with the advice of the Executive Council thereof, doth hereby declare that he is of the opinion that there are sufficient factories in that part of Victoria specified hereunder to deal with the milk and cream produced in such part (that is to say):—

"The Municipal District of the Shire of Rodney."

And the Honorable William Ronald Cumming, His Majesty's Minister of Agriculture for the State of Victoria, shall give the necessary directions herein accordingly.

C. W. KINSMAN,
Clerk of the Executive Council.

INFECTIOUS DISEASES HOSPITAL ACT 1928 (No. 3704).

At the Executive Council Chamber, Melbourne, the thirtieth day of October, 1945.

PRESENT:

His Excellency the Governor of Victoria.
Mr. Disney | Mr. Michaelis
Mr. McBrien |

CHARGES TO BE PAID BY NON-CONTRIBUTING MUNICIPALITIES IN RESPECT OF PATIENTS FROM THEIR DISTRICTS RECEIVED AT THE QUEEN'S MEMORIAL INFECTIOUS DISEASES HOSPITAL, FAIRFIELD.

WHEREAS the Queen's Memorial Infectious Diseases Hospital Board, incorporated under the Infectious Diseases Hospital Act 1928 (No. 3704), is by section 17 of the said Act empowered to receive into the hospital patients from the district of any municipality, though not a contributing municipality within the meaning of such Act, and to sue for and recover such reasonable charges and expenses as may be prescribed from the Council of such municipality: And whereas by the said Act the Governor in Council is empowered to make regulations for or with respect to any matter required or permitted by the said Act to be prescribed by regulations and generally for carrying out the provisions of the Act:

Now therefore His Excellency the Governor of the State of Victoria, with the advice of the Executive Council of the said State, doth hereby make the Regulations following (that is to say):—

1. These Regulations may be cited as the Infectious Diseases Hospital Regulations 1945, shall be published in the Government Gazette and shall come into operation on the 1st day of November, 1945.
2. The Regulations made on the 26th day of February, 1929, and published in the Government Gazette of the 6th March, 1929, at page 986, are hereby repealed.
3. The charges and expenses which the Queen's Memorial Infectious Diseases Hospital Board may sue for and recover from the Council of any municipality which is not a contributing municipality within the meaning of the Infectious Diseases Hospital Act 1928 (No. 3704) in respect of each patient from the municipal district of such Council which the Board may receive into the hospital shall be the sum of Sixteen shillings and three pence for each day or part of a day such patient is an inmate of such hospital.

And the Honorable William Crawford Haworth, His Majesty's Minister of Health for the State of Victoria, shall give the necessary directions herein accordingly.

C. W. KINSMAN,
Clerk of the Executive Council.

DEPARTMENT OF LAW.

At the Executive Council Chamber, Melbourne, the thirtieth day of October, 1945.

PRESENT:

His Excellency the Governor of Victoria.
Mr. Disney | Mr. Michaelis
Mr. McBrien |

TITLES OFFICE.—PERIODS OPEN TO PUBLIC.

UNDER and by virtue of the powers and authorities thereto me enabling, His Excellency the Governor of Victoria, by and with the advice of the Executive Council, doth hereby alter the periods heretofore appointed during which the Office of the Registrar-General and the Registrar of Titles shall be open to the public to the periods set out hereunder, to take effect as from and inclusive of the 29th October, 1945—

From Monday to Friday—from 9.30 a.m. to 3 p.m. daily.

And the Honorable Ian Macfarlan, His Majesty's Attorney-General for the State of Victoria, shall give the necessary directions herein accordingly.

C. W. KINSMAN,
Clerk of the Executive Council.

Water Acts.

STATE RIVERS AND WATER SUPPLY COMMISSION.

At the Executive Council Chamber, Melbourne, the twenty-third day of October, 1945.

PRESENT:

His Excellency the Governor of Victoria.
 Mr. Maltby | Mr. McBrien
 Mr. Disney | Mr. Michaelis.

MITIAMO WATERWORKS DISTRICT.

ADJUSTMENT OF OUTSTANDING LIABILITY FOR COST OF WORKS.

WHEREAS by section 2 of *Water Act 1944* (No. 5003), it is provided that the Governor in Council may, by Order published in the *Government Gazette*, adjust the outstanding liability of the Mitiamo Urban District within the Mitiamo Waterworks District by allotting to such district the liability for such amount of the cost of such works serving such district as the Governor in Council thinks fit, and by allotting to the State the liability for the remainder of the cost thereof (and any such adjustment shall be deemed to have been made under sub-section (1) of section four of the *Water Act 1937*): And whereas it is provided that the amount by which the liability is reduced as aforesaid shall forthwith be transferred to the account in the books of the Commission called the "Capital Expenditure Borne by the State Account": Now therefore His Excellency the Governor of the State of Victoria, acting by and with the advice of the Executive Council thereof, and in pursuance of the provisions of the said Act, doth hereby transfer from the capital account of the Mitiamo

Waterworks District to the "Capital Expenditure Borne by the State Account" the amount of £1,143 14s. 5d., and as on and from the first day of July, One thousand nine hundred and forty-five, such amount shall be deemed to have been so transferred.

LODDON UNITED WATERWORKS TRUST.

APPORTIONMENT AND TRANSFER OF COST OF WORKS AND OF RESPECTIVE INTERESTS.

WHEREAS by section 2 of *Water Act 1944* (No. 5003), it is provided that the Loddon United Waterworks Trust shall be abolished and the Governor in Council may, by Order published in the *Government Gazette*, provide for disposition of all the existing works and property of the Loddon United Waterworks Trust and apportion, settle, adjust, and determine the extent of the respective interests and obligations of any district affected or constituted by any Order under this section in regard to any property, income, assets, rights, or liabilities of the Loddon United Waterworks Trust: Now, therefore, His Excellency the Governor of the State of Victoria, acting by and with the advice of the Executive Council thereof, and in pursuance of the said Act, doth hereby apportion the cost of works of the Loddon United Waterworks Trust amounting in total to £24,694 3s. 6d. (Loan £24,148 14s. 7d., Revenue £545 8s. 11d.) and the respective interests of the aforesaid Trust amounting in total to £23,550 9s. 1d., and transfer the cost of works to the districts as set out in Schedule "A" hereto, and transfer to the districts as set out in Schedule "B" the respective interests, and as on and from the first day of July, One thousand nine hundred and forty-five, such amounts shall be deemed to be so transferred.

SCHEDULE "A."

Apportionment of Cost of Works of Loddon United Waterworks Trust.

District.	Total.	Amount Debitable to Loan.	Amount Debitable to Revenue.
	£ s. d.	£ s. d.	£ s. d.
Loddon Waterworks District	7,800 0 0	7,254 11 1	545 8 11
East Loddon Waterworks District	5,509 2 9	5,509 2 9	..
West Loddon Waterworks District	6,320 0 0	6,320 0 0	..
Mitiamo Waterworks and Mitiamo Urban Districts	5,065 0 0	5,065 0 0	..
	24,694 3 6	24,148 14 7	545 8 11

SCHEDULE "B."

Apportionment of Respective Interests of Loddon United Waterworks Trust.

District.	Total.	Redemption Paid by Loddon United Waterworks Trust.	Written Off from Loddon United W.W. Trust under Acts Nos. 1625, 4176.	Cost of Works from Revenue.
	£ s. d.	£ s. d.	£ s. d.	£ s. d.
Loddon Waterworks District	7,800 0 0	4,320 17 6	2,933 13 7	545 8 11
East Loddon Waterworks District	5,509 2 9	3,281 9 1	2,227 13 8	..
West Loddon Waterworks District	6,320 0 0	3,764 7 3	2,555 12 9	..
Mitiamo Waterworks and Mitiamo Urban Districts	3,921 6 4	3,921 6 4
	23,550 9 1	15,288 0 2	7,717 0 0	545 8 11

**DIRECTION TO CONTINUE SUPPLY OF WATER TO
MITIAMO URBAN DISTRICT.**

BY virtue of the provisions of section 2 of the *Water Act* 1944 (No. 5003), the cost of works serving the Mitiamo Urban District has been transferred to the Commission: Whereas by section 6 of the *Water Act* 1937 (No. 4513) it is provided that where Parliament or the Governor in Council directs the Commission to maintain any works in respect of which the Commission has submitted in writing a report that such works will not produce sufficient revenue to cover the expense of the maintenance and management thereof, the annual amount of the loss resulting from the maintenance and management of such works shall be transferred to an account in the books of the Commission to be called the "Revenue Expenditure Chargeable to the State Account," and whereas the Commission has submitted in writing a report that the works of the Mitiamo Urban District will not produce sufficient revenue to cover the expense of the maintenance and management thereof: Now, therefore, His Excellency the Governor of the State of Victoria, acting by and with the advice of the Executive Council thereof, and in pursuance of the provisions of the said section, doth hereby direct the State Rivers and Water Supply Commission to continue to supply water in the said district, and doth hereby direct that the annual amount of loss resulting from the maintenance and management of the works of the said district shall be transferred to an account in the books of the said Commission to be called the "Revenue Expenditure Chargeable to the State Account."

NORMANVILLE WATERWORKS DISTRICT.

TRANSFER OF PORTION OF CAPITAL LIABILITY.

WHEREAS by section 2 of *Water Act* 1944 (No. 5003), it is provided that portion of the Normanville Waterworks District shall be excised, and that the Governor in Council may, by Order published in the *Government Gazette*, apportion, settle, adjust, and determine the extent of the respective interests and obligations of any district affected or constituted by any Order under this section in regard to any property, income, assets, rights, or liabilities of the Normanville Waterworks District: Now, therefore, His Excellency the Governor of the State of Victoria, acting by and with the advice of the Executive Council thereof, and in pursuance of the said Act, doth hereby apportion and transfer from the Capital Liability of the Normanville Waterworks District to the West Loddon Waterworks District an amount of £6,020 16s. 7d., and as on and from the first day of July, One thousand nine hundred and forty-five, such amount shall be deemed to be so transferred.

And the Honorable Edwin Joseph Mackrell, His Majesty's Minister of Water Supply for the State of Victoria, shall give the necessary directions herein accordingly.

C. W. KINSMAN,
Clerk of the Executive Council.

APPROACHING LAND SALES.

SALES of Crown lands, in fee-simple, will be held at the under-mentioned places and dates, viz.:

	No. of Gazette.
Melbourne.—Wednesday, 7th November, 1945 ..	136
Melbourne.—Wednesday, 21st November, 1945 ..	139
St. Arnaud.—Wednesday, 28th November, 1945 ..	140

Lands and Survey Office, Melbourne.

SALE BY AUCTION.

The lands will be sold in fee-simple, and subject to the covenants, conditions, exceptions, and reservations, directed by the Governor in Council by an Order in Council dated the 5th August, 1930, and published in the *Government Gazette* of the 8th August, 1930, varied as herein.

A deposit of at least twelve and a half per centum of the price at which each lot is sold must be paid by the purchaser at the time of sale, and all such payments shall be made in bank notes or cheques approved by the officer conducting the sale, and the residue of such price will be payable in equal instalments, in accordance with the scale hereunder, on the last day of each successive period of six months from the time of sale, or, if the purchaser choose, at any earlier time or times; such residue of the price shall bear interest at the rate of 5 per centum per annum, to be computed between the time of sale and the time when payment of such residue is made. If the residue of the price be paid within thirty days after the time of the sale no interest will be payable thereon.

The transfer of the interest of any purchaser of an allotment sold by public auction may be effected prior to the final payment of the purchase money being made. The fee for transfer shall be One pound, and such transfer will be subject to payment of stamp duty.

SCALE OF PAYMENTS OF RESIDUE.

£20 and under, 6 instalments.
Over £20, and not exceeding £50, 8 instalments.
Over £50, and not exceeding £100, 10 instalments.
Over £100, and not exceeding £200, 12 instalments.
Over £200, and not exceeding £300, 14 instalments.
Over £300, and not exceeding £400, 16 instalments.
Over £400, and not exceeding £500, 18 instalments.
Over £500, 20 instalments.

FEEs, ETC.

The fees payable for Crown grant and assurance (One halfpenny for each pound of purchase price) must be paid with the balance of purchase money. The following is the scale:—

50 acres and under, £1 10s.
Over 50 acres, £2.

Where the purchase money does not exceed £5, the grant fee is £1.

Valuations of improvements (if not purchased by the owner thereof), and charges for survey, must also be paid at the time of sale.

SPECIAL CONDITION.

Before sale is approved the purchaser will be required to satisfy the requirements of the National Security (Lands Transfer) Regulations as regards nationality.

W. H. EVERARD,
Commissioner of Crown Lands and Survey.

Office of Lands and Survey,
Melbourne, 30th October, 1945.

ST. ARNAUD.—Sale (No. 10578) of Crown lands, in fee-simple, will be held at the LAND OFFICE, ST. ARNAUD, on WEDNESDAY, the 28th day of NOVEMBER, 1945, at TWO o'clock p.m. To be conducted by H. H. DODD, Land Officer.

ST. ARNAUD, PARISH OF ST. ARNAUD, COUNTY OF KARA KARA.

Fronting Millett-street.

Upset price £300. Charge for survey £3 2s. 6d.

Lot 1. Area 1r. 9p., subject to adjustment after survey, being allotment 4 of section D. Upset price includes all improvements on the area with the right to remove the wash-house on the adjoining allotment to this area within 30 days.

On West Side of Main Melbourne-road.

Upset price £25. Charge for survey £3 2s. 6d.

Lot 2. Area 1r. 17p., being allotment 9 of section T2. One month allowed to remove improvements.

BOROUGH OF ST. ARNAUD, PARISH OF ST. ARNAUD, COUNTY OF KARA KARA.

At Corner of Hopetoun and Clyde streets.

Upset price £10. Charge for survey £3 2s. 6d.

Lot 3. Area 2r. 12p., being allotment 10 of section 9. Valuation of improvements £65 (E. M. Love).

Fronting Hopetoun-street.

Upset price £15. Charge for survey £3 5s.

Lot 4. Area 3a. 2r. 26p., being allotment 26 of section E. Valuation of improvements £5 (W. Pownceby).

North-east of Butcher-street.

Upset price £5. Charge for survey £4 4s.

Lot 5. Area 2r. 0 and 4/10p., being allotment 6 of section 7. Valuation of improvements £30 (W. B. Aherne).

PARISH OF BOOLA BOLOKE, COUNTY OF KARA KARA.

West of Stuart Mill Township.

Upset price £13 10s. Charge for survey £3 5s.

Lot 6. Area 5 acres, subject to adjustment after survey, being allotment A19F of section A. Valuation of improvements £5 10s. (A. P. Frolich).

LIST OF CROWN LANDS AVAILABLE.

THE under-mentioned areas are available for application as provided by various sections of the *Land Act 1928*, and all applications received on or before Wednesday, 28th November, 1945, will be deemed to have been simultaneously made, but any application lodged after such date may be considered if received in time for inclusion in the advertisement of the cases to be heard at the Local Land Board.

Applications on proper form, accompanied by 5s. duty stamp uncanceled (registration fee), may be delivered or forwarded by post to the Local Land Officer or to any Crown Lands Office in Victoria. Applicants may obtain from Local Land Officers, or the Enquiry Office, Lands Department, Melbourne, a certificate authorizing the issue by the Railway Department of a return ticket at concession fares to enable them to inspect available areas or to attend Local Land Boards. When an applicant is granted an allotment he may, if travelling by rail, obtain reduced fares for his family and also freight concessions in regard to some of his effects.

Subject to the approval of the Minister, when the survey fee exceeds £10, a deposit of £5 may be paid, and the balance over six years in half-yearly instalments. Marked plans of any particular area, application forms, and any further information may be obtained from the Enquiry Office, Lands Department, Melbourne, and Land Officers, Ararat, Bairnsdale, Geelong, Hamilton and Horsham.

Department of Crown Lands and Survey, Melbourne, 29th October, 1945.

W. H. EVERARD,
Commissioner of Crown Lands and Survey.

Local Land Office.	County.	Parish.	Allotment.	Section.	Area.	How available.				Valuation of improvements (if any).	Location of Land, &c.	Nearest Railway Station or Township and Distance in miles therefrom.	How accessible.	Water Supply.	General Description of Land—Soil, Timber, Suitability (fencing, &c.).
						A.	B.	C.	D.						
AGRICULTURAL AND GRAZING LANDS—SELECTION PURCHASE ALLOTMENTS.—Division 4, Part I., Land Act 1928.															
Ararat (a)	Borong ..	Moyeton West	8c	C	261 1 13	3rd	0 10 0	17 12 6	To be valued	Near centre of parish ..	20 miles from Ararat R.S.	By road ..	By conservation	Undulating, sandy grey loam; stringybark, box, peppermint; grazing. Ararat 164/44-81	
Bairnsdale (a, b)	Dargo ..	Wy Yung	13a	C	131 0 14	3rd	0 10 0	9 7 6	£7 ..	In the centre of west of parish	10 miles from Hillside	Undulating light grey sandy loam, stony in parts; box, stringybark, gum. Bairnsdale 3862/54	
Bairnsdale (b)	16b	4	60 0 0	3rd	0 10 0	6 17 6	To be valued	In north-east of parish ..	8 miles from Bairnsdale	Undulating to hilly, stony light loam, being better in the gullies; box, stringybark, gum, ironbark; suitable for grazing. Bairnsdale 209/46-81	
Geelong ..	Heytesbury	Coortjeong	1A	..	152 3 34	2nd	0 15 0	10 7 6	To be valued	In north of parish ..	12 miles from Cobden R.S.	Heavy grey loam; saplings and scrub; suitable for dairying and general agriculture. Geelong 12/44	
Geelong (a)	Grant ..	Durdidwarrah	B22 and B23	..	295 2 22	3rd	0 10 0	13 7 6	Hut and fencing, £28 6s.	In south of parish ..	3 miles from Steigitz Township	Mainly grazing. Geelong 146/44-81.	
Hamilton (c)	Normanby	Winyayung	71A, 74, and 74E	..	219 3 37	3rd	0 10 0	9 7 6	£125 to Board of Land and Works	In east of parish ..	8 miles from Condam R.S.	Undulating, loamy soil; timbered with gum. Hamilton Z.27903	
Horsham ..	Karkaroo	Wirribial	17A	..	239 0 2	4th	0 7 0	8 15 0	To be valued	In north of parish ..	4 miles from Burriem R.S.	Light sand hills and a small portion of red sandy loam flats; scrub and Mallee timber; suitable for grazing and cultivation. Mallee 1071/189	

(a) Subject to a special mining condition.—(b) Subject to a timber condition.—(c) Subject to a drainage condition.

PROPOSED REVOCATION OF TEMPORARY RESERVATION OF LAND BY ORDER IN COUNCIL.

IN pursuance of the provisions of the *Land Act 1928*, notice is hereby given that it is the intention of the Governor in Council to revoke the Order in Council hereunder referred to, viz.:

The following Notice was published 1° on the 17th October, 1945, pursuant to Order of the 9th October, 1945.

VIOLET TOWN.—The Order in Council of the 18th August, 1879, temporarily reserving 19 acres 1 rood 28 perches of land in the Town of Violet Town as a site for a Cemetery and withholding from sale, leasing, and licensing, is about to be revoked so far as regards the portion comprising 3 acres 1 rood 39 perches as indicated by hachure on plan hereunder.—(V.3A(1) (Rs.5374).

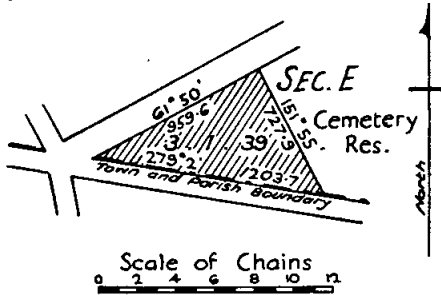

The following Notice was published 1° on the 24th October, 1945, pursuant to Order of the 16th October, 1945.

DEREEL.—The Order in Council of the 4th August, 1908, temporarily reserving 2 acres 2 roods of land in the Township of Dereel, being allotments 3, 4, 5, 6, and 7 of section 1 as a site for a State School is about to be revoked.—(D.172(a) (Rs.5678).

The following Notice was published 1° on the 31st October, 1945, pursuant to Order of the 23rd October, 1945.

UNDERHOOB.—The Order in Council of the 11th November, 1919, temporarily reserving 10 acres 0 roods 4 perches of land in the township of Underhoo (now Parish of Underhoo) as a Site for a Sanitary Depot is about to be revoked so far as regards the portion thereof indicated by hachure on plan hereunder.—(U.65A(1) (Rs.2044).

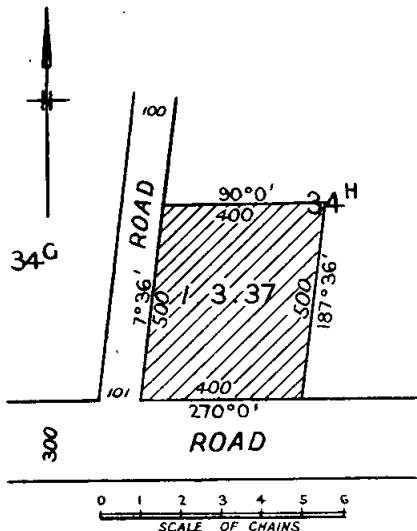

W. H. EVERARD,
Commissioner of Crown Lands and Survey.

TENDERS.

TENDERS will be received at this office until **TEN A.M.** on the days and for the purposes under mentioned.

Particulars may be learnt at this office, and also at the offices named in each instance.

The Board of Land and Works will not necessarily accept the lowest or any tender.

8th November, 1945.

Bahgallah.—Repairs and painting, State School No. 1586. Particulars at Inspector of Works Office, Stawell; Police Stations, Casterton, Coleraine, Hamilton; State School, Bahgallah. Deposit, £2.

Bendigo.—Alterations to Class Room, State School No. 877. Particulars at Inspector of Works Office, Bendigo; Police Station, Castlemaine; State School, Bendigo. Preliminary deposit, £5. Final deposit, 2 per cent.

Bendigo (Camp Hill).—Electrical installation, State School No. 1976 (Teachers' Training College). Particulars at Inspector of Works Office, Bendigo. Preliminary deposit, £3. Final deposit, 2 per cent.

Berwick.—Completion of contract partially erecting new residence, office, and out-buildings, Police Station. Particulars at Police Station, Berwick. Preliminary deposit, £15. Final deposit, 2 per cent.

Coburg.—Replacement of tanks, Pentridge. Deposit, £2.

Diapur.—Repairs, new windows, and painting, State School No. 2826. Particulars at Inspector of Works Office, Horsham; Police Stations, Kaniva, Nhill; State School, Diapur. Deposit, £2.

Lake Condah.—Repairs, No. 2, new skylights and painting, State School No. 2747. Particulars at Inspector of Works Office, Warrnambool; Police Stations, Hamilton, Heywood, Portland; State School, Lake Condah. Deposit, £2.

Little River.—Repairs, &c., and painting, State School No. 1961. Particulars at Inspector of Works Office, Geelong; Police Station, Werribee; State School, Little River. Deposit, £2.

Melbourne.—Alterations to Committee Room, State Relief Committee, 145 King-street. Deposit, £3.

Moolap.—Repairs and painting, State School No. 1911. Particulars at Inspector of Works Office, Geelong; State School, Moolap. Deposit, £3.

Preston.—Remodelling and additions, Technical School. Preliminary deposit, £100. Final deposit, 2 per cent.

Royal Park.—Electrical installation in additions to Laundry Block, Mental Hospital. Preliminary deposit, £3. Final deposit, 2 per cent.

South Yarra.—Repairs, &c., residences, Botanical Gardens. Preliminary deposit, £4. Final deposit, 2 per cent.

Terang.—Repairs and renovations, Police Station. Particulars at Inspector of Works Office, Warrnambool; Police Station, Terang. Preliminary deposit, £10. Final deposit, 2 per cent.

Timboon.—New Consolidated School building in brick, State School No. 2517. Particulars at Inspector of Works Offices, Warrnambool, Geelong, and Ballarat; State School, Timboon. Preliminary deposit, £50. Final deposit, 2 per cent.

15th November, 1945.

Ballarat.—Fitting up laboratory, Old Court House, Camp-street. Particulars at Inspector of Works Office, Ballarat. Deposit, £2.

Bendigo.—Removal of hut from Geelong and re-erection at High School. Particulars at Inspector of Works Offices, Bendigo, Geelong, Maryborough; Police Station, Castlemaine. Preliminary deposit, £4. Final deposit, 2 per cent.

Brunswick.—Lavatory accommodation, Court House. Particulars at Court House, Brunswick. Deposit, £2.

Camperdown.—Renovations and repairs, Court House. Particulars at Inspector of Works Office, Warrnambool; Police Stations, Camperdown, Colac. Deposit, £2.

Coburg.—Erection of brick residences, Pentridge. Preliminary deposit, £50. Final deposit, 2 per cent. (Amended specification.)

Olinda.—Erection of new out-offices and septic tank, State School No. 3494. Particulars at Police Station, Croydon; State School, Olinda. Preliminary deposit, £5. Final deposit, 2 per cent.

Warrnambool.—Repairs, &c., new fuel shed and painting, Police Station. Particulars at Inspector of Works Office, Warrnambool. Deposit, £4.

West Creek.—New timber school building, out-offices, and fencing, School. Particulars at Inspector of Works Office, Korumburra; Police Station, Wonthaggi. Preliminary deposit, £10. Final deposit, 2 per cent.

Woorinen North.—Painting and plaster sheeting walls internally of Residence, State School No. 4148. Particulars at Inspector of Works Office, Swan Hill; Police Stations, Kerang, Lake Boga; State School, Woorinen North. Preliminary deposit, £3. Final deposit, 2 per cent.

Tenders to be addressed to the Honorable the Commissioner of Public Works, and envelope containing tender marked "Tender for

L. H. MCBRIEN,
Commissioner of Public Works.

Melbourne, 30th October, 1945.

TENDERS FOR THE SERVICE, 1946.

REQUISITES FOR EDUCATION DEPARTMENT.

TENDERS will be received until Eleven o'clock a.m. on Friday, 23rd November, 1945, from persons willing to supply the under-mentioned articles, in such quantities as may be ordered by the Victorian Government, during the twelve months commencing on 1st January, 1946:—

Schedule No.	Preliminary Deposit.
1. Requisites (Junior School)	£3
2. Exercise Books and Requisites	3

The prices tendered must not include sales tax.

Security.—Five per cent. of total amount of tender accepted, but in no case will security of less than £3 be received.

Schedules as above, with full particulars, may be obtained from the Secretary to the Tender Board, by whom also the samples will be shown and any information afforded to persons tendering.

Should the tenderer be in a position to supply a suitable substitute of Commonwealth production or manufacture in place of any sample exhibited that may be of imported origin, he may tender for such substitute, but must submit with his tender a sample of the article offered.

In all cases the country of origin of the articles tendered must be stated, and the total cost of each item extended in the columns provided.

Tenders must be accompanied by the preliminary deposit, as shown above, preferably by non-negotiable cheque payable to the order of the Secretary to the Tender Board. The amount and designation of the preliminary deposit enclosed must be clearly stated in the tender. *Savings Bank deposit book, fixed deposit receipts, Commonwealth Treasury bonds, or reference to securities on existing contracts will in no case be received or entertained as preliminary deposits.* Preliminary deposits will be returned within 30 days to unsuccessful tenderers on their application.

Security will be required either in Commonwealth Treasury Bonds, or approved bank guarantee, fixed deposit receipt, Savings Bank deposit book, or non-negotiable cheque in favour of the Secretary to the Tender Board, as the tenderer may elect.

The security must be completed and the contract signed within five days of acceptance of the tender, failing which the contract may be again advertised, or another tender accepted.

The lowest or any tender will not necessarily be accepted.

In the event of tenderers withdrawing or attempting to withdraw their tenders before notification of acceptance of same, or failing to take up their accepted tenders within the prescribed period after notification of acceptance, the preliminary deposit will be forfeited and, in addition, they may be disqualified from tendering or holding any future contracts for Government supplies for a period of one year, such disqualification to date from the notification of acceptance of tender. It is also stipulated that, if a tenderer be a member of a firm and such firm be interested in the contract, the tender shall be in the name of the firm and not in that of the individual and that, for a breach of this condition, the preliminary deposit will be forfeited and the tender declared informal.

Tenders enclosed in a separate envelope, and having the words "Tender for ———" (as the case may be) written thereon, must be deposited in the Tender-box at the Tender Board Offices, Gisborne-street, Melbourne, or, if sent by post, postage must be prepaid, and the tenders addressed to the Chairman of the Tender Board, Tender Board Offices, Gisborne-street, Melbourne, C.2, which office they must reach not later than by first post on the date of closing of tenders.

CONDITIONS OF CONTRACT.

1. Except where definite quantities are specified the Government will not be bound to order from the contractor all the articles enumerated in the schedule, but only those articles, and such quantities of those articles, as it may be found necessary to order. Should the Government, however, require a larger supply of any article than the estimated quantity stated in the schedules, the contractor will nevertheless be bound to supply the same at contract rates.

The Government reserves the right to purchase otherwise than from the contractor articles of any of the several kinds enumerated in the schedules the purchase of which is, in the opinion of the Tender Board, necessary in order to meet special circumstances or special requirements.

2. The supplies are to be the same as sample where so stated, and of the particular manufacture indicated in the schedule of tenders. In the case of different makers' goods, the contractor will be required to supply the kind ordered. *The supplies are*

to be the best quality of their several kinds or manufacture. In the event of the tender having been accepted for goods manufactured within the Commonwealth or manufactured within any other part of the British Empire (as the case may be), all such goods supplied shall, if required by the Government, bear evidence that they are of the particular manufacture tendered for, and, in addition, the contractor may at any time during the currency of the contract be called on to furnish a statutory declaration as to the country of origin of the goods supplied.

3. Except where otherwise stated in the schedule, the value of all packages, cases, casks, &c., whether bulk be broken or not, must be included in the prices stated in the contractor's tender; all such packages, &c., to be considered the property of the Government, and no charges or expenses whatsoever beyond the price tendered and set out in the schedule will be allowed to the contractor for any articles or packages, cases, casks, &c. The net weight or quantity only will be paid for. Contractors must provide, without extra charge, whatever labour may be required in the packing of stores, and the stores shall be packed in such a manner as shall secure them from injury during transit, and until delivery such stores shall be at the risk of the contractor.

4. All orders for supplies will emanate from the Education Department. The goods shall be delivered as may be directed by the officer ordering the supply.

5. Supplies ordered for delivery in the Melbourne District are to be delivered free of all charges (whether cartage, freight, &c.), and, for the purposes of these contracts, Melbourne District will include a radius of 6 miles from the Elizabeth-street Post Office. For supplies outside that radius the goods must be delivered free on rails at Flinders-street or Spencer-street Railway Stations as required.

6. Arrangements as to time of delivery and inspection of goods will be made by the Secretary, Education Department, or such other officer whom he may appoint.

7. Orders must receive prompt execution; and in the event of the goods not being delivered within forty-eight hours after the contractor shall have received the order, or within such other time as the order may specify for delivery, it will be competent for the officer named in Clause 6, or the head of the department to whom the goods are to be supplied, on giving the contractor twenty-four hours' notice, to purchase the supplies, or any like supplies that are suitable for the service, at the contractor's risk, and the extra expense incurred over and above the contract price (if any) will be deducted from the contractor's account or from the security money.

8. Delivery will not be deemed to have been made until the goods have been approved. In case of the rejection or return of any supplies, the contractor shall bear the whole cost of replacing the supplies rejected or returned, otherwise purchases will be effected at the contractor's risk and the extra expense deducted as in Clause 7.

9. The official order issued by the Education Department shall be forwarded by the contractor to the officer authorized to accept delivery, who shall acknowledge thereon the receipt of the goods accepted and return the order to the contractor, who will attach same to his claim for payment.

10. All orders, duly receipted, shall be returned to the Education Department at the end of each month, accompanied by an account in the prescribed form for the articles supplied during the month, and, on receipt of same, the contractor shall be entitled to payment, due time to be allowed for the examination and verification of the claim.

11. The acceptance of the supplies shall be subject to the approval of the officer authorized to take delivery of the stores, or such other officer as shall be named in the schedules. Delivery of the articles will not be deemed to have been made until they have been handed in good order and condition to the head teacher of the school or such other person as may be authorized to accept delivery, &c. The contractor may, however, claim a survey on any goods objected to: but in that case he must, within twenty-four hours after objection is made, give notice thereof, in writing, to the officer rejecting the goods. If, after the delivery of the supplies has been taken, any deficiency or defect is discovered therein, such deficient or defective stores may be returned to the contractor.

12. The members of Boards of survey will be appointed by the Treasurer of the State for the time being, and the decision of the Board is to be considered as final. If the Board shall decide that the article is not of proper quality it must be immediately replaced by the contractor, failing which it, or any like supply that is suitable for the service, will be procured elsewhere, and the survey fees and extra expense (if any) will be deducted as in Clause 7.

13. All goods forwarded under these contracts shall, where practicable, be forwarded by rail, and all consignments shall bear the number of the consignment notes under which they are forwarded, and also the name of the contractor by whom consigned, on a legibly-written business label.

14. When the contractor is required to make delivery of goods at a railway station for transmission by rail, he shall obtain a receipt for the goods in duplicate on the Stores and

Transport consignment note, at the same time handing in a triplicate and quadruplicate of the form as an authority for the Railways to act as agent for, and charge the freight to, the Stores and Transport Office or such other Department as shall be named therein. He shall as soon as possible, and not later than twenty-four hours thereafter, deliver the original at the Tender Board Offices, the duplicate to be forwarded to consignee in accordance with Clause 15, and the quintuplicate to be retained by himself. Should the goods thus forwarded be rejected, the contractor must bear the cost of replacing such goods, for which service the departmental consignment note is not to be used. Any infringement of this condition will subject the contractor to such mulct as the Tender Board may recommend under Clause 17 of these conditions. Such mulct may be deducted as in clause 7.

15. Immediately after the consignment of the goods, the officer to whom they are forwarded shall be notified by the contractor, on the duplicate consignment note provided for the purpose, that the goods have been sent. On receipt of this document, the officer to whom it has been forwarded shall acknowledge thereon the receipt of the goods without delay to the Stores and Transport Office. In the event of loss through failure on the part of the contractor to comply with this condition he will be held responsible, and the amount of the loss incurred for same will be deducted as in Clause 7.

16. Should the order on the contractor specially provide that goods of a fragile character, or such as are liable to suffer loss by leakage, shall be consigned at the risk of the Railways Commissioners under special freight conditions, the contractor shall in such instance provide, in writing, on the consignment note an intimation to that effect, failing which, in the event of loss, he shall bear the whole cost of replacing the goods, the amount being deducted from the contractor's account or the security money.

17. A refusal to execute orders, irregularity in the quantity or quality of the supplies, delay in delivering or replacing them when required, or non-compliance with the terms of Clauses 14 and 15 of these conditions respecting the forwarding of consignment notes, &c., will subject the contractor, upon report from the Tender Board, to such mulct not exceeding Fifty pounds as the said Treasurer may direct and the amount may be deducted as in Clause 7. It will also be in the power of the said Treasurer upon such refusal, irregularity, or delay, to terminate the contract forthwith, and declare forfeit the whole or any portion of the security money; and, in addition, the contractor will be disqualified from tendering or holding any future contract or contracts for a period of one year from the date of such disqualification.

18. Contractors are not at liberty to transfer their contracts under cover of power of attorney, coupled with an interest or otherwise; and no such transfer will be recognized by the Government. If it is found during the currency of the contract that the contractor has not conformed to the condition of advertisement—which stipulates that if a tenderer be a member of a firm, and such firm be interested in the contract, the tender shall be in the name of the firm, and not in that of the individual—then the said Treasurer may, on the recommendation of the Tender Board, determine the contract, and forfeit the security money.

19. The contracts entered into under these conditions are not to be considered as being broken, infringed, or vitiated by the importation of stores for the Government service, or by any contracts or purchases made by the Agent-General for Victoria, or by any contracts or agreements made for supplies to Technical Schools, or by any article being made at any Government establishment and supplied for the use of the Education Department, or by the consumption of the surplus stock of any Government establishment.

20. Notwithstanding anything contained to the contrary in section 152 of the Customs Act 1901-36, it is hereby expressly provided that upon any alteration of the duty collected affecting the goods included in this contract, the contract price shall not be altered, and the contract may be terminated at the option of either party by two months' notice in writing from the first day of the calendar month next ensuing, and within the period for which the contract is made. The contract for the unaffected items shall remain in full force and effect. Any notice to be served under this condition shall be deemed to have been duly served if sent to the contractor in a registered letter to his last-known place of business or abode.

21. Under no circumstances, other than those mentioned in Clause 20, will a contractor be permitted to abandon his contract. In the event of the contractor failing to carry on the contract, the contract security money will in that case be absolutely forfeited; and, in addition, the contractor will be held liable for any loss which the Government may sustain in consequence of such failure.

22. Should the Minister of Public Instruction for the time being decide to discontinue the use of any book, map, or any other article in the schedule, or to direct that any book, map,

or any other article other than those enumerated therein be taken into use, he shall at any time give six months' notice of such intention or decision to the contractor, and after the expiration of the period of such notice the Education Department shall not be bound to take any further supply of such book, map, or any other article, nor shall the contractor be bound to supply the same, and all books or maps not in the schedule, but which it may be decided to introduce, shall be supplied by the contractor after expiration of such notice at a price to be agreed on between the Minister of Public Instruction for the time being and the contractor.

I. MACFARLAN,
Treasurer.

The Treasury,
Melbourne, 29th October, 1945.

TENDERS FOR THE SERVICE, 1946-47.

GENERAL STORES.

TENDERS will be received until Eleven o'clock a.m. on Friday, 23rd November, 1945, from persons willing to supply the under-mentioned articles required by the Victorian Government, from 1st January, 1946, to 31st December, 1947, delivery to be made as indicated in the schedule:—

Schedule No. 101.—Overcoats and Cloaks (Waterproof) for Police. Preliminary deposit, £3.

Security.—Five per cent. of total amount of tender accepted.

The prices tendered must not include sales tax.

Schedule as above, with full particulars and conditions of contract, may be obtained from the Secretary to the Tender Board, by whom also the samples will be shown and any information afforded to persons tendering.

If the tenderer is in a position to supply a suitable substitute of Commonwealth production or manufacture in place of the sample at the Tender Board Office he may tender for such substitute under column B in the schedule, but he must submit with his tender a sample of the article offered.

In all cases the country of origin of the articles offered must be stated, and the total cost of each item extended in the columns provided.

Tenders must be accompanied by the preliminary deposit, as shown above, by bank draft or marked cheque in favour of the Secretary to the Tender Board. Cheques, Savings Bank deposit books, fixed deposit receipts, Commonwealth Treasury bonds, or reference to securities on existing contracts will in no case be received or entertained as preliminary deposits. Preliminary deposits will be returned within ten days to unsuccessful tenderers on their application.

Security will be required either in Commonwealth Treasury Bonds, or approved bank guarantee, fixed deposit receipt, Savings Bank deposit book, or non-negotiable cheque in favour of the Secretary to the Tender Board, as the tenderer may elect.

The security must be completed and the contract signed within five days of acceptance of the tender, failing which the contract may be again advertised, or another tender accepted.

The lowest or any tender will not necessarily be accepted.

In the event of tenderers withdrawing or attempting to withdraw their tenders before notification of acceptance of same, or failing to take up their accepted tenders within the prescribed period after notification of acceptance, the preliminary deposit will be forfeited, and, in addition, they may be disqualified from tendering or holding any future contracts for Government supplies for a period of two years, such disqualification to date from the notification of acceptance of tender. It is also stipulated that, if a tenderer be a member of a firm and such firm be interested in the contract, the tender shall be in the name of the firm and not in that of the individual, and that for a breach of this condition the preliminary deposit will be forfeited and the tender declared informal.

Tenders, enclosed in a separate envelope, and having the words "Tender for ——" (as the case may be) written thereon, must be deposited in the Tender-box at the Tender Board Offices, Gishorne-street, Melbourne; or if sent by post, postage must be prepaid, and the tenders addressed to the Chairman of the Tender Board, Tender Board Offices, Gishorne-street, Melbourne, C.2, which office they must reach not later than by first post on the date of closing of tenders.

Conditions of Contract are those published in the *Victoria Government Gazette* of 7th March, 1945, pages 849 to 851.

I. MACFARLAN,
Treasurer.

The Treasury,
Melbourne, 29th October, 1945.

TENDERS FOR THE SERVICE, 1946-47.

GENERAL STORES.

TENDERS will be received until Eleven o'clock a.m. on Friday, 23rd November, 1945, from persons willing to supply the under-mentioned articles in such quantities as may be ordered by the Victorian Government from 1st January, 1946, to 30th June, 1947:—

Schedule No.	Preliminary Deposit.
	£
36. Earthenware	3

The prices tendered must not include sales tax.
 Security.—Five per cent of total amount of tender accepted.
 Schedule as above, with full particulars, may be obtained from the Secretary to the Tender Board, by whom also the samples will be shown and any information afforded to persons tendering.

In all cases the total cost of each item must be extended in the columns provided.

Tenders must be accompanied by the preliminary deposit, as shown above, preferably by non-negotiable cheque payable to the order of the Secretary to the Tender Board. The amount and designation of the preliminary deposit enclosed must be clearly stated in the tender. Savings Bank deposit book, fixed deposit receipts, Commonwealth Treasury bonds, or reference to securities on existing contracts will in no case be received or entertained as preliminary deposits. Preliminary deposits will be returned within 30 days to unsuccessful tenderers on their application.

Security will be required either in Commonwealth Treasury Bonds, or approved bank guarantee, fixed deposit receipt, Savings Bank deposit book, or non-negotiable cheque in favour of the secretary to the Tender Board, as the tenderer may elect.

The security must be completed and the contract signed within five days of acceptance of the tender, failing which the contract may be again advertised, or another tender accepted.

The lowest or any tender will not necessarily be accepted.

In the event of tenderers withdrawing or attempting to withdraw their tenders before notification of acceptance of same, or failing to take up their accepted tenders within the prescribed period after notification of acceptance, the preliminary deposit will be forfeited and, in addition, they may be disqualified from tendering or holding any future contracts for Government supplies for a period of twelve months, such disqualification to date from the notification of acceptance of tender. It is also stipulated that, if a tenderer be a member of a firm and such firm be interested in the contract, the tender shall be in the name of the firm and not in that of the individual and that, for a breach of this condition, the preliminary deposit will be forfeited and the tender declared informal.

Tenders enclosed in a separate envelope, and having the words "Tender for ———" (as the case may be) written thereon, must be deposited in the Tender-box at the Tender Board Offices, Gisborne-street, Melbourne, or, if sent by post, postage must be prepaid and the tenders addressed to the Chairman of the Tender Board, Tender Board Offices, Gisborne-street, Melbourne, C.2, which office they must reach not later than by first post on the date of closing of tenders.

The conditions of contract are those published in the Victoria Government Gazette, No. 30, dated 7th March, 1945, pages 849 to 851.

I. MACFARLAN,
 Treasurer.

The Treasury,
 Melbourne, 29th October, 1945.

TENDERS FOR THE SERVICE, 1946-47.

GENERAL STORES.

TENDERS will be received until Eleven o'clock a.m. on Friday, 23rd November, 1945, from persons willing to supply the under-mentioned articles in such quantities as may be ordered by the Victorian Government during the twelve months commencing 1st January, 1946:—

Schedule No.	Preliminary Deposit.
	£
52. Tools (General)	3
69. Stationery (General)	3
75. Tyers and Tubes, Pneumatic, for Motor Cars, Trucks, Buses, Motor Cycles and Side-cars, and Bicycles	3

The prices tendered must not include sales tax.
 Security.—Five per cent of total amount of tender accepted, but in no case will security of less than £3 be received.

Schedules as above, with full particulars, may be obtained from the Secretary to the Tender Board, by whom also the samples will be shown and any information afforded to persons tendering.

In all cases the total cost of each item must be extended in the columns provided.

Tenders must be accompanied by the preliminary deposit, as shown above, preferably by non-negotiable cheque payable to the order of the Secretary to the Tender Board. The amount and designation of the preliminary deposit enclosed must be clearly stated in the tender. Savings Bank deposit book, fixed deposit receipts, Commonwealth Treasury bonds, or reference to securities on existing contracts will in no case be received or entertained as preliminary deposits. Preliminary deposits will be returned within 30 days to unsuccessful tenderers on their application.

Security will be required either in Commonwealth Treasury Bonds, or approved bank guarantee, fixed deposit receipt, Savings Bank deposit book, or non-negotiable cheque in favour of the secretary to the Tender Board, as the tenderer may elect.

The security must be completed and the contract signed within five days of acceptance of the tender, failing which the contract may be again advertised, or another tender accepted.

The lowest or any tender will not necessarily be accepted.

In the event of tenderers withdrawing or attempting to withdraw their tenders before notification of acceptance of same, or failing to take up their accepted tenders within the prescribed period after notification of acceptance, the preliminary deposit will be forfeited and, in addition, they may be disqualified from tendering or holding any future contracts for Government supplies for a period of twelve months, such disqualification to date from the notification of acceptance of tender. It is also stipulated that, if a tenderer be a member of a firm and such firm be interested in the contract, the tender shall be in the name of the firm and not in that of the individual and that, for a breach of this condition, the preliminary deposit will be forfeited and the tender declared informal.

Tenders enclosed in a separate envelope, and having the words "Tender for ———" (as the case may be) written thereon, must be deposited in the tender-box at the Tender Board Offices, Gisborne-street, Melbourne, or, if sent by post, postage must be prepaid and the tenders addressed to the Chairman of the Tender Board, Tender Board Offices, Gisborne-street, Melbourne, C.2, which office they must reach not later than by first post on the date of closing of tenders.

The conditions of contract are those published in the Victoria Government Gazette, No. 30, dated 7th March, 1945, pages 849 to 851.

I. MACFARLAN,
 Treasurer.

The Treasury,
 Melbourne, 29th October, 1945.

PRIVATE ADVERTISEMENTS.

CITY OF BENDIGO.

BY-LAW No. 65.

A By-law of the City of Bendigo, made under the provisions of section 197 of the Local Government Act 1928 and section 80 of the Health Act 1928, and numbered 65, for suppressing nuisances: for the regulating or prohibiting of the keeping of animals (including birds) in the opinion of the Council offensive, injurious to health, or dangerous, and generally for maintaining the good rule and government of the municipality.

IN pursuance of the powers conferred by the Local Government Act 1928 and the Health Act 1928, the Mayor, Councillors, and Citizens of the City of Bendigo order as follows:—

1. In this By-law—
 "Animal" includes bird.
 "Premises" includes any building and any land.
2. (i) This clause shall apply in respect of any premises whenever—
 (a) At least six persons lodge with the Town Clerk a complaint, in writing, signed by them, in which they state that they are ratepayers residing within hearing of the sound of animals on the premises, and that the noise made by an animal or animals on the premises is a nuisance to persons who reside in the neighbourhood; and
 (b) the Council is satisfied that a prima facie case exists for the suppression of such nuisance; and
 (c) the Town Clerk gives to the occupier or one of the occupiers of the premises a notice stating that under this By-law there has been made a complaint that the noise made by an animal or animals on the premises is a nuisance to persons who reside in the neighbourhood, and calling on the occupier or occupiers of the premises to cause the nuisance to be abated within seven days after the service of the notice.

(ii) After the expiration of seven days from the service of a notice given pursuant to this clause, no persons shall have on the premises, or keep on the premises, or allow to remain on the premises, any animal or animals that make noises so as to be a nuisance to any persons residing in the neighbourhood of the premises.

3. (i) This clause shall apply in respect of any premises whenever—

(a) The Council resolves that, in its opinion, any dog or dogs that are on the premises, or are kept on the premises, or are allowed to remain on the premises, are, or are so kept, as to be offensive or injurious to health or dangerous; and

(b) the Town Clerk gives to the occupier or one of the occupiers of the premises a notice setting out the resolution of the Council, and calling on the occupier or occupiers of the premises, within seven days after service of the notice, to remove all dogs on the premises that are offensive or injurious to health, or dangerous.

(ii) After the expiration of seven days from the service of a notice given pursuant to this clause, no persons shall have on the premises, or keep on the premises, or allow to remain on the premises, any dog to which the resolution of the Council refers.

4. Any notice to an occupier of any premises for the purposes of this By-law shall be deemed to be properly given and served if the notice—

(a) is signed by the Town Clerk, or by any person acting as Town Clerk;

(b) is addressed either to the occupier by name, or to the occupier described as such without his name; and

(c) is left at any dwelling-house on the premises, or at the place of residence of the person who is the occupier, or is sent by registered letter directed to the occupier, either by name or described as such without his name, at the premises or at his place of residence—

and any notice so given and served shall be deemed to have been served on the day on which it is so left, or, if posted, on the day following the day of posting.

5. (i) Any person who is guilty of any wilful act or default contrary to any of the provisions of this By-law shall be liable, on conviction, to a penalty of not more than £5.

(ii) Any person who wilfully continues an offence in respect of a breach of any provisions of this By-law, after a conviction or order of the Court in respect of a breach of the same provisions, shall be liable, on conviction, to a further penalty of not more than £1 for each day on which the offence is so continued.

6. This By-law shall apply to and have operation throughout the whole of the municipal district of the City of Bendigo.

Resolution for passing this By-law agreed to by the Council on the 10th day of September, 1945, and confirmed on the 22nd day of October, 1945.

4573

(SEAL)

A. TRUSCOTT, Mayor.
L. W. GALVIN, Councillor.
F. T. AMER, Town Clerk.

CITY OF COBURG.

NOTICE OF INTENTION TO BORROW THE SUM OF SEVEN THOUSAND POUNDS (£7,000) UNDER THE PROVISIONS OF THE LOCAL GOVERNMENT ACT 1928.

NOTICE is hereby given that the Council of the City of Coburg proposes to borrow the sum of Seven thousand pounds (£7,000), on the credit of the Mayor, Councillors, and Citizens of the said City, by the issue of debentures for such amount, in accordance with the provisions of the *Local Government Act 1928*. The rate of interest to be paid is Three pounds seven shillings and six pence (£3 7s. 6d.) per centum per annum, such moneys shall be repayable by forty half-yearly instalments of Two hundred and forty-two pounds one shilling and seven pence (£242 1s. 7d.), including principal and interest, by providing out of Municipal Fund the above amounts on the 1st day of January and the 1st day of July in each respective year during the currency of the loan. Such moneys shall be repayable at Coburg, at the Commonwealth Bank of Australia, or at the Council's bankers for the time being.

The purposes for which the loan is to be applied are as follows:—

Erection of public conveniences ..	£1,500
Construction of underground drain ..	2,000
Acquisition of land for technical school ..	3,500
	£7,000

The plans, specifications, and estimates of the cost of the works referred to above, and statement showing the proposed expenditure of the money to be borrowed, are open for inspection, at the Town Hall, Coburg, during office hours.

Dated this 26th day of October, 1945.

4555

W. MITCHELL, Town Clerk.

CITY OF MALVERN.

BY-LAW No. 117.

A By-law of the City of Malvern, made under the Local Government Acts and the Uniform Building Regulations Victoria, and numbered 117, for determining, applying, or dispensing with, or regulating such matters or things as are left to be determined, applied, dispensed with, or regulated by the Council of the said City of Malvern under the Uniform Building Regulations Victoria.

IN pursuance of the powers conferred by the Local Government Acts and the Uniform Building Regulations Victoria and of any and every other power it thereunto enabling, the Mayor, Councillors, and Citizens of the City of Malvern order as follows:—

Brick Areas.

1. The areas set out and described in the Schedule hereto are hereby prescribed as brick areas and no person shall in any such area construct or cause to be constructed any building the external walls of which are of material other than brick, stone, or concrete.

Limit of Two Storeys.

2. The whole of the municipal district is hereby prescribed as an area in which buildings of Classes II, and III, occupancy shall not be constructed to contain more than two storeys, including the ground storey, and no person shall in such area construct a building of Class II, or III, occupancy to contain more than two storeys including the ground storey.

Minimum Area, Depth, and Width of Frontage.

3. The minimum area, depth, and width of frontage specified in Column 3 of Table 803 of the Uniform Building Regulations Victoria (hereinafter called the Regulations) are hereby adopted as the minimum area, depth, and width of frontage of land on which a building of Classes I, or II, shall be constructed throughout the whole of the municipal district.

Distance from Street Alinement.

4. (a) The minimum distance of the outer walls of any building of Classes I, or II, occupancy from the street alinement of any land is hereby specified as 25 feet.

(b) No person shall construct any building of Class I, or Class II, occupancy closer to the street alinement of any land than 25 feet.

Sites Below Minimum Requirements.

5. Notwithstanding anything contained in the Regulations any person may—

(a) construct a building of Class I, occupancy on land having a lesser area, depth, or width of frontage, or at a lesser distance from boundaries than those specified in Column 3 of Table 803 of the Regulations, or in Clause 4 of this By-law (as the case may be) or—

(b) construct a building of Class III, V, VI, VII, or VIII, occupancy or a building to which a building of Class IV, occupancy is attached on land having an area, depth, or width of frontage less than that prescribed in Clause 809 of the Regulations, in any case where on the date of commencement of the Regulations such land existed as a separate allotment and has not since been reduced in area or is shown on any plan of subdivision approved by the Council and lodged in the Office of Titles.

Rear Access.

6. In the case of a building on any land forming part of a subdivision approved by the Council and lodged with the Office of Titles prior to the date of commencement of the Regulations, the requirements of Clause 811 of the Regulations are hereby dispensed with.

7. This By-law shall come into operation and commence to have effect as on and from the 1st day of November, 1945.

SCHEDULE.

1. All that area within the City of Malvern, commencing at the intersection of Kooyong-road and Gardiner's Creek and bounded by Gardiner's Creek to Warrigal-road, Warrigal-road to Waverley-road, Waverley-road to Dandenong-road, Dandenong-road to Kooyong-road, and Kooyong-road to Gardiner's Creek.

2. All that area within the City of Malvern, commencing at the intersection of Dandenong-road and Waverley-road and bounded by Waverley-road to Burke-road, Burke-road to Dandenong-road, and Dandenong-road to Waverley-road.

3. All that area within the City of Malvern, commencing at the intersection of Darling-road and Waverley-road and bounded by Waverley-road to Chadstone-road, Chadstone-road to Dandenong-road, Dandenong-road to Darling-road, and Darling-road to Waverley-road.

4. All that area within the City of Malvern, being the land abutting on the south side of Waverley-road between Burke-road and Darling-road to a depth of 150 feet, abutting on the west side of Darling-road between Waverley-road and Dandenong-road to a depth of 150 feet, abutting on the north side of Dandenong-road between Darling-road and Burke-road to a depth of 150 feet, and abutting on the east side of Burke-road between Dandenong-road and Waverley-road to a depth of 150 feet.

5. All that area within the City of Malvern, being the land abutting on the south side of Waverley-road between Chadstone-road and Warrigal-road to a depth of 150 feet, abutting on the west side of Warrigal-road between Waverley-road and Dandenong-road to a depth of 150 feet, abutting on the north side of Dandenong-road between Warrigal-road and Chadstone-road to a depth of 150 feet, and abutting on the east side of Chadstone-road between Dandenong-road and Waverley-road to a depth of 150 feet.

Resolution for making and passing this By-law was agreed to by the Council on the 17th day of September, 1945, and confirmed on the 15th day of October, 1945.

The common seal of the Mayor, Councillors, and Citizens of the City of Malvern was hereto affixed in the presence of—

S. E. STEVENS, Mayor.
J. H. SNADDON, Councillor.
A. M. SEATMAN, Town Clerk.

Approved by the Governor in Council the 23rd day of October, 1945.—C. W. KINSMAN, Clerk of the Executive Council. 4565

CITY OF OAKLEIGH.

BY-LAW No. 69.

A By-law of the City of Oakleigh, made under the Local Government Acts and the Uniform Building Regulations Victoria, and numbered 69, for determining, applying, dispensing with or regulating such matters or things as are left to be determined, applied, dispensed with, or regulated by the Council of the said City under the Uniform Building Regulations Victoria.

IN pursuance of the powers conferred by the Local Government Acts and the Uniform Building Regulations Victoria and of any and every other power it thereunto enabling, the Mayor, Councillors, and Citizens of the City of Oakleigh order as follows:—

Brick Areas.

1. The areas set out and described in the First Schedule hereto are hereby prescribed as brick areas, and no person shall in any such area construct or cause to be constructed any building the external walls of which are of material other than brick, stone, or concrete.

Minimum Area, Depth, and Width of Frontage.

2. The minimum area, depth, and width of frontage specified in Column 3 of Table 803 of the Uniform Building Regulations Victoria (hereinafter called the Regulations) are hereby adopted as the minimum area, depth, and width of frontage of land on which a building shall be constructed throughout the whole of the municipal district.

Distance from Street Alinement.

3. (a) The minimum distance of the outer walls of any building of Classes I. or II. occupancy from the street alinement of any land is hereby specified as 25 feet.

(b) No person shall construct any building of Classes I. or II. occupancy closer to the street alinement of any land than 25 feet.

Sites Below Minimum Requirements.

4. Notwithstanding anything contained in the Regulations any person may:—

(a) construct a building of Class I. occupancy on land having a lesser area, depth, or width of frontage, or at a lesser distance from boundaries than those specified in Column 3 of Table 803 of the Regulations, or in Clause 3 of this By-law, or—

(b) construct a building of Class III., V., VI., VII., or VIII. occupancy, or a building to which a building of Class IV. occupancy is attached, on land having an area, depth, or width of frontage less than that prescribed in Clause 809 of the Regulations,

in any case where on the date of commencement of the Regulations such land existed as a separate allotment and has not since been reduced in area or is shown on any plan of subdivision approved by the Council and lodged in the Office of Titles.

FIRST SCHEDULE.

All land within a distance of 75 feet to the frontage of—
Albert-avenue.

Atherton-road (north side), between Warrigal-road and Lincoln-avenue.

Atherton-road (south side), between Warrigal-road and Connell-road.

Atkinson-street, between Atherton-road and Dandenong-road.

Chester-street, between Warrigal-road and Eaton-street.
Dandenong-road (north side), between Warrigal-road and Park-road.

Dandenong-road (south side), between Poath-road and Clyde-street.

Drummond-street, between Atherton-road and Dandenong-road.

Eaton-street.

Hanover-street (west side).

Haughton-road, between Warrigal-road and Bank-street.

Marnoo-street.

Neerim-road.

Poath-road, between Dandenong-road and Kangaroo-road.

Portman-street.

Station-street.

The Avenue.

Warrigal-road (west side), between Dandenong-road and North-road.

Warrigal-road (east side), between Allen-street and North-road.

Wilbur-erecent.

The Resolution for making and passing this By-law was agreed to by the Council at a meeting held on the 20th day of August, 1945, and confirmed at a meeting held on the 17th day of September, 1945.

In witness whereof the common seal of the Mayor, Councillors, and Citizens of the City of Oakleigh was hereunto affixed this 18th day of September, 1945.

(SEAL) L. R. FORD, Mayor.
H. G. JOHNSON, Councillor.
J. A. PRICE, Town Clerk.

Approved by the Governor in Council, 16th October, 1945.—
C. W. KINSMAN, Clerk of the Executive Council. 4557

Sewerage Districts Act.

SHIRE OF CHARLTON.

PROPOSED CHARLTON SEWERAGE AUTHORITY.

NOTICE is hereby given that the Council of the Shire of Charlton has made application to the Honorable the Minister for Water Supply for the constitution of a Sewerage Authority and for the proclamation of a Sewerage District at Charlton, and the construction, maintenance, and continuance of such for the whole of that portion of the Shire of Charlton situate within the boundaries of the Township of Charlton, under the District Sewerage Acts. A general plan and description of the proposed works have been submitted with the application, a copy of which may be inspected at the office of the Council of the Shire of Charlton, at Charlton.

Dated this 31st day of August, 1945.

4496

A. BEANLAND, Shire Secretary.

NOTICE is hereby given that Percy John McMillan has retired from the firm of **McMillan Bros., of Oakhill-avenue, Preston**, builders, and such firm will henceforth be carried on by the remaining partners—James Furness-McMillan, of 1 Swift-street, Preston, and Frederick Thomas McMillan, of Southernhay-street, Reservoir, builders.

A. E. O'CONNOR, solicitor, 899 High-street, Thornbury.

4575

NOTICE is hereby given that the partnership heretofore subsisting between Kenneth Charles Whitehead and Douglas Lobban Whitehead, carrying on business as farmers and graziers at Tintalra under the style or firm of K. C. and D. L. Whitehead, has been dissolved, by mutual consent, as from the 17th day of October, 1945. All debts due to and owing by the said late firm will be received and paid respectively by Douglas Lobban Whitehead and Wilfred Albert Whitehead, who will continue to carry on the said business in partnership under the style or firm of D. L. and W. A. Whitehead.

Dated the 26th day of October, 1945.

K. C. WHITEHEAD.
D. L. WHITEHEAD.

Benjamin and Anderson, solicitors, Corryong.

4606

NOTICE is hereby given that the partnership formerly carried on by Albert Goldfile, Hugh Williams, and David Gelbart, under the style or firm of Twentieth Century Utility Co., has been dissolved as from the 21st day of September, 1945.

Dated the 24th day of September, 1945.

HUGH WILLIAMS.
D. M. GELBART.
A. GOLDFILE.

4578

NOTICE is hereby given that the partnership heretofore subsisting between Daniel Charles Cunningham, of 236 Ballarat-road, Maidstone, and Leonard David Hunter, of 43 Monash-street, Ascot Vale, carrying on business as manufacturers of grocers' sundries at Nos. 236-240 Ballarat-road, Maidstone, under the firm name of Cunningham and Hunter, has been dissolved, by mutual consent, as and from the 15th day of October, 1945, the said Leonard David Hunter having retired from the said firm, and all debts due to and owing by the firm will be received and paid respectively by the said Daniel Charles Cunningham, who will continue to carry on the said business under the firm name of "Cunningham and Hunter."

Dated the 19th day of October, 1945.

L. D. HUNTER.
D. C. CUNNINGHAM.

Witness to all signatures—JOHN F. CARROLL, solicitor, 4 Paisley-street, Footscray. 4577

Companies Act 1938.

PERCY HENRY PROPRIETARY LIMITED
(IN LIQUIDATION).

PURSUANT TO SECTION 236.

IT is hereby notified that the Final General Meeting of the said company will be held at the office of the liquidator, 379 Collins-street, Melbourne, on 30th day of November, 1945, at Two o'clock p.m., for the purpose of receiving the liquidator's final account.

4608

D. C. ALLAN, Liquidator.

In the matter of HORN AND COMPANY PROPRIETARY LIMITED.

AT a General Meeting of the above-named company, held at 51 Hardware-street, Melbourne, on the 26th day of October, 1945, the following Resolution was duly passed as a Special Resolution, namely:—

"That the company be wound up voluntarily."

Dated the 26th day of October, 1945.

W. HORN, Chairman.
E. Aston Lloyd, solicitor, 34 Queen-street, Melbourne. 4576

THE STANDARD GREASE AND OIL CO. PTY. LTD.

AT an Extraordinary General Meeting of the above-named company, duly convened and held at 361 Collins-street, on Monday, the 22nd day of October, 1945, the following Resolution was duly passed as an Extraordinary Resolution:—

"That the company be wound up voluntarily, and that Malcolm Graeme Roberts, chartered accountant (Australia), be appointed liquidator of the company for the purposes of the winding up."

Dated the 22nd day of October, 1945.

4600

F. J. TAYLOR, Chairman.

CREDITORS, next of kin, and others having claims in respect of the estate of Mary Houlihan, late of 128 Albert-street, Windsor, in the State of Victoria, married woman, deceased (who died on the 20th day of September, 1945), are to send the particulars of their claims to the National Trustees, Executors, and Agency Company of Australasia Limited, whose registered office is situate at 95 Queen-street, Melbourne, by the 9th day of January, 1946, after which date it will distribute the assets, having regard only to the claims of which it then has notice.

VIRGIL B. GILL, of 101 Queen-street, Melbourne, and 15 Hughenden-road, East St. Kilda, solicitor. 4587

NOTICE TO CLAIMANTS.

ERMA HAZEL AFFLECK, of Toongabbie, married woman, and Herbert Watson Kesby, of Traralgon, pulp mill employee, the executors of the will of Isabella Gadd, formerly of Toongabbie, late of Bairnsdale, in the State of Victoria, spinster, deceased (who died on 27th June, 1945), require all creditors, next of kin, and others having claims against the property or estate of the said deceased to send to the said executors, care of the undersigned, on or before the 10th day of January, 1946, particulars, in writing, of such claims, after which date the said executors intend to convey or distribute such property or estate to or among the persons entitled thereto, having regard only to the claims of which they shall have had notice.

Dated the 23rd day of October, 1945.

C. H. FORD, LL.M., Traralgon, solicitor for the said executors. 4584

NOTICE TO CREDITORS AND OTHERS.—*RE* SYDNEY HENRY ROBERT BLACK, DECEASED.

NOTICE is hereby given that all persons having claims against the Victorian estate of Sydney Henry Robert Black, late of Killara, near Sydney, in the State of New South Wales, merchant, deceased, and who carried on business at 530 Collins-street, Melbourne, under the name of "Clement Black and Co.", and who died on the 1st day of May, 1943, and probate of whose will was, on the 23rd day of July, 1943, granted by the Supreme Court of the State of New South Wales, in its probate jurisdiction, to Permanent Trustee Company of New South Wales Limited, of 25 O'Connell-street, Sydney aforesaid, and which probate has now been resealed by the Supreme Court of the State of Victoria, are hereby required to send particulars of such claims to the said company, on or before the 31st day of December, 1945, after which date the said company will proceed to distribute the said estate amongst the persons entitled thereto, having regard only to the claims of which it shall then have had notice.

PHILLIPS, FOX, & MASEL, 100 Queen-street, Melbourne, solicitors for the said company. 4580

STELLA MARION OAKLEY, late of 36 Halstead-street, Caulfield, widow (who died on the 15th July, 1945).

CREDITORS, next of kin, and all other persons having claims against the estate of the deceased are required by the executor of the will, Reginald Percival Oakley, of 36 Halstead-street, Caulfield, storeman, to send particulars to him, in care of the undersigned, on or before 31st December, 1945, after which date he will distribute the estate, having regard only to the claims which he shall then have notice.

Dated the 26th day of October, 1945.

W. A. PRENDERGAST, M.A., LL.B., 17 Queen-street, Melbourne, solicitor for the executor. 4581

PURSUANT to the *Trustee Act 1928*, notice is hereby given that all persons having claims against the estate of Henry Isaac Cohen, formerly of "St. Enoch's," Kooyong-road, Elsternwick, late of 644 High-street, Armadale, and Selborne Chambers, Little Collins-street, Melbourne, King's counsel, deceased (who died on the 20th day of December, 1942, and letters of administration, with the will dated 14th September, 1905, annexed, of whose estate was granted by the Supreme Court of Victoria, in its probate jurisdiction, on the 20th day of October, 1945, to the Equity Trustees, Executors, and Agency Company Limited, of 472 Bourke-street, Melbourne, in the said State), are hereby required to send particulars of such claims to the said administrator, on or before the 2nd day of January, 1946, after which date the said administrator will proceed to distribute the assets of the said deceased among the persons entitled thereto, having regard only to the claims of which it shall then have had notice. Notice is hereby further given that the said administrator will not be liable for the assets so distributed, or any part thereof, to any person of whose claim the said administrator shall not have had notice as aforesaid.

Dated this 25th day of October, 1945.

ROBERT C. ROY, 472 Bourke-street, Melbourne, solicitor for the administrator. 4582

ROBERT JOHNSTON, late of Repatriation General Hospital, Kooyong-road, Caulfield, war pensioner, DECEASED.

ALL creditors and other persons having claims against the estate of the said Robert Johnston (who died on 5th December, 1944, and probate of whose will was granted on 12th February, 1945, by the Supreme Court of Victoria, to Ernest Claude Cole, of 9 Tashinny-road, Toorak; retired civil servant), are hereby required to send particulars of such claims to the said Ernest Claude Cole, care of the under-named solicitor, on or before the 1st day of January, 1946, after which date the executor will proceed to distribute the assets of the said Robert Johnston among the persons entitled thereto, having regard only to the claims of which he shall then have had notice.

P. S. COLTMAN, LL.B., solicitor, 443 Little Collins-street, Melbourne. 4584

CREDITORS, next of kin, and others having claims in respect of the estate of Charles Mortimer, late of Victoria-road, Lilydale, in the State of Victoria, builder and carpenter, deceased (who died on the 2nd day of December, 1943), are to send particulars of their claims to The Perpetual Executors and Trustees Association of Australia Limited, of 100-104 Queen-street, Melbourne, in the State of Victoria, by 10th day of January, 1946, after which date it will distribute the assets, having regard only to the claims to which it then has notice.

E. P. JOHNSON & DAVIES, solicitors, 339 Collins-street, Melbourne. 4605

NOTICE TO CLAIMANTS.

THE PERPETUAL EXECUTORS AND TRUSTEES ASSOCIATION OF AUSTRALIA LIMITED, whose registered office is situate at Nos. 100-104 Queen-street, Melbourne, in the State of Victoria, and Edward William Back, of 2 Walker-street, Balwyn, in the said State, the executors of the will of Anna Stokes Gregg, formerly of Bayswater, but late of Lower Ferntree Gully, in the said State, spinster, deceased (who died on the 23rd day of July, 1945), require all creditors, next of kin, and others having claims against the property or estate of the said deceased to send to the said executors, in the care of the said association, on or before the 2nd day of January, 1946, particulars, in writing, of such claims, after which date the said executors intend to convey or distribute such property or estate to or among the persons entitled thereto, having regard only to the claims of which they shall have had notice.

Dated this 31st day of October, 1945.

G. A. RUNDLE & CO., of 349 Collins-street, Melbourne, solicitors for the said association. 4601

RUBY ALICE HINDSON, late of "Fieldplace," Studley Park-road, Kew, gentlewoman (who died on the 17th day of February, 1945).

CREDITORS, next of kin, and all other persons having claims against the estate of the deceased are required by the executors of the will and codicil thereto, Elsie Mary Eliza Hindson, of "Fieldplace," Studley Park-road, Kew, gentlewoman, and The Trustees Executors, and Agency Company Limited, of 401 Collins-street, Melbourne, to send particulars to the said company, on or before the 3rd January, 1946, after which date the said executors will distribute the assets, having regard only to the claims of which they then have notice.

RYLAH & ANDERSON, solicitors, 349 Collins-street, Melbourne. 4602

ALL persons interested in or having claims upon the estate of Robert O'Brien, late of 21 Potter-street, Dandenong, in the State of Victoria, retired line repairer, deceased (who died on the 11th day of March, 1944, and probate of whose will and codicil was granted by the Supreme Court of Victoria on the 25th day of July, 1945, to Robert Michael O'Brien, of 24 Railway-road, Carnegie, in the said State, railways officer), are hereby required to send particulars, in writing, of their claims to the said Robert Michael O'Brien, care of his under-mentioned solicitor, on or before the 4th day of January, 1946, after which date the said executor intends to convey or distribute such property or estate in or amongst the persons entitled thereto, having regard only to the claims of which he shall then have had notice.

Dated the 31st day of October, 1945.

FRANCIS FIELD, M.A., LL.B., solicitor, 100 Queen-street, Melbourne. 4590

PURSUANT to the *Trustee Act 1928*, notice is hereby given that all persons having claims against the estate of Violet Gertrude Griffiths, late of 301 Beach-road, Mentone, in the State of Victoria, spinster, deceased (who died on the 22nd day of March, 1945, and probate of whose will and codicil was granted by the Supreme Court of Victoria on the 18th day of October, 1945, to Gwenda Lillian Abbott, of Mason-street, Dandenong, in the said State, spinster, with leave reserved to Arthur Edmund Griffiths, of Archie's Creek, in the said State, storekeeper, her co-executor, to come in and prove the same at any time), are hereby required to send particulars, in writing, of such claims to the said Gwenda Lillian Abbott, care of her under-mentioned solicitor, on or before the 4th day of January, 1946, after which date the said Gwenda Lillian Abbott intends to convey or distribute such estate amongst the persons entitled thereto, having regard only to the claims of which she shall then have had notice.

Dated this 31st day of October, 1945.

FRANCIS FIELD, M.A., LL.B., 100 Queen-street, Melbourne, proctor for the said executrix. 4591

RE THOMAS FRANCIS RYAN, DECEASED.

PURSUANT to the *Trustee Act 1928*, notice is hereby given that all creditors, next of kin, and other persons having claims against the estate of Thomas Francis Ryan, late of Tablik, in the State of Victoria, farmer, deceased (who died on the 27th day of August, 1945, and probate of whose will was granted by the Supreme Court of the said State on the 13th day of October, 1945, to Emmet O'Dwyer, of Tablik, farmer), are hereby required to send particulars of such claims to the said executor, in care of the undersigned, at his address hereunder set out, on or before the 8th day of January, 1946, after which date the said executor will proceed to distribute the assets of the said deceased amongst the persons entitled thereto, having regard only to the claims which he shall then have had notice.

W. J. OSBORNE, LL.B., solicitor, Station-street, Seymour. 4553

PURSUANT to the *Trustee Act 1928*, notice is hereby given that all persons having claims against the estate of Caroline Eastman, late of 27 Kerford-road, Glen Iris, in the State of Victoria, widow, deceased (who died on the 29th day of August, 1945, and probate of whose will was on the 8th day of October, 1945, granted by the Supreme Court of the State of Victoria, in its probate jurisdiction, to John Arthur Clerke Blair, of 317 Collins-street, Melbourne, in the said State, solicitor, the executor appointed therein), are required to send particulars, in writing, of such claims to the said John Arthur Clerke Blair, care of the undersigned, on or before the 2nd day of January, 1946, after which date the said executor will proceed to distribute the assets of the said Caroline Eastman, deceased, which shall have come to his hands amongst the persons entitled thereto, having regard only to the claims of which he shall then have had notice. And notice is hereby further given that the said John Arthur Clerke Blair will not be liable for the assets, or any part thereof, so distributed to any person to whose claim he shall not then have had notice as aforesaid.

Dated the 30th day of October, 1945.

W. R. R. BLAIR & SON, 317 Collins-street, Melbourne, proctors for the said executor. 4592

NOTICE TO CLAIMANTS.—SARAH ANN HALLETT, DECEASED.

FRANCIS LESLIE HALLETT, of 517 Swan-street, Burnley, town clerk, and Veronica Josephine Mackey, of 36 Clarendon-street, East Melbourne, widow, having made application to the Registrar of Probates for a grant of representation of the estate of Sarah Ann Hallett, late of 521 Swan-street, Burnley aforesaid, widow, deceased (who died on the 9th day of March, 1945), requires all creditors and other interested to send to them, care of the undersigned solicitor, on or before the 31st day of December, 1945, particulars of their claims against the estate of the said deceased, after which date the said Francis Leslie Hallett and Veronica Josephine Mackey intend to convey or distribute the said estate to or amongst the persons entitled thereto, having regard only to the claims of which they shall then have had notice.

Dated the 25th day of October, 1945.

JOHN F. CARROLL, solicitor, 95 Queen-street, Melbourne. 4579

NOTICE TO CLAIMANTS.

THE PERPETUAL EXECUTORS AND TRUSTEES ASSOCIATION OF AUSTRALIA LIMITED, whose registered office is situate at Nos. 100-104 Queen-street, Melbourne, in the State of Victoria, and Alfred David Matthew, of Gilbey-street, Maffra, in the said State, the executors of the will of Henry James Manson, late of "Summerlea," Newry, in the said State, grazier, deceased (who died on the 15th day of November, 1944), require all creditors, next of kin, and others having claims against the property or estate of the said deceased to send to the said executors, in the care of the said association, on or before the 31st day of December, 1945, particulars, in writing, of such claims, after which date the said executors intend to convey or distribute such property or estate to or among the persons entitled thereto, having regard only to the claims of which they shall have had notice.

Dated the 20th day of October, 1945.

ARTHUR F. RICE & CO., of Johnson-street, Maffra, solicitors for the said executors. 4551

RE VICTOR ALBERT BAKER, DECEASED.

PURSUANT to the *Trustee Act 1928*, notice is hereby given that all creditors, next of kin, and other persons having claims against the estate of Victor Albert Baker, late of Seymour, in the State of Victoria, railway employee, deceased (who died on the 4th day of August, 1945, and probate of whose will was granted by the Supreme Court of the said State on the 2nd day of October, 1945, to Ellen Christina Baker, of Seymour, widow), are hereby required to send particulars of such claims to the said executrix, in care of the undersigned, at his address hereunder set out, on or before the 8th day of January, 1946, after which date the said executrix will proceed to distribute the assets of the said deceased amongst the persons entitled thereto, having regard only to the claims of which she shall then have had notice.

W. J. OSBORNE, LL.B., solicitor, Station-street, Seymour. 4552

CREDITORS, next of kin, and others having claims in respect of the estate of Johanna Elinor Stafford, late of 29 Glengyle-street, East Coburg, married woman (who died 29th September, 1943), are to send the particulars of their claims to the National Trustees, Executors, and Agency Company of Australasia Limited, at its registered office, 95 Queen-street, Melbourne, by the 3rd January, 1946, after which date it will distribute the assets, having regard only to the claims of which it then has notice.

W. H. FLOOD & PERMEZEL, 379 Collins-street, Melbourne, solicitors for the company. 4585

JANE BARTLE, late of Hunter-street, Castlemaine, in the State of Victoria, spinster. DECEASED.

CREDITORS, next of kin, and all other persons having claims against the estate of the above-named Jane Bartle are required by the executors of her estate, Samuel Leech, law clerk, and William Arthur Sheridan, gentleman, both of Castlemaine aforesaid, to send particulars of such claims to the executors, in care of H. S. W. Lawson and Co., solicitors, Castlemaine, on or before the 15th day of February, 1946, after which date the said executors will distribute the assets of the estate, having regard only to the claims of which they will then have had notice.

Dated the 25th day of October, 1945.

H. S. W. LAWSON & CO., solicitors, Castlemaine. 4550

PURSUANT to the *Trustee Act* 1928, notice is hereby given that all persons having claims against the estate of Edward Mitchell, late of Casterton, in the State of Victoria, labourer, deceased (who died on the 18th day of September, 1945, and probate of whose will was granted by the Supreme Court of the said State, in its probate jurisdiction, on the 19th day of October, 1945, to Joseph Andrew Jones, of Casterton aforesaid, tobacconist, and Walter Edward Dalglish, of Casterton aforesaid, garage proprietor), are hereby required to send particulars, in writing, of such claims to the said Joseph Andrew Jones and Walter Edward Dalglish, at their above-mentioned addresses, on or before the 31st day of December, 1945, after which date the said Joseph Andrew Jones and Walter Edward Dalglish will proceed to distribute the assets of the said Edward Mitchell, deceased, which shall have come to their hands amongst the persons entitled thereto, having regard only to the claims of which they shall then have had notice. And notice is hereby further given that the said Joseph Andrew Jones and Walter Edward Dalglish will not be liable for the assets so distributed, or any part thereof, to any person of whose claim they shall not have had notice as aforesaid.

Dated this 26th day of October, 1945.

SILVESTER & SILVESTER, of Casterton, solicitors for the said executors. 4560

PURSUANT to the *Trustee Act* 1928, notice is hereby given that all persons having claims against the estate of James Storie, formerly of Wando Vale, near Casterton, in the State of Victoria, farmer, but late of Casterton aforesaid, retired farmer, deceased (who died on the 13th day of September, 1945, and probate of whose will was granted by the Supreme Court of the said State, in its probate jurisdiction, on the 22nd day of October, 1945, to Walter Storie, of Sandford, in the said State, farmer), are hereby required to send particulars, in writing, of such claims to the said Walter Storie, at his above-mentioned address, on or before the 31st day of December, 1945, after which date the said Walter Storie will proceed to distribute the assets of the said James Storie, deceased, which shall have come to his hands amongst the persons entitled thereto, having regard only to the claims of which he shall then have had notice. And notice is hereby further given that the said Walter Storie will not be liable for the assets so distributed, or any part thereof, to any person of whose claim he shall not have had notice as aforesaid.

Dated this 26th day of October, 1945.

SILVESTER & SILVESTER, of Casterton, solicitors for the said Walter Storie. 4561

PURSUANT to the *Trustee Act* 1928, all persons having claims in respect of the estate of Robert Charles Jeffreys, formerly of Casterton, but late of Marong, in the State of Victoria, storekeeper (who died on the 26th day of March, 1945), are required to send particulars to the personal representative, Farmers and Citizens Trustees Company Bendigo Limited, Charing Cross, Bendigo, on or before the 2nd day of January, 1946, after which date the said company intends to distribute the assets, having regard only to the claims of which notice has then been received.

NEAL & WOODWARD, View-street, Bendigo, solicitors for the said company. 4572

CLEMENT ROGERS, late of 92 Elphin-street, Newport, in the State of Victoria, retired railway officer. DECEASED (who died on the 25th May, 1945).

CREDITORS, next of kin, and all other persons having claims against the estate of the deceased are required by the executors of the will and codicil thereto, George Craven, of 11 Champion-road, Williamstown, oil furnaceman, and George Alexander Paine, of Woods-street, Newport, in the said State, contractor, to send particulars to them, care of the undersigned, on or before the 3rd day of January, 1946, after which date they will distribute the assets, having regard only to the claims of which they then have notice.

W. H. JONES & KENNEDY, 214 Nicholson-street, Footscray, solicitors. 4597

CREDITORS, next of kin, and others having claims in respect of the estate of Margaret Ella Purcell, of 82 Sutherland-road, Armadale, in the State of Victoria, spinster, deceased (who died on the 24th August, 1945), are to send the particulars of their claims to The Perpetual Executors and Trustees Association of Australia Limited, of 100-104 Queen-street, Melbourne, in the said State, by the 4th January, 1946, after which date it will distribute the assets, having regard only to the claims of which it then has notice.

H. S. W. LAWSON & CO., solicitors, 314 Collins-street, Melbourne. 4586

KATE McCARTHY, formerly of the Mental Hospital, Ararat, late of the Mental Hospital, Kew, mental nurse. DECEASED (who died 31st August, 1945).

CREDITORS, next of kin, and others having claims against the estate of the deceased are required by the executor of the will and codicil thereto, National Trustees, Executors, and Agency Company of Australasia Limited, of 95 Queen-street, Melbourne, to send particulars to the said company, at its said address, on or before 2nd January, 1946, after which date the said company will distribute the assets, having regard only to the claims of which it then has notice.

FITZGERALD & FITZGERALD, 396 Little Flinders-street, Melbourne, solicitors. 4594

CREDITORS, next of kin, and others having claims in respect of the estate of Reginald Patrick Fitzgerald, late of Littlethorpe, Herness-road, Kenilworth, Cape Division in the Union of South Africa, managing director, deceased (who died on the 27th day of March, 1945), are to send particulars of their claims to National Trustees, Executors, and Agency Company of Australasia Limited, of 95 Queen-street, Melbourne, in the State of Victoria, by the 3rd day of January, 1946, after which date it will distribute the assets, having regard only to the claims of which it then has notice.

GILLOTT, MOIR, & AHERN, solicitors, 95 Queen-street, Melbourne. 4595

CREDITORS, next of kin, and others having claims in respect of the estate of Alfred Piferer, late of 111 Shenton-road, Swanbourne, in the State of Western Australia, gentleman, deceased (who died on the 20th day of August, 1945), are to send particulars of their claims to National Trustees, Executors, and Agency Company of Australasia Limited, of 95 Queen-street, Melbourne, in the State of Victoria, by the 3rd day of January, 1946, after which date it will distribute the assets, having regard only to the claims of which it then has notice.

GILLOTT, MOIR, & AHERN, solicitors, 95 Queen-street, Melbourne. 4596

MARGARET PAARMANN, late of 14 Mary-street, Preston, widow. DECEASED (who died 7th September, 1945).

PURSUANT to the provisions of the Trustee Acts, notice is hereby given that Frederick Paarmann, of the above address, tailor, to whom a grant of letters of administration of the estate of the deceased was made on 23rd October, 1945, intends to convey or distribute the estate of the deceased to or among the persons entitled thereto, and hereby requires all persons having claims against the said estate to send to the administrator, in the care of the undersigned solicitors, particulars, in writing, thereof, on or before the 2nd day of January, 1946, after which date he will convey or distribute the said estate, to or among the persons entitled thereto, having regard only to the claims of which he shall then have had notice.

NORRIS & NORRIS, of 422 Collins-street, Melbourne, solicitors. 4598

PURSUANT to the *Trustee Act* 1928, notice is hereby given that all persons having any claim against the estate of Francis Edwin Killingsworth, late of Park-street, South Melbourne, in the State of Victoria, jeweller, deceased (who died on the 13th day of November, 1944, and probate of whose will was granted on the 23rd October, 1945, to Elvina Ethel Killingsworth, of 81 Bridge-street, Port Melbourne, in the said State, widow, and Likely Herman McBrien, of 71 Mount-street, Heidelberg, in the said State, secretary, by the Supreme Court of Victoria, in its probate jurisdiction), are hereby required to forward particulars to the said Elvina Ethel Killingsworth and Likely Herman McBrien, care of the undersigned, Norman A Miller, solicitor for the said executrix and executor, on or before the 3rd day of January, 1946, after which date the said executrix and executor will convey or distribute such property or estate to or amongst the persons entitled, having regard only to the claims, whether formal or not, of which they shall then have had notice.

Dated this 1st day of November, 1945.

NORMAN A. MILLER, of 100 Queen-street, Melbourne, solicitor for the executrix and executor. 4599

Trustee Act 1928.

NOTICE TO CLAIMANTS.

PURSUANT to the Trustee Act 1928, creditors, next of kin, and all other persons having claims in respect of the estate of the deceased person named below are required to send particulars to the legal personal representative or representatives at the address stated, on or before the date stated, after which date the representative or representatives will distribute the assets, having regard only to the claims of which notice has then been received:—

John Carter, late of Port Fairy, dairyman, died 5th January, 1945.—Claims to the executors, Francis John Carter and Maurice Alfred Carter, both of Port Fairy, farmers, care of J. W. Powling, solicitor, Port Fairy, by 11th January, 1946. 4564

Sarah Hildge Dixon, late of Summerland Mansions, Fitzroy-street, St. Kilda, spinster, deceased, died 28th September, 1945.—Claims to the executor, Herrmann Carl Just, care of Arthur Phillips and Just, solicitors, 472 Bourke-street, Melbourne, by 5th January, 1946. 4588

Edith Ethel Greene, late of "Laradoc," Huntingfield-road, Toorak, Victoria, widow, deceased, died 5th September, 1945.—Claims to the executors, Thomas Cavine Alston and Colin York Syme, both of 103 William-street, Melbourne, solicitors, by 31st December, 1945. Hedderwick, Fookes, and Alston, 103 William-street, Melbourne, solicitors for the executors. 4583

Florence Louise Brewer, late of Pagan Hill Lodge, Stroud, in England, married woman, deceased, who died 4th January, 1944.—Claims to the executor in Victoria, The Trustees, Executors, and Agency Company Limited, of 401 Collins-street, Melbourne, by 31st December, 1945. McEacharn and Shaw, solicitors, 352 Collins-street, Melbourne. 4589

Emma Resch, late of 835 Burwood-road, Upper Hawthorn, widow, died 12th March, 1945.—Claims to the executors, Carl Emil Resch and Ellis Davies, care of Arthur Robinson and Co., solicitors, 360 Collins-street, Melbourne, by 14th January, 1946. 4604

William Thomas Harrison, late of Pomborneit, farmer, died 7th September, 1945.—Claims to the executors, Florence Emillie Jane Harrison, of Pomborneit, widow, and Cedric Whilton Sewell, of Colac, solicitor, by 31st December, 1945. 4609

Joseph Bodey, late of Longerenong, retired farmer, who died 14th August, 1945.—Claims to executors, care of J. Weldon Power and Bennett, solicitors, Horsham, by 1st January, 1946. 4610

Catherine Butler, late of McKenzie Creek, via Horsham, widow, who died 9th September, 1945.—Claims to executors, care of J. Weldon Power and Bennett, solicitors, Horsham, by 1st January, 1946. 4611

MINING NOTICES.

IRONBARK SOUTH GOLD MINING COMPANY
NO LIABILITY.

ALL contributing shares (Nos. 1 to 60,000) upon which the 68th Call of Three pence per share (due and payable on 10th October, 1945) remains unpaid, will be sold by public auction at the Stock Exchange, Melbourne, on Tuesday, 13th November, 1945, at a quarter to Twelve o'clock a.m., unless the call be previously paid.

H. L. STEWART
(J. G. Stanfield and Stewart), Manager.
379 Collins-street, Melbourne. 4603

AUSTRALIAN GOLD DEVELOPMENT NO LIABILITY.

NOTICE is hereby given that all shares on which No. 2 (October) Call of Ten shillings per share remains unpaid will be forfeited and sold by public auction in the vestibule of the Stock Exchange, 428 Chancery-lane, Melbourne, on Thursday, 8th November, 1945, at a quarter to Twelve a.m., unless shares are redeemed on or before Wednesday, 7th November, 1945, at Five p.m.

By order of the Board,
JAMES L. MOORE, Manager.
Temple Court, 422 Collins-street, Melbourne, C.I. 4593

IMPOUNDINGS.

BROADMEADOWS.—Impounded at Campbellfield.

1 Red Poll steer, 2 years, tip off ear, no visible brand
If not claimed and expenses paid, to be sold on 15th November, 1945.

A. OLIVER,
4569—4/
Poundkeeper.

CAMPERDOWN.—Impounded at Camperdown, on 22nd October, 1945.

1 medium draught black mare, three white feet, white blaze on forehead, branded C over CA.

If not claimed and expenses paid, to be sold on 13th November, 1945.

J. ROBB,
4567—5/4
Poundkeeper.

CRESWICK.—Impounded in Creswick Pound, by Ranger, on 25th October, 1945.

1 brown horse, near hind foot white, no visible brand

If not claimed and expenses paid, to be sold on 15th November, 1945.

Mrs. ALICE ALLAN,
4563—4/8
Poundkeeper.

FERNTREE GULLY.—Impounded at Ferntree Gully, by Shire Ranger.

1 bay mare, light delivery sort, black points, collar marked, white hairs on shoulder, shod in front, no visible brand

If not claimed and expenses paid, to be sold on 15th November, 1945.

A. DINSDALE,
4612—5/4
Poundkeeper.

HAWKESDALE.—Impounded at Hawkesdale.

1 Corriedale cross weaner, two notches in back of near ear, black brand on top of shoulder

If not claimed and expenses paid, to be sold on 15th November, 1945.

H. EDWARDS,
4568—4/8
Poundkeeper.

HEIDELBERG.—Impounded at Heidelberg.

1 grey draught gelding, no visible brand

1 chestnut mare, no visible brand

If not claimed and expenses paid, to be sold on 14th November, 1945.

R. J. ADDICOTT,
4613—4/8
Poundkeeper.

MELBOURNE.—Impounded in the Arden-street Pound, by A. Thomas.

1 black gelding, white hind pasterns, like bar off shoulder

If not claimed and expenses paid, to be sold on 15th November, 1945.

D. CROWE,
4574—4/8
Poundkeeper.

MORTLAKE.—Impounded at Mortlake, on 25th October, 1945.

1 up-standing bay draught gelding, three white feet, blaze face, no visible brand

If not claimed and expenses paid, to be sold on 29th November, 1945.

GEO. ROBERTSON,
4560—5/4
Poundkeeper.

ORBOST.—Impounded in Orbost Pound.

1 black and white cow, X on near rump; baldy calf at foot

2 Jersey heifers, top off near ear, notch in front and back of off ear

1 Jersey heifer calf, small notch in top of off ear

1 brindle cow, XY on near rump

1 brown gelding, indistinct brand on each shoulder

If not claimed and expenses paid, to be sold after fourteen days.

H. DOMINEY,
4556—7/4
Poundkeeper.

SEYMOUR.—Impounded in Seymour Pound.

1 dark bay gelding, hack
 1 crossbred ewe
 1 weaner
 1 lamb
 If not claimed and expenses paid, to be sold on 23rd
 November, 1945.
 M. M. HALL,
 Poundkeeper.
 4571—6/

SMEATON.—Impounded at Smeaton, by Ranger, on 24th
 October, 1945.

1 red cow, earmarked, J.M. on rump; calf at foot
 If not claimed and expenses paid, to be sold on 15th
 November, 1945.
 W. J. BALFOUR,
 Poundkeeper.
 4562—4/S

TERANG.—Impounded at Terang, from Kenna's property,
 Framlingham-road, Terang.

1 bay heavy delivery gelding, one hind foot white, small white
 patch on forehead, like 2B on near shoulder
 1 light roan heavy delivery gelding, unbroken, white stockings,
 large white blaze down face
 If not claimed and expenses paid, to be sold on 19th
 November, 1945.
 DORIS M. KIDD,
 Poundkeeper.
 4570—6/8

WARRNAMBOOL.—Impounded at Warrnambool.

1 bay or brown delivery gelding, blaze face, little white on
 off hind leg and near front leg, near eye blind or con-
 tracted
 If not claimed and expenses paid, to be sold on 14th
 November, 1945.
 I. HILDER,
 Poundkeeper.
 4607—5/4

WODONGA.—Impounded at Wodonga, by E. O'Brien, on 25th
 October, 1945.

1 yearling Black Poll steer, V out of point off ear
 1 blue pole yearling heifer, V out of point off ear
 If not claimed and expenses paid, to be sold on 17th
 November, 1945.
 J. W. COLE,
 Poundkeeper.
 4558—5/4

STATE ACTS, 1944—continued.

No.	Price. s. d.
5014. Electoral (War Service Deaths)	0 6
5015. Cremorne Bridge	0 6
5016. Melbourne Harbor Trust	0 6
5017. Water	0 9
5018. Consolidated Revenue	0 6
5019. Mildura Irrigation and Water Trusts	0 6
5020. Farm Water Supplies Advances	0 6
5021. Sewerage Districts	0 6
5022. Trustee Companies	0 6
5023. Mildura Irrigation and Water Trusts (Super- annuation)	0 6
5024. Consolidated Revenue	0 6
5025. Cemeteries	0 6
5026. Border Railways	0 6
5027. Local Government (Shire of Blackburn and Mitcham)	0 6
5028. Electoral Districts	0 6
5029. Land	0 6
5030. Land Tax	0 6
5031. Administration and Probate Duties	0 6
5032. Stock Foods (Amendment)	0 6
5033. Stamps (Increased Duty Continuance)	0 6
5034. Maribyrnong and Ashburton Lands Exchange	0 6
5035. Financial Emergency (Grants and Funds)	0 6
5036. Farmers Advances	0 6
5037. Land Settlement (Acquisition) Amendment	0 6
5038. Railways	0 6
5039. Farmers Protection (Amendment)	0 6
5040. Country Fire Authority	1 9
5041. Country Roads Board Fund	0 6
5042. Railway Loan and Application	0 6
5043. Town and Country Planning	1 0
5044. Agricultural Colleges	0 9
5045. Heatherton Sanatorium	0 6
5046. Health (Infectious Diseases Hospitals)	0 6
5047. Surplus Revenue	0 6
5048. Water Supply Loans Application	0 9
5049. State Forests Loan and Application	0 6
5050. Public Works Loan and Application	0 6
5051. Commonwealth and States Financial Agreement	1 3
5052. The Constitution Act Amendment	0 6
5053. Public Library National Gallery and Museums	0 9
5054. Drought Relief	0 6
5055. Co-operative Housing Societies	1 0
5056. Local Government	1 0
5057. Melbourne and Metropolitan Board of Works	0 9
5058. Appropriation of Revenue	3 9

H. E. DAW,
 Government Printer.

STATE ACTS, 1944.

COPIES of the following Acts of Parliament of Victoria
 may be obtained at the Government Printing Office, or
 from any bookseller, at the price set opposite to each:—

No.	Price. s. d.
4999. Consolidated Revenue	0 6
5000. Local Government (Polling Booths)	0 6
5001. Police Offences (Unlawful Games)	0 6
5002. Hospitals and Charities	0 6
5003. Water (Loddon)	0 6
5004. Justices	0 6
5005. Coal Mines Regulation (Amendment)	0 6
5006. Consolidated Revenue	0 6
5007. Melbourne and Metropolitan Board of Works (Contributions)	0 6
5008. Marketing of Primary Products	0 6
5009. National Security (Emergency Powers) Continua- tion	0 6
5010. Outer Circle Railway (Partial Dismantling)	0 6
5011. Mines (Minerals)	0 6
5012. Goods (Textile Products)	0 6
5013. Masseurs	0 6

STATE ACTS, 1945.

COPIES of the following Acts of Parliament of Victoria
 may be obtained at the Government Printing Office, or
 from any bookseller, at the price set opposite to each:—

No.	Price. s. d.
5059. Mildura Irrigation and Water Trusts (Borrowing)	0 6
5060. Supreme Court (Judges)	0 6
5061. Oakleigh (Regent-street) Land	0 6
5062. Swine	0 6
5063. Drought Relief (Amendment)	0 6
5064. Unclaimed Moneys	0 6
5065. Consolidated Revenue	0 6
5066. Consolidated Revenue	0 6
5067. Agent-General's	0 6
5068. Land Surveyors (Amendment)	0 6
5069. State Development	0 6

H. E. DAW,
 Government Printer.

AGENTS FOR THE "VICTORIA GOVERNMENT GAZETTE."

THE following have been appointed agents to receive Advertisements and subscriptions for the *Victoria Government Gazette*:—

- ARMSTRONG'S AGENCY, 143 Queen-street, Melbourne.
- MESSRS. ARNALL & JACKSON, 115 Barkly-street, West Brunswick.
- MESSRS. GORDON & GOTCH, News Agents, 511 Little Collins-street, Melbourne; and corner Barrack and Clarence streets, Sydney.
- MESSRS. HARSTON, PARTRIDGE, & CO., 455 Little Collins-street, Melbourne.
- N. V. NIXON & CO., 20 Queen-street, Melbourne.
- THE PATON ADVERTISING SERVICE PTY. LTD.
- ROBERTSON & MULLENS LTD., Elizabeth-street, Melbourne.
- MESSRS. W. H. WADDELL and A. S. RICHARDSON, trading as The Mercantile Exchange, 330 Collins-street, Melbourne.
- MR. A. J. DIGBY, News Agent, Bairnsdale.
- MR. M. R. BADE, Tobacconist, Sturt-street, Ballarat.
- TRIGG'S NEWS AGENCY, Hargreaves-street, Bendigo.
- MR. G. H. K. PAYNE, 4 View Point, Bendigo.
- MR. G. F. LATIMER, News Agent, Casterton.
- MESSRS. HENRY FRANKS & CO., Booksellers and Stationers, Market-square, Geelong.
- MESSRS. SMITH & DUNNON, Hamilton.
- ARMSTRONG BROS., Kyneton.
- MR. WM. DAVIS, Mildura.
- PIKE'S AUTHORIZED NEWS AGENCY, Sale.
- MR. C. T. RUST, News Agent, Wangaratta.
- MR. F. T. MCCORMICK, Nunn-street, Benalla.
- F. R. & E. M. COOKE, Bridge-street, Benalla.

A copy of the *Gazette* filed at each place for public reference.

THE "VICTORIA GOVERNMENT GAZETTE."

SUBSCRIPTIONS.—*The subscription, including Postage, is £1 12s. 6d. per annum, 16s. 3d. half-yearly, or 8s. 2d. per quarter, payable in advance.*

Subscriptions are required to commence and terminate with a month.

A lesser period than three months cannot be subscribed for.

Subscribers do not receive the Acts of Parliament with the GAZETTE.

ADVERTISEMENTS are charged at the rate of EIGHT PENCE per line single column, and ONE SHILLING and FOUR PENCE per line double column.

The title (£5 Reward, Dissolution of Partnership, &c.) forms one or more lines as a heading.

On an average, eleven words make a line.

Every signature must likewise be counted as a line.

The final words of a paragraph, though only portion of a line, must be counted as one line.

SIGNATURES (in particular) and proper names must be written very plainly in the text; ONE SIDE ONLY of each slip of paper should be WRITTEN UPON.

ALL COMMUNICATIONS should be addressed to "The Government Printer, Melbourne."

ALL DOCUMENTS illegibly written will be returned unpublished, and, where brands occur unprovided for by the ordinary letters of the alphabet, a worded explanatory description must be furnished.

THE VICTORIA GOVERNMENT GAZETTE is published on WEDNESDAY EVENING in each week, and Notices for insertion will be received by the Government Printer at or before Two p.m., at ordinary rates, and late advertisements between Two p.m. and Five p.m. at double rates on the day preceding the day of publication.

Single copies of the VICTORIA GOVERNMENT GAZETTE are Six pence, posted Eight pence, each.

No GAZETTES prior to January, 1934, in stock.

***ALL PAYMENTS ARE REQUIRED IN ADVANCE.—Remittances should be made by postal note, money order, or draft in favour of the Government Printer. Advertisements unaccompanied by a remittance sufficient to cover the cost of insertion will be returned unpublished.

CONTENTS

	PAGE
Acts of Parliament on sale at the Government Printing Office	2723
Appointments	2694
Auction Sales Act	2702
Bank Holidays	2693
Business Agents Act 1930—Supplementary List	2702
Contracts	2704
Courts	2697
Estates of Deceased Persons	2707
Government Notices	2697
Impoundings	2722
Lands	2711
Melbourne Cup Holiday	2694
Melbourne and Metropolitan Board of Works—Notice	2697
Mining	2701, 2722
Orders in Council	2708
Private Advertisements	2716
Proclamations	2693
Public Holidays	2693
Public Service Notices	2695
Real Estate Agents Act—Supplementary List	2702
Resignations	2695
State Rivers and Water Supply Commission	2698
Stay Order	2707
Tenders	2713
Transport Regulation Acts—Public Hearings	2703