



# VICTORIA GOVERNMENT GAZETTE.

Published by Authority.

[Registered at the General Post Office, Melbourne, for transmission by post as a newspaper.]

No. 166]

WEDNESDAY, AUGUST 21.

[1946

## PUBLIC HIGHWAY.—CITY OF SANDRINGHAM.

## PROCLAMATION

By His Excellency the Lieutenant-Governor of the State of Victoria and its Dependencies in the Commonwealth of Australia, &c., &c., &c.

WHEREAS by the *Local Government Act 1928* (No. 3720), section 518, it is amongst other things enacted that it shall be lawful for the Governor in Council at any time, and from time to time, upon the request of the Council of any municipality, by notice in the *Government Gazette*, to declare any land reserved, used, or by purchase or exchange acquired for a street, road, highway, thoroughfare, bridge, square, court, alley, or right-of-way to be a public highway, and that such land shall thereupon and thenceforth from the date of such Proclamation become and be absolutely dedicated to the public as a public highway within the meaning of any law then or thereafter in force: And whereas the Council of the City of Sandringham has requested that the land hereinafter mentioned, which has been used as a road by the said Council within the said City, be so declared to be a public highway: Now therefore I, the Lieutenant-Governor of the State of Victoria, in the Commonwealth of Australia, by and with the advice of the Executive Council of the said State, do by this Proclamation declare the land used as a road hereinafter described, and situated within the City of Sandringham aforesaid, to be a public highway within the meaning of the said Act, viz.:—

## PUBLIC HIGHWAY.—CITY OF SANDRINGHAM.

All that piece and parcel of land between South-road and Ludstone-street and known as Olive-street, Hampton, as shown on plan of subdivision No. 2203, being part of Crown allotment 16, Parish of Moorabbin, County of Bourke.

Given under my Hand and the Seal of the State of Victoria aforesaid, at Melbourne, this thirteenth day of August, in the year of our Lord One thousand nine hundred and forty-six, and in the tenth year of the reign of His Majesty King George VI.

(L.S.)

E. F. HERRING.

By His Excellency's Command,

P. J. KENNELLY,  
Commissioner of Public Works.

GOD SAVE THE KING!

## PUBLIC HOLIDAYS.

## PROCLAMATION

By His Excellency the Lieutenant-Governor of the State of Victoria and its Dependencies in the Commonwealth of Australia, &c., &c., &c.

IN pursuance of the provisions contained in Part VII. of the *Public Service Act 1928* (19 Geo. V. No. 3757), 1, the Lieutenant-Governor of the State of Victoria, in the Commonwealth of Australia, by and with the advice of the Executive Council of the said State, do by this my Proclamation appoint the days and dates hereunder mentioned to be observed as Public Holidays or Public Half-Holidays (as the case may be) at the places respectively specified, viz.:—

## Public Holidays:—

- \*THURSDAY, 3RD OCTOBER, 1946, throughout the Shire of Wimmera.
- \*THURSDAY, 10TH OCTOBER, 1946, throughout the Shire of Numurkah.
- \*THURSDAY, 5TH SEPTEMBER, 1946, throughout the Shire of Minhamite.
- \*WEDNESDAY, 13TH NOVEMBER, 1946, throughout the Shire of Melvor.

## Public Half-Holiday from the Hour of Twelve o'clock noon:—

- \*THURSDAY, 3RD OCTOBER, 1946, throughout the Town of Horsham.

## \* Agricultural Show.

Given under my Hand and the Seal of the State of Victoria aforesaid, at Melbourne, this twentieth day of August, in the year of our Lord One thousand nine hundred and forty-six, and in the tenth year of the reign of His Majesty King George VI.

(L.S.)

E. F. HERRING.

By His Excellency's Command,

W. G. McKENZIE,  
for Chief Secretary.

GOD SAVE THE KING!

## BANK HALF-HOLIDAY.

## PROCLAMATION

By His Excellency the Lieutenant-Governor of the State of Victoria and its Dependencies in the Commonwealth of Australia, &c., &c., &c.

IN pursuance of the provisions contained in Part III. of the *Banks and Currency Act 1928*, I, the Lieutenant-Governor of the State of Victoria, in the Commonwealth of Australia, do by this my Proclamation appoint the day and date named hereunder a special day to be observed as a Bank Half-Holiday at the place mentioned, that is to say:—

*Bank Half-Holiday from the Hour of Twelve o'clock noon:—*  
WEDNESDAY, 16TH OCTOBER, 1946, at Boort.

Given under my Hand and the Seal of the State of Victoria aforesaid, at Melbourne, this twentieth day of August, in the year of our Lord One thousand nine hundred and forty-six, and in the tenth year of the reign of His Majesty King George VI.

(L.S.) E. F. HERRING.

By His Excellency's Command,

W. G. MCKENZIE,  
for Chief Secretary.

GOD SAVE THE KING!

## APPOINTMENTS.

HIS Excellency the Lieutenant-Governor of the State of Victoria, by and with the advice of the Executive Council thereof, has, by Orders made on the 13th August, 1946, been pleased to make the following appointments, viz.:—

## DEPARTMENT OF AGRICULTURE.

*Inspector.*

**HORACE WESLEY WALTER**  
to be an Inspector, General Division, Milk Board; a vacancy having occurred, and the Public Service Board having certified, on the 29th July, 1946, that an appointment is required, that there is no person available and fit in the Public Service to be promoted or transferred to fill the vacant office, and that the person named is entitled, under the provisions of the *Public Service Act 1928*, to be appointed to fill such vacancy on probation for six months, to date from and inclusive of the 17th May, 1946.

*Dairy Produce Inspector.*

**DAVID ANDREW LANCASTER**  
to be a Dairy Produce Inspector, General Division; a vacancy having occurred, and the Public Service Board having certified, on the 30th July, 1946, that an appointment is required, that there is no person available and fit in the Public Service to be promoted or transferred to fill the vacant office, and that the person named is entitled, under the provisions of the *Public Service Act 1928*, to be appointed to fill such vacancy on probation for six months, from and inclusive of the 18th June, 1946.

*Seeds Inspector.*

**WALTER KEITH BURGESS**  
to be a Seeds Inspector, General Division; a vacancy having occurred, and the Public Service Board having certified, on the 23rd July, 1946, that an appointment is required, that there is no person available and fit in the Public Service to be promoted or transferred to fill the vacant office, and that the person named is entitled, under the provisions of the *Public Service Act 1928*, to be appointed to fill such vacancy on probation for six months, to date from and inclusive of the 25th February, 1946.

*Fruit Inspector.*

**ALFRED CHARLES WARRURTON**  
to be a Fruit Inspector, General Division; a vacancy having occurred, and the Public Service Board having certified, on the 24th July, 1946, that an appointment is required, that there is no person available and fit in the Public Service to be promoted or transferred to fill the vacant office, and that the person named is entitled, under the provisions of the *Public Service Act 1928*, to be appointed to fill such vacancy on probation for six months, from and inclusive of the 17th May, 1946.

*Assistant Field Officer.*

**WALTER BUNNING GAYFER**  
to be an Assistant Field Officer, General Division; a vacancy having occurred, and the Public Service Board having certified, on the 22nd July, 1946, that an appointment is required, that there is no person available and fit in the Public Service to be promoted or transferred to fill the vacant office, and that the person named is entitled, under the provisions of the *Public Service Act 1928*, to be appointed to fill such vacancy on probation for six months, to date from and inclusive of the 24th June, 1946.

## DEPARTMENT OF CHIEF SECRETARY.

*Officer of the Fifth Class.*

## LEO WILLIAM THORP

to be an Officer of the Fifth Class, Clerical Division, Motor Registration Branch; a vacancy having occurred, and the Public Service Board having certified, on the 19th July, 1946, that an appointment is required, that there is no person available and fit in the Public Service to be promoted or transferred to fill the vacant office, and that the person named is entitled, under the provisions of the *Public Service Act 1928*, to be appointed to fill such vacancy on probation for six months.

*Member, Zoological Board of Victoria.*

## GEORGE HENRY GREEN,

pursuant to the provisions of section 5 of the *Zoological Gardens Act 1936*, to be a member of the Zoological Board of Victoria, for the period ending the 16th May, 1949.

*Assistants to the Inspector of Fisheries.*

## ARCHIBALD ALEXANDER HEPWORTH and

## VINCENT PATRICK JENNINGS,

pursuant to the provisions of the Fisheries Acts, to be Assistants to the Inspector of Fisheries.

## DEPARTMENT OF HEALTH.

*Laboratory Attendant.*

## JOHN COURTNEY HARRY

to be a Laboratory Attendant, General Division, Mental Hygiene Branch; a vacancy having occurred, and the Public Service Board having certified, on the 18th June, 1946, that an appointment is required, that there is no person available and fit in the Public Service to be promoted or transferred to fill the vacant office, and that the person named is entitled, under the provisions of the *Public Service Act 1928*, to be appointed to fill such vacancy on probation for twelve months.

*Cook (Female).*

## ZELMA GWEN GIBBS

to be a Cook (Female), General Division, Mental Hygiene Branch; a vacancy having occurred, and the Public Service Board having certified, on the 8th July, 1946, that an appointment is required, that there is no person available and fit in the Public Service to be promoted or transferred to fill the vacant office, and that the person named is entitled, under the provisions of the *Public Service Act 1928*, to be appointed to fill such vacancy on probation for twelve months.

## DEPARTMENT OF LANDS AND SURVEY.

*Bailiff of Crown Lands.*

**MORTON JAMES SEARLE**, an officer of the Shire of Mornington,  
to be a Bailiff of Crown Lands, without salary.

## DEPARTMENT OF LAW.

*Chairmen of General Sessions, &c.*FREDERICK BARKER GAMBLE and  
GEORGE LEO DETHRIDGE

to be Chairmen of General Sessions, under the provisions of the *Justices Act 1928*, and Judges of County Courts, under the County Court Acts, to take effect from the date of commencement of duty.

*Police Magistrate, &c.*

## JOHN PATRICK GLOSTER

to be a Police Magistrate, a Warden of the Goldfields in and for Victoria, and a Coroner for Victoria.

*Magistrates.*

**JOHN JOSEPH EGAN**, 5 Drysdale-street, Malvern,  
**IVY EVELYN WEDGWOOD**, 927 Mt. Alexander-road, Essendon,  
**MAX VERNON ROEBUCK BLEECHMORE**, 34 Thanet-street, Malvern,

**LAURENCE AITKEN LIVINGSTON**, 30 South-road, Brighton,  
**JAMES HERBERT HENRY DAHMEN WESTLEY**, 7A Royal-crescent, Camberwell,

**ALEC FIELDING TWEEDIE**, Manager, Central Hospital, Lonsdale-street, Melbourne, and

**ROLAND JOHN COLLINS**, Scoresby,  
to Keep the Peace in the Central Bailiwick of the State of Victoria;

**HAROLD HILL RODDIS**, Snake Valley,  
to Keep the Peace in the Southern Bailiwick of the State of Victoria;

**PETER LEWIN PETERS**, Castlemaine, and  
**GIOSEFATTO CAPICCHIANO**, Castlemaine,  
to Keep the Peace in the Midland Bailiwick of the State of Victoria; and

**HORACE NAGLE DAVENPORT**, Hansonville,  
to Keep the Peace in the Northern Bailiwick of the State of Victoria.

*Deputy Coroner.*

GERALD ERNEST EVELYN GRAY, J.P., Swan Hill, to be a Deputy Coroner, pursuant to the provisions of the *Coroners Act 1928*, to act and have jurisdiction for and during the absence of the Coroner at and in the vicinity of Swan Hill.

*Commissioners for Taking Declarations, &c.*

REGINALD SAMUEL CLARK, 226 Glenferrie-road, Hawthorn,  
ELSA ADA FLORA VOSS, 39 Chrystobel-erecent, Hawthorn,  
FRANCIS PHILLIP OLIVER JONES, Doveton-street, Castle-  
maine,

GEORGE EDWARD HOGARTH, Duke-street, Castlemaine,  
DONALD THOMAS MAGNER, 54 Creswick-street, Footscray,  
ERNEST WILLIAM LIDDY, 123 Rosamund-road, Braybrook,  
THOMAS SHARP, 17 Johns-street, Ballarat,  
GEORGE ROBERT GREGG, Swan Hill,  
COLIN DOUGLAS MACDONALD, 91 Church-street, Geelong  
West,

ARTHUR WALLACE BOURKE, Benalla,  
REBECCA ANN MCNEIL, 276 Lennox-street, Richmond,  
LEONARD PRUT WILLIAMS, 39 Murdoch-street, West  
Brunswick,

JAMES GILLIGAN, 21 Wallace-street, West Brunswick, and  
DANIEL HEALY, 12 Thistle-street, West Brunswick, to be Commissioners for taking Declarations and Affidavits, pursuant to the provisions of Division 8 of Part IV. of the *Evidence Act 1928*, to resign upon removing from the neighbourhood of the addresses stated; and

URBAN STANLEY O'TOOLE, Meat Inspector, Richmond Abattoirs, Richmond, to be a Commissioner for taking Declarations and Affidavits, pursuant to the provisions of Division 8 of Part IV. of the *Evidence Act 1928*, to resign upon ceasing to occupy his present position.

*Clerks of Petty Sessions, &c.*

FREDERICK CLISBY HILL

to be Clerk of Petty Sessions at Northcote and Preston, in the place of C. J. Thompson, transferred, to take effect from the date of commencement of duty;

CYRIL JOHN THOMPSON

to be Clerk of Petty Sessions and Clerk of the Children's Court at Nhill, Dimboola, Jeparit, Kaniva, and Rainbow, in the place of A. M. Foley, transferred, to take effect from the date of commencement of duty;

ALFRED MICHAEL FOLEY

to be Clerk of Petty Sessions at Northcote and Preston, in the place of F. C. Hill, relieved, to take effect from the date of commencement of duty;

HENRY VICTOR BOARDER

to be Clerk of Petty Sessions and Clerk of the Children's Court at Dandenong, Berwick, Cranbourne, and Pakenham, during the absence on annual leave of C. F. Lewis, to take effect from the date of commencement of duty; and

CHARLES EDGAR ELVISH

to be Clerk of Petty Sessions at St. Kilda, during the absence on annual leave of W. H. Johnston, to take effect from the date of commencement of duty.

*Assistant Registrar of County Court.*

CYRIL JOHN THOMPSON

to be an Assistant Registrar, pursuant to the provisions of sections 20 and 21 of the *County Court Act 1928*, for the County Court at Horsham, in the place of A. M. Foley, transferred, to take effect from the date of commencement of duty.

*Probation Officers for Children's Courts.*

FRANCIS THEODORE HURLEY O'GRADY, Waugh-street, Charlton, and

ALFRED MOURELL, The Vicarage, Charlton,

to be Probation Officers, pursuant to the provisions of section 8 of the *Children's Court Act 1928*, for the Children's Court at Charlton; and

JAMES FREDERICK CUGLEY, 144 Harold-street, Thornbury, and

FREDERICK WALTON MILLER, The Rectory, Lakes Entrance, to be Probation Officers, pursuant to the provisions of section 8 of the *Children's Court Act 1928*, for the Children's Courts at Northcote and Lakes Entrance, respectively.

*Sheriff's Bailiff, &c.*

LEWIS HAMILTON THOMAS, Senior Constable of Police, Wonthaggi,

to be also a Sheriff's Bailiff and a Bailiff of the County Court at Korumburra, with fees, in the place of J. H. Fewster, resigned, to take effect from the date of commencement of duty.

*Reporters and Shorthand Writers (Male).*

ROBERT MATHEW PETERSEN and

FRANCIS WILLIAM HATFIELD

to be Reporters and Shorthand Writers (Male), Classes "D" and "C," Professional Division, Crown Law Offices; vacancies having occurred, and the Public Service Board having certified, on the 3rd July, 1946, that appointments are required, that there are no persons available and fit in the Public Service

to be promoted or transferred to fill the vacant offices, and that the persons named are fit and proper persons and duly qualified to be appointed to fill such vacancies on probation for three months.

## DEPARTMENT OF PUBLIC INSTRUCTION.

*Acting Director of Education.*

CHARLES THOMPSON SCARFF, Chief Inspector of Secondary Schools,

to perform and exercise the duties, obligations, rights, and powers of the Director of Education from time to time, as occasion may arise, during the temporary absence, for any period in excess of one day, of John Arnold Seitz, up to the date upon which Ernest Percy Eltham, Chief Inspector of Technical Schools, whose services have been loaned to the Commonwealth Government, resumes duty in the Department of Public Instruction, as from and inclusive of the 19th August, 1946.

*Assistant Storeman.*

IVON REEVE RIDGWAY

to be an Assistant Storeman, General Division; a vacancy having occurred, and the Public Service Board having certified, on the 23rd July, 1946, that an appointment is required, that there is no person available and fit in the Public Service to be promoted or transferred to fill the vacant office, and that the person named is entitled, under the provisions of the *Public Service Act 1928*, to be appointed to fill such vacancy on probation for six months, from and inclusive of the 5th November, 1945.

## DEPARTMENT OF PUBLIC WORKS.

*Senior Labourer.*

VICTOR SYDNEY BULL

to be a Senior Labourer, General Division, Ports and Harbors Branch; a vacancy having occurred, and the Public Service Board having certified, on the 17th July, 1946; that an appointment is required, that there is no person available and fit in the Public Service to be promoted or transferred to fill the vacant office, and that the person named is entitled, under the provisions of the *Public Service Act 1928*, to be appointed to fill such vacancy on probation for six months, from and inclusive of the 5th November, 1945.

*Lighterman.*

WILLIAM WATKINS GRAHAM

to be a Lighterman, General Division, Ports and Harbors Branch; a vacancy having occurred, and the Public Service Board having certified, on the 22nd July, 1946, that an appointment is required, that there is no person available and fit in the Public Service to be promoted or transferred to fill the vacant office, and that the person named is entitled, under the provisions of the *Public Service Act 1928*, to be appointed to fill such vacancy on probation for six months, to date from and inclusive of the 5th November, 1945.

## DEPARTMENT OF TREASURER.

*Collectors of Imposts.*

WILLIAM GEORGE ARNEL

to act as Collector of Imposts, State Accommodation Office, during the absence of F. Frawley on leave; and

ANDREW JOHN GILMORE

to be Collector of Imposts, Inglewood, for the purpose of collecting fees payable for the issue of miners' rights (with a commission of 10 per cent. on all collections made as Issuer).

## DEPARTMENT OF WATER SUPPLY.

*Assistant Engineer.*

HENRY WILLIAM LEA

to be an Assistant Engineer, Class "C," Professional Division; a vacancy having occurred, and the Public Service Board having certified, on the 26th July, 1946, that an appointment is required, that there is no person available and fit in the Public Service to be promoted or transferred to fill the vacant office, and that the person named is a fit and proper person, and duly qualified, to be appointed to fill such vacancy on probation for three months.

*Water Bailiff.*

BRUCE JAMES GOURLAY

to be a Water Bailiff, General Division; a vacancy having occurred, and the Public Service Board having certified, on the 22nd July, 1946, that an appointment is required, that there is no person available and fit in the Public Service to be promoted or transferred to fill the vacant office, and that the person named is entitled, under the provisions of the *Public Service Act 1928*, to be appointed to fill such vacancy on probation for six months.

C. W. KINSMAN,  
Clerk of the Executive Council.

At the Executive Council Chamber,  
Melbourne, 13th August, 1946.

## RESIGNATIONS.

**H**IS Excellency the Lieutenant-Governor of the State of Victoria, by and with the advice of the Executive Council thereof, has by Orders made on the 13th day of August, 1946, accepted the resignations of the persons named hereunder of the offices mentioned, viz.:—

## DEPARTMENT OF CHIEF SECRETARY.

The Honorable Sir **HERRERT HORACE OLNEY** and the Honorable **HERBERT JOHN THORNHILL HYLAND, M.L.A.**, as members of the Zoological Board of Victoria.

## DEPARTMENT OF LABOUR.

**LESLIE THOMAS McGEARY**, Assistant (Male), General Division, as an Officer of the Public Service of Victoria, to take effect from and inclusive of the 17th July, 1946.

**JOHN PATRICK BARRY**, Supervising Inspector, General Division, as an Officer of the Public Service of Victoria, to take effect from and inclusive of the 18th July, 1946.

**ARTHUR JOHN ROBINSON**, Assistant (Male), General Division, as an Officer of the Public Service of Victoria, to take effect from and inclusive of the 19th July, 1946.

**FRANCIS HUGHES**, Clerk, Fifth Class, Clerical Division, as an Officer of the Public Service of Victoria, to take effect from and inclusive of the 23rd July, 1946.

## DEPARTMENT OF LANDS AND SURVEY.

**JOHN ALEXANDER EMSLIE**, Draughtsman, Class "D," Professional Division, as an Officer of the Public Service of Victoria, to date from and inclusive of the 4th August, 1946.

## DEPARTMENT OF LAW.

**AUGUSTUS JOHN NELSON** and **WILLIAM HENRY CASTELL**, as Probation Officers, pursuant to the provisions of the *Children's Court Act 1928*, for the Children's Court at Prahran and Ferntree Gully, respectively.

**JOHN HOLMAN FEWSTER**, as a Sheriff's Bailiff and a Bailiff of the County Court at Korumburra.

## DEPARTMENT OF PREMIER.

**WILLIAM JAMES TYNIMS**, Clerk, Class IV., Clerical Division, as an Officer of the Public Service of Victoria, from and inclusive of the 10th June, 1946.

## DEPARTMENT OF PUBLIC WORKS.

**COLIN BRUCE PURNELL**, Draughtsman, Class "D," Professional Division, as an Officer of the Public Service of Victoria, as from the close of business on 26th August, 1946.

## DEPARTMENT OF WATER SUPPLY.

**B. J. MUNDAY**, Water Bailiff, General Division, as an Officer of the Public Service of Victoria, from and inclusive of 18th August, 1946.

**C. W. KINSMAN**,  
Clerk of the Executive Council.

At the Executive Council Chamber,  
Melbourne, 13th August, 1946.

## PUBLIC SERVICE OF VICTORIA.—VACANCIES.

**A**PPPLICATIONS will be received by the Public Service Board up to Friday, the 30th August, 1946, from officers of the Public Service of Victoria, who are eligible and qualified, for appointment to the under-mentioned positions:—

## PROFESSIONAL DIVISION.

**Superintending Draughtsman, Classes "C" and "B,"**  
Department of Lands and Survey.

*Yearly Salary.*—£579, minimum; £618, maximum.

*Duties.*—Under the supervision of the Chief Draughtsman, to take charge of the adjusting and computing division of the draughting branch.

*Qualifications.*—To possess a sound knowledge of the methods to be observed by surveyors in the field and in the preparation of plans and field notes, also of all branches of mathematics applicable to surveys, and ability to report fully on the work of surveyors and to give directions for the preparation of plans for certification by the Surveyor-General, and to be thoroughly conversant with the survey regulations and office procedure.

**Senior Draughtsman, Class "C," Survey Branch, Office of Titles, Department of Law.** (Two vacancies.)

*Yearly Salary.*—£501, minimum; £579, maximum.

## Position No. 1.—

*Duties.*—To carry out the investigation, final examination, and correlation of surveys lodged in support of applications to amend title, and to investigate and report with respect to the amendment of title resultant on the closing of roads by departments and authorities.

*Qualifications.*—To have a sound knowledge of the practical application of survey, particularly with regard to the re-establishment of title boundaries, to be familiar with all legislation having application to the conveyance on transfer of land, and to have had extensive experience in Titles Office procedure.

## Position No. 2.—

*Duties.*—To carry out the final examination of new Certificates of Title and all phases of the work in connexion therewith.

*Qualifications.*—To have extensive experience in transfer dealings within the Office of Titles, and possess a good knowledge of the Transfer of Lands Acts and cognate Acts and of Titles Office procedure.

**Draughtsman, Class "E" (Frankston), Department of Water Supply.**

*Yearly Salary.*—£117, minimum; £351, maximum.

*Duties.*—To prepare drawings, under direction, and tracings of engineering structures and surveys, and to assist generally in draughting and other work in an engineering office.

*Qualifications.*—To have had at least one year's Senior Technical School (full day course) or other approved training in Engineering, Drawing, and allied subjects.

## CLERICAL DIVISION.

**First Class Clerk (Chief Clerk), Department of Lands and Survey.**

*Duties.*—Subject to the Secretary for Lands, to have general supervision of the work of the office and control of the staff.

*Qualifications.*—To have a thorough knowledge of the Acts and Regulations thereunder administered in the Department, a knowledge of the Public Service Act and Regulations, and ability to control a large staff.

**Second Class Clerk (Chief Clerk), Office of the Public Service Board, Department of Premier.**

*Qualifications.*—To have an intimate knowledge of the Public Service Acts and Regulations, of the functions of the various Departments, and of the procedure and practice of the Board's Office.

**Third Class Clerk, Office of the Housing Commission (Materials Supply Section), Department of Treasurer.**

*Duties.*—To act as Materials Procurement Officer; to maintain contacts with Materials Procurement Directorate, Commonwealth Disposals Commission, and other sources for supply of building material; to arrange bulk purchase of materials; to assist generally the Supply Superintendent, and to take charge of the section in his absence.

*Qualifications.*—To have initiative and organizing ability; to be capable of directing staff and conducting interviews in various spheres; to have a knowledge of the building trade and terms used therein, and a knowledge of the regulations respecting public accounts.

**Third Class Clerk (Frankston Centre), Department of Water Supply.**

*Duties.*—To supervise the collection of revenue; to keep Water Rate Books, Meter Ledgers, Water Sales Ledgers, Cash Books, and office records; to issue Rate Assessment Notices and receive revenue; to supervise the preparation of wages sheets, returns and statements, the payment of wages and district costing work; and to have charge of all clerical work connected with a district office.

*Qualifications.*—To possess a good knowledge of the Water Acts, a knowledge of the incidence of rating, and experience in rate collecting; ability to conduct negotiations and correspondence, and to represent the Commission in proceedings for recovery of rates, and to have a sound knowledge of the relevant provisions of the Local Government Act. Possession of accountancy qualifications desirable.

**Fourth Class Clerk, Office of the Public Service Board, Department of Premier.** (Two vacancies.)

*Duties.*—*Position No. 1.* To act as regulations and relieving clerk.

*Position No. 2.* To act as checking and information clerk.

*Qualifications.*—To have a good knowledge of the Public Service Acts and of the Regulations and procedure thereunder.

**Fourth Class Clerk, Office of the Government Statist, Department of Chief Secretary.**

*Duties.*—To deal with applications for and prepare necessary documents relating to late registrations, legitimations, additions of names and corrections or cancellation of entries in the Registers, and to deal with appointments and resignations of Registrars of Births and Deaths.

*Qualifications.*—To possess a sound knowledge of the Registration of Births, Deaths, and Marriages Acts, the Adoption of Children Acts, the Marriage Acts, and the Regulations thereunder, and of the procedure of the office.

**Fourth Class Clerk, Courts, Department of Law.**

Casterton—1 vacancy.

Charlton—1 vacancy.

Relieving—2 vacancies.

*Qualifications.*—To be qualified as a Clerk of Courts or Clerk of Petty Sessions.

**Fourth Class Clerk, Apprenticeship Commission, Department of Labour.**

*Duties.*—To act as Secretary to Trade Committees, to deal with correspondence and inquiries regarding apprenticeship matters, and to assist in the preparation of draft regulations.

*Qualifications.*—To have a good knowledge of Apprenticeship Acts and Regulations, Wages Board Determinations and Arbitration Court Awards, and the prescribed courses for training of apprentices, and experience in secretarial work of committees.

**Fourth Class Clerk, Department of Water Supply.**

*Duties.*—To assist generally in Rate and Rate Recovery Branch, and to relieve revenue officers in district centres when required.

*Qualifications.*—To possess a good knowledge of the Water Acts, and of the incidence of water rates and charges generally; to be familiar with the principles and procedure governing the making and collecting of rates and charges; to have ability to make investigations and reports in respect to all revenue matters. Accountancy qualifications are desirable.

*NOTE.*—In addition to the salary rates quoted, a cost of living adjustment at the rate of £15 a year in the case of minors and £30 a year in the case of adults is payable. The rates are subject to variation in accordance with the rise or fall in the index numbers of the cost of living.

By order,

J. FRAZER,  
Secretary.

Office of the Public Service Board,  
Melbourne, 20th August, 1946.

**TYPIST (FEMALE), GRADE II, GENERAL DIVISION, MOTOR REGISTRATION BRANCH, OFFICE OF THE CHIEF COMMISSIONER OF POLICE, DEPARTMENT OF CHIEF SECRETARY.**

**A**PPPLICATIONS will be received by the Public Service Board up to Friday, the 6th September, 1946, from officers of the Public Service of Victoria, who are eligible and qualified, for appointment to the above-mentioned position.

*Yearly Salary.*—£213, minimum; £221, maximum, plus £20 cost of living adjustment. The rates are subject to variation in accordance with the rise or fall in the index numbers of the cost of living.

*Duties.*—To type certificates and licences from schedules, &c., and to act as relief operator on Remington vertical adder and Dalton adding machines.

*Qualifications.*—To be a competent typist and to be capable of operating the machines mentioned. A knowledge of the provisions of the Motor Car Acts prescribing the fees and premiums payable thereunder is desirable.

By order,

J. FRAZER,  
Secretary.

Office of the Public Service Board,  
Melbourne, 20th August, 1946.

**PUBLIC SERVICE OF VICTORIA.—VACANCIES.**

**A**PPPLICATIONS will be received by the Public Service Board up to Friday, the 30th August, 1946, from officers of the Public Service of Victoria, who are eligible and qualified, for appointment to the under-mentioned positions:—

**PROFESSIONAL DIVISION.**

**Forester, Grade II, Class "D," Department of State Forests.** (Two vacancies.)

*Yearly Salary.*—£351, minimum; £436, maximum.

*Duties.*—To control district staff, stores and equipment, silvicultural operations, utilization of forest produce, and measures for fire protection, and to make recommendations *re* forest estate alterations and forest offences.

*Qualifications.*—To be a graduate of the School of Forestry, Creswick, or the Diploma of Forestry, or to have passed the examination prescribed by the Forests Board of Examiners for Forester; to have a thorough knowledge of the Forest Act and Regulations, and experience of field and office methods and procedure in the State Forests Department.

**CLERICAL DIVISION.**

**Inspecting Clerk of Courts, Class II, Department of Law.**

*Duties.*—To perform the duties of the office.

*Qualifications.*—To have passed the Police Magistrates Qualifying Examination and to have had at least ten years' experience as a Clerk of Courts, and to possess a thorough knowledge of the duties of such office and those of the office of receiver and paymaster.

*NOTE.*—In addition to the salary rates quoted, a cost of living adjustment at the rate of £30 a year is payable. The rates are subject to variation in accordance with the rise or fall in the index numbers of the cost of living.

By order,

J. FRAZER,  
Secretary.

Office of the Public Service Board,  
Melbourne, 20th August, 1946.

**PUBLIC SERVICE OF VICTORIA.—VACANCIES, GENERAL DIVISION.**

**A**PPPLICATIONS will be received by the Public Service Board up to Friday, the 6th September, 1946, from officers of the Public Service of Victoria, who are qualified, for appointment to the under-mentioned positions:—

**Attendance Officer, Department of Public Instruction.**

Shepparton . . . . . 1 vacancy.

Mildura . . . . . 1 vacancy.

*Yearly Salary.*—£260, minimum; £364, maximum.

*Duties.*—To report upon all cases of apparently deficient attendance at school and to conduct Court cases as required.

*Qualifications.*—To be physically and mentally alert, able to ride a bicycle, write satisfactory reports, and conduct prosecutions in Court.

The applicants selected will be required to reside in the district to which they are appointed.

**Engineer Mechanic, Grade II, Mental Hospital, Beechworth, Department of Health.**

*Salary.*—£354 a year, less deduction for quarters and allowances.

*Duties.*—To have charge of engineering plant, including steam boilers, hot and cold water services, cooking appliances, and electric installation.

*Qualifications.*—To possess a Boiler Attendant's Certificate or higher qualification, to have served an engineering apprenticeship, and to have a good knowledge of plumbing.

**Senior Searcher, Office of Titles, Department of Law.**

*Salary.*—£325 a year.

*Duties.*—To sort and assemble documents to be placed or re-placed in the Register Book; to compile a return of the total monetary amounts of mortgages registered each month, and to attend and produce at Court documents ordered by summons or subpoena.

*Qualifications.*—To possess a thorough knowledge of Titles Office practice and of the various documents registerable under the Transfer of Land Acts and cognate Acts, and the ability to distinguish and explain same.

**Gardener, Grade II, Botanic Gardens, Department of Lands and Survey.**

*Salary.*—£286 a year.

*Duties.*—To have charge of a section of the Gardens, and to carry out such general gardening as may be directed.

*Qualifications.*—To possess a practical knowledge of the various processes and methods of gardening, including a knowledge of plants and their treatment, and to have passed the prescribed examination as set out in Clause 19 of Chapter 5 of the Public Service Regulations 1928.

**NOTE.**—In addition to the salary rates quoted, a cost of living adjustment at the rate of £30 a year is payable. The rates are subject to variation in accordance with the rise or fall in the index numbers of the cost of living.

By order,

J. FRAZER,  
Secretary.

Office of the Public Service Board,  
Melbourne, 20th August, 1946.

**PUBLIC SERVICE OF VICTORIA.—VACANCIES, GENERAL DIVISION.**

**A**PPPLICATIONS will be received by the Public Service Board from persons, who are qualified, for appointment to the under-mentioned positions:—

**Forest Overseer, Grade II, Department of State Forests.**

*Yearly Salary.*—£273, minimum; £338, maximum.

*Duties.*—To supervise operation of forest employees and licensees, and to carry out general and fire patrol duties.

*Qualifications.*—A knowledge of the Victorian Forests Act and Regulations, and of office procedure; practical experience of field methods and operations in the State Forests Department.

**Fireman, Mental Hospital, Mont Park, Department of Health.**

*Yearly Salary.*—£252, minimum; £291, maximum.

*Duties.*—To fire boilers and to assist engineer mechanic.

*Qualifications.*—To possess Boiler Attendant's certificate or higher qualification.

**NOTE.**—In addition to the salary rates quoted, a cost of living allowance at the rate of £30 a year is payable. The rates are subject to variation in accordance with the rise or fall in the index numbers of the cost of living.

Applications (which should be accompanied by evidence of experience and qualifications, and a statement of date and place of birth) should be lodged at this office not later than Friday, the 6th September, 1946.

By order,

J. FRAZER,  
Secretary.

Office of the Public Service Board,  
Melbourne, 20th August, 1946.

**CARPENTER AND CABINETMAKER, GENERAL DIVISION, PUBLIC LIBRARY BRANCH, DEPARTMENT OF CHIEF SECRETARY.**

**A**PPPLICATIONS will be received by the Public Service Board from persons, who are qualified, for appointment to the above-mentioned position.

*Yearly Salary.*—£260, minimum; £299, maximum, plus £30 cost of living adjustment. The rates are subject to variation in accordance with the rise or fall in the index numbers of the cost of living.

*Duties.*—To build cabinets and show cases for exhibits, to construct shelves and other fittings for books, and to carry out general repair work as directed. To supervise the work of casual carpenters in the absence of the Carpenter and Modelmaker.

*Qualifications.*—To be a highly skilled cabinetmaker and joiner.

Applications (which should be accompanied by evidence of experience and qualifications, and a statement of date and place of birth) should be lodged at this Office not later than Friday, the 6th September, 1946.

By order,

J. FRAZER,  
Secretary.

Office of the Public Service Board,  
Melbourne, 20th August, 1946.

**Public Service Act 1928 (No. 3757), Sections 90 and 91.**

**EXEMPTIONS.**

**H**IS Excellency the Lieutenant-Governor of the State of Victoria, by and with the advice of the Executive Council thereof, and upon the recommendation of the Public Service Board, has, by Orders made on the 13th day of August, 1946, exempted the officers specified hereunder from the provisions of sections 90 and 91 of the Public Service Act 1928 (No. 3757):—

**DEPARTMENT OF AGRICULTURE.**

Officers engaged in the inspection of fruit, grain, seeds, plants, and sea-borne stock, who are required to work overtime—such exemption to be operative for the period from the 1st July, 1946, to the 30th June, 1947, both dates inclusive.

**DEPARTMENT OF LABOUR.**

Officers who are required to work overtime in connexion with the registration of factories and shops—such exemption to be operative for the period from the 1st June, 1946, to the 30th June, 1946, both dates inclusive.

**DEPARTMENT OF LAW.**

Labourers, Law Courts, Melbourne, who are required to work overtime—such exemption to be operative for a period of six months from and inclusive of the 1st July, 1946.

**DEPARTMENT OF PUBLIC WORKS.**

Officers of the Accounts Branch who are required to work overtime—such exemption to be operative for the period from the 18th June, 1946, to the 31st July, 1946, both dates inclusive.

**DEPARTMENT OF TREASURER.**

Labourers employed on the Cleaning Staff, Taxation Branch, who are required to work overtime—such exemption to be operative for the period from the 1st July, 1946, to the 30th June, 1947, both dates inclusive.

C. W. KINSMAN,  
Clerk of the Executive Council.

At the Executive Council Chamber,  
Melbourne, 13th August, 1946.

**Act No. 3757, Section 66 (VIII).**

**REGULATIONS.—CLASSIFICATION OF GENERAL DIVISION.**

**CHAPTER VII.**

**T**HE Public Service Board, in pursuance of the powers vested in it, hereby amends Chapter VII. of the Public Service Regulations as shown below, and submits the same for the approval of the Governor in Council:—

Department and Office.	Yearly Rate of Salary	
	Minimum.	Maximum.
DEPARTMENT OF AGRICULTURE.	£	£
MILK BOARD.		
Add— Inspector .. .. .	306	367
<i>To take effect as from and inclusive of the 17th May, 1946.</i>		

D. D. PAINE, Chairman.  
J. FRAZER, Secretary.

Office of the Public Service Board,  
Melbourne, 29th July, 1946.

Approved by the Governor in Council,  
13th August, 1946.

C. W. KINSMAN,  
Clerk of the Executive Council,

## Transport Regulation Acts.

## TRANSPORT REGULATION BOARD.

## NOTICES OF PUBLIC HEARINGS.

NOTICE is hereby given that the applications lodged by the persons named below for licences to operate the commercial passenger or goods vehicles on the route or routes, or in the manner set out opposite their names, will be heard at a time and place to be communicated to the parties:—

*Name of Applicant; Nature of Application.*

- ANSETT, R. M.; application for variation of licence A.1198, to operate between Walpolla and Merbein for the conveyance of children to South Merbein and Merbein schools.
- BAILEY, R. A.; application for variation of licences A.486 and A.485, to include extension of present stage omnibus route Castlemaine-Maldon to Cairn Currain Reservoir.
- BENTLEY AND HAWKER; 1 commercial passenger vehicle, with seating capacity for 5 persons, to operate as follows:—(a) separate and distinct fares 5 miles Nathalia, (b) private hire 30 miles Nathalia.
- BARRETT, A. C.; 1 commercial passenger vehicle, to be purchased, to operate as a stage omnibus between Yallourn and Melbourne.
- CUNNINGHAM, BROWN, AND RUTZON; 1 commercial passenger vehicle, with seating capacity for 27 persons, to operate as an additional vehicle between Mentone Railway Station and Mordialloc Railway Station, via Como-parade west, Como-parade east, Sixth-street, Pt. Nepean-road, White-street, Warren-road, Francis-street, McDonald-street.
- LANG, R. O.; application for renewal of licence A.414, lodged as follows:—(a) separate and distinct fares 10 miles Horsham, (b) private hire 50 miles Horsham.
- CUNNINGHAM, BROWN, AND RUTZON; application for variation of licence, to operate between Mentone Railway Station and corner of Evesham-road and Pt. Nepean-road, Cheltenham, via Swanston-street, Pt. Nepean-road.
- DAVEY, E. A. V.; 1 commercial passenger vehicle, with seating capacity for 5 persons, to operate—(a) separate and distinct fares 5 miles Boronia, (b) private hire within an unspecified radius.
- TOMASETTI, G. C., M. M. TOMASETTI, E. M. HALL, B. LUCAS, C. EVANS, R. M. BROWNING (trading as Traralgon Bus Service); 1 commercial passenger vehicle, to be purchased, to operate between Traralgon and Balook, via Traralgon South, Callignee North, and Callignee South, for the carriage of passengers, mails, papers, and parcels.
- GREYDA, G. F.; 1 commercial passenger vehicle, with seating capacity for 27 persons, to operate as an additional vehicle on Dandenong-Berwick route, subject to the same terms and conditions as licence A.1444.
- GREYDA, G. F.; application for variation of licence A.1444—1. To operate a journey from Dandenong to Campbell-street, Berwick, on Saturdays at 1.10 p.m., returning at 1.35 p.m., 2. To operate the following journeys between Dandenong and Berwick on Sundays, depart Dandenong 9.35 a.m. (Manuka-road), 11.30 a.m. (Campbell-street), 6.40 p.m. (Manuka-road), 7.40 p.m. (Campbell-street), depart Berwick 10.15 a.m. (Manuka-road), 1.5 p.m. (Campbell-street), 7.10 p.m. (Manuka-road), 8.35 p.m. (Campbell-street).
- GREYDA, G. F.; application for variation of licence A.1444, to extend Dandenong-Berwick service to Pakenham, mainly for the carriage of school children at the following times:—Monday to Friday, leave Dandenong 7.15 a.m. leave Pakenham 8.10 a.m., leave Dandenong 3.55 p.m. leave Pakenham 5 p.m.
- GUEST, J. E.; 1 commercial passenger vehicle, with seating capacity for 7 persons, to operate as follows:—(a) Sale P.O. to Cobain's P.O. and Fenton's Estate daily with mails, passengers, and small parcels, (b) private hire 25 miles Sale.
- HENDERSON, T. P. L.; application for renewal of licence A.858 (expired 14th August, 1946), lodged as follows:—“Separate and distinct fares 2 miles Hamilton P.O.”
- HORE, J. S.; 1 commercial passenger vehicle, to be purchased, to operate between Bonegilla and Albury.
- LITTLEHALES, E. J.; 1 commercial passenger vehicle, with seating capacity for 27 persons, to be purchased, to operate between Cowes, San Remo, Wonthaggi, Jumbunna, Korumburra, Ranceby, Hallora, Drouin, and Warragul, for the carriage of passengers, parcels, and papers up to 2 cwt.
- MEADE, D. J.; 1 commercial passenger vehicle, with seating capacity for 5 persons, to operate—(a) separate and distinct fares 5 miles Parkdale, (b) private hire 25 miles Parkdale.
- MORSON, W. J.; application for variation of A.1317, to—(a) include the ability to carry parcels up to 56 lb. on mail service Horsham-Polkemmet, (b) include the ability to carry not more than three passengers between Horsham and any point on mail route Horsham-Polkemmet.
- SHEIL, R. W.; 1 commercial passenger vehicle, with seating capacity for 16 persons, to be purchased, to operate as a stage omnibus between Mt. Macedon and Melbourne.
- STAMERS, K. N., AND C. G. R. STAMERS; 1 commercial passenger vehicle, with seating capacity for 7 persons, for the carriage of passengers at separate and distinct fares for each passenger within 20 miles Yinnar.
- U.S. MOTORS (BELGRAVE) PTY. LTD.; application for variation of all “A” licences, to include—(a) the right to operate under charter conditions to any place within a radius of 20 miles from any point on the routes over which the company is at present licensed to operate, but excluding the metropolitan area of the City of Melbourne and to the Mornington Peninsula, Marysville, Eildon Weir, Donna Buang, Ben Cairn, Warburton, and Tooradin, (b) the right to operate round tours at separate and distinct fares, commencing from any point on the routes over which the company is at present licensed to operate to any place within a radius of 10 miles of the starting point and to Ben Cairn, Donna Buang, Healesville Sanctuary, Warburton, Marysville, Eildon Weir, and Tooradin, (c) the right to operate four additional trips each way daily between Olinda and Ferntree Gully, via Sassafras, Sherbrooke Junction, Sherbrooke, Kallista, and Belgrave.
- WILLIAMS, J. C.; application for renewal of licence C.139 (expired 20th July, 1946), lodged as follows:—“Charter conditions within a 50 miles radius of Creswick.”
- WILLIAMS, F. P.; application for renewal of licence C.138 (expired 20th July, 1946), lodged as follows:—“Charter conditions within 50 miles radius of Creswick.”
- WOODS, G. M.; application for renewal of licence A.1125, lodged as follows:—“Timboon-Warrnambool.”
- WILSON, W. M.; application for renewal of licence A.996 (expired 25th February, 1946), allowing operations—(a) Croydon-Brushy Park, (b) Croydon-corner of Dorset-road and Lincoln-road, (c) Croydon-Bickleigh Vale, (d) Croydon-corner of Oxford and Ross roads.
- WILSON, W. M.; application for renewal of licence A.1069, allowing operations as a substitute vehicle.
- STEWART, E.; application for variation of “A” licences, to extend route Ringwood-Alexandra-road to corner of Liverpool and Canterbury roads, via Bedford-road and Canterbury-road.
- DE PIAZZA, W. J.; application for renewal of licence D.1665 (expired 11th August, 1946), allowing operations as follows:—(a) to Orbost from places between Cann River and the border of New South Wales—hewn timber, (b) to railway stations nearest to point of cutting in the Briagolong district and places between Bairnsdale and Orbost—railway sleepers and hewn timber.
- GRANTER, J.; 1 commercial goods vehicle, with load capacity for 22 cwt., for the carriage of delicatessen supplies throughout Gippsland.
- MARTIN, C. G.; 1 commercial goods vehicle for the carriage of general goods between Maryborough and Melbourne.
- MATTHEWS, F. G.; 1 commercial goods vehicle for the carriage of general goods between Melbourne and Woods Point, via Eildon Weir and Warburton (winter and summer, respectively).
- MOLIVENNA, W. H. AND R. K. (trading as Harry Williams); 2 commercial goods vehicles for the carriage of—(a) general goods 25 miles Melbourne, (b) household furniture and effects from dwelling to dwelling throughout Victoria.
- REID, G. H., AND SONS; application for renewal of licence D.641, allowing operations as a Group 2 road contractor.
- STEPHENS, K. W.; 1 commercial goods vehicle for the carriage of road contracting plant and material throughout Victoria.
- BURKE, R.; 1 commercial passenger vehicle, with seating capacity for 5 persons, for the carriage of passengers, mails, and newspapers and parcels between Ballarat, Scarsdale, and Werneth.
- WOODS, G. M.; application for variation of licence A.1125, to operate under charter conditions within 20 miles Timboon and between Timboon and Warrnambool.
- LAMBORN, W. H.; application for variation of “A” licence, to be issued to include charter conditions within 20 miles of Cohuna.

Notice of any objection should be forwarded to reach the Secretary to the Board not later than Wednesday, the 4th September, 1946.

E. V. FIELD,  
Secretary.

Exhibition Buildings, Rathdown-street, Carlton, 20th August, 1946.

## CITY OF SANDRINGHAM.

## ORDER CONFIRMED.

THE Minister of the Crown administering the *Local Government Act 1928*, on the tenth day of August, 1946, confirmed the Order hereinafter referred to, in pursuance of section 513 of the said Act, viz.:—

An Order of the Council of the City of Sandringham, made on the 18th day of June, 1946, for the purpose of acquiring certain land as a pleasure ground and a place of public resort and recreation, such land being allotments 4 and 7 on plan of subdivision lodged in the Office of Titles, and numbered 5861, and being part of Crown allotment B, portion 49, Parish of Moorabbin, County of Bourke, and being the lands more particularly described in certificates of title, volume 5063, folio 1012410, and volume 4038, folio 807405, and being land within the municipal district of the City of Sandringham.

P. J. KENNELLY,  
Commissioner of Public Works.

## VEGETATION AND VINE DISEASES ACT 1928.

I, THE undersigned William George McKenzie, being the responsible Minister of the Crown for the time being administering the *Vegetation and Vine Diseases Act 1928*, in pursuance of the powers conferred upon me under the provisions of section 9 of the said Act, do hereby appoint the under-mentioned persons to exercise with respect to any land whatsoever in that part of Victoria which lies within the limits of the Central Bailiwick of the Supreme Court of Victoria as defined by the *Supreme Court Act 1928*, the following powers, that is to say, to enter upon any such land whatsoever at any time with or without assistants to search for diseased trees, plants, or vegetables, and to remain thereon so long as may be reasonable for such purpose:—

JACK BEVERLEY ALLEN,  
DAVID MORRIS WEBSTER,  
JOHN SAMUEL BARNES,  
HENRY THOMAS JACK CARR, and  
JOHN SEED BLOOMFIELD.

Given under my hand, at Melbourne, the twenty-sixth day of July, 1946.

W. G. McKENZIE,  
Minister of Agriculture.

## VEGETATION AND VINE DISEASES ACT 1928.

I, THE undersigned William George McKenzie, being the responsible Minister of the Crown for the time being administering the *Vegetation and Vine Diseases Act 1928*, in pursuance of the powers conferred upon me under the provisions of section 9 of the said Act, do hereby appoint the under-mentioned persons to exercise with respect to any land whatsoever in that part of Victoria which lies within the limits of the Eastern, Western, Midland, Northern, and Southern Bailiwicks of the Supreme Court of Victoria as defined in the Third Schedule to the *Supreme Court Act 1928*, the following powers, that is to say, to enter upon any such land whatsoever at any time with or without assistants to search for diseased trees, plants, or vegetables, and to remain thereon as may be reasonable for such purpose:—

JACK BEVERLEY ALLEN,  
DAVID MORRIS WEBSTER,  
JOHN SAMUEL BARNES,  
HENRY THOMAS JACK CARR, and  
JOHN SEED BLOOMFIELD.

Given under my hand, at Melbourne, the twenty-ninth day of July, 1946.

W. G. McKENZIE,  
Minister of Agriculture.

## EXPLOSIVES MAGAZINE RESERVE AT TRUGANINA—BY-LAWS.

## CORRIGENDUM.

IN the By-laws fixing the rents which may be charged for the use of sites of magazines for the storage of explosives at the Explosives Magazine Reserve, at Truganina, and for other purposes, made by the Governor in Council on the 13th August, 1946, and published in the *Government Gazette* of the 14th idem, at page 2557, the words "or fractional thereof" in the last line of By-law No. 5 thereof should read "or fractional part thereof."

Gazette Office,  
Melbourne, 16th August, 1946.

## DEPARTMENT OF LAW—SOLICITOR-GENERAL.

## COURTS OF PETTY SESSIONS.

## ALTERATION OF DAYS.

HIS Excellency the Lieutenant-Governor of the State of Victoria, by and with the advice of the Executive Council thereof, and pursuant to the provisions of section 61 of the *Justices Act 1928*, has, by Order made on the 13th day of August, 1946, approved the alteration of the days heretofore appointed for the holding of Courts of Petty Sessions at the places named in the Schedule below to the days and hours set forth in the second column of such Schedule as from and inclusive of the dates indicated:—

## SCHEDULE.

Court.	Days and Hours Appointed.
Port Melbourne	Every Monday at 10 o'clock a.m., as from and inclusive of the 2nd September, 1946
Heidelberg	Alternate Mondays at 10 o'clock a.m., as from and inclusive of the 2nd September, 1946, and alternate Thursdays at 10 o'clock a.m., as from and inclusive of the 12th September, 1946

C. W. KINSMAN,  
Clerk of the Executive Council.

At the Executive Council Chamber,  
Melbourne, the 13th August, 1946.

## POLICE SALE.

POLICE LICENSING BRANCH, 43 LITTLE BOURKE-STREET,  
MELBOURNE.

AN auction sale of confiscated and unclaimed liquor in possession of the police will be held at the Police Licensing Branch, 43 Little Bourke-street, Melbourne, on Thursday, the 19th day of September, 1946, at 1 p.m.

ALEX. M. DUNCAN,  
Chief Commissioner.  
20th August, 1946.

## Water Acts.

STATE RIVERS AND WATER SUPPLY COMMISSION.  
CHELSEA-FRANKSTON AND DANDENONG-SPRINGVALE URBAN  
DISTRICTS AND HEYFIELD URBAN DIVISION.

NOTICE to owners of tenements in the under-mentioned streets in the above-mentioned urban districts and division and the private streets, lanes, courts, and alleys opening thereto:—

*Chelsea-Frankston Urban District.*

Carrum.

*Wright-street*, from McLeod-road to a point opposite lot 2, about 6 chains southerly.

Edithvale.

*Field-avenue*, from end of existing main, about 18½ chains easterly from Clyde Bank-road to Montrose-avenue.

*Derrybeg-place*, from the Foreshore Reserve to Turakina-avenue.

*Dandenong-Springvale Urban District.*

Springvale.

*Prince's-avenue*, from Windsor-avenue to a point opposite lot 82, about 6 chains southerly.

*Heyfield Urban Division.*

*Mary-street*, from end of existing main to Cemetery-road.  
*Licola-road*, from Cemetery-road to a point opposite allotment 11, section B, about 15 chains north-westerly.

The main pipe in the said streets being laid down, the owners of all tenements situated as above are hereby required, on or before the 21st day of September next, to cause proper pipes and stop cocks to be laid, so as to supply water within such tenements from the main pipe.

L. DUGGAN, Secretary,  
State Rivers and Water Supply Commission.

Melbourne, 20th August, 1946.



## Water Acts.

## MIRBOO NORTH WATERWORKS TRUST.

## BY-LAW No. 1.

*Standing Orders for Regulating and Appointing the Place and Hour of Meetings of the Mirboo North Waterworks Trust and providing for the management and conduct of business thereat, and for other purposes.*

THE Mirboo North Waterworks Trust, in pursuance and exercise of the powers and authorities conferred by the Water Acts, doth hereby make the By-law following:—

1. *General Conduct of Business.*—In all cases not provided for by the Acts of Parliament of Victoria relating to authorities, or by this By-law, resort shall be had to the rules, forms, and usages of the Parliament of Victoria, which shall be followed so far as the same are applicable to the proceedings of the Trust.

2. *Place and Hour of Meetings.*—Meetings of the Trust shall be held periodically on the third Tuesday in the month, at 8 o'clock p.m., at the Shire Hall, Mirboo North. Upon notice of motion the time, day, and hour of the meeting may be altered by a majority of the Commissioners.

3. *Meetings, Notice of.*—A notice of every regular meeting of the Commissioners shall be, by the Trust Secretary, delivered or sent by post, addressed to the usual address of Commissioner, three clear days at least prior to the day on which such intended meeting is to be held.

4. *Meeting, Resolutions at, Not to be Revoked.*—No resolution at any meeting of the Commissioners shall be revoked or altered at any subsequent meeting unless notice of intention to propose such revocation or alteration be given by the Trust Secretary to each of the Commissioners seven days at least before holding the meeting, nor unless such revocation or alteration be determined upon by a majority consisting of two-thirds of the Commissioners present at such subsequent meeting (if the number of the Commissioners present at such subsequent meeting be not greater than the number present when such resolution was come to), or by majority if the number of Commissioners present at such subsequent meeting be greater than the number present at such former meeting.

5. *Business, &c., Order of, Minutes.*—At every meeting of the Commissioners the first business thereof shall be reading and putting a question for the confirmation of the minutes of the proceedings at the preceding meeting, and no discussion shall be permitted thereon except as to their accuracy as a record of the proceedings; and the rough minutes of the proceedings of the Commissioners at any meeting shall be read at the close of such meeting, if required by any Commissioner present at such meeting.

6. After the signing of the minutes by the Chairman, the order of business of any ordinary meeting shall be as follows, or as near thereto as may be practicable; but for the greater convenience of the Commissioners at any particular meeting thereof it may be altered by resolution to that effect:—

- (1) Reading of copies of letters sent by the authority of the Commissioners, if called for.
- (2) Reading letters received and considering and ordering thereon.
- (3) Reception and reading of petitions and memorials.
- (4) Receiving deputations from the ratepayers.
- (5) Presentation of reports of committees and officers.
- (6) Payments.
- (7) Orders of the day, including subjects continued from proceedings of former meetings, and any business the Chairman may think desirable.
- (8) Other motions of which previous notice has been given.
- (9) Notices of motion and the order of business at a special meeting shall be the order in which such business stands in the notice thereof.

7. *Titles, Official.*—The Commissioners, in meeting, shall designate each other by their official titles, namely, that of Chairman, or Commissioner, as the case may require.

8. *Who to Speak.*—If two or more Commissioners rise to speak at the same time, the Chairman shall decide who is entitled to priority.

9. *Chairman to Rise Whilst Addressing Meeting.*—The Chairman shall rise in addressing the Commissioners to discuss any question, and shall not leave the Chair on such occasions.

10. *Commissioners Not to Speak Twice on Same Question.*—No Commissioner shall speak twice on the same question unless entitled to reply, or in the explanation when he has been misrepresented or misunderstood.

11. *Points of Order.*—The Chairman, when called upon to decide on points of order or practice, shall state the provision, rule, or practice which he deems applicable to the case, without discussing or commenting on the same, and his decision as to order or explanation in each case shall be final.

12. *Commissioners Not to Digress or Impute Improper Motives.*—No Commissioner shall digress from the subject-

matter of the question under discussion, nor impute improper motives, and all personal reflections on Commissioners shall be deemed disorderly, and every Commissioner so doing shall, upon being called to order by the Chairman, apologize for such conduct, and withdraw such imputations or reflections, as the case may be.

13. A Commissioner called to order shall sit down, unless permitted to explain.

14. *Persons not Commissioners to Leave when Requested.*—No person not being a Commissioner who, having been admitted to any meeting of the Commissioners, shall be guilty thereof of any improper or disorderly conduct, and every such person shall leave such meeting when requested by the Chairman to do so.

15. *Call of the Commissioners.*—No Commissioner shall absent himself from any meeting held in compliance with an order for a call of the whole Commissioners without reasonable excuse to the satisfaction of the majority thereof.

16. *Documents to be Produced.*—Any Commissioner may of right demand the production of any of the documents of the Trust applying to the question under discussion.

17. *Motions, Amendments, and Notice Thereof.*—All notices of motion shall be in writing, dated and numbered, and given by the intending mover to the Trust Secretary at the close of meeting of the Commissioners; or if not given at the meeting then seven days prior to the day upon which the next meeting of the Commissioners is to take place, and the Secretary shall enter the same in the notice of motion book in the order in which they may be received.

18. *No Motion without Notice.*—No Commissioner shall make any motion initiating a subject for discussion except in pursuance of notice given as prescribed in the last preceding clause.

19. *Motions and Petitions.*—No motion except that for the receiving the same shall, unless under most urgent circumstances, be made on any petition, memorial, or other like application until the next ordinary meeting of the Commissioners after that at which it has been presented.

20. *Motions to be Moved in Order.*—Except by leave of the Commissioners, motions shall be moved in the order in which they have been received and recorded by the Trust Secretary in the notice of motion book, and if not so moved or postponed shall be struck out.

21. *Motions Not to be Proceeded With in the Absence of the Mover.*—No motion entered in the notice of motion book shall be proceeded with in the absence of the Commissioner who gave notice of the same, unless by some other Commissioner producing written authority from him to that effect.

22. No motion for an address or petition shall be entertained unless the mover shall, at some previous meeting, have submitted a draft of the same.

23. *Mover of Motion or Amendment Not to be Interrupted.*—Any Commissioner desirous of making a motion or amendment, or taking part in discussion thereon, shall rise and address the Chairman, and shall not be interrupted unless called to order, when he shall sit down until the Commissioner calling to order shall have been heard thereon, and the question or order disposed of, when the Commissioner in possession of the chair may proceed with the subject.

24. *Nature of Motion to be Stated.*—Any Commissioner desirous of proposing an original motion or amendment must state the nature of the same before he addresses the Commissioners thereon.

25. *Leave to be Obtained Before Motion Withdrawn.*—No motion or amendment shall be withdrawn without the leave of the Commissioners.

26. *Motions to be Seconded Prior to Discussions.*—No motion or amendment shall be discussed or put to the vote of the Commissioners unless it be seconded; but a Commissioner may, however, require the enforcement of any standing order of the Commissioners by directing the Chairman's attention to the infraction thereof.

27. *Mover and Not the Seconder held to have Spoken.*—A Commissioner moving a motion shall be held to have spoken, thereon, but a Commissioner merely seconding shall not be held to have spoken upon it.

28. *Motions to be in Writing.*—At every meeting of the Commissioners all motions, whether original motions or amendments, shall be reduced to writing, signed by the mover, and be delivered to the Chairman immediately on their being moved and seconded.

29. *Amendments.*—No second or subsequent amendment, whether upon an original proposition or on an amendment, shall be taken into consideration until the previous amendment is disposed of.

30. *Amendment to Become the Question.*—If an amendment be carried, the amendment shall become itself the question, whereupon any further amendment upon any portion of the question may be moved.

31. *Second Amendment may be Moved.*—If an amendment be negatived, then a second may be moved to the question to which the first-mentioned amendment was moved, but only one amendment shall be submitted to the Commissioners for discussion at a time.

32. *Right of Mover to Reply.*—The mover of every original proposition, but not of any amendment, shall have a right to reply, immediately after which the question shall be put from the Chair, but no Commissioner shall be allowed to speak more than once on the same question unless permission be given to explain or the attention of the Chair be called to a point of order.

33. *Adjournment, Motion for.*—No discussion shall be allowed on any motion for adjournment of the Commissioners, but if, on the question being put, the motion be negatived, the subject then under consideration, or the next on the notice paper, shall be discussed, or any other that may be allowed precedence before any subsequent motion for adjournment be made.

34. *Protest, Commissioners May.*—Any Commissioner may protest against any resolution of the Commissioners, and notice of intention to protest shall in every case be given forthwith on the adoption of the resolution protested against, and the protest shall specify the reason for protesting, and shall be entered three days at least before the next ordinary meeting of the Commissioners by the protesting Commissioner in a book to be kept for that purpose in the Trust Secretary's office, and signed by such Commissioner, and shall also be entered in the minutes of the meeting at which notice of the intention to protest shall have been given previously to the confirmation thereof; but such protest may be expunged from the minutes if declared by a majority of the Commissioners to be not in accordance with truth or in its terms disrespectful to the Commissioners.

35. *Lapsed Questions.*—If a debate on any motion moved and seconded be interrupted by the number of Commissioners present becoming insufficient for the transaction of business, such debate may be resumed at the point where it was so interrupted on motion upon notice.

36. *Order of the Day to be Restored.*—If a debate on any order of the day be interrupted by such insufficiency of numbers as aforesaid happening, such order may be restored to the notice book for a future day on motion upon notice, and then such debate shall be resumed at the point where it was so interrupted.

37. *Voting.*—Whenever a division shall be demanded by any Commissioner, the Commissioners voting in the affirmative shall first hold up their hands, and then all those voting in the negative shall then hold up their hands, and result be declared by the Chairman. The Chairman shall have a deliberate vote, and in case of an equal division he shall have a casting vote, and every Commissioner present shall vote except he be disabled by law from so doing.

38. *Questions to be Put.*—The Chairman shall, in taking the sense of the Commissioners, put the question first in the affirmative, then in the negative, and the result thereof shall be recorded in the minutes.

39. *Contents of Petitions.*—It shall be incumbent on every Commissioner presenting a petition to acquaint himself with the contents thereof, and to ascertain that it does not contain language disrespectful to the Commissioners and that the contents do not violate any By-law or any provision thereof.

40. *Name at Beginning of Petition.*—Every Commissioner presenting a petition to the Commissioners shall write his name at the beginning thereof.

41. *Petition to be in Writing.*—Every petition shall be in writing and not printed or lithographed, and shall contain the prayer of the petitioner at the end thereof, and be signed by at least one person on every sheet on which it is written.

42. *How Signed.*—Every petition shall be signed by the persons whose names are appended thereto by their names or marks and by no one else, except in cases of incapacity by sickness.

43. *No Letters, &c., to be Attached.*—No letters, affidavits, or other documents shall be attached to any petition.

44. *Presentation of Petitions.*—Every Commissioner presenting a petition to the Commissioners shall confine himself to a statement of the persons from whom it comes, of the number of signatures attached to it, of the material allegations contained in it, and to the reading of the prayer thereof.

45. *Deputations.*—Deputations from the ratepayers wishing to be heard before the Commissioners in support of any petition or otherwise must send in an application, in writing, to the Trust Secretary the day before the meeting of the Commissioners at which such petition is intended to be presented.

46. *Cheques to be Signed.*—That all cheques shall be signed by two Commissioners and countersigned by the Secretary.

47. *Appointments to Permanent Office.*—No appointment to any permanent office at the disposal of the Commissioners shall take place until seven clear days' public notice shall have been given by advertisement in one or more newspapers circulating in the Township of Mirboo North inviting applications from qualified candidates for same.

48. *Salaries to be Fixed.*—The salary or allowances attached to all offices and places at the disposal of the Commissioners shall in all cases be fixed before they proceed to appoint any person to fill the same.

49. *Commissioners, &c., not to be Surety.*—No Commissioner or officer of the Commissioners, and no assessor or

auditor shall be received as a surety for any officer appointed by the Commissioners, or for any work to be done for the Commissioners.

50. *Contracts.*—In all cases of security being given for the faithful performance of any contract, the expenses of preparing such security shall be borne by the person providing the same.

51. *Plans, &c.*—All the plans and specifications for any public work shall be laid before the Commissioners at least six days prior to the same being considered and ordered upon, and be open for inspection by any Commissioner during that time, except in cases of emergency.

52. *Secretary to Expend Moneys.*—It shall be lawful for the Trust Secretary from time to time, on the written order of the Chairman, to disburse such moneys as shall have been appropriated by the Commissioners for the purpose of the clause, and as shall be required for any necessary occasions, not exceeding in the whole in an interval between two ordinary meetings of the Commissioners, the sum of Ten pounds.

53. *Addresses to the Governor, &c.*—All addresses to the Governor shall be presented by the Chairman and Trust Secretary, unless otherwise ordered by the Commissioners.

54. *Suspension of Regulations.*—Any one or more of the rules and provisions herein contained may be suspended for a certain purpose on motion upon notice being given, and shall not otherwise be suspended except by a unanimous vote of the Commissioners.

55. *Penalty.*—Every person who shall so offend against this By-law shall be liable to a penalty not exceeding Five pounds for each such offence.

56. *Common Seal.*—The common seal of the Trust shall be kept in a locked box, of which the key shall be kept by the Trust Secretary, and the corporate seal shall not be affixed to any document unless the Chairman of the Trust and the Secretary, or in the absence of the Chairman, unless two Commissioners and the Secretary be present.

Passed this 16th day of July, 1946.

(SEAL) WALTER J. TUCK, Chairman.  
B. T. DROWLEY, Commissioner.  
J. C. SUMMERS, Secretary.

Approved by the Governor in Council,  
13th August, 1946.

C. W. KINSMAN,  
Clerk of the Executive Council.

#### CHILTERN WATERWORKS TRUST. RATING BY-LAW FOR THE YEAR 1946.

THE Chiltern Waterworks Trust, in pursuance of and exercise of the powers conferred by the Water Acts, doth hereby make a rate for the supply of water for domestic purposes of Two shillings and six pence in the pound of the annual municipal valuation of lands and tenements liable to be rated within the Chiltern Urban District.

Provided that in no case shall the amount of rate payable per annum in respect of any tenement (other than land on which there is a building) be less than Two pounds, and in respect of land on which there is no building less than Twelve shillings and six pence.

Such rates are made and shall be levied upon the occupiers or owners of the said lands and tenements for the year commencing 1st January and ending 31st December, 1946, and shall be payable on the 21st day of August, 1946, at the office of the said Trust.

The maximum quantity of water to be supplied for the year, without further charge to any property rated by the Trust, is hereby fixed at the quantity which, at a charge of Two shillings and four pence per 1,000 gallons, would produce an amount equal to the amount of the rate levied on such property for the said year.

The charge for water supplied by measure to any property rated by the Trust in excess of such maximum quantity, computed as in the last preceding clause, is hereby fixed at Two shillings and four pence per 1,000 gallons.

The charge for water supplied by measure to any property not rated by the Trust is hereby fixed at Two shillings and four pence per 1,000 gallons, and the minimum quantity of water to be charged for in cases where water is so supplied is hereby fixed at 1,000 gallons.

The charge for water supplied by measure shall be payable, on demand, at the office of the Trust, Chiltern.

Passed this 27th day of March, 1946.

(SEAL) J. R. DOW, Chairman.  
H. SMYTH, Commissioner.  
B. I. HICKS, Secretary.

Approved by the Governor in Council,  
13th August, 1946.

C. W. KINSMAN,  
Clerk of the Executive Council.

## Farmers Debts Adjustment Act 1935.

## CANCELLATION OF STAY ORDERS.

NOTIFICATION is hereby given that the Stay Orders issued to the under-mentioned farmers have been cancelled by the Farmers' Debts Adjustment Board, such cancellation to take effect on Wednesday, 21st August, 1946:—

## No. of Stay Order; Name; Address.

- 2834; Hunt, Edward Howard; Langville.  
 958; Hynam, Walter George; Patchewollock.  
 4274; Irwin, Alexander; Meringur.  
 3109; Jamieson, Norman Edward; Baring.  
 4326; Hatt, Josiah James; Chinkapook.  
 3625; Jardine, James David; Kiamal.  
 3245; Jarry, John Peter; Pier Millan.  
 2784; Jones, Hugh Finlay (as executor of Hugh Shaw Jones, deceased); Natya.  
 3584; Jeffrey, John Thomas; Lake Charm.  
 1944; Jones, Edward Gurnhill; Underbool.  
 1945; Jones, Eva; Underbool.  
 2443; Davies, estate of Robert Alexander, deceased; Chinkapook.  
 67; Fordham, David Ernest; Ultima.  
 3936; Hinton, Uanita Jessie; Nowie.  
 3819; Hinton, Percy Norman; Nowie.  
 2007; Henderson, Alice May and Lillian Ruby (as executrices of William Thomas, deceased); Pier Millan.  
 4099; Henderson, Harry; Barraport.  
 1935; Hansen, Elizabeth (as executrix of Henry, deceased); Nyah West.  
 2951; Grant, Helenor Amelia; Chinkapook.  
 3546; Hose, Mary; Beulah.  
 3545; Hose, Arthur James, deceased; Beulah.  
 957; Hogben, Bert Clarence; Natya.  
 3759; Hogan, Michael James, deceased; Birchip.  
 1302; Hoffmann, Wilhelm George; Beulah.  
 772; Hunt, John Henry; Ouyen.  
 3108; Hately, Robert William; Patchewollock.  
 3670; Hart, Alexander Gordon; Sea Lake.  
 3483; Harris, Henry Walter; Birchip.  
 655; Hardefeldt, Otto Hans, deceased; Timberoo South.  
 1918; Hodder, Percy William; Manangatang.  
 3948; Hodgson, John Leslie and Oswald Gordon; Boigheat.  
 2395; Smith, Isaac; Cobden.  
 3123; Forsyth, John, deceased (J. J. and R. F. Forsyth, executors); Murrayville.  
 3425; Fort, Alfred Thomas; Ouyen.  
 698; Fowler, William Henry; Kerang.  
 3946; Frankel, James Frederick; Patchewollock.  
 3768; Frew, Walter Alexander; Yaapeet.  
 3990; Free, Adeline Ellen; Cowangie.  
 2739; Fletcher, William Henry; Lake Boga.  
 3151; Flavel, John Robert; Yaapeet.  
 3338; Gould, Arthur Wilfred; Rainbow.  
 3794; Gormann, Friedrich Wilhelm; Sea Lake.  
 3064; Goodrem, William Henry, deceased (Mrs. L. E. Goodrem, executrix); Ouyen.  
 3448; Gibson, Samuel Mowbray; Chinkapook.  
 3779; Gibson, Alexander Irvine; Chinkapook.  
 1655; George, John Thomas; Ouyen.  
 3136; Geary, Jane; Chillingollah.  
 3893; Gaylard, Henry Jubilee; Cocamba.  
 3403; Gale, William Charles Chester; Merrince.  
 3496; Friebe!, Friedrich Wilhelm, deceased (Perpetual Executors and Trustees Association of Australasia Ltd., executors); Rainbow.

W. J. EVANS, Deputy Secretary,  
Farmers' Debts Adjustment Board.

20th August, 1946.

## INDUSTRIAL AND PROVIDENT SOCIETIES ACT 1928.

NOTICE is hereby given that a society called the "Peninsular Co-operative Society Limited" is registered, under the provisions of the above Act.

\*Given under my hand this thirteenth day of August, 1946.

A. E. RASMUSSEN,  
Registrar of Friendly Societies.

## COUNTRY ROADS BOARD.

NOTICE is hereby given that, whereas the Board is of the opinion that, having regard to the nature of the construction of the main road described hereunder, the use on the said main road of motor cars, the weight of which and of the load (if any) carried thereon exceeds (six) 6 tons, should be prohibited, the Board, in exercise of the powers conferred upon it by section 11 (1) of the *Motor Car Act 1928* (No. 3741), as amended by section 24 of the *Motor Car Act 1930* (No. 3901), doth prohibit the use on main road described of motor cars, the weight of which and of the load (if any) carried thereon exceeds six (6) tons.

Main road referred to above—

SKENE'S CREEK-ROAD, in the Shire of Otway.

By order,

R. JANSEN,

Secretary.

Melbourne, 8th July, 1946.

## State Electricity Commission Act 1934.

## STATE ELECTRICITY COMMISSION OF VICTORIA.

## ELECTRICAL APPROVALS BOARD.

IN accordance with the requirements of the Electrical Approvals Regulations—Proceedings of Electrical Approvals Board, the State Electricity Commission of Victoria hereby gives notice that the following appointment has been made, pursuant to the provisions contained in section 7 of the *State Electricity Commission Act 1934*, viz.:—

BRYAN HARPER MILLER

as Chairman of the Electrical Approvals Board, to take effect on and from the 16th day of August, 1946, in the place of David Dunham.

Dated the 21st day of August, 1946.

W. J. PRICE,

Secretary.

SUBJECT to any necessary excisions, &c., it is proposed to grant the following leases:—

8997, Castlemaine; Charles Edmund Cording and Jeremiah Murphy; 46a. 2r. 24p.; Parish of Castlemaine.

7047, Mineral; Victoria Tile Co. Pty. Ltd.; 13a. 0r. 3p.; Parish of Bungal.

## APPLICATION FOR MINING LEASE ABANDONED.

8123, Beechworth; Robert James Woodward; 30 acres; at Harrietville.

## CONSENTS GRANTED TO TRANSFER MINING LEASES.

7976, Beechworth; Adelong Gold Estates N. L.; to Harrietville (Tronoh) Ltd.

8957, Beechworth; Adelong Gold Estates N. L.; to Harrietville (Tronoh) Ltd.

## MINING LEASES GRANTED.

8149; Beechworth; J. Aylward and F. W. Abbott.

8151; Beechworth; W. Aylward and F. W. Abbott.

## TAILINGS LICENCES GRANTED.

1950, Tailings Licence; Samuel H. Doran.

1947, Tailings Licence; Precious Metals Recovery N. L.

1967, Tailings Licence; Ernest A. Waller.

1968, Tailings Licence; Hume Pipe Company (Australia) Ltd.

## WATER RIGHT LICENCE GRANTED.

1189, Water Right Licence; Walter James Pabner.

W. G. MCKENZIE,

Minister of Mines.

## MINING LEASES DECLARED VOID.

8185, Castlemaine; C. H. Schultz.

8592, Castlemaine; Daylesford (Italian Hill) Deep Leads N. L.

6856, Maryborough; John Dickson.

GEO. BROWN,

Secretary for Mines.

THE STATE SAVINGS BANK OF VICTORIA  
CREDIT FONCIER.

MONTHLY STATEMENT of Credit Foncier Debentures, Mortgage Bonds, Advances, and Money in Hand, published in accordance with the provisions of the State Savings Bank Act.

	Debentures Made and Issued in course of Issue.		Credit Foncier Stock Inscribed.	Amount Received from Sale of Stock and Debentures.	Provision for Discount on Debentures and Stock.	Redeemed.		Debentures Current.		Credit Foncier Debenture Stock Current.			Stock in exchange for Debentures Redeemed.
	Number of Debentures.	Amount of Debentures.				Debentures.	Credit Foncier Debenture Stock.	Held by Public.	Held by State Savings Bank.	Total.	Owned by Public.	Owned by State Savings Bank.	
Total from last return, 30th June, 1946 ..	52,147	£ 219,109,450	£ 20,412,155 0 0	£ 236,524,776 10 7	£ 308,363 18 9	£ 210,657,750	£ 14,938,435	£ 8,000,000	£ 8,451,700	£ 4,540,770	£ 932,950	£ 5,473,720 0 0	£ 2,564,400
For month ending 31st July, 1946 ..	..	..	200 0 0	..	..	200 ..	-200 ..	..	-200 ..	200 ..	..	200 0 0	200
Total at 31st July, 1946 ..	52,147	£ 219,109,450	£ 20,412,355 0 0	£ 236,524,776 10 7	£ 308,363 18 9	£ 210,657,950	£ 14,938,435	£ 8,000,000	£ 8,451,500	£ 4,540,970	£ 932,950	£ 5,473,920 0 0	£ 2,564,600

\* Including Debentures for £121,550, which had been issued in exchange for Mortgage Bonds, and have since been redeemed and cancelled.

MORTGAGE BONDS.

43,244 Mortgage Bonds made and issued for .. ..	£1,083,600 0 0
<b>MORTGAGE BONDS REDEEMED—</b>	
By Repurchase .. ..	£926,675 0 0
" Repayment of Mortgage Principal .. ..	1,375 0 0
" Ballot .. ..	34,000 0 0
" Exchange for Debentures .. ..	121,550 0 0
Current .. ..	Nil
Amount received on sale of Mortgage Bonds .. ..	£1,083,650 3 10

NOTE.—No Mortgage Bonds have been issued since 16th January, 1901.

Countersigned—  
N. R. WILLIAMS, General Manager of the State Savings Bank of Victoria.  
W. H. COVE, Deputy Auditor-General for Victoria.  
Melbourne, 14th August, 1946.

	ADVANCES.		Amount of Money in Hand.
	Total Amount of Advances Made.	Balance, including Repayments in Advance.	
Amounts received in Repayment of Advances.	£ 42,123,326 16 10	£ 11,784,536 12 8	£ 3,603,750 0 0
Total from last return, 30th June, 1946 ..	£ 53,907,863 9 6	£ 11,685,035 16 0	£ 303,764 4 1
For month ending 31st July, 1946 ..	72,514 10 5	-89,500 16 8	250,000 0 0
Total at 31st July, 1946 ..	£ 53,980,377 19 11	£ 11,685,035 16 0	£ 79,453 16 10

JNO. KEAN,  
JAS. C. GATES, } Commissioners of the State Savings Bank of Victoria.



## LICENCES TO OCCUPY UNUSED ROADS—continued.

Number of Licence.	Name and Address of Licensee.	Municipality.	Parish.	Abutting— Allotments and Sections.	Area.		Fee for Licence.		Date of Issue of Licence.	Date of Expiry of Licence.
					A. R. P.	£ s. d.	£ s. d.			
34729	Bockworth Court Pastoral Co. Pty. Ltd., 139-141 Franklin-street, Melbourne	Clunes ..	Clunes ..	East of 44, 45, section 5, and 21K ..	5 0 11	1 0 3	1.1.45	31.12.47		
34730	Condon, Victoria Jane, Pennyroyal	Winchelsea	Bambra ..	West, north, and east of School Reserve; south of School Reserve; thence east to Pennyroyal Creek (southern part of 49A)	5 0 0	0 5 0	1.1.46	31.12.48		
34731	Toohy, J. P. and J. V., Millbrook	Buninyong	Kerit Baroot	South of 2, section 5 ..	4 2 18	2 6 3	1.1.45	31.12.47		
34732	Parkor, N. S., Linton ..	Hampden	Borriyalook (Mt. Bute estate)	Western half of N of part 23 of A; west of 23 of A	4 2 30	0 11 9	1.1.46	31.12.48		
34733	Ritchie, W. S., and Campbell, J. P., Camperdown	Hampden	Corangamite	West of 41A, 41B ..	7 3 24	1 19 6	1.1.46	31.12.48		
34734	Bourquin, F. G., Steiglitz ..	Bannockburn	Durrid-warrah	West of 70A ..	1 3 0	0 2 6	1.1.46	31.12.48		
34735	Maroko Pty. Ltd., "Kurweeton," Camperdown	Hampden	Perarra ..	East and west of 59A, 59B; east of 57A, 58A, and 58B	27 2 8	3 9 0	1.1.46	31.12.48		
34736	Molan, C. F., South Ecklin	Heytesbury	Brucknell ..	Portion of road north of part of 19B, commencing 1,800 links from eastern end of road; thence west for 2,238 links	2 0 38	0 2 6	1.1.46	31.12.48		
34737	Sharp, S. G., 26 Swanston-street, Terang	Heytesbury	Brucknell ..	Portion of road south of part of 7, from south-east boundary; thence west for 2,022 links	3 0 0	0 2 6	1.1.46	31.12.48		
34738	The Secretary, Education Department	Ararat ..	Wickliffe South	North-east of 4, 5, 6, 7, section A, town of Wickliffe	0 2 16	0 2 6	1.1.46	31.12.48		
34739	Holmes, E. S. (Mrs.), "Launchley," Ascot	Hampden	Toolirook	Through 7B, 7A, 8B, section 12	5 0 0	1 5 0	1.1.46	31.12.48		
34740	Rowler, T., Snake Valley ..	Ripon ..	Chepstowe	South of 2C, 2D, section 13; between 2D, 2E, section 13	7 0 0	1 2 9	1.1.46	31.12.48		
34741	Belfrage A. junior, Drysdale	Bellarine ..	Bellarine ..	South of C and D, section 3	4 0 0	1 0 0	1.1.46	31.12.48		
34742	Hamlyn, S. E., Church-street, West Geelong	Corio ..	Moorpanyal	Part of road north of 6 of section 14	1 3 24	1 8 0	1.1.46	31.12.48		
34743	Archer, T. S. L., Woorndoo	Mortlake ..	Towanway	South of 37B, 38B, west of part 38A, south of part 38A	11 0 0	1 18 6	1.1.46	31.12.48		
34744	Stewart, Norman George, Mollonghip	Bungaree ..	Dean ..	North of 3, section 9	2 0 0	1 10 0	1.1.46	31.12.48		
34745	Thompson, J. S., Tarneit-road, Werribee	Ballan ..	Beremboke	East of 4A, section B	6 2 0	0 13 6	1.1.46	31.12.48		
34746	Waterfall, G. C., the younger, Timboon	Heytesbury	Brucknell ..	West of 81 ..	2 0 0	0 2 6	1.1.46	31.12.48		
34747	King, Ronald Slater, 6 Brophy-street, Ballarat East	Creswick ..	Creswick ..	South of 2, section G	3 0 0	0 4 6	1.1.46	31.12.48		
34748	McWaters, Edwin Rey, Beaufort	Ripon ..	Mahkwullok	East of 2A, 2B, 3A, 3B, section 1; east of 2A, 2B, 3, section 2; east of 2A, 2B, 3B, section 2; east of 2B, 3, section 23; east of 2A, 2B, 3A, 3B, section 3; south of 4B, 3A, 3B, section 2; south of 4 and 3, section 23	56 2 32	9 18 6	1.1.46	31.12.48		
34749	Moffatt, D. McL., "Corra," Willaura	Mortlake ..	Towanway	South of 39A, 39B; west of 36A, 39A, 48A, 52CA	24 0 0	4 4 0	1.1.46	31.12.48		
34750	Ringin, David, Chepstowe	Ripon ..	Chepstowe	North of 5, 5A, section 10; east of 8B, section 10	10 1 11	1 12 6	1.1.46	31.12.48		
34751	de Clercq, Richard A., Woorndoo	Mortlake ..	Woorndoo	North of 109A, 110A, west of 109A	11 2 0	2 0 0	1.1.46	31.12.48		
34752	Nolan, John Vincent, Berri-nga	Grenville ..	Mindai ..	South of 5, 5A ..	2 1 0	0 7 9	1.1.46	31.12.48		
34753	Hughes, Wm. T., "Willow-Bryn," Barham Valley, Apollo Bay	Otway ..	Krambruk	Between 18c and 18D, section 2	1 0 0	0 2 6	1.1.46	31.12.48		
34754	Andrew, William Fairley, James Charles, Doris May, "Riverview," Timboon	Heytesbury	Brucknell ..	West part of 81B ..	3 0 0	0 3 0	1.1.46	31.12.48		
34755	Johnson, Leonard Thomas, Amphitheatre	Avoca ..	Glenlogie ..	West of 13, section A	3 0 10	0 3 0	1.1.45	31.12.47		
34756	Clarko, Charles Leslie, Manor	Hampden	Corangamite	South of 78B, 80A, 80B, west of G1, G2	18 0 0	4 10 0	1.1.46	31.12.48		
34757	Scherger, M., Jallukar, via Moyston	Ararat ..	Jallukar ..	North-west of 45A, section 1	2 0 7	0 6 0	1.1.46	31.12.48		
34758	Tepper, E. P. and K. W., Pomonal South	Ararat ..	Moyston West	Between 9 and 8 of A, north of part 8 of A	9 3 0	0 5 0	1.1.46	31.12.48		

LICENCES TO OCCUPY UNUSED ROADS—continued.

Number of Licence.	Name and Address of Licensee.	Municipality.	Parish.	Abutting— Allotments and Sections.	Area.		Date of Issue of Licence.	Date of Expiry of Licence.
					A. R. P.	E s. d.		
34759	Binks, Bros., Colbrook, via Ballan	Ballan ..	Moorarbool East	East of 18 .. ..	3 0 0	1 1 0	1.1.45	31.12.47
34760	Platt, Chas. H., Colbrook, via Ballan	Ballan ..	Moorarbool East	East of 17 .. ..	2 3 24	1 0 3	1.1.45	31.12.47
34761	Cox, H. S. and W. F., Miner's Rest	Ballaarat ..	Dowling Forest	West of 27, 34 ..	3 0 29	1 5 6	1.1.46	31.12.48
34762	Skuse, Francis, Lake Gilleear	Warrnambool	Mepunga ..	South of part 9A, 10, 12, 13	9 2 0	1 7 6	1.1.46	31.12.48
34763	Elliot, H. H., Gnotuk ..	Hampden	Colongulac	Northern part of east of A, section 6	0 2 5	0 10 6	1.1.46	31.12.48
34764	Schergor, Stanley Theodore, c/o Public Trustee, 412 Collins-street, Melbourne	Ararat ..	Moyston ..	North of 16A, 17A, 18A, west of 16A.	8 2 33	0 4 6	1.1.45	31.12.47
34765	Robinson, L., 405 Skipton-street, Ballarat	City of Ballaarat	Ballaarat ..	Portion of Raglan-street south, south of section 99, in the City of Ballaarat	0 1 0	0 12 6	1.1.46	31.12.48
34766	Simpkin, J. J., Lexton ..	Lexton ..	Township of Lexton	South of 38 .. ..	1 1 8	0 2 6	1.1.46	31.12.48
34767	Dellaca, R., 39 Lal Lal-street, Ballarat East	City of Ballaarat	Ballaarat ..	Part of Murphy-street extending for 10 chains south-westerly from Lal Lal-street, at Ballaarat East	1 0 0	0 2 6	1.1.46	31.12.48
34768	Slattery, Michael, 113 High-street, Terang	Heytesbury	Brucknell ..	Part north of 20, eastward for 2,000 links from north-western boundary	2 0 0	0 2 6	1.1.46	31.12.48
34769	Nolan, Bros., Berringa ..	Grenville ..	Mindai ..	North of 3B, west of 3 and 4	5 3 28	0 16 6	1.1.46	31.12.46
34770	Vassie, J. B., Kawarren, via Colac	Colac ..	Barongarook	Part west of 68 ..	7 2 0	0 7 6	1.1.46	31.12.48
34771	Walton, R. S. and W. R., "Wurrook South," Roke-wood	Leigh ..	Wurrook ..	North of 44, 47, 52, 113, 114, 115, 116, 117, 118, 119, 120, 137, 138, 139, 140, 151, 152, 156, 157, 158, 159, 160, 167, 168; south of 45, 46, 53; west of 113, 136, 137; south-east of 63, 64, 65, 66, 67; north-west of 55, 60	102 0 0	24 12 3	1.1.46	31.12.48
34772	Manifold, A. G., "Boortkoi," Hexham	Mortlake ..	Hexham East	North of 10, 11 ..	3 0 0	0 14 0	1.1.46	31.12.48
34773	Connor, John, Beremboke ..	Ballan ..	Ballark ..	North-west of 15A4 ..	2 0 0	0 8 0	1.1.46	31.12.48
34774	Kavanagh, M. J., "Bonnie Vale," Noorat	Mortlake ..	Kolora ..	Part west of 6A, section 9	1 1 0	0 5 9	1.1.46	31.12.48
34775	Gibson, M. L., Inverleigh ..	Bannockburn	Doroq ..	West of 62, 71, 80, section A	2 3 0	0 19 3	1.1.46	31.12.48
34776	McDonald, G. C., Mortlake	Mortlake ..	Ellerslie ..	East of 57 .. ..	1 0 0	0 6 0	1.1.46	31.12.48
34777	McConville, Wm. E., "Mindai Park," Cape Clear	Grenville ..	Mindai ..	East of 4A, 1, 17, 16, 28, section C	5 1 24	0 15 0	1.1.46	31.12.48
34778	Beggs, Arthur Ricardo, "Buln Ghiran," Beaufort	Ripon ..	Mahkwallok	East of 2A, 2B, 3A, 3B, section 6; east of 2B, section 5; east of 2A, 2B, 7A, 7B, section 8; east of 2A, 2B, 3A, 3B, section 7; south of 4B, 3B, section 6; south of 4B, 2B, section 5; south of 2B, 3A, 3B, section 5; south of 3A, 3B, section 8	56 0 4	9 16 3	1.1.46	31.12.48
34779	Allan, Ellen Frances, Framlingham	Mortlake ..	Framlingham East	West of part 33A, 2,076 links northerly from south-west angle	2 0 12	0 11 3	1.1.46	31.12.48
34780	Young, C. R., Gordon ..	Ballan ..	Moorarbool West	West of B5, section 9	4 2 0	4 2 0	1.1.46	31.12.48
35021	Leerson, C. H., Creek Junction P.O., via Violet Town	Benalla ..	Too-rour ..	Between 12 and 14, section G	3 0 0	0 2 6	1.1.45	31.12.47
35022	Read, W. F., "Melrose," Delegate River	Orbost ..	Kirkenong	North of 10A, between 10c, 10A, and 10B; between 10c and 10A	15 0 0	0 15 0	1.1.46	31.12.48
35023	Lewis, R. S., Omeo ..	Omeo ..	Bundara Munjic	Between 22 and 22A ..	6 0 0	0 2 6	1.1.46	31.12.48
35024	Coller, C. R. J., Eildon Weir, via Alexandra	Alexandra	Eildon ..	Between 5, 5A, 5B, and 2B, 2, 1A	5 3 0	0 2 9	1.1.46	31.12.48
35025	Brodorick, Y. K., Eildon Weir, via Alexandra	Alexandra	Eildon ..	Between 4A and 3 ..	2 2 0	0 2 6	1.1.46	31.12.48
35026	Johns, H. J., Omeo ..	Omeo ..	Cobungra ..	Between part of 152 and 153, 153A, 154	4 0 0	0 12 0	1.1.46	31.12.48
35027	Crocker, Vernon D., "Ashcombe," Violet Town	Violet Town	Boho ..	Through 52 and 53; north of eastern part of 52	19 0 0	0 19 0	1.1.46	31.12.48
35028	McMartin, Wm., "Warra-wee," Alexandra	Alexandra	Alexandra	East of part 1 ..	3 2 0	1 15 0	1.1.45	31.12.47

LICENCES TO OCCUPY UNUSED ROADS—*continued.*

Number of Licence.	Name and Address of Licensee.	Municipality.	Parish.	Abutting— Allotments and Sections.	Area.	Fee for Licence.	Date of Issue of Licence.	Date of Expiry of Licence.
35029	McMurtrie, T. J., Bullumwaal	Bairnsdale	Township of Bullumwaal	Between 1 of 9 and 12 of 5	A. R. P. 0 1 17	£ s. d. 0 2 6	1.1.46	31.12.48
35030	Crocker, E. H., Long Gully, Violet Town	Violet Town	Boho	Through 54, north of both parts of 54	20 0 0	1 0 0	1.1.46	31.12.48

Licences Nos. 34705, 34711, rent charged from 1st October, 1945.—Licences Nos. 34730, 34769, unlocked swing gates to be provided at each end of road.—Licences Nos. 34759, 34760, unlocked swing gates to be erected as provided by Shire Council.

L. W. GALVIN,  
Commissioner of Crown Lands and Survey.

Department of Lands and Survey (Unused Roads and Water Frontages Branch),  
Melbourne, 9th August, 1946.

## NOTICE.

ADMINISTRATION of the estate of each of the under-mentioned deceased persons has been granted to me, and creditors, next of kin, and all others having claims against the estate of any of the persons so mentioned are required to send particulars of their claims to the Public Trustee, No. 412 Collins-street, Melbourne, on or before the 23rd October, 1946, or they will be excluded from the distribution of the estate when the assets are being distributed:—

ANGERS, CHARLES, late of 59 George-street, Fitzroy, old-age pensioner, died 29th May, 1946, intestate.

\*BALDWIN, ARTHUR GEORGE, formerly of 6 Argyle-avenue, St. Kilda, but late of 1 Trymple-avenue, St. Kilda, gentleman, died 5th August, 1946.

\*BEADEL, KATHLEEN MAUD, late of 21 Vickery-street, Bentleigh, married woman, died 25th November, 1945.

†BEER, GLADYS SYBIL, late of 133 Pearson-street, West Brunswick, married woman, died 15th July, 1946.

BRADLEY, WILLIAM, late of 106 McPherson-street, Footscray, car builder, died 6th May, 1946, intestate.

\*BREAB, ELIZA ANN, late of 43 The Avenue, Windsor, spinster, died 7th June, 1946.

CAROLLTON, GEORGE WILLIAM, formerly of 23 Waltham-street, Richmond, but late of Mount Royal, Royal Park, bookseller, died 29th May, 1946, intestate.

CARROLL, MICHAEL, late of Mansfield, pensioner, died 27th June, 1946, intestate.

†COLLETT, LAVINIA CHARLOTTE, also known as Lavinia Charlett Collett, formerly of Amphitheatre, but late of Bur-rumbeet, married woman, died 9th December, 1942.

CORMACK, WILLIAM PETRIE, late of Heathfield-road, Brighton, medical practitioner, died 3rd June, 1946, intestate.

DAVENPORT, HENRY, late of 12 Fleet-street, Fitzroy, pensioner, died 19th June, 1946, intestate.

DAWSON, ELIZABETH IDA MAY, late of 15 Belmont-avenue, Malvern, married woman, died 16th June, 1946, intestate.

FEHMEL, RONALD WALTER, late of 44 Sycamore-street, South Caulfield, fitter and turner, died 16th June, 1946, intestate.

\*FLINTOFF, JOHN TOMLINSON, late of Harrismith, Western Australia, farmer, died 6th September, 1945.

GOODWIN, HENRY LOSEE, late of Kulwin, labourer, died 20th June, 1946, intestate.

HOPKINSON, ERNEST CHARLES, formerly of 134 Keele-street, Collingwood, but late of 13 Raleigh-grove, North Essendon, clerk, died 16th or 17th February, 1946, intestate.

HUDSON, ERNEST, late of 127A Campbell-street, Collingwood, labourer, died 13th June, 1946, intestate.

KENNY, JANET ISABEL, also known as Janet Kenny, formerly of Oxford-road, Croydon, but late of Cheltenham, pensioner, died 5th October, 1937, intestate.

LOUEY HAN, late of Finn-street, Bendigo, market gardener, died 4th June, 1946, intestate.

MARR, JAMES EDWARD, late of 1 Taranaki-avenue, East Brunswick, mechanic, died 4th September, 1941, intestate.

\*RIDDLE, ARTHUR WILLIAM, late of 27 Thomas-street, Unley, South Australia, electrical engineer, died 11th March, 1946.

SMITH, ENOCH, late of Burwood-road, Wantirna South, labourer, died 25th April, 1946, intestate.

THOMPSON, HARRIET, formerly of Scot-street, Camperdown, but late of Ballarat, widow, died 11th April, 1946, intestate.

TOOHEY, WILLIAM PATRICK, also known as Will Toohey, late of 87 Raglan-street, South Melbourne, retired, died 27th June, 1946, intestate.

\*WAKELING, ISABELLA, late of 122 Victoria-avenue, Albert Park, pensioner, died 21st July, 1945.

WHITE, JOSIAH JAMES, late of 487 Hawthorn-road, South Caulfield, railway employee, died 14th May, 1946, intestate.

WRIGHT, FREDERICK EDWIN, late of Australian Imperial Forces, soldier, died 1st March, 1945, intestate.

\* With the will annexed.

† According to the provisions of the will.

J. E. DON,  
Public Trustee.

Melbourne, 14th August, 1946.

## NOTICE.

ADMINISTRATION of the estate of \*Sidney Matthew Burns, formerly of 10 Gray-street, Yarraville, but late of 78 Henderson-street, Yarraville, mechanical engineer, deceased (who died on the 5th May, 1946), has been granted to me, and creditors, next of kin, and all others having claims against the estate are required to send in particulars of their claims to the Public Trustee, No. 412 Collins-street, Melbourne, on or before the 16th October, 1946, or they will be excluded from the distribution of the estate when the assets are being distributed.

\* With the will annexed.

J. E. DON,  
Public Trustee.

Melbourne, 16th August, 1946.

## 4 GEORGE VI. No. 4755, SECTION 6.

I HEREBY give notice that on the 9th August, 1946, I filed elections to administer the following deceased persons' estates, in accordance with section 6 of the *Public Trustee Act 1940*:—

ANGERS, CHARLES, late of 59 George-street, Fitzroy, old-age pensioner, died 29th May, 1946, intestate.

\*BEER, GLADYS SYBIL, late of 133 Pearson-street, West Brunswick, married woman, died 15th July, 1946.

CAROLLTON, GEORGE WILLIAM, formerly of 23 Waltham-street, Richmond, but late of Mount Royal, Royal Park, bookseller, died 29th May, 1946, intestate.

CARROLL, MICHAEL, late of Mansfield, pensioner, died 27th June, 1946, intestate.

†COLLETT, LAVINIA CHARLOTTE, also known as Lavinia Charlett Collett, formerly of Amphitheatre, but late of Bur-rumbeet, married woman, died 9th December, 1942.

CORMACK, WILLIAM PETRIE, late of Heathfield-road, Brighton, medical practitioner, died 3rd June, 1946, intestate.

DAVENPORT, HENRY, late of 12 Fleet-street, Fitzroy, pensioner, died 19th June, 1946, intestate.

DAWSON, ELIZABETH IDA MAY, late of 15 Belmont-avenue, Malvern, married woman, died 16th June, 1946, intestate.

FEHMEL, RONALD WALTER, late of 44 Sycamore-street, South Caulfield, fitter and turner, died 16th June, 1946, intestate.

GOODWIN, HENRY LOSEE, late of Kulwin, labourer, died 20th June, 1946, intestate.

HOPKINSON, ERNEST CHARLES, formerly of 134 Keele-street, Collingwood, but late of 13 Raleigh-grove, North Essendon, clerk, died 16th or 17th February, 1946, intestate.

HUDSON, ERNEST, late of 127A Campbell-street, Collingwood, labourer, died 13th June, 1946, intestate.

KENNY, JANET ISABEL, also known as Janet Kenny, formerly of Oxford-road, Croydon, but late of Cheltenham, pensioner, died 5th October, 1937, intestate.

LOUEY HAN, late of Finn-street, Bendigo, market gardener, died 4th June, 1946, intestate.

MARR, JAMES EDWARD, late of 1 Taranaki-avenue, East Brunswick, mechanic, died 4th September, 1941, intestate.

SMITH, ENOCH, late of Burwood-road, Wantirna South, labourer, died 25th April, 1946, intestate.

THOMPSON, HARRIET, formerly of Scot-street, Camperdown, but late of Ballarat, widow, died 11th April, 1946, intestate.

WRIGHT, FREDERICK EDWIN, late of Australian Imperial Forces, soldier, died 1st March, 1945, intestate.

\* According to the provisions of the will.

J. E. DON,  
Public Trustee.

412 Collins-street, Melbourne, C.I., 14th August, 1946.



CONTRACTS ACCEPTED.—(Series 1946-47.)

Contract No.	Particulars.	Amount.	Name of Contractor.	Charge against Vote or Fund.
GOVERNMENT PRINTER—				
Supply and delivery of Printing Paper, Writing Paper, &c., required by the Government Printer for the year 1946-47—				
863	Schedule No. 1.—Printing Paper, Writing Paper, &c.	Rates as per annex	Gordon and Gotch (Australasia) Ltd.	} Contingencies, 1946-47
864	" " "	"	Wiggins, Teape, and Alex. Pirie (Export) Ltd.	
865	" " "	"	B. J. Ball Pty. Ltd. ..	
866	" " "	"	Spicers and Detmold Ltd. ..	
867	" " "	"	Sands & McDougall Pty. Ltd.	
868	" " "	"	P. Rowe Pty. Ltd. ..	
869	" " "	"	Alex. Cowan and Sons Ltd. ..	
870	" " "	"	L. A. Wade Pty. Ltd. ..	
871	" " "	"	Edwards, Dunlop, & Co. Ltd.	
872	" " "	"	Harding and Halden Pty. Ltd.	

Approved—P. L. COLEMAN, Asst. Treasurer. 26.7.46.

ANNEX TO CONTRACTS Nos. 1946/863 to 1946/872.

Schedule No. 1.

PRINTING PAPER, WRITING PAPER, ETC.

- 1946/863—Gordon and Gotch (Australasia) Ltd. Security, £126.
- 1946/864—Wiggins, Teape, and Alex. Pirie (Export) Ltd. Security, £163.
- 1946/865—B. J. Ball Pty. Ltd. Security, £66.
- 1946/866—Spicers and Detmold Ltd. Security, £159.
- 1946/867—Sands and McDougall Pty. Ltd. Security, £12.
- 1946/868—P. Rowe Pty. Ltd. Security, £70.
- 1946/869—Alex. Cowan and Sons Ltd. Security, £131.
- 1946/870—L. A. Wade Pty. Ltd. Security, £83.
- 1946/871—Edwards, Dunlop, and Co. Ltd. Security, £202.
- 1946/872—Harding and Halden Pty. Ltd. Security, £28.

ADJUSTMENT OF CONTRACT RATES.

With the exception of Items 152, 248A, 257, 258, 262, 264, 267, and 308 to 313, all rates are subject to adjustment in accordance with the special conditions of the respective contracts.

Notification of such adjustments will be published in the *Government Gazette* as required.

Contracts for a number of items are subject to special conditions regarding availability of supplies, delivery dates, priority certificates, export and import licences, &c.

AGREEMENTS.

Where the name of the supplier opposite any item is shown in italics, with the sign (A), no contract has been executed nor security lodged; requirements of such items are to be purchased from the supplier named, under Tender Board Agreement.

B. British. C. Commonwealth.

Item No.	Description.	Quantity.	Rate.	Country of Origin.	Name of Contractor.
WHITE PRINTING PAPER.					
4	Sample No. 1— Double Royal, 38 lb., 25 in. x 40 in. .. .. .	1,000 reams	£ s. d. per ream. 0 19 6½	C.	L. A. Wade Pty. Ltd.
SUPER-CALENDERED PAPER.					
33	Sample No. 6— Quadruple Foolscap, 55 lb., 27 in. x 34 in. .. .. .	100 reams	1 8 3.4	C.	Gordon and Gotch (Australasia) Ltd.
36	Quadruple Crown, 72 lb., 30 in. x 40 in. .. .. .	1,500 ..	1 17 0.31	C.	Spicers and Detmold Ltd.
38	Reels, 39 in. .. .. .	75,000 lb.	per ton	C.	Edwards, Dunlop, and Co. Ltd.
			75,000 lb.		
38A	Sup. Cal. Double Imperial, 79½ lb., 30 in. x 44 in. .. .. .	750 reams	per ream. 2 0 9.05	C.	Gordon and Gotch (Australasia) Ltd.
					Wiggins, Teape, and Alex. Pirie (Export) Ltd.

§ Rate subject to surcharge of £2 10s. 4½d. per ton for packing in crates.

CONTRACTS ACCEPTED—continued.

Item No.	Description.	Quantity.	Rate.	Country of Origin.	Name of Contractor.
M.G. (LITHO.) PAPER.					
40A	Sample No. 7— Quadruple Crown, 80 lb., 30 in. x 40 in. .. .. .	100 reams	£. s. d. per ton 87 15 0*	C.	Australian Paper Manufacturers Ltd. (A)
TINTED BOND WRITING PAPER (STATIONERY).					
55H	Sample No. 12A— Buff Quadruple Foolscap, 40 lb., 27 in. x 34 in. .. .. .	100 reams	per ream 3 4 3	B.	Edwards, Dunlop, and Co. Ltd.
HAND-MADE PAPER (STATIONERY).					
58	Sample No. 13— Blue Laid Double Royal, 88 lb., 24 in. x 38 in. .. .. .	30 reams	16 1 5	B.	Wiggins, Teape, and Alex. Pirie (Export) Ltd.
LEDGER PAPER.					
63	Sample No. 14— Super Royal, 54 lb., 19 in. x 27 in. .. .. .	50 reams	5 1 11	B.	Wiggins, Teape, and Alex. Pirie (Export) Ltd.
CREAM LAID WRITING PAPER (STATIONERY).					
68A	Samples Nos. 15 and 16— Double Foolscap, 32 lb., 17 in. x 27 in. .. .. .	200 reams	0 17 5.56†	C.	Edwards, Dunlop, and Co. Ltd.
69	Quadruple, Foolscap, 48 lb., 27 in. x 34 in. .. .. .	2,000 reams	1 6 2.34†	C.	Alex. Cowan and Sons Ltd.
70	Double Large Post, 48 lb., 21 in. x 33 in. .. .. .	200 reams	1 6 2.34†	C.	L. A. Wade Pty. Ltd.
CREAM WOVE BOND WRITING PAPER (STATIONERY).					
83	Sample No. 18— Double Foolscap, 36 lb., 17 in. x 27 in. .. .. .	150 reams	2 16 1	B.	Edwards, Dunlop, and Co. Ltd.
84A	Double Large Post, 36 lb., 21 in. x 33 in. .. .. .	650 "	1 0 0.29	C.	} B. J. Ball Pty. Ltd.
84B	Quadruple Foolscap, 48 lb., 27 in. x 34 in. .. .. .	500 "	1 6 8.39	C.	
LOAN PAPER (STATIONERY).					
85	Sample No. 19— Medium, 34 lb., 17½ in. x 22 in. .. .. .	50 reams	6 11 9	B.	} Wiggins, Teape, and Alex. Pirie (Export) Ltd.
86	Double Foolscap, 50 lb., 17 in. x 27 in. .. .. .	75 " } T. H. Saunders, mould made	8 17 0	B.	
REINFORCED PAPER (STATIONERY).					
91	Sample No. 20— Reinforced Paper, 70 lb., 18 in. x 27 in. .. .. .	50 reams	15 3 8½	B.	Edwards, Dunlop, and Co. Ltd.
COLOURED BANK PAPER (STATIONERY).					
97	Sample No. 23— Pink Quadruple Foolscap, 28 lb., 27 in. x 34 in. .. .. .	250 reams	1 8 0	B.	Edwards, Dunlop, and Co. Ltd.
BLOTTING PAPER (STATIONERY).					
115	Sample No. 30— White Demy, 38 lb., 17½ in. x 22½ in., flat .. .. .	350 reams	1 3 11.14	C.	L. A. Wade Pty. Ltd.
BROWN PAPER (STATIONERY).					
124	Sample No. 31— Kraft, 80 lb., 29 in. x 45 in., flat M.F. .. .. .	750 reams	per ton 58 0 0*	C.	Australian Paper Manufacturers Ltd. (A)
COVER PAPER (STATIONERY).					
129	Sample No. 32— Wedgewood Blue, 20½ in. x 30½ in., 60 lb. .. .. .	50 reams	75 10 0	C.	} Australian Paper Manufacturers Ltd. (A)
131	Cream, 20½ in. x 30½ in., 60 lb. .. .. .	40 "	75 10 0	C.	
136	Hazel Brown, 23 in. x 36 in., 80 lb. .. .. .	40 "	75 10 0	C.	
137	Green, 23 in. x 36 in., 80 lb. .. .. .	30 "	75 10 0	C.	
140	Cream, 23 in. x 36 in., 80 lb. .. .. .	50 "	75 10 0	C.	

\* Rate less maximum rebate of £1 17s. 6d. per ton, less 2 per cent.—† Rate subject to surcharge of £3 0s. 5.4d. per ton for packing in cases.—|| Rate subject to 2 per cent. discount.

CONTRACTS ACCEPTED—continued.

Item No.	Description.	Quantity.	Rate.	Country of Origin.	Name of Contractor.
<b>TRACING CLOTH (STATIONERY).</b>					
<i>Sample No. 37—</i>					
162	Dull Back, 42 in. (25 yards), "Sapphire" .. .. .	75 rolls	per yard 0 3 7	B.	P. Rowe Pty. Ltd.
<b>PASTEBOARDS (STATIONERY).</b>					
<i>Sample No. 38—</i>					
156	Mottled, 4-sheet, 25½ in. x 30½ in., 44 lb. per gross .. .. .	2,000 gross	per ton 79 10 0	C.	Australian Paper Manufacturers Ltd. (A)
<b>GREY CHIP BOARDS (STATIONERY).</b>					
<i>Sample No. 39—</i>					
156*	Chip Board, 23 in. x 30 in., Grey '011/13 Calliper .. .. .	1 ton	per ton ..	C.	Purchase (Clause 4)
<b>SYSTEM BOARDS (STATIONERY).</b>					
<i>Sample No. 42—</i>					
167	Buff, 25½ x 30½ in., 6-sheet, 44 lb. per 100 boards .. .. .	5,000 boards	per 100 2 10 2½	B.	} Gordon and Gotch (Australasia) Ltd.
171	Fawn, 25½ in. x 30½ in., 6-sheet, 44 lb. per 100 boards .. .. .	3,000 "	2 10 2½	B.	
172	Primrose, 25½ in. x 30½ in., 6-sheet, 44 lb. per 100 boards .. .. .	3,000 "	2 10 2½	B.	
178	Fawn, 25½ in. x 30½ in., 4-sheet, 28 lb. per 100 boards .. .. .	5,000 "	1 11 11½	B.	
<b>STRAWBOARDS.</b>					
<i>Sample No. 43—</i>					
185	Imperial, 12 oz., 22½ in. x 32 in., 76 boards, 56 lb. .. .. .	40 bundles	per ton 24 5 0*	C.	} Australian Paper Manufacturers Ltd. (A)
186	Imperial, 16 oz., 22½ in. x 32 in., 56 boards, 56 lb. .. .. .	250 "	28 10 0*	C.	
189	Imperial, 36 oz., 22½ in. x 32 in., 25 boards, 56 lb. .. .. .	50 "	28 10 0*	C.	
203	Large Middle, 12 oz., 18½ in. x 23½ in., 122 boards, 56 lb. .. .. .	40 "	24 5 0†*	C.	
216	Double Foolscap, 16 oz., 18 in. x 27 in., 80 boards, 56 lb. .. .. .	50 "	28 10 0†*	C.	
<b>MILLBOARDS.</b>					
<i>Sample No. 44—</i>					
223	Imperial, 8xx, 32 in. x 22½ in., 24 boards 85 lb. .. .. .	5 bundles	..	B.	} Purchase (Clause 4)
227	Extra Royal 8xx, 21½ in. x 28½ in., 24 boards 72 lb. .. .. .	5 "	..	B.	
230	Royal, 10b, 26½ in. x 20½ in., 24 boards 84 lb. .. .. .	5 "	..	B.	
231	Royal, 8xx, 26½ in. x 20½ in., 24 boards 66 lb. .. .. .	10 "	..	B.	
235	Medium, 8xx, 23½ in. x 18½ in., 36 boards 78 lb. .. .. .	5 "	..	B.	
236	Medium, 8x, 23½ in. x 18½ in., 48 boards 78 lb. .. .. .	5 "	..	B.	
240	Crown, 8xx, 20 in. x 16½ in., 48 boards 77 lb. .. .. .	10 "	..	B.	
245	Double Foolscap, 8x, 18½ in. x 20 in., 48 boards 94 lb. .. .. .	5 "	..	B.	
248	Long Thin, 21 in. x 30 in., 77 boards 34 lb. .. .. .	5 "	..	B.	
<b>STATIONERY.</b>					
per roll					
248A	Tracing Paper, 30 in. x 50 yards, "Alliance," No. 2496 .. .. .	200 rolls	1 7 6	B.	Harding & Halden Pty. Ltd.
<b>ENVELOPES.</b>					
per 1,000					
257	10½ in. x 7½ in., pocket, gummed, Kraft, brown .. .. .	150,000	1 10 0	C.	} Spicers and Detmold Ltd.
258	15 in. x 6 in., pocket, gummed, Kraft, brown .. .. .	15,000	1 5 4	C.	
259	15 in. x 11 in., pocket, gummed, Kraft, brown .. .. .	10,000	..	C.	
262	7 in. x 5 in., pocket, gummed, Manilla .. .. .	150,000	0 14 6	C.	
264	5½ in. x 3½ in., pocket, gummed, Manilla .. .. .	100,000	0 9 3	C.	
267	6½ in. x 3½ in., window face, bankers, secretive, gummed .. .. .	150,000	0 16 0	C.	
<b>BOOKBINDERS' LEATHER.</b>					
per skin					
273	Basil, red, 30 in. x 27 in. .. .. .	180 skins	..	..	} Purchase (Clause 4)
274	Basil, green, 30 in. x 27 in. .. .. .	48 "	..	..	
275	Basil, black, 30 in. x 27 in. .. .. .	48 "	..	..	
276	Basil, blue, 30 in. x 27 in. .. .. .	48 "	..	..	
283	Roan, purple, straight-grained, 30 in. x 27 in. .. .. .	60 "	..	..	
287	Skiver, purple, paste-grained, 30 in. x 27 in. .. .. .	24 "	..	..	
290	Skiver, purple, straight-grained, 30 in. x 27 in. .. .. .	36 "	..	..	
292	Skiver, mauve, smooth, 30 in. x 27 in. .. .. .	120 "	..	..	
294	Skiver, basil, 30 in. x 27 in. .. .. .	24 "	..	..	
295	Banding Vellum, white, 32 in. x 22 in. .. .. .	12 "	..	..	
<b>BOOKBINDERS' CLOTH.</b>					
per yard					
308	Purple, 36 in. x 36 yards .. .. .	25 rolls	0 1 6½	B.	} P. Rowe Pty. Ltd.
309	Green, 36 in. x 36 yards .. .. .	25 "	0 1 6½	B.	
310	Black, 36 in. x 36 yards .. .. .	6 "	0 1 6½	B.	
311	Brown, 36 in. x 36 yards .. .. .	25 "	0 1 6½	B.	
312	Red, 36 in. x 36 yards .. .. .	25 "	0 1 6½	B.	
313	Blue, 36 in. x 36 yards .. .. .	25 "	0 1 6½	B.	

\* Rate less maximum rebate of £1 5s. per ton, less 2 per cent.—† Rate plus cutting charge of £1 5s. per ton.—  
|| Rate subject to 2 per cent. discount.

## CONTRACTS ACCEPTED.—(Series 1946-47.)

## VICTORIAN RAILWAYS.

22. Wood Fibre Board—Masonite Tempered Presdwood at rates (Contract 56028).—H. Beecham and Co. Pty. Ltd.  
 23. Mining Timbers at rates (Contract 55840).—Arthur Forster. 24. Ten-ton Crane Crab for £713 10s. (Contract 55724).—E. A. Austin Pty. Ltd. 25. Locomotive Rocker Parts, Item 2, at £53 5s. per set (Contract 55708).—Bradford, Kendall Ltd.  
 26. Mining Timbers at rates (Contract 55839).—H. Banks.  
 27. Mining Timbers at rates (Contract 55835).—J. A. Russell.  
 28. Mining Timbers at rates (Contract 55834).—J. R. Elkin.  
 29. Mining Timbers at rates (Contract 55833).—G. Allan.  
 30. Mining Timbers at rates (Contract 55832).—W. Banks, jr.  
 31. Mining Timbers at rates (Contract 55673).—C. G. Wilkinson.  
 32. Mining Timbers at rates (Contract 55842).—A. G. Wilkinson.  
 33. Wood Fibre Board, Masonite Tempered Presdwood at rates (Contract 56027).—Gunnerson, Nosworthy Pty. Ltd.  
 34. Sewerage (House connexion) to Departmental Residence at MacArthur-street Crossing, Bairnsdale, for £135 12s. 9d. (Contract 55745).—A. J. Legg.  
 35. Air Conditioning Equipment at rates (Contract 55721).—W. G. Crossle and Co.

By order of the Victorian Railways Commissioners,

E. C. EYERS, Secretary. 16.8.46.

## BURIALS OF DESTITUTE PERSONS (COUNTRY TOWNS, ETC.).

## WIMMERA DISTRICT.

861. Rupanyup—Coffins: Adults, 95s.; Children, 55s.; Graves: Adults, 40s.; Children, 25s.; Mileage, 25s. first mile, 2s. 6d. each extra mile, from 1st July, 1946, to 30th June, 1947.—V. R. Crouch.

## SUPPLY OF PRISONERS' MEALS IN LOCK-UPS.

862. Mornington—Breakfast and Tea, 1s. 6d.; Hot Dinner, 2s., from 1st July, 1946, to 30th June, 1947.—A. C. Campbell.  
 W. H. RUTHERFORD, Secretary to the Tender Board.  
 19.8.46.

## PUBLIC WORKS.

715. (2) Pentridge, Wire Netting Factory, cartage of wire netting for twelve months, from 1st July, 1946, to 30th June, 1947, rates.—F. C. Butcher.
716. (1) Melbourne, &c., Government Buildings, glazing for twelve months, from 1st July, 1946, to 30th June, 1947, rates.—H. White.
717. (4) Melbourne, Government Buildings, maintenance of electric lifts in Police Headquarters and Chief Secretary's Office for twelve months, from 1st July, 1946, to 30th June, 1947, £110.—Edmiston and O'Neill Pty. Ltd.
718. (4) Melbourne, maintenance of electric lifts in Department of Agriculture, Licences Reduction Office, Titles Office, and Government House for twelve months, from 1st July, 1946, to 30th June, 1947, £115 15s.—The Austral Otis Engineering Co. Ltd.
719. (1) Melbourne, Government Buildings, maintenance of hydraulic lifts for twelve months, from 1st July, 1946, to 30th June, 1947, £125.—Johns and Waygood Limited.
720. (1) Melbourne, Government Buildings, sweeping chimneys, &c., for twelve months, from 1st July, 1946, to 30th June, 1947, rates.—V. V. Evans.
721. (2) Alexandra, State School No. 912, removal of school residence from State School No. 2841, Cathkin, and re-erection at Alexandra, £595 10s.—D. J. Bullen.
722. (1) Ararat, Mental Hospital, supply and delivery of wood-working machines, &c., £457.—Wolfenden Bros. Pty. Ltd.
723. (1) Ashbourne, State School No. 1333, repairs and painting, £107.—F. H. Smith.
724. (4) Auburn, State School No. 2948, provision of display boards, £159.—R. B. Hallett.
725. (1) Ballarat, School of Mines, repairs to fencing and construction of brick retaining-wall, £269 8s.—W. G. Feary and Sons.
726. (1) Ballarat, School of Mines, electrical installation, new workshop block, £1,688.—Bayley and Grimster Pty. Ltd.
727. (2) Ballarat, Mental Hospital, supply and installation of three (3) steam oven cookers, in main kitchen, £617.—Anderson and Ritchie Pty. Ltd.
728. (4) Ballarat, Mental Hospital, supply and installation of electric refrigerator in male hospital ward, £115 15s.—Rickards Bros. Pty. Ltd.
729. (3) Ballarat, Mental Hospital, erection of two brick shelter pavilions, £2,339 11s.—H. G. Feary.
730. (5) Baringhup, State School No. 1087, repairs and painting, £212.—H. Sloan.
731. (1) Beechworth, Ovens District Hospital, new portico, painting, repairs, and louvres, £920.—D. Canfield.
732. (2) Bendigo, School of Mines, re-conditioning and erection of heat engines, laboratory equipment, £197.—F. W. Milne and Son.
733. (3) Bendigo East, State School No. 3893, repairs and internal painting, £211.—E. J. Boyd.
734. (2) Blackwood, State School No. 1074, repairs and painting, £127 8s.—R. House.
735. (3) Box Hill South, State School No. 4138, enclosing verandah, £190.—Linnell-French and Lane.
736. (1) Brighton, Technical School, providing and erecting black-out blinds and blind boxes in new classrooms, £221 16s. 6d.—Wm. Morgan and Company.
737. (4) Brighton, Technical School, supplying and fixing rostrum and drawing benches in new classrooms, £136 7s. 6d.—W. R. Brooks.
738. (1) Brown Coal Mine, State School No. 3067, repairs and painting, £1,100.—A. K. McCrabb.
739. (1) Bruthen, State School No. 1141, repairs to school and residence, £238 5s. 5d.—F. W. West.
740. (3) Buchan South, State School No. 3256, painting and repairs, £175.—C. Sedan.
741. (2) Buninyong, Police Station, repairs, painting, &c., £198.—E. E. Hutchings.
742. (2) Burnley, School of Primary Agriculture, removal of two army huts from Mount Martha and re-erection, £210.—J. McDonald Richardson Pty. Ltd.
743. (3) Burnley, Horticultural Gardens, erection of glass-house, Plant Research Laboratory, £2,775.—R. F. Anderson.
744. (2) Caniamba, State School No. 2230, repairs, painting, &c., school building and residence, £111.—L. A. Skelton.
745. (8) Canterbury, State School No. 3572, repairs and painting, £567 8s.—Aston and Lyons.
746. (2) Carlsruhe, State School No. 115, repairs and painting, £128 11s.—R. House.
747. (1) Carlton, Education Department Furniture Depot, removal of army hut from Coode Island and re-erection, £130.—Yellow Express Carriers Ltd.
748. (5) Carlton, Teachers' Training College, repairs and painting, £196 15s.—E. E. Thomas.
749. (2) Castlemaine, State School No. 119, extension of partitions, new sliding doors, &c., £235 10s. 6d.—W. T. Laby.
750. (3) Charlton, Court House, repairs and renovations, £152 8s.—O. J. McLoughlan.
751. (12) Clifton Hill, State School No. 1360, internal painting to school building, £466.—L. W. Friezer.
752. (2) Colignan, State School No. 4340, removal of school building from Boonoonar and re-erection, £415.—G. L. Ross.
753. (1) Darlimurla, State School No. 2782, re-blocking school building, repairs, and painting, £179 5s.—H. A. Williams.
754. (1) Daylesford, State School No. 1609, repairs to roof, &c., £105.—W. J. Hill.
755. (3) Camberwell East, Girls' School, repairs to eaves gutters, £101.—H. D. Munro.
756. (3) Doncaster, State School No. 197, renovations, painting, and repairs, £245.—J. W. Wood.
757. (3) Dookie, Agricultural College, removal of seven army huts from Mangalore and re-erection, £6,300.—S. B. Parsons.
758. (2) Dookie, Agricultural College, supply and installation of two steam oven cookers, £308.—Anderson and Ritchie Pty. Ltd.
759. (2) Elmhurst, State School No. 959, alterations, additions, and repairs, £573 10s. 6d.—J. J. Brennan.
760. (4) Ensay North, State School No. 3518, painting and repairs, £146.—D. Maher.
761. (4) Fairfield, Infectious Diseases Hospital, supply of wardrobes, nurses' and sisters' quarters, £204.—B. E. Purnell.
762. (4) Fairfield, Infectious Diseases Hospital, repairs to discharge house, £312.—F. T. Pulling.
763. (5) Flaggy Creek, State School No. 3453, repairs and painting, £195 16s.—P. A. Cox.
764. (2) Footscray, Technical School, Nicholson-street, supply and installation of core-drying oven, £710.—The Metropolitan Gas Company.
765. (2) Foster, State School No. 1172, repairs, painting, &c., residence, £325 10s.—H. N. Evans.
766. (1) French Island, McLeod Settlement, supply and delivery of one Diesel engine, £217 10s.—Southern Cross Windmills and Engines Pty. Ltd.
767. (2) Geelong, Emergency Housing, Albert Coffee Palace, alterations and extensions to electrical installations, £322 7s.—Electric Motor Guarantee and Trading Co. Pty. Ltd.
768. (3) Geelong, Emergency Housing, Albert Coffee Palace, additions and alterations to hot-water service, £428.—Nott and Drew Pty. Ltd.
769. (2) Geelong, High School, general plumbing, £586 15s. 6d.—J. Nott and Company.
770. (3) Glengarry, State School No. 2888, painting and repairs, school building and residence, £510.—J. McMahon.

771. (3) Glenlyon, State School No. 266, repairs and painting, £143 16s.—M. Leggo.
772. (3) Hamilton, Base Hospital, Tuberculosis Chalet, supply and installation of electric refrigerator, £103.—Quirk's All-Australian Refrigerators Pty. Ltd.
773. (3) Horsham, Base Hospital, Tuberculosis Chalet, supply and installation of electric refrigerator, £103.—Quirk's All-Australian Refrigerators Pty. Ltd.
774. (2) Kew, Mental Hospital, installation of additional lighting and re-conditioning of existing avenue lighting, £187 10s. 6d.—J. Joseph.
775. (3) Kew, Mental Hospital, supply and installation of refrigerator, £110.—Quirk's All-Australian Refrigerators Pty. Ltd.
776. (3) Kew, Mental Hospital, equipment in nurses' laundry and matron's quarters, £284.—H. D. Munro.
777. (4) Kew, Mental Hospital, provision of shower, &c., in farm workers' cottage, £169.—H. J. Gauntlett.
778. (3) Kew, Mental Hospital, supply, &c., of steam boiler and steel stack, children's cottages, £685.—Miller Bros. Iron-works.
779. (1) Leongatha, High School, removal of army hut from North Geelong and re-erection, £187 17s. 6d.—I. V. Osborne.
780. (1) Lismore, Police Station, erection of new residence, office, and out-buildings, £2,698 10s.—Russell and Hemsworth.
781. (2) Lubeck, State School No. 2494, repairs and painting, £118 15s.—W. C. Barker.
782. (2) Manangatang, State School No. 3863, removal of Lands Office from Kooloonong, and re-erection, &c., £390 10s.—M. Berg.
783. (5) Melbourne, City Court, Russell-street, external repairs and painting, £292.—G. H. Gahan.
784. (1) Melbourne, Education Department, painting and decorating centre section, &c., £682 10s.—J. Friedmann.
785. (2) Melbourne, Emily McPherson College of Domestic Economy, alterations to electrical installation, first floor, £649 15s.—R. G. Harris Pty. Ltd.
786. (1) Melbourne, Emily McPherson College of Domestic Economy, sewerage installation, £1,914 4s.—Bendle and Porter.
787. (1) Melbourne, Public Library, &c., bronzework, &c., to main entrance door, £120 5s.—Wm. Bedford Ltd.
788. (2) Melbourne, Police Depot, St. Kilda-road, supply and installation of steam oven cooker, £206.—Anderson and Ritchie Pty. Ltd.
789. (1) Melbourne, Public Works Department, supply of filing cabinets and plan presses for District Architect's Offices, £332 17s. 6d.—B. E. Purnell.
790. (4) Melbourne, Public Works Department, supply and delivery of hot cathode fluorescent lighting equipment, £177 17s. 3d.—Australian General Electric Pty. Ltd.
791. (2) Mickleham, State School No. 1051, repairs and painting, £142 5s.—Baker Bros.
792. (3) Mildura, Base Hospital, Tuberculosis Chalet, supply and installation of electric refrigerator, £103.—Quirk's All-Australian Refrigerators Pty. Ltd.
793. (1) Mildura, Police Station, additions, repairs, painting, and fencing, £403 19s. 6d.—A. and K. Dunn.
794. (1) Millgrove, State School No. 3655, repairs and painting, £260.—D. B. Tincknell.
795. (3) Mirboo North, State School No. 2383, repairs, painting, &c., residence, £169 10s.—J. P. Carter.
796. (3) Mitcham, State School No. 2904, general repairs and painting, £560.—H. C. Goldberg.
797. (2) Mitiamo, Police Station, repairs and renovations, £198 7s.—Saunders and Ross.
798. (3) Monbulk, State School No. 3265, painting, repairs, and fencing, £498.—D. B. Tincknell.
799. (3) Mont Park, Gresswell Sanatorium, supply and installation of exhaust system, main kitchen, £222.—Condon and Guy.
800. (2) Mont Park, Mental Hospital, external repairs and painting, secretary's residence, £176 15s. 6d.—F. J. White.
801. (4) Mont Park, Mental Hospital, supply, delivery, and installation of refrigerator for butter storage, main store, £576 10s.—Rickards Bros. Pty. Ltd.
802. (4) Mont Park, Mental Hospital, supply and installation of sixteen (16) electric refrigerators, £2,136 5s.—Rickards Bros. Pty. Ltd.
803. (4) Mont Park, Mental Hospital, supply and installation of one (1) electric refrigerator, farm workers' block, £152 10s.—Rickards Bros. Pty. Ltd.
804. (3) Mont Park, Mental Hospital, external repairs and painting, engineer's residence, £197.—E. Lewis.
805. (4) Mont Park, Mental Hospital, supply and installation of two (2) washing machines, £745.—Robert Lilley and Co.
806. (2) Mont Park, Mental Hospital, supply and delivery of six (6) broadcast receivers, £118 6s. 6d.—Lawrence and Hanson Electrical Pty. Ltd.
807. (1) Murrayville, Consolidated State School No. 3743, sinking of a bore hole, £242.—R. F. Forsyth.
808. (3) Napoleons, State School No. 1072, painting and repairs, school and residence, £185.—L. A. Milne.
809. (7) Northcote, State School No. 4329, repairs and painting, £300.—W. Hesketh.
810. (4) Notting Hill, State School No. 4305, general repairs and painting, £156.—D. Maher.
811. (6) Oakleigh, State School No. 4214 (nursery), repairs and painting, £144.—R. Bryant.
812. (1) Oakleigh, Technical School, plumbing, £330.—E. S. Ashton.
813. (4) Omeo, Police Station, repairs, painting, &c., £199 5s.—Cousins and Pike.
814. (2) Pascoe Vale, Police Station, electrical installation, police station and residence, £118 12s. 9d.—W. R. Gilchrist.
815. (3) Paraparap, State School No. 3634, repairs and painting, £129 13s. 6d.—R. Doolan.
816. (2) Pira, State School No. 4278, repairs and painting, school building, &c., £146.—H. A. Williams.
817. (2) Port Albert, State School No. 490, painting and repairs, residence, £102 15s. 6d.—S. Fennis.
818. (1) Port Albert, State School No. 400, new shelter shed, repairs and painting, &c., £389 10s.—J. Coulthard.
819. (8) Prahran, Police Station, alterations and renovations, £266.—R. Hallett.
820. (2) Rosedale, Police Station, alterations and repairs, £131 6s.—T. A. Duck.
821. (1) Rutherglen, Police Station, repairs and painting, £317 17s. 6d.—Buscall and Cullen.
822. (2) Sale, Technical School, installation of ventilating cowls, £145 5s.—H. J. Templeton.
823. (1) Sandringham, Technical School, supply and installation of electrically-heated hot-water service, £185 10s.—R. Nation.
824. (4) Sea Lake, Police Station, repairs and painting, £225.—Kennedy and Power.
825. (1) Serviceton, State School No. 2831, painting and repairs, school and residence, £356 15s.—G. Lange.
826. (2) Soora, Police Station, repairs and painting to residence, office, &c., and fencing, £450 10s.—H. Snell.
827. (2) Trentham, State School No. 1588, repairs and painting, £277 10s.—M. Maher and Sons.
828. (2) Wandin East, State School No. 3934, repairs and painting, and repairs and renewals to fencing, £348.—D. B. Tincknell.
829. (3) Wangaratta, Base Hospital, Tuberculosis Chalet, supply and installation of electric refrigerator, £103.—Quirk's All-Australian Refrigerators Pty. Ltd.
830. (1) Warrandyte South, State School No. 3476, repairs and painting, £131 18s.—Baker Bros.
831. (3) Warrnambool, High School, renovations and repairs, £144 5s. 9d.—Hammond and Sons.
832. (3) Whorouly South, State School No. 4208, repairs and painting, £112 15s.—J. Barker.
833. (2) Woodford, State School No. 648, conversion of classroom to temporary quarters for head teacher, £118 10s.—S. McKenzie.
834. (1) Wurruk, State School No. 2518, repairs and painting, £280.—Wynd Bros.
835. (4) Yarrowonga, State School No. 1819, alterations and renovations, £218 10s.—O. Syverson.
836. (1) Geelong, Emergency Housing, Albert Coffee Palace, supply, &c., of electric stoves, £181 6s.—Vulcan Electrics.
837. (1) Larundel, Mental Hospital, installation of electric light and power, £900.—S. Pearce.
838. (3) Bendigo, School of Mines, workshop equipment, £654 14s.—McPherson's Pty. Ltd.
839. Extras on Contract, Serial No. 870/1945-46, £65 1s.
840. Extras on Contract, Serial No. 1421/1945-46, £30 4s.

P. J. KENNELLY, Commissioner of Public Works. 13.8.46.

#### ORDERS IN COUNCIL.—(Series 1946-47.)

##### DEPARTMENT OF PUBLIC INSTRUCTION.

841. One new Visby lathe for Footscray Technical School, £388 15s. 6d.—Munitions Department, Maribyrnong Disposal Branch.

Approved by the Governor in Council, 13th August, 1946.—C. W. KINSMAN, Clerk of the Executive Council.

DEPARTMENT OF PUBLIC WORKS.

842. Provision of invalid chairs, Mental Hospital, Moint Park, £127.—Denyers Pty. Ltd.

843. Supply of bitumen to Public Works Department Depot, Salmon-street, Port Melbourne, £197 1s.—Vacuum Oil Company Pty. Ltd.

Approved by the Governor in Council, 13th August, 1946.—  
C. W. KINSMAN, Clerk of the Executive Council.

STATE ELECTRICITY COMMISSION.

844. For the supply of one only self-contained track pin press for general construction work, Kiewa Hydro-Electric Scheme, to Quotation No. 5384.—Charles Ruwolt Pty. Ltd.

845. For the supply of four only ex-Army utility vehicles.—Commonwealth Disposals Commission.

846. For the supply of 6.6 kV switchgear equipment for metropolitan sub-stations, to Quotation No. 4902.—British General Electric Co. Pty. Ltd.

847. For the supply of four only angledozers and one only double-drum power control unit, Kiewa Hydro-Electric Scheme, to Quotation No. 5484.—Tutt, Bryant Pty. Ltd.

848. For the supply of 61,628 super. feet sawn hardwood timber, for housing at Yallourn.—J. Gent.

849. For the supply of four tractors, for construction of the Kiewa-Melbourne transmission line.—Department of Works and Housing.

850. For the supply of mild-steel piping and fittings for cooling tower, Malvern Terminal Station, to Quotation No. 49.—Thos. Walker and Sons Pty. Ltd.

851. For the supply and fitting of one only angledozer, cable-operated, to tractor for Kiewa Hydro-Electric Scheme, to Quotation No. 211.—Tutt, Bryant Pty. Ltd.

852. For the supply of 1,000 pins for coal dredger bucket chains, Yallourn Open Cut, to Quotation No. 18.—Melbourne Iron and Steel Mills Pty. Ltd.

853. For the supply of 35,000 lineal feet oregon weatherboards for housing of personnel, Yaliourn, to Quotation No. 409.—John Sharp and Sons Pty. Ltd.

854. For the supply of maintenance stores for equipment being taken over by the Commission under agreement.—Corporation of the City of Melbourne.

855. For the erection of three workmen's cubicle blocks, at Brown Coal Mine township, Yallourn, to Specification No. 46-47/26.—Marr and Beards.

856. For the manufacture and installation of six only 11 cubic yard and six only 15 cubic yard heavy duty tipping bodies on Mack trucks, Yallourn Brown Coal Mine, to Quotation No. 108.—Ingramweld Welding Engineers.

857. For the supply of 1,500 tons red gum timber, delivered over a period of twelve months, for suction gas plant at Hamilton Generating Station, to Quotation No. 98.—R. S. and H. A. Pitman.

858. For the supply of four only electric motor-driven air compressors and spare parts, Kiewa Hydro-Electric Scheme, to Specification No. 45-46/138.—Ingersoll-Rand (Aust.) Pty. Ltd.

859. For the supply of four compressed air receivers of 70 cubic feet capacity for Kiewa Hydro-Electric Scheme, to Specification No. 45-46/138.—Steelweld Pty. Ltd.

860. For the reinstatement of a cable trench, to Requisition No. 256.—Corporation of the City of Melbourne.

Approved by the Governor in Council, 13th August, 1946.—  
C. W. KINSMAN, Clerk of the Executive Council.

provisions of section 304 of the *Land Act 1928* (No. 3709), the unused and unmade roads referred to hereunder be closed, viz.:

Township of Avenel, Parish of Avenel, County of Delatite, being the portion of Smythe-street lying between allotment 4, section 17, and allotment 11, section 7.—(A.74(4) (H.017922).

Parish of Argyle, County of Grenville, being the roads indicated by hachure on plan hereunder.—(A.152(3) (C.89124).

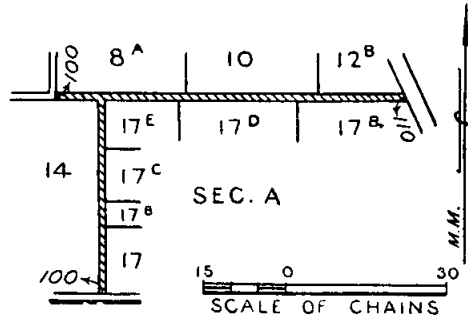

Parish of Olangolah, County of Polwarth, being the road indicated by hachure on plan hereunder.—(O.24(4) (C.89301).

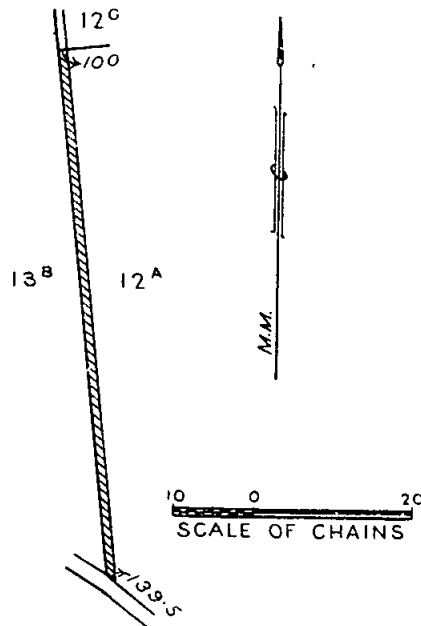

Parish of Yarrowee, County of Grenville, being the road indicated by hachure on plan hereunder.—(Y.2(1) (J.26979).

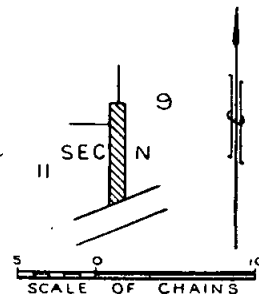

DEPARTMENT OF LANDS AND SURVEY.

At the Executive Council Chamber, Melbourne, the  
thirteenth day of August, 1946.

PRESENT:

His Excellency the Lieutenant-Governor of Victoria.

Mr. McKenzie | Mr. Hayes.

UNUSED AND UNMADE ROADS CLOSED.

HIS Excellency the Lieutenant-Governor of the State of Victoria, by and with the advice of the Executive Council thereof, doth hereby direct that, in pursuance of the

LANDS TEMPORARILY RESERVED.

HIS Excellency the Lieutenant-Governor of the State of Victoria, by and with the advice of the Executive Council thereof, doth hereby, in pursuance of the provisions of the *Land Act 1928*, reserve, temporarily, for certain purposes, and also except from occupation for mining purposes under any miner's right, the lands hereinafter described:—

WIRIDJIL.—Site for State School purposes—2 acres 0 roods 20 perches, Parish of Wiridjil, County of Heytesbury, as indicated by hachure on plan hereunder.—(W.367 (2) (Rs.5849).

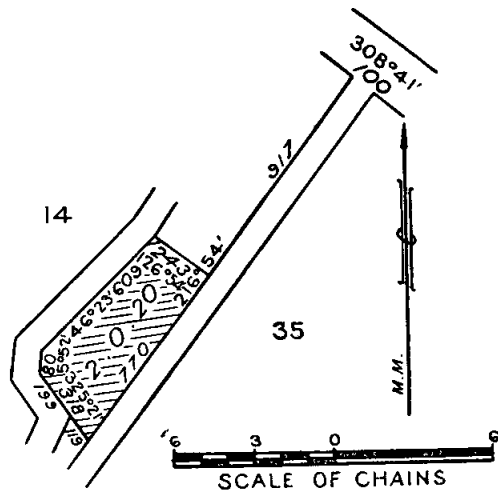

BARRAKEE.—Site for the Growth of Timber for the purpose of the manufacture or production of eucalyptus oil—10 acres, Parish of Barrakee, County of Gladstone, as indicated by hachure on plan hereunder.—(B.662 (4) (Rs.5846).

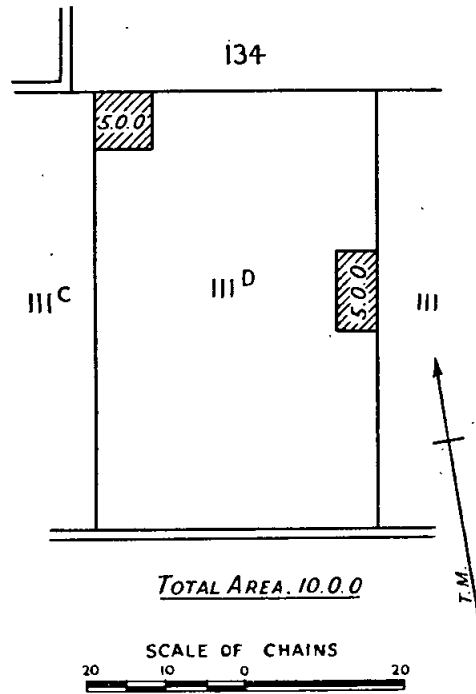

SANDHURST.—Site for the Growth of Timber for the purpose of the manufacture or production of eucalyptus oil—272 acres, more or less, Parish of Sandhurst, County of Bendigo, as indicated by hachure on plan hereunder.—(S.371 (15) (Rs.5844).

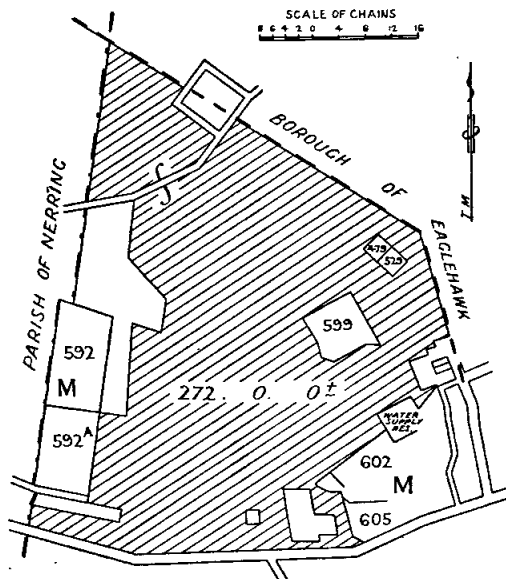

MARONG.—Site for the Growth of Timber for the purpose of the manufacture or production of eucalyptus oil—102 acres 2 roods 24 perches, Parish of Marong, County of Bendigo, as indicated by hachure on plan hereunder.—(M.32 (2) (Rs.5843).

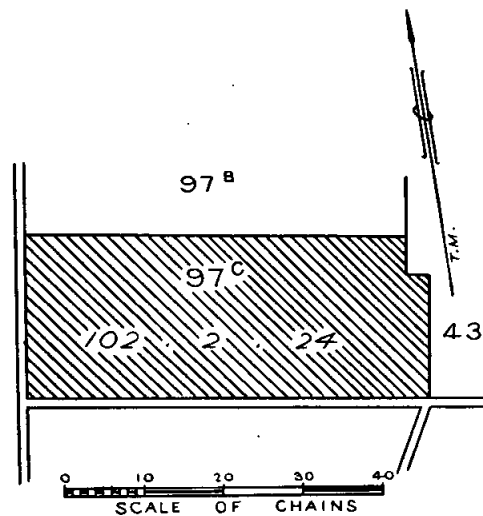

NERRING.—Site for the Growth of Timber for the purpose of the manufacture or production of eucalyptus oil—783 acres, more or less, Parish of Nerring, County of Bendigo, as indicated by hachure on plan hereunder.—(N.116(4) (Rs.5843).

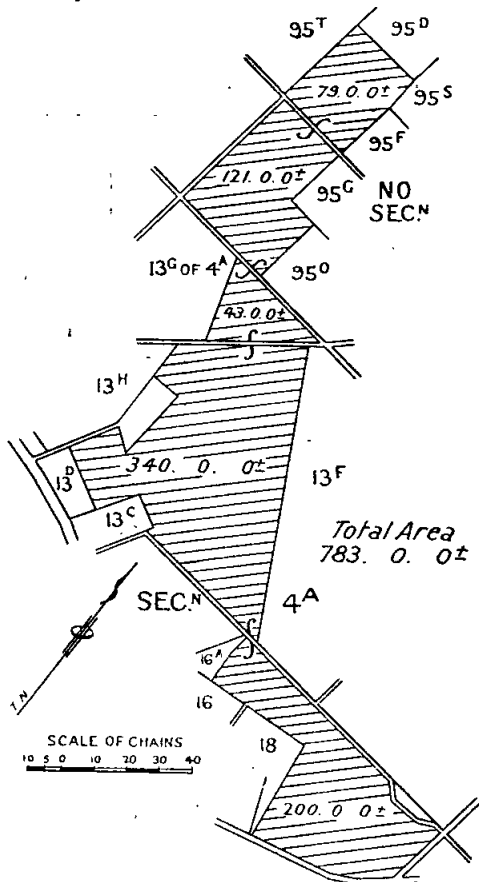

NERRING.—Site for the Growth of Timber for the purpose of the manufacture or production of eucalyptus oil—340 acres, more or less, Parish of Nerring, County of Bendigo, as indicated by hachure on plan hereunder.—(N.116(4) (Rs.5847).

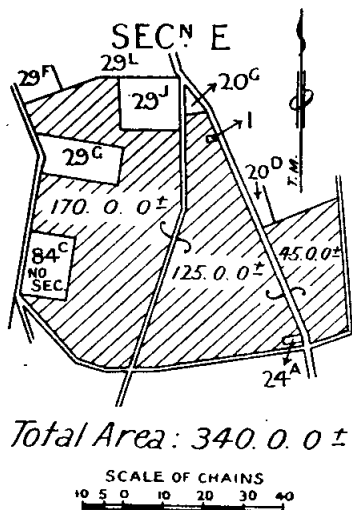

And the Honorable Leslie William Galvin, His Majesty's Commissioner of Crown Lands and Survey for the State of Victoria, shall give the necessary directions herein accordingly.

C. W. KINSMAN,  
Clerk of the Executive Council.

THE CONSTITUTION ACT AMENDMENT ACT 1928.

At the Executive Council Chamber, Melbourne, the thirteenth day of August, 1946.

PRESENT:

His Excellency the Lieutenant-Governor of Victoria.  
Mr. McKenzie | Mr. Hayes.

REVOCATION OF APPOINTMENT OF POLLING PLACE.

IN pursuance of the provisions contained in *The Constitution Act Amendment Act 1928*, section 192, His Excellency the Lieutenant-Governor of the State of Victoria, by and with the advice of the Executive Council thereof, doth hereby revoke the appointment of—

CHINTIN

as a Polling Place within and for the Gisborne Subdivision of the Electoral District of Mernda.

And the Honorable William Slater, His Majesty's Chief Secretary for the State of Victoria, shall give the necessary directions herein accordingly.

C. W. KINSMAN,  
Clerk of the Executive Council.

MOTOR OMNIBUS ACT 1928 (No. 3742).

At the Executive Council Chamber, Melbourne, the thirteenth day of August, 1946.

PRESENT:

His Excellency the Lieutenant-Governor of Victoria.  
Mr. McKenzie | Mr. Hayes.

APPOINTMENT OF MEMBER OF ADVISORY COMMITTEE.

HIS Excellency the Lieutenant-Governor of the State of Victoria, by and with the advice of the Executive Council thereof, and under the powers conferred by section 16 of the *Motor Omnibus Act 1928* (No. 3742), doth by this Order appoint—

WALTER SIMPSON (representing the Melbourne and Metropolitan Tramways Board),

to be a member, for a period of three (3) months from the thirteenth day of August, 1946, of the Advisory Committee constituted under the said Act, *vice* Stanley Morphett Richardson.

And the Honorable Patrick John Kennelly, His Majesty's Commissioner of Public Works for the State of Victoria, shall give the necessary directions herein accordingly.

C. W. KINSMAN,  
Clerk of the Executive Council.

GRAIN ELEVATORS ACTS.

At the Executive Council Chamber, Melbourne, the thirteenth day of August, 1946.

PRESENT:

His Excellency the Lieutenant-Governor of Victoria.  
Mr. McKenzie | Mr. Hayes.

APPOINTMENT OF MEMBER OF GRAIN ELEVATORS BOARD.

IN pursuance of the powers in that behalf conferred by the Grain Elevators Acts, His Excellency the Lieutenant-Governor of the State of Victoria, by and with the advice of the Executive Council thereof, doth by this Order hereby appoint—

MICHAEL JOSEPH CANNY, a Commissioner of Railways, to be a member of the Grain Elevators Board, in accordance with sub-section (2) (b) of section 5 of the *Grain Elevators Act 1934* (No. 4270), as amended by the *Grain Elevators Act 1943* (No. 4946), for a term of three (3) years from and inclusive of the 26th August, 1946.

And the Honorable William George McKenzie, His Majesty's Minister of Agriculture for the State of Victoria, shall give the necessary directions herein accordingly.

C. W. KINSMAN,  
Clerk of the Executive Council.



**BUILDING OPERATIONS AND BUILDING MATERIALS  
CONTROL ACT 1946 (No. 5116).**

*At the Executive Council Chamber, Melbourne, the  
thirteenth day of August, 1946.*

**PRESENT:**

His Excellency the Lieutenant-Governor of Victoria.

Mr. McKenzie

|                      Mr. Hayes

**REGULATIONS.**

**I**N pursuance of the powers conferred by the *Building Operations and Building Materials Control Act 1946* His Excellency the Lieutenant-Governor of Victoria, by and with the advice of the Executive Council thereof, doth hereby make the following Regulations (that is to say):—

1. These Regulations may be cited as the Building Operations and Building Materials Control Regulations (No. 1) and shall come into operation upon the publication thereof in the *Government Gazette*.

2. In these Regulations unless inconsistent with the context or subject matter—

“ Person ” includes a corporation.

“ Minister ” means the Minister of Housing.

Words importing the masculine gender shall include females, words in the singular shall include the plural and words in the plural shall include the singular.

3. (a) Every person who is a sawmiller wholly or partly engaged in the business of sawing any species of timber of the genus *Eucalyptus* other than Red Gum, except when specially exempted in writing by the Minister, shall produce during each calendar month sawn timber suitable for the manufacture of flooring and weatherboards in accordance with the specification set out in the Schedule hereto and to the extent therein specified of his total monthly output of sawn timber.

(b) Every such person shall furnish to the Controller of Timber at 125 Queen-street, Melbourne, within seven days after the expiration of each calendar month a true and correct return setting out, in respect of the preceding calendar month, the quantity of sawn timber produced in accordance with the specifications set out in the said Schedule.

4. Every person who owns any kiln-dried and dressed hardwood flooring shall use such flooring only for construction of floors in houses, or for such other purposes as the Minister may approve in writing.

5. Any person who—

(a) contravenes;

(b) fails to comply with; or

(c) commits a breach of

any of these Regulations shall be guilty of an offence and liable to a penalty of not more than One hundred pounds (£100).

**SCHEDULE.**

(a) (i) Not less than 10 per cent. of total monthly output of green sawn timber shall be in sizes 4 in. x 1 in. and/or 5 in. x 1 in. and/or 6 in. x 1 in. cut on the quarter and sawn full to size.

(ii) Not less than 5 per cent. of total monthly production of green sawn timber shall be in the sizes 6 in. x ¾ in. and/or 7 in. x ¾ in. cut on the quarter and sawn full to size.

(b) Lengths.—The lengths may vary from six (6) to twenty (20) feet with not more than ten per centum (10%) of the total number of pieces in six (6) seven (7) and eight (8) feet.

(c) Quality.—The timber shall be of a grade not lower than that of merchantable quality as defined by the Standard Association of Australia under Grading Rules Technical Standard No. 0.5.

And the Honorable William Peter Barry, His Majesty's Minister for Housing for the State of Victoria, shall give the necessary directions herein accordingly.

C. W. KINSMAN,

Clerk of the Executive Council.

## COUNTRY ROADS BOARD.

At the Executive Council Chamber, Melbourne, the  
thirteenth day of August, 1946.

PRESENT:

His Excellency the Lieutenant-Governor of Victoria.

Mr. McKenzie | Mr. Hayes.

ORDER APPROVING OF A NEW MAIN ROAD IN THE  
SHIRE OF DONCASTER AND TEMPLESTOWE.

WHEREAS the Country Roads Board constituted under the *Country Roads Act 1928* (No. 3662) has represented to His Excellency the Governor in Council that it appears to it desirable that the new Heidelberg-Warrandyte road in the Shire of Doncaster and Templestowe should be made by the said Board: And whereas the said Board in accordance with the requirements of section 19 of the said cited Act has caused to be prepared a map plan and estimate showing the points between which and on and through what land the said new road is proposed to be made and the cost of acquiring the land and constructing the said new road: And whereas on an inspection of the said map and plan and a consideration of the said estimate His Excellency the Governor in Council is satisfied that there are funds legally available for acquiring the land and constructing the said new road: Now therefore be it known by this present Order that His Excellency the Lieutenant-Governor of the State of Victoria with the advice of the Executive Council thereof doth hereby approve of the said road being made, that is to say:—

All those pieces of land in the Town of Templestowe, Parish of Bulleen, the boundaries of which are as follow:—

- (a) Commencing at the south-eastern angle of allotment 4, section B, of the said town; thence by lines bearing respectively 270 deg. 0 min. 227 links, 61 deg. 17½ min. 398.2 links, and 212 deg. 35 min. 227 links to the point of commencement.
- (b) Commencing at the north-western angle of allotment 8, section 25, of the said town; thence by lines bearing respectively 90 deg. 0 min. 86 links, 241 deg. 17½ min. 150.8 links, and 32 deg. 35 min. 86 links to the point of commencement—

which said pieces of land are particularly delineated and shown coloured red on survey plans numbered 4743 and 4744, lodged in the office of the Country Roads Board.

DECLARATION OF THE INVERLOCH-WONTHAGGI ROAD  
IN THE SHIRE OF WOORAYL.

WHEREAS by the Resolution set out below and dated the fifth day of August One thousand nine hundred and forty-six the Country Roads Board incorporated under the *Country Roads Act 1928* (No. 3662) being of opinion that the highway in the State of Victoria set out or described in the Schedule to the same is of sufficient importance to be a main road and acting under the powers in that behalf conferred upon it by the said Act declared such highway to be a main road within the meaning and for the purposes of the Act aforesaid: And whereas the said Act amongst other things provides that the Governor in Council may by Order published in the *Government Gazette* confirm such Resolution whereupon any road mentioned in such Resolution shall be a main road: And whereas it is deemed desirable to confirm the Resolution so made and passed by the said Country Roads Board: Now therefore His Excellency the Lieutenant-Governor of the State of Victoria by and with the advice of the Executive Council thereof doth hereby confirm such Resolution and declare upon the publication of this Order in the *Government Gazette* the road mentioned in the Schedule to such Resolution of the Country Roads Board a main road within the meaning and for the purposes of the *Country Roads Act 1928*.

*Resolution Declaring a Main Road under the Country Roads Act.*

The Country Roads Board incorporated under the *Country Roads Act 1928* (No. 3662) at a meeting now holden being of opinion that the highway within the State of Victoria set out or described in the Schedule hereunder written is of sufficient importance to be a main road acting under the powers conferred upon it by the said Act doth by this Resolution hereby declare such highway to be a main road within the meaning and for the purposes of the said *Country Roads Act 1928*.

## SCHEDULE.

*Shire of Woorayl.*

6. *Inverloch-Wonthaggi road* (18606).—A roadway 2 chains wide, the northern boundary of which commences at a point on the southern boundary of allotment 5A, section 1, Township of Inverloch, Parish of Kirrak, the said point being opposite the entrance to the Jetty south of the said allotment; thence south-westerly and north-westerly by the said southern boundary to the south-western angle of the said allotment.

NOTE.—The above description is in lieu of the description of the portion of the Inverloch-Wonthaggi road published in the *Government Gazette* of the 9th June, 1920, on page 2061.

The common seal of the Country Roads Board was hereto affixed, at Melbourne, this fifth day of August, One thousand nine hundred and forty-six, in the presence of—

(SEAL) W. L. DALE, Chairman.  
D. V. DARWIN, Member.  
R. JANSEN, Secretary.

ORDER APPROVING OF A NEW STATE HIGHWAY IN  
THE SHIRE OF SOUTH GIPPSLAND.

WHEREAS the Country Roads Board constituted under the *Country Roads Act 1928* (No. 3662) has represented to His Excellency the Governor in Council that it appears to it desirable that the new South Gippsland Highway in the Shire of South Gippsland should be made by the said Board: And whereas the said Board in accordance with the requirements of section 19 of the said cited Act has caused to be prepared a map plan and estimate showing the points between which and on and through what land the said new highway is proposed to be made and the cost of acquiring the land and constructing the said new highway: And whereas on an inspection of the said map and plan and a consideration of the said estimate His Excellency the Governor in Council is satisfied that there are funds legally available for acquiring the land and constructing the said new highway: Now therefore be it known by this present Order that His Excellency the Lieutenant-Governor of the State of Victoria with the advice of the Executive Council thereof doth hereby approve of the said highway being made, that is to say:—

All those pieces of land in the Parish of Toora, the boundaries of which are as follow:—

- (a) Commencing at a point on the southern boundary of allotment 7, section C, of the said parish, distant 1,705.6 links from the south-western angle of the said allotment; thence by lines bearing respectively 80 deg. 38 min. 445.8 links, and 67 deg. 19 min. 498 links to the Agnes River Reserve; thence south-easterly by the said Reserve to the said southern boundary; thence by lines bearing respectively 232 deg. 26 min. 600 links, and 285 deg. 48 min. 447.4 links to the point of commencement.
- (b) Commencing at a point on the northern boundary of allotment 15, section C, of the said Parish, distant 273 deg. 10 min. 277 links, 296 deg. 16 min. 1,568 links, and 271 deg. 56 min. 600 links from the north-eastern angle of the said allotment; thence by lines bearing respectively 230 deg. 32 min. 500 links, 36 deg. 11 min. 400 links, and 91 deg. 56 min. 150 links to the point of commencement—

which said pieces of land are particularly delineated and shown coloured red on survey plan numbered 4748, lodged in the office of the Country Roads Board.

AMENDMENT OF DECLARATION OF A DEVIATION  
FROM THE LANCEFIELD-ROAD IN THE SHIRE OF  
KEILOR.

HIS Excellency the Lieutenant-Governor of the State of Victoria, by and with the advice of the Executive Council thereof, doth hereby amend the Order in Council of the 16th day of July, 1946, and published in the *Gazette* of the 24th idem, at page 2309, declaring a deviation from an existing main road in the Shire of Keilor under the *Country Roads Act 1928*, by the substitution of the words—

“the Country Roads Board”

for the word

“Titles”

appearing in the last line of the said Order.

And the Honorable Patrick John Kennelly, His Majesty's Commissioner of Public Works for the State of Victoria, shall give the necessary directions herein accordingly.

C. W. KINSMAN,  
Clerk of the Executive Council.

## EDUCATION ACT 1928.

*At the Executive Council Chamber, Melbourne, the thirteenth day of August, 1946.*

## PRESENT:

His Excellency the Lieutenant-Governor of Victoria.

Mr. McKenzie | Mr. Hayes.

## REGULATION LIV.—RELIGIOUS INSTRUCTION IN STATE SCHOOLS.—AMENDED.

**HIS** Excellency the Lieutenant-Governor of the State of Victoria, by and with the advice of the Executive Council thereof, doth hereby, by Order made on the 13th day of August, 1946, amend Regulation LIV.—Religious Instruction in State Schools—of the Regulations made under the Education Act 1928, by adding to clause 2 the following paragraph, viz.:—

“(a) a recommendation from an accrediting committee of the Council for Christian Education in Schools as to the suitability as an instructor of any applicant who is a member of any religious denomination or organization which is affiliated with the said Council for Christian Education in Schools.”

And the Honorable Francis Field, His Majesty's Minister of Public Instruction for the State of Victoria, shall give the necessary directions herein accordingly.

C. W. KINSMAN,  
Clerk of the Executive Council.

## STATE RIVERS AND WATER SUPPLY COMMISSION.

*At the Executive Council Chamber, Melbourne, the thirteenth day of August, 1946.*

## PRESENT:

His Excellency the Lieutenant-Governor of Victoria.

Mr. McKenzie | Mr. Hayes.

## BOORT IRRIGATION AND WATER SUPPLY DISTRICT.—DISTRICT EXTENDED.

**UNDER** the powers conferred by the Water Acts and all other powers enabling him in that behalf, His Excellency the Lieutenant-Governor of the State of Victoria, with the advice of the Executive Council of the said State, on the recommendation of the State Rivers and Water Supply Commission, doth hereby declare, order, and direct as follows:—

That the Boort Irrigation and Water Supply District be extended by adding to the same the lands set out and described in the Schedule hereto, and as on and from the date of this Order such district shall be deemed to be so extended.

## SCHEDULE.

Allotment 20, section E, and the road forming the southern boundary of that allotment, Parish of Boort, County of Tatchera.

The lands described in the foregoing Schedule are shown on a plan approved by the Governor in Council, and deposited in the office of the State Rivers and Water Supply Commission, Melbourne.—(Corres. 45/16196.)

## NORMANVILLE WATERWORKS DISTRICT.—PORTION EXCISED.

**UNDER** the powers conferred by the Water Acts and all other powers enabling him in that behalf, His Excellency the Lieutenant-Governor of the State of Victoria, with the advice of the Executive Council of the said State, on the recommendation of the State Rivers and Water Supply Commission, doth hereby declare, order, and direct as follows:—

That there shall be excised from the Normanville Waterworks District that portion of the same set out and described in the Schedule hereto, which portion, as on and from the date of this Order, shall be deemed to be excised accordingly.

## SCHEDULE.

Allotment 20, section E, and the road forming the southern boundary of that allotment, Parish of Boort, County of Tatchera.

The portion set out and described in the foregoing Schedule is shown on a plan approved by the Governor in Council, and deposited in the office of the State Rivers and Water Supply Commission, Melbourne.—(Corres. 45/16196.)

## NYAH IRRIGATION AND WATER SUPPLY DISTRICT.—PORTION EXCISED.

**UNDER** the powers conferred by the Water Acts and all other powers enabling him in that behalf, His Excellency the Lieutenant-Governor of the State of Victoria, with the advice of the Executive Council of the said State, on the recommendation of the State Rivers and Water Supply Commission, doth hereby declare, order, and direct as follows:—

That there shall be excised from the Nyah Irrigation and Water Supply District that portion of the same set out and described in the Schedule hereto, which portion, as on and from the twelfth day of March, 1946, shall be deemed to be excised accordingly.

## SCHEDULE.

Commencing at the south-western angle of lot 11 on lodged plan of subdivision No. 6460, Parish of Tyntynder North, County of Tatchera: thence westerly by the northern boundary of Monash-avenue to the western boundary of Mary-street; thence northerly by the last-mentioned boundary, a distance of 3 chains 90 1/10 links; thence by lines bearing south 46 deg. 43 min. east 1 chain 22 2/10 links, north 89 deg. 59 min. east 6 chains 21 3/10 links, and north 9 deg. 41 min. west 1 chain; thence easterly by a line to the north-western angle of lot 13 on lodged plan of subdivision No. 6460 aforesaid; thence generally southerly by the eastern boundary of a channel reserve to the point of commencement.

The portion described in the foregoing Schedule is shown on a plan approved by the Governor in Council, and deposited in the office of the State Rivers and Water Supply Commission, Melbourne.—(Corres. 45/18467.)

## TYNTYNDER WATERWORKS DISTRICT.—DISTRICT EXTENDED.

**UNDER** the powers conferred by the Water Acts and all other powers enabling him in that behalf, His Excellency the Lieutenant-Governor of the State of Victoria, with the advice of the Executive Council of the said State, on the recommendation of the State Rivers and Water Supply Commission, doth hereby declare, order, and direct as follows:—

That the Tyntynder Waterworks District be extended by adding to the same the lands set out and described in the Schedule hereto, and as on and from the twelfth day of March, 1946, such district shall be deemed to be so extended.

## SCHEDULE.

Commencing at the south-western angle of lot 11 on lodged plan of subdivision No. 6460, Parish of Tyntynder North, County of Tatchera: thence westerly by the northern boundary of Monash-avenue to the western boundary of Mary-street; thence northerly by the last-mentioned boundary a distance of 3 chains 90 1/10 links; thence by lines bearing south 46 deg. 43 min. east 1 chain 22 2/10 links, north 89 deg. 59 min. east 6 chains 21 3/10 links, and north 9 deg. 41 min. west 1 chain; thence easterly by a line to the north-western angle of lot 13 on lodged plan of subdivision No. 6460 aforesaid; thence generally southerly by the eastern boundary of a channel reserve to the point of commencement.

The lands described in the foregoing Schedule are shown on a plan approved by the Governor in Council, and deposited in the office of the State Rivers and Water Supply Commission, Melbourne.—(Corres. 45/18467.)

And the Honorable Leslie William Galvin, His Majesty's Minister of Water Supply for the State of Victoria, shall give the necessary directions herein accordingly.

C. W. KINSMAN,  
Clerk of the Executive Council.

## Water Acts.

## WINCHELSEA WATERWORKS TRUST.

At the Executive Council Chamber, Melbourne, the  
thirteenth day of August, 1946.

## PRESENT:

His Excellency the Lieutenant-Governor of Victoria.  
Mr. McKenzie | Mr. Hayes.

## EXTENT OF DISTRICT INCREASED.

UNDER the powers conferred by the Water Acts and all other powers enabling him in that behalf, His Excellency the Lieutenant-Governor of the State of Victoria, by and with the advice of the Executive Council of the said State, doth hereby declare, order, and direct as follows:—

That the extent of the Waterworks District of the Winchelsea Waterworks Trust be increased by adding to same the lands set out and described in the Schedule hereto, and as on and from the date hereof the extent of such district shall be deemed to be increased accordingly.

## SCHEDULE.

## Portion 1.

Commencing at a point on the right bank of the Barwon River and in line with the southern boundary of Crown allotment 19, Town of Winchelsea, Parish of Lake Lake Wollard, County of Grant, being a point on the western boundary of the existing Waterworks District; thence generally north-westerly along the said right bank of the Barwon River to its intersection with the northern boundary of the Town of Winchelsea; thence easterly along the said northern boundary of the Town of Winchelsea to its intersection with the north-western boundary of Prince's Highway; thence north-easterly along the said north-western boundary of Prince's Highway to a point in line with the eastern boundary of Crown allotment 46A, Town of Winchelsea; thence southerly by a line across Prince's Highway to the most northerly angle of the said Crown allotment 46A, being a point on the western boundary of a road, and along the said western boundary of the road to its intersection with the southern boundary of the Town of Winchelsea; thence westerly along the said southern boundary of the Town of Winchelsea to its intersection with the centreline of Anderson-street, Town of Winchelsea, Parish of Mirree, County of Grenville; thence northerly along the said centreline of Anderson-street to its intersection with the centreline of Dwyer-street, being a point on the boundary of the existing Waterworks District; thence generally easterly, north-easterly, south-easterly, north-easterly, north-westerly, north-easterly, north-westerly, north-easterly, north-westerly, westerly, south-westerly, and westerly along the boundary of the existing Waterworks District to the point of commencement.

## Portion 2.

Commencing at the intersection of the south-western boundary of Crown allotment 49, Town of Winchelsea, Parish of Mirree, County of Grenville, with the south-eastern boundary of the Geelong and Colac Railway Reserve, being a point on the western boundary of the existing Waterworks District; thence north-westerly by a line being a continuation of the said south-western boundary of Crown allotment 49 across the Geelong and Colac Railway Reserve and across Crown allotment 50 to a point on the south-eastern boundary of Crown allotment 51; thence north-easterly along the said south-eastern boundary of Crown allotment 51, and by a line being a continuation thereof across Hesse-street to a point on the north-eastern boundary of Hesse-street; thence north-westerly along the said north-eastern boundary of Hesse-street to the most westerly angle of Crown allotment 24; thence easterly along the northern boundary of the said Crown allotment 24 to its intersection with the left bank of the Barwon River; thence northerly by a line across the said Barwon River to a point on the right bank of the said Barwon River and in line with the southern boundary of Crown allotment 19, Town of Winchelsea, Parish of Lake Lake Wollard, County of Grant, being a point on the western boundary of the existing Waterworks District; thence generally south-easterly, south-westerly, south-easterly and south-westerly along the western boundary of the existing Waterworks District to the point of commencement.

The lands set out and described in the foregoing Schedule are shown on a plan approved by the Governor in Council and deposited in the office of the State Rivers and Water Supply Commission, Melbourne.

## BROADFORD WATERWORKS TRUST.

## ADDITIONAL LOAN OF £7,000.

UNDER the powers conferred by the Water Acts and all other powers enabling him in that behalf, His Excellency the Lieutenant-Governor of the State of Victoria, by and with

the advice of the Executive Council of the said State, doth hereby grant an additional loan of Seven thousand pounds (£7,000) to the Broadford Waterworks Trust for the enlargement of service basin and pipe mains as set forth in the detailed statement bearing date the 2nd August, 1946, and verified under the seal of the State Rivers and Water Supply Commission.

The loan hereby granted shall be subject to the provisions of the Water Acts.

And the Honorable Leslie William Galvin, His Majesty's Minister of Water Supply for the State of Victoria, shall give the necessary directions herein accordingly.

C. W. KINSMAN,  
Clerk of the Executive Council.

## MOTOR OMNIBUS ACT 1928 (No. 3742).

At the Executive Council Chamber, Melbourne, the  
thirteenth day of August, 1946.

## PRESENT:

His Excellency the Lieutenant-Governor of Victoria.  
Mr. McKenzie | Mr. Hayes.

## AMENDMENT OF PRESCRIPTIONS OF CERTAIN METROPOLITAN MOTOR OMNIBUS ROUTES.

HIS Excellency the Lieutenant-Governor of the State of Victoria, by and with the advice of the Executive Council thereof, and in pursuance of the powers conferred by the Motor Omnibus Act 1928 (No. 3742), doth by this Order amend the prescriptions of certain routes within the metropolitan area along which motor omnibuses for which "regular service" licences are granted may ply for hire, viz.:—

*Route No. 16 (Kensington-North Melbourne).*—Under the heading "Time-tables to be Observed" amend "12.30 p.m. to 9.30 p.m." to read "9 a.m. to 6 p.m."

*Route No. 35 (Shrine of Remembrance-Port Melbourne).*—Under the heading "Time-tables to be Observed" amend "20" to read "30."

*Route No. 26 (Queen's Bridge-South Wharf).*—Under the heading "Maximum Number of Motor Omnibuses which may be Licensed on Route" amend "1" to read "2."

Under the heading "Description of Route, including Commencing and Terminal Points," delete "the corner of Lorimer-street and Ingles-street, Port Melbourne," and in place thereof insert "South Wharf."

*Route No. 24A (Gardiner-Caulfield).*—Under the heading "Maximum Number of Motor Omnibuses which may be Licensed on Route" amend "2" to read "5."

*Route No. 67A (Box Hill-Burwood).*—Under the heading "Time-tables to be Observed" delete "Saturdays and."

*Route No. 104A (North Melbourne-Broadmeadows).*—Under the heading "Sections on Route" delete the existing particulars, and in place thereof insert—

- (1) Between Baker's-road and Boundary-road;
- (2) between Boundary-road, and Fawcner Cemetery entrance;
- (3) between Fawcner Cemetery entrance and Juke's-road;
- (4) between Juke's-road and corner of Sydney-road and Campbellfield-road;
- (5) between corner of Sydney-road and Campbellfield-road and Broadmeadows Military Camp entrance;
- (6) between Broadmeadows Military Camp entrance and Broadmeadows Railway Station.

Under the heading "Fares to be Charged" delete the existing particulars, and in place thereof insert "Any one section, 2d.; each additional section, 1d.; through fare, Baker's-road to Broadmeadows Military Camp entrance, 6d. Section No. 6, 6d."

Under the heading "Time-tables to be Observed" amend "6 a.m." to read "6.25 a.m.," amend "11.30 p.m." to read "11.20 p.m.," delete "each day" and in place thereof insert "week days," add "2.5 p.m. to 11.15 p.m., Sundays."

*Licensing Authority.*—Pursuant to the provisions of section 15 (1) (c) of the said Act (No. 3742), the Governor in Council by this Order confers upon the Licensing Authority full power and authority for the carrying into effect by the said Licensing Authority of the foregoing provisions of this Order.

And the Honorable Patrick John Kennelly, His Majesty's Commissioner of Public Works for the State of Victoria, shall give the necessary directions herein accordingly.

C. W. KINSMAN,  
Clerk of the Executive Council.

SOIL CONSERVATION ACTS.

At the Executive Council Chamber, Melbourne, the thirteenth day of August, 1946.

PRESENT:

His Excellency the Lieutenant-Governor of Victoria.  
Mr. McKenzie | Mr. Hayes.

APPOINTMENT OF A MEMBER OF THE HUME CATCHMENT ADVISORY COMMITTEE.

IN pursuance of the provisions of the Soil Conservation Acts, the Acts Interpretation Act, and all other powers thereto enabling, His Excellency the Lieutenant-Governor of the State of Victoria, by and with the advice of the Executive Council thereof, doth hereby appoint—

WILLIAM HENRY JARVIS, of The Brothers, via Benambra, a representative of grazing, agricultural, or other relevant interests in the region or district for which the Committee is appointed, to be a member of the Hume Catchment Regional Advisory Committee for the remainder of the term of office of James Olaf Holston, in whose place he is appointed.

And the Honorable John Cain, His Majesty's Premier of the State of Victoria, shall give the necessary directions herein accordingly.

C. W. KINSMAN,  
Clerk of the Executive Council.

SLUM RECLAMATION AND HOUSING ACTS.

At the Executive Council Chamber, Melbourne, the twentieth day of August, 1946.

PRESENT:

His Excellency the Lieutenant-Governor of Victoria.  
Mr. Galvin | Mr. Fraser.

STREET CLOSED.

WHEREAS by virtue and in exercise of the powers contained in the Slum Reclamation and Housing Acts, the Housing Commission has recommended to the Governor in Council that the street shown hachured on the plan hereunder be closed: Now therefore the Lieutenant-Governor of the State of Victoria, by and with the advice of the Executive Council thereof, in pursuance of the powers conferred by the said Acts, and upon such recommendation, doth by this Order close the above-mentioned street.

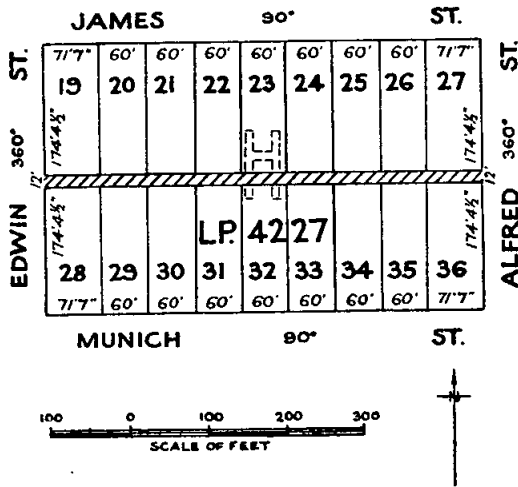

And the Honorable William Peter Barry, His Majesty's Minister of Housing for the State of Victoria, shall give the necessary directions herein accordingly.

C. W. KINSMAN,  
Clerk of the Executive Council.

THE SLUM RECLAMATION AND HOUSING ACTS.

At the Executive Council Chamber, Melbourne, the twentieth day of August, 1946.

PRESENT:

His Excellency the Lieutenant-Governor of Victoria.  
Mr. Galvin | Mr. Fraser.

STREETS CLOSED, ETC.

WHEREAS by virtue and in exercise of the powers contained in the Slum Reclamation and Housing Acts, the Housing Commission has recommended to the Governor in Council that, within the area described in the Schedule hereto, all the streets be closed and all the easements extinguished:

Now, therefore, His Excellency the Lieutenant-Governor of the State of Victoria, in the Commonwealth of Australia, by and with the advice of the Executive Council thereof, doth, in pursuance of the powers conferred by the said Acts and upon such recommendation, consent and by this Order hereby close such streets and extinguish such easements.

SCHEDULE.

All that land within the City of Heidelberg commencing at the intersection of the west boundary of Waterdale-road and the south boundary of Perkins-avenue; thence westerly by the said south boundary of Perkins-avenue to the south-east angle of lot 74 on plan of subdivision No. 12797, lodged in the Office of Titles; thence westerly by the south boundary of the said lot 74 to the Darebin Creek; thence generally northerly by the said Darebin Creek to the south boundary of Bell-street; thence generally easterly by the said south boundary of Bell-street to the west boundary of Waterdale-road; and thence southerly by the said west boundary of Waterdale-road to the point of commencement.

And the Honorable William Peter Barry, His Majesty's Minister of Housing for the State of Victoria, shall give the necessary directions herein accordingly.

C. W. KINSMAN,  
Clerk of the Executive Council.

APPROACHING LAND SALES.

SALES of Crown lands, in fee-simple, will be held at the under-mentioned places and dates, viz.:

	No. of Gazette.
Stanhope.—Wednesday, 28th August, 1946	145
Tongala.—Wednesday, 28th August, 1946	145

Lands and Survey Office, Melbourne.

CLOSER SETTLEMENT ACT.

TENDERS are invited for the purchase, in fee-simple, of the under-mentioned land, and will be received by the Secretary for Lands, Lands Department, Melbourne, up to Noon on Thursday, 12th September, 1946, endorsed "Tender for Closer Settlement Land."

Each tenderer is required to state clearly his full name, occupation and address, and the price offered, also to give particulars of his ability to carry out the conditions of the sale.

PARISH OF LODDON, COUNTY OF GUNBOWER.

Area 308 acres 0 roods 23 perches, allotments 21 and 21A, section A. Formerly held by F. W. Day. Situated about 18 miles west of Pyramid. Improvements consist of fencing.

TERMS AND CONDITIONS.

Deposit to be lodged with tender, 20 per cent. of price offered, balance payable in twenty half-yearly instalments, together with interest computed at the rate of 4½ per cent. per annum on the unpaid balance.

Purchaser may pay full balance of purchase money at any time prior to due date, or may, with the consent of the Board of Land and Works, transfer his interest in the purchase. Such transfer may be subject to payment of a further sum in reduction of the outstanding balance of purchase money.

The highest or any tender not necessarily accepted. The successful tenderer will be required to accept responsibility for payment of an amount of £3 4s. 2d. owing to the Shire of Gordon for rates.

Before sale is approved the purchaser will be required to comply with the provisions of the National Security (Lands Transfer) Regulations as regards nationality.

W. McILROY,  
Secretary for Lands,  
Melbourne, 19th August, 1946.

**HEARING OF REASONS AGAINST THE FORFEITURE OF CERTAIN LICENCES AND LEASES BY A PERSON APPOINTED UNDER 34TH SECTION OF THE LAND ACT 1928.**

NOTICE is hereby given that reasons against the forfeiture of the licence and lease in the Schedule hereto, which is deemed liable to forfeiture under the provisions of the Land Acts, will be publicly heard by the person appointed by me, the responsible Minister of the Crown administering the said Acts, to hear the same and report thereon in writing to me, when the person in the said Schedule mentioned as holder of such licence and lease will be allowed to show cause against the same at the place and on the date mentioned in the Schedule hereto.

L. W. GALVIN,  
 Commissioner of Crown Lands and Survey,  
 Department of Lands and Survey,  
 Melbourne, 19th August, 1946.

SCHEDULE.  
 SEYMOUR, Friday, 6th September, 1946, H. Ramsay, Land Officer—  
 075/129, Sarah Ann Wellington, 2a. 1r. Sp., Heathcote.

**PROPOSED REVOCATION OF TEMPORARY RESERVATIONS OF LANDS BY ORDERS IN COUNCIL.**

IN pursuance of the provisions of the Land Act 1928, notice is hereby given that it is the intention of the Governor in Council to revoke the temporary reservations of lands by Orders in Council hereunder referred to, viz.:—

The following Notices were published 1° on the 31st July, 1946, pursuant to Orders of the 23rd July, 1946.

DEUTGAM (WERRIBEE).—The Order in Council of the 23rd March, 1886, temporarily reserving 1 acre 3 roods 15 perches of land in the Town of Werribee as a Site for an Ornamental Plantation is about to be revoked so far as regards the portion thereof indicated by hachure on plan hereunder.—(W.230(2) (Rs.4786).

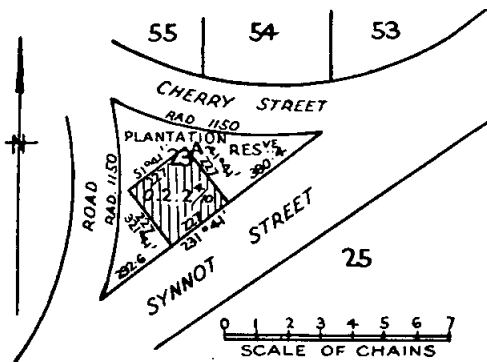

BAIRNSDALE.—The Order in Council of the 20th April, 1874, temporarily reserving 4 acres of land in the Parish of Bairnsdale, being part of allotment 255, as a Site for State School purposes, is about to be revoked.—(B.67(5) (Rs.5760).

The following Notice was published 1° on the 7th August, 1946, pursuant to Order of the 30th July, 1946.

MARYBOROUGH.—The Order in Council of the 27th September, 1897, temporarily reserving 2 roods 0 4/10 perches of land in the municipal district of Maryborough, being part of section 30, as a site for Municipal purposes, is about to be revoked.—(M.66(9) (Rs.5729).

**LAND PROPOSED TO BE PERMANENTLY RESERVED.**

IN pursuance of the provisions of the Land Act 1928, notice is hereby given that it is the intention of the Governor in Council to permanently reserve and except from occupation for mining purposes under any miner's right, the land hereunder described, viz.:—

The following Notice was published 1° on the 7th August, 1946, pursuant to an Order of the 3rd June, 1946.

WONGARRA.—Site for Road and Public purposes, 39 perches, Parish of Wongarra, County of Polwarth, as indicated by hachure on plan hereunder.—W.374(3) (Rs.3939).

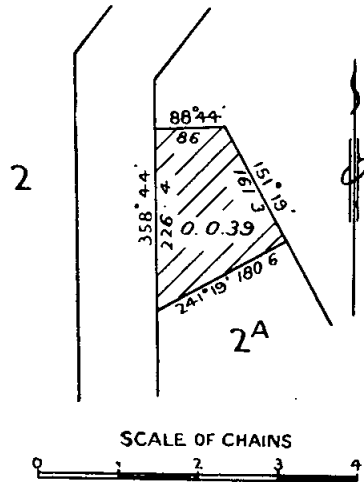

The following Notice was published 1° on the 21st August, 1946, pursuant to Order of the 13th August, 1946.

KILLAWARRA.—The Order in Council of the 23rd March, 1911, temporarily reserving 20 acres 1 rood 30 perches of land in the Parish of Killawarra, as a site for Water Supply purposes is about to be revoked so far as regards the portion comprising 14 acres 2 roods 31 perches, as indicated by hachure on plan hereunder.—(K.124(3) (Rs.1251).

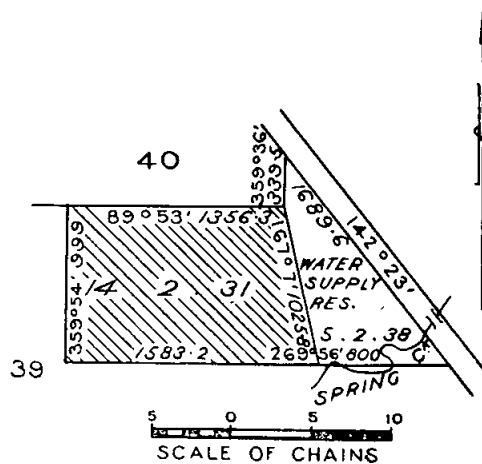

L. W. GALVIN,  
 Commissioner of Crown Lands and Survey.

## Land Act 1928.

## LEASE UNDER THE LAND ACT 1928 DECLARED VOID.

NOTICE is hereby given that the Lease mentioned in the Schedule hereunder has been declared void by the Governor in Council for the reason specified.

District.	Corr. No.	Name of Lessee.	Section of Land Act under which Leased.	Parish.	Allotment.	Area.	Class.	Annual Rental.	Reasons for Voiding.
Melbourne	0464/125	Arthur Ernest Gordon Webb	125	Melbourne South	1 and 2, section D	A. R. P. 1 0 5 <sup>1</sup> / <sub>10</sub>	..	£ s. d. 350 0 0	Expiry of lease. New lease to issue.

Department of Lands and Survey,  
Melbourne, 13th August, 1946.

L. W. GALVIN,  
Commissioner of Crown Lands and Survey.

## REGULATIONS FOR THE CARE, PROTECTION, AND MANAGEMENT OF THE "COHUNA RECREATION RESERVE."

WHEREAS by section 181 of the *Land Act 1928*, as re-enacted by section 9 of the *Land Act 1941*, power is given to the Board of Land and Works to make Regulations in respect of the care, protection, and management of any Crown land which has been reserved under the *Land Acts* for any public purpose whatsoever, and which has not been conveyed to or vested in trustees, and for the further purposes as enacted: Now therefore the Board of Land and Works, in pursuance of the powers conferred as aforesaid, doth hereby make the following Regulations in respect of the reserved lands in the Parish of Cohuna, as indicated by red and blue tinting on plan marked C over 8.3.1946 with Lands Department Correspondence Rs.5312, and hereinafter referred to as the "Reserve."

## REGULATIONS.

1. The Reserve shall be open to the public from sunrise to sunset, free of charge, except as hereinafter provided.

2. The Committee of Management (hereinafter in these Regulations referred to as "the Committee") may set the Reserve aside for fêtes, agricultural shows, sports, concerts, band recitals, or public amusements and the like, for not more than 52 days in any year, on any of which days a sum not exceeding Three shillings (3s.) for the admission of every person, and not exceeding Two shillings and six pence (2s. 6d.) for each conveyance, carriage, horse-drawn vehicle, or motor vehicle, exclusive of the driver or passengers, may be charged and taken, and no person shall be entitled to admission to the Reserve on such days unless he or she pays the proper fee.

3. No person shall enter or remain in the Reserve who may offend against decency as regards dress, language, or conduct, and no male person shall enter or remain in any lavatory, building, enclosure, or portion of the Reserve set apart for females.

4. No person shall enter into or remain in or on any room, building, structure, enclosure, or area set apart for players, performers, or competitors at any games, sports entertainments or competitions, or for any exhibits, exhibitors, or performers at any such shows, fêtes, entertainments, or competitions, and no person shall at any time enter into any building or structure set apart by the Committee for the use of any sporting body or other organization.

5. No person shall damage or interfere in any way with the trees, shrubs, or flowers in the Reserve.

6. No person shall light a fire in the Reserve without the consent of the Committee first obtained.

7. No person shall jump or climb over or pass under the fences or gates, in or around the Reserve, stick bills thereon, or cut names on the fences, trees, or seats, or damage them in any way, or roll or throw stones, sticks, or other missiles in the Reserve.

8. No person shall climb on any building, room, gate, or structure in the Reserve, nor open nor force any door or window of such building, room, or structure, or in any way deface, damage, or injure any such building, room, or structure.

9. No person shall bring into the Reserve or use or carry therein any firearm or offensive weapon.

10. No person shall leave or deposit any glass, paper, litter, or rubbish in the Reserve except in the receptacles provided.

11. No person shall put into the Reserve any horses, cattle, goats, or pigs without the consent or permission, in writing, of the Committee first obtained.

12. No person shall bring into the Reserve any dog, unless controlled by a chain or cord, without the authority, in writing, of the Committee.

13. No person shall camp in the Reserve or in any room, building, or structure therein, without consent of the Committee first obtained, nor shall any person erect therein any building, hut, or attachment without the consent, in writing, of the Committee first obtained. The Committee may issue a permit to camp upon payment of One shilling (1s.) per day or Five shillings (5s.) per week per party or vehicle.

14. No person shall buy, sell, or offer for sale in the Reserve any goods, wares, articles, or merchandise or stuff, without the consent, in writing, of the Committee first obtained.

15. No person shall take part in any public entertainment, meeting, or gathering in the Reserve without the consent, in writing, of the Committee first obtained.

16. No person shall play, practise, or engage in any organized sport, game, or competition, within the Reserve on Sundays, Good Friday, or Anzac Day.

17. No person shall bet or wager in the Reserve.

18. No person shall expectorate or otherwise foul or commit any nuisance in any part of the Reserve, or any room, building, structure, or enclosure therein.

19. No person shall play, practise, or engage in any sport, game, or competition except in the portions of the Reserve set apart by the Committee for that purpose, and such Committee may from time to time grant to any club, society, or association of clubs the use of the Reserve or any part so set apart, for the purpose of any lawful games, fêtes, sports, amusements, or entertainments and the like upon such terms, conditions, and the payment of such fees as the Committee deems reasonable.

20. No person shall obstruct, disturb, or interrupt or annoy any officer, employee, or authorized agent of the Committee or person permitted to use the Reserve.

21. No person shall bring into the Reserve any cycle, horse, carriage, cart, motor car, or any other vehicle except into such parts as may be set apart for the purpose.

22. Any person committing on any part of the Reserve, or in any of the rooms, buildings, structures, erections, or enclosures for the time being thereon, any of the following offences shall be guilty of breach of these Regulations:—

(a) Assaulting or threatening any person or persons.

(b) Being under the influence of liquor.

(c) Entering, crossing, being on, or trespassing on any playing ground area, enclosure or course, or building, room, or structure, or any part thereof, whilst any sport, game, competition, race, entertainment, or amusement is being played, conducted, or carried on, or at any time between the commencement and conclusion of such event without the consent of the Committee.

(d) Using profane, indecent, obscene, or unseemly language.

(e) Using threatening, abusive, offensive, or insulting words.

(f) Behaving improperly, offensively, or riotously.

(g) Interfering with, or interrupting any game, sports, competition, entertainment, or amusement or practice thereof.

(h) Obtaining or attempting to obtain admission to any part of the Reserve when not entitled to admission under these Regulations.

23. No persons except labourers and workmen employed in the Reserve shall enter any plots therein which may be enclosed for plantations of young trees or shrubs.

In respect of this Reserve, the Council of the Shire of Cohuna has been appointed a Committee of Management with power and authority to enforce these Regulations.

Every person who contravenes or fails to comply with these Regulations shall, in accordance with the provisions of section 181 of the *Land Act 1928*, as re-enacted by section 9 of the *Land Act 1941*, for each offence be liable to a penalty of not more than Five pounds, and every person who contravenes or fails to comply with any such Regulation and who after he has been warned by any bailiff of Crown lands or by any member of the Police Force does not desist therefrom may be forthwith apprehended by such bailiff or member of the Police Force and taken before some justice to be dealt with according to law, and shall be liable to a penalty of not more than Ten pounds.

The common seal of the Board of Land and Works was hereunto affixed this ninth day of August, 1946, in the presence of—

(SEAL)

L. W. GALVIN, President.

J. E. HUNTER, Member.

(Lands Department Corres. Rs.5312.)

## TENDERS.

**TENDERS** will be received at this office until **TEN A.M.** on the days and for the purposes under mentioned.

Particulars may be learnt at this office, and also at the offices named in each instance.

The Board of Land and Works will not necessarily accept the lowest or any tender.

27th August, 1946.

Allan's Flat.—Repairs, painting, &c., school and residence. State School No. 11. Particulars at Inspector of Works Office, Wangaratta; Police Station, Wodonga; State School, Allan's Flat. Deposit, £4.

Avenel.—Painting and repairs. State School No. 8. Particulars at Inspector of Works Office, Benalla; Police Stations, Euroa, Seymour; State School, Avenel. Preliminary deposit, £5. Final deposit, 2 per cent.

Avenel.—Repairs and painting. Police Station. Particulars at Inspector of Works Offices, Benalla, Wangaratta; Police Stations, Avenel, Euroa. Deposit, £4.

Ballarat East.—Purchase and removal of Police Department property at 36 Victoria-street. Particulars at Inspector of Works Office, Ballarat. Deposit, £5.

Balling East.—Alterations, additions, and repairs. State School No. 3787. Particulars at Inspector of Works Offices, Ballarat, Geelong; Police Station, Werribee; State School, Balling East. Preliminary deposit, £5. Final deposit, 2 per cent.

Burnley.—Installation of electric light and power in new School of Primary Agriculture, Horticultural Gardens. Preliminary deposit, £15. Final deposit, 2 per cent.

Dalyston.—Painting and repairs. State School No. 3376. Particulars at Inspector of Works Office, Korumburra; Police Stations, Leongatha, Wonthaggi; State School, Dalyston. Preliminary deposit, £5. Final deposit, 2 per cent.

Dimboola.—Sewerage. Police Station. Particulars at Inspector of Works Office, Horsham; Police Stations, Dimboola, Nhill. Deposit, £4.

Essendon.—Erection of brick workshop block, Technical School. Preliminary deposit, £25. Final deposit, 2 per cent.

Euroa.—Removal, re-building, and extension of out-offices, and provision of septic tank installation. State School No. 1706. Particulars at Inspector of Works Offices, Benalla, Wangaratta; State School, Euroa. Preliminary deposit, £10. Final deposit, 2 per cent.

Eurobin.—Renovations, painting, and repairs. State School No. 1355. Particulars at Inspector of Works Office, Wangaratta; Police Stations, Bright, Yackandandah; State School, Eurobin. Deposit, £4.

Frankston.—Repairs and painting. High School. Particulars at Police Station, Mornington; High School, Frankston. Preliminary deposit, £15. Final deposit, 2 per cent.

Gardenvale.—Repairs to fire damage. State School No. 3897. Particulars at State School, Gardenvale. Preliminary deposit, £10. Final deposit, 2 per cent.

Glenferrie.—Supply and delivery of hot cathode fluorescent lighting equipment. New Chemistry School, Swinburne Technical School. Preliminary deposit, £5. Final deposit, 2 per cent.

Gormandale East.—General repairs and painting. State School No. 2877. Particulars at Inspector of Works Office, Korumburra; Police Stations, Sale, Traralgon; State School, Gormandale East. Preliminary deposit, £5. Final deposit, 2 per cent.

Iona.—General repairs and painting. State School No. 3201. Particulars at Police Stations, Dandenong, Trafalgar; State School, Iona. Preliminary deposit, £5. Final deposit, 2 per cent.

Jumbunna.—Repairs and painting, residence. State School No. 2954. Particulars at Inspector of Works Office, Korumburra; Police Stations, Leongatha, Warragul; State School, Jumbunna. Deposit, £3.

Longerenong.—Erection of new quarters in timber for farm hands, Agricultural College. Particulars at Inspector of Works Offices, Ballarat, Horsham; Agricultural College, Longerenong. Preliminary deposit, £20. Final deposit, 2 per cent.

Longford.—Renovations, repairs, and painting. State School No. 1694. Particulars at Inspector of Works Office, Bairnsdale; Police Stations, Sale, Traralgon; State School, Longford. Preliminary deposit, £10. Final deposit, 2 per cent.

Mallacoota.—Painting and repairs. State School No. 3515. Particulars at Inspector of Works Office, Bairnsdale; Police Station, Orbost; State School, Mallacoota. Preliminary deposit, £5. Final deposit, 2 per cent.

Melbourne.—Gas hot-water installation. City Watch-house, Russell-street. Deposit, £2.

Nhill.—Erection of brick school, State School No. 2411. Particulars at Inspector of Works Offices, Horsham, Stawell; Police Station, Dimboola; State School, Nhill. Preliminary deposit, £20. Final deposit, 2 per cent.

Panton Hill.—Renovations, repairs, and painting, school and residence. State School No. 1134. Particulars at Police Station, Hurstbridge; State School, Panton Hill. Preliminary deposit, £5. Final deposit, 2 per cent.

Port Melbourne.—Supply of machines, Public Works Department Depot, Salmon-street. Deposit, 5 per cent.

Pyalong.—Painting and repairs, Police Station. Particulars at Police Stations, Kilmore, Pyalong. Deposit, £3.

Wahgunyah.—Repairs and painting. State School No. 644. Particulars at Inspector of Works Offices, Benalla, Wangaratta; Police Station, Wodonga. Preliminary deposit, £4. Final deposit, 2 per cent.

Wandin Yallock.—Erection of out-offices, &c., and installation of septic tank system. State School No. 1033. Particulars at Police Station, Lilydale; State School, Wandin Yallock. Preliminary deposit, £10. Final deposit, 2 per cent.

Wangaratta.—Repairs to verandahs. High School. Particulars at Inspector of Works Offices, Benalla, Wangaratta; High School, Wangaratta. Deposit, £4.

Whitfield.—Erection of new office, residence, and out-buildings. Police Station. Particulars at Inspector of Works Offices, Benalla, Wangaratta; Police Stations, Euroa, Whitfield. Preliminary deposit, £15. Final deposit, 2 per cent.

3rd September, 1946.

Allambee South.—Painting, repairs, new tank stand, &c., State School No. 3075. Particulars at Inspector of Works Office, Korumburra; Police Stations, Mirboo North, Warragul; State School, Allambee South. Deposit, £4.

Ararat.—Erection of timber and brick storage sheds, Mental Hospital. Particulars at Inspector of Works Office, Ballarat, Stawell; Police Station, Ararat; Mental Hospital, Ararat. Preliminary deposit, £15. Final deposit, 2 per cent.

Aspendale.—General repairs, external painting, and internal renovations. State School No. 4103. Particulars at Police Station, Frankston; State School, Aspendale. Preliminary deposit, £4. Final deposit, 2 per cent.

Bairnsdale.—Erection of Police Offices in brick, Police Station. Particulars at Inspector of Works Office, Bairnsdale; Police Stations, Bairnsdale, Sale. Preliminary deposit, £15. Final deposit, 2 per cent.

Ballendella.—Repairs, painting, and internal renovations, residence. State School No. 3732. Particulars at Inspector of Works Office, Bendigo; Police Stations, Rochester, Echuca; State School, Ballendella. Deposit, £3.

Beechworth.—Alterations and additions to hot-water service, Reformatory Prison. Particulars at Inspector of Works Office, Wangaratta; Police Station, Beechworth. Preliminary deposit, £5. Final deposit, 2 per cent.

Branxholme.—Alterations, repairs, and painting, Police Station. Particulars at Inspector of Works Office, Stawell; Police Stations, Ararat, Branxholme, and Hamilton. Deposit, £4.

Cowes.—Repairs, fencing, and painting. State School No. 1282. Particulars at Police Stations, Frankston, Wonthaggi; State School, Cowes. Preliminary deposit, £5. Final deposit, 2 per cent.

Eltham.—Repairs, painting, &c., school and residence. State School No. 209. Particulars at State School, Eltham. Deposit, £4.

Elwood.—Repairs to roof and shelter pavilions, Central School No. 3042. Particulars at Central School, Elwood. Deposit, £4.

Fitzroy.—Internal repairs, painting, and renovations, Girls' School. Particulars at Girls' School, Fitzroy. Preliminary deposit, £5. Final deposit, 2 per cent.

Glen Forbes.—Repairs and painting. State School No. 4008. Particulars at Inspector of Works Office, Korumburra; Police Stations, Wonthaggi, Loch; State School, Glen Forbes. Deposit, £3.

Hallam.—Repairs, painting, &c., State School No. 244. Particulars at Police Station, Dandenong; State School, Hallam. Deposit, £4.

Melbourne.—Supply and installation of propeller fans and ducting in chemistry laboratories, Technical College. Preliminary deposit, £5. Final deposit, 2 per cent.

Melbourne.—Supply and installation of cold cathode fluorescent lighting equipment, new extension, Emily McPherson College of Domestic Economy. Preliminary deposit, £3. Final deposit, 2 per cent.

Mont Park.—External renovations and painting, Nurses' Home, Mental Hospital. Preliminary deposit, £5. Final deposit, 2 per cent.

Newbridge.—Repairs and renovations. State School No. 457. Particulars at Inspector of Works Offices, Bendigo, Maryborough; Police Stations, Dunolly, Inglewood; State School, Newbridge. Deposit, £4.

Rushworth.—Repairs, painting, and fencing. Court House and Police Station. Particulars at Inspector of Works Office, Shepparton; Police Stations, Rushworth, Echuca, Seymour. Preliminary deposit, £4. Final deposit, 2 per cent.

Rye.—Repairs and painting, residence. State School No. 1667. Particulars at Police Stations, Frankston, Mornington; State School, Rye. Deposit, £3.



South Melbourne.—Alterations, additions, and painting. J. H. Boyd College of Domestic Economy. Deposit, £5.  
 St. James.—Repairs and painting, State School No. 2579. Particulars at Inspector of Works Offices, Benalla, Wangaratta; State School, St. James. Deposit, £3.  
 Swan Reach.—Repairs and painting, State School No. 1631. Particulars at Inspector of Works Office, Bairnsdale; Police Station, Sale; State School, Swan Reach. Preliminary deposit, £5. Final deposit, 2 per cent.  
 Tynong.—Repairs and painting, residence, State School No. 2854. Particulars at Police Stations, Dandenong, Warragul; State School, Tynong. Preliminary deposit, £4. Final deposit, 2 per cent.  
 Woolamai.—Repairs, renovations, and painting, State School No. 3856. Particulars at Police Stations, Wonthaggi, Mornington; State School, Woolamai. Preliminary deposit, £5. Final deposit, 2 per cent.  
 Yering.—Repairs, painting, and new wash-house and store-room, school and residence, State School No. 1034. Particulars at Police Stations, Healesville, Lilydale; State School, Yering. Preliminary deposit, £4. Final deposit, 2 per cent.

10th September, 1946.

Ballarat.—Supply and installation of one mechanical exhaust system, School of Mines. Particulars at Inspector of Works Office, Ballarat. Preliminary deposit, £4. Final deposit, 2 per cent.

Collingwood.—Electro-plating workshop, Technical School. Preliminary deposit, £100. Final deposit, 2 per cent.

Tenders to be addressed to the Honorable the Commissioner of Public Works, and envelope containing tender marked "Tender for \_\_\_\_\_ due

P. J. KENNELLY,  
 Commissioner of Public Works

Melbourne, 20th August, 1946.

#### TENDERS FOR THE SERVICE, 1946-47.

##### PROVISIONS.

##### BUTTER AND CHEESE.

TENDERS will be received until Eleven o'clock a.m. on Friday, 13th September, 1946, from persons willing to furnish the under-mentioned supplies, in such quantities as may be ordered by the Victorian Government during the twelve months commencing on 1st October, 1946, as per Schedule No. 21—delivery to be made at the institutions at the under-mentioned places.

The places and supplies for which tenders will be received and the amount of the preliminary deposit required are as follows:—

Schedule No. 21.—Preliminary Deposit, £10.

Melbourne, Mont Park, Ararat, Ballarat, Beechworth, and Sunbury Districts—Butter and Cheese.

Greenvale Sanatorium and Pleasant Creek Special School, Stawell—Butter.

The prices tendered must not include sales tax.

Schedule as above, with full particulars, may be obtained from the Secretary to the Tender Board, and for the several districts, from the Medical Superintendent, Mental Hospital, at Ararat, Ballarat, Beechworth, Mont Park, and Sunbury, respectively; for Greenvale, from the Superintendent at the Sanatorium; for Stawell, from the Secretary, Special School, by whom also any information or explanation will be afforded to persons tendering.

Tenders must be accompanied by the preliminary deposit, as shown above, preferably by non-negotiable cheque payable to the order of the Secretary to the Tender Board. The amount and designation of the preliminary deposit enclosed must be clearly stated in the tender. Savings Bank deposit book, fixed deposit receipts, Commonwealth Treasury bonds, or reference to securities on existing contracts will in no case be received or entertained as preliminary deposits. Preliminary deposits will be returned within 30 days to unsuccessful tenderers on their application.

Security will be required either in Commonwealth Treasury Bonds, or approved bank guarantee, fixed deposit receipt, Savings Bank deposit book, or non-negotiable cheque in favour of the Secretary to the Tender Board, as the tenderer may elect.

The security must be completed and the contract signed within ten days of acceptance of the tender; failing which the contract may be again advertised, or another tender accepted. The lowest or any tender will not necessarily be accepted.

In the event of tenderers withdrawing or attempting to withdraw their tenders before notification of acceptance of same, or failing to take up their accepted tenders within the prescribed period after notification of acceptance, the preliminary deposit will be forfeited and, in addition, they may be disqualified from tendering or holding any future contracts for Government supplies for a period of twelve months, such disqualification to date from the notification of acceptance of

No. 166.—8562/46.—3

tender. It is also stipulated that, if a tenderer be a member of a firm and such firm be interested in the contract, the tender shall be in the name of the firm and not in that of the individual, and that, for a breach of this condition, the preliminary deposit will be forfeited and the tender declared informal.

Tenders enclosed in a separate envelope, and having the words "Tender for \_\_\_\_\_ at \_\_\_\_\_" (as the case may be) written thereon, must be deposited in the Tender Box at the Tender Board Offices, Gisborne-street, Melbourne, or, if sent by post, postage must be prepaid, and the tenders addressed to the Chairman of the Tender Board, Tender Board Offices, Gisborne-street, Melbourne, C.2, which office they must reach not later than by first post on the date of closing of tenders.

The conditions of contract are those published in the *Victoria Government Gazette*, No. 113, dated 26th June, 1946, pages 1878 and 1879.

JOHN CAIN,  
 Treasurer.

The Treasury,  
 Melbourne, 19th August, 1946.

#### TENDERS FOR THE SERVICE, 1946-47.

##### GENERAL STORES.

TENDERS will be received until Eleven o'clock a.m. on Friday, 13th September, 1946, from persons willing to supply the under-mentioned articles in such quantities as may be ordered by the Victorian Government during the twelve months commencing on 1st October, 1946:—

Schedule No.	Preliminary Deposit.
68. Stamps, Rubber	£ 3

The prices tendered must not include sales tax.

Security.—Five per cent. of total amount of tender accepted, but in no case will security of less than £3 be received.

Schedules as above, with full particulars, may be obtained from the Secretary to the Tender Board, by whom also the samples will be shown and any information afforded to persons tendering.

In all cases the total cost of each item must be extended in the columns provided.

Tenders must be accompanied by the preliminary deposit, as shown above, preferably by non-negotiable cheque payable to the order of the Secretary to the Tender Board. The amount and designation of the preliminary deposit enclosed must be clearly stated in the tender. Savings Bank deposit book, fixed deposit receipts, Commonwealth Treasury bonds, or reference to securities on existing contracts will in no case be received or entertained as preliminary deposits. Preliminary deposits will be returned within 30 days to unsuccessful tenderers on their application.

Security will be required either in Commonwealth Treasury Bonds, or approved bank guarantee, fixed deposit receipt, Savings Bank deposit book, or non-negotiable cheque in favour of the Secretary to the Tender Board, as the tenderer may elect.

The security must be completed and the contract signed within five days of acceptance of the tender, failing which the contract may be again advertised, or another tender accepted.

The lowest or any tender will not necessarily be accepted.

In the event of tenderers withdrawing or attempting to withdraw their tenders before notification of acceptance of same, or failing to take up their accepted tenders within the prescribed period after notification of acceptance, the preliminary deposit will be forfeited and, in addition, they may be disqualified from tendering or holding any future contracts for Government supplies for a period of twelve months, such disqualification to date from the notification of acceptance of tender. It is also stipulated that, if a tenderer be a member of a firm and such firm be interested in the contract, the tender shall be in the name of the firm and not in that of the individual and that, for a breach of this condition, the preliminary deposit will be forfeited and the tender declared informal.

Tenders enclosed in a separate envelope, and having the words "Tender for \_\_\_\_\_" (as the case may be) written thereon, must be deposited in the Tender-box at the Tender Board Offices, Gisborne-street, Melbourne, or, if sent by post, postage must be prepaid; and the tenders addressed to the Chairman of the Tender Board, Tender Board Offices, Gisborne-street, Melbourne, C.2, which office they must reach not later than by first post on the date of closing of tenders.

The conditions of contract are those published in the *Victoria Government Gazette*, No. 50, dated 20th March, 1946, pages 1030 to 1032.

JOHN CAIN,  
 Treasurer.

The Treasury,  
 Melbourne, 19th August, 1946.

TENDERS FOR THE SERVICE 1946-47.  
FIREWOOD (COUNTRY TOWNS).

TENDERS will be received until Eleven o'clock a.m. on Friday, 13th September, 1946, for the supply of Firewood, in such quantities as may be required by the Government of Victoria at the under-mentioned places, including supplies for High Schools under the Education Department, from the 1st October, 1946, to the 30th September, 1947. Supplies for the Railways Department and State Schools are not included.

Place.	Departments for which Supply is Required.	Estimated Annual Quantity of Firewood Required for each Place.		
		In 1-ft. Billets.	In 2-ft. Lengths.	In 5-ft. Lengths.
		Tons of 40 cubic feet.	Tons of 40 cubic feet.	
Alexandra	Government Institutions, Offices, and High Schools	..	10	
Bairnsdale	" " " " " " " "	..	37	
Benalla	" " " " " " " "	..	64	
Camperdown	" " " " " " " "	..	31	
Colao	" " " " " " " "	..	41	
Dandenong	" " " " " " " "	..	38	
Daylesford	" " " " " " " "	..	15	
Dimboola	" " " " " " " "	3	20	
Echuca	" " " " " " " "	6	15	
Frankston	" " " " " " " "	..	20	
Geelong	" " " " " " " "	..	43	
Hamilton	" " " " " " " "	..	41	
Kerang	" " " " " " " "	..	27	
Kyneton	" " " " " " " "	..	38	
Leongatha	" " " " " " " "	..	14	
Maryborough	" " " " " " " "	..	41	
Mildura	" " " " " " " "	..	48	
Nhill	" " " " " " " "	..	28	
Portland	" " " " " " " "	..	39	
Rutherglen	" " " " " " " "	..	..	40
St. Arnaud	" " " " " " " "	..	23	
Sale	" " " " " " " "	..	27	50
Seymour	" " " " " " " "	..	16	
Shepparton	" " " " " " " "	20	..	
Swan Hill	" " " " " " " "	12	14	
Upwey	" " " " " " " "	..	30	
Warracknabeal	" " " " " " " "	..	17	
Warragul	" " " " " " " "	..	40	
Warrnambool	" " " " " " " "	..	70	
Yallourn	" " " " " " " "	..	25	

Printed forms of tender, showing estimates of requirements and conditions of contract, may be obtained from the Secretary to the Tender Board, Gisborne-street, Melbourne, C.2, or from the officer in charge of police at each of the above-mentioned places, by whom also any information or explanation will be afforded to persons tendering.

Prices, which must be expressed in words as well as in figures, and without alterations, erasures, or discrepancies, must be per ton of 40 cubic feet, including delivery and all charges.

Tenders, which must be upon the printed form, will be received for one or more of the above-mentioned places, and tenders for such places may be accepted separately; any of the lengths of wood stipulated may be tendered for and may be accepted separately.

**Tenderers must specify the kind or kinds of firewood offered.**

Telegrams or tenders not complying with the terms of advertisement will not be entertained.

**No security will be required.**

Tenderers failing to take up their accepted tenders, or failing to carry out their contracts satisfactorily, will be ineligible to again hold contracts for Government supplies.

Tenders must be enclosed in an envelope, marked "Tender for Firewood at ....." as the case may be, and deposited in the Tender Box, Tender Board Offices, Gisborne-street, Melbourne, C.2; or, if sent by post, they must be addressed to the Chairman of the Tender Board, Tender Board Offices, Gisborne-street, Melbourne, C.2.

The lowest or any tender will not necessarily be accepted.

Acceptance of tenders will be notified in the *Government Gazette* and by letter to successful tenderers.

CONDITIONS OF CONTRACT.

1. As the exact quantity of firewood which may be required cannot be stated, the estimate being approximate only, the Government will not be bound by the quantity stated, but will be at liberty to order more or less, according to circumstances, and the contractor will be bound to supply the same at contract rates.

2. All the firewood supplied under these contracts must be split out of large timber, must be perfectly sound, dry, and of the kind or kinds specified in the tender; neither burnt wood, heartwood, small branches, nor outside pieces of bark will be received. The billets must be not less than 4 inches nor more than 6 inches in diameter, and the long wood to be not less than 9 inches nor more than 18 inches in diameter. Delivery to be made on the written order of the authorized officer of the Department requiring the supply. The ton of firewood consists of 40 cubic feet. If the firewood be obtained from a State Forest Timber Reserve, or ordinary Crown lands, persons cutting or removing same must be provided with a licence or permit from the Forests Commission. Messmate wood will not be accepted.

3. Orders will be issued half-yearly (except in cases where the storage is small, when they will be issued quarterly).

4. The contractor will be bound to place the firewood in stacks for measurement in such places as may be directed by the officer receiving the supply. The stacks are to be 2 feet wide (or 5 feet for long wood) by 5 feet high, with space between each stack for measuring; and the billets (or lengths) are all to lie the same way, viz., crossways of the stacks in the form of a cord, and are to be laid as closely and solidly as possible in the stack, and to the satisfaction of the officer receiving the supply. In the event of any inconvenience being caused, either through delay in delivery or of stacking the wood, or failure to stack the wood in the places directed, the Department concerned will purchase elsewhere or re-stack that delivered, at the risk of the contractor, from whose account any expense incurred thereby will be deducted, provided that the contractor shall be given 48 hours' notice before purchases are made or the wood re-stacked at his risk.

5. The officer receiving the supply shall have full power to reject any wood which he may consider not in accordance with the contract, notice of which will be given to the contractor in writing, stating the reason. The contractor may, however, claim a survey; but in that case he must, within 48 hours after objection is made, give notice thereof in writing to the officer rejecting the wood.

6. The board of survey will be composed of persons appointed by the Tender Board, and the decision of the board of survey is to be considered as final.

7. If the board of survey shall decide that the supply is not of proper quality, it must be immediately replaced by the contractor; failing which it will be procured elsewhere, and the extra expense incurred thereby, if any, will be deducted from the contractor's account.

8. Accounts for firewood shall be rendered to the Department receiving the supply immediately upon completion of the order, which must be attached to the account. Payment will be made through the Treasury, Melbourne.

9. In the event of any irregularity on the part of the contractor being repeated, it will be competent for the Government, in case such irregularity should be established to the satisfaction of the Tender Board, to cancel the contract forthwith.

10. Contractors are not at liberty to transfer their contracts under cover of power of attorney, coupled with an interest or otherwise, and no such transfer will be recognized by the Government.

11. Under no circumstances will a contractor be permitted to abandon his contract.

The Treasury,  
Melbourne, 19th August, 1946.

JOHN CAIN,  
Treasurer.

## PRIVATE ADVERTISEMENTS.

## IN THE MATTER OF THE METROPOLITAN GAS COMPANY'S ACTS 1878, 1920, and 1942.

WE, Lionel Findon Miller, Sir Harold Daniel Luxton, and Leslie Gordon Francis Leckie, all of the City of Melbourne, gentlemen, do severally solemnly and sincerely declare as follows:—

First.—We, the said Lionel Findon Miller and Sir Harold Daniel Luxton, for ourselves, say that we are two of the Directors in The Metropolitan Gas Company.

And next.—I, the said Leslie Gordon Francis Leckie, for myself, say that I am the Secretary of the said company.

And next.—We, the said Lionel Findon Miller, Sir Harold Daniel Luxton, and Leslie Gordon Francis Leckie, say:—

That the nominal capital of the said company as on the thirtieth day of June, One thousand nine hundred and forty-six, was Two million pounds. The amount paid up thereon as on the thirtieth day of June, One thousand nine hundred and forty-six, was One million six hundred and sixty-two thousand five hundred pounds, divided into Three hundred and thirty-two thousand five hundred shares of Five pounds each.

That the amount which the company is legally authorized to borrow on debentures is the sum of Three million and sixty-three thousand seven hundred and thirty-seven pounds.

That the total amount raised by the company on debentures and unpaid does not exceed the amount which the said company is by The Metropolitan Gas Company's Acts 1878, 1920, and 1942 authorized to borrow.

That none of the debentures, bonds, and mortgages granted by the City of Melbourne Gas and Coke Company, The Collingwood-Fitzroy Gas and Coke Company, and The South Melbourne Gas Company referred to in the 55th section of the principal Act are now outstanding, the same respectively having been paid off.

And we severally make this solemn declaration conscientiously believing the same to be true and by virtue of the provisions of an Act of the Parliament of Victoria rendering persons making a false declaration punishable for wilful and corrupt perjury.

L. F. MILLER.

Declared by the said Lionel Findon Miller, at Melbourne aforesaid, this nineteenth day of August, One thousand nine hundred and forty-six, before me—R. J. McARTHUR, Notary Public, Melbourne, Victoria.

HAROLD LUXTON.

Declared by the said Sir Harold Daniel Luxton, at Melbourne aforesaid, this nineteenth day of August, One thousand nine hundred and forty-six, before me—R. J. McARTHUR, Notary Public, Melbourne, Victoria.

GORDON LECKIE.

Declared by the said Leslie Gordon Francis Leckie, at Melbourne aforesaid, this nineteenth day of August, One thousand nine hundred and forty-six, before me—R. J. McARTHUR, Notary Public, Melbourne, Victoria. 7461

## PUBLIC NOTICE TO GAS CONSUMERS.

GAS REGULATION (EMERGENCY POWERS) REGULATIONS No. 23. (Published *Victoria Government Gazette*, 19th August, 1946.)

NO person shall use gas except between the hours hereinafter specified:—

- (a) In the case of—
- |                              |                                                                |
|------------------------------|----------------------------------------------------------------|
| Tuesday, 20th August, 1946   | } 6 a.m. to 8 a.m.<br>12 noon to 1 p.m.<br>5.30 p.m. to 7 p.m. |
| Wednesday, 21st August, 1946 |                                                                |
| Thursday, 22nd August, 1946  |                                                                |
| Friday, 23rd August, 1946    |                                                                |
- (b) In the case of—
- |                             |                                                                   |
|-----------------------------|-------------------------------------------------------------------|
| Saturday, 24th August, 1946 | } 6 a.m. to 8 a.m.<br>11.30 a.m. to 2 p.m.<br>5.30 p.m. to 7 p.m. |
|                             |                                                                   |
|                             |                                                                   |
- (c) In the case of—
- |                           |                                                                         |
|---------------------------|-------------------------------------------------------------------------|
| Sunday, 25th August, 1946 | } 6 a.m. to 8 a.m.<br>10.30 a.m. to 1.30 p.m.<br>5.30 p.m. to 6.30 p.m. |
|                           |                                                                         |
|                           |                                                                         |

The restrictions shall not apply to persons using gas in connexion with the conduct of hospitals, medical services, or institutions rendering relief to the aged or infirm or to persons using gas for pilot lights on automatic appliances.

These Regulations shall apply to and have operation throughout the areas supplied with gas by The Metropolitan Gas Company, The Colonial Gas Association Limited (as to its Footscray, Box Hill, Frankston, and Oakleigh works), The Brighton Gas Company Limited, The Heidelberg City Council Gas Works, and The Mordialloc City Council Gas Works.

10th August, 1946.

7455

## DIOCESAN SYNOD.

NOTICE is hereby given that the Archbishop of Melbourne has convened the Synod of the Church of England within the Diocese of Melbourne, Victoria, for Monday, the 30th day of September next, at half-past Seven o'clock in the evening, at the Chapter House, Cathedral Buildings, Melbourne.

R. C. WARDLE,

Registrar of the Diocese of Melbourne.

7447

## QUEENSLIFFE BOROUGH COUNCIL.

## SEWERAGE DISTRICTS ACTS.

## Proposed Sewerage Authority.

NOTICE is here given that the Queenscliffe Borough Council has made application to the Honorable the Minister of Water Supply for the constitution of a Sewerage Authority, and for the proclamation of a Sewerage District at Queenscliffe and Point Lonsdale, and for the construction, maintenance, and continuance of sewerage works within that District under the provisions of the Sewerage Districts Acts.

A general plan and description of the proposed works have been submitted with the application, and copies of same may be seen at the Town Hall, Queenscliffe.

C. H. WHITE, A.M.I.E. Aust., Town Clerk.

Town Hall, Queenscliffe, 5th August, 1946.

7358

## COLAC WATERWORKS TRUST.

## EXTENSION OF WATERWORKS DISTRICT.

NOTICE is hereby given that Colac Waterworks Trust proposes to increase the extent of its waterworks district so as to supply the Townships of Cororooke, Coragulac, Alvie, Warrion, Beeac, and Cressy, all in the Shire of Colac.

An application for submission to the Governor in Council for his sanction, to such increase (together with a general plan and description of the proposed extension) has been forwarded to the Minister of Water Supply.

Copies of such general plan and description have been deposited for inspection, and may be inspected at the offices of the State Rivers and Water Supply Commission, 100-110 Exhibition-street, Melbourne, the office of the Shire of Colac, at the Shire Hall, Murray-street, Colac, the offices of the Trust's engineers, Messrs. Garlick and Stewart, at 34 Queen-street, Melbourne, and at the offices of Colac Waterworks Trust, Rae-street, Colac.

By order,

ALLAN McKENZIE,

Secretary.

Trust Office, 2 Rae-street, Colac,  
16th August, 1946.

7436

## CITY OF BOX HILL.

## By-LAW No. 79.

A By-law of the City of Box Hill, made under the Local Government Acts and the Uniform Building Regulations Victoria, and numbered 79, for determining, applying, dispensing with, or regulating such matters or things as are left to be determined, applied, dispensed with, or regulated by the Council of the said City of Box Hill under the Uniform Building Regulations Victoria for altering By-law number 78 of the said City of Box Hill, and for other purposes.

IN pursuance of the powers conferred by the Local Government Acts and the Uniform Building Regulations Victoria, and of any and every other power it thereunto enabling, the Mayor, Councillors, and Citizens of the City of Box Hill order as follows:—

1. The said By-law No. 78 of the City of Box Hill shall be altered as follows:—

- (a) By inserting in the first column of the First Schedule thereto immediately after the expression "Belmore-road" the expression "Begonia-street (from Elgar-road to Inverloch-street)."
- (b) By inserting in the second column of the said Schedule opposite to such last-mentioned expression the words "both sides."
- (c) By inserting in the first column of the said Schedule immediately after the expression "Elgar-road (between Piedmont-street and Naples-street)" the expression "Elgar-road (from Riversdale-road to Cadorna-street)."
- (d) By inserting in the second column of the said Schedule opposite to such last-mentioned expression the words "east side."

- (e) By inserting in the first column of the said Schedule immediately after the expression "Graham-place" the expression "Hamel-street (from Elgar-road to Inverloch-street)."
- (f) By inserting in the second column of the said Schedule opposite to such last-mentioned expression the words "both sides."
- (g) By inserting in the first column of the said Schedule immediately after the expression "Nelson-road between Arnold-street and Thames-street)" the expression "Neville-street (from Elgar-road to Inverloch-street)."
- (h) By inserting in the second column of the said Schedule opposite to such last-mentioned expression the words "both sides."

Resolution for passing of this By-law agreed to by the Council of the City of Box Hill on the sixth day of May, 1946, and confirmed on the third day of June, 1946.

The corporate seal of the Mayor, Councillors and Citizens of the City of Box Hill was hereto affixed, in the presence of—

E. J. ELLINGWORTH, Mayor.  
(SEAL) W. J. RICHARDS, Councillor.  
A. BRUCE CURREY, Town Clerk.

Approved by the Governor in Council, 30th July, 1946.—  
C. W. KINSMAN, Clerk of the Executive Council. 7480

## CITY OF COLLINGWOOD.

## BY-LAW No. 76.

*Altering Description of Residential Area No. 3 as Set Forth in By-law No. 69.*

By-law of the City of Collingwood, No. 76, made under the *Local Government Act 1928*, and particularly under section 197 of the said Act, amending By-law No. 69 of the said City.

IN pursuance of the powers conferred by the *Local Government Act 1928*, and every power thereunto enabling, the Mayor, Councillors, and Citizens of the City of Collingwood, with the approval of the Governor in Council, order as follows:—

That By-law No. 69 of the City of Collingwood, prescribing residential areas within the Municipal District of the City of Collingwood as to the Schedule thereof, be amended as follows:—

1. The description of residential area No. 3, Abbotsford Ward, set forth in Schedule of the said By-law, be altered and amended to read:—

"Commencing at the north-eastern corner of the intersection of Hoddle and Vere streets; thence easterly along the northern side of Vere-street and Marine-parade to Clarke-street; thence northerly along the west side of Clarke-street to a point opposite the south side of St. Helier's-street; thence south-easterly along the south-west side of St. Helier's-street; thence north-westerly to the intersection of Johnston-street and the western bank of the River Yarra; thence westerly along the south side of Johnston-street to the south-east corner of Johnston-street and Park-street; thence southerly along the eastern side of Park-street to the south-eastern intersection of Studley-street; thence westerly along the south side of Studley-street to Hoddle-street; thence southerly along the eastern side of Hoddle-street to the commencing point."

2. The description of residential area No. 3 (Abbotsford), as so amended, shall form part of the Schedule of the said By-law in substitution for the former description of residential area No. 3 (Abbotsford) and the amended description shall be deemed to have been inserted on the coming into operation of such By-law No. 69 in the place and stead of the former description.

A resolution for passing this By-law was agreed to by the Council on the 8th day of October, 1945.

Confirmed the 5th day of November, 1945.

The common seal of the Mayor, Councillors, and Citizens of the City of Collingwood was hereto affixed by order of the Council, the 6th day of November, 1945, in the presence of—

W. RUTHVEN, Mayor.  
(SEAL) W. A. JUPP, Councillor.  
G. J. BROWN, Town Clerk.

Confirmed by the Governor in Council, the 6th day of August, 1946.—C. W. KINSMAN, Clerk of the Executive Council. 7433

## CITY OF FOOTSCRAY.

## BY-LAW No. 116.

A By-law of the City of Footscray, numbered 116, made under section 197 of the *Local Government Act 1928*, for prohibiting the temporary herding of cattle within a residential area.

IN pursuance of the powers conferred by the *Local Government Acts*, and of every power it thereunto enabling, the Mayor, Councillors, and Citizens of the City of Footscray, with the approval of the Governor in Council, order as follows:—

1. The area within the municipal district specified in the Schedule hereto is hereby declared to be residential area.
2. The temporary herding of cattle within any of the said area is hereby prohibited.

## SCHEDULE.

All streets and lands included in that area bounded as follows:—Commencing at the intersection of the south side of Francis-street and the western boundary of the municipal district; thence east by the south side of Francis-street to the west side of Williamstown-road; thence south by the west side of Williamstown-road to the north side of The Avenue; thence west by the north side of The Avenue to a point east of Durham-street in line with the east side of Highgate-street; thence south along the said line at the rear of allotments on the east side of Stephenson-street to the north side of Blackshaws-road; thence west by the north side of Blackshaws-road to the east side of New-street; thence north by the east side of New-street to the north side of Watson-street; thence east by the north side of Watson-street to the Sunshine-Newport railway line; thence north-west by the Sunshine-Newport railway line to the commencing point.

Resolution for passing this By-law agreed to by the Council on the 24th day of June, 1946, and confirmed on the 22nd day of July, 1946.

The common seal of the Mayor, Councillors, and Citizens of the City of Footscray was hereto affixed in the presence of—

W. H. ANDERSON, Mayor.  
(SEAL) A. EDWARDS, Councillor.  
E. J. SMITH, Town Clerk.

Approved by the Governor in Council on the 6th day of August, 1946.—C. W. KINSMAN, Clerk of the Executive Council. 7434

## CITY OF SANDRINGHAM.

## BY-LAW No. 134.

A By-law of the City of Sandringham, made under the provisions of the *Local Government Acts*, with the approval of the Governor in Council, and numbered 134, for the purpose of altering By-law No. 105 and repealing By-law No. 125.

IN pursuance of the powers conferred by the *Local Government Acts* and of any and every other power it thereunto enabling, the Mayor, Councillors, and Citizens of the City of Sandringham order as follows:—

1. By-law number 105 of the City of Sandringham, prohibiting the leaving (whether unattended or not) of motor cars or other vehicles standing in parts of certain streets, is hereby altered by deleting therefrom all the provisions thereof relating to parts of Beach-road and by inserting after clause 3 of the said By-law the following new clause:—

3A. No person shall leave (whether unattended or not) a motor car or other vehicle standing in any part of Beach-road, in the City of Sandringham, from a line across such road which commences at Hampton at a point on the east boundary line of Beach-road, 30 feet north of the north building line of Small-street at its intersection with Beach-road and is perpendicular to the east building line of such road at that point to a line across Beach-road at Beaumaris which is the prolongation of the west building line of Cromer-road.

2. By-law number 125 is hereby repealed.  
Resolution for passing this By-law agreed to by the Council, the 7th day of May, 1946, and confirmed the 18th day of June, 1946.

In witness whereof the common seal of the Mayor, Councillors, and Citizens of the City of Sandringham was hereto affixed, this second day of July, 1946, in the presence of—

WM. MCKAY, Mayor.  
(SEAL) R. J. SILLITOE, Councillor.  
F. G. TRICKS, Town Clerk.

Approved by the Governor in Council, this 30th day of July, 1946.—C. W. KINSMAN, Clerk of the Executive Council. 7424

## CITY OF SANDRINGHAM.

## BY-LAW No. 135.

A By-law of the City of Sandringham, made under the provisions of the Local Government Acts, with the approval of the Governor in Council, and numbered 135, for the purpose of altering By-law No. 105.

IN pursuance of the powers conferred by the Local Government Acts and of any and every other power it thereunto enabling, the Mayor, Councillors, and Citizens of the City of Sandringham order as follows:—

By-law No. 105, of the City of Sandringham, prohibiting the leaving (whether unattended or not) of motor cars or other vehicles standing in parts of certain streets, is hereby amended by inserting after clause 4 (b) of the said By-law the following words:—

"Provided that motor omnibuses licensed under the *Motor Omnibus Act 1928* for routes to and from the Hampton Railway Station shall be permitted to stop alongside the kerb on the west side of that part of Hampton-street, Hampton, commencing at a point in line with the northern building alignment of the thoroughfare known as Railway-arcade, then southerly for a distance of 94 ft. 5 in. for such reasonable time as may be necessary for the purpose of taking up or setting down passengers."

Resolution for passing this By-law agreed to by the Council, the 21st day of May, 1946, and confirmed the 18th day of June, 1946.

In witness whereof the common seal of the Mayor, Councillors, and Citizens of the City of Sandringham was hereto affixed, this second day of July, 1946, in the presence of—

(SEAL) WM. McKAY, Mayor.  
R. J. SILLITOE, Councillor.  
F. G. TRICKS, Town Clerk.

Approved by the Governor in Council, this 30th day of July, 1946.—C. W. KINSMAN, Clerk of the Executive Council. 7426

## SHIRE OF COLAC.

## COLAC POUND.

NOTICE is hereby given that James McConnell has been appointed Poundkeeper, in lieu of Charles Dowling, resigned.

DAVID M. DUNOON, Shire Secretary.  
Colac, 19th August, 1946. 7441

## SHIRE OF RODNEY.

NOTICE is hereby given that the Council of the Shire of Rodney has forwarded to the Honorable the Minister for Water Supply—

- (a) an application for the proclamation of a sewerage district and for sanction for the construction, maintenance, and continuance of sewerage works for the Township of Tatura; and
- (b) a general plan and description of the proposed works.

Copies of the general plan and description may be inspected, without payment, by any person at the following places:—

Shire Offices, Tatura;  
State Rivers and Water Supply Commission, 100 Exhibition-street, Melbourne.  
Commission of Public Health, 295 Queen-street, Melbourne.

W. T. A. MARTIN, Shire Secretary.  
Shire Office, Tatura. 7260

## Water Acts.

## SHIRE OF WALPEUP.

## PROPOSED LOCAL GOVERNING BODY.

NOTICE is hereby given that the Council of the Shire of Walpeup has made application to the Honorable the Minister for Water Supply for the constitution of a Local Governing Body and for the proclamation of a Waterworks District at Cowangie, and for the construction, maintenance, and continuance of town water supply works within that district under the provisions of the Water Acts.

A general plan and description of the proposed works have been submitted with the application, and copies of same may be seen at Tavener's Store, Cowangie, and at the Shire Office, Ouyen.

By order of the Council,  
K. H. LOVETT,  
Shire Secretary.  
14th August, 1946. 7431

NOTICE is hereby given that the partnership heretofore subsisting between the undersigned, Alexander John Simpson and John Vincent Burns, carrying on business as farmers, at Tempy, in the State of Victoria, has been dissolved by mutual consent as and from the 30th June, 1946. All debts due to and owing by the said partnership will be received and paid by the said John Vincent Burns, who will continue to carry on farming at the same place.

Dated the 10th day of August, 1946.

J. V. BURNS.  
Witness to signature of John Vincent Burns—F. M. BURNS, Tempy, home duties.

A. J. SIMPSON.  
Witness to signature of Alexander John Simpson—ALLAN J. KELLY, solicitor, St. Arnaud.

H. L. DUNKLEY & KELLY, of 78 Napier-street, St. Arnaud, solicitors for both the above-named parties. 7419

NOTICE is hereby given that the partnership heretofore subsisting between us, Alfred Neil Vicary and Stanley Hugh Morgan, carrying on the business of manufacturers' agents, at premises situate at 328 Flinders-street, Melbourne, under the style name of "Morgan and Vicary," has been dissolved by mutual consent as and from the 12th day of August, 1946. All debts due to and owing by the said firm will be received and paid by the said Alfred Neil Vicary, who will carry on the said business under the same firm name as heretofore.

Dated the 13th day of August, 1946.

S. H. MORGAN.  
A. N. VICARY.  
Witness to both signatures—J. W. SACKVILLE, 379 Collins-street, Melbourne. 7423

NOTICE is hereby given that the partnership heretofore subsisting between the undersigned Harry Cheeseman, of McMahon-road, Reservoir, Patrick James Brown, of 42 Austin-street, Fairfield, and Kenneth Graham Hagger, of 122 Peel-street, North Melbourne, carrying on business as building contractors at McMahon-road, Reservoir, under the name of "Cheeseman, Brown, and Hagger," has been dissolved by mutual consent as from the 27th day of July, 1946. All debts due to and owing by the said firm will be received and paid by the said Harry Cheeseman and Patrick James Brown, who will continue to carry on the business at the same place, under the name of "Cheeseman and Brown."

Dated this 9th day of August, 1946.

H. CHEESEMAN.  
Witness.—THOMAS FORBES, solicitor, Richmond.  
P. J. BROWN.  
Witness.—THOMAS FORBES, solicitor, Richmond.  
K. G. HAGGER.  
Witness.—C. T. K. RODDA, solicitor, Melbourne. 7444

## NOTICE OF DISSOLUTION OF PARTNERSHIP.

NOTICE is hereby given that the partnership heretofore subsisting between the undersigned Wilfred Ernest Hooper and Richard Chandler Hooper, carrying on business at Wombelano, under the name of W. and R. Hooper, has been dissolved by mutual consent as from the 1st day of July, 1946. All debts due to and owing by the said firm will be received and paid by the said Richard Chandler Hooper.

Dated this 15th day of August, 1946.

W. E. HOOPER.  
RICHARD C. HOOPER.  
Moule, Hamilton, and Derham, solicitors, 394 Collins-street, Melbourne. 7449

NOTICE is hereby given that the partnership lately subsisting between Leslie Donald Emerson, of 74 Wheatley-road, McKinnon, Frank Emerson, of 7 Robertson-avenue, St. Kilda, Harry Emerson, of Robe-street, St. Kilda, and May Elizabeth Moore, of 74 Wheatley-road, McKinnon, carrying on business under the style or name of "Pearl Plate," at 28 Wellington-street, St. Kilda, has been dissolved by mutual consent as from the 29th day of July, 1946. All debts due to or owing by the said late partnership shall be received or paid by the said Frank Emerson, and the said Harry Emerson, and the said May Elizabeth Moore, who will continue the said business under the style or name of "Pearl Plate," at the same address.

Dated the 8th day of August, 1946.

LESLIE DONALD EMERSON.  
FRANK EMERSON.  
HARRY EMERSON.  
MAY ELIZABETH MOORE.  
Thomas J. Kane, solicitor, 101 Queen-street, Melbourne. 7448

## NOTICE OF DISSOLUTION OF PARTNERSHIP.

NOTICE is hereby given that the partnership heretofore subsisting between David Thomas Scurrah, Eric Arthur Jackson, and Albert Roy Whitton, under the name of Colour Castings, and carried on at 1 Cawkwell-street, Malvern, has been dissolved by mutual consent as from the 18th day of July, 1946. All debts due and owing by the said firm will be received by the said Eric Arthur Jackson, who will continue to carry on the business at the same address.

Dated at Malvern, the 19th day of August, 1946.

E. A. JACKSON.

Witness.—R. C. H. BEATTIE. 7453

## UPPER YARRA ELECTRIC SUPPLY COMPANY PROPRIETARY LIMITED (IN LIQUIDATION).

TAKE notice that a final meeting of the shareholders of the above company will be held at the registered office of the company, Warburton, on Saturday, the 21st day of September, 1946, at Two o'clock in the afternoon, to receive liquidator's final accounts of the winding up of the company.

7458 J. MAYER, Liquidator.

## HARRISONS INVESTMENTS PROPRIETARY LIMITED (IN LIQUIDATION).

NOTICE CONVENING FINAL MEETING, PURSUANT TO SECTION 236.

NOTICE is hereby given, in pursuance of section 236 of the Companies Act 1938, that a general meeting of the members of the above-named company will be held at 462 Little Collins-street, Melbourne, on Monday, the 30th September, 1946, at a quarter-past Two o'clock in the afternoon, for the purpose of having an account laid before them showing the manner in which the winding up has been conducted and the property of the company disposed of, and of hearing any explanation that may be given by the liquidator.

7457 J. S. EASTWOOD, Liquidator.

## Companies Act 1938.

## BATMAN EXPLORATION COMPANY PROPRIETARY LIMITED.

NOTICE OF RESOLUTION, PURSUANT TO SECTION 226.

AT an Extraordinary General Meeting of Batman Exploration Company Proprietary Limited, duly convened and held at 342 Flinders-lane, Melbourne, on the 15th day of August, 1946, the following resolution was duly passed as a special resolution, namely:—

"That the company be wound up voluntarily and that Stanley Burwood Holder, of 360 Collins-street, Melbourne, chartered accountant (Aust.), be appointed liquidator for the purposes of such winding up."

Dated this 15th day of August, 1946.  
7452 S. B. HOLDER, Liquidator.

CREDITORS, next of kin, and others having claims in respect of the estate of Eleanor Cooper, late of 25 Banfield-street, Ararat, widow, deceased, intestate (who died on the 25th day of March, 1946), are to send particulars of their claims to the National Trustees, Executors, and Agency Company of Australasia Limited, the registered office of which is situated at 95 Queen-street, Melbourne, by the 24th day of October, 1946, after which date it will distribute the assets, having regard only to the claims of which it then has notice.

PATRICIA G. GRANO, solicitor, 161 Barkly-street, Ararat. 7418

CREDITORS, next of kin, and all others having claims against the estate of the under-mentioned person are required to send particulars thereof to Helen McIntosh, in care of the under-mentioned solicitors, on or before the 22nd day of September, 1946, otherwise they may be excluded when the assets are being distributed:—

Name.—James David McIntosh.  
Usual Residence.—100 Watton-street, Werribee.  
Occupation or Other Description.—Foreman.  
Date of Death.—25th October, 1945.

DOYLE & KERR, "The Exchange," Market Square, Geelong, and at Terang, and 108 Queen-street, Melbourne, solicitors for the executrix. 7420

ELIZABETH BRIDGET SCOTT, late of 107 Clyde-street, Ballarat, spinster, DECEASED (who died on the 9th April, 1946).

CREDITORS, next of kin, and all other persons having claims against the estate of the deceased are required by the executors, George Kingsley Sutton, of 38 Lydiard-street south, Ballarat, solicitor, and Nellie Ivie Allan, of 15 Errard-street south, Ballarat, spinster, to send particulars to them, care of the undersigned, on or before the 1st November, 1946, after which date they will distribute the assets, having regard only to the claims of which they then have notice.

DOOLEY, SUTTON, & A. W. LONG, 38 Lydiard-street south, Ballarat, solicitors. 7426

## Trustee Act 1928.

## NOTICE TO CLAIMANTS.

PURSUANT to the Trustee Act 1928, creditors, next of kin, and all other persons having claims in respect of the estate of any deceased person named below are required to send particulars thereof to the legal personal representative or representatives at the address stated below, on or before the date stated, after which date the representative or representatives will distribute the assets, having regard only to the claims of which notice has been received:—

Fanny Wills, late of 195 View-street, Bendigo, widow, deceased, intestate, who died on the 5th day of April, 1946.—Claims to the administrator, Sandhurst and Northern District Trustees, Executors, and Agency Company Limited, of View-street, Bendigo, by 24th October, 1946. Tatchell, Dunlop, Smalley, and Balmer, solicitors, Bendigo. 7421

Henry Josiah Robe, late of Princetown, dairyman, deceased, died 26th January, 1946.—Claims to the executors, James Robe and David Henry Robe, care of Buckland and Nevett, solicitors, Camperdown, by 24th October, 1946. Buckland and Nevett, solicitors, Camperdown. 7427

William Torney, formerly of Carapooee, but late of Carapooee West, both in the State of Victoria, farmer, deceased, died 17th April, 1946.—Claims to the executors, David Alexander Simpson, of Paradise, and Victor Proctor, of Kooreh, both in the said State, both farmers, by 28th October, 1946. Dated this 16th day of August, 1946. H. L. Dunkley and Kelly, solicitors, St. Arnaud. 7430

Anna Victoria McNalty, formerly of Mangarra-road, Canterbury, but late of 12 Norbert-street, Balwyn, married woman, deceased, died 20th March, 1946.—Claims to The Equity Trustees, Executors, and Agency Company Limited, at 472 Bourke-street, Melbourne, the executor of deceased's will, by 23rd October, 1946. 7459

Winifred Clarke Wright, late of 10 Rodd-street, Dandenong, spinster, deceased, died 16th June, 1946.—Claims to executors, Ernest Samuel Wright and Claude William Phillips, care of A. G. Hall and Wilcox, solicitors, 20 Queen-street, Melbourne, by 23rd October, 1946. A. G. Hall and Wilcox, solicitors, 20 Queen-street, Melbourne. 7460

Duncan Livingston, formerly of 149, late of 163, Queensberry-street, North Melbourne, in the State of Victoria, brush manufacturer, deceased, died 29th June, 1946.—Claims to the executor, Leonard Ross Reid, of 56 Hanby-street, Middle Brighton, in Victoria, bank clerk, care of T. A. Kennedy, solicitor, 443 Bourke-street, Melbourne, by 30th October, 1946. T. A. Kennedy, LL.B., solicitor, 443 Bourke-street, Melbourne. 7474

Samuel Hamill, late of Irrewarra, farmer, died 26th April, 1946.—Claims to the executors, William Richard Hamill, of Warracoort, and Arthur Michael Lloyd, of Irrewarra, farmers, by 28th October, 1946. Sewell and Sewell, solicitors, Colac. 7471

CREDITORS, next of kin, and others having claims in respect of the estate of Reginald Pavey Henderson, formerly of Jackson's-road, Mulgrave, farmer, but late a member of the Australian Imperial Forces, deceased, intestate (who died on the 20th day of March, 1917), are to send particulars of their claims to The Perpetual Executors and Trustees Association of Australia Limited, at its registered office, at 100-104 Queen-street, Melbourne, by the 23rd day of October, 1946, after which date it will distribute the assets, having regard only to the claims of which it then has notice.

Dated the 15th day of August, 1946.

RYLAH & RYLAH, solicitors, 349 Collins-street, Melbourne. 7467

CREDITORS, next of kin, and others having claims in respect of the estate of Donald McInnis, late of Miram, in the State of Victoria, farmer, deceased (who died on the 13th day of June, 1946), are to send the particulars of their claims to The Trustees, Executors, and Agency Company Limited, of 401 Collins-street, Melbourne, in the said State, by the 23rd day of October, 1946, after which date it will distribute the assets, having regard only to the claims of which it then has notice.

Dated this 13th day of August, 1946.

TURNER & HOBDDAY, Victoria-street, Nhill, solicitors for the said The Trustees, Executors, and Agency Company Limited. 7468

CHRISTINA BARTHOLOMEW, late of 57 Briggs-street, Caulfield, widow (who died 8th March, 1946).

**CREDITORS**, next of kin, and all other persons having claims against the estate of the deceased are required by the executors of the will, The Equity Trustees, Executors, and Agency Company Limited, of 472 Bourke-street, Melbourne, and James Eric Bartholomew, of 125 Booran-road, Glenhuntly, clerk, to send particulars to them, care of the undersigned, on or before the 24th October, 1946, after which date they will distribute the assets, having regard only to the claims of which they then have notice.

JOHN D. MUSTOW, solicitor, 89 Queen-street, Melbourne.  
7462

THOMAS JAMES BAXTER, late of Tyabb, farmer, DECEASED, intestate (who died 13th January, 1946).

**CREDITORS**, next of kin, and all other persons having claims against the estate of the deceased are required by the administrator of the estate, The Equity, Trustees, Executors, and Agency Company Limited, of 472 Bourke-street, Melbourne, to send particulars to it, care of the undersigned, on or before 24th October, 1946, after which date it will distribute the assets, having regard only to the claims of which it then has notice.

JOHN D. MUSTOW, solicitor, 89 Queen-street, Melbourne.  
7463

ELIZABETH JANE WATKINSON, late of 63 Fairbairn-road, Toorak, in the State of Victoria, widow, DECEASED.

**CREDITORS**, next of kin, and others having claims in respect of the estate of the above-named deceased (who died between the 15th and the 18th days of April, 1946) are to send particulars of their claim to the executor, Charles Robert Woodhouse, care of Messrs. Rigby and Fielding, 60 Market-street, Melbourne, by the 24th of October, 1946, after which date he will distribute the assets, having regard only to the claims of which he then has notice.

RIGBY & FIELDING, solicitors, 60 Market-street, Melbourne.  
7464

NOTICE TO CREDITORS.—WALTER RICHARD PARKER, DECEASED.

**PURSUANT** to the provisions of the *Trustee Act 1928*, notice is hereby given that all persons having any claim against the estate of Walter Richard Parker, formerly of 13 Lara-street and Barry-street, South Yarra, civil servant, but late of 6 Chestnut-street, Carnegie, in the State of Victoria, retired civil servant, deceased (who died on the 9th day of April, 1946, and probate of whose will was granted to Annie Simpson Parker, of 6 Chestnut-street, Carnegie, widow), are hereby required to send particulars of such claims, in writing, to the said Annie Simpson Parker, in care of the undersigned solicitors, on or before the 23rd day of October, 1946. And notice is hereby given that after that date the said Annie Simpson Parker will proceed to distribute the assets of the said deceased which shall have come to her hands or possession amongst the persons entitled thereto, having regard only to the claims of which she shall then have had notice, and she will not be liable for the assets, or any part thereof, so distributed to any person of whose claim she shall not then have had notice.

Dated this 21st day of August, 1946.

G. A. RUNDLE & CO., solicitors, 349 Collins-street, Melbourne.  
7465

**CREDITORS**, next of kin, and others having claims in respect of the estate of Enid Bess Henderson, late of 37 Anderson-street, East Malvern, spinster, deceased, intestate (who died on the 1st day of March, 1919), are to send particulars of their claims to The Perpetual Executors and Trustees Association of Australia Limited, at its registered office at 100-104 Queen-street, Melbourne, by the 23rd day of October, 1946, after which date it will distribute the assets, having regard only to the claims of which it then has notice.

Dated the 15th day of August, 1946.

RYLAH & RYLAH, solicitors, 349 Collins-street, Melbourne.  
7466

**CREDITORS**, next of kin, and others having claims in respect of the estate of Octavia Darcy Paul, late of 177 Auburn-road, Auburn, married woman, deceased (who died on the 14th April, 1946), are to send the particulars of their claims to The Perpetual Executors and Trustees Association of Australia Limited, of 100-104 Queen-street, Melbourne, by the 31st day of October, 1946, after which date it will distribute the assets, having regard only to the claims of which it then had notice.

E. A. ATKYNS & SON, 422 Little Collins-street, Melbourne.  
7445

LYDIA EMILY WILLIAMS, late of 6 Black-street, Middle Brighton, in the State of Victoria, widow, DECEASED (who died on the 22nd day of May, 1946).

**CREDITORS**, and all others having claims against the estate of the deceased are required by the executor of her estate, The Trustees Executors and Agency Company Limited, of 401 Collins-street, Melbourne, in the said State, to send particulars to the said company at its registered office at the above address, on or before the 30th day of October, 1946, after which date the said executor will distribute the assets, having regard only to the claims of which it then has notice.

Dated this 15th day of August, 1946.

D. BRUCE TUNNOCK & CLARKE, of 87 Queen-street, Melbourne, solicitors for the applicant.  
7446

**CREDITORS**, next of kin, and others having claims in respect of the estate of Mildred Rhoda Reynolds, formerly of 314 Bell-street, Coburg, in the State of Victoria, but late of Concord, in the State of New South Wales, teacher, deceased (who died on the 26th day of May, 1946), are to send particulars of their claims to Percy Edward Reynolds, the administrator, with the will annexed, of the said estate, care of the undersigned, by the 23rd day of October, 1946, after which date he will distribute the assets, having regard only to the claims of which he then has notice.

Dated the 17th day of August, 1946.

GEOFFREY E. DAVIS, solicitor, 433 Little Collins-street, Melbourne.  
7450

**CREDITORS**, next of kin, and others having claims in respect of the estate of Eric Dudley Halliley, late of 8 Railway-avenue, Malvern, tramway motorman, deceased (who died on 13th April, 1946), are to send particulars of their claims to the National Trustees, Executors, and Agency Company of Australasia Limited, at its registered office, 95 Queen-street, Melbourne, by the 26th day of October, 1946, after which date it will distribute the assets, having regard only to the claims of which it then has notice.

R. C. H. BEATTIE, solicitor, 422 Little Collins-street, Melbourne.  
7451

CHARLES MARS BUCKLEY, formerly of Narrapumelap, Wickliffe, Victoria, but late of 124 Knightsbridge, County of London, England, gentleman, DECEASED (who died on the 4th February, 1946).

**CREDITORS**, next of kin, and all other persons having claims against the estate of the deceased are requested to send particulars thereof to William Frederick Weigall, the executor of the will of the said deceased, at the address of his solicitors, hereinafter named on or before the 24th October, 1946, otherwise they may be excluded when the assets are being distributed.

WEIGALL & CROWTHER, 459 Chancery-lane, Melbourne, C.1, solicitors for the executor.  
7454

**CREDITORS**, next of kin, and others having claims in respect of the estate of Martha Ann Johnson, late of 21 Empress-road, Surrey Hills, in the State of Victoria, widow (who died on the 3rd day of June, 1946), are to send the particulars of their claims to the Trustees, Executors, and Agency Company Limited, of 401 Collins-street, Melbourne, by the 25th day of October, 1946, after which date it will distribute the assets, having regard only to the claims which it then has notice.

HERBERT & GEER, solicitors, 20 Bank-place, Melbourne.  
7456

**CREDITORS**, next of kin, and others having claims in respect of the estate of Percy Nicholson Fletcher, late of 53 Bellerine-street, Geelong, traveller, deceased (who died on the 15th July, 1946), are to send particulars of their claims to The Ballarat Trustees, Executors, and Agency Company Limited, at its branch office, 8 Malop-street, Geelong, by the 21st October, 1946, after which date the said company will distribute the assets, having regard only to the claims of which it then has notice.

**CREDITORS**, next of kin, and others having claims in respect of the estate of Vera Olive England, late of 43 Retreat-road, Newtown, Geelong, spinster, deceased (who died on the 15th day of June, 1946), are to send the particulars of their claims to the executors, The Ballarat Trustees, Executors, and Agency Company Limited, of Lydiard-street north, Ballarat, and Gilbert George England, of Manning-street, Newtown, Geelong, accountant, care of the branch office of the said company, Trustees' Chambers, Malop-street, Geelong, by the 23rd day of October, 1946, after which date the said executors will distribute the assets, having regard only to the claims of which they then have notice.

F. RAYMOND APTED, 63 Yarra-street, Geelong, solicitor for the executors.  
7443

**CREDITORS**, next of kin, and others having claims in respect of the estate of Herbert Sydney Whelan, late of Swan Reach, in Victoria, farmer, deceased (who died on the 4th day of April, 1946), are to send the particulars of their claims to The Perpetual Executors and Trustees Association of Australia Limited, of 100 Queen-street, Melbourne, by the 31st day of October, 1946, after which date it will distribute the assets, having regard only to the claims of which it then has notice.

J. I. LANFRANCHI, Bairnsdale, solicitor for the applicant.  
7428

**NOTICE TO CLAIMANTS.—RE ROBERT ALAN TUDDENHAM, DECEASED.**

**DAVID COOKE**, of 1428 Sturt-street, Ballarat, estate agent, and Jack Alan Cooke, of 1510 Sturt-street, Ballarat, auctioneer, the executors of the will of the above-named deceased (who died on the 29th day of January, 1946), require all creditors, next of kin, and others having claims against the deceased or the estate of the said deceased, to send to them, care of their solicitors, D. and A. Aronson, 18 Lydiard-street, Ballarat, on or before the 25th day of October, 1946, particulars, in writing, of such claims after which date they intend to convey or distribute such property or estate to or amongst the persons entitled thereto, having regard only to the claims of which they shall then have had notice.

Dated this 16th day of August, 1946.  
D. & A. ARONSON, 18 Lydiard-street, Ballarat, solicitors for the executors.  
7429.

**JOSEPH WILSON McCLURE**, formerly of Drouin South, in the State of Victoria, farmer, but late of Drouin, in the said State, retired farmer, DECEASED (who died on the 5th day of July, 1946).

**CREDITORS**, next of kin, and all others having claims against the property or estate of above-named deceased are required by the executors, Margaret Jane McClure, gentlewoman, and William Charles Wesley McClure, retired farmer, both formerly of Drouin South, but now of Drouin, in the said State, to send particulars thereof to them, care of the under-mentioned solicitors, on or before the 31st October, 1946, after which date the executors will distribute the property and estate of said deceased, having regard only to the claims of which they shall then have had notice.

GRAY, FRIEND, & MOONIE, solicitors, Warragul. 7438

**NOTICE TO CLAIMANTS AND OTHERS.—SARAH JANE JENNINGS, DECEASED.**

**CREDITORS**, next of kin, and others having claims in respect of the estate of Sarah Jane Jennings, late of Boronia-road, Vermont, in the State of Victoria, widow, deceased (who died on the 13th day of February, 1946), are to send particulars of their claims to The Perpetual Executors and Trustees Association of Australia Limited, of 100 Queen-street, Melbourne, by the 31st day of October, 1946, after which date the said company will distribute the assets of the said deceased, having regard only to the claims of which it then has notice.

Dated the 15th August, 1946.  
TOLHURST, DRUCE, & EMMERSON, 352 Collins-street, Melbourne.  
7469

**CREDITORS**, next of kin, and others having claims in respect of the estate of Davidina Martin, late of 6 Bendigo-street, Richmond, in the State of Victoria, married woman, deceased (who died on the 18th day of April, 1946), are to send the particulars of their claims to The Perpetual Executors and Trustees Association of Australia Limited, of 100-104 Queen-street, Melbourne, in the said State, by the 31st day of October, 1946, after which date it will distribute the assets, having regard only to the claims of which it then has notice.

Dated this 14th day of August, 1946.  
FORD, ASPINWALL, & DE GRUCHY, solicitors, 104 Queen-street, Melbourne.  
7472

**NOTICE** is hereby given that all persons having claims in respect of the property or estate of William Papley, late of Tyrendarra, in the State of Victoria, farmer, deceased (who died on the 28th day of April, 1946, and probate of whose will was granted by the Supreme Court of Victoria on the 30th day of May, 1946, to Walter Stanford, of Tyrendarra aforesaid, farmer), are hereby required to send particulars of such claims to the said Walter Stanford, at Tyrendarra aforesaid, on or before the 20th day of October, 1946, after which date it is the intention of the said Walter Stanford to convey or distribute such property or estate to or among the persons entitled.

Dated this 12th day of August, 1946.  
NICOL, SILVESTER, & HOLT, Portland, solicitors for the executor.  
7473.

**CREDITORS**, next of kin, and others having claims in respect of the estate of David Craig, late of 43 Kennealy-street, Surrey Hills, in the State of Victoria, retired grazier, deceased (who died on the 24th day of August, 1944), are to send particulars of their claims to The Equity Trustees, Executors, and Agency Company Limited, of 472 Bourke-street, Melbourne, in the said State, the administrator or appointed by an order of the Supreme Court of Victoria dated the 29th day of May, 1946, by the 22nd day of October, 1946, after which date the said company will distribute the assets, having regard only to the claims of which it then has notice.

AITKEN, WALKER, & STRACHAN, 123 William-street, Melbourne, solicitors for the administrator.  
7475

In the Supreme Court of the State of Victoria.—*Fi. Fa.*

**NOTICE** is hereby given that under and by virtue of certain process issued out of the Supreme Court of the State of Victoria, and directed to the Sheriff, requiring him to levy certain moneys of the real and personal estate of James Mahoney, of 33 Vere-street, Richmond, the said Sheriff will, on Monday, the 30th day of September, 1946, at the hour of Eleven o'clock in the forenoon, cause to be sold at the Police Station, Bridge-road, Richmond (unless the said process shall have been previously satisfied or the said Sheriff be otherwise stayed) :—

All the right, title, estate, and interest (if any) of the said James Mahoney, in and to: (1) All those pieces of land, being parts of Crown portion 39, Parish of Jika Jika, County of Bourke, and being the land more particularly described in certificate of title, volume 6484, folio 1296794; (2) all that piece of land, being lot 65 on plan of subdivision number 1329, lodged in the Office of Titles, being part of Crown portion 38, at Richmond, Parish of Jika Jika, County of Bourke, and being the land more particularly described in certificate of title, volume 1983, folio 396430.

N.B.—Terms: Cash. No cheques taken.

Dated at Melbourne, this 19th day of August, 1946.  
7476 FRANCIS H. TUCKER, Sheriff's Officer.

**INSOLVENCY NOTICE.**

Notice of application for certificate of discharge, under section 228, in the matter of ERNEST WILLIAM WATKINS, trading as Clifton Furniture Works, at rear of 39 Clifton-road, Hawthorn, in the State of Victoria, furniture manufacturer, and insolvent, and in the matter of an application by the said Ernest William Watkins for a certificate of discharge.

**THE** above-named Ernest William Watkins intends to apply to the Court of Insolvency, at Melbourne, on the 18th day of September, 1946, at 10.30 o'clock in the forenoon, for a certificate of discharge pursuant to the provisions of the Insolvency Act, and to dispense with the condition mentioned in section 233 of the Act.

Dated the 19th day of August, 1946.

GREEN, DOBSON, & MIDDLETON, solicitors for the applicant.  
7437

**IMPOUNDINGS.**

**BALLARAT**.—Impounded in Ballarat City Pound.

1 grey pony gelding, aged, no visible brand.  
If not claimed and expenses paid, to be sold on 30th August, 1946.

C. J. BARKER,  
7440—4/  
Poundkeeper.

**BERWICK**.—Impounded in Berwick Pound.

1 bay gelding, five years, white face, wall eyes, hind feet white, rat tail, no visible brand.  
If not claimed and expenses paid, to be sold on 6th September, 1946.

M. NIXON,  
7470—4/8  
Poundkeeper.

**BROADMEADOWS**.—Impounded at Campbellfield.

1 brown mare, 15 hands, hind feet white, unshod, no visible brand.  
If not claimed and expenses paid, to be sold on 5th September, 1946.

A. OLIVER,  
7430—4/8  
Poundkeeper.



**DAYLESFORD.**—Impounded at Daylesford, by J. H. Graham, from Glenlyon.  
 1 red roan cow, no visible brand  
 1 red roan vealer, no visible brand  
 If not claimed and expenses paid, to be sold on 22nd August, 1946.

7477—5/4 D. NEIVANDT, Poundkeeper.

**DROMANA.**—Impounded at Dromana.

1 bay gelding, no visible brand  
 1 bay pony, shod, no visible brand  
 If not claimed and expenses paid, to be sold on 12th September, 1946.

7478—4/8 J. CHAPMAN, Poundkeeper.

**SMEATON.**—Impounded at Smeaton, by Ranger, on 14th August, 1946.

1 black Jersey cow, crumpled horn, cut right ear  
 If not claimed and expenses paid, to be sold on 5th September, 1946.

7435—4/8 W. J. BALFOUR, Poundkeeper.

**STANHOPE.**—Impounded at Stanhope.

1 brown medium draught gelding, white face, no visible brand  
 1 white medium gelding, aged, no visible brand  
 If not claimed and expenses paid, to be sold.

7422—4/ W. PAYNTER, Poundkeeper.

**STRATFORD.**—Impounded at Stratford, by J. D. Richardson, for trespassing, Stratford township, on 13th August, 1946.

1 yellow Jersey paddy heifer, top off near ear, slit in top off ear, like A off rump  
 If not claimed and expenses paid, to be sold on 2nd September, 1946.

7432—6/ E. C. BOCK, Poundkeeper.

STATE ACTS, 1944—continued.

No.	Price. s. d.
5027. Local Government (Shire of Blackburn and Mitcham)	0 6
5028. Electoral Districts	0 6
5029. Land	0 6
5030. Land Tax	0 6
5031. Administration and Probate Duties	0 6
5032. Stock Foods (Amendment)	0 6
5033. Stamps (Increased Duty Continuance)	0 6
5034. Maribyrnong and Ashburton Lands Exchange	0 6
5035. Financial Emergency (Grants and Funds)	0 6
5036. Farmers Advances	0 6
5037. Land Settlement (Acquisition) Amendment	0 6
5038. Railways	0 6
5039. Farmers Protection (Amendment)	0 6
5040. Country Fire Authority	1 9
5041. Country Roads Board Fund	0 6
5042. Railway Loan and Application	0 6
5043. Town and Country Planning	1 0
5044. Agricultural Colleges	0 9
5045. Heatherton Sanatorium	0 6
5046. Health (Infectious Diseases Hospitals)	0 6
5047. Surplus Revenue	0 6
5048. Water Supply Loans Application	0 9
5049. State Forests Loan and Application	0 6
5050. Public Works Loan and Application	0 6
5051. Commonwealth and States Financial Agreement	1 3
5052. The Constitution Act Amendment	0 6
5053. Public Library National Gallery and Museums	0 9
5054. Drought Relief	0 6
5055. Co-operative Housing Societies	1 6
5056. Local Government	1 0
5057. Melbourne and Metropolitan Board of Works	0 9
5058. Appropriation of Revenue	3 9

J. J. GOURLEY,  
 Government Printer.

STATE ACTS, 1944.

COPIES of the following Acts of Parliament of Victoria may be obtained at the Government Printing Office, or from any bookseller, at the price set opposite to each:—

No.	Price. s. d.
4999. Consolidated Revenue	0 6
5000. Local Government (Polling Booths)	0 6
5001. Police Offences (Unlawful Games)	0 6
5002. Hospitals and Charities	0 6
5003. Water (Loddon)	0 6
5004. Justices	0 6
5005. Coal Mines Regulation (Amendment)	0 6
5006. Consolidated Revenue	0 6
5007. Melbourne and Metropolitan Board of Works (Contributions)	0 6
5008. Marketing of Primary Products	0 6
5009. National Security (Emergency Powers) Continuation	0 6
5010. Outer Circle Railway (Partial Dismantling)	0 6
5011. Mines (Minerals)	0 6
5012. Goods (Textile Products)	0 6
5013. Masseurs	0 6
5014. Electoral (War Service Deaths)	0 6
5015. Cremorne Bridge	0 6
5016. Melbourne Harbor Trust	0 6
5017. Water	0 9
5018. Consolidated Revenue	0 6
5019. Mildura Irrigation and Water Trusts	0 6
5020. Farm Water Supplies Advances	0 6
5021. Sewerage Districts	0 6
5022. Trustee Companies	0 6
5023. Mildura Irrigation and Water Trusts (Superannuation)	0 6
5024. Consolidated Revenue	0 6
5025. Cemeteries	0 6
5026. Border Railways	0 6

No. 166.—8562/46.—4

STATE ACTS, 1945.

COPIES of the following Acts of Parliament of Victoria may be obtained at the Government Printing Office, or from any bookseller, at the price set opposite to each:—

No.	Price. s. d.
5059. Mildura Irrigation and Water Trusts (Borrowing)	0 6
5060. Supreme Court (Judges)	0 6
5061. Oakleigh (Regent-street) Land	0 6
5062. Swine	0 6
5063. Drought Relief (Amendment)	0 6
5064. Unclaimed Moneys	0 6
5065. Consolidated Revenue	0 6
5066. Consolidated Revenue	0 6
5067. Agent-General's	0 6
5068. Land Surveyors (Amendment)	0 6
5069. State Development	0 6
5070. Melbourne and Metropolitan Board of Works (Borrowing Powers)	0 6
5071. Education	0 6
5072. Water	0 6
5073. National Security (Repeal)	0 6
5074. Moorabbin (Unimproved Rating Poll)	0 6
5075. Licensing (Poll)	0 6
5076. Lilydale Waterworks Trust Abolition	0 6
5077. East Melbourne Land	0 6
5078. Health (Wines)	0 6
5079. Local Government (Emergency Housing Accommodation)	0 6
5080. Law Institute	0 6
5081. Bendigo Land	0 6
5082. Consolidated Revenue	0 6
5083. Consolidated Revenue	0 6
5084. Consolidated Revenue	0 6

STATE ACTS, 1945—continued.

No.	Price.
s.	d.
5085. Factories and Shops (Bread Holidays),	0 6
5086. Administration and Probate Duties,	0 6
5087. Land Tax	0 6
5088. Stamps (Increased Duty Continuance)	0 6
5089. Licensing Fund	0 6
5090. Employers and Employes	0 6
5091. Farmers Advances	0 6
5092. University (Veterinary) Research	0 6
5093. Surplus Revenue	0 6
5094. State Forests Loan and Application	0 6
5095. Mines (Amendment)	0 6
5096. Farmers Protection (Amendment)	0 6
5097. Railway Loan Application	0 6
5098. Public Works Loan and Application	0 6
5099. Water Supply Loans Application	0 9
5100. Public Account Advances (Amendment)	0 6
5101. Hospital Benefits	0 6
5102. Totalizator (Amendment)	0 6
5103. Financial Emergency (Municipal Endowment)	0 6
5104. Country Roads Board Fund (Amendment)	0 6
5105. Coal Mines Regulation (Amendment)	0 6
5106. Melbourne and Metropolitan Tramways (Chairman)	0 6
5107. Soldier Settlement	1 3
5108. Appropriation of Revenue	4 0

J. J. GOURLEY,  
Government Printer.

AGENTS FOR THE "VICTORIA GOVERNMENT GAZETTE."

THE following have been appointed agents to receive advertisements and subscriptions for the Victoria Government Gazette:—

- ARMSTRONG'S AGENCY, 143 Queen-street, Melbourne.
- MESSRS. ARNALL & JACKSON, 115 Barkly-street, West Brunswick.
- MESSRS. GORDON & GOTCH, News Agents, 511 Little Collins-street, Melbourne, and corner Barrack and Clarence streets, Sydney.
- MESSRS. HARSTON, PARTRIDGE, & CO., 455 Little Collins-street, Melbourne.
- N. V. NIXON & CO., 20 Queen-street, Melbourne.
- THE PATON ADVERTISING SERVICE PTY. LTD.
- ROBERTSON & MULLENS LTD., Elizabeth-street, Melbourne.
- MESSRS. W. H. WADDELL, and A. S. RICHARDSON, trading as The Mercantile Exchange, 380 Collins-street, Melbourne.
- MR. A. J. DIGBY, News Agent, Bairnsdale.
- MR. M. R. BADE, Tobacconist, Sturt-street, Ballarat.
- TRIGG'S NEWS AGENCY, Hargreaves-street, Bendigo.
- MR. G. H. K. PAYNE, 4 View Point, Bendigo.
- MR. G. F. LATIMER, News Agent, Casterton.
- MESSRS. HENRY FRANKS & CO., Booksellers and Stationers, Market-square, Geelong.
- MESSRS. SMITH & DUNNON, Hamilton.
- ARMSTRONG BROS., Kyneton.
- MR. WM. DAVIS, Mildura.
- PIKE'S AUTHORIZED NEWS AGENCY, Sale.
- MR. C. T. RUST, News Agent, Wangaratta.
- MR. F. T. MCCORMICK, Nunn-street, Benalla.
- F. R. & E. M. COOKE, Bridge-street, Benalla.
- W. GORDON HAMPTON, 243 Mitchell-street, Bendigo.
- R. & A. SMALLMAN, News Agents, Toora.

A copy of the Gazette filed at each place for public reference

By Authority: J. J. GOURLEY, Government Printer, Melbourne.

THE "VICTORIA GOVERNMENT GAZETTE."

SUBSCRIPTIONS.—The subscription, including Postage, is £1 12s. 6d. per annum, 16s. 3d. half-yearly, or 8s. 2d. per quarter, payable in advance.

Subscriptions are required to commence and terminate with a month.

A lesser period than three months cannot be subscribed for.

Subscribers do not receive the Acts of Parliament with the GAZETTE.

ADVERTISEMENTS are charged at the rate of EIGHT PENCE per line single column, and ONE SHILLING and FOUR PENCE per line double column.

The title (£5 Reward, Dissolution of Partnership, &c.) forms one or more lines as a heading.

On an average, ten words make a line.

Every signature must likewise be counted as a line.

The final words of a paragraph, though only portion of a line, must be counted as one line.

SIGNATURES (in particular) and proper names must be written very plainly in the text; ONE SIDE ONLY of each slip of paper should be WRITTEN UPON.

ALL COMMUNICATIONS should be addressed to "The Government Printer, Melbourne."

ALL DOCUMENTS illegibly written will be returned unpublished, and, where brands occur unprovided for by the ordinary letters of the alphabet, a worded explanatory description must be furnished.

THE VICTORIA GOVERNMENT GAZETTE is published, on WEDNESDAY EVENING in each week, and Notices for insertion, will be received by the Government Printer at or before Two p.m., at ordinary rates, and late advertisements between Two p.m. and FIVE p.m. at double rates on the day preceding the day of publication.

Single copies of the VICTORIA GOVERNMENT GAZETTE are Six pence, posted Eight pence, each.

No GAZETTES prior to January, 1936, in stock.

\*\*\*ALL PAYMENTS ARE REQUIRED IN ADVANCE.—Remittances should be made by postal note, money order, or draft in favour of the Government Printer. Advertisements unaccompanied by a remittance sufficient to cover the cost of insertion will be returned unpublished.

CONTENTS

	PAGE
Acts of Parliament on sale at the Government Printing Office	2623
Appointments	2584
Bank Half-holiday	2584
Contracts	2590
Country Roads Board	2593, 2608
Courts	2590
Estates of Deceased Persons	2598
Government Notices	2590
Impoundings	2622
Insolvency Notice	2622
Lands	2611
Licences to Occupy Unused Roads	2595
Mining	2593
Orders in Council	2604
Police Sale	2590
Private Advertisements	2617
Proclamations	2583
Public Holidays	2583
Public Service Notices	2586
Resignations	2586
State Rivers and Water Supply Commission	2590
Stay Orders	2593
Tenders	2614
The State Savings Bank of Victoria—Monthly Statement	2594
Transport Regulation Board—Public Hearings	2589
Waterworks Trusts	2591