



VICTORIA
GOVERNMENT GAZETTE.

Published by Authority.

[Registered at the General Post Office, Melbourne, for transmission by post as a newspaper.]

No. 201]

WEDNESDAY, OCTOBER 16.

[1946

Apprenticeship Acts.

APPRENTICESHIP COMMISSION OF VICTORIA.

APPRENTICESHIP TRADES PROCLAIMED.

PROCLAMATION

By His Excellency the Lieutenant-Governor of the State of Victoria and its Dependencies in the Commonwealth of Australia, &c., &c., &c.

IN pursuance of the provisions of section 13, sub-section 4, of the *Apprenticeship Act* 1928, I, the Lieutenant-Governor of the State of Victoria, in the Commonwealth of Australia, by and with the advice of the Executive Council of the said State, do by this my Proclamation proclaim the trades set out hereunder, as carried on in the Metropolitan District, to be apprenticeship trades, viz.:—

Lithographic Art and/or Lithographic Camera Operating.
Lithographic Camera Operating and/or Lithographic Plate Making.

Given under my Hand and the Seal of the State of Victoria aforesaid, at Melbourne, this fifteenth day of October, in the year of our Lord One thousand nine hundred and forty-six, and in the tenth year of the reign of His Majesty King George VI.

(L.S.) E. F. HERRING.

By His Excellency's Command,

P. J. CLAREY,
Minister of Labour.
GOD SAVE THE KING!

set out hereunder, as carried on in the whole of the State of Victoria, to be apprenticeship trades, viz.:—

Aircraft Mechanic (Electrical).
Aircraft Mechanic (Engine).
Aircraft Mechanic (Air-frame).

Given under my Hand and the Seal of the State of Victoria aforesaid, at Melbourne, this fifteenth day of October, in the year of our Lord One thousand nine hundred and forty-six, and in the tenth year of the reign of His Majesty King George VI.

(L.S.) E. F. HERRING.

By His Excellency's Command,

P. J. CLAREY,
Minister of Labour.
GOD SAVE THE KING!

Apprenticeship Acts.

APPRENTICESHIP COMMISSION OF VICTORIA.

VARIATION OF PROCLAMATION OF APPRENTICESHIP TRADE PROCLAIMED.

PROCLAMATION

By His Excellency the Lieutenant-Governor of the State of Victoria and its Dependencies in the Commonwealth of Australia, &c., &c., &c.

IN pursuance of the provisions of section 13, sub-section 6, of the *Apprenticeship Act* 1928, I, the Lieutenant-Governor of the State of Victoria, in the Commonwealth of Australia, by and with the advice of the Executive Council of the said State, do by this my Proclamation vary a Proclamation issued by the Governor in Council on the twenty-sixth day of February, 1929, and published in the *Government Gazette* of the twenty-seventh day of February, 1929, by substituting for the words "Lithographic printing" the words "Lithographic plate making and/or Lithographic printing."

Given under my Hand and the Seal of the State of Victoria aforesaid, at Melbourne, this fifteenth day of October, in the year of our Lord One thousand nine hundred and forty-six, and in the tenth year of the reign of His Majesty King George VI.

(L.S.) E. F. HERRING.

By His Excellency's Command,

P. J. CLAREY,
Minister of Labour.
GOD SAVE THE KING!

Apprenticeship Acts.

APPRENTICESHIP COMMISSION OF VICTORIA.

APPRENTICESHIP TRADES PROCLAIMED.

PROCLAMATION

By His Excellency the Lieutenant-Governor of the State of Victoria and its Dependencies in the Commonwealth of Australia, &c., &c., &c.

IN pursuance of the provisions of section 13, sub-section 4, of the *Apprenticeship Act* 1928, I, the Lieutenant-Governor of the State of Victoria, in the Commonwealth of Australia, by and with the advice of the Executive Council of the said State, do by this my Proclamation proclaim the trades

Police Offences Act 1928.

EXTENSION OF THE PROVISIONS OF PART I. TO THE SHIRE OF BUNINYONG.

PROCLAMATION

By His Excellency the Lieutenant-Governor of the State of Victoria and its Dependencies in the Commonwealth of Australia, &c., &c., &c.

IN pursuance of the provisions contained in section 4 of the *Police Offences Act 1928*, I, the Lieutenant-Governor of the State of Victoria, in the Commonwealth of Australia, by and with the advice of the Executive Council of the said State, do by this my Proclamation, extend all the provisions of Part I. of the said Act to the Municipal District of the Shire of Buninyong.

Given under my Hand and the Seal of the State of Victoria aforesaid, at Melbourne, this fifteenth day of October, in the year of our Lord One thousand nine hundred and forty-six, and in the tenth year of the reign of His Majesty King George VI.

(L.S.)

E. F. HERRING.

By His Excellency's Command,

W. SLATER,
Chief Secretary.

GOD SAVE THE KING!

MELBOURNE CUP HOLIDAY.

IT is hereby notified that on

TUESDAY, THE 5TH NOVEMBER, 1946,

the Public Offices throughout the Cities of Box Hill, Brighton, Brunswick, Camberwell, Caulfield, Chelsea, Coburg, Collingwood, Essendon, Fitzroy, Footscray, Hawthorn, Heidelberg, Kew, Malvern, Melbourne, Moorabbin, Mordialloc, Northcote, Nunawading, Oakleigh, Port Melbourne, Prahran, Preston, Richmond, St. Kilda, Sandringham, South Melbourne, and Williamstown, the Borough of Ringwood, and the Shires of Bacchus Marsh, Berwick, Braybrook, Broadmeadows, Bulla, Cranbourne, Dandenong, Doncaster and Templestowe, Eltham, Ferntree Gully, Frankston and Hastings, Gisborne, Keilor, Lillydale, Melton, Mornington, Mulgrave, Romsey, Werribee, and Whittlesea will be closed, that date having been proclaimed by the Governor in Council, under the powers conferred by the *Public Service Act 1928*, to be observed as a Holiday in the Public Offices.

W. SLATER,
Chief Secretary.

Chief Secretary's Office,
Melbourne, 10th October, 1946.

APPOINTMENTS.

HIS Excellency the Lieutenant-Governor of the State of Victoria, by and with the advice of the Executive Council thereof, has, by Orders made on the 8th day of October, 1946, been pleased to make the under-mentioned appointments, viz.:

DEPARTMENT OF AGRICULTURE.

Inspector of Stock.

ALFRED GEORGE HEYWOOD,
to be an Inspector of Stock, General Division; a vacancy having occurred, and the Public Service Board having certified, on the 3rd September, 1946, that an appointment is required, that there is no person available and fit in the Public Service to be promoted or transferred to fill the vacant office, and that the person named is entitled, under the provisions of the *Public Service Act 1928*, to be appointed to fill such vacancy on probation for six months.

Assistant Field Officer.

REX MILNE
to be an Assistant Field Officer, General Division; a vacancy having occurred, and the Public Service Board having certified, on the 26th August, 1946, that an appointment is required, that there is no person available and fit in the Public Service to be promoted or transferred to fill the vacant office, and that the person named is entitled, under the provisions of the *Public Service Act 1928*, to be appointed to fill such vacancy on probation for six months, to date from and inclusive of the 25th February, 1946.

DEPARTMENT OF CHIEF SECRETARY.

Inspector of Explosives.

EDGAR NEVILLE LAMB,
pursuant to the provisions of section 32 of the *Explosives Act 1928*, to be an Inspector for the purposes of Part I. of the said Act.

Acting Chief Commissioner of Police.

MURDOCK ALEXANDER McMILLAN, Superintendent of Police, pursuant to the provisions of section 6 of the *Police Regulation Act 1928*, to act in place of the Chief Commissioner of Police, from the 11th October, 1946, during the absence of Alexander Mitchell Duncan.

Returning Officer.

ANTHONY ASHLEY YUILLE
to be Returning Officer for the Electoral District of Goulburn, vice A. E. Howell, resigned.

DEPARTMENT OF LANDS AND SURVEY.

Member of Committee of Management.

ALLAN HOLLICK RAMSAY
to be a Member of the Committee of Management of the land temporarily reserved on the 24th August, 1909, as a site for the Recreation, Convenience, and Amusement of the People, and for a Children's Playground in the City of Melbourne, and known as "Olympic Park," in the place of Henry Heathcote Revell.

Bailiff of Crown Lands.

WILLIAM LEONARD KENNEDY
to be a Crown Lands Bailiff, without salary.

Managers of Common.

GEORGE W. UNDERWOOD,
EDWARD C. F. CATTON,
NORMAN GERALD BURNS,
DAVID ALEXANDER WEIR, and
GORDON JOSEPH MUNRO BROWN,
to be Managers of the Cape Clear Common, for the period ending the 31st December, 1947.

Trustee of Site.

WILLIAM ALFRED JUPP
to be a Trustee of the land permanently reserved on the 26th March, 1935, as a site for a Public Park and Recreation in the Parishes of Boroondara and Jika Jika, in the place of Lawrence McCann, resigned, provided, however, that the said William Alfred Jupp shall hold office as such Trustee for so long only as he continues to be a Councillor of the City of Collingwood.

DEPARTMENT OF LAW.

Deputy Clerk of the Peace, &c.

RONALD JOSEPH BROWN
to be Deputy Clerk of the Peace, Registrar of the County Court, Clerk of Petty Sessions, and Clerk of the Children's Court at Horsham, and Clerk of Petty Sessions and Clerk of the Children's Court at Natimuk, in the place of W. J. S. Maloney, relieved; and as Deputy Clerk of the Peace and Registrar of the County Court at Horsham, to be appointed by virtue of section 92 of the *Juries Act 1928*, to do and perform with respect to the Courts at that place, in the place and stead of the Sheriff, all such acts and things as the Sheriff is, by the said Act, authorized or required to do or perform in the place of W. J. S. Maloney, relieved.

Magistrates.

EDWARD LIONEL CLAUDE BIRCH LEESON, Deputy Director, Commonwealth Loans, Manchester Unity Buildings, corner Collins and Swanston streets, Melbourne,
ALAN CARNEGIE BUCHAN, 42 Grandview-grove, Armadale,
ARTHUR GEORGE FORD, Cockatoo, and
HENRY ALFRED LAURENCE ALLIBON, 369 Lonsdale-street, Melbourne,
to Keep the Peace in the Central Bailiwick of the State of Victoria;
WILLIAM ALFRED MOLESWORTH JEFFERY, Camanui, and
WILLIAM THOMAS MATTLAND WALTER, Genthompson,
to Keep the Peace in the Western Bailiwick of the State of Victoria; and
ALLAN HITCHCOCK, Annuello,
to Keep the Peace in the Midland Bailiwick of the State of Victoria,

Commissioners for Taking Declarations, &c.

JOHN ALBERT CASHMORE, Secretary, Soldier Settlement Committee, R.S.S. and A.L.L.A., Anzac House, 4 Collins-street, Melbourne,
to be a Commissioner for taking Declarations and Affidavits, pursuant to the provisions of Division 8 of Part IV. of the *Evidence Act 1928*, to resign upon ceasing to occupy his present position; and

ALAN VINCENT DUNN, 1 Arkaringa-road, Black Rock.
GEORGE THOMAS PETER JONES, 106 Weller-street, Geelong West.

JOHN GORDON HEDGES, 138 Humfray-street north, Ballarat,

JOHN FRANCIS O'LEARY, 35 Droop-street, Footscray,
EVELYN GRACE AHERN, 13 McDonald-street, Northcote,
GEORGE JOSEPH PEACH, 69 Rossmoyne-street, Northcote, and

ISABELLA CHARLOTTE EMBREY HAYES, 30 Penders-street, Thornbury,

to be Commissioners for taking Declarations and Affidavits, pursuant to the provisions of Division 8 of Part IV. of the *Evidence Act 1928*, to resign upon removing from the neighbourhood of the addresses stated.

DEPARTMENT OF PREMIER.

Secretary (Acting) to the Public Service Board.

EDWARD FRANCIS FITZGIBBON, Assistant Secretary, Office of the Public Service Board, Department of Premier, to perform and exercise the duties, obligations, rights, and powers of Secretary to the Public Service Board during the absence, on leave, of James Frazer, as from and inclusive of the 3rd October, 1946, pursuant to section 168 of the *Public Service Act 1928*.

DEPARTMENT OF PUBLIC WORKS.

Draughtsmen.

LIONEL MOY, and
PERCY THOMAS MARTIN WOODMAN,
to be Draughtsmen, Class "D," Professional Division; vacancies having occurred, and the Public Service Board having certified, on the 25th August, 1946, that appointments are required, that there are no persons available and fit in the Public Service to be promoted or transferred to fill the vacant offices, and that the persons named are entitled, under the provisions of the *Public Service Act 1928*, to be appointed to fill such vacancies on probation for three months.

Deckhands.

CHARLES HENRY RAY, and
JAMES MURRAY,
to be Deckhands, General Division, Ports and Harbors Branch; vacancies having occurred, and the Public Service Board having certified, on the 9th September, 1946, that appointments are required, that there are no persons available and fit in the Public Service to be promoted or transferred to fill the vacant offices, and that the persons named are fit and proper persons and duly qualified to be appointed to fill such vacancies on probation for six (6) months, to date from and inclusive of the 5th November, 1945.

DEPARTMENT OF TREASURER.

Receiver of Revenue.

RONALD JOSEPH BROWN
to be Receiver of Revenue, Horsham, *vice* W. J. S. Maloney.

Acting Public Trustee.

COLIN JAMES GARDNER,
pursuant to the provisions of section 6 of the *Public Trustee Act 1939* (No. 4654), to be Acting Public Trustee during the absence of the Public Trustee for the period 10th October, 1946, to the 1st November, 1946, both dates inclusive.

DEPARTMENT OF WATER SUPPLY.

Assistant Engineer.

ARCHIBALD CAMPBELL PAUL
to be an Assistant Engineer, Classes "D" and "C," Professional Division; a vacancy having occurred, and the Public Service Board having certified, on the 4th September, 1946, that an appointment is required, that there is no person available and fit in the Public Service to be promoted or transferred to fill the vacant office, and that the person named is entitled, under the provisions of the *Public Service Act 1928*, to be appointed to fill such vacancy on probation for three (3) months.

Turncock.

ROY ARTHUR SHERRIFF

to be a Turncock, General Division; a vacancy having occurred, and the Public Service Board having certified, on the 3rd September, 1946, that an appointment is required, that there is no person available and fit in the Public Service to be promoted or transferred to fill the vacant office, and that the person named is entitled, under the provisions of the *Public Service Act 1928*, to be appointed to fill such vacancy on probation for six months, to date from and inclusive of the 5th November, 1945.

Waterworks Trusts Commissioners.

DAVID GRANT MACCUBBIN

to be a Commissioner of the Traralgon Waterworks Trust, *vice* Alfred Henry Cross, deceased, and to hold office as such from the date hereof until the 24th September, 1947, subject to the provisions of the Water Acts; and

HENRY ALFRED EASTWOOD

to be a Commissioner of the Macedon Waterworks Trust, in place of Francis William Henry Mann, resigned, and to hold office as such from the date hereof until the 4th November, 1949, subject to the provisions of the Water Acts.

C. W. KINSMAN,

Clerk of the Executive Council.

At the Executive Council Chamber,
Melbourne, the 8th day of October, 1946.

RESIGNATIONS.

HIS Excellency the Lieutenant-Governor of the State of Victoria, by and with the advice of the Executive Council thereof, has, by Orders made on the 8th day of October, 1946, accepted the resignations of the persons named hereunder of the offices mentioned, *viz.*:—

DEPARTMENT OF CHIEF SECRETARY.

ARTHUR ERNEST HOWELL, as Returning Officer for the Electoral District of Goulburn.

DEPARTMENT OF WATER SUPPLY.

KEVIN BERNARD BREN, Fifth Class Clerk, Clerical Division, as an Officer of the Public Service of Victoria, from and inclusive of 29th September, 1946.

ROBERT WILLIAM THOMSETT, Mechanical Engineer, Class "C," Professional Division, as an Officer of the Public Service of Victoria, from and inclusive of 22nd September, 1946.

C. W. KINSMAN,

Clerk of the Executive Council.

At the Executive Council Chamber,
Melbourne, 8th October, 1946.

Public Service Act 1928 (No. 3757), Sections 90 and 91.

EXEMPTIONS.

HIS Excellency the Lieutenant-Governor of the State of Victoria, by and with the advice of the Executive Council thereof, and upon the recommendation of the Public Service Board, has, by Orders made on the 8th day of October, 1946, exempted the officers specified hereunder from the provisions of sections 90 and 91 of the *Public Service Act 1928* (No. 3757):—

DEPARTMENT OF CHIEF SECRETARY.

Two (2) officers of the Clerical Division, Children's Welfare Branch, Department of Chief Secretary, who are required to work overtime—such exemption to be operative for a period of two (2) months from and inclusive of the 15th August, 1946.

Officers of the Office of the Government Statist, Department of Chief Secretary, who are required to work overtime—such exemption to be operative for a period of six (6) months from and inclusive of the 1st July, 1946.

Officers of the Public Library, National Museums, and National Gallery, Department of Chief Secretary, when required to perform Sunday duty—such exemption to be operative for the period from the 1st July, 1946, to the 31st December, 1946, both dates inclusive.

DEPARTMENT OF LABOUR.

Officers of the Department of Labour who are required to work overtime in connexion with the adjustment of wages rates and piece-work prices fixed by determination of Wages Boards—such exemption to be operative for the period from the 1st July, 1946, to the 30th June, 1947, both dates inclusive.

C. W. KINSMAN,

Clerk of the Executive Council.

At the Executive Council Chamber,
Melbourne, 8th October, 1946.

EXAMINATION OF APPLICANTS FOR LICENCE AS SHORTHAND WRITER.

IT is hereby notified that an examination of applicants for Licence as Shorthand Writer will be held at the Law Courts, Melbourne, on Saturday, the 30th November, 1946, at eleven o'clock a.m.

Applications for permission to attend the examination, together with an entry fee of Ten shillings and six pence (10s. 6d.), must be forwarded to reach the Public Service Board's Office, Public Offices, Treasury-place, Melbourne, C.2 (where a copy of the Regulations may be obtained), not later than the 8th November, 1946.

Satisfactory evidence of—

- (1) Name in full;
- (2) having attained the age of twenty-one (21) years; and
- (3) good moral character—

should be submitted with application.

By order,

E. F. FITZGIBBON,
Acting Secretary.

Office of the Public Service Board,
Melbourne, 15th October, 1946.

Act No. 3757, Section 66 (1).

REGULATIONS.—PROFESSIONAL DIVISION.

CHAPTER II.

THE Public Service Board, in pursuance of the powers vested in it, hereby amends Chapter II. of the Public Service Regulations as shown below, and submits the same for the approval of the Governor in Council:—

Department and Office.	Yearly Rate of Salary.	
	Minimum.	Maximum.
DEPARTMENT OF PUBLIC INSTRUCTION.	£	£
CLASS "B."		
<i>Add—</i> Principal (Female), Emily McPherson College of Domestic Economy	625
<i>To take effect as from and inclusive of the 22nd May, 1946.</i>		
DEPARTMENT OF WATER SUPPLY.		
CLASS "C."		
<i>Add—</i> Research Officer (Catchments), Assistant	384	420
<i>To take effect as from and inclusive of the 2nd September, 1946.</i>		
DEPARTMENT OF LAW.		
CLASS "B."		
<i>Repeal—</i> Assistant Chief Draughtsman and Titles Office Survey Officer, Titles Office	650
<i>Add—</i> Assistant Chief Draughtsman, Titles Office	600	650
<i>To take effect as from and inclusive of the 9th September 1946.</i>		

D. D. PAINE, Chairman.
J. FRAZER, Secretary.

Office of the Public Service Board,
Melbourne, 7th August, 2nd and 9th September, 1946.

Approved by the Governor in Council,
8th October, 1946.

C. W. KINSMAN,
Clerk of the Executive Council.

Mines Act 1928.

REVOCATION OF ORDER IN COUNCIL EXEMPTING LAND FROM OCCUPATION FOR MINING PURPOSES, ETC.

HIS Excellency the Lieutenant-Governor of the State of Victoria, by and with the advice of the Executive Council thereof, and in pursuance of the provisions of the *Mines Act 1928*, has, by an Order made on the 8th day of October, 1946, revoked the Order in Council made on the 29th May, 1945, and published in the *Government Gazette* on the 30th May, 1945, exempting from occupation for mining purposes, under any miner's right, or from being leased under a mining lease, the land hereinafter described, viz.:—

Parish of Jumbunna East—allotments 39C, 39D, 39E, 44, 49, 50, 51, 51A, 51B, 51C, 51D, 51E, 52, 52A, 53, 54, 54A, 55, 56, and 57.

C. W. KINSMAN,
Clerk of the Executive Council.

At the Executive Council Chamber,
Melbourne, the 8th October, 1946.

GEELONG WATERWORKS AND SEWERAGE TRUST.

BY-LAW No. 77.

A By-law for Making and Levying the Rates for the Year commencing on the first day of July, 1946.

THE Geelong Waterworks and Sewerage Trust (hereinafter called "the Trust"), in pursuance of and in exercise of the powers and authorities conferred on such Trust by the *Geelong Waterworks and Sewerage Act 1928*, and of any other powers and authorities in any wise enabling the said Trust in that behalf, doth hereby make the By-law for the area supplied with water by the Geelong Water Supply Works, or any extension of such works.

1. The following rates are hereby made, and shall be levied upon the occupiers or owners of lands and tenements liable to be rated within the said area and supplied with water for domestic purposes:—

- (a) On any tenement (other than land on which there is no building) the annual valuation whereof does not exceed £17—Twenty shillings per annum.
- (b) On any such tenement the annual valuation whereof exceeds £17—One shilling and two pence in the pound of the amount of the annual valuation.
- (c) On any land (on which there is no building) the annual valuation whereof does not exceed £4—Five shillings per annum.
- (d) On any such land (on which there is no building) the annual valuation whereof exceeds £4—One shilling and two pence in the pound of the amount of the annual valuation.

2. Such rates are made and shall be levied for the year beginning with the first day of July, 1946, and ending with the thirtieth day of June, 1947, and shall be payable in two equal instalments on the nineteenth day of October, 1946, and the first day of January, 1947.

3. Such persons as the Trust may from time to time appoint for that purpose shall be and are hereby authorized to demand, receive, collect, sue for, and recover the said rates.

4. For making and levying such rates within the said area, the valuation for the time being of all lands and tenements for the municipal rate of the municipality in the municipal district of which such lands and tenements are situate shall be deemed and taken to be the valuation of such lands and tenements respectively; but if any such lands and tenements are not included in a valuation in force for the municipality in whose district they are situate, or if there is no such valuation, the net annual value thereof may for all the purposes for such rate be determined in accordance with the provisions of the Local Government Acts by the council of such municipality, on the written application of the Trust, as provided for in such case by the Water Acts.

The foregoing By-law was made and passed by the Geelong Waterworks and Sewerage Trust on the twenty-seventh day of September, 1946, and the common seal of the said Trust hereunto affixed, in the presence of—

(SEAL) N. M. FREEMAN, Chairman.
G. A. CAMERON, Vice-Chairman.
P. G. REILLY, A.I.C.A., Secretary.

Approved by the Governor in Council,
8th October, 1946.

C. W. KINSMAN,
Clerk of the Executive Council.

Transport Regulation Acts.

TRANSPORT REGULATION BOARD.

NOTICES OF PUBLIC HEARINGS.

NOTICE is hereby given that the applications lodged by the persons named below for licences to operate the commercial goods or passenger vehicles on the route or routes, or in the manner set out opposite their names, will be heard at a time and place to be communicated to the parties:—

Name of Applicant; Nature of Application.

- COLES, G. J., AND Co. LTD.; 1 commercial goods vehicle, with load capacity for 15 cwt., for the carriage of building materials, timber, tools for maintenance and repair work to metropolitan and country towns where stores are situated throughout Victoria.
- COLWELL, J.; 1 commercial goods vehicle for the carriage of general goods from and to Melbourne to and from Glenburn, Flowerdale, and Murrundindi.
- FAHEY, O. T.; 1 commercial goods vehicle for the carriage of—(a) general goods 20 miles Macarthur, (b) live stock from places in (a) to Hamilton and Warrnambool, (c) firewood from (a) to Koroit.
- HELMERS, W. F.; 1 commercial goods vehicle for the carriage of wool from Bombala district to Orbost.
- REED, J. L. AND P., PTY. LTD.; 2 commercial goods vehicles for the carriage of own manufactured goods, viz., aerated waters, cordials, syrups, flavourings, tomato sauce, tomato soup, Worcester sauce, vinegar, pickles, &c., within 100 miles Bendigo.
- ROBERTSON, R. S.; 1 commercial goods vehicle for the carriage of—(a) firewood from Willow Grove to Abbotsford Convent of the Good Shepherd, (b) general goods within 20 miles Trafalgar.
- VAUGHAN, W. J.; application for variation of licence D.3683 and D.3678, so as to permit the carriage of general goods between Lismore and Ballarat, via Cape Clear.
- DOWNNEY, C. V.; applications for licences to operate 2 commercial goods vehicles in the same terms as licences D.1201 and D.1522, at present held by R. J. Luckins, Orbost.
- WISE, J. M.; application for renewal of licences C.13, C.15, C.16, C.20, C.22, and C.26 (expire 21st December, 1946).
- WISE, J. M.; application for variation of above licences, to increase the radius to operate under charter conditions within 50 miles Geelong.
- BENDER, E. AND A. (trading as Bender's Ford V8 Bus Service); application for renewal of licences C.173, C.174 (expired 13th November, 1945), C.179 (expires 21st December, 1946), C.129, C.130, C.131, C.132 (expired 19th July, 1946).
- BENDER, E. AND A. (trading as Bender's Ford V8 Bus Service); application for variation of above licences to—(a) increase the radius to operate under charter conditions within 50 miles Geelong, (b) to operate on tours as follows:—
1. Geelong, via Winchelsea, Dean's Marsh, Lorne, returning via Ocean-road, 101 miles.
 2. Geelong, via Ocean-road, Lorne, detour to She Oak Falls and Cumberland River, return to Lorne, via Ocean-road, to Geelong, 100 miles.
 3. Geelong, Lorne, Apollo Bay, Laver's Hill, Beech Forest, Gellibrand, Colac, Winchelsea, Geelong, 191 miles.
 4. Geelong, Clifton Springs, Portarlington, Queenscliff, Pt. Lonsdale, Ocean Grove, Barwon Heads, Geelong, 81 miles.
 5. Geelong, Ballarat, Daylesford, Hepburn Springs, return Daylesford, Ballan, Geelong, 171 miles.
 6. Geelong, Melbourne, Lilydale, Warburton, Donna Buang, return same route, 210 miles.
 7. Geelong, Bacchus Marsh, Gisborne, Macedon, detour to Macedon and district, Woodend, Daylesford, Ballan, Geelong (two-day tour), 172 miles.
 8. Geelong, Ballarat, Daylesford, Hepburn Springs, Daylesford, Kyneton, Woodend, Gisborne, Bacchus Marsh, Geelong (two-day tour), 186 miles.
 9. Geelong, Lorne, Apollo Bay, Laver's Hill, Port Campbell, Peterborough, Warrnambool, Port Fairy, Warrnambool, Terang, Camperdown, Colac, Winchelsea, Geelong, 334 miles, two or three and four days.
 10. Geelong, Meredith, Ballarat, Avarat, Stawell, Hall's Gap, Dunkeld, Lake Bolac, Skipton, Lismore, Cressy, Geelong, 336 miles.
 11. Geelong, Winchelsea, Colac, Camperdown, Terang, Warrnambool, Port Fairy, Portland, Heywood, Winnap, Mt. Gambier, detour of Mt. Gambier, Casterton, Coleraine, Hamilton, Peshurst, Mortlake, Lismore, Cressy, Inverleigh, Geelong, four or five days, 550 miles.
- BENDER, E. AND A. (trading as Bender's Ford V8 Bus Service); 13 commercial passenger vehicles, with seating capacity for 30 persons each, to operate—(a) under charter conditions 50 miles Geelong, (b) on tours as set out above.
- ALLEN, G.; 1 commercial passenger vehicle, with seating capacity for 7 persons, to operate for the carriage of passengers, mails, and parcels between Ballarat and Mollonghip.
- BEATON, D. C.; application for variation of licence A.155, to include—(a) operations between Cowes, San Remo, Kilcunda, Dalyston to Wonthaggi pictures on Sunday nights, (b) charter conditions 30 miles Cowes.
- BRIDGES, O. J.; application for variation of licence A.1506, to operate between the corner of Pt. Nepean-road and Lower Dandenong-road, along Lower Dandenong-road to Keysborough, or the corner of Springvale-road and Lower Dandenong-road.
- CAMPBELL AND SOUTER; application for variation of licences A.890 and TA.1330, to operate between Knowsley and Bendigo once a fortnight for the purpose of attending entertainments and pictures.
- CLARK, W.; application for renewal of licences A.495 and A.496 (expired 6th September, 1946), allowing operations as follows:—Stage omnibus on any route within the Shire of Flinders.
- DANIELS, N. C. E.; 1 commercial passenger vehicle, with seating capacity for 27 persons, to operate (a) as a substitute vehicle for licensed vehicles, (b) under charter conditions within 50 miles Warracknabeal, and to The Grampians.
- FLEMING, G.; 1 commercial passenger vehicle, to be purchased, to operate as follows:—(a) Between Beverford, Woorinen, and Swan Hill; (b) between Lake Boga and Swan Hill.
- FULFORD, A. L.; 1 commercial passenger vehicle, with seating capacity for 8 persons, to operate under the same terms as licence A.1298, at present held by G. W. Fulford.
- HARDY, G. F.; 1 commercial passenger vehicle, with seating capacity for 5 persons, to operate for the carriage of passengers at separate and distinct fares for each passenger within 25 miles Bairnsdale.
- HATELY, E. G.; application for variation of licence A.356, to include private hire conditions within 50 miles Camperdown.
- TOULMIN, C. G.; application for variation of licence TA.1624, to include private hire conditions within 50 miles Camperdown.
- HUNT, L. C. E.; 1 commercial passenger vehicle, to be purchased, to operate as a stage omnibus between Beach-road, Mordialloc, via McDonald-street, Francis-street, Warren-road, Lower Dandenong-road, Boundary-road, Clayton-road, North-road, Box Hill-road, Bay View-road, Highbury-road, Station-street, Riversdale-road, Elgar-road, Windsor-crescent, Union-road, Kent-street, Middlesex-road, Prospect Hill-road, to Burke-road, Camberwell.

NOTICE is hereby given that the applications made by the persons named below for renewal of licences to operate the commercial passenger or goods vehicles in the manner set out hereunder, the numbers of which are also set out in each case, will be heard at a time and place to be communicated to the parties:—

Name and Address; Application Lodged in the Following Terms; Licence No.; Expiry Date.

- FLETCHER'S MOTOR SERVICES PTY. LTD., Geelong; Geelong-Lorne; A.610, A.611, A.613, A.614, A.615, A.617, A.685, A.686, A.769; 1st November, 1946.
- GAINGER, A. R. AND L. (trading as Gainger Bros.), Colac; Colac, Beac, Cressy; A.348, A.347; 24th November, 1946.
- GAINGER, A. R. AND L. (trading as Gainger Bros.), Colac; Colac, Beac, Cressy, co-ordinating with operators at Cressy to and from Ballarat; A.596; 24th November, 1946.
- GAINGER, A. R. AND L. (trading as Gainger Bros.), Colac; (a) stage omnibus on any route within 5 miles Colac, (b) private hire throughout Victoria; A.1090, A.1091; 24th November, 1946.
- GAINGER, A. R. AND L. (trading as Gainger Bros.), Colac; school children, Colac-Dean's Marsh; A.1041; 24th November, 1946.
- PARR & SPENCER PTY. LTD., Colac; (a) Colac-Camperdown, Darlington, Terang, Mortlake, Warrnambool, Koroit, racecourses, (b) township and racecourses at Camperdown, Darlington, Terang, Mortlake, (c) stage omnibus on any route within 5 miles Colac, (d) private hire 50 miles Colac; A.625; 22nd November, 1946.
- PARR & SPENCER PTY. LTD., Colac; (a) stage omnibus on any route within 5 miles Colac, (b) private hire 50 miles Colac; A.1088, A.1089; 22nd November, 1946.
- YALLOURN PASSENGER SERVICE PTY. LTD., Yallourn; (a) Yallourn-Trafalgar, Moe, Brown Coal Mine, Morwell, Yinnar, Maryvale, Traralgon, (b) charter 25 miles Yallourn; A.101-106 inclusive, A.744, A.788, A.797, A.798, A.1068; 19th November, 1946.

APPPLICATIONS for renewal of private hire licences expiring in November, 1946:—

BLANCHARD, J. W.; Clifton Hill.
 BRADLEY, F. C.; Essendon.
 BROCK, R. H.; Sale.
 GILLARD, C. L.; West Parkville.
 HARGREAVES, H. S.; Geelong (two vehicles).
 KEE, E. C.; Mordialloc.
 MARTIN, J. J.; Coburg.
 MUNT, G. E.; South Yarra.
 MCCLELLAND, R. J.; Erica.
 PRESTON, L.; Glenferrie.
 PULLEN, J. F. H.; South Preston.
 ROBINSON, J.; Brown Coal Mine.
 ROWE, J.; St. Kilda.
 SPEHER, E. A.; Geelong.
 STOLL, E. R.; Drouin.
 SWEENEY, J. P.; Balwyn.

APPPLICATIONS for licences to operate commercial passenger vehicles, with seating capacity, for 5 persons, for the carriage of passengers for reward, otherwise than at separate and distinct fares for each passenger throughout Victoria:—

ALLEN, R.; Bonbeach.
 BUCKLEY, D. C.; North Shore.
 CAROLLO, P.; Melbourne (three vehicles).
 CARRUTHERS, S. G.; Moe.
 MORLEY, N. C.; Moe.
 CARTWRIGHT, W. L.; Moe.
 CORNES, W. A. S.; Black Rock.
 DAVEY, E. A. V.; Boronia.
 CONWAY, J.; Tallangatta.
 DALEY, J. A.; Armadale.
 EMEY, R.; Ballarat.
 GANGE, A.; Fitzroy (three vehicles).
 MINEHAN, E. J.; Middle Park (to operate from Mordialloc).
 NANKIVELL, F. (trading as Warrandyte Garage and Warrandyte Taxi Service); Warrandyte.
 PENNY, C. A.; Echuca.
 WITTIERS, A. P.; Camberwell (two vehicles).

Notice of any objection should be forwarded to reach the Secretary to the Board not later than Wednesday, the 30th October, 1946.

E. V. FIELD,
 Secretary.

Exhibition Buildings, Rathdown-street, Carlton, 15th October, 1946.

SUBJECT to any necessary excisions, &c., it is proposed to grant the following leases:—

8155, Beechworth; Neville L. Wolff; 62a. 3r. 15p.. Parish of Harrierville.
 8157, Beechworth; Neville L. Wolff; 16a. 2r. 25p.. Parish of Harrierville.
 8161, Beechworth; Neville L. Wolff. 90a. 1r. 27p.. Parish of Harrierville.
 8162, Beechworth; Neville L. Wolff; 54a. 0r. 2p.. Parish of Harrierville.
 8170, Beechworth; John D. Bromley; 18a. 0r. 7p.. Parish of Maharatta.

APPPLICATIONS FOR MINING LEASES REFUSED.

8179, Beechworth; Henry James Udall; 40 acres, at Lightning Creek Bridge, on the Oneco Highway.
 5507, Gippsland; Cuthbert Charles Barrington; 20 acres, in Parish of Mirboo North.

APPPLICATIONS FOR MINING LEASES DECLARED ABANDONED.

6992, Maryborough; Joseph McDonald, 250 acres, in Parish of Glenmona.
 6993, Maryborough; Joseph McDonald, 200 acres, in Parish of Glenmona.

MINING LEASE EXPIRED.

5056, Mineral; Cyril A. Kerr; 13a. 1r. 24p.. in Parish of Mirboo.

W. G. McKENZIE,
 Minister of Mines.

CITY OF GEELONG WEST.

ORDER CONFIRMED.

THE Minister of the Crown administering the *Local Government Act 1928*, on the 7th day of October, 1946, confirmed the Order hereinafter referred to in pursuance of section 513 of the said Act, viz:—

An Order of the Council of the City of Geelong West, made on the 28th day of August, 1946, for the purpose of acquiring certain land as a place of public recreation, such land being part of Crown allotment 11, section 13, at Nerne Hill, Parish of Moorpanyal, County of Grant, and being land within the municipal district of the City of Geelong West.

P. J. KENNELLY,
 Commissioner of Public Works.

SUMMONING OFFICERS.

I HEREBY appoint the under-mentioned persons, under section 31 of the *Education Act 1928*, to summon parents within the State of Victoria:—

First Constable ROBIN LIONEL DUDLEY BADDELEY, No. 8920.
 First Constable DOUGLAS AMOR CLARKE, No. 8856.
 First Constable GEORGE MICHAEL WILLIS, No. 8720.

FRANCIS FIELD,
 Minister of Public Instruction.

Education Department,
 Melbourne, 8th October, 1946.

Farmers Debts Adjustment Act 1935.

CANCELLATION OF STAY ORDERS.

NOTIFICATION is hereby given that the Stay Orders issued to the under-mentioned farmers have been cancelled by the Farmers' Debts Adjustment Board, such cancellation to take effect on Wednesday, 16th October, 1946:—

No. of Stay Order; Name; Address.

3778; Brown, Frederick Donald Belcher; Bamawm.
 3042; Bassett, Osmond Herbert; Sandmount, via Katunga.
 1617; Banko, Margaret Mary; Nathalia.
 3008; Alder, Arthur Alfred; Echuca South.
 3997; Aitken, James Alfred; Mologa.
 2270; Holland, Theodore Francis; Picola.
 3295; Hill, Robert Austin; Stanhope.
 4114; Guiney, Gregory Vincent; Tongala.
 3437; Guiney, Francis; Tongala.
 3985; Grinter, Margaret Arnott, deceased (Robert James Grinter as executor); Nathalia.
 4223; Griffiths, David Emrys; Kamarooka.
 1856; Wilson, Robert James; Iona.
 1633; Beechey, William Henry; Longwarry.
 2519; Wright, Bernard; Sydenham.
 4000; White, Gerald Jervis; Glen Waverley.
 3868; Trethowan, Fred, William (now deceased); Donnybrook.
 2683; Vanstan, Evelyn George; Balliang.
 3113; Vanstan, Willie Lindon; Balliang.
 3382; Twite, James, deceased (Phillipa Ellen and James Thornton Twite as executors); Bena.
 3010; Trenery, Wilfred Dudley; Vervale.
 3662; Simpson, John Henry and Stanley Roy; Koo-wee-rup.
 3861; Spalding, Benjamin; Lara Lake.
 1937; Rigby, Henry Alfred; Vervale.
 1719; Reidy, Mary; Garfield.
 3715; Perry, William, deceased, and Kate Elizabeth Anne; Cranbourne.
 1673; O'Brien, Daniel Charles, John Patrick (now deceased), and Sarah Alice; Pakenham South.
 3056; McCraw, Edward James; Caldermeade.
 4313; Duggan, James; Campbell's Forest.
 4032; Dixon, Michael Willans, deceased (executrix, Mrs. M. A. Dixon); Echuca.
 2790; Davies, John David; Tocumwal, New South Wales.
 1989; Darrigan, Michael; Colbinabbin East.
 2557; Collie, Leslie Allan; Tatura.
 3238; Caine, John; Logan.
 1728; Gamble, Clement; Bamawm.
 3739; Gerrand, David; Eppalock, via Bendigo.
 1985; Gordon, George Leslie; Bealiba.
 3751; Fulton, John; Carag Carag.
 2334; Fitzpatrick, John Francis; Shelbourne.
 2333; Feltham, John Henry; Bamawm Extension.

W. J. EVANS, Deputy Secretary,
 Farmers' Debts Adjustment Board.

15th October, 1946.

Marriage Act 1928.

MINISTERS OF RELIGION REGISTERED TO CELEBRATE MARRIAGES IN VICTORIA.

IT is hereby notified that, in pursuance of the provisions of the *Marriage Act 1928*, 19 Geo. V. No. 3726, Sec. 11, the under-mentioned Officiating Ministers of Religion have been registered at this office for the celebration of marriages in Victoria :—

Number in Register.	Name.	Designation.	Denomination.	Residence.	Date of Registration.
9634	Fitzpatrick, Daniel Michael ..	Priest ..	Catholic ..	St. Patrick's College, East Melbourne	28.8.46
9635	Campbell, Kevin Sylvester ..	Priest ..	Catholic ..	"La Verna," Sackville-street, Kew	2.9.46
9636	Inglis, Gilbert Joseph ..	Brigadier ..	Salvation Army ..	The Basin ..	5.9.46
9637	Scott, Michael ..	Priest ..	Catholic ..	"Manresa," Burwood-road, Hawthorn	5.9.46
9638	Bautovich, Cyril Joseph ..	Adjutant ..	Salvation Army ..	30 Charles-street, East Brunswick ..	9.9.46
9639	Davison, Rowland Borrowman ..	Priest ..	Church of England ..	The Rectory, Violet Town ..	22.8.46
9640	Colvin, John ..	Minister ..	Presbyterian ..	The Manse, Mount-street, Wycheproof	12.9.46
9641	Kenna, William Keith ..	Priest ..	Church of England ..	6 Manor-street, Brighton ..	18.9.46
9642	McCristal, John Evangelist ..	Priest ..	Catholic ..	"La Verna," Sackville-street, Kew	21.9.46
9643	Hancock, Bertram Edgar ..	Priest ..	Church of England ..	Koondrook ..	21.9.46

Office of the Government Statist,
Melbourne, 8th October, 1946.

O. GAWLER,
Government Statist.

AUCTION SALES ACT 1928.

BAIRNSDALE.—Notice is hereby given that the Annual Meeting of Justices for the Licensing of Auctioneers will be held at the Court House, Bairnsdale, on the 26th day of November, 1946, at Ten o'clock in the forenoon.—M. L. KILLEEN, Clerk of Petty Sessions.

BENALLA.—Notice is hereby given that the Annual Meeting of Justices for the Licensing of Auctioneers will be held in the Court House, Benalla, on Tuesday, the 26th day of November, 1946, at Ten o'clock in the forenoon. Dated this 10th day of October, 1946.—V. A. PROSCHI, Clerk of Petty Sessions.

BENDIGO.—Notice is hereby given that the Annual Meeting of Justices for the Licensing of Auctioneers will be held at the Law Courts, Bendigo, on Tuesday, the 26th day of November, 1946, at Ten o'clock in the forenoon.—W. P. WALSH, Clerk of Petty Sessions.

CAMPERDOWN.—Notice is hereby given that the Annual Meeting of Justices for the Licensing of Auctioneers will be held at the Court House, at Camperdown, on Tuesday, the 26th day of November, 1946, at Ten o'clock in the forenoon. Dated at Camperdown, this 8th day of October, 1946.—A. R. PENFOLD, Clerk of Petty Sessions.

CHARLTON.—Notice is hereby given that the Annual Meeting of Justices for the Licensing of Auctioneers will be held at the Court House, Charlton, on Tuesday, the 26th day of November, 1946, at Ten o'clock in the forenoon.—R. H. GOSS, Clerk of Petty Sessions.

COLAC.—Notice is hereby given that the Annual Meeting of Justices for the Licensing of Auctioneers will be held at the Court House, Colac, on Tuesday, the 26th day of November, 1946, at Ten o'clock in the forenoon. Dated this 10th day of October, 1946.—L. S. GALAGHER, Clerk of Petty Sessions.

CORRYONG.—Notice is hereby given that the Annual Meeting of Justices for the Licensing of Auctioneers will be held at the Court House, Corryong, on Tuesday, the 26th day of November, 1946, at Ten o'clock in the forenoon. Dated this 8th day of October, 1946.—T. R. DUNLOP, Clerk of Petty Sessions.

EUROA.—Notice is hereby given that the Annual Meeting of Justices for the Licensing of Auctioneers will be held in the Court House, Euroa, on Tuesday, the 26th day of November, 1946, at Ten o'clock in the forenoon. Dated this tenth day of October, 1946.—V. A. PROSCHI, Clerk of Petty Sessions.

KYNETON.—The Annual Meeting of Justices for the Licensing of Auctioneers will be held at the Court House, at Kyneton, at Ten o'clock in the forenoon, on Tuesday, 26th November, 1946.—G. D. O'SULLIVAN, Clerk of Petty Sessions.

MELBOURNE.—Notice is hereby given that the Annual Meeting of Justices for the Licensing of Auctioneers will be held at the Court of Petty Sessions, Russell-street, Melbourne (District Court), on Tuesday, the 26th day of November, 1946, at the hour of Ten o'clock in the forenoon. Dated at Melbourne, this 10th day of October, 1946.—F. C. P. HILL, Clerk of Petty Sessions.

MILDURA.—Notice is hereby given that the Annual Meeting of Justices for the Licensing of Auctioneers will be held at the Court House, Deakin-avenue, Mildura, at Ten o'clock in the forenoon, on Tuesday, the 26th day of November, 1946.—R. PROWSE, Clerk of Petty Sessions.

NHILL.—Notice is hereby given that the Annual Meeting of Justices for the Licensing of Auctioneers will be held at the Court House, Nhill, on Tuesday, the 26th day of November, 1946, at the hour of Ten o'clock in the forenoon.—C. J. THOMPSON, Clerk of Petty Sessions.

NUMURKAH.—Notice is hereby given that the Annual Meeting of Justices for the Licensing of Auctioneers will be held at the Court House, Numurkah, at Ten o'clock in the forenoon, on Tuesday, 26th day of November, 1946.—J. L. COLLINS, Clerk of Petty Sessions.

RUSHWORTH.—Notice is hereby given that the Annual Meeting of Justices for the Licensing of Auctioneers will be held at the Court House, Rushworth, at Twelve o'clock noon on Tuesday, 26th day of November, 1946.—D. YEAMAN, Clerk of Petty Sessions.

SHEPPARTON.—Notice is hereby given that the Annual Meeting of Justices for the Licensing of Auctioneers will be held at the Court House, Shepparton, at Ten o'clock in the forenoon, on Tuesday, 26th day of November, 1946.—E. O'CONNELL, Clerk of Petty Sessions.

SWAN HILL.—Notice is hereby given that the Annual Meeting of Justices for the Licensing of Auctioneers will be held at the Court House, Swan Hill, on Tuesday, the 26th day of November, 1946, at Ten o'clock in the forenoon. Dated at Swan Hill this 11th day of October, 1946.—N. J. SCANNELL, Clerk of Petty Sessions.

TALLANGATTA.—Notice is hereby given that the Annual Meeting of Justices for the Licensing of Auctioneers will be held at the Court House, Tallangatta, on Tuesday, the 26th day of November, 1946, at Ten o'clock in the forenoon. Dated this 8th day of October, 1946.—T. R. DUNLOP, Clerk of Petty Sessions.

WARRAGUL.—Notice is hereby given that the Annual Meeting of Justices for the Licensing of Auctioneers will be held at the Court House at Warragul, on Tuesday, the 26th day of November, 1946, at Ten o'clock in the forenoon.—R. V. DAVIS, Clerk of Petty Sessions.

WONTHAGGI.—The Annual Meeting of Justices for the Licensing of Auctioneers will be held at the Court House, Wonthaggi, on Tuesday, the 26th day of November, 1946, at Ten o'clock in the forenoon.—J. W. EGAN, Clerk of Petty Sessions.

Town and Country Planning Act 1944.

TOWN OF HAMILTON.

INTERIM DEVELOPMENT ORDER.

WHEREAS, by virtue of the powers conferred by the *Town and Country Planning Act 1944* and every other power enabling them in that behalf, the preparation of a planning scheme, in accordance with the said Act, has been commenced by the Council of the Town of Hamilton (hereinafter referred to as the "Responsible Authority"), which hereby makes the following Interim Development Order:—

1. The development of all land referred to in the Schedule, and the erection, construction, and carrying out of any buildings, roads, or other works on any of the said land is hereby prohibited.

2. Any person may apply to the Responsible Authority for permission to develop, subdivide, or otherwise use any land, or erect or construct any buildings, roads, or other works, during the operation of this Order.

3. Any application for permission to develop, subdivide, or otherwise use any land, or erect or construct any building, roads, or other works, may be granted by the Responsible Authority, subject to such conditions as are specified in the permit, or may be refused.

4. Any owner of any land who, after service of a copy of this Order, contravenes any of the provisions contained herein, shall, when directed by notice, in writing, remove, pull down, take up, or alter any building, road, or other works, and, if any owner fails to do so within the time specified by the notice, the Responsible Authority may carry out all or any of such works, and recover all expenses incurred, after due notice has been given to the owner, lessee, and/or occupier, in accordance with the provisions of section 12, sub-section 3, of the Act.

5. None of the provisions of this Order shall prohibit the continuance of the use of any land or buildings for the purpose for which it was used immediately before the coming into operation of this Order.

6. This Order shall remain in operation until the approval of the Planning Scheme, in accordance with the *Town and Country Planning Act 1944*, or until this Interim Development Order is revoked by the Governor in Council.

7. Schedule of land affected: The whole of the municipality of the Town of Hamilton.

(SEAL) J. C. MOODIE, Mayor.
C. H. WOODBRIDGE, Councillor.
A. WALLS, Municipal Clerk.

Report by the Town and Country Planning Board on the ninth day of October, 1946. Recommended for approval.—J. S. GAWLER, Chairman.

Approved by the Governor in Council,
15th October, 1946.

C. W. KINSMAN,
Clerk of the Executive Council.

Town and Country Planning Act 1944.

BOROUGH OF PORTLAND.

INTERIM DEVELOPMENT ORDER.

WHEREAS, by virtue of the powers conferred by the *Town and Country Planning Act 1944* and every other power enabling them in that behalf, the preparation of a planning scheme in accordance with the said Act has been commenced by the Council of the Borough of Portland (hereinafter referred to as the "Responsible Authority"), which hereby makes the following Interim Development Order:—

1. The development of all land referred to in the Schedule and the erection, construction, and carrying out of any buildings, roads, or other works on any of the said land is hereby prohibited.

2. Any person may apply to the Responsible Authority for permission to develop, subdivide, or otherwise use any land or erect or construct any buildings, roads, or other works, during the operation of this Order.

3. Any application for permission to develop, subdivide, or otherwise use any land or erect or construct any building, roads, or other works, may be granted by the Responsible Authority, subject to such conditions as are specified in the permit, or may be refused.

4. Any owner of any land who, after the service of a copy of this Order, contravenes any of the provisions contained herein, shall, when directed by notice in writing, remove, pull down, take up, or alter any building, road, or other works, and, if any owner fails to do so within the time specified by the notice, the Responsible Authority may carry out all or

any of such works, and recover all expenses incurred, after due notice has been given to the owner, lessee, and/or occupier in accordance with the provisions of section 12, sub-section 3, of the Act.

5. None of the provisions of this Order shall prohibit the continuance of the use of any land or buildings for the purpose for which it was used immediately before the coming into operation of this Order.

6. This Order shall remain in operation until the approval of the Planning Scheme in accordance with the *Town and Country Planning Act 1944*, or until this Interim Development Order is revoked by the Governor in Council.

7. Schedule of land affected: The whole of the Borough of Portland.

The common seal of the Borough of Portland was hereunto affixed, this 17th day of September, 1946, in the presence of—

(SEAL) H. V. MACLEOD, Mayor.
G. ROGERS, Councillor.
E. NOEL T. HENRY, Town Clerk.

Report by the Town and Country Planning Board on the 9th day of October, 1946. Recommended for approval.—J. S. GAWLER, Chairman.

Approved by the Governor in Council,
15th October, 1946.

C. W. KINSMAN,
Clerk of the Executive Council.

4 GEORGE VI. No. 4755, SECTION 6.

I HEREBY give notice that, on the 2nd October, 1946, I filed elections to administer the following deceased persons' estates, in accordance with section 6 of the *Public Trustee Act 1940*:—

ROS VOSILE KHAN, late of North Cundare, near Colac, farmer, died 4th February, 1946, intestate.

CARTER, AGNES MADELINE, late of Gembrook, spinster, died 9th November, 1945, intestate.

ENGBERG, BINAR ALFRED, late of 400 Queen-street, West Melbourne, kitchen hand, died 25th August, 1946, intestate.

PADY, EMMA TRYPHENA, also known as Emma Pady, formerly of Ringwood, but late of 6 Edinboro-street, Mount Hawthorn, Western Australia, widow, died 29th May, 1942, intestate.

*POWRIE, JANE ANN, also known as Jean Powrie, late of 9 Sercombe-grove, Hawthorn, domestic, died 25th June, 1946.

*WATSON, RICHARD LANCELOT, formerly of Bonegilla, but late of Australian Imperial Forces, soldier, presumed to have died 23rd January, 1942.

*WITHEY, CATHERINE, late of 27 Erindale-street, Murrumbidgee, married woman, died 14th August, 1946.

*According to the provisions of the will.

J. E. DON,
Public Trustee.

412 Collins-street, Melbourne, 9th October, 1946.

4 GEORGE VI. No. 4755, SECTION 6.

I HEREBY give notice that, on the 8th October, 1946, I filed elections to administer the following deceased persons' estates, in accordance with section 6 of the *Public Trustee Act 1940*:—

*BARBER, JOHN, late of 14 Union-street, South Melbourne, musician, died 20th August, 1946.

DR MARTINO, ANTONIO, late of 37 Therry-street, West Melbourne, but formerly of 28 Victoria-street, North Melbourne, kitchenman, died 4th September, 1946, intestate.

EARNSHAW, CHARLES HENRY, late of 68 Wellington-street, Collingwood, labourer, died 4th August, 1946, intestate.

FLYNN, MARIA THERESA, also known as Marion Flynn, late of 16 Waterloo-street, St. Kilda, spinster, died 28th August, 1946, intestate.

*NEYLON, MARY ELLEN, late of 10 Nottingham-street, Prahran, spinster, died 17th June, 1946.

RICHMOND, PERCIVAL, also known as Henry Richmond, late of 5 Marine-parade, St. Kilda, pensioner, died 7th August, 1946, intestate.

*According to the provisions of the will.

J. E. DON,
Public Trustee.

412 Collins-street, Melbourne, 9th October, 1946.

NOTICE.

ADMINISTRATION of the estate of each of the under-mentioned deceased persons has been granted to me, and creditors, next of kin, and all others having claims against the estate of any of the persons so mentioned are required to send particulars of their claims to the Public Trustee, No. 412 Collins-street, Melbourne, on or before the 18th December, 1946, or they will be excluded from the distribution of the estate when the assets are being distributed:—

*BARBER, JOHN, late of 14 Union-street, South Melbourne, musician, died 20th August, 1946.

BOS VOSILE KHAN, late of North Cundare, near Colac, farmer, died 4th February, 1946, intestate.

BYRNES, CHARLES, late of 16 Rokeby-street, Collingwood, general dealer, died 17th June, 1946, intestate.

CARTER, AGNES MADELINE, late of Gembrook, spinster, died 9th November, 1945, intestate.

DI MARTINO, ANTONIO, late of 87 Therry-street, West Melbourne, but formerly of 28 Victoria-street, North Melbourne, kitchenman, died 4th September, 1946, intestate.

EARNSHAW, CHARLES HENRY, late of 68 Wellington-street, Collingwood, labourer, died 4th August, 1946, intestate.

ENGBERG, EINAR ALFRED, late of 400 Queen-street, West Melbourne, kitchen hand, died 25th August, 1946, intestate.

FLYNN, MARLA THERESA, also known as Marion Flynn, late of 16 Waterloo-street, St. Kilda, spinster, died 28th August, 1946, intestate.

† JONES, NORMAN ROBERT, late of 71 Ormond-esplanade, Elwood, estate agent, died 11th July, 1946.

*NEYLON, MARY ELLEN, late of 10 Nottingham-street, Prahran, spinster, died 17th June, 1946.

PADY, EMMA TRYPHENA, also known as Emma Pady, formerly of Ringwood, but late of 6 Edinboro-street, Mount Hawthorn, Western Australia, widow, died 29th May, 1942, intestate.

*POWRIE, JANE ANN, also known as Jean Powrie, late of 9 Sercombe-grove, Hawthorn, domestic, died 25th June, 1946.

RICHMOND, PEBIVAL, also known as Henry Richmond, late of 5 Marine-parade, St. Kilda, pensioner, died 7th August, 1946, intestate.

*WATSON, RICHARD LANCELOT, formerly of Bonegilla, but late of Australian Imperial Forces, soldier, presumed to have died 23rd January, 1942.

*WITHEY, CATHERINE, late of 27 Erindale-street, Murrumbidgee, married woman, died 14th August, 1946.

* According to the provisions of the will.

† With the will annexed.

J. E. DON,
Public Trustee.

Melbourne, 9th October, 1946.

CONTRACTS ACCEPTED.—(Series 1946-47.)

VICTORIAN RAILWAYS.

63. Screw Cutting Lathe, for £704 10s. (Contract 55482).—McPherson's Ltd. 64. Metallic Insulation "Turnall," at rates (Contract 55543).—A. L. Campbell and Co. Pty. Ltd. 65. Stainless Steel Sheets, at rates (Contract 55682).—Commonwealth Steel Co. Ltd. 66. Serew Cutting Lathe, for £1,201 0s. 6d. (Contract 55743).—Alfred Herbert (A'asia) Pty. Ltd. 67. Aluminium Alloy Sheets, at rates (Contract 55747).—Australian Aluminium Co. Pty. Ltd. 68. Removal of Departmental Residences, for £176 (Contract 55855).—Buckell and Jeffrey Pty. Ltd. 69. Hewn Bridge Beams and Cattle Pit Logs, at rates (Contract 56010).—E. F. Rawlinson, jun. 70. Printing Papers, at rates (Contract 56030).—Gordon and Gotch (A'asia) Ltd.

By order of the Victorian Railways Commissioners,

E. C. EYERS, Secretary. 11.10.46.

ORDERS IN COUNCIL.—(Series 1946-47.)

DEPARTMENT OF PUBLIC INSTRUCTION.

1157. One only gas-fired pottery kiln, 20 in. x 30 in. x 22 in., working temperature to 1,350°C. complete with blower, for Ballarat School of Mines, £222 10s.—The Metropolitan Gas Co., Melbourne.

1158. Receipt books for use in the training of personnel under the Commonwealth Defence Training Scheme, Melbourne Technical College, £207.—Lamson Paragon Ltd., The Boulevard, Richmond.

Approved by the Governor in Council, 8th October, 1946.—C. W. KINSMAN, Clerk of the Executive Council.

FORESTS COMMISSION.

Loan Act No. 5049, Item 5—

1159. To the purchase of allotments 71b and 71c, Parish of Binginwarri, County of Buln Buln, comprising 88 acres 1 rood 32 perches, for forest purposes, £50.—Miss A. G. McAree, Camberwell.

Approved by the Governor in Council, 6th August, 1946.—C. W. KINSMAN, Clerk of the Executive Council.

Loan Act No. 5049, Item 5—

1160. To the purchase of allotment 5, and portion of allotment 5A, section C, Parish of Woorarra, and allotment 73, Parish of Wonyip, County of Buln Buln, containing 231 acres 2 roods 18 perches, for forest purposes, £138 19s. 4d.—J. A. Wigglesworth, Albert Park.

Approved by the Governor in Council, 24th September, 1946.—C. W. KINSMAN, Clerk of the Executive Council.

STATE ELECTRICITY COMMISSION.

1161. For the supply of one only Diesel-operated footpath roller for Yallourn Township, to Quotation No. 565.—A. H. McDonald and Co. Pty. Ltd.

1162. For the erection of twelve timber houses and three outbuilding blocks for the housing of contractors' employees, Yallourn, to Specification No. 46-47/48.—Marr and Beards.

1163. For the erection of three cubicle blocks (each sixteen cubicles) for housing of personnel, Yallourn, to Specification No. 46-47/66.—Marr and Beards.

1164. For the supply of 1,200 feet of 4-core 6.6 kV trailing cable for R.C.M. Open Cut, Yallourn, to Specification No. 45-46/114.—Australian General Electric Pty. Ltd.

1165. For the supply of 1,200 feet four-core 6.6 kV trailing cable for R.C.M. Open Cut, Yallourn, to Specification No. 45-46/114.—W. T. Henley's Telegraph Works Co. Ltd.

1166. For the drilling of 40,000 feet of earth and brown coal in connexion with investigations in Gippsland and South Gippsland, to Specification No. 46-47/53.—W. L. Sides and Son Pty. Ltd.

1167. For the drilling of 20,000 feet of earth and brown coal in connexion with investigations in Gippsland and South Gippsland, to Specification No. 46-47/53.—B. G. Barry and J. T. Haire.

1168. For the drilling of 20,000 feet of earth and brown coal in connexion with investigations in Gippsland and South Gippsland, to Specification No. 46-47/53.—Chatterton Bros.

1169. For the supply of 12,420 feet paper insulated 22 kv three-core metal-sheathed armoured cable for main distribution feeders, to Specification No. 46-47/36.—British General Electric Co. Pty. Ltd.

1170. For the supply of 400 tons of rails and 360 pairs of fish-plates for railway tracks and building reinforcement, Yallourn, to Specification No. 46-47/45.—The Broken Hill Pty. Co. Ltd.

1171. For the supply of 20 tons of steel sheets for manufacture of transformers, to Specification No. 46-47/28.—N. W. Hutchinson and Sons.

1172. For the supply of 20 tons of steel sheets for manufacture of transformers, to Specification No. 46-47/28.—Armeo (Aust.) Pty. Ltd.

1173. For the supply of 18 tons of steel sheets for manufacture of transformers, to Specification No. 46-47/28.—F. W. Green and Co. Pty. Ltd.

1174. For the purchase by the Commission of land 128 ft. 6 in. x 106 ft. 8 in., at the corner of Point Nepean-road and Milroy-street, Brighton.—Messrs. Ingram Bros.

1175. For the purchase by the Commission of land and timber residence erected thereon, known as No. 11 Pleasant-street, Castlemaine.—F. Robbins.

1176. For the supply of 600 hewn sleepers for railway and dredger tracks, Yallourn Open Cut, to Specification No. 46-47/51.—R. J. Blick.

1177. For the supply of 2,300 hewn sleepers for railway and dredger tracks, Yallourn Open Cut, to Specification No. 46-47/51.—J. W. Hollingsworth.

1178. For the supply of 5,600 hewn sleepers for railway and dredger tracks, Yallourn Open Cut, to Specification No. 46-47/51.—H. Wilson.

1179. For the supply of 1,700 hewn sleepers for railway and dredger tracks, Yallourn Open Cut, to Specification No. 46-47/51.—Weston Bros. and Whitechurch.

1180. For the supply of four Westinghouse compressors for electric locomotives, Yallourn Open Cut, to Quotation No. 642.—Westinghouse Brake (Australasia) Pty. Ltd.

1181. For the supply of five only two-wheel log-hauling trailers for line construction.—Commonwealth Disposals Commission.

1182. For the supply of one only Southern Cross four-cylinder vertical Diesel engine for Kiewa Hydro-Electric Scheme.—Ministry of Munitions.

1183. For the supply of three only batteries for locomotives, Kiewa Hydro-Electric Scheme, to Specification No. 46-47/64.—A. P. Sutherland.

Approved by the Governor in Council, 8th October, 1946.—C. W. KINSMAN, Clerk of the Executive Council.

Water Acts.

STATE RIVERS AND WATER SUPPLY COMMISSION.

At the Executive Council Chamber, Melbourne, the eighth day of October, 1946.

PRESENT:

His Excellency the Lieutenant-Governor of Victoria.

Mr. McKenzie

Mr. Galvin.

RODNEY IRRIGATION AND WATER SUPPLY DISTRICT.
—PORTIONS EXCISED.

UNDER the powers conferred by the Water Acts and all other powers enabling him in that behalf, His Excellency the Lieutenant-Governor of the State of Victoria, with the advice of the Executive Council of the said State, on the recommendation of the State Rivers and Water Supply Commission, doth hereby declare, order, and direct as follows:—

That there shall be excised from the Rodney Irrigation and Water Supply District those portions of the same set out and described in the schedule hereto, which portions, as from the date of this Order, shall be deemed to be excised accordingly.

SCHEDULE.

Portion 1.—Commencing at the north-western angle of allotment 9, Town of Murchison, Parish of Murchison, County of Rodney; thence northerly by the eastern boundary of the Murchison-Tatura road to a point in line with the northern boundary of the land being part of allotment 9, Parish of Murchison, described in Book 564, Memorial No. 853, in the office of the Registrar-General; thence westerly by a line and the last-mentioned boundary to the north-western angle of the said land; thence southerly by the western boundary of the said land and by a line in continuation of that boundary to the northern boundary of allotment 8, Town of Murchison; thence easterly by the last-mentioned boundary and by a line to the point of commencement.

Portion 2.—The whole of the land, being part of allotment 7, Town of Murchison, Parish of Murchison, County of Rodney, described in Book 577, Memorial No. 833, in the office of the Registrar-General.

Portion 3.—Commencing at a point on the eastern boundary of allotment 7, Town of Murchison, Parish of Murchison, County of Rodney, a distance of 1 chain southerly from the north-eastern angle of that allotment; thence by lines bearing north 81 deg. 20 min. west 2 chains 50 links; south 8 deg. 36 min. west 4 chains and south 81 deg. 24 min. east to the Murchison-Tatura road; thence northerly by the western boundary of that road to the point of commencement.

Portion 4.—Commencing at the south-eastern angle of allotment 7, Town of Murchison, Parish of Murchison, County of Rodney; thence northerly by the western boundary of the Murchison-Tatura road a distance of 4 chains; thence by lines bearing north 81 deg. 24 min. west 2 chains 50 links, and south 8 deg. 36 min. west to the southern boundary of said allotment 7; thence easterly by the last-mentioned boundary to the point of commencement.

Portion 5.—Commencing at the north-western angle of lot 43 on lodged plan of subdivision No. 5706, Parish of Toolamba West, County of Rodney; thence easterly by the northern boundaries of lots 43, 42, 41, 40, and 39 to the north-eastern angle of the last-mentioned lot; thence northerly and easterly by the western and northern boundaries of lot 35, all on lodged plan of subdivision No. 5706, to the western boundary of Ross-street; thence northerly by the last-mentioned boundary to a point in line with the northern boundary of William-street; thence easterly by the last-mentioned boundary to a point in line with the eastern boundary of lot 125 on lodged plan of subdivision No. 3302; thence southerly by a line, the last-mentioned boundary, and the eastern boundaries of lots 124 and 123 to the south-eastern angle of the last-mentioned lot; thence westerly by the southern boundaries of that lot and lot 122A, and a line connecting those boundaries to the most western angle of said lot 122A, all on lodged plan of subdivision No. 3302; thence generally south-westerly by the south-eastern boundaries of a drain reserve to the north-eastern boundary of the Toolamba and Echuca Railway Reserve; thence south-easterly by the last-mentioned boundary to a point distant 5 chains at right angles from Hogan-street; thence westerly by a line parallel to the said Hogan-street to a point distant 5 chains westerly from the western boundary of Ross-street; thence southerly by a line parallel to Ross-street to the southern boundary of the land described in certificate of title, volume 2344, folio 468783; thence westerly by the southern boundaries of the land described in certificates of title, volume 2344, folio 468783, volume 5643, folio 1128437,

and volume 6366, folio 1273043, and northerly by the western boundary of the land described in the last-mentioned certificate of title to the southern boundary of Hogan-street; thence westerly by the last-mentioned boundary to a point in line with the western boundary of lot 43 on lodged plan of subdivision No. 5706; thence northerly by a line and that boundary to the point of commencement.

Portion 6.—The whole of the land comprised in lodged plan of subdivision No. 11967, Parish of Toolamba West, County of Rodney.

The portions described in the foregoing Schedule are shown on plans approved by the Governor in Council, and deposited in the office of the State Rivers and Water Supply Commission, Melbourne.—(Corres. Nos. 46/18463 and 18464.)

MURCHISON WATERWORKS TRUST.—EXTENT OF
DISTRICT INCREASED.

UNDER the powers conferred by the Water Acts and all other powers enabling him in that behalf, His Excellency the Lieutenant-Governor of the State of Victoria, with the advice of the Executive Council of the said State, doth hereby declare, order, and direct as follows:—

That the extent of the Waterworks District of the Murchison Waterworks Trust be increased by adding to the same the lands set out and described in the Schedule hereto, and as on and from the date of this Order the extent of such district shall be deemed to be increased accordingly.

SCHEDULE.

1. Commencing at the north-western angle of allotment 9, Town of Murchison, Parish of Murchison, County of Rodney; thence northerly by the eastern boundary of the Murchison-Tatura road to a point in line with the northern boundary of the land being part of allotment 9, Parish of Murchison, described in Book 564, Memorial No. 853, in the office of the Registrar-General; thence westerly by a line and the last-mentioned boundary to the north-western angle of the said land; thence southerly by the western boundary of the said land and by a line in continuation of that boundary to the northern boundary of allotment 8, Town of Murchison; thence easterly by the last-mentioned boundary and by a line to the point of commencement.

2. The whole of the land, being part of allotment 7, Town of Murchison, Parish of Murchison, County of Rodney, described in book 577, Memorial No. 833, in the office of the Registrar-General.

3. Commencing at a point on the eastern boundary of allotment 7, Town of Murchison, Parish of Murchison, County of Rodney, a distance of 1 chain southerly from the north-eastern angle of that allotment; thence by lines bearing north 81 deg. 20 min. west 2 chains 50 links, south 8 deg. 36 min. west 4 chains, and south 81 deg. 24 min. east to the Murchison-Tatura road; thence northerly by the western boundary of that road to the point of commencement.

4. Commencing at the south-eastern angle of allotment 7, Town of Murchison, Parish of Murchison, County of Rodney; thence northerly by the western boundary of the Murchison-Tatura road a distance of 4 chains; thence by lines bearing north 81 deg. 24 min. west 2 chains 50 links and south 8 deg. 36 min. west to the southern boundary of said allotment 7; thence easterly by the last-mentioned boundary to the point of commencement.

The lands described in the foregoing Schedule are shown on a plan approved by the Governor in Council, and deposited in the office of the State Rivers and Water Supply Commission, Melbourne.—(Corres. 46/18463.)

TATURA WATERWORKS TRUST.—EXTENT OF
DISTRICT INCREASED.

UNDER the powers conferred by the Water Acts and all other powers enabling him in that behalf, His Excellency the Lieutenant-Governor of the State of Victoria, with the advice of the Executive Council of the said State, doth hereby declare, order, and direct as follows:—

That the extent of the Waterworks District of the Tatura Waterworks Trust be increased by adding to the same the lands set out and described in the Schedule hereto, and as on and from the date of this Order, the extent of such district shall be deemed to be increased accordingly.

SCHEDULE.

1. Commencing at the north-western angle of lot 43 on lodged plan of subdivision No. 5706, Parish of Toolamba West, County of Rodney; thence easterly by the northern boundaries of lots 43, 42, 41, 40, and 39 to the north-eastern angle of the last-mentioned lot; thence northerly and easterly by the western and northern boundaries of lot 35, all on lodged plan

of subdivision No. 5706, to the western boundary of Ross-street; thence northerly by the last-mentioned boundary to a point in line with the northern boundary of William-street; thence easterly by the last-mentioned boundary to a point in line with the eastern boundary of lot 125, on lodged plan of subdivision No. 3302; thence southerly by a line, the last-mentioned boundary, and the eastern boundaries of lots 124 and 123 to the south-eastern angle of the last-mentioned lot; thence westerly by the southern boundaries of that lot and lot 122A and a line connecting those boundaries to the most western angle of said lot 122A, all on lodged plan of subdivision No. 3302; thence generally south-westerly by the south-eastern boundaries of a drain reserve to the north-eastern boundary of the Toolamba and Echuca Railway Reserve; thence south-easterly by the last-mentioned boundary to a point distant 5 chains at right angles from Hogan-street; thence westerly by a line parallel to the said Hogan-street to a point distant 5 chains westerly from the western boundary of Ross-street; thence southerly by a line parallel to Ross-street to the southern boundary of the land described in certificate of title, volume 2344, folio 468783; thence westerly by the southern boundaries of the land described in certificates of title, volume 2344, folio 468783, volume 5643, folio 1128437, and volume 6366, folio 1273043, and northerly by the western boundary of the land described in the last-mentioned certificate of title to the southern boundary of Hogan-street; thence westerly by the last-mentioned boundary to a point in line with the western boundary of lot 43 on lodged plan of subdivision No. 5706; thence northerly by a line and that boundary to the point of commencement.

2. The whole of the land comprised in lodged plan of subdivision No. 11967, Parish of Toolamba West, County of Rodney.

The lands described in the foregoing Schedule are shown on a plan approved by the Governor in Council, and deposited in the office of the State Rivers and Water Supply Commission, Melbourne.—(Corres. 46/18464.)

And the Honorable Leslie William Galvin, His Majesty's Minister of Water Supply for the State of Victoria, shall give the necessary directions herein accordingly.

C. W. KINSMAN,
Clerk of the Executive Council.

COUNTRY ROADS BOARD.

At the Executive Council Chamber, Melbourne, the eighth day of October, 1946.

PRESENT:

His Excellency the Lieutenant-Governor of Victoria.
Mr. McKenzie | Mr. Galvin.

ORDER APPROVING OF A DEVIATION FROM A STATE HIGHWAY IN THE SHIRE OF KARKAROOC.

WHEREAS the Country Roads Board constituted under the *Country Roads Act 1928* (No. 3662) has represented to His Excellency the Governor in Council that it appears to it desirable that the deviation hereinafter referred to from the existing Henty Highway in the Shire of Karkaroc (declared to be a State Highway under the said Act, which declaration was confirmed by the Order in Council published in the *Government Gazette* of the 17th August, 1938, on page 2461) should be made by the said Board: And whereas the said Board in accordance with the requirements of section 19 of the said cited Act has caused to be prepared a map plan and estimate showing the points between which and on and through what land the said deviation is proposed to be made and the cost of acquiring the land and constructing the said deviation: And whereas on an inspection of the said map and plan and a consideration of the said estimate His Excellency the Governor in Council is satisfied that there are funds legally available for acquiring the land and constructing the said deviation: Now therefore be it known by this present Order that His Excellency the Lieutenant-Governor of the State of Victoria, with the advice of the Executive Council thereof, doth hereby approve of the said highway being made, that is to say:—

All those pieces of land in the Parish of Chiprick, the boundaries of which are as follow:—

- (a) Commencing at a point on the eastern boundary of allotment 24 of the said parish, distant 5,346 links from the north-eastern angle of the said allotment; thence by lines bearing respectively 228 deg. 5 min. 200 links, 264 deg. 17 min. 200 links, and 66 deg. 11 min. 380.2 links to the point of commencement.
- (b) Commencing at the north-eastern angle of allotment 9c of the said parish; thence by lines bearing respectively 180 deg. 1 min. 164.6 links, 234 deg. 4 min. 2,743 links, 13 deg. 35 min. 462.1 links, 53 deg. 4 min. 2,082 links, and 76 deg. 23 min. 439 links to the point of commencement.

Also, all those pieces of land in the Parish of Minapre, the boundaries of which are as follow:—

- (a) Commencing at the north-eastern angle of allotment 26 of the said parish; thence by lines bearing respectively 223 deg. 24 min. 932.2 links, 25 deg. 17 min. 750.3 links, and 90 deg. 12 min. 320 links to the point of commencement.
- (b) Commencing at the intersection of the southern boundary of allotment 1 of the said parish and the western boundary of the existing Henty Highway through the said allotment; thence by lines bearing respectively 270 deg. 12 min. 246.6 links, 8 deg. 8 min. 1,260 links, and 176 deg. 52 min. 1,250 links to the point of commencement.

which said pieces of land are particularly delineated and shown coloured red on survey plans numbered 4762, 4763, and 4764, lodged in the office of the Country Roads Board.

ORDER APPROVING OF A NEW MAIN ROAD IN THE SHIRE OF WARRNAMBOOL.

WHEREAS the Country Roads Board constituted under the *Country Roads Act 1928* (No. 3662) has represented to His Excellency the Governor in Council that it appears to it desirable that the new Cobden-Warrnambool road in the Shire of Warrnambool should be made by the said Board: And whereas the said Board in accordance with the requirements of section 19 of the said cited Act has caused to be prepared a map plan and estimate showing the points between which and on and through what land the said new road is proposed to be made and the cost of acquiring the land and constructing the said new road: And whereas on an inspection of the said map and plan and a consideration of the said estimate His Excellency the Governor in Council is satisfied that there are funds legally available for acquiring the land and constructing the said new road: Now therefore be it known by this present Order that His Excellency the Lieutenant-Governor of the State of Victoria, with the advice of the Executive Council thereof, doth hereby approve of the said road being made, that is to say:—

All that piece of land in the Parish of Nullawarre, the boundaries of which are as follow:—Commencing at the north-western angle of allotment 66A of the said parish; thence by a line bearing 74 deg. 0 min. 515 links to the Brucknell Creek; thence south-easterly by the said creek a distance of 26 links, more or less; thence by lines bearing respectively 249 deg. 10½ min. 531.1 links and 0 deg. 17 min. 73 links to the point of commencement—which said piece of land is particularly delineated and shown coloured red on survey plan numbered 4765, lodged on the office of the Country Roads Board.

And the Honorable Patrick John Kennelly, His Majesty's Commissioner of Public Works for the State of Victoria, shall give the necessary directions herein accordingly.

C. W. KINSMAN,
Clerk of the Executive Council.

MACEDON WATERWORKS TRUST.

At the Executive Council Chamber, Melbourne, the eighth day of October, 1946.

PRESENT:

His Excellency the Lieutenant-Governor of Victoria.
Mr. McKenzie | Mr. Galvin.

ADDITIONAL LOAN OF £7,000.

UNDER the powers conferred by the Water Acts and all other powers enabling him in that behalf, His Excellency the Lieutenant-Governor of the State of Victoria, by and with the advice of the Executive Council of the said State, doth hereby grant an additional loan of Seven thousand pounds (£7,000) to the Macedon Waterworks Trust for construction of a storage reservoir and installation of a necessary pipe line, as set forth in the detailed statement bearing the date the 27th September, 1946, and verified under the seal of the State Rivers and Water Supply Commission.

The loan hereby granted shall be subject to the provisions of the Water Acts.

And the Honorable Leslie William Galvin, His Majesty's Minister of Water Supply for the State of Victoria, shall give the necessary directions herein accordingly.

C. W. KINSMAN,
Clerk of the Executive Council.

DEPARTMENT OF LANDS AND SURVEY.

At the Executive Council Chamber, Melbourne, the eighth day of October, 1946.

PRESENT:

His Excellency the Lieutenant-Governor of Victoria.
Mr. McKenzie | Mr. Galvin.

UNUSED AND UNMADE ROADS CLOSED.

HIS Excellency the Lieutenant-Governor of the State of Victoria, by and with the advice of the Executive Council thereof, doth hereby direct that, in pursuance of the provisions of section 304 of the *Land Act* 1928 (No. 3709), as amended by section 10 of the *Land Act* 1933, the unused and unmade roads referred to hereunder be closed, viz.:—

Parish of Kooroo, County of Kara Kara, being the roads indicated by hachure on plan hereunder.—(G.114A⁽³⁾) (W.62561).

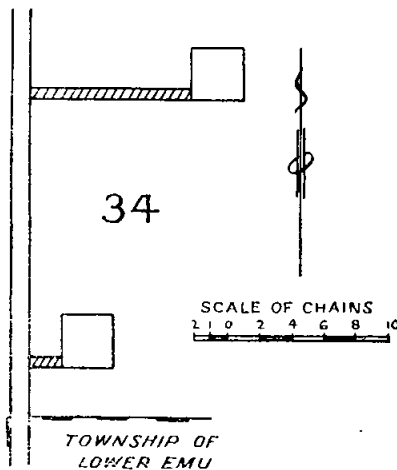

Parish of Gooramadda, County of Bogong, being the road indicated by hachure on plan hereunder.—(G.114A⁽³⁾) (H.016693).

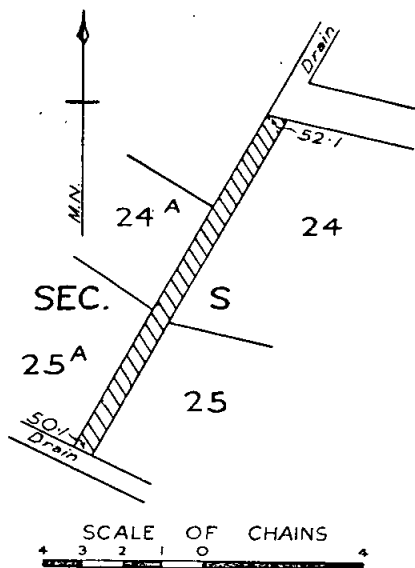

And the Honorable Leslie William Galvin, His Majesty's Commissioner of Crown Lands and Survey for the State of Victoria shall give the necessary directions herein accordingly.

C. W. KINSMAN,
Clerk of the Executive Council.

MOTOR OMNIBUS ACT 1928 (No. 3742).

At the Executive Council Chamber, Melbourne, the eighth day of October, 1946.

PRESENT:

His Excellency the Lieutenant-Governor of Victoria.
Mr. McKenzie | Mr. Galvin.

EXTENSION OF METROPOLITAN MOTOR OMNIBUS ROUTE No. 82A (BALWYN-CANTERBURY-HARTWELL).

HIS Excellency the Lieutenant-Governor of the State of Victoria, by and with the advice of the Executive Council thereof, and in pursuance of the powers conferred by the *Motor Omnibus Act* 1928 (No. 3742), doth by this Order extend, as set out hereunder, a certain route, i.e., No. 82A, within the metropolitan area, along which motor omnibuses for which "regular service" licences are granted may ply for hire, viz.:—

Under the heading "Description of Route, including Commencing and Terminal Points," delete all the particulars shown after "Shierlaw-avenue" and in place thereof insert "Canterbury-road, Maling-road, Logan-street, Prospect Hill-road, Hassett-avenue, Maysia-street, Quantock-street, Riversdale-road, Coolangatta-road, and Fordham-avenue, to a point in Fordham-avenue, adjacent to Hartwell Railway Station."

Under the heading "Sections on Route," delete "Rochester-road," and in place thereof insert "Canterbury Railway Station," also add "(3) Canterbury Railway Station to Riversdale-road; (4) Riversdale-road to Hartwell Railway Station."

Under the heading "Fares to be Charged" amend "3d." to read "5d."

Under the heading "Maximum Number of Motor Omnibuses which may be Licensed on Route" amend "2" to read "4."

Licensing Authority.—Pursuant to the provisions of section 15 (1) (c) of the said Act (No. 3742), the Governor in Council by this Order confers upon the Licensing Authority full power and authority for the carrying into effect by the said Licensing Authority of the foregoing provisions of this Order.

And the Honorable Patrick John Kennelly, His Majesty's Commissioner of Public Works for the State of Victoria, shall give the necessary directions herein accordingly.

C. W. KINSMAN,
Clerk of the Executive Council.

MOTOR OMNIBUS ACT 1928 (No. 3742).

At the Executive Council Chamber, Melbourne, the eighth day of October, 1946.

PRESENT:

His Excellency the Lieutenant-Governor of Victoria.
Mr. McKenzie | Mr. Galvin.

REDUCTIONS OF FARES ON NIGHT MOTOR OMNIBUS ROUTE No. 20 (COBURG-MELBOURNE-HAWTHORN BRIDGE).

HIS Excellency the Lieutenant-Governor of the State of Victoria, by and with the advice of the Executive Council thereof, and in pursuance of the powers conferred by the *Motor Omnibus Act* 1928 (No. 3742), doth by this Order amend, as set out hereunder, certain fares on a route, i.e., No. 20, within the metropolitan area, along which motor omnibuses for which "regular service" licences are granted may ply for hire, viz.:—

Under the heading "Fares to be Charged," delete the existing particulars, and in place thereof insert "All sections, 4d. each; through fare, Bell-street to corner of Flinders and Swanston streets, 1s.; through fare, corner of Flinders and Swanston streets to Hawthorn Bridge, 6d.; through fare, Bell-street to Hawthorn Bridge, 1s. 6d."

Licensing Authority.—Pursuant to the provisions of section 15 (1) (c) of the said Act (No. 3742), the Governor in Council by this Order confers upon the Licensing Authority full power and authority for the carrying into effect by the said Licensing Authority of the foregoing provisions of this Order.

And the Honorable Patrick John Kennelly, His Majesty's Commissioner of Public Works for the State of Victoria, shall give the necessary directions herein accordingly.

C. W. KINSMAN,
Clerk of the Executive Council.

MOTOR OMNIBUS ACT 1928 (No. 3742).

At the Executive Council Chamber, Melbourne, the eighth day of October, 1946.

PRESENT:

His Excellency the Lieutenant-Governor of Victoria.
Mr. McKenzie | Mr. Galvin.

VARIATIONS OF METROPOLITAN MOTOR OMNIBUS ROUTES Nos. 26A (GLEN IRIS-HARTWELL) AND 99A (ASHBURTON-EAST MALVERN).

HIS Excellency the Lieutenant-Governor of the State of Victoria, by and with the advice of the Executive Council thereof, and in pursuance of the powers conferred by the *Motor Omnibus Act 1928* (No. 3742), doth by this Order vary, as set out hereunder, the prescriptions of two routes, i.e., Nos. 26A and 99A, within the metropolitan area, along which motor omnibuses for which "regular service" licences are granted, may ply for hire, viz.:—

Route No. 26A (Glen Iris-Hartwell).—Under the heading "Description of Route, including Commencing and Terminal Points," (a) delete "Hartwell" from the sub-heading, and (b) delete all the particulars after "Ashburton Railway Station."

Under the heading "Sections on Route," delete sections (4) and (5).

Under the heading "Fares to be Charged," amend "5d." to read "3d."

Under the heading "Time-tables to be Observed," amend "20" to read "10," and amend "week-days; 2 p.m." to read "week-days; 20 minutes, 2 p.m."

Route No. 99A (Ashburton-East Malvern).—Under the heading "Description of Route, including Commencing and Terminal Points," (a) delete the sub-heading "Ashburton-Darling-East Malvern," and in place thereof insert "Hartwell-East Malvern," and (b) delete "at the corner of High and Ward streets, Ashburton, thence via," and in place thereof insert "in George-street, at Hartwell Railway Station, thence via George-street, Toorak and Summerhill roads, Fakenham-road, 'Y' street."

Under the heading "Sections on Route," delete the existing particulars, and in place thereof insert—

- (1) Hartwell Railway Station to Ferndale-road;
- (2) Ferndale-road to High-street;
- (3) High-street to Albion-road;
- (4) Albion-road to Darling Railway Station;
- (5) Darling Railway Station to Burke-road."

Under the heading "Fares to be Charged," amend "3d." to read "5d."

Under the heading "Maximum Number of Motor Omnibuses which may be Licensed on Route," amend "1" to read "2."

Under the heading "Time-tables to be Observed," amend "30 minutes" to read "20 minutes."

Licensing Authority.—Pursuant to the provisions of section 15 (1) (c) of the said Act (No. 3742), the Governor in Council by this Order confers upon the Licensing Authority full power and authority for the carrying into effect by the said Licensing Authority of the foregoing provisions of this Order.

And the Honorable Patrick John Kennelly, His Majesty's Commissioner of Public Works for the State of Victoria, shall give the necessary directions herein accordingly.

C. W. KINSMAN,
Clerk of the Executive Council.

MOTOR OMNIBUS ACT 1928 (No. 3742).

At the Executive Council Chamber, Melbourne, the eighth day of October, 1946.

PRESENT:

His Excellency the Lieutenant-Governor of Victoria.
Mr. McKenzie | Mr. Galvin.

EXTENSION OF METROPOLITAN MOTOR OMNIBUS ROUTE No. 7A (COBURG-COBURG WEST).

HIS Excellency the Lieutenant-Governor of the State of Victoria, by and with the advice of the Executive Council thereof, and in pursuance of the powers conferred by the *Motor Omnibus Act 1928* (No. 3742), doth by this Order extend, as set out hereunder, a certain route, i.e., No. 7A, within the metropolitan area, along which motor omnibuses

for which "regular service" licences are granted may ply for hire, viz.:—

Under the heading "Description of Route, including Commencing and Terminal Points," amend "North Coburg" to read "Coburg West," and amend "O'Heas-street, Sussex-street, to Gaffney-street," to read "O'Heas-street and Ray-street to corner of Ray and Gaffney streets (terminus)."

Under the heading "Sections on Route," delete sections Nos. (2) and (3), and in place thereof insert—

- "(2) between May-street and corner of O'Heas and Sussex streets;
- (3) between corner of O'Heas and Sussex streets and corner of Ray and Gaffney streets;
- (3A) between corner of O'Heas and Sussex streets and Essex-road."

Under the heading "Fares to be Charged," amend "through fare, 4d." to read "through fare to corner of Ray and Gaffney streets, or to Essex-road, 3d."

Licensing Authority.—Pursuant to the provisions of section 15 (1) (c) of the said Act (No. 3742), the Governor in Council by this Order confers upon the Licensing Authority full power and authority for the carrying into effect by the said Licensing Authority of the foregoing provisions of this Order.

And the Honorable Patrick John Kennelly, His Majesty's Commissioner of Public Works for the State of Victoria, shall give the necessary directions herein accordingly.

C. W. KINSMAN,
Clerk of the Executive Council.

MOTOR OMNIBUS ACT 1928 (No. 3742).

At the Executive Council Chamber, Melbourne, the eighth day of October, 1946.

PRESENT:

His Excellency the Lieutenant-Governor of Victoria.
Mr. McKenzie | Mr. Galvin.

METROPOLITAN MOTOR OMNIBUS SERVICES, HAMPTON-MOORABBIN-HIGHETT HOUSING AREA.

HIS Excellency the Lieutenant-Governor of the State of Victoria, by and with the advice of the Executive Council thereof, and in pursuance of the powers conferred by the *Motor Omnibus Act 1928* (No. 3742), doth by this Order amend, as set out hereunder, the prescription of a certain route, i.e., No. 83A, and doth prescribe, as set out hereunder, Route No. 118A, within the metropolitan area, along which motor omnibuses for which "regular service" licences are granted may ply for hire, viz.:—

Route No. 83A (Hampton-Highett).—Under the heading "Description of Route, including Commencing and Terminal Points," delete the existing particulars, and in place thereof insert "Commencing at Hampton Railway Station, via Hampton-street, Willis-street, Fewster-road, Edinburgh-street, Thomas-street, Bluff-road, and Highett-road, to Highett Railway Station."

ROUTE No. 118A (HAMPTON-MOORABBIN).

Description of Route, including Commencing and Terminal Points.—Commencing at Hampton Railway Station, via Hampton-street, Willis-street, Hood-street, Ludstone-street, and Bluff-road, to corner of Bluff-road and Thomas-street.

Sections on Route.—

- (1) Hampton Railway Station to Earlfield-road;
- (2) Earlfield-road to Thomas-street.

Fares to be Charged.—Any one section, 2d.; additional section, 1d.; through fare, 3d.

Time-tables to be Observed.—Minimum service, 20 minutes—7 a.m. to 12 midnight, week days; 2 p.m. to 11 p.m., Sundays.
Maximum Number of Motor Omnibuses which may be Licensed on Route.—One.

The Governor in Council doth also by this Order provide that the said amendment of Route No. 83A shall be brought into effect from, and the said Route No. 118A shall commence to operate from, the same time on the same day, such time and day to be determined by the Licensing Authority.

Licensing Authority.—Pursuant to the provisions of section 15 (1) (c) of the said Act (No. 3742), the Governor in Council by this Order confers upon the Licensing Authority full power and authority for the carrying into effect by the said Licensing Authority of the foregoing provisions of this Order.

And the Honorable Patrick John Kennelly, His Majesty's Commissioner of Public Works for the State of Victoria, shall give the necessary directions herein accordingly.

C. W. KINSMAN,
Clerk of the Executive Council.

MOTOR OMNIBUS ACT 1928 (No. 3742).

At the Executive Council Chamber, Melbourne, the eighth day of October, 1946.

PRESENT:

His Excellency the Lieutenant-Governor of Victoria.
Mr. McKenzie | Mr. Galvin.

AMENDMENT OF PRESCRIPTIONS OF METROPOLITAN MOTOR OMNIBUS ROUTES Nos. 6A AND 59A.

HIS Excellency the Lieutenant-Governor of the State of Victoria, by and with the advice of the Executive Council thereof, and in pursuance of the powers conferred by the *Motor Omnibus Act 1928* (No. 3742), doth by this Order amend, as set out hereunder, the prescriptions of certain routes, i.e., Nos. 6A and 59A, within the metropolitan area, along which motor omnibuses for which "regular service" licences are granted may ply for hire, viz.:—

Route No. 6A (Colburg-Heidelberg).—Under the heading "Maximum Number of Motor Omnibuses which may be Licensed on Route" amend "10" to read "11."

Route No. 59A (Caulfield-South Caulfield).—Under the heading "Description of Route, including Commencing and Terminal Points," delete "Bundeera" in both places where occurring, and in both instances insert "Bealiba" in place thereof.

Licensing Authority.—Pursuant to the provisions of section 15 (1) (c) of the said Act (No. 3742), the Governor in Council by this Order confers upon the Licensing Authority full power and authority for the carrying into effect by the said Licensing Authority of the foregoing provisions of this Order.

And the Honorable Patrick John Kennelly, His Majesty's Commissioner of Public Works for the State of Victoria, shall give the necessary directions herein accordingly.

C. W. KINSMAN,
Clerk of the Executive Council.

REGULATIONS RELATIVE TO THE DEFENCE OF DESTITUTE PERSONS CHARGED WITH CAPITAL CRIMES, AND OF ABORIGINALS CHARGED WITH INDICTABLE OFFENCES.

At the Executive Council Chamber, Melbourne, the fifteenth day of October, 1946.

PRESENT:

His Excellency the Lieutenant-Governor of Victoria.
Mr. McKenzie | Mr. Hayes.

HIS Excellency the Lieutenant-Governor of the State of Victoria, by and with the advice of the Executive Council thereof, doth hereby rescind the Regulations dated the ninth day of April, 1920, and in lieu thereof doth make the following Regulations (that is to say):—

1. When any person charged with an offence punishable by death, or any aboriginal accused of an indictable offence, requires legal assistance for his defence, he shall, seven days before the first day of the gaol delivery, Circuit Court, or Court of General Sessions at which he is to take his trial, or so soon as he shall know that he is to be tried for such offence, apply to the Sheriff for such assistance, and shall show to the satisfaction of such Sheriff that he is without sufficient means wherewith to employ legal assistance.

2. Upon the Sheriff being convinced of the truth of the allegations contained in such application, and having ascertained from the Crown Solicitor or the Clerk of the Peace, as the case may be, that the applicant is to be tried on a capital charge, or in the case of an aboriginal, that he is to be brought to trial, he shall communicate to the legal practitioner nominated by the applicant to act as his counsel the desire of the applicant to be defended by him, together with the amount of fees to be allowed, and forward notice of the same to the Attorney-General. The solicitor to be assigned in the case of every such application shall be the Public Solicitor. In the event of the accused being unaware of any suitable counsel, or failing to nominate one, the Public Solicitor shall follow the usual practice and assign counsel to him.

3. The Public Solicitor shall not withdraw from the defence unless requested to do so in writing by the applicant.

4. If the applicant desires to change his counsel he shall inform the Sheriff, in writing, as soon as possible, and shall nominate another, or request that the Public Solicitor assign another counsel for his defence.

5. The fees shall not (except in special cases, to be approved of by the Attorney-General) exceed the sum of £7 7s.

6. The above sums are exclusive of the expenses of any witnesses deemed by the Public Solicitor to have been material and necessary (which expenses shall be paid at the same rate as those of Crown witnesses). Provided, however, that where the evidence of experts is required (as in defences of insanity, &c.) the approval of the Attorney-General must first be obtained for the payment of any necessary fees.

7. Counsel nominated by the applicant, or assigned by the Public Solicitor, shall, after the trial, present his claim to the Sheriff. The Public Solicitor shall forward to the Attorney-General the application for legal aid, with a report on the trial and any recommendation as to increased fees as may be thought necessary.

8. Only those persons who comply with these Regulations shall be entitled to receive aid from the sum voted by Parliament.

9. The purport of these Regulations shall, as soon as possible after the commitment for trial of any prisoner to whom they apply, be communicated by every gaoler to such prisoner.

And the Honorable William Slater, His Majesty's Solicitor-General for Victoria, shall give the necessary directions herein accordingly.

C. W. KINSMAN,
Clerk of the Executive Council.

FACTORIES AND SHOPS ACTS.

At the Executive Council Chamber, Melbourne, the fifteenth day of October, 1946.

PRESENT:

His Excellency the Lieutenant-Governor of Victoria.
Mr. McKenzie | Mr. Hayes.

APPOINTMENT OF A FILEMAKERS BOARD.

UNDER the powers in that behalf conferred by the Factories and Shops Acts, His Excellency the Lieutenant-Governor of the State of Victoria, by and with the advice of the Executive Council thereof, doth hereby—

- (1) Declare that it is expedient to appoint a Wages Board to determine the lowest rates which may be paid to any person or persons or classes of persons employed in the process, trade, or business of manufacturing or preparing files or rasps of any description whatsoever for use as tools of trade.
- (2) Order that a Wages Board, consisting of six members and a chairman, three of such members being appointed as representatives of employers and three as representatives of employees, be constituted and appointed to determine the lowest rates which may be paid to any person or persons or classes of persons, excluding smiths (iron, brass, or copper), electrical fitters, electrical mechanics, machinist (1st and 2nd class), toolmakers, tradesmen, engineers, welders (1st and 2nd class), and pattern-makers employed in the process, trade, or business of manufacturing or preparing files or rasps of any description for use as tools of trade.

Also that such Wages Board may, in any regulation, determination, order, instrument, or legal proceeding be described for all purposes as the Filemakers Board, and the area or locality within which the determination of such Wages Board shall be operative shall be the whole of the State of Victoria.

And the Honorable Percy James Clarey, His Majesty's Minister of Labour and Employment for the State of Victoria, shall give the necessary directions herein accordingly.

C. W. KINSMAN,
Clerk of the Executive Council.

COUNTRY FIRE AUTHORITY ACT 1944.

At the Executive Council Chamber, Melbourne, the
fifteenth day of October, 1946.

PRESENT:

His Excellency the Lieutenant-Governor of Victoria.

Mr. McKenzie | Mr. Hayes.

COUNTRY FIRE AUTHORITY.

REGULATIONS.

WHEREAS by the *Country Fire Authority Act 1944*, it is amongst other things enacted that the Governor in Council may make regulations for regulating the business and proceedings of the Country Fire Authority and of the committees thereof, and for prescribing the notice to be given of such meetings and the expenses to be paid to members of the Authority:

Now therefore His Excellency the Lieutenant-Governor of the State of Victoria, in the Commonwealth of Australia, by and with the advice of the Executive Council of the said State, and in pursuance of the powers conferred by the *Country Fire Authority Act 1944*, doth hereby make the Regulations following (that is to say):—

Clause 30 of the Regulations made on the second day of January, 1945, and published in the *Government Gazette* of the third day of January, 1945, is hereby amended as follows:—

For the words—

“not exceeding Four pence half-penny per mile”

there shall be substituted the words—

“not exceeding Six pence half-penny per mile.”

And the Honorable William Slater, His Majesty's Chief Secretary for the State of Victoria, shall give the necessary directions herein accordingly.

C. W. KINSMAN,
Clerk of the Executive Council.

APPROACHING LAND SALES.

SALES of Crown lands, in fee-simple, will be held at the under-mentioned places and dates, viz.:—

	No. of Gazette.
Bairnsdale.—Thursday, 21st November, 1946	201
Bonang.—Tuesday, 12th November, 1946	196
Dingee.—Wednesday, 16th October, 1946	182
Melbourne.—Wednesday, 13th November, 1946	196
Omeo.—Tuesday, 26th November, 1946	201
Orbost.—Thursday, 14th November, 1946	196
Swan Hill.—Thursday, 7th November, 1946	201

Lands and Survey Office, Melbourne.

SALES BY AUCTION.

The lands will be sold in fee-simple, and subject to the covenants, conditions, exceptions, and reservations directed by the Governor in Council by an Order in Council dated the 5th August, 1930, and published in the *Government Gazette* of the 8th August, 1930, varied as herein.

A deposit of at least twelve and a half per centum of the price at which each lot is sold must be paid by the purchaser at the time of sale, and all such payments shall be made in bank notes or cheques approved by the officer conducting the sale, and the residue of such price will be payable in equal instalments, in accordance with the scale hereunder, on the last day of each successive period of six months from the time of sale, or, if the purchaser choose, at any earlier time or times; such residue of the price shall bear interest at the rate of £5 per centum per annum, to be computed between the time of sale and the time when payment of such residue or instalment of such residue is made. If the residue of the price be paid within thirty days after the time of the sale no interest will be payable thereon.

The transfer of the interest of any purchaser of an allotment sold by public auction may be effected prior to the final payment of the purchase money being made. The fee for transfer shall be One pound, and such transfer will be subject to payment of stamp duty.

SCALE OF PAYMENTS OF RESIDUE.

£20 and under, 6 instalments.
Over £20, and not exceeding £50, 8 instalments.
Over £50, and not exceeding £100, 10 instalments.
Over £100, and not exceeding £200, 12 instalments.
Over £200, and not exceeding £300, 14 instalments.
Over £300, and not exceeding £400, 16 instalments.
Over £400, and not exceeding £500, 18 instalments.
Over £500, 20 instalments.

FEES, ETC.

The fees payable for Crown grant and assurance (One halfpenny for each pound of purchase price) must be paid with the balance of purchase money. The following is the scale:—

50 acres and under, £1 10s.

Over 50 acres, £2.

Where the purchase money does not exceed £5, the grant fee is £1.

Valuations of improvements (if not purchased by the owner thereof) and charges for survey, must also be paid at the time of sale.

SPECIAL CONDITION.

Before sale is approved the purchaser will be required to satisfy the requirements of the National Security (Lands Transfer) Regulations as regards nationality.

L. W. GALVIN,

Commissioner of Crown Lands and Survey.

Office of Lands and Survey,
Melbourne, 14th October, 1946.

BAIRNSDALE.—Sale (No. 10599) of Crown lands, in fee-simple, by auction, will be held at the LAND OFFICE, on THURSDAY, 21st NOVEMBER, 1946, at TWO o'clock p.m. To be conducted by L. W. BIRCH, Land Officer, Bairnsdale.

TOWNSHIP OF NUNGURNER, PARISH OF COLQUHON, COUNTY OF TAMBO.

In south of Township, with frontage to road which abuts Reeves Channel.

Upset price £10 per lot. Charge for survey £3 2s. 6d.
Lot 1. Area 1a. 2r. 33p., allotment 1A.

PARISH OF BAIRNSDALE, COUNTY OF TANJIL.

At head of Corin's Creek.

Upset price £50 per lot. Charge for survey £5 5s.
Lot 2. Area 50 acres, allotment 273A.

North of Newlands Backwater.

Upset price £1 10s. per acre. Charge for survey £4 7s. 6d.
Lot 3. Area 24 acres (subject to survey), allotment 138c.

OMELO.—Sale (No. 10600) of Crown lands in fee-simple, by auction, will be held at the LAND OFFICE, on TUESDAY, 26th NOVEMBER, 1946, at TWO o'clock p.m. To be conducted by L. W. BIRCH, Land Officer, Bairnsdale.

PARISH OF WOLLONABY, COUNTY OF BOGONG.

Near Glen Valley Hall.

Upset price £5 per lot. Charge for survey £3 15s.
Lot 1. Area 1r. 5 4/10p., allotment 31A, section 2. Valuation of improvements. £400. (A. C. T. Wordsworth.)

PARISH OF NUMBIE-MUNJIE, COUNTY OF TAMBO.

In south-east of Parish.

Upset price £25 per lot. Charge for survey £5 15s.
Lot 2. Area 12a. 2r. 9p., allotment 27A. Subject to telephone easement 30 links wide and track condition.

CLOSER SETTLEMENT ACT.

A SALE of the under-mentioned land, in fee-simple, by auction, will be held at the LANDS DEPARTMENT OFFICE, SWAN HILL, on THURSDAY, 7th NOVEMBER, 1946, at half-past TEN o'clock a.m. To be conducted by H. J. HENKEL, Land Officer, Bendigo. Auctioneers: O'CONNOR, EGAN, & CO., Swan Hill.

PARISH OF BOGA, COUNTY OF TATCHERA.
Adjoining Mystic Park Township.

Lot 1. Area 620a. 2r. 36p., allotments 26 and 27, section 6, held under lease by P. J. F. Malone. Improvements include two small houses, sheds, mill, and fencing. Valuation of improvements, £56 in favour of P. J. F. Malone. Subject to channel easement.

PARISH OF BOGA, COUNTY OF TATCHERA.
Frontage to Little Murray River, near Lake Boga.

Lot 2. Area 206a. 1r. 15p., allotments 9A and 9B, section 1, formerly held by D. E. Turner. Improvements include house, outbuildings, and fencing. Subject to channel easement.

PARISHES OF BENJEROOP AND DARTAGOOK, COUNTY OF TATCHERA.

About 3½ miles north of Lake Charm Railway Station.

Lot 3. Area 1,387a. 0r. 8p., allotments 11 and 23, section 4, Parish of Benjeroop, and allotment 7, section A, Parish of Dartagook, formerly held by W. J. Davey. Improvements include house, sheds, and fencing. The purchaser will be required to accept responsibility for payment of rates amounting to £148 12s. 4d. owing to the Shire of Kerang.

CONDITION OF SALE FOR LOT 1.

The full amount of price offered to be paid at the sale, together with grant fee £2, and contribution to assurance fund (½d. per £1 of purchase price). Immediate possession. Crown grant will issue as soon as practicable.

TERMS AND CONDITIONS, LOTS 2 AND 3.

Deposit to be paid at sale:—20 per cent. of purchase price. Balance payable by fifteen equal half-yearly instalments, together with interest computed at the rate of 4½ per cent. per annum on the unpaid balance.

Purchaser may pay balance and fees at any time prior to due date, or may, with the consent of the Board of Land and Works, transfer his interest in the purchase (fee £1).

The registration of transfer may be subject to payment of such further sum as the Board may require in reduction of the outstanding balance.

Improvements to be maintained and insured with the Board of Land and Works.

Crown grants will be prepared and issued as soon as practical after payment of purchase money in full.

SPECIAL CONDITION ALL LOTS.

Before sale is approved, the purchaser will be required to comply with the provisions of the National Security (Land Transfer) Regulations as to nationality.

L. W. GALVIN,
Commissioner of Crown Lands and Survey.
Melbourne, 14th October, 1946.

PROPOSED REVOCATION OF TEMPORARY RESERVATIONS OF LANDS BY ORDERS IN COUNCIL.

IN pursuance of the provisions of the Land Act 1928, notice is hereby given that it is the intention of the Governor in Council to revoke the temporary reservations of lands by Orders in Council hereunder referred to, viz.:—

The following Notices were published 1° on the 2nd October, 1946, pursuant to Orders of the 24th September, 1946.

COORIEJONG (SCOTT'S CREEK).—The Order in Council of the 27th October, 1910, temporarily reserving 10 acres of land in the Township of Cooriejong, as a site for Supply of Gravel, is about to be revoked.—(C.428(4) (C.44147).

YEERUNG.—The Order in Council of the 17th February, 1891, temporarily reserving 2 acres of land in the Parish of Yeerung, as a site for a State School, is about to be revoked.—(Y.78(2) (2382/121).

EUROA.—The Order in Council of the 22nd March, 1887, temporarily reserving 12 acres 3 roods 6 perches of land in the Town of Euroa, as a site for Recreation purposes for the use of Friendly Societies, is about to be revoked.—(E.81(2) (Rs.5714).

EDENHOPE.—The Order in Council of the 6th March, 1905, temporarily reserving 5 acres of land in the Town of Edenhope, as a site for a Rubbish Depot, is about to be revoked.—(E.91(1) (Rs.4142).

The following Notice was published 1° on the 9th October, 1946, pursuant to Orders of the 1st October, 1946.

WANNAEUE.—The Order in Council of the 11th March, 1890, temporarily reserving 1 acre of land in the Parish of Wannaeue as a site for a State School is about to be revoked.—(W.32(2) (C.90294).

MURRAYVILLE.—The Order in Council of the 10th of October, 1922, temporarily reserving 1 rood and 35 perches of land in the Township of Murrayville as a site for Public purposes (Fire Brigade Station) is about to be revoked.—(M.575(2) (Rs.2629).

The following Notices were published 1° on the 16th October, 1946, pursuant to Orders of the 8th October, 1946.

RUTHERGLEN.—The Order in Council of the 30th September, 1889 (see Government Gazette, 4th October, 1889, page 3326), temporarily reserving 1 acre 0 roods 13 perches of land in the municipal district of Rutherglen as a site for Watering purposes, revoked as to part by Order of the 11th October, 1904, is about to be further revoked so far as regards the balance thereof, comprising 2 roods 22 perches.—(R.50(2) (Rs.5747).

PORT MELBOURNE.—The Order in Council of the 1st July, 1901, temporarily reserving 27 5/10 perches of land in the Town of Port Melbourne (now City of Port Melbourne), being allotment 50, section 16, as a site for a Public Hall is about to be revoked.—(M.334(14) (Rs.1949).

NGALLO.—The Order in Council of the 30th May, 1922, temporarily reserving 3 acres of land in the Parish of Ngallo as a site for a State School, is about to be revoked.—(N.133A(2) (C.72919).

L. W. GALVIN,
Commissioner of Crown Lands and Survey.

Land Act 1928.

LEASE SURRENDERED.

NOTICE is hereby given that the Governor in Council has accepted the surrender of the Lease mentioned in the Schedule hereunder for the reason specified.

District.	Corr. No.	Name.	Section of Land Act under which Leased.	Parish.	Allotment.	Arca.	Class.	Reason.
Mallee	949n/218	The President, Councillors, and Rate-payers of the Shire of Lowan	218	Propodollah	Part 9	A. R. P. 6 3 5 1/10	4th	Formal surrender. Road purposes.

Department of Lands and Survey,
Melbourne, 8th October, 1946.

L. W. GALVIN,
Commissioner of Crown Lands and Survey.

TENDERS.

TENDERS will be received at this office until **TEN A.M.** on the days and for the purposes under mentioned.

Particulars may be learnt at this office, and also at the offices named in each instance.

The Board of Land and Works will not necessarily accept the lowest or any tender.

22nd October, 1946.

Ballarat.—Supply and installation of refrigerator at Female Hospital Ward, Mental Hospital. Preliminary deposit, £3. Final deposit, 2 per cent.

Bulla.—Repairs and renovations, school and residence, State School No. 46. Particulars at Police Station, Sunbury; State School, Bulla. Preliminary deposit, £5. Final deposit, 2 per cent.

Clunes.—Supply and installation of hot water, heating, and mechanical equipment, New District Hospital. Preliminary deposit, £4. Final deposit, 2 per cent.

Dookie.—Erection of new brick building for domestic staff, Agricultural College. Particulars at Inspector of Works Offices, Benalla, Shepparton; Agricultural College, Dookie. Preliminary deposit, £15. Final deposit, 2 per cent.

Elmore.—Erection of new out-offices, septic tank, and sewerage installation, State School No. 1515. Particulars at Inspector of Works Offices, Bendigo, Shepparton; Police Station, Echuca; State School, Elmore. Preliminary deposit, £15. Final deposit, 2 per cent.

Geelong.—Repairs, painting, and new brick lavatory, Matthew Flinders Girls' School. Particulars at Inspector of Works Office, Geelong. Preliminary deposit, £10. Final deposit, 2 per cent.

Hamilton North.—Repairs and painting and erection of new out-office, State School No. 2035. Particulars at Inspector of Works Offices, Hamilton, Stawell; Police Station, Ararat; State School, Hamilton North. Deposit, £4.

Hawksburn.—Alterations, caretaker's quarters, State School No. 1467. Particulars at State School, Hawksburn. Preliminary deposit, £5. Final deposit, 2 per cent.

Kensington.—Repairs, &c., State School No. 2374. Preliminary deposit, £10. Final deposit, 2 per cent. (Amended specification.)

Mardan.—General repairs and painting, State School No. 2516. Particulars at Inspector of Works Office, Korumburra; Police Stations, Mirboo North, Traralgon; State School, Mardan. Preliminary deposit, £5. Final deposit, 2 per cent.

Melbourne.—Sound-proofing windows, Workers' Compensation Board, 412 Collins-street. Deposit, £2.

Melbourne.—Supply and installation of mechanical ventilation system, Workers' Compensation Board, 412 Collins-street. Preliminary deposit, £5. Final deposit, 2 per cent.

Mildura.—Conversion of guard house to caretaker's quarters, University. Particulars at Inspector of Works Offices, Ballarat, Mildura. Preliminary deposit, £15. Final deposit, 2 per cent.

Mont Park.—New brick scullery annexe, laundry block, Mental Hospital. Preliminary deposit, £5. Final deposit, 2 per cent.

Mornington.—Repairs and painting, State School No. 2033. Particulars at Police Station, Frankston; State School, Mornington. Preliminary deposit, £5. Final deposit, 2 per cent.

Muckatah.—Remodelling school building, State School No. 2496. Particulars at Inspector of Works Office, Shepparton; Police Stations, Cobram, Numurkah; State School, Muckatah. Preliminary deposit, £5. Final deposit, 2 per cent.

Nanneella West.—Repairs and painting, State School No. 3879. Particulars at Inspector of Works Offices, Bendigo, Shepparton; Police Stations, Echuca, Rochester; Preliminary deposit, £4. Final deposit, 2 per cent.

North Melbourne.—Repairs and renovations, State School No. 2566. Particulars at State School, North Melbourne. Preliminary deposit, £5. Final deposit, 2 per cent.

Ormond.—Repairs to roof, State School No. 3074. Deposit, £2.

Phillip Island.—Supply and delivery of light tower, Ports and Harbors Branch, Public Works Department. Final deposit, £4.

Rushworth.—Repairs and painting, School and Residence, State School No. 1057. Particulars at Inspector of Works Office, Shepparton; Police Stations, Murchison, Nagambie; State School, Rushworth. Preliminary deposit, £5. Final deposit, 2 per cent.

Simson.—Purchase and removal of State School No. 806. Particulars at Inspector of Works Office, Maryborough. Deposit, £2.

Swan Hill.—Repairs and painting, High School. Particulars at Inspector of Works Offices, Bendigo, Swan Hill; Police Stations, Echuca, Kerang. Preliminary deposit, £5. Final deposit, 2 per cent.

No. 201.—10729/46.—2

Tamleugh North.—Removal of State School No. 2297, Cosgrove South, and re-erection and reconditioning at State School No. 2453. Particulars at Inspector of Works Offices, Benalla, Shepparton; Police Station, Murchison; State School, Tamleugh North. Preliminary deposit, £4. Final deposit, 2 per cent.

Toolangi.—Removal of hut from Mangalore gravel pits camp and re-erection and remodelling, Experimental Barn. Particulars at Police Station, Healesville. Preliminary deposit, £10. Final deposit, 2 per cent.

Wangaratta.—Repairs to verandahs, High School. Particulars at Inspector of Works Offices, Benalla, Wangaratta; High School, Wangaratta. Deposit, £4.

Wensleydale.—Repairs, painting, and new skylights, State School No. 894. Particulars at Inspector of Works Office, Geelong; Police Station, Colac; State School, Wensleydale. Deposit, £3.

Won Wron.—Provision of skylights, concreting floor of entrance porch, school, and repairs and renovations, &c., residence, State School No. 1957. Particulars at Inspector of Works Office, Korumburra; Police Stations, Foster, Yarram; State School, Won Wron. Preliminary deposit, £10. Final deposit, 2 per cent.

Woodside.—Repairs and painting, State School No. 1176. Particulars at Inspector of Works Office, Korumburra; Police Stations, Foster, Yarram; State School, Woodside. Preliminary deposit, £4. Final deposit, 2 per cent.

Woolsthorpe.—New partition, repairs and renovations, State School No. 688. Particulars at Inspector of Works Offices, Hamilton, Warrnambool; Police Station, Port Fairy; State School, Woolsthorpe. Deposit, £4.

20th October, 1946.

Addington.—Additions, &c., and renovations to residence, State School No. 226. Particulars at Inspector of Works Office, Ballarat; State School Addington. Preliminary deposit, £5. Final deposit, 2 per cent.

Baddaginnie.—Repairs, painting, &c., State School No. 1731. Particulars at Inspector of Works Office, Benalla; Police Station, Euroa; State School, Baddaginnie. Deposit, £4.

Bayles.—General repairs, external and internal painting to school building, &c., State School No. 4374. Particulars at Police Stations, Dandenong, Loch; State School, Bayles. Deposit, £4.

Bright.—Repairs and painting, and repairs and alterations to out-offices, cookery, and sloyd buildings, State School No. 776. Particulars at Inspector of Works Office, Wangaratta; Police Station, Myrtleford; State School, Bright. Deposit, £4.

Brown Hill.—Internal repairs and renovations, State School No. 35. Particulars at Inspector of Works Office, Ballarat; State School Brown Hill. Deposit, £4.

Cavendish.—New partition, &c., and new windows, State School No. 116. Particulars at Inspector of Works Offices, Hamilton, Stawell; Police Station, Coleraine; State School, Cavendish. Deposit, £4.

Dunolly.—Electrical installation, New Nurses' Home, District Hospital. Particulars at Inspector of Works Offices, Ararat, Maryborough; Police Station, Dunolly. Preliminary deposit, £10. Final deposit, 2 per cent.

Glen Alvie.—Repairs and painting, State School No. 3203. Particulars at Inspector of Works Office, Korumburra; Police Station, Wonthaggi, State School, Glen Alvie. Deposit, £4.

Greenvale.—Erection of brick Concert Hall, Sanatorium. Preliminary deposit, £50. Final deposit, 2 per cent.

Heathcote.—Removal of State School No. 4288, Mt. Camel, and re-erection at State School No. 30. Particulars at Inspector of Works Offices, Bendigo, Maryborough; Police Station, Castlemaine; State School, Heathcote. Preliminary deposit, £5. Final deposit, 2 per cent.

Irymple.—New classroom and renovations, State School No. 3174. Particulars at Inspector of Works Office, Mildura; Police Stations, Merbein, Red Cliffs; State School, Irymple. Preliminary deposit, £15. Final deposit, 2 per cent.

Kongwak.—Repairs, painting, and fencing, State School No. 3323. Particulars at Inspector of Works Office, Korumburra; Police Station, Wonthaggi; State School, Kongwak. Preliminary deposit, £10. Final deposit, 2 per cent.

Koonwarra.—Repairs and painting, State School No. 3177. Particulars at Inspector of Works Office, Korumburra; Police Stations, Foster, Wonthaggi; State School, Koonwarra. Deposit, £3.

Longerenong.—Erection of new quarters in timber for farm hands, Agricultural College. Particulars at Inspector of Works Offices, Ballarat, Horsham; Agricultural College, Longerenong. Preliminary deposit, £20. Final deposit, 2 per cent.

Longwood.—Repairs and renovations, State School No. 2707. Particulars at Inspector of Works Office, Benalla; Police Stations, Euroa, Seymour; State School, Longwood. Preliminary deposit, £5. Final deposit, 2 per cent.

Melbourne.—Additional lavatory accommodation, Public Offices, 107 Russell-street. Preliminary deposit, £15. Final deposit, 2 per cent.

Melbourne.—External painting, Law Courts. Preliminary deposit, £20. Final deposit, 2 per cent.

Mologa North.—Removal of building from State School No. 2302, Jarklan, and re-erection at State School M.A. Particulars at Inspector of Works Office, Bendigo; Police Stations, Echuca, Inglewood, Wedderburn. Preliminary deposit, £5. Final deposit, 2 per cent.

Mont Park.—External renovations and painting, Curator's Residence, Mental Hospital. Preliminary deposit, £5. Final deposit, 2 per cent.

Nanneella South.—Repairs and painting, State School No. 1857. Particulars at Inspector of Works Office, Shepparton; Police Stations, Echuca, Elmore; State School, Nanneella South. Preliminary deposit, £3. Final deposit, 2 per cent.

Preston.—Electrical installation in additions to workshop block and classroom building, Technical School. Preliminary deposit, £15. Final deposit, 2 per cent.

Queenscliff.—Renovations and sliding partition, State School No. 1190. Particulars at Inspector of Works Office, Geelong; Police Station, Queenscliff. Preliminary deposit, £5. Final deposit, 2 per cent.

Research.—Repairs, external and internal painting, State School No. 2959. Particulars at Police Station, Eltham; State School, Research. Deposit, £4.

South Melbourne.—Supply of two (2) only four-ton motor trucks with about 12-ft. long steel trays, bodies with drop sides and back, Public Works Department, Storeyard, Wells-street. Final deposit, 2½ per cent. (Date of delivery to be stated.)

Surrey Hills.—Erection of new building, Police Station. Preliminary deposit, £25. Final deposit, 2 per cent. (Amended specification).

Thowgla.—Provision of new classroom, repairs and painting, State School No. 2661. Particulars at Inspector of Works Office, Wangaratta; Police Station, Tallangatta; State School, Thowgla. Preliminary deposit, £10. Final deposit, 2 per cent.

Tinamba.—Painting and minor repairs, school and Teachers' Residence, State School No. 1665. Particulars at Inspector of Works Office, Bairnsdale; Police Stations, Sale, Traralgon; State School, Tinamba. Preliminary deposit, £4. Final deposit, 2 per cent.

Wangaratta.—Removal of State School No. 2830, Yin Barum, and re-erection State School No. 643. Particulars at Inspector of Works Office, Benalla, Wangaratta; State School, Wangaratta. Preliminary deposit, £4. Final deposit, 2 per cent.

Warncoort.—Repairs, &c., and painting, Teacher's Residence, State School No. 2218. Particulars at Inspector of Works Office, Geelong; Police Station, Colac; State School, Warncoort. Preliminary deposit, £5. Final deposit, 2 per cent.

Werribee South.—Supply and delivery of stone spalls, Fore-shore Protection. Particulars at Inspector of Works Office, Geelong.

Wonwondah North.—Removal of State School No. 2896, Hardings, and re-erection, &c., at State School No. 3451. Particulars at Inspector of Works Office, Horsham; Police Station, Nhill. Deposit, £4.

Wooragee.—Repairs and painting, State School No. 653. Particulars at Inspector of Works Office, Wangaratta; Police Station, Yaekandandah; State School, Wooragee. Preliminary deposit, £5. Final deposit, 2 per cent.

5th November, 1946.

Bendigo.—Supply and delivery of electric and oxy-acetylene welding equipment, School of Mines. Preliminary deposit, £10. Final deposit, 2 per cent.

Tenders to be addressed to the Honorable the Commissioner of Public Works, and envelope containing tender marked "Tender for _____ due

P. J. KENNELLY,
Commissioner of Public Works.

Melbourne, 15th October, 1946.

TENDERS FOR THE SERVICE, 1946-47.

GENERAL STORES.

TENDERS will be received until Eleven o'clock a.m. on Friday, 15th November, 1946, from persons willing to supply the under-mentioned articles in such quantities as may be ordered by the Victorian Government during the twelve months commencing 1st January, 1947:—

Schedule No.	Preliminary Deposit.
52. Tools (General)	£ 3
69. Stationery (General)	3
75. Tires and Tubes, Pneumatic, for Motor Cars, Trucks, Buses, Motor Cycles and Side-cars, and Bicycles	3

The prices tendered must not include sales tax. Security.—Five per cent of total amount of tender accepted, but in no case will security of less than £3 be received.

Schedules as above, with full particulars, may be obtained from the Secretary to the Tender Board, by whom also the samples will be shown and any information afforded to persons tendering.

In all cases the total cost of each item must be extended in the columns provided.

Tenders must be accompanied by the preliminary deposit, as shown above, preferably by non-negotiable cheque payable to the order of the Secretary to the Tender Board. The amount and designation of the preliminary deposit enclosed must be clearly stated in the tender. Savings Bank deposit book, fixed deposit receipts, Commonwealth Treasury bonds, or reference to securities on existing contracts will in no case be received or entertained as preliminary deposits. Preliminary deposits will be returned within 30 days to unsuccessful tenderers on their application.

Security will be required either in Commonwealth Treasury Bonds, or approved bank guarantee, fixed deposit receipt, Savings Bank deposit book, or non-negotiable cheque in favour of the secretary to the Tender Board, as the tenderer may elect.

The security must be completed and the contract signed within five days of acceptance of the tender, failing which the contract may be again advertised, or another tender accepted.

The lowest or any tender will not necessarily be accepted. In the event of tenderers withdrawing or attempting to withdraw their tenders before notification of acceptance of same, or failing to take up their accepted tenders within the prescribed period after notification of acceptance, the preliminary deposit will be forfeited and, in addition, they may be disqualified from tendering or holding any future contracts for Government supplies for a period of twelve months, such disqualification to date from the notification of acceptance of tender. It is also stipulated that, if a tenderer be a member of a firm and such firm be interested in the contract, the tender shall be in the name of the firm and not in that of the individual and that, for a breach of this condition, the preliminary deposit will be forfeited and the tender declared informal.

Tenders enclosed in a separate envelope, and having the words "Tender for _____" (as the case may be) written thereon, must be deposited in the tender-box at the Tender Board Offices, Gishorne-street, Melbourne, or, if sent by post, postage must be prepaid and the tenders addressed to the Chairman of the Tender Board, Tender Board Offices, Gishorne-street, Melbourne, C.2, which office they must reach not later than by first post on the date of closing of tenders.

The conditions of contract are those published in the Victoria Government Gazette, No. 50, dated 20th March, 1946, pages 1030 to 1032.

JOHN CAIN,
Treasurer.

The Treasury,
Melbourne, 14th October, 1946.

TENDERS FOR THE SERVICE, 1947.

REQUISITES FOR EDUCATION DEPARTMENT.

TENDERS will be received until Eleven o'clock a.m. on Friday, 15th November, 1946, from persons willing to supply the under-mentioned articles, in such quantities as may be ordered by the Victorian Government, during the twelve months commencing on 1st January, 1947:—

Schedule No.	Preliminary Deposit.
1. Requisites (Junior School)	£3
2. Exercise Books and Requisites	3

The prices tendered must not include sales tax.

Security.—Five per cent of total amount of tender accepted, but in no case will security of less than £3 be received.

Schedules as above, with full particulars, may be obtained from the Secretary to the Tender Board, by whom also the samples will be shown and any information afforded to persons tendering.

Should the tenderer be in a position to supply a suitable substitute of Commonwealth production or manufacture in place of any sample exhibited that may be of imported origin, he may tender for such substitute, but must submit with his tender a sample of the article offered.

In all cases the country of origin of the articles tendered must be stated, and the total cost of each item extended in the columns provided.

Tenders must be accompanied by the preliminary deposit, as shown above, preferably by non-negotiable cheque payable to the order of the Secretary to the Tender Board. The amount and designation of the preliminary deposit enclosed must be clearly stated in the tender. Savings Bank deposit book, fixed deposit receipts, Commonwealth Treasury bonds, or reference to securities on existing contracts will in no case be received or entertained as preliminary deposits. Preliminary deposits will be returned within 30 days to unsuccessful tenderers on their application.

Security will be required either in Commonwealth Treasury Bonds, or approved bank guarantee, fixed deposit receipt, Savings Bank deposit book, or non-negotiable cheque in favour of the Secretary to the Tender Board, as the tenderer may elect.

The security must be completed and the contract signed within five days of acceptance of the tender, failing which the contract may be again advertised, or another tender accepted.

The lowest or any tender will not necessarily be accepted.

In the event of tenderers withdrawing or attempting to withdraw their tenders before notification of acceptance of same, or failing to take up their accepted tenders within the prescribed period after notification of acceptance, the preliminary deposit will be forfeited and, in addition, they may be disqualified from tendering or holding any future contracts for Government supplies for a period of one year, such disqualification to date from the notification of acceptance of tender. It is also stipulated that, if a tenderer be a member of a firm and such firm be interested in the contract, the tender shall be in the name of the firm and not in that of the individual and that, for a breach of this condition, the preliminary deposit will be forfeited and the tender declared informal.

Tenders enclosed in a separate envelope, and having the words "Tender for _____" (as the case may be) written thereon, must be deposited in the Tender-box at the Tender Board Offices, Gisborne-street, Melbourne, or, if sent by post, postage must be prepaid, and the tenders addressed to the Chairman of the Tender Board, Tender Board Offices, Gisborne-street, Melbourne, C.2, which office they must reach not later than by first post on the date of closing of tenders.

CONDITIONS OF CONTRACT.

1. Except where definite quantities are specified the Government will not be bound to order from the contractor all the articles enumerated in the schedule, but only those articles, and such quantities of those articles, as it may be found necessary to order. Should the Government, however, require a larger supply of any article than the estimated quantity stated in the schedules, the contractor will nevertheless be bound to supply the same at contract rates.

The Government reserves the right to purchase otherwise than from the contractor articles of any of the several kinds enumerated in the schedules the purchase of which is, in the opinion of the Tender Board, necessary in order to meet special circumstances or special requirements.

2. The supplies are to be the same as sample where so stated, and of the particular manufacture indicated in the schedule of tenders. In the case of different makers' goods, the contractor will be required to supply the kind ordered. *The supplies are to be the best quality of their several kinds or manufacture.* In the event of the tender having been accepted for goods manufactured within the Commonwealth or manufactured within any other part of the British Empire (as the case may be), all such goods supplied shall, if required by the Government, bear evidence that they are of the particular manufacture tendered for, and, in addition, the contractor may at any time during the currency of the contract be called on to furnish a statutory declaration as to the country of origin of the goods supplied.

3. Except where otherwise stated in the schedule, the value of all packages, cases, casks, &c., whether bulk be broken or not, must be included in the prices stated in the contractor's tender; all such packages, &c., to be considered the property of the Government, and no charges or expenses whatsoever beyond the price tendered and set out in the schedule will be allowed to the contractor for any articles or packages, cases, casks, &c. The net weight or quantity only will be paid for. Contractors must provide, without extra charge, whatever labour may be required in the packing of stores, and the stores shall be packed in such a manner as shall secure them from injury during transit, and until delivery such stores shall be at the risk of the contractor.

4. All orders for supplies will emanate from the Education Department. The goods shall be delivered as may be directed by the officer ordering the supply.

5. Supplies ordered for delivery in the Melbourne District are to be delivered free of all charges (whether cartage, freight, &c.), and, for the purposes of these contracts, Melbourne District will include a radius of 6 miles from the Elizabeth-street Post Office. For supplies outside that radius the goods must be delivered free on rails at Flinders-street or Spencer-street Railway Stations as required.

6. Arrangements as to time of delivery and inspection of goods will be made by the Secretary, Education Department, or such other officer whom he may appoint.

7. Orders must receive prompt execution; and in the event of the goods not being delivered within forty-eight hours after the contractor shall have received the order, or within such other time as the order may specify for delivery, it will be competent for the officer named in Clause 6, or the head of the department to whom the goods are to be supplied, on giving the contractor

twenty-four hours' notice, to purchase the supplies, or any like supplies that are suitable for the service, at the contractor's risk, and the extra expense incurred over and above the contract price (if any) will be deducted from the contractor's account or from the security money.

8. Delivery will not be deemed to have been made until the goods have been approved. In case of the rejection or return of any supplies, the contractor shall bear the whole cost of replacing the supplies rejected or returned, otherwise purchases will be effected at the contractor's risk and the extra expense deducted as in Clause 7.

9. The official order issued by the Education Department shall be forwarded by the contractor to the officer authorized to accept delivery, who shall acknowledge thereon the receipt of the goods accepted and return the order to the contractor, who will attach same to his claim for payment.

10. All orders, duly receipted, shall be returned to the Education Department at the end of each month, accompanied by an account in the prescribed form for the articles supplied during the month, and, on receipt of same, the contractor shall be entitled to payment, due time to be allowed for the examination and verification of the claim.

11. The acceptance of the supplies shall be subject to the approval of the officer authorized to take delivery of the stores, or such other officer as shall be named in the schedules. Delivery of the articles will not be deemed to have been made until they have been handed in good order and condition to the head teacher of the school or such other person as may be authorized to accept delivery, &c. The contractor may, however, claim a survey on any goods objected to; but in that case he must, within twenty-four hours after objection is made, give notice thereof, in writing, to the officer rejecting the goods. If, after the delivery of the supplies has been taken, any deficiency or defect is discovered therein, such deficient or defective stores may be returned to the contractor.

12. The members of Boards of survey will be appointed by the Treasurer of the State for the time being, and the decision of the Board is to be considered as final. If the Board shall decide that the article is not of proper quality it must be immediately replaced by the contractor, failing which it, or any like supply that is suitable for the service, will be procured elsewhere, and the survey fees and extra expense (if any) will be deducted as in Clause 7.

13. All goods forwarded under these contracts shall, where practicable, be forwarded by rail, and all consignments shall bear the number of the consignment notes under which they are forwarded, and also the name of the contractor by whom consigned, on a legibly-written business label.

14. When the contractor is required to make delivery of goods at a railway station for transmission by rail, he shall obtain a receipt for the goods in duplicate on the Stores and Transport consignment note, at the same time handing in a triplicate and quadruplicate of the form as an authority for the Railways to act as agent for, and charge the freight to, the Stores and Transport Office or such other Department as shall be named therein. He shall as soon as possible, and not later than twenty-four hours thereafter, deliver the original at the Tender Board Offices, the duplicate to be forwarded to consignee in accordance with Clause 15, and the quintuplicate to be retained by himself. Should the goods thus forwarded be rejected, the contractor must bear the cost of replacing such goods, for which service the departmental consignment note is not to be used. Any infringement of this condition will subject the contractor to such mulct as the Tender Board may recommend under Clause 17 of these conditions. Such mulct may be deducted as in clause 7.

15. *Immediately after the consignment of the goods, the officer to whom they are forwarded shall be notified by the contractor, on the duplicate consignment note provided for the purpose, that the goods have been sent. On receipt of this document, the officer to whom it has been forwarded shall acknowledge thereon the receipt of the goods without delay to the Stores and Transport Office. In the event of loss through failure on the part of the contractor to comply with this condition he will be held responsible, and the amount of the loss incurred for same will be deducted as in Clause 7.*

16. Should the order on the contractor specially provide that goods of a fragile character, or such as are liable to suffer loss by leakage, shall be consigned at the risk of the Railways Commissioners under special freight conditions, the contractor shall in such instance provide, in writing, on the consignment note an intimation to that effect, failing which, in the event of loss, he shall bear the whole cost of replacing the goods, the amount being deducted from the contractor's account or the security money.

17. A refusal to execute orders, irregularity in the quantity or quality of the supplies, delay in delivering or replacing them when required, or non-compliance with the terms of Clauses 14 and 15 of these conditions respecting the forwarding of consignment notes, &c., will subject the contractor, upon report from the Tender Board, to such mulct not exceeding Fifty pounds as the said Treasurer may direct and the amount may be deducted as in Clause 7. It will also be in the power of the said Treasurer upon such refusal, irregularity, or delay, to

terminate the contract forthwith, and declare forfeit the whole or any portion of the security money; and, in addition, the contractor will be disqualified from tendering or holding any future contract or contracts for a period of one year from the date of such disqualification.

18. Contractors are not at liberty to transfer their contracts under cover of power of attorney, coupled with an interest or otherwise; and no such transfer will be recognized by the Government. If it is found during the currency of the contract that the contractor has not conformed to the condition of advertisement—which stipulates that if a tenderer be a member of a firm, and such firm be interested in the contract, the tender shall be in the name of the firm, and not in that of the individual—then the said Treasurer may, on the recommendation of the Tender Board, determine the contract, and forfeit the security money.

19. The contracts entered into under these conditions are not to be considered as being broken, infringed, or vitiated by the importation of stores for the Government service, or by any contracts or purchases made by the Agent-General for Victoria, or by any contracts or agreements made for supplies to Technical Schools, or by any article being made at any Government establishment and supplied for the use of the Education Department, or by the consumption of the surplus stock of any Government establishment.

20. Notwithstanding anything contained to the contrary in section 152 of the *Customs Act* 1901-36, it is hereby expressly provided that upon any alteration of the duty collected affecting the goods included in this contract, the contract price shall not be altered, and the contract may be terminated at the option of either party by two months' notice in writing from the first day of the calendar month next ensuing, and within the period for which the contract is made. The contract for the unaffected items shall remain in full force and effect. Any notice to be served under this condition shall be deemed to have been duly served if sent to the contractor in a registered letter to his last-known place of business or abode.

21. Under no circumstances, other than those mentioned in Clause 20, will a contractor be permitted to abandon his contract. In the event of the contractor failing to carry on the contract, the contract security money will in that case be absolutely forfeited; and, in addition, the contractor will be held liable for any loss which the Government may sustain in consequence of such failure.

22. Should the Minister of Public Instruction for the time being decide to discontinue the use of any book, map, or any other article in the schedule, or to direct that any book, map, or any other article other than those enumerated therein be taken into use, he shall at any time give six months' notice of such intention or decision to the contractor, and after the expiration of the period of such notice the Education Department shall not be bound to take any further supply of such book, map, or any other article, nor shall the contractor be bound to supply the same, and all books or maps not in the schedule, but which it may be decided to introduce, shall be supplied by the contractor after expiration of such notice at a price to be agreed on between the Minister of Public Instruction for the time being and the contractor.

JOHN CAIN,
Treasurer.

The Treasury,
Melbourne, 14th October, 1946.

PRIVATE ADVERTISEMENTS.

NOTICE OF INTENTION TO APPLY FOR A LICENCE TO DIVERT WATER AND CUT RACES FROM THE MURRAY RIVER, AT WEMEN.

I HEREBY give notice that I intend to apply for a licence empowering me to divert water for a term of fifteen years to the extent of 40 acre feet per annum at a maximum rate of 4 acre feet per day of 24 hours for irrigation purposes, and to occupy certain Crown lands for works of storage and diversion, and to cut a race thereon.

Any objection to such application must be forwarded, in writing, to the State Rivers and Water Supply Commission, Melbourne, within 30 days of the date hereof.

EDWIN JOFFRE TAYLOR.
Bannerton, 9th October, 1946. 8045

Motor Car Act 1928.

COUNTRY ROADS BOARD.

NOTICE is hereby given that the Board has decided to lift the prohibition in respect of the use on the Taggerty-Thornton road, in the Shire of Alexandra, of motor cars, the weight of which and of the load (if any) carried thereon exceeds 6 tons.

By order,
R. JANSEN, Secretary.
Melbourne, 4th September, 1946. 18042

CITY OF BOX HILL.

BY-LAW No. 81.

A By-law of the City of Box Hill, made under the Local Government Acts, and numbered 81, for:—(a) Regulating, restricting, restraining, or prohibiting the erection, construction, use, occupation, conversion, and alteration of buildings or erections; (b) providing with respect to buildings thereafter erected for the minimum area to be covered by any dwelling house; (c) altering By-law No. 78 of the City of Box Hill, and for other purposes.

IN pursuance of the powers conferred by the Local Government Acts and of any and every other power it thereunto enabling, the Mayor, Councillors, and Citizens of the City of Box Hill hereby order as follows:—

1. This By-law shall apply to and have operation throughout the whole of the municipal district of Box Hill.

2. In this By-law "dwelling house" means a building used or constructed or adapted to be used wholly or principally for human habitation.

3. By-law No. 78 of the City of Box Hill, as amended by By-law No. 79 of the City of Box Hill, shall be and is hereby altered by adding the following new clauses:—

8. Every building that is to be used or that is intended or adapted to be used as a dwelling house only, and erected, built, or constructed in any part of the municipality, shall cover on the ground floor an area of not less than 1,000 square feet.

9. In the ascertainment of the area covered the area of verandahs forming part of the main building, but not exceeding 100 square feet in area, and the thickness of the external walls, will be allowed as part of the area covered, but no detached outbuildings or verandah area in excess of 100 square feet shall be so included.

10. Notwithstanding anything contained in clause 8, it shall be in the discretion of the Council, on written application being made, to permit of the building, erection, or construction of any dwelling house of a less area than is hereinbefore prescribed if, in its opinion, there is special reason for so doing.

Resolution for passing this By-law agreed to by the Council of the City of Box Hill, on the 3rd day of June, 1946, and confirmed on the 1st day of July, 1946.

The corporate seal of the Mayor, Councillors, and Citizens of the City of Box Hill was hereunto affixed, in the presence of—

E. J. ELLINGWORTH, Mayor.
W. J. RICHARDS, Councillor.
A. BRUCE CURREY, Town Clerk.

Approved by the Governor in Council on the 24th day of September, 1946.—C. W. KINSMAN, Clerk of the Executive Council. 8043

Local Government Act 1928.

CITY OF HEIDELBERG.

NOTICE TO ALL WHOM IT MAY CONCERN.

WHEREAS the Council of the Municipality of the City of Heidelberg, in the State of Victoria, deems it expedient to execute a certain work or undertaking for the purpose of extending Macleod Recreation Reserve, Macleod, for the purposes whereof it is, in the opinion of the said Council, necessary and desirable that the said Council exercise its power of taking land compulsorily within the municipal district of the said Council, as provided by the *Local Government Act* 1928, as amended by any Acts, and the said Council has caused its surveyor to prepare such specifications, maps, plans, sections, and elevations of the said work or undertaking as are necessary, and in which are expressed the nature and extent of such work or undertaking, and the exact site and admeasurements thereof, and on and through what lands the said work or undertaking is proposed to be placed, and the names of the owners or reputed owners, lessees, or reputed lessees, and the occupiers of such lands so proposed to be taken so far as known, and the said specifications, maps, plans, sections, and elevations so prepared have been approved by the said Council.

In pursuance of the provisions of the *Local Government Act* 1928, as amended by any Acts, the said Council doth hereby publish and give notice that the description shortly of the purport of the said work or undertaking, and of the said specifications, maps, plans, section, and elevations is as follows:—

The extension of Macleod Recreation Reserve situate within the Heidelberg Ward of the City of Heidelberg.

And the land through which the same is proposed to be extended and which it is necessary and desirable to take compulsorily is—All that piece of land comprised in allotments 491, 492, 493, and 497 on plan of subdivision No. 8663, lodged

in the Office of Titles, and being part of Crown portion 9, Parish of Keelbundora, County of Bourke, in the following names:—

Lot 491, William Hastings; Lot 492, William P. Smith and Thomas Quinn; Lot 493, Ethel May Main; Lot 497, Hazel Emma Jones.

And the said Council doth hereby give further notice that the said specifications, maps, plans, sections, and elevations are deposited at the office of the said Council, Town Hall, Upper Heidelberg-road, Ivanhoe, and are there open for inspection and perusal on all the days and between the hours the municipal office is appointed to be open, for the space of 40 clear days from the date of the publication of this notice in the *Government Gazette*. And the said Council doth hereby call upon all persons interested in or affected by the said proposed work or undertaking to set forth, in writing, addressed to the said Council or the Town Clerk thereof, at the Town Hall, Upper Heidelberg-road, Ivanhoe, within 40 clear days from the date of the publication of this notice as aforesaid all objections which they may have to the said work or undertaking.

Dated this 11th day of October, 1946.

The common seal of the Mayor, Councillors, and Citizens of the City of Heidelberg was hereto affixed by me—

F. PHILLIPS, Town Clerk.

in the presence of—

(SEAL) A. NUTTALL, Councillor.

8056

M. S. KINGSFORD, Councillor.

Health Act 1928.

SHIRE OF BERWICK.

BY-LAW No. 23.

A By-law of the Shire of Berwick, made under the *Health Act 1928*, the *Health Act 1935*, and the *Health Act 1941*, and numbered 23, for prescribing the fees to be charged for the registration of premises and for the renewal of such registration or for any transfer of registration thereof, pursuant to the said Acts.

IN pursuance of the powers conferred by the Health Acts and of every other power enabling them, the President, Councillors, and Ratepayers of the Shire of Berwick, with the approval of the Governor in Council, do hereby order as follows:—

1. By-law No. 8, as amended by By-law No. 22 of the Shire of Berwick, shall be and is hereby repealed.
2. The fees to be charged, received, and taken by the Shire of Berwick for the registration of premises and for annual renewals thereof, and for any transfers of such registration respectively, pursuant to the provisions of the *Health Act 1928*, as amended and added to by other acts, shall be as set out in the Schedule hereto.
3. Such fees shall be paid to the Shire Secretary by any person making application for such registration, renewal, or transfer respectively.

In witness whereof the common seal of the President, Councillors, and Ratepayers of the Shire of Berwick was hereto affixed this 19th day of July, 1946, in the presence of—

(SEAL) T. C. WHITESIDE, President.
A. G. ROBINSON, Councillor.
JAMES J. AHERN, Shire Secretary.

SCHEDULE REFERRED TO IN THIS BY-LAW.

(a) For every registration and for every annual renewal of registration of premises—

Nature of Premises; Fees Payable.

	£	s.	d.
Offensive trades premises (other than those referred to below)	3	0	0
Offensive trades premises (being fat extracting or melting or rendering works which are conducted at premises occupied principally as a butcher's shop and at which fat is extracted, melted, or rendered only from materials derived from such shop)	0	5	0
Offensive trade premises being piggeries	0	5	0
Offensive trade premises being poultry killing or cleaning or dressing premises	0	5	0
Cattle sale yards	0	10	0
Boarding houses	0	10	0
Common lodging houses	0	10	0
Eating houses	0	10	0
Premises (whether a licensed victualler's premises or not) on which are manufactured or prepared for sale ice cream, ices, ginger beer, hop beer, or any similar beer, lemonade, cordials, soda water, lithia water, or other mineral water, or any artificially aerated water	0	5	0

Nature of Premises; Fees Payable.

	£	s.	d.
Premises at or in any part of which eggs for sale are received or stored for the purpose of being chilled	1	0	0
(b) For any transfer of registration	0	2	6

The aforesaid By-law was passed by special order of the Council at a meeting held on the 21st day of June, 1946, and was confirmed at a meeting of the Council held on the 19th day of July, 1946.

JAMES J. AHERN, Shire Secretary.

Submitted to the Commission of Public Health on the 13th day of August, 1946.—J. WHITLOCK, Secretary.

Approved by the Governor in Council, on 10th September, 1946.—C. W. KINSMAN, Clerk of the Executive Council. 8063

SHIRE OF FERN TREE GULLY.

NOTICE is hereby given that at a meeting of the Council, held on 14th October, 1946, First Constable Edward Paul Opperman, of Boronia, was appointed Prosecuting Officer for the Shire of Fern Tree Gully.

8055

C. C. DANCE, Shire Secretary.

SHIRE OF GORDON.

NOTICE is hereby given that the following appointment has been made by the Council, viz.:—

First Constable Jonathan W. Ogdan, as Prosecuting Officer for the Township of Boort, *vice* First Constable Walter Graham Gale, resigned.

8058

ROSS M. GRAHAM, Shire Secretary.

SHIRE OF OMEO.

NOTICE OF INTENTION TO BORROW THE SUM OF THREE THOUSAND TWO HUNDRED AND FIFTY POUNDS FOR PERMANENT WORKS AND UNDERTAKINGS IN THE SHIRE OF OMEO.

TAKE notice that the Council of the Shire of Omeo proposes to borrow on the credit of the President, Councillors, and Ratepayers of the said Shire the sum of Three thousand two hundred and fifty pounds (£3,250), such sum to be raised by the issue of debentures in accordance with the provisions of the Local Government Acts.

The maximum rate of interest that may be paid is £3 7s. 6d. per centum per annum.

Such moneys shall be repayable by forty equal half-yearly instalments, each including principal and interest, by providing out of the Municipal Fund such amounts on the 1st day of January and the 1st day of July in each respective year during the currency of the loan.

Such moneys shall be repayable, at Melbourne, at the National Bank of Australasia Limited or at the Council's bankers for the time being in Melbourne.

The purpose for which the loan is to be applied is—

For the purchase of land and erection of dwellings for officers of the municipality £3,250

The plans, specifications, and estimate of the cost of the works referred to above, and a statement showing the proposed expenditure of money to be borrowed are open for inspection at the Shire Office, Omeo.

Dated this 27th day of September, One thousand nine hundred and forty-six.

8098

J. W. BALES, Shire Secretary.

SHIRE OF OMEO.

NOTICE OF INTENTION TO BORROW THE SUM OF ONE THOUSAND SIX HUNDRED POUNDS (£1,600) FOR PERMANENT WORKS AND UNDERTAKINGS IN THE SHIRE OF OMEO.

TAKE notice that the Council of the Shire of Omeo proposes to borrow on the credit of the President, Councillors, and Ratepayers of the said Shire the sum of One thousand six hundred pounds (£1,600), such sum to be raised by the issue of debentures in accordance with the provisions of the Local Government Acts.

The maximum rate of interest that may be paid is £3 7s. 6d. per centum per annum.

Such moneys shall be repayable by eight equal half-yearly instalments, each including principal and interest, by providing out of the Municipal Fund such amounts on the 1st day of January and the 1st day of July in each respective year during the currency of the loan.

Such moneys shall be repayable, at Melbourne, at the National Bank of Australasia Limited or at the Council's bankers for the time being in Melbourne.

The purpose for which the loan is to be applied is—

For the purchase of a motor truck £1,600

The plans, specifications, and estimate of the cost of the works referred to above, and a statement showing the proposed expenditure of money to be borrowed are open for inspection at the Shire Office, Omeo.

Dated this 27th day of September, One thousand nine hundred and forty-six.

8099

J. W. BALES, Shire Secretary.

Water Acts.
SHIRE OF WALPEUP.
PROPOSED WATERWORKS TRUST.

NOTICE is hereby given that the Council of the Shire of Walpeup has made application to the Honorable the Minister of Water Supply for the following:—

1. The constitution of a waterworks Trust and the proclamation of a waterworks district at Murrayville for the taking over from the Walpeup Shire Council of the existing water supply works at Murrayville.

2. For the construction, maintenance, and continuance of the town water supply works within that district, under the provisions of the Water Acts.

A general plan and description of the proposed works have been submitted with the application, and copies of same may be inspected at the Shire Office, Ouyen, and at the Post Office, Murrayville.

K. H. LOVETT, Shire Secretary.

1st October, 1946.

7980

NOTICE is hereby given that the partnership heretofore subsisting between Petros Nicholas Lolatgis and Tony Savaris, carrying on business at Horsham as cafe proprietors, poulterers, and fishmongers, under the business name of "Lolas Cafe," has been dissolved as from the 5th day of October, 1946. All debts due to and owing by the said late partnership will be received and paid by the said Petros Nicholas Lolatgis, who will continue to carry on the business at the same place under the same business name.

Dated this 7th day of October, 1946.

PETROS LOLATGIS.
TONY SAVARIS.

J. Weldon Power and Bennett, solicitors, Horsham. 8122

NOTICE is hereby given that the partnership heretofore subsisting between Mavis Irene Bolton and Jeffrey Pohl, under the style or firm names of "Raeton Leathersgoods" and "Universal Distributors," at 377 Post Office-place and 407 Swanston-street, Melbourne, has been dissolved as from the 9th October, 1946. All debts owing by and all moneys payable to the said late firm will be paid and received by the said Mavis Irene Bolton at 407 Swanston-street, Melbourne.

Dated the 11th day of October, 1946.

NORRIS & NORRIS, of 422 Collins-street, Melbourne, solicitors. 8103

NOTICE is hereby given that the partnership hitherto existing between Thomas Henderson, Robert George Rowland Ball, and Wallace John Ball, carrying on the practice of solicitors under the firm name of Henderson and Ball, at 430 Little Collins-street, Melbourne, was dissolved by mutual consent on the 1st day of October, 1946, on which date the said Thomas Henderson retired from the firm. The said Robert George Rowland Ball and Wallace John Ball will continue to practise as solicitors, under the same firm name at the above address, and will receive all moneys and pay all debts and liabilities of the partnership.

Dated the 10th day of October, 1946.

HENDERSON & BALL, solicitors, 430 Little Collins-street, Melbourne. 8067

NOTICE is hereby given that the partnership heretofore subsisting between Audree Loma Doyle, Lawrence Donald Young, and Felix Walter Young, carrying on the business of manufacturers under the style or firm of Mahleo Plastics, has been dissolved by mutual consent as from the 9th day of October, 1946, the said Audree Loma Doyle having retired from the firm, and all debts due and owing by the firm will be received and paid respectively by the said Lawrence Donald Young and Felix Walter Young, who will continue to carry on the business under the style or firm of Mahleo Plastics, at the corner of Malvern and Tooronga-roads, Glen Iris.

Dated the 9th day of October, 1946.

L. D. YOUNG.
F. W. YOUNG.

Witness to the signatures of Lawrence Donald Young and Felix Walter Young.—R. J. DAVIS.

A. L. DOYLE.

Witness to the signature of Audree Loma Doyle.—A. J. KENNEDY.

Russell, Kennedy, and Cook, solicitors, of 401 Collins-street, Melbourne. 8068

NOTICE is hereby given that the partnership formerly subsisting between Manuel Nicholas, of 146 Simpson-street, East Melbourne, and Dionisios Notarakis, of 168 Queen-street, Melbourne, carrying on business as cafe proprietors, at 168 Queen-street, Melbourne, under the style of "Sounion Cafe," has been dissolved as from the 23rd day of September, 1946, by mutual consent. All debts owing by the late partnership will be paid and satisfied by the said Dionisios Notarakis, who will in future carry on the said business on his own behalf.

Dated the 23rd day of September, 1946.

DIONISIOS NOTARAKIS.
MANUEL NICHOLAS.

Cole and O'Heave, solicitors, 465 Collins-street, Melbourne. 8086

Companies Act 1938.

CORPS OF COMMISSIONAIRES (VICTORIA).

NOTICE OF INTENTION TO APPLY TO ATTORNEY-GENERAL FOR LICENCE, PURSUANT TO SECTION 18 (1).

I, THOMAS EDGAR WEAVERS, of 221 William-street, Melbourne, in the State of Victoria, on behalf of Corps of Commissionaires, about to be formed for the purposes of providing for the welfare of persons who have had service in His Majesty's Forces and of assisting such persons to re-enter civilian life and particularly for obtaining employment for them, hereby give notice of intention to apply to the Attorney-General for a licence, directing that the said Corps be registered as a company with limited liability, without the addition of the word "Limited" to its name.

Dated the 8th day of October, 1946.

T. E. WEAVERS.

Whiting and Byrne, of 101 William-street, Melbourne, solicitors for the said Thomas Edgar Weavers. 8125

THE MANUFACTURERS' BOTTLE COMPANY OF
VICTORIA PTY. LTD.

Registered Office: 360 Collins-street, Melbourne.

NOTICE TO BOTTLE DEALERS AND OTHERS.

ALL bottles with the trade mark and brand viz., M.B. over C.V. in a spade moulded thereon are the sole property of The Manufacturers' Bottle Company of Victoria Proprietary Limited, from which company they have been hired, and such bottles have been delivered by such company solely for the purpose of enabling the contents to be used only once for retailing, consuming, or using ale or stout or other fermented or unfermented liquors contained in such bottles. The bottles so branded are not sold, and when the contents are once used the bottles must forthwith on demand be returned to such company or its duly authorized agents. The bottles may not be destroyed or damaged, or otherwise parted with, or in any way disposed of, and may not be used for any but the foregoing purpose. The allowance received by agents, collectors, &c., is simply for the collection and safe custody of the bottles.

Dated the 1st day of October, 1946.

A. J. SHEPHERD, Secretary.

Pavey, Wilson, and Cohen, solicitors, 360 Collins-street, Melbourne. 8115

The Companies Act 1938.—In the matter of KEW AND DONCASTER TIMBER COMPANY PROPRIETARY LIMITED (in Voluntary Liquidation), High-street, East Kew.

NOTICE is hereby given that a First and Final Dividend is intended to be declared in the above matter. Creditors who have not proved their debts by the 31st October, 1946, will be excluded from such dividend.

Dated this 12th day of October, 1946.

A. J. WEEKS, Liquidator.

Messrs. Wilson, Danby, and Giddy, chartered accountants (Aust.), 51 Queen-street, Melbourne, C.I. 8108

Companies Act 1938.

THE MUSICAL SOCIETY OF VICTORIA.

NOTICE OF INTENTION TO APPLY TO ATTORNEY-GENERAL FOR LICENCE, PURSUANT TO SECTION 18 (1).

I, HENRIETTA GREENWOOD, of 13 Compton-street, Canterbury, in the State of Victoria, for and on behalf of The Musical Society of Victoria, being a society about to be formed as a company limited by guarantee for the purpose of promoting music and elocutionary art, hereby give notice of intention to apply to the Attorney-General for licence directing that the said society be registered as a company with limited liability without the addition of the word "Limited" to its name.

Dated this 5th day of October, 1946.

HENRIETTA GREENWOOD, Secretary.

Rylah and Rylah, of 349 Collins-street, Melbourne, solicitors for the applicant. 8106

The Companies Acts.

PHILLIPS CO-OPERATIVE SOCIETY LTD. (IN LIQUIDATION), MINYIP.

AN Eighth and Final Dividend is about to be declared. All creditors whose proofs are not in the hands of the liquidator by 2nd November, 1946, will be excluded from participation in this dividend.

M. R. M. SMITH, Liquidator.
M. R. M. Smith, Peacock, and Henshaw, chartered accountants (Aust.), 59 Queen-street, Melbourne, C.I. 8107

TAKE notice that The Trustees, Executors, and Agency Company Limited, as the executor of the will of David Edward Lewis, has disposed of the business of "Love & Lewis," at 194-6 Bourke-street, Melbourne, as and from the 19th day of August, 1946, to Louisa Jones, Lorna Hannan, Robert Nathan, Lionel Newton, Lauri Joseph Newton, and Donald Lamond, trading as "Maples," of 258-264 Clarendon-street, South Melbourne.

DAVID THOMAS, of 140 Queen-street, Melbourne, solicitors for the executor. 8069

CREDITORS, next of kin, and others having claims in respect of the estate of Robert Hamilton, late of 23 Larnook-street, Armadale, in the State of Victoria, retired clergyman, deceased (who died on the 18th day of July, 1946), are to send particulars of their claims to National Trustees, Executors, and Agency Company of Australasia Limited, whose registered office is at 95 Queen-street, Melbourne, in the State of Victoria, by the 18th day of December, 1946, after which it will distribute the assets, having regard only to the claims of which it then has notice.

V. S. HOLLOW, M.A., LL.B., solicitor, 140 Queen-street, Melbourne. 8064

NOTICE TO CLAIMANTS.

CREDITORS, next of kin, and others having claims in respect of the estate of Charles John Godfree, formerly of Yapeen, in the State of Victoria, but late of 764 Canterbury-road, Surrey Hills, in the said State, retired farmer, deceased (who died on the 14th day of June, 1946), are to send particulars of their claims to The Equity Trustees, Executors, and Agency Company Limited, at its address, 472 Bourke-street, Melbourne, by the 20th day of December, 1946, after which date the company will distribute the assets, having regard only to the claims of which it then has notice.

Dated the 10th day of October, 1946.

BUGDALE, SIMMONS, & STEVENS, solicitors, "Peacock House," 486 Bourke-street, Melbourne. 8066

CREDITORS, next of kin, and others having claims against the estate of the under-mentioned person are hereby required to send particulars thereof to The Trustees, Executors, and Agency Company Limited, of 401 Collins-street, Melbourne, on or before the 28th day of December, 1946, otherwise they may be excluded when any assets are distributed:—

Name.—William Henry Hales.

Address.—Formerly of Maffra, but late of 151 Donald-street, East Brunswick.

Occupation.—Retired farmer.

Date of death.—1st January, 1946.

Dated this 14th day of October, 1946.

PEARCE & WEBSTER, solicitors, 191 Queen-street, Melbourne. 8070

CREDITORS, next of kin, and others having claims in respect of the estate of David John Gordon, late of 17 Victoria-avenue, Unley Park, South Australia, knight and company director, deceased (who died on the 12th February, 1946), are to send particulars of their claims to Elder's Trustee and Executor Company Limited, whose registered office is situate at Currie-street, Adelaide, South Australia, and Douglas Peel Gordon, of Mount Crawford Station, Williamstown, South Australia, pastoralist, by the 18th December, 1946, after which date the executors will distribute the estate, having regard only to the claims of which it and he then have notice.

MOULE, HAMILTON, & DERHAM, solicitors, 304 Collins-street, Melbourne. 8072

CREDITORS, next of kin, and others having claims in respect of the estate of Joseph Parker, late of Loch-avenue, Ballarat, gentleman, deceased (who died on the 20th day of July, 1946), are to send the particulars of their claims to The Ballarat Trustees, Executors, and Agency Company Limited, of 101 Lydiard-street north, Ballarat, by the 24th day of December, 1946, after which date it will distribute the assets, having regard only to the claims of which it then has notice.

J. CURWEN-WALKER, solicitor, Ballarat. 8060

CREDITORS, next of kin, and others having claims in respect of the estate of James Stewart, formerly of Beaconsfield-parade, St. Kilda, in the State of Victoria, but late of Goulburn, in the State of New South Wales, retired stock buyer, deceased (who died on the 10th day of October, 1945, and probate of whose will (as contained in a sealed certified copy, probate thereof issued out of the Supreme Court of New South Wales) was granted by the Supreme Court of Victoria on the 11th day of October, 1946, to The Trustees, Executors, and Agency Company Limited, of 401 Collins-street, Melbourne, the executor named in the said will), are to send particulars of their claims to the said The Trustees, Executors, and Agency Company Limited, at its address above mentioned, by the 17th day of December, 1946, after which date it will distribute the assets, having regard only to the claims of which it then has notice.

Dated this 15th day of October, 1946.

BLAKE & RIGGALL, 120 William-street, Melbourne, solicitors for the said executor. 8088

ALL persons having claims against the estate of William Jones, late of 79 Osborne-street, Williamstown, gentleman, deceased (who died on the 10th August, 1946, and letters of administration, with the will annexed, of whose estate were granted on the 16th day of September, 1946, by the Supreme Court of Victoria to The Trustees, Executors, and Agency Company Limited, of 401 Collins-street, Melbourne), are hereby required to send particulars, in writing, of such claims to the said company, at its said address, on or before the 18th December, 1946, after which date the said company will proceed to convey or distribute the said estate to or among the persons entitled thereto, having regard only to the claims of which it shall then have had notice, and will not be liable for the assets so distributed to any person of whose claim it shall not then have had notice.

FOWLER & HICK, 31 Queen-street, Melbourne, solicitors. 8121

NOTICE TO CREDITORS AND OTHERS.

PURSUANT to the *Trustee Act 1928*, notice is hereby given that all persons having claims against the estate of Margaret Flint, late of 10 The Grove, Coburg, in the State of Victoria, widow, deceased (who died on the 5th day of June, 1946, and probate of whose will was granted by the Supreme Court of the State of Victoria, in its probate jurisdiction, on the 4th day of October, 1946, to Theodore Sylvester Flint, of Merthyr-road, New Farm, Brisbane, in the State of Queensland, civil servant, and Arthur Loftus Christopher Flint, of 90 Queen-street, Melbourne, in the State of Victoria, solicitor, sons of the said deceased, the executors named in and appointed by the said will), are hereby required to send particulars, in writing, of such claims to the said Theodore Sylvester Flint and Arthur Loftus Christopher Flint, at the office of their under-mentioned solicitors, on or before the 20th day of December, 1946. And notice is hereby also given that after the last-mentioned date the said Theodore Sylvester Flint and Arthur Loftus Christopher Flint will proceed to distribute the assets of the said Margaret Flint, deceased, amongst the persons entitled thereto, having regard only to the claims of which they shall have had notice, and the said Theodore Sylvester Flint and Arthur Loftus Christopher Flint will not be liable for the assets, or any part thereof, so distributed to any person of whose claim they shall not then have had notice.

Dated the 9th day of October, 1946.

A. L. C. FLINT & MARRIE, of 90 Queen-street, Melbourne, solicitors for the applicants. 8123

PURSUANT to the *Trustee Act 1928*, notice is hereby given that all persons having claims against the estate of John Peter Campbell (sometimes called Peter John Campbell), late of 29 Grandview-grove, Armadale, in the State of Victoria, gentleman, deceased (who died on the 18th day of May, 1946, and probate of whose will was granted by the Supreme Court of Victoria, in its probate jurisdiction, on the 12th day of August, 1946, to William Blakiston Hodgson, of 360 Collins-street, Melbourne, in the said State, solicitor), are hereby required to send particulars, in writing, of such claims to the said William Blakiston Hodgson, in care of the under-mentioned solicitors, on or before the 21st day of December, 1946, after which date the above-named executor will proceed to distribute the assets of the said deceased which shall have come to his hands amongst the persons entitled thereto, having regard only to the claims of which he shall then have had notice. And notice is hereby further given that the said executor will not be liable for the assets so distributed, or any part thereof, to any person of whose claim he shall not have had notice as aforesaid.

Dated this 11th day of October, 1946.

HODGSON & FINLAYSON, 300 Collins-street, Melbourne, solicitors for the said executor. 8124

WALTER GEORGE LASCELLES, late of 3 Belgrave-street, Coburg; gentleman (who died 12th April, 1946).

CREDITORS, next of kin, and all other persons having claims against the estate of the deceased are required by the executors of the will, Walter John Lascelles, of 28 Belgrave-street, Hawthorn, brewery employee, and Violet Elizabeth Fletcher Allan, of 9 Station-street, Moreland, married woman, to send particulars to them, care of the undersigned, on or before 19th December, 1946, after which date they will distribute the assets, having regard only to the claims of which they then have notice.

JOHN D. MUSTOW, solicitor, 89 Queen-street, Melbourne. 8100

AMY EMILY KEYS, late of 234 Prince's Highway, Dandenong, married woman (who died 30th July, 1946).

CREDITORS, next of kin, and all other persons having claims against the estate of the deceased are required by the executor of the will, Thomas Frederick Holt, of Heatherton-road, Dandenong, manager, to send particulars to him, care of the undersigned, on or before 19th December, 1946, after which date he will distribute the assets, having regard only to the claims of which he then has notice.

JOHN D. MUSTOW, solicitor, 89 Queen-street, Melbourne. 8101

VERNON JOHN WEBB, late of 920 Burke-road, Canterbury, warehouseman, DECEASED (who died on 6th January, 1946).

PURSUANT to the provisions of the Trustee Acts, notice is hereby given that Irene Webb, of the same address, widow, and Geoffrey Vernon Webb, of 15 Chastleton-avenue, Toorak, secretary, the executors appointed by the deceased's will to whom probate was granted on 2nd May, 1946, intend to convey or distribute the estate of the deceased to or among the persons entitled thereto, and hereby require all persons having claims against the said estate to send to them, in the care of the undersigned solicitors, particulars thereof, on or before 19th December, 1946, after which date they will convey or distribute the said estate to or among the persons entitled thereto, having regard only to claims of which they shall then have had notice.

NORRIS & NORRIS, 422 Collins-street, Melbourne, solicitors. 8102

WILLIAM HUGH HUME-HUMPHREYS, late of "Irvine," The Parade, Ascot Vale, minister of religion, DECEASED (who died on 18th May, 1946).

CREDITORS, next of kin, and all other persons having claims against the estate of the deceased are required by Selina Paulin Hume-Humphreys, of "Irvine," The Parade, Ascot Vale, widow, and William Hargreaves Thompson, of 247 Burke-road, East Malvern, secretary, the executors to whom probate of deceased's will was granted on 29th August, 1946, to send particulars, in writing, of such claims to them, care of the undersigned solicitors, at their address hereunder mentioned, on or before the 17th day of November, 1946, after which date the said executors will proceed to convey or distribute the assets of the said deceased to or amongst the persons entitled thereto, having regard only to those claims of which they shall then have had notice.

PROUDFOOT, HORTON, & COX, solicitors, 87 Queen-street, Melbourne. 8104

CREDITORS, next of kin, and others having claims in respect of the estate of Hubert John Scott, late of 49 Foam-street, Elwood, in the State of Victoria, commission agent, deceased, intestate (who died on the 6th day of June, 1945), are to send particulars of their claims to John Edward Scott, care of Victor A. R. Chapple, solicitor, of 15 Queen-street, Melbourne, by the 20th day of December, 1946, after which date the said John Edward Scott will distribute the assets of the estate, having regard only to the claims of which he then has notice.

Dated this 14th day of October, 1946.

VICTOR A. R. CHAPPLE, of 15 Queen-street, Melbourne, solicitor for the administrator. 8105

CREDITORS, next of kin, and others having claims in respect of the estate of Colin Alexander Tait, late a member of the Australian Imperial Forces, but formerly of Barnsbury-road, Balwyn, in the State of Victoria, salesman (who became missing on the 1st day of July, 1942, on active service, and is presumed to be dead), are to send particulars of their claims to The Perpetual Executors and Trustees Association of Australia Limited, of Nos. 100-104 Queen-street, Melbourne, in the State of Victoria, by the 19th day of December, 1946, after which date it will distribute the assets, having regard only to the claims of which it then has notice.

Dated the 16th day of October, 1946.

W. ROSS RICHARDS, LL.B., solicitor, 191 Queen-street, Melbourne. 8109

CREDITORS, next of kin, and all others having claims in respect of the estate of William Bell, late of Sturt-street, Ballarat, chemist, deceased (who died on the 23rd day of June, 1946), are to send particulars of their claims to the executors, care of the undersigned, by the 24th day of December, 1946, after which date the assets will be distributed, having regard only to the claims of which the executors have notice.

J. CURWEN-WALKER, solicitor, Ballarat. 8059

JOSEPH WILLIAM BELCHER, formerly of Oxford Chambers, Bourke-street, Melbourne, in the State of Victoria, but late of 164 Hotham-street, East Melbourne, in the said State, gentleman (who died on the 19th day of March, 1946).

CREDITORS, next of kin, and all other persons having claims against the estate of the deceased are required by the executor of the will, The Trustees, Executors, and Agency Company Limited, of 401 Collins-street, Melbourne, to send particulars to the said company, on or before the 24th day of December, 1946, after which date the said company will distribute the assets, having regard only to the claims of which it then has notice.

ROY D. BIRDSEY, solicitor, Bank of New South Wales Building, Ryrie-street, Geelong. 8061

CAROLINE YEMMINGS SAYNOR, formerly of 321 Toorak-road, Burwood, but late of 36 Auburn-grove, Auburn, widow, DECEASED (who died 22nd June, 1946).

CREDITORS, next of kin, and all other persons having claims against the estate of the deceased are required by the executor of the will of the said deceased, Eric Valentine Saynor, of Methodist Parsonage, Monbulk, minister of religion, to send particulars of such claims to him, in the care of the undersigned solicitors, at their address hereunder appearing, on or before the 27th December, 1946, after which date the said executor will distribute the assets of the said deceased, having regard only to the claims of which he then has notice.

FARMER & RAMSAY, solicitors, 94 Queen-street, Melbourne. 8126

NOTICE TO CLAIMANTS.—GERTRUDE GEARY, DECEASED.

PURSUANT to the Trustee Act 1928, notice is hereby given that all persons having claims against the estate of Gertrude Geary, late of 489 Brunswick-street, North Fitzroy, in the State of Victoria, furrier, deceased (who died on the 8th day of August, 1946, and probate of whose will was granted by the Supreme Court of the said State, in its probate jurisdiction, on the 13th day of September, 1946, to Gertrude Howard, of 92 Fergie-street, North Fitzroy, in the said State, clerk), are hereby required to send particulars, in writing, of such claims to the above-named executrix, care of J. M. Smith and Emmerton, at the address hereunder mentioned, on or before the 20th day of December, 1946, after which date the said Gertrude Howard will proceed to distribute the assets of the said Gertrude Geary, deceased, which shall have come to her hands, amongst the persons entitled thereto, having regard only to the claims of which she shall then have had notice. And notice is hereby further given that the said Gertrude Howard will not be liable for the assets so distributed, or any part thereof, to any person of whose claim she shall not have had notice as aforesaid.

Dated this 9th day of October, 1946.

J. M. SMITH & EMMERTON, 480 Bourke-street, Melbourne, solicitors for the said Gertrude Howard. 8110

NOTICE TO CLAIMANTS.—MARY EVANS, DECEASED.

PURSUANT to the Trustee Act 1928, notice is hereby given that all persons having claims against the estate of Mary Evans, late of 6 Junction-road, Surrey Hills, in the State of Victoria, gentlewoman, deceased (who died on the 11th day of August, 1946, and probate of whose will was granted by the Supreme Court of the said State, in its probate jurisdiction, on the 13th day of September, 1946, to Mary Frances Tiernan, of 480 Bourke-street, Melbourne, in the said State, solicitor), are hereby required to send particulars, in writing, of such claims to the above-named executrix, care of J. M. Smith and Emmerton, at the address hereunder mentioned, on or before the 20th December, 1946, after which date the said Mary Frances Tiernan will proceed to distribute the assets of the said Mary Evans, deceased, which shall have come to her hands, amongst the persons entitled thereto, having regard only to the claims of which she shall then have had notice. And notice is hereby further given that the said Mary Frances Tiernan will not be liable for the assets so distributed, or any part thereof, to any person whose claim she shall not have had notice as aforesaid.

Dated this 9th day of October, 1946.

J. M. SMITH & EMMERTON, 480 Bourke-street, Melbourne, solicitors for the said Mary Frances Tiernan. 8111

Trustee Act 1928.

NOTICE TO CLAIMANTS.

PURSUANT to the *Trustee Act 1928*, creditors, next of kin, and all other persons having claims in respect of the estate of any deceased person named below are required to send particulars thereof to the legal personal representative or representatives at the address stated below, on or before the date stated, after which date the representative or representatives will distribute the assets, having regard only to the claims of which notice has been received:—

Henry Arthur Barnett, the elder, late of Barwon Heads, retired farmer, died 11th May, 1946.—Claims to the executors, Herbert Kitchener Barnett, farmer, and Ellen Dale, married woman, both of Barwon Heads, care of Doyle and Kerr, "The Exchange," Market Square, Geelong, by 17th December, 1946. 8037

Frederick Nicholls, formerly of Arnott-street, Geelong West, painter, but late of 1 King's-lane, Geelong West, retired painter, died 18th July, 1946.—Claims to the administrator, William Frederick Nicholls, of 49 Weller-street, Geelong West, painter, care of Wighton and McDonald, solicitors, 53 Yarra-street, Geelong, by 18th December, 1946. 8038

Mary Anne Watson, late of 6 Laurel Bank-parade, Newtown, Geelong, married woman, died 24th August, 1926.—Claims to the administrator, John Leslie Watson, of 3 McKillop-street, Geelong, service station proprietor, care of Wighton and McDonald, solicitors, 53 Yarra-street, Geelong, by 18th December, 1946. 8039

Kate Gavina Currie, late of "Millicent," Clendon-road, Toorak, widow, who died on 6th July, 1946.—Claims to the executors, George Wilson Bruce and Lionel Bruce, both of 483 Collins-street, Melbourne, chartered accountants (Aust.), by 18th December, 1946. Davies, Campbell, and Piesse, solicitors, 401 Collins-street, Melbourne. 8065

James Quilty (also known as Henry Quilty), late of 130 Barkly-street, West Brunswick, in the State of Victoria, labourer, deceased, died 19th August, 1946.—Claims to Henry George Beasley, care of Walter Kemp and Townsend, 340 Collins-street, Melbourne, solicitors, by 19th December, 1946. 8071

Florence Elizabeth Henderson, late of 13 Fallon-street, Caulfield, widow, deceased, died 19th August, 1946.—Claims to executor, Harold Drewitt Paroissien, care of A. G. Hall and Wilcox, solicitors, 20 Queen-street, Melbourne, by 18th December, 1946. A. C. Hall and Wilcox, solicitors, 20 Queen-street, Melbourne. 8093

Fanny Weeks, late of 71 Elm-street, Northcote, spinster, who died 25th July, 1946.—Claims to the executor, Reginald Rupert Gray, of 195 High-street, Northcote, solicitor, care of Gray and Gray, solicitors, 340 Collins-street, Melbourne, by 17th December, 1946. 8112

Robert Marshall Allan, formerly of South Brisbane, in the State of Queensland, medical practitioner, but late of 5 University Grounds, Carlton, in the State of Victoria, professor of obstetrics and gynaecology, deceased, who died on the 29th day of July, 1946.—Claims to the executrix, Maryanne Eleanor Dines Allan, of University Grounds, Carlton aforesaid, care of Aitken, Walker, and Strachan, 123 William-street, Melbourne, solicitors for the executrix, by the 17th day of December, 1946. 8117

Denis Patrick Foley, late of 385 Mount Alexander-road, Ascot Vale, hotel proprietor, died 19th July, 1946.—Claims to the executors, Lucy Blanche Mill, of 385 Mount Alexander-road, Ascot Vale, widow, and Archibald Frederick Cameron, of Studley-road, Heidelberg, secretary of the Austin Hospital for Cancer and Chronic Diseases, care of Maddock, Lonie, and Chisholm, solicitors, 339 Collins-street, Melbourne, by the 18th December, 1946. 8119

Christiana Heffernan, late of Pine Cottage, Alder-street, Caulfield, married woman, died 17th August, 1918.—Claims to the administrator, The Perpetual Executors and Trustees Association of Australia Limited, of 100-104 Queen-street, Melbourne, by the 23rd December, 1946. Maddock, Lonie, and Chisholm, solicitors, 339 Collins-street, Melbourne. 8120

Enma Stranger, late of 5 Exhibition-street, West Footscray, widow, deceased, died 11th June, 1946.—Claims to the executors, William Oxley, of 213 Ballarat-road, Maidstone, clerk, and William Mascotte Bracken, of Hopkins-street, Footscray, bank manager, care of John F. Carroll, solicitor, 4 Paisley-street, Footscray, by 19th December, 1946. John F. Carroll, LL.B., solicitor, 4 Paisley-street, Footscray. 8127

NOTICE TO CLAIMANTS.

THE PERPETUAL EXECUTORS AND TRUSTEES ASSOCIATION OF AUSTRALIA LIMITED, whose registered office is situated at Nos. 100-104 Queen-street, Melbourne, in the State of Victoria, and Simon John Cuddigan, of 22 Fernhill-road, Sandringham, in the said State, secretary, the executors of the will of James Edwin Fraser, formerly of Hampton Hotel, Hampton, in the said State, but late of 76 Orrong-road, Elsternwick, in the said State, gentleman, deceased (who died on the 16th day of June, 1946), require all creditors, next of kin, and others having claims against the property or estate of the said deceased to send to the said executors, in the care of the said association, on or before the 18th day of December, 1946, particulars, in writing, of such claims, after which date the said executors intend to convey or distribute such property or estate to or among the persons entitled thereto, having regard only to the claims of which they shall have had notice.

Dated the 4th day of October, 1946.
SYKES, CROTHERS, & DUCK, Deakin-avenue, Mildura, solicitors for the executors. 8041

NOTICE TO CLAIMANTS.

CREDITORS, next of kin, and all persons having claims against the estate of Patrick O'Connell, late of Kilmarty, in the State of Victoria, farmer and grazier, deceased (who died on the 22nd day of June, 1946, and probate of whose will and two codicils thereto has been granted to the executors, National Trustees, Executors, and Agency Company of Australasia Limited, whose registered office is situated at 95 Queen-street, Melbourne, and Charles Stanley Roberts, of Sale, auctioneer), are required to send particulars, in writing, of their claims to the said executors, care of the said executor company, at its address above set out, on or before the 31st day of December, 1946, after which date the executors will distribute the assets of the deceased amongst the persons entitled thereto, having regard only to claims of which it and he then has had notice.

Dated this 10th day of October, 1946.
L.F. C. STAVELEY, 14 Foster-street, Sale, solicitor. 8044

THE BALLARAT TRUSTEES, EXECUTORS, AND AGENCY COMPANY LIMITED, of Lydiard-street, Ballarat, the executor of the will of Eleanor Lange, late of Rocky Point, widow, deceased (who died on the 8th day of August, 1946), requires all creditors and others interested to send the said company, at its address, on or before the 28th day of December, 1946, particulars, in writing, of their claims against the estate of the said deceased, after which date the said company will distribute the assets, having regard only to the claims of which it shall then have notice.

STEWART W. IRWIN, solicitor, Ararat. 8046

NOTICE TO CLAIMANTS.

CREDITORS, next of kin, and others having claims in respect of the estate of Alexander Mackenzie, late of 108 Peel-street north, Ballarat, master plumber, deceased (who died on 1st May, 1946), are to send particulars of their claims to The Ballarat Trustees, Executors, and Agency Company Limited, at its address, 101 Lydiard-street north, Ballarat, by the 20th day of December, 1946, after which date the company will distribute the assets, having regard only to the claims of which it then has notice.

Dated 10th October, 1946.
BAIRD & BAIRD, solicitors, Ballarat. 8036

MARY KNIGHT, late of Palmerston-street, Bendigo, in the State of Victoria, widow, DECEASED.

CREDITORS, next of kin, and all other persons having claims against the estate of the said deceased are required by Sandhurst and Northern Districts Trustees, Executors, and Agency Company Limited, of View-street, Bendigo aforesaid, and Joseph Harold Victor Knight, of Charlton, gentleman, the executors of the will and codicil of the said deceased to send particulars thereof to them, care of the said company, on or before the twenty-third day of December, 1946, after which date they will distribute the assets, having regard only to the claims of which they then have notice.

Dated the 14th day of October, 1946.
T. M. WILLIAMS, WATSON, & JAMES, of Bull-street, Bendigo, solicitors for the executors. 8047

NOTICE TO CLAIMANTS.—*RE* HENRY MOON, DECEASED.

PURSUANT to the provisions of the *Trustee Act* 1928, notice is hereby given that all persons having claims against the estate of Henry Moon, late of Paraday, in the State of Victoria, grazier, deceased (who died on the 19th day of September, 1945, and probate of whose will and codicil thereto was granted by the Supreme Court of the said State, on the 29th day of March, 1946, to John Brock, of Sutton Grange, farmer, and James Leslie Moon, of Elphinstone, farmer), are required to send particulars, in writing, to the said John Brock and James Leslie Moon, care of the undersigned, at the address below, on or before the 20th day of December, 1946, after which date the said executors will proceed to convey or distribute the said estate to or among the persons entitled thereto, having regard only to the claims of which they then shall have had notice, and will not be liable for the assets so distributed to any person of whose claim they shall not then have had notice.

Dated this 12th day of October, 1946.

MCCAY, THWAITES, & LANGSLOW, solicitors, Castle-maine. 8048

CREDITORS and others having claims in respect of the estate of Alexander William Aram, late of 1 Gourlay-street, East St. Kilda, in Victoria, engineer, deceased (who died on the 14th August, 1946), are to send particulars of their claims to The Ballarat Trustees, Executors, and Agency Company Limited, of Lydiard-street, Ballarat, to its Melbourne office, 50 Market-street, Melbourne, by the 18th December, 1946, after which date the said company will distribute the assets, having regard only to the claims of which it shall then have notice.

Dated this 15th day of October, 1946.

HOAD & BONELLA, 101 Queen-street, Melbourne, solicitors for the said company. 8113

NOTICE TO CLAIMANTS.—*RE* HELEN RICHMOND FORSYTH HANCOCK, formerly of 14 Bokhara-road, Caulfield, in the State of Victoria, late of 26 Bent-street, Caulfield aforesaid, married woman, DECEASED.

WALTER JAMES PARR, of Bokhara-road, Caulfield aforesaid Justice of the Peace, State public servant, the executor of the will of the above-named deceased (who died on 30th June, 1946), requires all creditors and others having claims against the deceased or estate of the said deceased to send to him, care of his solicitors, Hoad and Bonella, 101 Queen-street, Melbourne, on or before the 18th December, 1946, particulars, in writing, of such claims, after which date he intends to convey or distribute such property or estate to or amongst the persons entitled thereto, having regard only to the claims of which he shall then have had notice.

Dated the 15th day of October, 1946.

HOAD & BONELLA, 101 Queen-street, Melbourne, solicitors for the said executor. 8114

NOTICE TO CLAIMANTS AND OTHERS.—ARTHUR KENNETH McCRAE, DECEASED.

CREDITORS, next of kin, and others having claims in respect of the estate of Arthur Kenneth McCrae, formerly of "Newmarket," Hay, New South Wales, but late of 6 Summerlea-grove, Hawthorn, in Victoria, grazier, deceased (who died on the 21st day of April, 1946), are to send particulars of their claims to The Equity Trustees, Executors, and Agency Company Limited, of 472 Bourke-street, Melbourne, by the 19th day of December, 1946, after which date the said company will distribute the assets of the said Arthur Kenneth McCrae, deceased, having regard only to the claims of which it then has notice.

Dated the 9th day of October, 1946.

J. M. SMITH & EMMERTON, 480 Bourke-street, Melbourne, solicitors. 8116

PURSUANT to the *Trustee Act* 1928, notice is hereby given that all persons having claims against the estate of George Archibald Fitzgerald, late of Jancourt East, via Cobden, in the State of Victoria, farmer, deceased (who died on the 13th day of June, 1946, and probate of whose will has been granted to Mary Fitzgerald, of Jancourt East, via Cobden aforesaid, widow), are hereby required to send particulars, in writing, of such claims to the executrix, care of the undersigned, on or before the 16th day of December, 1946, after which date the said executrix will proceed to distribute the estate of the testator amongst the persons entitled thereto, having regard only to the claims of which she shall then have had notice, and will not be liable for the assets so distributed, or any part thereof, to any person of whose claim she shall not have had notice.

Dated this 9th day of October, 1946.

CUNNINGHAM, BYRNE, & LARKINS, of Murray-street, Colac, solicitors for the applicant. 8118

KENNETH JOHN LAIRD MOWAT, late of Stradbroke, grazier (who died 11th July, 1946).

CREDITORS, next of kin, and all other persons having claims against the estate of the deceased are required by the executors of the will, Percival Alfred Mowat, of Stradbroke, farmer and grazier, and Rupert John Mowat, of Lialalong, farmer, to send particulars to them, care of the undersigned, on or before 18th December, 1946, after which date they will distribute the assets, having regard only to the claims of which they then have notice.

R. M. ROLLAND, solicitor, 57C Raymond-street, Sale. 8050

PURSUANT to the *Trustee Act* 1928, notice is hereby given that all persons having claims against the estate of George Henry Booth, late of Chiltern, in the State of Victoria, grazier, deceased (who died on the 26th August, 1943, and probate of whose will was granted to The Trustees, Executors, and Agency Company Limited, whose registered office is situate at 401 Collins-street, Melbourne), are hereby required to send particulars, in writing, of such claims to the above-mentioned company, at its address aforesaid, on or before the 19th December, 1946, after which date the said company will proceed to convey or distribute the said estate amongst the persons entitled thereto, having regard only to the claims, whether formal or not, of which it shall then have had notice. And notice is hereby further given that it will not, in respect of the property so conveyed or distributed, be liable to any person of whose claim it shall not have had such notice as aforesaid.

Dated this 10th day of October, 1946.

McSWINEY & DOYLE, of Wangaratta, solicitors for the said company. 8051

HENRY DOUGLAS SCOTT, formerly of "Buecleuch," Ross-town-road, East Caulfield, in the State of Victoria, but late of 2 Cleeland-street, Reservoir, in the said State, gentleman, DECEASED (who died on 14th June, 1946).

CREDITORS, next of kin, and all others having claims against the estate of the deceased are required by the executrix of the will, Rachel Scott, of 2 Cleeland-street, Reservoir aforesaid, widow, to send particulars to her, in care of the undersigned, on or before the 20th day of December, 1946, after which date she will distribute the assets, having regard only to the claims of which she then has notice.

MICHAEL NIALL & CO., solicitors, Collins House, 360 Collins-street, Melbourne. 8079

MARY MARGARET BYRNE, late of 121 Gamon-street, Yarraville, in the State of Victoria, married woman, DECEASED (who died on 7th February, 1945).

CREDITORS, next of kin, and all others having claims against the estate of the deceased are required by the administrator of the estate, John Edward Byrne, of 121 Gamon-street, Yarraville aforesaid, medical practitioner, to send particulars to him, care of the undersigned, on or before the 20th day of December, 1946, after which date he will distribute the assets, having regard only to the claims of which he then has notice.

MICHAEL NIALL & CO., solicitors, Collins House, 360 Collins-street, Melbourne. 8080

SARA FISHELSON, late of 39 Tennyson-street, St. Kilda, in the State of Victoria, married woman, DECEASED (who died on 10th August, 1946).

CREDITORS, next of kin, and all others having claims against the estate of the deceased are required by the executors of the will, Jacob Fishelson, gentleman, and Hannah Fishelson, gentlewoman, both of 39 Tennyson-street, St. Kilda, to send particulars to them, in care of the undersigned, on or before the 20th day of December, 1946, after which date they will distribute the assets, having regard only to the claims of which they then have notice.

MICHAEL NIALL & CO., solicitors, Collins House, 360 Collins-street, Melbourne. 8081

PERCY DIGNEY, late of 230 Punt-road, Prahran, in the State of Victoria, engine-driver, DECEASED (who died on the 3rd August, 1946).

CREDITORS, next of kin, and all others having claims against the estate of the deceased are required by the executrix of the estate, Fanny Digney, of 230 Punt-road, Prahran aforesaid, widow, to send particulars to her, in care of the undersigned, on or before the 20th day of December, 1946, after which date she will distribute the assets, having regard only to the claims of which she then has notice.

MICHAEL NIALL & CO., solicitors, Collins House, 360 Collins-street, Melbourne. 8082

MICHAEL FLANAGAN, late of 249 McKean-street, North Fitzroy, in the State of Victoria, gentleman, DECEASED (who died on 10th day of April, 1946).

CREDITORS, next of kin, and all others having claims against the estate of the deceased are required by the executor of the estate, John Flanagan, of 249 McKean-street, North Fitzroy aforesaid, gentleman, to send particulars to him, in care of the undersigned, on or before the 20th day of December, 1946, after which date he will distribute the assets, having regard only to the claims of which he then has notice.

MICHAEL NIALL & CO., solicitors, Collins House, 360 Collins-street, Melbourne. 8083

SAMUEL OLIVER FRANCIS, late of 108 Peel-street, Kew, in the State of Victoria, police constable, DECEASED (who died on 20th April, 1946).

CREDITORS, next of kin, and all others having claims against the estate of the deceased are required by the executor of the estate, Walter Gordon Francis, formerly of 365 Hawthorn-road, South Caulfield, but now of 172 Hawthorn-road, East Brighton, in the said State, tramway employee, to send particulars to him, in care of the undersigned, on or before the 20th day of December, 1946, after which date he will distribute the assets, having regard only to the claims of which he then has notice.

MICHAEL NIALL & CO., solicitors, Collins House, 360 Collins-street, Melbourne. 8084

PATRICK JOHN JOLLEY (also known as Patrick John Vincent Jolley, and also known as Joseph Vincent Jolley), late of 7 Murphy-street, Gardenvale, in the State of Victoria, pensioner, DECEASED (who died on 31st July, 1946).

CREDITORS, next of kin, and all others having claims against the estate of the deceased are required by the executrix of the will, Mary Teresa Jolley, of 7 Murphy-street, Gardenvale aforesaid, widow, to send particulars to her, in care of the undersigned, on or before the 20th day of October, 1946, after which date she will distribute the assets, having regard only to the claims of which she then has notice.

MICHAEL NIALL & CO., solicitors, 360 Collins-street, Melbourne. 8085

ALL persons interested in or having claims upon the estate of William Matthew McIlwrick, late of "Colleen," 5 Wattle-tree-road, Armadale, in Victoria, solicitor, deceased (who died on 4th October, 1945, and probate of whose will has been granted to The Union Trustee Company of Australia Limited, of 333 Collins-street, Melbourne), are hereby requested to send particulars, in writing, of their claims to the said company, on or before 16th December, 1946, after which date the said company may convey or distribute the said estate to or among the persons entitled thereto, having regard only to the claims, whether formal or not, of which it shall then have had notice.

Dated 15th October, 1946.

W. E. PEARCEY & IVEY, 413 Little Collins-street, Melbourne, proctors to the said company. 8087

PURSUANT to the *Trustee Act 1928*, all persons having claims against the property or estate of Thomas William Spence, late of Eagle-terrace, Brisbane, in the State of Queensland, formerly a member of the Royal Australian Air Force, but late an Australian National Airways Pilot, deceased (who died on the 10th day of March, 1946, and letters of administration to the will annexed, of whose estate were granted by the Supreme Court of Victoria, on the 27th day of September, 1946, to The Union Trustee Company of Australia Limited, of 333 Collins-street, Melbourne, in the State of Victoria), are hereby requested to send particulars, in writing, of such claims to the said company, at its above-mentioned address, on or before the 17th day of December, 1946, after which date the said company will proceed to distribute the assets of the said deceased which shall have come to its hands among the persons entitled thereto, having regard only to the claims of which it shall have had notice.

Dated this 14th day of October, 1946.

BLAKE & RIGGALL, 120 William-street, Melbourne, solicitors for the said company. 8089

HELEN ELIZABETH LAIDLAW, late of Kilgour-street, Geelong, in the State of Victoria, spinster, DECEASED (who died on the 19th day of July, 1946).

CREDITORS, next of kin, and all other persons having claims against the estate of the deceased are required by the executor of the will, Robert John Laidlaw, of Apsley, in the said State, station manager, to send particulars to him, in care of the undersigned, on or before the 18th day of December, 1946, after which date he will distribute the assets, having regard only to the claims of which he then has notice.

WHYTE, JUST, & MOORE, solicitors, 27 Malop-street, Geelong. 8052

PURSUANT to the *Trustee Act 1928*, notice is hereby given that all persons having claims against the estate of Joseph Teague, late of Yambuk, in the State of Victoria, hotel-keeper, deceased (who died on the 30th day of March, 1946, and probate of whose will was, on the 27th day of June, 1946, granted by the Supreme Court of Victoria, to Noel Charles Bower, of 95 Grandview-avenue, Pascoe Vale South, in the said State, carpenter, the executor appointed thereby), are hereby required to send particulars, in writing, of such claims to the said Noel Charles Bower, in care of the undersigned, at the address below, on or before the 17th day of December, 1946, after which date the said executor will proceed to convey or distribute the said estate to or among the persons entitled thereto, having regard only to the claims of which he shall then have had notice, and will not be liable for the assets so distributed to any person of whose claim he shall not then have had notice.

Dated this 9th day of October, 1946.

KEITH A. NESS, solicitor, 411 Collins-street, Melbourne. 8090

PURSUANT to the *Trustee Act 1928*, notice is hereby given that all persons having claims against the estate of Mary Louisa McGuinness, formerly of 12 Auburn-grove, Armadale, in the State of Victoria, and 7 Redan-road, Caulfield, in the said State, but late of Austin Hospital, Heidelberg, in the said State, widow, deceased (who died on the 8th day of July, 1946, and probate of whose will was on the 4th day of September, 1946, granted by the Supreme Court of Victoria to Leonard Herbert Adamson, of 7 Redan-road, Caulfield aforesaid, carpenter, and Frederick Campbell, of 28 Barrindi-road, Caulfield aforesaid, postal official, the executors appointed thereby), are hereby required to send particulars, in writing, of such claims to the said Leonard Herbert Adamson and Frederick Campbell, in care of the undersigned, at the address below, on or before the 17th day of December, 1946, after which date the said executors will proceed to convey or distribute the said estate to or among the persons entitled thereto, having regard only to the claims of which they shall then have had notice, and will not be liable for the assets so distributed to any person of whose claim they shall not then have had notice.

Dated this 9th day of October, 1946.

KEITH A. NESS, solicitor, 411 Collins-street, Melbourne. 8091

PURSUANT to the *Trustee Act 1928*, all persons having claims against the estate of Siegmund Defris, late of 110 Westbury-street, East St. Kilda, deceased, are required by the executor of his will, Maurice Cohen, of 50 Market-street, Melbourne, solicitor, to send particulars of such claims to him before the 21st December, 1946, after which date he will distribute the assets of the said deceased amongst the persons entitled thereto, having regard only to the claims of which he then has had notice.

8092

CREDITORS, next of kin, and others having claims in respect of the estate of Anne Jane Delany (sometimes called Annie Jane Delany), formerly of 124 Dandenong-road, Oakleigh, but late of 11 Dominic-street, East Camberwell, spinster, deceased (who died on the 13th day of July, 1946), are to send particulars of their claims to the executor and executrix, The Equity Trustees, Executors, and Agency Company Limited and Judith Mary Delany, in care of the said company, whose registered office is situated at 472 Bourke-street, Melbourne, by the 20th day of December, 1946, after which date the executor and executrix will distribute the assets, having regard only to the claims of which they then have notice.

H. H. HOWARD, solicitor, 303 Collins-street, Melbourne.

8094

PURSUANT to the provisions of the *Trustee Act 1928*, notice is hereby given that all persons having claims against the estate of Charles Edward Bright, late of "Carbrook," Humphries-road, Frankston, in the State of Victoria, retired Deputy Postmaster-General of the Commonwealth of Australia, deceased (who died on the 5th August, 1946, and probate of whose will and two codicils thereto was, on the 10th October, 1946, granted by the Supreme Court of Victoria to Norma Bright, of "Carbrook," Humphries-road, Frankston aforesaid, widow, and Mary Constance Bright, of 425 Sturt-street, Ballarat, in the said State, spinster, the executors appointed thereby), are hereby required to send particulars, in writing, of such claims to the said Norma Bright and Mary Constance Bright, in care of Malleson, Stewart, and Company, at the address below, on or before the 18th December, 1946, after which date the said executors will proceed to convey or distribute the said estate to or among the persons entitled thereto, having regard only to the claims, whether formal or not, of which they shall then have had notice, and will not be liable for the assets so distributed to any person of whose claim they shall not then have had notice.

MALLESON, STEWART, & CO., solicitors, 46 Queen-street, Melbourne. 8097

WILLIAM DAVID ALEXANDER, late of Stephen-street, Newtown, Geelong, in the State of Victoria, gentleman, DECEASED (who died 23rd April, 1946).

CREDITORS, next of kin, and all other persons having claims against the estate of the deceased are required by the executors of the will, The Union Trustee Company of Australia Limited, of 333 Collins-street, Melbourne, in the said State, and Aurel Victor Jung Just, of Malop-street, Geelong aforesaid, solicitor, to send particulars to the said The Union Trustee Company of Australia Limited, on or before the 18th December, 1946, after which date the said executors will distribute the assets, having regard only to the claims of which they then have notice.

WHYTE, JUST, & MOORE, solicitors, 27 Malop-street, Geelong. 8053

CREDITORS, next of kin, and all other persons having claims against the estate of John Watson, late of Laurel Bank-parade, Newtown, Geelong, grazier (who died 12th July, 1946), are required by the executors of the will, The Ballarat Trustees, Executors, and Agency Company Limited, of 101 Lydiard-street north, Ballarat, and Hubert James Leigh Watson, of 133 Aberdeen-street, Geelong West, butcher, to send particulars to them, care of The Ballarat Trustees, Executors, and Agency Company Limited, at its office, Malop-street, Geelong, on or before 18th December, 1946, after which date they will distribute the said estate, having regard only to the claims of which they then have notice.

WIGHTON & McDONALD, solicitors, 53 Yarra-street, Geelong. 8054

NOTICE TO CREDITORS.—*RE* MARY KIRKLAND NELSON, DECEASED.

PURSUANT to the provisions of the *Trustee Act* 1928, notice is hereby given that all persons having claims against the estate of Mary Kirkland Nelson, late of Cressy, in the State of Victoria, widow, deceased (who died on the 1st day of April, 1945, and probate of whose will was granted to John Griffat Nelson, of Cressy, in the State of Victoria, agent, and Leslie Gordon Nelson, of Weering, in the State of Victoria, farmer, the executors named therein), are hereby required to send particulars, in writing, of such claims on or before the 20th day of December, 1946, to the said executors. And notice is hereby given that after the said date the said executors will proceed to distribute the assets of the said deceased which shall have come to their hands or possession amongst the persons entitled thereto, having regard only to the claims of which the said executors may then have had notice, and the said executors will not then be liable for the assets, or any part thereof, so distributed to any person of whose claim he shall not then have had notice.

Dated the 9th day of October, 1946.

F. RUSSELL, COLDHAM & CO., of Lydiard-street south, Ballarat, proctors for the said executors. 8055

TRUSTEE ACT 1928.

NOTICE is hereby given that all persons having claims against the property or estate of Edith Eliza Flussey, late of 23 Derby-street, Camberwell, in the State of Victoria, widow, deceased (who died on the 2nd September, 1946, and probate of whose will was granted by the Supreme Court of Victoria on the 9th October, 1946, to Muriel Anne Peake, of 169 Canterbury-road, Canterbury, in the said State, spinster, and Douglas Herbert Knight, of 108 Queen-street, Melbourne, in the said State, solicitor, the executors thereby appointed), are hereby required to send particulars, in writing, of such claims to the said executors, care of the said Douglas Herbert Knight, on or before the 27th December, 1946, after which date the said executors will proceed to distribute the assets of the said deceased amongst the persons entitled thereto, having regard only to claims of which they shall then have had notice, and will not be liable for the assets so distributed, or any part thereof, to any person of whose claim they shall not then have had notice.

Dated this 14th day of October, 1946.

D. H. KNIGHT, solicitor, 108 Queen-street, Melbourne. 8076

CREDITORS, next of kin, and others having claims in respect of the estate of John Gibson Blayney, late of 1 Haynes-crescent, Glen Iris, gentleman, deceased (who died on the 22nd day of June, 1946), are to send particulars of their claims to The Equity Trustees, Executors, and Agency Company Limited, of 472 Bourke-street, Melbourne, by the 18th day of December, 1946, after which date it will distribute the assets, having regard only to the claims of which it then has notice.

GAIR & BRAHE, of 243 Collins-street, Melbourne, solicitors for the executor. 8077

CREDITORS, next of kin, and others having claims in respect of the estate of Elizabeth Hobbs, late of Cohuna, widow, deceased (who died on the 10th day of July, 1945), are requested to send particulars of their claims to Douglas Whyte, care of Myles O'Brien, jun., solicitor, Cohuna, by the 26th day of December, 1946, after which date he will distribute the assets, having regard only to the claims of which he then has notice.

Dated the 10th day of October, 1946.

MYLES O'BRIEN, jun., solicitor, Cohuna. 8073

CREDITORS, next of kin, and others having claims in respect of the estate of Sylvia Louise Hall, late of 37 Queen-street, North Williamstown, in the State of Victoria, married woman, deceased, intestate (who died on the 18th day of June, 1946), are to send the particulars of their claims to The Perpetual Executors and Trustees Association of Australia Limited, of 100-104 Queen-street, Melbourne, by the 25th day of November, 1946, after which date it will distribute the assets, having regard only to the claims of which it then has notice.

Dated this 12th day of October, 1946.

DUDLEY A. TREGENT, B.A., LL.M., solicitor, 422 Collins-street, Melbourne. 8074

CREDITORS, next of kin, and others having claims in respect of the estate of John Terence Clarke, late of 53 Wilson-street, Princes Hill, in the State of Victoria, Commonwealth public servant, deceased (who died on the 24th day of August, 1946), are to send the particulars of their claims to The Trustees, Executors, and Agency Company Limited, of 401 Collins-street, Melbourne, in the said State, the executor and legal personal representative of the said deceased, by the 29th day of December, 1946, after which date it will distribute the assets, having regard only to the claims of which it then has notice.

F. P. WILLIAMS, solicitor, Melbourne. 8075

CREDITORS, next of kin, and others having claims against the estate of William Duncan Millar, late of Sawyer's Valley, in the State of Western Australia, storekeeper, deceased (who died on the 11th day of April, 1946), are to send particulars of their claims to The Trustees, Executors, and Agency Company Limited, of 401 Collins-street, Melbourne, in the State of Victoria, by the 24th day of December, 1946, after which date it will distribute the estate, having regard to the claims of which it shall then have notice.

ABBOTT, BECKETT, STILLMAN, & GRAY, solicitors, 422 Little Collins-street, Melbourne. 8078

In the Supreme Court of the State of Victoria.—*Fi. Fa.*

NOTICE is hereby given that under and by virtue of certain process issued out of the Supreme Court of the State of Victoria and directed to the Sheriff, requiring him to levy certain moneys of the real and personal estate of Alfred Alexander Beardsley, formerly of Bendigo, later of Stawell, in the State of Victoria, now whereabouts unknown, the said Sheriff will on Friday, the 22nd day of November, 1946, at the hour of Three o'clock in the afternoon, cause to be sold at the Sheriff's Office, Bendigo Police Station (unless the said process shall have been previously satisfied or the said Sheriff be otherwise stayed):—

All the right, title, estate, and interest (if any) of the said Alfred Alexander Beardsley in and to—

(1) All that piece of land, being part of Crown allotment 4, section 1B, City of Bendigo, Parish of Sandhurst, County of Bendigo, being the whole of the land comprised in certificate of title, volume 6709, folio 1341789, standing in the Register Book in the names of Alfred Alexander Beardsley, chiropodist, and Joyce Raphael, married woman, both of Forest-street, Bendigo, as tenants in common in equal shares.

(2) All that piece of land, being lot marked as No. 18 on plan of subdivision made by William Merry of allotments 1, 4, 5, 6, 7, and 8, section 1, portion B, in the city parish and county aforesaid, as more particularly described in conveyance dated 23rd August, 1944, Elsie Maude McManus to Alfred Alexander Beardsley and Joyce Raphael, registered No. 930, book 577, which said land was conveyed to the said Alfred Alexander Beardsley and Joyce Raphael as tenants in common in equal shares.

N.B.—Terms: Cash. No cheques taken.

Dated at Bendigo, this 11th day of October, 1946.

8062 F. R. WARREN, Sheriff's Officer.

MINING NOTICES.

CHEWTON GOLD MINES NO LIABILITY.

NOTICE is hereby given that all shares forfeited for non-payment of the 57th (September) Call of Three pence per share will be sold by public auction at the Stock Exchange Hall, 428 Chancery-lane, Melbourne, on Wednesday, the 23rd day of October, 1946, at a quarter to Twelve a.m., unless redeemed on or before 5 p.m. on Tuesday, the 22nd day of October, 1946.

By order of the Board,
A. E. LLEWELLYN, Manager.

430 Little Collins-street, Melbourne, C.I, 15th October, 1946.
8095

AJAX SOUTH GOLD MINE N. L.

NOTICE is hereby given that all shares forfeited for non-payment of the 15th (September) Call of Three pence per share will be sold by public auction at the Stock Exchange Hall, 428 Chancery-lane, Melbourne, on Wednesday, the 23rd day of October, 1946, at a quarter to Twelve a.m., unless redeemed on or before 5 p.m. on Tuesday, the 22nd day of October, 1946.

By order of the Board,
A. E. LLEWELLYN, Manager.

430 Little Collins-street, Melbourne, C.I, 15th October, 1946.
8096

IMPOUNDINGS.

BERWICK.—Impounded in Berwick Pound.

1 brown Jersey heifer, about 8 months, W.M. off rump
If not claimed and expenses paid, to be sold on 25th October, 1946.

8040—4/
M. NIXON,
Poundkeeper.

KERANG.—Impounded at Kerang.

1 dark Jersey steer calf, about nine months, notch bottom left ear, silver nose, no visible brand
If not claimed and expenses paid, to be sold on 1st November, 1946.

8130—4/8
F. NANCARROW,
Poundkeeper.

MORTLAKE.—Impounded at Mortlake, on 6th October, 1946.

1 red Shorthorn steer, three years, piece out of bottom of near ear, no visible brand
If not claimed and expenses paid, to be sold on 31st October, 1946.

8049—4/8
GEO. ROBERTSON,
Poundkeeper.

SHEPPARTON.—Impounded in Shepparton Borough Pound.

1 bay draught gelding, shod, branded W
If not claimed and expenses paid, to be sold on 1st November, 1946.

8129—4/
J. MASON,
Poundkeeper.

TRAFALGAR.—Impounded in Trafalgar Pound.

1 black and white nobby cow, like ES (sideways) off rump
1 Jersey cow, tip off off ear, piece out of near ear, like FCW off rump
1 black bull, JS off rump
If not claimed and expenses paid, to be sold on 30th October, 1946.

8128—6/
E. MILLS,
Poundkeeper.

WERRIBEE.—Impounded at Werribee, from Tarneit, on 9th October, 1946, by W. A. King.

1 chestnut draught mare, white blaze, milky mouthed, white feet, white on hocks, short tail, fore feet shod, collar marked, no visible brand
If not claimed and expenses paid, to be sold on 31st October, 1946.

8057—6/
TIMOTHY MAHER,
Poundkeeper.

STATE ACTS, 1942.

COPIES of the following Acts of Parliament of Victoria may be obtained at the Government Printing Office, or from any bookseller, at the price set opposite to each:—

No.		Price
		s. d.
4880.	Consolidated Revenue	0 6
4881.	Consolidated Revenue	0 6
4882.	Hospitals and Charities	0 6
4883.	Sewerage Rates	0 6
4884.	Sheep Dipping	0 6
4885.	The Limbless Soldiers Trust	1 0
4886.	Consolidated Revenue	0 6
4887.	National Security (Emergency Powers) Continuation	0 6
4888.	Income Tax (War-time Collection)	0 6
4889.	Freezing Works (Overdraft Guarantee)	0 6
4890.	Consolidated Revenue	0 6
4891.	Melbourne Markets	0 6
4892.	Student Teachers (War Service)	0 6
4893.	Cattle and Swine Compensation	0 6
4894.	Drysdale United Service Home	0 6
4895.	Public Trustee	0 6
4896.	The Constitution Act Amendment	0 6
4897.	Entertainments Tax (War-time Suspension)	0 6
4898.	Melbourne and Metropolitan Tramways (Reserve Funds)	0 6
4899.	Milk and Dairy Supervision	0 6
4900.	Melbourne and Metropolitan Board of Works (Contributions)	0 6
4901.	Execution of Trusts	0 6
4902.	Melbourne and Metropolitan Board of Works (Rates)	0 6
4903.	Adoption of Children	0 6
4904.	Consolidated Revenue	0 6
4905.	Land Tax (Exemptions)	0 6
4906.	Land Tax	0 6
4907.	Stamps (Increased Duty Continuance)	0 6
4908.	Country Roads Board Fund	0 6
4909.	Financial Emergency (Grants and Funds)	0 6
4910.	Water Supply Loans Application	0 6
4911.	Administration and Probate Duties	0 6
4912.	Railway Loan Application	0 6
4913.	Public Account Advances (Amendment)	0 6
4914.	Farmers Protection (Amendment)	0 6
4915.	Water	0 6
4916.	Patriotic Funds	0 6
4917.	St. Vincent's Hospital Land	0 6
4918.	Survival of Actions	0 6
4919.	Mines	0 6
4920.	South Melbourne (Birrell-place) Land	0 6
4921.	Local Government (Loans and Debentures)	0 6
4922.	Local Government (Building Regulations) Amendment	0 6
4923.	Miners' Phthisis (Treasury Allowances) Amendment	0 6
4924.	Legal Profession Practice	0 6
4925.	Motor Car (Amendment)	0 6
4926.	Local Government (Street Construction)	1 0
4927.	Victorian Inland Meat Authority	1 0
4928.	Railway Construction Trusts Liabilities	0 6
4929.	Surplus Revenue	0 6
4930.	Railways (Long Service)	0 6
4931.	Grain Elevators	0 6
4932.	Coal Mine Workers Pensions	1 3
4933.	State Forests Loan Application	0 6
4934.	Health (Patent Medicines)	0 9
4935.	Metropolitan Gas Company's	0 6
4936.	Yannathan and Triholm Railway (Dismantling)	0 6
4937.	Soil Conservation	0 6
4938.	Forests	0 6
4939.	Land Surveyors	0 9
4940.	Administration and Probate (Amendment)	0 6
4941.	Appropriation of Revenue	3 3
4942.	Dietitians Registration	1 0

J. J. GOURLEY,
Government Printer.

STATE ACTS, 1943.

COPIES of the following Acts of Parliament of Victoria may be obtained at the Government Printing Office, or from any bookseller, at the price set opposite to each:—

No.	Price. s. d.
4943. Consolidated Revenue	0 6
4944. Consolidated Revenue	0 6
4945. State Development	0 6
4946. Grain Elevators	0 6
4947. Consolidated Revenue	0 6
4948. Lunacy	0 6
4949. National Security (Emergency Powers) Con- tinuation	0 6
4950. Commonwealth Powers	0 6
4951. Consolidated Revenue	0 6
4952. Factories and Shops (Chairmen of Wages Boards)	0 6
4953. Country Roads (Forest Roads and Stock Routes)	0 6
4954. State Schools (Bush Fire Relief)	0 6
4955. Consolidated Revenue	0 6
4956. Coal Mines Regulation	0 6
4957. Petrol Pumps (Licence Fees)	0 6
4958. Superannuation (Contributions)	0 6
4959. Coal Mine Workers Pensions	0 6
4960. Forests (Exchange of Lands)	0 6
4961. Local Government (Valuations)	0 6
4962. Railway Construction (Extensions)	0 6
4963. Mental Hygiene (Mode of Citation)	0 6
4964. Administration and Probate Duties	0 6
4965. Sewerage Districts	0 6
4966. Stamps (Increased Duty Continuance)	0 6
4967. Land Tax	0 6
4968. Surplus Revenue	0 6
4969. Financial Emergency (Grants and Funds)	0 6
4970. Partially Blinded Soldiers Fund	0 6
4971. Melbourne and Metropolitan Board of Works (Contributions)	0 6
4972. Milk Pasteurization	1 0
4973. Country Roads Board Fund	0 6
4974. Workers' Compensation	0 6
4975. Public Works Loan and Application	0 6
4976. Factories and Shops (Saturday Half-holiday)	0 6
4977. Springvale Necropolis Land	0 6
4978. South Melbourne to Melbourne Tramway Con- struction	0 6
4979. Water Supply Loans Application	0 6
4980. Forests	0 6
4981. State Forests Loan Application	0 6
4982. Administration and Probate (War Service)	0 6
4983. Water	0 9
4984. Farmers Protection (Amendment)	0 6
4985. Stamps	0 6
4986. Railway Loan Application	0 6
4987. Farmers Debts Adjustment	0 6
4988. Ministry of Health	1 0
4989. Discharged Servicemen's Preference	1 0
4990. Instruments (Insurance Contracts)	0 6
4991. Melbourne (Widening of Streets)	0 6
4992. Mines (Petroleum)	0 6
4993. Education	0 6
4994. Land Settlement (Acquisition)	0 6
4995. Land Settlement Loan and Application	0 6
4996. Housing	1 0
4997. Milk and Dairy Supervision	1 0
4998. Appropriation of Revenue	3 9

J. J. GOURLEY,
Government Printer.

STATE ACTS, 1944.

COPIES of the following Acts of Parliament of Victoria may be obtained at the Government Printing Office, or from any bookseller, at the price set opposite to each:—

No.	Price. s. d.
4999. Consolidated Revenue	0 6
5000. Local Government (Polling Booths)	0 6
5001. Police Offences (Unlawful Games)	0 6
5002. Hospitals and Charities	0 6
5003. Water (Loddon)	0 6
5004. Justices	0 6
5005. Coal Mines Regulation (Amendment)	0 6
5006. Consolidated Revenue	0 6
5007. Melbourne and Metropolitan Board of Works (Contributions)	0 6
5008. Marketing of Primary Products	0 6
5009. National Security (Emergency Powers) Continua- tion	0 6
5010. Outer Circle Railway (Partial Dismantling)	0 6
5011. Mines (Minerals)	0 6
5012. Goods (Textile Products)	0 6
5013. Masseurs	0 6
5014. Electoral (War Service Deaths)	0 6
5015. Cremorne Bridge	0 6
5016. Melbourne Harbor Trust	0 6
5017. Water	0 9
5018. Consolidated Revenue	0 6
5019. Mildura Irrigation and Water Trusts	0 6
5020. Farm Water Supplies Advances	0 6
5021. Sewerage Districts	0 6
5022. Trustee Companies	0 6
5023. Mildura Irrigation and Water Trusts (Super- annuation)	0 6
5024. Consolidated Revenue	0 6
5025. Cemeteries	0 6
5026. Border Railways	0 6
5027. Local Government (Shire of Blackburn and Mitcham)	0 6
5028. Electoral Districts	0 6
5029. Land	0 6
5030. Land Tax	0 6
5031. Administration and Probate Duties	0 6
5032. Stock Foods (Amendment)	0 6
5033. Stamps (Increased Duty Continuance)	0 6
5034. Muribyrnong and Ashburton Lands Exchange	0 6
5035. Financial Emergency (Grants and Funds)	0 6
5036. Farmers Advances	0 6
5037. Land Settlement (Acquisition) Amendment	0 6
5038. Railways	0 6
5039. Farmers Protection (Amendment)	0 6
5040. Country Fire Authority	1 9
5041. Country Roads Board Fund	0 6
5042. Railway Loan and Application	0 6
5043. Town and Country Planning	1 0
5044. Agricultural Colleges	0 9
5045. Heatherton Sanatorium	0 6
5046. Health (Infectious Diseases Hospitals)	0 6
5047. Surplus Revenue	0 6
5048. Water Supply Loans Application	0 9
5049. State Forests Loan and Application	0 6
5050. Public Works Loan and Application	0 6
5051. Commonwealth and States Financial Agreement	1 3
5052. The Constitution Act Amendment	0 6
5053. Public Library National Gallery and Museums	0 9
5054. Drought Relief	0 6
5055. Co-operative Housing Societies	1 6
5056. Local Government	1 0
5057. Melbourne and Metropolitan Board of Works	0 9
5058. Appropriation of Revenue	3 9

J. J. GOURLEY,
Government Printer.

STATE ACTS, 1945.

COPIES of the following Acts of Parliament of Victoria may be obtained at the Government Printing Office, or from any bookseller, at the price set opposite to each:—

No.	Price. s. d.
5059. Mildura Irrigation and Water Trusts (Borrowing)	0 6
5060. Supreme Court (Judges)	0 6
5061. Oakleigh (Regent-street) Land	0 6
5062. Swine	0 6
5063. Drought Relief (Amendment)	0 6
5064. Unclaimed Moneys	0 6
5065. Consolidated Revenue	0 0
5066. Consolidated Revenue	0 6
5067. Agent-General's	0 6
5068. Land Surveyors (Amendment)	0 6
5069. State Development	0 6
5070. Melbourne and Metropolitan Board of Works (Borrowing Powers)	0 6
5071. Education	0 6
5072. Water	0 6
5073. National Security (Repeal)	0 6
5074. Moorabbin (Unimproved Rating Poll)	0 6
5075. Licensing (Poll)	0 6
5076. Lilydale Waterworks Trust Abolition	0 6
5077. East Melbourne Land	0 6
5078. Health (Wines)	0 6
5079. Local Government (Emergency Housing Accommodation)	0 6
5080. Law Institute	0 6
5081. Bendigo Land	0 6
5082. Consolidated Revenue	0 6
5083. Consolidated Revenue	0 6
5084. Consolidated Revenue	0 6
5085. Factories and Shops (Bread Holidays)	0 6
5086. Administration and Probate Duties	0 6
5087. Land Tax	0 6
5088. Stamps (Increased Duty Continuance)	0 6
5089. Licensing Fund	0 6
5090. Employers and Employés	0 6
5091. Farmers Advances	0 6
5092. University (Veterinary Research)	0 6
5093. Surplus Revenue	0 6
5094. State Forests Loan and Application	0 6
5095. Mines (Amendment)	0 6
5096. Farmers Protection (Amendment)	0 6
5097. Railway Loan Application	0 6
5098. Public Works Loan and Application	0 6
5099. Water Supply Loans Application	0 9
5100. Public Account Advances (Amendment)	0 6
5101. Hospital Benefits	0 6
5102. Totalizator (Amendment)	0 6
5103. Financial Emergency (Municipal Endowment)	0 6
5104. Country Roads Board Fund (Amendment)	0 6
5105. Coal Mines Regulation (Amendment)	0 6
5106. Melbourne and Metropolitan Tramways (Chairman)	0 6
5107. Soldier Settlement	1 3
5108. Appropriation of Revenue	4 0

J. J. GOURLEY,
Government Printer.

STATE ACTS, 1946.

COPIES of the following Acts of Parliament of Victoria may be obtained at the Government Printing Office, or from any bookseller, at the price set opposite to each:—

No.	Price. s. d.
5109. Geelong Land	0 6
5110. Transport Regulation (Amendment)	0 6
5111. Factories and Shops (Annual Holidays)	0 9
5112. Mornington Sewerage Authority (Validation)	0 6
5113. Local Government (Emergency Housing Accommodation) Amendment	0 6
5114. Housing (Commonwealth and State Agreement)	1 0
5115. Factories and Shops (Early Closing)	0 6
5116. Building Operations and Building Materials Control	0 9
5117. Water (Levee Banks)	0 3
5118. Co-operative Housing Societies	0 6
5119. Local Government (Municipal Rolls)	0 6
5120. Public Works Loan and Application	0 6
5121. Totalizator (Charities)	0 6
5122. Drought Relief	0 6
5123. Taxation (Arrangements)	0 6
5124. Public Service	1 6
5125. Teaching Service	1 3
5126. Police Regulation	1 0
5127. Railways (Long Service)	0 6
5128. Workers' Compensation	1 6
5129. Sewerage Districts (Amendment)	0 6
5130. Factories and Shops (Bread)	0 6
5131. Crimes (Indeterminate Sentences)	0 6
5132. Medical (Chemists' Apprentices)	0 6
5133. Soldier Settlement (Amendment)	0 6
5134. Consolidated Revenue	0 6
5135. Consolidated Revenue	0 6
5136. Apprenticeship	0 6

J. J. GOURLEY,
Government Printer.

AGENTS FOR THE "VICTORIA GOVERNMENT GAZETTE."

THE following have been appointed agents to receive Advertisements and subscriptions for the *Victoria Government Gazette*:—

ARMSTRONG'S AGENCY, 143 Queen-street, Melbourne.

MESSRS. ARNALL & JACKSON, 115 Barkly-street, West Brunswick.

MESSRS. GORDON & GOTCH, News Agents, 511 Little Collins-street, Melbourne; and corner Barrack and Clarence streets, Sydney.

MESSRS. HARSTON, PARTRIDGE, & CO., 455 Little Collins-street, Melbourne.

N. V. NIXON & CO., 20 Queen-street, Melbourne.

THE PATON ADVERTISING SERVICE PTY. LTD.

ROBERTSON & MULLEN'S LTD., Elizabeth-street, Melbourne.

MESSRS. W. H. WADDELL and A. S. RICHARDSON, trading as The Mercantile Exchange, 380 Collins-street, Melbourne.

MR. A. J. DIGBY, News Agent, Bairnsdale.

MR. M. R. BADE, Tobacconist, Sturt-street, Ballarat.

TRIGG'S NEWS AGENCY, Hargreaves-street, Bendigo.

MR. G. H. K. PAYNE, 4 View Point, Bendigo.

MR. G. F. LATIMER, News Agent, Casterton.

MESSRS. HENRY FRANKS & CO., Booksellers and Stationers, Market-square, Geelong.

MESSRS. SMITH & DUNNON, Hamilton.

ARMSTRONG BROS., Kyneton.

AGENTS FOR THE "VICTORIA GOVERNMENT GAZETTE."—*continued.*M^r. WM. DAVIS, Mildura.

PIKE'S AUTHORIZED NEWS AGENCY, Sale.

MR. C. T. RUST, News Agent, Wangaratta.

MR. F. T. McCORMICK, Nunn-street, Benalla.

F. R. & E. M. COOKE, Bridge-street, Benalla.

W. GORDON HAMPTON, 243 Mitchell-street, Bendigo.

R. & A. SMALLMAN, News Agents, Toora.

A copy of the Gazette filed at each place for public reference.

THE VICTORIA GOVERNMENT GAZETTE is published on WEDNESDAY EVENING in each week, and Notices for insertion will be received by the Government Printer at or before TWO p.m., at ordinary rates, and late advertisements between TWO p.m. and FIVE p.m. at double rates on the day preceding the day of publication.

Single copies of the VICTORIA GOVERNMENT GAZETTE are Six pence, posted Eight pence, each.

No GAZETTES prior to January, 1936, in stock.

***ALL PAYMENTS ARE REQUIRED IN ADVANCE.—Remittances should be made by postal note, money order, or draft in favour of the Government Printer. Advertisements unaccompanied by a remittance sufficient to cover the cost of insertion will be returned unpublished.

THE "VICTORIA GOVERNMENT GAZETTE."

SUBSCRIPTIONS.—The subscription, including Postage, is £1 12s. 6d. per annum, 16s. 3d. half-yearly, or 8s. 2d. per quarter, payable in advance.

Subscriptions are required to commence and terminate with a month.

A lesser period than three months cannot be subscribed for.

Subscribers do not receive the Acts of Parliament with the GAZETTE.

ADVERTISEMENTS are charged at the rate of EIGHT PENCE per line single column, and ONE SHILLING and FOUR PENCE per line double column.

The title (£5 Reward, Dissolution of Partnership, &c.) forms one or more lines as a heading.

On an average, ten words make a line.

Every signature must likewise be counted as a line.

The final words of a paragraph, though only portion of a line, must be counted as one line.

SIGNATURES (in particular) and proper names must be written very plainly in the text; ONE SIDE ONLY of each slip of paper should be WRITTEN UPON.

ALL COMMUNICATIONS should be addressed to "The Government Printer, Melbourne."

ALL DOCUMENTS illegibly written will be returned unpublished, and, where brands occur unprovided for by the ordinary letters of the alphabet, a worded explanatory description must be furnished.

CONTENTS

	PAGE
Acts of Parliament on sale at the Government Printing Office	3301
Appointments	3274
Auction Sales Act	3279
Contracts	3281
Country Roads Board	3283
Estates of Deceased Persons	3280
Government Notices	3276
Impoundings	3301
Lands	3287
Melbourne Cup Day Holiday	3274
Mining	3278, 3301
Ministers of Religion Registered to Celebrate Marriages in Victoria	3279
Orders in Council	3282
Private Advertisements	3292
Proclamations	3273
Public Service Notices	3275
Resignations	3275
Stay Orders	3278
Tenders	3289
Transport Regulation Board—Public Hearings	3277