



VICTORIA  
GOVERNMENT GAZETTE.

Published by Authority.

[Registered at the General Post Office, Melbourne, for transmission by post as a newspaper.]

No. 62]

WEDNESDAY, APRIL 3.

[1946

## PUBLICATION OF THE "GOVERNMENT GAZETTE."

IT is hereby notified that, owing to the observance of the Easter Holidays and the Anzac Day Holiday, the *Government Gazette* will be published on—

FRIDAY, THE 26TH APRIL, 1946,

in lieu of Wednesday, the 24th April, 1946.

J. J. GOURLEY,  
Government Printer.

Melbourne, 29th March, 1946.

## LABOUR DAY HOLIDAY.

IT is hereby notified that—

MONDAY, THE 8TH APRIL, 1946.

will be observed as a Holiday in the Public Offices throughout the State of Victoria.

W. SLATER,  
Chief Secretary.

Chief Secretary's Office,

Melbourne, 14th March, 1946.

## PUBLIC HOLIDAYS.

## EASTER AND ANZAC DAY.

IT is hereby notified that on—

FRIDAY, THE 19TH,  
SATURDAY, THE 20TH,  
MONDAY, THE 22ND,  
TUESDAY, THE 23RD, and  
THURSDAY, THE 25TH OF APRIL, 1946,

the Public Offices will be closed, such days being appointed by the *Public Service Act 1928* to be observed as holidays in the Public Offices throughout Victoria.

W. SLATER,  
Chief Secretary.

Chief Secretary's Office,

Melbourne 20th March, 1946.

## PUBLIC HOLIDAYS.

## PROCLAMATION

By His Excellency the Governor of the State of Victoria and its Dependencies in the Commonwealth of Australia, &c., &c., &c.

IN pursuance of the provisions contained in Part VII. of the *Public Service Act 1928* (19 Geo. V. No. 3757), I, the Governor of the State of Victoria, in the Commonwealth of Australia, by and with the advice of the Executive Council of the said State, do by this my Proclamation appoint the days and dates hereunder mentioned to be observed as a Public Holiday or a Public Half-Holiday (as the case may be) at the places respectively specified, viz.:—

*Public Holiday:—*

WEDNESDAY, 1ST MAY, 1946, throughout the Borough of Wonthaggi.

*Public Half-Holiday from the Hour of Twelve o'clock noon:—*

THURSDAY, 28TH MARCH, 1946, throughout the Town of Sale.

Given under my Hand and the Seal of the State of Victoria aforesaid, at Melbourne, this twenty-seventh day of March, in the year of our Lord One thousand nine hundred and forty-six, and in the tenth year of the reign of His Majesty King George VI.

(L.S.) . . . . . WINSTON DUGAN.

By His Excellency's Command,

W. SLATER,  
Chief Secretary.

GOD SAVE THE KING!

## ACT OF PARLIAMENT.

## PROCLAMATION

By His Excellency the Governor of the State of Victoria and its Dependencies in the Commonwealth of Australia, &c., &c., &c.

I, THE Governor of the State of Victoria, in the Commonwealth of Australia, do hereby declare that I have this day assented, in His Majesty's name, to the Bill passed by the Parliament of the said State, the title whereof is hereunder set forth, that is to say:—

No. 5109. "An Act to provide for the Revocation of the Permanent Reservation of certain Land in the City of Geelong which is no longer required for the purpose of such Reservation and for the Alienation of such Land from the Crown, and for other purposes."

Given under my Hand and the Seal of the State of Victoria aforesaid, at Melbourne, this twenty-seventh day of March, in the year of our Lord One thousand nine hundred and forty-six, and in the tenth year of the reign of His Majesty King George VI.

(L.S.) WINSTON DUGAN.

By His Excellency's Command,

JOHN GAIN.

GOD SAVE THE KING!

## GAS REGULATION ACT 1933.

## PROCLAMATION

By His Excellency the Governor of the State of Victoria and its Dependencies in the Commonwealth of Australia, &c., &c., &c.

IN pursuance of the powers conferred by the provisions of the *Gas Regulation Act 1933*, 1, the Governor of the State of Victoria, by and with the advice of the Executive Council thereof, do by this my Proclamation revoke a Proclamation which was made on the twenty-fourth day of July, 1942, by virtue of and in accordance with the provisions contained in section 33 of the *Gas Regulation Act 1933* and which was published in the *Government Gazette* on the twenty-fifth day of July, 1942.

Given under my Hand and the Seal of the State of Victoria aforesaid, at Melbourne, this second day of April, in the year of our Lord One thousand nine hundred and forty-six, and in the tenth year of the reign of His Majesty King George VI.

(L.S.) WINSTON DUGAN.

By His Excellency's Command,

W. SLATER,  
Chief Secretary.

GOD SAVE THE KING!

*Country Fire Authority Act 1944.*

EXCISION OF AN AREA FROM URBAN DISTRICT AT UPWEY IN THE THIRTEENTH FIRE CONTROL REGION.

## PROCLAMATION

By His Excellency the Governor of the State of Victoria and its Dependencies in the Commonwealth of Australia, &c., &c., &c.

WHEREAS by Proclamation of the Governor in Council issued on the twentieth day of February, 1945, and published in the *Government Gazette* of the twenty-first day of February, 1945, the urban fire district at Upwey in the Thirteenth Fire Control Region was (amongst other things) proclaimed:

And whereas by section sixteen of the *Country Fire Authority Act 1944* it is (amongst other things) enacted that the Governor in Council may, from time to time, after consideration of a report submitted by the Country Fire Authority by proclamation published in the *Government Gazette*, add any area to or excise any area from any urban district, and amend or alter the boundaries of rural districts within any region.

And whereas the Country Fire Authority has submitted a report in relation to that part of the urban district at Upwey within the Thirteenth Fire Control Region, the boundaries of which are set forth and described in the Schedule hereunder:

Now therefore I, the Governor of Victoria, in the Commonwealth of Australia, by and with the advice of the Executive Council of the said State, after considering the report of the

Country Fire Authority, in pursuance of the powers conferred by section sixteen of the *Country Fire Authority Act 1944*, do by this my proclamation proclaim—

(a) That all those portions of the urban fire district at Upwey in the Thirteenth Fire Control Region within the boundaries set forth and described in the Schedule hereunder shall be and are hereby excised from the said urban district.

(b) That the boundaries of the rural fire district in the said Thirteenth Fire Control Region are hereby altered so that the area set forth and described in the said Schedule shall form part of the rural district in the said region.

## SCHEDULE.

Shire of Fern Tree Gully, Parishes of Narree Worrان and Scoresby, County of Mornington: Commencing at the north-eastern angle of allotment 10 of section B, Parish of Narree Worrان; thence generally in a south-easterly, southerly, and south-westerly direction by a road to its intersection with a line in production south-easterly of the north-eastern boundary of allotment A.2 in the aforementioned parish; thence south-easterly by the line last mentioned to Monbulk Creek; thence by that creek bearing generally south-westerly to the north-west angle of allotment 70A, no section; thence by a road bearing north-westerly, north-easterly, and north-westerly to the most western angle of allotment A.3; thence by that allotment bearing north-easterly to Ferny Creek; thence by that creek bearing westerly to the south-west angle of allotment 63B, Parish of Scoresby; thence by said allotment 63B bearing northerly and easterly to the south-west angle of allotment 72D; thence by that allotment, a line, and allotment 72E bearing northerly to the north-west angle thereof; thence by said allotment 72E bearing south-easterly to a road forming the western boundary of allotments 97, 99, and 101; thence by that road bearing northerly to the south-west angle of allotment 36 of section A; thence by a road bearing north-easterly and south-easterly, Parishes of Scoresby and Narree Worrان, to the point of commencement.

Given under my Hand and the Seal of the State of Victoria, this twenty-seventh day of March, in the year of our Lord One thousand nine hundred and forty-six, and in the tenth year of the reign of His Majesty King George VI.

(L.S.) WINSTON DUGAN.

By His Excellency's Command,

W. SLATER,  
Chief Secretary.

GOD SAVE THE KING!

*Milk and Dairy Supervision Act 1928 (No. 3736).*

DECLARING THE MUNICIPAL DISTRICTS OF THE SHIRES OF KOWREE AND TAMBO TO BE SUBJECT TO PART II. OF THE ACT.

## PROCLAMATION

By His Excellency the Governor of the State of Victoria and its Dependencies in the Commonwealth of Australia, &c., &c., &c.

WHEREAS by paragraph (c) of section 40 of the *Milk and Dairy Supervision Act 1928* (No. 3736) it is provided that Part II. of the said Act shall have effect as regards any municipal district outside any milk area on such date as such district is proclaimed by the Governor in Council to be subject to the provisions of Part II. of the said Act: Now therefore I, the Governor of the State of Victoria, by and with the advice of the Executive Council thereof do by this my Proclamation declare the municipal district of the Shires of Kowree and the municipal district of the Shire of Tambo which are municipal districts outside any milk area to be subject to the provisions of Part II. of the aforesaid Act on and from the first day of July, 1946, on which date Part II. of the said Act and all Regulations and Orders now in force or which may from time to time be made under Part II. of the said Act shall come into operation and be of full force and effect in such municipal districts.

Given under my Hand and the Seal of the State of Victoria aforesaid, at Melbourne, this twenty-seventh day of March, in the year of our Lord One thousand nine hundred and forty-six, and in the tenth year of the reign of His Majesty King George VI.

(L.S.) WINSTON DUGAN.

By His Excellency's Command,

W. G. MCKENZIE,  
Minister of Agriculture.

GOD SAVE THE KING!

*Local Government (Building Regulations) Act 1940.*  
**PROCLAMATION EXTENDING THE OPERATION OF THE  
 UNIFORM BUILDING REGULATIONS.**

**PROCLAMATION**

By His Excellency the Governor of the State of Victoria and its Dependencies in the Commonwealth of Australia, &c., &c., &c.

WHEREAS section 14 (2) of the *Local Government (Building Regulations) Act 1940* provides, *inter alia*, that the Governor in Council may, by Proclamation published in the *Government Gazette*, at the request of the council of any municipality (not being a city, or town) extend the operation of the Regulations made under that Act to the municipal district of such municipality, or any part thereof: And whereas the Council of the municipality of the Borough of Maryborough has requested that the operation of the said Regulations be extended to the municipal district of such municipality: Now, therefore, I, the Governor of the State of Victoria, by and with the advice of the Executive Council thereof, by this, my Proclamation, do hereby extend the operations of the Regulations made under the *Local Government (Building Regulations) Act 1940* to the municipal district of the Borough of Maryborough.

And do further provide that the said Regulations (other than those contained in Parts I. and II. of Chapter 8 thereof) shall come into operation in the municipal district of the said municipality on publication of this Proclamation in the *Government Gazette*, and that the Regulations contained in the said Parts I. and II. of Chapter 8 shall come into operation therein on the first day of July, 1946.

Given under my Hand and the Seal of the State of Victoria aforesaid, at Melbourne, this twenty-seventh day of March, in the year of our Lord One thousand nine hundred and forty-six, and in the tenth year of the reign of His Majesty King George VI.

(L.S.) WINSTON DUGAN.

By His Excellency's Command,  
 P. J. KENNELLY,  
 Commissioner of Public Works.  
 GOD SAVE THE KING!

**APPOINTMENTS.**

HIS Excellency the Governor of the State of Victoria, by and with the advice of the Executive Council thereof, has, by Orders made on the 27th day of March, 1946, been pleased to make the under-mentioned appointments, viz.:—

**DEPARTMENT OF AGRICULTURE.**  
*Officer of the Fifth Class.*

CLARENCE GERALD O'BRIEN  
 to be an Officer of the Fifth Class, Clerical Division; a vacancy having occurred, and the Public Service Board having certified, on the 27th February, 1946, that an appointment is required, that there is no person available and fit in the Public Service to be promoted or transferred to fill the vacant office, and that the person named is entitled, under the provisions of the Public Service Acts, to be appointed to fill such vacancy on probation for six (6) months.

**DEPARTMENT OF CHIEF SECRETARY.**  
 (PUBLIC LIBRARY BRANCH.)  
*Assistants (Female).*

MARY HOWARD MARSDEN,  
 NANCY LINDSAY WHITTINGHAM, and  
 HELEN JEAN THOMPSON  
 to be Assistants (Female), Class "E," Professional Division; vacancies having occurred, and the Public Service Board having certified, on the 25th February, 1946, that appointments are required, that there are no persons available and fit in the Public Service to be promoted or transferred to fill the vacant offices, and that the persons named are entitled, under the provisions of the Public Service Acts, to be appointed to fill such vacancies on probation for three (3) months.

**DEPARTMENT OF HEALTH.**  
*Pharmaceutical Chemist.*

ARTHUR FITZMAURICE PHILLIPS  
 to be Pharmaceutical Chemist, Classes "D" and "C," Professional Division, Mental Hygiene Branch; a vacancy having occurred, and the Public Service Board having certified, on the 14th February, 1946, that an appointment is required, that there is no person available and fit in the Public Service to be promoted or transferred to fill the vacant office, and that the person named is entitled, under the provisions of the Public Service Acts, to be appointed to fill such vacancy on probation for twelve (12) months.

*Attendant, Grade III.*

PHILIP JOHN DYNES  
 to be an Attendant, Grade III., General Division, Mental Hygiene Branch; a vacancy having occurred, and the Public Service Board having certified, on the 11th February, 1946, that an appointment is required, that there is no person available and fit in the Public Service to be promoted or transferred to fill the vacant office, and that the person named is entitled, under the provisions of the Public Service Acts, to be appointed to fill such vacancy on probation for twelve (12) months.

**DEPARTMENT OF LANDS AND SURVEY.**

*Inspector of Vermin and Noxious Weeds.*

WILLIAM JAMES CARRLE, Inspector of Land Settlement, to act also as an Inspector under the provisions of the *Vermin and Noxious Weeds Act 1928*, without additional salary, from and inclusive of the 10th December, 1945.

*Members of Committee of Management.*

STANDISH MICHAEL KEON, M.L.A., and  
 The Honorable Sir FRANCIS JOSEPH EDMUND BEAUREPAIRE,  
 M.L.C.,  
 to be Members of the Committee of Management of the land temporarily reserved on the 24th August, 1909, as a site for the Recreation, Convenience, and Amusement of the People and for a Children's Playground, at Melbourne, in the places of Hugh Weir, resigned, and as an additional member.

*Trustees of Sites.*

CLEMENT KEITH BULL  
 to be a Trustee of the land temporarily reserved on the 3rd August, 1868, as a site for a place of public worship in connexion with the Methodist Church, in the Parish of Bulban, in the place of George Ball, deceased;

JOHN MARTIN BUCHANAN  
 to be a Trustee, as a representative of the public of Flinders and district, of the land permanently reserved by Order in Council of the 4th August, 1922, as a site for Public Park and other purposes of Public Recreation in the Township of Flinders, in the place of Andrew Buchanan, deceased; and

ERNEST WESLEY MCCANN  
 to be a Trustee of the land permanently reserved on the 20th November, 1906, as a site for a Public Racecourse, Agricultural Show Grounds, and Recreation purposes at Geelong, in the place of Alfred Gilbert White, deceased.

*Managers of Common.*

JAMES WAIT,  
 LOUIS DINNER,  
 JAMES STOREY,  
 WILLIAM DWYER, and  
 JOHN V. MOLLOY  
 to be Managers of the Boort Common for a period ending 31st December, 1948.

**DEPARTMENT OF LAW.**

*Chairmen of General Sessions.*

WALTER ST. GEORGE SPOULE, and  
 MAURICE LEO CUSSEN,  
 Barristers at Law of Victoria of more than five years standing,  
 to be Chairmen of General Sessions, under the provisions of the *Justices Act 1928*, from 1st to 30th April, 1946, both dates inclusive.

*Magistrates.*

MAURICE CUNNINGHAM JAMES, Commonwealth Bank,  
 Hamilton,  
 to Keep the Peace in the Western Bailiwick of the State of Victoria;  
 HAROLD BRITAIN, 574 Malvern-road, East Prahran, and  
 CAMILLUS JOSEPH SHAW, Deputy Rent Controller of Victoria, 271 Lonsdale-street, Melbourne,  
 to Keep the Peace in the Central Bailiwick of the State of Victoria; and  
 HERBERT PETER BLAKISTON, 75 Esplanade, Geelong,  
 to Keep the Peace in the Southern Bailiwick of the State of Victoria.

*Commissioners for Taking Declarations, &c.*

GEORGE KINNAIRD COCKBURN,  
 CHARLES MONTGOMERY EWART,  
 WILLIAM THOMAS LONGBOTTOM, and  
 FINTON GEORGE GERRATY,  
 Officers of the Forests Commission of Victoria,  
 to be Commissioners for taking Declarations and Affidavits, pursuant to the provisions of Division 8 of Part IV. of the *Evidence Act 1928*—to refrain from charging fees and to resign upon ceasing to occupy their present positions.

*Sheriff's Bailiff, &c.*

CLYDE EMANUEL DENT, First Constable of Police, Rainbow,  
to be also a Sheriff's Bailiff and a Bailiff of the County Court at Horsham, in the place of K. A. Macklin, resigned, with fees, to take effect from the date of commencement of duty.

## DEPARTMENT OF PUBLIC WORKS.

*Inspectors of Works.*

WILLIAM HARLEY ROBINSON, and  
IRA IRWIN WEBSTER  
to be Inspectors of Works, Class "D," Professional Division; vacancies having occurred, and the Public Service Board having certified, on the 4th February, 1946, that appointments are required, that there are no persons available and fit in the Public Service to be promoted or transferred to fill the vacant offices, and that the persons named are fit and proper persons, and duly qualified to be appointed to fill such vacancies on probation for three months.

*Draughtsmen.*

NORMAN HAWORTH MILES,  
HENRY HUDSON, and  
CECIL BOMFORD  
to be Draughtsmen, Class "D," Professional Division; vacancies having occurred, and the Public Service Board having certified, on the 4th February, 1946, that appointments are required, that there are no persons available and fit in the Public Service to be promoted or transferred to fill the vacant offices, and that the persons named are fit and proper persons and duly qualified to be appointed to fill such vacancies on probation for three months.

*Draughtswoman.*

DOROTHEA BOIDDY  
to be a Draughtswoman, Class "E," Professional Division; a vacancy having occurred, and the Public Service Board having certified, on the 27th March, 1946, that an appointment is required, that there is no person available and fit in the Public Service to be transferred or promoted to fill the vacancy in question, and that the person named is a fit and proper person and duly qualified to fill the vacant office on probation for a period of three months.

## DEPARTMENT OF WATER SUPPLY.

*Waterworks Trust Commissioner.*

HUGH STEWART  
to be a Commissioner of the Mortlake Waterworks Trust, in place of Eric James Goldsworthy, resigned, and to hold office as such from the date hereof until 27th May, 1948, subject to the provisions of the Water Acts.

C. W. KINSMAN,  
Clerk of the Executive Council.

At the Executive Council Chamber,  
Melbourne, the 27th March, 1946.

## RESIGNATIONS.

HIS Excellency the Governor of the State of Victoria, by and with the advice of the Executive Council thereof, has, by Orders made on the 27th day of March, 1946, accepted the resignations of the persons named hereunder of the offices mentioned, viz.:—

## DEPARTMENT OF LAW.

BRIAN JAMES FINEMORE, Fifth Class Clerk, as an Officer of the Public Service of Victoria, to date from and inclusive of the 19th March, 1946.

THOMAS KEITH BURGIN, as a Commissioner for taking Declarations and Affidavits, pursuant to the provisions of the *Evidence Act 1923*.

GEORGE SPENCER CLARK, and JAMES ARCHIBALD SCHOFIELD, as Probation Officers, pursuant to the provisions of the *Children's Court Act 1928*, for the Children's Courts at Geelong and St. Kilda, respectively.

KENNETH ALFRED MACKLIN, as a Sheriff's Bailiff and a Bailiff of the County Court, at Horsham.

## DEPARTMENT OF WATER SUPPLY.

R. A. SWAN, Fifth Class Clerk, as an Officer of the Public Service of Victoria, to date from and inclusive of the 24th March, 1946.

C. W. KINSMAN,  
Clerk of the Executive Council.

At the Executive Council Chamber,  
Melbourne, the 27th March, 1946.

*Public Service Act 1928 (No. 3757), Sections 90 and 91.*

## EXEMPTION.

HIS Excellency the Governor of the State of Victoria, by and with the advice of the Executive Council thereof, and upon the recommendation of the Public Service Board, has, by an Order made on the 27th day of March, 1946, exempted the officers specified hereunder from the provisions of sections 90 and 91 of the *Public Service Act 1928* (No. 3757):—

## DEPARTMENT OF CHIEF SECRETARY.

Officers of the Motor Registration Branch, Office of the Chief Commissioner of Police, who are required to work overtime—such exemption to be operative for the period from the 12th December, 1945, to the 31st January, 1946, both dates inclusive.

C. W. KINSMAN,  
Clerk of the Executive Council.

At the Executive Council Chamber,  
Melbourne, the 27th March, 1946.

## PUBLIC SERVICE OF VICTORIA.—VACANCIES.

APPLICATIONS will be received by the Public Service Board up to Friday, the 12th April, 1946, from officers of the Public Service of Victoria, who are eligible and qualified, for appointment to the under-mentioned positions:—

## PROFESSIONAL DIVISION.

**Superintendent of Weights and Measures, Class "B," Weights and Measures Branch, Department of Chief Secretary.**

*Yearly Salary.*—£644, minimum; £722, maximum.

*Duties.*—To be responsible for the administration of the *Weights and Measures Act 1939*, including examination of the materials of which and the principles on which weighing and measuring instruments are constructed, and supervision of the periodical testing of the several classes of standard weights and measures.

*Qualifications.*—A University degree in Science or Engineering with extensive experience in the examination and testing of weights, measures, weighing instruments, and measuring instruments.

**Professional Assistant, Classes "C" and "B," Crown Solicitor's Office, Department of Law.**

*Yearly Salary.*—£527, minimum; £644, maximum.

*Duties.*—To prepare cases for prosecution in Courts of Petty Sessions in relation to breaches of the various Acts administered by the several Government departments, to prepare the informations in respect of such offences, and to conduct the cases in Court.

*Qualifications.*—To be a barrister and solicitor, and to have a working knowledge of the various Acts administered by the several Government departments. To possess a sound knowledge of the procedure in Courts of Petty Sessions and a capacity to conduct cases in Court.

**Manager, Seasoning Works (Newport), Classes "C" and "B," Department of State Forests.**

*Yearly Salary.*—£527, minimum; £644, maximum.

*Duties.*—To be Manager, Seasoning Works, Newport.

*Qualifications.*—To be a trained forester, to have a sound knowledge of Victorian timber utilization, to possess managerial capacity and the ability to conduct negotiations with sawmillers, timber merchants, and other trading organizations.

**Draughtsman, Class "C," Department of Public Works.**

*Yearly Salary.*—£449, minimum; £501, maximum.

*Duties.*—To prepare plans and designs of engineering projects, including harbour works, drainage, road and footpath construction, bridges, steel and reinforced concrete structures, tourist development, and foreshore protection works.

*Qualifications.*—To be a competent survey and engineering draughtsman, having technical school training in engineering, with wide experience in modern practice and the class of work outlined above.

## CLERICAL DIVISION.

**Chief Electoral Officer, First Class, Chief Secretary's Office, Department of Chief Secretary.**

*Duties.*—To administer, subject to the Chief Secretary, the *Constitution Act Amendment Act 1928* in so far as it relates to the registration and enrolment of electors and the conduct of elections for the State Parliament, and to supervise the conduct of other polls and departmental elections as may be authorized or required by the Minister.

*Qualifications.*—To be thoroughly conversant with the provisions of the *Constitution Act Amendment Act 1928* and other Acts and Regulations relating to the enrolment of electors and the conduct of elections. To have administrative and organizing ability, capacity to control staff and decide questions relating to electoral legislation, an aptitude for drafting Acts and Regulations, and a thorough knowledge of the electoral geography of Victoria.

**Second Class Clerk, Department of Lands and Survey.**

*Duties.*—To have charge of staff matters and dealings which relate to reserves and the management thereof, the closing and altering of roads, applications under the State Aid to Religion Abolition Act, the preparation of Parliamentary Bills and of cases for submission to the Executive Council and the Board of Land and Works.

*Qualifications.*—To have ability to control staff, a general knowledge of the Land Acts and other statutes, particularly the Local Government and Public Service Acts, together with experience of the regulations thereunder and in departmental procedure.

**Third Class Clerk, Office of the Housing Commission (Accountant and Personnel Officer, Holmesglen Concrete House Factory), Department of Treasurer.**

*Duties.*—To take charge of factory accounts sections and general office, to keep cost accounts, supervise time keeping and pay-roll section, and maintain statistical records. To act also as industrial officer in connexion with all factory personnel matters.

*Qualifications.*—To be a qualified accountant and to have had experience in the preparation and analysis of statistics and in the handling of staff. Experience in factory cost accounting and in the duties of an industrial personnel officer is desirable.

**Fourth Class Clerk, Children's Welfare Branch, Department of Chief Secretary.**

*Duties.*—To assist in the collection of maintenance payments by parents of children committed to or under the supervision of the branch; to conduct interviews and correspondence, to make reports and to attend court proceeding in connexion with such collections.

*Qualifications.*—To possess a thorough knowledge of the Children's Welfare Act, Maintenance Act, and Crimes Act in so far as they relate to the liability of parents for the maintenance of children committed to or under the supervision of the Children's Welfare Department or Department of Reformatory Schools.

**Fourth Class Clerk, Office of the Chief Commissioner of Police, Department of Chief Secretary.**

*Duties.*—To be in sub-charge of the Pay Branch of the Office, to prepare pay-rolls and re-imbursments, and to keep card indexes and statistics of police pay and allowances.

*Qualifications.*—To possess a thorough knowledge of the provisions of the Police Regulation Acts and Regulations thereunder dealing with salaries and allowances payable to members of the Police Force, experience in the operation of mechanized pay-roll system, and familiarity with departmental organization and procedure.

*NOTE.*—In addition to the salary rates quoted, a cost of living adjustment at the rate of £30 a year is payable. The rates are subject to variation in accordance with the rise or fall in the index numbers of the cost of living.

By order,  
E. F. FITZGIBBON,  
Acting Secretary.

Office of the Public Service Board,  
Melbourne, 2nd April, 1946.

**ASSISTANT STOREMAN, GENERAL DIVISION, ROCKLANDS RESERVOIR, DEPARTMENT OF WATER SUPPLY.**

APPLICATIONS will be received by the Public Service Board up to Friday, the 19th April, 1946, from officers of the Public Service of Victoria, who are qualified, for appointment to the above-mentioned position.

*Yearly Salary.*—£273, minimum; £286, maximum, plus cost of living adjustment (£30 at present).

*Qualifications.*—To be conversant with the instructions issued by the Commission in respect of the ordering, receipt, issue and transfer of material, and the keeping of stores books and records.

By order,

E. F. FITZGIBBON,

Acting Secretary.

Office of the Public Service Board,  
Melbourne, 2nd April, 1946.

**PUBLIC SERVICE OF VICTORIA.—VACANCIES, PROFESSIONAL DIVISION.**

APPLICATIONS will be received by the Public Service Board from persons, who are eligible and qualified, for appointment to the under-mentioned positions:—

**Assistant Engineer (Rocklands Reservoir), Class "C," Department of Water Supply. (Two vacancies.)**

*Yearly Salary.*—£449, minimum; £579, maximum.

*Duties.*—To prepare designs and estimates for hydraulic structures, dams and channels, and to supervise construction of works of this nature.

*Qualifications.*—To possess a University degree in Civil Engineering or other recognized engineering qualification. Experience in construction work is desirable.

**Mineralogist, Class "C," Public Library, National Gallery and National Museums Branch, Department of Chief Secretary.**

*Yearly Salary.*—£449, minimum; £527, maximum.

*Duties.*—To be curator of the mineral collections of the Museum; to catalogue and classify same with records of occurrences, accessibility, scientific and economic ability; to arrange the collections so as to be of value to the mineral industry, metallurgists, assayers, and students; and to undertake field laboratory research.

*Qualifications.*—To have a University degree or equivalent training in science, with geology as a major subject, ability to carry out chemical and microscopic tests on mineral specimens in the laboratory and experience in research work.

*NOTE.*—In addition to the salary rates quoted, a cost of living adjustment at the rate of £30 a year is payable. The rates are subject to variation in accordance with the rise or fall in the index numbers of the cost of living.

Applications (which should be accompanied by evidence of experience and qualifications, and a statement of date and place of birth) should be lodged at this office not later than Friday, the 12th April, 1946.

By order,

E. F. FITZGIBBON,

Acting Secretary.

Office of the Public Service Board,  
Melbourne, 2nd April, 1946.

**PUBLIC SERVICE OF VICTORIA.—VACANCIES.****TEMPORARY APPOINTMENTS.**

APPLICATIONS will be received by the Public Service Board from persons, who are qualified, for appointment to the under-mentioned positions:—

**Senior Investigation Officer, Rural Training, Department of Agriculture.**

*Salary.*—£579 a year.

*Duties.*—Subject to the Superintendent of Agricultural Education, to assist the Deputy Co-ordinator of Rural Training in (a) the determination of suitability of discharged servicemen for rural training, (b) the selection of suitable farms on which ex-servicemen may be trained, (c) the supervision of the training thereon; to assist in the supervision of the staff connected therewith, and to perform such other duties in connexion with rural training of ex-servicemen as may be directed.

*Qualifications.*—To have had sound practical experience of Victorian Agriculture; a knowledge of modern agricultural practice and the problems of discharged servicemen, and to have had sound administrative experience, and experience in the control of staff. The possession of a Diploma of a Victorian Agricultural College or its equivalent is desirable.

**Officer in Charge, Ex-servicemen's Training Centre, Dookie Agricultural College, Department of Agriculture.***Salary.*—£579 a year.*Duties.*—To take charge of the Training Centre for ex-servicemen at Dookie Agricultural College; to be responsible to the Principal of the College for all matters affecting discipline, training and general administration of the centre, and to co-ordinate time schedules for lectures and demonstrations.*Qualifications.*—To have had sound practical and theoretical experience in Victorian agriculture; experience in organization of training and control of students; and to have sound knowledge of the problems affecting ex-servicemen. The possession of a Diploma of Agriculture of a Victorian Agricultural College or its equivalent is desirable.

**NOTE.**—In addition to the salary rates quoted, a cost of living allowance at the rate of £30 a year is payable. The rates are subject to variation in accordance with the rise or fall in the index numbers of the cost of living.

Applications (which should be accompanied by evidence of experience and qualifications, and a statement of date and place of birth) should be lodged at this office not later than Friday, the 12th April, 1946.

By order,

E. F. FITZGIBBON,

Acting Secretary.

Office of the Public Service Board,  
Melbourne, 2nd April, 1946.

**PUBLIC SERVICE OF VICTORIA.—VACANCIES.****TEMPORARY APPOINTMENTS.**

**A** PPLICATIONS will be received by the Public Service Board from persons, who are qualified, for appointment to the under-mentioned positions:—

**Assistant Field Officer, Department of Agriculture.** (Three vacancies.)

*Salary.*—£234 a year.*Duties.*—To assist in the experimental and demonstrational work and general activities of the Agricultural Division.*Qualifications.*—To possess a Diploma or Certificate of an Agricultural College and to have had experience in the conduct of field experimental work.

**Nurse, Infant Welfare Division, Maternal and Child Hygiene Branch, Department of Health.**

*Yearly Salary.*—£273, minimum; £286, maximum.*Duties.*—To conduct Mobile Infant Welfare services in the Shires of Upper Murray and Toowoong.*Qualifications.*—To be a State registered general trained nurse with Infant Welfare Certificate, and to be licensed to drive a motor car. To have had experience in the management of Victorian Infant Welfare centres and to possess ability to conduct correspondence.

**Note.**—In addition to the salary rates quoted, a cost of living allowance at the rate of £20 a year in the case of females and £30 a year in the case of males is payable. The rates are subject to variation in accordance with the rise or fall in the index numbers of the cost of living.

Applications (which should be accompanied by evidence of experience and qualifications, and a statement of date and place of birth), should be lodged this office not later than Friday, the 19th April, 1946.

By order,

E. F. FITZGIBBON,

Acting Secretary.

Office of the Public Service Board,  
Melbourne, 2nd April, 1946.

**PUBLIC SERVICE OF VICTORIA.—VACANCIES.  
GENERAL DIVISION.**

**A** PPLICATIONS will be received by the Public Service Board from persons, who are qualified, for appointment to the under-mentioned positions:—

**Inspector of Stock, Department of Agriculture.**

*Yearly Salary.*—£345, minimum; £410, maximum.*Duties.*—To inspect stock under the *Stock Diseases Act 1928*, the *Cattle Compensation Act 1928*, and the *Swine Act 1928*, sheep under the *Sheep Dipping Act 1928*, bulls under the *Cattle Breeding Act 1928*, and huts under the *Shearers Hut Accommodation Act 1928*; to conduct post-mortem examinations, and such investigations under the *Sheep Owners Protection Act* and the *Stock Medicines Act* as are necessary or required by the Superintendent of Live Stock.

*Qualifications.*—To be acquainted with the requirements of the provisions of the above Acts and the Regulations thereunder, and to have a thorough knowledge of the contagious diseases of stock and the methods adopted for their control, and a practical knowledge of sheep dips and sheep dipping.

**Carpenter, Mental Hospital, Janefield, Department of Health.**

*Yearly Salary.*—£312, minimum; £325, maximum.*Duties.*—To carry out all carpentering work as directed by the Secretary.*Qualifications.*—To be a competent and experienced carpenter.

**Cook (Male), Mental Hospital, Ararat, Department of Health.** (Two vacancies.)

*Salary.*—£300 a year.*Duties.*—To assist, under the Senior Cook, in the preparation, cooking, and serving of patients' meals, and generally in the maintenance of the kitchen and cleanliness of the appliances and utensils used therein.*Qualifications.*—To have had experience in cooking for large numbers, and a knowledge of the working and maintenance of electric ovens and smokeless fuel cookers.

**Cook (Female), Mental Hospital, Royal Park, Department of Health.**

*Yearly Salary.*—£205, minimum; £218, maximum.*Duties.*—To assist in the preparation and cooking of meals, and to supervise patients working under her care.*Qualifications.*—To possess a knowledge of and experience in cooking.

**Note.**—In addition to the salary rates quoted, a cost of living allowance at the rate of £20 a year in the case of females and £30 a year in the case of males is payable. The rates are subject to variation in accordance with variation in the rise or fall in the index numbers of the cost of living.

Applications (which should be accompanied by evidence of experience and qualifications, and a statement of date and place of birth), should be lodged at this office not later than Friday, the 19th April, 1946.

By order,

E. F. FITZGIBBON,

Acting Secretary.

Office of the Public Service Board,  
Melbourne, 2nd April, 1946.

**YEA WATERWORKS TRUST.****BY-LAW RELATING TO RATES AND CHARGES FOR THE  
YEAR 1946.**

**T**HE Yea Waterworks Trust, in pursuance and exercise of the powers conferred by the Water Acts, hereby makes the following rates and charges for the supply of water within the Yea Urban District:—

On lands and tenements liable to be rated, a rate of Two shillings in the pound on the amount of the annual municipal valuation not exceeding Two hundred pounds, provided that in no case shall the amount of such rate payable in respect of any tenement (other than land on which there is no building) be less than Two pounds, and in respect of any land on which there is no building less than Ten shillings.

On such lands and tenements the annual municipal valuation of which exceeds Two hundred pounds, a rate of Twenty pounds.

Such rates are made and shall be levied upon the occupiers or owners of the said lands and tenements for the year commencing on the 1st day of January, 1946, and shall be payable on the 4th day of April, 1946, at the office of the said Trust, Shire Hall, Yea.

The maximum quantity of water to be supplied in any one year without further charge to any property rated by the Trust is hereby fixed at the quantity which, at the charge of One shilling per 1,000 gallons, would produce an amount equal to the amount of the rate levied on such property for the said year.

The charge for water supplied by measure to any property not rated by the Trust is hereby fixed at One shilling per 1,000 gallons, and the minimum quantity of water to be charged for in cases where water is so supplied is hereby fixed at 5,000 gallons.

The charge for water supplied by measure shall be payable, on demand, at the office of the said Trust, Shire Hall, Yea.

Passed this 22nd day of February, 1946.

(SEAL).

A. J. BETT, Chairman.

T. SINCLAIR, Secretary.

Approved by the Governor in Council,  
27th March, 1946.

C. W. KINSMAN,  
Clerk of the Executive Council,

Transport Regulation Acts.  
TRANSPORT REGULATION BOARD.  
NOTICES OF PUBLIC HEARINGS.

NOTICE is hereby given that the application lodged by the person named below for a licence to operate the commercial passenger vehicle on the route or routes, or in the manner set out opposite his name, will be heard at the Board Room, at these offices, at 10.15 a.m. on Wednesday, the 10th April, 1946:—

*Name of Applicant; Nature of Application.*

CLARK, A.; application for variation of licence T.A.1166, to charge fares as follows:—Hurstbridge to Cottel's Bridge, 2s.; Hurstbridge to Goldman's-road, 2s. 6d.; Hurstbridge to St. Andrews Post Office, 3s. 3d.; Hurstbridge to Smith's Gully Post Office, 3s. 3d.; Hurstbridge to Rushcutter's Creek, 4s. 6d.; Hurstbridge to Halley's Gully, 2s.; Hurstbridge to Nuffield, 2s.; Hurstbridge to Panton Hill Post Office, 2s.; Hurstbridge to Flat Rock-road, 2s. 6d.; Hurstbridge to Alma-road, via Panton Hill, 3s.; Hurstbridge to Shannon's-road, 2s.; Hurstbridge to Arthur's Creek, 3s. All special trips at 1s. per mile.

NOTICE is hereby given that the applications lodged by the persons named below for licences to operate the commercial passenger or goods vehicles on the route or routes, or in the manner set out opposite their names, will be heard at a time and place to be communicated to the parties:—

GREEN BUS LINES; application to substitute 29-seater vehicle on licence A.1385.

GRIEVE, T. R.; application for variation of licence A.910 to include charter conditions between Murchison and Shepparton, Seymour, and Kyabram.

PALMER, G. F.; 1 commercial passenger vehicle, with seating capacity for eighteen persons, as a substitute vehicle for licensed vehicle.

PALMER, G. F.; application for variation of licence T.A.1375 to operate an additional trip from Bairnsdale to the border of New South Wales *en route* to Bega, New South Wales, on Wednesdays, returning on Friday of each week.

BENGTSSON, G.; 1 commercial passenger vehicle to operate as follows:—(a) for the carriage of school children between Stony Creek, Grassy Spur, Buffalo, Meeniyan, Koonwarra, and Leongatha, (b) under charter conditions within 20 miles Stony Creek.

BENGTSSON, G.; application for variation of licence A.1259 to include charter conditions within 20 miles Stony Creek and to Yarram, Wilson's Promontory, and Wonthaggi.

WARRANTYTE TRANSPORT SERVICE; application for variation of licence so as to delete the time-table at present being operated on the service between Warrandyte and Box Hill, and to substitute therefor an amended time-table providing for the operation of through trips to the City of Melbourne as follows:—

1. *Departing Warrandyte*—Mondays-Fridays, 6.25 a.m., 6.55 a.m., 7.25 a.m., 7.45 a.m., 4.15 p.m. Saturdays only, 6.25 a.m., 6.55 a.m., 7.25 a.m., 12.10 p.m. *Departing Melbourne*—Mondays-Fridays, 8.15 a.m., 5 p.m., 5.30 p.m., 6 p.m., 6.30 p.m. Saturdays only, 12.30 p.m., 1 p.m., 1.30 p.m., 2 p.m.

2. *Departing Doncaster for Melbourne*—Mondays-Fridays, 6.45 a.m., 7.15 a.m., 7.45 a.m., 8.5 a.m., 4.35 p.m. Saturdays only, 6.45 a.m., 7.15 a.m., 7.45 a.m., 8.5 a.m., 12.30 p.m. *Departing Melbourne for Doncaster*—Mondays-Fridays, 8.15 a.m., 5 p.m., 5.30 p.m., 6 p.m., 6.30 p.m. Saturdays only, 12.30 p.m., 1 p.m., 1.30 p.m., 2 p.m.

3. On Sundays the service to continue operating only to Box Hill.

4. Service between Warrandyte and Box Hill to be maintained when the service is not operating through to the City.

5. On journeys to the City passengers to be set down anywhere *en route* but not picked up nearer to Melbourne than a point in Doncaster-road  $\frac{1}{2}$  mile from the North Balwyn tram terminus, and on journeys from Melbourne passengers to be picked up anywhere *en route* but not to be set down nearer than a point in Doncaster-road  $\frac{1}{2}$  mile beyond the North Balwyn tram terminus.

PARKER BROS.; application for variation of licences A.827 and A.185 to include charter conditions between Maryborough and Castlemaine, Chewton, Malmsbury, Taradale, Kyneton, Hepburn Springs, Waterloo, Beaufort, Ararat, Elmhurst, St. Arnaud, Emu, Wedderburn, Inglewood, Bridgewater, Newbridge, Harcourt, Bendigo, Woodend, Ballarat, Creswick, Allandale, Daylesford, Learmonth, Vaughan Springs, Skipton, Smeaton, Moonambel, Redbank, Macedon, Carapooce, Serpentine, Korong Vale, Landsborough, Waubra, Tourella, Ballan, and Newlyn.

MARTYR, H. J.; application for variation of licence A.351 to operate a school service between Warburton and Lilydale.

STANTON, G.; application for variation of licences A.1285 and A.986 to include charter conditions between Cohuna and Echuca, Swan Hill, and Rochester.

PIONEER TOURIST COACHES PTY. LTD.; application for variation of licences A.507 and A.588 allowing operations between Ballarat and Daylesford to operate on Sundays to the same schedules as Monday to Saturday.

McNAMARA, P. L.; application for variation of licences TA.1013, TA.1014, A.258, to include day tours as follows:—

1. Leave Healesville to Melbourne. Depart Government Tourist Bureau 10 a.m. via Doncaster to Healesville and Maroondah Dam. Luncheon at Maroondah Lake Hotel. Depart 2 p.m. for Sir Colin MacKenzie Sanctuary and then return to Melbourne. Depart 5.30 p.m. and return to Healesville.

2. Leave Healesville to Melbourne. Depart Government Tourist Bureau, 10 a.m. via Doncaster to Healesville and Maroondah Dam. Luncheon at Maroondah Lake Hotel, thence to Toolangi via Myers Creek, return via Chum Creek to Melbourne. Depart 5.30 p.m. and return to Healesville.

3. Leave Healesville to Melbourne. Depart Government Tourist Bureau, 10 a.m. via Doncaster to Healesville and Maroondah Dam. Luncheon at Maroondah Lake Hotel, thence to Ben Cairn Rock, Mt. Donna Buang, thence to Melbourne. Depart 5.30 p.m. and return to Healesville.

U.S. MOTORS (BELGRAVE) PTY. LTD.; application to substitute 31-seater vehicle on licence A.741.

LITTLEHALES, J. H.; application to substitute 21-seater vehicle on licence A.278.

CONWAY, J.; application for variation of licence A.1261 to include charter conditions within 20 miles Leongatha.

JAMES, R. S.; application for variation of licence A.135 to operate under charter conditions between Paynesville and Lake Tyers, Lakes Entrance, and Metung.

Notice of any objection should be forwarded to reach the Acting Secretary to the Board not later than Wednesday, the 10th April, 1946.

E. V. FIELD,

Acting Secretary.

Exhibition Buildings, Rathdown-street, Carlton, 2nd April, 1946.

THE MELBOURNE HARBOR TRUST COMMISSIONERS.

IN pursuance of the *Melbourne Harbor Trust Act 1928*, the Melbourne Harbor Trust Commissioners make the following Regulation:—

1. The Regulations made by the Commissioners on the 21st October, 1942, approved by the Governor in Council on 2nd November, 1942, and published in the *Government Gazette* on the 27th November, 1942, and any amendment thereto, are hereinafter referred to as "the Principal Regulations."

2. Regulation 322 is amended by deleting under the heading "South Wharf" the following words:—

"Berths Nos. 27 to 30 .. .. £0 5 0"

and inserting in lieu thereof the following:—

"Berths Nos. 27 to 30 .. .. £0 10 0"

Dated at Melbourne, this sixth day of March, 1946.

The common seal of the Melbourne Harbor Trust Commissioners was hereunto affixed by order of the Commissioners in the presence of—

(SEAL) F. DUNCAN, Presiding Commissioner.  
J. P. WEBB, Commissioner.  
S. R. KIMBER, Acting Secretary.

Approved by the Governor in Council.  
2nd April, 1946.

C. W. KINSMAN,  
Clerk of the Executive Council.

Factories and Shops Acts.

DETERMINATION OF THE CIGAR TRADE BOARD.

*Corrigendum.*

IN the Determination of the above Board, published in the *Government Gazette* on the 15th March, 1946, the classification "All others (females) 85 $\frac{1}{2}$  per cent. of the above rates for 'All others (Males)'" in clause 4 at page 979 should read "All others (females) 58 $\frac{1}{2}$  per cent. of the above rate for 'All others (Males)'"

RAY H. BEERS,

Secretary for Labour.

1st April, 1946.

## 4 GEORGE VI. No. 4755, SECTION 6.

I HEREBY give notice that on the 19th March, 1946, I filed elections to administer the following deceased persons' estates, in accordance with section 6 of the *Public Trustee Act 1940*:—

AH SUN, late of 23 Fleet-street, Fitzroy, laundryman, died 2nd January, 1946, interstate.  
 FARLEY, THOMAS, late of Peterborough, barman, died 7th November, 1945, intestate.

GRACE, PATRICK DANIEL, late of Korumburra South, labourer, died 9th January, 1946, intestate.  
 HICKEY, FRANCIS PATRICK, late of Digby, labourer, died 23rd May, 1943, intestate.

\*LEWIS, CHARLES JOHN, late of Mount Royal, Royal Park, retired salesman, died 12th December, 1945.

MAGHER, WILLIAM, late of Tinamba, pensioner, died 14th January, 1946, intestate.

PEARCE, MARGARET ANN, late of 15 Victoria-parade, Collingwood, pensioner, died 4th December, 1945, intestate.

THOMSON, WILLIAM, late of 57 Rathdown-street, Carlton, military pensioner, died 13th January, 1946, intestate.

\*TIPPETTS, WILLIAM ALAN, formerly of Forest-road, Boronia, but late of Australian Imperial Forces, soldier, presumed to have died on 1st July, 1942.

\* According to the provisions of the will.

I HEREBY give notice that on the 25th March, 1946, I filed elections to administer the following deceased persons' estates, in accordance with section 6 of the *Public Trustee Act 1940*:—

COOKSLEY, EMILY ALCINE, late of 10 Shower-street, Preston, married woman, died 18th September, 1945, intestate.

\*COOPER, AUBREY GORDON, also known as John Cooper, formerly of 12 Strettle-street, Thornbury, but late of A.M.F., soldier, died 10th April, 1944.

PORTER, ALMA ELIZABETH, late of 46 Stanley-street, West Melbourne, married woman, died 6th January, 1946, intestate.

ROSS, THOMAS, late of 28 Baillie-street, North Melbourne, retired municipal employee, died 23rd October, 1943, intestate.

SMITH, THOMAS HENDRY, also known as Thomas Smith, late of 17 Calembena-avenue, Oakleigh, packer, died 23rd May, 1943, intestate.

TAYLOR, ESTHER JANE, formerly of 196 Sternberg-street, Bendigo, but late of Sunbury, married woman, died 17th December, 1945, intestate.

\*TOMPSETT, GILBERT, formerly of The Basin, but late of Australian Imperial Forces, soldier, died 18th April, 1943.

\* According to the provisions of the will.

J. E. DON,  
 Public Trustee.

412 Collins-street, Melbourne. C.1, 27th March, 1946.

## NOTICE.

ADMINISTRATION of the estate of each of the under-mentioned deceased persons has been granted to me, and creditors, next of kin, and all others having claims against the estate of any of the persons so mentioned, are required to send particulars of their claims to the Public Trustee, No. 412 Collins-street, Melbourne, on or before the 5th June, 1946, or they will be excluded from the distribution of the estate when the assets are being distributed:—

AH SUN, late of 23 Fleet-street, Fitzroy, laundryman, died 2nd January, 1946, interstate.

COOKSLEY, EMILY ALCINE, late of 10 Shower-street, Preston, married woman, died 18th September, 1945, intestate.

\*COOPER, AUBREY GORDON, also known as John Cooper, formerly of 12 Strettle-street, Thornbury, but late of A.M.F., soldier, died 10th April, 1944.

FARLEY, THOMAS, late of Peterborough, barman, died 7th November, 1945, intestate.

GRACE, PATRICK DANIEL, late of Korumburra South, labourer, died 9th January, 1946, intestate.

HICKEY, FRANCIS PATRICK, late of Digby, labourer, died 23rd May, 1943, intestate.

\*LEWIS, CHARLES JOHN, late of Mount Royal, Royal Park, retired salesman, died 12th December, 1945.

MAGHER, WILLIAM, late of Tinamba, pensioner, died 14th January, 1946, intestate.

PEARCE, MARGARET ANN, late of 15 Victoria-parade, Collingwood, pensioner, died 4th December, 1945, intestate.

PORTER, ALMA ELIZABETH, late of 46 Stanley-street, West Melbourne, married woman, died 6th January, 1946, intestate.

ROSS, THOMAS, late of 28 Baillie-street, North Melbourne, retired municipal employee, died 23rd October, 1943, intestate.

SMITH, THOMAS HENDRY, also known as Thomas Smith, late of 17 Calembena-avenue, Oakleigh, packer, died 23rd May, 1943, intestate.

TAYLOR, ESTHER JANE, formerly of 196 Sternberg-street, Bendigo, but late of Sunbury, married woman, died 17th December, 1945, intestate.

THOMSON, WILLIAM, late of 57 Rathdown-street, Carlton, military pensioner, died 13th January, 1946, intestate.

\*TIPPETTS, WILLIAM ALAN, formerly of Forest-road, Boronia, but late of Australian Imperial Forces, soldier, presumed to have died on 1st July, 1942.

\*TOMPSETT, GILBERT, formerly of The Basin, but late of Australian Imperial Forces, soldier, died 18th April, 1943.

\* According to the provisions of the will.

J. E. DON,  
 Public Trustee.

Melbourne. 27th March, 1946.

## FORESTS COMMISSION OF VICTORIA.

## FOREST OFFICERS AUTHORIZED TO DIRECT SUSPENSION OF CERTAIN FOREST OPERATIONS.

PURSUANT to the provisions of section 7 of the *Forests Act 1939*, as amended by section 3 of the *Forests Act 1942* and section 2 of the *Forests Act 1943*, whereby the Minister of Forests is empowered, by notice published in the *Government Gazette*, to specify the names of forest officers for the purposes of the said section, whereupon every forest officer so specified shall be authorized, in any case where he is of opinion that a condition of acute fire danger exists in any district under his control, by notice to direct any person who is engaged within any fire protected area in any of the operations of felling, logging, snigging, skidding, sledging, or other like operation, or in the operation of driving any steam engine or steam locomotive, to suspend or cause to be suspended all or any of such operations until such time as such suspension is revoked by such officer by a like notice.

Now therefore I, William Barry, His Majesty's Minister of Forests for the State of Victoria, do hereby specify the names of the following forest officers for the purposes of the said section:—

ARCHIBALD WESTORY SHILLINGLAW,  
 FRANCIS SIDNEY INCOLL.

WM. BARRY,  
 Minister of Forests.

Melbourne, 5th March, 1946.

*Farmers Debts Adjustment Act 1935.*

## CANCELLATION OF STAY ORDER.

NOTIFICATION is hereby given that the Stay Order issued to the under-mentioned farmer has been cancelled by the Farmers' Debts Adjustment Board, such cancellation to take effect on Wednesday, 3rd April, 1946:—

*No. of Stay Order; Name; Address.*

3731: Miles, Walter; Mitiamo.

W. J. EVANS, Deputy Secretary,  
 Farmers' Debts Adjustment Board.

2nd April, 1946.

## DEPARTMENT OF LAW.

## SITTINGS OF THE SUPREME COURT.—WARRNAMBOOL.

HIS Excellency the Governor of the State of Victoria, by and with the advice of the Executive Council thereof, has, by Order made on the 27th day of March, 1946, appointed Tuesday, the 9th April, 1946, a day for the sittings of the Supreme Court for the Trial of Causes at Warrnambool.

C. W. KINSMAN,

Clerk of the Executive Council.

At the Executive Council Chamber,  
 Melbourne, the 27th March, 1946.

## DEPARTMENT OF LAW.

## COURT OF PETTY SESSIONS, LORNE.—ADDITIONAL DAY.

HIS Excellency the Governor of the State of Victoria, by and with the advice of the Executive Council thereof, has, by Order made on the 27th day of March, 1946, appointed Friday, the 12th April, 1946, at Two o'clock in the afternoon, as an additional day and hour for the holding of a Court of Petty Sessions at Lorne.

C. W. KINSMAN,

Clerk of the Executive Council.

At the Executive Council Chamber,  
 Melbourne, the 27th March, 1946.



CONTRACTS ACCEPTED.—(Series 1945-46.)  
PROVISIONS.—MEAT.

No. of Contract.	Particulars of each Tender Accepted.	Amount.	Name of Contractor.	Charge against Vote or Fund.
	PROVISIONS— Supply of Meat, in such quantities as may be ordered, from 1st April, 1946, to 30th June, 1946.			
1305	Schedule No. 1—Melbourne District— Kew Mental Hospital .. .. .	Rates as per annex	F. Watkins Pty. Ltd. ..	Contingencies, 1945-46
1306	Pentridge Penal Establishment, &c. .. .. .	" "	F. Watkins Pty. Ltd. ..	
1307	Children's Welfare Depot, Royal Park, and Police Hospital .. .. .	" "	J. H. Cooke Pty. Ltd. ..	
1308	Royal Park Mental Hospital and Receiving House .. .. .	" "	J. H. Cooke Pty. Ltd. ..	
1309	Schedule No. 2—Mont Park; Sanatorium, Gresswell, &c. .. .. .	" "	W. Angliss and Co. (Aust.) Pty. Ltd.	
1310	Schedule No. 3—s.s. Rip and Dredges .. .. .	" "	J. H. Cooke Pty. Ltd. ..	
1311	Schedule No. 4—Teachers' College, Carlton, and Travancore Developmental Centra, Flemington .. .. .	" "	J. H. Cooke Pty. Ltd. ..	
1312	Schedule No. 5—Ararat District .. .. .	" "	W. Newsome .. .. .	
1313	Schedule No. 6—Ballarat District .. .. .	" "	H. J. Symons Pty. Ltd. ..	
1314	Schedule No. 7—Beechworth District .. .. .	" "	E. Spencer .. .. .	
1315	Schedule No. 8—Castlemaine District .. .. .	" "	Ewing's "W.K. & H.S." ..	
1316	Schedule No. 9—School of Forestry, Cruswick .. .. .	" "	H. J. Symons Pty. Ltd. ..	
1317	Schedule No. 10—McLeod Settlement, French Island .. .. .	" "	W. F. Misson .. .. .	
1318	Schedule No. 11—Heatherton Sanatorium, Cheltenham .. .. .	" "	W. Angliss and Co. (Aust.) Pty. Ltd.	
1319	Schedule No. 12—Sanatorium, Greenvale .. .. .	" "	F. Watkins Pty. Ltd. ..	
1320	Schedule No. 13—Coorimungle Prison Camp, Heytesbury Forest .. .. .	" "	Tarrant Bros. .. .. .	
1321	Schedule No. 16—Sale, Gaol .. .. .	" "	H. L. G. Laws .. .. .	
1322	Schedule No. 17—Pleasant Creek Special School, Stawell .. .. .	" "	Ada J. West .. .. .	
1321	Schedule No. 18—Sunbury District .. .. .	" "	F. Watkins Pty. Ltd. ..	

Approved—P. L. COLEMAN, Assistant Treasurer. 26.3.16.

ANNEX TO CONTRACTS.

SCHEDULE No. 1.—MELBOURNE DISTRICT.

ANNEX TO CONTRACT No. 1945/1305.

F. Watkins Pty. Ltd., 184 Bourke-street, Melbourne, C.I.

Sub-schedule No. 7.

MEAT FOR MENTAL HOSPITAL, KEW.

Security, £35.

	£	s.	d.
1. Fresh Beef—Fore-quarters .. .. . per cwt.	2	16	3
2. " " Hind-quarters .. .. . do.	2	16	3
3. " " Buttocks .. .. . per lb.	0	0	9½
4. Corned Beef—Rolled or round, as ordered, without bone or cartilage .. .. . do.	0	0	10
5. Fresh Mutton .. .. . do.	0	0	6½
6. " Suet—Kidney .. .. . do.	0	0	5
7. Sausage—Meat .. .. . do.	0	0	5
8. Liver—Calves' .. .. . do.	0	0	6
9. Brains .. .. . per set	0	0	3
10. Sausages—Mixed .. .. . per lb.	0	0	8
11. Tripe—Fresh .. .. . do.	0	0	5

ANNEX TO CONTRACT No. 1945/1305.

F. Watkins Pty. Ltd., 184 Bourke-street, Melbourne, C.I.

Sub-schedule No. 8.

MEAT FOR PENAL ESTABLISHMENT (PENTRIDGE), FEMALE  
PENITENTIARY, AND METROPOLITAN GAOL (COBURG).

Security, £35.

	£	s.	d.
1. Fresh Beef—Fore-quarters .. .. . per cwt.	2	10	0
2. Fresh Mutton (whole sheep) .. .. . per lb.	0	0	6½
3. Sausages—Mixed .. .. . do.	0	0	8
4. Liver—Calves' .. .. . do.	0	0	6
5. Fresh Suet—Kidney .. .. . do.	0	0	5
6. Dripping—Beef .. .. . do.	0	0	7
7. Rabbits—Fresh .. .. . per pair	0	2	6

ANNEX TO CONTRACT No. 1945/1307.

J. H. Cooke Pty. Ltd., 378 Queen's-parade, Clifton Hill.

Sub-schedule No. 9.

MEAT FOR POLICE HOSPITAL, ST. KILDA-ROAD; CHILDREN'S  
WELFARE DEPOT, ROYAL PARK.

Security, £3.

	£	s.	d.
1. Fresh Beef .. .. . per cwt.	2	15	0
2. " Mutton .. .. . do.	2	12	1
3. Steak—Rump .. .. . per lb.	0	1	8
4. " Stewing .. .. . do.	0	0	9½
5. Beef, Corned—Silverside .. .. . do.	0	0	11½
6. " Rib .. .. . do.	0	0	10½
7. Fresh Mutton—Loin .. .. . do.	0	0	10
8. " " Leg .. .. . do.	0	0	11½
9. " " Cutlets .. .. . do.	0	0	11

Sub-schedule No. 9—continued.

MEAT FOR POLICE HOSPITAL, ST. KILDA-ROAD; CHILDREN'S  
WELFARE DEPOT, ROYAL PARK—continued.

	£	s.	d.
10. Chops—Mid Loin .. .. . per lb.	0	0	11
11. Shanks—Sheeps' .. .. . do.	0	0	5
12. Sausages—Mixed .. .. . do.	0	0	7
13. Tripe—Fresh .. .. . do.	0	0	6
14. Frys—Lamb's' .. .. . do.	0	0	6
15. Ox Tails .. .. . do.	0	0	8
16. Sausage—Beef, German .. .. . do.	0	0	8
17. " Strasburg—Pork .. .. . do.	0	0	10
18. Rabbits—Fresh .. .. . per pair	0	2	6
19. Frankfurts .. .. . per bundle	0	0	9
20. Ice .. .. . per cwt.	0	3	0

ANNEX TO CONTRACT No. 1945/1308.

J. H. Cooke Pty. Ltd., 378 Queen's-parade, Clifton Hill.

Sub-schedule No. 10.

MEAT FOR RECEIVING HOUSE AND MENTAL HOSPITAL, ROYAL PARK

Security, £10.

	£	s.	d.
1. Fresh Beef .. .. . per cwt.	2	15	0
2. " " Buttocks .. .. . do.	2	15	0
3. " Mutton .. .. . per lb.	0	0	6½
4. Corned Beef—Rolled or round, as ordered, without bone or cartilage .. .. . do.	0	0	11½
5. Fresh Suet—Kidney .. .. . do.	0	0	5
6. Sausages—Mixed .. .. . do.	0	0	7
7. Tripe—Fresh .. .. . do.	0	0	6
8. Ice .. .. . per cwt.	0	3	0

SCHEDULE No. 2.—MONT PARK SANATORIUM,  
GRESSWELL, ETC.

ANNEX TO CONTRACT No. 1945/1309.

W. Angliss and Co. (Aust.) Pty. Ltd., 42 Bourke-street,  
Melbourne, C.I.

Sub-schedule No. 4.

MEAT.\*

Security, £50.

	£	s.	d.
1. Fresh Beef—Forequarters .. .. . per cwt.	2	0	0
2. " " Hindquarters .. .. . do.	3	0	0
3. " " Buttocks .. .. . per lb.	0	0	8
4. " " Roast .. .. . do.	0	0	8½
5. Beef, Corned—Rolled or round, as ordered, without bone or cartilage .. .. . do.	0	0	9½
6. Mutton—Fresh .. .. . do.	0	0	5½
7. Chops—Forequarter .. .. . do.	0	0	7½
8. Lamb—Sides .. .. . do.	0	0	9½
9. Veal—Leg .. .. . do.	0	0	9½
10. Steak—Thick flank .. .. . do.	0	0	11½

**Sub-schedule No. 4—continued.**

MEAT FOR MONT PARK; SANATORIUM, GRESSWELL, ETC.—continued.

			£	s.	d.
11. Steak—Minced	..	..	per lb.	0	0 7½
12. Sausage Meat	..	..	do.	0	0 5
13. Sausages—Mixed	..	..	do.	0	0 7½
14. Shanks—Sheeps'	..	..	each	0	0 5
15. Tripe—Fresh	..	..	per lb.	0	0 3½
16. Brains—Sheeps'	..	..	per set	0	0 3
17. Frys—Lambs'	..	..	each	0	0 6
18. Kidneys—Ox	..	..	per lb.	0	0 11
19. Livers—Calves'	..	..	do.	0	0 9½
20. Sausage—Beef, German	..	..	do.	0	0 8
21. " Pork, Strasburg	..	..	do.	0	0 11
22. Rabbits—Fresh	..	..	per pair	0	2 4
23. Saveloys	..	..	per doz.	0	1 3

\* Rates subject to variation in accordance with determinations of Prices Commissioner.

**SCHEDULE No. 3.—S.S. RIP AND DREDGES.**

ANNEX TO CONTRACT No. 1945/1310.

*J. H. Cooke Pty. Ltd., 378 Queen's-parade, Clifton Hill, N.8.*

**Sub-schedule No. 3.**

MEAT.

(Delivery at River Yarra Wharfs.)

Security, £5.

			£	s.	d.
1. Fresh Beef—Roast	..	..	per lb.	0	0 10½
2. Beef, Corned—Silverside	..	..	do.	0	0 11½
3. " " Rolled	..	..	do.	0	0 8½
4. Fresh Mutton—Forequarter	..	..	do.	0	0 7
5. " " Legs	..	..	do.	0	0 11½
6. Chops—Forequarter	..	..	do.	0	0 7½
7. " " Loin	..	..	do.	0	0 11
8. Steak—Rump	..	..	do.	0	1 8
9. " Stewing	..	..	do.	0	0 9½
10. " Topside	..	..	do.	0	1 1
11. Sausages—Mixed	..	..	do.	0	0 7
12. Tripe—Fresh	..	..	do.	0	0 6
13. Frys—Lambs'	..	..	do.	0	0 6
14. Suet—Kidney	..	..	do.	0	0 5
15. Rabbits—Fresh	..	..	per pair	0	2 6
16. Ice	..	..	per cwt.	0	3 0

**SCHEDULE No. 4.—TEACHERS' COLLEGE, CARLTON, AND TRAVANJORE DEVELOPMENTAL CENTRE, FLEMINGTON.**

ANNEX TO CONTRACT No. 1945/1311.

*J. H. Cooke Pty. Ltd., 378 Queen's-parade, Clifton Hill, N.8.*

**Sub-schedule No. 3.**

MEAT.

Security, £8.

			£	s.	d.
1. Fresh Beef—Sirloin	..	..	per lb.	0	1 1
2. " Mutton—Forequarter	..	..	do.	0	0 7
3. " " Cutlets	..	..	do.	0	0 11
4. " " Chops, Mid. Loin	..	..	do.	0	0 11
5. " " Chops, Forequarter	..	..	do.	0	0 7½
6. " " Shoulder, Boned	..	..	do.	0	0 8
7. " " Legs	..	..	do.	0	0 11½
8. Beef, Corned—Silverside	..	..	do.	0	0 11½
9. Veal—Shoulder, Boned	..	..	do.	0	0 7
10. Steak—Blade	..	..	do.	0	0 11½
11. " (when required, minced)	..	..	do.	0	0 11½
12. Mince Meat	..	..	do.	0	0 7
13. Sausages—Mixed	..	..	do.	0	0 7
14. Sausage Meat	..	..	do.	0	0 5
15. " —Beef, German	..	..	do.	0	0 9
16. Kidneys—Ox	..	..	do.	0	0 11
17. Tongues—Ox	..	..	do.	0	0 8
18. Cheeks—Ox	..	..	do.	0	0 3
19. " Pigs'	..	..	do.	0	0 4
20. Frys—Lambs'	..	..	do.	0	0 6
21. Tripe—Fresh	..	..	do.	0	0 6
22. Suet—Kidney	..	..	do.	0	0 5
23. Bones—Soup	..	..	do.	0	0 1
24. Frankfurts	..	..	per bndle.	0	0 9
25. Rabbits—Fresh	..	..	per pair	0	2 6
26. Black Puddings	..	..	per lb.	0	0 4

**SCHEDULE No. 5.—ARARAT DISTRICT.**

ANNEX TO CONTRACT No. 1945/1312.

*W. Newsome, 139 Barkly-street, Ararat.*

**Sub-schedule No. 4.**

MEAT.\*

Security, £30.

			£	s.	d.
1. Fresh Beef—Fore-quarters	..	..	per ontl.	2	15 0
2. " " Hind-quarters	..	..	do.	2	15 0
3. " " Buttocks	..	..	per lb.	0	0 8½
4. " Mutton	..	..	do.	0	0 8½

\* Rates subject to variation in accordance with determination of Prices Commissioner.

**SCHEDULE No. 6.—BALLARAT DISTRICT.**

AGREEMENT FOR SUPPLIES TO 30.4.46.

*H. J. Symons Pty. Ltd., 1015 Macarthur-street, Ballarat.*

**Sub-schedule No. 4.**

MEAT.

Security, £35.

			£	s.	d.
1. Fresh Beef—Forequarters	..	..	per ontl.	3	3 0
2. " " Hindquarters	..	..	do.	3	3 0
3. " " Buttocks	..	..	do.	3	17 0
4. " Mutton	..	..	per lb.	0	0 7
5. Mince Meat	..	..	do.	0	0 7
6. Sausage—Beef, German	..	..	do.	0	0 8
7. Tripe—Fresh (alternative)	..	..	do.	0	0 5
8. Suet—Fresh, Kidney	..	..	do.	0	0 7
9. Sausages—Mixed	..	..	do.	0	0 8
10. Black Puddings	..	..	do.	0	0 6
11. Saveloys	..	..	per doz.	0	1 0

**SCHEDULE No. 7.—BEECHWORTH DISTRICT.**

ANNEX TO CONTRACT No. 1945/1313.

*E. Spencer, Camp-street, Beechworth.*

**Sub-schedule No. 4.**

MEAT.

Security, £30.

			£	s.	d.
1. Fresh Beef—Roast	..	..	per ontl.	2	3 9
2. " " (Group D)	..	..	per lb.	0	0 5½
3. " Mutton	..	..	do.	0	0 4½
4. " " (Group D)	..	..	do.	0	0 4½
5. Minced Meat	..	..	do.	0	0 5
6. Sausages—Mixed	..	..	do.	0	0 6
7. Sausage Meat	..	..	do.	0	0 4½
8. " —Beef, German	..	..	do.	0	0 8
9. Dripping, Beef	..	..	do.	0	0 5
10. Saveloys (alternative)	..	..	per doz.	0	0 8

**SCHEDULE No. 8.—CASTLEMAINE DISTRICT.**

ANNEX TO CONTRACT No. 1945/1314.

*Ewing's "W.K. & H.S.," 91 Mostyn-street, Castlemaine.*

**Sub-schedule No. 2.**

MEAT.

Security, £5.

			£	s.	d.
1. Fresh Beef	..	..	per lb.	0	0 9
2. Corned Beef—Rolled, without bone or cartilage	..	..	do.	0	0 8½
3. Fresh Mutton	..	..	do.	0	0 8
4. Sausages—Mixed	..	..	do.	0	0 7
5. Sausage Meat	..	..	do.	0	0 6

**SCHEDULE No. 9.—SCHOOL OF FORESTRY, CRESWICK.**

AGREEMENT FOR SUPPLIES TO 30.4.46.

*H. J. Symons Pty. Ltd., 1015 Macarthur-street, Ballarat.*

**Sub-schedule No. 4.**

MEAT.

Security, £3.

			£	s.	d.
1. Fresh Beef—Forequarters	..	..	per lb.	0	0 11
2. " Mutton	..	..	do.	0	0 10
3. Veal (Leg or Loin)	..	..	do.	0	0 10
4. Sausages—Mixed	..	..	do.	0	0 8½
5. Steak—Minced	..	..	do.	0	0 8½
6. Frys—Lambs'	..	..	do.	0	0 6
7. Fresh Suet—Kidney	..	..	do.	0	0 6
8. Hearts—Ox	..	..	do.	0	0 5
9. Tongues—Ox	..	..	do.	0	0 9
10. Tails—Ox	..	..	do.	0	0 9
11. Dripping, Beef	..	..	do.	0	0 6

**SCHEDULE No. 10.—MCLEOD SETTLEMENT, FRENCH ISLAND.**

ANNEX TO CONTRACT No. 1945/1315.

*W. F. Misson, Lang Lang.*

**Sub-schedule No. 3.**

MEAT.

Security, £5.

			£	s.	d.
1. Fresh Beef	..	..	per ontl.	3	6 8
2. " Mutton (Group D)	..	..	per lb.	0	0 7
3. Sausages—Mixed	..	..	do.	0	0 8

SCHEDULE No. 11.—HEATHERTON SANATORIUM, CHELTENHAM.

ANNEX TO CONTRACT No. 1945/1316.

W. Angliss and Co. (Aust.), Pty. Ltd., 42 Bourke-street, Melbourne, C.1.

Sub-schedule No. 3.

MEAT.\*

Security, £5.

			£	s.	d.
1. Fresh Beef, Roast	.. ..	per lb.	0	0	8½
2. Beef, Corned—Rolled or Round, as ordered, without bone or cartilage	.. ..	do.	0	0	9½
3. Mutton, Fresh..	.. ..	do.	0	0	5½
4. Chops—Forequarter	.. ..	do.	0	0	7½
5. Veal—Leg	.. ..	do.	0	0	9½
6. Steak—Blade Bone	.. ..	do.	0	0	11½
7. „ Mincéd..	.. ..	do.	0	0	7½
8. Sausage—Meat	.. ..	do.	0	0	5
9. Sausages—Mixed	.. ..	do.	0	0	7½
10. Tripe—Fresh	.. ..	do.	0	0	3½
11. Brains—Sheeps'	.. ..	per set	0	0	3
12. Frys—Lambs'	.. ..	each	0	0	6
13. Kidneys—Ox	.. ..	per lb.	0	0	11
14. Sausage—Beef, German	.. ..	do.	0	0	8
15. „ Strasburg, Pork	.. ..	do.	0	0	11
16. Rabbits—Fresh	.. ..	per pair	0	2	4
17. Saveloys	.. ..	per doz.	0	1	3

\* Rates subject to variation in accordance with determinations of Prices Commissioner.

SCHEDULE No. 12.—SANATORIUM, GREENVALE.

ANNEX TO CONTRACT No. 1945/1317.

F. Watkins Pty. Ltd., 184 Bourke-street, Melbourne, C.1.

Sub-schedule No. 3.

MEAT (cuts as ordered).

Security, £7.

			£	s.	d.
1. Fresh Beef—Roast	.. ..	per lb.	0	0	10
2. „ „ Topside	.. ..	do.	0	0	11
3. „ „ Rump	.. ..	do.	0	1	7
4. Beef, Corned—Silverside	.. ..	do.	0	0	11
5. Fresh Mutton—Sides	.. ..	do.	0	0	6½
6. Cutlets—Mutton	.. ..	do.	0	0	10
7. „ Veal	.. ..	do.	0	0	11
8. Chops—Mid. Loin	.. ..	do.	0	0	10
9. „ Leg	.. ..	do.	0	0	10
10. Steak—Mincéd	.. ..	do.	0	0	8
11. Mincéd Meat	.. ..	do.	0	0	5
12. Frys—Lambs'	.. ..	do.	0	0	6
13. Fresh Pork—Loin	.. ..	do.	0	1	3
14. Pickled Pork—Loin	.. ..	do.	0	1	3
15. Veal—Legs, Boned	.. ..	do.	0	0	10
16. Tripe—Fresh, Ox	.. ..	do.	0	0	5
17. Tails—Ox	.. ..	do.	0	0	8
18. Tongues—Ox	.. ..	do.	0	0	8
19. „ Sheep	.. ..	per doz.	0	2	0
20. Sausages—Mixed	.. ..	per lb.	0	0	8
21. „ Pork	.. ..	do.	0	0	10
22. Sausage—Strasburg, Pork	.. ..	do.	0	1	3
23. Suet—Fresh, Kidney	.. ..	do.	0	0	6
24. Kidneys—Ox	.. ..	do.	0	0	11
25. Brains	.. ..	per set	0	0	3
26. Fresh Rabbits	.. ..	per pair	0	2	8
27. Poultry—First Quality	.. ..	do.	0	15	0
28. Frankfurts	.. ..	per bundle	0	1	0
29. Saveloys	.. ..	per doz.	0	1	6

SCHEDULE No. 13.—COORIEMUNGLE PRISON CAMP, HEYTESBURY FOREST.

ANNEX TO CONTRACT No. 1945/1318.

Tarrant Bros., Timboon.

Sub-schedule No. 3.

MEAT.

Security, £4.

£ s. d.

1. Fresh Beef	.. ..	per lb.	0	0	11
2. „ Mutton	.. ..	do.	0	0	11½
3. Corned Beef, Rolled, without bone or cartilage	.. ..	do.	0	0	10
4. Mincéd Meat	.. ..	do.	0	0	8
5. Sausages—Mixed	.. ..	do.	0	0	8
6. Sausage Meat	.. ..	do.	0	0	6
7. Tripe—Fresh	.. ..	do.	0	0	8
8. Frys—Lambs'	.. ..	each	0	0	4
9. Dripping—Beef	.. ..	per lb.	0	0	6
10. Tongues—Ox	.. ..	each	0	4	0

SCHEDULE No. 16.—SALE GAOL.

ANNEX TO CONTRACT No. 1945/1319.

H. L. G. Laws, 111 Raymond-street, Sale.

Sub-schedule No. 2.

MEAT.

Security, £3.

£ s. d.

1. Fresh Beef—Stewing	.. ..	per lb.	0	0	6½
2. „ Mutton (Group D)	.. ..	do.	0	0	6½
3. Sausages—Mixed	.. ..	do.	0	0	6½
4. Sausage Meat (alternative)	.. ..	do.	0	0	6½
5. Tripe—Fresh	.. ..	do.	0	0	6½
6. Frys—Lambs'	.. ..	do.	0	0	6½
7. Livers—Calves' (alternative)	.. ..	do.	0	0	6½

SCHEDULE No. 17.—PLEASANT CREEK SPECIAL SCHOOL, STAWELL.

ANNEX TO CONTRACT No. 1945/1320.

Ada J. West, 65 Main-street, Stawell.

Sub-schedule No. 4.

MEAT.

Security, £3.

£ s. d.

1. Fresh Beef—Prime ribs	.. ..	per lb.	0	0	9½
2. „ „ Sirloin	.. ..	do.	0	0	9
3. „ „ „ Stewing (minced when required)	.. ..	do.	0	0	8
4. Beef—Corned, Silverside	.. ..	do.	0	0	9½
5. Fresh Mutton—Chops (loin)	.. ..	do.	0	0	7
6. „ „ Sides	.. ..	do.	0	0	6
7. Sausages—Mixed	.. ..	do.	0	0	6
8. Frys—Lambs'	.. ..	each	0	0	3
9. Tripe, fresh	.. ..	per lb.	0	0	9
10. Saveloys	.. ..	per doz.	0	1	3
11. Tongues—Ox	.. ..	per lb.	0	0	9

SCHEDULE No. 18.—SUNBURY DISTRICT.

ANNEX TO CONTRACT No. 1945/1321.

F. Watkins Pty. Ltd., 184 Bourke-street, Melbourne, C.1.

Sub-schedule No. 5.

MEAT.

Security, £40.

£ s. d.

1. Fresh Beef—Forequarter	.. ..	per cntl.	2	12	0
2. „ „ Buttocks	.. ..	per lb.	0	0	9½
3. „ Mutton	.. ..	do.	0	0	6½
4. Corned Beef, Rolled or Round, as ordered, without bone or cartilage	.. ..	do.	0	0	10
5. Sausages—Mixed	.. ..	do.	0	0	8
6. Sausage—Mince	.. ..	do.	0	0	6
7. Tripe—Fresh	.. ..	do.	0	0	5

**CONTRACTS ACCEPTED.**—(Series, 1945-46.)

**GENERAL STORES.**

*Gazette* No. 86, 28th June, 1945, Schedule No. 25, Item No. 73, Silver Nitrate.—For the amount shown opposite this item, substitute 3s. 6½d. per oz., as from 22nd March, 1946.

*Gazette* No. 86, 28th June, 1945, Schedule No. 72, Timber.—For the rates shown opposite the following items, substitute the rates as set out hereunder:—

Item No.		Rate for Lengths.		
		6 ft. to 9 ft.	10 ft. to 17 ft.	18 ft. to 25 ft.
		£ s. d.	£ s. d.	£ s. d.
38	Per 100 feet super. of 1 inch thick	2 15 9	3 0 0	3 4 0
39	" " " "	2 17 9	3 0 9	3 6 0
40	" " " "	2 16 3	2 19 9	3 4 3
41	" " " "	2 15 9	2 19 9	3 4 3
42	" " " "	2 16 3	3 1 3	3 5 9
43	" " " "	3 9 9	3 11 9	3 16 9
44	" " " "	2 16 3	3 0 3	3 4 9
45	" " " "	2 16 3	3 0 3	3 5 3
46	" " " "	3 5 9	3 5 9	3 11 0
47	" " " "	3 12 3	3 13 9	3 18 3
49	Per 100 feet lineal		2 6 6	

On the above items the surcharge of 5s. per 100 super. feet is cancelled and the additional charge for timber ordered in specified lengths, with the exception of Item 49, is now 2s. per 100 super. feet.

To take effect as from 6th March, 1946.

*Gazette* No. 86, 28th June, 1945, Schedule No. 36, Earthenware.—All rates subject to an increase of 6½ per cent., as from 27th March, 1946.

W. H. RUTHERFORD, Secretary to the Tender Board. 2.4.1946.

**ORDERS IN COUNCIL.**—(Series 1945-46.)

**DEPARTMENT OF PUBLIC INSTRUCTION.**

1301. Equipment of Essendon Technical School with four lathe driver units, £180.—Alfred Herbert (Asia) Pty. Ltd., Melbourne; and two drilling machines, £112 16s.—Servian Machine Tools (Aust.), Sydney-road, Brunswick.

1302. Equipment of Preston Technical School with one dividing head, &c., £131 4s.—Servian Machine Tools (Aust.), Brunswick.

1303. Equipment of Daylesford Technical School with one woodwork scroll saw, &c., £147.—McPherson's Pty. Ltd., Melbourne.

**DEPARTMENT OF PUBLIC WORKS.**

1304. Supply and delivery of earth filling and gravel for site works at State School No. 1165, Quarry Hill, £290 8s. 4d.—J. Spanosio, 9 Condon-street, Bendigo.

Approved by the Governor in Council, 27th March, 1946.—C. W. KINSMAN, Clerk of the Executive Council.

*Agricultural Education Act 1919, Section 2.*

**NOMINATION OF MEMBERS OF THE FACULTY OF AGRICULTURE.**

HIS Excellency the Governor of the State of Victoria, by and with the advice of the Executive Council thereof, and pursuant to the provisions of sub-section (2) of section 2 of the *Agricultural Education Act 1919*, has, by Order made on the 27th day of March, 1946, nominated

HUBERT ARTHUR MULLETT,  
GEORGE BARTLETT WOODGATE,  
ROBERT JOHN DE COURCY TALBOT,  
Dr. LIONEL BATLY BULL, and  
Sir CLIVE MCPHERSON, C.B.E.,

as members of the Faculty of Agriculture in the University of Melbourne.

C. W. KINSMAN,  
Clerk of the Executive Council.

At the Executive Council Chamber,  
Melbourne, the 27th March, 1946.

*Companies Act 1938, Section 17.*

**CONSENT TO THE USE OF THE WORD "CO-OPERATIVE."**

HIS Excellency the Governor of the State of Victoria, by and with the advice of the Executive Council thereof, doth by Order made on the 27th day of March, 1946, pursuant to the provisions of section 17 of the *Companies Act 1938*, consent to the use of the word "Co-operative" in the name of the company known as "Blue Moon Fruit Co-operative Limited," and which it is desired shall be registered in that name.

C. W. KINSMAN,  
Clerk of the Executive Council.

At the Executive Council Chamber,  
Melbourne, the 27th March, 1946.

*Crimes Act 1928, Section 323.*

**APPROVAL OF SUPERINTENDENT (ACTING) OF REFORMATORY SCHOOL.**

HIS Excellency the Governor of the State of Victoria, by and with the advice of the Executive Council thereof, and pursuant to the provisions of section 323 of the *Crimes Act 1928*, has, by Order made on the 27th day of March, 1946, approved of

DAVID CAPES

as Superintendent (Acting) of the Reformatory School for Protestant Boys at Bayswater Farm, from the 26th March, 1946, to the 14th April, 1946, during the absence on leave of Gill Inglis.

C. W. KINSMAN,  
Clerk of the Executive Council.

At the Executive Council Chamber,  
Melbourne, the 27th March, 1946.

*Factories and Shops Acts.*

**REGULATIONS UNDER THE FACTORIES AND SHOPS ACTS.—AMENDMENT TO CHAPTER V.**

At the Executive Council Chamber, Melbourne, the twenty-seventh day of March, 1946.

**PRESENT:**

His Excellency the Governor of Victoria.  
Mr. Field | Mr. McKenzie.

**THE GRANTING OF CERTIFICATES TO ENGINE-DRIVERS AND BOILER ATTENDANTS.**

IN pursuance of the powers conferred by the Factories and Shops Acts and the *Acts Interpretation Act 1928*, His Excellency the Governor of the State of Victoria, by and with the advice of the Executive Council thereof, doth by this Order amend Chapter V. of the Regulations under the Factories and Shops Acts made on the fourth day of March, 1930, as follows:—

In clause 8, sub-clause (a), paragraph 5—

For the words—

"stoker petty officer, leading stoker or chief stoker"

substitute the words—

"stoker petty officer, chief stoker, leading stoker, acting leading stoker or stoker."

In clause 11, sub-clause (a), paragraph 4—

For the word—

"Superior"

substitute the word—

"Satisfactory."

In clause 18, sub-clause (a)—

For the words—

"stoker petty officer, leading stoker, or chief stoker"

substitute the words—

"stoker petty officer, chief stoker, leading stoker, acting leading stoker or stoker."

Repeal sub-clause (b).

And the Honorable Percy James Clarey, His Majesty's Minister of Labour for the State of Victoria, shall give the necessary directions herein accordingly.

C. W. KINSMAN,  
Clerk of the Executive Council.

DEPARTMENT OF LANDS AND SURVEY.

COUNTRY ROADS BOARD.

At the Executive Council Chamber, Melbourne, the twenty-seventh day of March, 1946.

At the Executive Council Chamber, Melbourne, the twenty-seventh day of March, 1946.

PRESENT:

His Excellency the Governor of Victoria.  
Mr. Field | Mr. McKenzie.

PRESENT:

His Excellency the Governor of Victoria.  
Mr. Field | Mr. McKenzie.

UNUSED AND UNMADE ROADS CLOSED.

HIS Excellency the Governor of the State of Victoria, by and with the advice of the Executive Council thereof, doth hereby direct that, in pursuance of the provisions of section 304 of the *Land Act 1928* (No. 3709), the unused and unmade roads referred to hereunder be closed, viz.:—

Parish of Lilliput, County of Bogong, being the road lying between allotment 9A and allotment 9b, section L.—(L.115<sup>(2)</sup>) (H.017652).

Parish of Sedgwick, County of Bendigo, being the roads indicated by hachure on plan herewith.—(S.253<sup>(2)</sup>) (C.78166).

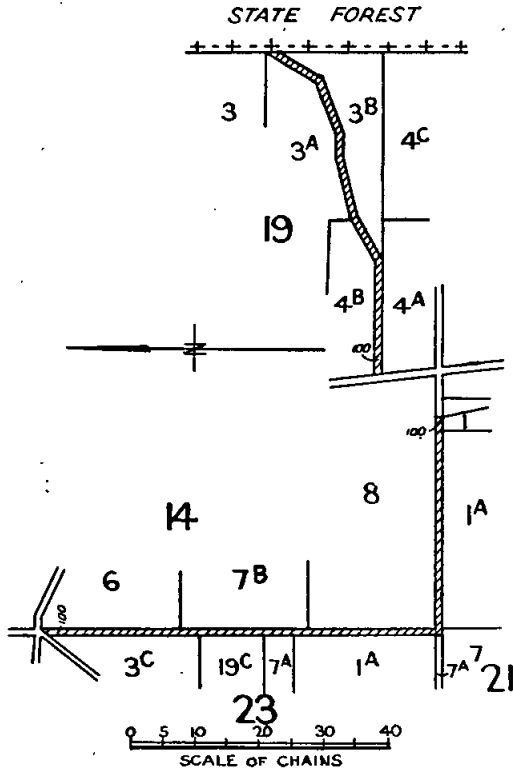

LAND WITHHELD FROM SALE, ETC., IN THE CITY OF SOUTH MELBOURNE.—ORDER IN COUNCIL REVOKED.

HIS Excellency the Governor of the State of Victoria, by and with the advice of the Executive Council thereof, doth hereby, in pursuance of the provisions of the *Land Act 1928*, revoke the Order in Council of the 28th April, 1885, withholding from sale, leasing, and licensing, 2 roods of land in the City of South Melbourne, being allotment 11 of section E.—(M.333<sup>(32)</sup>) (C.89496).

And the Honorable Leslie William Galvin, His Majesty's Commissioner of Crown Lands and Survey for the State of Victoria, shall give the necessary directions herein accordingly.

C. W. KINSMAN,  
Clerk of the Executive Council.

ORDER APPROVING OF A NEW STATE HIGHWAY IN THE BOROUGH OF ECHUCA.

WHEREAS the Country Roads Board constituted under the *Country Roads Act 1928* (No. 3602) has represented to His Excellency the Governor in Council that it appears to it desirable that the new Murray Valley Highway in the Borough of Echuca should be made by the said Board: And whereas the said Board in accordance with the requirements of section 19 of the said cited Act has caused to be prepared a map plan and estimate showing the points between which and on and through what land the said new highway is proposed to be made and the cost of acquiring the land and constructing the said new highway: And whereas on an inspection of the said map and plan and a consideration of the said estimate His Excellency the Governor in Council is satisfied that there are funds legally available for acquiring the land and constructing the said new highway: Now therefore be it known by this present Order that His Excellency the Governor of the State of Victoria with the advice of the Executive Council thereof doth hereby approve of the said highway being made, that is to say:—

All that piece of land in the Parish of Echuca North, the boundaries of which are as follow:—Commencing at a point on the northern boundary of Crown suburban allotment 34A of the said parish, distant 548 links from the north-western angle of the said allotment; thence by lines bearing respectively 90 deg. 0 min. 168 links, 168 deg. 0 min. 51.1 links, 270 deg. 0 min. 169 links, and 349 deg. 2 min. 50.9 links to the point of commencement—which said piece of land is particularly delineated and shown coloured red on survey plan numbered 3219, lodged in the office of the Country Roads Board.

ORDER APPROVING OF A NEW STATE HIGHWAY IN THE SHIRE OF CORIO.

WHEREAS the Country Roads Board constituted under the *Country Roads Act 1928* (No. 3602) has represented to His Excellency the Governor in Council that it appears to it desirable that the new Midland Highway in the Shire of Corio should be made by the said Board: And whereas the said Board in accordance with the requirements of section 19 of the said cited Act has caused to be prepared a map plan and estimate showing the points between which and on and through what land the said new highway is proposed to be made and the cost of acquiring the land and constructing the said new highway: And whereas on an inspection of the said map and plan and a consideration of the said estimate His Excellency the Governor in Council is satisfied that there are funds legally available for acquiring the land and constructing the said new highway: Now therefore be it known by this present Order that His Excellency the Governor of the State of Victoria with the advice of the Executive Council thereof doth hereby approve of the said highway being made, that is to say:—

All that piece of land in the Parish of Moorparanal, and being a road widening generally 34 feet wide, the north-eastern boundary of which commences at the south-eastern angle of allotment 86 of the said parish; thence north-westerly by the eastern boundaries of the said allotment and allotments 87 and 88 of the said parish to the northern angle of the allotment last named—which said piece of land is more particularly delineated and shown coloured red, blue, and yellow on survey plans numbered 4723, 4724, and 4725, lodged in the office of the Country Roads Board.

And the Honorable Patrick John Kennelly, His Majesty's Commissioner of Public Works for the State of Victoria, shall give the necessary directions herein accordingly.

C. W. KINSMAN,  
Clerk of the Executive Council.

**FACTORIES AND SHOPS ACTS.**

*At the Executive Council Chamber, Melbourne, the  
second day of April, 1946.*

PRESENT:

His Excellency the Governor of Victoria.

Mr. Galvin | Mr. Hayes,

**REGULATION OF FRUIT AND VEGETABLE SHOPS  
WITHIN THE GEELONG DISTRICT.**

UNDER the powers in that behalf conferred by the *Factories and Shops Act 1928* (No. 3677), His Excellency the Governor of Victoria, by and with the advice of the Executive Council thereof, upon a petition signed by a majority of all the shopkeepers (exclusive of hawkers and pedlars) of the particular class to be affected, doth hereby make the following Regulation, that is to say:—

All fruit and vegetable shops (being shops of a class or kind mentioned in the Fourth Schedule of the *Factories and Shops Act 1928* (No. 3677)), within the Geelong District as defined in the said Act shall be closed during the months of May, June, July, August, and September from the hour of Seven o'clock on the evenings of Monday, Tuesday, Wednesday, and Thursday in each week.

And the Honorable Percy James Clarey, His Majesty's Minister of Labour for the State of Victoria, shall give the necessary directions herein accordingly.

C. W. KINSMAN,  
Clerk of the Executive Council.

**Apprenticeship Acts.**

**APPRENTICESHIP COMMISSION OF VICTORIA.**

*At the Executive Council Chamber, Melbourne, the  
second day of April, 1946.*

PRESENT:

His Excellency the Governor of Victoria.

Mr. Galvin | Mr. Hayes.

**AMENDMENT OF FIBROUS PLASTERING TRADE  
REGULATIONS (No. 2).**

IN pursuance of the powers conferred by the Apprenticeship Acts and the *Acts Interpretation Act 1928*, His Excellency the Governor of the State of Victoria, by and with the advice of the Executive Council thereof, doth hereby make the following Regulations, that is to say:—

1. Regulation 8 of the Fibrous Plastering Trade Regulations No. 2) shall be and the same is hereby rescinded as on and from the beginning of the first pay period to commence on or after the 15th day of November, 1945.

2. Such rescission shall not affect any right accrued or accruing to any person or any liability of any person under the said rescinded Regulation before the commencement of these Regulations.

3. For the said rescinded Regulation substitute the following—

“8. The minimum rates of pay to be paid as wages to apprentices in the said trade in each year of their apprenticeship course shall be as follows, and shall commence on and from the beginning of the first pay period to commence on or after the 15th day of November, 1945, on, from, and after which date all indentures of apprenticeship heretofore executed under the provisions of the Acts and the Regulations made in respect of the aforesaid trade shall be deemed to be amended accordingly:—

(a) With respect to the term of apprenticeship of six years—

1st year—at the rate of 25s. 11d. per week.  
2nd year—at the rate of 38s. 8d. per week.  
3rd year—at the rate of 51s. 10d. per week.  
4th year—at the rate of 64s. 11d. per week.  
5th year—at the rate of 79s. 0d. per week.  
6th year—at the rate of 100s. 11d. per week.

(b) With respect to the term of apprenticeship of five years—

1st year—at the rate of 30s. 2d. per week.  
2nd year—at the rate of 40s. 11d. per week.  
3rd year—at the rate of 54s. 8d. per week.  
4th year—at the rate of 72s. 9d. per week.  
5th year—at the rate of 100s. 11d. per week.”

The above rates include allowances as compensation for time lost for prescribed holidays.

And the Honorable Percy James Clarey, His Majesty's Minister of Labour for the State of Victoria, shall give the necessary directions herein accordingly.

C. W. KINSMAN,  
Clerk of the Executive Council.

**APPROACHING LAND SALES.**

SALES of Crown lands, in fee-simple, will be held at the under-mentioned places and dates, viz.:—

	No. of Gazette
Ararat.—Thursday, 9th May, 1946 .. ..	62
Bendigo.—Monday, 29th April, 1946 .. ..	50
Underbool.—Wednesday, 8th May, 1946 .. ..	62
Lands and Survey Office, Melbourne.	

**SALES BY AUCTION.**

The lands will be sold in fee-simple, and subject to the covenants, conditions, exceptions, and reservations, directed by the Governor in Council by an Order in Council dated the 5th August, 1930, and published in the *Government Gazette* of the 8th August, 1930, varied as herein.

A deposit of at least twelve and a half per centum of the price at which each lot is sold must be paid by the purchaser at the time of sale, and all such payments shall be made in bank notes or cheques approved by the officer conducting the sale, and the residue of such price will be payable in equal instalments, in accordance with the scale hereunder, on the last day of each successive period of six months from the time of sale, or, if the purchaser choose, at any earlier time or times; such residue of the price shall bear interest at the rate of £5 per centum per annum, to be computed between the time of sale and the time when payment of such residue or instalment of such residue is made. If the residue of the price be paid within thirty days after the time of the sale no interest will be payable thereon.

The transfer of the interest of any purchaser of an allotment sold by public auction may be effected prior to the final payment of the purchase money being made. The fee for transfer shall be One pound, and such transfer will be subject to payment of stamp duty.

**SCALE OF PAYMENTS OF RESIDUE.**

£20 and under, 6 instalments.  
Over £20, and not exceeding £50, 8 instalments.  
Over £50, and not exceeding £100, 10 instalments.  
Over £100, and not exceeding £200, 12 instalments.  
Over £200, and not exceeding £300, 14 instalments.  
Over £300, and not exceeding £400, 16 instalments.  
Over £400, and not exceeding £500, 18 instalments.  
Over £500, 20 instalments.

**FEES, ETC.**

The fees payable for Crown grant and assurance (One halfpenny for each pound of purchase price) must be paid with the balance of purchase money. The following is the scale:—

50 acres and under, £1 10s.  
Over 50 acres, £2.  
Where the purchase money does not exceed £5, the grant fee is £1.

Valuations of improvements (if not purchased by the owner thereof), and charges for survey, must also be paid at the time of sale.

**SPECIAL CONDITION.**

Before sale is approved the purchaser will be required to satisfy the requirements of the National Security (Lands Transfer) Regulations as regards nationality.

L. W. GALVIN,  
Commissioner of Crown Lands and Survey.

Office of Lands and Survey,  
Melbourne, 2nd April, 1946.

**UNDERBOOL.**—Sale (No. 10585) of Crown lands in fee-simple will be held at the COURT HOUSE, UNDERBOOL, on WEDNESDAY, the 8th day of MAY, 1946, at TWO o'clock p.m. To be conducted by H. H. DODD, Land Officer, St. Arnaud.

UNDERBOOL, PARISH OF UNDERBOOL, COUNTY OF WEEAH.  
*Fronting Monash-avenue.*

Upset price £20 per lot. Charge for survey £3 per lot.  
Lot 1. Area 1r. 13p., being allotment 18 of section 2.  
Lot 2. Area 1r. 9p., being allotment 19 of section 2.  
Lot 3. Area 1r. 8p., being allotment 20 of section 2.  
*North of Water Tower Reserve.*

Upset price £20. Charge for survey £3.  
Lot 4. Area 1r. 13 9/10p., being allotment 8 of section 5. Valuation of improvements £7 (Henry Jones Pty. Ltd.).  
*Near State School.*

Upset price £20 per lot. Charge for survey £3 per lot.  
Lot 5. Area 1r. 27 5/10p., being allotment 1 of section 8.  
Lot 6. Area 1r. 20p., being allotment 2 of section 8.  
*Fronting Monash-avenue.*

Upset price £20 per lot. Charge for survey £3 per lot.  
Lot 7. Area 1r. 8p., being allotment 19 of section 1.  
Lot 8. Area 1r. 8p., being allotment 20 of section 1.  
Upset price £17 10s. per lot. Charge for survey £3 per lot.  
Lot 9. Area 1r. 8p., being allotment 21 of section 1.  
Lot 10. Area 1r. 8p., being allotment 22 of section 1.  
Lot 11. Area 1r. 9 5/10p., being allotment 7 of section 4.

OUYEN, PARISH OF OUYEN, COUNTY OF KARKAROOC.  
*In South of Township.*

Upset price £30. Charge for survey £3.  
Lot 12. Area 1r. 18p., being allotment 13 of section 19. One month allowed to remove fencing.

PARISH OF DANYO, COUNTY OF WEEAH.  
*Adjoining Murrayville Township.*

Upset price £20. Charge for survey £3 17s. 6d.  
Lot 13. Area 12a. 3r. 29p., being allotment 6B.  
*South-east of Murrayville Township.*  
Upset price £14. Charge for survey £3 17s. 6d.  
Lot 14. Area 13a. 1r. 27p., being allotment 6C.  
*South of Murrayville Township.*

Upset price £40. Charge for survey £3 17s. 6d.  
Lot 15. Area 16a. 2r. 32p., being allotment 6F. Valuation of improvements. £5.

PARISH OF WALPEUP, COUNTY OF KARKAROOC.  
*West of Walpeup Township.*

Upset price £30. Charge for survey £3 7s. 6d.  
Lot 16. Area 6a., being allotments 16c and 16d. Valuation of improvements £170 (Cecil Sly).

**ARARAT.**—Sale (No. 10586) of Crown lands in fee-simple will be held at the COURT HOUSE, ARARAT, on THURSDAY, the 9th day of MAY, 1946, at TEN o'clock a.m. To be conducted by R. J. THOMSON, Land Officer, Ballarat. Auctioneers: MESSRS. BEST & SPALDING.

ELMHURST, PARISH OF GLENPATRICK, COUNTY OF KARA KARA.  
*In South-east of Town.*

Upset price £10 per lot. Charge for survey £3 2s. 6d. per lot.  
Lot 1. Area 2a. 1r., being allotment 50 of section 18.  
Lot 2. Area 2a. 1r., being allotment 53 of section 18.

MOYSTON, PARISH OF MOYSTON, COUNTY OF BORUNG.  
*In South of Township.*

Upset price £10. Charge for survey £3.  
Lot 3. Area 1a. 0r. 38p., being allotment 101. Valuation of improvements, £2 (W. F. Shields).

PARISH OF DUNNEWORTHY, COUNTY OF BORUNG.  
*West of Dunneworthy Railway Station.*

Upset price £25 10s. Charge for survey £3 7s. 6d.  
Lot 4. Area 8a. 1r. 39p., being allotment 77c.  
*In Centre of Parish.*

Upset price £12. Charge for survey £3 2s. 6d.  
Lot 5. Area 5a., being allotment 33A<sup>1</sup>. Valuation of improvements £2 10s. (W. Moloney).

PARISH OF GLENLOGIE, COUNTY OF KARA KARA.  
*Fronting Amphitheatre-Avoca road.*

Upset price £6. Charge for survey £3 2s. 6d.  
Lot 6. Area 1a. 3r. 8p., being allotment 143D.

PARISH OF BURRUMBEEF, COUNTY OF RIPON.  
*In South of Parish.*

Upset price £13. Charge for survey £3 7s. 6d.  
Lot 7. Area 3a. 1r., being allotment 5A of section 7. Valuation of improvements £15 (L. W. and F. L. Harricks).  
*In East of Parish.*

Upset price £31 10s. Charge for survey £3 17s. 6d.  
Lot 8. Area 10a. 2r., being allotment 6A of section 14. One month allowed to remove fencing.

PARISH OF ARABAT, COUNTY OF RIPON.  
*In South-east of Parish.*

Upset price £13 10s. Charge for survey £3.  
Lot 9. Area 2a. 2r. 32p., being allotments 29A and 29B of section 19.

*In South of Parish.*

Upset price £25. Charge for survey £3 2s. 6d.  
Lot 10. Area 5a., being allotment 68 of section 12.

HEARING OF REASONS AGAINST THE FORFEITURE OF CERTAIN LICENCES AND LEASES BY PERSONS APPOINTED UNDER 34TH SECTION OF THE "LAND ACT 1928."

NOTICE is hereby given that reasons against the forfeiture of the licences and leases in the Schedule hereto, which are deemed liable to forfeiture under the provisions of the Land Acts, will be publicly heard by the persons appointed by me, the responsible Minister of the Crown administering the said Acts, to hear the same and report thereon in writing to me, when the persons in the said Schedule mentioned as holders of such licences and leases will be allowed to show cause against the same at the places and on the dates mentioned in the Schedule hereto.

L. W. GALVIN,

Commissioner of Crown Lands and Survey.  
Department of Lands and Survey.  
Melbourne, 2nd April, 1946.

SCHEDULE.

ALEXANDRA, 3rd May, 1946, H. Ramsay, Land Officer, Seymour—  
319/46.81, James Stone (deceased), A. A. Stone, executor, 41 acres, Parish of Eildon.  
285/46.81, James Stone (deceased), A. A. Stone, executor, 473 acres, Parish of Eildon.  
166/46.81, James Stone (deceased), A. A. Stone, executor, 403 acres, Parish of Eildon.  
334/50.81, Sarah Jane Stone, 236 acres, Maintongoon.

Land Act 1928.

LICENCE UNDER THE LAND ACT 1928 DECLARED CANCELLED.

NOTICE is hereby given that the Licence mentioned in the Schedule hereunder has been declared cancelled for the reason specified.

District.	Corr. No.	Name of Licensee.	Section of Land Act under which Licensed.	Parish.	Allotment.	Area.	Class.	Annual Rental.	Reason for Cancelling.
						A. R. P.		£ s. d.	
Sale	2/129	Morgan, S. J. R.	129/1928	Miowera	Part allotment 1	3 0 0	..	..	Surrendered at licensee's request

Department of Lands and Survey,  
Melbourne, 28th March, 1946.

L. W. GALVIN,  
Commissioner of Crown Lands and Survey.

THE CLOSER SETTLEMENT ACTS.

NOTICE is hereby given that the Leases mentioned in the Schedule hereunder have been forfeited by the Board of Land and Works for the reasons specified.

LEASES UNDER THE CLOSER SETTLEMENT ACT 1938.

Corr.	District.	Lessee.	Allotment.	Section.	Parish.	Area.	Remarks.
257/12	Mallee ..	McCaw, J. N. G. ..	49A, 50 ..	..	Woorinen	A. R. P. 1,037 2 4	Non-payment of instalments
514/12	Mallee ..	Cameron, J. T. . . .	9. 9A 12, 12A	..	Koorkab..	1,477 2 23	Non-payment of instalments

W. McIROY,  
Secretary for Lands.

PROPOSED REVOCATION OF TEMPORARY RESERVATIONS OF LANDS BY ORDERS IN COUNCIL.

IN pursuance of the provisions of the Land Act 1928, notice is hereby given that it is the intention of the Governor in Council to revoke the temporary reservations of lands by Orders in Council hereunder referred to, viz.:

The following Notice was gazetted 1° on 13th March, 1946, pursuant to Order of 5th March, 1946.

WHANREGARWEN.—The Order in Council of the 18th January, 1875, temporarily reserving as a site for State School purposes, and withholding from sale, leasing, and licensing, 5 acres of land in the Parish of Whanregarwen, is about to be revoked.—(W.278<sup>(3)</sup>) (63/121).

W. G. MCKENZIE,  
for Commissioner of Crown Lands and Survey.

The following Notice was published 1° on the 20th March, 1946, pursuant to Order of the 12th March, 1946.

QUAMBATOOK.—The Order in Council of the 18th June, 1900, temporarily reserving 16 acres, more or less, of land in the Parish of Quambatook as a site for Water Supply purposes is about to be revoked so far as regards the portion thereof indicated by hachure on plan hereunder.—(Q.37<sup>(5)</sup>) (Rs.2851).

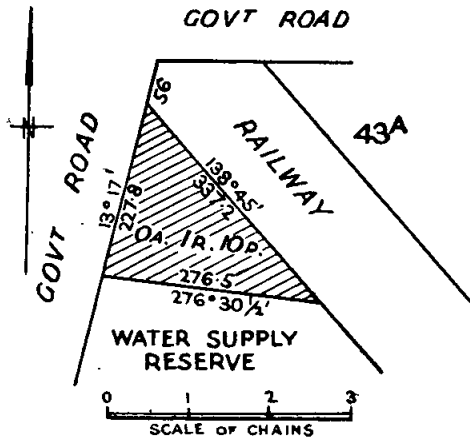

The following Notices were published 1° on the 3rd April, 1946, pursuant to Orders of the 27th March, 1946.

SOUTH MELBOURNE.—The Order in Council of the 20th May, 1901, see *Government Gazette* of the 24th May, 1901, page 1697, temporarily reserving 1 acre 0 roods 23 3/10 perches of land for Municipal purposes in the City of South Melbourne, being allotments 9 and 10 of section E, is about to be revoked.—(M.333<sup>(32)</sup>) (C.89496).

BUCHAN.—The Order in Council of the 24th April, 1888 (see *Government Gazette*, 27th April, 1888, page 1223), temporarily reserving 5 acres 3 roods 15 perches of land in the Parish of Buchan as a site for Watering purposes, is about to be revoked.—(B.605<sup>(7)</sup>) (C.81813).

DUNOLLY.—The Order in Council of the 24th February, 1931, temporarily reserving 350 acres, more or less, of land in the Parish of Dunolly as a site for Supply of Timber, is about to be revoked so far as regards the portion thereof indicated by hachure on plan hereunder.—(D.124<sup>(3)</sup>) (Rs.5484).

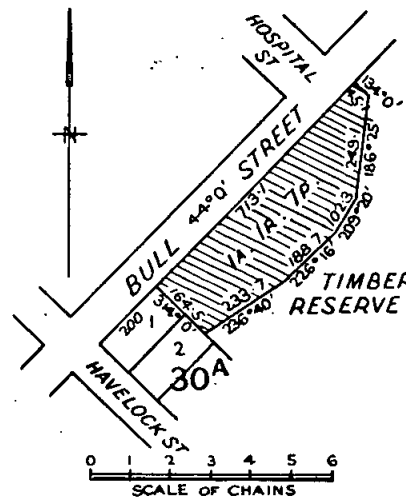

L. W. GALVIN,  
Commissioner of Crown Lands and Survey.

RESCISSION OF A REGULATION FOR THE CARE, PROTECTION, AND MANAGEMENT OF THE RESERVE FOR A PUBLIC PARK AND WATERING PLACE IN THE PARISH OF PRAHRAN, AND KNOWN AS "CAULFIELD PARK."

WHEREAS by section 181 of the Land Act 1928, as enacted by section 9 of the Land Act 1941, power is given to the Board of Land and Works to make Regulations with respect to, *inter alia*, the care, protection, and management of any land which has been reserved for any public purpose whatsoever, and which has not been conveyed to and vested in trustees, and whereas the Board is also empowered to rescind any such Regulations: Now therefore the Board, in pursuance of the powers conferred as aforesaid, doth hereby rescind clause 16 of the Regulations made by the Board on the 24th day of March, 1937, in respect of the land permanently reserved by Order in Council of the 27th October, 1879, as a site for Public Park and Watering Place in the Parish of Prahran.

The common seal of the Board of Land and Works was hereunto affixed this 27th day of March, 1946, in the presence of—

(SEAL) L. W. GALVIN, President.  
W. McIROY, Member.

(Rs.215.)



REGULATIONS FOR THE CARE, PROTECTION, AND MANAGEMENT OF THE "BURRAWANG RESERVE," IN THE CITY OF KEW.

WHEREAS by section 181 of the *Land Act* 1928, as re-enacted by section 9 of the *Land Act* 1941, power is given to the Board of Land and Works to make regulations in respect of the care, protection, and management of any land which has been reserved to or vested in trustees, and for the further purposes as enacted: Now therefore the Board of Land and Works, in pursuance of the powers conferred as aforesaid, doth hereby make the following Regulations in respect of the land temporarily reserved by Order in Council dated the 2nd January, 1945, as a site for Public purposes in the Parish of Boroondara, in the City of Kew, and now known as the "Burrawang Reserve," hereinafter referred to as "the reserve":—

REGULATIONS.

1. The reserve shall be open to the public at all times except on such days (not exceeding 26 in any one year) as the Committee of Management (hereinafter referred to as the Committee) may otherwise determine, and admission thereto shall be free except on such days and at such hours as a charge or entrance fee is made under the authority of the Committee.

2. No charge or entrance fee to the reserve shall exceed Two shillings for each person over the age of twelve years, and One shilling for children under twelve years of age.

3. No person shall enter any portion of the reserve when a charge is made for admission without first paying the fee charged, unless authorized by the Committee.

4. Except with the written permission of the Committee previously had and obtained, no person shall at any time play or practise cricket, football, golf, or other game, or engage in training or exercising for any sport, game, or contest in the reserve.

5. No person shall cross or trespass on the playing ground during any cricket or football match, or sports games, or amusements, or during practice at football, cricket, or other games when any such crossing or trespassing would be injurious to, or be an undue interference with, the progress of the aforesaid football, cricket, or sports.

6. No person shall climb, jump, or get upon or over or under any fences or gates of the reserve, or cut or in any way remove or damage any of such fences or gates, or any of the buildings, seats, trees, or shrubs in the reserve, or stick bills or advertisements or writings on any such fences, gates, buildings, seats, or trees, or light a fire in the reserve, or dig or remove any turf or soil, or enter any plots which may be enclosed for plantations of young trees, shrubs or plants, or commit any nuisance in the reserve, or damage or destroy any property or thing in the reserve.

7. No person shall throw or deposit any filth, rubbish, or refuse, or cause any filth, rubbish, or refuse to fall or to be thrown or deposited upon or in the reserve.

8. Persons using the reserve for any purpose shall, prior to leaving the area, collect and remove, or cause to be collected and removed, all waste material, scraps, bottles, glass, or litter of any kind brought or made by them.

9. No person shall bring, carry, or discharge any firearms in the reserve.

10. No person shall throw or discharge in the reserve any missile to the damage, danger, or annoyance of any person.

11. No person in a state of intoxication shall enter or remain in the reserve.

12. No person in the reserve shall behave in a noisy or disorderly manner, or create or take part in any disturbance, or commit any act of indecency, or offend against decency in dress, language, or conduct.

13. No person shall sell or offer for sale in the reserve any article of food or drink or any other commodity, or operate any money-making amusement, or erect any tent, booth, stand, building, or other structure without the permission in writing of the Committee.

14. No person shall make any wager for money or play any unlawful game within the reserve.

15. No person shall, in the reserve, wilfully obstruct, disturb, interrupt, or annoy any other person in the proper use of the reserve, or wilfully obstruct, disturb, interrupt, or annoy any member of the Police Force, or any servant of the Committee, in the proper execution of his duty or work.

16. No person shall remain in the reserve at any time when lawfully directed by any member of the Police Force, or any servant of the Committee, to leave the same.

17. No person shall camp in the reserve or assemble in the reserve for fetes, picnics, or concerts, or for the purpose of public worship, preaching, or public speaking of any kind, or meetings of a like character, without the permission in writing of the Committee.

18. No person shall make or cause to be made any violent outcry, noise, disturbance, or sound, or shall play any musical or noisy instrument, or sing in the reserve, nor shall any person preach or declaim, harangue, or deliver any address of any kind to members of the public in the reserve without the permission in writing of the Committee.

No. 62.—3315/46.—2

19. No person shall give out or distribute any handbills, placards, notices, advertisements, books, pamphlets, or papers in the reserve, or litter the same by scattering or throwing down handbills, placards, notices, advertisements, books, pamphlets, or papers.

20. No person shall ride a horse or other animal, or a bicycle or tricycle in or through the reserve, and no motor or other vehicle shall enter or pass over or through the reserve, except in, over, or through the portions of the reserve set apart by the Committee for such purpose.

21. No person shall bring into the reserve any dog, unless controlled by a chain or cord.

22. No dog shall be allowed in the reserve except as provided in clause 22, and all dogs, goats, pigs, and poultry found in the reserve shall be liable to be destroyed, and the owner shall make compensation to be recovered before any justice for any damage done.

23. No person shall put in the reserve any cattle, sheep, or other animal, and the Committee or any servant thereof shall have full power and authority to impound any cattle, sheep, or other animal found trespassing therein, and the owner of such cattle, sheep, or other animal shall be liable to the penalties provided in these Regulations.

24. No person shall remove, displace, or disfigure any board, plate, or tablet, or any support, fastening, or fitting used or constructed for the exhibition of any regulation or notice fixed or set up by the Committee in the reserve.

Every person who contravenes or fails to comply with these Regulations shall, in accordance with the provisions of section 181 of the *Land Act* 1928, as re-enacted by section 9 of the *Land Act* 1941, for each offence be liable to a penalty of not more than Five pounds, and every person who contravenes or fails to comply with any such regulation and who, after he has been warned by any bailiff of Crown Lands, or by any member of the Police Force, does not desist therefrom, may be forthwith apprehended by such bailiff or member of the Police Force and taken before some justice to be dealt with according to law, and shall be liable to a penalty of not more than Ten pounds.

The common seal of the Board of Land and Works was hereunto affixed, this 27th day of March, 1946, in the presence of—

(SEAL) L. W. GALVIN, President.  
W. McILROY, Member.

(Corres. Rs.5538.)

COMMITTEES OF MANAGEMENT OF RESERVES.

APPOINTMENTS.

WHEREAS by section 184 of the *Land Act* 1928 it is provided that it shall be lawful for the Governor in Council or the Board of Land and Works to appoint and remove any number of persons, not less than three, or any municipal council or the governing body of any corporation, to be a Committee of Management of any specified Crown land reserved either temporarily or permanently for any of the purposes set out in section 14 of the *Land Act* 1928, and not conveyed to or vested in trustees: Now therefore the Board of Land and Works doth hereby appoint the under-mentioned persons to be members of the Committee of Management of the reserves named:—

"MILLOO RECREATION RESERVE."

William John Francis Gladman, Thomas Henry Appleby, George Marshall, James Thomas Brereton, and Ernest Steen as a Committee of Management for a period of three years of the lands temporarily reserved by Orders in Council dated the 13th September, 1880, and 29th May, 1894, for Cricket and other purposes of Public Recreation in the Parish of Milloo, and known as the "Milloo Cricket and Recreation Reserve."—(Corres. Rs.4236.)

"OUYEN CHILDREN'S PLAYGROUND RESERVE."

Gerald Leo Walsh, Robert William Weir, William John Clarke, Ernest Reginald John Treadwell, James Bernard Sullivan, Hugo Frederick Ingwersen, and Lancelot David Harper as a Committee of Management for a period of three (3) years of the land temporarily reserved by Order in Council dated 26th October, 1926, as a site for a Children's Playground in the Township of Ouyen, Parish of Ouyen, and known as the "Ouyen Children's Playground Reserve."—(Corres. Rs.3238.)

"FIVE MILE HALL RESERVE," KOO-WEE-RUP.

Arthur Lewis Cork, Benjamin Turner, Percy Bazil Fechner, Desmond Thomas Walsh, Bernard Joseph Walsh, Alexander Henry Watson, and Chas. George Gordon Henwood as a Committee of Management for a period of three (3) years of the land temporarily reserved by Order in Council dated 4th April, 1911, as a site for a Mechanics' Institute in the Parish of Koo-wee-rup, and known as "Five Mile Hall Reserve."—(Corres. Rs.3604.)

"CANN RIVER TOURIST CAMP RESERVE."

Herbert Woolley, Massey Albert Herbert, Alan Douglas Conlley, Thomas Begley, and Eugene Patrick Reilly as a Committee of Management for a period of three (3) years of the land temporarily reserved by Order in Council dated the 11th January, 1938, as a site for Public purposes (Tourists' Camp) in the Township of Cann River, and known as the "Cann River Tourists' Camp Reserve."—(Corres. Rs.4763.)

"ECHUCA EAST RECREATION RESERVE."

The Council of the Borough of Echuca as a Committee of Management of the land temporarily reserved by Order in Council dated the 12th March, 1946, as a site for Public Recreation in the Town of Echuca, and known as the "Echuca East Recreation Reserve."—(Corres. Rs.5756.)

"MT. COLE CREEK PUBLIC HALL."

Arthur Keith Allender, Wilmot Keith Thomas, Francis Leonard de Clerg, Claude Harbour, Cecil Lindsay Hardy, Eugene Farish, and Thomas Henry Hardy as a Committee of Management for a period of three years of the land temporarily reserved by Order in Council dated the 8th May, 1928, as a site for a Public Hall in the Parish of Mt. Cole, and known as the "Mt. Cole Creek Public Hall."—(Corres. Rs.3663.)

"WARATAH BAY FORESHORE RESERVE."

Stephenson Percy Naunton, Michael Edward Farrell, Michael John Ryan, and William Augustus Gale, for a period of three (3) years, and Alexander Brown Hamilton, Leslie James Charlton, and Percy Laban Charles Vagg, for so long as they remain Councillors and the elect of the Shire of South Gippsland, as a Committee of Management of that portion of the reserved Crown lands in the Parish of Waratah North as is indicated in red colour on plan marked W over 2.12.1939 attached to Lands Department correspondence Rs.4799, and known as the "Waratah Bay Foreshore Reserve."—(Corres. Rs.4799.)

"FERNVALE SOLDIERS' MEMORIAL RESERVE."

John Michael O'Farrell, Thomas Daniel Ronan, Andrew Paton, William John Ronan, James Gordon Paton, William Geoffrey Paton, and John Thomas Mongan as a Committee of Management for a period of three (3) years of the land temporarily reserved by Order in Council dated 13th June, 1933, as a site for Public purposes in the Parish of Bolga, and now known as the "Fernvale Soldiers' Memorial Reserve."—(Corres. Rs.3155.)

"LANDSBOROUGH RACECOURSE RESERVE."

Ernest George Hodgetts as a Member of the Committee of Management, in the place of John Rahaley, deceased, for a period ending 14th November, 1948, of the land temporarily reserved as a site for a Racecourse in the Parish of Landsborough, and known as the "Landsborough Racecourse Reserve."—(Corres. Rs.646.)

"TOOMUNG RECREATION RESERVE."

Herbert H. Mitchell, George Challman, Charles Richardson, Keith Martin, and Otto Walter Bergmann as a Committee of Management for a period of three (3) years of the land temporarily reserved by Order in Council dated the 27th May, 1930, as a site for Public Recreation in the Parish of Callignee, Township of Toomung, and known as the "Toomung Recreation Reserve."—(Corres. Rs.3997.)

"ROCHESTER PUBLIC PARK RESERVE."

Harry Baker Williams, Charles Leonard Boysen, Leonard Fletcher, Sydney Leigh Johnston, Robert Stanley Iddles, George Henry Tyson, and James Arthur Hart as a Committee of Management for a period of three (3) years of the land temporarily reserved by Orders in Council dated 26th September, 1892, and 19th December, 1932, as a site for a Public Park in the Town, and known as the "Rochester Public Park Reserve."—(Corres. Rs.4280.)

"EXCELSIOR PUBLIC HALL RESERVE," AT WONYIP.

Frederick Clark, Horace James Clark, and William Piddington as a Committee of Management for a period of three (3) years of the land temporarily reserved by Order in Council dated 9th April, 1906, as a site for a Public Hall in the Parish of Binginwarri, and known as the "Excelsior Public Hall Reserve," at Wonyip.—(Corres. Rs.1448.)

"TUNGAMAH MECHANICS' INSTITUTE AND FREE LIBRARY RESERVE."

Charles Thomas Roberts, Edward Francis Buerekner, William McLean Stewart, Francis Edward Bartlett, Henry Pettit, Edward Joseph Bromley, and Colin Percival Nicholls as a Committee of Management for a period of three (3) years of the land permanently reserved by Order in Council dated 28th November, 1887, as a site for a Mechanics' Institute and Free Library at Tungamah, and known as the "Tungamah Mechanics' Institute and Free Library."—(Corres. Rs.5283.)

"EAST SHELBORNE RECREATION RESERVE."

Henrick Valentine Hinck, W. Hamilton, and William Harris as a Committee of Management for a period of three years of the land temporarily reserved for Public Recreation and Watering purposes in the Parish of Shelbourne, and known as the "East Shelbourne Recreation Reserve."—(Corres. Rs.3018.)

"BRIM SWIMMING POOL RESERVE."

Keith Neil McLennan, Albert John Wardle, Roy Vivian Quick, Stanley Archibald Rice, Edward Henry Crisp, John Warne Bartlett, and Victor William Henry Witney, as a Committee of Management for a period of three years of the land temporarily reserved by Order in Council dated the 11th December, 1945, as a site for Public purposes in the Township of Brim, and known as the "Brim Swimming Pool Reserve."—(Corres. Rs.5717.)

"KORUMBURRA RECREATION RESERVE."

Leslie Maurice Tolson, Arthur James Pullin, Frederick Hamilton Stocks, Peter Christian Petersen, Clive Thomas Jarvis, and David Gourley as a Committee of Management for a period of three (3) years of the land temporarily reserved by Order in Council dated 19th August, 1895, as a site for Public Recreation in the Township of Korumburra, and known as the "Korumburra Recreation Reserve."—(Corres. Rs.757.)

"LAANECORIE RECREATION RESERVE."

Linley Gladstone Curnow, Roy Cain, George Dillon Lawson, Allen Brownbill, and Thomas Geylls as a Committee of Management for a period of three (3) years of the land temporarily reserved by Order in Council dated 7th June, 1905, as a site for Public Recreation in the Township of Laanecorie, and known as the "Laanecorie Recreation Reserve."—(Corres. Rs.2004.)

"LAWSON BEACH RESERVE," IN THE PARISH OF TOORA.

Edward William Warner, William Louis Yeomans, Percy Bowen Martin, Edwin Walter Gasson, and Edward Franklin Martin as a Committee of Management for a period of three (3) years of the land temporarily reserved by Order in Council dated 24th December, 1935, as a site for Public purposes in the Parish of Toora, and known as the "Lawson Beach Reserve."—(Corres. Rs.4516.)

"KATAMATITE RACECOURSE RESERVE."

Donald Thomas McLean, William John Bollard, Charles George Sidebottom, Allan Johnstone McLean, Gordon Leslie Gillespie, William Henry Joseph Mead, and Hubert Edward Staggard as a Committee of Management for a period of three (3) years of the land temporarily reserved by Order in Council dated 24th February, 1885, as a site for Racecourse and other purposes of Public Recreation in the Parish of Katamatite, and known as the "Katamatite Racecourse Reserve."—(Corres. Rs.1369.)

"LEONGATHA RECREATION AND SHOW GROUNDS RESERVE."

Edward Bawden, William McIndoe, Hugh Jones, Lindsay R. C. Smith, Charles Louis Brumley, and John Welsford, for a period of three (3) years, and Cecil Augustus Salmund Bond, for so long only as he continues to be a Councillor and the elect of the Shire of Woorayl, as a Committee of Management of the land temporarily reserved by Order in Council dated 24th October, 1932, as a site for Public Recreation, Convenience, and Amusement of the People in the Parish and Township of Leongatha, and known as the "Leongatha Recreation and Show Grounds Reserve."—(Corres. Rs.2446.)

"MACARTHUR MARKET SQUARE RESERVE."

Laurence Joseph Kelly, Gordon McKenzie Munro, and Reginald John Brian as a Committee of Management for a period ending 29th September, 1946, of the land temporarily reserved by Order in Council dated 13th October, 1924, as a site for Recreation and other Public purposes in the Town of Macarthur, and known as the "Macarthur Market Square Reserve."—(Corres. Rs.3015.)

## "MACK'S CREEK PUBLIC HALL."

Allan Jeffrey Morris, Allan T. Morris, and William George Davis as a Committee of Management for a period of three years of the land temporarily reserved by Order in Council dated the 17th August, 1936, as a site for a Public Hall in the Parish of Bulga, and known as the "Mack's Creek Public Hall."—(Corres. Rs.4608.)

## "AVENEL PUBLIC PARK."

William Ewing, George Edwin James Saunders, George Andrew Stagg, Charles Henry Vearing, John P. McCosh, Thomas Grant Stewart, and Charles Richard Ewing as a Committee of Management for a period of three (3) years of the land temporarily reserved by Order in Council dated 30th May, 1939, as a site for a Public Park in the Parish and Town of Avenel, and known as "Avenel Public Park."—(Corres. Rs.4949.)

## "TRARALGON RECREATION RESERVE."

The Council of the Shire of Traralgon as a Committee of Management of the lands permanently reserved by Orders in Council dated 11th November, 1875, and 23rd August, 1932, for Recreation in the Township and Parish of Traralgon, and known as the "Traralgon Recreation Reserve."—(Corres. Rs.2039.)

In witness whereof the common seal of the Board of Land and Works were hereunto affixed, this twenty-seventh day of March, One thousand nine hundred and forty-six, in the presence of—

(SEAL) L. W. GALVIN, President.  
W. McILROY, Member.

## TENDERS.

**TENDERS** will be received at this office until **TEN A.M.** on the days and for the purposes under mentioned.

Particulars may be learnt at this office, and also at the offices named in each instance.

The Board of Land and Works will not necessarily accept the lowest or any tender.

## NOTICE TO CONTRACTORS.

**PUBLIC TENDERS NOW CLOSE AT 10 A.M. EACH TUESDAY, IN LIEU OF THURSDAY.**

9th April, 1946.

Alexandra.—Removal of school residence from State School No. 2841, Cathkin, and re-erection at State School No. 912. Particulars at Inspector of Works Office, Benalla; Police Stations, Mansfield, Seymour; State School, Alexandra. Preliminary deposit, £5. Final deposit, 2 per cent.

Bonn.—Purchase and removal of State School No. 2191. Particulars at Inspector of Works Office, Shepparton; Police Stations, Echuca, Kyabram, Rochester. Deposit, £2.

Collingwood.—Repairs and painting, Technical School. Particulars at Technical School, Collingwood. Preliminary deposit, 2 per cent.

Collingwood.—Sewerage, Workshop Block, Technical School. Preliminary deposit, £10. Final deposit, 2 per cent.

Footscray.—Brick additions to main building, Technical School, Ballarat-road. Preliminary deposit, £100. Final deposit, £15. Final deposit, 2 per cent.

Gaffney's Creek.—Re-straining of fences, repairs, and painting, State School No. 1049. Particulars at Inspector of Works Office, Benalla; Police Stations, Alexandra, Mansfield; State School, Gaffney's Creek. Deposit, £2.

Lorne.—Erection of residence for patrolman, Country Roads Board. Particulars at Inspector of Works Office, Geelong; Police Stations, Colac, Lorne. Preliminary deposit, £15. Final deposit, 2 per cent.

Malvern.—Repairs and painting, State School No. 1804, Spring-road. Particulars at State School, Malvern. Preliminary deposit, £15. Final deposit, 2 per cent.

Melbourne.—Supply and delivery of hot cathode fluorescent lighting equipment, Department of Public Works, State Public Offices. Preliminary deposit, £3. Final deposit, 2 per cent.

Meringur.—Removal of several school buildings and re-erection, together with remodelling, repairs, and painting, State School No. 4357. Particulars at Inspector of Works Office, Bendigo; Police Station, Maryborough, Mildura, Ouyen; State School, Meringur. Preliminary deposit, £15. Final deposit, 2 per cent.

Serviceton.—Painting, repairs, school and residence, State School No. 2831. Particulars at Inspector of Works Office, Horsham; Police Stations, Kaniva, Nhill; State School, Serviceton. Deposit, £4.

Traralgon.—Repairs to desks, State School No. 3584. Particulars at Inspector of Works Office, Bairnsdale; Police Stations, Traralgon, Sale. Deposit, £3.

Werribee.—Erection of two (2) timber cottages, State Research Farm. Particulars at Inspector of Works Office, Geelong; Police Station, Colac; State Research Farm, Werribee. Preliminary deposit, £15. Final deposit, 2 per cent.

West Melbourne.—Supply and installation of steam and brine piping pumps, and injector, &c., at the new concentrator house, Government Cool Stores, Victoria Dock. Preliminary deposit, £15. Final deposit, 2 per cent.

16th April, 1946.

Bendigo.—Supply and installation of electric hot-water service, Inspector of Works Residence. Particulars at Inspector of Works Office, Bendigo. Deposit, £2.

Castlemaine.—Repairs to roof, &c., Superintendent's Quarters, Reformatory Prison. Particulars at Inspector of Works Office, Bendigo; Police Station, Castlemaine. Preliminary deposit, £3. Final deposit, 2 per cent.

Dookie.—Erection of Technical Buildings, Agricultural College. Particulars at Inspector of Works Offices, Benalla, Shepparton, Wangaratta; Agricultural College, Dookie. Preliminary deposit, £50. Final deposit, 2 per cent.

Dookie.—New brick building for Domestic Staff, Agricultural College. Particulars at Inspector of Works Offices, Benalla, Shepparton; Agricultural College, Dookie. Preliminary deposit, £15. Final deposit, 2 per cent.

Footscray.—Alterations and additions to central heating, Technical School, Nicholson-street. Preliminary deposit, £4. Final deposit, 2 per cent.

Geelong.—Supply and installation of hot-water heating system, High School. Particulars at Inspector of Works Office, Geelong. Preliminary deposit, £15. Final deposit, 2 per cent.

Healesville.—New tile roof, State School No. 849. Particulars at Police Stations, Lilydale, Warburton; State School, Healesville. Preliminary deposit, £5. Final deposit, 2 per cent.

Kew.—Repairs to Bio Cabinet, Mental Hospital. Deposit, £4.

Koo-wee-rup North.—Repairs and painting, teacher's residence, State School No. 3198. Particulars at Police Stations, Dandenong, Koo-wee-rup. Preliminary deposit, £5. Final deposit, 2 per cent.

Melbourne.—Boiler room and chimney stack, State Rivers and Water Supply Commission, 31 Flinders-lane. Preliminary deposit, £4. Final deposit, 2 per cent.

Melbourne.—Repairs and renovations, Central Hospital, Lonsdale-street. Preliminary deposit, £15. Final deposit, 2 per cent.

Melbourne.—Supply and delivery of one steel explosives lighter. Preliminary deposit, £50. Final deposit, 2 per cent.

South Melbourne.—Supply of mechanical plant, Public Works Department Storeyard. Deposit, 2 per cent.

Traralgon.—External painting, repairs and renovations, Police Station. Particulars at Inspector of Works Office, Bairnsdale; Police Stations, Sale, Traralgon. Deposit, £4.

Wando Bridge.—Painting, repairs, fencing, State School No. 3842. Particulars at Inspector of Works Office, Stawell; Police Station, Casterton; State School, Wando Bridge. Deposit, £3.

Wangaratta.—Supply and installation of electric hot-water service, Inspector of Works Residence. Particulars at Inspector of Works Offices, Benalla, Shepparton, Wangaratta. Deposit, £2.

Woodbrook.—Purchase and removal of State School No. 1077. Particulars at Inspector of Works Offices, Bendigo, Maryborough; Police Stations, Castlemaine, Maldon. Deposit, £2.

23rd April, 1946.

Preston.—Erection of Workshop Block, Technical School. Preliminary deposit, £100. Final deposit, 2 per cent.

## NOTICE TO CONTRACTORS.

**PUBLIC TENDERS NOW CLOSE AT 10 A.M. EACH TUESDAY, IN LIEU OF THURSDAY.**

Tenders to be addressed to the Honorable the Commissioner of Public Works, and envelope containing tender marked "Tender for due

P. J. KENNELLY,  
Commissioner of Public Works.

Melbourne, 2nd April, 1946.

## PRIVATE ADVERTISEMENTS.

CITY OF CAMBERWELL.  
STREET NAMING.

NOTICE is hereby given that, in pursuance of the powers conferred by the *Local Government Act 1928*, the Council of the City of Camberwell, at a meeting held on the 18th day of March, 1946, did order that the name of the street heretofore known as "Lexton-street," extending from Doncaster-road to 621 ft. 9 in. south of Maylands-avenue, be changed to "Aylmer-street," and that such order take effect from the date of its publication in the *Victoria Government Gazette*, 5958

R. MOULDER, Town Clerk.

CITY OF KEW.  
BY-LAW No. 77.

NOTICE is hereby given that, in pursuance of the powers conferred by the *Local Government Acts* and the *Uniform Building Regulations Victoria*, the Mayor, Councillors, and Citizens of the City of Kew have made By-law No. 77. The By-law contains the following provisions:—

**Brick Areas.**—Prescribes certain areas within the municipality as brick areas.

**Limit of Two Stories.**—Prescribes the whole of the municipality as an area in which buildings of Class II. and Class III. occupancy, as defined by the *Uniform Building Regulations*, shall not be constructed to contain more than two stories, including the ground story.

**Minimum Area, Depth, and Width of Frontage.**—Adopting the minimum area depth and width of frontage prescribed in columns 2, 3, and 4 of Table 803 of the *Uniform Building Regulations* for specified areas.

**Distance from Street Alignment.**—Specifying the minimum distance from street alignment of the outer walls of any building of Class I. or Class II. occupancy as defined by the *Uniform Building Regulations*.

**Sites Below Minimum Requirements.**—Provides for the construction of a building of Class I. occupancy on land having a lesser area, depth, or width of frontage or at a lesser distance from boundaries than those specified in columns 2, 3, or 4 (as the case may be) of Table 803 of the *Uniform Building Regulations*, or in clause 7 of the By-law, or for the construction of a building of Classes III., V., VI., VII., or VIII. occupancy or a building to which a building of Class IV. occupancy is attached on land having an area, depth or width of frontage less than that prescribed in clause 809 of the *Uniform Building Regulations* in any case where, on the date of commencement of the Regulations, such land existed as a separate allotment, and has not since been reduced in area, or is shown on any plan of subdivision approved by the Council and lodged in the Office of Titles.

**Rear Access.**—Provides that on any land forming part of a subdivision, approved by the Council and lodged in the Office of Titles before the date of commencement of the *Uniform Building Regulations*, if no allotment has a greater frontage than 20 feet, a building may be constructed without direct access from the rear of the building to a street.

The By-law was passed by the Council of the City of Kew on 11th December, 1945, confirmed on 5th February, 1946, and approved by the Governor in Council on 26th February, 1946.

A true copy of the By-law is open for inspection, free of charge, during office hours, at the office of the Council, Town Hall, Kew.

W. D. BIRRELL, Town Clerk.

CITY OF SANDRINGHAM.  
BY-LAW No. 132.

A By-law of the City of Sandringham, made under section 198 of the *Local Government Act*, with the approval of the Governor in Council, and numbered 132, for regulating, restricting, restraining, or prohibiting the erection, construction, conversion, and alteration of and any addition to buildings or erections, and regulating and restraining the erection and construction of fences abutting on or within 10 feet of any street or road.

IN pursuance of the powers conferred by the *Local Government Act* and of every other power it thereunto enabling, the Mayor, Councillors, and Citizens of the City of Sandringham, with the approval of the Governor in Council, order as follows:—

1. That clause 1 of By-law No. 64 be amended by substituting for the words "600 square feet" the words "1,000 square feet."

2. No fence on or within 10 feet of the street alignment shall be constructed or added to or reconstructed for more than one-quarter of its length or for more than 15 feet in any 50 feet except in accordance with a plan and specification submitted to and approved by the surveyor, and subject to the following conditions:—

(a) **Timber.**—All timber used in posts, plinths, and strutting shall be of red gum or jarrah. All timber used in rails shall be of red gum, jarrah or hardwood.

(b) **Gate and Corner Posts.**—Gate-posts and corner posts shall be not less than 5 inches by 5 inches in sectional area, plated and strutted on all four sides, unless otherwise allowed by the surveyor.

(c) **Intermediate Posts.**—Intermediate posts shall be not less than 5 inches by 3 inches in sectional area spaced not more than 9 feet apart, and every post shall be plated and strutted on two sides.

(d) **Sole Plates and Struts.**—Sole plates shall be not less than 4 inches by 2 inches housed half an inch for post, and not less than 3 feet in length. Struts shall be not less than 2 feet in length, cut to correct levels, and securely nailed to posts and plates.

(e) **Depth in Ground.**—Posts shall be fixed vertical, and shall be sunk below the surface of the ground not less than 2 feet in the case of fences under 5 ft. 6 in. in height, and 2 ft. 6 in. in the case of fences 5 ft. 6 in. or over in height.

(f) **Rails.**—Rails for paling or corrugated iron fences shall be not less than 3 inches by 2 inches, spaced not less than 2 ft. 6 in. apart, centre to centre, except in the case of fences 5 feet or under in height, where the centre rail may be a 3 inch by 1 inch batten. Rails shall be in lengths sufficient to span two panels, and shall break joints on alternate posts.

(g) **Plinths.**—Where a plinth is used at the bottom of a fence it shall be not less than 6 inches by 1 inch full (full), shall be in lengths to span two panels, and be securely nailed to posts and supported on the inner side by a short upright, driven 15 inches into the ground, halved on to the bottom rail, and nailed thereto. One such upright shall be provided in the centre of each panel of fencing.

(h) **Palings.**—Split palings used as a covering shall be not less than  $\frac{1}{2}$  inch in thickness on the back, fixed vertically with a side lap of not less than 1 inch. Sawn palings shall not be less than  $\frac{1}{2}$  inch in thickness, and shall be fixed vertically. The tops of all paling fences shall be cut off to a regular line.

(i) **Corrugated Iron.**—Where corrugated iron is used as a covering it shall be fixed with the corrugations vertical. It shall be of new iron of not less than 26 gauge, and finished to a regular line along the top.

(j) **Special Fences.**—The methods of construction of ornamental wire fences, picket fences, brick fences, concrete fences, or other fences of special design must be approved by the surveyor before being erected.

(k) **Cyclone or Wire Fences.**—The condition as to spacing of posts hereinbefore mentioned shall not apply to cyclone or plain wire fences which may, in the discretion of the surveyor, have the posts spaced at longer intervals, provided that metal or timber droppers are fixed at such intervals as may be directed by the surveyor, and the wires are tightly strained. In this class of fence, the gate posts and corner posts must be braced to the approval of the surveyor.

(l) **Short Lengths.**—The use of short lengths of timber in posts, rails, pickets, or palings will not be permitted.

(m) **Height.**—No fence or any addition thereto shall exceed 7 feet in height.

3. **Fences at Intersections.**—Such fences of every allotment situated at any intersection of streets used for vehicular traffic as are within a distance of 30 feet from the point of intersection of the building alignments of such streets shall not be constructed to a greater height than 4 feet above the level of the footpath.

4. **Gates.**—All gates in boundary fences must be properly framed, braced, and constructed to the satisfaction of the surveyor, and hung with suitable hinges, but in no case must any gate be so hung as to swing out over any adjoining footpath.

5. **Hoods, Pergolas, &c.**—(a) Hoods, pergolas, and ornamental heads to gateways or fences shall be constructed in accordance with a design and of materials approved by the surveyor.

(b) No part of any such hood, pergola, or ornamental head shall project more than 12 inches beyond the building alignment, and no projection shall be at a lesser height than 9 feet from the level of the footpath.

6. **Paths, &c., Not to be Broken.**—No person shall dig, break, remove, or damage tar painted gravel, asphalt, flagging, pitchers, or concrete of any road, path, or other public highway for the purpose of erecting any strutted fence posts, or for similar purposes, without first obtaining a road opening permit, in addition to the fencing permit, to do so.

7. *Seepage to be Diverted.*—All retaining walls or brick or concrete fences shall have seepage diverted in a manner approved by the surveyor, but in no case shall seepage be discharged on to a public footpath.

8. *Barbed Wire Adjacent to Streets.*—Where barbed wire is erected adjacent to any street it shall be set back not less than 6 inches from the street alignment up to a height of 7 ft. 6 in. above the level of the street, but in no case shall barbed wire project beyond the street alignment.

9. Clause 3 of By-law numbered 130 is hereby repealed.

Resolution for passing this by-law agreed to by the Council, the 2nd day of October, 1945, and confirmed the 30th day of October, 1945.

In witness whereof the common seal of the Mayor, Councillors, and Citizens of the City of Sandringham was hereto affixed this 27th day of November, 1945, in the presence of—

(SEAL) W. MCKAY, Mayor.  
R. J. SILLITOE, Councillor.  
F. G. TRICKS, Town Clerk.

Approved by the Governor in Council, this 26th day of February, 1946.—J. C. MACGIBBON, Acting Clerk of the Executive Council. 5976

#### CITY OF SOUTH MELBOURNE.

##### BY-LAW No. 364.

A By-law of the City of South Melbourne, made under the Local Government Acts, and numbered 364, for the purpose of amending By-law No. 313 of the said City.

**T**HE Mayor, Councillors, and Citizens of the City of South Melbourne, in pursuance of the powers conferred by the Local Government Acts and every other Act or power enabling it in that behalf, doth hereby make the By-law and order as follows:—

That By-law No. 313 of the said City be amended—

1. By repealing Clause 4 and substituting therefor the following:—

“4. Notwithstanding anything contained in Clauses 2 and 3 of this By-law, shops may be erected, used, or established on land fronting any of the streets specified in the Second Schedule to this By-law, provided that the principal entrance to the said shops is gained from the streets so specified.”

2. By repealing the First Schedule and substituting therefor the following:—

##### “FIRST SCHEDULE.

All that piece of land commencing at the north-west corner of Fraser-street and Beaconsfield-parade; thence north-westerly along Beaconsfield-parade to the east corner of Pickles-street; thence north-easterly along Pickles-street to its intersection with Graham-street; thence easterly along Graham-street to its intersection with Foote-street; thence north-easterly along Foote-street to Bridport-street; thence north-easterly along Bridport-street to its intersection with Richardson-street; thence north-westerly along Richardson-street to its intersection with Pickles-street; thence northerly along Pickles-street to its intersection with City-road; thence north-easterly along City-road to its intersection with York-street; thence north-easterly along York-street to its intersection with Ferrars-street; thence south-easterly along Ferrars-street to its intersection with Coventry-street; thence north-easterly along Coventry-street to its intersection with Moray-street; thence south-easterly along Moray-street to its intersection with Bank-street; thence north-easterly along Bank-street to its intersection with Wells-street; thence northerly along Wells-street to its intersection with Grant-street; thence south-westerly along Grant-street to its intersection with Dodds-street; thence northerly along Dodds-street to its intersection with Nolan-street; thence north-easterly along Nolan-street to its intersection with St. Kilda-road; thence south-easterly along St. Kilda-road to its intersection with Lorne-street; thence south-westerly along the north side of Lorne-street to its intersection with Queens-road; thence in a direct line across the Albert Park to the intersection of Canterbury-road and Fraser-street; thence south-westerly along Fraser-street to the commencing point at the north-west corner of Fraser-street and Beaconsfield-parade; always excepting the sections of the railway reserve adjoining the Melbourne-St. Kilda railway as hereinafter described:—

(a) Adjoining Canterbury-road on the west side of the railway from a point in line with the north-west building line of McGregor-street; thence north-westerly for a distance of 700 feet.

(b) Adjoining Ferrars-street on the west side of the railway from a point in line with the north-west building line of Bridport-street thence north-westerly to a point in line with the south-east building line of Park-street.

(c) On the north-east side of the railway from the north-west building line of Park-street to the south-east side of Bank-street.

(d) On the north-east side of the railway from the north-west building line of Dorcas-street to the north-west side of Coventry-street.”

3. By repealing the Second Schedule and substituting therefor the following:—

##### “SECOND SCHEDULE.

(a) Armstrong-street, on the west side from a point 82 feet 7 inches south of Richardson-street to Canterbury-road, and on the east side from Richardson-street to Canterbury-road.

(b) Bridport-street, on the north side from Ferrars-street to Merton-street and on the south side from Madden-street to Dundas-place.

(c) Clarendon-street, on both sides from Thomson-street to Coventry-street.

(d) Coventry-street, on the south side from Clarendon-street to Cecil-street.

(e) Dundas-place, on the south side from Montague-street to Merton-street.

(f) Mills-street, on both sides from Herbert-street to Hambleton-street, and from Page-street to Ashworth-street.

(g) Park-street, on the north side from Wells-street to Law-street and from Clarendon-street to Cecil-street.

(h) Victoria-avenue, on the east side from Merton-street to Beaconsfield-parade and on the west side from Beaconsfield-lane to Beaconsfield-parade.”

4. By repealing the Third and Fourth Schedules.

Resolution adopting this By-law agreed to by the Council of the City of South Melbourne on the third day of October, 1945, and confirmed at a meeting of the said Council held on the thirty-first day of October, 1945.

(SEAL) W. ELLIOTT WELLS, Mayor.  
J. J. CURTAIN, Councillor.  
H. ALEXANDER, Town Clerk.

Approved by the Governor in Council, 20th March, 1946.—C. W. KINSMAN, Clerk of the Executive Council. 5979

#### TOWN OF NEWTOWN AND CHILWELL.

##### BY-LAW No. 38.

A By-law of the Town of Newtown and Chilwell, made under the Health Acts and the Local Government Acts and every other Act or power enabling it in that behalf, and numbered 38 for—

(a) regulating or prohibiting the keeping of any place or any animals (including birds) or the storage of any things in the opinion of the Council offensive, injurious to health, or dangerous;

(b) fixing the distance from any dwelling within which it shall be unlawful to keep any such place or animal, or to store any such thing;

(c) providing for the health of the residents in the municipal district and against the spreading of contagious or infectious diseases and for other purposes.

**T**HE Mayor, Councillors, and Burgesses of the Town of Newtown and Chilwell, in pursuance of the powers conferred by the Health Acts and the Local Government Acts and by every other Act or power enabling it in that behalf, doth hereby make the By-law and order as follows:—

1. In this By-law unless inconsistent with the context or subject matter—

“Animals” shall mean horses and dogs.

“Birds” shall mean fowls, ducks, geese, turkeys, and all other classes of poultry, and pigeons and doves.

“Dwelling” shall include bathrooms, kitchens, sculleries, and all rooms used for sleeping, living, cooking, or for like purposes.

2. No person shall keep or cause or permit to be kept any bird and/or animal in any dwelling or in the yard of or attached to any such dwelling, or in any land whatsoever in such a manner as to be offensive, injurious to health, or dangerous.

3. The occupier of the yard of or attached to any dwelling or of any other land in which any animals and/or birds are kept or housed, shall cause the place of keeping of such animals and/or birds to be maintained in a good state of repair, and thoroughly cleansed and effectually deodorized from time to time as may be necessary for the purpose of keeping such place in a clean, wholesome, and sanitary state and condition.

4. The occupier of any land on which is erected any stable for the keeping or housing of horses shall—

- (a) Cause all manure, refuse, and rubbish produced or accumulated therein to be placed in a properly constructed receptacle of brickwork walls 9 inches in thickness, with brick or concrete floor 6 inches in thickness, lined throughout internally with cement rendering composed of 2½ parts sand to 1 part cement;
- (b) maintain such receptacle in a good state of repair as to prevent the escape or leakage of the contents;
- (c) keep such receptacle constantly covered, and from time to time effectually deodorize the same and the contents thereof;
- (d) cause the contents of such receptacle to be removed from such land at least once in each and every week;
- (e) cause the floor of such stable to be properly drained and paved or flagged with brick, stone, concrete, or other impervious material;
- (f) keep such stable in a good state of repair and in a cleanly and sanitary condition.

5. No person shall keep or cause or permit to be kept any fowls, ducks, geese, turkeys, or other classes of poultry within 30 feet of any dwelling, nor in the yard thereof, or attached thereto, the area of which yard is less than 1,500 square feet, nor within 60 feet of the alignment of any street of 33 feet or more in width, nor unless such fowls, ducks, geese, turkeys, or other classes of poultry are housed or kept in a properly constructed and securely fastened shed, shelter, erection, structure, or other enclosure.

6. No such shed, shelter, erection, structure, or other enclosure for the housing or keeping of any fowls, ducks, geese, turkeys, or other classes of poultry shall be erected or placed within 30 feet from any dwelling, nor in the yard thereof, or attached thereto, the area of which yard is less than 1,500 square feet, nor within 60 feet of the alignment of any street of 33 feet or more in width.

7. No person shall keep or cause or permit to be kept any fowls, ducks, geese, turkeys, or other classes of poultry on any land within 60 feet of the alignment of any street of 33 feet or more in width.

8. No such shed, shelter, erection, structure, or other enclosure for the housing or keeping of any fowls, ducks, geese, turkeys, or other classes of poultry shall be erected or placed in the yard of or attached to any dwelling house, nor any other land, unless a plan and description thereof be first submitted to and approved of by the Engineer.

9. No person shall keep or cause or permit to be kept any pigeons or doves within 25 feet from any dwelling nor in the yard thereof or attached thereto, the area of which yard is less than 750 square feet, nor on any other land unless such pigeons or doves are housed or kept in a properly constructed pigeon loft or dove cote.

10. No pigeon loft or dove cote shall be erected or placed within 25 feet from any dwelling nor in the yard thereof or attached thereto the area of which yard is less than 750 square feet, nor to a greater height than 7 feet from the ground, nor unless a plan and description thereof be first submitted to and approved of by the Engineer.

11. No person shall keep or cause or permit to be kept—

- (a) More than one animal (excluding horses) in the yard of or attached to any dwelling, the area of which yard is less than 750 square feet;
- (b) more than two animals (excluding horses) in the yard of or attached to any dwelling, the area of which yard is less than 1,000 square feet;
- (c) more than three animals (excluding horses) in the yard of or attached to any dwelling, the area of which yard is less than 1,500 feet;
- (d) more than four animals (excluding horses) in the yard of or attached to any dwelling;
- (e) more than four animals (excluding horses) on any other land without the previous consent in writing of the Council having been first had and obtained;
- (f) such animals shall be kept not less than 30 feet from any dwelling.

12. Any shed, shelter, erection, structure, loft, cote, or other enclosure for the housing or keeping of any animals and/or birds erected or placed in the yard of or attached to any dwelling, or on any other land, contrary to the provisions of this By-law, shall be removed by the owner or occupier of such land, yard or dwelling within seven days after being required so to do by notice, in writing, under the hand of the Health Inspector.

13. No occupier of any yard or other land in or on which has been erected or placed any shed, shelter, erection, structure, loft, cote, or other enclosure for the housing or keeping of any animals and/or birds shall leave or suffer to remain therein for a longer period than is absolutely necessary any waste food or other matter likely to become offensive or injurious to health or attract or harbor rodents or other vermin.

14. No person shall keep or store or cause or permit to be kept or stored any food for consumption by animals or birds unless such food is kept or stored in rat-proof receptacles.

15. Any animals and/or birds which shall develop any infectious or contagious disease injurious to the health of the residents of the municipal district shall be forthwith destroyed, or caused to be destroyed, by the person keeping the same.

16. Any contravention of any of the foregoing sections by act or omission shall be an offence against this By-law. Every person who is guilty of an offence against this By-law shall be liable on conviction to a penalty of not more than Twenty pounds for each offence, to a further penalty of not more than Five pounds for each day such offence is continued after a conviction or order of any Court.

Resolution for passing this By-law agreed to by the Council this 26th day of September, One thousand nine hundred and forty-five.

Confirmed this 31st day of October, One thousand nine hundred and forty-five.

The common seal of the Mayor, Councillors, and Burgesses of the Town of Newtown and Chilwell was affixed hereto in the presence of—

(SEAL) A. L. DAVID, Mayor.  
ALEX. D. HOLLYHOKE, Councillor.  
I. S. LANCASTER, Town Clerk.

Submitted to the Commission of Public Health on the 15th day of January, 1946.—J. WHITLOCK, Secretary of the Commission.

Approved by the Governor in Council, 5th March, 1946.—  
J. G. MACCUMSON, Acting Clerk of the Executive Council.

5977

## SHIRE OF WALPEUP.

IN pursuance of the powers conferred in that behalf by section 4 of the *Dog Act 1936*, as amended, the President, Councillors, and Ratepayers of the Shire of Walpeup hereby specify the under-mentioned area in the Ouyen Township as a shopping area in which any dog (other than a dog being used in the droving of stock) must be under the effective control of some person by means of a chain or cord or leash:—

Oke-street, from Gregory-street to Cooper-street.

Pickering-street, from Scott-street to Rowe-street.

Rowe-street, from Pickering-street to Gregory-street.

By order of the Council,

K. H. LOVETT, Shire Secretary.

Shire Hall, Ouyen.

5951

## SHIRE OF LILLYDALE.

IN pursuance of the powers conferred by section 521 of the *Local Government Act 1928*, the Council of the Shire of Lillydale does hereby order that Mullins-road, Wonga Park, the land hereinafter described shall, from the date of this order in the *Government Gazette*, be a public highway:—

All that piece and parcel of land, 1 chain in width, being part of Crown section 12, Parish of Warrandyte, and shown on plan of subdivision numbered 4315, lodged in the Office of Titles, commencing at the most southerly angle of lot No. 58 and bearing north-easterly along the east boundaries of lots 58 and 55 on the said plan of subdivision to a road opened by the Lillydale Shire Council.

5984

E. WINTERBOTTOM, Shire Secretary.

## SHIRE OF LILLYDALE.

## BY-LAW No. 52.

A By-law of the Shire of Lillydale, made under the Local Government Acts, and numbered 52, for regulating, restricting, restraining, or prohibiting the erection, construction, conversion, and alteration of, and any addition to, buildings and erections, and for other purposes.

A SUMMARY of the provisions of the By-law is as follows:—

The By-law shall apply to and have operation throughout the whole of the municipal district.

By-laws Nos. 31, 33, and 35 are hereby repealed.

The By-law shall not apply to any fence, greenhouse, fernery, or conservatory on land having an area of more than 5 acres or temporary offices used by builders in course of erection of any building.

*Definitions under the By-law.*

Minimum area and width of frontage of dwellings.  
Semi-detached houses.  
Erection of shops.  
Sites below minimum requirements.  
Notice of intention to build and lodgment of plans.  
Minimum size of houses.  
General provisions as to buildings.  
Distance from street.  
Minimum size of dwelling rooms.  
Height of attic room.  
Steps, stairs, ramps, and handrails.  
Roofs to be fireproof.  
Angle on roof.  
Skillions.  
Kitchens.  
Bathrooms.  
Laundry accommodation.  
Yard space and separate entrance.  
Parapet walls.  
Sleepouts.  
Garages.  
Fowl houses.  
Shop or outbuilding on boundary.  
Flats.  
Valuation and lighting.  
Chimneys, flues, and fireplaces.  
Street verandahs.  
Removal of buildings.  
Brick areas.  
Materials used.  
Excavations, foundations, and footings.  
Veneer, construction and fixings for pipes in veneer walls.  
Brick construction.  
Drainage, drains, and sewerage.  
Fences.  
Penalties and enforcement of Regulations.  
Buildings constructed contrary to law.  
Provisions for appeal.

*First Schedule.*—Notice of intention to build, prescribed form.

*Second Schedule.*—Fees payable.

*Third Schedule.*—Minimum area of a house of six squares—area of shire to which it applies.

*Fourth Schedule.*—Brick areas in the shire.

*Fifth Schedule.*—Dimensions and spacing of all timbers and wood beams used in any building.

The Resolution for making and passing this By-law was agreed to by the Council at a meeting held on the 17th day of December, 1945, and confirmed at a meeting held on the 21st day of January, 1946.

In witness whereof the common seal of the President, Councillors, and Ratepayers of the Shire of Lillydale was hereunto affixed this 21st day of January, 1946—

HAROLD H. PARKER, President.  
(SEAL) A. H. CHANDLER, Councillor.  
E. WINTERBOTTOM, Shire Secretary.

Approved by the Governor in Council, 12th day of March, 1946.—J. C. MACGIBRON, Acting Clerk of the Executive Council.

A copy of the above By-law is open for inspection during office hours at the Shire Hall, Lillydale. 5985

## SHIRE OF YEA.

NOTICE is hereby given that the Council of the Shire of Yea has forwarded to the Hon. the Minister of Water Supply an application for proclamation of a sewerage district and the construction, maintenance, and continuance of sewerage works for the Township of Yea, together with a general plan and description of the proposed works.

A copy of the general plan and description may be inspected, without payment, by any person at the following places:—

Shire Hall, Yea.  
State Rivers and Water Supply Commission, 100 Exhibition-street, Melbourne.  
Commission of Public Health, 295 Queen-street, Melbourne.

5810

THOMAS SINCLAIR, Shire Secretary.

## NOTICE OF DISSOLUTION OF PARTNERSHIP.

NOTICE is hereby given that the partnership heretofore subsisting between the undersigned Henry Douglas Gordon Melville and William MacDonald Melville, carrying on business as solicitors, at 224 Glenferrie-road, Malvern, under the name of Melville and Melville, has been dissolved by mutual consent, as from the 31st day of March, 1946. All debts due to and owing by the said late firm will be received and paid by Henry Douglas Gordon Melville, who will continue to carry on the business at the same place.

Dated at Malvern, the 1st day of April, 1946.

H. D. G. MELVILLE.  
W. M. MELVILLE.

Witness—R. S. V. BOULTON, clerk to Melville and Melville. 5997

NOTICE is hereby given that the partnership heretofore subsisting between William James Harris and Frank Augustus Harris, carrying on business as master butchers, at 79 Glenferrie-road, Malvern, under the style or firm of W. J. Harris and Son, has been dissolved as from the 1st day of March, 1946, by the retirement of the said William James Harris from the said firm. All debts due to and owing by the said firm will be received and paid respectively by the said Frank Augustus Harris, who will continue to carry on the said business under the style or firm of W. J. Harris and Son.

Dated the 27th day of March, 1946.

WILLIAM JAMES HARRIS.  
FRANK AUGUSTUS HARRIS.

McCay and Thwaites, Collins House, 360 Collins-street, Melbourne, solicitors for the parties. 6011

NOTICE is hereby given that the partnership hereinbefore subsisting between Douglas Selby Neeson and Raymond Hamilton Mansergh, carrying on business as ornamental manufacturers, at 114 Balcombe-road, Mentone, under the style or firm name of Neeson and Mansergh, has been dissolved as and from the 25th day of March, 1946. The said Douglas Selby Neeson shall continue to carry on the said business under the name of Selby Precast Products. All debts due to and owing by the said late firm will be received and paid by the said Douglas Selby Neeson.

Dated this 27th day of March, 1946.

D. S. NEESON.  
R. MANSERGH.

6028

NOTICE is hereby given that the partnership between Gordon Wesley Croft and William Vernon Earle, formerly carrying on the business of manufacturers' agents under the style or firm of Earle-Croft, at Flinders-lane, Melbourne, and at Gowings Building, Market-street, Sydney, has been dissolved as from the 31st day of December, 1945; and notice is further given that the said William Vernon Earle will henceforth carry on the said business at the afore-mentioned address, under the style or firm of Earle Griffith and Co., and all debts owing by and moneys payable to the said firm will be paid and received by the said William Vernon Earle at the said addresses.

Dated the 15th day of February, 1946.

G. W. CROFT.  
W. V. EARLE.  
E. Aston Lloyd, solicitor, 34 Queen-street, Melbourne. 5989

## SIGMA CO. LTD.

NOTICE is hereby given that Sigma Company Limited has applied for a lease under section 125, *Land Act* 1928, for a term of 40 years from 1st June, 1946, of allotment 4A of section 60, City of Port Melbourne, as a site for manufacturing purposes. 5947

J. BOOTH, Accountant.

*Companies Act 1938.*

## KOORNONG.

NOTICE OF INTENTION TO APPLY TO ATTORNEY-GENERAL FOR LICENCE, PURSUANT TO SECTION 18 (1).

**I**, WILFRID STANLEY ARTHUR, of Kangaroo Grounds-road, Warrandyte, in the State of Victoria, on behalf of Koornong, an association about to be formed (as a company limited by guarantee) for the purposes of promoting education, hereby give notice of intention to apply to the Attorney-General for a licence directing that the said association be registered as a company with limited liability, without the addition of the word "Limited" to its name.

Dated this 26th day of March, 1946.

W. S. ARTHUR, Registrar and Secretary.  
Oswald Burt and Co., 394 Collins-street, Melbourne, solicitors for the applicant. 6021

## GEO. H. YOUNG PROPRIETARY LIMITED.

NOTICE OF SPECIAL RESOLUTION TO WIND UP, PURSUANT TO SECTION 226.

**A**T an Extraordinary General Meeting of the above-named company, duly convened and held at the office of R. A. H. Clements, chartered accountant (Aust.), 4 Bank-place, Melbourne, on Saturday, the 16th day of March, 1946, the following Resolution was duly passed as a Special Resolution:—

"That the company be wound up voluntarily."

And at such last-mentioned meeting R. A. H. Clements, chartered accountant (Aust.), 4 Bank-place, Melbourne, was appointed liquidator for the purposes of the winding up.

Dated the 30th day of March, 1946.

5978 GEO. H. YOUNG, Chairman.

*The Companies Act 1938.*—In the matter of SWIFF'S CREEK BUTTER FACTORY COMPANY LIMITED (in Liquidation).

**N**OTICE is hereby given that at an Extraordinary General Meeting of Swift's Creek Butter Factory Company Limited, held on the 26th day of March, 1946, the under-mentioned Special Resolutions were duly passed, viz.:—

1. That this company be wound up voluntarily, forthwith, as a "members' voluntary winding up" under the *Companies Act 1938*.

2. That Mr. Gilbert Stanley Swaine, chartered accountant (Aust.), of 395 Collins-street, Melbourne, be and is hereby appointed liquidator for the purposes of such winding up and that his remuneration and costs as liquidator shall not exceed £30 9s.

5973 G. S. SWAINE, Liquidator.

No. of Company—15561.

*Companies Act 1938.*

## T. D. PRATT &amp; COMPANY PROPRIETARY LIMITED.

COPY RESOLUTION OR AGREEMENT, PURSUANT TO SECTION 118.

**A**T a General Meeting of the members of T. D. Pratt and Company Proprietary Limited, duly convened and held at the registered office of the company on the 23rd day of March, 1946, the following Special Resolution was duly passed:—

"That the company be wound up voluntarily in accordance with Article 55 of the Articles of Association."

Dated this 27th day of March, 1946.

5974 E. E. MUIR, Director.

NOTICE TO CREDITORS AND OTHERS.—*RE* CHARLES PHILLIP SAUNDERS, DECEASED.

**P**URSUANT to the *Trustee Act 1928*, notice is hereby given that all persons having claims against the estate of Charles Phillip Saunders, late of Yourang, near Tungamah, in the State of Victoria, farmer, deceased (who died on the 19th day of September, 1945, and probate of whose will was granted by the Supreme Court of Victoria, in its probate jurisdiction, on the 25th day of February, 1946, to the Trustees, Executors, and Agency Company Limited, of 401 Collins-street, Melbourne, in the said State, and Louisa Saunders, of Yourang aforesaid, widow, the executors named therein), are hereby required to send particulars, in writing, of such claims to the said executors, in care of The Trustees, Executors, and Agency Company Limited, at its address set out above, on or before the 15th day of June, 1946, after which date the said executors will proceed to convey or distribute the said estate, or any part thereof, to or among the persons entitled thereto, having regard only to the claims, whether formal or not, of which they shall then have notice. And notice is further given that they will not be liable to any person of whose claims they shall not have had such notice as aforesaid.

Dated the 26th day of March, 1946.

HARGRAVE & HARGRAVE, Yarrowonga, proctors for the said executors. 5975

THOMAS LAWRENCE POUND, late of Leongatha, line inspector (who died 13th February, 1946).

**C**REDITORS, next of kin, and all other persons having claims against the estate of the deceased are required by the executrix of the will, Mary Isobel Pound, of Leongatha, widow, to send particulars to her, care of the undersigned, on or before the 15th day of June, 1946, after which date she will distribute the assets, having regard only to the claims of which she then has notice.

M. DAVINE, Trafalgar, solicitors. 5954

## ARTHUR TASS KEATING, DECEASED.

**C**REDITORS, next of kin, and others having claims in respect of the estate of Arthur Tass Keating, late of Woodend, in the State of Victoria, hotelkeeper, deceased (who died on the 27th day of November, 1945), are to send the particulars of their claims to The Equity Trustees, Executors, and Agency Company Limited, of 472 Bourke-street, Melbourne, in the said State, by the 15th day of June, 1946, after which date it will distribute the assets, having regard only to the claims of which it then has notice.

H. HURRY & SONS, solicitors, Kyneton, and at Woodend and Gisborne. 5946

## NOTICE TO CLAIMANTS.

**W**ILLIAM HEDLEY WALTER, of Ceres, near Geelong, in the State of Victoria, farmer, and Andrew Ralph Phillips, of Yarra-street, Geelong, in the said State, solicitor, the executors of the will of William Lewis Walter, formerly of No. 2 Park-crecent south, Geelong, in the State of Victoria, contractor, but late of St. Jude's Hospital, Minerva-road, Geelong West, in the said State, gentleman, deceased (who died on the 24th day of January, 1946), require all creditors, next of kin, and others having claims against the property or the estate of the said deceased to send to the said executors, at the office of the undersigned solicitor, on or before the 4th day of June, 1946, particulars, in writing, of such claims, after which date the said executors intend to convey or distribute such property or estate to or among the persons entitled thereto, having regard only to the claims of which they shall have had notice.

Dated the 26th day of March, 1946.

ANDREW R. PHILLIPS, LL.B., A.I.C.A., of 57A Yarra-street, Geelong, solicitor for the said William Hedley Walter and the said Andrew Ralph Phillips. 5948

**P**URSUANT to the *Trustee Act 1928*, notice is hereby given that all persons having claims upon the estate of Ernest John Blackwell, late of 56 Head-street, Elsternwick, retired jeweller, deceased (who died on the 14th day of December, 1945, and probate of whose will was granted by the Supreme Court of Victoria, on the 14th day of February, 1946, to Alban Rex Dunstan Opie, of 56 Head-street, Elsternwick, engineer, and Frederick Elwes Browning Wood, of St. Kilda-street, Brighton, veterinary surgeon), are hereby required to send particulars, in writing, of such claims to the executors at the office of the undermentioned solicitor, on or before the 15th day of June, 1946, after which date the executors will proceed to convey or distribute the said estate among the persons entitled thereto, having regard only to the claims of which they shall then have had notice.

KENNETH J. CLEMENTS, solicitor, 29 Glenhuntly-road, Elsternwick. 5959

**C**REDITORS, next of kin, and others having claims in respect of the estate of Donald John McVean (usually known as Donald McVean), late of York-avenue, Avoca, labourer, deceased (who died on 22nd February, 1946), are to send particulars of their claims to The Ballarat Trustees, Executors, and Agency Company Limited, of 101 Lydiard-street north, Ballarat, in the State of Victoria, by the 3rd day of June, 1946, after which date the company will distribute the assets, having regard only to the claims of which it then has notice.

5960

**A**LL persons having claims against the estate of Harry Ardron Townend, late of 43 Bloomfield-road, Ascot Vale, Victoria, Congregational minister, deceased (who died on 8th February, 1946, and probate of whose will was on 29th March, 1946, granted by the Supreme Court of Victoria to George Alfred Watkins, of 34 Cole-street, Elwood, Victoria, director, the executor appointed thereby), are hereby required to send particulars, in writing, of such claims to the said George Alfred Watkins, to care of Malleison, Stewart, and Co., at the address below, on or before 6th June, 1946, after which date the said executor will proceed to convey or distribute the said estate to or among the persons entitled thereto, having regard only to the claims of which he shall then have had notice, and will not be liable for the assets distributed to any person of whose claim he shall not then have had notice.

MALLEISON, STEWART, & CO., solicitors, 46 Queen-street, Melbourne. 6006



**CREDITORS**, next of kin, and others having claims in respect of the estate of Lorna Clark, late of Chapel-road, Keysborough, in the State of Victoria, spinster, deceased, intestate (who died on the 1st day of November, 1945), are to send the particulars of their claims to the Perpetual Executors and Trustees Association of Australia Limited, of 100-104 Queen-street, Melbourne, in the said State, by the 15th day of June, 1946, after which date it will distribute the assets, having regard only to the claims of which it then has notice.

Dated the 28th day of March, 1946.  
BRUCE, FROST-SAMUELS, LITTLETON, & WATT, Traralgon, solicitors for the said company. 5986

**CREDITORS**, next of kin, and others having claims in respect of the estate of Ethel Kate Newell Broadbent, of 1002 Malvern-road, Malvern, in the State of Victoria, widow (who died on the 26th day of November, 1945), are to send particulars of their claims to William Burleigh Broadbent, care of the undersigned, by the 1st day of June, 1946, after which date the executor will distribute the assets, having regard only to the claims of which he shall have had notice.

PURVES & PURVES, 448 Collins-street, Melbourne. 5987

**CREDITORS**, next of kin, and others having claims in respect of the estate of Constance Isabella Atkinson, formerly of 3 Raleigh-street, Windsor, and 26 Charnwood-road, St. Kilda, but late of 29A Herbert-street, St. Kilda, in the State of Victoria, widow (who died on the 7th day of May, 1945), are to send particulars of their claims to The Union Trustee Company of Australia Limited, of 333 Collins-street, Melbourne, in the said State, by the 1st day of June, 1946, after which date the said company will distribute the assets, having regard only to the claims of which it shall have had notice.

PURVES & PURVES, 448 Collins-street, Melbourne. 5988

JOHN O'BRIEN, late of Ultima, farmer, DECEASED.

**PURSUANT** to the provisions of the Trustee Acts, notice is hereby given that Alice Margaret O'Brien, of Ultima, widow; Michael Mark O'Brien, of Jeparit, medical practitioner; and Victor Thomas O'Brien, of Ultima, farmer, the executors of the will of the above-named deceased, intend to convey or distribute the estate of the said deceased to or among the persons entitled thereto, and hereby require all persons interested to send to the said executors, in care of Gerald Edward Delany, solicitor, 63 Campbell-street, Swan Hill, on or before the 15th June, 1946, particulars of their claims against the estate, and at the expiration of that time the said executors will convey or distribute the said estate to or among the persons entitled thereto, having regard only to the claims of which they shall then have had notice.

GERALD E. DELANY, LL.B., solicitor, 63 Campbell-street, Swan Hill. 5990

JAMES ALEXANDER WILKINS, late of Natya, farmer, DECEASED.

**PURSUANT** to the provisions of the Trustee Acts, notice is hereby given that Elsie Louisa Wilkins, widow, and Victor James Wilkins, farmer, both of Natya, the executors of the will of the above-named deceased, intend to convey or distribute the estate of the said deceased to or among the persons entitled thereto, and hereby require all persons interested to send to the said executors, in care of Gerald Edward Delany, solicitor, 63 Campbell-street, Swan Hill, on or before the 15th June, 1946, particulars of their claims against the estate, and at the expiration of that time the said executors will convey or distribute the said estate to or among the persons entitled thereto, having regard only to the claims of which they shall then have had notice.

GERALD E. DELANY, LL.B., solicitor, 63 Campbell-street, Swan Hill. 5991

**CREDITORS**, next of kin, and others having claims against the estate of Grace Marion Sparke, late of 69 Victoria-crescent, Mont. Albert, in the State of Victoria, widow, deceased (who died on the 25th day of September, 1945), probate of whose will, and the codicil thereto, was granted to the executor and executrix, The Union Trustee Company of Australia Limited, of 333 Collins-street, Melbourne, and Mary Grace Kerr, of 13 Muntz-street, Caulfield, married woman, are required to send particulars, in writing, of their claims, to the said executor and executrix, at 333 Collins-street, Melbourne, on or before the 11th day of June, 1946, after which date the executor and executrix will distribute the assets of the deceased amongst the persons entitled thereto, having regard only to the claims of which they shall then have had notice.

A. LESLIE ANDERSON, 405 Collins-street, Melbourne, solicitor for the executor and executrix. 5993

GERTRUDE CLIFTON, formerly of 29 Bevan-street, Balwyn, but late of "Stratherne," Power-street, Hawthorn, spinster, DECEASED (who died on the 10th August, 1945).

**CREDITORS**, next of kin, and all other persons having claims against the estate of the deceased are required by the executor of the will, Geoffrey Cheverton Wyatt, of 456 Little Collins-street, Melbourne, solicitor, to send particulars to him, care of the undersigned, on or before the 6th June, 1946, after which date he will distribute the assets, having regard only to the claims of which he then has notice.

HERMAN & COLTMAN, solicitors, 456 Little Collins-street, Melbourne. 5995

**PURSUANT** to the provisions of the Trustee Act 1928, notice is hereby given that all persons having claims against the estate of Albert Alfred Huggins, late of Tongio, in the State of Victoria, grazier, deceased (who died on the 8th day of November, 1945, and probate of whose will was on the 29th day of March, 1946, granted by the Supreme Court of Victoria to Percy Albert Huggins, of Omeo, in the said State, grazier, one of the executors appointed thereby), are hereby required to send particulars, in writing, of such claims to the said Percy Albert Huggins, in care of Malleson, Stewart, and Co., at the address below, on or before the 17th day of June, 1946, after which date the said executor will proceed to convey or distribute the said estate to or among the persons entitled thereto, having regard only to the claims, whether formal or not, of which he shall then have had notice, and will not be liable for the assets so distributed to any person of whose claim he shall not then have had notice.

MALLESON, STEWART, & CO., solicitors, 46 Queen-street, Melbourne. 6005

**ALL** persons having claims against the estate of Evelyn Elizabeth Sinclair, late of the Convalescent Home for Men, Centre Dandenong-road, Cheltenham, Victoria, spinster, deceased (who died on 27th December, 1945, and probate of whose will was on 25th March, 1946, granted by the Supreme Court of Victoria to James Merrieks Sinclair, of 6 Grace-street, Malvern, Victoria, gentleman, and John MacLean Sinclair, of 210 Orrong-road, Toorak, Victoria, gentleman, the executors appointed thereby), are hereby required to send particulars, in writing, of such claims to the said James Merrieks Sinclair and John MacLean Sinclair, to care of Malleson, Stewart, and Co., at the address below, on or before 6th June, 1946, after which date the said executors will proceed to convey or distribute the said estate to or among the persons entitled thereto, having regard only to the claims of which they shall then have had notice, and will not be liable for the assets so distributed to any person of whose claim they shall not then have had notice.

MALLESON, STEWART, & CO., solicitors, 46 Queen-street, Melbourne. 6009

**ALL** persons having claims against the estate of Annie May Thorpe, late of 33 Thanet-street, Malvern, Victoria, married woman, deceased (who died on 5th December, 1945, and probate of whose will and codicil was on 26th March, 1946, granted by the Supreme Court of Victoria to Percy Claude Stephens and Ernest Charles Frederick Stephens, both of 33 Thanet-street, Malvern, Victoria, clerks, and John Thomas Thorpe, of Cranbourne, Victoria, master baker, the executors appointed thereby), are hereby required to send particulars of such claims to the said Percy Claude Stephens, Ernest Charles Frederick Stephens, and John Thomas Thorpe, to care of Malleson, Stewart, and Co., at the address below, on or before 6th June, 1946, after which date the said executors will proceed to convey or distribute the said estate to or among the persons entitled thereto, having regard only to the claims of which they shall then have had notice, and will not be liable for the assets so distributed to any person of whose claim they shall not then have had notice.

MALLESON, STEWART, & CO., solicitors, 46 Queen-street, Melbourne. 6010

**CREDITORS**, next of kin, and others having claims in respect of the estate of Eva Winifred Wright, late of 51 Lewisham-road, Windsor, Victoria (who died on 30th December, 1945), are to send the particulars of their claims to The Trustees, Executors, and Agency Company Limited, the registered office of which is situate at 401 Collins-street, Melbourne, Victoria, by the 6th day of June, 1946, after which date it will distribute the assets, having regard only to the claims of which it then has notice.

MALLESON, STEWART, & CO., solicitors, 46 Queen-street, Melbourne. 6007

**CREDITORS**, next of kin, and others having claims in respect of the estate of Ellen Stewart, formerly of Hampton House, Grey-street, St. Kilda, Victoria, but late of Alma Private Hospital, Alma-road, St. Kilda, Victoria, widow, deceased (who died on 21st December, 1945), are to send the particulars of their claims to The Perpetual Executors, and Trustees Association of Australia Limited, at its registered office, Nos. 100-104 Queen-street, Melbourne, Victoria, by the 6th day of June, 1946, after which date it will distribute the assets, having regard only to the claims of which it then has notice.

MALLESON, STEWART, & CO., solicitors, 46 Queen-street, Melbourne. 6008

ELIZABETH CATHERINE MASTERSON, late of 78 Cobden-street, Mount Pleasant, in the State of Victoria, spinster, DECEASED (who died on the 14th day of February, 1945).

**CREDITORS**, next of kin, and all other persons having claims against the estate of the deceased are required by the executors, Thomas Francis Masterson, of 18 Barkly-street, East Brunswick, in the said State, ironmoulder, and John Joseph Larkins, of Murray-street, Colac, in the said State, solicitor, to send particulars to them, care of the undersigned, on or before the 12th day of June, 1946, after which date they will distribute the assets, having regard only to the claims of which they then have notice.

Dated the 1st day of April, 1946.

T. E. BYRNE & CO., solicitors, of 56 Lydiard-street south, Ballarat. 5977

MARY BRITT, late of Millbrook, in the State of Victoria, spinster, DECEASED, intestate (who died on the 2nd day of August, 1945).

**CREDITORS**, next of kin, and all other persons having claims against the estate of the deceased are required by the administrator, Thomas Edmund Byrne, of 56 Lydiard-street south, Ballarat, in the said State, solicitor, to send particulars to him, care of the undersigned, on or before the 12th day of June, 1946, after which date he will distribute the assets, having regard only to the claims of which he then has notice.

Dated the 1st day of April, 1946.

T. E. BYRNE & CO., solicitors, 56 Lydiard-street south, Ballarat. 5978

WILLIAM BRITT, late of Millbrook, in the State of Victoria, farmer, DECEASED (who died on the 23rd day of November, 1945).

**CREDITORS**, next of kin, and all other persons having claims against the estate of the deceased are required by the executor, Thomas Edmund Byrne, of 56 Lydiard-street, Ballarat, in the said State, solicitor, to send particulars to him, care of the undersigned, on or before the 12th day of June, 1946, after which date he will distribute the assets, having regard only to the claims of which he then has notice.

Dated the 1st day of April, 1946.

T. E. BYRNE & CO., solicitors, 56 Lydiard-street south, Ballarat. 5979

CORNELIUS JOSEPH CAREY, late of Wallace, in the State of Victoria, farmer, DECEASED (who died on the 5th day of August, 1945).

**CREDITORS**, next of kin, and all other persons having claims against the estate of the deceased are required by the executrix, Annie Teresa Carey, of Wallace aforesaid, widow, to send particulars to her, care of the undersigned, on or before the 12th day of June, 1946, after which date she will distribute the assets, having regard only to the claims of which she then has notice.

Dated the 1st day of April, 1946.

T. E. BYRNE & CO., solicitors, 56 Lydiard-street south, Ballarat. 5970

THERESA ELLEN KEALY, late of 66A Victoria-street, Ballarat, in the State of Victoria, widow, DECEASED (who died on the 2nd day of August, 1945).

**CREDITORS**, next of kin, and all other persons having claims against the estate of the deceased are required by the executrix, Josephine Curtain, of the Provincial Hotel, 121 Lydiard-street north, Ballarat, in the said State, widow, to send particulars to her, care of the undersigned, on or before the 12th day of June, 1946, after which date she will distribute the assets, having regard only to the claims of which she then has notice.

Dated the 1st day of April, 1946.

T. E. BYRNE & CO., solicitors, 56 Lydiard-street south, Ballarat. 5971

**CREDITORS**, next of kin, and others having claims in respect of the estate of Valentine Arthur Lothar Mackenzie, formerly of 480 Collins-street, Melbourne, shipping clerk, but late of Dickson-terrace and 100rak-road, Hamilton, Brisbane, Queensland, accountant, deceased (who died on the 3rd day of July, 1945), are to send particulars of their claims to The Perpetual Executors and Trustees Association of Australia Limited, of 100-104 Queen-street, Melbourne, by the 5th day of June, 1946, after which date it will distribute the assets, having regard only to the claims of which it then has notice.

GAIR AND BRAHE, solicitors, 243 Collins-street, Melbourne. 5996

**CREDITORS**, next of kin, and others having claims in respect of the estate of Hugh Robert Hector Ross, formerly of Cambridge, in the State of Tasmania, but late a flight-sergeant in the Royal Australian Air Force, deceased (who died on the 16th day of December, 1943, and of whose will and estate letters of administration, with the said will annexed, were granted by the Supreme Court of Victoria, on the 25th day of March, 1946, to The Union Trustee Company of Australia Limited, of 333 Collins-street, Melbourne, it having been duly authorized to apply for such letters of administration by Trevor Wilson Ross, the sole executor named in the said will, are to send particulars of their claims to the said company, at its address above-mentioned, by the 10th day of June, 1946, after which date the said company will distribute the assets, having regard only to the claims of which it then has notice.

Dated this 2nd day of April, 1946.

BLAKE & RIGGALL, 120 William-street, Melbourne, solicitors for the said company. 6002

**CREDITORS**, next of kin, and others having claims in respect of the estate of Edward Lyon, late of 203 Smith-street, Fitzroy, in the State of Victoria, bookseller, deceased (who died on the 28th day of August, 1945, and of whose will and estate letters of administration, with the said will annexed, were granted by the Supreme Court of Victoria on the 19th day of March, 1946, to The Union Trustee Company of Australia Limited, of 333 Collins-street, Melbourne, it having been duly authorized to apply for such letters of administration by Alfred Norman Oliver Lyon, a son and the sole beneficiary under the said will), are to send particulars of their claims to the said company, at its address above-mentioned, by the 10th day of June, 1946, after which date the said company will distribute the assets, having regard only to the claims of which it then has notice.

Dated this 2nd day of April, 1946.

BLAKE & RIGGALL, 120 William-street, Melbourne, solicitors for the said company. 6003

**CREDITORS**, next of kin, and others having claims in respect of the estate of Donald Carlos Gordon, formerly of "Dwarroon," Cudgee, in the State of Victoria, but late a flying-officer, D.F.C., in the Royal Australian Air Force, deceased, of whose will and estate letters of administration, with the said will annexed, were granted by the Supreme Court of Victoria on the 19th day of March, 1946, to The National Trustees, Executors, and Agency Company of Australasia Limited, of 95 Queen-street, Melbourne, the said company having been duly authorized to apply for such letters of administration by Marjory Baker, the executrix named in the said will, are to send particulars of their claims to the said company, at its address above-mentioned, by the 10th day of June, 1946, after which date the said company will distribute the assets, having regard only to the claims of which it then has notice.

Dated this 2nd day of April, 1946.

BLAKE & RIGGALL, 120 William-street, Melbourne, solicitors for the said company. 6004

**CREDITORS**, next of kin, and others having claims against the estate of the under-mentioned person, are required to send particulars thereof to Tessy Jane Singleton, of 126 Male-street, North Brighton, widow, the administratrix, in care of the undersigned, on or before the 8th day of May, 1946, otherwise they may be excluded when the assets are being distributed:—

Name.—Thomas Rupert Wills, late VX39952, "R" Company, 2/40th Infantry Battalion, Australian Imperial Force, soldier, deceased, intestate.

Date of death of deceased.—22nd day of February, 1942.

Dated this 25th day of March, 1946.

DUDLEY A. TREGENT, B.A., LL.M., of 422 Collins-street, Melbourne, solicitor for the administratrix. 5994

**THE PERPETUAL EXECUTORS AND TRUSTEES ASSOCIATION OF AUSTRALIA LIMITED**, whose registered office is situate at Nos. 100-104 Queen-street, Melbourne, in the State of Victoria, Jack Kingwell Suter, of 16 Tower Hill-road, Ashburton, in the said State, master butcher, and Marion Alice Grigg, of 852 Canterbury-road, Box Hill, in the said State, married woman, the executors of the will of Joshua Kingwell Suter, late of 9 Muntz-street, Caulfield, in the said State (who died on the 12th October, 1945), require all creditors, next of kin, and others having claims against the property or estate of the said deceased to send to the said executors, in the care of the said association, on or before the 4th June, 1946, particulars, in writing, of such claims, after which date the said executors intend to convey or distribute such property or estate to or among the persons entitled thereto, having regard only to the claims of which they shall have had notice.

Dated the 1st day of April, 1946.

W. H. FLOOD & PERMEZEL, 379 Collins-street, Melbourne, solicitors for the applicants. 5998

**NOTICE TO CREDITORS.—RE MARGARET ROBINSON, DECEASED.**

**PURSUANT** to the provisions of the *Trustee Act 1928*, notice is hereby given that all persons having claims against the estate of Margaret Robinson, late of Clunes, in the State of Victoria, widow, deceased (who died on the 22nd day of August, 1945), application for probate of whose will was granted to Edward Roy Lee, of Birchip, in the State of Victoria, the executor named therein, are hereby required to send particulars, in writing, of such claims, on or before the 4th day of June, 1946, to the said executor. And notice is hereby given that after the said date the said executor will proceed to distribute the assets of the said deceased which shall have come to his hands or possession amongst the persons entitled thereto, having regard only to the claims of which the said executor may then have had notice, and the said executor will not then be liable for the assets, or any part thereof, so distributed, to any person of whose claim it shall not then have had notice.

Dated this 1st day of April, 1946.

F. RUSSELL COLDHAM & CO., of Lydiard-street south, Ballarat, proctors for the said executor. 5961

**COLIN VALENTINE CHISHOLM** (in the will called Colin Chisholm), late of Windermere, in the State of Victoria, farmer, DECEASED (who died on the 8th day of February, 1946).

**CREDITORS**, next of kin, and all other persons having claims against the estate of the deceased are required by the executor, John Patrick Conaughton, of the corner of Doveton and Mair streets, Ballarat, in the said State, produce agent, to send particulars to him, care of the undersigned, on or before the 12th day of June, 1946, after which date he will distribute the assets, having regard only to the claims of which he then has notice.

Dated the 1st day of April, 1946.

T. E. BYRNE & CO., solicitors, 56 Lydiard-street south, Ballarat. 5962

**JAMES OWEN**, late of Smythes Creek, in the State of Victoria, farmer, DECEASED (who died on the 17th day of February, 1946).

**CREDITORS**, next of kin, and all other persons having claims against the estate of the deceased are required by the executors, Gladys Coral Owen, widow, James Owen, and Allen Owen, farmers, all of Smythes Creek aforesaid, to send particulars to them, care of the undersigned, on or before the 12th day of June, 1946, after which date they will distribute the assets, having regard only to the claims of which they then have notice.

Dated the 1st day of April, 1946.

T. E. BYRNE & CO., solicitors, 56 Lydiard-street south, Ballarat. 5963

**RICHARD JOLLY**, late of Corindhap, in the State of Victoria, storekeeper, DECEASED (who died on the 7th day of September, 1945).

**CREDITORS**, next of kin, and all other persons having claims against the estate of the deceased are required by Thomas Steele, of Armstrong-street, Ballarat, in the said State, cooper, to send particulars to him, care of the undersigned, on or before the 12th day of June, 1946, after which date he will distribute the assets, having regard only to the claims of which he then has notice.

Dated the 1st day of April, 1946.

T. E. BYRNE & CO., solicitors, 56 Lydiard-street south, Ballarat. 5964

**MARGARET CARROLL**, late of 106 Clarendon-street, Ballarat, in the State of Victoria, spinster, DECEASED (who died on the 2nd day of July, 1945).

**CREDITORS**, next of kin, and all other persons having claims against the estate of the deceased are required by the executors, Michael Carroll, of 217 Talbot-street, Ballarat aforesaid, public servant, and Mary Jane Frances Carroll, of 106 Clarendon-street, Ballarat aforesaid, spinster, to send particulars to them, care of the undersigned, on or before the 12th day of June, 1946, after which date they will distribute the assets, having regard only to the claims of which they then have notice.

Dated the 1st day of April, 1946.

T. E. BYRNE & CO., solicitors, 56 Lydiard-street south, Ballarat. 5965

**CATHERINE AMONICA DELANEY**, late of Gordon, in the State of Victoria, married woman, DECEASED (who died on the 15th day of May, 1945).

**CREDITORS**, next of kin, and all other persons having claims against the estate of the deceased are required by the administratrix, Annie Teresa Carey, of Wallace, in the said State, widow, to send particulars to her, care of the undersigned, on or before the 12th day of June, 1946, after which date she will distribute the assets, having regard only to the claims of which she then has notice.

Dated the 1st day of April, 1946.

T. E. BYRNE & CO., solicitors, 56 Lydiard-street south, Ballarat. 5966

**CREDITORS**, next of kin, and others having claims in respect of the estate of John Egbert Young, late of "Kilrush," Freeman's-road, Mt. Eliza, in the State of Victoria, gentleman, deceased (who died on the 13th day of January, 1946), are to send particulars of their claims to Phyllis Maud Young, of "Kilrush," Freeman's-road, Mt. Eliza aforesaid, widow, and The Equity Trustees, Executors, and Agency Company Limited, of 472 Bourke-street, Melbourne, in the said State, the executors appointed by the will of the said deceased, care of the said company, by the 4th day of June, 1946, after which date the said company will distribute the assets, having regard only to the claims of which it then has notice.

AITKEN, WALKER, & STRACHAN, 123 William-street, Melbourne, proctors for the executors. 6025

**BERTHA ALICE MAUD DREW.—NOTICE TO CLAIMANTS AND OTHERS.**

**CREDITORS**, next of kin, and others having claims in respect of the estate of Bertha Alice Maud Drew, late of 44 Orrong-erect, Caulfield, in Victoria, spinster, deceased (who died on the 13th day of August, 1945), are to send particulars of their claims to The Union Trustee Company of Australia Limited, of 333 Collins-street, Melbourne, by the 5th day of June, 1946, after which date the said company will distribute the assets of the said Bertha Alice Maud Drew, having regard only to the claims of which it then has notice.

Dated the 29th day of March, 1946.

J. M. SMITH & EMMERTON, 480 Bourke-street, Melbourne, solicitors for the above-named company. 6027

**WILLIAM GEORGE PETERS**, DECEASED, late of Ailsa, in the State of Victoria, farmer (who died on the 7th day of October, 1945).

**CREDITORS**, next of kin, and all other persons having claims against the estate of the deceased are required by the executors of his estate, Elsie May Maria Peters, of Ailsa, widow, and Reginald Gordon Peters, of 137 Orange-avenue, Mildura, to send particulars to them, care of the undersigned, on or before the 1st July, 1946, after which date they will distribute the assets, having regard only to the claims of which they then have notice.

McEACHARN & SHAW, solicitors, of Warracknabeal, and 352 Collins-street, Melbourne. 6029

**CREDITORS**, next of kin, and others having claims in respect of the estate of Victor Thomas Eastick, formerly of Nhill, in the State of Victoria, agent, but late of Queenscliff Hotel, Queenscliff, in the said State, gentleman, deceased (who died on the 2nd day of January, 1946), are to send the particulars of their claims to The Ballarat Trustees, Executors, and Agency Company Limited, at its branch office, 8 Malop-street, Geelong, in the said State, by the 15th day of June, 1946, after which date it will distribute the assets, having regard only to the claims of which it then has notice.

Dated this 1st day of April, 1946.

TURNER & HOBDDAY, Victoria-street, Nhill, solicitors for the said The Ballarat Trustees, Executors, and Agency Company Limited. 6015

## NOTICE TO CREDITORS AND OTHERS.

PURSUANT to the *Trustee Act 1928*, notice is hereby given that all persons having claims against the estate of Sidney Gibson, also known as Victor Sidney Gibson and Sidney James Simpson, late of 23 Veronica-street, Northcote, in the State of Victoria, builder, deceased (who died on the 17th day of December, 1944, and probate of whose will was granted by the Supreme Court of the State of Victoria, in its probate jurisdiction, on the 22nd day of March, 1946, to Arthur Loftus Christopher Flint, of 90 Queen-street, Melbourne, in the State of Victoria, solicitor, the executor named in and appointed by the said will), are hereby required to send particulars, in writing, of such claims to the said Arthur Loftus Christopher Flint, at the office of his under-mentioned solicitors, on or before the 7th day of June, 1946. And notice is hereby also given that after the last-mentioned date the said Arthur Loftus Christopher Flint will proceed to distribute the assets of the said Sidney Gibson, also known as Victor Sidney Gibson and Sidney James Simpson, deceased, amongst the persons entitled thereto, having regard only to the claims of which he shall then have had notice, and the said Arthur Loftus Christopher Flint will not be liable for the assets, or any part thereof, so distributed to any person of whose claim he shall not then have had notice.

Dated the 27th day of March, 1946.

A. L. C. FLINT & MARRIE, of 90 Queen-street, Melbourne, solicitors for the applicant. 6030

## NOTICE TO CREDITORS AND OTHERS.

PURSUANT to the *Trustee Act 1928*, notice is hereby given that all persons having claims against the estate of George Trigg, late of corner of The Crescent and Bloomfield-road, Ascot Vale, in the State of Victoria, gentleman, formerly greengrocer, deceased (who died on the 3rd day of September, 1945, probate of whose will and two codicils was granted by the Supreme Court of Victoria, in its probate jurisdiction, on the 9th day of November, 1945, to George Gordon Robert Trigg (in the second codicil called George Gordon Trigg), of 28 Milton-street, Ascot Vale aforesaid, aircraft worker), are hereby required to send particulars, in writing, of such claims to the said executor, care of Messrs. Hodgson and Finlayson, solicitors, 360 Collins-street, Melbourne, in the said State, on or before the 10th day of June, 1946, after which date the said executor intends to convey or distribute the assets of the said deceased to or amongst the persons entitled thereto, having regard only to the claims of which he shall then have had notice. And further, that the said executor will not be liable for the assets so conveyed or distributed, or any part thereof, to any person of whose claims he shall not have had notice as aforesaid.

Dated this 2nd day of April, 1946.

HODGSON & FINLAYSON, 360 Collins-street, Melbourne, solicitors for the said executor. 6031

## NOTICE TO CREDITORS AND OTHERS.

PURSUANT to the *Trustee Act 1928*, notice is hereby given that all persons having claims against the estate of Albert Harrison, formerly of 84 Queens-avenue, Caulfield, but late of 421 Wattletree-road, East Malvern, in the State of Victoria, managing director, deceased (who died on the 16th day of August, 1945, probate of whose will was granted by the Supreme Court of Victoria, in its probate jurisdiction, on the 23rd day of November, 1945, to Elvena May Harrison, of 421 Wattletree-road, East Malvern aforesaid, widow, the sole executrix named therein), are hereby required to send particulars, in writing of such claims to the said executrix, care of Messrs. Luke Murphy and Company, solicitors, 422 Bourke-street, Melbourne, in the said State, on or before the 10th day of June, 1946, after which date the said executrix intends to convey or distribute the assets of the said deceased to or amongst the persons entitled thereto, having regard only to the claims of which she shall then have had notice; and further that the said executrix will not be liable for the assets so conveyed or distributed, or any part thereof, to any person of whose claim she shall not have had notice as aforesaid.

Dated the 29th day of March, 1946.

LUKE MURPHY & CO., 422 Bourke-street, Melbourne, solicitors for the said executrix. 6032

CREDITORS, next of kin, and others having claims in respect of the estate of Isabella Dalglish, late of 145 Nelson-road, South Melbourne, in the State of Victoria, spinster, deceased, intestate (who died on the 3rd day of July, 1945), are to send the particulars of their claims to The Perpetual Executors and Trustees Association of Australia Limited, of 100-104 Queen-street, Melbourne, in the said State, by the 30th day of May, 1946, after which date it will distribute the assets, having regard only to the claims of which it then has notice.

Dated the 28th day of March, 1946.

ELLISON, HEWISON, & WHITEHEAD, solicitors, 352 Collins-street, Melbourne. 6020

*Trustee Act 1928.*

## NOTICE TO CLAIMANTS.

PURSUANT to the *Trustee Act 1928*, creditors, next of kin, and all other persons having claims in respect of the estate of any deceased person named below are required to send particulars thereof to the legal personal representative or representatives at the address stated below, on or before the date stated, after which date the representative or representatives will distribute the assets, having regard only to the claims of which notice has been received:—

John Patrick O'Donohue, formerly of Forest-street, Bendigo, but late of Harp and Shamrock Hotel, Hargreaves-street, Bendigo, labourer, deceased, who died on 4th January, 1946.—Claims to the executor, Sandhurst and Northern District Trustees Executors and Agency Company Limited, of View-street, Bendigo, by 7th June, 1946. Tatchell, Dunlop, Smalley and Balmer, solicitors, Bendigo. 5945

Rebecca Dixon, late of Clarence-street, Geelong West, widow, died on 27th September, 1945.—Claims to the executors, John George Dixon, of 173 Hope-street, Geelong West, electrical engineer, and Joseph Henry Dixon, of 30 Clarence-street, Geelong West, carrier, care of Doyle and Kerr, solicitors, Little Malop-street, Geelong, by 31st May, 1946. 5949

Samuel Gillett, late of "Warrambine," Shelford, farmer, died 24th September, 1945.—Claims to the executors, Joseph Samuel Gillett, labourer, and Vera Irene Gillett, spinster, both of "Warrambine," Shelford, care of Doyle and Kerr, solicitors, Little Malop-street, Geelong, by 31st May, 1946. 5950

Oliver Henry Kidman, late of Dergholm, farmer, died 18th December, 1945.—Claims to the executrix, Mary Elizabeth Kidman, of Dergholm, widow, care of Wighton and McDonald, solicitors, 53 Yarra-street, Geelong, by 5th June, 1946. 5952

Andrew James Carrick Ferguson, late of Latrobe-street, Geelong West, accountant, and a member of the Australian Imperial Forces, died 30th July, 1945.—Claims to the executor, Andrew Carrick Ferguson, of Latrobe-street, Geelong West, labourer, care of Wighton and McDonald, solicitors, 53 Yarra-street, Geelong, by 5th June, 1946. 5953

Sarah Ann Down, late of Tyrendarra East, widow, died 27th January, 1946.—Claims to the executor, Thomas Fordham Keller, formerly of Henty, but now of Allestree, farmer, care of Peter P. Conlan, solicitor, Bank-street, Port Fairy, by 6th June, 1946. 5956

David Collins, of Koroit, farmer, died 17th December, 1946.—Claims to the administratrix, Mary Collins, of Koroit, widow, care of Peter P. Conlan, solicitor, Bank-street, Port Fairy, by 10th June, 1946. 5957

John James Gardiner, late of Brisbane-street, Berwick, retired civil engineer, deceased, died 6th January, 1946.—Claims to National Trustees, Executors, and Agency Company of Australasia Limited and Matilda Ann Gardiner, c/o National Trustees, Executors, and Agency Company of Australasia Limited, whose registered office is situate at 95 Queen-street, Melbourne, before the 15th day of June, 1946. Leach and Thomson, solicitors, 472 Bourke-street, Melbourne. 5992

George James Carter, late of Rosebrook Wartook, grazier, deceased, died 20th July, 1945.—Claims to the executors, care of J. Weldon Power and Bennett, solicitors, Horsham, by 11th June, 1946. 6026

CREDITORS, next of kin, and all others having claims against the estate of Edmund Joseph Keogh, formerly of Red Hill, late of 16 Irving-avenue, Armadale, farmer, deceased (who died on 13th October, 1945, are required to send particulars to the administratrix, care of F. S. Newell and Marsh, solicitors, 360 Collins-street, Melbourne, on or before the 4th day of June, 1946, otherwise they may be excluded when assets are distributed. 6012

EMMA WARD, late of 5 Westbrook-street, East Kew, in Victoria, widow, DECEASED.

CREDITORS, next of kin, and others having claims in respect of the estate of the abovenamed deceased (who died on the 25th December, 1945), are to send the particulars of their claims to the executor, The Trustees, Executors, and Agency Company Limited, of 401 Collins-street, Melbourne, by the 8th day of June, 1946, after which date it will distribute the assets, having regard only to the claims of which it then has notice.

RIGBY & FIELDING, solicitors, 60 Market-street, Melbourne. 6013

MARY ANN COOT, late of Horsham, in Victoria, widow, DECEASED (who died on 14th January, 1946, and probate of whose will was, on 22nd February, 1946, granted by the Supreme Court of Victoria to Alfred Harold Millar, of Swan Hill, in the said State, valuer.

CREDITORS, next of kin, and all others having claims against the estate of the said deceased are required to send particulars of such claims to the said executor, care of R. J. Wilmoth, solicitor, Horsham, on or before the 3rd day of June, 1946, after which date he will distribute the assets, having regard only to the claims of which he shall then have notice.

Dated the 22nd March, 1946.

R. J. WILMOTH, solicitor, Horsham.

6022

CREDITORS, next of kin, and all others having claims against the estate of Edith Russell, late of 65 Melbourne-road, Williamstown, in the State of Victoria, spinster, deceased (who died on 29th January, 1946), are to send particulars of their claims to The Equity Trustees, Executors, and Agency Company Limited, of 472 Bourke-street, Melbourne, the executor appointed by deceased's will, by the 6th day of June, 1946, after which date the said company will distribute the assets, having regard only to the claims of which it then has notice.

FOWLER & HICK, 31 Queen-street, Melbourne, solicitors for the executor.

6023

CREDITORS, next of kin, and others having claims in respect of the estate of Bryan James Reardon (in the said will called Brian James Reardon), late of 50 Balaclava-road, East St. Kilda, in the State of Victoria, clerk, deceased (who died on the 19th day of June, 1945), are to send the particulars of their claims to the National Trustees, Executors, and Agency Company of Australasia Limited, the registered office of which is situate at 95 Queen-street, Melbourne, by the 10th day of June, 1946, after which date it will distribute the assets, having regard only to the claims of which it then has notice.

JOSEPH LYNCH, LL.B., 299 Bridge-road, Richmond, proctor for the applicant.

6024

### MINING NOTICES.

#### NELL GWYNNE REEF NO LIABILITY.

NOTICE.—A Call (the 2nd) of Six pence per share has been made on the capital of this company due and payable at the company's office, Charing Cross, Bendigo, on Wednesday, 10th April, 1946.

J. J. STANISTREET

5955 (McColl, Rankin, and Stanistreet), Manager.

#### NEW MILANO NO LIABILITY.

NOTICE is hereby given that a Call (No. 1) of Three pence per share (making shares paid up to 6s. 3d.) has been made on contributing shares in the above company, due and payable to me at the registered office, Temple Court, 422 Collins-street, Melbourne, on Wednesday, 10th April, 1946.

By order of the Board,

5999

JAMES L. MOORE, Manager.

#### NORTH NELL GWYNNE GOLD MINES NO LIABILITY.

NOTICE is hereby given that a Call (the 67th) of Three pence per share has been made on all shares in the company, numbered 1 to 60,000 (making such shares paid up to 25s. 9d. each), due and payable at the registered office of the company, 46 Queen-street, Melbourne, on Wednesday, the 10th April, 1946.

F. H. TADGELL, Manager.

Dickenson and Tadgell, chartered accountants (Aust.), 46 Queen-street, Melbourne. C.1.

6000

#### DEBORAH ASSOCIATED NO LIABILITY.

NOTICE is hereby given that a Call (No. 9) of Six pence per share has been made on the contributing shares of the company, due and payable to me at the registered office, 422 Collins-street, Melbourne, on Wednesday, 10th April, 1946.

By order of the Board,

6001

FRANK COOPER, Manager.

#### MAXWELL WEST GOLD MINE NO LIABILITY.

NOTICE is hereby given that a Call (the 6th) of Three pence per share has been made upon all the contributing shares in the company, due and payable to the manager at the registered office, 140 Queen-street, Melbourne, on Wednesday, 10th April, 1946.

6014

F. L. SMYTH, Manager.

#### HERCULES GOLD MINING COMPANY NO LIABILITY.

A CALL (the 43rd) of Three pence per share has been made on the capital of the company (making the shares paid to 12s. each), due and payable at the registered office of the company, 379 Collins-street, Melbourne, on Wednesday, 10th April, 1946.

H. L. STEWART

6017 (J. G. Stanfield and Stewart), Manager.

#### IRONBARK GOLD MINING COMPANY NO LIABILITY.

A CALL (the 91st) of Three pence per share has been made on the capital of the company (making the shares paid to 23s. 9d. each), due and payable at the registered office of the company, 379 Collins-street, Melbourne, on Wednesday, 10th April, 1946.

H. L. STEWART

6018 (J. G. Stanfield and Stewart), Manager.

#### IRONBARK SOUTH GOLD MINING COMPANY NO LIABILITY.

A CALL (the 71st) of Three pence per share has been made on the capital of the company (making the shares paid to 21s. 3d. each), due and payable at the registered office of the company, 379 Collins-street, Melbourne, on Wednesday, 10th April, 1946.

H. L. STEWART

6019 (J. G. Stanfield and Stewart), Manager.

### INSOLVENCY NOTICE.

The Insolvency Act 1928.

A SUPPLEMENTARY First and Final Dividend is intended to be declared in the matter of Frank Jonathan Reeve, formerly of 11 Davis-street, Kew, in the State of Victoria, builder, but now of 4 Creswick-street, Deerpene, carpenter, whose estate was sequestrated on the 13th February, 1925. Creditors who have not proved their debts by the 12th day of April, 1946, will be excluded.

Dated this 27th day of March, 1946.

J. WALLACE ROSS, Official Assignee.

Care of Wilson, Ross, and Company, chartered accountants (Aust.), 34 Queen-street, Melbourne, C.1. 6016

### IMPOUNDINGS.

#### ARARAT.—Impounded in Ararat Pound.

1 bay gelding, branded like G over 2  
1 brown gelding, aged

If not claimed and expenses paid, to be sold on 17th April, 1946.

R. STEPHENS,

Poundkeeper.

5982—4/8

#### BRAYBROOK.—Impounded at Braybrook.

1 medium draught bay mare, about 2 years, white star, hind feet white

If not claimed and expenses paid, to be sold on 20th April, 1946.

B. CRADDOCK,

Poundkeeper.

5980—4/8

#### DANDENONG.—Impounded at Dandenong.

1 light Jersey cow, dry, no visible brand  
1 dark Jersey heifer, no visible brand

If not claimed and expenses paid, to be sold on 18th April, 1946.

T. ROOKES,

Poundkeeper.

5981—4/8

#### HEIDELBERG.—Impounded at Heidelberg.

1 bay mare, star, off hind foot white, saddle marked

If not claimed and expenses paid, to be sold on 17th April, 1946.

R. J. ADDICOTT,

Poundkeeper.

6034—4/

**ROSEDALE.**—Impounded at Rosedale.

1 chestnut mare, two white feet, near side, star off forehead, like three half-circles conjoined over 4 near shoulder  
 1 brown or black draught gelding, white blaze on face, near hind foot white, no visible brand  
 1 bay thoroughbred gelding, white star on forehead, blemish on near front fetlock, no visible brand  
 If not claimed and expenses paid, to be sold on 18th April, 1946.

G. FARLEY,  
 Poundkeeper.

5983—7/4

**STRATFORD.**—Impounded in Stratford Pound, by J. D. Richardson, Impounding Officer, for trespass at Airly, on 26th March, 1946.

1 silver-colour Jersey heifer, piece out back near ear, like J sideways near rump  
 If not claimed and expenses paid, to be sold on 22nd April, 1946.

E. C. BOCK,  
 Poundkeeper.

6033—6/

**STATE ACTS, 1942.**

COPIES of the following Acts of Parliament of Victoria may be obtained at the Government Printing Office, or from any bookseller, at the price set opposite to each:—

No.	Price s. d.
4880. Consolidated Revenue .. .. .	0 6
4881. Consolidated Revenue .. .. .	0 6
4882. Hospitals and Charities .. .. .	0 6
4883. Sewerage Rates .. .. .	0 6
4884. Sheep Dipping .. .. .	0 6
4885. The Limbless Soldiers Trust .. .. .	1 0
4886. Consolidated Revenue .. .. .	0 6
4887. National Security (Emergency Powers) Continuation .. .. .	0 6
4888. Income Tax (War-time Collection) .. .. .	0 6
4889. Freezing Works (Overdraft Guarantee) .. .. .	0 6
4890. Consolidated Revenue .. .. .	0 6
4891. Melbourne Markets .. .. .	0 6
4892. Student Teachers (War Service) .. .. .	0 6
4893. Cattle and Swine Compensation .. .. .	0 6
4894. Drysdale United Service Home .. .. .	0 6
4895. Public Trustee .. .. .	0 6
4896. The Constitution Act Amendment .. .. .	0 6
4897. Entertainments Tax (War-time Suspension) .. .. .	0 6
4898. Melbourne and Metropolitan Tramways (Reserve Funds) .. .. .	0 6
4899. Milk and Dairy Supervision .. .. .	0 6
4900. Melbourne and Metropolitan Board of Works (Contributions) .. .. .	0 6
4901. Execution of Trusts .. .. .	0 6
4902. Melbourne and Metropolitan Board of Works (Rates) .. .. .	0 6
4903. Adoption of Children .. .. .	0 6
4904. Consolidated Revenue .. .. .	0 6
4905. Land Tax (Exemptions) .. .. .	0 6
4906. Land Tax .. .. .	0 6
4907. Stamps (Increased Duty Continuance) .. .. .	0 6
4908. Country Roads Board Fund .. .. .	0 6
4909. Financial Emergency (Grants and Funds) .. .. .	0 6
4910. Water Supply Loans Application .. .. .	0 6
4911. Administration and Probate Duties .. .. .	0 6
4912. Railway Loan Application .. .. .	0 6
4913. Public Account Advances (Amendment) .. .. .	0 6
4914. Farmers Protection (Amendment) .. .. .	0 6
4915. Water .. .. .	0 6
4916. Patriotic Funds .. .. .	0 6
4917. St. Vincent's Hospital Land .. .. .	0 6
4918. Survival of Actions .. .. .	0 6
4919. Mines .. .. .	0 6
4920. South Melbourne (Birrell-place) Land .. .. .	0 6
4921. Local Government (Loans and Debentures) .. .. .	0 6
4922. Local Government (Building Regulations) Amendment .. .. .	0 6
4923. Miners' Phthisis (Treasury Allowances) Amendment .. .. .	0 6
4924. Legal Profession Practice .. .. .	0 6
4925. Motor Car (Amendment) .. .. .	0 6

**STATE ACTS, 1942—continued.**

No.	Price s. d.
4926. Local Government (Street Construction) .. .. .	1 0
4927. Victorian Inland Meat Authority .. .. .	1 0
4928. Railway Construction Trusts Liabilities .. .. .	0 6
4929. Surplus Revenue .. .. .	0 6
4930. Railways (Long Service) .. .. .	0 6
4931. Grain Elevators .. .. .	0 6
4932. Coal Mine Workers Pensions .. .. .	1 3
4933. State Forests Loan Application .. .. .	0 6
4934. Health (Patent Medicines) .. .. .	0 9
4935. Metropolitan Gas Company's .. .. .	0 6
4936. Yannathan and Triholm Railway (Dismantling) .. .. .	0 6
4937. Soil Conservation .. .. .	0 6
4938. Forests .. .. .	0 6
4939. Land Surveyors .. .. .	0 9
4940. Administration and Probate (Amendment) .. .. .	0 6
4941. Appropriation of Revenue .. .. .	3 3
4942. Dietitians Registration .. .. .	1 0

J. J. GOURLY,  
 Government Printer.

**STATE ACTS, 1943.**

COPIES of the following Acts of Parliament of Victoria may be obtained at the Government Printing Office, or from any bookseller, at the price set opposite to each:—

No.	Price s. d.
4943. Consolidated Revenue .. .. .	0 6
4944. Consolidated Revenue .. .. .	0 6
4945. State Development .. .. .	0 6
4946. Grain Elevators .. .. .	0 6
4947. Consolidated Revenue .. .. .	0 6
4948. Lunacy .. .. .	0 6
4949. National Security (Emergency Powers) Continuation .. .. .	0 6
4950. Commonwealth Powers .. .. .	0 6
4951. Consolidated Revenue .. .. .	0 6
4952. Factories and Shops (Chairmen of Wages Boards) .. .. .	0 6
4953. Country Roads (Forest Roads and Stock Routes) .. .. .	0 6
4954. State Schools (Bush Fire Relief) .. .. .	0 6
4955. Consolidated Revenue .. .. .	0 6
4956. Coal Mines Regulation .. .. .	0 6
4957. Petrol Pumps (Licence Fees) .. .. .	0 6
4958. Superannuation (Contributions) .. .. .	0 6
4959. Coal Mine Workers Pensions .. .. .	0 6
4960. Forests (Exchange of Lands) .. .. .	0 6
4961. Local Government (Valuations) .. .. .	0 6
4962. Railway Construction (Extensions) .. .. .	0 6
4963. Mental Hygiene (Mode of Citation) .. .. .	0 6
4964. Administration and Probate Duties .. .. .	0 6
4965. Sewerage Districts .. .. .	0 6
4966. Stamps (Increased Duty Continuance) .. .. .	0 6
4967. Land Tax .. .. .	0 6
4968. Surplus Revenue .. .. .	0 6
4969. Financial Emergency (Grants and Funds) .. .. .	0 6
4970. Partially Blinded Soldiers Fund .. .. .	0 6
4971. Melbourne and Metropolitan Board of Works (Contributions) .. .. .	0 6
4972. Milk Pasteurization .. .. .	1 0
4973. Country Roads Board Fund .. .. .	0 6
4974. Workers' Compensation .. .. .	0 6
4975. Public Works Loan and Application .. .. .	0 6
4976. Factories and Shops (Saturday Half-holiday) .. .. .	0 6
4977. Springvale Necropolis Land .. .. .	0 6
4978. South Melbourne to Melbourne Tramway Construction .. .. .	0 6
4979. Water Supply Loans Application .. .. .	0 6
4980. Forests .. .. .	0 6
4981. State Forests Loan Application .. .. .	0 6
4982. Administration and Probate (War Service) .. .. .	0 6
4983. Water .. .. .	0 9
4984. Farmers Protection (Amendment) .. .. .	0 6
4985. Stamps .. .. .	0 6
4986. Railway Loan Application .. .. .	0 6
4987. Farmers Debts Adjustment .. .. .	0 6

## STATE ACTS, 1943—continued.

No.	Price.
	s. d.
4988. Ministry of Health .. .. .	1 0
4989. Discharged Servicemen's Preference .. .. .	1 0
4990. Instruments (Insurance Contracts) .. .. .	0 6
4991. Melbourne (Widening of Streets) .. .. .	0 6
4992. Mines (Petroleum) .. .. .	0 6
4993. Education .. .. .	0 6
4994. Land Settlement (Acquisition) .. .. .	0 6
4995. Land Settlement Loan and Application .. .. .	0 6
4996. Housing .. .. .	1 0
4997. Milk and Dairy Supervision .. .. .	1 0
4998. Appropriation of Revenue .. .. .	3 9

J. J. GOURLEY,  
Government Printer.

## STATE ACTS, 1944—continued.

No.	Price.
	s. d.
5047. Surplus Revenue .. .. .	0 6
5048. Water Supply Loans Application .. .. .	0 9
5049. State Forests Loan and Application .. .. .	0 6
5050. Public Works Loan and Application .. .. .	0 6
5051. Commonwealth and States Financial Agreement .. .. .	1 3
5052. The Constitution Act Amendment .. .. .	0 6
5053. Public Library National Gallery and Museums .. .. .	0 9
5054. Drought Relief .. .. .	0 6
5055. Co-operative Housing Societies .. .. .	1 6
5056. Local Government .. .. .	1 0
5057. Melbourne and Metropolitan Board of Works .. .. .	0 9
5058. Appropriation of Revenue .. .. .	3 9

J. J. GOURLEY,  
Government Printer.

## STATE ACTS, 1944.

COPIES of the following Acts of Parliament of Victoria may be obtained at the Government Printing Office, or from any bookseller, at the price set opposite to each:—

No.	Price.
	s. d.
4999. Consolidated Revenue .. .. .	0 6
5000. Local Government (Polling Booths) .. .. .	0 6
5001. Police Offences (Unlawful Games) .. .. .	0 6
5002. Hospitals and Charities .. .. .	0 6
5003. Water (Loddon) .. .. .	0 6
5004. Justices .. .. .	0 6
5005. Coal Mines Regulation (Amendment) .. .. .	0 6
5006. Consolidated Revenue .. .. .	0 6
5007. Melbourne and Metropolitan Board of Works (Contributions) .. .. .	0 6
5008. Marketing of Primary Products .. .. .	0 6
5009. National Security (Emergency Powers) Continuation .. .. .	0 6
5010. Outer Circle Railway (Partial Dismantling) .. .. .	0 6
5011. Mines (Minerals) .. .. .	0 6
5012. Goods (Textile Products) .. .. .	0 6
5013. Masseurs .. .. .	0 6
5014. Electoral (War Service Deaths) .. .. .	0 6
5015. Cremorne Bridge .. .. .	0 6
5016. Melbourne Harbor Trust .. .. .	0 6
5017. Water .. .. .	0 9
5018. Consolidated Revenue .. .. .	0 6
5019. Mildura Irrigation and Water Trusts .. .. .	0 6
5020. Farm Water Supplies Advances .. .. .	0 6
5021. Sewerage Districts .. .. .	0 6
5022. Trustee Companies .. .. .	0 6
5023. Mildura Irrigation and Water Trusts (Superannuation) .. .. .	0 6
5024. Consolidated Revenue .. .. .	0 6
5025. Cemeteries .. .. .	0 6
5026. Border Railways .. .. .	0 6
5027. Local Government (Shire of Blackburn and Mitcham) .. .. .	0 6
5028. Electoral Districts .. .. .	0 6
5029. Land .. .. .	0 6
5030. Land Tax .. .. .	0 6
5031. Administration and Probate Duties .. .. .	0 6
5032. Stock Foods (Amendment) .. .. .	0 6
5033. Stamps (Increased Duty Continuance) .. .. .	0 6
5034. Maribyrnong and Ashburton Lands Exchange .. .. .	0 6
5035. Financial Emergency (Grants and Funds) .. .. .	0 6
5036. Farmers Advances .. .. .	0 6
5037. Land Settlement (Acquisition) Amendment .. .. .	0 6
5038. Railways .. .. .	0 6
5039. Farmers Protection (Amendment) .. .. .	0 6
5040. Country Fire Authority .. .. .	1 9
5041. Country Roads Board Fund .. .. .	0 6
5042. Railway Loan and Application .. .. .	0 6
5043. Town and Country Planning .. .. .	1 0
5044. Agricultural Colleges .. .. .	0 9
5045. Heatherton Sanatorium .. .. .	0 6
5046. Health (Infectious Diseases Hospitals) .. .. .	0 6

J. J. GOURLEY,  
Government Printer.

## STATE ACTS, 1945.

COPIES of the following Acts of Parliament of Victoria may be obtained at the Government Printing Office, or from any bookseller, at the price set opposite to each:—

No.	Price.
	s. d.
5059. Mildura Irrigation and Water Trusts (Borrowing) .. .. .	0 6
5060. Supreme Court (Judges) .. .. .	0 6
5061. Oakleigh (Regent-street) Land .. .. .	0 6
5062. Swine .. .. .	0 6
5063. Drought Relief (Amendment) .. .. .	0 6
5064. Unclaimed Moneys .. .. .	0 6
5065. Consolidated Revenue .. .. .	0 6
5066. Consolidated Revenue .. .. .	0 6
5067. Agent-General's .. .. .	0 6
5068. Land Surveyors (Amendment) .. .. .	0 6
5069. State Development .. .. .	0 6
5070. Melbourne and Metropolitan Board of Works (Borrowing Powers) .. .. .	0 6
5071. Education .. .. .	0 6
5072. Water .. .. .	0 6
5073. National Security (Repeal) .. .. .	0 6
5074. Moorabbin (Unimproved Rating Poll) .. .. .	0 6
5075. Licensing (Poll) .. .. .	0 6
5076. Lilydale Waterworks Trust Abolition .. .. .	0 6
5077. East Melbourne Land .. .. .	0 6
5078. Health (Wines) .. .. .	0 6
5079. Local Government (Emergency Housing Accommodation) .. .. .	0 6
5080. Law Institute .. .. .	0 6
5081. Bendigo Land .. .. .	0 6
5082. Consolidated Revenue .. .. .	0 6
5083. Consolidated Revenue .. .. .	0 6
5084. Consolidated Revenue .. .. .	0 6
5085. Factories and Shops (Bread Holidays) .. .. .	0 6
5086. Administration and Probate Duties .. .. .	0 6
5087. Land Tax .. .. .	0 6
5088. Stamps (Increased Duty Continuance) .. .. .	0 6
5089. Licensing Fund .. .. .	0 6
5090. Employers and Employés .. .. .	0 6
5091. Farmers Advances .. .. .	0 6
5092. University (Veterinary Research) .. .. .	0 6
5093. Surplus Revenue .. .. .	0 6
5094. State Forests Loan and Application .. .. .	0 6
5095. Mines (Amendment) .. .. .	0 6
5096. Farmers Protection (Amendment) .. .. .	0 6
5097. Railway Loan Application .. .. .	0 6
5098. Public Works Loan and Application .. .. .	0 6
5099. Water Supply Loans Application .. .. .	0 9
5100. Public Account Advances (Amendment) .. .. .	0 6
5101. Hospital Benefits .. .. .	0 6
5102. Totalizator (Amendment) .. .. .	0 6
5103. Financial Emergency (Municipal Endowment) .. .. .	0 6
5104. Country Roads Board Fund (Amendment) .. .. .	0 6
5105. Coal Mines Regulation (Amendment) .. .. .	0 6
5106. Melbourne and Metropolitan Tramways (Chairman) .. .. .	0 6
5107. Soldier Settlement .. .. .	1 3

J. J. GOURLEY,  
Government Printer.

AGENTS FOR THE "VICTORIA GOVERNMENT GAZETTE."

THE following have been appointed agents to receive Advertisements and subscriptions for the *Victoria Government Gazette*:—

- ARMSTRONG'S AGENCY, 143 Queen-street, Melbourne.
- MESSRS. ARHALL & JACKSON, 115 Parkly-street, West Brunswick.
- MESSRS. GORDON & GOTCH, News Agents, 511 Little Collins-street, Melbourne; and corner Barrack and Clarence streets, Sydney.
- MESSRS. HARSTON, PARTRIDGE, & CO., 455 Little Collins-street, Melbourne.
- N. V. NIXON & CO., 20 Queen-street, Melbourne.
- THE PATON ADVERTISING SERVICE PTY. LTD.
- ROBERTSON, & MULLENS LTD., Elizabeth-street, Melbourne.
- MESSRS. W. H. WADDELL and A. S. RICHARDSON, trading as The Mercantile Exchange, 380 Collins-street, Melbourne.
- MR. A. J. DIGBY, News Agent, Bairnsdale.
- MR. M. R. BADE, Tobaccoist, Sturt-street, Ballarat.
- TRIGG'S NEWS AGENCY, Hargreaves-street, Bendigo.
- MR. G. H. K. PAYNE, 4 View Point, Bendigo.
- MR. G. F. LATIMER, News Agent, Casterton.
- MESSRS. HENRY FRANKS & CO., Booksellers and Stationers, Market-square, Geelong.
- MESSRS. SMITH & DUNNON, Hamilton.
- ARMSTRONG BROS., Kyneton.
- MR. WM. DAVIS, Mildura.
- PIKE'S AUTHORIZED NEWS AGENCY, Sale.
- MR. C. T. RUST, News Agent, Wangaratta.
- MR. F. T. McCORMICK, Nunn-street, Benalla.
- F. R. & E. M. COOKE, Bridge-street, Benalla.

A copy of the *Gazette* filed at each place for public reference

THE "VICTORIA GOVERNMENT GAZETTE."

SUBSCRIPTIONS.—The subscription, including Postage, is £1 12s. 6d. per annum, 16s. 3d. half-yearly, or 8s. 2d. per quarter, payable in advance.

Subscriptions are required to commence and terminate with a month.

A lesser period than three months cannot be subscribed for. Subscribers do not receive the Acts of Parliament with the GAZETTE.

ADVERTISEMENTS are charged at the rate of EIGHT PENCE per line single column, and ONE SHILLING and FOUR PENCE per line double column.

The title (£5 Reward, Dissolution of Partnership, &c.) forms one or more lines as a heading.

On an average, ten words make a line.

Every signature must likewise be counted as a line.

The final words of a paragraph, though only portion of a line, must be counted as one line.

SIGNATURES (in particular) and proper names must be written very plainly in the text; ONE SIDE ONLY of each slip of paper should be WRITTEN UPON.

ALL COMMUNICATIONS should be addressed to "The Government Printer, Melbourne."

ALL DOCUMENTS illegibly written will be returned unpublished, and, where brands occur unprovided for by the ordinary letters of the alphabet, a worded explanatory description must be furnished.

THE "VICTORIA GOVERNMENT GAZETTE" is published on WEDNESDAY EVENING in each week, and Notices for insertion will be received by the Government Printer at or before Two p.m., at ordinary rates, and late advertisements between Two p.m. and FIVE p.m. at double rates on the day preceding the day of publication.

Single copies of the VICTORIA GOVERNMENT GAZETTE are Six pence, posted Eight pence, each.

No GAZETTES prior to January, 1934, in stock.

\*\*\*ALL PAYMENTS ARE REQUIRED IN ADVANCE.—Remittances should be made by postal note, money order, or draft in favour of the Government Printer. Advertisements unaccompanied by a remittance sufficient to cover the cost of insertion will be returned unpublished.

CONTENTS

	PAGE
Act. of Parliament .. .. .	1144
Acts of Parliament on sale at the Government Printing Office .. .. .	1172
Appointments .. .. .	1145
Contracts .. .. .	1151
Country Roads Board .. .. .	1155
Courts .. .. .	1150
Easter and Anzac Day Holidays .. .. .	1143
Estates of Deceased Persons .. .. .	1150
Government Notices .. .. .	1149
Impoundings .. .. .	1171
Insolvency Notice .. .. .	1171
Labour Day Holiday .. .. .	1143
Lands .. .. .	1156
Mining .. .. .	1171
Orders in Council .. .. .	1154
Private Advertisements .. .. .	1162
Proclamations .. .. .	1143
Publication of the <i>Government Gazette</i> .. .. .	1143
Public Holidays .. .. .	1143
Public Service Notices .. .. .	1146
Resignations .. .. .	1146
Stay Order .. .. .	1150
Tenders .. .. .	1161
Transport Regulation Board—Public Hearings .. .. .	1149
Waterworks Trust .. .. .	1148