



VICTORIA
GOVERNMENT GAZETTE.

Published by Authority.

[Registered at the General Post Office, Melbourne, for transmission by post as a newspaper.]

No. 755]

WEDNESDAY, AUGUST 4.

[1948

ACT OF PARLIAMENT.

PROCLAMATION

By the Lieutenant-Governor, as Deputy for His Excellency the Governor of the State of Victoria, and its Dependencies in the Commonwealth of Australia, &c., &c., &c.

I, THE Lieutenant-Governor, as Deputy for the Governor of the State of Victoria, in the Commonwealth of Australia, do hereby declare that I have this day assented, in His Majesty's name, to the Bill passed by the Parliament of the said State, the title whereof is hereunder set forth, that is to say:—

No. 5282. "An Act to revoke the Reservation of certain Land in the Parish of Melbourne North permanently reserved as a Site for the use of the Victorian Horticultural Improvement Society."

Given under my Hand and the Seal of the State of Victoria aforesaid, at Melbourne, this third day of August, in the year of our Lord One thousand nine hundred and forty-eight, and in the twelfth year of the reign of His Majesty King George VI.

(L.S.)

E. F. HERRING.

By His Excellency's Command,

JOHN G. B. McDONALD,
Acting Premier.

GOD SAVE THE KING!

BANK HALF-HOLIDAY.

PROCLAMATION

By the Lieutenant-Governor, as Deputy for His Excellency the Governor of the State of Victoria and its Dependencies in the Commonwealth of Australia, &c., &c., &c.

IN pursuance of the provisions contained in Part III. of the *Banks and Currency Act 1928*, I, the Lieutenant-Governor, as Deputy for the Governor of the State of Victoria, in the Commonwealth of Australia, do by this my Proclamation appoint the day and date named hereunder a special day to be observed as a Bank Half-Holiday at the place mentioned, that is to say:—

*Bank Half-Holiday from the Hour of Twelve o'clock
noon:—*

WEDNESDAY, 11TH AUGUST, 1948, at Murrayville.

Given under my Hand and the Seal of the State of Victoria aforesaid, at Melbourne, this third day of August, in the year of our Lord One thousand nine hundred and forty-eight, and in the twelfth year of the reign of His Majesty King George VI.

(L.S.)

E. F. HERRING.

By His Excellency's Command,

K. DODGSHUN,
Chief Secretary.

GOD SAVE THE KING!

PUBLIC HOLIDAYS.

PROCLAMATION

By the Lieutenant-Governor, as Deputy for His Excellency the Governor of the State of Victoria and its Dependencies in the Commonwealth of Australia, &c., &c., &c.

IN pursuance of the provisions contained in Part III. of the *Public Service Act 1946* (10 Geo. VI. No. 5124), I, the Lieutenant-Governor, as Deputy for the Governor of the State of Victoria, in the Commonwealth of Australia, by and with the advice of the Executive Council of the said State, do by this my Proclamation appoint the days and dates hereunder mentioned to be observed as Public Holidays or Public Half-Holidays (as the case may be) at the places respectively specified, viz.:—

Public Holidays:—

- *THURSDAY, 2ND SEPTEMBER, 1948, throughout the Shire of Minhamite.
- *FRIDAY, 29TH OCTOBER, 1948, throughout the Shire of Marong.
- *THURSDAY, 7TH OCTOBER, 1948, throughout the Shire of Wimmera.

Public Half-Holidays from the Hour of Twelve o'clock noon:—

- *THURSDAY, 2ND SEPTEMBER, 1948, throughout the Town of Hamilton.
- *THURSDAY, 19TH AUGUST, 1948, throughout the Balmoral Riding of the Shire of Wannon.
- *TUESDAY, 17TH AUGUST, 1948, throughout the Shire of Stawell.
- *TUESDAY, 17TH AUGUST, 1948, throughout the Borough of Stawell.

* Agricultural Show.

Given under my Hand and the Seal of the State of Victoria aforesaid, at Melbourne, this third day of August, in the year of our Lord One thousand nine hundred and forty-eight, and in the twelfth year of the reign of His Majesty King George VI.

(L.S.)

E. F. HERRING.

By His Excellency's Command,

K. DODGSHUN,
Chief Secretary.

GOD SAVE THE KING!

WEIGHTS AND MEASURES ACT 1928.—PART II.
PROCLAMATION OF A "UNION."

PROCLAMATION

By the Lieutenant-Governor, as Deputy for His Excellency the Governor of the State of Victoria and its Dependencies in the Commonwealth of Australia, &c., &c., &c.

PURSUANT to the provisions of Part II. of the *Weights and Measures Act 1928*, I, the Lieutenant-Governor, as Deputy for the Governor of the State of Victoria, by and with the advice of the Executive Council thereof, do hereby proclaim the Borough of St. Arnaud, and the Shires of Donald, Birchip, and Kara Kara to be a "Union" for the purposes of the said Act; and do fix as follows the proportion in which the expenses devolving upon such Union under the said Act shall be borne by the several municipalities, that is to say:—

Borough of St. Arnaud	..	25 per cent.
Shire of Donald	..	25 per cent.
Shire of Birchip	..	25 per cent.
Shire of Kara Kara	..	25 per cent.

And, further, I do fix as follows the number of managers each Council in the said Union shall elect, that is to say:—

Borough of St. Arnaud	..	Two.
Shire of Donald	..	Two.
Shire of Birchip	..	Two.
Shire of Kara Kara	..	Two.

Given under my Hand and the Seal of the State of Victoria aforesaid, at Melbourne, this third day of August, in the year of our Lord One thousand nine hundred and forty-eight, and in the twelfth year of the reign of His Majesty King George VI.

(L.S.)

E. F. HERRING.

By His Excellency's Command,

K. DODGSHUN,
Chief Secretary.

GOD SAVE THE KING!

APPOINTMENTS.

HIS Excellency the Governor of the State of Victoria, by and with the advice of the Executive Council thereof, has, by Orders made on the 26th day of July, 1948, been pleased to make the under-mentioned appointments, viz.:—

DEPARTMENT OF CHIEF SECRETARY.

Registrar of Births and Deaths.

LAURIE BRYSE,
pursuant to the provisions of section 4 of the *Registration of Births Deaths and Marriages Act 1928*, to be Registrar of Births and Deaths at Croydon, to date from commencement of duty, with fees, *vice* Yvonne Smith, resigned.

Returning Officer.

ERNEST PETER McMASTER
to be Returning Officer for the Electoral District of Prahran, *vice* Robert James Grant, deceased.

Electoral Registrar (Acting).

HERBERT WILLIAM HODGSON
to be Electoral Registrar (Acting) for the Dimboola, Horsham, and Murtoa Subdivisions of the Electoral District of Borung; for the Casterton, Goroke, Hamilton, and Harrow Subdivisions of the Electoral District of Dundas; for the Branxholme, Koroit, Port Fairy, and Portland Subdivisions of the Electoral District of Portland; for the Jeparit, Kaniva, and Nhill Subdivisions of the Electoral District of Rainbow; and for the Horsham South and Stawell Subdivisions of the Electoral District of Ripon, to take effect on and from the 2nd August, 1948, during the absence on leave of Archibald James Milligan MacPherson.

DEPARTMENT OF LANDS AND SURVEY.

Bailiff of Crown Lands.

JOHN ROY GOODISSON, of "Langi Kal Kal" Estate, Beaufort,
to be a Bailiff of Crown lands, without salary.

Member of Committee of Management.

HOWARD KIRBY INGHAM
to be a Member of the Committee of Management of the land temporarily reserved on the 24th August, 1909, as a site for the Recreation, Convenience, and Amusement of the people, and for a Children's Playground in the City of Melbourne, and known as "Olympic Park," in the place of the Honorable Sir Francis Joseph Edmund Beaurepaire, Kt., M.L.C., resigned.

DEPARTMENT OF LAW.

Commissioners for Taking Declarations, &c.

KEITH COLIN CAMPBELL DAVEY, an officer of the Australian Mutual Provident Society, Melbourne,
to be a Commissioner for taking Declarations and Affidavits, pursuant to the provisions of Division 8 of Part IV. of the *Evidence Act 1928*, to resign upon ceasing to occupy his present position; and

GEOFFREY THOMAS SAYERS, 6 Hazeldine-road, Glen Iris,
and
BRIAN KELLY, 22 Alma-road, Camberwell,
to be Commissioners for taking Declarations and Affidavits, pursuant to the provisions of Division 8 of Part IV. of the *Evidence Act 1928*, to resign upon removing from the neighbourhood of the addresses stated.

Magistrates.

FRANCIS WILLIAM VASS, 190 Warrigal-road, Oakleigh South, and
HYMAN BARRKMAN, 10 Testar-grove, Caulfield,
to Keep the Peace in the Central Bailiwick of the State of Victoria;
EVAN LEWIS RICHARD, Bogong,
to Keep the Peace in the Northern Bailiwick of the State of Victoria;
FRANK JOSEPH GLEN, Walpeup,
to Keep the Peace in the Midland Bailiwick of the State of Victoria; and
DAVID KEITH PITCAIRN MILLER, Teesdale,
to Keep the Peace in the Southern Bailiwick of the State of Victoria.

Sheriff's Bailiff.

WILLIAM PATRICK HOARE, Senior Constable of Police, Charlton,
to be also a Sheriff's Bailiff and a Bailiff of the County Court at Bendigo, in the place of T. V. Brasier, resigned, to take effect from the date of commencement of duty.

Special Magistrate.

HAROLD LE PLASTRIER JACKSON, Police Magistrate, City Court, Melbourne,
to be also a Special Magistrate to exercise the jurisdiction of the Metropolitan Industrial Court, to take effect from the date of commencement of duty.

C. W. KINSMAN,
Clerk of the Executive Council.

At the Executive Council Chamber,
Melbourne, 26th July, 1948.

RESIGNATIONS.

HIS Excellency the Governor of the State of Victoria, by and with the advice of the Executive Council thereof, has, by Orders made on the 26th day of July, 1948, accepted the resignations of the persons named hereunder of the offices mentioned, viz.:—

DEPARTMENT OF CHIEF SECRETARY.

YVONNE SMITH, as Registrar of Births and Deaths at Croydon, to date from and inclusive of the 5th July, 1948.

DEPARTMENT OF LAW.

THOMAS VINCENT BRASIER, as a Sheriff's Bailiff and a Bailiff of the County Court at Bendigo.

C. W. KINSMAN,
Clerk of the Executive Council.

At the Executive Council Chamber,
Melbourne, 26th July, 1948.

PUBLIC SERVICE OF VICTORIA.—VACANCIES.

APPLICATIONS will be received by the Public Service Board up to Saturday, the 21st August, 1948, from persons employed in the Public Service of Victoria, who are eligible and qualified, for appointment to the under-mentioned positions:—

PROFESSIONAL DIVISION.

Supervisor of Herd Testing, Class "C," Department of Agriculture.

Yearly Salary.—£449, minimum; £501, maximum.

Duties.—Under the Superintendent of Dairying, to have charge of the herd-recording and herd-improvement research work of the Dairying Division, Department of Agriculture, and to control and direct the work of staff engaged in such work. To lecture on dairy herd improvement, stock-breeding, and dairy farming. To undertake the training of herd-recording officers and to prepare reports and articles for publication on herd-recording and related activities.

Qualifications.—A degree in Agricultural Science and experience in the practice of Herd Recording, including Bull Indexing. A sound knowledge of the breeding, feeding, and general management of dairy cattle, and ability to lecture on these subjects. Capacity to undertake research work into problems of dairy herd improvement.

Assistant, Class "D," Public Library Branch, Department of Chief Secretary. (Two vacancies.)

Yearly Salary.—£312, minimum; £436, maximum.

Duties.—To assist generally in the Professional work of the Reference Library, to take charge of the Enquiry Room staff of the Reference Library and of the Library night staff every alternate week.

Qualifications.—To have attained the age of 23 years, to have graduated at the Melbourne University or to have made substantial progress towards graduation in Arts, Science, or other relevant course, to have a good general knowledge of books and of contemporary affairs. Some knowledge of languages is desirable.

Preparator, Grade II, Class "D," National Museum Branch, Department of Chief Secretary.

Yearly Salary.—£364, minimum; £436, maximum.

Duties.—To collect, preserve, and prepare zoological and other specimens; to prepare museum exhibits, including diorama and models.

Qualifications.—To have had proved experience in modern methods of museum taxidermy and general preparation, including the preparation and mounting of diorama accessories. To possess a practical knowledge of modelling materials, including plastics and latex.

Draughtsman, Class "D," Investigations and Designs Branch, Department of Water Supply.

Yearly Salary.—£312, minimum; £436, maximum.

Duties.—To prepare plans of Civil and Hydraulic Engineering structures and machinery; to take out earthwork quantities and prepare designs and plans of irrigation channels.

Qualifications.—To have had Technical School Training in Engineering or Draughtsmanship or experience in the class of work outlined above.

Draughtsman (Cartographic), Class "D," Survey Branch, Department of Water Supply.

Yearly Salary.—£312, minimum; £436, maximum.

Duties.—The compilation of maps and plans for record and reproduction, including the preparation of mosaics from air photographs.

Qualifications.—To be a good penman and competent computer and to be conversant with departmental procedure and requirements in the application of survey principles to survey compilation.

TECHNICAL AND GENERAL DIVISION.

Field Officer, Department of Agriculture. (Two vacancies.)

Yearly Salary.—£358, minimum; £436, maximum.

Duties.—To assist in special irrigation surveys of horticultural blocks proposed for soldier settlement and in field experiments connected therewith; and, after suitable training, to give instruction to horticulturists, particularly soldier settlers, in irrigation methods.

Qualifications.—To possess the Diploma of an Australian Agricultural College, or its equivalent. Some knowledge of horticulture or viticulture under irrigation is desirable.

Chief Nurse, Repatriation Mental Hospital, Bundoora, Mental Hygiene Branch, Department of Health.

Salary.—£364 a year.

Duties.—Under direction of Medical Superintendent, to have charge of female staff.

Qualifications.—To be a trained Nurse with nursing service in the Defence Forces and experience in control of female staff. The possession of a Mental Hygiene Nursing Certificate or similar qualification is desirable.

Assistant (Male), Grade II, Taxation (Land Tax) Branch, Department of Treasurer. (Two vacancies.)

Yearly Salary.—Junior—according to age. Adult—£299, minimum; £364, maximum.

Duties.—To be responsible for a Section of the Index and the corresponding non-taxable files, to make all searches relating thereto, and to assist generally in the Records Branch.

Qualifications.—To be active and industrious and to possess a practical knowledge of office procedure in relation to Land Tax filing methods, together with a capacity for accuracy, neatness, and expedition in the performance of the duties. Possession of School Intermediate Certificate is desirable.

Nurse, Penal and Gaols Branch, Department of Chief Secretary.

Yearly Salary.—£305, minimum; £331, maximum.

Duties.—To supervise the Hospital at the Female Division of Penal Establishment, Pentridge.

Qualifications.—To be a qualified nurse with some experience in institutional and staff management and ability to control delinquent females.

NOTE.—Appointee will be required to live in quarters, when available, for which rental will be charged.

Labourer, Law Courts, Department of Law.

Yearly Salary.—£260, minimum; £273, maximum.

Shorthand Writer and Typist (Female), Grade III, Survey Branch, Office of Titles, Department of Law.

Yearly Salary.—£260, minimum; £273, maximum.

Duties.—To have charge of the keeping of records and indexing of all dealings in the Survey Branch. To supply relevant information to the public. To carry out any secretarial duties required and supervise general typing.

Qualifications.—To be an experienced typist and stenographer with a knowledge of filing and recording. To be able to control a small staff.

Machinist (Female), Grade III, Department of State Forests.

Yearly Salary.—£247, minimum; £273, maximum.

Duties.—To record and balance expenditure in districts under the various funds and to extract financial statements and expenditure in connexion with the Commission's Industrial Undertakings.

Qualifications.—To possess ability to operate Remington Accounting Machines Dual and Single Cross and Burroughs Calculator, and a sound knowledge of all phases of mechanized accounting of the Expenditure Section of the Commission.

Laundress, Mental Hospital, Mont Park, Department of Health.

Yearly Salary.—£245, minimum; £258, maximum.

Duties.—To assist in laundry.

Qualifications.—Ability to operate laundry machinery.

NOTE.—In addition to the salary rates quoted, a cost of living adjustment (£72 a year for adult males, £48 a year for adult females, and £36 a year for minors), which varies in accordance with the rise or fall in the index numbers of the cost of living, is payable.

By order,

E. F. FITZGIBBON,
Secretary.

Office of the Public Service Board,
Melbourne, 2nd August, 1948.

**FIELD OFFICER, SOIL CONSERVATION BOARD,
DEPARTMENT OF PREMIER. (Four vacancies.)**

TEMPORARY APPOINTMENT.

A PPLICATIONS will be received by the Public Service Board up to Saturday, the 21st August, 1948, from persons who are qualified, for appointment to the above-mentioned position.

Yearly Salary.—£358, minimum; £423, maximum, plus £72 cost of living adjustment. The rate is subject to variation in accordance with the rise or fall in the index numbers of the cost of living.

Duties.—The selection, layout, supervision, and maintenance of demonstration areas in soil erosion control; inspecting land, advising land holders on soil conservation, assisting land holders with planting, surveying, and carrying out of soil conservation works.

Qualifications.—To have a thorough knowledge of the characteristics and use of land (including the Mallee), experience in the practice of agriculture, a knowledge of the principles and application of soil erosion control methods, and preferably a diploma or certificate from an Agricultural College.

By order,

E. F. FITZGIBBON,
Secretary.

Office of the Public Service Board,
Melbourne, 2nd August, 1948.

No. 315.

PUBLIC SERVICE ACT 1946.

THE Public Service Board, in pursuance of the powers conferred by the *Public Service Act 1946*, hereby amends the Public Service (Public Service Board) Regulations as follows:—

REGULATIONS.—PART III.—SALARIES, INCREMENTS, AND ALLOWANCES.

After the word "shall" in Regulation 55 the words "unless otherwise determined by the Board" are inserted.

This Regulation shall have effect as on and from the 1st July, 1948.

D. D. PAINE, Chairman.
E. F. FITZGIBBON, Secretary.

Office of the Public Service Board,
Melbourne, 7th July, 1948.

No. 314.

Public Service Act 1946, Section 50.

REGULATIONS—PART III.—SALARIES, INCREMENTS, AND ALLOWANCES.

THE Public Service Board, in pursuance of the powers conferred by the *Public Service Act 1946*, hereby amends its Regulations as shown below:—

SIXTH SCHEDULE.

TEMPORARY EMPLOYEES.

Designations of Positions and Rates of Salaries.

Department and Designation of Position.	Yearly Rate of Salary.		Increments (Annual).
	Minimum.	Maximum.	
DEPARTMENT OF PREMIER.	£	£	
SOIL CONSERVATION BOARD.			
<i>Delete—</i> Field Officer	338	410	1 of £13, 1 of £26, 1 of £20, 1 of £13
<i>Add—</i> Field Officer	358	423	2 of £26, 1 of £13
DEPARTMENT OF WATER SUPPLY.			
<i>Delete—</i> Assistant Draughtsman (Designing)*—			
At 19 years of age	286
At 20 years of age	312
At 21 years of age	338
At 22 years of age	364
At 23 years of age	390
At 24 years of age	416
<i>Add—</i> Assistant Draughtsman (Designing)*—			
At 19 years of age	312
At 20 years of age	338
Adult	390	416	1 of £26

This Regulation shall have effect as on and from the 8th August, 1948.

D. D. PAINE, Chairman.
E. F. FITZGIBBON, Secretary.

Office of the Public Service Board,
Melbourne, 26th July, 1948.

No. 313.

Public Service Act 1946, Section 39.

REGULATIONS—PART III.—SALARIES, INCREMENTS, AND ALLOWANCES.

THE Public Service Board, in pursuance of the powers conferred by the *Public Service Act 1946*, hereby amends its Regulations as shown below:—

FIRST SCHEDULE.

PROFESSIONAL DIVISION.

Offices and Rates of Salaries.

Office.	Yearly Rate of Salary.	
	Minimum.	Maximum.
DEPARTMENT OF LAW.	£	£
CLASS "A1."		
<i>Add—</i> Assistant Crown Solicitor	1,050	1,250
CLASS "A."		
<i>Delete—</i> Assistant Crown Solicitor	850	950

D. D. PAINE, Chairman.
E. F. FITZGIBBON, Secretary.

Office of the Public Service Board,
Melbourne, 26th July, 1948.

PUBLIC SERVICE (PUBLIC SERVICE BOARD) REGULATION 36A.

NOTICE is hereby given that the Public Service Board has raised the classification of the undermentioned offices, as shown, and that the Permanent Heads of the Departments in which such offices are classified have recommended the officers named for appointment.

Present Office and Classification.	Revised Classification.	Duties.	Qualifications.	Name of Person Recommended.
ADMINISTRATIVE DIVISION.				
DEPARTMENT OF PUBLIC WORKS.				
Clerk, Class "C1"	Class "C2"	To be Assistant Accountant of the Departments of Public Works and Mines, to be responsible, under the Accountant, for the direction and supervision of the staff, and to prepare estimates and financial statements	To have a sound knowledge of Departmental procedure, the Regulations respecting Public Accounts, Treasury and Audit Practice, and the Customs House system of collecting and recording tonnage dues. To possess ability and proved experience in the control and operation of a completely mechanised accounting system	McLellan, A. J.
PROFESSIONAL DIVISION.				
DEPARTMENT OF HEALTH.				
<i>General Health Branch.</i>				
Medico - Legal Chemist, Class "B"	Medico - Legal Chemist, Class "B1"	To carry out analyses and investigations of medico-legal and other specimens submitted by the Coroner, the Police, &c., and to give expert evidence in court	To possess a science degree with chemistry as a major subject and approval as an analyst under the Health Act. To have had wide experience in medico-legal chemistry and in court proceedings	Taylor, C. A.
Analyst, Class "C1"	Senior Chemist (Female), Class "C2"	To act as chemist in charge of the Health Section of State Laboratories, to undertake specialized chemical analyses associated with food and other health matters, and to give evidence in court	To possess a science degree with chemistry as a major subject and approval as an analyst under the Health Act. To have had wide experience in the analysis of foods, &c., in controlling a chemical laboratory and in court procedure	Evans, Mattie K.
Analyst and Assistant Medico-Legal Chemist, Class "C1"	Deputy Medico-Legal Chemist, Class "C2"	To act as deputy to the Medico-Legal Chemist in the analysis of medico-legal and other specimen, to carry out the analysis of spirituous liquors and of such other samples as directed, and to give expert evidence in court	To be an Associate of the Australian Chemical Institute and an approved analyst under the Health Act. To have had wide experience in the special type of analytical work and in court procedure	Wignall, H. G.
DEPARTMENT OF MINES.				
Chemist and Assayer, Class "C2"	Senior Chemist, Grade II., Class "B"	To control and conduct the work of the Mines Section (State Laboratories), to conduct metallurgical and other analyses and investigations of metallurgical and allied problems	To be an Associate of the Australian Chemical Institute, with proved ability in assaying and kindred analyses, in metallurgical investigations, and in the control of staff	Field, F. F.
DEPARTMENT OF AGRICULTURE.				
Chemist, Class "B"	Senior Chemist, Grade I., Class "B1"	To act as chemist in charge of the general agricultural section of State Laboratories	To possess the degree of Master of Science with Chemistry as a major subject, and to be well experienced in agricultural chemistry and in controlling a chemical laboratory	Williams, F. H.
DEPARTMENT OF LAW.				
Professional Assistant, Class "C"	Class "C1"	Under the direction of the Officer in Charge, Common Law Branch, to conduct and manage civil actions, arbitrations, and other legal proceedings as required. To act as deputy to the Officer in Charge when necessary	To be a barrister and solicitor of the Supreme Court of Victoria with sufficient practical experience in Common Law work	Booth, A. G.
Professional Assistant, Class "C"	Class "C1"	Under the direction of the Officer in Charge, Common Law Branch, to conduct and manage civil actions, arbitrations, and other legal proceedings as required	To be a barrister and solicitor of the Supreme Court of Victoria with sufficient practical experience in Common Law work	Douglas, G. W. A.

Appeals against such recommendation should be lodged with the Secretary to the Public Service Board not later than Saturday, the 14th August, 1948.

By order,

E. F. FITZGIBBON,
Secretary.

Office of the Public Service Board,
Melbourne, 2nd August, 1948.

*Teaching Service Act 1946.*TEACHING SERVICE (TEACHERS' TRIBUNAL)
REGULATIONS.

THE Teachers' Tribunal, in pursuance of the powers conferred by the *Teaching Service Act 1946*, hereby amends Regulation 9 of the Teaching Service (Teachers' Tribunal) Regulations, made on the twenty-ninth day of October, 1946, and published in the *Government Gazette* of the thirtieth day of October, 1946, in the manner following, that is to say:—

To sub-clause 13 (b) (ii) after the expression "Primary Teacher's Certificate, Second Class," there shall be added the following expression:—"except Theory of Teaching II."

W. H. ELLWOOD, Chairman.
E. V. B. HIGGINS, Acting Secretary.

Office of the Teachers' Tribunal,
Melbourne, 28th July, 1948.

SUBJECT to any necessary excisions, &c., it is proposed to grant the following leases:—

- 8220, Beechworth; G.S.G. Amalgamated Gold Mining Company N. L.; 20a. 2r. 20p., in the Parish of Beechworth.
8205, Beechworth; John Joseph Ruel and Rolla Bonner; 14a. 2r. 24p., in the Parish of Myrtleford.
9032, Castlemaine; Thomas Harry Knoblock; 62a. 1r. 1p., in the Parish of Maldon.
9042, Castlemaine; Denzil Isidro Hartley; 50a. 0r. 16p., in the Parish of Wombat.

APPLICATION FOR MINING LEASE DECLARED
ABANDONED.

9075, Ballarat; James Tieman and Thomas Daniel Moloney; 14a. 1r. 7p., in the Parish of Kerrit Baret.

J. H. LIENHOP,
Minister of Mines.

CONSUL.

HIS Excellency the Governor directs the recognition of Don Tomas Maycas y de Meer as Consul of Spain at Melbourne.

JOHN G. B. McDONALD,
Acting Premier.

Premier's Office,
Melbourne, C.2, 26th July, 1948.

CONSUL.

HIS Excellency the Governor directs the recognition of Mr. Samuel J. Fletcher as Consul-General of the United States of America at Melbourne.

JOHN G. B. McDONALD,
Acting Premier.

Premier's Office,
Melbourne, C.2, 26th July, 1948.

DEPARTMENT OF LAW.—SOLICITOR-GENERAL.

COURT OF PETTY SESSIONS APPOINTED.

HIS Excellency the Governor of the State of Victoria, by and with the advice of the Executive Council thereof, has, by Order made on the 26th day of July, 1948, pursuant to the provisions of section 61 of the *Justices Act 1928*, appointed—

YALLOURN

a place at which a Court of Petty Sessions shall be held, and has directed that the sittings of such Court be held on every alternate Thursday at Ten o'clock a.m., commencing on the 9th September, 1948.

C. W. KINSMAN,
Clerk of the Executive Council.

At the Executive Council Chamber,
Melbourne, the 26th July, 1948.

DEPARTMENT OF LAW.—ATTORNEY-GENERAL.

COURTS OF PETTY SESSIONS, MORWELL.—
ALTERATION OF DAYS AND HOURS.

HIS Excellency the Governor of the State of Victoria, by and with the advice of the Executive Council thereof, has, by Order made on the 26th day of July, 1948, pursuant to the provisions of section 61 of the *Justices Act 1928*, appointed every Tuesday at Ten o'clock a.m., as the day and hour for the holding of Courts of Petty Sessions at Morwell, in lieu of the days and hours heretofore appointed—to take effect as from and inclusive of the 31st August, 1948.

C. W. KINSMAN,
Clerk of the Executive Council.

At the Executive Council Chamber,
Melbourne, the 26th July, 1948.

VICTORIAN RAILWAYS.

AMENDMENT OF BY-LAW No. 351.

THE Victorian Railways Commissioners, in the exercise of the powers conferred upon them by the Railways Acts, do hereby amend By-law No. 351, section 58, sub-section (iv), to read as follows:—

"A person shall not drive or attempt to drive or convey or attempt to convey across any railway at a level crossing—

- (iv) any road vehicle which will cause or create a risk of causing an obstruction to or interference with or displacement of the railway."

The common seal of the Victorian Railways Commissioners was hereto affixed this fourteenth day of July, One thousand nine hundred and forty-eight, in the presence of—

(L.S.) N. C. HARRIS } Victorian
M. J. CANNY } Railways
R. G. WISHART } Commissioners.

Confirmed by the Governor in Council,
the 3rd August, 1948.

C. W. KINSMAN,
Clerk of the Executive Council

Transport Regulations Acts.

TRANSPORT REGULATION BOARD.

NOTICE OF PUBLIC HEARINGS.

NOTICE is hereby given that the applications made by the persons named below for licences to operate the commercial goods vehicles on the route or routes, or in the manner set out opposite their names, will be heard at a time and place to be communicated to the parties concerned:—

Name of Applicant; Nature of Application.

- ALBURY TYRE SERVICE PTY. LTD., 524 Kiewa-street, Albury; 1 commercial goods vehicle for the carriage of tires for recapping, retreading, repairing, and renewing, within 100 miles radius of the point where the road from Albury, New South Wales, crosses the Victorian-New South Wales border.
- BANNAM, E. T., Milltown; 1 commercial goods vehicle (80 cwt.) for the carriage of telephone poles under contract to the Postmaster-General's Department within 100 miles radius of Milltown.
- BROWN, R. P., 149 Cromwell-street, Collingwood; 1 commercial goods vehicle (60 cwt.) for the carriage of scrap metal, bottles, and rags in the course of business as "marine dealer" throughout the State of Victoria.
- CHRISTMAS, R. E., Cann River; 1 commercial goods vehicle for the carriage of road-contracting plant and material throughout the State of Victoria.
- COLYER, F. G., Yarram Post Office; 1 commercial goods vehicle (80 cwt.) for the carriage of—(a) general goods within 20 miles radius of Yarram, (b) live stock within 50 miles radius of Yarram.
- FACEY, G. A. J., 46 Wilson-street, Colac; 1 commercial goods vehicle (90 cwt.) for the carriage of—(a) general goods within 20 miles radius of Colac, (b) second-hand household furniture throughout the State of Victoria.
- HANCOCK, J. J., 31 Macarthur-street, Sale; 1 commercial goods vehicle (15 cwt.) for the carriage of—(a) general goods within 20 miles radius of Sale, (b) mails and papers from Traralgon to Sale and Bairnsdale (Saturdays and public holidays only).
- HOFMAN, R., 49 Mary-street, St. Kilda; 1 commercial goods vehicle (15 cwt.) for the carriage of drapery, merchandise, and footwear throughout the State of Victoria, in the course of business as "hawker and wholesale distributor."
- HUMPHREYS, E. S., Box 39, Nullawil; 1 commercial goods vehicle (100 cwt.) for the carriage of road-contracting plant and material throughout the State of Victoria.
- LEWIS, H. W. C., Waterloo, via Beaufort; 1 commercial goods vehicle (80 cwt.) for the carriage of—(a) general goods within 20 miles radius of Waterloo, (b) posts, droppers, and firewood from Waterloo to Ballarat, (c) building materials and fodder from Ballarat to Waterloo, (d) bricks from Stawell to Ballarat.
- SNELL, H. W., 8 Henry-street, Oakleigh; 1 commercial goods vehicle (100 cwt.) for the carriage of road-contracting plant and material throughout the State of Victoria.
- VAUGHAN, W. J., Grey-street, Lismore; application for variation of licences Nos. D.3838, D.3683, D.3678, to include the right to carry general goods to and from Lismore from and to Ballarat via Cape Clear.
- RICHARDS, H. F., Greta-road, Wangaratta; 1 commercial goods vehicle (120 cwt.) for the carriage of—(a) own goods in the course of business as "sawmillers and timber suppliers" within 20 miles radius of Wangaratta, (b) logs from any forest landing within 50 miles radius of Wangaratta to own mill at Wangaratta.
- WATTS, L. C. R., 10 Errett-street, Horsham; 1 commercial goods vehicle (40 cwt.) for the carriage of own building materials in the course of business as "builder" within 125 miles radius of Horsham.
- WEBSTER, A. W., 14 Chapel-street, Morwell; 1 commercial goods vehicle (40 cwt.) for the carriage of—(a) polished stone, in the course of business as "monumental mason," from Melbourne to Morwell, (b) finished monumental masonry for erection, and materials and tools of trade incidental to such erections, throughout the State of Victoria.
- YAHL CO-OPERATIVE CHEESE AND BUTTER COMPANY LTD., P.O. Box 97, Mount Gambier; 1 commercial goods vehicle (20 cwt.) for the carriage of own cheese from the border of Victoria and South Australia en route from Mount Gambier, South Australia, to Portland.

NOTICE is hereby given that the applications made by the persons named below for renewal of licences to operate the commercial goods vehicles in the manner set out hereunder, the numbers of which are also set out in each case, will be heard at a time and place to be communicated to the parties concerned:—

Name and Address; Present Franchise; Licence No.; Date of Expiry.

- HINGSTON, C. E., 43 Dennis-street, Northcote; (a) general goods within 25 miles radius of Melbourne; (b) coursing greyhounds, owners, and trainers to meetings in the metropolitan area; D.3656; 24th June, 1948.
- LEAR, D. L., Walnut-avenue, Mildura; (a) general goods within 20 miles radius of Mildura, (b) furniture within 50 miles radius of Mildura; D.3663; 24th June, 1948.
- ROWLANDS PTY. LTD., 306 Dana-street, Ballarat; own goods in the course of trade as "cordial manufacturers" within 50 miles radius of Ballarat; D.3739, D.3750, D.3751, D.3752; 16th September, 1948.
- ROWE, W. H., & SONS, 10 Rowe-street, Shepparton; (a) general goods within 20 miles radius of Shepparton, (b) road-contracting plant and materials within 50 miles radius of Shepparton; D.3740; 19th August, 1948.

NOTICE is hereby given that the applications made by the persons named below for licences to operate the commercial passenger vehicles on the route or routes, or in the manner set out opposite their names, will be heard at a time and place to be communicated to the parties:—

Name of Applicant; Nature of Application.

- BOND'S MOTOR SERVICES LTD., 125 North-terrace, Adelaide, South Australia; application for renewal of licences Nos. B.106 to B.115 inclusive, expiring 2nd September, 1948, allowing operations on interstate tours through the State of Victoria.
- CHARLTON, R. G., Bannockburn; 1 commercial passenger vehicle, with seating capacity for 5 persons, to operate for the carriage only of employees of Federal Woollen Mills Limited, North Geelong, between Bannockburn and North Geelong.
- CLARKE, H. A., 608 Olive-street, Albury; application for renewal of licence No. PH.988, expired 30th July, 1948, allowing operations at otherwise than at separate and distinct fares from Albury, New South Wales, to places throughout Victoria.
- DEWAR, J., Ramsay-street, Rochester; application for variation of licences Nos. A.2420 and TA.2205 to include the ability to operate as follows:—(a) Under charter conditions within a 20 miles radius of Rochester, and to Bendigo, Shepparton, Rushworth, Kyabram, and Chuhna, (b) an additional trip on Sundays between Lockington and Melbourne.
- DREW, T. L., Main-street, Lang Lang; 1 commercial passenger vehicle, to be purchased, with seating capacity for 5 persons, to operate as follows:—(a) separate and distinct fares within a 5 miles radius of Lang Lang Railway Station, (b) private hire within a 50 miles radius of Lang Lang Railway Station.
- FASHAM, C. T., Canons-avenue, Kerang; application for variation of licence No. A.1252 to include the ability to operate as follows:—(a) under charter conditions within a 20 miles radius of Kerang, and to Macorna, Pyramid Hill, Swan Hill, Gunbower, Quambatook, Bendigo, and Wycheproof, (b) between the Kerang Township and Kerang Recreation Ground, as and when required.
- FORSTER, K. E., 17 Baker-street, Wangaratta; 1 commercial passenger vehicle, to be purchased, with seating capacity for 5 persons, to operate as follows:—(a) Separate and distinct fares within a 5 miles radius of Wangaratta Railway Station, (b) private hire within a 50 miles radius of Wangaratta Railway Station.
- LEIGHTON, G. A. H., & A. WALTERS (trading as "The Gatha Taxi Service"), 40 Peart-street, Leongatha; 2 commercial passenger vehicles, to be purchased, with seating capacity for 5 persons, to operate as follows:—(a) Separate and distinct fares within a 5 miles radius of Leongatha, (b) private hire within a 50 miles radius of Leongatha.
- GOOD, J. L., William-street, Korumburra; 1 commercial passenger vehicle, to be purchased, with seating capacity for 5 persons, to operate as follows:—(a) Separate and distinct fares within a 5 miles radius of Leongatha, (b) private hire within a 50 miles radius of Leongatha.
- GUEST, J. E., 55 Elgin-street, Sale; application for renewal of licence No. PH.532, expired 29th March, 1948, allowing operations at otherwise than at separate and distinct fares from Sale to places throughout Victoria.

- HARDY, P. A., 510 Main-street, Mordialloc; 1 commercial passenger vehicle, with seating capacity for 17 persons, to operate as follows:—(a) On a round route commencing at Bayswater Railway Station, via Bayswater-road, Canterbury-road, to corner of Canterbury and Liverpool roads; thence back along Canterbury-road; thence via Colchester-road, Mountain Highway, and Bayswater-road to the Bayswater Railway Station, (b) Bayswater Railway Station—point $\frac{1}{2}$ mile south of corner Scoresby and Boronia roads via Scoresby-road, (c) Bayswater Railway Station—Salvation Army Home, The Basin, via Bayswater-road and Mountain Highway, (d) Bayswater Railway Station—St. John's Catholic School, Ferntree Gully, via Scoresby-road, Boronia-road, Ringwood-road, and Burwood-road—subject to the cancellation of licence No. A.1949, at present held by J. T. Hogg, Bayswater.
- HARDY, P. A., 510 Main-street, Mordialloc; 1 commercial passenger vehicle, with seating capacity for 5 persons, to operate as follows:—(a) Separate and distinct fares to and from Bayswater Railway Station from and to places within a 5 miles radius of Bayswater Railway Station, (b) private hire within a 50 miles radius of Bayswater Railway Station—subject to the cancellation of licence No. A.1951, at present held by J. T. Hogg, Bayswater.
- HARDY, P. A., 510 Main-street, Mordialloc; 2 commercial passenger vehicles, with seating capacity for 7 persons respectively, to operate as substitute vehicles on routes as set out above—subject to the cancellation of licence No. A.1950, at present held by, and licence to be issued to, F. T. Hogg, Bayswater.
- HICKS, A. A., & H. L. WHYKES, 10 Campbell-crescent, Ballarat; application for renewal of licence No. PH.928, expired 15th May, 1948, allowing operations at otherwise than at separate and distinct fares from Ballarat to places throughout Victoria.
- LEE, R. F., Piper-street, Kyneton; 1 commercial passenger vehicle, with seating capacity for 23 persons, to operate for the carriage only of school children between North Goldie and Kyneton High School via Lancefield, Rochford, Newham, and Woodend.
- MARK, A. E., 119 Lydiard-street, Ballarat; application for variation of licence No. A.361 to include the ability to operate under charter conditions within a 20 miles radius of Skipton, and to Ballarat, Camperdown, Ararat, Stawell, Colac, Mortlake, and Terang.
- MILLER, T. H., Box 16, Terang; application for renewal of licence No. A.1427, expired 29th April, 1948, allowing operations for the carriage of passengers and mails between Terang and Noorat.
- O'BRIEN, H. G., 155 Madden-avenue, Mildura; 1 commercial passenger vehicle, to be purchased, with seating capacity for 5 persons, to operate as follows:—(a) Separate and distinct fares within a 5 miles radius of Mildura, (b) private hire within a 50 miles radius of Mildura.
- ORGAN, R. W., 32 Yaldwin-street west, Kyneton; one commercial passenger vehicle, with seating capacity for 29 persons, to operate as follows:—(a) For the carriage only of school children between Monument Creek and Kyneton High School, (b) under charter conditions within a 20 miles radius of Romsey and Lancefield, (c) at separate and distinct fares within a 20 miles radius of Romsey and Lancefield after 6 p.m., (d) substitute vehicle to licensed vehicles Nos. A.1432 and A.1588.
- ORGAN, R. W., 32 Yaldwin-street west, Kyneton; application for variation of licence No. A.1432 to include the ability to operate as follows:—(a) Separate and distinct fares within a 20 miles radius of Kyneton, and to advertise dance trips within this radius, (b) a picture trip between Gisborne to Woodend via Mount Macedon and Macedon on Wednesdays and Saturdays.
- PYLE, T. J., Post Office, Tawonga; 1 commercial passenger vehicle, to be purchased, with seating capacity for 5 persons, to operate as follows:—(a) Separate and distinct fares within a 5 miles radius of Tawonga, (b) private hire within a 50 miles radius of Tawonga.
- PYLE, T. J., Post Office, Tawonga; application for variation of "A" licences to include the ability to operate day trips from Tawonga to Mt. Buffalo on Sundays only, with the ability to pick up passengers between and including Tawonga and Bright. Fare: 15s. return from Tawonga; 10s. return from Bright.
- SIMMONS, G. C., 45 13th-street, Mildura; 1 commercial passenger vehicle, to be purchased, with seating capacity for 5 persons, to operate as follows:—(a) Separate and distinct fares within a 5 miles radius of Mildura, (b) private hire within a 50 miles radius of Mildura.
- SIMPSON, V. E., 5 Carr-street, Moorabbin; application for renewal of licence No. PH.539, expired 4th May, 1948, allowing operations at otherwise than at separate and distinct fares from the metropolitan area to places throughout Victoria.
- VENTURA MOTORS P/L., 885 Canterbury-road, Box Hill; 1 commercial passenger vehicle, with seating capacity for 25 persons, to operate as an additional vehicle between Box Hill and Aspendale.
- WEDGE, D. E., Curdie-street, Cobden; 1 commercial passenger vehicle, with seating capacity for 29 persons, to operate as follows:—(a) For the carriage only of school children between Eastern Creek and Timboon, (b) under charter conditions within a 20 miles radius of Port Campbell, and to Warrnambool, Cobden, Camperdown, Terang, Colac, Apollo Bay, Mortlake, Lismore, and Port Fairy, (c) day tours locally within the Port Campbell area. (This replaces application previously gazetted on 28th July, 1948.)
- WISE, G. M., 45 Albert-street, Kerang; 1 commercial passenger vehicle, with seating capacity for 24 persons, to operate for the carriage only of school children between Murrabit West and Kerang High School via Murrabit and Westby—subject to the cancellation of licence No. A.1130, at present held by H. A. Croton.
- YOUNG, F. S., Leongatha; 1 commercial passenger vehicle, to be purchased, with seating capacity for 5 persons, to operate as follows:—(a) Separate and distinct fares within a 5 miles radius of Leongatha, (b) private hire within a 50 miles radius of Leongatha—subject to the cancellation of "PH" licence being transferred from U. V. Knight, Leongatha.

APPLICATION for licences to operate commercial passenger vehicles, with seating capacity for 5 persons, to operate for the carriage of passengers otherwise than at separate and distinct fares for each passenger throughout Victoria:—

ASKEW, R., Timboon.

BOLTON, L. W., Chelsea—to operate from Carrum.

DANDENONG PARK MOTORS, Dandenong.

DIXON, J. H., North Balwyn.

ELLIOT, C., Mildura.

HANCOCK, J. J., Sale (subject to the cancellation of licence No. A.1811).

LINDSAY, K. A., Whittlesea.

PALMER, A. L., Healesville.

PARRY, H. R. & K. L., Korrumburra.

REED, S. J., Yea.

SPEAR, K. A., Hawthorn East.

STANLEY AUTO SERVICE PTY. LTD., Collingwood (subject to the cancellation of licences Nos. PH.226 and PH.1170, at present held by H. Lewis).

STEWART, H. W. R., Woods Point.

WHITTY, W. A., Nathalia.

YOUNG, F. S., Leongatha (subject to the cancellation of licence No. PH.570, at present held by U. V. Knight, of Leongatha).

Notices of any objection should be forwarded to reach the Secretary to the Board not later than Wednesday, 18th August, 1948.

E. V. FIELD,
Secretary.

Exhibition Buildings, Rathdown-street, Carlton, 3rd August, 1948.

Dietitians Registration Act (No. 4942).

SUPPLEMENTARY LIST OF DIETITIANS FOR 1948.

THE subjoined Supplementary Lists of Alterations, Revisions, and Removals made in or from the Register of Dietitians during the twelve months ended the 30th June, 1948, are published in accordance with the provisions of section 5 of the *Dietitians Registration Act 1942*.

ADDITIONAL REGISTRATIONS.

Number of Certificate and Date of Registration.		Name.	Address.	Qualifications.	Further Qualifications.
No.	Date.				
212	28.6.48	Beaumont, Marjorie Elizabeth (Mrs.)	1363 Dandenong-road, Oakleigh, S.E.12	Registered under section 6 of the <i>Dietitians Registration Act 1942</i>	
207	24.11.47	Blank, Joseph	c/o "Thalassa," 8 Fitzroy-street, St. Kilda	Registered under section 6 of the <i>Dietitians Registration Act 1942</i>	
213	28.6.48	Christian, Patricia Ellen	c/o Royal Melbourne Hospital, Parkville	Registered under section 6 of the <i>Dietitians Registration Act 1942</i>	
208	23.2.48	Cooper, Lorna	13 Newstead-street, Caulfield, S.E.8	Registered under section 6 of the <i>Dietitians Registration Act 1942</i>	
210	22.3.48	Coutts, Marjorie Alma Dunbar	231 Nelson-place, Williamstown	Registered under section 6 of the <i>Dietitians Registration Act 1942</i>	
205	24.11.47	Crang, Alison Caldwell ..	Queen Victoria Hospital, Lonsdale-street, C.1	Registered under section 6 of the <i>Dietitians Registration Act 1942</i>	
211	24.5.48	Crook, Flora Isobel ..	221 Centre-road, Bentleigh, S.E.14	Registered under section 6 of the <i>Dietitians Registration Act 1942</i>	
209	23.2.48	Fowler, Reginald Thomas	28 North-road, Newport, W.15	Registered under section 6 of the <i>Dietitians Registration Act 1942</i>	
206	24.11.47	Gerrand, Marjory Fenton	Queen Victoria Hospital, Lonsdale-street, C.1	Registered under section 6 of the <i>Dietitians Registration Act 1942</i>	
210	22.3.48	Hart, Marion Winifred ..	Dietary Department, Royal Melbourne Hospital, Parkville	Registered under section 6 of the <i>Dietitians Registration Act 1942</i>	
214	28.6.48	Laidler, Margaret Anne ..	70 Kerferd-street, East Malvern, S.E.5	Registered under section 6 of the <i>Dietitians Registration Act 1942</i>	
200	24.4.47	Livingston, Mary Elizabeth	10A Bindaring-parade, Cottesloe, Western Australia	Registered under section 6 of the <i>Dietitians Registration Act 1942</i>	

CHANGE OF ADDRESSES.

Number of Certificate.	Name.	New Address.
153	Campbell, Wilma Mary	Repatriation Hospital, Greenslopes, Brisbane, Queensland
170	Deimel, Merle Victor	c/o C. Burbidge, 379 Collins-street, Melbourne, C.1
64	Duigan, Gwynne Elizabeth (Mrs.)	"Raith," Herne Hill, Geelong
19	Forbes, Eleanor Frances	c/o Mr. L. Romey, Queenscliff
198	Gardner, Marie Therese	"Cringler," Tammin, Western Australia
24	Honey, Mavis Ellen	Children's Hospital, Carlton
189	Hyett, Joan Dorothy	c/o Mr. C. B. Hyett, "The Eyrie," Reginald-street, Bendigo
18	Newman, Kenneth Fossey	The Farmhouse, Mooroolbark
191	Pickhaver, Dorothy Beth (now Mrs. Hutton)	13 Sherbourne-road, Medindie Gardens, South Australia
86	Quinsey, Alma Irene	Dietary Department, Royal Melbourne Hospital, Parkville, N.2
151	Rapley, Ellen May	Flat 3, 33 Alexandra-avenue, South Yarra
25	Shoobridge, Margaret Anne	c/o Mr. A. W. Clemes, 56 Sevenoaks-road, Orpington, Kent, England
177	Sleeman, David Beatty	Betta Health Shop, Allan's Walk, Bendigo
43	Smith, Nita Frances Selwyn	Toorak College, Frankston
35	Walker, Denise Ann (now Mrs. McKinnon)	Longwood, South Australia

NAME REMOVED FROM THE REGISTER.

Number of Certificate.	Name.	Reason.
141	Jones, Mary Cecilia	Deceased

SUSPENDED REGISTRATIONS.

Number of Certificate.	Name.	Reason.
188	Billing, Allison Patricia	Non-payment of registration renewal fee
122	Cantlay, Nance Evelyn (Mrs.)	Non-payment of registration renewal fee
49	Kaye, Kathleen Patricia Allison (Mrs. Galletly)	Non-payment of registration renewal fee
197	Morris, Barbara Winifred	Non-payment of registration renewal fee
187	Sonnenberg, Ethel May	Non-payment of registration renewal fee
152	Wheeler, William John	Non-payment of registration renewal fee

P. E. JOSKE,
Registrar.

Dietitians Registration Board of Victoria,
Melbourne, 26th July, 1948.

Legal Profession Practice Act 1946.

SOLICITORS (PROFESSIONAL CONDUCT AND PRACTICE)
RULES 1948.

WHEREAS by section forty-three of the *Legal Profession Practice Act 1946* the Council of the Law Institute of Victoria is empowered to make rules regulating in respect of any matter the professional duties practice conduct and discipline of practitioners whether engaged in practice as principals on their own account or employed by other practitioners or by persons not practitioners:

Now therefore the Council of the Law Institute of Victoria in pursuance of section forty-three of the *Legal Profession Practice Act 1946* and all other powers thereto enabling hereby makes the following rules:—

1. These rules may be cited as the "Solicitors (Professional Conduct and Practice) Rules 1948" and, save as otherwise hereinafter declared, shall come into operation on the date of their publication in the *Victoria Government Gazette*.

2. (1) A solicitor shall not do or permit in the carrying on of his business any act or thing which can reasonably be regarded as touting or as calculated to attract business unfairly.

(2) A solicitor shall, whenever he becomes aware that any person is doing any act or thing which could reasonably be regarded as touting for or as calculated to attract business unfairly to that solicitor, immediately take all reasonable steps to prevent that person continuing to do such act or thing.

(3) A solicitor shall not insert or cause or permit to be inserted on his behalf any advertisement in any newspaper or other publication provided that—

(a) a solicitor may permit his name to be inserted in a law list or similar publication intended primarily for circulation amongst members of the legal profession, if such insertion contains no more than the name of the solicitor (or, in the case of a firm, the name of the firm and the names of the partners in such firm), his degrees (if any), his place of business, his telegraphic and cable address, his telephone number, the date of admission to practice of himself and his partners (if any), the fact that he is a commissioner for affidavits or notary public, and the names and addresses of his legal agents;

(b) where a solicitor—

- (i) has commenced or intends to commence practice in any district, or
- (ii) has changed or intends to change his place of practice in any district, or
- (iii) has entered or intends to enter into partnership with one or more other solicitors, or

where there has occurred or is about to occur any alteration in the name or constitution of any firm of solicitors engaged in practice in any district, such solicitor or (where the alteration in the constitution of the firm was due to the death or retirement of a member or members) the surviving member or members of the firm may, during a period of not more than one month before and three months after the date of the commencement of practice, change of address, entering into partnership or alteration in the constitution or the name of the firm (as the case may be) insert in a newspaper published in and circulating principally in that district an advertisement containing not more than brief particulars of the occurrence or intended occurrence, the name and telephone number of himself or the partnership or firm and the address at which he or the partnership or firm carries on or intends to carry on practice in that district;

- (c) a solicitor who periodically visits a place situated outside a radius of fifteen miles from the General Post Office at Melbourne in which he has not a permanent office may advertise in any newspaper circulating principally in that place and the neighbourhood thereof the date or dates on which and the place at which he may be interviewed and his telephone number thereat and the address and telephone number of his principal place of business; and
- (d) a solicitor who is acting for a client in any particular matter may permit his name and address and the fact that he acts for such client to be included in any advertisement in connexion with that matter whenever and to the extent to which it is customary among solicitors for such details to be included.

(4) A solicitor shall not hold himself out or allow himself to be held out directly or indirectly as being willing to perform work for a fee less than that fixed by the appropriate scale of costs for that work.

3. A solicitor shall at all times use his best endeavours to complete any work on behalf of his client as soon as is reasonably possible.

4. (1) A solicitor shall not carry on practice in any place, whether the same be his main practice or a branch thereof, unless he or some other solicitor entitled to practise in Victoria is in charge at that place and gives substantial attendance thereat during the normal business hours of his practice at that place: Provided that a solicitor may send a clerk who is not a solicitor to a branch office for the purpose only of receiving instructions for the preparation of income tax returns.

(2) Every solicitor who carries on practice under a business name within the meaning of the *Business Names Act 1928* shall have mentioned in legible characters on all letters written by him or any of his clerks in the course of or in connexion with his practice the business name and the name or names of all persons so registered or required to be registered under the said Act.

(3) The provisions of the last preceding sub-rule shall not come into operation until the first day of January, 1949.

5. A solicitor shall within a reasonable time after being so requested in writing by a client render to the client a bill of costs covering all work performed for that client to which such request relates and for which he has not already rendered a bill of costs or been paid. If he fails or neglects to render such bill of costs within one month after receiving such request or within such further period as the client in writing allows or as may in the circumstances be reasonable he shall forthwith pay to the client all moneys and deliver to the client all documents which he is holding on behalf of that client, notwithstanding that he might otherwise be entitled to a lien upon those moneys or documents for payment of his bill of costs.

Signed for and on behalf of the Council of the Law Institute of Victoria this fifteenth day of July, 1948—

DUNCAN MACKINNON, President.
ARTHUR HEYMANSON, Secretary.

I approve the above rules.

Dated this 21st day of July, 1948.

E. F. HERRING,
Chief Justice.

*Legal Profession Practice Act 1946.*SOLICITORS (AUDIT AND PRACTISING CERTIFICATES)
RULES 1948.

PURSUANT to section forty-three of the *Legal Profession Practice Act 1946* and all other provisions in that behalf enabling, the Council of the Law Institute of Victoria doth hereby make the following rules of the Institute (that is to say):—

1. (1) These rules may be cited as the Solicitors (Audit and Practising Certificates) Rules 1948.

(2) The Solicitors (Audit and Practising Certificates) Rules 19 are in these rules referred to as the Principal Rules.

(3) The Principal Rules as amended by these rules may be cited the Solicitors (Audit and Practising Certificates) Rules.

2. These rules shall come into operation on the publication thereof in the *Victoria Government Gazette*.

3. Rule 4 of the Principal Rules is amended by inserting after subparagraph (d) the words "and the legal representative of every solicitor who dies whilst still engaged in practice on his own behalf and not in partnership with any other solicitor."

4. After rule 4 of the Principal Rules the following rules are inserted:—

"4A. Every solicitor who takes over or acquires the practice or a branch of the practice of any other solicitor shall within fourteen days of such taking over or acquisition give notice thereof to the Council.

"4B. Every solicitor shall, within fourteen days after commencing practice or a branch of his practice and thereafter annually at the time of making application for a practising certificate, give to the Council notice of the address at which he carries on practice or a branch of his practice and shall notify the Council within fourteen days of any alteration of such address."

5. Rule 11 of the Principal Rules is amended by inserting after sub-rule (1) the following sub-rule:—

"(1A) The provisions of the last preceding sub-rule shall not apply where the auditor dies or retires from practice or ceases to be qualified to audit the solicitor's trust account."

6. Rule 12 of the Principal Rules is amended by inserting after the words "Every solicitor" the words "who does not lodge within the prescribed time a statutory declaration pursuant to rule 22."

7. Rule 17 of the Principal Rules is amended by adding at the end thereof the following sub-rule:—

"(3) Where a solicitor engages in practice in partnership with one or more other solicitors the auditor shall lodge with the secretary a separate report in respect of each member of the partnership, which report shall cover not merely the trust accounts of the partnership but all the trust account within the definition contained in section 3 of the *Legal Profession Practice Act 1946* of the solicitor concerned."

8. Rule 19 of the Principal Rules is amended by deleting from paragraph (b) the words "as had not" and inserting in lieu thereof the words "as appear from the register as not having."

9. Rule 22 of the Principal Rules is repealed and the following rule inserted in lieu thereof:—

"22. A solicitor (not being merely the employee of another solicitor) who at the commencement of any year ending on the 30th day of June did not hold any money which had been received by him in the course of or in connexion with his practice for or on behalf of any other person or persons and who has not during the course of that year received any such money shall within twenty-one days after the 30th day of June in that year deliver to the secretary a statutory declaration made by him stating those facts."

10. After rule 22 of the Principal Rules the following rule is inserted:—

“22A. Within one month after any solicitor ceases to carry on his practice or the dissolution of any partnership such solicitor or the respective partners (as the case may be) and the legal representative of any deceased solicitor shall cause the trust accounts of the solicitor or solicitors concerned to be audited and reported upon pursuant to the Act and these rules for the period from the previous first day of July up to the date of such cessation or dissolution and in such case all the relevant provisions of the Act and these Rules shall, as far as possible, apply to such audit and report save that the date of the cessation or dissolution shall be substituted for the thirtieth day of June.”

11. Rule 24 of the Principal Rules is amended—

(a) by inserting after the figures “24” the figure “(1)”;

(b) by adding at the end of the rule the following sub-rules:—

“(2) Where a solicitor receives trust account moneys and forthwith pays them to the credit of a non-trust account or forthwith transmits or hands over to the person due to receive the same any cheque drawn on a non-trust account and in every such case duly makes proper records of such receipts and disbursements in separate books of account kept in respect of such account, the auditor shall for the purposes of this rule accept the entries in those books as if they were entries in the trust accounts of the solicitor and no entries in respect thereof in the solicitor’s trust accounts shall be necessary.

“(3) In this rule ‘non-trust account’ means an account in a bank, the moneys to the credit of which are not solely or exclusively under the control of a solicitor or solicitors.”

12. Rule 39 of the Principal Rules is amended by adding at the end thereof the following paragraphs:—

“(f) A draft, postal note, money order or not negotiable crossed cheque payable to any person or persons other than the solicitor (either in his own name or any business name under which he is registered pursuant to the *Business Names Act 1928* as carrying on business) or any firm of which the solicitor is a member;

(g) a cheque or warrant payable to the solicitor or his client where the drawer requests that the payee acknowledge receipt on the cheque or warrant or on some special form of receipt sent by the drawer with the cheque.”

13. Rule 40 of the Principal Rules is amended by deleting the words “and (e)” and inserting in lieu thereof the words “(e) and (g).”

14. Rule 46 of the Principal Rules is amended by adding at the end thereof the following words:—

“provided further that a solicitor who engages in practice in the State of Victoria and in some adjoining State (which latter State is hereinafter referred to as the home State) and whose place or principal place of practice is situated in the home State shall not in respect of any year be required to pay as contribution to the Solicitors Guarantee Fund a sum in excess of Five pounds if he satisfies the secretary that he has already paid his contribution to the corresponding fund in the home State for the same or substantially the same period.”

15. After rule 47 of the Principal Rules the following rule is inserted:—

“47A. Every solicitor who engages in practice as a solicitor on his own account or in partnership with another practitioner or upon terms of sharing with another practitioner remuneration for any business and who applies for a practising certificate for the ensuing year shall lodge with his application a statutory declaration in or to the effect of Form 5A of the Schedule to these rules.”

16. Rule 49 of the Principal Rules is repealed and the following rule inserted in lieu thereof:—

“ 49. (1) Every practising certificate issued pursuant to the Act to a solicitor who intends to engage in practice as a solicitor on his own account or in partnership with another solicitor or upon terms of sharing with another practitioner remuneration for any business shall be in or to the effect of Form 7A of the Schedule to these rules.

(2) Every practising certificate issued pursuant to the Act to a solicitor who intends to practice as an employee and not otherwise shall be in or to the effect of Form 7B of the Schedule to these rules.”

17. Form 2 of the Schedule to the Principal Rules is repealed and the following form inserted in lieu thereof:—

Rule 17.

FORM 2.

Auditor's Report in Support of Application for Practising Certificate for any Year Subsequent to 1948.

I,.....of.....hereby certify:—

1. That I am a member in public practice of the..... and a practising public accountant within the meaning of the Legal Profession Practice Act 1946.

or

1. That pursuant to the Solicitors (Audit and Practising Certificates) Rules made under the Legal Profession Practice Act 1946 I was on the.....day of.....19.....approved by the Council of the Law Institute of Victoria for the audit of the trust accounts hereinafter referred to.

2. That in accordance with the said Act and the rules made thereunder I have made an audit of the whole of the trust accounts as defined by section three of the Legal Profession Practice Act 1946 of *..... a solicitor of the Supreme Court (who is a member of the firm of.....) practising at *..... (including the trust accounts of the said firm and the separate trust accounts of the said solicitor) for the period of twelve months ending on the thirtieth day of June, 19.....

3. That I was not at any time during which I was conducting the said audit nor at any time within two years before the last day of the period in respect of which the audit was made a clerk servant or partner of the said solicitor (or the said firm of solicitors or any member thereof).

4. That in carrying out the audit above referred to I have—

(a) made a general test examination of the trust accounts of the said *..... within the period covered by the audit;

(b) ascertained that a trust bank account (or trust bank accounts) was (or was not) kept by the said*..... during the said period;

(c) made a general test examination of the trust bank accounts and of the pass books and statements relating to the trust bank accounts during the said period;

(d) made a comparison as at—

(i) theday of.....19.....on (or within one week after) which day I (or..... a member of my staff acting under my instructions) visited the office of the said*..... without previous notice and examined the aforementioned trust accounts and the books and papers relating thereto; and

(ii) the thirtieth day of June, 19....., being the last day of the period of audit—

between—

the liabilities of the said *.....to his clients and to other persons in connexion with his practice as shown by his trust accounts and the balances standing to the credit of his trust bank accounts.

5. That the said *..... has supplied me with all such information and explanations as were required by me to enable me to enable me to carry out the said audit.

6. That there was not so far as shown by the said audit at any time during the period of the audit any deficiency in the trust bank accounts of the said *.....

or

6. That there was on (or about) the day of 19..... a deficiency of £....., more or less, in the trust bank account of the said *.....

or

6. That there was on (or about) the day of 19..... a deficiency of £....., more or less, in the trust bank accounts of the said *..... which was in my opinion attributable to inadvertence (or to.....) (here set out any other circumstances causing or contributing to the deficiency) and the amount of the deficiency was restored before the date of this report.

7. That the trust accounts of the said *..... have not been regularly kept and properly written up.

8. That the said *..... has not produced to me when so required all books of receipts used and unused supplied to the said *..... (or his firm).

I desire to bring to the notice of the Council the following additional matters:—

(Here set out such additional matters as the auditor considers should be brought to the notice of the Council.)

Dated the day of 19.....

(Sgd.)

Omit clauses and words not applicable.

* Full name of solicitor.

† Set out all the places of practice covered by the audit.

‡ Set out the approved body of accountants.

18. Form 3 of the Schedule to the Principal Rules is repealed and the following form inserted in lieu thereof:—

Rule 44.

FORM 3.

Application for Practising Certificate by a Solicitor in Practice.

I..... of....., solicitor, hereby make application for a practising certificate for the year 19..... and certify:—

1. That I am a barrister and solicitor of the Supreme Court of Victoria having been admitted to practice on the..... day of..... 19..... and I have paid the total fees (or all the fees due and payable) in respect of my admission.

2. I practise on my own behalf under my own name,

or

2. I practise on my own behalf under the firm name of.....

or

2. I am a member of the firm of solicitors practising under the name of....., of which firm..... are also partners,

or

2. I am an employee of....., solicitors, and I am not practising as a solicitor except as such employee and I do not as such employee share with any other practitioner remuneration for any business.

3. My place of business (or the places of business of my firm or firm employing me) is †..... are †.....

4. I commenced practice as a solicitor on the..... day of..... 19.....

5. I am not a member of the Law Institute of Victoria.

6. In relation to my application I forward herewith—

*(a) my declaration in compliance with rule 47A of the Solicitors (Audit and Practising Certificates) Rules; and

(b) my cheque for £....., being £..... the practising fee payable upon this application and £..... my contribution to the Solicitors Guarantee Fund for the year 19.....

*7. I am informed by my auditor Mr..... that he lodged with you on the..... day of..... 19..... the report upon the audit of my trust accounts.

Dated the..... day of 19.....

(Sgd.)

Omit clauses and words not applicable.

* Applicable only in respect of solicitor who is not an employee.

† Set out principal place of business and all branches.

19. Form 4 of the Schedule to the Principal Rules is repealed and the following form inserted in lieu thereof:—

Rule 44.

FORM 4.

Application for Practising Certificate by a Practitioner Desirous of Commencing or Recommencing Practice.

I.....of.....hereby make application for a practising certificate for the year 19.....(or as the case requires):—

1. I am a barrister and solicitor of the Supreme Court of Victoria having been admitted to practice on the.....day of.....19..... and I have paid the total fees (or all the fees so far due and payable) in respect of my admission.

2. I am not now and have never (or and have not at any time since the.....day of.....19.....) been practising as a solicitor within the meaning of Parts II. and III. of the *Legal Profession Practice Act 1946*.

3. I intend to practise on my own behalf under my own name.

or

3. I intend to practise on my own behalf under the firm name of.....

or

3. I intend to practise as a partner of.....under the firm name of.....

or

3. I intend to practise as an employee of.....solicitors, and not otherwise and I shall not as such employee share with any other practitioner remuneration for any business.

4. My place of business (or the place of business of my firm or the firm employing me) is (or will be) situated at.....

5. I am am not a member of the Law Institute of Victoria.

6. In relation to my application I forward herewith—

(a) my declaration in compliance with section 37 of the *Legal Profession Practice Act 1946*; and

(b) my cheque for £....., being £.....the practising fee payable upon this application and £.....my contribution to the Solicitors Guarantee Fund for the year 19.....

Dated the.....day of.....19.....

(Sgd.)

Omit clauses and words not applicable.

20. After Form 5 in the Schedule to the Principal Rules the following form is inserted:—

Rule 47A.

FORM 5A.

Declaration by a Practising Solicitor Applying for a Practising Certificate in Respect of any Year after 1948.

I.....of....., solicitor, do solemnly and sincerely declare:—

1. That I am a barrister and solicitor of the Supreme Court of Victoria.

2. That.....of.....was appointed to audit and report on my trust accounts (including the trust accounts of the firm of....., of which I am a member) for the period of twelve months ending the thirtieth day of June, 19.....

3. That all accounts books and papers necessary to enable him to make for the purposes of that report a complete audit in accordance with the Solicitors (Audit and Practising Certificates) Rules of my trust accounts as defined in section three of the *Legal Profession Practice Act 1946* (including the trust accounts of the said firm) have been produced to the said.....

4. That on the date of this declaration there is in a bank or banks to the credit of a trust bank account or trust bank accounts kept in accordance with the provisions of section 3 of the *Legal Profession Practice Act 1936* a sum or sums sufficient to pay all moneys received by me (or the said firm) for or on behalf of any person or persons and not previously paid by me (or the said firm) to those persons or in accordance with direction given by them.

And I make this solemn declaration conscientiously believing the same to be true and by virtue of the provisions of an Act of the Parliament of Victoria rendering persons making a false declaration punishable for wilful and corrupt perjury.

Declared at.....this.....day of.....19.....

Before me—

.....
Justice of the Peace.
A Commissioner for taking Declarations
and Affidavits.

The words in brackets are to be included when the solicitor practises in partnership with one or more other practitioners.

21. Form 6 of the Schedule to the Principal Rules is repealed and the following form inserted in lieu thereof:—

Rule 48.

FORM 6.

Declaration by Practitioner Desirous of Commencing or Recommencing Practice.

I..... of..... do solemnly and sincerely declare:—

1. That I am a barrister and solicitor of the Supreme Court of Victoria having been admitted to practice on the..... day of..... 19.....

2. That I have not previously practised as a solicitor within the meaning of Parts II. and III. of the Legal Profession Practice Act 1946.

or

2. That I have previously practised as a solicitor within the meaning of Parts II. and III. of the Legal Profession Practice Act 1946 and full particulars of my former practice are as follows:—

Date (or dates) of commencement.....

Date (or dates) of cessation.....

Place (or places) at which I have practised.....

Name (or names) under which I have practised.....

*3. Prior to the date on which I ceased to practise as aforesaid I paid to the persons entitled thereto or in accordance with their directions all moneys received by me for or on behalf of any other person or persons in the course of or in connexion with my practice and I did not on that date hold nor have I since received any trust account money within the meaning of the Solicitors (Audit and Practising Certificates) Rules.

4. I am desirous of commencing (or recommending) practice.

And I make this solemn declaration conscientiously believing the same to be true and by virtue of the provisions of an Act of the Parliament of Victoria rendering persons making a false declaration punishable for wilful and corrupt perjury.

Declared at.....this.....day of.....19.....

Before me—

Justice of the Peace.
A Commissioner for taking Declarations and Affidavits.

* Omit this clause and re-number paragraph 4 if never previously practised.

22. Form 7 of the Schedule to the Principal Rules is amended:—

(a) by deleting the figure " 7 " and inserting in lieu thereof the figure " 7A ";

(b) by adding at the end thereof the following form:—

Rule 49.

FORM 7B.

Practising Certificate.

Pursuant to the powers conferred by the Legal Profession Practice Act 1946 I hereby certify that..... of..... is authorized to practise as an employee from the..... day of..... 19..... to the 31st day of December, 19..... This certificate does not entitle the holder to engage in practice as a solicitor either on his own behalf or in partnership with any other solicitor or upon terms of sharing with any other practitioner remuneration for any business.

Dated the..... day of..... 19.....

Secretary of the Law Institute of Victoria.

Signed for and on behalf of the Council of the Law Institute of Victoria this fifteenth day of July, 1948—

DUNCAN MACKINNON, President.

ARTHUR HEYMANSON, Secretary.

I approve the above rules.

Dated this 21st day of July, 1948.

E. F. HERRING, Chief Justice.

MONEY LENDERS ACT 1938.

IN accordance with the provisions of the above-mentioned Act, the following is published for general information:—

List of Persons to whom Money Lenders' Licences have been issued for the Year ending 30th June, 1949.

Name.	Authorized Name.	Authorized Address.	Date of Issue.
Aarons, William	W. Aarons	118 Queen-street, Melbourne ..	1.7.48
Abraham, Isaac Pty. Ltd. (S. E. Abraham, appointee)	Isaac Abraham Pty. Ltd.	211 Main-street, Ballarat ..	1.7.48
Abraham, M. D.	M. D. Abraham, carrying on business as D. L. Abraham	44 Queen-street, Melbourne ..	1.7.48
Adams, Geo. Pty. Ltd. (C. J. Smith, appointee)	Geo. Adams Pty. Ltd.	89 North-street, Ascot Vale ..	1.7.48
Adams, Geo. Pty. Ltd. (G. M. Brooks, appointee)	Geo. Adams Pty. Ltd.	117 Pall Mall, Bendigo	1.7.48
Adams, Geo. Pty. Ltd. (J. N. Honey, appointee)	Geo. Adams Pty. Ltd.	304 Sydney-road, Brunswick ..	1.7.48
Adams, Geo. Pty. Ltd. (C. S. Jackson, appointee)	Geo. Adams Pty. Ltd.	351 Smith-street, Fitzroy ..	1.7.48
Adams, Geo. Pty. Ltd. (F. W. Brown, appointee)	Geo. Adams Pty. Ltd.	429 Chapel-street, South Yarra ..	1.7.48
Advance Providers Pty. Ltd. (H. Davis, appointee)	Advance Providers Pty. Ltd. ..	31 Leeds-street, Footscray ..	1.7.48
Advance Providers Pty. Ltd. (G. Thompson, appointee)	Advance Providers Pty. Ltd. ..	318 High-street, Northcote ..	1.7.48
Advance Providers Pty. Ltd. (J. Goodenday, appointee)	Advance Providers Pty. Ltd. ..	306 Little Collins-street, Melbourne	1.7.48
Advance Providers Pty. Ltd. (H. Davis, appointee)	Advance Providers Pty. Ltd. ..	443 Church-street, Richmond ..	1.7.48
Amalgamated Cash Orders Pty. Ltd. (F. O. Reinhart, appointee)	Amalgamated Cash Orders Pty. Ltd. ..	255 Smith-street, Fitzroy ..	1.7.48
Amalgamated Cash Orders Pty. Ltd. (F. O. Reinhart, appointee)	Amalgamated Cash Orders Pty. Ltd. ..	40 Leeds-street, Footscray ..	1.7.48
Amalgamated Cash Orders Pty. Ltd. (F. O. Reinhart, appointee)	Amalgamated Cash Orders Pty. Ltd. ..	Cr. Malop and Moorabool streets, Geelong	1.7.48
Amalgamated Cash Orders Pty. Ltd. (F. O. Reinhart, appointee)	Amalgamated Cash Orders Pty. Ltd. ..	327 Bourke-street, Melbourne ..	1.7.48
Amalgamated Cash Orders Pty. Ltd. (F. O. Reinhart, appointee)	Amalgamated Cash Orders Pty. Ltd. ..	132 Bourke-street, Melbourne ..	1.7.48
Assignment Mortgage and Finance Co. Pty. Ltd. (B. Young, appointee)	Assignment Mortgage and Finance Co. Pty. Ltd.	422 Collins-street, Melbourne ..	1.7.48
Atlas Loan and Finance Co. Pty. Ltd. (T. Marshall, appointee)	Atlas Loan and Finance Co. Pty. Ltd.	303-9 Collins-street, Melbourne ..	1.7.48
Australian Guarantee Corporation Ltd. (G. V. Beattie, appointee)	Australian Guarantee Corporation Ltd.	44 Queen-street, Melbourne ..	1.7.48
Australian Mont de Piete Loan and Deposit Co. Ltd. (A. J. Thaw, appointee)	Australian Mont de Piete Loan and Deposit Co. Ltd.	330 Little Collins-street, Melbourne	1.7.48
Automotive Cycle and Radio Finance Corporation Pty. Ltd. (J. C. C. Carr, appointee)	Automotive Cycle and Radio Finance Corporation Pty. Ltd.	451 Elizabeth-street, Melbourne ..	1.7.48
Autoterms Ltd. (A. Lewis, appointee) ..	Autoterms Ltd.	493 Elizabeth-street, Melbourne ..	1.7.48
Barnes, W. G.	W. G. Barnes	284 Plenty-road, Preston ..	1.7.48
Barnett, S.	S. Barnett, carrying on business as Henry Barrett	569 Swanston-street, Carlton ..	1.7.48
B. G. D. Industries Ltd. (E. H. Noske, appointee)	B. G. D. Industries Ltd.	118 Queen-street, Melbourne ..	1.7.48
Booth, E. V.	E. V. Booth	497 Brunswick-street, North Fitzroy	1.7.48
Bowring, C. B. O.	C. B. O. Bowring	100-4 Queen-street, Melbourne ..	1.7.48
Brighton Investments Co. Pty. Ltd. (M. H. Noske, appointee)	Brighton Investments Co. Pty. Ltd. ..	305 Collins-street, Melbourne ..	1.7.48
Brooks, A.	A. Brooks, carrying on business as the R.H.B. Cash Order Co.	99-109 Smith-street, Fitzroy ..	1.7.48
Bryant, H. T.	H. T. Bryant, carrying on business as H. T. Bryant and M. Kinder	282-4 Collins-street, Melbourne ..	1.7.48
Building Guarantee and Discount Co. Ltd. (E. J. Edwards, appointee)	Building Guarantee and Discount Co. Ltd.	118 Queen-street, Melbourne ..	1.7.48
Burke, M. B.	M. B. Burke	234 Collins-street, Melbourne ..	1.7.48
Burroughs, J. R.	J. R. Burroughs, carrying on business as Uneeda Cash Order Co.	224 Camberwell-road, Hawthorn East	1.7.48
Caplan, N.	N. Caplan, carrying on business as Brunswick Loan Co.	365 ^a Lygon-street, East Brunswick	1.7.48
Carrick, A.	A. Carrick, carrying on business as C. Finance and Cash Order Co.	183 Elgin-street, Carlton ..	1.7.48
Carrington Traders Pty. Ltd. (A. G. Maver, appointee)	Carrington Traders Pty. Ltd. ..	230 Collins-street, Melbourne ..	1.7.48
Case, H. E.	H. E. Case, carrying on business as H. and M. Case	38 Osborne-street, Williamstown ..	1.7.48
Case, M. A.	M. A. Case, carrying on business as H. and M. Case	38 Osborne-street, Williamstown ..	1.7.48
Casper, Edward Pty. Ltd. (A. C. Hodgkinson, appointee)	Edward Casper Pty. Ltd.	272 Bourke-street, Melbourne ..	1.7.48
Casper, Edward Pty. Ltd. (A. C. Hodgkinson, appointee)	Edward Casper Pty. Ltd.	225 Chapel-street, Prahran ..	1.7.48
Cassells Finance Pty. Ltd. (W. T. Vickers, appointee)	Cassells Finance Pty. Ltd.	45 Paisley-street, Footscray ..	1.7.48
Cassells Finance Pty. Ltd. (W. T. Vickers, appointee)	Cassells Finance Pty. Ltd.	343 Elizabeth-street, Melbourne ..	1.7.48
Cheney, E. A.	E. A. Cheney, carrying on business as F. and E. Cheney	146 Hopkins-street, Footscray ..	1.7.48
Cheney, J. F.	J. F. Cheney, carrying on business as F. and E. Cheney	146 Hopkins-street, Footscray ..	1.7.48

MONEY LENDERS ACT—continued.

Name.	Authorized Name.	Authorized Address.	Date of Issue.
City Insurance Finance Corporation Pty. Ltd. (T. D. Pollock, appointee)	City Insurance Finance Corporation Pty. Ltd.	105 Swanston-street, Melbourne ..	1.7.48
Clifford Cash Order Pty. Ltd. (A. H. Temple, appointee)	Clifford Cash Order Pty. Ltd.	225 Collins-street, Melbourne ..	1.7.48
Commercial Discounters (Victoria) Pty. Ltd. (G. H. Shaw, appointee)	Commercial Discounters (Victoria) Pty. Ltd.	325 Collins-street, Melbourne ..	8.7.48
Dennis, G. W.	G. W. Dennis	73 Nicholson-street, Footscray ..	1.7.48
Dickens, D. S.	D. S. Dickens, carrying on business as The Elsternwick Cash Order Co.	26 Riddell-parade, Elsternwick ..	1.7.48
Dome Cash Order Co. Pty. Ltd. (C. I. Watt, appointee)	Dome Cash Order Co. Pty. Ltd.	148 Swan-street, Richmond ..	1.7.48
Evans, J. W. H.	J. W. H. Evans	26 Holloway-road, Brunswick West	1.7.48
Everyone's Finance Co. Pty. Ltd. (H. L. Whykes, appointee)	Everyone's Finance Co. Pty. Ltd.	41 Lydiard-street south, Ballarat..	1.7.48
Extension Agency Pty. Ltd. (T. Mather, appointee)	Extension Agency Pty. Ltd.	172A Flinders-street, Melbourne ..	1.7.48
Field, K. E.	K. E. Field, carrying on business as The Star Cash Order and Finance Co.	48 Leeds-street, Footscray ..	1.7.48
Field, K. E.	K. E. Field, carrying on business as The Star Cash Order and Finance Co.	375 Bridge-road, Richmond ..	1.7.48
Finks, D. M.	D. M. Finks, carrying on business as the Carlton Cash Order Co.	308 Lygon-street, Carlton ..	1.7.48
Fleet Investments Pty. Ltd. (E. Hogan, appointee)	Fleet Investments Pty. Ltd.	60 Collins-place, Melbourne ..	1.7.48
Fleming, M.	M. Fleming, carrying on business as Archie Wells Finance and Cash Order Co.	17 The Centreway, Chapel-street, Prahran	1.7.48
Fowler, D. W.	D. W. Fowler, carrying on business as P.B. Supply and Finance Office	183 Kerferd-road, Albert Park ..	1.7.48
Gaffney, G. T.	G. T. Gaffney, carrying on business as G. T. Gaffney and R. K. McCleery	307 Sydney-road, Brunswick ..	1.7.48
Garrett, N. K.	N. K. Garrett	427 Elizabeth-street, Melbourne ..	1.7.48
Gates, L. E.	L. E. Gates	17 Osborne-street, Northcote ..	2.7.48
Gray, W.	W. Gray	130 Moorabool-street, Geelong ..	1.7.48
Grant, Geo. Pty. Ltd. (E. Jansen, appointee)	Geo. Grant Pty. Ltd.	33 Bridge-road, Richmond ..	1.7.48
Green, S.	S. Green	408 Collins-street, Melbourne ..	1.7.48
Hall, Harry Pty. Ltd. (T. C. Wood, appointee)	Harry Hall Pty. Ltd.	81 Nicholson-street, Footscray ..	1.7.48
Hall, Harry Pty. Ltd. (H. C. Duffield, appointee)	Harry Hall Pty. Ltd.	131 Ryrie-street, Geelong ..	1.7.48
Hall, Harry Pty. Ltd. (H. A. Phillips, appointee)	Harry Hall Pty. Ltd.	57 Swanston-street, Melbourne ..	1.7.48
Hall, Harry Pty. Ltd. (L. O. Worland, appointee)	Harry Hall Pty. Ltd.	389 Bridge-road, Richmond ..	1.7.48
Hall, J.	J. Hall	58 North-road, Newport ..	1.7.48
Harris, E. H.	E. H. Harris	285 Barkly-street, Footscray ..	1.7.48
Hastings, C. I.	C. I. Hastings, carrying on business as Quick Service Finance Co.	473 Bourke-street, Melbourne ..	1.7.48
Hocking, J. B.	J. B. Hocking	69 Ryrie-street, Geelong ..	1.7.48
Hore, D. E. A.	D. E. A. Hore, carrying on business as Horton Cash Order Co.	64 Elizabeth-street, Melbourne ..	1.7.48
Horsington, W. F.	W. F. Horsington, carrying on business as Aussie Finance Co.	6 Paisley-street, Footscray ..	1.7.48
Ireland, T. M.	T. M. Ireland	229 Collins-street, Melbourne ..	1.7.48
Irons, J. F.	J. F. Irons	1 Woodlawn-street, Richmond ..	1.7.48
Izzard, H. W.	H. W. Izzard	135 Woodlands-street, Essendon ..	1.7.48
James, S. L.	S. L. James	26 James-street, Box Hill ..	1.7.48
Jenkins, Stephen Alexander	S. A. Jenkins	140A Station-street, Fairfield ..	1.7.48
Johnson, E. E.	E. E. Johnson, carrying on business as Vestor Finance Co.	149A Pakington-street, Geelong West	1.7.48
Jones, Marcus, Pty. Ltd. (M. Southwick, appointee)	Marcus Jones Pty. Ltd.	49 Elizabeth-street, Melbourne ..	1.7.48
Jubilee Investments Pty. Ltd. (M. S. Sheeziel, appointee)	Jubilee Investments Pty. Ltd.	Cr. Bourke and Russell streets, Melbourne	1.7.48
K. and G. Business Finance Pty. Ltd. (G. A. Greenaway, appointee)	K. and G. Business Finance Pty. Ltd.	28 Elizabeth-street, Melbourne ..	1.7.48
*Kiernan, E. L.	E. L. Kiernan, carrying on business as "K" Cash Order Co.	220-228 Smith-street, Collingwood	1.7.48
*Kiernan, E. L.	E. L. Kiernan, carrying on business as "K" Cash Order Co.	189 Bourke-street, Melbourne ..	1.7.48
*Kiernan, E. L.	E. L. Kiernan, carrying on business as "K" Cash Order Co.	307-311 Elizabeth-street, Melbourne	1.7.48
Kiernan, F. A.	F. A. Kiernan, carrying on business as "K" Cash Order Co.	220-228 Smith-street, Collingwood	1.7.48
Kiernan, F. A.	F. A. Kiernan, carrying on business as "K" Cash Order Co.	189 Bourke-street, Melbourne ..	1.7.48
Kiernan, F. A.	F. A. Kiernan, carrying on business as "K" Cash Order Co.	307-311 Elizabeth-street, Melbourne	1.7.48
Kinder, M.	M. Kinder, carrying on business as H. J. Bryant and M. Kinder	282-4 Collins-street, Melbourne ..	1.7.48
Knibb, J. E.	James Knibb	80 Swanston-street, Melbourne ..	1.7.48
Knight, Ella May	Ella May Knight, carrying on business as H. Flanagan	5 Bath-lane, Ballarat ..	1.7.48
Lawson Trading Co. Pty. Ltd. (A. G. Maver, appointee)	Lawson Trading Co. Pty. Ltd.	230 Collins-street, Melbourne ..	1.7.48
Leon Finance Co. Pty. Ltd. (L. M. Sheeziel, appointee)	Leon Finance Co. Pty. Ltd.	Cr. Bourke and Russell streets, Melbourne	1.7.48
Livingstone, L. A.	L. A. Livingstone, carrying on business as General Cash Order Co.	270 Bridge-road, Richmond ..	1.7.48

* Licence for which no fee is payable.

MONEY LENDERS ACT—continued.

Name.	Authorized Name.	Authorized Address.	Date of Issue.
Love, Edward and Co. Pty. Ltd. (M. S. Sheezel, appointee)	Edward Love and Co. Pty. Ltd.	470 Chapel-street, South Yarra	1.7.48
Love, L.	L. Love	106 George-street, Fitzroy	1.7.48
McCleery, R. K.	R. K. McCleery, carrying on business as G. T. Gaffney and R. K. McCleery	307 Sydney-road, Brunswick	1.7.48
McKay, W.	W. McKay	327 Collins-street, Melbourne	8.7.48
McKeown, W. J.	The W. J. McKeown Finance and Cash Order Co.	548 Sydney-road, Brunswick	1.7.48
Madden, T. W.	T. W. Madden	495 Collins-street, Melbourne	1.7.48
Marshall, J. D.	J. D. Marshall	13 Miller-street, Thornbury	1.7.48
Mather, T. G.	T. G. Mather, carrying on business as Swanston Trading Agency	109 Swanston-street, Melbourne	1.7.48
Matthews, V. R.	V. R. Matthews, carrying on business as The Grattan Finance and Cash Order	209 Lygon-street, Carlton	1.7.48
Mayer, H. E.	H. E. Mayer	349 Collins-street, Melbourne	1.7.48
Melbourne Finance and Cash Order Co. Pty. Ltd. (M. Southwick, appointee)	Melbourne Finance and Cash Order Co. Pty. Ltd.	49 Elizabeth-street, Melbourne	1.7.48
Mutual Finance Co. Pty. Ltd. (E. Jansen, appointee)	Mutual Finance Co. Pty. Ltd.	57 Swanston-street, Melbourne	1.7.48
Mutual Traders Credits Pty. Ltd. (B. Redapple, appointee)	Mutual Traders Credits Pty. Ltd.	121-123 Johnston-street, Fitzroy	1.7.48
The New South Wales Monte de Piete Deposit and Investment Co. Ltd. (A. T. Howe, appointee)	The New South Wales Monte de Piete Deposit and Investment Co. Ltd.	309-11 Little Collins-street, Melbourne	1.7.48
The New South Wales Monte de Piete Deposit and Investment Co. Ltd. (H. W. Stephenson, appointee)	The New South Wales Monte de Piete Deposit and Investment Co. Ltd.	349 Swanston-street, Melbourne	1.7.48
New Trading Agency Pty. Ltd. (G. R. Angus, appointee)	New Trading Agency Pty. Ltd.	163 Swanston-street, Melbourne	1.7.48
Orr, F. H.	F. H. Orr	46 Lydiard-street south, Ballarat	1.7.48
Pembroke, F.	F. Pembroke	57 Elizabeth-street, Melbourne	1.7.48
Prahran Cash Order Pty. Ltd. (H. E. Goss, appointee)	The Prahran Cash Order Pty. Ltd.	26 The Centreway, Prahran	1.7.48
Provident Trading Agency Pty. Ltd. (J. F. Kendall, appointee)	Provident Trading Agency Pty. Ltd.	51 Leeds-street, Footscray	1.7.48
Rabinov, Harry	H. Rabinov	524 City-road, South Melbourne	1.7.48
Rabinov, S.	S. Rabinov, carrying on business as Simplex Finance and Cash Order Co.	75 Crockford-street, Port Melbourne	1.7.48
Rechners Ltd. (R. B. Rechner, appointee)	Rechners Ltd.	245 Latrobe-street, Melbourne	1.7.48
Redapple, J.	J. Redapple, carrying on business as Footwear Distributors Co.	121-123 Johnston-street, Fitzroy	1.7.48
Reddan, A. A.	A. A. Reddan, carrying on business as "K" Cash Order Co.	220-8 Smith-street, Collingwood	1.7.48
Reddan, A. A.	A. A. Reddan, carrying on business as "K" Cash Order Co.	189 Bourke-street, Melbourne	1.7.48
Reddan, A. A.	A. A. Reddan, carrying on business as "K" Cash Order Co.	307-311 Elizabeth-street, Melbourne	1.7.48
Rosen, L.	L. Rosen, carrying on business as Roseen Cash Order Co.	666 Sydney-road, Brunswick	1.7.48
Rosen, L.	L. Rosen, carrying on business as Roseen Cash Order Co.	412 Brunswick-street, Fitzroy	1.7.48
Scates, R. P.	R. P. Scates, carrying on business as Assurance Cash Order Co.	16 Koornang-road, Carnegie	1.7.48
Searson, A. J.	A. J. Searson, carrying on business as Harold Scott	296 Collins-street, Melbourne	1.7.48
Searson, A. J.	A. J. Searson, carrying on business as Harold Scott	8 Centreway, Chapel-street, Prahran	1.7.48
Shepherd, J. C.	J. C. Shepherd	79 Speight-street, Thornbury	1.7.48
Adam Smith Pty. Ltd. (P. J. Keiroe, appointee)	Adam Smith Pty. Ltd.	11. Elizabeth-street, Melbourne	1.7.48
Adam Smith Pty. Ltd. (T. H. Walsh, appointee)	Adam Smith Pty. Ltd.	519 High-street, Northcote	1.7.48
Smith, C. D. J.	C. D. J. Smith, carrying on business as The Smith Cash Order Co.	194 Bank-street, South Melbourne	1.7.48
Smith, D.	D. Smith	153 Chapel-street, St. Kilda	1.7.48
Steele, S. C.	S. C. Steele	57 Elizabeth-street, Melbourne	1.7.48
Steward, E. J.	E. J. Steward, carrying on business as Swanston Trading Agency	109 Swanston-street, Melbourne	1.7.48
Swan Cash Order Pty. Ltd. (T. D. Pollock, appointee)	Swan Cash Order Pty. Ltd.	383 Brunswick-street, Fitzroy	1.7.48
Swift's Pty. Ltd. (I. L. Schroeder, appointee)	Swift's Pty. Ltd.	257-9 Swanston-street, Melbourne	1.7.48
The Towns Supply Co. Pty. Ltd. (N. W. Towns, appointee)	The Towns Supply Co. Pty. Ltd.	105 Swanston-street, Melbourne	1.7.48
The Towns Supply Co. Pty. Ltd. (N. W. Towns, appointee)	The Towns Supply Co. Pty. Ltd.	216 Glenferrie-road, Glenferrie	1.7.48
Traders Finance Corporation Ltd. (G. V. Beattie, appointee)	Traders Finance Corporation Ltd.	44-6 Queen-street, Melbourne	1.7.48
Universal Providers Pty. Ltd. (E. Greenberg, appointee)	Universal Providers Pty. Ltd.	109 Swanston-street, Melbourne	1.7.48
Universal Shopping and Finance Co. Pty. Ltd. (C. A. Pitman, appointee)	Universal Shopping and Finance Co. Pty. Ltd.	327 Bourke-street, Melbourne	1.7.48
Warn, L.	L. Warn	243 Collins-street, Melbourne	1.7.48
Watkins, W. E.	W. E. Watkins	317 Collins-street, Melbourne	1.7.48
White, L. G.	L. G. White, carrying on business as C. Cleveland and Co.	94 Elizabeth-street, Melbourne	1.7.48
Wright, M. H.	M. H. Wright	138 Little Malop-street, Geelong	1.7.48

The Constitution Act Amendment Acts.

REMOVAL OF ELECTORAL REGISTRARS AND DEPUTY ELECTORAL REGISTRARS FOR DIVISIONS OF ELECTORAL PROVINCES.

HIS Excellency the Governor of the State of Victoria, by and with the advice of the Executive Council thereof, and in pursuance of the provisions of section 70 (1) of *The Constitution Act Amendment Act 1928*, as amended by section 5 of the *Legislative Council Elections Act 1935*, doth, by an Order made on the 26th day of July, 1948, hereby remove from their respective offices, on and from the 31st day of July, 1948, all persons who, on the said date, held any office as Electoral Registrar or Deputy Electoral Registrar for any Division of an electoral province.

APPOINTMENT OF ELECTORAL REGISTRARS AND DEPUTY ELECTORAL REGISTRARS FOR DIVISIONS OF ELECTORAL PROVINCES.

HIS Excellency the Governor of the State of Victoria, by and with the advice of the Executive Council thereof, and in pursuance of the provisions of section 70 (1) of *The Constitution Act Amendment Act 1928*, as amended by section 5 of the *Legislative Council Elections Act 1935*, doth, by an Order made on the 26th day of July, 1948, hereby appoint the persons named in the first column of the Schedule hereto and the persons named in the second column of the said Schedule to be Electoral Registrars and Deputy Electoral Registrars respectively from the first day of August, 1948, of and for the divisions of electoral provinces named in conjunction therewith in the fourth and third columns of the said Schedule.

SCHEDULE.

Electoral Registrars. (1)	Deputy Electoral Registrars. (2)	Provinces. (3)	Divisions. (4)
Isaac Harold Kenney	William David Millar	Higinbotham Monash Monash Monash	Brighton Caulfield Elsternwick St. Kilda
Laurence McMahon	William Reginald Buchanan	Doutta Galla Melbourne North Melbourne North Melbourne North	Fitzroy North Fairfield Northcote Preston
William Edward Ball	Alan Carlyle Verey	Doutta Galla Doutta Galla Doutta Galla Doutta Galla Melbourne North	Brunswick North-East Brunswick North-West Brunswick South-East Brunswick South-West Coburg
Horace Edward Finney	Herbert Leslie Spargo	Higinbotham Monash Monash Monash Monash Monash	Gardiner Malvern Prahran St. Kilda North South Yarra Toorak
Francis Arthur Morris	William John Champion Furlonger	Higinbotham Higinbotham Higinbotham Higinbotham Higinbotham South-Eastern South-Eastern South-Eastern	Bentleigh Caulfield East Malvern East Oakleigh Sandringham Black Rock Cheltenham Moorabbin
Daniel Fogarty	William Niel Robertson	East Yarra East Yarra East Yarra East Yarra East Yarra East Yarra	Auburn Camberwell Camberwell North-East Camberwell North-West Camberwell South Kew
Henry Charles Louis Giles	Bobbie Sydenham Nicholls	Doutta Galla Doutta Galla Doutta Galla Melbourne West Melbourne West	Ascot Vale Essendon Moonee Ponds Footscray North Footscray South
Jules Samuel Gascard	Keith Howlett	Doutta Galla Doutta Galla Doutta Galla Melbourne Melbourne Melbourne Melbourne Melbourne	Carlton Flemington Parkville Carlton South Fitzroy Melbourne East Melbourne West North Melbourne
William Wade	Oliver Hugh Robinson	Melbourne West Melbourne West Melbourne West Melbourne West	Port Melbourne St. Kilda West South Melbourne Williamstown
Sydney Allan Wilkes	Roy Charles Hingston	East Yarra Melbourne Melbourne Melbourne Melbourne North	Hawthorn Abbotsford Collingwood Richmond Clifton Hill

SCHEDULE—continued.

Electoral Registrars. (1)	Deputy Electoral Registrars. (2)	Provinces. (3)	Divisions. (4)
Charles Henry Grattan Anderson ..	Arthur Robert Mallett	Ballaarat Ballaarat Ballaarat Ballaarat Ballaarat Ballaarat Ballaarat Bendigo Bendigo Bendigo Bendigo	Bacchus Marsh Ballaarat Ballaarat East Ballan Bungaree Buninyong Creswick Learmonth Castlemaine Daylesford Kyneton Woodend
Gilbert Finlay Boyle	Charles Edwards	Bendigo Bendigo Bendigo Bendigo Bendigo Bendigo Bendigo Bendigo Bendigo Northern Northern Northern Northern Northern Northern Northern Northern Northern Northern	Barkly Darling Eaglehawk Golden Square Heathcote Huntly Marong Pyalong Romsey Strathfieldsaye Charlton Cohuna Deakin Dunolly Echuca Inglewood Mitiamo Pyramid Hill Rochester Rushworth
Francis Peter Mills	William Ewart Dunstan	Ballaarat Ballaarat Ballaarat Ballaarat Ballaarat Ballaarat Bendigo Bendigo Bendigo South-Western South-Western South-Western South-Western South-Western South-Western Western Western Western	Ararat Avoca Beaufort Clunes Grenville Lexton Maldon Maryborough Newstead Bannockburn Camperdown Colac Otway Winchelsea Cobden Mortlake Peshurst
Michael Francis McSherry ..	Leslie Vivian Dugan	Douatta Galla Melbourne West Bendigo Southern Southern Southern Southern South-Western South-Western South-Western South-Western South-Western South-Western	Essendon North Sunshine Gisborne Broadmeadows Keilor Sunbury Werribee Barrarbool Geelong Geelong West Lara Newtown and Chilwell Queenscliff
Keith Maxwell Campbell ..	Charles Cecil Williams	East Yarra Melbourne North Melbourne North Bendigo Bendigo North-Eastern North-Eastern North-Eastern Southern Southern Southern Southern Southern Southern Southern Southern	Box Hill Heidelberg Ivanhoe Kilmore Seymour Alexandra Mansfield Yea Blackburn Diamond Creek Doncaster Eltham Healesville Lilydale Warburton Whittlesea

NOTICE.

ADMINISTRATION of the estate of each of the under-mentioned deceased persons has been granted to me, and creditors, next of kin, and all others having claims against the estate of any of the persons so mentioned are required to send particulars of their claims to the Public Trustee, No. 412 Collins-street, Melbourne, on or before the 6th October, 1948, or they will be excluded from the distribution of the estate when the assets are being distributed:—

*ABBEY, ANNIE, late of Goldsmith-street, Maryborough, widow, died 17th April, 1948.

*AUGUSTINE, FREDERICK JOSEPH, also known as Frederick Augustine, late of 60 McCracken-street, Essendon, turner and fitter, died 24th March, 1948.

BERGIN, WILLIAM, late of North Cundare, via Beac, military pensioner, died 22nd February, 1946, intestate.

DOW, MARY ANN, also known as Mary Dow, late of 16 Avoca-street, South Yarra, spinster, died 3rd April, 1948, intestate.

DUFFY, STANLEY, late of 155 Barry-street, Carlton, mechanic, died 10th April, 1948, intestate.

*GOLDBERG, JOSEPH, late of 22 Bath-street, Mornington, traveller, died 16th May, 1948.

HOOD, HAROLD TURON RIDER, late of "Chestnut Row," Falls-road, Olinda, insurance superintendent, died 24th March, 1948, intestate.

†IRVINE, WILLIAM BEATTIE, late of Hicks-street, Mitchelton, Brisbane, Queensland, retired farmer, died 26th July, 1947.

LAWSON, FRANK WILLIAM, late of Gordon House, Melbourne, labourer, died 12th April, 1948, intestate.

PICKUP, CATHERINE, late of 338 Napier-street, Fitzroy, widow, died 3rd May, 1948, intestate.

QUINN, MICHAEL, late of 566 Rathdown-street, Carlton, retired public servant, died 13th May, 1948, intestate.

ROBINSON, JOSEPH, late of Smith-street, Bendigo, pensioner, died 13th March, 1948, intestate.

STAMERS, WILLIAM JOHN, late of Gippsland Benevolent Home, Bairnsdale, pensioner, died 29th December, 1947, intestate.

†WOOD, STANLEY GARTON, late of 49 Warleigh-grove, Brighton, clerk, died 1st June, 1948.

* According to the provisions of the will.

† With the will annexed.

C. J. GARDNER,
Public Trustee.

Melbourne, 28th July, 1948.

4 GEORGE VI. No. 4755, SECTION 6.

I HEREBY give notice that on the 20th July, 1948, I filed an election to administer the following deceased person's estate, in accordance with section 6 of the *Public Trustee Act 1940*:—

STAMERS, WILLIAM JOHN, late of Gippsland Benevolent Home, Bairnsdale, pensioner, died 29th December, 1947, intestate.

I HEREBY give notice that on the 22nd July, 1948, I filed elections to administer the following deceased persons' estates, in accordance with section 6 of the *Public Trustee Act 1940*:—

*ABBEY, ANNIE, late of Goldsmith-street, Maryborough, widow, died 17th April, 1948.

*AUGUSTINE, FREDERICK JOSEPH, also known as Frederick Augustine, late of 60 McCracken-street, Essendon, turner, and fitter, died 24th March, 1948.

*GOLDBERG, JOSEPH, late of 22 Bath-street, Mornington, traveller, died 16th May, 1948.

ROBINSON, JOSEPH, late of Smith-street, Bendigo, pensioner, died 13th March, 1948, intestate.

* According to the provisions of the will.

I HEREBY give notice that on the 27th July, 1948, I filed elections to administer the following deceased persons' estates, in accordance with section 6 of the *Public Trustee Act 1940*:—

DUFFY, STANLEY, late of 155 Barry-street, Carlton, mechanic, died 10th April, 1948, intestate.

LAWSON, FRANK WILLIAM, late of Gordon House, Melbourne, labourer, died 12th April, 1948, intestate.

C. J. GARDNER,
Public Trustee.

412 Collins-street, Melbourne, C.1, 28th July, 1948.

MELBOURNE AND METROPOLITAN BOARD
OF WORKS.

GENERAL NOTICE.

THE Melbourne and Metropolitan Board of Works, having made sewers for carrying off the sewage from each and every property which, or any part of which, abuts on the streets or parts of streets in which such sewers are laid, and which are included within the sewerage areas hereinafter described, doth hereby declare that on and after the fourth day of September, 1948, each and every property which, or any part of which, abuts on the said streets or parts of streets, shall be deemed to be a sewered property within the meaning of the *Melbourne and Metropolitan Board of Works Act 1928*.

The sewerage areas hereinbefore referred to are:—

Sewerage Area No. 1,213.

SHIRE OF BROADMEADOWS.—Commencing at the intersection of Boundary-road and the Fawkner railway line; thence generally easterly following Sewerage Areas Nos. 847 and 1,047 to the intersection of Queen's-parade and Princess-street, northerly along Princess-street, and continuing northerly by a line parallel to Sydney-road to a point in Lee-street 300 feet east of the east side of Sydney-road, westerly along Lee-street, northerly along the eastern boundaries of properties on the east side of Sydney-road to a point 362 feet north of the north side of Lorne-street, easterly by a line a distance of about 723 feet, northerly by a line a distance of 350 feet, westerly by a line a distance of 936 feet to Sydney-road, southerly along Sydney-road a distance of about 200 feet, westerly by a line to the Fawkner railway line, southerly along the Fawkner railway line to the commencing point.

Sewerage Area No. 1,214.

SHIRE OF BRAYBROOK.—Commencing at the intersection of Ballarat-road and Adelaide-street; thence southerly, westerly, southerly, and westerly following Sewerage Areas Nos. 1,013 and 1,014 to the intersection of Wyalong-street and Maylands-street, northerly along Maylands-street, easterly along Ballarat-road to the commencing point.

Sewerage Area No. 1,215.

CITY OF CAMBERWELL.—Commencing at the intersection of Belmore-road and Buchanan-avenue; thence westerly along Belmore-road, northerly along Lawson-street, easterly along Gildan-avenue, northerly along Severn-street, easterly along Moody-street, southerly along Cobham-street, easterly along Hood-street, southerly along Buchanan-avenue to the commencing point.

Sewerage Area No. 1,216.

CITY OF HEIDELBERG.—Commencing at the intersection of Carfax-road and Dalveen-road; thence easterly along Carfax-road, southerly along Merther-street, easterly along Jellicoe-street, southerly along Oriel-road, westerly along Beatty-street, northerly along Dalveen-road to the commencing point. (Victorian Housing Commission Area.)

Sewerage Area No. 1,217.

CITY OF MOORABBIN.—Commencing at the intersection of Point Nepean-road and Centre Dandenong-road; thence easterly along Centre Dandenong-road to a point about 280 feet east of the east side of Wilson-street, northerly by a line to a point about 333 feet north of the north side of Centre Dandenong-road, easterly by a line a distance of about 560 feet, southerly by a line a distance of about 333 feet to Centre Dandenong-road, easterly along Centre Dandenong-road to the eastern boundary of the property of the Melbourne Convalescent Home for Men, southerly, easterly, southerly, and westerly following the boundary of the said property to the north-east corner of lot 123, Evesham-road, southerly along the eastern boundary of the said lot 123, easterly along Evesham-road, southerly along the eastern boundaries of lot 85, Evesham-road, and lot 84, Wallingford-street, westerly along Wallingford-street, southerly along the eastern boundaries of lot 41, Wallingford-street, and lot 28, Swinden-avenue, westerly along Swinden-avenue, southerly along the eastern boundaries of lots 1 and 2, Point Nepean-road, easterly along portion of the northern boundary of lot 3, Point Nepean-road, southerly along the eastern boundaries of the said lot 3 and lot 4, Point Nepean-road, westerly along Cobham-street, north-westerly along Point Nepean-road to the commencing point.

Further particulars regarding the streets or parts of streets in which sewers have been laid may be ascertained on inquiry at the Board's office.

By order of the Board,

CHAS. J. W. BRIGGS,

Secretary.

110 Spencer-street, Melbourne, C.1,
3rd August, 1948.

CONTRACTS ACCEPTED.—(Series 1947-48.)

GENERAL STORES.

Gazette No. 437, 19th November, 1947, Stationery (General), Schedule No. 69.—For Item No. 85, substitute £3 15s. each as from 1st July, 1948.

Gazette No. 19, 21st January, 1948, Tools (General).—For Item No. 26, Hack Saw Blades, substitute 2s. 10d. per dozen for 10-in., and 3s. 5d. per dozen for 12-in., as from 1st July, 1948.

W. H. RUTHERFORD, Secretary to the Tender Board. 2.8.48.

CONTRACTS ACCEPTED.—(Series 1948-49.)

VICTORIAN RAILWAYS.

6. Asbestos mattresses, at rates (Contract 56609).—Bell's Asbestos and Engineering (Aust.) Ltd. 7. Hydraulic plain grinding machine, at £2.712 each (Contract 56928).—McPherson's Ltd. 8. Cleaning windows, &c., Flinders-street Station Buildings, for £264 (Contract 57015).—Utility Cleaning Co. 9. Bluestone spalls, at rates (Contract 57053).—H. W. Snell. 10. Bluestone spalls, at rates (Contract 57056).—L. J. Waller. 11. Cartage of firewood, at 8s. per ton of 50 cubic feet (Contract 57071).—R. Saunders. 12. Asbestos mattresses, at rates (Contract 57076).—Bell's Asbestos and Engineering (Aust.) Ltd. 13. Tarpaulin canvas, at 9s. 0½d. per lineal yard (Contract 57200).—Alexander and Paterson.

By order of the Victorian Railways Commissioners,
B. KELLY, Secretary. 30.7.48.

GENERAL STORES.

Gazette No. 708, 30th June, 1948, Schedule No. 39, Furniture, &c.—For Item No. 39, substitute £2 11s. each as from 1st July, 1948.

Gazette No. 708, 30th June, 1948, Schedule No. 67, Soap-makers' Materials, &c.—For Item No. 11, substitute 1s. 5½d. per gallon, as from 14th July, 1948.

W. H. RUTHERFORD, Secretary to the Tender Board. 2.8.48.

ORDERS IN COUNCIL.—(Series 1948-49.)

STATE ELECTRICITY COMMISSION.

263. The supply of four Bedford 27-passenger buses for transport of personnel, Yallourn and Kiewa Hydro-Electric Scheme, to Quotation No. 4791.—S. A. Cheney Pty. Ltd.

Approved by the Governor in Council, 20th July, 1948.—C. W. KINSMAN, Clerk of the Executive Council.

264. The supply of two conveyor belts for bucket wheel dredger, Yallourn Open Cut, to Quotation No. 4657.—Dunlop Rubber Australia Ltd.

265. The supply of four sets of fabricated galvanized steelwork, main sub-station, Terang, to Quotation No. 3364.—Johns and Waygood Ltd.

266. The supply of 560 dressed wooden poles, to Specification No. 47-48/182.—H. J. Joyce.

267. The supply of one addressograph machine, to Quotation No. 67.—Stott and Hoare Pty. Ltd.

268. The supply of one hydraulically-operated gate valve and auxiliary equipment for Clover Dam, Kiewa Hydro-Electric Scheme, to Specification No. 47-48/210.—Morison and Bearby Pty. Ltd.

Approved by the Governor in Council, 26th July, 1948.—C. W. KINSMAN, Clerk of the Executive Council.

DEPARTMENT OF LANDS AND SURVEY.

At the Executive Council Chamber, Melbourne, the twenty-sixth day of July, 1948.

PRESENT:

Hs Excellency the Governor of Victoria.	
Mr. McDonald	Lieut.-Colonel Dennett
Colonel Kent Hughes	Mr. Lienhop
Mr. Dodgshun	Mr. Hyland
Mr. Oldham	Mr. Warner
Sir Albert Dunstan	Mr. Byrnes.

LANDS TEMPORARILY RESERVED FROM SALE.

HIS Excellency the Governor of the State of Victoria, by and with the advice of the Executive Council thereof, doth hereby direct that, in pursuance of the provisions of

the *Land Act* 1928, reserve, temporarily, and also except from occupation for mining purposes under any miner's right, the lands hereinafter described:—

MILDURA.—Site for Public Recreation, in addition to and adjoining the site temporarily reserved therefor by Order in Council of the 18th November, 1935, 2 roods, more or less, Parish of Mildura, County of Karkaroc, as indicated by hachure on plan hereunder.—(M.556(4) (Rs.4244).

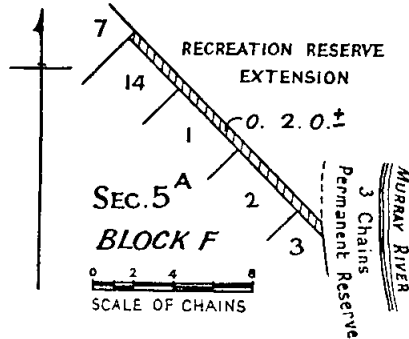

KYNETON.—Site for Hospital purposes, 1 rood, more or less, Township of Kyneton, Parish of Lauriston, County of Dalhousie, as indicated by hachure on plan hereunder.—(K.96(2) (Rs.5694).

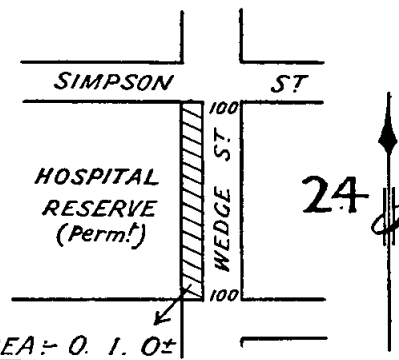

BRUNSWICK.—Site for Children's Playground, 20 5/10 perches, City of Brunswick, Parish of Jika Jika, County of Bourke, as indicated by hachure on plan hereunder.—(B.755B(2) (Rs.6198).

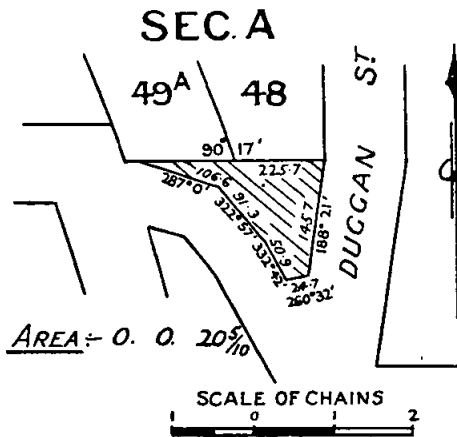

And the Honorable John Gladstone Black McDonald, His Majesty's Commissioner of Crown Lands and Survey for the State of Victoria, shall give the necessary directions herein accordingly.

C. W. KINSMAN,
Clerk of the Executive Council.

DEPARTMENT OF LANDS AND SURVEY.

At the Executive Council Chamber, Melbourne, the twenty-sixth day of July, 1948.

PRESENT:

Hs Excellency the Governor of Victoria.

Mr. McDonald	Lieut.-Colonel Dennett
Colonel Kent Hughes	Mr. Lienhop
Mr. Dodgshun	Mr. Hyland
Mr. Oldham	Mr. Warner
Sir Albert Dunstan	Mr. Byrnes.

REVOCATION OF TEMPORARY RESERVATIONS OF LANDS BY ORDERS IN COUNCIL.

HIS Excellency the Governor of the State of Victoria, by and with the advice of the Executive Council thereof, doth hereby, in pursuance of the provisions of the Land Act 1928, revoke the temporary reservations of the lands by Orders in Council hereinafter referred to, viz.:

BALLAARAT.—Order in Council of 1st May, 1871, of 1 acre of land in the Parish of Ballaarat, at Little Bendigo (now Nerrena), as a site for Wesleyan Place of Public Worship.—(C.52882).

CANNUM.—Order in Council of 10th December, 1883, of 5 acres of land in the Parish of Cannum, as a site for Public purposes (State school).—(C.91088).

And the Honorable John Gladstone Black McDonald, His Majesty's Commissioner of Crown Lands and Survey for the State of Victoria, shall give the necessary directions herein accordingly.

C. W. KINSMAN,
Clerk of the Executive Council.

Parish of Carraragarmungee, County of Bogong, being the road between allotments 4A, 4B, of section 20A, and allotments 1A, 1B, of section 21A.—(C.188⁽³⁾) (H.019191).

Parish of Tatong, County of Delatite, being the road between allotments 32, 33, and allotment 34, section B.—(T.231⁽⁶⁾) (H.019045).

Town of Warracknabeal, Parish of Werrigar, County of Borung, being the roads indicated by hachure on plan hereunder.—(W.293⁽⁷⁾) (C.90316).

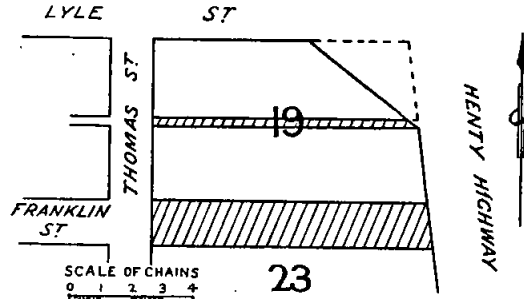

And the Honorable John Gladstone Black McDonald, His Majesty's Commissioner of Crown Lands and Survey for the State of Victoria, shall give the necessary directions herein accordingly.

C. W. KINSMAN,
Clerk of the Executive Council.

DEPARTMENT OF LANDS AND SURVEY.

At the Executive Council Chamber, Melbourne, the twenty-sixth day of July, 1948.

PRESENT:

Hs Excellency the Governor of Victoria.

Mr. McDonald	Lieut.-Colonel Dennett
Colonel Kent Hughes	Mr. Lienhop
Mr. Dodgshun	Mr. Hyland
Mr. Oldham	Mr. Warner
Sir Albert Dunstan	Mr. Byrnes.

UNUSED AND UNMADE ROADS CLOSED.

HIS Excellency the Governor of the State of Victoria, by and with the advice of the Executive Council thereof, doth hereby direct that, in pursuance of the provisions of section 304 of the Land Act 1928 (No. 3709), the unused and unmade roads referred to hereunder be closed, viz.:

Parish of Barrarbool, County of Grant, being the road indicated by hachure on plan hereunder.—(B.34⁽³⁾) (J.27286).

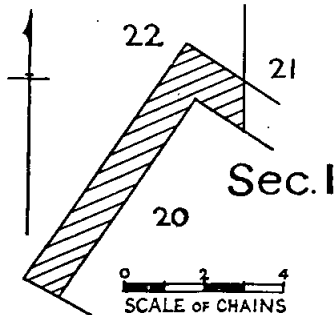

DRAINAGE AREAS ACT.

At the Executive Council Chamber, Melbourne, the twenty-sixth day of July, 1948.

PRESENT:

Hs Excellency the Governor of Victoria.

Mr. McDonald	Lieut.-Colonel Dennett
Colonel Kent Hughes	Mr. Lienhop
Mr. Dodgshun	Mr. Hyland
Mr. Oldham	Mr. Warner
Sir Albert Dunstan	Mr. Byrnes.

CONSTITUTION OF THE CONDAH SWAMP (No. 1) DRAINAGE AREA.

PURSUANT to the provisions of the Drainage Areas Act 1928 (No. 3668, section 7), and in compliance with the prayer of a petition presented by a majority of the owners of certain land within a portion of the Shire of Minhamite, notice of which petition was duly published in the Government Gazette of the 12th November, 1947, His Excellency the Governor of the State of Victoria, by and with the advice of the Executive Council thereof, doth by this Order direct that the portion of the said Shire described hereunder, being the land shown in red colour on plan marked "A" attached to correspondence No. LG.47/947, deposited in the Office of the Department of Public Works, Melbourne, be constituted a drainage area within the meaning of the above-mentioned Act, under the name of the Condah Swamp (No. 1) Drainage Area, that is to say:—

Commencing at a point in the centre of a drain between the most southerly corner of allotment 11A, of section 12, Parish of Byambynee, and the north-east corner of allotment 9A, section 1, Parish of Weerangourt, being on the boundary between the Parishes of Weerangourt and Byambynee; and thence in a westerly, south-westerly, south-easterly, southerly and south-westerly direction along the boundary between the Parishes of Weerangourt and Byambynee, Weerangourt and Greenhills, Ardonachie and Condah to a point on the latter boundary due west of the south-west corner of allotment 7A, section 14, Parish of Ardonachie; thence in a straight line to this corner; thence easterly, northerly, and north-easterly along the boundaries of this allotment to the north-east corner thereof; thence due north in a straight line to a point on

the southern boundary of allotment 1A, of section 15, Parish of Ardonachie; thence easterly, north-easterly, northerly, and north-easterly along the boundaries of allotments 1A, 1, and 2 to the north-east corner of allotment 2, continuing in the same line across a road and along the eastern boundaries of allotments 3, 4, and 5, continuing in the same line across another road and along the south-east boundary of allotment 6, to a corner of the boundary diagonally opposite the south-west corner of allotment not numbered but marked "Donald McKellar"; thence in a straight line across a road to this corner and continuing in a south-easterly and southerly direction to a Government road; thence north-easterly and south-easterly along the boundary of this allotment and an adjoining allotment also unnumbered to the southernmost corner thereof; thence north-easterly and northerly to the north-east corner of this allotment; thence in a westerly direction along the northern boundary to the north-west corner of this allotment; thence along the south-west boundary of a "proposed road" in a north-westerly direction to the north-east corner of the allotment unnumbered but in the name of Donald McKellar; thence across a road to the south-east corner of allotment 10, section 15, Parish of Ardonachie; thence in a northerly and north-westerly direction along the eastern boundary of this allotment and across a road to the south-east corner of allotment 11; thence along the eastern boundaries of allotments 11 and 14, across a road to the south-east corner of allotment 3, section 15, Parish of Weerangourt; thence along the eastern boundary of this allotment to the most eastern corner thereof; thence easterly along the southern boundary of allotment 4 to the south-east corner thereof; thence in a straight line from this corner to the south-west corner of the most southerly portion of allotment 6, section 15, marked J. A. J. Mackellar; thence in an easterly and north-easterly direction along the southern boundary of this allotment to its most eastern point; thence north-westerly along its north-east boundary and continuing across a road and along the south-west boundary of an "Exchanged Road" to a point diagonally opposite the south-west corner of allotment 6, section 10; thence in a straight line to this corner and continuing in a north-easterly direction along the southern boundaries of this allotment and a small portion of allotment 8 at the north-eastern end thereof to the most easterly corner; thence north-westerly along the north-eastern boundary of allotment 8 to the south-east corner of allotment 5; thence northerly and westerly along the east and north boundaries of this allotment to its north-west corner, continuing on the same line across a road to a point on the east boundary of allotment 7, of section 9, Parish of Weerangourt; thence in a northerly direction along the eastern boundary of the said allotment to the north-east corner thereof; thence in a westerly direction along the northern boundary and across a road to a point on the eastern boundary of allotment 7, of section 16; thence northerly, westerly, north-westerly, north-easterly, easterly and north-westerly to its north-east corner; thence continuing along the eastern and northern boundaries of an unnumbered allotment in the name of A. Cope to its most northern corner; thence diagonally in a straight line across a road to the most eastern corner of allotment 1D, section 2; thence south-westerly, north-westerly, north-easterly, north-westerly, south-westerly, and north-westerly along the boundary of this allotment to its north-east corner; thence in a straight line across a road to the south-east corner of allotment 5, of section 1, Parish of Weerangourt; thence in a northerly direction along the east boundaries of allotments 5, 5A, 6, 6A, and 6B and easterly along the south boundaries of allotments 7 and 7A to the most eastern corner of allotment 7A; thence north-west and north-east along the boundaries of allotments 7A, 8, 8A, and 8B to the south-eastern corner of allotment 8B; thence in a straight line across a road to the south-west corner of allotment 9; thence in an easterly direction along the southern boundary of allotment 9 to the south-east corner thereof; thence in a northerly direction along the eastern boundary thereof to a dotted line representing the boundary of the Swamp; thence easterly along this dotted line to its junction with the west boundary of a Government road; thence northerly along this boundary and its extension to the starting point.

And the Honorable James Arthur Kennedy, His Majesty's Commissioner of Public Works for the State of Victoria, shall give the necessary directions herein accordingly.

C. W. KINSMAN,
Clerk of the Executive Council.

DRAINAGE AREAS ACT.

At the Executive Council Chamber, Melbourne, the
twenty-sixth day of July, 1948.

PRESENT:

His Excellency the Governor of Victoria.

Mr. McDonald	Lieut.-Colonel Dennett
Colonel Kent Hughes	Mr. Lienhop
Mr. Dodgshun	Mr. Hyland
Mr. Oldham	Mr. Warner
Sir Albert Dunstan	Mr. Byrnes.

CONSTITUTION OF THE CONDAH SWAMP (No. 2)
DRAINAGE AREA.

PURSUANT to the provisions of the *Drainage Areas Act* 1928 (No. 3668), section 7, and in compliance with the prayer of a petition presented by a majority of the owners of certain land within a portion of the Shire of Portland, notice of which petition was duly published in the *Government Gazette* of the 22nd October, 1947, His Excellency the Governor of the State of Victoria, by and with the advice of the Executive Council thereof, doth by this Order, direct that the portion of the said Shire described hereunder, being the land shown in red colour on plan marked "A" attached to correspondence No. LG.47/700, deposited in the Office of the Department of Public Works, Melbourne, be constituted a drainage area within the meaning of the above-mentioned Act, under the name of the Condah Swamp (No. 2) Drainage Area, that is to say:—

Commencing at the north-east corner of allotment 14, section 17, Parish of Braxholme; thence in a westerly direction along the northern boundaries of allotments 14, 13, 12, 11, 10, 8 and 7 to the north-west corner of allotment 7; thence in a straight line across a drain to the north-east corner of allotment 24, section 14, continuing in a westerly direction along the northern boundary to the north-west corner thereof; thence in a southerly direction along the western boundaries of allotments 24, 23, 22 and 21 to the south-west corner of allotment 21; thence across a road to the north-west corner of allotment 20 of the same section; thence south-westerly along the north-western boundaries of allotments 20, 19, 18, 17, 16, 15, 14 and 13 to the most westerly corner of allotment 13, across a road to the north-east corner of allotment 12 of the same section, and north-westerly along the northern boundaries of allotments 12, 11, 10, 9 and 8B, across a road and continuing along the north boundaries of allotments 8A, 7 and 6 of the same section and parish to the most westerly corner of allotment 6; thence south-westerly in a straight line across a road to the most northern corner of allotment 4E, section 12, of Parish of Braxholme; thence in a south-easterly direction along the western and southern boundaries of allotments 4E, continuing along the south-west boundaries of allotments 4C and 4D, across a road and continuing along the boundaries of 4E, 4F, 4N and 4M to the southernmost corner of allotment 4M; thence due south across a road to a point on the northern boundary of allotment 10 of the same section; thence westerly along this boundary to the most western corner of the said allotment; thence continuing south-east and south along the western boundaries of allotments 10, 11, 13, 14, 15A and B, 16, 17, 18, 19, 20A and B, 21, 22, 23, 24, 25 and 26 to the south-west corner of allotment 26; thence due west across a road to a point on the north-west boundary of allotment 32 of the same section; thence in a north-westerly direction along the north-east boundaries of allotments 33, 34, 35, 36, 37, 38 and 39 and across a road to the most easterly corner of allotment 40; thence in a north-westerly direction along the north-east boundaries of allotments 40, 41, 42, 43, 44, 45, 46, 47, 48, 49A, 49B and 50 and continuing north-west and south-west along the north-east and north-west boundaries of allotment 51 to the westerly point thereof; thence south-west across a drain and along the north-west boundaries of allotments 52B, 52A, 53B and 53A; thence across the "Charcoal" Drain and continuing in a south-westerly direction along the west boundary of allotment 29, section 21, Parish of Greenhills, to the south-west corner thereof; thence east along the southern boundary and across a drain continuing east along the southern boundaries of allotments 28, 27 and 26, across a road and continuing in a south-easterly direction along the southern boundaries of allotments 25, 24, 23, 22, 21, 20, 19 and 18, continuing across a drain and along the south-west boundaries of allotments 17, 16, 15 and 14; thence south along the western

boundary of allotment 13, and across a road; thence along the western boundaries of allotments 5, 4A, 3A, 2A and 1 to the south-west corner of allotment 1; thence east along the southern boundary thereof to the south-east corner and north, north-east and east along the southern boundaries of allotments 1, 2, 3, 6, 7, 8 and 9 to the south-east corner of allotment 9, across a road in a straight line to the most westerly corner of allotment 5A, section 20; thence in a south-easterly, southerly, south-westerly and southerly direction along the western boundaries of allotments 5A, 5B, 6, State school site 7, 7A, 8 and 8A, continuing across a road and along the south-western boundaries of allotments 7 and 8, section 19, Parish of Greenhills, across a drain and along the western boundaries of allotments 9 and 10 to a point due east of the north-east corner of allotment 12; thence across a drain to the north-east corner of allotment 12; thence south-west and north-west along the northern boundaries of allotments 12 and 13, crossing a small drain, to the north-west corner of allotment 13; thence south and south-west along the western boundary of the said allotment to the south-west corner thereof; thence in a straight line due south across a drain to a point on the northern boundary of allotment 7A, section 9; thence west, south, east and south-east along the boundary of this allotment to the south-west corner thereof; thence in a straight line across a road to the north-west corner of allotment 4c, section 18, and south-east along the western boundary thereof to the south-west corner; thence in a straight line across allotment 6a, section 10, to the north-west corner of allotment 6c; thence south along the western boundary and east along the southern boundary to a point opposite the north-west corner of allotment 7b; thence south across a road and along the west boundary thereof, across a road and along the west boundary of allotment 7d to the south-west corner thereof; thence west along the north boundary of allotment 9, section 17, across a road and continuing along the north boundary of allotment 7e to the north-west corner; thence south-east along the west boundary to the south-west corner; thence in a straight line across a road to the north-west corner of allotment 3c; thence in a south-easterly direction along the west boundary and east along the south boundary to the south-east corner of this allotment; thence in a straight line due east across a road to a point on the west boundary of allotment 5; thence south-easterly along the west boundary to the south-west corner thereof, and across a drain to the north-west corner of allotment 4, continuing in a southerly direction along the west boundaries of allotments 4 and 1 to a point due east of the north-east corner of allotment 6c; thence due west to this corner and along the north boundary of allotment 6c to the north-west corner; thence south-east and east along the west and south boundaries to the south-east corner thereof; thence in a straight line across a road to the north-west corner of allotment 1, section 12, Parish of Condah; thence in a southerly direction along the western boundaries of allotments 1 and 2 to the south-west corner of allotment 2; thence across a road in a straight line to the north-west corner of allotment 3, continuing in a southerly direction along the western boundary thereof to the south-west corner; thence due south across a road to a point on the north-east boundary of allotment 4; thence north-west along the northern boundaries of allotments 4 and 5 to the north-west corner of allotment 5; thence south-westerly along the west boundary and across a drain to the north-east corner of allotment 3c; thence west to the north-west corner, and south-east along the south-west boundaries of allotments 3c and 9, and south-west to the south-west corner of allotment 9; thence west and south-west along the north and west boundaries of allotments 7 and 8, continuing south-east and south to the south-west corner of allotment 8; thence easterly to the south-east corner of said allotment, continuing east to the centre of the "Main" Drain; thence in a northerly direction along the centre of this "Main" Drain to its junction with the centre line of a main branch to the right at a point opposite the east boundary of allotment 2, section 20, Parish of Greenhills; thence along the centre of this drain in the Parish of Byambynee, in a north-easterly and south-easterly direction to a point due south of the most southerly corner of allotment 11A, section 11, Parish of Byambynee, this line being the boundary of the Parishes of Condah, Greenhills, Branxholme, and Byambynee; thence in a north-easterly direction along the south-east boundaries of allotments 11A, 11 and 10 to the north-east corner of allotment 10; thence north-west along the north boundary of allotment 10 and north-east along the boundaries of allotments 9 and 8 to the north-east corner of allotment 8, across a road to the most southerly corner of allotment 7b; thence north-easterly along the south-eastern boundaries of allotments 7b, 7A and 7 to the north-east corner of allotment 7; thence in a north-westerly direction along the northerly boundary of allotment 7,

and continuing along the northerly boundaries of allotments 11c, 11b and 11 to the most northerly corner of allotment 11; thence south along the west boundaries of allotments 11, 11A, across a road and continuing along the westerly boundaries of allotments 12, 12A, 12B, 12c, 13, 13B and 13A to the south-west corner of allotment 13A of the same section; thence westerly along the northern boundaries of allotments 14A and 14, across a drain and continuing along the northern boundaries of allotments 17, 18, 20, 20A and 24 to a point on the northern boundary of allotment 24 due south of the south-east corner of allotment 25; thence in a straight line to this corner and continuing north-easterly along the eastern boundaries of allotments 25, 26, 27, 28, 29, 30 and 31 across a road; thence north-west along the eastern boundaries of allotments 34, 35, 36, 37, 38 and 39, across a drain; thence north-east along the eastern boundaries of allotments 40, 41, 42, 44, 45, 47 and 48, across a road and north and north-east along the eastern boundaries of a State school reservation and allotments 53, 54, 55, 56, 57 and 58, across a road and continuing along the eastern boundaries of allotments 59, 60, 61 and 62, crossing a road and along the south and east boundaries of allotment 63 to the northernmost corner thereof; thence continuing in a straight line across a drain, and along the eastern boundary of allotment 14, section 17, Parish of Branxholme to the point of commencement.

And the Honorable James Arthur Kennedy, His Majesty's Commissioner of Public Works for the State of Victoria, shall give the necessary directions herein accordingly.

C. W. KINSMAN,
Clerk of the Executive Council.

GRAIN ELEVATORS ACTS 1934 AND 1935.

*At the Executive Council Chamber, Melbourne, the
twenty-seventh day of July, 1948.*

PRESENT:

The Lieutenant-Governor, as Deputy for His Excellency,
the Governor of Victoria.

Mr. Oldham | Mr. Warner.

APPOINTMENT, ETC., OF CHAIRMAN OF GRAIN- ELEVATORS BOARD.

IN pursuance of the powers in that behalf conferred by the Grain Elevators Acts 1934 (No. 4270) and 1935 (No. 4286), the Lieutenant-Governor, as Deputy for His Excellency the Governor of the State of Victoria, by and with the advice of the Executive Council thereof, doth by this Order hereby appoint—

HAROLD GLOWREY

to be a Member and Chairman of the Grain Elevators Board, for a term of five (5) years from and inclusive of the first of August, 1948, and to receive remuneration at the rate of One thousand five hundred and fifty pounds (£1,550) per annum, and doth further fix the travelling expenses which the Chairman of the said Board shall be entitled to receive as follows:—

Twenty shillings (20s.) per day during absence from Melbourne on duty outside the metropolitan area, and Forty shillings (40s.) per day when necessarily absent on duty in another State, and to the reimbursement of any amount reasonably expended on travelling by railway or, subject to the approval of the Minister, by other means of transport.

And the Honorable Alexander Henry Dennett, His Majesty's Minister of Agriculture for the State of Victoria, shall give the necessary directions herein accordingly.

C. W. KINSMAN,
Clerk of the Executive Council.

—————

FACTORIES AND SHOPS ACTS.

At the Executive Council Chamber, Melbourne, the
third day of August, 1948.

PRESENT:

The Lieutenant-Governor, as Deputy
for His Excellency the Governor of Victoria.
Mr. Kennedy | Mr. Hyland.

—————

A FIRE-FIGHTERS BOARD TO BE APPOINTED.

UNDER the powers in that behalf conferred by the Factories and Shops Acts, the Lieutenant-Governor, as Deputy for His Excellency the Governor of the State of Victoria, by and with the advice of the Executive Council thereof, doth hereby—

- (1) Declare that it is expedient to appoint a Wages Board to determine the lowest prices or rates which may be paid to any person or persons or classes of persons (other than fire brigade officers, and other than persons subject to the Determination of any Wages Board heretofore appointed) employed as permanent firemen, or (within the Metropolitan Fire District constituted by the *Fire Brigades Act 1928*) as partially-paid firemen, engaged in—

- (a) the prevention or suppression of fires,
(b) the protection or salvage of persons, property, or goods endangered by fire or as a result thereof.

- (2) Order that a Wages Board, consisting of six members and a chairman, three of such members being appointed as representatives of employers and three as representatives of employees, be constituted and appointed to determine the lowest prices or rates which may be paid to any person or persons or classes of persons (other than fire brigade officers, and other than persons subject to the Determination of any Wages Board heretofore appointed) employed as permanent firemen, or (within the Metropolitan Fire District constituted by the *Fire Brigades Act 1928*) as partially-paid firemen engaged in—

- (a) the prevention or suppression of fires,
(b) the protection or salvage of persons, property, or goods endangered by fire or as a result thereof.

Also that such Wages Board may in any Regulation, Determination, Order, instrument, or legal proceeding, be described for all purposes as the Fire-fighters Board, and that the area or locality within which the Determination of the said Wages Board shall be operative shall be the whole of the State of Victoria.

And the Honorable Herbert John Thornhill Hyland, His Majesty's Minister of Labour for the State of Victoria, shall give the necessary directions herein accordingly.

C. W. KINSMAN,
Clerk of the Executive Council.

—————

APPROACHING LAND SALES.

SALES of Crown lands, in fee-simple, will be held at the under-mentioned places and dates, viz.:—

	No. of Gazette.
Ballarat.—Wednesday, 11th August, 1948 ..	701
Bendigo.—Thursday, 19th August, 1948 ..	711
Daylesford.—Wednesday, 11th August, 1948 ..	701
Orbost.—Thursday, 2nd September, 1948 ..	755
Stanhope.—Thursday, 26th August, 1948 ..	720
Tongala.—Thursday, 26th August, 1948 ..	720

—————

SALES OF CROWN LANDS BY AUCTION.

The lands will be sold in fee-simple, and subject to the covenants, conditions, exceptions, and reservations directed by the Governor in Council by an Order in Council dated the 5th August, 1930, and published in the *Government Gazette* of the 8th August, 1930, varied as herein.

A deposit of at least twelve and a half per centum of the price at which each lot is sold must be paid by the purchaser at the time of sale, and all such payments shall be made in bank notes or cheques approved by the officer conducting the sale, and the residue of such price will be payable in equal instalments, in accordance with the scale hereunder, on the last day of each successive period of six months from the time of sale, or, if the purchaser choose, at any earlier time or times; such residue of the price shall bear interest at the rate of £5 per centum per annum, to be computed between the time of sale and the time when payment of such residue or instalment of such residue is made. If the residue of the price be paid within thirty days after the time of the sale no interest will be payable thereon.

The Governor in Council may allow a transfer of the purchaser's interest to an approved person at any time before the final payment of the purchase money is made. The fee for transfer shall be One pound, and such transfer will be subject to payment of stamp duty.

SCALE OF PAYMENTS OF RESIDUE.

£20 and under, 6 instalments.
Over £20, and not exceeding £50, 8 instalments.
Over £50, and not exceeding £100, 10 instalments.
Over £100, and not exceeding £200, 12 instalments.
Over £200, and not exceeding £300, 14 instalments.
Over £300, and not exceeding £400, 16 instalments.
Over £400, and not exceeding £500, 18 instalments.
Over £500, 20 instalments.

FEES, ETC.

The fees payable for Crown grant and assurance (One halfpenny for each pound of purchase price) must be paid with the balance of purchase money. The following is the scale:—

50 acres and under, £1 10s.
Over 50 acres, £2.

Where the purchase money does not exceed £5, the grant fee is £1.

Valuations of improvements (if not purchased by the owner thereof), and charges for survey must also be paid at the time of sale.

JOHN G. B. McDONALD,
Commissioner of Crown Lands and Survey.

Office of Lands and Survey,
Melbourne, 2nd August, 1948.

ORBOST.—Sale (No. 10681) of Crown lands in fee-simple, by auction, will be held at the MECHANICS' HALL, ORBOST, on THURSDAY, 2nd SEPTEMBER, 1948, at TWO o'clock p.m. To be conducted by L. W. BIRCH, Land Officer, Bairnsdale.

CLUB TERRACE, PARISH OF WINYAR, COUNTY OF
CROAJINGOLONG.

Fronting Bemm River.

Upset price £5 10s. the lot. Charge for survey £4.

Lot 1. Area 5a. 1r. 23p., allotment 13, of section 5. One month allowed for removal of fencing.

MARLO, PARISH OF ORBOST EAST, COUNTY OF CROAJINGOLONG.
In the East of the Township.

Upset price £35 per lot. Charge for survey £4 4s. per lot.

- | |
|--|
| Lot 2. Area 1r. 23 4/10p., allotment 6 of section 4. |
| Lot 3. Area 1r. 21 3/10p., allotment 7 of section 4. |
| Lot 4. Area 1r. 19 2/10p., allotment 8 of section 4. |

LIST OF CROWN LANDS AVAILABLE.

THE under-mentioned areas are available for application as provided by various sections of the Land Act 1928, and all applications received on or before Wednesday, 1st September, 1948, will be deemed to have been simultaneously made, but any application lodged after such date may be considered if received in time for inclusion in the advertisement of the cases to be heard at the Local Land Board. Applications on proper form, accompanied by 5s. duty stamp uncancelled (registration fee), may be delivered or forwarded by post to the Local Land Officer or to any Crown Lands Office in Victoria. Applicants may obtain form from Local Land Officers, or the Enquiry Office, Lands Department, Melbourne, a certificate authorizing the issue by the Railway Department of a return ticket at concession fares to enable them to inspect available areas or to attend Local Land Boards. When an applicant is granted an allotment he may, if travelling by rail, obtain reduced fares for his family and also freight concessions in regard to some of his effects. Subject to the approval of the Minister, when the survey fee exceeds £10, a deposit of £5 may be paid, and the balance over six years in half-yearly instalments. Marked plans of any particular area, application forms, and any further information may be obtained from the Enquiry Office, Lands Department, Melbourne, and Land Officers, Geelong, Ballarat, Bairnsdale, Sale, and Stawell.

Department of Crown Lands and Survey,
Melbourne, 4th August, 1948.

JOHN G. B. McDONALD,
Commissioner of Crown Lands and Survey.

* Improvements may be subject to re-valuation after land has been granted to an applicant.

Local Land Office.	County.	Parish.	Allotment.	Section.	Area.	How available.		Valuation of improvements (if any).	Location of Land, &c.	Nearest Railway Station or Township and Distance in miles therefrom.	How accessible.	Water supply.	General Description of Land—Soil, Timber, Suitability (grazing, &c.)
						Classification.	Value per Acre.						
AGRICULTURAL AND GRAZING LANDS—SELECTION PURCHASE ALLOTMENTS.													
DIVISION 4, PART I, LAND ACT 1928.													
To be valued													
Omeo (c)	Dargo	Jirneeke	11A	3	79 2 19	3rd	0 15 0	10 0	To be valued	Aljoining Cassilis township	By road	To be conserved	Mountainous stony loam; box, gum, and wattle; suitable for grazing. (132/121)
Sale (a, c)	Dargo	Cowa	5, 5A	2	200 0 0	3rd	0 15 0	2 6	To be valued	In west of parish	By road	Frontage to Wonnagan stringybark; suitable for grazing. (15/44, 81)	
Bairnsdale (a, b)	Tambo	Gillingall	2A	..	190 0 0	3rd	0 15 0	2 6	To be valued	In south-east of parish	By road	To be conserved	Hilly; grey stony soil; box, stringybark; suitable for grazing. (15/44, 81)
Geelong	Polwarth	Yaughter	17K, 17H	A	48 0 11	3rd	0 10 0	8 7 6	Nil	In north of parish	Formed road	Conservation	Granite, undulating; light and sandy; gum and stringybark; suitable for grazing. (202/44, 81)
AVAILABLE UNDER SECTION 129, LAND ACT 1928.													
Stawell	Borong	Borough and Parish of Stawell	9	49B	0 1 4 1/2	Dwelling	Annual rental, £1	3 0 0	To be valued	Corner of London-road and O'Regan-street	By road	To be conserved	Suitable for a dwelling. (035/129)
Melbourne (a)	Buln Buln	Town and Parish of Welshpool	5	15	0 2 0	Dwelling and garden	Rental to be fixed	1 0 0	3 2 6	Nil	By road	To be conserved	Suitable for a dwelling and garden. (G.54215)
Ballarat	Grant	Ballarat	10B	12	3 0 0	"	"	3 2 6	Nil	In south of parish	Sebastopol-road	Conservation	Suitable for a dwelling and garden. (J.27421)
Ballarat	Grant	Ballarat	21c	14	0 1 0	"	"	3 2 6	Nil	Fronting main road to Buninyong	Main road	Conservation	Suitable for a dwelling. (J.27466)
Geelong	Grant	Township of St. Leonards	10	3	3 0 0	Garden	"	3 0 0	Nil	In south of township	By road	Conservation	Suitable for a garden. (J.24529)

(a) Subject to survey.—(b) Subject to timber condition.—(c) Subject to mining condition.

LAND AVAILABLE UNDER THE SOLDIER SETTLEMENT ACTS.

NOTIFICATION is hereby given, in accordance with section 16 of the *Soldier Settlement Act 1946*, that the undermentioned lots are available or are about to become available for settlement.

Any discharged soldier who has applied to the Commission on or before the 4th August, 1948, for classification in the required class or classes of primary production for which the lots are made available, and whose application has not been finalized, or any discharged soldier who has been classified as suitable in such class or classes of primary production, may apply on the proper form for settlement on any lot or lots, indicating where he applies in respect of more than one lot, his order of preference therefor.

Application forms, plans, and further particulars may be obtained from the Enquiry Branch, Soldier Settlement Commission, State Public Offices, Melbourne, at which office completed applications for settlement should be lodged on or before the 30th August, 1948.

E. SINGLETON,
Secretary.

Soldier Settlement Commission,
Melbourne, 30th July, 1948.

SCHEDULE OF ALLOTMENTS.

SUBDIVISION OF PORTION OF "CHATSWORTH HOUSE" ESTATE.

PARISHES OF CHATSWORTH WEST AND NAREEB NAREEB.—COUNTY OF VILLIERS.

Suitable for Grazing (Sheep).

Lot Number on Plan of Subdivision.	Approximate Area in Acres (Subject to Survey).
1	709
2	775
3	775
4	774
5	775
6	670
7	786
8	670
9	760
10	824
11	920
12	903

MURRAY VALLEY IRRIGATION DISTRICT.

PARISHES OF KATUNGA AND YARROWEYAH.—COUNTY OF MOIRA.

Lot No. on Plan of Subdivision.	Approximate Area in Acres (Subject to Survey).
<i>Suitable for Dairying under Irrigation.</i>	
4	108
6	193
188 and 189	112
192	141
201	124
202	114
<i>Suitable for Growing of Soft Fruits under Irrigation.</i>	
1	46
2	47
193	48
203	43
204	59
207	55
208	47
209	46
210	53
211	45

TONGALA LAND (FORMER CLOSER SETTLEMENT ALLOTMENTS).

PARISH OF TONGALA.—COUNTY OF RODNEY.

Suitable for Dairying under Irrigation.

Allotments and Section.	Area.
	A. R. P.
108 and 109B, section C	114 3 10

SUPERINTENDENT OF VERMIN AND NOXIOUS WEEDS DESTRUCTION (ACTING).

I, JOHN GLADSTONE BLACK McDONALD, Commissioner of Crown Lands and Survey for the State of Victoria, pursuant to section 54 of the *Public Service Act 1946*, doth hereby direct—

ARTHUR WALLACE McILROY, Chief Inspector of Land Settlement,

to perform and exercise the duties, obligations, rights, and powers of the Superintendent of Vermin and Noxious Weeds Destruction, from time to time, as the occasion may arise, during the temporary absence of Edward James Elgin Gordon Pemberton, as from and inclusive of the 6th January, 1948.

JOHN G. B. McDONALD,
Commissioner of Crown Lands and Survey.

Department of Lands and Survey, Melbourne.

PUBLIC HEARING BY A PERSON APPOINTED UNDER THE 34TH SECTION OF THE LAND ACT 1928.

NOTICE is hereby given that at the time and place mentioned in the Schedule hereunder, applications for leases and licences under the Land Acts, objections to such applications, objections to proposed proclamations, alterations, additions, diminutions, revocations, or unions of commons, and reasons against forfeiture of any leases or licences under the Land Acts deemed liable to forfeiture, will be publicly heard by the person whose name is set opposite such place in such Schedule, being a person appointed by me, the responsible Minister of the Crown administering the Land Acts, to hear the same and report thereon in writing to me.

JOHN G. B. McDONALD,
Commissioner of Crown Lands and Survey, and
President of the Board of Land and Works.

Department of Lands and Survey,
Melbourne, 4th August, 1948.

SCHEDULE.

OFFICE OF LAND INSPECTOR, AVOCA, Friday, 20th August, 1948, at Ten a.m.—R. E. Lawes, Land Officer.

PROPOSED REVOCATIONS OF TEMPORARY RESERVATIONS OF LANDS BY ORDERS IN COUNCIL.

IN pursuance of the provisions of the *Land Act 1928*, notice is hereby given that it is the intention of the Governor in Council to revoke the temporary reservations of lands by Orders in Council hereunder referred to, viz.:

The following Notices were published 1° on the 21st July, 1948, pursuant to Orders of the 13th July, 1948.

MANGALORE.—The temporary reservation as a site for Public purposes (State School) and the withholding from sale, leasing, and licensing, by Order in Council of the 27th February, 1884, of 3 acres 31 perches of land in the Parish of Mangalore, being allotment 3 of section G at Mangalore Railway Station, is about to be revoked.—(M.501(*) (Rs.5413).

BYLANDS.—The temporary reservation, by Order in Council of the 11th July, 1916, of 5 acres 3 roods 6 perches of land as a site for Railway purposes in the Parish of Bylands is about to be revoked.—(B.563(2) Rs.1125).

ARGYLE.—The temporary reservation, by Order in Council of the 15th September, 1873, of 5 acres 20 perches of land as a site for a State School, situated in section C in the Parish of Argyle, is about to be revoked.—(A.152(*) (J.26858).

JOHN G. B. McDONALD,
Commissioner of Crown Lands and Survey.

PROPOSED REVOCATIONS OF TEMPORARY RESERVATIONS OF LANDS BY ORDER IN COUNCIL.

IN pursuance of the provisions of the *Land Act 1928*, notice is hereby given that it is the intention of the Governor in Council to revoke the temporary reservations of lands by Order in Council hereunder referred to, viz.:

The following Notice was published 1° on the 28th July, 1948, pursuant to Order of the 20th July, 1948.

TARRANGINNIE.—The temporary reservation by Order in Council of the 22nd of July, 1889, of 9 acres 3 roods 39 perches of land, as a site for Water Supply purposes in the Parish of Tarranginnie, is about to be revoked.—(T.199(*) (Rs.5831).

JOHN G. B. McDONALD,
Commissioner of Crown Lands and Survey.

PROPOSED REVOCATIONS OF TEMPORARY RESERVATIONS OF LANDS BY ORDERS IN COUNCIL.

IN pursuance of the provisions of the *Land Act 1928*, notice is hereby given that it is the intention of the Governor in Council to revoke the temporary reservations of lands by Orders in Council hereunder referred to, viz.:—

The following Notices were published 1° on the 14th July, 1948, pursuant to Orders of the 6th July, 1948.

BRUNSWICK.—The temporary reservation by Order in Council of the 10th August, 1874, of 1 rood 11 perches, more or less, of land in the Borough of Brunswick, as a site for Watering purposes and the Supply of Sand is about to be revoked.—(J.16(*) (Rs.6086)).

PORTARLINGTON.—The temporary reservation as a site for a Market and the withholding from sale, leasing, and licensing by Order in Council of the 5th January, 1880, of 1 acre of land in the Town of Portarlington, revoked as to part by Order of the 5th September, 1887, is about to be further revoked as regards the balance thereof containing 3 roods 8 perches.—(P.37(*) (C.91277)).

JOHN G. B. McDONALD,
Commissioner of Crown Lands and Survey.

PROPOSED REVOCATIONS OF TEMPORARY RESERVATIONS OF LANDS BY ORDERS IN COUNCIL.

IN pursuance of the provisions of the *Land Act 1928*, notice is hereby given that it is the intention of the Governor in Council to revoke the temporary reservations of lands by Orders in Council hereunder referred to, viz.:—

The following Notices were published 1° on the 4th August, 1948, pursuant to Orders of the 26th July, 1948.

GORAE.—The temporary reservation, by Order in Council of the 8th May, 1888, of 46 acres 3 roods 38 perches of land in the Parish of Gorae, as a site for Watering purposes, revoked as to part by various Orders, is about to be further revoked as regards the balance thereof, containing 43 acres 2 roods 22 3/10 perches.—(G.210(*) (Rs. 5145)).

WARRACKNABEAL.—The temporary reservation by Order in Council of the 10th November, 1927, of 1 rood 12 perches of land in the Town of Warracknabeal, as a site for Public purposes, is about to be revoked.—(W.293(*) (Rs.3568)).

JOHN G. B. McDONALD,
Commissioner of Crown Lands and Survey.

TENDERS.

TENDERS will be received at this office until **TEN A.M.** on the days and for the purposes under mentioned.

Particulars may be learnt at this office, and also at the offices named in each instance.

The Board of Land and Works will not necessarily accept the lowest or any tender.

10th August, 1948.

Allansford.—Provision of new septic tank system, Police Station. Particulars at Inspector of Works Office, Warranbool; Police Station, Allansford. Deposit, £4.

Ballarat.—Enclosing verandahs and provision of fly-wire screens and doors to Ward F.10, Mental Hospital. Particulars at Inspector of Works Office, Ballarat; Mental Hospital, Ballarat. Preliminary deposit, £15. Final deposit, 2 per cent.

Blackburn.—Replacements to fencing, State School No. 2923. Particulars at State School, Blackburn. Preliminary deposit, £5. Final deposit, 2 per cent.

Brim East.—Remodelling, repairs, and painting to residence, laundry, &c., State School No. 3733. Particulars at Inspector of Works Office, Horsham; Police Stations, Hopetoun, Nhill, Warracknabeal; State School, Brim East. Preliminary deposit, £10. Final deposit, 2 per cent.

Buffalo.—Repairs, renewals, and painting, State School No. 3240. Particulars at Inspector of Works Office, Korumburra; Police Stations, Leongatha, Yarram; State School, Buffalo. Preliminary deposit, £5. Final deposit, 2 per cent.

Darnum.—Repairs and painting to school and painting to residence, State School No. 2319. Particulars at Inspector of Works Office, Bairnsdale; Police Stations, Trafalgar, Warragul; State School, Darnum. Preliminary deposit, £10. Final deposit, 2 per cent.

Diamond Creek.—Painting and repairs, State School No. 1003. Particulars at Police Station, Eltham; State School, Diamond Creek. Deposit, £5.

Dooen.—Supply of one (1) 20 kw. D.C. Diesel generating set, Longerenong Agricultural College. Preliminary deposit, £10. Final deposit, 2 per cent.

Ferny Creek.—Renovations and erection of sleep-out, State School No. 3228. Particulars at Police Station, Ferntree Gully; State School, Ferny Creek. Preliminary deposit, £5. Final deposit, 2 per cent.

Foster.—Conversion of R.A.A.F. hut (80 feet) into classrooms, Higher Elementary School No. 1172. Particulars at Inspector of Works Office, Korumburra; Police Stations, Leongatha, Toora; Higher Elementary School, Foster. Preliminary deposit, £10. Final deposit, 2 per cent.

Geelong North.—Erection of new Police Station and residence, Police Station. Particulars at Inspectors of Works Offices, Ballarat, Geelong. Preliminary deposit, £25. Final deposit, 2 per cent.

Glenferrie.—Supply and installation of fume hood duct-work, New Chemistry School, Swinburne Technical School. Preliminary deposit, £4. Final deposit, 2 per cent.

Glenloch Estate (near Wycheproof).—Erection of six (6) timber residences, Soldier Settlement Commission. Particulars at Inspectors of Works Offices, Bendigo, Swan Hill; Police Stations, Charlton, Inglewood, Wycheproof. Preliminary deposit, £50. Final deposit, 2 per cent.

Gravel Hill.—Conversion of Army hut into two (2) classrooms, State School No. 1566. Particulars at Inspectors of Works Offices, Bendigo, Shepparton. Preliminary deposit, £10. Final deposit, 2 per cent.

Hughesdale.—Erection of glasshouse, State Schools' Nursery No. 4214, Poath-road. Preliminary deposit, £15. Final deposit, 2 per cent.

Katamatite.—Erection of new Police Station. Particulars at Inspectors of Works Offices, Benalla, Wangaratta; Police Stations, Euroa, Katamatite. Preliminary deposit, £20. Final deposit, 2 per cent.

Kialla West.—Repairs, remodelling, and painting, school and residence, State School No. 1727. Particulars at Inspector of Works Office, Shepparton; Police Stations, Echuca, Elmore, Kyabram; State School, Kialla West. Preliminary deposit, £5. Final deposit, 2 per cent.

Korrine.—Erection of new teacher's residence and out-buildings, State School No. 4558. Particulars at Inspector of Works Office, Korumburra; Police Stations, Leongatha, Wonthaggi; State School, Korrine. Preliminary deposit, £15. Final deposit, 2 per cent.

Lake Boga.—Alterations, repairs, and painting, State School No. 3278. Particulars at Inspector of Works Office, Swan Hill; Police Stations, Kerang, Pyramid Hill; State School, Lake Boga. Preliminary deposit, £10. Final deposit, 2 per cent.

Manangatang.—Repairs and painting and renewal of fencing, residence, State School No. 3863. Particulars at Inspectors of Works Offices, Bendigo, Swan Hill; Police Station, Sea Lake; State School, Manangatang. Preliminary deposit, £5. Final deposit, 2 per cent.

Marysville.—Repairs and renovations, Police Station. Particulars at Police Stations, Healesville, Lilydale, Marysville. Deposit, £4.

Melbourne.—Ventilation of garage, Transport Branch, Police Headquarters, Russell-street. Preliminary deposit, £5. Final deposit, 2 per cent.

Mildura.—Installation of electric light and power, Girls' Hostel, High School. Particulars at Inspector of Works Office, Mildura; Police Station, Red Cliffs. Preliminary deposit, £4. Final deposit, 2 per cent.

Mildura.—Supply and installation of fuel hot-water service, Girls' Hostel, High School. Particulars at Inspector of Works Office, Mildura. Preliminary deposit, £4. Final deposit, 2 per cent.

Mont Park.—Supply and installation of ventilation system in Staff Kitchen, Chronic Block, Mental Hospital. Preliminary deposit, £5. Final deposit, 2 per cent.

Murtoa.—Repairs and renovations to residence, erection of new "A" type office, Police Station. Particulars at Inspector of Works Office, Horsham; Police Stations, Murtoa, Nhill, Stawell. Preliminary deposit, £15. Final deposit, 2 per cent.

Nar-nar-goon South.—Extension of school, State School No. 4554. Particulars at Police Stations, Dandenong, Warragul; State School, Nar-nar-goon South. Deposit, £4.

Orbost.—Electrical installation, Higher Elementary School No. 2744. Particulars at Inspector of Works Office, Bairnsdale; Police Station, Orbost. Preliminary deposit, £5. Final deposit, 2 per cent.

Tongala East.—Repairs and painting, residence, State School No. 1851. Particulars at Inspector of Works Office, Shepparton; Police Station, Echuca; State School, Tongala East. Deposit, £3.

Trafalgar East.—Repairs to chimney, new floor, &c., State School No. 3499. Particulars at Inspector of Works Office, Bairnsdale; Police Station, Moe; State School, Trafalgar East. Preliminary deposit, £3. Final deposit, 2 per cent.

Whittlesea.—Alterations, repairs, painting, &c., State School No. 2090. Particulars at State School, Whittlesea. Preliminary deposit, £4. Final deposit, 2 per cent.

Yallourn.—Conversion of army hut (60 feet long) into No. 2 classrooms, High School. Particulars at Inspector of Works Office, Bairnsdale; Police Stations, Moe, Traralgon; High School, Yallourn. Preliminary deposit, £10. Final deposit, 2 per cent.

17th August, 1948.

Albion.—Additions, general repairs, and painting, State School No. 4265. Particulars at State School, Albion. Preliminary deposit, £10. Final deposit, 2 per cent.

Ashburton.—Conversion of hutment to classrooms, State School No. 4317. Particulars at State School, Ashburton. Preliminary deposit, £10. Final deposit, 2 per cent.

Balwyn.—Internal renovations to main buildings, external repairs and painting to main buildings, shelter sheds, out-offices and fences, State School No. 1026. Preliminary deposit, £10. Final deposit, 2 per cent.

Benalla.—Erection of three (3) brick veneer residences, Country Roads Board. Particulars at Inspectors of Works Offices, Benalla, Wangaratta; Police Station, Euroa. Preliminary deposit, £25. Final deposit, 2 per cent.

Bendigo.—Conversion of Army hut to students' common rooms, Teachers' College. Particulars at Inspectors of Works Offices, Bendigo, Shepparton. Preliminary deposit, £10. Final deposit, 2 per cent.

Boisdale.—Erection of junior and infant wings, Consolidated School. Particulars at Inspector of Works Office, Bairnsdale; Police Stations, Maffra, Sale. Preliminary deposit, £25. Final deposit, 2 per cent. (Revised specification.)

Brighton.—Installation of fire service mains, Technical School. Preliminary deposit, £10. Final deposit, 2 per cent.

Buchan.—Repairs and renovations, Police Station. Particulars at Inspector of Works Office, Bairnsdale; Police Stations, Buchan, Orbost. Preliminary deposit, £4. Final deposit, 2 per cent.

Coburg North.—Internal renovations, State School No. 4543. Particulars at State School, Coburg North. Deposit, £4.

Coghill's Creek.—External painting and repairs, and erection of new laundry, &c., State School No. 1523. Particulars at Inspector of Works Office, Ballarat; Police Station, Clunes; State School, Coghill's Creek. Preliminary deposit, £5. Final deposit, 2 per cent.

Collingwood.—Supply and installation of ducting for buffing wheel exhaust systems, Reconstruction Training, Technical School. Preliminary deposit, £4. Final deposit, 2 per cent.

Cooriemungle.—Supply and installation of petrol motor-driven refrigerator, Prison Camp. Preliminary deposit, £5. Final deposit, 2 per cent.

Dunolly.—Repairs and renovations to residence and fencing, Police Station. Particulars at Inspector of Works Office, Maryborough; Police Stations, Dunolly, Donald, Inglewood, St. Arnaud. Deposit, £3.

Eltham.—Conversion of Army hut into classrooms, Higher Elementary School. Particulars at Higher Elementary School, Eltham. Preliminary deposit, £10. Final deposit, 2 per cent.

Emu.—Repairs, painting, and provision of new fly-wire screens, State School No. 2011. Particulars at Inspector of Works Office, Maryborough; Police Stations, Donald, St. Arnaud; State School, Emu. Deposit, £3.

Fish Creek.—Removal of State School No. 3220, Hoddle Range, and re-erection, State School No. 3028. Particulars at Inspector of Works Office, Korumburra; Police Stations, Foster, Leongatha; State School, Fish Creek. Preliminary deposit, £10. Final deposit, 2 per cent.

Hampton Park.—Repairs and painting, State School No. 4062. Particulars at Police Station, Dandenong; State School, Hampton Park. Preliminary deposit, £5. Final deposit, 2 per cent.

Harrow.—Provision of new sleep-out, new skylight, and repairs and painting, school and residence, State School No. 2049. Particulars at Inspectors of Works Offices,

Hamilton, Horsham; Police Stations, Nhill, Stawell; State School, Harrow. Preliminary deposit, £5. Final deposit, 2 per cent.

Ivanhoe East.—Adaptation of hutments, State School No. 4336. Preliminary deposit, £15. Final deposit, 2 per cent.

Island Road.—Alterations, repairs, and painting, State School No. 3952. Particulars at Police Stations, Dandenong, Koo-wee-rup; State School, Island Road. Preliminary deposit, £10. Final deposit, 2 per cent.

Kaniva.—Erection of new junior wing, Consolidated School. Particulars at Inspectors of Works Offices, Ararat, Ballarat, Horsham; Police Station, Nhill; Consolidated School, Kaniva. Preliminary deposit, £25. Final deposit, 2 per cent.

Kew.—Alterations to bathroom, &c., Ward B.I., Mental Hospital. Preliminary deposit, £10. Final deposit, 2 per cent.

Kew.—Erection of lavatory conveniences, Children's Cottages, Mental Hospital. Preliminary deposit, £5. Final deposit, 2 per cent.

Kew.—Renovations to lavatories, Mental Hospital. Preliminary deposit, £5. Final deposit, 2 per cent.

Little River.—Erection of new porch, repairs and painting, State School No. 1961. Particulars at Inspector of Works Office, Geelong; Police Station, Werribee; State School, Little River. Deposit, £2.

Longerenong.—Erection of new timber residence for Research Officer, Agricultural College. Particulars at Inspectors of Works Offices, Ararat, Horsham; Police Stations, Dimboola, Nhill, Stawell. Preliminary deposit, £15. Final deposit, 2 per cent.

Manangatang.—Alterations and additions, District Hospital. Particulars at Inspector of Works Office, Swan Hill; Police Stations, Kerang, Manangatang, Piangil. Preliminary deposit, £20. Final deposit, 2 per cent.

Melbourne.—Installation of electric light and power, Public Works Department's Garage, State Offices Annexe, 107 Russell-street. Preliminary deposit, £5. Final deposit, 2 per cent.

Melbourne.—Supply and installation of electric refrigerator, State Laboratories, Gisborne-street. Preliminary deposit, £3. Final deposit, 2 per cent.

North Geelong.—Repairs and renovations, State School No. 1889. Particulars at Inspector of Works Office, Geelong; State School, North Geelong. Preliminary deposit, £15. Final deposit, 2 per cent.

South Melbourne.—Erection of new timber-framed residence, Public Works Department Storeyard, Wells-street. Preliminary deposit, £15. Final deposit, 2 per cent.

Stawell.—Supply and delivery of electric mixer for Kitchen, Pleasant Creek Special School. Preliminary deposit, £5. Final deposit, 2 per cent.

Sunbury.—Supply and installation of electric meat mincer for Main Kitchen, Mental Hospital. Deposit, £3.

Sunbury.—Supply and installation of refrigeration equipment, Mental Hospital. Preliminary deposit, £15. Final deposit, 2 per cent.

Surrey Hills.—Repairs and painting to school and out-buildings, State School No. 2778. Particulars at State School, Surrey Hills. Preliminary deposit, £15. Final deposit, 2 per cent.

Swan Hill.—Supply and delivery and installation of domestic electric refrigerator, High School. Preliminary deposit, £2. Final deposit, 2 per cent.

Tawonga.—Erection and completion of teacher's residence, State School No. 2282. Particulars at Inspector of Works Office, Wangaratta; Police Stations, Myrtleford, Tallangatta; State School, Tawonga. Preliminary deposit, £15. Final deposit, 2 per cent.

Toora.—Painting residence roof, new spouting and fencing, State School No. 2253. Particulars at Inspector of Works Office, Korumburra; Police Stations, Foster, Meeniyah; State School, Toora. Deposit, £3.

Wesburn.—Installation of electric light and power, residence, State School No. 3466. Particulars at Police Stations, Warburton, Yarra Junction.

Westbreen.—Erection of new porch, State School No. 4158. Deposit, £3.

Yallock.—Fencing, State School No. 3420. Particulars at Police Station, Dandenong; State School, Yallock. Preliminary deposit, £3. Final deposit, 2 per cent.

24th August, 1948.

Chilwell.—Repairs, &c., State School No. 2061. Particulars at Inspector of Works Office, Geelong; State School, Chilwell. Preliminary deposit, £5. Final deposit, 2 per cent.

Christmas Hills.—Repairs and painting, State School No. 1362. Particulars at State School, Christmas Hills. Deposit, £4.

Heyfield.—Repairs and painting, &c., school and residence, State School No. 1108. Particulars at Inspector of Works Office, Bairnsdale; Police Stations, Maffra, Sale; State School, Heyfield. Preliminary deposit, £15. Final deposit, 2 per cent.

Kew.—Erection of nurses' hostel in timber, one building only, Mental Hospital. Preliminary deposit, £50. Final deposit, 2 per cent.

Kew.—Extensions to shelter shed, Children's Cottages, Mental Hospital. Preliminary deposit, £10. Final deposit, 2 per cent.

Kiewa Valley.—Erection of junior and infant wings, Consolidated School. Particulars at Inspectors of Works Offices, Benalla, Wangaratta; Police Station, Tallangatta. Preliminary deposit, £10. Final deposit, 2 per cent. (Sectional quotes—excavator, concreter, bricklayer.)

Kinglake West.—Erection and completion of new teacher's residence and out-buildings, State School No. 3255. Particulars at Police Stations, Broadford, Kilmore; State School, Kinglake West. Preliminary deposit, £15. Final deposit, 2 per cent.

Melbourne.—External and internal painting and repairs, Central Tuberculosis Bureau, 364-370 Little Lonsdale-street. Preliminary deposit, £10. Final deposit, 2 per cent.

Molyullah.—Repairs and painting, new brick chimney, concrete assembly area, new concrete path, State School No. 2130. Particulars at Inspectors of Works Offices, Benalla, Wangaratta; State School, Molyullah. Preliminary deposit, £5. Final deposit, 2 per cent.

Mont Park.—Extension to main store, Mental Hospital. Preliminary deposit, £15. Final deposit, 2 per cent.

Mornington.—Erection of brick veneer residence, Police Station. Particulars at Police Station, Mornington. Preliminary deposit, £15. Final deposit, 2 per cent.

Oakleigh.—Erection of brick veneer caretaker's residence, Technical School. Preliminary deposit, £20. Final deposit, 2 per cent.

Pakenham.—Erection of junior wing, Consolidated School. Preliminary deposit, £25. Final deposit, 2 per cent. (Amended Specification.)

Riverslea.—Repairs and painting, State School No. 3667. Particulars at Inspector of Works Office, Bairnsdale; Police Stations, Maffra, Sale; State School, Riverslea. Deposit, £4.

Rutherglen.—Erection of new timber residence for Research Officer, Research Station. Particulars at Inspectors of Works Offices, Benalla, Wangaratta; Police Station, Beechworth; Research Station, Rutherglen. Preliminary deposit, £15. Final deposit, 2 per cent.

Sunshine.—Erection of caretaker's quarters, Technical School. Preliminary deposit, £20. Final deposit, 2 per cent.

Swan Hill.—Remodelling old school building, State School No. 1142. Particulars at Inspector of Works Office, Swan Hill; Police Stations, Kerang, Sea Lake. Preliminary deposit, £10. Final deposit, 2 per cent.

Walhalla.—Repairs, painting to school and residence, State School No. 957. Particulars at Inspector of Works Office, Bairnsdale; Police Station, Moe; State School, Walhalla. Preliminary deposit, £4. Final deposit, 2 per cent.

Wangaratta.—Additional out-office accommodation for girls, High School. Particulars at Inspectors of Works Offices, Benalla, Wangaratta; High School, Wangaratta. Preliminary deposit, £5. Final deposit, 2 per cent.

Warrnambool.—Erection of a sleep-out to caretaker's quarters, State School No. 1743. Particulars at Inspector of Works Office, Warrnambool; State School, Warrnambool. Deposit, £3.

Tenders to be addressed to the Honorable the Commissioner of Public Works, and envelope containing tender marked "Tender for due".

J. A. KENNEDY,
Commissioner of Public Works.

Melbourne, 3rd. August, 1948.

TENDERS FOR THE RIGHT TO REMOVE SALT.

TENDERS will be received up to Noon on Tuesday, 24th August, 1948, for the exclusive right to collect and remove salt from the area described below for a period of one year from 1st September, 1948, renewable annually for four years from 1st September, 1949.

The successful tenderer will be required to preserve the bottom of the lake or lakes or collecting grounds from injury, in accordance with instructions from any officer authorized by the Minister of Lands.

No tender will be received unless the total amount of fee offered for the period as stated, and Ten shillings (10s.) fee for preparation of licence, are enclosed. The licence is subject to a royalty charge of Two shillings (2s.) per ton on all salt collected or removed. Sworn declarations must be furnished to the Secretary for Lands by the licensee when required, setting out the quantity removed.

Plans of all buildings or other structures proposed to be erected on the licensed area must be submitted to and approved of by the Secretary for Lands, who reserves the right of entry for inspection by any officer authorized by him.

The licensee shall not assign, sublet, or part with his interest in the area, or any portion thereof, without the consent of the Minister of Lands.

The licence will be cancelled for non-payment of any annual fees or any royalty charges or breach of any conditions thereof, or if the licensee shall, for a period of twelve (12) months, fail to use the land bona fide for the purposes for which a licence has been issued.

The Governor in Council reserves the right to resume the area, or any part thereof, for public purposes.

Tenderers must forward full name and address and fee for the right to remove salt for the period and fee for the preparation of licence (10s.) to Secretary for Lands, Treasury Buildings, Melbourne, C.2, endorsed "Tender for the right to remove salt."

Plans may be seen and all information obtained at Lands Department, Melbourne.

The highest or any tender not necessarily accepted.

JOHN G. B. McDONALD,
Commissioner of Crown Lands and Survey.
Office of Lands and Survey,
Melbourne, 2nd August, 1948.

Description of Area.—29 acres, known as "Little Lake," being allotments 1 to 7 inclusive, section 3A, Parish of Benjeroop. Formerly licensed to T. A. Bowden. Period of occupation, one year from 1st September, 1948, with a right of renewal annually for four years from 1st September, 1949.

PRIVATE ADVERTISEMENTS.

CITY OF FOOTSCRAY.

BY-LAW No. 129.

A By-law of the City of Footscray, numbered 129, made under section 197 of the *Local Government Act 1946*, for prescribing areas within municipal district as residential areas, and prohibiting or regulating within the whole of the such residential areas the use of any land or the erection (including adaptation for use) or the use of any building or vacant land for the purposes of trades, industries, manufactures, businesses, or public amusements.

IN pursuance of the powers conferred by the *Local Government Act* and of every power it thereunder enabling, the Mayor, Councillors, and Citizens of the City of Footscray, with the approval of the Governor in Council, order as follows:—

(1) From and after the coming into operation of this By-law the provisions of clause 2 (a) of By-law No. 74 shall not apply to the following streets, or portions thereof, mentioned in Schedule "B" of the said By-law:—

Anderson-street, north side, from Williamstown-road to Fehon-street; south side, from Williamstown-road to Fehon-street.

Albert-road (now Essex-street), north side, from Summerhill-road to Gordon-street; south side, from Summerhill-road to Gordon-street.

Ballarat-road, north side, from Maddock to Wearing streets; south side, from Coral-avenue to Eleanor-street; south side, from 85 ft. 6 in. east of Gordon-street to Commercial-road.

Barkly-street, north side, from Ashley to Palmerston streets; north side, from Summerhill-road to Gordon-street; south side, from Ashley to First streets; south side, from Clarke-street to Warleigh-road; south side, from Hocking to Batman streets.

Droop-street, north-east side, from Geelong-road to a point opposite the building line of the south-east side of Hugh-street.

Gamon-street, east side, from Somerville-road to a point opposite the north building line of Little Smith-street; west side, from Station-road to Hood-street.

Gordon-street, west side, from Naismith to Barkly streets.

Shepherd-street, north side, from Gordon to Creswick streets; south side, from Gordon to Creswick streets.

Somerville-road, north side, from Williamstown-road to Hamilton-street; south side, from Fehon to Birmingham streets.

Summerhill-road, west side, from Essex-street north for 4 chains.

Sunbury-road (now Sunshine-road), from Aliwal to Cala streets.

Victoria-street, west side, from Barkly-street to the railway; east side, from Paisley to Pickett streets.

Williamstown-road, east side, from Pilgrim to Charles streets; east side, from Somerville-road to 193 feet north of Francis-street; east side, from Stone to Thomas streets.

(2) In so far as the said clause 2 (a) of By-law No. 74 is inconsistent with or repugnant to this By-law, it is hereby expressly repealed.

(3) This By-law shall not preclude the continuance of the use of any land or any building for the purpose of any trade, industry, manufacture, business, or public amusement where the same was used for any of the said purposes (whether of the same character or not) immediately before the coming into operation of this By-law, or the enlargement, rebuilding, or extension of any building used for any such purpose, whether or not such enlargement, rebuilding, or extension involves the use of any adjoining land which, immediately before the coming into operation of this By-law, was in the same ownership.

Resolution for passing this By-law agreed to by the Council of the City of Footscray on the 19th day of April, 1948, and confirmed on the 24th day of May, 1948.

The common seal of the Mayor, Councillors, and Citizens of the City of Footscray was hereunto affixed, in our presence, by order of the Council—

A. ROY McNAB, Mayor.
(SEAL) G. R. SCHINTLER, Councillor.
E. J. SMITH, Town Clerk.

Approved by the Governor in Council, 13th July, 1948.—
C. W. KINSMAN, Clerk of the Executive Council. 5295

Local Government Act 1946.

CITY OF HEIDELBERG.

NOTICE TO ALL WHOM IT MAY CONCERN.

WHEREAS the Council of the municipality of the City of Heidelberg, in the State of Victoria, deems it expedient to execute a certain work or undertaking for the purpose of widening Kitchener-street, and the creation and extension of Oriel-road from Bond-street to Ford-street, for the purposes whereof it is in the opinion of the said Council necessary and desirable that the said Council exercise its power of taking land compulsorily within the municipal district of the said Council, as provided by the *Local Government Act 1946*, and the said Council has caused its surveyor to prepare such specifications, maps, plans, sections, and elevations of the said work or undertaking as are necessary, and in which are expressed the nature and extent of such work or undertaking, and the exact site and admeasurements thereof, and on and through what land the said work or undertaking is proposed to be placed, and the names of the owners or reputed owners, lessees or reputed lessees, and the occupiers of such land so proposed to be taken so far as known, and the said specifications, maps, plans, sections, and elevations so prepared have been approved by the said Council.

In pursuance of the provisions of the *Local Government Act 1946*, the said Council doth hereby publish and give notice that the description shortly of the purport of the said work or undertaking, and of the said specifications, maps, plans, sections, and elevations is as follows:—

The widening of Kitchener-street and the creation and extension of Oriel-road from Bond-street to Ford-street.

And the said Council doth hereby give further notice that the said specifications, maps, plans, sections, and elevations are deposited at the office of the said Council, Town Hall, Upper Heidelberg-road, Ivanhoe, and are there open for inspection and perusal on all the days and between the hours the municipal office is appointed to be open, for the space of 40 clear days from the date of the publication of this notice in the *Government Gazette*. And the said Council doth hereby call upon all persons interested in or affected by the said proposed work or undertaking to set forth, in writing, addressed to the said Council or the Town Clerk thereof, at the Town Hall, Upper Heidelberg-road, Ivanhoe, within 40 clear days from the date of the publication of this notice as aforesaid all objections which they may have to the said work or undertaking.

Dated this 30th day of July, 1948.

The common seal of the Mayor, Councillors, and Citizens of the City of Heidelberg was hereto affixed by me—

F. PHILLIPS, Town Clerk,

in the presence of—

(SEAL) A. F. NUTTALL, Mayor.
W. C. ELWERS, Councillor.

5305

CITY OF MORDIALLOC.

BY-LAW No. 88.

Building Regulations.

A By-law of the City of Mordialloc (hereinafter referred to as the municipality), made under section 198 of the *Local Government Act 1946* and Part V. of the Fifteenth Schedule to the *Local Government Act 1946*, with the approval of the Governor in Council, and numbered No. 88, for regulating the erection of buildings, tents, hoardings, &c., and of fences abutting on or within 10 feet of any street or road, and certain other purposes provided for in the said section and Part.

IN pursuance of the powers conferred by the *Local Government Acts* and any other Act, the Mayor, Councillors, and Citizens of the City of Mordialloc order as follows:—

PART 1.

1. This By-law shall have force and effect throughout the whole of the municipality.

2. This By-law shall come into operation on its confirmation by the Governor in Council, and immediately after its publication in the *Victoria Government Gazette*.

3. From and after the date of this By-law coming into operation, By-laws 60, 66, 74, 76, and 81 of the City of Mordialloc shall be and the same are hereby repealed.

PART 2.

AREAS, FRONTAGES, SITES, DRAINAGE, ETC.

Dwelling-houses.

1. No dwelling-house shall hereafter be erected or built unless such dwelling-house has for its whole width a clear frontage to a street at least 50 feet wide, and no dwelling-house intended for separate use and occupation shall be built so as to deprive and leave without a clear frontage any dwelling-house which shall have previously been built.

2. No dwelling-house shall consist of a total area of less than 600 square feet.

Tents, Bungalows, and Sleep-outs.

3. No tent, bungalow, sleep-out, or detached room shall be erected on any allotment on which there is less than 3,000 square feet of space, exclusive of buildings, and not more than one tent, bungalow, or detached room for every 1,000 square feet of space in excess of 3,000 square feet, nor more than two such buildings in all, provided that no tent, bungalow, sleep-out, or detached room shall be erected on any allotment where such building, if erected, would reduce the area of such allotment, exclusive of buildings, to less than 50 per cent. of the total area thereof, and every tent, bungalow, or sleep-out divided into two rooms shall be classed as two structures when interpreting this clause.

4. No bungalow or sleep-out shall be erected closer to the street alignment than the house to which it is appurtenant.

5. No bungalow or sleep-out shall exceed 150 square feet in area.

6. No tent, bungalow, sleep-out, or detached room erected in pursuance of the provisions of this By-law shall be leased or sub-leased, except in conjunction with the dwelling-house erected on the same allotment, and shall not be used save for the accommodation of an inmate or inmates of the household of the occupier of such dwelling-house.

Fowl-houses.

7. Fowl-houses with a superficial area exceeding 100 square feet are only permitted in the areas described in Schedule III. of By-law No. 84.

Prevention of Water Falling on to Public Way.

8. Roofs and gutters and flashings of any building or erection, and of any projection therefrom, and also balconies, verandahs, and shop front, must be so arranged and constructed and supplied with gutters and pipes which must be maintained so as to prevent the water therefrom dropping or running over any public way.

Drainage to be Satisfactory.

9. The Council may refuse permission to build or erect any building, erection, or tent, or addition, unless and until it is satisfied that the proposed building, erection, or tent, or addition, and the site and curtilage thereof, can be properly drained.

PART 3.

REMOVED BUILDINGS.

1. In this clause the word "building" means wooden building, and includes any erection.

Removed Buildings to Comply with By-laws.

(a) No person shall remove or cause to be removed into the City of Mordialloc, or from any one part of the city to another part of the same, and erect and permit to remain for any longer period than seven days, any building which does not comply with the provisions of the by-laws and regulations of the said city.

Notice to be Given and Permit to be Obtained.

(b) Before any building intended to be so erected is removed into the city, or from one part of the city to another part, the owner or the person carrying out the removal shall give to the surveyor not less than ten clear days' notice, in writing, of his intention to remove and re-erect such building in the city, and shall accompany such notice supply the following particulars:—

- (1) Particulars of situation of building;
- (2) Particulars of situation of land;
- (3) Plan of dimensions;
- (4) A specification, &c.;
- (5) Further particulars;

and shall at the same time produce to the surveyor such information as will enable him to satisfy himself whether or not such building has been condemned as dilapidated, insanitary, or unfit for human habitation. On receipt of such notice, plans, specifications, particulars, and information, and the proper fee, the surveyor shall inspect such building before removal, and shall report to the Council whether, in his opinion, such building, when removed and re-erected, will be in compliance with the by-laws and regulations of the city or not. If the surveyor reports that such building, when removed and re-erected, will be in accordance with the by-laws and regulations, then the Council shall grant a permit for its removal and re-erection in the city, but not otherwise.

Condemned Buildings.

(c) No building that has been condemned as dilapidated, insanitary, or unfit for human habitation shall be removed and re-erected within the city, unless the requirements of sub-section (d) be complied with.

Infectious Disease and Fumigation.

(d) No building in which any case of infectious or contagious disease has occurred, and which is intended to be wholly or partly used as a dwelling-house, shall be removed into and erected within the city, or removed from one part of the city to another, unless the same shall have been thoroughly fumigated and disinfected to the satisfaction of a duly-qualified medical practitioner or of the health inspector of any municipal council, as testified by a certificate signed by either or both such authorities and produced to and retained by the surveyor.

No Permit until Building is Made to Comply with By-law.

2. No written permission shall be given unless such removed building, when erected or re-erected, shall comply with the provisions of this By-law, as applicable to new buildings.

Certificate of Surveyor.

3. No removed building shall be occupied until the surveyor shall have certified, in writing, that all the provisions of this By-law have been observed and complied with in respect of such building.

Alteration of Position of Building on Same Allotment

4. Nothing herein contained shall prevent the alteration of the position of any building within the boundaries of the land on which the same stands, provided that in its altered position it shall comply in all respects with this By-law.

PART 4.

VERANDAHS, PROJECTIONS, SIGNS, HOARDINGS, AND FENCES.

Verandahs.

1. Every verandah of all new brick buildings constructed over the footway of any street shall be of the cantilever type prescribed by the Uniform Building Regulations.

Hoardings, &c.

2. No hoardings shall be erected on land fronting to or abutting on the north side of Beach-road, from Cromer-road to Main-street, by a depth of 150 feet, nor on land fronting to or abutting on both sides of Nepean-highway, from Oak-avenue and Latrobe-street to the Mordialloc Creek Bridge, by a depth of 150 feet.

Hoardings, Signs.

3. Save as hereinafter provided, no person shall alter or add to any hoarding, signboard, or erection for advertising purposes without first obtaining the consent of the Council, and unless such hoarding, signboard, or erection is erected, built or constructed, altered or added to in accordance with the plan and specification prepared by such person, and previously approved of by the Council.

4. No hoarding, signboard, or erection shall be within a distance from the building line of any street or road equal to the greatest height of such hoarding, signboard, or erection, and the lowest part of such hoarding, other than the main supports thereof, shall not be less than 3 feet from the level of the land.

5. No hoarding shall exceed 20 feet in height.

6. No hoarding shall be erected over any building or in front of any dwelling-house.

Signboard, Hanging Lamp, &c.

7. No signboard, hanging lamp, or similar fixture shall be erected on or attached to any building or verandah, unless the permission, in writing, of the Council be first obtained. Each signboard, hanging lamp, or similar fixture shall be of material, construction, and design approved by the surveyor, and shall be in no part less than 8 ft. 6 in. above the level of the footpath. No signboard shall exceed in depth 3 feet nor, unless attached to a verandah, project over the footpath.

Sign as Disfigurement to.

8. No person shall exhibit any advertisements in any place in such manner or by such means as to affect injuriously the amenities of a public park or pleasure promenade, or disfigure the natural beauty of any landscape, within the municipal district of Mordialloc.

Fences.

9. No paling fences and no close fence of iron or other material exceeding 4 feet in height above the footpath level shall be erected abutting on or within 10 feet of any street or road, except that in the case of a corner allotment this clause shall apply only to the fence abutting on one of the streets and the first 30 feet of the other fence, measured from the intersection of the building lines of the two streets.

Unightly or Dangerous Fence.

10. When any fence abutting on or within 10 feet of any street or road within the municipal district is in a dangerous or unsightly state, the Council may, by notice, in writing, to be served on the owner of such fence, require such owner forthwith to take down, secure, or repair such fence, as the case may require.

Every Fence to Have a Plinth.

11. Every fence to be hereafter erected abutting on or within 10 feet of any street or road shall have affixed thereto a suitable base or plinth.

PART 5.

ENFORCEMENT OF BY-LAW AND PENALTIES.

The provisions of Chapter 3 of the Uniform Building Regulations relating to the penalties and enforcement of the regulations shall extend and apply to this By-law, and have full force and effect as if such provisions were specifically contained in this By-law.

A Resolution adopting the foregoing By-law was passed by the Council of the City of Mordialloc on the 8th day of March, 1948, and confirmed on the 15th day of June, 1948.

The common seal of the City of Mordialloc was heretofore affixed on the 15th day of June, 1948, in the presence of—

(SEAL.) H. PEARCE, Mayor.
J. McCULLY, Councillor.
E. C. OWBRIDGE, Town Clerk.

Approved by the Governor in Council, the 20th day of July, 1948.—C. W. KINSMAN, Clerk of the Executive Council. 5284

CITY OF RICHMOND.

BY-LAW No. 140.

A By-law of the City of Richmond, made under the Health Acts, and numbered 140, for or with respect to—

- (a) Management of the city abattoirs.
- (b) Prescribing the conditions on which animals may be received into or supplied or removed from abattoirs.
- (c) requiring persons engaged in tending and slaughtering animals and in dressing carcasses at abattoirs to be licensed and prescribing the conditions of licence.
- (d) Fixing the rates of fees or dues payable to the abattoirs.
- (e) Prescribing the times for slaughtering animals at the abattoirs.
- (f) The feeding, watering, and tending and the preventing of cruelty to and overcrowding of animals in abattoirs, and the milking of milch animals at abattoirs.

THE Mayor, Councillors, and Citizens of the City of Richmond, in pursuance of the powers conferred by the Health Acts and of every other Act or power enabling it on that behalf, doth hereby make the By-law and order as follows:—

By-laws Repealed.

1. The By-laws set out in the First Schedule of this By-law to the extent to which the same are thereby expressed to be repealed are hereby repealed. Provided that notwithstanding such repeal all matters and things of a continuing nature existing at the coming into operation of this By-law by virtue of or under any of such repealed By-laws shall so far as their continuance is not inconsistent with this By-law be deemed to continue and to have full force and effect as if such first-mentioned By-laws had not been repealed, and such repeal shall not affect any prosecution in respect of any offence under any of such repealed By-laws.

2. In this By-law, unless inconsistent with the context or subject matter—

Abattoirs Site.

"Abattoirs" means the site for abattoirs and general municipal purposes at Richmond permanently reserved by Order of 30th June, 1890, published in the *Victoria Government Gazette* on 4th July, 1890 (being the site temporarily reserved therefor by Order of the 13th May, 1890), together with all buildings and structures thereon, and appurtenances thereto and more particularly described as follows:—

Seven acres one rood and thirty-eight perches, County of Bourke, City of Richmond, being part of section 40:—Commencing at the intersection of the west side of Burnley-street and the north side of Berlin-street bounded thence by the last-mentioned street bearing N. 89 deg. 22 min. W. 10 chains 1 5/10 links; thence by allotments 3 and 4, and a line bearing north 7 chains 43 links; thence by a line and allotment bearing south 89 deg. 52 min. E. 10 chains 1 5/10 links; and thence by Burnley-street aforesaid bearing south 7 chains 52 links to the point of commencement. (Berlin-street name changed to Barkly-avenue by Council on 13th March, 1916, and published in *Government Gazette* of 22nd March, 1916.)

Definitions.

"Animal" means bull, ox, steer, cow, heifer, calf, ram, ewe, lamb, goat, kid, or swine.

"Acts" means the Health Acts and Regulations made thereunder.

"City" means the City of Richmond.

"Council" means the Council of the City of Richmond.

"Superintendent" means the Meat Inspector or any Assistant Meat Inspectors for the time being appointed by the Council for the enforcement of the Health Act, and the Regulations and By-laws made thereunder for the Council and management of the Abattoirs.

Superintendence.

3. The Abattoirs shall be under the charge, care, management, and direction of a Superintendent, with such assistants as the Council may appoint for that purpose.

Superintendent's Duties.

4. Along with such other duties as the Council shall assign to the Superintendent it shall be specially his duty to carry out and enforce the Regulations of the Council for the management of the Abattoirs as to cleanliness and otherwise.

Assistant Superintendent.

5. During absence of the Superintendent his duties shall devolve upon and be performed by the Assistant or other person in the service of the Council then in charge of the Abattoirs, and such Assistant or person shall for the time being have all the power, authority, and duty of the Superintendent.

Hours Abattoirs Open.

6. The Abattoirs shall be open for the slaughtering of animals on week days (Mondays to Fridays inc.) from 7.30 a.m. to 4.30 p.m. and at such other times as permitted by the Council or the Superintendent, provided, however, that the Abattoirs shall not be open on Good Friday, Easter Saturday, Easter Monday, Christmas Day, Boxing Day, New Year's Day, Anzac Day, Eight Hours Day, or on such other public holidays as may be determined by the Council.

Payment of Fee for Use of Abattoirs.

7. Every person who shall pay the fees and dues hereinafter referred to shall be entitled to use such portion of the Abattoirs as are assigned to him by the Superintendent, and such portion of the Abattoirs shall only be used over the period and for the purpose for which it was assigned.

8. The following fees and dues shall be payable to the Council for the use of the Abattoirs or portion thereof:—

Amount of Fees.—Slaughtering.

- (a) For slaughtering any—
 - (i) Bull, cow, heifer, ox, or steer 2/- per head
 - (ii) Goat, kid, lamb, or sheep 2½d. per head
 - (iii) Swine 9d. per head
 - (iv) Calf of a weight not exceeding 130 lb. 6d. per head
 - (v) Calf of a weight over 130 lb. and not exceeding 200 lb. 1/3 per head

Examining and Branding.

- (b) For examining and branding any carcass of or meat derived from any—
 - (i) Bull, cow, heifer, ox, or steer 6d. per head
 - (ii) Goat, kid, lamb, or sheep ½d. per head
 - (iii) Swine 3d. per head
 - (iv) Calf of a weight not exceeding 130 lb. 3d. per head
 - (v) Calf of a weight over 130 lb. and not exceeding 200 lb. 3d. per head

Certificate.

- (c) For any certificate as to an examination made by the Superintendent or Meat Inspector of any animal 2/6

Council to have Lien and may take over and Sell Animals Under Certain Conditions.

9. The Council shall have a lien on all animals for the time being in the Abattoirs of any person indebted to the Council and if any person after demand shall make default for seven days in payment of any of the fees and dues herein prescribed, the Council may by its

authorized officers and without further notice sell by public auction or private contract all or any of such animals, and after deducting the fees and dues payable to the Council pay the surplus thereof to the owners of such animals.

Number and Description of Animals Brought to Abattoirs to be Supplied to Superintendent.

10. Every person who shall bring any animals to the Abattoirs shall forthwith inform the Superintendent of the number and description thereof and all other details required by or under any Act of Parliament or Regulations made thereunder or by the Commission of Public Health or the Council, and the Superintendent shall forthwith record such information in a book to be kept at the Abattoirs for that purpose.

11. The owner or every person who shall bring any animals to the Abattoirs shall—

Animals to be Placed in Such Part of Abattoirs as Directed by Superintendent.

(a) Place such animals in the portion or portions of the Abattoirs as directed by the Superintendent and not otherwise, and not place a greater number of animals in any such portion or portions of the Abattoirs than the Superintendent allows.

Sufficient Food and Water to be Provided.

(b) Provide the same with sufficient food and water and provide that all milch animals shall be duly milked.

Notice of Intention to Slaughter to be given Superintendent.

(c) Before commencing to slaughter the same, give notice of his intention so to do to the Superintendent.

12. No person shall—

Animals Not to be Ill-treated.

(a) Ill-treat, frighten, or irritate any animals or resort to unnecessary cruelty in slaughtering any animals at the Abattoirs.

Animals Not to be Removed Without Consent.

(b) Remove any animals from the Abattoirs without the consent of the Superintendent being first had and obtained.

Animals not to be in Abattoirs for more than 96 Hours.

(c) Leave any animals in the Abattoirs for a longer period than 96 hours except with special permission in writing from the Superintendent.

Persons Tending or Slaughtering to be Licensed.

13. Any person who proposes to engage in tending and slaughtering animals or dressing carcasses at the Abattoirs shall make application to the Superintendent for a licence to tend or slaughter animals or to dress carcasses therein as the case may require.

Application for a Licence must be a Master Butcher or Experienced Slaughterman.

Every applicant for a licence must satisfy the Superintendent that he is a Master Butcher or that he is an experienced slaughterman, and with his application shall sign an undertaking to observe, obey, and comply with the Health Acts and the Regulations and By-laws made thereunder. The Superintendent may in his discretion grant or refuse to grant such licence. The name, residential address, and the place of business (if any) of every person to whom a licence is granted by the Superintendent shall be entered in the Register of Slaughtermen, and such register shall be kept by the Superintendent. The Superintendent may remove the name of any person from the Register of Slaughtermen upon breach by such person, of any requirements of the said Acts, Regulations, or By-laws.

Unregistered Persons not Permitted to Slaughter.

14. No person shall be permitted to engage in tending or slaughtering animals or in dressing carcasses unless his name shall be entered in the Register of Slaughtermen to be kept by the Superintendent, and he shall have signed an undertaking to observe, comply with, and obey each and every of the rules of the establishment under pain (apart from any other penalty) of having his name expunged from the Register of Slaughtermen.

Person Responsible for the Observance of the Acts.

15. In every compartment of the Abattoirs in which slaughtering shall be carried on one of the slaughtermen shall be especially responsible for the observance of the Acts, the By-laws, and Regulations of the Abattoirs in such compartment. If the master butcher or employer be

working in the compartment he shall be the responsible person, and if not he must nominate and appoint one of the other slaughtermen who is to be responsible, and must notify such appointment to the Superintendent. Such appointment, however, shall not absolve any other slaughterman from the consequences of wilful disregard or breach of the Acts, the By-laws, or the Regulations.

Discovery of Diseased Animal to be Reported to Superintendent.

16. Immediately any animal slaughtered is discovered to be diseased the slaughterman responsible under the preceding section hereof shall immediately stop the work of dressing such animal for food, and forthwith report the fact to the Superintendent, and shall not proceed further with such dressing unless and until authorized by the Superintendent so to do.

Animals known to be Affected with Disease not to be Taken into Abattoirs.

17. No animals visibly or known to be affected with any infectious or contagious disease shall be taken or received into the Abattoirs.

Council Not Responsible for Injury to Animals.

18. (a) The Council will take all reasonable care of animals brought into the Abattoirs for slaughter, but will not be responsible for any injury to or for the death or escape of any such animal.

Council Not Responsible for Loss or Damage to Carcasses.

(b) The Council will take all reasonable care of carcasses while in the Abattoirs, but will not be responsible for any loss thereof or damage thereto.

19. No slaughterman or person licensed or authorized to tend or slaughter animals or to dress carcasses shall—

Intoxicating Liquor.

(a) Bring any intoxicating liquor into the Abattoirs or enter or remain therein whilst in a state of intoxication.

Unseemly Conduct.

(b) Behave in an unseemly, improper, indecent, or offensive manner, or use any profane, indecent, or offensive language in the Abattoirs.

Injury to Fittings.

(c) Carelessly or negligently break, injure, or improperly interfere with any portion of the Abattoirs or fittings, conveniences, or equipment therein.

Obstructing Employees.

(d) Obstruct, hinder, or interfere with any person employed in the Abattoirs, or disturb, interrupt, or annoy any other person in the proper use thereof.

Smoking.

(e) Smoke whilst slaughtering animals dressing carcasses or handling meat.

Direction of Superintendent to be Obeyed.

(f) Refuse or neglect to obey or comply with any lawful direction of the Superintendent.

Offal.

20. No person shall remove from the Abattoirs any refuse, manure, inedible offal, or dead animals unless written permission of the Council has been first obtained.

Dogs Excluded.

21. No dogs shall be brought upon or allowed to remain upon the premises other than for the purpose of droving or yarding of stock.

Trespass.

22. No person shall enter or remain in the Abattoirs unless such person shall have lawful business to transact thereat, and while so entering or remaining shall not offend against any of the requirements of section 19 hereof.

Vehicles not to Park.

23. No person shall be permitted to use any part of the Abattoirs premises for the parking of motor and other vehicles.

Locking Rooms, &c.

24. No person shall be permitted to lock or chain any room, yard, or compartment at the Abattoirs without the written permission of the Superintendent, and then only in accordance with the conditions set out in such permit.

Alterations to Building or Fittings.

25. No person shall make any alterations to any building or room at the Abattoirs or install any machinery or fixture therein without having first obtained the permission of the Council to do so.

Offence.

26. Any contravention of any of the foregoing sections by act or omission shall be an offence against this By-law.

Penalty.

27. Every person who is guilty of an offence against this By-law shall be liable to a penalty of not more than Twenty pounds.

Application.

28. This By-law shall apply to and have application throughout that portion of the City known as the Richmond Abattoirs.

SCHEDULE OF BY-LAWS AND REGULATIONS REPEALED.

By-Law No.	Date.	Title.	Extent of Repeal.
19	1862	Establishment of Slaughter Houses	Whole
45	1924	Management of Abattoirs and altering dues	Whole
Regltn. No. 22	1901	Prescribing duties of Meat Inspectors and fixing fees for examining and branding Meat	Whole

Resolution for passing this By-law agreed to by the Council of the City of Richmond the 16th day of February, 1948.

Confirmed the 12th day of March, 1948.

Sealed with the common seal of the Mayor, Councillors, and Citizens of the City of Richmond this 18th day of March, 1948, in the presence of—

(SEAL) R. S. F. JACKSON, Mayor.
PAUL J. CARROLL, Councillor.
F. L. HALLETT, Town Clerk.

Submitted to the Commission of Public Health on the 4th day of May, 1948.

Approved by the Governor in Council 1st June, 1948.—
C. W. KINSMAN, Clerk of the Executive Council. 5294

BOROUGH OF CLUNES.

NOTICE is hereby given that First Constable Matthew John Campbell has been appointed prosecuting officer for the Borough of Clunes.

W. L. MOUNTJOY, Town Clerk.

28th July, 1948. 5286

SHIRE OF DEAKIN.

NOTICE OF INTENTION TO BORROW THE SUM OF £1,700.

Loan No. 4.

NOTICE is hereby given that the Council of the Shire of Deakin proposes to borrow the sum of £1,700, on the credit of the President, Councillors, and Ratepayers of the said shire, such sum to be raised by the issue of debentures in accordance with the provisions of the *Local Government Act 1946*.

The maximum rate of interest that may be paid is 3½ per cent. per annum. The period of the loan shall be 20 years. The loan shall be repayable by providing out of the municipal fund 40 half-yearly instalments of approximately £58, each instalment including principal and interest, and such money shall be repayable on the 1st day of February and the 1st day of August during the currency of the loan, at the Commercial Banking Company of Sydney Limited, Melbourne, or at the Council's bankers for the time being in the City of Melbourne.

The purpose for which the loan is to be applied is the erection of a dwelling in St. James-street, Tongala, for the use of a Council officer, under the provisions of section 238 of the *Local Government Act 1946*.

The plans and specifications, and estimate of cost of such works, and the statement showing the proposed expenditure of the money to be borrowed, are open for inspection at the office of the Council.

Dated this 30th day of July, 1948.

5300 K. C. GRAHAM, Shire Secretary.

SHIRE OF WIMMERA.

NOTICE OF INTENTION TO BORROW.

NOTICE is hereby given that the Council of the Shire of Wimmera intends to borrow, on the credit of the President, Councillors, and Ratepayers of the Shire, the sum of Three thousand seven hundred and ninety pounds (£3,790), such sum to be raised by the issue of debentures, in accordance with the provisions of the *Local Government Act 1946*. It is further proposed that:—

- (1) Such money is to be applied in the purchase of two power road graders.
- (2) The rate of interest to be named in such debentures is 3½ per cent.
- (3) Such moneys shall be repayable by twenty equal half-yearly instalments, including principal and interest, by providing out of the Municipal Fund the required amounts on the 1st day of April and the 1st day of October in each respective year. Such instalments shall be payable at the Commercial Bank of Australia Ltd., Horsham.

A detailed statement of the intended expenditure of moneys proposed to be borrowed is open for inspection at the Shire Office, Horsham.

5326 W. J. GRAY, Shire Secretary.

SHIRE OF WINCHELSEA.

NOTICE OF INTENTION TO ACQUIRE LAND COMPULSORILY.

WHEREAS the Council of the Shire of Winchelsea deem it expedient to execute the following work or undertaking, namely, the construction of a new road within the corporate limits of the said shire for the purpose whereof, the exercise of its compulsory powers of taking land will in opinion be necessary. Notice is hereby given as follows:—

1. The said shire has caused to be prepared, and has approved of such specifications, maps, plans, sections, and elevations as are necessary showing:—

- (a) The exact site of such work or undertaking, and the admeasurements thereof.
- (b) On what land the same is proposed to be placed.
- (c) The names of the owners or reputed owners, lessees or reputed lessees, and the occupiers thereof, so far as such names can be ascertained by the Council.

2. Such specifications, maps, plans, sections, and elevations are deposited for inspection at the Shire Hall, Winchelsea, and are now open for inspection at the place aforesaid, by all persons interested, during the office hours for the space of 40 clear days from the publication of this notice in the *Government Gazette*.

3. The Council hereby requires all persons affected by the proposed work or undertaking to set forth, in writing, addressed to the said Council or the shire secretary, within 40 clear days from the publication of this notice as aforesaid all objections which they may have to the said work or undertaking.

Dated this 21st day of July, 1948.

By order of the Council,

W. W. WESTHORPE, Shire Secretary.

Harwood and Pincott, 51 Yarra-street, Geelong, solicitors for the President, Councillors, and Ratepayers of the Shire of Winchelsea. 5299

NOTICE is hereby given that the partnership heretofore subsisting between the undersigned, Desmond Ernest Cleverly and Clifford Raymond Cleverly, carrying on business as manufacturers at 65 St. George's-road, Elsternwick, under the name of "Cleve Products," has been dissolved by mutual consent as from the 11th day of June, 1948. All debts due to and owing by the said firm will be received and paid by the said Desmond Ernest Cleverly, who will continue to carry on the business under the name of "Cleve Products," at 65 St. George's-road, Elsternwick.

Dated at Melbourne the 26th day of July, 1948.

DESMOND E. CLEVERLY.

Witness to the signature of Desmond Ernest Cleverly—
J. L. HEWISON.

C. R. CLEVERLY.

Witness to the signature of Clifford Raymond Cleverly—
J. L. HEWISON. 5346

NOTICE is hereby given that the partnership heretofore subsisting between Alfred George Mansell, Stephen Robert Mansell, Arthur Robert Mansell, and Victor Mansell, under the name or style of "Mansell and Sons," at Mildura, has been dissolved as from the 30th day of June, 1948, the said Alfred George Mansell having retired from the partnership. The said Stephen Robert Mansell, Arthur Robert Mansell, and Victor Mansell will continue to carry on the firm's business, and will receive and discharge debts due to and by the former partnership.

Dated this 30th day of June, 1948.

A. G. MANSELL.
S. R. MANSELL.
A. R. MANSELL.
V. MANSELL.

Sykes, Crothers, & Duck, solicitors, Deakin-avenue, Mildura. 5304

NOTICE is hereby given that the partnership heretofore subsisting between the undersigned Albert Osborne Hibbins and Harry Elisha Taylor, carrying on business as wholesale booksellers and stationers, at 366 Bourke-street, Melbourne, under the name of "Hibbins and Taylor," has been dissolved by mutual consent as from the 1st day of July, 1948. All debts due to and owing by the said late firm will be received and paid at the office of Hibbins, Taylor and Co., 366 Bourke-street, Melbourne, at which address Harry Elisha Taylor, Roy Howell Stretton, and Walter George Mason will carry on the business of wholesale booksellers and stationers.

A. HIBBINS.
H. E. TAYLOR.

Witness to the above signatures—J. L. O'CONNELL.

John L. O'Connell, solicitor, 317 Collins-street, Melbourne. 5313

P. L. JANSEN AND CO. PTY. LTD. (IN LIQUIDATION).
NOTICE CONVENING FINAL MEETING OF MEMBERS AND CREDITORS.

NOTICE is hereby given that, in pursuance of section 245 of the Companies Act 1938, that a General Meeting of the members and creditors of the above-named company will be held on Monday, the 30th day of August, 1948, at Three p.m. in the afternoon, at the Geelong Wool Exchange, Corio-street, Geelong, for the purpose of having an account laid before them showing the manner in which the winding up has been conducted and the property of the company disposed of, and of hearing any explanations that may be given by the liquidator.

Dated this 29th day of July, 1948.

5302 G. W. THOM, Liquidator.

Companies Act 1938.

KEW R.S.L. MEMORIAL TRUST PATRIOTIC FUND.
NOTICE OF INTENTION TO APPLY TO ATTORNEY-GENERAL FOR LICENCE, PURSUANT TO SECTION 18 (1).

KEW R. S. L. Memorial Trust Patriotic Fund, formed for the purpose of creating, raising, and administering funds to provide Memorial Hall and Club Room for the Kew Sub-branch of the R.S.L., hereby gives notice of intention to apply to the Attorney-General for a licence, directing that the said association be registered as a company with limited liability without the addition of the word "Limited" to its name.

Dated this 26th day of July, 1948.

FREDERICK BERNARD FISENDEN,
A Member of the Committee of the said Association. 5314

In the matter of the Companies Act 1938, and in the matter of BROKEN HILL CO-OPERATIVE COAL ASSOCIATION PTY. LTD. (in Voluntary Liquidation).

TAKE notice that, pursuant to section 236, a meeting of contributors in the above matter will be held at the office of Edwin V. Nixon and Partners, 401 Collins-street, Melbourne, on the 6th day of September, 1948, at half-past Nine a.m., for the purpose of receiving the final account of the winding up.

Dated this 30th day of July, 1948.

W. D. HIGGINS, F.C.A. (Aust.), Liquidator.
Edwin V. Nixon and Partners, 401 Collins-street, Melbourne. 5353

BENDIGO PRESERVING CO. LTD.

UNCLAIMED Dividends at the 1st January, 1948, on Dividend of 10 per cent. declared on the 30th November, 1946.

Name and Address.	Amount Owing.	Remarks.
	£ s. d.	
T. Conway, Sedgwick ..	0 14 0	Cheque unrepresented
K. Chambers, Inkerman-road, Caulfield	0 6 0	" "
H. Child, Kalorama ..	0 10 0	" "
Executors of K. Fogarty, Castle-maine	1 0 0	" "
Executors of G. Fone, c/o 31 Queen-street, Melbourne	0 10 0	" "
L. Gilfillan, 342 Glenferrie-road, Glenferrie	0 10 0	" "
Executors of T. Liddell, c/o 57 Swanston-street, Melbourne	0 14 0	" "
W. Loveland, Mt. Korong-road, California Gully	0 8 0	" "
L. T. Yick, c/o Sun Ack Goon, Bridge-street, Bendigo	1 18 0	" "
C. Rawsthorne, Marke-street, Moreland	0 16 0	" "
	7 6 0	

5291

HENRY GAWLER, late of 11 Adam-street, Burnley (in his will called Richmond), retired cabinetmaker, DECEASED (who died on the 21st day of April, 1948).

CREDITORS, next of kin, and all others having claims against the estate of the said deceased are required by the Trustees, Executors, and Agency Company Limited, of 401-403 Collins-street, Melbourne, the executor appointed by the said will, to send particulars to it, care of the undersigned, on or before the 6th day of October, 1948, after which date it will distribute the assets, having regard only to those claims of which it then has notice.

DUGDALE, SIMMONS & STEVENS, Peacock House, 486 Bourke-street, Melbourne, solicitors. 5311

CREDITORS, next of kin, and others having claims in respect of the estate of Lillie Hales Boase, late of 27 Tivoli-place, South Yarra, in the State of Victoria, widow, deceased (who died on the 29th day of April, 1948), are to send particulars of their claims to The Trustees, Executors, and Agency Company Limited, of 401 Collins-street, Melbourne, in the said State, by the 7th day of October, 1948, after which date the said company will distribute the assets, having regard only to the claims of which it then has notice.

Dated the 28th day of July, 1948.

GEOFFREY E. DAVIS, solicitor, 443 Little Collins-street, Melbourne. 5312

CREDITORS, next of kin, and others having claims against the estate of Mary Jane Martin, late of Werrington, Johnston-street, Castlemaine, in the State of Victoria, spinster, deceased, are requested to send particulars of such claims to her executor, William James Anderson, of 157 Barker-street, Castlemaine aforesaid, bank manager, in care of the undersigned, before the 10th day of October, 1948, after which date the executor will distribute the estate, having regard only to claims of which he shall then have had notice.

Dated the 30th July, 1948.

H. S. W. LAWSON & CO., solicitors, Castlemaine. 5315

PERCY JAMES LORD WILCOCK NEWTON, late of 33 Hotham-street, East Preston, retired commercial traveller, DECEASED.

CREDITORS, next of kin, and others having claims in respect of the estate of the above-named deceased (who died on the 20th December, 1947), are required to send the particulars of their claims to the executors, Sydney Knighton Goodfellow, and William Walker, care of the under-named solicitors, by the 6th day of October, 1948, after which date they will distribute the assets, having regard only to the claims of which they then have notice.

NORRIS & NORRIS, of 422 Collins-street, Melbourne, solicitors. 5356

CREDITORS, next of kin, and others having claims in respect of the estate of James Alfred Valentine Williams, late of Kongwak, dairy farmer, deceased (who died on the 10th day of May, 1948), are to send particulars of their claims to The Equity Trustees, Executors, and Agency Company Limited, of 472 Bourke-street, Melbourne, by the 11th day of October, 1948, after which date it will distribute the assets, having regard only to the claims of which it then has notice.

SHEGOG & BIRCH, solicitors, Korumburra. 5320

CREDITORS, next of kin, and others having claims in respect of the estate of Bernard Clarke, late of Bald Hills, Pakenham East, in the State of Victoria, farmer, deceased (who died on the 13th day of June, 1948), are to send the particulars of their claims to National Trustees, Executors, and Agency Company of Australasia Limited, to its registered office, situate at 95 Queen-street, Melbourne, by the 9th day of October, 1948, after which date it will distribute the assets, having regard only to the claims of which it then has notice.

LYNCH & MACDONALD, 360 Collins-street, Melbourne, solicitors for the said company. 5350

THE PERPETUAL EXECUTORS AND TRUSTEES ASSOCIATION OF AUSTRALIA LIMITED, whose registered office is situate at Nos. 100-104 Queen-street, Melbourne, in the State of Victoria, and Leslie Charles Trist, of 99 Queen-street, Melbourne aforesaid, chartered accountant, the executors of the will of May Verena Hyndman, late of "Minto," 70 Denbigh-road, Armadale, in the said State, spinster, deceased (who died on the 2nd day of April, 1948), require all creditors, next of kin, and others having claims against the property or estate of the said deceased, to send to the said executors, in the care of the said association, at its registered office aforesaid, on or before the 12th day of October, 1948, particulars, in writing, of such claims, after which date the said executors intend to convey or distribute such property or estate to or among the persons entitled thereto, having regard only to the claims of which they shall have had notice.

MALLESON, STEWART, & CO., solicitors, 46 Queen-street, Melbourne. 5351

THEODOOR SMITS, formerly of Singapore, Head of the Netherlands Indies Liquidation Organization, but late of Batavia, in the Netherlands Indies, assistant manager, DECEASED.

CREDITORS, next of kin, and others having claims in respect of the estate of the above-named deceased (who died on the 2nd day of December, 1947), are required to send the particulars of their claims to William George Coates, the duly appointed attorney under power of the executrix, Jean Dudley Wilkie Smits, care of the under-named solicitors, by the 6th day of October, 1948, after which date he will distribute the assets, having regard only to the claims of which he then has notice.

NORRIS & NORRIS, of 422 Collins-street, Melbourne, solicitors. 5354

EMILY DUNSTAN, late of 24 Emmaline-street, Croxton, in the State of Victoria, spinster, DECEASED.

CREDITORS, next of kin, and others having claims in respect of the estate of the above-named deceased (who died on the 8th day of April, 1948), are required to send the particulars of their claims to the executor, George Henderson, care of the under-named solicitors, by the 6th day of October, 1948, after which date he will distribute the assets, having regard only to the claims of which he then has notice.

NORRIS & NORRIS, of 422 Collins-street, Melbourne, solicitors. 5355

CREDITORS, next of kin, and others having claims in respect of the estate of Jack Sinclair Horsburgh, late of 93 Carlisle-crescent, Oakleigh, wood merchant (who died on the 27th February, 1948), are to send particulars of their claims to The Perpetual Executors and Trustees Association of Australia Limited, of 100-104 Queen-street, Melbourne, by the 9th October, 1948, after which date it will distribute the assets, having regard only to the claims of which it then has notice.

CORR & CORR, solicitors, 104 Queen-street, Melbourne. 5306

CREDITORS, next of kin, and others having claims in respect of the estate of Johanna Mulcare, late of Nar-Nar-Goon, in the State of Victoria, spinster, deceased (who died on the 25th day of November, 1947), are to send the particulars of their claims to The Equity Trustees, Executors, and Agency Company Limited, of 472 Bourke-street, Melbourne, in the said State, by the 6th day of October, 1948, after which date it will distribute the assets, having regard only to the claims of which it then has notice.

Dated the 30th day of July, 1948.

FRANCIS FIELD, M.A., LL.B., solicitor, 100 Queen-street, Melbourne, and at Dandenong. 5307

CREDITORS, next of kin, and others having claims in respect of the estate of Mary Ellen McManus, formerly of Mont Park Mental Hospital, but late of Hotham-street, East Melbourne, in the State of Victoria, married woman, deceased, intestate (who died on the 14th day of March, 1948), are to send particulars of their claims to The National Trustees, Executors, and Agency Company of Australasia Limited, whose registered office is situate at 95 Queen-street, Melbourne, by the 14th day of October, 1948, after which date it will distribute the assets, having regard only to the claims of which it then has notice.

C. G. HEFFEY, M.A., LL.B., solicitor, 422 Collins-street, Melbourne. 5308

NOTICE TO CLAIMANTS.

MERYLIN MANTON, of 415 Glenferrie-road, Hawthorn, married woman, the executrix of the will of Frances Gertrude Stephens, late of 44 Hopetoun-avenue, Canterbury, spinster, deceased (who died on the 22nd day of March, 1948), requires all creditors, next of kin, and others having claims against the property or estate of the said deceased, to send to the said executrix, care of Herbert Turner and Son, solicitors, 411 Collins-street, Melbourne, on or before the 10th day of October, 1948, full particulars, in writing, of such claims, after which date the said executrix intends to convey or distribute such property or estate to or among the persons entitled thereto, having regard only to the claims of which she shall then have had notice.

Dated the 29th day of July, 1948.

HERBERT TURNER & SON, solicitors, 411 Collins-street, Melbourne. 5309

MARY ELLEN PERRY (sometimes called Nellie Perry), formerly of Balcombe-road, Beaumaris, married woman, but late of 76 Bealiba-road, Caulfield, widow, DECEASED.

CREDITORS, next of kin, and all other persons having claims against the estate of the said deceased (who died on the 16th February, 1948, and probate of whose will was on the 20th July, 1948, granted by the Supreme Court of Victoria, in its probate jurisdiction, to Edward George Perry, of Balcombe-road, Beaumaris, horse trainer, and John William Pritchard, of 100 Queen-street, Melbourne, managing law clerk, the executors named therein), are hereby required to send particulars, in writing, to them, care of the undersigned, on or before the 11th October, 1948, after which date they will convey or distribute the assets of the said deceased, having regard only to the claims of which they shall then have notice.

GEORGE J. WISE, solicitor, 100 Queen-street, Melbourne. 5310

NOTICE TO CLAIMANTS.

RAYMOND STANMORE TURNER, of 127 North-terrace, Kensington Gardens, in the State of South Australia, accountant, Robert William Page, of Commercial-street, Mount Gambier, in the State of South Australia, manager, and Florence Alice Nosworthy, of 7 Alonso-street, Burwood, in the State of Victoria, widow, the executors of the will and codicil of William George Nosworthy, late of 21 Power-avenue, Toorak, merchant, deceased (who died on the 17th day of November, 1946), require all creditors, next of kin, and others having claims against the property or estate of the said deceased to send to the said executors, care of Akehurst, Friend, and Haack, solicitors, 405 Collins-street, Melbourne, on or before the 5th day of October, 1948, full particulars, in writing, of such claims, after which date the said executors intend to convey or distribute such property or estate to or among the persons entitled thereto, having regard only to the claims of which they shall then have had notice.

Dated the 4th day of August, 1948.

AKEHURST, FRIEND, & HAACK, solicitors, 405 Collins-street, Melbourne. 5341

Trustee Act 1928.
NOTICE TO CLAIMANTS.

PURSUANT to the *Trustee Act 1928*, creditors, next of kin, and all other persons having claims in respect of the estate of any deceased persons named below are required to send particulars thereof to the legal personal representative or representatives at the address stated below, on or before the date stated, after which date the representative or representatives will distribute the assets, having regard only to the claims of which notice has been received:—

Michael Downey, late of Koroit, farmer, deceased, died 27th April, 1948.—Claims to the executor, Michael Downey, junior, of Koroit, farmer, care of Peter P. Conlan, solicitor, 36 Bank-street, Port Fairy, by 6th October, 1948. 5297

Charles Richard James Friswell, late of Carpenter-street, Bendigo, grazier, deceased, who died on the 26th day of February, 1948.—Claims to the executors, Elsie Muriel Friswell, of Carpenter-street, Bendigo, widow, and Farmers and Citizens Trustees Company Bendigo Limited, of Charing Cross, Bendigo, in care of the undersigned, by the 7th day of October, 1948. Tatchell, Dunlop, Smalley, and Balmer, solicitors, Bendigo. 5287

Tomazin Elizabeth Cuthbertson, late of Colac, married woman, died 1st June, 1948.—Claims to the executors, Colin Percy Cuthbertson and Norman James Black, both of Cororooke, farmers, by 4th October, 1948. Sewell and Sewell, solicitors, Colac. 5322

Albert Edward Lear, late of 394 Richardson-street, Middle Park, retired saddler, deceased, died 19th June, 1948.—Claims to Walter Kemp, 340 Collins-street, Melbourne, solicitor, by 5th October, 1948. 5330

John Joseph O'Neill, late of Leongatha, gentleman, deceased, who died on the 7th November, 1941.—Claims to the executor, Mathew Brown, care of Michael Mornane, solicitor, 95 Queen-street, Melbourne, by the 7th October, 1948. 5331

James Duncan, late of 16 Station-road, Footscray, fitter, deceased, died 28th June, 1948.—Claims to the executrix, Minnie Duncan, of 16 Station-road, Footscray, widow, care of John F. Carroll, solicitor, 4 Paisley-street, Footscray, by 7th October, 1948. John F. Carroll, LL.B., solicitor, 4 Paisley-street, Footscray. 5319

William John Meehan, late of 54 Aberdeen-street, Newtown, Geelong, aviation manager, presumed to have died on or about 26th August, 1947.—Claims to the administratrix, Phyllis Myrtle Meehan, of 54 Aberdeen-street, Newtown, Geelong, widow, care of Wighton and McDonald, solicitors, 53 Yarra-street, Geelong, by 6th October, 1948. 5301

RE ARTHUR BAULCH, late of Kirkstall, in the State of Victoria, retired farmer, DECEASED.

CREDITORS, next of kin, and all other persons having claims against the estate of the above-named deceased (who died on the 30th day of March, 1948, and probate of whose will was, on the 19th day of May, 1948, granted to Eileen Jones, of Koroit, in the said State, married woman, and Nicholas Doolan, of Kirkstall aforesaid, farmer), are hereby requested to send particulars, in writing, to them of such claim, care of the undersigned, on or before the 30th day of September, 1948, after which date they will distribute the assets of the deceased which have come to their hands amongst the persons entitled thereto, having regard only to the claims of which they shall have had notice; and notice is further given that the executors will not be liable for the assets so distributed, or any part thereof, to any person of whose claim they shall not have had such notice as aforesaid.

Dated this 26th day of July, 1948.

DESMOND DUNNE & DWYER, 95 Kepler-street, Warrnambool, solicitors for the executors. 5292

CREDITORS, next of kin, and others having claims in the estate of Elizabeth Atkinson, late of 335 Waverley-road, East Malvern, widow, deceased (who died on the 29th day of May, 1948), are to send particulars of their claims to The Trustees, Executors, and Agency Company Limited, of 401 Collins-street, Melbourne, by the 6th day of October, 1948, after which date it will distribute the assets, having regard only to the claims of which it then has notice.

RUSSELL, KENNEDY, & COOK, solicitors, 401 Collins-street, Melbourne, C.1. 5328

ADA HELEN THOMAS, late of 11 Hotham-street, South Melbourne, spinster, DECEASED.

CREDITORS, next of kin, and others having claims against the estate of the above-named deceased (who died on 29th May, 1948), are required to send particulars of their claims to John Dickinson Bacon, the executor of deceased's will, in care of the undersigned, on or before 5th October, 1948, after which date he will distribute the assets, having regard only to claims of which he then has notice.

J. ROBERTSON MACMILLAN, solicitor, 191 Bank-street, South Melbourne. 5293

GEORGE DOUSSAITES, late of 18 Zervou-street, Patessia, Athens, Greece, retired confectioner, DECEASED, intestate.

CREDITORS, next of kin, and all other persons having claims against the estate of the deceased are required by Sandhurst and Northern District Trustees, Executors, and Agency Company Limited, of View-street, Bendigo, the administrator of the estate, to send particulars to the said company, care of the under-mentioned solicitors, on or before the 28th day of September, 1948, after which date the said company will distribute the assets, having regard only to the claims of which it shall then have notice.

Dated this 28th day of July, 1948.

T. M. WILLIAMS, WATSON, & JAMES, solicitors, 16 View-street, Bendigo. 5296

NOTICE TO CLAIMANTS.—*RE* HERBERT FORREST TONKIN, DECEASED.

NOTICE is hereby given that all persons having claims against the property or estate of Herbert Forrest Tonkin, formerly of 102 O'Hea's-street, Coburg, but late of 13 Alpine-grove, Pascoe Vale, in the State of Victoria, sales manager, deceased (who died on the 30th day of March, 1948, and probate of whose will was granted to The Equity Trustees, Executors, and Agency Company Limited, of 472 Bourke-street, Melbourne, in the said State), are hereby required to send, in writing, particulars of such claims to the said company, on or before the 5th day of October, 1948, after which date the said company will distribute such estate among the persons entitled thereto, having regard only to the claims of which it shall then have had notice.

Dated the 29th July, 1948.

UPTON, ETELSON, & OWEN, solicitors, 395 Collins-street, Melbourne. 5338

CREDITORS, next of kin, and others having claims in respect of the estate of Sir Edmund Ralph Cook, late of 95 Chiltern Court, London, N.W.1, England, knight, deceased (who died on the 13th day of February, 1942, and probate of whose will granted by His Majesty's High Court of Justice, England, was resealed in Victoria on the application of The Equity Trustees, Executors, and Agency Company Limited, of 472 Bourke-street, Melbourne, the attorney under power of the executors of the will and codicils of Dame Florence Ruth Cook, who was the executrix of the will of the said Sir Edmund Ralph Cook), are to send particulars, in writing, of such claims to the said company by the 5th day of October, 1948, after which date it will distribute the assets of the said Sir Edmund Ralph Cook, deceased, having regard only to the claims of which it shall then have notice.

HADEN SMITH & FITCHETT, solicitors, 405 Collins-street, Melbourne. 5347

RE ALAN BARTLETT SPLATT, late of Mountain View-road, Montmorency, in the State of Victoria, electrician, DECEASED.

PURSUANT to the *Trustee Act 1928*, notice is hereby given that Lillian Mary Splatt, of Mountain View-road, Montmorency aforesaid, widow (hereinafter called the administratrix), the administratrix of the estate of the said Alan Bartlett Splatt, deceased (who died on the 24th day of November, 1947), intends to convey or distribute the estate of the said deceased to or among the persons entitled thereto, and requires all persons or creditors interested to send to the administratrix, care of the undersigned, on or before the 8th day of October, 1948, particulars of their claims against the said estate, and after the said 8th day of October, 1948, the administratrix may convey or distribute the said estate to or among the persons entitled thereto, having regard only to the claims, whether formal or not, of which she shall then have had notice.

Dated the 4th day of August, 1948.

BEST, HOOPER, RINTOUL, & SHALLARD, solicitors, 100 Queen-street, Melbourne. 5342

JOHN LONG, late of 12 Campbell-street, East Kew, in the State of Victoria, retired, farmer, DECEASED (who died on the 25th March, 1948).

CREDITORS, next of kin, and all other persons having claims against the estate of the above-named deceased are required by the executor, Clarence Merton Long, of 12 Campbell-street, East Kew aforesaid, wool-buyer, to send particulars to him, care of the undersigned, on or before the 8th day of October, 1948, after which date he will distribute the assets, having regard only to the claims of which he then has notice.

W. H. JONES & KENNEDY, solicitors, 214 Nicholson-street, Footscray. 5348

PURSUANT to the *Trustee Act* 1928, notice is hereby given that all persons having claims against the estate of David Thomson Ewart, late of 35 Synnot-street, Werribee, in the State of Victoria, retired, farmer, deceased (who died on the 7th day of June, 1948, and probate of whose will was granted by the Supreme Court of Victoria on the 26th day of July, 1948, to George Wordie Furnage, of Myrtleford, in the said State, accountant, and Emil William Mumme, of 383 Little Flinders-street, Melbourne, in the said State, solicitor, the executors appointed by the said will), are hereby required to send particulars, in writing, of such claims to the said executors, care of the undersigned solicitors, on or before the 6th day of October, 1948, after which date the said executors will proceed to distribute the assets of the said deceased which shall have come to their hands among the persons entitled thereto, having regard only to the claims of which they shall then have had notice.

LUCAS & MUMME, solicitors, 383 Little Flinders-street, Melbourne, C.1. 5349

JOHN PILMORE, late of Dimboola, retired farmer, DECEASED (who died on the 5th day of January, 1948).

CREDITORS, next of kin, and all others having claims against the estate of the above-named deceased are required by the executors, Percival Conrad Pilmore, of Dimboola, agent, and Willie Pilmore, of Gerang Gerung, farmer, to send particulars thereof to them, care of the under-mentioned solicitor, on or before the 2nd day of October, 1948, after which date they will distribute the assets of the said deceased, having regard only to the claims of which they shall then have had notice.

W. N. MUNTZ, solicitor, Dimboola. 5324

RICHARD HENRY BUCKINGHAM FINNEY, of 92 Carlisle-street, St. Kilda, in the State of Victoria, gentleman, DECEASED (who died on the 4th April, 1947, probate of whose will was granted to Joseph Lynch, of 299 Bridge-road, Richmond, solicitor).

CREDITORS, next of kin, and others having claims against the estate of the above-named deceased are required by the said executor to send particulars thereof to the undersigned, on or before the 6th day of October, 1948, after which date the assets will be distributed, having regard only to the claims of which notice has been given.

JOSEPH LYNCH, LL.B., solicitor, 299 Bridge-road, Richmond. 5325

NOTICE TO CLAIMANTS.—RE WILLIAM GEORGE HUMPHREYS, DECEASED.

THE TRUSTEES, EXECUTORS, AND AGENCY COMPANY LIMITED, whose registered office is situate at 401 Collins-street, Melbourne, in the State of Victoria, the executor of the will of William George Humphreys, late of No. 33 Howard-street, Box Hill, in the said State, retired manufacturer, deceased (who died on the 7th day of April, 1948), requires all creditors, next of kin, and others having claims against the property or estate of the said deceased to send to the said company, at its registered office, on or before the 30th day of September, 1948, particulars, in writing, of such claims, after which date the said company intends to convey or distribute such property or estate to or among the persons or bodies entitled thereto, having regard only to the claims of which it shall have had notice.

Dated the 22nd day of July, 1948.

R. G. GALL, 40 Queen-street, Melbourne, solicitor for the said executor. 5327

AMY ADELINE KLINGE, late of Dimboola, widow, DECEASED (who died on the 20th day of June, 1948).

CREDITORS, next of kin, and all others having claims against the estate of the above-named deceased are required by the executors, Friedrich Gustav Klinge, of Gerang Gerung, farmer, and Theodor Wilfred Klinge, of Dimboola, motor garage proprietor, to send particulars thereof to them, care of the under-mentioned solicitor, on or before the 2nd day of October, 1948, after which date they will distribute the assets of the said deceased, having regard only to the claims of which they shall then have had notice.

W. N. MUNTZ, solicitor, Dimboola. 5323

CREDITORS, next of kin, and others having claims in the estate of Mary Ellen McGann, late of 1 Sharnrock-street, Essendon, widow, deceased (who died on the 5th day of April, 1948), are to send particulars of their claims to The Trustees, Executors, and Agency Company Limited, of 401 Collins-street, Melbourne, by the 6th day of October, 1948, after which date it will distribute the assets, having regard only to the claims of which it then has notice.

RUSSELL, KENNEDY, & COOK, solicitors, 401 Collins-street, Melbourne, C.1. 5329

MINING NOTICES.

CENTRAL NELL GWYNNE GOLD MINING COMPANY NO LIABILITY.

NOTICE.—A Call (the 43rd) of Six pence per share has been made on the capital of this company, due and payable at the company's office, Charing Cross, Bendigo, on Wednesday, 11th August, 1948.

J. J. STANISTREET
5288 (McCull, Rankin, and Stanistreet), Manager.

SOUTH DEBORAH GOLD MINES NO LIABILITY.

NOTICE.—A Call (the 25th) of Six pence per share has been made on the capital of this company, due and payable at the company's office, Charing Cross, Bendigo, on Wednesday, 11th August, 1948.

J. J. STANISTREET
5289 (McCull, Rankin, and Stanistreet), Manager.

DEBORAH GOLD MINES NO LIABILITY.

NOTICE.—A Call (the 47th) of Six pence per share has been made on the capital of this company, due and payable at the company's office, Charing Cross, Bendigo, on Wednesday, 11th August, 1948.

J. J. STANISTREET
5290 (McCull, Rankin, and Stanistreet), Manager.

CHEWTON GOLD MINES N. L.

NOTICE is hereby given that a Call (the 74th) of Three pence per share (making shares £1 2s. paid up) has been made upon the capital of the company, due and payable at the registered office of the company, 430 Little Collins-street, Melbourne, on Wednesday, the 11th day of August, 1948.

By order of the Board,
5359 A. E. LLEWELLYN, Manager.

AJAX SOUTH GOLD MINE N. L.

NOTICE is hereby given that a Call (the 33rd) of Three pence per share (making shares 9s. 3d. paid up) has been made upon the capital of the company, due and payable at the registered office of the company, 430 Little Collins-street, Melbourne, on Wednesday, the 11th day of August, 1948.

By order of the Board,
5360 A. E. LLEWELLYN, Manager.

NORTHERN STAR GOLD MINES NO LIABILITY.

NOTICE is hereby given that a Call (the 4th) of Three pence per share has been made upon all the contributing shares in the company, due and payable to the manager, at the registered office, 140 Queen-street, Melbourne, on Wednesday, 11th August, 1948.

5332 F. L. SMYTH, Manager.

SOUTH VIRGINIA GOLD MINING COMPANY
NO LIABILITY.

NOTICE is hereby given that a Call (the 40th) of Three pence per share has been made upon all the shares in the company, due and payable to the manager, at the registered office, 140 Queen-street, Melbourne, on Wednesday, 11th August, 1948.

F. L. SMYTH, Manager.

NEW CHUM SYNCLINE GOLD MINE NO LIABILITY.

NOTICE is hereby given that a Call (No. 98) of Three pence per share (making shares paid up to 30s. 3d.) has been made, and is due and payable to me at the registered office, 422 Collins-street, Melbourne, on Wednesday, 11th August, 1948.

By order of the Board,

5339

FRANK COOPER, Manager.

ARGUS HILL CHEWTON GOLD NO LIABILITY.

NOTICE is hereby given that a Call (No. 58) of Three pence per share (making shares paid up to 16s. 10½d.) has been made, and is due and payable to me at the registered office, 422 Collins-street, Melbourne, on Wednesday, 11th August, 1948.

By order of the Board,

5340

FRANK COOPER, Manager.

MOUNT TODD GOLD MINE NO LIABILITY.

NOTICE is hereby given that a Call (No. 6) of Six pence per share (making shares paid up to 8s. 6d.) has been made, and is due and payable to me, at the registered office, 422 Collins-street, Melbourne, on Wednesday, 11th August, 1948.

By order of the Board,

FRANK COOPER, Manager.

422 Collins-street, Melbourne, C.1. 5344

NORTH NELL GWYNNE GOLD MINES NO LIABILITY.

ALL shares upon which the 81st (July) Call of Three pence per share remains unpaid are forfeited, and will be sold by public auction at the Stock Exchange, Melbourne, on Thursday, 12th August, 1948, at a quarter to Twelve a.m., unless previously redeemed.

By order of the Board,

F. H. TADGELL, Manager.

Dickenson and Tadgell, chartered accountants (Aust.),
46 Queen-street, Melbourne, C.1. 5345

CENTRAL VICTORIA DREDGING COMPANY
NO LIABILITY.

NOTICE is hereby given that a Call (the 5th) of One shilling (1s.) per share on all the issued contributing shares (making such shares paid to 6s. each) has been made, due and payable at the registered office, 360 Collins-street, Melbourne, on Wednesday, 11th August, 1948.

By order of the Board,

L. EDWARDS, Manager.

360 Collins-street, Melbourne, 2nd August, 1948. 5337

MAXWELL CONSOLIDATED NO LIABILITY.

NOTICE is hereby given that a Call (the 40th) of Two pence half-penny (2½d.) per share on all the issued contributing shares in the capital of the company (making the said shares fully paid to 5s. each) has been made, due and payable at the registered office of the company, 360 Collins-street, Melbourne, on Wednesday, 11th August, 1948.

By order of the Board,

HADDON A. SMITH, Legal Manager.

Melbourne, 4th August, 1948. 5343

NORTHERN STAR GOLD MINES NO LIABILITY.

NOTICE is hereby given that all shares forfeited for non-payment of the 3rd (July) Call of Three pence per share will be sold by public auction at the Stock Exchange Hall, 428 Little Collins-street, Melbourne, on Thursday, 12th August, 1948, at a quarter to Twelve a.m., unless the shares be previously redeemed.

F. L. SMYTH, Manager.

Registered office: 140 Queen-street, Melbourne. 5333

SOUTH VIRGINIA GOLD MINING COMPANY
NO LIABILITY.

NOTICE is hereby given that all shares forfeited for non-payment of the 39th (July) Call of Three pence per share will be sold by public auction at the Stock Exchange Hall, 428 Little Collins-street, Melbourne, on Thursday, 12th August, 1948, at a quarter to Twelve a.m., unless the shares be previously redeemed.

F. L. SMYTH, Manager.

Registered office: 140 Queen-street, Melbourne. 5334

NEW COOLGARDIE GOLD MINES NO LIABILITY.

NOTICE is hereby given that all shares in New Coolgardie Gold Mines No Liability forfeited for non-payment of the 5th Call of One shilling per share (which was due and payable on 14th July, 1948), will be sold by public auction in the vestibule of the Stock Exchange of Melbourne, on Thursday, 12th August, 1948, at a quarter to Twelve a.m., if not redeemed by payment of the above call, on or before the day previous to the day of sale.

By order of the Board,

L. EDWARDS, Manager.

360 Collins-street, Melbourne, 2nd August, 1948. 5336

No. of Company—M10457. Form No. 71.
Companies Act 1938.

GREAT WESTERN CONSOLIDATED NO LIABILITY.

NOTICE OF NAME OF MANAGER OF A MINING COMPANY,
PURSUANT TO SECTION 413 (1).

To the Registrar-General.

GREAT WESTERN CONSOLIDATED NO LIABILITY hereby gives notice that the name of the manager of the said company is Leslie Edwards.
Dated this 30th day of July, 1948.

The common seal of Great Western Consolidated No Liability was hereto affixed, in the presence of—

G. LINDESAY CLARK, Director.
W. D. BROOKES, Director.
L. EDWARDS, Manager.

Arthur Robinson and Co., solicitors, 360 Collins-street,
Melbourne, C.1. 5357

No. of Company—M10457. Form No. 69.
Companies Act 1938.

GREAT WESTERN CONSOLIDATED NO LIABILITY.

NOTICE OF SITUATION OF REGISTERED OFFICE OF A MINING COMPANY, PURSUANT TO SECTION 410 (3).

To the Registrar-General.

GREAT WESTERN CONSOLIDATED NO LIABILITY hereby gives notice that the registered office of the company is situated at 360 Collins-street, Melbourne.
Dated this 30th day of July, 1948.

The common seal of Great Western Consolidated No Liability was hereto affixed, in the presence of—

G. LINDESAY CLARK, Director.
W. D. BROOKES, Director.
L. EDWARDS, Manager.

Arthur Robinson and Co., solicitors, 360 Collins-street,
Melbourne, C.1. 5358

Companies Act 1938.—Fifteenth Schedule—Part A.

BALLARAT SOUTH GOLDFIELDS NO LIABILITY.

I, THE undersigned, hereby make application to register Ballarat South Goldfields No Liability as a company under the provisions of Part II. of the *Companies Act 1938*.

1. The name of the company is to be Ballarat South Goldfields No Liability.
2. The place of intended operations is at Ballarat in the State of Victoria.
3. The registered office of the company will be situated at 422 Collins-street, Melbourne.
4. The value of the company's property, including leased ground and machinery, is £1,750.
5. The number of shares in the company is 190,000 shares of Five shillings each and 50,000 shares of One shilling each.
6. The number of shares subscribed for is 95,000 Five shilling shares, being not less than Twenty-five per centum of the entire number of shares in the company.
7. The amount of the subscribed capital which is paid up is £23,750, being not less than Five per centum of the subscribed capital.

8. The name of the manager is James Lorenzo Moore.
 9. The names and addresses and occupations of at least two shareholders who have subscribed for shares in the company and the number of shares subscribed for by each of them at this date is as follows:—

<i>Name; Address; Occupation; Number of Shares.</i>	
Edwin Gripper Banks, 360 Collins-street, Melbourne, consulting mining engineer	500
Robert Charles Philp, Union Bank Chambers, Queen-street, Brisbane, grazier	1,500
John Valentine Lake, 280 St. Kilda-street, Brighton, mining engineer	1,000
John Findlay McNab, 265 Ascot Vale-road, Ascot Vale, grazier	2,000

10. A majority in number and value of the shareholders in, and the creditors (if any) of the company in writing, have consented to its incorporation as a no liability company.

Dated the 30th day of July, 1948.

JAMES L. MOORE.

Witness to signature—H. P. OGILVIE.

I, JAMES LORENZO MOORE, do solemnly and sincerely declare that—

1. I am the manager of the said intended company.
2. The above statement is, to the best of my belief and knowledge, true in every particular. And I make this solemn declaration conscientiously believing the same to be true and by virtue of the provisions of an Act of the Parliament of Victoria rendering persons making a false declaration punishable for wilful and corrupt perjury.

JAMES L. MOORE.

Taken at Melbourne, in the State of Victoria, this 30th day of July, 1948, before me—H. P. OGILVIE, J.P.

Haden Smith and Fitchett, solicitors, 405 Collins-street, Melbourne. 5352

IMPOUNDINGS.

BEAUFORT.—Impounded at Beaufort.

- 1 dark Jersey heifer, no visible brand
 - 2 red Poll heifers, no visible brand
 - 1 red Jersey heifer, no visible brand
 - 1 Jersey Shorthorn Cross heifer, no visible brand
- If not claimed and expenses paid, to be sold on 19th August, 1948.

F. J. BLAY,
Poundkeeper.

5318—7/6

BEVERIDGE.—Impounded at Beveridge.

- 2 Border Leicester rams, aged, branded black G
- If not claimed and expenses paid, to be sold on 25th August, 1948.

J. THANE,
Poundkeeper.

5321—5/

GREENSBOROUGH.—Impounded at Greensborough.

- 1 roan semi-draught horse, no visible brand
 - 1 black gelding, no visible brand
- If not claimed and expenses paid, to be sold on 18th August, 1948.

S. THOMPSON,
Poundkeeper.

5361—5/10

LANCEFIELD.—Impounded at Lancefield, by E. Alston.

- 1 aged bay draught mare, white blaze, no visible brand
- 1 bay draught gelding, about 7 years, white blaze, no visible brand

If not claimed and expenses paid, to be sold on 13th August, 1948.

J. S. RUMMING,
Poundkeeper.

5303—6/8

ORBOST.—Impounded in Orbost Pound, by Shire Herdsman.

- 1 red heifer, white belly, notch out of bottom of off ear
 - 1 Jersey cow, small notch out of near ear, no visible brand
- If not claimed and expenses paid, to be sold after fourteen days.

H. DOMINEY,
Poundkeeper.

5283—6/8

SALE.—Impounded in Sale Pound.

- 1 bay mare, white hind feet, blaze face, no visible brand
 - 1 brown mare, white hind feet, blaze face, branded like D over blotch, chestnut creamy foal at foot
 - 1 black heifer, piece out under each ear, like S off rump
- If not claimed and expenses paid, to be sold on 3rd August, 1948.

G. CLARK,
Poundkeeper.

5298—7/6

SHEPPARTON.—Impounded at Shepparton.

- 1 Jersey cow, aged, no visible brand
- If not claimed and expenses paid, to be sold on 19th August, 1948.

G. F. WALTERS,
Poundkeeper.

5362—5/

TEMPLESTOWE.—Impounded at Templestowe.

- 1 young cow, mostly black, some white, no visible brand
- If not claimed and expenses paid, to be sold on 11th August, 1948.

A. W. AFFLECK,
Poundkeeper.

5285—5/

YARRAGON.—Impounded at Yarragon.

- 1 brown Jersey cow, milking, no visible brand
- If not claimed and expenses paid, to be sold on 18th August, 1948.

P. FLETCHER,
Poundkeeper.

5317—5/

YARRAM.—Impounded by Shire Herdsman, from Alberton, 21st July, 1948.

- 1 red poll springer heifer, top off off ear
 - 1 dark Jersey cow, slit bottom both ears, piece out both ears, indescribable brand off rump
 - 1 red steer calf, progeny of above, rope round neck
- If not claimed and expenses paid, to be sold on 13th August, 1948.

JAS. MITCHELL,
Poundkeeper.

5316—8/4

STATE ACTS, 1945.

COPIES of the following Acts of Parliament of Victoria may be obtained at the Government Printing Office, or from any bookseller, at the price set opposite to each:—

No.	Price.
	s. d.
5059. Mildura Irrigation and Water Trusts (Borrowing)	0 6
5060. Supreme Court (Judges)	0 6
5061. Oakleigh (Regent-street) Land	0 6
5062. Swine	0 6
5063. Drought Relief (Amendment)	0 6
5064. Unclaimed Moneys	0 6
5065. Consolidated Revenue	0 6
5066. Consolidated Revenue	0 6
5067. Agent-General's	0 6
5068. Land Surveyors (Amendment)	0 6
5069. Staté Development	0 6
5070. Melbourne and Metropolitan Board of Works (Borrowing Powers)	0 6
5071. Education	0 6
5072. Water	0 6
5073. National Security (Repeal)	0 6
5074. Moorabbin (Unimproved Rating Poll)	0 6
5075. Licensing (Poll)	0 6
5076. Lilydale Waterworks Trust Abolition	0 6
5077. East Melbourne Land	0 6
5078. Health (Wines)	0 6
5079. Local Government (Emergency Housing Accommodation)	0 6

STATE ACTS, 1945—*continued.*

No.	Description	Price.	
		s.	d.
5080.	Law Institute	0	6
5081.	Bendigo Land	0	6
5082.	Consolidated Revenue	0	6
5083.	Consolidated Revenue	0	6
5084.	Consolidated Revenue	0	6
5085.	Factories and Shops (Bread Holidays)	0	6
5086.	Administration and Probate Duties ..	0	6
5087.	Land Tax	0	6
5088.	Stamps (Increased Duty Continuance)	0	6
5089.	Licensing Fund	0	6
5090.	Employers and Employés	0	6
5091.	Farmers Advances	0	6
5092.	University (Veterinary Research) ..	0	6
5093.	Surplus Revenue	0	6
5094.	State Forests Loan and Application ..	0	6
5095.	Mines (Amendment)	0	6
5096.	Farmers Protection (Amendment) ..	0	6
5097.	Railway Loan Application	0	6
5098.	Public Works Loan and Application ..	0	6
5099.	Water Supply Loans Application ..	0	9
5100.	Public Account Advances (Amendment)	0	6
5101.	Hospital Benefits	0	6
5102.	Totalizator (Amendment)	0	6
5103.	Financial Emergency (Municipal Endowment)	0	6
5104.	Country Roads Board Fund (Amendment)	0	6
5105.	Coal Mines Regulation (Amendment) ..	0	6
5106.	Melbourne and Metropolitan Tramways (Chairman)	0	6
5107.	Soldier Settlement	1	3
5108.	Appropriation of Revenue	4	0

J. J. GOURLEY,
Government Printer.

STATE ACTS, 1946—*continued.*

No.	Description	Price.	
		s.	d.
5125.	Teaching Service	1	3
5126.	Police Regulation	1	0
5127.	Railways (Long Service)	0	6
5128.	Workers' Compensation	1	6
5129.	Sewerage Districts (Amendment) ..	0	6
5130.	Factories and Shops (Bread)	0	6
5131.	Crimes (Intermediate Sentences) ..	0	6
5132.	Medical (Chemists' Apprentices) ..	0	6
5133.	Soldier Settlement (Amendment) ..	0	6
5134.	Consolidated Revenue	0	6
5135.	Consolidated Revenue	0	6
5136.	Apprenticeship	0	6
5137.	Consolidated Revenue	0	6
5138.	Consolidated Revenue	0	6
5139.	Consolidated Revenue	0	6
5140.	Nicholson-street Tramway Construction	0	6
5141.	Burke-road Tramway Construction ..	0	6
5142.	Balluarat Gas Company's	0	6
5143.	Melbourne and Metropolitan Board of Works (Contributions)	0	6
5144.	Stamps (Betting Tax)	0	6
5145.	Juries (Fees)	0	6
5146.	Cattle and Swine Compensation ..	0	6
5147.	Marine (Pilots and Pilotage Rates) ..	0	6
5148.	Patriotic Funds	0	6
5149.	Stock Foods (Amendment)	0	6
5150.	Municipal Endowment (Temporary Discontinuance)	0	6
5151.	Medical Practitioners' Registration ..	0	6
5152.	Seeds	0	6
5153.	Water	0	6
5154.	Clifton Hill Land	0	6
5155.	Tobacco Sellers	0	6
5156.	Country Roads Board Fund (Amendment)	0	6
5157.	Moorpanyal Land	0	6
5158.	Factories and Shops (Annual Holidays) Amendment	0	6
5159.	Factories and Shops (Wages Boards) ..	0	6
5160.	Melbourne and Metropolitan Tramways (Amendment)	0	6
5161.	Infectious Diseases Hospital (Borrowing)	0	6
5162.	University (Mildura Branch)	0	6
5163.	Farmers Protection (Amendment) ..	0	6
5164.	Forests (Exchange of Lands) Extension	0	6
5165.	Money Lenders (Cash Orders)	0	6
5166.	Local Government (Dandenong Street Construction)	1	0
5167.	Stamps (Increased Duty Continuance)	0	6
5168.	Land Tax	0	6
5169.	Cattle Breeding	0	6
5170.	Administration and Probate Duties ..	0	6
5171.	Co-operative Housing Societies (Guarantees)	0	6
5172.	Railways (Sick Leave)	0	6
5173.	Fruit and Vegetables	0	6
5174.	Farm Water Supplies and Drainage Advances	0	6
5175.	State Forests Loan and Application ..	0	6
5176.	Melbourne South Land	0	6
5177.	Agricultural Colleges (Amendment) ..	0	6
5178.	Drought Relief (Amendment)	0	6
5179.	Soldier Settlement	1	9
5180.	Free Library Service Board	0	6
5181.	Adult Education	0	6

STATE ACTS, 1946.

COPIES of the following Acts of Parliament of Victoria may be obtained at the Government Printing Office, or from any bookseller, at the price set opposite to each:—

No.	Description	Price.	
		s.	d.
5109.	Geelong Land	0	6
5110.	Transport Regulation (Amendment) ..	0	6
5111.	Factories and Shops (Annual Holidays)	0	9
5112.	Mornington Sewerage Authority (Validation)	0	6
5113.	Local Government (Emergency Housing Accommodation) Amendment	0	6
5114.	Housing (Commonwealth and State Agreement)	1	0
5115.	Factories and Shops (Early Closing) ..	0	6
5116.	Building Operations and Building Materials Control	0	9
5117.	Water (Levee Banks)	0	9
5118.	Co-operative Housing Societies	0	6
5119.	Local Government (Municipal Rolls) ..	0	6
5120.	Public Works Loan and Application ..	0	6
5121.	Totalizator (Charities)	0	6
5122.	Drought Relief	0	6
5123.	Taxation (Arrangements)	0	6
5124.	Public Service	1	6

STATE ACTS, 1946—continued.

No.	Price.	
	s.	d.
5183. Evidence	0	6
5184. Housing (Discharged Servicemen) ..	0	6
5185. Parliamentary Contributory Retirement Fund	0	6
5186. Friendly Societies	0	6
5187. Police Offences (Race-meetings) ..	0	6
5188. Railways (Mont Park Siding)	0	6
5189. Land (Grazing Licences)	0	6
5190. Factories and Shops (Bread Carters)	0	6
5191. Country Fire Authority	1	0
5192. Supreme Court (Judges)	0	6
5193. Railway Loan Application	0	6
5194. Metropolitan Gas Company's	0	6
5195. Railways (Temporary Employés) ..	0	6
5196. Railways (State Coal Mine)	0	6
5197. Licensing	0	6
5198. Town and Country Planning	0	6
5199. Public Works Loan and Application (No. 2) ..	0	6
5201. Trotting Races	0	6
5202. Economic Stability	0	6
5204. Stamps	2	3
5206. Melbourne and Metropolitan Tramways (Appeal Board)	0	6

J. J. GOURLEY,
Government Printer.

STATE ACTS, 1947—continued.

No.	Price.	
	s.	d.
5232. State Forests Loan and Application ..	0	6
5233. Melbourne and Metropolitan Tramways (Amendment)	0	6
5234. Auditor-General's Salary	0	6
5235. Drought Relief (Amendment)	0	6
5236. Wheat Marketing (Winding Up) Amendment	0	6
5237. University (Mildura Branch)	0	6
5238. Factories and Shops (Bread)	0	6
5239. Water Supply Loan and Application ..	1	3
5240. Public Works Loan and Application ..	0	6
5241. Administration and Probate Duties ..	0	6
5242. Land Tax	0	6
5243. Country Roads Board Fund (Amendment) ..	0	6
5244. Ballarat Land	0	9
5245. Stamps (Increased Duty Continuance)	0	6
5246. Railway Loan Application	0	9
5247. Sewerage Districts (Amendment)	0	6
5248. State Electricity Commission (Financial) ..	0	6
5249. Public Account Advances (Amendment) ..	0	6
5250. Infectious Diseases Hospital (Amendment) ..	0	6
5251. Public Works Loan and Application (Amend- ment)	0	6
5252. Officials in Parliament	0	6
5253. Water	0	6
5254. Supreme Court (Judges Salaries)	0	6
5255. Superannuation	0	9
5256. Country Sewerage Loan and Application ..	0	6
5257. Melbourne and Metropolitan Board of Works (Contributions)	0	6
5258. Vegetation Diseases (Fruit Fly)	0	6
5259. Building Operations and Building Materials Control (Amendment)	0	6
5260. Police Regulation (Amendment)	0	6
5261. Factories and Shops (Determinations) ..	0	6

J. J. GOURLEY,
Government Printer.

STATE ACTS, 1947.

COPIES of the following Acts of Parliament of Victoria may be obtained at the Government Printing Office, or from any bookseller, at the price set opposite to each:—

No.	Price.	
	s.	d.
5207. Consolidated Revenue	0	6
5208. Custodian Trustee	0	6
5209. Revocation and Excision of Crown Reservations	0	9
5210. Farmers Advances (Amendment)	0	6
5211. Private Bill Committees	0	6
5212. Health (Amendment)	0	6
5213. Wills (Amendment)	0	6
5214. Old Colonists' Association	0	6
5215. Consolidated Revenue	0	6
5216. Local Authorities Superannuation	1	0
5217. Statute Law Revision	0	6
5218. Motor Car (Registration Fees)	0	6
5219. State Electricity Commission (Yallourn Area)	0	6
5220. Transport Regulation (Licences and Fees) ..	0	6
5221. Local Government (Private Street Construction)	0	6
5222. State Development (Amendment)	0	6
5223. Coal Mine Workers Pensions	0	6
5224. State Savings Bank	0	9
5225. Drought Relief	0	6
5226. Soil Conservation and Land Utilization ..	1	0
5227. Consolidated Revenue	0	6
5228. Consolidated Revenue	0	6
5229. Consolidated Revenue	0	6
5230. Municipal Endowment (Temporary Discontin- uance)	0	6
5231. Forests (Commissioners)	0	6

AGENTS FOR THE "VICTORIA GOVERNMENT GAZETTE."

THE following have been appointed agents to receive Advertisements and subscriptions for the *Victoria Government Gazette*:—

- ARMSTRONG'S AGENCY, 143 Queen-street, Melbourne.
- MESSRS. ARNALL & JACKSON, 115 Barkly-street, West Brunswick.
- MESSRS. GORDON & GOTCH, News Agents, 511 Little Collins-street, Melbourne; and corner Barrack and Clarence streets, Sydney.
- MESSRS. HARSTON, PARTRIDGE, & CO., 455 Little Collins-street, Melbourne.
- ROBERTSON & MULLENS LTD., Elizaoeth-street, Melbourne.
- MESSRS. A. S. RICHARDSON and T. C. GARDNER, trading as The Mercantile Exchange, 380 Collins-street, Melbourne.
- E. S. and N. W. CASH, Main-street, Bairnsdale.
- MR. M. R. BADE, Tobacconist, Sturt-street, Ballarat.

TRIGG'S NEWS AGENCY, Hargreaves-street, Bendigo.
 MR. G. H. K. PAYNE, 4 View Point, Bendigo.
 MR. C. F. LATIMER, News Agent, Casterton.
 MESSRS. HENRY FRANKS & CO., Booksellers and Stationers, Market-square, Geelong.
 MESSRS. SMITH & DUNNON, Hamilton.
 ARMSTRONG BROS., Kyneton.
 MR. WM. DAVIS, Mildura.
 PIKE'S AUTHORIZED NEWS AGENCY, Sale.
 MR. C. T. RUST, News Agent, Wangaratta.
 MR. F. T. McCORMICK, Nunn-street, Benalla.
 W. GORDON HAMPTON, 243 Mitchell-street, Bendigo.
 R. & A. SMALLMAN, News Agents, Toora.

A copy of the Gazette filed at each place for public reference.

THE "VICTORIA GOVERNMENT GAZETTE."

SUBSCRIPTIONS.—*The subscription, including Postage, is £1 12s. 6d. per annum, 16s. 3d. half-yearly, or 8s. 2d. per quarter, payable in advance.*

Subscriptions are required to commence and terminate with a month.

A lesser period than three months cannot be subscribed for.

Subscribers do not receive the Acts of Parliament with the GAZETTE.

ADVERTISEMENTS are charged at the rate of TEN PENCE per line single column, and ONE SHILLING and EIGHT PENCE per line double column.

The title (15 Reward, Dissolution of Partnership, &c.) forms one or more lines as a heading.

On an average, ten words make a line.

Every signature must likewise be counted as a line.

The final words of a paragraph, though only portion of a line must be counted as one line.

SIGNATURES (in particular) and proper names must be written very plainly in the text; ONE SIDE ONLY of each slip of paper should be WRITTEN UPON.

ALL COMMUNICATIONS should be addressed to "The Government Printer, Melbourne."

ALL DOCUMENTS illegibly written will be returned unpublished, and, where brands occur unprovided for by the ordinary letters of the alphabet, a worded explanatory description must be furnished.

THE VICTORIA GOVERNMENT GAZETTE is published on WEDNESDAY EVENING in each week, and Notices for insertion will be received by the Government Printer at or before Two p.m., at ordinary rates, and late advertisements between Two p.m. and FIVE p.m. at double rates on the day preceding the day of publication.

Single copies of the VICTORIA GOVERNMENT GAZETTE are Six pence, posted Eight pence, each.

No GAZETTES prior to January, 1938, in stock.

***ALL PAYMENTS ARE REQUIRED IN ADVANCE.—Remittances should be made by postal note, money order, or draft in favour of the Government Printer. Advertisements unaccompanied by a remittance sufficient to cover the cost of insertion will be returned unpublished.

CONTENTS

	PAGE.
Act of Parliament	4927
Acts of Parliament on sale at the Government Printing Office	4971
Appointments	4928
Bank Half-holidays	4927
Contracts	4951
Courts	4932
Estates of Deceased Persons	4950
Government Notices	4932
Impoundings	4971
Lands	4955
Melbourne and Metropolitan Board of Works— Notice	4950
Mining	4934, 4969
Money Lenders Act 1938—Supplementary List	4944
Orders in Council	4951
Private Advertisements	4960
Proclamations	4927
Public Holidays	4928
Public Service Notices	4929
Removal and Appointment of Electoral Registrars and Deputy Electoral Registrars for Divisions of Electoral Provinces	4947
Resignations	4929
Solicitors (Audit and Practising Certificates) Rules 1948	4938
Solicitors (Professional Conduct and Practice) Rules 1948	4936
Supplementary List of Dietitians	4935
Tenders	4958
Transport Regulation Board—Public Hearings	4933