



VICTORIA GOVERNMENT GAZETTE.

Published by Authority.

[Registered at the General Post Office, Melbourne, for transmission by post as a newspaper.]

No. 38]

WEDNESDAY, JANUARY 18.

[1950

Land Act 1928.

AREAS OF LANDS COMPRISED IN CERTAIN CLASSES DIMINISHED OR INCREASED.

PROCLAMATION

By His Excellency the Governor of the State of Victoria and its Dependencies in the Commonwealth of Australia, &c., &c., &c.

WHEREAS by the *Land Act 1928* it is amongst other things enacted that the Governor in Council may, by Proclamation to be published in the *Government Gazette*, at any time diminish or increase the area of land comprised in any of the classes mentioned in Part I., Division 1, section 5, of the said *Land Act 1928*, but that the area of lands which may be sold by auction (Class 6) shall not be increased except as in certain cases in the said Act provided: Now therefore I, the Governor of the State of Victoria, in the Commonwealth of Australia, by and with the advice of the Executive Council of the said State, and in accordance with the provisions of sections 94 and 117 of the *Land Act 1928* aforesaid, do hereby diminish or increase (as the case may be) the areas of Crown lands comprised in Classes 1, 2, 6 and 7 respectively of the classes mentioned in section 5 of the *Land Act 1928* aforesaid to the extent set forth in the subjoined Schedule (that is to say):—

Schedule referred to.

CLASSES DIMINISHED OR INCREASED.

County.	Parish.	Allotment.	Section.	Area.	Diminished.	Increased.	Description.
					Class.	Class.	
Talbot	Castlemaine ..	54	B ¹	A. R. P. 3 0 30	7	2	In the east of parish. (0547/121)
Delatite	Monea South ..	32B	1	12 3 12	2	..	In the east of parish. (H.016421)
Talbot	Craigie	90c	8A	12 0 0	..	1'	North of and adjacent to the Township of Craigie. (W.66544)
Kara Kara	St. Arnaud	2	15	0 1 15	7	2	North of Town of St. Arnaud (W.64010)
Kara Kara	St. Arnaud	14	11B	0 0 36 ³ / ₁₀	7	6	Fronting Wolfe-street. (W.60156)
Bendigo	Parish of Sandhurst, Borough of Eagle- hawk	5	54	0 1 16	7	6	Fronting Kirkwood-street. (W.66349)
Grenville	Carrnham	69B	26	1 0 0	7	..	In west of parish. (J.27418)

Given under my Hand and the Seal of the State of Victoria aforesaid, at Melbourne, this tenth day of January, in the year of our Lord One thousand nine hundred and fifty, and in the fourteenth year of the reign of His Majesty King George VI.

(L.S.)

DALLAS BROOKS.

By His Excellency's Command,

R. C. GUTHRIE,
Commissioner of Crown Lands and Survey.

GOD SAVE THE KING!

PUBLIC HOLIDAYS.

PROCLAMATION

By His Excellency the Governor of the State of Victoria and its Dependencies in the Commonwealth of Australia, &c., &c., &c.

IN pursuance of the provisions contained in Part III. of the *Public Service Act 1946* (10 Geo. VI. No. 5124), I, the Governor of the State of Victoria, in the Commonwealth of Australia, by and with the advice of the Executive Council of the said State, do by this my Proclamation appoint the days and dates hereunder mentioned to be observed as Public Holidays or Public Half-Holidays (as the case may be) at the places respectively specified, viz.:—

Public Holidays:—

SATURDAY, THE 4TH DAY OF FEBRUARY, 1950, throughout the Shire of Narracan.*

SATURDAY, THE 4TH DAY OF MARCH, 1950, throughout the Shire of Warragul.*

Public Half-Holidays from the Hour of Twelve o'clock noon:—

MONDAY, THE 13TH DAY OF FEBRUARY, 1950, throughout the Shire of Warragul.

MONDAY, THE 20TH DAY OF FEBRUARY, 1950, throughout the Shire of Newham and Woodend.

* Agricultural Show.

Given under my Hand and the Seal of the State of Victoria aforesaid, at Melbourne, this seventeenth day of January, in the year of our Lord One thousand nine hundred and fifty, and in the fourteenth year of the reign of His Majesty King George VI.

(L.S.) DALLAS BROOKS.

By His Excellency's Command,

W. WATT LEGGATT,
Chief Secretary.

GOD SAVE THE KING!

JUSTICES (SERVICE OF PROCESS) ACT 1949.

PROCLAMATION

By His Excellency the Governor of the State of Victoria and its Dependencies in the Commonwealth of Australia, &c., &c., &c.

WHEREAS by an Act of Parliament of the State of Victoria, passed in the thirteenth year of the reign of His Majesty King George VI., intituled the *Justices (Service of Process) Act 1949*, it is amongst other things enacted that the said Act shall come into operation on a date to be fixed by Proclamation of the Governor in Council published in the *Government Gazette*: Now therefore I, the Governor of the State of Victoria, acting by and with the advice of the Executive Council thereto, do by this my Proclamation fix Saturday the first day of April, One thousand nine hundred and fifty as the day upon which the *Justices (Service of Process) Act 1949* shall come into operation.

Given under my Hand and the Seal of the State of Victoria aforesaid, at Melbourne, this tenth day of January, in the year of our Lord, One thousand nine hundred and fifty, and in the fourteenth year of the reign of His Majesty King George VI.

(L.S.) DALLAS BROOKS.

By His Excellency's Command,

T. D. OLDHAM,
Attorney-General.

GOD SAVE THE KING!

PUBLIC HOLIDAY.—AUSTRALIA DAY.

IT is hereby notified that on—

MONDAY, THE 30TH JANUARY, 1950,

the Public Offices will be closed, that day being appointed by the *Public Service Act 1946* to be observed as a holiday in the Public Offices throughout Victoria.

W. WATT LEGGATT,
Chief Secretary.

Chief Secretary's Office,
Melbourne, 9th January, 1950.

APPOINTMENTS.

HIS Excellency the Governor of the State of Victoria, by and with the advice of the Executive Council thereof, has, by Orders made on the 10th day of January, 1950, been pleased to make the under-mentioned appointments, viz.:—

DEPARTMENT OF AGRICULTURE.

Inspectors, Stock Diseases Act 1928.

COLIN GILBERT GRAY, an officer of the Department of Agriculture,

to be an Inspector of Stock under the said Act without addition to salary and for the period during which he shall continue to be employed in his present capacity, in accordance with the provisions of section 5 of Part 1 of the *Stock Diseases Act 1928*; and

COONLEY EDWARDS PRICE (First Constable of Police) to be Inspector of Stock at Apsley (*vice* First Constable F. R. Sullivan, transferred) as from the 5th December, 1949, in accordance with the provisions of section 5 of Part 1 of the *Stock Diseases Act 1928*.

DEPARTMENT OF CHIEF SECRETARY.

Licensing Inspector.

JOHN ERNEST HUTCHINSON, Inspector of Police, pursuant to the provisions of the Licensing Acts, to be a Licensing Inspector for each and every Licensing District in the State of Victoria, *vice* David Vincent Burns, resigned.

DEPARTMENT OF HEALTH.

Director of Tuberculosis.

ESMOND VENNER KEOGH to be Director of Tuberculosis for a period of three years from the 1st February, 1950, pursuant to the provisions of section 4 of the *Health (Tuberculosis Arrangement) Act 1949* (No. 5432).

Member of Staff of Hospitals and Charities Commission.

JEAN CONNELL

to be a Member of the Staff of the Hospitals and Charities Commission, pursuant to the provisions of section 14 of the *Hospitals and Charities Act 1948* (No. 5300), as from the 2nd January, 1950, *vice* Irene Lillian Berrisford, resigned.

Acting Medical Superintendent.

VICTOR LEWIN MATCHETT

to be Acting Medical Superintendent of the Mental Hospital, Beechworth, pursuant to the provisions of section 35 of the *Mental Hygiene Act 1928* (No. 3721), from the 21st December, 1949, *vice* Harold Crawford Stone, on leave.

DEPARTMENT OF LANDS AND SURVEY.

Members, &c., of Settlers' Inquiry Committees.

No. 1 Committee—

WILLIAM TREVOR LONG and
WILLIAM EDMENDS,

No. 2 Committee—

WILLIAM MALCOLM CRAWFORD and
ROBERT JAMES THOMSON, and

No. 3 Committee—

GEORGE LESLIE WOOD and
WILLIAM HENRY BURNS,

officers of the Department of Lands and Survey, together with the person for the time being acting in the capacity of Secretary for Lands (who will be the Chairman of each Committee), to be Members of the Settlers' Inquiry Committee set out opposite their respective names, in pursuance of section 9 of the *Closer Settlement Act 1938*.

Member of Committee of Management.

JAMES ROY WALKER,

for so long only as he shall continue to be a Councillor and the elect of the Council of the Shire of Glenlyon, to be a Member of the Committee of Management of the reserves at Hepburn in the Parish of Wombat in respect of which Crown grants have been issued to the Board of Land and Works, the President, Councillors, and Ratepayers of the Shire of Mt. Franklin (now Glenlyon), and the Mayor, Councillors, and Burgesses of the Borough of Daylesford, and known as the "Hepburn Mineral Springs," in the place of William MacDonald, who has ceased to be the elect of the Council of the Shire of Glenlyon, in pursuance of section 183 of the *Land Act 1928*.

DEPARTMENT OF LAW.

Bailiff of County Court.

JAMES GIBSON, Senior Constable of Police, Lakes Entrance,

to be also a Bailiff of the County Court at Bairnsdale, vice J. D. Moore, resigned.

Clerk of Petty Sessions, Deputy Clerk of the Peace, &c.

EWEN LESLIE ROSS

to be also Clerk of Petty Sessions at Kew, and Clerk of Petty Sessions and Clerk of the Children's Courts at Healesville, Lilydale, and Warburton, during the absence on sick leave of E. G. Fisher;

JAMES EDMUND O'CONNOR

to be also Clerk of the Children's Courts at Cobram, Nathalia, and Numurkah, during the absence on annual leave of J. L. Collins;

JOHN MILLS

to be also Clerk of the Children's Courts at Beechworth, Bright, Myrtleford, and Yackandandah, during the absence on annual leave of F. C. Hill;

FREDERICK CLISBY HILL

to be also Deputy Clerk of the Peace, Registrar of the County Court, Clerk of the Children's Court at Wangaratta, and Clerk of the Children's Courts at Yarrowonga and Tungamah, during the absence on annual leave of J. Mills, and as Deputy Clerk of the Peace and Registrar of the County Court at Wangaratta, to be appointed by virtue of section 92 of the *Juries Act 1928* to do and perform with respect to the Courts at that place, in the place and stead of the Sheriff, all such acts as the Sheriff is, by the said Act, authorized or required to do or perform, during the absence on annual leave of J. Mills;

HAROLD EDWARD DALY

to be also Clerk of the Children's Courts at Horsham and Natimuk, during the absence on annual leave of R. J. Brown, and as Deputy Clerk of the Peace and Registrar of the County Court at Horsham, to be appointed by virtue of section 92 of the *Juries Act 1928* to do and perform with respect to the Courts at that place, in the place and stead of the Sheriff, all such acts and things as the Sheriff is, by the said Act, authorized or required to do or perform, during the absence on annual leave of R. J. Brown;

JOSEPH KEARNEY

to be Deputy Clerk of the Peace, Registrar of the County Court, Clerk of Petty Sessions, and Clerk of the Children's Court at Seymour, and Clerk of Petty Sessions and Clerk of the Children's Courts at Broadford, Kilmore, and Nagambie, during the absence on annual leave of J. L. McGaan, and as Deputy Clerk of the Peace and Registrar of the County Court at Seymour, to be appointed by virtue of section 92 of the *Juries Act 1928* to do and perform with respect to the Courts at that place, in the place and stead of the Sheriff, all such acts and things as the Sheriff is, by the said Act, authorized or required to do or perform, during the absence on annual leave of J. L. McGaan;

ERNEST JAMES DANAHER

to be also Deputy Clerk of the Peace, Registrar of the County Court, and Clerk of the Children's Courts at Portland, Heywood, Balmoral, Macarthur, and Peshurst, during the absence on annual leave of J. L. McArdle, and as Deputy Clerk of the Peace and Registrar of the County Court at Hamilton, to be appointed by virtue of section 92 of the *Juries Act 1928* to do and perform with respect to the Courts at that place, in the place and stead of the Sheriff, all such acts and things as the Sheriff is, by the said Act, authorized or required to do or perform, during the absence on annual leave of J. L. McArdle;

JOHN LEONARD MCARDLE

to be also Clerk of the Children's Courts at Casterton, Coleraine, Merino, Edenhope, and Harrow, during the absence on annual leave of E. J. Danaher;

PATRICK JOHN KELLY

to be also Deputy Clerk of the Peace, Registrar of the County Court, and Clerk of the Children's Court at Kerang, and Clerk of the Children's Courts at Cohuna, Koondrook, Quambatook, Boort, and Pyramid Hill, during the absence on annual leave of A. T. Ryall, and as Deputy Clerk of the Peace and Registrar of the County Court at Kerang, to be appointed by virtue of section 92 of the *Juries Act 1928* to do and perform with respect to the Courts at that place, in the place and stead of the Sheriff, all such acts as the Sheriff is, by the said Act, authorized or required to do or perform, during the absence on annual leave of A. T. Ryall;

ALFRED THOMAS RYALL

to be also Clerk of the Children's Courts at Echuca, Elmore, Kyabram, and Rochester, during the absence on annual leave of P. J. Kelly;

THOMAS RONALD DUNLOP

to be also Clerk of the Children's Courts at Wodonga, Chiltern, and Rutherglen, during the absence on annual leave of H. V. Boarder; and

HENRY VICTOR BOARDER

to be also Clerk of the Children's Courts at Tallangatta, Mitta Mitta, Corryong, and Walwa, during the absence on annual leave of T. R. Dunlop.

Commissioners for Taking Declarations, &c.

JOHN CROSSLAND WOODHOUSE, Academic Secretary, The University of Melbourne,

to be a Commissioner for taking Declarations and Affidavits, under the provisions of Division 8 of Part IV. of the *Evidence Act 1928*, to resign upon ceasing to occupy his present position; and

HAROLD WILLIAM FORD, 57 Wheatland-road, Malvern, and

JAMES HUBERT KELLEHER, 436 Lonsdale-street, Melbourne,

to be Commissioners for taking Declarations and Affidavits, under the provisions of Division 8 of Part IV. of the *Evidence Act 1928*, to resign upon removing from the neighbourhood of the addresses stated.

Magistrates.

PERCY CLARENCE LEWIS, Secretary, Freemasons' Hospital, East Melbourne,

CEDRIC WILLIAM GOWER, 4 Toora-street, Ivanhoe,

ROBERT HENRY CRAPPER, 200 Station-street, Fairfield, CLIFTON JAMES HENRY UPTON, 177 Waterdale-road, Ivanhoe,

JOHN WILLIAM ALLNUTT, Warrigal-road, Cheltenham, and

ASHLEY NORMAN HERBERT DYER, 219 Heidelberg-road, Fairfield,

to Keep the Peace in the Central Bailiwick of the State of Victoria;

REGINALD JOHN ALLWOOD, Dartmoor,

to Keep the Peace in the Western Bailiwick of the State of Victoria;

JAMES MOIR MALCOLM, Boisdale,

to Keep the Peace in the Eastern Bailiwick of the State of Victoria; and

ALFRED JOHN WILLIAM HOCKING, Bannerton,

to Keep the Peace in the Midland Bailiwick of the State of Victoria.

Probation Officer.

ERIC VICTOR CONSTABLE, Emerald,

to be a Probation Officer, pursuant to the provisions of section 8 of the *Children's Court Act 1928*, for the Children's Court at Ferntree Gully.

Prothonotary of the Supreme Court.

HAROLD BALDWIN DOWN

to act as Prothonotary of the Supreme Court of Victoria, during the absence on annual leave of R. D. McFarlane.

DEPARTMENT OF PUBLIC WORKS.

Members of the Marine Board of Victoria.

DOUGLAS SIMPSON STEVENSON,

ARTHUR TENNYSON SMITHERS, and

EDGAR MASTERS,

pursuant to the provisions of section 22 of the *Marine Act 1928*, to be Members of the Marine Board of Victoria (Government representative) for a period of three years from the 19th December, 1949;

DOUGLAS SIMPSON STEVENSON

to be President of the Marine Board of Victoria for three years from the 19th December, 1949, pursuant to the provisions of section 26 of the *Marine Act 1928*;

ARTHUR TENNYSON SMITHERS

to be Vice-President of the Marine Board of Victoria for three years from the 19th December, 1949, pursuant to the provisions of section 26 of the *Marine Act 1928*; and

WALTER WIMBLE BERRY and

RAYMOND RICHARD LAWSON,

pursuant to the provisions of section 27 of the *Marine Act 1928*, to be Members of the Marine Board of Victoria (representatives of merchants and traders) for three years from the 21st December, 1949.

STATE ELECTRICITY COMMISSION OF VICTORIA.

Deputy of Commissioner.

JAMES ADAM LOUIS MATHESON, M.B.E., M.Sc.(Manch.), Ph.D.(Birm.), M.C.E., A.M.I.C.E., A.M.I.Struc.E., M.I.E.(Aust.),

to act as the Deputy of Andrew Walker Fairley, a Commissioner of the State Electricity Commission of Victoria, during the absence of the said Andrew Walker Fairley, for the period commencing on the 10th day of January, 1950, and ending on the 28th day of February, 1950

DEPARTMENT OF TREASURER.

Receivers of Revenue (Acting).

ERNEST JAMES DANAHER
to act temporarily as Receiver of Revenue, Hamilton, during the absence of J. L. McArdle, on leave;

HAROLD EDWARD DALY
to act temporarily as Receiver of Revenue, Horsham, during the absence of R. J. Brown, on leave;

PATRICK JOHN KELLY
to act temporarily as Receiver of Revenue, Kerang, during the absence of A. T. Ryall, on leave;

JOSEPH KEARNEY
to act temporarily as Receiver of Revenue, Seymour, during the absence of J. L. McGaan, on leave;

STUART VERNON MORRIS
to act temporarily as Receiver of Revenue, Taxation Office, 179 Queen-street, Melbourne, during the absence of G. H. Thomas, on leave; and

THOMAS RONALD DUNLOP
to act temporarily as Receiver of Revenue, Wodonga, during the absence of H. V. Boarder, on leave.

Collector of Imposts (Acting).

FREDERICK GEORGE ROBOTHAM CLAYTON
to act temporarily as Collector of Imposts, Premier's Office, during the absence of P. H. Wallace, on leave;

JAMES TALBOT JONES
to act temporarily as Collector of Imposts, Workers Compensation Board, during the absence of G. T. Smith, on leave; and

ALAN FREDERICK LEIGH
to act temporarily as Collector of Imposts, Customs and Excise Office, Melbourne, during the absence of H. D. Hyland, on leave.

DEPARTMENT OF WATER SUPPLY.

Waterworks Trust Commissioners.

NOEL PATRICK O'BRIEN
to be a Commissioner of the Glenrowan Waterworks Trust, vice Noel McNulty, resigned, to hold such office from the date hereof until the 28th September, 1952, subject to the provisions of the Water Acts;

JAMES MCKINNON
to be a Commissioner of the Orbost Waterworks Trust for a period of four years from the date hereof, subject to the provisions of the Water Acts; and

HERBERT THOMAS LAWSON
to be a Commissioner of the Toora Waterworks Trust for a period of four years from the date hereof, subject to the provisions of the Water Acts.

Sewerage Authority Member.

JOHN KOENIG LIVINGSTON
to be a Member of the Jeparit Sewerage Authority for a period of four years from the date hereof, subject to the provisions of the Sewerage Districts Acts.

A. MAHLSTEDT,
Clerk of the Executive Council.
At the Executive Council Chamber,
Melbourne, 10th January, 1950.

RESIGNATIONS.

HIS Excellency the Governor of the State of Victoria, by and with the advice of the Executive Council thereof, has, by Orders made on the 10th day of January, 1950, accepted the resignations of the persons named hereunder of the offices mentioned, viz:—

DEPARTMENT OF LAW.

JAMES DANIEL MOORE, as a Bailiff of the County Court at Bairnsdale.

MAURICE BROWN, as a Commissioner for taking Declarations and Affidavits, pursuant to the provisions of the Evidence Act 1928.

BASIL JOSEPH RYAN, as a Commissioner for taking Declarations and Affidavits, pursuant to the provisions of the Evidence Act 1928.

A. MAHLSTEDT,
Clerk of the Executive Council.
At the Executive Council Chamber,
Melbourne, 10th January, 1950.

Marriage Act 1928.

MINISTERS OF RELIGION REGISTERED TO CELEBRATE MARRIAGES IN VICTORIA.

IT is hereby notified that, in pursuance of the provisions of the Marriage Act 1928, 19 Geo. V. No. 3726, Section 11, the under-mentioned Officiating Ministers of Religion have been registered at this Office for the celebration of marriages in Victoria:—

Number in Register.	Name.	Designation.	Denomination.	Residence.	Date of Registration.
10141	Peterson, Charles John ..	Priest ..	Church of England ..	Holy Trinity, Thornbury ..	12.12.49
10142	Smith, Colvil Lancelot ..	Minister ..	Churches of Christ ..	Boronia-road, Boronia ..	14.12.49
10143	Hingston, Antoninus Thomas ..	Priest ..	Roman Catholic ..	The Priory, East Camberwell ..	12.12.49
10144	Wilkinson, Reginald Henry ..	Elder ..	Latterday Saints ..	Skene-street, Bendigo ..	8.12.49
10145	Thickins, Percy Richard ..	Minister ..	Churches of Christ ..	34 Fyffe-street, Thornbury ..	21.12.49
10146	Mogilev, Athanasius ..	Priest ..	Russian Orthodox ..	Victoria-parade, East Melbourne ..	18.12.49
10147	Susemihl, Igor Wladimir ..	Priest ..	Russian Orthodox ..	Victoria-parade, East Melbourne ..	19.12.49
10148	Steer, Philip James ..	Pastor ..	Baptist Church ..	Baptist Manse, Rainbow ..	20.12.49
10149	Harper, Daniel Manson ..	Minister ..	Presbyterian ..	St. Andrew's, Kyneton ..	18.12.49
10150	Larsen, Francis ..	Priest ..	Roman Catholic ..	St. Patrick's, Melbourne ..	23.12.49
10151	O'Dwyer, Patrick ..	Priest ..	Roman Catholic ..	St. Joseph's, Warragul ..	4.1.50
10152	Neil, Herbert James ..	Deacon ..	Church of England ..	St. Mark's, Camberwell ..	4.1.50
10153	Webber, Eric ..	Priest ..	Church of England ..	Holy Trinity, Bendigo ..	29.12.49
10154	Strickland, Albert Edward John ..	Priest ..	Church of England ..	47 Sternberg-street, Bendigo ..	30.12.49
10155	Heggie, Ronald Neil ..	Pastor ..	Seventh Day Adventist ..	557 High-street, Golden Square ..	22.12.49
10156	Baird, Harold ..	Pastor ..	Seventh Day Adventist ..	64 Railway-parade, Shepparton ..	22.12.49

O. GAWLER,
Government Statist.

Office of the Government Statist,
Melbourne, 11th January, 1950.

Transport Regulation Acts.
TRANSPORT REGULATION BOARD.
NOTICES OF PUBLIC HEARINGS.

NOTICE is hereby given that the applications made by the persons named below for renewal of licences expiring 31st January, 1950, to operate commercial passenger vehicles in the manner set out in each case, will be heard at a time and place to be communicated to the parties:—

- Name and Address; Present Franchise; Licence No.*
- ANDERSON, G., Box 80, Cobram; (a) school service, Cobram-Numurkah, via Strathmerton, (b) under charter conditions within a radius of 20 miles of Cobram, and to named places; T.A.3293.
- ANDERSON, G., Box 80, Cobram; (a) school service, Cobram-Numurkah, via Katamatite, (b) under charter conditions within a radius of 20 miles of Cobram, and to named places; T.A.3301.
- BALDWIN, C. P., Box 21, Ultima, Vic.; school service, Ultima-Swan Hill; T.A.3309.
- BENNETT, O. L., 70 Baillie-street, Horsham; (a) school service, Dimboola-Dimboola East, (b) day tours from Horsham, (c) under charter conditions within a radius of 20 miles of Dimboola, and to named places; T.A.3310.
- CONWAY, J., Bair-street, Leongatha; (a) school service on a round route of Leongatha, (b) under charter conditions within a radius of 20 miles of Leongatha, with limiting conditions as to operations; T.A.3311.
- CUMMING, A. R., junr., Market-street, Inglewood; (a) school service on round route of Inglewood, (b) under charter conditions within a radius of 20 miles of Inglewood, and to named places; T.A.3302.
- DAVIS, H. A., Motor Service Pty. Ltd., 113 Doveton-street north, Ballarat; school service, Cape-Clear-Ballarart; T.A.3313.
- DAWSON, R. S., Elmore; school service, Neilson's Corner-Elmore; T.A.3314.
- DAY, H., Branxholme; (a) school service, Branxholme-Ardachy, (b) under charter conditions within a radius of 20 miles of Branxholme; T.A.3267.
- DUGINS, J. F., Lakes Entrance; (a) school service, Lakes Entrance-Bairnsdale, (b) under charter conditions within a radius of 20 miles of Lakes Entrance, and to named places; T.A.3312.
- EASTICK, E. H., Streatham; (a) school service, Nerrin Nerrin-Streatham, (b) under charter conditions within a radius of 20 miles of Streatham; T.A.3676.
- GAINGER BROS., 205 Murray-street, Colac; (a) school service, Ferguson-Lavers Hill, (b) under charter conditions within a radius of 20 miles of Colac, and to named places; T.A.3291.
- GAINGER BROS., 205 Murray-street, Colac; (a) school service, Hordern Vale-Lavers Hill, (b) under charter conditions within a radius of 20 miles of Colac, and to named places; T.A.3289.
- GAINGER BROS., 205 Murray-street, Colac; (a) school service, Lower Gellibrand-Lavers Hill, (b) under charter conditions within a radius of 20 miles of Colac, and to named places; T.A.3288.
- GAINGER BROS., 205 Murray-street, Colac; (a) school service, Kennedy's Creek-Lavers Hill, (b) under charter conditions within a radius of 20 miles of Colac, and to named places; T.A.3290.
- GAINGER BROS., 205 Murray-street, Colac; school service, Cressy-Colac; T.A.3316.
- GAINGER BROS., 205 Murray-street, Colac; (a) Barongarook-Elliminyt, (b) under charter conditions within a radius of 20 miles of Colac, and to named places; T.A.3320.
- GAINGER BROS., 205 Murray-street, Colac; school service, Pyles Siding-Lavers Hill; T.A.3683.
- GELDART BROS., Merrigum; (a) school service, Merrigum-Kyabram, (b) under charter conditions within a radius of 20 miles of Merrigum, and to named places; T.A.3318.
- GOLDSWORTHY, J. L., Kaniva; (a) school service, Lancelott-Kaniva, (b) under charter conditions within a radius of 20 miles of Kaniva, and to named places; T.A.3438.
- GRIEVE, T. R., Tatura; (a) school service, Murchison-Shepparton, (b) under charter conditions within a radius of 20 miles of Murchison, and to named places; T.A.3319.
- HUNTER, J., Winchelsea; (a) school service, Armitage-Winchelsea, (b) under charter conditions within a radius of 20 miles of Winchelsea; T.A.3678.
- IURST, R. R., Queen-street, Korumburra; (a) school service, Jeetho-Korumburra, via Moyarra, (b) under charter conditions within a radius of 20 miles of Korumburra; T.A.3429.
- JAY, E. G., Nundaly; school service, Chinkapook-Manangatang; T.A.3321.
- LANE, A. L. (trading as Lane's Bus Service), Warrnambool; school service on a round route of Port Fairy, via Moyne; T.A.3448.
- LANE, A. L. (trading as Lane's Bus Service), Warrnambool; school service, Port Fairy-Yambulk; T.A.3449.
- LANE, A. L. (trading as Lane's Bus Service), Warrnambool; school service, Orford-Port Fairy; T.A.3450.
- LANE, A. L. (trading as Lane's Bus Service), Warrnambool; (a) on a round route of Terang, via Booran, (b) under charter conditions within a radius of 20 miles of Terang; T.A.3689.
- LE FEVRE, G., Kergunyah; school service, Kergunyah-Wodonga; T.A.3322.
- LESLIE, W., Minyip; school service, Lillimur-Nhill; T.A.3304.
- LESLIE, W., Minyip; (a) school service, Noradjuha-Horsham, (b) under charter conditions within a radius of 20 miles of Natimuk, and to named places; T.A.3323.
- MAHER, A. A., Poowong; (a) school service on a round route of Poowong, via Ranceby, Bell View, and Poowong South, (b) under charter conditions within a radius of 20 miles of Poowong; T.A.3498.
- MENZEL, E. R., Cowangie; school service between block 25, Danyo and Danyo; T.A.3325.
- MONTI, E., Rochester; school service, Timmering-Rochester, and evening school students between Rochester and Echuca; T.A.3326.
- McKENZIE, L. R. (trading as McKenzie's Marysville Transport Service), Marysville; school service, Scrubby Creek-Alexandra; T.A.3665.
- PEACH, N. L., Macarthur; school service, Broadwood's Gate-Macarthur, via Hawker; T.A.3439.
- PEARCE, T. W., Bethanga Lower; school service, Bethanga-Wodonga; T.A.3328.
- POULTON, A. E., Hopetoun; (a) school service, Wathe-Hopetoun, (b) under charter conditions within a radius of 20 miles of Hopetoun, and to named places; T.A.3306.
- READ & BRACK, Benalla; (a) school service, Waggaranda-Benalla, (b) Lake Rowan-Benalla, (c) St. James-Yarrowonga, (d) specified day tours, (e) under charter conditions within a radius of 20 miles of Benalla, and to named places; T.A.3733.
- SUTTON, J. S., Culgoa; (a) school service, Culgoa-Sea Lake, (b) under charter conditions within a radius of 20 miles of Culgoa, and to named places; T.A.3452.
- STUCHBERRY, E. M., Dartmoor; (a) school service, Dartmoor-Portland, (b) under charter conditions within a radius of 20 miles of Dartmoor, and to named places; T.A.3331.
- SWEET, F. C., Daylesford; school service on a round route of Daylesford; T.A.3332.
- THOMAS, V. H., Maryborough; (a) school service, Laanecoorie-Maryborough, (b) under charter conditions within a radius of 20 miles of Maryborough, and to named places; T.A.3333.
- THOMAS, V. H., Maryborough; school service, Dunolly-Maryborough; T.A.3334.
- TURNER, E., Shelford; school service, Shelford-Geelong; T.A.3347.
- UNDERWOOD, G. H., Euroa; school service, Ruffy-Euroa, via Creighton's Creek; T.A.3447.
- UNDERWOOD, G. H., Euroa; (a) school service, Locksley-Euroa, via Lockwood, (b) under charter conditions within a radius of 20 miles of Euroa, and to named places; T.A.3440.
- UNDERWOOD, L. G., Euroa; (a) school service, Strathbogies-Euroa, (b) under charter conditions within a radius of 20 miles of Euroa; T.A.3280.
- WARRAGUL BUS LINES PTY. LTD., Frankston; (a) school service, Teetor-road-Warragul, (b) school service, Trafalgar-Warragul, (c) school service, Darnum-Warragul, (d) school service, Noojee-Warragul, (e) school service, Neerim-Warragul, (f) school service, Tynong-Warragul, (g) school service, Poowong North-Warragul, (h) school service, Nilma-Warragul, (i) school service, Garfield-Warragul, (j) school service, Lang Lang-Warragul, (k) between Teetor-road and Warragul Picture Theatre, (l) between Heath Hill, Poowong, and North Warragul Picture Theatre, (m) between Darnum and Warragul Picture Theatre, (n) between Tynong and Warragul Picture Theatre, (o) between Garfield and Warragul, (p) between Neerim Junction and Neerim South Picture Theatre, (q) under charter conditions within a radius of 20 miles of Heath Hill, Teetor-road, Tynong, Warragul, Drouin, Darnum, Neerim, Noojee, Trafalgar, and Lang Lang; T.A.3336, T.A.3337, T.A.3338, T.A.3339, T.A.3340, T.A.3341, T.A.3342.
- WILLIAMS, R. J., Walwa; (a) school service between Guys Forest and Walwa, via Shelley-road, (b) under charter conditions within a radius of 20 miles of Walwa, and to named places; T.A.3371.
- TAYLOR, G. C., Dunkeld; (a) school service, Woodhouse Soldier Settlement-Dunkeld, (b) under charter conditions within a radius of 20 miles of Dunkeld, and to named places; T.A.2507.

- SCRIVEN, W. R., Mystic Park; (a) school service, Lake Kangaroo-Kerang, (b) under charter conditions within a radius of 20 miles of Mystic Park; T.A.3330.
- TAYLOR, H. E., 922 High-street, Reservoir; (a) school service, Woolert-Northcote, (b) school service, Preston-Pender's-grove; T.A.3305.
- LEE, R. F., Piper-street, Kyneton; (a) school service, Lancefield-Kyneton, (b) under charter conditions within a radius of 20 miles of Kyneton, and to named places, (c) on specified day tours; T.A.3284.
- LEE, R. F., Piper-street, Kyneton; (a) school service, Redesdale-Kyneton, (b) under charter conditions within a radius of 20 miles of Kyneton, and to named places, (c) on specified day tours; T.A.3285.

NOTICE is hereby given that the applications made by the persons named below for licences to operate the commercial passenger vehicles on the route or routes, or in the manner set out opposite their names, will be heard at a time and place to be communicated to the parties:—

Name of Applicant; Nature of Application.

- BANKS SMITH, J. & R., Dandenong-road, Clayton; 1 commercial passenger vehicle, with seating capacity for 5 persons, to be purchased, to operate as follows:—(a) At separate and distinct fares within a radius of 5 miles of Clayton Railway Station, (b) under private hire conditions within a radius of 50 miles of Clayton Railway Station.
- COURTICE, W. J., Centre Dandenong-road, Dingley; 1 commercial passenger vehicle, with seating capacity for 5 persons, to operate as follows:—(a) At separate and distinct fares within a radius of 5 miles of Dingley, (b) under private hire conditions within a radius of 50 miles of Dingley (subject to the cancellation of licence No. P.H.1628, at present held by the applicant).
- FERRIS, I. L., 1 Pine-street, Nhill; 1 commercial passenger vehicle, with seating capacity for 29 persons, to operate for the carriage only of school children between Detpa and Nhill.
- FISHER, L. J., Main-street, Lang Lang; application for variation of licence No. T.A.2261, to include the ability to operate a shopping trip between Lang Lang and Warragul, via Drouin, on Thursdays only, with the proviso that on journeys to Warragul passengers may be set down anywhere *en route*, but shall not be picked up at any point nearer to Warragul than a point 1 mile south of Drouin, and on any journey from Warragul passengers may be picked up anywhere *en route*, but shall not be set down nearer to Warragul than the said point 1 mile south of Drouin. Fare, 4s. 6d. return.
- HEALESVILLE-ROAD SERVICE PTY. LTD., 414 Collins-street, Melbourne; 1 commercial passenger vehicle, with seating capacity for 5 persons, to operate as follows:—(a) To operate as a stage omnibus between—(1) Maroonda Lake Hotel and Lilydale Railway Station, (2) Healesville-Toolangi, (3) Healesville-Sir Colin McKenzie Sanctuary, (4) Healesville-Lilydale Higher Elementary School, (5) Healesville-Badger Creek, (6) Healesville-Strathairlie, (7) Healesville-Castella, (b) to operate as a touring omnibus as follows:—(1) Half-day tours—Healesville-Warburton, 8s., Healesville-Mt. Slide, 8s., Healesville-Stevenson's Falls, 9s., Healesville-Marysville, 6s., Healesville-Toolangi, 5s., Healesville-Mt. St. Leonard, 7s. 6d., Healesville-Carronderrils Weir and Badger Creek, 4s., Healesville-Maroonah Dam, 3s., (2) day tours—Healesville-Acheron Way, 12s. 6d., Healesville-Cumberland Valley, 15s., Healesville, via Don-road, Pantons Gap, Launching Place, Warburton, McVeigh's, Reefton's Gap to Cumberland-road, and return via Black Spur to Healesville, £1, plus picnic lunch 2s., (c) to operate for the carriage of passengers at separate and distinct fares within a radius of 5 miles of Healesville, and under private hire conditions within a radius of 50 miles of Healesville, (d) supplementary rights—on routes (a) 1 and 2 to carry up to 28 lb. of parcels, on routes (a) 6 and 7 to carry mails and newspapers and up to 2 cwt. of parcels, on route (a) 5 to carry up to 72 lb. of goods (subject to the cancellation of licence No. A.265, at present held by P. L. McNamara, Healesville).
- HEALESVILLE-ROAD SERVICE PTY. LTD., 414 Collins-street, Melbourne; 5 commercial passenger vehicles, with seating capacity for 27, 5, 27, 11, and 27 persons, respectively, to operate as follows:—(a) Between Maroonah Lake Hotel, Healesville, and Melbourne, via Lilydale, with the ability to pick up and set down passengers at guest-houses within a radius of 5 miles of Healesville, and in a northerly direction to Toolangi, (b) under all of the terms and conditions as at present contained in licences Nos. A.256, A.258, A.260, A.261, and A.632, at present in the course of transfer from P. L. McNamara, Healesville.

- HUNTER, J., Winchelsea; application for variation of licence No. T.A.3678, to include the ability to operate under charter conditions within a radius of 20 miles of Winchelsea.
- LOHREY, E. H. J. (trading as Hurstbridge Hire Car and Bus Service), Hurstbridge; 1 commercial passenger vehicle, with seating capacity for 17 persons, to be purchased, to operate as follows:—(a) From Hurstbridge Railway Station, via Arthur's Creek-road, Haley's Gully-road, Bingley-avenue, Wattle Tree-road, and Arthur's Creek-road, returning to Hurstbridge Railway Station, (b) under charter conditions within a radius of 20 miles of Hurstbridge and to Warburton and Seymour, (c) interchangeably with any large seating capacity vehicle of the applicant.
- MANSSELL, T., Tocumwal; 1 commercial passenger vehicle, with seating capacity for approximately 29 persons, to be purchased, to operate as follows:—(a) Between Tocumwal and Cobram Picture Theatre on Wednesday and Friday nights only, (b) under charter conditions within a radius of 20 miles of Tocumwal and to Shepparton, Echuca, Kyabram, Tatura, Mooroopna, Ardmona, Wahgunyah, Yarrowonga, and Nathalia.
- NEWTON, J. S., Whitfield; 1 commercial passenger vehicle, with seating capacity for 39 persons, to operate as follows:—(a) For the carriage only of school children between Whitfield and Wangaratta, via Moyhu, (b) as a substitute vehicle on the applicant's passenger service between Whitfield and Wangaratta, (c) under charter conditions within a radius of 20 miles of Whitfield and to Mansfield, Myrtleford, Mt. Buffalo, Beechworth, and Benalla.
- THOMAS, A., Inverloch; application for variation of licences Nos. A.207 and A.1681, to include the ability to operate between Inverloch and Leongatha and between Inverloch and Korumburra on market days, as and when required:—*Time tables*—depart Inverloch 10 a.m., depart Leongatha 5 p.m., fare, 7s. return, depart Inverloch 10 a.m., depart Korumburra 5 p.m., fare, 7s. return.
- WALSH, D. J., Wodonga; 1 commercial passenger vehicle, with seating capacity for 5 persons, to operate as follows:—(a) At separate and distinct fares within a radius of 5 miles of Wodonga Railway Station, (b) under private hire conditions within a radius of 50 miles of Wodonga Railway Station (subject to the cancellation of licence No. A.777, at present held by J. Mylon, Wodonga).
- WILLIAMSON, G. R., Stawell; application for variation of licence No. A.1740, to include the ability to operate under charter conditions within a radius of 20 miles of Stawell and to St. Arnaud, Murtoa, Horsham, Minyip, Rupanyup, Dunkeld, Beaufort, Avoca, Macorna, Navarre, Marnoo, Donald, Lake Bolac, Elmhurst, Barkly, Ampitheatre, Glenthompson, Willaura, Natimuk, Buangor, Bealiba, Pimpinio, Lexton, and between Great Western and Glenorchy to Hall's Gap and the Grampians, and on Saturdays, Sundays, and public holidays only from Stawell to Hall's Gap and the Grampians.

APPLICATIONS for licences to operate commercial passenger vehicles, with seating capacity for 5 persons, for the carriage of passengers, otherwise than at separate and distinct fares for each passenger throughout Victoria:—

- COOMBS, H. O., Ballarat.
CHRISTIE, L. S., West Coburg.
GANGE, A. J., Fitzroy.
GENTLE, T. L., Williamstown.
JONES, J. D., Gardenvale.
MARSH, L. G., Coleraine.
MCLEOD, J. R. E., Castlemaine.
SMITH, R. M., Mildura.

NOTICE is hereby given that the applications made by the persons named below for licences to operate the commercial goods vehicles on the route or routes, or in a manner set out opposite their names, will be heard at a time and place to be communicated to the parties concerned:—

Name and Address; Nature of Application.

- ARMSTRONG, E., 100 Bendigo-street, Prahran; 1 commercial goods vehicle (6 cwt.) to operate throughout the State of Victoria in the course of business as "hawker"—drapery.
- ASHBY, R. C., 80 Shaftsbury-parade, Thornbury; 1 commercial goods vehicle (10 cwt.) to operate throughout the State of Victoria in the course of business as "plumber"—tools of trade and installation materials incidental to own installation contracts.

- BATTY, A., 2 Addis-street, Geelong West; 1 commercial goods vehicle (78 cwt.) to operate throughout the State of Victoria in the course of business as "marine dealer"—marine stores.
- BELL, J. J., Tolmie; 1 commercial goods vehicle (200 cwt.) for the carriage of sawn timber from Bell and Son's sawmill at Tolmie to timber yards at Albury, Kyabram, and Echuca.
- BELYEA, R. J., 18 Queen-street, Colac; 1 commercial goods vehicle (10 cwt.) to operate throughout the State of Victoria in the course of business as "hawker"—drapery.
- CUTHBERT, M. B., 19 The Avenue, East Malvern; 1 commercial goods vehicle (6 cwt.) to operate throughout the State of Victoria in the course of business as "hawker"—drapery.
- DAVIES, R., 827 Brunswick-street, North Fitzroy; 1 commercial goods vehicle (12 cwt.) to operate throughout the State of Victoria in the course of business as "showman" at agricultural shows for the carriage of equipment required for the running of games, &c., and manufactured toy novelties for sale.
- DE BLAQUIERE, A. J., 183 Stewart-street, East Brunswick; 1 commercial goods vehicle (15 cwt.) for the carriage of own goods in the course of business as "drapery hawker and retailer"—(a) within a 50 miles radius of Melbourne, (b) from Melbourne to market stall at Warragul (one trip per week).
- DISHER, R. D., 20 Belmore-road, Balwyn; 1 commercial goods vehicle (168 cwt.) for the carriage of—
1. Logs from any forest landing in the Upper Yarra forestry district—(a) to the railway station at Noojee, or to any mill or dump which is located within a radius of 20 miles of such landing or of the railway station at Noojee, (b) to any mill situated—(i) on or within 5 miles of the Prince's Highway East between Warragul and Berwick, (ii) south of the River Yarra within a radius of 25 miles but not within 8 miles of the G.P.O., Melbourne.
2. Logs from such other area or to such other destinations as may be authorized, in writing, by the Board from time to time.
- FERRIES, GEORGE, 114 Barker-street, Castlemaine; 1 commercial goods vehicle (40 cwt.) to operate throughout the State of Victoria in the course of business as "building and monumental masons"—finished masonry, tools of trade, and materials incidental to the erection of masonry at own projects.
- HOLLOWAY, C. J., Mirimbah; 1 commercial goods vehicle (180 cwt.) for the carriage of—(a) logs from any forest landing in the Mt. Buller area to mills at Mansfield, (b) sawn timber from H. V. Doughty's mill at Mirimbah to consignees at Benalla, Albury, Shepparton, Echuca, and Kyabram, in house lots only.
- HARKER, T. W., William-street, Bacchus Marsh; 1 commercial goods vehicle (80 cwt.) to operate between Bacchus Marsh and Melbourne for the carriage of brown coal.
- HARRIS, A. K., Main-street, Mansfield; 1 commercial goods vehicle (180 cwt.) for the carriage of logs from Tolmie area to the D.S.M. sawmills at Mansfield, and from Mt. Buller area to M. Feigin's sawmills at Mansfield.
- HASSETT, E., & SONS, 626 Bourke-street, Melbourne; 1 commercial goods vehicle (15 cwt.) to operate throughout the State of Victoria for the purpose of servicing agricultural machinery—spare parts and tools of trade incidental to such servicing.
- LIMESTONE PRODUCTS PTY. LTD., Box 37, P.O., Mt. Gambier; 1 commercial goods vehicle (140 cwt.) for the carriage of crude carbonate of lime and own milling and mining equipment from the Victorian-South Australian border *en route* from Mt. Gambier to railheads at Casterton and Coleraine.
- MURPHY, J. B., 583 Victoria-street, Abbotsford; 1 commercial goods vehicle (55 cwt.) for the carriage of bulk confectionery from railway stations at—(a) Kyneton and Bendigo, (b) Seymour, Kyabram, Echuca, Shepparton, Yarrowonga, Wodonga, Benalla, and Euroa, (c) Ballarat, Stawell, Nhill, Rainbow, Hopetoun, Warracknabeal, and St. Arnaud, (d) Colac, Terang, Mortlake, Port Fairy, Portland, and Hamilton—to retailers tributary to such railway stations in the course of business as "confectionery distributor."
- MCDIARMID, D. D., Sarsfield, via Bairnsdale; 1 commercial goods vehicle (60 cwt.) for the carriage of road contracting plant and material throughout the State of Victoria.
- PLAIN, J. N., Rainbow; 1 commercial goods vehicle (6 cwt.) to operate throughout the State of Victoria in the course of business as "hawker"—drapery.
- RODDA, S. N., PTY. LTD., 65 Beach-street, Port Melbourne; 1 commercial goods vehicle (120 cwt.) for the carriage of crude carbonate of lime and own mining and milling plant from the Victorian-South Australian border *en route* from Mt. Gambier to railheads at Coleraine and Casterton.
- SIMS, W. E., Birmingham-road, Lilydale; 1 commercial goods vehicle (90 cwt.) for the carriage of—(a) general goods within a 20 miles radius of Lilydale, (b) road contracting plant and material within a 50 miles radius of Lilydale.
- SMEATH, J. E., 71 Spring-street, Regent; 1 commercial goods vehicle (120 cwt.) for the carriage of—(a) within a 25 miles radius of Melbourne—general goods, (b) within a 40 miles radius of Melbourne—bricks.
- THOMPSON, A. J., High-street, Mansfield; 1 commercial goods vehicle (100 cwt.) for the carriage of—(a) from and to Melbourne and Yarra Glen or Whittlesea to and from places on or reached from the road between Kinglake West and Yea, via Flowerdale, and to and from places on or reached from the road between Mt. Slide and Yea, via Glenburn—general goods, excluding wool, (b) from and to places on or reached from the road between Kinglake to and from Melbourne—general goods, (c) from places on or reached from the road between Mt. Slide and Yea, via Glenburn, to the railway station at Yarra Glen or Whittlesea—wool.
- WOOD, K. A., 59 Clow-street, Dandenong; 1 commercial goods vehicle (8 cwt.) to operate throughout the State of Victoria for the purpose of servicing sewing machines, and for the carriage of new machines for demonstration and sale and second-hand machines as trade-in units.
- BARKER, B. (trading as Yarra Valley Transport), Main-street, Lilydale; 1 commercial goods vehicle (200 cwt.) for the carriage of sawn timber from Victoria Hardwood Co. mill at Powelltown, E. Lloyd's mill at Gladysdale, and Moreland Timber Co. mill at Yarra Junction—(a) to the railway stations at Warburton and Yarra Junction, (b) to any customer, if delivered within a radius of 20 miles of the Warburton and Yarra Junction Railway Stations, (c) to any merchant or builder, if delivered to a timber yard or direct on to a building site which is located south of the River Yarra within a radius of 25 but not within 8 miles of the G.P.O., Melbourne.

Notice of any objection should be forwarded to reach the Secretary of the Board not later than Wednesday, 1st February, 1950.

E. V. FIELD,
Secretary.

Exhibition Buildings, Rathdown-street, Carlton, N.3, 17th January, 1950.

VICTORIAN RAILWAYS.

VICTORIAN RAILWAYS COMMISSIONERS.

HIS Excellency the Governor of the State of Victoria, by and with the advice of the Executive Council thereof, by Order made on the 10th day of January, 1950, in conformity with the provisions of sub-section (6) of section 901 of the Local Government Acts, doth hereby provide for and allow the relaxation of the requirements of all regulations under Part XLIX. of the Local Government Acts and of all other regulations, joint regulations, or by-laws under those Acts so far as relates to pre-cut houses imported for the Victorian Railways Commissioners which are erected within a period of twelve months after the commencement of the *Local Government Act 1949*.

A. MAHLSTEDT,

Clerk of the Executive Council.

At the Executive Council Chamber,
Melbourne, the 10th January, 1950.

Weights and Measures Act 1928.—Section 35.

FIRST MEETING OF MANAGERS FOR WIMMERA WEIGHTS AND MEASURES UNION.

PURSUANT to the provisions of section 35 of the *Weights and Measures Act 1928*, I hereby fix the time of the first meeting of the managers for the Wimmera Weights and Measures Union, comprising the City of Horsham, the Borough of Stawell, and the Shires of Arapiles, Ararat, Ripon, Stawell, and Wimmera as Three o'clock in the afternoon of Monday, the 20th day of February, 1950, and do fix the Town Hall, Stawell, as the place of such meeting.

W. WATT LEGGATT,

Chief Secretary.

Chief Secretary's Office,
Melbourne, 11th January, 1950.

CONTRACTS ACCEPTED.—(Series 1949-50.)**GENERAL STORES.**

Gazette No. 598, 18th July, 1949, Schedule No. 13, Acids, &c.—Rates for Items Nos. 6 and 7 increased by 1d. per lb., as from 19th December, 1949.

Gazette No. 598, 18th July, 1949, Schedule No. 25, Chemicals, &c.—For Item No. 73 substitute 5s. 9d. per oz., as from 24th November, 1949.

Gazette No. 598, 18th July, 1949, Schedule No. 37, Electric Lamps, &c.—For Item No. 24 substitute 6s. 4d. per dozen, as from 3rd January, 1950.

Gazette No. 598, 18th July, 1949, Schedule No. 39, Furniture.—For Items Nos. 46 and 47 substitute £3 18s. 6d. and £3 1s. 9d. each, as from 13th January, 1950.

Gazette No. 598, 18th July, 1949, Schedule No. 46, India-rubber Goods.—For Item No. 43 substitute 16s. 6d. per 60 feet, as from 3rd January, 1950.

Gazette No. 598, 18th July, 1949, Schedule No. 46, India-rubber Goods.—For Item No. 45 substitute the following rates, as from the 23rd November, 1949:— $\frac{1}{2}$ -in., 12s. 8d. per gross; $\frac{3}{4}$ -in., 13s. 3d. per gross; $\frac{1}{2}$ -in., 16s. 11d. per gross; $\frac{3}{4}$ -in., 17s. 6d. per gross; $\frac{1}{2}$ -in., 18s. 6d. per gross; $\frac{3}{4}$ -in., 20s. 1d. per gross; 1 in., 20s. 11d. per gross.

Gazette No. 598, 18th July, 1949, Schedule No. 67, Soap-makers' Materials, &c.—For Item No. 12 substitute 12 13/16d. per lb., as from 6th December, 1949.

Gazette No. 1102, 7th December, 1949, Schedule No. 1, Requisites (Junior School).—For Item No. 12 substitute 9s. 7d. per dozen skeins, as from 9th November, 1949.

Gazette No. 1102, 7th December, 1949, Schedule No. 1, Requisites (Junior School).—For Item No. 3 substitute 3s. 3d. per dozen packets, as from 4th January, 1950.

Gazette No. 1102, 7th December, 1949, Schedule No. 69, Stationery (General).—For Item No. 9 substitute 8s. 1d. per dozen boxes, as from 3rd January, 1950.

Gazette No. 1102, 7th December, 1949, Schedule No. 69, Stationery (General).—For Items Nos. 145, 248, and 249 substitute 15s. 1d. each, £1 11s., and 18s. per dozen respectively, as from 20th December, 1949.

PRINTING PAPERS, WRITING PAPER, ETC.

Gazette No. 869, 12th October, 1949, Schedule No. 1, Printing Paper, &c.—Rates for Items Nos. 1, 3, 4, 5, 8, 33, 34, 35, 36, 38, 38A, 45, 46, 49, 51, 53, 68A, 69, 70, 71, 84A, 84B, 107, 108, 146, and 146B increased by 1d. per lb., as from 23rd November, 1949, and by 3d. per lb., as from 19th December, 1949.

CARTAGE.

Gazette No. 535, 22nd June, 1949, Schedule No. 1, Cartage, &c. Delivery of goods and parcels—Substitute 33½ per cent. of surcharge, as from 1st January, 1950.

Gazette No. 535, 22nd June, 1949, Schedule No. 1A, Cartage of Migrants' Baggage.—Substitute 25 per cent. surcharge, as from 1st January, 1950.

SUPPLY OF PRISONERS' MEALS IN LOCK-UPS.**CONTRACT CANCELLED.**

Gazette No. 642, 17th August, 1949, Prisoners' Meals, Geelong.—Contract No. 706 is hereby cancelled.

CONTRACT ACCEPTED.

3399. For the supply of Prisoners' Meals at Geelong, from 1st January, 1950, to 30th June, 1950, at rates approved for Contract No. 706.—A. C. Barry.

W. H. RUTHERFORD, Secretary to the Tender Board.
16.1.50.

ORDER IN COUNCIL.—(Series 1949-50.)**FORESTS COMMISSION.**

Loan Act No. 5232, Item 8, and Loan Act No. 5333, Item 8—3317. To the purchase of parts of allotments 134B and 134D, Parish of Mirboo, County of Buln Buln, containing 237 acres 2 roods 13 perches, for forest purposes, £178 3s. 9d.—W. Scott, Wearing-street, Footscray.

Approved by the Governor in Council, 2nd November, 1949.—A. MAHLSTEDT, Clerk of the Executive Council.

DEPARTMENT OF EDUCATION.

3318. One Hounsfield tensometer (fitted with 2-ton spring beam, autographic recorder, one force scale, one stress scale, oak cover, manual and graph pad); four sets of tensile chucks, Nos. 11, 12, 14, and 16, £3 17s. per set; three extra stress scales to suit chucks, £1 9s. each; four pairs of rings for tensile chucks, 11s. 6d. each; gauges for elongation and reductions in area; compression and

punch shear apparatus (5 mm. ball); one Brinell microscope; one Hounsfield extensometer, for Warrnambool Technical School, £319 3s. 6d.—William Adams and Co. Ltd., 521 Collins-street, Melbourne, C.1.

Approved by the Governor in Council, 10th January, 1950.—A. MAHLSTEDT, Clerk of the Executive Council.

STATE ELECTRICITY COMMISSION.

3319. The supply of two Dodge chassis for equipping ambulance units, Morwell and Kiewa, to Quotation No. 3025.—Canada Cycle and Motor Co. (Vic.) Pty. Ltd.

Approved by the Governor in Council, 6th December, 1949.—A. MAHLSTEDT, Clerk of the Executive Council.

3320. The supply of ten power graders, Yallourn, Morwell Project, and Kiewa Hydro-Electric Scheme, to Quotation No. 2526.—Wm. Adams and Co. Ltd.

3321. The supply of spare parts for condensers and frequency changers in metropolitan terminal stations and sub-stations, to Quotation No. 224.—Australian General Electric Pty. Ltd.

3322. The supply of structural steelwork for 20-ton crane runway, Yallourn "C" Power Station, to Quotation No. 3070.—Australian Iron and Steel Ltd.

3323. The supply of 80 tons of mild steel plates for general maintenance and new works, to Quotation No. 3470.—Bridson James (A'asia) Ltd.

3324. The purchase of land containing 188½ acres, more or less, being part of Crown allotment 11E, Parish of Maryvale, County of Buln Buln, together with dwelling erected thereon for the Morwell Project Works area.—Reuben Spencer Brinsmead and Amy Margaret Bell.

3325. The supply of 85 40-watt fluorescent lighting units, to Quotation No. 2964.—British General Electric Co. Pty. Ltd.

3326. The supply of 237,500 yards of paper double-braided aerial copper cable for consumers' services, to Specification No. 49-50/136.—British Insulated Callender's Cables Ltd.

3327. The supply of 40 beds, 40 mattresses, and 80 pillows for staff cubicles, Kiewa Hydro-Electric Scheme, to Quotation No. 2785.—Buesst and Bills Bros. Pty. Ltd.

3328. The supply of 20 tons of mild steel reinforcing rounds for general maintenance and new works, to Quotation No. 3471.—Burns, Philp, and Co. Ltd.

3329. The supply of 110 tons of mild steel sections for general maintenance and new works, to Quotation No. 3472.—Burns, Philp, and Co. Ltd.

3330. The supply of 16 second-hand Dodge 15-cwt. weapon carriers, Morwell Project and Kiewa Hydro-Electric Scheme, to Quotation No. 2760.—Canada Cycle and Motor Co. (Vic.) Pty. Ltd.

3331. The supply of 24 second-hand Dodge 15-cwt. weapon carriers, Yallourn, Morwell Project, and Kiewa Hydro-Electric Scheme, to Quotation No. 2918.—Canada Cycle and Motor Co. (Vic.) Pty. Ltd.

3332. The supply of one tilting drum concrete mixer, to Quotation Nos. 5688 and 5688A.—Coates and Co. Pty. Ltd.

3333. The supply of 430 feet of reinforced concrete drain-pipe, Yallourn, to Quotation No. 2753.—Concrete Constructions Pty. Ltd.

3334. The supply of 200,000 super. feet of kiln-dried hardwood, Yallourn, Morwell Project, and Kiewa Hydro-Electric Scheme, to Quotation No. 2552.—Wm. Cook Pty. Ltd.

3335. The supply of 15,150 feet (approximately) of hewn hardwood girders, to Quotation No. 2485.—R. S. Couche and Co. Pty. Ltd.

3336. The supply of 24 galvanized corrugated iron tanks, Kiewa Hydro-Electric Scheme, to Quotation No. 2780.—Currie and Richards Pty. Ltd.

3337. The supply of 10,000 feet of air hose, to Quotation No. 2960.—Dunlop Rubber Australia Ltd.

3338. The supply of one "Cropmaster" tractor for rural research work, to Quotation No. 3053.—Emptor Pty. Ltd.

3339. The supply of 30 tents and 30 tent flies, Kiewa Hydro-Electric Scheme, to Quotation No. 2758.—Evan Evans Pty. Ltd.

3340. The supply of three Diesel locomotives for 90 cm. gauge railway tracks, Morwell Open Cut, to Specification No. 49-50/84.—John Fowler and Co. (Leeds) Ltd.

3341. The supply of idlers for belt conveyors, Newport Power Station, to Quotation No. 2503.—Gibson, Battle (Melb.) Pty. Ltd.

3342. The supply of 637,500 yards of polyvinyl chloride aerial cable for consumers' services, to Specification No. 49-50/136.—Gilbert Lodge and Co. Ltd.

3343. The supply of 10 tons of black steel sheet for general maintenance and new works, to Quotation No. 3468.—Gollin and Co. Pty. Ltd.

3344. The supply of 310 tons of rolled steel joists and 80 tons of mild steel angles, to Quotation No. 3469.—Gollin and Co. Pty. Ltd.

3345. The supply of 53 tons of mild steel chequer plate for general maintenance and new works, to Quotation No. 3473.—Gollin and Co. Pty. Ltd.
3346. The supply of 210 tons of mild steel plates, to Quotation No. 3481.—Gollin and Co. Pty. Ltd.
3347. The supply of 535 natural round wooden poles for transmission and distribution lines.—Gunnensen, Nosworthy Ltd. (as agents for Allen Taylor and Co. Ltd.).
3348. The supply of four second-hand reconditioned excavators, Yallourn and Kiewa Hydro-Electric Scheme.—Heavy Equipment Pty. Ltd.
3349. The supply of steel pipes and other steelwork for drainage purposes at Melbourne Swamp, to Quotation No. 2284.—Hume Steel Ltd.
3350. The supply of 348 tons (approximately) of black coal, Newport Power Station.—Interstate Steamships Pty. Ltd.
3351. The supply of 10 tons of mild steel sheet for general maintenance and new works, to Quotation No. 3487.—Kengear Industries.
3352. The supply of uniforms for tramways personnel, Ballarat, Bendigo, and Geelong, for period of twelve months, to Specification No. 49-50/160.—Klein and Cowen.
3353. The supply of 26½ tons of galvanized corrugated iron and 4 tons of galvanized plain iron for housing, Kiewa Hydro-Electric Scheme, to Quotation No. 3315.—John Lysaght (Aust.) Pty. Ltd.
3354. The supply of 20 tons of galvanized corrugated iron and 2½ tons of galvanized plain iron for housing, Kiewa Hydro-Electric Scheme, to Quotation No. 3316.—John Lysaght (Aust.) Pty. Ltd.
3355. The supply, delivery, and erection of two 15-ton electrically-operated overhead travelling cranes for regional power stations, Shepparton and Warrnambool, to Specification No. 49-50/146.—Malcolm Moore Ltd.
3356. The supply of 462 tons (approximately) of black coal, Newport Power Station.—Melbourne Steamship Co. Ltd.
3357. The supply of two pile-driving hammers, Yallourn and Morwell Project, to Quotation No. 3068.—Morison and Bearby Ltd.
3358. The supply of eight electrically-operated valve control units for boilers, Newport Power Station, to Quotation No. 3340.—Noyes Bros. (Melbourne) Ltd.
3359. The supply of 150 14-ply bar-tread tires for heavy duty tipping trucks and transporters, Kiewa Hydro-Electric Scheme, to Quotation No. 2457A.—Olympic Tyre and Rubber Co. Ltd.
3360. The supply of 10 tons of mild steel sheet for general maintenance and new works, to Quotation No. 3485.—Overseas Corporation (Australia) Ltd.
3361. The supply of 30 tons of mild steel roller level sheet for general maintenance and new works, to Quotation No. 3486.—Overseas Corporation (Australia) Ltd.
3362. The supply of 10 tons of mild steel sheet for general maintenance and new works, to Quotation No. 3484.—Overseas Corporation (Australia) Ltd.
3363. The supply of two 75 kVA Diesel-driven generating sets, Kiewa Hydro-Electric Scheme, to Quotation No. 2597.—Perkins (Aust.) Pty. Ltd.
3364. The supply of one power-operated track jack, Yallourn Open Cut, to Quotation No. 49-50/135.—Production Equipment Pty. Ltd.
3365. The supply of one pneumatic-tired fork lift truck, to Quotation No. 49-50/46.—Queen's Bridge Motor and Engineering Co. Pty. Ltd.
3366. The completion of 50 "Stawell" prefabricated houses and associated site works, Yallourn North, to Specification No. 49-50/161.—K. Rice.
3367. The supply of four telephone-ringing generators, Kiewa Hydro-Electric Scheme, to Quotation No. 2035.—Siemens (Aust.) Pty. Ltd.
3368. The supply of two battery-operated electric locomotives, Kiewa Hydro-Electric Scheme.—State Coal Mines Control Board, New South Wales.
3369. The cutting off and drilling of fishplates for movable rail and dredger tracks, Morwell Project, to Specification No. 49-50/152.—A. T. Stead.
3370. The supply of two concrete-mixing and batching plants, Morwell Project, to Quotation No. 5156.—Stothert and Pitt Ltd.
3371. The supply of one electrically-operated addressograph, Ballarat, to Quotation No. 2950.—Stott and Hoare Pty. Ltd.
3372. The supply of 10,000 natural round wooden poles for transmission and distribution lines.—Alex Sturrock and Sons Pty. Ltd. (as agents for R. J. White and Co. (Sydney) Pty. Ltd.
3373. The supply of 250,000 lineal-feet hardwood flooring, to Quotation No. 3185.—Neville Smith and Co. Pty. Ltd.
3374. The supply of 70,000-volt voltage regulating equipment, Sugarloaf Power Station and Geelong Terminal Station, to Specification No. 49-50/1.—R. and C. Thomas Bros. Pty. Ltd.
3375. The supply of two cast-iron twin strainers for stoker emulsion system, Yallourn Power Station, to Quotation No. 2654.—Thompsons (Castlemaine) Ltd.
3376. The supply of spare parts for Allis-Chalmers tractors, to Quotation No. 2233A.—Tutt, Bryant (Vic.) Pty. Ltd.
3377. The reconditioning of one 10-ton mobile crane, Kiewa Hydro-Electric Scheme, to Quotation No. 3488.—Tutt, Bryant (Vic.) Pty. Ltd.
3378. The supply of one front end loader for briquette and material handling at Newport Power Station, to Quotation No. 2199.—Victorian Industrial Sales and Service Pty. Ltd.
3379. The supply of three front end loaders for briquette and coal handling on wharves and at metropolitan depots, to Quotation No. 2200.—Victorian Industrial Sales and Service Pty. Ltd.
3380. The erection of office partitions at Pattern Store, Footscray Depot, to Quotation No. 3207.—E. A. Watts.
3381. The supply of galvanized cast-iron damper weights, to Quotation No. 1311.—Webb Industries Ltd.
3382. The supply of 480 cast-steel mufflers and 160 mild-steel coupling pins for 20-ton coal trucks, Yallourn Open Cut, to Specification No. 49-50/57.—W. Wills.
3383. The supply of 6,600-volt switchgear and accessories, Yallourn and Morwell Project, to Specification No. 49-50/21.—Alec Pty. Ltd.
3384. The supply of 6,600-volt switchgear and accessories, Yallourn and Morwell Project, to Specification No. 49-50/21.—Australian General Electric Pty. Ltd.
3385. The supply of 50 rail turnouts for raceline railway tracks, Kiewa Hydro-Electric Scheme, to Specification No. 49-50/28.—Cameron and Sutherland Ltd.
3386. The supply of 50 rail turnouts for raceline railway tracks, Kiewa Hydro-Electric Scheme, to Specification No. 49-50/28.—McKenzie and Holland (Australia) Pty. Ltd.
3387. The supply of distillate fuel oil, for a period of twelve months, to Specification No. 49-50/65.—Commonwealth Oil Refineries Ltd.
3388. The supply of distillate fuel oil, for a period of twelve months, to Specification No. 49-50/65.—Shell Co. of Australia Ltd.
3389. The supply of first-grade motor spirit, for a period of twelve months, to Quotation No. 3305.—Caltex Oil (Aust.) Pty. Ltd.
3390. The supply of first-grade motor spirit, for a period of twelve months, to Quotation No. 3305.—Alba Petroleum Co. of Australia Pty. Ltd.
3391. The supply of first-grade motor spirit, for a period of twelve months, to Quotation No. 3305.—Commonwealth Oil Refineries Ltd.
3392. The supply of first-grade motor spirit, for a period of twelve months, to Quotation No. 3305.—Shell Co. of Aust. Ltd.
3393. The supply of first-grade motor spirit, for a period of twelve months, to Quotation No. 3305.—H. C. Sleigh Ltd.
3394. The supply of first-grade motor spirit, for a period of twelve months, to Quotation No. 3305.—Vacuum Oil Co. Pty. Ltd.
3395. The supply of fitters' and mechanics' hand tools, to Quotation No. 6154.—Hardware Co. of Australia Pty. Ltd.
3396. The supply of fitters' and mechanics' hand tools, to Quotation No. 6154.—McPherson's Ltd.
3397. The supply of fitters' and mechanics' hand tools, to Quotation No. 6154.—E. A. Machin and Co. Pty. Ltd.
3398. The supply of fitters' and mechanics' hand tools, to Quotation No. 6154.—James Walker.

Approved by the Governor in Council, 10th January, 1950.
—A MAHLSTEDT, Clerk of the Executive Council.

Hospitals and Charities Act 1948 (No. 5300).—Section 46.
PETITION TO INCORPORATE VICTORIAN BABY HEALTH CENTRES ASSOCIATION.

IT is hereby notified, in accordance with the provisions of section 46 (2) of Act No. 5300, that the Hospitals and Charities Commission of Victoria has received a petition signed by not less than 25 contributors to the Victorian Baby Health Centres Association, an institution capable of incorporation under the provisions of the said Act, praying that the said association be incorporated.

If a counter petition signed by an equal or greater number of contributors is not lodged with the aforesaid Commission within one month after the publication of this notice, the Governor in Council may, by Order made pursuant to Act No. 5300 and published in the *Government Gazette*, declare the contributors for the time being to the said institution to be a body corporate by the name set forth in such Order.

C. P. GARTSIDE,
Minister of Health,

FIRST MILDURA IRRIGATION TRUST.—MILDURA
URBAN WATER TRUST.

PETITIONS UNDER THE MILDURA IRRIGATION AND WATER
TRUSTS ACT 1928.

IN pursuance of the provisions of the *Mildura Irrigation and Water Trusts Act 1928*, the substance and prayer of petitions which have been presented to His Excellency the Governor in Council are published, viz.:—

Petitions purporting to be the majority of the rate-payers in the areas described in the petitions, such areas being described in the Schedule hereto.

Joint petitions from the First Mildura Irrigation Trust and the Mildura Urban Water Trust in respect of the above areas.

The petitioners pray that His Excellency the Governor in Council may be pleased to sever such areas from the district of the First Mildura Irrigation Trust and annex the said areas to the district of the Mildura Urban Water Trust, in accordance with the provisions of the said Act.

Copies of such petitions, together with plans showing the areas proposed to be severed and annexed, may be seen at the office of the Mildura Urban Water Trust, Deakin-avenue, Mildura.

SCHEDULE.

Lots 1, 2, 3, 5, and 6 and parts of lots 4 and 7, section 31, lot 1, section 60, and lot 1, section 63, block D, on lodged plan of subdivision No. 2144, Parish of Mildura, County of Karkaroc.

Part of lot 4, section 30, block F, on lodged plan of subdivision No. 2168, Parish of Mildura, County of Karkaroc.

Part of lot 12, section 31, block F, on lodged plan of subdivision No. 2168, Parish of Mildura, County of Karkaroc.

Lot 3, section 84, block D, on lodged plan of subdivision No. 2144, Parish of Mildura, County of Karkaroc.

Lots 1, 2, 3, 4, 5, 6, 7, 8, 9, 10, 11, and 12, section 75, and lots 5, 6, 11, and 12, section 84, block D, on lodged plan of subdivision No. 2144, Parish of Mildura, County of Karkaroc.

Lot 1, section 33, block D, on lodged plan of subdivision No. 2144, Parish of Mildura, County of Karkaroc.

Lots 1, 2, 5, and 6, section 34, block D, on lodged plan of subdivision No. 2144, Parish of Mildura, County of Karkaroc.

Lots 4, 5, 10, and 12 and part of lots 3, 6, and 9, section 78, block D, on lodged plan of subdivision No. 2144, Parish of Mildura, County of Karkaroc.

HENRY EDWARD BOLTE,
Minister of Water Supply.

COLAC WATERWORKS TRUST.

RATING BY-LAW FOR THE YEAR 1950.

THE Colac Waterworks Trust, in pursuance and exercise of the powers conferred by the Water Acts, doth hereby make a rate for the supply of water for domestic purposes of Eleven pence in the pound on the annual municipal valuation of lands and tenements liable to be rated within the Colac Urban District.

Provided that in no case shall the amount of rate payable per annum in respect of any tenement (other than land on which there is no building) be less than Twenty shillings, and in respect of any land on which there is no building less than Ten shillings.

Such rates are made and shall be levied upon the occupiers or owners of the said lands and tenements for the year commencing on the 1st day of January, 1950, and shall be payable on the 17th day of May, 1950, at the office of the said Trust.

Water supplied to cricket, bowling, or tennis clubs, and to Government departments, mechanics' institutes, churches, showgrounds, and similar properties, shall be charged for by measurement at Six pence per 1,000 gallons, provided that the minimum quantity to be charged for shall not be less than 40,000 gallons per annum.

The maximum quantity of water to be supplied in any one year without further charge to any property rated by the Trust is hereby fixed at the quantity which, at a charge of Eleven pence per 1,000 gallons, would produce an amount equal to the amount of the rate levied on such property for the said year.

The charge for water supplied by measure to any property rated by the said Trust in excess of such maximum quantity, computed as in the last preceding clause, is hereby fixed at One shilling and six pence per 1,000 gallons.

The charge for water supplied by measure shall be payable, on demand, at the office of the Trust.

Passed this 19th day of December, 1949.

(SEAL) J. S. BROWN, Chairman.
ALLAN MCKENZIE, Secretary.

Approved by the Governor in Council,
10th January, 1950.

A. MAHLSTEDT,
Clerk of the Executive Council.

SHIRE OF NUMURKAH WATERWORKS TRUST.

RATING BY-LAW FOR THE WUNGHNU URBAN DISTRICT FOR
THE YEAR 1950.

THE Shire of Numurkah Waterworks Trust, in pursuance and exercise of the powers conferred by the Water Acts, doth hereby make a By-law and direct as follows:—

1. The said Shire of Numurkah Waterworks Trust doth hereby make a rate for the supply of water for domestic purposes of Forty-two pence in the pound on the annual municipal valuation of lands and tenements liable to be rated within the Wunghnu Urban District.

Provided that in no case shall the amount of the rate payable per annum in respect of any tenement (other than land upon which there is no building) be less than Fifteen shillings, and in respect of land on which there is no building less than Forty-two pence.

Such rates are made and shall be levied upon the occupiers or owners of the said lands and tenements for the year commencing on the 1st day of January, 1950, and shall be payable on the 20th day of January, 1950, at the office of the said Trust.

2. The maximum quantity of water to be supplied in any one year without further charge to any property rated by the Trust is hereby fixed at the quantity which, at a charge of Forty-two pence per 1,000 gallons, would produce an amount equal to the amount of the rate levied on such property for the said year.

3. The charge for water supplied by measure to any property rated by the Trust in excess of such maximum quantity, as computed in the last preceding clause, is hereby fixed at Six pence per 1,000 gallons.

4. The charge for water supplied by measure shall be payable, on demand, at the office of the Trust.

5. Such person or persons as the Commissioners of the Shire of Numurkah Waterworks Trust may from time to time appoint for the purpose shall be authorized to demand and receive, collect and recover, the rates and charges aforesaid, and each of them. And in the absence of such appointment the secretary and/or rate collector of the Trust shall be deemed to have been appointed for the purpose aforesaid, and every and each of them.

Passed the 12th day of December, 1949.

The common seal of the Shire of Numurkah Waterworks Trust was hereto affixed this 12th day of December, 1949, in the presence of—

(SEAL) ANDREW J. MATHER, Chairman.
LOUIS HAMON, Commissioner.
J. K. DANCOCKS, Secretary.

Approved by the Governor in Council,
10th January, 1950.

A. MAHLSTEDT,
Clerk of the Executive Council.

SHIRE OF NUMURKAH WATERWORKS TRUST.

RATING BY-LAW FOR NATHALIA URBAN DISTRICT FOR THE
YEAR 1950.

THE Shire of Numurkah Waterworks Trust, in pursuance and exercise of the powers conferred by the Water Acts, doth hereby make a By-law and direct as follows:—

1. The said Shire of Numurkah Waterworks Trust doth hereby make a rate for the supply of water for domestic purposes of Twenty pence in the pound on the annual municipal valuation of lands and tenements liable to be rated in the Nathalia Urban District.

Provided that in no case shall the amount of the rate payable per annum in respect of any tenement (other than land upon which there is no building) be less than Fifteen shillings, and in respect of any land on which there is no building less than Twenty pence.

Such rates are made and shall be levied upon the occupiers or owners of the said lands and tenements for the year commencing on the 1st day of January, 1950, and shall be payable on the 20th day of January, 1950, at the office of the said Trust.

2. The maximum quantity of water to be supplied in any one year without further charge to any property rated by the Trust is hereby fixed at the quantity which, at a charge of Twenty pence per 1,000 gallons, would produce an amount equal to the amount of the rate levied on such property for the said year.

3. The charge for water supplied by measure to any property rated by the Trust in excess of such maximum quantity, as computed in the last preceding clause, is hereby fixed at Six pence per 1,000 gallons.

4. The charge for water supplied by measure shall be payable, on demand, at the office of the said Trust.

5. Such person or persons as the Commissioners of the Shire of Numurkah Waterworks Trust may from time to time appoint for the purpose shall be authorized to demand and receive, collect and recover, the rates and charges aforesaid, and each of them. And in the absence of such appointment the secretary and/or rate collector of the Trust shall be deemed to have been appointed for the purpose aforesaid, and every and each of them.

Passed the 12th day of December, 1949.

The common seal of the Shire of Numurkah Waterworks Trust was hereto affixed this 12th day of December, 1949, in the presence of—

(SEAL) ANDREW J. MATHER, Chairman.
LOUIS HAMON, Commissioner.
J. K. DANCOCKS, Secretary.

Approved by the Governor in Council,
10th January, 1950.

A. MAHLSTEDT,
Clerk of the Executive Council.

SHIRE OF NUMURKAH WATERWORKS TRUST.

RATING BY-LAW FOR THE NUMURKAH URBAN DISTRICT FOR THE YEAR 1950.

THE Shire of Numurkah Waterworks Trust, in pursuance and exercise of the powers conferred by the Water Acts, doth hereby make a By-law and direct as follows:—

1. The said Shire of Numurkah Waterworks Trust doth hereby make a rate for the supply of water for domestic purposes of Fifteen pence in the pound on the annual municipal valuation of lands and tenements liable to be rated within the Numurkah Urban District.

Provided that in no case shall the amount of the rate payable per annum in respect of any tenement (other than land upon which there is no building) be less than Fifteen shillings, and in respect of any land on which there is no building less than Fifteen pence.

Such rates are made and shall be levied upon the occupiers or owners of the said lands and tenements for the year commencing on the 1st day of January, 1950, and shall be payable on the 20th day of January, 1950, at the office of the said Trust.

2. The maximum quantity of water to be supplied in any one year without further charge to any property rated by the Trust is hereby fixed at the quantity which, at a charge of Fifteen pence per 1,000 gallons, would produce an amount equal to the amount of the rate levied on such property for the said year.

3. The charge for water supplied by measure to any property rated by the Trust in excess of such maximum quantity, as computed in the last preceding clause, is hereby fixed at Six pence per 1,000 gallons.

4. The charge for water supplied by measure shall be payable, on demand, at the office of the Trust.

5. Such person or persons as the Commissioners of the Shire of Numurkah Waterworks Trust may from time to time appoint for the purpose shall be authorized to demand and receive, collect and recover, the rates and charges aforesaid, and each of them. And in the absence of such appointment the secretary and/or rate collector of the Trust shall be deemed to have been appointed for the purpose aforesaid, and every and each of them.

Passed the 12th day of December, 1949.

The common seal of the Shire of Numurkah Waterworks Trust was hereto affixed this 12th day of December, 1949, in the presence of—

(SEAL) LOUIS HAMON, Commissioner.
ANDREW J. MATHER, Chairman.
J. K. DANCOCKS, Secretary.

Approved by the Governor in Council,
10th January, 1950.

A. MAHLSTEDT,
Clerk of the Executive Council.

SHIRE OF NUMURKAH WATERWORKS TRUST.

RATING BY-LAW FOR PICOLA URBAN DISTRICT FOR THE YEAR 1950.

THE Shire of Numurkah Waterworks Trust, in pursuance and exercise of the powers conferred by the Water Acts, doth hereby make a By-law and direct as follows:—

1. The said Shire of Numurkah Waterworks Trust doth hereby make a rate of Six pence in the pound on the annual municipal valuation of lands and tenements within the Picola Urban District. Such rate is made and shall be levied upon the occupiers or owners of the said lands and tenements for the period commencing on the 1st day of January, 1950, and ending the 31st day of December, 1950, and shall be payable on the 20th day of January, 1950, at the office of the said Trust.

2. Such person or persons as the Shire of Numurkah Waterworks Trust may from time to time appoint for that purpose shall be and is or are hereby authorized to demand, receive, collect, and recover the said rate.

Passed the 12th day of December, 1949.

The common seal of the Shire of Numurkah Waterworks Trust was hereto affixed this 12th day of December, 1949, in the presence of—

(SEAL) ANDREW J. MATHER, Chairman.
LOUIS HAMON, Commissioner.
J. K. DANCOCKS, Secretary.

Approved by the Governor in Council,
10th January, 1950.

A. MAHLSTEDT,
Clerk of the Executive Council.

SHIRE OF NUMURKAH WATERWORKS TRUST.

RATING BY-LAW FOR THE STRATHMERTON URBAN DISTRICT FOR THE YEAR 1950.

THE Shire of Numurkah Waterworks Trust, in pursuance and exercise of the powers conferred by the Water Acts, doth hereby make a By-law and direct as follows:—

1. The said Shire of Numurkah Waterworks Trust doth hereby make a rate for the supply of water for domestic purposes of Forty-two pence in the pound on the annual municipal valuation of lands and tenements liable to be rated within the Strathmerton Urban District.

Provided that in no case shall the amount of rate payable per annum in respect of any tenement (other than land upon which there is no building) be less than Fifteen shillings, and in respect of any land on which there is no building less than Seven shillings.

Such rates are made and shall be levied upon the occupiers or owners of the said lands and tenements for the year commencing on the 1st day of January, 1950, and shall be payable on the 20th day of January, 1950, at the office of the said Trust.

2. The maximum quantity of water to be supplied in any one year without further charge to any property rated by the Trust is hereby fixed at the quantity which, at a charge of Forty-two pence per 1,000 gallons, would produce an amount equal to the amount of the rate levied on such property for the said year.

3. The charge for water supplied by measure to any property rated by the Trust in excess of such maximum quantity, as computed in the last preceding clause, is hereby fixed at Six pence per 1,000 gallons.

4. The charge for water supplied by measure shall be payable, on demand, at the office of the Trust.

5. Such person or persons as the Commissioners of the Shire of Numurkah Waterworks Trust may from time to time appoint for the purpose shall be authorized to demand and receive, collect and recover, the rates and charges aforesaid, and each of them. And in the absence of such appointment the secretary and/or rate collector of the Trust shall be deemed to have been appointed for the purpose aforesaid, and every and each of them.

Passed the 12th day of December, 1949.

The common seal of the Shire of Numurkah Waterworks Trust was hereto affixed this 12th day of December, 1949, in the presence of—

(SEAL) ANDREW J. MATHER, Chairman.
LOUIS HAMON, Commissioner.
J. K. DANCOCKS, Secretary.

Approved by the Governor in Council,
10th January, 1950.

A. MAHLSTEDT,
Clerk of the Executive Council.

ORBOST WATERWORKS TRUST.

RATING BY-LAW FOR THE YEAR 1950 (No. 31).

THE Orbst Waterworks Trust, in pursuance and exercise of the powers conferred by the Water Acts, doth hereby make a rate for the supply of water for domestic purposes of One shilling and eight pence (1s. 8d.) in the pound on the annual municipal valuation of all lands and tenements liable to be rated within the Orbst Urban District.

Provided that in no case shall the amount of rate payable in respect of any tenement (other than land on which there is no building) be less than Thirty-three shillings and four pence (33s. 4d.), and in respect of any allotment of land on which there is no building less than Thirteen shillings and four pence (13s. 4d.).

Such rates are made and shall be levied upon the occupiers or owners of the said lands and tenements for the year commencing the 1st day of January, 1950, and shall be payable on the 1st day of February, 1950, at the office of the said Trust.

Passed this 14th day of December, 1949.

(SEAL) ALASTER CAMERON, Chairman.
M. W. COWELL, Secretary.

Approved by the Governor in Council,
10th January, 1950.

A. MAHLSTEDT,
Clerk of the Executive Council.

SHIRE OF TUNGAMAH WATERWORKS TRUST.

RATING BY-LAW FOR 1950 IN THE URBAN DISTRICT OF TUNGAMAH.

By-law No. 210.

THE Shire of Tungamah Waterworks Trust, in pursuance and exercise of the powers conferred by the Water Acts, doth hereby make a rate for the supply of water for domestic purposes of Thirty-one pence in the pound on the annual municipal valuation of lands and tenements liable to be rated within the Tungamah Urban District.

Provided that in no case shall the amount of rate payable in respect of any tenement (other than land on which there is no building) be less than One pound six shillings and eight pence, and in respect of land on which there is no building less than Ten shillings.

Such rates are made and shall be levied upon the occupiers or owners of the said lands and tenements for the year commencing on the 1st day of January, 1950, and shall be payable on the 10th day of April, 1950, at the office of the Trust.

For every trough a minimum sum of Forty shillings per annum shall be charged.

The aforesaid charges shall be payable on demand.

Passed this 19th day of December, 1949.

The seal of the Trust was hereto affixed this 19th day of December, 1949, in the presence of—

(SEAL) N. McCORMACK, Chairman.
J. V. MAGEE, Commissioner.
R. B. WEBB, Secretary.

Approved by the Governor in Council,
10th January, 1950.

A. MAHLSTEDT,
Clerk of the Executive Council.

SHIRE OF TUNGAMAH WATERWORKS TRUST.

RATING BY-LAW FOR 1950 IN THE RURAL DISTRICT OF TUNGAMAH.

By-law No. 211.

THE Shire of Tungamah Waterworks Trust, in pursuance and exercise of the powers conferred by the Water Acts, doth hereby make a rate for the supply of water for stock and domestic purposes of Nine pence in the pound on the annual municipal valuation of lands and tenements liable to be rated within the Tungamah Rural District.

Provided that in no case shall the amount of rate payable in respect of any tenement or vacant land be less than Two shillings.

For supply of water to gardens and special plots of land the charge shall be by agreement.

The above-mentioned rate and charges are hereby made for the year commencing the 1st day of January, 1950, and are due and payable on the 10th day of April, 1950, at the office of the Trust.

Passed this 19th day of December, 1949.

The seal of the Trust was hereto affixed this 19th day of December, 1949, in the presence of—

(SEAL) N. McCORMACK, Chairman.
J. V. MAGEE, Commissioner.
R. B. WEBB, Secretary.

Approved by the Governor in Council,
10th January, 1950.

A. MAHLSTEDT,
Clerk of the Executive Council.

SHIRE OF TUNGAMAH WATERWORKS TRUST.

RATING BY-LAW FOR 1950 IN THE URBAN DISTRICT OF KATAMATITE.

By-law No. 212.

THE Shire of Tungamah Waterworks Trust, in pursuance and exercise of the powers conferred by the Water Acts, doth hereby make a rate for the supply of water for domestic purposes of Thirty-one pence in the pound on the annual municipal valuation of lands and tenements liable to be rated within the Katamatite Urban District.

Provided that in no case shall the amount of rate payable in respect of any tenement (other than land on which there is no building) be less than Twenty shillings, and in respect of land on which there is no building less than Five shillings.

Such rates are made and shall be levied upon the occupiers or owners of the said lands and tenements for the year commencing on the 1st day of January, 1950, and shall be payable on the 10th day of April, 1950, at the office of the Trust.

For every water trough a minimum sum of Forty shillings per annum shall be charged.

The aforesaid charges shall be payable on demand.

Passed this 19th day of December, 1949.

The seal of the Trust was hereto affixed this 19th day of December, 1949, in the presence of—

(SEAL) N. McCORMACK, Chairman.
J. V. MAGEE, Commissioner.
R. B. WEBB, Secretary.

Approved by the Governor in Council,
10th January, 1950.

A. MAHLSTEDT,
Clerk of the Executive Council.

SHIRE OF TUNGAMAH WATERWORKS TRUST.

RATING BY-LAW FOR 1950 IN THE URBAN DISTRICT OF ST. JAMES.

By-law No. 213.

THE Shire of Tungamah Waterworks Trust, in pursuance and exercise of the powers conferred by the Water Acts, doth hereby make a rate for the supply of water for domestic purposes of Twenty-seven pence in the pound on the annual municipal valuation of lands and tenements liable to be rated within the St. James Urban District.

Provided that in no case shall the amount of rate payable in respect of any tenement (other than land on which there is no building) be less than Twenty shillings, and in respect of any land on which there is no building less than Ten shillings.

Such rates are made and shall be levied upon the occupiers or owners of the said lands and tenements for the year commencing on the 1st day of January, 1950, and shall be payable on the 10th day of April, 1950, at the office of the Trust.

For every trough a minimum sum of Forty shillings per annum shall be charged.

The aforesaid charges shall be payable on demand.

Passed this 19th day of December, 1949.

The seal of the Trust was hereto affixed this 19th day of December, 1949, in the presence of—

(SEAL) N. McCORMACK, Chairman.
J. V. MAGEE, Commissioner.
R. B. WEBB, Secretary.

Approved by the Governor in Council,
10th January, 1950.

A. MAHLSTEDT,
Clerk of the Executive Council.

CITY OF WARRNAMBOOL.

RATING BY-LAW FOR THE YEAR 1949-50 (BY-LAW No. 61)

THE Municipal Council of the City of Warrnambool, in pursuance and exercise of the powers conferred by the Water Acts, doth hereby make a rate for the supply of water for domestic purposes of Sixteen pence (16d.) in the pound of the annual municipal valuation of lands and tenements liable to be rated within the Warrnambool Water Supply District.

Provided that in no case shall the amount of rate payable per annum in respect of any tenement (other than land on which there is no building) be less than Fifteen shillings, and in respect of any land on which there is no building less than Five shillings.

Such rates are made and shall be levied upon all occupiers or owners of the said lands and tenements for the year commencing the 1st day of October, 1949, and shall be payable on the 31st day of January, 1950, at the office of the said Council, Municipal Chambers, Warrnambool.

Such person or persons as the Council may appoint from time to time for the purpose shall be authorized to demand, receive, and collect the said rates.

The foregoing By-law was made and adopted by the Municipal Council of the City of Warrnambool on the 6th day of December, 1949, and the common seal of the Mayor, Councillors, and Citizens of the City of Warrnambool was hereto affixed by order of the said Council, in the presence of—

(SEAL) J. B. DWYER, Mayor.
JOHN A. WALSH, Councillor.
K. L. ARNEL, Town Clerk.

Approved by the Governor in Council,
10th January, 1950.

A. MAHLSTEDT,
Clerk of the Executive Council.

YATCHAW WATERWORKS TRUST.

RATING BY-LAW No. 44 FOR THE YEAR 1950.

THE Yatchaw Waterworks Trust, in pursuance of its powers by the Water Acts, doth hereby make a rate of Four shillings and three pence in the pound on the value of all rateable property, according to the value for the time being of all lands and tenements for the municipalities of the Shires of Dundas and Mount Rouse.

Such rate is made for the year commencing the first day of January, 1950, and shall be payable on the thirty-first day of January, 1950.

Passed on the 16th day of December, 1949.

(SEAL) WILLIAM KIRKWOOD, Chairman.
ALFRED RENTSCH, Commissioner.
J. W. TULLOCH, Secretary.

Approved by the Governor in Council,
10th January, 1950.

A. MAHLSTEDT,
Clerk of the Executive Council.

Water Acts.

STATE RIVERS AND WATER SUPPLY COMMISSION.

COHUNA AND ROBINVALE URBAN DIVISIONS, AND ANGLESEA, BARWON HEADS AND OCEAN GROVE, QUEENSCLIFF AND POINT LONSDALE, TORQUAY, CHELSEA-FRANKSTON, DANDENONG-SPRINGVALE, NANDALY, OUYEN, PYRAMID HILL, AND TERANG URBAN DISTRICTS.

NOTICE to owners of tenements in the under-mentioned streets in the above-mentioned urban divisions and districts, and the private streets, lanes, courts, and alleys opening thereto:—

COHUNA URBAN DIVISION.

Cullen-street, from Channel-street to a point about 1½ chain north-easterly.

Murray Valley Highway, from end of existing main (about 1 chain westerly from Cemetery-road) to a point about 6½ chains westerly from Cemetery-road.

ROBINVALE URBAN DIVISION.

Bromley-road, from the north-western angle of lot 1 on lodged plan of subdivision No. 11065 to Leonora-street.
Government-road, forming the northern boundary of lots 1, 44, 43, 42, 41, and 40 on lodged plan of subdivision No. 11065, from the north-western angle of said lot 1 to George-street.

Perrin-street, from Bromley-road to Caix-square.

ANGLESEA URBAN DISTRICT.

Colledge-lane, from end of existing main (opposite lot 3) to Mawson-avenue.
Holmwood-avenue, from Mawson-avenue to a point opposite lot 8, about 4½ chains south-westerly.

BARWON HEADS AND OCEAN GROVE URBAN DISTRICT.

Barwon Heads.

Geelong-road, from Golf-avenue to a point opposite lot 41, about 4 chains westerly.
Golf-avenue, from Noble-street to Geelong-road.

Ocean Grove.

Draper-street, from President's-avenue to a point opposite lot 288, about 8½ chains north-easterly.

QUEENSCLIFF AND POINT LONSDALE URBAN DISTRICT.

Point Lonsdale.

Anderson-street, from Point Lonsdale-road to Thomson-street.

TORQUAY URBAN DISTRICT.

Beach-road, from end of existing main (opposite lot 7) to Geelong-road.
Boston-road, from Geelong-road to a point opposite lot 145, about 4 chains easterly.
Central-avenue, from end of existing main (opposite lot 12) to Geelong-road.
Felix-crescent, from end of existing main (opposite lot 2, block 4, on lodged plan of subdivision No. 2379) to a point opposite lot 35, block 2, about 6 chains north-easterly, and from end of existing main (opposite lot 25, block 1) to a point opposite lot 37, about 6 chains north-easterly.
Geelong-road, from end of existing main (opposite lot 138) to Boston-road, from Bristol-road to Zeally Bay-road, and from Cowrie-road to Central-avenue.
Price-street, from end of existing main (opposite lot 5) to a point opposite lot 4, about 1 chain westerly.
Zeally Bay-road, from end of existing main (opposite lot 38) to Geelong-road.
Bristol-road, from end of existing main (about 2 chains easterly from Geelong-road) to Geelong-road.

CHELSEA-FRANKSTON URBAN DISTRICT.

Frankston.

David-street, from end of existing main (opposite lot 12) to Petrie-street.
Petrie-street, from end of existing main (opposite lot 21) to Tower-avenue.
Tower-avenue, from end of existing main (opposite lot 6) to Petrie-street.

Seaford.

Beckwith-grove, from Brodie-street to a point opposite lot 22, about 3½ chains northerly and from Brodie-street to a point opposite lot 14, about 2 chains southerly.

DANDENONG-SPRINGVALE URBAN DISTRICT.

Noble Park.

Corrigan-road, from end of existing main (opposite lot 59) to Lightwood-road.
Ellendale-road, from Heatherton-road to a point opposite lot 274, about 38 chains northerly.
Henry-street, from Joy-parade to a point opposite lot 32, about 1½ chain southerly.
Jasper-street, from Heatherton-road to a point opposite lot 98, about 14 chains north-westerly.
Joy-parade, from Allan-street to Henry-street.
Pau-street, from end of existing main (opposite lot 27) to a point opposite lot 38, about 5½ chains north-easterly from Mons-parade.
Raymond-street, from Buckley-road to a point opposite lot 24, about 5 chains westerly.
Robert-street.
Stuart-street, from Douglas-street to a point opposite lot 1, about 2 chains easterly from Leonard-avenue.

NANDALY URBAN DISTRICT.

McKenzie-street, from Allies-street to a point opposite allotment 13, section 2, about 3½ chains northerly.

OUYEN URBAN DISTRICT.

Rowe-street, from end of existing main (opposite allotment 11, section XIII.) to a point opposite allotment 14, about 4 chains southerly.

PYRAMID HILL URBAN DISTRICT.

Barber-street, from end of existing main (about 15 chains southerly from Victoria-street) to a point about 19½ chains southerly from Victoria-street.

TERANG URBAN DISTRICT.

Noel-street, from end of existing main (about 1½ chain westerly from Murnane-street) to Thomson-street.

The main pipe in the said streets being laid down, the owners of all tenements situated as above are hereby required, on or before the 20th day of February next, to cause proper pipes and stop cocks to be laid, so as to supply water within such tenements from the main pipe.

L. DUGGAN, Secretary,
State Rivers and Water Supply Commission.
Melbourne, 12th January, 1950.

Water Acts.

STATE RIVERS AND WATER SUPPLY COMMISSION.
URBAN DISTRICT SUPPLIED WITH WATER FROM THE COLIBAN
SYSTEM OF WATERWORKS.

NOTICE to owners of tenements in the under-mentioned street in the urban district supplied with water from the Coliban system of waterworks, and the private streets, lanes, courts, and alleys opening thereto:—

Bendigo.

Hammer-street, from end of existing main (opposite lot 126) to a point opposite lot 141, about 1 chain easterly.
Bendigo-crescent, from Neale-street to a point opposite lot 10, about 10 chains north-easterly.
Curtain-street, from Drechsler-street to Flora-lane.
Drechsler-street, from Neale-street to Curtain-street, and from Curtain-street to a point opposite lot 1, about 10 chains north-easterly.
Flora-lane, from end of existing main (opposite lot 17) to Curtain-street.

Castlemaine.

Wheeler-street, from Gainsborough-street to William-street.

The main pipe in the said streets being laid down, the owners of all tenements situated as above are hereby required, on or before the 20th day of February next, to cause proper pipes and stop cocks to be laid, so as to supply water within such tenements from the main pipe.

L. DUGGAN, Secretary,
State Rivers and Water Supply Commission.
Melbourne, 12th January, 1950.

Water Act 1928.

CONSENT TO SALE OF LAND.

HIS Excellency the Governor of the State of Victoria, by and with the advice of the Executive Council thereof, doth, by Order made on the 10th day of January, 1950, under the provisions of the *Water Act 1928*, consent to the sale by the State Rivers and Water Supply Commission, subject to a flood easement in favour of the said Commission, of an area of approximately 115 acres, being part of allotment 50, Parish of Tabilk, County of Moira, which land was purchased by or is vested in the said Commission.

A. MAHLSTEDT,
Clerk of the Executive Council.
At the Executive Council Chamber,
Melbourne, the 10th January, 1950.

THE MELBOURNE HARBOR TRUST COMMISSIONERS.

IN pursuance of the *Melbourne Harbor Trust Act 1928*, the Melbourne Harbor Trust Commissioners make the following Regulations:—

1. The Regulations made by the Commissioners on the 21st October, 1942, approved by the Governor in Council on 2nd November, 1942, and published in the *Government Gazette* on the 27th November, 1942, and any amendment thereto, are hereinafter referred to as "the principal Regulations."

2. Definitions.—Port, the Port. The definition of the Port is repealed and the following definition substituted therefor:—

Port.—the Port. "The Port" means so much of the Port of Melbourne, the waters falling into it, and the lands on the margin as is included within the metes and bounds described in Parts I. and IV. of the Second Schedule of the Act excluding therefrom the lands described in Part II. of the said Schedule.

3. Regulation No. 65 is repealed and the following new Regulation is substituted therefor:—

65. Should a collision take place whereby any damage is caused to any vessel, wharf, or property within the Port, or should any vessel ground or sink within the Port then the master of every such vessel and every other person concerned in any such collision, grounding, or sinking, shall immediately report the circumstances to the Harbor Master in writing.

Sub-regulation (7) of Regulation 286 is repealed and the following sub-regulation substituted therefor:—

286. (7) remove any stone, sand, shell, marl, seaweed, or other material whatever from any property or place within the Port without having first obtained a licence from the Commissioners so to do.

Sub-regulation (25) of Regulation 286 is repealed and the following sub-regulation substituted therefor:—

286. (25) Negligently or violently or otherwise than as directed by the Harbor Master discharge or unload from any vessel or vehicle pig iron, timber, stone, machinery, or other goods or packages on to any wharf within the Port or place any material or substance or draw or trail any sledge timber or other heavy material upon any road, street, wharf, or other property of the Commissioners within the Port to the injury or obstruction thereof.

Sub-regulation (36) of Regulation 286 is repealed and the following sub-regulation substituted therefor:—

286. (36) Hold any meeting or address any assemblage within the Port without the consent of the Commissioners in writing.

Sub-regulation (42) of Regulation 286 is repealed and the following sub-regulation substituted therefor:—

286. (42) Graze any sheep, cattle, or horses upon any lands within the Port, except on such terms as the Commissioners may from time to time determine.

Dated at Melbourne, this seventh day of December, 1949.

The common seal of the Melbourne Harbor Trust Commissioners was hereunto affixed by order of the Commissioners, in the presence of—

(SEAL) A. D. MACKENZIE, Chairman.
A. G. ALLNUTT, Commissioner.
A. C. COOK, Secretary.

Approved by the Governor in Council,
10th January, 1950.

A. MAHLSTEDT,
Clerk of the Executive Council.

COUNTRY ROADS BOARD.

NOTICE is hereby given that the Board has decided to lift the prohibition on the Murray Valley Highway, between Yarrowonga and Strathmerton, of motor cars, the weight of which and of the load (if any) carried thereon exceeds six (6) tons.

Dated at Melbourne, this fifth day of January, 1950.

By order,
W. H. NEVILLE,
Secretary.

DEPARTMENT OF LAW.—SOLICITOR-GENERAL.

COURTS OF PETTY SESSIONS.

ALTERATION OF HOURS.

HIS Excellency the Governor of the State of Victoria, by and with the advice of the Executive Council thereof, and pursuant to the provisions of section 61 of the *Justices Act 1928*, doth, by Order made on the 10th day of January, 1950, hereby alter the hour heretofore appointed for the holding of Courts of Petty Sessions at the places named in the Schedule below, so far as it relates to the sittings appointed to be held on Wednesday, the 1st day of February, 1950, from 10 o'clock a.m. to 2.15 o'clock p.m.

SCHEDULE.

Brunswick	Melbourne
Cheltenham	Moonee Ponds
Eltham	North Melbourne
Hawthorn	Preston
Kew	Sandringham
Malvern	South Melbourne.

A. MAHLSTEDT,
Clerk of the Executive Council.
At the Executive Council Chamber,
Melbourne, 10th January, 1950.

4 GEORGE VI. No. 4755, SECTION 6.

I HEREBY give notice that on the 4th January, 1950, I filed an election to administer the following deceased person's estate, in accordance with section 6 of the *Public Trustee Act 1940*:—

* KENT, WILLIAM GEORGE, formerly of Willaura, but late of 50 Dorritt-street, Carlton, apartment-house proprietor, died 7th November, 1949.

* According to the provisions of the will.

I HEREBY give notice that on the 11th January, 1950, I filed elections to administer the following deceased persons' estates, in accordance with section 6 of the *Public Trustee Act 1940*:—

BROWNHILL, ANNIE CATHERINE, late of 47 Cheddar-road, Reservoir, pensioner, died 24th October, 1949, intestate.

* CASTLING, ROBERT WILLIAM, late of 124 Francis-street, Yarraville, engine-driver, died 11th June, 1949.

* EDWARDS, JOHN IDRIS, late of 2 Somers-street, Bentleigh, gas worker, died 31st October, 1949.

* ELGAR, ANDREW MARVELL PACKER, also known as Andrew Marvel Elgar, late of Echuca, retired sawyer, died 15th July, 1949.

GIBSON, JOHN, late of Cheltenham, pensioner, died 20th September, 1949, intestate.

ISBEL, DONALD FREDERICK, late of the Queen Elizabeth Benevolent Home, Ballarat, pensioner, died 4th June, 1949, intestate.

KOUTSOUKALIS, GEORGE, late of 55 Fryer-street, Shepparton, labourer, died 25th August, 1949, intestate.

McNEE, ALEXANDER, late of Nandaly, pensioner, died 31st August, 1949, intestate.

NATHU KHAN, also known as Mazir Khan, late of Ludhiana, West Punjab, Pakistan, died between 1st and 30th September, 1947, intestate.

* RELF, WILLIAM, late of Mooroopna, pensioner, died 17th September, 1949.

SKELLY, RICHARD, late of 212 Mary-street, Richmond, carpenter, died 17th September, 1949, intestate.

SPENCE, ALLAN CAMPBELL, formerly of 15 Hawthorn-parade, Haberfield, but late of Lidcombe, both in New South Wales, sheet metal worker, died 19th December, 1946, intestate.

WATKINSON, ADA ELIZABETH, late of 27 Lyndhurst-street, Richmond, pensioner, died 20th November, 1949, intestate.

* WATT, WILLIAM JOHN, late of 22 Balloan-street, Coburg, retired, died 1st November, 1948.

WILLIAMS, ELIZABETH JANE, late of Sunbury, widow, died 23rd August, 1949, intestate.

WILSON, GLENCAIRN, late of Princetown, no occupation, died 25th April, 1933, intestate.

WRIGHT, VIOLET ALISON, formerly of 247 Raleigh-street, Northcote, but late of 227 Gooch-street, Thornbury, married woman, died 17th August, 1942, intestate.

* According to the provisions of the will.

C. J. GARDNER,
Public Trustee.

412 Collins-street, Melbourne, C.1, 12th January, 1950.

NOTICE.

ADMINISTRATION of the estate of each of the under-mentioned deceased persons has been granted to me, and creditors, next of kin, and all others having claims against the estate of any of the persons so mentioned are required to send particulars of their claims to the Public Trustee, No. 412 Collins-street, Melbourne, on or before the 20th March, 1950, or they will be excluded from the distribution of the estate when the assets are being distributed:—

BROWNHILL, ANNIE CATHERINE, late of 47 Cheddar-road, Reservoir, pensioner, died 24th October, 1949, intestate.

* CASTLING, ROBERT WILLIAM, late of 124 Francis-street, Yarraville, engine-driver, died 11th June, 1949.

* EDWARDS, JOHN IDRIS, late of 2 Somers-street, Bentleigh, gas worker, died 31st October, 1949.

* ELGAR, ANDREW MARVELL PACKER, also known as Andrew Marvel Elgar, late of Echuca, retired sawyer, died 15th July, 1949.

GIBSON, JOHN, late of Cheltenham, pensioner, died 20th September, 1949, intestate.

ISBEL, DONALD FREDERICK, late of the Queen Elizabeth Benevolent Home, Ballarat, pensioner, died 4th June, 1949, intestate.

* KENT, WILLIAM GEORGE, formerly of Willaura, but late of 50 Dorritt-street, Carlton, apartment-house proprietor, died 7th November, 1949.

KOUTSOUKALIS, GEORGE, late of 55 Fryer-street, Shepparton, labourer, died 25th August, 1949, intestate.

McNEE, ALEXANDER, late of Nandaly, pensioner, died 31st August, 1949, intestate.

NATHU KHAN, also known as Mazir Khan, late of Ludhiana, West Punjab, Pakistan, died between 1st and 30th September, 1947, intestate.

* RELF, WILLIAM, late of Mooroopna, pensioner, died 17th September, 1949.

SKELLY, RICHARD, late of 212 Mary-street, Richmond, carpenter, died 17th September, 1949, intestate.

SPENCE, ALLAN CAMPBELL, formerly of 15 Hawthorn-parade, Haberfield, but late of Lidcombe, both in New South Wales, sheet metal worker, died 19th December, 1946, intestate.

WATKINSON, ADA ELIZABETH, late of 27 Lyndhurst-street, Richmond, pensioner, died 20th November, 1949, intestate.

* WATT, WILLIAM JOHN, late of 22 Balloan-street, Coburg, retired, died 1st November, 1948.

WILLIAMS, ELIZABETH JANE, late of Sunbury, widow, died 23rd August, 1949, intestate.

WILSON, GLENCAIRN, late of Princetown, no occupation, died 25th April, 1933, intestate.

WRIGHT, VIOLET ALISON, formerly of 247 Raleigh-street, Northcote, but late of 227 Gooch-street, Thornbury, married woman, died 17th August, 1942, intestate.

* According to the provisions of the will.

C. J. GARDNER,
Public Trustee.

Melbourne, 12th January, 1950.

Dairy Products Acts.
QUOTAS FOR BUTTER AND CHEESE.

BUTTER QUOTA.

I, ALEXANDER HENRY DENNETT, Minister of Agriculture in the State of Victoria, after consultation with the Victorian Dairy Products Board, and after ascertaining that the supply and distribution of butter at reasonable prices to consumers thereof in Victoria will be ensured, hereby determine a quota for butter as follows:—

The proportion shall be Forty-eight point one five per cent.

The period for which this quota is to operate shall be the month of February, 1950.

CHEESE QUOTA.

I, ALEXANDER HENRY DENNETT, Minister of Agriculture in the State of Victoria, after consultation with the Victorian Dairy Products Board, and after ascertaining that the supply and distribution of cheese at reasonable prices to consumers thereof in Victoria will be ensured, hereby determine a quota for cheese as follows:—

The proportion shall be Fifty point nought nought per cent.

The period for which this quota is to operate shall be the month of February, 1950.

A. H. DENNETT,
Minister of Agriculture.

DEPARTMENT OF MINES.

SUBJECT to any necessary excisions, &c., it is proposed to grant the following leases:—

8240, Beechworth; Evelyn Maud Spargo and William Benjamin Spargo; 7a. 0r. 4p., in the Parish of Hotham.

8241, Beechworth; Evelyn Maud Spargo and William Benjamin Spargo; 13a. 2r. 24p., in the Parish of Hotham.

8242, Beechworth; William Harris; 52a. 2r. 39p., in the Parish of Hotham.

CONSENT GRANTED TO TRANSFER MINING LEASE.

8959, Castlemaine; from William John Crowe to Samuel George Lacy, Sidney Ellison Weeks, and Norma Scott.

H. E. BOLTE,
Minister of Mines.

MINING LEASES DECLARED VOID.

7563, Beechworth; Mount Firebrace (1935) Development No Liability; 21a. 1r. 30p., in the Parish of Bungil.

8425, Castlemaine; Raymond James Kilgariff and Edward Arthur Walker; 36a. 1r. 11p., in the Parishes of Faraday, Chewton, and Castlemaine.

8908, Castlemaine; Maxwell North (Daylesford) No Liability; 38a. 2r., in the Parish of Wombat.

GEO. BROWN,
Secretary for Mines.

DEPARTMENT OF LAW.

ANNUAL SITTINGS OF LICENSING COURTS.—
EXTENSION OF TIMES FOR HOLDING.

HIS Excellency the Governor of the State of Victoria, by and with the advice of the Executive Council thereof, doth, by Order made on the 10th day of January, 1950, extend the times for holding the Annual Sittings of the Licensing Courts for the Licensing Districts set out in the first column of the Schedule below (appointed to be held on the dates indicated) for a period not exceeding two months from the 31st December, 1949 (Act No. 3717, section 87).

SCHEDULE.

Licensing District.	Date of Sittings.
Benalla	8th November, 1949.
Gippsland South ..	3rd November, 1949.
Rainbow	22nd November, 1949.
Swan Hill	17th November, 1949.
Mornington	16th November, 1949.
Bendigo	10th November, 1949.
St. Kilda	16th November, 1949.
Borong	22nd November, 1949.
Preston	16th November, 1949.
Sunshine	16th November, 1949.
Polwarth	3rd November, 1949.
Northcote	16th November, 1949.
Box Hill	16th November, 1949.
Williamstown ..	16th November, 1949.
Hampden	4th November, 1949.
Essendon	16th November, 1949.
Shepparton	8th November, 1949.
Melbourne	16th November, 1949.
Malvern	16th November, 1949.
Korong	11th November, 1949.
Ripon	21st November, 1949.

A. MAHLSTEDT,
Clerk of the Executive Council.

At the Executive Council Chamber,
Melbourne, 10th January, 1950.

DEPARTMENT OF LAW.

CURATOR OF CONVICT'S PROPERTY.

HIS Excellency the Governor of the State of Victoria, by and with the advice of the Executive Council thereof, and pursuant to the provisions of section 576 of the *Crimes Act 1928*, doth, by Order made on the 10th day of January, 1950, direct that the custody and management of the property of the convict, John Henry Smith, be committed to George Smith, of 25 Albert-street, Footscray, hairdresser, as a curator hereby appointed in that behalf.

A. MAHLSTEDT,
Clerk of the Executive Council.

At the Executive Council Chamber,
Melbourne, 10th January, 1950.

SUMMONING OFFICER.

I HEREBY appoint the under-mentioned person, under section 31 of the *Education Act 1928*, to summon parents within the State of Victoria:—

Senior Constable GORDON MICHAEL HOWARD, No. 8048.

R. W. TOVELL,
Minister of Education.

Education Department,
Melbourne, 12th January, 1950.

MOTOR OMNIBUS ACT 1928 (No. 3742).

At the Executive Council Chamber, Melbourne, the
tenth day of January, 1950.

PRESENT:

His Excellency the Governor of Victoria.	
Mr. Oldham	Sir James Kennedy
Brigadier Tovell	Mr. Guthrie
Mr. Bolte	Lieut.-Col. Hipworth.

APPOINTMENT OF MEMBERS AND CHAIRMAN OF
ADVISORY COMMITTEE.

HIS Excellency the Governor of the State of Victoria, by and with the advice of the Executive Council thereof, and under the powers conferred by section 16 of the *Motor Omnibus Act 1928* (No. 3742), doth by this Order appoint—

CHARLES CLAUSS GALE (representing the Public Works Department),
JOSEPH LESLIE TIMEWELL (representing the Victorian Railways Commissioners),
GERALD FRANCIS WRAITH (representing the Melbourne and Metropolitan Tramways Board),
Councillor HECTOR JAMES MCIVOR (representing the Councils of the municipalities within the metropolitan area), and
ALURED SEYMOUR MACARTHUR GRAY (representing the interests of owners of motor omnibuses),
to be Members for a period of twelve (12) months from the twenty-first day of January, 1950, of the Advisory Committee constituted under the said Act.

And, further, His Excellency doth by this same Order appoint Charles Claus Gale to be Chairman of the said Committee.

And the Honorable James Arthur Kennedy, His Majesty's Commissioner of Public Works for the State of Victoria, shall give the necessary directions herein accordingly.

A. MAHLSTEDT,
Clerk of the Executive Council.

MOTOR OMNIBUS ACT 1928 (No. 3742).

At the Executive Council Chamber, Melbourne, the
tenth day of January, 1950.

PRESENT:

His Excellency the Governor of Victoria.	
Mr. Oldham	Sir James Kennedy
Brigadier Tovell	Mr. Guthrie
Mr. Bolte	Lieut.-Col. Hipworth.

AMENDMENT OF PRESCRIPTIONS OF METRO-
POLITAN MOTOR OMNIBUS ROUTES, Nos. 17 & 6A.

HIS Excellency the Governor of the State of Victoria, by and with the advice of the Executive Council thereof, and in pursuance of the powers conferred by the *Motor Omnibus Act 1928* (No. 3742), doth by this Order amend, as set out hereunder, the prescriptions of certain routes, i.e., Nos. 17 and 6A, within the metropolitan area along which motor omnibuses for which "regular service" licences are granted may ply for hire, viz.:—

Route No. 17 (Abbotsford-Clifton Hill-North Melbourne).—Under the heading "Maximum number of motor omnibuses which may be licensed on route," amend "8" to read "5."

Route No. 6A (Coburg-Heidelberg).—Under the heading "Maximum number of motor omnibuses which may be licensed on route," amend "12" to read "14."

Licensing Authority.—Pursuant to the provisions of section 15 (1) (c) of the said Act (No. 3742), the Governor in Council by this Order confers upon the Licensing Authority full power and authority for the carrying into effect by the said Licensing Authority of the foregoing provisions of this Order.

And the Honorable James Arthur Kennedy, His Majesty's Commissioner of Public Works for the State of Victoria, shall give the necessary directions herein accordingly.

A. MAHLSTEDT,
Clerk of the Executive Council.

DEPARTMENT OF LANDS AND SURVEY.

At the Executive Council Chamber, Melbourne, the tenth day of January, 1950.

PRESENT:

His Excellency the Governor of Victoria.

Mr. Oldham
Brigadier Tovell
Mr. Bolte

Sir James Kennedy
Mr. Guthrie
Lieut.-Col. Hipworth.

LANDS TEMPORARILY RESERVED FROM SALE.

HIS Excellency the Governor of the State of Victoria, by and with the advice of the Executive Council thereof, doth hereby, in pursuance of the provisions of the Land Act 1928, reserve, temporarily, and also except from occupation for mining purposes under any miner's right, the lands hereinafter described:—

COHUNA.—Site for Municipal Sale Yards, 16 acres 1 rood 19 perches, Parish of Cohuna, County of Gunbower, as indicated by hachure on plan hereunder.—(C.424^(*)) (Rs.6503).

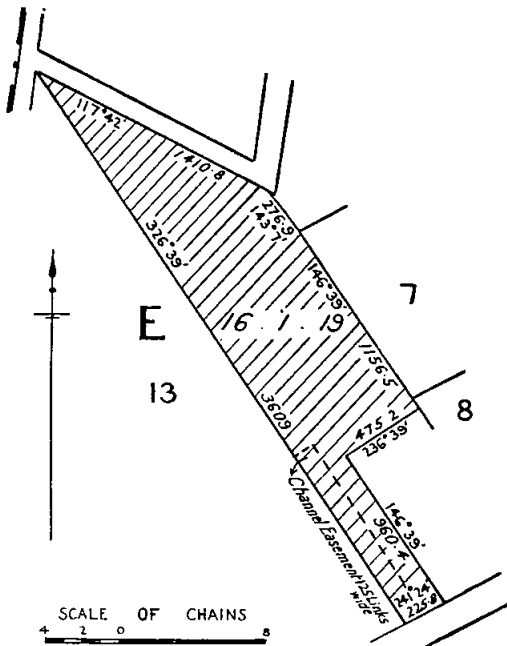

MURRAYVILLE.—Site for a Rubbish Depot, 2 acres, more or less, Township of Murrayville, Parish of Danyo, County of Weeah, as indicated by hachure on plan hereunder.—(M.575^(*)) (Rs.6464).

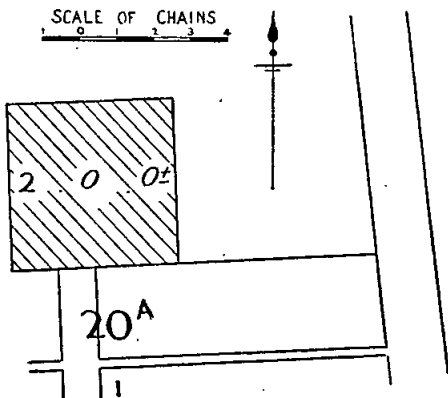

BARRARBOOL (HIGHTON).—Site for Plantation purposes, 3 roods 37 perches, Parish of Barrarbool, County of Grant, as indicated by hachure on plan hereunder.—(B.34^(*)) (Rs.6498).

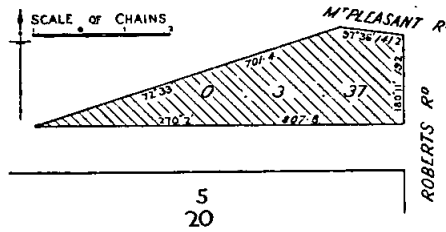

DEVON.—Site for Public purposes, 3 acres, more or less, Parish of Devon, County of Buln Buln, as indicated by hachure on plan hereunder, but excluding therefrom the land declared a main road under the Country Roads Act by Order in Council of the 4th July, 1938.—(D.171^(*)) (Rs.6489).

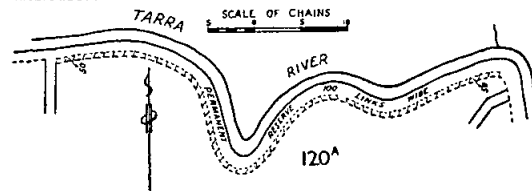

BENDIGO.—Site for Police purposes, 1 rood, City of Bendigo, Parish of Sandhurst, County of Bendigo, as indicated by hachure on plan hereunder.—(S.372^(*)) (Rs.6487).

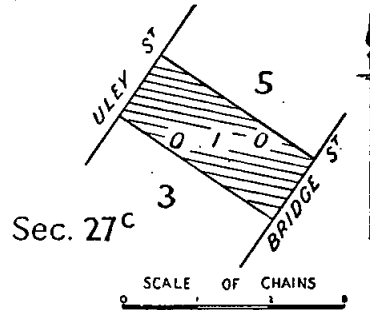

KANGERONG.—Site for Supply of Gravel, 81 acres 2 roods, more or less, Parish of Kangerong, County of Mornington, as indicated by hachure on plan hereunder.—(K.7^(*)) (Rs.6488).

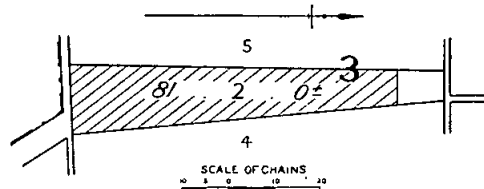

PRAHRAN (ELSTERNWICK).—Site for a Baby Health Centre, 1 rood 2 8/10 perches, at Elsternwick, Parish of Prahran, County of Bourke, as indicated by hachure on plan hereunder.—(P.81⁽¹⁵⁾) (Rs.6501).

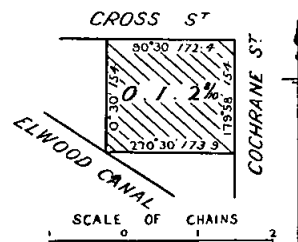

HEALESVILLE.—Site for State School purposes, 5 acres 0 roods 10 perches, Township of Healesville, Parish of Gracedale, County of Evelyn, as indicated by hachure on plan hereunder.—(H.113⁽²⁾) (Rs.6006).

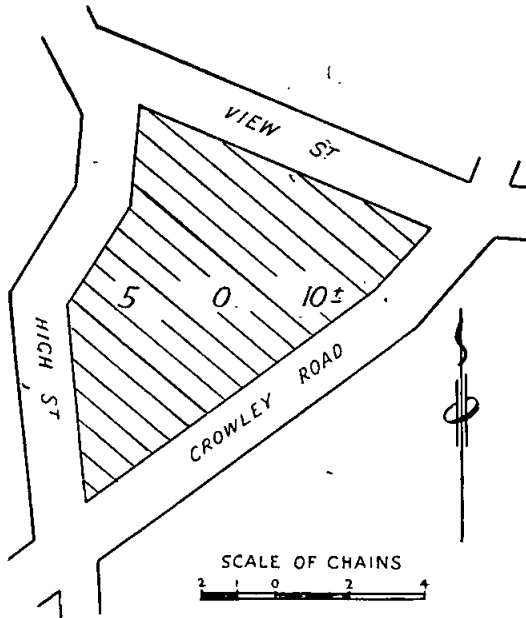

WILL-WILL-ROOK (GLENROY).—Site for Police purposes, 34 perches, Parish of Will-will-rook, County of Bourke, as indicated by hachure on plan hereunder.—(W.151⁽²⁾)

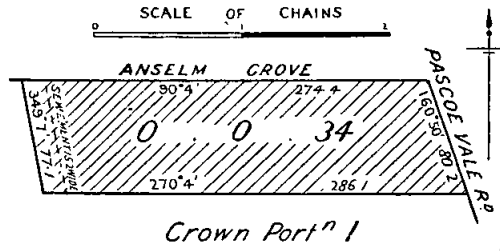

And the Honorable Rutherford Campbell Guthrie, His Majesty's Commissioner of Crown Lands and Survey for the State of Victoria, shall give the necessary directions herein accordingly.

A. MAHLSTEDT,
Clerk of the Executive Council.

DEPARTMENT OF LANDS AND SURVEY.

At the Executive Council Chamber, Melbourne, the tenth day of January, 1950.

PRESENT:

His Excellency the Governor of Victoria.
Mr. Oldham | Sir James Kennedy
Brigadier Tovell | Mr. Guthrie
Mr. Bolte | Lieut.-Col. Hipworth.

UNUSED AND UNMADE ROADS CLOSED.

HIS Excellency the Governor of the State of Victoria, by and with the advice of the Executive Council thereof, doth hereby direct that, in pursuance of the provisions of section 304 of the Land Act 1928 (No. 3709), the unused and unmade roads referred to hereunder be closed, viz.:

At Sebastopol, Parish of Ballaarat, County of Grenville, being the road indicated by hachure on plan hereunder.—(S.353⁽²⁾) (J.27559).

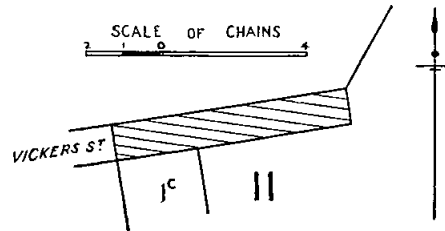

Parish of Ballyrogan, County of Ripon, being the road between allotments 237A, 237B, 248A, and 248B and allotments 238A, 238B, 247A, and 247B.—(B.596⁽²⁾) (J.27352).

Parish of Ecklin, County of Heytesbury, being the road between allotment 3A and allotment 3C, section 11.—(E.92⁽²⁾) (J.27411).

Village of Irrewillipe, Parish of Irrewillipe, County of Polwarth, being the road between allotments 1, 2, 3, 4, and 5 and allotments 10, 9, 8, and 7, section 9.—(I.15⁽⁶⁾) (J.27537).

Parish of Oxley, County of Bogong, being the road indicated by hachure on plan hereunder.—(O.16⁽²⁾) (H.019270).

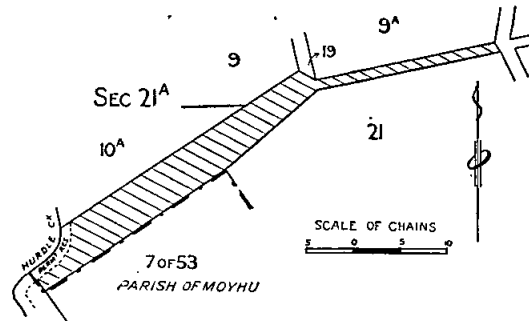

MALMSBURY.—Site for Watering purposes, 3 roods 20 perches, more or less, Town of Malmsbury, Parish of Edgecombe, County of Dalhousie, as indicated by hachure on plan hereunder.—(M.65⁽⁴⁾) (Rs.6490).

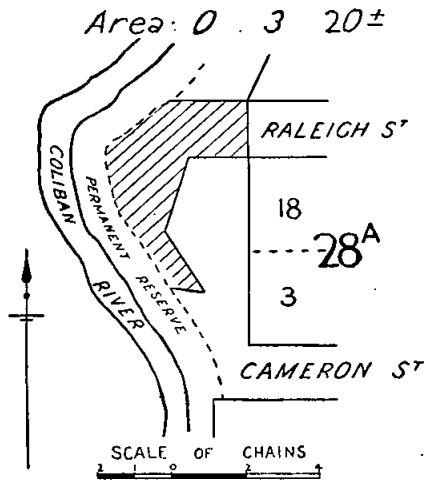

HASTINGS.—Site for Government Buildings, 1 rood 18 9/10 perches, Township of Hastings, Parish of Tyabb, County of Mornington, as indicated by hachure on plan hereunder.—(H.122⁽²⁾) (Rs.6491).

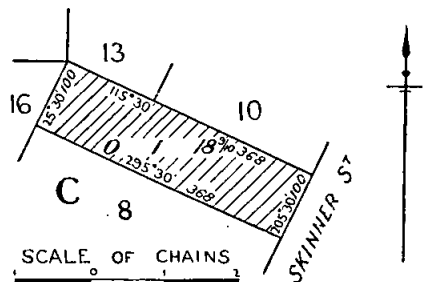

Parish of Lima, County of Delatite, being the road indicated by hachure on plan hereunder.—(L.153⁽³⁾) (H.018981).

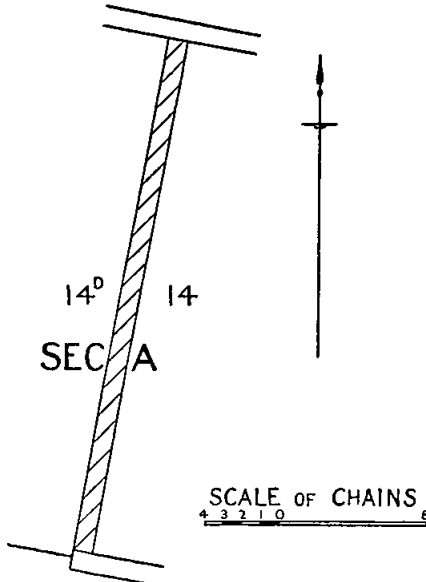

Parish of Mellier, County of Ripon, being the road between allotments 4A, 4B, 3A, and 3B, section 19, and allotments 1A, 1B, 2A, and 2B, section 30.—(M.415⁽²⁾) (J.27406).

Parish of Tatyoon, County of Ripon, being the road between allotments E1, E2, 130, and 141 and allotments 101, 101A, and 142.—(T.160^(A2)) (J.27483).

And the Honorable Rutherford Campbell Guthrie, His Majesty's Commissioner of Crown Lands and Survey for the State of Victoria, shall give the necessary directions herein accordingly.

A. MAHLSTEDT,
Clerk of the Executive Council.

DEPARTMENT OF LANDS AND SURVEY.

At the Executive Council Chamber, Melbourne, the tenth day of January, 1950.

PRESENT:

His Excellency the Governor of Victoria.	
Mr. Oldham	Sir James Kennedy
Brigadier Tovell	Mr. Guthrie
Mr. Bolte	Lieut.-Col. Hipworth.

REVOCATION OF TEMPORARY RESERVATIONS OF LANDS BY ORDERS IN COUNCIL.

HIS Excellency the Governor of the State of Victoria, by and with the advice of the Executive Council thereof, doth hereby, in pursuance of the provisions of the *Land Act 1928*, revoke the temporary reservations of lands by Orders in Council hereinafter referred to, viz.:

KIATA.—Order in Council of 6th September, 1881, of 1 acre of land in the Parish of Kiata as a site for Public purposes (State school).—(C.91904.)

GEE LONG.—Order in Council of 3rd August, 1921, of 1 rood 2 5/10 perches of land in the City of Geelong as a site for Plantation Reserve, so far only as regards the portion thereof comprised within the boundaries published in the *Government Gazette* of 30th November, 1949, and containing 29 5/10 perches.—(Rs.2332.)

And the Honorable Rutherford Campbell Guthrie, His Majesty's Commissioner of Crown Lands and Survey for the State of Victoria, shall give the necessary directions herein accordingly.

A. MAHLSTEDT,
Clerk of the Executive Council.

COUNTRY ROADS BOARD.

At the Executive Council Chamber, Melbourne, the tenth day of January, 1950.

PRESENT:

His Excellency the Governor of Victoria.	
Mr. Oldham	Sir James Kennedy
Brigadier Tovell	Mr. Guthrie
Mr. Bolte	Lieut.-Col. Hipworth.

DECLARATION OF A DEVIATION FROM THE GRAND RIDGE-ROAD IN THE SHIRE OF MORWELL.

WHEREAS by section 58 of the *Country Roads Act 1928* (No. 3662) it is amongst other things enacted that when the Country Roads Board under the provisions of the *Country Roads Act* has by Resolution declared a deviation to be a main road the said Board may also declare that such deviation shall be in lieu of any existing road or part thereof named in such Resolution and that on publication in the *Government Gazette* of the Order confirming such Resolution the existing road or part thereof shall cease to be a main road or be discontinued as provided in the Resolution: And whereas the said Board has by Resolution declared the deviation on the land described in the First Schedule to such Resolution to be a main road and has also declared that such deviation shall be in lieu of the part of the existing road being the land described in the Second Schedule to the said Resolution and that such part of the said existing road shall be discontinued: Now therefore His Excellency the Governor of the State of Victoria by and with the advice of the Executive Council thereof doth hereby confirm the said Resolution.

Resolution for Declaration of a Deviation under the *Country Roads Act*.

Whereas the land the site of the road the course of which is below set out was taken by the Board under the provisions of the *Country Roads Act 1928* for the purpose of constructing such road deviation which road deviation has now been laid out and formed on the same: And whereas the said Board (being the Country Roads Board incorporated under the said Act) thinks that the road aforesaid is fit to be used as a public highway such Board at a meeting now holden acting under the authority conferred upon it by section 58 of the said Act doth by this present Resolution hereby declare the said road deviation the course of which is described in the First Schedule hereto with the commencing and terminating points thereof respectively specified to be part of a main road within the meaning and for the purposes of the *Country Roads Act 1928*: And the said Board doth also declare that such deviation shall be in lieu of the existing road or part thereof described in the Second Schedule hereto, and that such part of the said existing road shall be discontinued.

FIRST SCHEDULE.

Shire of Morwell.

5. *The Grand Ridge-road* (10805).—All that piece of land in the Parish of Mirboo, the boundaries of which are as follow:—Commencing at a point on the southern boundary of allotment 57 of the said parish distant 88 deg. 10 min. 453.8 links from the south-western angle of that allotment; thence by lines bearing respectively 76 deg. 3 min. 454.9 links, 69 deg. 11 min. 543.6 links, 52 deg. 5 min. 171.2 links, 33 deg. 56 min. 191 links, 58 deg. 2 min. 532.3 links, 74 deg. 35 min. 584.9 links, 34 deg. 26 min. 51 links, 184 deg. 18 min. 141.3 links, 254 deg. 35 min. 561.7 links, 235 deg. 2 min. 496.5 links, 213 deg. 56 min. 185.7 links, 232 deg. 5 min. 748.2 links, 245 deg. 21 min. 471.2 links, and 268 deg. 10 min. 571.2 links to the point of commencement—which said piece of land is particularly delineated and shown coloured red and yellow on survey plan No. 1167, lodged in the office of the Country Roads Board.

SECOND SCHEDULE.

Shire of Morwell.

5. *The Grand Ridge-road*.—All that piece of land in the Parish of Mirboo, the boundaries of which are as follow:—Commencing at a point on the western boundary of allotment 57c of the said parish distant 358 deg. 10 min. 87 links from the south-western angle of that allotment; thence by lines bearing respectively 298 deg. 37 min. 231.3 links, 65 deg. 21 min. 471.2 links, 52 deg. 5 min. 343.1 links, 59 deg. 56 min. 632.7 links, 91 deg. 26 min. 423 links, 47 deg. 34 min. 549 links, 182 deg. 27 min. 282.2 links, 227 deg. 34 min. 430.6 links, 271 deg. 26 min. 447 links, and

239 deg. 56 min. 1,265 links to the point of commencement—which said piece of land is particularly delineated and shown coloured blue on survey plan No. 1167, lodged in the office of the Country Roads Board.

The common seal of the Country Roads Board was hereto affixed at Melbourne, this nineteenth day of December, One thousand nine hundred and forty-nine—

(SEAL.) D. V. DARWIN, Chairman.
F. M. CORRIGAN, Member.
W. H. NEVILLE, Secretary.

And the Honorable James Arthur Kennedy, His Majesty's Commissioner of Public Works for the State of Victoria, shall give the necessary directions herein accordingly.

A. MAHLSTEDT,
Clerk of the Executive Council.

COUNTRY ROADS BOARD.

At the Executive Council Chamber, Melbourne, the tenth day of January, 1950.

PRESENT:

His Excellency the Governor of Victoria.	
Mr. Oldham	Sir James Kennedy
Brigadier Tovell	Mr. Guthrie
Mr. Bolte	Lieut.-Col. Hipworth.

ORDER APPROVING OF A NEW MAIN ROAD IN THE SHIRE OF MORNINGTON.

WHEREAS the Country Roads Board constituted under the *Country Roads Act 1928* (No. 3662) has represented to His Excellency the Governor in Council that it appears to it desirable that the new Tyabb-road in the Shire of Mornington should be made by the said Board: And whereas the said Board in accordance with the requirements of section 19 of the said cited Act has caused to be prepared a map plan and estimate showing the points between which and on and through what land the said new road is proposed to be made and the cost of acquiring the land and constructing the said new road: And whereas on an inspection of the said map and plan and a consideration of the said estimate His Excellency the Governor in Council is satisfied that there are funds legally available for acquiring the land and constructing the said new road: Now therefore be it known by this present Order that His Excellency the Governor of the State of Victoria with the advice of the Executive Council thereof doth hereby approve of the said road being made, that is to say:—

All those pieces of land in the Parish of Moorooduc, the boundaries of which are as follow:—

- (a) Commencing at the south-western angle of allotment 4, section A, of the said parish; thence by lines bearing respectively 21 deg. 7½ min. 75.8 links, 163 deg. 5½ min. 84.7 links, and 281 deg. 17 min. 53 links to the point of commencement.
- (b) Commencing at the north-western angle of allotment 5, section A, of the said parish; thence by lines bearing respectively 101 deg. 17 min. 53 links, 225 deg. 30½ min. 91.7 links, and 10 deg. 11 min. 75.8 links to the point of commencement.
- (c) Commencing at the north-eastern angle of allotment 11, section 23, of the said parish; thence by lines bearing respectively 190 deg. 0 min. 60.6 links, 336 deg. 48 min. 81.3 links, and 111 deg. 0 min. 45.4 links to the point of commencement.
- (d) Commencing at the south-eastern angle of lot 10 on plan of subdivision numbered 6787, lodged in the Office of Titles, and being part of allotment B of the said parish; thence by lines bearing respectively 290 deg. 54½ min. 42.8 links, 56 deg. 48 min. 73.3 links, and 201 deg. 7½ min. 59.4 links to the point of commencement—

which said pieces of land are particularly delineated and shown coloured red on survey plan numbered 5130, lodged in the office of the Country Roads Board.

And the Honorable James Arthur Kennedy, His Majesty's Commissioner of Public Works for the State of Victoria, shall give the necessary directions herein accordingly.

A. MAHLSTEDT,
Clerk of the Executive Council.

COUNTRY ROADS BOARD.

At the Executive Council Chamber, Melbourne, the tenth day of January, 1950.

PRESENT:

His Excellency the Governor of Victoria.	
Mr. Oldham	Sir James Kennedy
Brigadier Tovell	Mr. Guthrie
Mr. Bolte	Lieut.-Col. Hipworth.

ORDER APPROVING OF A DEVIATION FROM A TOURISTS' ROAD IN THE SHIRES OF BASS AND PHILLIP ISLAND.

WHEREAS the Country Roads Board constituted under the *Country Roads Act 1928* (No. 3662) has represented to His Excellency the Governor in Council that it appears to it desirable that the deviation hereinafter referred to from the existing Phillip Island road in the Shires of Bass and Phillip Island (declared to be a tourists' road under the *Country Roads (Tourists' Roads) Act 1936*, which declaration was confirmed by the Order in Council published in the *Government Gazette* of the 22nd January, 1941, on page 203) should be made by the said Board: And whereas the said Board in accordance with the requirements of section 19 of the said cited Act and section 6 of the *Country Roads (Tourists' Roads) Act 1936* has caused to be prepared a map plan and estimate showing the points between which and on and through what land the said deviation is proposed to be made and the cost of acquiring the land and constructing the said deviation: And whereas on an inspection of the said map and plan and a consideration of the said estimate His Excellency the Governor in Council is satisfied that there are funds legally available for acquiring the land and constructing the said deviation: Now therefore be it known by this present Order that His Excellency the Governor of the State of Victoria with the advice of the Executive Council thereof doth hereby approve of the said road being made, that is to say:—

All those pieces of land in the Parish of Woolamai, the boundaries of which are as follow:—

- (a) Commencing at the north-western angle of Crown portion 9 of the said parish; thence by lines bearing respectively 90 deg. 0 min. 630 links, 261 deg. 49 min. 636 links, and 359 deg. 43 min. 90.6 links to the point of commencement.
- (b) Commencing at the north-eastern angle of allotment 20, section A, Township of San Remo, in the said parish; thence by lines bearing respectively 179 deg. 43 min. 77.7 links, 244 deg. 37 min. 512.6 links, and 57 deg. 16 min. 550 links to the point of commencement.
- (c) Commencing at a point on the southern boundary of allotment 18, section A, Township of San Remo, in the said parish, distant 237 deg. 14 min. 1,600 links from the south-eastern angle of allotment 19 of the said section; thence by lines bearing respectively 237 deg. 14 min. 627 links, 269 deg. 25 min. 632.5 links, 82 deg. 33 min. 610.5 links, and 64 deg. 21 min. 615.4 links to the point of commencement.
- (d) Commencing at the north-western angle of lot 1 on plan of subdivision numbered 13387, lodged in the Office of Titles, and being part of allotment 7A, section A, Township of San Remo, in the said parish; thence by lines bearing respectively 99 deg. 9½ min. 20 feet, 234 deg. 11 min. 28 ft. 3½ in., and 9 deg. 11 min. 20 feet to the point of commencement.

(e) Commencing at the north-eastern angle of lot 1 on plan of subdivision numbered 12778, lodged in the Office of Titles, and being part of allotment 5c, section A, Township of San Remo, in the said parish; thence by lines bearing respectively 189 deg. 11 min. 20 feet, 269 deg. 52 min. 118 feet, and 80 deg. 37 min. 122 ft. 10 in. to the point of commencement.

Also, all those pieces of land in the Parish of Phillip Land, the boundaries of which are as follow:—

(a) Commencing at the northern angle of allotment 121 of the said parish; thence by lines bearing respectively 142 deg. 24 min. 600 links, 305 deg. 50 min. 451.5 links, and 360 deg. 0 min. 211 links to the point of commencement.

(b) Commencing at a point on the eastern boundary of allotment 123 of the said parish, distant 180 deg. 0 min. 151.5 links from the north-eastern angle of the said allotment; thence by lines bearing respectively 180 deg. 0 min. 103.5 links, 289 deg. 36 min. 604.3 links, 274 deg. 58 min. 602 links, 90 deg. 0 min. 866 links, and 116 deg. 34 min. 338.8 links to the point of commencement.

(c) Commencing at a point on the southern boundary of allotment 105 of the said parish, distant 90 deg. 0 min. 500 links from the south-western angle of the said allotment; thence by lines bearing respectively 315 deg. 0 min. 707.1 links, 360 deg. 0 min. 1,498.7 links, 171 deg. 38 min. 751.7 links, 148 deg. 6 min. 833 links, 121 deg. 22 min. 866.3 links, 96 deg. 45 min. 824.4 links, and 270 deg. 0 min. 1,608 links to the point of commencement—

The said pieces of land are particularly delineated and coloured red on survey plans numbered 5134, 5135, and 5136, lodged in the office of the Country Roads Board.

And the Honorable James Arthur Kennedy, His Majesty's Minister of Public Works for the State of Victoria, give the necessary directions herein accordingly.

A. MAHLSTEDT,
Clerk of the Executive Council.

CHILTERN WATERWORKS TRUST.

At the Executive Council Chamber, Melbourne, the tenth day of January, 1950.

PRESENT:

His Excellency the Governor of Victoria.

Mr. Oldham	Sir James Kennedy
Brigadier Tovell	Mr. Guthrie
Mr. Bolte	Lieut.-Col. Hipworth.

ADDITIONAL LOAN OF £7,684.

Under the powers conferred by the Water Acts and all other powers enabling him in that behalf, His Excellency the Governor of the State of Victoria, by and with the advice of the Executive Council of the said State, doth hereby grant an additional loan of Seven thousand six hundred and eighty-four pounds (£7,684) to the Chiltern Waterworks Trust for improvements to springs, bores, reticulation, and the purchase and installation of mains as set forth in the detailed statement bearing date 19th December, 1949, and verified under the seal of the State Rivers and Water Supply Commission.

The loan hereby granted shall be subject to the provisions of the Water Acts.

And the Honorable Henry Edward Bolte, His Majesty's Minister of Water Supply for the State of Victoria, shall give the necessary directions herein accordingly.

A. MAHLSTEDT,
Clerk of the Executive Council.

SUPERANNUATION ACTS.

At the Executive Council Chamber, Melbourne, the tenth day of January, 1950.

PRESENT:

His Excellency the Governor of Victoria.

Mr. Oldham	Sir James Kennedy
Brigadier Tovell	Mr. Guthrie
Mr. Bolte	Lieut.-Col. Hipworth.

IN accordance with the provisions of section 2 of the Superannuation Act 1949 (No. 5395), His Excellency the Governor of the State of Victoria, by and with the advice of the Executive Council thereof, doth by this Order declare that the provisions of the Superannuation Acts shall apply to Inspectors of Municipal Accounts, appointed pursuant to the provisions of section 489 of the Local Government Act 1946.

And the Honorable Thomas Tuke Hollway, His Majesty's Treasurer for the State of Victoria, shall give the necessary directions herein accordingly.

A. MAHLSTEDT,
Clerk of the Executive Council.

DEPARTMENT OF MINES.

At the Executive Council Chamber, Melbourne, the tenth day of January, 1950.

PRESENT:

His Excellency the Governor of Victoria.

Mr. Oldham	Sir James Kennedy
Brigadier Tovell	Mr. Guthrie
Mr. Bolte	Lieut.-Col. Hipworth.

LAND EXCEPTED FROM OCCUPATION, ETC.

HIS Excellency the Governor of the State of Victoria, by and with the advice of the Executive Council thereof, in pursuance of the powers conferred by the Mines Act 1928, doth hereby except from occupation for mining purposes, or for residence on business under any miner's right or from being leased under a mining lease, the under-mentioned lands, being part of Crown allotment 116A and part of Crown portion 121, Parish of Nunawading, County of Bourke, viz.:—

From the north-east corner of Canterbury-road and Rooks-road on a line bearing north 7 deg. 44 min. west 734 8/10 links, north 25 deg. west 612 9/10 links, to the commencement point of the land referred to, being part of Crown allotment 116A; from this point bearing north 25 deg. west 593 4/10 links, east 3 4/10 links, north 17 deg. 30 min. west 822 3/10 links, south 89 deg. 47 min. east 786 8/10 links, south 25 deg. east 1,461 2/10 links, north 89 deg. 42 min. west 910 1/10 links, to the commencement point, comprising an area of 11 acres 2 roods 5 perches, more or less.

From the north-west corner of Canterbury-road and Mitcham-road on a line bearing north 12 deg. 38 min. west 1,430 2/10 links, to the commencement point of the land referred to, being part of Crown portion 121; from this point bearing south 84 deg. 17 min. west 1,010 9/10 links, south 84 deg. 3 min. west 1,334 2/10 links, north 25 deg. 3 min. west 2,269 8/10 links, north 84 deg. 50 min. east 2,840 7/10 links, south 12 deg. 38 min. east 2,124 2/10 links, to the commencement point, comprising an area of 55 acres and 4 perches more or less.

And the Honorable Henry Edward Bolte, His Majesty's Minister of Mines for the State of Victoria, shall give the necessary directions herein accordingly.

A. MAHLSTEDT,
Clerk of the Executive Council.

Apprenticeship Acts.
APPRENTICESHIP COMMISSION OF VICTORIA.

At the Executive Council Chamber, Melbourne, the
seventeenth day of January, 1950.

PRESENT:

His Excellency the Governor of Victoria.
Mr. Oldham | Brigadier Tovell
Mr. Guthrie | Lieut.-Col. Hipworth.

AMENDMENT OF DENTAL MECHANIC TRADE
REGULATIONS (No. 1).

IN pursuance of the powers conferred by the Apprenticeship Acts and the Acts Interpretation Acts, His Excellency the Governor of the State of Victoria, by and with the advice of the Executive Council thereof, doth hereby make the following Regulations, that is to say:—

1. Regulation 9 of the Dental Mechanic Trade Regulations (No. 1) shall be and the same is hereby rescinded as from the beginning of the first full pay period to commence in December, 1949.

2. Such rescission shall not affect any right accrued or accruing to any person or any liability of any person under the said rescinded Regulation before the commencement of these Regulations.

3. For the said rescinded Regulation the following Regulation shall be substituted:—

"9. The minimum rates of pay to be paid as wages to apprentices in the said trade in each year of their apprenticeship course shall be as follows as from the beginning of the first full pay period to commence in December, 1949, on, from, and after which date all indentures of apprenticeship heretofore executed under the provisions of the Acts and Regulations made in respect of the aforesaid trade shall be deemed to be amended accordingly—

1st year—at the rate of 40s. 0d. per week.
2nd year—at the rate of 54s. 6d. per week.
3rd year—at the rate of 72s. 0d. per week.
4th year—at the rate of 112s. 6d. per week.
5th year—at the rate of 140s. 6d. per week."

AMENDMENT OF PLUMBING AND GASFITTING
TRADES REGULATIONS.

IN pursuance of the powers conferred by the Apprenticeship Acts and the Acts Interpretation Acts, His Excellency the Governor of the State of Victoria, by and with the advice of the Executive Council thereof, doth hereby make the following Regulations, that is to say:—

1. Regulation 9 of the Plumbing and Gasfitting Trades Regulations shall be and the same is hereby rescinded as from the beginning of the first pay period to commence in December, 1949.

2. Such rescission shall not affect any right accrued or accruing to any person or any liability of any person under the said rescinded Regulation before the commencement of these Regulations.

3. For the said rescinded Regulation the following Regulation shall be substituted:—

"9. The minimum rates of pay to be paid as wages to apprentices in the said trades in each year of their apprenticeship course shall be as follows as from the beginning of the first pay period to commence in December, 1949, on, from, and after which date all indentures of apprenticeship heretofore executed under the provisions of the Acts and Regulations made in respect of the aforesaid trades shall be deemed to be amended accordingly—

(a) With respect to the term of apprenticeship of six years—

1st year—at the rate of 40s. 2d. per week.
2nd year—at the rate of 55s. 10d. per week.
3rd year—at the rate of 77s. 0d. per week.
4th year—at the rate of 108s. 2d. per week.
5th year—at the rate of 140s. 4d. per week.
6th year—at the rate of 173s. 0d. per week.

(b) With respect to the term of apprenticeship of five years—

1st year—at the rate of 40s. 2d. per week.
2nd year—at the rate of 55s. 10d. per week.
3rd year—at the rate of 77s. 0d. per week.
4th year—at the rate of 108s. 2d. per week.
5th year—at the rate of 140s. 0d. per week."

AMENDMENT OF AIRCRAFT TRADES REGULATIONS
(No. 1).

IN pursuance of the powers conferred by the Apprenticeship Acts and the Acts Interpretation Acts, His Excellency the Governor of the State of Victoria, by and with the advice of the Executive Council thereof, doth hereby make the following Regulations, that is to say:—

1. Regulation 9 of the Aircraft Trades Regulations (No. 1) shall be and the same is hereby rescinded as from the beginning of the first pay period to commence after the 14th day of December, 1949.

2. Such rescission shall not affect any right accrued or accruing to any person or any liability of any person under the said rescinded Regulation before the commencement of these Regulations.

3. For the said rescinded Regulation the following Regulation shall be substituted:—

"9. The minimum rates of pay to be paid as wages to apprentices in the said trades in each year of their apprenticeship course shall be as follows as from the beginning of the first pay period to commence after the 14th day of December, 1949, on, from, and after which date all indentures of apprenticeship heretofore executed under the provisions of the Acts and Regulations made in respect of the aforesaid trades shall be deemed to be amended accordingly—

1st year—at the rate of 36s. 6d. per week.
2nd year—at the rate of 51s. 6d. per week.
3rd year—at the rate of 68s. 6d. per week.
4th year—at the rate of 108s. 6d. per week.
5th year—at the rate of 136s. 0d. per week."

AMENDMENT OF BOILERMAKING AND/OR STEEL
CONSTRUCTION TRADES REGULATIONS (No. 2).

IN pursuance of the powers conferred by the Apprenticeship Acts and the Acts Interpretation Acts, His Excellency the Governor of the State of Victoria, by and with the advice of the Executive Council thereof, doth hereby make the following Regulations, that is to say:—

1. Regulation 7 of the Boilermaking and/or Steel Construction Trades Regulations (No. 2) shall be and the same is hereby rescinded as from the beginning of the first pay period to commence in December, 1949.

2. Such rescission shall not affect any right accrued or accruing to any person or any liability of any person under the said rescinded Regulation before the commencement of these Regulations.

3. For the said rescinded Regulation the following Regulation shall be substituted:—

"7. The minimum rates of pay to be paid as wages to apprentices in the said trades in each year of their apprenticeship course shall be as follows as from the beginning of the first pay period to commence in December, 1949, on, from, and after which date all indentures of apprenticeship heretofore executed under the provisions of the Acts and Regulations in respect of the aforesaid trades shall be deemed to be amended accordingly—

(a) With respect to the term of apprenticeship five years—

1st year—at the rate of 36s. 6d. per week.
2nd year—at the rate of 51s. 6d. per week.
3rd year—at the rate of 68s. 6d. per week.
4th year—at the rate of 108s. 6d. per week.
5th year—at the rate of 136s. 0d. per week.

(b) With respect to the terms of apprenticeship four years—

1st year—at the rate of 41s. 6d. per week.
2nd year—at the rate of 68s. 0d. per week.
3rd year—at the rate of 108s. 6d. per week.
4th year—at the rate of 136s. 0d. per week."

AMENDMENT OF ELECTRICAL TRADES
REGULATIONS.

IN pursuance of the powers conferred by the Apprenticeship Acts and the Acts Interpretation Acts, His Excellency the Governor of the State of Victoria, by and with the advice of the Executive Council thereof, doth hereby make the following Regulations, that is to say:—

1. Regulation 9 of the Electrical Trades Regulations shall be and the same is hereby rescinded as from the beginning of the first pay period to commence in December, 1949.

2. Such rescission shall not affect any right accrued or accruing to any person or any liability of any person under the said rescinded Regulation before the commencement of these Regulations.

3. For the said rescinded Regulation the following Regulation shall be substituted:—

"9. The minimum rates of pay to be paid as wages to apprentices in the said trades in each year of their apprenticeship course shall be as follows as from the beginning of the first pay period to commence in December, 1949, on, from, and after which date all indentures of apprenticeship heretofore executed under the provisions of the Acts and Regulations made in respect of the aforesaid trades shall be deemed to be amended accordingly—

Within 20 miles of G.P.O., Melbourne, within 10 miles of G.P.O., Geelong, at Warrnambool, and within Mildura and Gippsland districts.

1st year—at the rate of 36s. 6d. per week.
2nd year—at the rate of 51s. 6d. per week.
3rd year—at the rate of 68s. 6d. per week.
4th year—at the rate of 108s. 6d. per week.
5th year—at the rate of 136s. 0d. per week.

At Yallourn.

1st year—at the rate of 38s. 6d. per week.
2nd year—at the rate of 54s. 0d. per week.
3rd year—at the rate of 72s. 0d. per week.
4th year—at the rate of 114s. 0d. per week.
5th year—at the rate of 142s. 6d. per week.

Other Parts of Victoria where this Regulation applies.

1st year—at the rate of 36s. 0d. per week.
2nd year—at the rate of 50s. 6d. per week.
3rd year—at the rate of 67s. 0d. per week.
4th year—at the rate of 106s. 0d. per week.
5th year—at the rate of 133s. 0d. per week."

AMENDMENT OF ELECTROPLATING TRADE REGULATIONS (No. 1).

IN pursuance of the powers conferred by the Apprenticeship Acts and the Acts Interpretation Acts, His Excellency the Governor of the State of Victoria, by and with the advice of the Executive Council thereof, doth hereby make the following Regulations, that is to say:—

1. Regulation 9 of the Electroplating Trade Regulations (No. 1) shall be and the same is hereby rescinded as from the beginning of the first pay period to commence in December, 1949.

2. Such rescission shall not affect any right accrued or accruing to any person or any liability of any person under the said rescinded Regulation before the commencement of these Regulations.

3. For the said rescinded Regulation the following Regulation shall be substituted:—

"9. The minimum rates of pay to be paid as wages to apprentices in the said trade in each year of their apprenticeship course shall be as follows as from the beginning of the first pay period to commence in December, 1949, on, from, and after which date all indentures of apprenticeship heretofore executed under the provisions of the Acts and Regulations made in respect of the aforesaid trade shall be deemed to be amended accordingly—

(a) With respect to the term of apprenticeship of five years—

1st year—at the rate of 36s. 6d. per week.
2nd year—at the rate of 51s. 6d. per week.
3rd year—at the rate of 68s. 6d. per week.
4th year—at the rate of 108s. 6d. per week.
5th year—at the rate of 136s. 0d. per week.

(b) With respect to the term of apprenticeship of four years—

1st year—at the rate of 41s. 6d. per week.
2nd year—at the rate of 68s. 0d. per week.
3rd year—at the rate of 108s. 6d. per week.
4th year—at the rate of 136s. 0d. per week."

AMENDMENT OF ENGINEERING TRADES REGULATIONS (No. 2).

IN pursuance of the powers conferred by the Apprenticeship Acts and the Acts Interpretation Acts, His Excellency the Governor of the State of Victoria, by and with the advice of the Executive Council thereof, doth hereby make the following Regulations, that is to say:—

1. Regulation 7 of the Engineering Trades Regulations (No. 2) shall be and the same is hereby rescinded as from the beginning of the first pay period to commence in December, 1949.

2. Such rescission shall not affect any right accrued or accruing to any person or any liability of any person under the said rescinded Regulation before the commencement of these Regulations.

3. For the said rescinded Regulation the following Regulation shall be substituted:—

"7. The minimum rates of pay to be paid as wages to apprentices in the said trades in each year of their apprenticeship course shall be as follows as from the beginning of the first pay period to commence in December, 1949, on, from, and after which date all indentures of apprenticeship heretofore executed under the provisions of the Acts and Regulations made in respect of the aforesaid trades shall be deemed to be amended accordingly—

(a) With respect to the term of apprenticeship of five years—

1st year—at the rate of 36s. 6d. per week.
2nd year—at the rate of 51s. 6d. per week.
3rd year—at the rate of 68s. 6d. per week.
4th year—at the rate of 108s. 6d. per week.
5th year—at the rate of 136s. 0d. per week.

(b) With respect to the term of apprenticeship of four years—

1st year—at the rate of 41s. 6d. per week.
2nd year—at the rate of 68s. 0d. per week.
3rd year—at the rate of 108s. 6d. per week.
4th year—at the rate of 136s. 0d. per week.

The sum of 4s. 0d. per week shall be added to the above rates where the apprentice is in the trade of Patternmaking."

AMENDMENT OF ENGINEERING TRADES REGULATIONS (No. 4).

IN pursuance of the powers conferred by the Apprenticeship Acts and the Acts Interpretation Acts, His Excellency the Governor of the State of Victoria, by and with the advice of the Executive Council thereof, doth hereby make the following Regulations, that is to say:—

1. This Regulation shall apply to the whole of the State of Victoria outside and excepting the Metropolitan District.

2. Regulation 10 of the Engineering Trades Regulations (No. 4) shall be and the same is hereby rescinded as from the beginning of the first pay period to commence in December, 1949.

3. Such rescission shall not affect any right accrued or accruing to any person or any liability of any person under the said rescinded Regulation before the commencement of these Regulations.

4. For the said rescinded Regulation the following Regulation shall be substituted:—

"10. The minimum rates of pay to be paid as wages to apprentices in the said trades in each year of their apprenticeship course shall be as follows as from the beginning of the first pay period to commence in December, 1949, on, from, and after which date all indentures of apprenticeship heretofore executed under the provisions of the Acts and Regulations made in respect of the aforesaid trades shall be deemed to be amended accordingly—

Within 10 miles of G.P.O., Geelong, at Warrnambool, and within Mildura and Gippsland districts.

(a) With respect to the term of apprenticeship of five years—

1st year—at the rate of 36s. 6d. per week.
2nd year—at the rate of 51s. 6d. per week.
3rd year—at the rate of 68s. 6d. per week.
4th year—at the rate of 108s. 6d. per week.
5th year—at the rate of 136s. 0d. per week.

(b) With respect to the term of apprenticeship of four years—

1st year—at the rate of 41s. 6d. per week.
2nd year—at the rate of 68s. 0d. per week.
3rd year—at the rate of 108s. 6d. per week.
4th year—at the rate of 136s. 0d. per week.

Yallourn.

(a) With respect to the term of apprenticeship of five years—

1st year—at the rate of 38s. 6d. per week.
2nd year—at the rate of 54s. 0d. per week.
3rd year—at the rate of 72s. 0d. per week.
4th year—at the rate of 114s. 0d. per week.
5th year—at the rate of 142s. 6d. per week.

(b) With respect to the term of apprenticeship of four years—

1st year—at the rate of 44s. 0d. per week.
2nd year—at the rate of 71s. 6d. per week.
3rd year—at the rate of 114s. 0d. per week.
4th year—at the rate of 142s. 6d. per week.

Other Parts of Victoria where this Regulation applies.

(a) With respect to the term of apprenticeship of five years—

- 1st year—at the rate of 36s. 0d. per week.
- 2nd year—at the rate of 50s. 0d. per week.
- 3rd year—at the rate of 67s. 0d. per week.
- 4th year—at the rate of 106s. 0d. per week.
- 5th year—at the rate of 133s. 0d. per week.

(b) With respect to the term of apprenticeship of four years—

- 1st year—at the rate of 41s. 0d. per week.
- 2nd year—at the rate of 66s. 6d. per week.
- 3rd year—at the rate of 106s. 0d. per week.
- 4th year—at the rate of 133s. 0d. per week.

The sum of 4s. 0d. per week shall be added to the above rates where the apprentice is in the trade of Patternmaking."

AMENDMENT OF MOTOR MECHANICS TRADES REGULATIONS.

IN pursuance of the powers conferred by the Apprenticeship Acts and the Acts Interpretation Acts, His Excellency the Governor of the State of Victoria, by and with the advice of the Executive Council thereof, doth hereby make the following Regulations, that is to say:—

1. Regulation 9 of the Motor Mechanics Trades Regulations shall be and the same is hereby rescinded as from the beginning of the first pay period to commence in December, 1949.

2. Such rescission shall not affect any right accrued or accruing to any person or any liability of any person under the said rescinded Regulation before the commencement of these Regulations.

3. For the said rescinded Regulation the following Regulation shall be substituted:—

"9. The minimum rates of pay to be paid as wages to apprentices in the said trades in each year of their apprenticeship course shall be as follows as from the beginning of the first pay period to commence in December, 1949, on, from, and after which date all indentures of apprenticeship heretofore executed under the provisions of the Acts and Regulations made in respect of the aforesaid trades shall be deemed to be amended accordingly—

Within 20 miles of G.P.O., Melbourne, within 10 miles of G.P.O., Geelong, at Warrnambool, and within Mildura and Gippsland districts.

(a) With respect to the term of apprenticeship of five years—

- 1st year—at the rate of 36s. 6d. per week.
- 2nd year—at the rate of 51s. 6d. per week.
- 3rd year—at the rate of 68s. 6d. per week.
- 4th year—at the rate of 108s. 6d. per week.
- 5th year—at the rate of 136s. 0d. per week.

(b) With respect to the term of apprenticeship of four years—

- 1st year—at the rate of 41s. 6d. per week.
- 2nd year—at the rate of 68s. 0d. per week.
- 3rd year—at the rate of 108s. 6d. per week.
- 4th year—at the rate of 136s. 0d. per week.

Yallourn.

(a) With respect to the term of apprenticeship of five years—

- 1st year—at the rate of 38s. 6d. per week.
- 2nd year—at the rate of 54s. 0d. per week.
- 3rd year—at the rate of 72s. 0d. per week.
- 4th year—at the rate of 114s. 0d. per week.
- 5th year—at the rate of 142s. 6d. per week.

(b) With respect to the term of apprenticeship of four years—

- 1st year—at the rate of 44s. 0d. per week.
- 2nd year—at the rate of 71s. 6d. per week.
- 3rd year—at the rate of 114s. 0d. per week.
- 4th year—at the rate of 142s. 6d. per week.

Other Parts of Victoria.

(a) With respect to the term of apprenticeship of five years—

- 1st year—at the rate of 36s. 0d. per week.
- 2nd year—at the rate of 50s. 6d. per week.
- 3rd year—at the rate of 67s. 0d. per week.
- 4th year—at the rate of 106s. 0d. per week.
- 5th year—at the rate of 133s. 0d. per week.

(b) With respect to the term of apprenticeship of four years—

- 1st year—at the rate of 41s. 0d. per week.
- 2nd year—at the rate of 66s. 6d. per week.
- 3rd year—at the rate of 106s. 0d. per week.
- 4th year—at the rate of 133s. 0d. per week."

AMENDMENT OF MOULDING TRADES REGULATIONS (No. 2).

IN pursuance of the powers conferred by the Apprenticeship Acts and the Acts Interpretation Acts, His Excellency the Governor of the State of Victoria, by and with the advice of the Executive Council thereof, doth hereby make the following Regulations, that is to say:—

1. Regulation 8 of the Moulding Trades Regulations (No. 2) shall be and the same is hereby rescinded as from the beginning of the first pay period to commence in December, 1949.

2. Such rescission shall not affect any right accrued or accruing to any person or any liability of any person under the said rescinded Regulation before the commencement of these Regulations.

3. For the said rescinded Regulation the following Regulation shall be substituted:—

"8. The minimum rates of pay to be paid as wages to apprentices in the said trades in each year of their apprenticeship course shall be as follows as from the beginning of the first pay period to commence in December, 1949, on, from, and after which date all indentures of apprenticeship heretofore executed under the provisions of the Acts and Regulations made in respect of the aforesaid trades shall be deemed to be amended accordingly—

(a) With respect to the term of apprenticeship of five years—

- 1st year—at the rate of 36s. 6d. per week.
- 2nd year—at the rate of 51s. 6d. per week.
- 3rd year—at the rate of 68s. 6d. per week.
- 4th year—at the rate of 108s. 6d. per week.
- 5th year—at the rate of 136s. 0d. per week.

(b) With respect to the term of apprenticeship of four years—

- 1st year—at the rate of 41s. 6d. per week.
- 2nd year—at the rate of 68s. 0d. per week.
- 3rd year—at the rate of 108s. 6d. per week.
- 4th year—at the rate of 136s. 0d. per week."

AMENDMENT OF SHEET METAL TRADE REGULATIONS (No. 2).

IN pursuance of the powers conferred by the Apprenticeship Acts and the Acts Interpretation Acts, His Excellency the Governor of the State of Victoria, by and with the advice of the Executive Council thereof, doth hereby make the following Regulations, that is to say:—

1. Regulation 7 of the Sheet Metal Trade Regulations (No. 2) shall be and the same is hereby rescinded as from the beginning of the first pay period to commence in December, 1949.

2. Such rescission shall not affect any right accrued or accruing to any person or any liability of any person under the said rescinded Regulation before the commencement of these Regulations.

3. For the said rescinded Regulation the following Regulation shall be substituted:—

"7. The minimum rates of pay to be paid as wages to apprentices in the said trade in each year of their apprenticeship course shall be as follows as from the beginning of the first pay period to commence in December, 1949, on, from, and after which date all indentures of apprenticeship heretofore executed under the provisions of the Acts and Regulations made in respect of the aforesaid trade shall be deemed to be amended accordingly—

(a) With respect to the term of apprenticeship of five years—

- 1st year—at the rate of 36s. 6d. per week.
- 2nd year—at the rate of 51s. 6d. per week.
- 3rd year—at the rate of 68s. 6d. per week.
- 4th year—at the rate of 108s. 6d. per week.
- 5th year—at the rate of 136s. 0d. per week.

(b) With respect to the term of apprenticeship of four years—

- 1st year—at the rate of 41s. 6d. per week.
- 2nd year—at the rate of 68s. 0d. per week.
- 3rd year—at the rate of 108s. 6d. per week.
- 4th year—at the rate of 136s. 0d. per week."

And the Honorable Allan Elliott McDonald, His Majesty's Minister of Labour for the State of Victoria, shall give the necessary directions herein accordingly.

A. MAHLSTEDT,
Clerk of the Executive Council.

LANDLORD AND TENANT ACTS.

At the Executive Council Chamber, Melbourne, the seventeenth day of January, 1950.

PRESENT:

His Excellency the Governor of Victoria.
 Mr. Oldham | Brigadier Tovell
 Mr. Guthrie | Lieut.-Col. Hipworth.

ORDER EXCLUDING CERTAIN PREMISES FROM THE OPERATION OF PART V. OF THE LANDLORD AND TENANT ACT 1948.

IN pursuance of the powers conferred upon him by the *Landlord and Tenant Act 1948*, as amended by the *Landlord and Tenant (Amendment) Act 1948*, His Excellency the Governor of Victoria, by and with the advice of the Executive Council thereof, doth hereby declare that the premises known as No. 9 Mater-street, Collingwood, shall be excluded from the operation of the whole of the provisions contained in Part V. of the *Landlord and Tenant Act 1948*.

And the Honorable Trevor Donald Oldham, His Majesty's Attorney-General in and for the State of Victoria, shall give the necessary directions herein accordingly.

A. MAHLSTEDT,
 Clerk of the Executive Council.

LANDLORD AND TENANT ACTS.

At the Executive Council Chamber, Melbourne, the seventeenth day of January, 1950.

PRESENT:

His Excellency the Governor of Victoria.
 Mr. Oldham | Brigadier Tovell
 Mr. Guthrie | Lieut.-Col. Hipworth.

ORDER EXTENDING APPLICATION OF THE LANDLORD AND TENANT ACT 1948 TO CERTAIN PREMISES.

WHEREAS by an Order published in the *Government Gazette* of the 11th January, 1950, at page 152, the premises known as No. 15 Stone-street, Yarraville, were excluded from the operation of Parts III. and V. of the *Landlord and Tenant Act 1948*: And whereas it is expedient that such parts should again extend to such premises: Now, therefore, in pursuance of the powers conferred upon him by the *Landlord and Tenant Act 1948*, as amended by the *Landlord and Tenant (Amendment) Act 1948*, His Excellency the Governor of Victoria, by and with the advice of the Executive Council thereof, doth hereby declare that the application of the whole of the *Landlord and Tenant Act 1948* shall extend to such premises.

And the Honorable Trevor Donald Oldham, His Majesty's Attorney-General in and for the State of Victoria, shall give the necessary directions herein accordingly.

A. MAHLSTEDT,
 Clerk of the Executive Council.

APPROACHING LAND SALES.

SALES of Crown lands, in fee-simple, will be held at the under-mentioned places and dates, viz.:—

	No. of Gazette
Bairnsdale.—Thursday, 19th January, 1950	1122
Lorne.—Friday, 10th February, 1950	15
Melbourne.—Wednesday, 8th February, 1950	15

PROPOSED REVOCATIONS OF TEMPORARY RESERVATIONS OF LANDS BY ORDERS IN COUNCIL.

IN pursuance of the provisions of the *Land Act 1928*, notice is hereby given that it is the intention of the Governor in Council to revoke the temporary reservations of lands by Orders in Council hereunder referred to, viz.:—

The following Notices were published 1° on the 18th January, 1950, pursuant to Orders of the 10th January, 1950.

MELBOURNE.—The temporary reservation by Order in Council of the 22nd April, 1936, of 7 acres of land in the City of Melbourne as a site for Public purposes, is about to be revoked so far only as the portion containing 27 perches, indicated by hachure on plan hereunder, is concerned.—(M.314°) (Rs.4551).

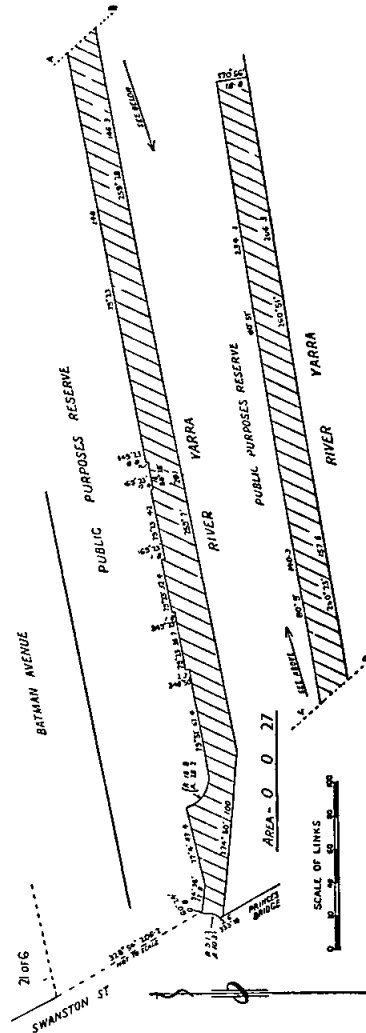

LAEN.—The temporary reservation as a site for Water Supply purposes and the withholding from sale, leasing, and licensing, by Order in Council of the 1st May, 1882, of 22 acres of land situate in section A in the Parish of Laen, is about to be revoked so far only as the portion

containing 7 acres 3 roods, more or less, indicated by hachure on plan hereunder, is concerned.—(L.146⁽²⁾) (Rs.6500).

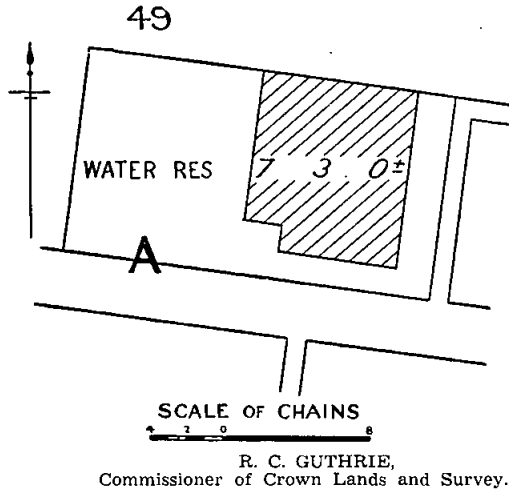

COMMITTEES OF MANAGEMENT OF RESERVES.
APPOINTMENTS.

WHEREAS by section 184 of the *Land Act* 1928 it is provided that it shall be lawful for the Governor in Council or the Board of Land and Works to appoint and remove any number of persons, not less than three, or any municipal council, or the governing body of any corporation, to be a Committee of Management of any specified Crown land reserved either temporarily or permanently for any of the purposes set out in section 14 of the *Land Act* 1928, and not conveyed to or vested in trustees: Now therefore the Board of Land and Works doth hereby appoint the under-mentioned persons to be members of the Committee of Management of the Reserves named:—

"COLAC RACECOURSE AND RECREATION RESERVE."

Francis Henry Scullion, Thomas Stephen Danaher, John Joseph Larkins, Thomas William Thomson, Donald Corstorphan, William John Ulysses Paine, and Ernest Albert McLeod as a Committee of Management for a period of three (3) years from the 16th January, 1950, of the land temporarily reserved by Order in Council dated the 16th January, 1934, as a site for Racing and other purposes of Public Recreation in the Parish of Elliminyt, and known as the "Colac Racecourse and Recreation Reserve."—(Corres. Rs.467.)

"RAYMOND ISLAND RECREATION AND CAMPING RESERVE."

Christopher Anthony Watson, George Richard Ray, Adam James Wilson, Joseph Amphlette Taylor, William Francis Haines, Reginald Frederick Medling, and Thomas George McCullagh as a Committee of Management for a period of three (3) years from the 23rd December, 1949, of the land temporarily reserved by Order in Council dated 15th November, 1949, as a site for Public Recreation and Camping purposes in the Parish of Bairnsdale, and known as the "Raymond Island Recreation and Camping Reserve."—(Corres. Rs.6461.)

"RHEOLA PUBLIC HALL RESERVE."

Charles Godfrey Leach, Louis Edward Webb, Charles Martin Queripel, William Yorothe, Raymond Henry Roberts, William Robert Soulsby, and Stanley Ross Catto as the Committee of Management for a period of three (3) years of the land in the Parish of Kingower temporarily reserved by Order in Council dated the 9th November, 1915, as a site for a Public Hall, and known as the "Rheola Public Hall Reserve."—(Corres. Rs.1064.)

"GELLIBRAND RECREATION RESERVE."

Gilbert Marshall Pell, John Thomas Denning, Ernest Oliver Denning, R. Castello, George Mitchell, Heinrich William Krause, Colin Eric Tucker, John Daffy, Rex Wade, Ernest Charles Armistead, Adolf Woodtli, Patrick Daffy, and Arthur Joseph Armistead as a Committee of Management for a period of three (3) years from the 5th January, 1950, of the land temporarily reserved by Order in Council dated the 26th October, 1928, as a site for Public Recreation in the Parish of Yaughner, Township of Gellibrand, and known as the "Gellibrand Recreation Reserve."—(Corres. Rs.3772.)

"MT. BUFFALO NATIONAL PARK."

Herbert Duncan Galbraith as an additional member of the Committee of Management of the land temporarily reserved by Order in Council dated 31st October, 1898, as a site for National Park in the Parish of Wandiligong, the land temporarily reserved by Order in Council dated 6th October, 1908, as a site for National Park in the Parishes of Wandiligong, Towamba, Dondangadale, and Eurandelong, and the land temporarily reserved by Order in Council dated 20th November, 1934, as a site for a National Park in the Parish of Wandiligong, which lands are together known as "Mt. Buffalo National Park."—(Corres. Rs.121.)

"SEASPRAY RESERVES."

Arthur George Nicholls, Arthur Frederick Gooding, William Henry Rowley, Alfred John McNeilly, James Kent Matthews, Ernest James Bock, and Edward James Simpson for a period of three (3) years of the land permanently reserved by Order in Council dated 17th January, 1928, for Public purposes (Plantations) in the Township of Seaspray, and of the land temporarily reserved by Order in Council dated 4th February, 1947, for Public purposes in the Parish of Giffard, both of which areas are tinted blue and pink respectively on plan marked S/21.147 on Lands Department correspondence No. Rs.3585.—(Corres. Rs.3585.)

"ESKDALE RACECOURSE AND RECREATION RESERVE (ESK PARK)."

Robert William Swasbrick, in lieu of Patrick Darcy, resigned, as a member of the Committee of Management for the period ending 14th March, 1952, of the land temporarily reserved by Order in Council dated 15th August, 1898, as a site for a Racecourse and for Public Recreation in the Township of Eskdale, and known as the "Eskdale Racecourse and Recreation Reserve (Esk Park)."—(Corres. Rs.165.)

"WOOLAMAI RECREATION RESERVE."

William Alford, Edward John Yann, Richard John Trew, Harold Harley MacKay, Edward George Churchill, Bernard Shackelford, and Francis Alexander Shackelford as a Committee of Management for a period of three (3) years from 14th December, 1949, of the remaining portion of the land temporarily reserved by Order in Council dated 25th June, 1888, as a site for a Racecourse in the Parish of Woolamai, and known as the "Woolamai Recreation Reserve."—(Corres. Rs.4350.)

"JEFFCOTT PUBLIC RECREATION RESERVE."

Thomas J. McKenna, James T. McKenna, M. J. Donnellon, James Mulquiny, M. J. Hogan, J. V. Brennan, and F. J. Brennan as the Committee of Management for a period of three (3) years of the land in the Parish of Jeffcott temporarily reserved by Order in Council dated the 12th February, 1929, as a site for Public Recreation, and known as the "Jeffcott Public Recreation Reserve."—(Corres. Rs.3803.)

"HUNTLY RECREATION RESERVE."

John Gordon Watts, Leslie Alfred Strauch, Frederick Elver Strauch, Norman Raymond Clay, Robert George Pennington, John Ernest Morris, and Alfred George Hamilton as the Committee of Management for a period of three (3) years of the land in the Township of Huntly temporarily reserved by Order in Council dated the 27th October, 1890, as a site for Public Recreation, and known as the "Huntly Recreation Reserve."—(Corres. Rs.1792.)

"BERRINGAMA RECREATION RESERVE."

Ernest Harold Nicholas, Arthur Caldwell Nugent, Joseph Henry Otty, Frederick William Smedley, Hugh John Laverty, Manuel Walter Jarvis, and Frederick Henry Mansell as a Committee of Management for a period of three (3) years from the 17th December, 1949, of the remaining portion of the lands temporarily reserved by Orders in Council dated 9th February, 1892, and 31st May, 1910, as sites for Public Recreation in the Township and Parish of Berringama, and known as "Berringama Recreation Reserve."—(Corres. Rs.2592.)

"WATERLOO RECREATION RESERVE."

John McErvale, Harold Lewis, Rex James Dunn, William John Kay, Charles Jones, Walter Ray Vowles, and William James McErvale as a Committee of Management for a period of three (3) years from the 17th December, 1949, of the land temporarily reserved by Order in Council dated the 17th October, 1892, as a site for Public Recreation in the Parish of Langi-Kal-Kal, and known as the "Waterloo Recreation Reserve."—(Corres. Rs.4729.)

"LANDSBOROUGH MEMORIAL PARK."

Patrick Michael Hogan as a member of the Committee of Management for the period ending the 9th January, 1951, of the land in the Township of Landsborough temporarily reserved by Order in Council dated the 23rd August, 1875, as a site for Recreation purposes, and known as the "Landsborough Memorial Park."—(Corres. Rs.1230.)

This appointment is in lieu of Frederick Robert Curnick, deceased.

"BOORONGIE PUBLIC HALL RESERVE."

John Patrick O'Callaghan, Thomas Henry Wills, James Edward O'Callaghan, Leo Joseph O'Callaghan, James Charles Bethune, Joseph William Marshall, and George McIvor Marshall as the Committee of Management for a period of three (3) years of the land in the Parish of Boorongie temporarily reserved by Order in Council dated the 16th December, 1913, as a site for a Public Hall, and known as the "Boorongie Public Hall Reserve."—(Corres. Rs.1953.)

"WOORINEN NORTH RECREATION RESERVE."

J. McFadyen, N. W. Harrop, H. Clutterbuck, E. J. L. Kay, R. E. Ferguson, A. W. Selleck, and E. Harvey as the Committee of Management for a period of three (3) years of the land in the Parish of Tyntynder West temporarily reserved by Order in Council dated the 5th March, 1946, as a site for Public Recreation purposes, and known as the "Woorinen North Recreation Reserve."—(Corres. Rs.5745.)

This appointment is in lieu of that made on the 14th December, 1949, which is hereby rescinded.

"RUBBISH DEPOT RESERVE AT WOORINEN."

The Council of the Shire of Swan Hill as the Committee of Management of the land in the Township of Woorinen temporarily reserved by Order in Council dated the 4th October, 1949, as a site for a Rubbish Tip.—(Corres. Rs.6443.)

In witness whereof the common seal of the Board of Land and Works was hereunto affixed this tenth day of January, One thousand nine hundred and fifty, in the presence of—

(SEAL) R. C. GUTHRIE, President.
J. E. HUNTER, Member.

Soldier Settlement Acts.

PRELIMINARY NOTICE OF COMPULSORY ACQUISITION.

TAKE notice that by virtue of the powers contained in the Soldier Settlement Acts, the Governor in Council, by an Order made on the 17th day of January, 1950, a copy of which appears hereunder, directed that the land described in the Schedule to such Order be acquired compulsorily for the purposes of the said Acts.

Copy of Order of the Governor in Council, made the 17th day of January, 1950.

"DIRECTION FOR ACQUISITION OF LAND BY COMPULSORY PROCESS."

Whereas it is provided (*inter alia*) by the Soldier Settlement Acts that where it appears to the Governor in Council that any land proposed to be acquired for the purposes of such Acts cannot be acquired by agreement or cannot be so acquired at a reasonable price the Governor in Council may direct that such land be acquired compulsorily: And whereas by virtue of such Acts the

Governor in Council has approved of the recommendation of the Soldier Settlement Commission that all those pieces of land comprising 363 acres and 13 perches being allotments 6 and 8, section A, Parish of Katunga, County of Moira, the owners of which land are David Bruce Tunnock, of 87 Queen-street, Melbourne, solicitor, Evelyn Alice Sage, of Katunga, married woman, and Reginald Hay, formerly of Katunga, and now of 219 Wellington-road, East Brisbane, member of the Royal Australian Air Force, as executors of the will of Francis Hay, late of Katunga, deceased, should be acquired by the said Commission, pursuant to and in accordance with the Soldier Settlement Acts: And whereas by virtue of such Acts the Governor in Council directed the said Commission to negotiate for the acquisition of such land: And whereas it appears to the Governor in Council that the said land cannot be acquired by agreement: And whereas it is proposed that the said land be acquired for the purposes of the said Acts: Now therefore His Excellency the Governor of the State of Victoria, by and with the advice of the Executive Council of the said State, doth by this Order direct that the land described herein be acquired compulsorily for the purposes of the said Acts.

A. MAHLSTEDT,
Clerk of the Executive Council.

At the Executive Council Chamber,
Melbourne, the 17th January, 1950."

Dated at Melbourne, this 17th day of January, One thousand nine hundred and fifty.

E. SINGLETON, Secretary,
Soldier Settlement Commission.

SOLDIER SETTLEMENT ACT 1946.

IN pursuance of section 88 (1) of the *Soldier Settlement Act 1946*, I, Rutherford Campbell Guthrie, Commissioner of Crown Lands and Survey, hereby declare that the farming land specified in the Schedule hereunder to be land suitable for soldier settlement.

Dated at Melbourne, this 10th day of January, 1950.

R. C. GUTHRIE,
Commissioner of Crown Lands and Survey.

SCHEDULE.

All those pieces of land comprising 7,047 acres 3 roods 24 perches, being allotments 74E, K1, K2, 69A, 54A1, 54B1, 74B, 75D, 76C, 52A, 52B, 53A, 53B, 54A2, 48A1, 72A, 72B, 74A, 74C, 74D, 75E, 75B, 36A2, 46A1, 46A2, 46A3, 46B1, 46B2, 46B3, 47A1, 47A2, 47B2, 47B3, 47B4, 48B, 48B1, 49A1, 49A2, 49B, 50A, 50B1, 50B2, 51A, 51B, 70, 71A, 71B, 73A, 73B, 75A, 39A, 39B, 55A, 56A, 57A, and 69, Parish of Cargerie, allotments A1, A2A, A2B, 191, 192B, 195, 196, 197, 198, 199, 190D, 190C, 188C, 186A, 188B, 188A, 190A, 190B, 61A, 61B, 62A, 62B1, 62B2, 63A1, 63A2, 63B, 64A, 64B, 64B1, 64C, 65A, 65B, 65C, and part of allotments 200, 17, and 32A, and Crown pre-emptive section A, Parish of Meredith.

PUBLIC HEARINGS BY PERSONS APPOINTED UNDER THE 34TH SECTION OF THE LAND ACT 1928.

NOTICE is hereby given that at the times and places mentioned in the Schedule hereunder, applications for leases and licences under the Land Acts, objections to such applications, objections to proposed proclamations, alterations, additions, diminutions, revocations, or unions of commons, and reasons against forfeiture of any leases or licences under the Land Acts deemed liable to forfeiture, will be publicly heard by the persons whose names are set opposite such places respectively in such Schedule, being persons appointed by me, the responsible Minister of the Crown administering the Land Acts, to hear the same and report thereon in writing to me.

R. C. GUTHRIE,
Commissioner of Crown Lands and Survey, and
President of the Board of Land and Works.
Department of Lands and Survey,
Melbourne, 18th January, 1950.

SCHEDULE.

COURT HOUSE, WARRAGUL, Wednesday, 1st February, 1950, at 11 a.m.—C. E. Rice, Land Officer.
LAND OFFICE, SALE, Friday, 3rd February, 1950, at 2 p.m.—Land Officer, Sale.

PUBLIC SERVICE NOTICES.

PUBLIC SERVICE OF VICTORIA.—VACANCIES.

APPPLICATIONS will be received by the Public Service Board up to Wednesday, the 1st of February, 1950, from persons employed in the Public Service of Victoria, who are eligible and qualified, for appointment to the under-mentioned positions:—

ADMINISTRATIVE DIVISION.

Clerk, Class "C1," Department of Labour.

Yearly Salary.—£553, minimum; £605, maximum.

Duties.—To be in charge of the detailed work connected with applications for the registration of premises as factories; to conduct the necessary correspondence in connexion therewith and ensure that steps are taken to enforce provisions of the Regulations; to prepare applications for registration for the signature of the Chief Inspector.

Qualifications.—To have a thorough knowledge of the provisions of the Factories and Shops Acts and the Regulations thereunder; to be conversant with the administrative practice of the Department with regard to the registration of factories, and to be experienced in dealing with the public.

Clerk, Class "C1," Department of Labour.

Yearly Salary.—£553, minimum; £605, maximum.

Duties.—To assist the Industrial Inquiry Officer in replying to inquiries by the public regarding wages, and to give advice concerning the application of State Wages Board Determinations and other industrial laws.

Qualifications.—To possess a thorough knowledge of the Factories and Shops Acts and other Acts administered by the Department, the Regulations thereunder, Determinations of Wages Boards, and the procedure of the Department.

Clerk, Class "C," Central Planning Authority, Department of Premier.

Yearly Salary.—£462, minimum; £534, maximum.

Duties.—To act as Statistical Research Officer, Central Planning Authority; to undertake the collation and preparation of statistical information for the purposes of regional resources surveys; to maintain liaison with Regional Committees and assist such Committees in carrying out resources surveys; and to assist in the preparation of reports on completed surveys.

Qualifications.—To have had experience in statistical work and be capable of interpreting statistics collated; possession of a degree or diploma in Economics or Commerce is desirable.

Clerk, Class "C," Department of Education. (Two vacancies.)

Yearly Salary.—£462, minimum; £534, maximum.

Position No. 1.

Duties.—To arrange for Teachers' proficiency certificate and scholarship examinations; to advise teachers of examinations to be passed for promotion; to deal with correspondence relating thereto; to assist generally in the work of the branch.

Qualifications.—A good knowledge of the Regulations and requirements with regard to examinations and ability to deal with correspondence.

Position No. 2.

Duties.—To assist the officer in charge of the superannuation group, taxation, and group insurance section; to supervise the recording of statistical information relating to schools and attendances.

Qualifications.—A knowledge of the Superannuation Acts, the relevant portions of the Teaching Service Acts, Taxation Acts, and the Teaching Service Regulations, and of departmental procedure.

PROFESSIONAL DIVISION.

Designing Draughtsman, Class "O2," Department of Water Supply.

Yearly Salary.—£631, minimum; £683, maximum.

Duties.—To prepare designs, estimates, and specifications for steam and Diesel engine driven pumping plant, and to supervise the work of other draughtsmen.

Qualifications.—To possess a Technical School Diploma in Mechanical Engineering or equivalent qualification, and several years' drawing office experience, including work on power plant installations.

Inspector of Works, Class "C," Department of Public Works.

Yearly Salary.—£462, minimum; £534, maximum.

Duties.—General inspection of public buildings and supervision of works carried out by the Department and the preparation of reports in connexion therewith.

Qualifications.—To possess ability to make reports; to prepare estimates of costs of works and to make sketch plans; to have a comprehensive knowledge of the building trades and suitable technical qualifications.

TECHNICAL AND GENERAL DIVISION.

Inspector of Factories and Shops (Junior), Department of Labour.

Yearly Salary.—£370, minimum; £409, maximum.

Duties.—To perform such duties of an Inspector of Factories and Shops as may be assigned to him from time to time.

Qualifications.—To be physically strong and active and mentally alert, and in the case of non-discharged servicemen under 36 years of age, and in the case of discharged servicemen under 41 years of age; to possess a School Intermediate or Technical Intermediate Certificate, or an approved equivalent qualification; to be willing to reside, if required, within the district to which he may, from time to time, be assigned; a knowledge of the provisions of the Factories and Shops Acts and Regulations is desirable.

Health Inspector (Female), Grade II, General Health Branch, Department of Health.

Yearly Salary.—£351, minimum; £403, maximum.

Duties.—Under the direction of the Senior Health Officer, to assist in the inspection of private hospitals.

Qualifications.—To be a registered General Trained Nurse and a registered Midwife. To hold the Certificate of the Royal Sanitary Institute (London).

Storekeeper, Ports and Harbours Branch, Department of Public Works.

Yearly Salary.—£364, minimum; £390, maximum.

Duties.—To act as Storekeeper at the Dredging Depot, Williamstown; to keep stock records and all books and other records incidental to the proper recording of stores and material received, issued, and in stock.

Qualifications.—To have a knowledge of stores recording and of the practical working of a store; to be familiar with the Stores and Transport Regulations; a knowledge of ship chandlery is desirable.

Shorthand Writer and Typist (Male), Grade II, Department of Agriculture.

Yearly Salary.—£332, minimum; £384, maximum.

Duties.—To carry out shorthand writing and typing duties in the Live Stock Division and to assist generally.

Qualifications.—To be an efficient shorthand writer and typist and to possess a good knowledge of English.

Inspector, Grade II. (Hopetoun), Department of Water Supply.

Yearly Salary.—£344, minimum; £383, maximum.

Duties.—To supervise maintenance and repairs of channels, and the establishment of soil erosion work; to handle gangs on construction work, and to co-operate with the land holder in the protection of the Commission's channels.

Qualifications.—Experience in the maintenance and repair of channels and channel structures, and in the regulation and distribution of water; capacity for handling men and supervising gangs on maintenance and repairs. A knowledge of Wimmera-Mallee conditions and agricultural experience are essential in connexion with the protection of the Commission's channels from sand drift and dealing with soil erosion on adjoining lands.

Inspector, Grade II. (Ouyen), Department of Water Supply.

Yearly Salary.—£344, minimum; £383, maximum.

Duties.—To be responsible for the maintenance of windmills and bores in the Walpeup West district.

Qualifications.—To possess a general knowledge of plumbing and machinery, and to be able and willing to climb and work in windmill towers of considerable heights.

Mechanic, Children's Welfare Branch, Department of Chief Secretary.

Salary.—£377 a year.

Duties.—To assist in the general care and maintenance of buildings, fittings and grounds, and to relieve the fireman as required.

Qualifications.—Ability to use wood-working and other tools generally employed by a handyman; possession of Boiler Attendant's Certificate.

Typist and Assistant (Male), Grade II, Office of the Government Statist, Department of Chief Secretary.

Yearly Salary.—£325, minimum; £377, maximum.

Duties.—To make searches in indexes of births, deaths, and marriages, and to type certificates relating thereto.

Qualifications.—To be a competent typist with a knowledge of index systems, and capable of handling heavy registers.

Searcher, Office of Titles, Department of Law.

Yearly Salary.—£299, minimum; £364, maximum.

Duties.—To attend to searches by the public of documents under the Transfer of Land Acts; to advise as to the nature of various dealings or titles, and to sort and replace documents required for searches and dealings.

Qualifications.—A good knowledge of the various documents registrable under the Transfer of Land Acts, and of the practice of the Office of Titles in respect of searches under such Acts and the fees thereon.

Attendant (Male), Children's Welfare Branch, Department of Chief Secretary. (Eight vacancies.)

Yearly Salary.—£299, minimum; £351, maximum.

Duties.—To assist in the care and supervision of junior and senior boys and to perform such duties as the Medical Superintendent may from time direct.

Qualifications.—To be temperamentally and otherwise competent to supervise boys either individually or in a group. The possession of First Aid and Home Nursing Certificate and experience in conducting physical training and organizing games are desirable.

Nurse and Attendant, Children's Welfare Branch, Department of Chief Secretary.

Yearly Salary.—£309, minimum; £335, maximum; less deduction of £45 a year for board and lodging.

Duties.—To act as Sister in charge of a ward, and, under the direction of the Medical Superintendent and Matron, to attend to children requiring medical or special treatment.

Qualifications.—General Hospital Nursing Certificate and ability to control and care for children and to control a small staff. Children's Hospital training or Baby Health Centre Certificate desirable.

Caretaker, Public Offices, Wangaratta, Department of Public Works.

Yearly Salary.—£299, minimum; £325, maximum.

Duties.—To act as caretaker of Wangaratta Public Offices and grounds; to perform labouring and cleaning work; to attend to hot-water heating system, and to carry out such other duties as may be allotted.

Qualifications.—To be physically capable of performing the duties required, to be reliable, and to be able to undertake minor repairs.

Labourer, Department of Public Works.

Yearly Salary.—£273, minimum; £286, maximum.

Laundress, Children's Welfare Branch, Department of Chief Secretary. (Three vacancies.)

Salary.—£262 a year, less deduction of £45 a year for board and lodging.

Duties.—To assist in the laundry.

Qualifications.—To possess ability to operate laundry machinery.

Attendant (Female), Children's Welfare Branch, Department of Chief Secretary. (Nine vacancies.)

Yearly Salary.—£224, minimum; £250, maximum; less deduction of £45 a year for board and lodging.

Duties.—To assist in the care of children and to perform such domestic and other duties as may be directed by the Medical Superintendent.

Qualifications.—To be of sound health and possess an aptitude for work amongst babies, toddlers, and school children. Experience in caring for children and in general routine of a children's institution is desirable. Applicants should not be less than 18 years of age.

NOTE.—Officers holding a Certificate of Competency as a Mothercraft Nurse are eligible for an allowance of £13 a year.

Mess Room Attendant (Female), Mont Park Mental Hospital, Department of Health. (Three vacancies.)

Salary.—£238 a year.

Duties.—To attend Staff Mess Room, prepare tables, serve meals, clear and wash dishes, and assist cook if required.

Qualifications.—Ability to carry out above duties and possession of an elementary knowledge of cooking.

NOTE.—In addition to the salary rates quoted, a cost of living adjustment (£102 a year for adult males and £68 a year for adult females), which varies in accordance with the rise or fall in the index number of the cost of living, is payable.

By order,

E. F. FITZGIBBON,
Secretary.

Office of the Public Service Board,
Melbourne, 17th January, 1950.

APPPLICATIONS are invited, from officers of the Administrative Division of the Public Service of Victoria in Classes "E," "D," and "C" for appointment to the position of PRIVATE SECRETARY to the CHIEF SECRETARY, up to Wednesday, the 1st February, 1950.

Duties.—To act as Private Secretary to the Minister and to assist in the Correspondence Branch of the office.

Qualifications.—To be experienced in the conduct of correspondence and to be capable of writing shorthand at the rate of 120 words a minute and of reporting deputations.

The successful applicant will be paid an allowance at the rate of £50 a year for 1st year, £75 a year for the 2nd year, and £100 a year for the 3rd and subsequent years, providing that his total emolument (standard) shall not exceed £605 a year.

By order,

E. F. FITZGIBBON,
Secretary.

Office of the Public Service Board,
Melbourne, 17th January, 1950.

PUBLIC SERVICE (PUBLIC SERVICE BOARD) REGULATION 36A.—VACANCIES.

THE Permanent Heads of the Departments shown have recommended the officers named hereunder for appointment to the under-mentioned vacancies.

Office and Classification.	Duties.	Qualifications.	Officer Recommended for Appointment.		
			Name.	Classification.	Date of Classification.
PROFESSIONAL DIVISION.					
DEPARTMENT OF PUBLIC WORKS.					
Senior Inspector of Works, Class "C1"	To supervise and inspect building works under contract and day labour, and to report upon the structural requirements of existing buildings	To be suitably qualified in building construction and to have wide practical experience in controlling the erection of important structures and major institutional buildings	Brown, G. W. . .	Inspector of Works, Class "C"	5.10.47
DEPARTMENT OF WATER SUPPLY.					
Assistant Chief Engineer, Eildon Dam, Class "A1" (£1,250—£1,400)	Under the direction of the Chief Engineer, Eildon Dam, to be responsible for the construction of the Eildon project	To possess a University Degree in Civil Engineering or other recognized civil engineering qualifications, as well as qualifications under the Water Acts; to have had extensive experience in design and construction of civil engineering work, including responsible charge of the construction of large dams and other civil engineering works, and in the operation of heavy earth-moving and other plant	Swanson, V. G.	Executive Engineer, Grade I., Classes "A" and "A1" (£950—£1,100)	1.1.50
Executive Engineer, Grade II., Class "A" (£900—£1,000)	Under the direction of the Chief Engineer, to organize and control the staff and activities of the Melbourne office of the Eildon Project; to act as liaison officer between the Eildon organization and the Designing, Purchasing, and Accounting Branches of the Commission; to prepare contract documents and to conduct negotiations where required with contractors	To possess a University Degree or other recognized qualification in Civil Engineering, as well as qualifications under the Water Acts; to have had experience in design and construction work. Experience in the preparation of contract documents and specifications for a major project is essential	Olsen, P. E. . .	Executive Engineer, Grade IV., Class "B1"	19.9.49
Estates Officer, Class "B"	To supervise the work of the Estates Branch; to deal with all claims for compensation arising out of any of the activities of the Commission, and to confer with the Crown Solicitor on all matters referred to him for advice	To have a detailed knowledge of the Water Acts and decisions, opinions, and rulings in respect thereto, and an intimate knowledge of the relevant provisions of the various Acts affecting the Commission's operations, including the Land, Land Compensation, and Local Government Acts	Horwood, J. F.	Assistant Estates Officer, Class "C2"	1.2.49

TECHNICAL AND GENERAL DIVISION.**DEPARTMENT OF LABOUR.**

Inspector of Factories and Shops	To visit and inspect factories, shops, and other places, for the purpose of advising upon and enforcing the provisions of the Factories and Shops Acts and other Acts administered in the Department, particularly in relation to wages, working conditions, and dangerous machinery in factories, and to the health, safety, and convenience of workers	To have had experience as a Junior Inspector of Factories and Shops, and have passed the prescribed examination for appointment as an Inspector; to be physically strong and mentally alert; to be capable of conducting investigations efficiently, and to be willing to reside, if required, within the district to which he is, from time to time, assigned	Sully, J. C. . .	Inspector of Factories and Shops (Junior)	26.5.47
----------------------------------	--	--	------------------	---	---------

Appeals against such recommendations should be lodged with the Secretary to the Public Service Board not later than Saturday, the 28th January, 1950.

Office of the Public Service Board,
Melbourne, 17th January, 1950.

By order,
E. F. FITZGIBBON,
Secretary.

PUBLIC SERVICE (PUBLIC SERVICE BOARD) REGULATION 36A.—RECLASSIFICATIONS.

THE Public Service Board has raised the classification of the under-mentioned offices as shown, and the Permanent Heads of the Departments have recommended the officers named for appointment.

Office and Present Classification.	Revised Classification.	Duties.	Qualifications.	Officer Recommended for Appointment.		
				Name.	Classification.	Date of Classification.

ADMINISTRATIVE DIVISION.

DEPARTMENT OF PREMIER.

Audit Office.

Auditor, Grade II., Class "C2"	Auditor, Grade III., Class "C1"	To conduct specific audits as required, examine special accounts and assist in preparation of Auditor General's Annual Report	To be a qualified accountant; to have a thorough knowledge of the Audit Act, and the regulations thereunder and of the Treasury Accounts. Ability to prepare statistical statements is essential	McGuinness, K. J.	Auditor Grade III., Class "C1"	10.11.48
--------------------------------	---------------------------------	---	--	-------------------	--------------------------------	----------

DEPARTMENT OF CHIEF SECRETARY.

Chief Secretary's Office.

Clerk, Class "C1"	Class "C2"	To assist the Chief Electoral Officer in the administration of the Electoral Acts, particularly in relation to the conduct of Parliamentary elections, to assist at all departmental polls and elections conducted under the supervision of the Chief Electoral Officer and to relieve the Chief Electoral Officer as required	To have a practical knowledge of the Constitution Act Amendment Acts and Regulations thereunder, particularly in their relation to the conduct of Parliamentary elections; of the procedure relating to the conduct of all polls and elections supervised by the Chief Electoral Officer; and of the electoral administration generally	Cahill, F. E. . .	Clerk, Class "C1"	1.1.48
-------------------	------------	--	---	-------------------	-------------------	--------

DEPARTMENT OF TREASURER.

Land Tax Branch.

Deputy Commissioner, Probate Duties, Class "B"	Deputy Commissioner of Probate, Class "B1"	To investigate and report upon special cases; to assess the value of shares in proprietary companies and the goodwill of businesses; to authorize refunds of Probate Duty; to assist and relieve the Commissioner	To be a qualified Accountant; to have a thorough knowledge of the Administration and Probate Acts	Morris, S. V.	Deputy Commissioner, Probate Duties, Class "B"	6.9.48
--	--	---	---	---------------	--	--------

DEPARTMENT OF EDUCATION.

Clerk, Classes "E" and "D" (7 offices)	Class "C" (7 offices)	To assist the officer in charge of the ledger and miscellaneous accounts section and to take charge in his absence; to control all ledger postings, the dissection of revenue and expenditure vouchers and advance account reconciliations; to assist the Accountant in the preparation of the statistical and financial portion of the annual report and to conduct special investigations as required	To possess accountancy qualifications and a sound knowledge of the regulations respecting public accounts, the relevant portions of the Education Acts and the Public Service and Teaching Service Regulations, machine accounting, and Departmental and Treasury procedure regarding accounts	Senior, R. J. C	Clerk, Classes "E" and "D"	3.9.40
		To deal with general correspondence and matters pertaining to the repair and renewal of school fences, particularly those involving liability of adjoining owners; to check and classify incoming correspondence	A good knowledge of the organization and administration of the Buildings branch and of the various practices followed, particularly with reference to the provisions of the Fences Act, and a knowledge of the organization of the Public Works Department	White, E. L.	Clerk, Classes "E" and "D"	23.5.40

PUBLIC SERVICE (PUBLIC SERVICE BOARD) REGULATION 36A—RECLASSIFICATIONS—*continued.*

Office and Present Classification.	Revised Classification.	Duties.	Qualifications.	Officer Recommended for Appointment.		
				Name.	Classification.	Date of Classification.

ADMINISTRATIVE DIVISION—*continued.*

DEPARTMENT OF EDUCATION—*continued.*

Clerk, Classes "E" and "D" (7 offices)— <i>continued</i>	Class "C" (7 offices)— <i>continued</i>	To deal with matters pertaining to land transactions and the purchase of residences for teachers; to conduct searches in the Titles Office, and to act as liaison officer between the Education Department, the Lands Department and the Crown Solicitor	A good knowledge of the procedure involved in the compulsory acquisition of land and of the administration and organization of the Buildings Branch, a knowledge of Titles Office procedure and ability to conduct negotiations for the purchase of property	O'Meara, J. S. G.	Clerk, Classes "E" and "D"	23.5.40
		To deal with temporary staffing and adjustments in primary schools; under the direction of the officer-in-charge to arrange for engaging temporary teachers and for computing their commencing salaries	A sound knowledge of the regulations relating to staffing and the salaries of temporary teachers; and experience in engaging temporary teachers	Donovan, P. J.	Clerk, Classes "E" and "D"	17.3.38
		To deal with applications from teachers for allowances in respect of higher duties, living away from home, excessive board, travelling, training and special schools	A sound knowledge of the regulations relating to special allowances and travelling expenses, and of the Department's practice in regard to these matters	McKenna, C. A.	Clerk, Classes "E" and "D"	11.11.37
		To deal with retirements and resignations of teachers, permanent exchanges between teachers in the Department, and exchanges between Victorian and overseas teachers; to act as assistant to the Secretary to the Committee of Classifiers for the Primary Schools Division, and to prepare information for the Committee	A sound knowledge of the Regulations relating to the staffing of primary schools and of the organization of the Teacher's branch	Robinson, J. W.	Clerk, Classes "E" and "D"	23.5.38
		Under the Supervisor of the C.R.T.S. Annexe, to supervise the duties of the office staff; to compile staff salaries and overtime allowances, pay staff and trainees salaries, collate stock sheets, and prepare accounts for payment; to attend to correspondence in connexion with these duties	A good knowledge of the public accounts regulations and of the functions of the annexe; experience in dealing with business firms and conducting correspondence	Coutts, J. P.	Clerk, Classes "E" and "D"	20.2.39

DEPARTMENT OF HEALTH.

Administrative Branch.

Clerk, Class "C" (2 offices)	Class "C1" (2 offices)	To be responsible for all staff matters dealing with increments, new appointments, continued employment, &c.; to be directly responsible for the tuberculosis allowance payments and the payments for overtime and penalty rates to officers of the Department and the State Sanatoria	To have a thorough knowledge of the Acts and Regulations administered by the Department and of the Regulations respecting Public Accounts	Comer, L. G.	Clerk, Class "C"	21.3.48
		To act as Private Hospital Benefits Inspector; to examine the books and accounts of Private Hospitals throughout the State under the Commonwealth Private Hospital Benefits Scheme	To be a qualified accountant and to have a thorough knowledge of the Regulations under the Private Hospital Benefits Scheme	Birkett, G. L.	Clerk, Class "C"	21.3.48

PUBLIC SERVICE (PUBLIC SERVICE BOARD) REGULATION 36A—RECLASSIFICATIONS—*continued.*

Office and Present Classification.	Revised Classification.	Duties.	Qualifications.	Officer Recommended for Appointment.		
				Name.	Classification.	Date of Classification.

ADMINISTRATIVE DIVISION—*continued.*

DEPARTMENT OF LABOUR.

Clerk, Class "C" (2 offices)	Class "C1" (2 offices)	To have charge of the registration of correspondences and of the compilation of statistics relating to factories and shops and the classification of persons employed therein	To be conversant with Departmental procedure and records, to possess ability to classify correspondence, and to have a thorough knowledge of Wages Board Determinations and Arbitration Court Awards	Macpherson, J. R.	Clerk, Class "C"	5.3.48
		To act as Secretary to Trades Committees, to prepare draft regulations, statements and explanatory literature; to assist in the preparation of the Annual Report of the Commission and to answer inquiries and correspondence	To have a good knowledge of Apprenticeship Acts and Regulations, Wages Board Determinations and Arbitration Court Awards and the prescribed courses for training of apprentices, and experience in secretarial work of Committees; to possess ability to deal with correspondence and to prepare draft regulations	Jeans, M. S. . .	Clerk, Class "C"	21.3.48

PROFESSIONAL DIVISION.

DEPARTMENT OF LAW.

Courts Branch.

Clerk of Courts, Grade II, Class "C1"	Class "C2"	As prescribed by Regulation 42A of the Public Service (Public Service Board) Regulations	Pfeifer, A. H. C.	Clerk of Courts, Grade II, Class "C1"	1.7.49
---------------------------------------	------------	--	-------------------	---------------------------------------	--------

Appeals against such recommendations should be lodged with the Secretary to the Public Service Board not later than Saturday, the 28th January, 1950.

By order,

Office of the Public Service Board,
Melbourne, 17th January, 1950.

E. F. FITZGIBBON,
Secretary.

No. 710.

Public Service Act 1946, Section 39.

REGULATIONS.—PART III.—SALARIES, INCREMENTS, AND ALLOWANCES.

THE Public Service Board, in pursuance of the powers conferred by the Public Service Act 1946, hereby amends its Regulations as shown below:—

FIRST SCHEDULE.

PROFESSIONAL DIVISION.

Offices and Rates of Salaries.

Office.	Yearly Rate of Salary.	
	Minimum.	Maximum.
DEPARTMENT OF LAW.	£	£
CLASS "C1."		
<i>Delete—</i> Officer in Charge of Children's Courts . .	553	605
CLASS "C2."		
<i>Add—</i> Officer in Charge of Children's Courts, Grade II.	631	683

D. D. PAINE, Chairman.
E. F. FITZGIBBON, Secretary.

Office of the Public Service Board,
Melbourne, 9th January, 1950.

No. 38.—260/50.—3

No. 712.

Public Service Act 1946, Section 50.

REGULATIONS.—PART III.—SALARIES, INCREMENTS, AND ALLOWANCES.

THE Public Service Board, in pursuance of the powers conferred by the Public Service Act 1946, hereby amends its Regulations as shown below:—

SIXTH SCHEDULE.

TEMPORARY EMPLOYEES.

Designations of Positions and Rates of Salaries.

Department and Designation of Position.	Yearly Rate of Salary.		Increments (Annual).
	Minimum.	Maximum.	
DEPARTMENT OF CHIEF SECRETARY.	£	£	
PUBLIC LIBRARY, NATIONAL MUSEUM, MUSEUM OF APPLIED SCIENCE, AND NATIONAL GALLERY.			
<i>Add—</i> Mineralogist (Female) . .	462	514	2 of £26

This Regulation shall have effect as on and from the 11th January, 1950.

D. D. PAINE, Chairman.
E. F. FITZGIBBON, Secretary.

Office of the Public Service Board,
Melbourne, 12th January, 1950.

No. 713.

Public Service Act 1946, Section 50.

REGULATIONS.—PART III.—SALARIES, INCREMENTS,
AND ALLOWANCES.

THE Public Service Board, in pursuance of the powers conferred by the *Public Service Act 1946*, hereby amends its Regulations as shown below:—

SIXTH SCHEDULE.
TEMPORARY EMPLOYEES.

Designations of Positions and Rates of Salaries.

Department and Designation of Position.	Yearly Rate of Salary.		Increments (Annual).
	Minimum.	Maximum.	
DEPARTMENT OF TREASURER. BUILDING PERMITS SECTION.	£	£	
Add— Inspector, Assistant	..	390	..

This Regulation shall have effect as on and from the 1st January, 1950.

D. D. PAINE, Chairman.
E. F. FITZGIBBON, Secretary.

Office of the Public Service Board,
Melbourne, 17th January, 1950.

No. 711.

Public Service Act 1946, Section 50.

REGULATIONS.—PART III.—SALARIES, INCREMENTS,
AND ALLOWANCES.

THE Public Service Board, in pursuance of the powers conferred by the *Public Service Act 1946*, hereby amends its Regulations as shown below:—

SIXTH SCHEDULE.

TEMPORARY EMPLOYEES.

Designations of Positions and Rates of Salaries.

Department and Designation of Position.	Yearly Rate of Salary.		Increments (Annual).
	Minimum.	Maximum.	
DEPARTMENT OF AGRICULTURE.	£	£	
Add— Camera-man	..	527	..

This Regulation shall have effect as on and from the 3rd January, 1950.

D. D. PAINE, Chairman.
E. F. FITZGIBBON, Secretary.

Office of the Public Service Board,
Melbourne, 13th January, 1950.

Teaching Service Act 1946.

TEACHING SERVICE (TEACHERS TRIBUNAL) REGULATIONS.

THE Teachers Tribunal, in pursuance of the powers conferred by the *Teaching Service Act 1946*, hereby amends Regulation 12 of the Teaching Service (Teachers Tribunal) Regulations made on the twenty-ninth day of October, 1946, and published in the *Government Gazette* of the thirtieth day of October, 1946, in the manner following, that is to say:—

REGULATION 12.

1. After the expression "corresponding initial salary" in sub-clause 21 (a) (ii) insert the following:—

"but when and if such a student successfully completes such final year he shall be restored, as from the 1st of January of the following year, to the subdivision in which he would have been had he not failed to complete his year, and shall be paid the corresponding salary. For the purposes of this sub-clause, the last year in which such student was engaged in a course of training shall be regarded as the final year."

2. After the expression "corresponding initial salary" in sub-clause 21 (c) insert the following:—

"If during his course, such a student successfully completes the requirements specified in this sub-clause he shall incur no penalty. If, subsequent to this course, he successfully completes the requirements specified in this sub-clause he shall be restored, as from the 1st of January of the following year, to the subdivision in which he would have been but for the operation of this sub-clause, and shall be paid the corresponding salary."

3. Insert a new sub-clause 21 (d) as follows:—

"21. (d) Notwithstanding anything contained in the previous sub-clauses of this clause, if a student who is granted an extended course at the University of Melbourne fails to complete successfully any year of such course, and if the Principal, Secondary Teachers' Training Centre, certifies that in his opinion the student has worked diligently and that such failure was not due to lack of effort or application, no penalty shall be incurred, and the student shall be classified in the salary subdivision in which he would have been classified if he had successfully completed the particular year of the course."

W. H. ELLWOOD, Chairman.
E. V. B. HIGGINS, Acting Secretary.

Office of the Teachers Tribunal,
Melbourne, 10th January, 1950.

Teaching Service Act 1946.

TEACHING SERVICE (TEACHERS TRIBUNAL) REGULATIONS.

THE Teachers Tribunal, in pursuance of the powers conferred by the *Teaching Service Act 1946*, hereby amends Regulation 12 of the Teaching Service (Teachers Tribunal) Regulations made on the twenty-ninth day of October, 1946, and published in the *Government Gazette* of the thirtieth day of October, 1946, in the manner following, that is to say:—

REGULATION 13.

1. After the expression "corresponding initial salary" in sub-clause 17 (a) (ii) insert the following:—

"but when and if such a student instructor successfully completes such final year he shall be restored as from the 1st of January of the following year to the subdivision in which he would have been but for the operation of this sub-clause and shall be paid the corresponding salary."

2. After the expression "such required qualifications" in sub-clause 17 (b) insert the following:—

"If during his course such a student instructor successfully completes the requirements specified in (ii) and (iii) of clause 5 (a) he shall incur no penalty.

If subsequent to his course, he successfully completes the requirements specified in (ii) and (iii) of clause 5 (a) he shall be restored, as from the 1st of January of the following year, to the subdivision in which he would have been had he not failed to complete his course successfully, and shall be paid the corresponding salary."

W. H. ELLWOOD, Chairman.

E. V. B. HIGGINS, Acting Secretary.

Office of the Teachers Tribunal,
Melbourne, 10th January, 1950.

Teaching Service Act 1946.

TEACHING SERVICE (TEACHERS TRIBUNAL) REGULATIONS.

THE Teachers Tribunal, in pursuance of the powers conferred by the *Teaching Service Act 1946*, hereby amends Regulation 12 of the Teaching Service (Teachers Tribunal) Regulations made on the twenty-ninth day of October, 1946, and published in the *Government Gazette* of the thirtieth day of October, 1946, in the manner following, that is to say:—

REGULATION 14.

1. In clause 2, after the proviso, insert the following additional proviso:—

"Provided also that when and if such holder successfully completes the prescribed course he shall be restored, as from the 1st of January of the following year, to the subdivision in which he would have been had he not failed to complete the course successfully, and shall be paid the corresponding salary."

2. After the expression "corresponding initial salary" in sub-clause 3 (c) insert the following:—

"but when and if such holder successfully completes the prescribed course he shall be restored, as from the 1st of January of the following year, to the subdivision in which he would have been had he not failed to complete the course successfully, and shall be paid the corresponding salary."

3. In sub-clause 4 (b) after the proviso, insert the following additional proviso:—

"Provided also that when and if such holder successfully completes the prescribed course he shall be restored, as from the 1st of January of the following year, to the subdivision in which he would have been had he not failed to complete the course successfully and shall be paid the corresponding salary."

W. H. ELLWOOD, Chairman.

E. V. B. HIGGINS, Acting Secretary.

Office of the Teachers Tribunal,
Melbourne, 10th January, 1950.

TENDERS.

TENDERS will be received at this office until **TEN A.M.** on the days and for the purposes under mentioned.

Particulars may be learnt at this Office and also at places shown in parenthesis.

W.O. means Inspector of Works Office; P.S.—Police Station; T.S.—Technical School; H.E.S.—Higher Elementary School; S.S.—State School; H.S.—High School; P.D.—Preliminary deposit; F.D.—Final deposit.

The Board of Land and Works will not necessarily accept the lowest or any tender.

NOTE.—Plans and specifications will not be shown at School Buildings from the 14th December, 1949, to the 31st January, 1950.

24th January, 1950.

Ararat.—Supply and delivery of stainless-steel steam-heated cooking pans, Mental Hospital. P.D., £20. F.D., 2 per cent.

Balwyn North.—Supply and installation of additions to central heating system, S.S. No. 4863. P.D., £5. F.D., 2 per cent.

Belgrave South.—Supply and installation of kerosene hot-water service, residence, S.S. No. 3551. P.D., £2. F.D., 2 per cent.

Bendigo.—Supply and installation of a kerosene hot-water service in Recreation Centre, Teachers' Training College. (W.O., Bendigo.) P.D., £2. F.D., 2 per cent.

Birchip.—Remodelling, Inspector's Residence, Lands Department. (W.O., Warracknabeal; P.S., Birchip.) P.D., £15. F.D., 2 per cent.

Cohuna.—Supply and installation of household type electric refrigerator for Cookery Room, Consolidated and Higher Elementary School. P.D., £2. F.D., 2 per cent.

Eltham.—Supply and installation of an electric hot-water service, teacher's residence, H.E.S. No. 209. P.D., £2. F.D., 2 per cent.

Korrine.—Supply and installation of fuel hot-water system, residence, S.S. No. 4558. (W.O., Korumburra; P.S., Wonthaggi.) P.D., £2. F.D., 2 per cent.

Longwarry.—Supply and installation of a fuel hot-water service, teacher's residence, S.S. No. 2505. Deposit, £3.

Longwarry North.—Supply and installation of a fuel hot-water service, teacher's residence, S.S. No. 4272. (P.S., Longwarry.) P.D., £2. F.D., 2 per cent.

Melbourne.—Supply and installation of additions to central heating system, Public Library. P.D., £50. F.D., 2 per cent.

Melbourne.—Supply, installation, and maintenance of cold cathode fluorescent lighting equipment in various rooms, Titles Office, corner Lonsdale and Queen streets. P.D., £15. F.D., 2 per cent. (Amended specification.)

Melbourne.—Inter-office communication system, Motor Registration Branch, Exhibition Buildings. P.D., £5. F.D., 2 per cent.

Merbein.—Fencing, S.S. No. 3687. (W.O., Mildura; P.S., Merbein.) P.D., £5. F.D., 2 per cent.

Mont Park.—Supply and installation of four (4) household type electric refrigerators for new hostel for nurses, Gresswell Sanatorium. P.D., £5. F.D., 2 per cent.

Mont Park.—Supply and delivery of stainless-steel steam-heated cooking pans for kitchen, Laundry Workers' Block, Mental Hospital. P.D., £5. F.D., 2 per cent.

Mont Park.—Supply and delivery of stainless-steel steam-heated cooking pans for main kitchen, Mental Hospital. P.D., £10. F.D., 2 per cent.

Nhill.—Adaptation of huts into classrooms, S.S. No. 2411. (W.O., Horsham, Warracknabeal.) P.D., £15. F.D., 2 per cent.

Oakleigh.—Supply and installation of gas hot water service, Technical School (Caretaker's quarters). P.D., £3. F.D., 2 per cent.

Sandringham.—Supply and installation of a kerosene hot-water service, residence, Police Station. P.D., £2. F.D., 2 per cent.

Torquay.—Extension to school, new porch and partition, general repairs and painting, State School No. 3368. (W.O., Geelong.) P.D., £15. F.D., 2 per cent.

Warrn Ponds.—Supply and installation of fuel hot-water system, residence, S.S. No. 1040. P.D., £2. F.D., 2 per cent.

31st January, 1950.

Ballarat.—Provision of display boards in classrooms, S.S. No. 34. (W.O., Ballarat.) Deposit, £4.

Beechworth.—Erection of fencing, Children's Cottages, Mental Hospital. (W.O., Wangaratta; P.S., Beechworth, Myrtleford.) P.D., £5. F.D., 2 per cent.

Beechworth.—Supply and installation of one household type refrigerator in Cookery Centre, S.S. No. 1560. P.D., £2. F.D., 2 per cent.

Beechworth.—Supply and delivery of stainless-steel food containers, Mental Hospital. P.D., £5. F.D., 2 per cent.

Burnley.—Erection of residence for Curator, Horticultural Gardens. P.D., £25. F.D., 2 per cent.

Camperdown.—Conversion of residence at Hopetoun-street, Camperdown, into two (2) self-contained flats, H.S. (W.O., Camperdown, Warrnambool.) P.D., £15. F.D., 2 per cent.

Castlemaine North.—Repairs, renovations, and painting, S.S. No. 2051. (W.O., Bendigo, Kyneton.) P.D., £15. F.D., 2 per cent.

Cohuna.—Supply and installation of electric refrigerator, P.S. P.D., £2. F.D., 2 per cent.

Dookie.—Erection of Women's University Hostel, Agricultural College. (W.O., Shepparton; P.S., Tallygaroopna, Tatura; Agricultural College, Dookie.) P.D., £15. F.D., 2 per cent.

Dookie.—Renovations and external painting to staff cottage, Agricultural College. (W.O., Shepparton; P.S., Benalla; Court House, Numurkah; Agricultural College, Dookie.) Deposit, £5.

Flemington.—Renovations to Main Block and Concert Hall, Travancore Developmental Centre. P.D., £10. F.D., 2 per cent.

Footscray.—Extension to coke storage, T.S., Nicholson-street. P.D., £10. F.D., 2 per cent.

Ferntree Gully.—Erection of brick veneer station and timber residence, P.S. (P.S., Ferntree Gully.) P.D., £20. F.D., 2 per cent.

Hawkesburn.—Internal renovations, S.S. No. 1467. P.D., £15. F.D., 2 per cent. (Amended specification.)

Hexham.—Internal and external renovations and painting and minor repairs to school, shelter, out-offices, and residence, S.S. No. 296. (W.O., Warrnambool; P.S., Camperdown, Terang.) P.D., £5. F.D., 2 per cent.

Hurstbridge.—Renovations to school and residence, removed from Gobur, S.S. No. 3939. P.D., £15. F.D., 2 per cent.

Inglewood.—Remodelling of school building, general repairs to residence, S.S. No. 1052. (W.O., Bendigo.) P.D., £20. F.D., 2 per cent.

Koorlong.—Internal painting and repairs to residence, S.S. No. 3470. (W.O., Mildura; P.S., Mildura.) P.D., £4. F.D., 2 per cent.

Leongatha South.—Erection and completion of teacher's residence and out-buildings, S.S. No. 3251. (W.O., Korumburra; P.S., Foster.) P.D., £15. F.D., 2 per cent.

Little Hampton.—Repairs and painting, school, dismantling existing residence and erection of new E4.R. type residence, using best of old materials, S.S. No. 1700. (W.O., Bendigo, Kyneton; P.S., Castlemaine, Daylesford.) P.D., £15. F.D., 2 per cent.

Macarthur.—Repairs to shelter-sheds and renovations to residence, S.S. No. 1571. (W.O., Hamilton, Warrnambool; P.S., Macarthur.) P.D., £5. F.D., 2 per cent.

Melbourne.—Electrical installation, Law Courts. P.D., £20. F.D., 2 per cent.

Merino.—Remodelling of teacher's residence removed from Henty, Consolidated School. (W.O., Hamilton, Warrnambool.) P.D., £15. F.D., 2 per cent.

Merino.—Alterations and additions, Consolidated School. (W.O., Hamilton, Warrnambool.) P.D., £20. F.D., 2 per cent.

Mont Park.—Supply and installation of electric refrigerator, Female Receiving Block, Larundel Mental Hospital. P.D., £3. F.D., 2 per cent.

Murtoa.—Re-building of brick wall, Court House. (W.O., Horsham; P.S., Murtoa.) P.D., £5. F.D., 2 per cent.

Port Fairy.—Erection of residence in timber for Inspector, Fisheries and Game Department. (W.O., Warrnambool; P.S., Port Fairy, Portland.) P.D., £15. F.D., 2 per cent.

Port Welshpool.—Erection and completion of new timber residence, out-buildings, &c., for Inspector, Fisheries and Game Department. (W.O., Korumburra, Traralgon; P.S., Toora.) P.D., £15. F.D., 2 per cent.

Portland.—Provision of new toilet and sewerage connexions to teacher's residence, S.S. No. 489. (W.O., Hamilton, Warrnambool; P.S., Port Fairy, Portland.) Deposit, £4.

Queenscliff.—Supply and installation of two electric refrigerators, Health and Recreation Camp, Crows Nest. P.D., £5. F.D., 2 per cent.

Royal Park.—Supply and delivery of stainless-steel food containers, Mental Hospital. P.D., £10. F.D., 2 per cent.

Stawell.—Additional out-office accommodation, H.S. (W.O., Ararat; P.S., Stawell.) P.D., £5. F.D., 2 per cent.

Stawell.—Additions and alterations, Gardener's Quarters, Pleasant Creek Special School. (W.O., Ararat; P.S., Stawell; Pleasant Creek Special School, Stawell.) P.D., £5. F.D., 2 per cent.

Sunbury.—Supply and delivery of stainless-steel food containers, Mental Hospital. P.D., £20. F.D., 2 per cent.

Warragul.—Electrical installation, H.S. (P.S., Warragul.) P.D., £15. F.D., 2 per cent.

Warrnambool.—Provision of skylight and sliding doors to model rack, &c., Art Room, H.S. (W.O., Warrnambool; P.S., Warrnambool.) Deposit, £3.

Won Wron.—Erection and completion of teacher's residence and out-buildings, S.S. No. 1957. (W.O., Traralgon; P.S., Mirboo North.) P.D., £15. F.D., 2 per cent.

7th February, 1950.

Beechworth.—Repairs, &c., to building and erection of new garage and woodshed, Court House. (W.O., Wangaratta; Court House, Beechworth.) P.D., £15. F.D., 2 per cent. (Amended specification.)

Caulfield.—Supply and installation of a kerosene hot-water service, residence, P.S. P.D., £2. F.D., 2 per cent.

Drouin.—Repairs to fencing, S.S. No. 1924. (W.O., Traralgon; P.S., Warragul.) P.D., £3. F.D., 2 per cent.

Inglewood.—Repairs and painting and attention to fencing, Court House. (W.O., Bendigo; P.S., Bridgewater-Loddon, Inglewood.) P.D., £5. F.D., 2 per cent.

Melbourne.—Supply and installation of oil-firing equipment, New Chemistry School, Technical College. P.D., £10. F.D., 2 per cent.

Sale.—Repairs to buildings and new fencing, Gaol. (W.O., Bairnsdale, Traralgon; P.S., Sale.) P.D., £5. F.D., 2 per cent.

Sale.—Erection of two (2) new teachers' residences, T.S. (W.O., Bairnsdale.) P.D., £20. F.D., 2 per cent.

Terang.—Supply and installation of a kerosene hot-water service in Head Teacher's Residence, S.S. No. 617. (W.O., Warrnambool.) P.D., £2. F.D., 2 per cent.

Trafalgar.—Alterations, additions, renovations, and painting, P.S. (W.O., Traralgon; P.S., Rosedale, Trafalgar.) P.D., £10. F.D., 2 per cent.

Yarragon.—Repairs to fencing, P.S. (W.O., Korumburra, Traralgon; P.S., Yarragon.) P.D., £4. F.D., 2 per cent.

Tenders to be addressed to the Honorable the Commissioner of Public Works, and envelope containing tender marked "Tender for
due

J. A. KENNEDY
Commissioner of Public Works.

Melbourne, 17th January, 1950.

PRIVATE ADVERTISEMENTS.

CITY OF HAWTHORN.

BY-LAW No. 164.

A By-law of the City of Hawthorn, made under the *Local Government Act 1946* and the Uniform Building Regulations (Victoria), and numbered 164, for altering By-law No. 147, and for determining, applying, dispensing with, or regulating such matters or things as are left to be determined, applied, dispensed with, or regulated by the Council of the said City under the Uniform Building Regulations (Victoria).

IN pursuance of the powers conferred by the *Local Government Act 1946* and the Uniform Building Regulations (Victoria) and of any and every other power it thereunto enabling, the Mayor, Councillors, and Citizens of the City of Hawthorn order as follows:—

1. By-law No. 147, made by the Council of the City of Hawthorn, is hereby altered as follows:—

- (a) In the First Schedule the following words shall be added:—"Heather-court," "Bristol-court," and "Laurel-court."
- (b) In the Fifth Schedule after the words "Hawthorn Glen" there shall be added the words "Heather-court," and after the words "Bowler-street" there shall be added the words "Bristol-court."
- (c) In the Sixth Schedule after the words "Kooyong-koot-road" there shall be added the words "Laurel-court."

Resolution for passing this By-law agreed to by the Council the 12th day of October, 1949, and confirmed the 23rd day of November, 1949.

The common seal of the Mayor, Councillors, and Citizens of the City of Hawthorn was hereto affixed, in the presence of—

(SEAL) H. W. MOFFAT, Mayor.
A. R. PATTERSON, Councillor.
H. A. SMITH, Town Clerk.

Approved by the Governor in Council, the 19th day of December, 1949.—A. MAHLSTEDT, Clerk of the Executive Council. 1469

CITY OF HAWTHORN.

REGULATION No. 25.

A Regulation of the City of Hawthorn, numbered 25, and made under sections 197 and 228 of the *Local Government Act 1946* and clause 2 of Part IV. of the Fifteenth Schedule to the said Act, as adopted by By-law numbered 114, and every other power thereunto enabling, for repealing Regulation numbered 17, and for the proper management and control of the Hawthorn Public Library.

IN pursuance of the powers conferred by the *Local Government Act 1946* and of any and every other power it thereunto enabling, the Mayor, Councillors, and Citizens of the City of Hawthorn make the following Regulation:—

1. Regulation numbered 17 of the said City is hereby repealed.

2. The Public Library belonging to and under the control of the Council of the City of Hawthorn shall be subject to the supervision and directions of the Council, acting by and through the Town Clerk of the said City.

3. The said library shall be open to the public during such hours as the Council may from time to time direct.

4. Any ratepayer of Hawthorn satisfying the Librarian of same or any resident who shall deliver to the Librarian a guarantee in the prescribed form signed by two ratepayers may borrow books from the library. Provided, however, that the Library Committee may, if it considers it expedient so to do, permit such other persons, on application by them in writing, to borrow books from the library in cases where such other persons—

- (a) own property in the municipality of Hawthorn and do not reside in the municipality;
- (b) work in the municipality;
- (c) attend schools in the municipality;
- (d) are nominees of corporations for enrolment on the municipal rolls of the municipality.

All such other persons permitted to borrow books from the library under this clause shall furnish the Librarian with the prescribed form of guarantee signed by two ratepayers.

5. All books borrowed are to be returned within fourteen days, and all magazines borrowed are to be returned within seven days, and in case of loss or damage the borrower or his guarantor or guarantors shall replace the book or pay to the Council the value of the book, set, or series lost or damaged within one week of the date on which the loss or damage is notified to him. The Council shall be the sole judge of the value of any book, set, or series lost or of any damage done.

6. Notwithstanding anything contained in the preceding clause, any borrower who does not return any book or magazine within the time specified in such clause 5 shall pay a fine in the case of borrowers in the adult section of the library of Three pence per day for each day a book or magazine is retained in excess of the period named, and in the case of borrowers in the junior section One penny per day for each day a book or magazine is retained in excess of the said period.

7. No borrower shall lend any book taken from the library or exchange any book with another borrower.

8. Any borrower ceasing to use the library shall return his membership card to the Librarian, and borrowers and their guarantors shall remain responsible for any book taken out in their names until the membership card shall have been cancelled.

9. Any borrower changing his residence shall forthwith notify the Librarian of such change.

10. No person shall write in or upon or mark or fold down any leaf of any book or document or deface, mutilate, or in any manner injure the same.

11. Any borrower finding any book written on or mutilated shall report the fact to the Librarian.

12. The loan of any book shall not be renewed if such book be required by another borrower.

13. The Librarian is hereby empowered to refuse to lend books to any person who neglects to comply with the rules of the library, or who is not entitled for any other reason to be entrusted with books.

14. Any person taking into the library books, magazines, and/or papers not belonging to the library, and/or any parcel or bag, must leave same at the attendant's desk until leaving the library.

15. Any person removing a book or books from the shelves for perusal shall leave such book or books on the library table for replacement in the shelves by the library attendants.

16. No person shall use any ink within the library, except by express permission of the Librarian.

17. No male person shall wear his hat within the library, except by express permission of the Librarian.

18. No person shall shift any article of furniture or any map, chart, or drawing placed in or hung upon the walls of the library or its precincts.

19. No dogs shall be taken into the library or its precincts, or any approach thereto.

20. No person shall take into the library building any bicycle or scooter or similar contrivance.

21. No person shall stand or place his feet upon any chair or table in the library.

22. No person shall smoke any tobacco or other substance or shall ignite any match or other article or thing within the library or its precincts, or any approach thereto.

23. No persons shall spit upon the floor or walls of the library, or upon any of the property of the Council therein.

24. No person shall remain or attempt to remain within the library after the appointed time for closing it.

25. No person shall enter or remain in the library who is not decently attired and cleanly in person in the opinion or judgment of the Librarian or the person for the time being in charge of the library.

26. Any person offending against any of the provisions of this Regulation may be forthwith removed from the library by the Librarian or the person for the time being in charge of the library or any officer of the Council, and such removal shall not prejudice or affect any proceedings against such person for so offending.

Resolution for passing this Regulation agreed to by the Council the 2nd day of November, 1949, and confirmed the 14th day of December, 1949.

The common seal of the Mayor, Councillors, and Citizens of the City of Hawthorn was hereto affixed, in the presence of—

(SEAL) H. W. MOFFAT, Mayor.
A. R. PATTERSON, Councillor.
1459 H. A. SMITH, Town Clerk.

CITY OF MOORABBIN.

BY-LAW No. 132.

A By-law of the City of Moorabbin, made under the provisions of the *Local Government Act 1946* and the *Uniform Building Regulations (Victoria)*, and numbered 132, for amending By-law No. 101 of the City of Moorabbin.

IN pursuance of the powers conferred by the *Local Government Act 1946* and the *Uniform Building Regulations*, the Mayor, Councillors, and Citizens of the City of Moorabbin order as follows:—

1. This By-law shall be read and construed as one with By-laws Nos. 101, 102, 103, 104, 105, 106, 107, 108, 109, 110, 111, 112, 113, 114, 115, 117, 119, 120, 121, 122, 123, 124, 125, 130, and 131 of the City of Moorabbin.

2. The First Schedule to By-law No. 101 aforesaid is hereby amended by:—

(a) The deletion of Area No. 13 therefrom.

(b) The deletion of Area No. 11 and the substitution of the following area therefor:—

“All the land fronting to or abutting on the west side of Jasper-road between the north side of South-road and a point 157 feet north therefrom to a depth of 110 feet.”

(c) The deletion of Area No. 22 and the substitution of the following area therefor:—

“All the land fronting to or abutting on the south side of Brewer-road between the west building line of Todd-street and a point 200 feet west therefrom to a depth of 125 feet.”

3. This By-law shall come into operation and have effect immediately on its publication in the *Victoria Government Gazette*.

Resolution for passing this By-law agreed to by the Council on the 18th day of July, 1949, and confirmed on the 15th day of August, 1949.

The common seal of the Mayor, Councillors, and Citizens of the City of Moorabbin was hereto affixed this 15th day of August, 1949, in pursuance of a Resolution of the Council, and in the presence of—

(SEAL) J. W. ALLNUTT, Mayor.
N. G. WISHART, Councillor.
W. B. THOMAS, Town Clerk.

Approved by the Governor in Council, the 19th day of December, 1949.—A. MAHLSTEDT, Clerk of the Executive Council. 1452

CITY OF SANDRINGHAM.

RENAMING OF STREET.

NOTICE is hereby given that the street running east and west between Beach-road and Bluff-road, previously known partly as Linacre-road and partly as Nell-street, is now renamed by the Council “Linacre-road” for its whole length.

F. G. TRICKS, Town Clerk.
16th January, 1950. 1501

CITY OF SOUTH MELBOURNE.

BY-LAW No. 368.

A By-law of the City of South Melbourne, made under the *Local Government Act*, and numbered 368, for the purpose of amending By-law No. 328 of the said City.

THE Mayor, Councillors, and Citizens of the City of South Melbourne, in pursuance of the powers conferred by the *Local Government Act* and every other Act or power enabling it in that behalf, doth hereby make the By-law and order as follows:—

1. That By-law No. 361 of the said City be repealed.

2. That By-law No. 328 of the said City be amended by striking out sub-clauses (1), (2), and (3) of clause 9, and inserting the following paragraphs in lieu thereof:—

(1) Cold sea baths for adults—	£	s.	d.
(a) Single bath	0	0	6
(b) Season ticket (1st October to 31st March in each year)	1	10	0
(c) Season ticket (1st April to 30th September in each year)	0	10	0
(2) Cold sea baths for children (under fourteen years)—			
(a) Single bath	0	0	2
(b) Season ticket (1st October to 31st March in each year)	0	10	0
(3) Hot sea baths for adults—			
(a) Single bath (up to twenty minutes' duration)	0	2	0
(b) Single bath—per dozen tickets	1	0	0

Resolution adopting this By-law agreed to by the Council of the City of South Melbourne on the 26th day of October, 1949, and confirmed at a meeting of the said Council on the 23rd day of November, 1949.

(L.S.) H. A. LAYFIELD, Mayor.
W. ELLIOTT WELLS, Councillor.
H. ALEXANDER, Town Clerk.

Approved by the Governor in Council, 19th December, 1949.—A. MAHLSTEDT, Clerk of the Executive Council. 1502

Local Government Act 1946.

CITY OF WILLIAMSTOWN.

IN compliance with the provisions of section 585, subsection (3), of the *Local Government Act 1946*, the Council of the City of Williamstown hereby declares the following streets within the municipality:—

Edina-street; Gem-street; Cerberus-crescent—to be dedicated to the public as public highways.

In witness whereof the common seal of the Mayor, Councillors, and Citizens of the City of Williamstown was hereunto affixed by me, this 21st day of September, 1948—

J. E. MORLEY, Town Clerk.

In the presence of—

(SEAL) ERNEST W. JACKSON, J.P., Mayor.
1451 W. L. FLOYD, Councillor.

SHIRE OF ARARAT.

APPOINTMENT OF RANGER.

NOTICE is hereby given that Leslie Copley has been appointed Ranger for the Shire of Ararat, in lieu of Frederick Pipkorn, resigned.

1458 K. N. BISHOP, Shire Secretary.

SHIRE OF BULLA.

NOTICE is hereby given that Senior Constable Campbell George Thomas Payne, No. 8801, of Sunbury, was appointed Prosecuting Officer for the Shire of Bulla, in the place of Sergeant F. T. Fennessy, resigned.

1461 THOS. F. McCORMACK, Shire Secretary.

SHIRE OF DANDENONG.

By-LAW No. 97.

A By-law of the Shire of Dandenong, made under the provisions of the Local Government Acts, for the purpose of amending By-law number 92 of the said Shire relating to buildings, and numbered 97.

IN pursuance of the powers conferred by the Local Government Acts, the President, Councillors, and Ratepayers of the Shire of Dandenong order as follows:—

1. Clause 11 of By-law 92 is hereby repealed, and the following clause is substituted in lieu thereof.

2. In this clause and in clauses 12, 13, 14, 15, 16, 17, 18, 19, and 20 of this By-law the word "building," in addition to any other meaning, shall include any erection or structure and any portion of a building or structure constructed of any material, and shall also include any structure of a moveable nature.

3. This By-law shall apply to and have operation throughout the whole of the municipal district.

Resolution for passing this By-law agreed to by the Council on the 20th day of June, 1949, and confirmed the 22nd day of August, 1949.

The common seal of the President, Councillors, and Ratepayers of the Shire of Dandenong was hereunto affixed, in the presence of—

(SEAL.) WINWOOD L. PODMORE, Shire President.
E. C. SMITH, Councillor.
C. C. MCPHEE, Councillor.
R. BOOTH, Shire Secretary.

Confirmed by the Governor in Council, the 19th day of December, 1949.—A. MAHLSTEIT, Clerk of the Executive Council. 1491

SHIRE OF HAMPDEN.

REGULATION No. 5.

A Regulation of the Shire of Hampden, numbered 5, made under section 44 of Part I. of the Fifteenth Schedule to the *Local Government Act 1946*, in force in the Shire of Hampden by virtue of a By-law of the above-named shire, numbered 33, for amending Regulation No. 3 of the Shire of Hampden.

IN pursuance of the powers conferred by the *Local Government Act 1946*, the President, Councillors, and Ratepayers of the Shire of Hampden make the following Regulation, which shall apply to and have operation to the parts of the shire described in Regulation No. 3 of the said shire, as amended by this Regulation:—

1. That Regulation No. 3 of the Shire of Hampden be amended as follows:—

(a) In the heading thereof the words "within the Town of Terang" shall be deleted and in lieu thereof there shall be substituted the words "within and adjoining the Town of Terang."

(b) In clause 2 thereof the words "within the Town of Terang" where first appearing shall be deleted and in lieu thereof there shall be substituted the words "within and adjoining the Town of Terang."

(c) In the said clause 2 the letter and words "A. Within the Town of Terang" shall be deleted and in lieu thereof there shall be substituted the letter and words "A. Within and adjoining the Town of Terang."

(d) In the said clause 2 the words "thence by the Prince's Highway to Dixie (otherwise Strong) street; thence by Dixie (otherwise Strong) street to the promenade on the south by the promenade from Dixie (otherwise Strong) street to High-street" shall be deleted, and in lieu thereof there shall be substituted the words "thence by the Prince's Highway to the Peterborough-road; thence southerly by the last-mentioned road to the Cobden-Terang road; thence westerly by the Cobden-Terang road to the promenade; thence northerly and north-westerly by the promenade to High-street."

2. That this Regulation and Regulation No. 3 shall be read and construed and take effect as if the provisions of this Regulation had been incorporated in the said Regulation No. 3.

Resolution for passing this Regulation agreed to by the Council the 2nd day of December, 1949, confirmed the 6th day of January, 1950.

The common seal of the President, Councillors, and Ratepayers of the Shire of Hampden was hereunto affixed, in the presence of—

(SEAL.) W. McC. TROUP, President.
P. G. COLE, Councillor.
THOS. F. LITTLE, Secretary. 1450

SHIRE OF KORUMBURRA.

By-LAW No. 29.

A By-law of the Shire of Korumburra, made under the *Local Government Act 1946* and the Uniform Building Regulations Victoria, and numbered 29, for determining, applying, dispensing with, or regulating such matters or things as are left to be determined, applied, dispensed with, or regulated by the Council of the Shire of Korumburra under the Uniform Building Regulations Victoria.

IN pursuance of the powers conferred by the *Local Government Act 1946* and the Uniform Building Regulations Victoria and of any and every other power it hereunto enabling, the President, Councillors, and Ratepayers of the Shire of Korumburra order as follows:—

That By-law No. 28 of the shire, passed by the Council on the 15th day of June, 1949, be amended by omitting from the First Schedule thereof the words "Crown allotments 1 to 24 inclusive and 29 to 32 inclusive, all of section 2 of the Township of Korumburra," and inserting in lieu thereof the words "Crown allotments 1 to 24 inclusive and 29 to 32 inclusive, all of section 3 of the Township of Korumburra."

The Resolution for making and passing this By-law was agreed to by the Council at its meeting held on the 19th day of October, 1949, and confirmed on the 16th day of November, 1949.

The common seal of the President, Councillors, and Ratepayers of the Shire of Korumburra was hereunto affixed, in the presence of—

(SEAL.) A. McDOUGALL, Councillor.
C. C. ADKINS, Councillor.
A. M. SIMMONS, Shire Secretary. 1449

SHIRE OF McIVOR.

LOAN No. 11.

TAKE notice that the Shire of McIvor proposes to borrow, on the credit of the President, Councillors, and Ratepayers of the Shire of McIvor, the sum of Four thousand five hundred pounds (£4,500), such sum to be raised by debentures, in accordance with provisions of the *Local Government Act 1946*, and amendments thereof.

The rate of interest to be paid is not to exceed 3 1/2 per centum per annum.

Such moneys to be repayable by twenty half-yearly instalments of principal and interest, by providing out of the municipal fund the required amounts, on the 1st day of April and the 1st day of October in each respective year during the currency of the loan.

Such moneys to be repayable at the Melbourne branch of the Commercial Bank of Australia, or at the Council's bankers for the time being in the City of Melbourne.

The purpose for which the loan is required is the purchase of road-making plant, i.e., power grader, front-end loader, and equipment.

The necessary specifications and estimates of cost of the equipment referred to, and a statement showing the proposed expenditure of money to be borrowed, are open for inspection at the Shire Office, Heathcote.

Dated this 12th day of January, 1950.

1494 R. J. MURRAY, Shire Secretary.

Town and Country Planning Act 1944.

SHIRE OF MORWELL.

NOTICE OF PREPARATION OF A PLANNING SCHEME—SHIRE OF MORWELL PLANNING SCHEME 1950.

NOTICE is hereby given that the Council of the Shire of Morwell, in pursuance of its powers under the *Town and Country Planning Act 1944*, has prepared a planning scheme for the area surrounding and including the Town of Morwell for the purpose of planning the development of this area.

All maps, plans, descriptions, and other data fully setting out and explaining the planning scheme have been deposited at the Shire Office, Shire Hall, Commercial-road, Morwell, and at the office of the Town and Country Planning Board, Treasury Gardens, Melbourne, C.2, and will be open for inspection, without payment of any fee, by all persons affected, between the hours of 9 a.m. and 4.45 p.m. on all days of the week except Saturdays, Sundays, and public holidays until and including the 18th day of April, 1950.

Any persons affected by the planning scheme are required to set forth, in writing, all objections they may have, addressed to W. K. Mathison, Shire Secretary, Shire Hall, Commercial-road, Morwell, on or before the 18th day of April, 1950.

At the next ordinary meeting of the responsible Authority to be held at the Council Chambers, Shire Hall, Commercial-road, Morwell, on Wednesday, the 19th day of April,

1950, it will consider any objections to the planning scheme. At this meeting any person affected by the scheme, or any person acting on his behalf, may appear before the responsible Authority in support of any written objections or may submit any other objections to the scheme.

W. K. MATHISON, Shire Secretary.

NOTE.—It is important that a full statement should be made giving the grounds of any objection to the planning scheme.

17th January, 1950.

1475

SHIRE OF WARANGA.

NOTICE OF INTENTION TO BORROW THE SUM OF £1,800 FOR PERMANENT WORKS AND UNDERTAKINGS.

NOTICE is hereby given that the Council of the Shire of Waranga proposes to borrow the sum of One thousand eight hundred pounds, on the credit of the municipal revenues of the President, Councillors, and Ratepayers of the said Shire, such sum to be raised by the issue of debentures, in accordance with the provisions of the Local Government Acts.

1. The maximum rate of interest that may be paid is 3½ per cent. per annum.
2. The purpose for which the loan is to be applied is reconstruction of gravel roads on the Stanhope Estate.
3. The period of the loan shall be ten years.
4. The moneys borrowed shall be repayable by providing out of the municipal fund twenty half-yearly instalments of approximately £106 2s. 9d. each, including principal and interest, on the 1st day of May and the 1st day of November during the currency of the loan. The first instalment shall be payable on the 1st day of November, 1950.

5. Such moneys shall be repayable at the Commercial Banking Company of Sydney Limited, Melbourne, or at the Council's bankers for the time being in Melbourne.

The plans and specifications and the estimate of the cost of the proposed works, and a statement showing the proposed expenditure of the moneys to be borrowed, are open for inspection at the Shire Office, Rushworth.

Dated 11th January, 1950.

1456

W. C. GEYLE, Shire Secretary.

WILL any one knowing the whereabouts of Nelson Theodore Frahm, formerly of Charlton, in the State of Victoria, storekeeper, but now of parts unknown, please give such information as he or she may possess to Mr. A. Beanland, Shire Secretary, Charlton. An assurance is hereby given that such information will not be used in any way detrimentally to the said Nelson Theodore Frahm.

J. F. WANNAN, solicitor, Charlton.

1354

NOTICE OF DISSOLUTION OF PARTNERSHIP.

NOTICE is hereby given that the partnership heretofore subsisting between the undersigned, Harold Malcom Lewis Oliver and David Michael John Mahony, and Arthur Leslie Price, carrying on business as engineers and manufacturers, under the name of "O.P.M. Products," has been dissolved by mutual consent as from the 6th day of January, 1950. All debts due to and owing by the said firm will be received and paid by Harold Malcom Lewis Oliver and David Michael John Mahony, who will carry on the business under the same name at 344 Bell-street, West Coburg.

Dated at Melbourne, this 10th day of January, 1950.

ARTHUR L. PRICE.

Witness—J. G. LINCOLNE.

DAVID MAHONY.

Witness—J. G. LINCOLNE.

H. OLIVER.

Witness—J. G. LINCOLNE.

J. G. Lincoln, LL.B., solicitor, 468 Little Collins-street, Melbourne. 1480

NOTICE is hereby given that the partnership heretofore subsisting between George Mortimer Cadby and Charles Ralph Cadby, in the business of retail dairymen carried on by them at Warragul, under the firm name of "Cadby Bros.," has been dissolved by mutual consent as from the 31st day of December, 1949, after which date the said business will be carried on by the said Charles Ralph Cadby under his own name, and all moneys owing to or by the said partnership will be received and paid by him.

Dated this 9th day of January, 1950.

G. M. CADBY.

C. R. CADBY.

Gray, Friend, and Moonie, solicitors, Warragul. 1477

NOTICE is hereby given that the partnership heretofore subsisting between Howard Irvine Cheney and Derek Smith, carrying on business at 262 Queen-street, Melbourne, under the name of "Alba Press," has been dissolved as from the date hereof so far as concerns Howard Irvine Cheney, who retires from the said firm. All debts due to and owing by the said firm will be received and paid respectively by the said Derek Smith, who will continue to carry on the said business under the name of "Alba Press."

Dated the 9th day of January, 1950.

H. CHENEY.
D. SMITH.

H. S. W. Lawson, Hughes, and Co., solicitors, 314 Collins-street, Melbourne, C.I. 1481

NOTICE is hereby given that the partnership heretofore subsisting between Alexander Hamilton White, the elder, and Alexander Hamilton White, the younger, carrying on the business of tailors at 59A Glenferrie-road, Malvern, under the name of A. H. White and Son, has been dissolved as from the 1st day of January, 1950. The business will be carried on by the said Alexander Hamilton White, the younger, under the same business name, at the above address, where he will receive and pay all debts.

ALEXR. HAMILTON WHITE (the elder).
A. H. WHITE (the younger).

Rupert F. Bullen, solicitor, 20 Queen-street, Melbourne. 1523

Companies Act 1938.

TIFFIN PRODUCTS PTY. LIMITED (IN VOLUNTARY LIQUIDATION).

NOTICE is hereby given, pursuant to section 236 of the Companies Act 1938, that a General Meeting of the members of the above-named company will be held at the Board Room, Temple Court, 422 Collins-street, Melbourne, on Monday, the 20th day of February, 1950, at half-past Ten a.m., for the purpose of having an account laid before the members showing the manner in which the winding up has been conducted and the property of the company disposed of, and hearing any explanation that may be given by the liquidator.

Dated this 16th day of January, 1950.

1522

R. F. HUGHES, Liquidator.

LUCIEN LOVELINESS PROPRIETARY LIMITED (IN VOLUNTARY LIQUIDATION).

NOTICE OF FINAL MEETING OF SHAREHOLDERS, PURSUANT TO SECTION 236.

NOTICE is hereby given that a Meeting of shareholders of the above company will be held at the office of the liquidator, T. E. Kempster, at 343 Little Collins-street, Melbourne, on Monday, the 20th February, 1950, at Two p.m., for the purpose of receiving a final statement of account of the winding up of the company.

T. E. KEMPSTER, Liquidator.

18th January, 1950.

1505

Companies Act 1938.

THE CASTLEMAINE BREWERY COMPANY MELBOURNE LIMITED.

REGISTER of Unclaimed Moneys held by above Company on 1st January, 1950.

Name of Owner on Books.	Total Amount due to Owner.	Description of Unclaimed Moneys.
T. Blake (deceased), address unknown	£ 3 7 8	Dividend 1943
H. Donovan, address unknown ..	0 11 8	Dividend 1943
J. H. Edwards, address unknown ..	6 17 8	Dividend 1943

1525

Thirty-second Schedule.

THE AUTOMOBILE FIRE AND GENERAL INSURANCE CO. OF AUST. LTD.

REGISTER of Unclaimed Money held by The Automobile Fire and General Insurance Company of Australia Limited.

Name of Owner on Books.	Total Amount Due to Owner.	Description of Unclaimed Money.	Date of Last Claim.
	£ s. d.		
Thorne, Francis Arthur, 349 Collins-street, Melbourne	1 10 0	Dividends on Shares in the Automobile Fire and General Insurance Co. of Australia Limited	30.4.25
James, Gideon J., 19 Athol-street, Moonee Ponds ..	3 0 0	" " " "	— 8.37
Greig, Vivienne W. (Mrs.), Flat 2, 3 Dudley-street, Brighton	3 0 0	" " " "	17.6.43
Oxer, Wing-Commander Gordon, 1290 Hay-street, West Perth	3 15 0	" " " "	19.12.46
Lyall, Henry Lawson, 303 Royal-parade, Royal Park	3 0 0	" " " "	19.12.46
Estate of late Henry E. Coane, c/o Mrs. Lilian M. Adams, "Tantara," Sherbrooke	6 0 0	" " " "	— 6.48
	20 5 0		

1490

MACINTOSH AUTO CONTROL GASIFICATION COMPANY PROPRIETARY LIMITED.
(In Voluntary Liquidation.)

REGISTER of Unclaimed Money held by the MacIntosh Auto Control Gasification Company Proprietary Limited (In Voluntary Liquidation).

Name of Owner on Books.	Total Amount Due to Owner.	Description of Unclaimed Money.	Date of Last Claim.
	£ s. d.		
John Bott, 53 Canterbury-road, Middle Park ..	0 10 0	First and final dividend on 100 shares ..	21.9.48
William Clements, Pyalong, Victoria ..	0 5 0	First and final dividend on 50 shares ..	21.9.48
Estate of C. P. McCormack, c/o O. W. Parkinson, 370 Little Collins-street, Melbourne	1 0 0	First and final dividend on 200 shares ..	21.9.48
Henry Gordon Beattie, 38 Lumeah-road, Caulfield ..	0 10 0	First and final dividend on 100 shares ..	21.9.48
Arthur J. Jenkin ..	0 10 0	First and final dividend on 100 shares ..	21.9.48
Edmund Roy Lodge, 252 Regent-street, London, England	5 0 0	First and final dividend on 1,000 shares	21.9.48
	7 15 0		

R. C. D. WARNE-SMITH, Liquidator.

1520

Companies Act 1938.—Thirty-second Schedule.

SWALLOW AND ARIELL LIMITED.

REGISTER of Unclaimed Money held by Swallow and Ariell Limited.

Name.	Address of Owner on Books.	Total Amount Due to Owner.	Description of Unclaimed Money.	Date of Last Claim.
		£ s. d.		
Bridge, James ..	57 Autumn-street, Geelong West	2 0 0	Dividend on ordinary shares	No claim has been made in respect of such money
Cross, John (deceased) ..	Hopkins-street, Footscray ..	1 0 0	" " " "	" " "
Dando, Henry (deceased) ..	159 Graham-street, Port Melbourne	0 5 0	" " " "	" " "
Dando, Edward Cunningham	Colac ..	0 3 0	" " " "	" " "
Mueller, Bertha (deceased)	Burwood-road, Hawthorn ..	0 10 0	" " " "	" " "
Berry ..	No address ..	0 5 0	Collected for purchase of War Savings Certificates; not completed	" " "
Porter, T. ..	204 Clarke-street, Port Melbourne	1 10 0	" " " "	" " "
Wright ..	No address ..	3 5 0	" " " "	" " "
James, Mrs. E. ..	Ingles-street, Port Melbourne ..	0 7 0	" " " "	" " "
Hollyburton ..	No address ..	0 5 0	" " " "	" " "
Hay, V. ..	22 Draper-street, South Melbourne	0 2 0	" " " "	" " "
Wilmot, E. ..	131 King-street, Melbourne	0 12 0	" " " "	" " "
MacRedmond ..	No address ..	1 4 0	" " " "	" " "
O'Sullivan ..	" " " "	0 2 0	" " " "	" " "
Compton ..	" " " "	1 10 0	" " " "	" " "
Newman, C. ..	39 Queen-street, Melbourne	0 12 0	" " " "	" " "
Porter ..	No address ..	1 0 0	" " " "	" " "
Hirst ..	" " " "	0 2 0	" " " "	" " "
Moreland ..	" " " "	0 10 0	" " " "	" " "

1470

E. T. BOREHAM, Secretary.

Companies Act 1938.—Thirty-second Schedule.

PERPETUAL GENERAL INSURANCE AND GUARANTEE COMPANY LIMITED.

REGISTER of Unclaimed Moneys held by the Perpetual General Insurance and Guarantee Company Limited, 44-46 Queen-street, Melbourne, as at 10th January, 1950.

Name of Owner on Books.	Total Amount Due to Owner.	Description of Unclaimed Money.	Date of Last Claim.
	£ s. d.		
W. Wood	1 10 0	Dividends on 15 shares declared 1943	No claim since inception of company
Executors of the late Judith Flexman ..	0 10 0	Dividends on 5 shares declared 1943	July, 1907

1519

Companies Act 1938.

THE AUSTRALIAN KNITTING MILLS LIMITED.

REGISTER of Unclaimed Moneys held by The Australian Knitting Mills Limited.

Name and Address of Owner.	Total Amount Due to Owner.	Description of Unclaimed Money.	Date of Last Claim.
	£ s. d.		
Blair, Mr., 32 Darling-street, East Malvern ..	4 15 9	Wages due	22nd December, 1943

1463

THE KAURI TIMBER COMPANY LIMITED.

LIST of Unclaimed Moneys held by the Kauri Timber Company Limited, January, 1950.

Name.	Address.	Amount.	Description.	Date of Last Claim.
		£ s. d.		
Hicks, C. H.	16 Bridge-street, Sydney	6 5 0	Dividend, 1945	December, 1940
Ryland, F. P.	Bathurst-road, Springwood	0 2 6	Dividend, 1945	December, 1925
Morris, Miss E. E. (deceased) ..	122 Esplanade, Sumner, N.Z. ..	0 18 9	Dividend, 1915	December, 1930
		7 6 3		

1468

For the Kauri Timber Company Limited,
C. R. PLOOG, Secretary.

REGISTER of Unclaimed Money held by O.T. Ltd., Registered Office, 193 High-street, Prahran, S.I., Victoria, as at 31st December 1949.

Name of Owner on Books.	Total Amount Due to Owner.	Description of Unclaimed Money.	Date of Last Claim.
	£ s. d.		
Francis James Tully, 8 Ripley-grove, Caulfield ..	0 3 2	Dividend on shares	14.10.43
Belle Bryson, 232 Toorak-road, South Yarra ..	0 16 0	Dividend on shares	14.10.43
Albert Edward Groves, 13 Arcade-street, Prahran ..	0 16 0	Dividend on shares	14.10.43
Roland E. Harrington, 72 Apollo-street, Bombay, India..	0 16 0	Dividend on shares	14.10.43
Martha Lydia Hughes, G.P.O., Box 7, Brisbane, Queensland	0 9 8	Dividend on shares	14.10.43
Grace Maddox, 64 Carson-street, Studley Park ..	0 8 0	Dividend on shares	14.10.43
Jane Sanderson, Commercial-road, Hobart, Tasmania ..	0 8 0	Dividend on shares	14.10.43
Matthew Smith, Dowling-street, Waterloo, N.S.W. ..	0 16 0	Dividend on shares	14.10.43
Thomas Taylor, Hastings-street, Northcote	0 8 0	Dividend on shares	14.10.43
Jane Beatrice Watson, 67 Orrong-road, Balaclava ..	2 0 0	Dividend on shares	14.10.43
Edward Albert James Millwood, 95 Avordale-square, Old Kent-road, London, England	6 0 0	Dividend on shares	14.10.43
Sarah A. Jaye, 119 Morgan-street, Wagga, N.S.W. ..	0 16 0	Dividend on shares	14.10.43
Caroline Truss, 10 Balmoral-street, Waitara, N.S.W. ..	0 16 0	Dividend on shares	14.10.43
	14 12 10		

1521

NORTH BROKEN HILL LIMITED.

REGISTER of Unclaimed Money held by North Broken Hill Limited as at 31st December, 1949.

Name and Address of Owner.	Total Amount Due to Owner.	Description of Unclaimed Money.	Date of Last Claim.
	£ s. d.		
<i>London Register.</i>			
Arthur Glover, Executor late Milward Selby Arter, Vernon-avenue, Handsworth Wood, Birmingham, England	115 9 8	No. 125 Dividends on 3,580 5s. shares
Henry John Nix, Executor late Edith Ann Barclay, 9 New-square, Lincoln's Inn, London, England	0 5 7	Refund of tax on 264 5s. shares
Paul Jules Charles Berard, 54 Rue Cardinet, Paris, France	99 19 11	Nos. 113, 114, 117-125 Dividends on 252 5s. shares less bank charges
Mrs. Mollie Ella Bishop, 36 Crescent-court, Surbiton, Surrey, England	0 2 2	Refund of tax on 100 5s. shares
Martins Bank Ltd., Administrator late Dr. Peter Russell Cairns, 4 Water-street, Liverpool, England	0 2 3	Refund of tax on 104 5s. shares
Mrs. Kathleen Mary Daniell, 9 Ormonde Gate, London, England	5 16 7	Nos. 124 and 125 Dividend on 100 5s. shares
Mrs. Marie Louise Neven Du Mont, 16 Grosvenor-street, London, England	0 2 2	Refund of tax on 100 5s. shares
Robert Charles Gillett, 35 Arundell-road, Croydon, England	0 9 3	Nos. 124 and 125 Dividends on 8 5s. shares
Edmund Walter Horniman, 55 North-street, Bridgewater, Somerset, England	0 1 8	Refund of tax on 75 5s. shares
Mrs. Janet Mary Malins, c/o Westminster Bank Ltd., Slough, Bucks, England	0 15 8	No. 124 Dividend on 30 5s. shares
Peter Miller, Cambus Cottage, Burn of Cambus, Doune, Perthshire, Scotland	1 7 11	Nos. 124 and 125 Dividends on 24 5s. shares
Miss Florence Elizabeth Mumford, 50 Hawkins-crescent, Lascelles-avenue, Harrow, England	0 1 6	Refund of tax on 40 5s. shares
Mrs. Margaret Garthwaite Owens, 27 Webster-avenue, Wallasey, Cheshire England	0 9 3	Nos. 124 and 125 Dividends on 8 5s. shares
Thomas Latham Porter, The Pines, Heswall, Cheshire, England	2 5 1	No. 125 Dividend on 70 5s. shares
Frederick George Robinson, Clent, Ferncroft-road, Ensbury, Dorset, England	1 12 3	No. 125 Dividend on 50 5s. shares
Mrs. Joyce Pauline Young Robley, Kingwold House, Middle Wallop, Hampshire, England	5 16 7	Nos. 124 and 125 Dividends on 100 5s. shares
Messrs. Gibbie and Wilson (A/c. Miss Jane Stobo), Strathaven, Scotland	0 0 5	Refund of tax on 20 5s. shares
Miss Inez Margery Sutro, 55 Tudor-close, Hampstead, England	0 3 9	Refund of tax on 100 5s. shares
Westminster Bank Ltd. (A/c. Eric Turk and another), 52 Threadneedle-street, London, England	2 4 4	Refund of tax on 1,200 5s. shares
Mrs. Julia Utrera-Y-Cestino, 16 Paseo De Colon, Malaga, Spain	41 18 7	Nos. 124 and 125 Dividends on 460 5s. shares
Harold Launcelott Wilkinson, c/o Commercial Banking Company of Sydney Ltd., 18 Birch-in-lane, London, England	0 1 1	Refund of tax on 80 5s. shares
Harold Launcelott Wilkinson, c/o Commercial Banking Company of Sydney Ltd., 18 Birch-in-lane, London, England	0 1 1	Refund of tax on 80 5s. shares
Konni Zilliacus, South Ridge, Shere, Surrey, England	11 8 11	Nos. 124 and 125 Dividends on 200 5s. shares
<i>Australian Register.</i>			
Miss Nancy Helen Atkinson, Crafers, South Australia	0 3 9	No. 124 Dividend on 5 5s. shares
Dr. John Edward Nihill, 7 Darling-street, South Yarra, Victoria	0 3 0	Refund of tax on 100 5s. shares

1518

DALGETY AND COMPANY LIMITED.

REGISTER of Unclaimed Money held by Dalgety and Company Limited, at 1st January, 1950.

Name of Owner on Books.	Total Amount Due to Owner.	Description.	Date of Last Claim
	£ s. d.		
Gregory, L.	3 10 9	Proceeds produce	30.1.1942
Trueman, R.	0 16 2	Proceeds produce	10.4.1942
Tucardo, V. C.	0 16 9	Proceeds produce	13.7.1942
Robinson, H.	7 9 3	Proceeds wool	16.4.1943
	12 12 11		

L. Y. BUTLER, Accountant.

Melbourne, 16th January, 1950.
1526

Companies Act 1938.

MASONIC CLUB HOUSE COMPANY OF VICTORIA LIMITED.

REGISTER of Unclaimed Moneys held by Masonic Club House Company of Victoria Limited.

Name of Owner on Books.	Total Amount Due to Owner.	Description of Unclaimed Money.	Date of Last Claim.
	£ s. d.		
Ah Ket, William (deceased)	0 7 6	16th dividend (paid 6th September, 1943)	Sept., 1941
Anderson, John Thomas	0 15 0	" "	Sept., 1930
Baker, James Neison (deceased)	0 0 9	" "	Sept., 1935
Benison, John	0 3 9	" "	Sept., 1942
Betts, Edward	0 3 9	" "	Sept., 1936
Black, Robert	0 18 9	" "	Sept., 1941
Bruce, Harold Archibald	0 3 9	" "	Sept., 1938
Burton, Alfred Edward	0 3 9	" "	Sept., 1940
Campbell, Colin Archibald (deceased)	0 7 6	" "	Sept., 1942
Chisholm, Andrew Stewart	0 3 9	" "	Sept., 1938
Claridge, Thomas George	0 3 9	" "	Sept., 1942
Coghill, Alex. Manson	0 3 9	" "	Sept., 1941
Collie, William	0 3 9	" "	Sept., 1935
Dolman, David (deceased)	0 3 9	" "	Sept., 1942
Dungey, Albert Collins	0 11 3	" "	Sept., 1939
Dunso, George	0 3 9	" "	Sept., 1930
Ferguson, William Stanley	0 3 9	" "	Sept., 1942
Flanagan, John P.	0 3 9	" "	Sept., 1942
Foster, Henry Pritchard	0 3 9	" "	Sept., 1932
Fox, Richard J. (estate of the late)	0 0 9	" "	Sept., 1941
Gibson, Simcon George	0 3 9	" "	Sept., 1940
Goodrich, Ernest Walter	0 3 9	" "	Sept., 1929
Gross, Frederick H. (deceased)	0 3 9	" "	Sept., 1939
Hall, Edgar Stanley	0 7 6	" "	Sept., 1942
Hamilton, Archibald	0 15 0	" "	Sept., 1939
Hamilton, James (deceased)	1 17 6	" "	Sept., 1939
Hodges, Henry Gordon (deceased)	0 15 0	" "	Sept., 1942
Johnston, Albert Edward	0 7 6	" "	Sept., 1940
Kean, Percy Thomas	0 3 9	" "	Sept., 1942
Knight, Frank Percival	0 7 6	" "	Sept., 1941
Knox, Herbert Latham (deceased)	0 15 0	" "	Sept., 1942
Lindsay, Robert (deceased)	0 11 3	" "	Sept., 1930
Moffett, George Stanley	0 3 9	" "	Sept., 1934
McCoy, James Edward (deceased)	0 3 9	" "	Sept., 1942
McDonald, John (deceased)	0 1 6	" "	Sept., 1942
McHutchinson, Percival Charles	0 7 6	" "	Sept., 1934
McKnight, John Wilson	0 3 9	" "	Sept., 1938
North, Richard Henry	0 11 3	" "	Sept., 1940
Onslow, Walter Keith	0 3 9	" "	Sept., 1934
Parker, Edward Bryant	0 7 6	" "	Sept., 1939
Parsons, William Walter Victor	0 1 6	" "	Sept., 1934
Kashleigh, Cecil William	0 3 9	" "	Sept., 1939
Reight, John Harvey	0 6 0	" "	Sept., 1942
Rogers, Edward Robert	0 1 6	" "	Sept., 1940
Selby, Gilbert Edward	0 7 6	" "	Sept., 1935
Smye, Frederick Joseph	0 3 9	" "	Sept., 1936
Stimson, John William	0 3 0	" "	Sept., 1937
Stirrett, Ernest Frederick	0 3 9	" "	Sept., 1938
Trickey, William Morris	0 11 3	" "	Sept., 1940
Trickey, Joseph John			
Trickey, Andrew			
Tuck, Walter Stanley	0 7 6	" "	Sept., 1941
Turrell, Joseph John	0 3 9	" "	Sept., 1942

NOTICE TO CREDITORS AND OTHERS.—RE JOHN LEE, DECEASED.

PURSUANT to the Trustee Acts, notice is hereby given that all persons having claims against the estate of John Lee, late of Mulwala, in the State of New South Wales, retired farmer, deceased (who died on the 10th day of September, 1947, and probate of whose will was granted by the Supreme Court of Victoria, in its probate jurisdiction, on the 20th day of July, 1948), to Edward James Lee, of Saverlake, in the State of New South Wales, farmer, and Jessie Maud Hargrave, of Yarrowonga, in the State of Victoria, solicitor, the executors therein named), are hereby required to send particulars, in writing, of such claims to the said executors, in care of Hargrave and Hargrave, solicitors, Yarrowonga, on or before the 31st day of March, 1950, after which date the said executors will proceed to convey or distribute the said estate, or any part thereof, to or among the persons entitled thereto, having regard only to the claims, whether formal or not, of which they shall then have notice. And notice is further given that they will not be liable to any person of whose claim they shall not have had such notice as aforesaid.

Dated the 5th day of January, 1950.

HARGRAVE & HARGRAVE, Yarrowonga, proctors for the said executors. 1509

PURSUANT to the Trustee Act 1928, notice is hereby given that all persons having claims against the estate of Terence Stephen Fitzpatrick, late of Yarra-street, Heidelberg, retired railway official (who died on the 12th day of July, 1949, and probate of whose will was granted by the Supreme Court of Victoria, in its probate jurisdiction, on the 21st day of November, 1949, to Brinsley Brooke Boothby, of 408 Collins-street, Melbourne, solicitor), are required to send particulars, in writing, of such claims to the said Brinsley Brooke Boothby, care of the undersigned solicitors, at their address hereunder mentioned, on or before the 22nd day of March, 1950, after which date the said Brinsley Brooke Boothby will proceed to distribute the assets of the said Terence Stephen Fitzpatrick, deceased, amongst the persons entitled thereto, having regard only to the claims of which he shall then have had notice.

BOOTHBY & BOOTHBY, solicitors, 408 Collins-street, Melbourne. 1508

PURSUANT to the Trustee Act 1928, notice is hereby given that all persons having claims against the estate of Charles William McRae, late of 466 Rae-street, North Fitzroy, in the State of Victoria, mill hand, deceased (who died on the 27th day of November, 1949, and probate of whose will was granted by the Supreme Court of the said State, in its probate jurisdiction, on the 6th day of January, 1950, to The Union Trustee Company of Australia Limited, of 333 Collins-street, Melbourne, in the said State), are hereby required to send particulars, in writing, of such claims to the said, The Union Trustee Company of Australia Limited, at its address above appearing, on or before the 31st day of March, 1950, after which date the said company will proceed to distribute the assets of the said Charles William McRae, deceased, which shall have come to its hands, amongst the persons entitled thereto, having regard only to the claims of which it shall then have had notice. And notice is hereby further given that the said company will not be liable for the assets so distributed, or any part thereof, to any person of whose claim it shall not have had notice as aforesaid.

Dated this 16th day of January, 1950.

GORDON GUMMOW, 422 Collins-street, Melbourne, solicitor for the said company. 1527

NOTICE TO CREDITORS.

NOTICE is hereby given, in pursuance of the Trustee Act 1928, that all persons having claims against the estate of Adam Tasman Amos, late of Caldermeade, farmer, deceased (who died on the 27th day of June, 1949, and probate of whose will has been granted to Roy Warbreck Amos, of Bundock-street, Randwick, New South Wales, Army officer, and Alan Tasman Amos, of Caldermeade, farmer, the executors named in the said will), are hereby requested to send particulars of such claims to the said Roy Warbreck Amos and Alan Tasman Amos, in care of the undersigned Stanley W. Misson, on or before the 23rd day of March, 1950.

Dated this 16th day of January, 1950.

STANLEY W. MISSON, solicitor, 59 Waverley-road, East Malvern. 1486

NOTICE TO CLAIMANTS.

PURSUANT to the *Trustee Act 1928*, creditors, next of kin, and others having claims against the estate of James Moorehead, formerly of Flinders-lane, Melbourne, in the State of Victoria, and McKinnon-road, Bentleigh, in the said State, but late of Latrobe-parade, Dromana, in the said State, retired storekeeper, deceased (who died on the 30th day of September, 1949, and probate of whose will was granted to Clarence Hubert Moorehead, of 5 Elm-grove, Bentleigh, in the State of Victoria, bond store proprietor, and William Anderson Stewart, of 34 Queen-street, Melbourne aforesaid, chartered accountant, the executors appointed by the said will on the 23rd day of December, 1949), are requested to send in particulars of such claims to the executors, care of Messrs. Mahony, O'Brien, and Duggan, of 20 Queen-street, Melbourne, on or before the 22nd day of March, 1950, after which date the executors will distribute the assets, having regard only to the claims of which they shall then have had notice.

Dated this 13th day of January, 1950.

MAHONY, O'BRIEN, & DUGGAN, 20 Queen-street, Melbourne, solicitors for the executors. 1517

PURSUANT to the *Trustee Act 1928*, creditors, next of kin, and all other persons having claims against the estate of Oswald James Price, late of Kyneton, retired painter, deceased, and probate of whose will and codicil was granted on the 28th day of December, 1949, to Maurice Gardiner Price, of 35 Gardenia-road, Gardenvale, Commonwealth civil servant, and John Alfred Collins, of Kyneton, solicitor), are hereby required to send particulars, in writing, of such claims to the said Maurice Gardiner Price and John Alfred Collins, care of the under-named solicitors, at the address hereunder, on or before the 24th day of March, 1950, after which date the said Maurice Gardiner Price and John Alfred Collins will proceed to distribute the assets of the said deceased, having regard only to the claims of which they shall then have had notice, and they will not be liable to any person of whose claim they shall not have received notice.

ARMSTRONG & COLLINS, solicitors, 2 Jennings-street, Kyneton. 1462

FRANCES MARY FROST, late of Sutton Forest, in the State of New South Wales, spinster (who died on 26th November, 1948, intestate).

CREDITORS, next of kin, and all other persons having claims against the estate of the said deceased), are required by The Public Trustee in and for the State of New South Wales, of 19 O'Connell-street, Sydney in the said State, to whom letters of administration of the estate of the said deceased have been granted, to send particulars of such claims to him, in writing, on or before 21st March, 1950, after which date the assets will be distributed, having regard only to the claims of which notice has then been received.

PLANTE & HENTY, 395 Collins-street, Melbourne, solicitors for the administrator. 1507

JAMES LINCOLN, late of "Glen Alvie," Portarlington, in the State of Victoria, farmer (who died on 7th September, 1949).

CREDITORS, next of kin, and all other persons having claims against the estate of the deceased are required by the administrator of the estate, the National Trustees, Executors, and Agency Company of Australasia Limited, whose registered office is at No. 95 Queen-street, Melbourne, to send particulars to the said company, at its said registered office, on or before 26th March, 1950, after which date the said company will distribute the assets, having regard only to the claims of which it then has notice.

ROY D. BIRDSEY, solicitor, Bank of New South Wales Building, Ryrie-street, Geelong. 1487

CHARLOTTE MARIA LANG (usually known as Minnie Lang), late of 29 Clarke-street, Newtown, Geelong, in the State of Victoria, married woman (who died on 14th August, 1949).

CREDITORS, next of kin, and all other persons having claims against the estate of the deceased are required by the executors of the will, Thomas Henry Lang, of Clarke-street, Newtown, Geelong, retired printer, and Roy Davison Birdsey, of Ryrie-street, Geelong, solicitor, to send particulars to the said Roy Davison Birdsey, on or before 26th March, 1950, after which date the said executors will distribute the assets, having regard only to the claims of which they then have notice.

ROY D. BIRDSEY, solicitor, Bank of New South Wales Building, Ryrie-street, Geelong. 1489

RE EMILY LOUISA MALLET, late of Drouin, widow DECEASED, intestate.

CREDITORS, next of kin, and all others having claims against the estate of the above-named deceased are required to send particulars thereof to the undersigned solicitors for Doris Rosewarne Mallet, of Drouin aforesaid, spinster, the administratrix of the estate of the said deceased, on or before the 26th day of March, 1950, after which date the said administratrix will distribute the assets, having regard only to the claims of which she shall then have had notice.

Dated this 12th day of January, 1950.

GRAY, FRIEND, & MOONIE, solicitors, Warragul. 1479

PATRICK WILLIAM SNOWSILL, DECEASED.

CREDITORS, next of kin, and others having claims in respect of the estate of Patrick William Snowsill, late of 56 Domain-street, South Yarra, cash merchant and general dealer, deceased (who died on the 18th September, 1949), are to send particulars of their claims to National Trustees, Executors, and Agency Company of Australasia Limited, of 95 Queen-street, Melbourne, by 23rd March, 1950, after which date the said company will distribute the assets, having regard only to the claims of which it then has notice.

WM. BROCKET, solicitor, 108 Queen-street, Melbourne. 1503

CREDITORS, next of kin, and others having claims in respect of the estate of Flora Colollo O'Reilly, formerly of 10 Charles-street, North Coburg, but late of 5 St. Albans-road, East Geelong, widow, deceased (who died on the 16th day of September, 1949), are to send the particulars of their claims to the executor, National Trustees, Executors, and Agency Company of Australasia Limited, of 95 Queen-street, Melbourne, by the 22nd day of March, 1950, after which date the said executor will distribute the assets, having regard only to the claims of which it then has notice.

F. RAYMOND APTED, 63 Yarra-street, Geelong, solicitor for the executor. 1460

CREDITORS, next of kin, and others having claims in respect of the estate of Ellen Hall, late of 102 Ascot-street south, Ballarat, in the State of Victoria, spinster, deceased (who died on the 1st day of November, 1949), are required to send particulars, in writing, of their claims to the executors, The Ballarat Trustees, Executors, and Agency Company Limited and Harrie Humphries, at the office of the company, at 101 Lydiard-street north, Ballarat aforesaid, by the 28th day of March, 1950, after which date the assets will be distributed, having regard only to the claims of which they then have notice.

A. H. BOWMAN & SON, solicitors, 43 Yarra-street, Geelong. 1453

ROBERT EWING BLYTH, late of Connewarre, in the State of Victoria, farmer (who died on 12th April, 1949).

CREDITORS, next of kin, and all other persons having claims against the estate of the deceased are required by the executors, Robert John Blyth, farmer, and Charlotte Amelia Blyth, spinster, both of Connewarre, to send particulars to them, in the care of the undersigned, on or before 26th March, 1950, after which date the said executors will distribute the assets, having regard only to the claims of which they then have notice.

ROY D. BIRDSEY, solicitor, Bank of New South Wales Building, Ryrie-street, Geelong. 1488

JOHN ROBERTSON WOTHERSPOON, late of Beaufort, in the State of Victoria, merchant DECEASED (who died on the 19th day of March, 1949).

CREDITORS, next of kin, and all other persons having claims against the estate of the said deceased are required by the executors, The Ballarat Trustees, Executors, and Agency Company Limited, of 101 Lydiard-street north, Ballarat, and John Felix Wotherspoon, of Beaufort, merchant, to send detailed particulars of their claims in respect of the said property to the said executors, at the office of the said company on or before the 22nd day of March, 1950, after which date it and he will proceed to distribute the said estate, having regard only to the claims of which it and he than have notice.

Dated this 10th day of January, 1950.

R. H. RAMSAY, 41 Lydiard-street, Ballarat, solicitor for the said executors. 1473

AMY WILLIAMS, late of 114 Brougham-street, Bendigo, widow, DECEASED (who died on the 10th day of November, 1949).

CREDITORS, next of kin, and all other persons having claims against the estate of the said deceased are required by the sole executor, Norman McLaren Young, of 16 View-street, Bendigo, chartered accountant, to send particulars to him, on or before the 23rd day of March, 1950, after which date he will distribute the assets, having regard only to the claims of which he then has notice.

Dated this 16th day of January, 1950.

HYETT, WILLIS, & HYETT, 51 Bull-street, Bendigo, solicitors for the executor. 1471

CREDITORS, next of kin, and others having claims against the estate of Mary Louisa Foss Jarrett, late of "Ithaca," Walsh-street, South Yarra, in the State of Victoria, spinster, deceased (who died on 2nd September, 1949), are to send particulars of their claims to The Union Trustee Company of Australia Limited, the registered office of which is situate at 333 Collins-street, Melbourne, in the said State, by 20th day of March, 1950, after which date it will distribute the assets, having regard only to the claims of which it then has notice.

MADDEN, BUTLER, ELDER, & GRAHAM, solicitors, 406 Collins-street, Melbourne. 1516

CREDITORS, next of kin, and others having claims in respect of the estate of Alice Mabel Raymond, late of 17 Alexandra-avenue, South Yarra, married woman, deceased, intestate (who died on the 22nd day of February, 1949), are to send particulars of their claims to the administrator, Reginald Nelson Raymond, care of the undersigned, by the 26th day of March, 1950, after which date he will distribute the assets, having regard only to the claims of which he then has notice.

HENDERSON & BALL, solicitors, 430 Little Collins-street, Melbourne. 1512

CREDITORS, next of kin, and others having claims in respect of the estate of Claud Noall Hobart, formerly of Katandra and Katandra West, farmer, but late of Cobram, orchardist, deceased (who died on the 28th day of May, 1949), are required by the administratrix (with the will annexed) of his estate, Frances Irene Hobart, of Cobram, widow, to send particulars of their claims to her, in care of the under-mentioned solicitor, by the 31st day of March, 1950, after which date she will distribute the assets, having regard only to the claims of which she then has notice.

K. A. EVANS, LL.B., solicitor, Cobram. 1466

CREDITORS, next of kin, and others having claims in respect of the estate of Henry Francis Weiss, late of Cobram, saddler and radio dealer, deceased, intestate (who died on the 27th day of September, 1947), are required by the administrator of his estate, Cyril Patrick Weiss, of Strathmerton, hotelkeeper, to send particulars of their claims to him, in care of the under-mentioned solicitor, by the 31st day of March, 1950, after which date he will distribute the assets, having regard only to the claims of which he then has notice.

K. A. EVANS, LL.B., solicitor, Cobram. 1465

CREDITORS, next of kin, and others having claims in respect of the estate of Percy Alexander Thomson (in the will called Percy Thomson), late of 70 Bluff-road (formerly called 62 Bluff-road), Black Rock, in the State of Victoria, gentleman, deceased (who died on the 4th day of September, 1949), are to send the particulars of their claims to The Union Trustees Company of Australia Limited, of 333 Collins-street, Melbourne, in the said State, by the 24th day of March, 1950, after which date it will distribute the assets, having regard only to the claims of which it then has notice.

HERBERT & GEER, solicitors, 20 Bank-place, Melbourne. 1482

CREDITORS, next of kin, and others having claims in respect of the estate of Harold Rymer Hughan, late of 35 Murray-street, West Coburg, in the State of Victoria, gentleman, deceased (who died on the 24th day of August, 1949), are to send the particulars of their claims to The Equity Trustees, Executors, and Agency Company Limited, of 472 Bourke-street, Melbourne, in the said State, by the 30th day of March, 1950, after which date the said company will distribute the assets, having regard only to the claims of which it then has notice.

SHEGOG & BIRCH, solicitors, Korumburra. 1506

ANNIE MADELINE WEST, DECEASED.

CREDITORS, next of kin, and others having claims in respect of the estate of Annie Madeline West, late of Cowes, widow, deceased (who died on 16th day of May, 1949), are to send particulars of their claims to The Equity Trustees, Executors, and Agency Company Limited, of 472 Bourke-street, Melbourne, by the 23rd day of March, 1950, after which date the said company will distribute the assets, having regard only to the claims of which it then has notice.

WM. BROCKET, solicitor, 108 Queen-street, Melbourne. 1483

RE HELENA MAUD MALLET, late of Longwarry South, spinster, DECEASED, intestate.

CREDITORS, next of kin, and all others having claims against the estate of the above-named deceased are required to send particulars thereof to the undersigned solicitors for Roy Lonsdale Mallett, of Drouin aforesaid, farmer, the administrator of the estate of the said deceased, on or before the 26th day of March, 1950, after which date the said administrator will distribute the assets, having regard only to the claims of which he shall then have had notice.

Dated this 12th day of January, 1950.

GRAY, FRIEND, & MOONIE, solicitors, Warragul. 1478

Trustee Act 1928.

NOTICE TO CLAIMANTS.

PURSUANT to the Trustee Act 1928, creditors, next of kin, and all other persons having claims in respect of the estate of any deceased person named below are required to send particulars thereof to the legal personal representative or representatives at the address stated below, on or before the date stated, after which date the representative or representatives will distribute the assets, having regard only to the claims of which notice has been received:—

Katherine Buchanan Philip, late of "Warrakook," Macarthur, widow, deceased, died 20th June, 1949.—Claims to the executors, Alexander Marshall Philip, of "Warrakook," Macarthur, grazier, James Alexander Hansen, of "The Braes," Macarthur, grazier, and Peter Paul Conlan, of 36 Bank-street, Port Fairy, solicitor, care of Peter Paul Conlan, solicitor, 36 Bank-street, Port Fairy, by the 23rd March, 1950. 1484

Violet Mary Hutton, late of "Cheviot," 50 Swanston-street, Geelong, spinster, deceased, died 13th April, 1949.—Claims to the executrix, Anne Clark, formerly of 2 Pasley-street, South Yarra, but now of Jolimont-avenue, Ascot, Brisbane, care of Donald A. Ingpen, solicitor, 54 Malop-street, Geelong, by 28th February, 1950. 1500

Maude Winifred Smiley, late of 43 Florence-street, Mentone, spinster, died 22nd September, 1948.—Claims to the executors, John William Sinclair, of 45 Florence-street, Mentone, and Dorothy Sercombe, of 15 Sebastopol-street, Caulfield, care of Patrick H. Kearney, solicitor, 116 Queen-street, Melbourne, by 8th April, 1950. 1513

MINING NOTICES.

CHEWTON GOLD MINES NO LIABILITY.

NOTICE is hereby given that all shares forfeited for non-payment of the 84th (December) Call of Three pence per share will be sold by public auction at the Stock Exchange Hall, 428 Chancery-lane, Melbourne, at a quarter to Twelve a.m., on Tuesday, the 24th day of January, 1950, unless redeemed on or before Five p.m., on Monday, the 23rd day of January, 1950.

By order of the Board,

A. E. LLEWELLYN, Manager.
430 Little Collins-street, Melbourne, C.1, 16th January, 1950. 1515

NEW CHUM SYNCLINE GOLD MINE NO LIABILITY.

NOTICE is hereby given that shares forfeited for non-payment of No. 112 (December) Call of Three pence per share will be sold by public auction in the vestibule of the Stock Exchange, 428 Chancery-lane, Melbourne, on Friday, 27th January, 1950, at a quarter to Twelve a.m., unless previously redeemed.

By order of the Board,

FRANK COOPER, Manager.
422 Collins-street, Melbourne, C.1. 1511

ARGUS HILL CHEWTON GOLD NO LIABILITY.

NOTICE is hereby given that all shares forfeited for non-payment of No. 73 (December) Call of Three pence per share will be sold by public auction in the vestibule of the Stock Exchange, 428 Chancery-lane, Melbourne, on Wednesday, 25th January, 1950, at a quarter to Twelve a.m., unless previously redeemed.

By order of the Board,

FRANK COOPER, Manager.

422 Collins-street, Melbourne, C.1. 1510

INSOLVENCY NOTICE.

The Insolvency Act.—In the Court of Insolvency.—
CENTRAL DISTRICT.

A FIRST and Final Dividend is intended to be declared in the matter of Leonard Robert Dockery, of 2 Roemer-street, Alphington, whose estate was assigned on the 28th day of July, 1928; creditors who have not proved their debts by the 31st day of January, 1950, will be excluded.

Dated this 11th day of January, 1950.

H. M. KENNEDY, Trustee, 31 Queen-street, Melbourne. 1514

IMPOUNDINGS.

BAIRNSDALE.—Impounded in Bairnsdale Pound, by Frank Southon from his Nicholson property.

1 Shorthorn red poll cross heifer, no visible brand

If not claimed and expenses paid, to be sold on 9th February, 1950.

1493—6/5 F. McPHERSON,
Poundkeeper.

BENDIGO.—Impounded at Bendigo.

1 roan Shorthorn bull calf, no visible brand

1 dark Jersey cow, no visible brand

1 black bull calf, no visible brand

If not claimed and expenses paid, to be sold on 2nd February, 1950.

1467, 1474—7/4 B. E. BOWER,
Poundkeeper.

BIRCHIP.—Impounded at Birchip, by J. Grace.

1 grey yearling filly, delivery sort, white blaze, white on hind feet, no visible brand

If not claimed and expenses paid, to be sold on 2nd February, 1950.

1457—6/5 E. B. DAVIS,
Poundkeeper.

BROADMEADOWS.—Impounded at Campbellfield.

1 bay delivery mare, white face, hind feet white

1 grey gelding, 15 hands, spots on body

1 chestnut gelding, 16 hands, near front foot and hind feet white

If not claimed and expenses paid, to be sold on 2nd February, 1950.

1497—8/3 A. OLIVER,
Poundkeeper.

COBDEN.—Impounded in Cobden Pound.

1 brown Jersey bull, 2 years, no visible brand

If not claimed and expenses paid, to be sold on 27th January, 1950.

1495—5/6 J. S. BRADD,
Poundkeeper.

COLERAINE.—Impounded at Coleraine, by K. Kenna from his property.

No. 7.—1 pale Jersey cow, no visible brand

No. 8.—1 brown Jersey cow, near hip down, no visible brand

If not claimed and expenses paid, to be sold on 4th February, 1950.

1476—8/3 S. R. DOLMAN,
Poundkeeper.

CROYDON.—Impounded at Croydon on 9th January, 1950.

1 black horse, aged, white hind rear foot, O over — on off shoulder

If not claimed and expenses paid, to be sold on 9th February, 1950.

1492—6/5 A. C. HALL,
Poundkeeper.

DANDENONG.—Impounded at Dandenong, by Shire Ranger, E. Osborne, from Springvale.

1 red heifer springer, cross in half circle off rump

If not claimed and expenses paid, to be sold on 31st January, 1950.

1496—6/5 A. WALKER,
Poundkeeper.

EPPING.—Impounded at Epping, by Ranger.

1 bay draught gelding, white face, near front white foot, white hind fetlocks, no visible brand

1 bay draught gelding, white hind fetlocks, white blaze, branded T13

If not claimed and expenses paid, to be sold on 2nd February, 1950.

1504—8/3 J. HERD,
Poundkeeper.

FERN TREE GULLY.—Impounded at Fern Tree Gully, by the Shire Ranger.

1 bay pony gelding, about 13.3 hands, shod, black points, small star, indistinct brand on near shoulder

If not claimed and expenses paid, to be sold on 2nd February, 1950.

1529—7/4 A. DINSDALE,
Poundkeeper.

KYNETON.—Impounded at Kyneton, on 7th January, 1950.

1 small aged bay pony gelding, scar on near shoulder

If not claimed and expenses paid, to be sold on 20th January, 1950.

1485—6/5 J. ROGERS,
Poundkeeper.

MARONG.—Impounded in Marong Pound.

1 black gelding, delivery sort, blaze, near hind foot white, branded J M

If not claimed and expenses paid, to be sold on 28th January, 1950.

1455—6/5 D. E. STEEL,
Poundkeeper.

MELBOURNE.—Impounded in Arden-street Pound, by A. Thomas.

1 grey gelding, no visible brand

1 ewe, no visible brand

If not claimed and expenses paid, to be sold on 2nd February, 1950.

1530—7/4 D. CROWE,
Poundkeeper.

MERINO.—Impounded at Merino.

1 brindle bull cub

1 yellow bull cub

1 Jersey cow, no visible brand

If not claimed and expenses paid, to be sold on 1st February, 1950.

1499—7/4 W. DAVIS,
Poundkeeper.

MORTLAKE.—Impounded at Mortlake, on 16th January, 1950.

1 red steer, about 15 months, no visible brand

If not claimed and expenses paid, to be sold on 9th February, 1950.

1532—6/5 GEO. ROBERTSON,
Poundkeeper.

ORBOST.—Impounded in Orbost Pound, by Shire Herdsman.

- 1 bay gelding pony, white star on forehead, no visible brand
- 1 Jersey heifer, no visible brand
- 1 brown mare, like C near shoulder

If not claimed and expenses paid, to be sold after fourteen days.

1472—9/2 H. DOMINEY,
Poundkeeper.

RED CLIFFS.—Impounded at Red Cliffs.

- 1 brown medium draught gelding, blaze face, long tail, hind feet white, no visible brand

If not claimed and expenses paid, to be sold on 2nd February, 1950.

1528—6/5 J. HERAUD,
Poundkeeper.

SHEPPARTON.—Impounded in Shepparton City Pound.

- 1 bay mare, white hind legs, off front fetlock white, white blaze on face, shod on front feet, no visible brand

If not claimed and expenses paid, to be sold on 1st February, 1950.

1531—6/5 J. MASON,
Poundkeeper.

STRATFORD.—Impounded in Stratford Pound, by J. S. Jenkins from East Riding, on 9th January, 1950.

- 1 bay mare, shod, W on near shoulder, rug on
- 1 black gelding, white blaze face, white hind feet, undistinguishable brand near shoulder
- 1 bay gelding, white sock on near hind leg, no visible brand

If not claimed and expenses paid, to be sold on 20th February, 1950.

1454—10/1 J. W. BREMNER,
Acting Poundkeeper.

TEMPLESTOWE.—Impounded at Templestowe.

- 1 chestnut gelding hack, 9 over J O on near shoulder
- If not claimed and expenses paid, to be sold on 25th January, 1950.

1464—5/6 A. W. AFFLECK,
Poundkeeper.

TRARALGON.—Impounded at Traralgon, by G. Freeman from his property at Glengarry, on 9th January, 1950.

- 1 dark-fawn Jersey heifer springer, notch top and bottom end of near ear, like crescent in circle near rump

If not claimed and expenses paid, to be sold on 6th February, 1950.

1498—7/4 ADAM WILSON,
Poundkeeper.

PUBLICATION OF OFFICIAL MATTER.

ATTENTION is invited to the following procedure in relation to the publication of official matter in the *Government Gazette*:—

1. *Matter submitted to the Executive Council.*

Matter submitted to the Executive Council which requires gazettal will normally be published in the issue of the following week.

Where urgent gazettal is required, special arrangements should be made with the *Gazette* Officer.

Publication will be facilitated by the submission of carbon copies for the use of the *Gazette* Officer.

2. *Other matter.*

(a) All other matter duly certified by a responsible officer for publication should be lodged with the *Gazette* Officer not later than half-past Ten a.m. on Tuesday.

(b) Lengthy or involved notices should be forwarded several days before publication.

(c) Proofs, which will be supplied only when specifically requested or at the direction of the *Gazette* Officer, should be returned promptly to avoid delay in publication.

(d) No additions or amendments to matter for publication will be accepted by telephone.

AGENTS FOR THE "VICTORIA GOVERNMENT GAZETTE."

THE following have been appointed agents to receive Advertisements and Subscriptions for the *Victoria Government Gazette*:—

- ARMSTRONG'S AGENCY, 143 Queen-street, Melbourne.
- ARMSTRONG BROS., Kyneton.
- MESSRS. ARNALL & JACKSON, 115 Barkly-street, West Brunswick.
- MR. M. R. BADE, Tobacconist, Sturt-street, Ballarat.
- MR. WM. DAVIS, Mildura.
- A. J. DIGBY (B. S. and N. W. CASH), Main-street, Bairnsdale.
- EDGAR'S NEWS AGENCY, Hargreaves-street, Bendigo.
- EDGAR'S NEWS AGENCY, 53 Murphy-street, Wangarratta.
- MESSRS. HENRY FRANKS & CO., Booksellers and Stationers, Market-square, Geelong.
- MESSRS. GORDON & GOTCH, News Agents, 511 Little Collins-street, Melbourne; and corner Barrack and Clarence streets, Sydney.
- W. GORDON HAMPTON, 243 Mitchell-street, Bendigo.
- MESSRS. HARSTON, PARTRIDGE, & CO., 455 Little Collins-street, Melbourne.
- Mr. C. F. LATIMER, News Agent, Casterton.
- MR. F. T. McCORMICK, Nunn-street, Benalla.
- MESSRS. H. PAYNE & R. N. LOWE, 4 View Point, Bendigo.
- MESSRS. R. H. & W. M. PETTY, News Agent, Wangarratta.
- PIKE'S AUTHORIZED NEWS AGENCY, Sale.
- J. PURDIE & CO., 138 Moorabool-street, Geelong.
- MESSRS. A. S. RICHARDSON and T. C. GARDNER, trading as The Mercantile Exchange, 380 Collins-street, Melbourne.
- ROBERTSON & MULLENS LTD., Elizabeth-street, Melbourne.
- R. & A. SMALLMAN, News Agents, Toora.
- MESSRS. SMITH & DUNNON, Hamilton.
- TRAINOR & McBRIDE, 246 Wyndham-street, Shepparton.
- E. W. B. WELSH, Hogan-street, Tatura.

A copy of the *Gazette* filed at each place for public reference.

CONTENTS.

	PAGE
Appointments	390
Australia Day Holiday	390
Contracts	396
Country Roads Board	402, 407
Courts	402, 404
Estates of Deceased Persons	403
Government Notices	395
impoundings	435
Insolvency Notice	435
Lands	413
Mining	403, 434
Ministers of Religion Registered to Celebrate Marriages in Victoria	392
Orders in Council	404
Private Advertisements	425
Proclamations	389
Public Holidays	390
Public Service Notices	416
Resignations	392
State Rivers and Water Supply Commission	401
Tenders	424
Transport Regulation Board—Public Hearings	393
Waterworks Trusts	398



VICTORIA GOVERNMENT GAZETTE.

Published by Authority.

[Registered at the General Post Office, Melbourne, for transmission by post as a newspaper.]

No. 39]

WEDNESDAY, JANUARY 18.

[1950

Prices Regulation Acts.

PRICES REGULATION ORDER No. 136.

BREAD—SALES OUTSIDE METROPOLITAN AREA.

IN pursuance of the powers conferred upon me by the Prices Regulation Acts, I, Ernest William Ryan, Acting Prices Decontrol Commissioner, hereby make the following Order:—

Citation.

1. This Order may be Cited as Prices Regulation Order No. 136.

Revocation.

2. Prices Regulation Order No. 1087 made under the Commonwealth National Security (Prices) Regulations and Prices Regulation Order No. 19 are hereby revoked.

Definitions.

3. In this Order, unless the contrary intention appears—
 - “Bread” includes white, brown, wholemeal, barley, rye or Vienna bread, whether or not containing fat or malt or sugar or milk or any product or by-product of malt or sugar or milk and whether or not made in accordance with the requirements of the *Bakers and Millers Act 1928* and whether in the form of loaves or of rolls;
 - “Starch Reduced Bread” means starched reduced bread known and sold under the following trade descriptions or brands:—“Borina,” “Bon Era,” “Broadway,” “Cenera,” “Ceralia,” “Conway,” “Denera,” “Dieteen,” “Glyx,” “Golden Rayceri,” “Maltine,” “New Era,” “New Way,” “New Process,” “Nucera,” “Nutrena,” “Nutty Loaf,” “Nu Vitera,” “Oslo,” “Peerless,” “Procera,” “Progress,” “Promax,” “Provena,” “Provita,” “Reform,” “Semola,” “Tricerum,” “Vita Loaf,” “Vitin”;
 - “By Wholesale” includes, in relation to any sale of bread, a sale by a retailer to a person to whom that retailer has, on the day of the sale, sold a quantity of bread (including that comprised in such first-mentioned sale) totalling not less than 12 lb. of bread; and for the purposes of this definition Vienna bread shall be reckoned as 2 lb. for every 24-oz. loaf and bread rolls as weighing 2 oz. each;
 - “Booked Sale” means, in relation to any sale of bread, that such sale is not a cash sale as defined in this clause;
 - “Cash Sale” means, in relation to any sale of bread, a sale where payment is made by the purchaser for the bread within 30 days of the date of delivery of that bread;
 - “Metropolitan Area” means the municipalities of Box Hill, Brighton, Brunswick, Camberwell, Caulfield, Chelsea, Coburg, Collingwood, Dandenong, Essendon, Fitzroy, Footscray, Hawthorn, Heidelberg, Kew, Malvern, Melbourne, Moorabbin, Mordialloc, Northcote, Oakleigh, Port Melbourne, Prahran, Preston, Richmond, Sandringham, South Melbourne, St. Kilda and Williamstown.

Maximum Prices.

4. I fix and declare the maximum price at which bread may be sold outside the metropolitan area to be—

- (a) in respect of sales by wholesale—
 - (i) for a cash sale—the price specified in the Schedule to this Order;
 - (ii) for a booked sale—the price so specified plus—
 - (aa) in the case of 1-lb. loaves— $\frac{1}{4}$ d.
 - (bb) in the case of 2-lb. loaves— $\frac{1}{4}$ d.
- (b) in respect of sales by retail—
 - (i) for a cash sale—the price specified in the Schedule to this Order;
 - (ii) for a booked sale—the price so specified plus—
 - (aa) in the case of 1-lb. loaves— $\frac{1}{4}$ d.
 - (bb) in the case of 2-lb. loaves— $\frac{1}{4}$ d.;

provided that in respect of sales by retail where 1-lb. loaves of bread are sold to the same purchaser at the same time to the extent that the total number sold is two or a multiple of two, two 1-lb. loaves shall, for the purposes of this Order, be deemed to be a 2-lb. loaf.

Fixation of Maximum Prices by Notice.

5. Notwithstanding the foregoing provisions of this Order, I declare the maximum price at which bread specified in a notice given in pursuance of this clause may be sold in Victoria outside the metropolitan area by any person to whom such notice is given to be such price as is fixed by the Commissioner by notice in writing to that person.

THE SCHEDULE.

Description.	MAXIMUM PRICES.		
	Sales by Wholesale.	Sales by Retail.	
		Not Delivered to Consumer's Premises.	Delivered to Consumer's Premises.
	per doz.	each	each
	s. d.	s. d.	s. d.
Bread—			
For sales in the cities of Ballarat, Bendigo, and Geelong :—			
Per 1-lb. loaf	3 7 $\frac{1}{2}$	0 4	0 4 $\frac{1}{2}$
Per 2-lb. loaf	7 3	0 8	0 9
For sales in the towns of Greensborough, Mitcham, Vermont, Ringwood, Croydon, Seaford, Thomastown, Epping, Eltham, Montmorency, Bayswater, Boronia, and the city of Frankston :—			
Per 1-lb. loaf	0 4 $\frac{1}{2}$	0 4 $\frac{1}{2}$
Per 2-lb. loaf	0 9	0 9
For sales in the towns of Omeo, Cann River, Buchan, Nowa Nowa, Orbost, Swift's Creek, Corryong, Tintaldra, Cudgewa, and Walwa :—			
Per 1-lb. loaf	0 5	0 5
Per 2-lb. loaf	0 9 $\frac{1}{2}$	0 9 $\frac{1}{2}$
For sales in the town of Leongatha :—			
Per 1-lb. loaf	0 4	..
Per 2-lb. loaf	0 8	..
For other sales outside the metropolitan area :—			
Per 1-lb. loaf	0 4 $\frac{1}{2}$	0 4 $\frac{1}{2}$
Per 2-lb. loaf	0 9	0 9
Starch reduced bread—			
For sales in all places outside the metropolitan area :—			
Per 1-lb. loaf	0 6	0 6
		per doz.	per doz.
		s. d.	s. d.
Bread rolls—			
For sales in all places outside the metropolitan area	1 1 $\frac{1}{2}$	1 3 $\frac{1}{2}$	1 3 $\frac{1}{2}$

Dated this thirteenth day of January, 1950.

E. W. RYAN,
Acting Prices Decontrol Commissioner.

Prices Regulation Acts.

PRICES REGULATION ORDER No. 137.

BREAD—METROPOLITAN AREA.

IN pursuance of the powers conferred upon me by the Prices Regulation Acts, I, Ernest William Ryan, Acting Prices Decontrol Commissioner, hereby make the following Order:—

Citation.

1. This Order may be cited as Prices Regulation Order No. 137.

Revocation.

2. Prices Regulation Order No. 1087 made under the Commonwealth National Security (Prices) Regulations and Prices Regulation Order No. 18 are hereby revoked.

Definitions.

3. In this Order, unless the contrary intention appears:—
 - “Bread” includes white, brown, wholemeal, barley, rye or Vienna bread, whether or not containing fat or malt or sugar or milk or any product or by-product of malt or sugar or milk and whether or not made in accordance with the requirements of the *Bakers and Millers Act 1928* and whether in the form of loaves or of rolls:
 - “Starch Reduced Bread” means starched reduced bread known and sold under the following trade descriptions or brands:—“Borina,” “Bon Era,” “Broadway,” “Cenera,” “Ceralia,” “Conway,” “Denera,” “Dieteen,” “Glyx,” “Golden Rayceri,” “Maltine,” “New Era,” “New Way,” “New Process,” “Nucera,” “Nutrena,” “Nutty Loaf,” “Nu Vitera,” “Oslo,” “Peerless,” “Procera,” “Progress,” “Promax,” “Provena,” “Provita,” “Reform,” “Semola,” “Tricerum,” “Vita Loaf,” “Vitin;”
 - “Metropolitan Area” means the municipalities of Box Hill, Brighton, Brunswick, Camberwell, Caulfield, Chelsea, Coburg, Collingwood, Dandenong, Essendon, Fitzroy, Footscray, Hawthorn, Heidelberg, Kew, Malvern, Melbourne, Moorabbin, Mordialloc, Northcote, Oakleigh, Port Melbourne, Prahran, Preston, Richmond, Sandringham, South Melbourne, St. Kilda, Williamstown;
 - “By Wholesale” includes, in relation to any sale of bread, a sale by a retailer to a person to whom that retailer has on the day of sale sold a quantity of bread (including that comprised in such first-mentioned sale) totalling not less than 12 lb. of bread and for the purposes of this definition Vienna bread shall be reckoned as 2 lb. for every 24-oz. loaf and bread rolls as weighing 2 oz. each.

Maximum Prices—Wholesale.

4. I fix and declare the maximum price at which bread specified in the Schedule to this Order may be sold by any person by wholesale in the Metropolitan Area to be the price specified in that Schedule.

Maximum Prices—Retail.

5. I fix and declare the maximum price at which bread specified in the Schedule to this Order may be sold by any person by retail in the Metropolitan Area to be the price specified in that Schedule, provided—

that where 1-lb. loaves of bread are sold to the same purchaser at the same time to the extent that the total number sold is two or a multiple of two, two 1-lb. loaves shall, for the purpose of this Order, be deemed to be a 2-lb. loaf.

Fixation of Maximum Price by Notice.

6. Notwithstanding the foregoing provisions of this Order, I declare the maximum price at which bread specified in a Notice given in pursuance of this clause may be sold in the Metropolitan Area by any person to whom such Notice is given to be such price as is fixed by the Commissioner by notice in writing to that person.

THE SCHEDULE.

Description.	MAXIMUM PRICES.		
	Sales by Wholesale.	Sales by Retail.	
		Not Delivered to Consumer's Premises.	Delivered to Consumer's Premises.
	per doz. <i>s. d.</i>	each <i>s. d.</i>	each <i>s. d.</i>
Bread other than Vienna, Starch Reduced, and Rye—			
Per 1-lb. loaf	3 6	0 4	0 4½
Per 2-lb. loaf	7 0	0 8	0 8½
Vienna bread—			
Per 12-oz. loaf	3 6	0 4	0 4½
Per 24-oz. loaf	7 0	0 8	0 8½
Starch reduced bread—			
Per 16-oz. loaf	4 9	0 5½	0 5½
Rye bread—			
Per 24-oz. loaf	7 3	0 9	0 9½
Bread rolls	0 11½	per doz. 1 2	per doz. 1 2

Dated this thirteenth day of January, 1950.

E. W. RYAN,
Acting Prices Decontrol Commissioner.